

2007 ARCC Spring Research Conference

“Green Challenges in Research, Practice, and Design Education”

16-18 April, 2007

Eugene, Oregon, USA



University of Oregon

Forward

Architectural research investigates issues related to the physical, aesthetic, and social aspects of the built environment, including the well-being of its inhabitants. Architectural education promotes the understanding of principles, concepts and lessons learned from practice and architectural research. In practice, designers and clients exchange a variety of ideas, problems, strategies, and solutions. Ultimately, we seek ways to link research and practice to the classroom so that our students will become better stewards of the environment.

This year's theme, "Green Challenges" offers a venue for participants to present research issues that help move architectural education to a greener and sustainable future. The conference is open to a diversity of topics yet focused on current research, innovations, programs, and activities, which participants will present in parallel sessions. Roundtable discussions will allow participants to discuss green topics, exchange ideas, and develop potential collaborations on research projects.

These proceedings present papers that address a number of issues including:

- Would applying (what are claimed to be) sustainable design principles be enough to protect and guarantee the sustainability of our environment?
- What are the new issues that architectural researchers and educators should now focus upon?
- How does current building design protect the inhabitants from extreme changing climates? Or should we be more adaptable in our behavior?
- What are the top ten, most important design moves that students should know how to do in order to design carbon neutral buildings?

All papers published in these proceedings went through rigorous, blind refereeing processes by the 3 reviewers from the ARCC Board and Technical Committee. We received 47 paper submissions by authors from 30 institutions in the United States, Canada, and Korea. Of these, 32 were accepted with revisions and 1 author withdrew. There were five invited presentations and five keynote presentations that are not included in the proceedings.

The final 31 papers presented in these proceedings are categorized into a number of topics:

- Building Case Studies
- Community and Urban Design
- Daylighting and Electric Lighting
- Education
- Energy and Resource Efficiency
- Human Context
- Materials and Construction
- Philosophy and Theory for Advancing Green Design

On behalf of the Architectural Research Centers Consortium, we would like to express our gratitude to all the reviewers who contributed their time in the review process of the papers.

Alison G. Kwok
Conference Organizer

Organizing and Technical Committees

Organizing Committee

Alison G. Kwok (Chair)	University of Oregon
Brook Muller (Paper Review Chair)	University of Oregon
Alexandra Rich (GRF)	University of Oregon

ARCC 2006-07 Board

Michel Mounayar (President)	Ball State University
Kirsten van Aalst (Vice President)	Norwich University
Stephen Weeks (Treasurer)	University of Minnesota
Leonard Bachman (Secretary)	University of Houston
Lucie Fontein	Carleton University
Jane Greenwood	Mississippi State University
Michael Kroelinger	University of Nevada Las Vegas
Brian Sinclair	University of Calgary

ARCC Ex-Officio	
Brooke Harrington	Temple University
Walter Grondzik	Tallahassee, Florida
Michael Hagge	University of Memphis
Fatih Rifki	American University of Sharjah

Technical Committee / Paper Reviewers

G.Z. Brown	University of Oregon
Mark Cabrinha	Rensselaer Polytechnic Institute
Virginia Cartwright	University of Oregon
Tim Castillo	University of New Mexico
Nancy Cheng	University of Oregon
Tom DiSanto	California Polytechnic State, San Luis Obispo
Stephen Duff	University of Oregon
Ihab Elzeyadi	University of Oregon
Michael Fifield	University of Oregon
Urs Peter Flueckiger	Texas Tech University
Tom Fowler	California Polytechnic State, San Luis Obispo
Mark Gillem	University of Oregon
Geoff Gjertson	University of Louisiana at Lafayette
Esther Hagenlocher	University of Oregon
Bruce Haglund	University of Idaho
Nico Larco	University of Oregon
Michael Lucas	California Polytechnic State, San Luis Obispo
Margot McDonald	California Polytechnic State, San Luis Obispo
Matt Powers	Florida A&M University
Nicholas Rajkovich	RSK Architects Inc.
John Reynolds	University of Oregon
Veronica Soebarto	University of Adelaide
Alison Snyder	University of Oregon
Sandy Stannard	California Polytechnic State, San Luis Obispo
Randy Teal	University of Idaho
Kevin Van Den Wymelenberg	University of Idaho, Integrated Design Lab
James Wasley	University of Wisconsin, Milwaukee
Jenny Young	University of Oregon

Table of Contents

Foreword	i
Organizing and Scientific Committees	ii
Theory For Advancing Green Design	
Ocean and Prairies: New Metaphors for Design* Laura Briggs	
Themes Of Function Donald Corner, Michael Magee	3
What's On Your Mind, What's In Your Heart? An Exploration on Our Perceived Environment Missa Aloisi	11
Expo 2005-Nature's Wisdom: An Ecological Pedagogy For Sustainable Transformation Michael Zaretsky	19
In Poetic Association: Acts of Architecture in the Realm of Landscape Ecology Brook Muller	27
Case Studies—Lighting	
Configuring Structure to Improve Daylight Access in Multistory Buildings Christine Theodoropoulos, G.Z. Brown, Arthur Johnson, Michael Hatten, Christopher Flint Chatto, Jeff Kline, Dale Northcutt	39
Green In The Balance: Visual Comfort Inside Offices With Tilted Facades Ihab Elzeyadi	47
A Lower Cost, Higher Performance Classroom: will innovation lead to market transformation? G.Z. Brown, Jeff Kline, Dale Northcutt	55
Measurement And Education	
How Are We Doing? A Protocol For Building Performance Reviews Cathy Turner	67
Considering The Whole: Developing a Whole-house Calculator Michael O'Brien, Ron Wakefield	75
A Systemic Model For Designing Energy Optimized Buildings Audrey Kay Werthan	83
Awareness: the ground for sustainable design Randall F. Teal	91
Innovative Sustainable Water Management Practices in Solar Residential Design C. Jason Mabry, Franca Trubiano	99

Case Studies—Human Context

Effect of Building Design on Pressure-related Problems In High-rise Residential Buildings Jae-Hun Jo, Myong-Souk Yeo, Kwang-Woo Kim	109
Thermal Comfort in a Naturally-Ventilated Educational Building David Mwale Ogoli	117
The Green Church Mark L. Gillem	125
Environmental Studies of Vernacular Architecture J. Brooke Harrington, Judith Bing	133

Materials and Construction

Straw-Bale Eco-Center: Demonstrating How to Live Sustainably in the Midwest Timothy Gray	143
The Design of Residential Building Skins—Solar Power and Structurally Insulated Panels Joe Jamgochian and Franca Trubiano	151
Enabling Material Constraints in the Digital Design Process Through a Plywood Gridshell Mark Cabrinha	157
In the Purple Palace: Environmentally Responsible Vocabulary for Materials and Construction* Richard Hayes	
Site Interface* Laura Briggs	

Education

Lab-coats Back in Studio. Can Sustainability Bring Design and Research Back Together? Fernando Luiz Lara	169
A Green Studio Pedagogy: Using Scale Changes to Influence Architectural Design for Sustainability Keelan P. Kaiser	175
Education, Environmental Attitudes and the Design Professions Traci Rose Rider, Jack Elliott	183
The Green Studio Handbook: Environmental Strategies for Schematic Design Alison G. Kwok, Walter Grondzik	191
Interdisciplinary Comprehensive Design Studio: Carbon Neutral Field Campus* Bruce Haglund	

Community and Urban Design

Research x Design: Urban Design Charrettes from the Design Centre for Sustainability
at the University of British Columbia*

Ron Kellett

Phantom Housing: The Rise and Fall of Public Housing in North America 203

Benjamin Gianni

Mapping Urbanity: A Trajectory of Urbanity and Its Role in the Morphology of the Biosphere 211

Maria del C. Vera, Shai Yeshayahu-Sharabi

School Environment and “Green” Transportation 217

Xuemei Zhu

Community Design Parameters and the Performance of Residential Cogeneration Systems 225

Hazem Rashed-Ali

Theory for Advancing Green Design

Intimate Encounters: Social Capital, Emotional Ecology, and Sustainable Design 237

Kaarin Knudson

The Role of Connectedness Theory in Sustainable Architecture 243

Anthony W. Layne

The Sustainability of an Architectural Practice 251

Lucas Gray

Advancing Green Design Through Theory*

Martha Bohm

The Trouble With Sustainability 259

Walter Grondzik

Author Index 265

The Archtiectural Research Centers Consortium 266

Sponsors 267

* Invited oral presentations

Theory For Advancing Green Design

Ocean and Prairies: New Metaphors for Design*
Laura Briggs

Themes Of Function
Donald Corner, Michael Magee

What's On Your Mind, What's In Your Heart? An Exploration on Our Perceived Environment
Missa Aloisi

Expo 2005–Nature's Wisdom: An Ecological Pedagogy For Sustainable Transformation
Michael Zaretsky

In Poetic Association: Acts of Architecture in the Realm of Landscape Ecology
Brook Muller

* Invited Oral Presentation

Themes of Function

Donald Corner

University of Oregon, Eugene, Oregon

ABSTRACT: Architects draw initial inspiration from “themes of function,” but as the project develops, and market forces demand ever more striking building expressions, fidelity to the originating concept is often lost. The tension between true function and the appearance of function is particularly evident in the design of building enclosure. Tracing the development of the rain screen principle and the double skin facade, the author illustrates how leading designers make reference to function while embarking on aesthetic explorations that clearly have other motivations. As facade systems become more complex, there are greater consequences associated with a lapse in attention to basic issues. Faced with dramatic climate change, public demand for green building solutions has risen very rapidly. To meet that demand, architects must discipline themselves to find poetics in real performance

Keywords: Green facade design theory

INTRODUCTION

Architects raised in the long shadow of modernism seek out concepts, relationships, and forms that capture the essence of a program activity or building performance attribute. The kernel of these investigations, the basic recurring concepts, are known in one school of thought as “themes of function.”(1) Once identified, these themes can be elaborated and expressed through an infinite number of design variations. The creative mind is driven to find new, fresh and ever more powerful expressions of basic ideas. As the process unfolds, new themes are added to the mix, and the search continues for a compelling synthesis. Too often a form of “mission creep” sets in. Along the creative journey, designers wander further and further away from the motivating principles. When the inspiration is fulfilled, all credit is assigned to the originating function, but there are clearly other competitive forces lurking behind the forms that we eventually see and celebrate.

The tension between true function and the appearance of function is never more evident than in the design of building enclosure. The facade carries with it all of the expectations of our cultural inheritance. One hopes that good manners and shared meaning will remain primary considerations in the urban environment. Add to these ever greater demands for technical performance. The well adapted building controls heat, light, moisture and oxygen supply through its skin. The architect has to span an intimidating range of issues. Facades are more and more likely to be our primary experience of buildings, particularly in an era when security concerns dictate that most of us will never be admitted to privately owned interiors. Corporate clients, desirous of an iconic building image, put increasing pressure on architects to deliver striking proposals. New technologies have been the time honored trigger for new forms, but performance of a technical function often marks the beginning rather than the end of a creative investigation.

Joseph Esherick, a master teacher in his time, warned us that architects make a practice of setting up straw men and expecting praise for their ability to knock those men down.(2) The real depth of a work, he cautioned, was revealed by which straw men were selected in the first place. As we now teach the integration of technology and design, we rely on the work of influential designers to both challenge and inspire our students. If we are mindful of Professor Esherick, we must recognize that leading designers, in some measure, re-define the rules as the game proceeds. It has always been our responsibility to question the effect of this process on accepted building technique. Is it enough that our best architects draw inspiration from important themes of function without being accountable for the ultimate performance of those functions? If we examine the evidence of our recent past, we will have a measure of the challenge this simple question presents in our immediate future.

1. THE RAIN SCREEN PRINCIPLE

In the 1970's the aluminum curtain wall industry propagated a new technical concept, "the rain screen principle for pressure equalized wall design." Industry documents described the technical imperatives for water tight construction, particularly in their growing segment of the building market.(3) It was a very "teachable" concept, eagerly taken up by materials and construction faculty, this author among them. It is rare to find such a well articulated principle that leads us through the mass of fact and fiction in detailing a building assembly. Seminal articles extended the argument for rain screens beyond the curtain wall to show how they had been and could be realized in a full range of enclosure systems. The principle was summarized in what remains one of the most compelling diagrams in building science; a simple set of geometric relationships that the skillful designer could realize with limitless variations. (Figure 1) It was the kind of fundamental "truth" sought out by architects working within the legacy of modernism.

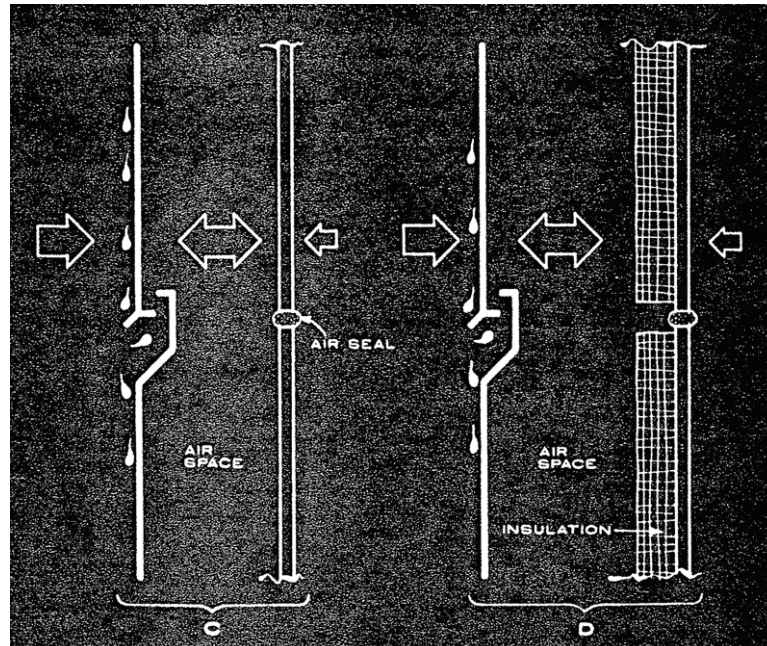

Figure 1: Diagram of the rain screen principle published by the AAMA in 1971.

Rain screen walls soon began to appear in architecture of the first rank. An outstanding early example was James Stirling's Neue Staatsgalerie in Stuttgart, that featured an open jointed system of thin stone slabs. The significance of the moment was not lost on Stirling who famously commented on it by "knocking" a hole in the wall of the parking level and leaving stones of traditional volume scattered around on the lawn. This conceit was in large part Stirling's sense of humor, but consistent with the exaggeration of material and detail in the Post-modern era. (Figure 2) Architects trained in modernism, indeed brutalism, were feeling their way back to traditional materials like stone. The rain screen wall was the answer to one of the difficult theoretical questions of the age: how does one make a facade with a rich masonry material and yet express the fact that it is no longer load bearing?

The rapid spread of open jointed masonry walls, especially in Europe, confirms the satisfaction architects found in this new theoretical position. But, what was their allegiance to the technical origins of the concept? The stone panels in Stuttgart have squared edges, a concession to economies of production, while the generic rain screen diagram demands a wash, overlap and drip at horizontal joints. By the time the building was fifteen years old extensive repairs were underway.(4) Dropped dowel fasteners bored into the edges of the stone were failing due to their weather exposure. Sealed joints, backed up by a drainage cavity would almost certainly have provided superior technical performance, but they would not have so vividly expressed the wall as a screen.

Perhaps the most accomplished champion of the screen wall has been Renzo Piano. The brick panels of the IRCAM project in Paris are sufficient example. Cored bricks are levitated around aluminum rods with the joints held open by plastic spacers. Here the wall panels also express a modern interest in rationalized production, although suspending brick in a steel frame and grillage cannot possibly be an economical strategy. (Figure 3)

At Piano's Rue de Meaux housing in Paris, terra cotta units were used as a screen in front of GFRC (glass-fiber-reinforced concrete) wall panels. The custom extrusions developed for the terra cotta at least permit a satisfying overlap of the horizontal joints, but the design is again not driven by true performance criteria. The rain screen of terra cotta protects the solid portions of the GFRC panels, areas that have no joints in the back-up wall and are the least likely to need protection. Meanwhile, the interfaces of panel to panel and panel to window are developed in a traditional manner. In both of these examples the rain screen has become the trigger for an aesthetic exploration that runs far beyond the functional basis of the idea. The ultimate objective is to re-introduce color, texture and scale to the building facade within a theoretical construct that gives comfort to the modern architect, but only marginally relates to actual building performance.



Figure 2: Solid blocks fall out of a rainscreen stone veneer. Neue Staatsgalerie, Stuttgart, Germany, 1988, James Stirling, Architect.

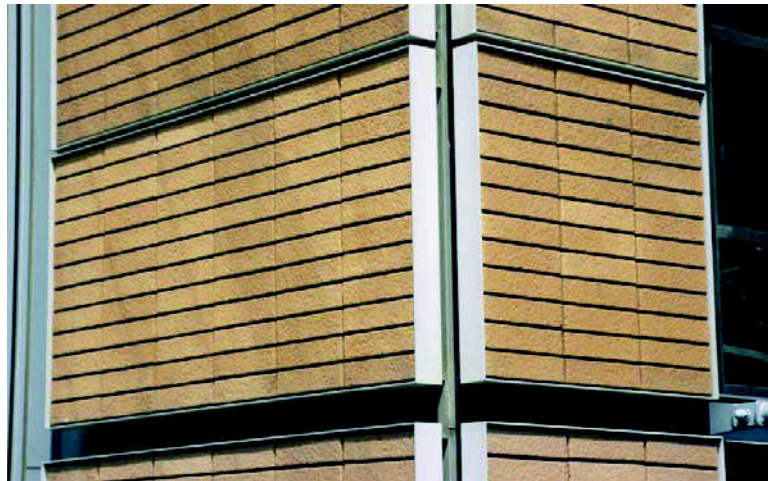

Figure 3: Cored bricks secured with plastic spacers on vertical rods. IRCAM, Paris, France, 1989. Renzo Piano Building Workshop.

2. MONO PIANO

At the same time as the early rain screen publicity, Renzo Piano first articulated a concept that he called "mono piano."⁽⁵⁾ The diagram called for an open, omni-directional layer of occupied space, served from above and below by all of the systems needed to condition that space. Below the floor was a plenum and

ductwork through which conditioned air was supplied. Above were independently expressed systems that controlled rainfall, humidity, the thermal gradient, daylight, solar gain and passive ventilation. (Figure 4) The roof surface was chosen for this elaborate development because it was only 1/5 of the exposed surface on any cube of space and these systems were understood to be too expensive to apply to the entire exterior. Each of the autonomous control systems required carefully formed components that were exposed to view, to the weather, or both. They were to be fit together as intricate layers of exquisite detail. The roof was the most demanding exposure, but it was also the one with the greatest potential contribution of daylight.

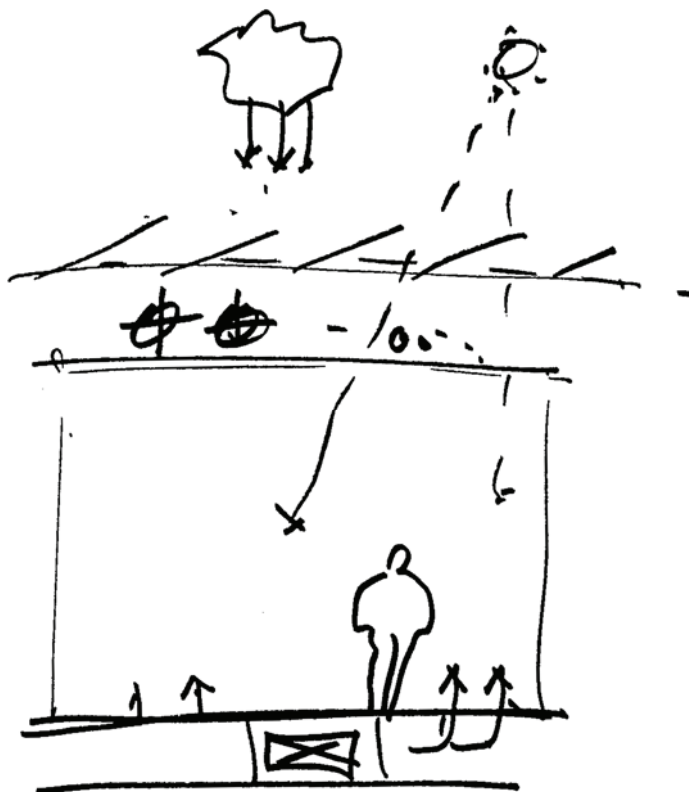

Figure 4: Summary of the “mono piano” concept drawn by Shunji Ishida, May 2005.

The thematic triggers in “mono piano” were once again technical, but over the years it has been the aesthetic content of this concept that has been refined and re-worked. The vehicle has been a series of truly poetic museum roofs in the United States and Europe. The building type is a good fit with the concept of a single layer of space exposed to the sky. The museum program justifies ambitious attention to environmental control and it provides considerable latitude in the ratio of cost to performance. These roofs are so beautiful it is almost heresy to ask if they actually work. However, the very heavy, final diffusing scrims above galleries at the Beyeler Foundation, in Basle, suggest that an overhead aperture with 100% of the plan area is not truly necessary.(6) Controlling this great expanse of glass is in fact solving a problem of one’s own making, however masterfully it may be done.

A visible critique of the museum roofs is provided by Renzo Piano’s own subsequent work. At the addition to the High Museum in Atlanta, conceptually simple boxes of space are perforated by literally 1000 skylights.(7) The economies of repetitive construction are applied to finely tuned units that simply plug-in to the site construction. Does this not make more sense, fundamentally, than what must have been the painstaking assembly of the earlier systems?

Renzo Piano’s roofs are important historically because they pre-figure the next stylistic explosion to be triggered by a shared theme of function. If the roof assemblies are rotated 90 degrees, they become wall sections in a double skin facade. Surely if we can develop interactive layers of control that face straight up into the falling rain, applying them to the wall plane should be an easy win. Indeed, for Piano’s veteran staff, their use of the double skin has not been an independent idea, but a logical evolution from their previous constructs.(8)

3. THE DOUBLE SKIN FACADE

Like the rain screen wall before it, the double skin facade also has a compelling diagram. Dramatic red and blue arrows trace the ventilation path through which heat gains in the facade cavity are returned to the exterior. The winter diagram suggests how controlled amounts of preheated air can be admitted to the interior. Again like the rain screen, double facades have a long history in vernacular forms: the box window, the storm glazing panel and the glass enclosed loggia. The concepts are simple, although the execution is not.

Architects who champion the double skin travel down a theoretical path that we should recognize, given the precedent of the rain screen. Certainly there are projects that have been very carefully studied both before and after construction.(9) (Figure 5) On the other hand, there are projects for which the double skin concepts have been a catalyst, but the ultimate goal has been an aesthetic expression that responds to many more factors than the quantitative performance.(10) (Figure 6) Like the rain screen, the double skin offers a solution to the ongoing theoretical challenge, developing an appropriate and contemporary building facade, free of previous stylistic associations. In addition to the production modules, overlapping layers and filtering screens that continue to fascinate designers, there is now a dynamic aspect to the composition, with vent flaps, louvers and operable shades that animate the facade. Taken to the extreme, the all glass facade becomes a self-adapting machine that can be deployed in any compass direction and across the face of any program configuration. Architects seem to have developed a crisis of confidence about the composition of the figure/ground, solid and void in the building elevation. They deeply fear over worked formulas or flimsy historical references. The dynamic, all glass facade completely eliminates the conflict.



Figure 5: A well integrated double facade that supplements the performance of a building with: a shallow floor plate, concrete mass, radiant cooling, ground water wells, displacement ventilation, and an earth tube. Münchner Tor, Munich, Germany, 2003. Allmann, Sattler, Wappner.

Double facades once again manifest the tension between function and the appearance of function, but the stakes have been raised. The systems themselves can be very expensive, and they are so complex that in many cases we will never know if they are truly effective. If the goals are energy and resource conservation, it is not enough to ask if the double facade works as designed. We must also ask how much energy could have been saved if the same material resources were applied through a different strategy. The rain screen wall is a discreet system, with costs and benefits that can be isolated. By contrast, a well developed double skin application interacts with virtually every other system in the building. Tallied below are design parameters that surfaced in a relatively brief discussion with Andrew Hall and his colleagues, sitting around a table at Arup Facade Engineering in London.(11)

Hard Costs:

- Building Structure: spanning system, thermal mass, aspect ratio.
- Facade Construction: leaves, layers, glass types, components.
- Mechanical system: plant size, ductwork, control systems.

Soft Costs:

- Energy: heating, cooling, lighting.
- Operation: control, maintenance, repair.
- Development: cost of capital, response to regulatory constraints.

Human Impacts:

- Thermal comfort
- Acoustic benefits
- Quality of light
- Access to fresh air
- Responsiveness to the user
- Imposed burdens of system control

Ecological Impacts:

- Sources of required materials.
- Risks in the fabrication process.
- Potential for re-use of materials and components.
- Carbon equivalent.

How often can we expect the building design team to have the patience and the skill to sift through all these factors to find a solution that is truly optimal. Is it in the nature of architects to do this? Is it not more likely that architects will filter the evidence through a series of a-priori assumptions? The double facade with 100% glazing is very fashionable at the moment. It is a choice that may be justified in terms of the optimal penetration of daylight into a deep plan. Large, unobstructed floor plates are commonplace in American building, and they are economically framed in steel. Without thermal storage capacity in the structural mass, the building may not be able to tolerate the heat gains that come along with the admission of daylight. To control those gains at the building enclosure a double skin may be indicated, leading neatly to the conclusion that the team wanted in the first place.

This admittedly simplified example demonstrates that the sequence of decisions may seem convincing, but if we challenge any of the assumptions within it, the conclusions could be entirely different. A shallow floor plate, built with a high mass structural system may require a much smaller glazing area and be able to tolerate the thermal gains until night ventilation can be applied at a much lower cost than a double skin. Even as the surface area of the building goes up, the actual cost of the skin could go down once the cost of operation and maintenance are considered. A retrospective case study of such a building has to penetrate very deeply into the design process to assess how much the architect was driven by function or fashion at each fork in the road.



Figure 6: The double facade as icon. With a teardrop shape in plan, much of the outer glass leaf has no occupied space behind it. Landesbank Baden Wurtemberg, Haus 5+6, Stuttgart, Germany, 2004. Wohn Mieslinger Architekten.

4. GREEN BUILDING

A recent issue of The Architectural Review includes a social housing project in France that is wrapped in a grillage of small diameter chestnut poles, held together with twisted wire.(12) The editors refer to the project as a "rustic rainscreen," although it is probably the farthest thing yet from a truly weather resistant building skin born of that principle. It is playful, probably not very expensive and perhaps quite harmless. Nevertheless, it is a marker along the meandering journey of fashion in design. Loose reference to function has been taken to its illogical limit. If we are serious about green architecture, we have to hold building technique to a higher standard. Through the evolution of the rain screen and the double skin we have seen that architects will trade principles for poetic references. This is our history. Can we afford, once more, to repeat it?

Green buildings can be orders of magnitude more complex than even the double skin facade. Good solutions again require the cooperative integration of virtually every system in the building. In addition, they require thoughtful attention to the entire delivery system. We must recognize the impacts of our design preferences from the sourcing of material all the way through to the daily experience of the occupants. Given this complexity, there will be errors along the way. If we are to learn from each other, we must frankly disclose our design motivations and honestly report our results. We cannot leave it to engineers and forensic scientists to debunk the myths propagated in the "design community."

The green building movement is unprecedented in the history of architecture. Never before has a set of ideals so deeply penetrated the building market in so short a period of time. Regardless of their reasons, there are an enormous number of people who want green buildings, and they want us to deliver them. Given the threat of permanent climate change, the risks are too high to wander off point. We have been challenged to make buildings that are both interesting *and* effective. Contrary to our own history, we must discipline ourselves to find poetics in *real* performance.

END NOTES

1. Gary Moyer, personal interview, December 2006. University of Oregon professor Moyer is a student and scholar of Louis I. Kahn.
2. Joseph Esherick, public lecture at the University of Oregon, May 1988.
3. "The Rain Screen Principle and Pressure Equalized Wall Design," Aluminum Curtain Walls, Chicago, Illinois: Architectural Aluminum Manufacturers Association, February, 1971.
4. Stuttgart, Germany, site visit by the author, July, 1990.
5. Shunji Ishida, personal interview, May, 2005. Renzo Piano Building Workshop, Vesima, Italy.
6. Basle, Switzerland, site visit by the author, May, 2005.
7. Mark Carroll, personal interview, May, 2005. Renzo Piano Building Workshop, Vesima, Italy.
8. Shunji Ishida, May, 2005.
9. Lee, Eleanor and Lawrence Berkeley National Laboratory. "High Performance Commercial Building Facades." Public Interest Energy Research Program: CEC 500-2006-052-AT15. Sacramento: California Energy Commission, 2006.
10. Corner, Donald. "All That Glass? Is there an appropriate future for double skin façades?" Journal of Building Enclosure Design, Washington, DC: NIBBS/BETEC, Summer 2006, 19-24.
11. Andrew Hall and Mikkel Kragh, roundtable discussion, April, 2005. Arup Facade Engineering, London, England.
12. "Rustic Rainscreen," The Architectural Review [London], November, 2006, 63-65.

What's On Your Mind, What's in Your Heart?

An Exploration on Our Perceived Environment

Missa Aloisi

University of Oregon, Eugene, Oregon

ABSTRACT: This paper reevaluates the current practices and valuation processes for sustainable design by examining the definition of what constitutes sustainable in relation to the metaphor of a building as person. This metaphor allows the reader to find a deeper meaning of sustainability behind its surface expression. The underlying goal is to explore a more humane approach to sustainability that goes beyond the surface of ourselves and our profession and develop a new, multidiscipline approach that touches our cores.

Keywords: human context, philosophy, theory or sustainability

INTRODUCTION

Architecture is an embodiment of the unmeasurable" ...architecture is an expression of man's institutions. These institutions stem from the 'beginning' when man came to realize his 'desires' or 'inspirations'. The main inspirations are those to learn, to live, to work, to meet, to question, and to express. (Norburg-Schulz: 31)

Sustainability is more than skin deep; it goes beyond the surface, into the intentions of a place. How do we find the vocabulary for this deeper meaning and how do we apply them to the architectural practice? The use words through metaphors allow us to jump out of the confining boxes of our individual professions and cross into other disciplines in order to create a common language and a collective understanding of our built environment that embodies sustainability.

SELF

Our minds and our hearts have created an undesired separation through our consciousness, when in fact one does not exist with out the other. We say, "what's on your mind? What's in your heart?" as if one is on the outside and can be touched and understood, while the other is on the inside unable to be rationally defined. The word sustainability in the field of architecture acts like the mind and heart; it's the façade and the sweat from the guts inside that face, and the unresolved between the two. However in our culture, sustainability has become merely an object that has become constrained through our society and placed upon hierarchical evaluation systems. By placing a value upon its every dissection we will never allow sustainability to actually achieve its greatest intentions.

As conscious humans we grapple with finding the most accurate descriptions to express how we understand the world around us. These descriptions come from our language and the way our culture has evolved its use of it. Language has become our direct link to the rational world. As aware humans we attempt to understand these descriptions through our senses. When we see the sunrise and the colors and textures make us breathless we know that this is beautiful even though its creation remains a mystery. When we perceive the world through this

process of our senses, perceptions and language, it influences how we as individuals express ourselves and create the environment around us. This circular process has no ending. It is about the journey. The more fused this encircling becomes the more we begin to really see. Only through the process of releasing the constraints of our world inside and out do we really see.

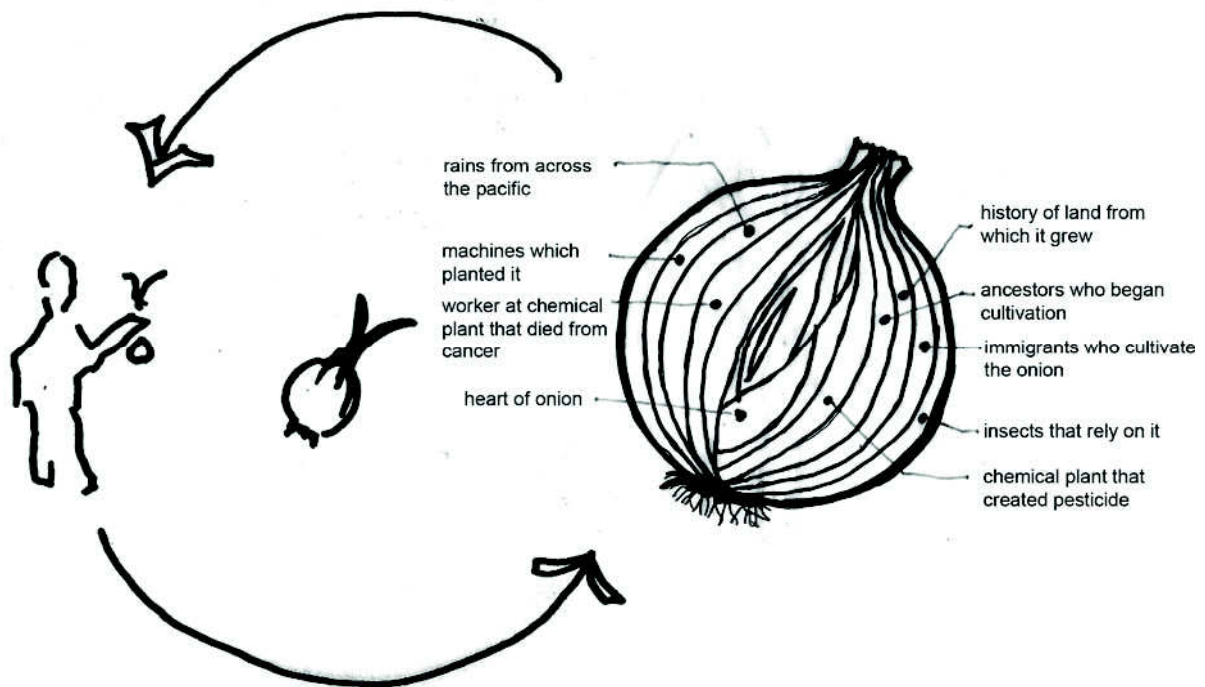

Figure 1: Intentions within the layers

Our minds and hearts are the property of the self; however in our society we define great minds or great hearts as something meaningful. Is this meaningfulness a creation from the individual or the collective whole? Can the body intervene with these definitions to enable us to make a difference in our own lives as a collective whole?

the social meanings which are attached to particular bodily forms and performances tend to become internalized and exert powerful influence on an individual's sense of self and feelings of inner worth.

(Schilling: 73)

The things that reside in our core are hard to put to words but they make up who we are. These inner values that come from our heart and our guts are impossible to quantify, and it would do harm to try -- who would want to place a limit on love? So the question becomes, is our outward expression of values (our rationalization / mind) acceptable to put into categories, quantify and qualify when in fact they stem from our root and are also part of our very being?

Values ebb and flow, they become priorities and then slip into the background again. Being a part of a western culture it is hard to decipher if the uses of these values are natural or if rather they have been taught to us as a way to dominate us as a population or as individuals.

in a culture where money is the measure of value, where it is believed that everything and everybody can be bought, it is difficult to sustain different values. (Hooks:47)

Values are entirely individualized; so how can we as a culture even try to place them on a hierarchical system?

the more people attach value to how we look and what we do with our bodies, the greater are the pressures for people's self-identities to become wrapped up with their bodies...increased individualization of our bodies is important, however the conflicts which used to occur between bodies have now moved within embodied individuals as a result of the rising demands of affect control. This situation tends to leave us alone with our bodies; investing more time and effort in their monitoring, control and appearance, and yet losing many of the sources of satisfaction we once gained from them. (Schilling: 110)

BUILDING AS SELF

Sustainability is a value and comes from within us; it lies on our skin and pumps through every vein. No one individual or system can define it for you. Living within a capitalist culture we have been influenced by the use of language around us. Often times our society misuses language in order to create a reaction from us instead of encouraging us to be more proactive. By doing so our culture has attempted to define the world around us, for us.

If body (architecture) is not a 'being' but a variable boundary, a surface whose permeability is politically regulated, a signifying practice within a cultural field of gender (sustainable) hierarchy and compulsory heterosexuality, then what language is left for understanding the corporeal enactment, gender (sustainability), that constitutes its 'interior' signification on its surface? (Rendell: 96)

Gender "like sustainability" is a social construct and it is not a tangible thing; it shifts over borders and boundaries into something deeper. It is the liminal; the threshold, the movement from one state to another, and it is within this place that we have the potential to be most alive and most aware. Confining the definition to an applied material can harm its intentions.

Capitalist societies control our built environment and are driven by the current economic system. The guts / heart become the shady region of our beings, whether it is within us or the layers within our built environment and is it then natural to try to quantify things we don't even have a vocabulary for?

we can still be moved deeply by buildings yet have no adequate terms to deal with the fact. We are normally very disinclined to talk about this in the same way that we find a verbal account of sexual attraction to be hopelessly inadequate. (Wilson: 3)

Can we reach a collective consensus for how we define our environment? Do we have senses that go beyond our rational capitalist thought (mind) that go directly to our cores (heart / gut); can these senses also help us define the world and influence our perceptions and built environment? Even better yet can they help us become aware of our own pre-conceived perceptions that society has determined for us and can they dissect the layers of social thought in order for us to really-see?

SUSTAINING OURSELVES

You do not 'create' or 'set' core ideology. You discover core ideology. It is not derived by looking to the external environment; you get it by looking inside. It has to be authentic. You can't fake an ideology." (Abrhams: 97)

With the creation of LEED our government has placed a value on the word sustainable, as if it is something that can be qualified or quantified uniformly over our entire population. This regulation can and is destructive and prohibitive to our culture and limits how we as individuals can express ourselves through the built environment. Depending on how much the building conforms to these regulations the higher the tax incentives the government rewards the project with for adhering to their values.

In buildings, high performance is better than low performance, but why rather than looking at performance why don't we look at the need to perform? As individuals we value what's in our core even more than what is on the outside, so why is this not also recognized and admired in the built world?

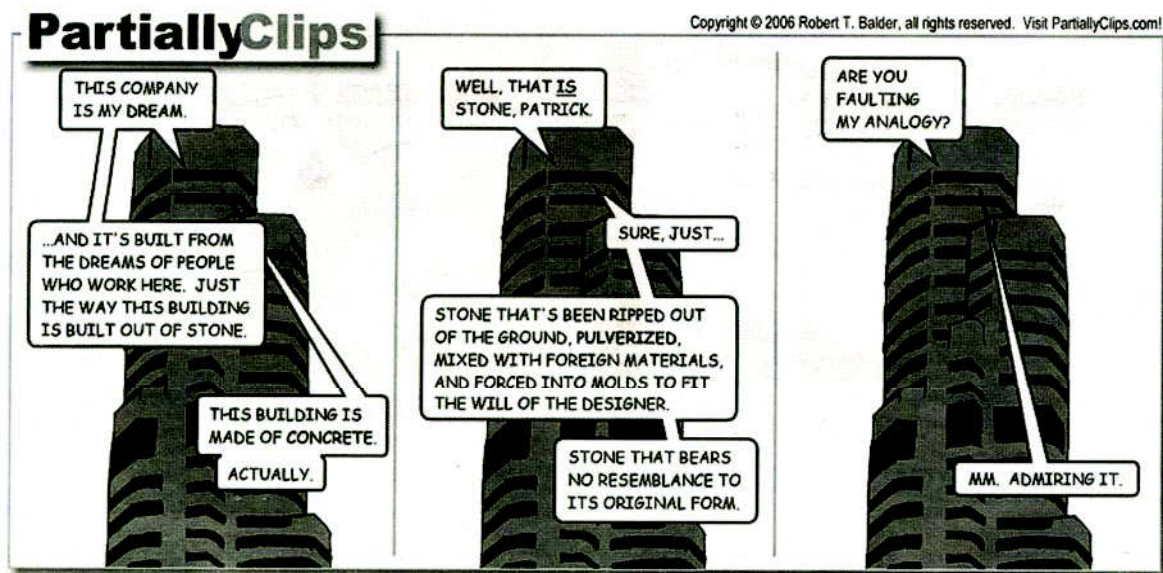

Figure 2. Cartoon depicting language use. (Source: Partiallyclips.com, used with permission by Rob Balder)

Social relations, inequalities and oppression are manifest not simply in the form of differential access to economic, educational or cultural resources but are embodied. (Schilling: 109)

When I look at great buildings which society has told me are sustainable, I ask myself what these buildings embody or more importantly what are their intentions? The buildings become a form of green expressionism or 'green washing': made up of quantifiable parts the green roof, the high reflective glass, the solar panels, etc. These quantifiable parts give the appearance of what our culture has defined as sustainable design, yet what are the things that go beyond the surface and can they have equal value? Within the core of a building are its values. This worth is not quantifiable given the limited vocabulary of our senses; however, it's within, that we have the ability to learn most about ourselves and our culture. Most architectural movements have reflected the issues of the time, whereas modernity has yet to reflect the people.

It is not the rationalization that was wrong in the first (and now past) period of modern architecture: the wrongness lies in the fact that the rationalization has not gone deep enough. Alvar Aalto (Wilson:2)

Architects decide every last detail of a building and qualify those materials they are made up of to complete the whole. Architects and planners over regulate and interfere with every aspect of design because we are afraid of

our inner fears, our vulnerabilities. As part of a capitalist society we have been trained to do this because there is no trust. We don't believe that a contractor will actually put quality into a project because they simply care about their work and how they are influencing society. We cannot get a LEED point for insisting that the construction workers that build a building get treated fairly and equally in our society. However, by doing so we allow those workers to be of worth and they in return get what they need to sustain themselves and their families in a healthy way. Imagine if people became important rather than things or objects, and quality could exist on its' own because everyone would feel they are getting what they are worth, that ultimately they do have a voice in expressing themselves in our society. He who knows he has enough is rich. (Abrams: 95)

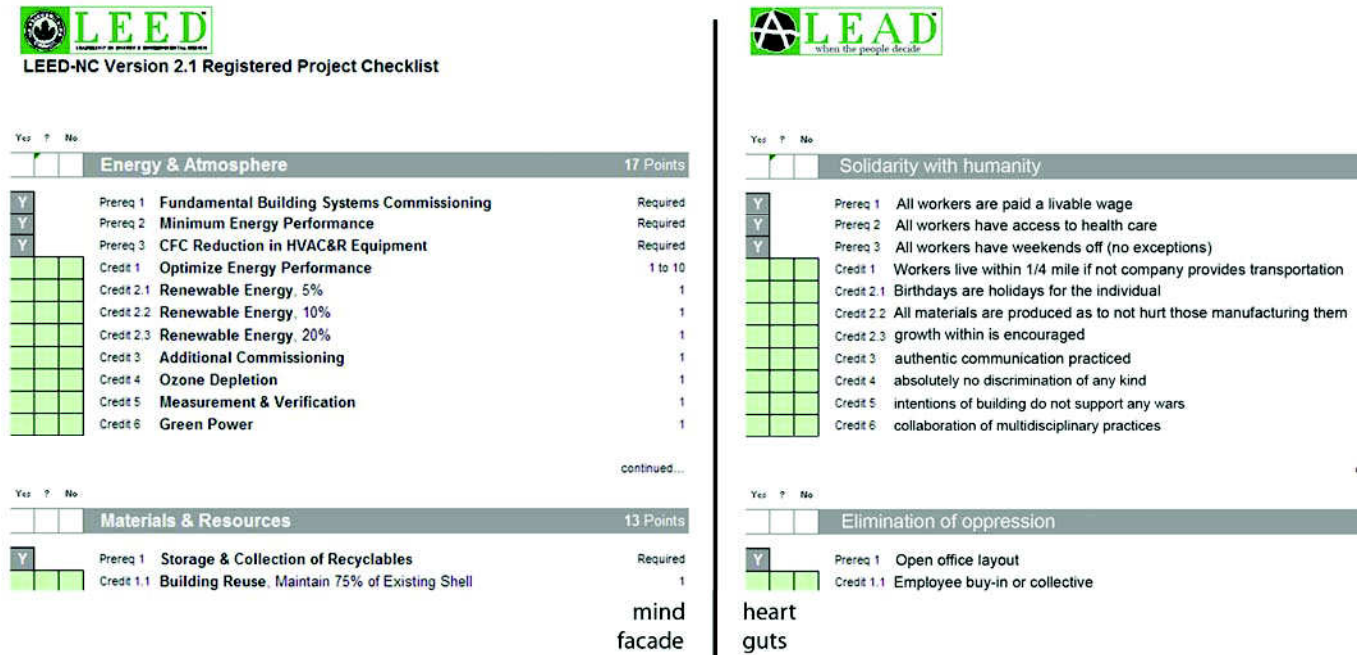

Figure 3: LEED re-defined to incorporate sustainability

PERCEPTIONS

The Ford Rouge Assembly in Michigan by William McDonough is thought to be a wonderful example of sustainable architecture. It is home to the largest green roof in the world and incorporates solar panels and state of the art 'green' technology. However, let's take a look beyond the surface to this building's intentions to sustain our culture. It is an assembly plant that manufactures Ford automobiles. To manufacture these vehicles the plant uses an exorbitant amount of resources such as, steel, oil, and water. I can only assume that William's rationale for taking on such a project was to make an already negative thing in our society a better thing, although in his book *Cradle to Cradle* he uses the phrase for one of his chapters, "Why being less bad, is no good." Is this an ethical way to practice architecture? "I ask myself." If this building is 'sustainable' who it is supposed to sustain? In order to get to the final product, the ethical factor becomes how many people became ill while mining the iron, how many seals died from the last oil tanker spill, how many inner city children have been diagnosed with asthma because of inhaling larger amounts of automobile exhaust? These events are all part of the intentions of the building. To manufacture more vehicles means that we as a culture become more dependent on a depleting substance that we are now engaged in war over. Having more cars does not promote walkable cities where the

community has the opportunity to interact with one another. Is this now a sustainable building? It neglects the core of our beings and fails to reflect our culture and the progress we would like to achieve as a society.

Co-housing is another example of sustainable architecture. It attempts to bring people together as a collective whole where everyone has a voice in the decisions made of how to live in a sustained manner. Co-housing is usually comprised of several housing units, detached or attached, with community buildings where people can have shared meals and services. They are providing for themselves the services our communities currently neglect. So then what makes them different from current gated communities that have these same intentions? Is one more “sustainable” than the other? Just like McDonough has possibly rationalized that working for the Ford factory and applying a “green wash” to the surface is a sustainable way to practice architecture, co-housing has possibly also rationalized that isolating a community in order to grow its own food and live together collectively is a sustainable way to live. Co-housing, just as our current government has defined sustainable architecture, has become a series of applied “green washing” tactics to give the appearance that the built form is reflective of its inner core. Can developing on green land even be considered sustainable? If the intention is to conserve land then why don't co-housing groups buy land that they refuse to build on, along with some inner city brown field sites already neglected within the urban fabric? This approach would allow for land conservation and a sustained interaction between the already existing communities and has the potential to strengthen those connections so that all people can be sustained.

a way to learn the true meaning of community (is to) enact sharing of resources that would necessarily dismantle hierarchy and the difference. (Hooks:39)



Figure 4: Inner values: Core of self

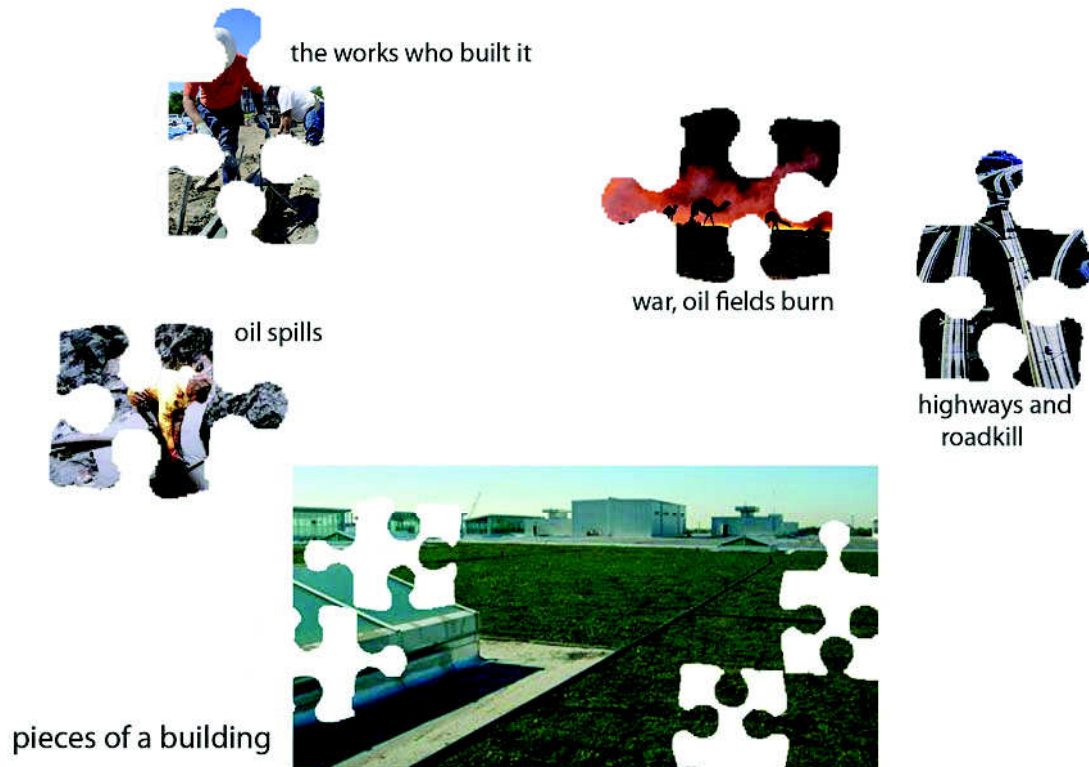

Figure 5: Inner values: Core of building

NEW APPROACHES

So the question becomes, how do we aspire to be in society? Do we wish to continue oppression and inequality or do we want to aspire to something more. If we can dissect the layers of self we can dissect the layers of a building, by doing so would not devalue the whole, but rather making the whole even clearer. As architects we are the mediators of these topics and can choose to address them or ignore them. If as a society we continue to not see the unseen, the things which are in our core then we will continue to decline, because no material, face, or façade can be sustained, we cannot regulate it, and if we did we would do harm to it and ourselves and never realize its fullest potential.

solidarity ...invites us to embrace an ethics of compassion and sharing that will renew a spirit of loving kindness and communion that can sustain and enable us to live in harmony with the whole world.

(Hooks: 49)

The practice of architecture needs to expand beyond its current boundaries to incorporate other fields of disciplines in order to be able to solve the design problems of today that truly touch the world in a sustainable manner.

ACKNOWLEDGEMENT

This document was adopted from a white paper developed for Professor Brook Muller at the University of Oregon, Sustainability theoretical undercurrents class, during the Spring term, 2006.

REFERENCES

- Abrams, John: *The Company we Keep: Reinventing small business for people, community and place*; Chelsea Green Publishing Company, 2005
- Hooks, Bell: *Where we Stand: Class Matters*; Routledge, 2000
- Noberg-Schulz, Christian: *Khan, Heidegger and the Language of Architecture*:
- McDonough, William; Braungart, Michael: *Cradle to Cradle: Remaking the Way We Make Things*; North Point Press: 2002
- Rendell, Jane; Penner, Barbara; Borden, Iain: *Gender Space Architecture, An Interdisciplinary Introduction*; Routledge: 2000
- Schilling, Chris: Second edition *The body and Social Theory*; SAGE Publications Ltd: 2003
- Wilson, Colin ST John: *Architectural Reflections, studies in the philosophy and practice of architecture*, Second Edition, Manchester University Press: 2000

Figure 3: LEED Checklist, <http://www.stanford.edu/class/cee243/LEEDchecklist.pdf>.

Figure 5: Inner values of building:

Oil fields burning: http://www.nationalgeographic.com/ngm/100best/images/storyD_main.jpg 4/12/06

Ford Rouge factory: www.ratical.org/co-globalize/images/giveback3.jpg

Construction workers: www.dailynews.com/.../jh12ma04-DLG-construc.jpg

EXPO 2005 – Nature’s Wisdom: An Ecological Pedagogy for Sustainable Transformation

Michael Zaretsky, Architect, LEED AP

University of Cincinnati, Cincinnati, Ohio

ABSTRACT: In Spring 2005, Expo 2005 opened in the Aichi Province of Japan. The theme of Nature’s Wisdom was recognized in a plethora of differing architectural expressions. The United States decided upon a rectangular box construction with a digital façade of a billowing American flag and Nature’s Wisdom as represented by a person dressed as Benjamin Franklin presenting the discovery of electricity.

My response to the chosen symbolism of this expression of Nature’s Wisdom in a global context was the impetus for a design studio at the Savannah College of Art and Design in Spring 2005. This studio was the test-bed for an approach to teaching ecological consciousness and testing the potential to improve design creativity and quality through a deeper understanding of ecological systems.

This paper describes the Nature’s Wisdom studio and an ecological systems process. It then asks if and how design educators might incorporate the study of ecological systems as a basis for conceptual design development.

Keywords: Eco-system, Pedagogy, Design Studio

INTRODUCTION

Expo 2005 offers to the people of the world an opportunity to come together and discuss the many global issues that face humankind. It is a place to bring together the world’s talent to create a model community for the future where humans can live in harmony with nature.¹

In Spring 2005, Expo 2005 opened in the Aichi Province of Japan. The theme of Nature’s Wisdom was recognized in a plethora of differing architectural expressions. The United States decided upon a rectangular box construction with a digital façade of a billowing American flag and Nature’s Wisdom as represented by a person dressed as Benjamin Franklin presenting the discovery of electricity.

My response to the chosen symbolism of this expression of Nature’s Wisdom in a global context was the impetus for a design studio at the Savannah College of Art and Design in Spring 2005. This studio was the test-bed for an approach to addressing the apparent lack of ecological consciousness in the existing American Pavilion and testing the potential to improve design creativity and quality through a deeper understanding of ecological systems.

This paper describes the Nature’s Wisdom studio and an attempt to directly incorporate an ecological systems process in design studio. It then asks if and how design educators might incorporate the study of ecological systems as a basis for conceptual design development. Typically, environmental and ecological curricula are distinct from architectural design studio. What I am addressing in this paper is an approach to applying ecological principles within the design process. I am not claiming that it was wholly successful, but it may offer a starting point for design educators.

As a student and educator, I have found that required classes on the environment in architecture education rarely have a direct affect on studio designwork.¹ While there has been an extensive amount of writing devoted to ecology and design in general, there has been little written about incorporating ecological principles in the design process. One of the most often-quoted authors on design education is David W. Orr, director of Environmental Studies at Oberlin University. His writing is unquestionably inspirational and informed, but he is not teaching in a design studio. The only text that I found that addressed the incorporation of these principles within the design process is a book devoted to landscape architecture entitled *Ecology and Design: Frameworks for Learning*. The authors clearly differentiate between ecology as a “framework for understanding” versus ecology as a science.

While I am seeking applications of ecology as a framework for understanding, they state that in this text, they are referring to the science of ecology,ⁱⁱⁱ I am seeking pedagogical approaches to embedding an inquisitive exploration of ecology deeply within the instinctual design response of students.

I was influenced by theories that Janine Benyus addressed in *Biomimicry* which she defined as – “a new science that studies nature’s models and then imitates or takes inspiration from these designs and processes to solve human problems.”^{iv} While the principles of biomimicry have much to offer, the examples have been largely technological as opposed to conceptual or pedagogical. I attended a Benyus lecture at Greenbuid 2005 which addressed the potential of collaborations between biology and other sciences as tools for answering design challenges. She discussed the importance of incorporating scientists within the design process from its inception, but clearly stated that she is a scientist, not a design studio professor. I completely agree with the need for collaboration, but also encourage design students to see the inherent potential of ecologically inspired design within their own process.

William McDonough and Michael Braungart’s influential text *Cradle To Cradle* is required reading for students of ecological design, but in my experience, it influences students’ material choices more than their conceptual design process. While their consideration of the lifecycle of the cherry tree refers to an ecosystem, it is less about the precedence of the ecosystem in design than it is about the beauty of the cherry blossoms.^v

I recognize how critical the collaboration of scientists, ecologists, landscape architects, planners, engineers and others are to a truly holistic ecological design process. As a professor of architecture, I see myself as a mediator between an overwhelming amount of critical information and young students eager to focus on design while “getting through” the other required course material.

EXPO 2005 – Nature’s Wisdom

Thanks to rapid technological development, the 20th Century was characterized by mass-production and mass-consumption, which in turn led to material improvements in our daily lives. At the same time, these trends resulted in various global issues such as desertification, global warming, and a shortage of natural resources. As these issues cannot be resolved by any one nation, the international community needs to unite in confronting them: we must come together and share our experience and wisdom, in order to create a new direction for humanity which is both sustainable and harmonious with nature.^{vi}

The quote listed above represents the vision set forth by the Japan Association for the 2005 World Exposition. The intentions of the Expo were impressive. Their “Ecological Declaration” included the following six factors:

1. Implementation of Conservation Measures identified in the Environmental Impact Assessment Report
2. Development of Site Planning with Environmental Consideration
3. Introduction of Advanced Technology Promoting an Eco-community
4. Introduction of the 3Rs (Reduce, Reuse, Recycle)
5. Promotion of Transportation with Minimal Environmental Impact
6. Providing Enjoyable Educational Opportunities through Events and Exhibitions



Anyone who has any sense of environmental consciousness can appreciate the vision set forth by the developers of EXPO 2005. The recognition that we must address environmental issues on a global context is something that had already been addressed in the Kyoto Protocol of 1997 in which 160 countries committed to mandate change that would result in a decrease in greenhouse gas emissions. The United States didn’t sign the Kyoto Protocol and the design decisions expressed in the American Pavilion seemed to ignore a response to “Nature’s Wisdom”.

The participation of the U.S. in Expo 2005 was largely political. The U.S. did not participate in Expo 2000 in Hanover, Germany and that is often listed as one of the reasons why it was financially unsuccessful. In 2003, President Bush promised Prime Minister Koizumi of Japan that the U.S. would be present at Expo 2005. They signed a contract on July 29, 2004 that guaranteed the presence of the U.S. with the support of private corporate funding. This left less than nine

Fig. 01 The American Pavilion at Expo 2005, Aichi, Japan

months to design, fabricate and build the American Pavilion.^{vii}

I learned of the foreshortened design timeline when I met with the pavilion designer Bud Holloman in April 2005. He runs a small firm in Jackson, Mississippi that had previously completed only small projects. They were awarded the commission because they had previously worked with the exhibit designers BRC Imagination Arts, Inc. There was no precedent in Holloman Architects or BRC Imagination Arts for any projects remotely devoted to "Nature's Wisdom."

The United States Pavilion was designed for goals that seem to have a tenuous relationship to "Nature's Wisdom."

The U.S. participation at EXPO 2005 showcases the dynamism and creativity of America and highlights our core national values--hope, optimism, enterprise and freedom.^{viii}

The response to the clearly stated objectives of Nature's Wisdom is found in one of the five exhibit spaces – The Franklin Spirit, as described here -

The main show in the U.S. Pavilion is The Franklin Spirit, a multi-media presentation that celebrates the EXPO theme of Nature's Wisdom with a visit from Benjamin Franklin on the eve of his 300th birthday. Few Americans have understood, captured and shared Nature's Wisdom with more success than the great U.S. statesman and founding father Benjamin Franklin. His studious observation of nature led to numerous life-changing innovations, most notably the harnessing of electricity through his experiments with lightning.

The Franklin Spirit reflects the uniquely American perspective of Benjamin Franklin. With a sense of wonderment, he leads Pavilion visitors through the technical, social and agricultural advances that have taken place since the 1700s. He acknowledges that the 21st century is an exciting time to be alive as he looks into the future, predicting advances that will improve the lives of people worldwide.^{ix}

In contrast to the United States, some countries responded with pavilions that engaged the concept of nature's wisdom as expressed within their culture. For example, Germany's pavilion brief states,

The theme of Expo 2005 - "Nature's Wisdom" - is to stimulate us to explore the principles of nature, and to respect and integrate these in our daily life. For continued development of harmony between nature and technology, it is necessary that we interpret natural phenomena not as contrary to technology, but rather as its foundation and source of inspiration. With the help of "bionics" - the theory of using technical applications of natural principles - Germany presents itself at Expo 2005 as a country of technological competence, innovative achievements and intensive research work, and illustrates how important and at the same time exciting the attempt to preserve our civilisation's harmony with nature can be.^x



Fig. 02 Expo 2005 German Pavilion



Fig. 03 Expo 2005 UK Pavilion

The Pavilion of the United Kingdom was entitled "Planet of Blessing and Budding." Their approach was unique -

Half the pavilion area is occupied by a woodland garden, including 40 lime trees and various familiar flowers that adorn the British seasons, such as daffodils, bluebells, foxgloves and angelicas. Among the trees are seven molded works produced by nine contemporary British artists. While walking through the woodland, visitors can appreciate the colorful works of art, inspired by nature. Upon passing through the woodland, they arrive at the pavilion.^{xi}

THE ALTERNATIVE U.S. PAVILION

Based on a belief that the chosen American Expo 2005 design may not have been the most sensitive of responses to an international discussion on Nature's Wisdom, I proposed a studio at the Savannah College of Art and Design in which fourth year design students would spend one ten-week quarter investigating alternatives for the American Pavilion in Expo 2005.

A deep understanding of the nature and processes of ecological systems is an opportunity for students to learn about the unbelievable capacity and creativity of the laws of nature and thermodynamics. I saw a project based on "Nature's Wisdom" as an ideal opportunity to test the potential of an eco-system investigation as a conceptual design derivative for a design project. The goal was to help us understand the complexity and creativity of ecological systems with respect to all forms of energy used and all transformations of that energy and then apply that to the conceptual design process. Any conception of waste was to be challenged.

The scale-less aspect of ecological systems was a critical component of this design studio. As scientific evidence continues to prove, there is no question that the form and fluidity of natural systems transcends scale.^{xiii} Patterns of planetary movement can be found at all scales in nature. This is one aspect of eco-systems that all of the students attempted to address in their research.

The studio sought to inspire the students through individual investigation and articulation of an architectural expression of Nature's Wisdom as influenced by specific ecological systems. Students were asked to begin with research of an existing natural ecological system at any scale. These included everything from the growth pattern of a redwood tree, the lifecycle of a fire ant, the way that water is dealt with on the skin of a tree frog and others. Students had one full week to explore these systems and diagram all energy and food that was coming in and all that was coming out to understand where it came from and where it went. We were comparing these closed-loops of production to our own species' utilization of resources. The uniqueness of the human proliferation of waste took on a new context.

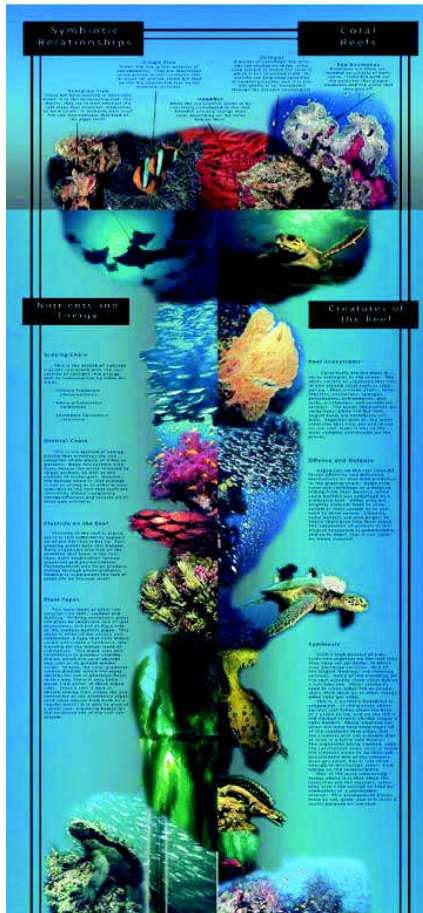

Fig. 04 Expo 2005 Matt Furedy

In the beginning of week two, there was a critique of the natural systems investigation and a discussion of these systems as precedents for design. The goal was a thorough set of diagrams that would transcend the specificity of the natural system and achieve a level of abstraction that could be translated to a design project at multiple scales.

The pre-design work included site and cultural analysis, precedent studies on previous Expositions as well as the architecture of United States and other significant pavilions. There was extensive programmatic and site analysis. The Expo 2005 layout concept placed countries in distinct regions called Global Commons in strategic locations in each commons. The U.S. pavilion was placed in Global Common 2 - "The Americas" at the far end of an oval shape with a police station directly in front of it and a steep slope behind it which had continuous police watch looking over the American pavilion.

The layers of complexity and learning opportunities to a project such as this are outstanding. Immediately apparent are issues of cultural difference, the perception of the United States in a global context, the expression of "Nature's Wisdom" by America, the history of Expo Pavilions, the challenge of designing without ever visiting the site, the challenge of designing in Japan (a country with whom the U.S. has a complex history) as well as many other factors. I wanted to limit the initial investigation to the architectural expression of Nature's Wisdom. The socio-political factors were addressed later in the quarter.

Our intention was to deepen the understanding of natural systems as a basis for design, though because of our 10-week quarter we had only one week for these investigations. At the end of the week, the students presented their work and the results were mixed. They included Matt Furedy (fig.04) who was investigating symbiotic relationships between forms of fish and animal life and the coral reef and Susan Dyer who was investigating the form of the coral reef as a

resultant of natural flows of water and air. Joe Sinclair developed an impressive investigation of the social structure of leafcutter ants. He then used this as a model for an ecological structure for his project. And Meghan Storm (fig.05) investigated the skin of the frog which, according to her, “colors, protects, breathes, moisturizes, protects, thermally regulates, and is a structural envelope.”

Anyone interested in sustainability is aware of the interconnectedness of natural systems. Investigating this process of eco-systems was inspirational and informative for all of us. However, the step of translating this to something meaningful for a designer was challenging. For Storm, it was only after schematic design explorations that she understood how to translate the permeability of the frog’s skin into a concept for a building’s skin. She did not look at the frog’s skin as a formal precedent, but instead translated the permeability of the layers into a project incorporating “the ideas of water circulation and osmosis for water collection through convective heat flow and condensation.” Her building design was an elegant monumental arch with a mobius strip pathway winding around it. She placed the porous skin on the interior of her arch where inhabitants could interact with the flows and pools of water.

Storm was a strong student before this studio. I can’t provide examples of her previous work, but the other projects of hers that I saw were all sensitive, simple, clear and graphically impressive. What shifted in this studio was a symbiosis of elegant form in a natural systemic context. In addition to the water cycle, the form evolved from a blade of grass and the mobius strip developed from an investigation of numerical patterns found in nature.

Fig. 05-08 Expo 2005 Meghan

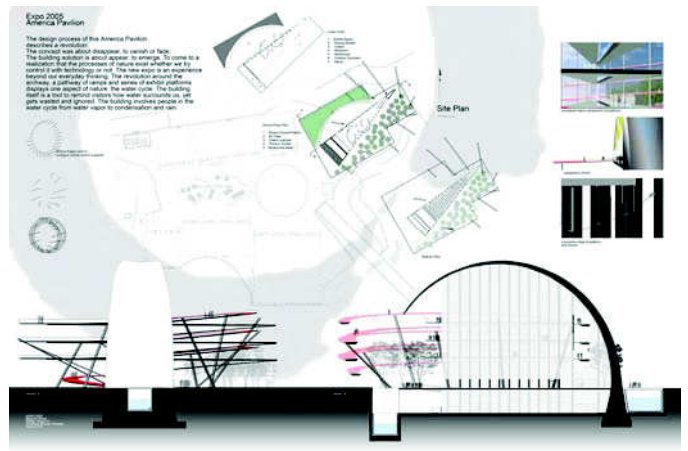
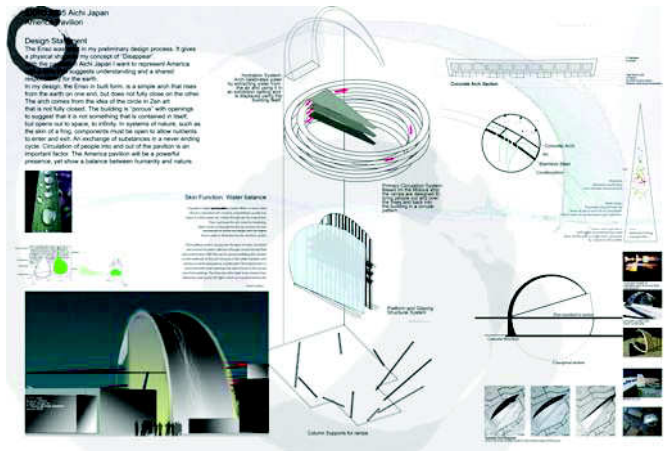
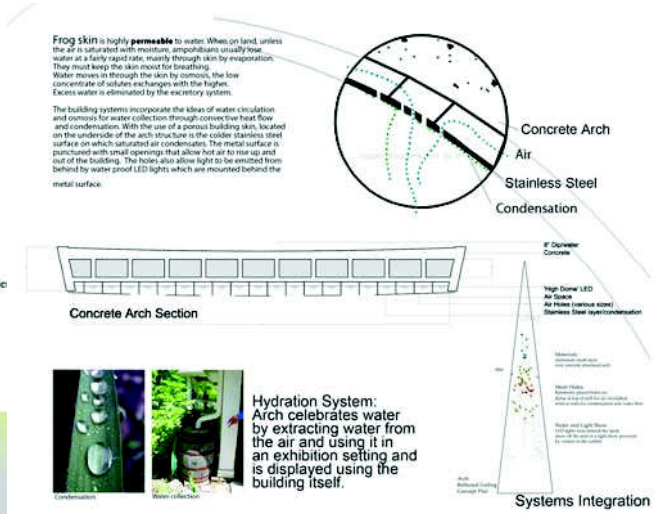
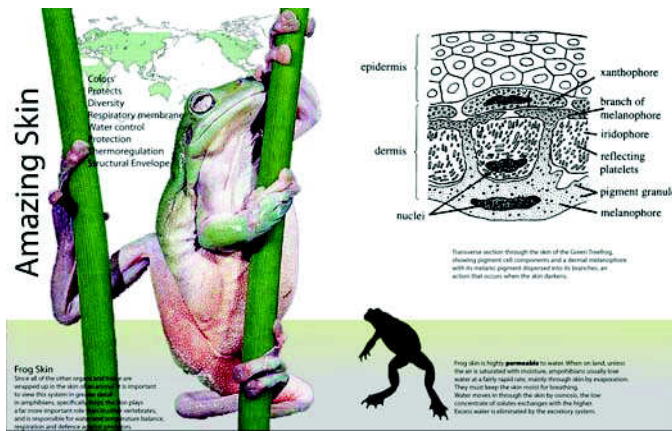

In my teaching, I ask students to translate all aspects of their design process into diagrammatic form. It is in an abstracted, scale-less diagram within which one can most clearly recognize design potential. Instead of abstractly diagramming the natural systems as requested, the students described them graphically (fig.04). Joe Sinclair's diagram of the social system of the leafcutter ants (fig.09-10) is one of the few attempts at diagramming the ecosystem. Though it was not a diagram of the comprehensive system, it was an abstraction that would lead to an organizational structure for his project. The full description of the social and nutritional structure of the leafcutter ants took four pages for Sinclair to describe, but he focused specifically on one diagram he found in a text. He abstracted this and explored sustainable strategies within this innovative structure.

The natural system exploration did encourage some innovative forms as well as investigations into the symbiotic nature of ecological systems. Sinclair's approach evolved from his investigation of the social structure of the ants. He decided that he needed to minimize his impact on the land and he derived the actual building form from the form of the leafcutter ant society.

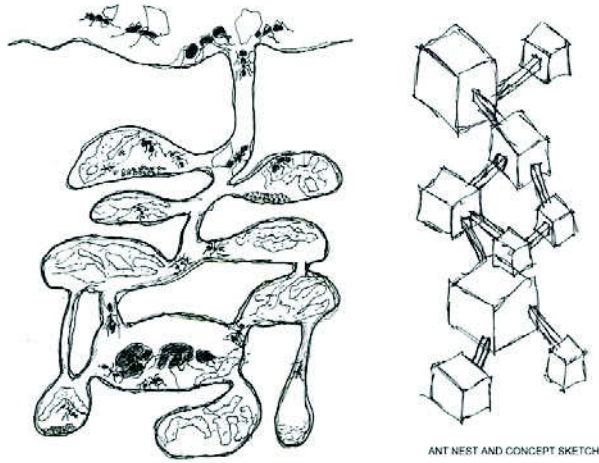

Fig. 09 Expo 2005 Joe Sinclair

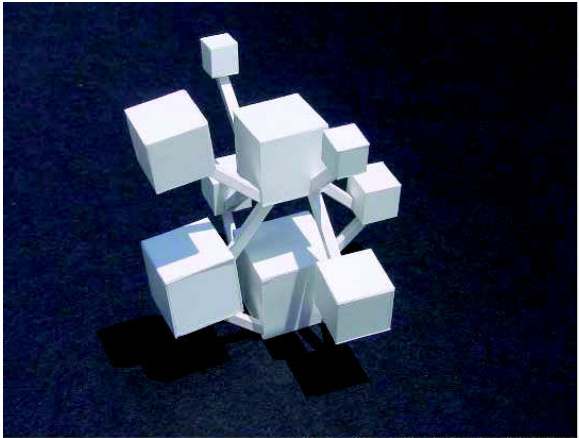

Fig. 10 Expo 2005 Joe Sinclair

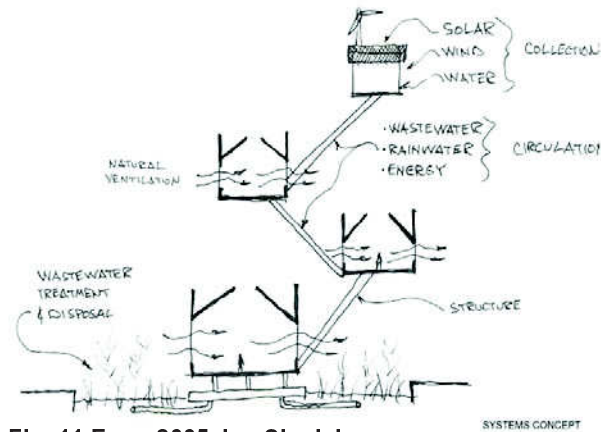

Fig. 11 Expo 2005 Joe Sinclair

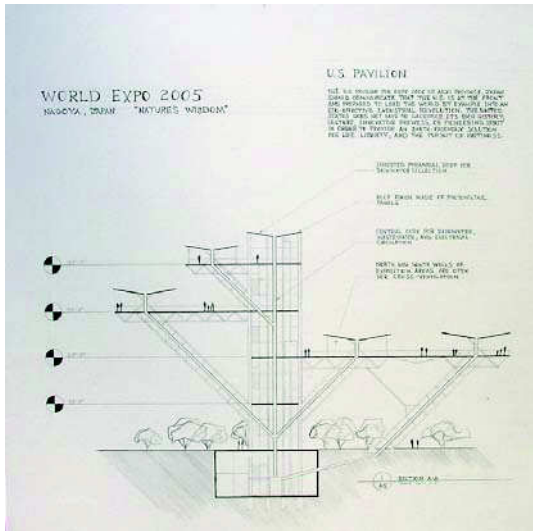

Fig. 12 Expo 2005 Joe Sinclair

ECOSYSTEMS AND SOCIOLOGY

Inherent within this studio program were many social and political struggles. As a studio, we addressed these issues, but more potently, we addressed the role of the designer in the social and political realm. The most intriguing design response from a socio-political perspective was Rebecca Morgan who developed a building-less design that was a pond with a translucent wall winding through it (fig.13). There were steps on each side representing each country at the Expo. When someone stepped on a stone and put their hand on the wall, they could hear a translation of whatever someone on the other side of the wall was saying. It was a poetic statement of what democracy and globalism could be. However, it was not specifically inspired by any natural systems.

Every design project has inherent social and political factors but a politically charged project offers exciting design challenges on its own grounds. Though socio-political aspects of design are often ignored by practice and educational systems, these factors couldn't be ignored in Expo 2005. Some students found a link between ecosystems and socio-political systems while others were overwhelmed by the multiplicity of design considerations. Given the realities of the design decision-making, I think design considerations beyond form need greater attention.

Addressing a design project with a previously defined systems model could go many ways. In this studio, what I discovered was that the creative and symbolic aspects of this design project could be vastly improved when a natural systems model was available.

FUTURE APPLICATIONS OF ECO-SYSTEMS APPLICATIONS

Taken to its logical conclusion, the goal of making all of our students ecologically literate would restore the idea that education is first and foremost a large conversation with technical aspects, not merely a technical subject.^{xiv}

As a designer and educator, I see my role as a creative problem solver seeking to help students become cognizant of their potential affect on the built world. With this studio, we introduced students to designs that have affects on the world that are fundamentally different from the water, energy and material depletion prevalent in our industries.

This studio was a first-step towards an application of ecological principles in the conceptual design process. Ideally, this class would include lectures from industrial ecologists, biologists, engineers and others. My hypothesis is that the deeper the understanding of ecological systems, the more inherently ecological principles will be ingrained into the design process of students in the future. I recognize that students are engaging with ecological systems in a manner that may be relatively cursory, but the hope is that this knowledge will inspire curiosity well beyond what is covered in ten weeks.

I believe that there is potential to address design problems well beyond the modernist formalism still coming out of many architecture schools. Cultural, social and economic issues all have the potential to be informed by a deep understanding of ecological principles.

There was mixed success amongst the students' abilities to abstract the ecological systems into meaningful conceptual design potential. One challenge was the need to remain sufficiently abstract that subjective association is minimized. Basically, some things were taken too literally. Some components of natural systems were directly translated into forms as opposed to being understood as fluid, evolving systems. As we saw in Storm's project, the investigation of a frog's skin led to a project in which water became both the energy source as well as the concept. In Sinclair's project, the different zones of an ant's habitat were literally transformed into zones of his project. Then, the different zones were assigned to address particular energy or water issues. A deeper understanding of the organization of the ant's habitat and processes might have led to a more abstract interpretation.

This is one approach to addressing the question, "How do we effectively teach ecological design?" I have found that the sun path diagrams and psychrometric charts are understood and incorporated in the design process by only a small percentage of architecture design students. The incorporation of ecological principles in the conceptual design process may offer one way of encouraging and developing applied systems thinking within the studio design process.



Fig. 13 Expo 2005 Rebecca Morgan

IMAGES

- Fig. 01 The American Pavilion Expo 2005 - <http://www.uspavilion.com/pavilion/index.htm>, dec.20, 2006.
Fig. 02 The German Pavilion Expo 2005 – from German Pavilion photobank - <http://koelnmesse.viabild.de/ixfiles/mandantlogin/koelnmesse/de/aktuelleexpo>, dec. 30, 2006
Fig. 03 The U.K. Pavilion Expo 2005 - <http://www.expo2005.or.jp/en/nations/4m.html>, dec. 21, 2006.
Fig. 04 Ecosystem investigation from Nature's Wisdom Expo 2005 studio – Matt Furedy
Fig. 05 Ecosystem investigation from Nature's Wisdom Expo 2005 studio – Meghan Storm
Fig. 06 Ecosystem investigation from Nature's Wisdom Expo 2005 studio – Meghan Storm
Fig. 07 Final Project from Nature's Wisdom Expo 2005 studio – Meghan Storm
Fig. 08 Final Project from Nature's Wisdom Expo 2005 studio – Meghan Storm
Fig. 09 Ecosystem investigation from Nature's Wisdom Expo 2005 studio – Joe Sinclair
Fig. 10 Ecosystem model from Nature's Wisdom Expo 2005 studio – Joe Sinclair
Fig. 11 Schematic sketch from Nature's Wisdom Expo 2005 studio – Joe Sinclair
Fig. 12 Final Project from Nature's Wisdom Expo 2005 studio – Joe Sinclair
Fig. 13 Final Project from Nature's Wisdom Expo 2005 studio – Rebecca Morgan

REFERENCES

- Associated Press, Partnership Briefing, www.uspavilion.com/pdf/partnership_briefing.pdf, dec. 6, 2006.
Benyus, Janine, *Biomimicry: Innovation Inspired by Nature*, Harper Perennial, 2002.
Constantine, David, *They Look Alike, But There's A Little Matter of Size*, New York Times, August 15, 2006.
Expo 2005 World Expo website, <http://www.expo2005.com/>, nov.10, 2006.
Japan Association for the 2005 World's Exposition, Message from Japan: "Nature's Wisdom", http://www.expo2005.or.jp/en/whatexpo/message_00.html, nov. 06, 2006.
Johnson, Bart and Kristina Hill, *Ecology and Design: Frameworks for Learning*, Island Press, 2002.
Kibert, Charles, et.al., *Construction Ecology: Nature as the Basis for Green Buildings*, Spon Press, 2002.
McDonough, William and Michael Braungart, *Cradle To Cradle: Remaking the Way We Make Things*, North Point Press, 2002.
Orr, David, "Ecoliteracy: The Learning Curve", Resurgence On-line magazine issue 226, <http://www.resurgence/issues/orr226.htm>, feb 17, 2007.
Van der Ryn, Sim and Stuart Cowan, *Ecological Design*, Island Press, 1996.
The U.S. Pavilion World Expo 2005 website, <http://www.uspavilion.com/pavilion/index.htm>, dec. 30, 2006.
Timpson, William M., et.al., *147 Practical Tips for Teaching Sustainability: Connecting the Environment, the Economy and Society*, Atwood Publishing, 2006.

ENDNOTES

- ⁱ Expo 2005 World Expo website, <http://www.expo2005.com/>, nov.10, 2006.
ⁱⁱ Some of the critical texts on ecology and design include McHarg, *Design With Nature*, van der Ryn, *Ecological Design*, Benyus, *Biomimicry*, McDonough and Braungert, *Cradle To Cradle*,
ⁱⁱⁱ Johnson, p.25, note 1.
^{iv} Benyus, *Biomimicry*, <http://www.biomimicry.net/intro.html>, dec.30, 2006.
^v McDonough, William and Michael Braungart, *Cradle To Cradle: Remaking the Way We Make Things*, pp.72-73
^{vi} Japan Association for the 2005 World's Exposition, Message from Japan: "Nature's Wisdom", http://www.expo2005.or.jp/en/whatexpo/message_00.html, nov. 06, 2006.
^{vii} Associated Press, Partnership Briefing, www.uspavilion.com/pdf/partnership_briefing.pdf, dec. 6, 2006.
^{viii} The U.S. Pavilion World Expo 2005 website, <http://www.uspavilion.com/pavilion/index.htm>, dec. 30, 2006.
^{ix} The U.S. Pavilion World Expo 2005 website, <http://www.uspavilion.com/expo/index.htm>, dec. 30, 2006.
^x Expo 2005, German Pavilion, <http://www.expo2005-deutschland.de/site/flash/index.php?lang=e>, dec. 30, 2006.
^{xi} Expo 2005, United Kingdom Pavilion, <http://www.expo2005.or.jp/en/nations/4m.html>, dec. 30, 2006.
^{xiii} Constantine, David, *They Look Alike, But There's A Little Matter of Size*, New York Times, August 15, 2006.
^{xiv} Orr, David, "Ecoliteracy: The Learning Curve", Resurgence On-line magazine issue 226, <http://www.resurgence/issues/orr226.htm>, feb 17, 2007.

In Poetic Association: Acts of Architecture in the Realm of Landscape Ecology

Brook Muller

University of Oregon, Eugene, OR

ABSTRACT: This paper describes metaphorical engagement of ecology as a strategy for designing human inhabitation catalyzed by and supportive of healthy urban ecosystems. A case is made for the importance and timeliness of collaboration and conceptual association between architects and landscape ecologists. Next, the Australian architect Richard Lepastrier's notion of architecture as "furnishing with particular purpose this larger room we are in" – suggestive of both the architect's role and the context of an architectural undertaking – is examined as a prototype for approaching problems of design in an environmentally sensitive manner. A pilot studio attempt to engage ecological issues through metaphor is described, and building from this experiment and Lepastrier's statement, a palette of "human act/environment" case study metaphors is offered for use in design. Lastly I offer a methodology for testing these metaphors in advanced architectural design studios and evaluating their influence on students' design thinking and the environmental responsiveness of projects that result.

Keywords: Architectural Design, Landscape Ecology, Metaphor

INTRODUCTION

While much research is underway to develop environmentally friendly building materials, advance energy performance and more efficiently "harvest" on site resources, and while flowing landscape-like forms captivate our collective imagination, architects' knowledge of principles of ecology and the site-specific ecological impacts of building interventions are limited. *What might rigorous engagement with the language of ecology, and more specifically landscape ecology, mean for architects?* Might we summon more encompassing portrayals of our activities, descriptions that better enable design professionals to realize projects that minimize damage and perhaps engage in beneficial relationships with surrounding ecosystems? Can a metaphorical appropriation of working concepts in landscape ecology such as "peninsular interdigitation," patch/matrix "breaks" and "edge/corridor effects" alter how we understand problems of architecture and encourage shifts in methodological tactics?¹ With continued pressure to develop remnant lands within and at the margins of our cities, can we envision a scenario where both architectural enterprise and ecological integrity are achievable?

In "revealing the importance of spatial patterning on the dynamics of interacting ecosystems," landscape ecology offers great relevance for architects.² Perhaps the most spatially oriented sub-discipline of ecology, landscape ecology embraces intervention, intentionality and design as a means of ensuring healthy, functional and diverse ecosystems. While landscape ecologists undertake projects in a multiplicity of ecosystems at many scales, involving public or private land holdings or both, the discipline finds itself increasingly contending with the Jeffersonian, democratic small scale lot. Joan Iverson Nassauer recognizes the critical importance of this trend,

"We must work at this democratic scale of ownership, the single lot or the single farm or ranch, to achieve ecological health beyond public lands and beyond the anomalies of privileged and enlightened land development. In the United States, where recent legal decisions have tended to narrowly interpret public interests in limiting private-property rights, and where strong cultural traditions favor the rights of landowners to do what they deem most suitable on their land, overall ecological health depends on the aggregation of innumerable individual landowner's decisions."³

With landscape ecologists increasingly concerned about environmental quality at the lot scale, even beginning to contemplate the impact of the building “footprint,” a growing number of architects seek to more sensitively apprehend larger landscape ecological processes that are influenced by the configuration of buildings, to address for example the morphological implications of architecture given the need to preserve wildlife corridors that may exist on a site, or repair a corridor previously fragmented. As regimes of thought between these disciplines converge, metaphors, “nomadic terms that link disparate discourses,” may be looked at as creative intellectual tools for extending ecological mediums into built form and built form into the landscape in a transformational and integrated manner.⁴ In developing a framework for metaphorical appropriation of concepts of landscape ecology so as to positively influence architectural thinking, I will first reflect on the Australian designer Richard Leplastrier’s suggestion of the primary task of the architect as that of “furnishing with particular purpose this larger room we are in,” a notion that continues to haunt me as an example of the profound influence novel articulations can have on conceptualizations of architecture at the outset of design investigations, and the environmental receptivity that poetic insight can encourage.⁵

1.0 METAPHORICS AND POETICS OF FURNISHING THIS LARGER ROOM

“People who have not lost the wholeness of their place can see their households and their regional mountains or woods as within the same sphere.” –Gary Snyder⁶

In the 2001 Glenn Murcutt Architecture “Master” Class in New South Wales, Australia, students were asked to design a gallery in a bowl-shaped meadow adjacent to Murcutt’s Riversdale Educational Retreat Center (1999). During a site visit in the preliminary stages of design, architect Richard Leplastrier suggested the task of the architect was to “furnish with particular purpose this larger room we are in,” a notion that fostered a novel understanding of the designer’s role and heightened receptivity towards landscape. Conceiving the gallery not as an object in a field but rather an assemblage of “furnishing-like” settings in a bowl-shaped room liberated students to “pull the building apart,” to consider minimal provisioning of shelter for many of the space as acceptable, and to propose projects of dramatic efficiency, richness and environmental response.

This account from my own experience is revealing of the manner in which use of metaphor involves attempts to explain complex phenomenon via something tangible and comprehensible.⁷ Leplastrier’s notion of “furnishing this larger room” may be said to involve two critical metaphorical presuppositions: (1) we may gain insight into the highly complex realm of architecture by assigning characteristics to architectural elements we more typically attribute to furnishings (such as economy, lightness and unpretentiousness), and (2) we gain insight into the highly complex realm of the environment by suggesting it has room-like qualities. Through a stratagem of poetic association, we combine these two notions to produce a strikingly new (third) meaning. I say striking and suggest Leplastrier’s statement encourages design thinking resonant with contemporary concern over the environment. In particular it (1) suggests architecture takes part in something larger that demands sensitive acknowledgement and (2) helps us sidestep the nature/culture dichotomy and acknowledge the energetic purposefulness inherent to humans and to suggest possibilities for applying such energy constructively as we interact with the world around us.

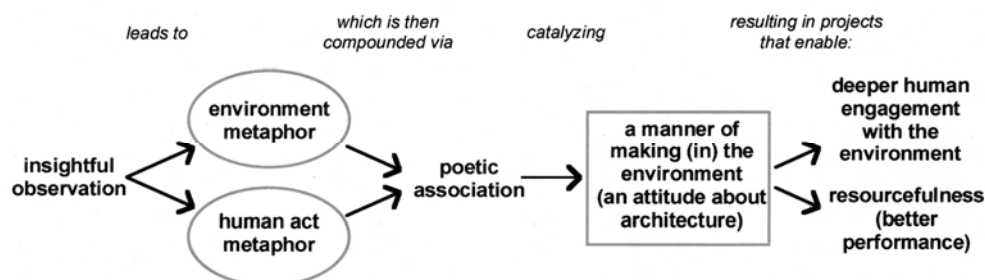

Figure 1: Two metaphors are compounded through poetic association to produce a new (third) meaning

With the notion of *architecture as furnishing this larger room*, a built entity is less a boundary and more a mediator between our selves and larger entities, rooms at once tremendously spatially complex and comforting in their bounding comprehensibility. Our architectural furnishings, surfaces as bodily extensions and settings for gathering, are “outfoldings” towards our primary inhabitation, an environment, a horizon, a landscape under the stars. That such mindfulness of dwelling/inhabitation practices that find registration in the landscape might inspire works of architecture corresponds vividly with David Leatherbarrow’s treatment of “The Topographical Horizon of Dwelling Equipment” in his groundbreaking work “Uncommon Ground.” I quote three passages from the book:

“No single element in a spatial ensemble is positioned to stand out from all the rest; no single piece of equipment obtrudes itself into one’s awareness, each coexists with others in a state of shared latency, waiting, one might say, not passively like a mirror, but with a tendency or disposition to prefigure patterns of behavior, which is how architecture confers orientation.”⁸

“Like that of its antecedent, the blind’s flexibility allowed it to serve as a register and receptacle of the landscape, welcoming it when it presented itself gently, excluding it when it raged with fury.”⁹

“We begin to see that this corporeal schema is enmeshed within an expanding range of distances, a structured topography that includes where I am, which is to say where the things I now need are within reach, a middle distance, and an expansion towards the clear blue horizon; an equipmental, practical and environmental horizon. Not one of these can be separated from the others, hence the lateral spread of the ensemble that integrates these “rings” into one field, terrain or topography – the dining room, the street, and the town or landscape – differentiated but reciprocating.”¹⁰

For Leatherbarrow furnishings are both register of the body *and* landscape *and* a critical mediator of their “lateral spread.” Both Leatherbarrow and Lepastrier would seem to suggest that the environmental philosopher Arnold Berleant’s strong distinction between participatory and neutrally distanced, picturesque aesthetics is inadequate, that simultaneity or constant rhythmic succession of acts of involvement in and contemplative comportment toward the world characterize aesthetically oriented human experience. But we may also raise the question of the extent to which the reining peacefulness intimated by Leatherbarrow throughout his work, the equipoise of living experience amidst “equipment,” has been arrived at after the dust has settled, with primary emphasis on experiential effect (that anticipates subsequent patterns of effects) as opposed to what is affected. Here we find usefulness and accountability in Lepastrier’s *to furnish*, communicating as it does what constitutes architecture *and* the manner in which it is to be constituted.

With respect to dwelling practices, Leatherbarrow’s descriptions of inhabitational behavior seem largely passive and as if our patterns are predetermined rather than in constant adjustment. If rhythms of flux and stasis characterize human existence, an intrinsic propensity to cycle through times of movement and activity and times of rest, what kind of arrangements of furnishings would support such living patterns? Dewey’s birdlike metaphor of human affairs as an “alternation of flights and perchings” provides a direction for exploration, as does Glenn Murcutt’s notion of architecture as “encampment,” suggesting a migratory patterning to human affairs, with residency as temporal and only one form of activity among others that also include gathering, commuting, encountering, bargaining, recreating, wandering, etc.¹¹ Dewey and Murcutt’s metaphors may offer a more complete – and lightened – accounting of the full range of our being amidst the lateral spread, even beginning to blur distinctions between the domestic and wild, an idea to be taken up shortly.

Lastly, and despite the promise of Leatherbarrow’s ideas, “clear blue horizon” as a summary portrayal of our environment seems an overly simple evocation of the enormous and legible complexity that the world as we experience it. Lepastrier’s “room” is more ample (with the clear blue horizon as wainscoting?) and hardly nondescript if we consider Heidegger’s thoughts on room as interpreted by the contemporary philosopher Edward Casey:

“Heidegger’s contribution to this history (of place) is to make room such a mediatrix expressly by virtue of the ingrency of region, whose amplitude and dynamism make possible the generation

of place and space alike. For the effect of region is the creation of the very spatiality (raeumlichkiet: literally, "roomliness") from which place is precipitated and space discerned." ¹²

As Casey interprets Heidegger, "room" is enriched in its inclusivity and powers of precipitation, providing full potency to Leplastrier's notion. As we consider how such understandings may play out in the realm of design, one wonders, however, whether room is too generous a term, and that it might be more helpful for architects to develop metaphorical characterizations that more specifically relate qualities of projects to particularities of context. This is a primary reason why engagement with ideas in landscape ecology may prove helpful.

2.0 THE FOLIAGE OF ARCHITECTURE

"The animal world and that of plant life are not utilized merely because they are there, but because they suggest a mode of thought." –Claude Levi-Strauss ¹³

"Now an increasingly urban population fears any intimacy with uncontrolled nature, especially darkness." -John Stilgoe ¹⁴

Students in the winter 2006 "Triumph of the Commons" architectural design studio were asked to consider increased urban density and improved ecological performance as *one interrelated problem*. The studio specifically explored simultaneous residential alley-access infill development *and* oak habitat restoration on a city block in a post war neighborhood in Eugene, Oregon, with a goal to provide for a growing human population resourcefully while reestablishing critical wildlife corridors linking core habitats for threatened species. A landscape ecologist with extensive experience in oak habitat restoration partnered with the author from day one, helping students develop proposals for secondary dwelling units on existing lots *and* block scale native vegetative structures – superimposed threads of woodland and savanna.

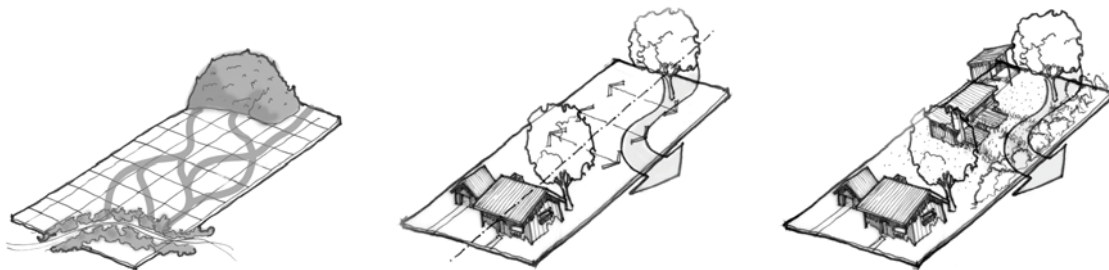

Figures 2, 3 & 4: (left): Neighborhood goal to (re)create wildlife corridors so as to connect "core" habitats; (middle, right): Siting and configuration of new infill dwelling unit on existing lot in response to neighborhood scale ecological goal of corridor connectivity (drawings by Alex Wyndham, Master of Architecture candidate)

Initial and exploratory assignments had students generate imagery and associated metaphorical descriptors capturing their insights from readings and discussions on the work of landscape ecologists and observations during field trips to both Eugene's alleys and nearby oak woodland communities. These served as the basis of three-dimensional "form analog" studies that hybridized oak and alley realms into one composite design language that influenced directly more 'pragmatic' design undertakings later in the quarter. Through these investigations, students considered both the architectural implications of the incorporation of landscape ecology principles as *they pertain to specific habitat conditions*, and the viability of ecological structures such as cores and corridors in a dense urban context. Investigations in section revealed the potential for multiple species to occupy different strata within one vertical band of space, with oaks growing alongside, up and over dwellings, providing summer shade for people below and corridor networks of limbs facilitating movement for the western grey squirrel and other creatures above.



Figures 5, 6 & 7: Brent Sturlaugson's oak pattern image," Rebekah Matheny's alleyway power lines image, and Missa Aloisi's "Lifelines" hybrid oak/alley "form analog" study

Gilles Deleuze and Felix Guattari, in their poststructuralist masterpiece *A Thousand Plateaus*, favor the "rhizomatic" over the "arborescent" model in describing societies and relationships, directing our understanding of arborescence towards the trunk, a metaphorical pillar of centralized command. In so doing they overlook the bud and the branch, the latter not predetermined in its course of growth and yet reacting to its neighbors in seeking light and continued livelihood. Extending our gaze upward, from understory and trunk to the tracery of interwoven limbs, we are afforded a pluralistic, democratic impression, inspiring possibilities for open, interconnected and "branching" spatial organizations of built and open space. With Brent Sturlaugson's scheme for example, a contiguous canopy overhead corresponds to a contiguous social understory, ribbons of outdoor space emanating from a ribbon-like toplight serving as his dwelling's primary organizational element. Missa Aloisi's inspirational insight was that of a bird descending from its home on an oak limb to pluck berries from a shrub below, experiencing a brief moment of exposure in flight. Her dwelling separates eating and living space from sleeping "pods" (reminiscent of oak galls), with the human inhabitant's periods of shelter in these book-ended realms offset by brief, vulnerable movements within translucent "lifeline" passages.

That oaks undergo seasonal changes – budding, leafing, shedding – and that these cycles generate dramatically different thermal and luminous microenvironments, had perhaps the greatest impact on perceptions of space making, inspiring dynamic architectures capable of expansion and contraction. With Alex Wyndham's "Deciduous House," insulated wall "leaves" fold upward and serve as south facing trellis-like shade screens in summer, filtering light from above. With several studio projects, the dwelling expands in summer as wall panels slide laterally into recessed niches, maximizing horizontal continuity between interior and exterior space. An 800 square foot dwelling unit suddenly feels spacious when open to a reinvigorated network of natural systems, where viewsheds extend to adjacent lots and beyond, thoughtfully and so as to not create conflicts of privacy.

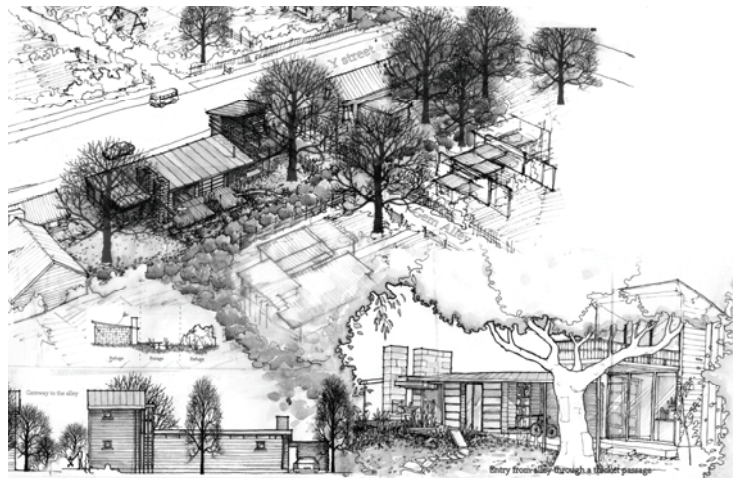

Figure 8: Alex Wyndham's final project "Deciduous House"

In winter mode, architectural elements contract and dwellings become snugly introspective, surrounded by silent matt grey light, gentle rain and black wet limbs of the Pacific Northwest. January dimness counterbalances the light exuberance of summer; our world becomes closer and more immediate, paralleling the inwardness of our own comportment. With Tanizaki, we recognize darkness not as blackness but consisting of countless gradients, from tangible opacity to endless depth.¹⁵ With Derrida, we harbor suspicion of a society's insistence on unceasing immersion in light:

"The heliological metaphor turns away our glance. For it has always been believed that metaphors exculpate, lift the weight of things and of acts. If there is no history, except through language, and if language is elementally metaphorical, Borges is correct, 'Perhaps universal history is but the history of several metaphors.' Light is only one example of 'several' fundamental 'metaphors,' but what an example! Who will ever dominate it, who will ever pronounce it's meaning without first being pronounced by it?"¹⁶

3.0 A PALETTE OF HUMAN ACT/ENVIRONMENT "CASE" METAPHORS

"The ephemerality of all our acts puts us into a kind of wilderness-in-time" –Gary Snyder¹⁷

"If the objects of the environment were only as plastic as the materials of poetic art, men would never have been obliged to have recourse to creation in the medium of words." –John Dewey¹⁸

The efforts and ruminations described above have coalesced in the development of a palette of "case study" metaphors for use in the design studio. Building from Lepastrier's compound notion and the "Triumph of the Commons" pilot studio experiment, and borrowing more explicitly from the language of landscape ecology, these metaphors, it is hoped, will catalyze possibilities for sensitive acknowledgment of context as a consequence of architectural intervention. A winter 2007 "Wild Urbanism" studio provides the first opportunity to introduce these to advanced design students. The project, a vertical mixed-use development adjacent to a riparian/mixed hardwood-conifer forest in Portland, OR, anticipates the brief for a fall 2007 Portland Metro Services "Nature in Neighborhoods" competition of which the author is serving as consultant. Students will develop 2D and 3D "esquisse" studies at several strategic points in the quarter that will require relating a case metaphor to the building program and site, with the expectation that both built and natural features are represented (that we contend with human and non-human habitation throughout). A goal will be to examine whether the metaphors influence the generation of design proposals that contend with human needs and aspirations *and* the ecological integrity and viability of critical and singular habitats.

The case metaphors include:

- *flights and perchings along a green frame*
- *peninsular interdigitation*
- *folds along waterpockets*
- *embroidered pleats in green wedges*
- *encampments in a green fabric*
- *dispersing corridors*
- *layers buffering cores*
- *stitching matrices and cores*
- *watermarks*
- *boulder garden and a braided stream*

Several of these case metaphors stem directly from operative concepts in landscape ecology. "Dispersing corridors" for example derives from the notion of a "dispersal corridor," typically a band of native vegetation facilitating migration of wildlife from one "core" habitat area to another. Others combine philosophical and landscape ecological notions, as with "alternations of flights and perchings along a green frame" that links Dewey's aforementioned birdlike articulation of human activity with a concept of a "network of green space for an urban area."¹⁹ Similarly, "embroidered pleats in green wedges" compounds Gilles Deleuze's cloth-like metaphor as the archetype of Baroque sensibility with an ecological concept for a landscape structure that "keeps developed areas apart while bringing greenspace closer to heart of settlement."²⁰ All case metaphors are intended to capture an understanding that return to ecological health in urban environments involves design, artfulness, intention and beauty. These inventive (re)characterizations attempt to reconcile ever-growing human presence with need for the wild in places largely compromised yet capable of rejuvenation.

In the aftermath of this studio experiment I will evaluate the impact of the case metaphors on the environmental performance and ecological impact of students' projects. This will entail (1) examination of the case metaphors that students utilized; (2) an appraisal of how students organized the building program for the project under consideration and an estimate of the effect of case metaphors on organization; (3) a determination of the percentage of spaces in students' projects that are fully, partially and unconditioned; (4) an estimation of energy savings of proposed designs over more traditionally organized buildings using the same program and where spaces are assumed fully conditioned. I also intend to assess the ecological impact of student projects through consideration of: extent of building footprint, where a small footprint would have less ecological impact than a large footprint; and degree of "permeability" of the site as a result of building configuration, with a goal to facilitate wildlife movement through the site to adjacent habitat areas and where wider, uninterrupted and more wildlife corridors are preferred over narrower, interrupted and fewer wildlife corridors.

4.0 TRAJECTORIES

"Ecosystem deterioration...needs to be addressed by a series of bold experiments to test the success of integrated management" –Jeremy Jackson et. al. ²¹

"Since man was constituted at a time when language was doomed to dispersion, will he not be dispersed when language regains its unity?" –Michael Foucault ²²

The philosopher Edward Casey maintains, "By 'strung out between wilderness and site,' I mean that we drastically lack viable and significant intermediate positions between these two extremities." ²³ Fellow philosopher Hans-Georg Gadamer suggests "discourse that is intended to reveal something requires that the thing be broken open by the question." ²⁴ Questions originating in the field of landscape ecology break the resolute "thingness" of architecture in compelling ways, and our responses as designers open stimulating paths of inquiry for our newfound collaborators. Together we can more effectively find those intermediate positions that Casey believes contemporary culture so desperately needs, discovering new life for our disciplines in the process.

Yet in our efforts to envision and describe more symbiotic relationships between built and natural environments, humans and other organisms, are we are compelled to speak in reductivist binaries, thereby confronting the limits of a language that necessarily presupposes the nature/culture duality we seek to circumvent? Perhaps not if we consider the connections between architectural and ecological systems as manifold, and our charge as not the portrayal of parallels but the rendering of entanglements through associative, metaphorical thinking. Encouraged by Richard Rorty to "replace the world of pictures constructed with the aid of Greek oppositions with a picture of a flux of continually changing relations," we may affect a redistribution of categories, a traversal and interdigitization of nature/culture binaries that increases the frequency of their oscillation. ²⁵

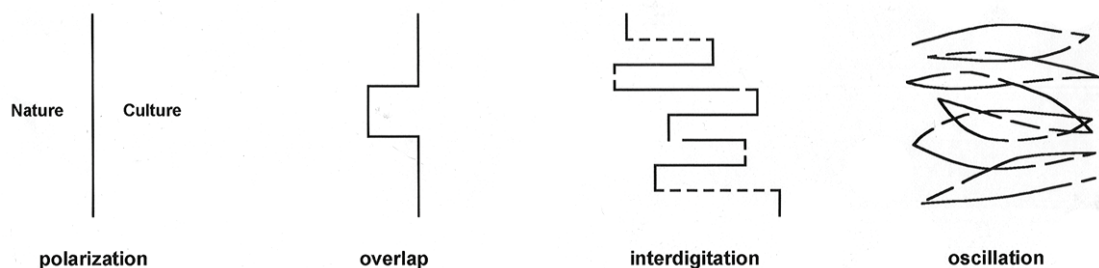

Figure 9: Evolving relationships of nature/culture and ecology/architecture (and our descriptions thereof)

For students in the studios described above, it is hoped that playful, tenacious engagement of metaphor and the language of landscape ecology generates an outward reverberation of thought, inspiring notions of ecological symbioses between buildings and sites, dramatic material and energy efficiencies, and profound engagement of humans and the natural world. Through exposure to human

act/environment metaphors, it is hoped, students are alerted to the inherent incompleteness of architectural undertakings, of the advantages of “a project that privileges unpredictable ecological processes,” and of the benefits of invitation of the wild in the design of urban environments.²⁶ Awareness that the identities of specific ecological structures can help us conceptualize our own relationships and artifacts opens us to radical possibilities for migratory proto-urbanism and community revitalization, to depictions of cross flows not yet appreciated, architectural ecologies both selectively porous and biologically complex.

REFERENCES

- ¹ From Richard T.T. Forman & Michel Godron, *Landscape Ecology*, New York: John Wiley & Sons, 1986
- ² Monica G. Turner, Robert H. Gardner and Robert V. O’Neil, *Landscape Ecology in Theory and Practice: Patterns and Process*, New York: Springer Science and Business Media, Inc., 2001, p. 1
- ³ Joan Iverson Nassuaer, “Cultural Sustainability: Aligning Aesthetics and Ecology” in *Placing Nature: Culture and Landscape Ecology*, Joan Iverson Nassuaer, ed. (Washington, D.C.: Island Press, 1997), p. 71
- ⁴ James D. Proctor and Brendon M. H. Larson, “Ecology, Complexity, and Metaphor,” in *Bioscience* Volume 55, No.12, December, 2005, p. 1066
- ⁵ For a thorough consideration of Leplastrier’s articulation, please see my papers “Metaphor, Architectural Design and Environmental Response,” *Architectural Research Centers Consortium/European Association of Architectural Education International Conference*, Philadelphia, PA, 2006 and “Lightness of Building: Furnishing a Regenerative Architecture,” *American Collegiate Schools of Architecture Annual Conference*, Louisville, KY, 2003
- ⁶ Gary Snyder, “Blue Mountains Constantly Walking,” in *The Practice of the Wild*, Washington, D.C.: Shoemaker and Hoard, 1990, p. 112
- ⁷ My understanding of metaphor has been influenced greatly by George Lakoff and Mark Johnson, in particular their pioneering works *Metaphors We Live By* and *Philosophy in the Flesh*
- ⁸ David Leatherbarrow, *Uncommon Ground: Architecture, Technology, Topography*, Cambridge: MIT Press, 2000, p. 157
- ⁹ David Leatherbarrow, p. 138
- ¹⁰ David Leatherbarrow, p. 66
- ¹¹ John Dewey, *Human Nature and Conduct*, Mineola, NY: Dover Publications, Inc., 2002 (originally published by Henry Holt & Company, New York, 1922), p. 179
- ¹² Edward S. Casey, *The Fate of Place: A Philosophical History*, Berkeley, CA: University of California Press, 1997, p. 252
- ¹³ Claude Levi-Strauss, *Totemism*, Rodney Needham, trans., Boston: Beacon Press, 1962, p. 13
- ¹⁴ John Stilgoe, “Land Fear: Wildness and the Bewilderment of the City Dweller,” in *Architecture Boston*, March/April 2003, pp. 20
- ¹⁵ See Jun’ichiro Tanizaki, *In Praise of Shadows*, Thomas J. Harper and Edward G. Seidensticker, trans, New Haven, CT: Leete’s Island Books, 1977
- ¹⁶ Jacques Derrida, “Violence and Metaphysics,” in *Writing and Difference*, Alan Bass, trans., Chicago: University of Chicago Press, 1978, p. 92
- ¹⁷ Gary Snyder, “On the Path, Off the Trail,” in *The Practice of the Wild*, Washington, D.C.: Shoemaker and Hoard, 1990, p. 165
- ¹⁸ John Dewey, pp. 256-257
- ¹⁹ Paul Caewood Hellmund and Daniel Somers Smith, *Designing Greenways: Sustainable Landscapes for Nature and People*, Washington, D.C.: Island Press, 2005, pp. 2-3
- ²⁰ See Gilles Deleuze’s *The Fold: Leibniz and the Baroque*, Tom Conley, trans., Minneapolis: University of Minnesota Press, 1993 and Paul Caewood Hellmund and Daniel Somers Smith, pp. 2-3
- ²¹ Jeremy B.B. Jackson, et. al., “Historical Overfishing and the Recent Collapse of Coastal Ecosystems,” *Science*, Volume 293 No. 5530, July 27, 2001, pp. 629-638
- ²² Michael Foucault, *The Order of Things: An Archaeology of the Human Sciences*, New York: Vintage Books, 1994 edition, p. 386
- ²³ Edward S. Casey, *Getting Back Into Place: Toward a New Understanding of the Place World*, Bloomington, IN: University of Indiana Press, 1993, p. 259
- ²⁴ Hans-Georg Gadamer, *Truth and Method*, Joel Weinsheimer and Donald G. Marshall, transl., London: Continuum Publishing Group, 2004 edition, p. 357
- ²⁵ Richard Rorty, “A World Without Substances or Essences,” in *Philosophy of Social Hope*, New York: Penguin Books, 1999, p. 46
- ²⁶ Eric Higgs, *Nature By Design: People, Natural Process and Ecological Restoration*, Cambridge, MA: MIT Press, 2003, p. 7

Case Studies—Lighting

Configuring Structure to Improve Daylight Access in Multistory Buildings
**Christine Theodoropoulos, G.Z. Brown, Arthur Johnson, Michael Hatten,
Christopher Flint Chatto, Jeff Kline, Dale Northcutt**

Green In The Balance: Visual Comfort Inside Offices With Tilted Facades
Ihab Elzeyadi

A Lower Cost, Higher Performance Classroom: will innovation lead to market
transformation?
G.Z. Brown, Jeff Kline, Dale Northcutt

Configuring Structure to Improve Daylight Access in Multistory Buildings

Christine Theodoropoulos¹, G.Z. Brown¹, Arthur Johnson², Michael Hatten³,
Christopher Flint Chatto¹, Jeff Kline¹, Dale Northcutt¹

¹Energy Studies in Buildings Laboratory, University of Oregon, Eugene, Oregon

²KPFF Consulting Engineers, Portland, Oregon

³SOLARC Architecture + Engineering, Eugene, Oregon

ABSTRACT: This paper describes a project to develop alternate configurations of structural systems that improve access to daylight at the perimeter of multistory office and hospital buildings. We examined structural systems typically used for office buildings and hospitals in the Pacific Northwest to determine the feasibility of changing or reconfiguring structural components to increase access to daylight. Based on the information gathered from ten case study buildings, five hospitals and five office buildings, we developed alternative approaches to structural framing. The most economically viable approaches were further evaluated for their effectiveness. We considered the interaction among structural components, HVAC, building enclosure systems, and daylight and identified integrated design approaches. Our investigations show that designers can generate economically viable alternatives to the structural systems in office and hospital buildings that increase access to daylight by:

reconfiguring structural components used at the building perimeter, particularly spandrel beams;

moving lateral load resisting systems from the perimeter zone to the interior or core zones of the building;

reconfiguring or using alternative HVAC systems at the building perimeter to reduce or eliminate ducts that obstruct access to the perimeter wall; and

shaping perimeter zone ceilings to increase window head height:

The internal wall height gained from the above strategies allows for increased access to daylight, the costs of which are offset by decreasing the exterior wall height—a cost neutral proposition.

Keywords: daylight access, perimeter zone design, spandrel beams, daylighting cost

INTRODUCTION

In design practice, the design team studies configurations of proposed structural systems, mechanical systems and building envelope systems to determine a cost-effective combination of these three systems that meets design objectives. In this project we added consideration of a fourth system – daylighting – to the design approach. Daylighting is a cost-effective method of reducing electrical energy use and the cooling load, saving both operating cost and first cost. In addition, daylight may increase the productivity of office workers and hospital staff as well as the well-being of patients.

Daylighting, whether for energy savings or occupant well-being, has a direct impact on other aspects of a room. Figure 1 summarizes these relationships. To realize energy savings, designers must consider the amount and distribution of daylight as well as the electric lights and controls; these factors in turn are related to the interior configuration of the room (zoning and reflectivity) and window factors, which are in turn related to the overall room geometry and the type and location of structural and HVAC system components. The coordination of HVAC and structural components can have a significant impact on daylight access. For example, the size and position of the perimeter beam directly affects the head height of the daylighting window.

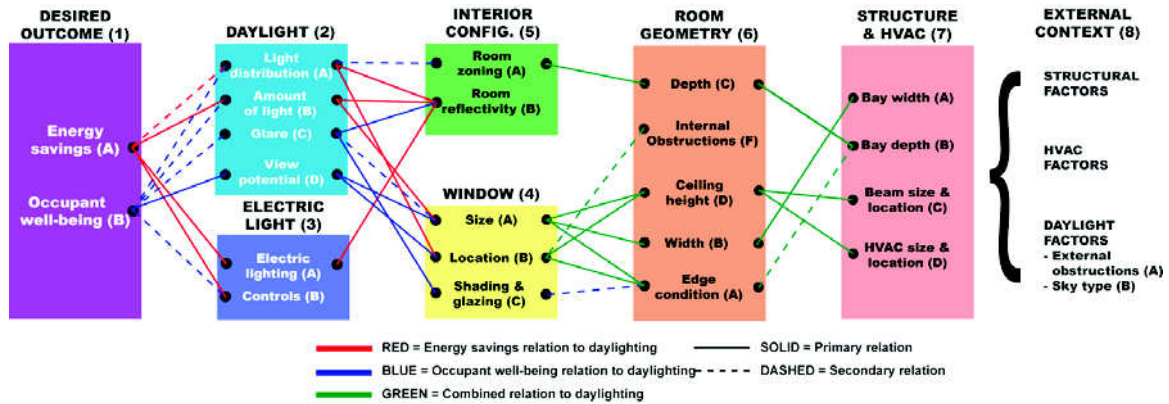

Figure 1: The relationship between daylight objectives and other architectural issues

Two types of buildings where daylight penetration as a design consideration has a large impact are hospitals and office buildings. The occupant well-being and energy benefits of increased access to daylight in hospital and office building environments are well known. However, in conventional construction, the cost associated with increased access to daylight can constrain a design team's ability to provide improved daylighting performance. Prior studies have shown that the reduction of energy costs associated with decreased electrical lighting demand rarely offsets the first construction costs associated with increased glazing areas or the increase in floor-to-floor heights that would accommodate higher daylight windows. The solution to this problem lies in a systems approach to integrating structure and HVAC systems with daylighting strategies. Figure 2 illustrates how a reduction in floor-to-floor height can be achieved through an integrated approach to window wall, ceiling, structural and HVAC design. The diagonal red lines indicate window head height and sun cutoff angle to achieve a given daylight factor at the back of the room. The length and angle of the lines are identical.

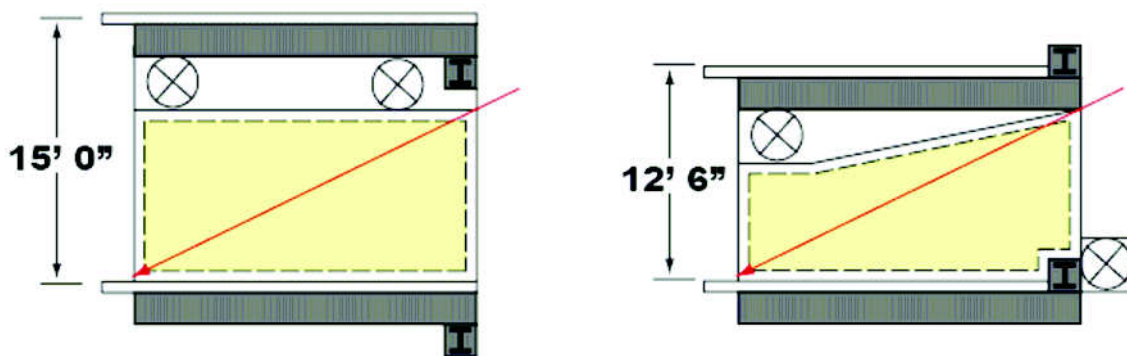

Figure 2: Uprturned spandrel beams, combined with revised HVAC systems and shaped ceilings provide increased access to daylight and reduced floor-to-floor height for hospital rooms. Source: (Brown 2005)

1. CASE STUDY APPROACH

We examined ten multistory buildings representing typical recent construction for office buildings and hospitals in the Pacific Northwest and identified appropriate alternatives to the existing structure that would increase access to daylight at the building perimeter.

Alternate designs that reduced the depth or changed the location of perimeter structural elements impacted many of the building systems (including HVAC, and building envelope), fire ratings, other structural elements, and occupant requirements. Each of these factors had associated cost or savings. In addition, alternatives to improve daylighting applied differently to hospitals than to office buildings. The more stringent functional requirements of hospitals, including patient room layout, location of heavy equipment, vibration control, and relative locations of areas such as emergency facilities, surgical areas, x-ray and triage had to be maintained. Access floors provided significant daylight advantages in office construction, but were not acceptable in

hospitals. Although hospital and office occupant needs are quite different overall, we found that daylighting design for both types of buildings could benefit from a close evaluation of how perimeter structural and HVAC components could be adjusted to improve access to daylight.

1.1 Hospitals

Hospitals in the Pacific Northwest have typically been constructed with conventional reinforced concrete beams and flat slabs. Concrete construction lends itself to good floor vibration control, which is often a significant factor in hospitals where there is sensitive equipment and patient comfort concerns. Concrete is also inherently rated well for fire-resistance. More recently, though, many hospitals have been constructed using structural steel framing with concrete over metal deck floor slabs. Four of the five recently constructed hospitals included in this study have steel frame structural systems. With steel framing, a fairly thick concrete topping can be used to achieve both fire resistance without the need for spray fireproofing, and floor vibration control. Steel framing sections that provide vibration control also tend to be two to four inches deeper. As hospitals are increasingly requiring more flexibility in how the building is used, steel presents more ease of construction or upgrade, allowing heavy equipment or large floor penetrations to be added in the future. (Post-tensioned concrete slabs are not typically suitable for this). Floor-to-floor heights in hospitals are often greater than offices, typically in the fourteen to eighteen foot range depending on the use at that particular floor, and framing bays are usually thirty feet. Finally, hospital design is, in part, driven by the building code Importance Factor. The main impact of the Importance Factor is on the building's lateral force resisting system (LFRS). Design lateral forces for this occupancy are increased by a factor of 1.5, thus increasing the size and weight of many of the elements in the LFRS.

Perimeter thermal zones in hospitals are generally dictated by the layouts of patient and exam rooms that tend to be located in the perimeter for access to views and/or daylight. Codes dictate minimum air rates for hospital patient rooms. Because of the potential need for air isolation and/or maintenance of pressure requirements between patient/exam rooms and adjacent corridors, many hospital HVAC systems are still designed as constant volume overhead ducted systems. However, overhead ducted variable air volume air distribution is increasingly being applied to perimeter patient rooms. Typically, this requires air valves (terminal unit devices above ceiling) for both supply and return air ducts. Vertical duct shafts are located in the core with supply and return mains routed above the corridor ceiling. Perimeter rooms are served with branch ducts routed from mains to terminal units and air inlets/outlets distributed over the room's ceiling plane. The typical depth of a branch duct is 6 to 12 inches. In this configuration, ductwork conflict with perimeter structure and daylight penetration is minimized. While some ductwork may be routed to the exterior wall, it runs perpendicular to the wall and tends to be small. Some hospital designs locate the return/exhaust duct loop near the perimeter wall to minimize total duct materials. These tend to be constant volume designs. In these designs, the potential for conflict with structure and daylighting elements is increased because the ductwork is run parallel to the wall edge and eventually obtains significant size as it nears connection with duct mains in vertical shafts.

1.2 Office buildings

Structural systems of office buildings in the Pacific Northwest are constructed with both steel and concrete, though steel is more common. All of the recently constructed office buildings in this study used steel frame structural systems. Requirements for offices are different from hospitals. Because offices usually have a less stringent floor vibration criterion, the floor framing sections tend to be lighter and shallower. However, office buildings also often have framing bays of greater than thirty feet in order to leave floor plates as open as possible, which makes framing members heavier. Office tenant requirements can change even more frequently than in hospitals. In offices access floors can occupy the zone of space behind upturned spandrel beams and also allow the use of post-tensioned concrete slabs without concern of damage from core drilling through the slab. Therefore, as described above, steel is an appropriate construction for anticipating of future changes to structure. Floor-to-floor heights are typically twelve and a half feet; however, buildings in this study showed floor-to-floor heights as great as 14 feet.

Office HVAC systems tend to be variable air volume overhead ducted systems. Supply and return air vertical shafts are located in the core; however, most multistory office HVAC designs serve distinct perimeter thermal zones having depths ranging from 10 to 15 feet in from the exterior wall. Moreover, because many office facades tend to have a significant amount of glazing, common practice is to route supply air ductwork from the perimeter terminal unit to a series of air outlets that "wash" the inside of the glass and exterior wall surface. This is often designed with a perimeter low pressure duct that is routed parallel to the wall edge and connected via flexible duct to slot-type air outlets. For large open offices, duct depths can be as large as 24 inches due to larger perimeter zone areas. For enclosed perimeter offices, supply branch duct depths tend to be smaller, typically 12 inches or less. Return air is often collected in a ceiling plenum arrangement with a minimum of hard duct.

2. RECOMMENDED STRATEGIES FOR IMPROVING DAYLIGHT ACCESS

2.1 Optimize daylight glazing size and placement

The daylight level at any given point in a space is determined by the amount of daylight glazing and the distance of that point from the window. Our goal is to improve the distribution of daylight within the interior. This can be accomplished by raising the height of the daylight window without increasing its area. Higher windows supply more light further into the interior, which evens the daylight throughout the space. Figures 3 and 4 show the relationship between window size, window height and the daylight factor, which is defined as the ratio of interior illumination from daylight (measured at a single point or expressed as an average for a space) to exterior illumination from an overcast sky. (In the Pacific Northwest, where overcast skies are common, the typical design objective is to achieve a daylight factor of 2.0 averaged over the entire daylighting zone, which may extend up to 30' in from the perimeter. A daylight factor of 2.0 means that 2% of the outside illumination reaches the measurement point; so a 1000 footcandle overcast sky would supply 20 footcandles at that point inside.)

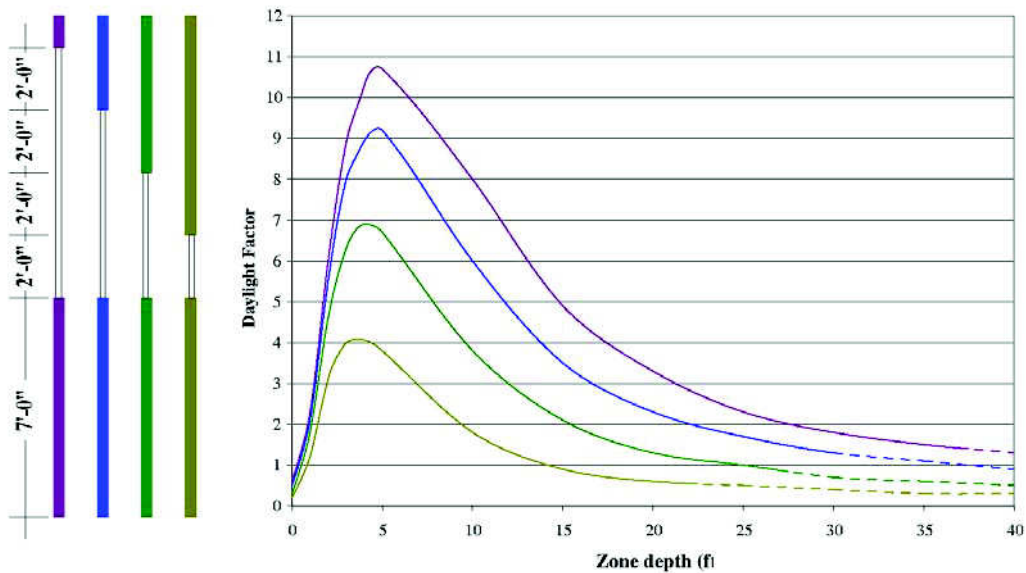

Figure 3: Daylight factor and window vertical size. Sources: (Longmore,1968. Hopkinson,1966. Robbins, 1986)

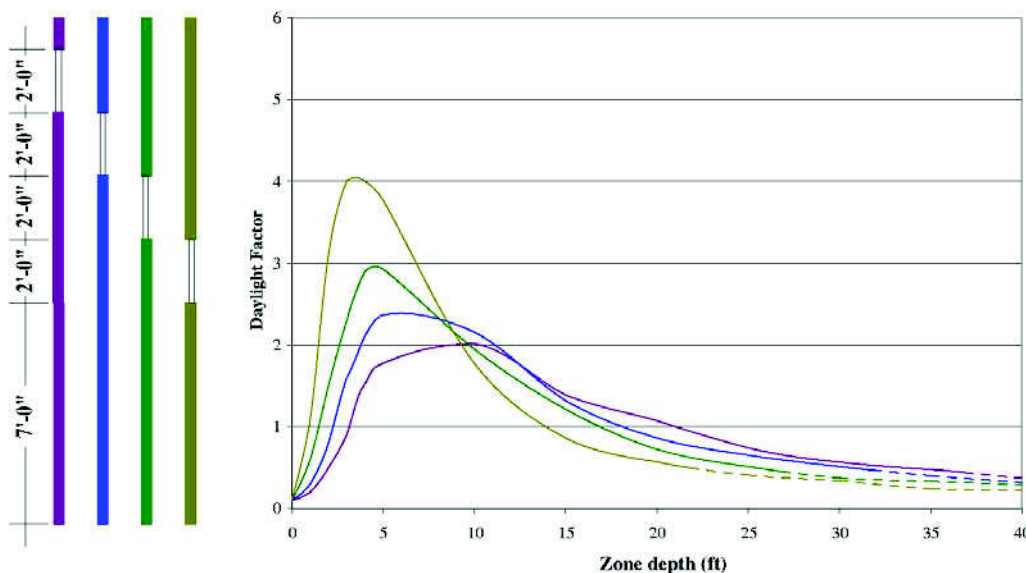

Figure 4: Daylight factor and window height in wall. Sources: (Longmore,1968. Hopkinson,1966. Robbins, 1986)

Three structural alternatives that increased the useable perimeter wall height and were applicable to most of our case study buildings are described below. The ranges of estimated costs and potential wall height that could be used to increase window head height and decrease exterior wall height are provided. The tradeoffs between increasing window head height and decreasing exterior wall height are a key economic consideration that is addressed in section 3 of this paper.

2.2 Reduce spandrel depth

The depth of the perimeter beam, commonly called the spandrel, can be reduced by designing heavier, shallower beam sections. However, doubling the number of exterior columns to reduce spandrel spans is generally more effective and reduces spandrel depths by approximately 50%, thus providing increased height or area for daylight windows. We examined alternatives in which the exterior columns were doubled with no changes to the interior column grid.

Table 1 shows the range of spandrel depth reduction and associated costs for doubling the number of perimeter columns in office and hospital case study buildings. It also includes the additional window head height gained from eliminating perimeter ducts and the associated HVAC costs.

Table 1: Doubling exterior columns: cost of potential window height increase or exterior wall height decrease

	Spandrel depth reduction	Costs per square foot to double the number of exterior columns	Elimination or reduction of the perimeter duct	HVAC costs per square foot
Offices	6 in. to 13 in.	\$0.20 increase	8 in. to 15 in.	\$0.30 to \$4.50 increase
Hospitals	5 in. to 12 in.	+\$0.60 to \$3.10 increase	10 in. to 18 in.	-\$0.70 decrease

2.3 Raise or upturn spandrels

Access to daylight can be increased by raising spandrels normally placed below the floor slabs such that the top of the spandrel beam aligns with the top of the floor slab. Depending on the thickness of the floor slab, this provides from 4 to 8 inches of additional exterior wall height. Even more wall height can be gained by upturning spandrel beams so that the floor slab rests on the bottom flange of the spandrel. This places the daylight obstructing spandrel zone next to the floor rather than the ceiling, allowing daylight glazing to be increased or raised to provide more daylight into the building interior. See figure 5. In the case study buildings, the presence of moment frames at the perimeter and the direction of the floor framing in the perimeter zone had a significant impact on the cost of raising or upturning spandrels. In many cases the most economical alternative was to either reconfigure the building frame in the vicinity of the spandrel or limit the use of upturned spandrels to particular conditions at the building perimeter.

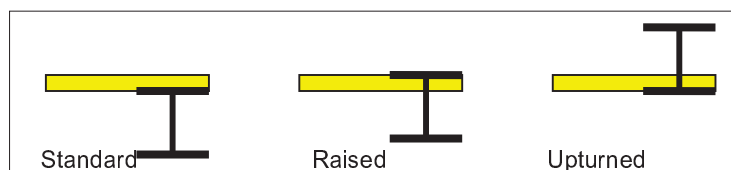

Figure 5: Standard, raised and upturned wide flange spandrels shown in relation to concrete floor slab

Table 2 shows the range of spandrel depths and associated costs for upturning the spandrel in office and hospital case study buildings. It also includes the additional wall height gained from eliminating perimeter ducts and the associated HVAC costs. Changing the position of the spandrel has the potential to reduce the wall height or raise the window height.

Table 2: Upturned spandrels: cost of potential window height increase or exterior wall height decrease

	spandrel depth	costs per square foot to upturn spandrel	Elimination or reduction of the perimeter duct	HVAC costs per square foot
Offices	12 in. to 24 in.	+\$0.10 to \$1.40 increase	8 in. to 15 in.	\$0.30 to \$4.50 increase
Hospitals	10 in. to 24 in.	+\$0.10 to \$1.05 increase	10 in. to 18 in.	-\$0.70 decrease

2.4 Relocate Lateral Load Resisting System Components

Lateral load resisting elements placed on the building perimeter limit window area. Moment frames require deeper beams and wider columns. The large gusset plates on braced frames designed to resist seismic forces are usually concealed in a way that increases the coverage of column and spandrel areas of the building façade. The relocation of these components to the interior of the building can be an effective method of increasing access to daylight at the perimeter.

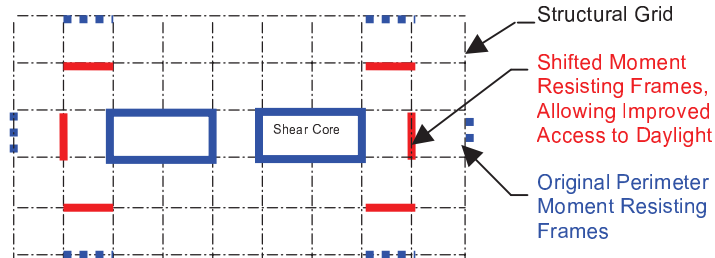

Figure 6: Plan Diagram, Perimeter moment frames shifted to an interior column line

Table 3 shows the additional window wall height gained when lateral load resisting elements in two of the case study office buildings were moved away from the building perimeter and the spandrels that replaced them were upturned. The additional wall area gained from eliminating perimeter ducts and the associated HVAC costs is the same as for the previous two schemes.

Table 3: Repositioned Moment Frames: cost of potential window height increase or wall height decrease

	spandrel depth	costs per square foot to move moment frame and upturn spandrel	Elimination or reduction of the perimeter duct	HVAC costs per square foot
Offices	24 in. to 27 in.	+\$1.20 to \$2.50 increase	8 in. to 15 in.	\$0.30 to \$4.50 increase

3. PAYING FOR DAYLIGHT USING STRUCTURAL, HVAC AND ENCLOSURE COST TRADEOFFS

In many cases, the additional first cost for structural and HVAC systems that allow for increased access to daylight can be offset by the savings in building envelope costs achieved by reducing the floor-to-floor height of the building. Table 4 shows a generalized example of a potential cost tradeoff for a representative ten-story steel frame office building. It is based on a case study office building in Portland, Oregon, with a 14-foot floor-to-floor height designed to accommodate a conventional structural, HVAC and ceiling system. By upturning the spandrels, reconfiguring the overhead ductwork and adding an alternative perimeter heating system, the available wall height at the building perimeter was increased by approximately 30 inches per floor. An 11-inch reduction of the exterior wall height per floor offset the cost of the changes to the structural and HVAC systems, thereby leaving approximately 19 additional inches available to increase the window area or raise the window head height.

Table 4: Potential cost tradeoff for a representative ten-story steel frame office building

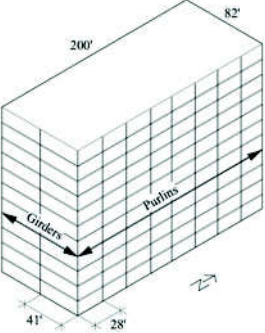
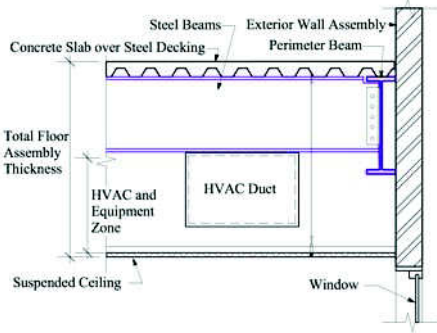
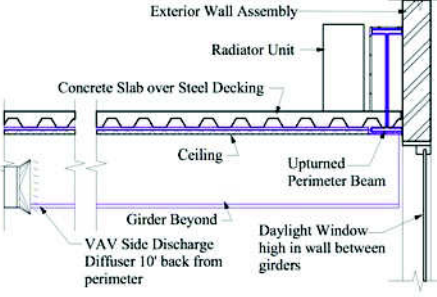
BUILDING DATA	BUILDING DESCRIPTION
<p>Average cost of skin: \$55 per square foot of exterior wall</p> <p>Original floor-to-floor height: 14 feet</p> <p>Perimeter length of a typical floor: 2 x 200 feet + 2 x 82 feet = 564 feet</p> <p>Spandrel depths below floor slab: 14 inches, East and West facades 24 inches, North and South facades</p>	<p>This ten-story steel frame office building has a building footprint of 82 feet by 200 feet with three rows of columns on a 28 by 41 foot grid. Structural steel girders, 24 inches to 27 inches deep, span 41 feet and support 16-inch deep purlins at ten feet on center. Lateral wind and seismic forces are resisted by exterior steel-braced frames.</p>  
<p>ADDED COST PER FLOOR</p> <p>Structure: Unit cost: \$1.10/sf Cost per floor: \$18,040</p> <p>HVAC: Unit cost: 0.60/sf Cost per floor: \$9,840</p> <p>Total \$27,880</p>	<p>PROPOSED MODIFICATIONS</p> <p>We propose to reduce the depth of the spandrels below the finished floor by reframing the north and south ends of the building so that purlins run parallel with the exterior wall and upturning the non-braced frame spandrels so that the floor slab rests on top of the bottom flanges. To further increase access to the exterior wall, we propose to replace perimeter ducts with wall-mounted radiator units and to relocate VAV air outlets 10 feet back from the perimeter wall.</p> 
<p>COST NEUTRAL HEIGHT REDUCTION</p> <p>Cost per linear foot of wall per floor: \$27,880/564 feet = \$49.40 per linear foot</p> <p>Height reduction that offsets cost ($\\$49.40 / \\55 per square foot) x 12 = 11 inches</p>	<p>The building skin is comprised of brick with metal studs supported by the slab edge. By upturning the spandrels instead of reducing their depth, deflection limits required to minimize cracking in the masonry cladding are maintained. A reduction of approximately 11 inches of exterior wall per floor offsets the cost of structural and HVAC modifications.</p>
<p>WINDOW HEAD HEIGHT INCREASE</p> <p>Height gained by upturning spandrels: 14 in. + 5.5 in. – 11 inches = 8.5 inches</p> <p>Height gained by eliminating perimeter duct: 10 inches</p> <p>Window head height increase achieved: 18.5 inches</p>	<p>The building was originally designed so that the floor slabs, which are 5 ½ inches thick, sit directly above the spandrels. In the proposed upturned spandrel scheme, the bottom flange of the spandrel is level with the bottom of the floor slab. This reduces the total depth of the perimeter structure by 5 ½ inches.</p> <p>The additional 18.5 inches of window head height achieved can be used to raise the window height and increase the window area to gain the daylight factor increases shown in figures 3 and 4, along with the associated energy cost savings and daylight performance improvements.</p>

CONCLUSION

Our investigations show that designers can generate economically viable alternatives to the structural systems in multistory office and hospital buildings that increase daylight in the building interior, thereby improving the quality of occupant experience and reducing the energy demands of electric lighting. For practitioners the key concept is to identify daylight as a building system

. To meet the challenges associated with an integrated approach that concurrently addresses and holistically optimizes the combined performance of structural, HVAC, wall, ceiling and daylight systems, architects must adopt an interdisciplinary approach in which all members of the design team are made aware of the daylight implications of their design efforts.

ACKNOWLEDGEMENTS

The authors would like to thank the Northwest Energy Efficiency Alliance for supporting this project and the staff of the University of Oregon's Energy Studies in Buildings Laboratory for their assistance.

REFERENCES

International Code Council, 2002. *The International Building Code 2003*. The International Code Council Inc.

Brown, G.Z. et. al. *2005 Daylighting Patient Rooms in Northwest Hospitals*. A project report prepared by the Energy Studies in Buildings Laboratory at the University of Oregon, Eugene, Oregon.

Longmore, J., 1968. *BRS Daylight Protractors*. Her Majesty's Stationery Office, London.

Hopkinson, R.G., Petherbridge, P., and Longmore, J., 1966. *Daylighting*. William Heinemann Ltd., London, p 250.

Robbins, Claude L., 1986. *Daylighting: Design and Analysis*. Van Nostrand Reinhold Co., New York. pp 492-493.

Green in the Balance: Visual Comfort Inside Offices with Tilted Facades

Ihab Elzeyadi, Ph.D.

University of Oregon, Eugene, Oregon

ABSTRACT: Tilted facades are increasingly being used in contemporary commercial buildings. Recent studies indicate that downward tilted facades can reduce cooling loads leading to an overall reduction in energy and building operation costs. Similarly, current trends in commercial buildings design use façade and window geometry as an aesthetic revolution on the traditional orthogonal space order. However, the effects of the resulting non-orthogonal interior space on the occupant visual and psychological comfort are not always considered. Previous studies indicate a gap in the existing literature related to these effects.

This paper reports on the results of a multi-methods research project combining a cross-sectional survey design and a participant observation design carried out in an office building in the United States with a tilted facade. The building studied had occupied offices next to orthogonal and 30°-tilted glazed facades. Independent variables were manipulated through different office settings in the building. The dependent variables were assessed by responses of clustered random sample (total of 115 participants) representing each of the two facade types. Both the physical and psychological variables that affect occupants' comfort with the indoor space resulting from tilted facades were evaluated. Data collected using four research instruments (questionnaire, structured interviews, photography, and field notes) showed that window tilt affected the occupant's perception of window proximity, perceived space order, stability, and spaciousness. Maintenance and discomfort glare were among the physical distractions reported as well.

The study's objective is to explore the parameters that affect the occupant's behavior in response to a green design strategy associated with tilting facade angles for shading and energy conservation. The findings led to a specific model for facade form evaluation, and specifically facade tilt. Results can help identify relevance of more specific hypothesis for future investigations. Most importantly, it suggests that designers need to look at green building strategies from a holistic perspective employing a whole-building approach that include the physical, psychological, and physiological dimensions of the environment and their impacts on building form.

Keywords: facade geometry/form, indoor comfort, office buildings, green architecture

INTRODUCTION

In a constantly changing environment, the field of architecture confronts many challenges to incorporate modern and sustainable technologies within its discipline. Concurrently, architecture is influenced by other disciplines such as engineering and psychology. However, due to a lack of sufficient communication between these disciplines, behavioral and environmental effects are not always considered when contemporary and energy efficient buildings are designed for occupant comfort (Griffiths, Huber & Baillie 1988). This research aims to explore how satisfied an occupant is with the physical and psychological effects resulting from a single design option: façade and window tilt. In this exploration, the individual (occupant) and his/her environment (building) are conceived as parts of one interactional system (Markus, 1972).

The occupant's visual satisfaction level, operationalized as visual comfort, is affected by the quality of the indoor space the occupant perceives from the physical configuration of the building (Elzeyadi, 2003). The tilt refers to the angle by which the window/facade plane is rotated around the gravitational vertical plane (Figure 1). A window can be either tilted upward to face the sky or downward to face the ground. Since downward tilted windows are increasingly being used as a green strategy in contemporary office buildings--for their proven solar

shading (Haus, 1994), energy conservation potential (Haus, 1994), as well as their aesthetic appeal (Elzeyadi, 1997)--this investigation concentrated on the effects of this specific design.

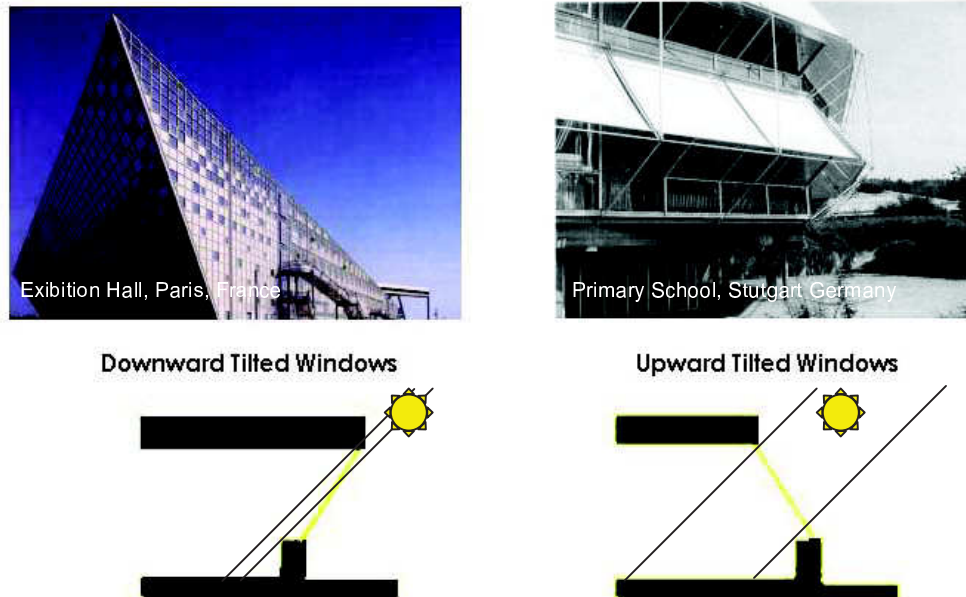

Figure 1: Upward and Downward Window/Facade Tilt

1. TILTED FACADES IN GREEN AND CONTEMPORARY ARCHITECTURE

Towards the achievement of energy efficient spaces and greener office buildings, the facade geometry is affected (Boubekri et al, 1991). Meanwhile, architects concerned with the building's formal aesthetics have created convoluted shapes of facade forms to increase the building's complexity (Flagge, 1994). This is evident in the works of some contemporary architects such as Frank Gehry and Rem Koolhaas (Figure 2). The revolution against the two dimensional facades of the modernist theories of pure forms led to the modification of the building envelope to create more complexity in the city's urban form (Flagge, 1994). In addition, tilted facades also helped to increase the elevation depth of the building and, hence, imposed a dramatic play of shades and shadows (Haus, 1994). However, sufficient attention is rarely given to the visual comfort of the occupant inside these buildings. Many previous studies recommended that future research should investigate the employee visual preference of window form and shape in the work environment (Heerwagen, 1990; Boubekri et al, 1991).



Figure 2: Contemporary Architecture and Tilted Facade Complexity

Historically, occupants' prefer orthogonality in buildings (Elzeyadi 1997). Studies show that humans can recognize deviations from the vertical with an accuracy of less than one degree (Gibson & Mowrer, 1938). Therefore, tilted facades cannot pass unnoticed by the building's occupants. Psychologically, facade tilt might have behavioral as well as physical effects on the occupant's perception of the outdoor environment (Heerwagen, 1990). To explore the relationship between window/facade tilt and occupant's visual comfort, a research model (conceptual framework) based on previous research was designed (Elzeyadi 1997). Through this model, both the physical and psychological variables that affect occupant's comfort with the indoor space resulting from tilted windows were evaluated. This study did not test a hypothetical statement due to a gap in the knowledge regarding the phenomenon under investigation. Instead, it used a deductive approach to investigate the following research questions: (1) Are the occupants comfortable with the shape of the indoor space resulting from window and façade tilt? (2) How do the occupants behave in response to the different angles of facade tilt? (3) Do the occupants adapt to the indoor non-orthogonal space? (4) What are the physical and psychological variables that affect the occupants' visual comfort regarding the shape of their offices, specifically the window shape? and (5) What changes or modifications do the occupants suggest to improve their indoor environment in order to maximize comfort?

2. VISUAL COMFORT AND TILTED FACADES

Window tilt can induce a variety of perceived or experienced distractions in the work place (Butler & Biner, 1989). Perceived distractions are mostly psychological, such as the degree of space stability, organization, or certainty; such constructs are subjective in nature and can differ from one person to the other (Butler & Biner, 1989). On the other hand, experienced distractions such as glare, reflectance, and maintenance tend to be more objective and constant in their effect (Boubekri et al, 1991) (Figure 3). Ultimately, whether perceived or experienced visual distractions, parameters of the built environment with regards to window geometry do affect the occupant's comfort (Heerwagen, 1990).

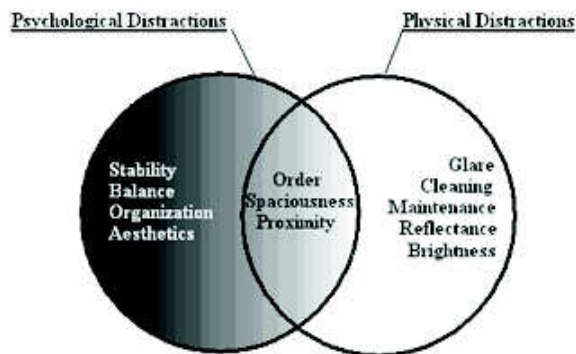

Figure 3: Perceived and Experienced Distractions

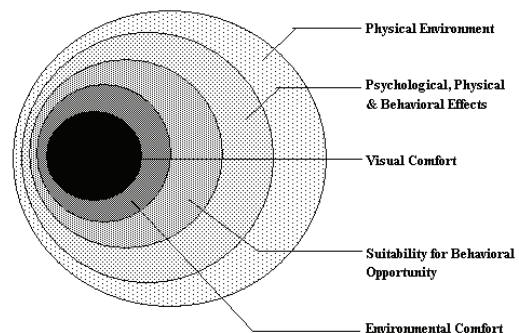

Figure 4: Nested Model of Visual Comfort

This study builds on the model of visual comfort previously designed by the author (see Elzeyadi, 1997). Visual comfort (VC) in this suggested model (Figure 4) is defined as *“that state of the mind that expresses satisfaction in viewing the surrounding environment and perceiving it as suitable for behavioral opportunity of the task performed. It is also the perceived physical and psychological quantities of indoor space that enable the individual to function and facilitates task performance.”* (Elzeyadi, 1997:22). In this model VC is assumed to be an outcome of two interactional constructs, physical and psychological visual distractions. These two types of distractions vary with the change of the study's independent variables, which are: angle of window tilt, proximity and position to window, shape of sill and lintel, outdoor view, area of window, glazing properties, and floor height. Visual distractions specified under physical effects include: glare, maintenance, flexibility, and reflectance. Psychological distractions are related to visual perception of non-orthogonal spaces, perception of the gravitational vertical, and diagnostic phobias. The interaction effect of these variables can induce 13 mediational responses: six physical (discomfort glare, visual acuity, brightness, space order, indoor reflections, & cleaning) and seven psychological (space organization, spaciousness, aesthetics, stability/fear, certainty, proximity and balance). Occupants adapt to this set of variables to achieve visual comfort or visual discomfort as predicted by this conceptual model (Figure 5).

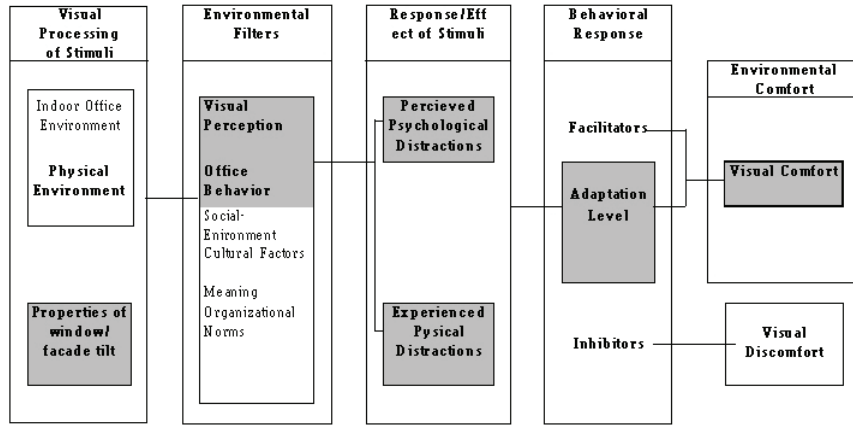

Figure 5: Conceptual Research Model of Visual Comfort and Tilted Facades

3. CASE STUDY: NATIONAL ASSOCIATION OF HOME BUILDERS, WASHINGTON, DC

After a careful archival survey of office buildings that possess tilted facades, the National Association of Home Builders (NAHB) old headquarters in Washington, DC was selected for the investigation. The criteria for this selection was based on: (1) the availability of office spaces with different façade tilt/geometry, within the same organization (since one façade of the building poses a 30 degree tilt angle while the other facades are vertical) and (2) the energy savings of these facades, as the tilted façade side of the building have proved to show savings in cooling loads (see Haus, 1994, Elzeyadi 1997). This five-story office building, designed by Vincent G. Kling & Partners of Philadelphia, is a combination of the "Tilted wall" and the "Vertical wall" window tilt types. The southwest facade of this building is tilted downward 30 degrees from the vertical while the rest of the facades (northeast, southeast, & northwest) are kept vertical. An indoor window sill having a triangular cross section with a three foot base houses the air handling equipment and vents for each office space (Figure 6).



Front Façade of NAAB with 30° Tilted Façade



Side Vertical Façade of NAAB



Interior views of offices



Interior views of offices

Figure 6: National Association of Home Builders Building in Washington, DC - Study Setting

The study used a survey design methodology using questionnaires, structured interviews, photography, and field notes as data collection instruments. The data was collected over a period of two summer months (June-August). Forty percent of both occupants in the tilted façade (southwest) section of the building and occupants in the vertical orthogonal façade sections (northwest, northeast, southeast) of the same building volunteered to participate in the study. This led to sample sizes of 62 and 53 respondents, respectively. Although sampling by percentage led to a slightly non-equivalent sample size, the objective was to ensure a random sample that represents the population occupying both the tilted windowed section and the vertical windowed section of the building. The tilted façade overlooked an urban landscaped plaza, while the three other facades faced mature trees in the setbacks between the building and the surrounding structures. Sun penetration was modulated by the 30° downward tilt of the southwest façade and by shading from mature trees on the three other facades. The facility manager randomly selected the subjects in clusters by floors. The clustering procedure ensured that the sample size was composed of employees working next to a tilted window and non-tilted (vertical) windows in the second, third, and fourth floors. There were no gender, age, or other specific population requirements linked to the study other than the status of office employee working in the researched settings.

Data collection was handled according to human subjects approved procedures so as not to breach the confidentiality of the participants, each questionnaire form was returned in a sealed plain envelope, which was attached to the distributed questionnaires. The procedure limited the publication of the data collection dates to protect employees' privacy. Respondents filled out the designed questionnaire, enclosed it in the attached envelope, and dropped the sealed envelope to be turned over to this investigator in preparation for data analysis. Respondents who expressed their willingness to be interviewed checked the appropriate box on the questionnaire form.

A simple descriptive statistical analysis of the questionnaire data collected from each site was conducted in order to develop an overview of the responses and a trend of the subjects' attitude in each setting. A theoretical sample of the respondents who indicated their willingness to be interviewed was developed. This theoretical sample was selected according to the participants' responses to the questionnaire. It was composed of employees who reported extreme responses to the facades geometry (i.e. employees who were extremely comfortable/uncomfortable with the tilt) and those who reported conflicting and ambiguous responses to the questionnaire questions.

The facility manager scheduled a 15-minute meeting with 18-20 different employees during one business day. These interviews took place in the interviewee's office space. During the same business day, the researcher occupied an office space next to the building's tilted facade and thus was able to experience the same physical situation of the occupants. The researcher walked through the facility offices, photographed physical traces of office and space arrangements, as well as observed the occupants' behavior in their workspaces. Informal casual conversation and non-structured interviews were also conducted with the building occupants, custodians, administrators, and the facility manager. Data collected in the form of recorded tapes, photographs, the researcher field notes, and questionnaire responses were analyzed to answer the research questions proposed earlier. Since there was no prior information on the phenomena under study in the scientific literature, the investigation did not propose a hypothetical statement to test, but instead used a deductive strategy to conclude the findings based on the research problem and questions presented earlier.

4. FINDINGS: OCCUPANTS' COMFORT AND FAÇADE TILT

Data corroboration from different sources was implemented not only to check for validity but also to produce richness in covering different aspects of the phenomena. The findings are presented to validate the research theoretical model, answer research questions, and provide insights for future research. The findings are classified under the two main categories discussed earlier in the form of physical and psychological visual distracters.

4.1. Physical Visual Distractions

Categorizing responses as experienced physical distractions followed the research model and the participants' perceptions of the distracter. Structured and casual interviews with the occupants identified whether a response was viewed as a physical or psychological distraction. Physical distractions were classified under two categories: (1) glare and reflectance on the windowpanes, and (2) maintenance and space economy of the indoor space resulting from window tilt.

4.1.1. Glare and Reflectance

The intention was to discover if the occupants were aware of the indoor reflections on the glass surface and whether these reflections were experienced as distractions during the occupant's daily routine. In the National Association of Home Builders (NAHB)—angle of tilt is 30 degrees—45% and 50% of the respondents reported

distractions from reflections and glare, respectively as compared to 10% and 15% only in the section of the building with vertical orthogonal façade (Figure 7). The glazing properties of the buildings' facades were constant between the tilted facade and the vertical facade sections of the building. Despite of the differences in solar orientation of the facades, sun penetration differences was not very highly perceived by the occupants due to shading by the façade tilt, mature trees, and a 3 foot window sill in the interior space (Figure 6).

4.1.2. Maintenance and Space Economics

Maintenance was operationalized as the frequency of cleaning the tilted windows as well as fixing one of the window components (such as broken glass panes or window coverings). The waste of space as a result of window tilt was perceived as a physical distracter that limits the occupants' use of the indoor space. Facility managers and custodians reported that tilted windows were difficult to handle in terms of cleaning and maintenance. As one of the employees who had worked for the NAHB for two years reported: *"They were never washed the whole time I've been here."* (Interview #4). Another respondent complained about maintenance of tilted windows. She stated:

The windows are nice but over the years they get dirty and dirty and that takes away from the view. They've never been able to wash them. This takes away from the overall comfort in the office space. As it affects the feeling of cleanness and sanitation of the organization. (Interview #29)

During a casual conversation with a different employee in the same facility, she reported the following:

There is a physical waste of space due to tilt, I would rather trade it for more space, though the office designers had to come up with other ways of making the office appealing as the window tilt is. (Interview #32)

It can be concluded that window tilt, though aesthetically pleasing to some occupants, was difficult to be maintained. The results showed that the occupants perceived the waste resulting from the tilt and some of them, especially those occupying small offices, indicated that they would trade the tilt for more floor space.

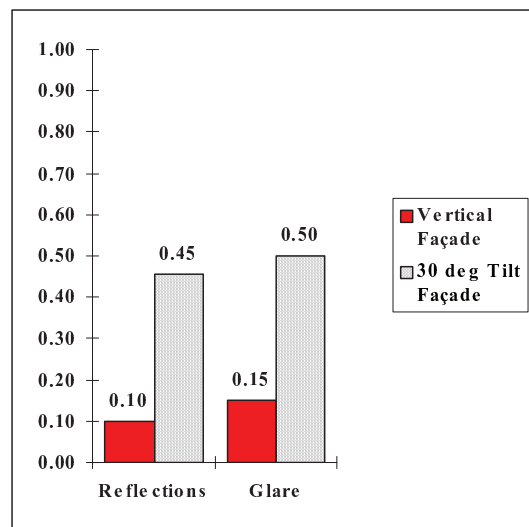

Figure 7: Percentage Reporting Discomfort from Reflection and Glare

4.2. Psychological Distractions

Psychological distractions as a result of facade tilt were operationalized in terms of the responses and space properties perceived by the occupant resulting from the visual processing of the facade tilt. Hence, these responses were subjective and differed from one occupant to the other. Two main classifications helped in itemizing these responses. The first category was window proximity, which is the ability to approach a tilted window or facade in comparison to approaching a vertical one. The second category was related to the occupant's perception of the significant space properties in a non-orthogonal environment and the effect of the physical properties of the facade tilt on the occupant's perception of comfort. The results of these two perceived categories follow.

4.2.1. Window Proximity

Window proximity, defined as the measured floor distance between the occupant's standing position—when approaching the window—and the window sill, was one of the main variables that affected the occupant's perception of visual comfort. This construct is considered a perceived distraction that inhibits the occupant's movement in the office space. Results showed the tendency of standing back due to tilt increases with the tilt angle over the vertical facade. It is interesting to note that the percentage of people still not able to approach the window due to fear of heights associated with the tilted angle increased by 60% in occupants of tilted facade

offices over those with vertical ones. This effects did not change much over time as occupants of tilted facade offices still felt that they need to stand back from the façade due to tilt even after spending a year in their offices (Figure 8 a & b).

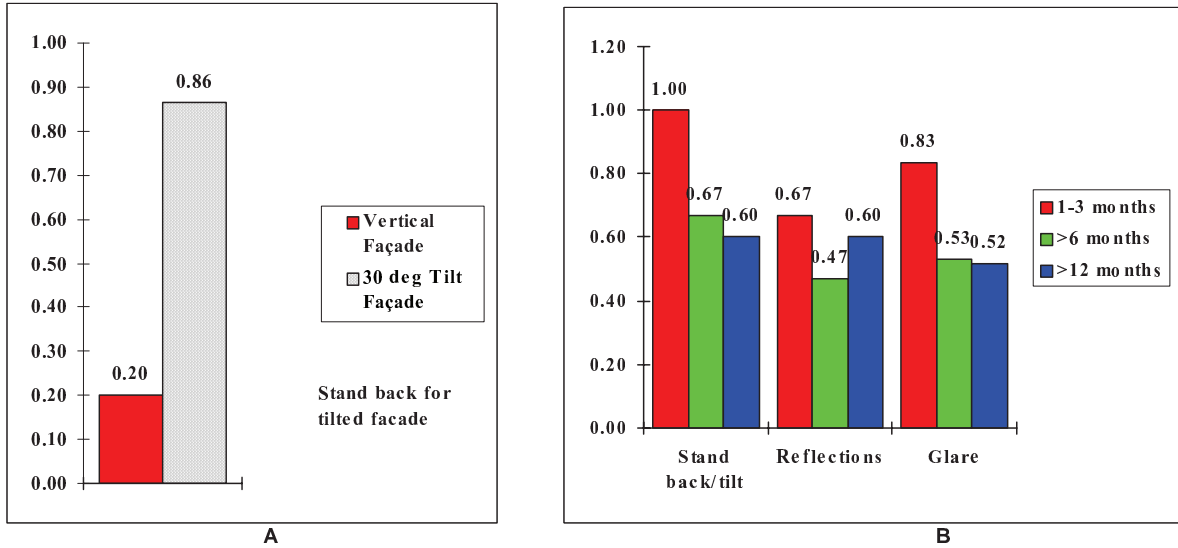

Figure 8: Percentage Reporting Window Proximity in General and Overtime

4.3.2 Analysis of Perceived Variables

The perceived space variables represented the average occupant's feelings and descriptions regarding the occupied space. The variables were itemized on a seven-point semantic differential scale using bi-polar adjectives. The tested variables were further classified in terms of perceived space properties (ordered, flexible, bright, pleasant & spacious) and occupant's feelings regarding window tilt (comfortable, fearless, stable, balanced, certain, & organized). The latter was further itemized according to the occupant standing/seated position. Figure 9 (A & B) present perceived qualities of the offices in the tilted facade section (A) and the vertical orthogonal facade section (B) of the office spaces, respectively. It is obvious that many indoor qualities such as balance, organization, stability, flexibility, and order were negatively perceived in offices with tilted facades.

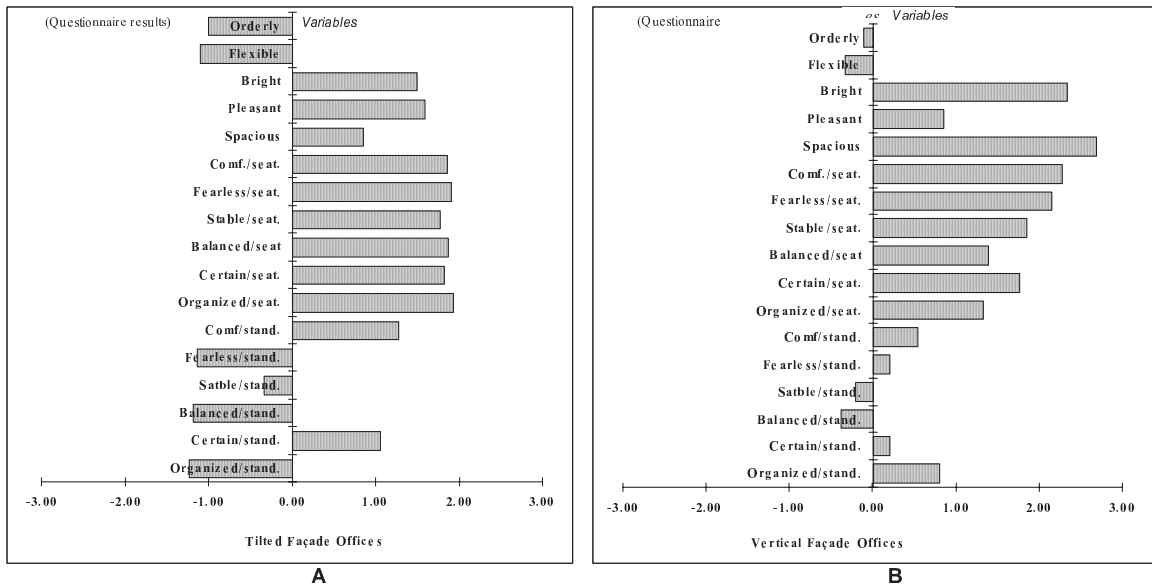

Figure 9: Comparison of Perceived Indoor Qualities and Comfort Inside Tilted and Vertical Façade Offices

5. CONCLUSION: GREEN IN THE BALANCE

Through exploring the effects of a single design option that have green implications—tilted facades—on occupants' indoor visual comfort in an office space, many of our existing design assumptions need further consideration. First, the environment and the occupant should be perceived as a system rather than a set of discrete components. As the study's findings showed, tilted windows imposed a variety of effects on the building's occupant. While some of these effects inhibited the occupant's movement in space and were perceived as distractions, such as window proximity, maintenance, and flexibility; tilted facade offices were perceived as more spacious than vertical windowed ones. Second, the study revealed that comfort implies subjective measures related to the occupants' feelings and behavior in space.

The effect of tilted facades on the occupant's ability to approach the window is one of the main factors that affected visual comfort and occupant's satisfaction. Usable indoor area and angle of facade tilt could also affect the space economics and should be taken into consideration when designing the form of the facade. Future research should also investigate the effect of tilted facades on the occupant's perception of space sanitation due to the maintenance difficulty of such design strategy. Preference for indoor handrails or vertical window sills in front of the windows should be researched before designing tilted facades as well. Solar penetration due to various facade orientations was one of the limitations of the study. Although occupants were not much affected by it during the data collection period, future studies should investigate the effect of glare related to sun penetration on occupant's comfort for tilted facade buildings.

Perceived spaciousness from tilted facades was one of the reported positive effects of such design option. Future studies could investigate whether the increase in floor area, ceiling area, or window tilt could contribute much to such a feeling. Tilted facades also limited windows operation (i.e. ability of the occupant to open the window). Future studies could compare the lack of ventilation benefits for such design versus its shading benefits. It was the objective of this study to contribute to the gap in existing knowledge related to the effects of facade tilt and geometry on the occupants' visual comfort in space. Most importantly is to stress the importance of whole-building design and the systemic evaluation of green design strategies by architects and designer before adopting them to a project.

ACKNOWLEDGEMENT

This study would have never been possible without the participation of the employees and occupants of the National Association of Home Builders (NAHB) in Washington, DC, USA. Many Thanks to Mr./ Chuck Smith and Mrs./ Dawn Harris. This study was partially funded by grants from the International Facility Management Association (IFMA) and Haworth Inc Research Grant. Their funding is hereby gratefully acknowledged. All Photos are by the author ©Ihab Elzeyadi.

REFERENCES

- Boubekri, M., Hulliv, R., & Boyer, L. (1991). Impact of Window Size and Sunlight penetration on Office Workers' Mood and Satisfaction. *Environment and Behavior*, Vol. 23: 4, pp. 474-493.
- Butler, D. and Biner, P. (1989). Effects of setting on Window Preferences and Factors Associated with Those Preference. *Environment and Behavior*, Vol. 21:1, pp. 17-31.
- Elzeyadi, I. (2003). Environmental Quality: A Systemic Framework for Conceptualizing People and their Workplaces. In: *Shaping Places for People: Proceedings of the Environmental Design Research Association EDRA 34th Conference*, pp. 71- 79.. May 22-26, Minneapolis, Minnesota.
- Elzeyadi, I. (1997). The effect of tilted windows on occupants' visual comfort in non-orthogonal office spaces. *International Facilities Program, Vol. (2)*. Houston, TX: IFMA Foundation/Haworth.
- Flagge, I. Ed. (1994). *Annual of Light and Architecture 1993*. Berlin: Ernst & Sohn Verlag für Architektur.
- Gibson, J.; and Mowrer, O. (1938). Determinants of the Perceived Vertical and Horizontal. *Psychological Review*, Vol. 45: 4, pp. 300-323.
- Griffiths, I., Huber, J., & Baillie, A. (1988). The Scope For Energy Conserving Action: A Comparison of The Attitudinal and Thermal Comfort Approaches. In Canter, D. et al., *Environmental Social Psychology*. Dordrecht: Kluwer Academic Publishers.
- Haus, T. (1994). The Energy Efficiency Of Tilted Windows in Office Buildings. *Unpublished Masters Thesis. The Pennsylvania State University*, University Park, PA.: Department of Architecture.
- Heerwagen, J. (1990). The Psychological Aspects of Windows and Window Design. *EDRA 21 Conference Proceedings*, pp. 269-280.
- Markus, T. (1972). *Building Performance*. New York: John Wiley & Sons.

A Lower Cost, Higher Performance Classroom: Will Innovation Lead to Market Transformation?

G.Z. Brown, Jeff Kline, Dale Northcutt

Energy Studies in Buildings Laboratory, University of Oregon, Eugene, Oregon

ABSTRACT: One of our primary goals at the Energy Studies in Buildings Laboratory is the transformation of the architectural design market to be more energy efficient. A large part of our efforts to this end are educational, both formally, in classes and workshops, and informally as in our consulting on specific projects. The innovative classroom design we have recently developed is a research project that exemplifies these efforts. This project, designed specifically for the Pacific Northwest climate, achieves energy performance that is 70% better than code and costs less to build than a conventional classroom. The positive reception of the concept and the ensuing interest within the design and construction community make us think that an innovative product can be an effective stimulator of market transformation. This paper describes our low cost, high performance classroom concept, its history, and the excitement it has generated. We have a hypothesis about why the concept has been successful, and we describe the evidence we will be looking for to support our ideas as the concept continues to be adapted and refined by others and ourselves.

Keywords: classroom, market transformation, energy efficiency, integrated design

INTRODUCTION

This paper describes a successful low cost, high performance classroom concept. We present a history of the concept, observations we have made, and a hypothesis about the value of an innovative product in driving market transformation. We conclude by laying out the types of evidence we wish to collect to evaluate our hypothesis.

1. DESCRIPTION OF THE HIGH PERFORMANCE CLASSROOM

1.1. Lighting Synergies

The High Performance Classroom design is an approximately 900 s.f. room, roughly square, with a ceiling sloping up to a large central skylight, as shown in figure 1. In targeting energy and operating cost savings, we focused on the three main sources of a classroom's energy use: heating, cooling, and lighting.

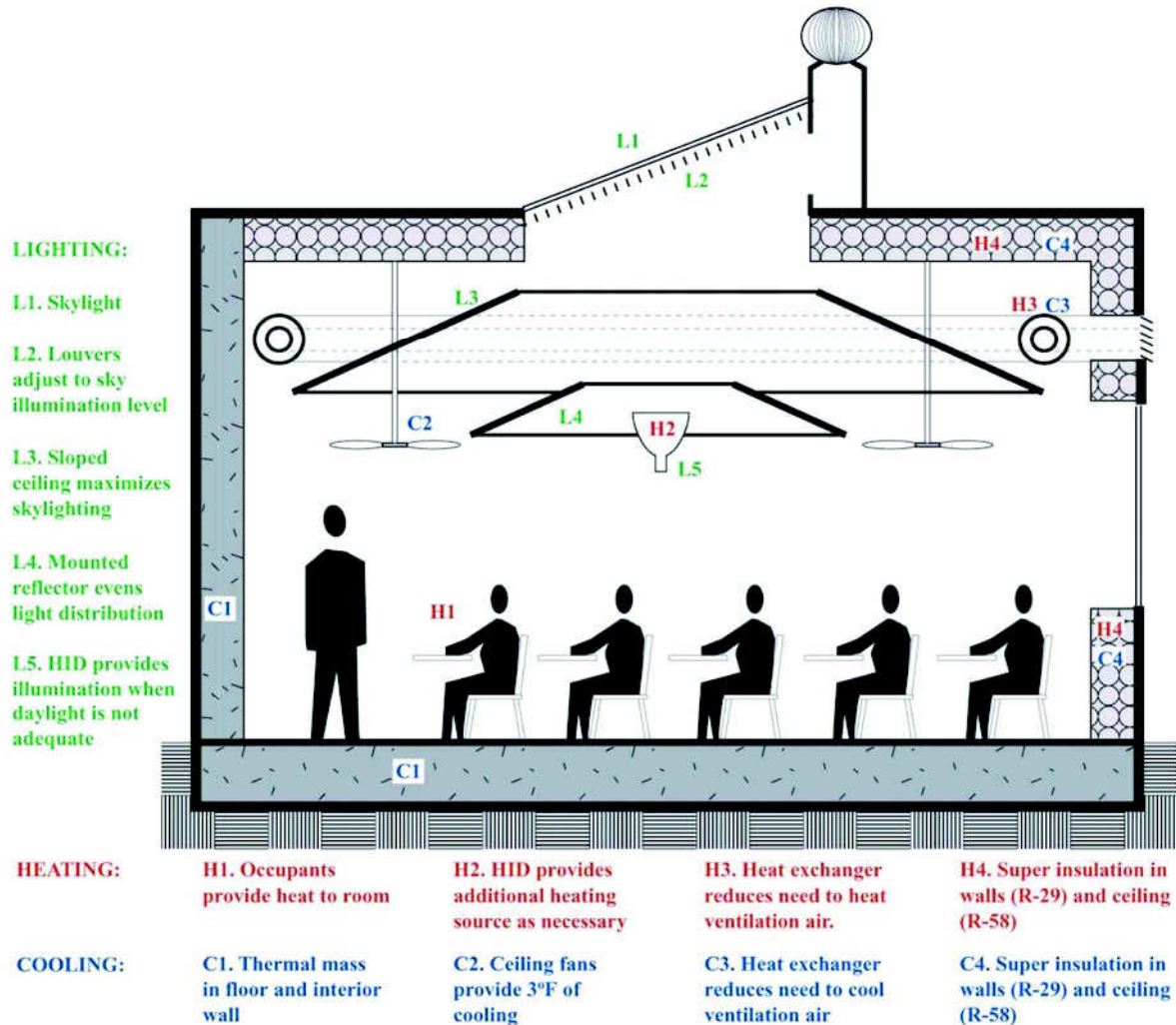

Figure 1: Diagram of the High Performance Classroom showing lighting, heating, and cooling synergistic elements

Schools present good opportunities for daylighting. School operating schedules generally coincide with daylight hours, and their illumination requirements are easily met with daylighting. Furthermore, research suggests that students learn better with daylight (Heschong Mahone Group, 1999). However, daylighting also incurs construction costs. Glazing and shading devices are more expensive than an opaque wall, and electric lights cannot be completely eliminated. Our approach, then, was to design the least costly daylight aperture that would provide adequate illumination over the largest portion of the operating schedule, and to supply an inexpensive electric light system that would be acceptable for the infrequent times it would be needed.

A single skylight (approximately 11 ft x 14 ft) can supply almost all the illumination needs of this typical classroom. Multiple skylights might provide better light distribution, but would significantly increase costs. Instead of multiple skylights, a central reflector hangs underneath the skylight to address the "hot spot" of concentrated light beneath a skylight. The reflector partially shades the room's center, reducing illumination, and its high reflectivity (95%) bounces light to the ceiling and to the room's edges. The ceiling is sloped to facilitate the distribution of light, permitting all work areas direct visual access to the skylight. The skylight is sized for the minimum exterior illumination case; adjustable louvers are programmed to reduce excess illumination and unwanted heat gain.

Because this arrangement can provide adequate illumination for 95% of operating hours, electric lighting can be minimized. A single high intensity discharge (HID) lamp, mounted in the center of the room and facing upwards, provides the sole source of electric light (besides code mandated emergency exit lighting). Aimed upward at the closed louvers (for insulation at night), it reflects off the louvers and uses the reflector to distribute light; as

daylight becomes available, the louvers begin to open, balancing electric light and daylight. When there is enough daylight to meet the illumination target the lamp is automatically switched off. Another, more expensive, option is a dimmable system, which can save a significant amount of electricity during times when partial daylighting is possible (during the hours in white in figure 2).

We developed a target illumination of 20 footcandles minimum to 40 footcandles maximum (IESNA, 2000). Increasing the minimum illumination above 20 footcandles, a level acceptable in other modernized countries, would necessitate larger apertures or increasing the amount of hours that electric light is necessary. Figure 2 shows that a room with a 4% daylight factor in Portland will achieve the minimum interior illumination of 20 footcandles for all but approximately 210 hours through the entire year (95% of operating hours), assuming a 9 a.m. to 4 p.m. schedule. Shifting the schedule an hour earlier, the number of hours with inadequate illumination would increase by approximately 43%. Our research showed that most school districts have the power to control their operating schedules, and that they choose their schedules for a variety of reasons.

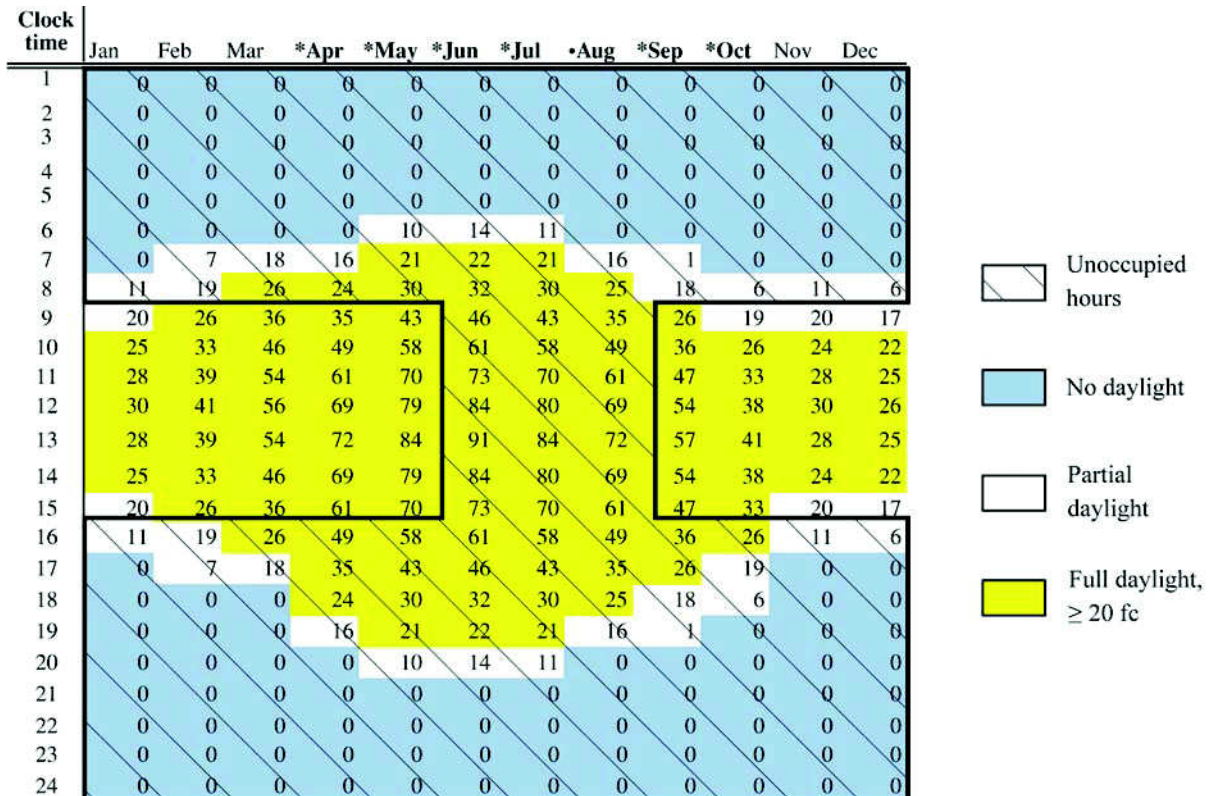

Figure 2: Interior illumination and operating hours with a 4% daylight factor under overcast skies in Portland, OR.

Because of the classroom's complex geometry, multiple methods of evaluation were used. The daylighting concept was developed using simulations, physical models, and a full-scale prototype to predict daylighting performance.

A full-scale prototype was then built a warehouse space, with a hole cut into the roof for the skylight. The materials used to construct the prototype were identical to those specified for the actual project. The prototype allowed for the testing and integration of systems difficult with other methods, such as the CPI ControlLite® product used for the skylight, which integrates louvers within its polycarbonate glazing and cannot be tested at smaller scales. Figure 3 shows daylight performance for the prototype, revealing that overall daylight is lower than the target (3.5 vs. 4.0) and that the corners are underlit. In the near future we will be collecting performance data from actual classrooms built at Mt. Angel Abbey, Oregon.

2.1	2.5	2.9	3.3	3.5	3.7	3.9	4.1	3.6	3.2	2.6	2.2	1.9
2.0	2.4	2.7	3.2	3.3	3.6	3.8	3.9	3.5	3.0	2.5	2.1	1.9
2.2	2.5	3.9	3.4	3.3	3.7	3.9	4.0	3.5	3.1	2.6	2.3	1.9
2.4	2.8	3.2	3.5	3.4	3.8	4.0	4.2	3.7	3.4	2.8	2.4	2.1
2.5	3.0	3.3	3.6	3.4	3.7	4.0	4.1	3.6	3.4	3.0	2.6	2.2
2.6	3.1	3.4	3.6	3.3	3.5	3.8	3.9	3.4	3.3	3.0	2.6	2.2
2.8	3.3	3.7	3.8	3.5	3.6	3.8	3.8	3.4	3.5	3.1	2.8	2.1
2.8	3.3	3.7	3.8	3.3	3.6	3.8	3.8	3.3	3.4	3.1	2.8	2.3
3.0	3.7	4.1	4.3	3.8	4.0	4.2	4.1	3.7	3.9	3.5	3.2	2.7
3.0	3.7	4.1	4.2	3.7	4.0	4.3	4.1	3.7	4.1	3.7	3.3	2.7
3.0	3.6	4.2	4.1	3.5	4.1	4.4	4.2	3.8	4.3	3.9	3.4	2.9
3.0	3.6	4.0	4.1	3.5	4.0	4.3	4.0	3.7	4.3	3.9	3.4	2.7
3.1	3.7	4.1	4.1	3.9	4.1	4.5	4.1	3.9	4.5	4.1	3.5	2.9
3.0	3.7	4.0	4.0	3.7	4.1	4.4	4.1	3.9	4.5	4.0	3.4	2.8
3.0	3.6	4.1	4.1	3.9	4.4	4.6	4.2	4.0	4.7	4.4	3.6	3.1
3.0	3.5	4.1	4.2	4.0	4.4	4.7	4.2	4.1	4.8	4.5	3.7	3.1
2.9	3.5	3.9	3.9	3.9	4.2	4.4	4.0	3.9	4.6	4.3	3.5	3.0
2.9	3.5	3.9	4.0	3.9	4.3	4.4	4.0	4.0	4.8	4.3	3.6	3.0
2.9	3.3	3.7	3.8	3.7	4.0	4.1	3.8	3.9	4.6	4.3	3.5	3.0
2.9	3.3	3.7	3.7	3.7	3.9	3.9	3.6	3.8	4.5	4.2	3.4	2.9
2.5	2.9	3.3	3.5	3.7	3.8	3.7	3.4	3.5	4.1	3.7	3.1	2.6
2.6	3.0	3.5	3.8	4.2	4.4	4.2	3.8	3.7	4.2	3.7	3.1	2.6
2.5	2.9	3.5	3.9	4.4	4.6	4.5	4.1	3.9	4.0	3.5	2.9	2.4
2.5	2.9	3.5	4.1	4.6	4.8	4.8	4.5	4.1	4.1	3.5	2.8	2.4
2.4	2.8	3.5	4.0	4.6	4.8	4.8	4.5	4.2	4.0	3.3	2.7	2.2
2.2	2.6	3.2	3.8	4.2	4.5	4.5	4.3	4.0	3.7	3.1	2.5	2.1
2.0	2.5	3.0	3.7	4.0	4.2	4.2	4.0	3.8	3.5	2.8	2.3	1.9
2.2	2.6	3.2	3.7	4.0	4.2	4.2	4.1	3.9	3.5	2.9	2.4	2.0

Figure 3: Daylight Performance of the Prototype. The numbers are the daylight factor (the ratio between the illumination at a point inside the space to the illumination available outside)at that point in the space.

1.2. Heating Synergies

Heating is a significant energy use for the typical classroom. However, winters are generally mild in the Pacific Northwest: while temperatures may occasionally drop below 30°F, they are typically over 40°F, as shown in figure 4. In addition, the largest portion of the heating load is due to the need for fresh air in the classroom.

By using a heat exchanger, we reduced the ventilation air load by approximately 50%. High levels of insulation in the envelope (R-29 in the walls, R-58 in the ceiling) greatly reduce heat loss over the entire day. The remaining load can be met by two unusual but practical sources: an electric light and the students themselves.

Classrooms are normally fully occupied, and the students themselves are a significant source of heat. Calculations showed that on most days their presence was enough to achieve a balance point within our expanded comfort zone. On the occasional day when this strategy was not enough, heat gain from the 450-watt HID was enough to achieve comfort. Ceiling fans recirculate stratified air near the ceiling.

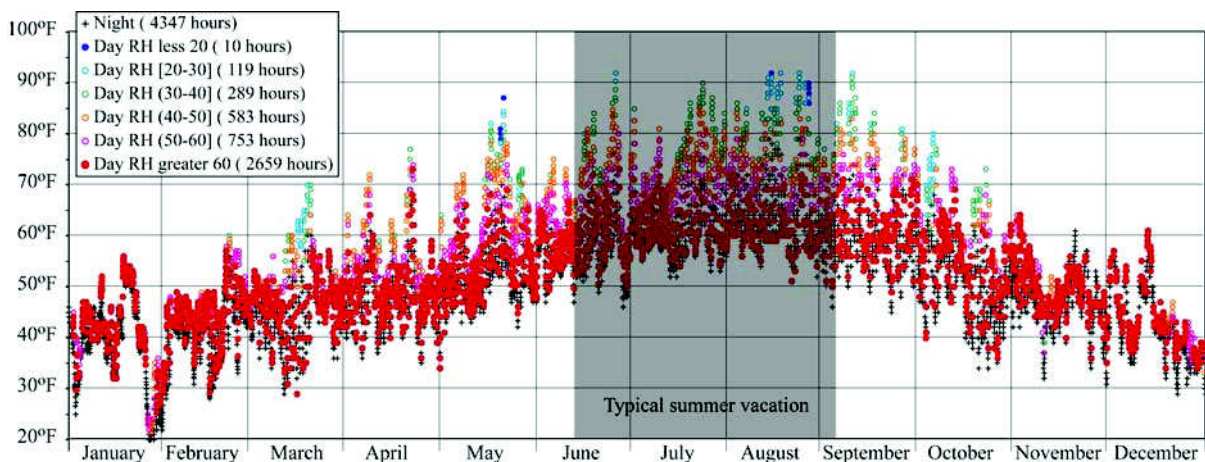

Figure 4: Annual temperature, Portland OR (TMY2 data)

1.3. Cooling Synergies

Conventional mechanical cooling was eliminated from the classroom. Elements from the heating synergies also serve to reduce cooling loads: high insulation values reduce the impact of afternoon temperatures peaking over 80°F, and the heat exchanger reduces the need to cool ventilation air.

The nine-month schedule typical of most schools is key, as it eliminates the hottest season and most peak temperatures (figure 4). Another critical synergy between climate and use involves the daily school schedule. The Pacific Northwest climate is characterized by night-time temperature depressions below 60°F, even on the hottest days. Since schools are (typically) unoccupied at night, they can be night ventilated with cool air. With thermal mass exposed in the floor and one interior wall, interior temperatures can be brought within the comfort zone on all but the hottest days.

With the expanded comfort zone, computer modelling showed that (based on monthly average temperatures) these strategies were enough to eliminate cooling needs except on the most extreme days. When occasional warmer night temperatures lead to insufficient mass cooling and interior temperatures peaking over 80°F, ceiling fans ensure occupant comfort, expanding the comfort zone by 2°F to 4°F (ASHRAE, 2004).

1.4. Lower cost

The synergies among climate, use, systems, and loads created by the architectural design resulted in sufficient to achieve a 70% reduction in classroom energy use (for the Portland, OR climate) while keeping costs lower than a typical reference classroom. We estimated a reference classroom to cost \$107,565, or \$112 per square foot, while the high performance design would cost \$106,801, or \$111 per square foot. Figure 5 shows how first costs compare on a square foot basis.

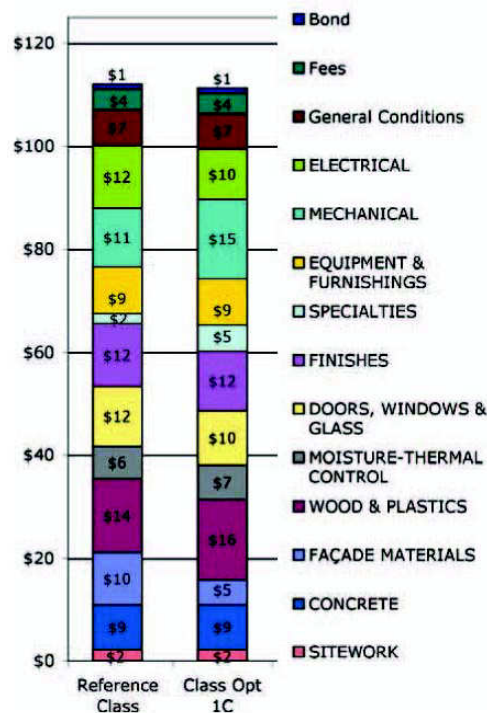

Figure 5: First cost comparison (per SF) between typical reference classroom and high performance classroom. (Source: BOORA Architects)

2. THE QUESTION OF INNOVATION AND MARKET TRANSFORMATION

2.1. Project history and current status

The concept was initially developed on paper in a study undertaken by the Energy Studies in Buildings Laboratory jointly with BOORA Architects and SOLARC Architecture and Engineering. This work was completed at the end of 2004. Subsequently, the design was refined and tested with a full-size prototype and then used by SRG Partnership for 7 classrooms at the new academic building at Mount Angel Abbey, St. Benedict, Oregon (directly across the plaza from Alvar Aalto's library). The classrooms range in size from 460 s.f. to 1300 s.f.

BOORA Architects is currently using the design for classrooms for a high school addition project in Portland. Recently, the concept was also specified in an Request For Proposals released by the Portland Public School District for a classroom building in Portland, Oregon, and this project is now under design by SRG Partnership. In addition, the Portland School District is looking into the possibility of adapting the design for modular classrooms. SRG Partnership is considering aspects of the concept for a 2400 s.f. space as part of a university building renovation. The Baker City School District has also been interested in the concept. After issuing a Request for Proposals, they stated that the concept should be used as a model for their new middle school (unfortunately their bond measure failed). We have also been asked to appear before the Yamhill Carlton School District 500' Subcommittee to discuss incorporating the design into their future school buildings.

The High Performance Classroom has also generated interest at the state level. The Oregon Department of Energy has begun promoting the concept to architects, engineers, and school districts around the state.

2.2. Hypothesis on the value of innovation for market transformation

Market transformation is relatively easy when the need or problem and the product or solution is well established. In the case of the new needs or products it is more difficult. However, if the product is innovative and addresses market transformation barriers, market transformation requires much less effort. Our hypothesis is that an innovative product can stimulate market transformation more rapidly than approaches that rely on educating owners and designers about existing concepts and strategies. Our High Performance Classroom uses less energy and costs less than the conventional alternative, and it provides opportunities for space variations. It was designed specifically for the Pacific Northwest climate, with the roof of the classroom having access to the sky. To achieve energy performance that can exceed 70% better than code at a lower cost, an integrated design process was used to identify synergies among climate, use, systems, and loads that could be created by the architectural design.

Our mission is to reduce the environmental impact of buildings, primarily by reducing the amount of energy needed for lighting, heating, cooling, and ventilation. Our market transformation efforts address energy-efficient design strategies and technologies, especially those involving daylighting and natural ventilation and focus on the key decision-makers: architects, engineers, and owners. In working with these stakeholders over the last 20 years of consulting and research we have repeatedly encountered several barriers to transformation. The most important include: 1) a perception that energy efficiency costs more – for instance, every owner has a limit to how much they are willing to spend for energy features beyond what is required by building codes; 2) a lack of awareness about the benefits of energy design, both energy related and non-energy related; 3) a lack of knowledge about how to design energy-efficient buildings; and 4) a fear of trying new technology (such as lighting controls).

The construction budget constrains design and is fundamental to all key decisions—whether to build, how much building is needed, what level of quality to design for, etc. Construction cost can be viewed as a barrier or an opportunity in the creation of energy-efficient buildings. Most often energy efficiency is perceived as adding to the cost of a building, and since construction budgets generally do not recognize energy features, they can act as a restraint on innovation. However, reconsidering the construction budget can encourage energy efficiency features. In this case we achieved synergies between energy goals and other design goals and so found opportunities to both reduce cost and improve performance. We explicitly showed the value of the energy savings and made sure that the construction budget included items that were critical to the design's success.

We can inform design professionals and owners about the proven energy benefits of the design because we have modelled the performance of the concept and tested prototypes. Non-energy benefits, such as increased occupant comfort and satisfaction, are also becoming increasingly important in making the case for energy features, especially as these relate to productivity. For instance, we performed computational fluid dynamics modelling of the thermal performance of the concept when it was being considered for a project at Mt. Angel Abbey, Oregon. This allowed us to describe the impact on thermal comfort of the mass and natural ventilation features.

The initial project was a collaboration with two professional design firms. When the concept was adopted by another firm for use in one of their projects we consulted with them during design and construction. All of this work involved project-based education – the informal teaching and learning that occurs while working side-by-side on a particular project. We believe this to be invaluable, both for transmitting how-to information and for conveying enthusiasm and a sense of the creative architectural opportunities of energy design. These people, who work in firms that have special expertise in school design, have since become the early adopters of the concept. By virtue of their design work the concept has achieved greater visibility and acceptance.

We have found that one of the most effective ways to allay fears of “unknown” technologies is through demonstration. In cases where the energy features have been used by others, the demonstration is as simple as providing information on successful buildings. However, when we develop new ideas, we build full-size prototypes. These provide multiple benefits in that we can work out the details in our designs, the architect and engineer can learn directly how to design the space, and the owner can have a tangible experience of the improved space, making it “real” for them. Arguably the greatest benefit of the full-scale prototype comes from being able to inhabit it. The experience of being in the classroom (figure 6) proved that it was a beautiful, well-daylit space. This was a useful and rewarding experience for both the design team and for visitors. During the course of the prototype’s existence, approximately one hundred people visited the classroom, including architects, teachers, school administrators, facility managers, utility representatives, reporters, and others interested in education and/or green building. Visitors were uniformly impressed with the quality of the classroom and its exceptional energy performance.



Figure 6: Visitors to the High Performance Classroom Prototype

The completed building at Mt. Angel is now an even more effective demonstration of how the High Performance Classroom concept can be used to create attractive, high performing spaces. Figure 7 shows one of the larger classrooms at Mt. Angel.



Figure 7: A Classroom at Mt. Angel Abbey. Source: SRG Partnership.

3. CONCLUSIONS

Our low cost, high performance classroom concept shows signs it will achieve a life of its own. We would argue that this is because it is a better design. Continued interest in the concept will allow us to test our market transformation hypothesis, for instance, by doing a statistical analysis of the number of classrooms built with our features in comparison to the number of more traditionally designed classrooms. It could be quite revealing to do this study to show geographical distribution over time. The concept has applicability outside of classrooms in the Northwest, although there certainly will be limits to aspects of its design. For example, while the daylighting features will be adaptable to warmer climates, the cooling features, in their current form, may not. If interest in the concept continues to grow, as we expect, we should have opportunities to test the limits of its applicability.

ACKNOWLEDGEMENTS

Mike Hatten of Solarc and Heinz Rudolf of BOORA Architects were partners in the development of the classroom prototype. Kent Duffy and SRG Partnership were partners in the development of the full-scale prototype space. Energy Studies in Buildings Laboratory staff involved with the project include Wade Jensen, Mark Wilkerson, and Emily Wright, who helped develop the high performance classroom design, and Crawford Smith, who helped develop of the full-scale prototype classroom. Mt. Angel Abbey agreed to the use of the High Performance Classroom concept for the design of their Academic Building, and provided warehouse space for the prototype construction. This project was designed with the support of the BetterBricks program of the Northwest Energy Efficiency Alliance.

REFERENCES

ASHRAE. 2004. ANSI/ASHRAE Standard 55-2004, *Thermal Environmental Conditions for Human Occupancy*. American Society of Heating, Refrigerating and Air-Conditioning Engineers, Inc.: Atlanta.

IESNA. 2000. *The IESNA Lighting Handbook, 9th ed.* Illuminating Engineering Society of North America: New York.

Heschong Mahone Group. 1999. *Daylighting in Schools: An Investigation into the Relationship Between Daylighting and Human Performance*. Pacific Gas and Electric Company: San Francisco.

Measurement And Education

How Are We Doing? A Protocol For Building Performance Reviews
Cathy Turner

Considering The Whole: Developing a Whole-house Calculator
Michael O'Brien, Ron Wakefield

A Systemic Model For Designing Energy Optimized Buildings
Audrey Kay Werthan

Awareness: the ground for sustainable design
Randall F. Teal

Innovative Sustainable Water Management Practices in Solar Residential Design
C. Jason Mabry, Franca Trubiano

How Are We Doing? A Protocol for Building Performance Reviews

Cathy Turner

New Buildings Institute, White Salmon, WA

ABSTRACT: This paper summarizes the state of post-occupancy evaluations (POEs), defines a new protocol designed to meet the marketplace needs and cost tolerance, and describes results of pilot testing. Initial research consisted of a literature review, interviews with potential POE users, and an exploratory study of actual energy use and occupant comfort in 11 LEED buildings. No single protocol in the past has met all the goals of budget, scope and direct applicability to the end user that were suggested by the market research. The new protocol breaks the POE into two stages, to keep costs as low as possible for a basic Level 1 evaluation. To draw the most useful inferences from readily available information, Level 1 input includes utility usage, an occupant survey, and an interview with the facility operator. An optional Level 2 review would implement diagnostics or actions recommended in the Level 1 report. An example is presented of the types of information learned from Level 1 pilot test results.

Post-occupancy, energy-use intensity, building performance

INTRODUCTION

Improving commercial building efficiency requires feedback to owners and designers on actual resource use and occupant comfort, but such building performance is rarely measured. Why? Barriers to achieving feedback through traditional post-occupancy evaluation have been well documented, but not yet overcome. This paper describes a protocol for reviewing actual building performance that grew out of market research conducted by the New Buildings Institute, covering who is potentially most interested in the results of such reviews and the most desired pieces of information. This paper consists of three primary areas:

1. Market research on the current interest in, and barriers to, performance evaluation.
2. Lessons from a review of 11 green buildings in Oregon and Washington.
3. Refined protocol development and implementation.

Successful implementation of this review protocol should achieve useful performance feedback on many more buildings. Knowing how buildings really perform has the potential to help owners optimize savings, further reduce utility costs, and foster a productive working environment for occupants. Completing the feedback loop to original designers can extend these lessons and results to future new buildings.

1. MARKET RESEARCH: WHY IS PERFORMANCE RARELY REVIEWED?

Post-occupancy evaluation (POE) is the general term for a broad range of activities aimed at understanding how buildings perform once they are built. Practitioners use the term with a variety of meanings, including occupant surveys, energy and water use analyses, and review of building system performance. A POE energy study may include any of the following: total building energy use intensity (EUI) compared to benchmarks, energy end-use analysis, and comparison between actual and anticipated energy use (with or without as-built calibration of the original energy model). Time and expense requirements are often seen as prohibitive for some of these activities. This section describes literature and market research done to determine whether any existing POE protocol could affordably meet the needs of those most interested in the results.

The most widely known POE tools may be the Post-Occupancy Review of Buildings and their Engineering (PROBE) work in Great Britain (Standeven, M., Bordass, B., Leaman, A., Cohen, R., 1995-2002 and survey tools developed and supported by the Center for the Built Environment at UC-Berkeley. It appears that even these better known products have been used on at most a few hundred buildings over ten or more years.

1.1. Literature review

The literature sought to determine whether an established protocol already existed for completing a POE that would meet the needs of building owners and other immediately interested parties. Two recent books on POE have brought together many of the key lessons learned to date. (Federal Facilities Council, 2002; Vischer, J. and Preiser, W., 2005). These materials describe a wide variety of POE protocols, but few focus on addressing the immediate interests of building owners. Although elements of several protocols appear to be useful, no single one accomplishes the goals of meeting building owner needs in terms of budget, scope and direct applicability of results. In addition, a useful and repeatable standard POE must address a series of critical market barriers.

Review of the literature indicates several well-documented barriers to achieving feedback from traditional POEs. Among the more substantial are:

- It is not clear who has responsibility to conduct POEs;
- Funding for POEs is not included in design budgets;
- The results may come too late to be perceived as useful for the design team, which has moved on to the next project, or to an owner who may not be planning any similar projects;
- Technical and logistical difficulties often arise in obtaining even basic data; and
- The POE report may uncover problems, possibly leading to awkward questions or even liability. At the very least, professionals are not that interested in other professionals reviewing their work.

Looking at the distribution by size of the country's commercial building stock helps frame the issues of technical difficulties and POE cost. As seen in Figure 1, the most recent Commercial Building Energy Consumption Survey (CBECS) shows that over 75% of U.S. commercial buildings are less than 930 m² (10,000 ft²). Buildings below 4,600 m² (50,000 ft²) comprise over 90% of all commercial buildings and a full 50% of all floorspace. Complex energy management systems with monitoring and diagnostic tools are often designed for much larger buildings and are not affordable by the managers of these smaller structures.

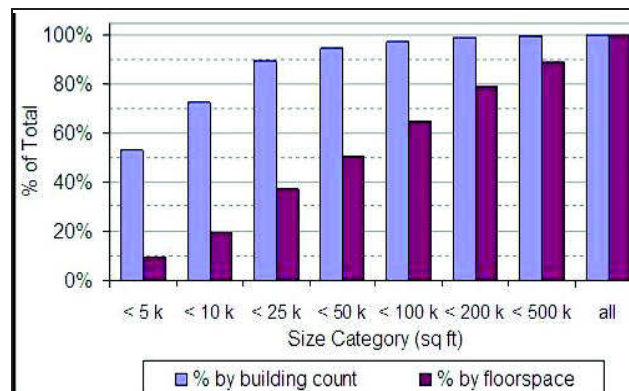

Figure 1: CBECS Building Size Distribution, Cumulative Percentages by Count and Area
(Data Source: Commercial Building Energy Consumption Survey 2003, www.eia.doe.gov/emeu/cbecs)

1.2. Market research

The next stage of the market research was to better understand key aspects of POE usage: current informal practices regarding feedback on building performance and occupant satisfaction; the most attractive and motivating elements of a potential POE tool; and the potential value of a POE to the end user. In-depth interviews gathered views from ten individuals representing three market perspectives: private developers/owners, public building owners and design team members. Discussions with these designers and owners helped identify professions most motivated to obtain building performance feedback, and the information most useful to them. Owners are clearly the audience most immediately interested in these reviews, although designers can also benefit. Both owners and design team members state they would use an affordable performance evaluation tool. Few owners systematically collect information on occupant satisfaction with their buildings. The cost of evaluation was cited as the largest barrier, followed by logistical or time constraints. It appears that \$2,000 to \$5,000 is the maximum that most interested parties would be willing to pay. Energy use and occupant satisfaction were seen as the most important elements to include.

The results of this market review are further described in Hewitt, 2006.

2. LESSONS FROM PACIFIC NORTHWEST LEED BUILDINGS

A study of 11 recent buildings certified by the US Green Building Council's Leadership in Energy and Environmental Design (LEED) program further informed research into a practical Building Performance Review protocol. This study was sponsored by the Cascadia Region Green Building Alliance and is further described in Turner, 2006. It gave preliminary feedback on practical considerations in gathering simple building data. It also provided insight into actual performance levels of these buildings. All buildings were in the Portland, Oregon to Seattle, Washington region, had been occupied for at least one year by the fall of 2005, and were certified under the US Green Building Council's LEED program. Beyond that similarity, the buildings varied widely and included office, library, and multifamily residential facilities. Sizes ranged from 12,000 to 360,000 square feet.

Thirty-one buildings met the criteria in the previous paragraph and were eligible to participate. The 11 buildings in the final study consist of all those with owners who were willing and able to provide the needed information during the limited study timeframe. While this is not a random sample of all green building, it should be a good snapshot of available information. Table 1 lists basic characteristics of the participating buildings.

Table 1: Participating Buildings
(LEED Level refers to the New Construction (NC) program except where noted)

Building (abbreviation used in later graph)	Size	LEED LEVEL (New Construction program except where noted)
OFFICES AND LIBRARIES		
Balfour Guthrie (BG) Portland OR	18,000 sq ft 3 stories	Silver
Jean Vollum Natural Capital Center (NCC) Portland OR	70,000 sq ft 3 stories	Gold
Hillsdale Branch, Multnomah County Library (HL) Portland OR	12,300 sq ft 1 story	Gold
King Street Center (KSC) Seattle WA	320,000 sq ft 8 stories	LEED-EB Gold (Existing Buildings program)
Seattle Public Library's Central Library (SL) Seattle WA	363,000 sq ft 11 stories	Silver
Viridian Place (VP) Portland OR	15,000 sq ft 3 stories	Certified
Building O-7 (anonymous) (O-7)	34,000 sq ft	Certified
RESIDENTIAL BUILDINGS		
Portland State University Broadway Building (B) (owned by the PSU foundation) Portland OR	198,400 sq ft 10 stories	Silver
Portland State University Epler Hall (E) Portland OR	64,000 sq ft 6 stories	Silver
The Henry Condominiums (H) Portland OR	220,000 sq ft 12 stories	Gold
Traugott Terrace (TT) Seattle WA	32,000 sq ft 6 stories	Certified

2.1 Energy Use

Six of the 11 buildings were using less total energy than suggested by their initial Design models. "Design" as used here refers to the modelling provided with the initial LEED submittal, reflecting energy use with all anticipated energy efficiency measures. The LEED models were prepared primarily to estimate the value of individual energy efficiency measures, not necessarily to accurately predict the absolute level of total utility usage in a building. Thus, the comparison of actual usage and the modelled Design usage is at best an approximate measure. More precise conclusions would require further analysis of changes between initial design and the as-built structure and systems. Other, non-efficiency-related differences, such as actual occupant numbers, building usage patterns, and building management practices would also need to be identified.

Figure 2 shows Actual and Design energy use intensities (EUIs), with office and residential buildings each sorted from lowest to highest actual EUI. Despite the variety of buildings in the study, eight of the eleven have actual EUIs in the relatively narrow range of 510 to 625 MJ/m²/y (44 to 55 kBtu/ft²/y). No single building's actual performance was within 20% of its Design model. The average actual/Design ratio was closer than that for any individual building: 110% for all buildings and 89% if the unusual results of building O-7 are excluded.

Building O-7's actual usage exceeded its Design model by 300%. This building represents a case where the owner was aware of problems even before this POE study was done. The facility had experienced a number of HVAC systems and lighting control problems during its first few years, and building managers felt they had finally succeeded in tuning the systems and replacing components where necessary by the end of the study period. A simple follow-up a year later would be instructive.

The Hillsdale Library, which shows the highest Design EUI of the group, had a number of site constraints and design requirements that may partially explain its energy usage level. In addition, as the only single story building in this study, it has a higher surface to volume ratio than the rest of the buildings, which can also lead to greater heating and cooling requirements.

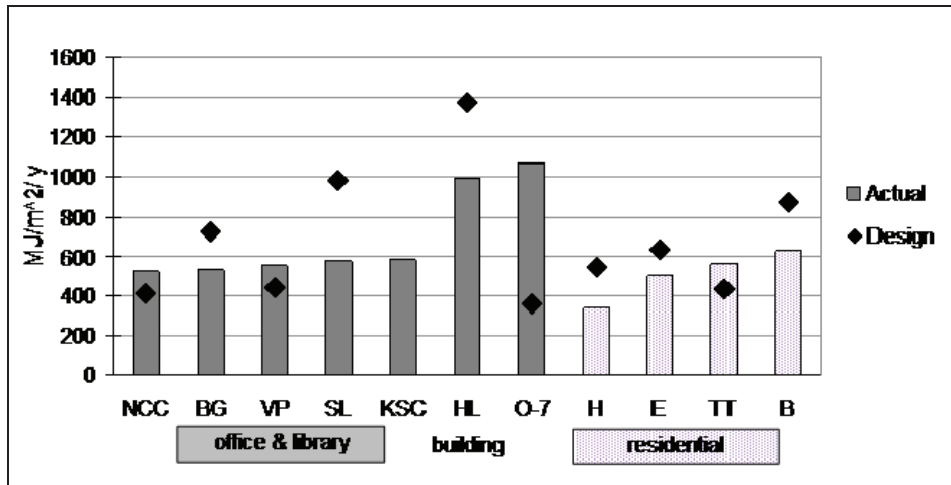

Figure 2: Comparing Actual Energy Use Intensity with Initial Design Models
No design modelling was available for King Street Center, which was LEED-certified several years after construction, under the Existing Building program.

2.2 Occupant Survey

An on-line occupant survey sought to determine perceptions of building comfort and functionality in the categories of temperature, air quality, lighting, noise, and plumbing fixtures. Response options were on a 5 point scale with a central neutral point. All those working in office buildings or living in residential buildings were invited via e-mail to participate. Figure 3 displays the general question structure for a typical question.

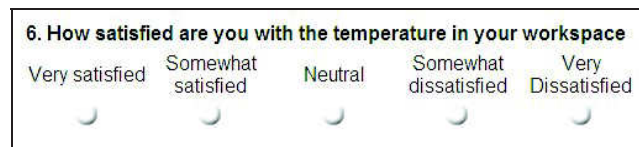

Figure 3: Sample survey question

The survey response rates of office building occupants ranged from 40% to 73%. A response rate of 50% or higher is a common target census surveys such as this, in which all occupants are invited to participate. While results from a building achieving a lower response rate, or with very few occupants, are not as statistically rigorous as one might prefer, they can still be useful in identifying issues in the building.

Residential response rates were extremely low, with the exception of Traugott Terrace, which conducted a paper survey during a meeting of residents. Thus the following paragraphs discuss only the office results.

Office respondents were generally very satisfied with their building overall and somewhat satisfied with their personal workspace. Satisfaction ratings for most categories, with the exception of noise level and sound privacy, were typically positive. Light levels and air quality were both generally perceived as being somewhat helpful in getting work done. The dissatisfaction with noise levels and sound privacy has also been reported on surveys by others, and is often associated with open office environments. Workspaces of survey respondents were typically low partition cubicles or desks with no partitions. Figure 4 summarizes the range of office building response averages for the primary survey questions.

Within the categories receiving positive ratings, temperature conditions had the lowest median scores, with satisfaction falling in the “somewhat satisfied” range. Also, a relatively low percentage of occupants perceived temperature conditions as helping to get their job done. A more in-depth occupant study could investigate whether these problems were concentrated in specific building locations or with specific types of occupants. Because this survey included only LEED buildings, there is no comparison with “non-green” offices. However, the similarly structured surveys from the Center for the Built Environment, which cover a broad spectrum of office buildings, have reported slightly negative thermal comfort satisfaction, as opposed to the slightly positive results here. (Huizenga et al, 2006)

One purpose of an occupant survey is to determine whether low energy consumption is possibly being achieved through reducing comfort for occupants. In this limited sample, there was no clear relationship (positive or negative) between the level of temperature satisfaction and building energy use intensity.

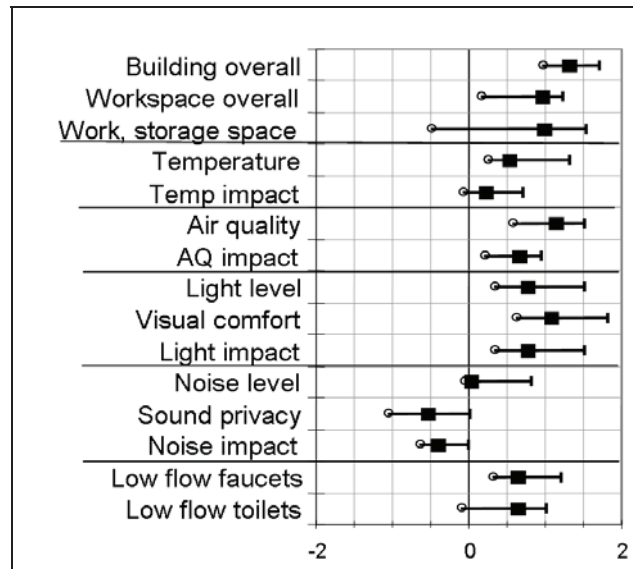

Figure 4: Average office building survey responses by category
 -2 = very dissatisfied; +2 = very satisfied
 ○–Least satisfied office; ■–Median office; |–Most satisfied office

2.3 Procedural Lessons

These simple whole-building calculations showed useful, though not diagnostic, snapshots of actual performance. Procedurally, considerable time was required for gathering even the basic energy usage data. Two primary factors underlie this time requirement: the fact that most building owners do not retain past energy billing information in readily accessible format, and difficulty in identifying the individuals who might have access to the information or be able to authorize utility company release of the information. The fact that this study was entirely funded by the sponsor, with no cost to participating building owners, may have reduced the degree to which study results were used by building owners.

This study also revealed some basic steps that, if taken during initial design and construction, could simplify later measurement of actual savings achieved and potentially increase total efficiency savings. The underlying theme is to plan from the outset for later simple monitoring. For example, one of the primary impediments to even the simplest studies can be the lack of basic utility usage information. Failure to meter individual buildings on an institutional campus prevents later summarization of whole-building performance.

3. MARKET-FRIENDLY PROTOCOL DESIGN

Using the market research results and experience of the LEED building study, we derived a refined protocol to perform simple Building Performance Reviews (BPRs) with cost and content that would be attractive to the marketplace. Lessons from the earlier steps fall into the main categories of audience, content, and delivery.

3.1 BPR Description

The primary audience for a market-friendly product is the building owner. While elements of POEs are of interest to design teams, the owners have a more compelling interest and greater ability to fund. Owners should be encouraged to create a feedback loop to influence design teams for future projects. Owners of institutional and

public buildings are particularly good candidates for a BPR, because of their long ownership period, need for public accountability, and portfolio of properties that can form a locally relevant benchmark.

The BPR results should cover total energy use and an occupant survey. Water efficiency may also be covered, although our experience is that meter readings in many smaller office buildings are often too infrequent or unreliable for useful results. The report should include information that focuses the attention of the owner on improving building operations. For buildings requiring attention, the focus should be on creating a pathway to action: defining steps to improve comfort and/or reduce operating costs. The BPR should not, on the other hand, include critiques of specific design elements (e.g., a daylighting design or unusual HVAC system design). That level of review would require the cost of additional time and expertise, without leading to more useful corrective actions than can be obtained by observations of end performance.

Procedurally, the entire BPR protocol should be broken into at least two stages. The first should be as simple and low-cost as possible. Low-cost Level 1 protocols could be repeated every year or two. The results would enable owners to compare one building over time and also to compare a range of buildings within their portfolio. To draw the most useful inferences from readily available information, Level 1 input should include a full year of actual utility usage, an occupant survey, and an interview with the facility operator. The resulting indicators will reflect whether the building is performing overall to desired benchmarks, which may be based on regional norms, established ratings systems such as Energy Star, or design expectations for the building. For buildings not meeting the desired standard, the Level 1 report should provide a limited set of findings regarding performance issues, including areas to address and diagnostic tools or steps that could be helpful. An optional Level Two review can implement the recommended diagnostics, to better identify underlying causes of, or solutions for, general issues that surfaced in Level One.

3.2 Pilot Test Example

The Level 1 protocol was piloted in four elementary schools in Washington. Figure 5 shows energy usage for one new school, in relation to the old building that it replaced and the entire district portfolio of elementary schools. In this example, the new building was using less energy per square foot than the district median, but slightly more than the old building it replaced. The Level 1 report suggested further investigation of the heating and ventilation set points, and the facility managers discovered that the boiler had been running at times that no heat was needed.

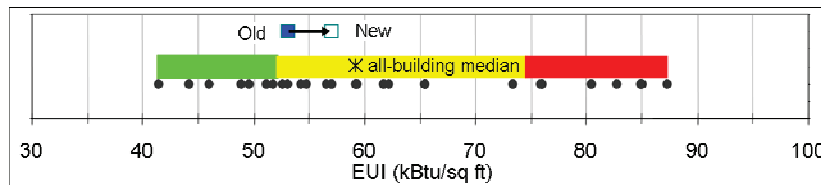

Figure 5: Energy Use Intensities for the New elementary school and the Old building it replaced. Dots represent all elementary schools in the district portfolio. Shaded rectangles represent the best (lowest EUI) quartile on the left, and worst (highest EUI) quartile on the right.

This example also demonstrates the benefit of gathering occupant feedback as well as utility usage. All teachers, staff, and survey workers were invited to complete a brief online survey. Response rates ranged from 60 to 68%. Figure 6 shows the average occupant comfort scores by category for each of the four schools studied. The two new school buildings are those on the left, with marked positive ratings in nearly every category, in sharp distinction to the two older schools on the right. The negative rating for acoustic comfort in one of the new schools was a previously unidentified problem and is currently being investigated.

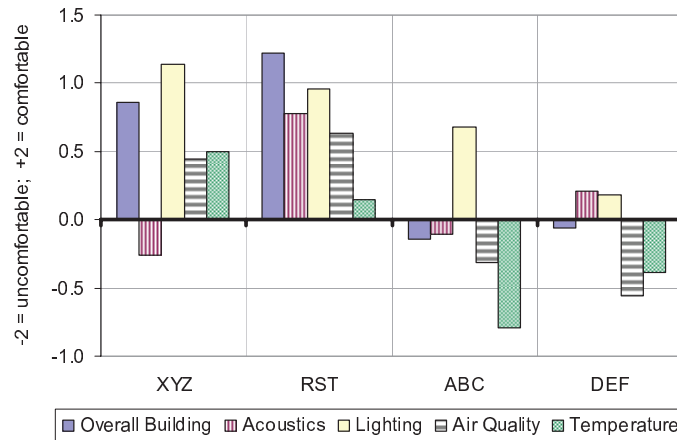

Figure 6: Average functional comfort scores for two new school buildings (XYZ and RST) and two older buildings (ABC and DEF)

Follow-up surveys done over a period of years will increase our understanding of the degree to which higher comfort ratings in new buildings decline as the buildings age.

CONCLUSION

While there is interest on the part of both owners and designers in knowing how well buildings perform, a number of factors have limited the frequency of measuring post-occupancy performance. The BPR protocol seeks to materially increase the number of useful performance reviews by extracting performance indicators from readily available data. A staged approach creates a simple Level 1 report which, if the building is not meeting overall expectations, identifies the next steps to take in diagnosing the underlying problems. Pilot tests of Level 1 have shown that useful insights can come from combining readily available data from multiple sources: utility bills, a simple occupant survey of functional comfort, and interviews with facility managers. For areas in which Level 1 suggests further investigation or correction, further development work is still needed to streamline the path to Level 2 diagnostics and action.

ACKNOWLEDGEMENT

This document draws on market research funded by the Northwest Energy Efficiency Alliance and a study of LEED building performance funded by the Cascadia Region Green Building Council. The support of both those organizations, as well as the participation of owners of buildings studied is gratefully acknowledged.

REFERENCES

- Federal Facilities Council, 2002, *Learning from Our Buildings, A State-of-the-Practice Summary of Post-Occupancy Evaluation*, Federal Facilities Council Technical Report No. 145, National Academy Press, Washington DC.
- Hewitt, D., 2006, *A Market-Friendly Post-Occupancy Evaluation: Building Performance Report*, New Buildings Institute contract C10091 for the Northwest Energy Efficiency Alliance, Portland, OR.
- Huizenga, C., Abbaszadeh, S., Zagreus, L., Arens, E., 2006, „Air Quality and Thermal Comfort in Office Buildings: Results of a Large Indoor Environmental Quality Survey,” *Proceedings of Healthy Buildings 2006*, Lisbon, Vol III, 393-397.
- Standeven, M., Bordass, B., Leaman, A., Cohen, R., 1995-2002, Probe Reports 1 through 23, *Building Services Journal* [available <http://www.usablebuildings.co.uk/>, 1/3/2007]
- Turner, C., 2006, *LEED Building Performance in the Cascadia Region: A Post Occupancy Evaluation Report*, Cascadia Region Green Building Council, Portland, OR.
- Vischer, J., Preiser, W., eds., 2005, *Assessing Building Performance*. Elsevier Butterworth-Heinemann, Burlington, MA.

Considering the Whole: Developing a Whole-house Calculator

Michael O'Brien¹, Ron Wakefield²

¹Myers-Lawson School of Construction, Virginia Tech, Blacksburg, Virginia

²School of Property, Construction and Project Management, The Royal Melbourne Institute of Technology, Melbourne, Australia

ABSTRACT: Comparing the characteristics of one house to another is one of the most difficult tasks facing a prospective homebuyer. Each house is the result of tens of thousands of decisions made by material suppliers, product manufacturers, designers, engineers, regulatory officials, marketing professionals, builders and subcontractors. Even though many appear similar, each house is effectively unique, a one of a kind assembly that will stand, breathe, manage water and shelter its inhabitants differently.

Professionals designing the house, selecting the materials and products to include and developing the processes used to design, engineer and produce the house face a daunting number of choices as well. Their choices affect how quickly the market accepts the house, how the house behaves when stressed by forces of nature and how efficiently the house uses energy, labor, and materials.

The whole-house calculator grew from a series of research projects sponsored by the Department of Housing and Urban Development's Office of Policy Development and Research: "PATH 13 Whole House Calculator", "A Preliminary Method to Develop a Calculator for Evaluating Physical Design Characteristics and Whole House Performance Scoring", "Creating Whole House System Solutions" and "Designing Whole House Solutions." The purpose of these projects was to investigate the feasibility of quantitative assessment of the performance of design and production processes, materials, systems, and the interactions between them for the purpose of comparative scoring.

This paper will present the approach, theory, method and current state of development of the web-deployable whole house calculator.

1.0 INTRODUCTION: As it exists today, a house is a product of almost two hundred years of trial and error development that have added and subtracted materials and subsystems to the house in response to changing technological, social and financial pressures. Over the last forty years some individual subsystems (structural/thermal) have been carefully scrutinized, researched, and discretely optimized to balance performance outcomes with financial inputs. Most remaining subsystems (foundation, envelope, plumbing, lighting) continue to be largely based on approaches that have evolved over time. The result is a complex federation of semi-independent systems of design, engineering, procurement and production, each having discrete standards, goals, and governing regulations. The intense focus on discrete system optimization has, in some highly visible cases, produced unexpected interactions with related or adjacent systems that have significantly compromised the integrity of the house as a whole (Brown et. al 1997). A common factor in these instances of diminished performance of the whole seems to be the confluence of an innovative substitution within a conventional approach to housing design and construction.

The conventional approach to residential building can be described as a series of innovations applied to a traditional construct. Builders often adopt a traditional approach to the processes, products and designs for the house to be able to focus on the production and sale of the house. Traditions are familiar, don't require extensive design or analysis that costs time and money, and generally, are safe in the marketplace. Some of the traditions have developed from personal success, while some have been handed down as best practices. Traditions are often perceived as having been established by tried and true methods and require no further investigation.

Traditions seldom provoke innovation, but the competitive marketplace demands it. Financial and legal risks temper the extent of innovation proposed by builders, and accepted by buyers. New processes, materials or

products are typically introduced into the traditional process slowly, in small increments, adding a new material or system or substituting a new material for an old one. Often this substitution is done without full consideration for its impact on related parts of the system or the whole. The innovation is introduced to the market often based on the reputation of its advocate. The better the reputation of the advocate, the greater the capacity to share risk with the builder or buyer (Koebel and Cavell, 2006)

The systems approach stands in contrast to the federation of components produced by the conventional approach. One of the many definitions of a system is “a dynamic entity, like a cell, organism, organization or environment which is comprised of interdependent parts, fundamentally characterized by inputs, processes or throughputs and outputs; parts in interrelationships that work together for the purposes of the whole.” The phrase “whole house” implicitly suggests all parts working for the benefit of the whole. The house itself is simultaneously the result, or output, of a much larger system and once completed, it is, ideally, a dynamic entity, a system itself.

Because a house is both the output of a system and a system itself, the concept of wholeness of the house extends beyond its walls. Its lineage extends back to its conception, so to consider a whole house is to consider both its completed end state *and the processes that produced it*.

Interrelatedness is a defining aspect of a system. The degree of interrelatedness of the parts and processes that comprise the system effectively set the level of performance of the system and the products of the system. Theoretically, all parts and processes interact with and affect all other parts and processes in the system as well as the environment in which the system is located.

There are approximately 143 separate parts that make up the 54,000+ total part count in a house. Given that there are at least four alternatives for each part, and taking the six climate zones and six seismic design categories identified in the International Residential Code (IRC) and conservatively assuming six alternative house designs facing one of eight possible compass orientations there are over five hundred million combinations of the system (O'Brien and Wakefield, 2005).

The conscious analysis of the interactions among all the parts, materials, subsystems processes making up a traditional light-wood-framed house and the climatic and geologic conditions of the site is seldom undertaken. A house design that worked well and possessed a subjective charm in rural New England becomes a higher risk when transplanted to a coastal community in Florida (ARA, 2002). A cladding system with decades of successful performance on masonry substrates puts the structural framing at risk in a warm, humid climate (Brown et. al. 1997). Even locating an HVAC unit in an attached garage may contribute to an increased risk for a family's health problems in certain climates (Emmerich et. al. 2003)

It seems unreasonable to ask a designer or builder to carefully analyze the numerous and complex interactions. Partly because there is little or no undisputed evidence to prove that a traditional architectural house form constructed using contemporary contracting and inspection methods from a combination of traditional and innovative materials and systems within a traditional visually-based method of quality assessment *will* fail at some aspect of performance, and partly because there is no accepted method for analyzing the house as a whole. ASCE – 7 considers the structural aspects, ASHRAE standard 62.2 considers the ventilation and air quality, but is not yet a required standard in the International Residential Code. Material innovations are being introduced faster than the residential building culture can thoughtfully adapt. This lack of consideration for the performance of the whole house sited on a unique parcel of land frequently contributes to performance failures significant enough that either FEMA or class-action litigation is the homeowner's only recourse.

2.0 APPROACHES TO CONSIDERING THE WHOLE: Some of the earliest public/private partnerships considering the house as a whole were undertaken by the U.S. Department of Energy Building America program and the U.S. Department of Housing and Urban Development and National Science Foundation's PATH program.

The Building America Program began in 1991 as a small group of partnerships between housing designers, engineers, research groups and residential builders. Today the program has five research teams that have completed over 20,000 homes in 24 states. The program is focused on:

- Reducing whole-house energy use by 40–70% and reduce construction time and waste;
- Improve indoor air quality and comfort;
- Integrate clean onsite power systems;
- Encourage a systems-engineering approach for design and construction of new homes;
- Accelerate the development and adoption of high-performance residential energy systems.

The focus on energy conservation through systems and field-process design has made improvements in structural systems performance as well through the implementation of formal quality processes. The “Best

Practices Guides” available on the Building America Program website contain outstanding examples of the benefits of considering the whole (Building America 2006)

The Partnership for Advancing Technology in Housing (PATH) began considering the house as a whole with the publication of “Whole House and Building Process Redesign” as part of its Technology Roadmap series (NAHB, 2002). In this roadmap, the vision for this research effort was succinctly stated as “Build Better Homes Faster and at Lower Cost”, which was further elaborated to mean development of efficient, controlled processes to construct a house in a 20 day period to provide cost savings making home ownership available to 90% of the U.S. population. The Whole House roadmap identified these key barriers to achieving the goal:

- A lack of systems engineering and analysis in the design and construction of homes;
- Consumers lacking education in the quality aspects of a home;
- Insufficient quantities of skilled labor;
- Complex and locally unique building regulations;
- Builder resistance to change;
- Builders lack of control of the home building process;
- Industry lack of collaboration and resistance to change;
- Industry fragmentation;
- Consistency of home quality.

The idea of a “Whole House” Calculator was developed to support the goals of rapid construction and affordability by being able to compare the performance of a house design on a specific piece of land to a recommended practices house and identify system weaknesses prior to construction.

2.1 EARLY METHODS: Literature searches failed to reveal a holistic assessment method for residential construction capable of quantifying subjective and objective characteristics of the processes, systems and materials used in residential construction. But the literature search did reveal an Environmental Evaluation method developed by Dr. Luna B. Leopold for the USGS which was further modified by Battelle laboratories. The Leopold/Battelle method uses a matrix to list possible actions on a horizontal axis and environmental quality outcomes on the vertical axis. An expert group identifies important interactions between a desired environmental quality and a project-related action in the first pass through the matrix. Hollick, (1993) documents Leopold’s proposition that if 100 construction actions were listed horizontally, and 88 environmental outcomes were listed vertically, that when carefully considered, a typical project would only have 25 to 50 interactions between them, a significant reduction from the possible 8,800 interactions in the matrix. (Hollick, 1993)

The second pass through the Leopold/Battelle matrix is a scoring pass. The interaction is ranked from –10 to 10 for its positive (benefit) or negative (cost) effect. A third pass through the matrix assigns the weighting factor for each interaction. Environmental professionals who have used the Leopold matrix offer two cautions. First, that the user be on guard to prevent double counting of nested effects, and second that each design alternative requires it’s own matrix.

The Leopold/Battelle interaction matrix was developed for the first generation whole house calculator. It listed the potential impacts of the system behavior vertically and the alternatives for the design and production methods and subsystems components horizontally. Two test-case houses were evaluated using this approach. The first was a convention production house made up of 93 systems choices that were scored on 23 performance characteristics and 4,324 systems interactions. This house scored 15.81% of a best possible score for a house with 93 systems choices. While the second house was a systems-approach house made up of 88 systems choices scored on 23 performance characteristics and 3,872 systems interactions. This house scored 26.8% of a best possible score for a house with 88 systems choices. The full calculation method and rationale is described in *“Developing a Calculator for Evaluating Physical Design Characteristics and Whole House Performance Scoring: A Preliminary Method”* (O’Brien and Wakefield, 2005).

This first generation approach was published on the HUDUSER website in 2005 (O’Brien and Wakefield, 2005). A post-publication assessment of this project, conducted by Newport Partners L.L.C. revealed critical weaknesses in the limited number of experts providing performance and interaction scoring, the difficulty the general public or professional builder or designer would have with describing the processes, systems and materials making up the house, the scoring method for systems interactions, the immense gaps in accepted research findings related to scoring, the lack of influence of local climatic and geologic factors, the abstract nature of the numerical score and the limited testing of this initial method. It was clear a new method was required.

3.0 The Second-Generation Whole House Calculator Theory: The core theoretical proposition of the whole house calculator is that the configuration, design, contracting form and quality-assurance methods that guide the

selection, location, specification, detailing and installation of subsystems and materials comprising a house, in a specific location having unique climate and geologic characteristics, plays a significant role in the performance of said design, subsystems, materials and the house as a whole.

3.1 THE SECOND GENERATION CALCULATOR METHOD: Like the first generation calculator, the second generation calculator uses a database of performance scores, modified by location-specific systems weighting factors, modified by performance interactions to arrive at a score for each systems choice. To develop a dataset of the performance of design, system and material characteristics, a panel of six building scientists with expertise in structural systems, thermal systems, moisture management, indoor air quality aspects, production methods and quality, durability and systems approaches to residential construction was assembled by Newport Partners L.L.C. The panel members were asked to score a set of 502 systems choices covering a range alternative methods of Design Characteristics and Production Processes, Foundations, Superstructure, Envelope, Interior Partitions and Finishes, Millwork and Appliances, Utility Distribution, Electric Power and Light, Sewer and Water and Thermal Systems. The scores were input at a website designed by G3 Systems Inc. and allowed the experts to rank the alternative as not applicable (NA) or as on a nine point scale from “Poor” to “Best” for each of six climate regions of the United States. The Expert Panel database web page is shown below in Figure 1.

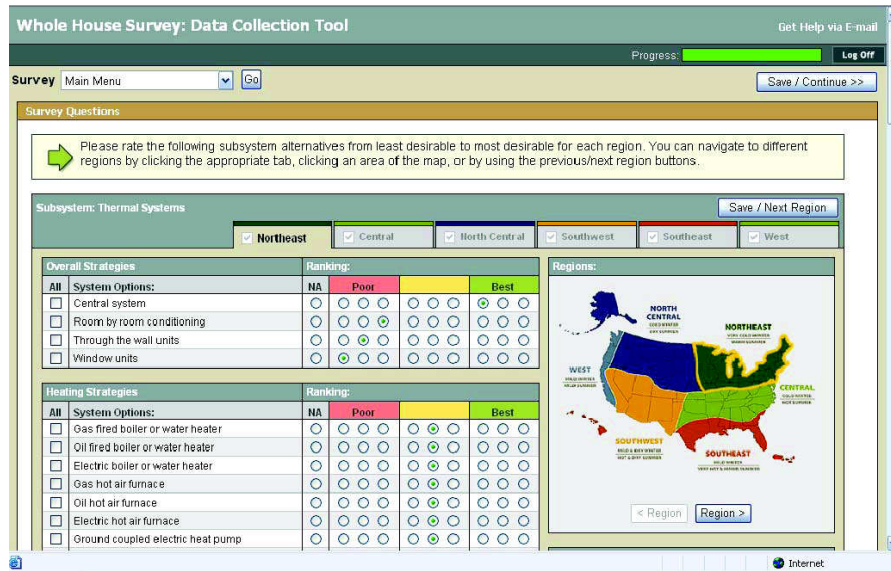

Figure 1. Expert Panel Database, Importance Scoring. Source: Author

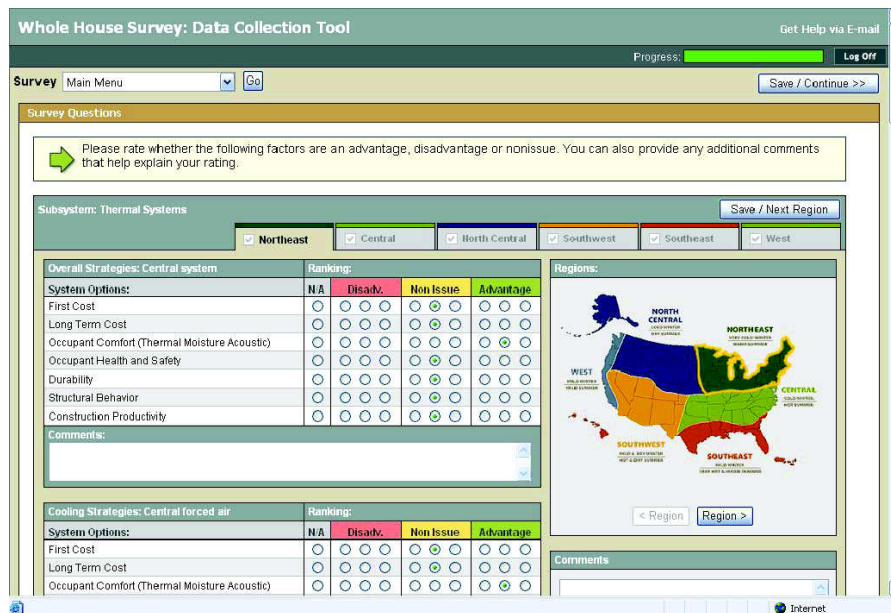

Figure 2. Expert Panel Database, Reasoning Scoring. Source: Author

The systems scored in the lower 10% and the upper 10% generated a set of follow-up questions to inquire into the reasoning behind these high and low rankings as shown in Figure 2. This way, the 502 alternative systems choices were scored across six U.S. regions by six members of the expert panel producing a database of approximately 18,000 entries. The scores for each alternative systems choice were averaged into a single performance factor for each systems choice in each region of the U.S. seen in the maps on Figures 1 and 2 above.

3.2 USER INPUT: The second-generation calculator is intended for use by residential designers and builders designing new single-family detached homes. The expert panel proposed this scope limitation as an initial prototyping step. To begin using the tool, the user logs into the website and inputs the location of the house as shown in Figure 3.

Figure 3: User Startup Screen. Source: Author

Figure 4 User Input Screen for Alternative Systems Choices showing glossary popup. Source: Author

The calculator delimits the performance, interaction, and systems weighting databases based on the location to speed processing responses. The user is presented with an input page, shown in Figure 4. The major subsystems of the house appear in the 10 tabs across the top of the screen. When the user clicks on the tab, the alternatives to each systems choice appears with either check boxes (allowing multiple selections) or radio buttons (for single selections). Glossary explanations pop up when the user allows the mouse cursor to hover over the systems choice for additional clarification of the terminology. Recommended practices for the location of the house are highlighted in light green. After entering the house configuration, the user clicks on the "Submit/View Summary" button to receive the report card for the house.

3.3 RECOMMENDED PRACTICES: Recommended Practices houses are configured for each climate region based upon the Building America "Recommended Practices Guides" (Building America, 2006) The design characteristics, quality processes, contracting methods, systems and materials choices are closely matched to those presented in the Building America Guides. The Calculator compares the house input by the user, to the recommended practices house to arrive at the score for each subsystem and the associated letter grade. It is possible to configure a house to exceed the score of the recommended practices house, as the recommended practices are not intended to represent the absolute highest values in performance, but have been developed as a balance between performance and cost.

3.4 SYSTEMS WEIGHTING FACTORS: Local conditions can significantly affect the importance of the performance of the subsystems. Thus a data table of climatic and geologic characteristics was developed for the 3,141 U.S. Counties for the following characteristics; Wind Speed, Seismic Risk, Radon Risk, Relative Humidity, Precipitation, Heating Degree Days and Cooling Degree Days. Whenever possible 50-year climate normals were used to establish these values. This data was further mapped to 42,192 Zip codes to simplify user input.

Systems weighting factors for each location were determined by dividing the expected intensity of the natural force for a county by the difference between the high and low value for that same force across all counties of the United States.

For Mobile County, Alabama, the anticipated peak wind speed (50 year recurrence) is 150 mph. The difference between the high value (150) and low value (85) is 65. Mobile's 150 mph design target divided by the national high-low difference, 65, equals a weighting factor of 2.3076923. This weighting factor is used to multiply the result of the performance scores for all systems choices pertaining to the superstructure of the house to arrive at a weighted importance for the superstructure system. During development and testing, a debug function was included in the calculator to allow manual checking of the calculations. Figure 5 below shows the 2.3076923 weighting factor (highlighted in the blue circle) applied to the floor framing systems choices



Figure 5. Whole House Survey Tool (debug mode on). Source: Author

The screenshot in Figure 5 was captured with debug mode on. It shows the performance score (5), weighting factors for wind (2.3076923), seismic (1) and heating degree-days (.2500313) and interaction factors for wind induced collapse +1 and moisture related structural degradation -1.

3.5 SYSTEMS INTERACTION FACTORS: Interaction factors were especially difficult to address in the static table format used in the first-generation whole house calculator. It was difficult for the experts to consider and score complex interactions between five to seven different alternative systems choices. The method employed in the second-generation calculator uses a set of logic subroutines selected by their appropriateness to the location of the house. At this time the second generation calculator has 11 systems interactions programmed. Each interaction subroutine is "triggered" by a characteristic of the climate or geology of the house location. Once triggered, the interaction subroutine checks the list of systems choices selected by the user. For every systems choice that has been characterized as a "contributing" factor to the interaction, the subroutine subtracts one from the score. For every systems choice that has been characterized as a "mitigating" factor in the interaction, the subroutine adds one to the score. These are the "+1" and "-1" that appear in Figure 3. Dimension lumber, site framed is a mitigating factor in the "High Wind Collapse" interaction subroutine (+1) and a contributing factor in the "Structural Degradation from Excessive Moisture Levels" interaction (-1).

3.6 THE WHOLE HOUSE REPORT CARD: After completing the selections for the systems choices under each systems tab, the user clicks the "Submit/View Summary" button to receive the grade-sheet for the house. Figure

6 shows the summary page. The house configured by the user is compared to the recommended practices house for the same location. Also visible in Figure 6 is the failure notice. Whenever a house configuration receives a grade of “D” or less for the superstructure system, the house as a whole is failed and a notice displayed to encourage the user to revisit some decisions in the superstructure system to enhance the anticipated performance. The user may also click on the “Detailed” button to display a more detailed display of the factors contributing or detracting from the performance of their house compared to the recommended practices house.

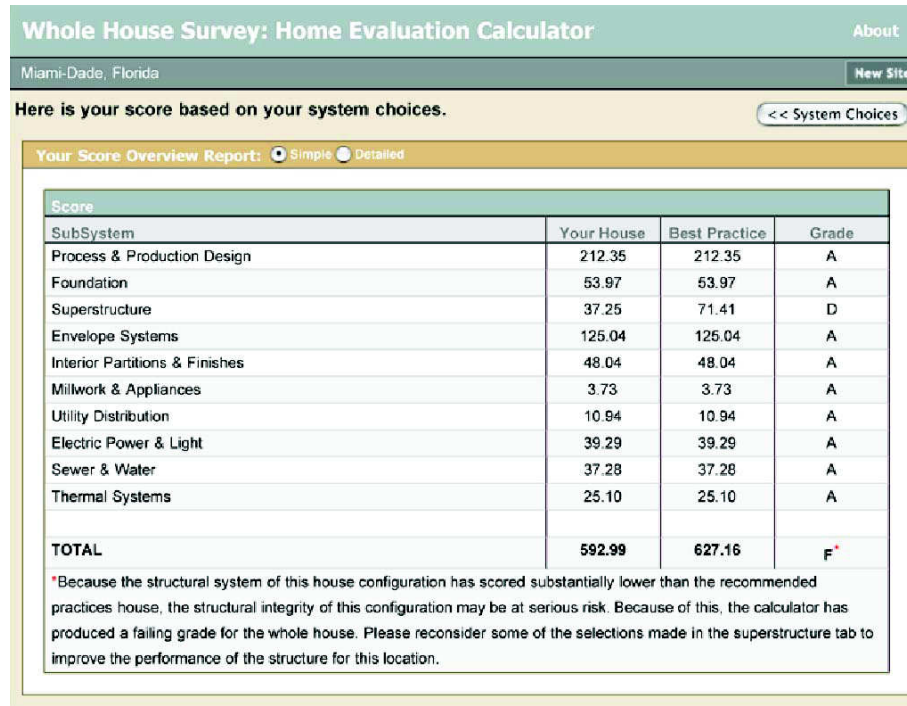

Figure 6. Whole House Report Card. Source: Author

4.0 CONCLUSIONS, LIMITATIONS and FUTURE STEPS: This second-generation calculator is not without its bugs; it is currently not evaluating slab-on-grade construction correctly. It is not valuing the location of ductwork appropriately, but otherwise, testing of 6 case houses across nine locations in the U.S. indicates that it seems to be generating appropriate scores. The calculator downgrades structural performance of a house optimized for the Middle Atlantic when tested in a high wind or seismic zone, upgrades configurations having radon mitigation strategies in high radon risk counties and downgrades thermal performance of houses configured for the Central U.S. when tested in either extreme hot or cold climates.

Comparing the user configured house to the recommended practices houses has made the output a bit more meaningful and if the user configuration equals or exceeds the recommended practice configuration, reduced energy consumption is likely because the recommended practices configurations are drawn from the Building America Recommended Practices. That the output simply compares the user configuration to the static recommended practices models must be considered an interim stage of development for the whole house calculator. Beyond gathering additional expertise input to the performance score database, next steps are intended to include simulations to provide more accurate accounts of performance and more insight into the contribution of each component to the performance of the structural, thermal and sustainable whole.

At this stage of development, the second-generation whole house calculator may be a useful tool for comparing alternative combinations of systems choices, *it cannot be considered a predictor of success or failure of the house as a whole*, but perhaps will stimulate thought and discussion in the larger community of Architects, Engineers, Scientists, Builders and Owners that will make the next generations more useful and enhance the perception of the house as a whole organism.

4.1 ACKNOWLEDGEMENTS: This project would not have been possible without the support of The Office of Policy Development and Research at the U.S. Department of Housing and Urban Development and the contributions from following people:

Subrato Chandra, The Florida Solar Energy Commission, Bill Colbourne, at the URS Corporation, Pat Huelman at the University of Minnesota, Mike Martin, The University of Central Florida and Brad Oberg at IBACOS.

Mike Blanford and Carlos Martin from the HUD Office of Policy Development and Research provided critical discussion and helpful input throughout the project.

Gordon Miller, John Smith and their team at G3 Systems Inc. developed the web-based tool for knowledge input by the outside systems experts and developed the interface and functionality for the final web-based whole house calculator.

Mark Nowak from Newport Partners L.L.C. authored the Whole House Calculator Critical Review and coordinated the expert panel meeting and input into the Performance Score Database. The small advances made in this second generation whole house calculator would not have been possible without his candid assessments of the first generation calculator.

Angie Baughman, who translated the expert meeting proceedings into preliminary logic interactions and translated Seismic, Wind, Precipitation, Cooling and Heating Degree day and Relative Humidity Data from maps to County-Level detailed spreadsheets and Manoj Mishra translated Radon maps to County-Level detailed spreadsheets. They are the significant contributors to this project.

Marilyn Cavell from the Center for Housing Research at Virginia Tech provided additional program support and financial oversight throughout the project.

References:

Applied Research Associates (ARA), (2002). Development of Loss Relatives for Wind Resistive Features of Residential Structures, Florida Department of Community Affairs, Tallahassee, FL, p 15.

Brown, William, Ullett, J. and Karragiozis, A., (1997). *Barrier EIFS Clad Walls: Results from a Moisture Engineering Study*, Journal of Building Physics, 1 1997; vol. 20: Sage Publications, Thousand Oaks, CA, pp. 206 - 226.

Building America, (2006). *Recommended Practices Guides*, http://www.eere.energy.gov/buildings/building_america/ viewed 12-2006.

Emmerich, Steven J., Gorfain, J., Huang, M and Howard-Reed, C., (2003). *Air and Pollutant Transport from Attached Garages to Residential Living Spaces*, National Institute of Standards and Technology, Washington D.C. p. 12.

Hollick, M. (1993). *An Introduction to Project Evaluation*, Longman Cheshire Pty. Limited, Melbourne, Australia. 153-164.

Koebel, Ted and Cavell, M., (2006). *Characteristics of Innovative Production Home Builders*, Office of Policy Development and Research, U.S. Department of Housing and Urban Development, Washington, D.C. p. vii.

Leopod, L.B., Clarke, F.E., Hanshaw, B.B. and Balsley, I.R. (1971). *A procedure for evaluating environmental impact*. Geological Survey Circular 645, Government Printing Office, Washington.

National Association of Home Builders, Research Center, (2002). *Whole House and Building Process Redesign*, PATH Technology Roadmap series, Office of Policy Development and Research, U.S. Department of Housing and Urban Development, Washington, D.C.

O'Brien, Michael and Wakefield, R., (2005). *Developing a Calculator for Evaluating Physical Design Characteristics and Whole House Performance Scoring: A Preliminary Method*, Office of Policy Development and Research, U.S. Department of Housing and Urban Development, Washington, D.C., Appendix 1.

A Systemic Model for Designing Energy Optimized Buildings

Audrey Kay Werthan

The University of Michigan, Ann Arbor, Michigan

ABSTRACT: Architects need to make a paradigm shift from relying primarily on mechanical systems for energy management to designing energy optimized buildings. To achieve this shift, architects can benefit from using a formal design model that delineates priorities for energy optimization in high performance building. In essence, this systemic model refines a well-established architectural concept for energy optimization by placing appropriate emphasis on the architects' role in designing for energy management and demarcating the primary responsibilities of architects and engineers. Fundamental design questions are filtered through the model, resulting in specific energy management strategies. The presentation of this model is an effort to contribute to the collective discussion on what defines a green, high performance building, and this author invites a further refinement of this model. Such a radical paradigm shift, which is supported by the model, is imperative if we are to reduce the role of buildings in environmental degradation.

Keywords: Energy, Optimization, Design, LEED

INTRODUCTION

According to the Department of Energy's (DOE) *2006 Buildings Energy Databook*, commercial and residential buildings consumed over 39% of all U.S. primary energy and emitted 1.6 billion metric tons of carbon into the atmosphere. Typically, modern U.S. architects have focused on designing buildings primarily for aesthetics and/or short-term cost savings rather than long-term energy optimization. In fact, many U.S. architects do not recognize the power they have to promote sustainability through their designs. As Edward Mazria, a pioneer of green building, stated, "the design of a building—its form, fenestration, construction materials, [lighting], and finishes—largely determines the building's lifetime energy consumption" (2003:50). Considering that the majority of building energy is used to light, heat, and cool for occupant comfort, designing for energy performance focuses on accommodating these needs as efficiently as possible, yet architects have depended primarily on engineers to meet these needs. Sometimes architects do intend to conserve energy and do so by adding on energy-saving technology, such as highly efficient HVAC systems or even photovoltaics, to their inefficient designs, yet these types of interventions are band-aid solutions to improving building energy consumption levels. To date, the few architects that have taken up the challenge to design high energy performance buildings have not had a logical system to facilitate their efforts but have had to apply energy management strategies in a piecemeal fashion. The systemic energy management model presented here, intended to integrate energy optimization into the early stages of building planning, sets design priorities and divides the primary responsibilities for energy management design between architects and engineers.

1. PURPOSE OF THE ENERGY MANAGEMENT MODEL

1.1 Rationale for greater involvement of architects in designing for energy management

Amory Lovins of the Rocky Mountain Institute declared:

When an architect is studying, do they ever talk to a mechanical engineer? Often they are too busy learning how to build something that is, as they say, all glass and not windows. When they're done, they toss the drawings to the mechanical engineers, and say, 'Here, cool this!' Designing a building nowadays isn't team play; it's a relay race. (Barnett 2004:62)

In this approach to building design, energy consumption is an afterthought, thermal and comfort control is achieved primarily by mechanical systems, and buildings are designed to be system intensive rather than envelope intensive (McGinn, 2005). High-performance building, however, requires an integrated, whole building approach to planning and design that requires architects and engineers to work closely together to achieve

energy optimization while each maintain their primary responsibilities. Indisputably, the architect is primarily responsible for a building's essential design, its form, its envelope characteristics, and its permanent fixtures; for the most part, the engineer is responsible for lighting, heating and cooling for occupant comfort *as demanded by the building design* by using some type of energy consuming peripheral system to meet design specifications. Generally speaking, engineers use energy; architects don't. Yet energy management is a direct function of a building's design. Therefore, architects need to better understand the building as a system and "the relationship between architecture and the natural environment" (Mazria 2003).

1.2 Available energy management principles

The basic approach to designing for energy optimization is not new; it is based on fundamental knowledge for sound architectural design for energy management. For example, Vaughn Bradshaw explains this approach in the environmental technology textbook, *Building Control Systems*:

The most simple and inexpensive ways to provide comfort-and the ones to consider first-are those that reduce the heating and cooling loads. Next consider ways of satisfying a portion or all of the reduced loads by passive solar heating or passive cooling methods. Only then after the loads have been reduced or satisfied by passive methods as far as economically feasible should active HVAC systems be designed. In some cases, it may be possible to dispense with a heating or cooling system entirely, or else the loads may be substantially reduced before the final selection and sizing of equipment. (1993:215)

This short but comprehensive explanation is a conceptual framework that aids in setting priorities in designing a climate-based, energy optimized building. Even though this is standard knowledge, it is rarely applied by architects. This important approach merits a name and should be refined so that it offers more design direction and can be easily followed by architects. LEED NC the most widely recognized U.S. green building standard offered by the U. S. Green Building Council, better solidified the concept in its 2.1 version into a "three-step approach." This approach included "Demand reduction," "Harvesting free energy," and "Increased efficiency" as a strategy of the Optimize Energy Performance (OEP) credit (LEED 2.1 2003:137-138), offering up to 10 points for increased energy optimization. However, the reference guide offered little further concrete direction, designating only one-and-a-half pages out of 300 on how to design a building for energy optimization. Also, LEED 2.1 did not require that the approach be followed even though it would be virtually impossible to achieve 10 points without reducing building demand and relying solely on HVAC system efficiency (Sacrison 2004). LEED NC 2.2, the most current version offers even less direction with a downsized adaptation, condensing the 2.1 three-step version into four, short, bulleted paragraphs. In addition, even though architects and engineers must work closely together for an integrated design (Sacrison 2004, Barnett 2004), neither the typical textbook nor LEED delineates who is ultimately responsible for doing what. An energy management model that formalizes, expands on, and brings attention to how to approach energy optimization is needed.

1.3 Rationale for energy management model

The following model takes LEED 2.2's four fundamental strategies, alters and expands them, and offers a process that design questions can be filtered through. This model is not intended to be a comprehensive tool to address all architectural and engineering issues that arise when designing a building but rather a template that can be added to and amended. Further, it can be adapted to any building design whether commercial or residential. The purpose of the model is to assist designers during the early stages of design and planning to prioritize energy management issues according to importance. Hopefully, this will make energy management in design simpler by providing a process, thereby encouraging architects to routinely incorporate principals of energy optimization into their designs. This in turn will reduce the environmental impacts caused by buildings.

2. ENERGY MANAGEMENT MODEL FOR BUILDING DESIGN AND SYSTEMS

The model begins with a four step overview that divides the responsibilities between architects and engineers. A rationale for each of the four steps follows.

Table 1: Energy management model overview for building design and systems.

Apply four steps to energy management design/systems question	Responsibility
Step 1. <i>Reduce load</i>	Architect
Step 2. <i>Harvest passive site energy</i>	Architect
Step 3. <i>Harvest active site energy</i>	Engineer
Step 4. <i>Increase HVAC and lighting efficiency</i>	Engineer

2.1. Step 1: Reduce load

Load reduction is the first and most important goal of energy management and includes reducing both thermal load and electric lighting load. Thermal load is defined as “the rate at which heat must be added or removed from a space to offset the heat losses or gains in order to maintain the interior air temperature and humidity at the desired levels” (Bradshaw 1993:94). He describes electric load as “a device that consumes electrical energy in the process of performing work” (Bradshaw 1993:298). The rationale for emphasizing load reduction in buildings can be likened to a bucket of water. If the bucket is leaky, water must continually be added to keep it full. If the bucket is structurally sound, water will stay in the bucket and minimal water will need to be added. A building is the same way. A well-designed building does not “leak” heat from or to the space causing a heating or cooling load. It *controls* the heat transfer in and out of the building envelope. As Kraushaar, author of *Energy and Problems of a Technical Society*, said, “A barrel of oil saved is entirely equivalent to a barrel of oil found, with the added benefit that saving oil generates no air pollution or other environmental degradation” (Kraushaar 1993:237). Building envelope, its shape, opaque surfaces and windows are the first line of defense against loads, both thermal and electric, and is incorporated into the building design. Thus, reducing the load is primarily the responsibility of the architect.

2.2. Step 2: Harvest passive site energy

Harvesting passive site energy refers to the gathering of energy that exists naturally on the site such as light or heat that the building can freely utilize through its envelope. “working with nature instead of against it” (Bradshaw 1993:215). Passive design refers to a building envelope that is actively designed to “receive” energy into the space, often through windows. Additionally, it may not be alterable once it is built. Once implemented, these strategies are free and harmless to the environment. Such energy may include solar radiation in the form of natural light or heat and natural ventilation. Harvesting site energy passively is the result of intentional building envelope design; as such, it also falls under the responsibilities of the architect.

2.3. Step 3: Harvest active site energy

Once the loads are minimized and harvesting passive site energy is optimized through design, less energy is required to maintain desired conditions. The remaining energy demand may then be supplemented by harvesting active site energy. This involves mechanical systems that collect, convert, store, and then distribute energy to the desired building location (Bradshaw 1993). Energy that can be harnessed from the site (such as solar or wind) is used to generate electricity or heat, which can then be obtained freely and distributed in the building. For example, photovoltaic cells collect solar rays and convert them to electricity. Solar collectors collect and distribute heat to spaces that need it. These systems are peripheral to the building itself and fall outside of the realm of architectural design, and are, therefore, the primary responsibility of the engineer.

2.4. Step 4. Increase HVAC and lighting efficiency

The final step in energy management is to use highly efficient, state-of-the-art mechanical and lighting equipment. Equipment that uses site-imported energy should only be used when reducing the loads, and harvesting site energy, both passively and actively, does not satisfy energy demands. Having optimized the first steps, equipment might be sized smaller or eliminated altogether.

Energy modeling input early during the concept and scheduling design process, optimal building massing and orientation, and a high performance envelope will yield a building with significantly smaller mechanical electrical systems than conventional designs. The mechanical/electrical cost savings are transferred into the high performance envelope and passive environmental systems. (McGinn 2005:18)

Since these systems are peripheral to the building and not directly related to building design, they are the engineer’s responsibility.

3. EXPANSION OF THE ENERGY MANAGEMENT MODEL

Now that an overview of the model and a brief explanation of the steps have been presented, the following tables present fundamental design questions that have been filtered through the separate steps of the model followed by strategies that achieve the goal of the individual step. Different climates and the building types must be accounted for within the model. In addition, computer simulations are required to determine optimal strategies or to fine tune a strategy.

Table 2: Building shape.

Question: What energy management factors need to be considered when determining a building’s shape and orientation?		
Model step	Responsibility	Sample building shape and orientation strategies
Step 1. Reduce load	Architect	

Minimize cooling load		Minimize east/west exposure Elongate along southern facade (with shade)
Minimize heating load		Minimize surface area, e.g., cube
Step 2. Harvest passive site energy	Architect	
Harvest light energy (daylight)		Maximize perimeter zones (e.g., T-, U-shape, courtyard and atrium)
Harvest cooling air		Elongate to augment cross breeze
Harvest solar heat		Elongate along southern facade for solar collection in winter with high thermal mass flooring to collect solar heat gain **
Step 3. Harvest active site energy	Engineer	N/A
Step 4. Increase system efficiency	Engineer	N/A

**If building is internally load dominated, ensure that cooling load is not increased.

Determining a building's shape and orientation are the most important architectural decisions from both an aesthetic and energy efficiency viewpoint. Table 2 addresses this question. The shape of the building not only impacts thermal loads but also lighting energy. Compact shapes reduce surface exposure to the outside, thereby reducing heat loss through conductance. Elongating the shape to minimize east and west facades reduces solar gain that is difficult to prevent using shading during the morning and afternoon. Therefore, southern exposure must be addressed along with the window design question that follows regarding window to wall ratio and external shading. Narrowing the building by using architectural design features such as courtyards and atriums or shapes such as U-, T-, E-, and L-shaped provides access to windows offering opportunities for natural lighting and ventilation. Computer simulation will help determine if it is more advantageous to minimize surface areas to reduce the heating load or to elongate surface areas facing south to reduce cooling load and harvest natural lighting and solar heat.

A building envelope materials add to the building's architectural design characteristics and determine how well the building controls heat transfer between the inside and outside. Table 3 addresses this question.

Table 3: Building envelope—Opaque surfaces.

Question: What energy management factors need to be considered when determining building envelope opaque surfaces (walls and roof)?		
Model step	Responsibility	Sample building envelope-Opaque surface strategies
Step 1. Reduce load	Architect	
Minimize cooling load		Optimize thermal mass to delay heat transfer into space during day* Light-colored roof
Minimize heating load		Optimize insulation R-value to prevent heat conduction out of space
Step 2. Harvest passive site energy	Architect	
Harvest cooling air		N/A
Harvest solar heat		Optimize thermal mass to release stored daytime heat into space at night (indirect solar gain)*
Step 3. Harvest active site energy	Engineer	N/A
Step 4. Increase system efficiency	Engineer	N/A

*Applies to climates with high diurnal temperature swing

Appropriate thermal mass does not actually reduce heat gain through the surface into the space but extends it over a period of time. Under the right climatic conditions, such as those with large diurnal temperature swings, the delay can cause the heat to be captured and stored within the surface during the heat of the day, reducing the daytime cooling load, and released into the space when temperatures are low and heat gain is desired during the night. Insulation is a standardized practice for reducing heating load, and ASHRAE 90.1, 2004 requires essentially the same amount for all climates (ASHRAE 2004). Yet increased insulation can significantly reduce

the load further in some climates. However, if a building is internally load dominated, such as an office building with high internal heat gain, it is possible that excess internal heat may become trapped within the building, thereby increasing the cooling load. A computer parametric study can determine the optimal amount of R-value for a specific climate and type of building.

A building envelope's fenestration design, a key building architectural design feature, can prove a benefit as well as an energy liability in buildings, presenting a challenge for designers to balance desirable harvesting of site energy with co-existing undesirable loads. Table 4 shows that window thermal loads must be weighed against harvested natural light and solar heat (during the heating season) and ventilation to enhance occupant comfort when considering window-to-wall ratio (WWR).

Table 4: Building envelope—windows and fenestration.

Question: What energy management factors need to be considered when determining window design?		
Model step	Responsibility	Sample building envelope—fenestration strategies
Step 1. Reduce load Minimize cooling load	Architect	Minimize WWR at E and W facades Replace electric light with daylight Optimize vertical shading on E & W; Horizontal on South
Minimize heating load Reduce electric light load		Optimize WWR to reduce window conduction Install daylight photosensors
Step 2. Harvest passive site energy Harvest cooling air	Architect	Equip with operable windows Align windows for optimal natural ventilation/cross breezes
Harvest solar heat		Optimize window placement along south façade for direct solar heat gain during heating periods Optimize external shading
Harvest natural light		Place daylight penetration high in space and other daylighting strategies
Step 3. Harvest active site energy	Engineer	N/A
Step 4. Increase system efficiency	Engineer	N/A

Harvesting daylight through windows is an architectural design strategy that reduces electrical consumption both from reducing the lighting demand and the cooling load caused by the lighting. Architectural daylighting design strategies include clerestory ceilings, lightshelves, skylights, high windows, and light chimneys. Daylighting serves as an energy conserver only when the daylight design is equipped with daylight photosensors that “track the daylight entering a room” and then “dim[s] the electric lighting in proportion to the amount of daylight detected” (Chen 2006:4). Francis Rubinstein of the Lawrence Berkeley National Laboratory has developed a new mathematical algorithm that enhances the ability of photosensors to effectively calibrate and maintain constant light levels (Chen 2006). Whether or not the window design is enhanced for daylighting, photosensors still offer the potential of reducing electric load by taking advantage of whatever natural light enters the space. Further, a large WWR provides for more daylight harvesting opportunities, yet allows heat loss through window conduction and heat gain from solar radiation. These interactions must be optimized using computer simulation both for energy and design for every climate, site, and facade to obtain the greatest net energy benefit.

Figure 1 illustrates how shading on the south can optimize energy facade by properly controlling heat gain. Such shading prevents solar heat gain during the summer months when the sun's altitude is high and allows solar heat gain during the winter months when the sun's altitude is low.

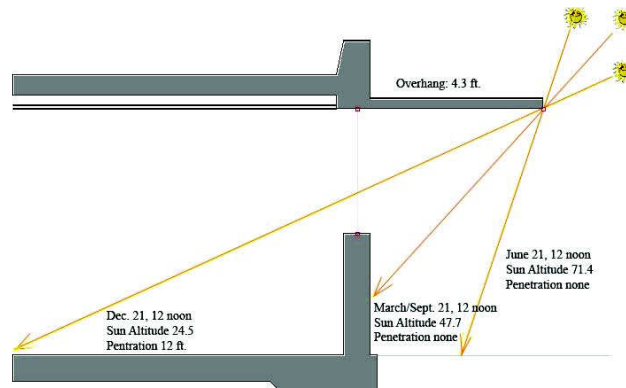

Figure1: Window with shading at two solar equinoxes and two solstices. (Ecotect 2006)

The shading overhang must be carefully sized in order not to increase heat gain in internally load-dominant buildings that may require cooling even during the heating months.

Window type selection, discussed next, is one of the most important decisions an architect can make in energy optimization because window selection and window design go hand in hand. Table 5 presents an overview of the factors to consider when selecting window type.

Table 5: Building envelope—window and fenestration selection.

Question: What energy management factors need to be considered when selecting windows?		
Model step	Responsibility	Sample window selection strategies
Step 1. Reduce load Minimize cooling load	Architect	Optimize SHGC Optimize external shading Optimize U-factor
Minimize heating load		
Step 2. Harvest passive site energy Harvest natural light Harvest cooling air	Architect	Increase T_v through windows Provide operable windows for occupant control of natural ventilation
Harvest solar heat		Optimize SHGC Optimize external shading
Step 3. Harvest active site energy	Engineer	N/A
Step 4. Increase system efficiency	Engineer	N/A

Even though windows offer architects many energy benefits, especially regarding daylighting, they also can be a major source of thermal loads into the space from solar radiation and heat conduction. Window technology has advanced significantly in recent years, yet when poorly selected, windows can allow 12 times the amount of heat transfer of a well-insulated wall (Bradshaw 1993). Therefore, a window's U-factor, the measure of non-solar heat conductance through the window over a period of time and its Solar Heat Gain Coefficient (SHGC), the ratio of solar radiation that penetrates through the window compared to the solar radiation of a standardized clear, single pane of glass, must both be appropriately determined for the climate, site, and façade. Determining SHGC is a challenging window characteristic to optimize because the same window that allows solar heat to enter the space in the winter may also prevent it from entering in the summer. In an internally load-dominated building, unless shading is implemented, a very low SHGC may be necessary even in a cold climate to minimize cooling load to ensure that the building does not overheat. The U-factor, an especially critical window characteristic in a cold climate, minimizes heating loads caused by window conductance. In addition, a window's visual transmission (T_v) of the window, the fraction of visible radiation from outdoor light that is transmitted through the glass, is an architecturally important design feature and must be as high as is possible in order to optimize daylighting features, as well as to aesthetically brighten the space. Technologically, however, it is a challenge for a window to allow light in while excluding solar gain. Low-emission windows have been developed that can accomplish this task while reducing heating and cooling loads. A parametric computer study may be required to determine optimal window characteristics for a particular site. See case study to follow.

Now that the major architectural questions addressing building load reduction and harvesting of passive site energy have been addressed, and the building is optimally functional as an independent unit, it is time for the engineer to ensure that all design comfort parameters are met.

Table 6: System supplements to building design.

Question: What peripheral cooling, heating, and electrical systems supplement building design?		
Model step	Responsibility	Sample HVAC and lighting systems
Step 1. <i>Reduce load</i>	Architect	
Step 2. <i>Harvest passive site energy</i>	Architect	
Step 3. <i>Harvest active site energy</i>	Engineer	Evaporative coolers* Photovoltaics Geothermal heat pump (Marriott 2006) Solar heating Solar lighting
Step 4. <i>Increase system efficiency</i>	Engineer	High efficiency lighting State-of-the-art HVAC system High SEER and EER Energy recovery (Marriott 2006) Optimal air system (Marriott 2006)
*Appropriate for hot, dry climates		**Appropriate for hot, humid climates

Table 5 addresses issues relating to engineering systems that supplement a building's architectural design. First, the engineer looks to the site to mechanically harvest all possible sources of free, renewable energy by using such systems as photovoltaic cells and geothermal heat pumps. Then, if thermal needs are still unmet a highly efficient, state-of-the-art HVAC system that runs on site-imported energy should be installed. Air conditioners should have a high Seasonal Energy Efficiency Ratio (SEER), and a high Energy Efficiency Ratio (EER). In her article, *3 Simple Approaches to Energy Efficiency: Optimal Air, Energy Recovery, Geothermal*, Carol Marriott presents three methods of increasing system efficiency for LEED NC 2.2 OEP points. Now that the model has been presented, a summary of a case study applying the model follows.

4. CASE STUDY AND LEED NC

A simplified computer simulation case study of a 2,323 m² (25,000 ft²) office building was undertaken to see how much energy would be reduced and how many LEED 2.1 OEP points, out of ten maximum, could be obtained by implementing some basic strategies under the first two steps of the energy management model. (Werthan 2006) Optimized building envelope and windows were compared to a benchmark based on ANSI/ASHRAE/IESNA Standard 90.1-2004, *Energy Standard for Buildings except Low-Rise Residential Buildings* Energy Cost Budget Method for Detroit, Michigan. eQUEST, an hourly weather data computer simulation program, was used to measure the energy consumption of the simulated buildings. Rates were based on the energy utility for Detroit. A computer simulation parametric analysis was first undertaken to determine optimal R-values for the roof and walls, and optimal SHGC and U-factor for the windows and R-values for the roof and walls and one window was chosen for the proposed design based on the optimal values. Daylight photosensors and shading were tested in the analysis and determined to be part of the design. LEED NC, 2.1 does not reward shape or orientation optimization whereas LEED NC, 2.2 rewards orientation optimization alone. Table 7 shows application of the model to windows alone.

Table 7: Computer simulation comparing proposed to baseline inputs.

Question: What energy management factors need to be considered when selecting windows?			
Model step	Resp.	Proposed strategy (input)	Baseline strategy (input)
Step 1. <i>Reduce load</i>	Arch.		
Minimize cooling load		SHGC: 0.47 with shading	SHGC: 0.26; no shading
Minimize heating load		U-factor: 0.18	U-factor: 0.47
Step 2. <i>Harvest passive site energy</i>	Arch.		
Harvest natural light		T _v : 0.66	T _v : 0.2
Harvest cooling air		Operable windows	Non-operable windows

Harvest solar heat		SHGC: 0.47 with shading	SHGC: 0.26; no shading
Step 3. Harvest active site energy	Eng.	N/A	N/A
Step 4. Increase system efficiency	Eng.	N/A	N/A

The proposed building combined the optimized values determined in the parametric study into one window-a triple pane, low-e, argon filled, roof and walls (R-values of 25 for both roof and walls), daylight photosensors and shading. The baseline used a double pane, reflective, air filled window and R-15 for roof and R-13 for walls, no daylight photosensors or shading.

Table 8: Energy cost, percentage reduction, and number of LEED NC 2.1 OEP points using various strategies.

	Proposed strategy (output)	Baseline strategy (output)
Electric energy	\$15,140 ; 158,830 kWh; 68.4 kWh/m ²	\$18,450 193,500kWh 83.3 kWh/m ²
Natural gas	\$3,915 143,600 kWh (4900 therms) 62.8 kWh/m ²	\$6,835 250,600 kWh (8550 therms) 107.9 kWh/m ²
Total annual energy	\$19,055 (\$8.20/m ² or \$0.76/ft ²)	\$25,285 (\$10.90/ m ² or \$1.01/ft ²)
Results	24.6% and 3 LEED NC 2.1 points	

The results in Table 8 show a 24.6% energy cost reduction that earned three LEED NC 2.1 points. It should be noted that LEED NC 2.2 awards five points for the same percentage reduction and thus offers more incentive to architects to use the model to optimize building design.

CONCLUSION

This model provides architects with an overview of energy management priorities and a clarification of their roles, thereby supporting them to integrate energy management into their designs and to work more successfully with engineers toward a common goal. Hopefully, it will help facilitate the paradigm shift necessary to stem the tide of global warming and environmental degradation.

REFERENCES

- American Society of Heating, Refrigerating and Air-Conditioning Engineers 2004. *Energy standard for buildings except low-rise residential buildings, 90.1-2004*. ANSI/ASHRAE/IESNA Standard: Atlanta, GA.
- Barnett, D. and Browning, W. 2004. *A primer on sustainable building*. Rocky Mountain Institute: Snowmass, CO.
- Bradshaw, V. 1993. *Building control systems*, 2nd Edition. John Wiley & Sons, Inc.: New York.
- Chen, Allan, 2005. *Improved control algorithm appears in a next-generation daylighting product*. Environmental Energy Technologies Division News: Berkeley, CA.
- Department of Energy 2006. *2006 Buildings energy databook*: Washington D.C.
- Ecotect, 2006. <http://squ1.com/ecotect>. Last viewed Feb. 28, 2007.
- Kraushaar, J., and Ristinen, R. A. 1993. *Energy and problems of a technical society*, 2nd edition. John Wiley and Sons, Inc.: New York.
- Marriott, Carol. 2006. *Three simple approaches to energy efficiency: Optimal air, energy recovery, geothermal*. ASHRAE Journal: Atlanta, GA.
- Mazria, E. 2003. *It's the architecture, stupid!* Solar Today. American Solar Energy Society: Boulder, CO.
- McGinn, T. 2005. *Setting fees for profitable green building projects*. ASHRAE Journal: Atlanta, GA.
- Sackrison, C. 2004. *LEED energy and atmosphere, credit 1-measuring efficiency to maximize points*. Engineering System Solutions. McQuay Int.: Minneapolis, MN.
- U. S. Green Building Council 2003. *LEED reference guide for new construction and major renovations version 2.1*. Second Edition. USGBC: Washington, D.C.
- U. S. Green Building Council 2005. *LEED reference guide for new construction version 2.2*. First Edition. USGBC: Washington, D.C.
- Werthan, A., and Navvab, M., 2006. *Building Design Strategies and Their Contribution to Energy Performance for LEED Certification*. Journal of Green Building. College Publishing: Glen Allen, VA.

Awareness: The Ground for Sustainable Design

Randall F. Teal

University of Idaho, Moscow, Idaho

ABSTRACT: The dominance of technology and 'productive' modes of thinking has tended to move humans deeper into the intellect and away from feeling states. Yet, sense, emotion, and intuition are the source of some of the most primary human connections. Within this societal bias, it follows that sustainability also has an inclination toward instrumental thinking, which although resulting in many measurable performance enhancements, also has a susceptibility to engendering results with a discernible lack of soul. As it is impossible to achieve comprehensive sustainability through mechanistic thinking alone, the tempering influence of feeling becomes critical to the appropriate implementation of technology within the context of sustainable design.

Rather than mastery and control, increased awareness and heightened perception encourage a reciprocal and mutually affective relationship with the places we live and the people with whom we interact. So it is central to the development of an integral notion of sustainability that the education of architects and designers include the cultivation such faculties, and understands them as essential tools for the making of human environments.

In this paper I will discuss ideas related to the development of these abilities in young designers and illustrate, through exercises undertaken in a second year studio sequence, my attempts to activate students' awareness and communicate the value of poetic understanding and phenomenological exchange in environmental design. Furthermore, I will describe these exercises with reference to their theoretical underpinnings so that others might view the examples as possibilities rather than rules. It is my earnest hope that by teaching holistic processes that sustainable architecture can begin to fuse building science with qualitative concerns, such as the facilitation of interpersonal relations, the valuation of culture and history, and the deepening of connections to both fellow human beings and the earth itself, creating a comprehensive vision of sustainable practice.

Keywords: perception, phenomenology, pedagogy.

INTRODUCTION

Sustainability in its highest aspirations moves us into a closer relationship with the earth and its processes. Living ecologically suggests cultivating a greater appreciation for our *interdependent* position within the environment and our kinship with the whole of humanity. By reducing the sense that we are somehow separate or different from the world in which we exist, it becomes possible to understand our position poetically as being 'of the earth' rather than 'on the earth'. This perceptual shift requires increased action as receptive participants rather than dominating machines.

Unfortunately in many fields, rational and technological viewpoints dominate modes of perception and assessment. These viewpoints are characterized primarily by active states of being, and thus lack receptive qualities and balanced understandings. The origins and nature of this duality are described by Johann Wolfgang von Goethe when he says,

We are well enough aware that some skill, some ability, usually predominates in the character of each human being. This leads necessarily to one sided thinking since man knows the world only through himself, and thus has the naïve arrogance to believe that the world is constructed for him and his sake. (Goethe 1988:45)

Within this imbalance progress and conquest start to become interchangeable and when pushed to extremes Dalibor Vesely believes,

There is little doubt that both technology and modern science are motivated by the same interest – the domination of reality and the will to power. (Vesely 2004:241)

Considering sustainability in light of this statement, a strange paradox arises wherein the same order of things (technology) that have hastened environmental degradation are the exact same order of things that we turn to for remediation. Escaping the grip of 'productive' thinking (Vesely 2004) requires that our relationship with the

environment be tempered by more open forms of interaction, or as Goethe goes on to say, “as a correction” we need to develop “all the manifestations of human character...into a coherent whole”, for if we fail to do so, we “labor on under painful limitations” not understanding why we have so many “stubborn enemies” and why sometimes we are even meeting ourselves as the enemy. (Goethe 1988:46) Heeding Goethe’s advice within the context of sustainable design suggests that instead of seeking solutions characterized by management, categorization, and control, the future of the environment might rather hinge upon a dialectic grounded in feeling and non-intellectual processes.

The notion of sustainability depends on holistic thinking transformed into holistic action. However, before one can engage either holistic thinking or holistic action it is necessary to first perceive in a holistic way. This type of perception is, as James Elkins points out, “... a question of trying to see more than details.” (Elkins 1996:95) The wholeness, suggested by Elkins’ comment cannot be fully attained via the dominant approach of analysis, as the nature of the analytical is to fragment and catalogue. (Bergson, 1946) Implicit in Goethe’s earlier statement, “some ability usually predominates in the character of each human being”, is the suggestion that, as training an atrophied muscle might restore balance in the body, correction of imbalanced perception might be facilitated through the training of the atrophied modes of assessment as well.

Bringing this wholeness to the built environment stands as the fundamental base for sustainable design and the search for the means of facilitating this vision is the challenge of our time as,

The distance separating the instrumental and communicative understanding of architecture represents a wide gap in our contemporary culture. Any serious attempt to bridge this gap requires a new kind of knowledge that can indicate how to reconcile genuine creativity and creative spontaneity with the productive power of contemporary science. (Vesely 2004:4)

To Alberto Perez-Gomez it is clear what this ‘knowledge’ is, as he says,

The issue for design is not merely ‘aesthetic’ or ‘technological’, if by these terms we understand exclusive, autonomous values. Rather the issue is primarily ethical. (Perez-Gomez 1999, 73)

And as he goes on to say,

In identifying truth with science and science with applied science, i.e. the theory of technology, the result is an incapacity to consider truly radical alternative modes of thinking architectural theory (Perez-Gomez 1999, 76)

It becomes clear that the onus is on those involved in architectural education to negotiate this schism by providing aspiring designers with not only a tangible skill set, but also a renewed sense of ontology in design that is concerned with the multifaceted interrelation of time, context, ecology, and the human psyche. New methods in which to dialog with the environment might be the beginnings for a more complete notion of sustainability, as David Leatherbarrow suggests, “...it is in reciprocity that the real drama of place building is played out.” (Leatherbarrow 2004:115)

1. APPLICATION IN A STUDIO SETTING



Figure1: Site Response: The Site, Morgan Maiolie and Staci Dobbins.

Recognizing and coming to terms with ‘place’ and the concept of ‘genius loci’ is an important starting point for ecological design. Investigating and engaging ‘place’ stands as a primary concern in situating technology and engendering environmental awareness in young designers. According to Christophe Girod,

A new way of looking at our urban landscapes could deliver a better, more complete understanding of the multiplicity of phenomena at hand. It could also greatly improve the potential for an appropriate and concerted response to site.” (Waldheim 2006: 94)

Our site for this second year studio was an abandoned agricultural industrial area, and as the first of several exercises that sought to “feel the site”, as several students later described it, I asked each individual to make five sketches in different locations as they walked the site, focusing on their experience of this place. Experience, as Hans Georg Gadamer explains, “...has a note of immediacy with which something real is grasped...” and, “...there is also a content that is like a yield or residue that acquires permanence...”. (Gadamer 1975:55) Reflecting on this immediacy and its residue as keys to understanding this place, students were then to create a

collage that communicated what they understood to be the essence of their experience (fig. 1). In requesting that they address the emotional/phenomenal content of this experience directly, I went so far as to emphasize the parameters on the assignment sheet which explicitly stated, “do not think in symbols, do not think sequentially, and do not attempt to communicate intellectually”. In a search for the essential the intention of this directive went along the lines of Gadamer’s ideas about the nature of art when he says, “That truth is experienced through a work of art,” in a way that “...asserts itself against all reasoning.” (Gadamer 1975: xii-xiii)

Although several projects were extraordinary in their visual interpretation, one expressing fear at the state of decay; another in peaceful repose amid the quiet emptiness, many students were stricken with reason. A number of responses fell back on generic comparison (i.e. pictures of old trains and industrial structures) and several students produced symbolic representation without even realizing that was what they had done. Additionally, within the approach of imbuing each piece with its own discreet meaning there was also a strong tendency toward cartographic representation.

These results were not surprising, as even at more advanced levels the seeming irrationality of an intuitive/experiential process is hard to understand, and in fact in some ways one is doomed the moment they attempt to ‘understand’ in the traditional sense. These difficulties stand as an example of how deeply ingrained ideas of generalization, objectification, and symbolism are in the human mind. But as Goethe has pointed out, “nothing happens in living nature that does not bear some relation to the whole.”(Goethe 1988:15) so too students’ earnest engagement with this place would inevitably carry some truth about their experience. With this in mind, after a short discussion I asked students to go back to the site again; then add something to their collage that reflected how their perception had been altered by the second visit. This return trip helped to uncover and clarify truths buried in the first collages, and in this return, students’ understandings of the site increased significantly, with many cases where the addition brought fragments together in a meaningful way.

2. COGNITIVE TRANSFORMATION



Figure 2: Cognitive Maps: Kyle Lepper, Mahsa Emam-Jomeh, Andy Carman.

For a second exercise, as a way of ‘visiting’ the site and considering the relationship between place and phenomena in a different way, I asked the students to create a three dimensional cognitive map of the site (fig. 2). The idea was that rather than a physical visit, that they were to mentally return to the site, and from this ‘visit’ make a model that represented the site as it existed relative to their mental reconstitution of the experience. As much of our understandings are relational, this map highlights the strongest impressions and associations for the individual. James Elkins describes the mental editing process in an exercise of his own:

Next time you come upon a beautiful view, make a small mental note of what seems interesting about it...Then turn away from the scene and take note of the blank spots in your mental picture...each time the mental picture will have gaps in it, often large ones – and in my experience it can be difficult to assemble a reasonably complete scene. (Elkins 1996:95)

However, these absences are not necessarily negative; rather they often reveal something particular about the way a place speaks and its underlying structure. To articulate their perceptions, students were encouraged to amplify or reduce certain elements, relationships, and aesthetic qualities as they stood out for them as being characteristic of the site and indicative of their connections to it. This exercise was interesting as it seemed easier to grapple with the idea of an essence by stripping away what ‘was not’ rather than trying to assemble ‘what is’, and the results appear to align with Edmund Husserl’s thought that it is through ‘parenthesizing’ one is able to approach a more pure phenomenological state. (Husserl 1964) Or as Alan Watts put it, “awakening is to know what reality is not.” (Watts 1957:171)

As students' relationships and consequent understandings of the site grew, one discussion was particularly memorable. A student made a comment about how she and many others had seemed to be viewing the site conventionally and had responded quite literally. However, one project in the group, comprised of a translucent cube inside an enclosure of wooden cutouts, was the flash that caused her to see the site more elementally - as a mysterious entity floating in the trees. Several others then commented on how this piece had also sparked them to (again) reevaluate the site.

These revelations seem to point to a necessary reciprocity between experience and our evaluations of those experiences, and how it often takes establishing this communication between lived knowledge and interpretation to arrive at deeper understandings, expanded vision, and a grasp of phenomena as they exist. In terms of sustainability this is point is critical, as again humans hold deeply learned patterns of understanding by empirical means, which touch only surfaces. Consequently when surfaces become the reality, solutions equally address only superficial concerns.

3. SIGNIFICANT INTERVENTION



Figure 3: Site Interventions: Alex Fraser, Staci Dobbins.

Connecting with meaning in our environment is an important element in humans' sense of well being and thus the overall health of the ecosystem. However, the intellect habitually pushes toward meaning that is both tangible and literal, in turn providing meanings that are often trivial. Within this mindset, uncovering and communicating deeper meaning proves difficult or as Elkins' puts it, "it is easy to make the invisible visible, but difficult to make it believable." (Elkins 1996:103)

Returning to the importance of an ongoing dialog to the discovery of a more ephemeral import, I asked students to begin an exchange with the site, once more testing and re-evaluating their understandings of what had been formerly absorbed and interpreted. In this project they were to augment the vision of the site that was beginning to manifest in their imagination. To this end, they were to suggest an intervention in a minimal but significant way; revealing, intensifying, or reinterpreting some particular aspect of this place (fig. 3).

In initiating the idea of intervention and its interpretive potential we looked at and discussed works by: Andy Goldsworthy; Nina Katchadourian; Christo and Jean-Claude; Donald Judd; Eves Klein; Allied Works; Archigram; Superstudio; Antfarm; Banksy; and Gordon Matta-Clark. Students then moved into sketching possible directions, developed a model of their most promising idea, and ultimately evolved this into their design, assembling it all in a Christo-esque layout, with: 'a before intervention' image; 'an after intervention' photomontage; one key image of their idea in process; and a plan diagram of the site.

At this stage more profound insights were beginning to blossom as a strong group of final products resonated with both visitors and reviewers. Several students actually performed within the site in Goldsworthy fashion and documented their physical manipulations, others introduced an artifice (some visual, some auditory) that modulated an initial impression of this place, while still others intervened with an incongruous element attempting to stimulate awareness via displacement. The successes in this project stand as evidence to students' growing sophistication in regards to the nature of the site, as many were starting to create connections to, and extensions of, the significant whole that they were beginning to uncover. In this way, generally speaking, a designer finds meaning or significance in their own work by its association with the inherent energy and specificity of a situation. When this notion is applied to architecture it can promote greater integration between form and place, or as David Leatherbarrow explains,

...for landscape architecture and architecture attention to the actual phenomena of their projects has come to mean concern for their enactments, for the emergence and disappearance of things, which means also their contingency, not their (presumed) stability, independent identity, and 'objectivity'. (Leatherbarrow 2004:12)

With this thought in mind it is interesting that possibly the strongest project was one where a student proposed a slight but detectable bend in the neglected (existing) train track directly beneath the grain loading shoot, suggesting simultaneously both the memory of years of service and the current derelict state of the rails. The magic of this work was held in its connection to, and reframing of, something greater than itself while employing only astute observation and a corresponding modification to suggest totality.

4. CONTINUITY



Figure 4: Movie Stills: Jesse Marble, Josh Anderson, Samantha Boucher

No image will replace the intuition of duration, but many different images, taken from quite different orders of things, will be able, through convergence of their action, to direct the consciousness to the precise point where there is a certain intuition to seize on. (Bergson 1949:195)

Representation always requires that an undifferentiated perception be broken so that it may be transformed and reconstituted. Likewise, environmental design depends not just on insightful observation but a development of that observation into a formal order, spatial continuity, and ultimately a functional system. Pertinent to this problem is the concept narrative in which, as the designer cycles between 'making' and the consideration of that making, there is an attempt to assimilate this process into verbal description. The concept narrative has to do with the depiction of intentions, as well as being a provocation of the mind to increase the continuity of the work in progress.

To further reveal nuances of the site, and to reinforce the notion that significance in a relationship evolves with this cyclical contact and narrative understanding, students were asked to develop one minute films inspired by the site (fig. 4). In this film, the goals were threefold; to practice the negotiation between idea and representation; to consider the site metaphorically; and to begin to explore continuity in a time based medium.

The strength of the dialectic for cultivating awareness was exemplified in one young woman's process for this film. After tremendous difficulty finding any inspiration whatsoever, she finally managed to create a first rough cut, which proved flat and lackluster. Frustrated, she tried several different directions until finally arriving at an idea of making a film that was about her search for inspiration. In her final rough cut, she showed her muse hovering right under her nose all the while with her unable to see it. Interestingly it wasn't until a day before the project was due, with her still unsure of how to end it or what it meant, that the whole experience crystallized. During a meeting, I had asked how her relationship to the site had changed as a result of this process. Without hesitating, she answered that when she first went there nothing spoke to her, but now all sorts of things were vivid and influential to her about this place; it was just that this appreciation just took some time. In this statement was her ending as well as another pointed reminder as to the difficulty in apprehending subtlety.

In fact, this project saw a number of students making films about being initially unaware of something, which marked a point in the studio where many started to perceive the unconventional beauty of this place along with the limitations of their own habitual methods of assessment. These lessons about listening stand out as an important step in this process, and are reflected in Alan Watts statement,

One seeks and seeks, but cannot find. One gives up, and the answer comes by itself. (Watts 1957:161)

Where the importance of the answer that 'comes by itself' is that it is substantial because it has sprung from direct communion with the deeper, more eternal aspects of a set of circumstances.

5. AG PARK



Figure 5: Additive Responses: Morgan Maiolie, Paris Bunkers, Edgar Reyes.

Perhaps the most eternal aspect of any architectural problem is the land itself, and yet within architecture the attitude towards the land has been historically narrow-minded. Reconsidering the way we speak and think about 'site' could bring important changes to the way a building comes into being and engages its surroundings. Again this reconsideration starts with a perceptual modification:

...to build landscape requires the ability to see it, and the inability to do so continues to permeate architectural design culture. This persistent blindness is evident in the still common recourse to the figure/ground plan, which fails to engage the material aspects of a site representing the ground as a void around buildings. (Waldheim 2006:127)

It then stands to reason that a pivotal shift in ecological design might occur when building and earth are not viewed as a duality, and the creation of a building is more widely understood as 'building the land' or as a critical interrelation between earth and sky such as "topography" (Leatherbarrow, 2004), thus opening opportunities for a transcendent union of humans and nature through the interplay of building and site.

Embracing this notion and working with the rich understandings students had developed through previous exercises, the approach for our final project aimed to dismantle the building as premeditated object and the site as a place to *put* a building, with both building and site developing in tandem, learning from one another along the way. Initiating this task, I had in mind trying to avert premature concretization, seeing *form* much in the way Friedrich Nietzsche understands *thought* when he says,

Nothing is more compromising than a thought. Rather than the state preceding thought, the throng of yet unborn thoughts, the promise of future thoughts, the world as it was before God created it – a recrudescence of chaos – chaos induces intimations. (Nietzsche 1967:167)

In this spirit, rather than creating buildings students were charged with finding the intimations within the chaos. Beginning with a series of additive spatial constructions where students were restricted to the use of precut basswood sticks, which was imposed as a means to limit thinking, diminish the importance of the object, and facilitate intuitive response. Each addition was first and foremost to be a spatial reply to forces emanating from the existing collection of buildings, spaces, roads, and natural features marking the area (fig. 5). Students then honed these interventions with a collection of qualitatively defined open areas that were the beginnings of the AG Park.

These interventions then underwent critical scrutiny as students were directed to select another's model, and using the same components, enhance the assets of said model. The original owners then reclaimed their models and were asked to introduce a new material that affected 4000 sq. ft., roughly the size of the gallery that was ultimately to find its way into this project. This step was interesting because while everything up to this point had been monochromatic, the 'new material' was open and introduced such things as: feathers, wires, broken CD's, chains of paper draped over the model, ribbons, and party horns. As you might imagine, many of these modifications proved distracting, and so during the next class students were again asked to choose someone else's model, this time removing any parts that they felt to be superfluous, then draw two perspectives with people to show how this place might be inhabited and activated. The goal of the model swapping in general was to diminish a sense of ownership so that the site could remain preeminent throughout initial development. Additionally, all of these exercises were given without the request for a 'building' in the hope that by reacting to the potential of particular areas in the site the final form might slowly gather itself, gaining further information from the program, structure, and consideration for the way people could interact there.

This choreographed chaos effectively subverted most impulses to make 'buildings' as students saw them in their minds, and fostered a surprising sensitivity among students about what types of responses would be considered

cliché and what might become authentic, with a majority retaining a handle on the question of what the *site* was saying, rather than doing what *they* wanted. Interestingly however, when students were finally given the program for the gallery space within the park, a large number of them locked onto the building, neglecting much about its interaction with the previous site design. The case of the disappearing site plan seems to be another clue as to the difficulty of holistic thinking as well as the power of our fears to draw us astray (in this case, students feeling overwhelmed by making a 'real' building). In spite of this digression, students did do an excellent job locating and orienting their buildings according to what they had learned from the previous exercises and tended to retain their emerging ideas about character as it related to this special place.

These beginnings seem encouraging as possible foundations for the development sustainable environments, in that, students began to create in a way that actively engaged and participated with a particular place. Without this type of sensitivity at the outset of the project, regardless of other modifications, there certainly would be grave implications for at least the longevity of the project and most likely its ability to facilitate human delight as well.

CONCLUSION

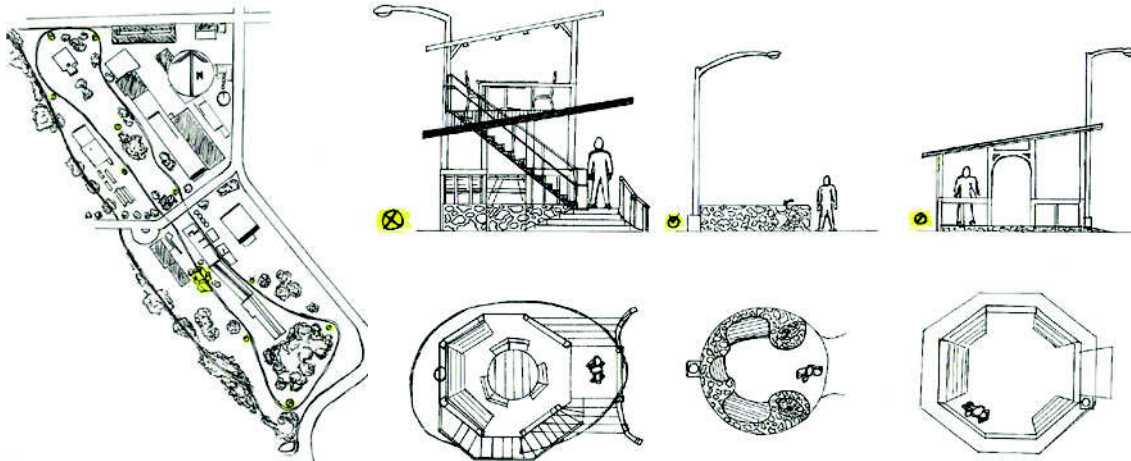

Figure 6: Final Details: Micah Leger

With a pressing need for sustainable and regenerative practices in all walks of life, it is essential that we become more in touch with our world:

In the case of dwelling, for instance, new construction, materials, and services are being developed on a different level and at a different rate than the nature and purpose of the dwelling, which are rooted in the customs, habits, and in the relative stability of primary human situations. (Vesely 2004:26)

'Primary human situations' are anchored by our primary human qualities. These qualities might be considered as the groundwork for sustainable design, as they encourage the reification and retention of those elements that make life meaningful and particular places special.

At the inception of this studio project, this site was certainly not sacred or special for most students. Despite its close proximity to the University this place had remained virtually invisible for most, yet through iterative interaction there emerged great understandings and appreciation for this place. Notwithstanding some difficulties with the total synthesis of building and site, I was encouraged by students' ability to discover form in response to phenomena and experience, as well their as later judgments in making refinements based on function and use that contributed to the emergence of some very believable, whole, projects. (fig. 6).

In a time where many aspects of life are viewed as temporary and disposable, made poignantly evident by the fact this site is now undergoing demolition, we must seek sustainability on a broader plane. Sustainability cannot be understood as stylistic, instrumental, or prescriptive, as lasting ecological practices will develop through the extension of meaning and the promotion of relationships built on complexity and longevity as they relate to place. In short, sustainability must be first understood as a product of our 'being-in-the-world' so that our environments may remain significant.

Student breakthroughs during this studio magnified the limitations of rationalistic and empirical modes of assessment as a means of connection with phenomenological aspects of place, and in a society that has arrived "...at the curious paradox..." where "...feeling has become more difficult than thinking..." (Gideon 1954: 585) it is heartening to see that our non-intellectual modes of engagement are not actually absent, and may in fact be

stimulated quite easily if given the right catalyst. In light of the students' realizations, I must return once more and end with Dalibor Vesely as he asks,

I wonder if it is necessary to argue any further that poetics is not a discipline based on dreams or improvisations and that it could be, as far as architecture is concerned, more rigorous than an analytical or causal approach. (Vesely 2004: 389)

I believe that greater awareness and poetic interpretation can help temper thinking with feeling and bring quantitative, technical, and intellectual methods back under the governance of an ethical framework. In this way ecological concerns and environmental remediation are not seen strictly as abstract problem solving or fixing a machine, rather they become the extension of a temporal humanistic existence where place, history, and culture are understood as essential elements of sustainability as well. This reestablished notion of ontology in design could strengthen interconnectedness, become a vehicle to transcend dualistic thinking, and offer a position to see sustainability exactly as it should be seen – as our fundamental oneness with the world in which we live.

REFERENCES

- Baudrillard, Jean. 2001. *Impossible exchange*. Verso: New York
- Bergson, Henri. Translated by Maybelle L. Andison. 1946. *The creative mind*. The Philosophical Library: New York
- Bergson, Henri. Translated by F.L. Pogson. 2001. *Time and free will*. Dover Publications: New York
- Elkins, James. 1996. *The object stares back : on the nature of seeing*. Simon and Schuster: New York
- Gadamer, Hans Georg. 1975. *Truth and method*. Seabury Press: New York
- Giedion, Sigfried. 1954. *Space, time, and architecture; the growth of a new tradition*. Harvard University Press:
- Goethe, Johan Wolfgang von. ed. Miller, Douglas. 1988. *Scientific studies*. Shurkamp Publishers: New York
Cambridge
- Husserl, Edmund. Translated by William P. Alston and George Nakhnikian. Introd. by George Nakhnikian. 1964. *The idea of phenomenology*. Nijhoff: The Hague
- Leach, Neil. 1997. *Rethinking architecture*. Routledge: New York
- Leatherbarrow, David. 2004. *Topographical stories: studies in landscape and architecture*. University of Pennsylvania Press: Philadelphia
- Nietzsche, Friedrich. Translated by Walter Kaufmann. 1967. *The birth of tragedy and the case of wagner*. Random House: New York
- Perez-Gomez, Alberto. *Hermeneutics as discourse in design*. From: Design Issues. Volume 15(2). Summer 1999. p. 71-79.
- Vesely, Dalibor. 2004. *Architecture in the age of divided representation: the question of creativity in the shadow of production*. MIT Press: Cambridge
- Waldheim, Charles ed. 2006 *The landscape urbanism reader*. Princeton Architectural Press: New York
- Watts, Alan. 1957. *The way of zen*. Vintage Books: New York
- Watts, Alan. 1967. *The supreme identity: an essay on oriental metaphysic and the christian religion*. The Noonday Press: New York
- Wittgenstein, Ludwig. 1958. *Philosophical investigations*. Macmillan: New York

Innovative Sustainable Water Management Practices in Solar Residential Design

C. Jason Mabry¹, Franca Trubiano¹

¹Georgia Institute of Technology, Atlanta, Georgia

ABSTRACT: This paper communicates the results of an architectural research project which sought innovative design strategies for achieving energy and resource efficiencies in water management systems traditionally used in single-family housing. It describes the engineering of an efficient, multifaceted, and fully integrated water management system for a domestic environment of 800 sq. ft., entirely powered by solar energy. The four innovations whose details are conveyed include the use of alternate materials for piping distribution and collection, the use of water in solar energy generation, the design of a building skin which capitalizes on water's capacity to store heat as well as the design of a ecological groundscape which re-uses and filters waste water and rain water.

Keywords: energy, plumbing, home design

INTRODUCTION

This paper communicates the results of an architectural research project which sought innovative design strategies for achieving energy and resource efficiencies in water management systems traditionally used in single-family housing. A building's plumbing infrastructure, such as its supply, distribution and waste collection is rarely addressed when developing initiatives for improving sustainable practices within the construction industry. And yet, it is precisely this network of pipes, valves and controls which plays a considerable role in the total energy and resource consumption of any building. With an eye to addressing this condition, the following describes the engineering of an efficient, multifaceted, and fully integrated water management system for a domestic environment of 800 sq. ft. The four innovations whose details are conveyed include the use of alternate materials for piping distribution and collection, the use of water in solar energy generation, the design of a building skin which capitalizes on water's capacity to store heat as well as the design of an ecological groundscape which re-uses and filters waste water and rain water.

This paper was written collaboratively by studio instructor and graduate architecture student at the College of Architecture of the Georgia Institute of Technology, highlighting a process which openly promoted the integration of both research and design methodologies within existing pedagogical structures typical of architecture studios. It details conditions which facilitated extensive collaborations between student and industry specialists, suppliers and associated engineers. And conducted under the auspices of the Solar Decathlon 2007 Competition, the studio held in the fall of 2006 involved the collaboration of sixteen architecture students and an equal number of engineering and building technology students operating as consultants. The mandate to design, build and transport to Washington DC, a highly efficient single-family house entirely operated using solar power was the immediate context within which the plumbing design was developed. Managing the water consumption and waste redistribution of a one bedroom, one bath living environment using the least amount of energy was the express goal. In addition, the accommodation of a grey water system for recycling waste and rainwater became an important feature of the landscape design. The studio was productively constrained by the real life necessity to physically build and operate the results of one's invention. All decisions will see the light of day and be submitted to the rigorous testing of an international competition. This is the context within which the full merit of the work described here below should be evaluated. But a sub-section of the research and design work undertaken by an entire class of architect and engineer collaborators, it registers the gains achieved when asking questions pertinent to building performance, sustainable water management practices and the construction of solar powered homes.

The results herein may be of interest to those involved in architectural education as well as those involved in the engineering of building systems. The adoption of sustainable practices and energy conservation, as they pertain to the operations of a building, has yet to become an essential component of architectural design as taught within most design studios. The perceived urgency to teach the language of form, site, program and circulation leaves little time for questions associated with architectural performance. And yet, with 40% of North America's energy consumption the result of operating a building's systems, the necessity to encourage dialogue between architect and engineer is imperative. This studio was the first initiative at Georgia Tech to posit questions of applied technology within the core of a collaborative studio and it is expected that a greater number of design studios will herein investigate the territory defined by architectural design, systems design and building performance. Architecture students collaborated extensively with undergraduate and graduate students from Mechanical, Civil, Electrical and Computing Engineering, and they constructively integrated the limitations of each within the process of design.

In addition, the outcome of such a project may be of keen interest to the building industry, who in this instance volunteered its services to help in the education of young architects. The project necessitated a large degree of collaboration between student and industry consultants as many working meetings were held with material and systems suppliers, installers and specialty contractors. Be it in the fields of heating, ventilating, cooling, lighting, electrical wiring, photovoltaic design or plumbing, students worked side by side with experts in each field and directly benefited from the practicum of those who have understand the in-situ operation of building systems. No longer are assumptions about details and performance acceptable in theory; they must accord with their measured values in practice.

And finally, the results of such a research and design project may be of interest to our future clients and home builders. The potential for ever more efficient building systems within residential construction is considerable given technological advances in non renewable energies during the past two decades. Housing projects such as Sutton, England's BedZED Development designed by Bill Dunster are showcases for the integration of innovative operating systems within contemporary architecture, particularly when architect and developer are intent on reducing to a minimum a project's daily consumption of non renewable energy (Sommerhoff, Emilie 2003). However, within the North American new housing market the evidence of such integration is scant. Reluctance still exists on the part of building contractors to install mechanical equipment which features such inventions when building single-family housing; not being the benefactors of their projected lower operating costs. Far more surprising, however, is the lack of advocacy on the part of architects and engineers to redress this situation. Surely, more awareness could be generated and information communicated to housing consumers on the long-term benefits of more energy efficient building systems and this paper is an attempt to facilitate this process.

1.0 SAVING ENERGY AND RESOURCES BY WAY OF INNOVATIONS IN HOUSEHOLD PLUMBING

What began as the need to engineer a simple plumbing diagram for a single-family residence expanded into an energy recycling, building integrated system of water management designed to capture the heat energy expended from a variety of sources. In so doing, it has made the plumbing system one of the most energy saving components of the contest house in question. The whole was accomplished by way of research using product data, manufacturer's recommendations, consultation with engineers and those with expert knowledge in plumbing design, and research into the operation of components in academic publications.

As mentioned previously, the four innovations in plumbing design and water management which resulted in energy efficiencies can be summarized as follows:

1. the use of alternate materials and distribution techniques for primary household needs
2. the adoption of water for solar energy collection
3. the use of water's capacity to store heat and the implication this has for the design of building skins
4. and the re-use of waste water and rain water in the development of more ecological landscapes

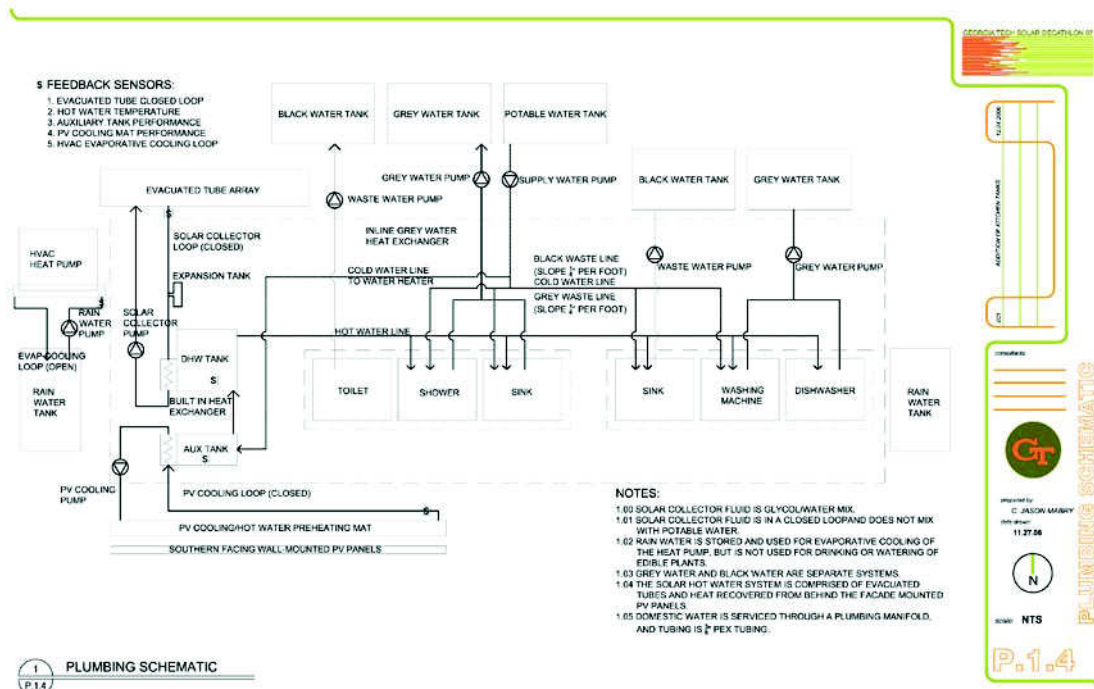

Figure 1: Plumbing schematic for the solar decathlon house. Source: Mabry 2006.

1.1 Saving energy using alternate materials and distribution techniques for primary household needs

The typical single-family home can greatly benefit from advances in the most ubiquitous of building products; pipes used in common plumbing applications. Research into innovative plumbing systems in the form of product searches yielded information on the newest technology to date: the *home run system*, or *plumbing manifold*. Two common companies manufacturing plumbing manifolds are Vanguard Industries, Inc. and REHAU, Inc., and while they have been around for several years, they are now coming into broader use.

The system functions by way of a central location from which all water is delivered to fixtures throughout the house. In this way water usage can be more easily monitored and controlled, leaks are easier to detect and fix, and it allows work being done on specific plumbing components to not hamper water delivery to the rest of the house (NAHB Research Center 2003). This plumbing manifold, essentially a breaker box for hot and cold water delivery, is both a method of saving energy in the plumbing system and a more efficient method of delivery. All water flows through the manifold and is then sent through individual lines to hot and cold water connections at each fixture.

The *home run system* saves energy by coupling the manifold with PEX piping as a delivery system. PEX is a flexible plastic made into tubes, and is especially well suited for plumbing due to its resistance to chemicals, heat, and creep (NAHB Research Center 2003). PEX runs as a single length of tubing between the manifold and the fixture, with no fittings required except at terminal points. Being made of cross-linked Polyethylene, it accommodates sharp bends, allows for quick and direct delivery of water with little pressure loss, and with resultant savings on pumping. Most critically, a smaller diameter PEX tube can be used than that of copper tubing, since the line runs are direct to each fixture without bends or material changes (Plastics Pipe Institute 2004). As such, instead of a 1/2" diameter supply tube (normally used with copper), a 3/8" diameter tube can be used in delivery to fixtures. This 1/8" has significant energy savings. The smaller diameter has approximately half the amount of water in it than the 1/2" tube (NAHB Research Center 2003). This means that there is less standing water in the tubes, and as a result less heated water will be left in the pipes to cool. Furthermore, the smaller diameter means that more water will be delivered in less time, since the velocity within the pipe will be higher (NAHB Research Center 2006).

In addition to being a more direct means of transferring water from the storage and hot water tank, PEX tubing has the added benefit of retaining more of the heat energy within the tube. Copper piping, the traditional method

of delivery, is an excellent conductor, meaning it must either be insulated, or risk transferring the heat energy into the air of the house. PEX tubing acts as an insulator, and thus does not have the same problem, saving energy by retaining more of the heat within it. The use of PEX is becoming a major competitor to copper, due to cost and environmental issues, and has been in widespread use in Europe since the late 1970s (NAHB Research Center Nov 2006*).

For all of the above reasons it was decided to use this system in the construction of our Solar Decathlon House and in collaboration with Mckenney's Inc. and OneWorld Sustainable Energy Corporation the system will be optimized to efficiently deliver hot water while saving both water and the energy used to heat it. The plumbing plan takes advantage of a "power spine" concept wherein all of the piping distribution is contained within this spine and the location of the plumbing manifold has been identified as adjacent to the spine, located within the bathroom and in close proximity to the kitchen, allowing for fast and efficient delivery.

2. Saving household energy with the use of solar hot water evacuated tubes

Another means of reducing the consumption of energy in the operations of a typical household involves the introduction of solar hot water. The ability to use the sun's rays in order to heat a family's daily water usage is yet another means of reducing reliance on non-renewable energies. When researching solar hot water systems, most research indicated that evacuated tubes would be the most effective at capturing usable solar energy (National Renewable Energy Laboratory 2006). Flat plate collectors would be another option. Evacuated tubes operate by absorbing solar radiation into a tube from which air has been evacuated. The trapped radiation then heats a smaller tube through which a heat transfer fluid flows, absorbing the thermal energy. Since there is virtually no air inside the tubes, almost all energy captured is retained, instead of being lost through convection or conduction. The heat transfer fluid is then piped to a heat exchanger or solar hot water tank.

Typical evacuated tube design yields a high volume of heat production to unit size, more so than competing flat plate collectors (National Renewable Energy Laboratory 2006). Consultation and collaboration with engineering students during the initial design charrette supported the decision to use evacuated tubes. Furthermore, the design of the system usually limits the amount of pumping needed for the solar collection fluid, or eliminates it altogether by using thermosiphoning. Most typically, thermosiphoning could be defined as a passive system of heat exchange that eliminates the need for pumps within a vertical closed-loop circuit. A difference in temperature and thus liquid density allow for a thermosiphon heat exchange system to effectively capture and store solar energy in a tank without requiring a conventional pump, though the design is somewhat restrictive.

Due to constraints on the site whose dimensions were dictated by the Solar Decathlon competition, various manufactures and evacuated tube systems were studied to determine which would deliver the most energy in the least amount of space. This research commenced with manufacturer's details to determine spatial dimensions and restrictions, and concluded with independent research conducted by collaborating PhD engineering students engaged in in-depth analyses of the competition house systems. Additionally, since the roof, usually the ideal location for such a system, is in our design completely covered in solar panels, it was necessary to move the system to a lower but equally effective location. Product research of various available manufacturers located a system that allowed horizontal operation instead of the usual angled vertical configuration. This coincided with a desire to integrate the system into the architecture and landscaping, showcasing the energy producing technology on the outside of the house, and produced a more cohesive architecture/systems and engineering design and approach to the project.

To save on losses due to pumping distance, the evacuated tubes were located as close to the water heater as possible. Several thermal storage systems were examined, both by speaking with industry professionals and studying as-built drawings showing how other groups had constructed evacuated tube thermal energy storage systems in the past, mainly from past Solar Decathlon competitions. The decision was made to keep the system as simple as possible while still creating and storing as much energy as possible. Using a large solar storage tank was ruled out since there was no room within the structure to house it, and because it would allow the dissipation of heat into the air had it been external to the building envelope. Additionally, the auxiliary tank would require extra pumping to deliver the energy to another tank. Therefore, a direct evacuated tube to hot water tank system was designed, at first as a conceptual design, then further refined with feedback from engineering students working on the project, and finally refined and approved by consultants from the engineering firm Mckenney's Inc. Utilizing a hot water tank with a built in heat exchanger will save energy losses due to pumping. Thus, the glycol/water loop delivers energy directly from the evacuated tube to the hot water tank by means of the integrated heat exchanger. With the exchange occurring within the tank, no heat is lost to the environment in the process, further saving on energy.

3. Saving Household Energy by way of Heat Storage in the Design of an Exterior Cavity Wall

The most elaborate component of the house's plumbing system will be located within the south facing structurally insulated panel (SIP) wall assembly. Comprising simultaneously building skin, cooling system, heating system, and systems/architecture integration, a so-named PV cooling loop will be introduced into the design of the house's front elevation. This particular section of the façade is comprised of solar collectors traditionally situated on the roof. They are offset from the SIP wall by a cavity in which the cooling loop will be located. In this instance a plumbing loop has been devised to act as both water heating element and PV cooling component. The water heating portion of the system was deemed necessary by engineering calculations due to site constraints in the sizing and location of the evacuated tubes, the primary water heating element. This heating system was required to be placed much farther than optimal from the water heater, and since the overall house design and other stringent criteria forced the evacuated tube system to be smaller than would be ideal, a secondary solar heating method was sought, which led directly to the water in the wall heating system. This was devised in collaboration with a fellow studio student working on the wall assembly and PV panel integration.

Due to the inclusion of solar panels on the wall, where less airflow would be available, it was determined that a method of cooling would be required to maintain their performance. It was also realized that the heat buildup behind the panel would be usable waste heat if it could be stored. By capturing this heat, it would be useful elsewhere within the house. Heating water was the obvious choice for the captured thermal energy. Coupling any retrievable heat from behind the panels with the output of the evacuated tubes seemed sufficient for all water heating needs. The question then revolved around how to best retrieve the heat from behind the panels.

A separate study, conducted by another studio participant, investigated the efficacy of wall-mounted PV panels (Krauter, Stefan 2001). This study examined methods of extracting heat from behind PV panels to allow them to operate most efficiently. Of the four viable methods, the most effective was using liquid to remove excess heat (Krauter, Stefan 2001). The research results identified by the student confirmed the studio led research assumptions and closely aligned with efforts of placing piping behind the PV panels on the SIP wall.

Research into specific cooling methods conducted by a fellow studio participant studying PV facades coincided with specific heating methods and piping choices examined from a plumbing standpoint, allowing for the system to serve multiple purposes. The study on extracting heat from behind the panels did not indicate which liquid would be most effective at extracting heat, but research into the evacuated tube system indicated that a glycol/water mixture would best transfer heat and be useful in the prevention of freezing within the system (National Renewable Energy Laboratory 1996). Advice from field experts at Mckenney's, Inc. also confirmed this conclusion. Thus, the same fluid used to transfer heat in the evacuated tubes will be used to extract heat from the PV panels and supplement the primary water heating system.

The final question remaining in the water system was which type of piping should be used. Due to the compact nature of the system, spatial restraints between the panel and the wall, investigation into a very slim heat extraction system was undertaken to determine whether or not there was a system that would fit. After searching for premade systems, of which none specific to this type of application were found, the decision was made to custom design and construct one. Such systems were initially developed in the 1970s for water heating, typically used in heated pool applications, but none are currently in production. Copper piping and PEX piping were the two products of investigation for carrying the fluid. After much research into the best methods of circulating liquid for heat extraction, primarily in the form of conversations with field experts, in addition to product data research, it was found that straight lines running vertically would not be as efficient at removing heat since they would not cover enough area. Copper piping, aside from being increasingly expensive, is not as maneuverable as PEX tubing, and given the space constraints, and the understanding that copper would be much more difficult to work with, PEX was chosen as the piping method of choice. OneWorld Sustainable Energy Corporation in Atlanta, Georgia has acted as a consultant in this process and their research into manufacturer's specifications and similar heating systems made with rubber mats and PEX tubing indicated that such a system would work well for the project's purposes. PEX can bend back and forth, snaking up the SIP wall and thereby extracting extra heat that would not be possible in a straight pipe configuration. This extra heat will allow for further energy savings by limiting the amount of time the auxiliary heating element would need to operate to deliver hot water.

In the end, it was determined that cooling the PV panels while heating water using the glycol/water mix and a heat exchanger would be very effective at saving energy used to heat hot water within the house, in addition to providing increased solar energy output from the PV panels by allowing them to operate more efficiently. Both the hot water system and the power production system will now operate better together than either would have alone. In addition, this coupling of plumbing components has resulted in a unified system integrating architecture and infrastructure.

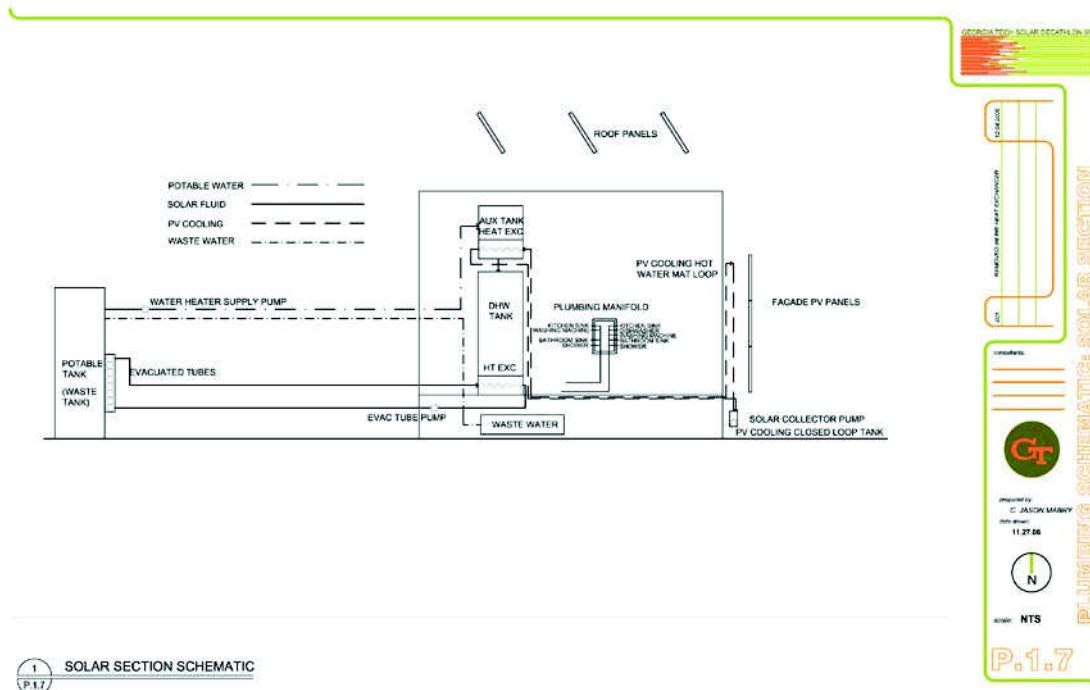

Figure 2: Solar schematic section for the solar decathlon house. Source: Mabry 2006.

4. Saving energy with water in the landscape

In the process of designing the house, whose plumbing systems both within and without have been described here above, the decision was made to render the larger site within which it was situated into a working landscape; a natural machine in support of the house. By using the ground which surrounds the house for the cleaning and storing of water, a net supply of energy will be saved in the house's operations. Water used both in the house and collected on site will not be immediately disposed of and sent afar to be processed and treated at a water purification plant. The design intent ensures that as much as possible of the water that is found on the site remains on the site. And to this end, some of the house's internal water will be recycled on site as will captured rain water. This will save on potable water usage and sustain the larger landscape while reducing both the house's and the municipality's operating costs, reducing piping required and energy required to treat the water.

The house has been designed to have both a grey water and black water system. They are kept separate, allowing for the onsite treatment of the grey water, and the eventual offsite processing of the black water. Grey water originates in plumbing sites such as the bathroom sink, shower, dishwasher, and washing machine, and when properly treated can be recycled for use in toilet flushing, clothes washing, and irrigation. Storm water collected from outdoor decks and the building roof is also considered grey water and it too can be used for the same purposes. Efforts are ongoing with engineers to attempt to extract thermal energy from grey water prior to storage or discharge into the landscape. This can be achieved by using an inline heat exchanger or by passing the heated grey water in immediate proximity of incoming supply water to transfer the heat between the lines prior to exiting the house envelope. Current research is determining feasibility of such a system and the technical difficulties in extracting the energy.

The system is designed to efficiently treat grey water in a limited footprint, due to competition constraints. Furthermore, a complex system of tanks is required as there is no municipal hookup and all water must be stored on site. The potable water supply tank is used in the landscape to supply water to edible plants, due to competition constraints disallowing edible plants to be treated with grey water. The grey water tank supplies water to a reed bed filtration system developed in collaboration with two fellow studio members focusing on the landscape design and implementation alongside a civil engineering student also working on grey water filtration. The filtration system pumps water to an elevated tank, and from there gravity moves the water from tank to tank.

A complex series of plants and organisms pull nutrients from the water for their own sustenance and then pass cleaner water to the next tank, ultimately releasing it into the landscape. There is also a living wall, essentially plants stacked vertically in containers that will be irrigated by grey water. Rainwater is being collected in two tanks, one on each end of the house. One of these tanks will store rainwater that will be circulated through an evaporative cooling loop which will cool the heat pump used for the houses heating and cooling needs. Excess water will be used to irrigate the landscape. The other tank will also be used to irrigate the landscape, but will be preceded by an overflow tank that acts as a landscape element, storing water from heavy rains that can potentially be used to passively cool the house.

In addition to saving energy, the integration of the landscape into the house system, often an overlooked component, especially when considering energy saving measures, can be just as important as the mechanical, electrical, and plumbing systems. Moreover, the landscape machine beautifies the environment while cleaning it. By utilizing a complex system of several types of natural environments, gravity, and storage, water can be recycled with virtually no energy used in the process.

CONCLUSION

In conclusion, design research was conducted within the modified structure of an architectural studio. It served as the main platform from which investigations could be made into energy savings measures associated with plumbing systems used in residential construction. To accomplish the like, the input of expert engineering consultants was essential as was that of engineering students. Whether in the form of design reviews or working conversations, collaboration with such partners in the building industry proved crucial to the decision making process. Only in this manner could conclusions be drawn which encourage the use of innovative materials in the housing sector, which promote the use of solar technologies for conditioning our daily consumption of household water, which integrate the distribution of water in the construction of residential building skins and which consider the effects of water management across the entire site of a single-family home.

ACKNOWLEDGEMENTS

The authors would like to express thanks to all consultants who worked on the project: Greg Jeffers and Mckenney's, Inc. Engineers, OneWorld Sustainable Energy Corporation, Professor Ruchi Choudhary, and students Toni Cliett [Architecture], Amanda Cook [Architecture], Erin Gibbons [Civil Engineering], Alex Jackson [Civil Engineering], and Joe Jamgochian [Architecture].

REFERENCES

- Krauter, S., Salhi, M., Schroer, S., Hanitsch, R. 2001. *New Façade System Consisting of Combined Photovoltaic and Solar Thermal Generators with Building Insulation.*
- NAHB Research Center. 2006. *Home Run Plumbing Systems.*
- NAHB Research Center. 2006*. *Design Guide: Residential PEX Water Supply Plumbing Systems.*
- NAHB Research Center. 2003. *PATH Technology Inventory Review.*
- National Renewable Energy Laboratory. 1996. *Residential Solar Heating Collectors.*
- National Renewable Energy Laboratory. 1996. *Solar Water Heating.*
- Plastic Pipe and Fittings Association. *PEX Offers Environmentally Sound Solutions.*
- Plastics Pipe Institute. 2004. *PEX Pipes for Plumbing.*
- Sommerhoff, Emilie. 2003. *Carbon Neutral Neighborhood. Architecture* Vol. 92 Issue 4.

Case Studies — Human Context

Effect of Building Design on Pressure-related Problems In High-rise Residential Buildings
Jae-Hun Jo, Myong-Souk Yeo, Kwang-Woo Kim

Thermal Comfort in a Naturally-Ventilated Educational Building
David Mwale Ogoli

The Green Church
Mark L. Gillem

Environmental Studies of Vernacular Architecture
J. Brooke Harrington, Judith Bing

Effect of Building Design on Pressure-related Problems in High-rise Residential Buildings

Jae-Hun Jo¹, Myong-Souk Yeo², Kwang-Woo Kim²

¹Technology Research Institute, DAELIM Industrial Co., Ltd., Seoul, South KOREA

²Department of Architecture, Seoul National University, Seoul, South KOREA

ABSTRACT: High-rise residential buildings in Seoul experience stack effect problems during the winter season, such as difficulties in opening residential entrance doors and whistling noises from elevator doors generated by airflow. Many researches have been performed on stack-induced problems of cold areas in high-rise office buildings, and several solutions have been proposed. However, it is not well known where exactly and how extensive, these problems are in residential buildings. The architectural design that comprises a building is known to be an important measure in minimizing or preventing stack effect problems; how a building is designed can affect the extent of the pressure distribution caused by the stack effect. We surveyed two buildings having different phases of stack effect problem through drawing examinations and field examinations, and conducted measurements of pressure distribution on these buildings. Through these two projects, we verified the problems associated with the stack effect and the influence of building designs on the extent of such problems. Finally, this paper presents the design implications for limiting the airflow in a building to prevent stack-induced problems occurring in high-rise residential buildings.

Keywords: high-rise building, building design, stack effect, field measurement

INTRODUCTION

In recent years, many high-rise residential buildings have been constructed in Korea. These buildings comprise of over 30 floors, up to 70 floors, and due to this height, they form a tall air column inside the building and another outside. During the winter season, the differential weight of these two columns of air, where one is warm and the other is cold, causes a pressure difference between the inside and outside of the building. This brings about the so-called stack effect.

It is known that there are many problems caused by the stack effect such as the elevator door sticking problem, washroom exhaust imbalance, air leakage, difficulty in opening doors, noise resulting from air flowing through cracks, and so forth. Thus, many studies have been performed to solve these problems in office buildings, and several solutions have been proposed. In the office building, as there is usually no compartmentation between the cores and working area, one possible solution could be to improve the airtightness of the exterior wall (Tamura 1967, ASHRAE 1993). For this reason, the National Association of Architectural Metal Manufacturers set a limit on the maximum leakage per unit of exterior wall area to be 1.10 CMH/m² at a pressure difference of 75 Pa, exclusive of leakage through operable windows (Tamura 1994). However, in the case of residential buildings, as residents of residential buildings demand openable windows which they can use even during the cold season, it makes much more difficult to maintain airtightness of the envelope in a residential building to the same level as that of an office building with fixed windows (Jacques 1996). Therefore, improving just the airtightness of the envelope is not a viable solution for resolving the problems due to the stack effect in high-rise residential buildings. Since a high-rise residential building consists of many units surrounding the core, the pressure profile of the high-rise residential building is different from that of the office building. Accordingly, the problems caused by the stack effect would differ as well, and would thereby require different approaches to be developed for resolving such problems in tall residential buildings.

The main objective of this study is to obtain the actual pressure differences across the architectural elements (exterior wall, entrance door, elevator door) in high-rise residential buildings as a preliminary examination to develop a guideline for preventing stack effect problems.

1. Survey of two high-rise residential buildings

1.1. Survey outline

We conducted surveys on two test buildings beginning from December 2003 to February 2004. First, the architectural drawings were examined to identify where the problems due to stack effect could occur. We particularly focused on the entrance doors on each floor, especially when the door is connected to the outside, and the core areas. After examining the drawings, we conducted field investigations of the two test buildings several times during the winter season. We verified suspected problems and measured the air tightness. Finally, the quality of construction of the two test buildings was evaluated with respect to airtightness.

1.2. Building description

Two newly built high-rise residential buildings in Seoul were selected as the test sample for our field measurements. The test buildings were both built recently and have similar types of envelope. However, it was reported that the two buildings had different problems due to the stack effect in different places. The information on these two buildings is given in Table 1.

Building A (40 stories) and building B (69 stories) are both residential buildings; typical floor plans and sections of each building are given in Fig. 1 and Fig. 2, respectively, which have been simplified to show the zone easily (i.e. each residence is represented as a single zone). Both buildings A and B have two main mechanical equipment floors. In building A, one is on the 8th floor and the other is on the top floor, and in building B, one is on the 16th floor and the other is on the 55th floor. HVAC systems and exhaust fans for washrooms are also located on these floors. There is no vertical zoning of the elevator shaft in building A; the elevators serve all floors (B5 to 40F). In building B, there are 4 vertical zones in the elevator shaft, which are for the shuttle elevators (B5 to 1F), low-rise elevators (1F-15F), middle-rise elevators (1F, 2F, 16F to 54F), and high-rise elevators (B1-2F, 54F to 69F).

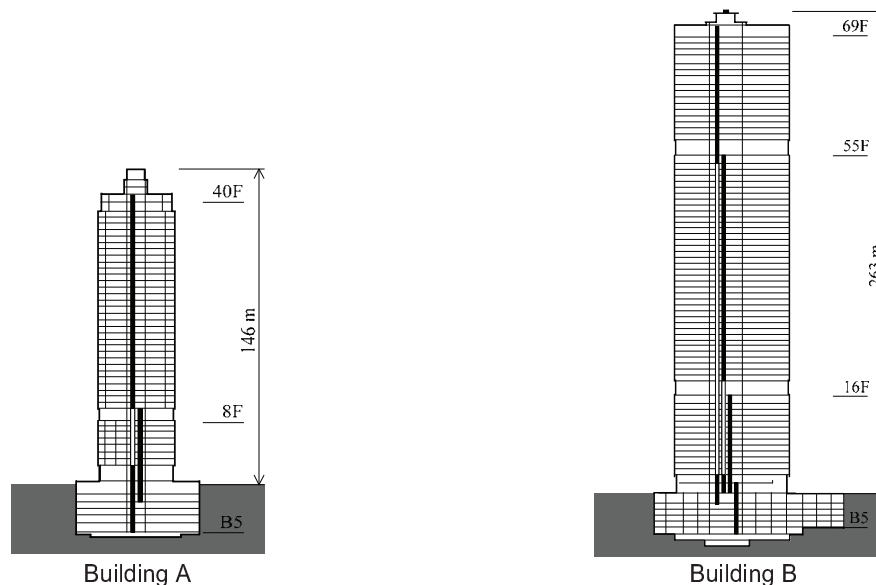

Figure 1: Sections and vertical elevator zonings of two test buildings

Table 1: Building description

	Building A	Building B
Location	Seoul, Korea	Seoul, Korea
Structure	SRC	SRC
Height	146 m	263 m
No. of floors above ground	40	69
No. of basement floors	5	3
Exterior walls	Aluminum curtain wall	Aluminum curtain wall
Date of completion	December 2003	February 2004

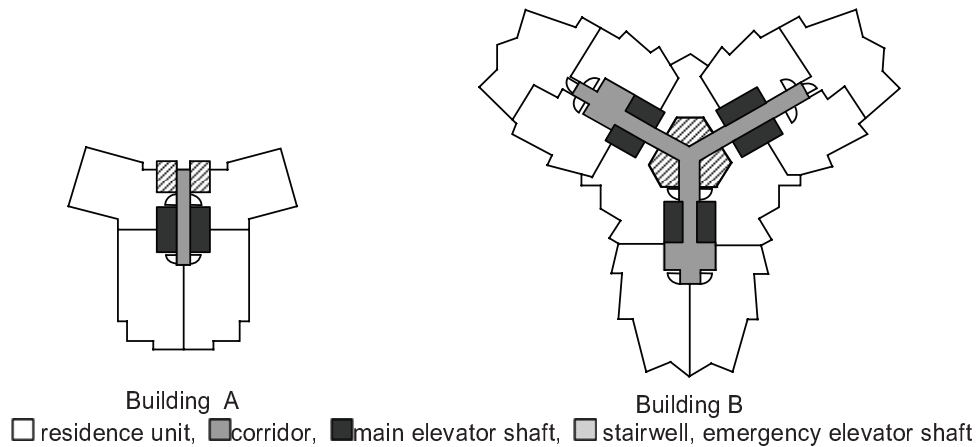

Figure 2: Typical plans of two test buildings

2. Survey results

2.1. Examination of architectural drawings

To minimize the problems caused by the stack effect, the airtightness of the whole building must be improved. It is very important to reduce the inflow and outflow of air, and therefore, careful consideration is required in the design of architectural factors which can decrease the airflow. During the winter season, when stack effect problems occur most frequently, the main path of airflow inside the building can be divided into three parts: an inflow part (R1), upward flow part (R2), and outflow part (R3) (Jo 2004) as shown in Fig. 3. Architectural drawings of buildings A and B were examined from this point of view as shown in Table 2. For the most part, we found that building B was more airtight than building A.

On the 1st floor, which is the inflow part, the doors for the elevator hall are installed in both test buildings, and no conspicuous difference is observed except that building B has revolving doors installed while building A has automatic doors at the main entrance. However, there are some differences between the two buildings at the entrance for the parking area on the basement floor; vestibules with double swing doors are installed in building B, while only single automatic doors and no vestibules are installed in building A. There is also a distinction between the elevator zonings of the two test buildings, which correspond to the upward flow part. In building B, 4 different elevators, namely, the shuttle elevator, low-rise elevator, middle-rise elevator, and high-rise elevator serve the basement floors, low part, middle part and high part of the building separately. In building A, however, 3 passenger elevators serve the entire residential floors from the 5th basement floor to the 40th floor. The doors for the machine room at the top floor are critical outflow paths from the inside to the outside of the building. These doors need to be sufficiently airtight in order to prevent stack effect problems from occurring. In building B, one needs to open two or three airtight doors to access the rooftop, whereas in building A, there is only single loose door that needs to be opened.

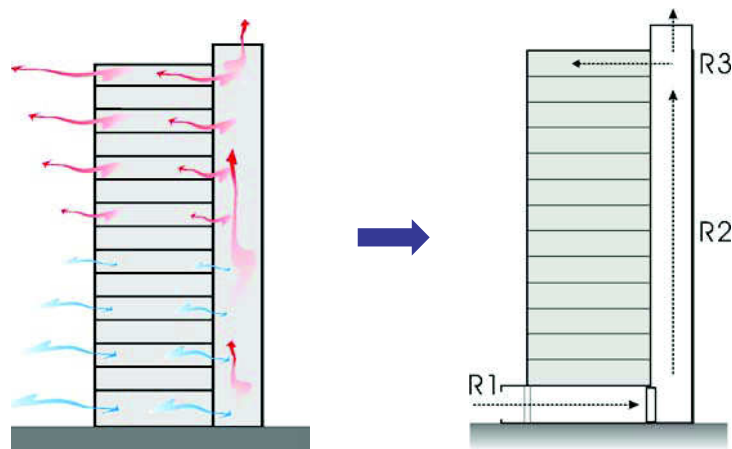

Figure 3: Diagram of main airflow paths during the winter season

Table 2: Comparison of architectural plans of building A and building B

	Location	Building A	Building B
Inflow part	Entrance on basement floor	-Not installed(vestibule) + Automatic door(entrance)	-Swing door(vestibule) + swing door(entrance)
	Main entrance on 1F	-Swing door(vestibule) + automatic door(main entrance)	-Swing door(vestibule) + revolving door(main entrance)
	Elevator hall on 1F	-Automatic door installed	-Swing door installed
Upward part	Elevator shaft	-3 Passenger elevators serving all floors, B5-40F	-3 shuttle elevators serving B5 to 1F -4 high-rise elevators serving B1 to 2F and 54F to 69F -9 middle-rise elevators serving 1F, 2F, and 15F to 54F -4 low-rise elevators serving 1F to 15F
	Stairwell shaft	-Serving all floors, B5 to 40F	-Serving all floors, B5 to 69F
	Mechanical shaft	-No caulking work on slab penetration part	-Caulking work on slab penetration part
Outflow part	Elevator air hole	-Elevator air hole on the shaft wall -Ventilation fan for elevator machine room	-No elevator air hole -Ventilation fan for elevator machine room
Envelope	Condenser room in residence unit	-Double weather strip installed at the door	-Triple weather strip installed at the door
	Exterior wall	-Aluminum curtain wall + pair glass -Manually operating windows	-Aluminum curtain wall + pair glass -Automatically operating windows

2.2. Field examinations: pressured-related problems

During the wintertime from December 2003 to January 2004, the authors conducted several field examinations of the two test buildings. Based on these examinations, the authors were able to verify the extent and locations of the problems caused by the stack effect which were anticipated during the architectural drawing examination. In building A, as shown in the architectural drawings, the entrance to the parking area on the basement floor was compartmentalized by a single automatic door without a vestibule, which allowed only little airflow with some noise. There was also loud noise, exceeding 60 or 70 dB, around the elevator doors on the lower floors and residence entrances on the higher floors. Although building B was constructed more tightly than building A, a slight noise resulting from air flowing through the elevator doors was heard on the lower floors. Particularly on the transfer floor (55th), where passengers can transfer to the high-rise elevators from the middle-rise elevators, airflow from the middle-rise elevator shaft to the high-rise elevator shaft was detected, and there was some noise caused by this airflow. In addition, the two test buildings were compared in terms of the quality of the construction based on architectural elements that can become essential airflow paths due to the stack effect. The two buildings differed significantly as shown in Fig. 4 to Fig. 9. In building A, there are numerous pipes and electric lines passing through the upper part of the entrance doors for the parking area on the basement floor. Without caulking work, this part can be a main inflow path of outside air entering from the parking area, which in turn can influence the pressure difference of the whole building. In building B, triple weather strips were tightly installed at the door for the multi-air-conditioner condenser room, while double weather strips were installed with some gaps at the corners of the door in building A. The summary of pressure-related problems investigated through field examinations is as follows:

- Energy losses from increased infiltration and exfiltration (excessive heating load)
- High-frequency noises from gaps in the elevator doors on the basement floors
- Difficulty in opening doors to rooms around the core area
- Elevator door sticking problems on the ground floor and on the basement floors
- Discomfort caused by drafts
- Exhaust air back-draft (flow reversal in washrooms and in kitchens)



Building A



Building B



Building A



Building B

Figure 4. Entrance for parking area on basement floor (inflow part): leaky automatic door vs. double airtight swing door

Figure 5. Door for elevator hall on 1st floor (inflow part): leaky automatic door vs. airtight swing door



Building A



Building B



Building A

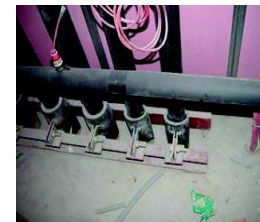

Building B

Figure 6. Door for condenser room (upward part): leaky double weather strips vs. triple weather strips

Figure 7. Electrical pipes through the slab (upward part): no caulking work in building A



Building A



Building B



Building A



Building B

Figure 8. Exterior wall (outflow part): noticeable difference in construction quality

Figure 9. Ventilation fan for elev. machine room (outflow part): leaky fan vs. fan with airtight damper

3. Field measurements of pressure distribution

3.1. Outline of field measurements

Field measurements were carried out on several occasions in January 2004 to verify the problems caused by the stack effect and to obtain the pressure profile of the building. Through an investigation of the site to prepare for practical measurement of the building, airflow paths inside the building were determined. After consulting with a manager of the building, locations for practical measurement were selected to determine the effective methods and a measurable range. Absolute pressures of essential zones on the airflow path; for example the elevator shaft, hallway, residence unit, and outdoors, were measured. The authors measured the absolute pressures of zones on a single floor simultaneously, going down from top to bottom of the building; pressure differences were calculated by these absolute pressure data. Field measurements were carried out at dawn in mild but cold weather, to minimize the influence of exterior conditions such as a sudden gust of wind, elevator use of dwellers, opening of doors, and so forth.

3.2 Field measurement results

Among the various measurement results, the one set least affected by exterior influences is shown in Fig.10 and Fig.11. The y-axis shows the pressure in the elevator shaft, and each line represents the pressure difference from the elevator shaft pressure. For example, "a" in Fig.10 is the pressure difference between the outside and inside of a residence, which in other words is the pressure difference of the exterior wall. Although building A is lower in height than building B by over 100 m, building A apparently displays more serious problems due to the stack effect. It should be noted that the pressure difference across the residence entrance door is greater than that across the exterior wall for both test buildings.

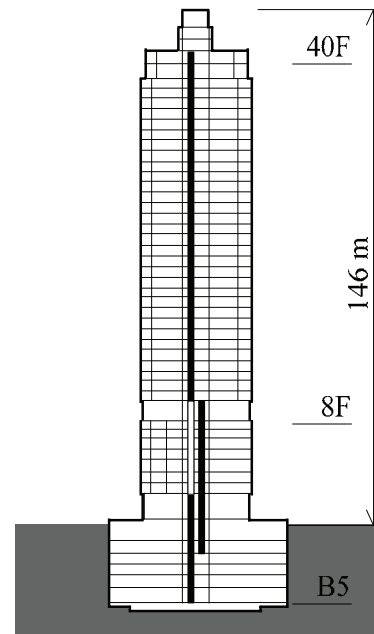
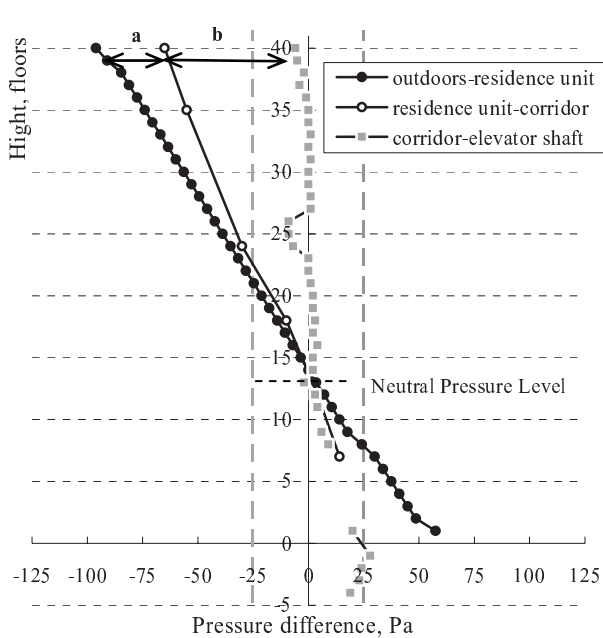

Figure 10. Field measurement results of building A

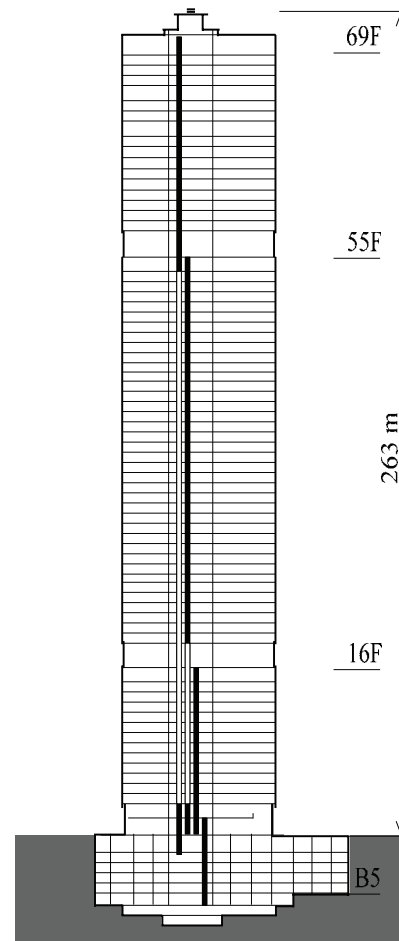
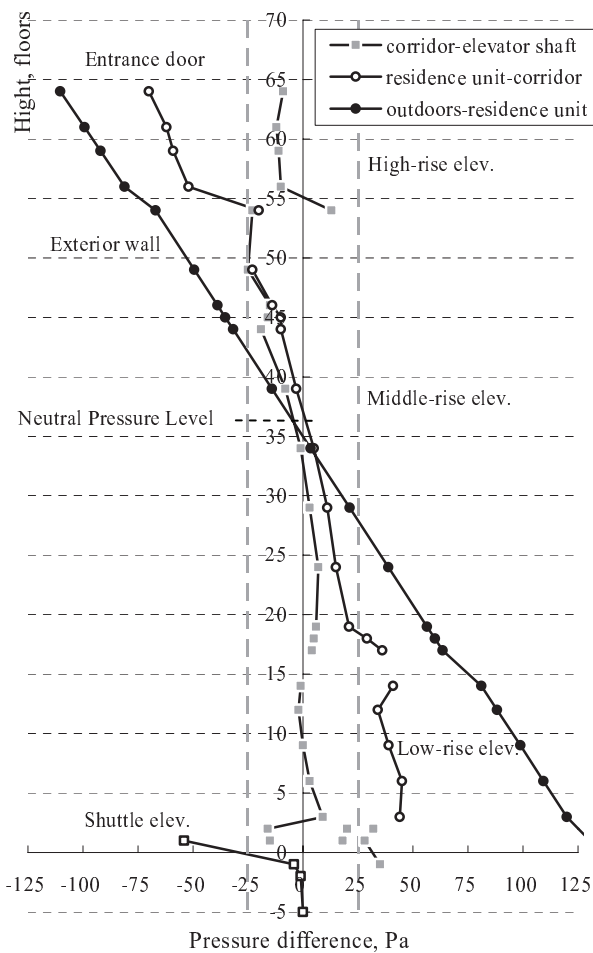

Figure 11. Field measurement results of building B

(1) Building A

As shown in Fig. 10, there are no significant problems for the elevator door on most floors; however, pressure differences are relatively high, of almost 25 Pa, on most basement floors. On the 1st basement floor, the pressure difference was over 25 Pa; problems such as the elevator door sticking problem and noise may occur under this level of pressure difference. Pressure difference at the residence entrance ("a" in the Fig. 10) can be twice as large as that of the exterior wall ("b" in the Fig. 10). On the 35th floor, for example, the pressure difference at the entrance door is about 50 Pa, while that at the exterior wall is about 25 Pa. The entrance doors at higher parts of the building having pressure differences of over 50 Pa cause difficulties in opening the doors, which will cause serious problems in emergency situations. The height of the Neutral Pressure Level (NPL) was lower than the center of the building height, such that the pressure difference at the entrance door and exterior wall increased at the higher parts of the building than at the lower parts. This in turn means that the lower parts of the building experienced more leakages.

(2) Building B

In building B, different types of elevators separate the elevator shaft vertically and serve different parts of the building (as shown in Fig. 11): the upper part, middle part, lower part, and basement part of the building. For this reason, the pressure differences across elevator doors in building B are generally lower than those of building A. There are two points where more than one elevator meet. These are transfer elevators which passengers use to transfer to one another. One point of access is on the 1st and 2nd floor where the lobby is, and the other is on the 55th floor where passengers can transfer to the high-rise elevator from the middle-rise elevator. On these floors, the pressure differences across the elevator doors are more than 25 Pa, which is over the standard limit. This may cause the elevator door not to operate well. In particular, on the 55th floor, air flows from the middle-rise elevator shaft to the hallway and then into the high-rise elevator shaft, which caused a low noise to be heard constantly during the field measurements. Pressure differences across the entrance door in building B were not as great as in building A.

CONCLUSION

In this paper, stack effect problems in high-rise residential buildings were discussed by analyzing the results of pressure profiles obtained through field measurements of two test buildings. Through the field measurement results, several problems due to excessive pressure differences caused by the stack effect were found to occur near the core area: the entrance doors for residence units and elevator doors. The problems mostly occurred at the elevator door at the lower parts of the building (lobby floor and basement floors) and at the residence entrance doors at higher parts of the building. Higher buildings tend to experience more stack-induced problems than lower buildings; however, building B showed less problems due to the stack effect because of the architectural aspects of the building that were designed in such a way to overcome such problems: improving the airtightness of entrances at the lower parts of the building, vertical shaft zoning, and efforts to achieve overall airtightness of the whole building during construction. These efforts at the design and construction stages are an efficient way to prevent the pressure-related problems from occurring.

Design implications against the stack effect

Problems at the residence entrance doors and at the elevator doors were verified by the field examinations and field measurements; these problems are caused by excessive pressure difference due to the stack effect. Since there are interior walls and entrance doors surrounding the core area, compartmentalizing residential areas and common areas can form airtight air barriers, thereby reducing the differences in pressure that act on these air barriers of the building. If an entrance door or elevator door is opened when there is pressure acting on it, excessive pressure will act on the other closed door, which may cause serious problems. In order to solve these problems, it has been suggested that vestibules be installed around the elevator hall to create resistance to airflow from the shaft to each floor (Jo 2004).

Some design implications against the stack effect are suggested based on the results of the two field investigations conducted in this study and previous researches related to stack effect problems, by the use of which architects and engineers can identify potential problems arising from the stack effect and minimize or eliminate them at the planning stages. The "design implications against the stack effect" can be summarized as follow:

- 1) Tightening the exterior skin: planning airtight structures and materials for the exterior skin, selecting walls without windows, and installing windows that are airtight when shut (ASHRAE 1993, Kim 2001).
- 2) Installing revolving doors and vestibules at the entrances on the ground floor levels, including basement floors, and installing a vestibule around the elevator hall of each of the ground floor levels (Donald 2004).
- 3) Vertical separation: vertically separating elevator shafts and stairwells (Lovatt 1994, Kim 2001)
- 4) Horizontal separation: installing vestibules around elevator halls; separation methods such as installing an 'air-lock door' between elevator doors and residence entrance doors on the typical floors where

pressure difference problems occur, are proper architectural solutions for decreasing the pressure differences across these doors (Jo 2007).

a. Elevator lobby design - add elevator vestibule doors to create an elevator lobby; in high-rise residential buildings, operable windows and doors for each unit are common, it is necessary to provide doors connecting the typical floor elevator lobby to the common corridor.

b. Residence unit entrance door - provide heavy duty door closers, even if not required by code, and provide weather-stripping around each door; with operable doors and windows on the building exterior under control of the residents, it is impractical to try to effectively seal these sources of air infiltration. Therefore, it is important to treat the residence unit entrance doors as if they were exterior (Kim 2006).

5) Tightening the elevator machine room at the upper parts of the building.

ACKNOWLEDGEMENT

This research (03 R&D C103A1040001-03A0204-00310) was financially supported by the Ministry of Construction & Transportation of South Korea and the Korea Institute of Construction and Transportation Technology Evaluation and Planning, and the authors wish to thank these governmental organizations for their support in this work.

REFERENCES

- Tamura, G. T. and Wilson, A. G., Pressure Differences Caused by Chimney Effect in Three High Buildings, ASHRAE Transactions, Vol. 73, Part 2, 1967.
- ASHRAE, Field Verification and Simulation of Problems Caused by Stack Effect in Tall Buildings, ASHRAE Research Project 661, 1993.
- Tamura, G. T., Smoke Movement and Control in High-rise Buildings, National Fire Protection Association, NFPA, 1994.
- Jacques Rousseau, Controlling stack pressure in high-rise buildings by compartmenting the Building, Technical Series 97-103, Canada Mortgage and Housing Corporation, 1996.
- Jo, J. H., Yeo, M. S., Yang, I. H., and Kim, K. W., Field measurement and evaluation of the impacts of the stack effect in high-rise buildings; case study, the 7th International Symposium on Building and Urban Environmental Engineering Proceedings, 2004.
- Jo, J. H., Prediction of pressure distribution due to stack effect in high-rise buildings and evaluation of its impact, Ph. D. thesis, Seoul National University, 2005.
- Jo, J. H., Yeo, M. S., Yang, I. H., and Kim, K. W., Solving the problems due to stack effect in tall Buildings, the CIB World Building Congress 2004, 2004.
- Lovatt, J. E., Stack effect in tall buildings. ASHRAE Transactions, Vol. 100, Part 2, 1994.
- Tamblyn, R. T., Coping with air pressure problems in tall buildings. ASHRAE Transactions, Vol. 97, Part 1, 1991.
- Kim, K. W., Development of architectural design guideline against the stack effect in high-rise buildings, KFMA, 2001.
- Donald, E. R., HVAC design guide for tall commercial building, ASHRAE, 2004.
- Jo, J. H., Lim, J. H., Song, S. Y., Yeo, M. S., and Kim, K. W., Characteristics of pressure distribution and solution to the problems caused by stack effect in high-rise residential buildings, Building and Environment, Vol. 42(1), 2007.
- Kim, K. W., The Impact of stack effect on the # 1st World, KFMA, 2006.

Thermal Comfort in a Naturally-Ventilated Educational Building

David Mwale Ogoli

Judson College, Elgin, IL

ABSTRACT: A comprehensive study of thermal comfort in a naturally ventilated education building (88,000 ft²) in a Chicago suburb will be conducted with 120 student subjects in 2007. This paper discusses some recent trends in worldwide thermal comfort studies and presents a proposal of research for this building through a series of questionnaire tables. Two research methods used in thermal comfort studies are field studies and laboratory experiments in climate-chambers. The various elements that constitute a “comfortable” thermal environment include physical factors (ambient air temperature, mean radiant temperature, air movement and humidity), personal factors (activity and clothing), classifications (gender, age, education, etc.) and psychological expectations (knowledge, experience, psychological effect of visual warmth by, say, a fireplace). Comparisons are made using data gathered from Nairobi, Kenya.

Keywords: Comfort, temperature, humidity and ventilation

INTRODUCTION

The “comfort zone” is an appropriate design goal for a deterministic mechanical system but analysis of many international field studies by researchers has questioned its relevance to passive solar buildings (Humphreys, 1976; Auliciems, 1978; Forwood, 1995; Baker and Standeven, 1996; Standeven and Baker, 1995; Milne, 1995;). Givoni (1998) revised his already authoritative and notable work on the building bio-climatic chart having recognized this new position. These revisions reflect a paradigm shift in thermal comfort for people relative to their thermal environment. The American Society of Heating, Ventilating and Air-conditioning Engineers (ASHRAE) has been discussing how people adapt to higher indoor temperatures in naturally ventilated buildings (Olesen, 2000).

There is mounting evidence (Humphreys, 1996; Karyono, 2000) that confirms that thermal perceptions are affected by factors that are not recognized by current comfort standards. The factors include thermal history, non-thermal stimuli and psychological expectations. These perceptions are most noticeable in naturally ventilated buildings where expectations are distinctly different from air-conditioned buildings. McIntyre (1980) stated that “a person’s reaction to a temperature which is less than perfect will depend very much on his expectations, personality and what else he is doing at the time”. A study (Brager and de Dear, 1998) noted that “anecdotal evidence suggests that building occupants become accustomed to levels of warmth prevailing within buildings on time scales of weeks to months”. They concluded that there is a distinction between thermal comfort responses in air-conditioned vs. naturally ventilated buildings. It leads to another emerging observation of psychological adaptation resulting from one’s thermal experiences and expectations. Psychologically, people perceive or respond to the thermal experiences in apparently altered manner. Paciuk (1990) and Williams (1995) found that perceived degree of control is one of the strongest predictors of thermal comfort. Leaman and Bordass (1999), Bunn (1993), Raja *et al.* (2001) and Brager (2000) documented that people who have greater control over their indoor environment are more tolerant of wider ranges in temperature. These “adaptive errors” are the cause of discrepancy between observed comfort temperatures from field studies and predicted comfort temperatures from climate chamber experiments.

1. THERMAL COMFORT STUDIES

1.1. Climate-chamber studies and thermal comfort scales

The climate chamber is based on a heat-balance model whereby subjects in a carefully controlled environment are subjected to different levels of physical environmental parameters and their “neutral” heat balance point established. Pioneer thermal comfort work by International Standards Organization (ISO), ASHRAE (2005) and Fanger (1969) was based on this model. Subjects in the comfort studies were asked to judge the conditions

(preferred temperature) in a space and record it using the ASHRAE thermal sensation numerical scale shown in Table 1. Other commonly used scales are shown in Tables 2-4.

Table 1: ASHRAE Thermal Comfort Scale

<i>Question</i>	<i>Scale</i>	<i>Thermal sensation</i>	<i>Vote</i>
<i>How do you feel about the thermal environment in this room?</i>	+3	<i>Hot</i>	
	+2	<i>Warm</i>	
	+1	<i>Slightly warm</i>	
	0	<i>Comfortable, neutral</i>	
	-1	<i>Slightly cool</i>	
	-2	<i>Cool</i>	
	-3	<i>Cold</i>	

Source: ASHRAE Standard 55-2004:5

Table 2: McIntyre Scale

<i>Question</i>	<i>Response</i>	<i>Vote</i>
<i>I would like to be. ...</i>	<i>Cooler</i>	
	<i>No change</i>	
	<i>Warmer</i>	

Source: Humphreys 1996:140

Table 3: Humidity Scale

<i>Question</i>	<i>Scale</i>	<i>Thermal sensation</i>	<i>Vote</i>
<i>How do you feel about the humidity in this room?</i>	+3	<i>Much too dry</i>	
	+2	<i>Too dry</i>	
	+1	<i>Slightly dry</i>	
	0	<i>Comfortable, neutral</i>	
	-1	<i>Slightly humid</i>	
	-2	<i>Too humid</i>	
	-3	<i>Much too humid</i>	

Source: Humphreys 1996:140

Table 4: Air movement Scale

<i>Question</i>	<i>Scale</i>	<i>Thermal sensation</i>	<i>Vote</i>
<i>How do you feel about the air movement in this room?</i>	+3	<i>Much too still</i>	
	+2	<i>Too still</i>	
	+1	<i>Slightly still</i>	
	0	<i>Comfortable, neutral</i>	
	-1	<i>Slightly breezy</i>	
	-2	<i>Too breezy</i>	
	-3	<i>Much too breezy</i>	

Source: De Dear and Brager, 1998

Climate-chamber studies done in the 1970's at the Institute for Environmental Research at Kansas State University by Rohles and Nevins (1971) and Rohles (1973) showed that there are correlations between comfort level, temperature, humidity, sex, and length of exposure. Rohles (1980) concluded: "To deny or ignore the psychology involved in comfort measurement is not only shortsighted, but treats the human subject as a machine, which it is not". Rohles (1981) also indicated that alongside control of physical variables, adjustments in the amount of furnishing in a space and lighting levels could probably provide a solution to improving thermal comfort. Their results, with various equations for predicting thermal sensation, have been published in ASHRAE *Handbook of Fundamentals* (2005:8.12).

While climate chambers lack the realism of an actual building and are unsuitable for longitudinal studies (those in which the thermal experience of a relatively small number of subjects is monitored over a period of time) or

transverse surveys (those in which a larger group of subjects, being a more representative sample of the population, is polled on a smaller number of occasions but with less information on each subject), they are nonetheless useful tools due to their high degree of control and reproducibility. These methods (longitudinal and transverse) are most suitable in field studies.

1.2. Field studies

Humphreys (1975) in summarizing 36 previous field studies on comfort in different countries derived a formula correlating comfort temperatures (T_{co}) with mean monthly outdoor air or globe temperature (T_m) of the location:

$$T_{co} = 2.56 + 0.831(T_m) \text{ (}^\circ\text{C)} \quad 1$$

Humphreys (1978) also compared “free-running” buildings (passive and naturally ventilated) with mechanically controlled buildings. He observed that:

$$T_{co} = 11.9 + 0.534(T_m) \text{ (}^\circ\text{C)} \text{ (passive solar building ranging between } 10 \leq T_m \leq 34^\circ\text{C)} \quad 2$$

$$T_{co} = 0.0065(T_m)^2 + 0.32(T_h) + 12.4 \text{ (}^\circ\text{C)} \text{ (mechanical-systems building ranging } -24 \leq T_m \leq 23^\circ\text{C} \text{ and } 18 \leq T_h \leq 30^\circ\text{C)} \quad 3$$

Where T_h is the average daily maximum temperature of the hottest months of the year

Nicol and Roaf (1996) proposed an adaptive algorithm suitable for determining comfort temperatures (T_{co}) in Pakistan. It used simple outdoor temperature calculated from the preceding month (T_m):

$$T_{co} = 17.0 + 0.38(T_m) \text{ (}^\circ\text{C)} \text{ (passive solar building)} \quad 4$$

A similar relationship of comfort temperature on mean outdoor temperature by Auliciems and de Dear (1978) is:

$$T_{co} = 17.6 + 0.31(T_m) \text{ (}^\circ\text{C)} \text{ (passive solar building)} \quad 5$$

The above algorithms were made in studies done under “free-running”, or natural or passive solar conditions in various climates. There are limitations to using these equations in differing locations like Chicago, IL or Nairobi, Kenya, because of the differences of latitude, altitude, geography, climate and the need to establish a localized thermal comfort standard. Climatic conditions for equatorial highland regions tend to be generally the same all year round (Ogoli, 2000). As an example, using outdoor temperature in Nairobi and the above stated equations for passive solar buildings, the following speculative comfort temperatures in Table 5 were established for the hottest month (February):

Table 5: Comfort temperatures in February for Nairobi, Kenya

	<i>Observed</i>	<i>Humphreys</i>	<i>Nicol and Roaf</i>	<i>Auliciems De Dear</i>
$^\circ\text{F}$	71.1	74.3	77.4	75.7
$^\circ\text{C}$	21.7	23.5	25.2	24.3

1.3. Adaptive “errors” in thermal comfort

Humphreys defined comfort as “the absence of discomfort, and discomfort is alleviated by making adjustments”. He is a strong proponent of the adaptive model, i.e. thermal neutrality can be attained by more human involvement rather than just more mechanical controls. Thermal neutrality is a temperature at which a sample population feels neither too hot nor too cold. Field studies on adaptive models have shown that thermal neutrality is a function of the climate that people are acclimatized to. Researchers are increasingly questioning whether the simplistic cause-and-effect approach embodied in these laboratory-derived models can be applied, without modification, to describe real-world thermal perception.

The adaptive model is the most effective way of assessing passive solar buildings, or what is sometimes called *free-running* buildings. The adaptive models allows people to make adjustments to their clothing, activity, posture, eating or drinking, shifting position in a room, operating a window or shading device, or other *adaptive opportunity* in order to achieve or maintain thermal comfort. It appears that when people are allowed greater adjustment and control over their own indoor environment, it extends the comfort zone. The adaptive model acknowledges that the occupant is not just a passive recipient of the environment but an active member.

2. OBSERVATIONS

Many studies are now being undertaken to establish thermal comfort standards around the world. Even ASHRAE commissioned a project to collect field-study data worldwide to relate comfort temperature and climate. There are limitations to using the previously stated models because “The use of ISO-PMV could lead to unnecessary cooling in warm climates and unnecessary heating in cool ones, and if applied in developing countries would lead to needless economic and environmental penalty” (Humphreys, 1996:142). A survey in Zambia in central Africa between latitudes 8° and 18° south, established the comfort temperature as 22.2°C, and comfort zone as 19.7–24.7°C for the cool season; ASHRAE *Standard 55* overestimates the lower comfort limit for this region by 2.7°C (Sharples and Mulama, 1997).

A recent study (Ogoli, 2000) was undertaken in Nairobi, Kenya, to observe indoor temperatures in passive solar buildings with different amounts of thermal mass. The stratified indoor temperatures in light mass building (Figure 1) and high mass building (Figure 2) are shown below. The low mass building was made of timber walls and galvanized corrugated iron (GCI) sheet roof while the high mass building was made of stone walls with concrete tile roof. These figures illustrate that the proper use of thermal mass can control indoor temperatures that in turn allow more “adaptive” adjustments for occupants. Temperatures in the low mass building generally follow the outdoor trends. In the case of the high mass building, indoor temperatures remain relatively in a narrow band, thus increasing the potential of thermal comfort through adaptation. A follow-up study (Ogoli, 2002) was made in the prediction of indoor temperatures of closed buildings with high thermal mass.

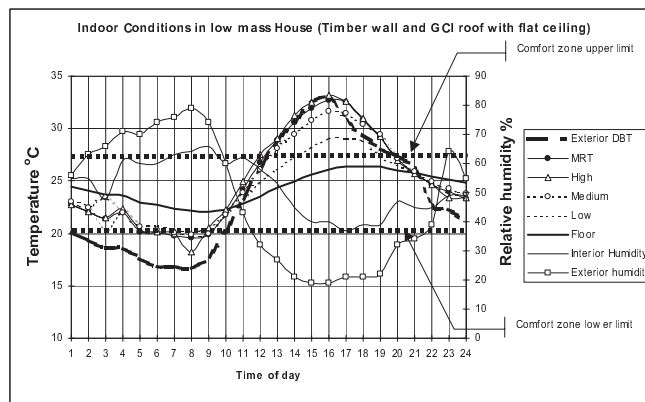

Figure 1: Conditions in a low mass building in Nairobi

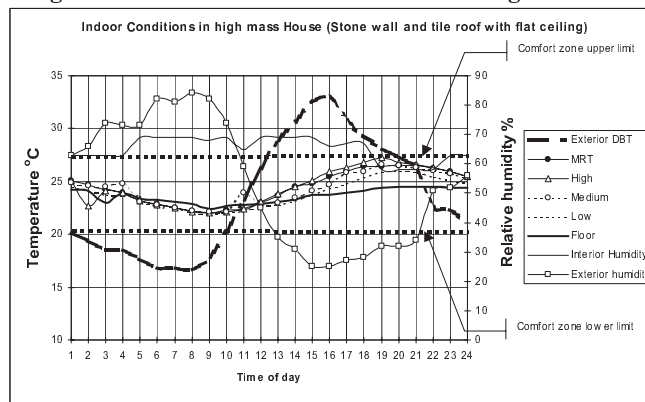

Figure 2: Conditions in a high mass building in Nairobi

3. ANALYSIS AND DISCUSSION

3.1. Proposal for thermal comfort studies (Questionnaires)

To fully determine the thermal comfort conditions in a given environment, there are a number of questions that should be administered to correct “adaptive errors” that account for the discrepancy between observed comfort temperatures from field studies and predicted comfort temperatures from climate chamber experiments. Five questions from previous studies that need to be asked are:

1. How do you feel about the thermal environment in this room?
2. Is the present environment acceptable?

3. Would you prefer some mechanical ventilation and air-conditioning?
4. What personal adjustment(s) have you made to yourself or to the room?
5. At the present moment would you like more, less, or no change in the level of air movement in this room?

These questions may be administered half hourly alongside the process of taking accurate measurements of the thermal environment. Tables 6-10 are an example for a proposed layout for a trial example of a 3-hour period. The tables are formulated using current technical literature and anecdotal evidence.

Table 6: How do you feel about the thermal environment in this room?

Thermal Sensation	Vote	Hour					
		½	1	1½	2	2½	3
<i>Hot</i>	+3						
<i>Warm</i>	+2						
<i>Slightly warm</i>	+1						
<i>Neutral</i>	±0						
<i>Slightly cool</i>	-1						
<i>Cool</i>	-2						
<i>Cold</i>	-3						

Table 7: Is the present thermal environment acceptable?

Response	Score	Hour					
		½	1	1½	2	2½	3
<i>Yes</i>	1						
<i>No</i>	0						

Table 8: Would you prefer some mechanical ventilation and air-conditioning?

Response	Score	Hour					
		½	1	1½	2	2½	3
<i>Cooler</i>	-1						
<i>None</i>	0						
<i>Warmer</i>	1						

Table 9: What personal adjustment(s) have you made to yourself or to the room?

Response	Score Range	Hour					
		½	1	1½	2	2½	3
<i>Clothing</i>	1 to 10						
<i>Activity</i>	1 to 10						
<i>Posture</i>	1 to 10						
<i>Eat/drink</i>	1 to 10						
<i>Moved</i>	1 to 10						
<i>Heat/cool</i>	1 to 10						
<i>Window</i>	1 to 10						

Table 10: At the present moment would you like more, less, or no change in the level of air movement in this room?

	Score	Hour					
		½	1	1½	2	2½	3
<i>Less air</i>	-1						
<i>No change</i>	0						
<i>More air</i>	+1						

The physical parameters that should be measured alongside the questionnaire include ambient air temperature, mean radiant temperature, air movement and humidity. The instruments should be accurate enough that meet specifications for accuracy and response times described by ISO *Standard 7726* and/or ANSI/ASHRAE *Standard 55-1992*, shown in Table 11.

Table 11: Measuring range and accuracy of instruments

Parameter	Measuring Range	Accuracy	Response Time (90%)
Dry Bulb Temperature	5-40°C (39-104°F)	±0.2°C (±0.4°F)	Appropriate
Wet Bulb Temperature	5-40°C (39-104°F)	±0.2°C (±0.4°F)	Appropriate
Mean Radiant Temperature	5-40°C (39-104°F)	±0.2°C (±0.4°F)	Appropriate
Air Speed	0.05-0.5 m/s (10-100 fpm)	±0.5°C (±1.0°F)	1-10 seconds

The response time is the time to reach 90% of the final value with a step change.

Source: ANSI/ASHRAE *Standard 55-1992*

3.2. Observations from other studies

Thermal comfort is a complex phenomenon, which is influenced by several parameters: environmental (physical), personal and psychological. Two of the most common ways to quantitatively expressing thermal comfort and thermal sensation is Predicted Mean Vote (PMV) and Predicted Percent Dissatisfied (PPD) after Fanger (1970). However, there have been several field studies that do not agree with the results of this method, especially in passive solar buildings.

Several extensive field studies summarized by De Dear and Brager (1998) show that the PMV model works best in buildings that have HVAC systems. The studies also show that in naturally ventilated buildings (free running with no mechanical systems) people seem to adapt (behavioral, psychological) and can accept “higher indoor temperatures than predicted by the PMV model” (Olesen, 2000:44).

Givoni defined thermal comfort as “the range of climatic conditions considered comfortable and acceptable inside buildings. It implies an absence of any sensation of thermal (heat or cold) discomfort” (Givoni, 1998:3). In 1976 he developed the building bio-climatic chart to address the problems associated with the charts by Olgyay. It was based on indoor temperatures and suggested boundaries of the climatic conditions on the psychrometric chart within which various building design strategies (including passive and low energy cooling systems) could provide indoor comfort in hot climates without air-conditioning. The boundaries of acceptable conditions for still air are shown on the psychrometric chart in Figure 3. They were extended due to the effect of adaptive factors.

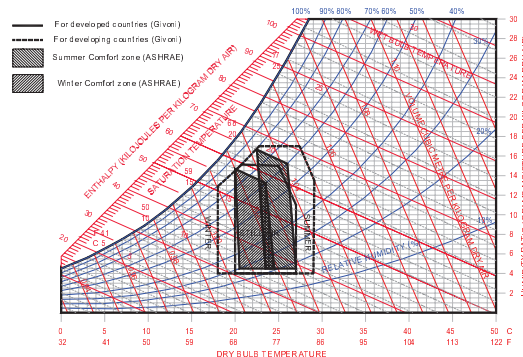

Figure 3: Boundaries of comfort conditions

Source: (Givoni, 1998: 38)

Brager and de Dear in 1996 noted that field studies show that the two most widely used thermal comfort standards (ISO *Standard 7730* and ASHRAE *Standard 55*) do not account for the effects of expectation, personal control and psychological adaptation. In fact, they discourage the use of naturally ventilated passive solar buildings because of the narrow band of comfort limits. Occupants in passive solar buildings have more relaxed expectations and can tolerate a wider temperature swing. On the other hand, occupants of air-conditioned buildings have a narrow rigid thermal environment and are more sensitive to thermal environments.

CONCLUSION

Thermal comfort in Nairobi or Chicago may offer insight on the fact people with different expectations, culture and history all require thermal comfort. Adaptive factors may be more easily visible in a low-tech society but even in industrialized countries, they offer an opportunity for modern usage. The universality hypothesis of comfort

temperatures based on ISO *Standard 7730* and ASHRAE *Standard 55-92* extrapolated as equally applicable to human beings around the world regardless of race, culture or climatic experience were the central theme of a strong argument made by Madhavi and Kumar (1996). Fanger in his work used a small group of “tropical travelers” winter swimmers and meat packers in two experiments in Copenhagen, Denmark, to derive the PMV. The sample size used was statistically too small and Auliciems succinctly put that: “It is not often realized that the claims of its universal applicability were based on remarkably limited and rather incompletely reported preference studies of only 16 travelers from Copenhagen and 32 Danes” (Auliciems, 1989:18). This article is a preparation for further research of thermal comfort in a new naturally-ventilated academic building (88,000ft²) to be completed in spring 2007 on the College campus.

ACKNOWLEDGEMENT

Author wishes to give many thanks to the staff, faculty and students of architecture at Judson College.

REFERENCES

- ANSI/ASHRAE. 1992. *Thermal Environmental Conditions for Human Occupancy ANSI/ASHRAE Standard 55-1992*. American Society of Heating, Ventilating and Air-conditioning Engineers, Inc.: Atlanta, GA.
- ANSI/ASHRAE. 2004. *Thermal Environmental Conditions for Human Occupancy ANSI/ASHRAE Standard 55-2004*. American Society of Heating, Ventilating and Air-conditioning Engineers, Inc.: Atlanta, GA.
- ASHRAE. 2005. *Handbook of Fundamentals*. American Society of Heating, Ventilating and Air-conditioning Engineers, Inc.: Atlanta, GA.
- Auliciems, A. 1989. *Thermal Comfort in Building Design and Human Performance* by N. C. Ruck (ed). Van Nostrand Reinhold: New York.
- Auliciems, A. and Richard de Dear. 1978. “Air conditioning in Australia, I. Human thermal factors”, in *Architectural Science Review* 29 (1978) 67-75.
- Baker, Nick and Mark Standeven. 1996. “Thermal Comfort in Free-Running Buildings” in *Energy and Buildings*, 23 (1996) 175-182.
- Brager, Gail Schiller. 2000. “A Standard for natural ventilation” in *ASHRAE Journal*, October 2000, page 21-27. American Society of Heating, Refrigerating and Air Conditioning Engineers Inc.: Atlanta GA.
- Brager, Gail S. and Richard J. de Dear. 1998. “Thermal adaptation in the built environment: a literature review” in *Energy and Buildings* 27 (1998) 83-96.
- Bunn, R. 1993. “Fanger: Face to face” in *Building Services*, June, 25-27, 1993.
- De Dear, R. and Brager, G. S. 1998. “Developing an adaptive model of thermal comfort and preference” in *ASHRAE Transactions* 104 (1).
- Fanger, P. O. 1967. “Calculation of thermal comfort: introduction of a basic comfort equation” in *ASHRAE Transactions* 73 (2): III.4.1.
- Fanger, P. O. 1970. *Thermal Comfort: Analysis and Applications in Environmental Engineering*. McGraw-Hill Book Company: New York
- Forwood, G. 1995. “What is thermal comfort in a naturally ventilated building?” in: Nicol, Humphreys, Sykes, Roaf (eds.) *Thermal Comfort*. London: E and F. N. Spon 1995, pp. 122-131.
- Givoni, Baruch. 1998. *Climate Considerations In Building And Urban Design*. John Wiley & Sons, New York
- Humphreys, Reverend Michael A. 1976. “Field Studies of thermal comfort compared and applied” in *Building Services Engineer*, 44, pp. 5-27
- Humphreys, Reverend Michael A. 1996. “Thermal comfort temperatures world-wide – The current position” in *Renewable Energy*, Vol. 8 Issues 1-5 May 1996, pp. 139-144.
- Humphreys, Reverend Michael A. 1975. “Field Studies of thermal comfort compared and applied”, *Building Research Establishment, Current Paper. CP 76/75*, Garston, Watford, UK.

Humphreys, Reverend Michael A. 1978. "Outdoor temperatures and comfort indoors" in *Building Research and Practice*, 62, pp. 92-105.

ISO 7730. 1994. *ISO Standard 7730: Moderate Thermal Environments – Determination of the PMV and PPD Indices and Specification of the Conditions for Thermal Comfort*. International Standards Organization: Geneva.

Karyono, Tri Harso. 2000. "Report on thermal comfort and building energy studies in Jakarta" in *Building and Environment* 35 (2000) 77-90.

Leaman, Adrian and Bill Bordass. 1999. "Productivity in buildings: the 'killer' variables", *Building Research & Information* (1999) 27 (1), 4-19.

Mahdavi, Ardeshir and Satish Kumar. 1996. Implications of indoor climate control for comfort, energy and environment in *Energy and Buildings*, 24 (1996) 167-177. Elsevier Science Limited: Amsterdam

McIntyre, D. A. 1980. "Design requirements for a comfortable environment" in *Bio-engineering, Thermal Physiology and Comfort* by K. Cena, J. A. Clark (eds), pp. 157-168.

Milne, G. R. 1995. "The energy implications of a climate-based indoor air temperature standard" in *Standards for Thermal Comfort: Indoor air temperatures for the 21st century* pp. 182-189 by F. Nicol, M. Humphreys, O. Sykes and S. Roaf (eds). E & FN Spon: London.

Nicol, J. Fergus and Susan Roaf. 1996. "Pioneering new indoor temperature standards: the Pakistan project" in *Energy and Buildings*, 23 (1996) 169-174. . Elsevier Science Limited: Amsterdam

Ogoli, David Mwale. 2000. *Energy-efficiency and Comfort Conditions in Passive Solar Buildings at Equatorial High Altitudes, Ph.D. Dissertation*. University of Florida: Gainesville, FL.

Ogoli, David Mwale. 2002. "Predicting indoor temperatures in enclosed buildings with high thermal mass" in *Energy and Buildings*, 35 (2002) 851-862. Elsevier Science Limited: Amsterdam

Rohles, F. H. 1973. "The revised modal comfort envelope" in *ASHRAE Transactions* 79 (2):52.

Olesen, Bjarne W. 2000. "Guidelines for comfort" in *ASHRAE Journal Vol. 42, No. 8, August 2000*.

Paciuk, M. 1990. "The role of personal control of the environment in thermal comfort and satisfaction at the workplace, Coming of age" in *Environmental Design Research Association* pp. 303-312 by R. I. Selby, K. H. Anthony, J. Choi, B. Orland (eds.), Environmental Design Research Association: Oklahoma City, OK.

Raja, Iftikhar A., Fergus Nicol, Kathryn J. McCartney, Michael A. Humphreys. 2001. "Thermal Comfort: use of controls in naturally ventilated buildings" in *Energy and Buildings* 33 (2001) 235-244.

Rohles, F. H. 1980. "Temperature or temperament: a psychologist looks at thermal comfort" in *ASHRAE Transactions*, 86, 541-551.

Rohles, F. H. 1981. "Thermal comfort and strategies for energy conservation" in *Journal of Social Issues*, 37, 132-149.

Rohles, F. H. and R. G. Nevins. 1971. "The nature of thermal comfort for sedentary man" in *ASHRAE Transactions*, 77 (1) pp. 239-246, 1971.

Sharples, Steve and Albert Malama. 1997. "A thermal comfort field survey in the cool season of Zambia" in *Building and Environment*, Vol. 32, No. 3, pp. 237 – 243, 1997. Elsevier Science Limited: Amsterdam.

Standeven, M. A. and Nick V. Baker. 1995. "Comfort conditions in PASCOOL surveys" in *Standards for Thermal Comfort: Indoor air temperatures for the 21st century* pp. 161-168 by F. Nicol, M. Humphreys, O. Sykes and S. Roaf (eds). E & FN Spon: London.

Williams, R. N. 1995. "Field investigation of thermal comfort, environmental satisfaction and perceived controls levels in UK office buildings", *Healthy Buildings*.

The Green Church

Mark L. Gillem, PhD, AIA, AICP

University of Oregon, Eugene, Oregon, USA

ABSTRACT: If “green” is an environmental concept applicable to the design and construction of buildings and landscapes, then we should not limit the scope of the concept solely to the natural environment. Rather, we should include key “environments” in which designers operate, including the socio-cultural, political, and natural environments. In this paper, I present a case study in “green” design that expands the scope of the concept and recognizes the interrelationship between these multiple environments. Using recent construction and renovation on the campus of the First Presbyterian Church of Berkeley as the case, I show how these environments are mutually supportive. Moreover, I argue that if designers simply consider the natural environment, their laudable goals may never be realized. In the first part of the paper, I provide a background on the project and its physical and socio-cultural setting. Second, I discuss how the different “environments” were addressed in the planning and design of the project. I then introduce specific “green” strategies that were employed in the design of the new and renovated buildings. These include considering renovation as the first imperative, thinking holistically about the entire campus, and applying a simplified approach to “greening” the buildings. I conclude by offering suggestions for future designers interested in reducing the environmental impact of their buildings.

Keywords: Sustainability, Adaptive Reuse, Human Context

INTRODUCTION

“That has never happened here before,” exclaimed Mark Rhoades, a planner for the City of Berkeley. I pointed upwards and offered, “It must be help from above.”
“What do you mean?” he asked.
“Well Mark,” I replied. “This **is** a church project.”
“Then it must be a miracle,” he concluded.

The “miracle” he was referring to was the unanimous approval in the spring of 2002 by the City of Berkeley’s Zoning Adjustment Board of the application by First Presbyterian Church of Berkeley to expand their campus. The Board even approved the project on their consent calendar, which means there was not any discussion about the project – just a vote. The Board could do this because there was no public opposition to the project – only support, which is highly unusual in Berkeley. At over \$25 million, with two levels of underground parking, a 3,716 sm (40,000 sf) new building for offices, classrooms, a chapel, and a music room, and renovation of a 819.2 sm (8,818 sf) historic structure for classrooms and a counselling center, the project was one of the largest proposed in Berkeley at the time. Just two weeks before, at an earlier meeting of the Zoning Adjustment Board, the commissioners spent nearly two hours debating the merits of a proposal for a small restaurant. With that kind of scrutiny given to such a small project, the church was prepared for a lengthy final debate on their application. But the debate was not needed. The church submitted a project that was designed with respect to the needs and desires of the church membership and the larger community. The design also responded to the importance of the socio-cultural, political, and natural environments in which all buildings reside.

Established in Berkeley in 1878, the First Presbyterian Church has grown from a small congregation to what can now be considered a mega-church – a regional church with over 1,800 members. The church supports a wide array of ministries and requires a variety of spaces to meet its mission needs. Rapid growth in the late 1990s spurred thinking about expansion and led to the goal of accommodating 2,500 members. This growth goal led to a long and arduous design process that eventually resulted in the proposal approved by the Zoning Adjustment Board.

1. PROJECT BACKGROUND

1.1. The First Proposal: A \$300,000 Lost Design Effort

In late 1990s, the church hired a design firm to help plan for the needed expansion. The designers coordinated visioning sessions with the congregation, conducted public workshops, and developed alternatives for the church to consider. While this was a textbook example of a participatory process, the outcome was less than ideal. The final design was largely unbuildable. It exceeded the church's budget by \$20 million. Given the proposed new building's 5-story height (3 is allowed in the zone) and excessive lot coverage, it would have required numerous variances from city zoning regulations that would likely not have been approved. It relied on air conditioning and it called for a design that one church member described as a "prison." Over 50% of the offices did not have windows, internal corridors were narrow and dark, classrooms were all nearly the same size (thus limiting flexibility), the ground floor was cut off from the public realm by fencing that separated child-care play areas from the street, and some of the most public spaces were placed on the floor with the least public access – the fifth floor. As one member of the building committee reported, the focus of the first design team was on aesthetics at the expense of almost every other concern.

From the community's perspective, the project ignored a city-designated historic building on the property. The issue of the historic building was quite sensitive. Several years earlier, the church purchased the run-down McKinley Annex and intended to demolish it to make way for new construction. At the time of the purchase, the three-story wood frame building, which was built in 1906 as a schoolhouse, had several apartments and an activist group of tenants. Given that this was one of the last remaining examples of a shingle-clad schoolhouse in Berkeley (even though it was converted during World War II to housing), the City of Berkeley's Landmark Preservation Commission designated the building a Structure of Merit. The designation came on the eve of demolition, after the city had issued the church a demolition permit. Since the city issued a permit, the church believed they had a right to demolish the building, regardless of the last-minute designation of the building as an historic property. The city thought otherwise. The church sued the city and eventually won on appeal. The city had to pay the church's substantial legal fees and the church could demolish the building if an Environmental Impact Report (EIR) justified demolition. This requirement would be difficult to meet since the EIR process by law required public input and the public was not in the mood to let the church demolish the building. Hence, the designers of the first proposal felt justified in ignoring rather than demolishing the building and its troubled history. Without upgrades, many neighbors of the church knew the building would certainly fall into disrepair and, at some point, deteriorate past the point of saving. As a result of this approach, members of a local preservation group, the Berkeley Architectural Heritage Association, actively opposed the project.

Other neighborhood groups had their own concerns with the first proposal. Members of a local business group, the Telegraph Area Association, did not like the variances the church would need to request. In a way, asking for a variance from a planning regulation is like asking for a special favor. Some neighbors did not want to see a church get special treatment. And a group of University of California graduate planning students, calling themselves Students for a Livable Southside, did not approve of the design's inward focus and its oversized (at least in their minds) parking garage. They also believed that the designers failed to provide adequate public open space on the site. With opposition from these groups, the plan had little chance of approval.

Shortly before the congregation was to vote on the proposed plan, members of the church's building committee decided that it was in fact unbuildable, despite assurances to the contrary by the initial architect. After it became clear that the first design firm was unwilling to modify their proposal, the church abandoned the effort and embarked on a new design. Given that the church spent approximately \$300,000 with the first firm, this was not an easy decision to make.

1.2. The Revised Plan: A Campus not a Building

Fortunately, in the initial planning effort, the church developed a compelling vision for the project. Namely, the church wanted the campus to be "warm, welcoming, and inviting" to its own members and to the larger community. The church also wanted the buildings to represent the best approaches to environmental stewardship while meeting the space needs of the growing congregation. These two goals – compatibility and stewardship became the basis for the revised plan. The focus shifted from the design of one building to the design of an entire campus that could be developed over several phases as funds permitted.

Before developing the revised plan, the new concept design team first reprogrammed the project through a series of workshops and user interviews. The goal was to minimize the need for new construction and prioritize uses in order to develop an approach that did not rely on a five-story new building. Given that three-stories was the maximum allowable height for the zone, anything taller would require special approval from the city, which would be nearly impossible to obtain in Berkeley. Also, by shrinking the required new area, the church's \$25 million budget would be more attainable. The new concept design team also met with the neighborhood

opposition to identify their concerns. Historic preservationists wanted the historic building (McKinley Annex) renovated. Local business leaders did not support the church's request for significant variances. The students did not want the large parking garage initially proposed by the church, which accommodated over 250 cars. They felt this would encourage driving over alternative means of transportation. And they wanted the building to be designed in a way that would minimize its environmental impact while providing publicly accessible open space.

In reconsidering the design, the concept design team stressed to the church that the project should respond to these concerns and it should fit within its context while contributing to the larger neighborhood structure. The historic building should be renovated and incorporated into the overall campus design, the height of the new building (Geneva Hall) should not exceed three floors (Fig. 1), a significant publicly accessible plaza should be part of the design, and structured parking should be kept to a minimum. In terms of environmental stewardship, the design should, at a minimum, allow for passive cooling and heating, and abundant natural lighting.



Figure 1. Channing Way Elevation, First Presbyterian Church of Berkeley
Known as Geneva Hall, the new building (center in image above) respects the cornice line established by an existing University of California dormitory (left) and the church's existing sanctuary (right)
[model photo by Treve Johnson]

Throughout the redesign, communication with the neighborhood groups and the congregation was essential to ensure that all parties remained committed to the new direction. For the congregation, perhaps the most difficult part of the redesign was the renovation of the historic building. Many members were still bitter about the lawsuit and were unimpressed with the building's appearance. The 100-year old building was rather rundown and its backside faced the church property. To address this concern, the revised plan called for all new exterior materials to replace the deteriorated roofing and siding and, more significantly, the plan called for rotating the building 180 degrees so that its entry porch could face a new plaza on the church's property. For the preservationists, this rotation caused some displeasure. Some thought that if the church could rotate a historic building, then other owners of historic properties might want to do the same. But after numerous discussions, all parties agreed that rotating the building was in the best interest of the church and the building. Because of this collaborative process, where each party's goals were met in a way that still allowed for rather creative solutions, the three neighborhood groups that opposed the initial project wrote letters to the Zoning Board in favor of the revised plan. This support was essential. In the end, the congregation unanimously adopted the revised project and the Zoning Board unanimously approved the application. Construction commenced in the summer of 2003 and full occupancy occurred in 2006.

2. EXPANDING THE CONCEPT OF "ENVIRONMENTAL" DESIGN

2.1. Uncovering the Project's Multiple Environments

A building exists within a context that has no property lines. While needs of property owners must be accounted for, the owners must also realize that their projects have impacts beyond their property lines. These include visual, aesthetic, and environmental impacts. But if designers only consider the environment in its narrowest terms, in terms of energy use and material selection, they may run the risk of not getting anything built. In the public approval process for this project, these ideas carried little weight, even in a city as progressive as Berkeley. More important was the fit between the proposed project and its socio-cultural context.

If "green" is an environmental concept applicable to the design and construction of buildings and landscapes, then we should not limit the scope of the concept solely to the natural environment. Rather, we should include key "environments" in which designers operate, including the socio-cultural, political, and natural environments. In this project, the design team recognized that to be "green," the design must recognize the interrelationship between these multiple environments.

2.2. The Socio-Cultural Environment

It is quite helpful for designers to consider the larger environments within which they are working. Focusing on one at the expense of another will result in an unbalanced and perhaps unbuildable project. The socio-cultural environment is perhaps the most challenging. It includes the system of relationships, rules, and cultural practices that govern the complex network of individuals, families, coworkers, neighbors, and members of the larger community (Anderson and Carter, 1990). This systems approach recognizes that, like buildings, people do not exist in isolation. Rather, they operate within an interdependent structure. This systems approach also applies to the buildings built by every culture. Amos Rapoport's (1992) concept of "cultural landscapes" is relevant here. Landscapes, which encompass the built and natural environments, respond to cultural values and express societal rules governing spatial priorities and development practices. In light of this, if culture can be defined in part as the evolving and shared beliefs, attitudes, and practices of a group, then that culture is reflected in the shape of the built environment. For the church, their initial proposal did not reflect their stated and practiced cultural position, which stressed community and connectedness. In attempting to demolish the McKinley Annex, the church ignored the desires of the larger community, which was clearly expressed through the listing of the building as an historic structure. In proposing a building that was completely isolated from its setting -- surrounded by chain link fences and security walls -- the church did not respond to its practice of integrating with and being open to the surrounding community. In ignoring the rules of the community and nonchalantly claiming these rules could be waived, the church set itself up for failure -- failure to respect the results of the planning process in place in its chosen community.

In reworking the design, the first priority was to create a campus that respected the church's socio-cultural environment. Internally, this meant that the proposed construction respond to the needs and norms of the church membership. In practical terms, for example, this meant that adult classrooms be designed to accommodate a range of sizes that reflected generational differences in learning. The most senior members of the church met in large groups, Baby Boomers met in smaller seminar-like settings and members of "Generation X" wanted even smaller places where their tight-knit circles could meet and share the most private aspects of their lives. This also meant that the typical measures of building efficiency were largely irrelevant. An efficiency ratio of 70%, for example, was not a measure of success considering that non-program spaces in religious education buildings are where important informal education and social bonding occurs. This meant that rather than program for two meter wide corridors, main corridors should be at least four meters wide and function like rooms in their own right, with places to sit and access to natural light. This also meant that there should be significant new open spaces that complemented the existing structure of patios and courtyards. The existing patio, for instance, functions as an outdoor lobby and meeting room and capitalizes on Berkeley's mild weather. These outdoor rooms add to the capacity and programmatic flexibility of the church. That the first design failed to provide such a space was surprising given that many of the staff and members of the church placed such a space near the top of their prioritized list of needs.

Externally, creating a campus that respected the socio-cultural environment meant that the proposed construction must, at a minimum, be what one building committee member called a "good neighbor." It should fit into its environment rather than stand out. Again, from a practical standpoint, this meant, for instance, that the building should maintain the street wall height and build-to lines of its neighbors. Also, the campus plan should in some way account for the mid-block pedestrian crossing that previously existed on the site. And the new building should provide protection for the area's homeless population in a way that allows for some dignity in where they sleep. In reconsidering the master plan for the church, the new concept design team also had to internalize the Senior Pastor's belief that, "Buildings are not that important. What matters is what they allow us to accomplish." But these accomplishments, from weekly meals and medical care for the area's homeless to subsidized preschool for the area's workforce, require space -- and design matters in the making of this space.

2.3. The Political Environment

The making of this space is a political act. It requires making judgements about who gets the space, who pays for it, and who sets the rules for its design. In a place as contentious as Berkeley, this political environment can be an unknown environment for designers. As social scientist Diana DiNitto (1991: 7) argues, the political environment of policymaking "...arises out of the nature of the problems confronting society and over what, if anything should be done about them." If politics can be defined as who gets what, when, and how, (Lasswell, 1936) then architects are constantly operating within the political arena. Multiple competing perspectives often clash in the political arena. Unfortunately, architects are not well educated on the complexities and nuances of the political approval process. Rarely do studio instructors discuss the politics of design. Designers usually learn through on-the-job training, which is less than ideal. For First Presbyterian Church of Berkeley, the political environment was a particularly challenging one. In Berkeley, all development proposals are viewed with some disdain. And religious institutions receive extra scrutiny. At the same time the First Presbyterian Church was going through the planning process, another congregation in north Berkeley was trying to get their own plans approved. Their well-known architect ignored the stated concerns of the community and pressed forward with a

controversial design that generated significant opposition. Neighborhood groups formed to block the project. Yard signs sprouted around the city urging denial of the congregation's permit application. After considerable delay, the project was approved by one commission then denied by another. The project ended up on appeal to the city council. At council direction, the parties went through several rounds of negotiations and redesign before a permit was finally issued. This was an outcome the design team and pastoral staff at First Presbyterian Church did not want. Fortunately, the collaborative process that brought First Presbyterian Church's political opponents into the design effort succeeded in creating a supportive political environment. There were no yard signs.

The political environment within the church was also a challenging one. Specifically, many members of the congregation did not want to spend any money on renovating the McKinley Annex. Several prominent members strenuously opposed removing a significant tree on the site, which was unfortunately in the way of construction. Other members wanted the budget devoted almost solely to building more parking. And there were members who simply could not justify spending so much money on construction when so many people around the world were in need of basic healthcare, food, and education. At one point, the Senior Pastor, Mark Labberton, reminded the design team that one main reason churches split is over construction projects. With dozens of committees and hundreds of constituents, this was a real possibility. Throughout the programming and design process, all of these constituents had to be heard, informed of the progress, and at times educated on the decision-making process and outcomes.

2.4. The Natural Environment

The natural environment is perhaps the easiest one to deal with in the design process. Architects are typically well educated in ways buildings should respond to climate and the environment. Moreover, many of the strategies employed by architects are not controversial and receive little notice. Numerous reference books exist that can guide the design process. In this case, G.Z. Brown's (2000) *Sun, Wind, and Light* was especially helpful. Deep overhangs that shade south elevations, recessed windows that block direct summer sun, narrow wings that allow light in on multiple sides, thick walls that accommodate ample insulation, and operable windows that support natural ventilation are common sense approaches to designing "green" buildings. For this project, the design team also benefited from the City of Berkeley's Green Building program, which provided peer evaluation of the design and a compliance report that noted the project's successful features and offered recommendations for improvements. The report noted, for example, that Berkeley's mild weather makes the area ideal for applying passive heating, cooling, and ventilation techniques. Annually, the city has just 63 cooling degree days (cumulative number of degrees per year above 18.3°C) and 1,612 heating degree days (below 18.3°C).

3. "GREEN" STRATEGIES

3.1. The First Imperative: Renovation

Before considering other strategies, designers and owners should look to renovation as the first "green" imperative. If a building's lifecycle can be extended, then the environmental and economic costs associated with demolition and the production of new materials can be avoided. For First Presbyterian Church, the 819.2 sm (8,818 sf) McKinley Annex (Fig. 2) and 5,253.3 sm (56,546 sf) Christian Education building were saved. Renovation of the former included bringing the old building up to California's strict energy, accessibility, and seismic standards. The only new building built as part of the project was Geneva Hall (Fig. 3).



Figures 2 (l) and 3 (r). McKinley Annex (left) and the new Geneva Hall (right)
The renovated annex defines one edge of the new plaza. Geneva Hall continues the street wall along Channing Way and provides arcades and a clearly defined tower marking the public entry into the plaza.
[photos by Treve Johnson]

Surprisingly, the cost for renovation was even 20% less than new construction. Moreover, the church was able to get a remarkable building, with large windows and 4-meter high ceilings. Although many members of the church were reluctant supporters of renovating McKinley Annex, now that it is in use the benefits are clear. One occupant who did not want to move from her old windowless counselling rooms, now raves about her light filled offices and said, “We’ve been counselling all these years in the dark and didn’t even realize it. Now we’re in the light, physically and spiritually” (Hedlund, 2006).

3.2. A Campus Approach to Green Design

The existing campus had three buildings, a surface parking lot, a little used courtyard, and a rather attractive patio that fronted the sanctuary. Little tied the buildings together other than a few walkways. The disconnected nature of the campus led the church to think of the buildings in isolation. The members considered McKinley Annex worthless and a candidate for demolition. Some saw the existing sanctuary as a glass-walled jewel that should stand alone. In addition, the existing education building (Westminster Hall) was, according to the first architect, too old to efficiently bring up to current seismic standards. However, once the new concept design team showed a sketch that used a large new plaza to link the three existing buildings with the new education and administration building, many in the church began to see the value in creating a real campus – a place where buildings shape outdoor rooms, where walks are direct and comfortable, and where landscaping softens the edges (Fig 4). This led to a more integrated view of the individual buildings, which were now part of a whole ensemble. Rather than sit in isolation; the buildings could work together to create a walkable campus. In fact, all the buildings were needed to provide spatial definition to the campus. The widely supported plan (at least within the church) to demolish the McKinley Annex and Westminster Hall was taken off the table largely because of the campus approach to design.

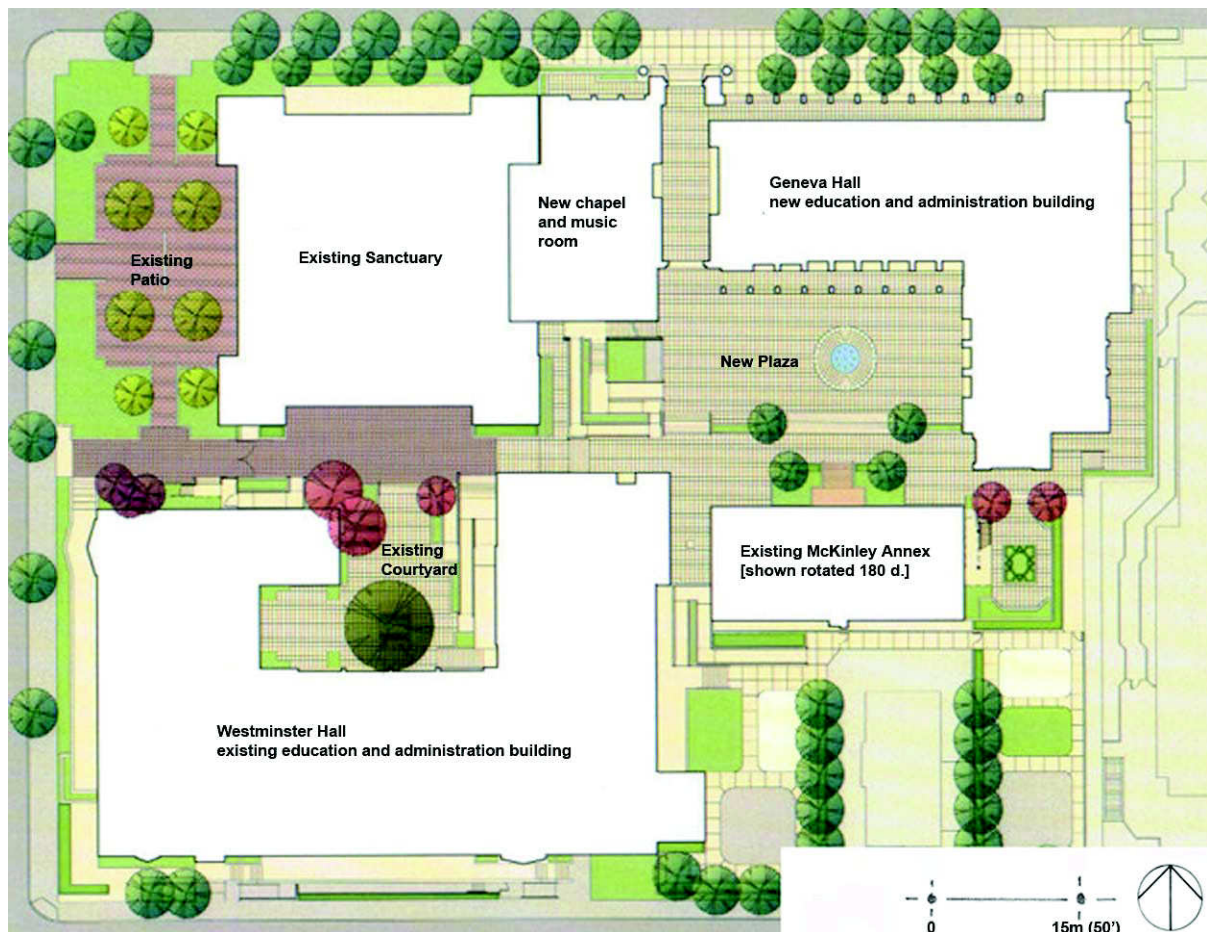

Figure 4. Campus Plan, First Presbyterian Church of Berkeley
 Geneva Hall's narrow wings and a renovated McKinley Annex help shape the new outdoor plaza.
 [image courtesy of First Presbyterian Church of Berkeley]

3.3. Greening the Buildings: A Simplified Approach

For the individual buildings, rather than rely on complex active systems, the concept design team focused on providing layouts that benefit from passive strategies for lighting, heating, and cooling. The first move was to narrow the new building substantially from the original design. Rather than design a 30-meter wide building, the new standard was for what architect Chris Alexander (1977) calls 'Wings of Light.' While not as narrow as Alexander's pattern, at 18 meters the new building's wings and internal glazing allow light to enter almost every space from two sides (Figure 5). This has a positive environmental and emotional effect. The overall layout and use of operable windows allows for passive ventilation and eliminates the need for air-conditioning. Using natural ventilation "...improves air quality, ensures good ventilation and saves both energy and money," according to Leon Glicksman, director of MIT's Building Technology Program (cited in Stauffer 2006: 1). Moreover, according to Nancy Stauffer of MIT's Laboratory for Energy and the Environment, studies have shown that people generally feel more comfortable in a naturally ventilated building than in an air-conditioned one (Stauffer 2006). It is unfortunate that few commercial buildings rely on natural ventilation. Even in Berkeley, two recently completed buildings with similar functions (i.e. education and administration) were built with fixed windows and a reliance on air conditioning. Perhaps too few building owners can tolerate the trade-off -- a greater internal temperature swing. Admittedly, the temperate climate of Berkeley certainly helps. Nevertheless, occupants still experience daily temperature swings of up to 4 degrees Celsius. Surprisingly, there have been few complaints on the office floor or in the classrooms about indoor temperatures either being too hot or too cold. This can be attributed in part to the fact that the occupants never became accustomed to the more exact temperatures available with air conditioning and to the fact that they can open or close the windows as needed, which gives occupants an important sense of control over their environments. If the occupants can accept more fluctuation in the interior temperature, the environmental benefits are substantial. With its natural ventilation, daylighting, and passive heating, using conservative measures, the revised plan saves an estimated 94,000 kWh per year, which translates into an annual estimated CO₂ emission reduction of 21,636 kilograms (47,700 pounds). This represents a 28% savings over the original plan. Over a 50-year period, this equates to savings of nearly 4.7 million kWh and nearly 1.1 million kilograms of CO₂ emissions.

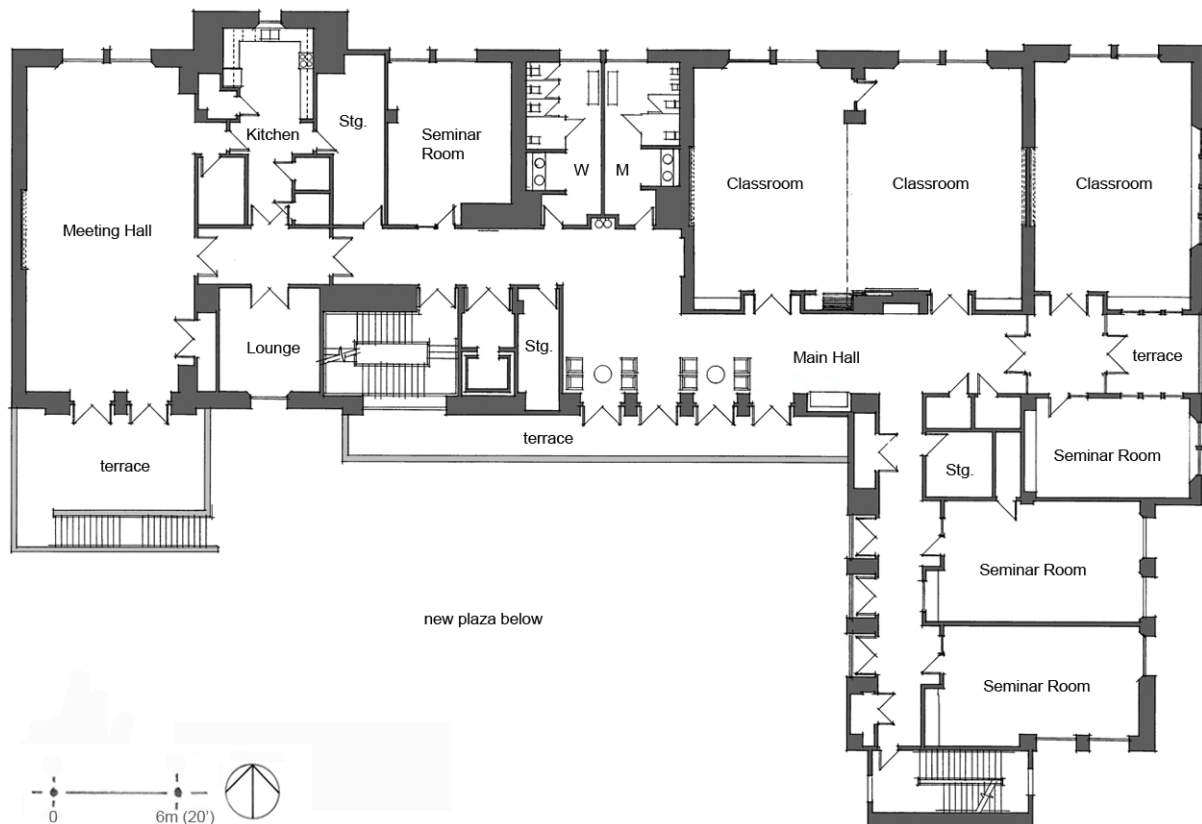

Figure 5. Second Floor Plan, Geneva Hall

The new building's narrow wings allow for light to enter two sides of every classroom, either directly through windows to the exterior, or indirectly through glass doors and sidelights. In addition, all occupied areas have windows, including the kitchen, stairways, corridors, and bathrooms. Small balconies and terraces on the south and west side connect the interior and exterior while shading the glazing below.

4. CONCLUSION

In this project, two architects had a very different understanding of the project. The original designers focused on aesthetic issues, not on issues of sustainability. While they did an admirable job of responding to the client's program needs in terms of space, they failed to validate those requirements against the limited budget or the site's contextual constraints. What emerged was an unbuildable project. The new concept design team reframed the design and encouraged the client to think of issues beyond space and aesthetics. The client needed to recognize that their 'community' extended beyond their property lines and understand that the site could not accommodate all of their desires, which led to a reprioritization of needs. The role of the designer is not simply to make an aesthetically-pleasing building, which in any case is highly subjective, nor should the designer simply meet the client's identified space needs. Rather, designers should collaborate with their clients to create designs that respond to the budget, mission and context (physical, political, cultural, and environmental).

The conference organizers asked participants to consider, 'What are the top ten, most important design moves that students should know how to do in order to design carbon neutral buildings?' While not overly technical, this case study provides students examples of numerous 'design moves.' Specifically, students should:

1. learn how to reuse buildings whenever possible,
2. design buildings with narrow wings to capture light on multiple sides,
3. layout primary rooms so that they have incoming natural light from at least two sides,
4. allow for natural light to access nearly every space – including lobbies, hallways, and bathrooms,
5. provide operable windows to allow for natural ventilation and user control,
6. add thermal mass where possible to capture solar gain and reduce heating demand,
7. include deep overhangs, arcades, and recessed windows to block the high summer sun,
8. avoid air-conditioning, and, if possible, avoid forced air systems all together,
9. make buildings so comfortable and flexible that future owners will avoid demolition, and
10. learn to operate within the socio-cultural, political, and natural environments.

While these concepts are hardly original, the disappointing fact remains that even newer buildings supporting similar uses are being built in Berkeley and around the country without following any of these points. A series of ten points and a well-intentioned process, like the one used by the initial architects, will not, by themselves, lead to green buildings. Designers must respect the socio-cultural environment and engage with the political environment in order to produce buildings that minimize our impact on the natural environment.

ACKNOWLEDGEMENTS

This author was the Concept Architect and Project Manager for the project and would like to acknowledge the work of the final Architect – ELS, and the members of the First Presbyterian Church's Facilities Task Force and Architecture and Engineering Committee. The author would especially like to thank Paul Berry and Jim Childers.

REFERENCES

- Alexander, Christopher, Sara Ishikawa, Murray Silverstein. 1977. *A Pattern Language: Towns, Buildings, Construction*. Oxford University Press: New York.
- Anderson, Ralph and Irl Carter. 1990. *Human Behavior and the Social Environment: A Social Systems Approach*. Aldine de Gruyter: New York.
- Brown, G.Z. and Mark Dekay. 2000. *Sun, Wind and Light: Architectural Design Strategies, 2nd Edition*. John Wiley and Sons: New York.
- DiNitto, Diana. 1991. *Social Welfare: Politics and Public Policy*. Prentice Hall: Englewood Cliffs, New Jersey.
- Hedlund, Sandi. 2006. Personal Interview.
- Lasswell, Harold. 1936. *Politics: Who Gets What, When, and How*. Free Press: New York.
- Rapoport, Amos. 1992. 'On Cultural Landscapes.' *Traditional Dwellings and Settlements Review* III, no. II: 33-47.
- Stauffer, Nancy. 2006. *Comfortable Buildings, Hold the Air Conditioning*. Laboratory for Energy and the Environment, Massachusetts Institute of Technology: Boston, MA. Available at <http://web.mit.edu/newsoffice/2006/buildings.html> [accessed January 3, 2007].

Environmental Studies of Vernacular Architecture

J. Brooke Harrington¹, Judith Bing²

¹Temple University, Philadelphia PA

²Drexel University, Philadelphia PA

ABSTRACT: The objective of this paper is to reveal vernacular building responses to environmental, cultural, social and economic issues present in a number of historic buildings and structures in the Balkans. The structures presented have been directly visited and analyzed by the authors over a number of visits and their roots and contexts discussed with regional and international scholars of the places presented. In the study of vernacular architecture, environmental contexts are always important factors yet the social and economic context are also major factors that often supersede what now may be emphasized as important for sustainable design responses. The structures selected include year-round dwellings as well as seasonal dwellings and economic buildings in a variety of geographic and climate settings. All of the places selected are in areas that were formerly part of the Socialist Republic of Yugoslavia and presently are in separate countries.

Keywords: vernacular, Balkan, wooden, dwellings

INTRODUCTION

In the study of vernacular architecture there are numerous approaches, each containing its own attributes as well as its own problems. In each there is a concern for environmental response that the builder has taken in design and building of residential, agricultural and ceremonial structures. In the writings of Amos Rapoport and Paul Oliver (who have contributed so much to the study of vernacular, indigenous and anonymous architecture) one finds agreement that the making of early and contemporary architecture that 'lack theoretical or aesthetic pretensions'ⁱ all exhibit responses to climatic issues. Disagreement arises in many scholarly studies as to whether the buildings that result are determined by climatological and basic issues or only influenced by these concerns within the broader context of people's belief systems, their security and economic means for survival. The most accurate approach demands that one recognizes the importance of climatological influences as important factors but not necessarily as primary determinants. This study explores and reveals the remnants of early vernacular and folk architecture in parts of former Yugoslavia and presents a number of examples that have survived in a variety of landscapes and climates in the mountains and plains of this area. The full scope of the study cannot be presented in this paper; however all of the sites included have been visited on numerous occasions by the authors, and interviews with local ethnographers, preservationists, architects and residents have been conducted and supplemented by secondary sources. The buildings presented are primarily made of wood and occur in areas that are now in Bosnia & Herzegovina, Croatia, FYSR Macedonia, Serbia, and Slovenia.

ZLATIBOR

In the Zlatibor Mountains of western Serbia, not far from the Serbian-Bosnian border, a small open air, ethnopark and museum have been established to exhibit the *national architecture* of the region, in a village known as Sirogojno. In 1988, preserved structures were still being relocated to this park, which was under the direction of the Institute for the Preservation of Natural and Cultural Monuments. The museum's director, Ranko Findrik, had spent a major part of his career, as an architect and preservationist, documentingⁱⁱ and preserving numerous buildings that dotted the Shumadija landscape. Zlatibor means golden or yellow pine and the forests contained a mix of these trees along with a variety of oaks. Most of the buildings present are yellow pine and range from ninety to one hundred and ninety years old. Today most people in the area are building concrete houses with cellular clay tile walls and cement plaster exteriors; in many cases the new buildings are built within several meters of the old wooden houses. The new stucco and concrete buildings are similar in plan and layout to those on the Adriatic coast and in Austria where many of the local men (or their sons) were able to find work as *guest workers* in Austria, Italy and Germany.

The *brvnara* (log cabins) of the region are actually carefully fabricated plank buildings that have been formed either with saws or adzes. Most of the buildings in Sirogojno were formed of planks cut at local sawmills driven by cascading streams. Typically the houses do not sit in isolation but within extended family compounds that reflect the structure of the society. The largest dwelling contains the hearth (in Serbo-Croatian *kuca*); the name *kuca* also is used to describe the individual dwelling and the family community. The organization of the community is patriarchal and dwelling buildings are added as the family expands. Separate wooden structures are included for the various functions that occur in this agricultural and animal husbandry economy.



Figure 1: Views of the *kuca* of Sirogojno, Serbia. Source: authors 1987

The focus of this paper will be on one central *kuca* that represents the ideal setting for a *kuca*. The building itself is located on the south facing slope of a mountain just below the crest to offer the best solar access while taking advantage of the pine trees and slope for protection from the cold winds of the north, typical of the continental climate of Southeastern Europe. The wooden portions of the building are set upon a field stone base that provides a full cellar height set into the slope and a stone foundation as a base wall for the main living area whose earthen floor is formed by digging back into the natural slope of the mountain. The long axis of the building is north-south and two entries occur for the living spaces, one on the east and one on the west. Cultural traditions designate the eastern door as the point of entry and the place where good things arrive; typically the bride is brought in through this door, along with foods for consumption are also and newborns. The western door traditionally is used to remove uneaten food, and when someone dies he or she is carried out the western door. These traditions are explained as direct symbolic connections to the rising and setting sun, the bringing of light and the coming of twilight and darkness. In this primarily Orthodox Christian area, the darkness of the dwelling is in harmony with the windowless and dark interiors of the Orthodox wooden chapels that still can be found in the landscape.

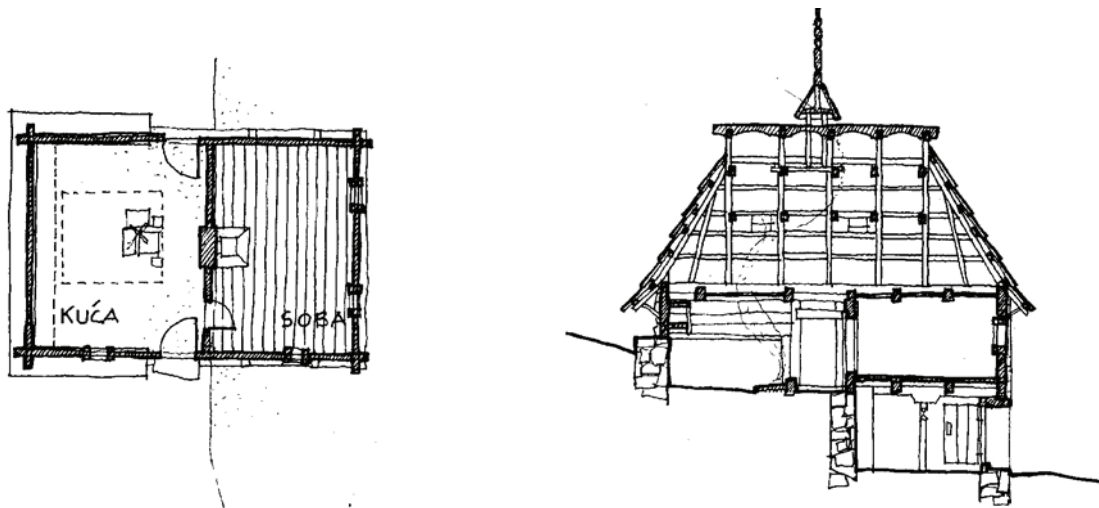

Figure 2: Plan & section of *kuca* at Sirogojno, Serbia. Source: Bing/Harrington 1994 (after Findrik)

The *podrum* (cellar) below is used as a root cellar and often contains the casks of plum brandy that are present in most rural communities where brandy is a traditional drink of the region. The main living area is divided into two areas, the earthen floor hearth area, and the enclosed *soba* (bedroom) area. The *soba* is formed by the perimeter walls, an interior plank wall that runs from east to west, a wooden floor (with the cellar below), a door to the *kuca*, and a wooden ceiling. Often only the *soba* has an opening in the exterior wall to allow daylight into the space. The roof of the *kuca* is a wooden, high-pitched, hipped roof with vents, and sometimes a cupola, for

the escape of smoke. The high pitch shed snows and within provides space above the hearth for racks to hang pots for cooking and thatched platforms to smoke meats. The roof is built of wooden trusses with purlins and *shindra* (shingles), and is extended over the walls for their protection. In some instances the ceiling above the *soba* is used as a loft for children to sleep but more often the earthen floor warmed by the hearth served as the primary sleeping area. In many mountainous areas of former Yugoslavia we found (in 1987-88 and 1991) that people were still living in this dwelling type with various modernization transformations. One final observation is that these buildings seem to survive when they are occupied. This may seem obvious, but the fact is that the preservation of the wooden roofs depends upon the smoke within to dry out the shingles and discourage infestation by destructive insects. One could surmise that a dwelling's survival depends upon its symbiotic relationship with the occupants.

BREST

On the land next to the oxbows of the Kupa River, before it joins the Sava River near Zagreb, is the village of Brest. In this region, architect and scholar Davor Salopek has spent much of his career documentingⁱⁱⁱ and seeking ways to preserve the traditional houses that exist in the *Korablja* region of Croatia. The climate in this region is humid and hot in the summer and damp and wet in the winter with snow occurring regularly. The properties along the river are typically formed with their narrow dimension to the river, and houses are built with their principal axes perpendicular to the river. Given the oxbow (switchback) nature of the river, this means that the solar orientation of the principal spaces sometimes requires inversion of the location of the stairs although the principal living space typically face the river. The *kuca jurinac*, shown here, represents one of four basic house types that Salopek identifies to represent the climate areas of the Croatian landscape (mountains, seashore, river and plains). This house sits on a site close to the Kupa River but behind levees built along the meandering river edge. The orientation is close to the idealized site orientation for this dwelling type with its principal axis north-south and entrance from the southeast side (more ideally the entrance would be on the southwest to serve as a buffer to the western summer sun). The ground level interior spaces hold animals, fowl and equipment and the upper level (first floor with loft) are used by the family. These buildings are constructed of logs and planks with pent-hipped, roofs of wood frame with clay tile shingles. The loft area of the roof was sometimes used for the storage of hay for animals. Most of the older buildings of the region are made of oak.

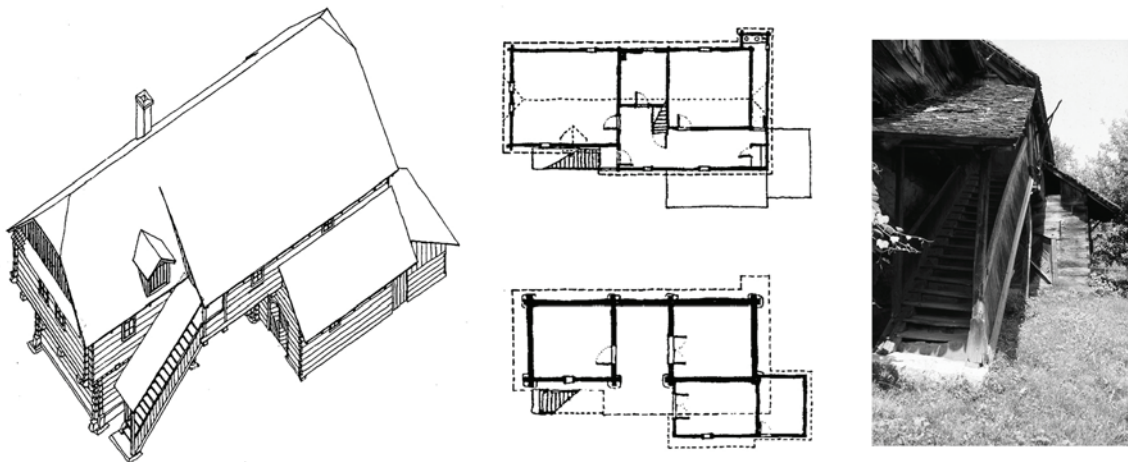

Figure 3: Drawings & photograph of the *kuca jurinac* at Brest, Croatia. Source: authors 1988

The *kuca jurinac* orientation places the exterior stair to the southeast leading to a corridor that runs along the same side of the building with a kitchen at the landing point, the main family room to the south end of the house and a bedroom to the north of the kitchen. An interior dry closet (toilet space) is located at the northwestern most point of the house.

The base of the dwelling is constructed using logs while the upper level is constructed using plank lumber. Where the Serbian mountain architecture had very few window openings (usually only one or two), these buildings contain multiple openings that are located to provide good ventilation and light for the interior spaces. Long beams run along the principal axis to support lighter crossbeams that allow the upper floor to cantilever beyond the base. The eaves typically project well beyond the walls to protect them from the rains and direct sun of the hot summers. The principal living space accommodates places for sitting, eating and sleeping. As one enters the door to this space, the corner for the family religious icons and the dining area are directly ahead; diagonally across from this is the hearth. The opening for the hearth is within the kitchen but the heating chamber is formed to serve as a heated bench and radiant object for use in the cold part of the year. As in other Slavic

countries and in Austria and Germany this element sometimes even has bedding placed on top of it to warm the occupants. The room to the north of the kitchen serves as a private room for the parents.

VELIKA PLANINA

In the Julian Alps of Slovenia, the high mountain pastures for cattle and goats have long served people and their animals as summer grazing areas. Huts were created there to protect both shepherds and their flocks from storms and wandering predators. These huts still serve a few for their original uses but most structures have been converted to weekend and summer retreats for people from the cities below who come for cooler weather, fresh air, magnificent vistas and hiking. The regional governments have created zoning and building regulations that demand that the building morphologies and construction maintain the traditional appearance and general detailing but these same regulations have produced a 'Disneyland' character that lessens the power of the authentic buildings of the pastures. Today one can take a funicular or follow the old winding shepherds path up to the plateau. Vehicles are not generally allowed on the plateau.



Figure 4: View of Velika Planina, Slovenia. Source: authors 1988

Dr. Tone Cevc, former Director of the Slovenian Institute of Science and Art, has been carefully studying the development of the various pasture dwellings of the high pastures and continues to research and document^v the ties between the patterns of animal husbandry of the Julian Alps and the dwellings that have evolved. One special building form that is most intriguing, and evolved into a special form, is the oval stone-based hut and shed structure. This structure combines the oval stone base, commonly used to corral animals, with a traditional square hut.

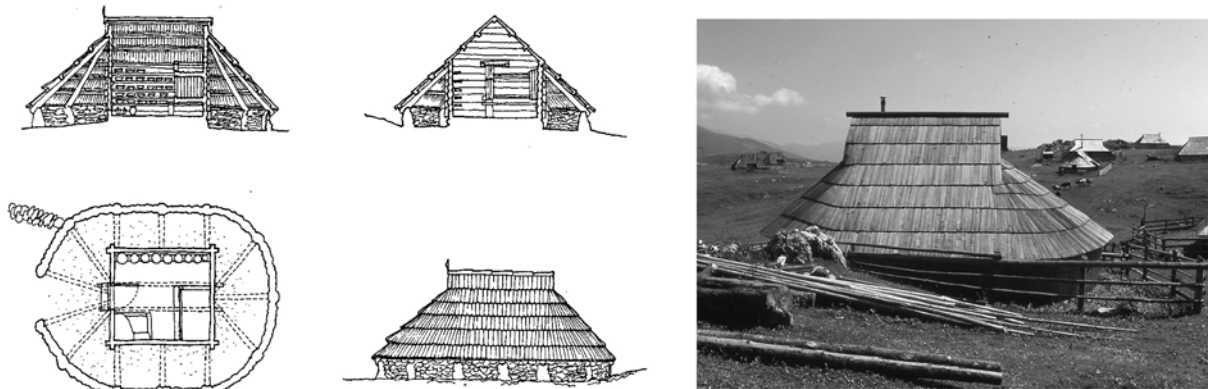

Figure 5: Drawings & photographs of pasture hut, Velika Planina, Slovenia. Source: authors (dwgs. after Cevc)

The traditional dry-set stone walls of the corral, which can also be found in the high mountains of Bosnia, are formed into ovals. These ovals are often formed of semi-circular ends with a center section of parallel walls. The entry is typically in one of the curved ends and has been found with lattice-structured wooden gates to close the entry. Within the oval is a small square (or rectangular) log or plank one room building that served as the sleeping quarters for the shepherd and storage for the aging of dairy products from the animals. The roof of the complex has a ridge that aligns with the long axis of the oval and extends just beyond the walls of the log enclosure. The roof surface is formed to extend beyond the log enclosure to cover the majority of the corral. The resulting roof form is a combination of straight and curved surfaces that creates a striking image in the high plateau landscape that exists just below and above the natural tree line of the mountains. The roof is made of

wooden rafters, purlins and shingles or planks. The wooden roofing is generally formed of elements that are set slightly askew from the slope of the roof to aid in preventing water from entering roofing seams.

The complex enclosure serves as a secure place for the animals, while their heat serves as a furnace to heat the shepherd in the cabin, and the cabin serves as a place to storage the valuable cheeses and other produce that the high pastures yield. Often the weather does not break until well into late May or early June to allow the pastures to be used effectively. But since the pastures have access to the late summer sun they can provide grazing when the valleys below are in the shade of the Julian Alp mountaintops. A few churches now exist on Velika Planina as an indication of the changing uses and new wooden fences occur on the broad landscape that that are further transforming this high plateau.

TETEVO

In the western district of the Former Social Republic of Yugoslavia Macedonia, is the town of Tetevo. It has been an important center for the Islamic population of Macedonia for over two hundred years and is the site of an impressive Arabati Baba Teke (Muslim monastery). This complex of several buildings has been preserved over the years and most recently has served as a heritage site and hotel. The monastery sits on the southeastern base of a Rudoka Panina of the Shar Planina on the edge of the modern town and is surrounded by a high stone wall that encompasses the complex. Although the compound contains many important ceremonial buildings, the most intriguing structure is a stone and wood structure built in the nineteenth century that adjoins the compound on the northeastern corner. This structure is a *kula* (tower) that beautifully combines the use of wood and masonry and includes a *chardak* space as the uppermost level. The author of this particular structure and its formal use remain in debate. Since it sits against, but outside of, the compound where the tombs of former religious dignitaries and the pavilion where the dervish monks performed their meditations and dances, it is thought to possibly be a dwelling for female members of the families of the holy men within the compound. One story indicates that it was built for the daughter of one pasha that was an important official of the *teke*. In any case the building has many compelling attributes.



Figure 6: Sketch & photographs of the *kula* at Arabati Baba Teke, Tetevo, FYR Macedonia. Source: authors

Tetevo sits just above the midpoint of a valley at the foot of the mountains and has rainy springs, hot and normally dry summers with cold winters. The *kula* has two interior levels. The base level is built of masonry and serves as a storage space that has been used keep goods (possibly also for animals at certain times). The upper level is constructed of stone and wood. Three of the faces of the upper level use large wooden panels that have operable sections (shutters) to open the entire interior to the views of the valley landscape. The northwest side, that faces the high mountains, is masonry and contains a built-in fireplace and chimney for the upper level occupants. On the three faces with wooden shutters, there is a stucco plaster frieze that contains oval openings to admit light. Each of these oval openings is surrounded by painted designs to accentuate the openings. The shuttered openings are constructed so that the upper leaf of each opening swings up and is supported to hold the it horizontal as a sunshade while the lower leaf serves as a backrest for those seated within. The openings of the *kula* allow views to the valley, the garden spaces of the *teke* compound, and the dervish pavilion. The wood structure of the roof is covered with clay tiles. The strong winds in this region demand heavy roof materials to combat the strong winds; often stones are added to the roof surfaces as ballast. An external stairway, typical of *kulas*, and is formed of a plinth of stone steps on the southeastern face that culminates in a landing from which a second run of steps, these of wood, rise along the northeastern face of the *kula* to arrive at a small wooden cantilevered landing outside the entrance door.

The upper space is often referred to as a *chardak*, 'a place between heaven and earth'. *Chardaks* are found in various forms across the Balkans and in Turkey. The character of this space is a perfect place to work and relax since it provides a wonderful place in the spring, summer and fall to sit under cover to catch the breezes that

travel through the valley while receiving the low winter sun while blocking the colder mountain breezes and winds that come from the mountains to the northwest. The two levels of openings in the chardak provide multiple sources of light and the operable shutters and oval openings allow for good ventilation of the space. This would seem to be an ideal place for either young dervish travelers to gather for teachings, or for women and children to gather to perform their daily chores.

MOSTAR

In Herzegovina, Mostar is the largest city and known for its famous four hundred and thirty year old Ottoman bridge, destroyed in the 1992-94 war. The town is located on the Neretva River in a valley about 40 miles from the Adriatic coast. Steep rocky mountains define the valley in which it sits and the hottest weather of Yugoslavia was consistently recorded in Mostar, often reaching 104°F in the day and over 85°F in the evenings. The city has a long history and grew along the Neretva River during the period when the Ottomans came into this part of Europe. The fabric of the old town (Stari Grad) is consistent with that of many oriental and Ottoman towns. The dense fabric of small courtyard houses is reached by narrow pedestrian paths that occur between the high walls that define the realm of each family's dwelling. The walls are built to define the house interiors but also form the courtyards where the families greet visitors, grow food and flowers and provide outdoor places for the family to live free from the eyes of their neighbors and strangers as is the tradition in many Muslim societies.

In Mostar the majority of the houses in the old town now belong to, or are occupied by, Muslim Bosnians who were caught in the fighting that left a substantial part of the old town uninhabitable. The old courtyard dwellings however are very well suited to the climate of Mostar. The typical courtyard house was built with its court formed to the south of the dwelling with the interior and covered spaces forming an L-shape to respond to the slope of the land and access to the sun. Since the Neretva River flows from north to south and steep mountains are on the east and west, the dwellings were formed to gather southern solar access and morning light if the dwelling was on the west and afternoon light if the dwelling was on the east side of the river. The steep slopes at the base of the mountains allow neighbors stepping back from the river to have good solar access above their down-slope neighbors. The daily winds that channel up the river in the morning and down the river in the evening aid in cooling the land that receives the sun with few showers during the summer months.

The typical dwelling was constructed of stone, clay or mud brick and wood. The dwelling was partially built into the mountain and the ground story typically was constructed of masonry with the raised story (first floor) built of timber frame with wattle & daub or lath with a thick plaster applied to the exterior and interior. The roofs typically provided broad eaves to shade the building from the summer sun and protect the exterior walls from seasonal rains and storms. Heavy stones (ploca) cover the roofs to resist the high winds of the winter.

The *Kajtazova kuca*, represented below, is an important house in the old town fabric. The house was originally built over three hundred years ago and has many of the characteristics that show the way people lived in a courtyard environment that responded to the cultural and natural patterns of the Neretva River valley.



Figure 7: Drawings & photograph of Kajtazova kuca, Mostar, BiH.

Source: authors (dwgs after A. Pasic)

The dwelling shown has two principal sectors that are divided by a two story wall that separates the places for family from the place for visitors. On the plans above, one can see the diagonal thick wall that separates the two realms on both floors. On the left is the realm of the family; it also includes the kitchen on the ground floor and access (on the far left, to the animal yard and orchard beyond). On the right, are rooms for meeting guests and business associates and rooms to socialize. On close inspection, one sees a single small opening on the upper floor; this is a point where food from the kitchen is passed through to those on the right. The broad overhang of the roof protects the closed and open parts of the house from the hot summer sun while allowing deep penetration of the low winter sun. The stone floor of the porch has a welcome feel as one sheds shoes to enter the dwelling in the summer and the enclosed spaces have wooden floors covered with carpeting and small samovars and fireplaces heat the interiors during the mild winter months.

As this is a very old house and the social settings have changed, the house as one family dwelling was split into two dwellings for two brothers who inherited the property. Over the years the part on the right was modernized a number of times and no longer retained its character in the 1980s. During the 1992 war, the right side was so badly damaged that its owner has pulled down the remaining parts and is building a new contemporary house for his family. The authors took the photograph above in 1988 but today the house still remains. The owners of the remaining dwelling still open their doors to visitors and offer rose water and allow travelers to spend time in their garden and house. Unfortunately the family has not been able to obtain funds for repair and restoration of this important Ottoman period dwelling, even though it is recognized as one of the four most important historic dwellings of the Old Town.

OBSERVATIONS / CONCLUSIONS

During 1987-88, the authors visited over four hundred villages^v in the former Yugoslavia seeking out examples of early wooden structures to better understand the complex formal and spatial attributes of the most interesting of these. The photographs and documents created in numerous cases are the only surviving comparative records of these buildings as the wars of the various regions have resulted in the destruction and decay of the structures. Even as new governments and historians rewrite the histories of the regions, folkloric genocide is occurring as dominant cultures either erase or reinterpret the meaning or significance of each building's attributes and importance. Any survey of buildings, can only serve as a snapshot of the present and past. The 30,000 kilometers of paved and unpaved roads traveled then are now in separate countries. The few examples briefly presented above demonstrate that the builders incorporated means to address the visceral requirements of life in the structures that were built. The longevity of each building studied gives proof that the decisions of building techniques and arrangements were sustainable for multiple generations of occupants. In fact the buildings, somewhat like the Stari Most (old bridge) in Mostar, outlived numerous societal, governmental and religious structures. And so in the end those decisions made to allow people to live in and care for the places they reside are those that allow the buildings to transcend their own times. One can see that many of the strategies that are being adopted today in order to address sustainable design approaches have been used for hundreds of years in the anonymous architecture of traditional societies and environments. As architects, we sometimes dwell too much on the formal aspects of design without looking more creatively for new or more sensitive ways to address all of the issues of architecture to insure that our buildings can sustain others who may come long after us. It is important for us to recognize the natural phenomena that surround us each day and respond to these in our designs for others.

ⁱ Description taken from *house form and culture* by Amos Rapoport, page 5, prentice Hall 1969

ⁱⁱ See the following books by Ranko Findrik: *Zlatiborska brvnara i muzej narodnog graditeljstva "staro celo" y Sirogojni*, 1987; *narodno neimarstvo*, 1994, *dinarska brvnara*, 1998; and *vajati znamenje mladosti*, 1999

ⁱⁱⁱ See the following book by Davor Salopek: *Arhitektura bez arhitekta*, 1974; and contributing author in *kuca, tradicionalna stambena*, 1978,

^{iv} See the following books by Dr. Tone Cevc: *Velika Planina*, 1987; *Bohinj in Njegove Planine*, 1992

^v In a recent review, our archives show that we have photographed at least one structure (dwelling, granary, chapel, church, mosque, watermill) in over 380 villages in Yugoslavia and at least an additional forty villages in the adjacent countries of Hungary, Austria, Bulgaria, Romania, Greece and Turkey during our studies.

Materials and Construction

Straw-Bale Eco-Center: Demonstrating How to Live Sustainably in the Midwest
Timothy Gray

The Design of Residential Building Skins—Solar Power and Structurally Insulated Panels
Joe Jamgochian and Franca Trubiano

Enabling Material Constraints in the Digital Design Process Through a Plywood Gridshell
Mark Cabrinha

In the Purple Palace: Environmentally Responsible Vocabulary for Materials and Construction*
Richard Hayes

Site Interface*
Laura Briggs

* Invited Oral Presentation

Straw-Bale Eco-Center: Demonstrating How to Live Sustainably in the Midwest

Timothy Gray; AIA, LEED AP

Ball State University, Muncie, IN

ABSTRACT: This paper presents a case study of a recently completed "Eco-Center", a student project intended to demonstrate how to live sustainably in the Midwest, reconnecting students and the community to sustainable relationships among buildings, sites, people and prosperity.

Phase one of this project was researched, designed, documented and constructed in the course of a single semester (Fall 2006) and resulted in the construction of one of the first load-bearing straw-bale structures in the region. This paper will discuss both the goals and the challenges of the project, provide a summary of decisions made through the design and construction of the project, and will conclude with a discussion of the lessons learned as well as the pedagogical merits (and shortcomings) of the process.



Figure 1: Eco-Center under construction sited at the south end of a restored prairie at the Cooper Field Station, Muncie, IN

DESIGN

The Straw Bale Eco-Center was conceived as the first built component of an environmental research facility envisioned for our University located in the Central Midwest. The project is sited at the south end of a restored prairie on a University "Field Station", an 80 acre parcel owned by the school but remote to campus. The first phase of the project was funded through an EPA P3 grant (with some local matching funds) and followed on a master plan for the property prepared by a colleague in the Department of Landscape Architecture in 2002 as well as a funded study prepared by a group of colleagues in 2004.¹ The project had three primary goals:

- To provide an immersive and comprehensive learning experience for the students involved in the project.
- To provide education and community outreach to promote awareness of and highlight issues relating to sustainable building practices while demonstrating a viable alternative to local conventions.
- To serve as an ongoing research facility.

The EPA funding for this project was confirmed only late in the summer and, as a condition of the grant the work needed to be complete by the following Spring (2007). This presented some logistical challenges within the school curriculum and as a result the class was offered as a three unit elective rather than a design studio. There was little time for preparation in advance of the class. We hit the ground running!

The class was composed of thirteen students, a mix of fourth year undergraduates and first year graduate students. In addition, fourteen third year architecture students enrolled in the design studio I was teaching at the time were involved in the project, the studio being structured to allow for a two week design charrette at the beginning of the semester and two weeks to participate in the construction at the semesters end. The contributions of the third year studio proved a key to the projects success.

From the outset the project was thought of in terms of two phases. Phase one would consist of researching, designing, permitting and building the project to the level of a watertight shell as well as documenting the sustainable features incorporated into the project. Phase two would consist of installing exterior claddings and finishes and completing the interior fit out of the building. In addition, site work would be completed in phase two including the construction of a series of integrated site systems. Phase one (the building shell) was to be completed by the semesters end with the relatively modest construction budget of \$9,000.

The third year students kicked off the design process working in teams to generate proposals for the building, finding their architectural expression in subtle design moves grounded in a creative manipulation of the building components. During this same period the elective class was broken into teams researching conventions of bale construction, sourcing and pricing local materials and researching the few local precedents we were able to find. At the end of this two week "burst" the elective class participated in the review of the third year student's proposals and used the third year work as a point of departure to synthesize and develop their own designs.

Parallel to these activities I was working with selected students from the group meeting with a variety of local officials (University Facilities Staff, County Building Department Inspectors, Property Governing Board, Bankers representing the Property Trust....) to both determine the approval process required for the project and to produce the necessary documentation to obtain these approvals within the framework of our very ambitious schedule. We were fortunate in that our plans were met in general with enthusiasm and support by all the parties involved. In addition, during this period members of the group solicited donations and matching funds for the project from a variety of sources.

As the design direction was narrowed student teams began sourcing straw and mocking up sections of the wall. Through hands-on experimentation students became familiar with the bale module, the behavior of the material and methods of pre-compressing the bales. This directly informed the design work going on in studio.

The final design was simplified as a result of the hands-on experimentation, the students exuberance grounded in a growing understanding of the behavior of the material and the realities of actually building the project. The main volume of the building is simply a rectangular room, room size and openings laid out on bale module and conforming to City of Austin, Texas Building Code requirements (there were no local codes available to help guide decisions) which were sourced from the web. This main volume was raised approximately 30" above finished grade on an insulated platform in response to poor drainage and potentially wet site conditions.

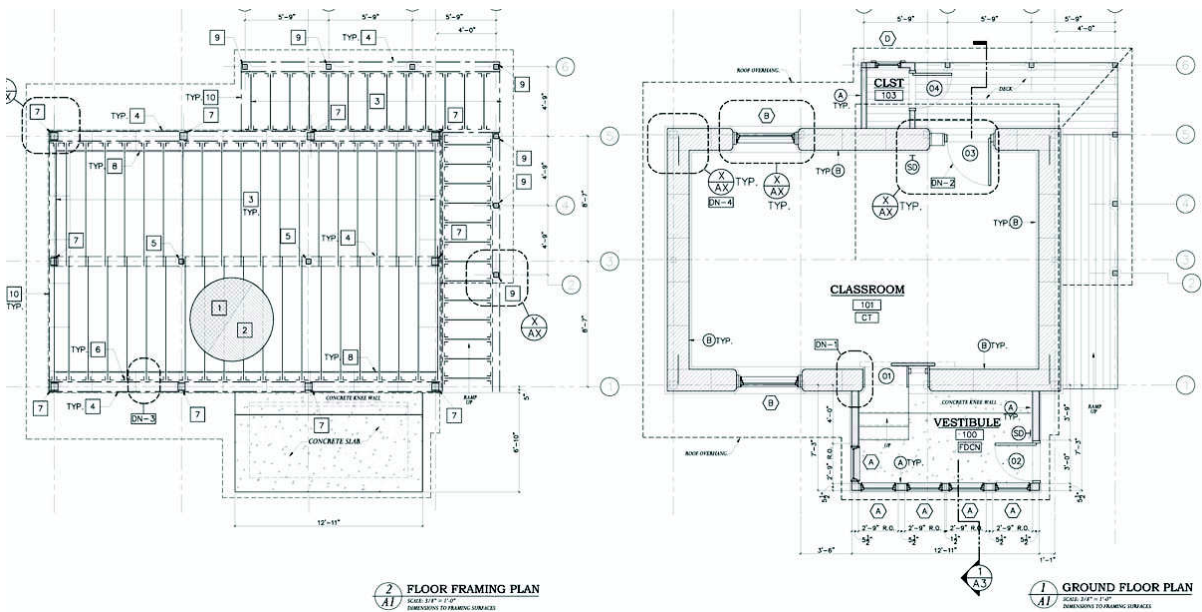

Figure 2: Floor framing and floor plan

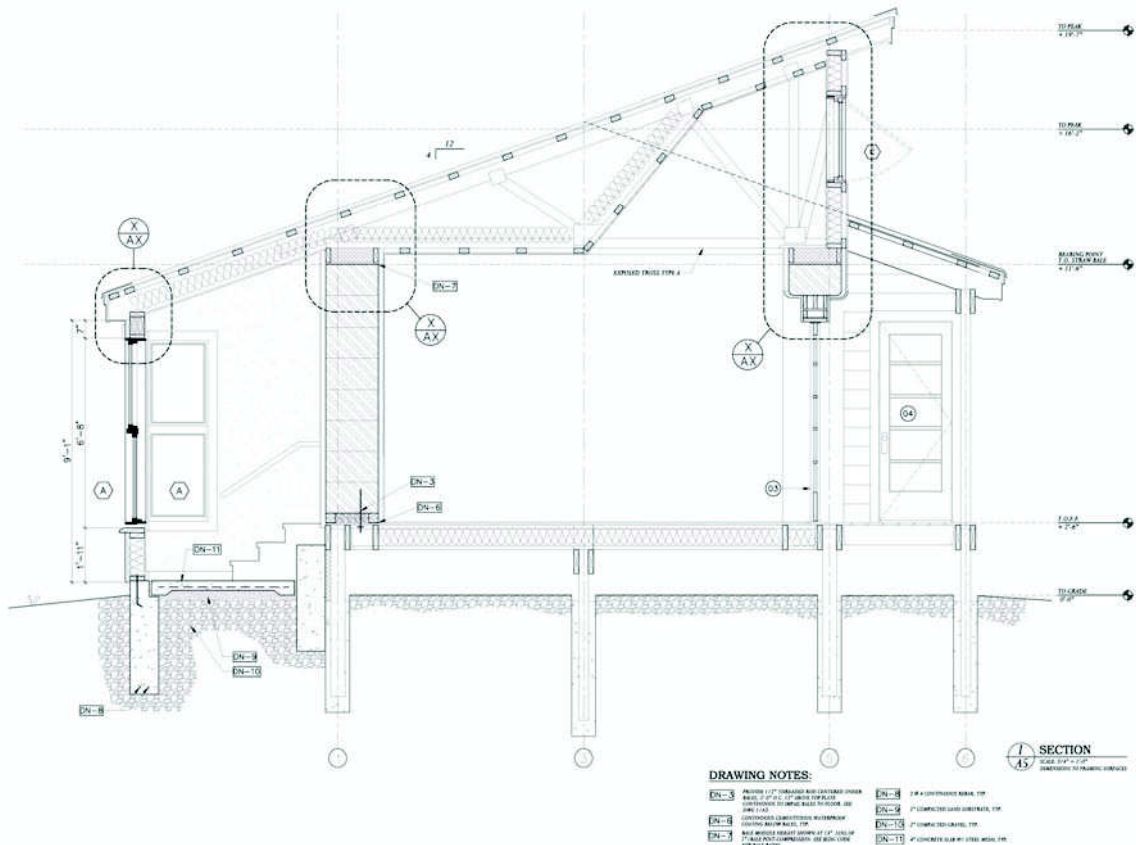

Figure 3: Section through the final design. (drawing by Dan Bajor)

Students researched, sourced and priced materials for the project, weighing material selections and methods of construction against our sustainable agenda; to educate both students and the community about how built sites can integrate with resource flows, promote sustainability and enhance quality of life. In addition to the use of straw-bale, some of the sustainable strategies employed include but are not limited to the following:

- Recycled content and locally sourced (and manufactured) materials including fly ash concrete, engineered lumber (LVL) for the primary deck rim joists supporting TJI floor joists, OSB decking and sheathing (where required), dry blown cellulose insulation. Finishes (phase II) are to include rapidly renewable resources such as bamboo flooring, and recycled content and durable materials such as wheat-board and cement fiber siding.
- Trusses composed of small scale (2x4) lumber with raised heel to allow continuous depth (continuous R- value) across the full width of the bale walls.
- Super insulated building envelope with passive entry / sun porch facing south. All windows in the conditioned space were double glazed vinyl windows, donated to the project. The central (straw-bale) room can be closed to the unconditioned sun porch to facilitate passive heating and cooling. If funding allows, photovoltaic panels will be installed in phase II.
- Numerous landscape features (phase II) including the installation of a cistern to capture roof water for use in irrigation systems, the development of living fences, wash water gardens and integrated water-wastewater-landscape-energy systems.
- “Smart” composting toilet (drying controlled by solid-state sensors and microchips); phase II.

CONSTRUCTION

A little over half way through the semester we had the necessary permits from the county, approvals from all responsible agencies and a design we were relatively confident we could build for our fixed budget.

We were ready to build!



Figures 4, 5: Ground break in mid-October (at last!); pouring the slab and footings of the entry porch with fly-ash concrete

There were a number of challenges that presented themselves through the course of construction, some foreseen and others not. We encountered our first significant challenge almost immediately on the day we met with the University Facilities Staff to schedule the groundbreaking (they had generously offered the use of some equipment to help with excavation). A change in staff since our initial meeting had resulted in a “new interpretation” of the applicable codes and it was now required that we get a building permit from the Office of the State Architect, a potentially higher hurdle! A considerable amount of drawing, scrambling and \$500 in fees later we obtained the necessary approval and were on our way having lost only one week to the mix up.

Our second big challenge came in the form of wet weather. The day after our groundbreaking it started to rain and marked the beginning of one of the wettest fall seasons on record for our area. Once the platform was framed we were thankful up out of the mud but also burdened with the task of keeping the jobsite dry at night. Using visquene and tarps we did manage to keep the assembly dry and even managed to survive a severe wind and driving rain storm toward the end of the project, but much of our collective energy went in to tarping and un-tarping the site. This was particularly challenging for students trying to squeeze two, three and four hour work shifts in between other classes and obligations. The students gained a first hand appreciation for the challenges of staging a construction project of even modest scale.



Figures 6, 7: Framing the platform with laminated veneer beams and truss joists, framing the roof trusses directly on the deck.



Figure 8: Erecting the bale walls; great lengths were taken to keep the materials dry through the course of construction.



Figure 9: Installing 2x10 “beam” on the flat at the top of the fourth bale course to stabilize the wall horizontally.



Figures 10-12: Installing the top plates on the bale walls; platform prepped to receive the bales; pre-compressing the bales;

Erecting the bale walls went relatively quickly and was a fun and energizing part of the process. The bales were pinned at the corners and tied together vertically with rebar pins. As the walls went up, however, we encountered a significant amount of lateral motion, particularly at the east and west ends which were not stiffened by door boxes. We knew from our mock-ups and our research that pre-compressing the walls would stiffen them considerably, however as a precaution we installed a 2x10 on the flat on top of the fourth bale course pinning it to the bales and bolting it to the door and window boxes (fig. 9). This acted as a lateral beam and stiffened the wall considerably.

Once the walls were complete the top plates were installed and the bales pre-compressed via cum-a-longs and ratcheting straps which were connected top eye bolts on each side of the base of the wall (fig. 12). 1 x 3 furring strips at 3' on center were screwed into the top and bottom plates to hold the bales in compression as well as acting as "hold downs" for the roof assembly.

Friends, colleagues and classmates were invited to the site for a "truss-raising" where the pre-assembled trusses were passed up and attached to the top plate. Over thirty people gathered on site for the event which, to my great pleasure, went according to plan (I did not tell the students that I had reserved a crane for the following morning just in case...). There was a great sense of shared community and accomplishment once the trusses were lifted into place.



Figure 13: the community "truss raising"

At the time of this writing the building currently sits with the bales wrapped in visquene for winter, awaiting an application of exterior sidings in the spring. An interdisciplinary group of students led by collaborator and colleague, Dr. John Motloch of the Department of Landscape Architecture is in the process of designing integrated site systems for the project which we hope to implement in the coming year (pending funding). In addition, the students are making proposals to monitor these integrated site systems; designing a program of base-lining, benchmarking and monitoring at key indicator stations, demonstrating the resource-balancing potentials of integrated built-site systems and regenerative technologies (i.e. greenhouses, rock-reed filter systems, wetlands, wastewater and wash water gardens and so on). These students are preparing boards to explain the sustainable features of the project to visitors and these will be displayed in the Eco Center when complete. The boards will document specific aspects of this project but also use the story of the Eco Center to frame a broader set of issues related to sustainable building practices in our region.

This process of recording and monitoring the performance of the eco-center has already begun with regard to the bales, a baseline reading of the moisture content of the bales has been taken at thirty points around the perimeter of the building and these points will continue to be monitored monthly, the results input to a spreadsheet which records changes. The behavior of the bales at different points (different exposures) around the perimeter and in response to different exterior sidings (earth plaster, corrugated plexiglas and cement fiber board) may suggest adaptations to the assembly in response to our local climate conditions.



LESSONS

At the time of this writing I am only three weeks removed from the whirlwind of constructing this project. Given this I admittedly may lack a degree of critical perspective relative to the (ongoing) project but also feel in some ways I benefit from the immediacy of the experience. My opinions and what I take away from this experience may continue to evolve with time.

With that said I would like to use the three goals identified at the outset of the paper as a lens to evaluate the projects successes and shortcomings.

With regard to providing an “immersive experience” for the students I think there were some significant shortcomings. The magnitude of the project relative to weight of the class (a three unit elective in the context of a typical 15 to 18 unit load for the students) was enormous, and the students had too many competing obligations, including the rigorous requirements of their design studios, to truly immerse in the experience. No one of the students could dedicate the time required to understand the critical path of events, secure the necessary permits, coordinate the purchase and delivery of materials, track the budget, coordinate schedules to keep crews running at the site, solve problems as they arose, adapt to setbacks caused by weather and schedule conflicts etc. As a result at times I felt that the only one truly immersed in the project was myself (at times to the point of drowning!). This had the unintended result of alienating some students who at times I’m sure felt that I was dictating the process, a bad cycle. Generating responsibility and commitment among the students and balancing the level of faculty involvement is a delicate formula which I am still working to refine.

My efforts to break the class into areas of “ownership” and responsibility were only marginally successful. The students did not self-organize effective lines of communication critical to pulling off a project of this scale on a tight schedule. In reflection I believe the project clearly demanded a greater block of the students academic schedule to truly immerse in the experience, allowing students to be guided by faculty input and critique but in the end responsible themselves for the product. I take responsibility for the structure of the class which in this case I believe was fundamentally problematic.

Despite these shortcomings I believe the learning experience overall was a very rich one for the students. First and foremost the project challenged the students to clearly marry their creative expression to a sustainable agenda while negotiating the complexities of budget, material and time. The project challenged the students to “invent the future on terms that are ecologically responsible”² and to find their own creative voice within that challenge. Students were asked to find their architecture in an intimate understanding of material, assembly and tectonics, areas of emphasis seldom successfully addressed in studio if addressed at all. I am confident that to a person, myself included, everyone involved in the project is excited and proud of our result. In this sense it could be argued that the end justifies the means. Many of the students commented individually to me that it was an incredibly rich learning experience for them which of course is very satisfying, and the student evaluations for the course were among the best I have received.

With regard to the second goal, education and community outreach, I believe time will tell if the project is truly successful in this regard however in my opinion it is off to a very promising start. The project has already generated a fair amount of attention in the media, including a TV spot on public television and significant coverage in the University, Muncie and Indianapolis press. Beginning next year, the Eco Center will be

included in a standing “nature tour” taken by most all Delaware County Elementary school children and will also be a feature destination at next years semi-annual “Greening of the Campus” conference at Ball State. We will be producing boards for display, a combination of graphic materials and text, to explain the center to visitors. We continue to try to raise awareness by promoting the project in the media, one of the challenges being to frame broader issues of sustainable development in the context of this modest project while trying to discourage media coverage focusing simply on the novelty of straw-bale construction, which is really only one small part of the story we want to tell.

With regard to the final goal, to serve as a vehicle for ongoing research, I believe the project is rich with potential although this work has really just begun. As previously described, we have already recorded a baseline measurement of the moisture content of the bales and are in the process of designing integrated site systems which include proposals for ongoing monitoring of the performance of these systems. Students are also in the process of preparing a LEED assessment of the building, identifying LEED criteria satisfied and providing required documentation where possible.

In addition, Dr. Motloch and selected students will be joining me traveling to Washington D.C. in the spring to present the results of this research at the annual EPA P3 conference at which time we will make our case to receive the next level of funding for the Center. To this end we are currently seeking research partners from across campus to use this facility to extend their research with the potential of obtaining funding for their proposed activities as part of our EPA proposal.

And finally, I share a broader vision for the eventual development of the site based on a master plan developed in 2002 by Professor Motloch, proposing the region’s first “Green Building and Green – Built “ site.³ Looking to such rich precedents such as the Center for Maximum Potential Building Systems in Texas or the Rocky Mountain Institute in Colorado, we share a vision where the buildings of our proposed Eco-Center are at once facilities to educate and stage research and innovative teaching / research projects in and of themselves.



Figure 16: The University community after taking part in the “truss raising”. Photo: Cheryl LeBlanc

- Notes:
- 1 “Field Station and Environmental Learning Center Strategic Planning and Charrette”, Badger, K., Brown, H., and Motloch, J., Funded by the National Science Foundation
 - 2 James Wines, 2000, Sustainable Architecture White Papers; “The Art of Architecture in the Age of Ecology”, Earth Pledge: NY
 - 3 “Resource-balancing Design for the Field Station and Environmental Education Center and LandLab: BSU’s First green – Building and Green – Built Site”, J. Motloch, Final Report for the 2001 -2002 CERES Fellowship, November 1, 2002

All photographs by the author unless otherwise noted

The Design of Residential Building Skins— Solar Power and Structurally Insulated Panels

Joe Jamgochian¹, Franca Trubiano¹

¹Georgia Institute of Technology, Atlanta, Georgia

ABSTRACT: The following paper addresses architectural design in the field of building materials and methods, particularly those which can positively contribute to the construction of sustainable environments. It attends to innovations in architectural building skins and the design research whose results are communicated herein was directed at discovering greener alternatives for the construction and operation of exterior walls; principally, those adopted in single family housing powered exclusively by solar technologies. To this end, the following paper will describe the development of an active, multi-functional wall assembly whose building integrated photovoltaic strategy supports the following range of properties; a high resistance to heat transmission, a rain screen, and a custom built system for the production of hot water.

Keywords: SIPs, rainscreen, photovoltaic

INTRODUCTION

The content of the following paper addresses architectural design research in the field of building materials and methods, particularly those which can positively contribute to the construction of sustainable environments. It attends to innovations in architectural building skins and the design research whose results are communicated herein was directed at discovering greener alternatives for the construction and operation of exterior walls; principally, those adopted in single family housing powered exclusively by solar technologies. To this end, the following paper will describe the development of an active, multi-functional wall assembly whose building integrated photovoltaic strategy supports the following range of properties; a high resistance to heat transmission, a rain screen, and a custom built system for the production of hot water.

The research and design methodology reflected in this report, jointly coauthored by studio instructor and graduate student at the Georgia Institute of Technology, promoted the integration of real and physical constraints within the pedagogical structure of the traditional design studio. It offered design students an opportunity to challenge accepted notions of what architectural design is and for proposing what it can be. Both undergraduate and graduate level students were encouraged to seek design solutions from within the professional field of building construction; an area of operations whose standard practices, whether in techniques of assembly, material integration or prototyping, can be studied with an eye to reinventing the nature of how architecture is taught. The highly determinate conditions under which building technology exists were design fodder for much invention throughout the studio's progress. Communication and collaboration with industry sponsors became an essential component of the process. Potential fabricators and suppliers of insulation, sheathing materials, and photovoltaic panels were carefully consulted with the merit of their various products and services assessed by students. This design process, which integrated a significant research component, offered the students analytical, objective and quantitative parameters within which to situate and evaluate their resulting architectural designs.

Governing this initiative to design a new exterior skin prototype for the residential housing market was the real-life imperative to construct and test the invention under rigorous conditions. As a participant to the Solar Decathlon 2007 Competition, a single family residence will be delivered to Washington DC in October 2007 which will physically incorporate the results of this research. The Competition is a venture of the College of Architecture, in collaboration with the College of Engineering, and its participants seek to build a fully operational residence whose needs for shelter will be met by its vertical enclosure. And in response to the competition brief, directed towards showcasing the benefits of solar technology, it was deemed of value to investigate the possibilities of integrating the use of sun power within the construction and operations of its exterior wall system.

Interest in facilitating the participation of the residential housing marketing in the greening of the building industry continues to be of the greatest concern. Continued attention must be brought to the growing depletion of non-renewable energies and the effects this has on the construction industry. Cultivating good ecological practices is a necessity of our age and conducting architectural research on innovative building materials and methods is more important than ever before. Investment in renewable energies such as wind power continues to grow at an impressive rate. *The Economist* noted in its story, "Tilting at Windmills" how greater amounts of money than ever before are now being introduced into clean technology sectors. And in the two years alone since 2004, venture capitalists have increased their investments in these sectors four fold (*The Economist* November 18th-24th, 2006).

The political necessity to invest in renewable energies is equally notable. In California, businesses and private parties have been offered subsidies to help finance the cost of purchasing the equipment and technologies needed for converting their energy uses to solar power, with wineries having been fairly successful in such conversions (*The Economist* November 18th-24th, 2006). In the end, and notwithstanding the economic benefits for doing so, all facets of the building sector would benefit from a realignment of its energy demands. Design research in our schools of architecture continues to offer an important avenue for the invention of ever more productive building applications and the wall/skin design whose details are offered here below is one such attempt.

1. THE PERFORMANCE OF EXTERIOR WALLS—BEYOND INSULATION

Standard construction practices are not necessarily the ideal model when seeking efficiencies in the use of materials or labor in the construction of a single family residence. What results is usually based on meeting the demands of local energy codes—which, in the United States, are substantially lower than what current technologies permit. This project addresses this condition by proposing alternative strategies for the design and construction of building components that make use of integrated building assemblies that can meet rigorous performance demands while providing an efficiency in both construction and operation.

The success of the exterior wall here designed is predicated on its capacity to be more than an insulating enclosure. Merely achieving a high resistance to heat transfer is insufficient for the purposes of this particular application. By examining the possibility of integrating within the wall assembly of a typical single family home both solar energy production and active building systems, an efficient system has been created using new materials and coupled building components. After researching structural insulated panels (SIPs), rainscreens and cavity wall construction, existing building integrated photovoltaic strategies, available and improvised solar hot water systems, and after making contact with industry representatives, a multi-functional exterior wall system has been designed that uses the potential inefficiencies of one system to the advantage of the other.

1.1. Structural insulated panels

Due to weight constraints (during the official Solar Decathlon Competition to be held in the month of October 2007 the house will be physically transported across a minimum of four states) and energy efficient measures inherent in the design problem, it was natural to begin this research by examining SIPs with regard to their material make-up and performance properties. SIPs are relatively new to the construction industry with only one percent of new homes built in the United States making use of them despite energy studies that prove SIPs are more airtight and energy efficient than traditional timber framing (Mullens 2006). While the unification of structure, insulation, and in some cases the exterior and interior finishes, is the goal of all SIPs, there are several different methods by which they are manufactured—each making use of different materials and resulting in different performance characteristics. The added structural benefit is that all panels in SIP construction are stressed when loaded; the outer sheathing in compression and tension while the core prevents buckling in shear (Cathcart 1998).

Several factors contribute to the reluctance of the home building industry to adopt this new method of construction for building envelopes including the general uncertainty which accompanies any changes in a proven model (Mullens 2006). Critics of SIP construction cite restraints on the design potential of the product due to the inherent modularity of the system. They also cite problems with joint details, uncertainty about the product's long-term performance, and what is perceived to be an inflated cost. Although SIPs are generally produced in either 4' x 8' panels or larger whole-wall panels, all of the different types of SIPs described in depth below offer the possibility of custom sized panels that allow for more flexibility in the design process than thought to be attainable when using standard timber framing. SIP manufacturers provide a variety of joint details, particular to the panels material composition, that eliminate thermal bridging and significantly reduce air infiltration. They reduce the number of seams required for both butt joints between SIPs and for connections to more typical building components. Because SIPs are manufactured in a controlled environment, the dimensions are more

precise and the overall quality of the material is higher than what is possible on a typical construction site where weather, coordination with other trades, and interpretation of drawings can reduce the quality of the finished construction. These characteristics make SIP construction prone to fewer problems throughout the life of a building since they not only have fewer joints but the joints that do exist provide for a tighter envelope. The entire assembly reduces the opportunity for water infiltration or air leakage that can cause building materials to decay and warp over time.

The cost of SIP construction is often cited as the primary deterrent preventing its widespread use. Material costs make the price of SIPs between 10 and 20% more expensive than comparable wood-frame construction, there are several other factors that influence the cost to both the building industry and the long-term homeowner. An experiment documented by the University of Central Florida Housing Construction Laboratory followed the construction of two similar Habitat for Humanity homes—one framed using traditional methods and one framed completely in SIPs (Mullens 2006). The number of labor hours, the amount of material waste, the necessary worker skill levels, issues of worker safety, and the general quality of workmanship were recorded for both building systems and analyzed yielding interesting results. The SIP construction saved about two-thirds of the required labor time, it produced less waste, required less skill, and generally resulted in a better quality building (Mullens 1996). While substantial results affecting worker safety did not emerge from this experiment, it did reveal that the building industry had the potential of achieving a cost efficiency through a reduction in labor and material waste.

Although SIPs have a higher initial cost, they also provide 30-50% more insulation. To achieve an equal amount of insulation using timber-framing construction would necessitate deeper dimensional wood members. This would invariably increase the cost of timber relative to that of SIPs. In regions with high labor and energy costs or in regions with extreme climate conditions, the higher insulation level of SIPs makes them all the more cost-effective (Cathcart 1998). In areas where the costs of energy, labor, or materials is high, the potential cost efficiency for the actual homeowner when using SIPs increases.

In the residential market, there are three main types of SIPs that are available. The most common type consists of oriented strand board (OSB) skins that are bonded to an expanded polystyrene insulation (EPS) core, available from numerous manufacturers around the country. This type of SIP generally offers a lower weight per square foot and a higher thermal resistance value than typical wood stud framing and has the potential to incorporate itself into the existing models of home construction due to its material composition.

A product known as Agriboard and produced in Kansas is a slight variation on the OSB/EPS SIP; it is constructed with the same type of OSB skins but the insulative core is made of compressed wheat straw, a waste by-product of the wheat industry. While this unique SIP allows for a stronger argument regarding the sustainability of its materials, it possesses a slightly lower thermal resistance at a weight that is nearly five times that of a typical OSB/EPS SIP—making it impractical for this design application.

An EPS insulated panel with galvanized steel studs has half of the weight per square foot compared to a panel of similar thickness and thermal resistance value composed of EPS insulation between faces of OSB. Reviewing the joint details that eliminate thermal bridging and in contact with the industry representative, the panel engineered by the ThermaSteel Corporation which operates out of Virginia, was assessed as exceeding our performance criteria in regards to thermal resistance and structural support for interior shelving and exterior cladding systems.

All of these types of SIPs require a cladding and this question of cladding is what ultimately led to the integration of building integrated photovoltaics on the facade—SIPs with integrated steel and aluminium cladding are available but pose issues with thermal bridging and water infiltration making them typically reserved for industrial applications.

1.2. Rainscreen principles in cladding design

When addressing the issue of cladding, looking at rainscreen and cavity wall construction was initially a way of expanding the possibilities for cladding the exterior of our SIP panels. This led however to a questioning of what materials could become the exterior skin of such a house. The basic problem addressed in rainscreen construction is that wall assemblies meant to be water-proof will leak in some capacity over the course of a building's life. As documented by others, the failures that lead to leakage of water through a building enclosure are often due to imprecise fabrication, poor installation of building components, decay and shifting of joints and sealants which come under constant exposure to solar radiation, driving rains, air and thermal movements natural to buildings in varying climates (Anderson 1988). All of these factors can contribute to water directly interacting with the assembly's vapor barrier and it is aspect of building physics which most often results in water

infiltration; a condition which residential building skins are not equipped to handle. In addition, once the water is trapped inside, this often leads to increase chances of mold build up, rot and decay of the cladding. A properly drained and back ventilated rainscreen wall is essentially designed to leak by managing the possible infiltration of water through proper drainage, pressure differentials, and ventilation. This design idea permits the wall assembly to breathe while reducing the direct impact of any possible water on the moisture barrier (Anderson 1988).

Research into various rainscreen assemblies demonstrates that provided a panelized system with properly dimensioned drainage, ventilation of the back cavity and with the use of cavity enclosures at the corners and ends of the system, what material could be specified for the skin itself was quite flexible (Anderson 1988). Given this fact, a number of prototypes were constructed in the design studio to understand the various arrays of skins and materials possible for our house. After modeling one-half scale mock-ups that examined several strategies for suspending aluminum tiles, the possibility of using photovoltaic (PV) modules in a rainscreen type construction was first considered (e.g. Fig. 1).



Figure 1: one-half scale model of preliminary rainscreen designs. Source: (Jamgochian 2006)

1.3. Building integrated photovoltaics (BIPV)

Skinning a building, particularly a house, with PV modules is not ordinarily thought of as a viable option. In part, this is due to a question of appearance but in part this is due to the reduced operating efficiency of the PV module when used vertically. And yet, there are architectural precedents for employing PV modules vertically on a façade, typically in skyscrapers and urban environments where the horizontal surface preferred for PV modules is at a premium. However, in most of these projects the PV modules are mounted on top of a wall assembly instead of being an integral component within it. Only in more recent projects, such as Fox and Fowle's design of the 4 Times Square building in New York City where custom PV modules designed by Kiss + Cathcart replace panes of glass on the Eastern and Southern facades, do PV modules become integrated fully into the design of the exterior wall assembly. As such, the ability for our Solar Decathlon design to incorporate an otherwise standard roof mounted PV panel within a vertical skin application yielding a larger total power draw for the house, offers architectural design an example of how to construct a building enclosure which integrates energy production with building construction.

BIPV products currently on the market include translucent glass embedded with solar cells, roof shingle replacements composed of solar cells on a backing, and flexible thin films of solar cells that can be incorporated into canopies, louvers, and more articulate building components. All of these products offer more flexibility in the incorporation of solar energy to building construction, however their energy conversion efficiencies are between 5-10%--extremely low by comparison to a 20% high efficiency PV module. The energy output required in this design demanded the use of full sized rigid PV modules, which made their integration one of the primary design challenges.

Integrating PVs into an assembly to replace a building component is one way that the relative cost of solar power can be reduced. When looked at in conjunction with projected trends of rising energy and building material costs, increased energy conversion efficiencies, and a reduction in the cost of PV modules themselves, building integrated solar power is becoming a more feasible option for the average homeowner. The full-scale mock-up

constructed in the design studio shows two different high-efficiency panels from SunPower Corporation and demonstrates how innovation in the design of the PV modules themselves has the potential to yield PV modules that can be integrated into a projects design aesthetic as well as its physical construction (e.g.Fig. 2).



Figure 2: Full scale mock-up of PVs mounted on SIPs. Source: (Jamgochian 2006)

The integration of PVs onto the façade required contacts within the solar energy industry. Speaking with consultants from One World, a solar installer located in Georgia, raised some issues that required further design detailing. PV modules become extremely hot during their operation. As the most efficient PV cells available today only convert 23% of the suns energy into usable electricity, there is a significant amount of radiation that becomes heat—creating temperatures in excess of 150 degrees Fahrenheit while ambient air temperature may be closer to 75 degrees Fahrenheit. This heat build-up substantially reduces a PV module's operating efficiency and mounting the PV module on the face of an insulated panel could trap this heat, only compounding the problem and reducing the energy conversion efficiency further (He 2005).

1.4. Hybrid photovoltaic and solar thermal collectors

Research from the Seventh International IBPSA Conference in 2001, informed the design by suggesting that the passive ventilation which was natural to rain screen principles would cool the air cavity by convective air-flow and in so doing lessen the effect of heat buildup on the PV modules—albeit not enough to obtain the maximum operating efficiency (Krauter 2001). As part of the experiments documented by (Krauter 2001), directly mounting PV's on an insulated enclosure served as the base condition by which different cooling methods were then evaluated. Passive ventilation through convective air-flow, active ventilation by the inclusion of electric fans, and the incorporation of a rubber mat that circulated water were all built to full scale and monitored during operation. In the experiment, the water cooling mat out performed the ventilation strategies, yet the energy that the water picked up as heat was not reclaimed in any way. Other research has demonstrated that it is possible and beneficial to tie a PV cooling system into a domestic hot water system but is not practical for commercial applications (Kalogirou 2006).

In this design, the rainscreen mounting of the PV modules will provide some cooling, but the final component of this wall assembly is a plumbing system whose primary role is cooling the PV modules so that their maximum operating efficiency can be achieved. It will also serve a secondary function as the heat extracted from the PV modules will be transferred to the domestic hot water system via a closed loop of a glycol solution.

Aside from evacuated tubes and flat plate collectors, there has not been much innovation within the building industry with regards to solar hot water systems. Since these typical products operate as standalone units that need direct exposure to the sun, they are not applicable in this design where the solar hot water system would be located within the ventilation cavity of the wall and behind the PV modules. Instead, a custom system using flexible PEX tubing, which is being used throughout the design of this house and is an alternate to polyvinyl chloride piping, will be detailed and constructed. This tubing will be adapted to suit the particular constraints of the wall assembly and will then be tied into a heat exchanger within the domestic hot water system.

CONCLUSION

In conclusion the status of this design is as follows; the wall assembly has been designed, detailed, and components of it have been built at one-half and full scale using the actual building products and materials specified (e.g. Fig. 1 and 2). The next phase in this research will be focused on fabrication of the entire system at full scale and on achieving an operating capacity so that testing of the systems performance with regards to PV electrical output, solar hot water output, ventilation of the assembly's cavity, and the structure of the assembly can be assessed and evaluated.

In addition, it is hoped that this paper has demonstrated the merit of introducing building construction constraints within the design studio. The project detailed here today, in which the design for an alternative building skin was engineered to meet the future demands of a more sustainably conscious residential housing market, is only one of many possible projects suited to this end. And a brief description of the process is here offered with the hope that an even greater number of such ventures will see the light of day in the near future.

ACKNOWLEDGEMENT

The authors of this paper would like to express thanks to OneWorld sustainable energy corporation, Alan Ristow, [Electrical engineering student], Mohamed-Amine Alami-Fettouhi [Electrical engineering student], Ajeet Rohatgi [Electrical engineering professor], Miroslav Begovic [Electrical engineering professor], C. Jason Mabry [Architecture student], Kevin Short [Architecture student], Nadine Kashlan [Architecture student], Jodi Bell-Quinn [Architecture student], and Ruchi Choudhary [Architecture professor].

REFERENCES

- Anderson, JM., and Gill, JR. 1988. *Rainscreen cladding: a guide to design principles and practice*. Butterworths: London.
- Cathcart, C. 1998. *SIPs, not studs*. Architecture.
- Economist, The. *Green dreams: the risky boom in the clean-energy business. Tilting at windmills and Dionysus, meet helios* 18th-24th, 2006.
- He, W., Chow, T., Ji, J., Lu, J., Pei, G., and Chan, L. 2005. *Hybrid photovoltaic and thermal solar-collector designed for natural circulation of water*. Elsevier, Ltd.
- Kalogirou, SA., Tripanagnostopoulos, Y. 2006. *Hybrid pv/t solar systems for domestic hot water and electricity production*. Elsevier, Ltd.
- Krauter, S., Salhi, M., Schroer, S., and Hannitsch, R. 2001. *New facade system consisting of combined photovoltaic and solar thermal generators with building insulation*. Seventh International IBPSA Conference.
- Mullens, M., and Arif, M. 2006. *Structural insulated panels: impact on the residential construction process*. *Journal of Construction Engineering and Management*.

Enabling Material Constraints in the Digital Design Process Through a Plywood Gridshell

Mark Cabrinha, RA

Rensselaer Polytechnic Institute, Troy, New York
University of Oregon, Eugene, Oregon

ABSTRACT: The motivation of this paper is to help bridge the gap between digital design culture and the culture of ecology. Through the context of a plywood gridshell, which encloses maximum volume with minimum material, form and structure are enabled by the constraints of material. The well-documented Downland Gridshell is used as precedence, outlining the principles of timber gridshells. The objectives of this research paper are to make explicit the principles relating material and geometry in the design and development of a plywood gridshell.

Keywords: CAD/CAM, digital fabrication, gridshells

INTRODUCTION

Over the last 15 years or so, digital design has emphasized formal novelty exemplified by the paperless studios in the early 90's. This formal novelty is largely the result of the lack of material and structural constraints in digital tools. Consequently, constraints are seen as a resistance to "pure design." The position of this paper is that constraints are enabling - the friction from which design develops its context. While accepting the formal flexibility brought on by digital tools, this research paper is concerned with enabling material and structural constraints in digital design through a plywood gridshell. Gridshells develop structural integrity through their double curvature and the bending strength of material. Gridshells provide an excellent context to exploit material and structural constraints as enabling design. Their expression of maximum effect with minimal means closely aligns them with one of the principles of sustainability – doing more with less. The motivation of this research is to help bridge the gap between digital design culture with the culture of sustainability. When constraints can be seen as productive, it is hoped that the flexibility and precision of digital tools will be well suited to the innovation of environmentally responsive design. The precedent, design, and development of a plywood gridshell provide the *context* to develop the principles of digital geometry in relation to material constraints.

My desire to pursue such structures developed from the current interest in computer-aided manufacture (CAM) in design education and practice. Despite the return to physical material as a result of these fabrication tools, they are typically used to cut complex shapes out of 2d material, or subtract 3d surfaces from a block of material. Both of these approaches are time intensive and create a lot of material waste. Developing a gridshell places emphasis on finding the form in the material, rather than cutting shape out of material. This, of course, is how gridshell's achieve maximum effect with minimal means. The simultaneous precision and flexibility of both software and computer numerically controlled (CNC) tools make pursuing such structures accessible, and alternately I would add, that pursuing such structures is necessary to better understand the productive capacity of material constraints before following the conventional uses of these technologies.

1. TOOL-DRIVEN DESIGN RESEARCH

Design research can be situated between the common "two-cultures" view of art and science (Cross 1999:7). This polarity between art and science is exemplified in the freedom of design expression exploited by digital tools and the structured research necessary to develop ecological design. Rather than encourage this false opposition between art and science, Nigel Cross's writing on design research focuses on design in its own terms, articulating knowledge that is peculiar to the awareness of the designer (Cross 1999: 5). He makes the important distinction between works of practice and works of research. While design is product driven, the product of design research is the communicable principles that others can use. Works of practice can generate works of research through the reflection of the practitioner and the communication of re-usable results from that reflection (Cross 1999:9). This distinction is crucial in this research, as the goal of this research is not to produce a gridshell structure, but rather the general relationship between material constraints and digital geometry that are teased out through the design and development of a gridshell.

Design, as in art and science, is produced through tools and the artifacts they produce. Tools and the

techniques developed in art can be used to aid in freedom of expression, whereas tools and the techniques used in science can be used for precision of measure. Situating design research as a field of inquiry in its own right likewise situates the relationship to tools as both expressive and for precision. This is not unique to design research. For example, the disciplinary strategy of experimental physics is to exploit materials through their tools and to locate these laboratory phenomena in a stable and repeatable way (Delanda 2002: 141). While design *process* is often aligned with art, it is the intention of *design research* to conjoin the expression of creative practice with the principles of this process in a stable and repeatable way. This only suggests the fundamental reciprocity between that favored false dichotomy of process and product. The notion of tool-driven research entails both the flexibility and expression of tools in the design *process*, along with the clearly articulated principles developed through their use, the *product* of research. Lawrence H. Summers, formerly the president of Harvard, has identified three qualities of tool-driven research: risk, accountability, and "interdisciplinarity". Risk is central to tool-driven research to tease out new possibilities and unexpected qualities. However, to qualify as research, systematic accountability is fundamental to identify the phenomena explored through these risks. As our tools become complex systems, such as the computer, research involves many people with overlapping goals and intentions and is therefore interdisciplinary in nature.

The few gridshells that have been built exemplify risk, accountability and interdisciplinary contribution. As a clear example of how a work of practice can develop into a work of research, the architects and engineers of the well celebrated Weald and Downland Gridshell have published research papers on this work (Harris et al 2003, Johnson 2006). As an exceptional example of the interdisciplinary nature of these structures, the collaborative design team included not only architects and engineers, but timber framers, scaffolding contractors, material scientists, and of course the client, were brought on early in the design phases of the project. As the project architect recalls, this was central to the "fluidity of thinking" which the primary material - wood - suggested (Johnson 2006). This project also exemplifies the connection between gridshell structures and sustainability. As one example, through the connective knowledge gathered through this project, the Timberbuild Network was formed to connect clients, builders, architects, and engineers around sustainable timber construction in the UK.

This research paper outlines briefly the precedence of gridshell construction. Through the design and development of a plywood gridshell, this research paper outlines the principle relationship between material and digital geometry as a means to enable material constraints in the digital design process.

2. PRECEDENCE: THE DOWNLAND GRIDSHELL

The first examples of gridshells were developed through the partnership of Architect Frei Otto and Engineers at Ove Arup, exemplified by the timber gridshell at Mannheim in Germany built in 1975. Although very few gridshells have been built, there has been a resurgence of these structures such as Shigeru Ban's Japanese Pavilion for Expo 2000 in Hannover, and Ville Hara's timber bubble at the Helsinki Zoo. The Downland Gridshell is another contemporary example that has been widely published. The architects and engineers of the Downland gridshell have published a thorough paper on the design and construction of this gridshell. (Harris et al 2003). They describe in detail the team working, risk sharing, and multidisciplinary nature of the design team along with the structural modeling, components, cladding, and complex construction process of gridshell forming. What is particularly risky and unique about these structures is that they are constructed as a flat mat and then lifted, or as the case of the Downland Gridshell, *lowered* taking their shape in this process. As a result, in the design and development of the Downland Gridshell physical models at multiple scales were used for form generation, as proof of construction concept, to highlight material behavior including "developing a feel" for the behavior of the structure, and were even used during construction altering the model in tandem with the actual lowering of the gridshell. From the physical models, the boundary conditions of the form were

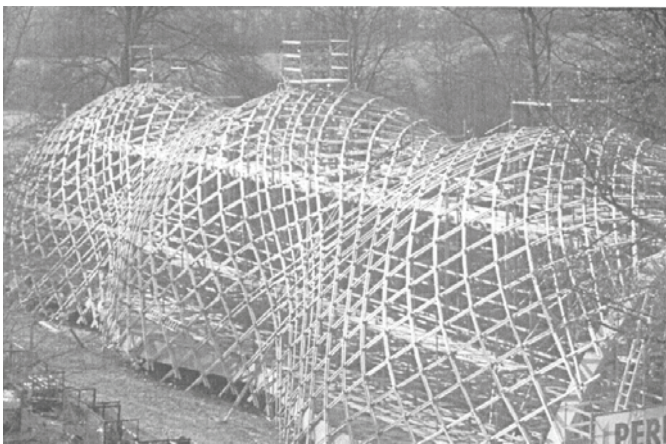

identified which was necessary to translate the material constraints into digital form. From these boundary conditions, a purpose built software program was written by the engineers to optimize this shape. This computer analysis was based on the dynamic relaxation technique - an interactive process of computer analysis that solves a set of non-linear equations. Not unlike the use of physical and digital models in the design and construction process, the Downland Gridshell exemplifies the combination of advanced technology and local craft based technique.

Figure 1: Weald and Downland Timber Gridshell being lowered into shape (Harris 2003).

2.1 Principle Definitions

A *shell* gains its strength and stiffness through curvature, with a shell formed from double curvature as the most efficient in terms of minimum use of material. A *gridshell* has large openings that allow the remaining openings to behave structurally as a shell. More typically, a gridshell is a grid arranged in such a way to have the properties of a shell. The benefits of a gridshell are that openings are easily created, the strips can be adjusted in dimension to adjust for local structural demands, and that pre-fabrication is possible. As timber is anisotropic, its strength changes in direction, no true shell is possible in timber. *Synclastic* surfaces are curved only in tension or only in compression. For example, an arch is formed using only compression, and a dome is a rotated arch. Geodesic domes are examples of synclastic shapes. *Anticlastic* surfaces have tension forces in one direction and compressive forces in the other stabilized by the tension forces. The significance of anticlastic surfaces is that they are more flexible in their formal morphology. As the designers of the Downland Gridshell acknowledge, shape is a compromise of many factors, not just structure, thus the flexibility of the gridshell can respond to both structural and architectural demands.

2.2 Materials and Construction

The Downland gridshell is constructed from a flat mat that is formed through the weight of the material pushing down to form the shape. The precise position of nodes in the grid mat develops the mat into the unique triple bulb hourglass shape (Figure 1). The patented nodes were purpose designed for this project to pin the center layers of the mat in position, while allowing the outer layers to travel as the structure took shape. The pin connection was necessary to allow the grid to rotate as the mat took shape. A complex articulating scaffolding system lowered this shape over 6 weeks. This is a clear example of finding the form in the material, as distinct from cutting shape out of material. The mat is composed of green Oak laths that are approximately 1.25" x 2". The high moisture content of the wood increased the lath's flexibility. The structure gains its strength and curvature through the laths ability bend, and therefore long sections of straight-grained material are desirable. In actuality, the short-grained sections were cut out and the longer straight-grained sections were finger jointed together, requiring a specially formulated polyurethane adhesive as a result of the high moisture content and acidity of the Oak. The mat construction, nodal connection, and lath material are critical factors in the construction of the gridshell.

3. PLYWOOD GRIDSHELL: TOOL-DRIVEN DESIGN RESEARCH

As a research project, the goal of developing a plywood gridshell is to outline the principles and issues that surface in the course of its development. This is motivated to help bridge the emphasis on formal novelty as a result of computer-generated surfaces with material and structural constraints. These constraints become enabling forces in gridshell design. In the same way that Nigel Cross identifies the "two cultures" view between art and science, it seems to me that digital design media fall prey to the same false opposition. The computer has been praised as a new expressive design medium, or it is used for exacting scientific research. The significance of this tool is that it is both – it is simultaneously a flexible medium and one of exacting precision. In my experience teaching in design education, the rigor of exacting precision is often ignored for emphasis on visual representation. Form making has become a focus as a result of the flexibility of Non-Uniform Rational B-Spline (NURBS) based software. However, in developing and constructing a plywood gridshell, shape is determinate on the precision of joints and material constraints more than simply the surface representation. As tool-driven research, this research project meets two of the three criteria Summers' outlines: risk and accountability. Regrettably, this paper lacks interdisciplinary input at this stage. My interest in these structures is clearly tool-driven through the current interest in CAD/CAM. However, my aim is that the gridshell is itself a pedagogical tool, whose products are the principles of shell structures and understanding material constraints as enabling, and whose further by-products are digital skills.

The design of this plywood gridshell was intended as a demonstration project that developed from a design build studio I taught. Students quickly developed form, and presumed that construction was a given despite my frequent consternation. Through the predilection of *visual* form in digital design, form is first developed and then frequently sliced, to then be cut from flat material to approximate the shape on the screen. As a result of the unique profiles of these shapes, material is wasted and furthermore the ability to understand the joint as a location of careful attention is overlooked. The gridshell provides an excellent context in the efficient use of material to achieve complex form generated by the fixed location of the joint. In contrast to the visual development of form, through the model making process in the Downland Gridshell, the form *and* structure is derived from the material properties of laths. In contrast to the visual criteria of *digital* form, this is truly *physical* form. It is ironic that the basis of contemporary NURBS design software is derived from the physical spline, which was based on material curvature.

3.1 Material and Technology: The 18th Century Spline

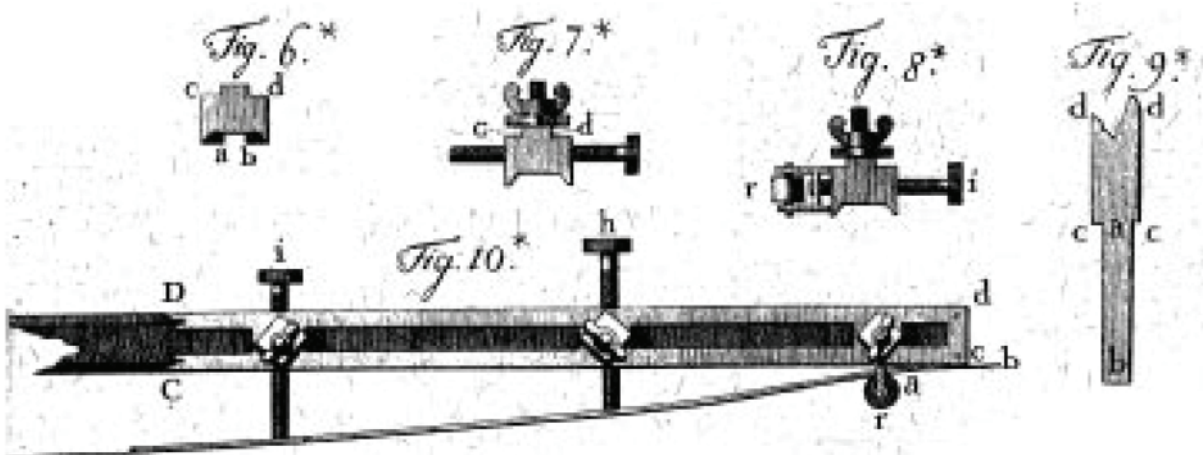

Figure 2: The 18th Century spline used in boat construction (Farin 2002).

The complexity of curves and wood is best understood by traditional boat building techniques. This can be seen in the 18th Century spline (Figure 2). This apparatus was used to draw curves in boat-design based on the material properties of the wood - a true analog device relating material curvature drawn to the curvature of the actual material constructed from. In the 1960's, mathematician engineers such as Pierre Bezier developed a parametric equation of splines abstracted from devices like the one shown. Furthermore, Bezier developed these mathematical techniques as a consequence of the use of computer-aided manufacture in car design and production (Bezier 1972). Bezier's goal was not simply to create a more efficient means of production, but to create a bi-directional link between parametric surface representation and material constraints (Bezier 1998). It is important to note the development of CAD is woven together with the development of CAM. In architecture, we are only recently seeing the material aspects of the CAD/CAM system. Consequently, the constraints of material and fabrication tools are only now becoming part of the digital design process. In relationship to timber gridshells, it is striking to me that the basic unit of NURBS-based geometry is derived from the physical spline – the ability of material to bend. It is with great irony that despite all of the complex technology in architectural design, material logic has been abstracted out of the system. In principle, the 18th Century spline illustrates that through controlling a few points, curvature is generated through material illustrating the difference between finding form in material. Harnessing the simplicity of this 18th Century spline, woven together in a network, is the basis of my interest in gridshells.

3.2 Basic Surface Design

The form of this gridshell was developed as a landscape installation at the corner of two perpendicular paths. Although timber gridshells gain their structure through double-curvature, they are typically simple longitudinal spaces. The crescent plan shape of this gridshell will provide unique challenges and conflicts between digital form generation and physical form finding.

This surface is generated from two edge or boundary curves, and three curves in section, one at the beginning, one at the end, and one offset from the middle (Figure 3). This is simply to note that fairly complex surfaces can be generated by a minimum of information, which contrasts the typical practice in digital design to over complicate formal morphology when based on visual criteria alone. As can be plainly seen, the shape of this surface is not terribly striking – it only provides the backbone from which pattern is applied to it.

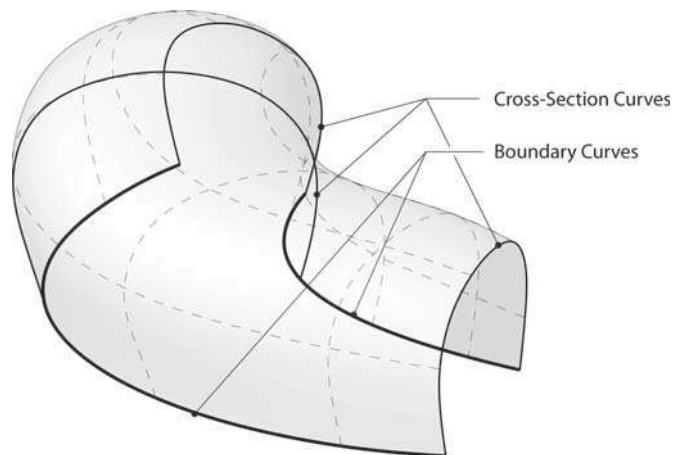

Figure 3: Surface generated from two boundary curves and three cross-section curves.

3.3 Patterning: Projected and Applied

The ease of generating complex surfaces in digital tools also provides the complex challenge of this project: how do material constraints inform these shapes? In the Downland Gridshell the original shape was developed from physical study models, and the precise gridshell pattern was determined by a purpose built computer software executed by Buro Happold. Although the history of NURBS software links back to the material constraints of the 18th Century spline, in actuality this material resistance is abstracted out of the equation. In addition, NURBS surfaces are developed through two opposing U and V spline networks creating a grid, indicated in the dashed lines in figure three. However, gridshells work through their X pattern. Therefore, a method is needed to develop an X pattern over the pre-existing UV grid of NURBS surfaces.

There are two approaches to doing this. Lines or patterns can be *projected* onto a surface or, lines or patterns can be *applied* to a surface. The difference is not minor in the case of gridshells. Lines that are projected are pulled straight to the surface creating a new line at the intersection of the projected line and the surface. The benefit of this method is that the lines applied to the surface only curve in one direction, defined as a *plane curve*. Because these lines are projected straight up, the limitation of this method is that any part of the surface that extends beyond this vertical projection is not included. Patterns that are applied to a surface do not have this limitation, as the pattern is mapped across the entire surface, twisting and stretching the original pattern to fit. This method can yield incredible variations in pattern, although its great limitation is that there is no inherent constraint. For example, whereas projecting straight lines will yield plane curves, applying straight lines will most likely yield curves that curve in both directions, defined as *space curves*. This is significant in terms of material constraints, as curving in two directions places much greater stress on material, and therefore cannot necessarily take the shape applied. Due to the crescent shape being developed, this project proceeds with applying curves to surfaces. This is also what gives this gridshell its dynamic pattern (Figure 4). It must be noted that this pattern does not have any more or less material logic than the underlying surface it is mapped onto. As this gridshell is intended to be fabricated from plywood and the aid of a CNC router with an 8' bed, numerous grid densities were applied to find the least number of nodes while maintaining a maximum 8' length from node to node. This digital trial and error process contrasts with the physical process of the Downland Gridshell. Physical models were first used to establish the overall shape and boundary conditions, and then used a purpose built computer analysis software by the engineers that optimized this basic shape. Additionally, projecting curves to surfaces should not be overlooked, particularly as this method may be a closer fit to the original hanging chain and inverted physical models studied by Frei Otto.

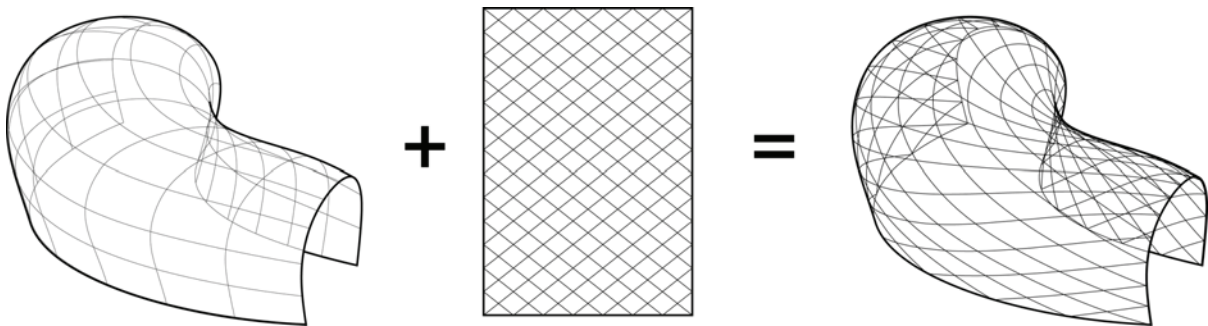

Figure 4: Basic surface with pattern applied to surface.

3.4 Lath Development

While the pattern developed is suggestive of the overall grid, giving this grid precise dimension and thickness must maintain a few simple parameters. The planar faces of the laths should follow the basic curvature as closely as possible, requiring them to twist. As they overlap each other at the nodes, their surfaces must be flush to each other at precisely the point of their overlap. In both cases, accuracy is based on understanding the surface normal. The surface normal is defined as the line drawn perpendicular to the tangent plane of any point along a surface. Put in the context of the gridshell, the line perpendicular to the intersection of pattern, which is the node, is at the surface normal. Therefore, the node is at the surface normal. For example, in the patented node in the Downland Gridshell, the pin that connects these laths is at the surface normal. Constructing the width and thickness of the laths must therefore be constructed from the surface normals of the original surface. Accuracy in this digital process, and the corresponding precision of CNC fabrication, is fundamental as the position of the joints is what will fix the shape of the structure.

A two-step process is necessary to construct the laths through the surface normal. First, depth is developed through drawing the surface normal at each intersection and the end points, and then creating a surface through sweeping each surface normal along the applied curve (Figure 5a). From this surface, width is generated in the same manner, this time extending the normal in equal directions from the previous surface developed. These normals are swept from the same line originally applied (Figure 5b). It is this secondary surface which will be developed into the gridshell lath structure. Although this process is indeed tedious, it is necessary to maintain that the lath surface follows the base surface as closely as possible and correspondingly, that at each node the surfaces are exactly flush to allow a pin to be drawn through at the surface normal.

3.5 Lapped Joint

From this precise geometry, giving depth and developing the joint of the gridshell is very straightforward. Following the Downland Gridshell, this plywood gridshell is to be constructed from a four-layer system. The lath surfaces can now simply be offset for each layer of lath at the precise distance of the lath material (Figure 5c). This process is simply repeated to develop the entire gridshell (Figure 6).

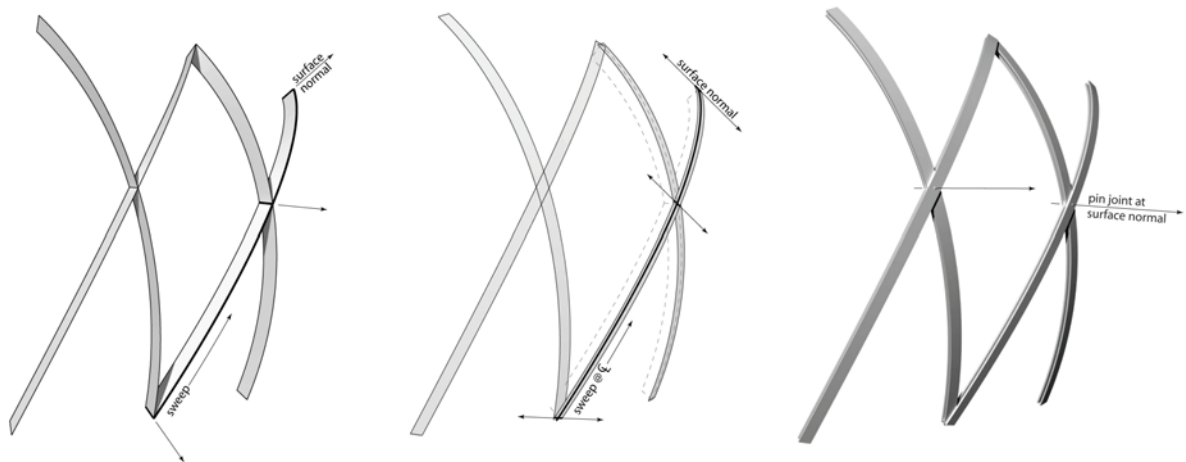

Figures 5a-c: Developing Laths through surface normals allows lath to follow surface curvature and for laths to align at each node. Develops into a four-layer construction with pin joint at surface normal

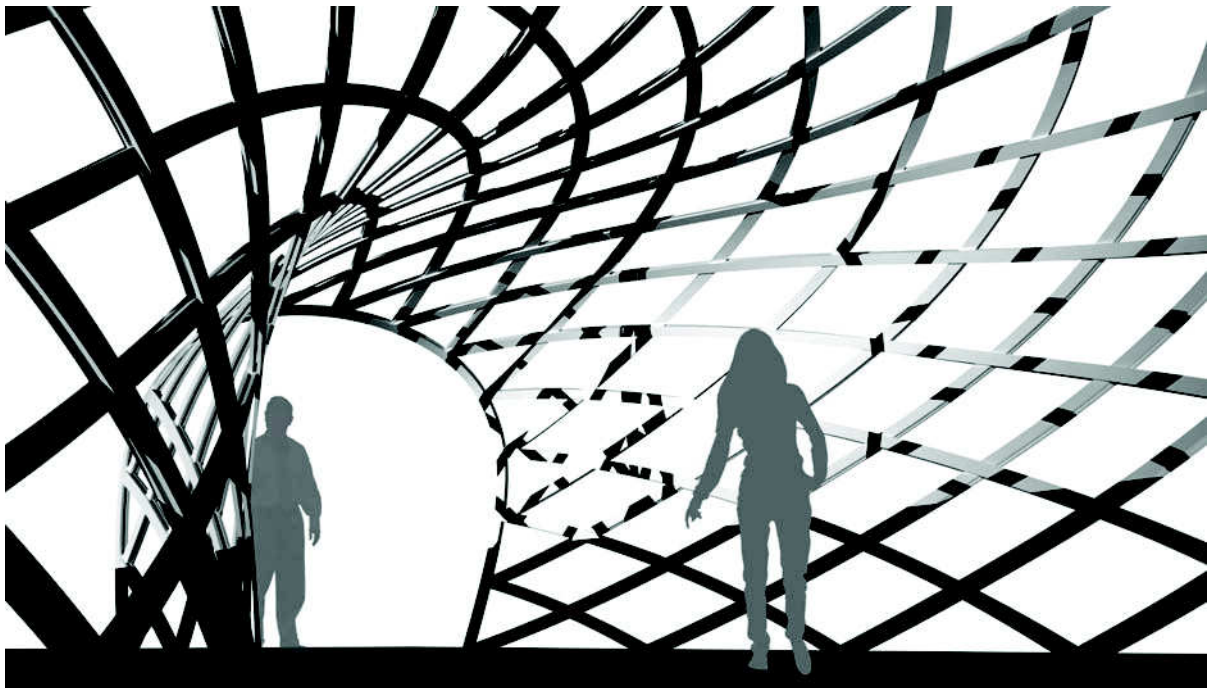

Figure 6: Interior Perspective of Gridshell

4. PHYSICAL PROTOTYPE

Unlike the Downland Gridshell, this structure is not intended to be formed from a flat mat, as this method requires advanced scaffolding. Based on the pre-fabricated location of pins along with the (presumed) ease of bending plywood strips and the small scale of this structure, bending these laths in place should be straight forward allowing the structure to take shape piece by piece. This also simplifies the nodal connection, as the outer pieces do not need to slide as the flat mat takes shape.

While material has been not been a part of the process up to this point, the knowledge of surface generation in relation to material is based on previously built projects. Unlike purely digital design, fabricating precisely from this digital data is the ultimate test of construction. Through curvature analysis, it is known that the radius of curvature is well within the limits of the plywood laths. What is not known is the behavior of the plywood as it twists slightly at each node. A series of scale models were developed to test the accuracy of the joint locations, the ability of the laths to take their shape, and the sequence of construction. One of the major limitations of applying the pattern to the surface is that the laths are not true straight members. Each lath is unrolled with the node location precisely marked. The unrolled laths are crescent shaped, rather than true straight laths. Consequently, each lath is unique and must be labeled in a logical manner to aid in the sequence of construction. As a result of these crescent shapes, this is one reason that plywood is proposed as a construction material as these shapes can be easily constructed with a CNC router. A 1/12th scale prototype section was used as a prototype of construction, demonstrating that the precision of the laser-cut prefabricated laths and precise location of nodes does establish the shape. As a method of construction, the node locations align only when the material is in its curved position, and pins are put in place, fixing the shape (Figure 7a).

4.1 Prototype Assessment: Sequence of Construction

The risk involved in this process was not knowing if the material could actually take this shape without failing, as well as the ability of the nodes to hold their position at the surface normal, necessary to accurately form the shape. The physical model alleviated this risk, but raised others. Although in principle plywood laths can bend to this shape, the force required to do so while simultaneously pinning the joint may not be a reasonable construction method. It would be possible to laminate two thinner sections of plywood, such as 3/8", aligning their shape with similar nodes at the normal, thereby pre-forming these laths. Because each joint has a single pin, there is an accordion effect while the surface is being assembled compounding the difficulty of simultaneously bending and pinning the plywood laths. Finally, when constructing piece by piece, some form of scaffolding or bracing will be required to support the flexible shape before it is fully constructed.

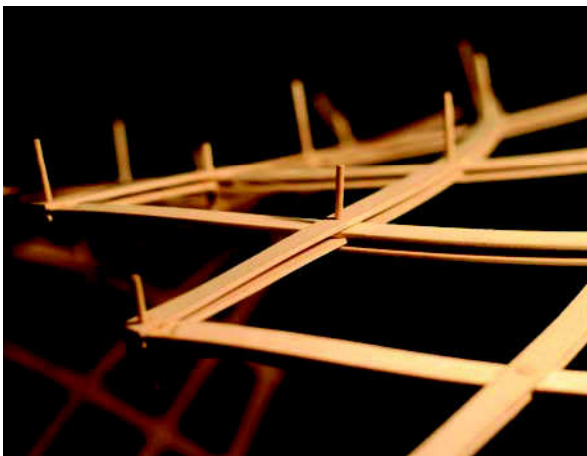

Figure 7a: Model joint with pins at surface normal

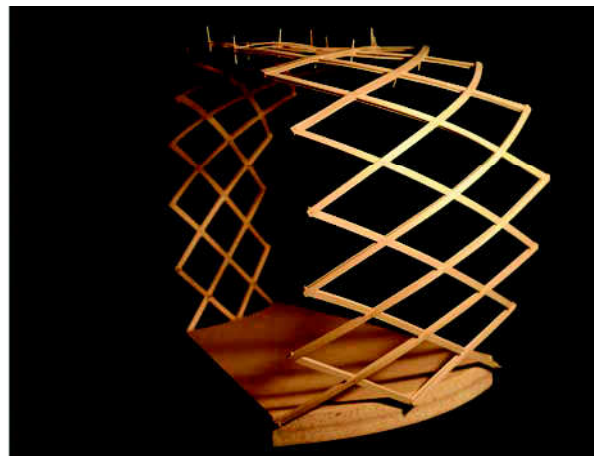

Figure 7b: Prototype Section Model

4.2 Prototype Assessment: Shape and Pattern

Although a complete shell was not constructed, the prototype shell suggests two important factors that were not considered in the digital model (Figure 7b). While the sides of the structure are considerably strong, there is a flat spot on the top of the surface that deflects under weight. The prototype section also flexes considerably when imposing a lateral load. This is to be anticipated as this is only a section, and yet it does suggest tracing these patterns to where the forces will be terminated. While the horizontal nature of the pattern applied gives a striking dynamic appearance (figure 6), each lath terminates in one direction at the end arch, not at the ground. Consequently, there would be considerable force at the end conditions likely requiring a preformed structural rib or possibly a tensile element. Alternatively, the pattern could be oriented 90 degrees from the applied orientation, and a majority of the laths will terminate at the ground. As expected, clearly structural input is needed in this process.

5. CONCLUSION

The plywood gridshell developed here is an excellent case study in the relationship between digitally derived and developed geometry and material properties. Rather than seeing material constraints as restricting design, the position of this paper is that a better and more thorough understanding of material constraints enables design. As CAD/CAM tools become increasingly part of design education and practice, further emphasis needs to be placed on material properties with the precision and flexibility of these technologies to extend these material properties. Through gridshell design, form and structure are closely bound together, conjoined through the close relationship between form and material. Pursuing this tight relationship also highlights the limitations of this approach, and gridshells in general.

Clearly this project would benefit from interdisciplinary design, particularly structural consultation. Although complex surfaces are easily developed in NURBS based software, it is the very first shape that is at issue: the cross section and boundary curves that define the surface. The structural integrity of these basic shapes warrants further investigation, and might suggest that physical modeling should precede digital modeling of these structures. Until a full-scale mock-up is constructed, the limitations of the piecewise construction approach proposed here is still in question. However, the physical model prototype suggests that pre-forming these laths would ease the sequence of construction, although doubling the number of unique parts and adding a step in pre-fabrication. Clearly plywood is not an ideal material to build these structures, and the grade of plywood will need to be certified void free and ideally a minimum of five plys, making marine plywood a good candidate. It would be possible to construct the proposed design from solid lumber, as the crescent shape of each lath could fit on a nominal 1x8 board. Plywood is considerably more cost-effective for testing the construction of the proposed gridshell.

Ultimately the goal of this research is to present gridshells as a pedagogical tool in itself. In this way, gridshells are seen as a context conjoining variability of form with the specificity of the joint. Understanding the connection between the surface normal and the nodal joint is a simple, yet fundamental relationship structuring the relationship between digital geometry and material joints. Furthermore, material constraints are seen as enabling the form and structure of gridshell design. Finally, these structures present a powerful motive to help bridge digital design culture with the values of ecological – maximum effect with minimal means.

REFERENCES

Bezier, Pierre. *Numerical Control*. John Wiley and Sons Ltd, 1972.

Bezier, Pierre. "A View of the CAD/CAM Development Period." *IEEE Annals of the History of Computing*. Vol. 20, No. 2 (1998): 37-40.

Cabrinha, Mark. "From Bezier to NURBS: Integrating Digital and Material Techniques in a Plywood Shell," *Smart Architecture: Proceedings of the Association for Computer-Aided Design in Architecture (ACADIA)*, Savannah, Georgia (2005).

Cross, Nigel. "Design Research: A Disciplined Conversation." *Design Issues*. Vol 15 No 2 (1999): 5-10.

Delanda, Manuel. *Intensive Science and Virtual Philosophy*. Continuum International Publishing Group, 2002.

Farin, G., J. Hoschek, and M.-S. Kim. *Handbook of Computer Aided Geometric Design*. North Holland, 2002.

Harris, Richard, John Romer, Oliver Kelly, and Stephen Johnson. "Design and construction of the Downland Gridshell." *Building Research and Information*. Vol 6, No 31. (2003): 427-454.

Johnson, Stephen. "The Architecture Ensemble." *Architectural Design*. (2006): 96-99.

Education

Lab-coats Back in Studio. Can Sustainability Bring Design and Research Back Together?
Fernando Luiz Lara

A Green Studio Pedagogy: Using Scale Changes to Influence Architectural Design for Sustainability
Keelan P. Kaiser

Education, Environmental Attitudes and the Design Professions
Traci Rose Rider, Jack Elliott

The Green Studio Handbook: Environmental Strategies for Schematic Design
Alison G. Kwok, Walter Grondzik

Interdisciplinary Comprehensive Design Studio: Carbon Neutral Field Campus*
Bruce Haglund

* Invited Oral Presentation

Lab-Coats Back in Studio. Can Sustainability Bring Design and Research Back Together?

Fernando Luiz Lara

University of Michigan, Ann Arbor

ABSTRACT: Ten years ago at the peak of the so called “critical theory” movement, somebody declared that the age of “lab-coats” in studio was over. Measurements and empirical tests were absolutely out, while subjective relativism was the main force behind every formal move. Decades of architectural research were deemed irrelevant for the future of the profession while new associations were formed with the humanities in general and literary criticism in particular. Form followed discourse.

However, the latest developments of sustainability as a mainstream force brought numbers, graphs, and hypotheses back to studio. From bio-degradable construction materials to nano-technology and life-cycle assessment, architecture is fascinated again with measurements and empirical tests. As if riding a new wave of scientific (or pseudo-scientific) investigation, the architectural pendulum seems to be swinging back to technology (be it energy efficiency of incorporations of new materials) and away from critical theory.

The main idea behind this paper is to discuss the challenges and opportunities of bringing design and research together under the urgent framework of a more sustainable built environment.

INTRODUCTION: LAB-COATS IN AND OUT

Looking back on architecture education over the last three decades show us moments of convergence and divergence between research and design. The crisis of the modernist paradigm in the 1960s generated many currents in search of anew articulation. Among historicisms, structuralisms and post-modernisms in general, there was a significant increase in architectural research, commonly known as design methods. Many doctoral programs were inaugurated under this framework and an alliance was forged between architecture and the emerging information sciences. The main goal of “turning transparent the dark box of creativity” associated with the dawn of computation left a large amount of rigorous and not-so-rigorous research into what we actually do when we design and how could we do it better. (LYNCH, 1981; HILLIER, 1984; SCHON, 1988).

But if the 1980s were to be named “the pink decade” by the Argentinean critic Marina Weisman, it was not only due to the colorful architecture of Graves and Rossi but also due to the abandonment of any transformative ambition. Architecture turned into a self-referential / discourse base endeavor. Along the utopian project, the idea of integrating design and research was also dismissed. If the main goal of the design methods program was to improve the way we design and consequentially what we design and later build, such was deemed irrelevant by the idea that architecture was less an artifact and more of a cultural object. (BLOOMER, 1993; INGRAHAM, 1998).

As a result of those changing values the research project was marginalized. The link between science and design was questioned and other links were formed with disciplines as faraway from architecture as literary criticism. Form followed discourse since the second half of the 1980s and most of the expansion of doctoral programs were now in the area of History and Theory.

For those of us who have been there before (or know the lessons of history), it is important to acknowledge that the change from methods to discourse was also due to the inability of the so-called lab-coats to deal with the studio culture.

If we can expose some of the failures of the 1970s research endeavor we shall perceive three main problems:

1. the focus on research was less interested in learning from the existing practice and more into re-inventing the whole of architectural design discipline. That led to dissociation between research and practice that ended up isolating the research community.

2. the fascination with the computer as form-generator created a culture of self-sufficiency in the research community. Programs and codes were written for computation sake and not for advancing the interface with design. The obsession with the development of generative software created even more misunderstanding and was understandably not embraced by the design community. Meanwhile, the evolution of CAD software made computers widely available in studio as substitutes for drafting and visualization tools, not for advancing the research endeavor.

3. another major problem with the 1970s research and design convergence was a widespread perception of research as something against the studio culture. Instead of embracing the studio ethos in order to transform it from within, the majority of the so called lab-coats positioned themselves against the studio. Architecture was supposed to be taught with logical rules, normative theories and precedents, with little space for experimentation. Such confrontation ended up pushing research and design further away from each other, as if no overlapping were possible and you were either with us or against us.

In summary, if there is something to learn from the failures of the 1970s research is the fact that studio is and will continue to be the core of architecture education. Therefore instead of dismissing it as many did in the past we should embrace it as a fundamental component of creativity and subjectivism that is central to our discipline and our profession.

And if there is something to learn from the decade that followed is that we should always try to ask better questions. The importance of a critical approach to our discourses cannot be dismissed and if there is any chance of reconciling design and research again it has to be without dismissing the studio culture and without marginalizing the contribution of the humanities.

Nevertheless, to ignore the importance of rigorous research to produce and systematize knowledge is to abandon a large part of our public responsibility towards a better built environment.

This paper aims at discussing new pedagogical practices that consciously attempt to integrate design and research in studio. Rather than accentuating its differences and its incompatibilities (which are many), we want to discuss the opportunities emerging from the overlapping of studio creativity and a robust knowledge base. Moving away from pedagogies that exclude one (research) or the other (design), we want to generate a conversation about the joys and risks of bringing them together.

THE EXPERIMENT AT MICHIGAN: A GRADUATE STUDIO WITH A RESEARCH INTERFACE

In the fall semester of 2006 I had the opportunity of conducting a graduate design studio at the University of Michigan based on the idea of integrating research and design. The studio was part of a first year graduate theme called perimeter projects with focus on “all that which is necessary to the city but not necessarily part of it: remote sites, unnoticed programs, far-reaching resource channels, forgotten industrial residues, emergent edge effects, and their many unintended consequences”(ADAMS, 2006).

Within this framework, our studio looked at the future of those perimeter programs under the premise of oil becoming expensive beyond affordability.

The studio brief affirmed that fifty years ago the Highway and Defense Act induced changes in the North-American landscape that pervasively informed our daily routines in every possible way. At the same time we are fully aware that this whole infrastructure is unsustainable from every possible point of view: sociological, environmental, economical, architectural. What can we expect ahead? Where are we going in terms of built environment?

The studio tackled the unbearable dependence we now have on the present perimeter articulation as we move (as many are warning) towards the collapse of such economy by oil depletion or environmental exhaustion.

Starting with a research base exercise, we documented and analyzed all the oil-dependent programs (the garage, the drive-through, the gas station, the parking lot) in a given area in the Detroit metropolitan region. In this initial phase I was able to introduce students to concepts of documentation, data collection, randomization and sampling in order to retrieve the most accurate information about the place. When

searching for information on the gravity of the oil crisis, for instance, students often found contradictory information with environmentalists predicting an imminent crisis and industry consultants preaching that technology advancement will take care of any future shortage of easy accessible oilfields. It was interesting to discuss the reliability of the data, analyzing how research results can be manipulated one way or the other even in “empirical” studies. Architectural students were fascinated to discover terms that are very familiar to the research community such as “control groups” or “standard deviation”. Moreover, when going past the press releases trying to access the real research report, students learned a lot about rigorous research and the obligation to describe with precision each step of the experiment or the premises of the analysis. In the end, they were able to find out how both sides of the debate overstate their part of the truth and understate their uncertainties. Nevertheless, what students were able to draw as common ground between two dissenting camps is the fact that energy costs will be more expensive in the future, the question being how much more?

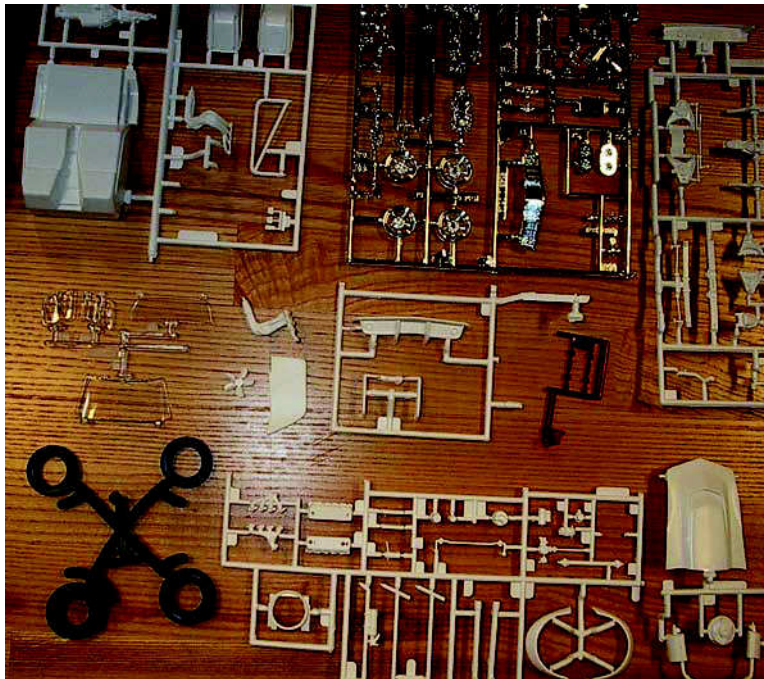

Figure 1: to assemble a scale model car was the departure point of the studio

Alternating research methods of data collection and analysis with creative studio-based exercises, students were then asked to freely and open-mindedly recycle one of those programs once gasoline becomes unaffordable. The first creative exercises departed from a car scale model (1:24) which they should assemble not exactly following the instructions but freely re-using those parts in the total absence of gasoline to run it (fig 1).

After this first exercise the studio got back to research mode and developed scenarios for the urban consequences of more expensive oil. At this point the connection between design and research became more problematic. Not accustomed to the use of data for future predictions, students moved too quickly towards images of apocalyptic post-oil society. While those early exercises did provided insights that would be useful later, they were much closer to science fiction than anything else. Images of a big-brother over controlled society in the likes of “brave new world” were combined with Detroit experiences of real estate devaluation, spatial abandoning and crumbling infrastructure. At this point it was disappointing to realize that all the students had developed a pessimistic scenario in which life would inevitably get worse with one single exception, a student that had lived in Japan for many years. Based on those scenarios which were scrutinized as research reports (with the inevitable failure to stand up to the research rigor we were crave for), students developed their own specific programs and or spaces of intervention. But before going

back to studio creative mode there was one more link with research to be explored and that was the analysis of household consumption data. Given that the main point was to develop spatial responses to the future unaffordability of fuel, it became important to ask in a more rigorous manner what the affordable threshold would be, Reports from the consumer confidence survey run by the University of Michigan Institute for Social Research introduced students to an array of new concepts in survey techniques, sampling, demographics and the surprising discovery of how many people live below or under the poverty line in the Metro Detroit region. The household survey data was then used to understand the impact of gasoline prices as 3, 5 and 8 dollars a gallon on family budgets, giving the students a more precise understanding of how forces acting on a micro scale would induce changes in a macro scale.

Each student then chose his or her own program of intervention and departed to the proposed site: an abandoned dealership in the so called perimeter of Ann Arbor, adjacent to a highway ramp. By navigating back and forth between research methods and studio-based creation I believe we were able to cross-contaminate each intellectual mode in search of a third and more robust attitude. For instance, when trying to understand how the middle-class would react to gasoline at 5 dollars a gallon, two of the students decided to pursue an investigation of how some programs would be transformed by the fact that instead of the current 1.2 travelers per car we move to about 3 persons in each automobile (fig 2). While one of them was dedicated to designing a new drive-through that encouraged car pooling, the other designed a public interface for car sharing.

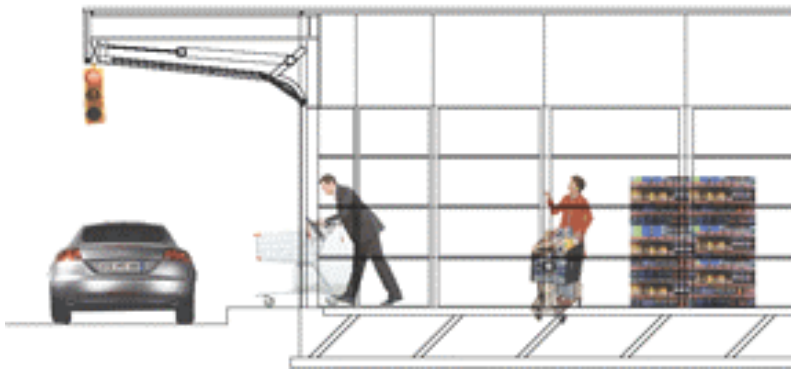

Figure 2: car sharing and car pooling being integrated into retail programs

Another student mapped with precision all the asphalt surface in about 1 mile of the arterial road leading to the highway ramp and after determining how much less parking and road lanes would be needed once mass transit becomes the most popular solution, when on to design a strategy for linking the necessary re-cycling of asphalt (by then expensive) with nature's re-conquering of the areas (fig 3).

It is my understanding that rather than trying to blend research thoroughness with creative freedom we should preserve the best of each approach and explore the mismatches, the collisions, the friction caused by the overlapping of two different mindsets. In this regard, my experiment with bringing design and research together is quite different from the 1970s peak of lab-coats in studio. To continue with the same metaphor, I should say that I am interested in changing wardrobes every week, from lab-coats to the all-black studio uniform. Moreover, I am interested in the folds and scratches that happen every time we change clothes or change hats.

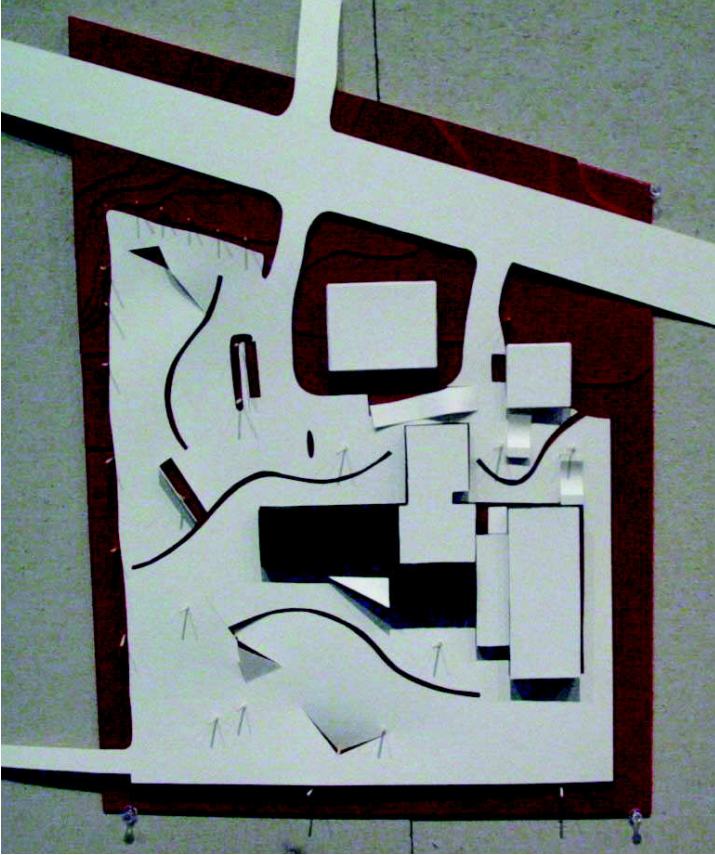

Figure 3: manipulating unused asphalt surface

LESSONS LEARNED SO FAR:

Not surprisingly, the integration of research and design takes a lot of work and attention. Architecture students are not always versed on research values and tend to confuse it with information gathering. It takes quite an effort to explain, in a studio setting, the proper steps of retrieving, systematizing and analyzing information. However, the presence of students with science backgrounds (be it natural, social or hard sciences) in a 3-year graduate program is an asset that we should be aware of. Some of the best discussion in our studio involved students with science major trying to explain research values to architecture majors. In the course of their encounter the studio mode often crashed with the research values and our best conversations (and I like to think our best educational moments) came out of such collision.

There are however some inherent differences. Some bridgeable, other not so much. One of the hardest have to do with the fact that research is always searching for generalizations while architecture design is almost always specific. While design can indeed be broad and generalizable in principle, the more attention paid to the local conditions the better. Research, on the other hand, can be made very specific or narrowed to a small sample or a case study, gaining in depth but losing in explanation power and applicability.

Other differences between research and design values are easier to deal with and can be very productive in studio. For instance, it seems to be very helpful when architects understand the notion that design knowledge can indeed be cumulative and that we should not re-invent the wheel with every building. Students are very comfortable with the idea that their design is a small but important contribution to architectural knowledge and also seem relieved from the anxiety of designing a master-work every semester.

While the research training, although brief and superficial, give students a foundation upon which to build their ideas, the studio ethos allow them to approach every project creatively and experimentally. Isn't that what we need to achieve a more sustainable built environment?

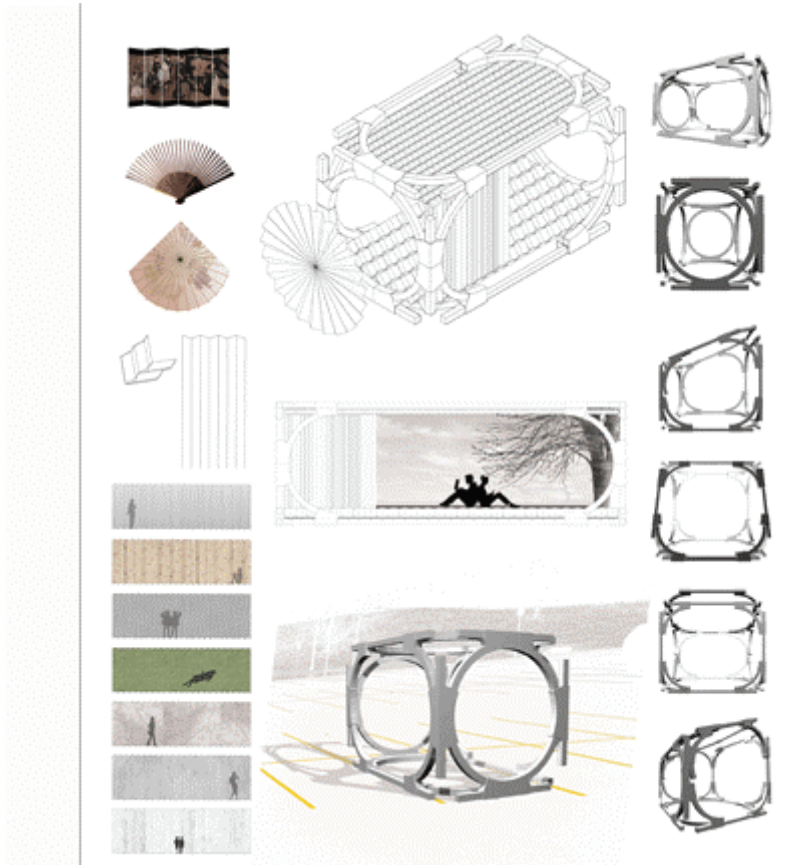

Figure 4: studio craft culture meets research attitude.

REFERENCES:

- ADAMS, Robert, "perimeter studio brief", TCAUP, University of Michigan, 2006.
- ANDERSON, Stanford, "Architectural design as a System of research program", *Design Studies*, 1984, pp.146-150.
- BLOOMER, Jennifer, *Architecture and Text: the (s)cripts of Joyce and Piranasi*, New Haven: Yale U Press, 1993.
- COLQUHOUN, Alan, "Post-modernism and structuralism: a retrospective glance", *Assemblage* no. 5, 1988, pp. 7-15.
- HILLIER, Bill et alli, *Knowledge and Design*, New York: John Wiley, 1984, pp. 245-264.
- INGRAHAM, Catherine, *Architecture and the burdens of linearity*, New Haven: Yale U Press, 1998, pp. 148-155.
- LYNCH, Kevin, "Is a general normative theory possible?", *Theory of good city form*, Cambridge: MIT Press, 1981, pp. 99-108.
- ROWE, Peter, "Architectural positions and their realms of inquiry", *Design Thinking*, Cambridge: MIT Press, 1987, pp. 153-201.
- SCHON, Donald, "Designing rules, types and words", *Design Studies*, Cambridge: Dept. Urban Plan. MIT, 1988.

A Green Studio Pedagogy: Using Scale Changes To Influence Architectural Design For Sustainability

Keelan P. Kaiser, AIA

Judson College, Elgin, Illinois

ABSTRACT: This paper discusses a design studio pedagogy which involves preparatory experiences in sustainable community design and sustainable technology as a means to inform subsequent architectural design. The paper speculates that influences at an urban scale and a detail scale can stimulate a holistic approach to the design process and allow the design student to think more broadly about sustainability. The process includes reflections on the new LEED – ND and its application in a design studio, precedent studies of high performance building façades and their formative effects upon preliminary massing and siting, and how these two types of investigations can broadly inform an approach to architectural design studio which strives toward sustainability.

Keywords: design pedagogy, LEED – ND, building façade

INTRODUCTION

This paper discusses a design studio pedagogy which involves preparatory experiences in sustainable community design and sustainable technology as a means to inform subsequent architectural design. The paper speculates that influences at an urban scale and a detail scale can stimulate a holistic approach to the design process and allow the design student to think more broadly about sustainability.

1. DESIGN STUDIO PEDAGOGY

Architecture design studio pedagogy involves a substantial amount of attention to design process. The faculty member assigns a studio problem partly to prompt motion toward a solution, and as often as not to begin the process of Bloom's Taxonomy (albeit adapted) of application, analysis, synthesis, and evaluation followed by a feedback to application. This cyclical process is a common approach for architecture studio pedagogy (Rowe 1991); and faculty members teach design through this iterative process. It is also a constructive process in that as the loop comes to completion, progress in the maturation of design work is expected. During the scope of a given project or term, a process is employed, somewhat linear though many times non-linear, from large scale considerations which narrow over time to more discrete scales (Figure 1).

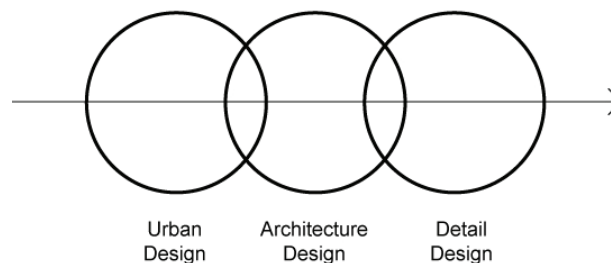

Figure 1: A common architecture design process. Source: (Author 2006)

While design process is seldom truly linear, it is not uncommon for urban scale or contextual considerations to preface architectural design decision making in some capacity or another. Likewise, it is often the case that design studio problems seek increased definition over time, and many times this takes the form of a detailed component of the design. The relationship of content from one arena to the other is substantial. However, in this diagram, a relationship between the two outer circles is not necessarily synergistic, and may not be present whatsoever.

This paper describes a pedagogical approach in design studio which changes the order of the process as presented. The adjustment took an ecological look at the original diagram, and sought to feed relevant content into the design process from a combination of inputs: both urban and detail. The approach inculcated broad concepts of sustainable community with those of sustainable technologies prior to beginning the building design exercise itself. An adaptation of the previous diagram might read as follows (Figure 2).

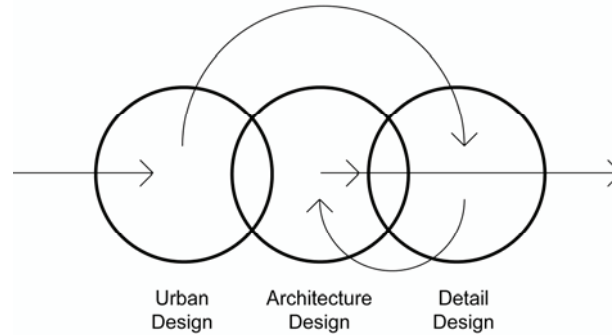

Figure 2: Adaptation of an architecture design process. Source: (Author 2006)

More specifically, the design studio conducted two investigations as a prelude to beginning building design. Sustainable community concepts found in the new Leadership in Energy and Environmental Design for Neighborhood Development (LEED – ND) was introduced first. LEED – ND was under review by the U.S. Green Building Council (USGBC) at the time that this design studio was offered (Fall, 2006), and is now in its pilot phase. It should be noted that many detailed changes were made to the working version in the newer pilot version, but the general scope remains largely the same. The students completed an urban neighborhood design exercise based upon the LEED – ND materials. Each student then researched contemporary precedents of high performance façades in an effort to understand contemporary applications of technology at their disposal to accommodate environmental and programmatic requirements. They created digital section models to document their negotiation of the assembly and systems at work in the precedents. The models also served as a visual taxonomy of contemporary building façade approaches. The pedagogical diagram is more appropriately labeled as such (Figure 3).

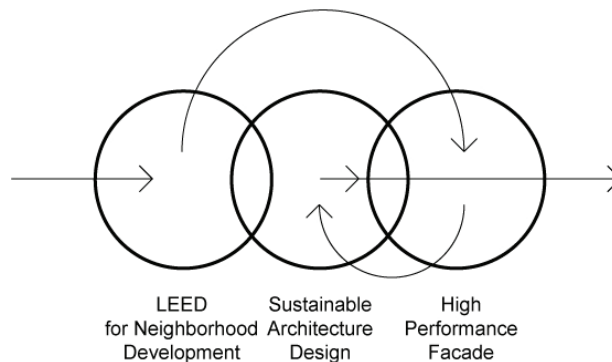

Figure 3: An alternative architecture design process. Source: (Author 2006)

This paper is concerned with outcomes and measurements of students integrating sustainability thinking into the formative stages of their design process. The assessment of this process is measured by the degree to which design students were able to understand and apply the sustainability concepts in the two preliminary investigations. Further assessments will be possible following the completion of the second studio in the sequence (Spring 2007) and will more specifically map the impact of these two formative investigations.

2. LEED – ND AS A VEHICLE FOR IDENTIFYING SUSTAINABLE COMMUNITY CONCEPTS

LEED – ND provided a basis by which to collect data about the downtown core, prioritize desired outcomes, and develop urban planning solutions suitable to the policies included therein. The USGBC describes LEED – ND as:

The U.S. Green Building Council, the Congress for the New Urbanism, and the Natural Resources Defense Council—three organizations which represent that nation's leaders among progressive design professionals, builders, planners, developers, and the environmental community—have come together to develop LEED for Neighborhood Development. This rating system will integrate the principles of smart growth, urbanism, and green building into the first national standard for neighborhood design. Whereas other LEED products focus primarily on green building practices, with only a few credits regarding site selection, LEED for Neighborhood Development will emphasize smart growth aspects and neighborhood design and development while still incorporating a selection of the most important green building practices. Guided by the Smart Growth Network's ten principles of smart growth and the Charter for New Urbanism it will include compact design, proximity to transit, mixed use, mixed housing type, and pedestrian- and bicycle- friendly design. In short, LEED for Neighborhood Development will create a label which could serve as a concrete signal of, and incentive for, better location, design, and construction of neighborhoods and buildings. Source: (USGBC 2007)

Serving as a municipal client, the Elgin Downtown Neighborhood Association director provided key guidance on city needs, in particular the neglect of the entry corridors to the city core, which ultimately became the focus of this particular study. The studio prioritized the potential points available for LEED certification and developed a summary to guide their design decision making. The categories of *Location Efficiency* and *Compactness* tend to address planning for density and connectivity principles while those of *Environmental Preservation* and *Resource Efficiency* tend to address technology and engineering (Table 1).

Table 1: A prioritization of LEED – ND point's based upon impact. Source: (Author 2006)

Location Efficiency (2 Prerequisites / 7 Credits / 28 Points / 25% of total points)	
Credit: Contaminated Brownfields Redevelopment	4
Credit: High Cost Contaminated Brownfields Redevelopment	1
Credit: Adjacent, Infill, or Redevelopment Site	3 to 10
Credit: Reduced Automobile Dependence	2 to 6
Credit: Contribution to Jobs-Housing Balance	4
Credit: School Proximity	1
Credit: Access to Public Space	2
Environmental Preservation (5 Prerequisites / 11 Credits / 13 Points / 11% of total points)	
Credit: Support Off-Site Land Conservation	2
Credit: Stormwater Treatment	2
Compact, Complete, & Connected Neighborhoods (3 Prerequisites / 22 Credits / 42 Points / 37% of total points)	
Credit: Compact Development	1 to 5
Credit: Diversity of Uses	1 to 3
Credit: Housing Diversity	4
Credit: Comprehensively Designed Walkable Streets	2
Credit: Superior Pedestrian Experience	1 to 2
Credit: Transit Subsidy	3
Resource Efficiency (0 Prerequisites / 17 Credits / 25 Points / 22% of total points)	
Credit: Certified Green Building	1 to 5
Credit: Energy Efficiency in Buildings	1 to 3
Credit: Water Efficiency in Buildings	1 to 2

The studio created an urban re-development proposal entitled *The Four Entry Corridors Study* which included strategies for encouraging increased density and future development along the four primary entry corridors to the Elgin, IL downtown which included: Route 31 from the north and south, Villa Street from the southeast, and Dundee Avenue from the northeast. The studio investigated how urban planning, urban design, and architecture can be used to improve the appearance and perceptual quality of a blighted downtown core and its primary vehicular circulation routes. Specifically, the study focused on the primary vehicular entry corridors and proposed increased investment and density as a solution to the overall vibrancy and sustainability of the City of Elgin (Figure 4).

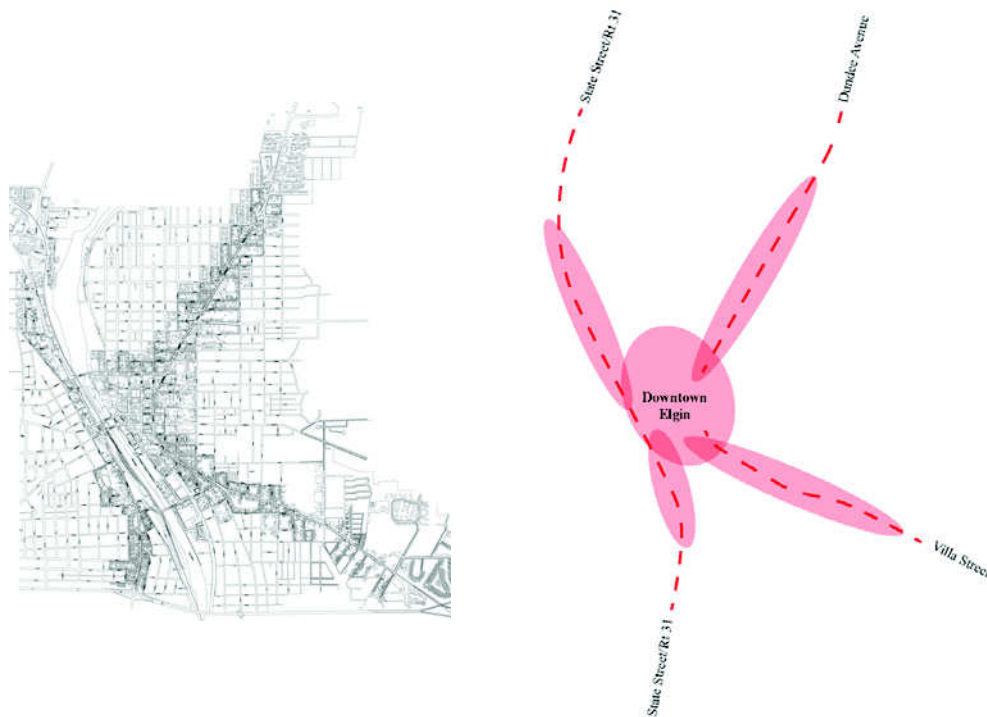

Figure 4: Elgin downtown core and primary entry corridors diagram. Source: (Author 2006)

The proposals combined ongoing capital investment and beautification efforts in the downtown core with significant capital investment along the corridor routes as alternatives to continued suburban sprawl and periphery development of green fields. The later types of developments are rampant in the northwest suburbs of Chicago and troubling given that Elgin is projected to be the fourth largest city in Illinois by 2030. The recommendation by the studio, supported by numerous case studies from other cities, is that density is a good, healthy, and more sustainable development approach.

The following findings were developed through teamwork and individual solutions. First, public and private investment in and re-urbanization of the downtown core and the entry corridors will significantly improve the visibility and sustainability of Elgin in the twenty-first century. Second, the four entry corridors in this study have the highest daily vehicular traffic counts and bring the largest volume of people in and through the downtown core. The corridors themselves bear a significant opportunity to affect the visibility and sustainability of the Elgin. Third, while notable developments and improvements abound on the periphery of the Elgin, a significant negative consequence is continued suburban sprawl. Instead, greater attention should be paid to significant re-urbanization of the downtown core and the extensions of the core that fall along the four primary vehicular corridors. Creating more density, mixed-use development, and a critical mass of housing and commerce within the downtown core and the corridors is a sustainable alternative to unrestrained periphery and green field development. Fourth, there is significant redevelopment potential within the study area, of a scale that is not intuitively apparent. The studio determined that there is a potential scope to the redevelopment of the study area of 4.1 million square feet, which does not include downtown core itself. The projected cost in 2006 dollars for these improvements is \$1.0 - 1.4 billion.

3. LEED – ND EXPERIENCES INFLUENCE PRELIMINARY DESIGN DECISION MAKING

Taking the point overview from LEED – ND, the students analyzed the areas that showed most promise for their particular context and site situation. Many of the titles and descriptions in the point overview document were familiar to the students, but many were new. In this way, LEED – ND introduced students to both individual areas of consideration, but more importantly, helped students see patterns and intensities of impact. For instance, locating a new project on a previously developed or infill site yields a significant percentage of points (up to 10 points). This confirmed to the students that there is great value in building on previously developed sites, primarily because of their level of connectedness. Students developed their point overviews to optimize site opportunities (Table 2).

Table 2: A Partial LEED – ND point overview. Source: (Stewart 2006)

LEED – ND POINT OVERVIEW		
Title	Description	Points
Location Efficiency		
<i>Prerequisite:</i> Transportation Efficiency	Locate the project on either an infill site or on a previously developed site	N/A
<i>Prerequisite:</i> Water and Storm water Infrastructure	Locate the project on a site served by existing water and sewer infrastructure replacement or other on-location improvements to existing infrastructure are considered "existing" for the purpose of achieving this compliance path.	N/A
<i>Credit:</i> Adjacent, Infill, or Redevelopment Site	Locate project on a previously developed site.	8
<i>Credit:</i> Reduced Automobile Dependence	Encourage development in locations that exhibit superior performance in providing transportation choices or otherwise reducing motor vehicle use.	2
<i>Credit:</i> Contribution to Jobs-Housing Balance	Encourage balanced communities with a diversity of uses and employment opportunities. Reduce energy consumption and pollution from motor vehicles by providing opportunities for shorter vehicle trips and/or use of alternative modes of transportation.	4
<i>Credit:</i> School Proximity	Promote public health through physical activity by facilitating walking to school. Promote community interaction and engagement.	1
<i>Credit:</i> Access to Public Space	Locate and/or design project so that a public space such as a park, plaza, town square, village green, etc., lies within 1/2 mile of the all the entrances to the project's residential and commercial buildings.	2

This student chose to develop neighborhood density just south of the downtown core, and placed the art museum at the intersection of Route 31, the north-south street, and Walnut Street, the east-west street. These local sites were previously developed but vacant and dilapidated. She subdivided the large architectural program into a “community” of buildings rather than a single structure. This allowed her the ability to maintain a massing scale consistent with the surrounding fabric and also spread the uses out among multiple sites (Figure 5). The massing strategies yielded a building on the north and south side of Walnut Street; and a third building mass on the east side of Route 31.

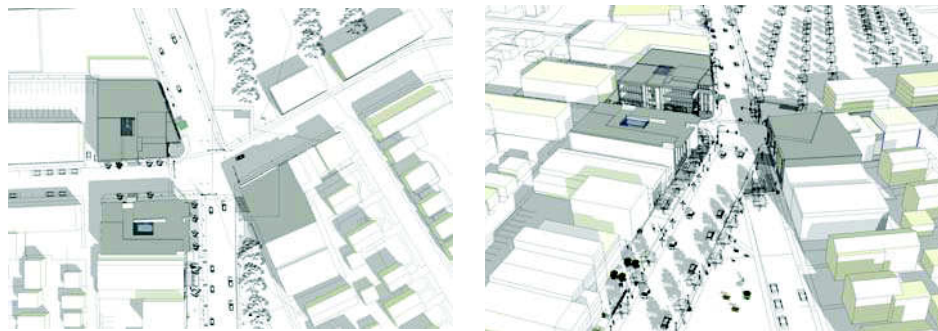

Figure 5: Redevelopment area at Route 31 and Walnut Street. Source: (Stewart 2006)

4. HIGH PERFORMANCE BUILDING FAÇADE PRECEDENT STUDY

Following the investigations at the neighborhood scale, the students developed an architectural program for the community art museum building type within their study area. The programmatic work concluded with a precedent study for high performance building façade that the student deemed appropriate given their site and orientation. One significant factor in the selection of precedents was a programmatic requirement that stipulated that the museum employ literal and/or phenomenological transparency. This requirement was a function of the idea that community art museums are public in nature and one means by which public-ness can be conveyed is by demonstrating material transparency. In addition, the students were advised to investigate building façades which operated as “integrated” systems (Lee 2002).

The previously mentioned student researched a number of buildings which included material transparency, day lighting and ventilating façade strategies. She documented and developed digital section models of the Bayer new Group headquarters, by Architect Helmut Jahn, including a north and south building façade based upon published design documents. She conveyed conceptual understanding of the building technology in a variety of ways. First, she demonstrated the understanding that different solar orientations require different applications of technology. The north façade and south façade are handled differently in this particular application and she purposefully modeled those differences. Secondly, she demonstrated an ability to effectively visualize and communicate differences by comparing and contrasting the two building façades (Figures 6 and 7).

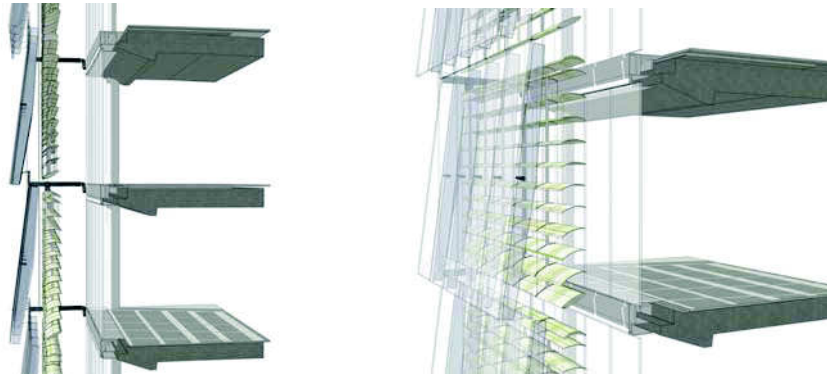

Figure 6: Digital Representation after Bayer new Group headquarters, north façade, Architect Helmut Jahn. Source: (Stewart 2006)



Figure 7: Digital Representation after Bayer new Group headquarters, south façade, Architect Helmut Jahn. Source: (Stewart 2006)

5. IMPACTS ON PRELIMINARY DESIGN

The impact of the precedent study on the example student's work is revealing. Because of siting choices, the northern building has a south façade along Walnut Street and the southern building has a north façade along Walnut Street (Figure 8). The student chose two different types of glazing systems for the façades along Walnut Street, demonstrating an understanding of the different solar orientations of the façades. The student also included operable louvers on the south facing elevation to further control summer heat gains and allow passive

solar in the winter. These combine to demonstrate the multiple layers of sustainable approaches early in the design process.

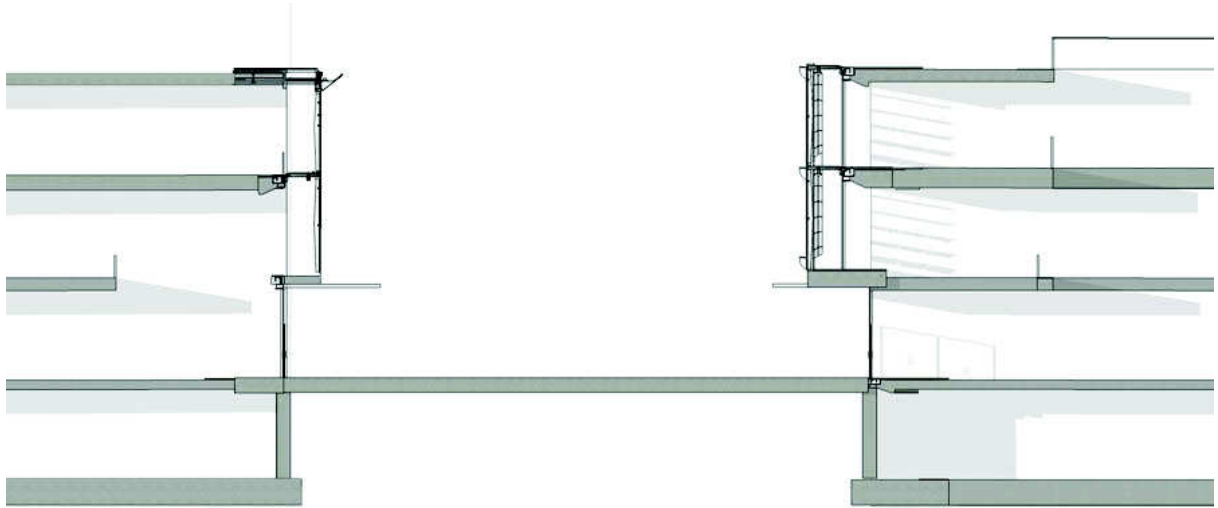

Figure 8: Elgin Community Art Center, schematic design section at Walnut Street. Source: (Stewart 2006)

CONCLUSION

The outcome of this approach was varied. Both the experience of applying LEED – ND criteria to a particular site within the *Four Entry Corridors Study* area and the research and documentation of a precedent high performance building façade yielded important formative student work. For the most part, students were able to negotiate the neighborhood scale following strategies derived from LEED – ND and they were able to understand the importance of connecting to existing infrastructure, transit, circulation, and working within existing site efficiencies. They developed a confidence in working with LEED. The students were enthusiastic about generating digital models of high performance building façades. They carefully chose relevant precedents with regard to solar orientation and building materials. On the other hand, value tensions at times arose because of the predictable struggles between design intent or programmatic need and environmental strategies. Reconciling those tensions in the massing and preliminary design stages of development was a difficult task for most students because of the leanness of their experience with sustainable approaches, yet most of the students remained enthusiastic about doing so. The design pedagogy was successful at energizing the students in this particular course and helped generate interest in sustainable design.

ACKNOWLEDGEMENTS

The author wishes to thank the M.Arch. degree students at Judson College Department of Architecture for their fine work in providing the content and materials for this paper; and the contributions of Dr. David M. Ogoli, Dr. Curtis Sartor, Professor Jack A. Kremers, and Mr. Marty Serena, architect.

REFERENCES

Lee, E., Selkowitz, S., Bajanac, V., Inkarojrit, V., Kohler, C., 2002, *High-Performance Commercial Building Façades*, Building Technologies Program, Environmental Energy Technologies Division, Ernest Orlando Lawrence Berkeley National Laboratory, University of California, Berkeley, CA.

Oesterle, E., Lieb, R., Lutz, M., Huesler, W., 2001. *Double-Skin Facades, Integrated Planning*. Prestel Verlag, Munich.

Rowe, P., 1991. *Design Thinking*. MIT Press: Cambridge.

Schittich, C., Staib, G., Balkow, D., Schuler, M., Sobek, W., 1999. *Glass Construction Manual*. Birkhauser: Basel.

www.bayer.com

www.usgbc.com

Education, Environmental Attitudes and the Design Professions

Traci Rose Rider¹ and Jack Elliott²

¹North Carolina State University, Raleigh, North Carolina

²Cornell University, Ithaca, New York

ABSTRACT: As the concept of sustainability continues to become more popular within society, a number of different professions are called on to help champion the movement. With the resource strain inflicted by the construction industry alone, dedicated architects and interior designers are important players in forward progress. Though many organizations and associations have been created to help the building industry embrace sustainability both practically and theoretically, the actual implementation of green building practices in construction has been minimal. The main focus of this study is to look at the influence of undergraduate education on designers' interest in sustainable design. Additional research interest was in environmental attitudes and the impact of interpersonal relations on those attitudes.

Self-proclaimed practitioners in the green building industry were surveyed through a specified email list of the U.S. Green Building Council. The survey was web-based and addressed issues including environmental attitudes, undergraduate education and professional training. Dunlap and Catton's widely-used New Ecological Paradigm scale was included to measure proenvironmental orientation of the professionals.

Contrary to the main hypothesis of the study, undergraduate education was not seen by subjects to be a fundamental force in the decision to concentrate on sustainability. A number of educational elements typically seen in environmental education, including interpersonal interactions, were mentioned by subjects as substantially influential and are therefore explored.

Conference theme: Education of future architects

Keywords: ethics, attitudes, design education

INTRODUCTION

"In the end we will conserve only what we love; we will love only what we understand; and we will understand only what we have been taught." ~ Baba Dioum

Sustainability has existed in the design world for centuries. At times labeled vernacular, these buildings responded to regional and local elements throughout history without the convenience of central air conditioning and complex drainage systems. As time and technology progressed, however, humanity became increasingly separated from nature and designs lost the necessity to reflect their surrounding environment. Much of design education has followed a similar path, slowly veering off regional and traditional knowledge to follow technological advancements, mobile professionals and lifestyles.

For the purposes of this research endeavour, "sustainability" and "green design" will be used synonymously. While there is much discussion about these two terms and their relationships to each other, this discussion is outside the scope of this paper; the terms will be used interchangeably.

Some schools have kept sustainability in the curriculum through fundamental dedication, and though these classes are not described as "sustainable" in either syllabi or course descriptions, some schools have a long-standing reputation as a "green school." With this integrated process, the students are exposed to a more comprehensive view and understanding of the impact of sustainability on both the final design and the process itself. Other programs seem to view sustainable design as a specialization that would require additional classes to be added to an already full curriculum.

Undergraduate education is a powerful factor in the forming of design ethics; it can be an equally powerful force regarding environmental ethics. Through the strategic integration of sustainability into whole

curriculum paths, students would begin to understand the interconnectedness between built forms and nature at an early stage in education, ingraining these ethics into the design process. With such an intense and longer-than-average curriculum, design programs have great potential to make an incredible difference in the direction of the ecological future of the design professions.

This study uses an online survey tool to address two of the most important foundational elements of design – sociology and education – through three distinct threads. First, Dunlap and Van Liere's New Ecological Paradigm Scale will be used to evaluate the environmental attitudes of current green design professionals. Second, the impact of undergraduate education as an influence on sustainability will be examined. Third, additional influences on pro-environmental attitudes will be reviewed and analyzed in conjunction with formal education. As important singular aspects of design, both sociology and education will be reviewed individually.

1. SOCIOLOGY

This study will create the argument that the environmental issues society faces are analogous to issues in the world of design and can be addressed through education and design training. Referencing Catton and Dunlap's New Ecological Paradigm (NEP) (Catton and Dunlap, 1978), which discusses foundational beliefs toward the environment, the importance of society's view of the environment in understanding the design profession will be illustrated through environmental sociology. Building on the parallel between the Human Exemptionalist Paradigm (HEP) (Catton and Dunlap, 1978) and the design field, similarities between the HEP and the foundation of education within the design profession will be explored, ultimately arguing that the design field is in dire need of a restructured paradigm, much like that outlined in the NEP.

Designers are, above all, both human and a part of society. Because of this underlying truth, both the history of environmentalism and influences on environmental attitudes must be looked at. Society's environmental attitudes have been addressed in the growing field of environmental sociology. There are understandably a number of shades of grey when discussing the field, but as growing organizations such as the Society of Building Science Educators, the AIA Committee on the Environment, the Association for the Advancement of Sustainability in Higher Education and others illustrate, there is something worth investigating as seen in the recent expansion and popularity of the views on the environment. This paper cannot do justice to the comprehensive works done on the topic of environmental sociology, but will attempt an overview for the sake of relation to the design field.

1.1 Environmental Sociology and the NEP Scale

The field of sociology has been well-established for centuries and throughout these years, sociology practitioners became comfortable within the field, allowing the evolution of assumed standards. Though these standard beliefs are never actually outlined, in the 1970's Catton and Dunlap felt that these assumptions had become prerequisites for the practicing of sociology and were dictating how scientists approached their topics. Because they now perceived the original root of the field of sociology to be primarily based on human centrality and a fundamental view that humans are exempt from ecological principles and limitations, Catton and Dunlap designated the traditional mindset as the Human Exemptionalism Paradigm (HEP) (Humphrey, 2002).

The HEP theory, which they feel dominates modern day society, is based upon a Dominant Western Worldview (DWW) (Buttel, 1992). The basic fundamentals of the DWW are: (1) People are fundamentally different from all other creatures on Earth, over which they have dominion; (2) People are masters of their destiny; they can choose their goals and learn to do whatever is necessary to achieve them; (3) The world is vast and thus provides unlimited opportunities for humans; and (4) The history of humanity is one of progress; for every problem there is a solution, and thus progress need never cease (Dunlap and Catton, 1980). Through this reasoning, the basic anthropocentric values of the DWW and the HEP are to blame for the current state of the environment. More significantly, in response to these traditional anthropocentric sociological theories, Catton and Dunlap created a "New Environmental Paradigm" (NEP) (Dunlap and VanLiere, 2000). The overarching intention of this creation was to identify core values of the environmental sociology realm that would not sway with the society's fickle interest in environmental issues. Catton and Dunlap's NEP revolved around the idea that humans are actually entwined in the circle of life where ecological laws cannot be overruled by human ingenuity.

When first created in the late seventies, the NEP environmental attitude scale itself addressed three proposed indicators of an environmental worldview: anti-anthropocentrism, limits to growth, and the balance of nature (Dunlap and VanLiere, 1978). In 1990 the original 12-question scale was revisited and adapted, with the addition of two new areas of concern: the possibility of an ecocrisis and the rejection of human exemptionalism (Dunlap and VanLiere, 2000). This new scale had fifteen questions and was found to be just as successful in the prediction of an ecological worldview while covering more topics. A number of studies on specific populations have helped to solidify the original findings that the scale denotes proenvironmental attitudes as well as establishing known-group validity (Pierce et al., 1992). Additional studies have supported predictive validity by illustrating a significant relationship between the NEP scale and a variety of intended behaviors and actual behaviors, both observed and self-reported (Edgell and Nowell, 1989).

1.2 HEP/NEP and the Design Practice

The HEP/NEP debate is easily applied to the design professions. Paralleling the field of sociology, designers' actions and beliefs are historically based on underlying presumptions reflecting the HEP view as stated earlier. Examples include the unchecked harvesting of forests, extracting of minerals for construction materials, and tearing down buildings no longer perceived to be attractive - only to replace them with other equally-dated structures likely to be torn down later. Though there are no direct correlations to the design professions found in the NEP literature, the foundations of the NEP translate easily. In sociological terms, non-green, conventional designers would be advocates of the HEP point-of-view. The market is the HEP-type designer's primary concern; demand is the ultimate design authority. In line with the Dominant Western World view and HEP perspective as covered earlier, a resource become scarcer, cost rises, and human ingenuity creates alternatives.

The HEP/NEP paradigm shift has been applied to a number of specific populations and could be applied to the design field. While no studies have been found to use the NEP scale on the design and construction professions, a number of the questions used within the scale can arguably relate directly to the field. For example, Statement Two in the NEP survey, "Humans have the right to modify the natural environment to suit their needs," directly addresses the very purpose of the design profession. While Dictionary.com has the definition of the term architecture as "the profession of designing buildings, open areas, communities, and other artificial constructions and environments," it is easily argued that in order to do this the profession is directly modifying the natural environment. Statement Four, "Human ingenuity will insure that we do NOT make the earth unlivable," can be translated to speak directly to technological advancements in the building industry. In Statement Six, "The earth has plenty of natural resources if we just learn how to develop them," references issues in design and construction including forestry management and energy conservation. By viewing these questions through an architect's lens, it is apparent how the HEP/NEP debate could be applied to design.

2. EDUCATION

The environmental education movement has its foundation in rural and local studies in the 1960's (Sterling, 2001). The term "environmental education" became popular in the 1970's, and began to encompass the ethical, political and urban issues that had been previously left to other fields. The 1980's wrapped global issues into the field while the 1990's allowed "environmental education" to be grouped with other movements looking to education for change, such as social equality. Some researchers and experts believe that traditional education is based on an outdated set of cultural beliefs and assumptions with an anthropocentric viewpoint and that a shift to environmental communication and education can be a catalyst for change (Bowers, 1995). In 1987, the World Commission on Environment and Development published The Brundtland Report, more commonly known as "Our Common Future," which helped to fuel change in education by articulating a unified world view and a global problem.

Public schools and higher education have been identified by many as a critical leverage point for change in environmental thinking. Some argue that the fundamental flaw with this is that the majority of education is primarily based on outdated assumptions and values, as noted above. Sterling (2001) claims that traditional education is behind the times in a number of ways: (1) it takes a "fundamentally mechanistic" view of the world; (2) it is primarily ignorant of issues concerning sustainability; and (3) it is uninformed of the growing ecological thinking that intends to more fully integrate humanity with the environment. In an effort to change the foundational emphasis and assumptions of education, much like the New Ecological Paradigm in sociology (Catton and Dunlap, 1978), new goals and values must be established. As the field of sociology was perceived by Catton and Dunlap to hold to anthropocentric views as an outdated foundation, the educational field is considered by some to be functioning on outdated fundamentals as well. In line with adjacent popular sociological theories, education is predicated on the assumption that human ingenuity will always prevail. Similar to the discussion on traditional education, much of the design curriculum has been established and accepted for decades at the very least, without much change in perspective. Design foundation classes revolve around perspectives, sight lines, traditional materials and traditional construction. Rarely are there required classes including ecological connections and sustainable design elements.

Sustainability education is felt by some to *not* have the goal of creating throngs of environmentalists, but to implement lifelong learning as well as civic, social, emotional and academic competencies, creating a better world at all levels in the future (Santone, 2003). Some elements addressed are critical thinking, transformative learning, participatory education, systematic education, ownership of learning, informal education and knowledge of place. While there is a wide range of literature on each of these individual subjects, not all can be addressed in this scope though many can easily be applied to design education.

2.1 Design Education

This paper supports the position that modern designers have historically envisioned themselves as separate from environmental problems, choosing to believe that the task at hand is, at a fundamental level, *only* an issue of composition and space formation. The primary concerns for design professionals typically hinge on two facets of design: the creation of spaces to enhance productivity through adjacencies, circulation and square footage and the aesthetics and composition of the proposed space.

It should be acknowledged that these statements seem overly jaded; design professionals often perceive themselves to have an enriched sense of duty beyond those stated above, which may be social responsibility, public design or improving the well-being of users. It is not too much of a stretch, however, to state that the typical designer is concerned primarily with the human relationship to the built-environment, not the built-environment's relationship to nature. This indirect defiance has been referred to as the "Ostrich Syndrome" in the business world, insinuating that professionals bury their heads to continue with their work, without disruption (Hasan, 1993); the thought being that if the professional is unaware of environmental problems to which they are contributing, there is no need to take steps to change ingrained habits. With these established behaviors come the loss of both the desire and at times the ability to question daily, habitual choices.

Many design education programs remain basically unchanged because they may be seen as beyond reproach and too entrenched in tradition. Though the history and reputation of conventional American design schools is important, it will be assumed that readers of this article are well aware of challenges and benefits of established paradigms such as breadth of classes, lack of electives, concentrated focus and technical expertise.

While there has been little research addressing sustainability within design education, a few articles and examples have been published addressing the topic. A yearly survey done by *Metropolis Magazine* in 2003 states that while it is fundamentally true that grassroots environmentalism is having an effect on design and architecture, the integration of sustainability into formal education leaves much to be desired. It was reported by educators that: two out of an average of eleven studios were dedicated to sustainability; twenty-seven percent said that between one and three required courses were focused on sustainability; forty-six percent were attempting to thread sustainability through the foundation of their program; and that funding was the biggest barrier to integrating sustainable design into the curriculum (Szenasy, 2003).

The topic of implementation pertaining to environment-based education in design programs is entirely too broad to tackle in this scope. However, some educational elements highlighted in the environmental education discussion, such as participatory education and informal influences, are appropriate to explore in relation to design training and environmental attitudes. By investigating the influences of established green building professionals, it will be possible to begin to identify some of the most effective means of sustainable education, as well as those elements that are consciously perceived to make design professionals to "go green."

3. METHODOLOGY

Three main objectives have been identified in this study. The first goal is to evaluate environmental attitudes of established green building professionals through the use of the NEP Scale. Second, determine the most effective factors in steering design professionals towards sustainability. The third goal is to look at the impact of design education on a professional's decision to go green. Each hypothesis was created to address different levels of influence on sustainability. The hypotheses of the current study are as follows:

HO1: Design professionals interested in green design will score high on the New Environmental Paradigm scale.

HO2: Design professionals interested in sustainable design will attribute their interest to the design education that they have experienced.

HO3: Personal interactions, such as attending a speech or the enthusiasm of a coworker, will be the most powerful influence second to formal education.

3.1 Research Design

The design of this study is a simple case study design, concentrating on the influences of a single group of environmentally-friendly designers. In efforts to maintain a manageable study, no second control group was implemented. The intention was to look at the influences that effect interest in sustainable design, as well as the possibility of an interaction of education. Because of the need to reach a large number of people across different locations, an online survey was determined to be the best medium for this study.

A short preliminary survey pertaining to undergraduate experiences and influences was developed and administered to just fewer than two hundred students and young professionals already interested in the green building movement. The preliminary survey was administered at Greenbuild, the U.S. Green Building Council's annual conference and expo held in Portland, Oregon, November 9-12, 2004. Because of the general scope of the survey, questions were both simple and broad. Five of the questions were simply for categorization. The total number of preliminary surveys handed out is unknown. Of the thirty-six responses to fully complete the survey, 86% said that they had an undergraduate experience dealing with green design. Of those, 61% claimed that that experience was integral in turning their interest towards a sustainable trajectory. Seventeen of the respondents were in either Architecture or Interior Design and of these respondents all claimed that they did have an undergraduate experience in green design. Of those respondents, nearly 59% of designers cite this undergraduate experience as integral to their interest in sustainable design. In addition to the correlation to undergraduate studies, other influences on their interest in sustainability were noted to be exposure to influential speakers and books; first hand experiences and service learning; upbringing and peer enthusiasm.

A Likert response scale was chosen because of the familiarity of the scale to the general population, in addition to the perceptual ease of completing the survey. By allowing for intensity of attitude expression through possible selections of "agree" or "strongly agree," a greater variance of results is received (Kerlinger, 2000). When the pool of questions was sufficiently compiled, the second version of the survey was sent to a small sample of professionals indicative of the larger target population to be studied. Thirteen responses were received. A blank section for feedback was provided on the survey for additional insight, and the survey was altered in light of these comments and was narrowed to forty-three questions. The well-known study performed in the late seventies by Dulap and Catton, which was created in an attempt to measure the popularity of an ecological worldview (Catton and Dunlap, 1978), was referenced and the full fifteen questions were added to the survey.

The final survey consisted of fifty-five questions allocated in the following way: fifteen questions addressed environmental attitudes per the NEP scale; eleven questions addressed general lifestyle choices and background; twenty-four questions addressed both education and professional experiences. The final question was a blank allowing for respondent email identification if they wished to be compensated through a drawing.

The final email survey was presented to a representative sample of green building professionals in April 2005. The survey was administered through a specific email from the Chapter Coordinator of the U.S. Green Building Council (USGBC), reaching approximately 200 professionals, specifically leaders of local USGBC chapters around the country. The leadership and members of each of the chapters are quite diverse, encompassing design firms as well as press, schools, financial firms, manufacturers and other interested parties. One follow-up request was sent out the following week. A total of sixty-eight survey responses were recorded through WebSurveyor's Desktop online program.

4. RESULTS

The overall environmental position of this group of green professionals on the attitude spectrum as outlined by the NEP scale will be assessed. Common view-points, as well as peculiarly uncommon view-points, will be noted as well. Thirty-five of the sixty-eight respondents indicated that they were either architects or interior designers, for 51.5% of the total responses. This narrowed population will be the overall focus of these results.

The overwhelming majority of green building professionals responding to the survey scored high on the NEP Scale, as did the group of proclaimed green design professionals. Each of the responses to the fifteen line items indicates the majority of respondents endorse ecologically-friendly positions and beliefs. For questions concerning Limits to Growth, the majority of subjects responded in line with a pro-ecological view. For questions addressing anti-anthropocentrism, the majority of subjects again responded in an environmentally friendly manner. While responses to certain questions were indicators of pro-environmental values, other similar questions were less polarized, with just 30.3% either agreeing or agreeing strongly with the statement regarding humans' right to modify the environment. Two questions addressed the rejection of exemptionalism and showed that the vast majority of designers are in agreement with pro-environmental views. However, when addressing human ingenuity responses spread across Agree, Unsure, and Disagree with approximately 30% in each.

The responses were most uniform for questions addressing the fragility of nature's balance and the possibility of an eco-crisis. When pertaining to nature's fragility, at least 75.8% of the total subjects indicated pro-ecological attitudes in all three. For questions addressing the possibility of an eco-crisis, the overwhelming majority indicated a pro-environmental stance with at least 87.9% in agreement. While a few indicated that they felt unsure, only one individual answered against pro-environmental values in all three of the questions.

Of the thirty-five respondents in this designer group, the majority finished their undergraduate work between 1980 and 2000. Seventeen (41%) indicated that education was not a factor in their interest in sustainable design. Only 34% cited some form of higher education as an influence. Of those, 83% felt that their undergraduate experiences were more formative than their graduate experiences. Sixty percent of respondents disagreed to some extent that sustainability was never addressed in their undergraduate education.

Only one of the responding designers indicated choosing their place of undergraduate education based on environmental view and sustainability reputation. Sixty-eight percent disagreed that sustainable reputation had anything to do with their choice in what program to attend. Only 5.9% of the total sample of sixty-eight selected their formal education based on the green reputation of the school. Eleven percent responded that they strongly agree that they entered the program with an intent to study green design; 23% simply agreed; 29% replied neutral; 23% disagreed; and 11% strongly disagree. Only one respondent of the designers indicated agreement with the statement that their school addressed sustainable issues more in curriculum than other design programs would have. The other 97% felt that their programs were on par with the environmental pulse throughout the rest of the design schools at the time.

The majority of responding designers (65.7%) do not attribute their interest in sustainability to education at all. Of the remaining 31% that do credit their education as a factor in their environmental views, 63.6% cite an elective class as the spark of interest. Of the 40% of respondents indicating that a class did influence them, 61.5% claimed that the class was design related, while 38.5% said it was an elective outside of the design school. Ten of the designers (28.6%) could point out a specific professor that was an influence on their green building position. This is consistent with 30.4% of the *total* respondents who could also identify one instructor

that they felt made a difference in their position. When asked about the inclusion of environmental authors such as Thoreau, Emerson, John Muir and Rachel Carson, 91.4% of designers agreed to some extent that these authors should be included more in design curriculum.

4.1 Professional Interests & Additional Influences

Two of the thirty-five designers (5.7%) did not view themselves as green designers, while the remaining thirty-three did. In the whole sample of sixty-eight subjects, twelve (17.4%) did not perceive themselves to be "green." One individual gave a neutral answer to the question addressing sustainable issues as honestly too bothersome to address on a daily basis. The respondents, both overall and only designers, unanimously agreed that they have the ability to make a difference in the environment through their profession.

None of the responding designers indicated that they were interested in sustainability due to marketability, professional reasons, internships, service learning, and recreation interests. The remaining proposed factors are fairly equal in response: two individuals (5.7%) indicated that they were influenced by a speaker; three (8.6%) were influenced by travel; five (14.3%) were influenced by formal education; five others (14.3%) were swayed by attending a conference; three more (8.6%) were influenced by a book or article; two (5.7%) credit a co-worker while one (2.3%) credits an acquaintance; five more (14.3%) tribute their upbringing; and eight (22.9%) attribute their interest in sustainability to other factors altogether.

5. DISCUSSION

While the surge in green design is at an all-time high, there is still far to go in the movement. The results of the survey indicate that those design professionals involved in green design are fundamentally dedicated to sustainability. All responses suggested that the interest in sustainability was sincere and heart-felt, as opposed to the possible interest for a career boost.

5.1 Hypothesis One - NEP

In reference to the NEP scale portion of the survey, the results reinforce earlier findings that special interest groups and environmental organizations score high on the NEP Scale (Edgell and Nowell, 1989). Proving Hypothesis One correct, the results illustrate pro-environmental tendencies within the group.

There are questions whose responses were not as significantly aligned with the pro-environmental indicators as the rest of the survey. Question six, which refers to the development of natural resources, was one of these questions. This may be the case due to the pre-determined nature of architecture and design as referenced earlier in the background section, which assumes that additional resources are ultimately needed to continue the growth of the built environment. Question two was also less clear, and may be attributed to the same reasoning; referring to the right of humans to modify the natural environment to suit their needs, this question addresses the very premise of architecture as currently understood.

Question four, speaking to the rejection of exemptionalism and human ingenuity, returned the most uniformly spread responses from the group of designers. This may be the case because designers are trained to be creative and rely on ingenuity to problem solve on a daily basis. This ingrained perception within the designer population may be at odds with their fundamental environmental positions, resulting in the spread out responses.

The responses were most uniform for questions addressing the fragility of nature's balance and the possibility of an eco-crisis. This may point to a lack of ecological knowledge in the design field, resulting from the narrow focus of design education. It could also indicate the perception that there is little interaction between the design fields and nature's balance and an eco-crisis, while the topics of anthropocentrism, limits to growth and exemptionalism may likely have a direct effect on the design professions.

5.2 Hypothesis Two - Education

Contrary to Hypothesis Two, the vast majority of green professionals did not attribute their desire to concentrate on sustainability to their formal education. There is some unclear data that should be looked at more carefully. While sixty percent of the respondents felt that sustainability was addressed in their undergraduate education, forty percent did not feel that their education affected their environmental ethics in relation to green building. This could be attributed to self-selection into the program for those already environmentally friendly or possibly credited to a delayed effect where the teachings were not fully realized until much later in their professional development. Similarly, it could be due to the differences in programs, teaching styles, curriculums or any number of other small differentiations in the schools. Regardless, education is not being identified by the majority of green designers as an influence on their interest in sustainability.

The large percentage of subjects that claim they did not choose their school based on sustainable reputation shows that many other elements of design education were playing a larger role in selection. This could be attributed to the possibility that not many programs had classes based in green design during the 1970s, 1980s and 1990's when many were entering school, or were simply not called them by those terms. A number of schools have a well-known reputation for being sustainable, but would be difficult to quantify for a researcher when looking at course titles, online descriptions and other easily accessible information. It may also be attributed to the fact that green building programs may not have existed at the time.

Of the thirty-five percent that did cite some form of higher education as an influence, the majority (83.3%) felt that their undergraduate experiences were more formative than their graduate experiences. This speaks to not only the importance and impact of undergraduate design curriculum, but also the possibilities for influence on the profession if there were a major swing in sustainability curriculum in formal design education.

Results indicate that the majority of those affected by classes were influenced most by electives and not by design classes. This points toward a lack of green classes offered as a required part of the curriculum. This confirms previous surveys on sustainability in design schools where 27% claim having one to three classes required (Szenasy, 2003). Other subjects indicate the importance of design related classes, which emphasizes the significance of applicability and practicality. Classes such as service learning and participatory education that are informative and explicitly illustrate the implications of green building elements are found to be most productive and useful. Still other subjects indicated that the class most influential was outside the design school, lending support to the importance of systems thinking and interdisciplinary learning as covered previously. While the theme of the overall responses indicates that formal education did not affect the professional choice to think green, the overwhelming majority of respondents advocated more environmental readings during undergraduate education. While the remaining did not advocate it, neither did they disagree with it. This would indicate that these designers felt that environmental readings would have been more beneficial in retrospect, and would be suggested for future courses in all design programs.

5.3 Hypothesis Three – Personal Interactions

Data supports Hypothesis Three by showing that personal interactions are important in emphasizing environmental attitudes. By combining interactive means such as travel, conferences, speakers, co-workers, and personal acquaintances, results show that 37% of professionals credit these methods of moving them toward sustainability, as opposed to the 14% that actually did credit higher education. In reality, a number of subjects indicated “other” in their responses, which was seen to include items such as “girl scouts,” “travel combined with education,” and “observation.” If these specific elements were teased apart in more detail, it seems that they would likely fall into the categories of either education or personal interaction. Though it was left out of this calculation, it may also be appropriate to include both “reading a book/article” and “upbringing” within the personal interaction category.

5.4 Limitations of Current Study

While the scope and parameters of the current study were selected for their ability to provide a wide range of data, a number of factors in the present research design are limiting. The limitation of personal bias must first be acknowledged. As a design professional deeply interested and dedicated to sustainable design, as well as deeply believing in the importance and impact of education, personal bias of the researcher may have had an effect in either the creation of questions or in the translation of responses.

By focusing on just one of the factors addressed in this study – environmental attitudes, formal education or environmental influences – research efforts would be able to dig deeper into each of these facets, likely revealing more concrete findings. While combining the three components into one research design does allow for additional relationships to be reviewed, it also has the potential to confuse the subjects. Another limitation is the sample size returned from the online survey, as well as the manner in which it was administered. Though the overall number of returned surveys was decent at sixty-eight, only thirty-five of the respondents fell into the categories of architect or interior designer, the two fields that were being targeted in the study.

A more representative sample would also help to increase the number of subjects that completed their study in the year 2000 or later, which is when the “sustainability” buzz word would have become most integrated into curriculums. Because the majority of subjects graduated between 1980 and 1990, results will reflect specifically what was happening historically in the field at that time. A better distribution of subjects would help to filter out that influence. Also, by concentrating on only a handful of schools and programs, some of the finer elements pertaining to classes and influences could begin to be teased out of the data.

5.5 Future Research and Implications

To thoroughly investigate the scope of this research, a number of additional studies should be conducted specific to each of the factors addressed. Research concentrating particularly on environmental attitudes within design as outlined through the NEP should be conducted (Dunlap and VanLiere, 1978). A comparative analysis of environmental attitudes between populations of designers should be performed. The NEP Scale could also be used on a larger sample of design professionals, with established green design professionals as a control group.

In light of these NEP survey results, the question then turns toward the actions and behaviors of these green design professionals within the workplace. While the group as a whole does declare their allegiance to pro-environmental attitudes, this does not mean that they exhibit pro-environmental behaviors. Additionally, differentiations between pro-environmental behavior in private and professional lives should be considered.

Educational influence can be researched further in a number of different ways. Students could be given the NEP survey as they enter design programs and again when they graduate; this would measure any change

in environmental attitudes while at school, providing a measurable aspect of the education experience. Detailed, objective program profiles should be created addressing green design, incorporating the program's dedication to sustainability. This could include an alumni tracking and comparison study focusing on the tracks and positions of alumnus of different programs, while attempting to discern the differences in environmental attitudes of the alumni. Closely related, the NEP Scale could be administered in conjunction with different levels of programs and types of curriculums. This would be helpful in understanding the true effects of university level design curriculum on environmental attitudes and behaviors by contrasting responses from entry-level cohorts. A list of the most effective school programs could also potentially be developed. Additionally, this vein of research could be easily extended into the realm of continuing education for both architects and interior designers.

Of great importance is the guidance that these results provide and the future research within environmental education and design. A future study should address the relationship between environmental education methods and design programs, highlighting effective ways to introduce sustainability to students regardless of the specific curricula and different programs. As noted previously, a number of informal and non-traditional efforts have a substantial impact on undergraduate students relating to the environment.

6. CONCLUSION

Contrary to Hypothesis Two, most green design professionals did not credit their undergraduate education with turning their professional interests toward sustainability. Though many programs and departments indicate that they do offer courses in sustainability and environmental design (Szenasy, 2003), graduates themselves are not feeling the effect. While many respondents did not credit their education with their interest in sustainability, a substantial portion of subjects cited electives as important in the forming of environmental ethics during school. One possibility is that there were not many required sustainable design classes available, making electives the only option, either within or outside the department.

Because of the responses pertaining to electives and education, it is believed that education has the possibility of being more important in turning toward sustainability than an initial glance as the results from this study seem to indicate. The subjects responded in great numbers to suggestions for design education reform, indicating a true interest and allegiance to design education. Suggestions, such as the reading of more environmental literature in the classroom, were met with overwhelmingly positive response. The combination of these responses lead to a sum greater than all the individual parts; while education itself is not ranked highly as a factor, each of the individual elements received high marks.

The results of this study indicate that the individual elements of environmental education, most likely found in electives, are what graduates remember in relation to environmental ethics in design education. This study supports the fact that a number of individual elements could be successfully incorporated into design education to encourage environmental behavior. The combination of various educational methods in design education provides undergraduate programs the potential to deliver necessary environmental knowledge, values and impact that future professionals in the design industry desperately need. By increasing the exposure to these different alternatives, current and future professionals alike will be reminded that design is not simply about aesthetics and functionality. With it comes that higher calling, to create healthy buildings not just for the users but also for the natural environment, allowing future generations to meet their resource needs as we are currently able to meet ours.

REFERENCES

- Bowers, C. A. (1995). *Educating for an Ecologically Sustainable Culture: Rethinking Moral Education, Creativity, Intelligence, and Other Modern Orthodoxies*. Albany, State University of New York Press.
- Buttel, F. H. (1992). "Environmentalization: Origins, processes, and implications for rural social change." *Rural Sociology* 57: 1-27.
- Catton, W. R. and R. E. Dunlap (1978). "Environmental sociology: a new paradigm." *American Sociologist* 13: 41-49.
- Dunlap, R. E. and W. R. Catton (1980). "A New Ecological Paradigm for a Post-Exuberant Sociology." *American Behavioural Scientist* 24(1): 15-47.
- Dunlap, R. E., K. D. VanLiere, et al. (2000). "Measuring Endorsement of the New Ecological Paradigm: A Revised NEP Scale." *Journal of Social Issues* 56(3): 433.
- Edgell, M. C. R. and D. E. Nowell (1989). "The new environmental paradigm scale: Wildlife and environmental beliefs in British Columbia." *Society and Natural Resources*(2): 285-296.
- Humphrey, C. R., T. L. Lewis, et al. (2002). *Environment, Energy and Society: A New Synthesis*. Belmont, CA, Wadsworth-Thomson Learning.
- Pierce, J. C., M. E. Steger, et al. (1992). *Citizens, political communication and interest groups: Environmental organizations in Canada and the United States*. Westport, CT, Praeger.
- Santone, S. (2003). "Education for Sustainability." *Educational Leadership*(December 2003/January 2004).
- Sterling, S. (2001). *Sustainable Education: Re-visioning Learning and Change*. Bristol, Schumacher Society.

The Green Studio Handbook: Environmental Strategies for Schematic Design

Alison G. Kwok, Ph.D.¹ and Walter T. Grondzik, P.E.²

¹University of Oregon, Eugene, Oregon, USA
²Architectural Engineer, Tallahassee, Florida, USA

ABSTRACT: In design studio projects we often see schemes with inspired, yet unvalidated, gestural sketches related to wishful green strategies. Yellow and blue magic arrows represent hypotheses about the behavior of daylight and/or air flow in and about buildings. This paper provides an overview of *The Green Studio Handbook*, recently published as a resource for designers seeking clear guidelines for integrating green design strategies into the conceptual and schematic phases of design. The book contains a discussion of the integration of green strategies and how building form, orientation, and spatial layout are critical to the proper performance of certain green strategies; 40 green design strategies in six broad topic areas, each providing a catalog of information for common strategies that must be implemented at the schematic design phase; and nine case studies that show how various green strategies work together in a finished building. This paper provides excerpts of several design strategies and one case study and suggests a variety of ways that the book may be used.

Keywords: green design, case studies, education, schematic design

INTRODUCTION

In design studio, students often draw upon precedents to inspire their design work. Gesture sketches are refined and further developed. Green design strategies are commonly relegated to magic arrows (to show air flow) or yellow lines (to show the path of the sun or flux of light). Often, design hypotheses are left untested or unquestioned simply because there is no readily available method or means to appropriately size windows for cross ventilation or determine how much light will enter a room under particular sky conditions. This paper gives an overview of a number of green design strategies and case studies from a recently published work—*The Green Studio Handbook* (Architectural Press: Oxford, 2007)—which is offered as a resource to assist students (and practitioners) in integrating green strategies into the beginning stages of design.

The Green Studio Handbook presents guidelines for the application of selected environmental strategies during the schematic design of green buildings. The *Handbook* provides a discussion of green design at the schematic design phase and an essay on integrated design. The majority of the book is devoted to 40 design strategies, each providing: brief descriptions of principles and concepts, step-by-step approaches for integrating the strategy into the early stages of design, annotated tables and charts to assist with preliminary design sizing, key issues to be aware of when implementing the strategy, and references to further resources. This information is reinforced with conceptual sketches and photos illustrating each strategy. A chapter with case studies of several green building projects provides context for the strategies presented.

The rationale for this book arose from an observed need for a resource that could provide a concise catalog of information for a range of green strategies to help the designer not only understand how each strategy functions, but also offer data, information, and a sequence of design steps to give a preliminary estimate of sizing, appropriateness, and links to related strategies. The designer may practice “smart aesthetics” by linearizing part of the design process to achieve valid, initial design moves. The fundamental premise of this book is that if appropriate strategies are not included during the schematic design phase of a project, they may never be included since many such strategies are demanding form-giving. Poor decisions related to building orientation, massing, and layout are nearly impossible to rectify in later design phases in an attempt to back-integrate high performance daylighting, passive heating, or passive cooling systems.

This paper includes four parts:

- a discussion of the schematic design process, where design decisions about certain green strategies become critical to building form, orientation, and spatial layout;
- a review of several strategies describing the principle/concept, design procedure, and examples;
- a description of one of the case studies and its integrated strategies, including information regarding the designers' intentions with regard to green design, related design criteria, design validation methods used (modeling, simulation, hand calculations), and post occupancy validation methods if available;
- a discussion of how this book may be used in design studio and potentially in other areas of the curriculum.

1. SCHEMATIC DESIGN PROCESS

As a multifaceted pursuit, the design process includes cultural, technical, formal, and programmatic emphases that ultimately result in a proposed architectural expression. The green design process, by necessity, requires the designer (at least in the early schematic stages) to assume a greater than normal degree of expertise in several technical areas in order to pursue an integrated design. This necessity also represents an opportunity for innovation.

1.1 Defining the Problem

1.1.1 Schema: The early design process incorporates the moments when the project is conceptualized, the intentions are elaborated, and an organizational logic is settled upon—whether that logic is strict or informal, internalized or driven by externalities, or simply a geometric gesture. The first sketches or outlines, a plan of action, a systematic or organized framework can provide the opportunity to define goals and to set criteria that will benchmark success. This is the time to set a direction for form and to gather ideas and concepts. It is not the time, however, to close the mind and crystallize all relationships. The initial steps toward achieving an integrated design, such as forming a team with a shared set of green goals and a desire for innovation (and learning), is the territory wherein green strategies are initially discussed, adopted, and integrated. Opportunities for many of green strategies will be lost forever if not incorporated during schematic design.

1.1.2 Intentions: At the beginning a project, it is important to define owner and design team expectations for building performance. It should be decided whether the building will perform to minimum standards (as embodied in building codes) or will strive to surpass them—which must be the case for a green building. What kinds of performance will be emphasized: energy efficiency, quality of light, or air quality? What degree of green design is to be considered? The intentions must be clear because they point to the refinements of process, the type of team, and the potential strategies and technologies that will be most appropriate for a given project. Sometimes, a charismatic and knowledgeable team member can convert others to a deep green commitment.

1.1.3 Criteria: Project criteria are the standards by which judgments and decisions are tested. They are often established by a legal authority, local/regional custom, or general consent; but for innovative projects the truly critical criteria are often internally established. What is really meant by green? Who decides; and on what basis? Criteria can be derived from quantitative standards (such as energy efficiency) or from qualitative values (such as a desired lighting effect). Criteria should be realistic so they can be met; they should also be stringent enough to provide a challenge and meet design intent.

1.1.4 Validation: The design team must be conscious of the types of issues to be framed and the most appropriate design methods and strategies to address the focus issues. The way a designer frames issues speaks to the outcomes. More importantly, a knowledge-based profession reflects upon previous efforts and specifically learns from successes and failures. Collapses occurred during the construction of Chartres. Calculations and formulations about how materials work under the forces of gravity were rethought and the building of the famous cathedral continued. Knowledge-based design is also needed when dealing with environmental forces, although they are often more subtle, complex, and variable than gravity. A different type of feedback loop is required, one not founded upon collapse, but one that is part of an integrated process—involving learning from others and learning from analysis. The analysis of an existing project (as a precedent or case study) informs the development of hypotheses of how things should work on future projects.

1.1.5 Prioritizing: It is important to give order to intentions and goals. Prioritizing goals helps the designer and client to understand what is most important, what can be discarded, and how flexible are proposed solutions. As with any design process, one works through sets of ideas to get to a clarification of goals. This is particularly important with green design because one strategy can negate or conflict with another.

1.2 Formgivers

1.2.1 Daylighting: Light has clearly been understood as a formgiver throughout the history of architecture. The Pantheon dramatically captures light from an enormous oculus; Alvar Aalto's buildings use light scoops to utilize the low solar resource of the northern latitudes. Traditional passive solar design uses solar-oriented glazing in combination with thermal mass to provide heating. Windows, however, must be carefully sized and arranged to provide a balance between the correct amount of thermal resistance, light admittance, and solar collection. To arrive at a daylighting strategy, appropriate lighting level criteria should be established based upon the functions and needs of the various spaces, then potential solutions proposed, tested, and evaluated using daylighting models or other available tools. Such studies should provide for distinct lighting effects—and result in a distinct building form.

1.2.2 Passive and Active Strategies: Passive design means that nature (and the architect) does the work. Passive strategies adjust to environmental conditions primarily through the architecture and should be considered before active. This means that the architect must be strategic. It means using the resources on site rather than importing energy from a remote source. The careful placement of walls, windows, and overhangs can help to "green" a project; otherwise mechanical equipment (and engineering consultants) will be forced to do the job.

2. GREEN DESIGN STRATEGIES

The book contains 40 strategies (see Table 1), each with a brief description of underlying principles and concepts, a discussion of architectural design and implementation issues, a step-by-step design procedure to assist with preliminary design sizing, key issues to be aware of when considering a given strategy, conceptual sketches and photographic examples, and pointers to sources for further information. There are both active and passive strategies, but many more passive strategies are included since they require early implementation during the design process and are typically more form-shaping. Many green strategies (such as material finishes) are not included as they have virtually no impact on schematic design decisions. The book is not a catalog of green design strategies—it is a catalog of green strategies for schematic design.

Table 1: Green Strategies in *The Green Studio Handbook*

TOPIC and STRATEGIES	TOPIC and STRATEGIES
ENVELOPE	COOLING
Insulation Materials	Cross Ventilation
Strawbale Construction	Stack Ventilation
Structural Insulated Panels	Evaporative Cool Towers
Double Envelopes	Night Ventilation of Mass
Green Roofs	Earth Cooling Tubes
	Earth Sheltering
LIGHTING	Absorption Chillers
Daylight Factor	
Daylight Zoning	HEATING
Toplighting	Direct Gain
Sidelighting	Indirect Gain
Light Shelves	Isolated Gain
Internal Reflectances	Active Solar Thermal Systems
Shading Devices	Ground Source Heat Pumps
Electric Lighting	
WATER AND WASTE	ENERGY PRODUCTION
Composting Toilets	Plug Loads
Water Reuse/Recycling	Air-to-Air Heat Exchangers
Living Machines	Energy Recovery Systems
Water Catchment Systems	Photovoltaics
Pervious Surfaces	Wind Turbines
Bioswales	Microhydro Turbines
Retention Ponds	Hydrogen Fuel Cells
	Combined Heat and Power

2.2 Sample Strategy: Green Roofs

Green roofs can be used for rainwater detention or retention, to increase the thermal resistance and capacitance of a roof assembly, to reduce the urban heat island effect, and/or to provide habitat for animals or an amenity for people on what would otherwise be a hard-surfaced area. Green roofs are of two basic types: extensive and intensive.

Extensive green roofs have a relatively shallow soil base, making them lighter, less expensive, and generally easier to maintain than intensive green roofs. Extensive roofs usually have limited plant diversity, typically consisting of sedum (succulents), grasses, mosses, and herbs. They are often not accessible to building users, but may provide for “natural” views from adjacent rooms or neighboring buildings. Extensive green roofs can work at slopes of up to 35 degrees, although slopes above 20 degrees require installation of a baffle system to prevent soil slump. These roofs can be used in both urban and rural settings, are applicable to a wide variety of building types, and can be used in both new and existing construction.

2.2.1 Key Architectural Issues: Successful green roofs require a building massing that permits appropriate solar exposure for the intended types of vegetation. Shading from adjacent buildings or trees can have a big impact on the success of rooftop plantings. Building massing can also be used to create rooftop surfaces that are relatively protected from wind. Building form will also determine how building occupants can interact with a green roof. A green roof is a user amenity only if it is at least visible to occupants. If it is also accessible to building occupants, greater integration of the green roof with appropriate interior spaces is desirable. Structural system design, careful detailing of drainage systems, irrigation systems, and penetrations of the roof membrane are key concerns.



Figure 1: 2005 Rhode Island School of Design Solar Decathlon House with a green roof for outdoor dining.

2.3 Sample Strategy: Cross Ventilation

Cross ventilation establishes a flow of cooler outdoor air through a space; this flow carries heat out of a building. Cross ventilation is a viable and energy-efficient alternative to mechanical (active) cooling under appropriate climate conditions. The design may focus upon direct cooling of occupants as a result of increased air speed and lowered interior air temperature or upon the cooling of building surfaces (as with nighttime flushing) to provide indirect comfort cooling. Air speed is critical to direct comfort cooling; air flow rate is critical to structural cooling. The effectiveness of cross ventilation is a function of the size of the inlets, outlets, wind speed, and outdoor air temperature.

Cross ventilation cooling capacity is fundamentally dependent upon the temperature difference between the indoor air and outdoor air. Cross-ventilation cooling is only viable when the outdoor air is at least 3°F [1.7°C] cooler than the indoor air. Lesser temperature differences provide only marginal cooling effect (circulating air at room temperature, for example, cannot remove heat or reduce room temperature). Outdoor air flow rate is another key capacity determinant. The greater the air flow, the greater the cooling capacity.

Buildings are typically best naturally-ventilated when they are very open to breezes yet shaded from direct solar radiation. Building materials in a cross ventilated building may be light in weight, unless night ventilation of mass is intended—in which case thermally massive materials are necessary.

2.3.1 Key Architectural Issues: Successful cross ventilation requires a building form that maximizes exposure to the prevailing wind direction, provides for adequate inlet area, minimizes internal obstructions (between inlet and outlet), and provides for adequate outlet area. An ideal building footprint is an elongated rectangle with no internal divisions. Siting should avoid external obstructions to wind flow (such as trees, bushes, or other buildings). On the other hand, proper placement of vegetation, berms, or wing walls can channel and enhance airflow to windward (inlet) openings.

2.3.2 Implementation Considerations: Cross ventilation for occupant comfort may direct air flow through any part of a space if the outdoor air temperature is low enough to provide for heat removal. At high outdoor air temperatures, cross ventilation may still be a viable comfort strategy if air flow is directed across the occupants (so they experience higher air speeds). Cross ventilation for nighttime structural cooling (when adequate wind speed exists) should be directed to maximize contact with thermally massive surfaces. A design caution: high outdoor relative humidity may compromise occupant comfort even when adequate sensible cooling capacity is available.

2.3.3 Design Procedure: Cross ventilation should normally be analyzed on a space by space basis. An exit opening equal in size to the inlet opening is necessary. This procedure considers only sensible loads and calculates the size of the inlet (assuming an equal sized outlet).

1. Arrange spaces to account for the fact that building occupants will find spaces near inlets (outdoor air) to be cooler than spaces near outlets (warmed air). Substantial heat sources should be placed near outlets, not near inlets.
2. Estimate design sensible cooling load (heat gain) for the space(s)—including all envelope and internal loads (but excluding ventilation/infiltration loads). [*units are Btu/h or W*]
3. State the design cooling load on a unit floor area basis. *Btu/h ft² or W/m²*
4. Establish the ventilation inlet area (this is free area, adjusted for the actual area of window that can be opened and the estimated impact of insect screens, mullions, shading devices) and the floor area of the space that will be cooled. The inlet area may be based upon other design decisions (such as view) or be a trial and error start to cooling system analysis. *ft² or m²*
5. Determine the inlet area as a *percentage* of the floor area: (inlet area / floor area) x 100
6. Using Figure 2 (see below), find the intersection of the inlet area percentage (Step 5) and the design wind speed (from local climate data). This intersection gives the estimated cross ventilation cooling capacity—assuming a 3°F [1.7°C] indoor-outdoor air temperature difference. Design wind speed should represent a wind speed that is likely to be available during the time of design cooling load.
7. Compare estimated cooling capacity (Step 6) with the required cooling capacity (Step 3).
8. Increase the proposed inlet area as required to achieve the necessary capacity; decrease the proposed inlet area as required to reduce excess cooling capacity.

This design procedure addresses “worst case” design conditions when outdoor air temperatures are usually high. Extrapolation beyond the values in Figure 2 for greater Δt s is not recommended as a means of sizing openings. On the other hand, greater temperature differences will exist during the cooling season permitting a reduction in inlet and outlet size under such conditions. Extrapolation for higher wind speeds is not recommended due to discomfort from too-high indoor air speeds. Also, wind speeds at airport locations can be very different than at the city center or in suburban areas, depending upon the terrain. During schematic design, adjustments can be made to account for these variations by comparing “local” and airport wind speed data. As a rough estimate, urban wind speeds are often only a third of airport wind speeds; suburban wind speeds two-thirds of airport speeds.

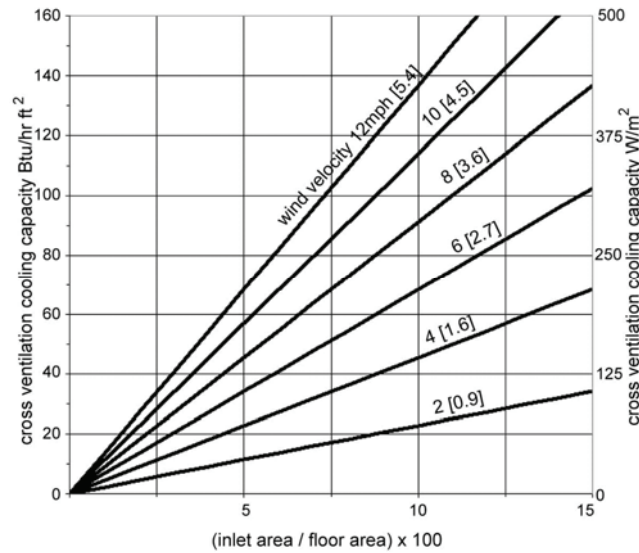

Figure 2: Cross ventilation cooling capacity. Heat removed per unit floor area (based upon a 3°F [1.7°C] temperature difference) as a function of size of inlet openings and wind speed.

3. CASE STUDIES

The nine case studies presented in the book (see Table 2) include a range of buildings selected to provide a diversity of geographic locations, climates, building types, and strategies. The design teams for these projects have made strong statements about green design intentions and have provided fertile ground for designers to learn from their projects. Each case study is organized as follows:

- A general description of the project
- A sidebar "scorecard" with building, climate, client, and design team information
- A statement of design intent and related design criteria
- Design validation methods employed (modeling, simulation, hand calculations, etc.)
- A description of the green strategies used
- Post occupancy validation results (if available).

Table 2: Case Study Projects in *The Green Studio Handbook*

PROJECT	LOCATION	ARCHITECT
Arup Campus Solihull	Solihull, UK	Arup Associates
Beddington Zero Energy Development	Surrey, UK	Bill Dunster Architects
Cornell Solar Decathlon House	Ithaca, NY, USA	Cornell University
Druk White Lotus School	Ladakh, India	Arup Associates & ARUP
Habitat Research and Development Centre	Windhoek, Namibia	Nina Maritz
The Helena Apartment Tower	New York, NY, USA	FX FOWLE
Lillis Business Complex	Eugene, OR, USA	SRG Partnership
National Association of Realtors Headquarters	Washington, DC, USA	The Gund Partnership
One Peking Road	Hong Kong, China	Rocco Design Ltd.

3.1 Sample Case Study: Lillis Business Complex

The University of Oregon's Lundquist College of Business needed to replace an aging building that connected three existing smaller buildings. The building's site, along an axis between the historic entrance to the college and the main library, gives it a high profile. The university had in place a campus-wide sustainable development plan and Lundquist College had a commitment to certain sustainability goals—as a result both parties had a mutual desire to aim for the greenest building possible.

The University engaged a Construction Manager/General Contractor who was brought into the project early in the design process. This enabled the design team to work closely with the GM/GC as the design developed, ensuring that the design was feasible and within the established financial parameters. Lillis was a complex project—to be built in the middle of an active campus, while minimally disrupting classes.

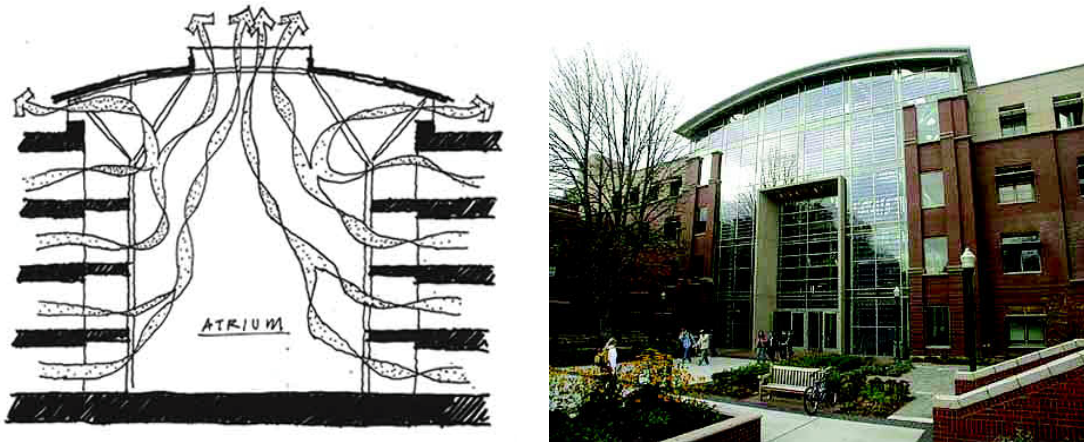

Figure 3: Early conceptual sketch (left) of air flow patterns through the Lillis Business Complex atrium (courtesy of SRG Partnership); entry plaza (right) with a façade of laminated glass with integrated photovoltaics.

3.1.1 Design Intent and Validation: The client and designers began with a goal to achieve a building that would be at least 40% more efficient than required by the Oregon Energy Code. The designers were also asked to follow a process that could result in a solution with the performance of a LEED (the US Green Building Council's Leadership in Energy and Environmental Design program) accredited building. The decision to pay for the formal LEED process, however, was not made until after the designers had finished working drawings. To make these goals a reality, the design team developed complementing strategies involving daylighting, solar control, natural ventilation, electricity generation using photovoltaic arrays, expanding the thermal comfort zone (by occupant cooling with ceiling fans), night ventilation of thermal mass, and wiring half of all the plug load receptacles and lighting circuits in faculty offices on occupancy sensors. A team of consultants, including energy engineers and daylighting experts, modeled various designs to determine how well design concepts were meeting project goals. The CM/GC agreed to recycle 95% of the demolition waste from the existing buildings (related to LEED Materials & Resources credits).

3.1.2 Strategies

3.1.2.1 Orientation and form. The designers conceived of the building as a long and thin form running along an east-west axis. The north- and south-facing windows are easy to control relative to daylighting and solar gain and they take advantage of the prevailing seasonal wind directions on site (from the north and south).

3.1.2.2 Natural ventilation. In addition to the long and thin form, the auditorium and lecture hall push out beyond the primary edge of the building, providing these rooms with more building skin, and more opportunity for clerestory windows and skylights to act as inlets/outlets for natural ventilation. A four-story atrium organizes the building spatially and provides a means for stack ventilation.

3.1.2.3 Solar control and daylighting. When the building is in cooling mode, computers automatically close shades or skylight louvers in unoccupied rooms to minimize solar gains. When people enter a room, the computer control opens the shades/louvers as far as necessary to reach a targeted illuminance for the space. Using daylight not only makes people happy and more productive, it is a "free" source of light and produces less heat for a given illuminance than electric lighting. Lightshelves are used on the south-facing windows. External overhangs shade the windows, especially from the high summer sun, and effectively reduce cooling loads.



Figure 4: Light shelves and ceiling fans in a south-facing Lillis classroom (left photo courtesy of Emily J. Wright; right photo courtesy of SRG Partnership).

3.1.2.4 Integrated cooling systems. Outside air is used to cool the building and the occupants as much as possible before relying on mechanically-cooled air. A mixed-mode cooling system, as well as night ventilation of mass, provides for a high-efficiency cooling approach.

3.1.2.5 Hybrid ventilation. Classrooms have raised concrete floors, arranged into risers for seating. Air is drawn in from the outdoors, passes under the floor slab and enters the room through outlets in the risers. If the outdoor air is too warm to effectively cool a space, it can be mixed in a plenum with mechanically-conditioned air. The air from the classroom is exhausted into the atrium, rising to the top and exiting through gravity ventilators. Eugene's cool nighttime temperatures make night ventilation of mass a viable strategy. The raised concrete floor slab absorbs heat during the day as the outside temperature rises and the sun and occupants add heat to the space.

3.1.2.6 Photovoltaics. The south-facing glass curtain wall with integrated polycrystalline photovoltaic cells comprises a 5.9 kW array. There are translucent PV panels in the skylights, which are equivalent to a 2.7 kW array. Roof panels on the mechanical room produce 6.2 kW, and other roof sub-arrays provide 29.9 kW—for a grand projected total of 45 kW of PV power. The local utility played a key role in providing financial incentives for this signature renewable energy feature.

CONCLUSIONS

The Green Studio Handbook is purposely not a comprehensive manual on building science; nor is it a “how-to-get-a-green-rating” handbook. Although the book is partly a compilation of strategies, it is intended that these strategies be applied in the context of a well-organized design process—where the architect is an active participant in the shaping of a green building and in coordinating the integration of green design strategies. Passive or active strategies can be used to achieve green building status. While these approaches may provide similar quantitative building performance, the way they reach that point is very different in both process and form.

It is our belief that architects are the ones who must guide the inclusion and integration of green strategies. The ability to do so is becoming increasingly critical in the face of growing client and societal interest in green buildings, burgeoning discussion of “sustainability,” and a recent call to develop carbon-neutral (or carbon-responsible) buildings. We hope and expect that this book is adopted by students as a self-selected required reading for their design courses. Practice is essential to confidence; the how-to experience gained through studio implementation will become more and more a part of the graduating designer's inner understanding. Then it will flow into practice. Students are likely to be the real agents of change.

ACKNOWLEDGEMENTS

The authors gratefully acknowledge the contributions of Laura Briggs and Jonathan Knowles to *The Green Studio Handbook's* chapter on design process, portions of which are presented (in edited form) in Section 1 of this paper. The nomograph shown in Figure 2 was developed by Kathy Bevers from equations in *Mechanical and Electrical Equipment for Buildings*, 10th edition.

Community and Urban Design

Research x Design: Urban Design Charrettes from the Design Centre for Sustainability at the University of British Columbia*

Ron Kellett

Phantom Housing: The Rise and Fall of Public Housing in North America

Benjamin Gianni

Mapping Urbanity: A Trajectory of Urbanity and Its Role in the Morphology of the Biosphere

Maria del C. Vera, Shai Yeshayahu-Sharabi

School Environment and “Green” Transportation

Xuemei Zhu

Community Design Parameters and the Performance of Residential Cogeneration Systems

Hazem Rashed-Ali

* Invited Oral Presentation

Phantom Housing: The Rise and Fall of Public Housing in North America

Benjamin Gianni

School of Architecture Carleton University, Ottawa, ON

ABSTRACT: This paper examines the rise and fall of public housing in North America in order to explore the principle of sustainability. By extension, it addresses the concept of sustainability as it relates to the city. Urbanity is simultaneously the most and least sustainable form of development. While extremely sustainable from the point of view of density (economies of scale, efficient use of infrastructure, etc.), it is highly vulnerable to social, political and economic forces. Such forces can easily trump the environmental sustainability of any building or community.

The death and transfiguration of key portions of our public housing stock provides insights into this phenomenon – for which I will use Toronto’s Regent Park as a case study. The redevelopment of this 69-acre parcel aims to transform a failed social vision into a model for sustainable community development.

Conference theme: Urban Design and Sustainable Elements

INTRODUCTION

Pruit-Igoe was demolished to great aplomb in 1972. The detonation of Yamasaki’s infamous housing project marked the beginning of the end of a social project and, arguably, of architectural modernism as a form of agency. The modernist *architect-qua-reformer* was discredited. By the mid ‘70s the building of large-scale public housing had all but ceased. It was determined that direct government involvement in the construction of housing (never not controversial in North America) was neither sustainable nor proven to have benefited the constituencies it was intended to benefit.

The bulk of public housing in North America was realized in the fifty-year period from the Depression through the 1970s. The traces of this activity are now being erased -- just as the neighborhoods it replaced were cleared to accommodate new approaches to housing and to city form. In the past decade, 125 different US housing authorities have received funding to demolish close to sixty thousand units of public housingⁱ. Among these are the usual suspects (i.e., the notorious “vertical ghettos” of the 1960s) as well as model, low-rise projects constructed during the Depression. Public housing is disappearing where you’d most expect it might – e.g., Chicago’s decimated South Sideⁱⁱ – but also in less likely places, namely the housing-starved neighborhoods of New Orleans. The demolition of the housing stock is less a question of its location, design or need than of the cost of life-cycle investment.

Given the focus of the conference, this paper explores the sustainability of public housing as a political, ideological, social, logistical and architectural undertaking. Key in the issue of sustainability is the ability to sustain public support. Given how controversial it was to build, it would be more controversial to invest in the life-cycle improvements required to upgrade the public housing stock to align with current standards. The alternative is to find innovative ways to replace it.

Although the dismantling of large-scale housing complexes in North America strongly suggests that public housing, in the manner it was realized, was not sustainable, there is a potential silver lining. Redevelopment presents an opportunity to apply sustainable design principles to the re-design of portions of our cities. Regent Park, a 69-acre public housing complex in downtown Toronto, is one example. Using Regent Park as a case study, this paper will consider what the history of public housing can teach us about the concept of sustainability as it applies to the city.

1.1. Public Housing

Public housing represents a relatively modest percentage of the overall housing stock in North America; in Canada it accounts for only 4%. For the purposes of housing policy the population is divided into five equal parts or *quintiles*. Targets project that the top three fifths (or 60%) should live in units they own while the remaining two fifths (40%) be accommodated in rental housing. It is expected that half of those who rent will pay market rates for their units while the remaining fifth, the lowest quintile, will qualify for rent subsidiesⁱⁱⁱ. Policies assume that no household should be forced to spend more than 25% of its income on housing.

Given that public housing comprises only 4% of the overall housing stock, only a fraction of the lowest quintile – the approximately 20% of households that qualify for subsidies – can be accommodated in government-sponsored housing. The majority of households receiving subsidies live in market (privately owned) rental housing^{iv}.

As these figures demonstrate, direct government participation in the building of housing in North America is extremely low. This is in marked contrast with Europe where percentages of home ownership are significantly lower and where the bulk of the (rental) housing stock was built under the auspices of the government. This is not to say that governments in the US and Canada do not exercise control over the housing market, indeed they do. But housing in North America is controlled indirectly, through codes and regulations, legislation, lending policies, loan guarantees, and a wide range of tax incentives. Together these mechanisms are applied and adjusted to produce the quintile targets described above.

Government-sponsored housing is both a fairly recent and relatively short-lived phenomenon. Among the first examples in North America were the dwellings built for military personnel during WWI. By the mid 1970s direct government building had all but ceased in North America, although small amounts of third party, non-profit housing continue to be built.

Government-sponsored housing falls into two general categories: “public” housing (housing built and administered by the government) and “social” housing (undertaken by a third party with some form of government support). Social housing includes rental units built by non-profit church groups, beneficent organizations, trade unions, and citizen’s groups. It also includes rental housing constructed by limited-dividend corporations (primarily insurance companies), much of which was built as market housing for the middle class during periods of housing shortages.

Public (as opposed to *social*) housing can be grouped into several categories:

- Wartime housing – built for military personnel and civilian workers involved in a war effort.
- The projects built for temporarily disadvantaged families from the late 1930s to the mid ‘50s. This housing was envisioned as a short-term way station, offering eligible families a “hand up not a hand out.” It was also promoted as a means of injecting money into the economy, shoring up a struggling construction industry and addressing acute shortages in rental housing.
- Projects from the late 1950s to the mid ‘70s built to accommodate the (predominantly poor) populations displaced by urban renewal projects.
- Housing for the elderly. This represents the largest percentage of the public housing stock. It should be noted, however, that much of the housing built for seniors is social housing, i.e., built and administered by third-party groups.

While the large-scale, high density and predominantly urban public housing projects built in the 1950s and ‘60s represent a relatively small percentage of the overall public housing stock, they have come to embody the idea of public housing in North America. These projects are conspicuous due not only to the scale at which they were realized (vast numbers of city blocks were razed and reconfigured to make way for them) but because of the form they took. More often than not, these agglomerations were conceived as of “tower-in-the-park” enclaves that broke open congested urban fabric and lifted tenants out of squalor.

In both scale and design the “tower in the park” ensembles represented an aggressive departure from the traditional grain of the city and from the more modest, Depression-era projects that preceded them. The radical design approach was intended both as an antidote to and a homily on the inability of the city to accommodate the myriad changes wrought by industrialization. Moreover, these enclaves are of particular interest to architects in that they embody the modernist vision of the architect as social engineer and reformer. They represented a new alliance between the architect/planner and the state -- an experiment with a new form of agency.

1.2. Regent Park

Toronto’s Regent Park is textbook example of the large, state-sponsored housing developments of the post WWII era. It comprises 69 acres on the east side of downtown Toronto and is home to 7500 people, all of whom

rent at subsidized rates. Prior to its redevelopment in the late '40s the area was a warren of small streets and laneways connecting a mix of wood-frame dwellings and light industrial buildings. The neighborhood was targeted for slum clearance as early as 1931 and was in exceptionally poor condition by the end of WWII.

To the planners who envisioned a new approach to the design of cities, the dilapidated condition of urban neighborhood testified to the fact that the city, as produced by market forces, was not sustainable. A new era called for new design principles, a new scale of intervention, and a more direct role for government in the stewardship of cities. Private initiatives could only address deficits in a piecemeal fashion; moreover the market (or the failure thereof) had produced the problem in the first place.

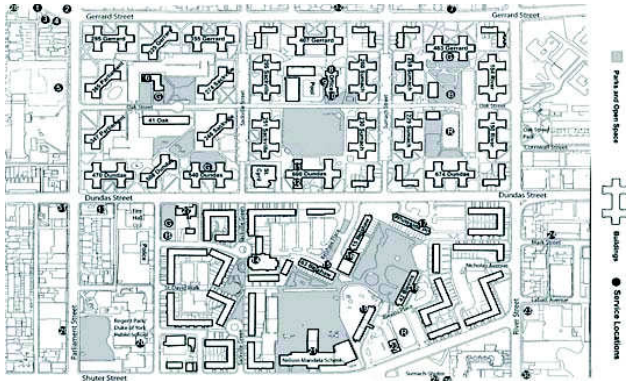

Figure 1: Plan of Regent Park, (pre-redevelopment), courtesy Toronto Community Housing Corporation

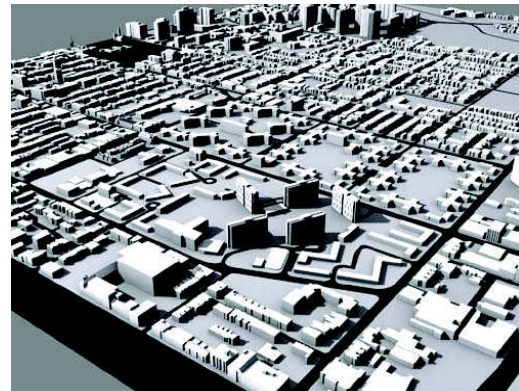

Figure 2: Model of Regent Park (pre-redevelopment), looking from southeast, courtesy author

Regent Park was constructed in two phases: the area north of Dundas St. (roughly 40 acres) in the late '40s and balance in the mid 1950s. Regent Park North was designed as an ensemble of three- and six-story walk-up buildings (“dumbbells” and “dog bones”), each with multiple, shared entrances and internal, double-loaded corridors. Ground level units had no direct access to the exterior, nor did many of the units include balconies or porches. The 6-story “dogbone” buildings were rotated at 45 degrees to the urban fabric to reinforce their separateness from adjacent neighborhoods. In all cases, buildings pulled away from and downplayed any relation to streets and access routes.

Pre-development, this 6-block area contained 765 dwelling units and several commercial properties, covering 36% of the area. Regent Park North was originally designed to accommodate 854 families and occupy only 15% of the land area. The goal of building higher was to free up land as “open space” for the community. Vacant land on the site meant that 248 new units could be constructed before any existing units were demolished.^v The new design of the neighborhood turned it inside out, consolidating all exterior spaces and eliminating private stewardship of land. Space became a community amenity under the aegis of the government.

Regent Park South (approximately 30 acres) was developed as a combination of townhouses and high-rise towers. While the inclusion of townhouses suggests a return to more time-honored urban housing types, the fourteen-story towers are resolutely modernist. These five towers are comprised of double-story units accessed through a skip-stop corridor system. And, as with Regent Park North, an effort was made to erase the pre-existing street grid and float the buildings in a sea of parkland to promote the feeling of a self-contained campus. Like the “dogbone” buildings of Regent Park North, the towers were positioned at 45 degrees to the pre-existing street grid.

As was the case for many public housing developments realized in the '30s and '40s, Regent Park was envisioned as way station for temporarily disadvantaged families. Given the anticipated brevity of the stay, the focus was on the quality of the unit (heat, running water, privacy) rather than on the provision of community infrastructure. Two-parent families with children were given priority as units came available. Social workers screened applicant families carefully to assure that those admitted had the best chance of success, i.e., would be most likely to move on in short order. Inevitably, however, the demographic of Regent Park changed over time. As policies increasingly privileged the most disadvantaged, the percentage of two-parent families dropped (as did the average household income) and the average length of stay increased substantially. In this context, the lack of community infrastructure in Regent Park became ever more problematic.

Crime rates climbed as the urban core deteriorated through the 1970s. The particularities of Regent Park’s design proved propitious for criminal activity – most of which was attributable to individuals living outside the

community. The lack of connection between individual units and the exterior meant that communal spaces were difficult to patrol; what was envisioned as a park became a collective no-man's land. Moreover, the absence of through streets made it difficult for police cruisers to patrol the neighborhood effectively. The designers' vision of Regent Park as an urban oasis proved problematic for an increasingly isolated and disenfranchised community.



Figure 3: Regent Park North, 6-story "dogbone" building, courtesy Toronto Community Housing Corporation



Figure 4: Regent Park South, "skip-stop" high-rise, courtesy Toronto Community Housing Corporation

Changes in the last several decades, however, have attracted segments of the middle class back to the city -- particularly households without children. As of the mid 1970s the average cost of a house in the suburbs outpaced the average cost of a house citywide. As a result, first-time homebuyers began looking for alternatives. With advances in birth control and the choice to wait longer to have children, urban living re-emerged as a viable alternative. Supporting this trend, the introduction of the condominium designation made it possible both to live in the city and own one's dwelling.

The net effect of this is as follows: the cities in opposition to which housing projects like Regent Park were built no longer exist. Urban centers have transformed twice in the past fifty years. The city is neither the overcrowded and under-served environment it was at the end of WWII, nor is it the abandoned and deteriorating carapace it had become by the 1970s (i.e., the city on which post-WWII suburbanization had taken its toll).

1.3. Circumstances Leading to an Opportunity

Unlike Europe where the focus was on rental housing, post WWII housing policy in North America encouraged home ownership. Mortgage programs promoted the purchase of small, detached, single-family homes, virtually all of which were produced by the private sector. The majority of the growth in the post-war period occurred on the periphery of large cities where land was abundant, inexpensive and increasingly accessible. Roughly 80% of the housing stock in Canada was built after WWII and the vast majority is suburban.

As the middle class migrated to newly built homes in the suburbs, the tax bases of most large cities dwindled. Diminished services (schools, etc.), in turn, exacerbated the drive to decamp. In reaction to the cumulative effects of suburbanization, governments supported the expropriation and large-scale redevelopment of the core. In some cases, e.g., Lafayette Park in Detroit, the goal was to encourage the middle class to return or remain in the city by providing viable alternatives to suburban homeownership. In most cases, however, urban renewal accommodated a shift from residential to commercial usages -- augmenting the desirability and accessibility of the core as a place to work and/or engage in leisure activities. Redevelopment also presented the opportunity to adjust the traditional grain of the city. Smaller blocks were consolidated into superblocks to accommodate buildings with larger floor plates and to make way for new transportation corridors.

Poor and lower middle class neighborhoods (comprised of high percentages of renters) were razed to make way for new cultural, commercial, and transportation infrastructure. The housing of those displaced was the *raison d'être* of many of the larger housing projects in the 1960s and '70s. Seen in its most positive light, urban redevelopment was envisioned as an opportunity for city to rebuild its tax base and offer displaced residents an improved standard of housing.

Whether they were built on (or adjacent to) the neighborhoods they replaced or in isolated corners of the city, these housing enclaves distinguished themselves from their surroundings. The design aspirations were inward, upward and away from adjacent neighborhoods. As was the case with Regent Park, many of these developments were cut off from city streets to discourage through-traffic. Planners envisioned protected green space over which children could roam freely; the effect, however, was ghettoization and stigmatization.

More often than not, modernism was adopted for its economy, not for its design. Although it was certainly promoted on the basis of design principles -- light and air, lifting the tenant out of the dirty morass of the adjacent fabric, creating green lungs to enable the city to breathe -- high-rise blocks were privileged for expediency and in service of open land (although the cost effectiveness of this can and has been argued). Given the decision to go vertical, many of the projects were built higher and/or at a greater density than originally designed.

Perhaps more importantly, the “tower in the park” model was often built without the park. Being the last thing to go in, landscaping was often the first thing to be sacrificed when facing (inevitable) cost overruns. Moreover landscaping requires ongoing maintenance and can present security risks. It is easier to bathe bare terrains in floodlight than to police parks of hedges and mature trees. Even if resources were available to maintain it, tenants might be forced to choose between security and landscape amenities.

Perhaps most significantly, the demographic of the housing projects was more homogeneous than the neighborhoods they replaced. A variety of factors contributed to this including the lag between the demolition of the neighborhood and the availability of replacement housing. As selection processes increasingly favored the most severely disadvantaged, those who could afford to either choose or were forced to live elsewhere. Part of the problem was that the building of this housing was an externality, driven by non-residential redevelopment elsewhere in the core. In such cases housing was a means to a different end and could not command or sustain a significant amount of investment. While there is little question that many of the units demolished were substandard, what tenants gained in the quality of their units, they often lost in the quality of the community.

1.4. The (sustainable) Redevelopment of the Redevelopment

These notoriously conspicuous and conspicuously notorious projects have reached or are reaching their 40-year life cycle. A significant investment is required to upgrade them to current standards. As there is little support for rehabilitating what many consider to be failed social projects, housing authorities across North America are opting to demolish and replace them with market-driven housing. Over the past eight years, the US Department of Housing and Urban Development (HUD) has funded local housing authorities to demolish 60,000 units of public housing. HUD is also providing funds to replace these units and/or cause them to be replaced. To this end, local housing authorities are courting private sector partners with offers of free land, long-term lease guarantees, and tax incentives.

The decision to demolish is a function both of pragmatics and of ideology. It is arguably more cost effective to shift the responsibility for the construction, maintenance and operation of subsidized housing to the private sector^{vi}. But from an ideological perspective, the razing of housing estates is symptomatic of an acute and longstanding antipathy toward government-sponsored housing in North America. The dismantling of the most visible manifestations of public housing stock points to the fact that the combined political, social, and design ideologies underpinning these experiments have not proven sustainable.



Figure 5: Regent Park Phase I redevelopment parcel, pre demolition, courtesy Toronto Community Housing Corporation (TCHC)

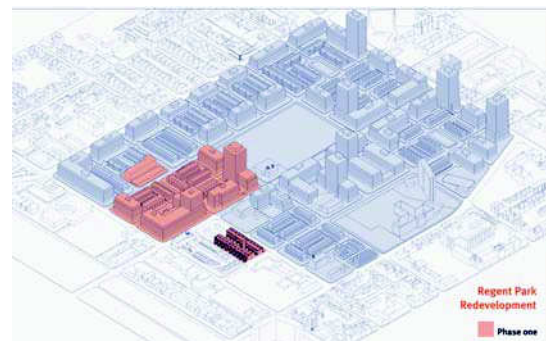

Figure 6: Proposed new construction, Phase 1, courtesy Toronto Community Housing Corporation

Where housing compounds are propitiously located in relation to desirable urban neighborhoods, the current real estate market presents its own incentives for redevelopment. Such is the case with Regent Park where Toronto Community Housing Corporation is brokering a \$1 billion redevelopment without the benefit of federal aid. While the form that the replacement housing takes varies with the project (in relation to its location and tenancy targets), subsidized units will be predominantly low rise^{vii}. These units are designed to engage streets and, where possible, have separate entrances and street addresses. Where feasible, market-rate rental and condominium units are included the mix both to offset costs and to diversify and stabilize the neighborhoods. With respect to community design, an effort is being made to return to pre WWII urban patterns and to knit these neighborhoods

back into the adjacent street fabric. The urban models once rejected in favor of modernist planning principles are now embraced as antidotes.

However much it might represent a failure of vision and design, the dismantling of the public housing stock presents an opportunity to apply sustainable design principles to large portions of the city in a coordinated way. Given that most large-scale housing projects were the result of urban renewal initiatives, their death and transfiguration provides another chance to engage in extensive renewal. Moreover the government's stake in these initiatives increases the chances that higher, more environmentally sustainable standards might be applied. That said, the presence of private investment means the short-term economics of these initiatives may drive what can and can't be done, i.e., that sustainability targets could be compromised in order to control costs and/or encourage private sector participation. As always, the question is who foots the bill, who receives the benefit, and how the benefit is defined and/or measured.

Within the context of this conference, sustainability is understood to mean a lessening of the negative impact of buildings (and by extension their inhabitants) on the environment. At issue are the design, construction and performance of buildings and communities throughout their life cycle. Engaging sustainability demands that we position buildings (and the activities they support) in a larger, temporal context. The way we define that context will determine the building materials we choose, the energy performance targets we set, the energy sources we exploit, the approaches taken to storm and waste water management, the amount, location and function of planting on the site, and the transportation alternatives offered to those who live and/or work in the community. A concerted and propitious approach to the choices made can mitigate the compound's environmental footprint and reduce the long-term costs. If the long-term costs are lower, the buildings have a greater chance of surviving.

Given its extremely favorable location within the urban core, Regent Park is poised to make significant advances both with respect to current conditions on the site and to other sectors of the city. Sustainability targets for the redevelopment have been set as follows^{viii}:

- 35% reduction in water use per capita
- 20% reduction in storm water runoff
- 84% removal of solids in storm water
- 35% – 60% solid waste diversion rates in all buildings
- 90% diversion of demolition and construction waste diversion
- reduced environmental impact in building products
- improved modal split and support for non-auto transportation
- improved natural environment and water use through low maintenance landscape strategies
- up to 50% below code for energy consumption
- reduction of up to 70% in green house gas emissions



Figure 7: Regent Park Sustainability Targets, courtesy Dillon Consulting

A central energy plant will service the entire 69-acre development, permitting significant economies of scale and decreasing dependence on the grid. A gas-fired generator will produce electricity for the community, heat from which will be captured and distributed using a hot water system. Both heating and cooling will be provided centrally with geothermal backup.^{ix}

Given these aggressive targets, it is significant to note that Regent Park will be redeveloped at more than double its current density. Accommodating more residents within the urban core will alleviate pressure on exurban expansion, leverage municipal services more efficiently, and reduce the number of commuters on the Toronto's overcrowded freeways. Figures are as follows:

- Built density:*
- Current: 0.75
 - Proposed: gross density of 2.1 -- 585,000 sq. m. of gross floor area (net density, subtracting streets and parks, will be 2.8)
 - Delta: x 2.8 (planned density will about triple the current density)

Population

- Current: 7500, all RGI (rent geared to income or subsidized units)
- Proposed: 12,500 people (101 persons per acre)
- Delta: x 1.666

Number of units

- Current: 2083
- Proposed: 5100 units (74 units per acre) of which 1500 will be RGI
- Delta: x 2.4

1.5. Stepping Back to Move Forward

Costs (long- and short-term, financial and environmental), however, are not the only factor. Indeed, the most compelling aspect of the current chapter in the history of public housing is what it tells us about the limits of sustainability within a larger social, political and historical context. The fact that 1) virtually no public housing has been built in North America for the past 30 years, and that 2) the bulk of the public housing stock is not likely to survive its 40-year life cycle, suggests the degree to which the undertaking was not sustainable. But doing nothing -- allowing neighborhoods to deteriorate and ignoring the forces at play in the urban core during an era of mass suburbanization -- would have been neither a prudent nor sustainable alternative.

In considering the rise and fall of public housing it is helpful to distinguish between related considerations, namely

- *that* public housing was built (a necessary evil, an unpopular undertaking, doomed from the start)
- compared/opposed to *what was intended* (design issues/ideology, social vision)
- compared/opposed to the *way it was realized* (where it was built, what components of the design were actually realized, the level of funding, the quality of the construction, the terms of reference, etc.)
- compared/opposed to *how and by whom it was inhabited*, related to *how and by whom it was administered*
- compared/opposed to the *cost of doing nothing* (assuming this was even an alternative).

Among the issues at play, then, when considering where we go next are (in no particular order):

- Sustainability as a design consideration, both at the scale of the building and of the community.
- The sustainability of the *idea* of public housing in North America in relation to the form it takes. The form affects the level of political support, which, in turn, determines the long-term success of the undertaking. In this context form can mean *architectural form* (e.g., high rise or low rise, apartment or townhouse) and/or *urban form* (e.g., high density or low density, ratio of public to private spaces/amenities, degree of connection to or isolation from adjacent fabric). Arguably the fact that public housing takes form at all is at issue; experience suggests that subsidized housing survives best when it is invisible and/or indistinguishable from the housing stock at large.
- The role that environmental sustainability might play in engendering support for investment in model, mixed demographic communities -- among or within which may be aggregations of government-sponsored housing.
- The government's role in any urban initiative, and the terms of reference by which it can or should participate/intervene, especially when it is contributing financially or by legislative fiat.
- Sustainability as a function of the demographic mix of a community -- as expressed in the ratio of subsidized to market-rate units and of owner-occupied to rental units. Our experience with public housing in the 20th century strongly suggests that homogeneity is sustainable only in relation to wealth. In this respect, it is less the form (urban or architectural) that public housing takes that is at issue (indeed high rise complexes are a viable alternative for many sectors of the population), but its form in relation to the demographic it is expected to accommodate.
- The urban context as a milieu in which economic and demographic forces are constantly at play. This affects the ability of any building or complex of buildings -- particularly housing -- to survive. Arguably the failure of public housing relates not only to the demographic that inhabits it, but also to the fact that it rarely accommodates the demographic for which it was designed. Housing and communities must be designed to support change in order to survive it.
- Given that the terms, conditions and technologies surrounding sustainability continuously transform, we might question whether any building should survive its 40-year life cycle. Which buildings (should and/or do) survive and why? As noted above, the ability to adapt is one of the key criteria in evaluating the long-term

sustainability of a building or complex. Sadly neither design excellence nor an extremely high quality of construction can save a building that, for whatever reason, finds itself in the wrong place at the wrong time.

CONCLUSION

What we're witnessing with respect to the public housing stock in the US and Canada is a double erasure. Traditional mixed-use neighborhoods like Cabbagetown were razed to make way for the housing that is now being cleared to make way for (neo) traditional mixed-use neighborhoods. As such, it is important to consider how these events reflect on the concept of sustainability as it applies to the city. Indeed the urban renewal efforts of the 1960s and '70s were predicated on the fact that the city had proven unsustainable and that massive interventions were required to shore it up. Moreover reformers had argued for alternative forms of urbanity for more than a century before urban renewal initiatives were finally undertaken. The fact that modernist housing compounds are now being replaced with the very fabric they once supplanted reminds us that what is not sustainable in one era may emerge as the most sustainable alternative in another.

Implicit in these observations is the suggestion that portions of our modernist public housing stock should be preserved, rehabilitated and directed toward a different demographic. Indeed, the same strategies that Yamasaki applied to the design of Pruitt-Igoe (public housing) appear in his proposals for Lafayette Park (middle-class housing). Moreover had erasure proven effective as a strategy it is unlikely we would be considering the same strategy for the same sites in such short order.

That said, our public housing stock has several strikes against it:

- Depression-era projects were required to be built of an equal or lesser quality than adjacent, privately owned rental housing lest they compete with (and further disadvantage) private landlords. More often than not, the adjacent housing stock was of questionable quality.
- Most of these projects were built without community infrastructure, lest they encourage (implicitly or explicitly) tenants to stay.
- More often than not, the public housing stock has been subject to changing demographics, meaning that complexes rarely accommodate the constituencies for whom they were designed. The effect has been to put the buildings under extraordinary stress. Arguably, the lower the income of the tenant, the more stress a unit is subjected to.
- Enmity toward the poor, racial discrimination, and a deeply ingrained anti-urban sentiment translated to a profound lack of support for much of what was built – meaning it was built with as little money possible and in the least desirable locations. In other words, it was not designed to last. Arguably this is consistent with the idea that public housing should serve as a temporary way station for temporarily disadvantaged families. As real solutions to poverty and housing were seen to lie elsewhere, investing in public housing was seen as treating the symptom, not the problem.
- Housing complexes often accompanied or were the result of adjacent infrastructure projects (e.g., interstates) that cut them off from the surrounding city. This isolation exacerbated their decline.

Thus where cities are concerned, principles of sustainability must take account of the concept of change in its myriad manifestations. Among these is the cyclical phenomenon of death and transfiguration. The opportunity to apply a *sustainability-informed* agenda to the redevelopment of public housing complexes represents an opportunity to re-write the ending to a story whose plot has been ambiguous at best. In both its previous (post WWII) and imminent incarnations, Regent Park has been a laboratory for the best minds and most worthy aspirations of our era. As a model sustainable community (assuming it manages to realize the goals it has set), Regent Park's transfiguration will be tantamount to redemption.

ⁱ Funding is provided under the Hope VI program.

ⁱⁱ The Chicago Housing Authority alone will demolish 12,000 units across 31 different projects. These include the high-rise structures such as the Robert Taylor Houses on Chicago's South Side as well as the 4-story Ida Wells and Jane Addams Houses built during the Depression.

ⁱⁱⁱ Both Canada and the US have exceeded their ownership targets; approximately 66% of households own homes.

^{iv} This program is known generally as Section 8 in the US.

^v "Statement by Mayor Robert H. Saunders in Connection with Regent Park Low-Cost Housing Project" (Toronto, December 1946), pg. 1, as cited in Rose, Albert, *Regent Park: a Study in Slum Clearance*, 1958, University of Toronto Press, pg. 64

^{vi} Much of the rental housing built by government authorities in Europe is also being sold off to the private sector.

^{vii} See description of housing being planned by the Chicago Housing Authority on the site of the former Robert Taylor houses, CHA web site.

^{viii} Source, Toronto Community Housing Corporation, November 2006.

^{ix} Another excellent example of a social housing rehabilitation that led to some significant sustainability results is the Benny Farm project in Montreal. See www.bennyfarm.org

Mapping Urbanity: A Trajectory of Urbanity and Its Role in the Morphology of the Biosphere

Maria del C. Vera, Shai Yeshayahu-Sharabi

Southern Illinois University, Carbondale, IL

ABSTRACT: The milieu of the city, propelled by the socio-economic agendas of urbanity, preclude city planners from imagining design strategies that can oversee the well being of life. As urbanity expands its presence in the planet; the introduction of *The City in History* [Mumford, 1961] –“*Will the city disappear or will the whole planet turn into a vast urban hive?*”–, visualizes the scope of urbanity in relationship to the size of this planet.

Through a macroscopic vintage and supporting theories from emerging sociologists, economists, geographers and political scientists, this presentation aims to extend urban discourse from concerns regarding the disappearance of the city, towards a managerial reality –how can the planet survive as one vast urban hive? –

In this context, general master plans executed by urbanist that defined the city with buildings, bridges, highways, trains, airports and water routes are blurred; instead increasing dependencies extending beyond local peripheries of richer and poorer cities are highlighted; to demonstrate that urbanized and un-urbanized sites merge their interdependencies beyond distinguishable scopes.

Keywords: scale, local/global, perspective, practice

INTRODUCTION

Professional urban planners accumulate collections of buildings, plans, text, and laws that fully explain the formation and vision of the city through the ages; yet unlike scientist, geologist, geographers, astronomers, and biologist, few have been able to visualize and track the effects or scale that urbanity post to the evolution of this small planet. Today, as accelerated changes made by new compositions in the geosphere erode the atmosphere, life's existence is at risk.

Thus, our study visualizes the complex relationships that exist between the ever-changing characteristics of earth and the built environment to advance the discourse of urbanity beyond the unsustainable scale of the city towards the managerial scopes of the “vast urban hive” [Mumford, 1961]. Primarily because, previous centuries were guided by socio-political agendas that capitalized on the strengths of networking; a strategy that has been re-organized into “spaces of flows” and “timeless time”; displacing the need for cities to exist, and obscuring the perception of where urbanity lies--[Castells, 1996].

The city of the 20th century that thrived under the repetition of malls, gated communities, and theme parks is obsolete [Barber, 2002]. New restrictions and possibilities within the biosphere are transcending our understanding of networks and economic wealth towards forgotten roots found in compact centers, civic arenas, and public spaces of our past. At the dawn of the 21st century it is possible to grasp how the planet and its ever-evolving system is capable of existing with or without the presence of life yet, life is conditioned to a specific formula directly dependant on a calibrated composition of 78% nitrogen, 21% oxygen, 0.93% argon, 0.04% carbon dioxide, and traces of other gases. Thus, living and non-living matter form one undistinguishable whole that can sustain or eradicate life.

Under such an umbrella, developments and dissemination of knowledge become the primary tools to propose new urban dispositions where planning is no longer a discovery configured by independent institutions in singular cities, but rather a morphological organism formed and informed by intelligent decisions capable of manipulating the atmosphere. [Vernadsky, 1926].

To truly exploit the intelligence of urban planning, relationships between site specificities and environmental constraints ought to scientifically and collectively sustain the existence of life. This discussion transfers urban

design from seeking solutions through aesthetics or geometrical principles to developing informed strategies based on scientific data. The underlying premises of this proposition are few: **SIZE** -cities relied on the whole planet for their prosperity. **TRANSFORMATION** –as urbanity becomes the dominant living force, the parameters and protocols for augmenting wealth will shift from consumerism to reason. **ADAPTATION** –informed knowledge transforms, constraints, and provides possibilities to manage the existence of life.

SIZE-cities rely on the whole planet for their prosperity.

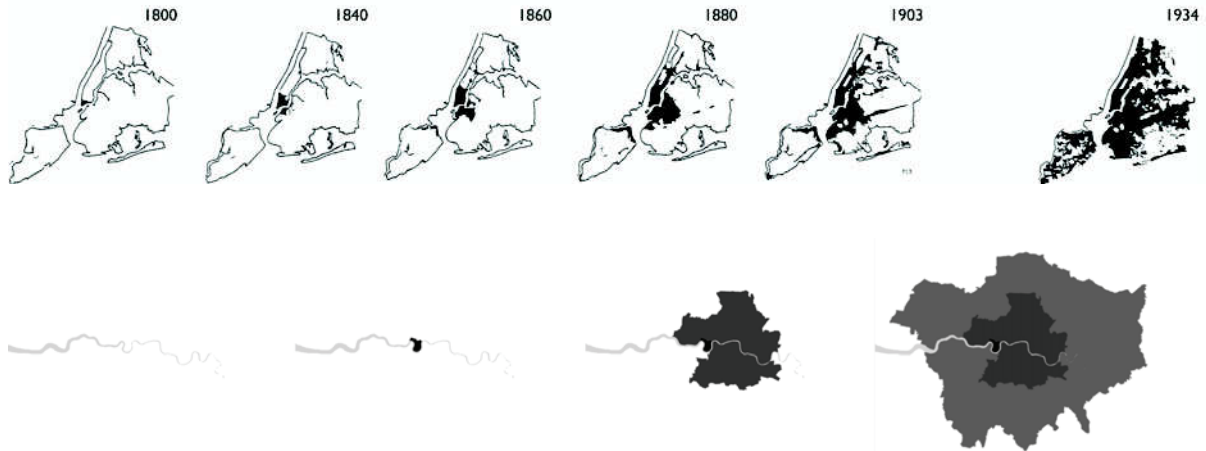

Fig.1 The Megapolis.

Source: (recomposed by author 2006)

Cities and their webs of foods and goods make up complex meshes and footprints that surpass their own physical realms. (Fig.1) Examples of such cities abound, London, and New York, are magnified to articulate how their megalopolis enterprise and occupy large territories across the globe. Such cities will not disappear. In addition, their interdependent networks are traceable and linked in similar modes to those of their ancient counterparts that ignited economic dominance of transcontinental scales, as discussed in Before European Hegemony [Abu-Lughod, 1989].

Thus, through a macroscopic point of view, a larger scale is ultimately recognized; one that transcends beyond European hegemony, beyond global hegemony, towards the dominance of a vast urban globe. Our mapping processes opportunistically identify a zone of urban hegemony (Fig.2) and magnifies the discourse about the production of capital and alliances among powerful networks. It shows how world cities physically interconnect through a geodetic zone where the production of environmental changes thrives.



Fig 2 The 30 60 zone of urban hegemony

Source: (Author 2006)

Human dominance places the survival of heterogeneous forms at risk. Viewing how a large portion of the earth is saturated with urban similarities and how all aspects of organic diversity are indistinguishably intertwined to the manmade objects; introduces the idea that the dispersal of world cities and their current networking systems impinges on the fundamental composition of the biosphere. The existence of urbanity is no longer resting among interconnected socio-economic places instead it is linked to the transformations of networks, alliances and selective morphologies that can regulate the atmospheric conditions necessary to sustain life.

TRANSFORMATION-to augment the planet's wealth cities must diversify their use of space.

Undoubtedly, as urbanity becomes the dominant living force in the planet, the parameters and protocols for augmenting wealth will shift from consumerism to reason because, cities exceeded their endless territorial extensions and entered a complex interdependency with all living and non-living matter. In this regard, the contradictions between current spaces of power and powerless spaces are now interchangeable. Urban places recognized as part of the world economy and unrecognized places supporting the economy of the world are intertwined systems attempting to survive. (Fig.3) Thus, the areas absent of light, population and food are also part of the equation as well as the deserts, jungles, rainforest, and oceans; all places house qualities to augment the wealth of the planet and stabilize the atmosphere.

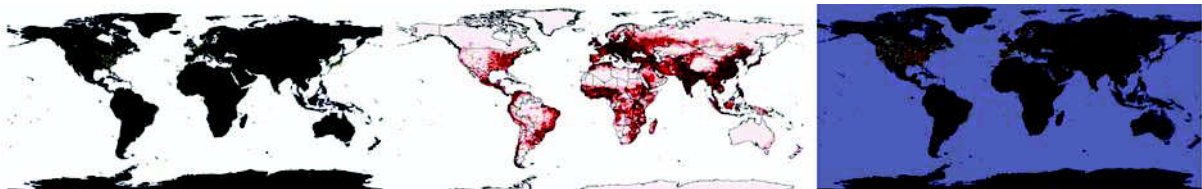

Fig 3 Superimposition of visible data to demonstrate inequalities

Source: (Rand McNally 2005)

A perceptual shift is occurring as mankind recognizes that cities and networks before the 21st century flourished under the affluence of land and resources; while the cities of this millennium intensify in population and built densities, under deficits of both. Thus, shifting from fields of infinite resources to compact places of limited scopes is necessary. Buckminster Fuller already discussed this premise in his text "Operating Manual for Spaceship Earth". Yet, this discourse does not intend to project catastrophic fatalities, instead, it heralds a enormous drift in design processes that can regain equilibrium of land, people, and resources as urbanity enters a small planet.

Grouping and reinventing resources are the tools of the day and noting that hives are adaptable, nest in diverse environments and exist under limiting conditions within compact habitats; physically and scientifically provide lessons to maximize efficiencies and augment wealth. Thus, the "vast urban hive" transcends political peripheries and continental limitations in order to rethink the size of urbanity.

ADAPTATION –knowledge transforms constraints and possibilities into managerial goals.



Fig 4 Towards diversity

Source: (multiple)

Informed design decisions are invaluable. In the age of ubiquitous knowledge, nourishing the atmosphere is scientifically possible. Accordingly, Vladimir Vernadsky defined the state of deliberate change in the biosphere when he identified that man's cognitive power could transform the formation of the biosphere into something new; he called it the noosphere. Thus, scientific knowledge and design abilities are necessary for the transformation of the biosphere. Designing the chemical composition of the biosphere will alter the self generative system, into the manmade noosphere. Thus, the noosphere will sustain life. However, the noosphere like the biosphere will continuously change and the formation of life will perpetually alter as new data creates new conditions and demand more precise calibration and modifications.

Thus, designing with knowledge is perhaps a form of hacking that can condition the perpetual existence of life. Accordingly, understanding that the composition of the planet is not made of prototypical patterns; it is made of unpredictable forms that are ever-changing as new characteristics unfold through time and in time, is essential.

INITIATIONS

In Brazil, fifty years ago, Curitiba sought an urban model to slow down its sprawl and effectively compress the city's growth. It was a site specific mode of seeking solutions that could sustain their economic growth. Thus, young architects, who were not impressed with urban trends that sought to produce large buildings and massive infrastructures, thought about the environment and its inhabitants. Their work became a case study for better planning that altered Curitiba's master plan. Jaime Lerner spearheaded the new planning goals by thinking small, cheap, and interdisciplinary. Through a participatory system, where citizens became involved he quickly solved the city's immediate problems of water, waste, transportation and education.

Today, Curitiba has become a model for cities outside and inside the zone of power to follow. These initiatives are improving and advancing the methods to contract the city's growth, despite their large influxes of people, waste and needs.

Among these visible undertakings is New York City's harbor agenda. Since the dawn of the 21st century, according to Cynthia Rosenzweig who is a research scientist at the National Aeronautic and Space Administration (NASA) Goddard Institute for Space Studies, NYC will set the example for a scientifically designed solution that seeks to alter the atmospheric composition as it becomes the first biosphere reserve. She and a team of interdisciplinary thinkers are engaged in the scientific initiative to implement corrective methods to actively safeguard the harbor area surrounding the five boroughs and its greater metropolitan zone. A botanical buffer is growing around its coastal peripheries, which will provide the tri-state area with a much needed flow of clean water. In addition, the elimination of the private car from its center core will reduce pollution and activate less intrusive modes for pedestrian circulation. Furthermore, their methods to collect data regarding both the short and long term effects of these implementations are the beginning of a lifetime commitment to the biosphere effect. Data collected will adjust as new implementations alter and transform the zone.

Emerging practices like this one where local solutions affect global changes herald the incoming noosphere where both science and design pivot the characteristics of the planet to perpetually sustain life. .

REMIX

Thus, political, environmental, and economic entities become interlaced systems of regulation that can capitalize on the wealth of knowledge. As the noosphere becomes a production of the human mind, the human mind, becomes the regulator that can neutralize urbanity and diversify a co-existing formula. This is a concept where careful investigations, rigorous data collection, and meditative fusions of ancient, local and emerging technologies can flourish. The idea is to brand not the built footprint of the city but the scientific observations extracted exclusively from local data. It suggests that a formula of cross mix information allows for design strategies to aid the planet in augmenting its evolutionary wealth. In addition, it implies that due to the ubiquitous nature of data filtration, an endless array of possibilities would form and inform the future characteristics of the planet.

This proposal lobbies for a nonlinear mode of practice, where if one imagines the possibility to affect life at the macro scale then one has to first think and act at the micro scale. Acting at the local scale, in specific ways, through a dynamic transdisciplinary mode of mixing ancient, local and emerging technologies, requires creative modes of processing. It suggests means to bank on the whole planet and augment the wealth of the city, without dwelling on simple examples as solutions and merging into complex relationships that are made up of intertwined forms that morph and transform the world.

This premise corresponds to the idea that the noosphere is an evolving cosmic governed by urbanity, and that one must envision the notion of learning to redesign life with actual information and knowledge provided by scientific facts, transcending plastic studies and flows of economies.

It signals mankind's full awareness of our small planet and the beginning of an adaptive mode that will trespass our vision of what we see and extend our brain to what we can get under an informed socio-economic agenda based on data.

REFERENCES

Abu-Lughod Janet, JAL., 1989, *Before European Hegemony: The World System AD 1250-1350*, Oxford University Press, New York, Oxford, Toronto.

- Barber Benjamin, BB. April 18, 2002. *Benjamin Barber, Examines Changing Character of Democracy in Suburbia*, Columbia University, New York, NY.
- Samson Paul, PS., Pitt David, DP., 1999, *The Biosphere Reader: Evolution of the Noosphere Concept*, Routledge, New York, NY.
- Castells Manuel, MC., 1996, *The Rise of the Network Society*, Blackwell Publishers Inc., Mandel, MA
- Castells Manuel, MC., 1997, *The Power of Identity*, Blackwell Publishers Ltd., Mandel, MA:
- Castells Manuel, MC., 1998, *End of the Millennium*, Blackwell Publishers Ltd., Mandel, MA.
- Delanda Manuel, MD. 1997, *A Thousand Years of Nonlinear History*, Zone Books, New York, NY.
- Delanda Manuel, MD., October 21 2004, *Non Organic Life*, Columbia University, New York, NY.
- Easterling Keller, KE. 2005, *Enduring Innocence: Global Architecture and its Political Masquerades*, MIT Press, Cambridge MA.
- Easterling Kelle, KE. 1999, *Organization Space*, MIT Press, Cambridge MA.
- Fishman Robert, RF., 1998, *Beyond Utopia: Urbanism After the End of Cities*, CCCB Urban Library, Barcelona.
- Friedman Thomas L, FLT., 2002, *Longitude and Attitudes: Exploring the World After September 11*, Ferrar, Straws and Groux, New York, NY.
- Friedman Thomas L, FLT., 2005, *The World is Flat: A Brief history of the Twenty First Century*, Ferrar, Straws and Groux, New York, NY.
- Fuller Buckminster R, BRF., 1969, *Operating Manual for Spaceship Earth*, Simon and Schuter, New York NY.
- Ebenezer Howard, HE., 1965, *Garden City of To-Morrow*, MIT Press, Cambridge MA:
- Irazabel Clara, Cl., 2005, *City, Making And Urban Governance In The Americas: Curitiba And Portlan [Design and the Built Environment]*, Ashgate Vermont.
- Mau Bruce, BM., 2004, *Massive Change*. New York: Phaidon Press.
- McHale John, JM., 1970, *The ecological Context*. New York, NY: George Braziller, Inc.
- Mumford Lewis, LM., 1961, *The City in History: Its Origins, Its Transformations, and Its Prospects*. Florida: Harcourt, Inc.
- Muñoz Francesc, FM., 2002, *The Multiply City: Metropolis of Territorians*. Venice: University Institute of Architecture in Venice
- Rosenzweig Cynthia, CR., 2001, Lecture at Columbia University: NASA/Goddard Institute for Space Studies. New York: Columbia University,
- Roger Richard, RR., 1998, *Cities for Small Planet*. Boulder, Colorado: West View Pres.
- Sassen Saskia, SS., 2000, *Cities in a World Economy*. Thousand Oaks: Pine Forge.
- Sassen Saskia, SS., 2001, *The Global City: New York London, Tokyo*. New Jersey: Princeton University.
- Vernadsky Vladimir I., VIV., 1998, *The Biosphere: Complete Annotated Edition*. New York: Copernicus.
- Yechayahu Shai, SY., Vera Maria, MV., 2005, *Territorial practices @ -1, 81*. Paper presented at the 2005 American Collegiate Schools of Architecture (ACSA) Southeast Regional; School of Architecture, Clemson University; Clemson, SC.

LIST OF FIGURES

3. Image source; De Agostini-Rand McNally, New World Atlas, Graphic Illustration; By Authors

4. After Janet Abu-Lughod, Before European Hegemony: The World System AD 1250-1350; After Saskia Sassen, The Global City: New York London, Tokyo; Movie clip <http://www.archive.org/details/CityTheP1939>, Graphic Illustration; By Authors

School Environment and “green” Transportation

Xuemei Zhu

Texas A&M University, College Station, Texas

ABSTRACT: School transportation in the U.S. is mainly made by vehicles, which consume a lot of energy and degrade our living environment. Walking and biking are alternative “green” modes of transportation with additional health and social benefits. However, the physical environment around school often makes walking and biking difficult, if not impossible, for children.

The primary section of this study reviews empirical studies on the relationship between physical environment and children’s walking and biking to school, or parents’ decision-making of such behaviors. A conceptual framework is proposed according to socio-ecological theory and the literature, and is used to organize research findings. For the relationship between objective physical environment and parents’ decision-making, perceptions of physical environment act as mediators, while personal and social factors function as moderators. The environmental support for walking and biking to school can be classified into macro-level walkability/bikability of urban forms (including distance, infrastructure, density, street connectivity, and land-use mix), micro-level walkability/bikability of urban design and architectural qualities (such as aesthetics, amenities, and maintenance), and safety from traffic and crime. Long distances, traffic dangers, and crime are topmost barriers for children’s walking and biking to school. A follow-up discussion explores the implications of these findings for evidence-based design and policy interventions.

The secondary section applies previous findings to a case study in Austin, TX, where 73 public elementary schools are analyzed for their attendance areas’ walkability and safety. Schools with higher percentages of Hispanic children appear to be more walkable in terms of macro-level urban forms, yet less walkable in terms of crime safety and micro-level urban design and architectural qualities.

Findings from this study supplement current knowledge about physical environment and “green” school transportation. They imply the importance of targeted interventions for specific contexts and populations in promoting walking and biking to school.

Keywords: School, environment, walking, biking

INTRODUCTION

In the U.S., children’s school transportation is mainly made by vehicles, which consume a lot of energy and degrade our living environment. Walking and biking are alternative “green” modes of school transportation, which also have additional benefits such as increasing children’s physical activity and fostering the sense of community. However, the physical environment around school often imposes barriers to this walking or biking trip. A national survey has been conducted with children’s (5-18 years) parents in 2004 by the Centers for Disease Control and Prevention (CDC), and has reported long distances, traffic dangers, and crime as topmost barriers for children’s walking to school (Martin & Carlson 2005). Currently, various programs are being developed to improve the relevant environmental support. In 2005, the United States federal transportation bill “Safe, Accountable, Flexible, Efficient Transportation Equity Act: A Legacy for Users” (SAFETEA-LU) authorized federal funding in the amount of \$612 million for the 5-year period (2005-2009) of the national Safe Routes to School Program.

The primary section of this study reviews empirical studies on the relationship between physical environment and children’s walking and biking to school, or parents’ decision-making about such behaviors. Fifteen articles and one dissertation were identified from online database, including the Web of Science, PubMed, and the National Transportation Library. The secondary section applies findings from literature review to a case study in Austin, Texas, where 73 public elementary schools are analyzed for their attendance areas’ walkability and safety.

1. LITERATURE REVIEW

1.1. Emerging Patterns and Conceptual Framework

The socio-ecological theory was widely employed in previous studies, addressing the impact of personal, social, and physical environmental factors, as well as the interactions among them. The physical environment has been measured both objectively and subjectively, and has shown related yet different results in terms of the environment itself or its impact on school travels. There was growing agreement that perceptions of physical environment acted as mediators between objective physical environment and parents' decision-making.

Based on socio-ecological theory, literature review, and McMillan's framework for children's school travels (McMillan 2005), I propose a conceptual framework to reflect the emerging patterns about the relationship between objective physical environment and elementary-aged children's school travels (Figure 1). As most previous studies, this framework assumes that parents are the primary decision-makers for children's school travels. Perceptions of physical environment act as mediators, while personal and social factors function as moderators, interacting with physical environment (both objective and subjective) and influencing the strength and direction of this environment-behavior relationship.

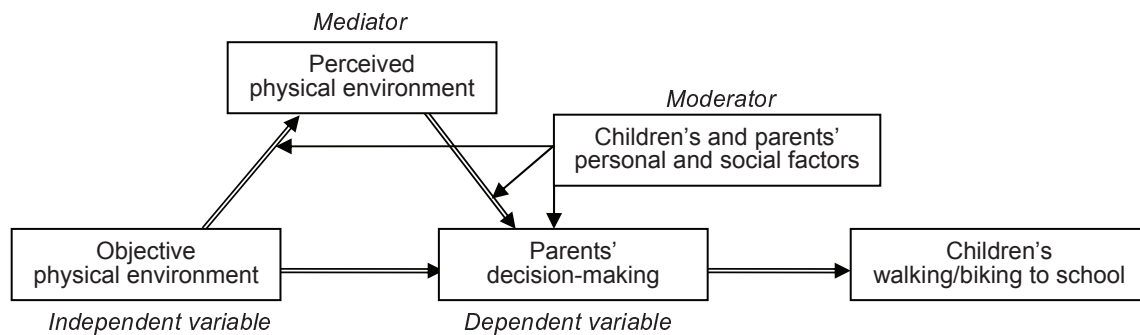

Figure 1: Conceptual framework for physical environmental correlates of elementary-aged children's walking and biking to school (Based on McMillan 2005)

1.2. Methods Used in Previous Studies

Previous studies varied from each other in terms of study settings, sample, research design, measures, data collection, and analysis, making it difficult to synthesize findings. Except two studies from Australia (Merom et al. 2003; Timperio et al. 2006), 14 other studies were conducted in the U.S. Two categories of research design were identified, including cross-sectional studies examining the environment-behavior relationship, which were the majority of studies and included two national surveys (Fulton et al. 2006; Martin & Carlson 2005), and intervention studies using pre-post comparisons or intervention-control comparisons, which might have the power to identify causality but were relatively rare (Boarnet et al. 2005 a, b; Staunton et al. 2003). The sample size varied across studies, ranging from 235 to 4,665 students. Elementary school children were the primary populations of these studies, although a few studies did focus on middle school or high school youth.

The dependent variable was either walking to and from school, or the combination of walking and biking as an active mode of school travels. The independent variable – physical environment – has been measured from various aspects and scales, and will be introduced in the following section. Ten studies out of 16 have controlled for one or more confounding variables, including personal factors of the child (such as age, gender, ethnicity, body mass index, and attitude toward walking) or the parents (such as education level, income level, marital status, and attitude toward walking, etc.). A few studies have also controlled for social factors such as family support or social and cultural norms about school travels.

Data collection primary relied on surveys with parents for information about children's school travels, family background, and parents' perceptions of the physical environment. In some studies, Geographic Information Systems (GIS) and field audits have been used for objective measures of the physical environment.

1.3. Physical Environmental Correlates

Various physical environmental variables have been examined in these studies. According to the units of analysis, they could be classified into two categories, including macro-level walkability/bikability of urban forms on relatively larger scales (such as the neighborhood or traffic analysis zone), and micro-level walkability/bikability of urban design and architectural qualities on smaller scales (such as the street segment). In addition, traffic danger and crime were also frequently studied variables with strong environment-dependent characteristics. They were also classified as physical environmental variables in this discussion. Details of selected studies are presented in Table 1.

Macro-Level Walkability/Bikability of Urban Forms

As would be expected, distance to school is a significant correlate of walking and biking to school, with longer distances hindering walking and biking. In the 2004 CDC survey, parents reported long distances as the most significant barrier (61.5% of parents reporting it) (Martin & Carlson 2005). Other studies have also provided empirical evidence, even after controlling for the child's age, gender, family's socioeconomic status, and some other background information (Black et al. 2001; Ewing et al. 2004; Merom et al. 2006; McMillan 2006; Timperio et al. 2006). Some studies have tried to identify threshold values of walkable distances for school travels, and reported that children living within 1.6 kilometers (1 mile) (McMillan 2003) or 0.8 kilometer (0.5 mile) (Timperio et al. 2006; Merom et al. 2006) from schools were significantly more likely to walk than those living further away.

However, it is important to recognize that the impact of distances may vary depending on the child's age, parents' perceptions, or other physical environmental factors. Meanwhile, in the U.S., even for students living within 1.6 kilometres (1 mile) from school, only 31% of trips were made by walking in 1995 (U.S. Department of Health and Human Services 2000), indicating there were other factors at work.

Quality of infrastructure is another important correlate of walking and biking to school, with better sidewalks, bike lanes, crosswalks, and traffic signals encouraging walking and biking. Evidence has been seen in not only cross-sectional studies (U.S. Environmental Protection Agency [EPA] 2003; Ewing et al. 2005; Fulton et al. 2005), but also pre-post intervention studies in California (Staunton et al. 2003). Among California's Safe Routes to School projects (Boarnet et al. 2005b), sidewalk gap closure at locations with moderate or heavy pre-existing pedestrian traffic showed great success, with 30%, 38%, and 70% increase in the rates of walking for three schools respectively. Replacement of four-way stops with traffic signals also showed evidence of success, while the pedestrian and bicycle crossing improvement showed only limited success.

Other urban form features such as population density, land-use mix, and street connectivity have also been studied, yet have reached less consistent findings. Although identified as significant correlates in a study of 34 California public elementary schools (Braza et al. 2004), population density (positive correlate) and land-use mix (negative correlate) were not significant in another study in Gainesville, Florida (Ewing et al. 2004). Also in the California study, street intersection density was significant in pairwise correlations, yet was not significant in multiple regressions. These findings also have some inconsistencies with the literature on adults' walking, where density, land-use mix, and street intersection density were often reported as positive correlates. One explanation might be that the school trip has fixed destinations (schools and homes) and specific populations (children), and therefore make factors such as the land-use mix less important. In addition, inconsistent findings were further complicated by various definitions and measures used across studies.

The difference between objective and perceived physical environment is also worth noting. A study in King County, Washington (Kerr et al. 2006) indicated that perceived land-use mix and street connectivity were significant correlates of walking and biking to school after controlling for socio-demographic features, yet their objective measures were insignificant. Furthermore, such perceived measures were no longer significant when entered together with the composite objective measure of walkability. Overall, there was a lack of attention on the relationship between objective and perceived measures of physical environment in the literature.

Micro-Level Walkability/Bikability of Urban Design and Architectural Qualities

As compared with the macro-level walkability/bikability of urban forms, the micro-level walkability/bikability of urban design and architectural qualities is understudied. However, the study in King County, Washington (Kerr, et al. 2006) did report neighborhood aesthetics as an independent predictor of walking and biking to school after considering socio-demographic features, parental safety concerns, and macro-level walkability. Amenities on streets also showed certain impact. A study in Australia (Timperio et al. 2006) identified the objectively assessed steep slope and perceived lack of lighting and crossing as negative correlates. The presence of street trees within 0.4 kilometre (0.25 mile) of school has also been reported as a positive correlate. McMillan's study (2003) examined the impact of amenities such as street lighting, street width, speed bumps, abandoned buildings, and windows facing streets. Yet the results were either insignificant or not in the theoretically derived direction. More targeted research is needed on these variables and their measurement methods.

Traffic Danger and Crime

In addition to walkability/bikability, traffic danger and crime also have significant impact on children's school travels. Kerr's study (2006) reported that parental safety concerns was a much stronger correlate than walkability, aesthetics, and access to local stores and facilities.

Traffic danger was a secondly important barrier reported in the 2004 CDC survey, with 30.4% of parents reporting it as a barrier (Martin & Carlson 2005). However, findings about real and perceived traffic dangers were not consistent. Although traffic accident is one of the leading causes of child death, the objective data showed that the pedestrian injury/death rate had declined 51% from 1987 to 2000 among children aged 14 years and under, suggesting parents' perceptions might be exaggerating the actual dangers. An Australian study reported the perceived lack of street lighting and crossings, and objectively assessed busy roads as negative correlates, indicating the roles of both real and perceived traffic dangers (Timperio et al. 2006). Yet in a Britain study, the real and perceived traffic dangers did not predict children's school travels by car (DiGiuseppi et al. 1998). More research is needed on real and perceived traffic dangers, their relationships, as well as their possible interactions with other factors such as walkability or perceived control.

Threat from crime was another important barrier identified in the 2004 CDC survey, with 11.7% of parents reporting it. Studies in UK (DiGiuseppi et al. 1998) and the U.S. (Eichelberger 1990) have reported the fear of abduction as a strong predictor of car travel to school. However, some scholars (e.g., Robin Moore 1986) argued that parents might have exaggerated the crime danger, and have overly limited children's freedom of movement and opportunities to interact with outdoor environments, which were very important for child development. On the other hand, as compared with parents' strong concerns about traffic danger and crime, a study has reported that children were most concerned about being approached to smoke or being bullied while in transit (Lee & Rowe).

Finally, in addition to previously mentioned variables, temperature and weather also played important roles in children's school travels (Martin & Carlson 2005; Sirard et al. 2005).

Table 1: Summary of empirical studies about physical environmental correlates of walking and biking to school

Author (year)	Sample size; grade/age Design; measure; outcome variable	Physical environmental variables as independent variables	Association	Statistical adjustment
Boarnet (2005a)	862; 3 rd -5 th grade Inte; O; W & B	Safe routes to school construction projects	(+)	None
Boarnet (2005b)	1,243; 3 rd -5 th grade Inte; O & P; W & B	Sidewalk gap closure Replacement of 4-way stops with traffic signals Pedestrian/bicycle improvement Development of bicycle facility	(+) (+) (+) (X)	None
Braza (2004)	2,993; 5 th grade CS; O; W & B	Population density Street intersection density School size	(+) (X) (-)	School level SES & Eth
EPA (2003); Ewing (2004, 2005)	709 trips; K-12 th grade CS; O; W	Sidewalk coverage on main roads Sidewalk completeness for origin and destination zones Travel time (distance) Population density Street tree coverage in vicinity of school Age of school School size (enrolment) (Residential + job) density Land-use mix	(+) (+) (-) (X) (X) (X) (X) (X) (X) (X)	SES, car ownership, students' driver license ownership, & number of family members
Fulton (2005)	1,395; 4 th -12 th grade CS; P; W & B	Perceived neighborhood safety Neighborhood location (including central city, small city, town, suburban, and rural)	(X) (+)	A, G, Eth, & some parental factors
Kerr (2006)	259; 5-18 year CS; O; W & B	Parental safety concerns Walkability in high-income neighborhood Walkability in low-income neighborhood Neighborhood aesthetics Perceived access to local stores and B/W facilities	(-) (+) (X) (+) (+)	A, G, & parental education
Martin 2005	4,213; 5-18 year CS; P; barrier for W	Distance (61.5% reporting it as a barrier) Traffic danger (30.4% reporting it as a barrier) Crime (11.7% reporting it as a barrier)	(-) (-) (-)	None
McMillan (2006)	1,244; 3 rd -5 th grade CS; P; W & B	Neighborhood safety Distance < 1.6 kilometres (1 mile)	(X) (+)	A, G, In, & other parental/ household factors
McMillan (2003)	2,128; 3 rd -5 th grade CS; O & P; W & B	Neighborhood not safe Need to travel on road with speed > 30 mph Perceived lack of sidewalks Sidewalk completeness within 1/4 mile buffer of school % of street segments with windows facing streets % of street segments with street lighting % of street segments with no abandoned buildings Average street width Average block length	(-) (-) (-) (X) (X) (-) (-) (+) (+) (X)	In, parental education, number of children, % of Hispanic students at school, household transportation option, & social/cultural norms

		% of street segments with speed humps	(X)	
		% of street segments with mixed land-use	(X)	
		Neighborhood location (urban vs. suburban)	(X)	
Merom (2006)	812; 5-12 year CS; P; W & B	Distance	(-)	A, G, Eth, & other child/parent/ household factors
		Unsafe roads to school	(-)	
Schlossberg (2006)	292; 6 th -8 th grade CS; O; W	Distance	(-)	None
		Intersection density	(-)	
		Dead end density	(-)	
		Route directness	(X)	
		Having major roads on route	(X)	
		Having railroad tracks on route	(-)	
Sirard (2005)	3,911; 1 st -6 th grade CS; O; W & B	School location (urban vs. suburban)	(X)	None
Timperio (2006)	235, 5-6 year; 677, 10-12 year CS; O & P; W & B	<u>Parents' perceptions:</u>		G, parental education, clustering of children by school, & area-level SES
		Heavy traffic	(X)	
		Strong concerns of strangers	(X)	
		Strong concerns of road safety	(X)	
		No light/crossings	(-)	
		Need to cross several roads	(X)	
		Limited public transport	(X)	
		Not many other children around	(-)	
		<u>Children's perceptions (10-12 year):</u>		
		Heavy traffic	(X)	
		Concerns about strangers	(X)	
		Roads not safe	(X)	
		<u>Objective measure of route to school</u>		
		Distance < 800m (0.5 mile)	(+)	
		Busy road barriers along route	(-)	
		Direct route to school for 5-6 year	(X)	
		Direct route to school for 9-12 year	(+)	
		Slope barriers for 5-6 year	(-)	
		Slope barriers for 9-12 year	(X)	
Staunton (2003)	4,665 Inte; O; W & B	Multi-level interventions including engineering improvement	(+)	None

Note: (+), positive association; (-) negative association; (X), insignificant; A, age; B, biking to and from school; CS, cross-sectional study; Eth, ethnicity; G, gender; In, family income; Inte, intervention study; O, objective measures of physical environment; P, perceptions of physical environment; SES, socioeconomic status; W, walking to and from school

1.4. Personal and Social Correlates

Personal and social factors were recognized as important correlates of walking and biking to school in most previous studies. Yet empirical findings were not always consistent. Child's gender has been reported as a significant factor (Cooper et al. 2003; McMillan et al. 2006; Fulton et al. 2005; Evenson et al. 2003), with girls being less likely to walk. Age differences were observed in a national survey (Fulton et al. 2006) and a statewide study in North Carolina (Evenson et al. 2003), yet was insignificant in an Oregon study (Schlossberg 2006). Overall, middle school and high school youth had a lower rate of walking to school than elementary school children. This might be explained by the longer distances that middle schools and high schools were located from students' homes. Finer age differences among 3rd-5th grade children have been reported by McMillan (2006), where the odds of active travel reduced by 27% with each year's increase in age. Yet in an Australian study, children aged 11-12 were more likely to walk than those aged 5-9 (Merom et al. 2003).

Ethnic differences were reported in several studies, where minority children (Evenson 2003; Braza 2004; Merom et al. 2003) or Hispanic children (Fulton et al. 2005) walked more often. Yet some other studies reported ethnicity as insignificant (Schlossberg 2006). The child's body mass index was a negative correlate in Evenson's study (2003), yet was insignificant in Fulton's study (2005). Child's positive attitude toward walking has been reported as a positive correlate (Merom et al. 2003).

Family income was identified as a negative correlate in a Florida transportation study (EPA 2003) and a California study, yet was found to be insignificant in an Oregon study (Schlossberg 2006). There were some other parental or household factors that have been reported as significant factors in a few studies yet had

conflicting findings from other studies. Examples of such factors included parental education level (Fulton et al. 2005), marital status (Fulton et al. 2005; Merom et al. 2003), perceived importance of physical activity, perceived convenience of driving (McMillan 2006), individual history of active transport to school, active commute to walk (Merom et al. 2003), the number of parents living in the home (Fulton et al. 2005), the gender of the responsible parent (Merom et al. 2003), car ownership (Merom et al. 2003; Schlossberg 2006), and the level of freedom given to children by parents (Merom et al. 2003; Ziviani et al. 2004).

As to social factors, family support has been reported as a positive correlate. Education programs have also shown significant effects on promoting walking and biking to school. In addition, in the 2004 CDC survey, 6% of parents reported those school policies that discouraged walking to school as a barrier (Martin & Carlson 2005).

1.5. Interactions among Personal, Social, and Physical Environmental Correlates

As indicated by socio-ecological theory and the conceptual framework proposed in this study, the personal, social, and physical environmental correlates of walking and biking to school are interrelated with each other. McMillan's study (2006) tested possible interactions between the child's gender and six variables, including parents' perceived neighborhood safety, family income, parents' walking behaviors, family approval of walking to school, parents born in the U.S., and parents' education levels. Findings only supported one significant interaction, where caregivers' own activity levels moderated the influence of gender on walking to school. Although girls were generally less likely to walk, an active caregiver increased the possibility that a girl would walk.

The King County study (Kerr et al. 2006) has also reported some significant interactions. Firstly, the interaction existed between the composite measure of macro-level walkability and neighborhood income level, where higher walkability encouraged walking to and from school only in high-income neighborhoods, but not in low-income neighborhoods. One possible explanation is the higher rate of parental safety concerns in low-income neighborhoods. Secondly, the interaction existed between walkability and parental safety concerns, where parents with serious safety concerns kept their children from walking even if the neighborhood was highly walkable in terms of urban forms.

Finally, it was noticed that most studies had ignored the differences between the trip to school and trip from school. Schlossberg's study (2006) of four middle schools found that although only 15% of students walked or biked to school, 25% of them walked or biked from school to home. A survey in California (1999) with children (9-11 years) found the walking-to-school rate was 18%, yet the walking-home-from-school rate was 26% (Braza et al. 2004). Since the trip from school is less limited by time constraint, children may engage in other activities before getting home. Future studies should explore the specific potential of trips from school to home.

1.6. Implications for Evidence-Based Design and Policy Interventions

In summary, a pattern emerged from the literature, indicating the perceived physical environment was mediating the effect of objective physical environment on parents' decision-making about children's school travel modes, while personal and social factors were moderating this environment-behavior relationship. Although evidence is still limited, it did provide important guidance for evidence-based design and policy interventions.

Firstly, personal, social, and physical environmental factors all have significant impact on walking and biking to school. Therefore, multi-level strategies should be emphasized in interventions. Secondly, pre-post intervention studies are especially valuable because they can identify causality between physical environment and behavior changes, and can compare effects of different interventions, as indicated by the study on the California Safe Routes to School projects (Boarnet et al. 2005b). More pre-post studies should be conducted by collaborating with various intervention programs that are being implemented. Such studies can help to develop a priority list for designers and policy-makers. On the other hand, research findings should be generalized with cautions about the contexts. For example, sidewalk gap closure was proven to be extremely useful in areas with moderate or heavy pre-existing pedestrian traffic, yet was much less effective in areas with low volumes of pre-existing pedestrian traffic (Boarnet et al. 2005b). Different interventions are needed for different contexts.

Thirdly, findings about significant interactions among personal, social, and physical environmental factors can inform the development of tailored interventions and policies. Gender-specific and neighborhood-specific strategies should be considered. For example, the interaction between walkability and neighborhood income level suggests different strategies for neighborhoods with different socioeconomic status (Kerr et al. 2006). In low-income neighborhoods, parents' safety concerns are more important barriers than the walkability itself.

From another perspective, some findings have significant implications for school siting. For example, significance of the distance implies the need for centrally located neighborhood schools (Ewing et al. 2005). A study found that schools built before 1983, which were small-scale neighborhood schools, had four times more students walking to school (Kouri 1999). However, some current policies tend to encourage constructions of new, large-scale schools in remotes sites that are difficult to access by walking or biking. Examples of such policies include the funding formulas in many states that favour new school constructions over renovations, the minimum acreage standards that may be met only at Greenfield locations, the school districts' exemptions from planning and zoning laws that enable them to disregard local policies and plans, as well as building codes that apply similar standards to new constructions and renovated schools (EPA 2003).

Overall, future research should phrase research questions, generate hypotheses, and design studies in a way that is knowledge-based and is more relevant to practice and policy, as suggested by Robinson and Sirard's solution-based paradigm (2005). Collaboratives should be developed between researchers and professionals, using intervention projects as research sites. Such pre-post studies can go beyond the limit of cross-sectional studies, and can generate solid knowledge about the causality between physical environment and children's walking and biking to school. In addition, various policies, such as school siting, transportation, urban development, and land use legislations should consider their potential impact on walking and biking to school.

2. CASE STUDY IN AUSTIN, TEXAS

Based on literature review, I conducted a case study in Austin, Texas, where 73 public elementary schools were analyzed for their attendance areas' walkability and safety. This study measured the environmental support for walking to school from three perspectives, and was presented in a conference (Zhu 2007). The macro-level walkability (urban forms) and safety were measured using GIS, with the school's attendance area as the unit of analysis. Variables for the macro-level walkability included distance-based walker estimates (percentages of residential units located within half a mile street network distance from school), pedestrian facilities (sidewalk completeness and traffic signal density), residential density, street connectivity (street density and street intersection density), and land-use mix. Variables for safety consisted of traffic safety (traffic volumes and percentages of high-speed streets) and yearly crime rates. The micro-level walkability (urban design and architectural qualities) was assessed through filed audits on 200-meter street segments sampled from the attendance areas. Relevant variables included various attributes of sidewalks, streets, and roadside buildings, as well as the overall impressions of convenience, aesthetics, amenities, maintenance, and perceived safety.

Regression analysis was run between the percentage of Hispanic students attending the school and each environmental variable. Results showed that the percentage of Hispanic students was positively associated with the crime rate and most macro-level walkability variables, but negatively associated with most micro-level walkability variables ($P < 0.05$). No significant association was found for traffic safety.

Analysis of variance was used to compare the means of each environmental variable between the top-quartile schools with the highest percentages of Hispanic students ($\geq 82.1\%$) and the bottom-quartile schools ($< 37.6\%$). For macro-level walkability, the group with the highest percentages of Hispanic students had 27.9% more students living within half a mile street network distance from school, had 15% higher sidewalk completeness, had one more traffic signal per 16-kilometer (10-mile) street segment, had about 427 more residents and eight more street intersections per 100 acres, and had a 0.165 higher land-use mix index on the zero to one scale ($P < 0.05$). In contrast, for micro-level walkability, the building maintenance, visual quality of buildings, and overall aesthetics, amenities, and maintenance were all rated at least one point lower on a five-point scale ($P < 0.05$). In addition, some micro-level variables were marginally significant at the 0.1 level, showing that street segments in the top-quartile schools' attendance areas were more likely to have sidewalk obstructions, on-street parking, and power lines along the segment. What's more important, these schools had 162 more criminal offenses per 1,000 persons per year in their attendance areas (mean = 239) ($P < 0.05$).

Findings showed that schools with higher percentages of Hispanic children featured attendance areas with higher macro-level walkability, but much lower micro-level walkability and crime safety. Threats from crime tended to grow with the increase of land-use mix and street connectivity, which were usually considered to encourage adults' walking. Therefore, targeted research is needed for the impact of these intertwining factors on children's walking to and from school, especially for low-income, Hispanic neighborhoods. In addition, the micro-level walkability should be studied as an important and holistic aspect parallel with the macro-level walkability of physical environment. For future practice, findings from this study suggested tailored intervention strategies for specific contexts and populations.

CONCLUSIONS

Overall, current knowledge about the relationship between physical environment and children's walking/biking to school is still constrained to associations for limited contexts and populations. More intervention studies are needed in order to identify causality for this environment-behavior relationship. In addition, more attention is needed for the relationships among various scales and aspects of physical environment, especially for the relationships between macro-level walkability and micro-level walkability, and between walkability and safety. Finally, more targeted research is needed to understand differences across various contexts and populations, so that tailored strategies can be developed for design and policy interventions.

REFERENCES

Black, CE, Collins A, Snell M. 2001. Encouraging walking: The case of journey-to-school trips in compact urban areas. *Urban Studies* 38(7):1121-41.

- Boarnet MG, Anderson CL, Day K, McMillan T, Alfonzo M. 2005a. Evaluation of the California Safe Routes to School legislation - Urban form changes and children's active transportation to school. *American Journal of Preventive Medicine* 28(2):134-40.
- Boarnet G, Day K, Anderson C, McMillan T, Alfonzo M. 2005b. California's Safe Routes to School program – Impact on walking, bicycling, and pedestrian safety. *Journal of the American Planning Association* 71(3):301-17.
- Braza M, Shoemaker W, Seeley A. 2004. Neighborhood design and rates of walking and biking to elementary school in 34 California communities. *American Journal of Health Promotion* 19(2):128-36.
- Cooper AR, Page AS, Foster LJ, Qahwaji D. 2003. Commuting to school - Are children who walk more physically active? *American Journal of Preventive Medicine* 25(4):273-76.
- DiGiuseppi C, Roberts I, Li L, Allen D. 1998. Determinants of car travel on daily journeys to school: Cross sectional survey of primary school children. *British Medical Journal* 316:1426-28.
- Eichelberger MR, Gotschall CS, Feely HB, Harstad P, Bowman LM. 1990. Parental attitudes and knowledge of child safety: A national survey. *American Journal of Diseases of Children* 144 (6):714-20.
- EPA. 2003. *Travel and Environmental Implications of School Sitting*. Publication EPA 231-R-03-004. U.S. Environmental Protection Agency: Washington, D.C.
- Evenson KR, Huston SL, McMillen BJ, Bors P, Ward DS. 2003. Statewide prevalence and correlates of walking and bicycling to school. *Archives of Pediatrics & Adolescent Medicine* 157(9):887-92.
- Ewing R, Forinash CV, Schroer W. 2005. Neighborhood schools and sidewalk connections: What are the impacts on travel mode choice and vehicle emissions? *Transportation Research News* 237:4-10.
- Ewing R, Schroer W, Greene W. 2004. School location and student travel - Analysis of factors affecting mode choice. *Transportation Research Record: Journal of the Transportation Research Board* 1895:55-63.
- Fulton JE, Shisler JL, Yore MM, Caspersen CJ. 2005. Active transportation to school: Findings from a national survey. *Research Quarterly for Exercise and Sport* 76(3):352-357.
- Kerr J, Rosenberg D, Sallis JF, Saelens BE, Frank LD, Conway TL. 2006. Active commuting to school: Associations with environment and parental concerns. *Medicine and Science in Sports and Exercise* 38(4):787-94.
- Kouri C. 1999. *Wait for the Bus: How Low Country School Site Selection and Design Deter Walking to School and Contribute to Urban Sprawl*. South Carolina Conservation League: Charleston, Carolina
- Lee TR, Rowe N. Parents' and children's perceived risks of the journey to school. *Architecture and Behavior* 10:379-89.
- Martin S, Carlson S. 2005. Barriers to children walking to or from school - United States, 2004 (Reprinted from MMWR 2005;54:949-52). *Journal of the American Medical Association* 294(17):2160-61.
- McMillan TE. 2003. *Walking and urban form: Modelling and testing parental decisions about children's travel*. Unpublished doctoral dissertation, University of California, Irvine,
- McMillan TE. 2005. Urban form and a child's trip to school: The current literature and a framework for future research. *Journal of Planning Literature* 19(4):440-56.
- McMillan T, Day K, Boarnet M, Alfonzo M, Anderson C. 2006. Johnny Walks to School- Does Jane? Sex Differences in Children's Active Travel to School. *Children, Youth and Environments* 16(1):75-89.
- Merom D, Tudor-Locke C, Bauman A, Rissel C. 2006. Active commuting to school among NSW primary school children: Implications for public health. *Health & Place* 12(4):678-87.
- Moore RC. 1986. *Childhood's Domain: Play and Place in Child Development*. Croom Helm: London.
- Robinson TN, Sirard JR. 2005. Preventing childhood obesity: A solution-oriented research paradigm. *American Journal of Preventive Medicine* 28(2S2):194-201.
- Schlossberg M, Greene J, Phillips PP, Johnson B, Parker B. 2006. School trips - Effects of urban form and distance on travel mode. *Journal of the American Planning Association* 72(3):337-46.
- Sirard JR, Ainsworth BE, Mclver K, Pate RR. 2005. Prevalence of active commuting at urban and suburban elementary schools in Columbia, SC. *American Journal of Public Health* 95(2):236-37.
- Staunton CE, Hubsmith D, Kallins W. 2003. Promoting safe walking and biking to school: The Marin County success story. *American Journal of Public Health* 93(9):1431-34.
- Timperio A, Ball K, Salmon J, Roberts R, Giles-Corti B, Simmons D, Baur LA, Crawford D. 2006. Personal, family, social, and environmental correlates of active commuting to school. *American Journal of Preventive Medicine* 30(1):45-51.
- U.S. Department of Health and Human Services. 2000. *Healthy People 2010 (2nd ed)*. U.S. Department of Health and Human Services: Washington, D. C.
- Zhu X. 2006. Ethnic disparity in environmental support for children's walking to school. Presented at *the Active Living Research 2007 Conference*. Coronado, CA.
- Ziviani J, Scott J, Wadley D. 2004. Walking to school: Incidental physical activity in the daily occupations of Australian children. *Occupational Therapy International* 11(1):1-11.

Community Design Parameters and the Performance of Residential Cogeneration Systems

Hazem Rashed-Ali, Ph.D.

University of Texas at San Antonio, San Antonio, TX

ABSTRACT: The integration of cogeneration systems in residential and mixed-use communities has the potential of reducing their energy demand and harmful emissions and can thus play a significant role in increasing their environmental sustainability. This study investigated the impact of selected planning and architectural design parameters on the environmental and economic performances of centralized cogeneration systems integrated into residential communities in U.S. cold climates. Parameters investigated include: 1) density, 2) use mix, 3) street configuration, 4) housing typology, 5) envelope and building systems' efficiencies, and 6) passive solar energy utilization. The study integrated several simulation tools into a procedure to assess the impact of each design parameter on the cogeneration system performance. This assessment procedure included: developing a base-line model representing typical design characteristics of U.S. residential communities; assessing the cogeneration system's performance within this model using three performance indicators: percentage of reduction in primary energy use, percentage of reduction in CO₂ emissions; and internal rate of return; assessing the impact of each parameter on the system performance through developing 46 design variations of the base-line model representing potential changes in each parameter and calculating the three indicators for each variation; and finally, using a multi-attribute decision analysis methodology to evaluate the relative impact of each parameter on the cogeneration system performance. The study results show that planning parameters had a higher impact on the cogeneration system performance than architectural ones. Also, a significant correlation was found between design characteristics identified as favorable for the cogeneration system performance and those of sustainable residential communities. These include high densities, high use mix, interconnected street networks, and mixing of housing typologies. This indicates a higher potential for integrating cogeneration systems in sustainable communities.

Keywords: cogeneration; residential & mixed use communities; energy efficiency; district heating

1. SUSTAINABILITY, THE BUILT ENVIRONMENT, AND COGENERATION

In the past three decades, the need for adopting the principles and practices of sustainability has been clearly established through research activities, political conventions, and protocols. While a lack of consensus still exists over the definition of sustainable development and the issues it should address, existing schools of thought agree over the need for balancing its three main components: environmental, economic, and social sustainability. The need for environmental sustainability stems from the growing sense of responsibility motivated by the realization of the serious environmental problems facing world communities (e.g. global warming, resources depletion, increased pollution, etc.). Energy is a central issue in the sustainability debate affecting all three of its components (Johansson & Goldemberg 2002). This wide impact of energy indicates that energy efficiency, while perhaps not a sufficient condition for sustainability, is certainly a necessary one. The built environment plays a major role in the U.S. energy system both directly, through energy use in the residential and commercial sectors, which in 2004 accounted for 21.2% & 17.5% of total U.S. consumption respectively (EIA 2005), and indirectly, through its impact on the transportation sector, which accounted for an additional 27.8% of that consumption (EIA 2005). Subsequently, increasing energy efficiency in the built environment can positively impact its sustainability. Numerous studies conducted on the relations among sustainability, urban form, and building design, some of which are listed in the coming section, indicate a clear potential for achieving significant reductions in energy consumption through intelligent and sustainable planning and architecture. Increasing the energy efficiency of new residential communities is of particular significance in light of the projected increases in residential energy use due to increases in population and new housing stock. However, statistics show that the majority of the new U.S. housing stock are detached single family houses that are typically larger in size and

consume more energy than current average U.S. homes. Such trends would further increase the environmental impact of the residential sector. A clear need, therefore, exists for research activities that aim to explore alternative design strategies, characteristics, systems, and technologies that aim to increase the energy efficiency and reduce the energy demand of the residential sector.

Electricity production resulted in 39% of energy-related U.S. CO₂ emissions in 2003 (EIA 2004). Distributed generation (DG) is an established alternative to existing power systems that has the potential of achieving considerable environmental and economic benefits. The use of cogeneration, a technology that generates electricity locally and utilizes the thermal energy byproduct of the generation process in thermal end uses such as space and water heating, further increases the efficiency and the potential benefits of DG. Combined with energy conservation measures, residential cogeneration systems offer the potential for meeting most or all of the energy needs of residential communities in a more economic and environmentally friendly manner. Consequently, integrating cogeneration technologies into new residential communities can mitigate the expected increases in their environmental impact. Residential cogeneration systems are currently utilized in several European communities (e.g. Kronsberg Community in Hannover, Germany; and Beddington Zero Energy Development in London, UK). In the U.S., however, while cogeneration is well established in many sectors, e.g. the industrial and educational ones, its use in the residential sector is still very limited in spite of the significant energy and emissions reductions potential that this technology presents (see Gunes & Ellis 2003; Braun et al. 2004). One of the main reasons cited for this limited use is the high initial system cost, especially for district heating networks (Phetteplace 1995), as well as the unsuitability of the energy use characteristics of conventional U.S. residential communities (with their high daily and seasonal variations) to the needs of cogeneration systems. A number of possible strategies for increasing the use of residential cogeneration have been discussed in the literature, one of which is to identify potential residential markets with more suitable energy use characteristics that can act as market entry points for these technologies (U.S. DOE, 2003).

Throughout the U.S., a number of new, sustainable, residential communities are being developed, which attempt to integrate the principles of sustainability and energy efficiency from the early stages of their design. The design characteristics of these communities are considerably different from those of conventional ones thus resulting in improved energy use characteristics. These communities are also used to demonstrate the performance of emerging technologies. While their number is still limited, such communities represent a potential market for the integration of cogeneration systems. This integration can result in further reductions in the communities' environmental impact as well as to wider acceptance of these emerging technologies and improvements in their economics making them suitable for other markets. Therefore, a need exists to investigate the impact of the different design characteristics of sustainable communities, compared to those of conventional ones, on the performance of the cogeneration systems and therefore on their feasibility. Such studies can then be used to develop design guidelines that can inform designers of sustainable communities who wish to integrate cogeneration into their projects. As the design of residential communities utilizing cogeneration systems involves a large number of parameters on the planning and architecture scales, this study focused on selected parameters on each scale and assessed their individual impact on the performance of cogeneration system. These selected parameters are: 1) density, 2) use mix, 3) street configuration, 4) housing typology, 5) envelope and building systems' efficiencies, and 6) passive solar energy utilization. This assessment aims to demonstrate the impact that informed design can have on increasing the feasibility of emerging technologies, such as residential cogeneration, and therefore on improving the environmental impact of residential communities. In this context, the following sections will present a brief literature review dealing with sustainability, how it relates to the built environment, distributed generation and cogeneration, and performance assessment studies of residential cogeneration. Subsequently, the methodology used in assessing the design parameters' impact on the cogeneration system performance will be described followed by a summary and analysis of the assessment results. Finally, several conclusions that can be drawn from these results will be outlined and discussed.

2. LITERATURE REVIEW

2.1. Sustainability, energy, and the built environment

While varying in emphasis, existing definitions of sustainability and sustainable development (e.g. WCED 1987) all stress the need for balancing environmental, economic and social considerations while maintaining a good quality of life. A strong and direct link exists between environmental sustainability: including issues of mitigation of existing environmental problems, protection of eco-systems, more efficient use of natural resources, and biodiversity; and between energy and energy systems. Johansson & Goldemberg (2002) describe conventional sources of and approaches to providing and using energy as unsustainable and link them to significant environmental, social, and health problems both currently and in the future. They also suggest several alternative strategies to achieve a more sustainable energy including: more efficient use of energy; accelerated development and deployment of new energy technologies; decentralization of the world energy systems; and increased use of renewable energy resources. Increasing the environmental sustainability of the built

environment, through more efficient use of resources and reduced environmental impact, is a major component of sustainable development and increasing energy efficiency is a necessary requirement for achieving that goal. Many studies conducted on the relations among sustainability, urban form, and building design (e.g. Breheny, 1992; Owens, 1986; Williams et al., 2000) indicate a considerable potential for increasing the energy efficiency of the built environment through intelligent and sustainable design. Grumman (2003) further argues that this potential is considerably larger when sustainability principles are applied in the early stages of the design process. Additionally, Barton (2000) argues that sustainable communities, many of which are currently in different stages of development throughout the U.S., can change the prevailing culture of local decision makers, professionals, and developers. These communities also offer a considerable opportunity for demonstrating emerging technologies under more favorable conditions.

2.2. Distributed generation & residential cogeneration

Distributed generation can offer several advantages compared to centralized systems. WADE (2003) identifies these advantages as: 1) lower CO₂ emission; 2) lower costs; 3) lower transmission and distribution losses; 4) greater power quality; and 5) less system vulnerability. Houghton (2000), arguing for developing small scale and locally-based community energy utilities, contended that such utilities can be a vital element of new sustainable communities offering many societal benefits including raising awareness of the consequences of energy use, increasing social responsibility, and improving local economy through lowering energy costs and providing local employment. Two approaches can be identified in the literature for integrating cogeneration systems in residential communities, to be described here as the centralized and the decentralized integration approaches. Centralized integration involves a central plant supplying electricity, heating and possibly cooling to a number of buildings through electrical distribution and district heating/cooling (DHC) networks (see Phetteplace, 1995). While decentralized integration is a newer alternative, in which smaller-sized micro-cogeneration systems are integrated into individual homes. Centralized integration utilizes larger sized, more established, and more efficient technologies, yet its economic performance is negatively impacted by the high initial cost and thermal losses of the DHC networks. On the other hand, micro-cogeneration technologies, while avoiding the penalties associated with DHC networks, are currently still lower in efficiency and higher in initial cost (per unit power) than their larger-sized counterparts (Knight and Ugursal 2005). In both approaches, the systems are mostly grid-connected and include a supplementary heating source. While the majority of existing cogeneration systems utilize conventional fossil fuels, e.g. natural gas, some existing systems utilize alternative, more renewable, fuels and the use of fuel cells in particular offers a large potential in this regard. The study reported in this paper, however, focuses on the more established centralized integration approach using natural gas.

2.3. Performance assessment of residential cogeneration systems

Higher awareness of the environmental implications of current energy systems and the potential impact of residential cogeneration on the sustainability of the residential sector, combined with recent advances in cogeneration technologies, have resulted in increased research activities in the area which aim to investigate the current potential for residential cogeneration systems, their benefits, and the optimum conditions under which they can be utilized. Conventional feasibility studies of cogeneration systems (e.g. Ellis 2002) have been limited to economic performance, i.e. identifying the optimum design characteristics of the cogeneration system (e.g. system type, size, operation strategy, configuration, etc.), which would achieve the maximum possible economic return over the project life cycle. However, the majority of recent studies (e.g. Gunes & Ellis 2003; Braun et al. 2004), which recognize the sustainability implications of these systems, have considered both economic and environmental impacts of the technology. In general, most studies addressing both environmental and economic performances of residential cogeneration show the potential for significant energy and environmental benefits from using the technology. However, the majority of these studies also generally agree that the economics of the technologies are still uncompetitive with conventional systems mainly because of their higher initial cost as well as the current low cost of electricity. However, most existing studies exclusively dealt with the issue at the scale of the individual building and not that of the community, and they also did not investigate the impact that improving the energy use characteristics of buildings, communities, or both can have on the energy use, and consequently the performance of the cogeneration system. Additionally, few studies have been conducted that aim to identify suitable markets for residential cogeneration, a goal identified as important for the wider use of the technology (U.S. DOE 2003). This study, while adopting a similar approach in assessing both the environmental and economic performances of residential cogeneration, using the concept of performance indicators, represents an attempt to investigate these issues thus addressing these gaps in the literature.

3. METHODOLOGY

This study utilized a quantitative research methodology, in which building energy simulation and cogeneration system performance simulation tools were used to investigate the impact of the selected design parameters on the performance of the cogeneration system. The research design, shown in figure 1, included developing a base-line model representing the design characteristics of conventional U.S. residential communities (see table 1

for model and cogeneration system characteristics). Subsequently, the annual community primary energy use and CO₂ emissions, with and without cogeneration, were calculated as will be described in more details later. Based on this, the cogeneration system performance within the base-line community was assessed using three performance indicators: the percentage of reduction in annual community primary energy use due to the use of cogeneration, the subsequent percentage of reduction in CO₂ emissions; and the internal rate of return (IRR) of the cogeneration system. The impact of each design parameter on the performance of the cogeneration system was then assessed through developing design variations of the base-line community model representing selected assessment values for each design parameter. In total, 46 of these design variations were developed as shown in table 2. The same three performance indicators were then assessed for each design variation and a Multi-Attribute Decision Analysis methodology (MADA) was used to calculate the environmental, economic, and combined performances of the cogeneration system in each of these design variations relative to its performance within the base-line community (see Lippiatt (2002) for a discussion of MADA). These results were then used to evaluate the relative impact of each design parameter on the cogeneration system performance.

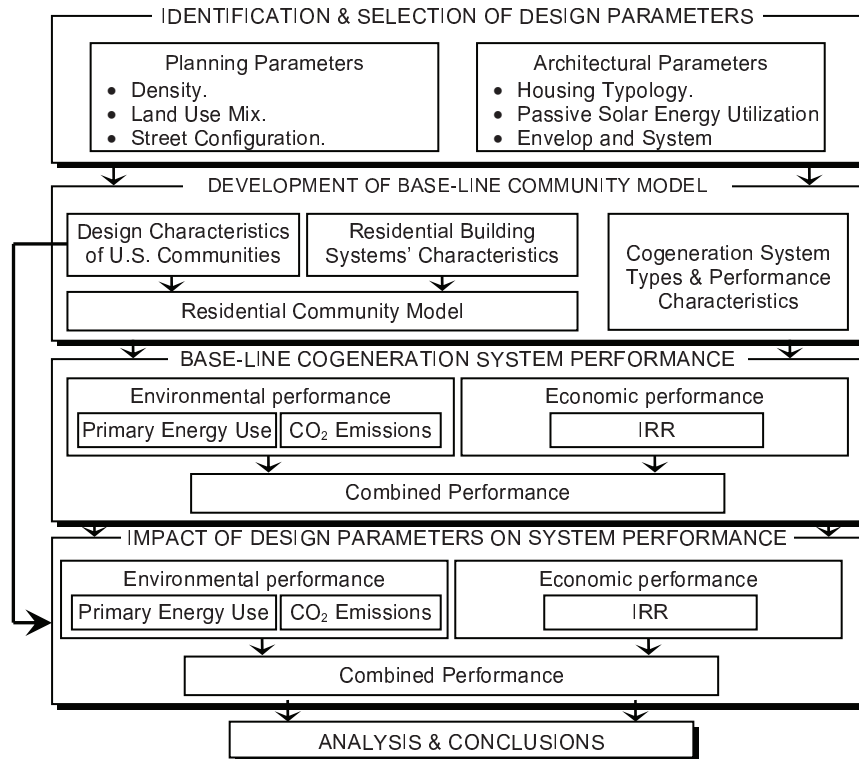

Figure 1: Schematic diagram of the research design

The cogeneration system performance assessment procedure involved several steps that utilized a number of existing software, tools, and databases. For both the base-line community case as well as each of the community design variations investigated in the study, assessing the performance of the cogeneration system involved first the development of building prototypes, either residential only or a mix of residential and commercial according to the design variation in question. In total, seven residential prototypes and 21 commercial prototypes, of different building typologies and sizes, were developed for this study using the simulation software eQUEST (Hirsch, 2003). The annual electrical and thermal energy consumptions of each model, without the cogeneration system, were simulated and the models were calibrated and the simulation results validated by comparing them to Energy Information Administration (EIA) energy use survey data. Following this, the annual primary energy use and annual CO₂ emissions of the community, without cogeneration, were calculated by adding the electrical and thermal energy uses of each building and accounting for generation efficiencies and distribution losses. Based on this, the hourly electrical and thermal loads of the centralized cogeneration system were calculated by adding the loads resulting from each building, designing a community district heating network, calculating the thermal losses within this network in the selected climate, and adjusting the community thermal loads accordingly. The annual community electrical and thermal energy use with cogeneration was then simulated using the HOMER software (Lambert et al., 2006); and the annual primary energy use and CO₂ emissions for the whole community were calculated similar to the “without cogeneration” case. The percentages of reduction in annual primary energy use and CO₂ emission for the community due to

the use of cogeneration were then calculated. These two values represented the environmental performance indicators used in this study. Finally, a life cycle cost analysis (LCCA) was conducted and the resulting IRR was calculated and represented the economic performance indicator used in the study. The three indicators were subsequently used to calculate an environmental and an economic performance for the cogeneration system, and the two performances were integrated into a combined performance following the MADA methodology mentioned previously. A more detailed description of the assessment procedures and the tools and assumptions involved can be found in Rashed-Ali (2006). The study utilized the climate of Helena, MT, which is considered as a representative city of the cold dry U.S. climate zone. The selection of the cold climate was based on previous studies (e.g. Gunes & Ellis, 2003), which identified it as more favorable for cogeneration systems.

Table 1: Design characteristics of the base-line community model

Design characteristics	Value
Community design characteristics:	
Community size	300 du
Gross density	4 du/ac
Land-use mix	Single use residential
Street configuration	Interconnected network / grid
Housing typology	Single-family detached
Single family house model characteristics:	
Floor area	197.9 m ² (2130 ft ²) [167.2 m ² (1800 ft ²) CFA]
Building form	Single-story, square, glazing distributed equally on four sides.
Envelope characteristics	
Wall R-value	R-25
Ceiling R-value	R-49
Slab perimeter insulation	R-14, 0.37 m (4 ft) deep
Window U-factor	0.33
Building systems' efficiencies	
Air-conditioning system	SEER 10
Furnace	AFUE = 78%
Domestic hot water system	E _r = 0.594
Internal loads:	Based on 2003 international energy efficiency code (ICC 2003) and performance analysis procedure developed for U.S. single family homes by the Building America program (Herndon, 2005).
Cogeneration system characteristics	
System type	Reciprocating Internal Combustion (IC) Engine
System size (power rating)	250 kW
Electrical efficiency (HHV)	31.1%
Thermal efficiency	46.2%
Overall system efficiency	77.3%
Operation strategy	Electric load-matching
System configuration	Baseline electrical load, grid connected, auxiliary boiler, central pump.

4. RESULTS AND ANALYSIS

Figure 2 shows the results of the impact assessment conducted in the study. Terms listed on the x-axis of the graph refer to the base-line community as well as the design alternatives, for both the planning and architectural design parameters, as described in table 2. While the y-axis represents the environmental & economic performance of the cogeneration system within each alternative. The results revealed a number of significant findings. In general, variations in mix of uses and density clearly had the most impact on the system performance each resulting in up to 50% improvement in combined (environmental and economic) performance. With regard to use mix, a direct relationship was found between increasing the mixing of non-residential uses within residential communities and improvements in cogeneration system performance. Increasing this mix resulted in the most improvements in the cogeneration system's economic performance (up to 125%) and combined performance (up to 53%). These significant improvements are primarily due to the improved daily load profiles of the community through increasing the availability of day-time and all-night loads to balance the typical morning and evening residential loads. The largest increase in economic performance was achieved through providing a high level of use mix combined with an optimization of non-residential building typologies within the community to reduce the daily load variations. While increasing the mix of uses resulted in slight reductions in environmental performance, the considerable increase in economic and combined performances indicate the potential for using larger cogeneration system sizes which would improve this environmental performance while still achieving an acceptable economic one. The largest improvement in combined performance was achieved by: first, providing

day-time electrical loads from building types such as retail, and office buildings; second, providing day-time non-seasonal thermal loads through the use of restaurants and a laundry, which increase the utilization of the thermal output of the cogeneration system; and third, providing all-night electrical and thermal loads through the use of a grocery and a bakery with 24 hour schedules. Similarly, increases in density were shown to have a significant positive impact on system performance especially with regard to economics resulting in up to 84% increase in IRR. This positive economic impact was primarily caused by reductions in the initial cost of the DHC network in the higher density design alternatives. Additional, though smaller, environmental improvements were also achieved with higher densities due to the reduced thermal energy losses in this network. The positive impact of higher density, however, is reduced as the community density increases. Finally, a density gradient resulted in a system performance comparable to a community with the equivalent average density.

Table 2: Measurement scales for selected design parameters

Design parameter		Design Alternatives
Planning parameters	Street configuration	1) Interconnected network/grid (BL*); 2) Fragmented network; 3) Modified, landscape-oriented network; 4) Loops & cul-de-sacs; 5) Dendritic network.
	Density of built form	1) 1 du/ac; 2) 4 du/ac (BL*); 3) 10 du/ac; 4) 15 du/ac; 5) Density gradient.
	Mix of uses	1) Single use (BL*); 2) Low use mix (suburban areas); 3) Medium use mix (main street grouping); 4) High use mix (town center grouping); 5) Optimized use mix.
Architectural parameters	Housing typologies	1) Detached single family houses (BL*); 2) Attached single family houses; 3) Town-homes; 4) Live-work units; 5) Multi-family houses.
	Envelope & building system efficiencies	1) Energy code (IECC 2003) compliant (BL*); 2) 5% more efficient than IECC 2003; 3) 10% more efficient than IECC 2003; 4) 15% more efficient than IECC 2003; 5) 20% more efficient than IECC 2003.
	Utilization of passive solar energy	1) Orientation-neutral (BL*); 2) Low renewable energy utilization; 3) Medium renewable energy utilization; 4) High renewable energy utilization; 5) High utilization /reduced internal loads.

* BL = base-line community characteristic

For the other design parameters, several alternative housing typologies also resulted in improved cogeneration system performance, the most notable of which were multi-family houses and live-work units. Multi-family houses performed the best resulting in an improvement in environmental performance of 24%, and in economics of 6%, adding to a 15% increase in combined performance; while live-work units resulted in larger economic improvements (46%) combined by a 26% drop in environmental performance, thus resulting in an improvement of only 10% in combined performance. However, both typologies were evaluated with the base-line density of 4 du/ac, which is lower than the densities typically associated with them. This indicates a clear potential for further performance improvements with actual densities. Single family house size had a varied impact on system performance with large sizes resulting in better economics and smaller sizes resulting in better environmental performance. However, both impacts were not significant and the resulting combined performance for both sizes showed no noticeable change from the base-line. With regard to street configuration, the interconnected configuration resulted in the best cogeneration performance especially with regard to economics because of the impact of the increased network lengths in the other alternatives. On the other hand, increases in either envelope and building systems' efficiencies or in the utilization of passive solar energy within the community's buildings resulted in a reduction in economic performance due to the reduced availability of thermal loads and the

subsequent increasing mismatch between the fuel to electricity ratio of the buildings and the heat to power ratio of the reciprocating engine based cogeneration systems used in the assessment.

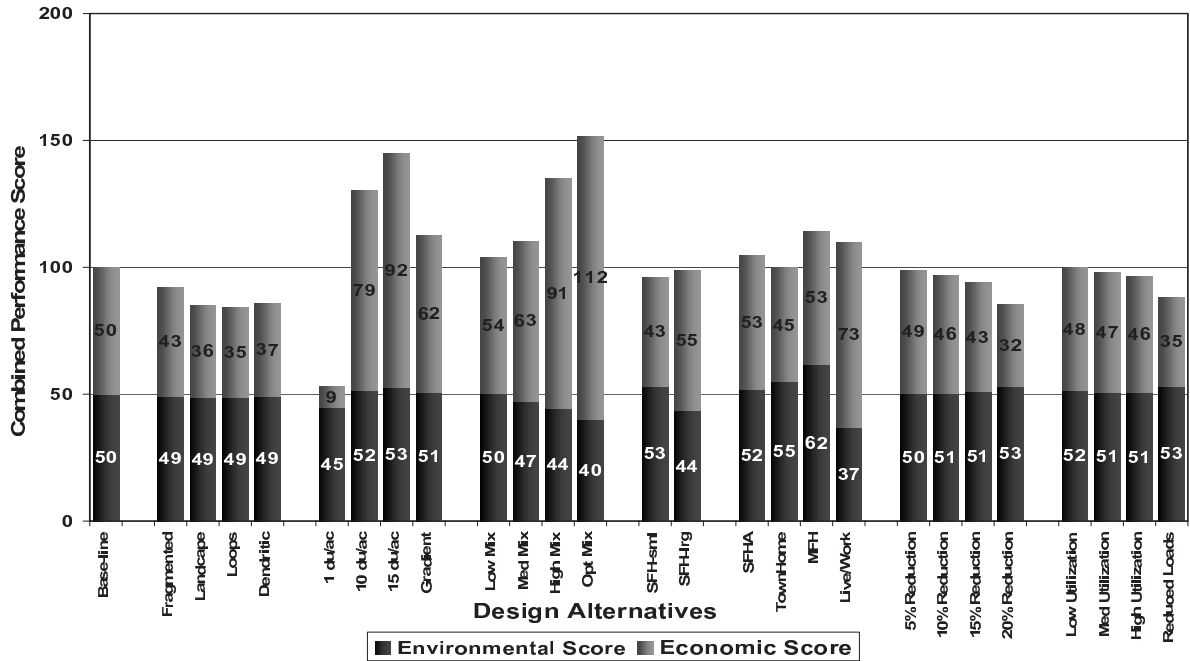

Figure 2: Summary of impacts of design parameters on combined performance of cogeneration system

5. CONCLUSION

This study represents part of the author's PhD research which aimed to identify the optimum community and cogeneration system design characteristics for residential communities utilizing cogeneration systems. This performance-based optimization aimed to improve the potential for using cogeneration systems in these communities thus achieving their potential environmental benefits. The results of this study can be utilized in one of two methods: 1) to inform designers of residential communities aiming to utilize cogeneration systems of the design parameters having the most impact on the system performance, and the design characteristics achieving the best performance, and 2) to assess the potential for integrating cogeneration systems in residential communities with a certain set of design characteristics and therefore identify potential market entry point for these emergent technologies. The major conclusions of the study can be summarized as follows:

- 1) *The design of residential communities has a significant impact on the performance of cogeneration systems.* Variations in density, mix of uses, and housing typology caused improvements as high as 120% in economic performance, and 52% in combined performance. This indicates a significant role for planners and architects in increasing the potential for utilizing cogeneration in residential communities through design optimization.
- 2) *Through community design optimization, existing cogeneration technologies can be both economically feasible and result in considerable environmental benefits.* Cogeneration systems investigated in this study resulted in up to 16.8% reduction in primary energy use and up to 33% reduction in CO₂ emissions compared to the base-line case. Additionally, the majority of the design variations investigated in this study resulted in an economically feasible IRR (higher than 10%).
- 3) *Planning parameters generally had a larger impact on the cogeneration system performance than architectural ones.* Increases in use mix and density resulted in the highest improvements in performance. With regard to architectural parameters, mixing of housing typologies offered the most potential for performance improvements.
- 4) *A strong correlation was found between design characteristics identified as favorable for cogeneration system performance and characteristics of sustainable residential communities.* These design characteristics included high density, high mix of uses, interconnected street configurations, and mixing of housing typologies, all of which are also characteristics of sustainable residential communities. This indicates the higher potential for integrating cogeneration systems in sustainable residential communities compared to conventional ones.

It should be noted that the results of this study are only applicable to the cold U.S. climate zone. As climate can significantly affect both community energy use characteristics and cogeneration system performance and possible configurations, repeating the study in other climate zones is recommended as an area of future study.

Additional future studies recommended include investigating other cogeneration system configurations, such as the possible integration of active renewable energy systems (e.g. photovoltaics), investigating the impact of the size of the residential/mixed-use community on the performance of cogeneration systems, as well as investigating the impact of the proposed design changes on transportation energy use within the community.

ACKNOWLEDGEMENT

The study reported in this paper represents part of the author's PhD dissertation research conducted in Texas A&M University. The author would like to thank Dr. Phillip Tabb, the Ph.D. dissertation committee chair, for his valuable support and guidance, as well as all the other members of the committee: Dr. Jeff Haberl, Dr. Robert Johnson, and Dr. Michael Neuman, for their insightful feedback. The work was partially funded through the William W. Caudill Research Fellowship in the Department of Architecture, Texas A&M University; and the Fellowship for Advanced Study and Research of the American Institute of Architects (AIA) and the American Architectural Foundation (AAF) and the author would like to thank both organizations for their generous support.

REFERENCES

- Barton, H. (ed.) 2000. *Sustainable communities, the potential for eco-neighborhoods*, Earth Scan Publications Limited, London, UK.
- Braun, R., Klien, S., and Reindl, D. 2004. Considerations in the design and application of solid oxide fuel cell energy systems in residential markets. *ASHRAE Transactions*, 110(1):14-24.
- Breheny, M. (ed.) 1992. *Sustainable development and urban form*, European Research in Regional Science 2, Pion Limited, London.
- EIA (Energy Information Administration) 2004. *Emissions of green house gases in the United States 2003*, Energy Information Administration, U.S. Department of Energy, Washington, DC.
- EIA (Energy Information Administration) 2005. *Annual Energy Review 2004*, Energy Information Administration, U.S. Department of Energy, Washington, DC.
- Ellis, M. 2002. *Fuel cells for building applications*, American Society of Heating, Refrigeration, and Air-Conditioning Engineers, Atlanta, GA.
- Grumman, D. (ed.) 2003. *ASHRAE green guide*, American Society of Heating, Refrigeration and Air-Conditioning Engineers, Atlanta, GA.
- Gunes, M. and Ellis, M. 2003. Evaluation of energy, environmental, and economic characteristics of fuel cell combined heat and power systems for residential applications. *Transactions of the ASME*, 125:208-220.
- Hendron, R. 2005. *Building America research benchmark definition*, updated 29 December 2004. National Renewable Energy Laboratories, Golden, CO.
- Hirsch, J. 2003. *eQUEST, quick energy simulation tool: Introductory tutorial*. James J. Hirsch and Associates [http://www.doe2.com/download/equest/eQUESTv3-40_Tutorial.exe].
- Houghton, T. 2000. The community energy utility, in H. Barton (ed.): *Sustainable communities, the potential for eco-neighborhoods*, Earth Scan Publications Limited, London.
- ICC (International Code Council) 2003. *International energy efficiency code, 2003*, International Code Council, Club Hills, IL.
- Johansson, T., and Goldemberg, J. (eds.) 2002. *Energy for sustainable development, a policy agenda*, United Nations Development Program, New York, NY.
- Knight, I. and Ugursal, I. (eds) 2005. *Residential cogeneration systems: a review of the current technologies*. A Report of Subtask A of Annex 42 of the International Energy Agency.
- Lambert, T., Gilman, P., and Lilienthal, P. 2006. Micropower system modeling with HOMER, in: F. A. Farret, and Simões (eds.): *Integration of alternative sources of energy*, Wiley-IEEE Press, pp. 379-418.
- Lippiatt, B. 2002. *BEES® 3.0, Building for environmental and economic sustainability technical manual and user guide*, National Institute of Standards and Technology, Gaithersburg, MD.
- Owens, S. 1986. *Energy, planning and urban form*, Pion Limited, London, UK.
- Phetteplace, G. 1995. *Optimal design of piping system for district heating*. CRREL Report. 95-17, Cold Regions Research & Engineering Laboratory, US Army Corps of Engineers, Hanover, NH.
- Rashed-Ali, H. 2006. *Cogeneration and community design: performance based model for optimization of the design of U.S. residential communities utilizing cogeneration systems in cold climates*. PhD dissertation, Texas A&M University, College Station, TX.
- U.S. DOE (U. S. Department of Energy) 2003. *The micro-CHP technologies roadmap, meeting 21st century residential energy needs*, U. S. Department of Energy, Greenbelt, MD.
- WADE (World Alliance for Decentralized Energy) 2003. *Guide to decentralized energy technologies*, World Alliance for Decentralized Energy, Edinburgh, UK.
- WCED (World Commission on Environment & Development) 1987. *Our common future*, Oxford University Press, Oxford, UK.
- Williams, K.; Burton, E.; and Jenks, M. (eds.) 2000. *Achieving sustainable urban form*, E&FN Spon, London, UK.

Theory for Advancing Green Design

Intimate Encounters: Social Capital, Emotional Ecology, and Sustainable Design
Kaarin Knudson

The Role of Connectedness Theory in Sustainable Architecture
Anthony W. Layne

The Sustainability of an Architectural Practice
Lucas Gray

Advancing Green Design Through Theory*
Martha Bohm

The Trouble With Sustainability
Walter Grondzik

* Invited Oral Presentation

Intimate Encounters: Social Capital, Emotional Ecology, and Sustainable Design

Kaarin Knudson

University of Oregon, Eugene, Oregon

ABSTRACT: Drawing from the fields of psychology, anthropology, sociology and human geography, this paper will draw connections among emotional ecology, sustainable design, and an expanded definition of social capital in the United States. It argues that a complete definition of social capital would include environmental intimacy; that we are affected in meaningful, substantial ways by our intimate attachment to the natural world; and that our interactions with the environment, like our interpersonal interactions, are not one-way. Fundamental to this discussion is an understanding of our personal identification with the environment, the importance of intimate connections between the individual and her surroundings, the function of social capital in our communities, and the hypothesis that people are ecological creatures, not simply social. It is this author's belief that the widespread adoption of sustainability depends to a great degree on social capital and experiences of environmental intimacy.

Keywords: ecology, social capital, environmental intimacy

INTRODUCTION

Inspired by the different ways in which we relate to and idealize our external environments and communities, the initial hypothesis of this paper was that a correlation might exist between declining social capital in America and the resurgent interest in sustainability and conservation—that we, as a culture, were transferring our need for intimacy from people to places. That hypothesis quickly, and optimistically, gave way to a supposition that the presence of greater social capital could generate a greater sense of environmental intimacy and, more importantly, that the reverse could also be true. The existence of this continuous feedback loop and the simultaneous advancement of our connection to other people and our environment have the potential to be a tremendous support to any enduring philosophy of sustainable design.

SOCIAL CAPITAL + SUSTAINABILITY

Independently coined more than a half dozen times since 1900, the term “social capital” refers to the stored, non-monetary value of relationships held between individuals who share communities and physical space (Putnam 2000). It is a means by which we can express the value of interpersonal experiences and connections, things as simple as being “one of the regulars” at the corner café or knowing your neighbors would respond in the event of emergency. Considering the historical factors used to evaluate social capital, an intimate connection with the natural world is conspicuously absent. Though our authors, artists and theorists have alluded to and proven the adverse effects of disassociation from the natural world, social capital researchers do not include it among their indicators of civic engagement—most likely because it is not “civic” by definition and because it draws from a largely qualitative pool of research.

Research has shown that social capital assists in translating our social aspirations into reality in several ways. In areas of high social capital, citizens resolve collective problems more easily; communities progress toward shared goals more smoothly because of the high levels of trust they share; and the collective understanding of the ways in which our fates are intertwined is better understood (Putnam 2000). Social capital rises from norms of reciprocity and trustworthiness that are embedded within a dense network of social relations, and it allows the public and private good to simultaneously advance. Thus, the existence of social capital is crucial to the philosophy and practice of sustainability, which depends almost entirely upon the integration of decisions that benefit the individual and the collective in the short and long term. As just one example, organizations like

Architecture 2030 emphasize the professional unity and policy change needed to address CO₂ omissions and climate change. Tremendous social capital is requisite in such an ambitious endeavor.

However, during the last third of the 20th century, the trend of social engagement in America reversed abruptly and our country began a slow process of social disassociation within its communities. Though this change was concurrent with several dramatic cultural shifts, only four factors have been identified as actual “contributors” to the decline: the increased pressures of time and money (10%); the influence of suburbia and sprawl (10%); the privatization of social interaction via electronic media (25%); and the slow generational shift from a generation with high civic engagement to a less engaged generation (40%). This author speculates that our slow, simultaneous disassociation from the natural world and loss of environmental intimacy also contributes to declining social capital. Indeed, the four identified contributors also imply a concurrent lack of connection to the environment—be that due to a lack of time, lack of wilderness, or the pervasiveness of virtual realities. If social capital encompasses the unquantifiable interactions that “count for most in the daily lives of people,” it is reasonable to suppose that a relationship with the natural world would be included (Putnam 2000:19).

EMOTIONAL ECOLOGY

Emotions and rational thought are the two primary ways in which people make sense of all that we experience through sensations, perceptions and conceptions (Tuan, 1976). But rather than continuing western culture’s polarization of reason and feeling, emotional ecology utilizes them simultaneously. It argues for the incorporation of feelings with rational thought in the study of our ecosystem, and for the consideration of people as organisms within a larger environment to which we dynamically relate. In the words of Benton and Short, emotional ecology is a challenge to the assumption that our environment is merely a physical entity and a refusal to categorize it exclusively in scientific terms (Guy and Farmer 2001).

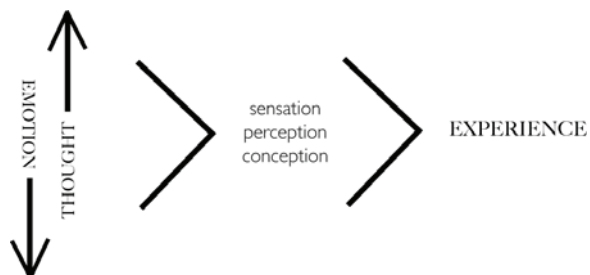

Figure 2: Emotion + Rational Thought = Experience. A diagram of how we construct reality based on Yi-Fu Tuan’s *Space and Place* (1976).

Many contemporary anthropologists say we understand the world primarily through cultural and social constructs, but others such as social anthropologist Kay Milton disagree. Milton has suggested that people, like any other animal, can also gain knowledge directly from the natural environment, without social mediation. Furthermore, she argues that emotions play a central role in this direct experience, in our acquisition of knowledge, and in the decision to take action based on that knowledge. It is an attempt, along the lines of human geographer Yi-Fu Tuan and others, to define experiences by both what we think (that which can be measured) and what we feel (that which is not easily quantified or explained).

This is the point at which emotional ecology, social capital and sustainable design might intersect. As social beings, people inherently seek intimate connections with others. However, as components of an ecosystem, humans also have a desire for this connection with their environment. It is possible that when we identify with an environment, our relationship with it becomes a component of our social capital. Social intimacy and sense of belonging are often the result of deep, personal identification with one’s surroundings—described by Arne Naess as the “expansion of the self to include other beings, so that one’s *own self* is no longer adequately delimited by the personal ego or by the organism” (Naess 1989, emphasis in original). Drawing from this description of deep ecology, one can speculate that an overall erosion of a person’s sense of belonging—contributed to by a lack of environmental intimacy—could also manifest itself in the form of other disassociations and declining social capital in our communities.

The connection being drawn is a simple one, yet incredibly complicated to demonstrate in quantifiable terms. Who we are is constructed by the people and places to which we feel the most intimate connections, but emotional intimacy and attachment are enormously private processes, the depth of which we have great difficulty

expressing or even detecting. This is also delicate ground, as the environmental movement still faces regular attacks from those who seek to isolate and exploit the “touchy-feely” components of environmentalism or sustainability as a means of undermining the whole. Tuan wrote extensively about the difficulties that humans have in quantifying the intimate—“people tend to suppress that which they cannot express.” He also noted that “relatively few works attempt to understand how people feel about space and place, to take into account the different modes of experience (sensorimotor, tactile, visual, conceptual), and to interpret space and place as images of complex—often ambivalent—feelings” (Tuan 1977:7).

ENVIRONMENTAL INTIMACY

Intimacy and identification with a place or natural environment can be built over years or created within a brief experience of authenticity, just as intimacy among persons “does not require knowing the details of each other’s life; it glows in the moments of true awareness and exchange” (Tuan 1977:141). This idea of an envisioned sense of intimacy with the environment could be considered universal—for some it may exist at the tops of mountains, for others it is in the view of a coastline or quiet glen. But the emotional attachment is the same. From Edward Relph’s *Place and Placelessness*, we understand place attachment to be a fundamental human need, but this is a need that contemporary society is increasingly unable to satisfy “owing to its tendency toward gradual spatial uniformity, increased mobility, and hence a purely functionalistic relationship with places” (Giuliani, 146). Given this, the numerous theories put forth by psychologists and sociologists about why humans seek solace and connection in the natural world make sense. Practically, we know it as something that simply *feels* good, something people do because they “need” it. A presence is felt and an intimate interaction is simultaneously projected and perceived (called “simultaneous intersubjectivity” by psychologists). This sense of connection to the natural world is not unlike the unspoken exchange between mother and child or two sleeping lovers. In such moments, we are defined by our relationship to our surroundings—be they human or non-human in form. With regard to both relationships and our ecological system, as we perceive our environments, we perceive ourselves (Milton 2002).

In 1960, H.F. Searles argued that the non-human environment constitutes one of the most important ingredients of human psychological existence (Gebhard 2003). Recently, anthropologists have suggested that there is no line dividing the interpersonal and ecological self. Milton wrote that our “understanding of personhood” develops within our “relationship with our total environment, not just within our relationships with other human beings” (Milton 2002:47). If our concept of personhood is created through experience with both people and our environment, and if our relationship with the non-human environment represents one of the strongest components to our existence, is it possible that as we form more intimate relationships with our surroundings, we no longer require that intimacy of other people? One could not argue that an individual’s non-human and interpersonal experiences are interchangeable, but could they be means to the same end—that “end” being a sense of intimacy with one’s total environment? It is an important parallel to consider, given our shared belief that architecture shapes the people who use it. How does what we build contribute to our sense of intimacy with the environment? Do the things we construct contribute to our sense of intimacy? Does the architecture we build reveal how we feel?

Architecture does reflect our cultures, philosophies and politics, but it does so on timed-delay. It follows our thinking and reveals our priorities. The speed and style in which we build or rebuild also belies a great deal about how we express ourselves and which emotions we can collectively tolerate. It also says a great deal about our desire for intimacy with the natural world. Many technical approaches to sustainability—from double-skin facades to fully automated, photosensor lighting systems—imply that we feel more comfortable with technology than we do with a reconsidering of our basic relationship to the environment. Collectively, we are more comfortable advancing our relationship with the environment through a mediator, in this case technology. Efficiencies and quantifiable results are prioritized, and people most often operate as managers of the system, rather than intimate participants in it.

A sense of environmental intimacy is crucial to nurturing a philosophy of sustainability because our ability to identify with and relate to non-human entities plays an important role in the protection of nature and natural things (Milton 2002). According to Naess, identification with nature makes moral rules about our interaction with the natural world redundant because personal identification departs from a moralistic approach. Anyone who personally identifies with nature is likely to feel inclined to protect it. It is an extension of Kant’s observation that benevolent action can be performed either out of duty or inclination: we act protectively toward nature not simply because we ought to, but because we want to. How could sustainability ever be more than market driven if this is not the case?

ENVIRONMENT + AFFECT

Tying together these various fields with regard to sustainable design is challenging—in part because of the caution with which psychologists, sociologists, geographers and architects approach any discussion of “affect” related to environmental psychology. This stems, in part, from a cultural disdain for determinism. The idea that not every person can achieve anything given any circumstance is inherently un-American, and the idea that our level of ecological intimacy might affect us in meaningful ways is exceedingly inconclusive. In the western or even Modernist tradition, we approach deterministic statements with uncertainty (or overt objection) and believe a person or thing to be defined by what it *is*.

Nevertheless, psychologists specializing in place attachment agree that our environment has an undeniable influence on our lives: “Affect related to places exists, and is of a nature that, albeit not fully explicit or defined, nevertheless distinguishes it from other affective ‘systems’ (towards objects, persons, ideas, etc.); furthermore, it is perceived as one of those important factors that sometimes help and sometimes hinder our equilibrium, our material and spiritual well-being” (Giuliani 2003:137). Within a framework of relational epistemology, personhood emerges from what something *does* in relationship to others. If we used such a framework to address elusive topics such as place-making or emotional ecology, a more subtle and sophisticated middle ground might be gained. Furthermore, this framework could be applied to sustainable design. Using a macro-relational epistemological approach (though perhaps fewer words to describe it), our architectural works could be valued and evaluated according to how they participate in our ecological system and how they relate to other entities within that ecology. In essence, we could reasonably judge our buildings by what they do, what they catalyze, and what they impede.

If we built according to this value system and with the incorporation of an emotional ecology, our communities would reflect a more equitable, symbiotic relationship to the natural world and with its residents, rather than reinforcing social stratification, economic injustice and enormous waste. Our buildings would be able to supply their own energy and work cooperatively with surrounding structures to account for the needs of the whole. We would choose architecture according to a shared value system that acknowledges our interdependence and emotional intimacy with the natural world, and these driving factors would trump the single bottom line every time.

CONCLUSION

Every person on this planet, by virtue of his or her self-awareness and biology, has a unique perceptual experience. This makes it extraordinarily challenging to make even broad generalizations about how and where people create intimacy with the environment or “about how they come to know nature as personal” (Milton 2002:49). Most psychologists consider this an accepted, irreconcilable issue, and they note the additional research required to address the intimate relationship between people and our environment. Others argue that a more pointed definition of “place attachment” will be required before any true similarities or dissimilarities with psychology’s well-documented theory of attachment can be drawn. Until such time, conclusive theories about the value of environmental intimacy and its influence on sustainable design will also have to wait.

Many articles addressing these subjects end with that rather tidy, compartmentalized point—and perhaps that is my point. At present, we are unwilling to specifically address the idea of place attachment and identification with nature (let alone the concept of an emotional exchange with nature) without a greater body of quantifiable evidence. This is understandable; additional research and case studies are necessary. However, this also returns us to a point made by Tuan and later expanded upon by Milton and others—that our experiences and our knowledge are comprised of both rational thought and emotion. As such, it may not be possible to scientifically confirm all the things that we know. Nevertheless, the idea that we are affected by environmental intimacy, and that our social capital is in turn affected this bond, is a worthy line of research to continue. Based upon trust and the simple desire to remain connected with the world we would protect, these issues relate directly to an enduring and widely accepted philosophy of sustainable design.

REFERENCES

Giuliani, Maria Vittoria. “Theory of Attachment and Place Attachment.” *Psychological Theories for Environmental Issues*. Burlington, VT: Ashgate, 2003: 137.

Guy, Simon and Farmer, Graham. "Interpreting Sustainable Architecture: The Place of Technology," *Journal of Architectural Education*. February 2001.

Milton, Kay. *Loving Nature: Towards Ecology of Emotion*. New York: Routledge, 2002.

Naess, Arne. *Ecology, Community and Lifestyle: Outline of an Ecosophy*. Translated and edited by D. Rothenberg. Cambridge: Cambridge University Press, 1989.

Putnam, Robert. *Bowling Alone: The Collapse and Revival of American Community*. New York: Simon & Schuster, 2000.

Relph, Edward. *Place and Placelessness*. London: Pion, 1976.

Searles, H.F. *The Non-human Environment in Normal Development and Schizophrenia*. New York: International Universities Press, 1960. Reprinted in Gebhard, Nevers and Billmann-Mahecha's essay, "Moralizing Trees: Anthropomorphism and Identity in Children's Relationships to Nature" in *Identity and the Natural Environment*. Cambridge: MIT Press, 2003.

Tuan, Yi-Fu. *Space and Place: The Perspective of Experience* Minneapolis: University of Minneapolis, 1977.

The Role of Connectedness Theory in Sustainable Architecture

Anthony W. Layne

University of Minnesota, Minneapolis, Minnesota

ABSTRACT: While generally discussed in terms of economics or technology sustainability is a behavioral problem rooted in the unsustainable lifestyles of the Western world. A cultural paradigm shift is necessary to truly address this issue. Recent psychological research suggests that this paradigm shift can be brought about through *connectedness*. This paper examines both how architecture can foster connectedness and how connectedness can influence architecture.

Architectural connectedness is both about what one creates and how it is created. The connectedness design process fundamentally requires an awareness and understanding of the various systems affected or created by design and more importantly, the relationships between them. It is an iterative process involving the progressive layering or integration of systems and requires continual re-evaluation of design decisions in light of the newest layer of systems information. Once designed this multilayered integration of systems facilitates connectedness through human experience.

Architecture alone cannot create or cause connectedness, but by applying connectedness theory to the process of design, a method is generated that forces the architect to design in a holistic and systems-based manner and allows the architect to design the human experience. Ultimately, this process can create an architecture that facilitates connectedness. It is a both/and proposition. It is not a question of one or the other but *both*: 'how can architecture bring about connectedness?' and 'how can connectedness bring about architecture?'

Keywords: connectedness, psychology, design process

INTRODUCTION

For several years a near consensus of the world's scientists has warned that the environment that supports life on earth is in crisis. According to the Union of Concerned Scientists, every living system on the planet is in decline and the rate of that decline is increasing. In fact, planet earth is experiencing the fastest period of mass extinction in history, even faster than during the extinction of the dinosaurs (Eldredge 2001).

Motivated by the certainty of the deterioration of the environment and the realization that humans are dependent upon this environment for their own health and survival, several groups and individuals have taken action in an attempt to reverse these alarming trends. The last thirty years has been a time of unprecedented ecological and environmental awareness. Tactics as varied as Smart Growth, the Kyoto Protocol and carbon trading as well as numerous energy conserving initiatives have been implemented by groups as disparate as the European Union and the American homeowner in efforts to live a more sustainable existence. Yet, during this same time period, energy use, greenhouse gas emissions, deforestation, and destruction of habitat has continued to rise to unprecedented levels (*Annual Energy Outlook 2002*, Addington 2003).

Why has this mobilization of policy and design not made a significant impact in the crisis of environmental degradation? The answer lies in examining the broader picture. The current strategies for addressing sustainability are compromises focused on symptoms, not true solutions. Technology and various forms of economic policy have been put in place in an effort to resolve the current environmental crisis. The problem is that this crisis has not been caused by technological or economic factors alone and therefore will not be solved just through technological or economic solutions. The dilemma that faces the human race, and especially the Western world, is embedded in unsustainable lifestyles (Wang 2003). Sustainability is a behavioral problem.

Environmental degradation, or the deterioration of the planet's ability to sustain life due to industrialized human activities, is among the most difficult and complex issues ever faced by modern society. One would not think this is the case however, from the existing architectural discourse regarding the subject. The prevailing logic is that solutions are known and straightforward and that these solutions merely need implementing (Addington 2003). Indeed the human built environment, the buildings, roads and infrastructure of man's cities and towns and the industrial processes that come along with them, are responsible for a significant portion of the present negative impact on our natural environment. Currently, the built environment, and the method in which it

is designed and constructed, consumes energy and natural resources, pollutes air and water, and destroys diversity and natural habitat. This has led architects to work towards implementing technologies and strategies in their designs that mitigate the deleterious effects of buildings. This strategy however, merely addresses the symptoms of the problem and not the root cause. If environmental reparation is to be made, the behavioral source of humanity's unsustainable tendencies must be transformed.

Several methods are often employed in an attempt to bring about change in a population's behavior. Proscriptive measures such as laws forbidding certain actions are one popular technique. Dissemination of information with the hope that awareness of an issue will bring about behavioral change is another. The most powerful however, is to change the paradigm out of which the behavior arises. The paradigm, specifically a society's collective belief about how the world works, contains a leverage point that once changed transforms the entire system (Meadows 1997). Recent research in psychology suggests that the shift to a sustainable paradigm could be brought about through *connectedness*. Connectedness refers to the extent to which individuals believe that they are a part of the natural world or the capacity of a person to see their own life and its conditions as part of a larger matrix (Schultz 2002, Cock 2002). The role of the architect is as important in this critical mission of change as it has been in working to implement sustainable technologies and strategies into design. Architecture can promote a necessary paradigm shift towards a sustainable lifestyle through facilitating *connectedness* and encourage the growth of responsible, engaged, self-actualized citizens.

1. RESEARCH PROCESS

1.1. Research objectives

The general intent of this research was to gather evidence of strategies that successfully bring about behavioral change and distill several principles from these strategies that can guide future efforts to direct sustainable behavior. The ultimate goal of this research was to determine the role of architecture in supporting and promoting these sustainable behavior change principles. This research contributes to a dialog about the responsibility of architecture in affecting behavior regarding sustainability and begins to develop tools or strategies that can be applied during design to affect positive change.

1.2. Research method

This research consisted of five parts:

Part I. A general background into the current crisis of sustainability was established. This identified major issues contributing to the problem, investigated predominant strategies for addressing it and provided support for the supposition that the crisis of sustainability is a behavioral problem, rooted in the unsustainable lifestyles of the Western world.

Part II. Issues involving behavioral change regarding sustainability were established. This identified popular methods currently employed to attempt to bring about behavioral change, the limitations to these methods and provided support for a paradigm shift as a more effective method of bringing about change.

Part III. Through a review of recent research in the psychology and sociology of sustainable development and research in sustainable development learning and education the concept of behavioral change and paradigm shift were investigated further. Through this research review, guiding principles affecting change regarding sustainable behavior were established. The role of architecture in supporting and promoting these change principles was then identified.

Part IV. Through precedent study and identification of current architectural work involving these principles, their direct application in design and architecture were explored further in an effort to be better understood. This precedent study targeted facilities focused on environmental and sustainable education in order to support part V, the design component of the project.

Part V. Finally, these change principles and their corollary architectural principles were investigated and illustrated through the design of the Kettle River Environmental Education Center located on a 160 acre site just west of the Kettle River in Sandstone, Minnesota. This project served as a vehicle to test the validity and refine the developed processes and principles.

2. CONNECTEDNESS THEORY

2.1. Man's relationship with nature

At the center of the discussion on sustainable behavior is the recurring theme of a *relationship* with nature.

Philosophers talk about this in terms of ethics, or morality. Sociologists talk about culture, values and the ways in which societies interact with nature. Conservationists talk about land ethics, and the experiences that result from encounters in nature. But at the core is the individual, and his or her understanding of his place in nature (Schultz 2002:66).

Psychologists and researchers point to the concept of *connectedness* as central in this discussion. Broadly the term connectedness describes the extent to which individuals believe that they are a part of the natural physical universe (Schultz 2002). Recent research suggests that an individual or group's level of connectedness directly

affects their level of sustainable behavior (Clayton 1998, Kidner 2001). Some even argue that this psychological connection with nature will be required to achieve sustainability. Consider this quote from Tarnas:

Only the experience of connectedness will save the earth – and us with it. Any attempt, however grandiose and with however much commitment to its cause, will fall short if it does not have at its root the transformation of human experience in which human thinking knows connectedness as such and itself with that (Tarnas 1991:73).

2.2. Inclusion with nature

In later work, Schultz argues that connectedness is one part of a larger notion he terms “inclusion with nature.” Higher levels of connectedness ultimately leads to caring for nature which leads to a commitment to protect nature and higher levels of inclusion with nature which, in turn, leads to more sustainable behavior. He goes on to say that the core of a connection with nature is cognitive and defines connectedness as “the extent to which an individual includes nature within his/her cognitive representation of self (Schultz 2002).”

The term self is used to refer to a range of constructs, but in this work it refers to a person’s thoughts and feelings about who they are. Self knowledge is organized into hierarchical cognitive structures known as self schemas. A person may have a schema of self that includes physical characteristics like brown hair, social identities like father or husband, or leisure activities like camping and skiing (Brown 1998). These self schemas serve to organize experiences and provide a coherent understanding of identity (Schultz 2002). Furthermore this allows definition of self in relation to others. Some researchers argue that in close relationships, the cognitive representations of self and other can become integrated (Aron 1999). Taken to the extreme, self and other become one (fig. 1). Schultz concludes:

This is the central aspect of inclusion [or connectedness] with nature. Individuals who define themselves as part of nature have cognitive representations of self that overlap extensively with their cognitive representations of nature. In contrast, individuals who do not define themselves as part of nature will not have overlapping schemas of self and nature (Schultz 2002:68).

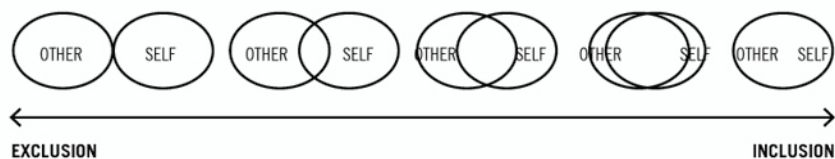

Figure 1: Integrated cognitive representation of self and other. Source: (Schultz 2002:72)

This research also shows that the relationship between a commitment to protect nature and caring for nature and connectedness is, in fact, causal. “Commitment to protecting the environment cannot occur in the absence of caring. Likewise, it would seem that caring is unlikely to occur in the absence of connectedness (Schultz 2002:70).” Therefore, it would seem that strategies to increase connectedness would ultimately result in positive sustainable behavioral change. It is on the aspect of connectedness and strategies to encourage it that this paper will focus.

2.3. Connectedness sub-categories

This paper proposes that connectedness can be further defined as containing at least three sub-categories, physical connectedness, social connectedness and emotional connectedness. Physical connectedness refers to a tangible connection to and understanding of nature and its cycles and flows (e.g. the cycles of the sun, the seasons or cycles in microclimate). Social connectedness refers to the extent an individual believes that he or she is a part of larger social groups and through this maintains an ability to empathize with others. Emotional connectedness refers to the emotional component affecting an individual’s behavior. The level of intensity in each of these sub-categories ultimately comprises one’s overall connectedness. While each of these sub-categories is defined separately and contains distinct and individual concepts, they are also interrelated and overlap.

2.4. The role of architecture

Understanding connectedness and its components along with methods in which it is being addressed is fundamental in advancing a solution in the crisis of sustainability. Developing change strategies that engender connectedness is essential. Once identified, successful change strategies must be implemented. Because of the multifaceted nature of the crisis of sustainability, implementation of change strategies will also be intricate and multidisciplinary. Research that translates general tactics into discipline specific approaches to change is vital to their useful application. Specifically, the research undertaken for this paper explores the part that architecture plays in facilitating or impeding connectedness.

Up to this point, the architectural profession’s approach to addressing the crisis of sustainability has predominantly been applying sustainable design technology to building design. While an important component in

the journey to a sustainable society, the simple application of technology does little to address the larger issue of unsustainable behavior. This is identified as one of several contradictions in sustainability.

The development and application of technology for practically all purposes has enabled an increase in our consumption of resources and production of wastes, to the point where this duality of allied problems threatens The Biosphere, as well as our own and Nature's survival. We have become evermore dependent on technological support systems even when we could meet our needs in other ways (Dovers 1993:217).

Architecture can do more. In its design and construction, architecture can contribute significantly to its inhabitant's connectedness and as a result, to their overall sustainable awareness and behavior.

3. DESIGN RESEARCH

3.1. Design methodology

Utilizing the principles of physical, social and emotional connectedness as parameters to guide sustainable design requires a modified design process. While the connectedness process may run parallel to a traditional architectural process with typical project phases and sequence (e.g., pre-design/concept design, schematic design, design development, construction documentation, qualifications and bidding, and construction administration), the process requires more time spent in early phases of the project, identifying specific goals and strategies, and any synergies that may be obtained through the combination of these strategies. In some ways this is true of all sustainable design processes when compared to a traditional architectural design process. However, while any sustainable design process would look for design and construction strategies to make a building more sustainable, the connectedness process goes beyond looking for strategies or techniques that simply make a building more sustainable and seeks strategies that will actually facilitate sustainable behavior on the part of the building's occupants.

To accomplish this, relevant principles affecting the level of connectedness in each of the three categories (physical, social and emotional) were identified from the research (column 1, fig. 2). Then, each of these principles were evaluated with regard to their relationship to architecture along a continuum ranging from a physical manifestation characterizing a low level of connectedness to a physical manifestation characterizing a high level of connectedness. Next, specific project goals were established from architectural qualities that fostered a high level of connectedness (column 2, fig. 2). Once project goals and criteria were generated, specific sustainable strategies could be identified to address each goal (column 3, fig. 2). For instance, operable windows, daylighting, separation of building elements, integrated site design, choice of materials, outdoor gathering spaces, and access to views were all identified as sustainable strategies to achieve the project goal of a 'strong indoor/outdoor connection' as a part of the 'awareness of natural cycles principle' under the 'physical connectedness' category. After this process was repeated for each project goal, all the goals and strategies were mapped against one another to identify overlap and opportunities for integration and synergy. For instance, outdoor gathering spaces, identified as a strategy to achieve a 'strong indoor/outdoor connection,' was also identified to achieve project goals such as 'project is accessible with areas designed to promote interaction,' 'project is integrated into context and community, promoting a culture of trust,' 'project encourages time spent in nature,' 'project encourages time spent with significant others,' and 'project encourages interest in nature.' Each of these goals was also linked to other strategies (fig. 2).

By tracing the linkages back and forth between the project goals and the sustainable strategies, a web of interconnectedness was revealed. This provided an understanding of the motivation behind each of the proposed strategies and how certain strategies could be partnered to achieve the most significant impact toward the project goals. The integration map could then be used to guide the subsequent design process, helping to identify, prioritize and evaluate design strategies and their usefulness toward facilitating sustainable behavior. In order to follow the application of the three categories of connectedness their nine criteria were color coded. This allowed program areas and design elements to be readily understood as supporting one or more of the connectedness criteria.

Once this integration map was generated it was utilized to generate an architectural schematic design concept for the Kettle River Environmental Education Center from a previously established space program. The resulting design concept functionally accommodated all the necessary spaces and adjacencies as well as employed many of the sustainable design strategies identified in the integration map. The design certainly would have produced a 'sustainable' building, but in many ways it was no different than a design produced through any other sustainable design process and it was unclear how it ultimately related to connectedness.

Connectedness Strategy Matrix & Integration Diagram

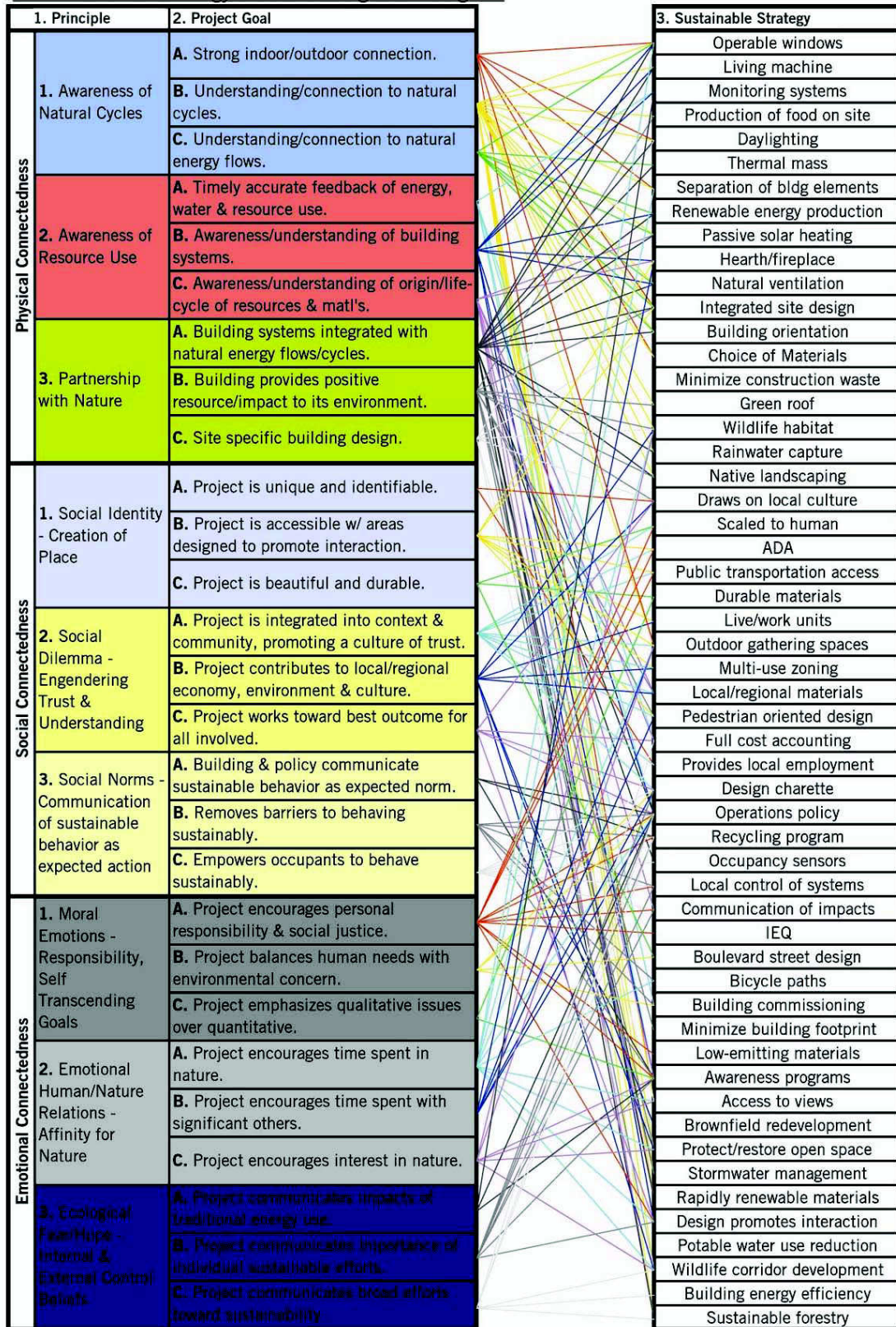

Figure 2: Connectedness strategy matrix and integration diagram illustrating connectedness principles, connectedness project goals and correlating sustainable strategies. Source: (Image by author)

3.2. Connectedness logic

It was at this point in the process that a fundamental shift occurred in the way connectedness, as it applies to architecture, was conceptualized. Here, the question broadened from 'how can architecture bring about connectedness?' to include 'how can connectedness bring about architecture?' This widening of focus provided a more holistic way of exploring the issue of modifying behavior through connectedness. This also brought about the realization that if architecture is to bring about connectedness it would be through human experience. Therefore, this process is ultimately about the *design* of human experience.

3.3. Design process

With this shift in thinking, the design and exploration process also shifted. The schematic design generated earlier was maintained in order to serve as a vehicle in the subsequent shifted process. It would serve as a baseline in a concept test method. Additionally it was recognized that in order to design a human experience that facilitated connectedness, the design process itself and the designer must have a high level of connectedness. In order to achieve this, building program components, processes, materials and activities and their interrelationship must be understood and the process must include a rigorous analysis of these components and their relationships.

This analysis began with the site and examined both the existing and proposed natural and manmade site elements. The analysis also investigated the relationship between these elements. This analysis was not exhaustive but, chose to focus on ten specific site components. These included site topography, water/hydrology, under-story vegetation, over-story vegetation, wildlife path, natural landmarks, agricultural plots, pedestrian path, vehicular path and man-made landmarks.

The analysis then shifted from site elements to the existing and proposed systems of the site and focused on seven systems - wildlife habitat, stormwater system, energy production, food production, research process, learning process, and rainwater cycle. By graphically mapping the components and flows of these systems common elements between them and their relationship to each other became readily apparent.

The examination of the site systems and their interrelationships helped shift the thinking of the project from element or object based to relationship based. It was not necessarily the objects themselves that were most important, but the relationships between the objects and the realization that the objects were simply a collection of other relationships. In fact, once the analysis shifted to a relationship based paradigm, new objects were revealed. For instance, objects initially viewed separately like a pond or a tree were seen in a larger context as part of a habitat system. Without a shift in the way these systems were thought about these new objects would never have been recognized.

This shift to a relationship-based analysis paradigm motivated by the need to design the human experience necessitated a change in the way the architectural building program was conceptualized. To this point, the program was thought about in a typical space-based model. However, this change in thinking provoked the awareness that an activity-based program model would allow a better analysis of human experience and provide a more useful method of exploring connectedness (fig. 3).

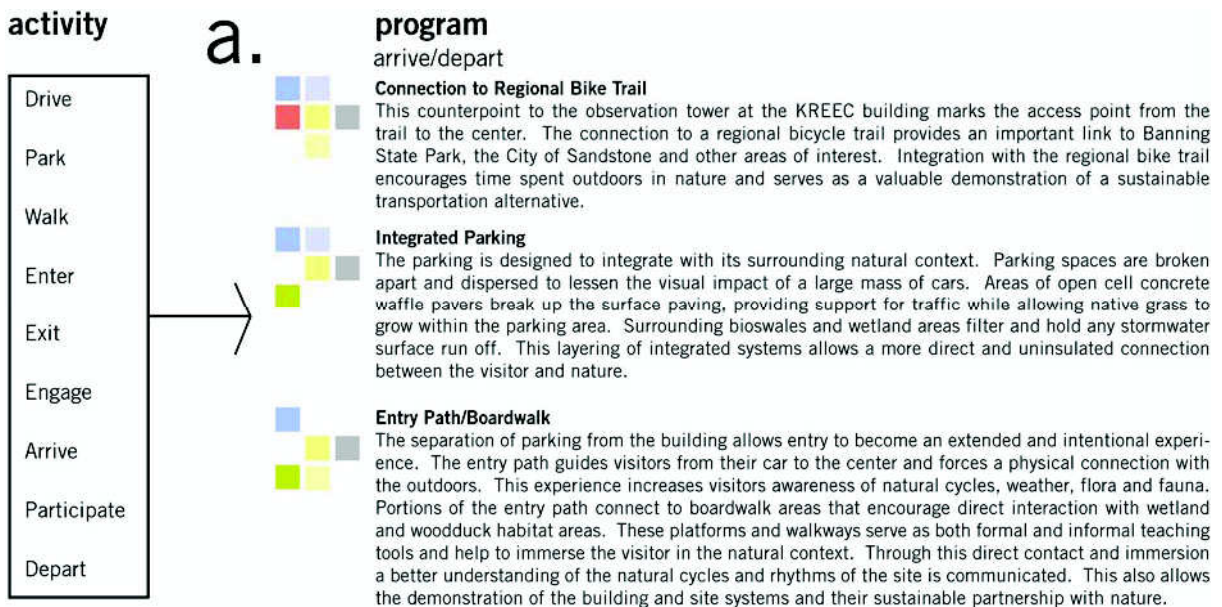

Figure 3: A portion of the activity program showing identified activities, corresponding program spaces and related connectedness principles. Source: (Image by author)

In order to generate this new program a list of activities that participants would engage in on site was developed. This list included activities such as walk, gather, observe, eat and harvest. These activities were then sorted by their relationship to each other. For instance, the activities read, listen, communicate, research, gather, think, test/experiment, observe, and explore were all grouped under the broader activity category teach/learn. This process identified three program categories: arrive/depart, teach/learn, and produce/consume. Once these categories were generated program space components could be identified to support the given activities. For instance, classrooms, an observation tower, site trails and teaching stations were listed in support of the teach/learn activity category. Further, each of the space program components were scrutinized for their potential to promote the earlier developed connectedness criteria.

With an activity program developed, the next step was to begin to integrate the program with the site. A site/activity map was created to begin to integrate the two and identify zones of activity on the site. This helped to visually organize proposed and existing elements and activities. After mapping the activities on the site another map was generated to relate the activity program to the space program. This map involved tracking the proposed human experience chronologically across the site. Here too each of the proposed experiences was referenced with the earlier established connectedness criteria. Because so much of the exploration of this project dealt with human experience, it was determined that traditional architectural drawings alone could not be effectively utilized in the design process. Therefore, an iterative process of design was developed using collage as the tool for exploration. Each of the three program activity categories were investigated through this process. This iterative process involved the progressive layering and integration of systems and required continual re-evaluation of design decisions in light of the newest layer of systems information (fig. 4).

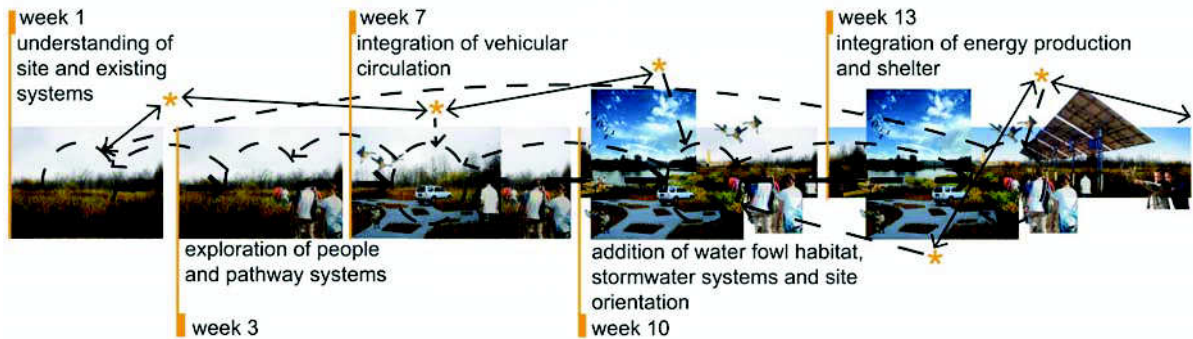

Figure 4: Iterative process diagram showing how new understanding from inside and outside the design process influences further discovery. Source: (Image by author)

Once these experiential collages were created, they were used as the basis for exploring the design further through more traditional architectural representations such as plan, elevation and section drawings. Additionally, the previously mapped systems information was then re-mapped onto the design plans or sections (fig. 5). This furthered the understanding of the design and the site systems and the integration between the two.

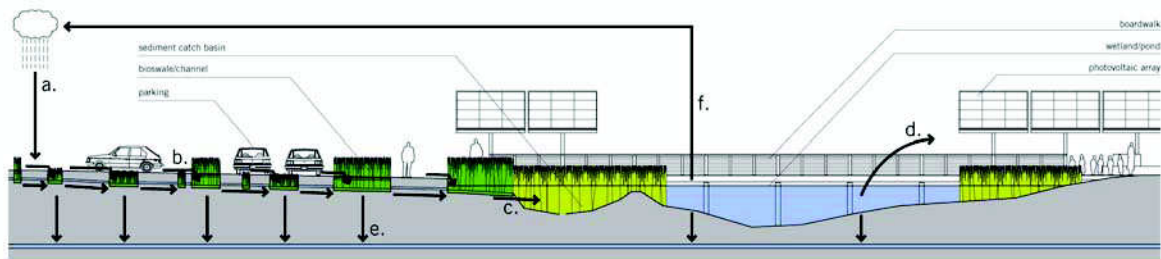

Figure 5: Arrival/departure site section with overlaid stormwater system map. Source: (Image by author)

CONCLUSION

This paper began with the assertion that the crisis of sustainability is, at its root, a behavioral problem. A critical survey of recent psychological research suggested that behavior could be modified through connectedness and

that a higher level of connectedness was correlated to more sustainable behavior. It was thought that architecture could play a strong part in achieving connectedness through the design of human experience.

Through the course of the work, a new method for approaching the design process was uncovered. This iterative process focuses heavily on understanding the relationships and systems created or affected by building and then relies on this knowledge to guide subsequent design. As more is understood, the design is continually revised and adapted to incorporate this new knowledge. This process of knowing is extremely valuable not only in working to create sustainable buildings but more importantly in functioning to facilitate sustainable behavior through connectedness.

So, can architecture facilitate connectedness and therefore encourage sustainable behavior? The answer is yes, however, connectedness is not created through the simple application of sustainable design strategies or technologies, but through the design of human experience and architecture that encourages connectedness cannot be created in the absence of a connectedness design process. Encouraging connectedness through architecture requires: 1. a high level of connectedness on the part of the architect, 2. a holistic understanding of the systems created or affected by the project, and 3. a holistic understanding of the potential human experience.

Architectural connectedness is both about what one creates and how it is created. The connectedness design process fundamentally requires an awareness and understanding of the various systems affected or created by design and more importantly, the relationships between them. Architecture alone does not cause connectedness, but by applying connectedness theory to the process of design, a method is generated that allows the architect to design the human experience of a building's occupants in a holistic and systems based way. Ultimately, this creates an architecture that facilitates connectedness through human experience.

REFERENCES

Addington, Michele. Energy, Body, Building: Rethinking Sustainable Design Solutions. *Harvard Design Magazine*, Spring/Summer 2003, Number 18.

Annual Energy Outlook 2002 with Projections to 20. 2002. [Online]. Available: <http://www.eia.doe.gov/oiarf/archive/aeo02/pdf/0383>. [2005, October 28].

Aron, A.; Fraley, B. 1999. Relationship Closeness as Including Other in the Self: Cognitive Underpinnings and Measures. *Social Cognition*. pp 17,140-160.

Brown, J.D. *The Self*. Boston MA. McGraw-Hill. 1998.

Clayton, P. 1998. *Connection on the Ice: Environmental Ethics in Theory and Practice*. Temple University Press: Philadelphia PA.

Cock, P.H. 2002. Partnerships for Sustainability: Psychology for Ecology. *Psychology of Sustainable Development*. Kluwer Academic Publishers: Boston MA.

Dovers, S. R. & Handmer, J. W. 1993. Contradictions in Sustainability. *Environmental Conservation*. Vol. 20. pp 217-21.

Eldredge, N. 2001. The Sixth Extinction. [Online]. Available: <http://www.actionbioscience.org/newfrontiers/eldredge2.html>. [2006, May 8].

Kidner, D. 2001. *Nature and Psyche: Radical Environmentalism and the Politics of Subjectivity*. State University of New York Press: New York NY.

Meadows, Donella. Places to Intervene in a System. *Whole Earth*, Winter 1997.

Schultz, P.W. 2002. Inclusion with Nature: The Psychology of Human-Nature Relations. *Psychology of Sustainable Development*. Kluwer Academic Publishers: Boston MA.

Tarnas, R. 1991. *The Passion of the Western Mind*. cited in: Schultz, P. 2002. p 73.

Wang, Wilfried. Sustainability is a Cultural Problem. *Harvard Design Magazine*, Spring/Summer 2003, Number 18.

The Sustainability of an Architectural Practice

Lucas Gray

University of Oregon, Eugene, Oregon

ABSTRACT: If the world's population lived with an average American lifestyle we would require five and a half planets to sustain human society. It is imperative that we adapt our lifestyles so we can meet our demands with the one planet we have. I used the Ecological Footprint Quiz on myfootprint.org to analyse how our daily choices impact the sustainability of our lives. Based on the varying results I present ways to change how we live and design in order to reduce our individual and community's footprints. I offer suggestions on lifestyle choices while also addressing larger issues like sustainable energy sources and transportation methods. I argue that in this time of environmental crisis we should add environmental cost to economic thinking. If the general population adopts some of these arguments and we as architects incorporate strategic features into our designs we can change the destructive course our civilization is heading in. We will thus create a society that lives in harmony with planet Earth.

Keywords: sustainability, ecological footprint, environment

INTRODUCTION

There is a growing trend in architecture towards sustainable design. Yet, how many firms have changed the way they operate to make themselves sustainable? How many architects live sustainably?

Our ecological impact is derived from our lifestyle choices. The website, www.myfootprint.org, offers a short quiz that roughly estimates an individual's degree of sustainability. The questions survey personal decisions regarding food, goods and services, housing, and transportation. It calculates the area of land needed to provide sufficient resources to meet personal demands. This land is referred to as a 'footprint.' The quiz is based on national consumption averages, and it allows individuals to compare their results to these averages. Some parts of the footprint are beyond the individual's control, such as municipal infrastructure, roads, government buildings, schools, etc.

Each footprint is measured in a unit called a "global acre", which is an acre of land with average global bioproductivity. Measuring the footprint in global acres allows easy comparison across different regions with varying land use. The Earth currently has approximately 26.7 billion acres of biologically productive space, equal to less than 1/4 of the planet's surface. These 26.7 billion acres are broken down into 5.7 billion acres of productive ocean and 21 billion acres of productive land. Dividing the total biologically productive area by the world's population gives each person approximately 4.5 acres to meet all of their needs (rprogress.org). This also means that the average footprint is inversely proportional to the world's population. As the population continues to rise our footprints must correspondingly decrease.

When humanity's footprint exceeds the amount of renewable biocapacity a decline in natural resources occurs. Currently, humanity's footprint exceeds ecological limits and is thus unsustainable (rprogress.org).

Based on my lifestyle as an environmentally aware architecture student at the University of Oregon, I have a footprint of 11 acres. This means we would need 2.4 planets to sustain the world's population if everyone lived as I live. In comparison, the average ecological footprint in America is 24 acres per person needing 5.35 planets. As an architect living and working in Shanghai, China, I needed upwards of 5.5 planets due to my heavy reliance on automobile and airplane transportation, as well as consuming a diet relying on a large consumption of meat. It is our mandate as residents of Earth to have a footprint of 1 Earth or less, thus living completely sustainably. What do we have to do to reduce our impact? What can an architect do to reduce his or her footprint, and how can an architect work to reduce the footprint of others?

By analyzing major choices in our lives we can determine ways to drastically reduce our footprints. We must examine our consumption of food, goods and materials, as well as our use of transportation, and energy. Our

consumption levels cause harmful emissions and create waste. It is the responsibility of the architect to consider how these issues influence the built environment.

1. FOOD

All people need to make smarter choices concerning the food they eat. Eating meat and dairy is not environmentally sustainable. It takes over half an acre of land to produce the meat consumed in one dinner per week. Footprints needed to cultivate different types of food vary widely. “A plant-based diet generally requires less land, energy, and other resources. Crop-based food requires an average of 1.9 global acres per ton of food, compared to 5.2 global acres required to produce one ton of animal-based food” (Redefining Progress). Residents of South West England consumed about twice as much plant-based food as animal based food in 2001. However, the footprint needed to sustain the animal based food was over three times larger (Figure 1) (www.steppingforward.org.uk).

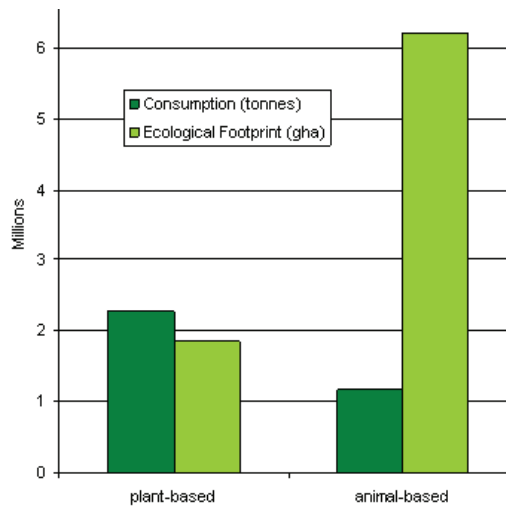

Figure 1: Food footprint of South West England residents, compared with tonnages consumed, in 2001
- Steppingforward.org.uk

We must purchase food that is grown within a 200-mile radius of where we live. According to the Lane County, Oregon magazine, *Locally Grown*, “The food on an average American’s plate travels 1300 miles to get from the farm to the plate, and during that time, changes hands six times” (Battson 06). The number one influence on these food miles, as this is referred to, is individual customers driving to the grocery store. In America on average almost 75% of food consumed is processed, packaged and not locally grown. In addition, 26% of food that is purchased in America is thrown away and not eaten. (Household Ecological Footprint Calculator). If we can design communities that have the infrastructure to produce 50 percent of our food locally then we can reduce the average American’s footprint by 1 acre, thus bringing our planets from 5.35 down to 5. If we consume almost all of our food from local, unprocessed, unpackaged sources we can lower our footprint by another acre and another 0.3 planets. “With current agricultural land, Lane County could grow or produce 100% of the county residents’ grain, vegetable and fruit needs, but only 83% of dairy needs and 10% of meat needs” (Battson 06).

We must choose to buy organic and sustainably grown foods that are unprocessed and unpackaged. Food grown this way reduces our dependence on chemicals and preservatives, and improves our health while allowing us to compost food wastes and return nutrients to the ecosystem. Too often our food waste ends up in landfills where it has no value. Composting our food and other biological waste is the only way to return nutrients to the ecosystem. If we don’t consciously change our approach to food, our resources will run out within our or our children’s lifetimes, and these decisions may be forced upon us.

As architects we need to consider whether the land we are building on can support agriculture. If so, it is a waste to build large housing communities and strip malls that increase suburban sprawl on valuable arable land. Architects should dedicate parts of each site to allow for local food gardens and thus promote consumption of locally grown produce. The Douglas Hospital in Montreal supports a large community garden on part of its sprawling campus. Parks throughout Eugene, Oregon also dedicate land to community gardening and composting initiatives. When designing landscapes and choosing tree types, landscapers and designers should

specify fruit trees that supply food to the community, and plant berry bushes as hedges if the local climate can support them. In this way plants give back to the community, providing free food and supporting cooperation between humanity and the environment.

Architects need to design alternatives to wasteful uses of land such as lawns. We must change the preconception that lawns are a desirable feature of a property. Today millions of Americans spend approximately 30 billion dollars a year on the maintenance of over 23 million acres of lawns. The lawns in the US consume around 270 billion gallons of water a week. That's enough water to sustain 81 million acres of organic vegetables for an entire summer. If every house with 1/3 of an acre of lawn converted the grass to a vegetable garden they could grow enough food to feed a family of 6. (Flores 06).

"The average urban lawn could produce several hundred pounds of food a year" (Flores 06). If we have to build on fertile land it should be required that we replace the building footprint with planted roofs. This will not only benefit the energy consumption of the building and help control storm water run off but also support local plant species and create habitats for indigenous animals. It is also possible to design rooftop vegetable gardens - imagine a city where each building grows enough food on its roof to support its inhabitants.

2. GOODS AND MATERIALS

Our consumption of goods and services and our consequent waste is another aspect of our lives that needs to be addressed. The majority of products on the market are not built with sustainability in mind. Even recycled products are often created from materials that require just as much energy to adapt and create just as much waste as producing a virgin product (Braungart 02). It is our job as architects to research materials and find those that positively impact our environment; materials that have low embodied energy, no harmful waste byproducts, and can be endlessly recycled without a decrease in quality or require massive amounts of energy. These materials do or can exist; it is our job to find or design them.

Like with food, the movement of materials over great distances is a tremendous drain on resources. Architects should specify products produced within a 200 mile radius of the project site. (Figure 2). The energy costs involved in their transportation is vast and unnecessary. Designing with local climates in mind should extend to using local materials. Local materials should be easier to find, transport and be more plentiful. This should drastically reduce their cost. By using local materials our buildings will become more grounded in the communities they are built in. Local labor and craftsmen can be involved in the construction thus supporting local economy and giving residents a closer connection to the buildings they live in.

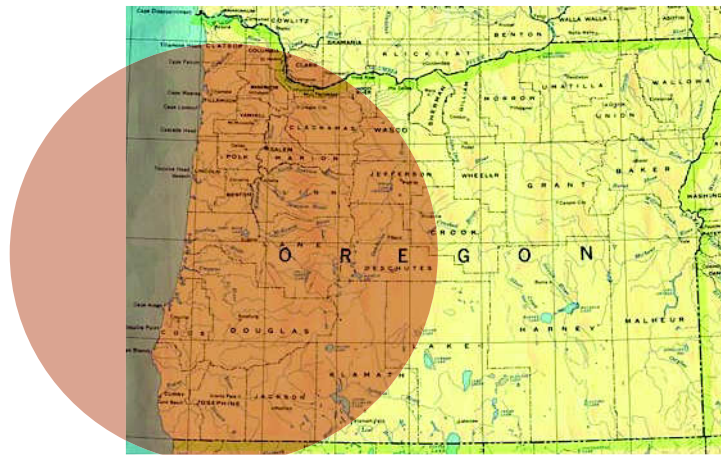

Figure 2: For projects in Eugene, OR, materials should be sourced from within a 200 mile radius: the region highlighted in red.

In order for architects to take advantage of local goods and services, we should choose to limit our work to local projects. This would decrease travel time and costs. It would also allow the architect to have an intimate understanding of the people and culture within the community. This also gives an understanding of the unique materials and skilled labor of the local building culture.

Conversely, architects may follow their projects. For example, if an architect took a project in Shanghai, she would relocate her office to China, living there for the duration of the job. She would then move again for her next project. In this way she would cut down on travelling to and from the site. Living in her new surroundings would provide a closer relationship to the site. She would experience the variations in climate over the course of a longer period, and have a glimpse of the local community and culture, making it easier to specify local materials or integrate recycled materials from local sources.

3. TRANSPORTATION

While transportation is not directly affected by the buildings we design, it dramatically affects the design process. Architects need to address the problem of separation between the site, the office, and the home. The first and easier decision we must make is living near our workplace, meaning within an easily walkable distance in all weather conditions. Living in a suburb and commuting to work by car or even public transportation is not sustainable. The reliance on fossil fuels to move us around cannot continue. The average American drives for 25 miles a day (Household Ecological Footprint Calculator). For every 100 miles per month we drive (assuming we get 25-35 miles per gallon and we carpool) our footprint is increased by about 1 acre. However, America's obsession with SUVs, trucks and other large vehicles that get as little as 10 or less miles per gallon dramatically increases our average footprint.

Bikes offer an excellent alternative for automobiles. Biking is less sustainable than walking; however, it drastically increases one's commuting radius making it such a great alternative to the car. As architects we need to better address the difficulties in biking as a mode of transportation. Both urban design and individual building design need to be readdressed with bikes rather than cars in mind as the primary mode of transportation. Bike lanes need to be incorporated into city planning and road design. Bike lanes require a distinct separation from automobiles and pedestrians. This can be created using a simple line or preferably an actual curb or hedge (Figure 3). Support utilities for bikes and their riders must be designed into our buildings, such as ample sheltered parking areas and locker rooms with showers where those who bike to work can clean up and prepare for their day.

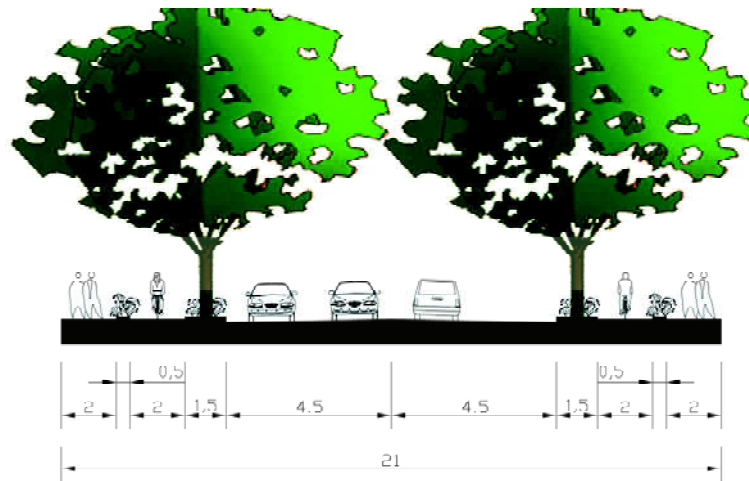

Figure 3: A multi-use street design providing safe separation between pedestrians, bicycles and automobiles.
- James Brearley

A more difficult challenge is how architects get to, experience, and work with the site. First-hand experience of the site should be an integral part of the design process. It is vitally important that our designs relate to the context in which they are located. There are three ways we can bridge this gap: design locally, follow projects, or use technology to replace physically visiting the site.

The extreme, and perhaps most sustainable approach, as mentioned above, is to work locally. This would be a distance that is easily walkable or bikable. This radius could easily expand however, if we develop transportation that runs on renewable resources: solar electric cars for example. Another approach, as discussed earlier is moving our workspaces to the site; working out of a mobile studio/living space. This option has been successfully implemented by designers, as seen by the work of Jersey Devil Architects (Piedmont 97).

Architects who do not work locally may replace travelling to the site with the use of technology. Could a new profession arise to support architectural designers? “Architectural Annalists” should start regional companies that document building sites within their communities. They digitally document each site and its surrounding context with images and write a report analyzing local climate (short and long term), report on local materials, possible recycled content, and local building culture and craftsman skills. They will have a much better understanding of the forces acting on a local site than a designer who only comes to visit a site for a few hours or even a few days. This could be a system that allows big name international architects to work throughout the world in a truly locally sensitive way.

One way this may come to pass is if we change the economics of travelling. There is a cost that doesn't currently register in our budgets: environmental impact (Figure 4). Natural resources are not free. Clean air and water are limited. We need to regard these resources as objects of value and consider the cost of depleting them. Harmful emissions from burning fossil fuels destroy the air and water we rely on for sustaining plants and animals, food and materials. We should be charged an environmental cost above the monetary cost of each flight or tank of gas.



Figure 4: Shows the additional environmental cost associated with the cost of air travel

“The myth that environmental protection must come at the expense of economic growth is dead. Short-sided policies and approaches to producing the energy and other products we need can and do have harmful impacts on society and the environment. Pollution, traffic congestion, and health risks are examples of such impacts which often disproportionately effect communities of color and people living in poverty. RP’s Sustainable Economics Program works to develop and promote creative, market-based policies that protect the environment, grow the economy, and promote social equity” (rprogress.org).

4. ENERGY USE

We must live and work in buildings that use fossil fuels for 0% of their energy needs. It is not possible to live with modern amenities and appliances and also have a footprint at or below one earth unless the buildings we design produce all their energy needs with renewable energy sources harnessed by the building itself. Living in a house that uses electricity produced by standard power factories (coal, nuclear, etc) vastly increases our footprint. If we incorporate passive energy systems and build houses that still rely on the standard energy grid, but use energy conservation and efficiency we can slightly reduce our footprint by about 1 acre and .3 planets. However, living in a home with no electricity can reduce a footprint by up to 4 acres equalling a reduction of almost 1 planet. We must employ active systems that generate the energy needed to run the important electrical systems in our homes. Solar hot water heaters, geothermal heating systems, photo voltaic panels and wind turbines should be the primary sources of energy in our built environment. If each building uses these renewable energy systems for all of their energy needs we can lower our footprint to that of a no electricity home.

Our planet is bombarded with enough solar energy each day to provide us with more energy than the entire human population needs. Harnessing this energy along with wind power and geothermal heating sources can make our buildings produce more energy than they consume. Once a building's energy production exceeds its energy needs, the surplus can be sold back to the grid, and be reallocated to a place of need.

Design also has to relate to the climate where each building is located. The concept of an international style is fundamentally flawed. Our buildings need to respond to local climates rather than a globalized building culture.

We can't survive using the 'brute force approach' our industry has been relying on for the past two hundred years, in which buildings are heated cooled, and artificially ventilated to create a comfortable interior climate (Braungart 02). Relying on mechanical systems is gross negligence on our part. We need to work with nature in a way that is mutually beneficial.

5. BUILT ENVIRONMENT

Offices and living spaces should be combined. This saves money, resources and time. We thus use one building instead of two and we no longer have long commutes. This shift will give us more time to spend with our families and to pursue interests outside of work. This would also promote living downtown instead of in the suburbs, thus developing safe and lively cities while increasing population density. Conversely, architects who choose to live in rural areas can use technology to bridge the gap between their home office and their clients. Phone and internet conferencing have made it possible to communicate with people anywhere in the world. The savings in time, the reduction of harmful emissions from driving and flying, and the minimal use of fossil fuels and other resources make moving the office an ideal solution for sustainable living and working.

Within contemporary culture, we have come to seek a separation between work and home. Perhaps there is a way to combine work and play. Work should be enjoyable and the office should be a place where we enjoy spending time. The office needs to take on a natural atmosphere. We need to work in buildings with natural light and ventilation and in spaces where the users have control over their microclimate.

As mentioned above, population density needs to be restructured. Urban sprawl is claiming land that would be better used for agricultural production. As there is a limited amount of resources there is also limited land that can support agriculture. "Every acre of productive land we lose to suburban sprawl, erosion and industrial development...could have provided 36 people all of their vegetable needs, 12 people all of their grain needs, or 26 people all of their fruit needs" (Battson 06). We need to consider this as we design new communities or expand existing ones. Instead of clearing farmland to build suburbs we should revisit urban spaces, such as vacant lots, that can be redeveloped. Large open expanses in downtown areas should be subdivided and redeveloped as housing before we expand beyond the city limits.

We need to become accustomed to smaller dwelling units and larger shared space. As in Europe, Asia and many other parts of the world we in the US should use public parks and plazas as additional living spaces instead of having vast sprawling private houses and lawns. Right now the average per capita housing size is 582 square feet. This needs to be reduced. Communal living can be promoted through design by combining comfortable private spaces with shared space. For example, increasing the occupancy from one to two within a 500 to 1000 square foot house will save about 5 acres of land, or more than a whole planet. If we further increase the occupancy to three, we reduce the footprint by an additional two acres and .4 planets. When given the opportunity to design whole communities, architects must consider designing for an increased density. It is our job to convince developers and other town planners of the consequences of design choices.

Each site needs to be designed as a self-sufficient project. All energy requirements need to be produced on site. All waste materials need to be processed on site, either through reuse or by treating it in a way that renders it no longer harmful. For example, storm water should be retained on site, thus reducing reliance on storm water systems. "Living within the means of nature is sustainable when all consumption and absorption of ensuing waste occurs in the place where consumption directly occurs" (rprogress.org).

Designs also need to address the thousands of other species that rely on the land we build on. Architectural designs need to support and promote local vegetation and animal life. These plants and animals can also benefit us by assisting in accomplishing some of our goals. I have already mentioned some of the benefits of green rooftops. Another option is to create bioswales, which can retain and purify storm water and other contaminated wastewater. They can also beautify the site while providing valuable habitats to local plants and animals.

CONCLUSION

As architects we need to realize that it is our responsibility to promote sustainable living through our designs and our lifestyle choices. We need to hold ourselves to standards well above the rest of the population. As humans and as architects, we need to change the way we live and work. We must create continuity between our sustainable designs and our personal lives. In *Greed to Green*, David Gottfried said "*We harm the planet because we don't feel connection between our actions and the environmental impact.*" To begin, we must evaluate lifestyle choices, and consider the environmental cost of our actions. Environmental impact must precede economic factors. Our planet is in a dire crisis, and as humans, it is our primary responsibility to create

a solution. Within our profession lies the potential to make a powerful impact on society. Many people put forth negative energy in protesting and working against issues such as logging, carbon emissions, chemical wastes, etc. Conversely, our profession has the ability to work towards a positive ideal. We can build communities with communal gardens, housing complexes that create habitats for wildlife, buildings that produce naturally renewable energy that satisfies 100 percent of their energy needs. In short we can start building a sustainable society. As we take on this challenge now we work to prevent future crisis (Figure 5). We can focus our efforts on long-term change now, before we run out of the resources we rely on today.

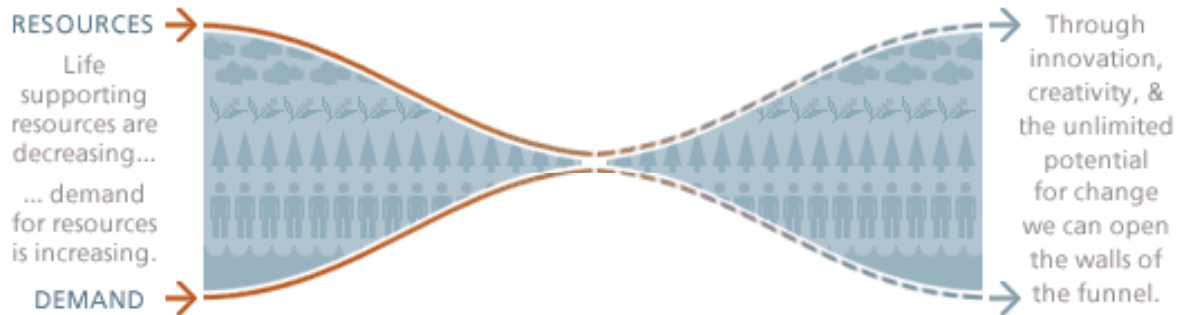

Figure 5: Within the next 30 years our demands will surpass our available resources unless we make changes to the way we live.
- naturalstep.org

REFERENCES

- Battson, Harry Executive Director. 2006. *Locally Grown – Lane County Food Directory*. Eugene, OR
- Braungart, Michael and McDonough, William. 2002. *Cradle to Cradle*. New York, NY: North Point Press.
- Brearely, James. Architect . *BAU - Brearely Architects and Urbanists*. Shanghai, China.
- Dictionary. 2005. *New Oxford American Dictionary 2nd Edition*. Apple Computer, Inc.,
- Flores, H.C. 2006. *Food Not Lawns*. White River junction, VT: Chelsea Green Publishing Company.
- Gottfried, David. 2004. *Greed to Green*. Berkley, CA: Worldbuild Publishing.
- Gore, Al. 2006. *An Inconvenient Truth*. New York, NY: Rodale.

<http://carbonfootprint.com>
<http://eweb.org>
<http://myfootprint.org>
<http://naturalstep.org>
<http://rprogress.org>
<http://sonyclassics.com/whokilledtheelectriccar/electric.html>
<http://steppingforward.org.uk>
<http://thegreenoffice.com>
<http://travelmatters.org>
<http://wikipedia.org>

Owens, Larissa N. 2006. *The Green Book – The Directory of Business With Heart*. Ashland, OR: The Green Book

Piedmont-Palladino, Susan and Branch, Mark Alden. 1997. Devil's Workshop : 25 Years of Jersey Devil Architecture. New York, NY: Prinston Architectural Press.

Wackernagel, Mathis; Monfreda, Chad; Deumling, Diana and Dholakia, Ritik. 2003. *Household Ecological Footprint Calculator v. 3.2*. The Center for Sustainability Studies at the Universidad Anahuac de Xalapa, Mexico. Redefining Progress.

The Trouble with Sustainability

Walter T. Grondzik, P.E.

Architectural Engineer, Tallahassee, Florida, USA

ABSTRACT: This paper laments the intellectual dishonesty inherent in the unbridled use of the term “sustainability” in architecture and related professions. Reasons why misplaced use of this term is undesirable are outlined, evidence of the misuse of this important term (and critical concept) is presented, and a proposal to address the current problem of semantic misrepresentation is presented.

Conference theme: philosophy and theory for advancing green design
Keywords: sustainability, green design, design intent, benchmarking

INTRODUCTION

The terms “sustainable” and “sustainability” are seemingly both de rigueur and mandatory in current architectural discourse—in architectural education, architectural practice, and architectural publications. Pretty much anywhere one looks today he/she will see something that is touted as sustainable (see Section 2 below). There are papers, announcements, and advertisements for sustainable design, sustainable houses, sustainable systems, sustainable products ... ad infinitum. The same is true, to a somewhat lesser extent, in buildings-related engineering disciplines. The reason that misuse of this terminology is of concern is simple—sustainability is a critically important concept that society must address with intellectual honesty. This honesty is arguably not seen in today’s design milieu.

It appears that many in the architectural community have adopted the term “sustainable” as a mark of environmental distinction or are using it as a would-be shield against environmental criticism. This is unfortunate, as sustainability is too important a concept to be used as an environmental amulet or magic cloak. The purpose of this paper is to outline concerns with the misuse and abuse of “sustainable,” to provide evidence that such abuse exists, and to propose corrective actions to stem further semantic misconduct. The overriding premise of the paper is that words do often make a difference.

1. THE CONCERN

The essential trouble with sustainability is that it is a critically important concept. Sustainability deals with life safety, with health, and with well-being—not just of individuals or assemblies of people, but of societies. It could easily be argued that sustainability should be the ultimate driver behind building code or design professional licensure requirements. For the human race sustainability may literally mean the difference between life and extinction. At the very least, it will mean the difference between the developed world’s current lifestyle and a much reduced standard of living. What is being sustained via sustainability is what we currently have. Most people, at least in the developed countries, seem to intuitively believe this a worthwhile objective.

The operational trouble with sustainability is that it is often used to describe some amorphous condition that is somewhat or somehow different from the status quo—without any definition or clarification of what that intended condition actually represents. This vagueness allows the term to be freely used, with little or no guilt, under an amazingly wide range of circumstances by an amazingly wide variety of individuals and institutions. Such a loose approach to grammar masks the seriousness of the concerns that underlie the very terminology in question. Sometimes semantics are much more than just a question of semantics.

The systemic trouble with sustainability is that it is often treated as an attribute of a part rather than as a property of a whole. The thought of seriously promoting hurricane-resistant nails, roof clips, or metal studs seems ludicrous. The nail does not have to be hurricane-resistant; the assembly it is used in must be so. In virtually all cases, it is not the parts that need to be sustainable, but rather the resulting larger product—the building, the

neighborhood, the community, the society. Erroneously promoting "sustainable" parts deflects attention from the true objective. Acquiescing in such promotion contributes to the problem.

The trouble with sustainability from the design perspective is that it seems to be commonly viewed as a process rather than as an outcome. It is quite likely that the design process will change to ensure sustainable outcomes; nevertheless the making of artifacts is often touted as sustainable instead of the products resulting from the process. One hears of "sustainable" curricula and "sustainable" design approaches. It is not the trip itself that matters, it is the destination. Sustainability is a definite destination. Close does not count. Being almost sustainable is probably not good enough. A society is either sustainable or it is not. If it is not, there is no question as to the outcome—which is the end of whatever is trying to be sustained (comfort, health, mobility, education)—the only question is how long it will take to reach that outcome.

The technical trouble with sustainability is that it is often viewed as a qualitative construct rather than as a quantitative reality. Sustainability is a very specific condition (see more on this below). A product or outcome (such as a building or community) is either sustainable or not. Sustainability cannot rationally be allowed to reside in the eye of the beholder—just as structural adequacy or visual acuity are not conditions that can be wished into becoming reality through force of conviction or successful public relations.

The trouble with sustainability as a destination is that it's opposite—unsustainability—is seldom discussed. We hear "sustainable" this, "sustainable" that (it's everywhere; it's everywhere). Seldom do we explicitly hear that a system, building, or development is unsustainable. It is the unsustainable that is truly worrisome; it is the unsustainable that should draw our attention and concern. It's great to honestly laud the truly sustainable (although anything less is really foolish), but as a society we should be actively blasting the unsustainable.

The fundamental trouble with sustainability is that it's meaning and acceptable usage have not been defined by the design professions. Today sustainable may literally mean anything from "meets building code" to "receives LEED certification" to "has zero energy consumption." Sustainable is a word that has been horribly abused and misused. The terms "energy efficient" and "green" have been well benchmarked by the design professions. Misuse of these terms can be (and is) challenged by peers, by clients, and by authorities having jurisdiction. This is not the case with "sustainability" which seems to be the pseudo-technical buzz-word of the decade for the design professions.

2. THE EVIDENCE

It might be easy to dismiss the above concerns as the rantings of a mere grammarian if not supported by some evidence. The following are typical examples of the free-wheeling (and thus generally meaningless) use of the term sustainable in current professional discourse. These examples are drawn from print and Internet sources and deal with both products (where some creative license may be understandable, if not acceptable) and from pronouncements of technical organizations (who should know better). The evidence is not statistically robust or representative of the design professions collectively or as a whole. It is, however, believed to be compelling in its pervasiveness and perverseness.

From the American Society of Heating, Refrigerating and Air-Conditioning Engineers (ASHRAE), the primary North American professional organization dealing with active building climate control systems:

Proposed Standard to Provide Minimum Design Requirements for Sustainable Buildings

WASHINGTON, D.C.—ASHRAE, The U.S. Green Building Council (USGBC) and the Illuminating Engineering Society of North America (IESNA) have agreed to cosponsor the development of a new minimum standard for **sustainable** high-performance buildings. Proposed Standard 189, *Standard for the Design of High-Performance **Green** Buildings Except Low-Rise Residential Buildings*, will provide minimum requirements for the design of **sustainable** buildings. (ASHRAE 2006a)

The above announcement (the text in bold was highlighted by the author of this paper) clearly equates "green" and "sustainable." There is no reason for anyone reading this announcement to suspect that green and sustainable are not synonymous concepts—so synonymous, in fact, that the terms can be freely interchanged within the course of a single paragraph.

Not to pick on ASHRAE, but the following announcement further suggests that "green" design and "sustainable" design are identical:

Online Program Designed to Simplify Sustainable Building

PORTLAND, Ore.—The nonprofit Green Building Initiative (GBI) is sponsoring pilot design projects around the U.S. to promote its Green Globes online tool. The program enables users to plug in information about proposed commercial building projects and receive feedback about how to maximize **sustainability** in the project. The GBI is touting the program as a user-friendly way to incorporate **green** concepts in designs. It expects Green Globes to be active in 30 major U.S. building markets by the end of 2007. (ASHRAE 2006b)

Even more intriguing than the casual interchange of the green/sustainable terminologies found in the above (see author's bolding of text) is the suggestion that one can *maximize* sustainability. Apparently, one could also choose to super-size sustainability. This leads to the even more disturbing thought that it might also be possible to go sustainable-lite or sustainable lo-cal. In fact, ASHRAE provides ammunition for this argument in the following announcement (with author's bolds and underline):

Semiconductor Plant Aims for High Sustainability

RICHARDSON, Texas—Texas Instruments is building a semiconductor fabrication plant that could be a model for **sustainable** building. The plant, scheduled to open in 2007, is expected to produce an estimated millions of dollars in annual energy savings due to HVAC systems using chilled water, heat recovery, solar water heating, daylighting and other technologies. The \$1.5 million HVAC systems are expected to pay for themselves within two years. If the office building and plant receive gold and silver **LEED® certification**, respectively, it is believed that it will be the largest facility to do so. (ASHRAE 2006c)

Although recent ASHRAE announcements provide fertile ground for concern about term-banding, ASHRAE is not alone in spreading confusion. See the following (with author's bolds) from the U.S. Green Building Council's (USGBC) WWW site. To be fair, the USGBC is usually very good about distinguishing green and sustainable; such distinction can perhaps be inferred from the implication that green is suggested as an approach to sustainable.

What is LEED®?

The Leadership in Energy and Environmental Design (LEED) Green Building Rating System™ is the nationally accepted benchmark for the design, construction, and operation of high performance **green** buildings. LEED gives building owners and operators the tools they need to have an immediate and measurable impact on their buildings' performance. LEED promotes a whole-building approach to **sustainability** by recognizing performance in five key areas of human and environmental health: sustainable site development, water savings, energy efficiency, materials selection, and indoor environmental quality. (USGBC)

Entering the realm of popular architectural journalism yields an onslaught of claims for sustainability. The following examples were selected from a single issue of *Environmental Design + Construction*, a reputable and influential monthly trade magazine. The question posed by the following evidentiary examples seems important: does the use of the term "sustainable" hold any meaning whatsoever? It appears clear that some importance was ascribed to the term by the writers of these articles and ads; but what do they really mean by this very prominently employed word? Copyright concerns preclude reproduction of the articles and advertisements in graphic form; thus they are verbally summarized.

_____ Carpets: Sustainability from Top to Bottom

_____ Technologies: Utilize your roof as a sustainable and renewable asset ...

Health, Quality, Sustainability: They're built into every _____ product.

Is your non-PVC screen recyclable and sustainable? _____ is the only product on the market that meets this criteria. _____ is 87% green.

_____ (insulating forms): The sustainable choice.

_____: Products that provide: sustainability; energy efficiency; vinyl window and door designs, ...

"Sustainable Home": _____ tailors various sustainable aspects to specifically suit each property.

“A Study in Sustainable Adaptive Reuse”: The sustainable adaptive reuse of Montgomery Park was achieved through the intimate knowledge of the building; its infrastructure, patient planning, and application of Leadership in Energy and Environmental Design (LEED) sustainable strategies. (ED+C)

3. A PROPOSAL

If it is accepted that a profession should control key terms that are used to communicate important ideas both within the profession and to outsiders, then “sustainability” must surely be brought into the family of terms that have real meaning and convey useful and replicable information. Such terms include “registered architect,” “energy efficient,” “green,” “accessible,” and numerous others. None of these terms is allowed to be used indiscriminately or incorrectly (at least blatantly so). They have well-established meanings and application. Correct use of these terms is monitored and enforced within the profession; by architectural licensing boards, code authorities, the USGBC, the U.S. Department of Justice. Sustainability must join the ranks of these respected terms.

Rather than reinvent the wheel, it is proposed that the Brundtland Commission’s definition of sustainability is an appropriate starting point for consensus. (Wikipedia) To paraphrase, the Commission suggested that sustainability is a condition whereby a generation meets their needs while not impairing the ability of future generations to meet their needs. This is a simple and terribly compelling blueprint for intergenerational respect and the survival of society as we generally know it—but perhaps a hard reference by which to design a roof assembly. Sustainability must be benchmarked in such a way that a design team can make rational decisions on the hundreds of issues that come up on any project. This has been done for energy efficiency (meeting ASHRAE 90.1 or California Title 24), for green (meeting LEED-NC or complying with Green Globes requirements), for accessibility (complying with ADA mandates), and every day for budgets (meeting a limit of xx\$/sq ft). Surely it can be done for sustainability (and perhaps, along the way, carbon neutrality). But it will only be done if the term sustainable is perceived to have ethical importance to the design professions.

The following are offered as interim working definitions of some key terms surrounding sustainability:

Energy efficient: A building that exceeds the minimum requirements of the prevailing energy efficiency (building) code.

Green: A building that reduces negative site/global environmental impacts by addressing energy, water, and materials consumption.

Carbon-neutral: A building that produces no net carbon emissions, thereby reducing greenhouse gas emissions and helping to reduce global warming.

Sustainable: A building that produces no net negative site/global environmental impacts by seriously addressing energy, water, and materials consumption.

Regenerative: A building that produces net positive site/global environmental impacts by very seriously addressing energy, water, and materials consumption.

Generally accepted (although actively debated) benchmarks for energy-efficient and green buildings have been established and promulgated. This allows these terms to be used in a meaningful way as design adjectives. No such benchmarks have been established for carbon-neutral (although this may be easy), sustainable, or regenerative. Until such reference criteria have been developed and placed into use these terms will remain squarely in the realm of hyperbole instead of useful conversation.

Until such time as sustainability is benchmarked, it is proposed that all professional organizations refrain from the use of this word as an adjective. Such use strongly suggests, if not explicitly implies, a clear understanding and general consensus of what the word means. As argued above, this is not the case. This prohibition request is especially true for educational institutions—and in particular the National Architectural Accrediting Board, which requires students (under condition 15: Sustainable Design) to have an:

Understanding of the principles of sustainability in making architecture and urban design decisions that conserve natural and built resources, including culturally important buildings and sites, and in the creation of healthful buildings and communities (NAAB 2006)

Unfortunately, NAAB does not define “sustainability,” making its understanding by students tenuous and its achievement in studio designs highly suspect. Surely we can do better in preparing future generations to assume the roles of architect and environmental steward—which are believed (by the author) to be coincident roles as this is being written. Surely the leading organizations in the design professions can develop definitions and benchmarks for sustainability. The trouble with doing otherwise is simple. If it is believed that green is synonymous with sustainability, and sustainability is the ultimate objective, then designing and building green buildings is enough. Green will become the ultimate objective, not sustainability. This will not cut it—but it will deceive us. Green is a necessary, but not self-sufficient, component of sustainability. It is absolutely critical at this critical juncture in how we think about building design (Architecture 2030 and the 2010 Imperative come to mind) that design intent (sustainability) not be confused with design criteria (such as LEED) or methods (such as shading devices). Confusing methods with intent is a common, and often fatal, design process error.

CONCLUSIONS

The trouble with sustainability is that the word has been so overused, without the benefit of benchmarking, that it has become an essentially meaningless term. The trouble with sustainability is that it is just so darn important a concept. So here is a proposal and a plea. Please don't use sustainable to mean green; please don't use sustainable to mean LEED code. Reserve the word to describe the truly sustainable—that which will reasonably allow future generations to meet their needs. There is no way that a building can be rightfully called sustainable if it is guzzling, slurping, or even sipping non-renewable fossil fuels, water, and material resources. What will future generations do? To assume they'll somehow get by or invent a miraculous solution to energy, water, and material needs seems a bit callous.

REFERENCES

ASHRAE. *The HVAC&R Industry for February 23, 2006(a)* - Vol. 5, No. 8. The American Society of Heating, Refrigerating and Air-Conditioning Engineers, Atlanta, GA. <http://images.ashrae.biz/eNewsletters/HVACR/022306.html> (accessed 5 January 2007).

ASHRAE. *The HVAC&R Industry for March 23, 2006(b)* - Vol. 5, No. 12. The American Society of Heating, Refrigerating and Air-Conditioning Engineers, Atlanta, GA. <http://images.ashrae.biz/eNewsletters/HVACR/032306.html> (accessed 5 January 2007).

ASHRAE. *The HVAC&R Industry for June 15, 2006(c)* – Vol. 5, No. 24. The American Society of Heating, Refrigerating and Air-Conditioning Engineers, Atlanta, GA. <http://images.ashrae.biz/eNewsletters/HVACR/061506.html> (accessed 5 January 2007).

ED+C: Various articles and advertisements found in the January/February 2006 issue of *Environmental Design + Construction*.

NAAB: "NAAB Conditions for Accreditation For Professional Degree Programs in Architecture" (2004 Edition). The National Architectural Accrediting Board, Washington, DC. <http://www.naab.org/> (accessed 5 January 2007).

USGBC. Information from the USGBC WWW site. <http://www.usgbc.org/DisplayPage.aspx?CategoryID=19> (accessed 5 January 2007).

Wikipedia. Topic: "Brundtland Commission." http://en.wikipedia.org/wiki/Brundtland_Commission (accessed 5 January 2007).

Author Index

Last Name

Aloisi, Missa	11
Bing, Judith	133
Brown, G. Z. 1	39
Brown, G. Z. 2	55
Cabrinha, Mark	157
Chatto, Christopher	39
Corner, Donald	3
Elzeyadi, Ihab	47
Elliott, Jack	183
Gianni, Benjamin	203
Gillem, Mark	125
Gray, Lucas	251
Gray, Timothy	143
Grondzik, Walter 1	191
Grondzik, Walter 2	259
Harrington, J Brooke	133
Hatten, Michael	39
Jamgochian, Joe	151
Jo, Jae-Hun	109
Johnson, Arthur	39
Kaiser, Keelan P.	175
Kim, Kwang Woo	109
Kline, Jeff 1	39
Kline, Jeff 2	55

Last Name

Knudson, Karrin	237
Kwok, Alison G.	191
Layne, Anthony W.	243
Luiz Lara, Fernando	169
Mabry, C Jason	99
Muller, Brook	27
Northcutt, Dale 1	39
Northcutt, Dale 2	55
O'Brien, Michael	75
Ogoli, David Mwale	117
Rashed-Ali, Hazem	225
Rider, Tracy Rose	183
Teal, Randall F.	91
Theodoropoulos, Christine	39
Trubiano, Franca 1	99
Trubiano, Franca 2	151
Turner, Cathy	67
Vera, Maria del C.	211
Wakefield, Ron	75
Werthan, Audrey Kay	83
Yeo, Myong-Souk	109
Yeshayahu-Sharabi, Shai	211
Zaretsky, Michael	19
Zhu, Xuemei	217

The Architectural Research Centers Consortium

The Architectural Research Centers Consortium, Inc. (ARCC) is an international association of architectural research centers committed to the expansion of the research culture and a supporting infrastructure in architecture and related design disciplines. Since its founding as a non-profit corporation in 1976, ARCC has represented a concerted commitment to the improvement of the physical environment and the quality of life.

Historically, ARCC's members have been schools of architecture who have made substantial commitments to architectural research, often by forming centers directed to research programs. At the same time, ARCC has sponsored many projects, conferences, and other activities involving the broader architectural research community, including industrial laboratories, government agencies, and private practitioners engaged in research.

ARCC members are engaged in sponsored research and in graduate studies intended to develop a more comprehensive research infrastructure for architecture -- an infrastructure of researchers, facilities, equipment, research centers, and academic programs working to expand the knowledge base for practice. A recent survey of members identified over \$21 million in funded research projects in areas such as:

•Acoustics •Adaptive environments •Building economics •Building systems •Commercial and institutional buildings •Community development and design •Computer-aided design •Construction materials and processes •Earthquake, fire, and environmental hazards •Energy, resources, and sustainability •History and theory of architecture •Health and related facilities •Housing •Indoor environments •Lighting and daylighting •Practice of architecture •Preservation and rehabilitation •Simulation and representation •Tropical planning and design •Urban and rural design

As an organization of researchers and research centers, ARCC sponsors workshops, undertakes sponsored projects, sustains networks, and exchanges information and experience intended to help build a research culture and infrastructure -- in architecture schools and beyond.

*for more information and contact details visit our website: www.arccweb.org

Sponsors

A big thank you to the following sponsors who made this conference possible:



The University of Oregon



The School of Architecture and Allied Arts



**THE AMERICAN INSTITUTE
OF ARCHITECTS**



The Architectural Research Centers Consortium

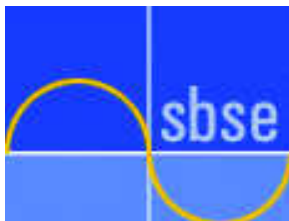

The Society of Building Science Educators



THE AMERICAN INSTITUTE
OF ARCHITECTS

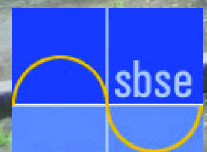

ARCC

ISBN: XXXXXXXXXX





ARCC

CONFERENCE PROCEEDINGS

2007

“Green Challenges in Research, Practice, and Design Education”

Architectural Research Centers Consortium
The School of Architecture and Allied Arts,
University of Oregon, Eugene 16-18 April 2007

2007 ARCC Spring Research Conference

“Green Challenges in Research, Practice, and Design Education”

16-18 April, 2007

Eugene, Oregon, USA



University of Oregon

Forward

Architectural research investigates issues related to the physical, aesthetic, and social aspects of the built environment, including the well-being of its inhabitants. Architectural education promotes the understanding of principles, concepts and lessons learned from practice and architectural research. In practice, designers and clients exchange a variety of ideas, problems, strategies, and solutions. Ultimately, we seek ways to link research and practice to the classroom so that our students will become better stewards of the environment.

This year's theme, "Green Challenges" offers a venue for participants to present research issues that help move architectural education to a greener and sustainable future. The conference is open to a diversity of topics yet focused on current research, innovations, programs, and activities, which participants will present in parallel sessions. Roundtable discussions will allow participants to discuss green topics, exchange ideas, and develop potential collaborations on research projects.

These proceedings present papers that address a number of issues including:

- Would applying (what are claimed to be) sustainable design principles be enough to protect and guarantee the sustainability of our environment?
- What are the new issues that architectural researchers and educators should now focus upon?
- How does current building design protect the inhabitants from extreme changing climates? Or should we be more adaptable in our behavior?
- What are the top ten, most important design moves that students should know how to do in order to design carbon neutral buildings?

All papers published in these proceedings went through rigorous, blind refereeing processes by the 3 reviewers from the ARCC Board and Technical Committee. We received 47 paper submissions by authors from 30 institutions in the United States, Canada, and Korea. Of these, 32 were accepted with revisions and 1 author withdrew. There were five invited presentations and five keynote presentations that are not included in the proceedings.

The final 31 papers presented in these proceedings are categorized into a number of topics:

- Building Case Studies
- Community and Urban Design
- Daylighting and Electric Lighting
- Education
- Energy and Resource Efficiency
- Human Context
- Materials and Construction
- Philosophy and Theory for Advancing Green Design

On behalf of the Architectural Research Centers Consortium, we would like to express our gratitude to all the reviewers who contributed their time in the review process of the papers.

Alison G. Kwok
Conference Organizer

Organizing and Technical Committees

Organizing Committee

Alison G. Kwok (Chair)	University of Oregon
Brook Muller (Paper Review Chair)	University of Oregon
Alexandra Rich (GRF)	University of Oregon

ARCC 2006-07 Board

Michel Mounayar (President)	Ball State University
Kirsten van Aalst (Vice President)	Norwich University
Stephen Weeks (Treasurer)	University of Minnesota
Leonard Bachman (Secretary)	University of Houston
Lucie Fontein	Carleton University
Jane Greenwood	Mississippi State University
Michael Kroelinger	University of Nevada Las Vegas
Brian Sinclair	University of Calgary

ARCC Ex-Officio	
Brooke Harrington	Temple University
Walter Grondzik	Tallahassee, Florida
Michael Hagge	University of Memphis
Fatih Rifki	American University of Sharjah

Technical Committee / Paper Reviewers

G.Z. Brown	University of Oregon
Mark Cabrinha	Rensselaer Polytechnic Institute
Virginia Cartwright	University of Oregon
Tim Castillo	University of New Mexico
Nancy Cheng	University of Oregon
Tom DiSanto	California Polytechnic State, San Luis Obispo
Stephen Duff	University of Oregon
Ihab Elzeyadi	University of Oregon
Michael Fifield	University of Oregon
Urs Peter Flueckiger	Texas Tech University
Tom Fowler	California Polytechnic State, San Luis Obispo
Mark Gillem	University of Oregon
Geoff Gjertson	University of Louisiana at Lafayette
Esther Hagenlocher	University of Oregon
Bruce Haglund	University of Idaho
Nico Larco	University of Oregon
Michael Lucas	California Polytechnic State, San Luis Obispo
Margot McDonald	California Polytechnic State, San Luis Obispo
Matt Powers	Florida A&M University
Nicholas Rajkovich	RSK Architects Inc.
John Reynolds	University of Oregon
Veronica Soebarto	University of Adelaide
Alison Snyder	University of Oregon
Sandy Stannard	California Polytechnic State, San Luis Obispo
Randy Teal	University of Idaho
Kevin Van Den Wymelenberg	University of Idaho, Integrated Design Lab
James Wasley	University of Wisconsin, Milwaukee
Jenny Young	University of Oregon

Table of Contents

Foreword	i
Organizing and Scientific Committees	ii
Theory For Advancing Green Design	
Ocean and Prairies: New Metaphors for Design* Laura Briggs	
Themes Of Function Donald Corner, Michael Magee	3
What's On Your Mind, What's In Your Heart? An Exploration on Our Perceived Environment Missa Aloisi	11
Expo 2005-Nature's Wisdom: An Ecological Pedagogy For Sustainable Transformation Michael Zaretsky	19
In Poetic Association: Acts of Architecture in the Realm of Landscape Ecology Brook Muller	27
Case Studies—Lighting	
Configuring Structure to Improve Daylight Access in Multistory Buildings Christine Theodoropoulos, G.Z. Brown, Arthur Johnson, Michael Hatten, Christopher Flint Chatto, Jeff Kline, Dale Northcutt	39
Green In The Balance: Visual Comfort Inside Offices With Tilted Facades Ihab Elzeyadi	47
A Lower Cost, Higher Performance Classroom: will innovation lead to market transformation? G.Z. Brown, Jeff Kline, Dale Northcutt	55
Measurement And Education	
How Are We Doing? A Protocol For Building Performance Reviews Cathy Turner	67
Considering The Whole: Developing a Whole-house Calculator Michael O'Brien, Ron Wakefield	75
A Systemic Model For Designing Energy Optimized Buildings Audrey Kay Werthan	83
Awareness: the ground for sustainable design Randall F. Teal	91
Innovative Sustainable Water Management Practices in Solar Residential Design C. Jason Mabry, Franca Trubiano	99

Case Studies—Human Context

Effect of Building Design on Pressure-related Problems In High-rise Residential Buildings Jae-Hun Jo, Myong-Souk Yeo, Kwang-Woo Kim	109
Thermal Comfort in a Naturally-Ventilated Educational Building David Mwale Ogoli	117
The Green Church Mark L. Gillem	125
Environmental Studies of Vernacular Architecture J. Brooke Harrington, Judith Bing	133

Materials and Construction

Straw-Bale Eco-Center: Demonstrating How to Live Sustainably in the Midwest Timothy Gray	143
The Design of Residential Building Skins—Solar Power and Structurally Insulated Panels Joe Jamgochian and Franca Trubiano	151
Enabling Material Constraints in the Digital Design Process Through a Plywood Gridshell Mark Cabrinha	157
In the Purple Palace: Environmentally Responsible Vocabulary for Materials and Construction* Richard Hayes	
Site Interface* Laura Briggs	

Education

Lab-coats Back in Studio. Can Sustainability Bring Design and Research Back Together? Fernando Luiz Lara	169
A Green Studio Pedagogy: Using Scale Changes to Influence Architectural Design for Sustainability Keelan P. Kaiser	175
Education, Environmental Attitudes and the Design Professions Traci Rose Rider, Jack Elliott	183
The Green Studio Handbook: Environmental Strategies for Schematic Design Alison G. Kwok, Walter Grondzik	191
Interdisciplinary Comprehensive Design Studio: Carbon Neutral Field Campus* Bruce Haglund	

Community and Urban Design

Research x Design: Urban Design Charrettes from the Design Centre for Sustainability
at the University of British Columbia*

Ron Kellett

Phantom Housing: The Rise and Fall of Public Housing in North America 203

Benjamin Gianni

Mapping Urbanity: A Trajectory of Urbanity and Its Role in the Morphology of the Biosphere 211

Maria del C. Vera, Shai Yeshayahu-Sharabi

School Environment and “Green” Transportation 217

Xuemei Zhu

Community Design Parameters and the Performance of Residential Cogeneration Systems 225

Hazem Rashed-Ali

Theory for Advancing Green Design

Intimate Encounters: Social Capital, Emotional Ecology, and Sustainable Design 237

Kaarin Knudson

The Role of Connectedness Theory in Sustainable Architecture 243

Anthony W. Layne

The Sustainability of an Architectural Practice 251

Lucas Gray

Advancing Green Design Through Theory*

Martha Bohm

The Trouble With Sustainability 259

Walter Grondzik

Author Index 265

The Archtiectural Research Centers Consortium 266

Sponsors 267

* Invited oral presentations

Theory For Advancing Green Design

Ocean and Prairies: New Metaphors for Design*
Laura Briggs

Themes Of Function
Donald Corner, Michael Magee

What's On Your Mind, What's In Your Heart? An Exploration on Our Perceived Environment
Missa Aloisi

Expo 2005–Nature's Wisdom: An Ecological Pedagogy For Sustainable Transformation
Michael Zaretsky

In Poetic Association: Acts of Architecture in the Realm of Landscape Ecology
Brook Muller

* Invited Oral Presentation

Themes of Function

Donald Corner

University of Oregon, Eugene, Oregon

ABSTRACT: Architects draw initial inspiration from “themes of function,” but as the project develops, and market forces demand ever more striking building expressions, fidelity to the originating concept is often lost. The tension between true function and the appearance of function is particularly evident in the design of building enclosure. Tracing the development of the rain screen principle and the double skin facade, the author illustrates how leading designers make reference to function while embarking on aesthetic explorations that clearly have other motivations. As facade systems become more complex, there are greater consequences associated with a lapse in attention to basic issues. Faced with dramatic climate change, public demand for green building solutions has risen very rapidly. To meet that demand, architects must discipline themselves to find poetics in real performance

Keywords: Green facade design theory

INTRODUCTION

Architects raised in the long shadow of modernism seek out concepts, relationships, and forms that capture the essence of a program activity or building performance attribute. The kernel of these investigations, the basic recurring concepts, are known in one school of thought as “themes of function.”(1) Once identified, these themes can be elaborated and expressed through an infinite number of design variations. The creative mind is driven to find new, fresh and ever more powerful expressions of basic ideas. As the process unfolds, new themes are added to the mix, and the search continues for a compelling synthesis. Too often a form of “mission creep” sets in. Along the creative journey, designers wander further and further away from the motivating principles. When the inspiration is fulfilled, all credit is assigned to the originating function, but there are clearly other competitive forces lurking behind the forms that we eventually see and celebrate.

The tension between true function and the appearance of function is never more evident than in the design of building enclosure. The facade carries with it all of the expectations of our cultural inheritance. One hopes that good manners and shared meaning will remain primary considerations in the urban environment. Add to these ever greater demands for technical performance. The well adapted building controls heat, light, moisture and oxygen supply through its skin. The architect has to span an intimidating range of issues. Facades are more and more likely to be our primary experience of buildings, particularly in an era when security concerns dictate that most of us will never be admitted to privately owned interiors. Corporate clients, desirous of an iconic building image, put increasing pressure on architects to deliver striking proposals. New technologies have been the time honored trigger for new forms, but performance of a technical function often marks the beginning rather than the end of a creative investigation.

Joseph Esherick, a master teacher in his time, warned us that architects make a practice of setting up straw men and expecting praise for their ability to knock those men down.(2) The real depth of a work, he cautioned, was revealed by which straw men were selected in the first place. As we now teach the integration of technology and design, we rely on the work of influential designers to both challenge and inspire our students. If we are mindful of Professor Esherick, we must recognize that leading designers, in some measure, re-define the rules as the game proceeds. It has always been our responsibility to question the effect of this process on accepted building technique. Is it enough that our best architects draw inspiration from important themes of function without being accountable for the ultimate performance of those functions? If we examine the evidence of our recent past, we will have a measure of the challenge this simple question presents in our immediate future.

1. THE RAIN SCREEN PRINCIPLE

In the 1970's the aluminum curtain wall industry propagated a new technical concept, "the rain screen principle for pressure equalized wall design." Industry documents described the technical imperatives for water tight construction, particularly in their growing segment of the building market.(3) It was a very "teachable" concept, eagerly taken up by materials and construction faculty, this author among them. It is rare to find such a well articulated principle that leads us through the mass of fact and fiction in detailing a building assembly. Seminal articles extended the argument for rain screens beyond the curtain wall to show how they had been and could be realized in a full range of enclosure systems. The principle was summarized in what remains one of the most compelling diagrams in building science; a simple set of geometric relationships that the skillful designer could realize with limitless variations. (Figure 1) It was the kind of fundamental "truth" sought out by architects working within the legacy of modernism.

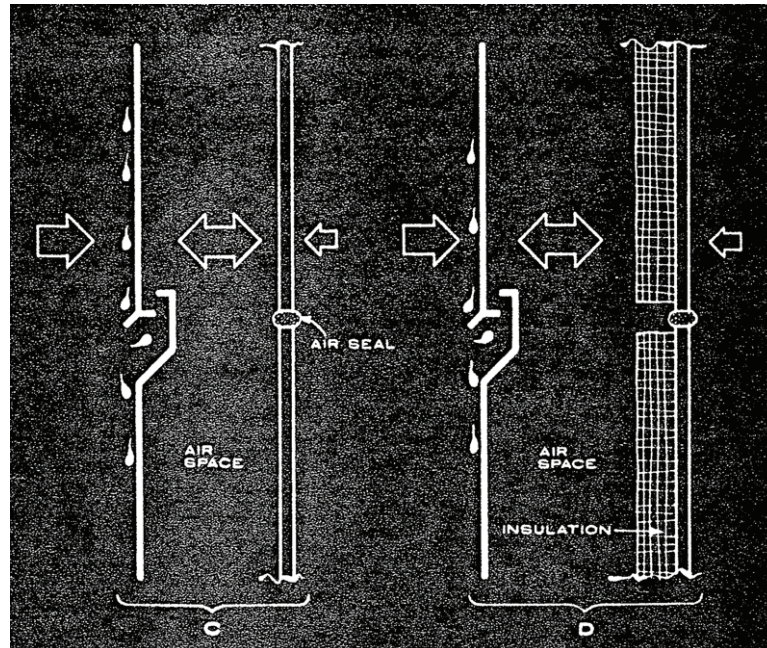

Figure 1: Diagram of the rain screen principle published by the AAMA in 1971.

Rain screen walls soon began to appear in architecture of the first rank. An outstanding early example was James Stirling's Neue Staatsgalerie in Stuttgart, that featured an open jointed system of thin stone slabs. The significance of the moment was not lost on Stirling who famously commented on it by "knocking" a hole in the wall of the parking level and leaving stones of traditional volume scattered around on the lawn. This conceit was in large part Stirling's sense of humor, but consistent with the exaggeration of material and detail in the Post-modern era. (Figure 2) Architects trained in modernism, indeed brutalism, were feeling their way back to traditional materials like stone. The rain screen wall was the answer to one of the difficult theoretical questions of the age: how does one make a facade with a rich masonry material and yet express the fact that it is no longer load bearing?

The rapid spread of open jointed masonry walls, especially in Europe, confirms the satisfaction architects found in this new theoretical position. But, what was their allegiance to the technical origins of the concept? The stone panels in Stuttgart have squared edges, a concession to economies of production, while the generic rain screen diagram demands a wash, overlap and drip at horizontal joints. By the time the building was fifteen years old extensive repairs were underway.(4) Dropped dowel fasteners bored into the edges of the stone were failing due to their weather exposure. Sealed joints, backed up by a drainage cavity would almost certainly have provided superior technical performance, but they would not have so vividly expressed the wall as a screen.

Perhaps the most accomplished champion of the screen wall has been Renzo Piano. The brick panels of the IRCAM project in Paris are sufficient example. Cored bricks are levitated around aluminum rods with the joints held open by plastic spacers. Here the wall panels also express a modern interest in rationalized production, although suspending brick in a steel frame and grillage cannot possibly be an economical strategy. (Figure 3)

At Piano's Rue de Meaux housing in Paris, terra cotta units were used as a screen in front of GFRC (glass-fiber-reinforced concrete) wall panels. The custom extrusions developed for the terra cotta at least permit a satisfying overlap of the horizontal joints, but the design is again not driven by true performance criteria. The rain screen of terra cotta protects the solid portions of the GFRC panels, areas that have no joints in the back-up wall and are the least likely to need protection. Meanwhile, the interfaces of panel to panel and panel to window are developed in a traditional manner. In both of these examples the rain screen has become the trigger for an aesthetic exploration that runs far beyond the functional basis of the idea. The ultimate objective is to re-introduce color, texture and scale to the building facade within a theoretical construct that gives comfort to the modern architect, but only marginally relates to actual building performance.



Figure 2: Solid blocks fall out of a rainscreen stone veneer. Neue Staatsgalerie, Stuttgart, Germany, 1988, James Stirling, Architect.



Figure 3: Cored bricks secured with plastic spacers on vertical rods. IRCAM, Paris, France, 1989. Renzo Piano Building Workshop.

2. MONO PIANO

At the same time as the early rain screen publicity, Renzo Piano first articulated a concept that he called "mono piano."⁽⁵⁾ The diagram called for an open, omni-directional layer of occupied space, served from above and below by all of the systems needed to condition that space. Below the floor was a plenum and

ductwork through which conditioned air was supplied. Above were independently expressed systems that controlled rainfall, humidity, the thermal gradient, daylight, solar gain and passive ventilation. (Figure 4) The roof surface was chosen for this elaborate development because it was only 1/5 of the exposed surface on any cube of space and these systems were understood to be too expensive to apply to the entire exterior. Each of the autonomous control systems required carefully formed components that were exposed to view, to the weather, or both. They were to be fit together as intricate layers of exquisite detail. The roof was the most demanding exposure, but it was also the one with the greatest potential contribution of daylight.

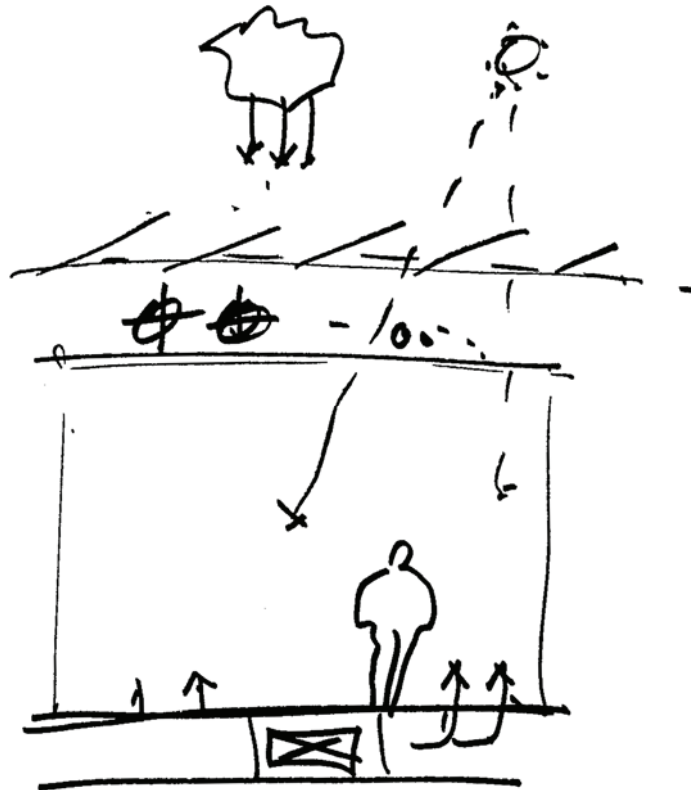

Figure 4: Summary of the "mono piano" concept drawn by Shunji Ishida, May 2005.

The thematic triggers in "mono piano" were once again technical, but over the years it has been the aesthetic content of this concept that has been refined and re-worked. The vehicle has been a series of truly poetic museum roofs in the United States and Europe. The building type is a good fit with the concept of a single layer of space exposed to the sky. The museum program justifies ambitious attention to environmental control and it provides considerable latitude in the ratio of cost to performance. These roofs are so beautiful it is almost heresy to ask if they actually work. However, the very heavy, final diffusing scrims above galleries at the Beyeler Foundation, in Basle, suggest that an overhead aperture with 100% of the plan area is not truly necessary.(6) Controlling this great expanse of glass is in fact solving a problem of one's own making, however masterfully it may be done.

A visible critique of the museum roofs is provided by Renzo Piano's own subsequent work. At the addition to the High Museum in Atlanta, conceptually simple boxes of space are perforated by literally 1000 skylights.(7) The economies of repetitive construction are applied to finely tuned units that simply plug-in to the site construction. Does this not make more sense, fundamentally, than what must have been the painstaking assembly of the earlier systems?

Renzo Piano's roofs are important historically because they pre-figure the next stylistic explosion to be triggered by a shared theme of function. If the roof assemblies are rotated 90 degrees, they become wall sections in a double skin facade. Surely if we can develop interactive layers of control that face straight up into the falling rain, applying them to the wall plane should be an easy win. Indeed, for Piano's veteran staff, their use of the double skin has not been an independent idea, but a logical evolution from their previous constructs.(8)

3. THE DOUBLE SKIN FACADE

Like the rain screen wall before it, the double skin facade also has a compelling diagram. Dramatic red and blue arrows trace the ventilation path through which heat gains in the facade cavity are returned to the exterior. The winter diagram suggests how controlled amounts of preheated air can be admitted to the interior. Again like the rain screen, double facades have a long history in vernacular forms: the box window, the storm glazing panel and the glass enclosed loggia. The concepts are simple, although the execution is not.

Architects who champion the double skin travel down a theoretical path that we should recognize, given the precedent of the rain screen. Certainly there are projects that have been very carefully studied both before and after construction.(9) (Figure 5) On the other hand, there are projects for which the double skin concepts have been a catalyst, but the ultimate goal has been an aesthetic expression that responds to many more factors than the quantitative performance.(10) (Figure 6) Like the rain screen, the double skin offers a solution to the ongoing theoretical challenge, developing an appropriate and contemporary building facade, free of previous stylistic associations. In addition to the production modules, overlapping layers and filtering screens that continue to fascinate designers, there is now a dynamic aspect to the composition, with vent flaps, louvers and operable shades that animate the facade. Taken to the extreme, the all glass facade becomes a self-adapting machine that can be deployed in any compass direction and across the face of any program configuration. Architects seem to have developed a crisis of confidence about the composition of the figure/ground, solid and void in the building elevation. They deeply fear over worked formulas or flimsy historical references. The dynamic, all glass facade completely eliminates the conflict.



Figure 5: A well integrated double facade that supplements the performance of a building with: a shallow floor plate, concrete mass, radiant cooling, ground water wells, displacement ventilation, and an earth tube. Münchner Tor, Munich, Germany, 2003. Allmann, Sattler, Wappner.

Double facades once again manifest the tension between function and the appearance of function, but the stakes have been raised. The systems themselves can be very expensive, and they are so complex that in many cases we will never know if they are truly effective. If the goals are energy and resource conservation, it is not enough to ask if the double facade works as designed. We must also ask how much energy could have been saved if the same material resources were applied through a different strategy. The rain screen wall is a discreet system, with costs and benefits that can be isolated. By contrast, a well developed double skin application interacts with virtually every other system in the building. Tallied below are design parameters that surfaced in a relatively brief discussion with Andrew Hall and his colleagues, sitting around a table at Arup Facade Engineering in London.(11)

Hard Costs:

- Building Structure: spanning system, thermal mass, aspect ratio.
- Facade Construction: leaves, layers, glass types, components.
- Mechanical system: plant size, ductwork, control systems.

Soft Costs:

- Energy: heating, cooling, lighting.
- Operation: control, maintenance, repair.
- Development: cost of capital, response to regulatory constraints.

Human Impacts:

- Thermal comfort
- Acoustic benefits
- Quality of light
- Access to fresh air
- Responsiveness to the user
- Imposed burdens of system control

Ecological Impacts:

- Sources of required materials.
- Risks in the fabrication process.
- Potential for re-use of materials and components.
- Carbon equivalent.

How often can we expect the building design team to have the patience and the skill to sift through all these factors to find a solution that is truly optimal. Is it in the nature of architects to do this? Is it not more likely that architects will filter the evidence through a series of a-priori assumptions? The double facade with 100% glazing is very fashionable at the moment. It is a choice that may be justified in terms of the optimal penetration of daylight into a deep plan. Large, unobstructed floor plates are commonplace in American building, and they are economically framed in steel. Without thermal storage capacity in the structural mass, the building may not be able to tolerate the heat gains that come along with the admission of daylight. To control those gains at the building enclosure a double skin may be indicated, leading neatly to the conclusion that the team wanted in the first place.

This admittedly simplified example demonstrates that the sequence of decisions may seem convincing, but if we challenge any of the assumptions within it, the conclusions could be entirely different. A shallow floor plate, built with a high mass structural system may require a much smaller glazing area and be able to tolerate the thermal gains until night ventilation can be applied at a much lower cost than a double skin. Even as the surface area of the building goes up, the actual cost of the skin could go down once the cost of operation and maintenance are considered. A retrospective case study of such a building has to penetrate very deeply into the design process to assess how much the architect was driven by function or fashion at each fork in the road.



Figure 6: The double facade as icon. With a teardrop shape in plan, much of the outer glass leaf has no occupied space behind it. Landesbank Baden Wurtemberg, Haus 5+6, Stuttgart, Germany, 2004. Wohn Mieslinger Architekten.

4. GREEN BUILDING

A recent issue of The Architectural Review includes a social housing project in France that is wrapped in a grillage of small diameter chestnut poles, held together with twisted wire.(12) The editors refer to the project as a "rustic rainscreen," although it is probably the farthest thing yet from a truly weather resistant building skin born of that principle. It is playful, probably not very expensive and perhaps quite harmless. Nevertheless, it is a marker along the meandering journey of fashion in design. Loose reference to function has been taken to its illogical limit. If we are serious about green architecture, we have to hold building technique to a higher standard. Through the evolution of the rain screen and the double skin we have seen that architects will trade principles for poetic references. This is our history. Can we afford, once more, to repeat it?

Green buildings can be orders of magnitude more complex than even the double skin facade. Good solutions again require the cooperative integration of virtually every system in the building. In addition, they require thoughtful attention to the entire delivery system. We must recognize the impacts of our design preferences from the sourcing of material all the way through to the daily experience of the occupants. Given this complexity, there will be errors along the way. If we are to learn from each other, we must frankly disclose our design motivations and honestly report our results. We cannot leave it to engineers and forensic scientists to debunk the myths propagated in the "design community."

The green building movement is unprecedented in the history of architecture. Never before has a set of ideals so deeply penetrated the building market in so short a period of time. Regardless of their reasons, there are an enormous number of people who want green buildings, and they want us to deliver them. Given the threat of permanent climate change, the risks are too high to wander off point. We have been challenged to make buildings that are both interesting *and* effective. Contrary to our own history, we must discipline ourselves to find poetics in *real* performance.

END NOTES

1. Gary Moyer, personal interview, December 2006. University of Oregon professor Moyer is a student and scholar of Louis I. Kahn.
2. Joseph Esherick, public lecture at the University of Oregon, May 1988.
3. "The Rain Screen Principle and Pressure Equalized Wall Design," Aluminum Curtain Walls, Chicago, Illinois: Architectural Aluminum Manufacturers Association, February, 1971.
4. Stuttgart, Germany, site visit by the author, July, 1990.
5. Shunji Ishida, personal interview, May, 2005. Renzo Piano Building Workshop, Vesima, Italy.
6. Basle, Switzerland, site visit by the author, May, 2005.
7. Mark Carroll, personal interview, May, 2005. Renzo Piano Building Workshop, Vesima, Italy.
8. Shunji Ishida, May, 2005.
9. Lee, Eleanor and Lawrence Berkeley National Laboratory. "High Performance Commercial Building Facades." Public Interest Energy Research Program: CEC 500-2006-052-AT15. Sacramento: California Energy Commission, 2006.
10. Corner, Donald. "All That Glass? Is there an appropriate future for double skin façades?" Journal of Building Enclosure Design, Washington, DC: NIBBS/BETEC, Summer 2006, 19-24.
11. Andrew Hall and Mikkel Kragh, roundtable discussion, April, 2005. Arup Facade Engineering, London, England.
12. "Rustic Rainscreen," The Architectural Review [London], November, 2006, 63-65.

What's On Your Mind, What's in Your Heart?

An Exploration on Our Perceived Environment

Missa Aloisi

University of Oregon, Eugene, Oregon

ABSTRACT: This paper reevaluates the current practices and valuation processes for sustainable design by examining the definition of what constitutes sustainable in relation to the metaphor of a building as person. This metaphor allows the reader to find a deeper meaning of sustainability behind its surface expression. The underlying goal is to explore a more humane approach to sustainability that goes beyond the surface of ourselves and our profession and develop a new, multidiscipline approach that touches our cores.

Keywords: human context, philosophy, theory or sustainability

INTRODUCTION

Architecture is an embodiment of the unmeasurable" ...architecture is an expression of man's institutions. These institutions stem from the 'beginning' when man came to realize his 'desires' or 'inspirations'. The main inspirations are those to learn, to live, to work, to meet, to question, and to express. (Norburg-Schulz: 31)

Sustainability is more than skin deep; it goes beyond the surface, into the intentions of a place. How do we find the vocabulary for this deeper meaning and how do we apply them to the architectural practice? The use words through metaphors allow us to jump out of the confining boxes of our individual professions and cross into other disciplines in order to create a common language and a collective understanding of our built environment that embodies sustainability.

SELF

Our minds and our hearts have created an undesired separation through our consciousness, when in fact one does not exist with out the other. We say, "what's on your mind? What's in your heart?" as if one is on the outside and can be touched and understood, while the other is on the inside unable to be rationally defined. The word sustainability in the field of architecture acts like the mind and heart; it's the façade and the sweat from the guts inside that face, and the unresolved between the two. However in our culture, sustainability has become merely an object that has become constrained through our society and placed upon hierarchical evaluation systems. By placing a value upon its every dissection we will never allow sustainability to actually achieve its greatest intentions.

As conscious humans we grapple with finding the most accurate descriptions to express how we understand the world around us. These descriptions come from our language and the way our culture has evolved its use of it. Language has become our direct link to the rational world. As aware humans we attempt to understand these descriptions through our senses. When we see the sunrise and the colors and textures make us breathless we know that this is beautiful even though its creation remains a mystery. When we perceive the world through this

process of our senses, perceptions and language, it influences how we as individuals express ourselves and create the environment around us. This circular process has no ending. It is about the journey. The more fused this encircling becomes the more we begin to really see. Only through the process of releasing the constraints of our world inside and out do we really see.

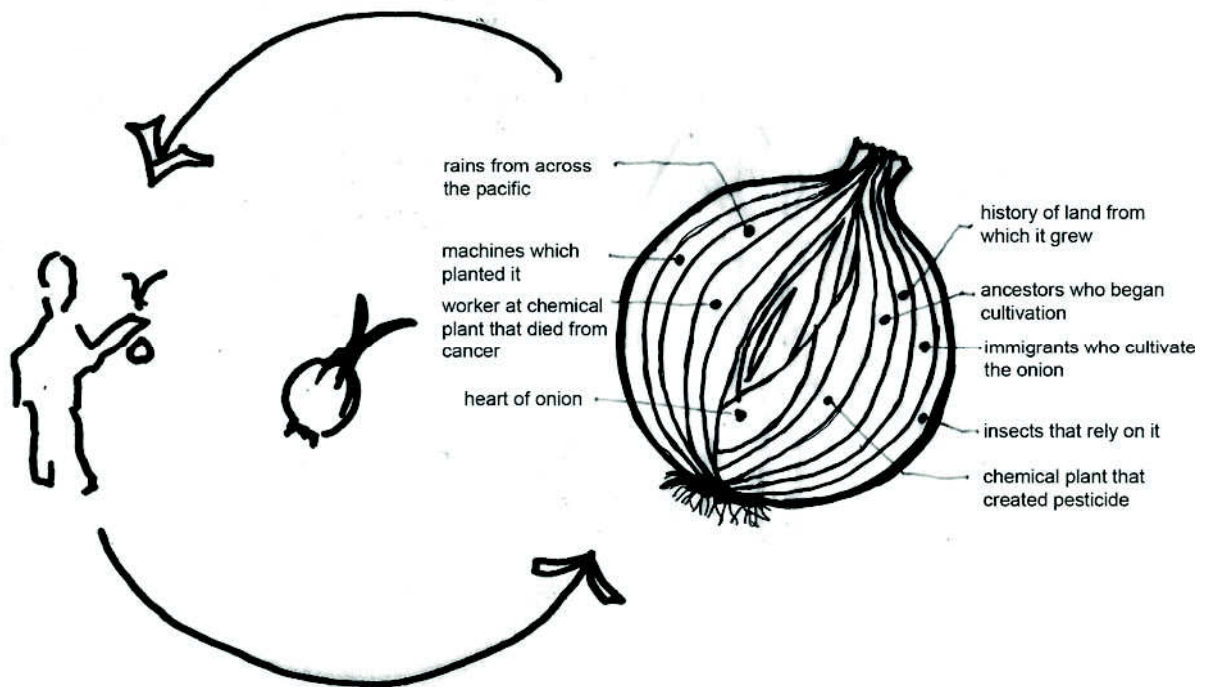

Figure 1: Intentions within the layers

Our minds and hearts are the property of the self; however in our society we define great minds or great hearts as something meaningful. Is this meaningfulness a creation from the individual or the collective whole? Can the body intervene with these definitions to enable us to make a difference in our own lives as a collective whole?

the social meanings which are attached to particular bodily forms and performances tend to become internalized and exert powerful influence on an individual's sense of self and feelings of inner worth.

(Schilling: 73)

The things that reside in our core are hard to put to words but they make up who we are. These inner values that come from our heart and our guts are impossible to quantify, and it would do harm to try -- who would want to place a limit on love? So the question becomes, is our outward expression of values (our rationalization / mind) acceptable to put into categories, quantify and qualify when in fact they stem from our root and are also part of our very being?

Values ebb and flow, they become priorities and then slip into the background again. Being a part of a western culture it is hard to decipher if the uses of these values are natural or if rather they have been taught to us as a way to dominate us as a population or as individuals.

in a culture where money is the measure of value, where it is believed that everything and everybody can be bought, it is difficult to sustain different values. (Hooks:47)

Values are entirely individualized; so how can we as a culture even try to place them on a hierarchical system?

the more people attach value to how we look and what we do with our bodies, the greater are the pressures for people's self-identities to become wrapped up with their bodies...increased individualization of our bodies is important, however the conflicts which used to occur between bodies have now moved within embodied individuals as a result of the rising demands of affect control. This situation tends to leave us alone with our bodies; investing more time and effort in their monitoring, control and appearance, and yet losing many of the sources of satisfaction we once gained from them. (Schilling: 110)

BUILDING AS SELF

Sustainability is a value and comes from within us; it lies on our skin and pumps through every vein. No one individual or system can define it for you. Living within a capitalist culture we have been influenced by the use of language around us. Often times our society misuses language in order to create a reaction from us instead of encouraging us to be more proactive. By doing so our culture has attempted to define the world around us, for us.

If body (architecture) is not a 'being' but a variable boundary, a surface whose permeability is politically regulated, a signifying practice within a cultural field of gender (sustainable) hierarchy and compulsory heterosexuality, then what language is left for understanding the corporeal enactment, gender (sustainability), that constitutes its 'interior' signification on its surface? (Rendell: 96)

Gender "like sustainability" is a social construct and it is not a tangible thing; it shifts over borders and boundaries into something deeper. It is the liminal; the threshold, the movement from one state to another, and it is within this place that we have the potential to be most alive and most aware. Confining the definition to an applied material can harm its intentions.

Capitalist societies control our built environment and are driven by the current economic system. The guts / heart become the shady region of our beings, whether it is within us or the layers within our built environment and is it then natural to try to quantify things we don't even have a vocabulary for?

we can still be moved deeply by buildings yet have no adequate terms to deal with the fact. We are normally very disinclined to talk about this in the same way that we find a verbal account of sexual attraction to be hopelessly inadequate. (Wilson: 3)

Can we reach a collective consensus for how we define our environment? Do we have senses that go beyond our rational capitalist thought (mind) that go directly to our cores (heart / gut); can these senses also help us define the world and influence our perceptions and built environment? Even better yet can they help us become aware of our own pre-conceived perceptions that society has determined for us and can they dissect the layers of social thought in order for us to really-see?

SUSTAINING OURSELVES

You do not 'create' or 'set' core ideology. You discover core ideology. It is not derived by looking to the external environment; you get it by looking inside. It has to be authentic. You can't fake an ideology." (Abrhams: 97)

With the creation of LEED our government has placed a value on the word sustainable, as if it is something that can be qualified or quantified uniformly over our entire population. This regulation can and is destructive and prohibitive to our culture and limits how we as individuals can express ourselves through the built environment. Depending on how much the building conforms to these regulations the higher the tax incentives the government rewards the project with for adhering to their values.

In buildings, high performance is better than low performance, but why rather than looking at performance why don't we look at the need to perform? As individuals we value what's in our core even more than what is on the outside, so why is this not also recognized and admired in the built world?

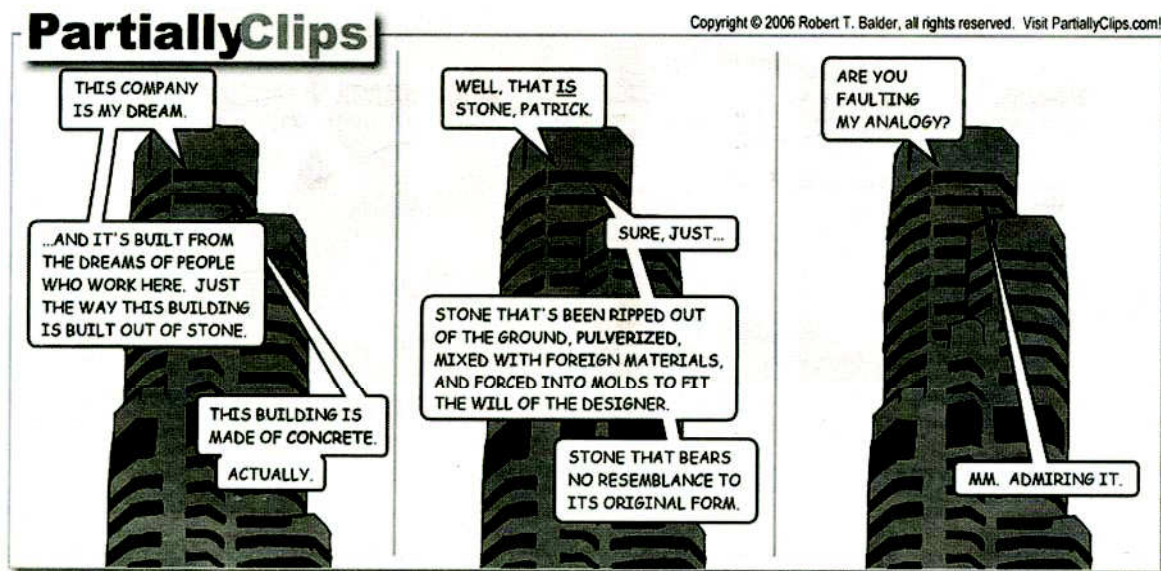

Figure 2. Cartoon depicting language use. (Source: Partiallyclips.com, used with permission by Rob Balder)

Social relations, inequalities and oppression are manifest not simply in the form of differential access to economic, educational or cultural resources but are embodied. (Schilling: 109)

When I look at great buildings which society has told me are sustainable, I ask myself what these buildings embody or more importantly what are their intentions? The buildings become a form of green expressionism or 'green washing': made up of quantifiable parts the green roof, the high reflective glass, the solar panels, etc. These quantifiable parts give the appearance of what our culture has defined as sustainable design, yet what are the things that go beyond the surface and can they have equal value? Within the core of a building are its values. This worth is not quantifiable given the limited vocabulary of our senses; however, it's within, that we have the ability to learn most about ourselves and our culture. Most architectural movements have reflected the issues of the time, whereas modernity has yet to reflect the people.

It is not the rationalization that was wrong in the first (and now past) period of modern architecture: the wrongness lies in the fact that the rationalization has not gone deep enough. Alvar Aalto (Wilson:2)

Architects decide every last detail of a building and qualify those materials they are made up of to complete the whole. Architects and planners over regulate and interfere with every aspect of design because we are afraid of

our inner fears, our vulnerabilities. As part of a capitalist society we have been trained to do this because there is no trust. We don't believe that a contractor will actually put quality into a project because they simply care about their work and how they are influencing society. We cannot get a LEED point for insisting that the construction workers that build a building get treated fairly and equally in our society. However, by doing so we allow those workers to be of worth and they in return get what they need to sustain themselves and their families in a healthy way. Imagine if people became important rather than things or objects, and quality could exist on its' own because everyone would feel they are getting what they are worth, that ultimately they do have a voice in expressing themselves in our society. He who knows he has enough is rich. (Abrams: 95)

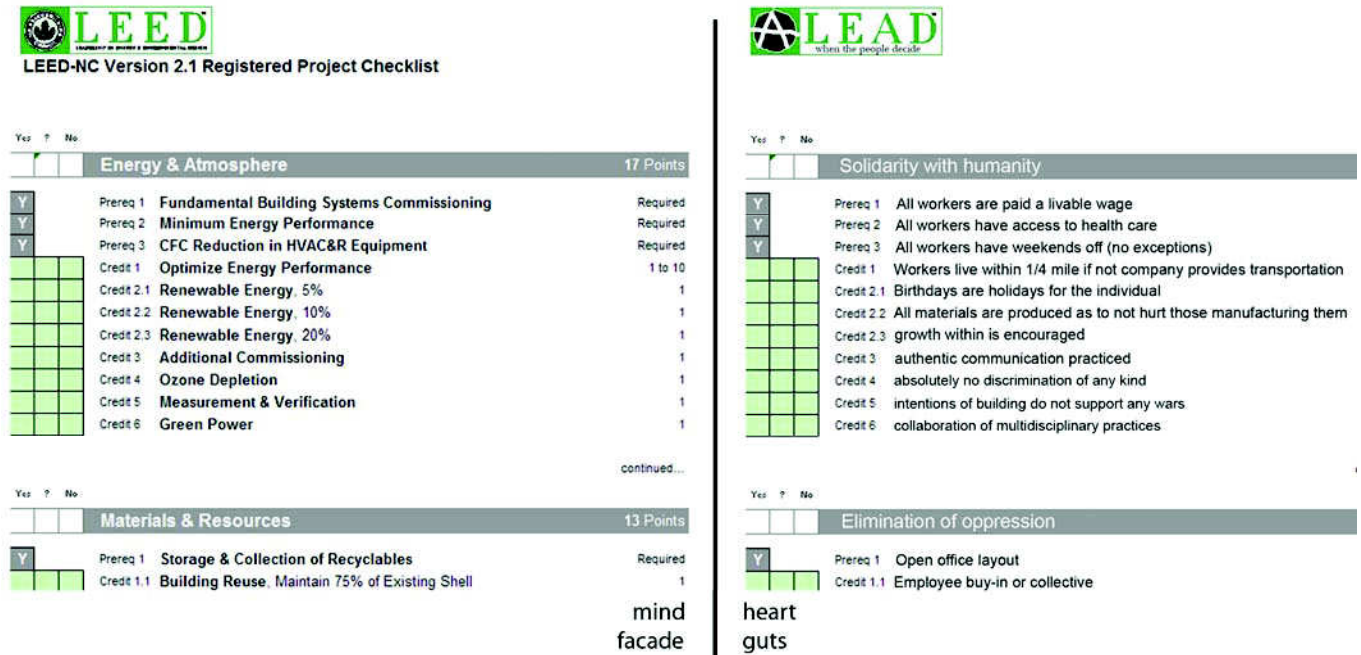

Figure 3: LEED re-defined to incorporate sustainability

PERCEPTIONS

The Ford Rouge Assembly in Michigan by William McDonough is thought to be a wonderful example of sustainable architecture. It is home to the largest green roof in the world and incorporates solar panels and state of the art 'green' technology. However, let's take a look beyond the surface to this building's intentions to sustain our culture. It is an assembly plant that manufactures Ford automobiles. To manufacture these vehicles the plant uses an exorbitant amount of resources such as, steel, oil, and water. I can only assume that William's rationale for taking on such a project was to make an already negative thing in our society a better thing, although in his book *Cradle to Cradle* he uses the phrase for one of his chapters, "Why being less bad, is no good." Is this an ethical way to practice architecture? "I ask myself." If this building is 'sustainable' who it is supposed to sustain? In order to get to the final product, the ethical factor becomes how many people became ill while mining the iron, how many seals died from the last oil tanker spill, how many inner city children have been diagnosed with asthma because of inhaling larger amounts of automobile exhaust? These events are all part of the intentions of the building. To manufacture more vehicles means that we as a culture become more dependent on a depleting substance that we are now engaged in war over. Having more cars does not promote walkable cities where the

community has the opportunity to interact with one another. Is this now a sustainable building? It neglects the core of our beings and fails to reflect our culture and the progress we would like to achieve as a society.

Co-housing is another example of sustainable architecture. It attempts to bring people together as a collective whole where everyone has a voice in the decisions made of how to live in a sustained manner. Co-housing is usually comprised of several housing units, detached or attached, with community buildings where people can have shared meals and services. They are providing for themselves the services our communities currently neglect. So then what makes them different from current gated communities that have these same intentions? Is one more “sustainable” than the other? Just like McDonough has possibly rationalized that working for the Ford factory and applying a “green wash” to the surface is a sustainable way to practice architecture, co-housing has possibly also rationalized that isolating a community in order to grow its own food and live together collectively is a sustainable way to live. Co-housing, just as our current government has defined sustainable architecture, has become a series of applied “green washing” tactics to give the appearance that the built form is reflective of its inner core. Can developing on green land even be considered sustainable? If the intention is to conserve land then why don't co-housing groups buy land that they refuse to build on, along with some inner city brown field sites already neglected within the urban fabric? This approach would allow for land conservation and a sustained interaction between the already existing communities and has the potential to strengthen those connections so that all people can be sustained.

a way to learn the true meaning of community (is to) enact sharing of resources that would necessarily dismantle hierarchy and the difference. (Hooks:39)



Figure 4: Inner values: Core of self

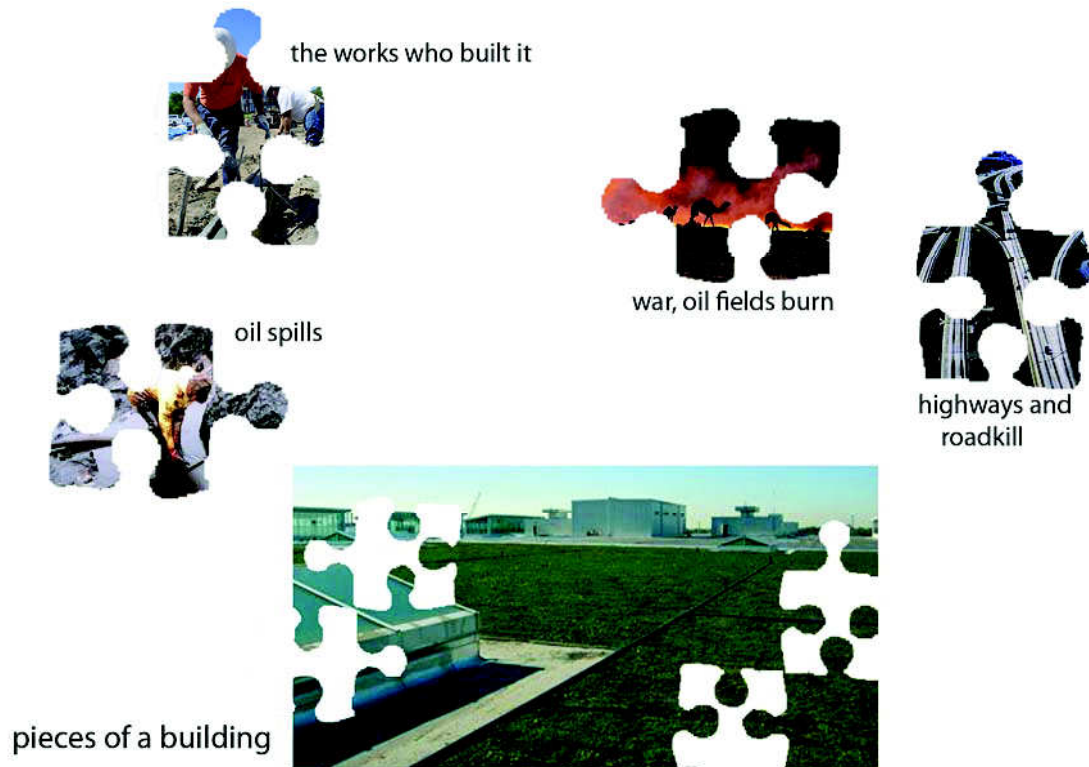

Figure 5: Inner values: Core of building

NEW APPROACHES

So the question becomes, how do we aspire to be in society? Do we wish to continue oppression and inequality or do we want to aspire to something more. If we can dissect the layers of self we can dissect the layers of a building, by doing so would not devalue the whole, but rather making the whole even clearer. As architects we are the mediators of these topics and can choose to address them or ignore them. If as a society we continue to not see the unseen, the things which are in our core then we will continue to decline, because no material, face, or façade can be sustained, we cannot regulate it, and if we did we would do harm to it and ourselves and never realize its fullest potential.

solidarity ...invites us to embrace an ethics of compassion and sharing that will renew a spirit of loving kindness and communion that can sustain and enable us to live in harmony with the whole world.

(Hooks: 49)

The practice of architecture needs to expand beyond its current boundaries to incorporate other fields of disciplines in order to be able to solve the design problems of today that truly touch the world in a sustainable manner.

ACKNOWLEDGEMENT

This document was adopted from a white paper developed for Professor Brook Muller at the University of Oregon, Sustainability theoretical undercurrents class, during the Spring term, 2006.

REFERENCES

- Abrams, John: *The Company we Keep: Reinventing small business for people, community and place*; Chelsea Green Publishing Company, 2005
- Hooks, Bell: *Where we Stand: Class Matters*; Routledge, 2000
- Noberg-Schulz, Christian: *Khan, Heidegger and the Language of Architecture*:
- McDonough, William; Braungart, Michael: *Cradle to Cradle: Remaking the Way We Make Things*; North Point Press: 2002
- Rendell, Jane; Penner, Barbara; Borden, Iain: *Gender Space Architecture, An Interdisciplinary Introduction*; Routledge: 2000
- Schilling, Chris: Second edition *The body and Social Theory*; SAGE Publications Ltd: 2003
- Wilson, Colin ST John: *Architectural Reflections, studies in the philosophy and practice of architecture*, Second Edition, Manchester University Press: 2000

Figure 3: LEED Checklist, <http://www.stanford.edu/class/cee243/LEEDchecklist.pdf>.

Figure 5: Inner values of building:

Oil fields burning: http://www.nationalgeographic.com/ngm/100best/images/storyD_main.jpg 4/12/06

Ford Rouge factory: www.ratical.org/co-globalize/images/giveback3.jpg

Construction workers: www.dailynews.com/.../jh12ma04-DLG-construc.jpg

EXPO 2005 – Nature’s Wisdom: An Ecological Pedagogy for Sustainable Transformation

Michael Zaretsky, Architect, LEED AP

University of Cincinnati, Cincinnati, Ohio

ABSTRACT: In Spring 2005, Expo 2005 opened in the Aichi Province of Japan. The theme of Nature’s Wisdom was recognized in a plethora of differing architectural expressions. The United States decided upon a rectangular box construction with a digital façade of a billowing American flag and Nature’s Wisdom as represented by a person dressed as Benjamin Franklin presenting the discovery of electricity.

My response to the chosen symbolism of this expression of Nature’s Wisdom in a global context was the impetus for a design studio at the Savannah College of Art and Design in Spring 2005. This studio was the test-bed for an approach to teaching ecological consciousness and testing the potential to improve design creativity and quality through a deeper understanding of ecological systems.

This paper describes the Nature’s Wisdom studio and an ecological systems process. It then asks if and how design educators might incorporate the study of ecological systems as a basis for conceptual design development.

Keywords: Eco-system, Pedagogy, Design Studio

INTRODUCTION

Expo 2005 offers to the people of the world an opportunity to come together and discuss the many global issues that face humankind. It is a place to bring together the world’s talent to create a model community for the future where humans can live in harmony with nature.¹

In Spring 2005, Expo 2005 opened in the Aichi Province of Japan. The theme of Nature’s Wisdom was recognized in a plethora of differing architectural expressions. The United States decided upon a rectangular box construction with a digital façade of a billowing American flag and Nature’s Wisdom as represented by a person dressed as Benjamin Franklin presenting the discovery of electricity.

My response to the chosen symbolism of this expression of Nature’s Wisdom in a global context was the impetus for a design studio at the Savannah College of Art and Design in Spring 2005. This studio was the test-bed for an approach to addressing the apparent lack of ecological consciousness in the existing American Pavilion and testing the potential to improve design creativity and quality through a deeper understanding of ecological systems.

This paper describes the Nature’s Wisdom studio and an attempt to directly incorporate an ecological systems process in design studio. It then asks if and how design educators might incorporate the study of ecological systems as a basis for conceptual design development. Typically, environmental and ecological curricula are distinct from architectural design studio. What I am addressing in this paper is an approach to applying ecological principles within the design process. I am not claiming that it was wholly successful, but it may offer a starting point for design educators.

As a student and educator, I have found that required classes on the environment in architecture education rarely have a direct affect on studio designwork.² While there has been an extensive amount of writing devoted to ecology and design in general, there has been little written about incorporating ecological principles in the design process. One of the most often-quoted authors on design education is David W. Orr, director of Environmental Studies at Oberlin University. His writing is unquestionably inspirational and informed, but he is not teaching in a design studio. The only text that I found that addressed the incorporation of these principles within the design process is a book devoted to landscape architecture entitled *Ecology and Design: Frameworks for Learning*. The authors clearly differentiate between ecology as a “framework for understanding” versus ecology as a science.

While I am seeking applications of ecology as a framework for understanding, they state that in this text, they are referring to the science of ecology,ⁱⁱⁱ I am seeking pedagogical approaches to embedding an inquisitive exploration of ecology deeply within the instinctual design response of students.

I was influenced by theories that Janine Benyus addressed in *Biomimicry* which she defined as – “a new science that studies nature’s models and then imitates or takes inspiration from these designs and processes to solve human problems.”^{iv} While the principles of biomimicry have much to offer, the examples have been largely technological as opposed to conceptual or pedagogical. I attended a Benyus lecture at Greenbuid 2005 which addressed the potential of collaborations between biology and other sciences as tools for answering design challenges. She discussed the importance of incorporating scientists within the design process from its inception, but clearly stated that she is a scientist, not a design studio professor. I completely agree with the need for collaboration, but also encourage design students to see the inherent potential of ecologically inspired design within their own process.

William McDonough and Michael Braungart’s influential text *Cradle To Cradle* is required reading for students of ecological design, but in my experience, it influences students’ material choices more than their conceptual design process. While their consideration of the lifecycle of the cherry tree refers to an ecosystem, it is less about the precedence of the ecosystem in design than it is about the beauty of the cherry blossoms.^v

I recognize how critical the collaboration of scientists, ecologists, landscape architects, planners, engineers and others are to a truly holistic ecological design process. As a professor of architecture, I see myself as a mediator between an overwhelming amount of critical information and young students eager to focus on design while “getting through” the other required course material.

EXPO 2005 – Nature’s Wisdom

Thanks to rapid technological development, the 20th Century was characterized by mass-production and mass-consumption, which in turn led to material improvements in our daily lives. At the same time, these trends resulted in various global issues such as desertification, global warming, and a shortage of natural resources. As these issues cannot be resolved by any one nation, the international community needs to unite in confronting them: we must come together and share our experience and wisdom, in order to create a new direction for humanity which is both sustainable and harmonious with nature.^{vi}

The quote listed above represents the vision set forth by the Japan Association for the 2005 World Exposition. The intentions of the Expo were impressive. Their “Ecological Declaration” included the following six factors:

1. Implementation of Conservation Measures identified in the Environmental Impact Assessment Report
2. Development of Site Planning with Environmental Consideration
3. Introduction of Advanced Technology Promoting an Eco-community
4. Introduction of the 3Rs (Reduce, Reuse, Recycle)
5. Promotion of Transportation with Minimal Environmental Impact
6. Providing Enjoyable Educational Opportunities through Events and Exhibitions



Anyone who has any sense of environmental consciousness can appreciate the vision set forth by the developers of EXPO 2005. The recognition that we must address environmental issues on a global context is something that had already been addressed in the Kyoto Protocol of 1997 in which 160 countries committed to mandate change that would result in a decrease in greenhouse gas emissions. The United States didn’t sign the Kyoto Protocol and the design decisions expressed in the American Pavilion seemed to ignore a response to “Nature’s Wisdom”.

The participation of the U.S. in Expo 2005 was largely political. The U.S. did not participate in Expo 2000 in Hanover, Germany and that is often listed as one of the reasons why it was financially unsuccessful. In 2003, President Bush promised Prime Minister Koizumi of Japan that the U.S. would be present at Expo 2005. They signed a contract on July 29, 2004 that guaranteed the presence of the U.S. with the support of private corporate funding. This left less than nine

Fig. 01 The American Pavilion at Expo 2005, Aichi, Japan

months to design, fabricate and build the American Pavilion.^{vii}

I learned of the foreshortened design timeline when I met with the pavilion designer Bud Holloman in April 2005. He runs a small firm in Jackson, Mississippi that had previously completed only small projects. They were awarded the commission because they had previously worked with the exhibit designers BRC Imagination Arts, Inc. There was no precedent in Holloman Architects or BRC Imagination Arts for any projects remotely devoted to "Nature's Wisdom."

The United States Pavilion was designed for goals that seem to have a tenuous relationship to "Nature's Wisdom."

The U.S. participation at EXPO 2005 showcases the dynamism and creativity of America and highlights our core national values--hope, optimism, enterprise and freedom.^{viii}

The response to the clearly stated objectives of Nature's Wisdom is found in one of the five exhibit spaces – The Franklin Spirit, as described here -

The main show in the U.S. Pavilion is The Franklin Spirit, a multi-media presentation that celebrates the EXPO theme of Nature's Wisdom with a visit from Benjamin Franklin on the eve of his 300th birthday. Few Americans have understood, captured and shared Nature's Wisdom with more success than the great U.S. statesman and founding father Benjamin Franklin. His studious observation of nature led to numerous life-changing innovations, most notably the harnessing of electricity through his experiments with lightning.

The Franklin Spirit reflects the uniquely American perspective of Benjamin Franklin. With a sense of wonderment, he leads Pavilion visitors through the technical, social and agricultural advances that have taken place since the 1700s. He acknowledges that the 21st century is an exciting time to be alive as he looks into the future, predicting advances that will improve the lives of people worldwide.^{ix}

In contrast to the United States, some countries responded with pavilions that engaged the concept of nature's wisdom as expressed within their culture. For example, Germany's pavilion brief states,

The theme of Expo 2005 - "Nature's Wisdom" - is to stimulate us to explore the principles of nature, and to respect and integrate these in our daily life. For continued development of harmony between nature and technology, it is necessary that we interpret natural phenomena not as contrary to technology, but rather as its foundation and source of inspiration. With the help of "bionics" - the theory of using technical applications of natural principles - Germany presents itself at Expo 2005 as a country of technological competence, innovative achievements and intensive research work, and illustrates how important and at the same time exciting the attempt to preserve our civilisation's harmony with nature can be.^x



Fig. 02 Expo 2005 German Pavilion



Fig. 03 Expo 2005 UK Pavilion

The Pavilion of the United Kingdom was entitled "Planet of Blessing and Budding." Their approach was unique -

Half the pavilion area is occupied by a woodland garden, including 40 lime trees and various familiar flowers that adorn the British seasons, such as daffodils, bluebells, foxgloves and angelicas. Among the trees are seven molded works produced by nine contemporary British artists. While walking through the woodland, visitors can appreciate the colorful works of art, inspired by nature. Upon passing through the woodland, they arrive at the pavilion.^{xi}

THE ALTERNATIVE U.S. PAVILION

Based on a belief that the chosen American Expo 2005 design may not have been the most sensitive of responses to an international discussion on Nature's Wisdom, I proposed a studio at the Savannah College of Art and Design in which fourth year design students would spend one ten-week quarter investigating alternatives for the American Pavilion in Expo 2005.

A deep understanding of the nature and processes of ecological systems is an opportunity for students to learn about the unbelievable capacity and creativity of the laws of nature and thermodynamics. I saw a project based on "Nature's Wisdom" as an ideal opportunity to test the potential of an eco-system investigation as a conceptual design derivative for a design project. The goal was to help us understand the complexity and creativity of ecological systems with respect to all forms of energy used and all transformations of that energy and then apply that to the conceptual design process. Any conception of waste was to be challenged.

The scale-less aspect of ecological systems was a critical component of this design studio. As scientific evidence continues to prove, there is no question that the form and fluidity of natural systems transcends scale.^{xiii} Patterns of planetary movement can be found at all scales in nature. This is one aspect of eco-systems that all of the students attempted to address in their research.

The studio sought to inspire the students through individual investigation and articulation of an architectural expression of Nature's Wisdom as influenced by specific ecological systems. Students were asked to begin with research of an existing natural ecological system at any scale. These included everything from the growth pattern of a redwood tree, the lifecycle of a fire ant, the way that water is dealt with on the skin of a tree frog and others. Students had one full week to explore these systems and diagram all energy and food that was coming in and all that was coming out to understand where it came from and where it went. We were comparing these closed-loops of production to our own species' utilization of resources. The uniqueness of the human proliferation of waste took on a new context.

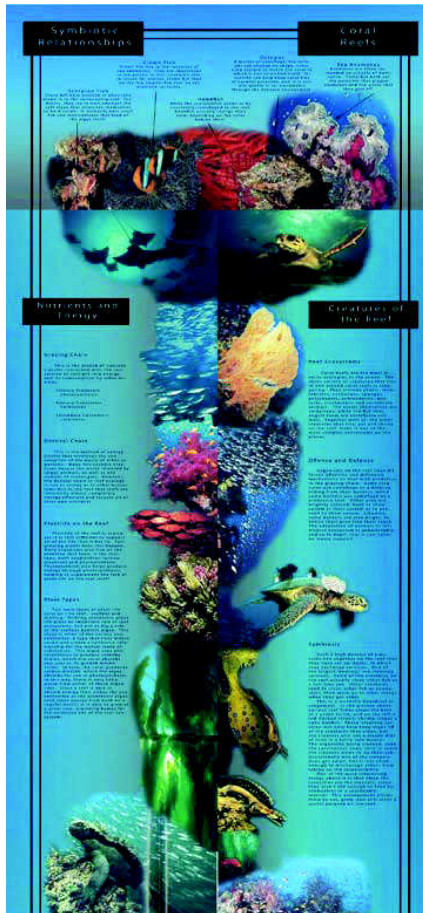

Fig. 04 Expo 2005 Matt Furedy

In the beginning of week two, there was a critique of the natural systems investigation and a discussion of these systems as precedents for design. The goal was a thorough set of diagrams that would transcend the specificity of the natural system and achieve a level of abstraction that could be translated to a design project at multiple scales.

The pre-design work included site and cultural analysis, precedent studies on previous Expositions as well as the architecture of United States and other significant pavilions. There was extensive programmatic and site analysis. The Expo 2005 layout concept placed countries in distinct regions called Global Commons in strategic locations in each commons. The U.S. pavilion was placed in Global Common 2 - "The Americas" at the far end of an oval shape with a police station directly in front of it and a steep slope behind it which had continuous police watch looking over the American pavilion.

The layers of complexity and learning opportunities to a project such as this are outstanding. Immediately apparent are issues of cultural difference, the perception of the United States in a global context, the expression of "Nature's Wisdom" by America, the history of Expo Pavilions, the challenge of designing without ever visiting the site, the challenge of designing in Japan (a country with whom the U.S. has a complex history) as well as many other factors. I wanted to limit the initial investigation to the architectural expression of Nature's Wisdom. The socio-political factors were addressed later in the quarter.

Our intention was to deepen the understanding of natural systems as a basis for design, though because of our 10-week quarter we had only one week for these investigations. At the end of the week, the students presented their work and the results were mixed. They included Matt Furedy (fig.04) who was investigating symbiotic relationships between forms of fish and animal life and the coral reef and Susan Dyer who was investigating the form of the coral reef as a

resultant of natural flows of water and air. Joe Sinclair developed an impressive investigation of the social structure of leafcutter ants. He then used this as a model for an ecological structure for his project. And Meghan Storm (fig.05) investigated the skin of the frog which, according to her, “colors, protects, breathes, moisturizes, protects, thermally regulates, and is a structural envelope.”

Anyone interested in sustainability is aware of the interconnectedness of natural systems. Investigating this process of eco-systems was inspirational and informative for all of us. However, the step of translating this to something meaningful for a designer was challenging. For Storm, it was only after schematic design explorations that she understood how to translate the permeability of the frog’s skin into a concept for a building’s skin. She did not look at the frog’s skin as a formal precedent, but instead translated the permeability of the layers into a project incorporating “the ideas of water circulation and osmosis for water collection through convective heat flow and condensation.” Her building design was an elegant monumental arch with a mobius strip pathway winding around it. She placed the porous skin on the interior of her arch where inhabitants could interact with the flows and pools of water.

Storm was a strong student before this studio. I can’t provide examples of her previous work, but the other projects of hers that I saw were all sensitive, simple, clear and graphically impressive. What shifted in this studio was a symbiosis of elegant form in a natural systemic context. In addition to the water cycle, the form evolved from a blade of grass and the mobius strip developed from an investigation of numerical patterns found in nature.

Fig. 05-08 Expo 2005 Meghan

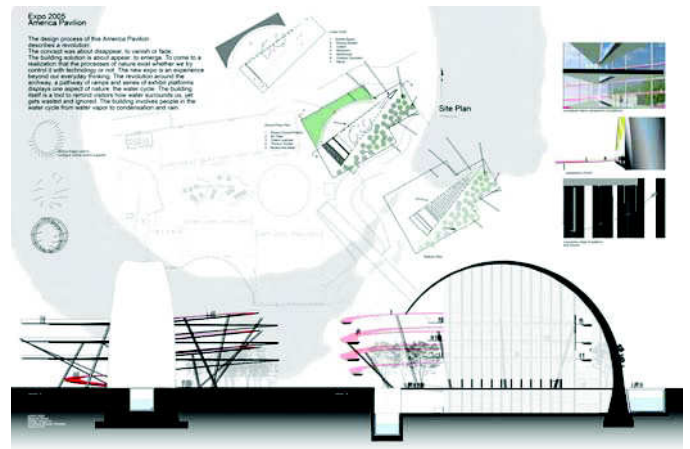
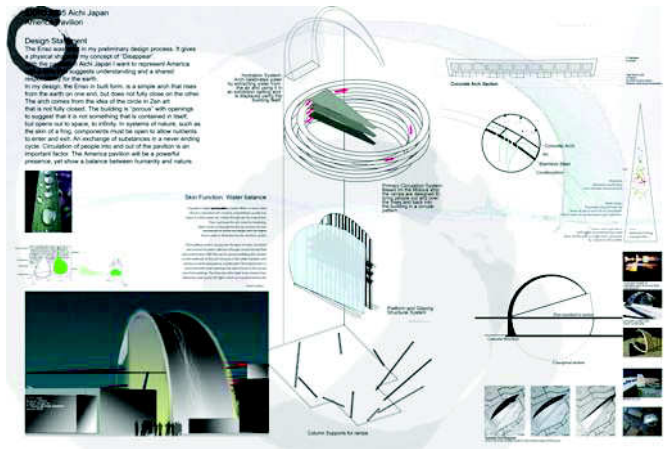
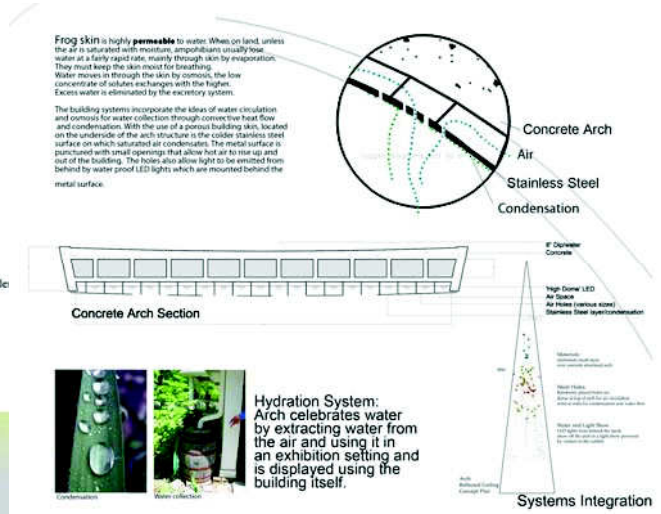
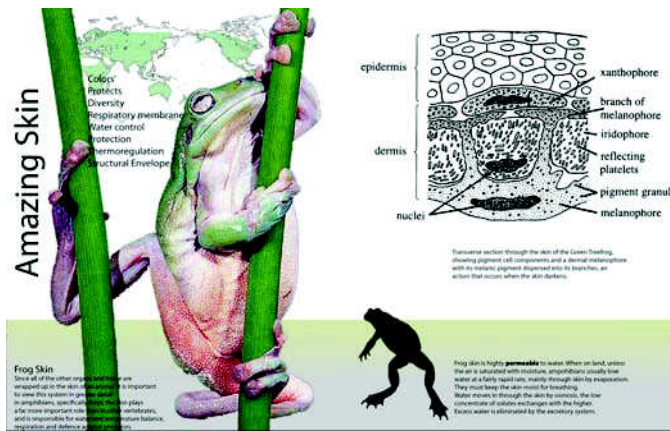

In my teaching, I ask students to translate all aspects of their design process into diagrammatic form. It is in an abstracted, scale-less diagram within which one can most clearly recognize design potential. Instead of abstractly diagramming the natural systems as requested, the students described them graphically (fig.04). Joe Sinclair's diagram of the social system of the leafcutter ants (fig.09-10) is one of the few attempts at diagramming the ecosystem. Though it was not a diagram of the comprehensive system, it was an abstraction that would lead to an organizational structure for his project. The full description of the social and nutritional structure of the leafcutter ants took four pages for Sinclair to describe, but he focused specifically on one diagram he found in a text. He abstracted this and explored sustainable strategies within this innovative structure.

The natural system exploration did encourage some innovative forms as well as investigations into the symbiotic nature of ecological systems. Sinclair's approach evolved from his investigation of the social structure of the ants. He decided that he needed to minimize his impact on the land and he derived the actual building form from the form of the leafcutter ant society.

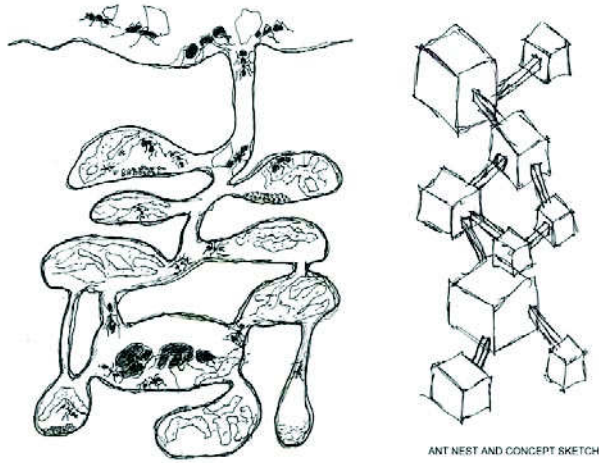

Fig. 09 Expo 2005 Joe Sinclair

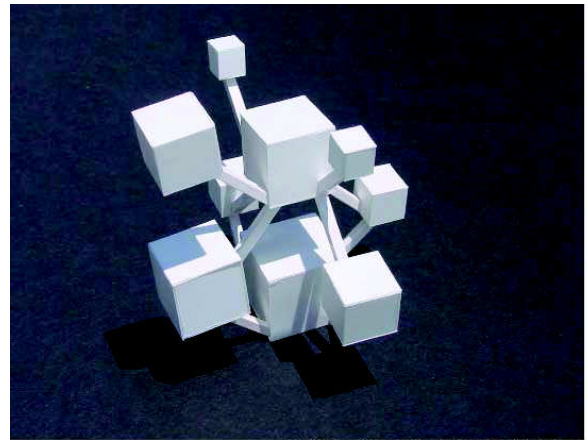

Fig. 10 Expo 2005 Joe Sinclair

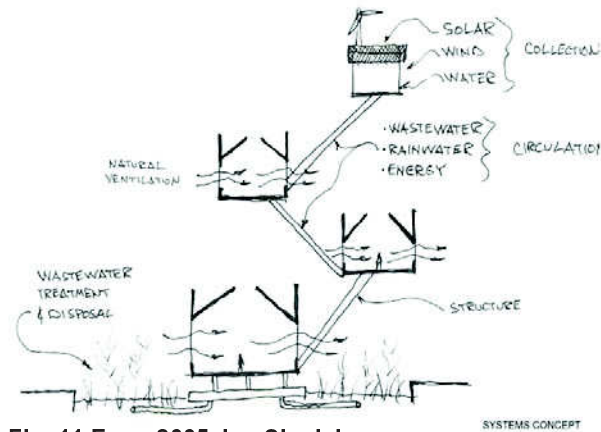

Fig. 11 Expo 2005 Joe Sinclair

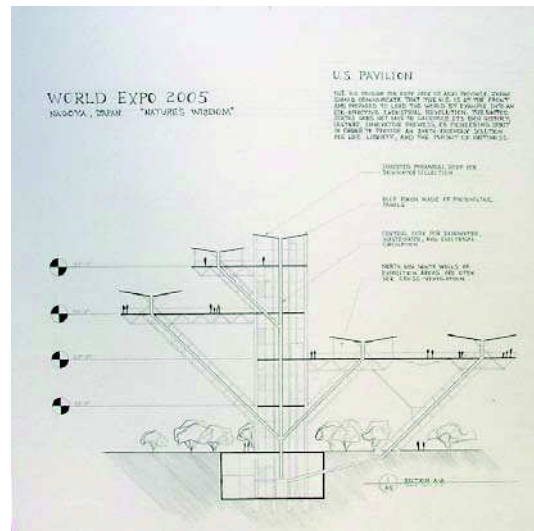

Fig. 12 Expo 2005 Joe Sinclair

ECOSYSTEMS AND SOCIOLOGY

Inherent within this studio program were many social and political struggles. As a studio, we addressed these issues, but more potently, we addressed the role of the designer in the social and political realm. The most intriguing design response from a socio-political perspective was Rebecca Morgan who developed a building-less design that was a pond with a translucent wall winding through it (fig.13). There were steps on each side representing each country at the Expo. When someone stepped on a stone and put their hand on the wall, they could hear a translation of whatever someone on the other side of the wall was saying. It was a poetic statement of what democracy and globalism could be. However, it was not specifically inspired by any natural systems.

Every design project has inherent social and political factors but a politically charged project offers exciting design challenges on its own grounds. Though socio-political aspects of design are often ignored by practice and educational systems, these factors couldn't be ignored in Expo 2005. Some students found a link between ecosystems and socio-political systems while others were overwhelmed by the multiplicity of design considerations. Given the realities of the design decision-making, I think design considerations beyond form need greater attention.

Addressing a design project with a previously defined systems model could go many ways. In this studio, what I discovered was that the creative and symbolic aspects of this design project could be vastly improved when a natural systems model was available.

FUTURE APPLICATIONS OF ECO-SYSTEMS APPLICATIONS

Taken to its logical conclusion, the goal of making all of our students ecologically literate would restore the idea that education is first and foremost a large conversation with technical aspects, not merely a technical subject.^{xiv}

As a designer and educator, I see my role as a creative problem solver seeking to help students become cognizant of their potential affect on the built world. With this studio, we introduced students to designs that have affects on the world that are fundamentally different from the water, energy and material depletion prevalent in our industries.

This studio was a first-step towards an application of ecological principles in the conceptual design process. Ideally, this class would include lectures from industrial ecologists, biologists, engineers and others. My hypothesis is that the deeper the understanding of ecological systems, the more inherently ecological principles will be ingrained into the design process of students in the future. I recognize that students are engaging with ecological systems in a manner that may be relatively cursory, but the hope is that this knowledge will inspire curiosity well beyond what is covered in ten weeks.

I believe that there is potential to address design problems well beyond the modernist formalism still coming out of many architecture schools. Cultural, social and economic issues all have the potential to be informed by a deep understanding of ecological principles.

There was mixed success amongst the students' abilities to abstract the ecological systems into meaningful conceptual design potential. One challenge was the need to remain sufficiently abstract that subjective association is minimized. Basically, some things were taken too literally. Some components of natural systems were directly translated into forms as opposed to being understood as fluid, evolving systems. As we saw in Storm's project, the investigation of a frog's skin led to a project in which water became both the energy source as well as the concept. In Sinclair's project, the different zones of an ant's habitat were literally transformed into zones of his project. Then, the different zones were assigned to address particular energy or water issues. A deeper understanding of the organization of the ant's habitat and processes might have led to a more abstract interpretation.

This is one approach to addressing the question, "How do we effectively teach ecological design?" I have found that the sun path diagrams and psychrometric charts are understood and incorporated in the design process by only a small percentage of architecture design students. The incorporation of ecological principles in the conceptual design process may offer one way of encouraging and developing applied systems thinking within the studio design process.



Fig. 13 Expo 2005 Rebecca Morgan

IMAGES

- Fig. 01 The American Pavilion Expo 2005 - <http://www.uspavilion.com/pavilion/index.htm>, dec.20, 2006.
Fig. 02 The German Pavilion Expo 2005 – from German Pavilion photobank - <http://koelnmesse.viabild.de/ixfiles/mandantlogin/koelnmesse/de/aktuelleexpo>, dec. 30, 2006
Fig. 03 The U.K. Pavilion Expo 2005 - <http://www.expo2005.or.jp/en/nations/4m.html>, dec. 21, 2006.
Fig. 04 Ecosystem investigation from Nature's Wisdom Expo 2005 studio – Matt Furedy
Fig. 05 Ecosystem investigation from Nature's Wisdom Expo 2005 studio – Meghan Storm
Fig. 06 Ecosystem investigation from Nature's Wisdom Expo 2005 studio – Meghan Storm
Fig. 07 Final Project from Nature's Wisdom Expo 2005 studio – Meghan Storm
Fig. 08 Final Project from Nature's Wisdom Expo 2005 studio – Meghan Storm
Fig. 09 Ecosystem investigation from Nature's Wisdom Expo 2005 studio – Joe Sinclair
Fig. 10 Ecosystem model from Nature's Wisdom Expo 2005 studio – Joe Sinclair
Fig. 11 Schematic sketch from Nature's Wisdom Expo 2005 studio – Joe Sinclair
Fig. 12 Final Project from Nature's Wisdom Expo 2005 studio – Joe Sinclair
Fig. 13 Final Project from Nature's Wisdom Expo 2005 studio – Rebecca Morgan

REFERENCES

- Associated Press, Partnership Briefing, www.uspavilion.com/pdf/partnership_briefing.pdf, dec. 6, 2006.
Benyus, Janine, *Biomimicry: Innovation Inspired by Nature*, Harper Perennial, 2002.
Constantine, David, *They Look Alike, But There's A Little Matter of Size*, New York Times, August 15, 2006.
Expo 2005 World Expo website, <http://www.expo2005.com/>, nov.10, 2006.
Japan Association for the 2005 World's Exposition, Message from Japan: "Nature's Wisdom", http://www.expo2005.or.jp/en/whatexpo/message_00.html, nov. 06, 2006.
Johnson, Bart and Kristina Hill, *Ecology and Design: Frameworks for Learning*, Island Press, 2002.
Kibert, Charles, et.al., *Construction Ecology: Nature as the Basis for Green Buildings*, Spon Press, 2002.
McDonough, William and Michael Braungart, *Cradle To Cradle: Remaking the Way We Make Things*, North Point Press, 2002.
Orr, David, "Ecoliteracy: The Learning Curve", Resurgence On-line magazine issue 226, <http://www.resurgence/issues/orr226.htm>, feb 17, 2007.
Van der Ryn, Sim and Stuart Cowan, *Ecological Design*, Island Press, 1996.
The U.S. Pavilion World Expo 2005 website, <http://www.uspavilion.com/pavilion/index.htm>, dec. 30, 2006.
Timpson, William M., et.al., *147 Practical Tips for Teaching Sustainability: Connecting the Environment, the Economy and Society*, Atwood Publishing, 2006.

ENDNOTES

- ⁱ Expo 2005 World Expo website, <http://www.expo2005.com/>, nov.10, 2006.
ⁱⁱ Some of the critical texts on ecology and design include McHarg, *Design With Nature*, van der Ryn, *Ecological Design*, Benyus, *Biomimicry*, McDonough and Braungert, *Cradle To Cradle*,
ⁱⁱⁱ Johnson, p.25, note 1.
^{iv} Benyus, *Biomimicry*, <http://www.biomimicry.net/intro.html>, dec.30, 2006.
^v McDonough, William and Michael Braungart, *Cradle To Cradle: Remaking the Way We Make Things*, pp.72-73
^{vi} Japan Association for the 2005 World's Exposition, Message from Japan: "Nature's Wisdom", http://www.expo2005.or.jp/en/whatexpo/message_00.html, nov. 06, 2006.
^{vii} Associated Press, Partnership Briefing, www.uspavilion.com/pdf/partnership_briefing.pdf, dec. 6, 2006.
^{viii} The U.S. Pavilion World Expo 2005 website, <http://www.uspavilion.com/pavilion/index.htm>, dec. 30, 2006.
^{ix} The U.S. Pavilion World Expo 2005 website, <http://www.uspavilion.com/expo/index.htm>, dec. 30, 2006.
^x Expo 2005, German Pavilion, <http://www.expo2005-deutschland.de/site/flash/index.php?lang=e>, dec. 30, 2006.
^{xi} Expo 2005, United Kingdom Pavilion, <http://www.expo2005.or.jp/en/nations/4m.html>, dec. 30, 2006.
^{xiii} Constantine, David, *They Look Alike, But There's A Little Matter of Size*, New York Times, August 15, 2006.
^{xiv} Orr, David, "Ecoliteracy: The Learning Curve", Resurgence On-line magazine issue 226, <http://www.resurgence/issues/orr226.htm>, feb 17, 2007.

In Poetic Association: Acts of Architecture in the Realm of Landscape Ecology

Brook Muller

University of Oregon, Eugene, OR

ABSTRACT: This paper describes metaphorical engagement of ecology as a strategy for designing human habitation catalyzed by and supportive of healthy urban ecosystems. A case is made for the importance and timeliness of collaboration and conceptual association between architects and landscape ecologists. Next, the Australian architect Richard Lepastrier's notion of architecture as "furnishing with particular purpose this larger room we are in" – suggestive of both the architect's role and the context of an architectural undertaking – is examined as a prototype for approaching problems of design in an environmentally sensitive manner. A pilot studio attempt to engage ecological issues through metaphor is described, and building from this experiment and Lepastrier's statement, a palette of "human act/environment" case study metaphors is offered for use in design. Lastly I offer a methodology for testing these metaphors in advanced architectural design studios and evaluating their influence on students' design thinking and the environmental responsiveness of projects that result.

Keywords: Architectural Design, Landscape Ecology, Metaphor

INTRODUCTION

While much research is underway to develop environmentally friendly building materials, advance energy performance and more efficiently "harvest" on site resources, and while flowing landscape-like forms captivate our collective imagination, architects' knowledge of principles of ecology and the site-specific ecological impacts of building interventions are limited. *What might rigorous engagement with the language of ecology, and more specifically landscape ecology, mean for architects?* Might we summon more encompassing portrayals of our activities, descriptions that better enable design professionals to realize projects that minimize damage and perhaps engage in beneficial relationships with surrounding ecosystems? Can a metaphorical appropriation of working concepts in landscape ecology such as "peninsular interdigitation," patch/matrix "breaks" and "edge/corridor effects" alter how we understand problems of architecture and encourage shifts in methodological tactics?¹ With continued pressure to develop remnant lands within and at the margins of our cities, can we envision a scenario where both architectural enterprise and ecological integrity are achievable?

In "revealing the importance of spatial patterning on the dynamics of interacting ecosystems," landscape ecology offers great relevance for architects.² Perhaps the most spatially oriented sub-discipline of ecology, landscape ecology embraces intervention, intentionality and design as a means of ensuring healthy, functional and diverse ecosystems. While landscape ecologists undertake projects in a multiplicity of ecosystems at many scales, involving public or private land holdings or both, the discipline finds itself increasingly contending with the Jeffersonian, democratic small scale lot. Joan Iverson Nassauer recognizes the critical importance of this trend,

"We must work at this democratic scale of ownership, the single lot or the single farm or ranch, to achieve ecological health beyond public lands and beyond the anomalies of privileged and enlightened land development. In the United States, where recent legal decisions have tended to narrowly interpret public interests in limiting private-property rights, and where strong cultural traditions favor the rights of landowners to do what they deem most suitable on their land, overall ecological health depends on the aggregation of innumerable individual landowner's decisions."³

With landscape ecologists increasingly concerned about environmental quality at the lot scale, even beginning to contemplate the impact of the building “footprint,” a growing number of architects seek to more sensitively apprehend larger landscape ecological processes that are influenced by the configuration of buildings, to address for example the morphological implications of architecture given the need to preserve wildlife corridors that may exist on a site, or repair a corridor previously fragmented. As regimes of thought between these disciplines converge, metaphors, “nomadic terms that link disparate discourses,” may be looked at as creative intellectual tools for extending ecological mediums into built form and built form into the landscape in a transformational and integrated manner.⁴ In developing a framework for metaphorical appropriation of concepts of landscape ecology so as to positively influence architectural thinking, I will first reflect on the Australian designer Richard Leplastrier’s suggestion of the primary task of the architect as that of “furnishing with particular purpose this larger room we are in,” a notion that continues to haunt me as an example of the profound influence novel articulations can have on conceptualizations of architecture at the outset of design investigations, and the environmental receptivity that poetic insight can encourage.⁵

1.0 METAPHORICS AND POETICS OF FURNISHING THIS LARGER ROOM

“People who have not lost the wholeness of their place can see their households and their regional mountains or woods as within the same sphere.” –Gary Snyder⁶

In the 2001 Glenn Murcutt Architecture “Master” Class in New South Wales, Australia, students were asked to design a gallery in a bowl-shaped meadow adjacent to Murcutt’s Riversdale Educational Retreat Center (1999). During a site visit in the preliminary stages of design, architect Richard Leplastrier suggested the task of the architect was to “furnish with particular purpose this larger room we are in,” a notion that fostered a novel understanding of the designer’s role and heightened receptivity towards landscape. Conceiving the gallery not as an object in a field but rather an assemblage of “furnishing-like” settings in a bowl-shaped room liberated students to “pull the building apart,” to consider minimal provisioning of shelter for many of the space as acceptable, and to propose projects of dramatic efficiency, richness and environmental response.

This account from my own experience is revealing of the manner in which use of metaphor involves attempts to explain complex phenomenon via something tangible and comprehensible.⁷ Leplastrier’s notion of “furnishing this larger room” may be said to involve two critical metaphorical presuppositions: (1) we may gain insight into the highly complex realm of architecture by assigning characteristics to architectural elements we more typically attribute to furnishings (such as economy, lightness and unpretentiousness), and (2) we gain insight into the highly complex realm of the environment by suggesting it has room-like qualities. Through a stratagem of poetic association, we combine these two notions to produce a strikingly new (third) meaning. I say striking and suggest Leplastrier’s statement encourages design thinking resonant with contemporary concern over the environment. In particular it (1) suggests architecture takes part in something larger that demands sensitive acknowledgement and (2) helps us sidestep the nature/culture dichotomy and acknowledge the energetic purposefulness inherent to humans and to suggest possibilities for applying such energy constructively as we interact with the world around us.

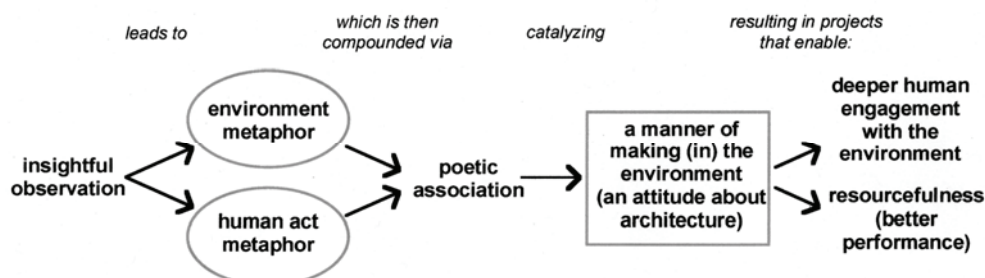

Figure 1: Two metaphors are compounded through poetic association to produce a new (third) meaning

With the notion of *architecture as furnishing this larger room*, a built entity is less a boundary and more a mediator between our selves and larger entities, rooms at once tremendously spatially complex and comforting in their bounding comprehensibility. Our architectural furnishings, surfaces as bodily extensions and settings for gathering, are “outfoldings” towards our primary inhabitation, an environment, a horizon, a landscape under the stars. That such mindfulness of dwelling/inhabitation practices that find registration in the landscape might inspire works of architecture corresponds vividly with David Leatherbarrow’s treatment of “The Topographical Horizon of Dwelling Equipment” in his groundbreaking work “Uncommon Ground.” I quote three passages from the book:

“No single element in a spatial ensemble is positioned to stand out from all the rest; no single piece of equipment obtrudes itself into one’s awareness, each coexists with others in a state of shared latency, waiting, one might say, not passively like a mirror, but with a tendency or disposition to prefigure patterns of behavior, which is how architecture confers orientation.”⁸

“Like that of its antecedent, the blind’s flexibility allowed it to serve as a register and receptacle of the landscape, welcoming it when it presented itself gently, excluding it when it raged with fury.”⁹

“We begin to see that this corporeal schema is enmeshed within an expanding range of distances, a structured topography that includes where I am, which is to say where the things I now need are within reach, a middle distance, and an expansion towards the clear blue horizon; an equipmental, practical and environmental horizon. Not one of these can be separated from the others, hence the lateral spread of the ensemble that integrates these “rings” into one field, terrain or topography – the dining room, the street, and the town or landscape – differentiated but reciprocating.”¹⁰

For Leatherbarrow furnishings are both register of the body *and* landscape *and* a critical mediator of their “lateral spread.” Both Leatherbarrow and Lepastrier would seem to suggest that the environmental philosopher Arnold Berleant’s strong distinction between participatory and neutrally distanced, picturesque aesthetics is inadequate, that simultaneity or constant rhythmic succession of acts of involvement in and contemplative comportment toward the world characterize aesthetically oriented human experience. But we may also raise the question of the extent to which the reining peacefulness intimated by Leatherbarrow throughout his work, the equipoise of living experience amidst “equipment,” has been arrived at after the dust has settled, with primary emphasis on experiential effect (that anticipates subsequent patterns of effects) as opposed to what is affected. Here we find usefulness and accountability in Lepastrier’s *to furnish*, communicating as it does what constitutes architecture *and* the manner in which it is to be constituted.

With respect to dwelling practices, Leatherbarrow’s descriptions of inhabitational behavior seem largely passive and as if our patterns are predetermined rather than in constant adjustment. If rhythms of flux and stasis characterize human existence, an intrinsic propensity to cycle through times of movement and activity and times of rest, what kind of arrangements of furnishings would support such living patterns? Dewey’s birdlike metaphor of human affairs as an “alternation of flights and perchings” provides a direction for exploration, as does Glenn Murcutt’s notion of architecture as “encampment,” suggesting a migratory patterning to human affairs, with residency as temporal and only one form of activity among others that also include gathering, commuting, encountering, bargaining, recreating, wandering, etc.¹¹ Dewey and Murcutt’s metaphors may offer a more complete – and lightened – accounting of the full range of our being amidst the lateral spread, even beginning to blur distinctions between the domestic and wild, an idea to be taken up shortly.

Lastly, and despite the promise of Leatherbarrow’s ideas, “clear blue horizon” as a summary portrayal of our environment seems an overly simple evocation of the enormous and legible complexity that the world as we experience it. Lepastrier’s “room” is more ample (with the clear blue horizon as wainscoting?) and hardly nondescript if we consider Heidegger’s thoughts on room as interpreted by the contemporary philosopher Edward Casey:

“Heidegger’s contribution to this history (of place) is to make room such a mediatrix expressly by virtue of the ingrency of region, whose amplitude and dynamism make possible the generation

of place and space alike. For the effect of region is the creation of the very spatiality (raeumlichkiet: literally, "roomliness") from which place is precipitated and space discerned." ¹²

As Casey interprets Heidegger, "room" is enriched in its inclusivity and powers of precipitation, providing full potency to Leplastrier's notion. As we consider how such understandings may play out in the realm of design, one wonders, however, whether room is too generous a term, and that it might be more helpful for architects to develop metaphorical characterizations that more specifically relate qualities of projects to particularities of context. This is a primary reason why engagement with ideas in landscape ecology may prove helpful.

2.0 THE FOLIAGE OF ARCHITECTURE

"The animal world and that of plant life are not utilized merely because they are there, but because they suggest a mode of thought." –Claude Levi-Strauss ¹³

"Now an increasingly urban population fears any intimacy with uncontrolled nature, especially darkness." -John Stilgoe ¹⁴

Students in the winter 2006 "Triumph of the Commons" architectural design studio were asked to consider increased urban density and improved ecological performance as *one interrelated problem*. The studio specifically explored simultaneous residential alley-access infill development *and* oak habitat restoration on a city block in a post war neighborhood in Eugene, Oregon, with a goal to provide for a growing human population resourcefully while reestablishing critical wildlife corridors linking core habitats for threatened species. A landscape ecologist with extensive experience in oak habitat restoration partnered with the author from day one, helping students develop proposals for secondary dwelling units on existing lots *and* block scale native vegetative structures – superimposed threads of woodland and savanna.

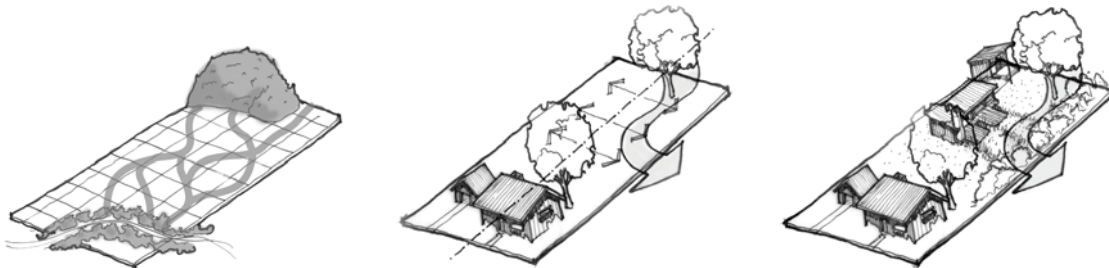

Figures 2, 3 & 4: (left): Neighborhood goal to (re)create wildlife corridors so as to connect "core" habitats; (middle, right): Siting and configuration of new infill dwelling unit on existing lot in response to neighborhood scale ecological goal of corridor connectivity (drawings by Alex Wyndham, Master of Architecture candidate)

Initial and exploratory assignments had students generate imagery and associated metaphorical descriptors capturing their insights from readings and discussions on the work of landscape ecologists and observations during field trips to both Eugene's alleys and nearby oak woodland communities. These served as the basis of three-dimensional "form analog" studies that hybridized oak and alley realms into one composite design language that influenced directly more 'pragmatic' design undertakings later in the quarter. Through these investigations, students considered both the architectural implications of the incorporation of landscape ecology principles as *they pertain to specific habitat conditions*, and the viability of ecological structures such as cores and corridors in a dense urban context. Investigations in section revealed the potential for multiple species to occupy different strata within one vertical band of space, with oaks growing alongside, up and over dwellings, providing summer shade for people below and corridor networks of limbs facilitating movement for the western grey squirrel and other creatures above.



Figures 5, 6 & 7: Brent Sturlaugson's oak pattern image," Rebekah Matheny's alleyway power lines image, and Missa Aloisi's "Lifelines" hybrid oak/alley "form analog" study

Gilles Deleuze and Felix Guattari, in their poststructuralist masterpiece *A Thousand Plateaus*, favor the "rhizomatic" over the "arborescent" model in describing societies and relationships, directing our understanding of arborescence towards the trunk, a metaphorical pillar of centralized command. In so doing they overlook the bud and the branch, the latter not predetermined in its course of growth and yet reacting to its neighbors in seeking light and continued livelihood. Extending our gaze upward, from understory and trunk to the tracery of interwoven limbs, we are afforded a pluralistic, democratic impression, inspiring possibilities for open, interconnected and "branching" spatial organizations of built and open space. With Brent Sturlaugson's scheme for example, a contiguous canopy overhead corresponds to a contiguous social understory, ribbons of outdoor space emanating from a ribbon-like toplight serving as his dwelling's primary organizational element. Missa Aloisi's inspirational insight was that of a bird descending from its home on an oak limb to pluck berries from a shrub below, experiencing a brief moment of exposure in flight. Her dwelling separates eating and living space from sleeping "pods" (reminiscent of oak galls), with the human inhabitant's periods of shelter in these book-ended realms offset by brief, vulnerable movements within translucent "lifeline" passages.

That oaks undergo seasonal changes – budding, leafing, shedding – and that these cycles generate dramatically different thermal and luminous microenvironments, had perhaps the greatest impact on perceptions of space making, inspiring dynamic architectures capable of expansion and contraction. With Alex Wyndham's "Deciduous House," insulated wall "leaves" fold upward and serve as south facing trellis-like shade screens in summer, filtering light from above. With several studio projects, the dwelling expands in summer as wall panels slide laterally into recessed niches, maximizing horizontal continuity between interior and exterior space. An 800 square foot dwelling unit suddenly feels spacious when open to a reinvigorated network of natural systems, where viewsheds extend to adjacent lots and beyond, thoughtfully and so as to not create conflicts of privacy.

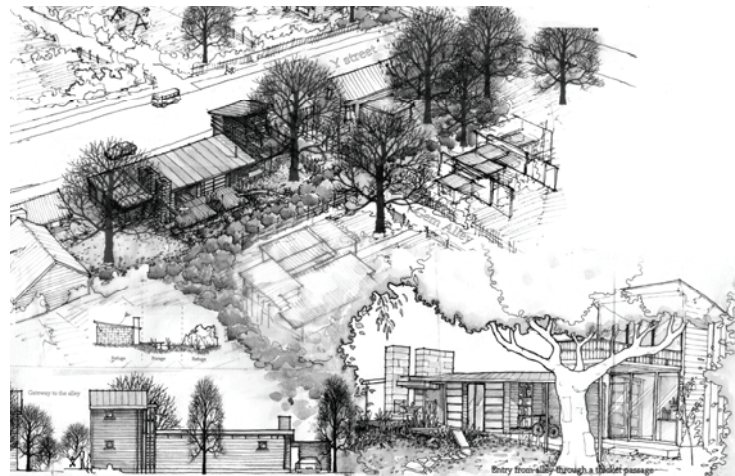

Figure 8: Alex Wyndham's final project "Deciduous House"

In winter mode, architectural elements contract and dwellings become snugly introspective, surrounded by silent matt grey light, gentle rain and black wet limbs of the Pacific Northwest. January dimness counterbalances the light exuberance of summer; our world becomes closer and more immediate, paralleling the inwardness of our own comportment. With Tanizaki, we recognize darkness not as blackness but consisting of countless gradients, from tangible opacity to endless depth.¹⁵ With Derrida, we harbor suspicion of a society's insistence on unceasing immersion in light:

"The heliological metaphor turns away our glance. For it has always been believed that metaphors exculpate, lift the weight of things and of acts. If there is no history, except through language, and if language is elementally metaphorical, Borges is correct, 'Perhaps universal history is but the history of several metaphors.' Light is only one example of 'several' fundamental 'metaphors,' but what an example! Who will ever dominate it, who will ever pronounce it's meaning without first being pronounced by it?"¹⁶

3.0 A PALETTE OF HUMAN ACT/ENVIRONMENT "CASE" METAPHORS

"The ephemerality of all our acts puts us into a kind of wilderness-in-time" –Gary Snyder¹⁷

"If the objects of the environment were only as plastic as the materials of poetic art, men would never have been obliged to have recourse to creation in the medium of words." –John Dewey¹⁸

The efforts and ruminations described above have coalesced in the development of a palette of "case study" metaphors for use in the design studio. Building from Lepastrier's compound notion and the "Triumph of the Commons" pilot studio experiment, and borrowing more explicitly from the language of landscape ecology, these metaphors, it is hoped, will catalyze possibilities for sensitive acknowledgment of context as a consequence of architectural intervention. A winter 2007 "Wild Urbanism" studio provides the first opportunity to introduce these to advanced design students. The project, a vertical mixed-use development adjacent to a riparian/mixed hardwood-conifer forest in Portland, OR, anticipates the brief for a fall 2007 Portland Metro Services "Nature in Neighborhoods" competition of which the author is serving as consultant. Students will develop 2D and 3D "esquisse" studies at several strategic points in the quarter that will require relating a case metaphor to the building program and site, with the expectation that both built and natural features are represented (that we contend with human and non-human habitation throughout). A goal will be to examine whether the metaphors influence the generation of design proposals that contend with human needs and aspirations *and* the ecological integrity and viability of critical and singular habitats.

The case metaphors include:

- *flights and perchings along a green frame*
- *peninsular interdigitation*
- *folds along waterpockets*
- *embroidered pleats in green wedges*
- *encampments in a green fabric*
- *dispersing corridors*
- *layers buffering cores*
- *stitching matrices and cores*
- *watermarks*
- *boulder garden and a braided stream*

Several of these case metaphors stem directly from operative concepts in landscape ecology. "Dispersing corridors" for example derives from the notion of a "dispersal corridor," typically a band of native vegetation facilitating migration of wildlife from one "core" habitat area to another. Others combine philosophical and landscape ecological notions, as with "alternations of flights and perchings along a green frame" that links Dewey's aforementioned birdlike articulation of human activity with a concept of a "network of green space for an urban area."¹⁹ Similarly, "embroidered pleats in green wedges" compounds Gilles Deleuze's cloth-like metaphor as the archetype of Baroque sensibility with an ecological concept for a landscape structure that "keeps developed areas apart while bringing greenspace closer to heart of settlement."²⁰ All case metaphors are intended to capture an understanding that return to ecological health in urban environments involves design, artfulness, intention and beauty. These inventive (re)characterizations attempt to reconcile ever-growing human presence with need for the wild in places largely compromised yet capable of rejuvenation.

In the aftermath of this studio experiment I will evaluate the impact of the case metaphors on the environmental performance and ecological impact of students' projects. This will entail (1) examination of the case metaphors that students utilized; (2) an appraisal of how students organized the building program for the project under consideration and an estimate of the effect of case metaphors on organization; (3) a determination of the percentage of spaces in students' projects that are fully, partially and unconditioned; (4) an estimation of energy savings of proposed designs over more traditionally organized buildings using the same program and where spaces are assumed fully conditioned. I also intend to assess the ecological impact of student projects through consideration of: extent of building footprint, where a small footprint would have less ecological impact than a large footprint; and degree of "permeability" of the site as a result of building configuration, with a goal to facilitate wildlife movement through the site to adjacent habitat areas and where wider, uninterrupted and more wildlife corridors are preferred over narrower, interrupted and fewer wildlife corridors.

4.0 TRAJECTORIES

"Ecosystem deterioration...needs to be addressed by a series of bold experiments to test the success of integrated management" –Jeremy Jackson et. al. ²¹

"Since man was constituted at a time when language was doomed to dispersion, will he not be dispersed when language regains its unity?" –Michael Foucault ²²

The philosopher Edward Casey maintains, "By 'strung out between wilderness and site,' I mean that we drastically lack viable and significant intermediate positions between these two extremities." ²³ Fellow philosopher Hans-Georg Gadamer suggests "discourse that is intended to reveal something requires that the thing be broken open by the question." ²⁴ Questions originating in the field of landscape ecology break the resolute "thingness" of architecture in compelling ways, and our responses as designers open stimulating paths of inquiry for our newfound collaborators. Together we can more effectively find those intermediate positions that Casey believes contemporary culture so desperately needs, discovering new life for our disciplines in the process.

Yet in our efforts to envision and describe more symbiotic relationships between built and natural environments, humans and other organisms, are we are compelled to speak in reductivist binaries, thereby confronting the limits of a language that necessarily presupposes the nature/culture duality we seek to circumvent? Perhaps not if we consider the connections between architectural and ecological systems as manifold, and our charge as not the portrayal of parallels but the rendering of entanglements through associative, metaphorical thinking. Encouraged by Richard Rorty to "replace the world of pictures constructed with the aid of Greek oppositions with a picture of a flux of continually changing relations," we may affect a redistribution of categories, a traversal and interdigitization of nature/culture binaries that increases the frequency of their oscillation. ²⁵

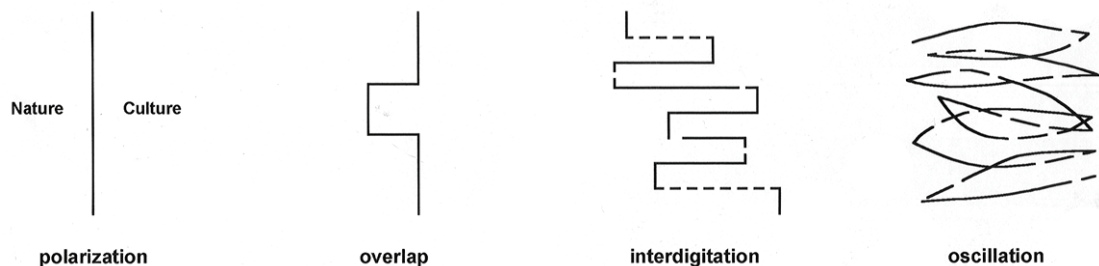

Figure 9: Evolving relationships of nature/culture and ecology/architecture (and our descriptions thereof)

For students in the studios described above, it is hoped that playful, tenacious engagement of metaphor and the language of landscape ecology generates an outward reverberation of thought, inspiring notions of ecological symbioses between buildings and sites, dramatic material and energy efficiencies, and profound engagement of humans and the natural world. Through exposure to human

act/environment metaphors, it is hoped, students are alerted to the inherent incompleteness of architectural undertakings, of the advantages of “a project that privileges unpredictable ecological processes,” and of the benefits of invitation of the wild in the design of urban environments.²⁶ Awareness that the identities of specific ecological structures can help us conceptualize our own relationships and artifacts opens us to radical possibilities for migratory proto-urbanism and community revitalization, to depictions of cross flows not yet appreciated, architectural ecologies both selectively porous and biologically complex.

REFERENCES

- ¹ From Richard T.T. Forman & Michel Godron, *Landscape Ecology*, New York: John Wiley & Sons, 1986
- ² Monica G. Turner, Robert H. Gardner and Robert V. O’Neil, *Landscape Ecology in Theory and Practice: Patterns and Process*, New York: Springer Science and Business Media, Inc., 2001, p. 1
- ³ Joan Iverson Nassuaer, “Cultural Sustainability: Aligning Aesthetics and Ecology” in *Placing Nature: Culture and Landscape Ecology*, Joan Iverson Nassuaer, ed. (Washington, D.C.: Island Press, 1997), p. 71
- ⁴ James D. Proctor and Brendon M. H. Larson, “Ecology, Complexity, and Metaphor,” in *Bioscience* Volume 55, No.12, December, 2005, p. 1066
- ⁵ For a thorough consideration of Leplastrier’s articulation, please see my papers “Metaphor, Architectural Design and Environmental Response,” *Architectural Research Centers Consortium/European Association of Architectural Education International Conference*, Philadelphia, PA, 2006 and “Lightness of Building: Furnishing a Regenerative Architecture,” *American Collegiate Schools of Architecture Annual Conference*, Louisville, KY, 2003
- ⁶ Gary Snyder, “Blue Mountains Constantly Walking,” in *The Practice of the Wild*, Washington, D.C.: Shoemaker and Hoard, 1990, p. 112
- ⁷ My understanding of metaphor has been influenced greatly by George Lakoff and Mark Johnson, in particular their pioneering works *Metaphors We Live By* and *Philosophy in the Flesh*
- ⁸ David Leatherbarrow, *Uncommon Ground: Architecture, Technology, Topography*, Cambridge: MIT Press, 2000, p. 157
- ⁹ David Leatherbarrow, p. 138
- ¹⁰ David Leatherbarrow, p. 66
- ¹¹ John Dewey, *Human Nature and Conduct*, Mineola, NY: Dover Publications, Inc., 2002 (originally published by Henry Holt & Company, New York, 1922), p. 179
- ¹² Edward S. Casey, *The Fate of Place: A Philosophical History*, Berkeley, CA: University of California Press, 1997, p. 252
- ¹³ Claude Levi-Strauss, *Totemism*, Rodney Needham, trans., Boston: Beacon Press, 1962, p. 13
- ¹⁴ John Stilgoe, “Land Fear: Wildness and the Bewilderment of the City Dweller,” in *Architecture Boston*, March/April 2003, pp. 20
- ¹⁵ See Jun’ichiro Tanizaki, *In Praise of Shadows*, Thomas J. Harper and Edward G. Seidensticker, trans, New Haven, CT: Leete’s Island Books, 1977
- ¹⁶ Jacques Derrida, “Violence and Metaphysics,” in *Writing and Difference*, Alan Bass, trans., Chicago: University of Chicago Press, 1978, p. 92
- ¹⁷ Gary Snyder, “On the Path, Off the Trail,” in *The Practice of the Wild*, Washington, D.C.: Shoemaker and Hoard, 1990, p. 165
- ¹⁸ John Dewey, pp. 256-257
- ¹⁹ Paul Caewood Hellmund and Daniel Somers Smith, *Designing Greenways: Sustainable Landscapes for Nature and People*, Washington, D.C.: Island Press, 2005, pp. 2-3
- ²⁰ See Gilles Deleuze’s *The Fold: Leibniz and the Baroque*, Tom Conley, trans., Minneapolis: University of Minnesota Press, 1993 and Paul Caewood Hellmund and Daniel Somers Smith, pp. 2-3
- ²¹ Jeremy B.B. Jackson, et. al., “Historical Overfishing and the Recent Collapse of Coastal Ecosystems,” *Science*, Volume 293 No. 5530, July 27, 2001, pp. 629-638
- ²² Michael Foucault, *The Order of Things: An Archaeology of the Human Sciences*, New York: Vintage Books, 1994 edition, p. 386
- ²³ Edward S. Casey, *Getting Back Into Place: Toward a New Understanding of the Place World*, Bloomington, IN: University of Indiana Press, 1993, p. 259
- ²⁴ Hans-Georg Gadamer, *Truth and Method*, Joel Weinsheimer and Donald G. Marshall, transl., London: Continuum Publishing Group, 2004 edition, p. 357
- ²⁵ Richard Rorty, “A World Without Substances or Essences,” in *Philosophy of Social Hope*, New York: Penguin Books, 1999, p. 46
- ²⁶ Eric Higgs, *Nature By Design: People, Natural Process and Ecological Restoration*, Cambridge, MA: MIT Press, 2003, p. 7

Case Studies—Lighting

Configuring Structure to Improve Daylight Access in Multistory Buildings
**Christine Theodoropoulos, G.Z. Brown, Arthur Johnson, Michael Hatten,
Christopher Flint Chatto, Jeff Kline, Dale Northcutt**

Green In The Balance: Visual Comfort Inside Offices With Tilted Facades
Ihab Elzeyadi

A Lower Cost, Higher Performance Classroom: will innovation lead to market
transformation?
G.Z. Brown, Jeff Kline, Dale Northcutt

Configuring Structure to Improve Daylight Access in Multistory Buildings

Christine Theodoropoulos¹, G.Z. Brown¹, Arthur Johnson², Michael Hatten³,
Christopher Flint Chatto¹, Jeff Kline¹, Dale Northcutt¹

¹Energy Studies in Buildings Laboratory, University of Oregon, Eugene, Oregon

²KPFF Consulting Engineers, Portland, Oregon

³SOLARC Architecture + Engineering, Eugene, Oregon

ABSTRACT: This paper describes a project to develop alternate configurations of structural systems that improve access to daylight at the perimeter of multistory office and hospital buildings. We examined structural systems typically used for office buildings and hospitals in the Pacific Northwest to determine the feasibility of changing or reconfiguring structural components to increase access to daylight. Based on the information gathered from ten case study buildings, five hospitals and five office buildings, we developed alternative approaches to structural framing. The most economically viable approaches were further evaluated for their effectiveness. We considered the interaction among structural components, HVAC, building enclosure systems, and daylight and identified integrated design approaches. Our investigations show that designers can generate economically viable alternatives to the structural systems in office and hospital buildings that increase access to daylight by:

reconfiguring structural components used at the building perimeter, particularly spandrel beams;

moving lateral load resisting systems from the perimeter zone to the interior or core zones of the building;

reconfiguring or using alternative HVAC systems at the building perimeter to reduce or eliminate ducts that obstruct access to the perimeter wall; and

shaping perimeter zone ceilings to increase window head height:

The internal wall height gained from the above strategies allows for increased access to daylight, the costs of which are offset by decreasing the exterior wall height—a cost neutral proposition.

Keywords: daylight access, perimeter zone design, spandrel beams, daylighting cost

INTRODUCTION

In design practice, the design team studies configurations of proposed structural systems, mechanical systems and building envelope systems to determine a cost-effective combination of these three systems that meets design objectives. In this project we added consideration of a fourth system – daylighting – to the design approach. Daylighting is a cost-effective method of reducing electrical energy use and the cooling load, saving both operating cost and first cost. In addition, daylight may increase the productivity of office workers and hospital staff as well as the well-being of patients.

Daylighting, whether for energy savings or occupant well-being, has a direct impact on other aspects of a room. Figure 1 summarizes these relationships. To realize energy savings, designers must consider the amount and distribution of daylight as well as the electric lights and controls; these factors in turn are related to the interior configuration of the room (zoning and reflectivity) and window factors, which are in turn related to the overall room geometry and the type and location of structural and HVAC system components. The coordination of HVAC and structural components can have a significant impact on daylight access. For example, the size and position of the perimeter beam directly affects the head height of the daylighting window.

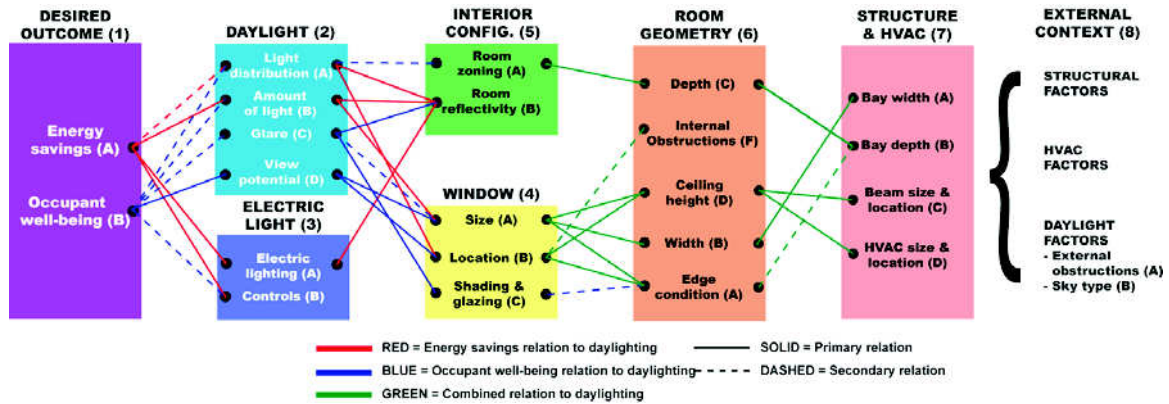

Figure 1: The relationship between daylight objectives and other architectural issues

Two types of buildings where daylight penetration as a design consideration has a large impact are hospitals and office buildings. The occupant well-being and energy benefits of increased access to daylight in hospital and office building environments are well known. However, in conventional construction, the cost associated with increased access to daylight can constrain a design team's ability to provide improved daylighting performance. Prior studies have shown that the reduction of energy costs associated with decreased electrical lighting demand rarely offsets the first construction costs associated with increased glazing areas or the increase in floor-to-floor heights that would accommodate higher daylight windows. The solution to this problem lies in a systems approach to integrating structure and HVAC systems with daylighting strategies. Figure 2 illustrates how a reduction in floor-to-floor height can be achieved through an integrated approach to window wall, ceiling, structural and HVAC design. The diagonal red lines indicate window head height and sun cutoff angle to achieve a given daylight factor at the back of the room. The length and angle of the lines are identical.

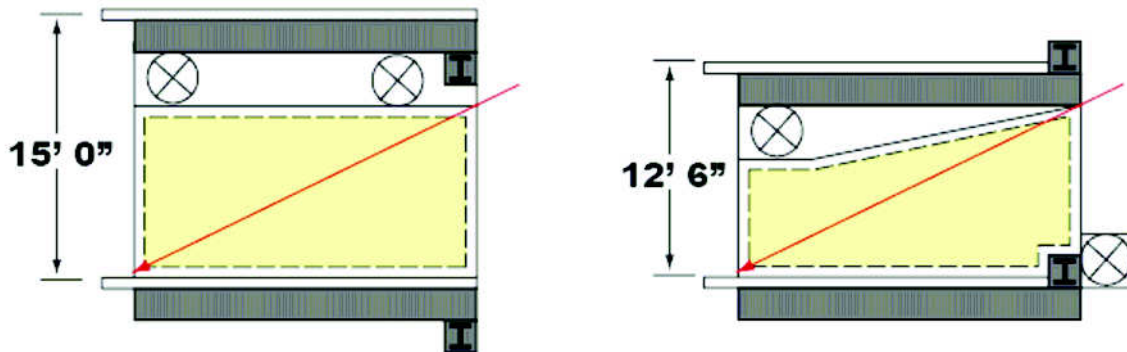

Figure 2: Upturned spandrel beams, combined with revised HVAC systems and shaped ceilings provide increased access to daylight and reduced floor-to-floor height for hospital rooms. Source: (Brown 2005)

1. CASE STUDY APPROACH

We examined ten multistory buildings representing typical recent construction for office buildings and hospitals in the Pacific Northwest and identified appropriate alternatives to the existing structure that would increase access to daylight at the building perimeter.

Alternate designs that reduced the depth or changed the location of perimeter structural elements impacted many of the building systems (including HVAC, and building envelope), fire ratings, other structural elements, and occupant requirements. Each of these factors had associated cost or savings. In addition, alternatives to improve daylighting applied differently to hospitals than to office buildings. The more stringent functional requirements of hospitals, including patient room layout, location of heavy equipment, vibration control, and relative locations of areas such as emergency facilities, surgical areas, x-ray and triage had to be maintained. Access floors provided significant daylight advantages in office construction, but were not acceptable in

hospitals. Although hospital and office occupant needs are quite different overall, we found that daylighting design for both types of buildings could benefit from a close evaluation of how perimeter structural and HVAC components could be adjusted to improve access to daylight.

1.1 Hospitals

Hospitals in the Pacific Northwest have typically been constructed with conventional reinforced concrete beams and flat slabs. Concrete construction lends itself to good floor vibration control, which is often a significant factor in hospitals where there is sensitive equipment and patient comfort concerns. Concrete is also inherently rated well for fire-resistance. More recently, though, many hospitals have been constructed using structural steel framing with concrete over metal deck floor slabs. Four of the five recently constructed hospitals included in this study have steel frame structural systems. With steel framing, a fairly thick concrete topping can be used to achieve both fire resistance without the need for spray fireproofing, and floor vibration control. Steel framing sections that provide vibration control also tend to be two to four inches deeper. As hospitals are increasingly requiring more flexibility in how the building is used, steel presents more ease of construction or upgrade, allowing heavy equipment or large floor penetrations to be added in the future. (Post-tensioned concrete slabs are not typically suitable for this). Floor-to-floor heights in hospitals are often greater than offices, typically in the fourteen to eighteen foot range depending on the use at that particular floor, and framing bays are usually thirty feet. Finally, hospital design is, in part, driven by the building code Importance Factor. The main impact of the Importance Factor is on the building's lateral force resisting system (LFRS). Design lateral forces for this occupancy are increased by a factor of 1.5, thus increasing the size and weight of many of the elements in the LFRS.

Perimeter thermal zones in hospitals are generally dictated by the layouts of patient and exam rooms that tend to be located in the perimeter for access to views and/or daylight. Codes dictate minimum air rates for hospital patient rooms. Because of the potential need for air isolation and/or maintenance of pressure requirements between patient/exam rooms and adjacent corridors, many hospital HVAC systems are still designed as constant volume overhead ducted systems. However, overhead ducted variable air volume air distribution is increasingly being applied to perimeter patient rooms. Typically, this requires air valves (terminal unit devices above ceiling) for both supply and return air ducts. Vertical duct shafts are located in the core with supply and return mains routed above the corridor ceiling. Perimeter rooms are served with branch ducts routed from mains to terminal units and air inlets/outlets distributed over the room's ceiling plane. The typical depth of a branch duct is 6 to 12 inches. In this configuration, ductwork conflict with perimeter structure and daylight penetration is minimized. While some ductwork may be routed to the exterior wall, it runs perpendicular to the wall and tends to be small. Some hospital designs locate the return/exhaust duct loop near the perimeter wall to minimize total duct materials. These tend to be constant volume designs. In these designs, the potential for conflict with structure and daylighting elements is increased because the ductwork is run parallel to the wall edge and eventually obtains significant size as it nears connection with duct mains in vertical shafts.

1.2 Office buildings

Structural systems of office buildings in the Pacific Northwest are constructed with both steel and concrete, though steel is more common. All of the recently constructed office buildings in this study used steel frame structural systems. Requirements for offices are different from hospitals. Because offices usually have a less stringent floor vibration criterion, the floor framing sections tend to be lighter and shallower. However, office buildings also often have framing bays of greater than thirty feet in order to leave floor plates as open as possible, which makes framing members heavier. Office tenant requirements can change even more frequently than in hospitals. In offices access floors can occupy the zone of space behind upturned spandrel beams and also allow the use of post-tensioned concrete slabs without concern of damage from core drilling through the slab. Therefore, as described above, steel is an appropriate construction for anticipating of future changes to structure. Floor-to-floor heights are typically twelve and a half feet; however, buildings in this study showed floor-to-floor heights as great as 14 feet.

Office HVAC systems tend to be variable air volume overhead ducted systems. Supply and return air vertical shafts are located in the core; however, most multistory office HVAC designs serve distinct perimeter thermal zones having depths ranging from 10 to 15 feet in from the exterior wall. Moreover, because many office facades tend to have a significant amount of glazing, common practice is to route supply air ductwork from the perimeter terminal unit to a series of air outlets that "wash" the inside of the glass and exterior wall surface. This is often designed with a perimeter low pressure duct that is routed parallel to the wall edge and connected via flexible duct to slot-type air outlets. For large open offices, duct depths can be as large as 24 inches due to larger perimeter zone areas. For enclosed perimeter offices, supply branch duct depths tend to be smaller, typically 12 inches or less. Return air is often collected in a ceiling plenum arrangement with a minimum of hard duct.

2. RECOMMENDED STRATEGIES FOR IMPROVING DAYLIGHT ACCESS

2.1 Optimize daylight glazing size and placement

The daylight level at any given point in a space is determined by the amount of daylight glazing and the distance of that point from the window. Our goal is to improve the distribution of daylight within the interior. This can be accomplished by raising the height of the daylight window without increasing its area. Higher windows supply more light further into the interior, which evens the daylight throughout the space. Figures 3 and 4 show the relationship between window size, window height and the daylight factor, which is defined as the ratio of interior illumination from daylight (measured at a single point or expressed as an average for a space) to exterior illumination from an overcast sky. (In the Pacific Northwest, where overcast skies are common, the typical design objective is to achieve a daylight factor of 2.0 averaged over the entire daylighting zone, which may extend up to 30' in from the perimeter. A daylight factor of 2.0 means that 2% of the outside illumination reaches the measurement point; so a 1000 footcandle overcast sky would supply 20 footcandles at that point inside.)

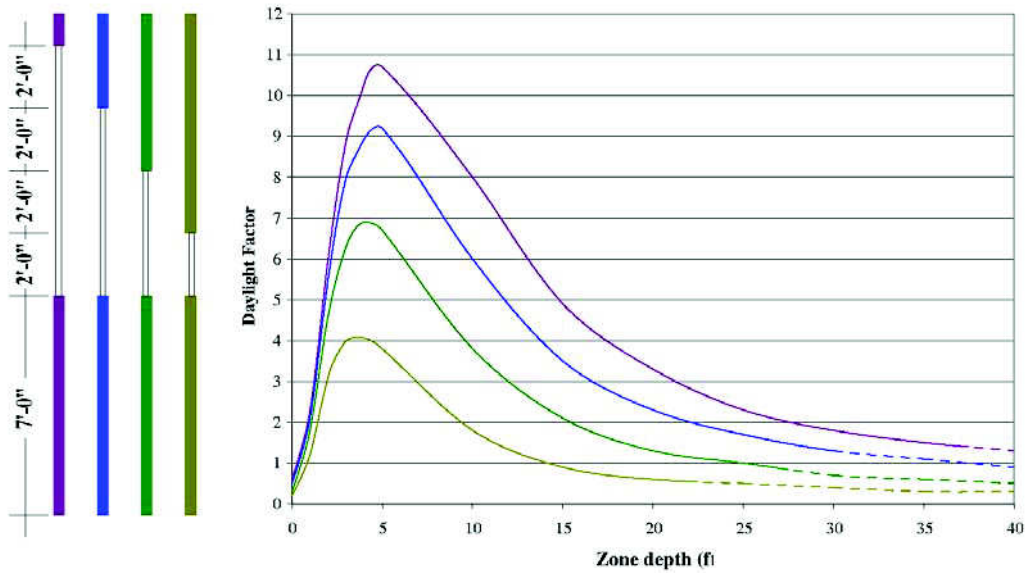

Figure 3: Daylight factor and window vertical size. Sources: (Longmore,1968. Hopkinson,1966. Robbins, 1986)

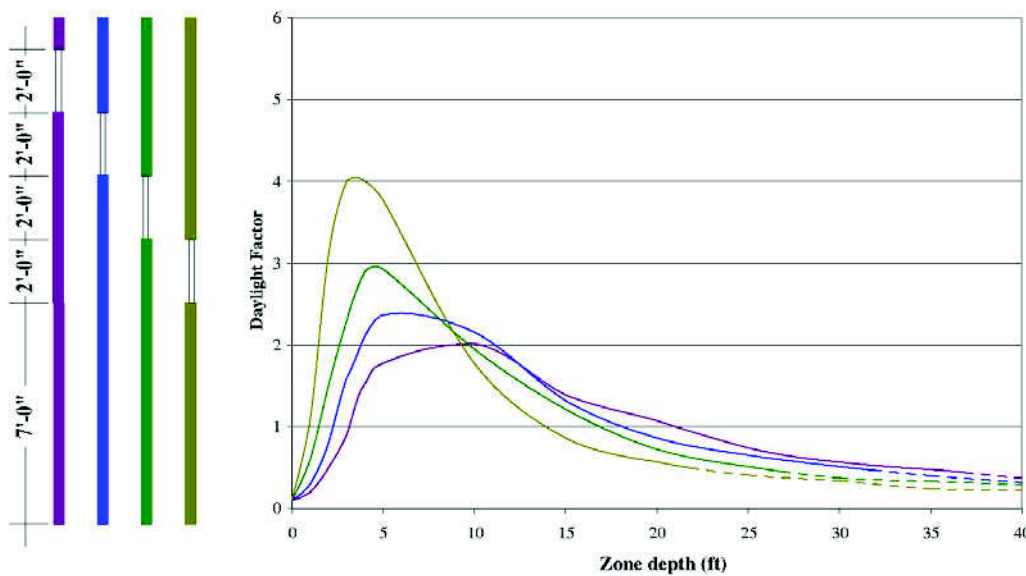

Figure 4: Daylight factor and window height in wall. Sources: (Longmore,1968. Hopkinson,1966. Robbins, 1986)

Three structural alternatives that increased the useable perimeter wall height and were applicable to most of our case study buildings are described below. The ranges of estimated costs and potential wall height that could be used to increase window head height and decrease exterior wall height are provided. The tradeoffs between increasing window head height and decreasing exterior wall height are a key economic consideration that is addressed in section 3 of this paper.

2.2 Reduce spandrel depth

The depth of the perimeter beam, commonly called the spandrel, can be reduced by designing heavier, shallower beam sections. However, doubling the number of exterior columns to reduce spandrel spans is generally more effective and reduces spandrel depths by approximately 50%, thus providing increased height or area for daylight windows. We examined alternatives in which the exterior columns were doubled with no changes to the interior column grid.

Table 1 shows the range of spandrel depth reduction and associated costs for doubling the number of perimeter columns in office and hospital case study buildings. It also includes the additional window head height gained from eliminating perimeter ducts and the associated HVAC costs.

Table 1: Doubling exterior columns: cost of potential window height increase or exterior wall height decrease

	Spandrel depth reduction	Costs per square foot to double the number of exterior columns	Elimination or reduction of the perimeter duct	HVAC costs per square foot
Offices	6 in. to 13 in.	\$0.20 increase	8 in. to 15 in.	\$0.30 to \$4.50 increase
Hospitals	5 in. to 12 in.	+\$0.60 to \$3.10 increase	10 in. to 18 in.	-\$0.70 decrease

2.3 Raise or upturn spandrels

Access to daylight can be increased by raising spandrels normally placed below the floor slabs such that the top of the spandrel beam aligns with the top of the floor slab. Depending on the thickness of the floor slab, this provides from 4 to 8 inches of additional exterior wall height. Even more wall height can be gained by upturning spandrel beams so that the floor slab rests on the bottom flange of the spandrel. This places the daylight obstructing spandrel zone next to the floor rather than the ceiling, allowing daylight glazing to be increased or raised to provide more daylight into the building interior. See figure 5. In the case study buildings, the presence of moment frames at the perimeter and the direction of the floor framing in the perimeter zone had a significant impact on the cost of raising or upturning spandrels. In many cases the most economical alternative was to either reconfigure the building frame in the vicinity of the spandrel or limit the use of upturned spandrels to particular conditions at the building perimeter.

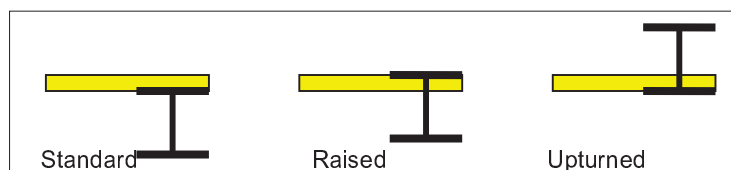

Figure 5: Standard, raised and upturned wide flange spandrels shown in relation to concrete floor slab

Table 2 shows the range of spandrel depths and associated costs for upturning the spandrel in office and hospital case study buildings. It also includes the additional wall height gained from eliminating perimeter ducts and the associated HVAC costs. Changing the position of the spandrel has the potential to reduce the wall height or raise the window height.

Table 2: Upturned spandrels: cost of potential window height increase or exterior wall height decrease

	spandrel depth	costs per square foot to upturn spandrel	Elimination or reduction of the perimeter duct	HVAC costs per square foot
Offices	12 in. to 24 in.	+\$0.10 to \$1.40 increase	8 in. to 15 in.	\$0.30 to \$4.50 increase
Hospitals	10 in. to 24 in.	+\$0.10 to \$1.05 increase	10 in. to 18 in.	-\$0.70 decrease

2.4 Relocate Lateral Load Resisting System Components

Lateral load resisting elements placed on the building perimeter limit window area. Moment frames require deeper beams and wider columns. The large gusset plates on braced frames designed to resist seismic forces are usually concealed in a way that increases the coverage of column and spandrel areas of the building façade. The relocation of these components to the interior of the building can be an effective method of increasing access to daylight at the perimeter.

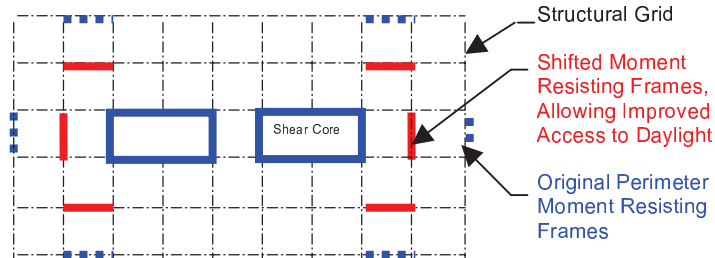

Figure 6: Plan Diagram, Perimeter moment frames shifted to an interior column line

Table 3 shows the additional window wall height gained when lateral load resisting elements in two of the case study office buildings were moved away from the building perimeter and the spandrels that replaced them were upturned. The additional wall area gained from eliminating perimeter ducts and the associated HVAC costs is the same as for the previous two schemes.

Table 3: Repositioned Moment Frames: cost of potential window height increase or wall height decrease

	spandrel depth	costs per square foot to move moment frame and upturn spandrel	Elimination or reduction of the perimeter duct	HVAC costs per square foot
Offices	24 in. to 27 in.	+\$1.20 to \$2.50 increase	8 in. to 15 in.	\$0.30 to \$4.50 increase

3. PAYING FOR DAYLIGHT USING STRUCTURAL, HVAC AND ENCLOSURE COST TRADEOFFS

In many cases, the additional first cost for structural and HVAC systems that allow for increased access to daylight can be offset by the savings in building envelope costs achieved by reducing the floor-to-floor height of the building. Table 4 shows a generalized example of a potential cost tradeoff for a representative ten-story steel frame office building. It is based on a case study office building in Portland, Oregon, with a 14-foot floor-to-floor height designed to accommodate a conventional structural, HVAC and ceiling system. By upturning the spandrels, reconfiguring the overhead ductwork and adding an alternative perimeter heating system, the available wall height at the building perimeter was increased by approximately 30 inches per floor. An 11-inch reduction of the exterior wall height per floor offset the cost of the changes to the structural and HVAC systems, thereby leaving approximately 19 additional inches available to increase the window area or raise the window head height.

Table 4: Potential cost tradeoff for a representative ten-story steel frame office building

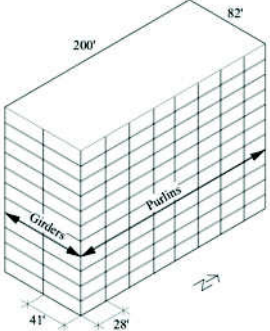
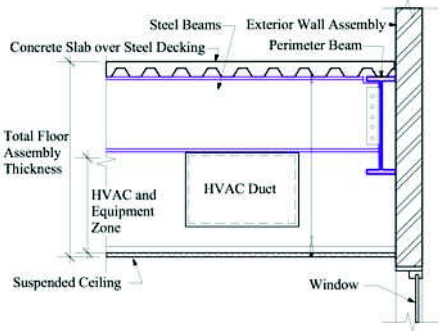
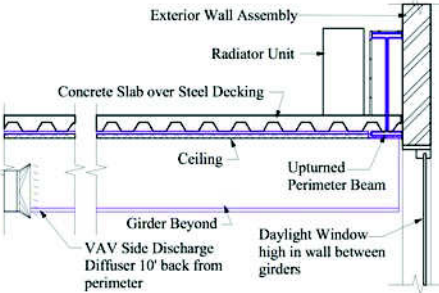
BUILDING DATA	BUILDING DESCRIPTION
<p>Average cost of skin: \$55 per square foot of exterior wall</p> <p>Original floor-to-floor height: 14 feet</p> <p>Perimeter length of a typical floor: 2 x 200 feet + 2 x 82 feet = 564 feet</p> <p>Spandrel depths below floor slab: 14 inches, East and West facades 24 inches, North and South facades</p>	<p>This ten-story steel frame office building has a building footprint of 82 feet by 200 feet with three rows of columns on a 28 by 41 foot grid. Structural steel girders, 24 inches to 27 inches deep, span 41 feet and support 16-inch deep purlins at ten feet on center. Lateral wind and seismic forces are resisted by exterior steel-braced frames.</p>  
<p>ADDED COST PER FLOOR</p> <p>Structure: Unit cost: \$1.10/sf Cost per floor: \$18,040</p> <p>HVAC: Unit cost: 0.60/sf Cost per floor: \$9,840</p> <p>Total \$27,880</p>	<p>PROPOSED MODIFICATIONS</p> <p>We propose to reduce the depth of the spandrels below the finished floor by reframing the north and south ends of the building so that purlins run parallel with the exterior wall and upturning the non-braced frame spandrels so that the floor slab rests on top of the bottom flanges. To further increase access to the exterior wall, we propose to replace perimeter ducts with wall-mounted radiator units and to relocate VAV air outlets 10 feet back from the perimeter wall.</p> 
<p>COST NEUTRAL HEIGHT REDUCTION</p> <p>Cost per linear foot of wall per floor: \$27,880/564 feet = \$49.40 per linear foot</p> <p>Height reduction that offsets cost ((\$49.40/\$55 per square foot) x 12 = 11 inches</p>	<p>The building skin is comprised of brick with metal studs supported by the slab edge. By upturning the spandrels instead of reducing their depth, deflection limits required to minimize cracking in the masonry cladding are maintained. A reduction of approximately 11 inches of exterior wall per floor offsets the cost of structural and HVAC modifications.</p>
<p>WINDOW HEAD HEIGHT INCREASE</p> <p>Height gained by upturning spandrels: 14 in. + 5.5 in. – 11 inches = 8.5 inches</p> <p>Height gained by eliminating perimeter duct: 10 inches</p> <p>Window head height increase achieved: 18.5 inches</p>	<p>The building was originally designed so that the floor slabs, which are 5 ½ inches thick, sit directly above the spandrels. In the proposed upturned spandrel scheme, the bottom flange of the spandrel is level with the bottom of the floor slab. This reduces the total depth of the perimeter structure by 5 ½ inches.</p> <p>The additional 18.5 inches of window head height achieved can be used to raise the window height and increase the window area to gain the daylight factor increases shown in figures 3 and 4, along with the associated energy cost savings and daylight performance improvements.</p>

CONCLUSION

Our investigations show that designers can generate economically viable alternatives to the structural systems in multistory office and hospital buildings that increase daylight in the building interior, thereby improving the quality of occupant experience and reducing the energy demands of electric lighting. For practitioners the key concept is to identify daylight as a building system

. To meet the challenges associated with an integrated approach that concurrently addresses and holistically optimizes the combined performance of structural, HVAC, wall, ceiling and daylight systems, architects must adopt an interdisciplinary approach in which all members of the design team are made aware of the daylight implications of their design efforts.

ACKNOWLEDGEMENTS

The authors would like to thank the Northwest Energy Efficiency Alliance for supporting this project and the staff of the University of Oregon's Energy Studies in Buildings Laboratory for their assistance.

REFERENCES

International Code Council, 2002. *The International Building Code 2003*. The International Code Council Inc.

Brown, G.Z. et. al. *2005 Daylighting Patient Rooms in Northwest Hospitals*. A project report prepared by the Energy Studies in Buildings Laboratory at the University of Oregon, Eugene, Oregon.

Longmore, J., 1968. *BRS Daylight Protractors*. Her Majesty's Stationery Office, London.

Hopkinson, R.G., Petherbridge, P., and Longmore, J., 1966. *Daylighting*. William Heinemann Ltd., London, p 250.

Robbins, Claude L., 1986. *Daylighting: Design and Analysis*. Van Nostrand Reinhold Co., New York. pp 492-493.

Green in the Balance: Visual Comfort Inside Offices with Tilted Facades

Ihab Elzeyadi, Ph.D.

University of Oregon, Eugene, Oregon

ABSTRACT: Tilted facades are increasingly being used in contemporary commercial buildings. Recent studies indicate that downward tilted facades can reduce cooling loads leading to an overall reduction in energy and building operation costs. Similarly, current trends in commercial buildings design use façade and window geometry as an aesthetic revolution on the traditional orthogonal space order. However, the effects of the resulting non-orthogonal interior space on the occupant visual and psychological comfort are not always considered. Previous studies indicate a gap in the existing literature related to these effects.

This paper reports on the results of a multi-methods research project combining a cross-sectional survey design and a participant observation design carried out in an office building in the United States with a tilted facade. The building studied had occupied offices next to orthogonal and 30°-tilted glazed facades. Independent variables were manipulated through different office settings in the building. The dependent variables were assessed by responses of clustered random sample (total of 115 participants) representing each of the two facade types. Both the physical and psychological variables that affect occupants' comfort with the indoor space resulting from tilted facades were evaluated. Data collected using four research instruments (questionnaire, structured interviews, photography, and field notes) showed that window tilt affected the occupant's perception of window proximity, perceived space order, stability, and spaciousness. Maintenance and discomfort glare were among the physical distractions reported as well.

The study's objective is to explore the parameters that affect the occupant's behavior in response to a green design strategy associated with tilting facade angles for shading and energy conservation. The findings led to a specific model for facade form evaluation, and specifically facade tilt. Results can help identify relevance of more specific hypothesis for future investigations. Most importantly, it suggests that designers need to look at green building strategies from a holistic perspective employing a whole-building approach that include the physical, psychological, and physiological dimensions of the environment and their impacts on building form.

Keywords: facade geometry/form, indoor comfort, office buildings, green architecture

INTRODUCTION

In a constantly changing environment, the field of architecture confronts many challenges to incorporate modern and sustainable technologies within its discipline. Concurrently, architecture is influenced by other disciplines such as engineering and psychology. However, due to a lack of sufficient communication between these disciplines, behavioral and environmental effects are not always considered when contemporary and energy efficient buildings are designed for occupant comfort (Griffiths, Huber & Baillie 1988). This research aims to explore how satisfied an occupant is with the physical and psychological effects resulting from a single design option: façade and window tilt. In this exploration, the individual (occupant) and his/her environment (building) are conceived as parts of one interactional system (Markus, 1972).

The occupant's visual satisfaction level, operationalized as visual comfort, is affected by the quality of the indoor space the occupant perceives from the physical configuration of the building (Elzeyadi, 2003). The tilt refers to the angle by which the window/facade plane is rotated around the gravitational vertical plane (Figure 1). A window can be either tilted upward to face the sky or downward to face the ground. Since downward tilted windows are increasingly being used as a green strategy in contemporary office buildings--for their proven solar

shading (Haus, 1994), energy conservation potential (Haus, 1994), as well as their aesthetic appeal (Elzeyadi, 1997)--this investigation concentrated on the effects of this specific design.

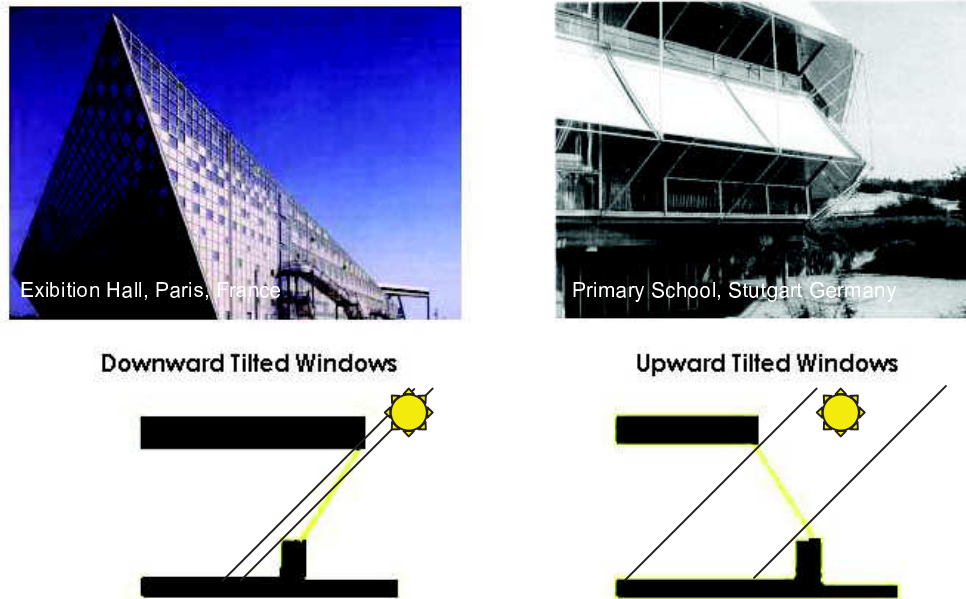

Figure 1: Upward and Downward Window/Facade Tilt

1. TILTED FACADES IN GREEN AND CONTEMPORARY ARCHITECTURE

Towards the achievement of energy efficient spaces and greener office buildings, the facade geometry is affected (Boubekri et al, 1991). Meanwhile, architects concerned with the building's formal aesthetics have created convoluted shapes of facade forms to increase the building's complexity (Flagge, 1994). This is evident in the works of some contemporary architects such as Frank Gehry and Rem Koolhaas (Figure 2). The revolution against the two dimensional facades of the modernist theories of pure forms led to the modification of the building envelope to create more complexity in the city's urban form (Flagge, 1994). In addition, tilted facades also helped to increase the elevation depth of the building and, hence, imposed a dramatic play of shades and shadows (Haus, 1994). However, sufficient attention is rarely given to the visual comfort of the occupant inside these buildings. Many previous studies recommended that future research should investigate the employee visual preference of window form and shape in the work environment (Heerwagen, 1990; Boubekri et al, 1991).



Figure 2: Contemporary Architecture and Tilted Facade Complexity

Historically, occupants' prefer orthogonality in buildings (Elzeyadi 1997). Studies show that humans can recognize deviations from the vertical with an accuracy of less than one degree (Gibson & Mowrer, 1938). Therefore, tilted facades cannot pass unnoticed by the building's occupants. Psychologically, facade tilt might have behavioral as well as physical effects on the occupant's perception of the outdoor environment (Heerwagen, 1990). To explore the relationship between window/facade tilt and occupant's visual comfort, a research model (conceptual framework) based on previous research was designed (Elzeyadi 1997). Through this model, both the physical and psychological variables that affect occupant's comfort with the indoor space resulting from tilted windows were evaluated. This study did not test a hypothetical statement due to a gap in the knowledge regarding the phenomenon under investigation. Instead, it used a deductive approach to investigate the following research questions: (1) Are the occupants comfortable with the shape of the indoor space resulting from window and façade tilt? (2) How do the occupants behave in response to the different angles of facade tilt? (3) Do the occupants adapt to the indoor non-orthogonal space? (4) What are the physical and psychological variables that affect the occupants' visual comfort regarding the shape of their offices, specifically the window shape? and (5) What changes or modifications do the occupants suggest to improve their indoor environment in order to maximize comfort?

2. VISUAL COMFORT AND TILTED FACADES

Window tilt can induce a variety of perceived or experienced distractions in the work place (Butler & Biner, 1989). Perceived distractions are mostly psychological, such as the degree of space stability, organization, or certainty; such constructs are subjective in nature and can differ from one person to the other (Butler & Biner, 1989). On the other hand, experienced distractions such as glare, reflectance, and maintenance tend to be more objective and constant in their effect (Boubekri et al, 1991) (Figure 3). Ultimately, whether perceived or experienced visual distractions, parameters of the built environment with regards to window geometry do affect the occupant's comfort (Heerwagen, 1990).

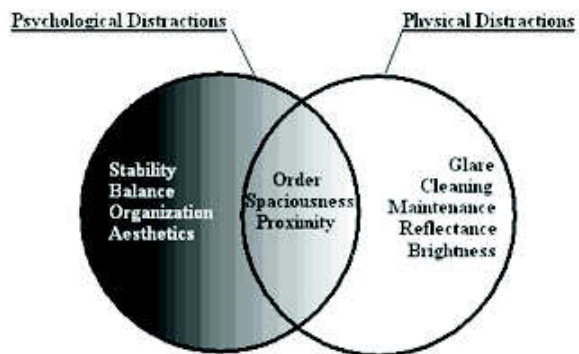

Figure 3: Perceived and Experienced Distractions

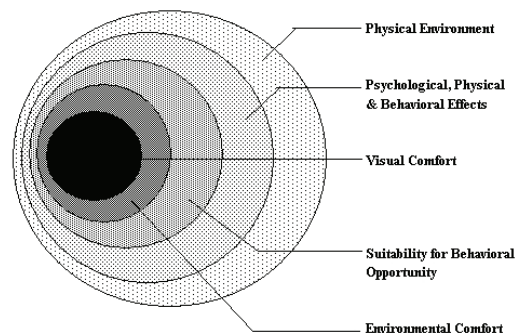

Figure 4: Nested Model of Visual Comfort

This study builds on the model of visual comfort previously designed by the author (see Elzeyadi, 1997). Visual comfort (VC) in this suggested model (Figure 4) is defined as *“that state of the mind that expresses satisfaction in viewing the surrounding environment and perceiving it as suitable for behavioral opportunity of the task performed. It is also the perceived physical and psychological quantities of indoor space that enable the individual to function and facilitates task performance.”* (Elzeyadi, 1997:22). In this model VC is assumed to be an outcome of two interactional constructs, physical and psychological visual distractions. These two types of distractions vary with the change of the study's independent variables, which are: angle of window tilt, proximity and position to window, shape of sill and lintel, outdoor view, area of window, glazing properties, and floor height. Visual distractions specified under physical effects include: glare, maintenance, flexibility, and reflectance. Psychological distractions are related to visual perception of non-orthogonal spaces, perception of the gravitational vertical, and diagnostic phobias. The interaction effect of these variables can induce 13 mediational responses: six physical (discomfort glare, visual acuity, brightness, space order, indoor reflections, & cleaning) and seven psychological (space organization, spaciousness, aesthetics, stability/fear, certainty, proximity and balance). Occupants adapt to this set of variables to achieve visual comfort or visual discomfort as predicted by this conceptual model (Figure 5).

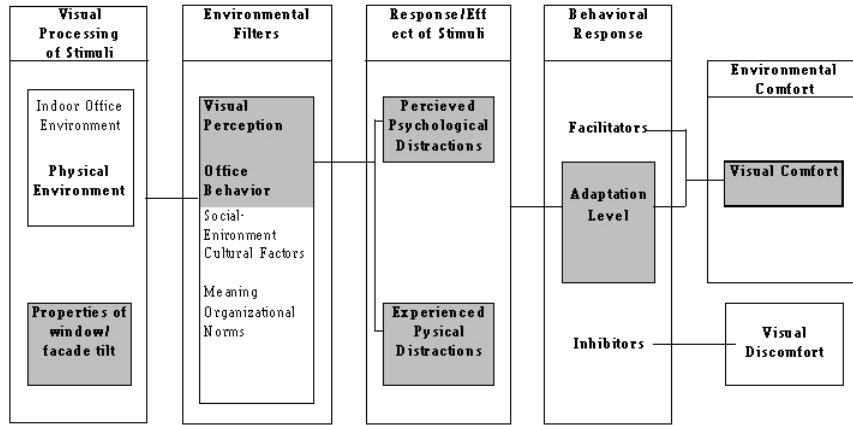

Figure 5: Conceptual Research Model of Visual Comfort and Tilted Facades

3. CASE STUDY: NATIONAL ASSOCIATION OF HOME BUILDERS, WASHINGTON, DC

After a careful archival survey of office buildings that possess tilted facades, the National Association of Home Builders (NAHB) old headquarters in Washington, DC was selected for the investigation. The criteria for this selection was based on: (1) the availability of office spaces with different façade tilt/geometry, within the same organization (since one façade of the building poses a 30 degree tilt angle while the other facades are vertical) and (2) the energy savings of these facades, as the tilted façade side of the building have proved to show savings in cooling loads (see Haus, 1994, Elzeyadi 1997). This five-story office building, designed by Vincent G. Kling & Partners of Philadelphia, is a combination of the "Tilted wall" and the "Vertical wall" window tilt types. The southwest facade of this building is tilted downward 30 degrees from the vertical while the rest of the facades (northeast, southeast, & northwest) are kept vertical. An indoor window sill having a triangular cross section with a three foot base houses the air handling equipment and vents for each office space (Figure 6).



Front Façade of NAAB with 30° Tilted Façade



Side Vertical Façade of NAAB



Interior views of offices



Interior views of offices

Figure 6: National Association of Home Builders Building in Washington, DC - Study Setting

The study used a survey design methodology using questionnaires, structured interviews, photography, and field notes as data collection instruments. The data was collected over a period of two summer months (June-August). Forty percent of both occupants in the tilted façade (southwest) section of the building and occupants in the vertical orthogonal façade sections (northwest, northeast, southeast) of the same building volunteered to participate in the study. This led to sample sizes of 62 and 53 respondents, respectively. Although sampling by percentage led to a slightly non-equivalent sample size, the objective was to ensure a random sample that represents the population occupying both the tilted windowed section and the vertical windowed section of the building. The tilted façade overlooked an urban landscaped plaza, while the three other facades faced mature trees in the setbacks between the building and the surrounding structures. Sun penetration was modulated by the 30° downward tilt of the southwest façade and by shading from mature trees on the three other facades. The facility manager randomly selected the subjects in clusters by floors. The clustering procedure ensured that the sample size was composed of employees working next to a tilted window and non-tilted (vertical) windows in the second, third, and fourth floors. There were no gender, age, or other specific population requirements linked to the study other than the status of office employee working in the researched settings.

Data collection was handled according to human subjects approved procedures so as not to breach the confidentiality of the participants, each questionnaire form was returned in a sealed plain envelope, which was attached to the distributed questionnaires. The procedure limited the publication of the data collection dates to protect employees' privacy. Respondents filled out the designed questionnaire, enclosed it in the attached envelope, and dropped the sealed envelope to be turned over to this investigator in preparation for data analysis. Respondents who expressed their willingness to be interviewed checked the appropriate box on the questionnaire form.

A simple descriptive statistical analysis of the questionnaire data collected from each site was conducted in order to develop an overview of the responses and a trend of the subjects' attitude in each setting. A theoretical sample of the respondents who indicated their willingness to be interviewed was developed. This theoretical sample was selected according to the participants' responses to the questionnaire. It was composed of employees who reported extreme responses to the facades geometry (i.e. employees who were extremely comfortable/uncomfortable with the tilt) and those who reported conflicting and ambiguous responses to the questionnaire questions.

The facility manager scheduled a 15-minute meeting with 18-20 different employees during one business day. These interviews took place in the interviewee's office space. During the same business day, the researcher occupied an office space next to the building's tilted facade and thus was able to experience the same physical situation of the occupants. The researcher walked through the facility offices, photographed physical traces of office and space arrangements, as well as observed the occupants' behavior in their workspaces. Informal casual conversation and non-structured interviews were also conducted with the building occupants, custodians, administrators, and the facility manager. Data collected in the form of recorded tapes, photographs, the researcher field notes, and questionnaire responses were analyzed to answer the research questions proposed earlier. Since there was no prior information on the phenomena under study in the scientific literature, the investigation did not propose a hypothetical statement to test, but instead used a deductive strategy to conclude the findings based on the research problem and questions presented earlier.

4. FINDINGS: OCCUPANTS' COMFORT AND FAÇADE TILT

Data corroboration from different sources was implemented not only to check for validity but also to produce richness in covering different aspects of the phenomena. The findings are presented to validate the research theoretical model, answer research questions, and provide insights for future research. The findings are classified under the two main categories discussed earlier in the form of physical and psychological visual distracters.

4.1. Physical Visual Distractions

Categorizing responses as experienced physical distractions followed the research model and the participants' perceptions of the distracter. Structured and casual interviews with the occupants identified whether a response was viewed as a physical or psychological distraction. Physical distractions were classified under two categories: (1) glare and reflectance on the windowpanes, and (2) maintenance and space economy of the indoor space resulting from window tilt.

4.1.1. Glare and Reflectance

The intention was to discover if the occupants were aware of the indoor reflections on the glass surface and whether these reflections were experienced as distractions during the occupant's daily routine. In the National Association of Home Builders (NAHB)—angle of tilt is 30 degrees—45% and 50% of the respondents reported

distractions from reflections and glare, respectively as compared to 10% and 15% only in the section of the building with vertical orthogonal façade (Figure 7). The glazing properties of the buildings' facades were constant between the tilted facade and the vertical facade sections of the building. Despite of the differences in solar orientation of the facades, sun penetration differences was not very highly perceived by the occupants due to shading by the façade tilt, mature trees, and a 3 foot window sill in the interior space (Figure 6).

4.1.2. Maintenance and Space Economics

Maintenance was operationalized as the frequency of cleaning the tilted windows as well as fixing one of the window components (such as broken glass panes or window coverings). The waste of space as a result of window tilt was perceived as a physical distracter that limits the occupants' use of the indoor space. Facility managers and custodians reported that tilted windows were difficult to handle in terms of cleaning and maintenance. As one of the employees who had worked for the NAHB for two years reported: *"They were never washed the whole time I've been here."* (Interview #4). Another respondent complained about maintenance of tilted windows. She stated:

The windows are nice but over the years they get dirty and dirty and that takes away from the view. They've never been able to wash them. This takes away from the overall comfort in the office space. As it affects the feeling of cleanness and sanitation of the organization. (Interview #29)

During a casual conversation with a different employee in the same facility, she reported the following:

There is a physical waste of space due to tilt, I would rather trade it for more space, though the office designers had to come up with other ways of making the office appealing as the window tilt is. (Interview #32)

It can be concluded that window tilt, though aesthetically pleasing to some occupants, was difficult to be maintained. The results showed that the occupants perceived the waste resulting from the tilt and some of them, especially those occupying small offices, indicated that they would trade the tilt for more floor space.

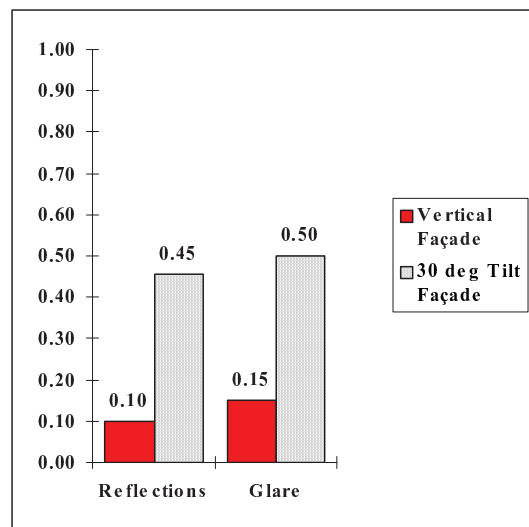

Figure 7: Percentage Reporting Discomfort from Reflection and Glare

4.2. Psychological Distractions

Psychological distractions as a result of facade tilt were operationalized in terms of the responses and space properties perceived by the occupant resulting from the visual processing of the facade tilt. Hence, these responses were subjective and differed from one occupant to the other. Two main classifications helped in itemizing these responses. The first category was window proximity, which is the ability to approach a tilted window or facade in comparison to approaching a vertical one. The second category was related to the occupant's perception of the significant space properties in a non-orthogonal environment and the effect of the physical properties of the facade tilt on the occupant's perception of comfort. The results of these two perceived categories follow.

4.2.1. Window Proximity

Window proximity, defined as the measured floor distance between the occupant's standing position—when approaching the window—and the window sill, was one of the main variables that affected the occupant's perception of visual comfort. This construct is considered a perceived distraction that inhibits the occupant's movement in the office space. Results showed the tendency of standing back due to tilt increases with the tilt angle over the vertical facade. It is interesting to note that the percentage of people still not able to approach the window due to fear of heights associated with the tilted angle increased by 60% in occupants of tilted facade

offices over those with vertical ones. This effects did not change much over time as occupants of tilted facade offices still felt that they need to stand back from the façade due to tilt even after spending a year in their offices (Figure 8 a & b).

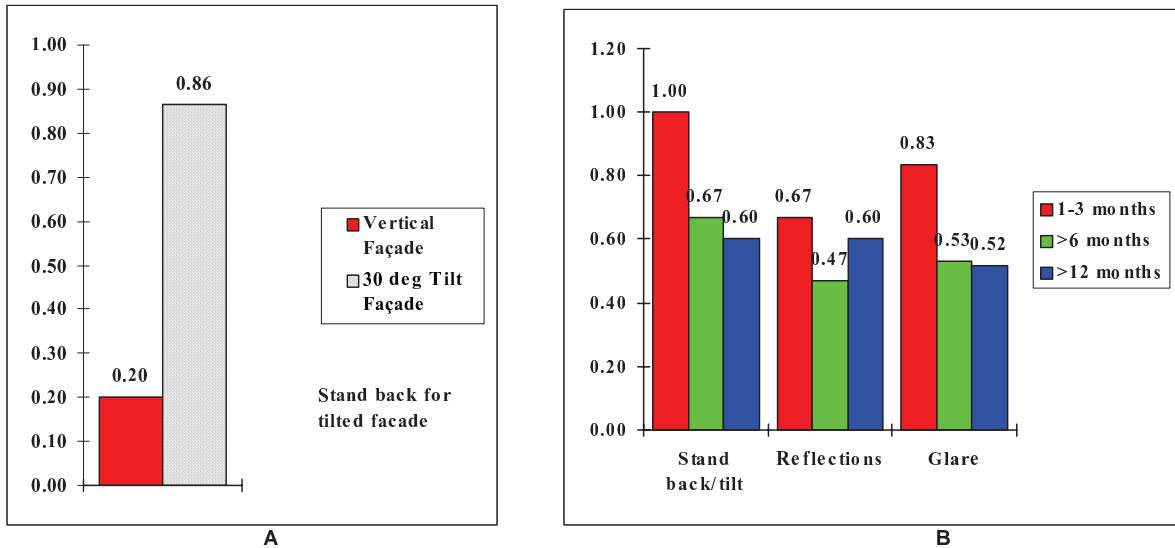

Figure 8: Percentage Reporting Window Proximity in General and Overtime

4.3.2 Analysis of Perceived Variables

The perceived space variables represented the average occupant's feelings and descriptions regarding the occupied space. The variables were itemized on a seven-point semantic differential scale using bi-polar adjectives. The tested variables were further classified in terms of perceived space properties (ordered, flexible, bright, pleasant & spacious) and occupant's feelings regarding window tilt (comfortable, fearless, stable, balanced, certain, & organized). The latter was further itemized according to the occupant standing/seated position. Figure 9 (A & B) present perceived qualities of the offices in the tilted facade section (A) and the vertical orthogonal facade section (B) of the office spaces, respectively. It is obvious that many indoor qualities such as balance, organization, stability, flexibility, and order were negatively perceived in offices with tilted facades.

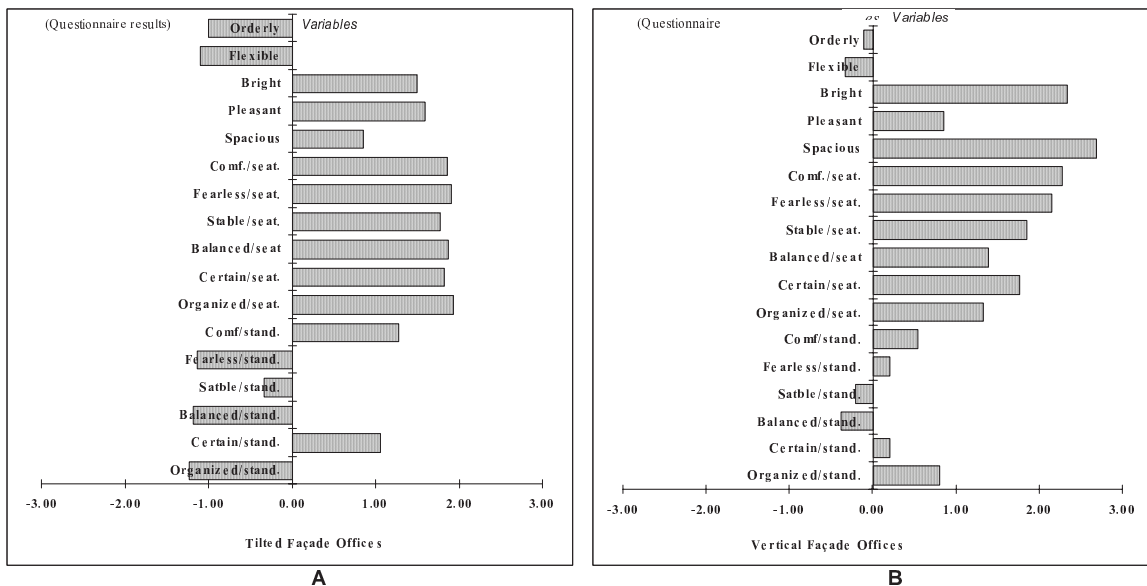

Figure 9: Comparison of Perceived Indoor Qualities and Comfort Inside Tilted and Vertical Façade Offices

5. CONCLUSION: GREEN IN THE BALANCE

Through exploring the effects of a single design option that have green implications—tilted facades—on occupants' indoor visual comfort in an office space, many of our existing design assumptions need further consideration. First, the environment and the occupant should be perceived as a system rather than a set of discrete components. As the study's findings showed, tilted windows imposed a variety of effects on the building's occupant. While some of these effects inhibited the occupant's movement in space and were perceived as distractions, such as window proximity, maintenance, and flexibility; tilted facade offices were perceived as more spacious than vertical windowed ones. Second, the study revealed that comfort implies subjective measures related to the occupants' feelings and behavior in space.

The effect of tilted facades on the occupant's ability to approach the window is one of the main factors that affected visual comfort and occupant's satisfaction. Usable indoor area and angle of facade tilt could also affect the space economics and should be taken into consideration when designing the form of the facade. Future research should also investigate the effect of tilted facades on the occupant's perception of space sanitation due to the maintenance difficulty of such design strategy. Preference for indoor handrails or vertical window sills in front of the windows should be researched before designing tilted facades as well. Solar penetration due to various facade orientations was one of the limitations of the study. Although occupants were not much affected by it during the data collection period, future studies should investigate the effect of glare related to sun penetration on occupant's comfort for tilted facade buildings.

Perceived spaciousness from tilted facades was one of the reported positive effects of such design option. Future studies could investigate whether the increase in floor area, ceiling area, or window tilt could contribute much to such a feeling. Tilted facades also limited windows operation (i.e. ability of the occupant to open the window). Future studies could compare the lack of ventilation benefits for such design versus its shading benefits. It was the objective of this study to contribute to the gap in existing knowledge related to the effects of facade tilt and geometry on the occupants' visual comfort in space. Most importantly is to stress the importance of whole-building design and the systemic evaluation of green design strategies by architects and designer before adopting them to a project.

ACKNOWLEDGEMENT

This study would have never been possible without the participation of the employees and occupants of the National Association of Home Builders (NAHB) in Washington, DC, USA. Many Thanks to Mr./ Chuck Smith and Mrs./ Dawn Harris. This study was partially funded by grants from the International Facility Management Association (IFMA) and Haworth Inc Research Grant. Their funding is hereby gratefully acknowledged. All Photos are by the author ©Ihab Elzeyadi.

REFERENCES

- Boubekri, M., Hulliv, R., & Boyer, L. (1991). Impact of Window Size and Sunlight penetration on Office Workers' Mood and Satisfaction. *Environment and Behavior*, Vol. 23: 4, pp. 474-493.
- Butler, D. and Biner, P. (1989). Effects of setting on Window Preferences and Factors Associated with Those Preference. *Environment and Behavior*, Vol. 21:1, pp. 17-31.
- Elzeyadi, I. (2003). Environmental Quality: A Systemic Framework for Conceptualizing People and their Workplaces. In: *Shaping Places for People: Proceedings of the Environmental Design Research Association EDRA 34th Conference*, pp. 71- 79.. May 22-26, Minneapolis, Minnesota.
- Elzeyadi, I. (1997). The effect of tilted windows on occupants' visual comfort in non-orthogonal office spaces. *International Facilities Program, Vol. (2)*. Houston, TX: IFMA Foundation/Haworth.
- Flagge, I. Ed. (1994). *Annual of Light and Architecture 1993*. Berlin: Ernst & Sohn Verlag für Architektur.
- Gibson, J.; and Mowrer, O. (1938). Determinants of the Perceived Vertical and Horizontal. *Psychological Review*, Vol. 45: 4, pp. 300-323.
- Griffiths, I., Huber, J., & Baillie, A. (1988). The Scope For Energy Conserving Action: A Comparison of The Attitudinal and Thermal Comfort Approaches. In Canter, D. et al., *Environmental Social Psychology*. Dordrecht: Kluwer Academic Publishers.
- Haus, T. (1994). The Energy Efficiency Of Tilted Windows in Office Buildings. *Unpublished Masters Thesis. The Pennsylvania State University*, University Park, PA.: Department of Architecture.
- Heerwagen, J. (1990). The Psychological Aspects of Windows and Window Design. *EDRA 21 Conference Proceedings*, pp. 269-280.
- Markus, T. (1972). *Building Performance*. New York: John Wiley & Sons.

A Lower Cost, Higher Performance Classroom: Will Innovation Lead to Market Transformation?

G.Z. Brown, Jeff Kline, Dale Northcutt

Energy Studies in Buildings Laboratory, University of Oregon, Eugene, Oregon

ABSTRACT: One of our primary goals at the Energy Studies in Buildings Laboratory is the transformation of the architectural design market to be more energy efficient. A large part of our efforts to this end are educational, both formally, in classes and workshops, and informally as in our consulting on specific projects. The innovative classroom design we have recently developed is a research project that exemplifies these efforts. This project, designed specifically for the Pacific Northwest climate, achieves energy performance that is 70% better than code and costs less to build than a conventional classroom. The positive reception of the concept and the ensuing interest within the design and construction community make us think that an innovative product can be an effective stimulator of market transformation. This paper describes our low cost, high performance classroom concept, its history, and the excitement it has generated. We have a hypothesis about why the concept has been successful, and we describe the evidence we will be looking for to support our ideas as the concept continues to be adapted and refined by others and ourselves.

Keywords: classroom, market transformation, energy efficiency, integrated design

INTRODUCTION

This paper describes a successful low cost, high performance classroom concept. We present a history of the concept, observations we have made, and a hypothesis about the value of an innovative product in driving market transformation. We conclude by laying out the types of evidence we wish to collect to evaluate our hypothesis.

1. DESCRIPTION OF THE HIGH PERFORMANCE CLASSROOM

1.1. Lighting Synergies

The High Performance Classroom design is an approximately 900 s.f. room, roughly square, with a ceiling sloping up to a large central skylight, as shown in figure 1. In targeting energy and operating cost savings, we focused on the three main sources of a classroom's energy use: heating, cooling, and lighting.

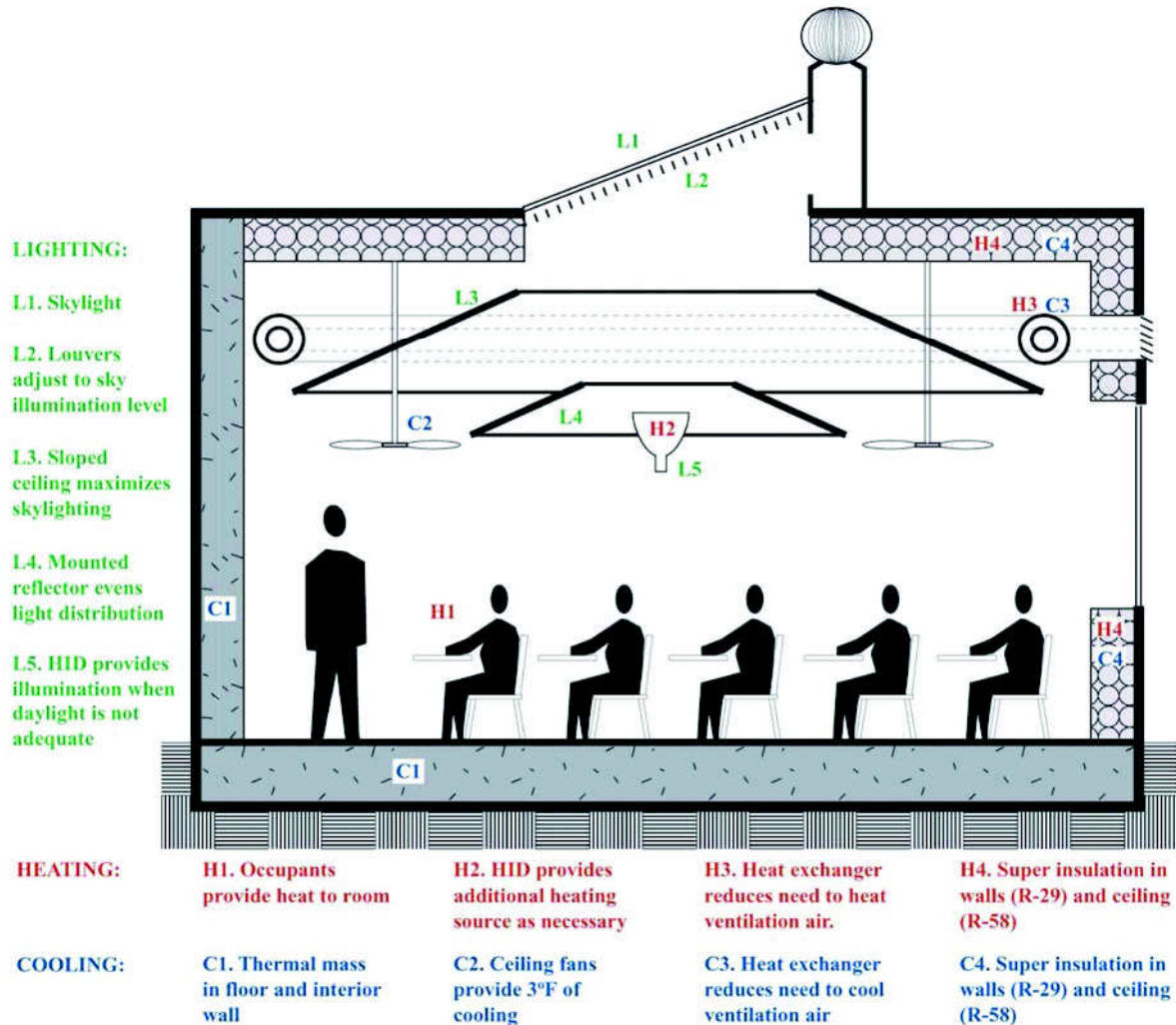

Figure 1: Diagram of the High Performance Classroom showing lighting, heating, and cooling synergistic elements

Schools present good opportunities for daylighting. School operating schedules generally coincide with daylight hours, and their illumination requirements are easily met with daylighting. Furthermore, research suggests that students learn better with daylight (Heschong Mahone Group, 1999). However, daylighting also incurs construction costs. Glazing and shading devices are more expensive than an opaque wall, and electric lights cannot be completely eliminated. Our approach, then, was to design the least costly daylight aperture that would provide adequate illumination over the largest portion of the operating schedule, and to supply an inexpensive electric light system that would be acceptable for the infrequent times it would be needed.

A single skylight (approximately 11 ft x 14 ft) can supply almost all the illumination needs of this typical classroom. Multiple skylights might provide better light distribution, but would significantly increase costs. Instead of multiple skylights, a central reflector hangs underneath the skylight to address the "hot spot" of concentrated light beneath a skylight. The reflector partially shades the room's center, reducing illumination, and its high reflectivity (95%) bounces light to the ceiling and to the room's edges. The ceiling is sloped to facilitate the distribution of light, permitting all work areas direct visual access to the skylight. The skylight is sized for the minimum exterior illumination case; adjustable louvers are programmed to reduce excess illumination and unwanted heat gain.

Because this arrangement can provide adequate illumination for 95% of operating hours, electric lighting can be minimized. A single high intensity discharge (HID) lamp, mounted in the center of the room and facing upwards, provides the sole source of electric light (besides code mandated emergency exit lighting). Aimed upward at the closed louvers (for insulation at night), it reflects off the louvers and uses the reflector to distribute light; as

daylight becomes available, the louvers begin to open, balancing electric light and daylight. When there is enough daylight to meet the illumination target the lamp is automatically switched off. Another, more expensive, option is a dimmable system, which can save a significant amount of electricity during times when partial daylighting is possible (during the hours in white in figure 2).

We developed a target illumination of 20 footcandles minimum to 40 footcandles maximum (IESNA, 2000). Increasing the minimum illumination above 20 footcandles, a level acceptable in other modernized countries, would necessitate larger apertures or increasing the amount of hours that electric light is necessary. Figure 2 shows that a room with a 4% daylight factor in Portland will achieve the minimum interior illumination of 20 footcandles for all but approximately 210 hours through the entire year (95% of operating hours), assuming a 9 a.m. to 4 p.m. schedule. Shifting the schedule an hour earlier, the number of hours with inadequate illumination would increase by approximately 43%. Our research showed that most school districts have the power to control their operating schedules, and that they choose their schedules for a variety of reasons.

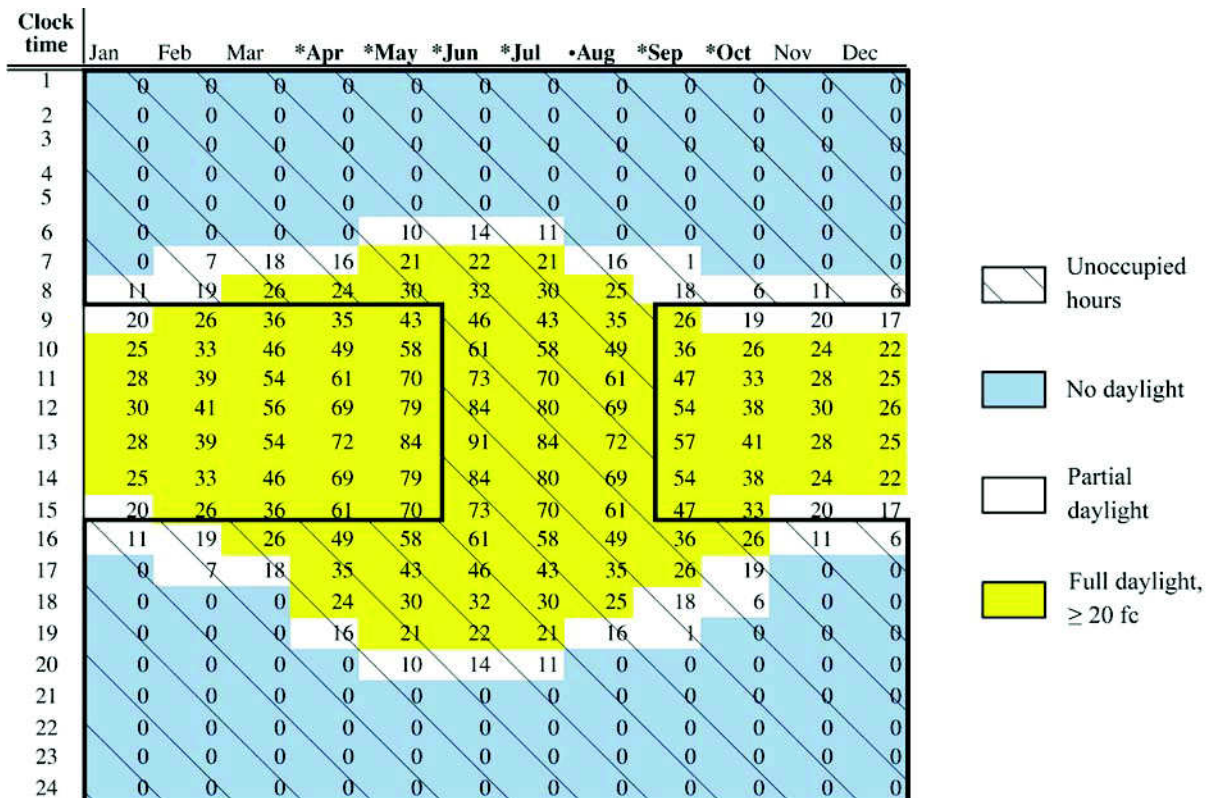

Figure 2: Interior illumination and operating hours with a 4% daylight factor under overcast skies in Portland, OR.

Because of the classroom's complex geometry, multiple methods of evaluation were used. The daylighting concept was developed using simulations, physical models, and a full-scale prototype to predict daylighting performance.

A full-scale prototype was then built a warehouse space, with a hole cut into the roof for the skylight. The materials used to construct the prototype were identical to those specified for the actual project. The prototype allowed for the testing and integration of systems difficult with other methods, such as the CPI ControlLite® product used for the skylight, which integrates louvers within its polycarbonate glazing and cannot be tested at smaller scales. Figure 3 shows daylight performance for the prototype, revealing that overall daylight is lower than the target (3.5 vs. 4.0) and that the corners are underlit. In the near future we will be collecting performance data from actual classrooms built at Mt. Angel Abbey, Oregon.

2.1	2.5	2.9	3.3	3.5	3.7	3.9	4.1	3.6	3.2	2.6	2.2	1.9
2.0	2.4	2.7	3.2	3.3	3.6	3.8	3.9	3.5	3.0	2.5	2.1	1.9
2.2	2.5	3.9	3.4	3.3	3.7	3.9	4.0	3.5	3.1	2.6	2.3	1.9
2.4	2.8	3.2	3.5	3.4	3.8	4.0	4.2	3.7	3.4	2.8	2.4	2.1
2.5	3.0	3.3	3.6	3.4	3.7	4.0	4.1	3.6	3.4	3.0	2.6	2.2
2.6	3.1	3.4	3.6	3.3	3.5	3.8	3.9	3.4	3.3	3.0	2.6	2.2
2.8	3.3	3.7	3.8	3.5	3.6	3.8	3.8	3.4	3.5	3.1	2.8	2.1
2.8	3.3	3.7	3.8	3.3	3.6	3.8	3.8	3.3	3.4	3.1	2.8	2.3
3.0	3.7	4.1	4.3	3.8	4.0	4.2	4.1	3.7	3.9	3.5	3.2	2.7
3.0	3.7	4.1	4.2	3.7	4.0	4.3	4.1	3.7	4.1	3.7	3.3	2.7
3.0	3.6	4.2	4.1	3.5	4.1	4.4	4.2	3.8	4.3	3.9	3.4	2.9
3.0	3.6	4.0	4.1	3.5	4.0	4.3	4.0	3.7	4.3	3.9	3.4	2.7
3.1	3.7	4.1	4.1	3.9	4.1	4.5	4.1	3.9	4.5	4.1	3.5	2.9
3.0	3.7	4.0	4.0	3.7	4.1	4.4	4.1	3.9	4.5	4.0	3.4	2.8
3.0	3.6	4.1	4.1	3.9	4.4	4.6	4.2	4.0	4.7	4.4	3.6	3.1
3.0	3.5	4.1	4.2	4.0	4.4	4.7	4.2	4.1	4.8	4.5	3.7	3.1
2.9	3.5	3.9	3.9	3.9	4.2	4.4	4.0	3.9	4.6	4.3	3.5	3.0
2.9	3.5	3.9	4.0	3.9	4.3	4.4	4.0	4.0	4.8	4.3	3.6	3.0
2.9	3.3	3.7	3.8	3.7	4.0	4.1	3.8	3.9	4.6	4.3	3.5	3.0
2.9	3.3	3.7	3.7	3.7	3.9	3.9	3.6	3.8	4.5	4.2	3.4	2.9
2.5	2.9	3.3	3.5	3.7	3.8	3.7	3.4	3.5	4.1	3.7	3.1	2.6
2.6	3.0	3.5	3.8	4.2	4.4	4.2	3.8	3.7	4.2	3.7	3.1	2.6
2.5	2.9	3.5	3.9	4.4	4.6	4.5	4.1	3.9	4.0	3.5	2.9	2.4
2.5	2.9	3.5	4.1	4.6	4.8	4.8	4.5	4.1	4.1	3.5	2.8	2.4
2.4	2.8	3.5	4.0	4.6	4.8	4.8	4.5	4.2	4.0	3.3	2.7	2.2
2.2	2.6	3.2	3.8	4.2	4.5	4.5	4.3	4.0	3.7	3.1	2.5	2.1
2.0	2.5	3.0	3.7	4.0	4.2	4.2	4.0	3.8	3.5	2.8	2.3	1.9
2.2	2.6	3.2	3.7	4.0	4.2	4.2	4.1	3.9	3.5	2.9	2.4	2.0

Figure 3: Daylight Performance of the Prototype. The numbers are the daylight factor (the ratio between the illumination at a point inside the space to the illumination available outside)at that point in the space.

1.2. Heating Synergies

Heating is a significant energy use for the typical classroom. However, winters are generally mild in the Pacific Northwest: while temperatures may occasionally drop below 30°F, they are typically over 40°F, as shown in figure 4. In addition, the largest portion of the heating load is due to the need for fresh air in the classroom.

By using a heat exchanger, we reduced the ventilation air load by approximately 50%. High levels of insulation in the envelope (R-29 in the walls, R-58 in the ceiling) greatly reduce heat loss over the entire day. The remaining load can be met by two unusual but practical sources: an electric light and the students themselves.

Classrooms are normally fully occupied, and the students themselves are a significant source of heat. Calculations showed that on most days their presence was enough to achieve a balance point within our expanded comfort zone. On the occasional day when this strategy was not enough, heat gain from the 450-watt HID was enough to achieve comfort. Ceiling fans recirculate stratified air near the ceiling.

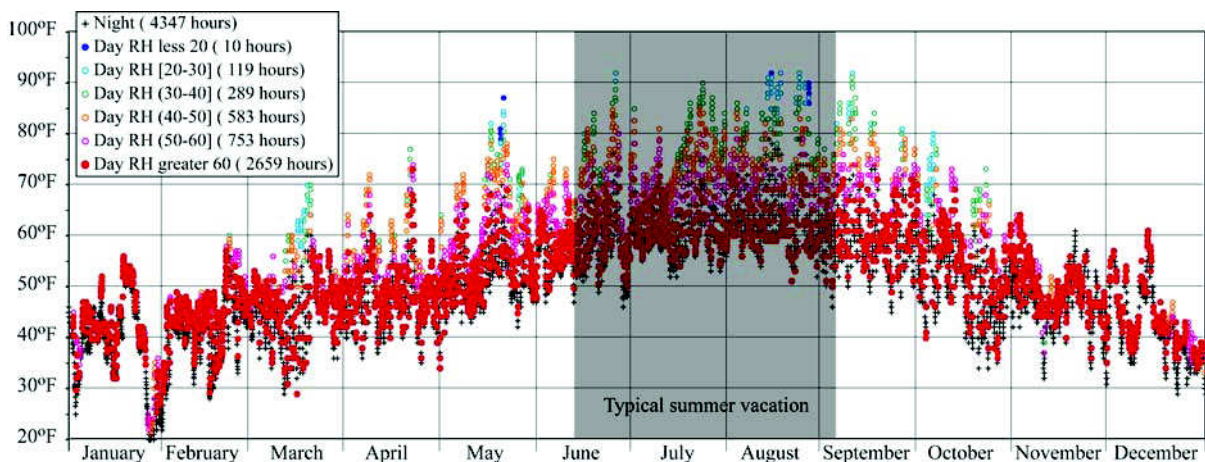

Figure 4: Annual temperature, Portland OR (TMY2 data)

1.3. Cooling Synergies

Conventional mechanical cooling was eliminated from the classroom. Elements from the heating synergies also serve to reduce cooling loads: high insulation values reduce the impact of afternoon temperatures peaking over 80°F, and the heat exchanger reduces the need to cool ventilation air.

The nine-month schedule typical of most schools is key, as it eliminates the hottest season and most peak temperatures (figure 4). Another critical synergy between climate and use involves the daily school schedule. The Pacific Northwest climate is characterized by night-time temperature depressions below 60°F, even on the hottest days. Since schools are (typically) unoccupied at night, they can be night ventilated with cool air. With thermal mass exposed in the floor and one interior wall, interior temperatures can be brought within the comfort zone on all but the hottest days.

With the expanded comfort zone, computer modelling showed that (based on monthly average temperatures) these strategies were enough to eliminate cooling needs except on the most extreme days. When occasional warmer night temperatures lead to insufficient mass cooling and interior temperatures peaking over 80°F, ceiling fans ensure occupant comfort, expanding the comfort zone by 2°F to 4°F (ASHRAE, 2004).

1.4. Lower cost

The synergies among climate, use, systems, and loads created by the architectural design resulted in sufficient to achieve a 70% reduction in classroom energy use (for the Portland, OR climate) while keeping costs lower than a typical reference classroom. We estimated a reference classroom to cost \$107,565, or \$112 per square foot, while the high performance design would cost \$106,801, or \$111 per square foot. Figure 5 shows how first costs compare on a square foot basis.



Figure 5: First cost comparison (per SF) between typical reference classroom and high performance classroom. (Source: BOORA Architects)

2. THE QUESTION OF INNOVATION AND MARKET TRANSFORMATION

2.1. Project history and current status

The concept was initially developed on paper in a study undertaken by the Energy Studies in Buildings Laboratory jointly with BOORA Architects and SOLARC Architecture and Engineering. This work was completed at the end of 2004. Subsequently, the design was refined and tested with a full-size prototype and then used by SRG Partnership for 7 classrooms at the new academic building at Mount Angel Abbey, St. Benedict, Oregon (directly across the plaza from Alvar Aalto's library). The classrooms range in size from 460 s.f. to 1300 s.f.

BOORA Architects is currently using the design for classrooms for a high school addition project in Portland. Recently, the concept was also specified in an Request For Proposals released by the Portland Public School District for a classroom building in Portland, Oregon, and this project is now under design by SRG Partnership. In addition, the Portland School District is looking into the possibility of adapting the design for modular classrooms. SRG Partnership is considering aspects of the concept for a 2400 s.f. space as part of a university building renovation. The Baker City School District has also been interested in the concept. After issuing a Request for Proposals, they stated that the concept should be used as a model for their new middle school (unfortunately their bond measure failed). We have also been asked to appear before the Yamhill Carlton School District 500' Subcommittee to discuss incorporating the design into their future school buildings.

The High Performance Classroom has also generated interest at the state level. The Oregon Department of Energy has begun promoting the concept to architects, engineers, and school districts around the state.

2.2. Hypothesis on the value of innovation for market transformation

Market transformation is relatively easy when the need or problem and the product or solution is well established. In the case of the new needs or products it is more difficult. However, if the product is innovative and addresses market transformation barriers, market transformation requires much less effort. Our hypothesis is that an innovative product can stimulate market transformation more rapidly than approaches that rely on educating owners and designers about existing concepts and strategies. Our High Performance Classroom uses less energy and costs less than the conventional alternative, and it provides opportunities for space variations. It was designed specifically for the Pacific Northwest climate, with the roof of the classroom having access to the sky. To achieve energy performance that can exceed 70% better than code at a lower cost, an integrated design process was used to identify synergies among climate, use, systems, and loads that could be created by the architectural design.

Our mission is to reduce the environmental impact of buildings, primarily by reducing the amount of energy needed for lighting, heating, cooling, and ventilation. Our market transformation efforts address energy-efficient design strategies and technologies, especially those involving daylighting and natural ventilation and focus on the key decision-makers: architects, engineers, and owners. In working with these stakeholders over the last 20 years of consulting and research we have repeatedly encountered several barriers to transformation. The most important include: 1) a perception that energy efficiency costs more – for instance, every owner has a limit to how much they are willing to spend for energy features beyond what is required by building codes; 2) a lack of awareness about the benefits of energy design, both energy related and non-energy related; 3) a lack of knowledge about how to design energy-efficient buildings; and 4) a fear of trying new technology (such as lighting controls).

The construction budget constrains design and is fundamental to all key decisions—whether to build, how much building is needed, what level of quality to design for, etc. Construction cost can be viewed as a barrier or an opportunity in the creation of energy-efficient buildings. Most often energy efficiency is perceived as adding to the cost of a building, and since construction budgets generally do not recognize energy features, they can act as a restraint on innovation. However, reconsidering the construction budget can encourage energy efficiency features. In this case we achieved synergies between energy goals and other design goals and so found opportunities to both reduce cost and improve performance. We explicitly showed the value of the energy savings and made sure that the construction budget included items that were critical to the design's success.

We can inform design professionals and owners about the proven energy benefits of the design because we have modelled the performance of the concept and tested prototypes. Non-energy benefits, such as increased occupant comfort and satisfaction, are also becoming increasingly important in making the case for energy features, especially as these relate to productivity. For instance, we performed computational fluid dynamics modelling of the thermal performance of the concept when it was being considered for a project at Mt. Angel Abbey, Oregon. This allowed us to describe the impact on thermal comfort of the mass and natural ventilation features.

The initial project was a collaboration with two professional design firms. When the concept was adopted by another firm for use in one of their projects we consulted with them during design and construction. All of this work involved project-based education – the informal teaching and learning that occurs while working side-by-side on a particular project. We believe this to be invaluable, both for transmitting how-to information and for conveying enthusiasm and a sense of the creative architectural opportunities of energy design. These people, who work in firms that have special expertise in school design, have since become the early adopters of the concept. By virtue of their design work the concept has achieved greater visibility and acceptance.

We have found that one of the most effective ways to allay fears of “unknown” technologies is through demonstration. In cases where the energy features have been used by others, the demonstration is as simple as providing information on successful buildings. However, when we develop new ideas, we build full-size prototypes. These provide multiple benefits in that we can work out the details in our designs, the architect and engineer can learn directly how to design the space, and the owner can have a tangible experience of the improved space, making it “real” for them. Arguably the greatest benefit of the full-scale prototype comes from being able to inhabit it. The experience of being in the classroom (figure 6) proved that it was a beautiful, well-daylit space. This was a useful and rewarding experience for both the design team and for visitors. During the course of the prototype’s existence, approximately one hundred people visited the classroom, including architects, teachers, school administrators, facility managers, utility representatives, reporters, and others interested in education and/or green building. Visitors were uniformly impressed with the quality of the classroom and its exceptional energy performance.



Figure 6: Visitors to the High Performance Classroom Prototype

The completed building at Mt. Angel is now an even more effective demonstration of how the High Performance Classroom concept can be used to create attractive, high performing spaces. Figure 7 shows one of the larger classrooms at Mt. Angel.



Figure 7: A Classroom at Mt. Angel Abbey. Source: SRG Partnership.

3. CONCLUSIONS

Our low cost, high performance classroom concept shows signs it will achieve a life of its own. We would argue that this is because it is a better design. Continued interest in the concept will allow us to test our market transformation hypothesis, for instance, by doing a statistical analysis of the number of classrooms built with our features in comparison to the number of more traditionally designed classrooms. It could be quite revealing to do this study to show geographical distribution over time. The concept has applicability outside of classrooms in the Northwest, although there certainly will be limits to aspects of its design. For example, while the daylighting features will be adaptable to warmer climates, the cooling features, in their current form, may not. If interest in the concept continues to grow, as we expect, we should have opportunities to test the limits of its applicability.

ACKNOWLEDGEMENTS

Mike Hatten of Solarc and Heinz Rudolf of BOORA Architects were partners in the development of the classroom prototype. Kent Duffy and SRG Partnership were partners in the development of the full-scale prototype space. Energy Studies in Buildings Laboratory staff involved with the project include Wade Jensen, Mark Wilkerson, and Emily Wright, who helped develop the high performance classroom design, and Crawford Smith, who helped develop of the full-scale prototype classroom. Mt. Angel Abbey agreed to the use of the High Performance Classroom concept for the design of their Academic Building, and provided warehouse space for the prototype construction. This project was designed with the support of the BetterBricks program of the Northwest Energy Efficiency Alliance.

REFERENCES

ASHRAE. 2004. ANSI/ASHRAE Standard 55-2004, *Thermal Environmental Conditions for Human Occupancy*. American Society of Heating, Refrigerating and Air-Conditioning Engineers, Inc.: Atlanta.

IESNA. 2000. *The IESNA Lighting Handbook, 9th ed.* Illuminating Engineering Society of North America: New York.

Heschong Mahone Group. 1999. *Daylighting in Schools: An Investigation into the Relationship Between Daylighting and Human Performance*. Pacific Gas and Electric Company: San Francisco.

Measurement And Education

How Are We Doing? A Protocol For Building Performance Reviews
Cathy Turner

Considering The Whole: Developing a Whole-house Calculator
Michael O'Brien, Ron Wakefield

A Systemic Model For Designing Energy Optimized Buildings
Audrey Kay Werthan

Awareness: the ground for sustainable design
Randall F. Teal

Innovative Sustainable Water Management Practices in Solar Residential Design
C. Jason Mabry, Franca Trubiano

How Are We Doing? A Protocol for Building Performance Reviews

Cathy Turner

New Buildings Institute, White Salmon, WA

ABSTRACT: This paper summarizes the state of post-occupancy evaluations (POEs), defines a new protocol designed to meet the marketplace needs and cost tolerance, and describes results of pilot testing. Initial research consisted of a literature review, interviews with potential POE users, and an exploratory study of actual energy use and occupant comfort in 11 LEED buildings. No single protocol in the past has met all the goals of budget, scope and direct applicability to the end user that were suggested by the market research. The new protocol breaks the POE into two stages, to keep costs as low as possible for a basic Level 1 evaluation. To draw the most useful inferences from readily available information, Level 1 input includes utility usage, an occupant survey, and an interview with the facility operator. An optional Level 2 review would implement diagnostics or actions recommended in the Level 1 report. An example is presented of the types of information learned from Level 1 pilot test results.

Post-occupancy, energy-use intensity, building performance

INTRODUCTION

Improving commercial building efficiency requires feedback to owners and designers on actual resource use and occupant comfort, but such building performance is rarely measured. Why? Barriers to achieving feedback through traditional post-occupancy evaluation have been well documented, but not yet overcome. This paper describes a protocol for reviewing actual building performance that grew out of market research conducted by the New Buildings Institute, covering who is potentially most interested in the results of such reviews and the most desired pieces of information. This paper consists of three primary areas:

1. Market research on the current interest in, and barriers to, performance evaluation.
2. Lessons from a review of 11 green buildings in Oregon and Washington.
3. Refined protocol development and implementation.

Successful implementation of this review protocol should achieve useful performance feedback on many more buildings. Knowing how buildings really perform has the potential to help owners optimize savings, further reduce utility costs, and foster a productive working environment for occupants. Completing the feedback loop to original designers can extend these lessons and results to future new buildings.

1. MARKET RESEARCH: WHY IS PERFORMANCE RARELY REVIEWED?

Post-occupancy evaluation (POE) is the general term for a broad range of activities aimed at understanding how buildings perform once they are built. Practitioners use the term with a variety of meanings, including occupant surveys, energy and water use analyses, and review of building system performance. A POE energy study may include any of the following: total building energy use intensity (EUI) compared to benchmarks, energy end-use analysis, and comparison between actual and anticipated energy use (with or without as-built calibration of the original energy model). Time and expense requirements are often seen as prohibitive for some of these activities. This section describes literature and market research done to determine whether any existing POE protocol could affordably meet the needs of those most interested in the results.

The most widely known POE tools may be the Post-Occupancy Review of Buildings and their Engineering (PROBE) work in Great Britain (Standeven, M., Bordass, B., Leaman, A., Cohen, R., 1995-2002 and survey tools developed and supported by the Center for the Built Environment at UC-Berkeley. It appears that even these better known products have been used on at most a few hundred buildings over ten or more years.

1.1. Literature review

The literature sought to determine whether an established protocol already existed for completing a POE that would meet the needs of building owners and other immediately interested parties. Two recent books on POE have brought together many of the key lessons learned to date. (Federal Facilities Council, 2002; Vischer, J. and Preiser, W., 2005). These materials describe a wide variety of POE protocols, but few focus on addressing the immediate interests of building owners. Although elements of several protocols appear to be useful, no single one accomplishes the goals of meeting building owner needs in terms of budget, scope and direct applicability of results. In addition, a useful and repeatable standard POE must address a series of critical market barriers.

Review of the literature indicates several well-documented barriers to achieving feedback from traditional POEs. Among the more substantial are:

- It is not clear who has responsibility to conduct POEs;
- Funding for POEs is not included in design budgets;
- The results may come too late to be perceived as useful for the design team, which has moved on to the next project, or to an owner who may not be planning any similar projects;
- Technical and logistical difficulties often arise in obtaining even basic data; and
- The POE report may uncover problems, possibly leading to awkward questions or even liability. At the very least, professionals are not that interested in other professionals reviewing their work.

Looking at the distribution by size of the country's commercial building stock helps frame the issues of technical difficulties and POE cost. As seen in Figure 1, the most recent Commercial Building Energy Consumption Survey (CBECS) shows that over 75% of U.S. commercial buildings are less than 930 m² (10,000 ft²). Buildings below 4,600 m² (50,000 ft²) comprise over 90% of all commercial buildings and a full 50% of all floorspace. Complex energy management systems with monitoring and diagnostic tools are often designed for much larger buildings and are not affordable by the managers of these smaller structures.

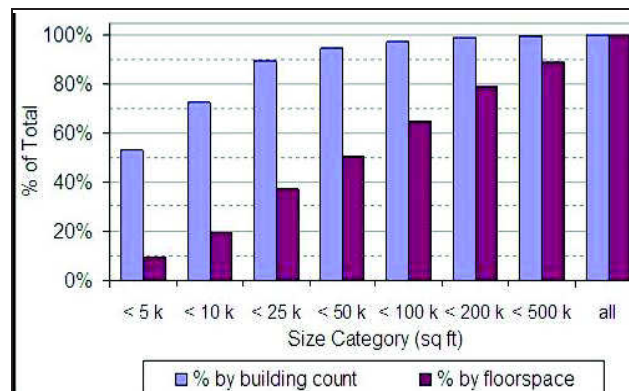

Figure 1: CBECS Building Size Distribution, Cumulative Percentages by Count and Area
(Data Source: Commercial Building Energy Consumption Survey 2003, www.eia.doe.gov/emeu/cbecs)

1.2. Market research

The next stage of the market research was to better understand key aspects of POE usage: current informal practices regarding feedback on building performance and occupant satisfaction; the most attractive and motivating elements of a potential POE tool; and the potential value of a POE to the end user. In-depth interviews gathered views from ten individuals representing three market perspectives: private developers/owners, public building owners and design team members. Discussions with these designers and owners helped identify professions most motivated to obtain building performance feedback, and the information most useful to them. Owners are clearly the audience most immediately interested in these reviews, although designers can also benefit. Both owners and design team members state they would use an affordable performance evaluation tool. Few owners systematically collect information on occupant satisfaction with their buildings. The cost of evaluation was cited as the largest barrier, followed by logistical or time constraints. It appears that \$2,000 to \$5,000 is the maximum that most interested parties would be willing to pay. Energy use and occupant satisfaction were seen as the most important elements to include.

The results of this market review are further described in Hewitt, 2006.

2. LESSONS FROM PACIFIC NORTHWEST LEED BUILDINGS

A study of 11 recent buildings certified by the US Green Building Council's Leadership in Energy and Environmental Design (LEED) program further informed research into a practical Building Performance Review protocol. This study was sponsored by the Cascadia Region Green Building Alliance and is further described in Turner, 2006. It gave preliminary feedback on practical considerations in gathering simple building data. It also provided insight into actual performance levels of these buildings. All buildings were in the Portland, Oregon to Seattle, Washington region, had been occupied for at least one year by the fall of 2005, and were certified under the US Green Building Council's LEED program. Beyond that similarity, the buildings varied widely and included office, library, and multifamily residential facilities. Sizes ranged from 12,000 to 360,000 square feet.

Thirty-one buildings met the criteria in the previous paragraph and were eligible to participate. The 11 buildings in the final study consist of all those with owners who were willing and able to provide the needed information during the limited study timeframe. While this is not a random sample of all green building, it should be a good snapshot of available information. Table 1 lists basic characteristics of the participating buildings.

Table 1: Participating Buildings
(LEED Level refers to the New Construction (NC) program except where noted)

Building (abbreviation used in later graph)	Size	LEED LEVEL (New Construction program except where noted)
OFFICES AND LIBRARIES		
Balfour Guthrie (BG) Portland OR	18,000 sq ft 3 stories	Silver
Jean Vollum Natural Capital Center (NCC) Portland OR	70,000 sq ft 3 stories	Gold
Hillsdale Branch, Multnomah County Library (HL) Portland OR	12,300 sq ft 1 story	Gold
King Street Center (KSC) Seattle WA	320,000 sq ft 8 stories	LEED-EB Gold (Existing Buildings program)
Seattle Public Library's Central Library (SL) Seattle WA	363,000 sq ft 11 stories	Silver
Viridian Place (VP) Portland OR	15,000 sq ft 3 stories	Certified
Building O-7 (anonymous) (O-7)	34,000 sq ft	Certified
RESIDENTIAL BUILDINGS		
Portland State University Broadway Building (B) (owned by the PSU foundation) Portland OR	198,400 sq ft 10 stories	Silver
Portland State University Epler Hall (E) Portland OR	64,000 sq ft 6 stories	Silver
The Henry Condominiums (H) Portland OR	220,000 sq ft 12 stories	Gold
Traugott Terrace (TT) Seattle WA	32,000 sq ft 6 stories	Certified

2.1 Energy Use

Six of the 11 buildings were using less total energy than suggested by their initial Design models. "Design" as used here refers to the modelling provided with the initial LEED submittal, reflecting energy use with all anticipated energy efficiency measures. The LEED models were prepared primarily to estimate the value of individual energy efficiency measures, not necessarily to accurately predict the absolute level of total utility usage in a building. Thus, the comparison of actual usage and the modelled Design usage is at best an approximate measure. More precise conclusions would require further analysis of changes between initial design and the as-built structure and systems. Other, non-efficiency-related differences, such as actual occupant numbers, building usage patterns, and building management practices would also need to be identified.

Figure 2 shows Actual and Design energy use intensities (EUIs), with office and residential buildings each sorted from lowest to highest actual EUI. Despite the variety of buildings in the study, eight of the eleven have actual EUIs in the relatively narrow range of 510 to 625 MJ/m²/y (44 to 55 kBtu/ft²/y). No single building's actual performance was within 20% of its Design model. The average actual/Design ratio was closer than that for any individual building: 110% for all buildings and 89% if the unusual results of building O-7 are excluded.

Building O-7's actual usage exceeded its Design model by 300%. This building represents a case where the owner was aware of problems even before this POE study was done. The facility had experienced a number of HVAC systems and lighting control problems during its first few years, and building managers felt they had finally succeeded in tuning the systems and replacing components where necessary by the end of the study period. A simple follow-up a year later would be instructive.

The Hillsdale Library, which shows the highest Design EUI of the group, had a number of site constraints and design requirements that may partially explain its energy usage level. In addition, as the only single story building in this study, it has a higher surface to volume ratio than the rest of the buildings, which can also lead to greater heating and cooling requirements.

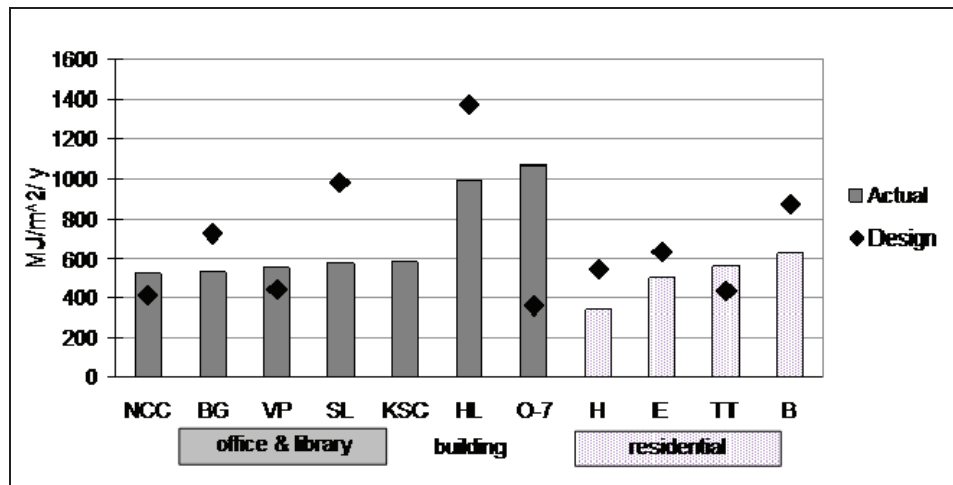

Figure 2: Comparing Actual Energy Use Intensity with Initial Design Models
No design modelling was available for King Street Center, which was LEED-certified several years after construction, under the Existing Building program.

2.2 Occupant Survey

An on-line occupant survey sought to determine perceptions of building comfort and functionality in the categories of temperature, air quality, lighting, noise, and plumbing fixtures. Response options were on a 5 point scale with a central neutral point. All those working in office buildings or living in residential buildings were invited via e-mail to participate. Figure 3 displays the general question structure for a typical question.

6. How satisfied are you with the temperature in your workspace

Very satisfied Somewhat satisfied Neutral Somewhat dissatisfied Very Dissatisfied

Figure 3: Sample survey question

The survey response rates of office building occupants ranged from 40% to 73%. A response rate of 50% or higher is a common target census surveys such as this, in which all occupants are invited to participate. While results from a building achieving a lower response rate, or with very few occupants, are not as statistically rigorous as one might prefer, they can still be useful in identifying issues in the building.

Residential response rates were extremely low, with the exception of Traugott Terrace, which conducted a paper survey during a meeting of residents. Thus the following paragraphs discuss only the office results.

Office respondents were generally very satisfied with their building overall and somewhat satisfied with their personal workspace. Satisfaction ratings for most categories, with the exception of noise level and sound privacy, were typically positive. Light levels and air quality were both generally perceived as being somewhat helpful in getting work done. The dissatisfaction with noise levels and sound privacy has also been reported on surveys by others, and is often associated with open office environments. Workspaces of survey respondents were typically low partition cubicles or desks with no partitions. Figure 4 summarizes the range of office building response averages for the primary survey questions.

Within the categories receiving positive ratings, temperature conditions had the lowest median scores, with satisfaction falling in the “somewhat satisfied” range. Also, a relatively low percentage of occupants perceived temperature conditions as helping to get their job done. A more in-depth occupant study could investigate whether these problems were concentrated in specific building locations or with specific types of occupants. Because this survey included only LEED buildings, there is no comparison with “non-green” offices. However, the similarly structured surveys from the Center for the Built Environment, which cover a broad spectrum of office buildings, have reported slightly negative thermal comfort satisfaction, as opposed to the slightly positive results here. (Huizenga et al, 2006)

One purpose of an occupant survey is to determine whether low energy consumption is possibly being achieved through reducing comfort for occupants. In this limited sample, there was no clear relationship (positive or negative) between the level of temperature satisfaction and building energy use intensity.

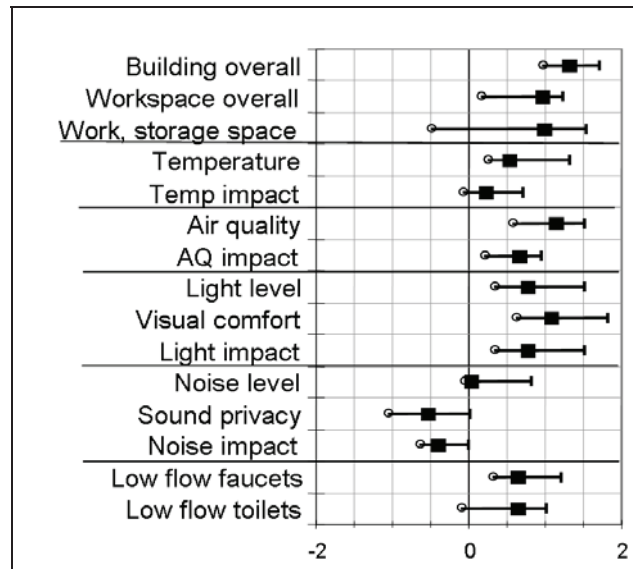

Figure 4: Average office building survey responses by category
 -2 = very dissatisfied; +2 = very satisfied
 o–Least satisfied office; ■–Median office; |–Most satisfied office

2.3 Procedural Lessons

These simple whole-building calculations showed useful, though not diagnostic, snapshots of actual performance. Procedurally, considerable time was required for gathering even the basic energy usage data. Two primary factors underlie this time requirement: the fact that most building owners do not retain past energy billing information in readily accessible format, and difficulty in identifying the individuals who might have access to the information or be able to authorize utility company release of the information. The fact that this study was entirely funded by the sponsor, with no cost to participating building owners, may have reduced the degree to which study results were used by building owners.

This study also revealed some basic steps that, if taken during initial design and construction, could simplify later measurement of actual savings achieved and potentially increase total efficiency savings. The underlying theme is to plan from the outset for later simple monitoring. For example, one of the primary impediments to even the simplest studies can be the lack of basic utility usage information. Failure to meter individual buildings on an institutional campus prevents later summarization of whole-building performance.

3. MARKET-FRIENDLY PROTOCOL DESIGN

Using the market research results and experience of the LEED building study, we derived a refined protocol to perform simple Building Performance Reviews (BPRs) with cost and content that would be attractive to the marketplace. Lessons from the earlier steps fall into the main categories of audience, content, and delivery.

3.1 BPR Description

The primary audience for a market-friendly product is the building owner. While elements of POEs are of interest to design teams, the owners have a more compelling interest and greater ability to fund. Owners should be encouraged to create a feedback loop to influence design teams for future projects. Owners of institutional and

public buildings are particularly good candidates for a BPR, because of their long ownership period, need for public accountability, and portfolio of properties that can form a locally relevant benchmark.

The BPR results should cover total energy use and an occupant survey. Water efficiency may also be covered, although our experience is that meter readings in many smaller office buildings are often too infrequent or unreliable for useful results. The report should include information that focuses the attention of the owner on improving building operations. For buildings requiring attention, the focus should be on creating a pathway to action: defining steps to improve comfort and/or reduce operating costs. The BPR should not, on the other hand, include critiques of specific design elements (e.g., a daylighting design or unusual HVAC system design). That level of review would require the cost of additional time and expertise, without leading to more useful corrective actions than can be obtained by observations of end performance.

Procedurally, the entire BPR protocol should be broken into at least two stages. The first should be as simple and low-cost as possible. Low-cost Level 1 protocols could be repeated every year or two. The results would enable owners to compare one building over time and also to compare a range of buildings within their portfolio. To draw the most useful inferences from readily available information, Level 1 input should include a full year of actual utility usage, an occupant survey, and an interview with the facility operator. The resulting indicators will reflect whether the building is performing overall to desired benchmarks, which may be based on regional norms, established ratings systems such as Energy Star, or design expectations for the building. For buildings not meeting the desired standard, the Level 1 report should provide a limited set of findings regarding performance issues, including areas to address and diagnostic tools or steps that could be helpful. An optional Level Two review can implement the recommended diagnostics, to better identify underlying causes of, or solutions for, general issues that surfaced in Level One.

3.2 Pilot Test Example

The Level 1 protocol was piloted in four elementary schools in Washington. Figure 5 shows energy usage for one new school, in relation to the old building that it replaced and the entire district portfolio of elementary schools. In this example, the new building was using less energy per square foot than the district median, but slightly more than the old building it replaced. The Level 1 report suggested further investigation of the heating and ventilation set points, and the facility managers discovered that the boiler had been running at times that no heat was needed.

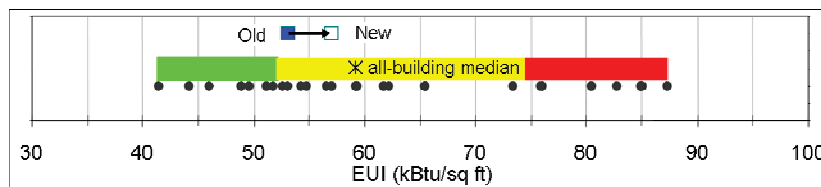

Figure 5: Energy Use Intensities for the New elementary school and the Old building it replaced. Dots represent all elementary schools in the district portfolio. Shaded rectangles represent the best (lowest EUI) quartile on the left, and worst (highest EUI) quartile on the right.

This example also demonstrates the benefit of gathering occupant feedback as well as utility usage. All teachers, staff, and survey workers were invited to complete a brief online survey. Response rates ranged from 60 to 68%. Figure 6 shows the average occupant comfort scores by category for each of the four schools studied. The two new school buildings are those on the left, with marked positive ratings in nearly every category, in sharp distinction to the two older schools on the right. The negative rating for acoustic comfort in one of the new schools was a previously unidentified problem and is currently being investigated.

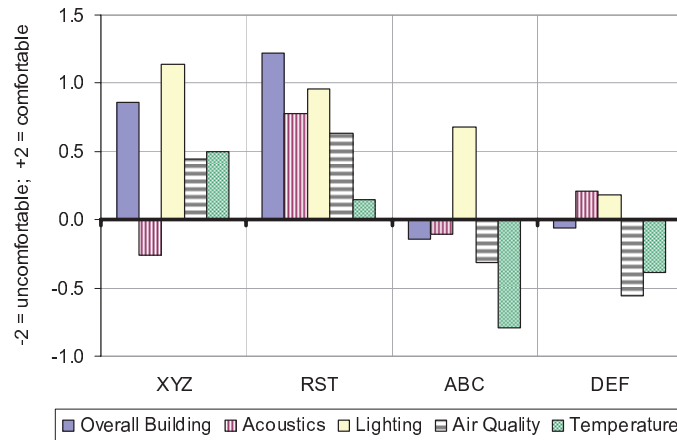

Figure 6: Average functional comfort scores for two new school buildings (XYZ and RST) and two older buildings (ABC and DEF)

Follow-up surveys done over a period of years will increase our understanding of the degree to which higher comfort ratings in new buildings decline as the buildings age.

CONCLUSION

While there is interest on the part of both owners and designers in knowing how well buildings perform, a number of factors have limited the frequency of measuring post-occupancy performance. The BPR protocol seeks to materially increase the number of useful performance reviews by extracting performance indicators from readily available data. A staged approach creates a simple Level 1 report which, if the building is not meeting overall expectations, identifies the next steps to take in diagnosing the underlying problems. Pilot tests of Level 1 have shown that useful insights can come from combining readily available data from multiple sources: utility bills, a simple occupant survey of functional comfort, and interviews with facility managers. For areas in which Level 1 suggests further investigation or correction, further development work is still needed to streamline the path to Level 2 diagnostics and action.

ACKNOWLEDGEMENT

This document draws on market research funded by the Northwest Energy Efficiency Alliance and a study of LEED building performance funded by the Cascadia Region Green Building Council. The support of both those organizations, as well as the participation of owners of buildings studied is gratefully acknowledged.

REFERENCES

- Federal Facilities Council, 2002, *Learning from Our Buildings, A State-of-the-Practice Summary of Post-Occupancy Evaluation*, Federal Facilities Council Technical Report No. 145, National Academy Press, Washington DC.
- Hewitt, D., 2006, *A Market-Friendly Post-Occupancy Evaluation: Building Performance Report*, New Buildings Institute contract C10091 for the Northwest Energy Efficiency Alliance, Portland, OR.
- Huizenga, C., Abbaszadeh, S., Zagreus, L., Arens, E., 2006, „Air Quality and Thermal Comfort in Office Buildings: Results of a Large Indoor Environmental Quality Survey,” *Proceedings of Healthy Buildings 2006*, Lisbon, Vol III, 393-397.
- Standeven, M., Bordass, B., Leaman, A., Cohen, R., 1995-2002, Probe Reports 1 through 23, *Building Services Journal* [available <http://www.usablebuildings.co.uk/>, 1/3/2007]
- Turner, C., 2006, *LEED Building Performance in the Cascadia Region: A Post Occupancy Evaluation Report*, Cascadia Region Green Building Council, Portland, OR.
- Vischer, J., Preiser, W., eds., 2005, *Assessing Building Performance*. Elsevier Butterworth-Heinemann, Burlington, MA.

Considering the Whole: Developing a Whole-house Calculator

Michael O'Brien¹, Ron Wakefield²

¹Myers-Lawson School of Construction, Virginia Tech, Blacksburg, Virginia

²School of Property, Construction and Project Management, The Royal Melbourne Institute of Technology, Melbourne, Australia

ABSTRACT: Comparing the characteristics of one house to another is one of the most difficult tasks facing a prospective homebuyer. Each house is the result of tens of thousands of decisions made by material suppliers, product manufacturers, designers, engineers, regulatory officials, marketing professionals, builders and subcontractors. Even though many appear similar, each house is effectively unique, a one of a kind assembly that will stand, breathe, manage water and shelter its inhabitants differently.

Professionals designing the house, selecting the materials and products to include and developing the processes used to design, engineer and produce the house face a daunting number of choices as well. Their choices affect how quickly the market accepts the house, how the house behaves when stressed by forces of nature and how efficiently the house uses energy, labor, and materials.

The whole-house calculator grew from a series of research projects sponsored by the Department of Housing and Urban Development's Office of Policy Development and Research: "PATH 13 Whole House Calculator", "A Preliminary Method to Develop a Calculator for Evaluating Physical Design Characteristics and Whole House Performance Scoring", "Creating Whole House System Solutions" and "Designing Whole House Solutions." The purpose of these projects was to investigate the feasibility of quantitative assessment of the performance of design and production processes, materials, systems, and the interactions between them for the purpose of comparative scoring.

This paper will present the approach, theory, method and current state of development of the web-deployable whole house calculator.

1.0 INTRODUCTION: As it exists today, a house is a product of almost two hundred years of trial and error development that have added and subtracted materials and subsystems to the house in response to changing technological, social and financial pressures. Over the last forty years some individual subsystems (structural/thermal) have been carefully scrutinized, researched, and discretely optimized to balance performance outcomes with financial inputs. Most remaining subsystems (foundation, envelope, plumbing, lighting) continue to be largely based on approaches that have evolved over time. The result is a complex federation of semi-independent systems of design, engineering, procurement and production, each having discrete standards, goals, and governing regulations. The intense focus on discrete system optimization has, in some highly visible cases, produced unexpected interactions with related or adjacent systems that have significantly compromised the integrity of the house as a whole (Brown et. al 1997). A common factor in these instances of diminished performance of the whole seems to be the confluence of an innovative substitution within a conventional approach to housing design and construction.

The conventional approach to residential building can be described as a series of innovations applied to a traditional construct. Builders often adopt a traditional approach to the processes, products and designs for the house to be able to focus on the production and sale of the house. Traditions are familiar, don't require extensive design or analysis that costs time and money, and generally, are safe in the marketplace. Some of the traditions have developed from personal success, while some have been handed down as best practices. Traditions are often perceived as having been established by tried and true methods and require no further investigation.

Traditions seldom provoke innovation, but the competitive marketplace demands it. Financial and legal risks temper the extent of innovation proposed by builders, and accepted by buyers. New processes, materials or

products are typically introduced into the traditional process slowly, in small increments, adding a new material or system or substituting a new material for an old one. Often this substitution is done without full consideration for its impact on related parts of the system or the whole. The innovation is introduced to the market often based on the reputation of its advocate. The better the reputation of the advocate, the greater the capacity to share risk with the builder or buyer (Koebel and Cavell, 2006)

The systems approach stands in contrast to the federation of components produced by the conventional approach. One of the many definitions of a system is “a dynamic entity, like a cell, organism, organization or environment which is comprised of interdependent parts, fundamentally characterized by inputs, processes or throughputs and outputs; parts in interrelationships that work together for the purposes of the whole.” The phrase “whole house” implicitly suggests all parts working for the benefit of the whole. The house itself is simultaneously the result, or output, of a much larger system and once completed, it is, ideally, a dynamic entity, a system itself.

Because a house is both the output of a system and a system itself, the concept of wholeness of the house extends beyond its walls. Its lineage extends back to its conception, so to consider a whole house is to consider both its completed end state *and the processes that produced it*.

Interrelatedness is a defining aspect of a system. The degree of interrelatedness of the parts and processes that comprise the system effectively set the level of performance of the system and the products of the system. Theoretically, all parts and processes interact with and affect all other parts and processes in the system as well as the environment in which the system is located.

There are approximately 143 separate parts that make up the 54,000+ total part count in a house. Given that there are at least four alternatives for each part, and taking the six climate zones and six seismic design categories identified in the International Residential Code (IRC) and conservatively assuming six alternative house designs facing one of eight possible compass orientations there are over five hundred million combinations of the system (O'Brien and Wakefield, 2005).

The conscious analysis of the interactions among all the parts, materials, subsystems processes making up a traditional light-wood-framed house and the climatic and geologic conditions of the site is seldom undertaken. A house design that worked well and possessed a subjective charm in rural New England becomes a higher risk when transplanted to a coastal community in Florida (ARA, 2002). A cladding system with decades of successful performance on masonry substrates puts the structural framing at risk in a warm, humid climate (Brown et. al. 1997). Even locating an HVAC unit in an attached garage may contribute to an increased risk for a family's health problems in certain climates (Emmerich et. al. 2003)

It seems unreasonable to ask a designer or builder to carefully analyze the numerous and complex interactions. Partly because there is little or no undisputed evidence to prove that a traditional architectural house form constructed using contemporary contracting and inspection methods from a combination of traditional and innovative materials and systems within a traditional visually-based method of quality assessment *will* fail at some aspect of performance, and partly because there is no accepted method for analyzing the house as a whole. ASCE – 7 considers the structural aspects, ASHRAE standard 62.2 considers the ventilation and air quality, but is not yet a required standard in the International Residential Code. Material innovations are being introduced faster than the residential building culture can thoughtfully adapt. This lack of consideration for the performance of the whole house sited on a unique parcel of land frequently contributes to performance failures significant enough that either FEMA or class-action litigation is the homeowner's only recourse.

2.0 APPROACHES TO CONSIDERING THE WHOLE: Some of the earliest public/private partnerships considering the house as a whole were undertaken by the U.S. Department of Energy Building America program and the U.S. Department of Housing and Urban Development and National Science Foundation's PATH program.

The Building America Program began in 1991 as a small group of partnerships between housing designers, engineers, research groups and residential builders. Today the program has five research teams that have completed over 20,000 homes in 24 states. The program is focused on:

- Reducing whole-house energy use by 40–70% and reduce construction time and waste;
- Improve indoor air quality and comfort;
- Integrate clean onsite power systems;
- Encourage a systems-engineering approach for design and construction of new homes;
- Accelerate the development and adoption of high-performance residential energy systems.

The focus on energy conservation through systems and field-process design has made improvements in structural systems performance as well through the implementation of formal quality processes. The “Best

Practices Guides” available on the Building America Program website contain outstanding examples of the benefits of considering the whole (Building America 2006)

The Partnership for Advancing Technology in Housing (PATH) began considering the house as a whole with the publication of “Whole House and Building Process Redesign” as part of its Technology Roadmap series (NAHB, 2002). In this roadmap, the vision for this research effort was succinctly stated as “Build Better Homes Faster and at Lower Cost”, which was further elaborated to mean development of efficient, controlled processes to construct a house in a 20 day period to provide cost savings making home ownership available to 90% of the U.S. population. The Whole House roadmap identified these key barriers to achieving the goal:

- A lack of systems engineering and analysis in the design and construction of homes;
- Consumers lacking education in the quality aspects of a home;
- Insufficient quantities of skilled labor;
- Complex and locally unique building regulations;
- Builder resistance to change;
- Builders lack of control of the home building process;
- Industry lack of collaboration and resistance to change;
- Industry fragmentation;
- Consistency of home quality.

The idea of a “Whole House” Calculator was developed to support the goals of rapid construction and affordability by being able to compare the performance of a house design on a specific piece of land to a recommended practices house and identify system weaknesses prior to construction.

2.1 EARLY METHODS: Literature searches failed to reveal a holistic assessment method for residential construction capable of quantifying subjective and objective characteristics of the processes, systems and materials used in residential construction. But the literature search did reveal an Environmental Evaluation method developed by Dr. Luna B. Leopold for the USGS which was further modified by Battelle laboratories. The Leopold/Battelle method uses a matrix to list possible actions on a horizontal axis and environmental quality outcomes on the vertical axis. An expert group identifies important interactions between a desired environmental quality and a project-related action in the first pass through the matrix. Hollick, (1993) documents Leopold’s proposition that if 100 construction actions were listed horizontally, and 88 environmental outcomes were listed vertically, that when carefully considered, a typical project would only have 25 to 50 interactions between them, a significant reduction from the possible 8,800 interactions in the matrix. (Hollick, 1993)

The second pass through the Leopold/Battelle matrix is a scoring pass. The interaction is ranked from –10 to 10 for its positive (benefit) or negative (cost) effect. A third pass through the matrix assigns the weighting factor for each interaction. Environmental professionals who have used the Leopold matrix offer two cautions. First, that the user be on guard to prevent double counting of nested effects, and second that each design alternative requires it’s own matrix.

The Leopold/Battelle interaction matrix was developed for the first generation whole house calculator. It listed the potential impacts of the system behavior vertically and the alternatives for the design and production methods and subsystems components horizontally. Two test-case houses were evaluated using this approach. The first was a convention production house made up of 93 systems choices that were scored on 23 performance characteristics and 4,324 systems interactions. This house scored 15.81% of a best possible score for a house with 93 systems choices. While the second house was a systems-approach house made up of 88 systems choices scored on 23 performance characteristics and 3,872 systems interactions. This house scored 26.8% of a best possible score for a house with 88 systems choices. The full calculation method and rationale is described in *“Developing a Calculator for Evaluating Physical Design Characteristics and Whole House Performance Scoring: A Preliminary Method”* (O’Brien and Wakefield, 2005).

This first generation approach was published on the HUDUSER website in 2005 (O’Brien and Wakefield, 2005). A post-publication assessment of this project, conducted by Newport Partners L.L.C. revealed critical weaknesses in the limited number of experts providing performance and interaction scoring, the difficulty the general public or professional builder or designer would have with describing the processes, systems and materials making up the house, the scoring method for systems interactions, the immense gaps in accepted research findings related to scoring, the lack of influence of local climatic and geologic factors, the abstract nature of the numerical score and the limited testing of this initial method. It was clear a new method was required.

3.0 The Second-Generation Whole House Calculator Theory: The core theoretical proposition of the whole house calculator is that the configuration, design, contracting form and quality-assurance methods that guide the

selection, location, specification, detailing and installation of subsystems and materials comprising a house, in a specific location having unique climate and geologic characteristics, plays a significant role in the performance of said design, subsystems, materials and the house as a whole.

3.1 THE SECOND GENERATION CALCULATOR METHOD: Like the first generation calculator, the second generation calculator uses a database of performance scores, modified by location-specific systems weighting factors, modified by performance interactions to arrive at a score for each systems choice. To develop a dataset of the performance of design, system and material characteristics, a panel of six building scientists with expertise in structural systems, thermal systems, moisture management, indoor air quality aspects, production methods and quality, durability and systems approaches to residential construction was assembled by Newport Partners L.L.C. The panel members were asked to score a set of 502 systems choices covering a range alternative methods of Design Characteristics and Production Processes, Foundations, Superstructure, Envelope, Interior Partitions and Finishes, Millwork and Appliances, Utility Distribution, Electric Power and Light, Sewer and Water and Thermal Systems. The scores were input at a website designed by G3 Systems Inc. and allowed the experts to rank the alternative as not applicable (NA) or as on a nine point scale from “Poor” to “Best” for each of six climate regions of the United States. The Expert Panel database web page is shown below in Figure 1.

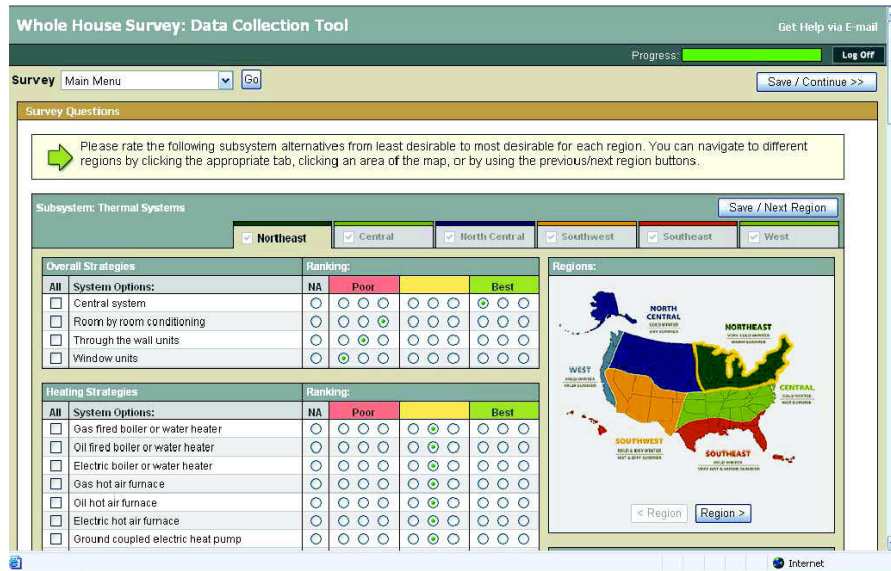

Figure 1. Expert Panel Database, Importance Scoring. Source: Author

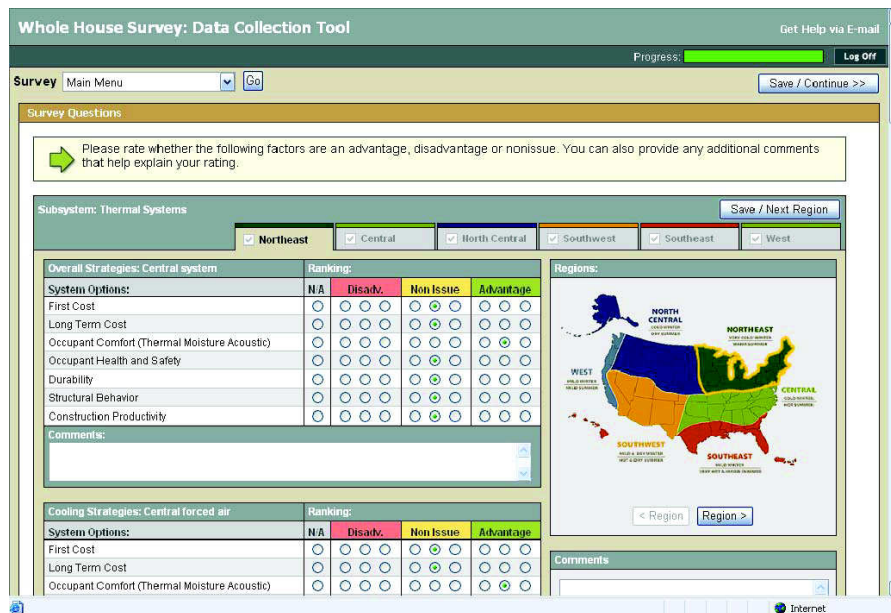

Figure 2. Expert Panel Database, Reasoning Scoring. Source: Author

The systems scored in the lower 10% and the upper 10% generated a set of follow-up questions to inquire into the reasoning behind these high and low rankings as shown in Figure 2. This way, the 502 alternative systems choices were scored across six U.S. regions by six members of the expert panel producing a database of approximately 18,000 entries. The scores for each alternative systems choice were averaged into a single performance factor for each systems choice in each region of the U.S. seen in the maps on Figures 1 and 2 above.

3.2 USER INPUT: The second-generation calculator is intended for use by residential designers and builders designing new single-family detached homes. The expert panel proposed this scope limitation as an initial prototyping step. To begin using the tool, the user logs into the website and inputs the location of the house as shown in Figure 3.

Figure 3: User Startup Screen. Source: Author

1. Design & Engineering Credentials	
All	System Options:
<input checked="" type="checkbox"/>	Architect & engineer
<input type="checkbox"/>	Architect only
<input type="checkbox"/>	Engineer only
<input type="checkbox"/>	Unlicensed Designer
<input type="checkbox"/>	Energy rater
<input type="checkbox"/>	Part of Building America program
<input type="checkbox"/>	Part of Energy Star program
<input type="checkbox"/>	Builder / developer
<input type="checkbox"/>	None

2. Design & Engineering Services		
All	System Options:	
<input checked="" type="radio"/>	Custom design & siting	
<input type="radio"/>	Production design, custom siting	
<input type="radio"/>	Production design, production siting	Production design, custom siting A pre-designed home that has been constructed in large numbers but is specifically oriented and located on a specific parcel to meet the needs of a specific owner.
<input type="radio"/>	Production siting, production design	
<input type="radio"/>	Purchased design, no siting	

Figure 4 User Input Screen for Alternative Systems Choices showing glossary popup. Source: Author

The calculator delimits the performance, interaction, and systems weighting databases based on the location to speed processing responses. The user is presented with an input page, shown in Figure 4. The major subsystems of the house appear in the 10 tabs across the top of the screen. When the user clicks on the tab, the alternatives to each systems choice appears with either check boxes (allowing multiple selections) or radio buttons (for single selections). Glossary explanations pop up when the user allows the mouse cursor to hover over the systems choice for additional clarification of the terminology. Recommended practices for the location of the house are highlighted in light green. After entering the house configuration, the user clicks on the “Submit/View Summary” button to receive the report card for the house.

3.3 RECOMMENDED PRACTICES: Recommended Practices houses are configured for each climate region based upon the Building America “Recommended Practices Guides” (Building America, 2006) The design characteristics, quality processes, contracting methods, systems and materials choices are closely matched to those presented in the Building America Guides. The Calculator compares the house input by the user, to the recommended practices house to arrive at the score for each subsystem and the associated letter grade. It is possible to configure a house to exceed the score of the recommended practices house, as the recommended practices are not intended to represent the absolute highest values in performance, but have been developed as a balance between performance and cost.

3.4 SYSTEMS WEIGHTING FACTORS: Local conditions can significantly affect the importance of the performance of the subsystems. Thus a data table of climatic and geologic characteristics was developed for the 3,141 U.S. Counties for the following characteristics; Wind Speed, Seismic Risk, Radon Risk, Relative Humidity, Precipitation, Heating Degree Days and Cooling Degree Days. Whenever possible 50-year climate normals were used to establish these values. This data was further mapped to 42,192 Zip codes to simplify user input.

Systems weighting factors for each location were determined by dividing the expected intensity of the natural force for a county by the difference between the high and low value for that same force across all counties of the United States.

For Mobile County, Alabama, the anticipated peak wind speed (50 year recurrence) is 150 mph. The difference between the high value (150) and low value (85) is 65. Mobile’s 150 mph design target divided by the national high-low difference, 65, equals a weighting factor of 2.3076923. This weighting factor is used to multiply the result of the performance scores for all systems choices pertaining to the superstructure of the house to arrive at a weighted importance for the superstructure system. During development and testing, a debug function was included in the calculator to allow manual checking of the calculations. Figure 5 below shows the 2.3076923 weighting factor (highlighted in the blue circle) applied to the floor framing systems choices



Figure 5. Whole House Survey Tool (debug mode on). Source: Author

The screenshot in Figure 5 was captured with debug mode on. It shows the performance score (5), weighting factors for wind (2.3076923), seismic (1) and heating degree-days (.2500313) and interaction factors for wind induced collapse +1 and moisture related structural degradation -1.

3.5 SYSTEMS INTERACTION FACTORS: Interaction factors were especially difficult to address in the static table format used in the first-generation whole house calculator. It was difficult for the experts to consider and score complex interactions between five to seven different alternative systems choices. The method employed in the second-generation calculator uses a set of logic subroutines selected by their appropriateness to the location of the house. At this time the second generation calculator has 11 systems interactions programmed. Each interaction subroutine is “triggered” by a characteristic of the climate or geology of the house location. Once triggered, the interaction subroutine checks the list of systems choices selected by the user. For every systems choice that has been characterized as a “contributing” factor to the interaction, the subroutine subtracts one from the score. For every systems choice that has been characterized as a “mitigating” factor in the interaction, the subroutine adds one to the score. These are the “+1” and “-1” that appear in Figure 3. Dimension lumber, site framed is a mitigating factor in the “High Wind Collapse” interaction subroutine (+1) and a contributing factor in the “Structural Degradation from Excessive Moisture Levels” interaction (-1).

3.6 THE WHOLE HOUSE REPORT CARD: After completing the selections for the systems choices under each systems tab, the user clicks the “Submit/View Summary” button to receive the grade-sheet for the house. Figure

6 shows the summary page. The house configured by the user is compared to the recommended practices house for the same location. Also visible in Figure 6 is the failure notice. Whenever a house configuration receives a grade of “D” or less for the superstructure system, the house as a whole is failed and a notice displayed to encourage the user to revisit some decisions in the superstructure system to enhance the anticipated performance. The user may also click on the “Detailed” button to display a more detailed display of the factors contributing or detracting from the performance of their house compared to the recommended practices house.

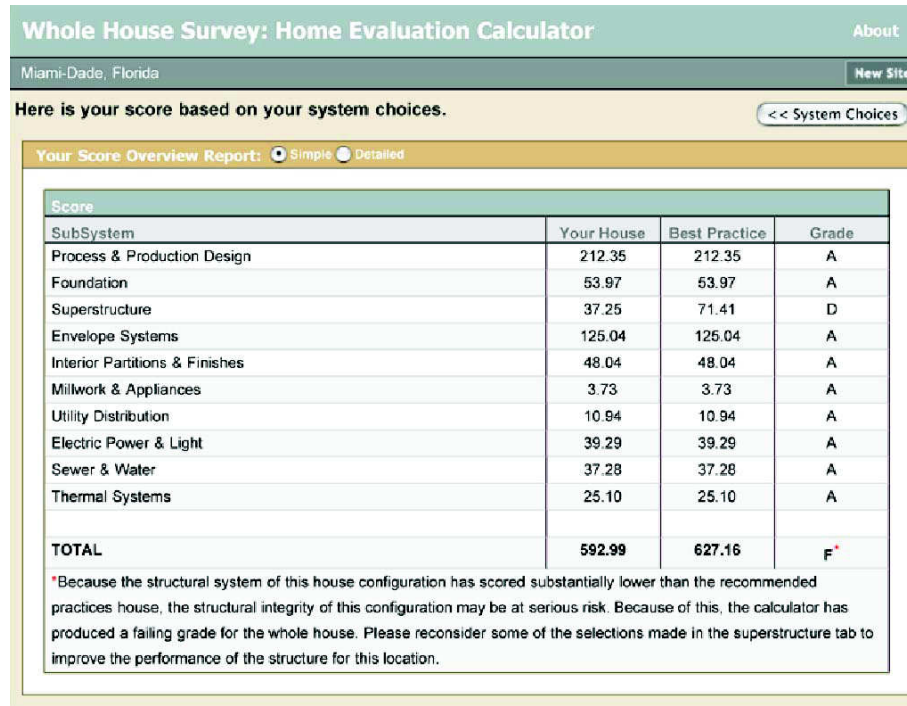

Figure 6. Whole House Report Card. Source: Author

4.0 CONCLUSIONS, LIMITATIONS and FUTURE STEPS: This second-generation calculator is not without its bugs; it is currently not evaluating slab-on-grade construction correctly. It is not valuing the location of ductwork appropriately, but otherwise, testing of 6 case houses across nine locations in the U.S. indicates that it seems to be generating appropriate scores. The calculator downgrades structural performance of a house optimized for the Middle Atlantic when tested in a high wind or seismic zone, upgrades configurations having radon mitigation strategies in high radon risk counties and downgrades thermal performance of houses configured for the Central U.S. when tested in either extreme hot or cold climates.

Comparing the user configured house to the recommended practices houses has made the output a bit more meaningful and if the user configuration equals or exceeds the recommended practice configuration, reduced energy consumption is likely because the recommended practices configurations are drawn from the Building America Recommended Practices. That the output simply compares the user configuration to the static recommended practices models must be considered an interim stage of development for the whole house calculator. Beyond gathering additional expertise input to the performance score database, next steps are intended to include simulations to provide more accurate accounts of performance and more insight into the contribution of each component to the performance of the structural, thermal and sustainable whole.

At this stage of development, the second-generation whole house calculator may be a useful tool for comparing alternative combinations of systems choices, *it cannot be considered a predictor of success or failure of the house as a whole*, but perhaps will stimulate thought and discussion in the larger community of Architects, Engineers, Scientists, Builders and Owners that will make the next generations more useful and enhance the perception of the house as a whole organism.

4.1 ACKNOWLEDGEMENTS: This project would not have been possible without the support of The Office of Policy Development and Research at the U.S. Department of Housing and Urban Development and the contributions from following people:

Subrato Chandra, The Florida Solar Energy Commission, Bill Colbourne, at the URS Corporation, Pat Huelman at the University of Minnesota, Mike Martin, The University of Central Florida and Brad Oberg at IBACOS.

Mike Blanford and Carlos Martin from the HUD Office of Policy Development and Research provided critical discussion and helpful input throughout the project.

Gordon Miller, John Smith and their team at G3 Systems Inc. developed the web-based tool for knowledge input by the outside systems experts and developed the interface and functionality for the final web-based whole house calculator.

Mark Nowak from Newport Partners L.L.C. authored the Whole House Calculator Critical Review and coordinated the expert panel meeting and input into the Performance Score Database. The small advances made in this second generation whole house calculator would not have been possible without his candid assessments of the first generation calculator.

Angie Baughman, who translated the expert meeting proceedings into preliminary logic interactions and translated Seismic, Wind, Precipitation, Cooling and Heating Degree day and Relative Humidity Data from maps to County-Level detailed spreadsheets and Manoj Mishra translated Radon maps to County-Level detailed spreadsheets. They are the significant contributors to this project.

Marilyn Cavell from the Center for Housing Research at Virginia Tech provided additional program support and financial oversight throughout the project.

References:

Applied Research Associates (ARA), (2002). Development of Loss Relatives for Wind Resistant Features of Residential Structures, Florida Department of Community Affairs, Tallahassee, FL, p 15.

Brown, William, Ullett, J. and Karragiozis, A., (1997). *Barrier EIFS Clad Walls: Results from a Moisture Engineering Study*, Journal of Building Physics, 1 1997; vol. 20: Sage Publications, Thousand Oaks, CA, pp. 206 - 226.

Building America, (2006). *Recommended Practices Guides*, http://www.eere.energy.gov/buildings/building_america/ viewed 12-2006.

Emmerich, Steven J., Gorfain, J., Huang, M and Howard-Reed, C., (2003). *Air and Pollutant Transport from Attached Garages to Residential Living Spaces*, National Institute of Standards and Technology, Washington D.C. p. 12.

Hollick, M. (1993). *An Introduction to Project Evaluation*, Longman Cheshire Pty. Limited, Melbourne, Australia. 153-164.

Koebel, Ted and Cavell, M., (2006). *Characteristics of Innovative Production Home Builders*, Office of Policy Development and Research, U.S. Department of Housing and Urban Development, Washington, D.C. p. vii.

Leopold, L.B., Clarke, F.E., Hanshaw, B.B. and Balsley, I.R. (1971). *A procedure for evaluating environmental impact*. Geological Survey Circular 645, Government Printing Office, Washington.

National Association of Home Builders, Research Center, (2002). *Whole House and Building Process Redesign*, PATH Technology Roadmap series, Office of Policy Development and Research, U.S. Department of Housing and Urban Development, Washington, D.C.

O'Brien, Michael and Wakefield, R., (2005). *Developing a Calculator for Evaluating Physical Design Characteristics and Whole House Performance Scoring: A Preliminary Method*, Office of Policy Development and Research, U.S. Department of Housing and Urban Development, Washington, D.C., Appendix 1.

A Systemic Model for Designing Energy Optimized Buildings

Audrey Kay Werthan

The University of Michigan, Ann Arbor, Michigan

ABSTRACT: Architects need to make a paradigm shift from relying primarily on mechanical systems for energy management to designing energy optimized buildings. To achieve this shift, architects can benefit from using a formal design model that delineates priorities for energy optimization in high performance building. In essence, this systemic model refines a well-established architectural concept for energy optimization by placing appropriate emphasis on the architects' role in designing for energy management and demarcating the primary responsibilities of architects and engineers. Fundamental design questions are filtered through the model, resulting in specific energy management strategies. The presentation of this model is an effort to contribute to the collective discussion on what defines a green, high performance building, and this author invites a further refinement of this model. Such a radical paradigm shift, which is supported by the model, is imperative if we are to reduce the role of buildings in environmental degradation.

Keywords: Energy, Optimization, Design, LEED

INTRODUCTION

According to the Department of Energy's (DOE) *2006 Buildings Energy Databook*, commercial and residential buildings consumed over 39% of all U.S. primary energy and emitted 1.6 billion metric tons of carbon into the atmosphere. Typically, modern U.S. architects have focused on designing buildings primarily for aesthetics and/or short-term cost savings rather than long-term energy optimization. In fact, many U.S. architects do not recognize the power they have to promote sustainability through their designs. As Edward Mazria, a pioneer of green building, stated, "the design of a building—its form, fenestration, construction materials, [lighting], and finishes—largely determines the building's lifetime energy consumption" (2003:50). Considering that the majority of building energy is used to light, heat, and cool for occupant comfort, designing for energy performance focuses on accommodating these needs as efficiently as possible, yet architects have depended primarily on engineers to meet these needs. Sometimes architects do intend to conserve energy and do so by adding on energy-saving technology, such as highly efficient HVAC systems or even photovoltaics, to their inefficient designs, yet these types of interventions are band-aid solutions to improving building energy consumption levels. To date, the few architects that have taken up the challenge to design high energy performance buildings have not had a logical system to facilitate their efforts but have had to apply energy management strategies in a piecemeal fashion. The systemic energy management model presented here, intended to integrate energy optimization into the early stages of building planning, sets design priorities and divides the primary responsibilities for energy management design between architects and engineers.

1. PURPOSE OF THE ENERGY MANAGEMENT MODEL

1.1 Rationale for greater involvement of architects in designing for energy management

Amory Lovins of the Rocky Mountain Institute declared:

When an architect is studying, do they ever talk to a mechanical engineer? Often they are too busy learning how to build something that is, as they say, all glass and not windows. When they're done, they toss the drawings to the mechanical engineers, and say, 'Here, cool this!' Designing a building nowadays isn't team play; it's a relay race. (Barnett 2004:62)

In this approach to building design, energy consumption is an afterthought, thermal and comfort control is achieved primarily by mechanical systems, and buildings are designed to be system intensive rather than envelope intensive (McGinn, 2005). High-performance building, however, requires an integrated, whole building approach to planning and design that requires architects and engineers to work closely together to achieve

energy optimization while each maintain their primary responsibilities. Indisputably, the architect is primarily responsible for a building's essential design, its form, its envelope characteristics, and its permanent fixtures; for the most part, the engineer is responsible for lighting, heating and cooling for occupant comfort *as demanded by the building design* by using some type of energy consuming peripheral system to meet design specifications. Generally speaking, engineers use energy; architects don't. Yet energy management is a direct function of a building's design. Therefore, architects need to better understand the building as a system and "the relationship between architecture and the natural environment" (Mazria 2003).

1.2 Available energy management principles

The basic approach to designing for energy optimization is not new; it is based on fundamental knowledge for sound architectural design for energy management. For example, Vaughn Bradshaw explains this approach in the environmental technology textbook, *Building Control Systems*:

The most simple and inexpensive ways to provide comfort-and the ones to consider first-are those that reduce the heating and cooling loads. Next consider ways of satisfying a portion or all of the reduced loads by passive solar heating or passive cooling methods. Only then after the loads have been reduced or satisfied by passive methods as far as economically feasible should active HVAC systems be designed. In some cases, it may be possible to dispense with a heating or cooling system entirely, or else the loads may be substantially reduced before the final selection and sizing of equipment. (1993:215)

This short but comprehensive explanation is a conceptual framework that aids in setting priorities in designing a climate-based, energy optimized building. Even though this is standard knowledge, it is rarely applied by architects. This important approach merits a name and should be refined so that it offers more design direction and can be easily followed by architects. LEED NC the most widely recognized U.S. green building standard offered by the U. S. Green Building Council, better solidified the concept in its 2.1 version into a "three-step approach." This approach included "Demand reduction," "Harvesting free energy," and "Increased efficiency" as a strategy of the Optimize Energy Performance (OEP) credit (LEED 2.1 2003:137-138), offering up to 10 points for increased energy optimization. However, the reference guide offered little further concrete direction, designating only one-and-a-half pages out of 300 on how to design a building for energy optimization. Also, LEED 2.1 did not require that the approach be followed even though it would be virtually impossible to achieve 10 points without reducing building demand and relying solely on HVAC system efficiency (Sacrison 2004). LEED NC 2.2, the most current version offers even less direction with a downsized adaptation, condensing the 2.1 three-step version into four, short, bulleted paragraphs. In addition, even though architects and engineers must work closely together for an integrated design (Sacrison 2004, Barnett 2004), neither the typical textbook nor LEED delineates who is ultimately responsible for doing what. An energy management model that formalizes, expands on, and brings attention to how to approach energy optimization is needed.

1.3 Rationale for energy management model

The following model takes LEED 2.2's four fundamental strategies, alters and expands them, and offers a process that design questions can be filtered through. This model is not intended to be a comprehensive tool to address all architectural and engineering issues that arise when designing a building but rather a template that can be added to and amended. Further, it can be adapted to any building design whether commercial or residential. The purpose of the model is to assist designers during the early stages of design and planning to prioritize energy management issues according to importance. Hopefully, this will make energy management in design simpler by providing a process, thereby encouraging architects to routinely incorporate principals of energy optimization into their designs. This in turn will reduce the environmental impacts caused by buildings.

2. ENERGY MANAGEMENT MODEL FOR BUILDING DESIGN AND SYSTEMS

The model begins with a four step overview that divides the responsibilities between architects and engineers. A rationale for each of the four steps follows.

Table 1: Energy management model overview for building design and systems.

Apply four steps to energy management design/systems question	Responsibility
Step 1. <i>Reduce load</i>	Architect
Step 2. <i>Harvest passive site energy</i>	Architect
Step 3. <i>Harvest active site energy</i>	Engineer
Step 4. <i>Increase HVAC and lighting efficiency</i>	Engineer

2.1. Step 1: Reduce load

Load reduction is the first and most important goal of energy management and includes reducing both thermal load and electric lighting load. Thermal load is defined as “the rate at which heat must be added or removed from a space to offset the heat losses or gains in order to maintain the interior air temperature and humidity at the desired levels” (Bradshaw 1993:94). He describes electric load as “a device that consumes electrical energy in the process of performing work” (Bradshaw 1993:298). The rationale for emphasizing load reduction in buildings can be likened to a bucket of water. If the bucket is leaky, water must continually be added to keep it full. If the bucket is structurally sound, water will stay in the bucket and minimal water will need to be added. A building is the same way. A well-designed building does not “leak” heat from or to the space causing a heating or cooling load. It *controls* the heat transfer in and out of the building envelope. As Kraushaar, author of *Energy and Problems of a Technical Society*, said, “A barrel of oil saved is entirely equivalent to a barrel of oil found, with the added benefit that saving oil generates no air pollution or other environmental degradation” (Kraushaar 1993:237). Building envelope, its shape, opaque surfaces and windows are the first line of defense against loads, both thermal and electric, and is incorporated into the building design. Thus, reducing the load is primarily the responsibility of the architect.

2.2. Step 2: Harvest passive site energy

Harvesting passive site energy refers to the gathering of energy that exists naturally on the site such as light or heat that the building can freely utilize through its envelope. “working with nature instead of against it” (Bradshaw 1993:215). Passive design refers to a building envelope that is actively designed to “receive” energy into the space, often through windows. Additionally, it may not be alterable once it is built. Once implemented, these strategies are free and harmless to the environment. Such energy may include solar radiation in the form of natural light or heat and natural ventilation. Harvesting site energy passively is the result of intentional building envelope design; as such, it also falls under the responsibilities of the architect.

2.3. Step 3: Harvest active site energy

Once the loads are minimized and harvesting passive site energy is optimized through design, less energy is required to maintain desired conditions. The remaining energy demand may then be supplemented by harvesting active site energy. This involves mechanical systems that collect, convert, store, and then distribute energy to the desired building location (Bradshaw 1993). Energy that can be harnessed from the site (such as solar or wind) is used to generate electricity or heat, which can then be obtained freely and distributed in the building. For example, photovoltaic cells collect solar rays and convert them to electricity. Solar collectors collect and distribute heat to spaces that need it. These systems are peripheral to the building itself and fall outside of the realm of architectural design, and are, therefore, the primary responsibility of the engineer.

2.4. Step 4. Increase HVAC and lighting efficiency

The final step in energy management is to use highly efficient, state-of-the-art mechanical and lighting equipment. Equipment that uses site-imported energy should only be used when reducing the loads, and harvesting site energy, both passively and actively, does not satisfy energy demands. Having optimized the first steps, equipment might be sized smaller or eliminated altogether.

Energy modeling input early during the concept and scheduling design process, optimal building massing and orientation, and a high performance envelope will yield a building with significantly smaller mechanical electrical systems than conventional designs. The mechanical/electrical cost savings are transferred into the high performance envelope and passive environmental systems. (McGinn 2005:18)

Since these systems are peripheral to the building and not directly related to building design, they are the engineer’s responsibility.

3. EXPANSION OF THE ENERGY MANAGEMENT MODEL

Now that an overview of the model and a brief explanation of the steps have been presented, the following tables present fundamental design questions that have been filtered through the separate steps of the model followed by strategies that achieve the goal of the individual step. Different climates and the building types must be accounted for within the model. In addition, computer simulations are required to determine optimal strategies or to fine tune a strategy.

Table 2: Building shape.

Question: What energy management factors need to be considered when determining a building’s shape and orientation?		
Model step	Responsibility	Sample building shape and orientation strategies
Step 1. Reduce load	Architect	

Minimize cooling load		Minimize east/west exposure Elongate along southern facade (with shade)
Minimize heating load		Minimize surface area, e.g., cube
Step 2. Harvest passive site energy	Architect	
Harvest light energy (daylight)		Maximize perimeter zones (e.g., T-, U-shape, courtyard and atrium)
Harvest cooling air		Elongate to augment cross breeze
Harvest solar heat		Elongate along southern facade for solar collection in winter with high thermal mass flooring to collect solar heat gain **
Step 3. Harvest active site energy	Engineer	N/A
Step 4. Increase system efficiency	Engineer	N/A

**If building is internally load dominated, ensure that cooling load is not increased.

Determining a building's shape and orientation are the most important architectural decisions from both an aesthetic and energy efficiency viewpoint. Table 2 addresses this question. The shape of the building not only impacts thermal loads but also lighting energy. Compact shapes reduce surface exposure to the outside, thereby reducing heat loss through conductance. Elongating the shape to minimize east and west facades reduces solar gain that is difficult to prevent using shading during the morning and afternoon. Therefore, southern exposure must be addressed along with the window design question that follows regarding window to wall ratio and external shading. Narrowing the building by using architectural design features such as courtyards and atriums or shapes such as U-, T-, E-, and L-shaped provides access to windows offering opportunities for natural lighting and ventilation. Computer simulation will help determine if it is more advantageous to minimize surface areas to reduce the heating load or to elongate surface areas facing south to reduce cooling load and harvest natural lighting and solar heat.

A building envelope materials add to the building's architectural design characteristics and determine how well the building controls heat transfer between the inside and outside. Table 3 addresses this question.

Table 3: Building envelope—Opaque surfaces.

Question: What energy management factors need to be considered when determining building envelope opaque surfaces (walls and roof)?		
Model step	Responsibility	Sample building envelope-Opaque surface strategies
Step 1. Reduce load	Architect	
Minimize cooling load		Optimize thermal mass to delay heat transfer into space during day* Light-colored roof
Minimize heating load		Optimize insulation R-value to prevent heat conduction out of space
Step 2. Harvest passive site energy	Architect	
Harvest cooling air		N/A
Harvest solar heat		Optimize thermal mass to release stored daytime heat into space at night (indirect solar gain)*
Step 3. Harvest active site energy	Engineer	N/A
Step 4. Increase system efficiency	Engineer	N/A

*Applies to climates with high diurnal temperature swing

Appropriate thermal mass does not actually reduce heat gain through the surface into the space but extends it over a period of time. Under the right climatic conditions, such as those with large diurnal temperature swings, the delay can cause the heat to be captured and stored within the surface during the heat of the day, reducing the daytime cooling load, and released into the space when temperatures are low and heat gain is desired during the night. Insulation is a standardized practice for reducing heating load, and ASHRAE 90.1, 2004 requires essentially the same amount for all climates (ASHRAE 2004). Yet increased insulation can significantly reduce

the load further in some climates. However, if a building is internally load dominated, such as an office building with high internal heat gain, it is possible that excess internal heat may become trapped within the building, thereby increasing the cooling load. A computer parametric study can determine the optimal amount of R-value for a specific climate and type of building.

A building envelope's fenestration design, a key building architectural design feature, can prove a benefit as well as an energy liability in buildings, presenting a challenge for designers to balance desirable harvesting of site energy with co-existing undesirable loads. Table 4 shows that window thermal loads must be weighed against harvested natural light and solar heat (during the heating season) and ventilation to enhance occupant comfort when considering window-to-wall ratio (WWR).

Table 4: Building envelope—windows and fenestration.

Question: What energy management factors need to be considered when determining window design?		
Model step	Responsibility	Sample building envelope—fenestration strategies
Step 1. Reduce load Minimize cooling load	Architect	Minimize WWR at E and W facades Replace electric light with daylight Optimize vertical shading on E & W; Horizontal on South
Minimize heating load Reduce electric light load		Optimize WWR to reduce window conduction Install daylight photosensors
Step 2. Harvest passive site energy Harvest cooling air	Architect	Equip with operable windows Align windows for optimal natural ventilation/cross breezes
Harvest solar heat		Optimize window placement along south façade for direct solar heat gain during heating periods Optimize external shading
Harvest natural light		Place daylight penetration high in space and other daylighting strategies
Step 3. Harvest active site energy	Engineer	N/A
Step 4. Increase system efficiency	Engineer	N/A

Harvesting daylight through windows is an architectural design strategy that reduces electrical consumption both from reducing the lighting demand and the cooling load caused by the lighting. Architectural daylighting design strategies include clerestory ceilings, lightshelves, skylights, high windows, and light chimneys. Daylighting serves as an energy conserver only when the daylight design is equipped with daylight photosensors that “track the daylight entering a room” and then “dim[s] the electric lighting in proportion to the amount of daylight detected” (Chen 2006:4). Francis Rubinstein of the Lawrence Berkeley National Laboratory has developed a new mathematical algorithm that enhances the ability of photosensors to effectively calibrate and maintain constant light levels (Chen 2006). Whether or not the window design is enhanced for daylighting, photosensors still offer the potential of reducing electric load by taking advantage of whatever natural light enters the space. Further, a large WWR provides for more daylight harvesting opportunities, yet allows heat loss through window conduction and heat gain from solar radiation. These interactions must be optimized using computer simulation both for energy and design for every climate, site, and facade to obtain the greatest net energy benefit.

Figure 1 illustrates how shading on the south can optimize energy facade by properly controlling heat gain. Such shading prevents solar heat gain during the summer months when the sun's altitude is high and allows solar heat gain during the winter months when the sun's altitude is low.

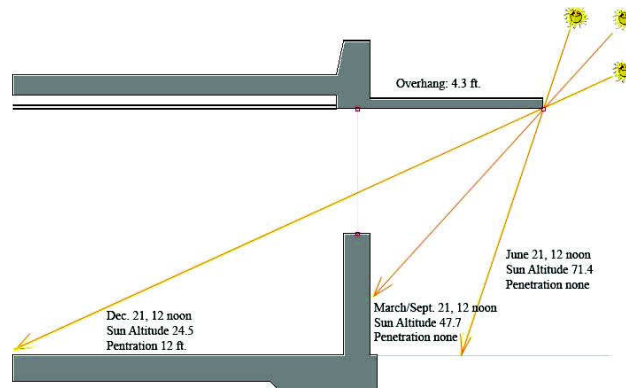

Figure1: Window with shading at two solar equinoxes and two solstices. (Ecotect 2006)

The shading overhang must be carefully sized in order not to increase heat gain in internally load-dominant buildings that may require cooling even during the heating months.

Window type selection, discussed next, is one of the most important decisions an architect can make in energy optimization because window selection and window design go hand in hand. Table 5 presents an overview of the factors to consider when selecting window type.

Table 5: Building envelope—window and fenestration selection.

Question: What energy management factors need to be considered when selecting windows?		
Model step	Responsibility	Sample window selection strategies
Step 1. Reduce load Minimize cooling load	Architect	Optimize SHGC Optimize external shading Optimize U-factor
Minimize heating load		
Step 2. Harvest passive site energy Harvest natural light Harvest cooling air	Architect	Increase T_v through windows Provide operable windows for occupant control of natural ventilation
Harvest solar heat		Optimize SHGC Optimize external shading
Step 3. Harvest active site energy	Engineer	N/A
Step 4. Increase system efficiency	Engineer	N/A

Even though windows offer architects many energy benefits, especially regarding daylighting, they also can be a major source of thermal loads into the space from solar radiation and heat conduction. Window technology has advanced significantly in recent years, yet when poorly selected, windows can allow 12 times the amount of heat transfer of a well-insulated wall (Bradshaw 1993). Therefore, a window's U-factor, the measure of non-solar heat conductance through the window over a period of time and its Solar Heat Gain Coefficient (SHGC), the ratio of solar radiation that penetrates through the window compared to the solar radiation of a standardized clear, single pane of glass, must both be appropriately determined for the climate, site, and façade. Determining SHGC is a challenging window characteristic to optimize because the same window that allows solar heat to enter the space in the winter may also prevent it from entering in the summer. In an internally load-dominated building, unless shading is implemented, a very low SHGC may be necessary even in a cold climate to minimize cooling load to ensure that the building does not overheat. The U-factor, an especially critical window characteristic in a cold climate, minimizes heating loads caused by window conductance. In addition, a window's visual transmission (T_v) of the window, the fraction of visible radiation from outdoor light that is transmitted through the glass, is an architecturally important design feature and must be as high as is possible in order to optimize daylighting features, as well as to aesthetically brighten the space. Technologically, however, it is a challenge for a window to allow light in while excluding solar gain. Low-emission windows have been developed that can accomplish this task while reducing heating and cooling loads. A parametric computer study may be required to determine optimal window characteristics for a particular site. See case study to follow.

Now that the major architectural questions addressing building load reduction and harvesting of passive site energy have been addressed, and the building is optimally functional as an independent unit, it is time for the engineer to ensure that all design comfort parameters are met.

Table 6: System supplements to building design.

Question: What peripheral cooling, heating, and electrical systems supplement building design?		
Model step	Responsibility	Sample HVAC and lighting systems
Step 1. <i>Reduce load</i>	Architect	
Step 2. <i>Harvest passive site energy</i>	Architect	
Step 3. <i>Harvest active site energy</i>	Engineer	Evaporative coolers* Photovoltaics Geothermal heat pump (Marriott 2006) Solar heating Solar lighting
Step 4. <i>Increase system efficiency</i>	Engineer	High efficiency lighting State-of-the-art HVAC system High SEER and EER Energy recovery (Marriott 2006) Optimal air system (Marriott 2006)
*Appropriate for hot, dry climates		**Appropriate for hot, humid climates

Table 5 addresses issues relating to engineering systems that supplement a building's architectural design. First, the engineer looks to the site to mechanically harvest all possible sources of free, renewable energy by using such systems as photovoltaic cells and geothermal heat pumps. Then, if thermal needs are still unmet a highly efficient, state-of-the-art HVAC system that runs on site-imported energy should be installed. Air conditioners should have a high Seasonal Energy Efficiency Ratio (SEER), and a high Energy Efficiency Ratio (EER). In her article, *3 Simple Approaches to Energy Efficiency: Optimal Air, Energy Recovery, Geothermal*, Carol Marriott presents three methods of increasing system efficiency for LEED NC 2.2 OEP points. Now that the model has been presented, a summary of a case study applying the model follows.

4. CASE STUDY AND LEED NC

A simplified computer simulation case study of a 2,323 m² (25,000 ft²) office building was undertaken to see how much energy would be reduced and how many LEED 2.1 OEP points, out of ten maximum, could be obtained by implementing some basic strategies under the first two steps of the energy management model. (Werthan 2006) Optimized building envelope and windows were compared to a benchmark based on ANSI/ASHRAE/IESNA Standard 90.1-2004, *Energy Standard for Buildings except Low-Rise Residential Buildings* Energy Cost Budget Method for Detroit, Michigan. eQUEST, an hourly weather data computer simulation program, was used to measure the energy consumption of the simulated buildings. Rates were based on the energy utility for Detroit. A computer simulation parametric analysis was first undertaken to determine optimal R-values for the roof and walls, and optimal SHGC and U-factor for the windows and R-values for the roof and walls and one window was chosen for the proposed design based on the optimal values. Daylight photosensors and shading were tested in the analysis and determined to be part of the design. LEED NC, 2.1 does not reward shape or orientation optimization whereas LEED NC, 2.2 rewards orientation optimization alone. Table 7 shows application of the model to windows alone.

Table 7: Computer simulation comparing proposed to baseline inputs.

Question: What energy management factors need to be considered when selecting windows?			
Model step	Resp.	Proposed strategy (input)	Baseline strategy (input)
Step 1. <i>Reduce load</i>	Arch.		
Minimize cooling load		SHGC: 0.47 with shading	SHGC: 0.26; no shading
Minimize heating load		U-factor: 0.18	U-factor: 0.47
Step 2. <i>Harvest passive site energy</i>	Arch.		
Harvest natural light		T _v : 0.66	T _v : 0.2
Harvest cooling air		Operable windows	Non-operable windows

Harvest solar heat		SHGC: 0.47 with shading	SHGC: 0.26; no shading
Step 3. Harvest active site energy	Eng.	N/A	N/A
Step 4. Increase system efficiency	Eng.	N/A	N/A

The proposed building combined the optimized values determined in the parametric study into one window-a triple pane, low-e, argon filled, roof and walls (R-values of 25 for both roof and walls), daylight photosensors and shading. The baseline used a double pane, reflective, air filled window and R-15 for roof and R-13 for walls, no daylight photosensors or shading.

Table 8: Energy cost, percentage reduction, and number of LEED NC 2.1 OEP points using various strategies.

	Proposed strategy (output)	Baseline strategy (output)
Electric energy	\$15,140 ; 158,830 kWh; 68.4 kWh/m ²	\$18,450 193,500kWh 83.3 kWh/m ²
Natural gas	\$3,915 143,600 kWh (4900 therms) 62.8 kWh/m ²	\$6,835 250,600 kWh (8550 therms) 107.9 kWh/m ²
Total annual energy	\$19,055 (\$8.20/m ² or \$0.76/ft ²)	\$25,285 (\$10.90/ m ² or \$1.01/ft ²)
Results	24.6% and 3 LEED NC 2.1 points	

The results in Table 8 show a 24.6% energy cost reduction that earned three LEED NC 2.1 points. It should be noted that LEED NC 2.2 awards five points for the same percentage reduction and thus offers more incentive to architects to use the model to optimize building design.

CONCLUSION

This model provides architects with an overview of energy management priorities and a clarification of their roles, thereby supporting them to integrate energy management into their designs and to work more successfully with engineers toward a common goal. Hopefully, it will help facilitate the paradigm shift necessary to stem the tide of global warming and environmental degradation.

REFERENCES

- American Society of Heating, Refrigerating and Air-Conditioning Engineers 2004. *Energy standard for buildings except low-rise residential buildings, 90.1-2004*. ANSI/ASHRAE/IESNA Standard: Atlanta, GA.
- Barnett, D. and Browning, W. 2004. *A primer on sustainable building*. Rocky Mountain Institute: Snowmass, CO.
- Bradshaw, V. 1993. *Building control systems*, 2nd Edition. John Wiley & Sons, Inc.: New York.
- Chen, Allan, 2005. *Improved control algorithm appears in a next-generation daylighting product*. Environmental Energy Technologies Division News: Berkeley, CA.
- Department of Energy 2006. *2006 Buildings energy databook*: Washington D.C.
- Ecotect, 2006. <http://squ1.com/ecotect>. Last viewed Feb. 28, 2007.
- Kraushaar, J., and Ristinen, R. A. 1993. *Energy and problems of a technical society*, 2nd edition. John Wiley and Sons, Inc.: New York.
- Marriott, Carol. 2006. *Three simple approaches to energy efficiency: Optimal air, energy recovery, geothermal*. ASHRAE Journal: Atlanta, GA.
- Mazria, E. 2003. *It's the architecture, stupid!* Solar Today. American Solar Energy Society: Boulder, CO.
- McGinn, T. 2005. *Setting fees for profitable green building projects*. ASHRAE Journal: Atlanta, GA.
- Sackrison, C. 2004. *LEED energy and atmosphere, credit 1—measuring efficiency to maximize points*. Engineering System Solutions. McQuay Int.: Minneapolis, MN.
- U. S. Green Building Council 2003. *LEED reference guide for new construction and major renovations version 2.1*. Second Edition. USGBC: Washington, D.C.
- U. S. Green Building Council 2005. *LEED reference guide for new construction version 2.2*. First Edition. USGBC: Washington, D.C.
- Werthan, A., and Navvab, M., 2006. *Building Design Strategies and Their Contribution to Energy Performance for LEED Certification*. Journal of Green Building. College Publishing: Glen Allen, VA.

Awareness: The Ground for Sustainable Design

Randall F. Teal

University of Idaho, Moscow, Idaho

ABSTRACT: The dominance of technology and 'productive' modes of thinking has tended to move humans deeper into the intellect and away from feeling states. Yet, sense, emotion, and intuition are the source of some of the most primary human connections. Within this societal bias, it follows that sustainability also has an inclination toward instrumental thinking, which although resulting in many measurable performance enhancements, also has a susceptibility to engendering results with a discernible lack of soul. As it is impossible to achieve comprehensive sustainability through mechanistic thinking alone, the tempering influence of feeling becomes critical to the appropriate implementation of technology within the context of sustainable design.

Rather than mastery and control, increased awareness and heightened perception encourage a reciprocal and mutually affective relationship with the places we live and the people with whom we interact. So it is central to the development of an integral notion of sustainability that the education of architects and designers include the cultivation such faculties, and understands them as essential tools for the making of human environments.

In this paper I will discuss ideas related to the development of these abilities in young designers and illustrate, through exercises undertaken in a second year studio sequence, my attempts to activate students' awareness and communicate the value of poetic understanding and phenomenological exchange in environmental design. Furthermore, I will describe these exercises with reference to their theoretical underpinnings so that others might view the examples as possibilities rather than rules. It is my earnest hope that by teaching holistic processes that sustainable architecture can begin to fuse building science with qualitative concerns, such as the facilitation of interpersonal relations, the valuation of culture and history, and the deepening of connections to both fellow human beings and the earth itself, creating a comprehensive vision of sustainable practice.

Keywords: perception, phenomenology, pedagogy.

INTRODUCTION

Sustainability in its highest aspirations moves us into a closer relationship with the earth and its processes. Living ecologically suggests cultivating a greater appreciation for our *interdependent* position within the environment and our kinship with the whole of humanity. By reducing the sense that we are somehow separate or different from the world in which we exist, it becomes possible to understand our position poetically as being 'of the earth' rather than 'on the earth'. This perceptual shift requires increased action as receptive participants rather than dominating machines.

Unfortunately in many fields, rational and technological viewpoints dominate modes of perception and assessment. These viewpoints are characterized primarily by active states of being, and thus lack receptive qualities and balanced understandings. The origins and nature of this duality are described by Johann Wolfgang von Goethe when he says,

We are well enough aware that some skill, some ability, usually predominates in the character of each human being. This leads necessarily to one sided thinking since man knows the world only through himself, and thus has the naïve arrogance to believe that the world is constructed for him and his sake. (Goethe 1988:45)

Within this imbalance progress and conquest start to become interchangeable and when pushed to extremes Dalibor Vesely believes,

There is little doubt that both technology and modern science are motivated by the same interest – the domination of reality and the will to power. (Vesely 2004:241)

Considering sustainability in light of this statement, a strange paradox arises wherein the same order of things (technology) that have hastened environmental degradation are the exact same order of things that we turn to for remediation. Escaping the grip of 'productive' thinking (Vesely 2004) requires that our relationship with the

environment be tempered by more open forms of interaction, or as Goethe goes on to say, “as a correction” we need to develop “all the manifestations of human character...into a coherent whole”, for if we fail to do so, we “labor on under painful limitations” not understanding why we have so many “stubborn enemies” and why sometimes we are even meeting ourselves as the enemy. (Goethe 1988:46) Heeding Goethe’s advice within the context of sustainable design suggests that instead of seeking solutions characterized by management, categorization, and control, the future of the environment might rather hinge upon a dialectic grounded in feeling and non-intellectual processes.

The notion of sustainability depends on holistic thinking transformed into holistic action. However, before one can engage either holistic thinking or holistic action it is necessary to first perceive in a holistic way. This type of perception is, as James Elkins points out, “... a question of trying to see more than details.” (Elkins 1996:95) The wholeness, suggested by Elkins’ comment cannot be fully attained via the dominant approach of analysis, as the nature of the analytical is to fragment and catalogue. (Bergson, 1946) Implicit in Goethe’s earlier statement, “some ability usually predominates in the character of each human being”, is the suggestion that, as training an atrophied muscle might restore balance in the body, correction of imbalanced perception might be facilitated through the training of the atrophied modes of assessment as well.

Bringing this wholeness to the built environment stands as the fundamental base for sustainable design and the search for the means of facilitating this vision is the challenge of our time as,

The distance separating the instrumental and communicative understanding of architecture represents a wide gap in our contemporary culture. Any serious attempt to bridge this gap requires a new kind of knowledge that can indicate how to reconcile genuine creativity and creative spontaneity with the productive power of contemporary science. (Vesely 2004:4)

To Alberto Perez-Gomez it is clear what this ‘knowledge’ is, as he says,

The issue for design is not merely ‘aesthetic’ or ‘technological’, if by these terms we understand exclusive, autonomous values. Rather the issue is primarily ethical. (Perez-Gomez 1999, 73)

And as he goes on to say,

In identifying truth with science and science with applied science, i.e. the theory of technology, the result is an incapacity to consider truly radical alternative modes of thinking architectural theory (Perez-Gomez 1999, 76)

It becomes clear that the onus is on those involved in architectural education to negotiate this schism by providing aspiring designers with not only a tangible skill set, but also a renewed sense of ontology in design that is concerned with the multifaceted interrelation of time, context, ecology, and the human psyche. New methods in which to dialog with the environment might be the beginnings for a more complete notion of sustainability, as David Leatherbarrow suggests, “...it is in reciprocity that the real drama of place building is played out.” (Leatherbarrow 2004:115)

1. APPLICATION IN A STUDIO SETTING



Figure1: Site Response: The Site, Morgan Maiolie and Staci Dobbins.

Recognizing and coming to terms with ‘place’ and the concept of ‘genius loci’ is an important starting point for ecological design. Investigating and engaging ‘place’ stands as a primary concern in situating technology and engendering environmental awareness in young designers. According to Christophe Girot,

A new way of looking at our urban landscapes could deliver a better, more complete understanding of the multiplicity of phenomena at hand. It could also greatly improve the potential for an appropriate and concerted response to site.” (Waldheim 2006: 94)

Our site for this second year studio was an abandoned agricultural industrial area, and as the first of several exercises that sought to “feel the site”, as several students later described it, I asked each individual to make five sketches in different locations as they walked the site, focusing on their experience of this place. Experience, as Hans Georg Gadamer explains, “...has a note of immediacy with which something real is grasped...” and, “...there is also a content that is like a yield or residue that acquires permanence...”. (Gadamer 1975:55) Reflecting on this immediacy and its residue as keys to understanding this place, students were then to create a

collage that communicated what they understood to be the essence of their experience (fig. 1). In requesting that they address the emotional/phenomenal content of this experience directly, I went so far as to emphasize the parameters on the assignment sheet which explicitly stated, “do not think in symbols, do not think sequentially, and do not attempt to communicate intellectually”. In a search for the essential the intention of this directive went along the lines of Gadamer’s ideas about the nature of art when he says, “That truth is experienced through a work of art,” in a way that “...asserts itself against all reasoning.” (Gadamer 1975: xii-xiii)

Although several projects were extraordinary in their visual interpretation, one expressing fear at the state of decay; another in peaceful repose amid the quiet emptiness, many students were stricken with reason. A number of responses fell back on generic comparison (i.e. pictures of old trains and industrial structures) and several students produced symbolic representation without even realizing that was what they had done. Additionally, within the approach of imbuing each piece with its own discreet meaning there was also a strong tendency toward cartographic representation.

These results were not surprising, as even at more advanced levels the seeming irrationality of an intuitive/experiential process is hard to understand, and in fact in some ways one is doomed the moment they attempt to ‘understand’ in the traditional sense. These difficulties stand as an example of how deeply ingrained ideas of generalization, objectification, and symbolism are in the human mind. But as Goethe has pointed out, “nothing happens in living nature that does not bear some relation to the whole.”(Goethe 1988:15) so too students’ earnest engagement with this place would inevitably carry some truth about their experience. With this in mind, after a short discussion I asked students to go back to the site again; then add something to their collage that reflected how their perception had been altered by the second visit. This return trip helped to uncover and clarify truths buried in the first collages, and in this return, students’ understandings of the site increased significantly, with many cases where the addition brought fragments together in a meaningful way.

2. COGNITIVE TRANSFORMATION



Figure 2: Cognitive Maps: Kyle Lepper, Mahsa Emam-Jomeh, Andy Carman.

For a second exercise, as a way of ‘visiting’ the site and considering the relationship between place and phenomena in a different way, I asked the students to create a three dimensional cognitive map of the site (fig. 2). The idea was that rather than a physical visit, that they were to mentally return to the site, and from this ‘visit’ make a model that represented the site as it existed relative to their mental reconstitution of the experience. As much of our understandings are relational, this map highlights the strongest impressions and associations for the individual. James Elkins describes the mental editing process in an exercise of his own:

Next time you come upon a beautiful view, make a small mental note of what seems interesting about it...Then turn away from the scene and take note of the blank spots in your mental picture...each time the mental picture will have gaps in it, often large ones – and in my experience it can be difficult to assemble a reasonably complete scene. (Elkins 1996:95)

However, these absences are not necessarily negative; rather they often reveal something particular about the way a place speaks and its underlying structure. To articulate their perceptions, students were encouraged to amplify or reduce certain elements, relationships, and aesthetic qualities as they stood out for them as being characteristic of the site and indicative of their connections to it. This exercise was interesting as it seemed easier to grapple with the idea of an essence by stripping away what ‘was not’ rather than trying to assemble ‘what is’, and the results appear to align with Edmund Husserl’s thought that it is through ‘parenthesizing’ one is able to approach a more pure phenomenological state. (Husserl 1964) Or as Alan Watts put it, “awakening is to know what reality is not.” (Watts 1957:171)

As students' relationships and consequent understandings of the site grew, one discussion was particularly memorable. A student made a comment about how she and many others had seemed to be viewing the site conventionally and had responded quite literally. However, one project in the group, comprised of a translucent cube inside an enclosure of wooden cutouts, was the flash that caused her to see the site more elementally - as a mysterious entity floating in the trees. Several others then commented on how this piece had also sparked them to (again) reevaluate the site.

These revelations seem to point to a necessary reciprocity between experience and our evaluations of those experiences, and how it often takes establishing this communication between lived knowledge and interpretation to arrive at deeper understandings, expanded vision, and a grasp of phenomena as they exist. In terms of sustainability this is point is critical, as again humans hold deeply learned patterns of understanding by empirical means, which touch only surfaces. Consequently when surfaces become the reality, solutions equally address only superficial concerns.

3. SIGNIFICANT INTERVENTION



Figure 3: Site Interventions: Alex Fraser, Staci Dobbins.

Connecting with meaning in our environment is an important element in humans' sense of well being and thus the overall health of the ecosystem. However, the intellect habitually pushes toward meaning that is both tangible and literal, in turn providing meanings that are often trivial. Within this mindset, uncovering and communicating deeper meaning proves difficult or as Elkins' puts it, "it is easy to make the invisible visible, but difficult to make it believable." (Elkins 1996:103)

Returning to the importance of an ongoing dialog to the discovery of a more ephemeral import, I asked students to begin an exchange with the site, once more testing and re-evaluating their understandings of what had been formerly absorbed and interpreted. In this project they were to augment the vision of the site that was beginning to manifest in their imagination. To this end, they were to suggest an intervention in a minimal but significant way; revealing, intensifying, or reinterpreting some particular aspect of this place (fig. 3).

In initiating the idea of intervention and its interpretive potential we looked at and discussed works by: Andy Goldsworthy; Nina Katchadourian; Christo and Jean-Claude; Donald Judd; Eves Klein; Allied Works; Archigram; Superstudio; Antfarm; Banksy; and Gordon Matta-Clark. Students then moved into sketching possible directions, developed a model of their most promising idea, and ultimately evolved this into their design, assembling it all in a Christo-esque layout, with: 'a before intervention' image; 'an after intervention' photomontage; one key image of their idea in process; and a plan diagram of the site.

At this stage more profound insights were beginning to blossom as a strong group of final products resonated with both visitors and reviewers. Several students actually performed within the site in Goldsworthy fashion and documented their physical manipulations, others introduced an artifice (some visual, some auditory) that modulated an initial impression of this place, while still others intervened with an incongruous element attempting to stimulate awareness via displacement. The successes in this project stand as evidence to students' growing sophistication in regards to the nature of the site, as many were starting to create connections to, and extensions of, the significant whole that they were beginning to uncover. In this way, generally speaking, a designer finds meaning or significance in their own work by its association with the inherent energy and specificity of a situation. When this notion is applied to architecture it can promote greater integration between form and place, or as David Leatherbarrow explains,

...for landscape architecture and architecture attention to the actual phenomena of their projects has come to mean concern for their enactments, for the emergence and disappearance of things, which means also their contingency, not their (presumed) stability, independent identity, and 'objectivity'. (Leatherbarrow 2004:12)

With this thought in mind it is interesting that possibly the strongest project was one where a student proposed a slight but detectable bend in the neglected (existing) train track directly beneath the grain loading shoot, suggesting simultaneously both the memory of years of service and the current derelict state of the rails. The magic of this work was held in its connection to, and reframing of, something greater than itself while employing only astute observation and a corresponding modification to suggest totality.

4. CONTINUITY



Figure 4: Movie Stills: Jesse Marble, Josh Anderson, Samantha Boucher

No image will replace the intuition of duration, but many different images, taken from quite different orders of things, will be able, through convergence of their action, to direct the consciousness to the precise point where there is a certain intuition to seize on. (Bergson 1949:195)

Representation always requires that an undifferentiated perception be broken so that it may be transformed and reconstituted. Likewise, environmental design depends not just on insightful observation but a development of that observation into a formal order, spatial continuity, and ultimately a functional system. Pertinent to this problem is the concept narrative in which, as the designer cycles between 'making' and the consideration of that making, there is an attempt to assimilate this process into verbal description. The concept narrative has to do with the depiction of intentions, as well as being a provocation of the mind to increase the continuity of the work in progress.

To further reveal nuances of the site, and to reinforce the notion that significance in a relationship evolves with this cyclical contact and narrative understanding, students were asked to develop one minute films inspired by the site (fig. 4). In this film, the goals were threefold; to practice the negotiation between idea and representation; to consider the site metaphorically; and to begin to explore continuity in a time based medium.

The strength of the dialectic for cultivating awareness was exemplified in one young woman's process for this film. After tremendous difficulty finding any inspiration whatsoever, she finally managed to create a first rough cut, which proved flat and lackluster. Frustrated, she tried several different directions until finally arriving at an idea of making a film that was about her search for inspiration. In her final rough cut, she showed her muse hovering right under her nose all the while with her unable to see it. Interestingly it wasn't until a day before the project was due, with her still unsure of how to end it or what it meant, that the whole experience crystallized. During a meeting, I had asked how her relationship to the site had changed as a result of this process. Without hesitating, she answered that when she first went there nothing spoke to her, but now all sorts of things were vivid and influential to her about this place; it was just that this appreciation just took some time. In this statement was her ending as well as another pointed reminder as to the difficulty in apprehending subtlety.

In fact, this project saw a number of students making films about being initially unaware of something, which marked a point in the studio where many started to perceive the unconventional beauty of this place along with the limitations of their own habitual methods of assessment. These lessons about listening stand out as an important step in this process, and are reflected in Alan Watts statement,

One seeks and seeks, but cannot find. One gives up, and the answer comes by itself. (Watts 1957:161)

Where the importance of the answer that 'comes by itself' is that it is substantial because it has sprung from direct communion with the deeper, more eternal aspects of a set of circumstances.

5. AG PARK



Figure 5: Additive Responses: Morgan Maiolie, Paris Bunkers, Edgar Reyes.

Perhaps the most eternal aspect of any architectural problem is the land itself, and yet within architecture the attitude towards the land has been historically narrow-minded. Reconsidering the way we speak and think about 'site' could bring important changes to the way a building comes into being and engages its surroundings. Again this reconsideration starts with a perceptual modification:

...to build landscape requires the ability to see it, and the inability to do so continues to permeate architectural design culture. This persistent blindness is evident in the still common recourse to the figure/ground plan, which fails to engage the material aspects of a site representing the ground as a void around buildings. (Waldheim 2006:127)

It then stands to reason that a pivotal shift in ecological design might occur when building and earth are not viewed as a duality, and the creation of a building is more widely understood as 'building the land' or as a critical interrelation between earth and sky such as "topography" (Leatherbarrow, 2004), thus opening opportunities for a transcendent union of humans and nature through the interplay of building and site.

Embracing this notion and working with the rich understandings students had developed through previous exercises, the approach for our final project aimed to dismantle the building as premeditated object and the site as a place to *put* a building, with both building and site developing in tandem, learning from one another along the way. Initiating this task, I had in mind trying to avert premature concretization, seeing *form* much in the way Friedrich Nietzsche understands *thought* when he says,

Nothing is more compromising than a thought. Rather than the state preceding thought, the throng of yet unborn thoughts, the promise of future thoughts, the world as it was before God created it – a recrudescence of chaos – chaos induces intimations. (Nietzsche 1967:167)

In this spirit, rather than creating buildings students were charged with finding the intimations within the chaos. Beginning with a series of additive spatial constructions where students were restricted to the use of precut basswood sticks, which was imposed as a means to limit thinking, diminish the importance of the object, and facilitate intuitive response. Each addition was first and foremost to be a spatial reply to forces emanating from the existing collection of buildings, spaces, roads, and natural features marking the area (fig. 5). Students then honed these interventions with a collection of qualitatively defined open areas that were the beginnings of the AG Park.

These interventions then underwent critical scrutiny as students were directed to select another's model, and using the same components, enhance the assets of said model. The original owners then reclaimed their models and were asked to introduce a new material that affected 4000 sq. ft., roughly the size of the gallery that was ultimately to find its way into this project. This step was interesting because while everything up to this point had been monochromatic, the 'new material' was open and introduced such things as: feathers, wires, broken CD's, chains of paper draped over the model, ribbons, and party horns. As you might imagine, many of these modifications proved distracting, and so during the next class students were again asked to choose someone else's model, this time removing any parts that they felt to be superfluous, then draw two perspectives with people to show how this place might be inhabited and activated. The goal of the model swapping in general was to diminish a sense of ownership so that the site could remain preeminent throughout initial development. Additionally, all of these exercises were given without the request for a 'building' in the hope that by reacting to the potential of particular areas in the site the final form might slowly gather itself, gaining further information from the program, structure, and consideration for the way people could interact there.

This choreographed chaos effectively subverted most impulses to make 'buildings' as students saw them in their minds, and fostered a surprising sensitivity among students about what types of responses would be considered

cliché and what might become authentic, with a majority retaining a handle on the question of what the *site* was saying, rather than doing what *they* wanted. Interestingly however, when students were finally given the program for the gallery space within the park, a large number of them locked onto the building, neglecting much about its interaction with the previous site design. The case of the disappearing site plan seems to be another clue as to the difficulty of holistic thinking as well as the power of our fears to draw us astray (in this case, students feeling overwhelmed by making a 'real' building). In spite of this digression, students did do an excellent job locating and orienting their buildings according to what they had learned from the previous exercises and tended to retain their emerging ideas about character as it related to this special place.

These beginnings seem encouraging as possible foundations for the development sustainable environments, in that, students began to create in a way that actively engaged and participated with a particular place. Without this type of sensitivity at the outset of the project, regardless of other modifications, there certainly would be grave implications for at least the longevity of the project and most likely its ability to facilitate human delight as well.

CONCLUSION

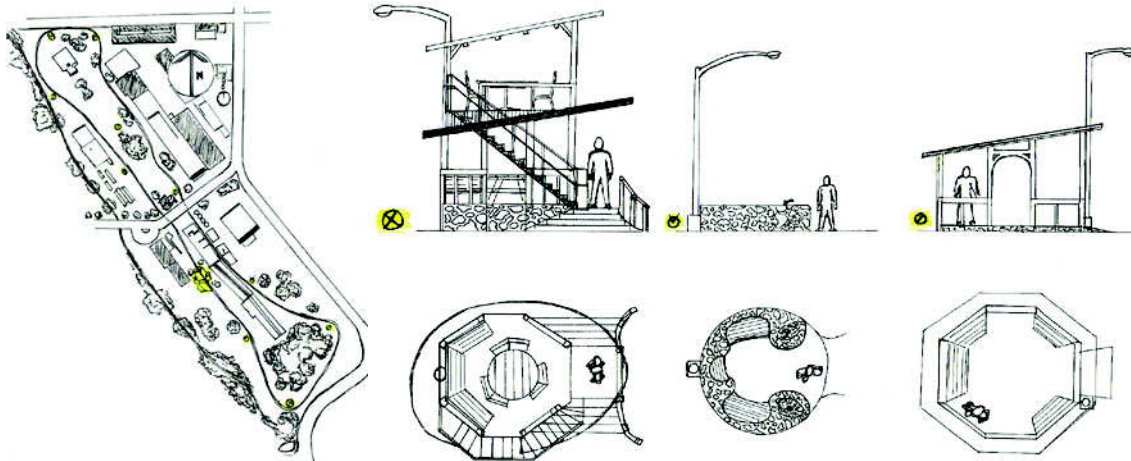

Figure 6: Final Details: Micah Leger

With a pressing need for sustainable and regenerative practices in all walks of life, it is essential that we become more in touch with our world:

In the case of dwelling, for instance, new construction, materials, and services are being developed on a different level and at a different rate than the nature and purpose of the dwelling, which are rooted in the customs, habits, and in the relative stability of primary human situations. (Vesely 2004:26)

'Primary human situations' are anchored by our primary human qualities. These qualities might be considered as the groundwork for sustainable design, as they encourage the reification and retention of those elements that make life meaningful and particular places special.

At the inception of this studio project, this site was certainly not sacred or special for most students. Despite its close proximity to the University this place had remained virtually invisible for most, yet through iterative interaction there emerged great understandings and appreciation for this place. Notwithstanding some difficulties with the total synthesis of building and site, I was encouraged by students' ability to discover form in response to phenomena and experience, as well their as later judgments in making refinements based on function and use that contributed to the emergence of some very believable, whole, projects. (fig. 6).

In a time where many aspects of life are viewed as temporary and disposable, made poignantly evident by the fact this site is now undergoing demolition, we must seek sustainability on a broader plane. Sustainability cannot be understood as stylistic, instrumental, or prescriptive, as lasting ecological practices will develop through the extension of meaning and the promotion of relationships built on complexity and longevity as they relate to place. In short, sustainability must be first understood as a product of our 'being-in-the-world' so that our environments may remain significant.

Student breakthroughs during this studio magnified the limitations of rationalistic and empirical modes of assessment as a means of connection with phenomenological aspects of place, and in a society that has arrived "...at the curious paradox..." where "...feeling has become more difficult than thinking..." (Gideon 1954: 585) it is heartening to see that our non-intellectual modes of engagement are not actually absent, and may in fact be

stimulated quite easily if given the right catalyst. In light of the students' realizations, I must return once more and end with Dalibor Vesely as he asks,

I wonder if it is necessary to argue any further that poetics is not a discipline based on dreams or improvisations and that it could be, as far as architecture is concerned, more rigorous than an analytical or causal approach. (Vesely 2004: 389)

I believe that greater awareness and poetic interpretation can help temper thinking with feeling and bring quantitative, technical, and intellectual methods back under the governance of an ethical framework. In this way ecological concerns and environmental remediation are not seen strictly as abstract problem solving or fixing a machine, rather they become the extension of a temporal humanistic existence where place, history, and culture are understood as essential elements of sustainability as well. This reestablished notion of ontology in design could strengthen interconnectedness, become a vehicle to transcend dualistic thinking, and offer a position to see sustainability exactly as it should be seen – as our fundamental oneness with the world in which we live.

REFERENCES

- Baudrillard, Jean. 2001. *Impossible exchange*. Verso: New York
- Bergson, Henri. Translated by Maybelle L. Andison. 1946. *The creative mind*. The Philosophical Library: New York
- Bergson, Henri. Translated by F.L. Pogson. 2001. *Time and free will*. Dover Publications: New York
- Elkins, James. 1996. *The object stares back : on the nature of seeing*. Simon and Schuster: New York
- Gadamer, Hans Georg. 1975. *Truth and method*. Seabury Press: New York
- Giedion, Sigfried. 1954. *Space, time, and architecture; the growth of a new tradition*. Harvard University Press:
- Goethe, Johan Wolfgang von. ed. Miller, Douglas. 1988. *Scientific studies*. Shurkamp Publishers: New York
Cambridge
- Husserl, Edmund. Translated by William P. Alston and George Nakhnikian. Introd. by George Nakhnikian. 1964. *The idea of phenomenology*. Nijhoff: The Hague
- Leach, Neil. 1997. *Rethinking architecture*. Routledge: New York
- Leatherbarrow, David. 2004. *Topographical stories: studies in landscape and architecture*. University of Pennsylvania Press: Philadelphia
- Nietzsche, Friedrich. Translated by Walter Kaufmann. 1967. *The birth of tragedy and the case of wagner*. Random House: New York
- Perez-Gomez, Alberto. *Hermeneutics as discourse in design*. From: Design Issues. Volume 15(2). Summer 1999. p. 71-79.
- Vesely, Dalibor. 2004. *Architecture in the age of divided representation: the question of creativity in the shadow of production*. MIT Press: Cambridge
- Waldheim, Charles ed. 2006 *The landscape urbanism reader*. Princeton Architectural Press: New York
- Watts, Alan. 1957. *The way of zen*. Vintage Books: New York
- Watts, Alan. 1967. *The supreme identity: an essay on oriental metaphysic and the christian religion*. The Noonday Press: New York
- Wittgenstein, Ludwig. 1958. *Philosophical investigations*. Macmillan: New York

Innovative Sustainable Water Management Practices in Solar Residential Design

C. Jason Mabry¹, Franca Trubiano¹

¹Georgia Institute of Technology, Atlanta, Georgia

ABSTRACT: This paper communicates the results of an architectural research project which sought innovative design strategies for achieving energy and resource efficiencies in water management systems traditionally used in single-family housing. It describes the engineering of an efficient, multifaceted, and fully integrated water management system for a domestic environment of 800 sq. ft., entirely powered by solar energy. The four innovations whose details are conveyed include the use of alternate materials for piping distribution and collection, the use of water in solar energy generation, the design of a building skin which capitalizes on water's capacity to store heat as well as the design of a ecological groundscape which re-uses and filters waste water and rain water.

Keywords: energy, plumbing, home design

INTRODUCTION

This paper communicates the results of an architectural research project which sought innovative design strategies for achieving energy and resource efficiencies in water management systems traditionally used in single-family housing. A building's plumbing infrastructure, such as its supply, distribution and waste collection is rarely addressed when developing initiatives for improving sustainable practices within the construction industry. And yet, it is precisely this network of pipes, valves and controls which plays a considerable role in the total energy and resource consumption of any building. With an eye to addressing this condition, the following describes the engineering of an efficient, multifaceted, and fully integrated water management system for a domestic environment of 800 sq. ft. The four innovations whose details are conveyed include the use of alternate materials for piping distribution and collection, the use of water in solar energy generation, the design of a building skin which capitalizes on water's capacity to store heat as well as the design of an ecological groundscape which re-uses and filters waste water and rain water.

This paper was written collaboratively by studio instructor and graduate architecture student at the College of Architecture of the Georgia Institute of Technology, highlighting a process which openly promoted the integration of both research and design methodologies within existing pedagogical structures typical of architecture studios. It details conditions which facilitated extensive collaborations between student and industry specialists, suppliers and associated engineers. And conducted under the auspices of the Solar Decathlon 2007 Competition, the studio held in the fall of 2006 involved the collaboration of sixteen architecture students and an equal number of engineering and building technology students operating as consultants. The mandate to design, build and transport to Washington DC, a highly efficient single-family house entirely operated using solar power was the immediate context within which the plumbing design was developed. Managing the water consumption and waste redistribution of a one bedroom, one bath living environment using the least amount of energy was the express goal. In addition, the accommodation of a grey water system for recycling waste and rainwater became an important feature of the landscape design. The studio was productively constrained by the real life necessity to physically build and operate the results of one's invention. All decisions will see the light of day and be submitted to the rigorous testing of an international competition. This is the context within which the full merit of the work described here below should be evaluated. But a sub-section of the research and design work undertaken by an entire class of architect and engineer collaborators, it registers the gains achieved when asking questions pertinent to building performance, sustainable water management practices and the construction of solar powered homes.

The results herein may be of interest to those involved in architectural education as well as those involved in the engineering of building systems. The adoption of sustainable practices and energy conservation, as they pertain to the operations of a building, has yet to become an essential component of architectural design as taught within most design studios. The perceived urgency to teach the language of form, site, program and circulation leaves little time for questions associated with architectural performance. And yet, with 40% of North America's energy consumption the result of operating a building's systems, the necessity to encourage dialogue between architect and engineer is imperative. This studio was the first initiative at Georgia Tech to posit questions of applied technology within the core of a collaborative studio and it is expected that a greater number of design studios will herein investigate the territory defined by architectural design, systems design and building performance. Architecture students collaborated extensively with undergraduate and graduate students from Mechanical, Civil, Electrical and Computing Engineering, and they constructively integrated the limitations of each within the process of design.

In addition, the outcome of such a project may be of keen interest to the building industry, who in this instance volunteered its services to help in the education of young architects. The project necessitated a large degree of collaboration between student and industry consultants as many working meetings were held with material and systems suppliers, installers and specialty contractors. Be it in the fields of heating, ventilating, cooling, lighting, electrical wiring, photovoltaic design or plumbing, students worked side by side with experts in each field and directly benefited from the practicum of those who have understand the in-situ operation of building systems. No longer are assumptions about details and performance acceptable in theory; they must accord with their measured values in practice.

And finally, the results of such a research and design project may be of interest to our future clients and home builders. The potential for ever more efficient building systems within residential construction is considerable given technological advances in non renewable energies during the past two decades. Housing projects such as Sutton, England's BedZED Development designed by Bill Dunster are showcases for the integration of innovative operating systems within contemporary architecture, particularly when architect and developer are intent on reducing to a minimum a project's daily consumption of non renewable energy (Sommerhoff, Emilie 2003). However, within the North American new housing market the evidence of such integration is scant. Reluctance still exists on the part of building contractors to install mechanical equipment which features such inventions when building single-family housing; not being the benefactors of their projected lower operating costs. Far more surprising, however, is the lack of advocacy on the part of architects and engineers to redress this situation. Surely, more awareness could be generated and information communicated to housing consumers on the long-term benefits of more energy efficient building systems and this paper is an attempt to facilitate this process.

1.0 SAVING ENERGY AND RESOURCES BY WAY OF INNOVATIONS IN HOUSEHOLD PLUMBING

What began as the need to engineer a simple plumbing diagram for a single-family residence expanded into an energy recycling, building integrated system of water management designed to capture the heat energy expended from a variety of sources. In so doing, it has made the plumbing system one of the most energy saving components of the contest house in question. The whole was accomplished by way of research using product data, manufacturer's recommendations, consultation with engineers and those with expert knowledge in plumbing design, and research into the operation of components in academic publications.

As mentioned previously, the four innovations in plumbing design and water management which resulted in energy efficiencies can be summarized as follows:

1. the use of alternate materials and distribution techniques for primary household needs
2. the adoption of water for solar energy collection
3. the use of water's capacity to store heat and the implication this has for the design of building skins
4. and the re-use of waste water and rain water in the development of more ecological landscapes

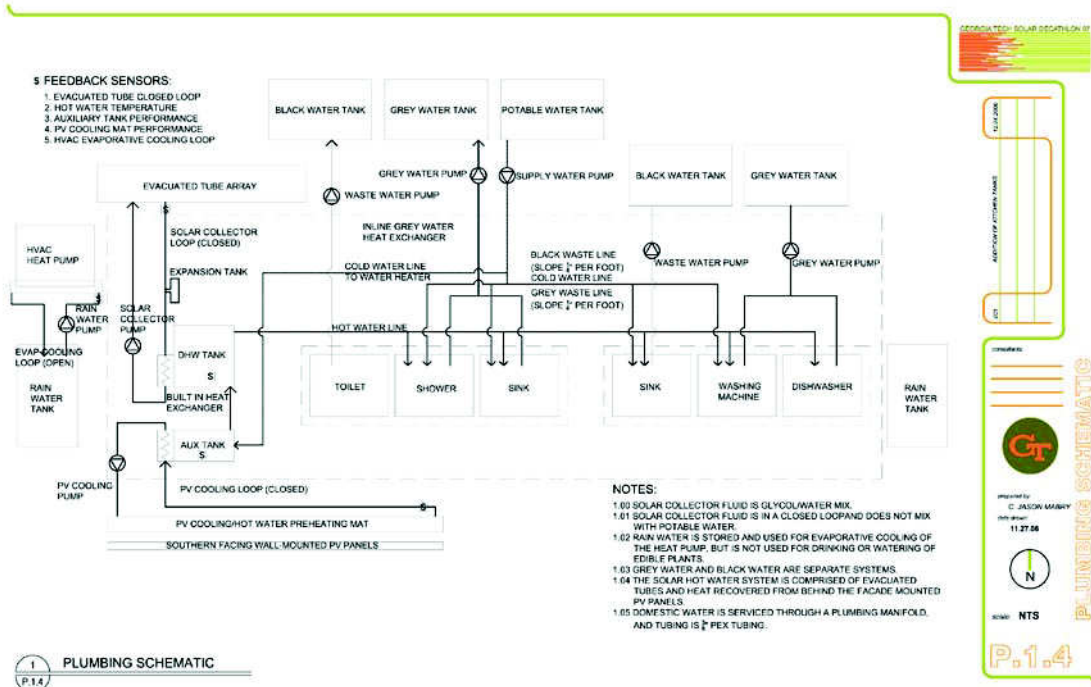

Figure 1: Plumbing schematic for the solar decathlon house. Source: Mabry 2006.

1.1 Saving energy using alternate materials and distribution techniques for primary household needs

The typical single-family home can greatly benefit from advances in the most ubiquitous of building products; pipes used in common plumbing applications. Research into innovative plumbing systems in the form of product searches yielded information on the newest technology to date: the *home run system*, or *plumbing manifold*. Two common companies manufacturing plumbing manifolds are Vanguard Industries, Inc. and REHAU, Inc., and while they have been around for several years, they are now coming into broader use.

The system functions by way of a central location from which all water is delivered to fixtures throughout the house. In this way water usage can be more easily monitored and controlled, leaks are easier to detect and fix, and it allows work being done on specific plumbing components to not hamper water delivery to the rest of the house (NAHB Research Center 2003). This plumbing manifold, essentially a breaker box for hot and cold water delivery, is both a method of saving energy in the plumbing system and a more efficient method of delivery. All water flows through the manifold and is then sent through individual lines to hot and cold water connections at each fixture.

The *home run system* saves energy by coupling the manifold with PEX piping as a delivery system. PEX is a flexible plastic made into tubes, and is especially well suited for plumbing due to its resistance to chemicals, heat, and creep (NAHB Research Center 2003). PEX runs as a single length of tubing between the manifold and the fixture, with no fittings required except at terminal points. Being made of cross-linked Polyethylene, it accommodates sharp bends, allows for quick and direct delivery of water with little pressure loss, and with resultant savings on pumping. Most critically, a smaller diameter PEX tube can be used than that of copper tubing, since the line runs are direct to each fixture without bends or material changes (Plastics Pipe Institute 2004). As such, instead of a 1/2" diameter supply tube (normally used with copper), a 3/8" diameter tube can be used in delivery to fixtures. This 1/8" has significant energy savings. The smaller diameter has approximately half the amount of water in it than the 1/2" tube (NAHB Research Center 2003). This means that there is less standing water in the tubes, and as a result less heated water will be left in the pipes to cool. Furthermore, the smaller diameter means that more water will be delivered in less time, since the velocity within the pipe will be higher (NAHB Research Center 2006).

In addition to being a more direct means of transferring water from the storage and hot water tank, PEX tubing has the added benefit of retaining more of the heat energy within the tube. Copper piping, the traditional method

of delivery, is an excellent conductor, meaning it must either be insulated, or risk transferring the heat energy into the air of the house. PEX tubing acts as an insulator, and thus does not have the same problem, saving energy by retaining more of the heat within it. The use of PEX is becoming a major competitor to copper, due to cost and environmental issues, and has been in widespread use in Europe since the late 1970s (NAHB Research Center Nov 2006*).

For all of the above reasons it was decided to use this system in the construction of our Solar Decathlon House and in collaboration with Mckenney's Inc. and OneWorld Sustainable Energy Corporation the system will be optimized to efficiently deliver hot water while saving both water and the energy used to heat it. The plumbing plan takes advantage of a "power spine" concept wherein all of the piping distribution is contained within this spine and the location of the plumbing manifold has been identified as adjacent to the spine, located within the bathroom and in close proximity to the kitchen, allowing for fast and efficient delivery.

2. Saving household energy with the use of solar hot water evacuated tubes

Another means of reducing the consumption of energy in the operations of a typical household involves the introduction of solar hot water. The ability to use the sun's rays in order to heat a family's daily water usage is yet another means of reducing reliance on non-renewable energies. When researching solar hot water systems, most research indicated that evacuated tubes would be the most effective at capturing usable solar energy (National Renewable Energy Laboratory 2006). Flat plate collectors would be another option. Evacuated tubes operate by absorbing solar radiation into a tube from which air has been evacuated. The trapped radiation then heats a smaller tube through which a heat transfer fluid flows, absorbing the thermal energy. Since there is virtually no air inside the tubes, almost all energy captured is retained, instead of being lost through convection or conduction. The heat transfer fluid is then piped to a heat exchanger or solar hot water tank.

Typical evacuated tube design yields a high volume of heat production to unit size, more so than competing flat plate collectors (National Renewable Energy Laboratory 2006). Consultation and collaboration with engineering students during the initial design charrette supported the decision to use evacuated tubes. Furthermore, the design of the system usually limits the amount of pumping needed for the solar collection fluid, or eliminates it altogether by using thermosiphoning. Most typically, thermosiphoning could be defined as a passive system of heat exchange that eliminates the need for pumps within a vertical closed-loop circuit. A difference in temperature and thus liquid density allow for a thermosiphon heat exchange system to effectively capture and store solar energy in a tank without requiring a conventional pump, though the design is somewhat restrictive.

Due to constraints on the site whose dimensions were dictated by the Solar Decathlon competition, various manufactures and evacuated tube systems were studied to determine which would deliver the most energy in the least amount of space. This research commenced with manufacturer's details to determine spatial dimensions and restrictions, and concluded with independent research conducted by collaborating PhD engineering students engaged in in-depth analyses of the competition house systems. Additionally, since the roof, usually the ideal location for such a system, is in our design completely covered in solar panels, it was necessary to move the system to a lower but equally effective location. Product research of various available manufacturers located a system that allowed horizontal operation instead of the usual angled vertical configuration. This coincided with a desire to integrate the system into the architecture and landscaping, showcasing the energy producing technology on the outside of the house, and produced a more cohesive architecture/systems and engineering design and approach to the project.

To save on losses due to pumping distance, the evacuated tubes were located as close to the water heater as possible. Several thermal storage systems were examined, both by speaking with industry professionals and studying as-built drawings showing how other groups had constructed evacuated tube thermal energy storage systems in the past, mainly from past Solar Decathlon competitions. The decision was made to keep the system as simple as possible while still creating and storing as much energy as possible. Using a large solar storage tank was ruled out since there was no room within the structure to house it, and because it would allow the dissipation of heat into the air had it been external to the building envelope. Additionally, the auxiliary tank would require extra pumping to deliver the energy to another tank. Therefore, a direct evacuated tube to hot water tank system was designed, at first as a conceptual design, then further refined with feedback from engineering students working on the project, and finally refined and approved by consultants from the engineering firm Mckenney's Inc. Utilizing a hot water tank with a built in heat exchanger will save energy losses due to pumping. Thus, the glycol/water loop delivers energy directly from the evacuated tube to the hot water tank by means of the integrated heat exchanger. With the exchange occurring within the tank, no heat is lost to the environment in the process, further saving on energy.

3. Saving Household Energy by way of Heat Storage in the Design of an Exterior Cavity Wall

The most elaborate component of the house's plumbing system will be located within the south facing structurally insulated panel (SIP) wall assembly. Comprising simultaneously building skin, cooling system, heating system, and systems/architecture integration, a so-named PV cooling loop will be introduced into the design of the house's front elevation. This particular section of the façade is comprised of solar collectors traditionally situated on the roof. They are offset from the SIP wall by a cavity in which the cooling loop will be located. In this instance a plumbing loop has been devised to act as both water heating element and PV cooling component. The water heating portion of the system was deemed necessary by engineering calculations due to site constraints in the sizing and location of the evacuated tubes, the primary water heating element. This heating system was required to be placed much farther than optimal from the water heater, and since the overall house design and other stringent criteria forced the evacuated tube system to be smaller than would be ideal, a secondary solar heating method was sought, which led directly to the water in the wall heating system. This was devised in collaboration with a fellow studio student working on the wall assembly and PV panel integration.

Due to the inclusion of solar panels on the wall, where less airflow would be available, it was determined that a method of cooling would be required to maintain their performance. It was also realized that the heat buildup behind the panel would be usable waste heat if it could be stored. By capturing this heat, it would be useful elsewhere within the house. Heating water was the obvious choice for the captured thermal energy. Coupling any retrievable heat from behind the panels with the output of the evacuated tubes seemed sufficient for all water heating needs. The question then revolved around how to best retrieve the heat from behind the panels.

A separate study, conducted by another studio participant, investigated the efficacy of wall-mounted PV panels (Krauter, Stefan 2001). This study examined methods of extracting heat from behind PV panels to allow them to operate most efficiently. Of the four viable methods, the most effective was using liquid to remove excess heat (Krauter, Stefan 2001). The research results identified by the student confirmed the studio led research assumptions and closely aligned with efforts of placing piping behind the PV panels on the SIP wall.

Research into specific cooling methods conducted by a fellow studio participant studying PV facades coincided with specific heating methods and piping choices examined from a plumbing standpoint, allowing for the system to serve multiple purposes. The study on extracting heat from behind the panels did not indicate which liquid would be most effective at extracting heat, but research into the evacuated tube system indicated that a glycol/water mixture would best transfer heat and be useful in the prevention of freezing within the system (National Renewable Energy Laboratory 1996). Advice from field experts at Mckenney's, Inc. also confirmed this conclusion. Thus, the same fluid used to transfer heat in the evacuated tubes will be used to extract heat from the PV panels and supplement the primary water heating system.

The final question remaining in the water system was which type of piping should be used. Due to the compact nature of the system, spatial restraints between the panel and the wall, investigation into a very slim heat extraction system was undertaken to determine whether or not there was a system that would fit. After searching for premade systems, of which none specific to this type of application were found, the decision was made to custom design and construct one. Such systems were initially developed in the 1970s for water heating, typically used in heated pool applications, but none are currently in production. Copper piping and PEX piping were the two products of investigation for carrying the fluid. After much research into the best methods of circulating liquid for heat extraction, primarily in the form of conversations with field experts, in addition to product data research, it was found that straight lines running vertically would not be as efficient at removing heat since they would not cover enough area. Copper piping, aside from being increasingly expensive, is not as maneuverable as PEX tubing, and given the space constraints, and the understanding that copper would be much more difficult to work with, PEX was chosen as the piping method of choice. OneWorld Sustainable Energy Corporation in Atlanta, Georgia has acted as a consultant in this process and their research into manufacturer's specifications and similar heating systems made with rubber mats and PEX tubing indicated that such a system would work well for the project's purposes. PEX can bend back and forth, snaking up the SIP wall and thereby extracting extra heat that would not be possible in a straight pipe configuration. This extra heat will allow for further energy savings by limiting the amount of time the auxiliary heating element would need to operate to deliver hot water.

In the end, it was determined that cooling the PV panels while heating water using the glycol/water mix and a heat exchanger would be very effective at saving energy used to heat hot water within the house, in addition to providing increased solar energy output from the PV panels by allowing them to operate more efficiently. Both the hot water system and the power production system will now operate better together than either would have alone. In addition, this coupling of plumbing components has resulted in a unified system integrating architecture and infrastructure.

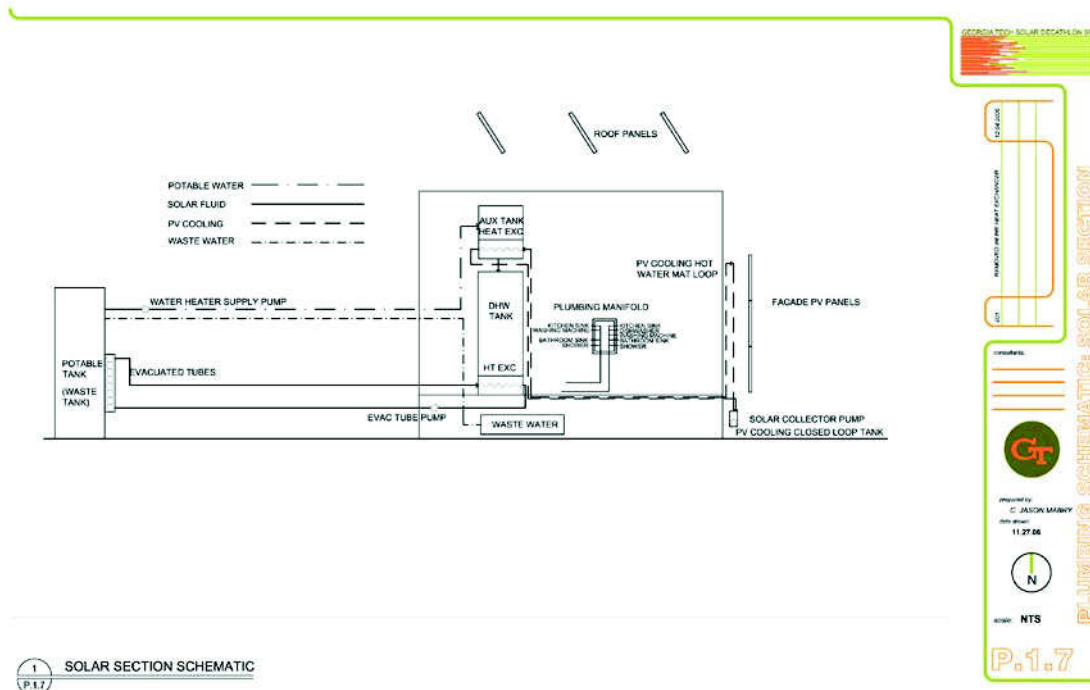

Figure 2: Solar schematic section for the solar decathlon house. Source: Mabry 2006.

4. Saving energy with water in the landscape

In the process of designing the house, whose plumbing systems both within and without have been described here above, the decision was made to render the larger site within which it was situated into a working landscape; a natural machine in support of the house. By using the ground which surrounds the house for the cleaning and storing of water, a net supply of energy will be saved in the house's operations. Water used both in the house and collected on site will not be immediately disposed of and sent afar to be processed and treated at a water purification plant. The design intent ensures that as much as possible of the water that is found on the site remains on the site. And to this end, some of the house's internal water will be recycled on site as will captured rain water. This will save on potable water usage and sustain the larger landscape while reducing both the house's and the municipality's operating costs, reducing piping required and energy required to treat the water.

The house has been designed to have both a grey water and black water system. They are kept separate, allowing for the onsite treatment of the grey water, and the eventual offsite processing of the black water. Grey water originates in plumbing sites such as the bathroom sink, shower, dishwasher, and washing machine, and when properly treated can be recycled for use in toilet flushing, clothes washing, and irrigation. Storm water collected from outdoor decks and the building roof is also considered grey water and it too can be used for the same purposes. Efforts are ongoing with engineers to attempt to extract thermal energy from grey water prior to storage or discharge into the landscape. This can be achieved by using an inline heat exchanger or by passing the heated grey water in immediate proximity of incoming supply water to transfer the heat between the lines prior to exiting the house envelope. Current research is determining feasibility of such a system and the technical difficulties in extracting the energy.

The system is designed to efficiently treat grey water in a limited footprint, due to competition constraints. Furthermore, a complex system of tanks is required as there is no municipal hookup and all water must be stored on site. The potable water supply tank is used in the landscape to supply water to edible plants, due to competition constraints disallowing edible plants to be treated with grey water. The grey water tank supplies water to a reed bed filtration system developed in collaboration with two fellow studio members focusing on the landscape design and implementation alongside a civil engineering student also working on grey water filtration. The filtration system pumps water to an elevated tank, and from there gravity moves the water from tank to tank.

A complex series of plants and organisms pull nutrients from the water for their own sustenance and then pass cleaner water to the next tank, ultimately releasing it into the landscape. There is also a living wall, essentially plants stacked vertically in containers that will be irrigated by grey water. Rainwater is being collected in two tanks, one on each end of the house. One of these tanks will store rainwater that will be circulated through an evaporative cooling loop which will cool the heat pump used for the houses heating and cooling needs. Excess water will be used to irrigate the landscape. The other tank will also be used to irrigate the landscape, but will be preceded by an overflow tank that acts as a landscape element, storing water from heavy rains that can potentially be used to passively cool the house.

In addition to saving energy, the integration of the landscape into the house system, often an overlooked component, especially when considering energy saving measures, can be just as important as the mechanical, electrical, and plumbing systems. Moreover, the landscape machine beautifies the environment while cleaning it. By utilizing a complex system of several types of natural environments, gravity, and storage, water can be recycled with virtually no energy used in the process.

CONCLUSION

In conclusion, design research was conducted within the modified structure of an architectural studio. It served as the main platform from which investigations could be made into energy savings measures associated with plumbing systems used in residential construction. To accomplish the like, the input of expert engineering consultants was essential as was that of engineering students. Whether in the form of design reviews or working conversations, collaboration with such partners in the building industry proved crucial to the decision making process. Only in this manner could conclusions be drawn which encourage the use of innovative materials in the housing sector, which promote the use of solar technologies for conditioning our daily consumption of household water, which integrate the distribution of water in the construction of residential building skins and which consider the effects of water management across the entire site of a single-family home.

ACKNOWLEDGEMENTS

The authors would like to express thanks to all consultants who worked on the project: Greg Jeffers and Mckenney's, Inc. Engineers, OneWorld Sustainable Energy Corporation, Professor Ruchi Choudhary, and students Toni Cliett [Architecture], Amanda Cook [Architecture], Erin Gibbons [Civil Engineering], Alex Jackson [Civil Engineering], and Joe Jamgochian [Architecture].

REFERENCES

- Krauter, S., Salhi, M., Schroer, S., Hanitsch, R. 2001. *New Façade System Consisting of Combined Photovoltaic and Solar Thermal Generators with Building Insulation.*
- NAHB Research Center. 2006. *Home Run Plumbing Systems.*
- NAHB Research Center. 2006*. *Design Guide: Residential PEX Water Supply Plumbing Systems.*
- NAHB Research Center. 2003. *PATH Technology Inventory Review.*
- National Renewable Energy Laboratory. 1996. *Residential Solar Heating Collectors.*
- National Renewable Energy Laboratory. 1996. *Solar Water Heating.*
- Plastic Pipe and Fittings Association. *PEX Offers Environmentally Sound Solutions.*
- Plastics Pipe Institute. 2004. *PEX Pipes for Plumbing.*
- Sommerhoff, Emilie. 2003. *Carbon Neutral Neighborhood. Architecture* Vol. 92 Issue 4.

Case Studies — Human Context

Effect of Building Design on Pressure-related Problems In High-rise Residential Buildings
Jae-Hun Jo, Myong-Souk Yeo, Kwang-Woo Kim

Thermal Comfort in a Naturally-Ventilated Educational Building
David Mwale Ogoli

The Green Church
Mark L. Gillem

Environmental Studies of Vernacular Architecture
J. Brooke Harrington, Judith Bing

Effect of Building Design on Pressure-related Problems in High-rise Residential Buildings

Jae-Hun Jo¹, Myong-Souk Yeo², Kwang-Woo Kim²

¹Technology Research Institute, DAELIM Industrial Co., Ltd., Seoul, South KOREA

²Department of Architecture, Seoul National University, Seoul, South KOREA

ABSTRACT: High-rise residential buildings in Seoul experience stack effect problems during the winter season, such as difficulties in opening residential entrance doors and whistling noises from elevator doors generated by airflow. Many researches have been performed on stack-induced problems of cold areas in high-rise office buildings, and several solutions have been proposed. However, it is not well known where exactly and how extensive, these problems are in residential buildings. The architectural design that comprises a building is known to be an important measure in minimizing or preventing stack effect problems; how a building is designed can affect the extent of the pressure distribution caused by the stack effect. We surveyed two buildings having different phases of stack effect problem through drawing examinations and field examinations, and conducted measurements of pressure distribution on these buildings. Through these two projects, we verified the problems associated with the stack effect and the influence of building designs on the extent of such problems. Finally, this paper presents the design implications for limiting the airflow in a building to prevent stack-induced problems occurring in high-rise residential buildings.

Keywords: high-rise building, building design, stack effect, field measurement

INTRODUCTION

In recent years, many high-rise residential buildings have been constructed in Korea. These buildings comprise of over 30 floors, up to 70 floors, and due to this height, they form a tall air column inside the building and another outside. During the winter season, the differential weight of these two columns of air, where one is warm and the other is cold, causes a pressure difference between the inside and outside of the building. This brings about the so-called stack effect.

It is known that there are many problems caused by the stack effect such as the elevator door sticking problem, washroom exhaust imbalance, air leakage, difficulty in opening doors, noise resulting from air flowing through cracks, and so forth. Thus, many studies have been performed to solve these problems in office buildings, and several solutions have been proposed. In the office building, as there is usually no compartmentation between the cores and working area, one possible solution could be to improve the airtightness of the exterior wall (Tamura 1967, ASHRAE 1993). For this reason, the National Association of Architectural Metal Manufacturers set a limit on the maximum leakage per unit of exterior wall area to be 1.10 CMH/m² at a pressure difference of 75 Pa, exclusive of leakage through operable windows (Tamura 1994). However, in the case of residential buildings, as residents of residential buildings demand openable windows which they can use even during the cold season, it makes much more difficult to maintain airtightness of the envelope in a residential building to the same level as that of an office building with fixed windows (Jacques 1996). Therefore, improving just the airtightness of the envelope is not a viable solution for resolving the problems due to the stack effect in high-rise residential buildings. Since a high-rise residential building consists of many units surrounding the core, the pressure profile of the high-rise residential building is different from that of the office building. Accordingly, the problems caused by the stack effect would differ as well, and would thereby require different approaches to be developed for resolving such problems in tall residential buildings.

The main objective of this study is to obtain the actual pressure differences across the architectural elements (exterior wall, entrance door, elevator door) in high-rise residential buildings as a preliminary examination to develop a guideline for preventing stack effect problems.

1. Survey of two high-rise residential buildings

1.1. Survey outline

We conducted surveys on two test buildings beginning from December 2003 to February 2004. First, the architectural drawings were examined to identify where the problems due to stack effect could occur. We particularly focused on the entrance doors on each floor, especially when the door is connected to the outside, and the core areas. After examining the drawings, we conducted field investigations of the two test buildings several times during the winter season. We verified suspected problems and measured the air tightness. Finally, the quality of construction of the two test buildings was evaluated with respect to airtightness.

1.2. Building description

Two newly built high-rise residential buildings in Seoul were selected as the test sample for our field measurements. The test buildings were both built recently and have similar types of envelope. However, it was reported that the two buildings had different problems due to the stack effect in different places. The information on these two buildings is given in Table 1.

Building A (40 stories) and building B (69 stories) are both residential buildings; typical floor plans and sections of each building are given in Fig. 1 and Fig. 2, respectively, which have been simplified to show the zone easily (i.e. each residence is represented as a single zone). Both buildings A and B have two main mechanical equipment floors. In building A, one is on the 8th floor and the other is on the top floor, and in building B, one is on the 16th floor and the other is on the 55th floor. HVAC systems and exhaust fans for washrooms are also located on these floors. There is no vertical zoning of the elevator shaft in building A; the elevators serve all floors (B5 to 40F). In building B, there are 4 vertical zones in the elevator shaft, which are for the shuttle elevators (B5 to 1F), low-rise elevators (1F-15F), middle-rise elevators (1F, 2F, 16F to 54F), and high-rise elevators (B1-2F, 54F to 69F).

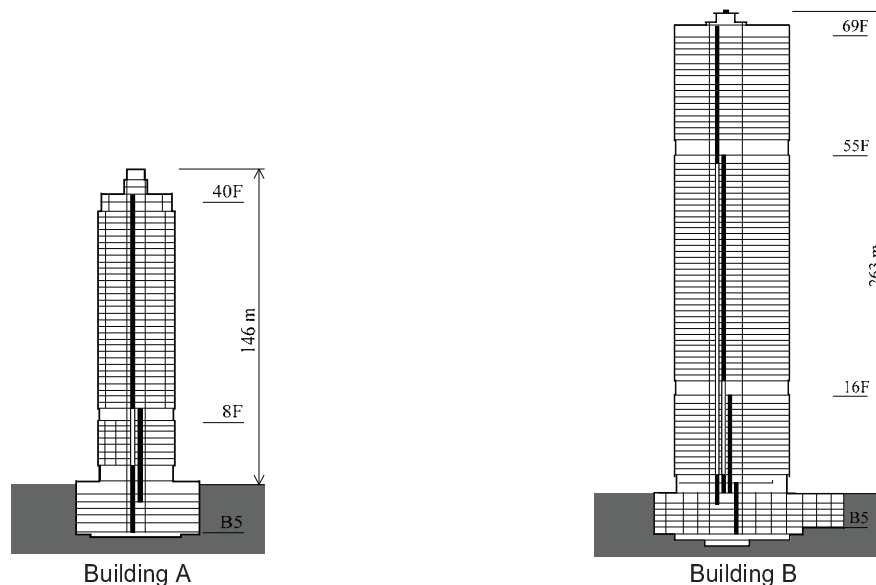

Figure 1: Sections and vertical elevator zonings of two test buildings

Table 1: Building description

	Building A	Building B
Location	Seoul, Korea	Seoul, Korea
Structure	SRC	SRC
Height	146 m	263 m
No. of floors above ground	40	69
No. of basement floors	5	3
Exterior walls	Aluminum curtain wall	Aluminum curtain wall
Date of completion	December 2003	February 2004

Table 2: Comparison of architectural plans of building A and building B

	Location	Building A	Building B
Inflow part	Entrance on basement floor	-Not installed(vestibule) + Automatic door(entrance)	-Swing door(vestibule) + swing door(entrance)
	Main entrance on 1F	-Swing door(vestibule) + automatic door(main entrance)	-Swing door(vestibule) + revolving door(main entrance)
	Elevator hall on 1F	-Automatic door installed	-Swing door installed
Upward part	Elevator shaft	-3 Passenger elevators serving all floors, B5-40F	-3 shuttle elevators serving B5 to 1F -4 high-rise elevators serving B1 to 2F and 54F to 69F -9 middle-rise elevators serving 1F, 2F, and 15F to 54F -4 low-rise elevators serving 1F to 15F
	Stairwell shaft	-Serving all floors, B5 to 40F	-Serving all floors, B5 to 69F
	Mechanical shaft	-No caulking work on slab penetration part	-Caulking work on slab penetration part
Outflow part	Elevator air hole	-Elevator air hole on the shaft wall -Ventilation fan for elevator machine room	-No elevator air hole -Ventilation fan for elevator machine room
Envelope	Condenser room in residence unit	-Double weather strip installed at the door	-Triple weather strip installed at the door
	Exterior wall	-Aluminum curtain wall + pair glass -Manually operating windows	-Aluminum curtain wall + pair glass -Automatically operating windows

2.2. Field examinations: pressured-related problems

During the wintertime from December 2003 to January 2004, the authors conducted several field examinations of the two test buildings. Based on these examinations, the authors were able to verify the extent and locations of the problems caused by the stack effect which were anticipated during the architectural drawing examination. In building A, as shown in the architectural drawings, the entrance to the parking area on the basement floor was compartmentalized by a single automatic door without a vestibule, which allowed only little airflow with some noise. There was also loud noise, exceeding 60 or 70 dB, around the elevator doors on the lower floors and residence entrances on the higher floors. Although building B was constructed more tightly than building A, a slight noise resulting from air flowing through the elevator doors was heard on the lower floors. Particularly on the transfer floor (55th), where passengers can transfer to the high-rise elevators from the middle-rise elevators, airflow from the middle-rise elevator shaft to the high-rise elevator shaft was detected, and there was some noise caused by this airflow. In addition, the two test buildings were compared in terms of the quality of the construction based on architectural elements that can become essential airflow paths due to the stack effect. The two buildings differed significantly as shown in Fig. 4 to Fig. 9. In building A, there are numerous pipes and electric lines passing through the upper part of the entrance doors for the parking area on the basement floor. Without caulking work, this part can be a main inflow path of outside air entering from the parking area, which in turn can influence the pressure difference of the whole building. In building B, triple weather strips were tightly installed at the door for the multi-air-conditioner condenser room, while double weather strips were installed with some gaps at the corners of the door in building A. The summary of pressure-related problems investigated through field examinations is as follows:

- Energy losses from increased infiltration and exfiltration (excessive heating load)
- High-frequency noises from gaps in the elevator doors on the basement floors
- Difficulty in opening doors to rooms around the core area
- Elevator door sticking problems on the ground floor and on the basement floors
- Discomfort caused by drafts
- Exhaust air back-draft (flow reversal in washrooms and in kitchens)



Building A



Building B



Building A



Building B

Figure 4. Entrance for parking area on basement floor (inflow part): leaky automatic door vs. double airtight swing door

Figure 5. Door for elevator hall on 1st floor (inflow part): leaky automatic door vs. airtight swing door



Building A



Building B



Building A

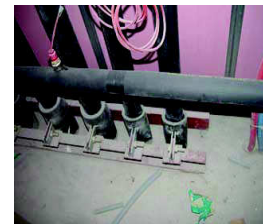

Building B

Figure 6. Door for condenser room (upward part): leaky double weather strips vs. triple weather strips

Figure 7. Electrical pipes through the slab (upward part): no caulking work in building A



Building A



Building B



Building A



Building B

Figure 8. Exterior wall (outflow part): noticeable difference in construction quality

Figure 9. Ventilation fan for elev. machine room (outflow part): leaky fan vs. fan with airtight damper

3. Field measurements of pressure distribution

3.1. Outline of field measurements

Field measurements were carried out on several occasions in January 2004 to verify the problems caused by the stack effect and to obtain the pressure profile of the building. Through an investigation of the site to prepare for practical measurement of the building, airflow paths inside the building were determined. After consulting with a manager of the building, locations for practical measurement were selected to determine the effective methods and a measurable range. Absolute pressures of essential zones on the airflow path; for example the elevator shaft, hallway, residence unit, and outdoors, were measured. The authors measured the absolute pressures of zones on a single floor simultaneously, going down from top to bottom of the building; pressure differences were calculated by these absolute pressure data. Field measurements were carried out at dawn in mild but cold weather, to minimize the influence of exterior conditions such as a sudden gust of wind, elevator use of dwellers, opening of doors, and so forth.

3.2 Field measurement results

Among the various measurement results, the one set least affected by exterior influences is shown in Fig.10 and Fig.11. The y-axis shows the pressure in the elevator shaft, and each line represents the pressure difference from the elevator shaft pressure. For example, "a" in Fig.10 is the pressure difference between the outside and inside of a residence, which in other words is the pressure difference of the exterior wall. Although building A is lower in height than building B by over 100 m, building A apparently displays more serious problems due to the stack effect. It should be noted that the pressure difference across the residence entrance door is greater than that across the exterior wall for both test buildings.

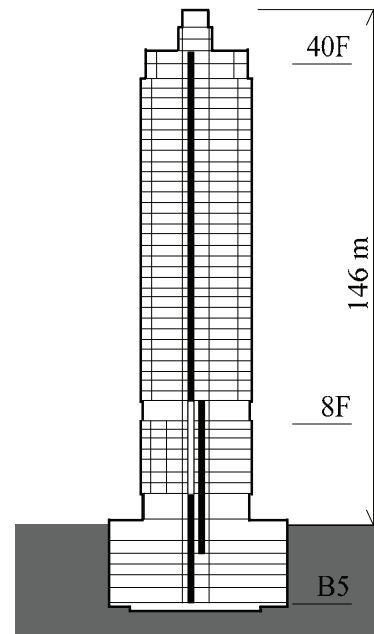
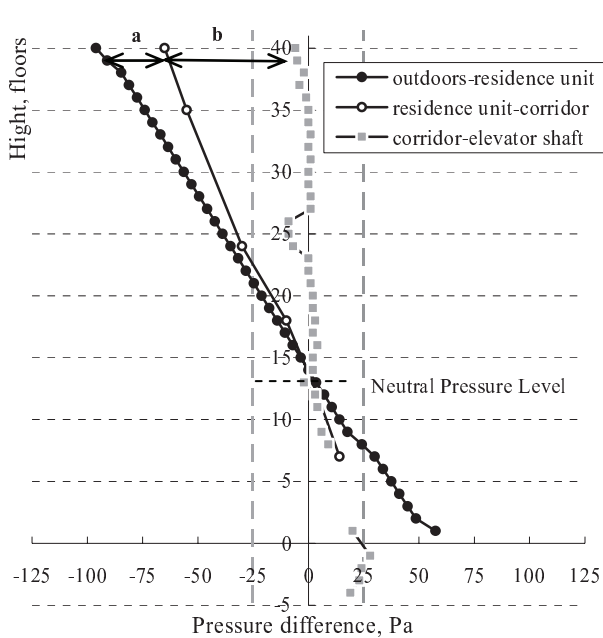

Figure 10. Field measurement results of building A

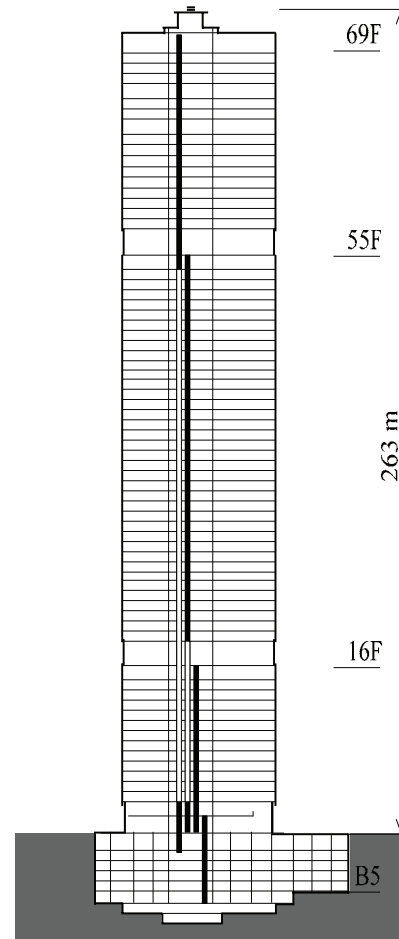
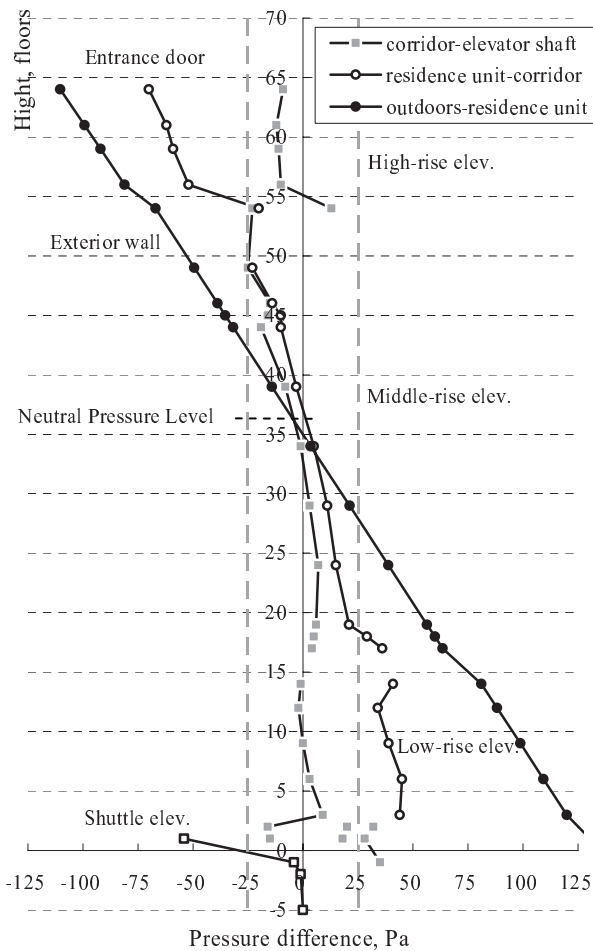

Figure 11. Field measurement results of building B

(1) Building A

As shown in Fig. 10, there are no significant problems for the elevator door on most floors; however, pressure differences are relatively high, of almost 25 Pa, on most basement floors. On the 1st basement floor, the pressure difference was over 25 Pa; problems such as the elevator door sticking problem and noise may occur under this level of pressure difference. Pressure difference at the residence entrance ("a" in the Fig. 10) can be twice as large as that of the exterior wall ("b" in the Fig. 10). On the 35th floor, for example, the pressure difference at the entrance door is about 50 Pa, while that at the exterior wall is about 25 Pa. The entrance doors at higher parts of the building having pressure differences of over 50 Pa cause difficulties in opening the doors, which will cause serious problems in emergency situations. The height of the Neutral Pressure Level (NPL) was lower than the center of the building height, such that the pressure difference at the entrance door and exterior wall increased at the higher parts of the building than at the lower parts. This in turn means that the lower parts of the building experienced more leakages.

(2) Building B

In building B, different types of elevators separate the elevator shaft vertically and serve different parts of the building (as shown in Fig. 11): the upper part, middle part, lower part, and basement part of the building. For this reason, the pressure differences across elevator doors in building B are generally lower than those of building A. There are two points where more than one elevator meet. These are transfer elevators which passengers use to transfer to one another. One point of access is on the 1st and 2nd floor where the lobby is, and the other is on the 55th floor where passengers can transfer to the high-rise elevator from the middle-rise elevator. On these floors, the pressure differences across the elevator doors are more than 25 Pa, which is over the standard limit. This may cause the elevator door not to operate well. In particular, on the 55th floor, air flows from the middle-rise elevator shaft to the hallway and then into the high-rise elevator shaft, which caused a low noise to be heard constantly during the field measurements. Pressure differences across the entrance door in building B were not as great as in building A.

CONCLUSION

In this paper, stack effect problems in high-rise residential buildings were discussed by analyzing the results of pressure profiles obtained through field measurements of two test buildings. Through the field measurement results, several problems due to excessive pressure differences caused by the stack effect were found to occur near the core area: the entrance doors for residence units and elevator doors. The problems mostly occurred at the elevator door at the lower parts of the building (lobby floor and basement floors) and at the residence entrance doors at higher parts of the building. Higher buildings tend to experience more stack-induced problems than lower buildings; however, building B showed less problems due to the stack effect because of the architectural aspects of the building that were designed in such a way to overcome such problems: improving the airtightness of entrances at the lower parts of the building, vertical shaft zoning, and efforts to achieve overall airtightness of the whole building during construction. These efforts at the design and construction stages are an efficient way to prevent the pressure-related problems from occurring.

Design implications against the stack effect

Problems at the residence entrance doors and at the elevator doors were verified by the field examinations and field measurements; these problems are caused by excessive pressure difference due to the stack effect. Since there are interior walls and entrance doors surrounding the core area, compartmentalizing residential areas and common areas can form airtight air barriers, thereby reducing the differences in pressure that act on these air barriers of the building. If an entrance door or elevator door is opened when there is pressure acting on it, excessive pressure will act on the other closed door, which may cause serious problems. In order to solve these problems, it has been suggested that vestibules be installed around the elevator hall to create resistance to airflow from the shaft to each floor (Jo 2004).

Some design implications against the stack effect are suggested based on the results of the two field investigations conducted in this study and previous researches related to stack effect problems, by the use of which architects and engineers can identify potential problems arising from the stack effect and minimize or eliminate them at the planning stages. The "design implications against the stack effect" can be summarized as follow:

- 1) Tightening the exterior skin: planning airtight structures and materials for the exterior skin, selecting walls without windows, and installing windows that are airtight when shut (ASHRAE 1993, Kim 2001).
- 2) Installing revolving doors and vestibules at the entrances on the ground floor levels, including basement floors, and installing a vestibule around the elevator hall of each of the ground floor levels (Donald 2004).
- 3) Vertical separation: vertically separating elevator shafts and stairwells (Lovatt 1994, Kim 2001)
- 4) Horizontal separation: installing vestibules around elevator halls; separation methods such as installing an 'air-lock door' between elevator doors and residence entrance doors on the typical floors where

pressure difference problems occur, are proper architectural solutions for decreasing the pressure differences across these doors (Jo 2007).

a. Elevator lobby design - add elevator vestibule doors to create an elevator lobby; in high-rise residential buildings, operable windows and doors for each unit are common, it is necessary to provide doors connecting the typical floor elevator lobby to the common corridor.

b. Residence unit entrance door - provide heavy duty door closers, even if not required by code, and provide weather-stripping around each door; with operable doors and windows on the building exterior under control of the residents, it is impractical to try to effectively seal these sources of air infiltration. Therefore, it is important to treat the residence unit entrance doors as if they were exterior (Kim 2006).

5) Tightening the elevator machine room at the upper parts of the building.

ACKNOWLEDGEMENT

This research (03 R&D C103A1040001-03A0204-00310) was financially supported by the Ministry of Construction & Transportation of South Korea and the Korea Institute of Construction and Transportation Technology Evaluation and Planning, and the authors wish to thank these governmental organizations for their support in this work.

REFERENCES

- Tamura, G. T. and Wilson, A. G., Pressure Differences Caused by Chimney Effect in Three High Buildings, ASHRAE Transactions, Vol. 73, Part 2, 1967.
- ASHRAE, Field Verification and Simulation of Problems Caused by Stack Effect in Tall Buildings, ASHRAE Research Project 661, 1993.
- Tamura, G. T., Smoke Movement and Control in High-rise Buildings, National Fire Protection Association, NFPA, 1994.
- Jacques Rousseau, Controlling stack pressure in high-rise buildings by compartmenting the Building, Technical Series 97-103, Canada Mortgage and Housing Corporation, 1996.
- Jo, J. H., Yeo, M. S., Yang, I. H., and Kim, K. W., Field measurement and evaluation of the impacts of the stack effect in high-rise buildings; case study, the 7th International Symposium on Building and Urban Environmental Engineering Proceedings, 2004.
- Jo, J. H., Prediction of pressure distribution due to stack effect in high-rise buildings and evaluation of its impact, Ph. D. thesis, Seoul National University, 2005.
- Jo, J. H., Yeo, M. S., Yang, I. H., and Kim, K. W., Solving the problems due to stack effect in tall Buildings, the CIB World Building Congress 2004, 2004.
- Lovatt, J. E., Stack effect in tall buildings. ASHRAE Transactions, Vol. 100, Part 2, 1994.
- Tamblyn, R. T., Coping with air pressure problems in tall buildings. ASHRAE Transactions, Vol. 97, Part 1, 1991.
- Kim, K. W., Development of architectural design guideline against the stack effect in high-rise buildings, KFMA, 2001.
- Donald, E. R., HVAC design guide for tall commercial building, ASHRAE, 2004.
- Jo, J. H., Lim, J. H., Song, S. Y., Yeo, M. S., and Kim, K. W., Characteristics of pressure distribution and solution to the problems caused by stack effect in high-rise residential buildings, Building and Environment, Vol. 42(1), 2007.
- Kim, K. W., The Impact of stack effect on the # 1st World, KFMA, 2006.

Thermal Comfort in a Naturally-Ventilated Educational Building

David Mwale Ogoli

Judson College, Elgin, IL

ABSTRACT: A comprehensive study of thermal comfort in a naturally ventilated education building (88,000 ft²) in a Chicago suburb will be conducted with 120 student subjects in 2007. This paper discusses some recent trends in worldwide thermal comfort studies and presents a proposal of research for this building through a series of questionnaire tables. Two research methods used in thermal comfort studies are field studies and laboratory experiments in climate-chambers. The various elements that constitute a “comfortable” thermal environment include physical factors (ambient air temperature, mean radiant temperature, air movement and humidity), personal factors (activity and clothing), classifications (gender, age, education, etc.) and psychological expectations (knowledge, experience, psychological effect of visual warmth by, say, a fireplace). Comparisons are made using data gathered from Nairobi, Kenya.

Keywords: Comfort, temperature, humidity and ventilation

INTRODUCTION

The “comfort zone” is an appropriate design goal for a deterministic mechanical system but analysis of many international field studies by researchers has questioned its relevance to passive solar buildings (Humphreys, 1976; Auliciems, 1978; Forwood, 1995; Baker and Standeven, 1996; Standeven and Baker, 1995; Milne, 1995;). Givoni (1998) revised his already authoritative and notable work on the building bio-climatic chart having recognized this new position. These revisions reflect a paradigm shift in thermal comfort for people relative to their thermal environment. The American Society of Heating, Ventilating and Air-conditioning Engineers (ASHRAE) has been discussing how people adapt to higher indoor temperatures in naturally ventilated buildings (Olesen, 2000).

There is mounting evidence (Humphreys, 1996; Karyono, 2000) that confirms that thermal perceptions are affected by factors that are not recognized by current comfort standards. The factors include thermal history, non-thermal stimuli and psychological expectations. These perceptions are most noticeable in naturally ventilated buildings where expectations are distinctly different from air-conditioned buildings. McIntyre (1980) stated that “a person’s reaction to a temperature which is less than perfect will depend very much on his expectations, personality and what else he is doing at the time”. A study (Brager and de Dear, 1998) noted that “anecdotal evidence suggests that building occupants become accustomed to levels of warmth prevailing within buildings on time scales of weeks to months”. They concluded that there is a distinction between thermal comfort responses in air-conditioned vs. naturally ventilated buildings. It leads to another emerging observation of psychological adaptation resulting from one’s thermal experiences and expectations. Psychologically, people perceive or respond to the thermal experiences in apparently altered manner. Paciuk (1990) and Williams (1995) found that perceived degree of control is one of the strongest predictors of thermal comfort. Leaman and Bordass (1999), Bunn (1993), Raja *et al.* (2001) and Brager (2000) documented that people who have greater control over their indoor environment are more tolerant of wider ranges in temperature. These “adaptive errors” are the cause of discrepancy between observed comfort temperatures from field studies and predicted comfort temperatures from climate chamber experiments.

1. THERMAL COMFORT STUDIES

1.1. Climate-chamber studies and thermal comfort scales

The climate chamber is based on a heat-balance model whereby subjects in a carefully controlled environment are subjected to different levels of physical environmental parameters and their “neutral” heat balance point established. Pioneer thermal comfort work by International Standards Organization (ISO), ASHRAE (2005) and Fanger (1969) was based on this model. Subjects in the comfort studies were asked to judge the conditions

(preferred temperature) in a space and record it using the ASHRAE thermal sensation numerical scale shown in Table 1. Other commonly used scales are shown in Tables 2-4.

Table 1: ASHRAE Thermal Comfort Scale

Question	Scale	Thermal sensation	Vote
How do you feel about the thermal environment in this room?	+3	Hot	
	+2	Warm	
	+1	Slightly warm	
	0	Comfortable, neutral	
	-1	Slightly cool	
	-2	Cool	
	-3	Cold	

Source: ASHRAE Standard 55-2004:5

Table 2: McIntyre Scale

Question	Response	Vote
I would like to be. ...	Cooler	
	No change	
	Warmer	

Source: Humphreys 1996:140

Table 3: Humidity Scale

Question	Scale	Thermal sensation	Vote
How do you feel about the humidity in this room?	+3	Much too dry	
	+2	Too dry	
	+1	Slightly dry	
	0	Comfortable, neutral	
	-1	Slightly humid	
	-2	Too humid	
	-3	Much too humid	

Source: Humphreys 1996:140

Table 4: Air movement Scale

Question	Scale	Thermal sensation	Vote
How do you feel about the air movement in this room?	+3	Much too still	
	+2	Too still	
	+1	Slightly still	
	0	Comfortable, neutral	
	-1	Slightly breezy	
	-2	Too breezy	
	-3	Much too breezy	

Source: De Dear and Brager, 1998

Climate-chamber studies done in the 1970's at the Institute for Environmental Research at Kansas State University by Rohles and Nevins (1971) and Rohles (1973) showed that there are correlations between comfort level, temperature, humidity, sex, and length of exposure. Rohles (1980) concluded: "To deny or ignore the psychology involved in comfort measurement is not only shortsighted, but treats the human subject as a machine, which it is not". Rohles (1981) also indicated that alongside control of physical variables, adjustments in the amount of furnishing in a space and lighting levels could probably provide a solution to improving thermal comfort. Their results, with various equations for predicting thermal sensation, have been published in ASHRAE *Handbook of Fundamentals* (2005:8.12).

While climate chambers lack the realism of an actual building and are unsuitable for longitudinal studies (those in which the thermal experience of a relatively small number of subjects is monitored over a period of time) or

transverse surveys (those in which a larger group of subjects, being a more representative sample of the population, is polled on a smaller number of occasions but with less information on each subject), they are nonetheless useful tools due to their high degree of control and reproducibility. These methods (longitudinal and transverse) are most suitable in field studies.

1.2. Field studies

Humphreys (1975) in summarizing 36 previous field studies on comfort in different countries derived a formula correlating comfort temperatures (T_{co}) with mean monthly outdoor air or globe temperature (T_m) of the location:

$$T_{co} = 2.56 + 0.831(T_m) \text{ (}^\circ\text{C)} \quad 1$$

Humphreys (1978) also compared “free-running” buildings (passive and naturally ventilated) with mechanically controlled buildings. He observed that:

$$T_{co} = 11.9 + 0.534(T_m) \text{ (}^\circ\text{C)} \text{ (passive solar building ranging between } 10 \leq T_m \leq 34^\circ\text{C)} \quad 2$$

$$T_{co} = 0.0065(T_m)^2 + 0.32(T_h) + 12.4 \text{ (}^\circ\text{C)} \text{ (mechanical-systems building ranging } -24 \leq T_m \leq 23^\circ\text{C} \text{ and } 18 \leq T_h \leq 30^\circ\text{C)} \quad 3$$

Where T_h is the average daily maximum temperature of the hottest months of the year

Nicol and Roaf (1996) proposed an adaptive algorithm suitable for determining comfort temperatures (T_{co}) in Pakistan. It used simple outdoor temperature calculated from the preceding month (T_m):

$$T_{co} = 17.0 + 0.38(T_m) \text{ (}^\circ\text{C)} \text{ (passive solar building)} \quad 4$$

A similar relationship of comfort temperature on mean outdoor temperature by Auliciems and de Dear (1978) is:

$$T_{co} = 17.6 + 0.31(T_m) \text{ (}^\circ\text{C)} \text{ (passive solar building)} \quad 5$$

The above algorithms were made in studies done under “free-running”, or natural or passive solar conditions in various climates. There are limitations to using these equations in differing locations like Chicago, IL or Nairobi, Kenya, because of the differences of latitude, altitude, geography, climate and the need to establish a localized thermal comfort standard. Climatic conditions for equatorial highland regions tend to be generally the same all year round (Ogoli, 2000). As an example, using outdoor temperature in Nairobi and the above stated equations for passive solar buildings, the following speculative comfort temperatures in Table 5 were established for the hottest month (February):

Table 5: Comfort temperatures in February for Nairobi, Kenya

	<i>Observed</i>	<i>Humphreys</i>	<i>Nicol and Roaf</i>	<i>Auliciems De Dear</i>
$^\circ\text{F}$	71.1	74.3	77.4	75.7
$^\circ\text{C}$	21.7	23.5	25.2	24.3

1.3. Adaptive “errors” in thermal comfort

Humphreys defined comfort as “the absence of discomfort, and discomfort is alleviated by making adjustments”. He is a strong proponent of the adaptive model, i.e. thermal neutrality can be attained by more human involvement rather than just more mechanical controls. Thermal neutrality is a temperature at which a sample population feels neither too hot nor too cold. Field studies on adaptive models have shown that thermal neutrality is a function of the climate that people are acclimatized to. Researchers are increasingly questioning whether the simplistic cause-and-effect approach embodied in these laboratory-derived models can be applied, without modification, to describe real-world thermal perception.

The adaptive model is the most effective way of assessing passive solar buildings, or what is sometimes called *free-running* buildings. The adaptive models allows people to make adjustments to their clothing, activity, posture, eating or drinking, shifting position in a room, operating a window or shading device, or other *adaptive opportunity* in order to achieve or maintain thermal comfort. It appears that when people are allowed greater adjustment and control over their own indoor environment, it extends the comfort zone. The adaptive model acknowledges that the occupant is not just a passive recipient of the environment but an active member.

2. OBSERVATIONS

Many studies are now being undertaken to establish thermal comfort standards around the world. Even ASHRAE commissioned a project to collect field-study data worldwide to relate comfort temperature and climate. There are limitations to using the previously stated models because “The use of ISO-PMV could lead to unnecessary cooling in warm climates and unnecessary heating in cool ones, and if applied in developing countries would lead to needless economic and environmental penalty” (Humphreys, 1996:142). A survey in Zambia in central Africa between latitudes 8° and 18° south, established the comfort temperature as 22.2°C, and comfort zone as 19.7–24.7°C for the cool season; ASHRAE *Standard 55* overestimates the lower comfort limit for this region by 2.7°C (Sharples and Mulama, 1997).

A recent study (Ogoli, 2000) was undertaken in Nairobi, Kenya, to observe indoor temperatures in passive solar buildings with different amounts of thermal mass. The stratified indoor temperatures in light mass building (Figure 1) and high mass building (Figure 2) are shown below. The low mass building was made of timber walls and galvanized corrugated iron (GCI) sheet roof while the high mass building was made of stone walls with concrete tile roof. These figures illustrate that the proper use of thermal mass can control indoor temperatures that in turn allow more “adaptive” adjustments for occupants. Temperatures in the low mass building generally follow the outdoor trends. In the case of the high mass building, indoor temperatures remain relatively in a narrow band, thus increasing the potential of thermal comfort through adaptation. A follow-up study (Ogoli, 2002) was made in the prediction of indoor temperatures of closed buildings with high thermal mass.

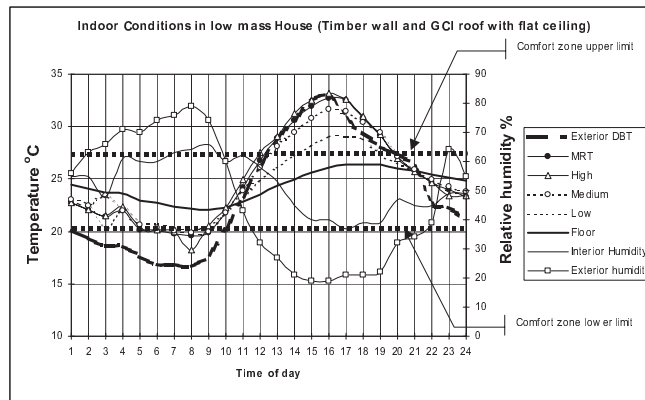

Figure 1: Conditions in a low mass building in Nairobi

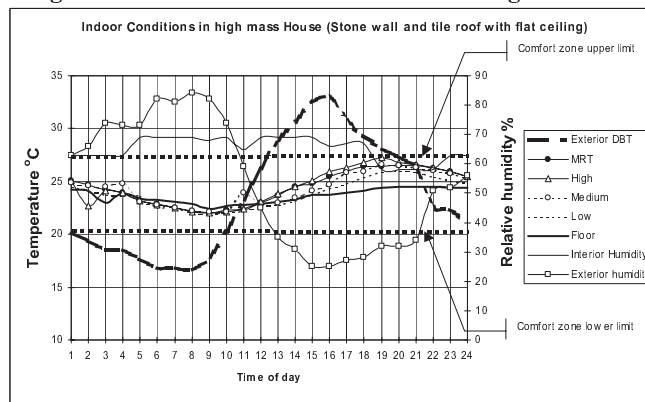

Figure 2: Conditions in a high mass building in Nairobi

3. ANALYSIS AND DISCUSSION

3.1. Proposal for thermal comfort studies (Questionnaires)

To fully determine the thermal comfort conditions in a given environment, there are a number of questions that should be administered to correct “adaptive errors” that account for the discrepancy between observed comfort temperatures from field studies and predicted comfort temperatures from climate chamber experiments. Five questions from previous studies that need to be asked are:

1. How do you feel about the thermal environment in this room?
2. Is the present environment acceptable?

3. Would you prefer some mechanical ventilation and air-conditioning?
4. What personal adjustment(s) have you made to yourself or to the room?
5. At the present moment would you like more, less, or no change in the level of air movement in this room?

These questions may be administered half hourly alongside the process of taking accurate measurements of the thermal environment. Tables 6-10 are an example for a proposed layout for a trial example of a 3-hour period. The tables are formulated using current technical literature and anecdotal evidence.

Table 6: How do you feel about the thermal environment in this room?

Thermal Sensation	Vote	Hour					
		½	1	1½	2	2½	3
<i>Hot</i>	+3						
<i>Warm</i>	+2						
<i>Slightly warm</i>	+1						
<i>Neutral</i>	±0						
<i>Slightly cool</i>	-1						
<i>Cool</i>	-2						
<i>Cold</i>	-3						

Table 7: Is the present thermal environment acceptable?

Response	Score	Hour					
		½	1	1½	2	2½	3
<i>Yes</i>	1						
<i>No</i>	0						

Table 8: Would you prefer some mechanical ventilation and air-conditioning?

Response	Score	Hour					
		½	1	1½	2	2½	3
<i>Cooler</i>	-1						
<i>None</i>	0						
<i>Warmer</i>	1						

Table 9: What personal adjustment(s) have you made to yourself or to the room?

Response	Score Range	Hour					
		½	1	1½	2	2½	3
<i>Clothing</i>	1 to 10						
<i>Activity</i>	1 to 10						
<i>Posture</i>	1 to 10						
<i>Eat/drink</i>	1 to 10						
<i>Moved</i>	1 to 10						
<i>Heat/cool</i>	1 to 10						
<i>Window</i>	1 to 10						

Table 10: At the present moment would you like more, less, or no change in the level of air movement in this room?

	Score	Hour					
		½	1	1½	2	2½	3
<i>Less air</i>	-1						
<i>No change</i>	0						
<i>More air</i>	+1						

The physical parameters that should be measured alongside the questionnaire include ambient air temperature, mean radiant temperature, air movement and humidity. The instruments should be accurate enough that meet specifications for accuracy and response times described by ISO *Standard 7726* and/or ANSI/ASHRAE *Standard 55-1992*, shown in Table 11.

Table 11: Measuring range and accuracy of instruments

Parameter	Measuring Range	Accuracy	Response Time (90%)
Dry Bulb Temperature	5-40°C (39-104°F)	±0.2°C (±0.4°F)	Appropriate
Wet Bulb Temperature	5-40°C (39-104°F)	±0.2°C (±0.4°F)	Appropriate
Mean Radiant Temperature	5-40°C (39-104°F)	±0.2°C (±0.4°F)	Appropriate
Air Speed	0.05-0.5 m/s (10-100 fpm)	±0.5°C (±1.0°F)	1-10 seconds

The response time is the time to reach 90% of the final value with a step change.

Source: ANSI/ASHRAE *Standard 55-1992*

3.2. Observations from other studies

Thermal comfort is a complex phenomenon, which is influenced by several parameters: environmental (physical), personal and psychological. Two of the most common ways to quantitatively expressing thermal comfort and thermal sensation is Predicted Mean Vote (PMV) and Predicted Percent Dissatisfied (PPD) after Fanger (1970). However, there have been several field studies that do not agree with the results of this method, especially in passive solar buildings.

Several extensive field studies summarized by De Dear and Brager (1998) show that the PMV model works best in buildings that have HVAC systems. The studies also show that in naturally ventilated buildings (free running with no mechanical systems) people seem to adapt (behavioral, psychological) and can accept “higher indoor temperatures than predicted by the PMV model” (Olesen, 2000:44).

Givoni defined thermal comfort as “the range of climatic conditions considered comfortable and acceptable inside buildings. It implies an absence of any sensation of thermal (heat or cold) discomfort” (Givoni, 1998:3). In 1976 he developed the building bio-climatic chart to address the problems associated with the charts by Olgyay. It was based on indoor temperatures and suggested boundaries of the climatic conditions on the psychrometric chart within which various building design strategies (including passive and low energy cooling systems) could provide indoor comfort in hot climates without air-conditioning. The boundaries of acceptable conditions for still air are shown on the psychrometric chart in Figure 3. They were extended due to the effect of adaptive factors.

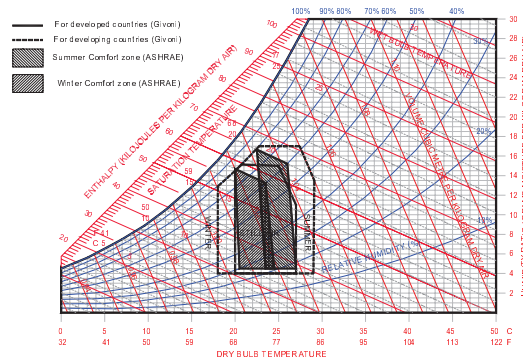

Figure 3: Boundaries of comfort conditions

Source: (Givoni, 1998: 38)

Brager and de Dear in 1996 noted that field studies show that the two most widely used thermal comfort standards (ISO *Standard 7730* and ASHRAE *Standard 55*) do not account for the effects of expectation, personal control and psychological adaptation. In fact, they discourage the use of naturally ventilated passive solar buildings because of the narrow band of comfort limits. Occupants in passive solar buildings have more relaxed expectations and can tolerate a wider temperature swing. On the other hand, occupants of air-conditioned buildings have a narrow rigid thermal environment and are more sensitive to thermal environments.

CONCLUSION

Thermal comfort in Nairobi or Chicago may offer insight on the fact people with different expectations, culture and history all require thermal comfort. Adaptive factors may be more easily visible in a low-tech society but even in industrialized countries, they offer an opportunity for modern usage. The universality hypothesis of comfort

temperatures based on ISO *Standard 7730* and ASHRAE *Standard 55-92* extrapolated as equally applicable to human beings around the world regardless of race, culture or climatic experience were the central theme of a strong argument made by Madhavi and Kumar (1996). Fanger in his work used a small group of “tropical travelers” winter swimmers and meat packers in two experiments in Copenhagen, Denmark, to derive the PMV. The sample size used was statistically too small and Auliciems succinctly put that: “It is not often realized that the claims of its universal applicability were based on remarkably limited and rather incompletely reported preference studies of only 16 travelers from Copenhagen and 32 Danes” (Auliciems, 1989:18). This article is a preparation for further research of thermal comfort in a new naturally-ventilated academic building (88,000ft²) to be completed in spring 2007 on the College campus.

ACKNOWLEDGEMENT

Author wishes to give many thanks to the staff, faculty and students of architecture at Judson College.

REFERENCES

- ANSI/ASHRAE. 1992. *Thermal Environmental Conditions for Human Occupancy ANSI/ASHRAE Standard 55-1992*. American Society of Heating, Ventilating and Air-conditioning Engineers, Inc.: Atlanta, GA.
- ANSI/ASHRAE. 2004. *Thermal Environmental Conditions for Human Occupancy ANSI/ASHRAE Standard 55-2004*. American Society of Heating, Ventilating and Air-conditioning Engineers, Inc.: Atlanta, GA.
- ASHRAE. 2005. *Handbook of Fundamentals*. American Society of Heating, Ventilating and Air-conditioning Engineers, Inc.: Atlanta, GA.
- Auliciems, A. 1989. *Thermal Comfort in Building Design and Human Performance* by N. C. Ruck (ed). Van Nostrand Reinhold: New York.
- Auliciems, A. and Richard de Dear. 1978. “Air conditioning in Australia, I. Human thermal factors”, in *Architectural Science Review 29 (1978) 67-75*.
- Baker, Nick and Mark Standeven. 1996. “Thermal Comfort in Free-Running Buildings” in *Energy and Buildings, 23 (1996) 175-182*.
- Brager, Gail Schiller. 2000. “A Standard for natural ventilation” in *ASHRAE Journal, October 2000*, page 21-27. American Society of Heating, Refrigerating and Air Conditioning Engineers Inc.: Atlanta GA.
- Brager, Gail S. and Richard J. de Dear. 1998. “Thermal adaptation in the built environment: a literature review” in *Energy and Buildings 27 (1998) 83-96*.
- Bunn, R. 1993. “Fanger: Face to face” in *Building Services, June, 25-27, 1993*.
- De Dear, R. and Brager, G. S. 1998. “Developing an adaptive model of thermal comfort and preference” in *ASHRAE Transactions 104 (1)*.
- Fanger, P. O. 1967. “Calculation of thermal comfort: introduction of a basic comfort equation” in *ASHRAE Transactions 73 (2): III.4.1*.
- Fanger, P. O. 1970. *Thermal Comfort: Analysis and Applications in Environmental Engineering*. McGraw-Hill Book Company: New York
- Forwood, G. 1995. “What is thermal comfort in a naturally ventilated building?” in: Nicol, Humphreys, Sykes, Roaf (eds.) *Thermal Comfort*. London: E and F. N. Spon 1995, pp. 122-131.
- Givoni, Baruch. 1998. *Climate Considerations In Building And Urban Design*. John Wiley & Sons, New York
- Humphreys, Reverend Michael A. 1976. “Field Studies of thermal comfort compared and applied” in *Building Services Engineer, 44*, pp. 5-27
- Humphreys, Reverend Michael A. 1996. “Thermal comfort temperatures world-wide – The current position” in *Renewable Energy, Vol. 8 Issues 1-5 May 1996*, pp. 139-144.
- Humphreys, Reverend Michael A. 1975. “Field Studies of thermal comfort compared and applied”, *Building Research Establishment, Current Paper. CP 76/75*, Garston, Watford, UK.

Humphreys, Reverend Michael A. 1978. "Outdoor temperatures and comfort indoors" in *Building Research and Practice*, 62, pp. 92-105.

ISO 7730. 1994. *ISO Standard 7730: Moderate Thermal Environments – Determination of the PMV and PPD Indices and Specification of the Conditions for Thermal Comfort*. International Standards Organization: Geneva.

Karyono, Tri Harso. 2000. "Report on thermal comfort and building energy studies in Jakarta" in *Building and Environment* 35 (2000) 77-90.

Leaman, Adrian and Bill Bordass. 1999. "Productivity in buildings: the 'killer' variables", *Building Research & Information* (1999) 27 (1), 4-19.

Mahdavi, Ardeshir and Satish Kumar. 1996. Implications of indoor climate control for comfort, energy and environment in *Energy and Buildings*, 24 (1996) 167-177. Elsevier Science Limited: Amsterdam

McIntyre, D. A. 1980. "Design requirements for a comfortable environment" in *Bio-engineering, Thermal Physiology and Comfort* by K. Cena, J. A. Clark (eds), pp. 157-168.

Milne, G. R. 1995. "The energy implications of a climate-based indoor air temperature standard" in *Standards for Thermal Comfort: Indoor air temperatures for the 21st century* pp. 182-189 by F. Nicol, M. Humphreys, O. Sykes and S. Roaf (eds). E & FN Spon: London.

Nicol, J. Fergus and Susan Roaf. 1996. "Pioneering new indoor temperature standards: the Pakistan project" in *Energy and Buildings*, 23 (1996) 169-174. . Elsevier Science Limited: Amsterdam

Ogoli, David Mwale. 2000. *Energy-efficiency and Comfort Conditions in Passive Solar Buildings at Equatorial High Altitudes, Ph.D. Dissertation*. University of Florida: Gainesville, FL.

Ogoli, David Mwale. 2002. "Predicting indoor temperatures in enclosed buildings with high thermal mass" in *Energy and Buildings*, 35 (2002) 851-862. Elsevier Science Limited: Amsterdam

Rohles, F. H. 1973. "The revised modal comfort envelope" in *ASHRAE Transactions* 79 (2):52.

Olesen, Bjarne W. 2000. "Guidelines for comfort" in *ASHRAE Journal Vol. 42, No. 8, August 2000*.

Paciuk, M. 1990. "The role of personal control of the environment in thermal comfort and satisfaction at the workplace, Coming of age" in *Environmental Design Research Association* pp. 303-312 by R. I. Selby, K. H. Anthony, J. Choi, B. Orland (eds.), Environmental Design Research Association: Oklahoma City, OK.

Raja, Iftikhar A., Fergus Nicol, Kathryn J. McCartney, Michael A. Humphreys. 2001. "Thermal Comfort: use of controls in naturally ventilated buildings" in *Energy and Buildings* 33 (2001) 235-244.

Rohles, F. H. 1980. "Temperature or temperament: a psychologist looks at thermal comfort" in *ASHRAE Transactions*, 86, 541-551.

Rohles, F. H. 1981. "Thermal comfort and strategies for energy conservation" in *Journal of Social Issues*, 37, 132-149.

Rohles, F. H. and R. G. Nevins. 1971. "The nature of thermal comfort for sedentary man" in *ASHRAE Transactions*, 77 (1) pp. 239-246, 1971.

Sharples, Steve and Albert Malama. 1997. "A thermal comfort field survey in the cool season of Zambia" in *Building and Environment*, Vol. 32, No. 3, pp. 237 – 243, 1997. Elsevier Science Limited: Amsterdam.

Standeven, M. A. and Nick V. Baker. 1995. "Comfort conditions in PASCOOL surveys" in *Standards for Thermal Comfort: Indoor air temperatures for the 21st century* pp. 161-168 by F. Nicol, M. Humphreys, O. Sykes and S. Roaf (eds). E & FN Spon: London.

Williams, R. N. 1995. "Field investigation of thermal comfort, environmental satisfaction and perceived controls levels in UK office buildings", *Healthy Buildings*.

The Green Church

Mark L. Gillem, PhD, AIA, AICP

University of Oregon, Eugene, Oregon, USA

ABSTRACT: If “green” is an environmental concept applicable to the design and construction of buildings and landscapes, then we should not limit the scope of the concept solely to the natural environment. Rather, we should include key “environments” in which designers operate, including the socio-cultural, political, and natural environments. In this paper, I present a case study in “green” design that expands the scope of the concept and recognizes the interrelationship between these multiple environments. Using recent construction and renovation on the campus of the First Presbyterian Church of Berkeley as the case, I show how these environments are mutually supportive. Moreover, I argue that if designers simply consider the natural environment, their laudable goals may never be realized. In the first part of the paper, I provide a background on the project and its physical and socio-cultural setting. Second, I discuss how the different “environments” were addressed in the planning and design of the project. I then introduce specific “green” strategies that were employed in the design of the new and renovated buildings. These include considering renovation as the first imperative, thinking holistically about the entire campus, and applying a simplified approach to “greening” the buildings. I conclude by offering suggestions for future designers interested in reducing the environmental impact of their buildings.

Keywords: Sustainability, Adaptive Reuse, Human Context

INTRODUCTION

“That has never happened here before,” exclaimed Mark Rhoades, a planner for the City of Berkeley. I pointed upwards and offered, “It must be help from above.”

“What do you mean?” he asked.

“Well Mark,” I replied. “This **is** a church project.”

“Then it must be a miracle,” he concluded.

The “miracle” he was referring to was the unanimous approval in the spring of 2002 by the City of Berkeley’s Zoning Adjustment Board of the application by First Presbyterian Church of Berkeley to expand their campus. The Board even approved the project on their consent calendar, which means there was not any discussion about the project – just a vote. The Board could do this because there was no public opposition to the project – only support, which is highly unusual in Berkeley. At over \$25 million, with two levels of underground parking, a 3,716 sm (40,000 sf) new building for offices, classrooms, a chapel, and a music room, and renovation of a 819.2 sm (8,818 sf) historic structure for classrooms and a counselling center, the project was one of the largest proposed in Berkeley at the time. Just two weeks before, at an earlier meeting of the Zoning Adjustment Board, the commissioners spent nearly two hours debating the merits of a proposal for a small restaurant. With that kind of scrutiny given to such a small project, the church was prepared for a lengthy final debate on their application. But the debate was not needed. The church submitted a project that was designed with respect to the needs and desires of the church membership and the larger community. The design also responded to the importance of the socio-cultural, political, and natural environments in which all buildings reside.

Established in Berkeley in 1878, the First Presbyterian Church has grown from a small congregation to what can now be considered a mega-church – a regional church with over 1,800 members. The church supports a wide array of ministries and requires a variety of spaces to meet its mission needs. Rapid growth in the late 1990s spurred thinking about expansion and led to the goal of accommodating 2,500 members. This growth goal led to a long and arduous design process that eventually resulted in the proposal approved by the Zoning Adjustment Board.

1. PROJECT BACKGROUND

1.1. The First Proposal: A \$300,000 Lost Design Effort

In late 1990s, the church hired a design firm to help plan for the needed expansion. The designers coordinated visioning sessions with the congregation, conducted public workshops, and developed alternatives for the church to consider. While this was a textbook example of a participatory process, the outcome was less than ideal. The final design was largely unbuildable. It exceeded the church's budget by \$20 million. Given the proposed new building's 5-story height (3 is allowed in the zone) and excessive lot coverage, it would have required numerous variances from city zoning regulations that would likely not have been approved. It relied on air conditioning and it called for a design that one church member described as a "prison." Over 50% of the offices did not have windows, internal corridors were narrow and dark, classrooms were all nearly the same size (thus limiting flexibility), the ground floor was cut off from the public realm by fencing that separated child-care play areas from the street, and some of the most public spaces were placed on the floor with the least public access – the fifth floor. As one member of the building committee reported, the focus of the first design team was on aesthetics at the expense of almost every other concern.

From the community's perspective, the project ignored a city-designated historic building on the property. The issue of the historic building was quite sensitive. Several years earlier, the church purchased the run-down McKinley Annex and intended to demolish it to make way for new construction. At the time of the purchase, the three-story wood frame building, which was built in 1906 as a schoolhouse, had several apartments and an activist group of tenants. Given that this was one of the last remaining examples of a shingle-clad schoolhouse in Berkeley (even though it was converted during World War II to housing), the City of Berkeley's Landmark Preservation Commission designated the building a Structure of Merit. The designation came on the eve of demolition, after the city had issued the church a demolition permit. Since the city issued a permit, the church believed they had a right to demolish the building, regardless of the last-minute designation of the building as an historic property. The city thought otherwise. The church sued the city and eventually won on appeal. The city had to pay the church's substantial legal fees and the church could demolish the building if an Environmental Impact Report (EIR) justified demolition. This requirement would be difficult to meet since the EIR process by law required public input and the public was not in the mood to let the church demolish the building. Hence, the designers of the first proposal felt justified in ignoring rather than demolishing the building and its troubled history. Without upgrades, many neighbors of the church knew the building would certainly fall into disrepair and, at some point, deteriorate past the point of saving. As a result of this approach, members of a local preservation group, the Berkeley Architectural Heritage Association, actively opposed the project.

Other neighborhood groups had their own concerns with the first proposal. Members of a local business group, the Telegraph Area Association, did not like the variances the church would need to request. In a way, asking for a variance from a planning regulation is like asking for a special favor. Some neighbors did not want to see a church get special treatment. And a group of University of California graduate planning students, calling themselves Students for a Livable Southside, did not approve of the design's inward focus and its oversized (at least in their minds) parking garage. They also believed that the designers failed to provide adequate public open space on the site. With opposition from these groups, the plan had little chance of approval.

Shortly before the congregation was to vote on the proposed plan, members of the church's building committee decided that it was in fact unbuildable, despite assurances to the contrary by the initial architect. After it became clear that the first design firm was unwilling to modify their proposal, the church abandoned the effort and embarked on a new design. Given that the church spent approximately \$300,000 with the first firm, this was not an easy decision to make.

1.2. The Revised Plan: A Campus not a Building

Fortunately, in the initial planning effort, the church developed a compelling vision for the project. Namely, the church wanted the campus to be "warm, welcoming, and inviting" to its own members and to the larger community. The church also wanted the buildings to represent the best approaches to environmental stewardship while meeting the space needs of the growing congregation. These two goals – compatibility and stewardship became the basis for the revised plan. The focus shifted from the design of one building to the design of an entire campus that could be developed over several phases as funds permitted.

Before developing the revised plan, the new concept design team first reprogrammed the project through a series of workshops and user interviews. The goal was to minimize the need for new construction and prioritize uses in order to develop an approach that did not rely on a five-story new building. Given that three-stories was the maximum allowable height for the zone, anything taller would require special approval from the city, which would be nearly impossible to obtain in Berkeley. Also, by shrinking the required new area, the church's \$25 million budget would be more attainable. The new concept design team also met with the neighborhood

opposition to identify their concerns. Historic preservationists wanted the historic building (McKinley Annex) renovated. Local business leaders did not support the church's request for significant variances. The students did not want the large parking garage initially proposed by the church, which accommodated over 250 cars. They felt this would encourage driving over alternative means of transportation. And they wanted the building to be designed in a way that would minimize its environmental impact while providing publicly accessible open space.

In reconsidering the design, the concept design team stressed to the church that the project should respond to these concerns and it should fit within its context while contributing to the larger neighborhood structure. The historic building should be renovated and incorporated into the overall campus design, the height of the new building (Geneva Hall) should not exceed three floors (Fig. 1), a significant publicly accessible plaza should be part of the design, and structured parking should be kept to a minimum. In terms of environmental stewardship, the design should, at a minimum, allow for passive cooling and heating, and abundant natural lighting.

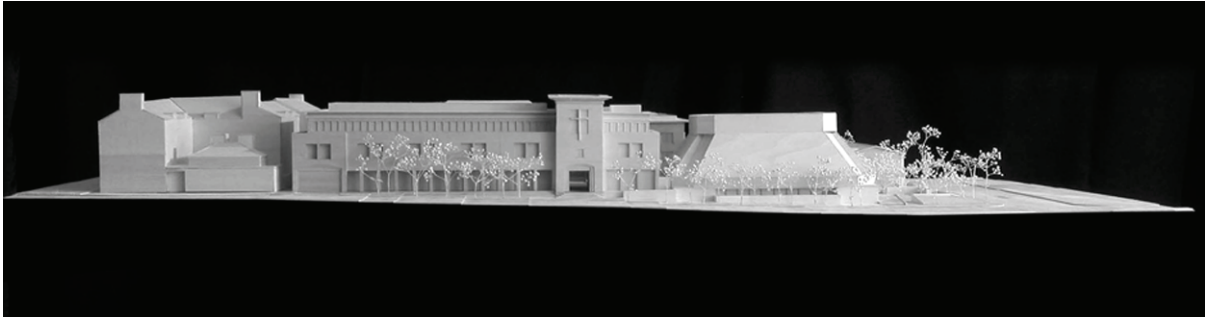

Figure 1. Channing Way Elevation, First Presbyterian Church of Berkeley
Known as Geneva Hall, the new building (center in image above) respects the cornice line established by an existing University of California dormitory (left) and the church's existing sanctuary (right)
[model photo by Treve Johnson]

Throughout the redesign, communication with the neighborhood groups and the congregation was essential to ensure that all parties remained committed to the new direction. For the congregation, perhaps the most difficult part of the redesign was the renovation of the historic building. Many members were still bitter about the lawsuit and were unimpressed with the building's appearance. The 100-year old building was rather rundown and its backside faced the church property. To address this concern, the revised plan called for all new exterior materials to replace the deteriorated roofing and siding and, more significantly, the plan called for rotating the building 180 degrees so that its entry porch could face a new plaza on the church's property. For the preservationists, this rotation caused some displeasure. Some thought that if the church could rotate a historic building, then other owners of historic properties might want to do the same. But after numerous discussions, all parties agreed that rotating the building was in the best interest of the church and the building. Because of this collaborative process, where each party's goals were met in a way that still allowed for rather creative solutions, the three neighborhood groups that opposed the initial project wrote letters to the Zoning Board in favor of the revised plan. This support was essential. In the end, the congregation unanimously adopted the revised project and the Zoning Board unanimously approved the application. Construction commenced in the summer of 2003 and full occupancy occurred in 2006.

2. EXPANDING THE CONCEPT OF "ENVIRONMENTAL" DESIGN

2.1. Uncovering the Project's Multiple Environments

A building exists within a context that has no property lines. While needs of property owners must be accounted for, the owners must also realize that their projects have impacts beyond their property lines. These include visual, aesthetic, and environmental impacts. But if designers only consider the environment in its narrowest terms, in terms of energy use and material selection, they may run the risk of not getting anything built. In the public approval process for this project, these ideas carried little weight, even in a city as progressive as Berkeley. More important was the fit between the proposed project and its socio-cultural context.

If "green" is an environmental concept applicable to the design and construction of buildings and landscapes, then we should not limit the scope of the concept solely to the natural environment. Rather, we should include key "environments" in which designers operate, including the socio-cultural, political, and natural environments. In this project, the design team recognized that to be "green," the design must recognize the interrelationship between these multiple environments.

2.2. The Socio-Cultural Environment

It is quite helpful for designers to consider the larger environments within which they are working. Focusing on one at the expense of another will result in an unbalanced and perhaps unbuildable project. The socio-cultural environment is perhaps the most challenging. It includes the system of relationships, rules, and cultural practices that govern the complex network of individuals, families, coworkers, neighbors, and members of the larger community (Anderson and Carter, 1990). This systems approach recognizes that, like buildings, people do not exist in isolation. Rather, they operate within an interdependent structure. This systems approach also applies to the buildings built by every culture. Amos Rapoport's (1992) concept of "cultural landscapes" is relevant here. Landscapes, which encompass the built and natural environments, respond to cultural values and express societal rules governing spatial priorities and development practices. In light of this, if culture can be defined in part as the evolving and shared beliefs, attitudes, and practices of a group, then that culture is reflected in the shape of the built environment. For the church, their initial proposal did not reflect their stated and practiced cultural position, which stressed community and connectedness. In attempting to demolish the McKinley Annex, the church ignored the desires of the larger community, which was clearly expressed through the listing of the building as an historic structure. In proposing a building that was completely isolated from its setting -- surrounded by chain link fences and security walls -- the church did not respond to its practice of integrating with and being open to the surrounding community. In ignoring the rules of the community and nonchalantly claiming these rules could be waived, the church set itself up for failure -- failure to respect the results of the planning process in place in its chosen community.

In reworking the design, the first priority was to create a campus that respected the church's socio-cultural environment. Internally, this meant that the proposed construction respond to the needs and norms of the church membership. In practical terms, for example, this meant that adult classrooms be designed to accommodate a range of sizes that reflected generational differences in learning. The most senior members of the church met in large groups, Baby Boomers met in smaller seminar-like settings and members of "Generation X" wanted even smaller places where their tight-knit circles could meet and share the most private aspects of their lives. This also meant that the typical measures of building efficiency were largely irrelevant. An efficiency ratio of 70%, for example, was not a measure of success considering that non-program spaces in religious education buildings are where important informal education and social bonding occurs. This meant that rather than program for two meter wide corridors, main corridors should be at least four meters wide and function like rooms in their own right, with places to sit and access to natural light. This also meant that there should be significant new open spaces that complemented the existing structure of patios and courtyards. The existing patio, for instance, functions as an outdoor lobby and meeting room and capitalizes on Berkeley's mild weather. These outdoor rooms add to the capacity and programmatic flexibility of the church. That the first design failed to provide such a space was surprising given that many of the staff and members of the church placed such a space near the top of their prioritized list of needs.

Externally, creating a campus that respected the socio-cultural environment meant that the proposed construction must, at a minimum, be what one building committee member called a "good neighbor." It should fit into its environment rather than stand out. Again, from a practical standpoint, this meant, for instance, that the building should maintain the street wall height and build-to lines of its neighbors. Also, the campus plan should in some way account for the mid-block pedestrian crossing that previously existed on the site. And the new building should provide protection for the area's homeless population in a way that allows for some dignity in where they sleep. In reconsidering the master plan for the church, the new concept design team also had to internalize the Senior Pastor's belief that, "Buildings are not that important. What matters is what they allow us to accomplish." But these accomplishments, from weekly meals and medical care for the area's homeless to subsidized preschool for the area's workforce, require space -- and design matters in the making of this space.

2.3. The Political Environment

The making of this space is a political act. It requires making judgements about who gets the space, who pays for it, and who sets the rules for its design. In a place as contentious as Berkeley, this political environment can be an unknown environment for designers. As social scientist Diana DiNitto (1991: 7) argues, the political environment of policymaking "...arises out of the nature of the problems confronting society and over what, if anything should be done about them." If politics can be defined as who gets what, when, and how, (Lasswell, 1936) then architects are constantly operating within the political arena. Multiple competing perspectives often clash in the political arena. Unfortunately, architects are not well educated on the complexities and nuances of the political approval process. Rarely do studio instructors discuss the politics of design. Designers usually learn through on-the-job training, which is less than ideal. For First Presbyterian Church of Berkeley, the political environment was a particularly challenging one. In Berkeley, all development proposals are viewed with some disdain. And religious institutions receive extra scrutiny. At the same time the First Presbyterian Church was going through the planning process, another congregation in north Berkeley was trying to get their own plans approved. Their well-known architect ignored the stated concerns of the community and pressed forward with a

controversial design that generated significant opposition. Neighborhood groups formed to block the project. Yard signs sprouted around the city urging denial of the congregation's permit application. After considerable delay, the project was approved by one commission then denied by another. The project ended up on appeal to the city council. At council direction, the parties went through several rounds of negotiations and redesign before a permit was finally issued. This was an outcome the design team and pastoral staff at First Presbyterian Church did not want. Fortunately, the collaborative process that brought First Presbyterian Church's political opponents into the design effort succeeded in creating a supportive political environment. There were no yard signs.

The political environment within the church was also a challenging one. Specifically, many members of the congregation did not want to spend any money on renovating the McKinley Annex. Several prominent members strenuously opposed removing a significant tree on the site, which was unfortunately in the way of construction. Other members wanted the budget devoted almost solely to building more parking. And there were members who simply could not justify spending so much money on construction when so many people around the world were in need of basic healthcare, food, and education. At one point, the Senior Pastor, Mark Labberton, reminded the design team that one main reason churches split is over construction projects. With dozens of committees and hundreds of constituents, this was a real possibility. Throughout the programming and design process, all of these constituents had to be heard, informed of the progress, and at times educated on the decision-making process and outcomes.

2.4. The Natural Environment

The natural environment is perhaps the easiest one to deal with in the design process. Architects are typically well educated in ways buildings should respond to climate and the environment. Moreover, many of the strategies employed by architects are not controversial and receive little notice. Numerous reference books exist that can guide the design process. In this case, G.Z. Brown's (2000) *Sun, Wind, and Light* was especially helpful. Deep overhangs that shade south elevations, recessed windows that block direct summer sun, narrow wings that allow light in on multiple sides, thick walls that accommodate ample insulation, and operable windows that support natural ventilation are common sense approaches to designing "green" buildings. For this project, the design team also benefited from the City of Berkeley's Green Building program, which provided peer evaluation of the design and a compliance report that noted the project's successful features and offered recommendations for improvements. The report noted, for example, that Berkeley's mild weather makes the area ideal for applying passive heating, cooling, and ventilation techniques. Annually, the city has just 63 cooling degree days (cumulative number of degrees per year above 18.3°C) and 1,612 heating degree days (below 18.3°C).

3. "GREEN" STRATEGIES

3.1. The First Imperative: Renovation

Before considering other strategies, designers and owners should look to renovation as the first "green" imperative. If a building's lifecycle can be extended, then the environmental and economic costs associated with demolition and the production of new materials can be avoided. For First Presbyterian Church, the 819.2 sm (8,818 sf) McKinley Annex (Fig. 2) and 5,253.3 sm (56,546 sf) Christian Education building were saved. Renovation of the former included bringing the old building up to California's strict energy, accessibility, and seismic standards. The only new building built as part of the project was Geneva Hall (Fig. 3).



Figures 2 (l) and 3 (r). McKinley Annex (left) and the new Geneva Hall (right)

The renovated annex defines one edge of the new plaza. Geneva Hall continues the street wall along Channing Way and provides arcades and a clearly defined tower marking the public entry into the plaza.

[photos by Treve Johnson]

Surprisingly, the cost for renovation was even 20% less than new construction. Moreover, the church was able to get a remarkable building, with large windows and 4-meter high ceilings. Although many members of the church were reluctant supporters of renovating McKinley Annex, now that it is in use the benefits are clear. One occupant who did not want to move from her old windowless counselling rooms, now raves about her light filled offices and said, “We’ve been counselling all these years in the dark and didn’t even realize it. Now we’re in the light, physically and spiritually” (Hedlund, 2006).

3.2. A Campus Approach to Green Design

The existing campus had three buildings, a surface parking lot, a little used courtyard, and a rather attractive patio that fronted the sanctuary. Little tied the buildings together other than a few walkways. The disconnected nature of the campus led the church to think of the buildings in isolation. The members considered McKinley Annex worthless and a candidate for demolition. Some saw the existing sanctuary as a glass-walled jewel that should stand alone. In addition, the existing education building (Westminster Hall) was, according to the first architect, too old to efficiently bring up to current seismic standards. However, once the new concept design team showed a sketch that used a large new plaza to link the three existing buildings with the new education and administration building, many in the church began to see the value in creating a real campus – a place where buildings shape outdoor rooms, where walks are direct and comfortable, and where landscaping softens the edges (Fig 4). This led to a more integrated view of the individual buildings, which were now part of a whole ensemble. Rather than sit in isolation; the buildings could work together to create a walkable campus. In fact, all the buildings were needed to provide spatial definition to the campus. The widely supported plan (at least within the church) to demolish the McKinley Annex and Westminster Hall was taken off the table largely because of the campus approach to design.

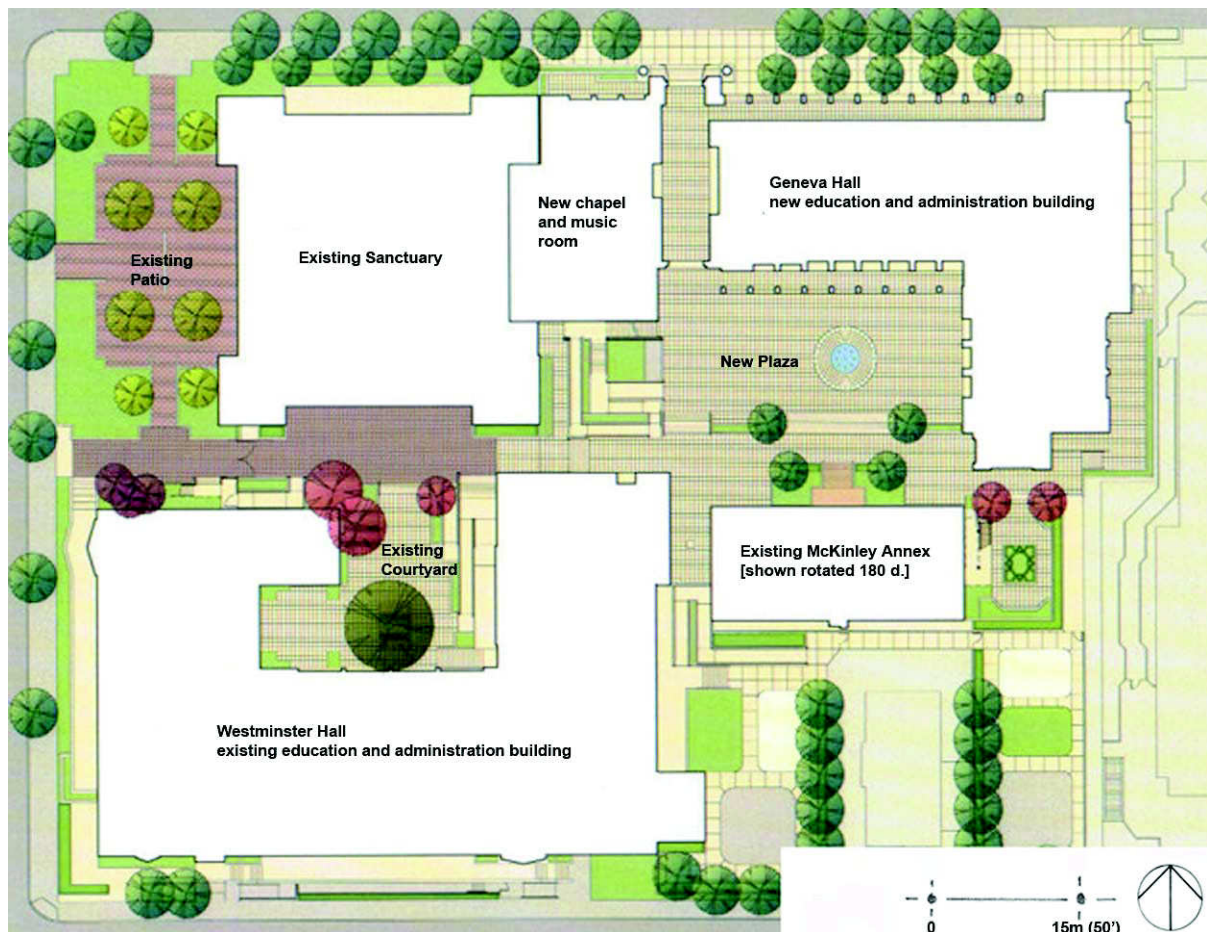

Figure 4. Campus Plan, First Presbyterian Church of Berkeley
 Geneva Hall's narrow wings and a renovated McKinley Annex help shape the new outdoor plaza.
 [image courtesy of First Presbyterian Church of Berkeley]

3.3. Greening the Buildings: A Simplified Approach

For the individual buildings, rather than rely on complex active systems, the concept design team focused on providing layouts that benefit from passive strategies for lighting, heating, and cooling. The first move was to narrow the new building substantially from the original design. Rather than design a 30-meter wide building, the new standard was for what architect Chris Alexander (1977) calls 'Wings of Light.' While not as narrow as Alexander's pattern, at 18 meters the new building's wings and internal glazing allow light to enter almost every space from two sides (Figure 5). This has a positive environmental and emotional effect. The overall layout and use of operable windows allows for passive ventilation and eliminates the need for air-conditioning. Using natural ventilation "...improves air quality, ensures good ventilation and saves both energy and money," according to Leon Glicksman, director of MIT's Building Technology Program (cited in Stauffer 2006: 1). Moreover, according to Nancy Stauffer of MIT's Laboratory for Energy and the Environment, studies have shown that people generally feel more comfortable in a naturally ventilated building than in an air-conditioned one (Stauffer 2006). It is unfortunate that few commercial buildings rely on natural ventilation. Even in Berkeley, two recently completed buildings with similar functions (i.e. education and administration) were built with fixed windows and a reliance on air conditioning. Perhaps too few building owners can tolerate the trade-off -- a greater internal temperature swing. Admittedly, the temperate climate of Berkeley certainly helps. Nevertheless, occupants still experience daily temperature swings of up to 4 degrees Celsius. Surprisingly, there have been few complaints on the office floor or in the classrooms about indoor temperatures either being too hot or too cold. This can be attributed in part to the fact that the occupants never became accustomed to the more exact temperatures available with air conditioning and to the fact that they can open or close the windows as needed, which gives occupants an important sense of control over their environments. If the occupants can accept more fluctuation in the interior temperature, the environmental benefits are substantial. With its natural ventilation, daylighting, and passive heating, using conservative measures, the revised plan saves an estimated 94,000 kWh per year, which translates into an annual estimated CO₂ emission reduction of 21,636 kilograms (47,700 pounds). This represents a 28% savings over the original plan. Over a 50-year period, this equates to savings of nearly 4.7 million kWh and nearly 1.1 million kilograms of CO₂ emissions.

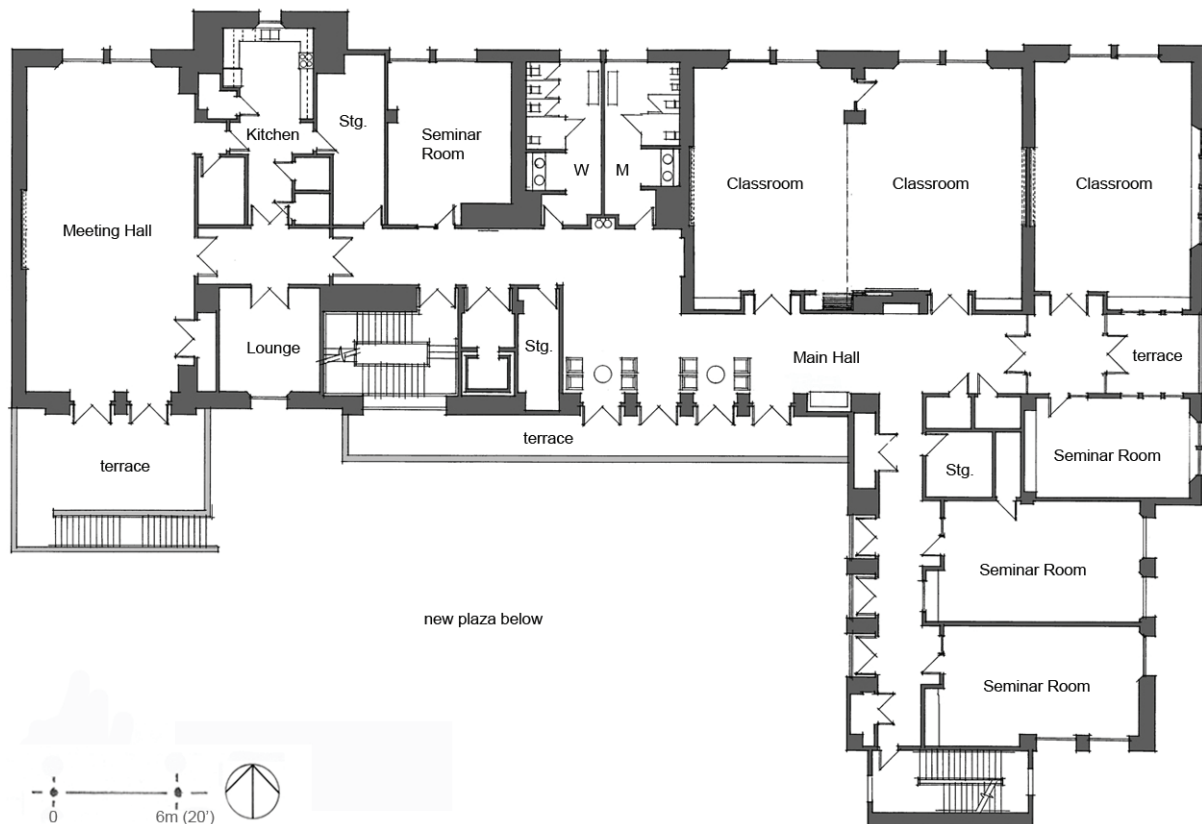

Figure 5. Second Floor Plan, Geneva Hall

The new building's narrow wings allow for light to enter two sides of every classroom, either directly through windows to the exterior, or indirectly through glass doors and sidelights. In addition, all occupied areas have windows, including the kitchen, stairways, corridors, and bathrooms. Small balconies and terraces on the south and west side connect the interior and exterior while shading the glazing below.

4. CONCLUSION

In this project, two architects had a very different understanding of the project. The original designers focused on aesthetic issues, not on issues of sustainability. While they did an admirable job of responding to the client's program needs in terms of space, they failed to validate those requirements against the limited budget or the site's contextual constraints. What emerged was an unbuildable project. The new concept design team reframed the design and encouraged the client to think of issues beyond space and aesthetics. The client needed to recognize that their 'community' extended beyond their property lines and understand that the site could not accommodate all of their desires, which led to a reprioritization of needs. The role of the designer is not simply to make an aesthetically-pleasing building, which in any case is highly subjective, nor should the designer simply meet the client's identified space needs. Rather, designers should collaborate with their clients to create designs that respond to the budget, mission and context (physical, political, cultural, and environmental).

The conference organizers asked participants to consider, 'What are the top ten, most important design moves that students should know how to do in order to design carbon neutral buildings?' While not overly technical, this case study provides students examples of numerous 'design moves.' Specifically, students should:

1. learn how to reuse buildings whenever possible,
2. design buildings with narrow wings to capture light on multiple sides,
3. layout primary rooms so that they have incoming natural light from at least two sides,
4. allow for natural light to access nearly every space – including lobbies, hallways, and bathrooms,
5. provide operable windows to allow for natural ventilation and user control,
6. add thermal mass where possible to capture solar gain and reduce heating demand,
7. include deep overhangs, arcades, and recessed windows to block the high summer sun,
8. avoid air-conditioning, and, if possible, avoid forced air systems all together,
9. make buildings so comfortable and flexible that future owners will avoid demolition, and
10. learn to operate within the socio-cultural, political, and natural environments.

While these concepts are hardly original, the disappointing fact remains that even newer buildings supporting similar uses are being built in Berkeley and around the country without following any of these points. A series of ten points and a well-intentioned process, like the one used by the initial architects, will not, by themselves, lead to green buildings. Designers must respect the socio-cultural environment and engage with the political environment in order to produce buildings that minimize our impact on the natural environment.

ACKNOWLEDGEMENTS

This author was the Concept Architect and Project Manager for the project and would like to acknowledge the work of the final Architect – ELS, and the members of the First Presbyterian Church's Facilities Task Force and Architecture and Engineering Committee. The author would especially like to thank Paul Berry and Jim Childers.

REFERENCES

- Alexander, Christopher, Sara Ishikawa, Murray Silverstein. 1977. *A Pattern Language: Towns, Buildings, Construction*. Oxford University Press: New York.
- Anderson, Ralph and Irl Carter. 1990. *Human Behavior and the Social Environment: A Social Systems Approach*. Aldine de Gruyter: New York.
- Brown, G.Z. and Mark Dekay. 2000. *Sun, Wind and Light: Architectural Design Strategies, 2nd Edition*. John Wiley and Sons: New York.
- DiNitto, Diana. 1991. *Social Welfare: Politics and Public Policy*. Prentice Hall: Englewood Cliffs, New Jersey.
- Hedlund, Sandi. 2006. Personal Interview.
- Lasswell, Harold. 1936. *Politics: Who Gets What, When, and How*. Free Press: New York.
- Rapoport, Amos. 1992. 'On Cultural Landscapes.' *Traditional Dwellings and Settlements Review* III, no. II: 33-47.
- Stauffer, Nancy. 2006. *Comfortable Buildings, Hold the Air Conditioning*. Laboratory for Energy and the Environment, Massachusetts Institute of Technology: Boston, MA. Available at <http://web.mit.edu/newsoffice/2006/buildings.html> [accessed January 3, 2007].

Environmental Studies of Vernacular Architecture

J. Brooke Harrington¹, Judith Bing²

¹Temple University, Philadelphia PA

²Drexel University, Philadelphia PA

ABSTRACT: The objective of this paper is to reveal vernacular building responses to environmental, cultural, social and economic issues present in a number of historic buildings and structures in the Balkans. The structures presented have been directly visited and analyzed by the authors over a number of visits and their roots and contexts discussed with regional and international scholars of the places presented. In the study of vernacular architecture, environmental contexts are always important factors yet the social and economic context are also major factors that often supersede what now may be emphasized as important for sustainable design responses. The structures selected include year-round dwellings as well as seasonal dwellings and economic buildings in a variety of geographic and climate settings. All of the places selected are in areas that were formerly part of the Socialist Republic of Yugoslavia and presently are in separate countries.

Keywords: vernacular, Balkan, wooden, dwellings

INTRODUCTION

In the study of vernacular architecture there are numerous approaches, each containing its own attributes as well as its own problems. In each there is a concern for environmental response that the builder has taken in design and building of residential, agricultural and ceremonial structures. In the writings of Amos Rapoport and Paul Oliver (who have contributed so much to the study of vernacular, indigenous and anonymous architecture) one finds agreement that the making of early and contemporary architecture that 'lack theoretical or aesthetic pretensions'ⁱ all exhibit responses to climatic issues. Disagreement arises in many scholarly studies as to whether the buildings that result are determined by climatological and basic issues or only influenced by these concerns within the broader context of people's belief systems, their security and economic means for survival. The most accurate approach demands that one recognizes the importance of climatological influences as important factors but not necessarily as primary determinants. This study explores and reveals the remnants of early vernacular and folk architecture in parts of former Yugoslavia and presents a number of examples that have survived in a variety of landscapes and climates in the mountains and plains of this area. The full scope of the study cannot be presented in this paper; however all of the sites included have been visited on numerous occasions by the authors, and interviews with local ethnographers, preservationists, architects and residents have been conducted and supplemented by secondary sources. The buildings presented are primarily made of wood and occur in areas that are now in Bosnia & Herzegovina, Croatia, FYSR Macedonia, Serbia, and Slovenia.

ZLATIBOR

In the Zlatibor Mountains of western Serbia, not far from the Serbian-Bosnian border, a small open air, ethnopark and museum have been established to exhibit the *national architecture* of the region, in a village known as Sirogojno. In 1988, preserved structures were still being relocated to this park, which was under the direction of the Institute for the Preservation of Natural and Cultural Monuments. The museum's director, Ranko Findrik, had spent a major part of his career, as an architect and preservationist, documentingⁱⁱ and preserving numerous buildings that dotted the Shumadija landscape. Zlatibor means golden or yellow pine and the forests contained a mix of these trees along with a variety of oaks. Most of the buildings present are yellow pine and range from ninety to one hundred and ninety years old. Today most people in the area are building concrete houses with cellular clay tile walls and cement plaster exteriors; in many cases the new buildings are built within several meters of the old wooden houses. The new stucco and concrete buildings are similar in plan and layout to those on the Adriatic coast and in Austria where many of the local men (or their sons) were able to find work as *guest workers* in Austria, Italy and Germany.

The *brvnara* (log cabins) of the region are actually carefully fabricated plank buildings that have been formed either with saws or adzes. Most of the buildings in Sirogojno were formed of planks cut at local sawmills driven by cascading streams. Typically the houses do not sit in isolation but within extended family compounds that reflect the structure of the society. The largest dwelling contains the hearth (in Serbo-Croatian *kuca*); the name *kuca* also is used to describe the individual dwelling and the family community. The organization of the community is patriarchal and dwelling buildings are added as the family expands. Separate wooden structures are included for the various functions that occur in this agricultural and animal husbandry economy.



Figure 1: Views of the *kuca* of Sirogojno, Serbia. Source: authors 1987

The focus of this paper will be on one central *kuca* that represents the ideal setting for a *kuca*. The building itself is located on the south facing slope of a mountain just below the crest to offer the best solar access while taking advantage of the pine trees and slope for protection from the cold winds of the north, typical of the continental climate of Southeastern Europe. The wooden portions of the building are set upon a field stone base that provides a full cellar height set into the slope and a stone foundation as a base wall for the main living area whose earthen floor is formed by digging back into the natural slope of the mountain. The long axis of the building is north-south and two entries occur for the living spaces, one on the east and one on the west. Cultural traditions designate the eastern door as the point of entry and the place where good things arrive; typically the bride is brought in through this door, along with foods for consumption are also and newborns. The western door traditionally is used to remove uneaten food, and when someone dies he or she is carried out the western door. These traditions are explained as direct symbolic connections to the rising and setting sun, the bringing of light and the coming of twilight and darkness. In this primarily Orthodox Christian area, the darkness of the dwelling is in harmony with the windowless and dark interiors of the Orthodox wooden chapels that still can be found in the landscape.

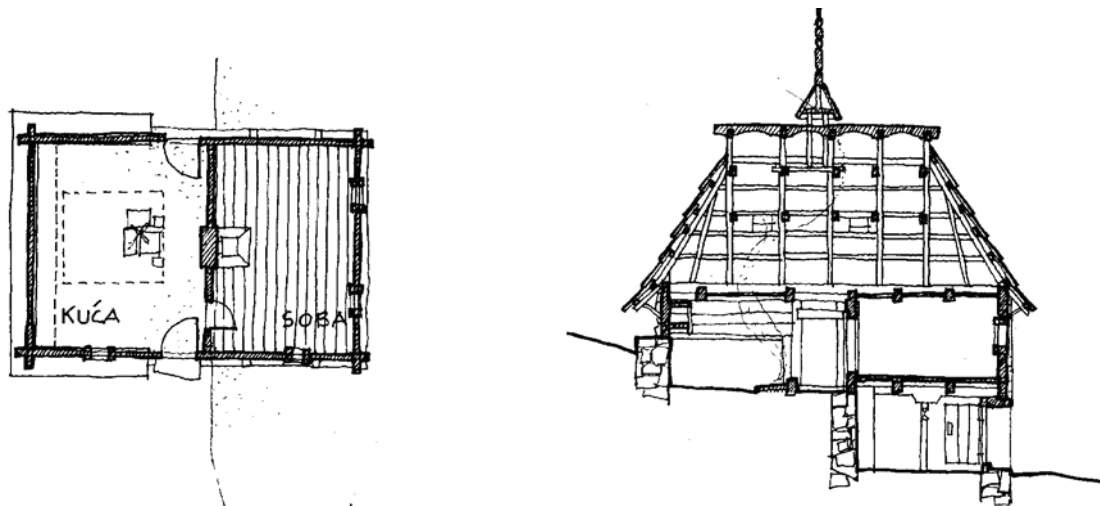

Figure 2: Plan & section of *kuca* at Sirogojno, Serbia. Source: Bing/Harrington 1994 (after Findrik)

The *podrum* (cellar) below is used as a root cellar and often contains the casks of plum brandy that are present in most rural communities where brandy is a traditional drink of the region. The main living area is divided into two areas, the earthen floor hearth area, and the enclosed *soba* (bedroom) area. The *soba* is formed by the perimeter walls, an interior plank wall that runs from east to west, a wooden floor (with the cellar below), a door to the *kuca*, and a wooden ceiling. Often only the *soba* has an opening in the exterior wall to allow daylight into the space. The roof of the *kuca* is a wooden, high-pitched, hipped roof with vents, and sometimes a cupola, for

the escape of smoke. The high pitch shed snows and within provides space above the hearth for racks to hang pots for cooking and thatched platforms to smoke meats. The roof is built of wooden trusses with purlins and *shindra* (shingles), and is extended over the walls for their protection. In some instances the ceiling above the *soba* is used as a loft for children to sleep but more often the earthen floor warmed by the hearth served as the primary sleeping area. In many mountainous areas of former Yugoslavia we found (in 1987-88 and 1991) that people were still living in this dwelling type with various modernization transformations. One final observation is that these buildings seem to survive when they are occupied. This may seem obvious, but the fact is that the preservation of the wooden roofs depends upon the smoke within to dry out the shingles and discourage infestation by destructive insects. One could surmise that a dwelling's survival depends upon its symbiotic relationship with the occupants.

BREST

On the land next to the oxbows of the Kupa River, before it joins the Sava River near Zagreb, is the village of Brest. In this region, architect and scholar Davor Salopek has spent much of his career documentingⁱⁱⁱ and seeking ways to preserve the traditional houses that exist in the *Korablja* region of Croatia. The climate in this region is humid and hot in the summer and damp and wet in the winter with snow occurring regularly. The properties along the river are typically formed with their narrow dimension to the river, and houses are built with their principal axes perpendicular to the river. Given the oxbow (switchback) nature of the river, this means that the solar orientation of the principal spaces sometimes requires inversion of the location of the stairs although the principal living space typically face the river. The *kuca jurinac*, shown here, represents one of four basic house types that Salopek identifies to represent the climate areas of the Croatian landscape (mountains, seashore, river and plains). This house sits on a site close to the Kupa River but behind levees built along the meandering river edge. The orientation is close to the idealized site orientation for this dwelling type with its principal axis north-south and entrance from the southeast side (more ideally the entrance would be on the southwest to serve as a buffer to the western summer sun). The ground level interior spaces hold animals, fowl and equipment and the upper level (first floor with loft) are used by the family. These buildings are constructed of logs and planks with pent-hipped, roofs of wood frame with clay tile shingles. The loft area of the roof was sometimes used for the storage of hay for animals. Most of the older buildings of the region are made of oak.

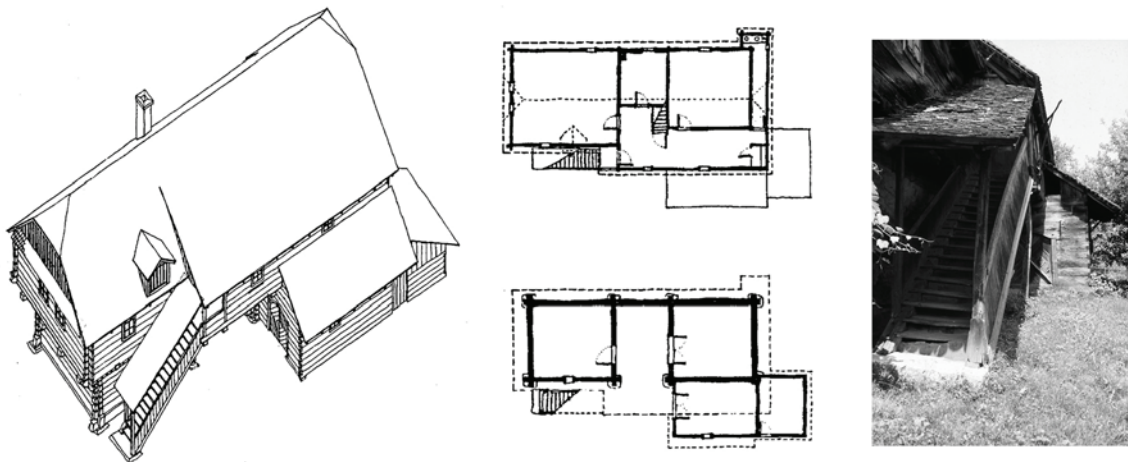

Figure 3: Drawings & photograph of the *kuca jurinac* at Brest, Croatia. Source: authors 1988

The *kuca jurinac* orientation places the exterior stair to the southeast leading to a corridor that runs along the same side of the building with a kitchen at the landing point, the main family room to the south end of the house and a bedroom to the north of the kitchen. An interior dry closet (toilet space) is located at the northwestern most point of the house.

The base of the dwelling is constructed using logs while the upper level is constructed using plank lumber. Where the Serbian mountain architecture had very few window openings (usually only one or two), these buildings contain multiple openings that are located to provide good ventilation and light for the interior spaces. Long beams run along the principal axis to support lighter crossbeams that allow the upper floor to cantilever beyond the base. The eaves typically project well beyond the walls to protect them from the rains and direct sun of the hot summers. The principal living space accommodates places for sitting, eating and sleeping. As one enters the door to this space, the corner for the family religious icons and the dining area are directly ahead; diagonally across from this is the hearth. The opening for the hearth is within the kitchen but the heating chamber is formed to serve as a heated bench and radiant object for use in the cold part of the year. As in other Slavic

countries and in Austria and Germany this element sometimes even has bedding placed on top of it to warm the occupants. The room to the north of the kitchen serves as a private room for the parents.

VELIKA PLANINA

In the Julian Alps of Slovenia, the high mountain pastures for cattle and goats have long served people and their animals as summer grazing areas. Huts were created there to protect both shepherds and their flocks from storms and wandering predators. These huts still serve a few for their original uses but most structures have been converted to weekend and summer retreats for people from the cities below who come for cooler weather, fresh air, magnificent vistas and hiking. The regional governments have created zoning and building regulations that demand that the building morphologies and construction maintain the traditional appearance and general detailing but these same regulations have produced a 'Disneyland' character that lessens the power of the authentic buildings of the pastures. Today one can take a funicular or follow the old winding shepherds path up to the plateau. Vehicles are not generally allowed on the plateau.



Figure 4: View of Velika Planina, Slovenia. Source: authors 1988

Dr. Tone Cevc, former Director of the Slovenian Institute of Science and Art, has been carefully studying the development of the various pasture dwellings of the high pastures and continues to research and document^v the ties between the patterns of animal husbandry of the Julian Alps and the dwellings that have evolved. One special building form that is most intriguing, and evolved into a special form, is the oval stone-based hut and shed structure. This structure combines the oval stone base, commonly used to corral animals, with a traditional square hut.

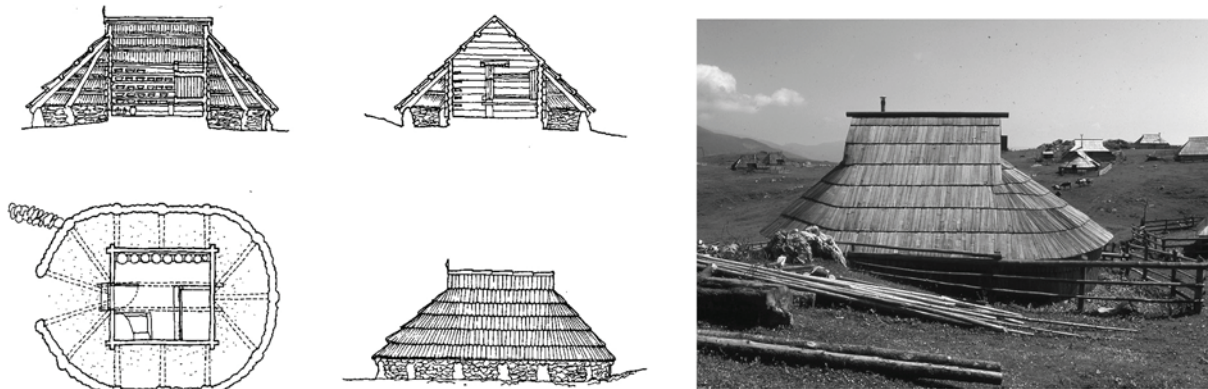

Figure 5: Drawings & photographs of pasture hut, Velika Planina, Slovenia. Source: authors (dwgs. after Cevc)

The traditional dry-set stone walls of the corral, which can also be found in the high mountains of Bosnia, are formed into ovals. These ovals are often formed of semi-circular ends with a center section of parallel walls. The entry is typically in one of the curved ends and has been found with lattice-structured wooden gates to close the entry. Within the oval is a small square (or rectangular) log or plank one room building that served as the sleeping quarters for the shepherd and storage for the aging of dairy products from the animals. The roof of the complex has a ridge that aligns with the long axis of the oval and extends just beyond the walls of the log enclosure. The roof surface is formed to extend beyond the log enclosure to cover the majority of the corral. The resulting roof form is a combination of straight and curved surfaces that creates a striking image in the high plateau landscape that exists just below and above the natural tree line of the mountains. The roof is made of

wooden rafters, purlins and shingles or planks. The wooden roofing is generally formed of elements that are set slightly askew from the slope of the roof to aid in preventing water from entering roofing seams.

The complex enclosure serves as a secure place for the animals, while their heat serves as a furnace to heat the shepherd in the cabin, and the cabin serves as a place to storage the valuable cheeses and other produce that the high pastures yield. Often the weather does not break until well into late May or early June to allow the pastures to be used effectively. But since the pastures have access to the late summer sun they can provide grazing when the valleys below are in the shade of the Julian Alp mountaintops. A few churches now exist on Velika Planina as an indication of the changing uses and new wooden fences occur on the broad landscape that that are further transforming this high plateau.

TETEVO

In the western district of the Former Social Republic of Yugoslavia Macedonia, is the town of Tetevo. It has been an important center for the Islamic population of Macedonia for over two hundred years and is the site of an impressive Arabati Baba Teke (Muslim monastery). This complex of several buildings has been preserved over the years and most recently has served as a heritage site and hotel. The monastery sits on the southeastern base of a Rudoka Panina of the Shar Planina on the edge of the modern town and is surrounded by a high stone wall that encompasses the complex. Although the compound contains many important ceremonial buildings, the most intriguing structure is a stone and wood structure built in the nineteenth century that adjoins the compound on the northeastern corner. This structure is a *kula* (tower) that beautifully combines the use of wood and masonry and includes a *chardak* space as the uppermost level. The author of this particular structure and its formal use remain in debate. Since it sits against, but outside of, the compound where the tombs of former religious dignitaries and the pavilion where the dervish monks performed their meditations and dances, it is thought to possibly be a dwelling for female members of the families of the holy men within the compound. One story indicates that it was built for the daughter of one pasha that was an important official of the *teke*. In any case the building has many compelling attributes.



Figure 6: Sketch & photographs of the *kula* at Arabati Baba Teke, Tetevo, FYR Macedonia. Source: authors

Tetevo sits just above the midpoint of a valley at the foot of the mountains and has rainy springs, hot and normally dry summers with cold winters. The *kula* has two interior levels. The base level is built of masonry and serves as a storage space that has been used keep goods (possibly also for animals at certain times). The upper level is constructed of stone and wood. Three of the faces of the upper level use large wooden panels that have operable sections (shutters) to open the entire interior to the views of the valley landscape. The northwest side, that faces the high mountains, is masonry and contains a built-in fireplace and chimney for the upper level occupants. On the three faces with wooden shutters, there is a stucco plaster frieze that contains oval openings to admit light. Each of these oval openings is surrounded by painted designs to accentuate the openings. The shuttered openings are constructed so that the upper leaf of each opening swings up and is supported to hold the it horizontal as a sunshade while the lower leaf serves as a backrest for those seated within. The openings of the *kula* allow views to the valley, the garden spaces of the *teke* compound, and the dervish pavilion. The wood structure of the roof is covered with clay tiles. The strong winds in this region demand heavy roof materials to combat the strong winds; often stones are added to the roof surfaces as ballast. An external stairway, typical of *kulas*, and is formed of a plinth of stone steps on the southeastern face that culminates in a landing from which a second run of steps, these of wood, rise along the northeastern face of the *kula* to arrive at a small wooden cantilevered landing outside the entrance door.

The upper space is often referred to as a *chardak*, 'a place between heaven and earth'. *Chardaks* are found in various forms across the Balkans and in Turkey. The character of this space is a perfect place to work and relax since it provides a wonderful place in the spring, summer and fall to sit under cover to catch the breezes that

travel through the valley while receiving the low winter sun while blocking the colder mountain breezes and winds that come from the mountains to the northwest. The two levels of openings in the chardak provide multiple sources of light and the operable shutters and oval openings allow for good ventilation of the space. This would seem to be an ideal place for either young dervish travelers to gather for teachings, or for women and children to gather to perform their daily chores.

MOSTAR

In Herzegovina, Mostar is the largest city and known for its famous four hundred and thirty year old Ottoman bridge, destroyed in the 1992-94 war. The town is located on the Neretva River in a valley about 40 miles from the Adriatic coast. Steep rocky mountains define the valley in which it sits and the hottest weather of Yugoslavia was consistently recorded in Mostar, often reaching 104°F in the day and over 85°F in the evenings. The city has a long history and grew along the Neretva River during the period when the Ottomans came into this part of Europe. The fabric of the old town (Stari Grad) is consistent with that of many oriental and Ottoman towns. The dense fabric of small courtyard houses is reached by narrow pedestrian paths that occur between the high walls that define the realm of each family's dwelling. The walls are built to define the house interiors but also form the courtyards where the families greet visitors, grow food and flowers and provide outdoor places for the family to live free from the eyes of their neighbors and strangers as is the tradition in many Muslim societies.

In Mostar the majority of the houses in the old town now belong to, or are occupied by, Muslim Bosnians who were caught in the fighting that left a substantial part of the old town uninhabitable. The old courtyard dwellings however are very well suited to the climate of Mostar. The typical courtyard house was built with its court formed to the south of the dwelling with the interior and covered spaces forming an L-shape to respond to the slope of the land and access to the sun. Since the Neretva River flows from north to south and steep mountains are on the east and west, the dwellings were formed to gather southern solar access and morning light if the dwelling was on the west and afternoon light if the dwelling was on the east side of the river. The steep slopes at the base of the mountains allow neighbors stepping back from the river to have good solar access above their down-slope neighbors. The daily winds that channel up the river in the morning and down the river in the evening aid in cooling the land that receives the sun with few showers during the summer months.

The typical dwelling was constructed of stone, clay or mud brick and wood. The dwelling was partially built into the mountain and the ground story typically was constructed of masonry with the raised story (first floor) built of timber frame with wattle & daub or lath with a thick plaster applied to the exterior and interior. The roofs typically provided broad eaves to shade the building from the summer sun and protect the exterior walls from seasonal rains and storms. Heavy stones (ploca) cover the roofs to resist the high winds of the winter.

The *Kajtazova kuca*, represented below, is an important house in the old town fabric. The house was originally built over three hundred years ago and has many of the characteristics that show the way people lived in a courtyard environment that responded to the cultural and natural patterns of the Neretva River valley.



Figure 7: Drawings & photograph of Kajtazova kuca, Mostar, BiH.

Source: authors (dwgs after A. Pasic)

The dwelling shown has two principal sectors that are divided by a two story wall that separates the places for family from the place for visitors. On the plans above, one can see the diagonal thick wall that separates the two realms on both floors. On the left is the realm of the family; it also includes the kitchen on the ground floor and access (on the far left, to the animal yard and orchard beyond). On the right, are rooms for meeting guests and business associates and rooms to socialize. On close inspection, one sees a single small opening on the upper floor; this is a point where food from the kitchen is passed through to those on the right. The broad overhang of the roof protects the closed and open parts of the house from the hot summer sun while allowing deep penetration of the low winter sun. The stone floor of the porch has a welcome feel as one sheds shoes to enter the dwelling in the summer and the enclosed spaces have wooden floors covered with carpeting and small samovars and fireplaces heat the interiors during the mild winter months.

As this is a very old house and the social settings have changed, the house as one family dwelling was split into two dwellings for two brothers who inherited the property. Over the years the part on the right was modernized a number of times and no longer retained its character in the 1980s. During the 1992 war, the right side was so badly damaged that its owner has pulled down the remaining parts and is building a new contemporary house for his family. The authors took the photograph above in 1988 but today the house still remains. The owners of the remaining dwelling still open their doors to visitors and offer rose water and allow travelers to spend time in their garden and house. Unfortunately the family has not been able to obtain funds for repair and restoration of this important Ottoman period dwelling, even though it is recognized as one of the four most important historic dwellings of the Old Town.

OBSERVATIONS / CONCLUSIONS

During 1987-88, the authors visited over four hundred villages^v in the former Yugoslavia seeking out examples of early wooden structures to better understand the complex formal and spatial attributes of the most interesting of these. The photographs and documents created in numerous cases are the only surviving comparative records of these buildings as the wars of the various regions have resulted in the destruction and decay of the structures. Even as new governments and historians rewrite the histories of the regions, folkloric genocide is occurring as dominant cultures either erase or reinterpret the meaning or significance of each building's attributes and importance. Any survey of buildings, can only serve as a snapshot of the present and past. The 30,000 kilometers of paved and unpaved roads traveled then are now in separate countries. The few examples briefly presented above demonstrate that the builders incorporated means to address the visceral requirements of life in the structures that were built. The longevity of each building studied gives proof that the decisions of building techniques and arrangements were sustainable for multiple generations of occupants. In fact the buildings, somewhat like the Stari Most (old bridge) in Mostar, outlived numerous societal, governmental and religious structures. And so in the end those decisions made to allow people to live in and care for the places they reside are those that allow the buildings to transcend their own times. One can see that many of the strategies that are being adopted today in order to address sustainable design approaches have been used for hundreds of years in the anonymous architecture of traditional societies and environments. As architects, we sometimes dwell too much on the formal aspects of design without looking more creatively for new or more sensitive ways to address all of the issues of architecture to insure that our buildings can sustain others who may come long after us. It is important for us to recognize the natural phenomena that surround us each day and respond to these in our designs for others.

ⁱ Description taken from *house form and culture* by Amos Rapoport, page 5, prentice Hall 1969

ⁱⁱ See the following books by Ranko Findrik: *Zlatiborska brvnara i muzej narodnog graditeljstva "staro celo" y Sirogojni*, 1987; *narodno neimarstvo*, 1994, *dinarska brvnara*, 1998; and *vajati znamenje mladosti*, 1999

ⁱⁱⁱ See the following book by Davor Salopek: *Arhitektura bez arhitekta*, 1974; and contributing author in *kuca, tradicionalna stambena*, 1978,

^{iv} See the following books by Dr. Tone Cevc: *Velika Planina*, 1987; *Bohinj in Njegove Planine*, 1992

^v In a recent review, our archives show that we have photographed at least one structure (dwelling, granary, chapel, church, mosque, watermill) in over 380 villages in Yugoslavia and at least an additional forty villages in the adjacent countries of Hungary, Austria, Bulgaria, Romania, Greece and Turkey during our studies.

Materials and Construction

Straw-Bale Eco-Center: Demonstrating How to Live Sustainably in the Midwest
Timothy Gray

The Design of Residential Building Skins—Solar Power and Structurally Insulated Panels
Joe Jamgochian and Franca Trubiano

Enabling Material Constraints in the Digital Design Process Through a Plywood Gridshell
Mark Cabrinha

In the Purple Palace: Environmentally Responsible Vocabulary for Materials and Construction*
Richard Hayes

Site Interface*
Laura Briggs

* Invited Oral Presentation

Straw-Bale Eco-Center: Demonstrating How to Live Sustainably in the Midwest

Timothy Gray; AIA, LEED AP

Ball State University, Muncie, IN

ABSTRACT: This paper presents a case study of a recently completed "Eco-Center", a student project intended to demonstrate how to live sustainably in the Midwest, reconnecting students and the community to sustainable relationships among buildings, sites, people and prosperity.

Phase one of this project was researched, designed, documented and constructed in the course of a single semester (Fall 2006) and resulted in the construction of one of the first load-bearing straw-bale structures in the region. This paper will discuss both the goals and the challenges of the project, provide a summary of decisions made through the design and construction of the project, and will conclude with a discussion of the lessons learned as well as the pedagogical merits (and shortcomings) of the process.



Figure 1: Eco-Center under construction sited at the south end of a restored prairie at the Cooper Field Station, Muncie, IN

DESIGN

The Straw Bale Eco-Center was conceived as the first built component of an environmental research facility envisioned for our University located in the Central Midwest. The project is sited at the south end of a restored prairie on a University "Field Station", an 80 acre parcel owned by the school but remote to campus. The first phase of the project was funded through an EPA P3 grant (with some local matching funds) and followed on a master plan for the property prepared by a colleague in the Department of Landscape Architecture in 2002 as well as a funded study prepared by a group of colleagues in 2004.¹ The project had three primary goals:

- To provide an immersive and comprehensive learning experience for the students involved in the project.
- To provide education and community outreach to promote awareness of and highlight issues relating to sustainable building practices while demonstrating a viable alternative to local conventions.
- To serve as an ongoing research facility.

The EPA funding for this project was confirmed only late in the summer and, as a condition of the grant the work needed to be complete by the following Spring (2007). This presented some logistical challenges within the school curriculum and as a result the class was offered as a three unit elective rather than a design studio. There was little time for preparation in advance of the class. We hit the ground running!

The class was composed of thirteen students, a mix of fourth year undergraduates and first year graduate students. In addition, fourteen third year architecture students enrolled in the design studio I was teaching at the time were involved in the project, the studio being structured to allow for a two week design charrette at the beginning of the semester and two weeks to participate in the construction at the semesters end. The contributions of the third year studio proved a key to the projects success.

From the outset the project was thought of in terms of two phases. Phase one would consist of researching, designing, permitting and building the project to the level of a watertight shell as well as documenting the sustainable features incorporated into the project. Phase two would consist of installing exterior claddings and finishes and completing the interior fit out of the building. In addition, site work would be completed in phase two including the construction of a series of integrated site systems. Phase one (the building shell) was to be completed by the semesters end with the relatively modest construction budget of \$9,000.

The third year students kicked off the design process working in teams to generate proposals for the building, finding their architectural expression in subtle design moves grounded in a creative manipulation of the building components. During this same period the elective class was broken into teams researching conventions of bale construction, sourcing and pricing local materials and researching the few local precedents we were able to find. At the end of this two week "burst" the elective class participated in the review of the third year student's proposals and used the third year work as a point of departure to synthesize and develop their own designs.

Parallel to these activities I was working with selected students from the group meeting with a variety of local officials (University Facilities Staff, County Building Department Inspectors, Property Governing Board, Bankers representing the Property Trust....) to both determine the approval process required for the project and to produce the necessary documentation to obtain these approvals within the framework of our very ambitious schedule. We were fortunate in that our plans were met in general with enthusiasm and support by all the parties involved. In addition, during this period members of the group solicited donations and matching funds for the project from a variety of sources.

As the design direction was narrowed student teams began sourcing straw and mocking up sections of the wall. Through hands-on experimentation students became familiar with the bale module, the behavior of the material and methods of pre-compressing the bales. This directly informed the design work going on in studio.

The final design was simplified as a result of the hands-on experimentation, the students exuberance grounded in a growing understanding of the behavior of the material and the realities of actually building the project. The main volume of the building is simply a rectangular room, room size and openings laid out on bale module and conforming to City of Austin, Texas Building Code requirements (there were no local codes available to help guide decisions) which were sourced from the web. This main volume was raised approximately 30" above finished grade on an insulated platform in response to poor drainage and potentially wet site conditions.

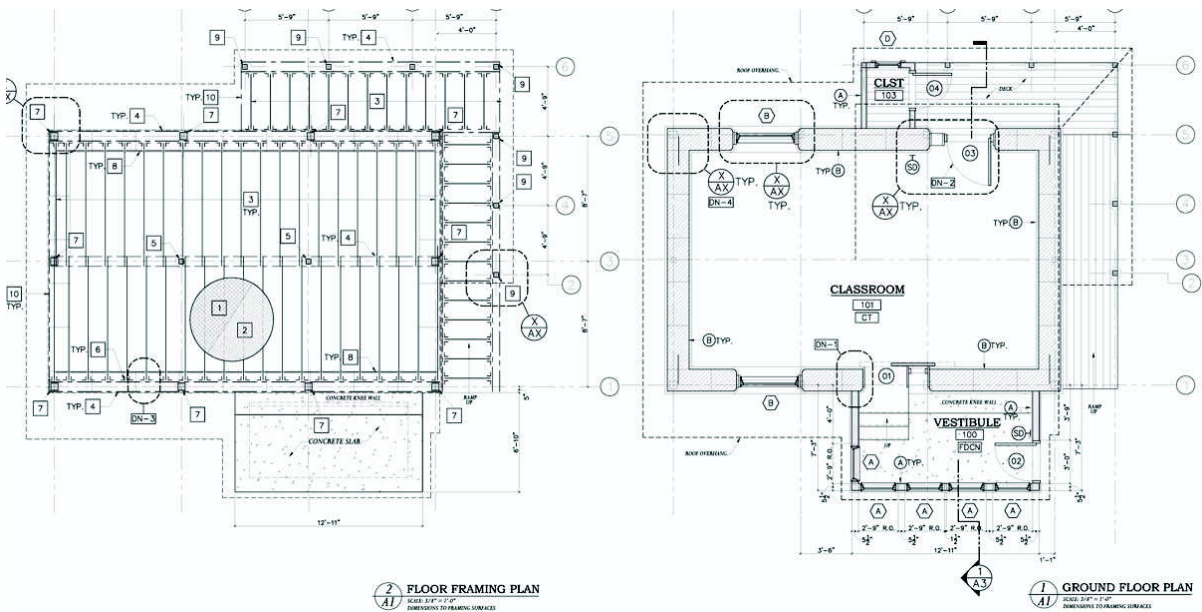

Figure 2: Floor framing and floor plan

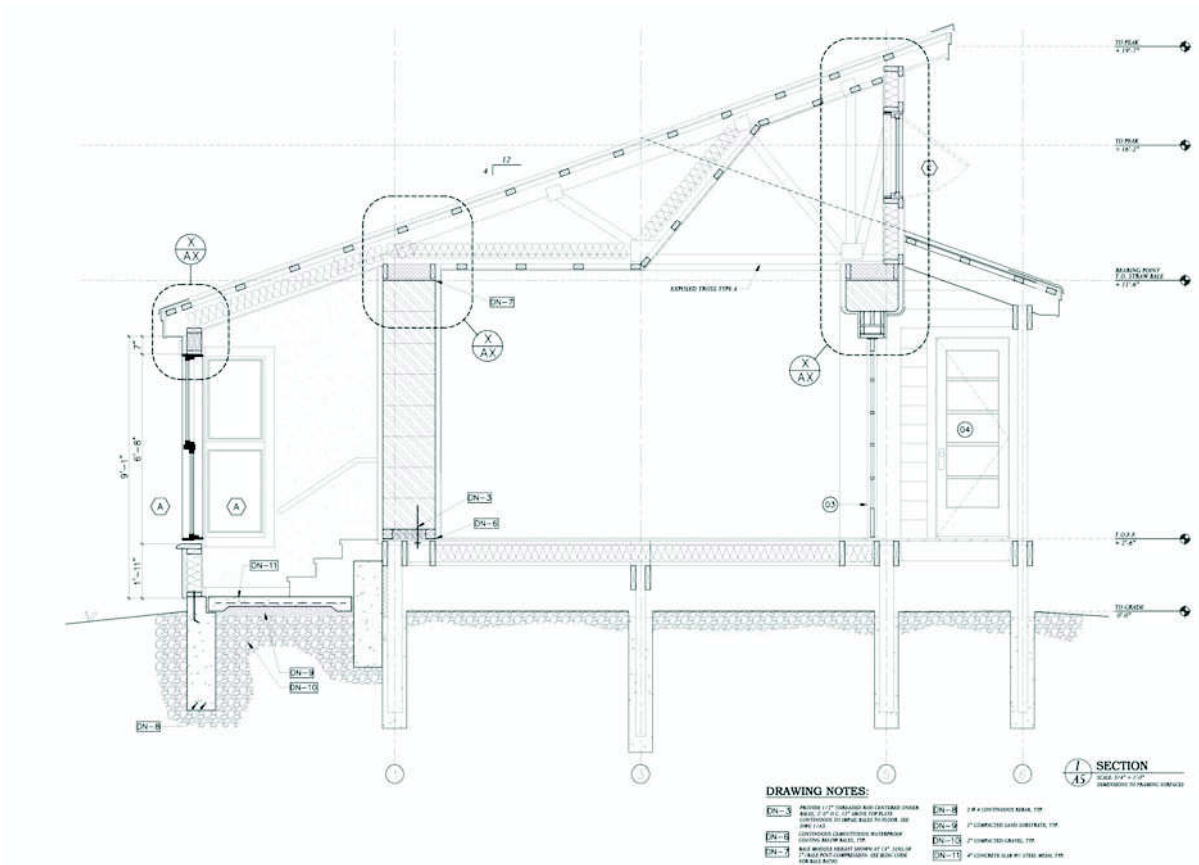

Figure 3: Section through the final design. (drawing by Dan Bajor)

Students researched, sourced and priced materials for the project, weighing material selections and methods of construction against our sustainable agenda; to educate both students and the community about how built sites can integrate with resource flows, promote sustainability and enhance quality of life. In addition to the use of straw-bale, some of the sustainable strategies employed include but are not limited to the following:

- Recycled content and locally sourced (and manufactured) materials including fly ash concrete, engineered lumber (LVL) for the primary deck rim joists supporting TJI floor joists, OSB decking and sheathing (where required), dry blown cellulose insulation. Finishes (phase II) are to include rapidly renewable resources such as bamboo flooring, and recycled content and durable materials such as wheat-board and cement fiber siding.

- Trusses composed of small scale (2x4) lumber with raised heel to allow continuous depth (continuous R- value) across the full width of the bale walls.

- Super insulated building envelope with passive entry / sun porch facing south. All windows in the conditioned space were double glazed vinyl windows, donated to the project. The central (straw-bale) room can be closed to the unconditioned sun porch to facilitate passive heating and cooling. If funding allows, photovoltaic panels will be installed in phase II.

- Numerous landscape features (phase II) including the installation of a cistern to capture roof water for use in irrigation systems, the development of living fences, wash water gardens and integrated water-wastewater-landscape-energy systems.

- “Smart” composting toilet (drying controlled by solid-state sensors and microchips); phase II.

CONSTRUCTION

A little over half way through the semester we had the necessary permits from the county, approvals from all responsible agencies and a design we were relatively confident we could build for our fixed budget.

We were ready to build!



Figures 4, 5: Ground break in mid-October (at last!); pouring the slab and footings of the entry porch with fly-ash concrete

There were a number of challenges that presented themselves through the course of construction, some foreseen and others not. We encountered our first significant challenge almost immediately on the day we met with the University Facilities Staff to schedule the groundbreaking (they had generously offered the use of some equipment to help with excavation). A change in staff since our initial meeting had resulted in a “new interpretation” of the applicable codes and it was now required that we get a building permit from the Office of the State Architect, a potentially higher hurdle! A considerable amount of drawing, scrambling and \$500 in fees later we obtained the necessary approval and were on our way having lost only one week to the mix up.

Our second big challenge came in the form of wet weather. The day after our groundbreaking it started to rain and marked the beginning of one of the wettest fall seasons on record for our area. Once the platform was framed we were thankful up out of the mud but also burdened with the task of keeping the jobsite dry at night. Using visquene and tarps we did manage to keep the assembly dry and even managed to survive a severe wind and driving rain storm toward the end of the project, but much of our collective energy went in to tarping and un-tarping the site. This was particularly challenging for students trying to squeeze two, three and four hour work shifts in between other classes and obligations. The students gained a first hand appreciation for the challenges of staging a construction project of even modest scale.



Figures 6, 7: Framing the platform with laminated veneer beams and truss joists, framing the roof trusses directly on the deck.



Figure 8: Erecting the bale walls; great lengths were taken to keep the materials dry through the course of construction.



Figure 9: Installing 2x10 “beam” on the flat at the top of the fourth bale course to stabilize the wall horizontally.



Figures 10-12: Installing the top plates on the bale walls; platform prepped to receive the bales; pre-compressing the bales;

Erecting the bale walls went relatively quickly and was a fun and energizing part of the process. The bales were pinned at the corners and tied together vertically with rebar pins. As the walls went up, however, we encountered a significant amount of lateral motion, particularly at the east and west ends which were not stiffened by door boxes. We knew from our mock-ups and our research that pre-compressing the walls would stiffen them considerably, however as a precaution we installed a 2x10 on the flat on top of the fourth bale course pinning it to the bales and bolting it to the door and window boxes (fig. 9). This acted as a lateral beam and stiffened the wall considerably.

Once the walls were complete the top plates were installed and the bales pre-compressed via cum-a-longs and ratcheting straps which were connected top eye bolts on each side of the base of the wall (fig. 12). 1 x 3 furring strips at 3' on center were screwed into the top and bottom plates to hold the bales in compression as well as acting as "hold downs" for the roof assembly.

Friends, colleagues and classmates were invited to the site for a "truss-raising" where the pre-assembled trusses were passed up and attached to the top plate. Over thirty people gathered on site for the event which, to my great pleasure, went according to plan (I did not tell the students that I had reserved a crane for the following morning just in case...). There was a great sense of shared community and accomplishment once the trusses were lifted into place.



Figure 13: the community "truss raising"

At the time of this writing the building currently sits with the bales wrapped in visquene for winter, awaiting an application of exterior sidings in the spring. An interdisciplinary group of students led by collaborator and colleague, Dr. John Motloch of the Department of Landscape Architecture is in the process of designing integrated site systems for the project which we hope to implement in the coming year (pending funding). In addition, the students are making proposals to monitor these integrated site systems; designing a program of base-lining, benchmarking and monitoring at key indicator stations, demonstrating the resource-balancing potentials of integrated built-site systems and regenerative technologies (i.e. greenhouses, rock-reed filter systems, wetlands, wastewater and wash water gardens and so on). These students are preparing boards to explain the sustainable features of the project to visitors and these will be displayed in the Eco Center when complete. The boards will document specific aspects of this project but also use the story of the Eco Center to frame a broader set of issues related to sustainable building practices in our region.

This process of recording and monitoring the performance of the eco-center has already begun with regard to the bales, a baseline reading of the moisture content of the bales has been taken at thirty points around the perimeter of the building and these points will continue to be monitored monthly, the results input to a spreadsheet which records changes. The behavior of the bales at different points (different exposures) around the perimeter and in response to different exterior sidings (earth plaster, corrugated plexiglas and cement fiber board) may suggest adaptations to the assembly in response to our local climate conditions.



LESSONS

At the time of this writing I am only three weeks removed from the whirlwind of constructing this project. Given this I admittedly may lack a degree of critical perspective relative to the (ongoing) project but also feel in some ways I benefit from the immediacy of the experience. My opinions and what I take away from this experience may continue to evolve with time.

With that said I would like to use the three goals identified at the outset of the paper as a lens to evaluate the projects successes and shortcomings.

With regard to providing an “immersive experience” for the students I think there were some significant shortcomings. The magnitude of the project relative to weight of the class (a three unit elective in the context of a typical 15 to 18 unit load for the students) was enormous, and the students had too many competing obligations, including the rigorous requirements of their design studios, to truly immerse in the experience. No one of the students could dedicate the time required to understand the critical path of events, secure the necessary permits, coordinate the purchase and delivery of materials, track the budget, coordinate schedules to keep crews running at the site, solve problems as they arose, adapt to setbacks caused by weather and schedule conflicts etc. As a result at times I felt that the only one truly immersed in the project was myself (at times to the point of drowning!). This had the unintended result of alienating some students who at times I’m sure felt that I was dictating the process, a bad cycle. Generating responsibility and commitment among the students and balancing the level of faculty involvement is a delicate formula which I am still working to refine.

My efforts to break the class into areas of “ownership” and responsibility were only marginally successful. The students did not self-organize effective lines of communication critical to pulling off a project of this scale on a tight schedule. In reflection I believe the project clearly demanded a greater block of the students academic schedule to truly immerse in the experience, allowing students to be guided by faculty input and critique but in the end responsible themselves for the product. I take responsibility for the structure of the class which in this case I believe was fundamentally problematic.

Despite these shortcomings I believe the learning experience overall was a very rich one for the students. First and foremost the project challenged the students to clearly marry their creative expression to a sustainable agenda while negotiating the complexities of budget, material and time. The project challenged the students to “invent the future on terms that are ecologically responsible”² and to find their own creative voice within that challenge. Students were asked to find their architecture in an intimate understanding of material, assembly and tectonics, areas of emphasis seldom successfully addressed in studio if addressed at all. I am confident that to a person, myself included, everyone involved in the project is excited and proud of our result. In this sense it could be argued that the end justifies the means. Many of the students commented individually to me that it was an incredibly rich learning experience for them which of course is very satisfying, and the student evaluations for the course were among the best I have received.

With regard to the second goal, education and community outreach, I believe time will tell if the project is truly successful in this regard however in my opinion it is off to a very promising start. The project has already generated a fair amount of attention in the media, including a TV spot on public television and significant coverage in the University, Muncie and Indianapolis press. Beginning next year, the Eco Center will be

included in a standing “nature tour” taken by most all Delaware County Elementary school children and will also be a feature destination at next years semi-annual “Greening of the Campus” conference at Ball State. We will be producing boards for display, a combination of graphic materials and text, to explain the center to visitors. We continue to try to raise awareness by promoting the project in the media, one of the challenges being to frame broader issues of sustainable development in the context of this modest project while trying to discourage media coverage focusing simply on the novelty of straw-bale construction, which is really only one small part of the story we want to tell.

With regard to the final goal, to serve as a vehicle for ongoing research, I believe the project is rich with potential although this work has really just begun. As previously described, we have already recorded a baseline measurement of the moisture content of the bales and are in the process of designing integrated site systems which include proposals for ongoing monitoring of the performance of these systems. Students are also in the process of preparing a LEED assessment of the building, identifying LEED criteria satisfied and providing required documentation where possible.

In addition, Dr. Motloch and selected students will be joining me traveling to Washington D.C. in the spring to present the results of this research at the annual EPA P3 conference at which time we will make our case to receive the next level of funding for the Center. To this end we are currently seeking research partners from across campus to use this facility to extend their research with the potential of obtaining funding for their proposed activities as part of our EPA proposal.

And finally, I share a broader vision for the eventual development of the site based on a master plan developed in 2002 by Professor Motloch, proposing the region’s first “Green Building and Green – Built “ site.³ Looking to such rich precedents such as the Center for Maximum Potential Building Systems in Texas or the Rocky Mountain Institute in Colorado, we share a vision where the buildings of our proposed Eco-Center are at once facilities to educate and stage research and innovative teaching / research projects in and of themselves.



Figure 16: The University community after taking part in the “truss raising”. Photo: Cheryl LeBlanc

- Notes:
- 1 “Field Station and Environmental Learning Center Strategic Planning and Charrette”, Badger, K., Brown, H., and Motloch, J., Funded by the National Science Foundation
 - 2 James Wines, 2000, Sustainable Architecture White Papers; “The Art of Architecture in the Age of Ecology”, Earth Pledge: NY
 - 3 “Resource-balancing Design for the Field Station and Environmental Education Center and LandLab: BSU’s First green – Building and Green – Built Site”, J. Motloch, Final Report for the 2001 -2002 CERES Fellowship, November 1, 2002

All photographs by the author unless otherwise noted

The Design of Residential Building Skins— Solar Power and Structurally Insulated Panels

Joe Jamgochian¹, Franca Trubiano¹

¹Georgia Institute of Technology, Atlanta, Georgia

ABSTRACT: The following paper addresses architectural design in the field of building materials and methods, particularly those which can positively contribute to the construction of sustainable environments. It attends to innovations in architectural building skins and the design research whose results are communicated herein was directed at discovering greener alternatives for the construction and operation of exterior walls; principally, those adopted in single family housing powered exclusively by solar technologies. To this end, the following paper will describe the development of an active, multi-functional wall assembly whose building integrated photovoltaic strategy supports the following range of properties; a high resistance to heat transmission, a rain screen, and a custom built system for the production of hot water.

Keywords: SIPs, rainscreen, photovoltaic

INTRODUCTION

The content of the following paper addresses architectural design research in the field of building materials and methods, particularly those which can positively contribute to the construction of sustainable environments. It attends to innovations in architectural building skins and the design research whose results are communicated herein was directed at discovering greener alternatives for the construction and operation of exterior walls; principally, those adopted in single family housing powered exclusively by solar technologies. To this end, the following paper will describe the development of an active, multi-functional wall assembly whose building integrated photovoltaic strategy supports the following range of properties; a high resistance to heat transmission, a rain screen, and a custom built system for the production of hot water.

The research and design methodology reflected in this report, jointly coauthored by studio instructor and graduate student at the Georgia Institute of Technology, promoted the integration of real and physical constraints within the pedagogical structure of the traditional design studio. It offered design students an opportunity to challenge accepted notions of what architectural design is and for proposing what it can be. Both undergraduate and graduate level students were encouraged to seek design solutions from within the professional field of building construction; an area of operations whose standard practices, whether in techniques of assembly, material integration or prototyping, can be studied with an eye to reinventing the nature of how architecture is taught. The highly determinate conditions under which building technology exists were design fodder for much invention throughout the studio's progress. Communication and collaboration with industry sponsors became an essential component of the process. Potential fabricators and suppliers of insulation, sheathing materials, and photovoltaic panels were carefully consulted with the merit of their various products and services assessed by students. This design process, which integrated a significant research component, offered the students analytical, objective and quantitative parameters within which to situate and evaluate their resulting architectural designs.

Governing this initiative to design a new exterior skin prototype for the residential housing market was the real-life imperative to construct and test the invention under rigorous conditions. As a participant to the Solar Decathlon 2007 Competition, a single family residence will be delivered to Washington DC in October 2007 which will physically incorporate the results of this research. The Competition is a venture of the College of Architecture, in collaboration with the College of Engineering, and its participants seek to build a fully operational residence whose needs for shelter will be met by its vertical enclosure. And in response to the competition brief, directed towards showcasing the benefits of solar technology, it was deemed of value to investigate the possibilities of integrating the use of sun power within the construction and operations of its exterior wall system.

Interest in facilitating the participation of the residential housing marketing in the greening of the building industry continues to be of the greatest concern. Continued attention must be brought to the growing depletion of non-renewable energies and the effects this has on the construction industry. Cultivating good ecological practices is a necessity of our age and conducting architectural research on innovative building materials and methods is more important than ever before. Investment in renewable energies such as wind power continues to grow at an impressive rate. *The Economist* noted in its story, "Tilting at Windmills" how greater amounts of money than ever before are now being introduced into clean technology sectors. And in the two years alone since 2004, venture capitalists have increased their investments in these sectors four fold (*The Economist* November 18th-24th, 2006).

The political necessity to invest in renewable energies is equally notable. In California, businesses and private parties have been offered subsidies to help finance the cost of purchasing the equipment and technologies needed for converting their energy uses to solar power, with wineries having been fairly successful in such conversions (*The Economist* November 18th-24th, 2006). In the end, and notwithstanding the economic benefits for doing so, all facets of the building sector would benefit from a realignment of its energy demands. Design research in our schools of architecture continues to offer an important avenue for the invention of ever more productive building applications and the wall/skin design whose details are offered here below is one such attempt.

1. THE PERFORMANCE OF EXTERIOR WALLS—BEYOND INSULATION

Standard construction practices are not necessarily the ideal model when seeking efficiencies in the use of materials or labor in the construction of a single family residence. What results is usually based on meeting the demands of local energy codes—which, in the United States, are substantially lower than what current technologies permit. This project addresses this condition by proposing alternative strategies for the design and construction of building components that make use of integrated building assemblies that can meet rigorous performance demands while providing an efficiency in both construction and operation.

The success of the exterior wall here designed is predicated on its capacity to be more than an insulating enclosure. Merely achieving a high resistance to heat transfer is insufficient for the purposes of this particular application. By examining the possibility of integrating within the wall assembly of a typical single family home both solar energy production and active building systems, an efficient system has been created using new materials and coupled building components. After researching structural insulated panels (SIPs), rainscreens and cavity wall construction, existing building integrated photovoltaic strategies, available and improvised solar hot water systems, and after making contact with industry representatives, a multi-functional exterior wall system has been designed that uses the potential inefficiencies of one system to the advantage of the other.

1.1. Structural insulated panels

Due to weight constraints (during the official Solar Decathlon Competition to be held in the month of October 2007 the house will be physically transported across a minimum of four states) and energy efficient measures inherent in the design problem, it was natural to begin this research by examining SIPs with regard to their material make-up and performance properties. SIPs are relatively new to the construction industry with only one percent of new homes built in the United States making use of them despite energy studies that prove SIPs are more airtight and energy efficient than traditional timber framing (Mullens 2006). While the unification of structure, insulation, and in some cases the exterior and interior finishes, is the goal of all SIPs, there are several different methods by which they are manufactured—each making use of different materials and resulting in different performance characteristics. The added structural benefit is that all panels in SIP construction are stressed when loaded; the outer sheathing in compression and tension while the core prevents buckling in shear (Cathcart 1998).

Several factors contribute to the reluctance of the home building industry to adopt this new method of construction for building envelopes including the general uncertainty which accompanies any changes in a proven model (Mullens 2006). Critics of SIP construction cite restraints on the design potential of the product due to the inherent modularity of the system. They also cite problems with joint details, uncertainty about the product's long-term performance, and what is perceived to be an inflated cost. Although SIPs are generally produced in either 4' x 8' panels or larger whole-wall panels, all of the different types of SIPs described in depth below offer the possibility of custom sized panels that allow for more flexibility in the design process than thought to be attainable when using standard timber framing. SIP manufacturers provide a variety of joint details, particular to the panels material composition, that eliminate thermal bridging and significantly reduce air infiltration. They reduce the number of seams required for both butt joints between SIPs and for connections to more typical building components. Because SIPs are manufactured in a controlled environment, the dimensions are more

precise and the overall quality of the material is higher than what is possible on a typical construction site where weather, coordination with other trades, and interpretation of drawings can reduce the quality of the finished construction. These characteristics make SIP construction prone to fewer problems throughout the life of a building since they not only have fewer joints but the joints that do exist provide for a tighter envelope. The entire assembly reduces the opportunity for water infiltration or air leakage that can cause building materials to decay and warp over time.

The cost of SIP construction is often cited as the primary deterrent preventing its widespread use. Material costs make the price of SIPs between 10 and 20% more expensive than comparable wood-frame construction, there are several other factors that influence the cost to both the building industry and the long-term homeowner. An experiment documented by the University of Central Florida Housing Construction Laboratory followed the construction of two similar Habitat for Humanity homes—one framed using traditional methods and one framed completely in SIPs (Mullens 2006). The number of labor hours, the amount of material waste, the necessary worker skill levels, issues of worker safety, and the general quality of workmanship were recorded for both building systems and analyzed yielding interesting results. The SIP construction saved about two-thirds of the required labor time, it produced less waste, required less skill, and generally resulted in a better quality building (Mullens 1996). While substantial results affecting worker safety did not emerge from this experiment, it did reveal that the building industry had the potential of achieving a cost efficiency through a reduction in labor and material waste.

Although SIPs have a higher initial cost, they also provide 30-50% more insulation. To achieve an equal amount of insulation using timber-framing construction would necessitate deeper dimensional wood members. This would invariably increase the cost of timber relative to that of SIPs. In regions with high labor and energy costs or in regions with extreme climate conditions, the higher insulation level of SIPs makes them all the more cost-effective (Cathcart 1998). In areas where the costs of energy, labor, or materials is high, the potential cost efficiency for the actual homeowner when using SIPs increases.

In the residential market, there are three main types of SIPs that are available. The most common type consists of oriented strand board (OSB) skins that are bonded to an expanded polystyrene insulation (EPS) core, available from numerous manufacturers around the country. This type of SIP generally offers a lower weight per square foot and a higher thermal resistance value than typical wood stud framing and has the potential to incorporate itself into the existing models of home construction due to its material composition.

A product known as Agriboard and produced in Kansas is a slight variation on the OSB/EPS SIP; it is constructed with the same type of OSB skins but the insulative core is made of compressed wheat straw, a waste by-product of the wheat industry. While this unique SIP allows for a stronger argument regarding the sustainability of its materials, it possesses a slightly lower thermal resistance at a weight that is nearly five times that of a typical OSB/EPS SIP—making it impractical for this design application.

An EPS insulated panel with galvanized steel studs has half of the weight per square foot compared to a panel of similar thickness and thermal resistance value composed of EPS insulation between faces of OSB. Reviewing the joint details that eliminate thermal bridging and in contact with the industry representative, the panel engineered by the ThermaSteel Corporation which operates out of Virginia, was assessed as exceeding our performance criteria in regards to thermal resistance and structural support for interior shelving and exterior cladding systems.

All of these types of SIPs require a cladding and this question of cladding is what ultimately led to the integration of building integrated photovoltaics on the facade—SIPs with integrated steel and aluminium cladding are available but pose issues with thermal bridging and water infiltration making them typically reserved for industrial applications.

1.2. Rainscreen principles in cladding design

When addressing the issue of cladding, looking at rainscreen and cavity wall construction was initially a way of expanding the possibilities for cladding the exterior of our SIP panels. This led however to a questioning of what materials could become the exterior skin of such a house. The basic problem addressed in rainscreen construction is that wall assemblies meant to be water-proof will leak in some capacity over the course of a building's life. As documented by others, the failures that lead to leakage of water through a building enclosure are often due to imprecise fabrication, poor installation of building components, decay and shifting of joints and sealants which come under constant exposure to solar radiation, driving rains, air and thermal movements natural to buildings in varying climates (Anderson 1988). All of these factors can contribute to water directly interacting with the assembly's vapor barrier and it is aspect of building physics which most often results in water

infiltration; a condition which residential building skins are not equipped to handle. In addition, once the water is trapped inside, this often leads to increase chances of mold build up, rot and decay of the cladding. A properly drained and back ventilated rainscreen wall is essentially designed to leak by managing the possible infiltration of water through proper drainage, pressure differentials, and ventilation. This design idea permits the wall assembly to breathe while reducing the direct impact of any possible water on the moisture barrier (Anderson 1988).

Research into various rainscreen assemblies demonstrates that provided a panelized system with properly dimensioned drainage, ventilation of the back cavity and with the use of cavity enclosures at the corners and ends of the system, what material could be specified for the skin itself was quite flexible (Anderson 1988). Given this fact, a number of prototypes were constructed in the design studio to understand the various arrays of skins and materials possible for our house. After modeling one-half scale mock-ups that examined several strategies for suspending aluminum tiles, the possibility of using photovoltaic (PV) modules in a rainscreen type construction was first considered (e.g. Fig. 1).



Figure 1: one-half scale model of preliminary rainscreen designs. Source: (Jamgochian 2006)

1.3. Building integrated photovoltaics (BIPV)

Skinning a building, particularly a house, with PV modules is not ordinarily thought of as a viable option. In part, this is due to a question of appearance but in part this is due to the reduced operating efficiency of the PV module when used vertically. And yet, there are architectural precedents for employing PV modules vertically on a façade, typically in skyscrapers and urban environments where the horizontal surface preferred for PV modules is at a premium. However, in most of these projects the PV modules are mounted on top of a wall assembly instead of being an integral component within it. Only in more recent projects, such as Fox and Fowle's design of the 4 Times Square building in New York City where custom PV modules designed by Kiss + Cathcart replace panes of glass on the Eastern and Southern facades, do PV modules become integrated fully into the design of the exterior wall assembly. As such, the ability for our Solar Decathlon design to incorporate an otherwise standard roof mounted PV panel within a vertical skin application yielding a larger total power draw for the house, offers architectural design an example of how to construct a building enclosure which integrates energy production with building construction.

BIPV products currently on the market include translucent glass embedded with solar cells, roof shingle replacements composed of solar cells on a backing, and flexible thin films of solar cells that can be incorporated into canopies, louvers, and more articulate building components. All of these products offer more flexibility in the incorporation of solar energy to building construction, however their energy conversion efficiencies are between 5-10%--extremely low by comparison to a 20% high efficiency PV module. The energy output required in this design demanded the use of full sized rigid PV modules, which made their integration one of the primary design challenges.

Integrating PVs into an assembly to replace a building component is one way that the relative cost of solar power can be reduced. When looked at in conjunction with projected trends of rising energy and building material costs, increased energy conversion efficiencies, and a reduction in the cost of PV modules themselves, building integrated solar power is becoming a more feasible option for the average homeowner. The full-scale mock-up

constructed in the design studio shows two different high-efficiency panels from SunPower Corporation and demonstrates how innovation in the design of the PV modules themselves has the potential to yield PV modules that can be integrated into a projects design aesthetic as well as its physical construction (e.g. Fig. 2).



Figure 2: Full scale mock-up of PVs mounted on SIPs. Source: (Jamgochian 2006)

The integration of PVs onto the façade required contacts within the solar energy industry. Speaking with consultants from One World, a solar installer located in Georgia, raised some issues that required further design detailing. PV modules become extremely hot during their operation. As the most efficient PV cells available today only convert 23% of the sun's energy into usable electricity, there is a significant amount of radiation that becomes heat—creating temperatures in excess of 150 degrees Fahrenheit while ambient air temperature may be closer to 75 degrees Fahrenheit. This heat build-up substantially reduces a PV module's operating efficiency and mounting the PV module on the face of an insulated panel could trap this heat, only compounding the problem and reducing the energy conversion efficiency further (He 2005).

1.4. Hybrid photovoltaic and solar thermal collectors

Research from the Seventh International IBPSA Conference in 2001, informed the design by suggesting that the passive ventilation which was natural to rain screen principles would cool the air cavity by convective air-flow and in so doing lessen the effect of heat buildup on the PV modules—albeit not enough to obtain the maximum operating efficiency (Krauter 2001). As part of the experiments documented by (Krauter 2001), directly mounting PV's on an insulated enclosure served as the base condition by which different cooling methods were then evaluated. Passive ventilation through convective air-flow, active ventilation by the inclusion of electric fans, and the incorporation of a rubber mat that circulated water were all built to full scale and monitored during operation. In the experiment, the water cooling mat outperformed the ventilation strategies, yet the energy that the water picked up as heat was not reclaimed in any way. Other research has demonstrated that it is possible and beneficial to tie a PV cooling system into a domestic hot water system but is not practical for commercial applications (Kalogirou 2006).

In this design, the rainscreen mounting of the PV modules will provide some cooling, but the final component of this wall assembly is a plumbing system whose primary role is cooling the PV modules so that their maximum operating efficiency can be achieved. It will also serve a secondary function as the heat extracted from the PV modules will be transferred to the domestic hot water system via a closed loop of a glycol solution.

Aside from evacuated tubes and flat plate collectors, there has not been much innovation within the building industry with regards to solar hot water systems. Since these typical products operate as standalone units that need direct exposure to the sun, they are not applicable in this design where the solar hot water system would be located within the ventilation cavity of the wall and behind the PV modules. Instead, a custom system using flexible PEX tubing, which is being used throughout the design of this house and is an alternate to polyvinyl chloride piping, will be detailed and constructed. This tubing will be adapted to suit the particular constraints of the wall assembly and will then be tied into a heat exchanger within the domestic hot water system.

CONCLUSION

In conclusion the status of this design is as follows; the wall assembly has been designed, detailed, and components of it have been built at one-half and full scale using the actual building products and materials specified (e.g. Fig. 1 and 2). The next phase in this research will be focused on fabrication of the entire system at full scale and on achieving an operating capacity so that testing of the systems performance with regards to PV electrical output, solar hot water output, ventilation of the assembly's cavity, and the structure of the assembly can be assessed and evaluated.

In addition, it is hoped that this paper has demonstrated the merit of introducing building construction constraints within the design studio. The project detailed here today, in which the design for an alternative building skin was engineered to meet the future demands of a more sustainably conscious residential housing market, is only one of many possible projects suited to this end. And a brief description of the process is here offered with the hope that an even greater number of such ventures will see the light of day in the near future.

ACKNOWLEDGEMENT

The authors of this paper would like to express thanks to OneWorld sustainable energy corporation, Alan Ristow, [Electrical engineering student], Mohamed-Amine Alami-Fettouhi [Electrical engineering student], Ajeet Rohatgi [Electrical engineering professor], Miroslav Begovic [Electrical engineering professor], C. Jason Mabry [Architecture student], Kevin Short [Architecture student], Nadine Kashlan [Architecture student], Jodi Bell-Quinn [Architecture student], and Ruchi Choudhary [Architecture professor].

REFERENCES

- Anderson, JM., and Gill, JR. 1988. *Rainscreen cladding: a guide to design principles and practice*. Butterworths: London.
- Cathcart, C. 1998. *SIPs, not studs*. Architecture.
- Economist, The. *Green dreams: the risky boom in the clean-energy business. Tilting at windmills and Dionysus, meet helios* 18th-24th, 2006.
- He, W., Chow, T., Ji, J., Lu, J., Pei, G., and Chan, L. 2005. *Hybrid photovoltaic and thermal solar-collector designed for natural circulation of water*. Elsevier, Ltd.
- Kalogirou, SA., Tripanagnostopoulos, Y. 2006. *Hybrid pv/t solar systems for domestic hot water and electricity production*. Elsevier, Ltd.
- Krauter, S., Salhi, M., Schroer, S., and Hannitsch, R. 2001. *New facade system consisting of combined photovoltaic and solar thermal generators with building insulation*. Seventh International IBPSA Conference.
- Mullens, M., and Arif, M. 2006. *Structural insulated panels: impact on the residential construction process*. *Journal of Construction Engineering and Management*.

Enabling Material Constraints in the Digital Design Process Through a Plywood Gridshell

Mark Cabrinha, RA

Rensselaer Polytechnic Institute, Troy, New York
University of Oregon, Eugene, Oregon

ABSTRACT: The motivation of this paper is to help bridge the gap between digital design culture and the culture of ecology. Through the context of a plywood gridshell, which encloses maximum volume with minimum material, form and structure are enabled by the constraints of material. The well-documented Downland Gridshell is used as precedence, outlining the principles of timber gridshells. The objectives of this research paper are to make explicit the principles relating material and geometry in the design and development of a plywood gridshell.

Keywords: CAD/CAM, digital fabrication, gridshells

INTRODUCTION

Over the last 15 years or so, digital design has emphasized formal novelty exemplified by the paperless studios in the early 90's. This formal novelty is largely the result of the lack of material and structural constraints in digital tools. Consequently, constraints are seen as a resistance to "pure design." The position of this paper is that constraints are enabling - the friction from which design develops its context. While accepting the formal flexibility brought on by digital tools, this research paper is concerned with enabling material and structural constraints in digital design through a plywood gridshell. Gridshells develop structural integrity through their double curvature and the bending strength of material. Gridshells provide an excellent context to exploit material and structural constraints as enabling design. Their expression of maximum effect with minimal means closely aligns them with one of the principles of sustainability – doing more with less. The motivation of this research is to help bridge the gap between digital design culture with the culture of sustainability. When constraints can be seen as productive, it is hoped that the flexibility and precision of digital tools will be well suited to the innovation of environmentally responsive design. The precedent, design, and development of a plywood gridshell provide the *context* to develop the principles of digital geometry in relation to material constraints.

My desire to pursue such structures developed from the current interest in computer-aided manufacture (CAM) in design education and practice. Despite the return to physical material as a result of these fabrication tools, they are typically used to cut complex shapes out of 2d material, or subtract 3d surfaces from a block of material. Both of these approaches are time intensive and create a lot of material waste. Developing a gridshell places emphasis on finding the form in the material, rather than cutting shape out of material. This, of course, is how gridshell's achieve maximum effect with minimal means. The simultaneous precision and flexibility of both software and computer numerically controlled (CNC) tools make pursuing such structures accessible, and alternately I would add, that pursuing such structures is necessary to better understand the productive capacity of material constraints before following the conventional uses of these technologies.

1. TOOL-DRIVEN DESIGN RESEARCH

Design research can be situated between the common "two-cultures" view of art and science (Cross 1999:7). This polarity between art and science is exemplified in the freedom of design expression exploited by digital tools and the structured research necessary to develop ecological design. Rather than encourage this false opposition between art and science, Nigel Cross's writing on design research focuses on design in its own terms, articulating knowledge that is peculiar to the awareness of the designer (Cross 1999: 5). He makes the important distinction between works of practice and works of research. While design is product driven, the product of design research is the communicable principles that others can use. Works of practice can generate works of research through the reflection of the practitioner and the communication of re-usable results from that reflection (Cross 1999:9). This distinction is crucial in this research, as the goal of this research is not to produce a gridshell structure, but rather the general relationship between material constraints and digital geometry that are teased out through the design and development of a gridshell.

Design, as in art and science, is produced through tools and the artifacts they produce. Tools and the

techniques developed in art can be used to aid in freedom of expression, whereas tools and the techniques used in science can be used for precision of measure. Situating design research as a field of inquiry in its own right likewise situates the relationship to tools as both expressive and for precision. This is not unique to design research. For example, the disciplinary strategy of experimental physics is to exploit materials through their tools and to locate these laboratory phenomena in a stable and repeatable way (Delanda 2002: 141). While design *process* is often aligned with art, it is the intention of *design research* to conjoin the expression of creative practice with the principles of this process in a stable and repeatable way. This only suggests the fundamental reciprocity between that favored false dichotomy of process and product. The notion of tool-driven research entails both the flexibility and expression of tools in the design *process*, along with the clearly articulated principles developed through their use, the *product* of research. Lawrence H. Summers, formerly the president of Harvard, has identified three qualities of tool-driven research: risk, accountability, and "interdisciplinarity". Risk is central to tool-driven research to tease out new possibilities and unexpected qualities. However, to qualify as research, systematic accountability is fundamental to identify the phenomena explored through these risks. As our tools become complex systems, such as the computer, research involves many people with overlapping goals and intentions and is therefore interdisciplinary in nature.

The few gridshells that have been built exemplify risk, accountability and interdisciplinary contribution. As a clear example of how a work of practice can develop into a work of research, the architects and engineers of the well celebrated Weald and Downland Gridshell have published research papers on this work (Harris et al 2003, Johnson 2006). As an exceptional example of the interdisciplinary nature of these structures, the collaborative design team included not only architects and engineers, but timber framers, scaffolding contractors, material scientists, and of course the client, were brought on early in the design phases of the project. As the project architect recalls, this was central to the "fluidity of thinking" which the primary material - wood - suggested (Johnson 2006). This project also exemplifies the connection between gridshell structures and sustainability. As one example, through the connective knowledge gathered through this project, the Timberbuild Network was formed to connect clients, builders, architects, and engineers around sustainable timber construction in the UK.

This research paper outlines briefly the precedence of gridshell construction. Through the design and development of a plywood gridshell, this research paper outlines the principle relationship between material and digital geometry as a means to enable material constraints in the digital design process.

2. PRECEDENCE: THE DOWNLAND GRIDSHELL

The first examples of gridshells were developed through the partnership of Architect Frei Otto and Engineers at Ove Arup, exemplified by the timber gridshell at Mannheim in Germany built in 1975. Although very few gridshells have been built, there has been a resurgence of these structures such as Shigeru Ban's Japanese Pavilion for Expo 2000 in Hannover, and Ville Hara's timber bubble at the Helsinki Zoo. The Downland Gridshell is another contemporary example that has been widely published. The architects and engineers of the Downland gridshell have published a thorough paper on the design and construction of this gridshell. (Harris et al 2003). They describe in detail the team working, risk sharing, and multidisciplinary nature of the design team along with the structural modeling, components, cladding, and complex construction process of gridshell forming. What is particularly risky and unique about these structures is that they are constructed as a flat mat and then lifted, or as the case of the Downland Gridshell, *lowered* taking their shape in this process. As a result, in the design and development of the Downland Gridshell physical models at multiple scales were used for form generation, as proof of construction concept, to highlight material behavior including "developing a feel" for the behavior of the structure, and were even used during construction altering the model in tandem with the actual lowering of the gridshell. From the physical models, the boundary conditions of the form were

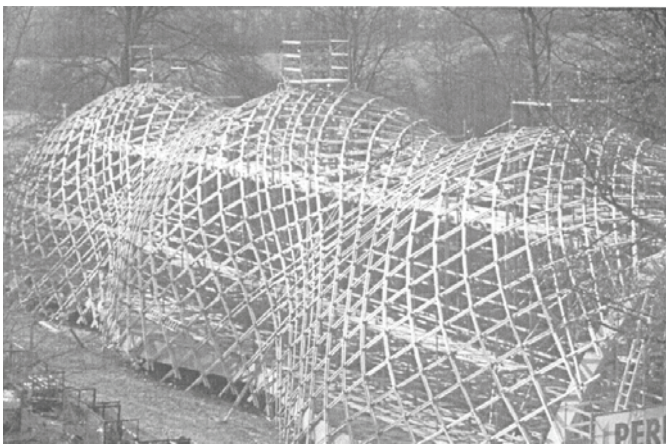

identified which was necessary to translate the material constraints into digital form. From these boundary conditions, a purpose built software program was written by the engineers to optimize this shape. This computer analysis was based on the dynamic relaxation technique - an interactive process of computer analysis that solves a set of non-linear equations. Not unlike the use of physical and digital models in the design and construction process, the Downland Gridshell exemplifies the combination of advanced technology and local craft based technique.

Figure 1: Weald and Downland Timber Gridshell being lowered into shape (Harris 2003).

2.1 Principle Definitions

A *shell* gains its strength and stiffness through curvature, with a shell formed from double curvature as the most efficient in terms of minimum use of material. A *gridshell* has large openings that allow the remaining openings to behave structurally as a shell. More typically, a gridshell is a grid arranged in such a way to have the properties of a shell. The benefits of a gridshell are that openings are easily created, the strips can be adjusted in dimension to adjust for local structural demands, and that pre-fabrication is possible. As timber is anisotropic, its strength changes in direction, no true shell is possible in timber. *Synclastic* surfaces are curved only in tension or only in compression. For example, an arch is formed using only compression, and a dome is a rotated arch. Geodesic domes are examples of synclastic shapes. *Anticlastic* surfaces have tension forces in one direction and compressive forces in the other stabilized by the tension forces. The significance of anticlastic surfaces is that they are more flexible in their formal morphology. As the designers of the Downland Gridshell acknowledge, shape is a compromise of many factors, not just structure, thus the flexibility of the gridshell can respond to both structural and architectural demands.

2.2 Materials and Construction

The Downland gridshell is constructed from a flat mat that is formed through the weight of the material pushing down to form the shape. The precise position of nodes in the grid mat develops the mat into the unique triple bulb hourglass shape (Figure 1). The patented nodes were purpose designed for this project to pin the center layers of the mat in position, while allowing the outer layers to travel as the structure took shape. The pin connection was necessary to allow the grid to rotate as the mat took shape. A complex articulating scaffolding system lowered this shape over 6 weeks. This is a clear example of finding the form in the material, as distinct from cutting shape out of material. The mat is composed of green Oak laths that are approximately 1.25" x 2". The high moisture content of the wood increased the lath's flexibility. The structure gains its strength and curvature through the laths ability bend, and therefore long sections of straight-grained material are desirable. In actuality, the short-grained sections were cut out and the longer straight-grained sections were finger jointed together, requiring a specially formulated polyurethane adhesive as a result of the high moisture content and acidity of the Oak. The mat construction, nodal connection, and lath material are critical factors in the construction of the gridshell.

3. PLYWOOD GRIDSHELL: TOOL-DRIVEN DESIGN RESEARCH

As a research project, the goal of developing a plywood gridshell is to outline the principles and issues that surface in the course of its development. This is motivated to help bridge the emphasis on formal novelty as a result of computer-generated surfaces with material and structural constraints. These constraints become enabling forces in gridshell design. In the same way that Nigel Cross identifies the "two cultures" view between art and science, it seems to me that digital design media fall prey to the same false opposition. The computer has been praised as a new expressive design medium, or it is used for exacting scientific research. The significance of this tool is that it is both – it is simultaneously a flexible medium and one of exacting precision. In my experience teaching in design education, the rigor of exacting precision is often ignored for emphasis on visual representation. Form making has become a focus as a result of the flexibility of Non-Uniform Rational B-Spline (NURBS) based software. However, in developing and constructing a plywood gridshell, shape is determinate on the precision of joints and material constraints more than simply the surface representation. As tool-driven research, this research project meets two of the three criteria Summers' outlines: risk and accountability. Regrettably, this paper lacks interdisciplinary input at this stage. My interest in these structures is clearly tool-driven through the current interest in CAD/CAM. However, my aim is that the gridshell is itself a pedagogical tool, whose products are the principles of shell structures and understanding material constraints as enabling, and whose further by-products are digital skills.

The design of this plywood gridshell was intended as a demonstration project that developed from a design build studio I taught. Students quickly developed form, and presumed that construction was a given despite my frequent consternation. Through the predilection of *visual* form in digital design, form is first developed and then frequently sliced, to then be cut from flat material to approximate the shape on the screen. As a result of the unique profiles of these shapes, material is wasted and furthermore the ability to understand the joint as a location of careful attention is overlooked. The gridshell provides an excellent context in the efficient use of material to achieve complex form generated by the fixed location of the joint. In contrast to the visual development of form, through the model making process in the Downland Gridshell, the form *and* structure is derived from the material properties of laths. In contrast to the visual criteria of *digital* form, this is truly *physical* form. It is ironic that the basis of contemporary NURBS design software is derived from the physical spline, which was based on material curvature.

3.1 Material and Technology: The 18th Century Spline

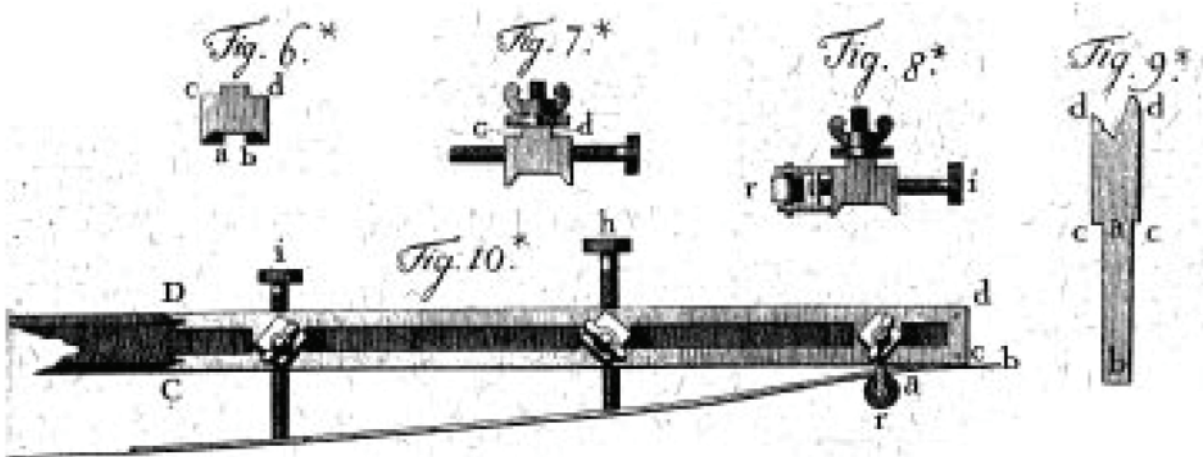

Figure 2: The 18th Century spline used in boat construction (Farin 2002).

The complexity of curves and wood is best understood by traditional boat building techniques. This can be seen in the 18th Century spline (Figure 2). This apparatus was used to draw curves in boat-design based on the material properties of the wood - a true analog device relating material curvature drawn to the curvature of the actual material constructed from. In the 1960's, mathematician engineers such as Pierre Bezier developed a parametric equation of splines abstracted from devices like the one shown. Furthermore, Bezier developed these mathematical techniques as a consequence of the use of computer-aided manufacture in car design and production (Bezier 1972). Bezier's goal was not simply to create a more efficient means of production, but to create a bi-directional link between parametric surface representation and material constraints (Bezier 1998). It is important to note the development of CAD is woven together with the development of CAM. In architecture, we are only recently seeing the material aspects of the CAD/CAM system. Consequently, the constraints of material and fabrication tools are only now becoming part of the digital design process. In relationship to timber gridshells, it is striking to me that the basic unit of NURBS-based geometry is derived from the physical spline – the ability of material to bend. It is with great irony that despite all of the complex technology in architectural design, material logic has been abstracted out of the system. In principle, the 18th Century spline illustrates that through controlling a few points, curvature is generated through material illustrating the difference between finding form in material. Harnessing the simplicity of this 18th Century spline, woven together in a network, is the basis of my interest in gridshells.

3.2 Basic Surface Design

The form of this gridshell was developed as a landscape installation at the corner of two perpendicular paths. Although timber gridshells gain their structure through double-curvature, they are typically simple longitudinal spaces. The crescent plan shape of this gridshell will provide unique challenges and conflicts between digital form generation and physical form finding.

This surface is generated from two edge or boundary curves, and three curves in section, one at the beginning, one at the end, and one offset from the middle (Figure 3). This is simply to note that fairly complex surfaces can be generated by a minimum of information, which contrasts the typical practice in digital design to over complicate formal morphology when based on visual criteria alone. As can be plainly seen, the shape of this surface is not terribly striking – it only provides the backbone from which pattern is applied to it.

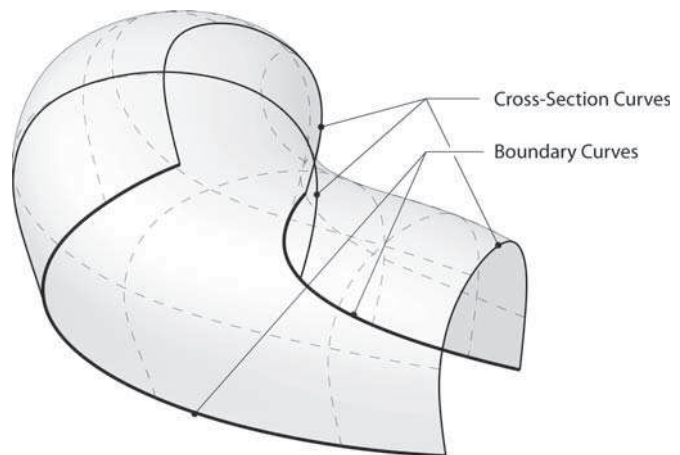

Figure 3: Surface generated from two boundary curves and three cross-section curves.

3.3 Patterning: Projected and Applied

The ease of generating complex surfaces in digital tools also provides the complex challenge of this project: how do material constraints inform these shapes? In the Downland Gridshell the original shape was developed from physical study models, and the precise gridshell pattern was determined by a purpose built computer software executed by Buro Happold. Although the history of NURBS software links back to the material constraints of the 18th Century spline, in actuality this material resistance is abstracted out of the equation. In addition, NURBS surfaces are developed through two opposing U and V spline networks creating a grid, indicated in the dashed lines in figure three. However, gridshells work through their X pattern. Therefore, a method is needed to develop an X pattern over the pre-existing UV grid of NURBS surfaces.

There are two approaches to doing this. Lines or patterns can be *projected* onto a surface or, lines or patterns can be *applied* to a surface. The difference is not minor in the case of gridshells. Lines that are projected are pulled straight to the surface creating a new line at the intersection of the projected line and the surface. The benefit of this method is that the lines applied to the surface only curve in one direction, defined as a *plane curve*. Because these lines are projected straight up, the limitation of this method is that any part of the surface that extends beyond this vertical projection is not included. Patterns that are applied to a surface do not have this limitation, as the pattern is mapped across the entire surface, twisting and stretching the original pattern to fit. This method can yield incredible variations in pattern, although its great limitation is that there is no inherent constraint. For example, whereas projecting straight lines will yield plane curves, applying straight lines will most likely yield curves that curve in both directions, defined as *space curves*. This is significant in terms of material constraints, as curving in two directions places much greater stress on material, and therefore cannot necessarily take the shape applied. Due to the crescent shape being developed, this project proceeds with applying curves to surfaces. This is also what gives this gridshell its dynamic pattern (Figure 4). It must be noted that this pattern does not have any more or less material logic than the underlying surface it is mapped onto. As this gridshell is intended to be fabricated from plywood and the aid of a CNC router with an 8' bed, numerous grid densities were applied to find the least number of nodes while maintaining a maximum 8' length from node to node. This digital trial and error process contrasts with the physical process of the Downland Gridshell. Physical models were first used to establish the overall shape and boundary conditions, and then used a purpose built computer analysis software by the engineers that optimized this basic shape. Additionally, projecting curves to surfaces should not be overlooked, particularly as this method may be a closer fit to the original hanging chain and inverted physical models studied by Frei Otto.

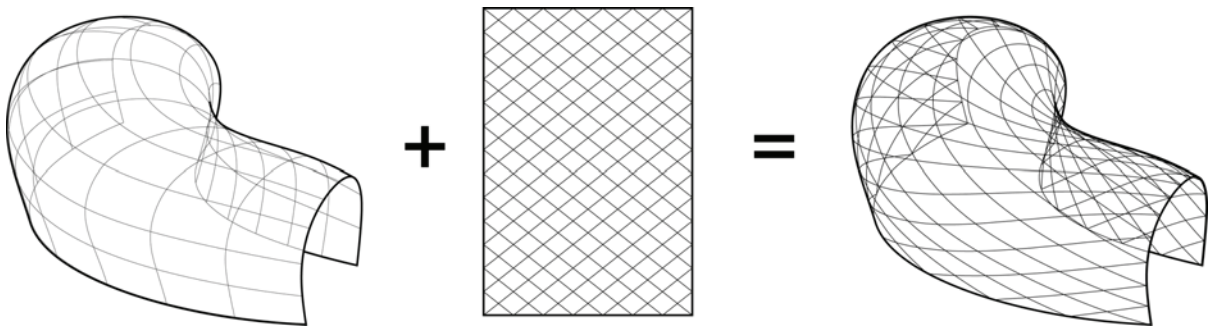

Figure 4: Basic surface with pattern applied to surface.

3.4 Lath Development

While the pattern developed is suggestive of the overall grid, giving this grid precise dimension and thickness must maintain a few simple parameters. The planar faces of the laths should follow the basic curvature as closely as possible, requiring them to twist. As they overlap each other at the nodes, their surfaces must be flush to each other at precisely the point of their overlap. In both cases, accuracy is based on understanding the surface normal. The surface normal is defined as the line drawn perpendicular to the tangent plane of any point along a surface. Put in the context of the gridshell, the line perpendicular to the intersection of pattern, which is the node, is at the surface normal. Therefore, the node is at the surface normal. For example, in the patented node in the Downland Gridshell, the pin that connects these laths is at the surface normal. Constructing the width and thickness of the laths must therefore be constructed from the surface normals of the original surface. Accuracy in this digital process, and the corresponding precision of CNC fabrication, is fundamental as the position of the joints is what will fix the shape of the structure.

A two-step process is necessary to construct the laths through the surface normal. First, depth is developed through drawing the surface normal at each intersection and the end points, and then creating a surface through sweeping each surface normal along the applied curve (Figure 5a). From this surface, width is generated in the same manner, this time extending the normal in equal directions from the previous surface developed. These normals are swept from the same line originally applied (Figure 5b). It is this secondary surface which will be developed into the gridshell lath structure. Although this process is indeed tedious, it is necessary to maintain that the lath surface follows the base surface as closely as possible and correspondingly, that at each node the surfaces are exactly flush to allow a pin to be drawn through at the surface normal.

3.5 Lapped Joint

From this precise geometry, giving depth and developing the joint of the gridshell is very straightforward. Following the Downland Gridshell, this plywood gridshell is to be constructed from a four-layer system. The lath surfaces can now simply be offset for each layer of lath at the precise distance of the lath material (Figure 5c). This process is simply repeated to develop the entire gridshell (Figure 6).

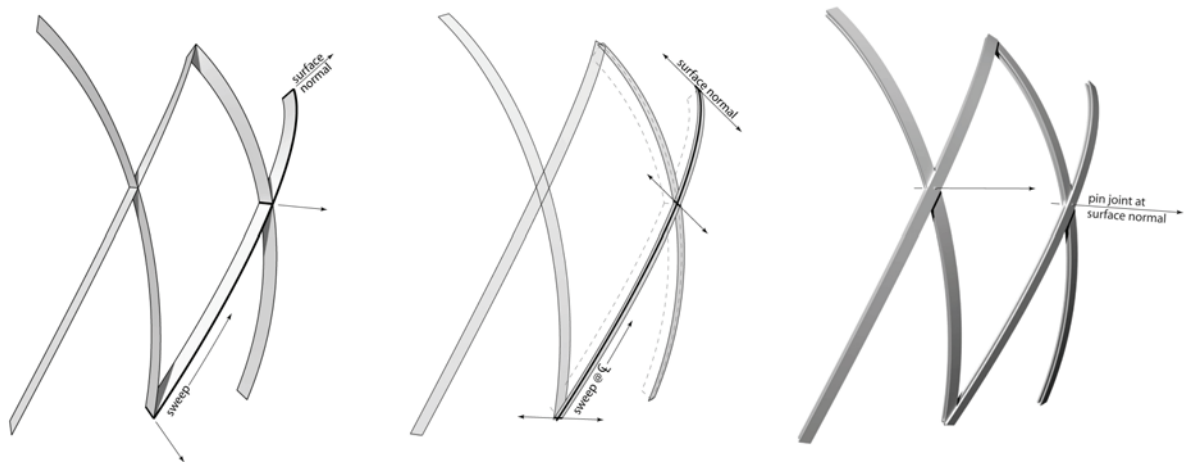

Figures 5a-c: Developing Laths through surface normals allows lath to follow surface curvature and for laths to align at each node. Develops into a four-layer construction with pin joint at surface normal

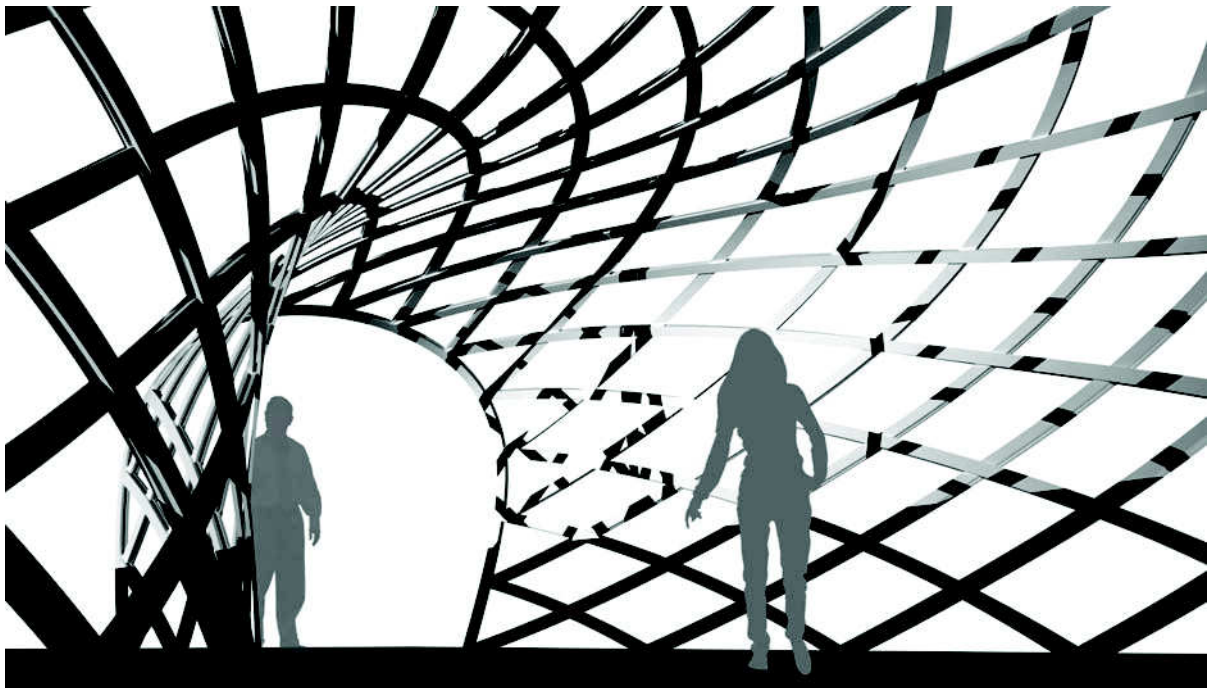

Figure 6: Interior Perspective of Gridshell

4. PHYSICAL PROTOTYPE

Unlike the Downland Gridshell, this structure is not intended to be formed from a flat mat, as this method requires advanced scaffolding. Based on the pre-fabricated location of pins along with the (presumed) ease of bending plywood strips and the small scale of this structure, bending these laths in place should be straight forward allowing the structure to take shape piece by piece. This also simplifies the nodal connection, as the outer pieces do not need to slide as the flat mat takes shape.

While material has been not been a part of the process up to this point, the knowledge of surface generation in relation to material is based on previously built projects. Unlike purely digital design, fabricating precisely from this digital data is the ultimate test of construction. Through curvature analysis, it is known that the radius of curvature is well within the limits of the plywood laths. What is not known is the behavior of the plywood as it twists slightly at each node. A series of scale models were developed to test the accuracy of the joint locations, the ability of the laths to take their shape, and the sequence of construction. One of the major limitations of applying the pattern to the surface is that the laths are not true straight members. Each lath is unrolled with the node location precisely marked. The unrolled laths are crescent shaped, rather than true straight laths. Consequently, each lath is unique and must be labeled in a logical manner to aid in the sequence of construction. As a result of these crescent shapes, this is one reason that plywood is proposed as a construction material as these shapes can be easily constructed with a CNC router. A 1/12th scale prototype section was used as a prototype of construction, demonstrating that the precision of the laser-cut prefabricated laths and precise location of nodes does establish the shape. As a method of construction, the node locations align only when the material is in its curved position, and pins are put in place, fixing the shape (Figure 7a).

4.1 Prototype Assessment: Sequence of Construction

The risk involved in this process was not knowing if the material could actually take this shape without failing, as well as the ability of the nodes to hold their position at the surface normal, necessary to accurately form the shape. The physical model alleviated this risk, but raised others. Although in principle plywood laths can bend to this shape, the force required to do so while simultaneously pinning the joint may not be a reasonable construction method. It would be possible to laminate two thinner sections of plywood, such as 3/8", aligning their shape with similar nodes at the normal, thereby pre-forming these laths. Because each joint has a single pin, there is an accordion effect while the surface is being assembled compounding the difficulty of simultaneously bending and pinning the plywood laths. Finally, when constructing piece by piece, some form of scaffolding or bracing will be required to support the flexible shape before it is fully constructed.

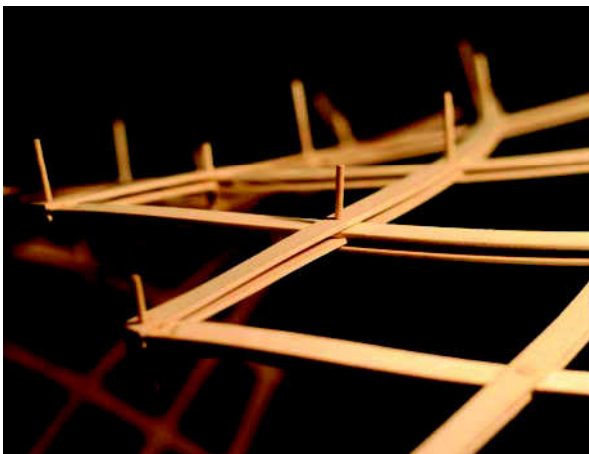

Figure 7a: Model joint with pins at surface normal

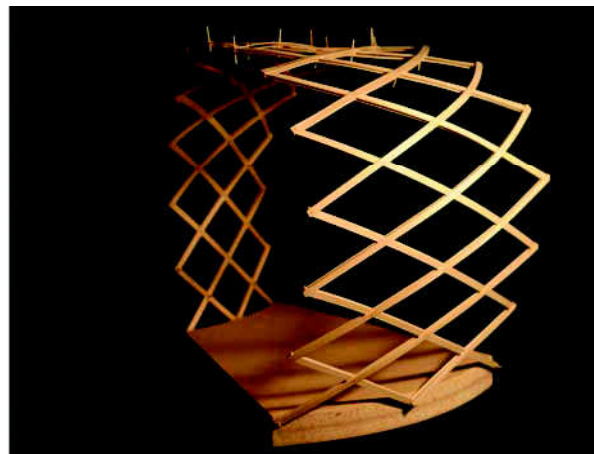

Figure 7b: Prototype Section Model

4.2 Prototype Assessment: Shape and Pattern

Although a complete shell was not constructed, the prototype shell suggests two important factors that were not considered in the digital model (Figure 7b). While the sides of the structure are considerably strong, there is a flat spot on the top of the surface that deflects under weight. The prototype section also flexes considerably when imposing a lateral load. This is to be anticipated as this is only a section, and yet it does suggest tracing these patterns to where the forces will be terminated. While the horizontal nature of the pattern applied gives a striking dynamic appearance (figure 6), each lath terminates in one direction at the end arch, not at the ground. Consequently, there would be considerable force at the end conditions likely requiring a preformed structural rib or possibly a tensile element. Alternatively, the pattern could be oriented 90 degrees from the applied orientation, and a majority of the laths will terminate at the ground. As expected, clearly structural input is needed in this process.

5. CONCLUSION

The plywood gridshell developed here is an excellent case study in the relationship between digitally derived and developed geometry and material properties. Rather than seeing material constraints as restricting design, the position of this paper is that a better and more thorough understanding of material constraints enables design. As CAD/CAM tools become increasingly part of design education and practice, further emphasis needs to be placed on material properties with the precision and flexibility of these technologies to extend these material properties. Through gridshell design, form and structure are closely bound together, conjoined through the close relationship between form and material. Pursuing this tight relationship also highlights the limitations of this approach, and gridshells in general.

Clearly this project would benefit from interdisciplinary design, particularly structural consultation. Although complex surfaces are easily developed in NURBS based software, it is the very first shape that is at issue: the cross section and boundary curves that define the surface. The structural integrity of these basic shapes warrants further investigation, and might suggest that physical modeling should precede digital modeling of these structures. Until a full-scale mock-up is constructed, the limitations of the piecewise construction approach proposed here is still in question. However, the physical model prototype suggests that pre-forming these laths would ease the sequence of construction, although doubling the number of unique parts and adding a step in pre-fabrication. Clearly plywood is not an ideal material to build these structures, and the grade of plywood will need to be certified void free and ideally a minimum of five plies, making marine plywood a good candidate. It would be possible to construct the proposed design from solid lumber, as the crescent shape of each lath could fit on a nominal 1x8 board. Plywood is considerably more cost-effective for testing the construction of the proposed gridshell.

Ultimately the goal of this research is to present gridshells as a pedagogical tool in itself. In this way, gridshells are seen as a context conjoining variability of form with the specificity of the joint. Understanding the connection between the surface normal and the nodal joint is a simple, yet fundamental relationship structuring the relationship between digital geometry and material joints. Furthermore, material constraints are seen as enabling the form and structure of gridshell design. Finally, these structures present a powerful motive to help bridge digital design culture with the values of ecological – maximum effect with minimal means.

REFERENCES

Bezier, Pierre. *Numerical Control*. John Wiley and Sons Ltd, 1972.

Bezier, Pierre. "A View of the CAD/CAM Development Period." *IEEE Annals of the History of Computing*. Vol. 20, No. 2 (1998): 37-40.

Cabrinha, Mark. "From Bezier to NURBS: Integrating Digital and Material Techniques in a Plywood Shell," *Smart Architecture: Proceedings of the Association for Computer-Aided Design in Architecture (ACADIA)*, Savannah, Georgia (2005).

Cross, Nigel. "Design Research: A Disciplined Conversation." *Design Issues*. Vol 15 No 2 (1999): 5-10.

Delanda, Manuel. *Intensive Science and Virtual Philosophy*. Continuum International Publishing Group, 2002.

Farin, G., J. Hoschek, and M.-S. Kim. *Handbook of Computer Aided Geometric Design*. North Holland, 2002.

Harris, Richard, John Romer, Oliver Kelly, and Stephen Johnson. "Design and construction of the Downland Gridshell." *Building Research and Information*. Vol 6, No 31. (2003): 427-454.

Johnson, Stephen. "The Architecture Ensemble." *Architectural Design*. (2006): 96-99.

Education

Lab-coats Back in Studio. Can Sustainability Bring Design and Research Back Together?
Fernando Luiz Lara

A Green Studio Pedagogy: Using Scale Changes to Influence Architectural Design for Sustainability
Keelan P. Kaiser

Education, Environmental Attitudes and the Design Professions
Traci Rose Rider, Jack Elliott

The Green Studio Handbook: Environmental Strategies for Schematic Design
Alison G. Kwok, Walter Grondzik

Interdisciplinary Comprehensive Design Studio: Carbon Neutral Field Campus*
Bruce Haglund

* Invited Oral Presentation

Lab-Coats Back in Studio. Can Sustainability Bring Design and Research Back Together?

Fernando Luiz Lara

University of Michigan, Ann Arbor

ABSTRACT: Ten years ago at the peak of the so called “critical theory” movement, somebody declared that the age of “lab-coats” in studio was over. Measurements and empirical tests were absolutely out, while subjective relativism was the main force behind every formal move. Decades of architectural research were deemed irrelevant for the future of the profession while new associations were formed with the humanities in general and literary criticism in particular. Form followed discourse.

However, the latest developments of sustainability as a mainstream force brought numbers, graphs, and hypotheses back to studio. From bio-degradable construction materials to nano-technology and life-cycle assessment, architecture is fascinated again with measurements and empirical tests. As if riding a new wave of scientific (or pseudo-scientific) investigation, the architectural pendulum seems to be swinging back to technology (be it energy efficiency of incorporations of new materials) and away from critical theory.

The main idea behind this paper is to discuss the challenges and opportunities of bringing design and research together under the urgent framework of a more sustainable built environment.

INTRODUCTION: LAB-COATS IN AND OUT

Looking back on architecture education over the last three decades show us moments of convergence and divergence between research and design. The crisis of the modernist paradigm in the 1960s generated many currents in search of anew articulation. Among historicisms, structuralisms and post-modernisms in general, there was a significant increase in architectural research, commonly known as design methods. Many doctoral programs were inaugurated under this framework and an alliance was forged between architecture and the emerging information sciences. The main goal of “turning transparent the dark box of creativity” associated with the dawn of computation left a large amount of rigorous and not-so-rigorous research into what we actually do when we design and how could we do it better. (LYNCH, 1981; HILLIER, 1984; SCHON, 1988).

But if the 1980s were to be named “the pink decade” by the Argentinean critic Marina Weisman, it was not only due to the colorful architecture of Graves and Rossi but also due to the abandonment of any transformative ambition. Architecture turned into a self-referential / discourse base endeavor. Along the utopian project, the idea of integrating design and research was also dismissed. If the main goal of the design methods program was to improve the way we design and consequentially what we design and later build, such was deemed irrelevant by the idea that architecture was less an artifact and more of a cultural object. (BLOOMER, 1993; INGRAHAM, 1998).

As a result of those changing values the research project was marginalized. The link between science and design was questioned and other links were formed with disciplines as faraway from architecture as literary criticism. Form followed discourse since the second half of the 1980s and most of the expansion of doctoral programs were now in the area of History and Theory.

For those of us who have been there before (or know the lessons of history), it is important to acknowledge that the change from methods to discourse was also due to the inability of the so-called lab-coats to deal with the studio culture.

If we can expose some of the failures of the 1970s research endeavor we shall perceive three main problems:

1. the focus on research was less interested in learning from the existing practice and more into re-inventing the whole of architectural design discipline. That led to dissociation between research and practice that ended up isolating the research community.

2. the fascination with the computer as form-generator created a culture of self-sufficiency in the research community. Programs and codes were written for computation sake and not for advancing the interface with design. The obsession with the development of generative software created even more misunderstanding and was understandably not embraced by the design community. Meanwhile, the evolution of CAD software made computers widely available in studio as substitutes for drafting and visualization tools, not for advancing the research endeavor.

3. another major problem with the 1970s research and design convergence was a widespread perception of research as something against the studio culture. Instead of embracing the studio ethos in order to transform it from within, the majority of the so called lab-coats positioned themselves against the studio. Architecture was supposed to be taught with logical rules, normative theories and precedents, with little space for experimentation. Such confrontation ended up pushing research and design further away from each other, as if no overlapping were possible and you were either with us or against us.

In summary, if there is something to learn from the failures of the 1970s research is the fact that studio is and will continue to be the core of architecture education. Therefore instead of dismissing it as many did in the past we should embrace it as a fundamental component of creativity and subjectivism that is central to our discipline and our profession.

And if there is something to learn from the decade that followed is that we should always try to ask better questions. The importance of a critical approach to our discourses cannot be dismissed and if there is any chance of reconciling design and research again it has to be without dismissing the studio culture and without marginalizing the contribution of the humanities.

Nevertheless, to ignore the importance of rigorous research to produce and systematize knowledge is to abandon a large part of our public responsibility towards a better built environment.

This paper aims at discussing new pedagogical practices that consciously attempt to integrate design and research in studio. Rather than accentuating its differences and its incompatibilities (which are many), we want to discuss the opportunities emerging from the overlapping of studio creativity and a robust knowledge base. Moving away from pedagogies that exclude one (research) or the other (design), we want to generate a conversation about the joys and risks of bringing them together.

THE EXPERIMENT AT MICHIGAN: A GRADUATE STUDIO WITH A RESEARCH INTERFACE

In the fall semester of 2006 I had the opportunity of conducting a graduate design studio at the University of Michigan based on the idea of integrating research and design. The studio was part of a first year graduate theme called perimeter projects with focus on “all that which is necessary to the city but not necessarily part of it: remote sites, unnoticed programs, far-reaching resource channels, forgotten industrial residues, emergent edge effects, and their many unintended consequences”(ADAMS, 2006).

Within this framework, our studio looked at the future of those perimeter programs under the premise of oil becoming expensive beyond affordability.

The studio brief affirmed that fifty years ago the Highway and Defense Act induced changes in the North-American landscape that pervasively informed our daily routines in every possible way. At the same time we are fully aware that this whole infrastructure is unsustainable from every possible point of view: sociological, environmental, economical, architectural. What can we expect ahead? Where are we going in terms of built environment?

The studio tackled the unbearable dependence we now have on the present perimeter articulation as we move (as many are warning) towards the collapse of such economy by oil depletion or environmental exhaustion.

Starting with a research base exercise, we documented and analyzed all the oil-dependent programs (the garage, the drive-through, the gas station, the parking lot) in a given area in the Detroit metropolitan region. In this initial phase I was able to introduce students to concepts of documentation, data collection, randomization and sampling in order to retrieve the most accurate information about the place. When

searching for information on the gravity of the oil crisis, for instance, students often found contradictory information with environmentalists predicting an imminent crisis and industry consultants preaching that technology advancement will take care of any future shortage of easy accessible oilfields. It was interesting to discuss the reliability of the data, analyzing how research results can be manipulated one way or the other even in “empirical” studies. Architectural students were fascinated to discover terms that are very familiar to the research community such as “control groups” or “standard deviation”. Moreover, when going past the press releases trying to access the real research report, students learned a lot about rigorous research and the obligation to describe with precision each step of the experiment or the premises of the analysis. In the end, they were able to find out how both sides of the debate overstate their part of the truth and understate their uncertainties. Nevertheless, what students were able to draw as common ground between two dissenting camps is the fact that energy costs will be more expensive in the future, the question being how much more?

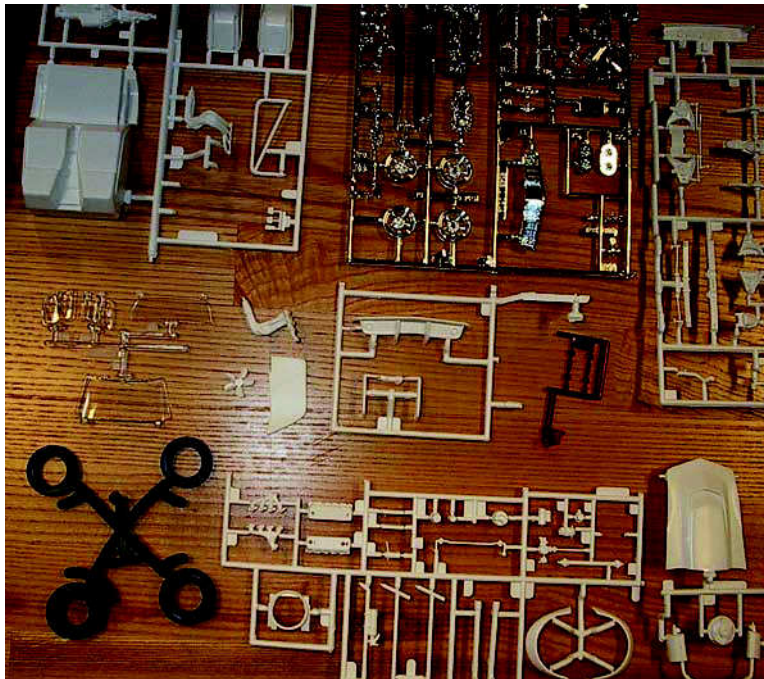

Figure 1: to assemble a scale model car was the departure point of the studio

Alternating research methods of data collection and analysis with creative studio-based exercises, students were then asked to freely and open-mindedly recycle one of those programs once gasoline becomes unaffordable. The first creative exercises departed from a car scale model (1:24) which they should assemble not exactly following the instructions but freely re-using those parts in the total absence of gasoline to run it (fig 1).

After this first exercise the studio got back to research mode and developed scenarios for the urban consequences of more expensive oil. At this point the connection between design and research became more problematic. Not accustomed to the use of data for future predictions, students moved too quickly towards images of apocalyptic post-oil society. While those early exercises did provided insights that would be useful later, they were much closer to science fiction than anything else. Images of a big-brother over controlled society in the likes of “brave new world” were combined with Detroit experiences of real estate devaluation, spatial abandoning and crumbling infrastructure. At this point it was disappointing to realize that all the students had developed a pessimistic scenario in which life would inevitably get worse with one single exception, a student that had lived in Japan for many years. Based on those scenarios which were scrutinized as research reports (with the inevitable failure to stand up to the research rigor we were crave for), students developed their own specific programs and or spaces of intervention. But before going

back to studio creative mode there was one more link with research to be explored and that was the analysis of household consumption data. Given that the main point was to develop spatial responses to the future unaffordability of fuel, it became important to ask in a more rigorous manner what the affordable threshold would be, Reports from the consumer confidence survey run by the University of Michigan Institute for Social Research introduced students to an array of new concepts in survey techniques, sampling, demographics and the surprising discovery of how many people live below or under the poverty line in the Metro Detroit region. The household survey data was then used to understand the impact of gasoline prices as 3, 5 and 8 dollars a gallon on family budgets, giving the students a more precise understanding of how forces acting on a micro scale would induce changes in a macro scale.

Each student then chose his or her own program of intervention and departed to the proposed site: an abandoned dealership in the so called perimeter of Ann Arbor, adjacent to a highway ramp. By navigating back and forth between research methods and studio-based creation I believe we were able to cross-contaminate each intellectual mode in search of a third and more robust attitude. For instance, when trying to understand how the middle-class would react to gasoline at 5 dollars a gallon, two of the students decided to pursue an investigation of how some programs would be transformed by the fact that instead of the current 1.2 travelers per car we move to about 3 persons in each automobile (fig 2). While one of them was dedicated to designing a new drive-through that encouraged car pooling, the other designed a public interface for car sharing.

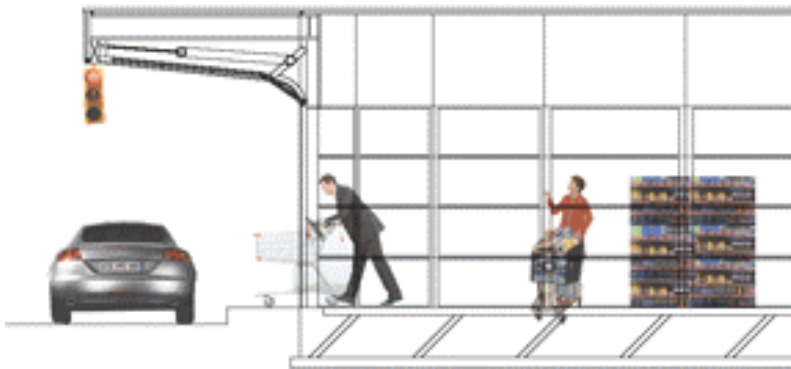

Figure 2: car sharing and car pooling being integrated into retail programs

Another student mapped with precision all the asphalt surface in about 1 mile of the arterial road leading to the highway ramp and after determining how much less parking and road lanes would be needed once mass transit becomes the most popular solution, when on to design a strategy for linking the necessary re-cycling of asphalt (by then expensive) with nature's re-conquering of the areas (fig 3).

It is my understanding that rather than trying to blend research thoroughness with creative freedom we should preserve the best of each approach and explore the mismatches, the collisions, the friction caused by the overlapping of two different mindsets. In this regard, my experiment with bringing design and research together is quite different from the 1970s peak of lab-coats in studio. To continue with the same metaphor, I should say that I am interested in changing wardrobes every week, from lab-coats to the all-black studio uniform. Moreover, I am interested in the folds and scratches that happen every time we change clothes or change hats.

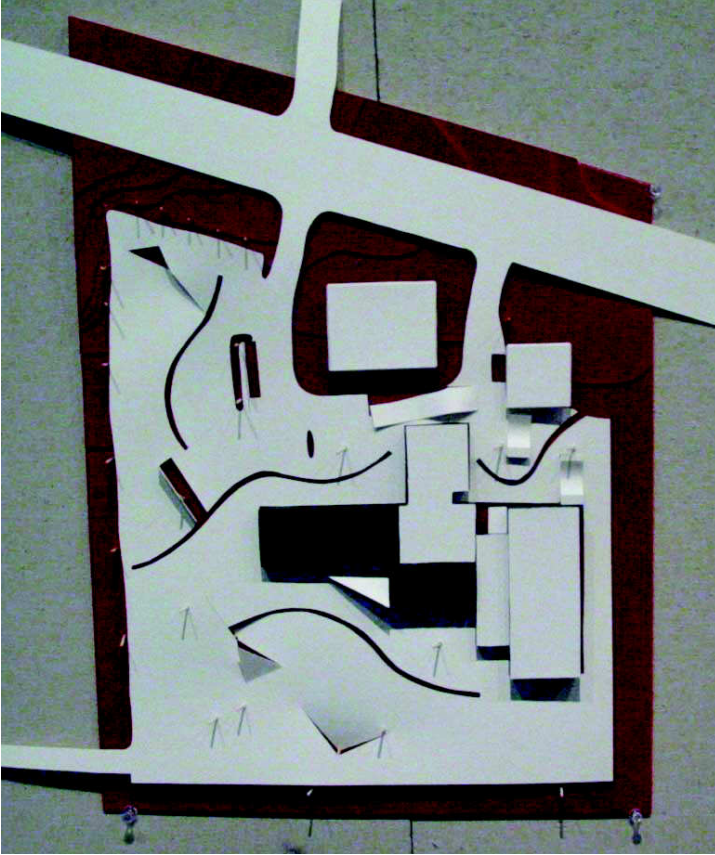

Figure 3: manipulating unused asphalt surface

LESSONS LEARNED SO FAR:

Not surprisingly, the integration of research and design takes a lot of work and attention. Architecture students are not always versed on research values and tend to confuse it with information gathering. It takes quite an effort to explain, in a studio setting, the proper steps of retrieving, systematizing and analyzing information. However, the presence of students with science backgrounds (be it natural, social or hard sciences) in a 3-year graduate program is an asset that we should be aware of. Some of the best discussion in our studio involved students with science major trying to explain research values to architecture majors. In the course of their encounter the studio mode often crashed with the research values and our best conversations (and I like to think our best educational moments) came out of such collision.

There are however some inherent differences. Some bridgeable, other not so much. One of the hardest have to do with the fact that research is always searching for generalizations while architecture design is almost always specific. While design can indeed be broad and generalizable in principle, the more attention paid to the local conditions the better. Research, on the other hand, can be made very specific or narrowed to a small sample or a case study, gaining in depth but losing in explanation power and applicability.

Other differences between research and design values are easier to deal with and can be very productive in studio. For instance, it seems to be very helpful when architects understand the notion that design knowledge can indeed be cumulative and that we should not re-invent the wheel with every building. Students are very comfortable with the idea that their design is a small but important contribution to architectural knowledge and also seem relieved from the anxiety of designing a master-work every semester.

While the research training, although brief and superficial, give students a foundation upon which to build their ideas, the studio ethos allow them to approach every project creatively and experimentally. Isn't that what we need to achieve a more sustainable built environment?

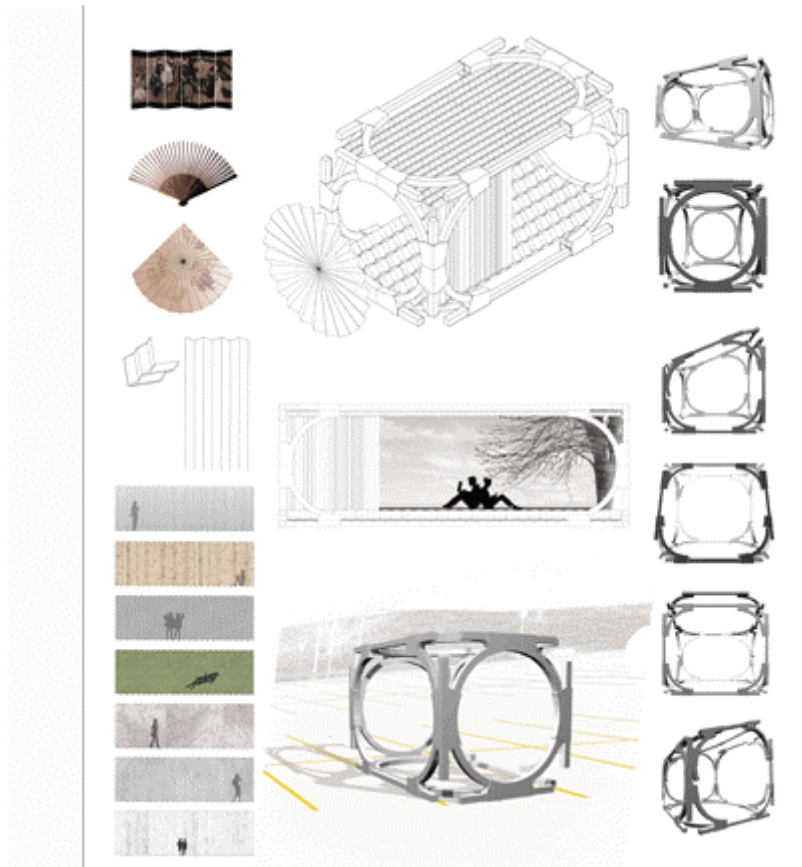

Figure 4: studio craft culture meets research attitude.

REFERENCES:

- ADAMS, Robert, "perimeter studio brief", TCAUP, University of Michigan, 2006.
- ANDERSON, Stanford, "Architectural design as a System of research program", *Design Studies*, 1984, pp.146-150.
- BLOOMER, Jennifer, *Architecture and Text: the (s)cripts of Joyce and Piranasi*, New Haven: Yale U Press, 1993.
- COLQUHOUN, Alan, "Post-modernism and structuralism: a retrospective glance", *Assemblage* no. 5, 1988, pp. 7-15.
- HILLIER, Bill et alli, *Knowledge and Design*, New York: John Wiley, 1984, pp. 245-264.
- INGRAHAM, Catherine, *Architecture and the burdens of linearity*, New Haven: Yale U Press, 1998, pp. 148-155.
- LYNCH, Kevin, "Is a general normative theory possible?", *Theory of good city form*, Cambridge: MIT Press, 1981, pp. 99-108.
- ROWE, Peter, "Architectural positions and their realms of inquiry", *Design Thinking*, Cambridge: MIT Press, 1987, pp. 153-201.
- SCHON, Donald, "Designing rules, types and words", *Design Studies*, Cambridge: Dept. Urban Plan. MIT, 1988.

A Green Studio Pedagogy: Using Scale Changes To Influence Architectural Design For Sustainability

Keelan P. Kaiser, AIA

Judson College, Elgin, Illinois

ABSTRACT: This paper discusses a design studio pedagogy which involves preparatory experiences in sustainable community design and sustainable technology as a means to inform subsequent architectural design. The paper speculates that influences at an urban scale and a detail scale can stimulate a holistic approach to the design process and allow the design student to think more broadly about sustainability. The process includes reflections on the new LEED – ND and its application in a design studio, precedent studies of high performance building façades and their formative effects upon preliminary massing and siting, and how these two types of investigations can broadly inform an approach to architectural design studio which strives toward sustainability.

Keywords: design pedagogy, LEED – ND, building façade

INTRODUCTION

This paper discusses a design studio pedagogy which involves preparatory experiences in sustainable community design and sustainable technology as a means to inform subsequent architectural design. The paper speculates that influences at an urban scale and a detail scale can stimulate a holistic approach to the design process and allow the design student to think more broadly about sustainability.

1. DESIGN STUDIO PEDAGOGY

Architecture design studio pedagogy involves a substantial amount of attention to design process. The faculty member assigns a studio problem partly to prompt motion toward a solution, and as often as not to begin the process of Bloom's Taxonomy (albeit adapted) of application, analysis, synthesis, and evaluation followed by a feedback to application. This cyclical process is a common approach for architecture studio pedagogy (Rowe 1991); and faculty members teach design through this iterative process. It is also a constructive process in that as the loop comes to completion, progress in the maturation of design work is expected. During the scope of a given project or term, a process is employed, somewhat linear though many times non-linear, from large scale considerations which narrow over time to more discrete scales (Figure 1).

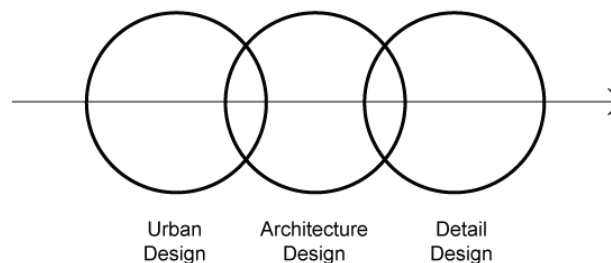

Figure 1: A common architecture design process. Source: (Author 2006)

While design process is seldom truly linear, it is not uncommon for urban scale or contextual considerations to preface architectural design decision making in some capacity or another. Likewise, it is often the case that design studio problems seek increased definition over time, and many times this takes the form of a detailed component of the design. The relationship of content from one arena to the other is substantial. However, in this diagram, a relationship between the two outer circles is not necessarily synergistic, and may not be present whatsoever.

This paper describes a pedagogical approach in design studio which changes the order of the process as presented. The adjustment took an ecological look at the original diagram, and sought to feed relevant content into the design process from a combination of inputs: both urban and detail. The approach inculcated broad concepts of sustainable community with those of sustainable technologies prior to beginning the building design exercise itself. An adaptation of the previous diagram might read as follows (Figure 2).

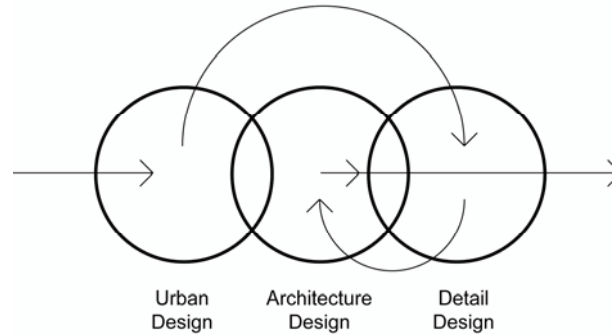

Figure 2: Adaptation of an architecture design process. Source: (Author 2006)

More specifically, the design studio conducted two investigations as a prelude to beginning building design. Sustainable community concepts found in the new Leadership in Energy and Environmental Design for Neighborhood Development (LEED – ND) was introduced first. LEED – ND was under review by the U.S. Green Building Council (USGBC) at the time that this design studio was offered (Fall, 2006), and is now in its pilot phase. It should be noted that many detailed changes were made to the working version in the newer pilot version, but the general scope remains largely the same. The students completed an urban neighborhood design exercise based upon the LEED – ND materials. Each student then researched contemporary precedents of high performance façades in an effort to understand contemporary applications of technology at their disposal to accommodate environmental and programmatic requirements. They created digital section models to document their negotiation of the assembly and systems at work in the precedents. The models also served as a visual taxonomy of contemporary building façade approaches. The pedagogical diagram is more appropriately labeled as such (Figure 3).

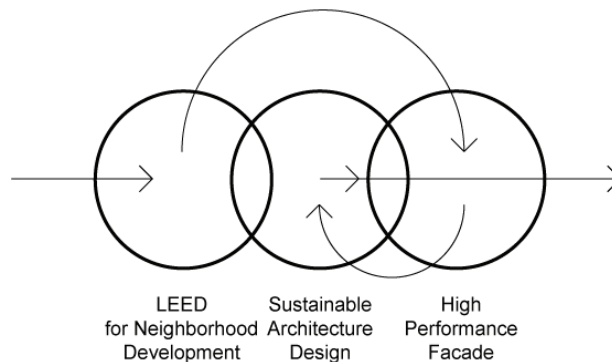

Figure 3: An alternative architecture design process. Source: (Author 2006)

This paper is concerned with outcomes and measurements of students integrating sustainability thinking into the formative stages of their design process. The assessment of this process is measured by the degree to which design students were able to understand and apply the sustainability concepts in the two preliminary investigations. Further assessments will be possible following the completion of the second studio in the sequence (Spring 2007) and will more specifically map the impact of these two formative investigations.

2. LEED – ND AS A VEHICLE FOR IDENTIFYING SUSTAINABLE COMMUNITY CONCEPTS

LEED – ND provided a basis by which to collect data about the downtown core, prioritize desired outcomes, and develop urban planning solutions suitable to the policies included therein. The USGBC describes LEED – ND as:

The U.S. Green Building Council, the Congress for the New Urbanism, and the Natural Resources Defense Council—three organizations which represent that nation's leaders among progressive design professionals, builders, planners, developers, and the environmental community—have come together to develop LEED for Neighborhood Development. This rating system will integrate the principles of smart growth, urbanism, and green building into the first national standard for neighborhood design. Whereas other LEED products focus primarily on green building practices, with only a few credits regarding site selection, LEED for Neighborhood Development will emphasize smart growth aspects and neighborhood design and development while still incorporating a selection of the most important green building practices. Guided by the Smart Growth Network's ten principles of smart growth and the Charter for New Urbanism it will include compact design, proximity to transit, mixed use, mixed housing type, and pedestrian- and bicycle- friendly design. In short, LEED for Neighborhood Development will create a label which could serve as a concrete signal of, and incentive for, better location, design, and construction of neighborhoods and buildings. Source: (USGBC 2007)

Serving as a municipal client, the Elgin Downtown Neighborhood Association director provided key guidance on city needs, in particular the neglect of the entry corridors to the city core, which ultimately became the focus of this particular study. The studio prioritized the potential points available for LEED certification and developed a summary to guide their design decision making. The categories of *Location Efficiency* and *Compactness* tend to address planning for density and connectivity principles while those of *Environmental Preservation* and *Resource Efficiency* tend to address technology and engineering (Table 1).

Table 1: A prioritization of LEED – ND point's based upon impact. Source: (Author 2006)

Location Efficiency (2 Prerequisites / 7 Credits / 28 Points / 25% of total points)	
Credit: Contaminated Brownfields Redevelopment	4
Credit: High Cost Contaminated Brownfields Redevelopment	1
Credit: Adjacent, Infill, or Redevelopment Site	3 to 10
Credit: Reduced Automobile Dependence	2 to 6
Credit: Contribution to Jobs-Housing Balance	4
Credit: School Proximity	1
Credit: Access to Public Space	2
Environmental Preservation (5 Prerequisites / 11 Credits / 13 Points / 11% of total points)	
Credit: Support Off-Site Land Conservation	2
Credit: Stormwater Treatment	2
Compact, Complete, & Connected Neighborhoods (3 Prerequisites / 22 Credits / 42 Points / 37% of total points)	
Credit: Compact Development	1 to 5
Credit: Diversity of Uses	1 to 3
Credit: Housing Diversity	4
Credit: Comprehensively Designed Walkable Streets	2
Credit: Superior Pedestrian Experience	1 to 2
Credit: Transit Subsidy	3
Resource Efficiency (0 Prerequisites / 17 Credits / 25 Points / 22% of total points)	
Credit: Certified Green Building	1 to 5
Credit: Energy Efficiency in Buildings	1 to 3
Credit: Water Efficiency in Buildings	1 to 2

The studio created an urban re-development proposal entitled *The Four Entry Corridors Study* which included strategies for encouraging increased density and future development along the four primary entry corridors to the Elgin, IL downtown which included: Route 31 from the north and south, Villa Street from the southeast, and Dundee Avenue from the northeast. The studio investigated how urban planning, urban design, and architecture can be used to improve the appearance and perceptual quality of a blighted downtown core and its primary vehicular circulation routes. Specifically, the study focused on the primary vehicular entry corridors and proposed increased investment and density as a solution to the overall vibrancy and sustainability of the City of Elgin (Figure 4).

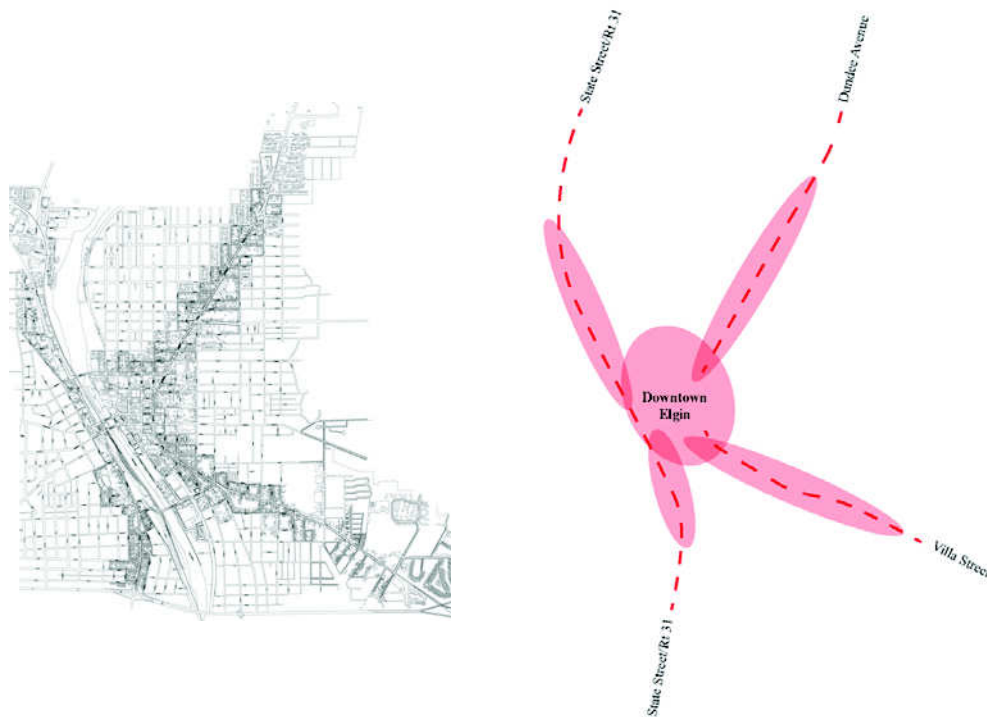

Figure 4: Elgin downtown core and primary entry corridors diagram. Source: (Author 2006)

The proposals combined ongoing capital investment and beautification efforts in the downtown core with significant capital investment along the corridor routes as alternatives to continued suburban sprawl and periphery development of green fields. The later types of developments are rampant in the northwest suburbs of Chicago and troubling given that Elgin is projected to be the fourth largest city in Illinois by 2030. The recommendation by the studio, supported by numerous case studies from other cities, is that density is a good, healthy, and more sustainable development approach.

The following findings were developed through teamwork and individual solutions. First, public and private investment in and re-urbanization of the downtown core and the entry corridors will significantly improve the visibility and sustainability of Elgin in the twenty-first century. Second, the four entry corridors in this study have the highest daily vehicular traffic counts and bring the largest volume of people in and through the downtown core. The corridors themselves bear a significant opportunity to affect the visibility and sustainability of the Elgin. Third, while notable developments and improvements abound on the periphery of the Elgin, a significant negative consequence is continued suburban sprawl. Instead, greater attention should be paid to significant re-urbanization of the downtown core and the extensions of the core that fall along the four primary vehicular corridors. Creating more density, mixed-use development, and a critical mass of housing and commerce within the downtown core and the corridors is a sustainable alternative to unrestrained periphery and green field development. Fourth, there is significant redevelopment potential within the study area, of a scale that is not intuitively apparent. The studio determined that there is a potential scope to the redevelopment of the study area of 4.1 million square feet, which does not include downtown core itself. The projected cost in 2006 dollars for these improvements is \$1.0 - 1.4 billion.

3. LEED – ND EXPERIENCES INFLUENCE PRELIMINARY DESIGN DECISION MAKING

Taking the point overview from LEED – ND, the students analyzed the areas that showed most promise for their particular context and site situation. Many of the titles and descriptions in the point overview document were familiar to the students, but many were new. In this way, LEED – ND introduced students to both individual areas of consideration, but more importantly, helped students see patterns and intensities of impact. For instance, locating a new project on a previously developed or infill site yields a significant percentage of points (up to 10 points). This confirmed to the students that there is great value in building on previously developed sites, primarily because of their level of connectedness. Students developed their point overviews to optimize site opportunities (Table 2).

Table 2: A Partial LEED – ND point overview. Source: (Stewart 2006)

LEED – ND POINT OVERVIEW		
Title	Description	Points
Location Efficiency		
<i>Prerequisite:</i> Transportation Efficiency	Locate the project on either an infill site or on a previously developed site	N/A
<i>Prerequisite:</i> Water and Storm water Infrastructure	Locate the project on a site served by existing water and sewer infrastructure replacement or other on-location improvements to existing infrastructure are considered "existing" for the purpose of achieving this compliance path.	N/A
<i>Credit:</i> Adjacent, Infill, or Redevelopment Site	Locate project on a previously developed site.	8
<i>Credit:</i> Reduced Automobile Dependence	Encourage development in locations that exhibit superior performance in providing transportation choices or otherwise reducing motor vehicle use.	2
<i>Credit:</i> Contribution to Jobs-Housing Balance	Encourage balanced communities with a diversity of uses and employment opportunities. Reduce energy consumption and pollution from motor vehicles by providing opportunities for shorter vehicle trips and/or use of alternative modes of transportation.	4
<i>Credit:</i> School Proximity	Promote public health through physical activity by facilitating walking to school. Promote community interaction and engagement.	1
<i>Credit:</i> Access to Public Space	Locate and/or design project so that a public space such as a park, plaza, town square, village green, etc., lies within 1/2 mile of the all the entrances to the project's residential and commercial buildings.	2

This student chose to develop neighborhood density just south of the downtown core, and placed the art museum at the intersection of Route 31, the north-south street, and Walnut Street, the east-west street. These local sites were previously developed but vacant and dilapidated. She subdivided the large architectural program into a “community” of buildings rather than a single structure. This allowed her the ability to maintain a massing scale consistent with the surrounding fabric and also spread the uses out among multiple sites (Figure 5). The massing strategies yielded a building on the north and south side of Walnut Street; and a third building mass on the east side of Route 31.

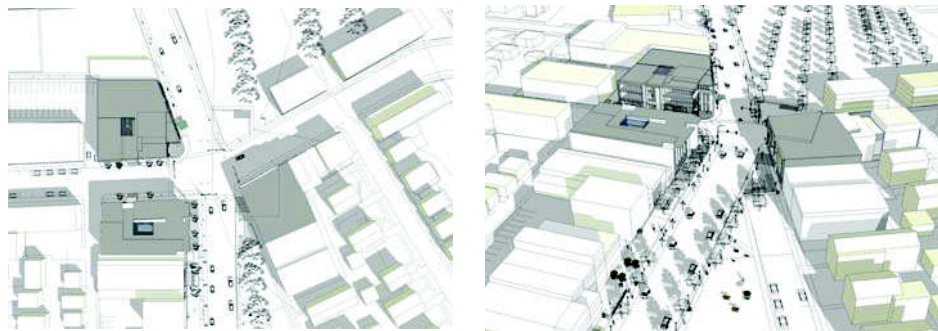

Figure 5: Redevelopment area at Route 31 and Walnut Street. Source: (Stewart 2006)

4. HIGH PERFORMANCE BUILDING FAÇADE PRECEDENT STUDY

Following the investigations at the neighborhood scale, the students developed an architectural program for the community art museum building type within their study area. The programmatic work concluded with a precedent study for high performance building façade that the student deemed appropriate given their site and orientation. One significant factor in the selection of precedents was a programmatic requirement that stipulated that the museum employ literal and/or phenomenological transparency. This requirement was a function of the idea that community art museums are public in nature and one means by which public-ness can be conveyed is by demonstrating material transparency. In addition, the students were advised to investigate building façades which operated as “integrated” systems (Lee 2002).

The previously mentioned student researched a number of buildings which included material transparency, day lighting and ventilating façade strategies. She documented and developed digital section models of the Bayer new Group headquarters, by Architect Helmut Jahn, including a north and south building façade based upon published design documents. She conveyed conceptual understanding of the building technology in a variety of ways. First, she demonstrated the understanding that different solar orientations require different applications of technology. The north façade and south façade are handled differently in this particular application and she purposefully modeled those differences. Secondly, she demonstrated an ability to effectively visualize and communicate differences by comparing and contrasting the two building façades (Figures 6 and 7).

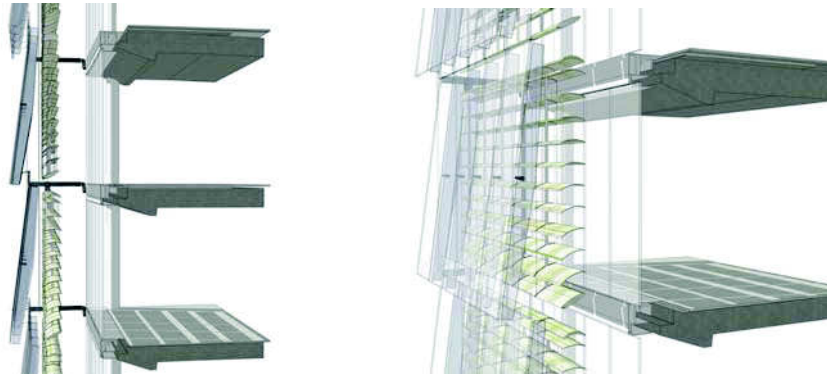

Figure 6: Digital Representation after Bayer new Group headquarters, north façade, Architect Helmut Jahn. Source: (Stewart 2006)

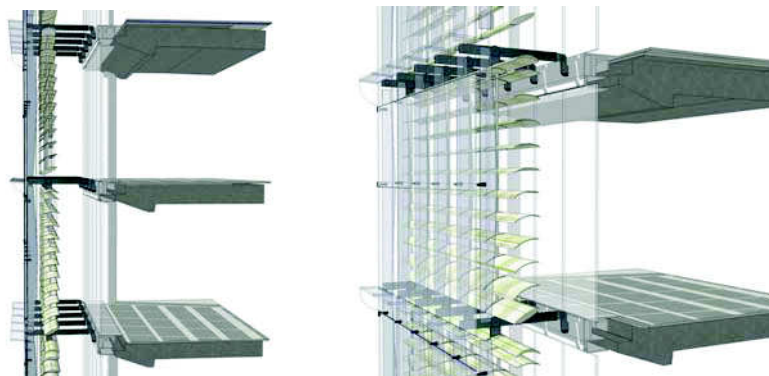

Figure 7: Digital Representation after Bayer new Group headquarters, south façade, Architect Helmut Jahn. Source: (Stewart 2006)

5. IMPACTS ON PRELIMINARY DESIGN

The impact of the precedent study on the example student's work is revealing. Because of siting choices, the northern building has a south façade along Walnut Street and the southern building has a north façade along Walnut Street (Figure 8). The student chose two different types of glazing systems for the façades along Walnut Street, demonstrating an understanding of the different solar orientations of the façades. The student also included operable louvers on the south facing elevation to further control summer heat gains and allow passive

solar in the winter. These combine to demonstrate the multiple layers of sustainable approaches early in the design process.

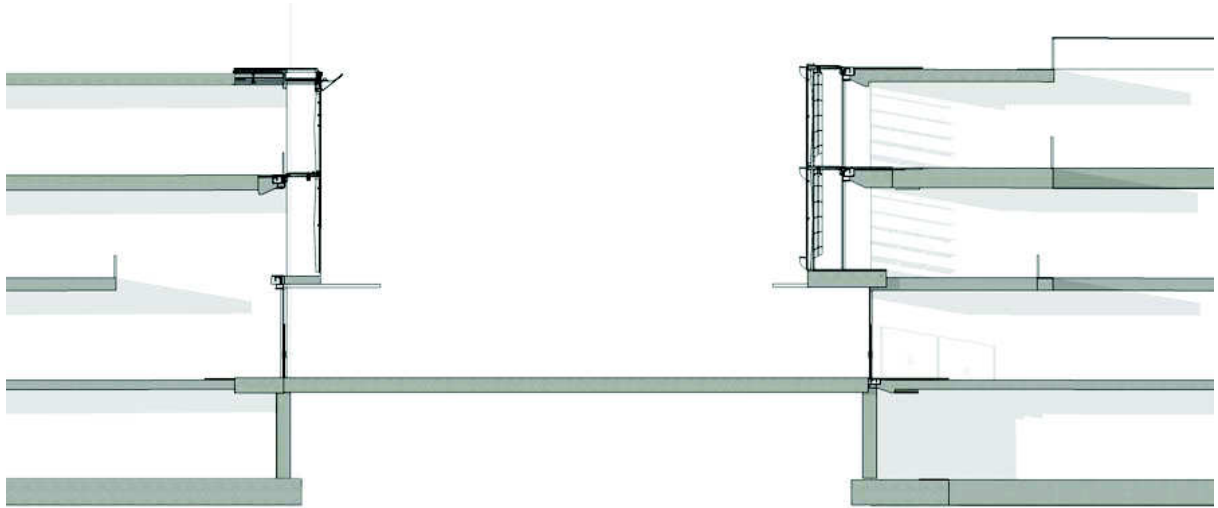

Figure 8: Elgin Community Art Center, schematic design section at Walnut Street. Source: (Stewart 2006)

CONCLUSION

The outcome of this approach was varied. Both the experience of applying LEED – ND criteria to a particular site within the *Four Entry Corridors Study* area and the research and documentation of a precedent high performance building façade yielded important formative student work. For the most part, students were able to negotiate the neighborhood scale following strategies derived from LEED – ND and they were able to understand the importance of connecting to existing infrastructure, transit, circulation, and working within existing site efficiencies. They developed a confidence in working with LEED. The students were enthusiastic about generating digital models of high performance building façades. They carefully chose relevant precedents with regard to solar orientation and building materials. On the other hand, value tensions at times arose because of the predictable struggles between design intent or programmatic need and environmental strategies. Reconciling those tensions in the massing and preliminary design stages of development was a difficult task for most students because of the leanness of their experience with sustainable approaches, yet most of the students remained enthusiastic about doing so. The design pedagogy was successful at energizing the students in this particular course and helped generate interest in sustainable design.

ACKNOWLEDGEMENTS

The author wishes to thank the M.Arch. degree students at Judson College Department of Architecture for their fine work in providing the content and materials for this paper; and the contributions of Dr. David M. Ogoli, Dr. Curtis Sartor, Professor Jack A. Kremers, and Mr. Marty Serena, architect.

REFERENCES

Lee, E., Selkowitz, S., Bajanac, V., Inkarojrit, V., Kohler, C., 2002, *High-Performance Commercial Building Façades*, Building Technologies Program, Environmental Energy Technologies Division, Ernest Orlando Lawrence Berkeley National Laboratory, University of California, Berkeley, CA.

Oesterle, E., Lieb, R., Lutz, M., Huesler, W., 2001. *Double-Skin Facades, Integrated Planning*. Prestel Verlag, Munich.

Rowe, P., 1991. *Design Thinking*. MIT Press: Cambridge.

Schittich, C., Staib, G., Balkow, D., Schuler, M., Sobek, W., 1999. *Glass Construction Manual*. Birkhauser: Basel.

www.bayer.com

www.usgbc.com

Education, Environmental Attitudes and the Design Professions

Traci Rose Rider¹ and Jack Elliott²

¹North Carolina State University, Raleigh, North Carolina

²Cornell University, Ithaca, New York

ABSTRACT: As the concept of sustainability continues to become more popular within society, a number of different professions are called on to help champion the movement. With the resource strain inflicted by the construction industry alone, dedicated architects and interior designers are important players in forward progress. Though many organizations and associations have been created to help the building industry embrace sustainability both practically and theoretically, the actual implementation of green building practices in construction has been minimal. The main focus of this study is to look at the influence of undergraduate education on designers' interest in sustainable design. Additional research interest was in environmental attitudes and the impact of interpersonal relations on those attitudes.

Self-proclaimed practitioners in the green building industry were surveyed through a specified email list of the U.S. Green Building Council. The survey was web-based and addressed issues including environmental attitudes, undergraduate education and professional training. Dunlap and Catton's widely-used New Ecological Paradigm scale was included to measure proenvironmental orientation of the professionals.

Contrary to the main hypothesis of the study, undergraduate education was not seen by subjects to be a fundamental force in the decision to concentrate on sustainability. A number of educational elements typically seen in environmental education, including interpersonal interactions, were mentioned by subjects as substantially influential and are therefore explored.

Conference theme: Education of future architects

Keywords: ethics, attitudes, design education

INTRODUCTION

"In the end we will conserve only what we love; we will love only what we understand; and we will understand only what we have been taught." ~ Baba Dioum

Sustainability has existed in the design world for centuries. At times labeled vernacular, these buildings responded to regional and local elements throughout history without the convenience of central air conditioning and complex drainage systems. As time and technology progressed, however, humanity became increasingly separated from nature and designs lost the necessity to reflect their surrounding environment. Much of design education has followed a similar path, slowly veering off regional and traditional knowledge to follow technological advancements, mobile professionals and lifestyles.

For the purposes of this research endeavour, "sustainability" and "green design" will be used synonymously. While there is much discussion about these two terms and their relationships to each other, this discussion is outside the scope of this paper; the terms will be used interchangeably.

Some schools have kept sustainability in the curriculum through fundamental dedication, and though these classes are not described as "sustainable" in either syllabi or course descriptions, some schools have a long-standing reputation as a "green school." With this integrated process, the students are exposed to a more comprehensive view and understanding of the impact of sustainability on both the final design and the process itself. Other programs seem to view sustainable design as a specialization that would require additional classes to be added to an already full curriculum.

Undergraduate education is a powerful factor in the forming of design ethics; it can be an equally powerful force regarding environmental ethics. Through the strategic integration of sustainability into whole

curriculum paths, students would begin to understand the interconnectedness between built forms and nature at an early stage in education, ingraining these ethics into the design process. With such an intense and longer-than-average curriculum, design programs have great potential to make an incredible difference in the direction of the ecological future of the design professions.

This study uses an online survey tool to address two of the most important foundational elements of design – sociology and education – through three distinct threads. First, Dunlap and Van Liere's New Ecological Paradigm Scale will be used to evaluate the environmental attitudes of current green design professionals. Second, the impact of undergraduate education as an influence on sustainability will be examined. Third, additional influences on pro-environmental attitudes will be reviewed and analyzed in conjunction with formal education. As important singular aspects of design, both sociology and education will be reviewed individually.

1. SOCIOLOGY

This study will create the argument that the environmental issues society faces are analogous to issues in the world of design and can be addressed through education and design training. Referencing Catton and Dunlap's New Ecological Paradigm (NEP) (Catton and Dunlap, 1978), which discusses foundational beliefs toward the environment, the importance of society's view of the environment in understanding the design profession will be illustrated through environmental sociology. Building on the parallel between the Human Exemptionalist Paradigm (HEP) (Catton and Dunlap, 1978) and the design field, similarities between the HEP and the foundation of education within the design profession will be explored, ultimately arguing that the design field is in dire need of a restructured paradigm, much like that outlined in the NEP.

Designers are, above all, both human and a part of society. Because of this underlying truth, both the history of environmentalism and influences on environmental attitudes must be looked at. Society's environmental attitudes have been addressed in the growing field of environmental sociology. There are understandably a number of shades of grey when discussing the field, but as growing organizations such as the Society of Building Science Educators, the AIA Committee on the Environment, the Association for the Advancement of Sustainability in Higher Education and others illustrate, there is something worth investigating as seen in the recent expansion and popularity of the views on the environment. This paper cannot do justice to the comprehensive works done on the topic of environmental sociology, but will attempt an overview for the sake of relation to the design field.

1.1 Environmental Sociology and the NEP Scale

The field of sociology has been well-established for centuries and throughout these years, sociology practitioners became comfortable within the field, allowing the evolution of assumed standards. Though these standard beliefs are never actually outlined, in the 1970's Catton and Dunlap felt that these assumptions had become prerequisites for the practicing of sociology and were dictating how scientists approached their topics. Because they now perceived the original root of the field of sociology to be primarily based on human centrality and a fundamental view that humans are exempt from ecological principles and limitations, Catton and Dunlap designated the traditional mindset as the Human Exemptionalism Paradigm (HEP) (Humphrey, 2002).

The HEP theory, which they feel dominates modern day society, is based upon a Dominant Western Worldview (DWW) (Buttel, 1992). The basic fundamentals of the DWW are: (1) People are fundamentally different from all other creatures on Earth, over which they have dominion; (2) People are masters of their destiny; they can choose their goals and learn to do whatever is necessary to achieve them; (3) The world is vast and thus provides unlimited opportunities for humans; and (4) The history of humanity is one of progress; for every problem there is a solution, and thus progress need never cease (Dunlap and Catton, 1980). Through this reasoning, the basic anthropocentric values of the DWW and the HEP are to blame for the current state of the environment. More significantly, in response to these traditional anthropocentric sociological theories, Catton and Dunlap created a "New Environmental Paradigm" (NEP) (Dunlap and VanLiere, 2000). The overarching intention of this creation was to identify core values of the environmental sociology realm that would not sway with the society's fickle interest in environmental issues. Catton and Dunlap's NEP revolved around the idea that humans are actually entwined in the circle of life where ecological laws cannot be overruled by human ingenuity.

When first created in the late seventies, the NEP environmental attitude scale itself addressed three proposed indicators of an environmental worldview: anti-anthropocentrism, limits to growth, and the balance of nature (Dunlap and VanLiere, 1978). In 1990 the original 12-question scale was revisited and adapted, with the addition of two new areas of concern: the possibility of an ecocrisis and the rejection of human exemptionalism (Dunlap and VanLiere, 2000). This new scale had fifteen questions and was found to be just as successful in the prediction of an ecological worldview while covering more topics. A number of studies on specific populations have helped to solidify the original findings that the scale denotes proenvironmental attitudes as well as establishing known-group validity (Pierce et al., 1992). Additional studies have supported predictive validity by illustrating a significant relationship between the NEP scale and a variety of intended behaviors and actual behaviors, both observed and self-reported (Edgell and Nowell, 1989).

1.2 HEP/NEP and the Design Practice

The HEP/NEP debate is easily applied to the design professions. Paralleling the field of sociology, designers' actions and beliefs are historically based on underlying presumptions reflecting the HEP view as stated earlier. Examples include the unchecked harvesting of forests, extracting of minerals for construction materials, and tearing down buildings no longer perceived to be attractive - only to replace them with other equally-dated structures likely to be torn down later. Though there are no direct correlations to the design professions found in the NEP literature, the foundations of the NEP translate easily. In sociological terms, non-green, conventional designers would be advocates of the HEP point-of-view. The market is the HEP-type designer's primary concern; demand is the ultimate design authority. In line with the Dominant Western World view and HEP perspective as covered earlier, a resource become scarcer, cost rises, and human ingenuity creates alternatives.

The HEP/NEP paradigm shift has been applied to a number of specific populations and could be applied to the design field. While no studies have been found to use the NEP scale on the design and construction professions, a number of the questions used within the scale can arguably relate directly to the field. For example, Statement Two in the NEP survey, "Humans have the right to modify the natural environment to suit their needs," directly addresses the very purpose of the design profession. While Dictionary.com has the definition of the term architecture as "the profession of designing buildings, open areas, communities, and other artificial constructions and environments," it is easily argued that in order to do this the profession is directly modifying the natural environment. Statement Four, "Human ingenuity will insure that we do NOT make the earth unlivable," can be translated to speak directly to technological advancements in the building industry. In Statement Six, "The earth has plenty of natural resources if we just learn how to develop them," references issues in design and construction including forestry management and energy conservation. By viewing these questions through an architect's lens, it is apparent how the HEP/NEP debate could be applied to design.

2. EDUCATION

The environmental education movement has its foundation in rural and local studies in the 1960's (Sterling, 2001). The term "environmental education" became popular in the 1970's, and began to encompass the ethical, political and urban issues that had been previously left to other fields. The 1980's wrapped global issues into the field while the 1990's allowed "environmental education" to be grouped with other movements looking to education for change, such as social equality. Some researchers and experts believe that traditional education is based on an outdated set of cultural beliefs and assumptions with an anthropocentric viewpoint and that a shift to environmental communication and education can be a catalyst for change (Bowers, 1995). In 1987, the World Commission on Environment and Development published The Brundtland Report, more commonly known as "Our Common Future," which helped to fuel change in education by articulating a unified world view and a global problem.

Public schools and higher education have been identified by many as a critical leverage point for change in environmental thinking. Some argue that the fundamental flaw with this is that the majority of education is primarily based on outdated assumptions and values, as noted above. Sterling (2001) claims that traditional education is behind the times in a number of ways: (1) it takes a "fundamentally mechanistic" view of the world; (2) it is primarily ignorant of issues concerning sustainability; and (3) it is uninformed of the growing ecological thinking that intends to more fully integrate humanity with the environment. In an effort to change the foundational emphasis and assumptions of education, much like the New Ecological Paradigm in sociology (Catton and Dunlap, 1978), new goals and values must be established. As the field of sociology was perceived by Catton and Dunlap to hold to anthropocentric views as an outdated foundation, the educational field is considered by some to be functioning on outdated fundamentals as well. In line with adjacent popular sociological theories, education is predicated on the assumption that human ingenuity will always prevail. Similar to the discussion on traditional education, much of the design curriculum has been established and accepted for decades at the very least, without much change in perspective. Design foundation classes revolve around perspectives, sight lines, traditional materials and traditional construction. Rarely are there required classes including ecological connections and sustainable design elements.

Sustainability education is felt by some to *not* have the goal of creating throngs of environmentalists, but to implement lifelong learning as well as civic, social, emotional and academic competencies, creating a better world at all levels in the future (Santone, 2003). Some elements addressed are critical thinking, transformative learning, participatory education, systematic education, ownership of learning, informal education and knowledge of place. While there is a wide range of literature on each of these individual subjects, not all can be addressed in this scope though many can easily be applied to design education.

2.1 Design Education

This paper supports the position that modern designers have historically envisioned themselves as separate from environmental problems, choosing to believe that the task at hand is, at a fundamental level, *only* an issue of composition and space formation. The primary concerns for design professionals typically hinge on two facets of design: the creation of spaces to enhance productivity through adjacencies, circulation and square footage and the aesthetics and composition of the proposed space.

It should be acknowledged that these statements seem overly jaded; design professionals often perceive themselves to have an enriched sense of duty beyond those stated above, which may be social responsibility, public design or improving the well-being of users. It is not too much of a stretch, however, to state that the typical designer is concerned primarily with the human relationship to the built-environment, not the built-environment's relationship to nature. This indirect defiance has been referred to as the "Ostrich Syndrome" in the business world, insinuating that professionals bury their heads to continue with their work, without disruption (Hasan, 1993); the thought being that if the professional is unaware of environmental problems to which they are contributing, there is no need to take steps to change ingrained habits. With these established behaviors come the loss of both the desire and at times the ability to question daily, habitual choices.

Many design education programs remain basically unchanged because they may be seen as beyond reproach and too entrenched in tradition. Though the history and reputation of conventional American design schools is important, it will be assumed that readers of this article are well aware of challenges and benefits of established paradigms such as breadth of classes, lack of electives, concentrated focus and technical expertise.

While there has been little research addressing sustainability within design education, a few articles and examples have been published addressing the topic. A yearly survey done by *Metropolis Magazine* in 2003 states that while it is fundamentally true that grassroots environmentalism is having an effect on design and architecture, the integration of sustainability into formal education leaves much to be desired. It was reported by educators that: two out of an average of eleven studios were dedicated to sustainability; twenty-seven percent said that between one and three required courses were focused on sustainability; forty-six percent were attempting to thread sustainability through the foundation of their program; and that funding was the biggest barrier to integrating sustainable design into the curriculum (Szenasy, 2003).

The topic of implementation pertaining to environment-based education in design programs is entirely too broad to tackle in this scope. However, some educational elements highlighted in the environmental education discussion, such as participatory education and informal influences, are appropriate to explore in relation to design training and environmental attitudes. By investigating the influences of established green building professionals, it will be possible to begin to identify some of the most effective means of sustainable education, as well as those elements that are consciously perceived to make design professionals to "go green."

3. METHODOLOGY

Three main objectives have been identified in this study. The first goal is to evaluate environmental attitudes of established green building professionals through the use of the NEP Scale. Second, determine the most effective factors in steering design professionals towards sustainability. The third goal is to look at the impact of design education on a professional's decision to go green. Each hypothesis was created to address different levels of influence on sustainability. The hypotheses of the current study are as follows:

HO1: Design professionals interested in green design will score high on the New Environmental Paradigm scale.

HO2: Design professionals interested in sustainable design will attribute their interest to the design education that they have experienced.

HO3: Personal interactions, such as attending a speech or the enthusiasm of a coworker, will be the most powerful influence second to formal education.

3.1 Research Design

The design of this study is a simple case study design, concentrating on the influences of a single group of environmentally-friendly designers. In efforts to maintain a manageable study, no second control group was implemented. The intention was to look at the influences that effect interest in sustainable design, as well as the possibility of an interaction of education. Because of the need to reach a large number of people across different locations, an online survey was determined to be the best medium for this study.

A short preliminary survey pertaining to undergraduate experiences and influences was developed and administered to just fewer than two hundred students and young professionals already interested in the green building movement. The preliminary survey was administered at Greenbuild, the U.S. Green Building Council's annual conference and expo held in Portland, Oregon, November 9-12, 2004. Because of the general scope of the survey, questions were both simple and broad. Five of the questions were simply for categorization. The total number of preliminary surveys handed out is unknown. Of the thirty-six responses to fully complete the survey, 86% said that they had an undergraduate experience dealing with green design. Of those, 61% claimed that that experience was integral in turning their interest towards a sustainable trajectory. Seventeen of the respondents were in either Architecture or Interior Design and of these respondents all claimed that they did have an undergraduate experience in green design. Of those respondents, nearly 59% of designers cite this undergraduate experience as integral to their interest in sustainable design. In addition to the correlation to undergraduate studies, other influences on their interest in sustainability were noted to be exposure to influential speakers and books; first hand experiences and service learning; upbringing and peer enthusiasm.

A Likert response scale was chosen because of the familiarity of the scale to the general population, in addition to the perceptual ease of completing the survey. By allowing for intensity of attitude expression through possible selections of "agree" or "strongly agree," a greater variance of results is received (Kerlinger, 2000). When the pool of questions was sufficiently compiled, the second version of the survey was sent to a small sample of professionals indicative of the larger target population to be studied. Thirteen responses were received. A blank section for feedback was provided on the survey for additional insight, and the survey was altered in light of these comments and was narrowed to forty-three questions. The well-known study performed in the late seventies by Dulap and Catton, which was created in an attempt to measure the popularity of an ecological worldview (Catton and Dunlap, 1978), was referenced and the full fifteen questions were added to the survey.

The final survey consisted of fifty-five questions allocated in the following way: fifteen questions addressed environmental attitudes per the NEP scale; eleven questions addressed general lifestyle choices and background; twenty-four questions addressed both education and professional experiences. The final question was a blank allowing for respondent email identification if they wished to be compensated through a drawing.

The final email survey was presented to a representative sample of green building professionals in April 2005. The survey was administered through a specific email from the Chapter Coordinator of the U.S. Green Building Council (USGBC), reaching approximately 200 professionals, specifically leaders of local USGBC chapters around the country. The leadership and members of each of the chapters are quite diverse, encompassing design firms as well as press, schools, financial firms, manufacturers and other interested parties. One follow-up request was sent out the following week. A total of sixty-eight survey responses were recorded through WebSurveyor's Desktop online program.

4. RESULTS

The overall environmental position of this group of green professionals on the attitude spectrum as outlined by the NEP scale will be assessed. Common view-points, as well as peculiarly uncommon view-points, will be noted as well. Thirty-five of the sixty-eight respondents indicated that they were either architects or interior designers, for 51.5% of the total responses. This narrowed population will be the overall focus of these results.

The overwhelming majority of green building professionals responding to the survey scored high on the NEP Scale, as did the group of proclaimed green design professionals. Each of the responses to the fifteen line items indicates the majority of respondents endorse ecologically-friendly positions and beliefs. For questions concerning Limits to Growth, the majority of subjects responded in line with a pro-ecological view. For questions addressing anti-anthropocentrism, the majority of subjects again responded in an environmentally friendly manner. While responses to certain questions were indicators of pro-environmental values, other similar questions were less polarized, with just 30.3% either agreeing or agreeing strongly with the statement regarding humans' right to modify the environment. Two questions addressed the rejection of exemptionalism and showed that the vast majority of designers are in agreement with pro-environmental views. However, when addressing human ingenuity responses spread across Agree, Unsure, and Disagree with approximately 30% in each.

The responses were most uniform for questions addressing the fragility of nature's balance and the possibility of an eco-crisis. When pertaining to nature's fragility, at least 75.8% of the total subjects indicated pro-ecological attitudes in all three. For questions addressing the possibility of an eco-crisis, the overwhelming majority indicated a pro-environmental stance with at least 87.9% in agreement. While a few indicated that they felt unsure, only one individual answered against pro-environmental values in all three of the questions.

Of the thirty-five respondents in this designer group, the majority finished their undergraduate work between 1980 and 2000. Seventeen (41%) indicated that education was not a factor in their interest in sustainable design. Only 34% cited some form of higher education as an influence. Of those, 83% felt that their undergraduate experiences were more formative than their graduate experiences. Sixty percent of respondents disagreed to some extent that sustainability was never addressed in their undergraduate education.

Only one of the responding designers indicated choosing their place of undergraduate education based on environmental view and sustainability reputation. Sixty-eight percent disagreed that sustainable reputation had anything to do with their choice in what program to attend. Only 5.9% of the total sample of sixty-eight selected their formal education based on the green reputation of the school. Eleven percent responded that they strongly agree that they entered the program with an intent to study green design; 23% simply agreed; 29% replied neutral; 23% disagreed; and 11% strongly disagree. Only one respondent of the designers indicated agreement with the statement that their school addressed sustainable issues more in curriculum than other design programs would have. The other 97% felt that their programs were on par with the environmental pulse throughout the rest of the design schools at the time.

The majority of responding designers (65.7%) do not attribute their interest in sustainability to education at all. Of the remaining 31% that do credit their education as a factor in their environmental views, 63.6% cite an elective class as the spark of interest. Of the 40% of respondents indicating that a class did influence them, 61.5% claimed that the class was design related, while 38.5% said it was an elective outside of the design school. Ten of the designers (28.6%) could point out a specific professor that was an influence on their green building position. This is consistent with 30.4% of the *total* respondents who could also identify one instructor

that they felt made a difference in their position. When asked about the inclusion of environmental authors such as Thoreau, Emerson, John Muir and Rachel Carson, 91.4% of designers agreed to some extent that these authors should be included more in design curriculum.

4.1 Professional Interests & Additional Influences

Two of the thirty-five designers (5.7%) did not view themselves as green designers, while the remaining thirty-three did. In the whole sample of sixty-eight subjects, twelve (17.4%) did not perceive themselves to be "green." One individual gave a neutral answer to the question addressing sustainable issues as honestly too bothersome to address on a daily basis. The respondents, both overall and only designers, unanimously agreed that they have the ability to make a difference in the environment through their profession.

None of the responding designers indicated that they were interested in sustainability due to marketability, professional reasons, internships, service learning, and recreation interests. The remaining proposed factors are fairly equal in response: two individuals (5.7%) indicated that they were influenced by a speaker; three (8.6%) were influenced by travel; five (14.3%) were influenced by formal education; five others (14.3%) were swayed by attending a conference; three more (8.6%) were influenced by a book or article; two (5.7%) credit a co-worker while one (2.3%) credits an acquaintance; five more (14.3%) tribute their upbringing; and eight (22.9%) attribute their interest in sustainability to other factors altogether.

5. DISCUSSION

While the surge in green design is at an all-time high, there is still far to go in the movement. The results of the survey indicate that those design professionals involved in green design are fundamentally dedicated to sustainability. All responses suggested that the interest in sustainability was sincere and heart-felt, as opposed to the possible interest for a career boost.

5.1 Hypothesis One - NEP

In reference to the NEP scale portion of the survey, the results reinforce earlier findings that special interest groups and environmental organizations score high on the NEP Scale (Edgell and Nowell, 1989). Proving Hypothesis One correct, the results illustrate pro-environmental tendencies within the group.

There are questions whose responses were not as significantly aligned with the pro-environmental indicators as the rest of the survey. Question six, which refers to the development of natural resources, was one of these questions. This may be the case due to the pre-determined nature of architecture and design as referenced earlier in the background section, which assumes that additional resources are ultimately needed to continue the growth of the built environment. Question two was also less clear, and may be attributed to the same reasoning; referring to the right of humans to modify the natural environment to suit their needs, this question addresses the very premise of architecture as currently understood.

Question four, speaking to the rejection of exemptionalism and human ingenuity, returned the most uniformly spread responses from the group of designers. This may be the case because designers are trained to be creative and rely on ingenuity to problem solve on a daily basis. This ingrained perception within the designer population may be at odds with their fundamental environmental positions, resulting in the spread out responses.

The responses were most uniform for questions addressing the fragility of nature's balance and the possibility of an eco-crisis. This may point to a lack of ecological knowledge in the design field, resulting from the narrow focus of design education. It could also indicate the perception that there is little interaction between the design fields and nature's balance and an eco-crisis, while the topics of anthropocentrism, limits to growth and exemptionalism may likely have a direct effect on the design professions.

5.2 Hypothesis Two - Education

Contrary to Hypothesis Two, the vast majority of green professionals did not attribute their desire to concentrate on sustainability to their formal education. There is some unclear data that should be looked at more carefully. While sixty percent of the respondents felt that sustainability was addressed in their undergraduate education, forty percent did not feel that their education affected their environmental ethics in relation to green building. This could be attributed to self-selection into the program for those already environmentally friendly or possibly credited to a delayed effect where the teachings were not fully realized until much later in their professional development. Similarly, it could be due to the differences in programs, teaching styles, curriculums or any number of other small differentiations in the schools. Regardless, education is not being identified by the majority of green designers as an influence on their interest in sustainability.

The large percentage of subjects that claim they did not choose their school based on sustainable reputation shows that many other elements of design education were playing a larger role in selection. This could be attributed to the possibility that not many programs had classes based in green design during the 1970s, 1980s and 1990's when many were entering school, or were simply not called them by those terms. A number of schools have a well-known reputation for being sustainable, but would be difficult to quantify for a researcher when looking at course titles, online descriptions and other easily accessible information. It may also be attributed to the fact that green building programs may not have existed at the time.

Of the thirty-five percent that did cite some form of higher education as an influence, the majority (83.3%) felt that their undergraduate experiences were more formative than their graduate experiences. This speaks to not only the importance and impact of undergraduate design curriculum, but also the possibilities for influence on the profession if there were a major swing in sustainability curriculum in formal design education.

Results indicate that the majority of those affected by classes were influenced most by electives and not by design classes. This points toward a lack of green classes offered as a required part of the curriculum. This confirms previous surveys on sustainability in design schools where 27% claim having one to three classes required (Szenasy, 2003). Other subjects indicate the importance of design related classes, which emphasizes the significance of applicability and practicality. Classes such as service learning and participatory education that are informative and explicitly illustrate the implications of green building elements are found to be most productive and useful. Still other subjects indicated that the class most influential was outside the design school, lending support to the importance of systems thinking and interdisciplinary learning as covered previously. While the theme of the overall responses indicates that formal education did not affect the professional choice to think green, the overwhelming majority of respondents advocated more environmental readings during undergraduate education. While the remaining did not advocate it, neither did they disagree with it. This would indicate that these designers felt that environmental readings would have been more beneficial in retrospect, and would be suggested for future courses in all design programs.

5.3 Hypothesis Three – Personal Interactions

Data supports Hypothesis Three by showing that personal interactions are important in emphasizing environmental attitudes. By combining interactive means such as travel, conferences, speakers, co-workers, and personal acquaintances, results show that 37% of professionals credit these methods of moving them toward sustainability, as opposed to the 14% that actually did credit higher education. In reality, a number of subjects indicated “other” in their responses, which was seen to include items such as “girl scouts,” “travel combined with education,” and “observation.” If these specific elements were teased apart in more detail, it seems that they would likely fall into the categories of either education or personal interaction. Though it was left out of this calculation, it may also be appropriate to include both “reading a book/article” and “upbringing” within the personal interaction category.

5.4 Limitations of Current Study

While the scope and parameters of the current study were selected for their ability to provide a wide range of data, a number of factors in the present research design are limiting. The limitation of personal bias must first be acknowledged. As a design professional deeply interested and dedicated to sustainable design, as well as deeply believing in the importance and impact of education, personal bias of the researcher may have had an effect in either the creation of questions or in the translation of responses.

By focusing on just one of the factors addressed in this study – environmental attitudes, formal education or environmental influences – research efforts would be able to dig deeper into each of these facets, likely revealing more concrete findings. While combining the three components into one research design does allow for additional relationships to be reviewed, it also has the potential to confuse the subjects. Another limitation is the sample size returned from the online survey, as well as the manner in which it was administered. Though the overall number of returned surveys was decent at sixty-eight, only thirty-five of the respondents fell into the categories of architect or interior designer, the two fields that were being targeted in the study.

A more representative sample would also help to increase the number of subjects that completed their study in the year 2000 or later, which is when the “sustainability” buzz word would have become most integrated into curriculums. Because the majority of subjects graduated between 1980 and 1990, results will reflect specifically what was happening historically in the field at that time. A better distribution of subjects would help to filter out that influence. Also, by concentrating on only a handful of schools and programs, some of the finer elements pertaining to classes and influences could begin to be teased out of the data.

5.5 Future Research and Implications

To thoroughly investigate the scope of this research, a number of additional studies should be conducted specific to each of the factors addressed. Research concentrating particularly on environmental attitudes within design as outlined through the NEP should be conducted (Dunlap and VanLiere, 1978). A comparative analysis of environmental attitudes between populations of designers should be performed. The NEP Scale could also be used on a larger sample of design professionals, with established green design professionals as a control group.

In light of these NEP survey results, the question then turns toward the actions and behaviors of these green design professionals within the workplace. While the group as a whole does declare their allegiance to pro-environmental attitudes, this does not mean that they exhibit pro-environmental behaviors. Additionally, differentiations between pro-environmental behavior in private and professional lives should be considered.

Educational influence can be researched further in a number of different ways. Students could be given the NEP survey as they enter design programs and again when they graduate; this would measure any change

in environmental attitudes while at school, providing a measurable aspect of the education experience. Detailed, objective program profiles should be created addressing green design, incorporating the program's dedication to sustainability. This could include an alumni tracking and comparison study focusing on the tracks and positions of alumnus of different programs, while attempting to discern the differences in environmental attitudes of the alumni. Closely related, the NEP Scale could be administered in conjunction with different levels of programs and types of curriculums. This would be helpful in understanding the true effects of university level design curriculum on environmental attitudes and behaviors by contrasting responses from entry-level cohorts. A list of the most effective school programs could also potentially be developed. Additionally, this vein of research could be easily extended into the realm of continuing education for both architects and interior designers.

Of great importance is the guidance that these results provide and the future research within environmental education and design. A future study should address the relationship between environmental education methods and design programs, highlighting effective ways to introduce sustainability to students regardless of the specific curricula and different programs. As noted previously, a number of informal and non-traditional efforts have a substantial impact on undergraduate students relating to the environment.

6. CONCLUSION

Contrary to Hypothesis Two, most green design professionals did not credit their undergraduate education with turning their professional interests toward sustainability. Though many programs and departments indicate that they do offer courses in sustainability and environmental design (Szenasy, 2003), graduates themselves are not feeling the effect. While many respondents did not credit their education with their interest in sustainability, a substantial portion of subjects cited electives as important in the forming of environmental ethics during school. One possibility is that there were not many required sustainable design classes available, making electives the only option, either within or outside the department.

Because of the responses pertaining to electives and education, it is believed that education has the possibility of being more important in turning toward sustainability than an initial glance as the results from this study seem to indicate. The subjects responded in great numbers to suggestions for design education reform, indicating a true interest and allegiance to design education. Suggestions, such as the reading of more environmental literature in the classroom, were met with overwhelmingly positive response. The combination of these responses lead to a sum greater than all the individual parts; while education itself is not ranked highly as a factor, each of the individual elements received high marks.

The results of this study indicate that the individual elements of environmental education, most likely found in electives, are what graduates remember in relation to environmental ethics in design education. This study supports the fact that a number of individual elements could be successfully incorporated into design education to encourage environmental behavior. The combination of various educational methods in design education provides undergraduate programs the potential to deliver necessary environmental knowledge, values and impact that future professionals in the design industry desperately need. By increasing the exposure to these different alternatives, current and future professionals alike will be reminded that design is not simply about aesthetics and functionality. With it comes that higher calling, to create healthy buildings not just for the users but also for the natural environment, allowing future generations to meet their resource needs as we are currently able to meet ours.

REFERENCES

- Bowers, C. A. (1995). *Educating for an Ecologically Sustainable Culture: Rethinking Moral Education, Creativity, Intelligence, and Other Modern Orthodoxies*. Albany, State University of New York Press.
- Buttel, F. H. (1992). "Environmentalization: Origins, processes, and implications for rural social change." *Rural Sociology* 57: 1-27.
- Catton, W. R. and R. E. Dunlap (1978). "Environmental sociology: a new paradigm." *American Sociologist* 13: 41-49.
- Dunlap, R. E. and W. R. Catton (1980). "A New Ecological Paradigm for a Post-Exuberant Sociology." *American Behavioural Scientist* 24(1): 15-47.
- Dunlap, R. E., K. D. VanLiere, et al. (2000). "Measuring Endorsement of the New Ecological Paradigm: A Revised NEP Scale." *Journal of Social Issues* 56(3): 433.
- Edgell, M. C. R. and D. E. Nowell (1989). "The new environmental paradigm scale: Wildlife and environmental beliefs in British Columbia." *Society and Natural Resources*(2): 285-296.
- Humphrey, C. R., T. L. Lewis, et al. (2002). *Environment, Energy and Society: A New Synthesis*. Belmont, CA, Wadsworth-Thomson Learning.
- Pierce, J. C., M. E. Steger, et al. (1992). *Citizens, political communication and interest groups: Environmental organizations in Canada and the United States*. Westport, CT, Praeger.
- Santone, S. (2003). "Education for Sustainability." *Educational Leadership*(December 2003/January 2004).
- Sterling, S. (2001). *Sustainable Education: Re-visioning Learning and Change*. Bristol, Schumacher Society.

The Green Studio Handbook: Environmental Strategies for Schematic Design

Alison G. Kwok, Ph.D.¹ and Walter T. Grondzik, P.E.²

¹University of Oregon, Eugene, Oregon, USA
²Architectural Engineer, Tallahassee, Florida, USA

ABSTRACT: In design studio projects we often see schemes with inspired, yet unvalidated, gestural sketches related to wishful green strategies. Yellow and blue magic arrows represent hypotheses about the behavior of daylight and/or air flow in and about buildings. This paper provides an overview of *The Green Studio Handbook*, recently published as a resource for designers seeking clear guidelines for integrating green design strategies into the conceptual and schematic phases of design. The book contains a discussion of the integration of green strategies and how building form, orientation, and spatial layout are critical to the proper performance of certain green strategies; 40 green design strategies in six broad topic areas, each providing a catalog of information for common strategies that must be implemented at the schematic design phase; and nine case studies that show how various green strategies work together in a finished building. This paper provides excerpts of several design strategies and one case study and suggests a variety of ways that the book may be used.

Keywords: green design, case studies, education, schematic design

INTRODUCTION

In design studio, students often draw upon precedents to inspire their design work. Gesture sketches are refined and further developed. Green design strategies are commonly relegated to magic arrows (to show air flow) or yellow lines (to show the path of the sun or flux of light). Often, design hypotheses are left untested or unquestioned simply because there is no readily available method or means to appropriately size windows for cross ventilation or determine how much light will enter a room under particular sky conditions. This paper gives an overview of a number of green design strategies and case studies from a recently published work—*The Green Studio Handbook* (Architectural Press: Oxford, 2007)—which is offered as a resource to assist students (and practitioners) in integrating green strategies into the beginning stages of design.

The Green Studio Handbook presents guidelines for the application of selected environmental strategies during the schematic design of green buildings. The *Handbook* provides a discussion of green design at the schematic design phase and an essay on integrated design. The majority of the book is devoted to 40 design strategies, each providing: brief descriptions of principles and concepts, step-by-step approaches for integrating the strategy into the early stages of design, annotated tables and charts to assist with preliminary design sizing, key issues to be aware of when implementing the strategy, and references to further resources. This information is reinforced with conceptual sketches and photos illustrating each strategy. A chapter with case studies of several green building projects provides context for the strategies presented.

The rationale for this book arose from an observed need for a resource that could provide a concise catalog of information for a range of green strategies to help the designer not only understand how each strategy functions, but also offer data, information, and a sequence of design steps to give a preliminary estimate of sizing, appropriateness, and links to related strategies. The designer may practice “smart aesthetics” by linearizing part of the design process to achieve valid, initial design moves. The fundamental premise of this book is that if appropriate strategies are not included during the schematic design phase of a project, they may never be included since many such strategies are demanding form-giving. Poor decisions related to building orientation, massing, and layout are nearly impossible to rectify in later design phases in an attempt to back-integrate high performance daylighting, passive heating, or passive cooling systems.

This paper includes four parts:

- a discussion of the schematic design process, where design decisions about certain green strategies become critical to building form, orientation, and spatial layout;
- a review of several strategies describing the principle/concept, design procedure, and examples;
- a description of one of the case studies and its integrated strategies, including information regarding the designers' intentions with regard to green design, related design criteria, design validation methods used (modeling, simulation, hand calculations), and post occupancy validation methods if available;
- a discussion of how this book may be used in design studio and potentially in other areas of the curriculum.

1. SCHEMATIC DESIGN PROCESS

As a multifaceted pursuit, the design process includes cultural, technical, formal, and programmatic emphases that ultimately result in a proposed architectural expression. The green design process, by necessity, requires the designer (at least in the early schematic stages) to assume a greater than normal degree of expertise in several technical areas in order to pursue an integrated design. This necessity also represents an opportunity for innovation.

1.1 Defining the Problem

1.1.1 Schema: The early design process incorporates the moments when the project is conceptualized, the intentions are elaborated, and an organizational logic is settled upon—whether that logic is strict or informal, internalized or driven by externalities, or simply a geometric gesture. The first sketches or outlines, a plan of action, a systematic or organized framework can provide the opportunity to define goals and to set criteria that will benchmark success. This is the time to set a direction for form and to gather ideas and concepts. It is not the time, however, to close the mind and crystallize all relationships. The initial steps toward achieving an integrated design, such as forming a team with a shared set of green goals and a desire for innovation (and learning), is the territory wherein green strategies are initially discussed, adopted, and integrated. Opportunities for many of green strategies will be lost forever if not incorporated during schematic design.

1.1.2 Intentions: At the beginning a project, it is important to define owner and design team expectations for building performance. It should be decided whether the building will perform to minimum standards (as embodied in building codes) or will strive to surpass them—which must be the case for a green building. What kinds of performance will be emphasized: energy efficiency, quality of light, or air quality? What degree of green design is to be considered? The intentions must be clear because they point to the refinements of process, the type of team, and the potential strategies and technologies that will be most appropriate for a given project. Sometimes, a charismatic and knowledgeable team member can convert others to a deep green commitment.

1.1.3 Criteria: Project criteria are the standards by which judgments and decisions are tested. They are often established by a legal authority, local/regional custom, or general consent; but for innovative projects the truly critical criteria are often internally established. What is really meant by green? Who decides; and on what basis? Criteria can be derived from quantitative standards (such as energy efficiency) or from qualitative values (such as a desired lighting effect). Criteria should be realistic so they can be met; they should also be stringent enough to provide a challenge and meet design intent.

1.1.4 Validation: The design team must be conscious of the types of issues to be framed and the most appropriate design methods and strategies to address the focus issues. The way a designer frames issues speaks to the outcomes. More importantly, a knowledge-based profession reflects upon previous efforts and specifically learns from successes and failures. Collapses occurred during the construction of Chartres. Calculations and formulations about how materials work under the forces of gravity were rethought and the building of the famous cathedral continued. Knowledge-based design is also needed when dealing with environmental forces, although they are often more subtle, complex, and variable than gravity. A different type of feedback loop is required, one not founded upon collapse, but one that is part of an integrated process— involving learning from others and learning from analysis. The analysis of an existing project (as a precedent or case study) informs the development of hypotheses of how things should work on future projects.

1.1.5 Prioritizing: It is important to give order to intentions and goals. Prioritizing goals helps the designer and client to understand what is most important, what can be discarded, and how flexible are proposed solutions. As with any design process, one works through sets of ideas to get to a clarification of goals. This is particularly important with green design because one strategy can negate or conflict with another.

1.2 Formgivers

1.2.1 Daylighting: Light has clearly been understood as a formgiver throughout the history of architecture. The Pantheon dramatically captures light from an enormous oculus; Alvar Aalto's buildings use light scoops to utilize the low solar resource of the northern latitudes. Traditional passive solar design uses solar-oriented glazing in combination with thermal mass to provide heating. Windows, however, must be carefully sized and arranged to provide a balance between the correct amount of thermal resistance, light admittance, and solar collection. To arrive at a daylighting strategy, appropriate lighting level criteria should be established based upon the functions and needs of the various spaces, then potential solutions proposed, tested, and evaluated using daylighting models or other available tools. Such studies should provide for distinct lighting effects—and result in a distinct building form.

1.2.2 Passive and Active Strategies: Passive design means that nature (and the architect) does the work. Passive strategies adjust to environmental conditions primarily through the architecture and should be considered before active. This means that the architect must be strategic. It means using the resources on site rather than importing energy from a remote source. The careful placement of walls, windows, and overhangs can help to "green" a project; otherwise mechanical equipment (and engineering consultants) will be forced to do the job.

2. GREEN DESIGN STRATEGIES

The book contains 40 strategies (see Table 1), each with a brief description of underlying principles and concepts, a discussion of architectural design and implementation issues, a step-by-step design procedure to assist with preliminary design sizing, key issues to be aware of when considering a given strategy, conceptual sketches and photographic examples, and pointers to sources for further information. There are both active and passive strategies, but many more passive strategies are included since they require early implementation during the design process and are typically more form-shaping. Many green strategies (such as material finishes) are not included as they have virtually no impact on schematic design decisions. The book is not a catalog of green design strategies—it is a catalog of green strategies for schematic design.

Table 1: Green Strategies in *The Green Studio Handbook*

TOPIC and STRATEGIES	TOPIC and STRATEGIES
ENVELOPE	COOLING
Insulation Materials	Cross Ventilation
Strawbale Construction	Stack Ventilation
Structural Insulated Panels	Evaporative Cool Towers
Double Envelopes	Night Ventilation of Mass
Green Roofs	Earth Cooling Tubes
	Earth Sheltering
LIGHTING	Absorption Chillers
Daylight Factor	
Daylight Zoning	HEATING
Toplighting	Direct Gain
Sidelighting	Indirect Gain
Light Shelves	Isolated Gain
Internal Reflectances	Active Solar Thermal Systems
Shading Devices	Ground Source Heat Pumps
Electric Lighting	
WATER AND WASTE	ENERGY PRODUCTION
Composting Toilets	Plug Loads
Water Reuse/Recycling	Air-to-Air Heat Exchangers
Living Machines	Energy Recovery Systems
Water Catchment Systems	Photovoltaics
Pervious Surfaces	Wind Turbines
Bioswales	Microhydro Turbines
Retention Ponds	Hydrogen Fuel Cells
	Combined Heat and Power

2.2 Sample Strategy: Green Roofs

Green roofs can be used for rainwater detention or retention, to increase the thermal resistance and capacitance of a roof assembly, to reduce the urban heat island effect, and/or to provide habitat for animals or an amenity for people on what would otherwise be a hard-surfaced area. Green roofs are of two basic types: extensive and intensive.

Extensive green roofs have a relatively shallow soil base, making them lighter, less expensive, and generally easier to maintain than intensive green roofs. Extensive roofs usually have limited plant diversity, typically consisting of sedum (succulents), grasses, mosses, and herbs. They are often not accessible to building users, but may provide for “natural” views from adjacent rooms or neighboring buildings. Extensive green roofs can work at slopes of up to 35 degrees, although slopes above 20 degrees require installation of a baffle system to prevent soil slump. These roofs can be used in both urban and rural settings, are applicable to a wide variety of building types, and can be used in both new and existing construction.

2.2.1 Key Architectural Issues: Successful green roofs require a building massing that permits appropriate solar exposure for the intended types of vegetation. Shading from adjacent buildings or trees can have a big impact on the success of rooftop plantings. Building massing can also be used to create rooftop surfaces that are relatively protected from wind. Building form will also determine how building occupants can interact with a green roof. A green roof is a user amenity only if it is at least visible to occupants. If it is also accessible to building occupants, greater integration of the green roof with appropriate interior spaces is desirable. Structural system design, careful detailing of drainage systems, irrigation systems, and penetrations of the roof membrane are key concerns.



Figure 1: 2005 Rhode Island School of Design Solar Decathlon House with a green roof for outdoor dining.

2.3 Sample Strategy: Cross Ventilation

Cross ventilation establishes a flow of cooler outdoor air through a space; this flow carries heat out of a building. Cross ventilation is a viable and energy-efficient alternative to mechanical (active) cooling under appropriate climate conditions. The design may focus upon direct cooling of occupants as a result of increased air speed and lowered interior air temperature or upon the cooling of building surfaces (as with nighttime flushing) to provide indirect comfort cooling. Air speed is critical to direct comfort cooling; air flow rate is critical to structural cooling. The effectiveness of cross ventilation is a function of the size of the inlets, outlets, wind speed, and outdoor air temperature.

Cross ventilation cooling capacity is fundamentally dependent upon the temperature difference between the indoor air and outdoor air. Cross-ventilation cooling is only viable when the outdoor air is at least 3°F [1.7°C] cooler than the indoor air. Lesser temperature differences provide only marginal cooling effect (circulating air at room temperature, for example, cannot remove heat or reduce room temperature). Outdoor air flow rate is another key capacity determinant. The greater the air flow, the greater the cooling capacity.

Buildings are typically best naturally-ventilated when they are very open to breezes yet shaded from direct solar radiation. Building materials in a cross ventilated building may be light in weight, unless night ventilation of mass is intended—in which case thermally massive materials are necessary.

2.3.1 Key Architectural Issues: Successful cross ventilation requires a building form that maximizes exposure to the prevailing wind direction, provides for adequate inlet area, minimizes internal obstructions (between inlet and outlet), and provides for adequate outlet area. An ideal building footprint is an elongated rectangle with no internal divisions. Siting should avoid external obstructions to wind flow (such as trees, bushes, or other buildings). On the other hand, proper placement of vegetation, berms, or wing walls can channel and enhance airflow to windward (inlet) openings.

2.3.2 Implementation Considerations: Cross ventilation for occupant comfort may direct air flow through any part of a space if the outdoor air temperature is low enough to provide for heat removal. At high outdoor air temperatures, cross ventilation may still be a viable comfort strategy if air flow is directed across the occupants (so they experience higher air speeds). Cross ventilation for nighttime structural cooling (when adequate wind speed exists) should be directed to maximize contact with thermally massive surfaces. A design caution: high outdoor relative humidity may compromise occupant comfort even when adequate sensible cooling capacity is available.

2.3.3 Design Procedure: Cross ventilation should normally be analyzed on a space by space basis. An exit opening equal in size to the inlet opening is necessary. This procedure considers only sensible loads and calculates the size of the inlet (assuming an equal sized outlet).

1. Arrange spaces to account for the fact that building occupants will find spaces near inlets (outdoor air) to be cooler than spaces near outlets (warmed air). Substantial heat sources should be placed near outlets, not near inlets.
2. Estimate design sensible cooling load (heat gain) for the space(s)—including all envelope and internal loads (but excluding ventilation/infiltration loads). [*units are Btu/h or W*]
3. State the design cooling load on a unit floor area basis. *Btu/h ft² or W/m²*
4. Establish the ventilation inlet area (this is free area, adjusted for the actual area of window that can be opened and the estimated impact of insect screens, mullions, shading devices) and the floor area of the space that will be cooled. The inlet area may be based upon other design decisions (such as view) or be a trial and error start to cooling system analysis. *ft² or m²*
5. Determine the inlet area as a *percentage* of the floor area: (inlet area / floor area) x 100
6. Using Figure 2 (see below), find the intersection of the inlet area percentage (Step 5) and the design wind speed (from local climate data). This intersection gives the estimated cross ventilation cooling capacity—assuming a 3°F [1.7°C] indoor-outdoor air temperature difference. Design wind speed should represent a wind speed that is likely to be available during the time of design cooling load.
7. Compare estimated cooling capacity (Step 6) with the required cooling capacity (Step 3).
8. Increase the proposed inlet area as required to achieve the necessary capacity; decrease the proposed inlet area as required to reduce excess cooling capacity.

This design procedure addresses “worst case” design conditions when outdoor air temperatures are usually high. Extrapolation beyond the values in Figure 2 for greater Δt s is not recommended as a means of sizing openings. On the other hand, greater temperature differences will exist during the cooling season permitting a reduction in inlet and outlet size under such conditions. Extrapolation for higher wind speeds is not recommended due to discomfort from too-high indoor air speeds. Also, wind speeds at airport locations can be very different than at the city center or in suburban areas, depending upon the terrain. During schematic design, adjustments can be made to account for these variations by comparing “local” and airport wind speed data. As a rough estimate, urban wind speeds are often only a third of airport wind speeds; suburban wind speeds two-thirds of airport speeds.

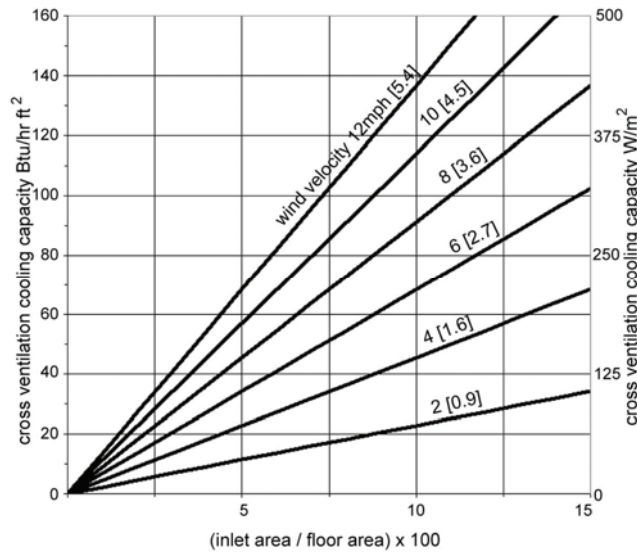

Figure 2: Cross ventilation cooling capacity. Heat removed per unit floor area (based upon a 3°F [1.7°C] temperature difference) as a function of size of inlet openings and wind speed.

3. CASE STUDIES

The nine case studies presented in the book (see Table 2) include a range of buildings selected to provide a diversity of geographic locations, climates, building types, and strategies. The design teams for these projects have made strong statements about green design intentions and have provided fertile ground for designers to learn from their projects. Each case study is organized as follows:

- A general description of the project
- A sidebar "scorecard" with building, climate, client, and design team information
- A statement of design intent and related design criteria
- Design validation methods employed (modeling, simulation, hand calculations, etc.)
- A description of the green strategies used
- Post occupancy validation results (if available).

Table 2: Case Study Projects in *The Green Studio Handbook*

PROJECT	LOCATION	ARCHITECT
Arup Campus Solihull	Solihull, UK	Arup Associates
Beddington Zero Energy Development	Surrey, UK	Bill Dunster Architects
Cornell Solar Decathlon House	Ithaca, NY, USA	Cornell University
Druk White Lotus School	Ladakh, India	Arup Associates & ARUP
Habitat Research and Development Centre	Windhoek, Namibia	Nina Maritz
The Helena Apartment Tower	New York, NY, USA	FX FOWLE
Lillis Business Complex	Eugene, OR, USA	SRG Partnership
National Association of Realtors Headquarters	Washington, DC, USA	The Gund Partnership
One Peking Road	Hong Kong, China	Rocco Design Ltd.

3.1 Sample Case Study: Lillis Business Complex

The University of Oregon's Lundquist College of Business needed to replace an aging building that connected three existing smaller buildings. The building's site, along an axis between the historic entrance to the college and the main library, gives it a high profile. The university had in place a campus-wide sustainable development plan and Lundquist College had a commitment to certain sustainability goals—as a result both parties had a mutual desire to aim for the greenest building possible.

The University engaged a Construction Manager/General Contractor who was brought into the project early in the design process. This enabled the design team to work closely with the GM/GC as the design developed, ensuring that the design was feasible and within the established financial parameters. Lillis was a complex project—to be built in the middle of an active campus, while minimally disrupting classes.

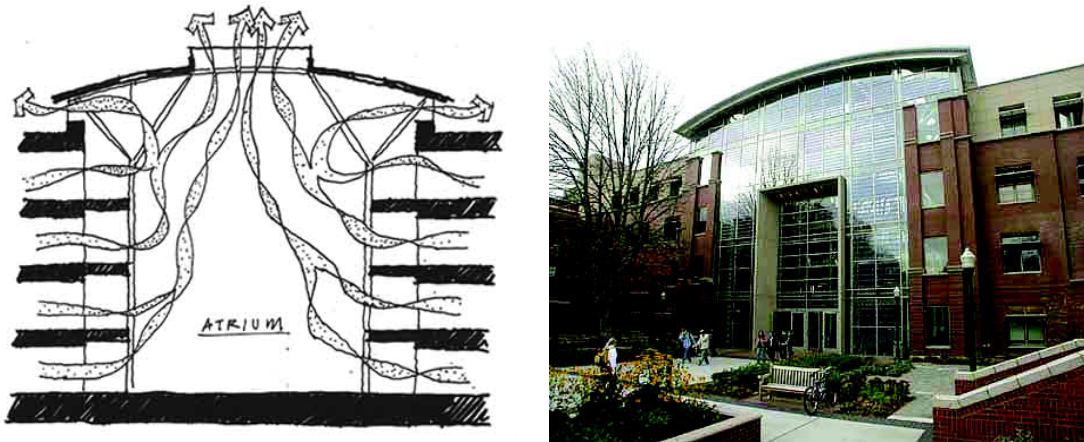

Figure 3: Early conceptual sketch (left) of air flow patterns through the Lillis Business Complex atrium (courtesy of SRG Partnership); entry plaza (right) with a façade of laminated glass with integrated photovoltaics.

3.1.1 Design Intent and Validation: The client and designers began with a goal to achieve a building that would be at least 40% more efficient than required by the Oregon Energy Code. The designers were also asked to follow a process that could result in a solution with the performance of a LEED (the US Green Building Council's Leadership in Energy and Environmental Design program) accredited building. The decision to pay for the formal LEED process, however, was not made until after the designers had finished working drawings. To make these goals a reality, the design team developed complementing strategies involving daylighting, solar control, natural ventilation, electricity generation using photovoltaic arrays, expanding the thermal comfort zone (by occupant cooling with ceiling fans), night ventilation of thermal mass, and wiring half of all the plug load receptacles and lighting circuits in faculty offices on occupancy sensors. A team of consultants, including energy engineers and daylighting experts, modeled various designs to determine how well design concepts were meeting project goals. The CM/GC agreed to recycle 95% of the demolition waste from the existing buildings (related to LEED Materials & Resources credits).

3.1.2 Strategies

3.1.2.1 Orientation and form. The designers conceived of the building as a long and thin form running along an east-west axis. The north- and south-facing windows are easy to control relative to daylighting and solar gain and they take advantage of the prevailing seasonal wind directions on site (from the north and south).

3.1.2.2 Natural ventilation. In addition to the long and thin form, the auditorium and lecture hall push out beyond the primary edge of the building, providing these rooms with more building skin, and more opportunity for clerestory windows and skylights to act as inlets/outlets for natural ventilation. A four-story atrium organizes the building spatially and provides a means for stack ventilation.

3.1.2.3 Solar control and daylighting. When the building is in cooling mode, computers automatically close shades or skylight louvers in unoccupied rooms to minimize solar gains. When people enter a room, the computer control opens the shades/louvers as far as necessary to reach a targeted illuminance for the space. Using daylight not only makes people happy and more productive, it is a "free" source of light and produces less heat for a given illuminance than electric lighting. Lightshelves are used on the south-facing windows. External overhangs shade the windows, especially from the high summer sun, and effectively reduce cooling loads.



Figure 4: Light shelves and ceiling fans in a south-facing Lillis classroom (left photo courtesy of Emily J. Wright; right photo courtesy of SRG Partnership).

3.1.2.4 Integrated cooling systems. Outside air is used to cool the building and the occupants as much as possible before relying on mechanically-cooled air. A mixed-mode cooling system, as well as night ventilation of mass, provides for a high-efficiency cooling approach.

3.1.2.5 Hybrid ventilation. Classrooms have raised concrete floors, arranged into risers for seating. Air is drawn in from the outdoors, passes under the floor slab and enters the room through outlets in the risers. If the outdoor air is too warm to effectively cool a space, it can be mixed in a plenum with mechanically-conditioned air. The air from the classroom is exhausted into the atrium, rising to the top and exiting through gravity ventilators. Eugene's cool nighttime temperatures make night ventilation of mass a viable strategy. The raised concrete floor slab absorbs heat during the day as the outside temperature rises and the sun and occupants add heat to the space.

3.1.2.6 Photovoltaics. The south-facing glass curtain wall with integrated polycrystalline photovoltaic cells comprises a 5.9 kW array. There are translucent PV panels in the skylights, which are equivalent to a 2.7 kW array. Roof panels on the mechanical room produce 6.2 kW, and other roof sub-arrays provide 29.9 kW—for a grand projected total of 45 kW of PV power. The local utility played a key role in providing financial incentives for this signature renewable energy feature.

CONCLUSIONS

The Green Studio Handbook is purposely not a comprehensive manual on building science; nor is it a “how-to-get-a-green-rating” handbook. Although the book is partly a compilation of strategies, it is intended that these strategies be applied in the context of a well-organized design process—where the architect is an active participant in the shaping of a green building and in coordinating the integration of green design strategies. Passive or active strategies can be used to achieve green building status. While these approaches may provide similar quantitative building performance, the way they reach that point is very different in both process and form.

It is our belief that architects are the ones who must guide the inclusion and integration of green strategies. The ability to do so is becoming increasingly critical in the face of growing client and societal interest in green buildings, burgeoning discussion of “sustainability,” and a recent call to develop carbon-neutral (or carbon-responsible) buildings. We hope and expect that this book is adopted by students as a self-selected required reading for their design courses. Practice is essential to confidence; the how-to experience gained through studio implementation will become more and more a part of the graduating designer's inner understanding. Then it will flow into practice. Students are likely to be the real agents of change.

ACKNOWLEDGEMENTS

The authors gratefully acknowledge the contributions of Laura Briggs and Jonathan Knowles to *The Green Studio Handbook's* chapter on design process, portions of which are presented (in edited form) in Section 1 of this paper. The nomograph shown in Figure 2 was developed by Kathy Bevers from equations in *Mechanical and Electrical Equipment for Buildings*, 10th edition.

Community and Urban Design

Research x Design: Urban Design Charrettes from the Design Centre for Sustainability at the University of British Columbia*

Ron Kellett

Phantom Housing: The Rise and Fall of Public Housing in North America

Benjamin Gianni

Mapping Urbanity: A Trajectory of Urbanity and Its Role in the Morphology of the Biosphere

Maria del C. Vera, Shai Yeshayahu-Sharabi

School Environment and "Green" Transportation

Xuemei Zhu

Community Design Parameters and the Performance of Residential Cogeneration Systems

Hazem Rashed-Ali

* Invited Oral Presentation

Phantom Housing: The Rise and Fall of Public Housing in North America

Benjamin Gianni

School of Architecture Carleton University, Ottawa, ON

ABSTRACT: This paper examines the rise and fall of public housing in North America in order to explore the principle of sustainability. By extension, it addresses the concept of sustainability as it relates to the city. Urbanity is simultaneously the most and least sustainable form of development. While extremely sustainable from the point of view of density (economies of scale, efficient use of infrastructure, etc.), it is highly vulnerable to social, political and economic forces. Such forces can easily trump the environmental sustainability of any building or community.

The death and transfiguration of key portions of our public housing stock provides insights into this phenomenon – for which I will use Toronto’s Regent Park as a case study. The redevelopment of this 69-acre parcel aims to transform a failed social vision into a model for sustainable community development.

Conference theme: Urban Design and Sustainable Elements

INTRODUCTION

Pruit-Igoe was demolished to great aplomb in 1972. The detonation of Yamasaki’s infamous housing project marked the beginning of the end of a social project and, arguably, of architectural modernism as a form of agency. The modernist *architect-qua-reformer* was discredited. By the mid ‘70s the building of large-scale public housing had all but ceased. It was determined that direct government involvement in the construction of housing (never not controversial in North America) was neither sustainable nor proven to have benefited the constituencies it was intended to benefit.

The bulk of public housing in North America was realized in the fifty-year period from the Depression through the 1970s. The traces of this activity are now being erased -- just as the neighborhoods it replaced were cleared to accommodate new approaches to housing and to city form. In the past decade, 125 different US housing authorities have received funding to demolish close to sixty thousand units of public housingⁱ. Among these are the usual suspects (i.e., the notorious “vertical ghettos” of the 1960s) as well as model, low-rise projects constructed during the Depression. Public housing is disappearing where you’d most expect it might – e.g., Chicago’s decimated South Sideⁱⁱ – but also in less likely places, namely the housing-starved neighborhoods of New Orleans. The demolition of the housing stock is less a question of its location, design or need than of the cost of life-cycle investment.

Given the focus of the conference, this paper explores the sustainability of public housing as a political, ideological, social, logistical and architectural undertaking. Key in the issue of sustainability is the ability to sustain public support. Given how controversial it was to build, it would be more controversial to invest in the life-cycle improvements required to upgrade the public housing stock to align with current standards. The alternative is to find innovative ways to replace it.

Although the dismantling of large-scale housing complexes in North America strongly suggests that public housing, in the manner it was realized, was not sustainable, there is a potential silver lining. Redevelopment presents an opportunity to apply sustainable design principles to the re-design of portions of our cities. Regent Park, a 69-acre public housing complex in downtown Toronto, is one example. Using Regent Park as a case study, this paper will consider what the history of public housing can teach us about the concept of sustainability as it applies to the city.

1.1. Public Housing

Public housing represents a relatively modest percentage of the overall housing stock in North America; in Canada it accounts for only 4%. For the purposes of housing policy the population is divided into five equal parts or *quintiles*. Targets project that the top three fifths (or 60%) should live in units they own while the remaining two fifths (40%) be accommodated in rental housing. It is expected that half of those who rent will pay market rates for their units while the remaining fifth, the lowest quintile, will qualify for rent subsidiesⁱⁱⁱ. Policies assume that no household should be forced to spend more than 25% of its income on housing.

Given that public housing comprises only 4% of the overall housing stock, only a fraction of the lowest quintile – the approximately 20% of households that qualify for subsidies – can be accommodated in government-sponsored housing. The majority of households receiving subsidies live in market (privately owned) rental housing^{iv}.

As these figures demonstrate, direct government participation in the building of housing in North America is extremely low. This is in marked contrast with Europe where percentages of home ownership are significantly lower and where the bulk of the (rental) housing stock was built under the auspices of the government. This is not to say that governments in the US and Canada do not exercise control over the housing market, indeed they do. But housing in North America is controlled indirectly, through codes and regulations, legislation, lending policies, loan guarantees, and a wide range of tax incentives. Together these mechanisms are applied and adjusted to produce the quintile targets described above.

Government-sponsored housing is both a fairly recent and relatively short-lived phenomenon. Among the first examples in North America were the dwellings built for military personnel during WWI. By the mid 1970s direct government building had all but ceased in North America, although small amounts of third party, non-profit housing continue to be built.

Government-sponsored housing falls into two general categories: “public” housing (housing built and administered by the government) and “social” housing (undertaken by a third party with some form of government support). Social housing includes rental units built by non-profit church groups, beneficent organizations, trade unions, and citizen’s groups. It also includes rental housing constructed by limited-dividend corporations (primarily insurance companies), much of which was built as market housing for the middle class during periods of housing shortages.

Public (as opposed to *social*) housing can be grouped into several categories:

- Wartime housing – built for military personnel and civilian workers involved in a war effort.
- The projects built for temporarily disadvantaged families from the late 1930s to the mid ‘50s. This housing was envisioned as a short-term way station, offering eligible families a “hand up not a hand out.” It was also promoted as a means of injecting money into the economy, shoring up a struggling construction industry and addressing acute shortages in rental housing.
- Projects from the late 1950s to the mid ‘70s built to accommodate the (predominantly poor) populations displaced by urban renewal projects.
- Housing for the elderly. This represents the largest percentage of the public housing stock. It should be noted, however, that much of the housing built for seniors is social housing, i.e., built and administered by third-party groups.

While the large-scale, high density and predominantly urban public housing projects built in the 1950s and ‘60s represent a relatively small percentage of the overall public housing stock, they have come to embody the idea of public housing in North America. These projects are conspicuous due not only to the scale at which they were realized (vast numbers of city blocks were razed and reconfigured to make way for them) but because of the form they took. More often than not, these agglomerations were conceived as of “tower-in-the-park” enclaves that broke open congested urban fabric and lifted tenants out of squalor.

In both scale and design the “tower in the park” ensembles represented an aggressive departure from the traditional grain of the city and from the more modest, Depression-era projects that preceded them. The radical design approach was intended both as an antidote to and a homily on the inability of the city to accommodate the myriad changes wrought by industrialization. Moreover, these enclaves are of particular interest to architects in that they embody the modernist vision of the architect as social engineer and reformer. They represented a new alliance between the architect/planner and the state -- an experiment with a new form of agency.

1.2. Regent Park

Toronto’s Regent Park is textbook example of the large, state-sponsored housing developments of the post WWII era. It comprises 69 acres on the east side of downtown Toronto and is home to 7500 people, all of whom

rent at subsidized rates. Prior to its redevelopment in the late '40s the area was a warren of small streets and laneways connecting a mix of wood-frame dwellings and light industrial buildings. The neighborhood was targeted for slum clearance as early as 1931 and was in exceptionally poor condition by the end of WWII.

To the planners who envisioned a new approach to the design of cities, the dilapidated condition of urban neighborhood testified to the fact that the city, as produced by market forces, was not sustainable. A new era called for new design principles, a new scale of intervention, and a more direct role for government in the stewardship of cities. Private initiatives could only address deficits in a piecemeal fashion; moreover the market (or the failure thereof) had produced the problem in the first place.

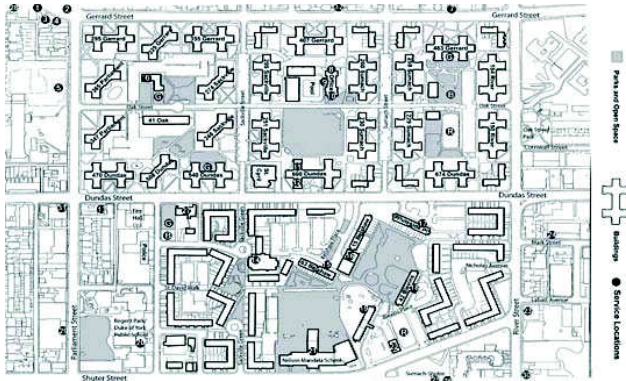

Figure 1: Plan of Regent Park, (pre-redevelopment), courtesy Toronto Community Housing Corporation

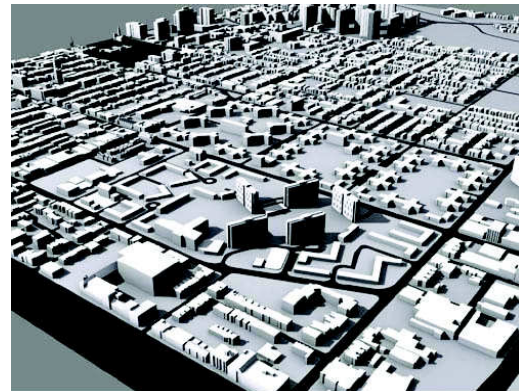

Figure 2: Model of Regent Park (pre-redevelopment), looking from southeast, courtesy author

Regent Park was constructed in two phases: the area north of Dundas St. (roughly 40 acres) in the late '40s and balance in the mid 1950s. Regent Park North was designed as an ensemble of three- and six-story walk-up buildings (“dumbbells” and “dog bones”), each with multiple, shared entrances and internal, double-loaded corridors. Ground level units had no direct access to the exterior, nor did many of the units include balconies or porches. The 6-story “dogbone” buildings were rotated at 45 degrees to the urban fabric to reinforce their separateness from adjacent neighborhoods. In all cases, buildings pulled away from and downplayed any relation to streets and access routes.

Pre-development, this 6-block area contained 765 dwelling units and several commercial properties, covering 36% of the area. Regent Park North was originally designed to accommodate 854 families and occupy only 15% of the land area. The goal of building higher was to free up land as “open space” for the community. Vacant land on the site meant that 248 new units could be constructed before any existing units were demolished.^v The new design of the neighborhood turned it inside out, consolidating all exterior spaces and eliminating private stewardship of land. Space became a community amenity under the aegis of the government.

Regent Park South (approximately 30 acres) was developed as a combination of townhouses and high-rise towers. While the inclusion of townhouses suggests a return to more time-honored urban housing types, the fourteen-story towers are resolutely modernist. These five towers are comprised of double-story units accessed through a skip-stop corridor system. And, as with Regent Park North, an effort was made to erase the pre-existing street grid and float the buildings in a sea of parkland to promote the feeling of a self-contained campus. Like the “dogbone” buildings of Regent Park North, the towers were positioned at 45 degrees to the pre-existing street grid.

As was the case for many public housing developments realized in the '30s and '40s, Regent Park was envisioned as way station for temporarily disadvantaged families. Given the anticipated brevity of the stay, the focus was on the quality of the unit (heat, running water, privacy) rather than on the provision of community infrastructure. Two-parent families with children were given priority as units came available. Social workers screened applicant families carefully to assure that those admitted had the best chance of success, i.e., would be most likely to move on in short order. Inevitably, however, the demographic of Regent Park changed over time. As policies increasingly privileged the most disadvantaged, the percentage of two-parent families dropped (as did the average household income) and the average length of stay increased substantially. In this context, the lack of community infrastructure in Regent Park became ever more problematic.

Crime rates climbed as the urban core deteriorated through the 1970s. The particularities of Regent Park's design proved propitious for criminal activity – most of which was attributable to individuals living outside the

community. The lack of connection between individual units and the exterior meant that communal spaces were difficult to patrol; what was envisioned as a park became a collective no-man's land. Moreover, the absence of through streets made it difficult for police cruisers to patrol the neighborhood effectively. The designers' vision of Regent Park as an urban oasis proved problematic for an increasingly isolated and disenfranchised community.



Figure 3: Regent Park North, 6-story "dogbone" building, courtesy Toronto Community Housing Corporation



Figure 4: Regent Park South, "skip-stop" high-rise, courtesy Toronto Community Housing Corporation

Changes in the last several decades, however, have attracted segments of the middle class back to the city -- particularly households without children. As of the mid 1970s the average cost of a house in the suburbs outpaced the average cost of a house citywide. As a result, first-time homebuyers began looking for alternatives. With advances in birth control and the choice to wait longer to have children, urban living re-emerged as a viable alternative. Supporting this trend, the introduction of the condominium designation made it possible both to live in the city and own one's dwelling.

The net effect of this is as follows: the cities in opposition to which housing projects like Regent Park were built no longer exist. Urban centers have transformed twice in the past fifty years. The city is neither the overcrowded and under-served environment it was at the end of WWII, nor is it the abandoned and deteriorating carapace it had become by the 1970s (i.e., the city on which post-WWII suburbanization had taken its toll).

1.3. Circumstances Leading to an Opportunity

Unlike Europe where the focus was on rental housing, post WWII housing policy in North America encouraged home ownership. Mortgage programs promoted the purchase of small, detached, single-family homes, virtually all of which were produced by the private sector. The majority of the growth in the post-war period occurred on the periphery of large cities where land was abundant, inexpensive and increasingly accessible. Roughly 80% of the housing stock in Canada was built after WWII and the vast majority is suburban.

As the middle class migrated to newly built homes in the suburbs, the tax bases of most large cities dwindled. Diminished services (schools, etc.), in turn, exacerbated the drive to decamp. In reaction to the cumulative effects of suburbanization, governments supported the expropriation and large-scale redevelopment of the core. In some cases, e.g., Lafayette Park in Detroit, the goal was to encourage the middle class to return or remain in the city by providing viable alternatives to suburban homeownership. In most cases, however, urban renewal accommodated a shift from residential to commercial usages -- augmenting the desirability and accessibility of the core as a place to work and/or engage in leisure activities. Redevelopment also presented the opportunity to adjust the traditional grain of the city. Smaller blocks were consolidated into superblocks to accommodate buildings with larger floor plates and to make way for new transportation corridors.

Poor and lower middle class neighborhoods (comprised of high percentages of renters) were razed to make way for new cultural, commercial, and transportation infrastructure. The housing of those displaced was the *raison d'être* of many of the larger housing projects in the 1960s and '70s. Seen in its most positive light, urban redevelopment was envisioned as an opportunity for city to rebuild its tax base and offer displaced residents an improved standard of housing.

Whether they were built on (or adjacent to) the neighborhoods they replaced or in isolated corners of the city, these housing enclaves distinguished themselves from their surroundings. The design aspirations were inward, upward and away from adjacent neighborhoods. As was the case with Regent Park, many of these developments were cut off from city streets to discourage through-traffic. Planners envisioned protected green space over which children could roam freely; the effect, however, was ghettoization and stigmatization.

More often than not, modernism was adopted for its economy, not for its design. Although it was certainly promoted on the basis of design principles -- light and air, lifting the tenant out of the dirty morass of the adjacent fabric, creating green lungs to enable the city to breathe -- high-rise blocks were privileged for expediency and in service of open land (although the cost effectiveness of this can and has been argued). Given the decision to go vertical, many of the projects were built higher and/or at a greater density than originally designed.

Perhaps more importantly, the “tower in the park” model was often built without the park. Being the last thing to go in, landscaping was often the first thing to be sacrificed when facing (inevitable) cost overruns. Moreover landscaping requires ongoing maintenance and can present security risks. It is easier to bathe bare terrains in floodlight than to police parks of hedges and mature trees. Even if resources were available to maintain it, tenants might be forced to choose between security and landscape amenities.

Perhaps most significantly, the demographic of the housing projects was more homogeneous than the neighborhoods they replaced. A variety of factors contributed to this including the lag between the demolition of the neighborhood and the availability of replacement housing. As selection processes increasingly favored the most severely disadvantaged, those who could afford to either choose or were forced to live elsewhere. Part of the problem was that the building of this housing was an externality, driven by non-residential redevelopment elsewhere in the core. In such cases housing was a means to a different end and could not command or sustain a significant amount of investment. While there is little question that many of the units demolished were substandard, what tenants gained in the quality of their units, they often lost in the quality of the community.

1.4. The (sustainable) Redevelopment of the Redevelopment

These notoriously conspicuous and conspicuously notorious projects have reached or are reaching their 40-year life cycle. A significant investment is required to upgrade them to current standards. As there is little support for rehabilitating what many consider to be failed social projects, housing authorities across North America are opting to demolish and replace them with market-driven housing. Over the past eight years, the US Department of Housing and Urban Development (HUD) has funded local housing authorities to demolish 60,000 units of public housing. HUD is also providing funds to replace these units and/or cause them to be replaced. To this end, local housing authorities are courting private sector partners with offers of free land, long-term lease guarantees, and tax incentives.

The decision to demolish is a function both of pragmatics and of ideology. It is arguably more cost effective to shift the responsibility for the construction, maintenance and operation of subsidized housing to the private sector^{vi}. But from an ideological perspective, the razing of housing estates is symptomatic of an acute and longstanding antipathy toward government-sponsored housing in North America. The dismantling of the most visible manifestations of public housing stock points to the fact that the combined political, social, and design ideologies underpinning these experiments have not proven sustainable.



Figure 5: Regent Park Phase I redevelopment parcel, pre demolition, courtesy Toronto Community Housing Corporation (TCHC)

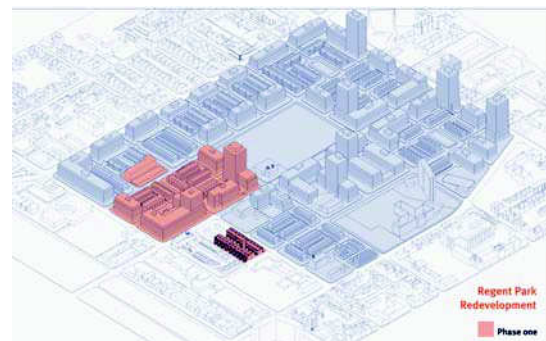

Figure 6: Proposed new construction, Phase 1, courtesy Toronto Community Housing Corporation

Where housing compounds are propitiously located in relation to desirable urban neighborhoods, the current real estate market presents its own incentives for redevelopment. Such is the case with Regent Park where Toronto Community Housing Corporation is brokering a \$1 billion redevelopment without the benefit of federal aid. While the form that the replacement housing takes varies with the project (in relation to its location and tenancy targets), subsidized units will be predominantly low rise^{vii}. These units are designed to engage streets and, where possible, have separate entrances and street addresses. Where feasible, market-rate rental and condominium units are included the mix both to offset costs and to diversify and stabilize the neighborhoods. With respect to community design, an effort is being made to return to pre WWII urban patterns and to knit these neighborhoods

Population

- Current: 7500, all RGI (rent geared to income or subsidized units)
- Proposed: 12,500 people (101 persons per acre)
- Delta: x 1.666

Number of units

- Current: 2083
- Proposed: 5100 units (74 units per acre) of which 1500 will be RGI
- Delta: x 2.4

1.5. Stepping Back to Move Forward

Costs (long- and short-term, financial and environmental), however, are not the only factor. Indeed, the most compelling aspect of the current chapter in the history of public housing is what it tells us about the limits of sustainability within a larger social, political and historical context. The fact that 1) virtually no public housing has been built in North America for the past 30 years, and that 2) the bulk of the public housing stock is not likely to survive its 40-year life cycle, suggests the degree to which the undertaking was not sustainable. But doing nothing -- allowing neighborhoods to deteriorate and ignoring the forces at play in the urban core during an era of mass suburbanization -- would have been neither a prudent nor sustainable alternative.

In considering the rise and fall of public housing it is helpful to distinguish between related considerations, namely

- *that* public housing was built (a necessary evil, an unpopular undertaking, doomed from the start)
- compared/opposed to *what was intended* (design issues/ideology, social vision)
- compared/opposed to the *way it was realized* (where it was built, what components of the design were actually realized, the level of funding, the quality of the construction, the terms of reference, etc.)
- compared/opposed to *how and by whom it was inhabited*, related to *how and by whom it was administered*
- compared/opposed to the *cost of doing nothing* (assuming this was even an alternative).

Among the issues at play, then, when considering where we go next are (in no particular order):

- Sustainability as a design consideration, both at the scale of the building and of the community.
- The sustainability of the *idea* of public housing in North America in relation to the form it takes. The form affects the level of political support, which, in turn, determines the long-term success of the undertaking. In this context form can mean *architectural form* (e.g., high rise or low rise, apartment or townhouse) and/or *urban form* (e.g., high density or low density, ratio of public to private spaces/amenities, degree of connection to or isolation from adjacent fabric). Arguably the fact that public housing takes form at all is at issue; experience suggests that subsidized housing survives best when it is invisible and/or indistinguishable from the housing stock at large.
- The role that environmental sustainability might play in engendering support for investment in model, mixed demographic communities -- among or within which may be aggregations of government-sponsored housing.
- The government's role in any urban initiative, and the terms of reference by which it can or should participate/intervene, especially when it is contributing financially or by legislative fiat.
- Sustainability as a function of the demographic mix of a community -- as expressed in the ratio of subsidized to market-rate units and of owner-occupied to rental units. Our experience with public housing in the 20th century strongly suggests that homogeneity is sustainable only in relation to wealth. In this respect, it is less the form (urban or architectural) that public housing takes that is at issue (indeed high rise complexes are a viable alternative for many sectors of the population), but its form in relation to the demographic it is expected to accommodate.
- The urban context as a milieu in which economic and demographic forces are constantly at play. This affects the ability of any building or complex of buildings -- particularly housing -- to survive. Arguably the failure of public housing relates not only to the demographic that inhabits it, but also to the fact that it rarely accommodates the demographic for which it was designed. Housing and communities must be designed to support change in order to survive it.
- Given that the terms, conditions and technologies surrounding sustainability continuously transform, we might question whether any building should survive its 40-year life cycle. Which buildings (should and/or do) survive and why? As noted above, the ability to adapt is one of the key criteria in evaluating the long-term

sustainability of a building or complex. Sadly neither design excellence nor an extremely high quality of construction can save a building that, for whatever reason, finds itself in the wrong place at the wrong time.

CONCLUSION

What we're witnessing with respect to the public housing stock in the US and Canada is a double erasure. Traditional mixed-use neighborhoods like Cabbagetown were razed to make way for the housing that is now being cleared to make way for (neo) traditional mixed-use neighborhoods. As such, it is important to consider how these events reflect on the concept of sustainability as it applies to the city. Indeed the urban renewal efforts of the 1960s and '70s were predicated on the fact that the city had proven unsustainable and that massive interventions were required to shore it up. Moreover reformers had argued for alternative forms of urbanity for more than a century before urban renewal initiatives were finally undertaken. The fact that modernist housing compounds are now being replaced with the very fabric they once supplanted reminds us that what is not sustainable in one era may emerge as the most sustainable alternative in another.

Implicit in these observations is the suggestion that portions of our modernist public housing stock should be preserved, rehabilitated and directed toward a different demographic. Indeed, the same strategies that Yamasaki applied to the design of Pruitt-Igoe (public housing) appear in his proposals for Lafayette Park (middle-class housing). Moreover had erasure proven effective as a strategy it is unlikely we would be considering the same strategy for the same sites in such short order.

That said, our public housing stock has several strikes against it:

- Depression-era projects were required to be built of an equal or lesser quality than adjacent, privately owned rental housing lest they compete with (and further disadvantage) private landlords. More often than not, the adjacent housing stock was of questionable quality.
- Most of these projects were built without community infrastructure, lest they encourage (implicitly or explicitly) tenants to stay.
- More often than not, the public housing stock has been subject to changing demographics, meaning that complexes rarely accommodate the constituencies for whom they were designed. The effect has been to put the buildings under extraordinary stress. Arguably, the lower the income of the tenant, the more stress a unit is subjected to.
- Enmity toward the poor, racial discrimination, and a deeply ingrained anti-urban sentiment translated to a profound lack of support for much of what was built – meaning it was built with as little money possible and in the least desirable locations. In other words, it was not designed to last. Arguably this is consistent with the idea that public housing should serve as a temporary way station for temporarily disadvantaged families. As real solutions to poverty and housing were seen to lie elsewhere, investing in public housing was seen as treating the symptom, not the problem.
- Housing complexes often accompanied or were the result of adjacent infrastructure projects (e.g., interstates) that cut them off from the surrounding city. This isolation exacerbated their decline.

Thus where cities are concerned, principles of sustainability must take account of the concept of change in its myriad manifestations. Among these is the cyclical phenomenon of death and transfiguration. The opportunity to apply a *sustainability-informed* agenda to the redevelopment of public housing complexes represents an opportunity to re-write the ending to a story whose plot has been ambiguous at best. In both its previous (post WWII) and imminent incarnations, Regent Park has been a laboratory for the best minds and most worthy aspirations of our era. As a model sustainable community (assuming it manages to realize the goals it has set), Regent Park's transfiguration will be tantamount to redemption.

ⁱ Funding is provided under the Hope VI program.

ⁱⁱ The Chicago Housing Authority alone will demolish 12,000 units across 31 different projects. These include the high-rise structures such as the Robert Taylor Houses on Chicago's South Side as well as the 4-story Ida Wells and Jane Addams Houses built during the Depression.

ⁱⁱⁱ Both Canada and the US have exceeded their ownership targets; approximately 66% of households own homes.

^{iv} This program is known generally as Section 8 in the US.

^v "Statement by Mayor Robert H. Saunders in Connection with Regent Park Low-Cost Housing Project" (Toronto, December 1946), pg. 1, as cited in Rose, Albert, *Regent Park: a Study in Slum Clearance*, 1958, University of Toronto Press, pg. 64

^{vi} Much of the rental housing built by government authorities in Europe is also being sold off to the private sector.

^{vii} See description of housing being planned by the Chicago Housing Authority on the site of the former Robert Taylor houses, CHA web site.

^{viii} Source, Toronto Community Housing Corporation, November 2006.

^{ix} Another excellent example of a social housing rehabilitation that led to some significant sustainability results is the Benny Farm project in Montreal. See www.bennyfarm.org

Mapping Urbanity: A Trajectory of Urbanity and Its Role in the Morphology of the Biosphere

Maria del C. Vera, Shai Yeshayahu-Sharabi

Southern Illinois University, Carbondale, IL

ABSTRACT: The milieu of the city, propelled by the socio-economic agendas of urbanity, preclude city planners from imagining design strategies that can oversee the well being of life. As urbanity expands its presence in the planet; the introduction of *The City in History* [Mumford, 1961] –“*Will the city disappear or will the whole planet turn into a vast urban hive?*”–, visualizes the scope of urbanity in relationship to the size of this planet.

Through a macroscopic vintage and supporting theories from emerging sociologists, economists, geographers and political scientists, this presentation aims to extend urban discourse from concerns regarding the disappearance of the city, towards a managerial reality –how can the planet survive as one vast urban hive? –

In this context, general master plans executed by urbanist that defined the city with buildings, bridges, highways, trains, airports and water routes are blurred; instead increasing dependencies extending beyond local peripheries of richer and poorer cities are highlighted; to demonstrate that urbanized and un-urbanized sites merge their interdependencies beyond distinguishable scopes.

Keywords: scale, local/global, perspective, practice

INTRODUCTION

Professional urban planners accumulate collections of buildings, plans, text, and laws that fully explain the formation and vision of the city through the ages; yet unlike scientist, geologist, geographers, astronomers, and biologist, few have been able to visualize and track the effects or scale that urbanity post to the evolution of this small planet. Today, as accelerated changes made by new compositions in the geosphere erode the atmosphere, life's existence is at risk.

Thus, our study visualizes the complex relationships that exist between the ever-changing characteristics of earth and the built environment to advance the discourse of urbanity beyond the unsustainable scale of the city towards the managerial scopes of the “vast urban hive” [Mumford, 1961]. Primarily because, previous centuries were guided by socio-political agendas that capitalized on the strengths of networking; a strategy that has been re-organized into “spaces of flows” and “timeless time”; displacing the need for cities to exist, and obscuring the perception of where urbanity lies--[Castells, 1996].

The city of the 20th century that thrived under the repetition of malls, gated communities, and theme parks is obsolete [Barber, 2002]. New restrictions and possibilities within the biosphere are transcending our understanding of networks and economic wealth towards forgotten roots found in compact centers, civic arenas, and public spaces of our past. At the dawn of the 21st century it is possible to grasp how the planet and its ever-evolving system is capable of existing with or without the presence of life yet, life is conditioned to a specific formula directly dependant on a calibrated composition of 78% nitrogen, 21% oxygen, 0.93% argon, 0.04% carbon dioxide, and traces of other gases. Thus, living and non-living matter form one undistinguishable whole that can sustain or eradicate life.

Under such an umbrella, developments and dissemination of knowledge become the primary tools to propose new urban dispositions where planning is no longer a discovery configured by independent institutions in singular cities, but rather a morphological organism formed and informed by intelligent decisions capable of manipulating the atmosphere. [Vernadsky, 1926].

To truly exploit the intelligence of urban planning, relationships between site specificities and environmental constraints ought to scientifically and collectively sustain the existence of life. This discussion transfers urban

design from seeking solutions through aesthetics or geometrical principles to developing informed strategies based on scientific data. The underlying premises of this proposition are few: **SIZE** -cities relied on the whole planet for their prosperity. **TRANSFORMATION** –as urbanity becomes the dominant living force, the parameters and protocols for augmenting wealth will shift from consumerism to reason. **ADAPTATION** –informed knowledge transforms, constraints, and provides possibilities to manage the existence of life.

SIZE-cities rely on the whole planet for their prosperity.

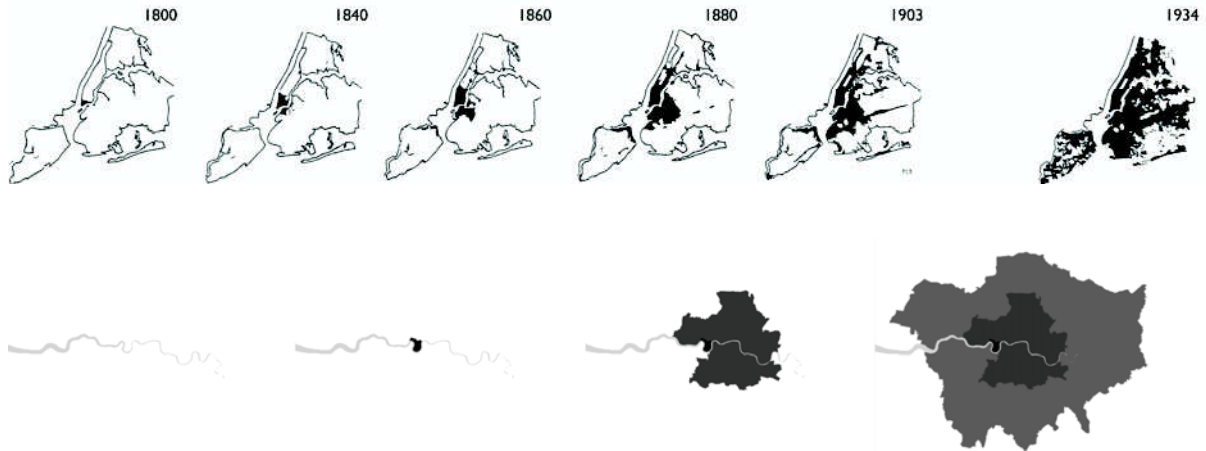

Fig.1 The Megapolis.

Source: (recomposed by author 2006)

Cities and their webs of foods and goods make up complex meshes and footprints that surpass their own physical realms. (Fig.1) Examples of such cities abound, London, and New York, are magnified to articulate how their megalopolis enterprise and occupy large territories across the globe. Such cities will not disappear. In addition, their interdependent networks are traceable and linked in similar modes to those of their ancient counterparts that ignited economic dominance of transcontinental scales, as discussed in Before European Hegemony [Abu-Lughod, 1989].

Thus, through a macroscopic point of view, a larger scale is ultimately recognized; one that transcends beyond European hegemony, beyond global hegemony, towards the dominance of a vast urban globe. Our mapping processes opportunistically identify a zone of urban hegemony (Fig.2) and magnifies the discourse about the production of capital and alliances among powerful networks. It shows how world cities physically interconnect through a geodetic zone where the production of environmental changes thrives.



Fig 2 The 30 60 zone of urban hegemony

Source: (Author 2006)

Human dominance places the survival of heterogeneous forms at risk. Viewing how a large portion of the earth is saturated with urban similarities and how all aspects of organic diversity are indistinguishably intertwined to the manmade objects; introduces the idea that the dispersal of world cities and their current networking systems impinges on the fundamental composition of the biosphere. The existence of urbanity is no longer resting among interconnected socio-economic places instead it is linked to the transformations of networks, alliances and selective morphologies that can regulate the atmospheric conditions necessary to sustain life.

TRANSFORMATION-to augment the planet's wealth cities must diversify their use of space.

Undoubtedly, as urbanity becomes the dominant living force in the planet, the parameters and protocols for augmenting wealth will shift from consumerism to reason because, cities exceeded their endless territorial extensions and entered a complex interdependency with all living and non-living matter. In this regard, the contradictions between current spaces of power and powerless spaces are now interchangeable. Urban places recognized as part of the world economy and unrecognized places supporting the economy of the world are intertwined systems attempting to survive. (Fig.3) Thus, the areas absent of light, population and food are also part of the equation as well as the deserts, jungles, rainforest, and oceans; all places house qualities to augment the wealth of the planet and stabilize the atmosphere.

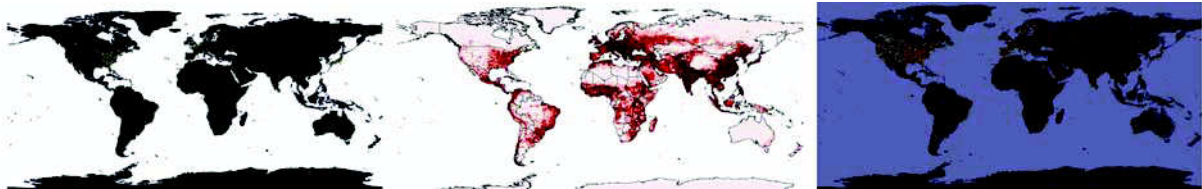

Fig 3 Superimposition of visible data to demonstrate inequalities

Source: (Rand McNally 2005)

A perceptual shift is occurring as mankind recognizes that cities and networks before the 21st century flourished under the affluence of land and resources; while the cities of this millennium intensify in population and built densities, under deficits of both. Thus, shifting from fields of infinite resources to compact places of limited scopes is necessary. Buckminster Fuller already discussed this premise in his text "[Operating Manual for Spaceship Earth](#)". Yet, this discourse does not intent to project catastrophic fatalities, instead, it heralds a enormous drift in design processes that can regain equilibrium of land, people, and resources as urbanity enters a small planet.

Grouping and reinventing resources are the tools of the day and noting that hives are adaptable, nest in diverse environments and exist under limiting conditions within compact habitats; physically and scientifically provide lessons to maximize efficiencies and augment wealth. Thus, the "vast urban hive" transcends political peripheries and continental limitations in order to rethink the size of urbanity.

ADAPTATION –knowledge transforms constraints and possibilities into managerial goals.



Fig 4 Towards diversity

Source: (multiple)

Informed design decisions are invaluable. In the age of ubiquitous knowledge, nourishing the atmosphere is scientifically possible. Accordingly, Vladimir Vernadsky defined the state of deliberate change in the biosphere when he identified that man's cognitive power could transform the formation of the biosphere into something new; he called it the noosphere. Thus, scientific knowledge and design abilities are necessary for the transformation of the biosphere. Designing the chemical composition of the biosphere will alter the self generative system, into the manmade noosphere. Thus, the noosphere will sustain life. However, the noosphere like the biosphere will continuously change and the formation of life will perpetually alter as new data creates new conditions and demand more precise calibration and modifications.

Thus, designing with knowledge is perhaps a form of hacking that can condition the perpetual existence of life. Accordingly, understanding that the composition of the planet is not made of prototypical patterns; it is made of unpredictable forms that are ever-changing as new characteristics unfold through time and in time, is essential.

INITIATIONS

In Brazil, fifty years ago, Curitiba sought an urban model to slow down its sprawl and effectively compress the city's growth. It was a site specific mode of seeking solutions that could sustain their economic growth. Thus, young architects, who were not impressed with urban trends that sought to produce large buildings and massive infrastructures, thought about the environment and its inhabitants. Their work became a case study for better planning that altered Curitiba's master plan. Jaime Lerner spearheaded the new planning goals by thinking small, cheap, and interdisciplinary. Through a participatory system, where citizens became involved he quickly solved the city's immediate problems of water, waste, transportation and education.

Today, Curitiba has become a model for cities outside and inside the zone of power to follow. These initiatives are improving and advancing the methods to contract the city's growth, despite their large influxes of people, waste and needs.

Among these visible undertakings is New York City's harbor agenda. Since the dawn of the 21st century, according to Cynthia Rosenzweig who is a research scientist at the National Aeronautic and Space Administration (NASA) Goddard Institute for Space Studies, NYC will set the example for a scientifically designed solution that seeks to alter the atmospheric composition as it becomes the first biosphere reserve. She and a team of interdisciplinary thinkers are engaged in the scientific initiative to implement corrective methods to actively safeguard the harbor area surrounding the five boroughs and its greater metropolitan zone. A botanical buffer is growing around its coastal peripheries, which will provide the tri-state area with a much needed flow of clean water. In addition, the elimination of the private car from its center core will reduce pollution and activate less intrusive modes for pedestrian circulation. Furthermore, their methods to collect data regarding both the short and long term effects of these implementations are the beginning of a lifetime commitment to the biosphere effect. Data collected will adjust as new implementations alter and transform the zone.

Emerging practices like this one where local solutions affect global changes herald the incoming noosphere where both science and design pivot the characteristics of the planet to perpetually sustain life. .

REMIX

Thus, political, environmental, and economic entities become interlaced systems of regulation that can capitalize on the wealth of knowledge. As the noosphere becomes a production of the human mind, the human mind, becomes the regulator that can neutralize urbanity and diversify a co-existing formula. This is a concept where careful investigations, rigorous data collection, and meditative fusions of ancient, local and emerging technologies can flourish. The idea is to brand not the built footprint of the city but the scientific observations extracted exclusively from local data. It suggests that a formula of cross mix information allows for design strategies to aid the planet in augmenting its evolutionary wealth. In addition, it implies that due to the ubiquitous nature of data filtration, an endless array of possibilities would form and inform the future characteristics of the planet.

This proposal lobbies for a nonlinear mode of practice, where if one imagines the possibility to affect life at the macro scale then one has to first think and act at the micro scale. Acting at the local scale, in specific ways, through a dynamic transdisciplinary mode of mixing ancient, local and emerging technologies, requires creative modes of processing. It suggests means to bank on the whole planet and augment the wealth of the city, without dwelling on simple examples as solutions and merging into complex relationships that are made up of intertwined forms that morph and transform the world.

This premise corresponds to the idea that the noosphere is an evolving cosmic governed by urbanity, and that one must envision the notion of learning to redesign life with actual information and knowledge provided by scientific facts, transcending plastic studies and flows of economies.

It signals mankind's full awareness of our small planet and the beginning of an adaptive mode that will trespass our vision of what we see and extend our brain to what we can get under an informed socio-economic agenda based on data.

REFERENCES

Abu-Lughod Janet, JAL., 1989, *Before European Hegemony: The World System AD 1250-1350*, Oxford University Press, New York, Oxford, Toronto.

- Barber Benjamin, BB. April 18, 2002. *Benjamin Barber, Examines Changing Character of Democracy in Suburbia*, Columbia University, New York, NY.
- Samson Paul, PS., Pitt David, DP., 1999, *The Biosphere Reader: Evolution of the Noosphere Concept*, Routledge, New York, NY.
- Castells Manuel, MC., 1996, *The Rise of the Network Society*, Blackwell Publishers Inc., Mandel, MA
- Castells Manuel, MC., 1997, *The Power of Identity*, Blackwell Publishers Ltd., Mandel, MA:
- Castells Manuel, MC., 1998, *End of the Millennium*, Blackwell Publishers Ltd., Mandel, MA.
- Delanda Manuel, MD. 1997, *A Thousand Years of Nonlinear History*, Zone Books, New York, NY.
- Delanda Manuel, MD., October 21 2004, *Non Organic Life*, Columbia University, New York, NY.
- Easterling Keller, KE. 2005, *Enduring Innocence: Global Architecture and its Political Masquerades*, MIT Press, Cambridge MA.
- Easterling Kelle, KE. 1999, *Organization Space*, MIT Press, Cambridge MA.
- Fishman Robert, RF., 1998, *Beyond Utopia: Urbanism After the End of Cities*, CCCB Urban Library, Barcelona.
- Friedman Thomas L, FLT., 2002, *Longitude and Attitudes: Exploring the World After September 11*, Ferrar, Straws and Groux, New York, NY.
- Friedman Thomas L, FLT., 2005, *The World is Flat: A Brief history of the Twenty First Century*, Ferrar, Straws and Groux, New York, NY.
- Fuller Buckminster R, BRF., 1969, *Operating Manual for Spaceship Earth*, Simon and Schuter, New York NY.
- Ebenezer Howard, HE., 1965, *Garden City of To-Morrow*, MIT Press, Cambridge MA:
- Irazabel Clara, Cl., 2005, *City, Making And Urban Governance In The Americas: Curitiba And Portlan [Design and the Built Environment]*, Ashgate Vermont.
- Mau Bruce, BM., 2004, *Massive Change*. New York: Phaidon Press.
- McHale John, JM., 1970, *The ecological Context*. New York, NY: George Braziller, Inc.
- Mumford Lewis, LM., 1961, *The City in History: Its Origins, Its Transformations, and Its Prospects*. Florida: Harcourt, Inc.
- Muñoz Francesc, FM., 2002, *The Multiply City: Metropolis of Territorians*. Venice: University Institute of Architecture in Venice
- Rosenzweig Cynthia, CR., 2001, Lecture at Columbia University: NASA/Goddard Institute for Space Studies. New York: Columbia University,
- Roger Richard, RR., 1998, *Cities for Small Planet*. Boulder, Colorado: West View Pres.
- Sassen Saskia, SS., 2000, *Cities in a World Economy*. Thousand Oaks: Pine Forge.
- Sassen Saskia, SS., 2001, *The Global City: New York London, Tokyo*. New Jersey: Princeton University.
- Vernadsky Vladimir I., VIV., 1998, *The Biosphere: Complete Annotated Edition*. New York: Copernicus.
- Yechayahu Shai, SY., Vera Maria, MV., 2005, *Territorial practices @ -1, 81*. Paper presented at the 2005 American Collegiate Schools of Architecture (ACSA) Southeast Regional; School of Architecture, Clemson University; Clemson, SC.

LIST OF FIGURES

3. Image source; De Agostini-Rand McNally, New World Atlas, Graphic Illustration; By Authors

4. After Janet Abu-Lughod, Before European Hegemony: The World System AD 1250-1350; After Saskia Sassen, The Global City: New York London, Tokyo; Movie clip <http://www.archive.org/details/CityTheP1939>, Graphic Illustration; By Authors

School Environment and “green” Transportation

Xuemei Zhu

Texas A&M University, College Station, Texas

ABSTRACT: School transportation in the U.S. is mainly made by vehicles, which consume a lot of energy and degrade our living environment. Walking and biking are alternative “green” modes of transportation with additional health and social benefits. However, the physical environment around school often makes walking and biking difficult, if not impossible, for children.

The primary section of this study reviews empirical studies on the relationship between physical environment and children’s walking and biking to school, or parents’ decision-making of such behaviors. A conceptual framework is proposed according to socio-ecological theory and the literature, and is used to organize research findings. For the relationship between objective physical environment and parents’ decision-making, perceptions of physical environment act as mediators, while personal and social factors function as moderators. The environmental support for walking and biking to school can be classified into macro-level walkability/bikability of urban forms (including distance, infrastructure, density, street connectivity, and land-use mix), micro-level walkability/bikability of urban design and architectural qualities (such as aesthetics, amenities, and maintenance), and safety from traffic and crime. Long distances, traffic dangers, and crime are topmost barriers for children’s walking and biking to school. A follow-up discussion explores the implications of these findings for evidence-based design and policy interventions.

The secondary section applies previous findings to a case study in Austin, TX, where 73 public elementary schools are analyzed for their attendance areas’ walkability and safety. Schools with higher percentages of Hispanic children appear to be more walkable in terms of macro-level urban forms, yet less walkable in terms of crime safety and micro-level urban design and architectural qualities.

Findings from this study supplement current knowledge about physical environment and “green” school transportation. They imply the importance of targeted interventions for specific contexts and populations in promoting walking and biking to school.

Keywords: School, environment, walking, biking

INTRODUCTION

In the U.S., children’s school transportation is mainly made by vehicles, which consume a lot of energy and degrade our living environment. Walking and biking are alternative “green” modes of school transportation, which also have additional benefits such as increasing children’s physical activity and fostering the sense of community. However, the physical environment around school often imposes barriers to this walking or biking trip. A national survey has been conducted with children’s (5-18 years) parents in 2004 by the Centers for Disease Control and Prevention (CDC), and has reported long distances, traffic dangers, and crime as topmost barriers for children’s walking to school (Martin & Carlson 2005). Currently, various programs are being developed to improve the relevant environmental support. In 2005, the United States federal transportation bill “Safe, Accountable, Flexible, Efficient Transportation Equity Act: A Legacy for Users” (SAFETEA-LU) authorized federal funding in the amount of \$612 million for the 5-year period (2005-2009) of the national Safe Routes to School Program.

The primary section of this study reviews empirical studies on the relationship between physical environment and children’s walking and biking to school, or parents’ decision-making about such behaviors. Fifteen articles and one dissertation were identified from online database, including the Web of Science, PubMed, and the National Transportation Library. The secondary section applies findings from literature review to a case study in Austin, Texas, where 73 public elementary schools are analyzed for their attendance areas’ walkability and safety.

1. LITERATURE REVIEW

1.1. Emerging Patterns and Conceptual Framework

The socio-ecological theory was widely employed in previous studies, addressing the impact of personal, social, and physical environmental factors, as well as the interactions among them. The physical environment has been measured both objectively and subjectively, and has shown related yet different results in terms of the environment itself or its impact on school travels. There was growing agreement that perceptions of physical environment acted as mediators between objective physical environment and parents' decision-making.

Based on socio-ecological theory, literature review, and McMillan's framework for children's school travels (McMillan 2005), I propose a conceptual framework to reflect the emerging patterns about the relationship between objective physical environment and elementary-aged children's school travels (Figure 1). As most previous studies, this framework assumes that parents are the primary decision-makers for children's school travels. Perceptions of physical environment act as mediators, while personal and social factors function as moderators, interacting with physical environment (both objective and subjective) and influencing the strength and direction of this environment-behavior relationship.

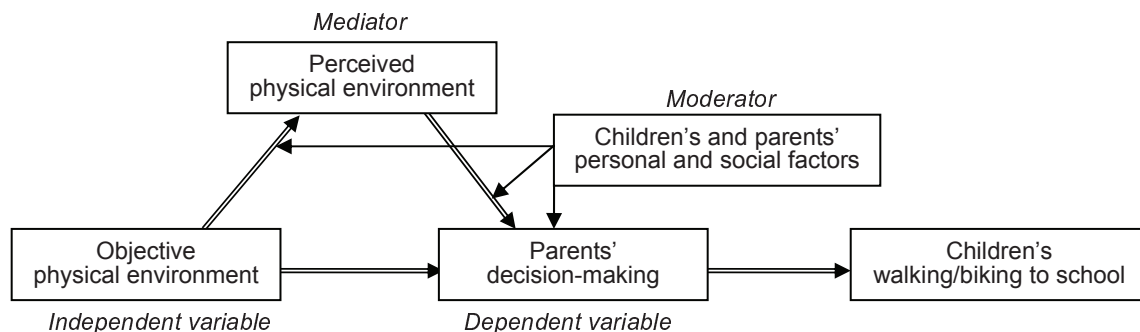

Figure 1: Conceptual framework for physical environmental correlates of elementary-aged children's walking and biking to school (Based on McMillan 2005)

1.2. Methods Used in Previous Studies

Previous studies varied from each other in terms of study settings, sample, research design, measures, data collection, and analysis, making it difficult to synthesize findings. Except two studies from Australia (Merom et al. 2003; Timperio et al. 2006), 14 other studies were conducted in the U.S. Two categories of research design were identified, including cross-sectional studies examining the environment-behavior relationship, which were the majority of studies and included two national surveys (Fulton et al. 2006; Martin & Carlson 2005), and intervention studies using pre-post comparisons or intervention-control comparisons, which might have the power to identify causality but were relatively rare (Boarnet et al. 2005 a, b; Staunton et al. 2003). The sample size varied across studies, ranging from 235 to 4,665 students. Elementary school children were the primary populations of these studies, although a few studies did focus on middle school or high school youth.

The dependent variable was either walking to and from school, or the combination of walking and biking as an active mode of school travels. The independent variable – physical environment – has been measured from various aspects and scales, and will be introduced in the following section. Ten studies out of 16 have controlled for one or more confounding variables, including personal factors of the child (such as age, gender, ethnicity, body mass index, and attitude toward walking) or the parents (such as education level, income level, marital status, and attitude toward walking, etc.). A few studies have also controlled for social factors such as family support or social and cultural norms about school travels.

Data collection primary relied on surveys with parents for information about children's school travels, family background, and parents' perceptions of the physical environment. In some studies, Geographic Information Systems (GIS) and field audits have been used for objective measures of the physical environment.

1.3. Physical Environmental Correlates

Various physical environmental variables have been examined in these studies. According to the units of analysis, they could be classified into two categories, including macro-level walkability/bikability of urban forms on relatively larger scales (such as the neighborhood or traffic analysis zone), and micro-level walkability/bikability of urban design and architectural qualities on smaller scales (such as the street segment). In addition, traffic danger and crime were also frequently studied variables with strong environment-dependent characteristics. They were also classified as physical environmental variables in this discussion. Details of selected studies are presented in Table 1.

Macro-Level Walkability/Bikability of Urban Forms

As would be expected, distance to school is a significant correlate of walking and biking to school, with longer distances hindering walking and biking. In the 2004 CDC survey, parents reported long distances as the most significant barrier (61.5% of parents reporting it) (Martin & Carlson 2005). Other studies have also provided empirical evidence, even after controlling for the child's age, gender, family's socioeconomic status, and some other background information (Black et al. 2001; Ewing et al. 2004; Merom et al. 2006; McMillan 2006; Timperio et al. 2006). Some studies have tried to identify threshold values of walkable distances for school travels, and reported that children living within 1.6 kilometers (1 mile) (McMillan 2003) or 0.8 kilometer (0.5 mile) (Timperio et al. 2006; Merom et al. 2006) from schools were significantly more likely to walk than those living further away.

However, it is important to recognize that the impact of distances may vary depending on the child's age, parents' perceptions, or other physical environmental factors. Meanwhile, in the U.S., even for students living within 1.6 kilometres (1 mile) from school, only 31% of trips were made by walking in 1995 (U.S. Department of Health and Human Services 2000), indicating there were other factors at work.

Quality of infrastructure is another important correlate of walking and biking to school, with better sidewalks, bike lanes, crosswalks, and traffic signals encouraging walking and biking. Evidence has been seen in not only cross-sectional studies (U.S. Environmental Protection Agency [EPA] 2003; Ewing et al. 2005; Fulton et al. 2005), but also pre-post intervention studies in California (Staunton et al. 2003). Among California's Safe Routes to School projects (Boarnet et al 2005b), sidewalk gap closure at locations with moderate or heavy pre-existing pedestrian traffic showed great success, with 30%, 38%, and 70% increase in the rates of walking for three schools respectively. Replacement of four-way stops with traffic signals also showed evidence of success, while the pedestrian and bicycle crossing improvement showed only limited success.

Other urban form features such as population density, land-use mix, and street connectivity have also been studied, yet have reached less consistent findings. Although identified as significant correlates in a study of 34 California public elementary schools (Braza et al. 2004), population density (positive correlate) and land-use mix (negative correlate) were not significant in another study in Gainesville, Florida (Ewing et al. 2004). Also in the California study, street intersection density was significant in pairwise correlations, yet was not significant in multiple regressions. These findings also have some inconsistencies with the literature on adults' walking, where density, land-use mix, and street intersection density were often reported as positive correlates. One explanation might be that the school trip has fixed destinations (schools and homes) and specific populations (children), and therefore make factors such as the land-use mix less important. In addition, inconsistent findings were further complicated by various definitions and measures used across studies.

The difference between objective and perceived physical environment is also worth noting. A study in King County, Washington (Kerr et al. 2006) indicated that perceived land-use mix and street connectivity were significant correlates of walking and biking to school after controlling for socio-demographic features, yet their objective measures were insignificant. Furthermore, such perceived measures were no longer significant when entered together with the composite objective measure of walkability. Overall, there was a lack of attention on the relationship between objective and perceived measures of physical environment in the literature.

Micro-Level Walkability/Bikability of Urban Design and Architectural Qualities

As compared with the macro-level walkability/bikability of urban forms, the micro-level walkability/bikability of urban design and architectural qualities is understudied. However, the study in King County, Washington (Kerr, et al. 2006) did report neighborhood aesthetics as an independent predictor of walking and biking to school after considering socio-demographic features, parental safety concerns, and macro-level walkability. Amenities on streets also showed certain impact. A study in Australia (Timperio et al. 2006) identified the objectively assessed steep slope and perceived lack of lighting and crossing as negative correlates. The presence of street trees within 0.4 kilometre (0.25 mile) of school has also been reported as a positive correlate. McMillan's study (2003) examined the impact of amenities such as street lighting, street width, speed bumps, abandoned buildings, and windows facing streets. Yet the results were either insignificant or not in the theoretically derived direction. More targeted research is needed on these variables and their measurement methods.

Traffic Danger and Crime

In addition to walkability/bikability, traffic danger and crime also have significant impact on children's school travels. Kerr's study (2006) reported that parental safety concerns was a much stronger correlate than walkability, aesthetics, and access to local stores and facilities.

Traffic danger was a secondly important barrier reported in the 2004 CDC survey, with 30.4% of parents reporting it as a barrier (Martin & Carlson 2005). However, findings about real and perceived traffic dangers were not consistent. Although traffic accident is one of the leading causes of child death, the objective data showed that the pedestrian injury/death rate had declined 51% from 1987 to 2000 among children aged 14 years and under, suggesting parents' perceptions might be exaggerating the actual dangers. An Australian study reported the perceived lack of street lighting and crossings, and objectively assessed busy roads as negative correlates, indicating the roles of both real and perceived traffic dangers (Timperio et al. 2006). Yet in a Britain study, the real and perceived traffic dangers did not predict children's school travels by car (DiGiuseppi et al. 1998). More research is needed on real and perceived traffic dangers, their relationships, as well as their possible interactions with other factors such as walkability or perceived control.

Threat from crime was another important barrier identified in the 2004 CDC survey, with 11.7% of parents reporting it. Studies in UK (DiGiuseppi et al. 1998) and the U.S. (Eichelberger 1990) have reported the fear of abduction as a strong predictor of car travel to school. However, some scholars (e.g., Robin Moore 1986) argued that parents might have exaggerated the crime danger, and have overly limited children's freedom of movement and opportunities to interact with outdoor environments, which were very important for child development. On the other hand, as compared with parents' strong concerns about traffic danger and crime, a study has reported that children were most concerned about being approached to smoke or being bullied while in transit (Lee & Rowe).

Finally, in addition to previously mentioned variables, temperature and weather also played important roles in children's school travels (Martin & Carlson 2005; Sirard et al. 2005).

Table 1: Summary of empirical studies about physical environmental correlates of walking and biking to school

Author (year)	Sample size; grade/age Design; measure; outcome variable	Physical environmental variables as independent variables	Association	Statistical adjustment
Boarnet (2005a)	862; 3 rd -5 th grade Inte; O; W & B	Safe routes to school construction projects	(+)	None
Boarnet (2005b)	1,243; 3 rd -5 th grade Inte; O & P; W & B	Sidewalk gap closure Replacement of 4-way stops with traffic signals Pedestrian/bicycle improvement Development of bicycle facility	(+) (+) (+) (X)	None
Braza (2004)	2,993; 5 th grade CS; O; W & B	Population density Street intersection density School size	(+) (X) (-)	School level SES & Eth
EPA (2003); Ewing (2004, 2005)	709 trips; K-12 th grade CS; O; W	Sidewalk coverage on main roads Sidewalk completeness for origin and destination zones Travel time (distance) Population density Street tree coverage in vicinity of school Age of school School size (enrolment) (Residential + job) density Land-use mix	(+) (+) (-) (X) (X) (X) (X) (X) (X) (X)	SES, car ownership, students' driver license ownership, & number of family members
Fulton (2005)	1,395; 4 th -12 th grade CS; P; W & B	Perceived neighborhood safety Neighborhood location (including central city, small city, town, suburban, and rural)	(X) (+)	A, G, Eth, & some parental factors
Kerr (2006)	259; 5-18 year CS; O; W & B	Parental safety concerns Walkability in high-income neighborhood Walkability in low-income neighborhood Neighborhood aesthetics Perceived access to local stores and B/W facilities	(-) (+) (X) (+) (+)	A, G, & parental education
Martin 2005	4,213; 5-18 year CS; P; barrier for W	Distance (61.5% reporting it as a barrier) Traffic danger (30.4% reporting it as a barrier) Crime (11.7% reporting it as a barrier)	(-) (-) (-)	None
McMillan (2006)	1,244; 3 rd -5 th grade CS; P; W & B	Neighborhood safety Distance < 1.6 kilometres (1 mile)	(X) (+)	A, G, In, & other parental/ household factors
McMillan (2003)	2,128; 3 rd -5 th grade CS; O & P; W & B	Neighborhood not safe Need to travel on road with speed > 30 mph Perceived lack of sidewalks Sidewalk completeness within 1/4 mile buffer of school % of street segments with windows facing streets % of street segments with street lighting % of street segments with no abandoned buildings Average street width Average block length	(-) (-) (-) (X) (X) (-) (-) (+) (+) (X)	In, parental education, number of children, % of Hispanic students at school, household transportation option, & social/cultural norms

		% of street segments with speed humps	(X)	
		% of street segments with mixed land-use	(X)	
		Neighborhood location (urban vs. suburban)	(X)	
Merom (2006)	812; 5-12 year CS; P; W & B	Distance	(-)	A, G, Eth, & other child/parent/ household factors
		Unsafe roads to school	(-)	
Schlossberg (2006)	292; 6 th -8 th grade CS; O; W	Distance	(-)	None
		Intersection density	(-)	
		Dead end density	(-)	
		Route directness	(X)	
		Having major roads on route	(X)	
		Having railroad tracks on route	(-)	
Sirard (2005)	3,911; 1 st -6 th grade CS; O; W & B	School location (urban vs. suburban)	(X)	None
Timperio (2006)	235, 5-6 year; 677, 10-12 year CS; O & P; W & B	<u>Parents' perceptions:</u>		G, parental education, clustering of children by school, & area-level SES
		Heavy traffic	(X)	
		Strong concerns of strangers	(X)	
		Strong concerns of road safety	(X)	
		No light/crossings	(-)	
		Need to cross several roads	(X)	
		Limited public transport	(X)	
		Not many other children around	(-)	
		<u>Children's perceptions (10-12 year):</u>		
		Heavy traffic	(X)	
		Concerns about strangers	(X)	
		Roads not safe	(X)	
		<u>Objective measure of route to school</u>		
		Distance < 800m (0.5 mile)	(+)	
		Busy road barriers along route	(-)	
		Direct route to school for 5-6 year	(X)	
		Direct route to school for 9-12 year	(+)	
		Slope barriers for 5-6 year	(-)	
		Slope barriers for 9-12 year	(X)	
Staunton (2003)	4,665 Inte; O; W & B	Multi-level interventions including engineering improvement	(+)	None

Note: (+), positive association; (-) negative association; (X), insignificant; A, age; B, biking to and from school; CS, cross-sectional study; Eth, ethnicity; G, gender; In, family income; Inte, intervention study; O, objective measures of physical environment; P, perceptions of physical environment; SES, socioeconomic status; W, walking to and from school

1.4. Personal and Social Correlates

Personal and social factors were recognized as important correlates of walking and biking to school in most previous studies. Yet empirical findings were not always consistent. Child's gender has been reported as a significant factor (Cooper et al. 2003; McMillan et al. 2006; Fulton et al. 2005; Evenson et al. 2003), with girls being less likely to walk. Age differences were observed in a national survey (Fulton et al. 2006) and a statewide study in North Carolina (Evenson et al. 2003), yet was insignificant in an Oregon study (Schlossberg 2006). Overall, middle school and high school youth had a lower rate of walking to school than elementary school children. This might be explained by the longer distances that middle schools and high schools were located from students' homes. Finer age differences among 3rd-5th grade children have been reported by McMillan (2006), where the odds of active travel reduced by 27% with each year's increase in age. Yet in an Australian study, children aged 11-12 were more likely to walk than those aged 5-9 (Merom et al. 2003).

Ethnic differences were reported in several studies, where minority children (Evenson 2003; Braza 2004; Merom et al. 2003) or Hispanic children (Fulton et al. 2005) walked more often. Yet some other studies reported ethnicity as insignificant (Schlossberg 2006). The child's body mass index was a negative correlate in Evenson's study (2003), yet was insignificant in Fulton's study (2005). Child's positive attitude toward walking has been reported as a positive correlate (Merom et al. 2003).

Family income was identified as a negative correlate in a Florida transportation study (EPA 2003) and a California study, yet was found to be insignificant in an Oregon study (Schlossberg 2006). There were some other parental or household factors that have been reported as significant factors in a few studies yet had

conflicting findings from other studies. Examples of such factors included parental education level (Fulton et al. 2005), marital status (Fulton et al. 2005; Merom et al. 2003), perceived importance of physical activity, perceived convenience of driving (McMillan 2006), individual history of active transport to school, active commute to walk (Merom et al. 2003), the number of parents living in the home (Fulton et al. 2005), the gender of the responsible parent (Merom et al. 2003), car ownership (Merom et al. 2003; Schlossberg 2006), and the level of freedom given to children by parents (Merom et al. 2003; Ziviani et al. 2004).

As to social factors, family support has been reported as a positive correlate. Education programs have also shown significant effects on promoting walking and biking to school. In addition, in the 2004 CDC survey, 6% of parents reported those school policies that discouraged walking to school as a barrier (Martin & Carlson 2005).

1.5. Interactions among Personal, Social, and Physical Environmental Correlates

As indicated by socio-ecological theory and the conceptual framework proposed in this study, the personal, social, and physical environmental correlates of walking and biking to school are interrelated with each other. McMillan's study (2006) tested possible interactions between the child's gender and six variables, including parents' perceived neighborhood safety, family income, parents' walking behaviors, family approval of walking to school, parents born in the U.S., and parents' education levels. Findings only supported one significant interaction, where caregivers' own activity levels moderated the influence of gender on walking to school. Although girls were generally less likely to walk, an active caregiver increased the possibility that a girl would walk.

The King County study (Kerr et al. 2006) has also reported some significant interactions. Firstly, the interaction existed between the composite measure of macro-level walkability and neighborhood income level, where higher walkability encouraged walking to and from school only in high-income neighborhoods, but not in low-income neighborhoods. One possible explanation is the higher rate of parental safety concerns in low-income neighborhoods. Secondly, the interaction existed between walkability and parental safety concerns, where parents with serious safety concerns kept their children from walking even if the neighborhood was highly walkable in terms of urban forms.

Finally, it was noticed that most studies had ignored the differences between the trip to school and trip from school. Schlossberg's study (2006) of four middle schools found that although only 15% of students walked or biked to school, 25% of them walked or biked from school to home. A survey in California (1999) with children (9-11 years) found the walking-to-school rate was 18%, yet the walking-home-from-school rate was 26% (Braza et al. 2004). Since the trip from school is less limited by time constraint, children may engage in other activities before getting home. Future studies should explore the specific potential of trips from school to home.

1.6. Implications for Evidence-Based Design and Policy Interventions

In summary, a pattern emerged from the literature, indicating the perceived physical environment was mediating the effect of objective physical environment on parents' decision-making about children's school travel modes, while personal and social factors were moderating this environment-behavior relationship. Although evidence is still limited, it did provide important guidance for evidence-based design and policy interventions.

Firstly, personal, social, and physical environmental factors all have significant impact on walking and biking to school. Therefore, multi-level strategies should be emphasized in interventions. Secondly, pre-post intervention studies are especially valuable because they can identify causality between physical environment and behavior changes, and can compare effects of different interventions, as indicated by the study on the California Safe Routes to School projects (Boarnet et al. 2005b). More pre-post studies should be conducted by collaborating with various intervention programs that are being implemented. Such studies can help to develop a priority list for designers and policy-makers. On the other hand, research findings should be generalized with cautions about the contexts. For example, sidewalk gap closure was proven to be extremely useful in areas with moderate or heavy pre-existing pedestrian traffic, yet was much less effective in areas with low volumes of pre-existing pedestrian traffic (Boarnet et al. 2005b). Different interventions are needed for different contexts.

Thirdly, findings about significant interactions among personal, social, and physical environmental factors can inform the development of tailored interventions and policies. Gender-specific and neighborhood-specific strategies should be considered. For example, the interaction between walkability and neighborhood income level suggests different strategies for neighborhoods with different socioeconomic status (Kerr et al. 2006). In low-income neighborhoods, parents' safety concerns are more important barriers than the walkability itself.

From another perspective, some findings have significant implications for school siting. For example, significance of the distance implies the need for centrally located neighborhood schools (Ewing et al. 2005). A study found that schools built before 1983, which were small-scale neighborhood schools, had four times more students walking to school (Kouri 1999). However, some current policies tend to encourage constructions of new, large-scale schools in remotes sites that are difficult to access by walking or biking. Examples of such policies include the funding formulas in many states that favour new school constructions over renovations, the minimum acreage standards that may be met only at Greenfield locations, the school districts' exemptions from planning and zoning laws that enable them to disregard local policies and plans, as well as building codes that apply similar standards to new constructions and renovated schools (EPA 2003).

Overall, future research should phrase research questions, generate hypotheses, and design studies in a way that is knowledge-based and is more relevant to practice and policy, as suggested by Robinson and Sirard's solution-based paradigm (2005). Collaboratives should be developed between researchers and professionals, using intervention projects as research sites. Such pre-post studies can go beyond the limit of cross-sectional studies, and can generate solid knowledge about the causality between physical environment and children's walking and biking to school. In addition, various policies, such as school siting, transportation, urban development, and land use legislations should consider their potential impact on walking and biking to school.

2. CASE STUDY IN AUSTIN, TEXAS

Based on literature review, I conducted a case study in Austin, Texas, where 73 public elementary schools were analyzed for their attendance areas' walkability and safety. This study measured the environmental support for walking to school from three perspectives, and was presented in a conference (Zhu 2007). The macro-level walkability (urban forms) and safety were measured using GIS, with the school's attendance area as the unit of analysis. Variables for the macro-level walkability included distance-based walker estimates (percentages of residential units located within half a mile street network distance from school), pedestrian facilities (sidewalk completeness and traffic signal density), residential density, street connectivity (street density and street intersection density), and land-use mix. Variables for safety consisted of traffic safety (traffic volumes and percentages of high-speed streets) and yearly crime rates. The micro-level walkability (urban design and architectural qualities) was assessed through filed audits on 200-meter street segments sampled from the attendance areas. Relevant variables included various attributes of sidewalks, streets, and roadside buildings, as well as the overall impressions of convenience, aesthetics, amenities, maintenance, and perceived safety.

Regression analysis was run between the percentage of Hispanic students attending the school and each environmental variable. Results showed that the percentage of Hispanic students was positively associated with the crime rate and most macro-level walkability variables, but negatively associated with most micro-level walkability variables ($P < 0.05$). No significant association was found for traffic safety.

Analysis of variance was used to compare the means of each environmental variable between the top-quartile schools with the highest percentages of Hispanic students ($\geq 82.1\%$) and the bottom-quartile schools ($< 37.6\%$). For macro-level walkability, the group with the highest percentages of Hispanic students had 27.9% more students living within half a mile street network distance from school, had 15% higher sidewalk completeness, had one more traffic signal per 16-kilometer (10-mile) street segment, had about 427 more residents and eight more street intersections per 100 acres, and had a 0.165 higher land-use mix index on the zero to one scale ($P < 0.05$). In contrast, for micro-level walkability, the building maintenance, visual quality of buildings, and overall aesthetics, amenities, and maintenance were all rated at least one point lower on a five-point scale ($P < 0.05$). In addition, some micro-level variables were marginally significant at the 0.1 level, showing that street segments in the top-quartile schools' attendance areas were more likely to have sidewalk obstructions, on-street parking, and power lines along the segment. What's more important, these schools had 162 more criminal offenses per 1,000 persons per year in their attendance areas (mean = 239) ($P < 0.05$).

Findings showed that schools with higher percentages of Hispanic children featured attendance areas with higher macro-level walkability, but much lower micro-level walkability and crime safety. Threats from crime tended to grow with the increase of land-use mix and street connectivity, which were usually considered to encourage adults' walking. Therefore, targeted research is needed for the impact of these intertwining factors on children's walking to and from school, especially for low-income, Hispanic neighborhoods. In addition, the micro-level walkability should be studied as an important and holistic aspect parallel with the macro-level walkability of physical environment. For future practice, findings from this study suggested tailored intervention strategies for specific contexts and populations.

CONCLUSIONS

Overall, current knowledge about the relationship between physical environment and children's walking/biking to school is still constrained to associations for limited contexts and populations. More intervention studies are needed in order to identify causality for this environment-behavior relationship. In addition, more attention is needed for the relationships among various scales and aspects of physical environment, especially for the relationships between macro-level walkability and micro-level walkability, and between walkability and safety. Finally, more targeted research is needed to understand differences across various contexts and populations, so that tailored strategies can be developed for design and policy interventions.

REFERENCES

Black, CE, Collins A, Snell M. 2001. Encouraging walking: The case of journey-to-school trips in compact urban areas. *Urban Studies* 38(7):1121-41.

- Boarnet MG, Anderson CL, Day K, McMillan T, Alfonzo M. 2005a. Evaluation of the California Safe Routes to School legislation - Urban form changes and children's active transportation to school. *American Journal of Preventive Medicine* 28(2):134-40.
- Boarnet G, Day K, Anderson C, McMillan T, Alfonzo M. 2005b. California's Safe Routes to School program – Impact on walking, bicycling, and pedestrian safety. *Journal of the American Planning Association* 71(3):301-17.
- Braza M, Shoemaker W, Seeley A. 2004. Neighborhood design and rates of walking and biking to elementary school in 34 California communities. *American Journal of Health Promotion* 19(2):128-36.
- Cooper AR, Page AS, Foster LJ, Qahwaji D. 2003. Commuting to school - Are children who walk more physically active? *American Journal of Preventive Medicine* 25(4):273-76.
- DiGiuseppi C, Roberts I, Li L, Allen D. 1998. Determinants of car travel on daily journeys to school: Cross sectional survey of primary school children. *British Medical Journal* 316:1426-28.
- Eichelberger MR, Gotschall CS, Feely HB, Harstad P, Bowman LM. 1990. Parental attitudes and knowledge of child safety: A national survey. *American Journal of Diseases of Children* 144 (6):714-20.
- EPA. 2003. *Travel and Environmental Implications of School Sitting*. Publication EPA 231-R-03-004. U.S. Environmental Protection Agency: Washington, D.C.
- Evenson KR, Huston SL, McMillen BJ, Bors P, Ward DS. 2003. Statewide prevalence and correlates of walking and bicycling to school. *Archives of Pediatrics & Adolescent Medicine* 157(9):887-92.
- Ewing R, Forinash CV, Schroerer W. 2005. Neighborhood schools and sidewalk connections: What are the impacts on travel mode choice and vehicle emissions? *Transportation Research News* 237:4-10.
- Ewing R, Schroerer W, Greene W. 2004. School location and student travel - Analysis of factors affecting mode choice. *Transportation Research Record: Journal of the Transportation Research Board* 1895:55-63.
- Fulton JE, Shisler JL, Yore MM, Caspersen CJ. 2005. Active transportation to school: Findings from a national survey. *Research Quarterly for Exercise and Sport* 76(3):352-357.
- Kerr J, Rosenberg D, Sallis JF, Saelens BE, Frank LD, Conway TL. 2006. Active commuting to school: Associations with environment and parental concerns. *Medicine and Science in Sports and Exercise* 38(4):787-94.
- Kouri C. 1999. *Wait for the Bus: How Low Country School Site Selection and Design Deter Walking to School and Contribute to Urban Sprawl*. South Carolina Conservation League: Charleston, Carolina
- Lee TR, Rowe N. Parents' and children's perceived risks of the journey to school. *Architecture and Behavior* 10:379-89.
- Martin S, Carlson S. 2005. Barriers to children walking to or from school - United States, 2004 (Reprinted from MMWR 2005;54:949-52). *Journal of the American Medical Association* 294(17):2160-61.
- McMillan TE. 2003. *Walking and urban form: Modelling and testing parental decisions about children's travel*. Unpublished doctoral dissertation, University of California, Irvine.
- McMillan TE. 2005. Urban form and a child's trip to school: The current literature and a framework for future research. *Journal of Planning Literature* 19(4):440-56.
- McMillan T, Day K, Boarnet M, Alfonzo M, Anderson C. 2006. Johnny Walks to School- Does Jane? Sex Differences in Children's Active Travel to School. *Children, Youth and Environments* 16(1):75-89.
- Merom D, Tudor-Locke C, Bauman A, Rissel C. 2006. Active commuting to school among NSW primary school children: Implications for public health. *Health & Place* 12(4):678-87.
- Moore RC. 1986. *Childhood's Domain: Play and Place in Child Development*. Croom Helm: London.
- Robinson TN, Sirard JR. 2005. Preventing childhood obesity: A solution-oriented research paradigm. *American Journal of Preventive Medicine* 28(2S2):194-201.
- Schlossberg M, Greene J, Phillips PP, Johnson B, Parker B. 2006. School trips - Effects of urban form and distance on travel mode. *Journal of the American Planning Association* 72(3):337-46.
- Sirard JR, Ainsworth BE, Mclver K, Pate RR. 2005. Prevalence of active commuting at urban and suburban elementary schools in Columbia, SC. *American Journal of Public Health* 95(2):236-37.
- Staunton CE, Hubsmith D, Kallins W. 2003. Promoting safe walking and biking to school: The Marin County success story. *American Journal of Public Health* 93(9):1431-34.
- Timperio A, Ball K, Salmon J, Roberts R, Giles-Corti B, Simmons D, Baur LA, Crawford D. 2006. Personal, family, social, and environmental correlates of active commuting to school. *American Journal of Preventive Medicine* 30(1):45-51.
- U.S. Department of Health and Human Services. 2000. *Healthy People 2010 (2nd ed)*. U.S. Department of Health and Human Services: Washington, D. C.
- Zhu X. 2006. Ethnic disparity in environmental support for children's walking to school. Presented at *the Active Living Research 2007 Conference*. Coronado, CA.
- Ziviani J, Scott J, Wadley D. 2004. Walking to school: Incidental physical activity in the daily occupations of Australian children. *Occupational Therapy International* 11(1):1-11.

Community Design Parameters and the Performance of Residential Cogeneration Systems

Hazem Rashed-Ali, Ph.D.

University of Texas at San Antonio, San Antonio, TX

ABSTRACT: The integration of cogeneration systems in residential and mixed-use communities has the potential of reducing their energy demand and harmful emissions and can thus play a significant role in increasing their environmental sustainability. This study investigated the impact of selected planning and architectural design parameters on the environmental and economic performances of centralized cogeneration systems integrated into residential communities in U.S. cold climates. Parameters investigated include: 1) density, 2) use mix, 3) street configuration, 4) housing typology, 5) envelope and building systems' efficiencies, and 6) passive solar energy utilization. The study integrated several simulation tools into a procedure to assess the impact of each design parameter on the cogeneration system performance. This assessment procedure included: developing a base-line model representing typical design characteristics of U.S. residential communities; assessing the cogeneration system's performance within this model using three performance indicators: percentage of reduction in primary energy use, percentage of reduction in CO₂ emissions; and internal rate of return; assessing the impact of each parameter on the system performance through developing 46 design variations of the base-line model representing potential changes in each parameter and calculating the three indicators for each variation; and finally, using a multi-attribute decision analysis methodology to evaluate the relative impact of each parameter on the cogeneration system performance. The study results show that planning parameters had a higher impact on the cogeneration system performance than architectural ones. Also, a significant correlation was found between design characteristics identified as favorable for the cogeneration system performance and those of sustainable residential communities. These include high densities, high use mix, interconnected street networks, and mixing of housing typologies. This indicates a higher potential for integrating cogeneration systems in sustainable communities.

Keywords: cogeneration; residential & mixed use communities; energy efficiency; district heating

1. SUSTAINABILITY, THE BUILT ENVIRONMENT, AND COGENERATION

In the past three decades, the need for adopting the principles and practices of sustainability has been clearly established through research activities, political conventions, and protocols. While a lack of consensus still exists over the definition of sustainable development and the issues it should address, existing schools of thought agree over the need for balancing its three main components: environmental, economic, and social sustainability. The need for environmental sustainability stems from the growing sense of responsibility motivated by the realization of the serious environmental problems facing world communities (e.g. global warming, resources depletion, increased pollution, etc.). Energy is a central issue in the sustainability debate affecting all three of its components (Johansson & Goldemberg 2002). This wide impact of energy indicates that energy efficiency, while perhaps not a sufficient condition for sustainability, is certainly a necessary one. The built environment plays a major role in the U.S. energy system both directly, through energy use in the residential and commercial sectors, which in 2004 accounted for 21.2% & 17.5% of total U.S. consumption respectively (EIA 2005), and indirectly, through its impact on the transportation sector, which accounted for an additional 27.8% of that consumption (EIA 2005). Subsequently, increasing energy efficiency in the built environment can positively impact its sustainability. Numerous studies conducted on the relations among sustainability, urban form, and building design, some of which are listed in the coming section, indicate a clear potential for achieving significant reductions in energy consumption through intelligent and sustainable planning and architecture. Increasing the energy efficiency of new residential communities is of particular significance in light of the projected increases in residential energy use due to increases in population and new housing stock. However, statistics show that the majority of the new U.S. housing stock are detached single family houses that are typically larger in size and

consume more energy than current average U.S. homes. Such trends would further increase the environmental impact of the residential sector. A clear need, therefore, exists for research activities that aim to explore alternative design strategies, characteristics, systems, and technologies that aim to increase the energy efficiency and reduce the energy demand of the residential sector.

Electricity production resulted in 39% of energy-related U.S. CO₂ emissions in 2003 (EIA 2004). Distributed generation (DG) is an established alternative to existing power systems that has the potential of achieving considerable environmental and economic benefits. The use of cogeneration, a technology that generates electricity locally and utilizes the thermal energy byproduct of the generation process in thermal end uses such as space and water heating, further increases the efficiency and the potential benefits of DG. Combined with energy conservation measures, residential cogeneration systems offer the potential for meeting most or all of the energy needs of residential communities in a more economic and environmentally friendly manner. Consequently, integrating cogeneration technologies into new residential communities can mitigate the expected increases in their environmental impact. Residential cogeneration systems are currently utilized in several European communities (e.g. Kronsberg Community in Hannover, Germany; and Beddington Zero Energy Development in London, UK). In the U.S., however, while cogeneration is well established in many sectors, e.g. the industrial and educational ones, its use in the residential sector is still very limited in spite of the significant energy and emissions reductions potential that this technology presents (see Gunes & Ellis 2003; Braun et al. 2004). One of the main reasons cited for this limited use is the high initial system cost, especially for district heating networks (Phetteplace 1995), as well as the unsuitability of the energy use characteristics of conventional U.S. residential communities (with their high daily and seasonal variations) to the needs of cogeneration systems. A number of possible strategies for increasing the use of residential cogeneration have been discussed in the literature, one of which is to identify potential residential markets with more suitable energy use characteristics that can act as market entry points for these technologies (U.S. DOE, 2003).

Throughout the U.S., a number of new, sustainable, residential communities are being developed, which attempt to integrate the principles of sustainability and energy efficiency from the early stages of their design. The design characteristics of these communities are considerably different from those of conventional ones thus resulting in improved energy use characteristics. These communities are also used to demonstrate the performance of emerging technologies. While their number is still limited, such communities represent a potential market for the integration of cogeneration systems. This integration can result in further reductions in the communities' environmental impact as well as to wider acceptance of these emerging technologies and improvements in their economics making them suitable for other markets. Therefore, a need exists to investigate the impact of the different design characteristics of sustainable communities, compared to those of conventional ones, on the performance of the cogeneration systems and therefore on their feasibility. Such studies can then be used to develop design guidelines that can inform designers of sustainable communities who wish to integrate cogeneration into their projects. As the design of residential communities utilizing cogeneration systems involves a large number of parameters on the planning and architecture scales, this study focused on selected parameters on each scale and assessed their individual impact on the performance of cogeneration system. These selected parameters are: 1) density, 2) use mix, 3) street configuration, 4) housing typology, 5) envelope and building systems' efficiencies, and 6) passive solar energy utilization. This assessment aims to demonstrate the impact that informed design can have on increasing the feasibility of emerging technologies, such as residential cogeneration, and therefore on improving the environmental impact of residential communities. In this context, the following sections will present a brief literature review dealing with sustainability, how it relates to the built environment, distributed generation and cogeneration, and performance assessment studies of residential cogeneration. Subsequently, the methodology used in assessing the design parameters' impact on the cogeneration system performance will be described followed by a summary and analysis of the assessment results. Finally, several conclusions that can be drawn from these results will be outlined and discussed.

2. LITERATURE REVIEW

2.1. Sustainability, energy, and the built environment

While varying in emphasis, existing definitions of sustainability and sustainable development (e.g. WCED 1987) all stress the need for balancing environmental, economic and social considerations while maintaining a good quality of life. A strong and direct link exists between environmental sustainability: including issues of mitigation of existing environmental problems, protection of eco-systems, more efficient use of natural resources, and biodiversity; and between energy and energy systems. Johansson & Goldemberg (2002) describe conventional sources of and approaches to providing and using energy as unsustainable and link them to significant environmental, social, and health problems both currently and in the future. They also suggest several alternative strategies to achieve a more sustainable energy including: more efficient use of energy; accelerated development and deployment of new energy technologies; decentralization of the world energy systems; and increased use of renewable energy resources. Increasing the environmental sustainability of the built

environment, through more efficient use of resources and reduced environmental impact, is a major component of sustainable development and increasing energy efficiency is a necessary requirement for achieving that goal. Many studies conducted on the relations among sustainability, urban form, and building design (e.g. Breheny, 1992; Owens, 1986; Williams et al., 2000) indicate a considerable potential for increasing the energy efficiency of the built environment through intelligent and sustainable design. Grumman (2003) further argues that this potential is considerably larger when sustainability principles are applied in the early stages of the design process. Additionally, Barton (2000) argues that sustainable communities, many of which are currently in different stages of development throughout the U.S., can change the prevailing culture of local decision makers, professionals, and developers. These communities also offer a considerable opportunity for demonstrating emerging technologies under more favorable conditions.

2.2. Distributed generation & residential cogeneration

Distributed generation can offer several advantages compared to centralized systems. WADE (2003) identifies these advantages as: 1) lower CO₂ emission; 2) lower costs; 3) lower transmission and distribution losses; 4) greater power quality; and 5) less system vulnerability. Houghton (2000), arguing for developing small scale and locally-based community energy utilities, contended that such utilities can be a vital element of new sustainable communities offering many societal benefits including raising awareness of the consequences of energy use, increasing social responsibility, and improving local economy through lowering energy costs and providing local employment. Two approaches can be identified in the literature for integrating cogeneration systems in residential communities, to be described here as the centralized and the decentralized integration approaches. Centralized integration involves a central plant supplying electricity, heating and possibly cooling to a number of buildings through electrical distribution and district heating/cooling (DHC) networks (see Phetteplace, 1995). While decentralized integration is a newer alternative, in which smaller-sized micro-cogeneration systems are integrated into individual homes. Centralized integration utilizes larger sized, more established, and more efficient technologies, yet its economic performance is negatively impacted by the high initial cost and thermal losses of the DHC networks. On the other hand, micro-cogeneration technologies, while avoiding the penalties associated with DHC networks, are currently still lower in efficiency and higher in initial cost (per unit power) than their larger-sized counterparts (Knight and Ugursal 2005). In both approaches, the systems are mostly grid-connected and include a supplementary heating source. While the majority of existing cogeneration systems utilize conventional fossil fuels, e.g. natural gas, some existing systems utilize alternative, more renewable, fuels and the use of fuel cells in particular offers a large potential in this regard. The study reported in this paper, however, focuses on the more established centralized integration approach using natural gas.

2.3. Performance assessment of residential cogeneration systems

Higher awareness of the environmental implications of current energy systems and the potential impact of residential cogeneration on the sustainability of the residential sector, combined with recent advances in cogeneration technologies, have resulted in increased research activities in the area which aim to investigate the current potential for residential cogeneration systems, their benefits, and the optimum conditions under which they can be utilized. Conventional feasibility studies of cogeneration systems (e.g. Ellis 2002) have been limited to economic performance, i.e. identifying the optimum design characteristics of the cogeneration system (e.g. system type, size, operation strategy, configuration, etc.), which would achieve the maximum possible economic return over the project life cycle. However, the majority of recent studies (e.g. Gunes & Ellis 2003; Braun et al. 2004), which recognize the sustainability implications of these systems, have considered both economic and environmental impacts of the technology. In general, most studies addressing both environmental and economic performances of residential cogeneration show the potential for significant energy and environmental benefits from using the technology. However, the majority of these studies also generally agree that the economics of the technologies are still uncompetitive with conventional systems mainly because of their higher initial cost as well as the current low cost of electricity. However, most existing studies exclusively dealt with the issue at the scale of the individual building and not that of the community, and they also did not investigate the impact that improving the energy use characteristics of buildings, communities, or both can have on the energy use, and consequently the performance of the cogeneration system. Additionally, few studies have been conducted that aim to identify suitable markets for residential cogeneration, a goal identified as important for the wider use of the technology (U.S. DOE 2003). This study, while adopting a similar approach in assessing both the environmental and economic performances of residential cogeneration, using the concept of performance indicators, represents an attempt to investigate these issues thus addressing these gaps in the literature.

3. METHODOLOGY

This study utilized a quantitative research methodology, in which building energy simulation and cogeneration system performance simulation tools were used to investigate the impact of the selected design parameters on the performance of the cogeneration system. The research design, shown in figure 1, included developing a base-line model representing the design characteristics of conventional U.S. residential communities (see table 1

for model and cogeneration system characteristics). Subsequently, the annual community primary energy use and CO₂ emissions, with and without cogeneration, were calculated as will be described in more details later. Based on this, the cogeneration system performance within the base-line community was assessed using three performance indicators: the percentage of reduction in annual community primary energy use due to the use of cogeneration, the subsequent percentage of reduction in CO₂ emissions; and the internal rate of return (IRR) of the cogeneration system. The impact of each design parameter on the performance of the cogeneration system was then assessed through developing design variations of the base-line community model representing selected assessment values for each design parameter. In total, 46 of these design variations were developed as shown in table 2. The same three performance indicators were then assessed for each design variation and a Multi-Attribute Decision Analysis methodology (MADA) was used to calculate the environmental, economic, and combined performances of the cogeneration system in each of these design variations relative to its performance within the base-line community (see Lippiatt (2002) for a discussion of MADA). These results were then used to evaluate the relative impact of each design parameter on the cogeneration system performance.

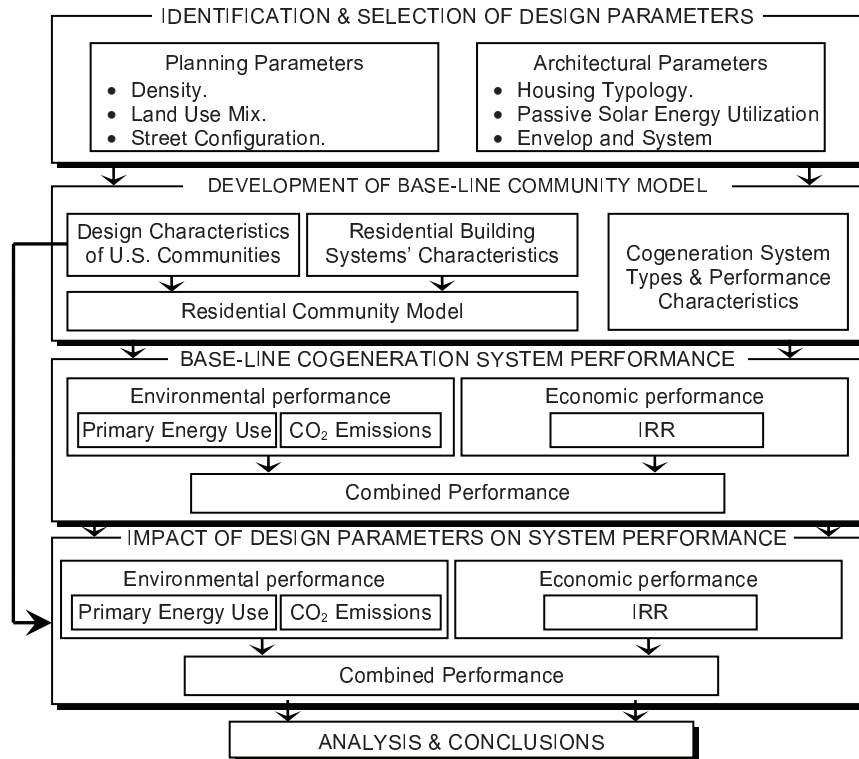

Figure 1: Schematic diagram of the research design

The cogeneration system performance assessment procedure involved several steps that utilized a number of existing software, tools, and databases. For both the base-line community case as well as each of the community design variations investigated in the study, assessing the performance of the cogeneration system involved first the development of building prototypes, either residential only or a mix of residential and commercial according to the design variation in question. In total, seven residential prototypes and 21 commercial prototypes, of different building typologies and sizes, were developed for this study using the simulation software eQUEST (Hirsch, 2003). The annual electrical and thermal energy consumptions of each model, without the cogeneration system, were simulated and the models were calibrated and the simulation results validated by comparing them to Energy Information Administration (EIA) energy use survey data. Following this, the annual primary energy use and annual CO₂ emissions of the community, without cogeneration, were calculated by adding the electrical and thermal energy uses of each building and accounting for generation efficiencies and distribution losses. Based on this, the hourly electrical and thermal loads of the centralized cogeneration system were calculated by adding the loads resulting from each building, designing a community district heating network, calculating the thermal losses within this network in the selected climate, and adjusting the community thermal loads accordingly. The annual community electrical and thermal energy use with cogeneration was then simulated using the HOMER software (Lambert et al., 2006); and the annual primary energy use and CO₂ emissions for the whole community were calculated similar to the “without cogeneration” case. The percentages of reduction in annual primary energy use and CO₂ emission for the community due to

the use of cogeneration were then calculated. These two values represented the environmental performance indicators used in this study. Finally, a life cycle cost analysis (LCCA) was conducted and the resulting IRR was calculated and represented the economic performance indicator used in the study. The three indicators were subsequently used to calculate an environmental and an economic performance for the cogeneration system, and the two performances were integrated into a combined performance following the MADA methodology mentioned previously. A more detailed description of the assessment procedures and the tools and assumptions involved can be found in Rashed-Ali (2006). The study utilized the climate of Helena, MT, which is considered as a representative city of the cold dry U.S. climate zone. The selection of the cold climate was based on previous studies (e.g. Gunes & Ellis, 2003), which identified it as more favorable for cogeneration systems.

Table 1: Design characteristics of the base-line community model

Design characteristics	Value
Community design characteristics:	
Community size	300 du
Gross density	4 du/ac
Land-use mix	Single use residential
Street configuration	Interconnected network / grid
Housing typology	Single-family detached
Single family house model characteristics:	
Floor area	197.9 m ² (2130 ft ²) [167.2 m ² (1800 ft ²) CFA]
Building form	Single-story, square, glazing distributed equally on four sides.
Envelope characteristics	
Wall R-value	R-25
Ceiling R-value	R-49
Slab perimeter insulation	R-14, 0.37 m (4 ft) deep
Window U-factor	0.33
Building systems' efficiencies	
Air-conditioning system	SEER 10
Furnace	AFUE = 78%
Domestic hot water system	E _r = 0.594
Internal loads:	Based on 2003 international energy efficiency code (ICC 2003) and performance analysis procedure developed for U.S. single family homes by the Building America program (Herndon, 2005).
Cogeneration system characteristics	
System type	Reciprocating Internal Combustion (IC) Engine
System size (power rating)	250 kW
Electrical efficiency (HHV)	31.1%
Thermal efficiency	46.2%
Overall system efficiency	77.3%
Operation strategy	Electric load-matching
System configuration	Baseline electrical load, grid connected, auxiliary boiler, central pump.

4. RESULTS AND ANALYSIS

Figure 2 shows the results of the impact assessment conducted in the study. Terms listed on the x-axis of the graph refer to the base-line community as well as the design alternatives, for both the planning and architectural design parameters, as described in table 2. While the y-axis represents the environmental & economic performance of the cogeneration system within each alternative. The results revealed a number of significant findings. In general, variations in mix of uses and density clearly had the most impact on the system performance each resulting in up to 50% improvement in combined (environmental and economic) performance. With regard to use mix, a direct relationship was found between increasing the mixing of non-residential uses within residential communities and improvements in cogeneration system performance. Increasing this mix resulted in the most improvements in the cogeneration system's economic performance (up to 125%) and combined performance (up to 53%). These significant improvements are primarily due to the improved daily load profiles of the community through increasing the availability of day-time and all-night loads to balance the typical morning and evening residential loads. The largest increase in economic performance was achieved through providing a high level of use mix combined with an optimization of non-residential building typologies within the community to reduce the daily load variations. While increasing the mix of uses resulted in slight reductions in environmental performance, the considerable increase in economic and combined performances indicate the potential for using larger cogeneration system sizes which would improve this environmental performance while still achieving an acceptable economic one. The largest improvement in combined performance was achieved by: first, providing

day-time electrical loads from building types such as retail, and office buildings; second, providing day-time non-seasonal thermal loads through the use of restaurants and a laundry, which increase the utilization of the thermal output of the cogeneration system; and third, providing all-night electrical and thermal loads through the use of a grocery and a bakery with 24 hour schedules. Similarly, increases in density were shown to have a significant positive impact on system performance especially with regard to economics resulting in up to 84% increase in IRR. This positive economic impact was primarily caused by reductions in the initial cost of the DHC network in the higher density design alternatives. Additional, though smaller, environmental improvements were also achieved with higher densities due to the reduced thermal energy losses in this network. The positive impact of higher density, however, is reduced as the community density increases. Finally, a density gradient resulted in a system performance comparable to a community with the equivalent average density.

Table 2: Measurement scales for selected design parameters

Design parameter		Design Alternatives
Planning parameters	Street configuration	1) Interconnected network/grid (BL*); 2) Fragmented network; 3) Modified, landscape-oriented network; 4) Loops & cul-de-sacs; 5) Dendritic network.
	Density of built form	1) 1 du/ac; 2) 4 du/ac (BL*); 3) 10 du/ac; 4) 15 du/ac; 5) Density gradient.
	Mix of uses	1) Single use (BL*); 2) Low use mix (suburban areas); 3) Medium use mix (main street grouping); 4) High use mix (town center grouping); 5) Optimized use mix.
Architectural parameters	Housing typologies	1) Detached single family houses (BL*); 2) Attached single family houses; 3) Town-homes; 4) Live-work units; 5) Multi-family houses.
	Envelope & building system efficiencies	1) Energy code (IECC 2003) compliant (BL*); 2) 5% more efficient than IECC 2003; 3) 10% more efficient than IECC 2003; 4) 15% more efficient than IECC 2003; 5) 20% more efficient than IECC 2003.
	Utilization of passive solar energy	1) Orientation-neutral (BL*); 2) Low renewable energy utilization; 3) Medium renewable energy utilization; 4) High renewable energy utilization; 5) High utilization /reduced internal loads.

* BL = base-line community characteristic

For the other design parameters, several alternative housing typologies also resulted in improved cogeneration system performance, the most notable of which were multi-family houses and live-work units. Multi-family houses performed the best resulting in an improvement in environmental performance of 24%, and in economics of 6%, adding to a 15% increase in combined performance; while live-work units resulted in larger economic improvements (46%) combined by a 26% drop in environmental performance, thus resulting in an improvement of only 10% in combined performance. However, both typologies were evaluated with the base-line density of 4 du/ac, which is lower than the densities typically associated with them. This indicates a clear potential for further performance improvements with actual densities. Single family house size had a varied impact on system performance with large sizes resulting in better economics and smaller sizes resulting in better environmental performance. However, both impacts were not significant and the resulting combined performance for both sizes showed no noticeable change from the base-line. With regard to street configuration, the interconnected configuration resulted in the best cogeneration performance especially with regard to economics because of the impact of the increased network lengths in the other alternatives. On the other hand, increases in either envelope and building systems' efficiencies or in the utilization of passive solar energy within the community's buildings resulted in a reduction in economic performance due to the reduced availability of thermal loads and the

subsequent increasing mismatch between the fuel to electricity ratio of the buildings and the heat to power ratio of the reciprocating engine based cogeneration systems used in the assessment.

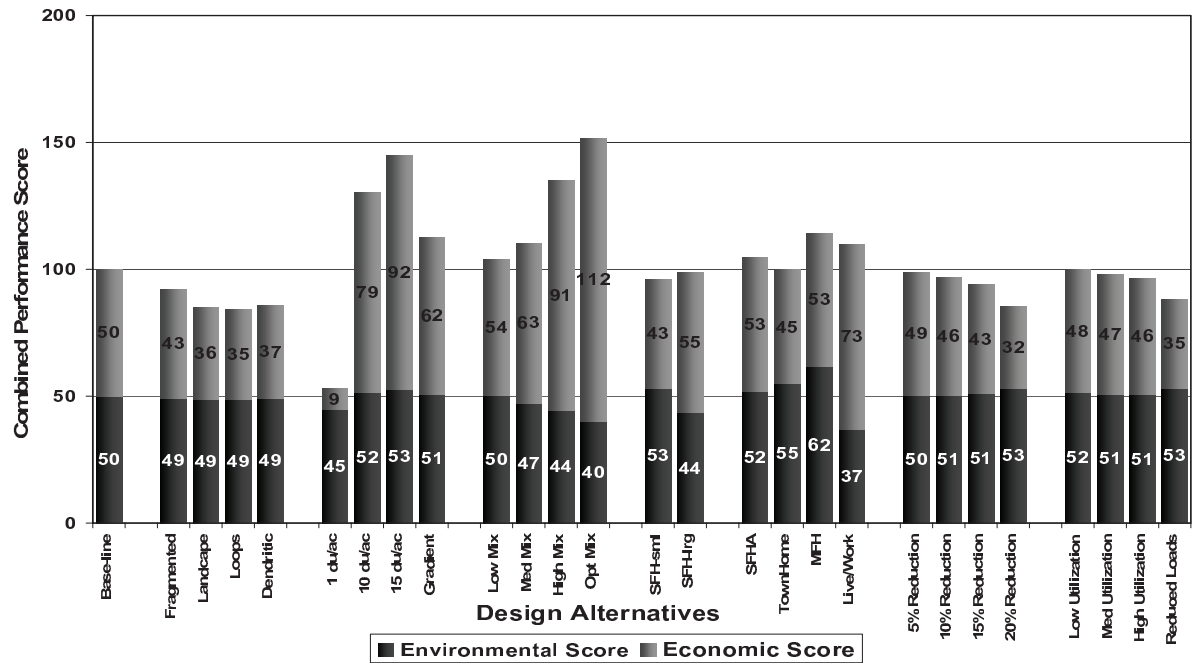

Figure 2: Summary of impacts of design parameters on combined performance of cogeneration system

5. CONCLUSION

This study represents part of the author's PhD research which aimed to identify the optimum community and cogeneration system design characteristics for residential communities utilizing cogeneration systems. This performance-based optimization aimed to improve the potential for using cogeneration systems in these communities thus achieving their potential environmental benefits. The results of this study can be utilized in one of two methods: 1) to inform designers of residential communities aiming to utilize cogeneration systems of the design parameters having the most impact on the system performance, and the design characteristics achieving the best performance, and 2) to assess the potential for integrating cogeneration systems in residential communities with a certain set of design characteristics and therefore identify potential market entry point for these emergent technologies. The major conclusions of the study can be summarized as follows:

- 1) *The design of residential communities has a significant impact on the performance of cogeneration systems.* Variations in density, mix of uses, and housing typology caused improvements as high as 120% in economic performance, and 52% in combined performance. This indicates a significant role for planners and architects in increasing the potential for utilizing cogeneration in residential communities through design optimization.
- 2) *Through community design optimization, existing cogeneration technologies can be both economically feasible and result in considerable environmental benefits.* Cogeneration systems investigated in this study resulted in up to 16.8% reduction in primary energy use and up to 33% reduction in CO₂ emissions compared to the base-line case. Additionally, the majority of the design variations investigated in this study resulted in an economically feasible IRR (higher than 10%).
- 3) *Planning parameters generally had a larger impact on the cogeneration system performance than architectural ones.* Increases in use mix and density resulted in the highest improvements in performance. With regard to architectural parameters, mixing of housing typologies offered the most potential for performance improvements.
- 4) *A strong correlation was found between design characteristics identified as favorable for cogeneration system performance and characteristics of sustainable residential communities.* These design characteristics included high density, high mix of uses, interconnected street configurations, and mixing of housing typologies, all of which are also characteristics of sustainable residential communities. This indicates the higher potential for integrating cogeneration systems in sustainable residential communities compared to conventional ones.

It should be noted that the results of this study are only applicable to the cold U.S. climate zone. As climate can significantly affect both community energy use characteristics and cogeneration system performance and possible configurations, repeating the study in other climate zones is recommended as an area of future study.

Additional future studies recommended include investigating other cogeneration system configurations, such as the possible integration of active renewable energy systems (e.g. photovoltaics), investigating the impact of the size of the residential/mixed-use community on the performance of cogeneration systems, as well as investigating the impact of the proposed design changes on transportation energy use within the community.

ACKNOWLEDGEMENT

The study reported in this paper represents part of the author's PhD dissertation research conducted in Texas A&M University. The author would like to thank Dr. Phillip Tabb, the Ph.D. dissertation committee chair, for his valuable support and guidance, as well as all the other members of the committee: Dr. Jeff Haberl, Dr. Robert Johnson, and Dr. Michael Neuman, for their insightful feedback. The work was partially funded through the William W. Caudill Research Fellowship in the Department of Architecture, Texas A&M University; and the Fellowship for Advanced Study and Research of the American Institute of Architects (AIA) and the American Architectural Foundation (AAF) and the author would like to thank both organizations for their generous support.

REFERENCES

- Barton, H. (ed.) 2000. *Sustainable communities, the potential for eco-neighborhoods*, Earth Scan Publications Limited, London, UK.
- Braun, R., Klien, S., and Reindl, D. 2004. Considerations in the design and application of solid oxide fuel cell energy systems in residential markets. *ASHRAE Transactions*, 110(1):14-24.
- Breheny, M. (ed.) 1992. *Sustainable development and urban form*, European Research in Regional Science 2, Pion Limited, London.
- EIA (Energy Information Administration) 2004. *Emissions of green house gases in the United States 2003*, Energy Information Administration, U.S. Department of Energy, Washington, DC.
- EIA (Energy Information Administration) 2005. *Annual Energy Review 2004*, Energy Information Administration, U.S. Department of Energy, Washington, DC.
- Ellis, M. 2002. *Fuel cells for building applications*, American Society of Heating, Refrigeration, and Air-Conditioning Engineers, Atlanta, GA.
- Grumman, D. (ed.) 2003. *ASHRAE green guide*, American Society of Heating, Refrigeration and Air-Conditioning Engineers, Atlanta, GA.
- Gunes, M. and Ellis, M. 2003. Evaluation of energy, environmental, and economic characteristics of fuel cell combined heat and power systems for residential applications. *Transactions of the ASME*, 125:208-220.
- Hendron, R. 2005. *Building America research benchmark definition*, updated 29 December 2004. National Renewable Energy Laboratories, Golden, CO.
- Hirsch, J. 2003. *eQUEST, quick energy simulation tool: Introductory tutorial*. James J. Hirsch and Associates [http://www.doe2.com/download/equest/eQUESTv3-40_Tutorial.exe].
- Houghton, T. 2000. The community energy utility, in H. Barton (ed.): *Sustainable communities, the potential for eco-neighborhoods*, Earth Scan Publications Limited, London.
- ICC (International Code Council) 2003. *International energy efficiency code, 2003*, International Code Council, Club Hills, IL.
- Johansson, T., and Goldemberg, J. (eds.) 2002. *Energy for sustainable development, a policy agenda*, United Nations Development Program, New York, NY.
- Knight, I. and Ugursal, I. (eds) 2005. *Residential cogeneration systems: a review of the current technologies*. A Report of Subtask A of Annex 42 of the International Energy Agency.
- Lambert, T., Gilman, P., and Lilienthal, P. 2006. Micropower system modeling with HOMER, in: F. A. Farret, and Simões (eds.): *Integration of alternative sources of energy*, Wiley-IEEE Press, pp. 379-418.
- Lippiatt, B. 2002. *BEES® 3.0, Building for environmental and economic sustainability technical manual and user guide*, National Institute of Standards and Technology, Gaithersburg, MD.
- Owens, S. 1986. *Energy, planning and urban form*, Pion Limited, London, UK.
- Phetteplace, G. 1995. *Optimal design of piping system for district heating*. CRREL Report. 95-17, Cold Regions Research & Engineering Laboratory, US Army Corps of Engineers, Hanover, NH.
- Rashed-Ali, H. 2006. *Cogeneration and community design: performance based model for optimization of the design of U.S. residential communities utilizing cogeneration systems in cold climates*. PhD dissertation, Texas A&M University, College Station, TX.
- U.S. DOE (U. S. Department of Energy) 2003. *The micro-CHP technologies roadmap, meeting 21st century residential energy needs*, U. S. Department of Energy, Greenbelt, MD.
- WADE (World Alliance for Decentralized Energy) 2003. *Guide to decentralized energy technologies*, World Alliance for Decentralized Energy, Edinburgh, UK.
- WCED (World Commission on Environment & Development) 1987. *Our common future*, Oxford University Press, Oxford, UK.
- Williams, K.; Burton, E.; and Jenks, M. (eds.) 2000. *Achieving sustainable urban form*, E&FN Spon, London, UK.

Theory for Advancing Green Design

Intimate Encounters: Social Capital, Emotional Ecology, and Sustainable Design
Kaarin Knudson

The Role of Connectedness Theory in Sustainable Architecture
Anthony W. Layne

The Sustainability of an Architectural Practice
Lucas Gray

Advancing Green Design Through Theory*
Martha Bohm

The Trouble With Sustainability
Walter Grondzik

* Invited Oral Presentation

Intimate Encounters: Social Capital, Emotional Ecology, and Sustainable Design

Kaarin Knudson

University of Oregon, Eugene, Oregon

ABSTRACT: Drawing from the fields of psychology, anthropology, sociology and human geography, this paper will draw connections among emotional ecology, sustainable design, and an expanded definition of social capital in the United States. It argues that a complete definition of social capital would include environmental intimacy; that we are affected in meaningful, substantial ways by our intimate attachment to the natural world; and that our interactions with the environment, like our interpersonal interactions, are not one-way. Fundamental to this discussion is an understanding of our personal identification with the environment, the importance of intimate connections between the individual and her surroundings, the function of social capital in our communities, and the hypothesis that people are ecological creatures, not simply social. It is this author's belief that the widespread adoption of sustainability depends to a great degree on social capital and experiences of environmental intimacy.

Keywords: ecology, social capital, environmental intimacy

INTRODUCTION

Inspired by the different ways in which we relate to and idealize our external environments and communities, the initial hypothesis of this paper was that a correlation might exist between declining social capital in America and the resurgent interest in sustainability and conservation—that we, as a culture, were transferring our need for intimacy from people to places. That hypothesis quickly, and optimistically, gave way to a supposition that the presence of greater social capital could generate a greater sense of environmental intimacy and, more importantly, that the reverse could also be true. The existence of this continuous feedback loop and the simultaneous advancement of our connection to other people and our environment have the potential to be a tremendous support to any enduring philosophy of sustainable design.

SOCIAL CAPITAL + SUSTAINABILITY

Independently coined more than a half dozen times since 1900, the term “social capital” refers to the stored, non-monetary value of relationships held between individuals who share communities and physical space (Putnam 2000). It is a means by which we can express the value of interpersonal experiences and connections, things as simple as being “one of the regulars” at the corner café or knowing your neighbors would respond in the event of emergency. Considering the historical factors used to evaluate social capital, an intimate connection with the natural world is conspicuously absent. Though our authors, artists and theorists have alluded to and proven the adverse effects of disassociation from the natural world, social capital researchers do not include it among their indicators of civic engagement—most likely because it is not “civic” by definition and because it draws from a largely qualitative pool of research.

Research has shown that social capital assists in translating our social aspirations into reality in several ways. In areas of high social capital, citizens resolve collective problems more easily; communities progress toward shared goals more smoothly because of the high levels of trust they share; and the collective understanding of the ways in which our fates are intertwined is better understood (Putnam 2000). Social capital rises from norms of reciprocity and trustworthiness that are embedded within a dense network of social relations, and it allows the public and private good to simultaneously advance. Thus, the existence of social capital is crucial to the philosophy and practice of sustainability, which depends almost entirely upon the integration of decisions that benefit the individual and the collective in the short and long term. As just one example, organizations like

Architecture 2030 emphasize the professional unity and policy change needed to address CO₂ omissions and climate change. Tremendous social capital is requisite in such an ambitious endeavor.

However, during the last third of the 20th century, the trend of social engagement in America reversed abruptly and our country began a slow process of social disassociation within its communities. Though this change was concurrent with several dramatic cultural shifts, only four factors have been identified as actual “contributors” to the decline: the increased pressures of time and money (10%); the influence of suburbia and sprawl (10%); the privatization of social interaction via electronic media (25%); and the slow generational shift from a generation with high civic engagement to a less engaged generation (40%). This author speculates that our slow, simultaneous disassociation from the natural world and loss of environmental intimacy also contributes to declining social capital. Indeed, the four identified contributors also imply a concurrent lack of connection to the environment—be that due to a lack of time, lack of wilderness, or the pervasiveness of virtual realities. If social capital encompasses the unquantifiable interactions that “count for most in the daily lives of people,” it is reasonable to suppose that a relationship with the natural world would be included (Putnam 2000:19).

EMOTIONAL ECOLOGY

Emotions and rational thought are the two primary ways in which people make sense of all that we experience through sensations, perceptions and conceptions (Tuan, 1976). But rather than continuing western culture’s polarization of reason and feeling, emotional ecology utilizes them simultaneously. It argues for the incorporation of feelings with rational thought in the study of our ecosystem, and for the consideration of people as organisms within a larger environment to which we dynamically relate. In the words of Benton and Short, emotional ecology is a challenge to the assumption that our environment is merely a physical entity and a refusal to categorize it exclusively in scientific terms (Guy and Farmer 2001).

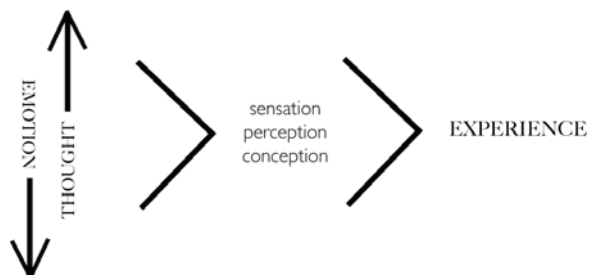

Figure 2: Emotion + Rational Thought = Experience. A diagram of how we construct reality based on Yi-Fu Tuan’s *Space and Place* (1976).

Many contemporary anthropologists say we understand the world primarily through cultural and social constructs, but others such as social anthropologist Kay Milton disagree. Milton has suggested that people, like any other animal, can also gain knowledge directly from the natural environment, without social mediation. Furthermore, she argues that emotions play a central role in this direct experience, in our acquisition of knowledge, and in the decision to take action based on that knowledge. It is an attempt, along the lines of human geographer Yi-Fu Tuan and others, to define experiences by both what we think (that which can be measured) and what we feel (that which is not easily quantified or explained).

This is the point at which emotional ecology, social capital and sustainable design might intersect. As social beings, people inherently seek intimate connections with others. However, as components of an ecosystem, humans also have a desire for this connection with their environment. It is possible that when we identify with an environment, our relationship with it becomes a component of our social capital. Social intimacy and sense of belonging are often the result of deep, personal identification with one’s surroundings—described by Arne Naess as the “expansion of the self to include other beings, so that one’s *own self* is no longer adequately delimited by the personal ego or by the organism” (Naess 1989, emphasis in original). Drawing from this description of deep ecology, one can speculate that an overall erosion of a person’s sense of belonging—contributed to by a lack of environmental intimacy—could also manifest itself in the form of other disassociations and declining social capital in our communities.

The connection being drawn is a simple one, yet incredibly complicated to demonstrate in quantifiable terms. Who we are is constructed by the people and places to which we feel the most intimate connections, but emotional intimacy and attachment are enormously private processes, the depth of which we have great difficulty

expressing or even detecting. This is also delicate ground, as the environmental movement still faces regular attacks from those who seek to isolate and exploit the “touchy-feely” components of environmentalism or sustainability as a means of undermining the whole. Tuan wrote extensively about the difficulties that humans have in quantifying the intimate—“people tend to suppress that which they cannot express.” He also noted that “relatively few works attempt to understand how people feel about space and place, to take into account the different modes of experience (sensorimotor, tactile, visual, conceptual), and to interpret space and place as images of complex—often ambivalent—feelings” (Tuan 1977:7).

ENVIRONMENTAL INTIMACY

Intimacy and identification with a place or natural environment can be built over years or created within a brief experience of authenticity, just as intimacy among persons “does not require knowing the details of each other’s life; it glows in the moments of true awareness and exchange” (Tuan 1977:141). This idea of an envisioned sense of intimacy with the environment could be considered universal—for some it may exist at the tops of mountains, for others it is in the view of a coastline or quiet glen. But the emotional attachment is the same. From Edward Relph’s *Place and Placelessness*, we understand place attachment to be a fundamental human need, but this is a need that contemporary society is increasingly unable to satisfy “owing to its tendency toward gradual spatial uniformity, increased mobility, and hence a purely functionalistic relationship with places” (Giuliani, 146). Given this, the numerous theories put forth by psychologists and sociologists about why humans seek solace and connection in the natural world make sense. Practically, we know it as something that simply *feels* good, something people do because they “need” it. A presence is felt and an intimate interaction is simultaneously projected and perceived (called “simultaneous intersubjectivity” by psychologists). This sense of connection to the natural world is not unlike the unspoken exchange between mother and child or two sleeping lovers. In such moments, we are defined by our relationship to our surroundings—be they human or non-human in form. With regard to both relationships and our ecological system, as we perceive our environments, we perceive ourselves (Milton 2002).

In 1960, H.F. Searles argued that the non-human environment constitutes one of the most important ingredients of human psychological existence (Gebhard 2003). Recently, anthropologists have suggested that there is no line dividing the interpersonal and ecological self. Milton wrote that our “understanding of personhood” develops within our “relationship with our total environment, not just within our relationships with other human beings” (Milton 2002:47). If our concept of personhood is created through experience with both people and our environment, and if our relationship with the non-human environment represents one of the strongest components to our existence, is it possible that as we form more intimate relationships with our surroundings, we no longer require that intimacy of other people? One could not argue that an individual’s non-human and interpersonal experiences are interchangeable, but could they be means to the same end—that “end” being a sense of intimacy with one’s total environment? It is an important parallel to consider, given our shared belief that architecture shapes the people who use it. How does what we build contribute to our sense of intimacy with the environment? Do the things we construct contribute to our sense of intimacy? Does the architecture we build reveal how we feel?

Architecture does reflect our cultures, philosophies and politics, but it does so on timed-delay. It follows our thinking and reveals our priorities. The speed and style in which we build or rebuild also belies a great deal about how we express ourselves and which emotions we can collectively tolerate. It also says a great deal about our desire for intimacy with the natural world. Many technical approaches to sustainability—from double-skin facades to fully automated, photosensor lighting systems—imply that we feel more comfortable with technology than we do with a reconsidering of our basic relationship to the environment. Collectively, we are more comfortable advancing our relationship with the environment through a mediator, in this case technology. Efficiencies and quantifiable results are prioritized, and people most often operate as managers of the system, rather than intimate participants in it.

A sense of environmental intimacy is crucial to nurturing a philosophy of sustainability because our ability to identify with and relate to non-human entities plays an important role in the protection of nature and natural things (Milton 2002). According to Naess, identification with nature makes moral rules about our interaction with the natural world redundant because personal identification departs from a moralistic approach. Anyone who personally identifies with nature is likely to feel inclined to protect it. It is an extension of Kant’s observation that benevolent action can be performed either out of duty or inclination: we act protectively toward nature not simply because we ought to, but because we want to. How could sustainability ever be more than market driven if this is not the case?

ENVIRONMENT + AFFECT

Tying together these various fields with regard to sustainable design is challenging—in part because of the caution with which psychologists, sociologists, geographers and architects approach any discussion of “affect” related to environmental psychology. This stems, in part, from a cultural disdain for determinism. The idea that not every person can achieve anything given any circumstance is inherently un-American, and the idea that our level of ecological intimacy might affect us in meaningful ways is exceedingly inconclusive. In the western or even Modernist tradition, we approach deterministic statements with uncertainty (or overt objection) and believe a person or thing to be defined by what it *is*.

Nevertheless, psychologists specializing in place attachment agree that our environment has an undeniable influence on our lives: “Affect related to places exists, and is of a nature that, albeit not fully explicit or defined, nevertheless distinguishes it from other affective ‘systems’ (towards objects, persons, ideas, etc.); furthermore, it is perceived as one of those important factors that sometimes help and sometimes hinder our equilibrium, our material and spiritual well-being” (Giuliani 2003:137). Within a framework of relational epistemology, personhood emerges from what something *does* in relationship to others. If we used such a framework to address elusive topics such as place-making or emotional ecology, a more subtle and sophisticated middle ground might be gained. Furthermore, this framework could be applied to sustainable design. Using a macro-relational epistemological approach (though perhaps fewer words to describe it), our architectural works could be valued and evaluated according to how they participate in our ecological system and how they relate to other entities within that ecology. In essence, we could reasonably judge our buildings by what they do, what they catalyze, and what they impede.

If we built according to this value system and with the incorporation of an emotional ecology, our communities would reflect a more equitable, symbiotic relationship to the natural world and with its residents, rather than reinforcing social stratification, economic injustice and enormous waste. Our buildings would be able to supply their own energy and work cooperatively with surrounding structures to account for the needs of the whole. We would choose architecture according to a shared value system that acknowledges our interdependence and emotional intimacy with the natural world, and these driving factors would trump the single bottom line every time.

CONCLUSION

Every person on this planet, by virtue of his or her self-awareness and biology, has a unique perceptual experience. This makes it extraordinarily challenging to make even broad generalizations about how and where people create intimacy with the environment or “about how they come to know nature as personal” (Milton 2002:49). Most psychologists consider this an accepted, irreconcilable issue, and they note the additional research required to address the intimate relationship between people and our environment. Others argue that a more pointed definition of “place attachment” will be required before any true similarities or dissimilarities with psychology’s well-documented theory of attachment can be drawn. Until such time, conclusive theories about the value of environmental intimacy and its influence on sustainable design will also have to wait.

Many articles addressing these subjects end with that rather tidy, compartmentalized point—and perhaps that is my point. At present, we are unwilling to specifically address the idea of place attachment and identification with nature (let alone the concept of an emotional exchange with nature) without a greater body of quantifiable evidence. This is understandable; additional research and case studies are necessary. However, this also returns us to a point made by Tuan and later expanded upon by Milton and others—that our experiences and our knowledge are comprised of both rational thought and emotion. As such, it may not be possible to scientifically confirm all the things that we know. Nevertheless, the idea that we are affected by environmental intimacy, and that our social capital is in turn affected this bond, is a worthy line of research to continue. Based upon trust and the simple desire to remain connected with the world we would protect, these issues relate directly to an enduring and widely accepted philosophy of sustainable design.

REFERENCES

Giuliani, Maria Vittoria. “Theory of Attachment and Place Attachment.” *Psychological Theories for Environmental Issues*. Burlington, VT: Ashgate, 2003: 137.

Guy, Simon and Farmer, Graham. "Interpreting Sustainable Architecture: The Place of Technology," *Journal of Architectural Education*. February 2001.

Milton, Kay. *Loving Nature: Towards Ecology of Emotion*. New York: Routledge, 2002.

Naess, Arne. *Ecology, Community and Lifestyle: Outline of an Ecosophy*. Translated and edited by D. Rothenberg. Cambridge: Cambridge University Press, 1989.

Putnam, Robert. *Bowling Alone: The Collapse and Revival of American Community*. New York: Simon & Schuster, 2000.

Relph, Edward. *Place and Placelessness*. London: Pion, 1976.

Searles, H.F. *The Non-human Environment in Normal Development and Schizophrenia*. New York: International Universities Press, 1960. Reprinted in Gebhard, Nevers and Billmann-Mahecha's essay, "Moralizing Trees: Anthropomorphism and Identity in Children's Relationships to Nature" in *Identity and the Natural Environment*. Cambridge: MIT Press, 2003.

Tuan, Yi-Fu. *Space and Place: The Perspective of Experience* Minneapolis: University of Minneapolis, 1977.

The Role of Connectedness Theory in Sustainable Architecture

Anthony W. Layne

University of Minnesota, Minneapolis, Minnesota

ABSTRACT: While generally discussed in terms of economics or technology sustainability is a behavioral problem rooted in the unsustainable lifestyles of the Western world. A cultural paradigm shift is necessary to truly address this issue. Recent psychological research suggests that this paradigm shift can be brought about through *connectedness*. This paper examines both how architecture can foster connectedness and how connectedness can influence architecture.

Architectural connectedness is both about what one creates and how it is created. The connectedness design process fundamentally requires an awareness and understanding of the various systems affected or created by design and more importantly, the relationships between them. It is an iterative process involving the progressive layering or integration of systems and requires continual re-evaluation of design decisions in light of the newest layer of systems information. Once designed this multilayered integration of systems facilitates connectedness through human experience.

Architecture alone cannot create or cause connectedness, but by applying connectedness theory to the process of design, a method is generated that forces the architect to design in a holistic and systems-based manner and allows the architect to design the human experience. Ultimately, this process can create an architecture that facilitates connectedness. It is a both/and proposition. It is not a question of one or the other but *both*: 'how can architecture bring about connectedness?' and 'how can connectedness bring about architecture?'

Keywords: connectedness, psychology, design process

INTRODUCTION

For several years a near consensus of the world's scientists has warned that the environment that supports life on earth is in crisis. According to the Union of Concerned Scientists, every living system on the planet is in decline and the rate of that decline is increasing. In fact, planet earth is experiencing the fastest period of mass extinction in history, even faster than during the extinction of the dinosaurs (Eldredge 2001).

Motivated by the certainty of the deterioration of the environment and the realization that humans are dependent upon this environment for their own health and survival, several groups and individuals have taken action in an attempt to reverse these alarming trends. The last thirty years has been a time of unprecedented ecological and environmental awareness. Tactics as varied as Smart Growth, the Kyoto Protocol and carbon trading as well as numerous energy conserving initiatives have been implemented by groups as disparate as the European Union and the American homeowner in efforts to live a more sustainable existence. Yet, during this same time period, energy use, greenhouse gas emissions, deforestation, and destruction of habitat has continued to rise to unprecedented levels (*Annual Energy Outlook 2002*, Addington 2003).

Why has this mobilization of policy and design not made a significant impact in the crisis of environmental degradation? The answer lies in examining the broader picture. The current strategies for addressing sustainability are compromises focused on symptoms, not true solutions. Technology and various forms of economic policy have been put in place in an effort to resolve the current environmental crisis. The problem is that this crisis has not been caused by technological or economic factors alone and therefore will not be solved just through technological or economic solutions. The dilemma that faces the human race, and especially the Western world, is embedded in unsustainable lifestyles (Wang 2003). Sustainability is a behavioral problem.

Environmental degradation, or the deterioration of the planet's ability to sustain life due to industrialized human activities, is among the most difficult and complex issues ever faced by modern society. One would not think this is the case however, from the existing architectural discourse regarding the subject. The prevailing logic is that solutions are known and straightforward and that these solutions merely need implementing (Addington 2003). Indeed the human built environment, the buildings, roads and infrastructure of man's cities and towns and the industrial processes that come along with them, are responsible for a significant portion of the present negative impact on our natural environment. Currently, the built environment, and the method in which it

is designed and constructed, consumes energy and natural resources, pollutes air and water, and destroys diversity and natural habitat. This has led architects to work towards implementing technologies and strategies in their designs that mitigate the deleterious effects of buildings. This strategy however, merely addresses the symptoms of the problem and not the root cause. If environmental reparation is to be made, the behavioral source of humanity's unsustainable tendencies must be transformed.

Several methods are often employed in an attempt to bring about change in a population's behavior. Proscriptive measures such as laws forbidding certain actions are one popular technique. Dissemination of information with the hope that awareness of an issue will bring about behavioral change is another. The most powerful however, is to change the paradigm out of which the behavior arises. The paradigm, specifically a society's collective belief about how the world works, contains a leverage point that once changed transforms the entire system (Meadows 1997). Recent research in psychology suggests that the shift to a sustainable paradigm could be brought about through *connectedness*. Connectedness refers to the extent to which individuals believe that they are a part of the natural world or the capacity of a person to see their own life and its conditions as part of a larger matrix (Schultz 2002, Cock 2002). The role of the architect is as important in this critical mission of change as it has been in working to implement sustainable technologies and strategies into design. Architecture can promote a necessary paradigm shift towards a sustainable lifestyle through facilitating *connectedness* and encourage the growth of responsible, engaged, self-actualized citizens.

1. RESEARCH PROCESS

1.1. Research objectives

The general intent of this research was to gather evidence of strategies that successfully bring about behavioral change and distill several principles from these strategies that can guide future efforts to direct sustainable behavior. The ultimate goal of this research was to determine the role of architecture in supporting and promoting these sustainable behavior change principles. This research contributes to a dialog about the responsibility of architecture in affecting behavior regarding sustainability and begins to develop tools or strategies that can be applied during design to affect positive change.

1.2. Research method

This research consisted of five parts:

Part I. A general background into the current crisis of sustainability was established. This identified major issues contributing to the problem, investigated predominant strategies for addressing it and provided support for the supposition that the crisis of sustainability is a behavioral problem, rooted in the unsustainable lifestyles of the Western world.

Part II. Issues involving behavioral change regarding sustainability were established. This identified popular methods currently employed to attempt to bring about behavioral change, the limitations to these methods and provided support for a paradigm shift as a more effective method of bringing about change.

Part III. Through a review of recent research in the psychology and sociology of sustainable development and research in sustainable development learning and education the concept of behavioral change and paradigm shift were investigated further. Through this research review, guiding principles affecting change regarding sustainable behavior were established. The role of architecture in supporting and promoting these change principles was then identified.

Part IV. Through precedent study and identification of current architectural work involving these principles, their direct application in design and architecture were explored further in an effort to be better understood. This precedent study targeted facilities focused on environmental and sustainable education in order to support part V, the design component of the project.

Part V. Finally, these change principles and their corollary architectural principles were investigated and illustrated through the design of the Kettle River Environmental Education Center located on a 160 acre site just west of the Kettle River in Sandstone, Minnesota. This project served as a vehicle to test the validity and refine the developed processes and principles.

2. CONNECTEDNESS THEORY

2.1. Man's relationship with nature

At the center of the discussion on sustainable behavior is the recurring theme of a *relationship* with nature.

Philosophers talk about this in terms of ethics, or morality. Sociologists talk about culture, values and the ways in which societies interact with nature. Conservationists talk about land ethics, and the experiences that result from encounters in nature. But at the core is the individual, and his or her understanding of his place in nature (Schultz 2002:66).

Psychologists and researchers point to the concept of *connectedness* as central in this discussion. Broadly the term connectedness describes the extent to which individuals believe that they are a part of the natural physical universe (Schultz 2002). Recent research suggests that an individual or group's level of connectedness directly

affects their level of sustainable behavior (Clayton 1998, Kidner 2001). Some even argue that this psychological connection with nature will be required to achieve sustainability. Consider this quote from Tarnas:

Only the experience of connectedness will save the earth – and us with it. Any attempt, however grandiose and with however much commitment to its cause, will fall short if it does not have at its root the transformation of human experience in which human thinking knows connectedness as such and itself with that (Tarnas 1991:73).

2.2. Inclusion with nature

In later work, Schultz argues that connectedness is one part of a larger notion he terms “inclusion with nature.” Higher levels of connectedness ultimately leads to caring for nature which leads to a commitment to protect nature and higher levels of inclusion with nature which, in turn, leads to more sustainable behavior. He goes on to say that the core of a connection with nature is cognitive and defines connectedness as “the extent to which an individual includes nature within his/her cognitive representation of self (Schultz 2002).”

The term self is used to refer to a range of constructs, but in this work it refers to a person’s thoughts and feelings about who they are. Self knowledge is organized into hierarchical cognitive structures known as self schemas. A person may have a schema of self that includes physical characteristics like brown hair, social identities like father or husband, or leisure activities like camping and skiing (Brown 1998). These self schemas serve to organize experiences and provide a coherent understanding of identity (Schultz 2002). Furthermore this allows definition of self in relation to others. Some researchers argue that in close relationships, the cognitive representations of self and other can become integrated (Aron 1999). Taken to the extreme, self and other become one (fig. 1). Schultz concludes:

This is the central aspect of inclusion [or connectedness] with nature. Individuals who define themselves as part of nature have cognitive representations of self that overlap extensively with their cognitive representations of nature. In contrast, individuals who do not define themselves as part of nature will not have overlapping schemas of self and nature (Schultz 2002:68).

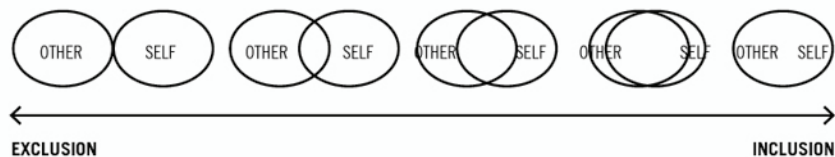

Figure 1: Integrated cognitive representation of self and other. Source: (Schultz 2002:72)

This research also shows that the relationship between a commitment to protect nature and caring for nature and connectedness is, in fact, causal. “Commitment to protecting the environment cannot occur in the absence of caring. Likewise, it would seem that caring is unlikely to occur in the absence of connectedness (Schultz 2002:70).” Therefore, it would seem that strategies to increase connectedness would ultimately result in positive sustainable behavioral change. It is on the aspect of connectedness and strategies to encourage it that this paper will focus.

2.3. Connectedness sub-categories

This paper proposes that connectedness can be further defined as containing at least three sub-categories, physical connectedness, social connectedness and emotional connectedness. Physical connectedness refers to a tangible connection to and understanding of nature and its cycles and flows (e.g. the cycles of the sun, the seasons or cycles in microclimate). Social connectedness refers to the extent an individual believes that he or she is a part of larger social groups and through this maintains an ability to empathize with others. Emotional connectedness refers to the emotional component affecting an individual’s behavior. The level of intensity in each of these sub-categories ultimately comprises one’s overall connectedness. While each of these sub-categories is defined separately and contains distinct and individual concepts, they are also interrelated and overlap.

2.4. The role of architecture

Understanding connectedness and its components along with methods in which it is being addressed is fundamental in advancing a solution in the crisis of sustainability. Developing change strategies that engender connectedness is essential. Once identified, successful change strategies must be implemented. Because of the multifaceted nature of the crisis of sustainability, implementation of change strategies will also be intricate and multidisciplinary. Research that translates general tactics into discipline specific approaches to change is vital to their useful application. Specifically, the research undertaken for this paper explores the part that architecture plays in facilitating or impeding connectedness.

Up to this point, the architectural profession’s approach to addressing the crisis of sustainability has predominantly been applying sustainable design technology to building design. While an important component in

the journey to a sustainable society, the simple application of technology does little to address the larger issue of unsustainable behavior. This is identified as one of several contradictions in sustainability.

The development and application of technology for practically all purposes has enabled an increase in our consumption of resources and production of wastes, to the point where this duality of allied problems threatens The Biosphere, as well as our own and Nature's survival. We have become evermore dependent on technological support systems even when we could meet our needs in other ways (Dovers 1993:217).

Architecture can do more. In its design and construction, architecture can contribute significantly to its inhabitant's connectedness and as a result, to their overall sustainable awareness and behavior.

3. DESIGN RESEARCH

3.1. Design methodology

Utilizing the principles of physical, social and emotional connectedness as parameters to guide sustainable design requires a modified design process. While the connectedness process may run parallel to a traditional architectural process with typical project phases and sequence (e.g., pre-design/concept design, schematic design, design development, construction documentation, qualifications and bidding, and construction administration), the process requires more time spent in early phases of the project, identifying specific goals and strategies, and any synergies that may be obtained through the combination of these strategies. In some ways this is true of all sustainable design processes when compared to a traditional architectural design process. However, while any sustainable design process would look for design and construction strategies to make a building more sustainable, the connectedness process goes beyond looking for strategies or techniques that simply make a building more sustainable and seeks strategies that will actually facilitate sustainable behavior on the part of the building's occupants.

To accomplish this, relevant principles affecting the level of connectedness in each of the three categories (physical, social and emotional) were identified from the research (column 1, fig. 2). Then, each of these principles were evaluated with regard to their relationship to architecture along a continuum ranging from a physical manifestation characterizing a low level of connectedness to a physical manifestation characterizing a high level of connectedness. Next, specific project goals were established from architectural qualities that fostered a high level of connectedness (column 2, fig. 2). Once project goals and criteria were generated, specific sustainable strategies could be identified to address each goal (column 3, fig. 2). For instance, operable windows, daylighting, separation of building elements, integrated site design, choice of materials, outdoor gathering spaces, and access to views were all identified as sustainable strategies to achieve the project goal of a 'strong indoor/outdoor connection' as a part of the 'awareness of natural cycles principle' under the 'physical connectedness' category. After this process was repeated for each project goal, all the goals and strategies were mapped against one another to identify overlap and opportunities for integration and synergy. For instance, outdoor gathering spaces, identified as a strategy to achieve a 'strong indoor/outdoor connection,' was also identified to achieve project goals such as 'project is accessible with areas designed to promote interaction,' 'project is integrated into context and community, promoting a culture of trust,' 'project encourages time spent in nature,' 'project encourages time spent with significant others,' and 'project encourages interest in nature.' Each of these goals was also linked to other strategies (fig. 2).

By tracing the linkages back and forth between the project goals and the sustainable strategies, a web of interconnectedness was revealed. This provided an understanding of the motivation behind each of the proposed strategies and how certain strategies could be partnered to achieve the most significant impact toward the project goals. The integration map could then be used to guide the subsequent design process, helping to identify, prioritize and evaluate design strategies and their usefulness toward facilitating sustainable behavior. In order to follow the application of the three categories of connectedness their nine criteria were color coded. This allowed program areas and design elements to be readily understood as supporting one or more of the connectedness criteria.

Once this integration map was generated it was utilized to generate an architectural schematic design concept for the Kettle River Environmental Education Center from a previously established space program. The resulting design concept functionally accommodated all the necessary spaces and adjacencies as well as employed many of the sustainable design strategies identified in the integration map. The design certainly would have produced a 'sustainable' building, but in many ways it was no different than a design produced through any other sustainable design process and it was unclear how it ultimately related to connectedness.

Connectedness Strategy Matrix & Integration Diagram

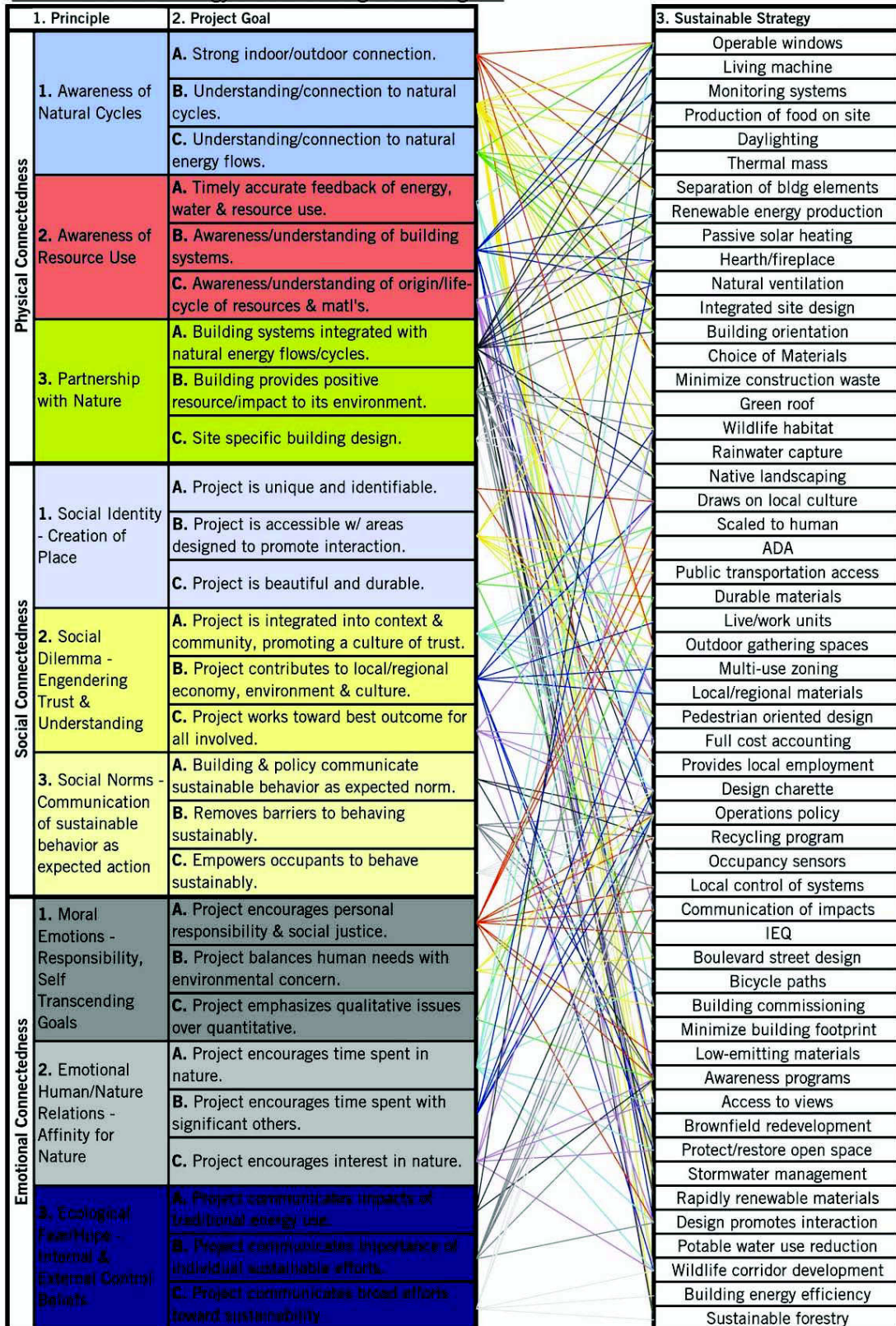

Figure 2: Connectedness strategy matrix and integration diagram illustrating connectedness principles, connectedness project goals and correlating sustainable strategies. Source: (Image by author)

3.2. Connectedness logic

It was at this point in the process that a fundamental shift occurred in the way connectedness, as it applies to architecture, was conceptualized. Here, the question broadened from 'how can architecture bring about connectedness?' to include 'how can connectedness bring about architecture?' This widening of focus provided a more holistic way of exploring the issue of modifying behavior through connectedness. This also brought about the realization that if architecture is to bring about connectedness it would be through human experience. Therefore, this process is ultimately about the *design* of human experience.

3.3. Design process

With this shift in thinking, the design and exploration process also shifted. The schematic design generated earlier was maintained in order to serve as a vehicle in the subsequent shifted process. It would serve as a baseline in a concept test method. Additionally it was recognized that in order to design a human experience that facilitated connectedness, the design process itself and the designer must have a high level of connectedness. In order to achieve this, building program components, processes, materials and activities and their interrelationship must be understood and the process must include a rigorous analysis of these components and their relationships.

This analysis began with the site and examined both the existing and proposed natural and manmade site elements. The analysis also investigated the relationship between these elements. This analysis was not exhaustive but, chose to focus on ten specific site components. These included site topography, water/hydrology, under-story vegetation, over-story vegetation, wildlife path, natural landmarks, agricultural plots, pedestrian path, vehicular path and man-made landmarks.

The analysis then shifted from site elements to the existing and proposed systems of the site and focused on seven systems - wildlife habitat, stormwater system, energy production, food production, research process, learning process, and rainwater cycle. By graphically mapping the components and flows of these systems common elements between them and their relationship to each other became readily apparent.

The examination of the site systems and their interrelationships helped shift the thinking of the project from element or object based to relationship based. It was not necessarily the objects themselves that were most important, but the relationships between the objects and the realization that the objects were simply a collection of other relationships. In fact, once the analysis shifted to a relationship based paradigm, new objects were revealed. For instance, objects initially viewed separately like a pond or a tree were seen in a larger context as part of a habitat system. Without a shift in the way these systems were thought about these new objects would never have been recognized.

This shift to a relationship-based analysis paradigm motivated by the need to design the human experience necessitated a change in the way the architectural building program was conceptualized. To this point, the program was thought about in a typical space-based model. However, this change in thinking provoked the awareness that an activity-based program model would allow a better analysis of human experience and provide a more useful method of exploring connectedness (fig. 3).

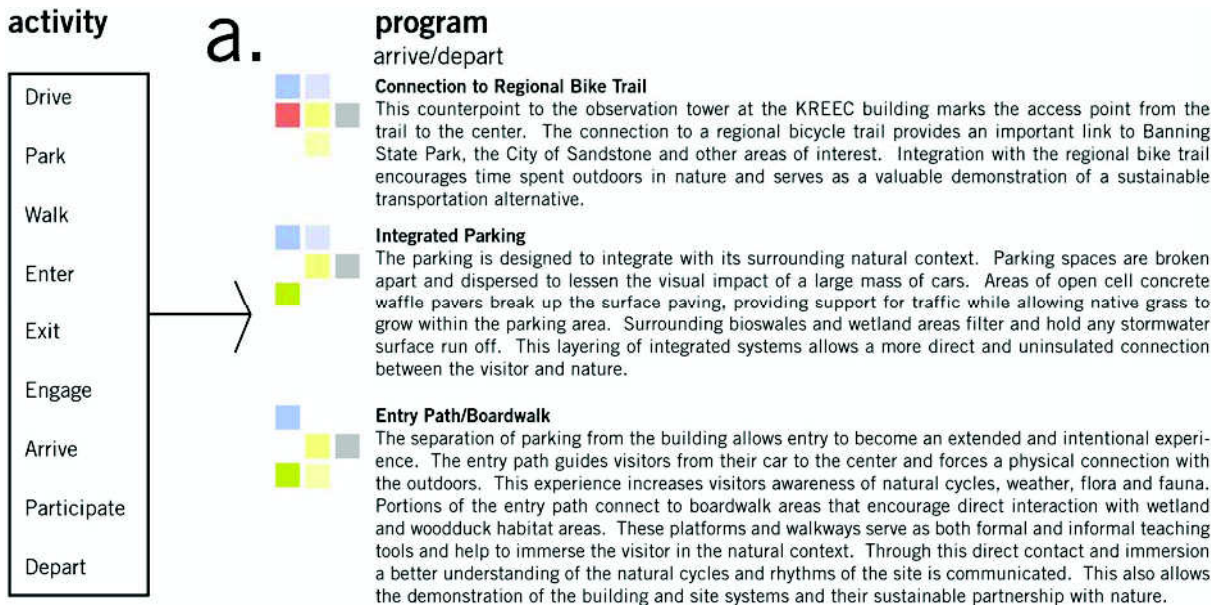

Figure 3: A portion of the activity program showing identified activities, corresponding program spaces and related connectedness principles. Source: (Image by author)

In order to generate this new program a list of activities that participants would engage in on site was developed. This list included activities such as walk, gather, observe, eat and harvest. These activities were then sorted by their relationship to each other. For instance, the activities read, listen, communicate, research, gather, think, test/experiment, observe, and explore were all grouped under the broader activity category teach/learn. This process identified three program categories: arrive/depart, teach/learn, and produce/consume. Once these categories were generated program space components could be identified to support the given activities. For instance, classrooms, an observation tower, site trails and teaching stations were listed in support of the teach/learn activity category. Further, each of the space program components were scrutinized for their potential to promote the earlier developed connectedness criteria.

With an activity program developed, the next step was to begin to integrate the program with the site. A site/activity map was created to begin to integrate the two and identify zones of activity on the site. This helped to visually organize proposed and existing elements and activities. After mapping the activities on the site another map was generated to relate the activity program to the space program. This map involved tracking the proposed human experience chronologically across the site. Here too each of the proposed experiences was referenced with the earlier established connectedness criteria. Because so much of the exploration of this project dealt with human experience, it was determined that traditional architectural drawings alone could not be effectively utilized in the design process. Therefore, an iterative process of design was developed using collage as the tool for exploration. Each of the three program activity categories were investigated through this process. This iterative process involved the progressive layering and integration of systems and required continual re-evaluation of design decisions in light of the newest layer of systems information (fig. 4).

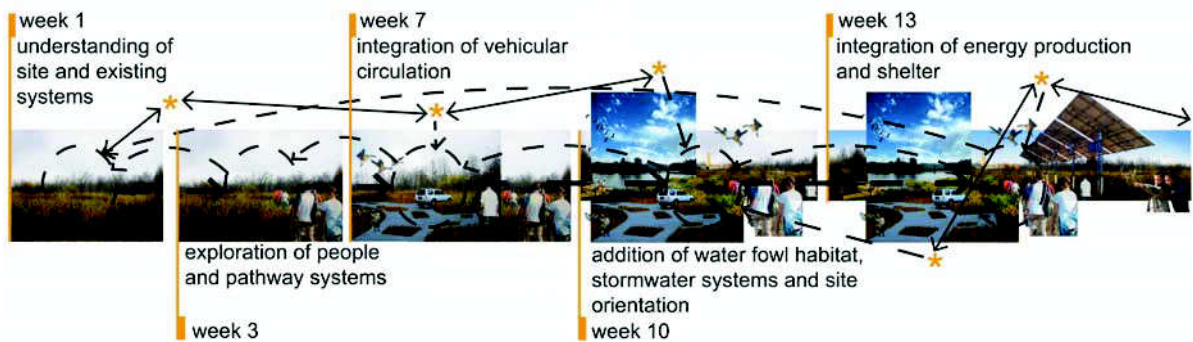

Figure 4: Iterative process diagram showing how new understanding from inside and outside the design process influences further discovery. Source: (Image by author)

Once these experiential collages were created, they were used as the basis for exploring the design further through more traditional architectural representations such as plan, elevation and section drawings. Additionally, the previously mapped systems information was then re-mapped onto the design plans or sections (fig. 5). This furthered the understanding of the design and the site systems and the integration between the two.

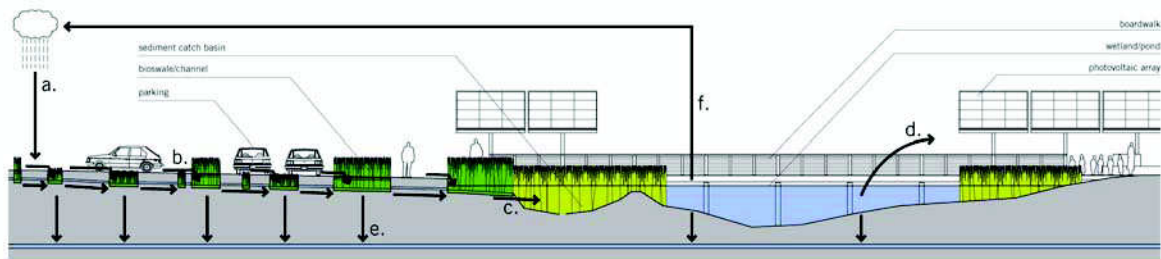

Figure 5: Arrival/departure site section with overlaid stormwater system map. Source: (Image by author)

CONCLUSION

This paper began with the assertion that the crisis of sustainability is, at its root, a behavioral problem. A critical survey of recent psychological research suggested that behavior could be modified through connectedness and

that a higher level of connectedness was correlated to more sustainable behavior. It was thought that architecture could play a strong part in achieving connectedness through the design of human experience.

Through the course of the work, a new method for approaching the design process was uncovered. This iterative process focuses heavily on understanding the relationships and systems created or affected by building and then relies on this knowledge to guide subsequent design. As more is understood, the design is continually revised and adapted to incorporate this new knowledge. This process of knowing is extremely valuable not only in working to create sustainable buildings but more importantly in functioning to facilitate sustainable behavior through connectedness.

So, can architecture facilitate connectedness and therefore encourage sustainable behavior? The answer is yes, however, connectedness is not created through the simple application of sustainable design strategies or technologies, but through the design of human experience and architecture that encourages connectedness cannot be created in the absence of a connectedness design process. Encouraging connectedness through architecture requires: 1. a high level of connectedness on the part of the architect, 2. a holistic understanding of the systems created or affected by the project, and 3. a holistic understanding of the potential human experience.

Architectural connectedness is both about what one creates and how it is created. The connectedness design process fundamentally requires an awareness and understanding of the various systems affected or created by design and more importantly, the relationships between them. Architecture alone does not cause connectedness, but by applying connectedness theory to the process of design, a method is generated that allows the architect to design the human experience of a building's occupants in a holistic and systems based way. Ultimately, this creates an architecture that facilitates connectedness through human experience.

REFERENCES

Addington, Michele. Energy, Body, Building: Rethinking Sustainable Design Solutions. *Harvard Design Magazine*, Spring/Summer 2003, Number 18.

Annual Energy Outlook 2002 with Projections to 20. 2002. [Online]. Available: <http://www.eia.doe.gov/oiaf/archive/aeo02/pdf/0383>. [2005, October 28].

Aron, A.; Fraley, B. 1999. Relationship Closeness as Including Other in the Self: Cognitive Underpinnings and Measures. *Social Cognition*. pp 17,140-160.

Brown, J.D. *The Self*. Boston MA. McGraw-Hill. 1998.

Clayton, P. 1998. *Connection on the Ice: Environmental Ethics in Theory and Practice*. Temple University Press: Philadelphia PA.

Cock, P.H. 2002. Partnerships for Sustainability: Psychology for Ecology. *Psychology of Sustainable Development*. Kluwer Academic Publishers: Boston MA.

Dovers, S. R. & Handmer, J. W. 1993. Contradictions in Sustainability. *Environmental Conservation*. Vol. 20. pp 217-21.

Eldredge, N. 2001. The Sixth Extinction. [Online]. Available: <http://www.actionbioscience.org/newfrontiers/eldredge2.html>. [2006, May 8].

Kidner, D. 2001. *Nature and Psyche: Radical Environmentalism and the Politics of Subjectivity*. State University of New York Press: New York NY.

Meadows, Donella. Places to Intervene in a System. *Whole Earth*, Winter 1997.

Schultz, P.W. 2002. Inclusion with Nature: The Psychology of Human-Nature Relations. *Psychology of Sustainable Development*. Kluwer Academic Publishers: Boston MA.

Tarnas, R. 1991. *The Passion of the Western Mind*. cited in: Schultz, P. 2002. p 73.

Wang, Wilfried. Sustainability is a Cultural Problem. *Harvard Design Magazine*, Spring/Summer 2003, Number 18.

The Sustainability of an Architectural Practice

Lucas Gray

University of Oregon, Eugene, Oregon

ABSTRACT: If the world's population lived with an average American lifestyle we would require five and a half planets to sustain human society. It is imperative that we adapt our lifestyles so we can meet our demands with the one planet we have. I used the Ecological Footprint Quiz on myfootprint.org to analyse how our daily choices impact the sustainability of our lives. Based on the varying results I present ways to change how we live and design in order to reduce our individual and community's footprints. I offer suggestions on lifestyle choices while also addressing larger issues like sustainable energy sources and transportation methods. I argue that in this time of environmental crisis we should add environmental cost to economic thinking. If the general population adopts some of these arguments and we as architects incorporate strategic features into our designs we can change the destructive course our civilization is heading in. We will thus create a society that lives in harmony with planet Earth.

Keywords: sustainability, ecological footprint, environment

INTRODUCTION

There is a growing trend in architecture towards sustainable design. Yet, how many firms have changed the way they operate to make themselves sustainable? How many architects live sustainably?

Our ecological impact is derived from our lifestyle choices. The website, www.myfootprint.org, offers a short quiz that roughly estimates an individual's degree of sustainability. The questions survey personal decisions regarding food, goods and services, housing, and transportation. It calculates the area of land needed to provide sufficient resources to meet personal demands. This land is referred to as a 'footprint.' The quiz is based on national consumption averages, and it allows individuals to compare their results to these averages. Some parts of the footprint are beyond the individual's control, such as municipal infrastructure, roads, government buildings, schools, etc.

Each footprint is measured in a unit called a "global acre", which is an acre of land with average global bioproductivity. Measuring the footprint in global acres allows easy comparison across different regions with varying land use. The Earth currently has approximately 26.7 billion acres of biologically productive space, equal to less than 1/4 of the planet's surface. These 26.7 billion acres are broken down into 5.7 billion acres of productive ocean and 21 billion acres of productive land. Dividing the total biologically productive area by the world's population gives each person approximately 4.5 acres to meet all of their needs (rprogress.org). This also means that the average footprint is inversely proportional to the world's population. As the population continues to rise our footprints must correspondingly decrease.

When humanity's footprint exceeds the amount of renewable biocapacity a decline in natural resources occurs. Currently, humanity's footprint exceeds ecological limits and is thus unsustainable (rprogress.org).

Based on my lifestyle as an environmentally aware architecture student at the University of Oregon, I have a footprint of 11 acres. This means we would need 2.4 planets to sustain the world's population if everyone lived as I live. In comparison, the average ecological footprint in America is 24 acres per person needing 5.35 planets. As an architect living and working in Shanghai, China, I needed upwards of 5.5 planets due to my heavy reliance on automobile and airplane transportation, as well as consuming a diet relying on a large consumption of meat. It is our mandate as residents of Earth to have a footprint of 1 Earth or less, thus living completely sustainably. What do we have to do to reduce our impact? What can an architect do to reduce his or her footprint, and how can an architect work to reduce the footprint of others?

By analyzing major choices in our lives we can determine ways to drastically reduce our footprints. We must examine our consumption of food, goods and materials, as well as our use of transportation, and energy. Our

consumption levels cause harmful emissions and create waste. It is the responsibility of the architect to consider how these issues influence the built environment.

1. FOOD

All people need to make smarter choices concerning the food they eat. Eating meat and dairy is not environmentally sustainable. It takes over half an acre of land to produce the meat consumed in one dinner per week. Footprints needed to cultivate different types of food vary widely. “A plant-based diet generally requires less land, energy, and other resources. Crop-based food requires an average of 1.9 global acres per ton of food, compared to 5.2 global acres required to produce one ton of animal-based food” (Redefining Progress). Residents of South West England consumed about twice as much plant-based food as animal based food in 2001. However, the footprint needed to sustain the animal based food was over three times larger (Figure 1) (www.steppingforward.org.uk).

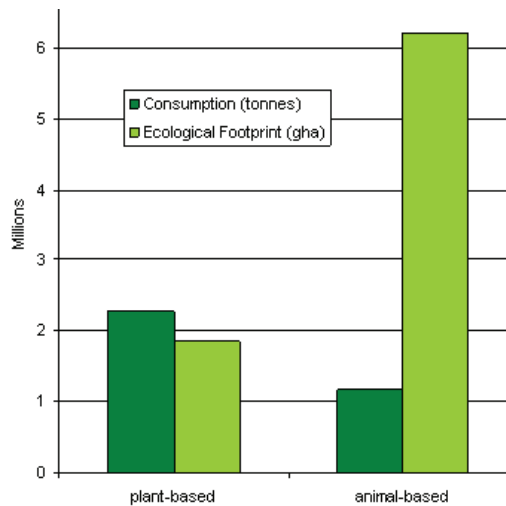

Figure 1: Food footprint of South West England residents, compared with tonnages consumed, in 2001
- Steppingforward.org.uk

We must purchase food that is grown within a 200-mile radius of where we live. According to the Lane County, Oregon magazine, *Locally Grown*, “The food on an average American’s plate travels 1300 miles to get from the farm to the plate, and during that time, changes hands six times” (Battson 06). The number one influence on these food miles, as this is referred to, is individual customers driving to the grocery store. In America on average almost 75% of food consumed is processed, packaged and not locally grown. In addition, 26% of food that is purchased in America is thrown away and not eaten. (Household Ecological Footprint Calculator). If we can design communities that have the infrastructure to produce 50 percent of our food locally then we can reduce the average American’s footprint by 1 acre, thus bringing our planets from 5.35 down to 5. If we consume almost all of our food from local, unprocessed, unpackaged sources we can lower our footprint by another acre and another 0.3 planets. “With current agricultural land, Lane County could grow or produce 100% of the county residents’ grain, vegetable and fruit needs, but only 83% of dairy needs and 10% of meat needs” (Battson 06).

We must choose to buy organic and sustainably grown foods that are unprocessed and unpackaged. Food grown this way reduces our dependence on chemicals and preservatives, and improves our health while allowing us to compost food wastes and return nutrients to the ecosystem. Too often our food waste ends up in landfills where it has no value. Composting our food and other biological waste is the only way to return nutrients to the ecosystem. If we don’t consciously change our approach to food, our resources will run out within our or our children’s lifetimes, and these decisions may be forced upon us.

As architects we need to consider whether the land we are building on can support agriculture. If so, it is a waste to build large housing communities and strip malls that increase suburban sprawl on valuable arable land. Architects should dedicate parts of each site to allow for local food gardens and thus promote consumption of locally grown produce. The Douglas Hospital in Montreal supports a large community garden on part of its sprawling campus. Parks throughout Eugene, Oregon also dedicate land to community gardening and composting initiatives. When designing landscapes and choosing tree types, landscapers and designers should

specify fruit trees that supply food to the community, and plant berry bushes as hedges if the local climate can support them. In this way plants give back to the community, providing free food and supporting cooperation between humanity and the environment.

Architects need to design alternatives to wasteful uses of land such as lawns. We must change the preconception that lawns are a desirable feature of a property. Today millions of Americans spend approximately 30 billion dollars a year on the maintenance of over 23 million acres of lawns. The lawns in the US consume around 270 billion gallons of water a week. That's enough water to sustain 81 million acres of organic vegetables for an entire summer. If every house with 1/3 of an acre of lawn converted the grass to a vegetable garden they could grow enough food to feed a family of 6. (Flores 06).

"The average urban lawn could produce several hundred pounds of food a year" (Flores 06). If we have to build on fertile land it should be required that we replace the building footprint with planted roofs. This will not only benefit the energy consumption of the building and help control storm water run off but also support local plant species and create habitats for indigenous animals. It is also possible to design rooftop vegetable gardens - imagine a city where each building grows enough food on its roof to support its inhabitants.

2. GOODS AND MATERIALS

Our consumption of goods and services and our consequent waste is another aspect of our lives that needs to be addressed. The majority of products on the market are not built with sustainability in mind. Even recycled products are often created from materials that require just as much energy to adapt and create just as much waste as producing a virgin product (Braungart 02). It is our job as architects to research materials and find those that positively impact our environment; materials that have low embodied energy, no harmful waste byproducts, and can be endlessly recycled without a decrease in quality or require massive amounts of energy. These materials do or can exist; it is our job to find or design them.

Like with food, the movement of materials over great distances is a tremendous drain on resources. Architects should specify products produced within a 200 mile radius of the project site. (Figure 2). The energy costs involved in their transportation is vast and unnecessary. Designing with local climates in mind should extend to using local materials. Local materials should be easier to find, transport and be more plentiful. This should drastically reduce their cost. By using local materials our buildings will become more grounded in the communities they are built in. Local labor and craftsmen can be involved in the construction thus supporting local economy and giving residents a closer connection to the buildings they live in.

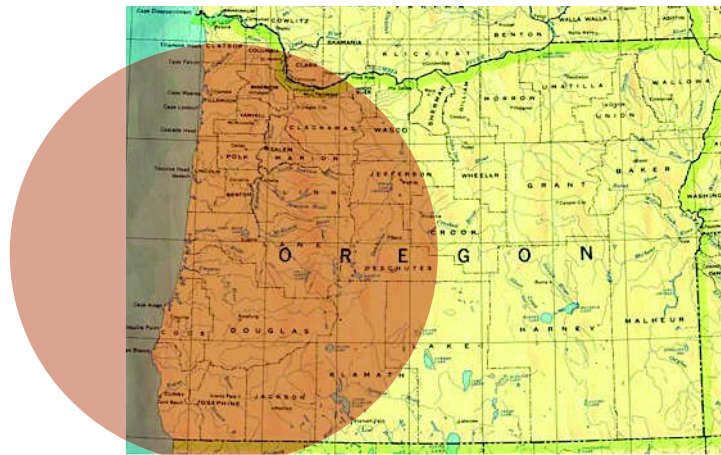

Figure 2: For projects in Eugene, OR, materials should be sourced from within a 200 mile radius: the region highlighted in red.

In order for architects to take advantage of local goods and services, we should choose to limit our work to local projects. This would decrease travel time and costs. It would also allow the architect to have an intimate understanding of the people and culture within the community. This also gives an understanding of the unique materials and skilled labor of the local building culture.

Conversely, architects may follow their projects. For example, if an architect took a project in Shanghai, she would relocate her office to China, living there for the duration of the job. She would then move again for her next project. In this way she would cut down on travelling to and from the site. Living in her new surroundings would provide a closer relationship to the site. She would experience the variations in climate over the course of a longer period, and have a glimpse of the local community and culture, making it easier to specify local materials or integrate recycled materials from local sources.

3. TRANSPORTATION

While transportation is not directly affected by the buildings we design, it dramatically affects the design process. Architects need to address the problem of separation between the site, the office, and the home. The first and easier decision we must make is living near our workplace, meaning within an easily walkable distance in all weather conditions. Living in a suburb and commuting to work by car or even public transportation is not sustainable. The reliance on fossil fuels to move us around cannot continue. The average American drives for 25 miles a day (Household Ecological Footprint Calculator). For every 100 miles per month we drive (assuming we get 25-35 miles per gallon and we carpool) our footprint is increased by about 1 acre. However, America's obsession with SUVs, trucks and other large vehicles that get as little as 10 or less miles per gallon dramatically increases our average footprint.

Bikes offer an excellent alternative for automobiles. Biking is less sustainable than walking; however, it drastically increases one's commuting radius making it such a great alternative to the car. As architects we need to better address the difficulties in biking as a mode of transportation. Both urban design and individual building design need to be readdressed with bikes rather than cars in mind as the primary mode of transportation. Bike lanes need to be incorporated into city planning and road design. Bike lanes require a distinct separation from automobiles and pedestrians. This can be created using a simple line or preferably an actual curb or hedge (Figure 3). Support utilities for bikes and their riders must be designed into our buildings, such as ample sheltered parking areas and locker rooms with showers where those who bike to work can clean up and prepare for their day.

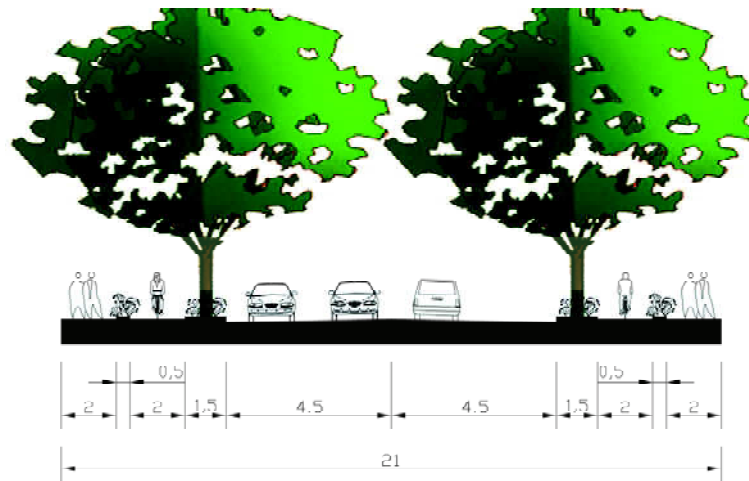

Figure 3: A multi-use street design providing safe separation between pedestrians, bicycles and automobiles.
- James Brearley

A more difficult challenge is how architects get to, experience, and work with the site. First-hand experience of the site should be an integral part of the design process. It is vitally important that our designs relate to the context in which they are located. There are three ways we can bridge this gap: design locally, follow projects, or use technology to replace physically visiting the site.

The extreme, and perhaps most sustainable approach, as mentioned above, is to work locally. This would be a distance that is easily walkable or bikable. This radius could easily expand however, if we develop transportation that runs on renewable resources: solar electric cars for example. Another approach, as discussed earlier is moving our workspaces to the site; working out of a mobile studio/living space. This option has been successfully implemented by designers, as seen by the work of Jersey Devil Architects (Piedmont 97).

Architects who do not work locally may replace travelling to the site with the use of technology. Could a new profession arise to support architectural designers? “Architectural Annalists” should start regional companies that document building sites within their communities. They digitally document each site and its surrounding context with images and write a report analyzing local climate (short and long term), report on local materials, possible recycled content, and local building culture and craftsman skills. They will have a much better understanding of the forces acting on a local site than a designer who only comes to visit a site for a few hours or even a few days. This could be a system that allows big name international architects to work throughout the world in a truly locally sensitive way.

One way this may come to pass is if we change the economics of travelling. There is a cost that doesn’t currently register in our budgets: environmental impact (Figure 4). Natural resources are not free. Clean air and water are limited. We need to regard these resources as objects of value and consider the cost of depleting them. Harmful emissions from burning fossil fuels destroy the air and water we rely on for sustaining plants and animals, food and materials. We should be charged an environmental cost above the monetary cost of each flight or tank of gas.



Figure 4: Shows the additional environmental cost associated with the cost of air travel

“The myth that environmental protection must come at the expense of economic growth is dead. Short-sided policies and approaches to producing the energy and other products we need can and do have harmful impacts on society and the environment. Pollution, traffic congestion, and health risks are examples of such impacts which often disproportionately effect communities of color and people living in poverty. RP’s Sustainable Economics Program works to develop and promote creative, market-based policies that protect the environment, grow the economy, and promote social equity” (rprogress.org).

4. ENERGY USE

We must live and work in buildings that use fossil fuels for 0% of their energy needs. It is not possible to live with modern amenities and appliances and also have a footprint at or below one earth unless the buildings we design produce all their energy needs with renewable energy sources harnessed by the building itself. Living in a house that uses electricity produced by standard power factories (coal, nuclear, etc) vastly increases our footprint. If we incorporate passive energy systems and build houses that still rely on the standard energy grid, but use energy conservation and efficiency we can slightly reduce our footprint by about 1 acre and .3 planets. However, living in a home with no electricity can reduce a footprint by up to 4 acres equalling a reduction of almost 1 planet. We must employ active systems that generate the energy needed to run the important electrical systems in our homes. Solar hot water heaters, geothermal heating systems, photo voltaic panels and wind turbines should be the primary sources of energy in our built environment. If each building uses these renewable energy systems for all of their energy needs we can lower our footprint to that of a no electricity home.

Our planet is bombarded with enough solar energy each day to provide us with more energy than the entire human population needs. Harnessing this energy along with wind power and geothermal heating sources can make our buildings produce more energy than they consume. Once a building’s energy production exceeds its energy needs, the surplus can be sold back to the grid, and be reallocated to a place of need.

Design also has to relate to the climate where each building is located. The concept of an international style is fundamentally flawed. Our buildings need to respond to local climates rather than a globalized building culture.

We can't survive using the 'brute force approach' our industry has been relying on for the past two hundred years, in which buildings are heated cooled, and artificially ventilated to create a comfortable interior climate (Braungart 02). Relying on mechanical systems is gross negligence on our part. We need to work with nature in a way that is mutually beneficial.

5. BUILT ENVIRONMENT

Offices and living spaces should be combined. This saves money, resources and time. We thus use one building instead of two and we no longer have long commutes. This shift will give us more time to spend with our families and to pursue interests outside of work. This would also promote living downtown instead of in the suburbs, thus developing safe and lively cities while increasing population density. Conversely, architects who choose to live in rural areas can use technology to bridge the gap between their home office and their clients. Phone and internet conferencing have made it possible to communicate with people anywhere in the world. The savings in time, the reduction of harmful emissions from driving and flying, and the minimal use of fossil fuels and other resources make moving the office an ideal solution for sustainable living and working.

Within contemporary culture, we have come to seek a separation between work and home. Perhaps there is a way to combine work and play. Work should be enjoyable and the office should be a place where we enjoy spending time. The office needs to take on a natural atmosphere. We need to work in buildings with natural light and ventilation and in spaces where the users have control over their microclimate.

As mentioned above, population density needs to be restructured. Urban sprawl is claiming land that would be better used for agricultural production. As there is a limited amount of resources there is also limited land that can support agriculture. "Every acre of productive land we lose to suburban sprawl, erosion and industrial development...could have provided 36 people all of their vegetable needs, 12 people all of their grain needs, or 26 people all of their fruit needs" (Battson 06). We need to consider this as we design new communities or expand existing ones. Instead of clearing farmland to build suburbs we should revisit urban spaces, such as vacant lots, that can be redeveloped. Large open expanses in downtown areas should be subdivided and redeveloped as housing before we expand beyond the city limits.

We need to become accustomed to smaller dwelling units and larger shared space. As in Europe, Asia and many other parts of the world we in the US should use public parks and plazas as additional living spaces instead of having vast sprawling private houses and lawns. Right now the average per capita housing size is 582 square feet. This needs to be reduced. Communal living can be promoted through design by combining comfortable private spaces with shared space. For example, increasing the occupancy from one to two within a 500 to 1000 square foot house will save about 5 acres of land, or more than a whole planet. If we further increase the occupancy to three, we reduce the footprint by an additional two acres and .4 planets. When given the opportunity to design whole communities, architects must consider designing for an increased density. It is our job to convince developers and other town planners of the consequences of design choices.

Each site needs to be designed as a self-sufficient project. All energy requirements need to be produced on site. All waste materials need to be processed on site, either through reuse or by treating it in a way that renders it no longer harmful. For example, storm water should be retained on site, thus reducing reliance on storm water systems. "Living within the means of nature is sustainable when all consumption and absorption of ensuing waste occurs in the place where consumption directly occurs" (rprogress.org).

Designs also need to address the thousands of other species that rely on the land we build on. Architectural designs need to support and promote local vegetation and animal life. These plants and animals can also benefit us by assisting in accomplishing some of our goals. I have already mentioned some of the benefits of green rooftops. Another option is to create bioswales, which can retain and purify storm water and other contaminated wastewater. They can also beautify the site while providing valuable habitats to local plants and animals.

CONCLUSION

As architects we need to realize that it is our responsibility to promote sustainable living through our designs and our lifestyle choices. We need to hold ourselves to standards well above the rest of the population. As humans and as architects, we need to change the way we live and work. We must create continuity between our sustainable designs and our personal lives. In *Greed to Green*, David Gottfried said "*We harm the planet because we don't feel connection between our actions and the environmental impact.*" To begin, we must evaluate lifestyle choices, and consider the environmental cost of our actions. Environmental impact must precede economic factors. Our planet is in a dire crisis, and as humans, it is our primary responsibility to create

a solution. Within our profession lies the potential to make a powerful impact on society. Many people put forth negative energy in protesting and working against issues such as logging, carbon emissions, chemical wastes, etc. Conversely, our profession has the ability to work towards a positive ideal. We can build communities with communal gardens, housing complexes that create habitats for wildlife, buildings that produce naturally renewable energy that satisfies 100 percent of their energy needs. In short we can start building a sustainable society. As we take on this challenge now we work to prevent future crisis (Figure 5). We can focus our efforts on long-term change now, before we run out of the resources we rely on today.

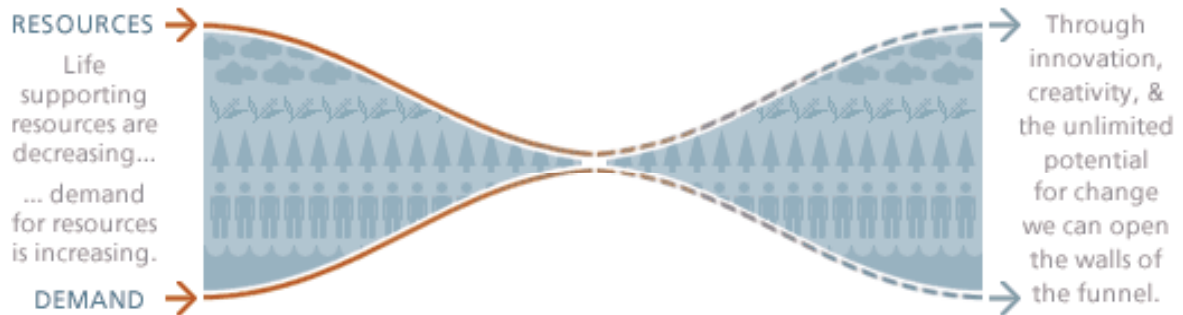

Figure 5: Within the next 30 years our demands will surpass our available resources unless we make changes to the way we live.
- naturalstep.org

REFERENCES

- Battson, Harry Executive Director. 2006. *Locally Grown – Lane County Food Directory*. Eugene, OR
- Braungart, Michael and McDonough, William. 2002. *Cradle to Cradle*. New York, NY: North Point Press.
- Brearely, James. Architect . *BAU - Brearely Architects and Urbanists*. Shanghai, China.
- Dictionary. 2005. *New Oxford American Dictionary 2nd Edition*. Apple Computer, Inc.,
- Flores, H.C. 2006. *Food Not Lawns*. White River junction, VT: Chelsea Green Publishing Company.
- Gottfried, David. 2004. *Greed to Green*. Berkley, CA: Worldbuild Publishing.
- Gore, Al. 2006. *An Inconvenient Truth*. New York, NY: Rodale.

<http://carbonfootprint.com>
<http://eweb.org>
<http://myfootprint.org>
<http://naturalstep.org>
<http://rprogress.org>
<http://sonyclassics.com/whokilledtheelectriccar/electric.html>
<http://steppingforward.org.uk>
<http://thegreenoffice.com>
<http://travelmatters.org>
<http://wikipedia.org>

Owens, Larissa N. 2006. *The Green Book – The Directory of Business With Heart*. Ashland, OR: The Green Book

Piedmont-Palladino, Susan and Branch, Mark Alden. 1997. Devil's Workshop : 25 Years of Jersey Devil Architecture. New York, NY: Prinston Architectural Press.

Wackernagel, Mathis; Monfreda, Chad; Deumling, Diana and Dholakia, Ritik. 2003. *Household Ecological Footprint Calculator v. 3.2*. The Center for Sustainability Studies at the Universidad Anahuac de Xalapa, Mexico. Redefining Progress.

The Trouble with Sustainability

Walter T. Grondzik, P.E.

Architectural Engineer, Tallahassee, Florida, USA

ABSTRACT: This paper laments the intellectual dishonesty inherent in the unbridled use of the term “sustainability” in architecture and related professions. Reasons why misplaced use of this term is undesirable are outlined, evidence of the misuse of this important term (and critical concept) is presented, and a proposal to address the current problem of semantic misrepresentation is presented.

Conference theme: philosophy and theory for advancing green design
Keywords: sustainability, green design, design intent, benchmarking

INTRODUCTION

The terms “sustainable” and “sustainability” are seemingly both de rigueur and mandatory in current architectural discourse—in architectural education, architectural practice, and architectural publications. Pretty much anywhere one looks today he/she will see something that is touted as sustainable (see Section 2 below). There are papers, announcements, and advertisements for sustainable design, sustainable houses, sustainable systems, sustainable products ... ad infinitum. The same is true, to a somewhat lesser extent, in buildings-related engineering disciplines. The reason that misuse of this terminology is of concern is simple—sustainability is a critically important concept that society must address with intellectual honesty. This honesty is arguably not seen in today’s design milieu.

It appears that many in the architectural community have adopted the term “sustainable” as a mark of environmental distinction or are using it as a would-be shield against environmental criticism. This is unfortunate, as sustainability is too important a concept to be used as an environmental amulet or magic cloak. The purpose of this paper is to outline concerns with the misuse and abuse of “sustainable,” to provide evidence that such abuse exists, and to propose corrective actions to stem further semantic misconduct. The overriding premise of the paper is that words do often make a difference.

1. THE CONCERN

The essential trouble with sustainability is that it is a critically important concept. Sustainability deals with life safety, with health, and with well-being—not just of individuals or assemblies of people, but of societies. It could easily be argued that sustainability should be the ultimate driver behind building code or design professional licensure requirements. For the human race sustainability may literally mean the difference between life and extinction. At the very least, it will mean the difference between the developed world’s current lifestyle and a much reduced standard of living. What is being sustained via sustainability is what we currently have. Most people, at least in the developed countries, seem to intuitively believe this a worthwhile objective.

The operational trouble with sustainability is that it is often used to describe some amorphous condition that is somewhat or somehow different from the status quo—without any definition or clarification of what that intended condition actually represents. This vagueness allows the term to be freely used, with little or no guilt, under an amazingly wide range of circumstances by an amazingly wide variety of individuals and institutions. Such a loose approach to grammar masks the seriousness of the concerns that underlie the very terminology in question. Sometimes semantics are much more than just a question of semantics.

The systemic trouble with sustainability is that it is often treated as an attribute of a part rather than as a property of a whole. The thought of seriously promoting hurricane-resistant nails, roof clips, or metal studs seems ludicrous. The nail does not have to be hurricane-resistant; the assembly it is used in must be so. In virtually all cases, it is not the parts that need to be sustainable, but rather the resulting larger product—the building, the

neighborhood, the community, the society. Erroneously promoting "sustainable" parts deflects attention from the true objective. Acquiescing in such promotion contributes to the problem.

The trouble with sustainability from the design perspective is that it seems to be commonly viewed as a process rather than as an outcome. It is quite likely that the design process will change to ensure sustainable outcomes; nevertheless the making of artifacts is often touted as sustainable instead of the products resulting from the process. One hears of "sustainable" curricula and "sustainable" design approaches. It is not the trip itself that matters, it is the destination. Sustainability is a definite destination. Close does not count. Being almost sustainable is probably not good enough. A society is either sustainable or it is not. If it is not, there is no question as to the outcome—which is the end of whatever is trying to be sustained (comfort, health, mobility, education)—the only question is how long it will take to reach that outcome.

The technical trouble with sustainability is that it is often viewed as a qualitative construct rather than as a quantitative reality. Sustainability is a very specific condition (see more on this below). A product or outcome (such as a building or community) is either sustainable or not. Sustainability cannot rationally be allowed to reside in the eye of the beholder—just as structural adequacy or visual acuity are not conditions that can be wished into becoming reality through force of conviction or successful public relations.

The trouble with sustainability as a destination is that it's opposite—unsustainability—is seldom discussed. We hear "sustainable" this, "sustainable" that (it's everywhere; it's everywhere). Seldom do we explicitly hear that a system, building, or development is unsustainable. It is the unsustainable that is truly worrisome; it is the unsustainable that should draw our attention and concern. It's great to honestly laud the truly sustainable (although anything less is really foolish), but as a society we should be actively blasting the unsustainable.

The fundamental trouble with sustainability is that it's meaning and acceptable usage have not been defined by the design professions. Today sustainable may literally mean anything from "meets building code" to "receives LEED certification" to "has zero energy consumption." Sustainable is a word that has been horribly abused and misused. The terms "energy efficient" and "green" have been well benchmarked by the design professions. Misuse of these terms can be (and is) challenged by peers, by clients, and by authorities having jurisdiction. This is not the case with "sustainability" which seems to be the pseudo-technical buzz-word of the decade for the design professions.

2. THE EVIDENCE

It might be easy to dismiss the above concerns as the rantings of a mere grammarian if not supported by some evidence. The following are typical examples of the free-wheeling (and thus generally meaningless) use of the term sustainable in current professional discourse. These examples are drawn from print and Internet sources and deal with both products (where some creative license may be understandable, if not acceptable) and from pronouncements of technical organizations (who should know better). The evidence is not statistically robust or representative of the design professions collectively or as a whole. It is, however, believed to be compelling in its pervasiveness and perverseness.

From the American Society of Heating, Refrigerating and Air-Conditioning Engineers (ASHRAE), the primary North American professional organization dealing with active building climate control systems:

Proposed Standard to Provide Minimum Design Requirements for Sustainable Buildings

WASHINGTON, D.C.—ASHRAE, The U.S. Green Building Council (USGBC) and the Illuminating Engineering Society of North America (IESNA) have agreed to cosponsor the development of a new minimum standard for **sustainable** high-performance buildings. Proposed Standard 189, *Standard for the Design of High-Performance **Green** Buildings Except Low-Rise Residential Buildings*, will provide minimum requirements for the design of **sustainable** buildings. (ASHRAE 2006a)

The above announcement (the text in bold was highlighted by the author of this paper) clearly equates "green" and "sustainable." There is no reason for anyone reading this announcement to suspect that green and sustainable are not synonymous concepts—so synonymous, in fact, that the terms can be freely interchanged within the course of a single paragraph.

Not to pick on ASHRAE, but the following announcement further suggests that "green" design and "sustainable" design are identical:

Online Program Designed to Simplify Sustainable Building

PORTLAND, Ore.—The nonprofit Green Building Initiative (GBI) is sponsoring pilot design projects around the U.S. to promote its Green Globes online tool. The program enables users to plug in information about proposed commercial building projects and receive feedback about how to maximize **sustainability** in the project. The GBI is touting the program as a user-friendly way to incorporate **green** concepts in designs. It expects Green Globes to be active in 30 major U.S. building markets by the end of 2007. (ASHRAE 2006b)

Even more intriguing than the casual interchange of the green/sustainable terminologies found in the above (see author's bolding of text) is the suggestion that one can *maximize* sustainability. Apparently, one could also choose to super-size sustainability. This leads to the even more disturbing thought that it might also be possible to go sustainable-lite or sustainable lo-cal. In fact, ASHRAE provides ammunition for this argument in the following announcement (with author's bolds and underline):

Semiconductor Plant Aims for High Sustainability

RICHARDSON, Texas—Texas Instruments is building a semiconductor fabrication plant that could be a model for **sustainable** building. The plant, scheduled to open in 2007, is expected to produce an estimated millions of dollars in annual energy savings due to HVAC systems using chilled water, heat recovery, solar water heating, daylighting and other technologies. The \$1.5 million HVAC systems are expected to pay for themselves within two years. If the office building and plant receive gold and silver **LEED® certification**, respectively, it is believed that it will be the largest facility to do so. (ASHRAE 2006c)

Although recent ASHRAE announcements provide fertile ground for concern about term-banding, ASHRAE is not alone in spreading confusion. See the following (with author's bolds) from the U.S. Green Building Council's (USGBC) WWW site. To be fair, the USGBC is usually very good about distinguishing green and sustainable; such distinction can perhaps be inferred from the implication that green is suggested as an approach to sustainable.

What is LEED®?

The Leadership in Energy and Environmental Design (LEED) Green Building Rating System™ is the nationally accepted benchmark for the design, construction, and operation of high performance **green** buildings. LEED gives building owners and operators the tools they need to have an immediate and measurable impact on their buildings' performance. LEED promotes a whole-building approach to **sustainability** by recognizing performance in five key areas of human and environmental health: sustainable site development, water savings, energy efficiency, materials selection, and indoor environmental quality. (USGBC)

Entering the realm of popular architectural journalism yields an onslaught of claims for sustainability. The following examples were selected from a single issue of *Environmental Design + Construction*, a reputable and influential monthly trade magazine. The question posed by the following evidentiary examples seems important: does the use of the term "sustainable" hold any meaning whatsoever? It appears clear that some importance was ascribed to the term by the writers of these articles and ads; but what do they really mean by this very prominently employed word? Copyright concerns preclude reproduction of the articles and advertisements in graphic form; thus they are verbally summarized.

_____ Carpets: Sustainability from Top to Bottom

_____ Technologies: Utilize your roof as a sustainable and renewable asset ...

Health, Quality, Sustainability: They're built into every _____ product.

Is your non-PVC screen recyclable and sustainable? _____ is the only product on the market that meets this criteria. _____ is 87% green.

_____ (insulating forms): The sustainable choice.

_____: Products that provide: sustainability; energy efficiency; vinyl window and door designs, ...

"Sustainable Home": _____ tailors various sustainable aspects to specifically suit each property.

“A Study in Sustainable Adaptive Reuse”: The sustainable adaptive reuse of Montgomery Park was achieved through the intimate knowledge of the building; its infrastructure, patient planning, and application of Leadership in Energy and Environmental Design (LEED) sustainable strategies. (ED+C)

3. A PROPOSAL

If it is accepted that a profession should control key terms that are used to communicate important ideas both within the profession and to outsiders, then “sustainability” must surely be brought into the family of terms that have real meaning and convey useful and replicable information. Such terms include “registered architect,” “energy efficient,” “green,” “accessible,” and numerous others. None of these terms is allowed to be used indiscriminately or incorrectly (at least blatantly so). They have well-established meanings and application. Correct use of these terms is monitored and enforced within the profession; by architectural licensing boards, code authorities, the USGBC, the U.S. Department of Justice. Sustainability must join the ranks of these respected terms.

Rather than reinvent the wheel, it is proposed that the Brundtland Commission’s definition of sustainability is an appropriate starting point for consensus. (Wikipedia) To paraphrase, the Commission suggested that sustainability is a condition whereby a generation meets their needs while not impairing the ability of future generations to meet their needs. This is a simple and terribly compelling blueprint for intergenerational respect and the survival of society as we generally know it—but perhaps a hard reference by which to design a roof assembly. Sustainability must be benchmarked in such a way that a design team can make rational decisions on the hundreds of issues that come up on any project. This has been done for energy efficiency (meeting ASHRAE 90.1 or California Title 24), for green (meeting LEED-NC or complying with Green Globes requirements), for accessibility (complying with ADA mandates), and every day for budgets (meeting a limit of xx\$/sq ft). Surely it can be done for sustainability (and perhaps, along the way, carbon neutrality). But it will only be done if the term sustainable is perceived to have ethical importance to the design professions.

The following are offered as interim working definitions of some key terms surrounding sustainability:

Energy efficient: A building that exceeds the minimum requirements of the prevailing energy efficiency (building) code.

Green: A building that reduces negative site/global environmental impacts by addressing energy, water, and materials consumption.

Carbon-neutral: A building that produces no net carbon emissions, thereby reducing greenhouse gas emissions and helping to reduce global warming.

Sustainable: A building that produces no net negative site/global environmental impacts by seriously addressing energy, water, and materials consumption.

Regenerative: A building that produces net positive site/global environmental impacts by very seriously addressing energy, water, and materials consumption.

Generally accepted (although actively debated) benchmarks for energy-efficient and green buildings have been established and promulgated. This allows these terms to be used in a meaningful way as design adjectives. No such benchmarks have been established for carbon-neutral (although this may be easy), sustainable, or regenerative. Until such reference criteria have been developed and placed into use these terms will remain squarely in the realm of hyperbole instead of useful conversation.

Until such time as sustainability is benchmarked, it is proposed that all professional organizations refrain from the use of this word as an adjective. Such use strongly suggests, if not explicitly implies, a clear understanding and general consensus of what the word means. As argued above, this is not the case. This prohibition request is especially true for educational institutions—and in particular the National Architectural Accrediting Board, which requires students (under condition 15: Sustainable Design) to have an:

Understanding of the principles of sustainability in making architecture and urban design decisions that conserve natural and built resources, including culturally important buildings and sites, and in the creation of healthful buildings and communities (NAAB 2006)

Unfortunately, NAAB does not define “sustainability,” making its understanding by students tenuous and its achievement in studio designs highly suspect. Surely we can do better in preparing future generations to assume the roles of architect and environmental steward—which are believed (by the author) to be coincident roles as this is being written. Surely the leading organizations in the design professions can develop definitions and benchmarks for sustainability. The trouble with doing otherwise is simple. If it is believed that green is synonymous with sustainability, and sustainability is the ultimate objective, then designing and building green buildings is enough. Green will become the ultimate objective, not sustainability. This will not cut it—but it will deceive us. Green is a necessary, but not self-sufficient, component of sustainability. It is absolutely critical at this critical juncture in how we think about building design (Architecture 2030 and the 2010 Imperative come to mind) that design intent (sustainability) not be confused with design criteria (such as LEED) or methods (such as shading devices). Confusing methods with intent is a common, and often fatal, design process error.

CONCLUSIONS

The trouble with sustainability is that the word has been so overused, without the benefit of benchmarking, that it has become an essentially meaningless term. The trouble with sustainability is that it is just so darn important a concept. So here is a proposal and a plea. Please don't use sustainable to mean green; please don't use sustainable to mean LEED code. Reserve the word to describe the truly sustainable—that which will reasonably allow future generations to meet their needs. There is no way that a building can be rightfully called sustainable if it is guzzling, slurping, or even sipping non-renewable fossil fuels, water, and material resources. What will future generations do? To assume they'll somehow get by or invent a miraculous solution to energy, water, and material needs seems a bit callous.

REFERENCES

ASHRAE. *The HVAC&R Industry for February 23, 2006(a)* - Vol. 5, No. 8. The American Society of Heating, Refrigerating and Air-Conditioning Engineers, Atlanta, GA. <http://images.ashrae.biz/eNewsletters/HVACR/022306.html> (accessed 5 January 2007).

ASHRAE. *The HVAC&R Industry for March 23, 2006(b)* - Vol. 5, No. 12. The American Society of Heating, Refrigerating and Air-Conditioning Engineers, Atlanta, GA. <http://images.ashrae.biz/eNewsletters/HVACR/032306.html> (accessed 5 January 2007).

ASHRAE. *The HVAC&R Industry for June 15, 2006(c)* – Vol. 5, No. 24. The American Society of Heating, Refrigerating and Air-Conditioning Engineers, Atlanta, GA. <http://images.ashrae.biz/eNewsletters/HVACR/061506.html> (accessed 5 January 2007).

ED+C: Various articles and advertisements found in the January/February 2006 issue of *Environmental Design + Construction*.

NAAB: "NAAB Conditions for Accreditation For Professional Degree Programs in Architecture" (2004 Edition). The National Architectural Accrediting Board, Washington, DC. <http://www.naab.org/> (accessed 5 January 2007).

USGBC. Information from the USGBC WWW site. <http://www.usgbc.org/DisplayPage.aspx?CategoryID=19> (accessed 5 January 2007).

Wikipedia. Topic: "Brundtland Commission." http://en.wikipedia.org/wiki/Brundtland_Commission (accessed 5 January 2007).

Author Index

Last Name

Aloisi, Missa	11
Bing, Judith	133
Brown, G. Z. 1	39
Brown, G. Z. 2	55
Cabrinha, Mark	157
Chatto, Christopher	39
Corner, Donald	3
Elzeyadi, Ihab	47
Elliott, Jack	183
Gianni, Benjamin	203
Gillem, Mark	125
Gray, Lucas	251
Gray, Timothy	143
Grondzik, Walter 1	191
Grondzik, Walter 2	259
Harrington, J Brooke	133
Hatten, Michael	39
Jamgochian, Joe	151
Jo, Jae-Hun	109
Johnson, Arthur	39
Kaiser, Keelan P.	175
Kim, Kwang Woo	109
Kline, Jeff 1	39
Kline, Jeff 2	55

Last Name

Knudson, Karrin	237
Kwok, Alison G.	191
Layne, Anthony W.	243
Luiz Lara, Fernando	169
Mabry, C Jason	99
Muller, Brook	27
Northcutt, Dale 1	39
Northcutt, Dale 2	55
O'Brien, Michael	75
Ogoli, David Mwale	117
Rashed-Ali, Hazem	225
Rider, Tracy Rose	183
Teal, Randall F.	91
Theodoropoulos, Christine	39
Trubiano, Franca 1	99
Trubiano, Franca 2	151
Turner, Cathy	67
Vera, Maria del C.	211
Wakefield, Ron	75
Werthan, Audrey Kay	83
Yeo, Myong-Souk	109
Yeshayahu-Sharabi, Shai	211
Zaretsky, Michael	19
Zhu, Xuemei	217

The Architectural Research Centers Consortium

The Architectural Research Centers Consortium, Inc. (ARCC) is an international association of architectural research centers committed to the expansion of the research culture and a supporting infrastructure in architecture and related design disciplines. Since its founding as a non-profit corporation in 1976, ARCC has represented a concerted commitment to the improvement of the physical environment and the quality of life.

Historically, ARCC's members have been schools of architecture who have made substantial commitments to architectural research, often by forming centers directed to research programs. At the same time, ARCC has sponsored many projects, conferences, and other activities involving the broader architectural research community, including industrial laboratories, government agencies, and private practitioners engaged in research.

ARCC members are engaged in sponsored research and in graduate studies intended to develop a more comprehensive research infrastructure for architecture -- an infrastructure of researchers, facilities, equipment, research centers, and academic programs working to expand the knowledge base for practice. A recent survey of members identified over \$21 million in funded research projects in areas such as:

•Acoustics •Adaptive environments •Building economics •Building systems •Commercial and institutional buildings •Community development and design •Computer-aided design •Construction materials and processes •Earthquake, fire, and environmental hazards •Energy, resources, and sustainability •History and theory of architecture •Health and related facilities •Housing •Indoor environments •Lighting and daylighting •Practice of architecture •Preservation and rehabilitation •Simulation and representation •Tropical planning and design •Urban and rural design

As an organization of researchers and research centers, ARCC sponsors workshops, undertakes sponsored projects, sustains networks, and exchanges information and experience intended to help build a research culture and infrastructure -- in architecture schools and beyond.

*for more information and contact details visit our website: www.arccweb.org

Sponsors

A big thank you to the following sponsors who made this conference possible:



The University of Oregon



The School of Architecture and Allied Arts



**THE AMERICAN INSTITUTE
OF ARCHITECTS**



The Architectural Research Centers Consortium

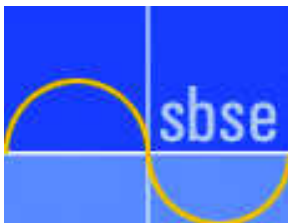

The Society of Building Science Educators

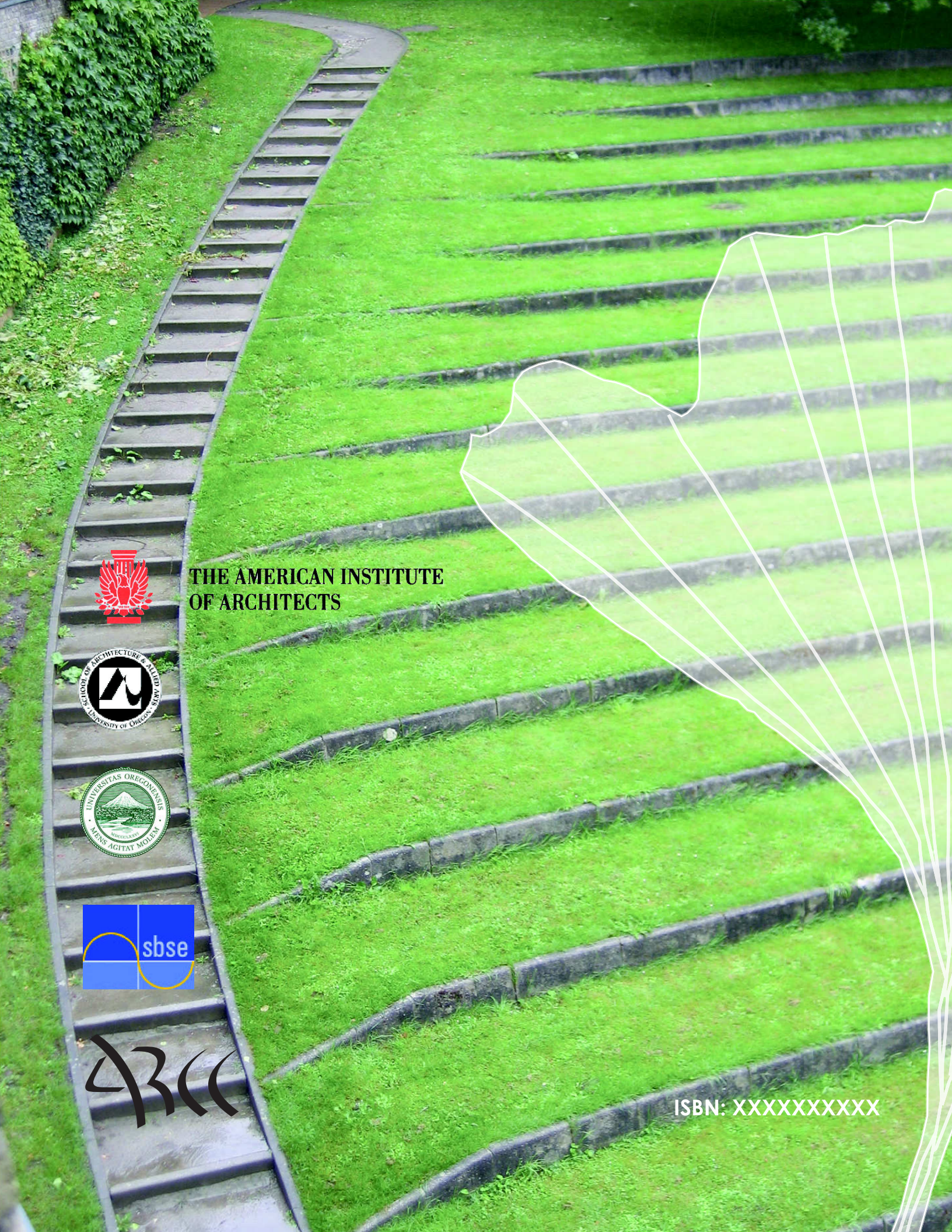

**THE AMERICAN INSTITUTE
OF ARCHITECTS**



4300

ISBN: XXXXXXXXXX