

How to select toolholding

1 Select tool assembly method

- For modular or solid, from the overview on pages G6-G7.

2 Select an adapter style

- Use the program overview for the system to choose an adapter based on the type of machining and machine tool application.
- Coromant Capto® rotating, page G6

3 Select a coupling size

- Turn to the ordering page and
- Select the right coupling size
 - Select adapter for assembly

4 Select basic holder

- Use the program overview to choose a holder based on machine type.
- Select the right coupling type and taper size.

5 Add extensions if necessary

- Add extensions where needed to complete gauge length requirements. Use the program overview to find a suitable extension.

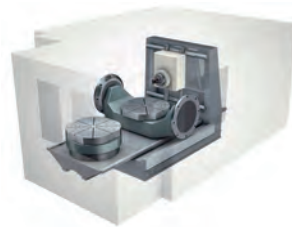
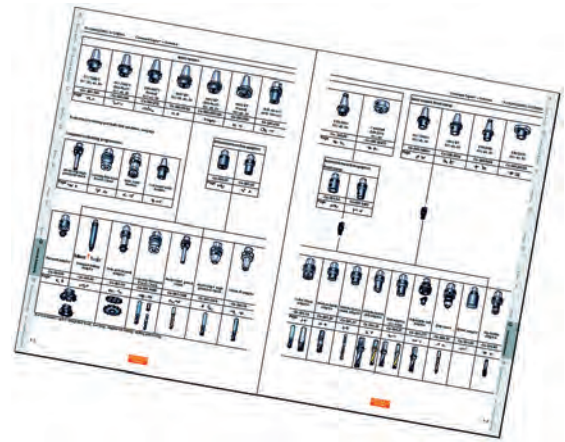

For more technical information, see our Metalcutting Technical Guide.

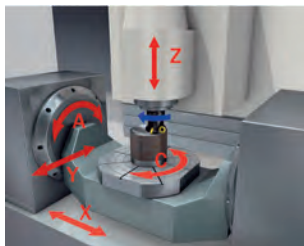

Symbols for page references:



How to choose tool, overview



Toolholding Systems, overview



Spare parts/accessories



Conversion table, formulas and definitions

TOOLING SYSTEMS

Tooling guide

Machining centers

G4

Products

For machining centers - rotating tools

Modular tools - Coromant Capto®

Toolholder overview

G6

Basic holders

G8

Extension/reduction adapters

G24

Tool adapters

G27

Solid tools

Solid holding tools - Overview

G49

HSK solid holding tools - Overview

G65

HydroGrip® high precision chuck

G78

Modular tools - Coromant Capto®

G80

Coromant solid holding tools

G85

HSK solid holding tools

G89

Holders for exchangeable head system

Coromant Capto adapter

G93

Solid holder

G95

HSK solid holder

G96

Bridgeport holder

G96

Cylindrical holder

G97

Tool holders for CoroMill modular tools with threaded coupling

G99

Spare parts and accessories

G106

For turning centers - non-rotating tools

See main catalog for turning tools.

Coromant Capto®

Tooling system

Machine tool interface and true modular tooling system



Coromant Capto® - the coupling

Provides a unique combination of properties:

- high torque transmission
- high bending strength
- balanced and concentric
- self centering
- high basic stability and accuracy
- flexibility with extensive modularity
- quick-change and automated tool change
- through-tool delivery of coolant, from machine to cutting edge

Fulfills the needs of a tooling system in all machine types:

- lathes and turning centers - quick-change, modular tooling and high pressure coolant delivery.
- multi-task machines and machining centers - rotating spindle interface and modular tooling.







The right combination is the optimum solution

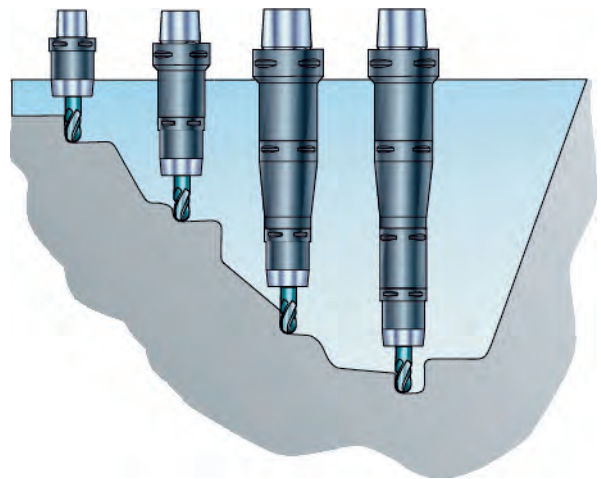

Coromant Capto® modular holding tools

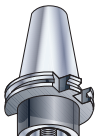
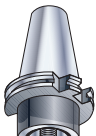
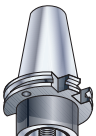

- When changing production, a flexible toolholding system is essential, as different component sizes often lead to varying gauge lengths. Coromant Capto allows the correct length tool to be built in order to maintain maximum performance.
- When tooling is required for a variety of machines with different taper size or designs.
- When component complexity demands a high number of special tools.
- Coromant Capto offers significant reductions in tool inventory and makes it possible to have only one standard system of modular tools for a variety of operations on lathes and machining centers.

















Basic holders





							
Cat V-Flange	Cat V-Flange DIN 69871 Form B	Cat V-Flange BIG-PLUS / 90° rotated	ISO 7388/1	ISO 7388/1 BIG-PLUS	DIN 69871 Form B	MAS BT	MAS BT BIG-PLUS / 90° rotated
Cx-A390.45	Cx-A390.455	Cx-A390.545/ 546/547	Cx- 390.140	Cx-390.540	Cx-390.272	Cx-390.55/58	Cx-390.555/558/ 562/605
Page G17	G18	G19	G8	G10	G11	G12	G13



Integrated Coromant Capto® tools		
		
Milling Chapter D	Drilling Chapter E	Boring Chapter F



Extension/reduction adapters	
	
Cx-391.01	Cx-391.02
Page G24	G25



Tool holding for turning and multi-task machines, see main catalog for turning tools.

								
Facemill adapter	HydroGrip facemill adapter	Silent Tools® Dampened milling adapter	Side and facemill adapter	Hydro-Grip Heavy Duty	HydroGrip® pencil chuck	HydroGrip® high precision chuck	HydroGrip® high precision chuck, slender	Shrink fit adapter
Cx391.05C/ Cx-A391.05C	Cx- 391.05CG	Cx391.05CD/ Cx-A391.05CD	Cx-391.10/Cx- A391.10	Cx-391.CGD	Cx-391.CGB/ Cx-A391.CGB	Cx-391.CGA/ Cx-A391.CGA	Cx-391.CGC	Cx-391.19
Page G27	G84	G31	G33	G80	G83	G81	G82	G36
								















			
MAS BT Form B	HSK 50,63,100 & 125-A/C HSK 80-F	DIN 2080 NMTB Form B	Camshaft DIN 2079
Cx-390.369	Cx-390.612 Cx-390.410	Cx- 390.00 Cx-A390.00	Cx-390.34705
Page G15	G15	G21, G23	G22

Basic holders Front clamp		
		
Cat V-Flange	ISO 7388/1	MAS BT
Cx-A390.4504	Cx-390.14004	Cx-390.5504/.5804
Page G18	G9	G12

Extension/reduction adapters Front clamp	
	
Cx-391.04	Cx-391.0204
Page G26	G26

	
NMTB DIN 2080	DIN 2079
Cx-390.0004 Cx-A390.004	Cx-390.34704
Page G21, G23	G22



								
Collet chuck adapter	Weldon shank adapter	Whistle Notch shank adapter	Whistle Notch drill adapter	Drill adapter ISO 9766	Adjustable drill adapter	Drill chuck	Blank adapter	Tap holder adapter
Cx-391.14	Cx-391.20 Cx-A391.20	Cx-391.21	Cx-391.25	Cx-391.27	Cx-391.277	Cx-391.31	Cx-391.50	Cx-391.62/63
Page G35	G37	G39	G41	G40	E91	G43	G43	G47
								

D
Milling
E
Drilling
F
Boring
G
Tooling Systems
J
General Information

TOOLING SYSTEMS Coromant Capto® – Basic holders

Basic holder
ISO 7388/1 (DIN 69871-A)
390.140

For light machining only.
C6-390.140-40 085

l_1 = programming length

Metric thread

Taper	Coupling size	Ordering code	Coolant ¹⁾	Dimensions							Balanced by design	
				D_{st}	D_1	D_{21}	l_1	l_{21}	l_{22}	D_{th}		$\frac{\sigma}{E}$
30	C3	C3-390.140-30 030	1	32		45	30	35		12	0.5	
30		C3-390.140-30 060	1	32		45	60	35		12	0.7	
40		C3-390.140-40 030	1	32		50	30	35		16	0.8	⊙
40		C3-390.140-40 060	1	32		50	60	35		16	1.2	⊙
50		C3-390.140-50 030	1	32		80	30	35		24	2.6	
50		C3-390.140-50 060	1	32		80	60	35		24	2.8	
40	C4	C4-390.140-40 030	1	40		50	30	35		16	0.8	⊙
40		C4-390.140-40 060	1	40		50	60	35		16	1.2	⊙
50		C4-390.140-50 030	1	40		80	30	35		24	2.6	
50		C4-390.140-50 060	1	40		80	60	35		24	2.8	
40	C5	C5-390.140-40 030	1	50		50	30	35		16	0.8	⊙
40		C5-390.140-40 070	1	50		50	70	35		16	1.2	⊙
50		C5-390.140-50 030	1	50		80	30	35		24	2.6	
50		C5-390.140-50 070	1	50		80	70	35		24	2.8	
40	C6	C6-390.140-40 085	1	63	50		85		35	16	2.3	
50		C6-390.140-50 030	1	63		80	30	35		24	2.6	
50		C6-390.140-50 080	1	63		80	80	35		24	3.7	
50	C8	C8-390.140-50 070	1	80		80	70	35		24	3.9	
50		C8-390.140-50 120	1	80		80	120	35		24	5.5	
60	C10	C10-390.140-60 050	1	100		130	50	38		30	9.2	

¹⁾ 1 = coolant through center
Note! Tighten the screw with a torque wrench. Information on page G111.

G126 G6 G2 J2

G 8 SANDVIK Coromant

Basic holder

ISO 7388/1 (DIN 69871-A)

Front clamp

390.14004

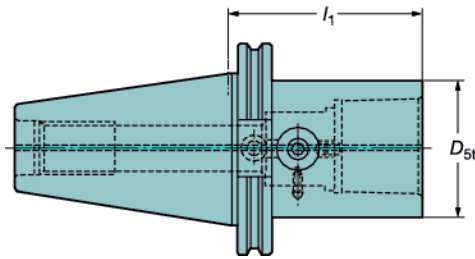
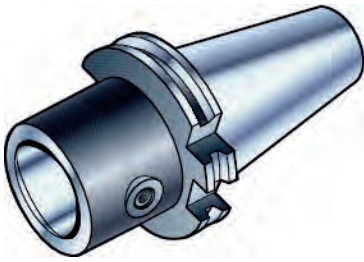

Note! One drawbolt for each adapter/cutting tool is required.

l_1 = programming length

Metric thread

Taper	Coupling size	Ordering code	Coolant ¹⁾	Dimensions		
				D_{5t}	l_1	
40	C5	C5-390.14004-40 080	1	50	80	1.6
50		C5-390.14004-50 080	1	50	80	3.3
50	C6	C6-390.14004-50 090	1	63	90	3.9
50	C8	C8-390.14004-50 105	1	80	105	4.3

¹⁾ 1 = coolant through center

Note! Tighten the screw with a torque wrench. Information on page G111.
For drawbolt, see page G108.

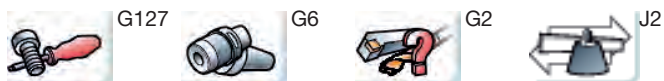

D
E
F
G
J

TOOLING SYSTEMS Coromant Capto® – Basic holders

Basic holder
BIG-PLUS, ISO 7388/1 (DIN 69871-ADB)
390.540

Modified holder with A at the end of the code²⁾

C6-390.540-40 085
For light machining only.

l_1 = programming length

BIG-PLUS SYSTEM - License BIG DAISHOWA

Metric thread

Taper	Coupling size	Ordering code	Coolant ¹⁾	Dimensions							Balanced by design
				D_{5t}	D_1	D_{21} max	l_1	l_{21} min	l_{22}	$\frac{R}{R_{21}}$	
40	C3	C3-390.540-40 030	1	32		50	30	35		0.8	⊙
50		C3-390.540-50 030A	7	32		80	30	35		2.6	
40	C4	C4-390.540-40 040	1	40		50	40	35		0.8	⊙
50		C4-390.540-50 030A	7	40		80	30	35		2.6	
40	C5	C5-390.540-40 050	1	50		50	50	35		0.8	⊙
50		C5-390.540-50 030A	7	50			30	35		2.6	
40	C6	C6-390.540-40 085	1	63	50		85		35	2.3	
50		C6-390.540-50 050A	7	63		80	50	35		2.6	
50	C8	C8-390.540-50 070A	7	80		80	70	35		3.7	

¹⁾ 1 = coolant through center, 7 = coolant through center and through flange

Note! Tighten the screw with a torque wrench. Information on page G111.

²⁾ The new design is prepared for coolant also through the flange which means the coolant could be lead either through the center or through the flange. The inlet channels in the flange are plugged with screws, which can easily be removed when coolant supply should be led through the flange. For technical information, see Metalcutting Technical guide.

G126 G6 G2 J2

G 10

General Information

Basic holder

DIN 69871 Form B

Coolant through flange

390.272

For light machining only.

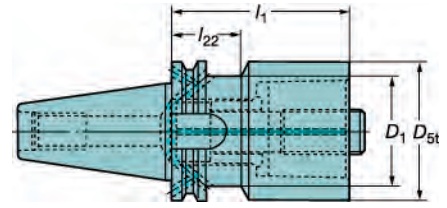
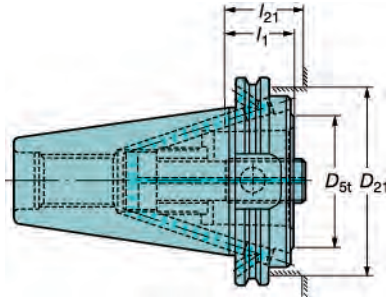
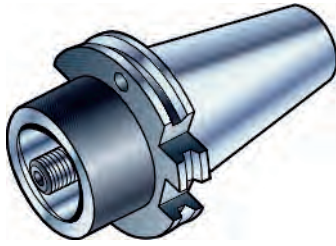

C6-390.272-40 085

l_1 = programming length

Metric thread

Taper	Coupling size	Ordering code	Coolant ¹⁾	Dimensions						Balanced by design	
				D_{5t}	D_1	D_{21}	l_1	l_{21}	l_{22}		$\frac{R}{mm}$
40	C3	C3-390.272-40 030	6	32		50	30	35		0.8	⊙
40		C3-390.272-40 060	6	32		50	60	35		1.2	⊙
50		C3-390.272-50 030	6	32		80	30	35		2.6	
50		C3-390.272-50 060	6	32		80	60	35		2.8	
40	C4	C4-390.272-40 030	6	40		50	30	35		0.8	⊙
40		C4-390.272-40 060	6	40		50	60	35		1.2	⊙
50		C4-390.272-50 030	6	40		80	30	35		2.6	
50		C4-390.272-50 060	6	40		80	60	35		2.8	
40	C5	C5-390.272-40 040	6	50		50	40	35		0.9	⊙
40		C5-390.272-40 080	6	50		50	80	35		1.5	⊙
50		C5-390.272-50 030	6	50		80	30	35		2.9	
50		C5-390.272-50 070	6	50		80	70	35		3.4	
40	C6	C6-390.272-40 085	6	63	50		85		35	2.3	
50		C6-390.272-50 030	6	63		80	30	35		2.9	
50		C6-390.272-50 080	6	63		80	80	35		4.0	
50	C8	C8-390.272-50 070	6	80		80	70	35		3.9	
50		C8-390.272-50 120	6	80		80	120	35		5.6	

¹⁾ 6 = coolant through flange

Note! Tighten the screw with a torque wrench. Information on page G111.

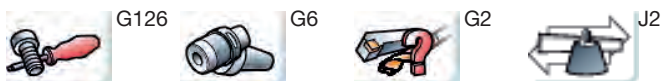

Basic holder

MAS-BT 403
390.55/ .58

Milling

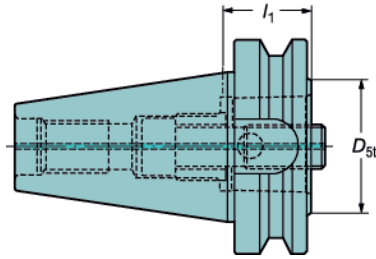
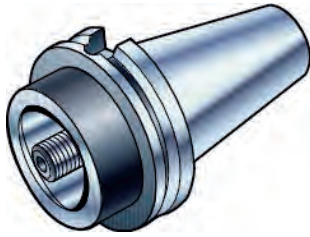
 l_1 = programming length

E

Metric thread

Drilling

Taper	Coupling size	Ordering code	Coolant ¹⁾	Dimensions			Balanced by design
				D_{st}	l_1	$\frac{\sigma}{\rho g}$	
30	C3	C3-390.55-30 030	1	32	30	0.5	⊕
30		C3-390.55-30 060	1	32	60	0.7	⊕
40		C3-390.55-40 030	1	32	30	1.0	⊕
40		C3-390.55-40 060	1	32	60	0.7	⊕
50		C3-390.58-50 040	1	32	40	2.5	
50		C3-390.58-50 070	1	32	70	2.7	
40	C4	C4-390.55-40 030	1	40	30	1.0	⊕
40		C4-390.55-40 060	1	40	60	1.2	⊕
50		C4-390.58-50 040	1	40	40	2.5	
50		C4-390.58-50 070	1	40	70	2.7	
40	C5	C5-390.55-40 030	1	50	30	0.9	⊕
40		C5-390.55-40 070	1	50	70	1.4	⊕
50		C5-390.58-50 040	1	50	40	3.5	
50		C5-390.58-50 080	1	50	80	4.0	
40	C6	C6-390.55-40 075	1	63	75	1.6	
50		C6-390.58-50 040	1	63	40	3.4	
50		C6-390.58-50 090	1	63	90	4.5	
50	C8	C8-390.58-50 070	1	80	70	4.1	
50		C8-390.58-50 120	1	80	120	5.8	

¹⁾ 1 = coolant through center

Boring

MAS-BT 403

Front clamp
390.5504/ .5804

G

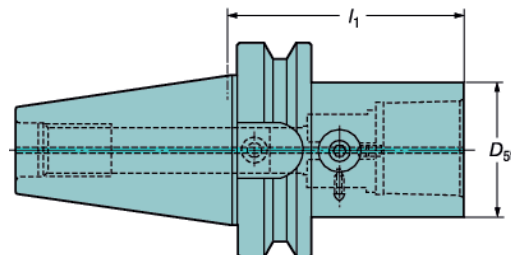
 l_1 = programming length**Note!** One drawbolt for each adapter/cutting tool is required.

Metric thread

Tooling Systems

Taper	Coupling size	Ordering code	Coolant ¹⁾	Dimensions		
				D_{st}	l_1	$\frac{\sigma}{\rho g}$
40	C5	C5-390.5504-40 090	1	50	90	1.8
50		C5-390.5804-50 100	1	50	100	4.2
50	C6	C6-390.5804-50 110	1	63	110	4.7
50	C8	C8-390.5804-50 125	1	80	125	4.6

¹⁾ 1 = coolant through center**Note!** Tighten the screw with a torque wrench. Information on page G111.
For drawbolt, see page G109.

Basic holder

90° rotated polygon for precision tool tip control

Designed for Mazak™ e-machine and Mori Seiki NT Series

MAS-BT 403
390.605

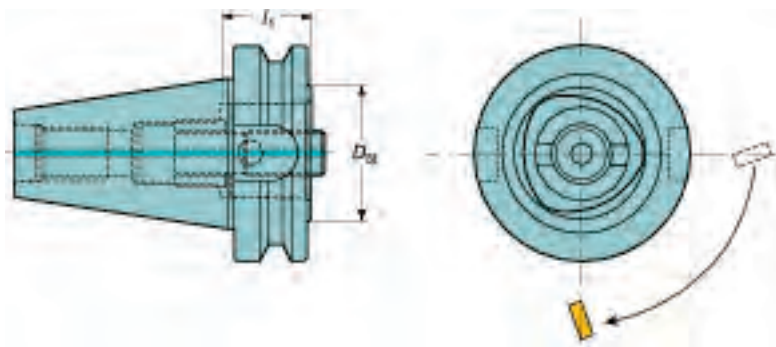
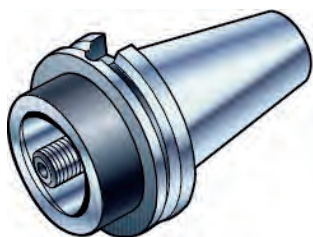

l_1 = programming length

Metric thread

Taper	Coupling size	Ordering code	Coolant ¹⁾	Dimensions		
				D_{st}	l_1	$\frac{kg}{kg}$
40	C5	C5-390.605-40 030	1	50	30	0.8
50	C6	C6-390.605-50 040	1	63	40	3.3
50	C8	C8-390.605-50 070	1	80	70	4.0

¹⁾ 1 = coolant through center

Note! Tighten the screw with a torque wrench. Information on page G111.

BIG-PLUS
MAS-BT 403
390.555/ .558

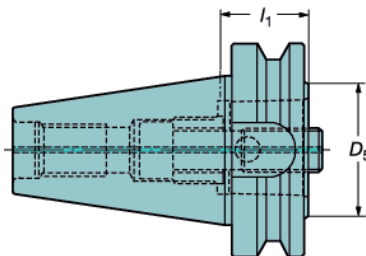
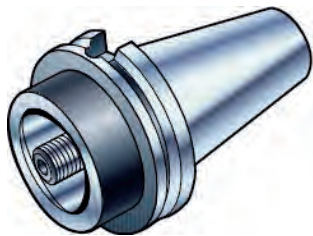

l_1 = programming length

BIG-PLUS SYSTEM - License BIG DAISHOWA

Metric thread

Taper	Coupling size	Ordering code	Coolant ¹⁾	Dimensions			Balanced by design
				D_{st}	l_1	$\frac{kg}{kg}$	
40	C3	C3-390.555-40 030	1	32	30	1.0	⊙
40	C4	C4-390.555-40 040	1	40	40	1.0	⊙
50		C4-390.558-50 040	1	40	40	3.6	
40	C5	C5-390.555-40 050	1	50	50	1.2	⊙
50		C5-390.558-50 040	1	50	40	3.5	
40	C6	C6-390.555-40 075	1	63	75	1.7	
50		C6-390.558-50 050	1	63	50	3.6	
50	C8	C8-390.558-50 070	1	80	70	4.1	

¹⁾ 1 = coolant through center

Note! Tighten the screw with a torque wrench. Information on page G111.



D

TOOLING SYSTEMS

Coromant Capto® – Basic holders

Basic holder

BIG-PLUS

90° rotated polygon for precision tool tip control

Designed for Mazak™ e-machine and Mori Seiki NT Series

MAS-BT 403

390.562

Milling

E

Drilling

F

BIG-PLUS SYSTEM - License BIG DAISHOWA

 l_1 = programming length

Metric thread

Taper	Coupling size	Ordering code	Coolant ¹⁾	Dimensions			Balanced by design
				D_{St}	l_1		
40	C5	C5-390.562-40 050	1	50	50	1.4	⊙
50	C6	C6-390.562-50 050	1	63	50	3.6	
50	C8	C8-390.562-50 070	1	80	70	4.1	

1) 1 = coolant through center

Boring

G

Tooling Systems

J

General Information

G126

G6

G2

J2

G 14

Basic holder

MAS-BT 403 Form B

Coolant through flange

390.369

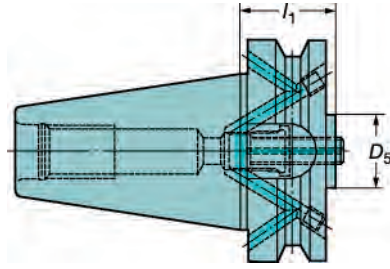
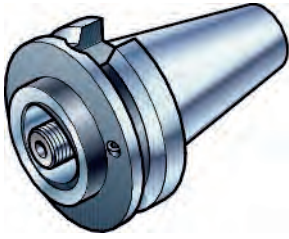

l_1 = programming length

Metric thread

Taper	Coupling size	Ordering code	Coolant ¹⁾	Dimensions			Balanced by design
				D_{5t}	l_1	$\frac{\sigma}{K_{5t}}$	
40	C3	C3-390.369-40 030	6	32	30	1.0	⊙
50		C3-390.369-50 040	6	32	40	2.3	
40	C4	C4-390.369-40 030	6	40	30	1.0	⊙
50		C4-390.369-50 040	6	40	40	2.3	
40	C5	C5-390.369-40 050	6	50	50	1.8	⊙
50		C5-390.369-50 040	6	50	40	3.2	
50	C6	C6-390.369-50 050	6	63	50	3.4	
50	C8	C8-390.369-50 070	6	80	70	4.1	

¹⁾ 6 = coolant through flange

HSK F
Pin style
390.612

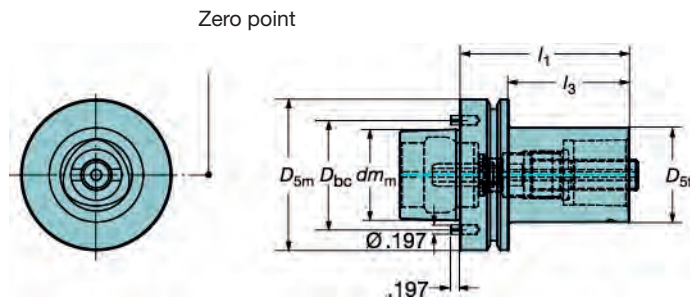
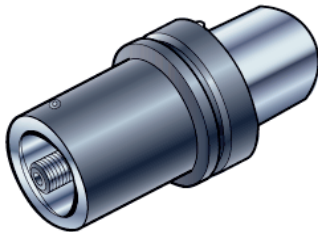

l_1 = programming length

Flange	HSK taper	Coupling size	Ordering code	Coolant ¹⁾	Dimensions, mm, inch						
					dm_m	D_{5m}	D_{5t}	D_{bc}	l_1	l_3	$\frac{\sigma}{K_{5t}}$
80	63	C5	C5-390.612-80 090	1	48	80	50	58	90	64	1.9
					1.890	3.150	1.968	2.283	3.543	2.520	
80	63	C6	C6-390.612-80 105	1	48	80	63	58	105	79	2.6
					1.890	3.150	2.480	2.283	4.134	3.110	

¹⁾ 1 = coolant through center

A special coolant tube is delivered together with the HSK basic holders.

HSK80F - Compatible with the Makino MAG1, MAG3, MAG4, MAG7, A7 - for Aerospace frame aluminum machining.



Basic holder

HSK A/C

390.410

Zero point

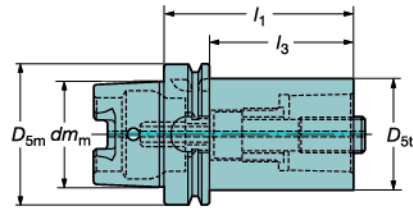
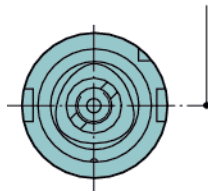
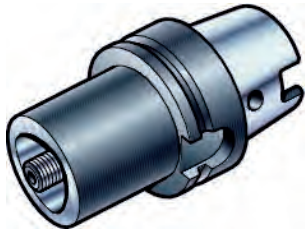
 l_1 = programming length

Flange	Coupling size	Ordering code	Coolant ¹⁾	Dimensions, mm, inch						Balanced by design
				dm_m	D_{5m}	D_{5t}	l_1	l_3	$\frac{D_{5m}}{dm_m}$	
50	C3	C3-390.410-50 075A	1	38	50	32	75	49	0.6	⊙
				1.496	1.968	1.260	2.953	1.929		
	C4	C4-390.410-50 080A	1	38	50	40	80	54	0.8	⊙
				1.496	1.968	1.575	3.150	2.126		
63	C3	C3-390.410-63 075C	1	48	63	32	75	49	1.4	⊙
				1.890	2.480	1.260	2.953	1.929		
	C4	C4-390.410-63 080C	1	48	63	40	80	54	1.6	⊙
				1.890	2.480	1.575	3.150	2.126		
	C5	C5-390.410-63 090C	1	48	63	50	90	64	1.5	⊙
				1.890	2.480	1.968	3.543	2.520		
100	C3	C3-390.410-100 080A	1	75	100	32	80	51	3.8	
				2.953	3.937	1.260	3.150	2.008		
	C4	C4-390.410-100 090A	1	75	100	40	90	61	4.1	
				2.953	3.937	1.575	3.543	2.402		
	C5	C5-390.410-100 100A	1	75	100	50	100	71	3.0	
				2.953	3.937	1.968	3.937	2.795		
	C6	C6-390.410-100 110A	1	75	100	63	110	81	3.6	
				2.953	3.937	2.480	4.331	3.189		
	C8	C8-390.410-100 120A	1	75	100	80	120	91	4.7	
				2.953	3.937	3.150	4.724	3.583		
125	C6	C6-390.410-125 120 ²⁾	1	95	125	63	120	91	5.2	
				3.740	4.921	2.480	4.724	3.583		
	C8	C8-390.410-125 130 ²⁾	1	95	125	80	130	101	6.5	
				3.740	4.921	3.150	5.118	3.976		
	C10	C10-390.410-125 160 ²⁾	1	95	125	100	160	131	9.5	
				3.740	4.921	3.937	6.299	5.158		

1) 1 = coolant through center

2) The holders HSK A/C size 125 don't have the holes on the conical surface according to DIN69893

A special coolant tube is delivered together with the HSK basic holders.

Note!

In machines with automatic tool change the coolant tube must be assembled in the basic holder. The outpush function of the clamping mechanism can be jeopardized without an assembled coolant tube/thread ring.

HSK125A - Compatible with the Makino T4 and MAG Cincinnati Ti Profiler, for titanium machining.**HSK50A** - Compatible with the Makino SLIM 3.

Basic holder

Cat V-Flange

A390.45

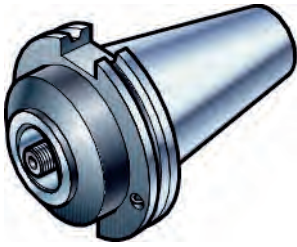

Design 1

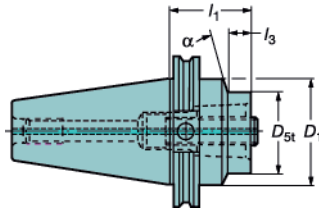

Design 2

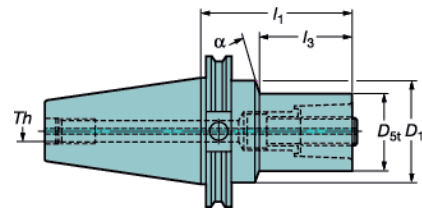

Design 3

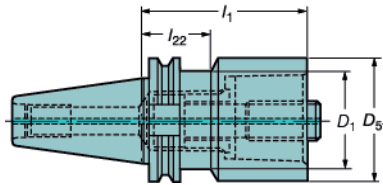

l_1 = programming length

Inch thread

Taper	Coupling size	Ordering code	Design	Coolant ¹⁾	Dimensions, inch							
					D_1	D_{st}	l_1	l_3	l_{22}	α_0	D_{th}	$\frac{lb}{lb}$
40	C3	C3-A390.45-40 040	1	1	1.760	1.260	1.575	.197		20	.625	4.0
40	C3	C3-A390.45-40 070	2	1	1.760	1.260	2.756	1.378		30	.625	5.7
50		C3-A390.45-50 040	1	1	2.760	1.260	1.575	.197		10	1.000	10.1
50		C3-A390.45-50 070	2	1	2.760	1.260	2.756	1.378		15	1.000	15.0
40	C4	C4-A390.45-40 040	1	1	1.760	1.575	1.575	.197		30	.625	4.0
40	C4	C4-A390.45-40 070	2	1	1.760	1.575	2.756	1.378		30	.625	5.7
50		C4-A390.45-50 040	1	1	2.760	1.575	1.575	.197		10	1.000	14.1
50		C4-A390.45-50 070	2	1	2.760	1.575	2.756	1.378		10	1.000	15.0
40	C5	C5-A390.45-40 050	3	1	1.760	1.968	1.969		1.378		.625	4.9
40	C5	C5-A390.45-40 090	3	1	1.760	1.968	3.543		1.378		.625	6.4
45		C5-A390.45-45 040	1	1	2.260	1.968	1.575	.118		30	.750	8.4
50		C5-A390.45-50 040	1	1	2.760	1.968	1.575	.091		15	1.000	13.2
50		C5-A390.45-50 080	2	1	2.760	1.968	3.150	1.693		15	1.000	14.1
40	C6	C6-A390.45-40 090	3	1	1.760	2.480	3.543		1.378		.625	9.9
45		C6-A390.45-45 050	1	1	2.260	2.480	1.969	.591	1.378	20	.750	10.8
50		C6-A390.45-50 040	3	1	2.760	2.480	1.575	.118		30	1.000	14.6
50		C6-A390.45-50 090	3	1	2.760	2.480	3.543	2.087		30	1.000	19.8
50	C8	C8-A390.45-50 100	3	1	2.760	3.150	3.937	2.559	1.378	20	1.000	22.9
60		C8-A390.45-60 050	1	1	4.260	3.150	1.969	1.220		30	1.250	47.2
60	C10	C10-A390.45-60 050	1	1	4.250	3.937	1.968	.413			1.250	19.8

¹⁾ 1 = coolant through center

Note! Tighten the screw with a torque wrench. Information on page G111.



D
Milling
E
Drilling
F
Boring
G
Tooling Systems
J
General information

Basic holder

CAT V-Flange, similar to DIN 69871, form B

Coolant through flange
A390.455

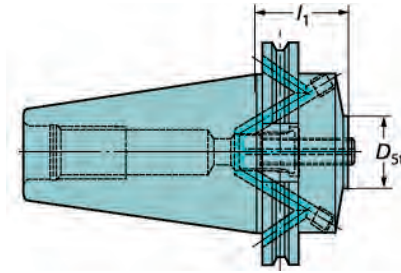
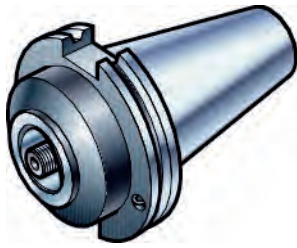

l_1 = programming length

Inch thread

Taper	Coupling size	Ordering code	Coolant ¹⁾	Dimensions, inch				Balanced by design
				D_{st}	l_1	α_0		
40	C3	C3-A390.455-40 040	6	1.260	1.575	4.4	⊙	
50		C3-A390.455-50 040	6	1.260	1.575	14.1		
40	C4	C4-A390.455-40 040	6	1.575	1.575	4.4	⊙	
50		C4-A390.455-50 040	6	1.575	1.575	13.2		
40	C5	C5-A390.455-40 050	6	1.968	1.969	4.9	⊙	
50		C5-A390.455-50 040	6	1.968	1.575	13.2		
50	C6	C6-A390.455-50 040	6	2.480	1.575	14.1		
50	C8	C8-A390.455-50 100	6	3.150	3.937	22.9		

¹⁾ 6 = coolant through flange

Cat V-Flange
Front clamp
A390.4504

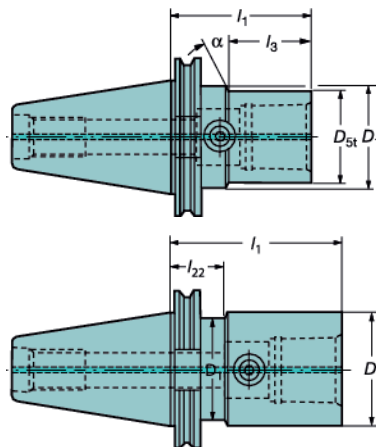
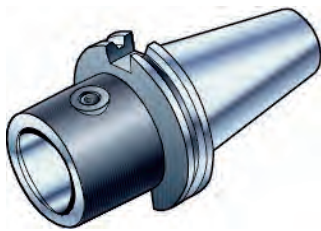

Note! One drawbolt for each adapter/cutting tool is required.

l_1 = programming length

Inch thread

Taper	Coupling size	Ordering code	Coolant ¹⁾	Dimensions, inch						
				D_1	D_{st}	l_1	l_3	l_{22}	α_0	α_0
40	C5	C5-A390.4504-40 100	1	1.760	1.9685	3.937		1.378	4.0	
50		C5-A390.4504-50 080	1	2.760	1.9685	3.150	1.634		8.6	
50	C6	C6-A390.4504-50 090	1	2.760	2.4803	3.543	2.087		9.0	
50	C8	C8-A390.4504-50 125	1	2.760	3.1496	4.921		1.378	12.3	

¹⁾ 1 = coolant through center

Note! Tighten the screw with a torque wrench. Information on page G111.
For drawbolt, see page G108.



Basic holder

BIG-PLUS
Cat V-Flange
A390.545

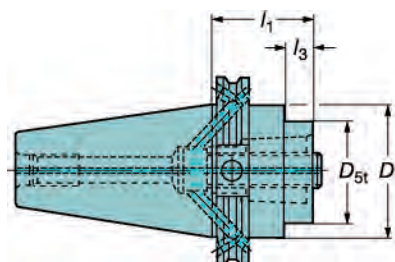
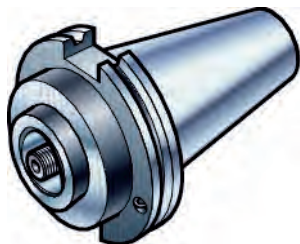

BIG-PLUS SYSTEM - License BIG DAISHOWA

l_1 = programming length

Inch thread

Taper	Coupling size	Ordering code	Coolant ¹⁾	Dimensions, inch				
				D_1	D_{st}	l_1	l_3	
40	C3	C3-A390.545-40 040A	7	1.750	1.260	1.575	.106	2.0
50		C3-A390.545-50 040A	7	2.750	1.260	1.575	.063	6.8
40	C4	C4-A390.545-40 040A	7	1.750	1.575	1.575	.142	2.2
50		C4-A390.545-50 040A	7	2.750	1.575	1.575	.091	6.8
40	C5	C5-A390.545-40 050A	7	1.750	1.968	1.968		2.2
50		C5-A390.545-50 040A	7	2.750	1.968	1.575	.091	6.6
50	C6	C6-A390.545-50 040A	7	2.750	2.480	1.575	.118	6.4
50	C8	C8-A390.545-50 100A	7	2.750	3.150	3.937		10.4

¹⁾ 7 = coolant through center and through flange

Ordering code
5514 011-02 (CAT 40)
5514 011-01 (CAT 50)

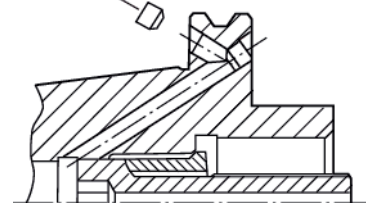

The new design is prepared for coolant also through the flange which means the coolant could be lead either through the center or through the flange. The inlet channels in the flange are plugged with screws, which can easily be removed when coolant supply should be led through the flange. For technical information, see Metalcutting Technical guide.

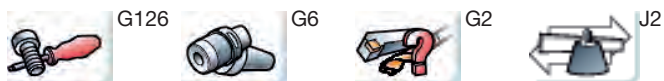

Basic holder

BIG-PLUS

90° rotated polygon for precision tool tip control

Designed for Mazak™ e-machine and Mori Seiki NT Series

Cat V-Flange

A390.546

Milling

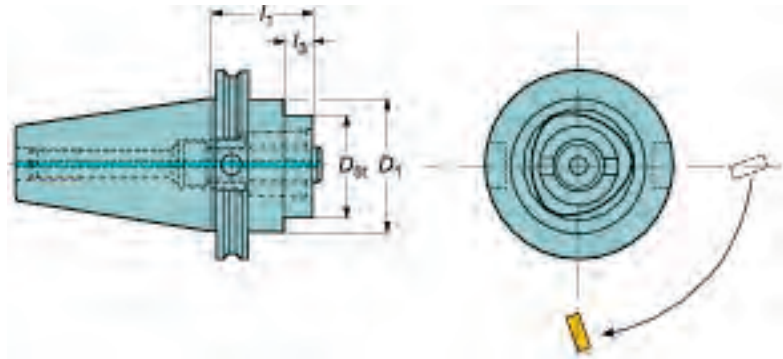
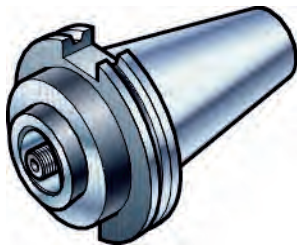

BIG-PLUS SYSTEM - License BIG DAISHOWA

l_1 = programming length

E

Drilling

Inch thread

F

Taper	Coupling size	Ordering code	Coolant ¹⁾	Dimensions, inch				
				D_1	D_{st}	l_1	l_3	$\frac{\Delta_{max}}{L_{tot}}$
40	C4	C4-A390.546-40 040	1	1.750	1.575	1.575	.142	2.2
40	C5	C5-A390.546-40 050	1	1.750	1.968	1.968	.591	2.3
50	C6	C6-A390.546-50 050	1	2.750	2.480	1.968	.512	6.8
50	C8	C8-A390.546-50 070	1	2.750	3.150	2.756	1.378	7.9

¹⁾ 1 = coolant through center

BIG-PLUS

90° rotated polygon

Designed for Mazak™ e-machine and Mori Seiki NT Series

Cat V-Flange

A390.547

Boring

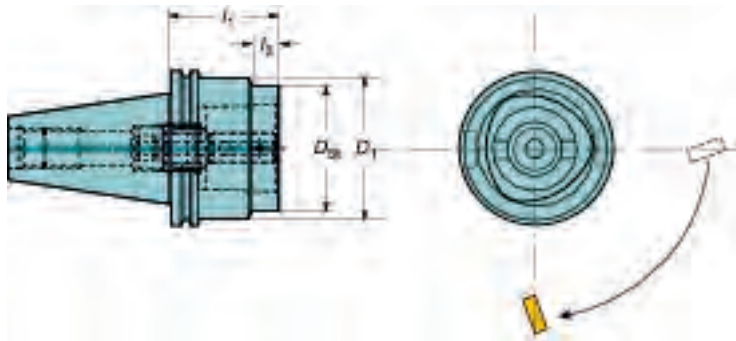
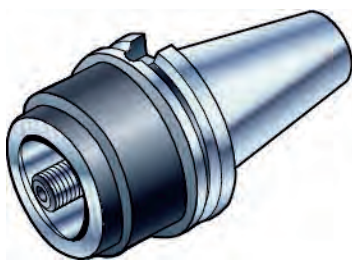

BIG-PLUS SYSTEM - License BIG DAISHOWA

l_1 = programming length

Tooling Systems

Inch thread

J

Taper	Coupling size	Ordering code	Coolant ¹⁾	Dimensions, inch				
				D_1	D_{st}	l_1	l_3	$\frac{\Delta_{max}}{L_{tot}}$
50	C8	C8-A390.547-50 070	1	3.543	3.150	2.756	.669	9.0

¹⁾ 1 = coolant through center



Basic holder

DIN 2080

For manual tool change
390.00

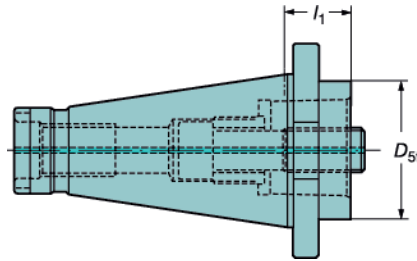
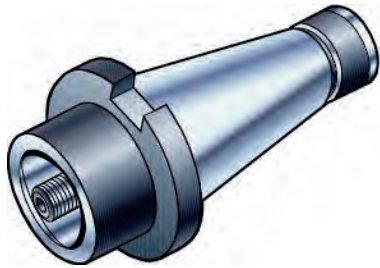

l_1 = programming length

Metric thread

Taper	Coupling size	Ordering code	Coolant ¹⁾	Dimensions		
				D_{st}	l_1	$\frac{kg}{kg}$
40	C3	C3-390.00-40 030	1	32	30	0.8
50		C3-390.00-50 030	1	32	30	2.5
50		C3-390.00-50 060	1	32	60	2.5
40	C4	C4-390.00-40 030	1	40	30	0.8
40		C4-390.00-40 060	1	40	60	0.8
50		C4-390.00-50 030	1	40	30	2.5
50		C4-390.00-50 060	1	40	60	2.5
40	C5	C5-390.00-40 030	1	50	30	0.9
40		C5-390.00-40 070	1	50	70	1.4
50		C5-390.00-50 030	1	50	30	2.6
50		C5-390.00-50 070	1	50	70	3.1
40	C6	C6-390.00-40 075	1	63	75	1.9
50		C6-390.00-50 030	1	63	30	2.6
50		C6-390.00-50 080	1	63	80	3.7
50	C8	C8-390.00-50 070	1	80	70	3.8
50		C8-390.00-50 120	1	80	120	5.6

¹⁾ 1 = coolant through center

DIN 2080

For manual tool change
Front clamp
390.0004

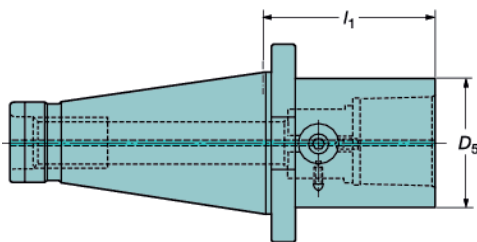
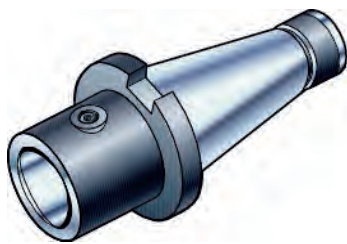

Note! One drawbolt for each adapter/cutting tool is required.

l_1 = programming length

Metric thread

Taper	Coupling size	Ordering code	Coolant ¹⁾	Dimensions		
				D_{st}	l_1	$\frac{kg}{kg}$
40	C5	C5-390.0004-40 075	1	50	75	1.5
50		C5-390.0004-50 080	1	50	80	3.4
50	C6	C6-390.0004-50 085	1	63	85	3.8
50	C8	C8-390.0004-50 100	1	80	100	5.0

¹⁾ 1 = coolant through center

Note! Tighten the screw with a torque wrench. Information on page G111.
For drawbolt, see page G108.



Basic holder

DIN 2079

For manual tool change

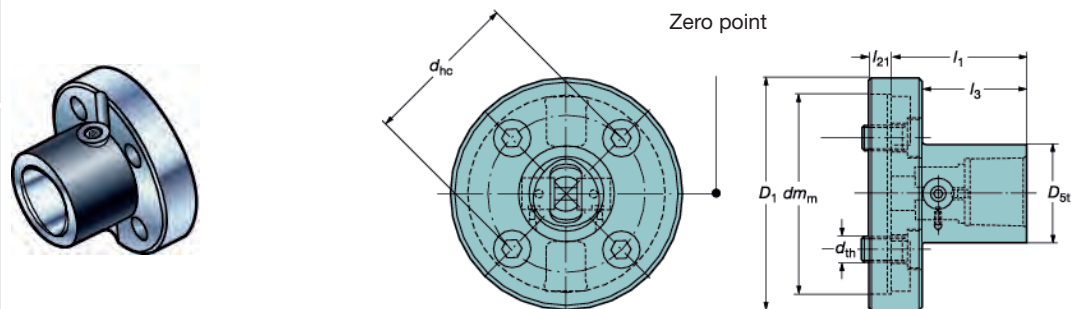
Front clamp
390.34704**Note!** One drawbolt for each adapter/cutting tool is required. l_1 = programming length

Metric thread

Taper	Coupling size	Ordering code	Coolant ¹⁾	Dimensions								
				d_m	D_{hc}	D_1	D_{st}	l_1	l_3	l_{21}	D_{th}	
40	C5	C5-390.34704-40 075	0	88.9	66.7	110	50	75	61	10	M12	2.2
50	C6	C6-390.34704-50 090	0	128.6	101.6	150	63	90	69	14	M16	4.2
50	C8	C8-390.34704-50 100	0	128.6	101.6	150	80	100	79	14	M16	4.4

¹⁾ 0 = no coolant

DIN 2079

For manual tool change, flange mounting

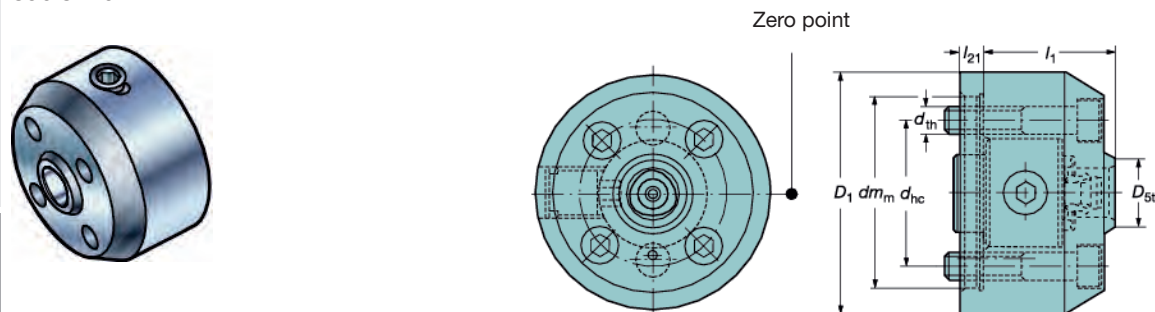
Camshaft clamping
390.34705 l_1 = programming length

Metric thread

Taper	Coupling size	Ordering code	Coolant ¹⁾	Dimensions							
				D_{hc}	d_m	D_{th}	D_1	D_{st}	l_1	l_{21}	
40	C3	C3-390.34705-40 060	0	66.7	88.88	M12	110	32	60	10	4.4
40	C4	C4-390.34705-40 070	0	66.7	88.88	M12	110	40	70	10	5.2

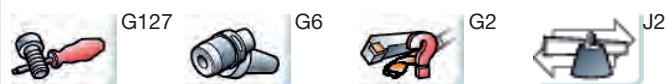
¹⁾ 0 = no coolant**Note!** These flange mounted holders fit many standard spindle configurations. The bolt hole configurations and pilot diameter are standard 40 and 50 taper solutions for CAT V-Flange and NMTB tapers.**Note!** Tighten the screw with a torque wrench. Information on page G111.
For drawbolt, see page G108.

Basic holder

NMTB

A390.00

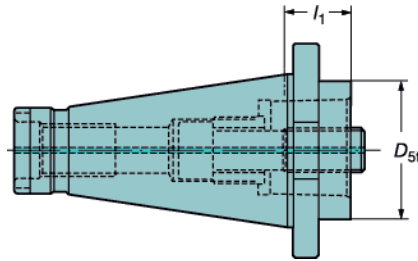
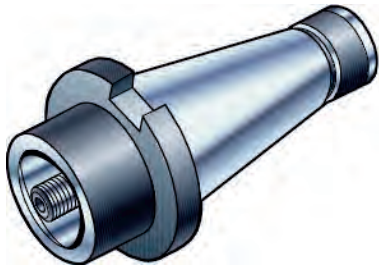
 l_1 = programming length

Inch thread

Taper	Coupling size	Ordering code	Coolant ¹⁾	Dimensions, inch		
				D_{5t}	l_1	
40	C5	C5-A390.00-40 030	1	1.968	1.181	4.2
50	C5	C5-A390.00-50 030	1	1.968	1.181	12.6
50	C5	C5-A390.00-50 070	1	1.968	2.756	15.0
50	C6	C6-A390.00-50 030	1	2.480	1.181	12.6
50	C8	C8-A390.00-50 070	1	3.150	2.756	18.5

1) 1 = coolant through center

NMTB

Front clamp

A390.0004

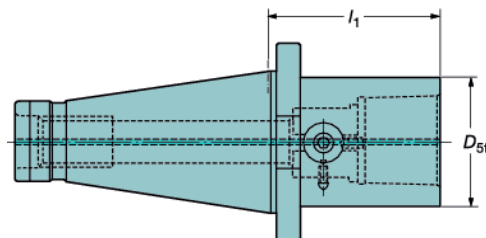
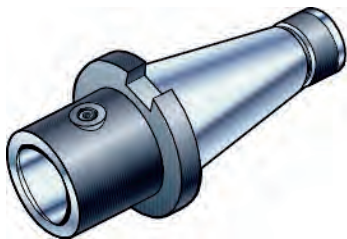

Note! One drawbolt for each adapter/cutting tool is required.

 l_1 = programming length

Inch thread

Taper	Coupling size	Ordering code	Coolant ¹⁾	Dimensions, inch		
				D_{5t}	l_1	
50	C5	C5-A390.0004-50 080	1	1.968	3.150	16.5
50	C6	C6-A390.0004-50 085	1	2.480	3.346	18.5
50	C8	C8-A390.0004-50 100	1	3.150	3.937	24.3

1) 1 = coolant through center

Note! Tighten the screw with a torque wrench. Information on page G111.
For drawbolt, see page G108.



G126



G6



G2



J2

D
Milling
E
Drilling
F
Boring
G
Tooling Systems
J
General Information

TOOLING SYSTEMS Coromant Capto® – Adapters for rotating tools

Extension adapter

391.01

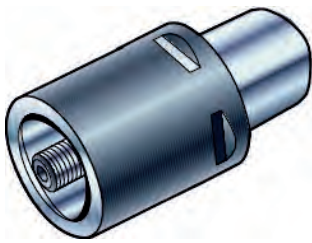
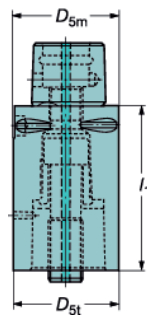
l_1 = programming length

Coupling size		Ordering code	Coolant ¹⁾	Dimensions, millimeter, inch (mm, in.)						
Machine side	Tool side			D_{5m} mm	D_{5m} in.	D_{5t} mm	D_{5t} in.	l_1 mm	l_1 in.	$\frac{kg}{kg}$
C3	C3	C3-391.01-32 060A	1	32	1.260	32	1.260	60	2.362	0.4
		C3-391.01-32 080A	1	32	1.260	32	1.260	80	3.150	0.5
C4	C4	C4-391.01-40 060A	1	40	1.575	40	1.575	60	2.362	0.5
		C4-391.01-40 080A	1	40	1.575	40	1.575	80	3.150	0.7
C5	C5	C5-391.01-50 080A	1	50	1.968	50	1.968	80	3.150	1.1
		C5-391.01-50 100A	1	50	1.968	50	1.968	100	3.937	1.4
C6	C6	C6-391.01-63 100A	1	63	2.480	63	2.480	100	3.937	2.2
		C6-391.01-63 140A	1	63	2.480	63	2.480	140	5.512	3.1
C8	C8	C8-391.01-80 100A	1	80	3.150	80	3.150	100	3.937	3.6
		C8-391.01-80 125A	1	80	3.150	80	3.150	125	4.921	4.6
C10	C10	C10-391.01-100 140	1	100	3.937	100	3.937	140	5.512	8.5

¹⁾ 1 = coolant through center

Short version, for segment clamping only

391.01

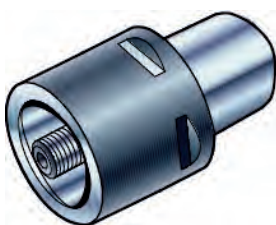
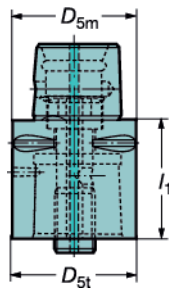
Note!

Not possible to use together with basic holders using center bolt clamping.

l_1 = programming length

Coupling size		Ordering code	Coolant ¹⁾	Dimensions, millimeter, inch (mm, in.)						
Machine side	Tool side			D_{5m} mm	D_{5m} in.	D_{5t} mm	D_{5t} in.	l_1 mm	l_1 in.	$\frac{kg}{kg}$
C3	C3	C3-391.01-32 035	1	32	1.260	32	1.260	35	1.378	0.2
C4	C4	C4-391.01-40 040	1	40	1.575	40	1.575	40	1.575	0.4
C5	C5	C5-391.01-50 050	1	50	1.968	50	1.968	50	1.968	0.9

¹⁾ 1 = coolant through center



G 24



Reduction adapter

391.02

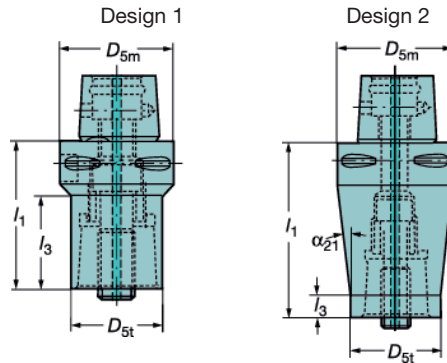
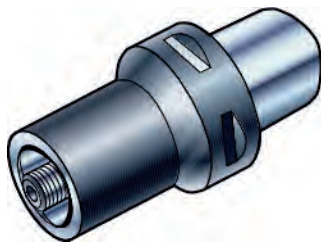

l₁ = programming length

Coupling size		Ordering code	Design	Coolant ¹⁾	Dimensions, millimeter, inch (mm, in.)									
Machine side	Tool side				D _{5m} mm	D _{5m} in.	D _{5t} mm	D _{5t} in.	l ₁ mm	l ₁ in.	l ₃ mm	l ₃ in.	α ₂₁	
C4	C3	C4-391.02-32 055A	1	1	40	1.575	32	1.260	55	2.165	31	1.220		0.5
	C3	C4-391.02-32 070A	2	1	40	1.575	32	1.260	70	2.756	12	.472	6.0°	0.6
C5	C3	C5-391.02-32 060A	1	1	50	1.968	32	1.260	60	2.362	34.8	1.370		0.6
	C4	C5-391.02-40 065A	1	1	50	1.968	40	1.575	65	2.559	40	1.575		0.8
	C4	C5-391.02-40 085A	2	1	50	1.968	40	1.575	85	3.346	12	.472	5.4°	1.1
C6	C3	C6-391.02-32 070A	1	1	63	2.480	32	1.260	70	2.756	39	1.535		1.1
	C4	C6-391.02-40 080A	1	1	63	2.480	40	1.575	80	3.150	51.4	2.024		1.2
	C5	C6-391.02-50 080A	1	1	63	2.480	50	1.968	80	3.150	51.5	2.028		1.5
	C5	C6-391.02-50 110A	2	1	63	2.480	50	1.968	110	4.331	12	.472	4.9°	2.2
C8	C3	C8-391.02-32 060A	1	1	80	3.150	32	1.260	60	2.362	29.3	1.154		1.7
	C4	C8-391.02-40 070A	1	1	80	3.150	40	1.575	70	2.756	36.5	1.437		1.9
	C5	C8-391.02-50 080A	1	1	80	3.150	50	1.968	80	3.150	49.3	1.941		2.2
	C6	C8-391.02-63 080A	1	1	80	3.150	63	2.480	80	3.150	53.1	2.091		2.5
	C6	C8-391.02-63 120A	1	1	80	3.150	63	2.480	120	4.724	12	.472		4.0
C10	C6	C10-391.02-63 095	1	1	100	3.937	63	2.480	95	3.740	48.3	1.902		4.5
	C8	C10-391.02-80 100	1	1	100	3.937	80	3.150	100	3.937	58.2	2.291		5.1

¹⁾ 1 = coolant through center

Short version, for segment clamping only

391.02

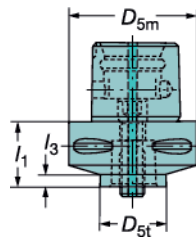
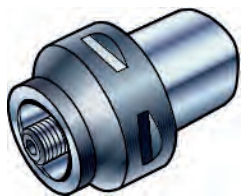

Note! Not possible to use together with basic holders using center bolt clamping.

l₁ = programming length

Coupling size		Ordering code	Coolant ¹⁾	Dimensions, millimeter, inch (mm, in.)									
Machine side	Tool side			D _{5m} mm	D _{5m} in.	D _{5t} mm	D _{5t} in.	l ₁ mm	l ₁ in.	l ₃ mm	l ₃ in.		
C5	C3	C5-391.02-32 033	1	50	1.968	32	1.260	33	1.299	10	.394	0.5	
	C4	C5-391.02-40 040	1	50	1.968	40	1.575	40	1.575	18	.709	0.6	
C6	C3	C6-391.02-32 032	1	63	2.480	32	1.260	32	1.260	6	.236	0.8	
	C4	C6-391.02-40 040	1	63	2.480	40	1.575	40	1.575	11	.433	0.9	
	C5	C6-391.02-50 050	1	63	2.480	50	1.968	50	1.968	26.5	1.043	1.0	
C8	C5	C8-391.02-50 045	1	80	3.150	50	1.968	45	1.772	10	.394	1.8	
	C6	C8-391.02-63 055	1	80	3.150	63	2.480	55	2.165	20	.787	2.0	
C10	C6	C10-391.02-63 055	1	100	3.937	63	2.480	55	2.165	14	.551	3.2	
	C8	C10-391.02-80 065	1	100	3.937	80	3.150	65	2.559	25.4	1.000	3.5	

¹⁾ 1 = coolant through center



D
E
F
G
J

TOOLING SYSTEMS Coromant Capto® – Adapters for rotating tools

Front clamp extension adapter

Note! One drawbolt for each adapter/cutting tool is required.

l_1 = programming length

Coupling size		Ordering code	Coolant ¹⁾	Dimensions, millimeter, inch (mm, in.)							
Basic holder	Adapter			D_{5m} mm	D_{5m} in.	D_{5t} mm	D_{5t} in.	l_1 mm	l_1 in.		
C5	C5	C5-391.04-50 075	1	50	1.9685	50	1.968	75	2.953	1.4	
C6	C6	C6-391.04-63 085	1	63	2.4803	63	2.480	85	3.346	2.0	
C8	C8	C8-391.04-80 100	1	80	3.1496	80	3.150	100	3.937	3.8	

¹⁾ 1 = coolant through center

Front clamp reduction adapter

391.0204

Note! One drawbolt for each adapter/cutting tool is required.

l_1 = programming length

Coupling size		Ordering code	Coolant ¹⁾	Dimensions, millimeter, inch (mm, in.)								
Basic holder	Adapter			D_{5m} mm	D_{5m} in.	D_{5t} mm	D_{5t} in.	l_1 mm	l_1 in.	l_3 mm	l_3 in.	
C6	C5	C6-391.0204-50 080	1	63	2.4803	50	1.968	80	3.150	54	2.126	1.4
C8	C5	C8-391.0204-50 080	1	80	3.1496	50	1.968	80	3.150	49	1.929	2.3
	C6	C8-391.0204-63 090	1	80	3.1496	63	2.480	90	3.543	63	2.480	2.3

¹⁾ 1 = coolant through center

Note! Tighten the screw with a torque wrench. Information on page G111.
For drawbolt, see page G108.

G 26

General Information

Adapter for facemills and square shoulder facemills

With coolant through arbor
391.05C

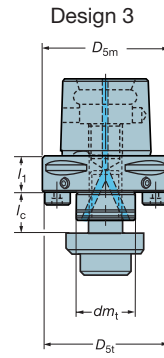
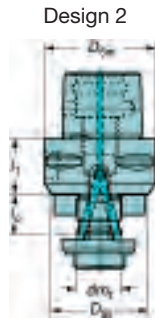
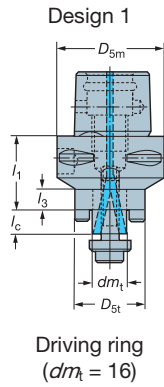

Driving ring
($dm_1 = 16$)

Round driving keys

l_1 = programming length

Metric pilot

Coupling size	Ordering code	Coolant ¹⁾			Design	Dimensions						Balanced by design
		Entry	Exit			dm_1	D_{sm}	D_{st}	l_c	l_1	l_3	
C3	C3-391.05C-16 030	1	4	1	16	32	32	11	30	10	0.3	⊕
C4	C4-391.05C-16 032	1	4	1	16	40	32	11	32	10	0.3	⊕
	C4-391.05C-22 025	1	4	2	22	40	40	16	25	0.4	⊕	
C5	C5-391.05C-16 035	1	4	1	16	50	32	11	35	10	0.6	⊕
	C5-391.05C-22 025	1	4	3	22	50	50	16	25	0.6	⊕	
	C5-391.05C-27 025	1	4	3	27	50	56	18	25	0.7	⊕	
	C5-391.05C-32 040	1	4	2	32	50	63	20	40	1.2	⊕	
C6	C6-391.05C-16 040	1	4	1	16	63	32	11	40	10	0.9	
	C6-391.05C-22 025	1	4	3	22	63	55	16	25	0.9		
	C6-391.05C-27 025	1	4	3	27	63	63	18	25	1.0		
	C6-391.05C-32 025	1	4	3	32	63	65	20	25	1.1		
	C6-391.05C-40 040	1	4	2	40	63	70	23	40	1.6		
C8	C8-391.05C-16 050	1	4	1	16	80	32	11	50	10	1.6	
	C8-391.05C-22 030	1	4	3	22	80	55	16	30	1.8		
	C8-391.05C-27 030	1	4	3	27	80	65	18	30	1.9		
	C8-391.05C-32 030	1	4	3	32	80	79	20	30	2.0		
	C8-391.05C-40 030	1	4	3	40	80	80	23	30	2.1		
C10	C10-391.05C-40 040	1	4	3	40	100	100	23	40	4.0		

¹⁾ 0 = no coolant, 1 = coolant through center, 4 = coolant through arbor



D
Milling
E
Drilling
F
Boring
G
Tooling Systems
J
General Information

D
Milling
E
Drilling
F
Boring
G
Tooling Systems
J
General Information

TOOLING SYSTEMS Coromant Capto® – Adapters for rotating tools

Adapter for facemills and square shoulder facemills

With coolant through arbor

A391.05C

Design 2

Design 3

Round driving keys

h_1 = programming length

Inch pilot

Coupling size	Ordering code	Coolant ¹⁾			Dimensions, inch							Balanced by design
		Entry	Exit	Design	d_{m1}	D_{sm}	D_{st}	l_c	h_1	$\frac{L_{sm}}{L_{st}}$		
C3	C3-A391.05C-19 030	1	4	2	.750	1.260	1.575	.709	1.181	0.8	⊙	
C4	C4-A391.05C-19 025	1	4	3	.750	1.575	1.575	.709	.984	0.8	⊙	
	C4-A391.05C-25 035	1	4	2	1.000	1.575	1.968	.709	1.378	1.2	⊙	
C5	C5-A391.05C-19 025	1	4	3	.750	1.968	1.968	.709	.984	1.4	⊙	
	C5-A391.05C-25 025	1	4	3	1.000	1.968	2.126	.709	.984	1.4	⊙	
	C5-A391.05C-31 040	1	4	2	1.250	1.968	2.480	.709	1.575	2.6	⊙	
	C5-A391.05C-38 045	1	4	2	1.500	1.968	3.150	.906	1.772	4.0	⊙	
C6	C6-A391.05C-19 030	1	4	3	.750	2.480	2.047	.709	1.181	2.2		
	C6-A391.05C-25 030	1	4	3	1.000	2.480	2.480	.709	1.181	2.4		
	C6-A391.05C-31 030	1	4	3	1.250	2.480	2.559	.709	1.181	2.6		
	C6-A391.05C-38 045	1	4	2	1.500	2.480	3.150	.906	1.772	4.4		
C8	C8-A391.05C-19 030	1	4	3	.750	3.150	2.047	.709	1.181	4.0		
	C8-A391.05C-25 030	1	4	3	1.000	3.150	2.480	.709	1.181	4.2		
	C8-A391.05C-31 030	1	4	3	1.250	3.150	2.835	.709	1.181	4.2		
	C8-A391.05C-38 030	1	4	3	1.500	3.150	3.150	.906	1.181	4.6		
C10	C10-A391.05C-38 040	1	4	3	1.500	3.937	3.937	.906	1.575	8.6		

¹⁾ 0 = no coolant, 1 = coolant through center, 4 = coolant through arbor

G 28

Adapter for facemills and square shoulder facemills

391.05

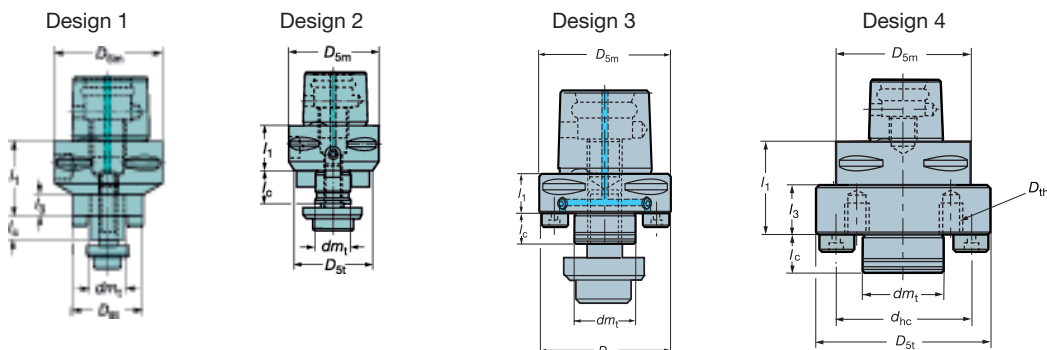
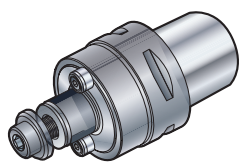

Driving ring
($dm_\lambda = 16$)

Round driving keys

l = programming length

Metric pilot

Coupling size	Ordering code	Design	Coolant ¹⁾	Dimensions										Balanced by design
				dm_λ	D_{sm}	D_{st}	l_c	l_1	D_{th}	d_{hc}	l_3	$\frac{kg}{cm^3}$		
C3	C3-391.05-16 030	1	1	16	32	32	11	30				10	0.3	⊙
C4	C4-391.05-16 032	1	1	16	40	32	11	32				10	0.3	⊙
	C4-391.05-16 055	1	1	16	40	32	11	55				33	0.4	⊙
C4	C4-391.05-22 025	2	1	22	40	40	16	25					0.4	⊙
	C4-391.05-22 055	2	1	22	40	40	16	55					0.7	⊙
C5	C5-391.05-16 035	1	1	16	50	32	11	35				10	0.6	⊙
	C5-391.05-16 070	1	1	16	50	32	11	70				44.8	0.7	⊙
	C5-391.05-22 025A	3	1	22	50	50	16	25					0.6	⊙
	C5-391.05-22 070	2	1	22	50	40	16	70				47	1.0	⊙
	C5-391.05-27 025A	3	1	27	50	56	18	25					0.7	⊙
C6	C5-391.05-32 040	2	1	32	50	63	20	40					1.2	⊙
	C6-391.05-16 040	1	1	16	63	32	11	40				10	0.9	
	C6-391.05-22 025A	3	1	22	63	55	16	25					0.9	
	C6-391.05-27 025A	3	1	27	63	63	18	25					1.0	
	C6-391.05-32 025A	3	1	32	63	65	20	25					1.1	
C8	C6-391.05-40040A	2	1	40	63	70	23	40					1.6	
	C8-391.05-16 050	1	1	16	80	32	11	50				10	1.6	
	C8-391.05-22 030A	3	1	22	80	55	16	30					1.8	
	C8-391.05-27 030A	3	1	27	80	65	18	30					1.9	
	C8-391.05-32 030A	3	1	32	80	72	20	30					2.0	
C8	C8-391.05-40 030B ²⁾	3	1	40	80	80	23	30					2.1	
	C8-391.05-60 060	4	0	60	80	130	29	60	M16	101.6			5.3	
	C10-391.05-40 040	3	1	40	100	90	23	40				0.5	4.0	
C10	C10-391.05-60 075	4	0	60	100	130	29	75	M16	101.6	37.8	7.9		

¹⁾ 0 = no coolant, 1 = coolant through center

²⁾ Coolant for boring

All holders are delivered with a standard screw without hole for coolant. For cutters with coolant channels a new screw with radial coolant holes is necessary and can be ordered separately. See page G134.



D
Milling
E
Drilling
F
Boring
G
Tooling Systems
J
General Information

TOOLING SYSTEMS Coromant Capto® – Adapters for rotating tools

Adapter for facemills and square shoulder facemills

A391.05

Design 2

Design 3

Round driving keys

Design 4

l_1 = programming length

Inch pilot

Coupling size	Ordering code	Design	Coolant ¹⁾	Dimensions, inch										Balanced by design
				d_{mt}	D_{sm}	D_{st}	l_c	l_1	D_{th}	d_{hc}	l_3	$\frac{\Delta}{100}$		
C3	C3-A391.05-19 030	2	1	.750	1.260	1.575	.709	1.181					2.0	⊙
C4	C4-A391.05-19 025A	3	1	.750	1.575	1.575	.709	.984					0.8	⊙
	C4-A391.05-19 055	2	1	.750	1.575	1.575	.709	2.165					2.9	⊙
	C4-A391.05-25 035	2	1	1.000	1.575	1.968	.709	1.378					2.9	⊙
C5	C5-A391.05-19 025A	3	1	.750	1.968	1.968	.709	.984					1.4	⊙
	C5-A391.05-19 070	2	1	.750	1.968	1.693	.709	2.756					5.3	⊙
	C5-A391.05-25 025A	3	1	1.000	1.968	2.126	.709	.984					1.4	⊙
	C5-A391.05-31 040	2	1	1.250	1.968	2.480	.709	1.575					5.7	⊙
	C5-A391.05-38 045	2	1	1.500	1.968	3.150	.906	1.772					8.8	⊙
C6	C6-A391.05-19 030A	3	1	.750	2.480	2.047	.709	1.181					2.2	
	C6-A391.05-25 030A	3	1	1.000	2.480	2.480	.709	1.181					2.4	
	C6-A391.05-31 030A	3	1	1.250	2.480	2.559	.709	1.181					2.6	
	C6-A391.05-38 045	2	1	1.500	2.480	3.150	.906	1.772					9.7	
C8	C8-A391.05-19 030A	3	1	.750	3.150	2.047	.709	1.181					4.0	
	C8-A391.05-25 030A	3	1	1.000	3.150	2.480	.709	1.181					4.2	
	C8-A391.05-31 030A	3	1	1.250	3.150	2.835	.709	1.181					4.2	
	C8-A391.05-38 030A	3	1	1.500	3.150	3.150	.906	1.181					4.6	
	C8-A391.05-50 060	4	0	2.000	3.150	5.118	1.142	2.362	5/8"-11 UNC	101.6			24.3	
	C8-A391.05-63 060	4	0	2.500	3.150	5.118	1.142	2.362	5/8"-11 UNC	101.6			25.8	
C10	C10-A391.05-38 040	3	1	1.500	3.937	3.543	.906	1.575				.020	8.6	
	C10-A391.05-63 075	4	0	2.500	3.937	5.118	1.142	2.953	5/8"-11 UNC	101.6	1.488	17.6		

¹⁾ 0 = no coolant, 1 = coolant through center

All holders are delivered with a standard screw without hole for coolant.
For cutters with coolant channels a new screw with radial coolant holes is necessary and can be ordered separately.
See page G133.

G 30

Dampened adapter for facemills and square shoulder facemills

With coolant through arbor

391.05CD



Design 1

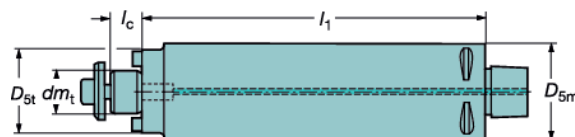

Design 2

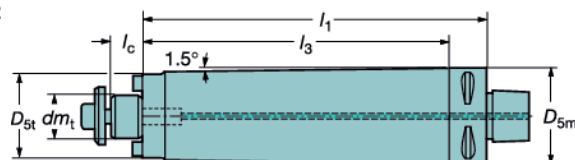

l_1 = programming length

Metric pilot

Coupling size	Ordering code	Coolant ¹⁾		Design	Dimensions							
		Entry	Exit		dm_t	D_{5m}	D_{st}	l_c	l_1	l_3	r_{max}	$\frac{kg}{kg}$
C5	C5-391.05CD-22 220	1	4	2	22	50	40	16	220	200	6000	3.3
C6	C6-391.05CD-22 260	1	4	2	22	63	48	16	260	238	6000	5.8
C8	C8-391.05CD-27 320	1	4	2	27	80	55	18	320	290	4000	10.9
	C8-391.05CD-32 320	1	4	1	32	80	70	20	320		4000	13.6

¹⁾ 1 = coolant through center, 4 = coolant through arbor

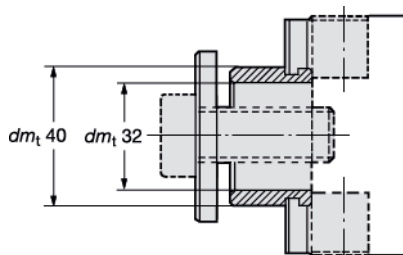

Sleeve set

Sleeve set to allow 40 mm pilot diameter to be mounted on adapter C8-391.05CD-32 320.

Ordering code: 5638 035-011

For proper assembly fixtures, see information in Metal cutting technical guide

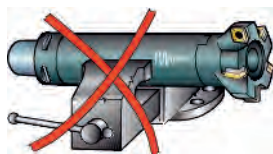

D
E
F
G
J

TOOLING SYSTEMS Coromant Capto® – Adapters for rotating tools

Dampened adapter for facemills and square shoulder facemills
With coolant through arbor
A391.05CD



Silent Tools®

Design 1

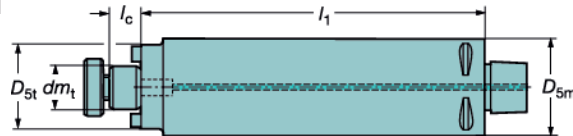

Design 2

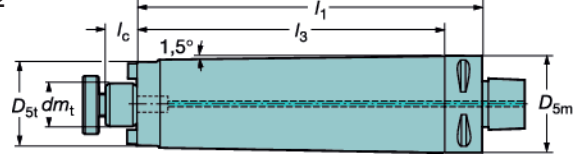

l_1 = programming length

Inch pilot

Coupling size	Ordering code	Coolant ¹⁾		Design	Dimensions, inch							
		Entry	Exit		dm_t	D_{5m}	D_{st}	l_c	l_1	l_3	n_{max}	$\frac{L}{D}$
C5	C5-A391.05CD-19 220	1	4	2	.750	1.968	1.575	.710	8.661	7.874	6000	7.3
C6	C6-A391.05CD-25 260	1	4	1	1.000	2.480	2.165	.710	10.236		6000	15.9
C8	C8-A391.05CD-38 320	1	4	1	1.500	3.150	2.756	.910	12.598		4000	30.2

¹⁾ 1 = coolant through center, 4 = coolant through arbor

For proper assembly fixtures, see information in Metal cutting technical guide



All holders are delivered with a standard screw without hole for coolant.
For cutters with coolant channels a new screw with radial coolant holes is necessary and can be ordered separately.
See page G133.



G 32



General Information

Adapter for side and facemills

391.10

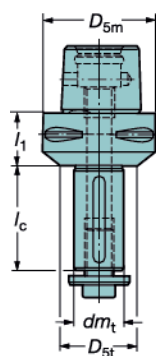
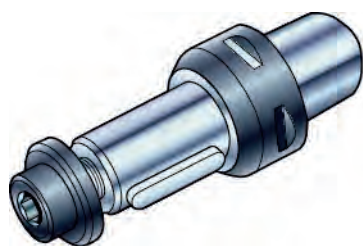

Spacing collars must be ordered separately.

l_1 = programming length

Metric pilot

Coupling size	Ordering code	Coolant ¹⁾	Dimensions						
			dm_1	D_{5m}	D_{5t}	l_c	l_1		
C3	C3-391.10-16 020	0	16	32	28	30	20	0.2	
C4	C4-391.10-16 025	0	16	40	28	30	25	0.3	
	C4-391.10-22 025	0	22	40	36	40	25	0.4	
	C4-391.10-27 025	0	27	40	40	60	25	0.6	
C5	C5-391.10-22 025	0	22	50	36	40	25	0.7	
	C5-391.10-27 025	0	27	50	43	60	25	0.8	
	C5-391.10-32 025	0	32	50	50	60	25	0.9	
C6	C6-391.10-16 030	0	16	63	28	30	30	0.9	
	C6-391.10-22 030	0	22	63	36	40	30	1	
	C6-391.10-27 030	0	27	63	43	60	30	1.2	
	C6-391.10-32 025	0	32	63	48	60	25	1.2	
	C6-391.10-40 025	0	40	63	56	60	25	1.4	
C8	C8-391.10-22 040	0	22	80	36	40	40	2	
	C8-391.10-27 030	0	27	80	43	60	30	2.1	
	C8-391.10-32 030	0	32	80	48	60	30	2.2	
	C8-391.10-40 030	0	40	80	56	60	30	2.5	
	C8-391.10-50 030	0	50	80	70	60	30	2.8	
	C8-391.10-60 030	0	60	80	80	60	30	3.4	

¹⁾ 0 = no coolant

Spacing collars

For milling adapter 391.10 ISO 839/2 1977	Ordering code	For adapter	Dimensions												
			l_2	0.5	1.0	1.5	2.0	3.0	4.0	5.0	6.0	10.0	20.0	30.0	
	Spacing collars		dm_1	D_1	D_1	D_1	D_1	D_1	D_1	D_1	D_1	D_1	D_1	D_1	
	5549 091-011	391.10-16...	16	25	25	25	26	26	26	26	26	26	26	–	
	5549 091-021	391.10-22...	22	33	33	33	34	34	34	34	34	34	34	34	
	5549 091-031	391.10-27...	27	39	39	39	40	40	40	40	40	40	40	40	
	5549 091-041	391.10-32...	32	45	45	45	46	46	46	46	46	46	46	46	
	5549 091-051	391.10-40...	40	54	54	54	55	55	55	55	55	55	55	55	
	5549 091-061	391.10-50...	50	67	67	–	68	68	68	68	68	68	68	68	
	5549 091-071	391.10-60...	60	84	84	–	84	84	84	84	84	84	84	84	



G130



G6



G2

D
Milling
E
Drilling
F
Boring
G
Tooling Systems
J
General Information

TOOLING SYSTEMS Coromant Capto® – Adapters for rotating tools

Adapter for side and facemills

A391.10

Spacing collars must be ordered separately. l_1 = programming length

Inch pilot

Coupling size	Ordering code	Coolant ¹⁾	Dimensions, inch						
			dm_t	D_{5m}	D_{5t}	l_c	l_1		
C4	C4-A391.10-25 025	0	1.000	1.575	1.575	1.969	.984	2.4	
	C4-A391.10-31 035	0	1.250	1.575	1.969	2.362	1.378	4.0	
C5	C5-A391.10-25 025	0	1.000	1.968	1.693	1.969	.984	3.7	
	C5-A391.10-31 025	0	1.250	1.968	1.969	2.362	.984	4.4	
	C5-A391.10-38 030	0	1.500	1.968	2.244	2.362	1.181	5.5	
C6	C6-A391.10-25 030	0	1.000	2.480	1.693	1.969	1.181	5.3	
	C6-A391.10-31 025	0	1.250	2.480	1.890	2.362	.984	6.2	
	C6-A391.10-38 025	0	1.500	2.480	2.205	2.362	.984	6.8	
C8	C8-A391.10-25 030	0	1.000	3.150	1.693	1.969	1.181	9.7	
	C8-A391.10-31 030	0	1.250	3.150	1.890	2.362	1.181	10.1	
	C8-A391.10-38 030	0	1.500	3.150	2.205	2.362	1.181	12.1	
	C8-A391.10-50 030	0	2.000	3.150	2.756	2.362	1.181	13.7	
	C8-A391.10-63 040	0	2.500	3.150	3.346	2.362	1.575	17.4	

¹⁾ 0 = no coolant

Spacing collars

For adapter	Dimensions											
	dm_t	D_1	B_{KW}	l_2								
				1/4	3/8	7/16	1/2	5/8	3/4	1	1 1/2	
	Ordering code for one spacing collar											
Cx-A391.10-25 xxx	1.000	1.500	1/4	-	-	SC407	SC408	SC410	-	-	-	-
Cx-A391.10-31 xxx	1.250	1.750	5/16	-	SC506	-	SC508	-	-	-	SC516	-
Cx-A391.10-38 xxx	1.500	2.125	3/8	SC604	SC606	-	SC608	-	-	-	SC616	-
Cx-A391.10-50 xxx	2.000	2.750	1/2	-	SC806	-	-	-	-	SC812	SC816	-
Cx-A391.10-63 xxx	2.500	3.250	5/8	SC904	SC906	-	-	-	-	SC912	SC916	SC920

G130 G6 G2

G 34

ER-Collet chuck adapter

391.14
DIN6499

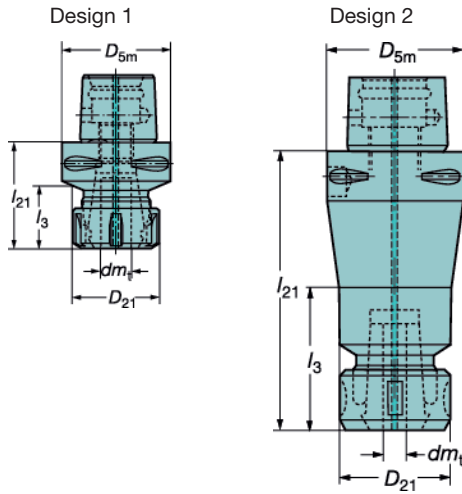
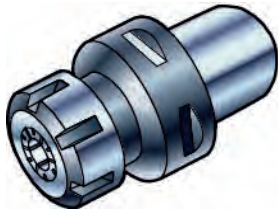

Accessories

Not delivered with the tool, must be ordered separately.

393.14



Page G119

Coupling size	Design	Ordering code	Coolant ¹⁾	Dimensions, millimeter, inch (mm, in.)														Balanced by design
				D _{5m} mm	D _{5m} in.	dm _t min mm	dm _t max mm	dm _t min in.	dm _t max in.	D ₂₁ mm	D ₂₁ in.	l ₃ mm	l ₃ in.	l ₂₁ mm	l ₂₁ in.	⊖ _{KG}		
C3	1	C3-391.14-16 045	1	32	1.260	1	10	.039	.394	28	1.102	29	1.142	45	1.772	0.2	⊕	
	1	C3-391.14-20 045	1	32	1.260	1	13	.039	.512	35	1.378	45	1.772	45	1.772	0.3	⊕	
C4	2	C4-391.14-16 070	1	40	1.575	1	10	.039	.394	28	1.102	44	1.732	70	2.756	0.4	⊕	
	1	C4-391.14-20 052	1	40	1.575	1	13	.039	.512	35	1.378	31	1.220	52	2.047	0.3	⊕	
	1	C4-391.14-25 052	1	40	1.575	1	16	.039	.630	42	1.654	52	2.047	52	2.047	0.4	⊕	
C5	1	C4-391.14-32 054	1	40	1.575	2	20	.079	.787	50	1.968	54	2.126	54	2.126	0.5	⊕	
	2	C5-391.14-16 100	1	50	1.969	1	10	.039	.394	28	1.102	60	2.362	100	3.937	0.9	⊕	
	1	C5-391.14-20 055	1	50	1.969	1	13	.039	.512	35	1.378	31	1.220	55	2.165	0.5	⊕	
C6	1	C5-391.14-25 055	1	50	1.969	1	16	.039	.630	42	1.654	33	1.299	55	2.165	0.5	⊕	
	1	C5-391.14-32 057	1	50	1.969	2	20	.079	.787	50	1.968	57	2.244	57	2.244	0.6	⊕	
	2	C6-391.14-16 100	1	63	2.480	1	10	.039	.394	28	1.102	60	2.362	100	3.937	1.3	⊕	
	1	C6-391.14-20 060	1	63	2.480	1	13	.039	.512	35	1.378	31	1.220	60	2.362	0.8	⊕	
	1	C6-391.14-25 060	1	63	2.480	1	16	.039	.630	42	1.654	33	1.299	60	2.362	0.9	⊕	
C8	2	C6-391.14-25 100	1	63	2.480	1	16	.039	.630	42	1.654	75	2.953	100	3.937	1.3	⊕	
	1	C6-391.14-32 060	1	63	2.480	2	20	.079	.787	50	1.968	35	1.378	60	2.362	0.9	⊕	
	2	C6-391.14-32 100	1	63	2.480	2	20	.079	.787	50	1.968	75	2.953	100	3.937	1.5	⊕	
	1	C6-391.14-40 065	1	63	2.480	3	26	.118	1.024	63	2.480	65	2.559	65	2.559	1.1	⊕	
	1	C8-391.14-20 065	1	80	3.150	1	13	.039	.512	35	1.378	30	1.181	65	2.559	1.4	⊕	
C8	1	C8-391.14-25 070	1	80	3.150	1	16	.039	.630	42	1.654	32	1.260	70	2.756	1.6	⊕	
	1	C8-391.14-32 070	1	80	3.150	2	20	.079	.787	50	1.968	35	1.378	70	2.756	1.8	⊕	
	1	C8-391.14-40 070	1	80	3.150	3	26	.118	1.024	63	2.480	38	1.496	70	2.756	2.0	⊕	
	1	C8-391.14-50 080	1	80	3.150	6	34	.236	1.339	78	3.071	50	1.968	80	3.150	2.3	⊕	

1) 1 = coolant through center

Long version

Coupling size	Ordering code	Coolant ¹⁾	Dimensions, millimeter, inch (mm, in.)														Balanced by design
			D _{5m} mm	D _{5m} in.	dm _t min mm	dm _t max mm	dm _t min in.	dm _t max in.	D ₂₁ mm	D ₂₁ in.	l ₃ mm	l ₃ in.	l ₂₁ mm	l ₂₁ in.	⊖ _{KG}		
C5	C5-391.14-20 100	1	50	1.969	1	13	.039	.512	35	1.378	55	2.165	100	3.937	1.0	⊕	
	C5-391.14-20 130	1	50	1.969	1	13	.039	.512	35	1.378	55	2.165	130	5.118	1.3	⊕	
	C5-391.14-25 100	1	50	1.969	1	16	.039	.630	42	1.654	65	2.559	100	3.937	1.1	⊕	
	C5-391.14-32 100	1	50	1.969	1	16	.039	.630	50	1.968	100	3.937	100	3.937	1.3	⊕	
C6	C6-391.14-25 130	1	63	2.480	1	16	.039	.630	42	1.654	65	2.559	130	5.118	1.9	⊕	
	C6-391.14-25 160	1	63	2.480	1	16	.039	.630	42	1.654	65	2.559	160	6.299	2.5	⊕	
	C6-391.14-32 130	1	63	2.480	2	20	.079	.787	50	1.968	75	2.953	130	5.118	2.2	⊕	
	C6-391.14-40 130	1	63	2.480	3	26	.118	1.024	63	2.480	130	5.118	130	5.118	2.8	⊕	
C8	C8-391.14-32 160	1	80	3.150	2	20	.079	.787	50	1.968	75	2.953	160	6.299	4.1	⊕	
	C8-391.14-40 160	1	80	3.150	3	26	.118	1.024	63	2.480	95	3.740	160	6.299	4.6	⊕	



Coromant Capto® shrink fit adapter

For cylindrical shank

391.19

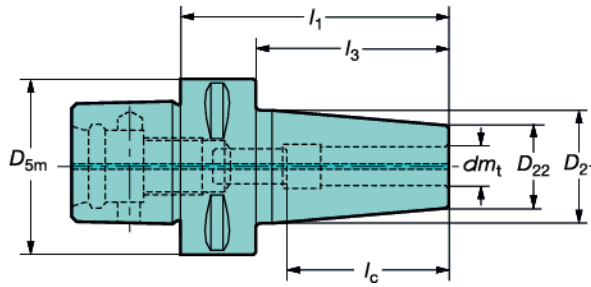
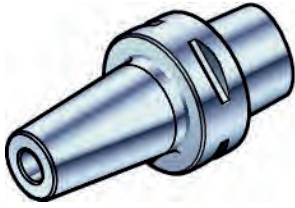

Coupling size	Ordering code	Coolant ¹⁾	Dimensions, millimeter, inch (mm, in.)																		Balanced by design
			D _{5m} mm	D _{5m} in.	d _m mm	d _m in.	D ₂₁ mm	D ₂₁ in.	D ₂₂ mm	D ₂₂ in.	l _c min mm	l _c max mm	l _c min in.	l _c max in.	h mm	h in.	h mm	h in.	α _{ISO}		
C4	C4-391.19-06	1	40	1.575	6	.236	27.0	1.063	20	.787	26	36	1.024	1.417	75	2.953	55	2.165	0.4	⊙	
	C4-391.19-08	1	40	1.575	8	.315	27.0	1.063	20	.787	26	36	1.024	1.417	75	2.953	55	2.165	0.5	⊙	
	C4-391.19-10	1	40	1.575	10	.394	32.0	1.260	24	.945	31	41	1.220	1.614	75	2.953	55	2.165	0.5	⊙	
	C4-391.19-12	1	40	1.575	12	.472	32.0	1.260	24	.945	36	46	1.417	1.811	75	2.953	55	2.165	0.5	⊙	
	C4-391.19-14	1	40	1.575	14	.551	34.0	1.339	27	1.063	36	46	1.417	1.811	80	3.150	60	2.362	0.6	⊙	
	C4-391.19-16	1	40	1.575	16	.630	34.0	1.339	27	1.063	39	49	1.535	1.929	80	3.150	60	2.362	0.6	⊙	
	C4-391.19-18	1	40	1.575	18	.709	42.0	1.654	33	1.299	39	49	1.535	1.929	80	3.150	60	2.362	0.7	⊙	
C4-391.19-20	1	40	1.575	20	.787	42.0	1.654	33	1.299	41	51	1.614	2.008	85	3.346	65	2.559	0.7	⊙		
C5	C5-391.19-06	1	50	1.968	6	.236	27.0	1.063	20	.787	26	36	1.024	1.417	75	2.953	55	2.165	0.6	⊙	
	C5-391.19-08	1	50	1.968	8	.315	27.0	1.063	20	.787	26	36	1.024	1.417	75	2.953	55	2.165	0.6	⊙	
	C5-391.19-10	1	50	1.968	10	.394	32.0	1.260	24	.945	31	41	1.220	1.614	75	2.953	55	2.165	0.7	⊙	
	C5-391.19-12	1	50	1.968	12	.472	32.0	1.260	24	.945	36	46	1.417	1.811	75	2.953	55	2.165	0.7	⊙	
	C5-391.19-14	1	50	1.968	14	.551	34.0	1.339	27	1.063	36	46	1.417	1.811	80	3.150	60	2.362	0.8	⊙	
	C5-391.19-16	1	50	1.968	16	.630	34.0	1.339	27	1.063	39	49	1.535	1.929	80	3.150	60	2.362	0.7	⊙	
	C5-391.19-18	1	50	1.968	18	.709	42.0	1.654	33	1.299	39	49	1.535	1.929	80	3.150	60	2.362	0.9	⊙	
C5-391.19-20	1	50	1.968	20	.787	42.0	1.654	33	1.299	41	51	1.614	2.008	85	3.346	65	2.559	0.9	⊙		
C5-391.19-25	1	50	1.968	25	.984	53.0	2.087	44	1.732	47	57	1.850	2.244	90	3.543	68	2.677	1.3	⊙		
C6	C6-391.19-06	1	63	2.480	6	.236	27.0	1.063	20	.787	26	36	1.024	1.417	80	3.150	58	2.284	1.0	⊙	
	C6-391.19-08	1	63	2.480	8	.315	27.0	1.063	20	.787	26	36	1.024	1.417	80	3.150	58	2.284	1.0	⊙	
	C6-391.19-10	1	63	2.480	10	.394	32.0	1.260	24	.945	31	41	1.220	1.614	80	3.150	58	2.284	1.0	⊙	
	C6-391.19-12	1	63	2.480	12	.472	32.0	1.260	24	.945	36	46	1.417	1.811	80	3.150	58	2.284	1.0	⊙	
	C6-391.19-14	1	63	2.480	14	.551	34.0	1.339	27	1.063	36	46	1.417	1.811	85	3.346	63	2.480	1.1	⊙	
	C6-391.19-16	1	63	2.480	16	.630	34.0	1.339	27	1.063	39	49	1.535	1.929	85	3.346	63	2.480	1.1	⊙	
	C6-391.19-18	1	63	2.480	18	.709	42.0	1.654	33	1.299	39	49	1.535	1.929	85	3.346	63	2.480	1.3	⊙	
C6-391.19-20	1	63	2.480	20	.787	42.0	1.654	33	1.299	41	51	1.614	2.008	85	3.346	63	2.480	1.2	⊙		
C6-391.19-25	1	63	2.480	25	.984	53.0	2.087	44	1.732	47	57	1.850	2.244	90	3.543	68	2.677	1.6	⊙		
C6-391.19-32	1	63	2.480	32	1.260	53.0	2.087	44	1.732	51	61	2.008	2.402	95	3.740	73	2.874	1.5	⊙		

¹⁾ 1 = coolant through center

The cylindrical tool shank should be kept free from dirt and burrs before mounting into the adapter to maintain a safe grip and precision. It should be mounted without use of any collets.

Note! Tolerance on tool shank diameter must be h6, or closer.

Inch sizes quoted upon request.

Heating equipment

Coromant Capto shrink fit adapters depend on applying heat to expand the adapter. When cooled, the adapter contracts to grip around the tool shank. For guaranteed function, optimal tool performance and for safe and easy handling of the clamping process, it is required that Bilz ThermoGrip® ISG induction heating equipment be used and that the instructions from Bilz are followed. Further information is available on www.bilzusa.com.

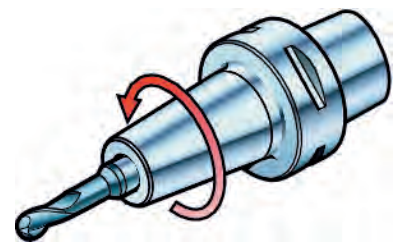

The balance class is G6.3 at 15,000 rpm.

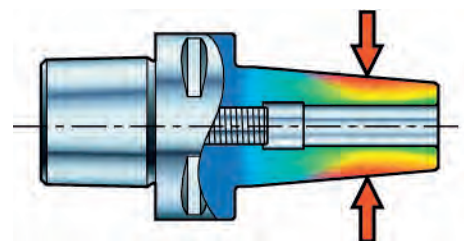

G138



G6



G2

Weldon shank adapter

For shanks according to DIN 6535-HB

391.20

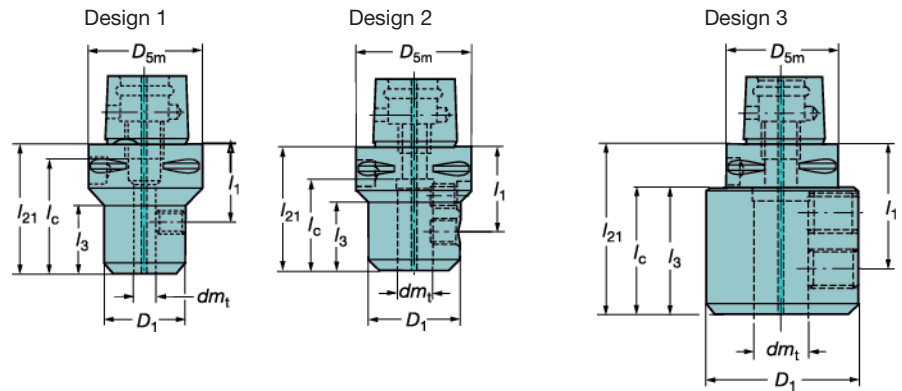
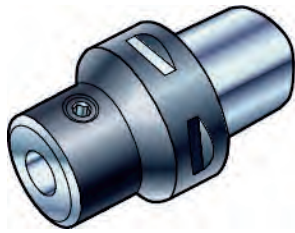

l₁ = programming length

Metric bore

Coupling size	Ordering code	Design	Coolant ¹⁾	Dimensions									Balanced by design
				D _{5m}	dm ₁	D ₁	l ₁	l ₃	l ₂₁	l _c	R _{KG}		
C3	C3-391.20-06 045A	1	1	32	8	25	28	27.5	46	37	0.3	⊕	
	C3-391.20-08 045A	1	1	32	8	28	28	29	46	37	0.3	⊕	
	C3-391.20-10 050	1	1	32	10	35	30	35	50	41	0.4	⊕	
	C3-391.20-12 055	1	1	32	12	42	32.5	40	55	48	0.3	⊕	
C4	C4-391.20-06 050	1	1	40	6	25	32	25.5	50	40	0.4	⊕	
	C4-391.20-08 050	1	1	40	8	28	32	26.5	50	40	0.4	⊕	
	C4-391.20-10 050A	1	1	40	10	35	30	29.6	51	41	0.5	⊕	
	C4-391.20-12 055A	1	1	40	12	42	33.5	36	56	46	0.6	⊕	
	C4-391.20-14 055	1	1	40	14	44	35	32.5	55	48	0.6	⊕	
	C4-391.20-16 055	1	1	40	16	48	31	35	55	50	0.7	⊕	
	C4-391.20-20 060	1	1	40	20	52	35	40	60	54	1.0	⊕	
C5	C5-391.20-06 050	1	1	50	6	25	32	25.5	50	39	0.6	⊕	
	C5-391.20-08 050	1	1	50	8	28	32	26	50	39	0.7	⊕	
	C5-391.20-10 055	1	1	50	10	35	35	27.5	55	44	0.7	⊕	
	C5-391.20-12 060	1	1	50	12	42	37.5	36	60	49	0.9	⊕	
	C5-391.20-14 060	1	1	50	14	44	37.5	37	60	49	0.8	⊕	
	C5-391.20-16 060	1	1	50	16	48	36	39	60	53	1.0	⊕	
	C5-391.20-18 060	1	1	50	18	50	36		60	53	1.0	⊕	
	C5-391.20-20 060	1	1	50	20	52	35	40	60	54	1.0	⊕	
	C5-391.20-25 080	3	1	50	25	65	56	60	80	60	1.8	⊕	
	C5-391.20-32 090	3	1	50	32	72	66	68	90	64	2.4	⊕	
C6	C6-391.20-06 055	1	1	63	6	25	37	25	55	41	0.9	⊕	
	C6-391.20-08 055	1	1	63	8	28	37	26	55	41	0.9	⊕	
	C6-391.20-10 060	1	1	63	10	35	40	30	60	46	1.0	⊕	
	C6-391.20-12 060	1	1	63	12	42	37.5	33	60	46	1.1	⊕	
	C6-391.20-14 060	1	1	63	14	44	37.5	33.5	60	46	1.1	⊕	
	C6-391.20-16 065	1	1	63	16	48	41	35.5	65	51	1.2	⊕	
	C6-391.20-18 065	1	1	63	18	50	41	39	65	51	1.2	⊕	
	C6-391.20-20 065	1	1	63	20	52	40	37.5	65	54	1.5	⊕	
	C6-391.20-25 080	1	1	63	25	65	56	58	80	60	1.9	⊕	
	C6-391.20-32 090	3	1	63	32	72	66	68	90	64	2.4	⊕	
C8	C8-391.20-06 070	1	1	80	6	25	52	27	70	59	2.1	⊕	
	C8-391.20-08 070	1	1	80	8	28	52	28	70	59	2.1	⊕	
	C8-391.20-10 070	1	1	80	10	35	50	29.5	70	59	2.2	⊕	
	C8-391.20-12 070	1	1	80	12	42	47.5	31	70	59	2.2	⊕	
	C8-391.20-14 070	1	1	80	14	44	47.5	31.6	70	59	2.3	⊕	
	C8-391.20-16 070	1	1	80	16	48	46	32.5	70	59	2.3	⊕	
	C8-391.20-18 070	1	1	80	18	50	46	33	70	59	2.3	⊕	
	C8-391.20-20 070	1	1	80	20	52	45	35	70	54	2.4	⊕	
	C8-391.20-25 080	2	1	80	25	65	56	53.7	80	60	2.3	⊕	
	C8-391.20-32 080	2	1	80	32	72	56	53.7	80	64	2.9	⊕	
C8-391.20-40 110	3	1	80	40	90	80	79	110	74	4.5	⊕		
C8-391.20-50 120	3	1	80	50	100	85	89	120	84	5.5	⊕		

1) 1 = coolant through center



D
E
F
G
J

TOOLING SYSTEMS Coromant Capto® – Adapters for rotating tools

Weldon shank adapter

A391.20

l_1 = programming length

Inch bore

Coupling size	Ordering code	Design	Coolant ¹⁾	Dimensions, inch								Balanced by design
				dm_t	D_{5m}	D_1	l_1	l_2	l_{21}	l_c	$\frac{m}{n}$	
C3	C3-A391.20-09 050	1	1	.375	1.260	.984	1.181	1.248	1.969	1.575	0.9	⊙
	C3-A391.20-12 055	1	1	.500	1.260	1.260	1.280	1.563	2.165	1.772	2.0	⊙
C4	C4-A391.20-09 050A	1	1	.375	1.575	1.000	1.220	1.1142	2.008	1.575	1.3	⊙
	C4-A391.20-12 055A	1	1	.500	1.575	1.250	1.319	1.252	2.205	1.772	1.3	⊙
	C4-A391.20-15 055	1	1	.625	1.575	1.625	1.213	1.378	2.165	1.890	3.3	⊙
	C4-A391.20-19 060	1	1	.750	1.575	1.752	1.378	1.575	2.362	2.008	4.0	⊙
C5	C5-A391.20-09 055	1	1	.375	1.968	1.000	1.378	1.102	2.165	1.575	3.3	⊙
	C5-A391.20-12 060	1	1	.500	1.968	1.250	1.476	1.406	2.362	1.772	4.4	⊙
	C5-A391.20-15 060A	1	1	.625	1.968	1.625	1.409	1.472	2.362	1.890	4.9	⊙
	C5-A391.20-19 060	1	1	.750	1.968	1.752	1.378	1.512	2.362	2.008	4.9	⊙
	C5-A391.20-22 075	3	1	.875	1.968	1.969	1.953	2.166	2.953	2.244	5.3	⊙
	C5-A391.20-25 085	3	1	1.000	1.968	2.248	2.402	2.559	3.346	2.362	8.8	⊙
C6	C5-A391.20-31 085	3	1	1.250	1.968	2.480	2.402	2.559	3.347	2.520	8.8	⊙
	C6-A391.20-09 060	1	1	.375	2.480	1.000	1.575	1.142	2.362	1.575	4.9	⊙
	C6-A391.20-12 060	1	1	.500	2.480	1.250	1.484	1.260	2.362	1.772	5.3	⊙
	C6-A391.20-15 065	1	1	.625	2.480	1.625	1.595	1.441	2.560	1.890	5.7	⊙
	C6-A391.20-19 065A	1	1	.750	2.480	1.752	1.575	1.484	2.560	2.008	6.4	⊙
	C6-A391.20-22 080	3	1	.875	2.480	1.969	2.150	2.205	2.560	2.244	6.8	⊙
	C6-A391.20-25 085	3	1	1.000	2.480	2.248	2.402	2.402	3.347	2.262	8.4	⊙
C8	C6-A391.20-31 085	3	1	1.250	2.480	2.480	2.402	3.347	3.347	2.520	8.8	⊙
	C6-A391.20-38 090	3	1	1.500	2.480	2.756	2.362	2.677	3.543	2.717	9.7	⊙
	C8-A391.20-09 070	1	1	.375	3.150	1.000	1.968	1.0827	2.756	1.428	4.4	⊙
	C8-A391.20-12 070	1	1	.500	3.150	1.248	1.870	1.2205	2.756	1.628	4.4	⊙
	C8-A391.20-15 070	1	1	.625	3.150	1.614	1.803	1.3386	2.756	1.823	4.6	⊙
	C8-A391.20-19 075	1	1	.750	3.150	1.752	1.968	1.437	2.953	1.890	4.9	⊙
	C8-A391.20-22 080	2	1	.875	3.150	1.968	2.150	1.6339	3.150	2.008	5.2	⊙
	C8-A391.20-25 080	2	1	1.000	3.150	2.248	2.205	2.0236	3.150	2.126	5.2	⊙
	C8-A391.20-31 080	2	1	1.250	3.150	2.480	2.205	2.0906	3.150	2.284	5.3	⊙
	C8-A391.20-38 085	2	1	1.500	3.150	2.756	2.165	2.3661	3.346	2.559	5.8	⊙
	C8-A391.20-50 115	3	1	2.000	3.150	3.681	3.402	3.3071	4.528	3.071	10.6	⊙

¹⁾ 1 = coolant through center

G 38

General Information

Whistle Notch shank adapter

For shanks according to DIN 6535-HE

391.21

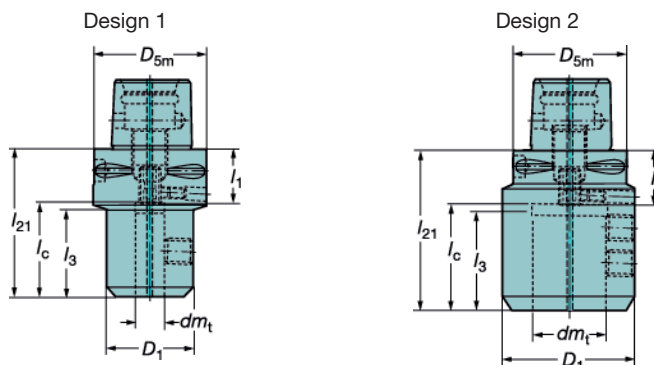
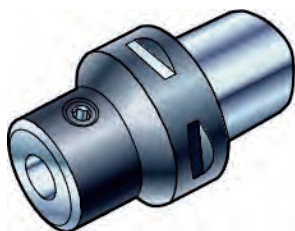

l_1 = programming length

Metric bore

Coupling size	Ordering code	Design	Coolant ¹⁾	Dimensions										Balanced by design
				dm_t	D_{5m}	D_1	l_1 min	max	l_{21}	l_3	l_c	$\frac{kg}{cm^3}$		
C3	C3-391.21-06 070A	1	1	6	32	25	32	40	70	53	30	0.3	⊙	
	C3-391.21-08 070A	1	1	8	32	28	32	40	70	53	30	0.4	⊙	
	C3-391.21-10 070	1	1	10	32	35	28	38	70	55	32	0.5	⊙	
	C3-391.21-12 075	1	1	12	32	42	28	40	75	60	35	0.7	⊙	
C4	C4-391.21-06 070A	1	1	6	40	25	32	40	70	37	30	0.5	⊙	
	C4-391.21-08 070A	1	1	8	40	28	32	40	70	37	30	0.5	⊙	
	C4-391.21-10 070	1	1	10	40	35	28	38	70	39	32	0.6	⊙	
	C4-391.21-12 075	1	1	12	40	42	28	40	75	45	35	0.8	⊙	
	C4-391.21-14 075	1	1	14	40	44	28	40	75	45	35	0.8	⊙	
C5	C5-391.21-06 070A	1	1	6	50	25	32	40	70	37	30	0.7	⊙	
	C5-391.21-08 070A	1	1	8	50	28	32	40	70	37	30	0.8	⊙	
	C5-391.21-10 070	1	1	10	50	35	28	38	70	38	32	0.9	⊙	
	C5-391.21-12 075	1	1	12	50	42	28	40	75	43	35	1.1	⊙	
	C5-391.21-14 075	1	1	14	50	44	28	40	75	44	35	1.1	⊙	
	C5-391.21-16 080	1	1	16	50	48	30	42	80	48	38	1.2	⊙	
	C5-391.21-18 080	1	1	18	50	50	30	42	80		38	1.3	⊙	
C5-391.21-20 085	1	1	20	50	52	33	45	85	65	40	1.4	⊙		
C6	C6-391.21-06 075A	1	1	6	63	25	37	45	75	35	30	1.3		
	C6-391.21-08 075A	1	1	8	63	28	37	45	75	35	30	1.3		
	C6-391.21-10 075	1	1	10	63	35	33	43	75	36	32	1.4		
	C6-391.21-12 080	1	1	12	63	42	33	45	80	42	35	1.5		
	C6-391.21-14 080	1	1	14	63	44	33	45	80	42	35	1.6		
	C6-391.21-16 080	1	1	16	63	48	30	42	80	47	38	1.6		
	C6-391.21-18 080	1	1	18	63	50	30	42	80	47	38	1.6		
	C6-391.21-20 085	1	1	20	63	52	33	45	85	51	40	1.7		
	C6-391.21-25 090	2	1	25	63	65	32	44	90	60	46	2.3		
	C6-391.21-32 095	2	1	32	63	72	33	45	95	73	50	2.5		
C8	C8-391.21-06 065A	1	1	6	80	25	27	35	65	25	30	2.1		
	C8-391.21-08 065A	1	1	8	80	28	27	35	65	25.5	30	2.2		
	C8-391.21-10 065	1	1	10	80	35	23	33	65	27	32	2.2		
	C8-391.21-12 070	1	1	12	80	42	23	35	70	33	35	2.4		
	C8-391.21-14 070	1	1	14	80	44	23	35	70	33.5	35	2.5		
	C8-391.21-16 075	1	1	16	80	48	25	37	75	39	38	2.6		
	C8-391.21-18 075	1	1	18	80	50	25	37	75	39.5	38	2.6		
	C8-391.21-20 080	1	1	20	80	52	28	40	80	45	40	2.7		
	C8-391.21-25 090	2	1	25	80	65	32	44	90	57	46	3.1		
C8-391.21-32 095	2	1	32	80	72	33	45	95	63	50	3.4			

¹⁾ 1 = coolant through center

Note! Tighten the screw with a torque wrench. Information on page G111.



G139



G6



G2

Adapter for drills

Shank according to ISO 9766

391.27

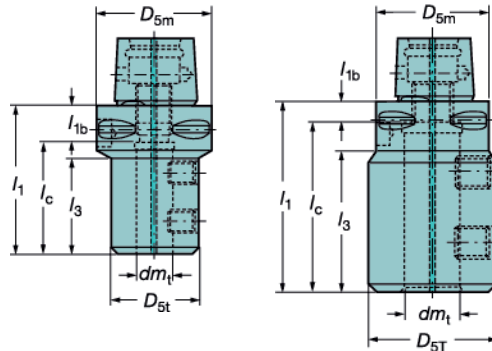
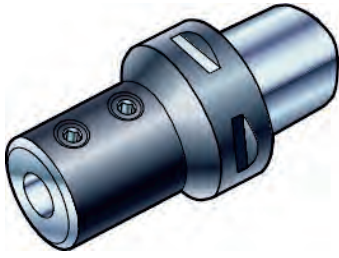

l_1, l_{1b} = programming length

Metric bore

Coupling size	Ordering code	Coolant ¹⁾	Dimensions							
			dm_1	D_{5m}	D_{5t}	$l_1^{(2)}$	$l_{1b}^{(3)}$	l_3	l_c	$\frac{\text{kg}}{\text{kg}}$
C3	C3-391.27-16 056	1	16	32	36	56	6.5	41	49.5	0.4
	C3-391.27-20 060	1	20	32	40	60	8.5	45	51.5	0.4
C4	C4-391.27-16 056	1	16	40	36	56	6.5	32.5	49.5	0.6
	C4-391.27-20 060	1	20	40	40	60	8.5	60	51.5	0.6
	C4-391.27-25 077	1	25	40	45	77	19.5	57	57.5	0.7
C5	C5-391.27-16 065	1	16	50	36	65	15.5	41.7	49.5	0.7
	C5-391.27-20 060	1	20	50	40	60	8.5	37.7	51.5	0.7
	C5-391.27-25 071	1	25	50	45	71	8.5	46.7	62.5	0.8
	C5-391.27-32 075	1	32	50	52	75	13.5	55	61.5	1
C6	C6-391.27-16 070	1	16	63	36	70	20.5	43	49.5	1.2
	C6-391.27-20 070	1	20	63	40	70	18.5	43.8	51.5	1.1
	C6-391.27-25 070A	1	25	63	45	72	12.5	45.8	59.5	1.2
	C6-391.27-32 075	1	32	63	52	75	13.5	49.8	61.5	1.3
	C6-391.27-40 085	1	40	63	65	85	13.5	63	71.5	1.6
	C6-391.27-50 115	1	50	63	75	115	33.5	93	81.5	2.6
C8	C8-391.27-16 080	1	16	80	36	80	30.5	42	49.5	2.1
	C8-391.27-20 080	1	20	80	40	80	28.5	43.8	51.5	2.2
	C8-391.27-25 085	1	25	80	45	85	27.5	49.8	57.5	2.4
	C8-391.27-32 090	1	32	80	52	90	28.5	53.8	61.5	2.6
	C8-391.27-40 095	1	40	80	65	95	23.5	62.8	71.5	2.8
	C8-391.27-50 100	1	50	80	75	100	18.5	68.6	81.5	3.1

¹⁾ 1 = coolant through center

²⁾ Programming length for Coromant U drills and CoroDrill® 880.

³⁾ Programming length for Coromant Delta drills.



G140



G6



G2

Adapter for drills

For Coromant Whistle Notch shank

391.25

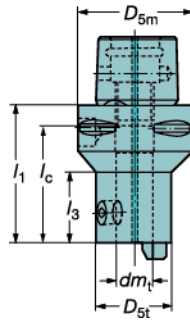
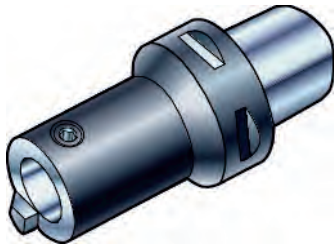

l_1 = programming length

Metric bore

Coupling size	Ordering code	Coolant ¹⁾	Dimensions						
			dm_1	D_{5m}	D_{st}	l_1	l_3	l_c	$\frac{kg}{kg}$
C4	C4-391.25-16 060	1	16	40	32	60	36	51	0.5
	C4-391.25-20 060	1	20	40	32	60	36	51	0.4
	C4-391.25-25 075	1	25	40	40	75	56	56	0.5
C5	C5-391.25-16 060	1	16	50	32	60	31	51	0.7
	C5-391.25-20 060	1	20	50	32	60	31	51	0.6
	C5-391.25-25 065	1	25	50	40	65	42	56	0.7
	C5-391.25-32 070	1	32	50	50	70	60	60	0.7
C6	C6-391.25-16 060	1	16	63	32	60	29	60	0.8
	C6-391.25-20 060	1	20	63	32	60	29	51	0.7
	C6-391.25-25 065	1	25	63	40	65	36	56	1.1
	C6-391.25-32 070	1	32	63	50	70	41.5	60	1.2
	C6-391.25-40 085	1	40	63	60	85	61.5	70	1.4

¹⁾ 1 = coolant through center



Coromant Capto® adapter for Varilock tools

391.01

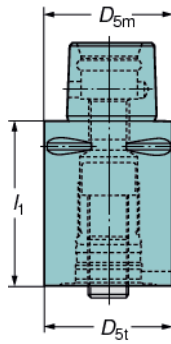
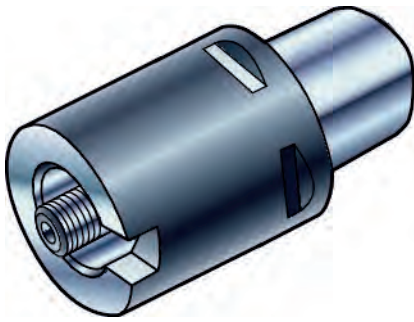
 l_1 = programming length

Coupling size			Coolant ¹⁾	Dimensions, millimeter, inch (mm, in.)						
Coromant Capto®	Varilock	Ordering code		D_{5m} mm	D_{5m} in.	D_{St} mm	D_{St} in.	l_1 mm	l_1 in.	 kg
C5	50	C5-391.01-V50 060	1	50	1.968	50	1.968	60	2.362	1
C6	63	C6-391.01-V63 080	1	63	2.480	63	2.480	80	3.150	1.9
C8	80	C8-391.01-V80 065	1	80	3.150	80	3.150	65	2.559	3.2

1) 0 = no coolant, 1 = coolant through center



G129



G6



G2

Drill chuck

391.31

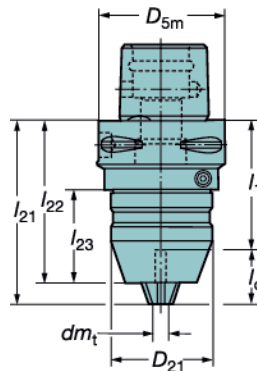
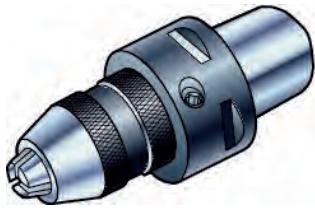
 l_1 = programming length

Metric bore

Coupling size	Ordering code	Coolant ¹⁾	Dimensions										
			D_{5m}	dm_T min	dm_T max	D_{21}	l_1 min	l_1 max	l_{21} max	l_{22}	l_{23}	l_C	R_{KS}
C3	C3-391.31-10 083M	0	32	1	10	44.0	43	56	83	72.0	42.0	27	0.4
	C3-391.31-13 100	0	32	1	13	49.5	56	73	100	89.5	46.5	27	0.7
C4	C4-391.31-10 087M	0	40	1	10	44.0	47	60	87	76.0	42.0	27	0.9
	C4-391.31-13 100	0	40	1	13	49.5	56	73	100	89.5	46.5	27	1.1
C5	C5-391.31-10 085M	0	50	1	10	44.0	45	58	85	74.0	42.0	27	1
	C5-391.31-13 090	0	50	1	13	49.5	46	63	90	79.5	46.5	27	1.3
C6	C6-391.31-13 092	0	63	1	13	49.5	48	65	92	81.5	46.5	27	1.8

¹⁾ 0 = no coolant

Blank adapter

391.50

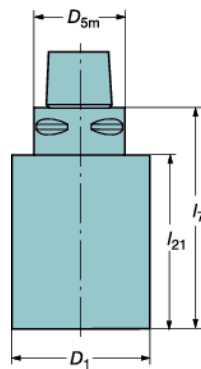
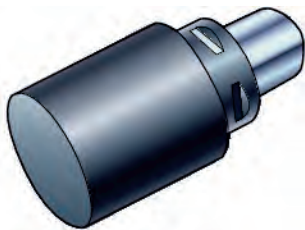

Coromant Capto® coupling blanks have a “soft” front, which allows machining of special shapes.

The blanks for making rotating units have a center hole.

The material is 25 CR MoS 4, low alloy steel.
Tensile strength 700 N/mm². HB 270 – 352.

Equilibrium temperature: 1544-1598°F
Cooling medium: Polymer
Tempering: 1 hour 392°F

If localized hardening is required, induction type hardening is to be used. Max. hardness which can be attained with this material ≈ 50 HRC.

Coupling size	Ordering code	Coolant ¹⁾	Dimensions, millimeter, inch (mm, in.)									
			D_{5m} mm	D_{5m} in.	D_1 mm	D_1 in.	l_7 mm	l_7 in.	l_{21} mm	l_{21} in.	R_{KS}	
C3	C3-391.50-32 090-B	0	32	1.260	32	1.260	90	3.543			0.6	
	C3-391.50-60 090-B	0	32	1.260	60	2.362	90	3.543	73.8	2.906	1.7	
C4	C4-391.50-40 120-B	0	40	1.575	40	1.575	120	4.724			1.3	
	C4-391.50-80 120-B	0	40	1.575	80	3.150	120	4.724	100	3.937	4.2	
C5	C5-391.50-50 150-B	0	50	1.968	50	1.968	150	5.906			2.5	
	C5-391.50-95 150-B	0	50	1.968	95	3.740	150	5.906	130	5.118	7.7	
C6	C6-391.50-63 180-B	0	63	2.480	63	2.480	180	7.087			4.6	
	C6-391.50-120 180-B	0	63	2.480	120	4.724	180	7.087	158	6.220	15.0	
C8	C8-391.50-80 200-B	0	80	3.150	80	3.150	200	7.874			8.5	
	C8-391.50-145 200-B	0	80	3.150	145	5.709	200	7.874	169	6.654	24.5	
C10	C10-391.50-100 200-B	0	100	3.937	100	3.937	200	7.874			13.5	
	C10-391.50-145 200-B	0	100	3.937	145	5.709	200	7.874	163	6.417	24.5	

¹⁾ 0 = no coolant

G140



G6



G2

Tapping adapter

391.60/391.61

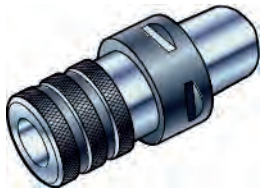

Without coolant through

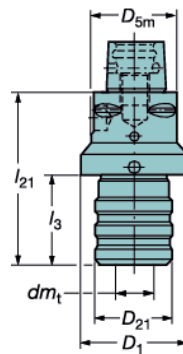

Cx-391.60

With coolant through

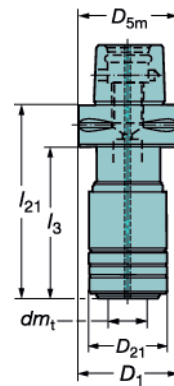

Cx-391.61

Tap range						Dimensions, mm, inch										
min	max	dm_t	Coupling size	Ordering code	Coolant ²⁾	D_{5m}	D_1	D_{21}	l_1	l_3	l_{21}	- z	+ z	$\frac{\Omega}{rpm}$	Nm ³⁾	
M3	M12	19	C3	C3-391.60-01 080A	0	32	50	36	80	40.5	80	7.5	7.5	0.4	35	
M3	M12	.748			0	1.260	1.968	1.417	3.150	1.594	3.150	7.5	7.5	0.4	35	
M3	M12	19	C4	C4-391.60-01 080A	0	40	50	36	80	40.5	80	7.5	7.5	0.7	35	
M3	M12	.748			0	1.575	1.968	1.417	3.150	1.594	3.150	7.5	7.5	0.7	35	
M8	M20	31		C4-391.60-02 110A	0	40	63	53	110	64.5	110	12.5	12.5	1.4	110	
M8	M20	1.220			0	1.575	2.480	2.087	4.331	2.539	4.331	12.5	12.5	1.4	110	
M3	M12	19		C4-391.61-01 096 ¹⁾	1	40	40	39	96	75	96	7.5	7.5	1.1	35	
M3	M12	.748			1	1.575	1.575	1.535	3.780	2.953	3.780	7.5	7.5	1.1	35	
M3	M12	19	C5	C5-391.60-01 080A	0	50	50	36	80	40.5	80	7.5	7.5	1.0	35	
M3	M12	.748			0	1.968	1.968	1.417	3.150	1.594	3.150	7.5	7.5	1.0	35	
M8	M20	31		C5-391.60-02 115A	0	50	63	53	115	64.5	115	12.5	12.5	1.7	110	
M8	M20	1.220			0	1.968	2.480	2.087	4.528	2.539	4.528	12.5	12.5	1.7	110	
M3	M12	19		C5-391.61-01 097 ¹⁾	1	50	50	39	97	76	97	7.5	7.5	1.1	35	
M3	M12	.748			1	1.968	1.968	1.535	3.819	2.992	3.819	7.5	7.5	1.1	35	
M8	M20	31		C5-391.61-02 129 ¹⁾	1	50		60	129		129	10	10	2.1	110	
M8	M20	1.220			1	1.968		2.362	5.079		5.079	10	10	2.1	110	
M3	M12	19	C6	C6-391.60-01 090A	0	63	50	36	90	40.5	90	7.5	7.5	1.4	35	
M3	M12	.748			0	2.480	1.968	1.417	3.543	1.594	3.543	7.5	7.5	1.4	35	
M8	M20	31		C6-391.60-02 120A	0	63	63	53	120	64.5	120	12.5	12.5	2.3	110	
M8	M20	1.220			0	2.480	2.480	2.087	4.724	2.539	4.724	12.5	12.5	2.3	110	
M14	M33	48		C6-391.60-03 170A	0	63		78	170		170	20	20	3.5	500	
M14	M33	1.890			0	2.480		3.071	6.693		6.693	20	20	3.5	500	
M8	M20	31		C6-391.61-02 131 ¹⁾	1	63	63	60	131	108	131	10	10	2.4	110	
M8	M20	1.220			1	2.480	2.480	2.362	5.158	4.252	5.158	10	10	2.4	110	
M14	M33	48		C6-391.61-03 196 ¹⁾	1	63		86	196		196	17.5	17.5	4.5	500	
M14	M33	1.890			1	2.480		3.386	7.716		7.716	17.5	17.5	4.5	500	
M3	M12	19	C8	C8-391.60-01 085A	0	80	80	36	85	40.5	85	7.5	7.5	2.3	35	
M3	M12	.748			0	3.150	3.150	1.417	3.346	1.594	3.346	7.5	7.5	2.3	35	
M8	M20	31		C8-391.60-02 110A	0	80	63	53	110	64.5	110	12.5	12.5	3.2	110	
M8	M20	1.220			0	3.150	2.480	2.087	4.331	2.539	4.331	12.5	12.5	3.2	110	
M14	M33	48		C8-391.60-03 160A	0	80	80	78	160	129	160	20	20	3.7	500	
M14	M33	1.890			0	3.150	3.150	3.071	6.299	5.079	6.299	20	20	3.7	500	

1) Max. cutting fluid pressure 50 bar.

2) 0 = no coolant, 1 = coolant through center

3) Max torque

Recommendations:

In order to get the best result from machines not equipped for synchronized tapping, the following recommendations should be observed.

Program machine feed 10% lower than theoretical value (thread pitch rpm).

This enables the tap to cut precisely on pitch.

- Reduce tapping depth by 10% to avoid tap breakage.

Note that when tapping deep holes in soft materials, e.g. aluminum, feed and depth should only be reduced by 3-5%.



G141



G6



G2

Tapping adapter

with friction clutch and for external / internal coolant supply

393.03-SES



External coolant supply

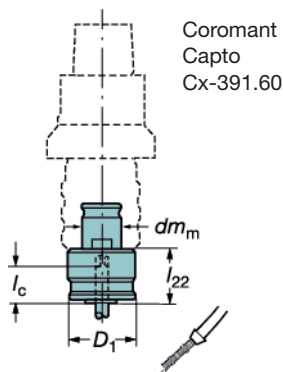

Internal coolant supply

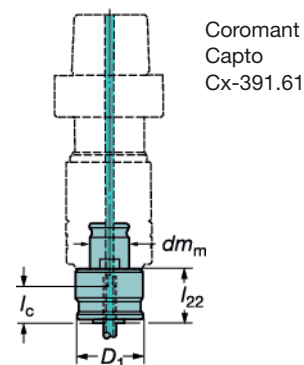

Preset for ¹⁾	Tap shank, mm	Øx□ <i>dm_m</i>	Ordering code	Dimensions			
				<i>D₁</i>	<i>l_c</i>	<i>l₂₂</i>	
M3	3.50 x 2.7	19	393.03-SES1 D035X027	32.5	17	25	0.2
M3.5	4.00 x 3.0	19	393.03-SES1 D040X030	32.5	17	25	0.2
M4	3.15 x 2.5	19	393.03-SES1 D031X025	32.5	17	25	0.2
M4	4.50 x 3.4	19	393.03-SES1 D045X034	32.5	17	25	0.2
M5	4.00 x 3.1	19	393.03-SES1 D040X031	32.5	17	25	0.2
M5	5.00 x 4.0	19	393.03-SES1 D050X040	32.5	17	25	0.2
M6	4.50 x 3.5	19	393.03-SES1 D045X035	32.5	17	25	0.2
M8	6.00 x 4.9	19	393.03-SES1 D060X049	32.5	17	25	0.2
M8	6.00 x 4.9	31	393.03-SES2 D060X049	50.5	30	34	0.6
M8	6.30 x 5.0	19	393.03-SES1 D063X050	32.5	17	25	0.2
M8	8.00 x 6.2	19	393.03-SES1 D080X062	32.5	17	25	0.2
M8	8.00 x 6.2	31	393.03-SES2 D080X062	50.5	30	34	0.6
M8	8.00 x 6.3	19	393.03-SES1 D080X063	32.5	17	25	0.2
M8	8.00 x 6.3	31	393.03-SES2 D080X063	50.5	30	34	0.6
M10	7.00 x 5.5	19	393.03-SES1 D070X055	32.5	17	25	0.2
M10	7.00 x 5.5	31	393.03-SES2 D070X055	50.5	30	34	0.6
M10	10.00 x 8.	19	393.03-SES1 D100X080	32.5	17	25	0.2
M10	10.00 x 8.	31	393.03-SES2 D100X080	50.5	30	34	0.6
M12	9.00 x 7.0	19	393.03-SES1 D090X070	32.5	17	25	0.2
M12	9.00 x 7.0	31	393.03-SES2 D090X070	50.5	30	34	0.6
M12	9.00 x 7.1	19	393.03-SES1 D090X071	32.5	17	25	0.2
M12	9.00 x 7.1	31	393.03-SES2 D090X071	50.5	30	34	0.6
M14	11.00 x 9.	31	393.03-SES2 D110X090	50.5	30	34	0.6
M14	11.20 x 9.	31	393.03-SES2 D112X090	50.5	30	34	0.6
M14	11.00 x 9.	48	393.03-SES3 D110X090	72	44	45	1.7
M16	11.20 x 9.	48	393.03-SES3 D112X090	72	44	45	1.7
M16	12.00 x 9.	48	393.03-SES3 D120X090	72	44	45	1.7
M16	12.50 x 10	31	393.03-SES2 D125X100	50.5	30	34	0.6
M18	14.00 x 11	31	393.03-SES2 D140X110	50.5	30	34	0.6
M18	14.00 x 11	48	393.03-SES3 D140X110	72	44	45	1.7
M18	14.00 x 11	31	393.03-SES2 D140X112	50.5	30	34	0.6
M20	14.00 x 11	48	393.03-SES3 D140X112	72	44	45	1.7
M20	16.00 x 12	31	393.03-SES2 D160X120	50.5	30	34	0.6
M20	16.00 x 12	48	393.03-SES3 D160X120	72	44	45	1.7
M22	16.00 x 12	48	393.03-SES3 D160X125	72	44	45	1.7
M24	18.00 x 14	48	393.03-SES3 D180X140	72	44	45	1.7
M24	18.00 x 14	48	393.03-SES3 D180X145	72	44	45	1.7
M27	20.00 x 16	48	393.03-SES3 D200X160	72	44	45	1.7
M30	22.00 x 18	48	393.03-SES3 D220X180	72	44	45	1.7
M33	25.00 x 20	48	393.03-SES3 D250X200	72	44	45	1.7

For cutting data, follow tap manufacturer's recommendations.

1) For more technical information, see our Metalcutting Technical Guide.

Tapping adapter

without friction clutch and for external / internal coolant supply

393.03-SE

Milling

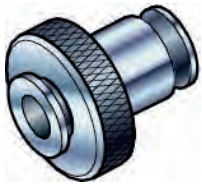

E

External coolant supply

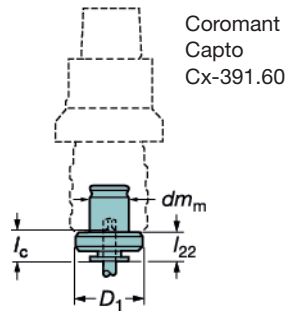

393.03-SE

Internal coolant supply

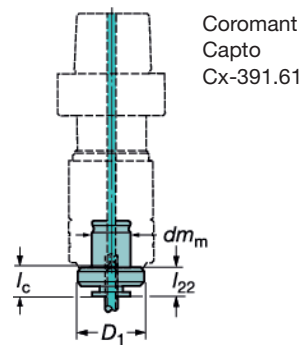

393.03-SE

Drilling

F

Boring

G

Tap shank, mm	Øx□ <i>dm_m</i>	Ordering code	Dimensions			
			<i>D₁</i>	<i>l_c</i>	<i>l₂₂</i>	 <i>m_{kg}</i>
3.15 x 2.2	19	393.03-SE1 D0315X022	30	17	7	0.1
4.00 x 3.1	19	393.03-SE1 D040X031	30	17	7	0.1
4.50 x 3.4	19	393.03-SE1 D045X034	30	17	7	0.1
5.00 x 4.0	19	393.03-SE1 D050X040	30	17	7	0.1
6.00 x 4.9	19	393.03-SE1 D060X049	30	17	7	0.1
6.00 x 4.9	31	393.03-SE2 D060X049	48	30	11	0.1
6.30 x 5.0	19	393.03-SE1 D063X050	30	17	7	0.1
6.30 x 5.0	31	393.03-SE2 D063X050	48	30	11	0.1
7.00 x 5.5	19	393.03-SE1 D070X055	30	17	7	0.1
7.00 x 5.5	31	393.03-SE2 D070X055	48	30	11	0.3
8.00 x 6.2	19	393.03-SE1 D080X062	30	17	7	0.1
8.00 x 6.2	31	393.03-SE2 D080X062	48	30	11	0.3
8.00 x 6.3	19	393.03-SE1 D080X063	30	17	7	0.1
8.00 x 6.3	31	393.03-SE2 D080X063	48	30	11	0.3
9.00 x 7.0	19	393.03-SE1 D090X070	30	17	7	0.1
9.00 x 7.0	31	393.03-SE2 D090X070	48	30	11	0.3
9.00 x 7.1	19	393.03-SE1 D090X071	30	17	7	0.1
9.00 x 7.1	31	393.03-SE2 D090X071	48	30	11	0.3
10.00 x 8.	19	393.03-SE1 D100X080	30	17	7	0.1
10.00 x 8.	31	393.03-SE2 D100X080	48	30	11	0.3
11.00 x 9.	31	393.03-SE2 D110X090	48	30	11	0.3
11.20 x 9.	31	393.03-SE2 D112X090	48	30	11	0.3
12.00 x 9.	31	393.03-SE2 D120X090	48	30	11	0.3
12.50 x 10	31	393.03-SE2 D125X100	48	30	11	0.3
14.00 x 11	31	393.03-SE2 D140X110	48	30	11	0.3
14.00 x 11	31	393.03-SE2 D140X112	48	30	11	0.3
16.00 x 12	31	393.03-SE2 D160X120	48	30	11	0.3

For cutting data, follow tap manufacturer's recommendations.

Tooling Systems

J

General Information

Tapping adapter

SynchroFlex® for synchronized tapping

Coromant Capto® tap adapter

ER-collet type
391.62 / 391.63

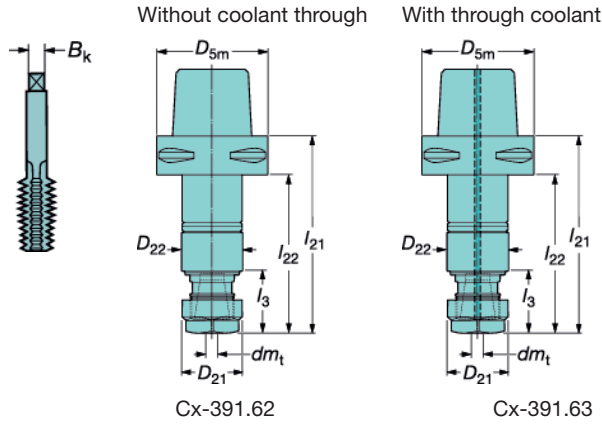
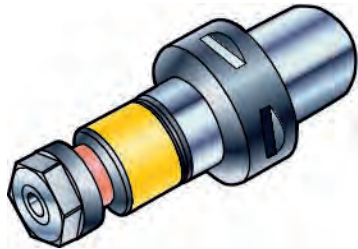

Accessories

ER tapping collets
Not delivered with the tool, must be ordered separately.



393.14

See page G119.

* SynchroFlex is a registered trademark of Tapmatic Corp., USA

For synchronized machines

Tap range		Coupling size	Ordering code	Collet size	Coolant ¹⁾	Tap shank dimensions, mm, inch		Dimensions, mm, inch									
min	max					B _k min	B _k max	D _{5m}	dm _t min	dm _t max	D ₂₁	D ₂₂	l ₃	l ₂₁	l ₂₂	l ₂	l ₁
M4	M12	C4	C4-391.62-20 107	ER 20	0	3.15	8	40	4	10	34	35	35.4	106.5	86.5	0.7	
						.124	.315	1.575	.157	.394	1.339	1.378	1.394	4.193	3.406		
M8	M20		C4-391.62-25 126	ER 25	0	6.2	12	40	8	16	42	44	37	125.9	105.9	1.1	
						.244	.472	1.575	.315	.630	1.654	1.732	1.457	4.957	4.169		
M4	M12		C4-391.63-20 112	ER 20	1	3.15	8	40	4	10	34	35	40.5	111.6	91.6	0.7	
						.124	.315	1.575	.157	.394	1.339	1.378	1.594	4.394	3.606		
M8	M20		C4-391.63-25 131	ER 25	1	6.2	12	40	8	16	42	44	42.2	131.1	111.1	1.1	
						.244	.472	1.575	.315	.630	1.654	1.732	1.661	5.161	4.374		
M4	M12	C5	C5-391.62-20 109	ER 20	0	3.15	8	50	4	10	34	35	35.4	108.5	88.5	0.9	
						.124	.315	1.968	.157	.394	1.339	1.378	1.394	4.272	3.484		
M8	M20		C5-391.62-25 128	ER 25	0	6.2	12	50	8	16	42	44	37	127.9	107.9	1.3	
						.244	.472	1.968	.315	.630	1.654	1.732	1.457	5.035	4.248		
M16	M30		C5-391.62-40 158	ER 40	0	9	18	50	12	22	63	62	43	157.5	137.5	2.6	
						.354	.709	1.968	.472	.866	2.480	2.441	1.693	6.201	5.413		
M4	M12		C5-391.63-20 114	ER 20	1	3.15	8	50	4	10	34	35	40.5	113.6	93.6	0.9	
						.124	.315	1.968	.157	.394	1.339	1.378	1.594	4.472	3.685		
M4	M20		C5-391.63-25 133	ER 25	1	6.2	12	50	8	16	42	44	42.2	133.1	113.1	1.3	
						.244	.472	1.968	.315	.630	1.654	1.732	1.661	5.240	4.453		
M8	M30		C5-391.63-40 163	ER 40	1	9	18	50	12	22	63	62	48	162.5	142.5	2.7	
						.354	.709	1.968	.472	.866	2.480	2.441	1.890	6.398	5.610		
M16	M12	C6	C6-391.62-20 113	ER 20	0	3.15	8	63	4	10	34	35	35.4	112.5	90.5	1.2	
						.124	.315	2.480	.157	.394	1.339	1.378	1.394	4.429	3.563		
M4	M12		C6-391.62-25 132	ER 25	0	6.2	12	63	8	16	42	44	37	131.9	109.9	1.6	
						.244	.472	2.480	.315	.630	1.654	1.732	1.457	5.193	4.327		
M8	M20		C6-391.62-40 162	ER 40	0	9	18	63	12	22	63	62	43	161.5	139.5	3.0	
						.354	.709	2.480	.472	.866	2.480	2.441	1.693	6.358	5.492		
M16	M30		C6-391.63-20 118	ER 20	1	3.15	8	63	4	10	34	35	40.5	117.6	95.6	1.3	
						.124	.315	2.480	.157	.394	1.339	1.378	1.594	4.630	3.764		
M8	M20		C6-391.63-25 137	ER 25	1	6.2	12	63	8	16	42	44	42.2	137.1	115.1	1.7	
						.244	.472	2.480	.315	.630	1.654	1.732	1.661	5.398	4.532		
M16	M30		C6-391.63-40 167	ER 40	1	9	18	63	12	22	63	62	48	166.5	144.5	3.1	
						.354	.709	2.480	.472	.866	2.480	2.441	1.890	6.555	5.689		
M4	M12	C8	C8-391.62-20 107	ER 20	0	3.15	8	80	4	10	34	35	35.4	106.5	76.5	2.1	
						.124	.315	3.150	.157	.394	1.339	1.378	1.394	4.193	3.012		
M8	M20		C8-391.62-25 126	ER 25	0	6.2	12	80	8	16	42	44	37	125.9	95.9	2.5	
						.244	.472	3.150	.315	.630	1.654	1.732	1.457	4.957	3.776		
M16	M30		C8-391.62-40 156	ER 40	0	9	18	80	12	22	63	62	43	155.5	125.5	3.9	
						.354	.709	3.150	.472	.866	2.480	2.441	1.693	6.122	4.941		
M4	M12		C8-391.63-20 112	ER 20	1	3.15	8	80	4	10	34	35	40.5	111.6	81.6	2.2	
						.124	.315	3.150	.157	.394	1.339	1.378	1.594	4.394	3.213		
M8	M20		C8-391.63-25 131	ER 25	1	6.2	12	80	8	16	42	44	42.2	131.1	101.1	2.6	
						.244	.472	3.150	.315	.630	1.654	1.732	1.661	5.161	3.980		
M16	M30		C8-391.63-40 161	ER 40	1	9	18	80	12	22	63	62	48	160.5	130.5	4.0	
						.354	.709	3.150	.472	.866	2.480	2.441	1.890	6.319	5.138		

¹⁾ 0 = no coolant, 1 = coolant through center

D
E
F
G
J

TOOLING SYSTEMS Coromant Capto® – Adapters for rotating tools

Tap adapters
Collet type with external coolant supply
391.60B

“Slim” design, floating
(for machining centers)

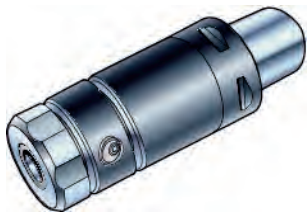
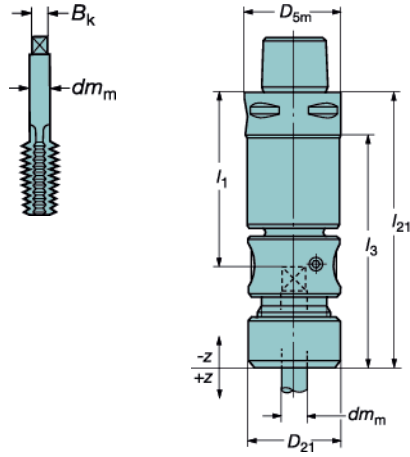
Tap range			Coupling size	Ordering code	Coolant ¹⁾	Tap shank				Dimensions, mm, inch											
min	max	B_k min				B_k max	dm_m min	dm_m max	D_{5m}	D_{22}	l_1	l_3	l_{21}	- z	+ z	σ_{20}	Nm ²⁾				
M5	M12	C3	C3-391.60B-01 095A	0	2	8	3.5	10	.079	.315	.138	.394	1.260	1.220	2.362	3.150	3.740	2	10	0.6	35.0
M7	M16	C4	C4-391.60B-02 101A	0	4	10	2.8	13	.157	.394	.110	.512	1.575	1.575	2.362		3.976	2	10	0.7	60.0
M14	M32	C5	C5-391.60B-03 158A	0	8	18	10	23	.315	.709	.394	.906	1.968	2.220	4.055		6.220	2	10	2.4	380.0

¹⁾ 0 = no coolant

²⁾ Max allowed tightening torque, Nm

Collets must be ordered separately, see below.

Collets

Collet size		dm_m mm (inch)	Ordering code	Shank DIN 374 ¹⁾	Suitable for:
1	3.5-6.5	(.138-.256)	391.60A-OZ J421	M4-M8 (0-1/4)	...01 xxxA
2	6.5-10	(.256-.394)	391.60A-OZ J422	M6-M12 (1/4-9/16)	...01 xxxA
3	2.8-7	(.110-.276)	391.60A-OZ J443	M5-M10 (0-1/4)	...02 xxxA
4	7-13	(.276-.512)	391.60A-OZ J440	M7-M16 (5/16-5/8)	...02 xxxA
5	10-16	(.394-.630)	391.60A-OZ J461	M10-M16 (1/6-3/4)	...03 xxxA
6	16-23	(.30-.906)	391.60A-OZ J462	M20-M30 (3/16-1 1/8)	...03 xxxA

¹⁾ For other standards, check shank dimensions B_k and dm_m



















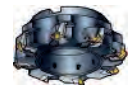











G 48





General Information

Coromant solid holding tools

Face mill holder  CAT V MAS-BT 403	Face mill holder  ISO 7388/1 MAS-BT 403	Facemill holder for flange mounting  ISO 7388/1 MAS-BT 403	HydroGrip® high precision holder for facemills  CAT V ISO 7388/1 MAS-BT 403	Hydro-Grip Heavy Duty 	HydroGrip high precision chuck  ISO 7388/1 MAS-BT 403
AA2B05 / AA3B05	A1B05 / A2B05	A1F05/A2F05	AA3B05CG / A1B05CG/A2B05CG	392.45CGD / .272CGD / .55CGD	392.272CG / .55CG / .45CG
Page G52	G51	G53	G88	G85	G86
					

HydroGrip® high precision chuck pencil type  ISO 7388/1 MAS-BT 403 CAT V	Collet chuck  CAT V ISO 7388/1 MAS-BT 403	Endmill holder, Weldon type  CAT V ISO 7388/1 MAS-BT 403	Short endmill holder, Weldon type  ISO 7388/1 MAS-BT 403	Holder for drills  ISO 7388/1 MAS-BT 403 CAT V	Adjustable drill holder  DIN 69871-A MAS-BT 403	Tapping chucks collet type  DIN 7388/1	Tap holder Weldon shank 
392.272/55/45CGB	AA3B14 / A1B14 / A2B14	AA2B20 / AA3B20 / AA220-30 / A1B20	A1X20 / A2X20	A1B27 / A2B27 AA3B27	392.140277 / .272277 / .55277 / .58277 / .45277	A393.2062 / .2063	393.2060 / 2061
Page G87	G54	G56	G57	G61	E91	G64	G63
							

Collet chuck extension  DIN 6499	HydroGrip® high precision chuck 	Tap holder 
393.14	393.CGP 393.CGA	A392.4560B
Page G55	G118	G62

Code key for solid holding tools

A	A	1	B	05	-	50	32	060
1	2	3	4	5		6	7	8

1 Inch version

2 Coolant through center

3 Spindle type

1=ISO 7388/1 (DIN 69871)
2= MAS-BT
3=CAT V-Flange

4 Options

B= Coolant through flange
F= Flange mounting
X= Extra short

5 Holder type

05 = Face mill holder
14= ER Collet chuck
20=End mill holder weldon type
27= Short hole drill holder-shank ISO 9766

6 Taper size 30, 40, 50

7 Size bore or pilot, dm_1

mm (inch)	19 (0.750)	38 (1.500)
09 (0.375)	25 (1.000)	51 (2.000)
13 (0.500)	32 (1.250)	63 (2.500)

8 Programming length, mm

060 = 60 mm

Face mill holder

A1B05 / A2B05

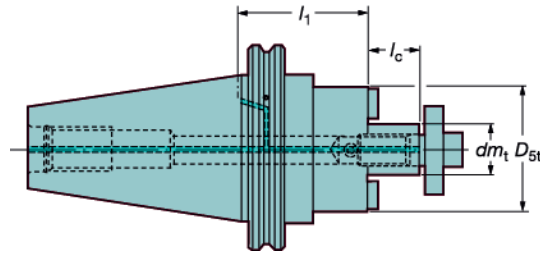
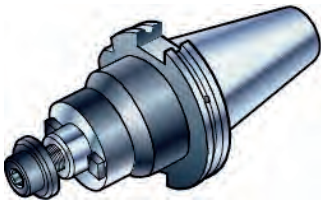
 l_1 = programming length

Metric pilot

Machine design	Taper	Ordering code	Coolant ²⁾	Dimensions				
				dm_t	D_{st}	l_1	l_c	$\frac{R}{mm}$
ISO7388.1	40	A1B05-40 16 035	7	16	36	35	17	0.9
		A1B05-40 16 100	7	16	36	100	17	1.8
		A1B05-40 22 035	7	22	48	35	19	1.0
		A1B05-40 22 100	7	22	48	100	19	1.9
		A1B05-40 27 035	7	27	48	35	21	1.1
		A1B05-40 27 100	7	27	60	100	21	2.4
	50	A1B05-40 32 050	7	32	78	50	24	1.6
		A1B05-50 22 035	7	22	48	35	19	2.8
		A1B05-50 22 100	7	22	48	100	19	3.7
		A1B05-50 27 035	7	27	60	35	21	3.0
		A1B05-50 27 100	7	27	60	100	21	4.4
		A1B05-50 32 035	7	32	78	35	24	3.2
		A1B05-50 32 100	7	32	78	100	24	5.6
		A1B05-50 40 050 ¹⁾	7	40	89	50	27	3.9
MAS-BT 403	30	A2B05-30 16 045 ³⁾	1	16	32	45	27	0.6
		A2B05-30 22 047 ³⁾	1	22	40	47	31	0.7
		A2B05-30 27 049 ³⁾	1	27	48	49	33	0.8
	40	A2B05-40 16 035	7	16	36	35	17	1.0
		A2B05-40 16 100	7	16	36	100	17	1.9
		A2B05-40 22 035	7	22	48	35	19	1.1
		A2B05-40 22 100	7	22	48	100	19	2.0
		A2B05-40 27 035	7	27	48	35	21	1.2
		A2B05-40 27 100	7	27	59	100	21	2.5
		A2B05-40 32 065	7	32	78	65	24	1.7
		A2B05-40 40 070	7	40	87	70	27	1.8
	50	A2B05-50 22 055	7	22	48	55	19	3.6
		A2B05-50 22 100	7	22	48	100	19	4.5
		A2B05-50 27 055	7	27	60	55	21	3.8
		A2B05-50 27 100	7	27	60	100	21	5.2
		A2B05-50 32 055	7	32	78	55	24	4.0
		A2B05-50 32 100	7	32	78	100	24	6.4
		A2B05-50 40 055	7	40	89	55	27	4.7

1) Holder for flange clamping. For flange clamping use four screws, 3212 020-514 are used.

2) 1 = coolant through center, 7 = coolant through center and through flange

3) Combi Face mill holder

All holders are delivered with a standard screw without hole for coolant.
For cutters with coolant channels a new screw with radial coolant holes is necessary and can be ordered separately.
See page G143.



G144



G49



G2

Face mill holder

AA2B05/ AA3B05/ AA205-30

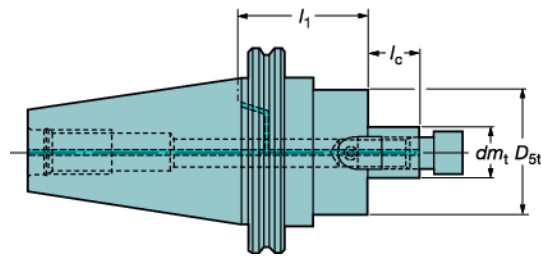
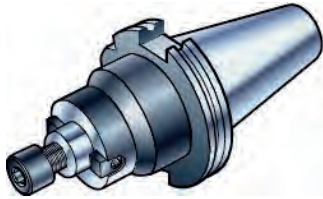
 l_1 = programming length

Inch pilot

Machine design	Taper	Ordering code	Coolant ²⁾	Dimensions, inch				
				dm_t	D_{st}	l_1	l_c	
CAT V	40	AA3B05-40 19 038	7	.750	1.750	1.500	.687	2.4
		AA3B05-40 25 051	7	1.000	2.250	2.000	.687	3.1
		AA3B05-40 32 057	7	1.250	2.750	2.250	.687	4.0
		AA3B05-40 38 061	7	1.500	3.750	2.400	.937	6.0
	50	AA3B05-50 19 038	7	.750	1.750	1.500	.687	6.8
		AA3B05-50 19 089	7	.750	1.750	3.500	.687	7.9
		AA3B05-50 25 051	7	1.000	2.250	2.000	.687	7.5
		AA3B05-50 25 101	7	1.000	2.250	4.000	.687	9.5
		AA3B05-50 32 038	7	1.250	2.750	1.500	.687	7.1
		AA3B05-50 32 089	7	1.250	2.750	3.500	.687	10.1
		AA3B05-50 38 061	7	1.500	3.750	2.400	.937	10.4
		AA3B05-50 38 101	7	1.500	3.750	4.000	.937	14.1
		AA3B05-50 51 061 ¹⁾	7	2.000	4.875	2.400	.937	13.0
		AA3B05-50 63 061 ¹⁾	7	2.500	4.875	2.400	1.125	14.1
MAS-BT 403	30	AA205-30 19 030 ³⁾	1	.750	1.750	1.190	.690	1.1
		AA205-30 25 045 ³⁾	1	1.000	2.390	1.770	.690	2.2
	40	AA2B05-40 19 051	7	.750	1.750	2.000	.687	2.9
		AA2B05-40 25 051	7	1.000	2.250	2.000	.687	3.3
		AA2B05-40 32 057	7	1.250	2.750	2.250	.687	4.2
AA2B05-40 38 057	7	1.500	3.750	2.250	.937	6.0		

¹⁾ Includes (4) 5/8-11 tapped holes on 4" bolt circle²⁾ 1 = coolant through center, 7 = coolant through center and through flange³⁾ Combi Face mill holder

Torque chart for arbor screws

Ordering code	Screw	Torque
5512 065-01	3/8"-24	45 ft-lbs
5512 065-02	3/8"-24	45 ft-lbs
5512 065-03	1/2"-20	100 ft-lbs
5512 065-04	3/4"-16	200 ft-lbs
5512 065-05	1/2"-20	100 ft-lbs
5512 065-06	5/8"-18	150 ft-lbs
5512 065-07	3/8"-24	45 ft-lbs
5512 065-08	1/2"-20	100 ft-lbs
5512 065-09	5/8"-18	150 ft-lbs
5512 065-10	3/4"-16	200 ft-lbs
5512 065-11	1"-14	220 ft-lbs
3212 030-606	3/8"-24	45 ft-lbs
3212 030-707	1/2"-20	100 ft-lbs



G143



G49



G2

Facemill holder for flange mounting

A1F05 / A2F05

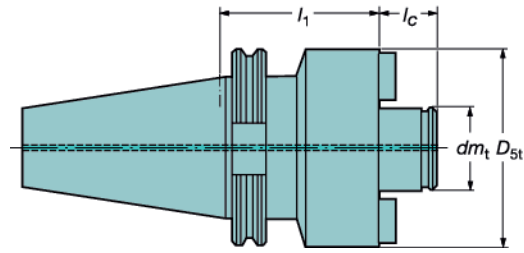
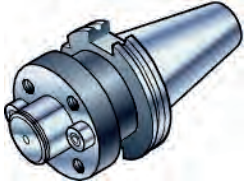
 l_1 = programming length

Metric pilot

Machine design	Taper	Ordering code	Coolant ¹⁾	Dimensions				
				dm_t	D_{st}	l_1	l_c	
ISO7388.1	50	A1F05-50 60 070	7	60	127	70	40	6.9
MAS-BT 403	50	A2F05-50 60 080	7	60	127	80	40	7.7

1) 7 = coolant through center and through flange



G143



G49



G2

ER collet chuck

For DIN 6499 collets

ISO 7388, MAS-BT 403

A1B14 / A2B14 / AA3B14

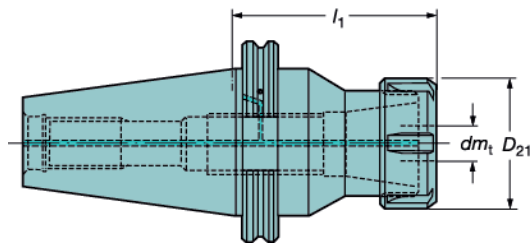
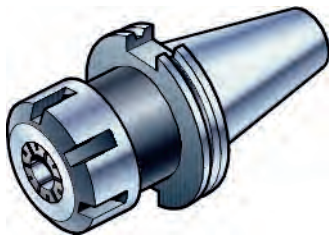

Accessories

393.14

Not delivered with the tool, must be ordered separately.



See page G119.

Machine design	Taper	Ordering code	Coolant ¹⁾	Dimensions					Collet size
				dm_1 min	dm_1 max	D_{21}	l_1	$\frac{\Delta}{mm}$	
ISO7388.1	40	A1B14-40 16 070	7	0.5	10	28	70	0.9	ER 16
		A1B14-40 16 100	7	0.5	10	28	100	1.0	ER 16
		A1B14-40 20 070	7	1	13	34	70	0.9	ER 20
		A1B14-40 20 100	7	1	13	34	100	1.3	ER 20
		A1B14-40 25 070	7	1.5	16	42	70	1.0	ER 25
		A1B14-40 25 100	7	1.5	16	42	100	1.3	ER 25
		A1B14-40 32 070	7	2	20	50	70	1.0	ER 32
	50	A1B14-40 40 070	7	3	26	63	70	1.0	ER 40
		A1B14-50 20 070	7	1	13	34	70	2.8	ER 20
		A1B14-50 20 100	7	1	13	34	100	3.2	ER 20
		A1B14-50 25 070	7	1.5	16	42	70	2.9	ER 25
		A1B14-50 25 100	7	1.5	16	42	100	3.2	ER 25
		A1B14-50 32 070	7	2	20	50	70	2.9	ER 32
		A1B14-50 32 100	7	2	20	50	100	3.2	ER 32
MAS-BT 403	30	A2B14-30 11 050	1	0.75	7	19	50	0.4	ER 11
		A2B14-30 16 050	1	0.5	10	28	50	0.4	ER 16
		A2B14-30 20 050	1	1	13	34	50	0.4	ER 20
		A2B14-30 25 062	1	1.5	16	42	62	0.5	ER 25
	40	A2B14-30 32 060	1	2	20	50	60	0.4	ER 32
		A2B14-40 16 070	7	0.5	10	28	70	1.0	ER 16
		A2B14-40 16 100	7	0.5	10	28	100	1.2	ER 16
		A2B14-40 20 070	7	1	13	34	70	1.0	ER 20
		A2B14-40 20 100	7	1	13	34	100	1.4	ER 20
		A2B14-40 25 070	7	1.5	16	42	70	1.0	ER 25
		A2B14-40 25 100	7	1.5	16	42	100	1.4	ER 25
		A2B14-40 32 070	7	2	20	50	70	1.0	ER 32
		A2B14-40 40 070	7	3	26	63	70	1.0	ER 40
		A2B14-40 40 070	7	3	26	63	70	1.0	ER 40
50	A2B14-50 20 070	7	1	13	34	70	3.6	ER 20	
	A2B14-50 20 100	7	1	13	34	100	4.0	ER 20	
	A2B14-50 25 070	7	1.5	16	42	70	3.7	ER 25	
	A2B14-50 25 100	7	1.5	16	42	100	4.0	ER 25	
	A2B14-50 32 070	7	2	20	50	70	3.6	ER 32	
	A2B14-50 32 100	7	2	20	50	100	4.1	ER 32	
A2B14-50 40 080	7	3	26	63	80	3.6	ER 40		

Machine design	Taper	Ordering code	Coolant ¹⁾	Dimensions, inch					Collet size
				dm_1 min	dm_1 max	D_{21}	l_1	$\frac{\Delta}{mm}$	
CAT V	40	AA3B14-40 16 067	7	.020	.394	1.102	2.620	2.1	ER 16
		AA3B14-40 16 105	7	.020	.394	1.102	4.120	2.7	ER 16
		AA3B14-40 20 105	7	.039	.512	1.339	4.120	2.7	ER 20
		AA3B14-40 20 156	7	.039	.512	1.339	6.120	3.3	ER 20
		AA3B14-40 25 105	7	.059	.630	1.654	4.120	2.9	ER 25
		AA3B14-40 25 156	7	.059	.630	1.654	6.120	3.9	ER 25
		AA3B14-40 32 079	7	.079	.787	1.968	3.120	2.7	ER 32
		AA3B14-40 32 105	7	.079	.787	1.968	4.120	3.3	ER 32
		AA3B14-40 40 105	7	.118	1.024	2.480	4.120	3.9	ER 40
		50	AA3B14-50 16 105	7	.020	.394	1.102	4.120	7.0
	AA3B14-50 20 105		7	.039	.512	1.339	4.120	7.0	ER 20
	AA3B14-50 25 105		7	.059	.630	1.654	4.120	7.4	ER 25
	AA3B14-50 32 105		7	.079	.787	1.968	4.120	7.8	ER 32
	AA3B14-50 40 105	7	.118	1.024	2.480	4.120	8.6	ER 40	

1) 7 = coolant through center and through flange



G145



G49



G2

ER-collet chuck extension

For DIN 6499 collets

Plain parallel shank

A393.14
393.14

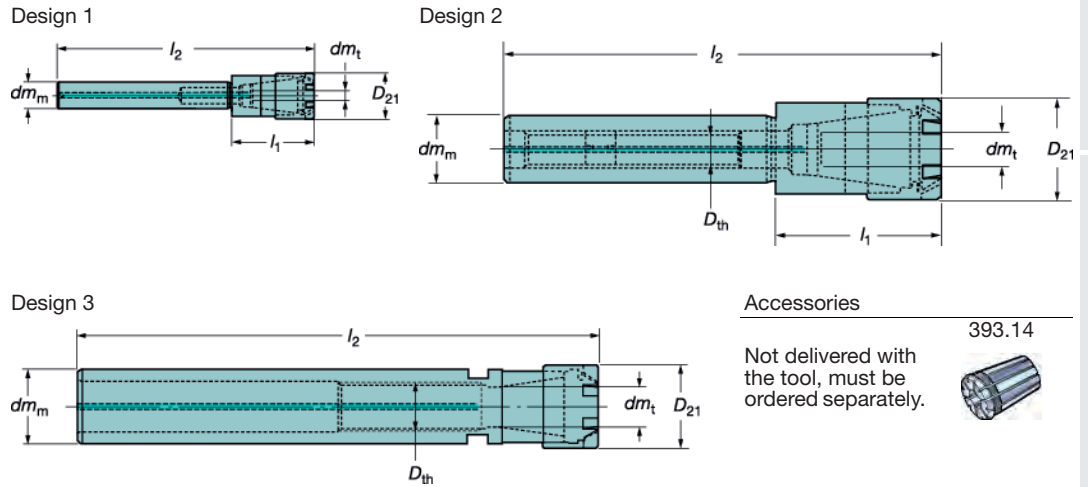

Accessories

Not delivered with the tool, must be ordered separately.



393.14

See page

G119



Metric shank

Ordering code	Design	Coolant ¹⁾	Dimensions							Collet size
			dm_m	dm_t	D_{21}	l_1	l_2	D_{th}	$\frac{kg}{lb}$	
393.14-12 16 080	1	1	12	7	22	38.5	118.500		0.1	ER 16
393.14-08 11 056	1	1	8	4	16	26.5	82.500		0.0	ER 11
393.14-16 11 150	2	1	16	8	16	21	171.000	M8x1	0.2	ER 11
393.14-20 16 155	2	1	20	12	22	26.5	181.500	M12x1	0.3	ER 16
393.14-25 20 170A	3	1	25	13.5	28		182.000	M14x1	0.4	ER 20

Inch shank

Ordering code	Design	Coolant ¹⁾	Dimensions, inch							Collet size
			dm_m	D_{21}	l_1	l_2	D_{th}	$\frac{kg}{lb}$		
A393.14-13 16 182	2	1	.500	.866	1.457	6.968	M6x1	0.7	ER 16	
A393.14-19 20 187	2	1	.750	1.102	1.457	7.362	M12x1	0.9	ER 20	
A393.14-19 25 203	2	1	.750	1.642	1.850	7.992	M12x1	2.2	ER 25	
A393.14-26 25 203	2	1	1.000	1.642	1.850	7.992	M18x1.5	3.5	ER 25	
A393.14-26 32 203	2	1	1.000	1.957	2.087	7.992	M18x1.5	2.6	ER 32	
A393.14-19 16 182	3	1	.750	.866		7.146	M12x1	0.8	ER 16	
A393.14-26 20 203	3	1	1.000	1.102		7.992	M14x1	1.8	ER 20	

¹⁾ 1 = coolant through center



Endmill holder, Weldon type

Shank according to DIN 6535-HB

AA2B20/ AA3B20/ AA220-30

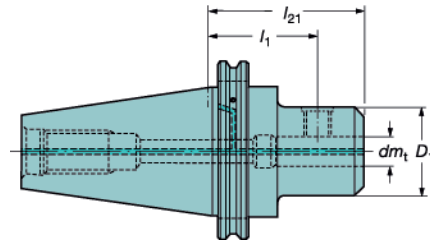
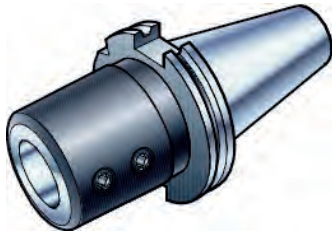

l_1 = programming length

Inch bore

Machine design	Taper	Ordering code	Coolant ¹⁾	Dimensions, inch				
				dm_k	D_1	l_1	l_{21}	$\frac{R}{mm}$
CAT V	40	AA3B20-40 03 044	7	.125	.688	1.375	1.750	1.8
		AA3B20-40 06 063	7	.250	.875	2.125	2.500	2.4
		AA3B20-40 09 044	7	.375	1.000	1.125	1.750	2.0
		AA3B20-40 09 063	7	.375	1.000	1.750	2.500	2.4
		AA3B20-40 13 044	7	.500	1.750	.875	1.750	2.2
		AA3B20-40 13 067	7	.500	1.750	1.745	2.620	2.4
		AA3B20-40 16 044	7	.625	1.750	.875	1.750	2.2
		AA3B20-40 16 070	7	.625	1.750	1.812	2.750	2.6
		AA3B20-40 19 044	7	.750	1.750	.750	1.750	2.2
		AA3B20-40 19 089	7	.750	1.750	2.500	3.500	3.1
	AA3B20-40 22 095	7	.875	1.850	2.750	3.750	3.3	
	AA3B20-40 25 044	7	1.000	1.900	.625	1.750	2.0	
	AA3B20-40 25 101	7	1.000	2.000	2.875	4.000	3.3	
	AA3B20-40 32 101	7	1.250	2.500	2.875	4.000	4.4	
	AA3B20-40 38 101	7	1.500	2.620	2.875	4.000	4.6	
	50	AA3B20-50 09 063	7	.375	1.000	1.750	2.500	6.6
		AA3B20-50 09 165	7	.375	1.000	5.750	6.500	7.5
		AA3B20-50 13 067	7	.500	1.250	1.775	2.625	6.8
		AA3B20-50 13 168	7	.500	1.250	5.750	6.625	8.4
		AA3B20-50 16 095	7	.625	1.500	2.812	3.750	7.3
AA3B20-50 16 197		7	.625	1.500	6.812	7.750	9.3	
AA3B20-50 19 095		7	.750	1.750	2.750	3.750	7.7	
AA3B20-50 19 197		7	.750	1.750	6.750	7.750	10.4	
AA3B20-50 22 095		7	.875	1.850	2.750	3.750	7.7	
AA3B20-50 22 197		7	.875	1.875	6.750	7.750	10.8	
AA3B20-50 25 101	7	1.000	2.000	2.875	4.000	7.9		
AA3B20-50 25 203	7	1.000	2.000	6.866	8.000	11.5		
AA3B20-50 32 101	7	1.250	2.750	2.885	4.000	8.8		
AA3B20-50 32 203	7	1.250	2.500	6.875	8.000	13.7		
AA3B20-50 38 101	7	1.500	2.750	2.875	4.000	8.6		
AA3B20-50 38 203	7	1.500	2.750	6.875	8.000	14.8		
AA3B20-50 51 143	7	2.000	3.750	4.219	5.625	15.7		
AA3B20-50 51 244	7	2.000	3.750	8.219	9.625	27.6		
MAS-BT 403	30	AA220-30 03 060	1	.125	.750	2.000	2.380	1.1
		AA220-30 06 060	1	.250	.810	2.000	2.380	1.1
		AA220-30 09 060	1	.375	1.380	1.630	2.380	1.3
		AA220-30 13 060	1	.500	1.380	1.500	2.380	1.3
	40	AA2B20-40 09 057	7	.375	1.000	1.500	2.250	2.2
		AA2B20-40 13 057	7	.500	1.250	1.375	2.250	2.4
		AA2B20-40 16 057	7	.625	1.500	1.312	2.250	2.4
		AA2B20-40 19 086	7	.750	1.750	2.375	3.375	3.1
		AA2B20-40 25 101	7	1.000	2.000	2.875	4.000	3.7
		AA2B20-40 32 101	7	1.250	2.500	2.875	4.000	4.9

1) 1 = coolant through center, 7 = coolant through center and through flange

Endmill holder, Weldon type, short version

Shank according to DIN 6535-HB

A1X20 / A2X20

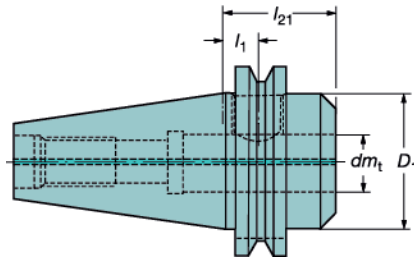
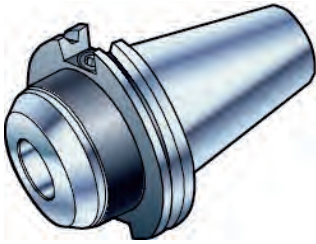

l_1 = programming length

Metric bore

Machine design	Taper	Ordering code	Coolant ¹⁾	Dimensions				
				dm_t	D_1	l_1	l_{21}	$\frac{\mu\text{m}}{\text{mm}}$
ISO7388.1	40	A1X20-40 16 035	1	16	48	11.5	35	0.8
		A1X20-40 18 035	1	18	48	11.5	35	0.9
		A1X20-40 20 040	1	20	49.8	15	40	0.9
		A1X20-40 25 060	1	25	62	36	60	1.3
		A1X20-40 32 070	1	32	72	48	70	1.7
MAS-BT 403	40	A2X20-40 16 035	1	16	48	11	35	0.9
		A2X20-40 18 035	1	18	50	11	35	1.0
		A2X20-40 20 035	1	20	52	11	35	1.0
		A2X20-40 25 060	1	25	59	36	60	1.4
		A2X20-40 32 065	1	32	59	41	65	1.8

¹⁾ 1 = coolant through center



Endmill holder, Weldon type

Shank according to DIN 6535-HB

A1B20

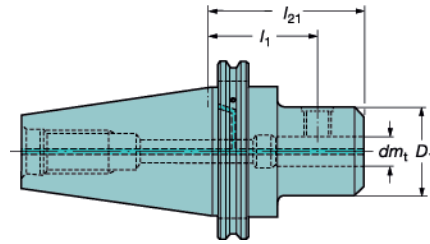
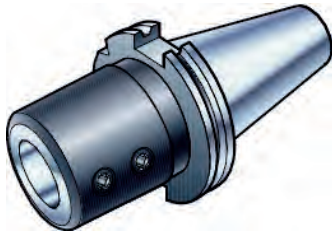

l_1 = programming length

Metric bore

Machine design	Taper	Ordering code	Coolant ¹⁾	Dimensions				
				dm_1	D_1	l_1	l_{21}	$\frac{\mu\text{m}}{\text{mm}}$
ISO7388.1	40	A1B20-40 06 050	7	6	25	32	50	0.9
		A1B20-40 06 100	7	6	25	82	100	1.0
		A1B20-40 08 050	7	8	28	32	50	0.9
		A1B20-40 08 100	7	8	28	82	100	1.1
		A1B20-40 10 050	7	10	35	30	50	1.0
		A1B20-40 10 100	7	10	35	80	100	1.3
		A1B20-40 12 050	7	12	42	27.5	50	1.0
		A1B20-40 12 100	7	12	42	77.5	100	1.8
		A1B20-40 16 063	7	16	48	39	63	1.0
		A1B20-40 16 100	7	16	48	76	100	1.8
	50	A1B20-40 18 063	7	18	48	39	63	1.2
		A1B20-40 18 100	7	18	48	76	100	1.7
		A1B20-40 20 063	7	20	52	38	63	1.3
		A1B20-40 20 100	7	20	52	75	100	1.8
		A1B20-40 25 100	7	25	65	76	100	2.3
		A1B20-40 32 100	7	32	72	76	100	2.5
		A1B20-50 06 063	7	6	25	45	63	2.8
		A1B20-50 08 063	7	8	28	45	63	2.7
		A1B20-50 10 063	7	10	35	43	63	2.9
		A1B20-50 12 063	7	12	42	40.5	63	3.0
G	A1B20-50 16 063	7	16	48	39	63	3.1	
	A1B20-50 18 063	7	18	48	39	63	3.0	
	A1B20-50 20 063	7	20	52	38	63	3.1	
	A1B20-50 20 100	7	20	52	75	100	3.7	
	A1B20-50 25 080	7	25	65	56	80	3.8	
	A1B20-50 25 100	7	25	65	76	100	4.3	
	A1B20-50 32 100	7	32	72	76	100	4.5	
	A1B20-50 32 160	7	32	72	136	160	6.5	
	A1B20-50 40 120	7	40	78	90	120	4.7	

1) 7 = coolant through center and through flange



G148



G49



G2

Endmill holder, Weldon type

Convertible to coolant through the flange
392.45520

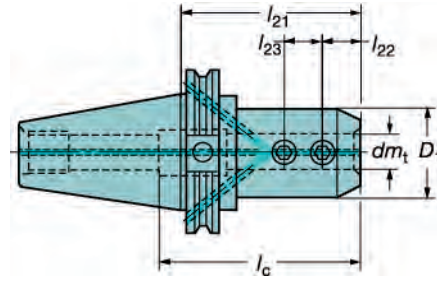
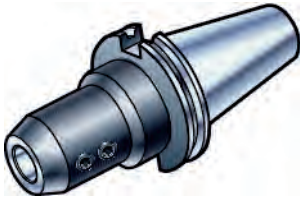

l_1 = programming length

Metric bore with CAT V-flange

Machine design	Taper	Ordering code	Coolant ¹⁾	Dimensions, mm, inch														
				dm_1 mm	dm_1 in.	D_1 mm	D_1 in.	l_c mm	l_c in.	l_1 mm	l_1 in.	l_2 mm	l_2 in.	l_3 mm	l_3 in.			
CAT V	40	392.45520-40 20 089	7	20	0.787	44.45	1.750	57.15	2.250	88.9	3.500	25.4	1.000					1.5
		392.45520-40 25 100	7	25	0.984	50.8	2.000	76.2	3.000	101.6	4.000	28.7	1.130	25.4	1.000			1.6
	50	392.45520-50 20 095	7	20	0.787	44.45	1.750	57.15	2.250	95.25	3.750	25.4	1.000					3.5
		392.45520-50 25 100	7	25	0.984	50.8	2.000	76.2	3.000	101.6	4.000	28.7	1.130	24.4	0.961			3.8
		392.45520-50 32 100	7	32	1.260	63.5	2.500	66.04	2.600	101.6	4.000	28.7	1.130	25.4	1.000			4.1
		392.45520-50 40 100	7	40	1.575	69.85	2.750	82.55	3.250	101.6	4.000	28.7	1.130	25.4	1.000			4.1

¹⁾ 7 = coolant through center and through flange



Endmill holder, Weldon type

Shank according to DIN 6535-HB

A2B20

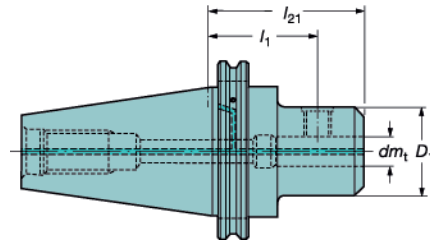
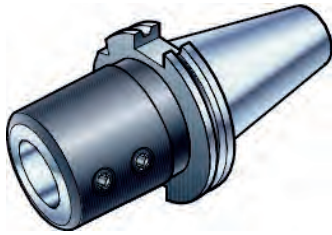

l_1 = programming length

Metric bore

Machine design	Taper	Ordering code	Coolant ¹⁾	Dimensions				
				dm	D_1	l_1	l_{21}	$\frac{\mu\text{m}}{\text{mm}}$
MAS-BT 403	30	A2B20-30 06 050	1	6	24.5	32.5	50	0.5
		A2B20-30 08 050	1	8	27.5	32.5	50	0.5
		A2B20-30 10 050	1	10	34.5	30.5	50	0.5
		A2B20-30 12 052	1	12	41.5	30	52	0.6
		A2B20-30 16 063	1	16	47.5	39.5	63	0.8
		A2B20-30 20 063	1	20	51.5	38.5	63	0.8
	40	A2B20-40 06 050	7	6	25	32	50	0.9
		A2B20-40 06 100	7	6	25	82	100	1.1
		A2B20-40 08 050	7	8	28	32	50	1.0
		A2B20-40 08 100	7	8	28	82	100	1.2
		A2B20-40 10 063	7	10	35	43	63	1.1
		A2B20-40 10 100	7	10	35	80	100	1.4
		A2B20-40 12 063	7	12	42	40.5	63	1.2
		A2B20-40 12 100	7	12	42	77.5	100	1.9
		A2B20-40 16 063	7	16	48	39	63	1.2
		A2B20-40 16 100	7	16	48	76	100	1.9
		A2B20-40 20 063	7	20	52	38	63	1.4
		A2B20-40 20 100	7	20	52	75	100	1.9
		A2B20-40 25 090	7	25	59	66	90	2.4
		A2B20-40 25 160	7	25	59	136	160	3.9
A2B20-40 32 100	7	32	72	76	100	2.6		
	50	A2B20-50 06 063	7	6	25	45	63	3.6
		A2B20-50 08 063	7	8	28	45	63	3.5
		A2B20-50 10 070	7	10	35	50	70	3.7
		A2B20-50 12 080	7	12	42	57.5	80	3.8
		A2B20-50 16 080	7	16	48	56	80	3.9
		A2B20-50 20 080	7	20	52	55	80	3.9
		A2B20-50 20 100	7	20	52	75	100	4.1
		A2B20-50 25 100	7	25	65	76	100	4.6
		A2B20-50 25 160	7	25	65	136	160	6.5
		A2B20-50 32 105	7	32	72	81	105	5.3
		A2B20-50 32 160	7	32	72	136	160	7.3
		A2B20-50 40 115	7	40	78	85	115	5.5

1) 1 = coolant through center, 7 = coolant through center and through flange



G148



G49



G2

Drill holder, ISO 9766 shank

Shank according to ISO 9766

A1B27 / A2B27 / AA3B27

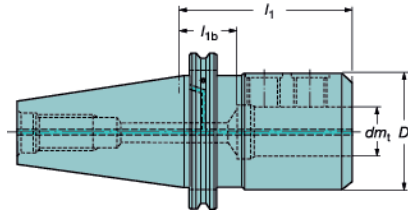
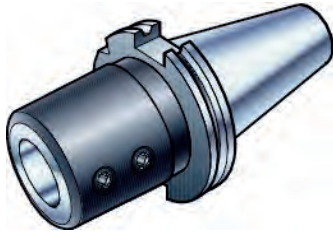

l_1 = programming length

Metric bore

Machine design	Taper	Ordering code	Coolant ¹⁾	Dimensions				
				dm_1	D_1	l_1	l_{1b}	ρ_{KG}
ISO7388.1	40	A1B27-40 16 080	7	16	36	80	27	1.2
		A1B27-40 20 080	7	20	40	80	25	1.2
		A1B27-40 25 085	7	25	45	85	25	1.4
		A1B27-40 32 090	7	32	52	90	26	1.5
	50	A1B27-50 16 080	7	16	36	80	27	3.0
		A1B27-50 20 080	7	20	40	80	25	3.1
		A1B27-50 25 085	7	25	45	85	25	3.3
		A1B27-50 32 090	7	32	52	90	26	3.4
		A1B27-50 40 090	7	40	76	90	16	3.9
		A1B27-50 50 100	7	50	76	100	16	3.7
MAS-BT 403	40	A2B27-40 16 070	7	16	36	70	17	1.2
		A2B27-40 20 075	7	20	40	75	20	1.3
		A2B27-40 25 080	7	25	45	80	20	1.4
		A2B27-40 32 085	7	32	52	85	21	1.5
	50	A2B27-50 16 080	7	16	36	80	27	3.9
		A2B27-50 20 085	7	20	40	85	30	3.9
		A2B27-50 25 090	7	25	45	90	30	4.0
		A2B27-50 32 095	7	32	52	95	31	4.2
		A2B27-50 40 105	7	40	76	105	31	4.5
		A2B27-50 50 113	7	50	76	113	29	5.0

¹⁾ 7 = coolant through center and through flange

Inch bore

Machine design	Taper	Ordering code	Coolant ¹⁾	Dimensions, inch				
				dm_1	D_1	l_1	l_{1b}	ρ_{KG}
CAT V	40	AA3B27-40 19 080	7	.750	1.575	3.150	1.024	2.9
		AA3B27-40 25 085	7	1.000	1.772	3.346	.965	3.1
		AA3B27-40 32 090	7	1.250	2.047	3.543	1.024	3.3
	50	AA3B27-50 19 080	7	.750	1.575	3.150	1.024	6.6
		AA3B27-50 25 085	7	1.000	1.772	3.346	.965	6.8
		AA3B27-50 32 090	7	1.250	2.047	3.543	1.024	7.3
		AA3B27-50 38 090	7	1.500	2.559	3.543	.846	8.2
		AA3B27-50 51 110	7	2.000	2.953	4.331	1.122	9.3

¹⁾ 7 = coolant through center and through flange



Tap holder

Collet type tension and compression

A392.4560B

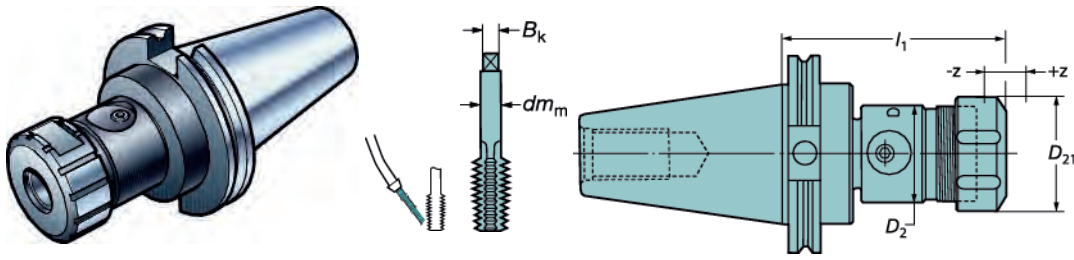

Accessories

391.60A

Not delivered with the tool, must be ordered separately.



See page G48.

l_1 = programming length

Inch bore

Machine design	Taper	Ordering code	Coolant ¹⁾	Tap size range				Dimensions, inch					
				B_k min	B_k max	dm_m min	dm_m max	D_2	D_{21}	l_1	-z	+z	
CAT V	40	A392.4560B-40 01 085	0	.079	.315	.138	.394	1.220	1.220	3.375	2.007	10.008	6.0
		A392.4560B-40 02 089	0	.157	.394	.110	.512	1.575	1.575	3.515	2.007	10.008	6.2
		A392.4560B-40 03 175	0	.315	.709	.394	.906	1.969	2.220	6.875	3.988	15.011	7.1
	50	A392.4560B-50 02 089	0	.157	.394	.110	.512	1.575	1.575	3.500	2.007	10.008	15.9
		A392.4560B-50 03 112	0	.315	.709	.394	.906	1.969	2.220	4.406	3.988	15.011	17.6

¹⁾ 0 = no coolant



G150



G49



G2

Tap holder

Weldon shank

393.2060 / 393.2061

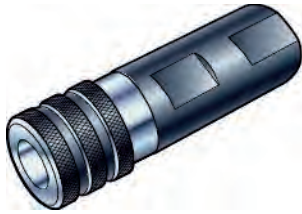

Without coolant through

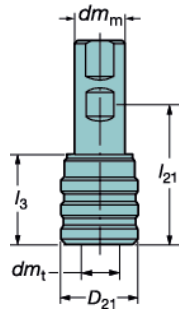

393.2060

With through coolant

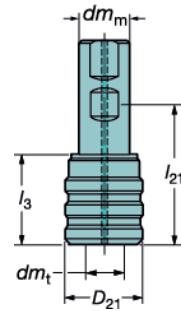

393.2061

Metric bore

Tap range		dm_t	Coupling size, dm_m	Ordering code	Coolant ¹⁾	Length compensation, mm Compression/ Expansion	Dimensions				
min	max						D_{21}	l_3	l_{21}	$\frac{\sigma}{K_{10}}$	Nm ²⁾
M3	M12	19	25	393.2060-25 01 045	0	7.5	39	45	66	0.5	35
M8	M20	31		393.2060-25 02 068	0	10	60	68	89	1.6	110
M3	M12	19		393.2061-25 01 062	1	7.5	39	62	83	0.5	35
M8	M20	31		393.2061-25 02 098	1	10	60	98	119	1.6	110
M14	M33	48	32	393.2060-32 03 099	0	17.5	86	99	123	4.6	500
M14	M33	48		393.2061-32 03 147	1	17.5	86	147	171	4.6	500

¹⁾ 0 = no coolant, 1 = coolant through center

²⁾ Max torque, Nm

For tap adapters, see page G46.

Recommendations:

In order to get the best result from machines not equipped for synchronized tapping, the following recommendations should be observed.

- Program machine feed 10% lower than theoretical value (thread pitch rpm). This enables the tap to cut precisely on pitch.
- • Reduce tapping depth by 10% to avoid tap breakage.
- Note that when tapping deep holes in soft materials, e.g. aluminum, feed and depth should only be reduced by 3-5%.



Tapping chucks

SynchroFlex® for synchronized tapping

Collet type

393.2062 / 393.2063

Weldon/Whistle Notch

Milling

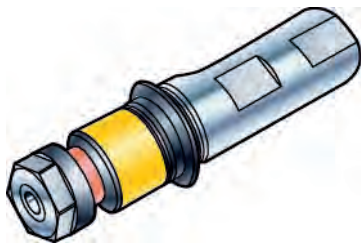

E

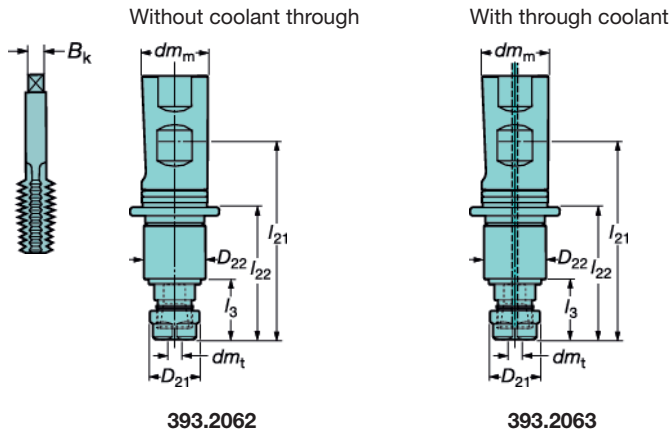

Drilling

Accessories

ER tapping collets

Not delivered with the tool, must be ordered separately.



393.14

F

See page G119.

Boring

For synchronized machines

Metric bore

Tap range		Coupling size	Ordering code	Coolant ¹⁾	Tap shank		Dimensions										Collet size
min	max	dm_m inch/mm			B_k min	B_k max	dm_m min	dm_m max	D_{21}	d_{22}	l_1	l_3	l_{21}	l_{22}	$R_{0.3}$		
M2	M5	25	393.2062-25 11 051	0	2.1	4.9	2.8	6.0	18.7	23.5	75.4	23.5	75.4	51.4	0.3	ER 11	
M4	M12	25	393.2062-25 20 063	0	3.15	8	4	10.0	34.0	35.0	87.5	35.3	87.5	63.5	0.4	ER 20	
M8	M20	25	393.2062-25 25 083	0	6.2	12	8	16.0	42.0	44.0	106.9	36.9	106.9	82.9	0.8	ER 25	
M4	M12	25	393.2063-25 20 068	1	3.15	8	4	10.0	34.0	35.0	92.6	40.5	92.6	68.6	0.4	ER 20	
M8	M20	25	393.2063-25 25 088	1	6.2	12	8	16.0	42.0	44.0	112.1	42.2	112.1	88.1	0.8	ER 25	

¹⁾ 0 = no coolant, 1 = coolant through center

G

Inch bore

Tap range		Coupling size	Ordering code	Coolant ¹⁾	Tap shank		Dimensions, inch										Collet size
min	max	dm_m inch			B_k min	B_k max	dm_m min	dm_m max	D_{21}	d_{22}	l_1	l_3	l_{21}	l_{22}	$R_{0.3}$		
M2	M5	1	A393.2062-25 11 051	0	.0827	.1929	.110	.236	.736	.925	3.165	.925	3.165	2.024	0.7	ER 11	
M4	M12	1	A393.2062-25 20 063	0	.124	.315	.157	.394	1.339	1.378	3.642	1.390	3.642	2.500	0.9	ER 20	
M8	M20	1	A393.2062-25 25 083	0	.2441	.4724	.315	.630	1.654	1.732	4.402	1.453	4.402	3.264	1.8	ER 25	
M4	M12	1	A393.2063-25 20 068	1	.124	.315	.157	.394	1.339	1.378	3.842	1.594	3.842	2.701	0.9	ER 20	
M8	M20	1	A393.2063-25 25 088	1	.2441	.4724	.315	.630	1.654	1.732	4.610	1.661	4.610	3.468	1.8	ER 25	

¹⁾ 0 = no coolant, 1 = coolant through center

* SynchroFlex is a registered trademark of Tapmatic Corp., USA













Tooling Systems

J



General Information

HSK solid holding tools

Face mill holder	Face mill holder	Hydro-Grip Heavy Duty	HydroGrip high precision chuck	HydroGrip high precision chuck Pencil type	ER collet chuck DIN 6499
					
A392.41005 392.41005	41005CG	392.410CGD	392.410CGA	392.410CGB	392.41014
Page G67	G66	G89	G90	G91	G69
					

Endmill holder, Weldon type	Endmill holder, Whistle Notch	Adjustable drill holder	Holder for drills According to ISO 9766	Tapping chucks	Tapping chucks	Blank
						
A392.41020 392.41020	392.14021	392.410227	392.41027	392.41062 392.41063	392.41060B	392.41050
Page G70	G72	E92	G73	G75	G76	G77
						

Basic holder with Coromant Capto®



Cx-390.410/612

Page G15

Integrated tools for boring, see chapter F

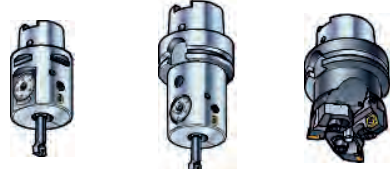

HSK adapters for CoroMill® modular cutting tools, see page G101.



Face mill holder

392.41005C

HSK form A/C

Milling

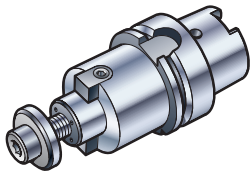

Design 1

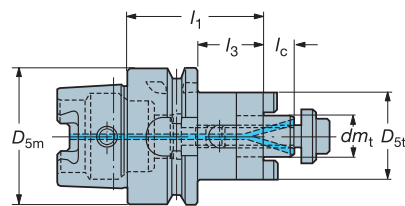

Design 2

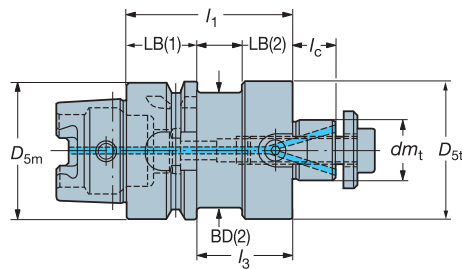

Note: Hole for data carrier is not standard.

 l_1 = programming length

E

Drilling

F

Metric pilot

HSK size	Ordering code	Coolant ¹⁾		Design	Dimensions											Balanced by design		
		Entry	Exit		D_{sm}	dm_t	D_{st}	l_c	D_{hc}	l_1	l_3	D_{th}	LB(2)	LB(1)	BD(2)		$\frac{\Omega}{1000}$	
63	392.41005C6316050	1	4	1	63	16	32	11		50	24						0.8	⊙
	392.41005C6322050	1	4	2	63	22	50	16		50	24						1.1	⊙
	392.41005C6327060	1	4	2	63	27	60	18		60	34	18	26	53			1.4	⊙
	392.41005C6332060	1	4	2	63	32	78	20		60		18	26	53			1.7	⊙
	392.41005C6340060	1	4	2	63	40	87	23		60		18	26	53			2.1	⊙
100	392.41005C10022100	1	4	2	100	22	50	16		100	71						3.1	⊙
	392.41005C10027100	1	4	2	100	27	60	18		100	71						3.6	⊙
	392.41005C10032100	1	4	2	100	32	78	20		100	71						4.8	⊙
	392.41005C10040100	1	4	2	100	40	87	23		100	71						5.5	⊙
125	392.41005C12532100	1	4	2	125	32	78	20		100	71						6.0	⊙
	392.41005C12540100	1	4	2	125	40	87	23		100	71						6.8	⊙

1) 0 = no coolant, 1 = coolant through center, 4 = coolant through arbor

Coolant tube must be ordered separately, see page G77.

Boring

Tooling Systems

J



G153



G65



G2

General Information

Face mill holder

A392.41005C

HSK form A/C

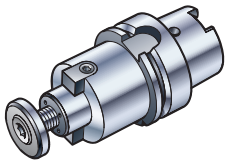

Design 2

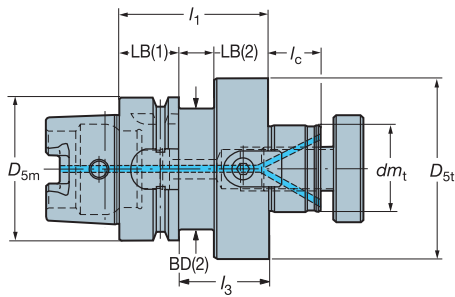

Note: Hole for data carrier is not standard.

l_1 = programming length

Inch pilot

HSK size	Ordering code	Coolant ¹⁾		Design	Dimensions, inch										Balanced by design		
		Entry	Exit		D_{5m}	dm	D_{5t}	l_c	l_1	l_3	LB(2)	LB(1)	BD(2)	$\frac{\sigma}{E}$			
63	A392.41005C6319050	1	4	2	2.480	.750	1.693	.709	1.968	.945						2.1	⊙
	A392.41005C6325060	1	4	2	2.480	1.000	1.969	.709	2.362	1.339						2.8	⊙
	A392.41005C6338065	1	4	2	2.480	1.500	3.150	.906	2.559		.630	1.024	2.087			4.6	⊙
100	A392.41005C10019100	1	4	2	3.937	.750	1.693	.709	3.937	2.795						6.2	⊙
	A392.41005C10025100	1	4	2	3.937	1.000	1.969	.709	3.937	2.795						6.9	⊙
	A392.41005C10038100	1	4	2	3.937	1.500	3.150	.906	3.937	2.795						11.1	⊙
125	A392.41005C12525100	1	4	2	4.921	1.000	1.969	.709	3.937	2.795						9.7	⊙
	A392.41005C12538100	1	4	2	4.921	1.500	3.150	.906	3.937	2.795						14.0	⊙

¹⁾ 0 = no coolant, 1 = coolant through center, 4 = coolant through arbor

Coolant tube must be ordered separately, see page G77.



Face mill holder

392.41005

HSK form A/C

Milling

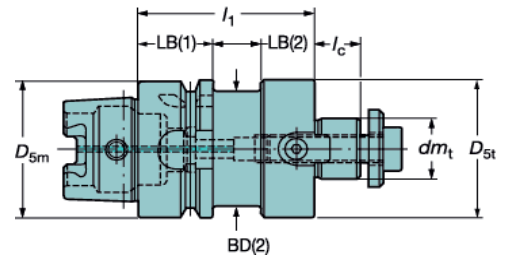
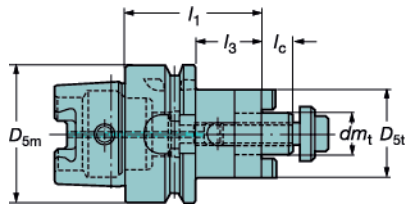
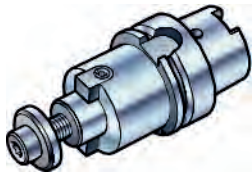

Note: Hole for data carrier is not standard.

l₁ = programming length

Metric pilot

Drilling

HSK size	Ordering code	Coolant ¹⁾	Dimensions											Balanced by design		
			dm _t	D _{5m}	D _{5t}	l _c	l ₁	l ₃	d _{hc}	LB(1)	LB(2)	BD(2)	⊖ _{R63}			
63	392.41005-63 16 050	1	16	63	32	11	50	24							1.0	⊙
	392.41005-63 22 050B	1	22	63	50	16	50	24							1.1	⊙
	392.41005-63 27 060B	1	27	63	50	18	60	34							1.4	⊙
	392.41005-63 32 060B	1	32	63	63	20	60		26	16	53				1.5	⊙
	392.41005-63 40 060B	1	40	63	80	23	60		26	16	53				2.0	⊙
100	392.41005-100 22 050A	1	22	100	50	16	50	21							2.4	⊙
	392.41005-10022100	1	22	100	50	16	100	71							3.2	⊙
	392.41005-100 27 050A	1	27	100	50	18	50	21							2.4	⊙
	392.41005-10027100	1	27	100	50	18	100	71							3.2	⊙
	392.41005-100 32 050A	1	32	100	63	20	50	21							2.8	⊙
	392.41005-10032100	1	32	100	63	20	100	71							4.0	⊙
	392.41005-100 40 060A	1	40	100	80	23	60	31							3.6	⊙
	392.41005-10040100	1	40	100	80	23	100	71							3.6	⊙
	392.41005-10060075	1	60	100	130	29	75			29	17	84			6.3	⊙
125	392.41005-12560085	1	60	125	130	29	85		101.6	29	17	110.5			9.2	⊙

¹⁾ 1 = coolant through center

Coolant tube must be ordered separately, see page G77.

A392.41005

HSK form A/C

Boring

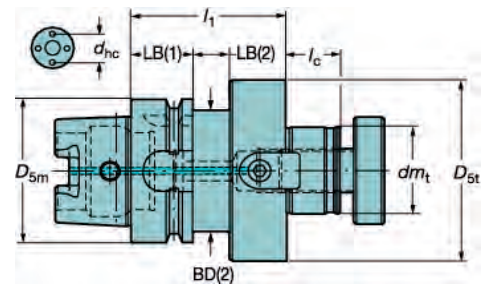
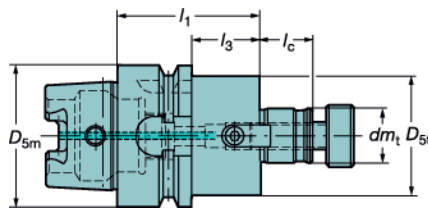
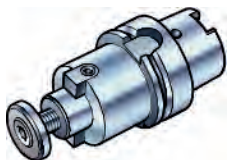

Note: Hole for data carrier is not standard.

l₁ = programming length

Inch pilot

Tooling Systems

HSK size	Ordering code	Coolant ¹⁾	Dimensions, inch											Balanced by design		
			dm _t	D _{5m}	D _{5t}	l _c	l ₁	l ₃	d _{hc}	LB(1)	LB(2)	BD(2)	⊖ _{R63}			
63	A392.41005-63 19 050B	1	.750	2.480	1.693	.709	1.969	.945							2.4	⊙
	A392.41005-63 25 060B	1	1.000	2.480	1.969	.709	2.362	1.339							2.9	⊙
	A392.41005-63 31 065B	1	1.250	2.480	2.756	.709	2.559		1.024	0.630	2.087				3.7	⊙
	A392.41005-63 38 065B	1	1.500	2.480	3.150	.906	2.559		1.024	0.630	2.087				4.9	⊙
100	A392.41005-100 19 050A	1	.750	3.937	1.693	.709	1.969	.827							5.1	⊙
	A392.41005-100 25 050A	1	1.000	3.937	1.969	.709	1.969	.827							5.3	⊙
	A392.41005-100 38 060A	1	1.500	3.937	3.150	.906	2.362	1.220							7.9	⊙
	A392.41005-10063075	1	2.500	3.937	5.118	1.142	2.953		4	1.142	.669	3.445			14.2	⊙
125	A392.41005-12563085	1	2.500	4.921	5.118	1.142	3.346		4	1.142	.669	4.350			20.3	⊙



G152



G65



G2

ER collet chuck

For DIN 6499 collets

392.41014

HSK form A/C

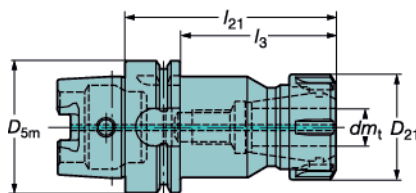
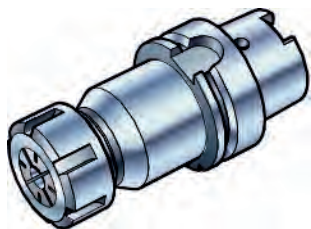

Accessories

Not delivered with the tool, must be ordered separately.

393.14



See page G119.

Note: Hole for data carrier is not standard.

HSK size	Ordering code	Coolant ¹⁾	Dimensions, inch							Collet size
			D_{5m}	dm_1 min	dm_1 max	D_{21}	l_3	l_{21}	$\frac{\sigma}{100}$	
63	392.41014-6325100	1	2.480	.059	.630	1.654	2.913	3.937	2.6	ER 25
	392.41014-63 32 100B	1	2.480	.079	.787	1.968	2.913	3.937	2.8	ER 32
	392.41014-63 40 120B	1	2.480	.118	1.024	2.480	3.701	4.724	4.1	ER 40
100	392.41014-10032100A	1	3.937	.079	.787	1.968	2.795	3.937	5.7	ER 32
	392.41014-10040120A	1	3.937	.118	1.024	2.480	3.583	4.724	7.7	ER 40
	392.41014-10050130A	1	3.937	.236	1.339	3.071	3.976	5.118	9.9	ER 50

1) 1 = coolant through center

Coolant tube must be ordered separately, see page G77.



Endmill holder, Weldon type

Shank according to DIN 6535-HB

392.41020

HSK form A/C

Milling

E

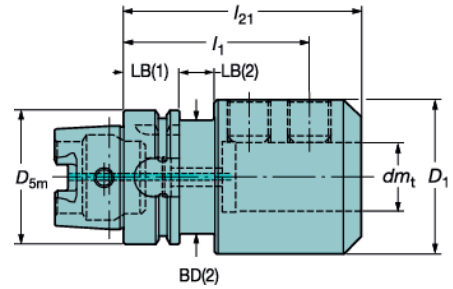
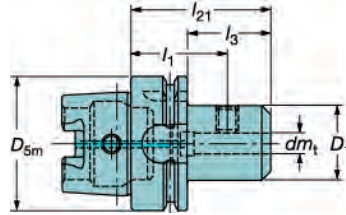

Note: Hole for data carrier is not standard.

l_1 = programming length

Metric bore

Drilling

F

HSK size	Ordering code	Coolant ¹⁾	Dimensions										Balanced by design
			dm_t	D_{5m}	D_1	l_1	l_3	l_{21}	LB(1)	LB(2)	BD(2)	$\frac{\sigma}{kg}$	
63	392.41020-63 08 065B	1	8	63	28	47	39	65				0.9	⊙
	392.41020-63 10 065B	1	10	63	35	45	39	65				1.0	⊙
	392.41020-63 12 080B	1	12	63	42	57.5	54	80				1.2	⊙
	392.41020-63 16 080B	1	16	63	48	56	54	80				1.4	⊙
	392.41020-63 20 080B	1	20	63	52	55	54	80				1.5	⊙
	392.41020-63 25 110B	1	25	63	65	86		110	26	16	53	2.6	⊙
100	392.41020-63 32 110B	1	32	63	72	86		110	26	16	53	2.8	⊙
	392.41020-100 12 080A	1	12	100	42	57.5	51	80				2.8	⊙
	392.41020-100 16 100A	1	16	100	48	76	71	100				3.0	⊙
	392.41020-100 20 100A	1	20	100	52	75	71	100				3.2	⊙
	392.41020-100 25 100A	1	25	100	65	76	71	100				3.7	⊙
	392.41020-100 32 100A	1	32	100	72	76	71	100				4.0	⊙
	392.41020-100 40 120A	1	40	100	90	90		120	29	16	87.5	5.8	⊙

¹⁾ 1 = coolant through center

Coolant tube must be ordered separately, see page G77.

Boring

G

Tooling Systems

J

General Information



G155



G65



G2

Endmill holder, Weldon type

A392.41020

HSK form A/C

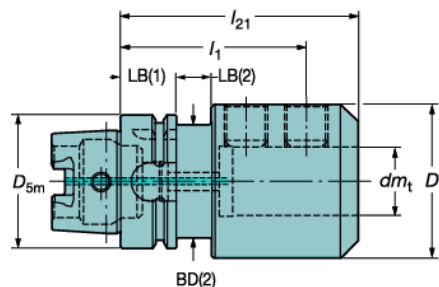
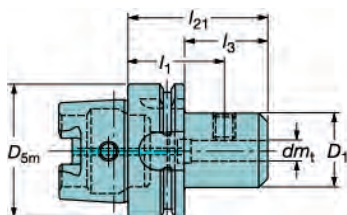
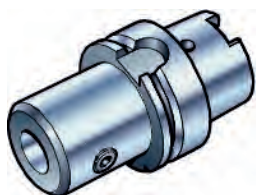

Note: Hole for data carrier is not standard.

l_1 = programming length

Inch bore

HSK size	Ordering code	Coolant ¹⁾	Dimensions, inch										Balanced by design
			dm_t	D_{5m}	D_1	l_1	l_3	l_{21}	LB(1)	LB(2)	BD(2)	$\frac{\sigma}{\text{lbs}}$	
63	A392.41020-63 19 080B	1	.750	2.480	1.750	2.165	2.126	3.150				6.6	⊙
	A392.41020-63 25 105B	1	1.000	2.480	2.250	3.189	3.110	4.134	1.024	0.630	2.087	9.7	⊙
	A392.41020-63 31 105B	1	1.250	2.480	2.480	3.189	3.110	4.134	1.024	0.630	2.087	10.1	⊙
100	A392.41020-100 19 090A	1	.750	3.937	1.750	2.598	2.402	3.543				12.6	⊙
	A392.41020-100 25 100A	1	1.000	3.937	2.250	2.992	2.795	3.937				15.2	⊙
	A392.41020-100 31 100A	1	1.250	3.937	2.480	2.992	2.795	3.937				16.1	⊙
	A392.41020-100 38 110A	1	1.500	3.937	2.756	3.150	3.189	4.331				18.5	⊙
	A392.41020-100 50 130A	1	2.000	3.937	3.661	3.976	3.976	5.118	1.142	0.630	3.445	12.8	⊙

¹⁾ 1 = coolant through center

Coolant tube must be ordered separately, see page G77.



Whistle Notch holder

Shank according to DIN 6535-HE

Short design for carbide drills

Adjustable presetting length

392.41021

HSK form A/C

Milling

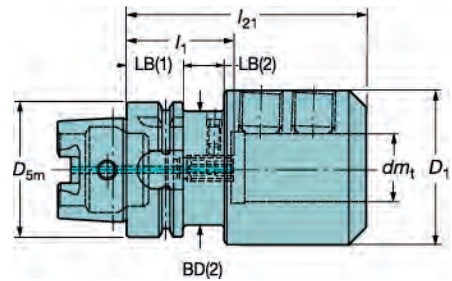
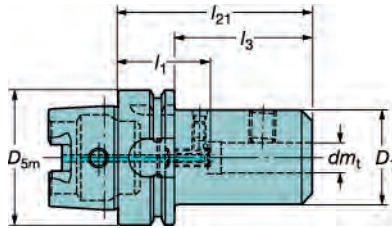
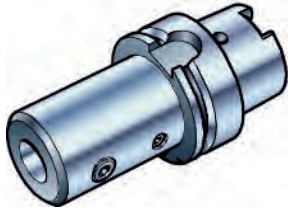

Note: Hole for data carrier is not standard.

l_1 = programming length

Metric bore

Drilling

HSK size	Ordering code	Coolant ¹⁾	Dimensions											
			dm_t	D_1	D_{5m}	l_1 min	max	l_3	l_{21}	LB(1)	LB(2)	BD(2)		
63	392.41021-63 06 080B	1	6	25	63	42	52	54	80					1
	392.41021-63 08 080B	1	8	28	63	42	52	54	80					1
	392.41021-63 10 080B	1	10	35	63	38	48	54	80					1.1
	392.41021-63 12 090B	1	12	42	63	43	53	64	90					1.3
	392.41021-63 16 100B	1	16	48	63	50	60	74	100					1.6
	392.41021-63 20 100B	1	20	52	63	48	58	74	100					1.8
	392.41021-63 25 110B	1	25	65	63	52	62		110	26	24	53		2.6
	392.41021-63 32 110B	1	32	72	63	49	59		110	26	19	53		2.8
100	392.41021-100 10 090A	1	10	35	100	48	58	61	90					2.5
	392.41021-100 12 100A	1	12	42	100	53	63	71	100					2.7
	392.41021-100 16 100A	1	16	48	100	50	60	71	100					2.9
	392.41021-100 20 110A	1	20	52	100	58	68	81	110					3.3
	392.41021-100 25 120A	1	25	65	100	62	72	91	120					4.2
	392.41021-100 32 120A	1	32	72	100	59	69	91	120					4.5

1) 1 = coolant through center

Coolant tube must be ordered separately, see page G77.

Boring

G

Tooling Systems

J



G156



G65



G2

Drill holder, ISO 9766 shank

392.41027

HSK form A/C

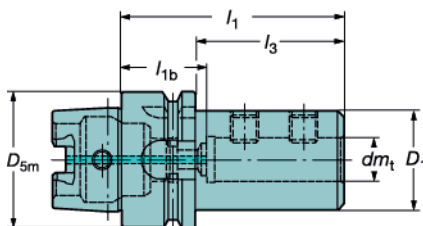
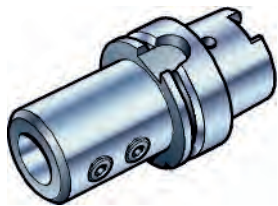

Note: Hole for data carrier is not standard.

l_1 = programming length

Metric bore

HSK size	Ordering code	Coolant ³⁾	Dimensions						
			dm_t	D_{5m}	D_1	$l_1^{1)}$	$l_{1b}^{2)}$	l_3	$\frac{kg}{kg}$
63	392.41027-63 16 080B	1	16	63	36	80	30.5	54	1.1
	392.41027-63 20 080B	1	20	63	40	80	28.5	54	1.1
	392.41027-63 25 090B	1	25	63	45	90	32.5	64	1.2
	392.41027-63 32 090B	1	32	63	52	90	28.5	64	1.3
100	392.41027-100 16 090A	1	16	100	36	90	40.5	61	2.6
	392.41027-100 20 090A	1	20	100	40	90	38.5	61	2.6
	392.41027-100 25 100A	1	25	100	45	100	42.5	71	2.7
	392.41027-100 32 100A	1	32	100	52	100	38.5	71	2.9
	392.41027-100 40 110A	1	40	100	65	110	38.5	81	3.5
	392.41027-100 50 120	1	50	100	75	120	38.5	91	3.8

¹⁾ Programming length for Coromant U drills and CoroDrill® 880.

²⁾ Programming length for Coromant Delta drills.

³⁾ 1 = coolant through center

Coolant tube must be ordered separately, see page G77.



D
Milling
E
Drilling
F
Boring
G
Tooling Systems
J
General Information

TOOLING SYSTEMS HSK solid holding tools

Tap holder

HSK

392.41060 / 392.41061

Without coolant through With through coolant

392.41060 392.41061

Metric bore

Tap range		dm_t	HSK size	Ordering code	Coolant ³⁾	Dimensions								
min	max					D_{5m}	D_1	D_{21}	l_3	l_{21}	-z	+z		Nm ²⁾
M3	M12	19	63	392.41060-6301072	0	63	63	39	46	72	7.5	7.5	0.9	35
M8	M20	31		392.41060-6302110	0	63	63	60	84	110	10	10	1.8	110
M14	M33	48		392.41060-6303141	0	63	63	86	115	141	17.5	17.5	3.3	500
M3	M12	19	100	392.41060-10001080	0	100	100	39	50.5	80	7.5	7.5	2.3	35
M14	M20	31		392.41060-10002100	0	100	100	60	71	100	10	10	3.0	110
M14	M33	48		392.41060-10003144	0	100	100	86	115	144	17.5	17.5	4.9	500
M3	M12	19	63	392.41061-6301105 ¹⁾	1	63	63	39	79	105	7.5	7.5	1.1	35
M8	M20	31		392.41061-6302140 ¹⁾	1	63	63	60	114	140	10	10	2.3	110
M14	M33	48		392.41061-6303203 ¹⁾	1	63	86	86	177	203	17.5	17.5	5.4	500
M3	M12	19	100	392.41061-10001112 ¹⁾	1	100	100	39	83	112	7.5	7.5	2.5	35
M8	M20	31		392.41061-10002144 ¹⁾	1	100	100	60	115	144	10	10	3.7	110
M14	M33	48		392.41061-10003210 ¹⁾	1	100	100	86	181	210	17.5	17.5	7.3	500

¹⁾ Max. cutting fluid pressure 50 bar.

²⁾ Max torque, Nm

³⁾ 0 = no coolant, 1 = coolant through center

For tap adapters, see page G45.

Recommendations:

In order to get the best result from machines not equipped for synchronized tapping, the following recommendations should be observed.

- Program machine feed 10% lower than theoretical value (thread pitch rpm). This enables the tap to cut precisely on pitch.
- • Reduce tapping depth by 10% to avoid tap breakage.
- Note that when tapping deep holes in soft materials, e.g. aluminum, feed and depth should only be reduced by 3-5%.

G141 G65 G2

G 74

Tapping chucks

SynchroFlex® for synchronized tapping

ER-collet type

392.41062 / 392.41063

HSK form A/C

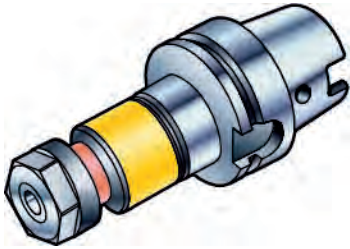

Without coolant through

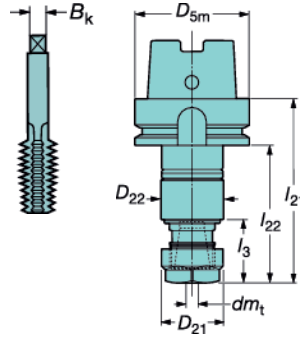

392.41062

With through coolant

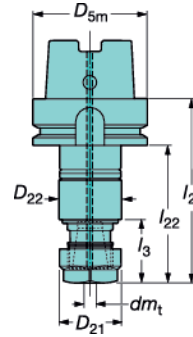

392.41063

Accessories

ER tapping collets

Not delivered with the tool, must be ordered separately.



393.14

See page G119.

For synchronized machines

Tap range		HSK size	Ordering code	Collet size	Coolant ¹⁾	Tap shank dimensions, mm, inch		Dimensions, mm, inch									
min	max					B_k min	B_k max	D_{5m}	dm_t min	dm_t max	D_{21}	D_{22}	l_3	l_{21}	l_{22}	l_{23}	l_{24}
M4	M12	63	392.41062-63 20 102	ER 20	0	3.15	8	63	4	10	34	35	35.4	102.9	76.9	1.0	
						.124	.315	2.480	.157	.394	1.339	1.378	1.394	4.051	3.028		
M8	M20		392.41062-63 25 122	ER 25	0	6.2	12	63	8	16	42	44	37	122.3	96.3	1.4	
						.244	.472	2.480	.315	.630	1.654	1.732	1.457	4.815	3.791		
M16	M30		392.41062-63 40 152	ER 40	0	9	18	63	12	22	63	62	43	151.9	125.9	2.8	
						.354	.709	2.480	.472	.866	2.480	2.441	1.693	5.980	4.957		
M4	M12		392.41063-63 20 107	ER 20	1	3.15	8	63	4	10	34	35	40.5	108	82	1.1	
						.124	.315	2.480	.157	.394	1.339	1.378	1.594	4.252	3.228		
M8	M20		392.41063-63 25 127	ER 25	1	6.2	12	63	8	16	42	44	42.2	127.5	101.5	1.5	
						.244	.472	2.480	.315	.630	1.654	1.732	1.661	5.020	3.996		
M16	M30		392.41063-63 40 157	ER 40	1	9	18	63	12	22	63	62	48	157.4	131.4	2.8	
						.354	.709	2.480	.472	.866	2.480	2.441	1.890	6.197	5.173		
M16	M30	100	392.41062-100 40 159	ER 40	0	9	18	100	12	22	63	62	43	158.4	129.4	4.2	
						.354	.709	3.937	.472	.866	2.480	2.441	1.693	6.236	5.094		
M4	M12		392.41062-10020109	ER 20	0	3.15	8	100	4	10	34	35	35.4	109.4	80.4	2.4	
						.124	.315	3.937	.157	.394	1.339	1.378	1.394	4.307	3.165		
M8	M20		392.41062-10025129	ER 25	0	6.2	12	100	8	16	42	44	37	128.8	99.8	2.8	
						.244	.472	3.937	.315	.630	1.654	1.732	1.457	5.071	3.929		
M16	M30		392.41063-100 40 164	ER 40	1	9	18	100	12	22	63	62	48	163.4	134.4	4.3	
						.354	.709	3.937	.472	.866	2.480	2.441	1.890	6.433	5.291		
M4	M12		392.41063-10020114	ER 20	1	3.15	8	100	4	10	34	35	40.5	114.5	85.5	2.5	
						.124	.315	3.937	.157	.394	1.339	1.378	1.594	4.508	3.366		
M8	M20		392.41063-10025134	ER 25	1	6.2	12	100	8	16	42	44	42.2	134	105	2.9	
						.244	.472	3.937	.315	.630	1.654	1.732	1.661	5.276	4.134		

¹⁾ 0 = no coolant, 1 = coolant through center

* SynchroFlex is a registered trademark of Tapmatic Corp., USA



D
Milling
E
Drilling
F
Boring
G
Tooling Systems
J
General information

Tapping chucks

Collet type

392.41060B
HSK form A/C

Milling

E

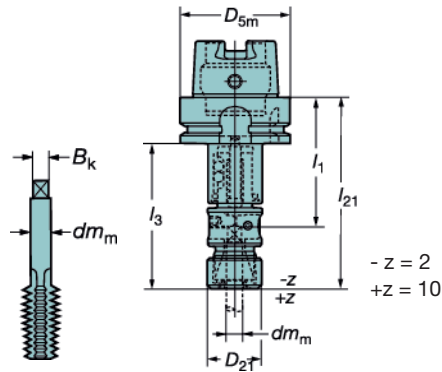
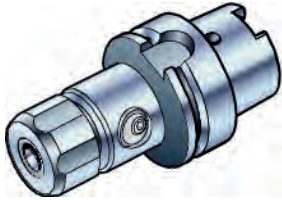

Note: Hole for data carrier is not standard.

Drilling

Floating design

F

Tap range			HSK size	Ordering code	Coolant ¹⁾	Tap shank				Dimensions, mm, inch						
min	max					B_k min	B_k max	dm_m min	dm_m max	D_{5m}	D_{21}	l_1	l_3	l_{21}		Nm
M7	M16		63	392.41060B-63 02 113B	0	2	10	2.8	13	63	40	72	87	113	1.1	60
M7	M16					.079	.394	.110	.512	2.480	1.575	2.835	3.425	4.449	1.1	60
M14	M32			392.41060B-63 03 165B	0	8	18	10	23	63	56.4	110	139	165	2.6	380
M14	M32					.315	.709	.394	.906	2.480	2.220	4.331	5.472	6.496	2.6	380
M7	M16		100	392.41060B-100 02 120 A	0	2	10	2.8	13	100	40	79	91	120	2.6	60
M7	M16					.079	.394	.110	.512	3.937	1.575	3.110	3.583	4.724	2.6	60
M14	M32			392.41060B-100 03 172 A	0	8	18	10	23	100	56.4	117	143	172	4.2	380
M14	M32					.315	.709	.394	.906	3.937	2.220	4.606	5.630	6.772	4.2	380

¹⁾ 0 = no coolant

Coolant tube must be ordered separately, see page G77.
Collets, spanners and keys must be ordered separately.

Boring

G

Collets

Collet size		Ordering code		Shank DIN 374 ¹⁾		Suitable for:
1	3.5-6.5 (.138-.256)		391.60A-OZ J421	M4-M8	(0-1/4)	...01 xxxA
2	6.5-10 (.256-.394)		391.60A-OZ J422	M6-M12	(1/4-9/16)	...01 xxxA
3	2.8-7 (.110-.276)		391.60A-OZ J440	M5M10	(0-1/4)	...02 xxxA
4	7-13 (.276-.512)		391.60A-OZ J443	M7-M16	(5/16-5/8)	...02 xxxA
5	10-16 (.394-.630)		391.60A-OZ J461	M10-M16	(9/16-3/4)	...03 xxxA
6	16-23 (.630-.906)		391.60A-OZ J462	M20-M33	(13/16-1 1/8)	...03 xxxA

¹⁾ For other standards, check shank dimensions B_k and dm_m

Tooling Systems

J



G157



G65



G2

Blanks

392.41050

HSK form A/C

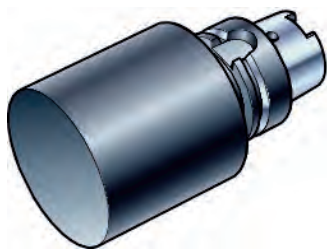

Material: 42 CrMo4
 Tensile strength: 800N/mm²
 HB ≅ 235

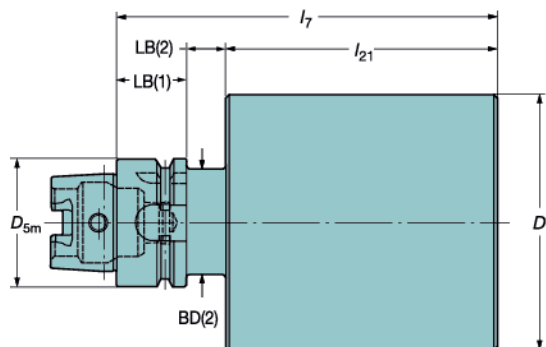

Coolant ¹⁾	HSK size	Ordering code	Dimensions, mm, inch														
			D ₁ mm	D ₁ in.	D _{5m} mm	D _{5m} in.	l ₇ mm	l ₇ in.	l ₂₁ mm	l ₂₁ in.	LB(1) mm	LB(1) in.	LB(2) mm	LB(2) in.	BD(2) mm	BD(2) in.	RS
0	63	392.41050-63 64 250A	64	2.520	63	2.480	250	9.842	208	8.189	26	1.024	16	.630	53	2.087	6.3
0		392.41050-63 130 150A	130	5.118	63	2.480	150	5.906	108	4.252	26	1.024	16	.630	53	2.087	12.2
0	100	392.41050-100104250A	104	4.094	100	3.937	250	9.842	205	8.071	29	1.142	16	.630	87.5	3.445	16.4
0		392.41050-100 145 200A	145	5.709	100	3.937	200	7.874	155	6.102	29	1.142	16	.630	87.5	3.445	22.4

¹⁾ 0 = no coolant

Note: These HSK blanks are equipped with a thread inside the HSK coupling to allow for connection of a coolant tube.

If localized hardening is required, induction type hardening is suggested.

Coolant tube

For solid HSK assortment

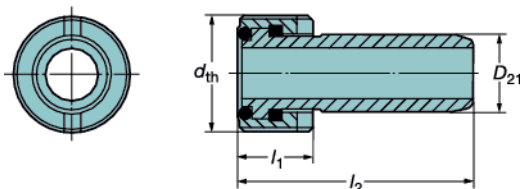

HSK size	Ordering code	Dimensions, mm, inch				
		D ₂₁	d _{th}	l ₁	l ₂	RS
63	5692 022-04	12	M18x1	11.5	36.5	0.03
		.472	M18x1	.453	1.437	
100	5692 022-06	16	M24x1.5	15.5	44.5	0.05
		.630	M24x1.5	.610	1.752	
125	5692 022-07	18	M30x1.5	17.5	48	0.08
		.709	M30x1.5	.689	1.890	

Key for coolant tube must be ordered separately, see spare parts.

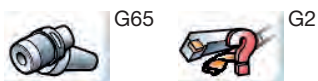

Hydro-Grip®

High precision chuck

Stable and secure machining for every need

The secret with Hydro-Grip is the precise symmetrical clamping. This makes it possible to get very high run-out accuracy. When you have good run-out all teeth of your tool is cutting. When all teeth are cutting you get better surface quality, prevent vibrations and prolong tool life. All together you save money.



Bore diameter, mm (inch)

32 (1.260)

25 (.984)

20 (.787)

16 (.630)

12 (.472)

6 (.236)

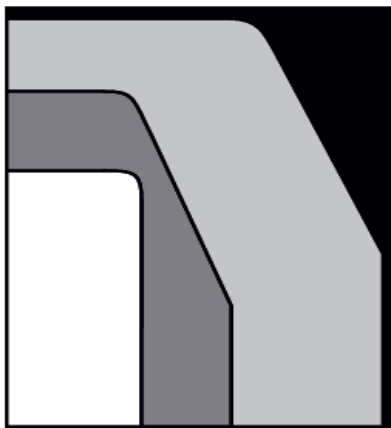

Finishing

Roughing

- Hydro-Grip pencil
- Hydro-Grip slender
- Hydro-Grip short
- Hydro-Grip HD

Low runout

Prolong tool life
Improve surface quality
Prevent vibrations

Highest clamping force on market

Improved cutting data
Higher productivity
Secure machining

Easy to clamp

Time saving in set up
User friendly for operator
Correct clamping independent of use.

Individual balanced products

Enables high speed machining
Increased productivity

* Hydro-Grip is a registered trademark of ETP Transmission AB.

HydroGrip® Face mill holder

Precise concentric location to eliminate radial runout

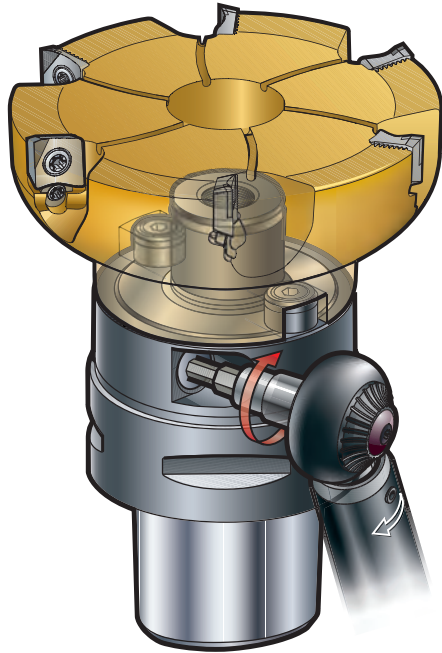

When machining with high performing Face mills it is very important to also use a high performing tool holder. Otherwise you will not get any advantages compared to a normal face mill. The hydraulic expanding arbor provides precise concentric location to eliminate radial run out. Balanced to g 2.5 at 23 000 rpm for the smallest size. It is your best choice for high speed machining without vibration.

Hydro-Grip® Face mill holder is the perfect partner to Coromill® Century in finishing milling, where minimal radial run out ensures an even tooth load and wear pattern. This, in turn, secures an improved tool life and surface finish in high demanding, shoulder face milling operations

Low runout

- Prolong tool life
- Improve surface quality
- Prevent vibrations

Easy to clamp

- Time saving in set up
- User friendly for operator
- Correct clamping independent of use.

Individual balanced products

- Enables high speed machining
- Increased productivity

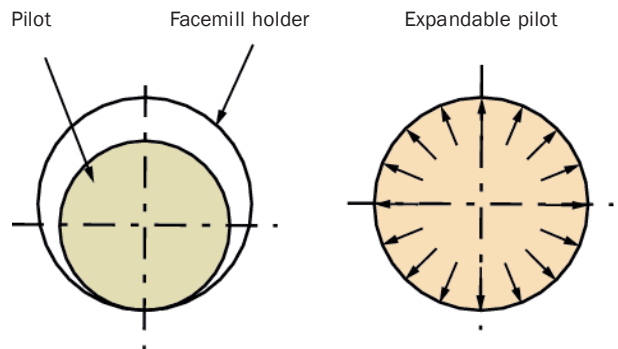

Conventional competitor tool holder

* Hydro-Grip is a registered trademark of ETP Transmission AB.

Hydro-Grip HD

High precision chuck adapter

Coromant Capto®
391.CGD

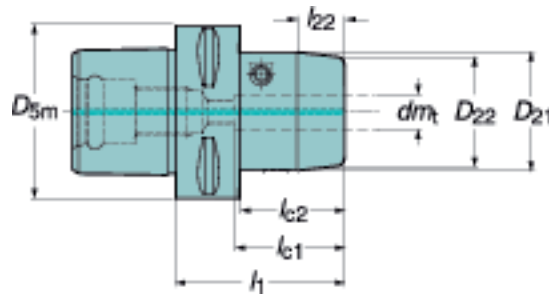
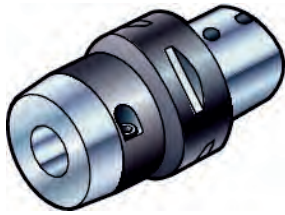

Accessories

Not delivered with the tool, must be ordered separately. 393.CG 393.CGS

Adjustment screw 5512 100-03



See main catalog.

l_1 = programming length

Coupling size	Ordering code	Coolant ¹⁾	Dimensions, mm, inch										BLQ ²⁾	NBLQ ³⁾	Collet size
			D_{5m}	dm_t	D_{21}	D_{22}	l_1	l_{22}	l_{c1}	l_{c2}	$\frac{\sigma}{\mu s}$				
C5	C5-391.CGD-20 079	1	50	20	63	59	79	17	52		1.6	2.5	25000	20	
			1.968	.787	2.480	2.323	3.110	.669	2.047						
C6	C6-391.CGD-20 073	1	63	20	63	59	73	17	52		1.8	2.5	25000	20	
			2.480	.787	2.480	2.323	2.874	.669	2.047						
	C6-391.CGD-25 080	1	63	25	74	70	80	17	56		2.4	2.5	25000	25	
			2.480	.984	2.913	2.756	3.150	.669	2.205						
C6-391.CGD-32 086	1	63	32	80	76	86	17	60		2.8	2.5	25000	32		
		2.480	1.260	3.150	2.992	3.386	.669	2.362							
C8	C8-391.CGD-20 079	1	80	20	63	59	79	17	52	49	2.8	2.5	14000	20	
			3.150	.787	2.480	2.323	3.110	.669	2.047	1.929					
	C8-391.CGD-25 083	1	80	25	74	70	83	17	56	53	3.3	2.5	14000	25	
			3.150	.984	2.913	2.756	3.268	.669	2.205	2.087					
C8-391.CGD-32 087	1	80	32	80	76	87	17	60		3.5	2.5	14000	32		
		3.150	1.260	3.150	2.992	3.425	.669	2.362							
C10	C10-391.CGD-20 085	1	100	20	63	59	85	17	52	49	4.5	2.5	14000	20	
			3.937	.787	2.480	2.323	3.346	.669	2.047	1.929					
	C10-391.CGD-25 089	1	100	25	74	70	89	17	56	53	5.0	2.5	14000	25	
			3.937	.984	2.913	2.756	3.504	.669	2.205	2.087					

¹⁾ 1 = coolant through center

²⁾ Balance quality code.

³⁾ Rotational speed at balance quality.

Adjustment screws must be ordered separately, see page G118



G161



G6



G2

Hydro-Grip short

High precision adapter for facemills and square shoulder facemills

High precision chuck adapter

Short version
Coromant Capto®
391.CGA

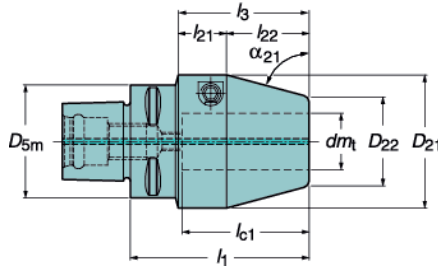

Accessories

Not delivered with the tool, must be ordered separately. 393.CG 393.CGS

Adjustment screw 5512100-xx



Page G115

l₁ = programming length

Machine design	Taper	Ordering code	Coolant ¹⁾	Dimensions, mm, inch										BLQ ²⁾	NBLQ ³⁾	Collet size
				dm ₁	D ₂₁	D ₂₂	h ₁	l ₃	l ₂₁	l ₂₂	l ₁	kg				
Coromant Capto	C4	C4-391.CGA-12 062A	1	12	43.5	19.8	62		21.000	20.5	40	0.6	2.5	25000	12	
		C4-391.CGA-12 100	1	.472	1.713	.780	2.441		.827	.807	1.575		2.5	25000	12	
			1	.472	1.713	.780	3.937		.827	.807	1.575		2.5	25000	12	
		C4-391.CGA-20 075	1	20	52	28.3	75		20.900	32.5	52	0.8	2.5	25000	20	
		1	.787	2.047	1.114	2.953		.823	1.280	2.047		2.5	25000	20		
	C5	C5-391.CGA-12 062	1	12	43.5	19.8	62	42	21.500	20.5	40	0.8	2.5	25000	12	
		C5-391.CGA-20 074A	1	.472	1.713	.780	2.441	1.654	.846	.807	1.575		2.5	25000	12	
			1	.787	2.047	1.114	2.913		.835	1.280	2.047	1.0	2.5	25000	20	
		C5-391.CGA-20 125	1	20	52	28.3	125		21.200	32.5	52	1.8	2.5	25000	20	
		1	.787	2.047	1.114	4.921		.835	1.280	2.047		2.5	25000	20		
	C6	C6-391.CGA-25 079	1	25	59	39.4	79		21.300	36.5	56	1.3	2.5	25000	25	
			1	.984	2.323	1.551	3.110		.839	1.437	2.205		2.5	25000	25	
C6-391.CGA-12 064		1	12	43.5	19.8	64	42	21.500	20.5	40	1.1	2.5	25000	12		
C6-391.CGA-20 076		1	.472	1.713	.780	2.520	1.654	.846	.807	1.575		2.5	25000	12		
	1	.787	2.047	1.114	2.992	2.126	.846	1.280	2.047	1.4	2.5	25000	20			
	1	.787	2.047	1.114	5.906	5.039	3.760	1.280	2.047	2.6	2.5	25000	20			
	1	.787	2.047	1.114	5.906	5.039	3.760	1.280	2.047		2.5	25000	20			
	1	.984	2.323	1.551	3.150	2.284	.846	1.437	2.205	1.6	2.5	25000	25			
	1	.984	2.323	1.551	3.150	2.284	.846	1.437	2.205		2.5	25000	25			
	1	32	69.5	47.8	84		20.600	40.5	60	1.9	2.5	25000	32			
	1	1.260	2.736	1.882	3.307		.811	1.594	2.362		2.5	25000	32			
C8	C8-391.CGA-20 079	1	20	52	28.3	79	49	16.500	32.5	52	2.3	2.5	14000	20		
		1	.787	2.047	1.114	3.110	1.929	.650	1.280	2.047		2.5	14000	20		
	C8-391.CGA-25 083	1	25	59	39.4	83	53	16.500	36.5	56	2.5	2.5	14000	25		
		1	.984	2.323	1.551	3.268	2.087	.650	1.437	2.205		2.5	14000	25		
	1	.984	2.323	1.551	3.268	2.087	.650	1.437	2.205		2.5	14000	25			
	1	32	69.5	47.8	87	57	16.500	40.5	60	2.8	2.5	14000	32			
	1	1.260	2.736	1.882	3.425	2.244	.650	1.594	2.362		2.5	14000	32			

1) 1 = coolant through center
2) Balance quality code.
3) Rotational speed at balance quality.



D
E
F
G
J

TOOLING SYSTEMS Hydro-Grip - Coromant Capto tools

Hydro-Grip slender
High precision chuck adapter
Slender version

Coromant Capto®
391.CGC



Accessories
Not delivered with the tool, must be ordered separately.

Adjustment screw
5512100-xx

Page G115

l_1 = programming length

Coupling size	Ordering code	Coolant ¹⁾	Dimensions, mm, inch											BLQ ²⁾	NBLQ ³⁾	Collet size	
			D_{5m}	dm_t	D_1	D_{21}	D_{22}	l_1	l_{22}	l_{23}	l_{c1}	$l_{c2}^{4)}$	$R_{0.05}$				
C4	C4-391.CGC-12 081	1	40	12	40	32	28	81	10			40	35	0.7	2.5	25000	25
			1.575	.472	1.575	1.260	1.102	3.189	.394				1.575	1.378			25000
	C4-391.CGC-12 100	1	40	12	40	32	28	100	10			40	35	0.9	2.5	25000	12
			1.575	.472	1.575	1.260	1.102	3.937	.394				1.575	1.378			25000
	C4-391.CGC-20 101	1	40	20	50	40	36	101	10			52	46	1.0	2.5	25000	20
			1.575	.787	1.968	1.575	1.417	3.976	.394				2.047	1.811			25000
C5	C5-391.CGC-12 085	1	50	12	40	32	28	85	10	20	40	35	0.9	2.5	25000	12	
			1.968	.472	1.575	1.260	1.102	3.346	.394	.787	1.575	1.378					25000
	C5-391.CGC-20 093	1	50	20	50	40	36	93	10			52	46	1.1	2.5	25000	20
			1.968	.787	1.968	1.575	1.417	3.661	.394				2.047	1.811			25000
	C5-391.CGC-25 097	1	50	25	50	45	41	97	10			56	50	1.2	2.5	25000	25
			1.968	.984	1.968	1.772	1.614	3.819	.394				2.205	1.968			25000
C6	C6-391.CGC-12 087	1	63	12	40	32	28	87	10	65	40	35	1.2	2.5	25000	12	
			2.480	.472	1.575	1.260	1.102	3.425	.394	2.559	1.575	1.378					25000
	C6-391.CGC-20 097	1	63	20	50	40	36	97	10	75	52	46	1.5	2.5	25000	20	
			2.480	.787	1.968	1.575	1.417	3.819	.394	2.953	2.047	1.811					25000
	C6-391.CGC-20 150	1	63	20	50	40	36	150	10	128	52	46	2.3	2.5	25000	20	
			2.480	.787	1.968	1.575	1.417	5.906	.394	5.039	2.047	1.811					25000
	C6-391.CGC-25 101	1	63	25	50	45	41	101	10	79	56	50	1.6	2.5	25000	25	
			2.480	.984	1.968	1.772	1.614	3.976	.394	3.110	2.205	1.968					25000
C8	C8-391.CGC-20 103	1	80	20	50	40	36	103	10	72	52	46	2.5	2.5	14000	20	
			3.150	.787	1.968	1.575	1.417	4.055	.394	2.835	2.047	1.811					14000
	C8-391.CGC-25 107	1	80	25	50	45	41	107	10	76	56	50	2.6	2.5	14000	25	
			3.150	.984	1.968	1.772	1.614	4.213	.394	2.992	2.205	1.968					14000

1) 1 = coolant through center
 2) Balance quality code.
 3) Rotational speed at balance quality.
 4) Min. clamping length

G159 G6 G2

G 82

General Information

Hydro-Grip pencil

High precision chuck adapter
Coromant Capto®

Pencil type
391.CGB

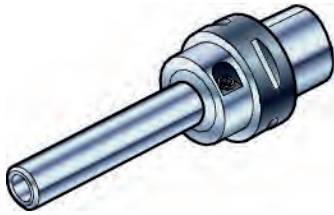

Design 1

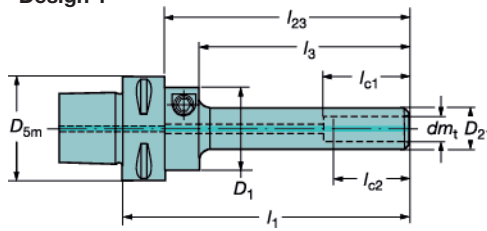

Design 2

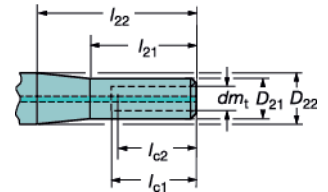

Design 3

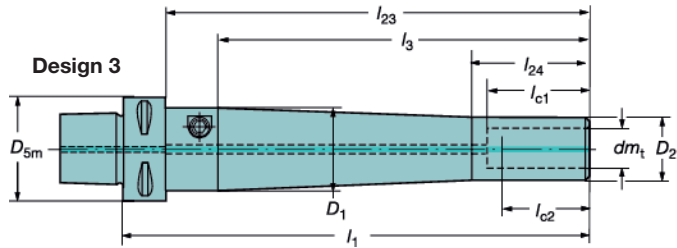

Accessories

Not delivered with the tool, must be ordered separately. 393.CG
393.CGS

Adjustment screw 5512100-xx



Page G115

l₁ = programming length

Coupling size	Design	Ordering code	Coolant ⁴⁾	Dimensions, mm, inch																BLQ ²⁾	NBLQ ³⁾	Collet size
				dm _t	D ₁	D ₂₁	D ₂₂	D _{5m}	l ₁	l ₃	l ₂₃	l ₂₄	l _{c1}	l _{c2}	b ₁	b ₂	b ₃	b ₄	k ₁			
C4	1	C4-391.CGB-06 086	1	6	40	12		40	86	50							40	37	0.5	2.5	25000	6
	1		1	.236	1.57	.472		1.57	3.38	1.96							1.57	1.45			25000	6
	1	C4-391.CGB-12 098A	1	12	40	19.5		40	98	50							40	37	0.7	2.5	25000	12
	1		1	.472	1.57	.768		1.57	3.85	1.96							1.57	1.45			25000	12
	1	C4-391.CGB-12 148A	1	12	40	19.5		40	148	100							40	37	0.8	2.5	15000	12
	1		1	.472	1.57	.768		1.57	5.82	3.93							1.57	1.45			15000	12
C4	2	C4-391.CGB-12 198A	1	12	40	19.5	24.5	40	198	150	50	75				40	37	0.9	2.5	10000	12	
	2		1	.472	1.57	.768	.965	1.57	7.79	5.90	1.96	2.95				1.57	1.45			10000	12	
	C5	1	C5-391.CGB-06 086	1	6	40	12		50	86	50			66			40	37	0.5	2.5	25000	6
		1		1	.236	1.57	.472		1.96	3.38	1.96			2.59			1.57	1.45			25000	6
		1	C5-391.CGB-12 086	1	12	40	19.5		50	86	50			66			40	37	1.0	2.5	25000	12
		1		1	.472	1.57	.768		1.96	3.38	1.96			2.59			1.57	1.45			25000	12
1		C5-391.CGB-12 136	1	12	40	19.5		50	136	100			116			40	37	1.1	2.5	15000	12	
1			1	.472	1.57	.768		1.96	5.35	3.93			4.56			1.57	1.45			15000	12	
C5	2	C5-391.CGB-12 186	1	12	40	19.5	24.5	50	186	150	50	75	166			40	37	1.2	2.5	10000	12	
	2		1	.472	1.57	.768	.965	1.96	7.32	5.90	1.96	2.95	6.53			1.57	1.45			10000	12	
	3	C5-391.CGB-20 158A	1	20	40	32		50	158	110			138	60	52	49	1.3	2.5	20000	20		
	3		1	.787	1.57	1.26		1.96	6.22	4.33			5.43	2.36	2.04	1.92					20000	20
	3	C5-391.CGB-20 238A	1	20	40	32		50	238	190			218	60	52	49	1.7	2.5	10000	20		
	3		1	.787	1.57	1.26		1.96	9.37	7.48			8.58	2.36	2.04	1.92					10000	20
C6	1	C6-391.CGB-06 088	1	6	40	12		63	88	50			66			40	37	1.9	2.5	25000	6	
	1		1	.236	1.57	.472		2.48	3.46	1.96			2.59			1.57	1.45			25000	6	
	1	C6-391.CGB-12 092A	1	12	40	19.5		63	92	50			70			40	37	1.1	2.5	25000	12	
	1		1	.472	1.57	.768		2.48	3.62	1.96			2.75			1.57	1.45			25000	12	
	1	C6-391.CGB-12 142A	1	12	40	19.5		63	142	100			120			40	37	1.3	2.5	15000	12	
	1		1	.472	1.57	.768		2.48	5.59	3.93			4.72			1.57	1.45			15000	12	
	2	C6-391.CGB-12 192A	1	12	40	19.5	24.5	63	192	150	50	75	170			40	37	1.5	2.5	10000	12	
	2		1	.472	1.57	.768	.965	2.48	7.55	5.90	1.96	2.95	6.69			1.57	1.45			10000	12	
	3	C6-391.CGB-20 152A	1	20	40	32		63	152	110			130	60	52	49	1.9	2.5	20000	20		
	3		1	.787	1.57	1.26		2.48	5.98	4.33			5.11	2.36	2.04	1.92					20000	20
	3	C6-391.CGB-20 232A	1	20	40	32		63	232	190			210	60	52	49	2.9	2.5	10000	20		
	3		1	.787	1.57	1.26		2.48	9.13	7.48			8.26	2.36	2.04	1.92					10000	20
C8	1	C8-391.CGB-12 100	1	12	40	19.5		80	100	50			70			40	37	2.2	2.5	14000	12	
	1		1	.472	1.57	.768		3.15	3.93	1.96			2.75			1.57	1.45			14000	12	
	1	C8-391.CGB-12 150	1	12	40	19.5		80	150	100			120			40	37	2.4	2.5	14000	12	
	1		1	.472	1.57	.768		3.15	5.90	3.93			4.72			1.57	1.45			14000	12	
	2	C8-391.CGB-12 200	1	12	40	19.5	24.5	80	200	150	50	75	170			40	37	2.4	2.5	14000	12	
	2		1	.472	1.57	.768	.965	3.15	7.87	5.90	1.96	2.95	6.69			1.57	1.45			14000	12	
	3	C8-391.CGB-20 160	1	20	40	32		80	160	110			130	60	52	49	2.7	2.5	14000	20		
	3		1	.787	1.57	1.26		3.15	6.29	4.33			5.11	2.36	2.04	1.92					14000	20
	3	C8-391.CGB-20 240	1	20	40	32		80	240	190			210	60	52	49	3.3	2.5	14000	20		
	3		1	.787	1.57	1.26		3.15	9.44	7.48			8.26	2.36	2.04	1.92					14000	20

1) Min. clamping length
2) Balance quality code.

3) Rotational speed at balance quality.
4) 1 = coolant through center



G159



G6



G2

Hydro-Grip®

High precision adapter for facemills and square shoulder facemills

Coromant Capto®

391.05CG

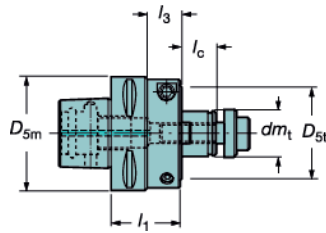
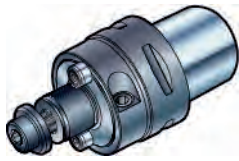

All holders are delivered with a standard screw without hole for coolant.
For cutters with coolant channels a new screw with radial coolant holes is necessary and can be ordered separately.
See page G154.

l_1 = programming length

Metric pilot

Coupling size	Ordering code	Coolant ¹⁾	Dimensions								BLQ ²⁾	NBLQ ³⁾
			dm_t	D_{5m}	D_{5t}	l_c	l_1	l_3	$\frac{m}{kg}$			
C5	C5-391.05CG-22 048	1	22	50	48	19	48	28	0.8	2.5	23000	
	C5-391.05CG-27 048	1	27	50	48	21	48	28	1.0	2.5	14000	
	C5-391.05CG-32 052	1	32	50	63	24	52	32	1.3	2.5	11200	
C6	C6-391.05CG-22 050	1	22	63	48	19	50	28	1.2	2.5	23000	
	C6-391.05CG-27 050	1	27	63	53	21	50	28	1.3	2.5	14000	
	C6-391.05CG-32 050	1	32	63	63	24	50		1.5	2.5	11200	
C6	C6-391.05CG-40 054	1	40	63	76	27	54	32	2.0	2.5	8900	
	C8	C8-391.05CG-22 050	1	22	80	48	19	50	20	2.1	2.5	14000
		C8-391.05CG-27 050	1	27	80	53	21	50	20	2.2	2.5	14000
C8-391.05CG-32 050		1	32	80	63	24	50	20	2.4	2.5	12000	
C8	C8-391.05CG-40 050	1	40	80	76	27	50	20	2.6	2.5	8900	

1) 1 = coolant through center

2) Balance quality code.

3) Rotational speed at balance quality.



G159



G6



G2

Hydro-Grip HD

High precision chuck

392.45CGD/.272CGD/.55CGD

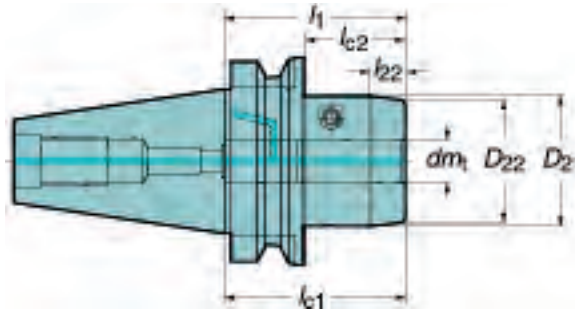
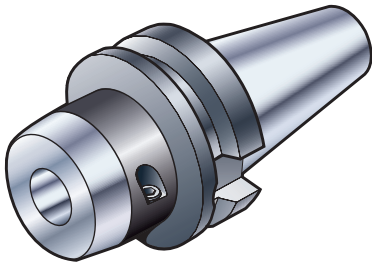

Accessories

Not delivered with the tool, must be ordered separately. 393.CG 393.CGS

Adjustment screw 5512 100-03



Page G115

l_1 = programming length

Metric version

Machine design	Taper	Ordering code	Coolant ¹⁾	Dimensions									BLQ ²⁾	NBLQ ³⁾	Collet size
				dm_t	D_{21}	D_{22}	l_1	l_{22}	l_{c1}	l_{c2}	σ_{10}				
ISO7388.1	40	392.272CGD-40 20 090	7	20	63	59	90	17	90	71	2.1	2.5	25000	20	
	50	392.272CGD-50 20 068	7	20	63	59	68	17	68	49	3.6	2.5	14000	20	
		392.272CGD-50 25 079	7	25	74	70	79	17	79	60	4.2	2.5	14000	25	
MAS-BT 403	40	392.272CGD-50 32 083	7	32	80	76	83	17	83	64	4.6	2.5	14000	32	
		392.55CGD-40 20 079	7	20	63	59	79	17	79	79	2.0	2.5	25000	20	
	50	392.55CGD-50 20 087	7	20	63	59	87	17	87	49	4.6	2.5	14000	20	
	50	392.55CGD-50 25 091	7	25	74	70	91	17	91	53	5.0	2.5	14000	25	
		392.55CGD-50 32 095	7	32	80	76	95	17	95	57	5.3	2.5	14000	32	

Machine design	Taper	Ordering code	Coolant ¹⁾	Dimensions, mm, inch									BLQ ²⁾	NBLQ ³⁾	Collet size
				dm_t	D_{21}	D_{22}	l_1	l_{22}	l_{c1}	l_{c2}	σ_{10}				
CAT V	40	392.45CGD-40 20 090	7	20	63	59	90	17	90	71	2.1	2.5	25000	20	
				.787	2.480	2.323	3.543	.669	3.543	2.795					
	50	392.45CGD-50 20 068	7	20	63	59	68	17	68	49	3.5	2.5	14000	20	
				.787	2.480	2.323	2.677	.669	2.677	1.929					
				25	74	70	92	17	92	73	4.6				2.5
.984	2.913	2.756	3.622	.669	3.622	2.874									
	50	392.45CGD-50 32 097	7	32	80	76	97	17	97	78	4.9	2.5	14000	32	
				1.260	3.150	2.992	3.819	.669	3.819	3.071					

1) 7 = coolant through center and through flange
 2) Balance quality code.
 3) Rotational speed at balance quality.

Note: Toolholders are convertible to coolant through flange by removing two screws on the back of the V-Flange.



Hydro-Grip short

High precision chuck

392.272CG/ .55CG

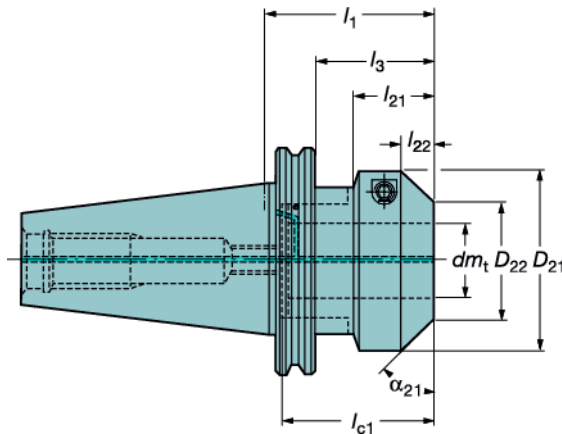

Accessories

Not delivered with the tool, must be ordered separately.

Adjustment screw
5512100-xx



Page G115

 l_1 = programming length

Machine design	Taper	Ordering code	Coolant ⁴⁾	Dimensions, mm, inch											BLQ ⁵⁾	NBLQ ⁶⁾	Collet size	
				dm_1	D_{21}	D_{22}	l_1	l_3	l_{21}	l_{22}	l_{c1}	α_{21}	$\frac{m}{kg}$					
CAT V	40	392.45CG-40 12 056	7	12	43.5	19.8	56	36.9				20.5	40	60	1.2	2.5	25000	12
		392.45CG-40 20 060 ¹⁾	7	.472	1.713	.780	2.205	1.453				.807	1.575	60		2.5	25000	12
		392.45CG-40 20 125	7	.787	2.047	1.075	2.362	1.610	.720	.177	2.047	20				2.5	25000	20
		392.45CG-40 25 064	7	25	59	37.6	64	44.9	26.80	7.5	56	35	1.4	2.5	14000	25		
		392.45CG-40 20 125	7	.984	2.323	1.480	2.520	1.768	1.055	.295	2.205	35				2.5	14000	25
		392.45CG-40 20 125	7	.787	2.047	1.114	4.921	4.169	.803	1.280	2.047	70	2.0	2.5	25000	20		
	50	392.45CG-50 20 060 ²⁾	7	20	52	29.2	60	40.9				24.5	52	65	3.2	2.5	14000	20
		392.45CG-50 20 125	7	.787	2.047	1.150	2.362	1.610				.965	2.047	65		2.5	14000	20
		392.45CG-50 25 064	7	25	59	38.3	64	44.9				28.5	56	70	3.4	2.5	14000	25
		392.45CG-50 20 125	7	.984	2.323	1.508	2.520	1.768				1.122	2.205	70		2.5	14000	25
		392.45CG-50 32 068 ³⁾	7	32	69.5	46.6	68	48.9				31.5	60	70	3.6	2.5	14000	32
		392.45CG-50 32 068 ³⁾	7	1.260	2.736	1.835	2.677	1.925				1.240	2.362	70		2.5	14000	32

Machine design	Taper	Ordering code	Coolant ⁴⁾	Dimensions											BLQ ⁵⁾	NBLQ ⁶⁾	Collet size
				dm_1	D_{21}	D_{22}	l_1	l_3	l_{21}	l_{22}	l_{c1}	$\frac{m}{kg}$					
ISO7388.1	40	392.272CG-40 12 056	7	12.0	43.5	19.8	56.0	36.9				20.5	40.0	1.1	2.5	25000	12
		392.272CG-40 20 060A	7	20.0	52.0	27.3	60.0	40.9	23.8	4.5	52.0	1.3	2.5	25000	20		
		392.272CG-40 20 125	7	20.0	52.0	28.3	125.0	105.9	51.8	32.5	52.0	1.9	2.5	25000	20		
	50	392.272CG-40 25 064	7	25.0	59.0	37.6	64.0	44.9	26.8	7.5	56.0	1.4	2.5	25000	25		
		392.272CG-50 20 060	7	20.0	52.0	29.2	60.0	40.9				24.5	52.0	3.2	2.5	14000	20
		392.272CG-50 25 064	7	25.0	59.0	38.3	64.0	44.9				28.5	56.0	3.3	2.5	14000	25
		392.272CG-50 25 150	7	25.0	59.0	39.4	150.0	130.9				36.5	56.0	5.1	2.5	14000	25
392.272CG-50 32 068A	7	32.0	69.5	46.6	68.0	48.9				31.5	60.0	3.5	2.5	14000	32		
MAS-BT 403	40	392.55CG-40 12 052	7	12.0	43.5	19.3	52.0	25.0				8.5	40.0	1.2	2.5	25000	12
		392.55CG-40 20 056A	7	20.0	52.0	26.0	56.0	29.0				13.0	52.0	1.3	2.5	25000	20
		392.55CG-40 20 125	7	20.0	52.0	28.3	125.0	98.0				32.5	52.0	2.3	2.5	25000	20
	50	392.55CG-40 25 060	7	25.0	59.0	39.4	60.0	33.0				17.0	56.0	1.4	2.5	25000	25
		392.55CG-50 20 067	7	20.0	52.0	26.0	67.0	29.0				13.0	52.0	4.1	2.5	14000	20
		392.55CG-50 25 071	7	25.0	59.0	39.4	71.0	33.0				17.0	56.0	4.2	2.5	14000	25
		392.55CG-50 25 150	7	25.0	59.0	39.4	150.0	112.0				36.5	56.0	5.7	2.5	14000	25
392.55CG-50 32 075A	7	32.0	69.5	45.8	75.0	37.0				20.5	60.0	4.3	2.5	14000	32		

- 1) 392.45CG-40 20 060 replaces 40 MM-VF 060 CG20
- 2) 392.45CG-50 20 060 replaces 50 MM-VF 060 CG20
- 3) 392.45CG-50 32 068 replaces 50 MM-VF 068 CG32
- 4) 7 = coolant through center and through flange
- 5) Balance quality code.
- 6) Rotational speed at balance quality.

Note: Toolholders are convertible to coolant through flange by removing two screws on the back of the V-Flange.



G161



G49



G2

Hydro-Grip pencil

High precision chuck

Pencil type

Metric bore
392.272CGB/.55CGB
392.45CGB

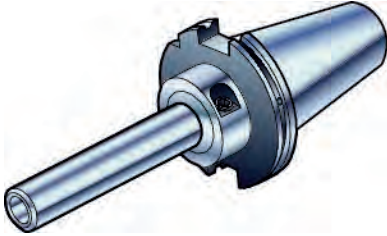

Design 1

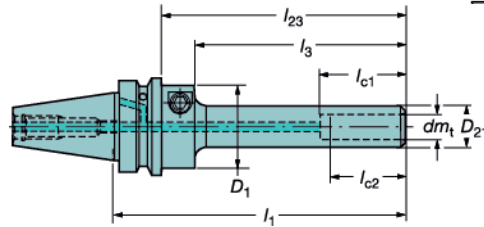

Design 2

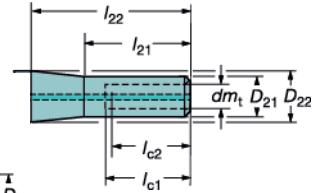

Design 3

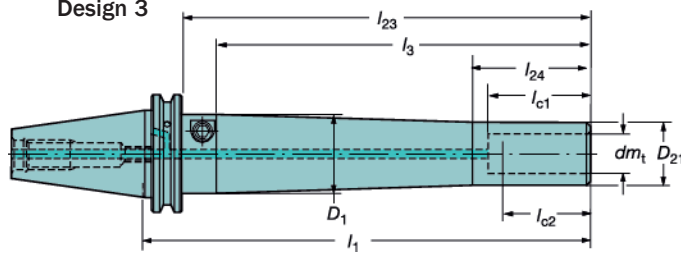

Accessories

Not delivered with the tool, must be ordered separately. 393.CG 393.CGS

Adjustment screw 5512 100-03



See page G115.

l_1 = programming length

Cat V-Flange

Design	Taper	Ordering code	Coolant ¹⁾	Dimensions, mm, inch											BLQ ³⁾	NBLQ ⁴⁾	Collet size
				dm_t	D_1	D_{21}	l_1	l_3	l_{23}	l_{24}	l_{c1}	$l_{c2}^{2)}$	ρ_{kg}				
1	40	392.45CGB-40 12 086	7	12	40	19.5	86	50	66.95			40	37	1.1	2.5	25000	12
1		392.45CGB-40 12 136	7	.472	1.575	.768	3.386	1.968	2.636			1.575	1.457	1.2	2.5	15000	
3		392.45CGB-40 20 146	7	20	40	32	146	110	126.9	60	52	49	1.6	2.5	20000	20	
				.787	1.575	1.260	5.748	4.331	4.998	2.362	2.047	1.929					

ISO 7388/I

Design	Taper	Ordering code	Coolant ¹⁾	Dimensions											BLQ ³⁾	NBLQ ⁴⁾	Collet size		
				dm_t	D_1	D_{21}	D_{22}	l_1	l_3	l_{21}	l_{22}	l_{23}	l_{24}	l_{c1}				$l_{c2}^{2)}$	ρ_{kg}
1	40	392.272CGB-40 12 085	7	12	40	19.5		85	50			65.9		40	37	1.1	2.5	25000	12
1		392.272CGB-40 12 135	7	12	40	19.5		135	100			115.9		40	37	1.2	2.5	15000	
2		392.272CGB-40 12 185	7	12	40	19.5	24.5	185	150	50	75	165.9		40	37	1.4	2.5	10000	
3		392.272CGB-40 20 225	7	20	40	32		225	190			205.9	60	52	49	2.2	2.5	10000	20

MAS-BT 403

Design	Taper	Ordering code	Coolant ¹⁾	Dimensions											BLQ ³⁾	NBLQ ⁴⁾	Collet size		
				dm_t	D_1	D_{21}	D_{22}	l_1	l_3	l_{21}	l_{22}	l_{23}	l_{24}	l_{c1}				$l_{c2}^{2)}$	ρ_{kg}
1	30	392.55CGB-30 06 088	7	6	40	12		88	50			66		40	37	0.6	2.5	25000	6
1		392.55CGB-30 12 088	7	12	40	19.5		88	50			66		40	37	0.6	2.5	25000	12
1		392.55CGB-30 12 138	7	12	40	19.5		138	100			116		40	37	0.7	2.5	15000	
1	40	392.55CGB-40 12 093	7	12	40	19.5		93	50			66		40	37	1.3	2.5	25000	12
1		392.55CGB-40 12 143	7	12	40	19.5		143	100			116		40	37	1.4	2.5	15000	
2		392.55CGB-40 12 193	7	12	40	19.5	24.5	193	150	50	75	166		40	37	1.6	2.5	10000	
3		392.55CGB-40 20 153	7	20	40	32		153	110			126	60	52	49	1.8	2.5	20000	20

- 1) 7 = coolant through center and through flange
- 2) Min. clamping length
- 3) Balance quality code.
- 4) Rotational speed at balance quality.

Note: Toolholders are convertible to coolant through flange by removing two screws on the back of the V-Flange.



Hydro-Grip®

High precision holder for facemills and square shoulder facemills

A1B05CG / A2B05CG

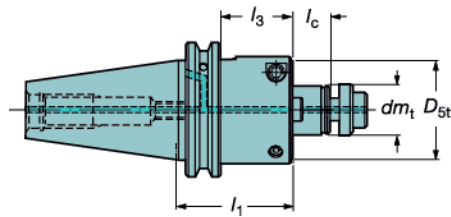
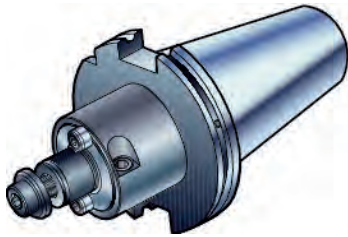

l_1 = programming length

Metric pilot

Machine design	Taper	Ordering code	Coolant ¹⁾	Dimensions						BLQ ²⁾	NBLQ ³⁾
				dm_1	D_{st}	l_c	l_1	l_3	$\frac{m}{kg}$		
ISO7388.1	40	A1B05CG-40 22 051	7	22	48	19	51	31.9	1.3	2.5	23000
		A1B05CG-40 27 067	7	27	53	21	67	31.9	1.6	2.5	14000
		A1B05CG-40 32 071	7	32	63	24	71	35.9	1.9	2.5	11200
	50	A1B05CG-50 22 040	7	22	48	19	40	20.9	2.9	2.5	14000
		A1B05CG-50 27 040	7	27	53	21	40	20.9	3.0	2.5	14000
		A1B05CG-50 32 040	7	32	63	24	40	20.9	3.2	2.5	11200
MAS-BT 403	40	A2B05CG-40 22 050	7	22	48	19	50	23	1.3	2.5	23000
		A2B05CG-40 27 050	7	27	53	21	50	23	1.4	2.5	23000
		A2B05CG-40 32 050	7	32	63	24	50	23	1.6	2.5	23000
	50	A2B05CG-50 22 061	7	22	48	19	61	23	4.0	2.5	23000
		A2B05CG-50 27 061	7	27	53	21	61	23	4.1	2.5	14000
		A2B05CG-50 32 061	7	32	63	24	61	23	4.3	2.5	11200
		A2B05CG-50 40 061	7	40	76	27	61	23	4.6	2.5	8900

¹⁾ 7 = coolant through center and through flange

²⁾ Balance quality code.

³⁾ Rotational speed at balance quality.

AA3B05CG

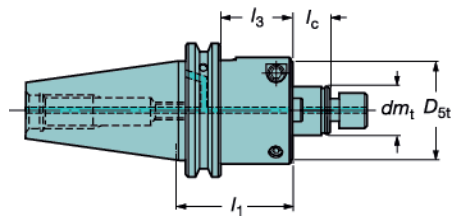
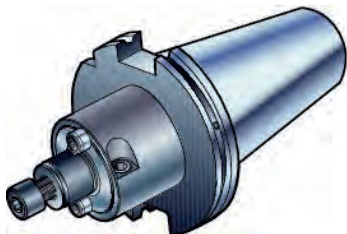

l_1 = programming length

Inch pilot

Machine design	Taper	Ordering code	Coolant ¹⁾	Dimensions, inch						BLQ ²⁾	NBLQ ³⁾
				dm_1	D_{st}	l_c	l_1	l_3	$\frac{m}{kg}$		
CAT V	40	AA3B05CG-40 19 066	7	.750	1.890	.748	2.598	1.216	3.1	2.50	23000
		AA3B05CG-40 25 067	7	1.000	2.087	.748	2.638	1.256	3.3	2.50	14000
		AA3B05CG-40 38 073	7	1.500	2.992	.984	2.874	1.492	5.3	2.50	8900
	50	AA3B05CG-50 19 039	7	.750	1.890	.748	1.535	.785	6.4	2.50	14000
		AA3B05CG-50 25 039	7	1.000	2.087	.748	1.535	.785	6.6	2.50	14000
		AA3B05CG-50 38 067	7	1.500	2.992	.984	2.638	1.256	9.5	2.50	8900

¹⁾ 7 = coolant through center and through flange

²⁾ Balance quality code.

³⁾ Rotational speed at balance quality.

Note: Toolholders are convertible to coolant through flange by removing two screws on the back of the V-Flange.

All holders are delivered with a standard screw without hole for coolant.

For cutters with coolant channels a new screw with radial coolant holes is necessary and can be ordered separately. See page G144.



Hydro-Grip HD

High precision chuck adapter

HSK form A/C
392.410CGD

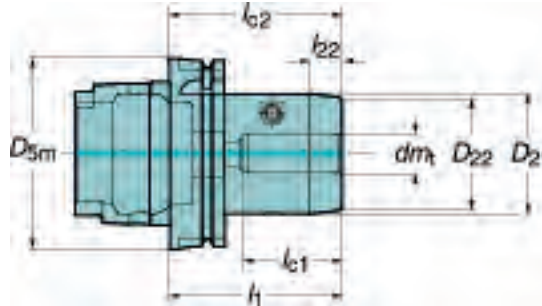
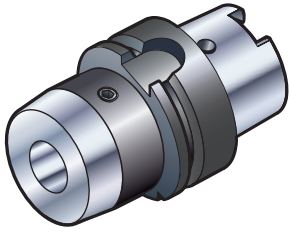

Accessories

Not delivered with the tool, must be ordered separately. 393.CG 393.CGS

Adjustment screw 5512100-xx



Page G115

Note: Hole for data carrier is not standard.

l_1 = programming length

HSK size	Ordering code	Coolant ¹⁾	Dimensions, mm, inch									BLQ ²⁾	NBLQ ³⁾
			D_{5m}	dm_1	D_{21}	D_{22}	l_1	l_{22}	l_{c1}	l_{c2}	l_{c2}		
63	392.410CGD-63 20 096	1	63	20	63	59	96	17	52	70	2.0	2.5	25000
			2.480	.787	2.480	2.323	3.780	.669	2.047	2.756			
100	392.410CGD-100 20 091	1	100	20	63	59	91	17	52	62	3.3	2.5	14000
			3.937	.787	2.480	2.323	3.583	.669	2.047	2.441			
	392.410CGD-100 25 095	1	100	25	74	70	95	17	56	66	3.9	2.5	14000
			3.937	.984	2.913	2.756	3.740	.669	2.205	2.598			
392.410CGD-100 32 099	1	100	32	80	76	99	17	60	70	4.2	2.5	14000	
		3.937	1.260	3.150	2.992	3.898	.669	2.362	2.756				

- ¹⁾ 1 = coolant through center
- ²⁾ Balance quality code.
- ³⁾ Rotational speed at balance quality.

Coolant tube must be ordered separately, see page G77.



Hydro-Grip pencil

High precision chuck
HSK

Pencil type
392.410CGB

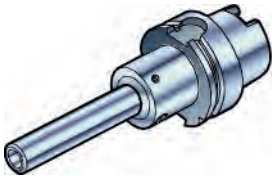

Design 1

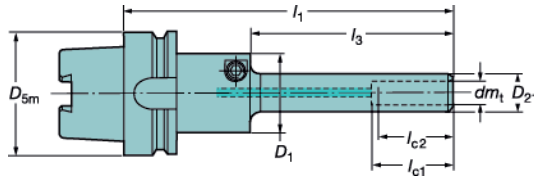

Design 2

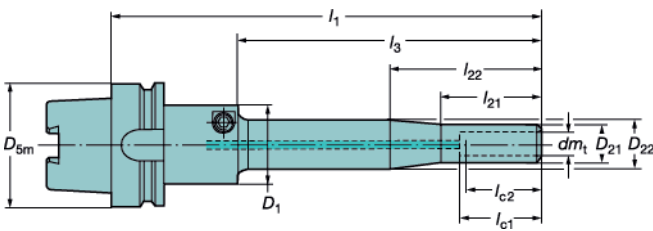

Accessories

Not delivered with the 393.CG tool, must be ordered 393.CGS separately.

Adjustment screw 5512100-xx



Page G115

Note: Hole for data carrier is not standard.

l_{c2} = Min clamping length, l_1 = programming length

Design	Taper	Ordering code	Coolant ¹⁾	Dimensions, mm, inch													BLQ ³⁾	NBLQ ⁴⁾	Collet size	
				dm_1	D_1	D_{21}	D_{22}	D_{5m}	l_1	l_3	l_{21}	l_{22}	l_{c1}	$l_{c2}^{(2)}$	$\frac{\sigma}{kg}$					
1	63	392.410CGB-63 06 095	1	6	40	12		63	94.5	50					40	37	1	2.5	25000	6
1			1	.236	1.575	.472		2.480	3.720	1.968					1.575	1.457			25000	
1		392.410CGB-63 12 112B	1	12	40	19.5		63	112	50				40	37	1.2	2.5	25000	12	
1			1	.472	1.575	.768		2.480	4.409	1.968				1.575	1.457			25000		
1		392.410CGB-6312162B	1	12	40	19.5		63	162	100				40	37	1.3	2.5	15000		
1			1	.472	1.575	.768		2.480	6.378	3.937				1.575	1.457			15000		
2		392.410CGB-6312212B	1	12	40	19.5	24.5	63	212	150	50	75		40	37	1.6	2.5	10000		
2			1	.472	1.575	.768	.965	2.480	8.346	5.906	1.968	2.953		1.575	1.457			10000		
1	100	392.410CGB-100 12 165B	1	12	40	19.5		100	165	100				40	37	2.9	2.5	14000	12	
1			1	.472	1.575	.768		3.937	6.496	3.937				1.575	1.457			14000		
1		392.410CGB-10012115B	1	12	40	19.5		100	115	50				40	37	2.8	2.5	14000		
1			1	.472	1.575	.768		3.937	4.528	1.968				1.575	1.457			14000		
2		392.410CGB-10012215B	1	12	40	19.5	24.5	100	215	150	50	75		40	37	3.1	2.5	10000		
2			1	.472	1.575	.768	.965	3.937	8.465	5.906	1.968	2.953		1.575	1.457			10000		

- 1) 1 = coolant through center
- 2) Min. clamping length
- 3) Balance quality code.
- 4) Rotational speed at balance quality.

Coolant tube must be ordered separately, see page G77.



D
Milling
E
Drilling
F
Boring
G
Tooling Systems
J
General Information

Hydro-Grip

High precision adapter for facemills and square shoulder facemills

HSK form A/C
41005CG

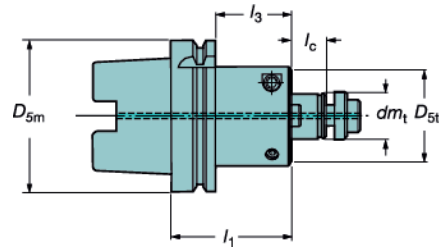
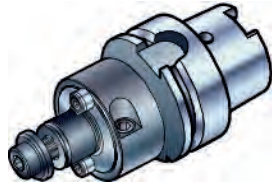

l_1 = programming length

Note: Hole for data carrier is not standard.

Metric pilot

HSK size	Ordering code	Coolant ¹⁾	Dimensions							$\frac{\Omega}{\text{kg}}$	BLQ ²⁾	NBLQ ³⁾
			dm_t	D_{5m}	D_{5t}	l_c	l_1	l_3	l_4			
63	41005CG-63 22 057	1	22	63	48	19	57	31	1.1	2.5	23000	
	41005CG-63 27 057	1	27	63	53	21	57	31	1.2	2.5	14000	
	41005CG-63 32 074	1	32	63	63	24	74	32	1.8	2.5	11200	
	41005CG-63 40 079	1	40	63	76	27	79	37	2.3	2.5	8900	
100	41005CG-100 22 064	1	22	100	48	19	64	35	2.5	2.5	14000	
	41005CG-100 27 064	1	27	100	48	21	64	35	2.6	2.5	14000	
	41005CG-100 32 064	1	32	100	63	24	64	35	2.8	2.5	12000	
	41005CG-100 40 064	1	40	100	76	27	64	35	3.3	2.5	8900	

1) 1 = coolant through center

2) Balance quality code.

3) Rotational speed at balance quality.

All holders are delivered with a standard screw without hole for coolant.

For cutters with coolant channels a new screw with radial coolant holes is necessary and can be ordered separately. See page G154.



G162



G65



G2

Coromant Capto® adapter for exchangeable head

Cx-391.EH
Cx-A391.EH

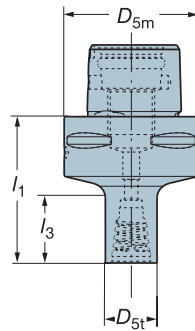

Without gripper grooves for manual tool change

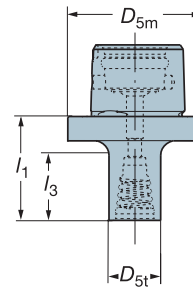

l_1 = programming length

Metric version

Coromant Capto size	Coupling size	Ordering code	Coolant ¹⁾	Dimensions				
				D_{5m}	D_{5t}	l_1	l_3	$\frac{\text{kg}}{\text{kg}}$
C3	E10	C3-391.EH-10 035	1	32	9.6	35	13.2	0.1
	E12	C3-391.EH-12 038	1	32	11.6	38	16.4	0.1
	E16	C3-391.EH-16 043	1	32	15.4	43	21.9	0.1
C4	E10	C4-391.EH-10 041	1	40	9.6	41	13.1	0.3
	E12	C4-391.EH-12 044	1	40	11.6	44	16.4	0.3
	E16	C4-391.EH-16 049	1	40	15.4	49	21.9	0.3
	E20	C4-391.EH-20 046	1	40	19.2	46	19.4	0.3
C5	E10	C5-391.EH-10 042	1	50	9.6	42	12.8	0.5
	E12	C5-391.EH-12 045	1	50	11.6	45	16	0.5
	E16	C5-391.EH-16 050	1	50	15.4	50	21.5	0.5
	E20	C5-391.EH-20 047	1	50	19.2	47	19	0.5
	E25	C5-391.EH-25 052	1	50	24.1	52	24.7	0.5
C6	E12	C6-391.EH-12 049	1	63	11.6	49	16.3	0.8
	E16	C6-391.EH-16 054	1	63	15.4	54	21.8	0.8
	E20	C6-391.EH-20 051	1	63	19.2	51	19.3	0.8
	E25	C6-391.EH-25 056	1	63	24.1	56	25	0.9
Coromant Capto short (for manual tool change in turning centers)								
C3	E10	C3-391.EH-10 026	1	32	9.6	26	13	0.1
	E12	C3-391.EH-12 029	1	32	11.6	29	16	0.1
C4	E10	C4-391.EH-10 026	1	40	9.6	26	13	0.2
	E12	C4-391.EH-12 029	1	40	11.6	29	16	0.2
	E16	C4-391.EH-16 035	1	40	15.4	35	22	0.2
C5	E10	C5-391.EH-10 026	1	50	9.6	26	13	0.3
	E12	C5-391.EH-12 029	1	50	11.6	29	16	0.3
	E16	C5-391.EH-16 035	1	50	15.4	35	22	0.3

¹⁾ 1 = coolant through center

Assortment of exchangeable heads
See page D203



G97

Coromant Capto® adapter for exchangeable head

Cx-391.EH
Cx-A391.EH

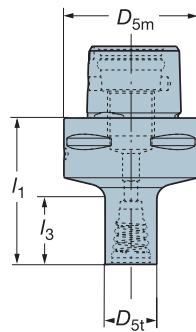

Without gripper grooves for manual tool change

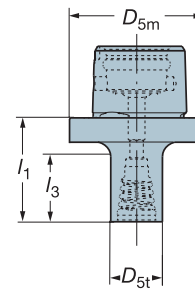

l_1 = programming length

Inch version

Coromant Capto size	Coupling size	Ordering code	Coolant ¹⁾	Dimensions, inch					
				D_{5m}	D_{5t}	l_1	l_3		
C3	E10	C3-A391.EH-10 034	1	1.260	.360	1.339	.476	0.3	
	E12	C3-A391.EH-12 039	1	1.260	.480	1.535	.689	0.3	
	E16	C3-A391.EH-16 043	1	1.260	.606	1.693	.862	0.3	
C4	E10	C4-A391.EH-10 040	1	1.575	.360	1.575	.472	0.6	
	E12	C4-A391.EH-12 045	1	1.575	.480	1.772	.685	0.6	
	E16	C4-A391.EH-16 049	1	1.575	.606	1.929	.862	0.6	
C5	E20	C4-A391.EH-20 044	1	1.575	.724	1.732	.681	0.6	
	E10	C5-A391.EH-10 041	1	1.968	.360	1.614	.461	1.0	
	E12	C5-A391.EH-12 047	1	1.968	.480	1.850	.713	1.0	
C6	E16	C5-A391.EH-16 050	1	1.968	.606	1.968	.846	1.1	
	E20	C5-A391.EH-20 045	1	1.968	.724	1.772	.665	1.1	
	E25	C5-A391.EH-25 053	1	1.968	.961	2.087	1.012	1.2	
	E12	C6-A391.EH-12 050	1	2.480	.480	1.968	.685	1.8	
C3	E16	C6-A391.EH-16 054	1	2.480	.606	2.126	.858	1.9	
	E20	C6-A391.EH-20 049	1	2.480	.724	1.929	.677	1.9	
	E25	C6-A391.EH-25 057	1	2.480	.961	2.244	1.024	2.0	
Coromant Capto short (for manual tool change in turning centers)									
C3	E10	C3-A391.EH-10 025	1	1.260	.360	.984	.472	0.2	
	E12	C3-A391.EH-12 031	1	1.260	.480	1.220	.709	0.2	
C4	E10	C4-A391.EH-10 025	1	1.575	.360	.984	.472	0.4	
	E12	C4-A391.EH-12 031	1	1.575	.480	1.220	.709	0.4	
	E16	C4-A391.EH-16 034	1	1.575	.606	1.339	.827	0.4	
C5	E10	C5-A391.EH-10 025	1	1.968	.360	.984	.472	0.6	
	E12	C5-A391.EH-12 031	1	1.968	.480	1.220	.709	0.6	

¹⁾ 1 = coolant through center

Assortment of exchangeable heads
See page D203

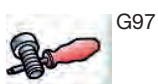

G97

Solid holders for exchangeable head

392.140EH
392.55EH
A392.45EH

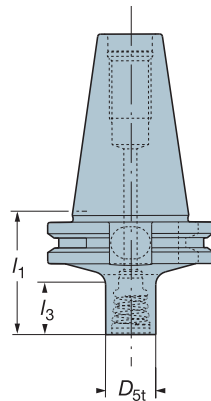

l_1 = programming length

Metric version

Machine design	Taper	Coupling size		Coolant ¹⁾	Dimensions			
		D_{th}	Ordering code		D_{st}	l_1	l_3	$\frac{kg}{mm^3}$
ISO7388.1	40	E10	392.140EH-40 10 041	1	9.6	41	12.7	0.9
		E12	392.140EH-40 12 044	1	11.6	44	16	0.9
		E16	392.140EH-40 16 049	1	15.4	49	21.5	0.9
		E20	392.140EH-40 20 046	1	19.2	46	19	0.9
		E25	392.140EH-40 25 051	1	24.1	51	24.6	0.9
MAS-BT403	30	E10	392.55EH-30 10 044	1	9.6	44	13.3	0.4
		E12	392.55EH-30 12 046	1	11.6	46	15.6	0.4
		E16	392.55EH-30 16 052	1	15.4	52	22.1	0.4
		E20	392.55EH-30 20 049	1	19.2	49	19.6	0.4
		E25	392.55EH-30 25 054	1	24.1	54	25.2	0.5
	40	E10	392.55EH-40 10 051	1	9.6	51	13	1.1
		E12	392.55EH-40 12 054	1	11.6	54	16.3	1.1
		E16	392.55EH-40 16 060	1	15.4	60	22.8	1.1
		E20	392.55EH-40 20 056	1	19.2	56	19.3	1.1
		E25	392.55EH-40 25 062	1	24.1	62	26	1.1

¹⁾ 1 = coolant through center

Inch version

Machine design	Taper	Coupling size		Coolant ¹⁾	Dimensions, inch			
		D_{th}	Ordering code		D_{st}	l_1	l_3	$\frac{kg}{mm^3}$
CAT V	40	E10	A392.45EH-40 10 056	1	.360	2.205	.472	2.3
		E12	A392.45EH-40 12 060	1	.480	2.362	.646	2.3
		E16	A392.45EH-40 16 065	1	.606	2.559	.858	2.4
		E20	A392.45EH-40 20 060	1	.724	2.362	.677	2.4
		E25	A392.45EH-40 25 068	1	.961	2.677	1.024	2.5

¹⁾ 1 = coolant through center

Assortment of exchangeable heads
See page D203



G97

HSK holder for exchangeable head

Form A/C
392.410EH

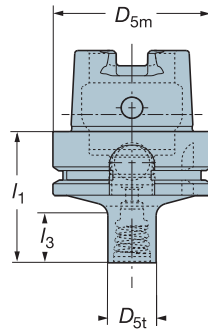
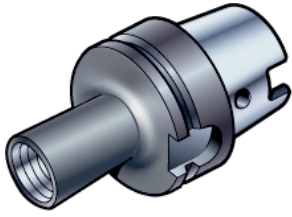

l_1 = programming length

Metric version

HSK size	Coupling size	Ordering code	Coolant ¹⁾	Dimensions, millimeter, inch (mm, in.)									
				D_{5m} mm	D_{5m} in.	D_{5t} mm	D_{5t} in.	l_1 mm	l_1 in.	l_3 mm	l_3 in.		
63	E10	392.410EH-63 10 049	1	63	2.480	9.6	.378	49	1.929	13.5	.532	0.7	
	E12	392.410EH-63 12 051	1	63	2.480	11.6	.457	51	2.008	15.8	.622	0.7	
	E16	392.410EH-63 16 056	1	63	2.480	15.4	.606	56	2.205	21.3	.839	0.7	
	E20	392.410EH-63 20 053	1	63	2.480	19.2	.756	53	2.087	18.8	.740	0.7	
	E25	392.410EH-63 25 059	1	63	2.480	24.1	.949	59	2.323	25.5	1.004	0.7	

1) 1 = coolant through center

Milling

E

Drilling

F

Bridgeport holders for exchangeable heads

A392.R8EH

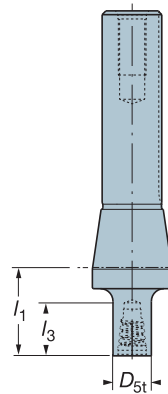

l_1 = programming length

Inch version

Coupling size	Ordering code	Coolant ¹⁾	Dimensions, inch			
			D_{5t}	l_1	l_3	
E10	A392.R8EH-32 10 025	0	.360	.984	.457	0.9
E12	A392.R8EH-32 12 031	0	.480	1.220	.693	0.9
E16	A392.R8EH-32 16 035	0	.606	1.378	.850	1.0
E20	A392.R8EH-32 20 031	0	.724	1.220	.693	1.0
E25	A392.R8EH-32 25 039	0	.961	1.535	1.016	1.1

1) 0 = no coolant

Boring

G

Tooling Systems

J

Assortment of exchangeable heads
See page D203



G97

G 96

Cylindrical holder for exchangeable head

Milling system

Steel and solid carbide shank

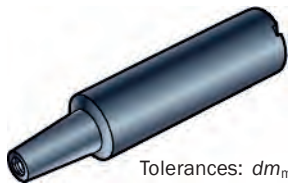
Tolerances: $dm_m = h6$

Tailor Made

Even more possibilities thanks to tailored design! See page J3.

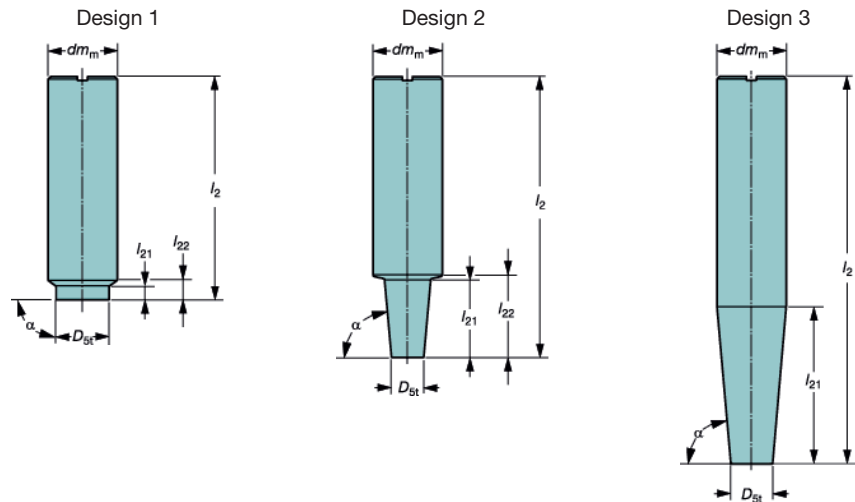

Metric version

Ordering code	Coupling size	Design	Coolant ¹⁾	Dimensions							σ_{RG}	n_{max}
				dm_m	D_{St}	l_2	l_{21}	l_{22}	a			
Steel												
E10-A16-SS-065	E10	1	1	16	9.6	65	5	7	90	0.1	40000	
E10-A10-SS-075		1	1	10	9.6	75	20	21	90	0.1	40000	
E10-A16-CS-140		3	1	16	9.6	140	36.5		85	0.2	16000	
E10-A16-CS-160		2	1	16	9.6	160	50	52	89	0.3	12000	
E10-A32-CS-250		3	1	32	9.6	250	63.5		80	1.5	10000	
E12-A16-SS-065	E12	1	1	16	11.6	65	5	7	90	0.1	40000	
E12-A12-SS-100		1	1	12	11.6	100	22	23	90	0.1	31000	
E12-A16-CS-140		3	1	16	11.6	140	25.1		85	0.2	16000	
E12-A16-CS-170		2	1	16	11.6	170	60	62	89	0.3	12000	
E12-A32-CS-250		3	1	32	11.6	250	57.8		80	1.5	10000	
E16-A20-SS-070	E16	1	1	20	15.4	70	5	7	90	0.2	40000	
E16-A20-SS-110		1	1	20	15.4	110	25	27	90	0.3	40000	
E16-A25-CS-170		3	1	25	15.4	170	54.8		85	0.6	18000	
E16-A20-CS-190		2	1	20	15.4	190	75	78	89	0.4	13000	
E20-A25-SS-080	E20	1	1	25	19.2	80	5	7	90	0.3	40000	
E20-A20-SS-120		1	1	20	19.2	120	30	31	90	0.3	34000	
E20-A32-CS-180		3	1	32	19.2	180	73.1		85	1.1	20000	
E25-A32-SS-080	E25	1	1	32	24.1	80	5	7	90	0.5	40000	
E25-A25-SS-140		1	1	25	24.1	140	40	41	90	0.5	25000	
E25-A32-CS-200		3	1	32	24.1	200	45.1		85	1.2	15000	
Carbide												
E10-A10-SE-100	E10	1	1	10	9.6	100	50	51	90	0.1	35000	
E10-A16-CE-155		2	1	16	9.6	155	100	103	89	0.4	22000	
E12-A12-SE-100	E12	1	1	12	11.6	100	48	49	90	0.2	40000	
E12-A16-CE-150		2	1	16	11.6	150	90	92	89	0.4	23000	
E16-A16-SE-135	E16	1	1	16	15.4	135	80	81	90	0.4	27000	
E16-A20-CE-175		2	1	20	15.4	175	118	120	89	0.8	22000	
E20-A20-SE-095	E20	1	1	20	19.2	95	38	39	90	0.4	40000	
E20-A20-SE-180		1	1	20	19.2	180	110	111	90	0.8	20000	
E25-A25-SE-200	E25	1	1	25	24.1	200	120	121	90	1.4	19000	

¹⁾ 1 = coolant through center

Assortment of exchangeable heads

See page D203

Main spare parts

Coupling size	Key	Torque wrench head ¹⁾	Torque value		Torque wrench ¹⁾	Torque range	
			Nm	In-lbs		Nm	In-lbs
E10	5680 093-01	5680 089-01	12	106	5680 088-01	10-20	88-177
E12	5680 093-02	5680 089-02	15	132	5680 088-01	10-20	88-177
E16	5680 093-03	5680 089-03	30	265	5680 088-02	25-65	221-575
E20	5680 093-04	5680 089-04	50	442	5680 088-02	25-65	221-575
E25	5680 093-05	5680 089-05	65	575	5680 088-02	25-65	221-575

¹⁾ Accessories, must be ordered separately.

Cylindrical holder for exchangeable head

Milling system

Steel and solid carbide shank

Design 1

Design 2

Design 3



Tolerances: $dm_m = h6$

Tailor Made

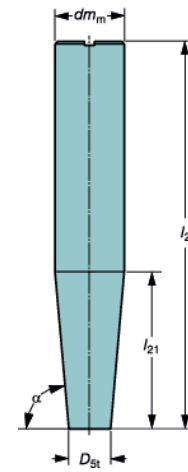
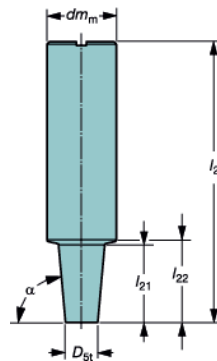
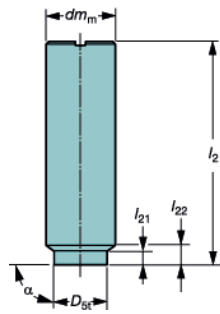

Even more possibilities thanks to tailored design! See page J3.

Inch version

Ordering code	Coupling size	Design	Coolant ¹⁾	Dimensions, inch								n_{max}
				dm_m	D_{bt}	l_2	l_{21}	l_{22}	a	$\frac{a}{L_{21}}$		
Steel												
AE10-A12-SS-025	E10	1	1	.500	.360	2.500	.250	.330	90	0.2	40000	
AE10-A10-SS-030		1	1	.375	.360	3.000	.799	.839	90	0.1	40000	
AE10-A12-SS-030		1	1	.500	.360	3.000	1.000	1.080	90	0.2	40000	
AE10-A16-CS-055	E12	3	1	.625	.360	5.500	1.512		85	0.4	17000	
AE10-A16-CS-065		2	1	.625	.360	6.500	2.000	2.080	89	0.4	12000	
AE12-A12-SS-030		1	1	.500	.480	3.000	.250	.290	90	0.2	40000	
AE12-A12-SS-045	E12	1	1	.500	.480	4.500	1.000	1.040	90	0.2	30000	
AE12-A16-CS-065		3	1	.625	.480	6.500	.827		85	0.4	12000	
AE12-A16-CS-075		2	1	.625	.480	7.500	2.400	2.480	89	0.7	10000	
AE16-A16-SS-030	E16	1	1	.625	.606	3.000	.250	.290	90	0.2	40000	
AE16-A16-SS-045		1	1	.625	.606	4.500	1.000	1.040	90	0.2	30000	
AE16-A19-CS-065		3	1	.750	.606	6.500	.823		85	0.9	16000	
AE16-A19-CS-075	E20	2	1	.750	.606	7.500	3.000	3.080	89	0.9	12000	
AE20-A19-SS-030		1	1	.750	.724	3.000	.250	.290	90	0.4	40000	
AE20-A19-SS-045		1	1	.750	.724	4.500	1.000	1.040	90	0.7	40000	
AE20-A25-CS-060	E25	3	1	1.000	.724	6.000	1.575		85	1.3	23000	
AE20-A32-CS-070		3	1	1.250	.724	7.000	3.000		85	2.4	20000	
AE20-A25-CS-080		2	1	1.000	.724	8.000	3.150	3.250	89	1.5	12000	
AE25-A25-SS-035	E25	1	1	1.000	.961	3.500	.250	.290	90	0.7	40000	
AE25-A25-SS-045		1	1	1.000	.961	4.500	1.500	1.540	90	0.9	40000	
AE25-A32-SS-065		1	1	1.250	.961	6.500	2.500	2.580	90	2.1	23000	
AE25-A32-CS-075	E25	3	1	1.250	.961	7.500	1.650		85	2.4	17000	
AE25-A32-CS-085		3	1	1.250	.961	8.500	1.650		85	2.7	11000	
AE25-A32-SE-065		1	1	1.250	.961	6.500	2.500	2.580	90	3.3	37000	
Carbide												
AE10-A16-CE-055	E10	3	1	.625	.360	5.500	1.512		85	0.9	28000	
AE10-A16-CE-065		2	1	.625	.360	6.500	2.000	2.080	89	1.1	19000	
AE12-A16-CE-065	E12	3	1	.625	.480	6.500	.827		85	1.1	18000	
AE12-A16-CE-075		2	1	.625	.480	7.500	2.400	2.480	89	1.2	13000	
AE16-A19-CE-065	E16	3	1	.750	.606	6.500	.823		85	1.5	25000	
AE16-A19-CE-075		2	1	.750	.606	7.500	3.000	3.080	89	1.7	18000	
AE20-A25-CE-060	E20	3	1	1.000	.724	6.000	1.575		85	2.4	36000	
AE20-A32-CE-070		3	1	1.250	.724	7.000	3.000		85	4.6	33000	
AE20-A25-CE-080	E25	2	1	1.000	.724	8.000	3.150	3.250	89	3.2	19000	
AE25-A32-CE-075		3	1	1.250	.961	7.500	1.650		85	3.8	21000	
AE25-A32-CE-085		3	1	1.250	.961	8.500	1.650		85	4.4	18000	
AE25-A32-SE-065	E25	1	1	1.250	.961	6.500	2.500	2.580	90	3.3	37000	

1) 1 = coolant through center

Main spare parts

Coupling size	Key	Torque wrench head ¹⁾	Torque value		Torque wrench ¹⁾	Torque range	
			Nm	In-lbs		Nm	In-lbs
E10	5680 093-01	5680 089-01	12	106	5680 088-01	10-20	88-177
E12	5680 093-02	5680 089-02	15	132	5680 088-01	10-20	88-177
E16	5680 093-03	5680 089-03	30	265	5680 088-02	25-65	221-575
E20	5680 093-04	5680 089-04	50	442	5680 088-02	25-65	221-575
E25	5680 093-05	5680 089-05	65	575	5680 088-02	25-65	221-575

1) Accessories, must be ordered separately.

CoroMill® modular cutting tools with threaded coupling

A system of small CoroMill® screw type cutters and a variety of shanks for demanding die and mold making.

Tool setups with CoroMill® performance

Slim, but rigid assemblies with accessibility for milling of deep and narrow cavities. Opportunities to optimize the total gauge length of the setup for best performance in each application.

Many tool solutions with minimum number of modules will reduce inventory costs. Dampened milling adapter for high productivity at extremely long overhangs - with no vibration.

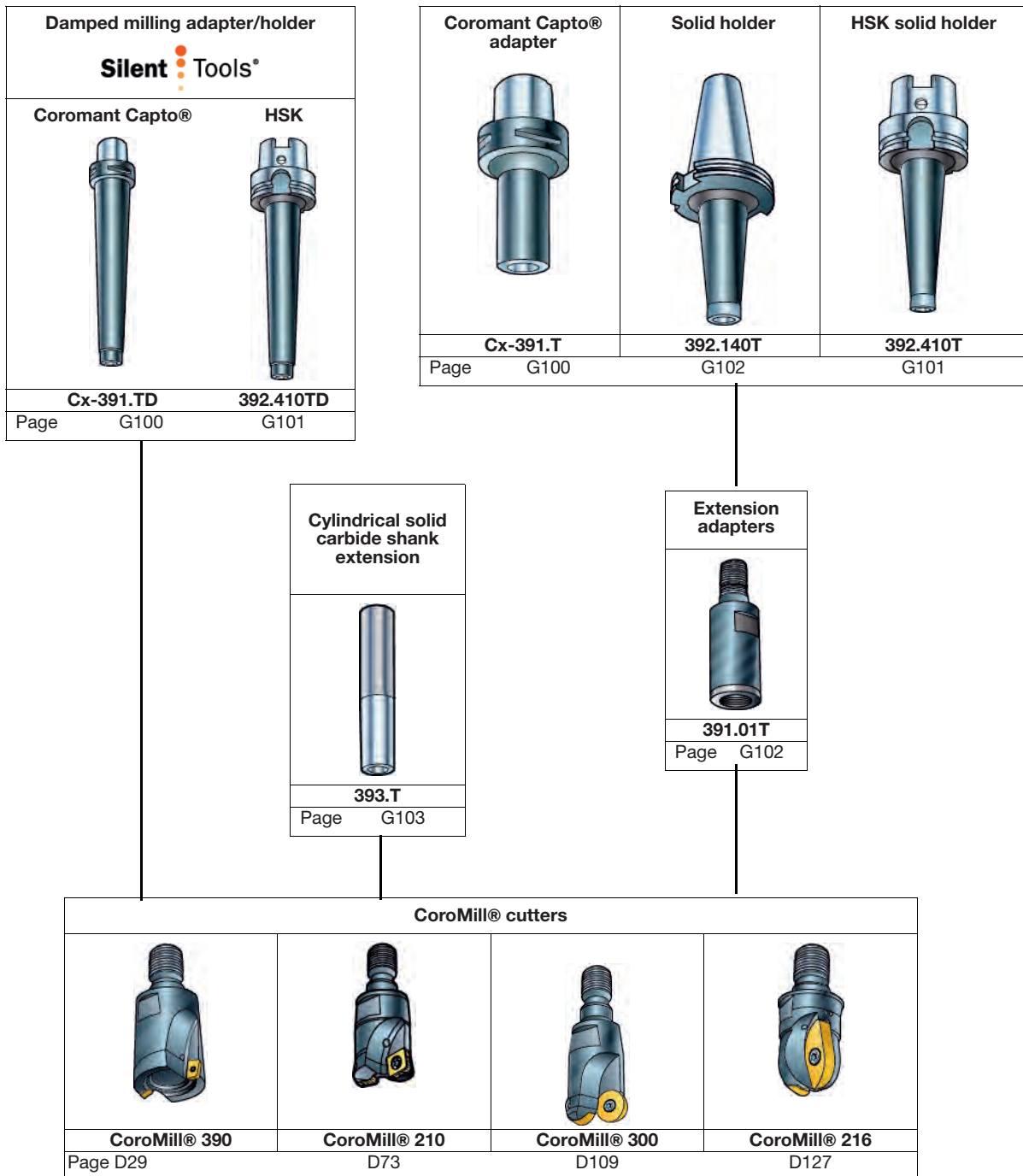

Coromant Capto® milling adapter

Shank with threaded coupling (MSSC)

391.T

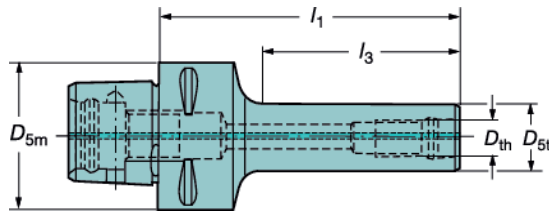

l_1 = programming length

Coupling size	Thread	Ordering code	Coolant ¹⁾	Dimensions, millimeter, inch (mm, in.)									
				D_{5m} mm	D_{5m} in.	D_{5t} mm	D_{5t} in.	l_1 mm	l_1 in.	l_3 mm	l_3 in.	α kg	
C3	M8	C3-391.T-08 060	1	32	1.260	12.8	.504	60	2.362	37.8	1.488	0.2	
	M10	C3-391.T-10 070	1	32	1.260	17.8	.701	70	2.756	48.5	1.909	0.2	
C4	M8	C4-391.T-08 070	1	40	1.575	12.8	.504	70	2.756	41.8	1.646	0.3	
	M10	C4-391.T-10 080	1	40	1.575	17.8	.701	80	3.150	52.4	2.063	0.4	
C5	M12	C4-391.T-12 080	1	40	1.575	20.8	.819	80	3.150	52.8	2.079	0.4	
	M10	C5-391.T-10 080	1	50	1.968	17.8	.701	80	3.150	51.1	2.012	0.5	
	M12	C5-391.T-12 080	1	50	1.968	20.8	.819	80	3.150	51.5	2.028	0.6	
C6	M16	C5-391.T-16 080	1	50	1.968	28.8	1.134	80	3.150	52.6	2.071	0.7	
	M10	C6-391.T-10 090	1	63	2.480	17.8	.701	90	3.543	55.8	2.197	0.9	
	M12	C6-391.T-12 100	1	63	2.480	20.8	.819	100	3.937	66.2	2.606	1.0	
C6	M16	C6-391.T-16 100	1	63	2.480	28.8	1.134	100	3.937	67.3	2.650	1.1	

1) 1 = coolant through center

Coromant Capto® Dampened milling adapter

Shank with threaded coupling (MSSC)

391.TD

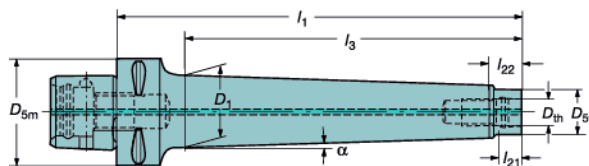

l_1 = programming length

Coupling size	Thread	Ordering code	Coolant ¹⁾	Dimensions, mm, inch									
				D_1	D_{5m}	D_{5t}	l_1	l_3	l_{21}	l_{22}	a	α kg	
C4	M10	C4-391.TD-10 175	1	30	40	17.8	175	150	10.5	13.5	2.1	1.0	
	M12		1	1.181	1.575	.701	6.890	5.906	.413	.532	2.098		
C5	M12	C5-391.TD-12 186	1	34	50	21	186	160	12	15.5	1.78	1.5	
	M16		1	1.339	1.968	.827	7.323	6.299	.472	.610	1.782		
C6	M16	C5-391.TD-16 279	1	50	50	29	279	259	15.8	19	2.15	3.4	
	M16		1	1.968	1.968	1.142	10.984	10.197	.622	.748	2.148		
C6	M16	C6-391.TD-16 279	1	50	63	29	279	251.6	15.8	19	2.22	3.8	
	M16		1	1.968	2.480	1.142	10.984	9.906	.622	.748	2.216		

1) 1 = coolant through center



G6



G2

HSK milling holder

Form A/C

Shank with threaded coupling (MSSC)

392.410T

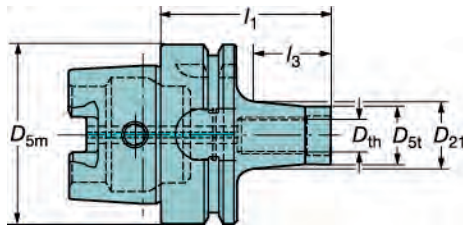

l_1 = programming length

Coupling size	Thread	Ordering code	Coolant ¹⁾	Dimensions, millimeter, inch (mm, in.)										
				D_{21} mm	D_{21} in.	D_{5m} mm	D_{5m} in.	D_{st} mm	D_{st} in.	l_1 mm	l_1 in.	l_3 mm	l_3 in.	μ MG
63	M8	392.410T-63 08 084	1	20	0.787	63	2.480	12.8	.504	84	3.307	50	1.968	0.8
	M10	392.410T-63 10 084	1	24	0.945	63	2.480	17.8	.701	84	3.307	50	1.968	0.8
	M12	392.410T-63 12 084	1	24	0.945	63	2.480	20.8	.819	84	3.307	50	1.968	0.8
	M16	392.410T-63 16 084	1	34	1.339	63	2.480	28.8	1.134	84	3.307	50	1.968	1.0

1) 1 = coolant through center

HSK 63 dampened milling holder

Form A/C

Shank with threaded coupling (MSSC)

392.410TD

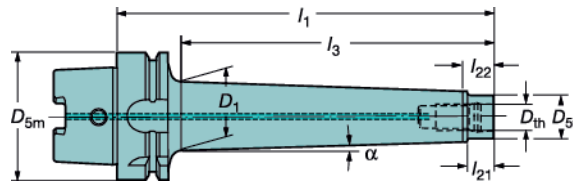

l_1 = programming length

Coupling size	Thread	Ordering code	Coolant ¹⁾	Dimensions, millimeter, inch (mm, in.)									
				D_1	D_{5m}	D_{st}	l_1	l_3	l_{21}	l_{22}	a	μ MG	
63	M10	392.410TD-63 10 183A	1	30	63	17.8	183	150.1	10.5	13.5	2.09	1.2	
	M10		1	1.181	2.480	.701	7.205	5.909	.413	.532	2.094		
	M12	392.410TD-63 12 193A	1	34	63	21	193	160.77	12.2	15.5	1.77	1.6	
	M12		1	1.339	2.480	.827	7.598	6.330	.480	.610	1.77		
	M16	392.410TD-63 16 280A	1	50	63	29	280	252	15.8	19	2.21	3.5	
	M16		1	1.968	2.480	1.142	11.024	9.921	.622	.748	2.212		

1) 1 = coolant through center

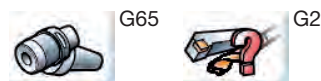

D
Milling
E
Drilling
F
Boring
G
Tooling Systems
J
General Information

TOOLING SYSTEMS CoroMill® modular cutting tools

Solid holders

Shank with threaded coupling (MSSC)

392.140T / 392.55T

l_1 = programming length

Metric version

Machine design	Taper	Thread		Coolant ¹⁾	Dimensions				
		D_{th}	Ordering code		D_{5t}	D_{21}	l_1	l_3	$\frac{kg}{kg}$
ISO7388-1	40	M10	392.140T-40 10 058	1	17.8	20	58	30	1.0
		M12	392.140T-40 12 058	1	20.8	24	58	30	1.0
		M12	392.140T-40 12 098	1	20.8	31	98	70	1.2
		M16	392.140T-40 16 058	1	28.8	34	58	30	1.0
		M16	392.140T-40 16 098	1	28.8	34	98	70	1.3
MAS-BT 403	40	M10	392.55T-40 10 098	1	17.8	28	98	70	1.3
		M12	392.55T-40 12 098	1	20.8	31	98	70	1.3
		M16	392.55T-40 16 098	1	28.8	34	98	70	1.4

¹⁾ 1 = coolant through center

Extension adapter

Shank with threaded coupling (MSSC)

391.01T

l_1 = programming length

Thread type		Ordering code	Coolant ¹⁾	Dimensions, millimeter, inch (mm, in.)						
d_{th}	D_{th}			D_{5t} mm	D_{5t} in.	D_{5m} mm	D_{5m} in.	l_1 mm	l_1 in.	$\frac{kg}{kg}$
M8	8	391.01T-08 08 030	1	12.8	.504	12.8	.504	30	1.181	0.0
M10	10	391.01T-10 10 035	1	17.8	.701	17.8	.701	35	1.378	0.1
M12	12	391.01T-12 12 040	1	20.8	.819	20.8	.819	40	1.575	0.1
M16	16	391.01T-16 16 040	1	28.8	1.134	28.8	1.134	40	1.575	0.2

¹⁾ 1 = coolant through center

G 102

Cylindrical solid carbide shank extensions

A393.T / A393.T

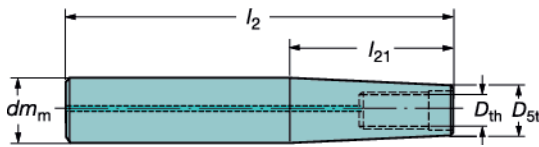

Metric version

Thread type			Dimensions				
D_{th}	Ordering code	Coolant ¹⁾	dm_m	D_{st}	l_2	l_{21} min	
M8	393.T-16 08 110	1	16	12.8	110	60	0.3
M8	393.T-16 08 150	1	16	12.8	155	100	0.4
M10	393.T-20 10 115	1	20	17.8	120	60	0.2
M10	393.T-20 10 175	1	20	17.8	180	120	0.3

Inch version

Thread type			Dimensions, inch				
D_{th}	Ordering code	Coolant ¹⁾	dm_m	D_{st}	l_2	l_{21} min	
M8	A393.T-15 08 110	1	.625	.504	4.330	2.362	1.3
M8	A393.T-15 08 150	1	.625	.504	5.905	3.937	1.8
M10	A393.T-19 10 115	1	.750	.701	4.527	2.362	1.8
M10	A393.T-19 10 175	1	.750	.701	6.890	4.724	2.4

¹⁾ 1 = coolant through center



G99



G2

Recommended drill diameter

M	Metric coarse thread		UNF Unified fine thread			UNC Unified coarse thread			Pg	Steel conduit thread		
	Thread dim.	Drill dia. mm (inch)	Pitch mm (inch)	Thread dim.	Drill dia. mm (inch)	Pitch t.p.i. ¹⁾	Thread dim.	Drill dia. mm (inch)		Pitch t.p.i. ¹⁾	Thread dim.	Drill dia. mm (inch)
M4	3.30 (.130)	0.7 (.028)	UNF No 6	3.00 (.118)	40	UNC No 6	2.85 (.112)	32	Pg7	11.40 (.449)	20	
M4.5	3.70 (.146)	0.75 (.030)	UNF No 8	3.50 (.138)	36	UNC No 8	3.50 (.138)	32	Pg9	14.00 (.551)	18	
M5	4.20 (.165)	0.8 (.031)	UNF No 10	4.10 (.161)	32	UNC No 10	3.90 (.154)	24	Pg11	17.25 (.679)	18	
M6	5.00 (.197)	1 (.039)	UNF No 12	4.65 (.183)	28	UNC No 12	4.50 (.177)	24	Pg13.5	19.00 (.748)	18	
M7	6.00 (.236)	1 (.039)	UNF 1/4"	5.50 (.217)	28	UNC 1/4"	5.20 (.205)	20	Pg16	21.25 (.837)	18	
M8	6.80 (.268)	1.25 (.049)	UNF 5/16"	6.90 (.272)	24	UNC 5/16"	6.60 (.260)	18	Pg21	27.00 (1.063)	16	
M9	7.80 (.307)	1.25 (.049)	UNF 3/8"	8.50 (.335)	24	UNC 3/8"	8.00 (.315)	16	Pg29	35.50 (1.398)	16	
M10	8.50 (.335)	1.5 (.059)	UNF 7/16"	9.90 (.390)	20	UNC 7/16"	9.40 (.370)	14	Pg36	45.50 (1.791)	16	
M11	9.50 (.374)	1.5 (.059)	UNF 1/2"	11.50 (.453)	20	UNC 1/2"	10.75 (.423)	13				
M12	10.20 (.402)	1.75 (.069)	UNF 9/16"	12.90 (.508)	18	UNC 9/16"	12.25 (.482)	12				
M14	12.00 (.472)	2 (.079)	UNF 5/8"	14.50 (.571)	18	UNC 5/8"	13.50 (.531)	11				
M16	14.00 (.551)	2 (.079)	UNF 3/4"	17.50 (.689)	16	UNC 3/4"	16.50 (.650)	10	NTP	American tapered pipe thread		
M18	15.50 (.610)	2.5 (.098)	UNF 7/8"	20.50 (.807)	14	UNC 7/8"	19.50 (.768)	9				
M20	17.50 (.689)	2.5 (.098)	UNF 1"	23.25 (.915)	12	UNC 1"	22.25 (.876)	8	Thread dim.	Drill dia. mm (inch)	Pitch t.p.i. ¹⁾	
M22	19.50 (.768)	2.5 (.098)	UNF 1 1/8"	26.50 (1.043)	12	UNC 1 1/8"	25.00 (.984)	7	NPT 1/16"	6.10 (.240)	27	
M24	21.00 (.827)	3 (.118)	UNF 1 1/4"	29.75 (1.171)	12	UNC 1 1/4"	28.25 (1.112)	7	NPT 1/8"	8.50 (.335)	27	
M27	24.00 (.945)	3 (.118)	UNF 1 3/8"	33.00 (1.299)	12	UNC 1 3/8"	31.00 (1.220)	6	NPT 1/4"	11.00 (.433)	18	
M30	26.50 (1.043)	3.5 (.138)	UNF 1 1/2"	36.00 (1.417)	12	UNC 1 1/2"	34.00 (1.339)	6	NPT 3/8"	14.50 (.571)	18	
M33	29.50 (1.161)	3.5 (.138)				UNC 1 3/4"	39.50 (1.555)	5	NPT 1/2"	17.80 (.701)	14	
M36	32.00 (1.260)	4 (.157)				UNC 2"	45.25 (1.781)	4 1/2	NPT 3/4"	23.0 (.906)	14	
M39	35.00 (1.378)	4 (.157)							NPT 1"	29.0 (1.142)	11 1/2	
M42	37.50 (1.476)	4.5 (.177)							NPT 1 1/4"	37.5 (1.476)	11 1/2	
M45	40.50 (1.594)	4.5 (.177)							NPT 1 1/2"	44.0 (1.732)	11 1/2	
M48	43.00 (1.693)	5 (.197)							NPT 2"	56.0 (2.205)	11 1/2	
M52	47.00 (1.850)	5 (.197)										
M	Metric fluteless		Rc Whitworth tapered pipe thread			G Whitworth cylindrical pipe thread			NPTF	American tapered pipe thread		
Thread dim.	Drill dia. mm (inch)	Pitch	Thread dim.	Drill dia. mm (inch)	Pitch t.p.i. ¹⁾	Thread dim.	Drill dia. mm (inch)	Pitch t.p.i. ¹⁾	Thread dim.	Drill dia. mm (inch)	Pitch t.p.i. ¹⁾	
M4	3.70 (.146)	0.7	Rc 1/8"	8.40 (.331)	28	G 1/8"	8.80 (.346)	28	NPTF 1/16"	6.00 (.236)	27	
M5	4.63 (.182)	0.8	Rc 1/4"	11.20 (.441)	19	G 1/4"	11.80 (.465)	19	NPTF 1/8"	8.40 (.331)	27	
M6	5.50 (.217)	1	Rc 3/8"	14.75 (.581)	19	G 3/8"	15.25 (.600)	19	NPTF 1/4"	10.90 (.429)	18	
M7	6.51 (.256)	1	Rc 1/2"	18.25 (.719)	14	G 1/2"	19.00 (.748)	14	NPTF 3/8"	14.25 (.561)	18	
M8	7.40 (.291)	1.25	Rc 3/4"	23.75 (.935)	14	G 5/8"	21.00 (.827)	14	NPTF 1/2"	17.75 (.699)	14	
M10	9.25 (.364)	1.5	Rc 1"	30.00 (1.181)	11	G 3/4"	24.50 (.965)	14	NPTF 3/4"	23.00 (.906)	14	
M12	11.12 (.438)	1.75				G 7/8"	28.25 (1.112)	14	NPTF 1"	29.00 (1.142)	11 1/2	
M14	13.00 (.512)	2				G 1"	30.75 (1.211)	11	NPTF 1 1/16"	37.75 (1.486)	11 1/2	
M16	15.00 (.591)	2				G 1 1/4"	39.50 (1.555)	11	NPTF 1/2"	43.75 (1.722)	11 1/2	
						G 1 1/2"	45.50 (1.791)	11	NPTF 3/4"	55.75 (2.195)	11 1/2	
						G 1 3/4"	51.40 (2.024)	11				
						G 2"	57.20 (2.252)	11				

¹⁾ TPI = No of threads/inch.

Diameter recommendations when using CoroDrill Delta-C drills

Many tables containing recommended tapping drill sizes are not valid for modern drills such as CoroDrill Delta-C. These drills normally produce a slightly smaller but more accurate hole than conventional HSS drills. If these tables are used, therefore, tap breakages may occur.

Recommended drill type	Thread	Drill dia.	Pitch, mm
CoroDrill® Delta-C	M4	3.35 - 3.4	0.7
	M5	4.25 - 4.3	0.8
	M6	5.0 - 5.1	1
	M8	6.85 - 6.9	1.25
	M10	8.6 - 8.7	1.5
	M12	10.3 - 10.4	1.75
	M14	12.1 - 12.2	2
	M16	14.1 - 14.2	2
	M18	15.5	
	M20	17.5	

The drill diameters are chosen for a depth of thread engagement of 75 - 66%. See section E, CoroDrill Delta-C for correct drill dimension.

Recommended torques for tapping operations

Torque value Nm (ft-lbs)	Metric taps	Whitworth	Whitworth G	BSF	BSP	BA	Pg	NPT	UNC	UNF	Torque value Nm (ft-lbs)
0.5 (1) 1.2 (1) 1.6 (1) 2 (1) 2.5 (2)	M 3 M 4 M 5	5/32"				No. 7 No. 3 No. 2			No. 3 No. 6 No. 8	No. 4 No. 8 No. 10 No. 12	0.5 (1) 1.2 (1) 1.6 (1) 2 (1) 2.5 (2)
3 (2) 4 (3) 5 (4) 6 (4) 8 (6)	M 6 M 8	3/16" 7/32" 1/4"	G 1/8"	7/32" 1/4" 9/32" 5/16"		No. 1 No. 0			No. 10 No. 12 1/4"	1/4" 5/16" 3/8"	3 (2) 4 (3) 5 (4) 6 (4) 8 (6)
10 (7) 12 (9) 16 (12) 18 (13) 20 (15)	M 10	5/16" 3/8"	G 1/4"	3/8" 7/16"			Pg 7 Pg 9		5/16" 3/8"	7/16" 1/2" 9/16" 5/8"	10 (7) 12 (9) 16 (12) 18 (13) 20 (15)
22 (16) 25 (18) 28 (21) 32 (24) 36 (26)	M 12 M 14	7/16" 1/2"	G 3/8"	1/2" 9/16"			Pg 11 Pg 16		7/16" 1/2"	 3/4"	22 (16) 25 (18) 28 (21) 32 (24) 36 (26)
40 (29) 45 (33) 50 (37) 56 (41) 63 (46)	M 16 M 18	9/16" 5/8"	G 1/2" G 5/8"	5/8" 11/16"			Pg 21 Pg 29		9/16" 5/8"	7/8"	40 (29) 45 (33) 50 (37) 56 (41) 63 (46)
70 (52) 80 (59) 90 (66) 100 (74) 110 (81)	M 20 M 22	3/4" 7/8"	G 3/4" G 7/8"	3/4" 13/16" 7/8"	1/2" 5/8" 3/4"		Pg 36 Pg 42 Pg 48	3/8"	3/4" 7/8"	1" 1.1/8" 1.1/4" 1.3/8" 1.1/2"	70 (52) 80 (59) 90 (66) 100 (74) 110 (81)
125 (92) 140 (103) 160 (118) 180 (133) 200 (147)	M 24 M 27	1"	G 1" G 1.1/8" G 1.1/4" G 1.3/8"	1" 1.1/8" 1.1/4"				1/2" 3/4"	1" 1.1/8"		125 (92) 140 (103) 160 (118) 180 (133) 200 (147)
220 (162) 240 (177)	M 30 M 33	1.1/8" 1.1/4"	G 1.1/2" G 1.3/4"		1"				1.1/4"		220 (162) 240 (177)

Recommended torque for tapping

Torque values include a wear factor of 100%.

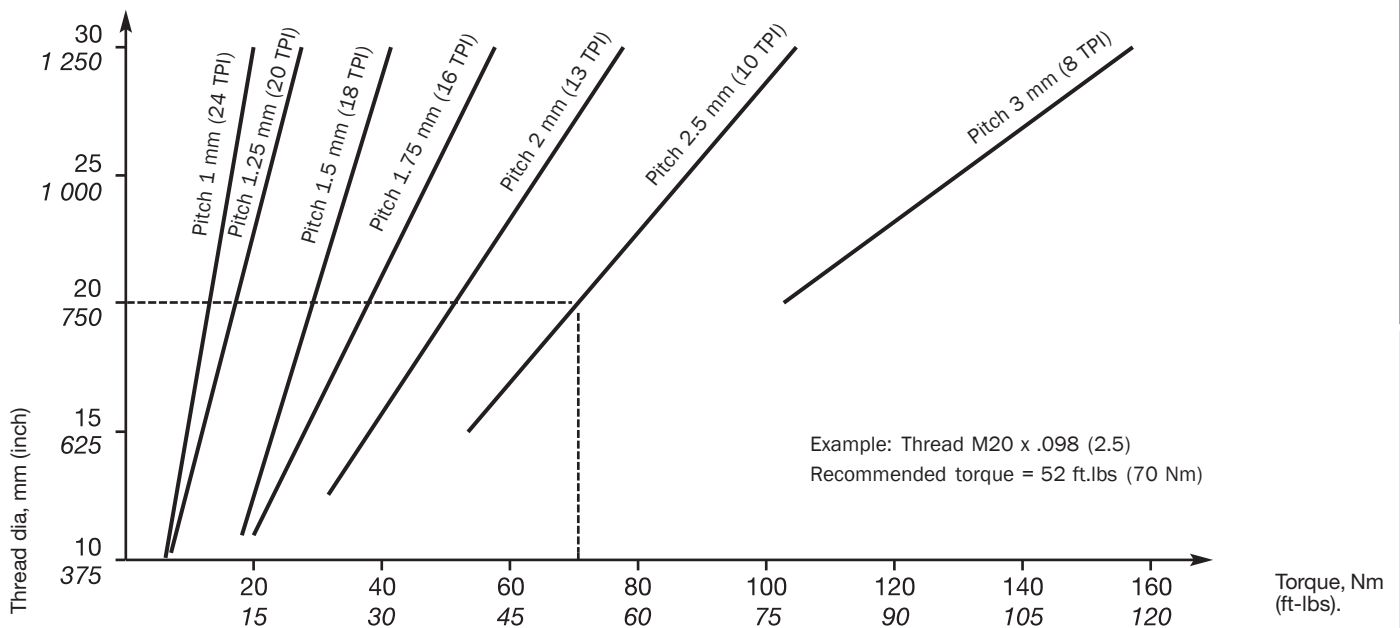

Accessories

	Page		Page
Hydro-Grip® cylindrical shank	G118	Collets, DIN 6499-B	G119
Fixtures	G107	ER collets, sealed	G120
Drawbolts	G108	ER tapping collets	G123
Coolant tubes for Coromant Capto®	G109	ER Collet sealing discs	G121
Torque wrench for tool changing	G110	ER collet nuts for through coolant	G122
Tightening torque recommendations	G111	Master setting gauges	G124
Cassettes with tapered polygon seating	G112	Alignment tool	G124
Pull studs	G114	Lockscrews for arbors	G124
Cylindrical collets, sealed	G115		
Cylindrical collets, slitted	G116		
Extractor for cylindrical collets	G117		
Hydro-Grip® Pencil collet	G118		
Adjustment screws for Hydro-Grip	G118		

Spare parts

	Page		Page
Rotating toolholders		Coromant solid holding tools	
Coromant Capto® basic holders	G126	Holders for facemills and square shoulder facemills	G143
Coromant Capto® adapters		Collet chuck holders	G145
Extension/reduction adapters	G129	Holders for Weldon shanks	G146
Coromant Capto adapter for Varilock	G129	Holders for drills	G148
Adapters with ISO gripper groove	G131	Tapping chucks	G149
Adapters for side and facemills	G130	HSK solid holders	
Adapters for facemills and square shoulder facemills	G132	Basic holders	G151
Shrink fit adapter	G138	Face mill holder	G152
Adapters for Weldon shanks	G138	Collet chuck holder	G155
Adapters for drills with Whistle Notch shanks	G139	Weldon shank holder	G155
Adapters for drills with Coromant Whistle Notch shank	G140	Whistle Notch holder	G155
		Holder for drills	G157
		Tapping chucks	G157
		Coolant tube	G157
		HydroGrip high precision chuck	
Adapters for drills with ISO 9766 shank	G140	Coromant Capto® adapter for facemills	G159
Drill chuck	G140	Coromant Capto® chuck adapter	G159
Collet chuck adapters	G140	Coromant solid holder for facemills	G160
Tap adapters	G141	Coromant solid collet chuck	G160
		Solid holder for facemills	G161
		Heavy Duty	G161
		HSK solid holder for facemills	G162
		HSK solid collet chuck	G162

For spare parts for Coromant Capto® Multi-Task machining tools, see chapter H.

Assembly fixture

for mounting and dismounting of modular tools

391.500

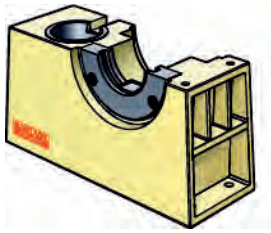

Fixture body

Ordering code: 391.500

391.501

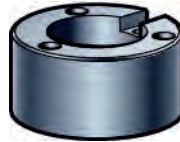

Fixture body

Ordering code: 391.501

Ordering code



Sleeve

For holder type, size

391.540-C3	Coromant Capto Size C3
391.540-C4	Coromant Capto Size C4
391.540-C5	Coromant Capto Size C5
391.540-C6	Coromant Capto Size C6
391.540-C8	Coromant Capto Size C8
391.540-C10	Coromant Capto Size C10
391.540-HA05	HSK 50 Form A/C
391.540-HA06	HSK 63 Form A/C
391.540-HA08	HSK 80 Form A/C
391.540-HA10	HSK 100 Form A/C
391.540-50	MAS-BT 50/CAT/ISO
391.540-30	MAS-BT 30/CAT/ISO
391.540-40	MAS-BT 40/CAT/ISO

Ordering code



Flange



Collar

For holder type, size

391.510-140 50	391.530-C3	Coromant Capto Size C3
391.510-140 50	391.530-C4	Coromant Capto Size C4
391.510-140 50	391.530-C5	Coromant Capto Size C5
391.510-140 50	391.530-C6	Coromant Capto Size C6
391.510-140 50	391.530-C8	Coromant Capto Size C8
	391.530-C10*	Coromant Capto Sizes C10 and C8X
391.510-HA05	391.530-50	HSK 50 Form A
391.510-HA06	391.530-63	HSK 63 Form A
391.510-HA08	391.530-80	HSK 80 Form A
391.510-HA10		HSK 100 Form A
391.510-HA13		HSK 125 Form A
391.510-55 30		MAS-BT 30
391.510-55 40		MAS-BT 40
391.510-55 50		MAS-BT 50
391.510-562-40		BIG PLUS, MAS BT 40
391.510-562-50		BIG PLUS, MAS BT 50
391.510-140 40		DIN 69871/40, ANSIB 5.50-40. ISO7388/1-40, CAT 40
391.510-140 50		DIN 69871/50, ANSIB 5.50-40. ISO7388/1-50, CAT 50
391.510-540 40		BIG PLUS DIN69871/1-40, BIG PLUS 7388/1-40
391.510-540 50		BIG PLUS DIN69871/1-50, BIG PLUS 7388/1-50
391.510-00 40		DIN 2080-40
391.510-00 50		DIN 2080-50
391.510-140 50		Varilock size 50
391.510-140 50		Varilock size 63
391.510-140 50		Varilock size 80

* Combined collar/flange for C10 and C8X.

Note: Key is delivered with the sleeve.

Assembly fixture 391.500

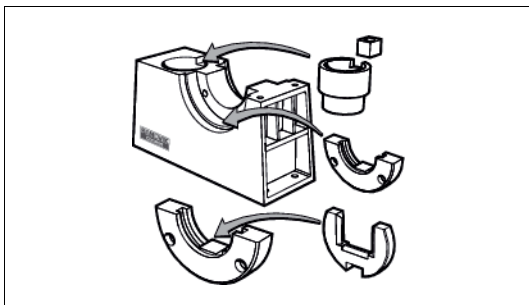

Choose flange, collar and sleeve to suit tool to be assembled.

Fixture 391.501 for maintenance of tools with Coromant Capto and HSK couplings

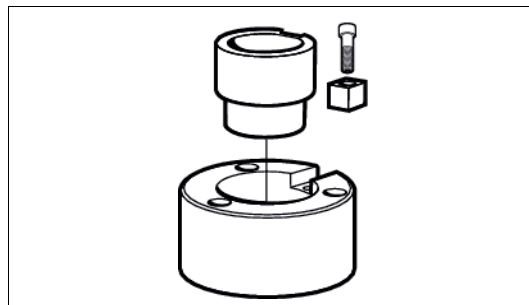

Choose sleeve to suit coupling. The fixture should be fastened to the bench with three socket head screws (not delivered with fixture).

Assembly fixture

for assembling and dismantling basic holders

Pneumatically operated
391.200

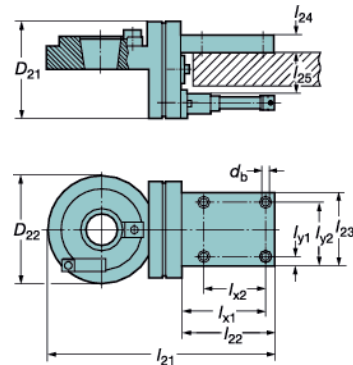
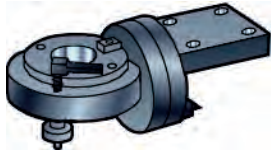

Note!

Assembly fixture 391.200-xx includes foot pedal.

Instructions are enclosed with fixture.

Air supply of 85 PSI (6 bar) is required for connection to the pedal.

Size		Ordering code	Dimensions, mm, inch												
Taper	HSK		d_b	D_{21}	D_{22}	l_{21}	l_{22}	l_{23}	l_{24}	l_{25}	k_1	k_2	l_{11}	l_{12}	
40	-	391.200-40	11	160	180	370	150	120	30	67	135	100	15	105	20
			.433	6.299	7.087	14.567	5.906	4.724	1.181	2.637	5.315	3.737	.590	4.134	
45	-	391.200-45	11	160	180	370	150	120	30	67	135	100	15	105	20
			.433	6.299	7.087	14.567	5.906	4.724	1.181	2.637	5.315	3.737	.590	4.134	
50	-	391.200-50	11	160	180	370	150	120	30	67	135	100	15	105	20
			.433	6.299	7.087	14.567	5.906	4.724	1.181	2.637	5.315	3.737	.590	4.134	
-	50	391.200-H050	11	160	180	370	150	120	30	67	135	100	15	105	20
			.433	6.299	7.087	14.567	5.906	4.724	1.181	2.637	5.315	3.737	.590	4.134	
-	63	391.200-H063	11	160	180	370	150	120	30	67	135	100	15	105	20
			.433	6.299	7.087	14.567	5.906	4.724	1.181	2.637	5.315	3.737	.590	4.134	
-	100	391.200-H100	11	160	180	370	150	120	30	67	135	100	15	105	20
			.433	6.299	7.087	14.567	5.906	4.724	1.181	2.637	5.315	3.737	.590	4.134	

Drawbolts for Coromant Capto® front clamp

Coupling size	Ordering code		
	Drawbolt	Drawbolt	O-ring ²⁾
C5	C5-390.00-M16-01	C5-390.00-M16-02 ¹⁾	3671 010-125
C6	C6-390.00-M20-01	C6-390.00-M20-02 ¹⁾	3671 010-128
C8	C8-390.00-M20-01	C8-390.00-M20-02 ¹⁾	3671 010-130

1) To be used together with turning cutting units.

2) Delivered together with the drawbolt.

Coolant tubes for Coromant Capto®

Cx-CT for Coromant Capto®

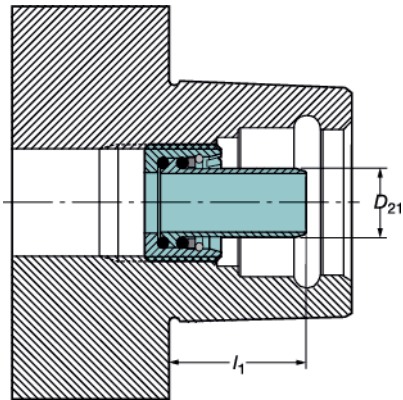

The requirement for use of coolant tubes is machine related, see machine information before installing.

Ensure the clamping device and/or machine are able to accept/handle the coolant tube before using.

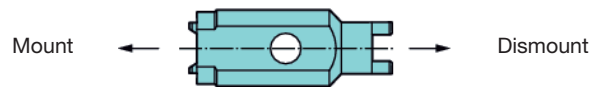

Please refer to M/C manual

Safe control

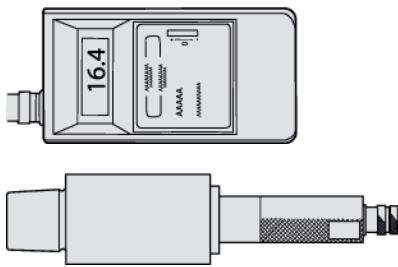

The safe control is used for measuring the clamping force of a machine's clamping system. If the clamping force is too low, the dynamic reaction between spindle and tool deteriorates.

Contact your local Sandvik Coromant representative for more information.

D

TOOLING SYSTEMS

Accessories

Assembly tools for extension / reduction adapters

All these accessories are supplied to separate order, and we recommend that they be ordered with the first Coromant Capto parts.

Milling

E

Coupling size	Retaining nut spanner	Extension key	Torque wrench	Length
C3	5680 065-13	5680 015-05	C-TK-02	440
C4	5680 065-10	5680 015-05	C-TK-02	440
C5	5680 065-11	5680 015-01	C-TK-02	440
C6-C8	5680 065-12	5680 015-02	C-TK-02	440
C10	5680 065-14	5680 015-06	C-TK-04	683

Drilling

C-TK-02

40-200Nm
30-148 ft-lbs

F

C-TK-04

Torque wrench for Coromant Capto® front clamping

TW-30-01

Pre-set 30 Nm (22 ft-lbs)

TW-60-01

Pre-set 60 Nm (44 ft-lbs)

Boring

G

Coupling size			Ordering code	Size mm	Spare parts
	ft-lbs	Nm	Torque wrench		Key adapter
C5	22	30	TW-30-01	5	5680 035-08
C6	22	30	TW-30-01	5	5680 035-08
C8	44	60	TW-60-01	7	5680 035-09

Tooling Systems

J

G 110

General Information

Tightening torque recommendations

Coromant Capto tightening torque:

Manual clamping units types 2000 and 3000

Coupling size	Torque	
	Nm	ft-lbs
C3	35	26
C4	50	37
C5	70	52

Coromant Capto tightening torque:

Manual clamping units and driven tool holders with camshaft mechanism

Coupling size	Torque	
	Nm	ft-lbs
C3	35	26
C4	50	37
C5	70	52
C6	90	66
C8	130	96

Coromant Capto® required pressure:

Hydraulic clamping units type 5000

Coupling size	Clamping	Ejecting
	Pressure, bar (PSI)	Pressure, bar (PSI)
C4	100 (1450)	100 (1450)
C5	80 (1160)	80 (1160)
C6	80 (1160)	80 (1160)
C8	80 (1160)	80 (1160)
C8X	80 (1160)	80 (1160)
C10	80 (1160)	80 (1160)

Required oil flow in all cases: 6 l/min (1.6 gal/min)

Coromant Capto® basic holders

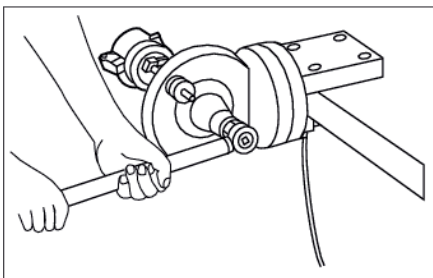

Center bolt clamping

Coupling size	Torque	
	Nm	ft-lbs
C3	45	33
C4	55	40
C5	95	70
C6	170	125
C8	170	125
C10	380	277

Front clamp

Coupling size	Torque	
	Nm	ft-lbs
C5	30	22
C6	30	22
C8	60	44

Cassettes with tapered polygon seating

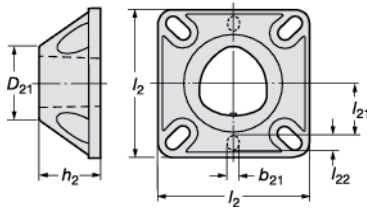
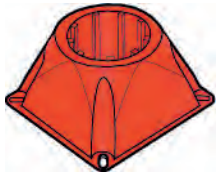

-4000
Plastic storage cassettes (red)

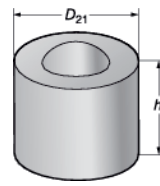
-6000-B

Aluminum cassette blanks

Milling

E

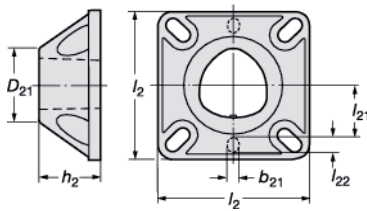
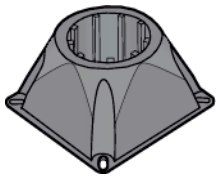

-5000
High grade plastic in-machine tool storage (black)

Drilling

F

Coupling size	Ordering code	Dimensions, mm, inch						All plastic cassettes conforming to hole pattern 17 mm, 20 mm, 25 mm and 1". High grade plastic. Red color. To be used: – alone for upright storage – with mechanism type PL-01 for horizontal or upright position.
		b_{21}	D_{21}	h_2	l_2	l_{21}	l_{22}	
C3	C3-C-4000	-	32	26	65	-	-	High grade reinforced black plastic. For in-machine tool storage with mechanism AL-01.
C4	C4-C-4000	6	50	39	74	26	8	
C5	C5-C-4000	6	50	39	74	26	8	
C6	C6-C-4000	8	80	63	116	41	10	
C8	C8-C-4000	8	80	63	116	41	10	
C4	C4-C-5000	6	50	39	74	26	8	
C5	C5-C-5000	6	50	39	74	26	8	
C6	C6-C-5000	8	80	63	116	41	10	
C8	C8-C-5000	8	80	63	116	41	10	
C10	C10-C-5000	8	100	80	150	60	68	
C6	C6-C-6000-B	-	120	63	-	-	-	Aluminum cassette blanks for individual adaptation. To be used with AL-01.
C8	C8-C-6000-B	-	120	63	-	-	-	
C10	C10-C-6000-B	-	138	80	-	-	-	
			120	63	-	-	-	

Boring

G

Tooling Systems

J

General Information

Locking mechanism for cassettes

-PL-01

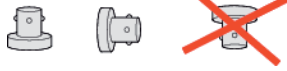
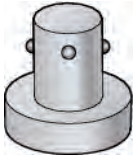

Passive locking mechanism

For vertical upwards and horizontal storage.
NEVER upside down storage.

-AL-01

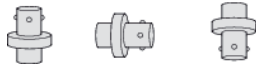
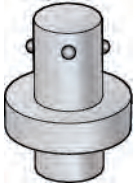

Active locking mechanism

For storage at all angles: vertical upwards and downwards or horizontal.

Coupling size	Ordering code	Pull action force		
		Pull action force, N	Pull action force, lbf	
C4	C4-PL-01	55	12.36	Central passive locking mechanism. Spring loaded clamping. Fits directly into all cassettes type 4000.
C5	C5-PL-01	120	26.98	
C6	C6-PL-01	150	33.72	
C8	C8-PL-01	240	53.95	
		Rec. max. tool weight		Active locking mechanism – mechanical push action. Fits directly into all cassettes type 5000/6000.
		Rec. max. tool weight, Kg	Rec. max. tool weight, lbs	
C4	C4-AL-01	40	88	
C5	C5-AL-01	60	132	
C6	C6-AL-01	75	165	
C8	C8-AL-01	110	243	
C10	C10-AL-01	150	330.7	

Pull studs

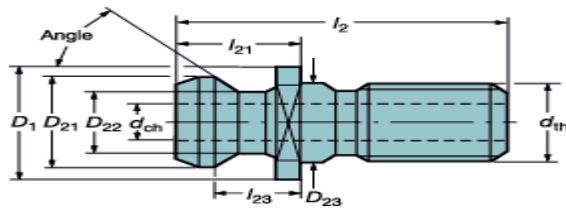

Metric

Machine design	Taper	Ordering code	Coolant ¹⁾	d_{ch}	D_1	D_{21}	D_{22}	D_{23}	l_2	l_{21}	l_{23}	d_{th}	a	B_{KW}	Info
ISO	40	393.140-40 M16-75	0		23	19	14	17	54	26	20	M16	75	19	DIN 69872
	40	393.140C-40 M16-45	1	7.35	22.5	18.95	12.95	17	44.5	16.4	11.15	M16	45	18	ISO 7388 B
	40	393.140C-40 M16-75-1	1	7	23	19	14	17	54	26	20	M16	75	19	ISO 7388
	40	393.140C-40 M16-75-2	1	7	23	19	14	17	54	26	20	M16	75	19	DIN 69872
	50	393.140-50 M24-75 ²⁾	0		36	28	21	25	74	34	25	M24	75	30	DIN 69872
	50	393.140C-50 M24-45	1	11.5	37	29.1	19.6	25	65.5	25.55	17.95	M24	45	30	ISO 7388 B
	50	393.140C-50 M24-75-1	1	11.5	36	28	21	25	74	34	25	M24	75	30	ISO 7388
	50	393.140C-50 M24-75-2	1	11.5	36	28	21	25	74	34	25	M24	75	30	DIN 69872
MAS-BT 403	30	393.55-30 M12-45	0		16.5	11	7	12.5	43	23	18	M12	45	13	
	30	393.55-30 M12-60	0		16.5	11	7	12.5	43	23	18	M12	60	13	
	30	393.55C-30 M12-45	1	2.4	16.5	11	7	12.5	43	23	18	M12	45	13	
	30	393.55C-30 M12-60	1	2.4	16.5	11	7	12.5	43	23	18	M12	60	13	
	40	393.55-40 M16-45	0		23	15	10	17	60	35	28	M16	45	19	
	40	393.55-40 M16-60	0		23	15	10	17	60	35	28	M16	60	19	
	40	393.55-40 M16-90	0		23	15	10	17	60	35	28	M16	90	19	
	40	393.55C-40 M16-45	1	4	23	15	10	17	60	35	28	M16	45	19	
	40	393.55C-40 M16-75	1	10	23	19	14	17	54	29	23	M16	75	19	JIS 40
	50	393.55-50 M24-45	0		38	23	17	25	85	45	35	M24	45	30	
	50	393.55-50 M24-60	0		38	23	17	25	85	45	35	M24	60	30	
	50	393.55-50 M24-90	0		38	23	17	25	85	45	25	M24	90	30	
	50	393.55C-50 M24-75	1	11.5	36	28	21	25	74	34	25	M24	75	30	JIS 50

Inch

Machine design	Taper	Ordering code	Coolant ¹⁾	d_{ch}	D_1	D_{21}	D_{22}	D_{23}	l_2	l_{21}	l_{23}	d_{th}	a	B_{KW}	Info
CAT-V	40	393.45-40 5/8-45-1	0	.940	.590	.390			2.120	1.260	.990	5/8"-11	45	.750	
	40	393.45-40 5/8-45-2	0	.940	.591	.394	.641		2.250	1.266	.990	5/8"-11	45	.750	
	40	393.45-40 5/8-90	0	.860	.590	.390			2.140	1.280	.990	5/8"-11	90	.690	
	40	393.45C-40 5/8-45-1	1	.281	.940	.740	.490		1.500	.640	.440	5/8"-11	45	.750	
	40	393.45C-40 5/8-45-2	1	.197	.940	.590	.390		2.120	1.260	.990	5/8"-11	45	.751	
	40	393.45C-40 5/8-45-3	1	.236	.858	.740	.490		1.624	.640	.440	5/8"-11	45	.750	
	40	393.45C-40 5/8-75	1	.276	.900	.744	.550		1.880	1.020	.790	5/8"-11	75	.740	
	40	393.45C-40 M16-45-1	1	.276	.860	.739	.490	.669	1.624	.640	.440	M16	45	.750	
	40	393.45C-40 M16-45-2	1	.252	.866	.740	.490	.669	1.736	.752	.552	M16	45	.750	
	50	393.45-50 1-90	0		1.370	.900	.670		3.070	1.770	1.380	1"-8	90	1.190	
	50	393.45C-50 1-45-1	1	.468	1.440	1.140	.820		2.300	1.000	.700	1"-8	45	1.250	
	50	393.45C-50 1-45-2	1	.250	1.370	.900	.660		3.090	1.790	1.380	1"-8	45	1.190	
	50	393.45C-50 1-45-3	1	.394	1.437	1.140	.820		2.575	1.000	.700	1"-8	45	1.250	
	50	393.45C-50 1-45-4	1	.468	1.430	1.140	.820	1.030	2.300	1.000	.700	1"-8	45	1.250	
	50	393.45C-50 1-60 ³⁾	1	.240	1.500	.910	.670	1.020	3.250	1.770	1.380	1"-8	60	1.180	
	50	393.45C-50 M24-45	1	.394	1.437	1.140	.820	.984	2.575	1.000	.700	M24	45	1.280	

1) 1 = coolant through center

2) With O-ring 2.5x20mm

3) With O-ring 3x20mm

Warning!

Machine tool manufacturers have used many various styles and sizes of retention knobs. They often look very similar and appear to be interchangeable. The use of the incorrect knob, or the incorrect use of a knob, may result in injury or property damage. We try to ensure that we specify the correct knob, but due to the variety, it is the responsibility of the end user to check that the supplied knobs are correct for the machine tool and taper type. Be sure to fully tighten the retention knob. Failure to do so may result in the toolholder coming loose during operation.

Cylindrical collets for Hydro-Grip®

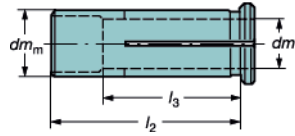
Sealed
393.CGS

l_3 = clamping length required to achieve sealing effect.

Metric bore

Inch bore

Collet size	Ordering code	Dimensions				Collet size	Ordering code	Dimensions, mm (inch)			
		dm_1	dm_2	l_2	l_3			dm_1	dm_2	l_2	l_3
12	393.CGS-12 03 40	3	12	40	25	12	A393.CGS-12 02 40	3.175 (1/8)	12	40	26
	393.CGS-12 04 40	4	12	40	25		A393.CGS-12 03 40	4.763 (3/16)	12	40	27
	393.CGS-12 05 40	5	12	40	25		A393.CGS-12 04 40	6.35 (1/4)	12	40	28
	393.CGS-12 06 40	6	12	40	32		A393.CGS-12 05 40	7.938 (5/16)	12	40	40
	393.CGS-12 07 40	7	12	40	33		A393.CGS-12 06 40	9.525 (3/8)	12	40	40
	393.CGS-12 08 40	8	12	40	33						
	393.CGS-12 09 40	9	12	40	33						
	393.CGS-12 10 40	10	12	40	36						
20	393.CGS-20 03 52	3	20	50	24	20	A393.CGS-20 02 52	3.175 (1/8)	20	50	26
	393.CGS-20 04 52	4	20	50	24		A393.CGS-20 03 52	4.763 (3/16)	20	50	26
	393.CGS-20 05 52	5	20	50	24		A393.CGS-20 04 52	6.35 (1/4)	20	50	26
	393.CGS-20 06 52	6	20	50	32		A393.CGS-20 05 52	7.938 (5/16)	20	50	40
	393.CGS-20 07 52	7	20	50	33		A393.CGS-20 06 52	9.525 (3/8)	20	50	40
	393.CGS-20 08 52	8	20	50	33		A393.CGS-20 07 52	11.113 (7/16)	20	50	40
	393.CGS-20 09 52	9	20	50	34		A393.CGS-20 08 52	12.7 (1/2)	20	50	40
	393.CGS-20 10 52	10	20	50	36		A393.CGS-20 09 52	14.288 (9/16)	20	50	40
	393.CGS-20 12 52	12	20	50	36		A393.CGS-20 10 52	15.875 (5/8)	20	50	45
	393.CGS-20 14 52	14	20	50	41						
	393.CGS-20 16 52	16	20	50	41						
	393.CGS-20 18 52	18	20	50	44						
25	393.CGS-25 03 56	3	25	56	25	25	A393.CGS-25 02 56	3.175 (1/8)	25	56	25
	393.CGS-25 04 56	4	25	56	25		A393.CGS-25 03 56	4.763 (3/16)	25	56	25
	393.CGS-25 05 56	5	25	56	25		A393.CGS-25 04 56	6.35 (1/4)	25	56	33
	393.CGS-25 06 56	6	25	56	33		A393.CGS-25 05 56	7.938 (5/16)	25	56	33
	393.CGS-25 07 56	7	25	56	33		A393.CGS-25 06 56	9.525 (3/8)	25	56	34
	393.CGS-25 08 56	8	25	56	33		A393.CGS-25 07 56	11.113 (7/16)	25	56	36
	393.CGS-25 09 56	9	25	56	34		A393.CGS-25 08 56	12.7 (1/2)	25	56	42
	393.CGS-25 10 56	10	25	56	36		A393.CGS-25 09 56	14.288 (9/16)	25	56	43
	393.CGS-25 12 56	12	25	56	42		A393.CGS-25 10 56	15.875 (5/8)	25	56	44
	393.CGS-25 14 56	14	25	56	43		A393.CGS-25 11 56	17.463 (11/16)	25	56	45
	393.CGS-25 16 56	16	25	56	44		A393.CGS-25 12 56	19.05 (3/4)	25	56	45
	393.CGS-25 18 56	18	25	56	44		A393.CGS-25 13 56	20.638 (13/16)	25	56	46
393.CGS-25 20 56	20	25	56	45							
32	393.CGS-32 07 60	7	32	60	33	32	A393.CGS-32 03 60	4.763 (3/16)	32	60	26
	393.CGS-32 08 60	8	32	60	33		A393.CGS-32 04 60	6.35 (1/4)	32	60	26
	393.CGS-32 09 60	9	32	60	33		A393.CGS-32 05 60	7.938 (5/16)	32	60	40
	393.CGS-32 10 60	10	32	60	36		A393.CGS-32 06 60	9.525 (3/8)	32	60	40
	393.CGS-32 12 60	12	32	60	41		A393.CGS-32 07 60	11.113 (7/16)	32	60	40
	393.CGS-32 14 60	14	32	60	42		A393.CGS-32 08 60	12.7 (1/2)	32	60	40
	393.CGS-32 16 60	16	32	60	44		A393.CGS-32 09 60	14.288 (9/16)	32	60	40
	393.CGS-32 18 60	18	32	60	45		A393.CGS-32 10 60	15.875 (5/8)	32	60	40
	393.CGS-32 20 60	20	32	60	46		A393.CGS-32 11 60	17.463 (11/16)	32	60	40
	393.CGS-32 25 60	25	32	60	47		A393.CGS-32 12 60	19.05 (3/4)	32	60	40
							A393.CGS-32 13 60	20.638 (13/16)	32	60	40
							A393.CGS-32 14 60	22.225 (7/8)	32	60	40
					A393.CGS-32 15 60	23.813 (15/16)	32	60	40		
					A393.CGS-32 16 60	25.4 (1)	32	60	45		

For extractors for cylindrical collets, see page G117.

Cylindrical collets for Hydro-Grip®

Slitted

393.CG

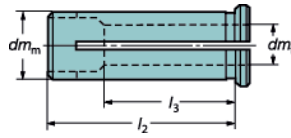
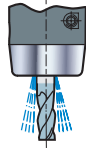

Metric bore

Collet size	Ordering code	Dimensions			
		dm_t	dm_m	l_2	l_3
12	393.CG-12 03 40	3	12	40	25
	393.CG-12 04 40	4	12	40	25
	393.CG-12 05 40	5	12	40	25
	393.CG-12 06 40	6	12	40	32
	393.CG-12 07 40	7	12	40	33
	393.CG-12 08 40	8	12	40	33
	393.CG-12 09 40	9	12	40	33
16	393.CG-12 10 40	10	12	40	36
	393.CG-16 06 50	6	16	50	32
	393.CG-16 08 50	8	16	50	32
	393.CG-16 10 50	10	16	50	36
20	393.CG-16 12 50	12	16	50	36
	393.CG-20 03 52	3	20	50	24
	393.CG-20 04 52	4	20	50	24
	393.CG-20 05 52	5	20	50	24
	393.CG-20 06 52	6	20	50	32
	393.CG-20 07 52	7	20	50	33
	393.CG-20 08 52	8	20	50	33
	393.CG-20 09 52	9	20	50	34
	393.CG-20 10 52	10	20	50	36
	393.CG-20 12 52	12	20	50	41
25	393.CG-20 14 52	14	20	50	41
	393.CG-20 16 52	16	20	50	44
	393.CG-25 03 56	3	25	56	25
	393.CG-25 04 56	4	25	56	25
	393.CG-25 05 56	5	25	56	25
	393.CG-25 06 56	6	25	56	33
	393.CG-25 07 56	7	25	56	33
	393.CG-25 08 56	8	25	56	33
	393.CG-25 09 56	9	25	56	34
	393.CG-25 10 56	10	25	56	36
	393.CG-25 12 56	12	25	56	42
	393.CG-25 14 56	14	25	56	43
32	393.CG-25 16 56	16	25	56	44
	393.CG-25 18 56	18	25	56	44
	393.CG-25 20 56	20	25	56	46
	393.CG-32 06 60	6	32	60	26
	393.CG-32 07 60	7	32	60	40
	393.CG-32 08 60	8	32	60	40
	393.CG-32 09 60	9	32	60	40
	393.CG-32 10 60	10	32	60	40
	393.CG-32 12 60	12	32	60	40
	393.CG-32 14 60	14	32	60	40
32	393.CG-32 16 60	16	32	60	40
	393.CG-32 18 60	18	32	60	40
	393.CG-32 20 60	20	32	60	40
	393.CG-32 25 60	25	32	60	45

For extractors for cylindrical collets, see page G117.

Cylindrical collets for CoroGrip®

Inch bore

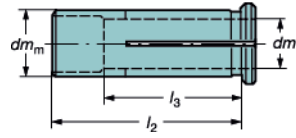
Sealed
A393.CGS

l_3 = clamping length required to achieve sealing effect.

Inch bore

Collet size	Ordering code	Dimensions, inch			
		dm_t	dm_m	l_2	l_3
13	A393.CGS-13 02 40	.125 (1/8)	.500	1.575	.984
	A393.CGS-13 03 40	.187 (3/16)	.500	1.575	.984
	A393.CGS-13 04 40	.250 (1/4)	.500	1.575	1.260
	A393.CGS-13 05 40	.312 (5/16)	.500	1.575	1.299
	A393.CGS-13 06 40	.375 (3/8)	.500	1.575	1.417
15	A393.CGS-15 04 50	.250 (1/4)	.625	1.969	1.260
	A393.CGS-15 05 50	.312 (5/16)	.625	1.969	1.260
	A393.CGS-15 06 50	.375 (3/8)	.625	1.969	1.417
	A393.CGS-15 08 50	.500 (1/2)	.625	1.969	1.417
19	A393.CGS-19 02 52	.125 (1/8)	.750	2.047	1.023
	A393.CGS-19 03 52	.187 (3/16)	.750	2.047	1.023
	A393.CGS-19 04 52	.250 (1/4)	.750	2.047	1.023
	A393.CGS-19 05 52	.312 (5/16)	.750	2.047	1.575
	A393.CGS-19 06 52	.375 (3/8)	.750	2.047	1.575
	A393.CGS-19 07 52	.437 (7/16)	.750	2.047	1.575
	A393.CGS-19 08 52	.500 (1/2)	.750	2.047	1.575
	A393.CGS-19 09 52	.562 (9/16)	.750	2.047	1.575
	A393.CGS-19 10 52	.625 (5/8)	.750	2.047	1.772
	26	A393.CGS-26 02 56	.125 (1/8)	1.000	2.205
A393.CGS-26 03 56		.187 (3/16)	1.000	2.205	.984
A393.CGS-26 04 56		.250 (1/4)	1.000	2.205	1.299
A393.CGS-26 05 56		.312 (5/16)	1.000	2.205	1.299
A393.CGS-26 06 56		.375 (3/8)	1.000	2.205	1.339
A393.CGS-26 07 56		.437 (7/16)	1.000	2.205	1.417
A393.CGS-26 08 56		.500 (1/2)	1.000	2.205	1.654
A393.CGS-26 09 56		.562 (9/16)	1.000	2.205	1.693
A393.CGS-26 10 56		.625 (5/8)	1.000	2.205	1.732
A393.CGS-26 11 56		.687 (11/16)	1.000	2.205	1.732
A393.CGS-26 12 56		.750 (3/4)	1.000	2.205	1.732
31	A393.CGS-31 03 60	.187 (3/16)	1.250	2.362	1.023
	A393.CGS-31 04 60	.250 (1/4)	1.250	2.362	1.575
	A393.CGS-31 05 60	.312 (5/16)	1.250	2.362	1.575
	A393.CGS-31 06 60	.375 (3/8)	1.250	2.362	1.575
	A393.CGS-31 07 60	.437 (7/16)	1.250	2.362	1.575
	A393.CGS-31 08 60	.500 (1/2)	1.250	2.362	1.575
	A393.CGS-31 09 60	.562 (9/16)	1.250	2.362	1.575
	A393.CGS-31 10 60	.625 (5/8)	1.250	2.362	1.575
	A393.CGS-31 11 60	.687 (11/16)	1.250	2.362	1.575
	A393.CGS-31 12 60	.750 (3/4)	1.250	2.362	1.575
	A393.CGS-31 16 60	1.000 (1)	1.250	2.362	1.772

Extractor for cylindrical collets

Extractor	For collet size	
	Metric	Inch
5680 061-01	12	13 (1/2")
5680 061-02	16	15 (5/8")
5680 061-03	20	19 (3/4")
5680 061-04	25	26 (1")
5680 061-05	32	31 (1 1/4")



Hydro-Grip® Pencil collet

Pencil collet
393.CGP

Milling

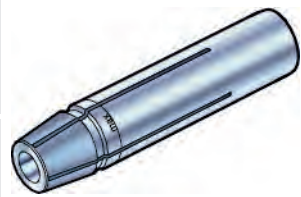

Max recommended protrusion

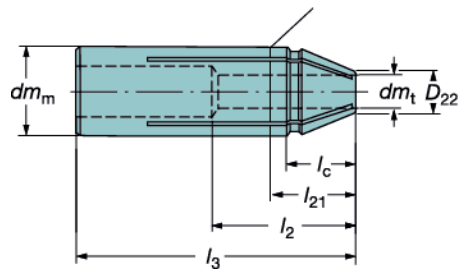

E

Collet size	Ordering code	Dimensions							
		dm_m	dm_t	D_{22}	l_c	$l_2^{1)}$	l_3	l_{21}	$\frac{kg}{kg}$
20	Metric								
	393.CGP-20 06 72	20	6	9	17	37	72	21	0.1
	393.CGP-20 08 72	20	8	11	17	37	72	21	0.1
	393.CGP-20 10 72	20	10	13	17	41	72	21	0.1
	393.CGP-20 12 72	20	12	15	17	41	72	21	0.1

1) Min. tool length to be clamped inside collet

Drilling

Accessories for Hydro-Grip

F

Adjustment screw

Ordering code	For type		
	Coromant Capto	Solid holder	HSK holder
5512 100-01	C4-391.CGA Cx-391.CGC-12xxx		
5512 100-02	C5-C8-391.CGA Cx-391.CGC-20xxx Cx-391.CGC-25	392.272CG 392.55CG 392.45CG	392.CGA
5512 100-03	Cx-391.CGD	392.45CGD 392.55CGD 392.272CGD	392.410CGD



Boring

Hydro-Grip® cylindrical shank

Pencil HydroGrip®

G

High precision chuck

Cylindrical shank
393.CGA

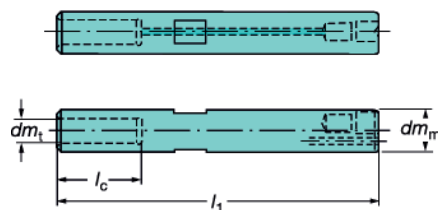
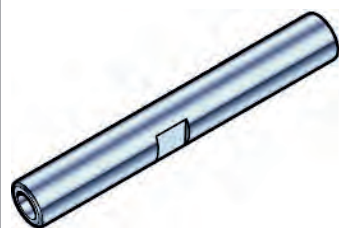

Accessories

Not delivered with the 393.CG tool, must be ordered 393.CGS separately.



Page G119

Tooling Systems

l_1 = programming length

J

Coupling size	Ordering code	Coolant ¹⁾	Dimensions, mm, inch								$\frac{kg}{kg}$	BLQ ²⁾	NBLQ ³⁾	Collet size
			dm_t mm	dm_t in.	dm_m mm	dm_m in.	l_1 mm	l_1 in.	l_c mm	l_c in.				
20	393.CGA-20 12 150	1	12	.472	20	.787	150	5.906	40	1.575	0.4	2.5	15000	12

- 1) 1 = coolant through center
- 2) Balance quality code
- 3) Rotational speed at balance quality

General Information



ER collets

DIN 6499-B

393.14

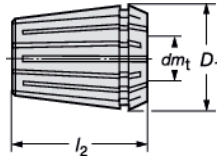

Size	D_1		l_2	
	mm	Inch	mm	Inch
ER11	11.4	.449	18	.709
ER16	17	.669	27.5	1.062
ER20	21	.827	31.5	1.240
ER25	26	1.024	34	1.330
ER32	33	1.291	40	1.575
ER40	41	1.614	46	1.811
ER50	52	2.047	60	2.362

Size 11			Size 16			Size 20			Size 25		
Range	dm_1	Ordering code	Range	dm_1	Ordering code	Range	dm_1	Ordering code	Range	dm_1	Ordering code
1.00–0.75	.039-.030	393.14-11 0100	1.0–0.5	.039-.020	393.14-16 0100	1.5–1.0	.059-.039	393.14-20 015	2.0–1.5	.079-.059	393.14-25 020
1.25–1.00	.049-.039	393.14-11 0125	1.5–1.0	.059-.039	393.14-16 0150	2.0–1.5	.079-.059	393.14-20 020	2.5–2.0	.098-.079	393.14-25 025
1.50–1.25	.059-.049	393.14-11 0150	2.0–1.0	.079-.039	393.14-16 0200	2.5–2.0	.098-.079	393.14-20 025	3.0–2.5	.118-.098	393.14-25 030
1.75–1.50	.069-.059	393.14-11 0175	2.5–1.5	.098-.059	393.14-16 0250	3.0–2.5	.118-.098	393.14-20 030	4.0–3.0	.157-.118	393.14-25 040
2.00–1.75	.079-.069	393.14-11 0200	3.0–2.0	.118-.079	393.14-16 0300	4.0–3.0	.157-.118	393.14-20 040	5.0–4.0	.197-.157	393.14-25 050
2.25–2.00	.089-.079	393.14-11 0225	4.0–3.0	.157-.118	393.14-16 0400	5.0–4.0	.197-.157	393.14-20 050	6.0–5.0	.236-.197	393.14-25 060
2.50–2.25	.098-.089	393.14-11 0250	5.0–4.0	.197-.157	393.14-16 0500	6.0–5.0	.236-.197	393.14-20 060	7.0–6.0	.275-.236	393.14-25 070
3.00–2.50	.118-.098	393.14-11 0300	6.0–5.0	.236-.197	393.14-16 0600	7.0–6.0	.275-.236	393.14-20 070	8.0–7.0	.315-.275	393.14-25 080
3.50–3.00	.138-.118	393.14-11 0350	7.0–6.0	.276-.236	393.14-16 0700	8.0–7.0	.315-.275	393.14-20 080	9.0–8.0	.354-.315	393.14-25 090
4.00–3.50	.157-.138	393.14-11 0400	8.0–7.0	.315-.276	393.14-16 0800	9.0–8.0	.354-.315	393.14-20 090	10.0–9.0	.394-.354	393.14-25 100
4.50–4.00	.177-.157	393.14-11 0450	9.0–8.0	.354-.315	393.14-16 0900	10.0–9.0	.394-.354	393.14-20 100	11.0–10.0	.433-.394	393.14-25 110
5.00–4.50	.197-.177	393.14-11 0500	10.0–9.0	.394-.354	393.14-16 1000	11.0–10.0	.433-.394	393.14-20 110	12.0–11.0	.472-.433	393.14-25 120
5.50–5.00	.217-.197	393.14-11 0550				12.0–11.0	.472-.433	393.14-20 120	13.0–12.0	.512-.472	393.14-25 130
6.00–5.50	.236-.217	393.14-11 0600				13.0–12.0	.512-.472	393.14-20 130	14.0–13.0	.551-.512	393.14-25 140
6.50–6.00	.256-.236	393.14-11 0650							15.0–14.0	.591-.551	393.14-25 150
7.00–6.50	.276-.256	393.14-11 0700							16.0–15.0	.630-.591	393.14-25 160

Size 32			Size 40			Size 50		
Range	dm_1	Ordering code	Range	dm_1	Ordering code	Range	dm_1	Ordering code
2.5–2.0	.098-.079	393.14-32 025	4.0–3.0	.157-.118	393.14-40 040	8.0–6.0	.315-.236	393.14-50 080
3.0–2.5	.118-.098	393.14-32 030	5.0–4.0	.197-.157	393.14-40 050	10.0–8.0	.394-.315	393.14-50 100
4.0–3.0	.157-.118	393.14-32 040	6.0–5.0	.236-.197	393.14-40 060	12.0–10.0	.472-.394	393.14-50 120
5.0–4.0	.197-.157	393.14-32 050	7.0–6.0	.275-.236	393.14-40 070	14.0–12.0	.551-.472	393.14-50 140
6.0–5.0	.236-.197	393.14-32 060	8.0–7.0	.315-.275	393.14-40 080	16.0–14.0	.630-.551	393.14-50 160
7.0–6.0	.275-.236	393.14-32 070	9.0–8.0	.354-.315	393.14-40 090	18.0–16.0	.709-.630	393.14-50 180
8.0–7.0	.315-.275	393.14-32 080	10.0–9.0	.394-.354	393.14-40 100	20.0–18.0	.787-.709	393.14-50 200
9.0–8.0	.354-.315	393.14-32 090	11.0–10.0	.433-.394	393.14-40 110	22.0–20.0	.866-.787	393.14-50 220
10.0–9.0	.394-.354	393.14-32 100	12.0–11.0	.472-.433	393.14-40 120	24.0–22.0	.945-.866	393.14-50 240
11.0–10.0	.433-.394	393.14-32 110	13.0–12.0	.512-.472	393.14-40 130	26.0–24.0	1.024-.945	393.14-50 260
12.0–11.0	.472-.433	393.14-32 120	14.0–13.0	.551-.512	393.14-40 140	28.0–26.0	1.102-1.024	393.14-50 280
13.0–12.0	.512-.472	393.14-32 130	15.0–14.0	.591-.551	393.14-40 150	30.0–28.0	1.181-1.102	393.14-50 300
14.0–13.0	.551-.512	393.14-32 140	16.0–15.0	.630-.591	393.14-40 160	32.0–30.0	1.260-1.181	393.14-50 320
15.0–14.0	.591-.551	393.14-32 150	17.0–16.0	.669-.630	393.14-40 170	34.0–32.0	1.339-1.260	393.14-50 340
16.0–15.0	.630-.591	393.14-32 160	18.0–17.0	.709-.669	393.14-40 180			
17.0–16.0	.699-.630	393.14-32 170	19.0–18.0	.748-.709	393.14-40 190			
18.0–17.0	.709-.669	393.14-32 180	20.0–19.0	.787-.748	393.14-40 200			
19.0–18.0	.748-.709	393.14-32 190	21.0–20.0	.827-.787	393.14-40 210			
20.0–19.0	.787-.748	393.14-32 200	22.0–21.0	.866-.827	393.14-40 220			
			23.0–22.0	.906-.866	393.14-40 230			
			24.0–23.0	.945-.906	393.14-40 240			
			25.0–24.0	.984-.945	393.14-40 250			
			26.0–25.0	1.024-.984	393.14-40 260			

ER collets, metallic sealed

393.15
A393.15

- High precision runout to $\leq 6 \mu\text{m}$
- HPC applicable

Milling

E

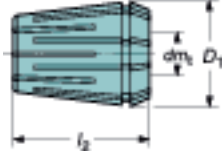

Drilling

F

Boring

G

Tooling Systems

J

General Information

Metric Collet size	dm ₁ mm			Dimensions		Tightening torque, ft-lbs	Collet size	Inch			Dimensions, inch		Tightening torque, ft-lbs	
	max	min	Ordering code	D ₁	l ₂			dm ₁ inch	max	min	Ordering code	D ₁		l ₂
16	3	2.97	393.15-16 03	17	27.5	71	16	1/4	.250	.2303	A393.15-16 1/4	.669	1.082	52
	4	3.97	393.15-16 04	17	27.5	71		5/16	.3125	.2929	A393.15-16 5/16	.669	1.082	52
	5	4.5	393.15-16 05	17	27.5	71		3/8	.375	.3556	A393.15-16 3/8	.669	1.082	52
	6	5.5	393.15-16 06	17	27.5	71								
	8	7.5	393.15-16 08	17	27.5	71								
	10	9.5	393.15-16 10	17	27.5	71								
20	3	2.97	393.15-20 03	21	31.5	100	20	1/4	.250	.2488	A393.15-20 1/4	.827	1.240	74
	4	3.97	393.15-20 04	21	31.5	100		5/16	.3125	.2929	A393.15-20 5/16	.827	1.240	74
	5	4.97	393.15-20 05	21	31.5	100		3/8	.375	.3556	A393.15-20 3/8	.827	1.240	74
	6	5.97	393.15-20 06	21	31.5	100		1/2	.500	.4803	A393.15-20 1/2	.827	1.240	74
	8	7.5	393.15-20 08	21	31.5	100								
	10	9.5	393.15-20 10	21	31.5	100								
25	6	5.97	393.15-25 06	26	34	129	25	1/4	.250	.2488	A393.15-25 1/4	1.024	1.339	95
	8	7.5	393.15-25 08	26	34	129		5/16	.3125	.2929	A393.15-25 5/16	1.024	1.339	95
	10	9.5	393.15-25 10	26	34	129		3/8	.375	.3556	A393.15-25 3/8	1.024	1.339	95
	12	11.5	393.15-25 12	26	34	129		1/2	.500	.4803	A393.15-25 1/2	1.024	1.339	95
	14	13.5	393.15-25 14	26	34	129		5/8	.625	.6055	A393.15-25 5/8	1.024	1.339	95
	16	15.5	393.15-25 16	26	34	129								
32	6	5.97	393.15-32 06	33	40	170	32	1/4	.250	.2488	A393.15-32 1/4	1.291	1.575	125
	8	7.5	393.15-32 08	33	40	170		5/16	.3125	.2929	A393.15-32 5/16	1.291	1.575	125
	10	9.5	393.15-32 10	33	40	170		3/8	.375	.3556	A393.15-32 3/8	1.291	1.575	125
	12	11.5	393.15-32 12	33	40	170		1/2	.500	.4803	A393.15-32 1/2	1.291	1.575	125
	14	13.5	393.15-32 14	33	40	170		5/8	.625	.6055	A393.15-32 5/8	1.291	1.575	125
	16	15.5	393.15-32 16	33	40	170		3/4	.750	.7303	A393.15-32 3/4	1.291	1.575	125
	18	17.5	393.15-32 18	33	40	170								
	20	19.5	393.15-32 20	33	40	170								
40	6	5.97	393.15-40 06	41	46	220	40	1/4	.250	.2488	A393.15-40 1/4	1.614	1.811	162
	8	7.97	393.15-40 08	41	46	220		5/16	.3125	.3111	A393.15-40 5/16	1.614	1.811	162
	10	9.5	393.15-40 10	41	46	220		3/8	.375	.3556	A393.15-40 3/8	1.614	1.811	162
	12	11.5	393.15-40 12	41	46	220		1/2	.500	.4803	A393.15-40 1/2	1.614	1.811	162
	14	13.5	393.15-40 14	41	46	220		5/8	.625	.6055	A393.15-40 5/8	1.614	1.811	162
	16	15.5	393.15-40 16	41	46	220		3/4	.750	.7303	A393.15-40 3/4	1.614	1.811	162
	18	17.5	393.15-40 18	41	46	220		1	.1000	.9646	A393.15-40 1	1.614	1.811	162
	20	19.5	393.15-40 20	41	46	220								
	25	24.5	393.15-40 25	41	46	220								

ER Collet sealing discs

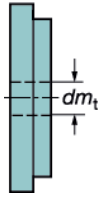

0.5 mm (.020 inch) capacity per disc. Max 150 bar (2000 psi) coolant pressure.

Size 16		Size 25		Size 32		Size 40	
Range, mm (inch)	Ordering code	Range, mm (inch)	Ordering code	Range, mm (inch)	Ordering code	Range, mm (inch)	Ordering code
3.0-2.5 (.118-.098)	3916.00300	3.0-2.5 (.118-.098)	3925.00300	3.0-2.5 (.118-.098)	3932.00300	3.0-2.5 (.118-.098)	3940.0030
3.5-3.0 (.138-.118)	3916.00350	3.5-3.0 (.138-.118)	3925.00350	3.5-3.0 (.138-.118)	3932.00350	3.5-3.0 (.138-.118)	3940.0035
4.0-3.5 (.157-.138)	3916.00400	4.0-3.5 (.157-.138)	3925.00400	4.0-3.5 (.157-.138)	3932.00400	4.0-3.5 (.157-.138)	3940.0040
4.5-4.0 (.177-.157)	3916.00450	4.5-4.0 (.177-.157)	3925.00450	4.5-4.0 (.177-.157)	3932.00450	4.5-4.0 (.177-.157)	3940.0045
5.0-4.5 (.197-.177)	3916.00500	5.0-4.5 (.197-.177)	3925.00500	5.0-4.5 (.197-.177)	3932.00500	5.0-4.5 (.197-.177)	3940.0050
5.5-5.0 (.217-.197)	3916.00550	5.5-5.0 (.217-.197)	3925.00550	5.5-5.0 (.217-.197)	3932.00550	5.5-5.0 (.217-.197)	3940.0055
6.0-5.5 (.236-.217)	3916.00600	6.0-5.5 (.236-.217)	3925.00600	6.0-5.5 (.236-.217)	3932.00600	6.0-5.5 (.236-.217)	3940.0060
6.5-6.0 (.256-.236)	3916.00650	6.5-6.0 (.256-.236)	3925.00650	6.5-6.0 (.256-.236)	3932.00650	6.5-6.0 (.256-.236)	3940.0065
7.0-6.5 (.276-.256)	3916.00700	7.0-6.5 (.276-.256)	3925.00700	7.0-6.5 (.276-.256)	3932.00700	7.0-6.5 (.276-.256)	3940.0070
7.5-7.0 (.295-.276)	3916.00750	7.5-7.0 (.295-.276)	3925.00750	7.5-7.0 (.295-.276)	3932.00750	7.5-7.0 (.295-.276)	3940.0075
8.0-7.5 (.315-.295)	3916.00800	8.0-7.5 (.315-.295)	3925.00800	8.0-7.5 (.315-.295)	3932.00800	8.0-7.5 (.315-.295)	3940.0080
8.5-8.0 (.335-.315)	3916.00850	8.5-8.0 (.335-.315)	3925.00850	8.5-8.0 (.335-.315)	3932.00850	8.5-8.0 (.335-.315)	3940.0085
9.0-8.5 (.354-.335)	3916.00900	9.0-8.5 (.354-.335)	3925.00900	9.0-8.5 (.354-.335)	3932.00900	9.0-8.5 (.354-.335)	3940.0090
9.5-9.0 (.374-.354)	3916.00950	9.5-9.0 (.374-.354)	3925.00950	9.5-9.0 (.374-.354)	3932.00950	9.5-9.0 (.374-.354)	3940.0095
10.0-9.5 (.394-.374)	3916.01000	10.0-9.5 (.394-.374)	3925.01000	10.0-9.5 (.394-.374)	3932.01000	10.0-9.5 (.394-.374)	3940.0100
		10.5-10.0 (.413-.394)	3925.01050	10.5-10.0 (.413-.394)	3932.01050	10.5-10.0 (.413-.394)	3940.0105
		11.0-10.5 (.433-.413)	3925.01100	11.0-10.5 (.433-.413)	3932.01100	11.0-10.5 (.433-.413)	3940.0110
		11.5-11.0 (.453-.433)	3925.01150	11.5-11.0 (.453-.433)	3932.01150	11.5-11.0 (.453-.433)	3940.0115
		12.0-11.5 (.472-.453)	3925.01200	12.0-11.5 (.472-.453)	3932.01200	12.0-11.5 (.472-.453)	3940.0120
		12.5-12.0 (.492-.472)	3925.01250	12.5-12.0 (.492-.472)	3932.01250	12.5-12.0 (.492-.472)	3940.0125
		13.0-12.5 (.512-.492)	3925.01300	13.0-12.5 (.512-.492)	3932.01300	13.0-12.5 (.512-.492)	3940.0130
		13.5-13.0 (.531-.512)	3925.01350	13.5-13.0 (.531-.512)	3932.01350	13.5-13.0 (.531-.512)	3940.0135
		14.0-13.5 (.551-.531)	3925.01400	14.0-13.5 (.551-.531)	3932.01400	14.0-13.5 (.551-.531)	3940.0140
		14.5-14.0 (.571-.551)	3925.01450	14.5-14.0 (.571-.551)	3932.01450	14.5-14.0 (.571-.551)	3940.0145
		15.0-14.5 (.591-.571)	3925.01500	15.0-14.5 (.591-.571)	3932.01500	15.0-14.5 (.591-.571)	3940.0150
		15.5-15.0 (.610-.591)	3925.01550	15.5-15.0 (.610-.591)	3932.01550	15.5-15.0 (.610-.591)	3940.0155
		16.0-15.5 (.630-.610)	3925.01600	16.0-15.5 (.630-.610)	3932.01600	16.0-15.5 (.630-.610)	3940.0160
				16.5-16.0 (.650-.630)	3932.01650	16.5-16.0 (.650-.630)	3940.0165
				17.0-16.5 (.669-.650)	3932.01700	17.0-16.5 (.669-.650)	3940.0170
				17.5-17.0 (.689-.669)	3932.01750	17.5-17.0 (.689-.669)	3940.0175
				18.0-17.5 (.709-.689)	3932.01800	18.0-17.5 (.709-.689)	3940.0180
				18.5-18.0 (.728-.709)	3932.01850	18.5-18.0 (.728-.709)	3940.0185
				19.0-18.5 (.748-.728)	3932.01900	19.0-18.5 (.748-.728)	3940.0190
				19.5-19.0 (.768-.748)	3932.01950	19.5-19.0 (.768-.748)	3940.0195
				20.0-19.5 (.787-.768)	3932.02000	20.0-19.5 (.787-.768)	3940.0200
						20.5-20.0 (.807-.787)	3940.0205
						21.0-20.5 (.827-.807)	3940.0210
						21.5-21.0 (.846-.827)	3940.0215
						22.0-21.5 (.866-.846)	3940.0220
						22.5-22.0 (.886-.866)	3940.0225
						23.0-22.5 (.906-.886)	3940.0230
						23.5-23.0 (.925-.906)	3940.0235
						24.0-23.5 (.945-.925)	3940.0240
						24.5-24.0 (.965-.945)	3940.0245
						25.0-24.5 (.984-.965)	3940.0250
						25.5-25.0 (1.004-.984)	3940.0255
						26.0-25.5 (1.024-1.004)	3940.0260

ER collet nuts for through coolant

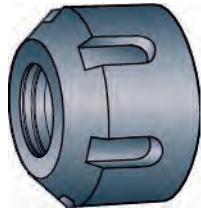
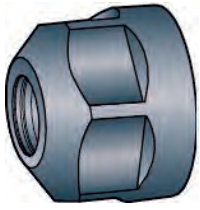

Sizes 16 and 20

Sizes 25, 32 and 40

Collet size	Ordering code	Spare parts		Thread size
		Wrench	O-ring	
ER16	5533 051-01	5680 091-01	5641005-085	M22 x 1.5
ER20	5533 051-02	5680 091-02	5641005-086	M25 x 1.5
ER25	5533 051-03	5680 096-02	5641005-087	M32 x 1.5
ER32	5533 051-04	5680 096-03	5641005-088	M40 x 1.5
ER40	5533 051-05	5680 096-04	5641005-089	M50 x 1.5

Assembly instructions for sealing discs for through coolant nuts

Assembly

1. Locate the smallest outside diameter on the disc.
2. Insert the small diameter into the center of the coolant nut and apply even pressure until the disc is properly seated into the nut.

Removal

1. To remove the disc, simply press on the outside of the disc evenly until it snaps out.

Max. tightening torques, ER collet nuts

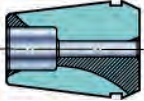
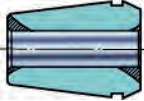
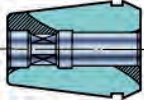
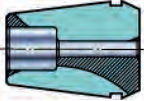
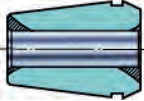
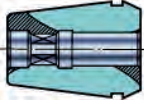
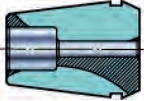
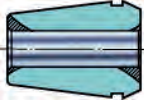
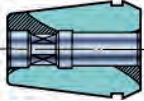
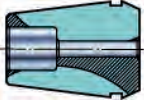
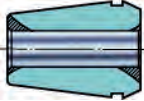
Collet nut	Collet size	ER Counterbore				ER Throughbore				ER Tapping	
		d_{m1} mm	Torque Nm	d_{m1} inch	Torque ft-lbs	d_{m1} mm	Torque Nm	d_{m1} inch	Torque ft-lbs	Torque Nm	Torque ft-lbs
	5533 050-07 ER11	1.0-2.5	9	.039-.098	7	3.0-5.0	24	.118-.197	18	16	12
		1.0	8	.039	5						
	5533 050-06 5533 051-01 ER16	1.5-3.5	22	.059-.138	16	5.0-10.0	54	.197-.394	40	43	32
		4.0-4.5	43	.157-.177	32						
	5533 050-08 5533 051-02 ER20	1.0	16	.039	12	7.0-13.0	80	.276-.512	60	32	24
		1.5-6.5	32	.059-.256	24						
	5533 050-02 5533 051-03 ER25	1.0-3.5	21	.039-.138	16	8.0-16.0	108	.315-.630	80	108	80
		4.0-4.5	54	.157-.177	40						
		5.0-7.5	81	.197-.295	60						
	5533 050-03 5533 051-04 ER32	2.0-2.5	22	.079-.098	16	8.0-20.0	135	.315-.787	100	135	100
		3.0-7.5	135	.118-.295	100						
	5533 050-04 5533 051-05 ER40	3.0-8.5	170	.118-.335	125	9.0-26.0	170	.354-1.024	125	170	125
	5533 050-05 ER50	6.0-10.0	237	.236-.394	175	12.0-	237	.472-1.339	175	-	-
	5533 065-02 ER11	1.0-2.5	8	.039-.098	6	3.0-5.0	16	.118-.197	12	12	9
		1.0	16	.039	6						
	5533 065-03 ER16	1.5-3.5	19	.059-.138	14	5.0-10.0	24	.197-.394	18	24	18
		4.0-4.5	24	.157-.177	18						
		1.0	16	.039	12	7.0-13.0	28	.276-.512	21	28	21
	5533 065-01 ER20	1.5-6.5	28	.059-.256	21						
		1.0-3.5	23	.039-.138	17	8.0-16.0	33	.315-.630	24	28	24
	ER25	4.0-7.5	33	.157-.295	24						

ER tapping collets

Compatible with DIN 6499-B

For metric standard taps

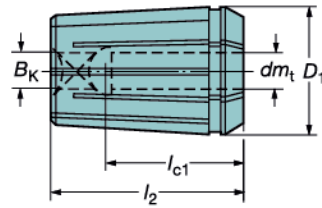

Collet size	Dimensions	
	D_1	l_2
20	20.8	31.5
25	25.8	34
40	40.8	46

Collet tap size		Ordering code						dm_t mm	B_k mm
DIN	ISO	Collet size 20	l_{c1} mm	Collet size 25	l_{c1} mm	Collet size 40	l_{c1} mm		
M4/M6	M5/M4*	393.14-20 D040X0315	18	-	-	-	-	4.0	3.15
M5/M6	M5*	393.14-20 D045X034	18	-	-	-	-	4.5	3.4
M5/M6/M8		393.14-20 D050X040	18	-	-	-	-	5.0	4.0
		393.14-20 D060X049	18	-	-	-	-	6.0	4.9
	M8/M6*	393.14-20 D063X050	18	-	-	-	-	6.3	5.0
M7/M9/M10		393.14-20 D070X055	18	-	-	-	-	7.0	5.5
M8/M10	M10/M8*	393.14-20 D080X063	22	393.14-25 D080X063	18	-	-	8.0	6.3
M12	M12	393.14-20 D090X071	22	393.14-25 D090X071	18	-	-	9.0	7.1
	M10*	393.14-20 D100X080	25	393.14-25 D100X080	18	-	-	10.0	8.0
M14		-	-	393.14-25 D110X090	18	-	-	11.0	9.0
	M14	-	-	393.14-25 D112X090	18	-	-	11.2	9.0
M16		-	-	393.14-25 D120X090	18	393.14-40 D120X090	25	12.0	9.0
	M16	-	-	393.14-25 D125X100	22	393.14-40 D125X100	25	12.5	10.0
M18	M18/M20	-	-	393.14-25 D140X112	22	393.14-40 D140X112	25	14.0	11.2
M20		-	-	393.14-25 D160X120	25	-	-	16.0	12.0
M20	M22					393.14-40 D160X125	25	16.0	12.5
M22/24	M24					393.14-40 D180X145	25	18.0	14.5
M27	M27/M28/30					393.14-40 D200X160	28	20.0	16.0
M30/M32	M30					393.14-40 D220X180	28	22.0	18.0

For inch standard taps

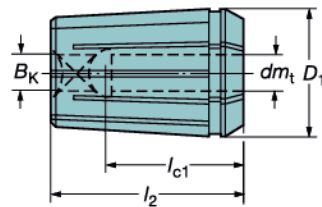

Collet size	Dimensions, inch	
	D_1	l_2
20	.819	1.240
25	1.016	1.339
40	1.606	1.811

Tap size		Ordering code						dm_t inch	B_k inch
Inch	Number	Collet size 20	l_{c1} inch	Collet size 25	l_{c1} inch	Collet size 40	l_{c1} inch		
	8	A393.14-20-8 NO	.709					.168	.131
	10	A393.14-20-10 NO	.709					.194	.152
	12	A393.14-20-12 NO	.709					.220	.165
1/4		A393.14-20-1/4	.709	A393.14-25-1/4	.709			.255	.191
5/16		A393.14-20-5/16	.866	A393.14-25-5/16	.866			.318	.238
3/8		A393.14-20-3/8	.866	A393.14-25-3/8	.866			.381	.286
7/16				A393.14-25-7/16	.866			.323	.242
1/2				A393.14-25-1/2	.866			.367	.275
9/16				A393.14-25-9/16	.984			.429	.322
5/8				A393.14-25-5/8	.984			.480	.360
3/4				A393.14-25-3/4	.984			.590	.442
5/8						A393.14-40-5/8	.984	.480	.360
3/4						A393.14-40-3/4	.984	.590	.442
7/8						A393.14-40-7/8	.984	.697	.523
1						A393.14-40-1	1.102	.800	.600

* Shank diameter enlarged, both tap sizes have the same shaft diameter.

D
E
F
G
J

TOOLING SYSTEMS Accessories

Master setting gauges

Checking position for grippers Spindle orientation

Tool post center line

Tool presetting Component fixture geometric control

The Coromant Capto system guarantees exceptional, repeatable accuracy but this is of little use unless the various other components in the total machining process are correctly and accurately positioned.

Coromant offers a range of axial and center height master setting gauges for the various coupling sizes, which are strongly recommended for setting important parameters such as:

- The centerline of the tool post
- Spindle orientation
- The position of the tool for grippers
- Tool center height and cutting edge position (f_1 and l_1 dimensions). Gauges can be used in a pre-measuring fixture.
- Component fixtures

Axial gauge

Master setting gauges MAS-11

Coupling size	Ordering code	Dimensions, mm (inch)	
		D_g	l_g
C3	C3-MAS-11	25 (.98)	160 (6.30)
C4	C4-MAS-11	25 (.98)	160 (6.30)
C5	C5-MAS-11	32 (1.26)	210 (8.27)
C6	C6-MAS-11	40 (1.57)	315 (12.40)
C8	C8-MAS-11	40 (1.57)	315 (12.40)
C10	C10-MAS-11	60 (2.362)	420 (16.535)

Center height gauge

Master setting gauges MAS-01 (Polygon) Gripper groove

Coupling size	Ordering code	Dimensions, mm (inch)		
		f_g	l_g	D_g
C3	C3-MAS-01	22 (.87)	40 (1.57)	34 (1.34)
C4	C4-MAS-01	27 (1.06)	50 (1.97)	42 (1.65)
C5	C5-MAS-01	35 (1.38)	60 (2.36)	52 (2.05)
C6	C6-MAS-01	45 (1.77)	65 (2.56)	65 (2.56)
C8/C8X	C8-MAS-01	55 (2.17)	80 (3.15)	82 (3.23)
C10	C10-MAS-01	65 (2.559)	10 (3.937)	102 (4.016)

Alignment tool

This tool is used to check the Automatic Tool Change positioning tolerance between the gripper arm and magazine and the clamping unit/spindle. If the tolerance is not achieved the result can be abnormal wear on cutting tool or Coromant Capto interface, wrong clamping, dropped tools, personal injuries etc. Instructions and tolerances are available in the box together with the tool.

Coupling size	Ordering code	Spare parts	
		1 Gauge pin	2 Gauge pin
C4	C4-AMT-01	5552 069-03	5552 069-01
C5	C5-AMT-01	5552 069-04	5552 069-01
C6	C6-AMT-01	5552 069-05	5552 069-02
C8	C8-AMT-01	5552 069-05	5552 069-02
C8X	C8X-AMT-01	5552 089-09	5552 069-08
C10	C10-AMT-01	5552 069-09	5552 069-08

G 124

General Information

Lockscrews for arbors

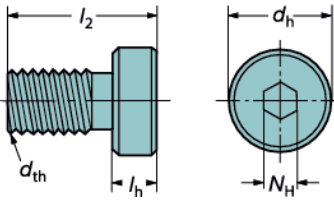

Ordering code	Dimensions, inch				
	d_{th}	d_h	l_2	l_h	N_H
5512 065-07	3/8"-24	7/8	1-1/16	3/8	1/4
5512 065-02	3/8"-24	5/8	1-1/4	13/64	3/16
5512 065-08	1/2"-20	13/16	1-1/16	3/8	5/16
5512 065-05	1/2"-20	1-1/4	1-5/8	3/8	5/16
5512 065-03	1/2"-20	13/16	1-3/4	11/32	5/16
5512 065-09	5/8"-18	1-1/2	1-3/8	1/2	5/16
5512 065-06	5/8"-18	1-1/2	1-3/4	1/2	5/16
5512 065-10	3/4"-16	1-7/8	1-7/16	1/2	3/8
5512 065-04	3/4"-16	1-1/4	1-3/4	1/2	3/8

Milling

E

Drilling

F

Boring

G

Tooling Systems

J

General Information

Basic holders

Cx-A390.00 **Cx-390.00**
Cx-A390.45 **Cx-390.55**
Cx-A390.455 **Cx-390.58**
Cx-A390.545 **Cx-390.140**
 Cx-390.140HD
 Cx-390.272
 Cx-390.369
 Cx-390.540
 Cx-390.555
 Cx-390.558

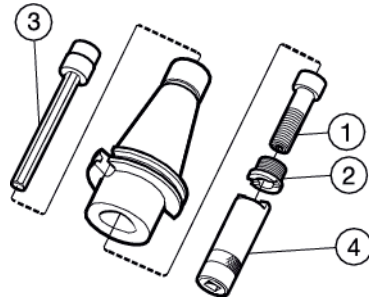

	1	2	3 ¹⁾	4 ¹⁾
	Center screw	Retaining nut	Extension key (mm)	Retaining nut spanner
C3-A390.xx/C3-390.xx-	5512 063-10	5512 091-04	5680 015-05 (8.0)	5680 065-13
C4-A390.xx-/C4-390.xx-	5512 063-07	5512 091-03	5680 015-05 (8.0)	5680 065-10
C5-A390.xx-/C5-390.xx-	5512 063-08	5512 091-01	5680 015-01 (10.0)	5680 065-11
C6-A390.xx-/C6-390.xx-	5512 063-09	5512 091-02	5680 015-02 (14.0)	5680 065-12
C6-390.xx-40 075	5512 063-13	5512 091-02	5680 015-01 (10.0)	5680 065-12
C6-390.xx-40 085	5512 063-13	5512 091-02	5680 015-01 (10.0)	5680 065-12
C8-A390.xx/C8-390.xx-/C8X-390.xx	5512 063-09	5512 091-02	5680 015-02 (14.0)	5680 065-12
C10-390.xx/C10-A390.xx5	5512 063-14	5512 091-02	5680 015-06 (17)	5680 065-14
Cx-A390.546, Cx-A390.547, Cx-A390.562, Cx-A390.605	1	2	3 ¹⁾	4 ¹⁾
	Center screw	Retaining nut	Extension key (mm)	Retaining nut spanner
C4-A390.546-40 040	5512 067-02	5512 091-03	5680 015-05 (8.0)	5680 065-10
C5-A390.546-40 050	5512 067-03	5512 091-01	5680 015-01 (10.0)	5680 065-11
C6-A390.546-50 050	5512 067-04	5512 091-02	5680 015-02 (14.0)	5680 065-12
C8-A390.546-50 070	5512 067-04	5512 091-02	5680 015-02 (14.0)	5680 065-12
C8-A390.547-50 070	5512 067-04	5512 091-02	5680 015-02 (14.0)	5680 065-12
C5-390.562-40 050	5512 067-03	5512 091-01	5680 015-01 (10.0)	5680 065-11
C6-390.562-50 050	5512 067-04	5512 091-02	5680 015-02 (14.0)	5680 065-12
C8-390.562-50 070	5512 067-04	5512 091-02	5680 015-02 (14.0)	5680 065-12
C5-390.605-40 030	5512 067-03	5512 091-01	5680 015-01 (10.0)	5680 065-11
C6-390.605-50 040	5512 067-04	5512 091-02	5680 015-02 (14.0)	5680 065-12
C8-390.605-50 070	5512 067-04	5512 091-02	5680 015-02 (14.0)	5680 065-12

¹⁾ Accessories, must be ordered separately.

Screw with radial hole for internal coolant for turning tools

When using a turning tool prepared for internal coolant directly into a basic holder, the center screw has to be replaced with one with a radial hole, to be able to transfer coolant through the cutting tool.

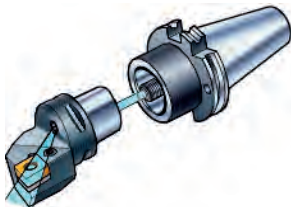

Coupling size

Existing screw in basic holders

Exchangeable screw with radial hole

C3	5512 063-10	5512 067-01
C4	5512 063-07	5512 067-02
C5	5512 063-08	5512 067-03
C6	5512 063-09	5512 067-04
C6/40 taper	5512 063-13	5512 067-05



Basic holders

Front clamp

Cx-A390.0004
 Cx-A390.4504
 Cx-390.0004
 Cx-390.5504
 Cx-390.5804
 Cx-390.14004

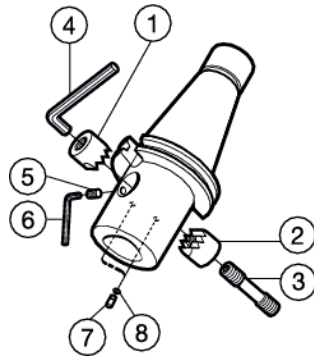

	1	2	3	4 ¹⁾	5	6	7	8
	Gripping jaws							
	left	right	Screw	Key (mm)	Screw	Key (mm)	Pin	O-ring
C5-A390.xx/C5-390.xx-	5412 094-02	5412 094-01	5516 010-03	3021 013-050 (5.0)	5514 060-01	174.1-870 (2.0)	5552 065-01	5641 001-28
C6-A390.xx/C6-390.xx-	5412 094-04	5412 094-03	5516 010-04	3021 013-050 (5.0)	5514 060-01	174.1-870 (2.0)	5552 065-01	5641 001-28
C8-A390.xx/C8-390.xx-	5412 094-06	5412 094-05	5516 013-01	3021 013-070 (7.0)	5514 060-02	174.1-864 (3.0)	5552 065-02	5641 001-11

¹⁾ Accessories, must be ordered separately.

Cx-390.34704

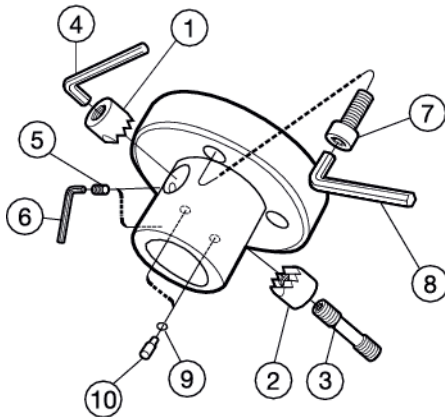

	1	2	3	4 ¹⁾	5	6 ¹⁾	7	8 ¹⁾	9	10
	Gripping jaws									
	left	right	Screw	Key (mm)	Screw	Key (mm)	Screw	Key (mm)	O-ring	Pin
C5-390.34704-xx xxx	5412 094-02	5412 094-01	5516 010-03	3021 013-050	5514 060-01	174.1-870	10-1353-21178	3021 010-080	5641 001-28	5552 065-01
C6-390.34704-xx xxx	5412 094-04	5412 094-03	5516 010-04	3021 013-050	5514 060-01	174.1-870	3212 020-562	3021 010-120	5641 001-28	5552 065-01
C8-390.34704-xx xxx	5412 094-06	5412 094-05	5516 013-01	3021 013-070	5514 060-02	174.1-864	3212 020-562	3021 010-120	5641 001-11	5552 065-02

¹⁾ Accessories, must be ordered separately.

Basic holders

Camshaft clamping

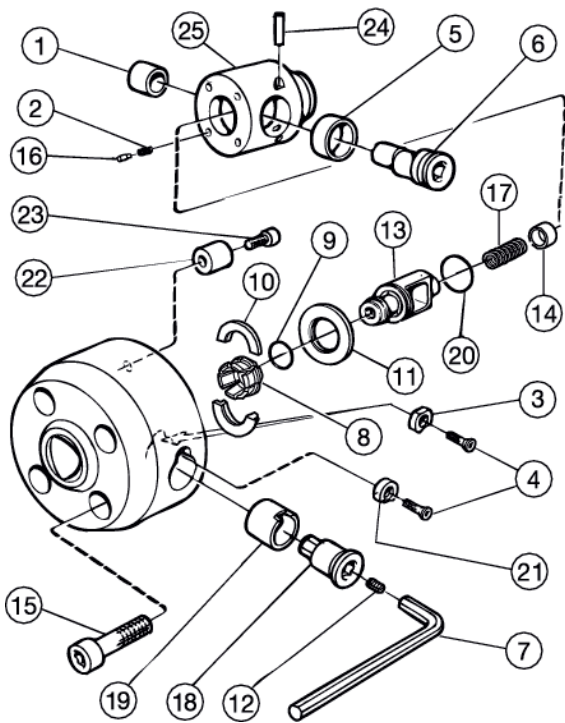

	1	2	3	4	5	6	7 ¹⁾
	Plain bearing	Compression spring (4 x)	Locking washer	Screw	Plain bearing	Cam shaft	Key (mm)
Cx-390.34705-40 060	3823 010-101	5561 001-37	5541 030-06	416.1-834	5638 022-01	5333 025-01	3021 013-080 (8.0)
40 070	3823 010-123	5561 001-36	–	416.1-834	5638 022-01	5333 025-01	3021 013-100 (10.0)
	8	9	10	11	12	13	14
	Segment (6 x)	O-ring	Holder ring (2 x)	Outer ring	Screw	Drawbar	Plain bearing
Cx-390.34705-40 060	5549 120-08	5641 005-01	5546 001-08	5541 025-01	3214 010-355	5461 100-08	5638 023-02
40 070	5549 120-06	5641 005-05	5546 001-06	5541 025-06	3214 010-355	5461 100-06	5638 023-02
	15	16	17	18	19	20	
	Screw	Pin (4 x)	Compression spring	Key extension	Plain bearing	O-ring	
Cx-390.34705-40 060	3212 010-518	5552 005-01	5546 001-41	5680 038-02	3823 011-182	3671 010-126	
40 070	3212 010-520	–	5561 001-42	5680 038-01	3823 011-205	3671 010-127	
	21	22	23	24	25		
	Locking washer	Driving key	Screw	Pin	Housing		
Cx-390.34705-40 060	5541 030-01	5635 012-01	3212 010-309	–	5251 030-02		
40 070	5541 030-02	5635 012-01	3212 010-309	3111 020-511	5251 030-01		

1) Accessories, must be ordered separately.

Extension/reduction adapters

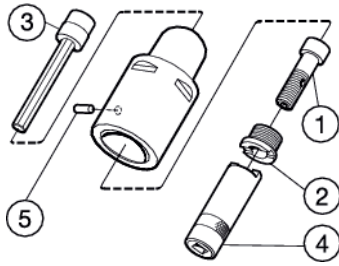
Cx-391.01A/ Cx-391.01HD
Cx-391.02/ Cx-391.02HD

	1	2	3 ¹⁾	4 ¹⁾	5
	Center screw	Retaining ring	Extension key (mm)	Key	Pin
C3-391.01-32 xxxA	5512 067-01	5512 091-04	5680 015-05 (8.0)	5680 065-13	3113 020-304
C4-391.01-40 xxxA	5512 067-02	5512 091-03	5680 015-05 (8.0)	5680 065-10	3113 020-355
C5-391.01-50 xxxA	5512 067-03	5512 091-01	5680 015-01 (10.0)	5680 065-11	3113 020-406
C6-391.01-63 xxxA	5512 067-04	5512 091-02	5680 015-02 (14.0)	5680 065-12	3113 020-457
C8-391.01-80 xxxA	5512 067-04	5512 091-02	5680 015-02 (14.0)	5680 065-12	3113 020-509
C8X-391.01-100 xxx	5512 067-04	5512 091-02	5680 015-02 (14.0)	5680 065-12	3113 020-509
C4-391.02-32 055A	5512 067-01	5512 091-04	5680 015-05 (8.0)	5680 065-13	3113 020-304
C4-391.02-32 070A	5512 067-01	5512 091-04	5680 015-05 (8.0)	5680 065-13	3113 020-304
C5-391.02-32 060A	5512 067-01	5512 091-04	5680 015-05 (8.0)	5680 065-13	3113 020-304
C5-391.02-40 065A	5512 067-02	5512 091-03	5680 015-05 (8.0)	5680 065-10	3113 020-355
C5-391.02-40 085A	5512 067-02	5512 091-03	5680 015-05 (8.0)	5680 065-10	3113 020-355
C6-391.02-32 070A	5512 067-01	5512 091-04	5680 015-05 (8.0)	5680 065-13	3113 020-304
C6-391.02-40 080A	5512 067-02	5512 091-03	5680 015-05 (8.0)	5680 065-10	3113 020-355
C6-391.02-50 080A	5512 067-03	5512 091-01	5680 015-01 (10.0)	5680 065-11	3113 020-406
C6-391.02-50 110A	5512 067-03	5512 091-01	5680 015-01 (10.0)	5680 065-11	3113 020-406
C8-391.02-32 060A	5512 067-01	5512 091-04	5680 015-05 (8.0)	5680 065-13	3113 020-304
C8-391.02-40 070A	5512 067-02	5512 091-03	5680 015-05 (8.0)	5680 065-10	3113 020-355
C8-391.02-50 080A	5512 067-03	5512 091-01	5680 015-01 (10.0)	5680 065-11	3113 020-406
C8-391.02-63 080A	5512 067-04	5512 091-02	5680 015-02 (14.0)	5680 065-12	3113 020-457
C8-391.02-63 120A	5512 067-04	5512 091-02	5680 015-02 (14.0)	5680 065-12	3113 020-457
C8X-391.02-63 080	5512 067-04	5512 091-02	5680 015-02 (14.0)	5680 065-12	3113 020-457
C8X-391.02-80 100	5512 067-04	5512 091-02	5680 015-02 (14.0)	5680 065-12	3113 020-509
C8X-391.02-80 150	5512 067-04	5512 091-02	5680 015-02 (14.0)	5680 065-12	3113 020-509

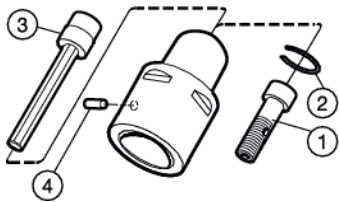
¹⁾ Accessories, must be ordered separately.Short version
Cx-391.01/ Cx-391.02

	1	2	3 ¹⁾	4
	Center screw	Retaining ring	Extension key (mm)	Pin
C3-391.01-32 035	5512 068-01	5545 040-02	5680 015-05 (8.0)	3113 020-304
C4-391.01-40 040	5512 068-02	5545 040-03	5680 015-05 (8.0)	3113 020-355
C5-391.01-50 050	5512 068-03	5545 040-07	5680 015-05 (8.0)	3113 020-406
C6-391.01-63 060	5512 068-04	5545 040-08	5680 015-02 (14.0)	3113 020-457
C8-391.01-80 065	5512 068-05	5545 040-08	5680 015-02 (14.0)	3113 020-509
C5-391.02-32 033	5512 068-01	5545 040-02	5680 015-05 (8.0)	-
C5-391.02-40 040	5512 068-06	5545 040-07	5680 015-05 (8.0)	-
C6-391.02-32 032	5512 068-01	5545 040-02	5680 015-05 (8.0)	-
C6-391.02-40 040	5512 068-02	5545 040-03	5680 015-05 (8.0)	-
C6-391.02-50 050	5512 068-07	5545 040-08	5680 015-01 (10.0)	-
C8-391.02-50 045	5512 068-08	5545 040-08	5680 015-01 (10.0)	-
C8-391.02-63 055	5512 068-05	5545 040-08	5680 015-02 (14.0)	-
C8X-391.02-63 055	5512 068-05	5545 040-08	5680 015-02 (14.0)	-
C8X-391.02-80 065	5512 068-05	5545 040-08	5680 015-02 (14.0)	-

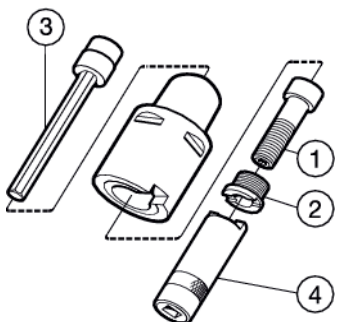
¹⁾ Accessories, must be ordered separately.Coromant Capto adapter for
Varilock
Cx-391.01-Vxx

	1	2	3	4
	Center screw	Retaining nut	Extension key (mm)	Retaining nut spanner
C5-391.01-V50 060	5512 063-01	5512 091-01	5680 015-01 (10.0)	5680 065-01
C6-391.01-V63 080	5512 063-02	5512 091-02	5680 015-02 (14.0)	5680 065-02
C8-391.01-V80 065	5512 063-03	5512 091-02	5680 015-02 (14.0)	5680 065-02

¹⁾ Accessories, must be ordered separately.

D
E
F
G
J

TOOLING SYSTEMS Spare parts – Coromant Capto® – Rotating

Extension/reduction adapters

Front clamp

Cx-391.0204

Cx-391.04

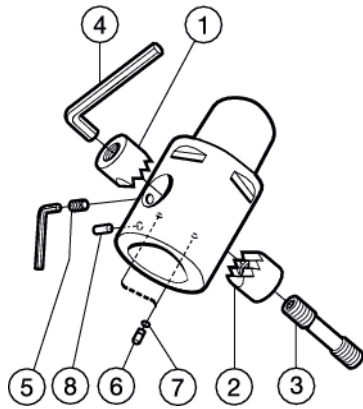

	1	2	3	4 ¹⁾	5	6	7	8
	Gripping jaw left	right	Screw	Key (mm)	Stop screw	Pin	O-ring	Pin
Cx-391.0204-50 xxx	5412 094-02	5412 094-01	5516 010-03	3021 013-050 (5.0)	5514 060-01	5552 065-01	5641 001-28	3113 020-406
Cx-391.0204-63 xxx	5412 094-04	5412 094-03	5516 010-04	3021 013-050 (5.0)	5514 060-01	5552 065-01	5641 001-28	3113 020-457
Cx-391.04-50 xxx	5412 094-02	5412 094-01	5516 010-03	3021 013-050 (5.0)	5514 060-01	5552 065-01	5641 001-28	3113 020-406
Cx-391.04-63 xxx	5412 094-04	5412 094-03	5516 010-04	3021 013-050 (5.0)	5514 060-01	5552 065-01	5641 001-28	3113 020-457
Cx-391.04-80 xxx	5412 094-06	5412 094-05	5516 013-01	3021 013-070 (7.0)	5514 060-02	5552 065-02	5641 001-11	3113 020-509

1) Accessories, must be ordered separately.

Adapters for side and facemills

Cx-A391.10/Cx-A391.10HD

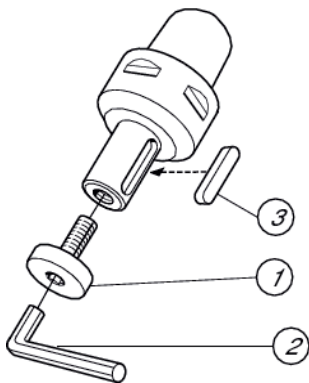

Inch pilot	1	2 ¹⁾	3
	Screw	Key	Parallel key
Cx-A391.10-25 xxx	5512 065-05	3021 011-516 (5/16)	SK 414
Cx-A391.10-31 xxx	5512 065-06	3021 011-516 (5/16)	SK 517
Cx-A391.10-38 xxx	5512 065-10	3021 011-380 (3/8)	SK 617
Cx-A391.10-50 xxx	5512 065-11	3021 011-916 (9/16)	SK 817
Cx-A391.10-63 xxx	3212 020-666	3021 010-170 (17.0 mm)	5631 065-01

1) Accessories, must be ordered separately.

Cx-391.10/ Cx-391.10HD

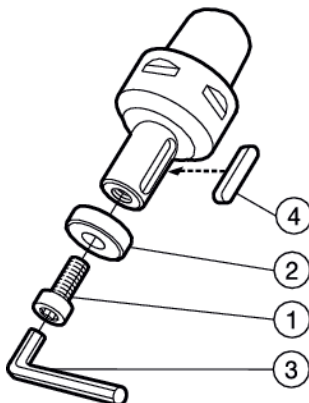

Metric pilot	1	2	3 ¹⁾	4
	Screw	Washer	Key (mm)	Parallel key
Cx-391.10-16 xxx	3212 020-411	5541 015-01	3021 010-060 (6.0)	3191 010-461
Cx-391.10-22 xxx	3212 020-461	5541 015-02	3021 010-080 (8.0)	3191 010-564
Cx-391.10-27 xxx	3212 020-512	5541 015-03	3021 010-100 (10.0)	5632 010-01
Cx-391.10-32 xxx	3212 020-563	5541 015-04	3021 010-120 (12.0)	3191 010-621
Cx-391.10-40 xxx	3212 020-614	5541 015-05	3021 010-140 (14.0)	3191 010-671
Cx-391.10-50 xxx	3212 020-666	5541 015-06	3021 010-170 (17.0)	3191 010-721
Cx-391.10-60 xxx	3212 020-666	5541 015-08	3021 010-170 (17.0)	3191 010-771

1) Accessories, must be ordered separately.

G 130



General Information

Adapters with ISO gripper groove

Spare parts

491.01

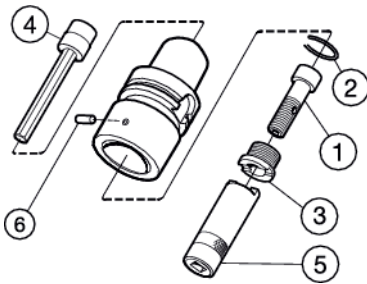

491.02

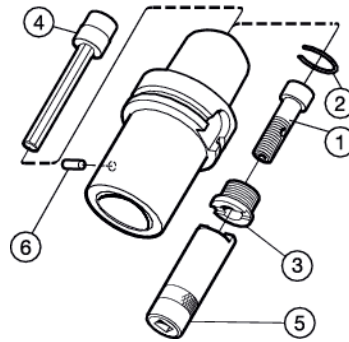

	1	2	3	4 ²⁾	5 ²⁾	6
491.01/02	Center screw	Retaining ring	Retaining nut	Extension key	Retaining nut spanner	Location screw/ Pin
C6 - 491.01 - 063 100	5512 067-04		5512 091-02	5680 015-02	5680 065-12	3113 020-457
C6 - 491.01 - 063 060 ¹⁾	5512 068-04	5545 040-08		5680 015-02		3214 020-305
C10 - 491.01 -100 135	5512 063-14		5512 091-05	5680 015-06	5680 065-14	3113 020-561
C10 - 491.01 -100 090	5512 068-09	5545 040-09		5680 015-06		3214 020-358
C6 - 491.02 - 040 070	5512 067-02		5512 091-03	5680 015-05	5680 065-10	3113 020-355
C6 - 491.02 - 050 080	5512 067-03		5512 091-01	5680 015-01	5680 065-11	3113 020-406
C6 - 491.02 - 040 040 ¹⁾	5512 068-02	5545 040-03		5680 015-05		3113 020-355
C6 - 491.02 - 050 050 ¹⁾	5512 068-07	5545 040-08		5680 015-01		3214 020-307
C10 - 491.02 -063 095	5512 067-04		5512 091-02	5680 015-02	5680 065-12	3113 020-457
C10 - 491.02 -080 100	5512 067-04		5512 091-02	5680 015-02	5680 065-12	3113 020-509
C10 - 491.02 -068 055 ¹⁾	5512 068-05	5545 040-08		5680 015-02		3113 020-462
C10 - 491.02 -080 065 ¹⁾	5512 068-05	5545 040-08		5680 015-02		3113 020-509

¹⁾ Short version, for segment clamping only

²⁾ Accessories, must be ordered separately.

D
E
F
G
J

TOOLING SYSTEMS Spare parts – Coromant Capto® – Rotating

Adapter for facemills and square shoulder facemills

With coolant through arbor

Cx-391.05C
Cx-A391.05C

Cx-A391.05C

Cx-391.05C-16 xxx
Driving ring

Metric pilot

	1	2	3 ¹⁾	4	5	6	7 ¹⁾
	Mounting screw	Washer	Key (mm)	Driving ring	Driving key	Screw	Key (mm)
C3-391.05C-16 030	3212 020-414	5541 015-01	3021 010-060 (6.0)	3193 010-160	-	-	-
C4-391.05C-16 032	3212 020-414	5541 015-01	3021 010-060 (6.0)	3193 010-160	-	-	-
C4-391.05C-22 025	3212 020-464	5541 015-02	3021 010-080 (8.0)	-	5631 011-01	3213 010-258	3021 010-030 (3.0)
C5-391.05C-16 035	3212 020-414	5541 015-01	3021 010-060 (6.0)	3193 010-160	-	-	-
C5-391.05C-22 025	3212 020-464	5541 015-02	3021 010-080 (8.0)	-	5635 025-01	3212 010-258	3021 010-030 (3.0)
C5-391.05C-27 025	3212 020-514	5541 015-03	3021 010-100 (10.0)	-	5635 025-02	3212 010-308	3021 010-040 (4.0)
C5-391.05C-32 040	3212 020-564	5541 015-04	3021 010-120 (12.0)	-	5631 010-04	3212 010-308	3021 010-040 (4.0)
C6-391.05C-16 040	3212 020-414	5541 015-01	3021 010-060 (6.0)	3193 010-160	-	-	-
C6-391.05C-22 025	3212 020-464	5541 015-02	3021 010-080 (8.0)	-	5635 025-01	3212 010-258	3021 010-030 (3.0)
C6-391.05C-27 025	3212 020-514	5541 015-03	3021 010-100 (10.0)	-	5635 025-02	3212 010-308	3021 010-040 (4.0)
C6-391.05C-32 025	3212 020-564	5541 015-04	3021 010-120 (12.0)	-	5635 025-03	3212 010-358	3021 010-050 (5.0)
C6-391.05C-40 040	3212 020-614	5541 015-05	3021 010-140 (14.0)	-	5631 010-02	3212 010-358	3021 010-050 (5.0)
C8-391.05C-16 050	3212 020-414	5541 015-01	3021 010-060 (6.0)	3193 010-160	-	-	-
C8-391.05C-22 030	3212 020-464	5541 015-02	3021 010-080 (8.0)	-	5635 025-01	3212 010-258	3021 010-030 (3.0)
C8-391.05C-27 030	3212 020-514	5541 015-03	3021 010-100 (10.0)	-	5635 025-02	3212 010-308	3021 010-040 (4.0)
C8-391.05C-32 030	3212 020-564	5541 015-04	3021 010-120 (12.0)	-	5635 025-03	3212 010-358	3021 010-050 (5.0)
C8-391.05C-40 030	3212 020-614	5541 015-05	3021 010-140 (14.0)	-	5635 025-04	3212 020-409	3021 010-060 (6.0)
C10-391.05C-40 040	3212 020-614	5541 015-05	3021 010-140 (14.0)	-	5635 025-04	3212 020-409	3021 010-060 (6.0)

1) Accessories, must be ordered separately.

Inch pilot

	1	3 ¹⁾	1	3 ¹⁾	5	6	7 ¹⁾
	Mounting screw	Key	Mounting screw	Key	Drive key	Screw	Key
C3-A391.05C-19 030	5512 065-07	3021 011-140	5512 065-02	3021 011-316	5631 013-01	8-32 x 3/8M	(9/64)
C4-A391.05C-19 025	5512 065-07	3021 011-140	5512 065-02	3021 011-316	5635 025-07	3212 010-207	3021 010-025 (2.5)
C4-A391.05C-25 035	5512 065-05	3021 011-516 ²⁾	5512 065-03	3021 011-516	5631 013-02	10-32 x 3/8	3021 011-532
C5-A391.05C-19 025	5512 065-07	3021 011-140	5512 065-02	3021 011-316	5635 025-07	3212 010-207	3021 010-025 (2.5)
C5-A391.05C-25 025	5512 065-05	3021 011-516 ²⁾	5512 065-03	3021 011-516	5635 025-06	3212 010-257	3021 010-030 (3.0)
C5-A391.05C-31 040	5512 065-06	3021 011-516 ²⁾	-	-	5631 010-06	10-32 x 3/8	3021 011-532
C5-A391.05C-38 045	5512 065-10	3021 011-380	5512 065-04	3021 011-380	5631 013-04	1/4-20 x 3/4	3021 011-316
C6-A391.05C-19 030	5512 065-07	3021 011-140	5512 065-02	3021 011-316	5635 025-07	3212 010-207	3021 010-025 (2.5)
C6-A391.05C-25 030	5512 065-05	3021 011-516 ²⁾	5512 065-03	3021 011-516	5635 025-06	3212 010-257	3021 010-030 (3.0)
C6-A391.05C-31 030	5512 065-06	3021 011-516 ²⁾	-	-	5635 025-08	3212 010-308	3021 010-040 (4.0)
C6-A391.05C-38 045	5512 065-10	3021 011-380	5512 065-04	3021 011-380	5631 013-04	1/4-20 x 3/4	3021 011-316
C8-A391.05C-19 030	5512 065-07	3021 011-140	5512 065-02	3021 011-316	5635 025-07	3212 010-207	3021 010-025 (2.5)
C8-A391.05C-25 030	5512 065-05	3021 011-516 ²⁾	5512 065-03	3021 011-516	5635 025-06	3212 010-257	3021 010-030 (3.0)
C8-A391.05C-31 030	5512 065-06	3021 011-516 ²⁾	-	-	5635 025-08	3212 010-308	3021 010-040 (4.0)
C8-A391.05C-38 030	5512 065-10	3021 011-380	5512 065-04	3021 011-380	5635 025-05	3212 010-409	3021 010-060 (6.0)
C10-A391.05C-38 040	5512 065-10	3021 011-380	5512 065-04	3021 011-380	5635 025-05	3212 010-409	3021 010-060 (6.0)

1) Accessories, must be ordered separately.

2) ANSI - Code = DIN 911-5/16 ZDLL

G 132

General Information

Adapters for facemills, inch pilot

Cx-A391.05
Cx-A391.05HD

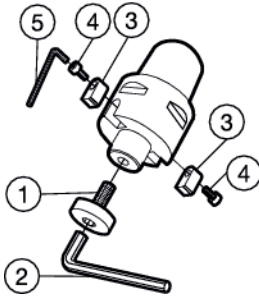

C8-A391.05- 50 xxx
C8-A391.05- 63 xxx

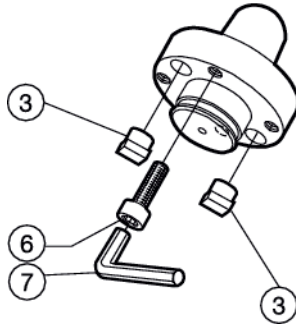

	1	2 ¹⁾	3	4	5 ¹⁾	6	7 ¹⁾
	Mounting screw	Key	Drive key	Screw	Key	Screw	Key
C3-A391.05- 19 xxx	5512 065-07	3021 011-140	5631 013-01	8-32 x 3/8M	(9/64)	-	-
C4-A391.05- 19 xxx	5512 065-07	3021 011-140	5631 013-01	8-32 x 3/8M	(9/64)	-	-
C4-A391.05- 25 xxx	5512 065-05	3021 011-516 ²⁾	5631 013-02	10-32 x 3/8	(5/32)	-	-
C5-A391.05- 19 xxx	5512 065-07	3021 011-140	5631 013-01	8-32 x 3/8M	(9/64)	-	-
C5-A391.05- 25 xxx	5512 065-05	3021 011-516 ²⁾	5631 013-02	10-32 x 3/8	(5/32)	-	-
C5-A391.05- 31 xxx	5512 065-06	3021 011-516 ²⁾	5631 010-06	10-32 x 3/8	(5/32)	-	-
C5-A391.05- 38 xxx	5512 065-10	3021 011-380	5631 013-04	1/4-20 x 3/4	(3/16)	-	-
C6-A391.05- 19 xxx	5512 065-07	3021 011-140	5631 013-01	8-32 x 3/8M	(9/64)	-	-
C6-A391.05- 25 xxx	5512 065-05	3021 011-516 ²⁾	5631 013-02	10-32 x 3/8	(5/32)	-	-
C6-A391.05- 31 xxx	5512 065-06	3021 011-516 ²⁾	5631 010-06	10-32 x 3/8	(5/32)	-	-
C6-A391.05- 38 xxx	5512 065-10	3021 011-380	5631 013-04	1/4-20 x 3/4	(3/16)	-	-
C8-A391.05- 19 xxx	5512 065-07	3021 011-140	5631 013-01	8-32 x 3/8M	(9/64)	-	-
C8-A391.05- 25 xxx	5512 065-05	3021 011-516 ²⁾	5631 013-02	10-32 x 3/8	(5/32)	-	-
C8-A391.05- 31 xxx	5512 065-06	3021 011-516 ²⁾	5631 010-06	10-32 x 3/8	(5/32)	-	-
C8-A391.05- 38 xxx	5512 065-10	3021 011-380	5631 013-04	1/4-20 x 3/4	(3/16)	-	-
C8-A391.05- 50 xxx	-	-	5631 060-01	-	-	3212 031-761	(1/2")
C8-A391.05- 63 xxx	-	-	5631 013-01	-	-	3212 031-761	(1/2")
C8X-A391.05- 63 070	-	-	5631 060-01	-	-	3212 031-761	(1/2")
C8-A391.05HD- 63 xxx	-	-	5631 060-01	-	-	3212 031-761	(1/2")

1) Accessories, must be ordered separately.

2) ANSI - Code = DIN 911-5/16 ZDLL

Dampened adapter for facemills and square shoulder facemills, inch pilot

With coolant through arbor

Cx-A391.06

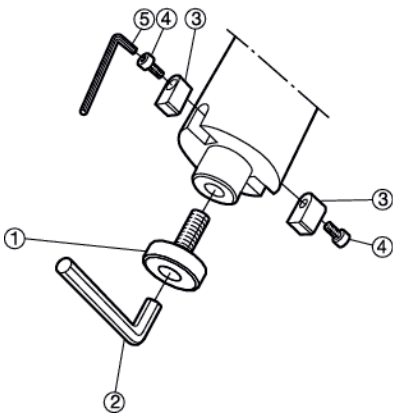

	1 ¹⁾	2 ¹⁾	3	4	5 ¹⁾
	Screw	Key	Drive key	Screw	Key
Cx-A391.06- 19 xxx	5512 065-02	3021 011-316	5631 013-01	8-32 x 3/8M	(9/64)
Cx-A391.06- 25 xxx	5512 065-08	3021 011-352	5631 013-02	10-32 x 3/8	(5/32)
Cx-A391.06- 38 xxx	5512 065-04	3021 011-380	5631 013-04	1/4-20 x 3/4	(3/16)

Arbor mounting screws with coolant hole

	1	2
Arbor size	Screw	Key
Inch		
.750	5512 074-01 (3/8"-24 UNF)	3021 011-516 (5/16)
.750 ¹⁾	5512 074-03 (3/8"-24 UNF) ¹⁾	3021 011-516 (5/16)
1.000	5512 074-02 (1/2"-20 UNF)	3021 011-380 (3/8)
1.250	5512 074-04 (5/8"-18 UNF)	- (1/2)
1.500	5512 074-05 (3/4"-16 UNF)	- (5/8)

1) Optimized: Low head/small head diameter

Adapter for face mills and square shoulder face mill

Coolant for boring

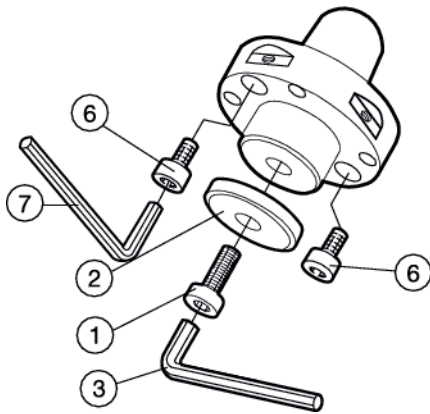

	1	2	3	4	5	6
	Screw	Washer	Key (mm)	Driving key	Screw	Key (mm)
C8/C8X-391.05-40 xxxB	3212 020-614	5541 015-05	3021 010-140 (14.0)	5635 025-04	3212 020-409	3021 010-060 (6.0)

Dampened adapter for facemills and square shoulder facemills, metric pilot

With coolant through arbor

Cx-391.06

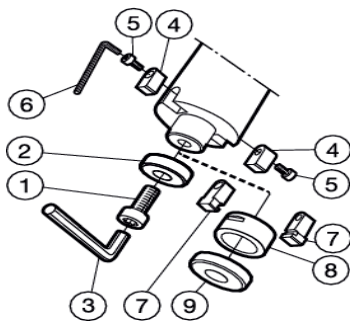

	1	2	3 ¹⁾	4	5	6 ¹⁾
	Screw	Washer	Key (mm)	Driving key	Screw	Key (mm)
Cx-391.06-22 xxx	3212 020-464	5541 015-02	3021 010-080 (8.0)	5631 011-01	3213 010-258	174.1-864 (3.0)
Cx-391.06-27 xxx	3212 020-514	5541 015-03	3021 010-100 (10.0)	5631 010-01	3212 010-258	174.1-864 (3.0)
Cx-391.06-32 xxx	3212 020-564	5541 015-04	3021 010-120 (12.0)	5631 010-04	3212 010-308	3021 010-040 (4.0)
Sleeve set for Cx-391.06	7	8	9			
	Driving key	Sleeve	Washer			
5638 035-011	5631 016-01	5638 035-01	5541 015-09			

1) Accessories, must be ordered separately.

Arbor mounting screws with coolant hole

Arbor size	Screw	Key ²⁾
Metric		
16	5512 073-03 (M8)	3021 010-060
22	5512 073-01 (M10)	3021 010-080
22 ¹⁾	5512 073-04 ¹⁾ (M10)	3021 010-080
27	5512 073-02 (M12)	3021 010-100
32	5512 073-05 (M16)	3021 010-140

1) Optimized: Low head/small head diameter

2) Accessories, must be ordered separately.

For CoroMill® 365, CoroMill® Century and CoroMill® 210, a unique screw with coolant hole is used. This must be ordered separately. See ordering pages for these cutters.

Adapters for facemills and square shoulder facemills

Cx-391.05/ Cx-391.05HD

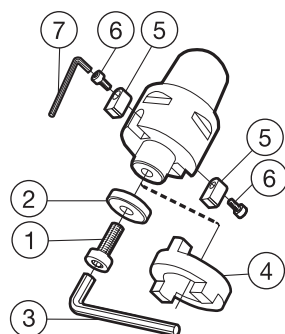

C8-391.05-60 060

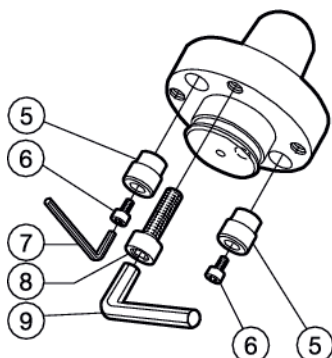

	1	2	3 ¹⁾	4	5	6
	Screw	Washer	Key (mm)	Driving ring	Driving key	Screw
C3-391.05-16 030	3212 020-414	5541 015-01	3021 010-060 (6.0)	3193 010-160	-	-
C4-391.05-16 032	3212 020-414	5541 015-01	3021 010-060 (6.0)	3193 010-160	-	-
C4-391.05-16 055	3212 020-414	5541 015-01	3021 010-060 (6.0)	3193 010-160	-	-
C4-391.05-22 025	3212 020-464	5541 015-02	3021 010-080 (8.0)	-	5631 011-01	3213 010-258
C4-391.05-22 055	3212 020-464	5541 015-02	3021 010-080 (8.0)	-	5631 011-01	3213 010-258
C5-391.05-16 035	3212 020-414	5541 015-01	3021 010-060 (6.0)	3193 010-160	-	-
C5-391.05-16 070	3212 020-414	5541 015-01	3021 010-060 (6.0)	3193 010-160	-	-
C5-391.05-22 025	3212 020-464	5541 015-02	3021 010-080 (8.0)	-	5631 012-01	3212 010-258
C5-391.05-22 070	3212 020-464	5541 015-02	3021 010-080 (8.0)	-	5631 011-01	3213 010-258
C5-391.05-27 025	3212 020-514	5541 015-03	3021 010-100 (10.0)	-	5631 010-01	3212 010-258
C5-391.05-32 040	3212 020-564	5541 015-04	3021 010-120 (12.0)	-	5631 010-04	3212 010-308
C6-391.05-16 040	3212 020-414	5541 015-01	3021 010-060 (6.0)	3193 010-160	-	-
C6-391.05-22 025	3212 020-464	5541 015-02	3021 010-080 (8.0)	-	5631 012-01	3212 010-258
C6-391.05-27 025	3212 020-514	5541 015-03	3021 010-100 (10.0)	-	5631 010-01	3212 010-258
C6-391.05-32 025	3212 020-564	5541 015-04	3021 010-120 (12.0)	-	5631 010-04	3212 010-308
C6-391.05-40 030B	3212 020-614	5541 015-05	3021 010-140 (14.0)	-	5635 025-04	3212 020-409
C8-391.05-16 050	3212 020-414	5541 015-01	3021 010-060 (6.0)	3193 010-160	-	-
C8-391.05-22 030	3212 020-464	5541 015-02	3021 010-080 (8.0)	-	5631 012-01	3212 010-258
C8-391.05-27 030	3212 020-514	5541 015-03	3021 010-100 (10.0)	-	5631 010-01	3212 010-258
C8/C8X-391.05-32 030	3212 020-564	5541 015-04	3021 010-120 (12.0)	-	5631 010-04	3212 010-308
C8-391.05-40 xxxB ²⁾	3212 020-614	5541 015-05	3021 010-140 (14.0)	-	5635 025-04	3212 020-409
C8/C8X-391.05-60 xxx	-	-	-	-	5635 010-01	3212 010-363
	7 ¹⁾	8	9 ¹⁾			
	Key (mm)	Screw	Key (mm)			
C3-391.05-16 030	-	-	-			
C4-391.05-16 032	-	-	-			
C4-391.05-16 055	-	-	-			
C4-391.05-22 025	-	-	-			
C4-391.05-22 055	-	-	-			
C5-391.05-16 035	-	-	-			
C5-391.05-16 070	-	-	-			
C5-391.05-22 025	174.1-864 (3.0)	-	-			
C5-391.05-22 070	-	-	-			
C5-391.05-27 025	174.1-864 (3.0)	-	-			
C5-391.05-32 040	3021 010-040 (4.0)	-	-			
C6-391.05-16 040	-	-	-			
C6-391.05-22 025	174.1-864 (3.0)	-	-			
C6-391.05-27 025	174.1-864 (3.0)	-	-			
C6-391.05-32 025	3021 010-040 (4.0)	-	-			
C6-391.05-40 030B	3021 010-060 (6.0)	-	-			
C8-391.05-16 050	-	-	-			
C8-391.05-22 030	174.1-864 (3.0)	-	-			
C8-391.05-27 030	174.1-864 (3.0)	-	-			
C8-391.05-32 030	3021 010-040 (4.0)	-	-			
C8/C8X-391.05-40 xxxA ²⁾	3021 010-050 (5.0)	-	-			
C8/C8X-391.05-60 xxx	3021 010-050 (5.0)	3212 010-568	3021 010-140 (14.0)			

1) Accessories, must be ordered separately.

2) For HD adapters use locking screw 3214 010-406 for mounting cutters with single bolt circle (style C).

Adapters for facemills and square shoulder facemills

Cx-A391.05/ Cx-391.05

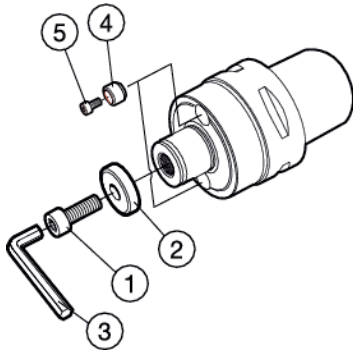

C10-A391.05-38 040/ C10-391.05-40 040

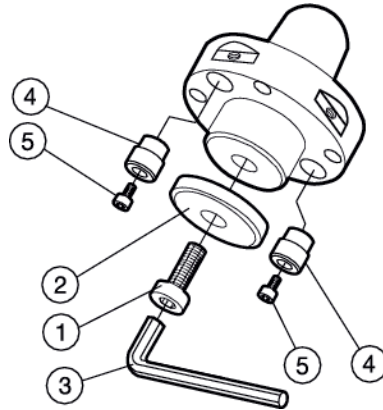

C10-A391.05-63 075/ C10-391.05-60 075

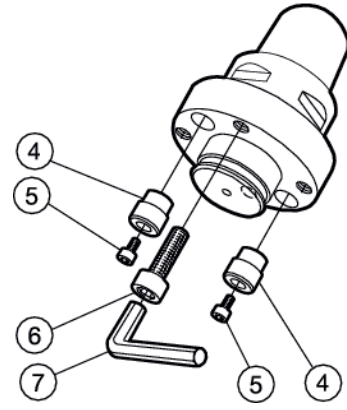

Metric pilot

	1	2	3 ¹⁾	4	5	6	7 ¹⁾
Ordering code	Screw	Washer	Key (mm)	Driving key	Screw	Screw	Key (mm)
C5-391.05-22 025A	3212 020-464	5541 015-02	3021 010-080 (8.0)	5635 025-01	3212 010-258	-	-
C5-391.05-27 025A	3212 020-514	5541 015-03	3021 010-100 (10.0)	5635 025-02	3212 010-308	-	-
C6-391.05-22 025A	3212 020-464	5541 015-02	3021 010-080 (8.0)	5635 025-01	3212 010-258	-	-
C6-391.05-27 025A	3212 020-514	5541 015-03	3021 010-100 (10.0)	5635 025-02	3212 010-308	-	-
C6-391.05-32 025A	3212 020-564	5541 015-04	3021 010-120 (12.0)	5635 025-03	3212 010-358	-	-
C8-391.05-22 030A	3212 020-464	5541 015-02	3021 010-080 (8.0)	5635 025-01	3212 010-258	-	-
C8-391.05-27 030A	3212 020-514	5541 015-03	3021 010-100 (10.0)	5635 025-02	3212 010-308	-	-
C8-391.05-32 030A	3212 020-564	5541 015-04	3021 010-120 (12.0)	5635 025-03	3212 010-358	-	-
C10-391.05-40 040	3212 020-614	5541 015-05	3021 010-140 (14.0)	5635 025-04	3212 020-409	-	-
C10-391.05-60 075	-	-	-	5635 010-01	3212 010-363	3212 010-568	3021 010-140 (14.0)

1) Accessories, must be ordered separately.

Inch pilot

	1	3 ¹⁾	4	5	6	7 ¹⁾
Ordering code	Screw	Key	Drive key	Screw	Screw	Key
C4-A391.05- 19 025A	5512 065-07	3021 011-140	5635 025-07	3212 010-207	-	-
C5-A391.05- 19 025A	5512 065-07	3021 011-140	5635 025-07	3212 010-207	-	-
C5-A391.05- 25 025A	5512 065-05	3021 011-516 ²⁾	5635 025-06	3212 010-257	-	-
C6-A391.05- 19 030A	5512 065-07	3021 011-140	5635 025-07	3212 010-207	-	-
C6-A391.05- 25 030A	5512 065-05	3021 011-516 ²⁾	5635 025-06	3212 010-257	-	-
C6-A391.05- 31 030A	5512 065-06	3021 011-516 ²⁾	5635 025-08	3212 010-308	-	-
C8-A391.05- 19 030A	5512 065-07	3021 011-140	5635 025-07	3212 010-207	-	-
C8-A391.05- 25 030A	5512 065-05	3021 011-516 ²⁾	5635 025-06	3212 010-257	-	-
C8-A391.05- 31 030A	5512 065-06	3021 011-516 ²⁾	5635 025-08	3212 010-308	-	-
C8-A391.05- 38 030A	5512 065-10	3021 011-380	5635 025-05	3212 020-409	-	-
C10-A391.05- 38 040	5512 065-04	3021 011-380	5635 025-05	3212 020-409	-	-
C10-A391.05- 63 075	-	-	5631 060-01	3212 010-363	3212 031-761	(1/2")

1) Accessories, must be ordered separately.

2) ANSI - Code = DIN 911-5/16 ZDLL

Arbor mounting screws with coolant hole

Arbor size Inch	Screw	Key	Arbor size Metric	Screw	Key ²⁾
.750	5512 074-01	(3/8"-24 UNF)	16	5512 073-03	(M8)
.750 ¹⁾	5512 074-03	(3/8"-24 UNF)	22	5512 073-01	(M10)
.1000	5512 074-02	(1/2"-20 UNF)	22 ¹⁾	5512 073-04 ¹⁾	(M10)
1.250	5512 074-04	(5/8"-18 UNF)	27	5512 073-02	(M12)
1.500	5512 074-05	(3/4"-16 UNF)	32	5512 073-05	(M16)
					3021 010-060
					3021 010-080
					3021 010-080
					3021 010-100
					3021 010-120

1) Optimized: Low head/small head diameter

2) Accessories, must be ordered separately.

Spare parts

Dampened adapter for facemills and square shoulder facemills

With coolant through arbor

Metric pilot

Cx.391.05CD

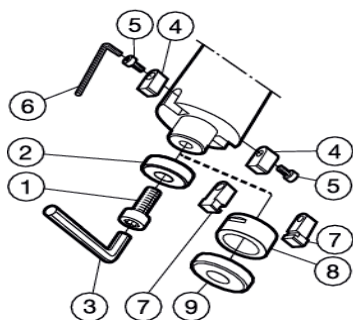

	1	2	3 ¹⁾	4	5	6 ¹⁾
	Screw	Washer	Key (mm)	Driving key	Screw	Key (mm)
Cx-391.05CD-22 xxx	3212 020-464	5541 015-02	3021 010-080 (8.0)	5631 012-01	3212 010-258	3021 010-030 (3.0)
Cx-391.05CD-27 xxx	3212 020-514	5541 015-03	3021 010-100 (10.0)	5631 010-01	3212 010-258	3021 010-030 (3.0)
Cx-391.05CD-32 xxx	3212 020-564	5541 015-04	3021 010-120 (12.0)	5631 010-04	3212 010-308	3021 010-040 (4.0)
Sleeve set for Cx-391.05CD	7	8	9			
	Driving key	Sleeve	Washer			
5638 035-011	5631 016-01	5638 035-01	5541 015-09			

¹⁾ Accessories, must be ordered separately.

Inch pilot

Cx-A391.05CD

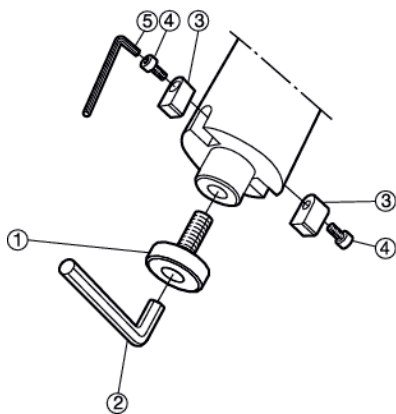

	1 ¹⁾	2 ¹⁾	3	4	5 ¹⁾
	Screw	Key	Drive key	Screw	Key
Cx-A391.05CD-19 xxx	5512 065-02	3021 011-316	5631 013-01	8-32 x 3/8M	(9/64)
Cx-A391.05CD-25 xxx	5512 065-08	3021 011-352	5631 013-02	10-32 x 3/8	3021 011 532
Cx-A391.05CD-38 xxx	5512 065-04	3021 011-380	5631 013-04	1/4-20 x 3/4	3021 011 316

Coromant Capto® shrink fit adapter

Cx-391.19

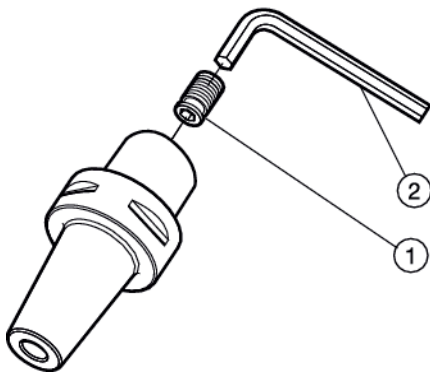

	1	2 ¹⁾
	Adjustment screw	Key (mm)
Cx-391.19-06 xxx	5512 066-09	3021 010-025 (2.5)
Cx-391.19-08 xxx	5512 066-10	3021 010-030 (3.0)
Cx-391.19-10 xxx	5512 066-11	3021 010-040 (4.0)
Cx-391.19-12 xxx	5512 066-12	3021 010-050 (5.0)
Cx-391.19-14 xxx	5512 066-12	3021 010-050 (5.0)
Cx-391.19-16 xxx	5512 066-13	3021 010-060 (6.0)
Cx-391.19-18 xxx	5512 066-13	3021 010-060 (6.0)
Cx-391.19-20 xxx	5512 066-14	3021 010-080 (8.0)
Cx-391.19-25 xxx	5512 066-14	3021 010-080 (8.0)
Cx-391.19-32 xxx	5512 066-14	3021 010-080 (8.0)

¹⁾ Accessories, must be ordered separately.

Adapters for Weldon shanks

Cx-A391.20

Cx-391.20

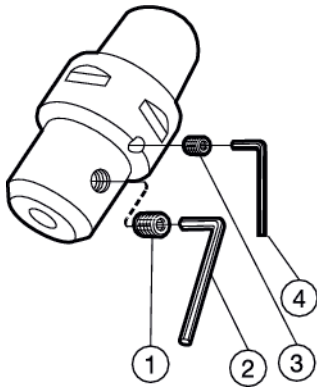

Inch version	1	2 ¹⁾	3	4 ¹⁾
	Screw	Key	Screw	Key
Cx-A391.20-09 xxx	5514 021-01	3021 011-316 (3/16)	-	-
Cx-A391.20-12 xxx	5514 021-02	3021 011-732 (7/32)	-	-
Cx-A391.20-15 xxx	5514 021-03	3021 011-140 (1/4)	-	-
Cx-A391.20-19 xxx	5514 021-04	3021 011- 516 (5/16)	-	-
Cx-A391.20-22 xxx	5514 021-04	3021 011-516 (5/16)	5514 021-04	3021 011-516 (5/16)
Cx-A391.20-25 xxx	5514 021-05	3021 011-380 (3/8)	5514 021-05	3021 011-380 (3/8)
Cx-A391.20-31 xxx	5514 021-05	3021 011-380 (3/8)	5514 021-05	3021 011-380 (3/8)
Cx-A391.20-38 xxx	5514 021-05	3021 011-380 (3/8)	5514 021-05	3021 011-380 (3/8)
Cx-A391.20-50 xxx	5514 021-07	3021 011-916 (9/16)	5514 021-07	3021 011-916 (9/16)
Metric version	1	2 ¹⁾	3	4 ¹⁾
	Screw	Key (mm)	Screw	Key (mm)
Cx-391.20-06 xxx	3214 050-357	174.1-864 (3.0)	-	-
Cx-391.20-08 xxx	3214 050-407	3021 010-040 (4.0)	-	-
Cx-391.20-10 xxx	3214 050-458	3021 010-050 (5.0)	-	-
Cx-391.20-12 xxx	3214 050-509	3021 010-060 (6.0)	-	-
Cx-391.20-14 xxx	3214 050-509	3021 010-060 (6.0)	-	-
Cx-391.20-16 xxx	3214 050-539	3021 010-060 (6.0)	-	-
Cx-391.20-18 xxx	3214 050-539	3021 010-060 (6.0)	-	-
Cx-391.20-20 xxx	3214 050-559	3021 010-080 (8.0)	-	-
Cx-391.20-25 xxx	3214 050-590	3021 010-100 (10.0)	3214 050-590	3021 010-100 (10.0)
Cx-391.20-32 xxx	3214 050-610	3021 010-100 (10.0)	3214 050-610	3021 010-100 (10.0)
Cx-391.20-40 xxx	3214 050-611	3021 010-100 (10.0)	3214 050-611	3021 010-100 (10.0)
Cx-391.20-50 xxx	3214 050-661	3021 010-120 (12.0)	3214 050-611	3021 010-100 (10.0)

¹⁾ Accessories, must be ordered separately.

Adapters for Whistle Notch shanks

Cx-391.21

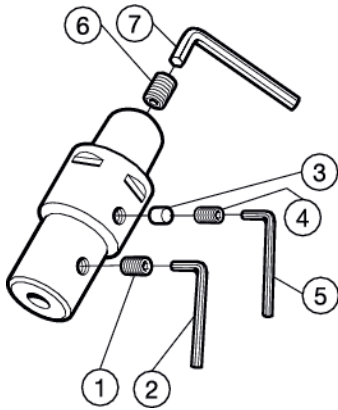

	1	2 ¹⁾	3	4	5 ¹⁾	6	7 ¹⁾
	Screw	Key (mm)	Plug	Screw	Key (mm)	Screw	Key (mm)
C3-391.21-06 070A	3214 050-357	174.1-864 (3.0)	470-841	3214 010-355	174.1-864 (3.0)	5512 066-09	174.1-864 (3.0)
C3-391.21-08 070A	3214 050-407	3021 010-040 (4.0)	470-841	3214 010-355	174.1-864 (3.0)	5512 066-08	3021 010-040 (4.0)
C3-391.21-10 070	3214 050-458	3021 010-050 (5.0)	470-841	3214 010-355	174.1-864 (3.0)	5512 066-03	3021 010-040 (4.0)
C3-391.21-12 075	3214 050-509	3021 010-060 (6.0)	470-841	3214 010-357	174.1-864 (3.0)	5512 066-05	3021 010-050 (5.0)
C4-391.21-06 070A	3214 050-357	174.1-864 (3.0)	470-841	3214 010-355	174.1-864 (3.0)	5512 066-09	174.1-864 (3.0)
C4-391.21-08 070A	3214 050-407	3021 010-040 (4.0)	470-841	3214 010-355	174.1-864 (3.0)	5512 066-08	3021 010-040 (4.0)
C4-391.21-10 070	3214 050-458	3021 010-050 (5.0)	470-841	3214 010-355	174.1-864 (3.0)	5512 066-03	3021 010-040 (4.0)
C4-391.21-12 075	3214 050-509	3021 010-060 (6.0)	470-841	3214 010-357	174.1-864 (3.0)	5512 066-05	3021 010-050 (5.0)
C4-391.21-14 075	3214 050-509	3021 010-060 (6.0)	470-841	3214 010-357	174.1-864 (3.0)	5512 066-05	3021 010-050 (5.0)
C5-391.21-06 070A	3214 050-357	174.1-864 (3.0)	470-841	3214 010-355	174.1-864 (3.0)	5512 066-09	174.1-864 (3.0)
C5-391.21-08 070A	3214 050-407	3021 010-040 (4.0)	470-841	3214 010-355	174.1-864 (3.0)	5512 066-08	3021 010-040 (4.0)
C5-391.21-10 070	3214 050-458	3021 010-050 (5.0)	470-841	3214 010-355	174.1-864 (3.0)	5512 066-03	3021 010-040 (4.0)
C5-391.21-12 075	3214 050-509	3021 010-060 (6.0)	470-841	3214 010-357	174.1-864 (3.0)	5512 066-05	3021 010-050 (5.0)
C5-391.21-14 075	3214 050-509	3021 010-060 (6.0)	470-841	3214 010-357	174.1-864 (3.0)	5512 066-05	3021 010-050 (5.0)
C5-391.21-16 080	3214 050-539	3021 010-060 (6.0)	470-841	3214 010-357	174.1-864 (3.0)	5512 066-05	3021 010-060 (6.0)
C5-391.21-18 080	3214 050-539	3021 010-060 (6.0)	470-841	3214 010-357	174.1-864 (3.0)	5512 066-06	3021 010-060 (6.0)
C5-391.21-20 085	3214 050-559	3021 010-080 (8.0)	470-841	3214 010-357	174.1-864 (3.0)	5512 066-07	3021 010-060 (6.0)
C6-391.21-06 075A	3214 050-357	174.1-864 (3.0)	470-841	3214 010-355	174.1-864 (3.0)	5512 066-09	174.1-864 (3.0)
C6-391.21-08 075A	3214 050-407	3021 010-040 (4.0)	470-841	3214 010-355	174.1-864 (3.0)	5512 066-08	3021 010-040 (4.0)
C6-391.21-10 075	3214 050-458	3021 010-050 (5.0)	470-841	3214 010-355	174.1-864 (3.0)	5512 066-03	3021 010-040 (4.0)
C6-391.21-12 080	3214 050-509	3021 010-060 (6.0)	470-841	3214 010-357	174.1-864(3.0)	5512 066-05	3021 010-050 (5.0)
C6-391.21-14 080	3214 050-509	3021 010-060 (6.0)	470-841	3214 010-357	174.1-864 (3.0)	5512 066-05	3021 010-050 (5.0)
C6-391.21-16 080	3214 050-539	3021 010-060 (6.0)	470-841	3214 010-357	174.1-864 (3.0)	5512 066-06	3021 010-060 (6.0)
C6-391.21-18 080	3214 050-539	3021 010-060 (6.0)	470-841	3214 010-357	174.1-864 (3.0)	5512 066-06	3021 010-060 (6.0)
C6-391.21-20 085	3214 050-559	3021 010-080 (8.0)	470-841	3214 010-357	174.1-864 (3.0)	5512 066-07	3021 010-060 (6.0)
C6-391.21-25 090	3214 050-590	3021 010-100 (10.0)	470-841	3214 010-357	174.1-864(3.0)	5512 066-07	3021 010-060 (6.0)
C6-391.21-32 095	3214 050-610	3021 010-100 (10.0)	470-841	3214 010-357	174.1-864 (3.0)	5512 066-07	3021 010-060 (6.0)
C8-391.21-06 065A	3214 050-357	174.1-864 (3.0)	470-841	3214 010-355	174.1-864(3.0)	5512 066-09	174.1-864 (3.0)
C8-391.21-08 065A	3214 050-407	3021 010-040 (4.0)	470-841	3214 010-355	174.1-864(3.0)	5512 066-08	3021 010-040 (4.0)
C8-391.21-10 065	3214 050-458	3021 010-050 (5.0)	470-841	3214 010-355	174.1-864(3.0)	5512 066-03	3021 010-040 (4.0)
C8-391.21-12 070	3214 050-509	3021 010-060 (6.0)	470-841	3214 010-357	174.1-864(3.0)	5512 066-05	3021 010-050 (5.0)
C8-391.21-14 070	3214 050-509	3021 010-060 (6.0)	470-841	3214 010-357	174.1-864(3.0)	5512 066-05	3021 010-050 (5.0)
C8-391.21-16 075	3214 050-539	3021 010-060 (6.0)	470-841	3214 010-357	174.1-864(3.0)	5512 066-06	3021 010-060 (6.0)
C8-391.21-18 075	3214 050-539	3021 010-060 (6.0)	470-841	3214 010-357	174.1-864(3.0)	5512 066-06	3021 010-060 (6.0)
C8-391.21-20 080	3214 050-559	3021 010-080 (8.0)	470-841	3214 010-357	174.1-864(3.0)	5512 066-07	3021 010-060 (6.0)
C8-391.21-25 090	3214 050-590	3021 010-100 (10.0)	470-841	3214 010-357	174.1-864(3.0)	5512 066-07	3021 010-060 (6.0)
C8-391.21-32 095	3214 050-610	3021 010-100 (10.0)	470-841	3214 010-357	174.1-864(3.0)	5512 066-07	3021 010-060 (6.0)

1) Accessories, must be ordered separately.

Adapters for drills

Cx-391.25

For Coromant Whistle Notch shank

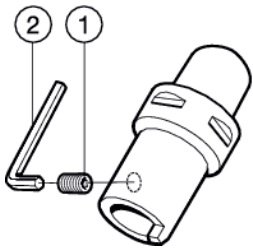

	1	2 ¹⁾
	Screw	Key (mm)
Cx-391.25-16 xxx	416.1-836	3021 010-040 (4.0)
Cx-391.25- 20 xxx	416.1-836	3021 010-040 (4.0)
Cx-391.25- 25 xxx	416.1-837	3021 010-050 (5.0)
Cx-391.25- 32 xxx	416.1-838	3021 010-060 (6.0)
Cx-391.25- 40 xxx	416.1-839	3021 010-080 (8.0)

¹⁾ Accessories, must be ordered separately.

Cx-391.27

ISO 9766 Shank

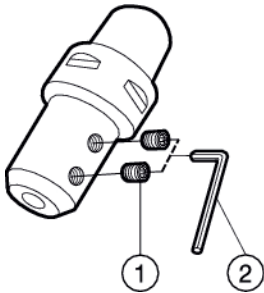

	1	2 ¹⁾
	Screw	Key (mm)
Cx-391.27- 10 xxx	5514 042-04	3021 010-040 (4.0)
Cx-391.27- 20 xxx	5514 042-04	3021 010-040 (4.0)
Cx-391.27- 25 xxx	416.1-838	3021 010-060 (6.0)
Cx-391.27- 32 xxx	416.1-838	3021 010-060 (6.0)
Cx-391.27- 40 xxx	5514 042-06	3021 010-080 (8.0)
Cx-391.27- 50 xxx	5514 042-06	3021 010-080 (8.0)

¹⁾ Accessories, must be ordered separately.

Drill chuck

Cx-391.31

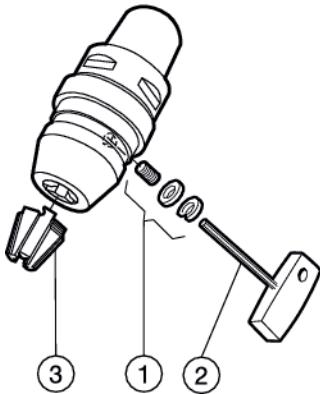

	1	2 ¹⁾	3
	Worm screw set	Key	Chuck jaw set
Cx-391.31-10 xxxM	5519 070-021	5680 017-03	5471 010-03
Cx-391.31-13 xxx	5519 070-011	5680 017-03	5471 010-01

¹⁾ Accessories, must be ordered separately.

ER collet chuck adapters

Cx-391.14

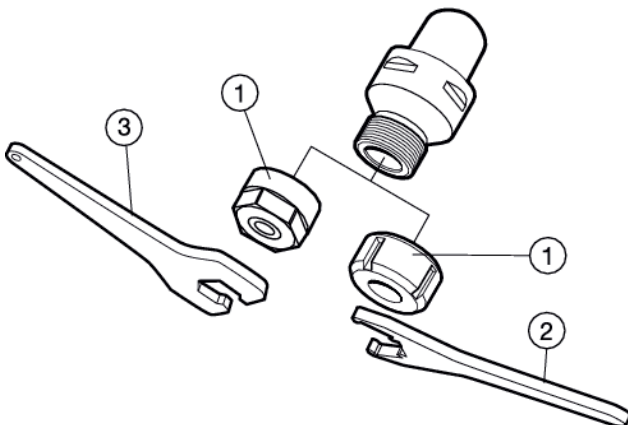

	1	2 ¹⁾	3 ¹⁾
	Locking nut	Wrench	Wrench
Cx-391.14-16 xxx	5533 050-06	-	5680 091-01
Cx-391.14-20 xxx	5533 050-08	-	5680 091-02
Cx-391.14-25 xxx	5533 050-02	5680 096-02	-
Cx-391.14-32 xxx	5533 050-03	5680 096-03	-
Cx-391.14-40 xxx	5533 050-04	5680 096-04	-
Cx-391.14-50 xxx	5533 050-05	5680 096-05	-

¹⁾ Accessories, must be ordered separately.

Tap adapters

Cx-391.60A

Cx-391.60B

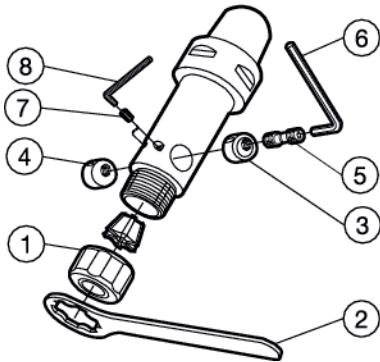

	1	2 ¹⁾	3	4
Cx-391.60A- Cx-391.60B-	Locking nut	Wrench	Jaw right	Jaw left
01 xxx	391.60A-OZ 3158	5680 090-01	5412 093-01	5412 093-02
02 xxx	391.60A-OZ 3159	5680 090-02	5412 093-01	5412 093-02
03 xxx	391.60A-OZ N460	5680 092-01	5412 093-03	5412 093-04
	5	6 ¹⁾	7	8 ¹⁾
Cx-391.60A- Cx-391.60B-	Adjusting screw	Key for jaws (mm)	Socket screw	Key (mm)
01 xxx	5516 050-01	3021 010-040 (4.0)	3214 020-255	174.1-870 (2.0)
02 xxx	5516 050-01	3021 010-040 (4.0)	3214 020-255	174.1-870 (2.0)
03 xxx	5516 050-02	3021 010-050 (5.0)	3214 020-305	174.1-863 (2.5)

1) Accessories, must be ordered separately.

Set of spare parts

391.60/392.41060/393.2060

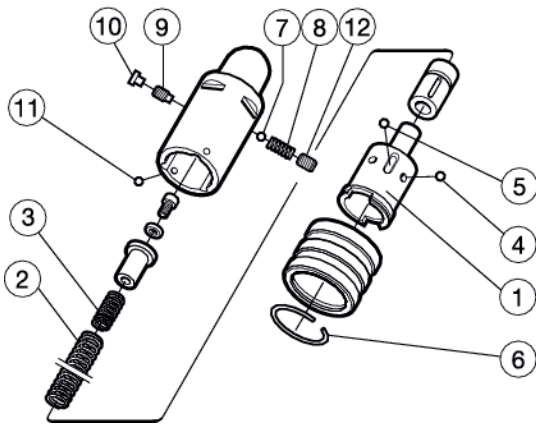

- | | |
|-----------------------|-------------------------|
| 1. Barrel | 7. Ball |
| 2. Compression spring | 8. Compression spring |
| 3. Compression spring | 9. Stop screw |
| 4. Ball | 10. Plastic plug |
| 5. Ball | 11. Clamp ring (size 1) |
| 6. Circlip | 12. Screw |

	Adapter size		
	393.2060-xx01	393.2060-xx02	393.2060-xx03
	392.41060-xx01	392.41060-xx02	392.41060-xx03
	Cx-391.60/61-01	Cx-391.60/61-02	Cx-391.60/61-03
Barrel	5638 055-01	5638 055-02	5638 055-03
Complete spare part set items 2-12	5471 020-01	5471 020-02	5471 020-03

For technical information, see the Metalcutting Technical Guide.

Tap adapters

Coromant Capto® tap adapter

Collet type

391.62/391.63

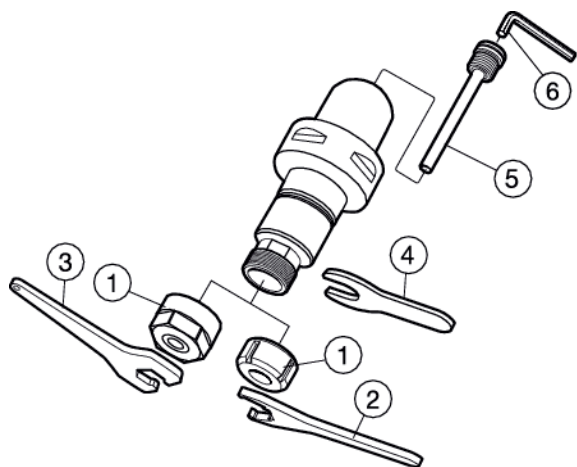

	1	2 ¹⁾	3 ¹⁾	4 ¹⁾	5	6 ¹⁾
Ordering code	Nut	Wrench	Wrench	Wrench	Coolant tube	Key (mm)
Cx-391.62-20 xxx	5533 050-08	-	5680 091-02	5680 092-04	-	-
Cx-391.62-25 xxx	5533 050-02	5680 096-02	-	5680 092-05	-	-
Cx-391.62-40 xxx	5533 050-04	5680 096-04	-	5680 092-06	-	-
Cx-391.63-20 xxx	5533 051-02	-	5680 091-02	5680 092-04	5692 031-01	3021 010-030 (3.0)
Cx-391.63-25 xxx	5533 051-03	5680 096-02	-	5680 092-05	5692 031-02	3021 010-030 (3.0)
Cx-391.63-40 xxx	5533 051-05	5680 096-04	-	5680 092-06	5692 031-03	3021 010-030 (3.0)

1) Accessories, must be ordered separately.

Facemill holder for flange mounting

A1F05 / A2F05

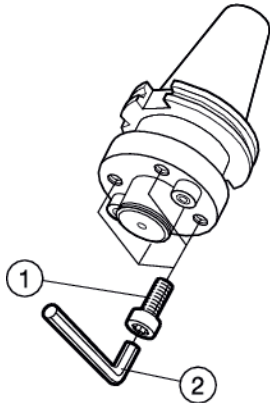

	1	2
A1F05 A2F05	Screw (4 x)	Key ¹⁾
-xx 60 xxx	3212 010-514	3021 010-100 (10.0)

¹⁾ Accessories, not delivered with the tool, must be ordered separately.

Face mill holder

AA205 / AA305

Inch pilot

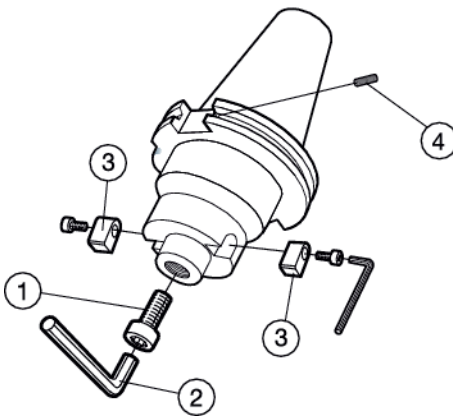

	1	2	3	4 ²⁾
AA3B05 AA2B05/AA205	Center screw	Key (inch) ¹⁾	Drive key	Coolant screw
AA3B05-40 19 xxx	3212 030-606	3021 011-516 (5/16")	5631 062-01	3214 010-253
AA3B05-40 25 xxx	3212 030-707	3021 011-380 (3/8")	5631 062-02	3214 010-253
AA3B05-40 32 xxx	3212 030-757	-	5631 062-03	3214 010-253
AA3B05-40 38 xxx	5512 065-10	3021 011-380 (3/8")	5631 062-04	3214 010-253
AA3B05-50 19 xxx	3212 030-606	3021 011-516 (5/16")	5631 062-01	3214 010-355
AA3B05-50 25 xxx	3212 030-707	3021 011-380 (3/8")	5631 062-02	3214 010-355
AA3B05-50 32 xxx	3212 030-757	-	5631 062-03	3214 010-355
AA3B05-50 38 xxx	5512 065-10	3021 011-380 (3/8")	5631 062-04	3214 010-355
AA3B05-50 51 xxx	5512 065-11	3021 011-916 (9/16")	5631 062-05	3214 010-355
AA3B05-50 63 xxx	5512 065-11	3021 011-916 (9/16")	5631 062-06	3214 010-355
AA205-30 19 xxx	3212 030-606	3021 011-516 (5/16")	5631 062-01	-
AA205-30 25 xxx	3212 030-707	3021 011-380 (3/8")	5631 062-02	-
AA2B05-40 19 xxx	3212 030-606	3021 011-516 (5/16")	5631 062-01	3214 010-253
AA2B05-40 25 xxx	3212 030-707	3021 011-380 (3/8")	5631 062-02	3214 010-253
AA2B05-40 32 xxx	3212 030-757	-	5631 062-03	3214 010-253
AA2B05-40 38 xxx	5512 065-10	3021 011-380 (3/8")	5631 062-04	3214 010-253

¹⁾ Accessories, not delivered with the tool, must be ordered separately.

Arbor mounting screws with coolant hole

Arbor size	Screw	Key, inch (mm)
Metric		
16	5512 073-03 (M8)	3021 010-060 (6.0)
22	5512 073-01 (M10)	3021 010-080 (8.0)
22 ¹⁾	5512 073-04 ¹⁾ (M10)	3021 010-080 (8.0)
27	5512 073-02 (M12)	3021 010-100 (10.0)
32	5512 073-05 (M16)	3021 010-120 (12.0)
Inch		
.750	5512 074-01 (3/8"-24 UNF)	3021 011-516 (5/16")
.750 ¹⁾	5512 074-03 (3/8"-24 UNF) ¹⁾	3021 011-516 (5/16")
1.000	5512 074-02 (1/2"-20 UNF)	3021 011-380 (3/8")
1.250	5512 074-04 (5/8"-18 UNF)	-
1.500	5512 074-05 (3/4"-16 UNF)	3021 011-580 (3/8")

¹⁾ Optimized: Low head/small head diameter

D
E
F
G
J

TOOLING SYSTEMS Spare parts - Coromant solid holders

Facemill holder

A1B05 / A2B05

Arbor mounting screws with coolant hole

Arbor size	Screw		Key (mm) ²⁾
16	5512 073-03	(M8)	3021 010-060 (6.0)
22	5512 073-01	(M10)	3021 010-080 (8.0)
22 ¹⁾	5512 073-04 ¹⁾	(M10)	3021 010-080 (8.0)
27	5512 073-02	(M12)	3021 010-100 (10.0)
32	5512 073-05	(M16)	3021 010-140 (14.0)

¹⁾ Optimized: Low head/small head-diameter.
²⁾ Accessories, must be ordered separately.

For CoroMill® 365, CoroMill® Century and CoroMill® 210, a unique screw with coolant hole is used. This must be ordered separately. See ordering pages for these cutters.

Metric pilot

A1B05 A2B05	1	2	3 ¹⁾	4	
	Washer	Center screw	Key (mm)	ISO 40	ISO 50
-xx 16 xxx	5541 015-01	3212 020-410	3021 010-060 (6.0)	5643 017-01	5643 017-02
-xx 22 xxx	5541 015-02	3212 020-461	3021 010-080 (8.0)	5643 017-01	5643 017-02
-xx 27 xxx	5541 015-03	3212 020-512	3021 010-100 (10.0)	5643 017-01	5643 017-02
-xx 32 xxx	5541 015-04	3212 020-563	3021 010-120 (12.0)	5643 017-01	5643 017-02
-xx 40 xxx	5541 015-05	3212 020-614	3021 010-140 (14.0)	5643 017-01	5643 017-02

¹⁾ Accessories, must be ordered separately.

Combi Face mill holder

A2B05

A2B05	1	2	3	4	5 ¹⁾
	Driving ring	Parallel key	Washer	Center screw	Key (mm)
-xx 16 xxx	3193 010-160	3191 010-460	5541 015-01	3212 020-410	3021 010-060 (6.0)
-xx 22 xxx	3193 010-220	3191 010-562	5541 015-02	3212 020-461	3021 010-080 (8.0)
-xx 27 xxx	3193 010-270	5632 010-06	5541 015-03	3212 020-512	3021 010-100 (10.0)

¹⁾ Accessories, must be ordered separately.

G 144

General Information

ER collet chuck

For DIN 6499 collets

Cat V

AA3B14

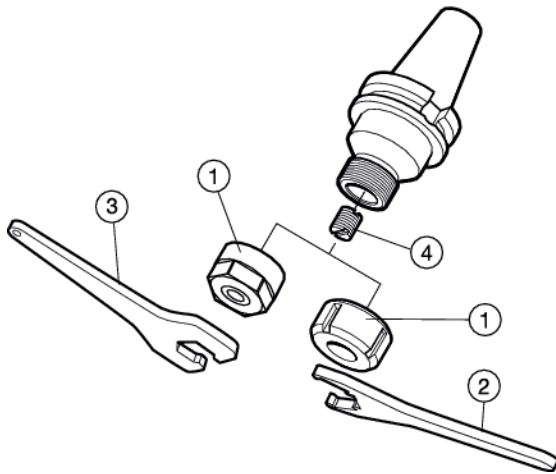

AA3B14	1	2 ¹⁾	3 ¹⁾	4 ¹⁾
	Locking nut	Wrench	Wrench	Stop screw
-xx 16 xxx	5533 050-06	-	5680 091-01	5514 044-01
-xx 20 xxx	5533 050-08	-	5680 091-02	5514 018-01
-xx 25 xxx	5533 050-02	5680 096-02	-	5514 018-03
-xx 32 xxx	5533 050-03	5680 096-03	-	5514 018-04
-xx 40 xxx	5533 050-04	5680 096-04	-	5514 018-02

¹⁾ Accessories, not delivered with the tool, must be ordered separately.

Collet chuck

For DIN 6499 collets

ISO 7388, MAS-BT 403

A1B14 / A2B14

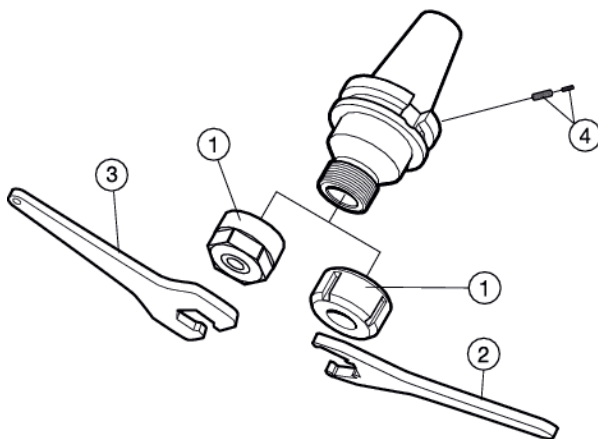

A1B14 A2B14	1	2 ¹⁾	3 ¹⁾	4 ¹⁾	5 ¹⁾	
	Locking nut	Wrench	Wrench	ISO 30	ISO 40	ISO 50
-xx 11 xxx	5533 050-07	-	-	-	-	-
-xx 16 xxx	5533 050-06	-	5680 091-01	-	5643 017-01	5643 017-02
-xx 20 xxx	5533 050-08	-	5680 091-02	-	5643 017-01	5643 017-02
-xx 25 xxx	5533 050-02	5680 096-02	-	-	5643 017-01	5643 017-02
-xx 32 xxx	5533 050-03	5680 096-03	-	-	5643 017-01	5643 017-02
-xx 40 xxx	5533 050-04	5680 096-04	-	-	5643 017-01	5643 017-02

¹⁾ Accessories, not delivered with the tool, must be ordered separately.

Endmill holder, Weldon type, short version

Shank according to DIN 6535-HB

A1X20 / A2X20

Milling

E

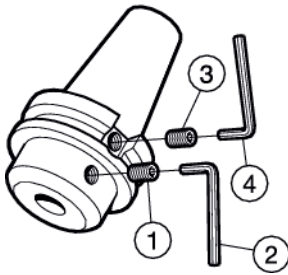

	1	2	3	4
A1X20 A2X20	Screw	Key (mm) ¹⁾	Screw	Key (mm) ¹⁾
A1X20-xx 16 xxx	3214 050-539	3021 010-060 (6.0)		
A1X20-xx 18	5514 023-03	3021 010-060 (6.0)		
A1X20-xx 20	5514 023-04	3021 010-080 (8.0)		
A1X20-xx 25 xxx	5514 023-05	3021 010-100 (10.0)		
A1X20-xx 32	3214 050-610	3021 010-100 (10.0)	5514 023-02	3021 010-040 (4.0)
A2X20-xx 16 xxx	5514 023-03	3021 010-060 (6.0)		
A2X20-xx 18 xxx	5514 023-03	3021 010-060 (6.0)		
A2X20-xx 20	5514 023-04	3021 010-060 (6.0)		
A2X20-xx 25	5514 023-06	3021 010-100 (10.0)	3214 050-407	3021 010-040 (4.0)
A2X20-xx 32	5514 023-08	3021 010-100 (10.0)	3214 010-406	3021 010-040 (4.0)

¹⁾ Accessories, not delivered with the tool, must be ordered separately.

Collet chuck extension

Drilling

F

A393.14
393.14

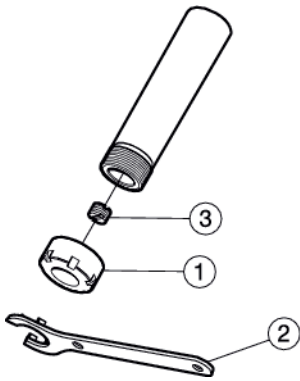

	1	2 ¹⁾	3 ¹⁾
A393.14-13 16 182	5533 065-03	5680 098-03	3214 010-360
A393.14-19 16 182	5533 065-03	5680 098-03	5514 014-02
A393.14-19 20 187	5533 065-01	5680 098-01	5514 014-02
A393.14-26 20 203	5533 065-01	5680 098-01	5514 014-03
A393.14-19 25 203	5533 050-02	5680 096-02	5514 014-02
A393.14-26 25 203	5533 050-02	5680 096-02	5514 014-04
A393.14-26 32 203	5533 050-03	5680 096-03	5514 014-04
393.14-08 11 056	5533 065-02	5680 098-02	-
393.14-12 16 080	5533 065-03	5680 098-03	-
393.14-16 11 150	5533 065-02	5680 098-02	5514 014-01
393.14-20 16 155	5533 065-03	5680 098-03	5514 014-02
393.14-25 20 170A	5533 065-01	5680 098-01	5514 014-03

¹⁾ Accessories, must be ordered separately.

Boring

G

Endmill holder, Weldon type

Metric bore with CAT V-flange

392.45520

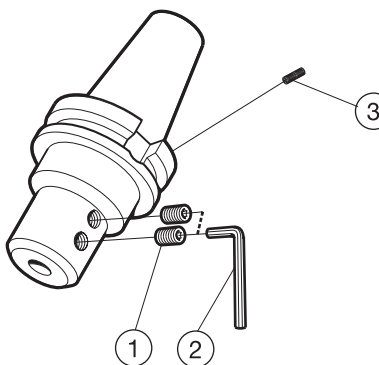

	1	2 ¹⁾
	Screw	Key
-xx 06 xxx	5514 022-03	3021 011-316
-xx 08 xxx	5514 022-03	3021 011-316
-xx 10 xxx	5514 022-04	3021 011-516
-xx 12 xxx	5514 022-05	3021 011-732
-xx 14 xxx	5514 022-05	3021 011-732
-xx 16 xxx	5514 022-06	3021 011-140
-xx 20 xxx	5514 022-08	3021 011-516
-xx 25 xxx	5514 022-09	3021 011-380
-xx 32 xxx	5514 022-07	3021 011-380
-xx 40 xxx	5514 022-07	3021 011-380

¹⁾ Accessories, not delivered with the tool, must be ordered separately.

Tooling Systems

J

General Information

Endmill holder, Weldon type

AA3B20/ AA2B20/AA220

AA3B27

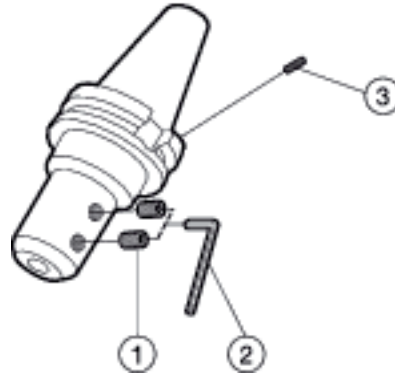
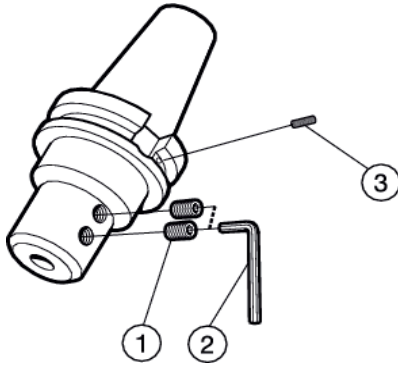

Endmill holder, Weldon type

	1	2	3 ²⁾
AA3B20 AA2B20/AA220	Screw	Key (inch) ¹⁾	Coolant screw
AA3B20-40 03 xxx	5514 022-01	3021 011-532 (5/32")	3214 010-253
AA3B20-40 06 xxx	5514 022-03	3021 011-316 (3/16")	3214 010-253
AA3B20-40 09 xxx	5514 022-04	3021 011-140 (1/4")	3214 010-253
AA3B20-40 13 xxx	5514 022-05	3021 011-732 (7/32")	3214 010-253
AA3B20-40 16 xxx	5514 022-06	3021 011-140 (1/4")	3214 010-253
AA3B20-40 19 xxx	5514 022-08	3021 011-516 (5/16")	3214 010-253
AA3B20-40 22 xxx	5514 022-08	3021 011-516 (5/16")	3214 010-253
AA3B20-40 25 044	5514 022-10	3021 010-080 (8 mm)	3214 010-253
AA3B20-40 25 101	5514 022-09	3021 011-380 (3/8")	3214 010-253
AA3B20-40 32 xxx	5514 022-07	3021 011-380 (3/8")	3214 010-253
AA3B20-40 38 xxx	5514 022-07	3021 011-380 (3/8")	3214 010-253
AA3B20-50 09 xxx	5514 022-04	3021 011-140 (1/4")	3214 010-355
AA3B20-50 13 xxx	5514 022-05	3021 011-732 (7/32")	3214 010-355
AA3B20-50 16 xxx	5514 022-06	3021 011-140 (1/4")	3214 010-355
AA3B20-50 19 xxx	5514 022-08	3021 011-516 (5/16")	3214 010-355
AA3B20-50 22 xxx	5514 022-08	3021 011-516 (5/16")	3214 010-355
AA3B20-50 25 xxx	5514 022-09	3021 011-380 (3/8")	3214 010-355
AA3B20-50 32 xxx	5514 022-07	3021 011-516 (5/16")	3214 010-355
AA3B20-50 38 xxx	5514 022-07	3021 011-380 (3/8")	3214 010-355
AA3B20-50 51 xxx	5514 022-02	- (1/2")	3214 010-355
AA220-30 03 xxx	5514 022-01	3021 011-532 (5/32")	-
AA220-30 06 xxx	5514 022-03	3021 011-316 (3/16")	-
AA220-30 09 xxx	5514 022-04	3021 011-140 (1/4")	-
AA2B20-40 09 xxx	5514 022-04	3021 011-140 (1/4")	3214 010-253
AA2B20-40 13 xxx	5514 022-05	3021 011-732 (7/32")	3214 010-253
AA2B20-40 16 xxx	5514 022-06	3021 011-140 (1/4")	3214 010-253
AA2B20-40 19 xxx	5514 022-08	3021 011-516 (5/16")	3214 010-253
AA2B20-40 25 xxx	5514 022-09	3021 011-380 (3/8")	3214 010-253
AA2B20-40 32 xxx	5514 022-07	3021 011-516 (5/16")	3214 010-253

¹⁾ Accessories, not delivered with the tool, must be ordered separately.

²⁾ Only new products with B in the code have coolant through center and flange.

Endmill holder, Weldon type

Inch bore

Shank according to DIN 6535-HB

Metric bore

ISO 7388/I

A1B20

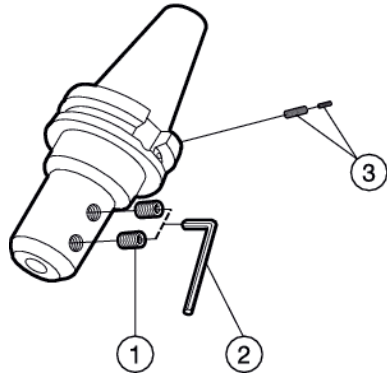

	1	2	3	
			Plastic dowel and screw (set of 50 pieces each) ¹⁾	
A1B20	Screw	Key (mm) ¹⁾	ISO 40	ISO 50
-xx 06 xxx	3214 050-357	174.1-864 (3.0)	5643 017-01	5643 017-02
-xx 08 xxx	3214 050-407	3021 010-040 (4.0)	5643 017-01	5643 017-02
-xx 10 xxx	3214 050-458	3021 010-050 (5.0)	5643 017-01	5643 017-02
-xx 12 xxx	3214 050-509	3021 010-060 (6.0)	5643 017-01	5643 017-02
-xx 16 xxx	3214 050-539	3021 010-060 (6.0)	5643 017-01	5643 017-02
-xx 18 xxx	3214 050-539	3021 010-060 (6.0)	5643 017-01	5643 017-02
-xx 20 xxx	3214 050-559	3021 010-080 (8.0)	5643 017-01	5643 017-02
-xx 25 xxx	3214 050-590	3021 010-100 (10.0)	5643 017-01	5643 017-02
-xx 32 xxx	3214 050-610	3021 010-100 (10.0)	5643 017-01	5643 017-02
-xx 40 xxx	3214 050-610	3021 010-100 (10.0)	5643 017-01	5643 017-02

¹⁾ Accessories, not delivered with the tool, must be ordered separately.

Shank according to DIN 6535-HB

Metric bore

MAS 403 BT

A2B20

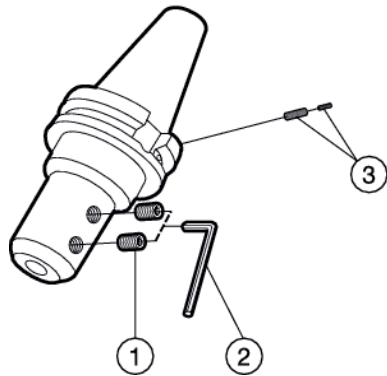

	1	2	3		
			Plastic dowel and screw (set of 50 pieces each) ¹⁾		
A2B20	Screw	Key (mm) ¹⁾	ISO 30	ISO 40	ISO 50
-xx 06 xxx	3214 050-357	174.1-864 (3.0)	-	5643 017-01	5643 017-02
-xx 08 xxx	3214 050-407	3021 010-040 (4.0)	-	5643 017-01	5643 017-02
-xx 10 xxx	3214 050-458	3021 010-050 (5.0)	-	5643 017-01	5643 017-02
-xx 12 xxx	3214 050-509	3021 010-060 (6.0)	-	5643 017-01	5643 017-02
-xx 16 xxx	3214 050-539	3021 010-060 (6.0)	-	5643 017-01	5643 017-02
-xx 20 xxx	3214 050-559	3021 010-080 (8.0)	-	5643 017-01	5643 017-02
-40 25 xxx	5514 023-06	3021 010-100 (10.0)	-	5643 017-01	5643 017-02
-50 25 xxx	3214 050-590	3021 010-100 (10.0)	-	5643 017-01	5643 017-02
-50 32 xxx	3214 050-610	3021 010-100 (10.0)	-	5643 017-01	5643 017-02
-40 32 xxx	5514 023-07	3021 010-100 (10.0)	-	5643 017-01	5643 017-02
-40 32 100 ²⁾	3214 050-610	3021 010-100	-	-	-
-xx 40 xxx	3214 050-610	3021 010-100 (10.0)	-	5643 017-01	5643 017-02

¹⁾ Accessories, not delivered with the tool, must be ordered separately.

²⁾ Two screws are used, 3214 050-610 and 5514 023-07. Key for both is 3021 010-100.

Holder for Coromant Delta drills, CoroDrill® 880 and Coromant U drills

A1B27 / A2B27

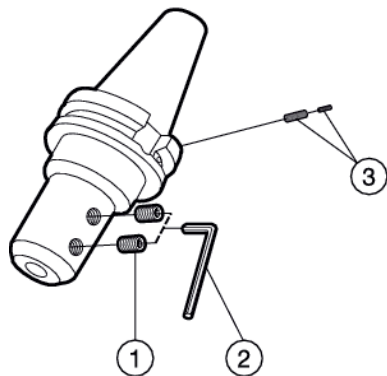

	1	2 ¹⁾	3 ¹⁾	
			Plastic dowel and screw (set of 50 pieces each)	
A1B27 A2B27	Screw	Key (mm)	ISO 40	ISO 50
-xx 16 xxx	5514 042-04	3021 010-040 (4.0)	5643 017-01	5643 017-02
-xx 20 xxx	5514 042-04	3021 010-040 (4.0)	5643 017-01	5643 017-02
-xx 25 xxx	416-1-838	3021 010-060 (6.0)	5643 017-01	5643 017-02
-xx 32 xxx	416.1-838	3021 010-060 (6.0)	5643 017-01	5643 017-02
-xx 40 xxx	5514 042-03	3021 010-080 (8.0)	5643 017-01	5643 017-02
-xx 50 xxx	416.1-839	3021 010-080 (8.0)	5643 017-01	5643 017-02

¹⁾ Accessories, must be ordered separately

Drill holder, ISO 9766 shank

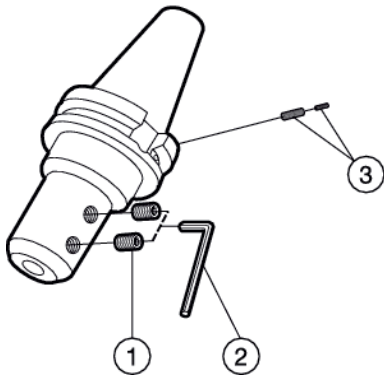

	1	2	3 ¹⁾
	Screw	Key (inch) ¹⁾	Coolant screw
AA3B27			
AA3B27-40 19 080	5514 022-05	3021 011-732 (7/32")	3214 010-253
AA3B27-40 25 085	5514 022-05	3021 011-732 (7/32")	3214 010-253
AA3B27-40 32 090	5514 022-06	3021 011-140 (1/4")	3214 010-253
AA3B27-50 19 080	5514 022-05	3021 011-732 (7/32")	3214 010-355
AA3B27-50 25 085	5514 022-06	3021 011-140 (1/4")	3214 010-355
AA3B27-50 32 090	5514 022-06	3021 011-140 (1/4")	3214 010-355
AA3B27-50 38 090	5514 022-09	3021 011-916 (9/16")	3214 010-355
AA3B27-50 51 110	5514 022-09	3021 011-916 (9/16")	3214 010-355

¹⁾ Accessories, must be ordered separately

Tapping chucks

Collet type

393.2062/393.2063

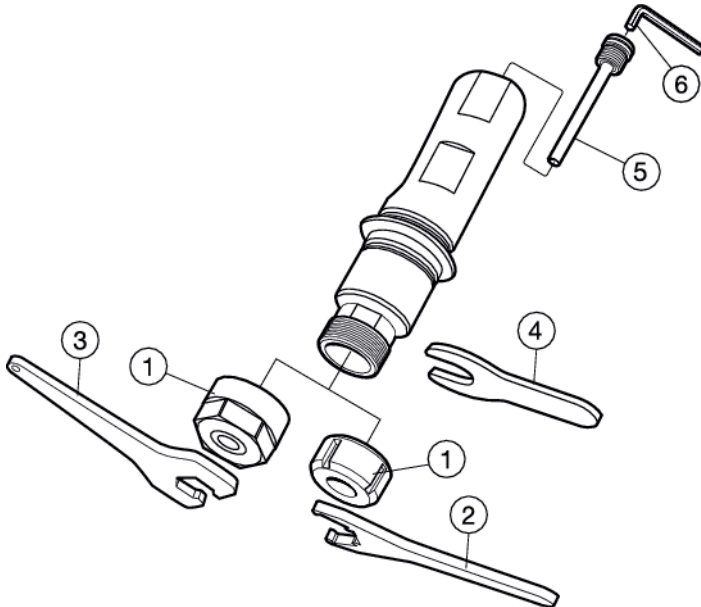

Weldon shank

	1	2 ¹⁾	3 ¹⁾	4 ¹⁾	5	6
	Nut	Wrench	Wrench	Wrench	Coolant tube	Key
393.2062 25-11	5533 050-07	-	5680 091-03	5680 092-03	-	-
393.2062 25-20	5533 050-08	-	5680 091-02	5680 092-04	-	-
393.2062 25-25	5533 050-02	5680 096-02	-	5680 092-05	-	-
393.2063 25-20	5533 051-02	-	5680 091-02	5680 092-04	5692 031-01	3021010- 030
393.2063 25-25	5533 051-03	5680 096-02	-	5680 092-05	5692 031-02	3021010- 030

¹⁾ Accessories, must be ordered separately.

Tap holders

A392.4560B

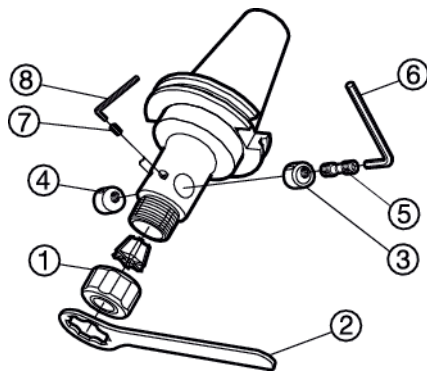

A393.60B

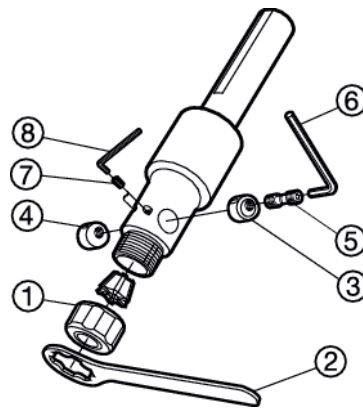

A392.4560B A393.60B	1	2 ¹⁾	3	4	5	6 ¹⁾	7	8 ¹⁾
	Collet nut	Wrench	Gripping jaw right	Gripping jaw left	Adjusting screw	Key for jaws (mm)	Socket screw	Key (mm)
A392.4560B-xx 01 xxx	391.60A-OZ 3158	5680 090-01	5412 093-01	5412 093-02	5516 050-01	3021 010-040 (4.0)	3214 020-255	174.1-870 (2.0)
A392.4560B-xx 02 xxx	391.60A-OZ 3159	5680 090-02	5412 093-01	5412 093-02	5516 050-01	3021 010-040 (4.0)	3214 020-255	174.1-870 (2.0)
A392.4560B-xx 03 xxx	391.60A-OZ N460	5680 092-01	5412 093-03	5412 093-04	5516 050-02	3021 010-040 (4.0)	3214 020-305	174.1-863 (2.5)
A393.60B-2501168	391.60A-OZ 3158	5680 090-01	5412 093-01	5412 093-02	5516 050-01	3021 010-040 (4.0)	3214 020-255	174.1-870 (2.0)
A393.60B-2502171	391.60A-OZ 3159	5680 090-02	5412 093-01	5412 093-02	5516 050-01	3021 010-040 (4.0)	3214 020-255	174.1-870 (2.0)
A393.60B-3803300	391.60A-OZ N460	5680 092-01	5412 093-03	5412 093-04	5516 050-02	3021 010-040 (4.0)	3214 020-305	174.1-863 (2.5)

¹⁾ Accessories, must be ordered separately.

Basic holders

Cx390.410

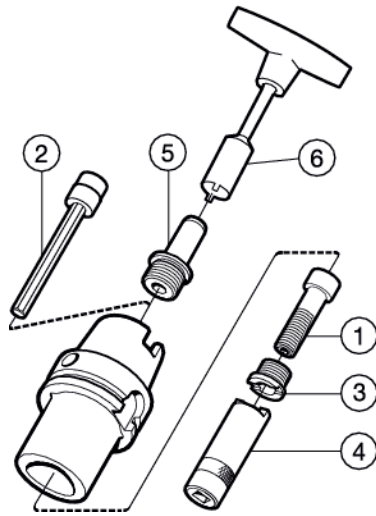
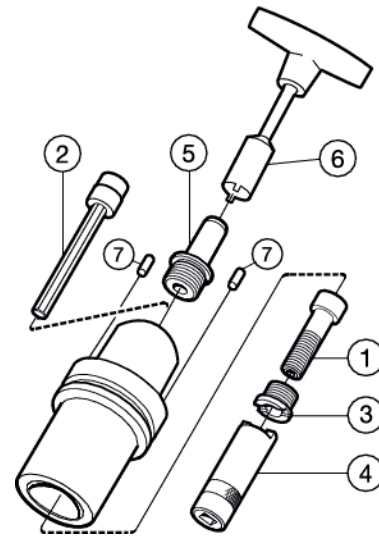
HSK F
Cx.390.612

Coromant Capto®	1	2 ¹⁾	3	4 ¹⁾	5	6 ¹⁾
	Center screw	Extension key (mm)	Retaining nut	Retaining nut spanner	Coolant tube	Key
C3-390.410-40 065	5512 067-01	5680 015-05 (8.0)	5512 091-04	5680 065-13	5692 020-02	5680 094-02
C3-390.410-50 075A	5512 067-01	5680 015-05 (8.0)	5512 091-04	5680 065-13	5692 020-03	5680 094-03
C3-390.410-63 075C	5512 067-01	5680 015-05 (8.0)	5512 091-04	5680 065-13	5692 020-04	5680 094-04
C3-390.410-80 080	5512 067-01	5680 015-05 (8.0)	5512 091-04	5680 065-13	5692 020-05	5680 094-05
C3-390.410-100 080A	5512 067-01	5680 015-05 (8.0)	5512 091-04	5680 065-13	5692 020-06	5680 094-06
C4-390.410-50 080A	5512 067-02	5680 015-05 (8.0)	5512 091-03	5680 065-10	5692 020-03	5680 094-03
C4-390.410-63 080C	5512 067-02	5680 015-05 (8.0)	5512 091-03	5680 065-10	5692 020-04	5680 094-04
C4-390.410-80 090	5512 067-02	5680 015-05 (8.0)	5512 091-03	5680 065-10	5692 020-05	5680 094-05
C4-390.410-100 090A	5512 067-02	5680 015-05 (8.0)	5512 091-03	5680 065-10	5692 020-06	5680 094-06
C5-390.410-63 090C	5512 067-03	5680 015-01 (10.0)	5512 091-01	5680 065-11	5692 020-04	5680 094-04
C5-390.410-80 095	5512 067-03	5680 015-01 (10.0)	5512 091-01	5680 065-11	5692 020-05	5680 094-05
C5-390.410-100 100A	5512 067-03	5680 015-01 (10.0)	5512 091-01	5680 065-11	5692 020-06	5680 094-06
C6-390.410-80 110	5512 067-04	5680 015-02 (14.0)	5512 091-02	5680 065-12	5692 020-05	5680 094-05
C6-390.410-100 110A	5512 067-04	5680 015-02 (14.0)	5512 091-02	5680 065-12	5692 020-06	5680 094-06
C6-390.410-100 120A	5512 067-04	5680 015-02 (14.0)	5512 091-02	5680 065-12	5692 020-06	5680 094-06
C6-390.410-125 120	5512 067-04	5680 015-02 (14.0)	5512 091-02	5680 065-12	5692 020-07	5680 094-07
C8-390.410-125 130	5512 067-04	5680 015-02 (14.0)	5512 091-02	5680 065-12	5692 020-07	5680 094-07
C10-390.410-125 160	5512 067-06	5680 015-06 (17.0)	5512 091-05	5680 065-14	5692 020-07	5680 094-07

1) Accessories, must be ordered separately.

HSK F

Pin style

Coromant Capto®	1	2 ¹⁾	3	4 ¹⁾	5	6 ¹⁾	7
	Center screw	Extension key (mm)	Retaining nut	Retaining nut spanner	Coolant tube	Key	Spring pin
C5-390.612 80 090	5512 063-08	5680 015-01 (10.0)	5512 091-01	5680 065-11	5692 020-04	5680 094-04	3113 030-508
C6-390.612-80 105	5512 063-09	5680 015-01 (10.0)	5512 091-02	5680 065-11	5692 020-04	5680 094-04	3113 030-508

1) Accessories, must be ordered separately.

Facemill holders

Inch pilot

A392.41005

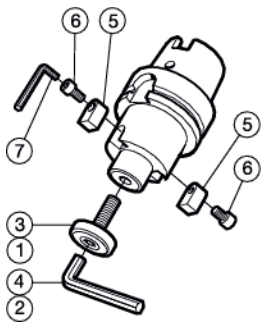

A392.41005-100 50 075 A

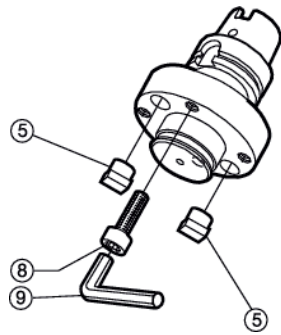

	1	2 ¹⁾	3	4 ¹⁾	5	6	7 ¹⁾	8	9 ¹⁾
	Center screw	Key	Screw	Key	Driving key	Screw	Key	Screw	Key
A392.41005-50 19 050 A	5512 065-07	3021 011-140	5512 065-02	3021 011-316	5631 013-01	8-32 X 3/8M	(9/64")	-	-
A392.41005-50 25 060 A	5512 065-03	3021 011-516	5512 065-05	3021 011-516	5631 013-02	10-32 x 3/8	(5/32")	-	-
A392.41005-50 31 065 A	5512 065-06	3021 011-516	-	-	5631 010-06	10-32 x 5/8	(5/32")	-	-
A392.41005-63 19 050 B	5512 065-07	3021 011-140	5512 065-02	3021 011-316	5631 013-01	8-32 X 3/8M	(9/64")	-	-
A392.41005-63 25 060 B	5512 065-03	3021 011-516	5512 065-05	3021 011-516	5631 013-02	10-32 x 3/8	(5/32")	-	-
A392.41005-63 31 065 B	5512 065-06	3021 011-516	-	-	5631 013-03	10-32 x 3/4	(5/32")	-	-
A392.41005-63 38 065 B	5512 065-10	3021 011-380	5512 065-04	3021 011-380	5631 013-04	8-32 X 3/8M	(3/16")	-	-
A392.41005-100 19 050 A	5512 065-07	3021 011-140	5512 065-02	3021 011-316	5631 013-01	8-32 x 3/8M	(9/64")	-	-
A392.41005-100 25 050 A	5512 065-03	3021 011-516	5512 065-05	3021 011-516	5631 013-02	10-32 x 3/8	(5/32")	-	-
A392.41005-100 31 060 A	5512 065-06	3021 011-516	-	-	5631 013-03	10-32 x 3/4	(5/32")	-	-
A392.41005-100 38 060 A	5512 065-10	3021 011-380	5512 065-04	3021 011-380	5631 013-04	1/4-20 x 3/4	(3/16")	-	-
A392.41005-100 50 075 A	-	-	-	-	5631 060-01	-	-	3212 031-761	(1/2")

1) Accessories, must be ordered separately.

Metric pilot

392.41005

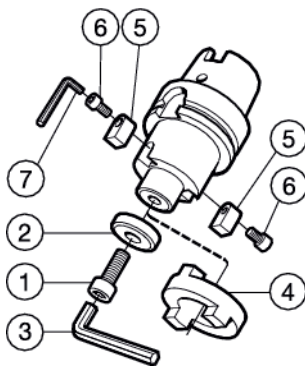

	1	2	3 ¹⁾	4	5	6	7 ¹⁾
	Center screw	Washer	Key (mm)	Driving ring	Driving key	Screw	Key (mm)
392.41005-xx 16 xxx	3212 020-414	5541 015-01	3021 010-060 (6.0)	3193 010-160	-	-	-
392.41005-xx 22 xxx	3212 020-464	5541 015-02	3021 010-080 (8.0)	-	5631 012-01	3212 010-258	174.1-864 (3.0)
392.41005-xx 27 xxx	3212 020-514	5541 015-03	3021 010-100 (10.0)	-	5631 010-01	3212 010-258	174.1-864 (3.0)
392.41005-xx 32 xxx	3212 020-564	5541 015-04	3021 010-120 (12.0)	-	5631 010-11	3212 010-308	3021 010-040 (4.0)
392.41005-63 40 xxx	3212 020-614	5541 015-05	3021 010-140 (14.0)	-	5631 051-02	3212 010-359	3021 010-050 (5.0)
392.41005-100 40 xxx	3212 020-614	5541 015-05	3021 010-140 (14.0)	-	5631 010-03	3212 010-360	3021 010-050 (5.0)
392.41005-xxx 60 xxx	3212 010-568 ²⁾	-	3021 010-140 (14.0)	-	5635 010-01	3212 010-363	3021 010-140 (14.0)

1) Accessories, must be ordered separately.

2) Holder with flange clamping. For flange clamping, four screws, 3212 010-568, are used.

Facemill holders

392.41005 / 392.41005C

392.41005-125 60 085

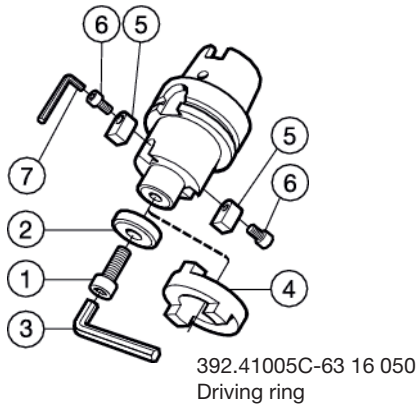
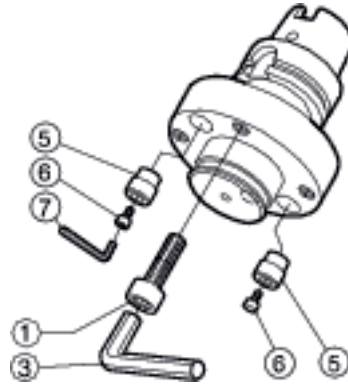
392.41005C-63 16 050
Driving ring

Metric pilot

	1	2	3 ¹⁾	4	5	6	7 ¹⁾
	Mounting screw	Washer	Key (mm)	Driving ring	Driving key	Screw	Key (mm)
392.41005C6316050	3212 020-414	5541 015-01	3021 010-060 (6.0)	3193 010-160	–	–	–
392.41005C6322050	3212 020-464	5541 015-02	3021 010-080 (8.0)	–	5631 010-01	3212 010-258	3021 010-030 (3.0)
392.41005C6327060	3212 020-514	5541 015-03	3021 010-100 (10.0)	–	5631 010-01	3212 010-258	3021 010-030 (3.0)
392.41005C6332060	3212 020-564	5541 015-04	3021 010-120 (12.0)	–	5631 010-11	3212 010-308	3021 010-040 (4.0)
392.41005C6340060	3212 020-614	5541 015-05	3021 010-140 (14.0)	–	5631 051-02	3212 010-359	3021 010-050 (5.0)
392.41005C10022100	3212 020-564	5541 015-02	3021 010-080 (8.0)	–	5631 012-01	3212 010-258	3021 010-030 (3.0)
392.41005C-10027100	3212 020-614	5541 015-03	3021 010-100 (10.0)	–	5631 010-01	3212 010-258	3021 010-030 (3.0)
392.41005C-10032100	3212 020-564	5541 015-04	3021 010-120 (12.0)	–	5631 010-11	3212 010-308	3021 010-040 (4.0)
392.41005C-10040100	3212 020-614	5541 015-05	3021 010-140 (14.0)	–	5631 010-03	3212 010-360	3021 010-050 (5.0)
392.41005C-12532100	3212 020-564	5541 015-04	3021 010-120 (12.0)	–	5631 010-11	3212 010-308	3021 010-040 (4.0)
392.41005C-12540100	3212 020-614	5541 015-05	3021 010-140 (14.0)	–	5631 010-03	3212 010-360	3021 010-050 (5.0)
392.41005-12560085	3212 010-568 ²⁾	–	3021 010-140 (14.0)	–	5635 010-01	3212 010-363	3021 010-140 (14.0)

1) Accessories, must be ordered separately.

2) Holder with flange clamping. For flange clamping, four screws, 3212 010-568, are used.

A392.41005 / A392.41005C

A392.41005-100 63 075, A392.41005-125 63 085

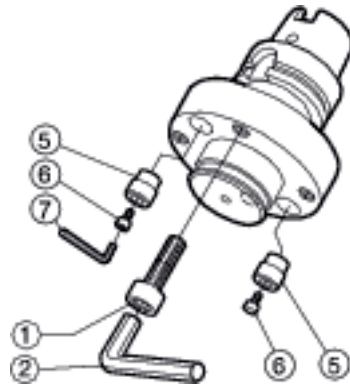
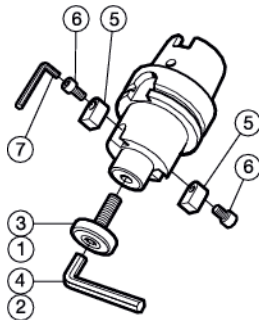

Inch pilot

	1	2 ¹⁾	3	4 ¹⁾	5	6	7 ¹⁾
	Mounting screw	Key	Mounting screw	Key	Driving key	Screw	Key
A392.41005C6319050	5512 065-07	3021 011-140	5512 065-02	3021 011-316	5631 013-01	8-32 X 3/8M	(9/64")
A392.41005C6325060	5512 065-03	3021 011-516	5512 065-05	3021 011-516	5631 013-02	10-32 x 3/8	3021 011-532
A392.41005C6338065	5512 065-10	3021 011-380	5512 065-04	3021 011-380	5631 013-04	8-32 X 3/8M	3021 011-316
A392.41005C10019100	5512 065-07	3021 011-140	5512 065-02	3021 011-316	5631 013-01	8-32 X 3/8M	(9/64")
A392.41005C10025100	5512 065-03	3021 011-516	5512 065-05	3021 011-516	5631 013-02	10-32 x 3/8	3021 011-532
A392.41005C10038100	5512 065-10	3021 011-380	5512 065-04	3021 011-380	5631 013-04	8-32 X 3/8M	3021 011-316
A392.41005-10063075	3212 031-761 ²⁾	(1/2")	–	–	5631 060-01	3212 010-363	3021 010-050
A392.41005C12525100	5512 065-03	3021 011-516	5512 065-05	3021 011-516	5631 013-02	10-32 x 3/8	3021 011-532
A392.41005C12538100	5512 065-10	3021 011-380	5512 065-04	3021 011-380	5631 013-04	8-32 X 3/8M	3021 011-316
A392.41005-12563085	3212 031-761 ²⁾	(1/2")	–	–	5631 060-01	3212 010-363	3021 010-050

1) Accessories, must be ordered separately.

2) Holder with flange clamping. For flange clamping, four screws, 3212 031-761, are used.

Dampened facemill holders

392.41006

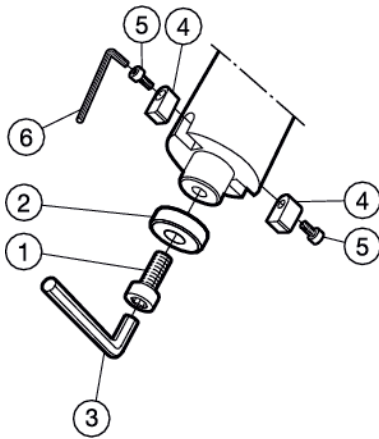

	1	2	3 ¹⁾	4	5	6 ¹⁾
	Center screw	Washer	Key (mm)	Driving key	Screw	Key (mm)
A392.41006- xx 19 xxx	5512 065-02	-	3/16	5631 013-01	8-32 x 3/8M	9/64
A392.41006- xx 25 xxx	5512 065-08	-	5/16	5631 031-02	10-32 x 3/8	5/32
A392.41006- xx 38 xxx	5512 065-04	-	3/8	5631 031-04	1/4-20 x 3/4	3/16
392.41006-xx 22 xxx	3212 020-464	5541 015-02	3021 010-080 (8.0)	5631 011-01	3213 010-258	174.1-864 (3.0)
392.41006-xx 27 xxx	3212 020-514	5541 015-03	3021 010-100 (10.0)	5631 010-01	3212 010-258	174.1-864 (3.0)
392.41006-xx 32 xxx	3212 020-564	5541 015-04	3021 010-120 (12.0)	5631 010-04	3212 010-308	3021 010-040 (4.0)

1) Accessories, must be ordered separately.

Arbor mounting screws with coolant hole

Arbor size	Screw	Key
Metric		
16	5512 073-03 (M8)	3021 010-060
22	5512 073-01 (M10)	3021 010-080
22 ¹⁾	5512 073-04 ¹⁾ (M10)	3021 010-080
27	5512 073-02 (M12)	3021 010-100
32	5512 073-05 (M16)	3021 010-140
Inch		
.750	5512 074-01 (3/8"-24 UNF)	3021 011-516
.750 ¹⁾	5512 074-03 (3/8"-24 UNF) ¹⁾	3021 011-516
1.000	5512 074-02 (1/2"-20 UNF)	3021 011-380
1.250	5512 074-04 (5/8"-18 UNF)	-
1.500	5512 074-05 (3/4"-16 UNF)	3021 011-580 (5/8")

1) Optimized: Low head/small head diameter

For CoroMill® 365, CoroMill® Century and CoroMill® 210, a unique screw with coolant hole is used. This must be ordered separately. See ordering pages for these cutters.

Collet holder

392.41014

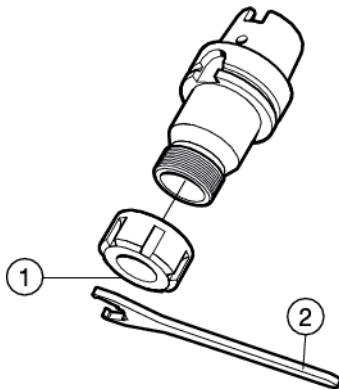

	1	2 ¹⁾
	Locking nut	Wrench
392.41014-xx 25xxx	5533 050-02	5680 096-02
392.41014-xx 32xxx	5533 050-03	5680 096-03
392.41014-xx 40xxx	5533 050-04	5680 096-04
392.41014-xx 50xxx	5533 050-05	5680 096-05

1) Accessories, must be ordered separately.

Weldon shank holder

A392.41020

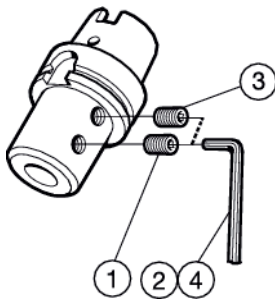

	1	2 ¹⁾	3	4 ¹⁾
	Screw	Key (Size)	Screw	Key (Size)
A392.41020-xx 09	5514 021-01	3021 011-316 (3/16)	–	–
A392.41020-xx 12	5514 021-02	3021 011-732 (7/32)	–	–
A392.41020-xx 15	5514 021-03	3021 011-140 (1/4)	–	–
A392.41020-xx 19	5514 021-04	3021 011-516 (5/16)	–	–
A392.41020-xx 22	5514 021-05	3021 011-516 (5/16)	–	–
A392.41020-xx 25	5514 021-06	3021 011-380 (3/8)	5514 021-05	3021 011-380 (3/8)
A392.41020-xx 31	5514 021-07	3021 011-380 (3/8)	5514 021-05	3021 011-380 (3/8)
A392.41020-xx 38	5514 021-08	3021 011-380 (3/8)	5514 021-05	3021 011-380 (3/8)
A392.41020-xx 50	5514 021-09	3021 011-916 (9/16)	5514 021-07	3021 011-916 (9/16)

1) Accessories, must be ordered separately.

392.41020

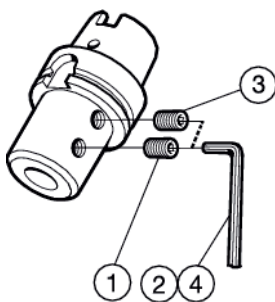

	1	2 ¹⁾	3	4 ¹⁾
	Screw	Key (mm)	Screw	Key (mm)
392.41020-xx 06	3214 050-357	174.1-864 (3.0)	–	–
392.41020-xx 08	3214 050-407	3021 010-040 (4.0)	–	–
392.41020-xx 10	3214 050-458	3021 010-050 (5.0)	–	–
392.41020-xx 12	3214 050-509	3021 010-060 (6.0)	–	–
392.41020-xx 14	3214 050-509	3021 010-060 (6.0)	–	–
392.41020-xx 16	3214 050-539	3021 010-060 (6.0)	–	–
392.41020-xx 18	3214 050-539	3021 010-060 (6.0)	–	–
392.41020-xx 20	3214 050-559	3021 010-080 (8.0)	–	–
392.41020-xx 25	3214 050-590	3021 010-100 (10.0)	3214 050-590	3021 010-100 (10.0)
392.41020-xx 32	3214 050-610	3021 010-100 (10.0)	3214 050-610	3021 010-100 (10.0)
392.41020-xx 40	3214 050-611	3021 010-100 (10.0)	3214 050-611	3021 010-100 (10.0)

1) Accessories, must be ordered separately.

Whistle Notch holder

392.41021

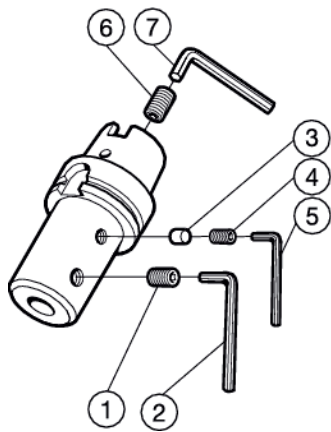

	1	2 ¹⁾	3	4	5 ¹⁾	6	7 ¹⁾
	Screw	Key (mm)	Plug	Screw	Key (mm)	Screw	Key (mm)
392.41021-xx 06xxx	3214 050-357	174.1-864 (3.0)	–	–	–	5512 066-08	174.1-864 (3.0)
392.41021-xx 08xxx	3214 050-407	3021 010-040 (4.0)	470-841	3214 010-355	174.1-864 (3.0)	5512 066-08	174.1-864 (3.0)
392.41021-xx 10xxx	3214 050-458	3021 010-050 (5.0)	470-841	3214 010-355	174.1-864 (3.0)	5512 066-03	3021 010-040 (4.0)
392.41021-xx 12xxx	3214 050-509	3021 010-060 (6.0)	470-841	3214 010-357	174.1-864 (3.0)	5512 066-04	3021 010-040 (4.0)
392.41021-xx 14xxx	3214 050-509	3021 010-060 (6.0)	470-841	3214 010-357	174.1-864 (3.0)	5512 066-04	3021 010-040 (4.0)
392.41021-xx 16xxx	3214 050-539	3021 010-060 (6.0)	470-841	3214 010-357	174.1-864 (3.0)	5512 066-04	3021 010-040 (4.0)
392.41021-xx 18xxx	3214 050-539	3021 010-060 (6.0)	470-841	3214 010-357	174.1-864 (3.0)	5512 066-04	3021 010-040 (4.0)
392.41021-xx 20xxx	3214 050-559	3021 010-080 (8.0)	470-841	3214 010-357	174.1-864 (3.0)	5512 066-05	3021 010-050 (5.0)
392.41021-xx 25xxx	3214 050-590	3021 010-100 (10.0)	470-841	3214 010-357	174.1-864 (3.0)	5512 066-06	3021 010-060 (6.0)
392.41021-xx 32xxx	3214 050-610	3021 010-100 (10.0)	470-841	3214 010-357	174.1-864 (3.0)	5512 066-06	3021 010-060 (6.0)

1) Accessories, must be ordered separately.

Drill holder, ISO 9766

392.41027

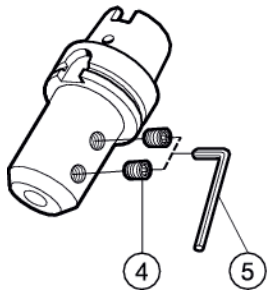

	4	5 ¹⁾
	Screw	Key (mm)
392.41027-16 xxx	5514 042-04	3021 010-040 (4.0)
392.41027-20 xxx	5514 042-04	3021 010-040 (4.0)
392.41027-25 xxx	416.1-838	3021 010-060 (6.0)
392.41027-32 xxx	416.1-838	3021 010-060 (6.0)
392.41027-40 xxx	5514 042-06	3021 010-080 (8.0)
392.41027-50 xxx	5514 042-06	3021 010-080 (8.0)

¹⁾ Accessories, must be ordered separately.

Tapping chuck

392.41060A

392.41060B

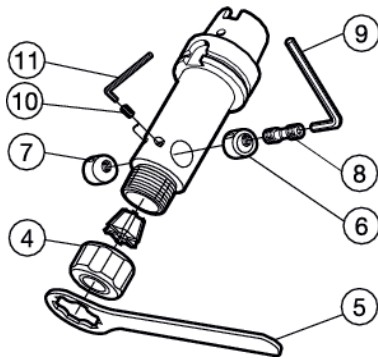

	4	5 ¹⁾	6	7	8	9 ¹⁾	10	11 ¹⁾
	Locking nut	Wrench	Jaw right	Jaw left	Adjusting screw	Key for jaws (mm)	Socket screw	Key (mm)
xx 01 xxx	391.60A-OZ 3158	5680 090-01	5412 093-01	5412 093-02	5516 050-01	3021 010-040 (4.0)	3214 020-255	174.1-870
xx 02 xxx	391.60A-OZ 3159	5680 090-02	5412 093-01	5412 093-02	5516 050-01	3021 010-040 (4.0)	3214 020-255	174.1-870
xx 03 xxx	391.60A-OZ N460	5680 092-01	5412 093-03	5412 093-04	5516 050-02	3021 010-050 (5.0)	3214 020-305	174.1-863

¹⁾ Accessories, must be ordered separately.

Coolant tube

5692 022-

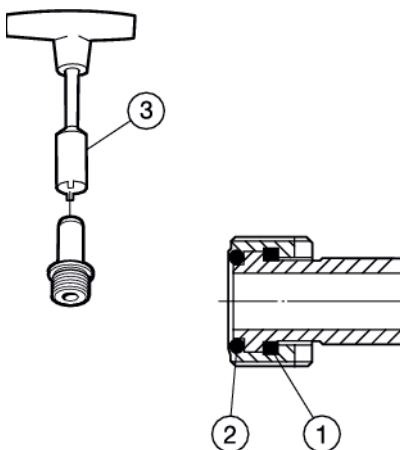

	1	2	3	
Coupling size	O-ring	O-ring	Key ¹⁾	Torque (Nm)
63-A/C	5641 001-37	5641 001-72	5680 094-04	8
100-A/C	5641 001-38	5641 001-38	5680 094-06	12
125-A/C	5641 001-91	5641 001-91	5680 094-07	20

¹⁾ Accessories, must be ordered separately.

Tapping chucks

HSK

Tap adapter

Collet type

Milling

E

Drilling

F

Boring

G

Tooling Systems

J

General Information

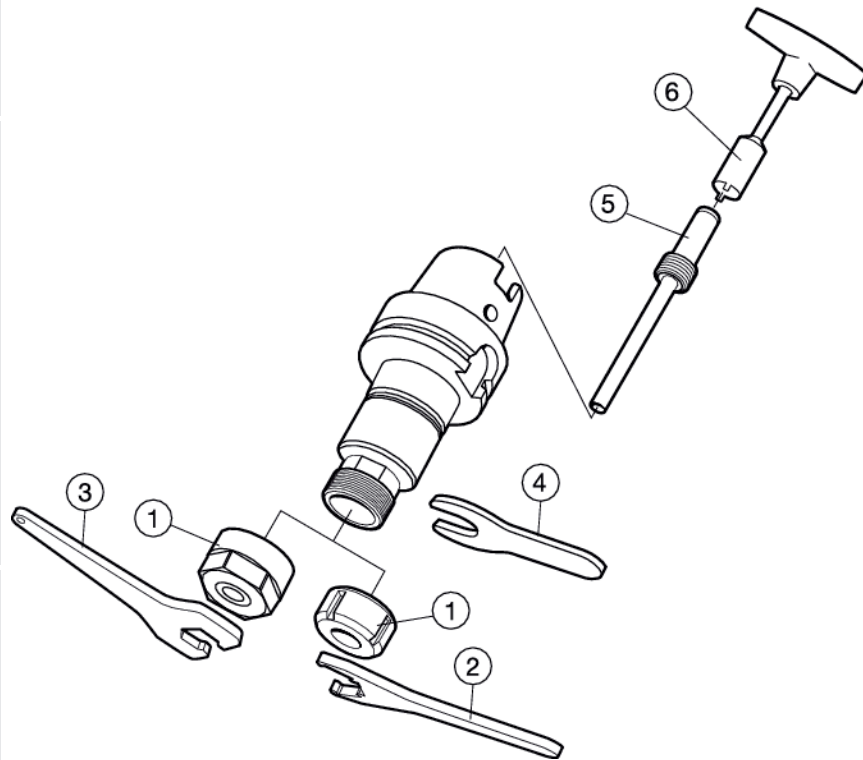

	1	2 ¹⁾	3 ¹⁾	4 ¹⁾	5	6
Ordering code	Nut	Wrench	Wrench	Wrench	Coolant tube	Key
392.41062-63 20 xxx	5533 050-08	-	5680 091-02	5680 092-04	-	-
392.41062-63 25 xxx	5533 050-02	5680 096-02	-	5680 092-05	-	-
392.41062-63 40 xxx	5533 050-04	5680 096-04	-	5680 092-06	-	-
392.41062-100 20 xxx	5533 050-08	-	5680 091-02	5680 092-04	-	-
392.41062-100 25 xxx	5533 050-02	5680 096-02	-	5680 092-05	-	-
392.41062-100 40 xxx	5533 050-04	5680 096-04	-	5680 092-06	-	-
392.41063-63 20 xxx	5533 051-02	-	5680 091-02	5680 092-04	5692 032-01	5680 094-04
392.41063-63 25 xxx	5533 051-03	5680 096-02	-	5680 092-05	5692 032-02	5680 094-04
392.41063-63 40 xxx	5533 051-05	5680 096-04	-	5680 092-06	5692 032-05	5680 094-04
392.41063-100 20 xxx	5533 051-02	-	5680 091-02	5680 092-04	5692 032-03	5680 094-06
392.41063-100 25 xxx	5533 051-03	5680 096-02	-	5680 092-05	5692 032-04	5680 094-06
392.41063-100 40 xxx	5533 051-05	5680 096-04	-	5680 092-06	5692 032-06	5680 094-06

1) Accessories, must be ordered separately.

Hydro-Grip®**Coromant Capto®**

High precision adapter for facemills and square shoulder facemills

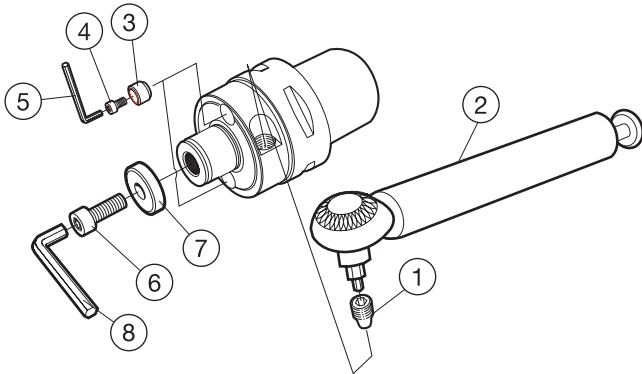
Cx-391.05CG

Note: Tightening torque 4.4 ft-lbs (6.0 Nm)

Cx-391.05CG	1	2	3	4	5	6	7	8	
	Pressure screw	Torque wrench ¹⁾	Nm ³⁾	Driving key	Screw	Key (mm) ¹⁾	Center screw ²⁾	Washer	Key (mm) ¹⁾
-22 xxx	3214 020-457	5680 099-01	10	5635 025-01	3212 010-257	3021 010-030 (3.0)	3212 020-464	5541 015-02	3021 010-080 (8.0)
-27 xxx	3214 020-457	5680 099-01	10	5635 025-02	3212 010-307	3021 010-040 (4.0)	3212 020-514	5541 015-03	3021 010-100 (10.0)
-32 xxx	3214 020-457	5680 099-01	10	5635 025-03	3212 010-357	3021 010-050 (5.0)	3212 020-564	5541 015-04	3021 010-120 (12.0)
-40 xxx	3214 020-458	5680 099-01	10	5635 025-04	3212 020-409	3021 010-060 (6.0)	3212 020-614	5541 015-05	3021 010-140 (14.0)

¹⁾ Accessories, not delivered with the tool, must be ordered separately.²⁾ Screw for through coolant, must be ordered separately.³⁾ Tightening torque, ft-lbs**High precision chuck****Cx-391.CGA****Cx-391.CGB****Pencil type**

1

2

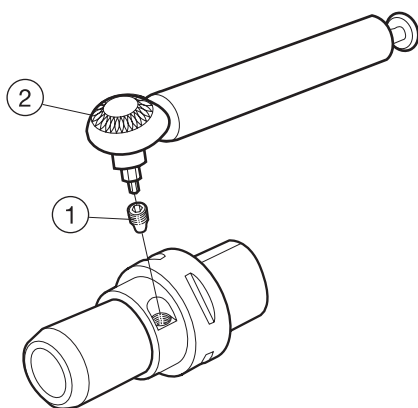
Cx-391.CGC**Slender**

	Pressure screw	Nm ²⁾	Torque wrench ¹⁾
C4-391.CGA-12 062A	3214 020-457	10	5680 099-01
C4-391.CGA-12 100	3214 020-457	10	5680 099-01
C4-391.CGA-20 075	3214 020-457	10	5680 099-01
C5-391.CGA-12 062	3214 020-457	10	5680 099-01
C5-391.CGA-20 074A	3214 020-457	10	5680 099-01
C5-391.CGA-20 125	3214 020-457	10	5680 099-01
C5-391.CGA-25 079	3214 020-458	10	5680 099-01
C6-391.CGA-12 064	3214 020-457	10	5680 099-01
C6-391.CGA-20 076	3214 020-457	10	5680 099-01
C6-391.CGA-20 150	3214 020-457	10	5680 099-01
C6-391.CGA-25 080	3214 020-458	10	5680 099-01
C6-391.CGA-32 084A	3214 020-497	10	5680 099-01
C8-391.CGA-20 079	3214 020-457	10	5680 099-01
C8-391.CGA-25 083	3214 020-458	10	5680 099-01
C8-391.CGA-32 087	3214 020-497	10	5680 099-01
Pencil type			
Cx-391.CGB-06 xxx	3214 020-457	10	5680 099-01
Cx-391.CGB-12 xxx	3214 020-457	10	5680 099-01
Cx-391.CGB-20 xxx	3214 020-458	10	5680 099-01
Slender type			
Cx-391.CGC-12 xxx	3214 020-457	10	5680 099-01
Cx-391.CGC-20 xxx	3214 020-497	10	5680 099-01
Cx-391.CGC-25 xxx	3214 020-498	10	5680 099-01

¹⁾ Accessories, not delivered with the tool, must be ordered separately.²⁾ Tightening torque, ft-lbs

D
E
F
G
J

TOOLING SYSTEMS Spare parts – HydroGrip

Hydro-Grip®

HydroGrip holder for facemills and square shoulder facemills

AA3B05
Inch pilot

Note: Tightening torque 4.4 ft-lbs (6.0 Nm)

AA3B05	1	2	3	4	5	6	7	
	Pressure screw	Torque wrench ¹⁾	Nm ²⁾	Driving key	Screw	Key (mm) ¹⁾	Center screw	Key (inch) ¹⁾
-xx 19 xxx	3214 020-457	5680 099-01	10	5635 025-07	3212 010-207	3021 010-025 (2.5)	5512 065-07	3021 011-140 (1/4")
-xx 25 xxx	3214 020-457	5680 099-01	10	5635 025-06	3212 010-257	3021 010-030 (3.0)	5512 065-08	3021 011-516 (5/16")
-xx 38 xxx	3214 020-458	5680 099-01	10	5635 025-05	3212 020-409	3021 010-060 (6.0)	5512 065-10	3021 011-380 (3/8")

¹⁾ Accessories, not delivered with the tool, must be ordered separately.

²⁾ Tightening torque, Nm

Coromant solid holder
A1B05CG / A2B05CG
Metric pilot

A1B05CG A2B05CG	1	2	3	4	5	6	7	8	
	Pressure screw	Torque wrench ¹⁾	Nm ³⁾	Driving key	Screw	Key (mm) ¹⁾	Center screw ²⁾	Washer	Key (mm) ¹⁾
-22 xxx	3214 020-457	5680 099-01	10	5635 025-01	3212 010-257	3021 010-030 (3.0)	3212 020-464	5541 015-02	3021 010-080 (8.0)
-27 xxx	3214 020-457	5680 099-01	10	5635 025-02	3212 010-307	3021 010-040 (4.0)	3212 020-514	5541 015-03	3021 010-100 (10.0)
-32 xxx	3214 020-457	5680 099-01	10	5635 025-03	3212 010-357	3021 010-050 (5.0)	3212 020-564	5541 015-04	3021 010-120 (12.0)
-40 xxx	3214 020-458	5680 099-01	10	5635 025-04	3212 020-409	3021 010-060 (6.0)	3212 020-614	5541 015-05	3021 010-140 (14.0)

¹⁾ Accessories, not delivered with the tool, must be ordered separately.

²⁾ Screw for through coolant, must be ordered separately.

³⁾ Tightening torque, ft-lbs

G 160

General Information

Hydro-Grip®

High precision adapter for facemills and square shoulder facemills

Solid holder

392.140CG/55CG
393.CGA

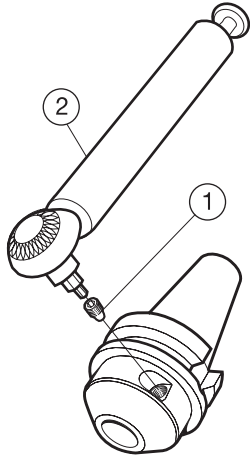

	1	2	
	Pressure screw	Torque wrench ¹⁾	Nm ²⁾
392.272CG-40 12 056	3214 020-457	5680 099-01	10
392.272CG-40 20 060A	3214 020-457	5680 099-01	10
392.272CG-40 20 125	3214 020-457	5680 099-01	10
392.272CG-40 25 064	3214 020-458	5680 099-01	10
392.272CG-50 20 060	3214 020-457	5680 099-01	10
392.272CG-50 25 064	3214 020-458	5680 099-01	10
392.272CG-50 32 068A	3214 020-497	5680 099-01	10
392.272CG-50 25 150	3214 020-458	5680 099-01	10
392.55CG-40 12 052	3214 020-457	5680 099-01	10
392.55CG-40 20 056A	3214 020-457	5680 099-01	10
392.55CG-40 20 125	3214 020-457	5680 099-01	10
392.55CG-40 25 060	3214 020-458	5680 099-01	10
392.55CG-50 20 067	3214 020-457	5680 099-01	10
392.55CG-50 25 071	3214 020-458	5680 099-01	10
392.55CG-50 32 075A	3214 020-497	5680 099-01	10
392.55CG-50 25 150	3214 020-458	5680 099-01	10
Pencil type, cylindrical shank			
393.CGA-20 12 150	3214 020-457	5680 099-01	10
Pencil type, taper shank			
392.xxxCGB-xx-06	3214 020-457	5680 099-01	10
392.xxxCGB-xx-12	3214 020-457	5680 099-01	10
392.xxxCGB-xx-20	3214 020-458	5680 099-01	10

¹⁾ Accessories, not delivered with the tool, must be ordered separately.

²⁾ Tightening torque, ft-lbs

Hydro-Grip Heavy Duty

Cx-391.CGD
392.45CGD
392.272CGD
392.55CGD
392.410CGD

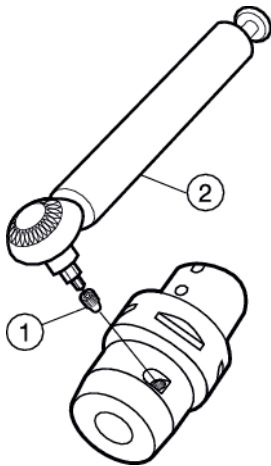

	1		2	
Ordering code	Pressure screw	Nm ²⁾	ft-lbs ²⁾	Torque wrench ¹⁾
C5-391.CGD-20079		10	7.38	5680 099-01
C6-391.CGD-20073	3214 020-460	10	7.38	5680 099-01
C6-391.CGD-25080	3214 020-461	10	7.38	5680 099-01
C6-391.CGD-32086	3214 020-461	10	7.38	5680 099-01
C6-391.CGD-20079	3214 020-460	10	7.38	5680 099-01
C6-391.CGD-25083	3214 020-461	10	7.38	5680 099-01
C6-391.CGD-32087	3214 020-461	10	7.38	5680 099-01
C6-391.CGD-20085	3214 020-460	10	7.38	5680 099-01
C6-391.CGD-25089	3214 020-461	10	7.38	5680 099-01
C6-391.CGD-32093	3214 020-461	10	7.38	5680 099-01
392.272CGD-40 20 090		10	7.38	5680 099-01
392.272CGD-50 20 068	3214 020-460	10	7.38	5680 099-01
392.272CGD-50 25 079	3214 020-461	10	7.38	5680 099-01
392.272CGD-50 32 083	3214 020-461	10	7.38	5680 099-01
392.45CGD-40 20 090		10	7.38	5680 099-01
392.45CGD-50 20 068	3214 020-460	10	7.38	5680 099-01
392.45CGD-50 25 092	3214 020-461	10	7.38	5680 099-01
392.45CGD-50 32 097	3214 020-461	10	7.38	5680 099-01
392.55CGD-40 20 087	3214 020-460	10	7.38	5680 099-01
392.55CGD-50 20 087	3214 020-460	10	7.38	5680 099-01
392.55CGD-50 25 091	3214 020-461	10	7.38	5680 099-01
392.55CGD-50 32 095	3214 020-461	10	7.38	5680 099-01
392.410CGD-63 20 096		10	7.38	5680 099-01
392.410CGD-100 20 091	3214 020-460	10	7.38	5680 099-01
392.410CGD-100 25 095	3214 020-461	10	7.38	5680 099-01
392.410CGD-100 32 099	3214 020-461	10	7.38	5680 099-01

¹⁾ Accessories, not delivered with the tool, must be ordered separately.

²⁾ Tightening torque Nm, ft-lbs.

Hydro-Grip®

High precision holder for facemills and square shoulder facemills

HSK

41005CG

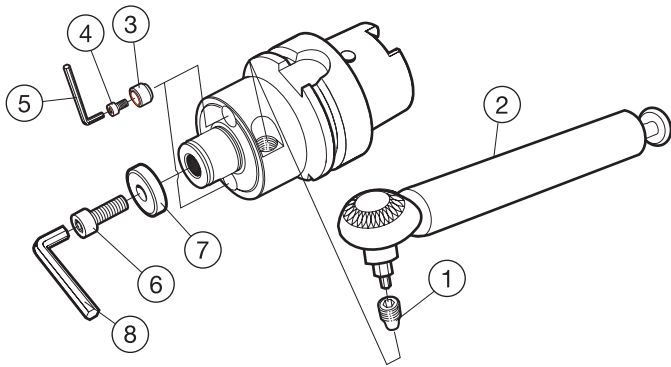

41005CG	1	2	3	4	5	6	7	8	
	Pressure screw	Torque wrench ¹⁾	Nm ³⁾	Driving key	Screw	Key (mm) ¹⁾	Center screw ²⁾	Washer	Key (mm) ¹⁾
-22 xxx	3214 020-457	5680 099-01	10	5635 025-01	3212 010-257	3021 010-030 (3.0)	3212 020-464	5541 015-02	3021 010-080 (8.0)
-27 xxx	3214 020-457	5680 099-01	10	5635 025-02	3212 010-307	3021 010-040 (4.0)	3212 020-514	5541 015-03	3021 010-100 (10.0)
-32 xxx	3214 020-457	5680 099-01	10	5635 025-03	3212 010-357	3021 010-050 (5.0)	3212 020-564	5541 015-04	3021 010-120 (12.0)
-40 xxx	3214 020-458	5680 099-01	10	5635 025-04	3212 020-409	3021 010-060 (6.0)	3212 020-614	5541 015-05	3021 010-140 (14.0)

¹⁾ Accessories, not delivered with the tool, must be ordered separately.

²⁾ Screw for through coolant, must be ordered separately.

³⁾ Tightening torque, ft-lbs

High precision chuck

HSK

392.410CGA

392.410CGB

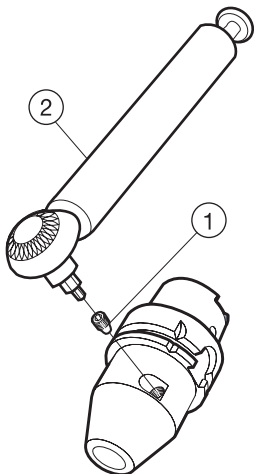

	1	2	
	Pressure screw	Torque wrench ¹⁾	Nm ²⁾
392.410CGA-63 12 076B	3214 020-457	5680 099-01	10
392.410CGA-63 20 088B	3214 020-457	5680 099-01	10
392.410CGA-63 20 150	3214 020-457	5680 099-01	10
392.410CGA-63 25 092	3214 020-458	5680 099-01	10
392.410CGA-63 32 096A	3214 020-497	5680 099-01	10
392.410CGA-100 12 079B	3214 020-457	5680 099-01	10
392.410CGA-100 20 091B	3214 020-457	5680 099-01	10
392.410CGA-100 25 095	3214 020-458	5680 099-01	10
392.410CGA-100 32 099B	3214 020-497	5680 099-01	10
Pencil type			
392.410CGB-63 12 xxx	3214 020-457	5680 099-01	10
392.410CGB-100 12 xxx	3214 020-457	5680 099-01	10

¹⁾ Accessories, not delivered with the tool, must be ordered separately.

²⁾ Tightening torque, ft-lbs