

Laser Marker Communication Interface User's Manual

for MD-X1000/1500 Series
MD-F3200/5200 Series
MD-U1000 Series
ML-Z9600 Series



Read this manual before using the system in order to achieve maximum performance.
Keep this manual in a safe place for future reference.

Symbol

The following symbols alert you to important messages. Be sure to read these messages carefully.

	It indicates a hazardous situation which, if not avoided, will result in death or serious injury.
	It indicates a hazardous situation which, if not avoided, could result in death or serious injury.
	It indicates a hazardous situation which, if not avoided, could result in minor or moderate injury.
	It indicates a situation which, if not avoided, could result in product damage as well as property damage.
	It indicates cautions and limitations that must be followed during operation.
	It indicates additional information on proper operation.
	It indicates tips for better understanding or useful information.

□ It indicates the reference pages and items in this manual.

1	Interface
2	Communication Specifications
3	Command Details
4	Applied Functions
5	Communication Errors
A	Appendix

Contents

1.	Interface	8
1-1	RS-232C Interface	8
1-2	Ethernet interface	9
2.	Communication Specifications	10
2-1	Write/Read command formats	10
2-2	Target specifier	10
2-3	Communication format	11
2-4	Communication priority	11
3.	Command Details	12
3-1	Basic	12
3-2	Laser marker operation	13
3-3	Current values and statuses	14
3-4	Unit setup/management	15
3-5	Program setting	16
3-6	String/Logo/Barcode setting	21
3-7	Marking parameters	27
3-8	Code overprinting parameters	32
3-9	3D shape setting	34
3-10	Matrix setting	37
3-11	Group/Counter setting	39
3-12	Operation time	40
3-13	Laser power measurement	41
4.	Applied Functions	42
4-1	Variable-length support	42
4-2	Omission of target specifiers	42
4-3	Omission of parameters	42
4-4	Sending of linked commands	43
4-5	Creating new settings	44
5.	Communication Errors	46
5-1	Error response	46
5-2	Error list	46
A	Appendix	48
Appendix-1	ASCII code list	48
Appendix-2	Model-Specific Input Value List	49

Communication command list

Basic

Command function	Command	Ref.
Delete a program	DeleteProgram	12
Confirm the READY status	Ready	12

Commands related to the guide laser operation

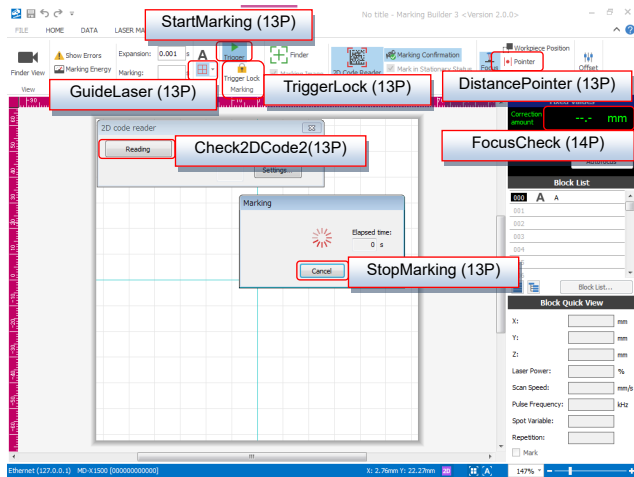

Command function	Command	Ref.
Start the marking	StartMarking	13
Guide laser printing	GuideLaser	13
Stop the guide laser	StopMarking	13
Enable/disable the acceptance of start marking	TriggerLock	13
Turn the distance pointer on/off	DistancePointer	13
Read a 2D code	Check2DCode2	13
Check the focus distance	FocusCheck	14

Current values and statuses

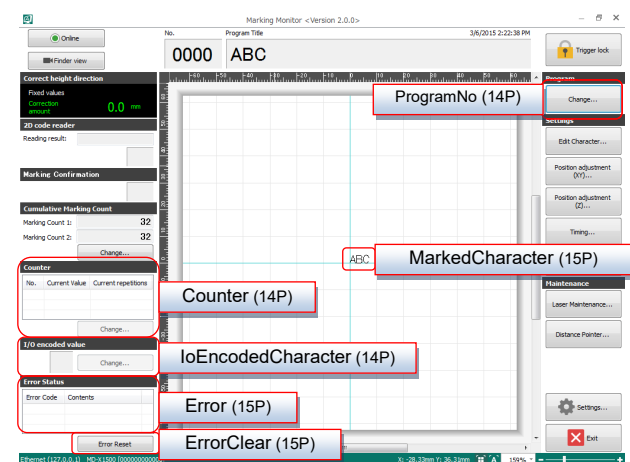

Command function	Command	Ref.
Running program No. (Change/Request)	ProgramNo	14
Current counter value setting (Change/Request)	Counter	14
I/O encoded character (Change/Request)	IoEncodedCharacter	14
Request the final marking string	MarkedCharacter	15
Request the error status	Error	15
Clear an error	ErrorClear	15

Unit setup/management

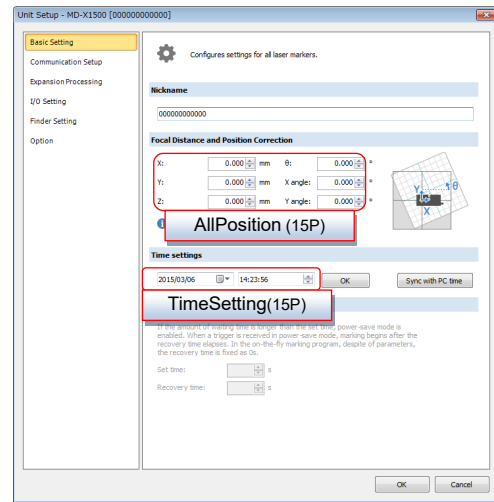

Command function	Command	Ref.
Position correction (Change/Request)	AllPosition	15
Date/time setting (Change/Request)	TimeSetting	15

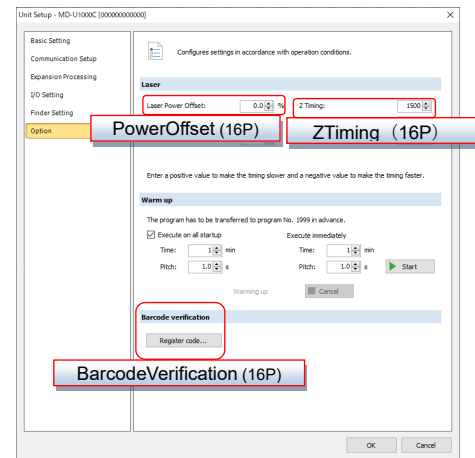

Command function	Command	Ref.
Laser power offset (Change/Request)	PowerOffset	16
Barcode verification	BarcodeVerification	16
Z timing (Set/Request)	ZTiming	16

Program information

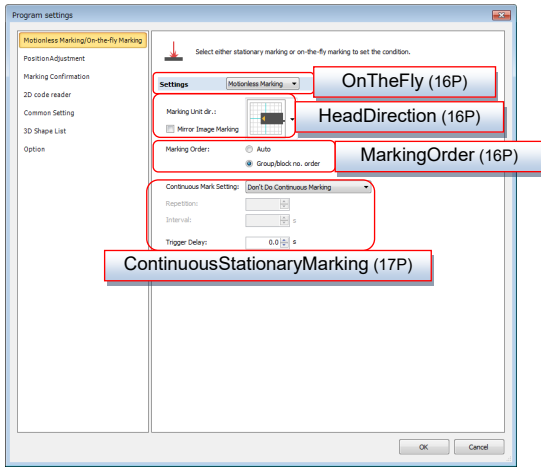

Command function	Command	Ref.
Movement/stationary marking setting (Change/Request)	OnTheFly	16
Head orientation (Change/Request)	HeadDirection	16
Marking order (Change/Request)	MarkingOrder	16
Continuous stationary marking (Change/Request)	Continuous StationaryMarking	17

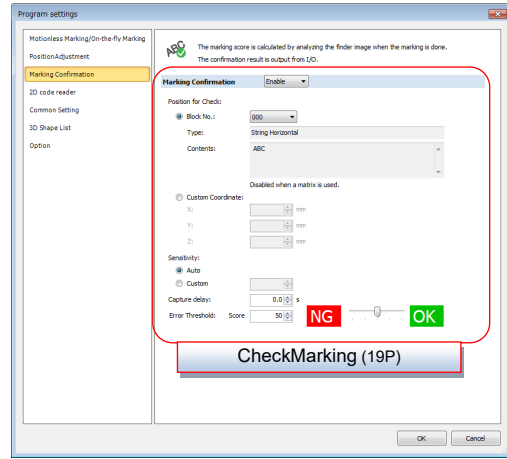

Command function	Command	Ref.
Marking confirmation function (Change/Request)	CheckMarking	19

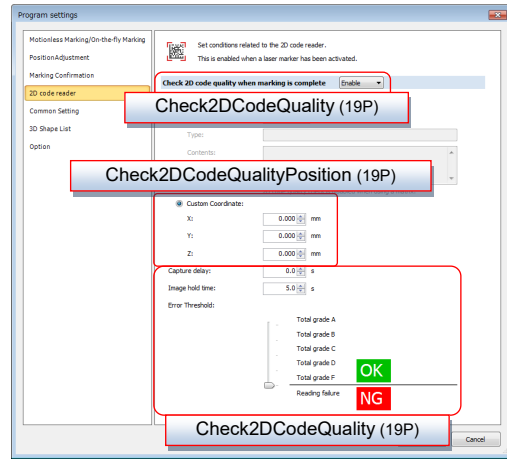

Command function	Command	Ref.
2D code reader function (Change/Request)	Check2DCode Quality	19
Reading coordinates of the 2D code reader function (Change/Request)	Check2DCode QualityPosition	19

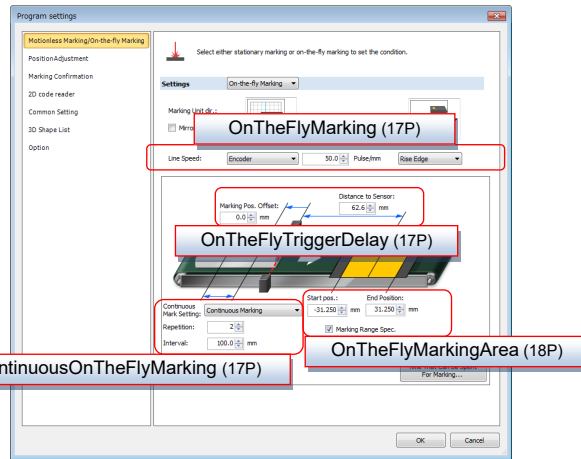

Command function	Command	Ref.
Movement parameters (Change/Request)	OnTheFlyMarking	17
Movement marking trigger delay (Change/Request)	OnTheFlyTrigger Delay	17
Continuous movement marking (Change/Request)	Continuous OnTheFlyMarking	17
Marking range setting (Change/Request)	OnTheFlyMarking Area	18

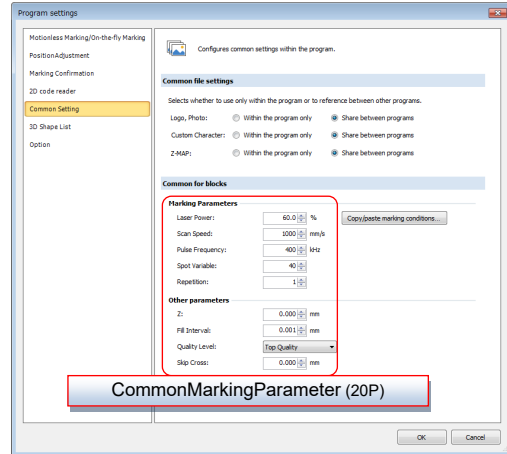

Command function	Command	Ref.
Common block marking parameters (Change/Request)	CommonMarking Parameter	20

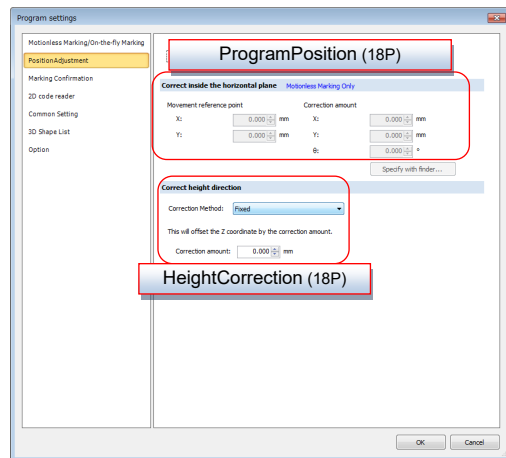

Command function	Command	Ref.
Workpiece position adjustment (Plane) (Change/Request)	ProgramPosition	18
Correct the height direction (Change/Request)	HeightCorrection	18

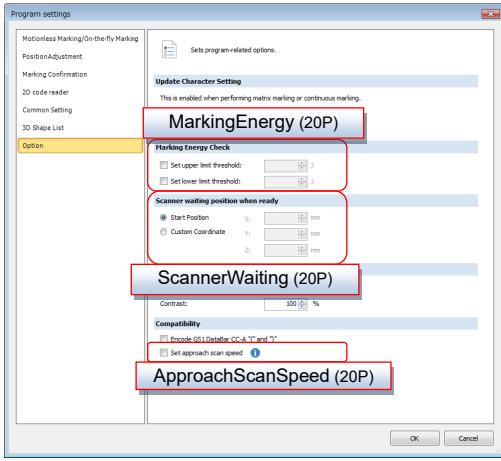

Command function	Command	Ref.
Marking Energy Check (Change/Request)	MarkingEnergy	20
Scanner waiting position when ready (Change/Request)	ScannerWaiting	20
Approach scan speed (Change/Request)	ApproachScanSpeed	20

String/Logo/Barcode setting

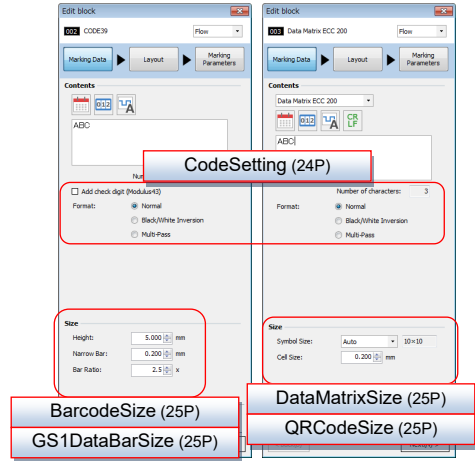

Command function	Command	Ref.
Barcode/2D code related (Change/Request)	CodeSetting	24
Barcode size (Change/Request)	BarcodeSize	25
GS1DataBar size (Change/Request)	GS1DataBarSize	25
DataMatrix size (Change/Request)	DataMatrixSize	25
QR Code size (Change/Request)	QRCodeSize	25

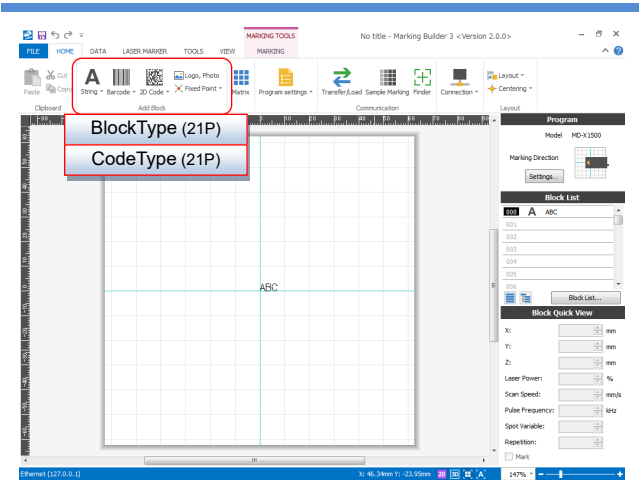

Command function	Command	Ref.
Block type (Change/Request)	BlockType	21
Barcode type (Change/Request)	CodeType	21

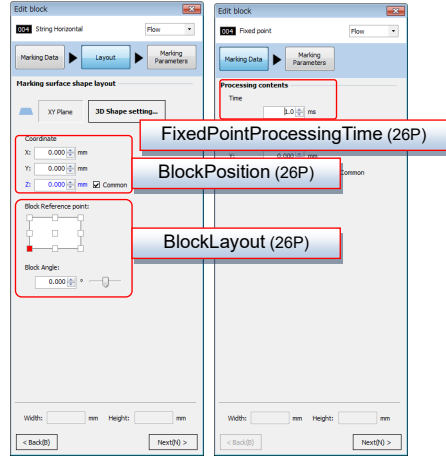

Command function	Command	Ref.
Block position (Change/Request)	BlockPosition	26
Block layout (Change/Request)	BlockLayout	26
Fixed point emission time (Change/Request)	FixedPointProcessingTime	26

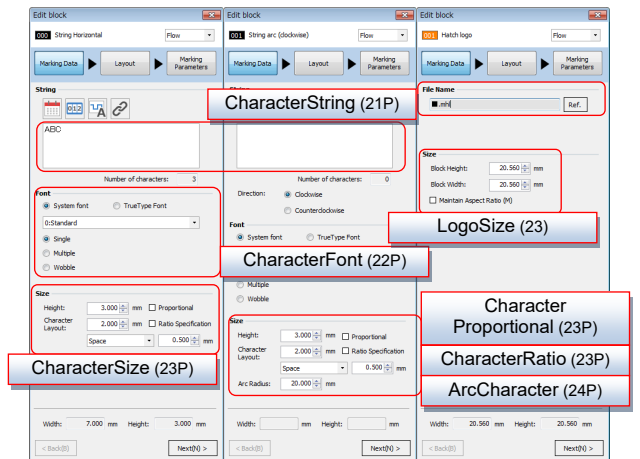

Command function	Command	Ref.
String and logo files (Change/Request)	CharacterString	21
Font related (Change/Request)	CharacterFont	22
Character size (Change/Request)	CharacterSize	23
Logo size (Change/Request)	LogoSize	23
String proportional setting (Change/Request)	CharacterProportional	23
String ratio setting (Change/Request)	CharacterRatio	23
Arc string character layout setting (Change/Request)	ArcCharacter	24

Marking parameters

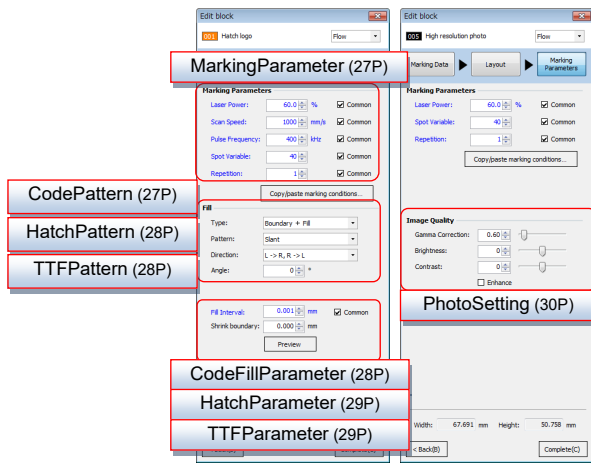

Command function	Command	Ref.
Marking parameters (Change/Request)	MarkingParameter	27
Barcode/2D code pattern setting (Change/Request)	CodePattern	27
Hatch logo pattern setting (Change/Request)	HatchPattern	28
TrueType font pattern setting (Change/Request)	TTFPattern	28
Barcode/2D code fill marking parameters (Change/Request)	CodeFillParameter	28
Hatch logo fill marking parameters	HatchParameter	29
TrueType font fill marking parameters (Change/Request)	TTFParameter	29
Photo setting (Change/Request)	PhotoSetting	30

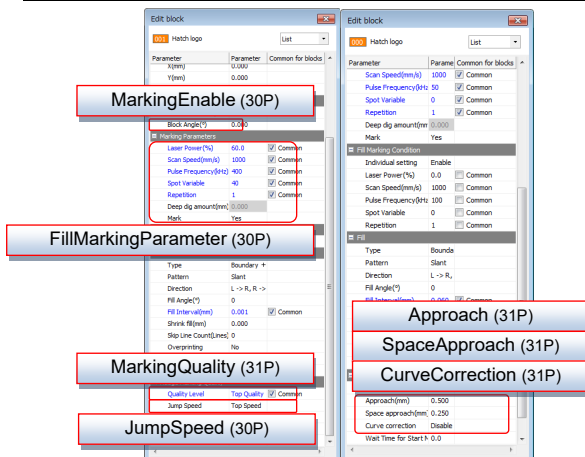

Command function	Command	Ref.
Marking flag (Change)	MarkingEnable	30
Individual fill marking parameters (Change/Request)	FillMarkingParameter	30
Jump Speed (Change/Request)	JumpSpeed	30
Nudge marking quality setting (Change/Request)	MarkingQuality	31
Approach (Change/Request)	Approach	31
Space approach (Change/Request)	SpaceApproach	31
Curve correction (Change/Request)	CurveCorrection	31

Code overprinting parameters

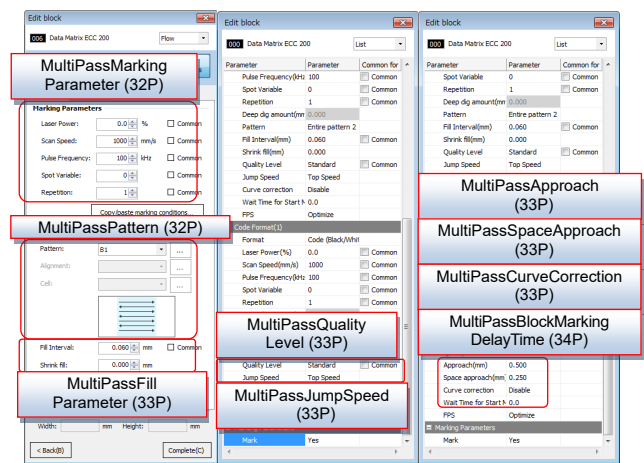

Command function	Command	Ref.
Barcode/2D code overprinting marking parameters (Change/Request)	MultiPassMarkingParameter	32
Barcode/2D code overprinting pattern setting (Change/Request)	MultiPassPattern	32
Barcode/2D code overprinting fill parameters (Change/Request)	MultiPassFillParameter	33
Quality level of barcode/2D code overprinting (Change/Request)	MultiPassQualityLevel	33
Approach of barcode/2D code overprinting (Change/Request)	MultiPassApproach	33
Jump speed of barcode/2D code overprinting (Change/Request)	MultiPassJumpSpeed	33
Space approach of barcode/2D code overprinting (Change/Request)	MultiPassSpaceApproach	33
Curve correction of barcode/2D code overprinting (Change/Request)	MultiPassCurveCorrection	33
Wait time for start marking of barcode/2D code overprinting (Change/Request)	MultiPassBlockMarkingDelayTime	34

3D shape setting

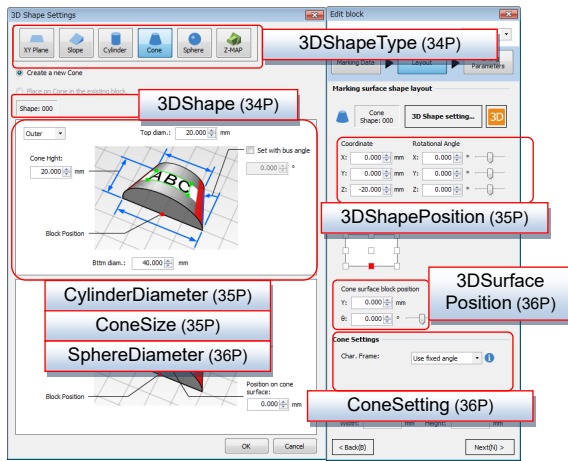

Command function	Command	Ref.
3D shape setting (Change/Request)	3DShape	34
3D shape type (Change/Request)	3DShapeType	34
3D shape position (Change/Request)	3DShapePosition	35
Diameter of cylinder shape (Change/Request)	CylinderDiameter	35
Cone shape size setting (Change/Request)	ConeSize	35
Diameter of sphere shape (Change/Request)	SphereDiameter	36
Position on 3D shape (Change/Request)	3DSurfacePosition	36
Cone setting (Change/Request)	ConeSetting	36

Matrix setting

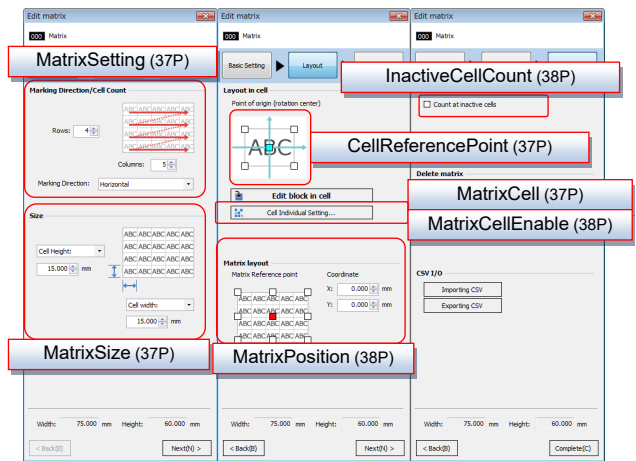

Command function	Command	Ref.
Matrix row & column setting (Change/Request)	MatrixSetting	37
Matrix size setting (Change/Request)	MatrixSize	37
Matrix cell reference point (Change/Request)	CellReferencePoint	37
Cell individual setting (Change/Request)	MatrixCell	37
Cell marking flag (Change)	MatrixCellEnable	38
Matrix position setting (Change/Request)	MatrixPosition	38
Count using invalid marking cells (Change/Request)	InactiveCellCount	38

Group/Counter setting

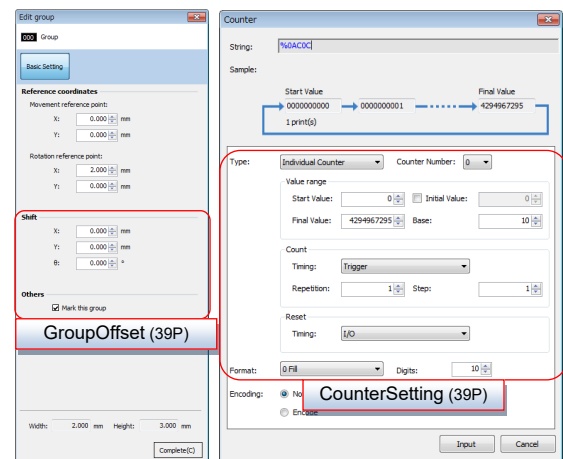

Command function	Command	Ref.
Group setting (Change/Request)	GroupOffset	39
Counter setting (Change/Request)	CounterSetting	39

Operation information

The followings are operation information that can be requested on MD-U1000 series.

The followings are operation information that can be requested on ML-Z9600 series.
The undescribed portions of operation information/cumulative marking count are the same command as MD-U1000 series.

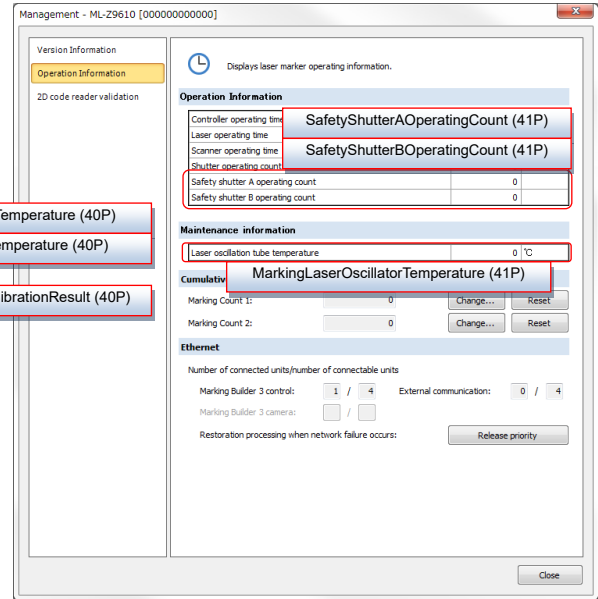
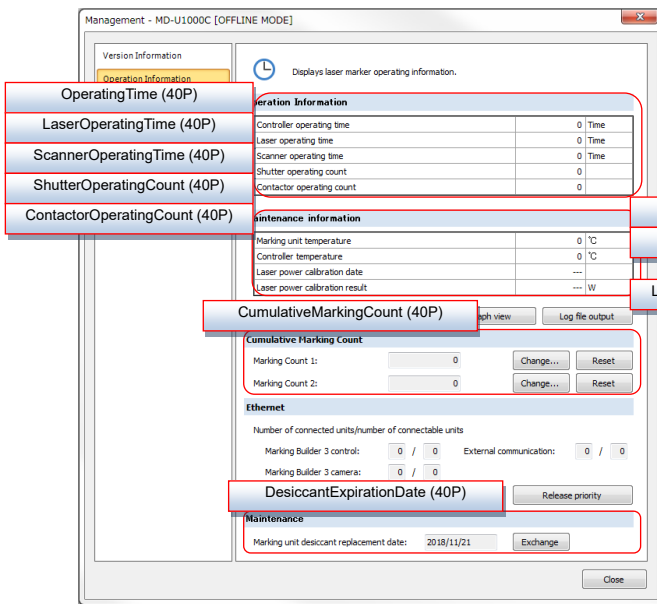

Command function	Command	Ref.
Request on controller operating time	OperatingTime	40
Request on laser exited time	LaserOperatingTime	40
Request on scanner operating time	ScannerOperatingTime	40
Request on number of shutter operations	ShutterOperatingCount	40
Request on number of contactor operations	ContactorOperatingCount	40
Request on head temperature	MarkingUnitTemperature	40
Request on controller temperature (°C)	ControllerTemperature	40
Request on the result of laser power calibration	LaserPowerCalibrationResult	40
Cumulative marking count 1 and 2 (change/request)	CumulativeMarkingCount	40
Request on replacing expiration of the dry agent for the head	DesiccantExpirationDate	40

Command function	Command	Ref.
Request on number of operations of safety shutter A	SafetyShutterAOperatingCount	41
Request on number of operations of safety shutter B	SafetyShutterBOperatingCount	41
Request on laser oscillating tube temperature	MarkingLaserOscillatorTemperature	41

Laser power measurement (MD-U1000 series only)

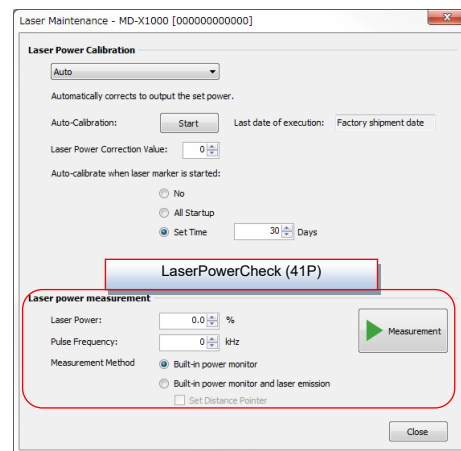

Command function	Command	Ref.
Laser power measurement	LaserPowerCheck	41

1. Interface

- WARNING**
- Read the "Chapter 2 Safety Information" in the user's manual for the applicable model to perform operation in the state that the safety is secured by using security function even when the network failure occurs.
 - Confirm the safe operation by considering the communication delay due to the communication time or network overload state.

1-1 RS-232C Interface

This section explains how to communicate using RS-232C connection.

Connection cables

The connector type on the laser marker unit side is D-Sub 9-Pin (Male). When connecting with an external device (PLC, etc.), connect as shown below in solid lines using RS-232C straight cable. The following is an example of connection with an external device with D-Sub 9-Pin connector.

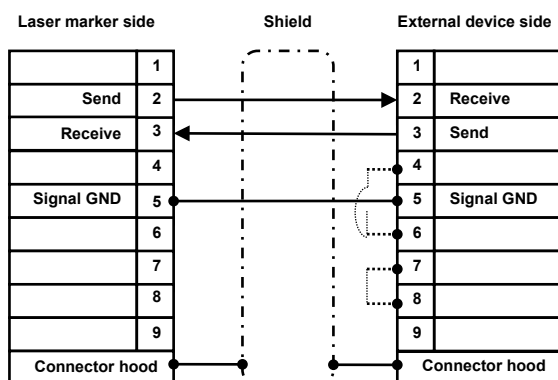

- Important**
- The connector will be more susceptible to noise if the connector hood is not conducted with the shield.
 - On some external devices, communication cannot be established without short-circuiting No. 4/6 pins and No. 7/8 pins on the external device side. Refer to the manual of the external device.

- Reference**
- Only No. 2, 3 and 5 pins are used on the laser marker side.
 - If the external device also has 9 pins, data is sent from the laser marker to the external device between No.2 pins and data is sent from the external device to the laser marker between No.3 pins.
 - Use #4-40 inch screws to fix the connector to the controller.

Communication settings

The RS-232C communication settings must be configured the same on the laser marker and the external device. Using Marking Builder 3 or the console, configure the settings such that all of the following items are the same.

Setting item	
Baud rate	2400/4800/9600/19200/38400 (Default value)/57600/115200 bps
Parity check	None (Default value)/Odd/Even
Stop bit	1 (Default value)/2 bit
Check sum	None (Default value)/Yes

- Reference**
- The delimiter automatically detects the delimiter setting of the external device. [EXT] and [CR] are supported.
 - The data length is "8 bits fixed", communication mode is "Full duplex", synchronization mode is "Start-stop synchronization", flow control is "None", and inter-frame timeout is "3500ms".
 - It is compliant with the EIA (Electronic Industries Association) RS-232C.
 - When sending a non-ASCII string, specify the character code from Unicode (UTF-8), Shift-JIS, or Latin-1. The default value is Unicode (UTF-8). If you are using Marking Builder 3, you can change the setting from [Unit Setup] under [Communication Setup] in the [Laser Marker] tab.

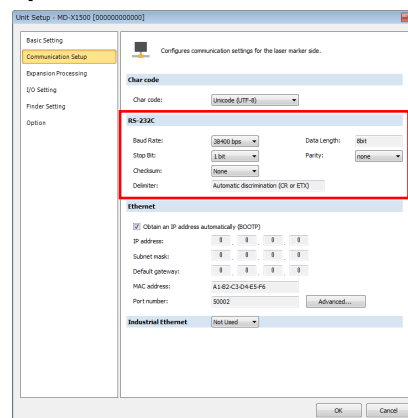

- WARNING**
- RS-232C is the protocol that may occur the destruction of the part of data (data corruption or failure) due to some noise or poor contacting. Be sure to use the parity or checksum to construct the communication environment with advanced reliability.

1-2 Ethernet interface

This section explains how to communicate using TCP/IP (Non-procedure) via Ethernet.

Connection cables

Connect the laser marker with the external device using a LAN (STP or UTP) cable.

No. 1 to 8 from top



RJ-45
Modular connector

Pin number	MDI signal	Signal function
1	TD+	Sent data (+)
2	TD-	Sent data (-)
3	RD+	Received data (+)
4	-	-
5	-	-
6	RD-	Received data (-)
7	-	-
8	-	-

- Reference**
- Both straight and cross cables are supported. Category 5 cable or higher is recommended.
 - Optional LAN cross cable (OP-66843) is sold separately.

Communication settings

When connecting the laser marker with the external device using TCP/IP via Ethernet, set the IP addresses and subnet masks such that they are in the same local area network. The default port number is "50002".

For details on how to configure the settings, refer to "5-3 Unit Setup: Ethernet settings" in the Marking Builder 3 User's Manual.

- Important**
- In the case of Ethernet communication, the delimiter is fixed to [CR] and the check sum is fixed to [None], respectively.
 - If you are using Marking Builder 3, you can change the setting from [Unit Setup] under [Communication Setup] in the [Laser Marker] tab.

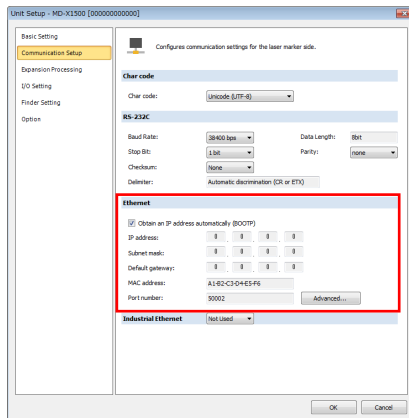

- Reference**
- For details about communication methods using Profinet and Ethernet/IP, refer to each manual.

- Point**
- When the command is received from multiple external equipment via TCP/IP communication, the command is saved to the buffer (queue) by received order, and the next command is processed after sending out the response.

2. Communication Specifications

2-1 Write/Read command formats

If you wish to send a command from the external device to the laser marker, it should be sent/received in the format described below.

Write command format

If the command is changing the setting value of the laser marker or executing an operation, add "WX" on the beginning of the command.

Command	WX,Command [CR]
Response	Normal: WX,OK [CR] Error: WX,NG,S***,ErrCode [CR]

An OK response is returned if the change or instruction specified by the command is successful and returns an error response if it fails. For more information on the error, refer to "Communication errors" (Page46).

A response is returned in the timing when the specified change or instruction has completed.

- Reference**
- The spelling of "Command" is not case-sensitive. Both cases will be accepted.
 - The maximum command byte length is 4096 bytes. You need to split the command if you wish to send a longer byte length.
 - The command other than strings is sent in ASCII format.**

Read command format

If the command is requesting the setting value or the status of the laser marker, add "RX" on the beginning of the command.

Command	RX,Command [CR]
Response	RX,OK,Response [CR]

The value and status specified by the command are returned in a response. Since request commands can be sent/received at any time, no errors will occur as long as the communication format is correct. The RX command returns a fixed-length response.

- Reference**
- The information in brackets [] indicates the control code. [CR] is 0Dh in hexadecimal.
 - Use ASCII when sending double-type characters such as Kanji characters or a Unicode string.
 - Insert a ", " (comma) separator after a command, response or check sum.
 - The maximum response byte length is 4096 bytes.

2-2 Target specifier

When sending a command to the laser marker, for most commands, you need to determine the change target in advance. A target specifier is inserted before the command in the form of "Target specifier = Target No.". If you wish to specify multiple targets, they need to be arranged side-by-side. The types of target specifiers and target number ranges are as described below.

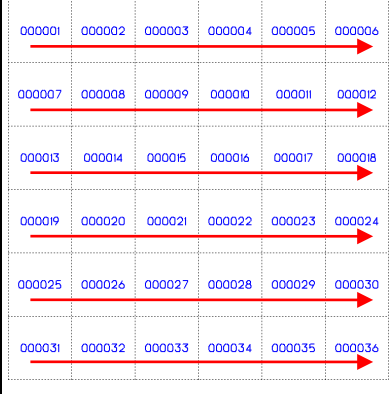
Target Specifier	Target Range No.	Description
PRG	0000 to 1999	Specifies the program No.
BLK	000 to 255	Specifies the block No.
OLP	0 to 9	Specifies the overprinting No.
3DS	000 to 255	Specifies the 3D shape No.
CEL	00001 to 65025	Specifies the number of rows and columns of the matrix. The number will be assigned with priority given to rows, in reference to the top left of the matrix. 
GRP	000 to 255	Specifies the group No.
CTR	0 to 9/A to J	Specifies the counter No.

- Reference**
- A ", " (comma) separator is inserted between the target specifier and the command.
 - A target specifier may be unnecessary for commands that directly operate the laser marker.
 - You can also specify CEL using row & column headers. It is specified in the form of "Row number-Column number" in the range between "001-001" and "255-255".

For example, to change a string, you need to specify the program No. and block No. in advance. The command will therefore be as an example described below.

■ Example of command for changing the string of block No.1 and program No. 1 to "ABC"

Command	WX,PRG=0001,BLK=001,CharacterString=ABC [CR]
Response	WX,OK [CR]

2-3 Communication format

Header/Delimiter setting

- RS-232C connection
A response is returned automatically detecting the header/delimiter as [STX] / [ETX] or [None] / [CR].
- Ethernet connection
Only [None]/[CR] are supported.

■ [STX]/[ETX] command examples

Command	[STX]WX,Command[ETX]
Response	[STX] WX,OK [ETX]

■ [None]/[CR] command examples

Command	WX,Command [CR]
Response	WX,OK [CR]

Check sum setting

You can add a check sum for checking the data integrity for RS-232C communication only. A check sum is added immediately before the delimiter as a 2-digit hexadecimal string. The 2-digit string is calculated based on the horizontal parity (XOR). The following shows an example of the commands and calculating formulas.

■ A command example with check sum added

Command	WX,Command,48 [CR]
Response	WX,OK,3B [CR]

Sent code		Received code	
W	57h	W	57h
	XOR		XOR
X	58h	X	58h
	XOR		XOR
,	2Ch	,	2Ch
	XOR		XOR
C	43h	O	4Fh
	XOR		XOR
o	6Fh	K	4B
	XOR		XOR
m	6Dh	,	2Ch
	XOR		XOR
m	6Dh		
	XOR		0011 1011b
a	61h		ASCII conversion
	XOR		3Bh
n	6Eh		
	XOR		
d	64h		
	XOR		
,	2Ch		
	XOR		
			0100 1000b
			ASCII conversion
			48h

- Reference**
- The check sum is calculated excluding the header, delimiter and check sum sections.

2-4 Communication priority

The laser marker has 6 types of communication paths that generally support simultaneous connections. However, when the laser marker shifts to a specific status via a communication path, priority will be given to the specific communication path. This means that only request commands will be accepted for communication paths other than the priority communication path. The following table shows the conditions under which a priority communication path will occur.

Communication path	Priority acquisition period
External communication (RS-232C/Ethernet)	<ul style="list-style-type: none"> • The length of time from when the WX command is sent until a response is returned • The length of time from when the CreateProgram command is sent until a response is returned from the EndProgram command
Marking Builder 3 (USB/Ethernet)	<ul style="list-style-type: none"> • During [Marking] tab transition • During sample marking mode transition • During I/O terminal monitor mode transition • During transition of settings and backup data • During laser maintenance • During power monitor adjustment • During auto focus adjustment • During finder use
Console (Dedicated cable)	<ul style="list-style-type: none"> • During test marking mode transition • During terminal block simulate mode transition • During transition of settings and backup data • During laser maintenance
MB3 ActiveX (USB/Ethernet)	<ul style="list-style-type: none"> • Blocking communication: The length of time from when the setting change command is sent until a response is returned • Non-blocking communication: The length of time from when the setting change command is sent until the next event is completed
Profinet and EtherNet/IP (Ethernet)	<ul style="list-style-type: none"> • The length of time from the start of a setting change instruction, etc. until the operation is completed

3. Command Details

How to interpret the command details

This section explains how to interpret the command details using the following command as an example.

This shows the target specifier required for this command.	Command	ScannerWaiting	
	Description	Changes/requests the scanner waiting position when ready.	
This is the default value of the program parameters.	Target	PRG=0000 to 1999	
	WX	Command	WX,PRG=0000,ScannerWaiting= A,B,C,D [CR]
The input range varies depending on the laser marker area size. The applicable models for each area size are as described below. - Normal(X): MD-X1000/1500 Series - Normal(F): MD-F3200/5200 Series - Normal(U): MD-U1000 Series - Normal(Z): ML-Z9610 Series - Wide(X): MD-X1020/1520 Series - Wide(F): MD-F3220/5220 Series - Wide(U): MD-U1020 Series - Wide(Z): ML-Z9620 Series - Small(X): MD-X1050 Series - Small(Z): ML-Z9650 Series	Response	WX,OK [CR]	
	RX	Command	RX,PRG=0000,ScannerWaiting [CR]
Input range is listed in the appendix of "Model-Specific Input Value List"	Response	RX,OK, A,B,C,D [CR]	
	Parameter	A:	0/1
B:		Depends on the area size Normal(X/F/U): -062.500 to 0062.500 Normal(Z): 0060.000 to -060.000 Wide(X/U): -165.000 to 0165.000 Wide(F/Z): -150.000 to 0150.000 Small(X/Z): -025.000 to 0025.000	Standby X coordinate (mm) *A: Fixed value of "0" when 0
C:		Differs depending on the model Normal(X): -062.500 to 0062.500 Other model: □ "Y coordinate" of "Appendix-2 Model-Specific Input Value List" (Page49).	Standby Y coordinate (mm) *A: Fixed value of "0" when 0
D:		Depends on the area size Normal(X): -021.000 to 0021.000 Other model: □ "Z coordinate" of "Appendix-2 Model-Specific Input Value List" (Page49).	Standby Z coordinate (mm) *A: Fixed value of "0" when 0

Enter a fixed value when the value of the specific parameter is "0".
* Since the fixed values are ignored on the laser marker side, values other than the fixed values will be accepted as long as they are within the parameter input range.

WX command example

This command changes the scanner waiting position when ready (X: 5mm, Y: 10mm, Z: -5mm) of program No.0005.

Command	WX,PRG=0005,ScannerWaiting=1,0005.000,0010.000,-005.000 [CR]
Response	WX,OK [CR]

RX command example

This command requests the scanner waiting position when ready (X: 5mm, Y: 10mm, Z: -5mm) from program No. 0005.

Command	RX,PRG=0005,ScannerWaiting [CR]
Response	RX,OK,1,0005.000,0010.000,-005.000 [CR]

3-1 Basic

1. Delete a program

Command	DeleteProgram	
Description	Deletes the programs in the laser marker.	
Target	No	
WX	Command	WX,DeleteProgram= A,A,A,A . . . [CR]
	Response	WX,OK [CR]
RX	Command	No
	Response	No
Parameter	A:	0000 to 1999/9999
		Deletes all programs if the program No. to delete/9999 You can specify multiple program No. for deletion by separating them with commas.

- Reference**
- To delete multiple programs simultaneously, send the command as described below.
WX,DeleteProgram=0001,0002,0005,0006 [CR]
 - When you specify multiple programs, an error will occur if any one of the specified program No. does not exist.
 - If a running program is specified, an error occurs.

2. Confirm the READY status

Command	Ready	
Description	Requests whether the laser marker is in ready status.	
Target	No	
WX	Command	No
	Response	No
RX	Command	RX,Ready [CR]
	Response	RX,OK, A [CR]
Parameter	A:	0/1/2
		0: READY ON 1: READY OFF (Error occurring) 2: READY OFF (Marking or expansion in progress)

- Reference**
- If the value of parameter A is "1", you cannot perform any marking until the error is cleared. Clear the error using the ErrorClear command. However, if the occurring error is a terminal block status error (T***), check the ON/OFF status of the terminal block.

3-2 Laser marker operation

1. Start the marking

Command	StartMarking	
Description	Starts the marking.	
Target	No	
WX	Command	WX,StartMarking [CR]
	Response	WX,OK [CR]
RX	Command	No
	Response	No
Parameter	No	

 • An error response is returned when marking is canceled from the terminal block, etc.

2. Guide laser printing

Command	GuideLaser	
Description	Starts the guide laser marking using the guide laser type specified by parameter A. The guide laser is emitted once for the same length of time as the marking time; and it is emitted continuously for 30 consecutive seconds for all other emissions.	
Target	No	
WX	Command	WX,GuideLaser=A [CR]
	Response	WX,OK [CR]
RX	Command	No
	Response	No
Parameter	A: 1 to 5	Guide laser type 1: Once 2: Continuous 3: Area frame 4: Workpiece 5: Block frame

 • This command returns a response as soon as the guide laser emission starts.
• The emission can be canceled using the "StopMarking" command.

3. Stop the guide laser

Command	StopMarking	
Description	Cancels the guide laser marking.	
Target	No	
WX	Command	WX,StopMarking [CR]
	Response	WX,OK [CR]
RX	Command	No
	Response	No
Parameter	No	

4. Enable/disable the acceptance of start marking

Command	TriggerLock	
Description	Enables/disables acceptance of triggers from the terminal block and/or communication path.	
Target	No	
WX	Command	WX,TriggerLock=A [CR]
	Response	WX,OK [CR]
RX	Command	RX,TriggerLock [CR]
	Response	RX,OK,A [CR]
Parameter	A: 0/1	Acceptance of start marking 0: Enabled 1: Disabled * Default value "0"

 • If this command is received during marking, the marking will not stop but the next marking start input will be rejected.

5. Turn the distance pointer on/off

Command	DistancePointer	
Description	Turns on/off the distance pointer.	
Target	No	
WX	Command	WX,DistancePointer=A [CR]
	Response	WX,OK [CR]
RX	Command	RX,DistancePointer [CR]
	Response	RX,OK,A [CR]
Parameter	A: 0/1	Distance Pointer 0: Off 1: On

 • This command returns a response as soon as the distance pointer is turned on/off.

6. Read a 2D code

Command	Check2DCode2	
Description	Reads the 2D code inside the area using the built-in camera.	
Target	No	
WX	Command	WX,Check2DCode2=A,B,C,D,E,F [CR]
	Response	WX,OK,G,H [CR]
RX	Command	No
	Response	No
Parameter	A: 0/1/2	Capture position 0: Current scanner position 1: Custom coordinate 2: Block coordinate
	B: Depends on the area size Normal(X): -062.500 to 0062.500 Other model: □"X coordinate" of "Appendix-2 Model-Specific Input Value List" (Page49).	X coordinate (mm) *A: Fixed value of "0" when 0/2
	C: Depends on the area size Normal(X): -062.500 to 0062.500 Other model: □"Y coordinate" of "Appendix-2 Model-Specific Input Value List" (Page49).	Y coordinate (mm) *A: Fixed value of "0" when 0/2
	D: Depends on the area size Normal(X): -021.000 to 0021.000 Other model: □"Z coordinate" of "Appendix-2 Model-Specific Input Value List" (Page49).	Z coordinate (mm) *A: Fixed value of "0" when 0/2
	E: 0 to 100	Reading area (%) "0" for no specified area (A: Same as 100% when 0/1, A: Auto area specification when 2)
	F: 0 to 255	Block No. *A: Fixed value of "0" when 0/1
	G: A to D/F	AIM-DPM total grade
	H: Encoded string	Encoded string of 2D code

 • The S087 communication error "2D code reading error" is returned if the 2D code cannot be found.
• You cannot use on the MD-X1000L/1500L series, MD-F3200/5200 series and ML-Z9600 series.
• A: When it is 2, what can be read is from after marking to the next marking.

7. Check the focus distance

Command		FocusCheck
Description		Measures the difference between the distance to the workpiece and the reference distance for the number of times specified in parameter A and returns its average value as the focus deviation amount.
Target		No
WX	Command	WX,FocusCheck= A [CR]
	Response	WX,OK, B [CR]
RX	Command	No
	Response	
Parameter		A : 01 to 10 Measurement count (times) B : -100.0 to 0100.0 Focus deviation amount (mm)

-  Reference
- If the Z coordinate of the position correction has been input, this value will be subtracted from the focus deviation amount.
 - You cannot use on the MD-X1000L/1500L series, MD-F3200/5200 series and ML-Z9600 series.

3-3 Current values and statuses

1. Running program No. (Change/Request)

Command		ProgramNo
Description		Changes/requests the currently running program No.
Target		No
WX	Command	WX,ProgramNo= A [CR]
	Response	WX,OK [CR]
RX	Command	RX,ProgramNo [CR]
	Response	RX,OK, A [CR]
Parameter		A : 0000 to 1999 Specifies the Program No.

-  Reference
- The S021 communication error "Program No. Not Registered Error" is returned if you specify a non-registered program No.
 - An OK response is returned when a currently running program No. has been specified. At that point in time, the READY output becomes OFF for an instant due to switching of the program No.

2. Current counter value setting (Change/Request)

Command		Counter
Description		Specifies the counter No. and changes/requests the current counter value and the current repetitive marking count.
Target		PRG=0000 to 1999,CTR=0 to 9/A to J,
WX	Command	WX,PRG= 0000 ,CTR= 0 ,Counter= A,B [CR]
	Response	WX,OK [CR]
RX	Command	RX,PRG= 0000 ,CTR= 0 ,Counter [CR]
	Response	RX,OK, A,B [CR]
Parameter		A : 00000000 to 4294967295 Current counter value B : 00000000 to 4294967295 Repetitive marking count

3. I/O encoded character (Change/Request)

Command		IoEncodedCharacter
Description		Changes/requests the string to use as the I/O encoded character.
Target		No
WX	Command	WX,IoEncodedCharacter= A [CR]
	Response	WX,OK [CR]
RX	Command	RX,IoEncodedCharacter [CR]
	Response	RX,OK, A [CR]
Parameter		A : 00 to 35 Specify the I/O encoded character

-  Reference
- This command returns a response very quickly as it is processed immediately regardless of the program's expansion time.

4. Request final marking string

Command	MarkedCharacter	
Description	Specifies the program No. and block No. and requests the string marked by the laser marker.	
Target	No	
WX	Command	No
	Response	No
RX	Command	RX,MarkedCharacter= A,B [CR]
	Response	RX,OK, C [CR]
Parameter	A: 0000 to 1999	Program No.
	B: 000 to 255	Block No.
	C: Text	Marking string

- Reference** • The update characters are returned in the form of an actual marking string.
- Make sure to send this command after the marking. The S029 communication error "Mark data request error" is returned if you send the command without performing any marking.
 - In matrix marking, the response returns the mark data of the last marked cell (block).
 - If you requested something in relation to the block other than the character strings, " " (blank data) will be returned in the response.

5. Request the error status

Command	Error	
Description	Requests the error occurring in the laser marker.	
Target	No	
WX	Command	No
	Response	No
RX	Command	RX,Error [CR]
	Response	RX,OK, A,B,B * * * [CR]
Parameter	A: 0,1	Displays the status of the errors. If no error is occurring, the response returns "0", if it is, "1".
	B: E001 to E400/ W100 to W200/ T000 to T100	Displays the currently occurring errors in comma delimited format.

- Reference** • If multiple errors are occurring in the laser marker, a response is returned in comma delimited format as follows.
RX,OK,1,E001,E002,W100,T000 [CR]
- For details of each error, refer to the User's Manual of the laser marker unit.

6. Clear an error

Command	ErrorClear	
Description	Clears the errors currently occurring in the laser marker.	
Target	No	
WX	Command	WX,ErrorClear [CR]
	Response	WX,OK [CR]
RX	Command	No
	Response	No
Parameter	No	

- Reference** • An error cannot be cleared unless its cause has been rectified.
- When you send the ErrorClear command with the cause of the laser marker error unresolved, an "OK" response is returned but the error status will not be cleared.
 - Check the ON/OFF state of the terminal block because the error clear cannot be performed for the terminal block error (T*** error except T000).
 - The error clear can be performed for T000 (during remote interlock) if the remote interlock terminal is in a short-circuit.

3-4 Unit setup/management

1. Position correction (Change/Request)

Command	AllPosition	
Description	Changes/requests the position correction in the Unit Setup.	
Target	No	
WX	Command	WX,AllPosition= A,B,C,D,E,F [CR]
	Response	WX,OK [CR]
RX	Command	RX,AllPosition [CR]
	Response	RX,OK, A,B,C,D,E,F [CR]
Parameter	A: -090.000 to 0090.000	X rotation angle (°) * Default value "0"
	B: -090.000 to 0090.000	Y rotation angle (°) * Default value "0"
	C: -180.000 to 0180.000	θ angle (°) * Default value "0"
	D: Depends on the area size Normal(X): -062.500 to 0062.500 Other model: □"X/Y coordinates position correction in the unit setup" of "Appendix-2 Model-Specific Input Value List" (Page49).	X coordinate correction amount (mm) * Default value "0"
	E: Depends on the area size Normal(X): -062.500 to 0062.500 Other model: □"X/Y coordinates position correction in the unit setup" of "Appendix-2 Model-Specific Input Value List" (Page49).	Y coordinate correction amount (mm) * Default value "0"
	F: Depends on the area size Normal(X): -021.000 to 0021.000 Other model: □"Z coordinate position correction in the unit setup" of "Appendix-2 Model-Specific Input Value List" (Page49).	Z correction amount (mm) * Default value "0"

- Reference** • This command is applied to all programs. If the program pre-expansion function is enabled, it takes time because the response is returned after all program expansion processings are finished.
- The X/Y rotations angle will be disabled in programs containing blocks having other than a 3D shape of "XY plane".
 - The following restrictions exist in the case of on-the-fly marking.
 - The coordinate correction with the same coordinate on the movement direction (X/Y coordinate) is disabled
 - The rotation correction of the coordinate that crosses orthogonally on the movement direction (X/Y rotation angle) is disabled
 - θ angle can be corrected up to ±2.000°

2. Date/time setting (Change/Request)

Command	TimeSetting	
Description	Changes/requests the date and time of the internal clock.	
Target	No	
WX	Command	WX,TimeSetting= A,B,C,D,E,F [CR]
	Response	WX,OK [CR]
RX	Command	RX,TimeSetting [CR]
	Response	RX,OK, A,B,C,D,E,F [CR]
Parameter	A: 2000 to 2099	Year: 4 digits
	B: 01 to 12	Month
	C: 01 to 31	Day
	D: 00 to 24	Hour
	E: 00 to 60	Minute
	F: 00 to 60	Second

3. Laser power offset (Change/Request)

Command		PowerOffset	
Description		Changes/requests the laser power offset in the Unit Setup.	
Target		No	
WX	Command	WX,PowerOffset= A [CR]	
	Response	WX,OK [CR]	
RX	Command	RX,PowerOffset [CR]	
	Response	RX,OK, A [CR]	
Parameter		A : -100.0 to 0100.0	Power offset amount (%) * Default value "0"

-  • If the power offset value set to the block's laser power exceeds 100%, the value will be fixed at 100%.
- This command is applied to all programs. If the program pre-expansion function is enabled, it takes time because the response is returned after all program expansion processings are finished.
 - This command is not applied to the block whose laser power is 0%.

4. Barcode verification

Command		BarcodeVerification	
Description		This command is used in the barcode verification function. When this command is accepted on the barcode verification screen, the collation string will be associated with the program No. When this command is accepted in Run mode, the settings will switch to the program No. matching the collation string.	
Target		No	
WX	Command	WX,BarcodeVerification= A [CR]	
	Response	WX,OK [CR]	
RX	Command	No	
	Response		
Parameter		A : Text	Barcode verification string (Max. 20 characters)

-  • You can access Marking Builder 3's barcode verification screen by following the procedure below.
[Laser Marker] tab > [Unit Setup] > [Options] > [Register code] under "Barcode verification"

5. Z timing (Set/Request)

Command		ZTiming	
Description		Sets/Requests the Z timing value.	
Target		No	
WX	Command	WX,ZTiming= A,B [CR]	
	Response	WX,OK [CR]	
RX	Command	RX,ZTiming [CR]	
	Response	RX,OK, A,B [CR]	
Parameter		A : 0000 to 4000 B : 0/1	Z timing value (μs) Application to matrix setting 0: Do not apply the ZTiming setting to the matrix setting. 1: Apply the ZTiming setting to the matrix setting.

-  • For program files that do not include matrix settings, the Z timing value is applied regardless of the parameter B setting.

3-5 Program setting

1. Movement/stationary marking setting (Change/Request)

Command		OnTheFly	
Description		Toggles the stationary/movement marking setting and changes/requests the movement direction.	
Target		PRG=0000 to 1999	
WX	Command	WX,PRG= 0000 ,OnTheFly= A,B [CR]	
	Response	WX,OK [CR]	
RX	Command	RX,PRG= 0000 ,OnTheFly [CR]	
	Response	RX,OK, A,B [CR]	
Parameter		A : 0/1	Stationary/Movement marking setting 0: Stationary marking 1: Movement marking * Default value "0"
Parameter		B : 0 to 3	Moving direction Sets the line flow direction. 0: Bottom 1: Right 2: Top 3: Left *A: Fixed value of "0" when 0

-  • The line flow direction will be determined in reference to the positional relationship with the head orientation.

2. Head orientation (Change/Request)

Command		HeadDirection	
Description		Changes/requests the head orientation.	
Target		PRG=0000 to 1999	
WX	Command	WX,PRG= 0000 ,HeadDirection= A [CR]	
	Response	WX,OK [CR]	
RX	Command	RX,PRG= 0000 ,HeadDirection [CR]	
	Response	RX,OK, A [CR]	
Parameter		A : 0 to 7	Head orientation Sets the orientation of the head with reference to the marking area. 0: Left 1: Left (Mirror invert) 2: Right (Mirror invert) 3: Right 4: Bottom (Mirror invert) 5: Top 6: Bottom 7: Top (Mirror invert) * Default value "0"

3. Marking order (Change/Request)

Command		MarkingOrder	
Description		Changes/requests the marking order.	
Target		PRG=0000 to 1999	
WX	Command	WX,PRG= 0000 ,MarkingOrder= A [CR]	
	Response	WX,OK [CR]	
RX	Command	RX,PRG= 0000 ,MarkingOrder [CR]	
	Response	RX,OK, A [CR]	
Parameter		A : 0/1	Marking order 0: Group/block no. order 1: Auto * Default value "0"

-  • This command is only enabled for stationary marking.

4. Continuous stationary marking (Change/Request)

Command		ContinuousStationaryMarking	
Description		Changes/requests the enable/disable, marking count and interval of the continuous marking function in stationary marking.	
Target		PRG=0000 to 1999	
WX	Command	WX,PRG= 0000 ,ContinuousStationaryMarking= A,B,C [CR]	
	Response	WX,OK [CR]	
RX	Command	RX,PRG= 0000 ,ContinuousStationaryMarking [CR]	
	Response	RX,OK, A,B,C [CR]	
Parameter	A: 1/2	Continuous marking setting 1: Disabled 2: Enabled * Default value "1"	
	B: 00002 to 65535	Continuous marking count (times) *A: Fixed value of "2" when 1	
	C: 0000.0 to 0009.9	Continuous interval (s) *A: Fixed value of "0" when 1	

 This command is only enabled for stationary marking.

5. Movement parameters (Change/Request)

Command		OnTheFlyMarking	
Description		Changes/requests the movement parameters of the movement marking function.	
Target		PRG=0000 to 1999	
WX	Command	WX,PRG= 0000 ,OnTheFlyMarking= A,B,C,D [CR]	
	Response	WX,OK [CR]	
RX	Command	RX,PRG= 0000 ,OnTheFlyMarking [CR]	
	Response	RX,OK, A,B,C,D [CR]	
Parameter	A: 0/1	Moving method 0: Constant 1: Encoder * Default value "0"	
	B: Depends on the area size Normal(X): 0000.1 to 4000.0 Other model: □"Line speed" of "Appendix-2 Model-Specific Input Value List" (Page49).	Line speed (mm/s) *A: Fixed value of "0.1" when 1 * Default value "Normal: 300"/"Wide: 450"/"Small: 150"	
	C: 0	Fixed value	
	D: 001.0 to 200.0	Encoder pulse count (Pulse/mm) * Default value "Normal: 50"/ "Wide: 20"/"Small: 100"	

 This command is only enabled for movement marking.

6. Movement marking trigger delay (Change/Request)

Command		OnTheFlyTriggerDelay	
Description		Changes/requests the "distance to the sensor" and "marking position offset" of the movement marking function.	
Target		PRG=0000 to 1999	
WX	Command	WX,PRG= 0000 ,OnTheFlyTriggerDelay= A,B [CR]	
	Response	WX,OK [CR]	
RX	Command	RX,PRG= 0000 ,OnTheFlyTriggerDelay [CR]	
	Response	RX,OK, A,B [CR]	
Parameter	A: 0000.0 to 1200.0	Distance to sensor (mm) * Default value "Normal: 62.6(X/F/U), 60.1(Z)"/ "Wide:165.1(X/U), 150.1(F/Z)"/ "Small: 25.1"	
	B: -1200.0 to 01200.0	Marking position offset (mm) * Default value "0"	

-  This command is only enabled for movement marking.
- Configure the setting such that the sum of "the distance to the sensor" and "marking position offset" is greater than the start position in the movement range setting. If the movement range setting is disabled, values smaller than the default value will not be accepted.

7. Continuous movement marking (Change/Request)

Command		OnTheFlyContinuousMarking	
Description		Changes/requests the enable/disable, marking count and interval of the continuous marking function in movement marking.	
Target		PRG=0000 to 1999	
WX	Command	WX,PRG= 0000 , OnTheFlyContinuousMarking= A,B,C [CR]	
	Response	WX,OK [CR]	
RX	Command	RX,PRG= 0000 , OnTheFlyContinuousMarking [CR]	
	Response	RX,OK, A,B,C [CR]	
Parameter	A: 0/1/2	Continuous marking setting 0: Mark while trigger ON 1: Continuous marking disabled 2: Continuous marking enabled * Default value "1"	
	B: 00002 to 65535	Continuous marking count (times) *A: Fixed value of "2" when 0/1	
	C: 0000.1 to 1200.0	Continuous interval (mm) *A: Fixed value of "100" when 1	

 This command is only enabled for movement marking.

8. Marking range setting (Change/Request)

Command		OnTheFlyMarkingArea	
Description		Changes/requests the enable/disable, start position and end position of the marking range setting of the movement marking function.	
Target		PRG=0000 to 1999	
WX	Command	WX,PRG=0000,OnTheFlyMarkingArea=A,B,C [CR]	
	Response	WX,OK [CR]	
RX	Command	RX,PRG=0000,OnTheFlyMarkingArea [CR]	
	Response	RX,OK,A,B,C [CR]	
Parameter	A: 0/1	Marking range setting 0: Disabled 1: Enabled * Default value "0"	
	B: Depends on the area size Normal(X):-062.500 to 0062.500 Other model: □"Start Position" of "Appendix-2 Model-Specific Input Value List" (Page49).	Start position (mm) * Default value "Normal: 31.25(X/F/U), 30.00(Z)"/ "Wide:82.5(X/U),75(F/Z)"/ "Small: 12.5"	
	C: Depends on the area size Normal(X):-062.500 to 0062.500 Other model: □"End Position" of "Appendix-2 Model-Specific Input Value List" (Page49).	End position (mm) * Default value "Normal: -31.25(X/F/U), -30.00(Z)"/ "Wide:-82.5(X/U),-75(F/Z)"/ "Small: -12.5"	

 This command is only enabled for movement marking.

9. Workpiece position adjustment (Plane) (Change/Request)

Command		ProgramPosition	
Description		Changes/requests the correction inside the horizontal plane in the workpiece position adjustment.	
Target		PRG=0000 to 1999	
WX	Command	WX,PRG=0000,ProgramPosition=A,B,C,D,E [CR]	
	Response	WX,OK [CR]	
RX	Command	RX,PRG=0000,ProgramPosition [CR]	
	Response	RX,OK,A,B,C,D,E [CR]	
Parameter	A: Depends on the area size Normal(X):-062.500 to 0062.500 Other model: □"Movement reference point X/Y coordinates" of "Appendix-2 Model-Specific Input Value List" (Page49).	Movement reference point X(mm) * Default value "0"	
	B: Depends on the area size Normal(X):-062.500 to 0062.500 Other model: □"Movement reference point X/Y coordinates" of "Appendix-2 Model-Specific Input Value List" (Page49).	Movement reference point Y(mm) * Default value "0"	
	C: Depends on the area size Normal(X):-125.000 to 0125.000 Other model: □"Correction amount X/Y" of "Appendix-2 Model-Specific Input Value List" (Page49).	X coordinate correction amount (mm) * Default value "0"	
	D: Depends on the area size Normal(X):-125.000 to 0125.000 Other model: □"Correction amount X/Y" of "Appendix-2 Model-Specific Input Value List" (Page49).	Y coordinate correction amount (mm) * Default value "0"	
	E: -180.000 to 0180.000	θ angle correction amount (°) * Default value "0"	

 The θ angle correction is performed, where the origin is the position where the correction amount has been applied to the movement reference point.

- Workpiece position adjustment is only enabled for stationary marking.

10. Correct the height direction (Change/Request)

Command		HeightCorrection	
Description		Changes/requests the correction method and setting values for the workpiece position correction in the height direction.	
Target		PRG=0000 to 1999	
WX	Command	WX,PRG=0000,HeightCorrection=A,B,C,D,E,F [CR]	
	Response	WX,OK [CR]	
RX	Command	RX,PRG=0000,HeightCorrection [CR]	
	Response	RX,OK,A,B,C,D,E,F [CR]	
Parameter	A: 0/5/6	Height correction method 0: Fixed 5: External displacement sensor 6: Auto focus * Default value "0"	
	B: Depends on the area size □"Z coordinate correction amount" of "Appendix-2 Model-Specific Input Value List" (Page49).	Correction amount Z coordinate (mm) *A: Fixed value of "0" when 5/6 * Default value "0"	
	C: 1 to 9	Measurement count (times) *A: Fixed value of "3" when 0 * Default value "3"	
	D: Depends on the area size Normal(X): -20.999 to 042.000 Other model: □"Upper tolerance limit" of "Appendix-2 Model-Specific Input Value List" (Page49).	Upper tolerance limit (mm) *A: Fixed value of "21" when 0 * Default value "21"	
	E: Depends on the area size Normal(X): -42.999 to 020.999 □"Lower tolerance limit" of "Appendix-2 Model-Specific Input Value List" (Page49).	Lower tolerance limit (mm) *A: Fixed value of "-21" when 0 * Default value "-21"	
	F: 1/2	If out of range, 1: Mark (warning output) 2: Do not mark (error output) *A: Fixed value of "1" when 0 * Default value "1"	

-  The auto focus function of parameter A will be disabled for movement marking.
- You cannot use Auto Focus on the MD-X1000L/1500L series, MD-F3200/5200 series and ML-Z9600 series.

11. Marking confirmation function (Change/Request)

Command		CheckMarking	
Description		Changes/requests the enable/disable of the marking confirmation function and the various settings.	
Target		PRG=0000 to 1999	
WX	Command	WX,PRG= 0000 ,CheckMarking= A,B,C,D,E,F,G,H,I,J [CR]	
	Response	WX,OK [CR]	
RX	Command	RX,PRG= 0000 ,CheckMarking [CR]	
	Response	RX,OK, A,B,C,D,E,F,G,H,I,J [CR]	
Parameter	A: 0/1	Marking confirmation 0: Disabled 1: Enabled * Default value "0"	
	B: 0/1	Position to check 0: Block No. specification 1: Custom coordinate specification * Default value "0"	
	C: 000 to 255	Block No. * B: Fixed value of "0" when 1 * Default value "0"	
	D: Depends on the area size Normal(X): -062.500 to 0062.500 Other model: □"X coordinate" of "Appendix-2 Model-Specific Input Value List" (Page49).	Reading X coordinate * B: Fixed value of "0" when 0 * Default value "0"	
	E: Depends on the area size Normal(X): -062.500 to 0062.500 Other model: □"Y coordinate" of "Appendix-2 Model-Specific Input Value List" (Page49).	Reading Y coordinate * B: Fixed value of "0" when 0 * Default value "0"	
	F: Depends on the area size Normal(X): -021.000 to 0021.000 Other model: □"Z coordinate" of "Appendix-2 Model-Specific Input Value List" (Page49).	Reading Z coordinate * B: Fixed value of "0" when 0 * Default value "0"	
	G: 0/1	Sensitivity setting 0: Auto 1: Any value * Default value "0"	
	H: 000 to 100	Sensitivity * G: Fixed value of "50" when 0 * Default value "50"	
	I: 000 to 100	Error threshold * Default value "50"	
	J: 0.0 to 9.9	Capture delay * Default value "0"	

- Reference** • This command is only enabled for stationary marking.
- You cannot use on the MD-X1000L/1500L series, MD-F3200/5200 series and ML-Z9600 series.
 - Cannot be set when the 2D code reader function is enabled.
 - Specify the reading coordinate in the "Custom Coordinate Specification" when the matrix function is used or 3D shaped block is read.

12. 2D code reader function (Change/Request)

Command		Check2DCodeQuality	
Description		Changes/requests the enable/disable of the 2D code quality check function when the marking is complete and the various setting values.	
Target		PRG=0000 to 1999	
WX	Command	WX,PRG= 0000 ,Check2DCodeQuality= A,B,C,D,E [CR]	
	Response	WX,OK [CR]	
RX	Command	RX,PRG= 0000 ,Check2DCodeQuality [CR]	
	Response	RX,OK, A,B,C,D,E [CR]	
Parameter	A: 0/1	0: Quality check disabled 1: Quality check enabled * Default value "0"	
	B: 000 to 255	Reading target block No. * Only a 2D code block can be specified * A: Fixed value of "0" when 0 * Default value "0"	
	C: 0.0 to 9.0	Capture delay (s) * A: Fixed value of "0" when 0 * Default value "0"	
	D: 0.0 to 9.0	Image hold time (s) * Default value "5"	
	E: 0 to 4	Error threshold 0: Total grade A or higher 1: Total grade B or higher 2: Total grade C or higher 3: Total grade D or higher 4: Total grade F or higher * Default value "4"	

- Reference** • This command is only enabled for stationary marking.
- You cannot use on the MD-X1000L/1500L series, MD-F3200/5200 series and ML-Z9600 series.
 - Cannot be set when the marking confirmation function is enabled.

13. Reading coordinates of the 2D code reader function (Change/Request)

Command		Check2DCodeQualityPosition	
Description		Changes/requests whether the reading destination of the 2D code quality check function when the marking is complete is a block No. or Custom coordinates.	
Target		PRG=0000 to 1999	
WX	Command	WX,PRG= 0000 ,Check2DCodeQualityPosition= A,B,C,D [CR]	
	Response	WX,OK [CR]	
RX	Command	RX,PRG= 0000 ,Check2DCodeQualityPosition [CR]	
	Response	RX,OK, A,B,C,D,E [CR]	
Parameter	A: 0/1	0: Block No. specification 1: Custom coordinate specification * Default value "0"	
	B: Depends on the area size Normal(X): -062.500 to 0062.500 Other model: □"X coordinate" of "Appendix-2 Model-Specific Input Value List" (Page49).	Reading X coordinate * A: Fixed value of "0" when 0 * Default value "0"	
	C: Depends on the area size Normal(X): -062.500 to 0062.500 Other model: □"Y coordinate" of "Appendix-2 Model-Specific Input Value List" (Page49).	Reading Y coordinate * A: Fixed value of "0" when 0 * Default value "0"	
	D: Depends on the area size Normal(X): -021.000 to 0021.000 Other model: □"Z coordinate" of "Appendix-2 Model-Specific Input Value List" (Page49).	Reading Z coordinate * A: Fixed value of "0" when 0 * Default value "0"	

- Reference** • This function is only applied when the 2D code reader function is enabled.
- You cannot use on the MD-X1000L/1500L series, MD-F3200/5200 series and ML-Z9600 series.
 - Specify the reading coordinate in the "Custom Coordinate Specification" when the matrix function is used.

14. Common block marking parameters (Change/Request)

Command		CommonMarkingParameter	
Description		Changes/requests the common block marking parameters that can be used commonly in programs.	
Target		PRG=0000 to 1999	
WX	Command	WX,PRG=0000,CommonMarkingParameter=A,B,C,D,E,F,G,H,I,J,K,L [CR]	
	Response	WX,OK [CR]	
RX	Command	RX,PRG=0000,CommonMarkingParameter [CR]	
	Response	RX,OK,A,B,C,D,E,F,G,H,I,J,K,L [CR]	
Parameter	A: 000.0 to 100.0	Common laser power (%) * Default value "0"	
	B: Depends on the area size Normal(X):00001 to 12000 Other model: □"Scan speed" of "Appendix-2 Model-Specific Input Value List" (Page49).	Common scan speed (mm/s) * Default value "1000"	
	C: Differs depending on the model Normal(X):000 to 400 Other model: □"Pulse frequency" of "Appendix-2 Model-Specific Input Value List" (Page49).	Common pulse frequency (kHz) * Default value "100"	
	D: Depends on the area size Normal(X):-210 to 0210 Other model: □"Spot variable" of "Appendix-2 Model-Specific Input Value List" (Page49).	Common spot variable * Default value "0"	
	E: 001 to 100	Common marking count (times) * Default value "1"	
	F: Depends on the area size Normal(X): -21.000 to 0021.000 Other model: □"Z coordinate" of "Appendix-2 Model-Specific Input Value List" (Page49).	Common Z coordinate (mm) * Default value "0"	
	G: 0.000 to 1.000	Common fill interval (mm) * Default value "0.06"	
	H: 00 to 04/06	Common quality level 00: Top speed 01: Speed priority 02: Standard 03: High quality 04: Top quality 06: Top speed 2 * Default value "2"	
	I: 00.000 to 10.000	Common skip cross (mm) * Default value "0"	
	J: 0/1	End Point Control: 0: Optimize 1: Custom	
	K: 000 to 200	End Point ON Control (%) *J: Only enabled when "1" is set Default value: "100"	
	L: 000 to 200	End Point OFF Control (%) *J: Only enabled when "1" is set Default value: "100"	

- Reference
- You cannot use Top Speed 2 on the MD-F3200/5200 series, MD-U1000/1500 series and ML-Z9600 series.
 - You cannot use End Point Control on the MD-X1000/1500 series and MD-U1000/1500 series.

15. Marking energy check (Change/Request)

Command		MarkingEnergy	
Description		Changes/requests the ON/OFF of the marking energy check function and the threshold setting.	
Target		PRG=0000 to 1999	
WX	Command	WX,PRG=0000,MarkingEnergy=A,B,C,D [CR]	
	Response	WX,OK [CR]	
RX	Command	RX,PRG=0000,MarkingEnergy [CR]	
	Response	RX,OK,A,B,C,D [CR]	
Parameter	A: 0/1	Lower limit threshold 0: Disabled 1: Enabled * Default value "0"	
	B: 0/1	Upper limit threshold 0: Disabled 1: Enabled * Default value "0"	
	C: 00000.01 to 99999.99	Lower limit threshold (J) *A: Fixed value of "0.01" when 0	
	D: 00000.01 to 99999.99	Upper limit threshold (J) *B: Fixed value of "0.01" when 0	

- Reference
- Marking energy check will be canceled when the next trigger is accepted within 2 seconds of completion of the marking. Therefore, make sure to allow at least 2 seconds between the marking completion and the next marking start.
 - You cannot use on the ML-Z9600 series.

16. Scanner waiting position when ready (Change/Request)

Command		ScannerWaiting	
Description		Changes/requests the scanner waiting position when ready.	
Target		PRG=0000 to 1999	
WX	Command	WX,PRG=0000,ScannerWaiting=A,B,C,D [CR]	
	Response	WX,OK [CR]	
RX	Command	RX,PRG=0000,ScannerWaiting [CR]	
	Response	RX,OK,A,B,C,D [CR]	
Parameter	A: 0/1	Standby coordinate 0: Drawing Start Position 1: Custom coordinate * Default value "0"	
	B: Depends on the area size Normal(X): -062.500 to 0062.500 Other model: □"X coordinate" of "Appendix-2 Model-Specific Input Value List" (Page49).	Standby X coordinate (mm) *A: Fixed value of "0" when 0	
	C: Depends on the area size Normal(X): -062.500 to 0062.500 Other model: □"Y coordinate" of "Appendix-2 Model-Specific Input Value List" (Page49).	Standby Y coordinate (mm) *A: Fixed value of "0" when 0	
	D: Depends on the area size Normal(X): -021.000 to 0021.000 Other model: □"Z coordinate" of "Appendix-2 Model-Specific Input Value List" (Page49).	Standby Z coordinate (mm) *A: Fixed value of "0" when 0	

- Reference
- If you set the start position as the standby coordinate, the scanner will wait near the first block to be marked.

17. Approach scan speed (Change/Request)

Command		ApproachScanSpeed	
Description		Changes/requests the approach scan speed.	
Target		PRG=0000 to 1999	
WX	Command	WX,PRG=0000,ApproachScanSpeed=A [CR]	
	Response	WX,OK [CR]	
RX	Command	RX,PRG=0000,ApproachScanSpeed [CR]	
	Response	RX,OK,A [CR]	
Parameter	A: Depends on the area size Normal(X):00000 to 04000 Other model: □"Approach scan speed" of "Appendix-2 Model-Specific Input Value List" (Page49).	Approach scan speed (mm/s) * Default value "1000"	

3-6 String/Logo/Barcode setting

1. Block type (Change/Request)

Command		BlockType	
Description		Changes/requests the block type.	
Target		PRG=0000 to 1999, BLK=000 to 255	
WX	Command	WX,PRG= 0000 ,BLK= 000 ,BlockType= A [CR]	
	Response	WX,OK [CR]	
RX	Command	RX,PRG= 0000 ,BLK= 000 ,BlockType [CR]	
	Response	RX,OK, A [CR]	
Parameter		A: -04 to 004/009	Block type -04: Hatch logo -03: Photo -02: Workpiece image logo -01: Logo 000: Horizontal characters 001: Vertical characters 002: Arc clockwise 003: Arc counterclockwise 004: Fixed point 009: Barcode, 2D code

- Reference**
- When creating a new block, send this command to a non-registered block No.
 - When you change the block type, the association with the 3D shape No. and the X/Y/Z coordinate layout information will be initialized.
 - Fixed point is only supported in stationary marking.
 - When the changing command is sent, the character string becomes (a) space(s).

2. Barcode type (Change/Request)

Command		CodeType	
Description		Changes/requests the barcode type.	
Target		PRG=0000 to 1999, BLK=000 to 255	
WX	Command	WX,PRG= 0000 ,BLK= 000 ,CodeType= A [CR]	
	Response	WX,OK [CR]	
RX	Command	RX,PRG= 0000 ,BLK= 000 ,CodeType [CR]	
	Response	RX,OK, A [CR]	
Parameter		A: 01 to 18	Barcode type 01: CODE39 02: ITF 03: 2of5 04: NW7 05: JAN 06: CODE128 07: QR Code Model 1 08: QR Code Model 2 09: Micro QR Code 10: DataMatrix ECC200 11: GS1 DataBar(Truncated) 12: GS1 DataBar(Truncated) CC-A 13: GS1 DataBar Stacked 14: GS1 DataBar Stacked CC-A 15: GS1 DataBar Limited 16: GS1 DataBar Limited CC-A 17 : GS1 DataMatrix 18 : CODE93 * Default value "1"

- Reference**
- This command can be sent to a block No. having the block type (BlockType) of "09: Barcode/2D Code".

3. String and logo files (Change/Request)

Command		CharacterString	
Description		Changes/requests the string or logo/photo file.	
Target		PRG=0000 to 1999, BLK=000 to 255	
WX	Command	WX,PRG= 0000 ,BLK= 000 ,CharacterString= A [CR]	
	Response	WX,OK [CR]	
RX	Command	RX,PRG= 0000 ,BLK= 000 ,CharacterString [CR]	
	Response	RX,OK, A [CR]	
Parameter		A: String /Logo file name	<ul style="list-style-type: none"> If the block type is "-4 to -1", the parameters are sent in the following format: Logo: %L<File name> External character %F<File name> Workpiece image: %K<File name> Hatch logo: %T<File name> Photo: %Z<File name> Grayscale photo(X/U only): %l<File name> High resolution photo (X/U only): %X<File name> If the block type is "0 to 3", send the parameter in string format (in less than 510 single-byte or double-byte characters). If the block type is "9", send a string that adheres to the barcode/2D code character input rules.

- Reference**
- This command can be sent to a block No. having the block type (BlockType) of "-4: Hatch logo/-3: Photo/-2: Workpiece image/-1: Logo/00: Horizontal characters/01: Vertical characters/02: Arc clockwise/03: Arc counterclockwise/09: Barcode/2D Code".
 - To send a ", (comma)" as a string, send it in the form of "%044A" (ASCII).
 - To send a "%" as a string, send it in the form of "%%" (ASCII).
 - To set update characters, send the following in ASCII format.

Type	Encoding	Without zero suppression		With zero suppression	
		Without expiration	With expiration	Without expiration	With expiration
Year 4	No	%4T■Y	%4Y	-	-
	Yes	%4T■Y	%4Y	-	-
Year 2	No	%2T■Y	%2Y	-	-
	Yes	%2P■T■Y	%2P■Y	-	-
Year 1	No	%1T■Y	%1Y	-	-
	Yes	%1P■T■Y	%1P■Y	-	-
Month	No	%02T■M	%02M	Right-aligned %2T■M Left-aligned %2T■M	Right-aligned %2M Left-aligned %2M
	Yes	%2P■T■M	%2P■M	-	-
Day	No	%02T■D	%02D	Right-aligned %2T■D Left-aligned %2T■D	Right-aligned %2D Left-aligned %2D
	Yes	%2P■T■D	%2P■D	-	-
Hour	No	%02T■h	%02h	Right-aligned %2T■h Left-aligned %2T■h	Right-aligned %2h Left-aligned %2h
	Yes	%2P■T■h	%2P■h	-	-
Minute	No	%02T■m	%02m	Right-aligned %2T■m Left-aligned %2T■m	Right-aligned %2m Left-aligned %2m
	Yes	%2P■T■m	%2P■m	-	-
Second	No		%02s		Right-aligned %2s Left-aligned %2s
	Yes		%2P■s		
365 days	No	%03T■X	%03X	Right-aligned %3T■X Left-aligned %3T■X	Right-aligned %3X Left-aligned %3X
	Yes	%3P■T■X	%3P■X	-	-
Day of week	No	%1T■B	%1B	-	-
	Yes	%1P■T■B	%1P■B	-	-
Week	Yes	%2P■T■W	%2P■W	-	-
Time zone	Yes	-	%P■S	-	-
I/O encoded character	No	-	%1R	-	-
	Yes	-	%1P■R	-	-

- is the encoding No. (0 to 9) and ■ is the expiration No. (0 to 9).

- To set a counter, send the following in ASCII format.

Type	Zero suppression	Padding	Alignment	Encoding	
				Yes	No
Serial counter	No	-	-	%0▲P●C■C	%0▲C■C
	Yes	Auto	-	%P●C■C	%C■C
		Specify Digits	Right-aligned	%▲P●C■C	%▲C■C
		Left-aligned	%-▲P●C■C	%-▲C■C	

- is the encoding No. (0 to 9), ▲ is the counter No. (0 to 9, A to J), and ■ is the No. of digits (1 to 10).

- To set a link, send the following in ASCII format.

Reference	Reference parameters	Setting code
GS1 DataBar	GS1 DataBar	%H<●●●1>
GS1 DataBar & CC-A	CC-A	%H<●●●2>
Barcode	Add check digit	%H<●●●C>
	Add start-stop character	%H<●●●*>
	Add check digit & Add start-stop character	%H<●●●C*>
GS1 DataMatrix	Entire encoded string	%H<●●●00A>
	Specify AI number (AI added)	%H<●●●▲▲A>
	Specify AI number (AI not added)	%H<●●●▲▲>
Other blocks	-	%H<●●●>

- is the block No. (000 to 255) and ▲▲ is the referenced AI number (Nth AI).
- The range specification options add the following before the ">" symbol.
"SxxxLxxx": S is set with the start position, L is set with the number of reference characters, and XXX is set with the number of characters (001 to 510).
- Send the following by ASCII when a control code is set to the barcode or 2D code.

Control code	Setting code	Control code	Setting code	Control code	Setting code
NUL	%000A	CR	%013A	SUB	%026A
SOH	%001A	SO	%014A	ESC	%027A
STX	%002A	SI	%015A	FS	%028A
ETX	%003A	DLE	%016A	GS	%029A
EOT	%004A	DC1	%017A	RS	%030A
ENQ	%005A	DC2	%018A	US	%031A
ACK	%006A	DC3	%019A	DEL	%127A
BEL	%007A	DC4	%020A	FNC1	%901A
BS	%008A	NAK	%021A	FNC2	%902A
HT	%009A	SYN	%022A	FNC3	%903A
LF	%010A	ETB	%023A	FNC4	%904A
VT	%011A	CAN	%024A		
FF	%012A	EM	%025A		

4. Font related (Change/Request)

Command	CharacterFont	
Description	Changes/requests the font No., line type, line width, line count and overlap rate used in a string.	
Target	PRG=0000 to 1999, BLK=000 to 255	
WX	Command	WX,PRG= 0000 ,BLK= 000 ,CharacterFont= A,B,C,D,E,F [CR]
	Response	WX,OK [CR]
RX	Command	RX,PRG= 0000 ,BLK= 000 ,CharacterFont [CR]
	Response	RX,OK, A,B,C,D,E,F [CR]
Parameter	A: 0 to 11	Font No. -1: Quick 00: Standard 01: Small 02 to 11: User font * Quick: Available on only MD-U1000 series * Default value "0"
	B: 0 to 2	Line type 0: Single 1: Multiple 2: Wobble * Default value "0"
	C: Depends on the area size Normal(X):0.010 to 5.000 Other model: □"Line Width" of "Appendix-2 Model-Specific Input Value List" (Page49).	Thickness (mm) *B: Fixed value of "0.1" when 0 * Default value "Normal: 0.2"/"Wide: 0.3"/"Small: 0.1"
	D: 0/1	Auto number of lines 0: Any value 1: Auto *B: Fixed value of "0" when 0 * Default value "0"
	E: 002 to 100	Number of multiples (lines) *D: Fixed value of "2" when 1 * Default value "4"
F: 75.0 to 98.0	Overlap rate (%) *B: Fixed value of "80" when other than 2 * Default value "80"	

- Reference** This command can be sent to a block No. having the block type (BlockType) of "00: Horizontal characters/01: Vertical characters/02: Arc clockwise/03: Arc counterclockwise". Cannot be sent to the block of TrueTypeFont.
- Multiple and Wobble thicknesses can be set to a ratio of up to x0.2 compared to the smaller character height or width.

5. Character size (Change/Request)

Command		CharacterSize	
Description		Changes/requests the height, width, character layout, space, full width/full height of a string.	
Target		PRG=0000 to 1999, BLK=000 to 255	
WX	Command	WX,PRG= 0000 ,BLK= 000 ,CharacterSize= A,B,C,D,E,F [CR]	
	Response	WX,OK [CR]	
RX	Command	RX,PRG= 0000 ,BLK= 000 ,CharacterSize [CR]	
	Response	RX,OK, A,B,C,D,E,F [CR]	
Parameter	A: Depends on the area size Normal(X):000.100 to 125.000 Other model: □"Height/width" of "Appendix-2 Model-Specific Input Value List" (Page49).	Height (mm) * Default value "3"	
	B: Depends on the area size Normal(X):000.100 to 125.000 Other model: □"Height/width" of "Appendix-2 Model-Specific Input Value List" (Page49).	Character width (mm) * Default value "2"	
	C: 0/2/3	Character Layout 0: Character space 1: Distribute 3: Character pitch	
	D: Depends on the area size Normal(X):000.000 to 180.000 Other model: □"Space" of "Appendix-2 Model-Specific Input Value List" (Page49).	Space (mm) * Default value "0.5"	
	E: Depends on the area size Normal(X):000.100 to 180.000 Other model: □"Character full width/full height" of "Appendix-2 Model-Specific Input Value List" (Page49).	Full width/Full height (mm) * Default value "7"	
	F: Depends on the area size Normal(X):-180.000 to 0180.000 Other model: □"Character pitch" of "Appendix-2 Model-Specific Input Value List" (Page49).	Character pitch * Default value "2"	

- Reference** • This command can be sent to a block No. having the block type (BlockType) of "00: Horizontal characters/01: Vertical characters/02: Arc clockwise/03: Arc counterclockwise".
- You can only set the character height/width ratio between x0.2 and x5.
 - The character width and character spacing cannot be set when the ratio specification or proportional is enabled and when it is TrueTypeFont. Also, they cannot be set when the character spacing of **C** is other than 0.
 - C** to **F**: Cannot be set when the character string is circle layout.
 - The character pitch can be set for a TrueType font only.

6. Logo size (Change/Request)

Command		LogoSize	
Description		Changes/requests the height and width of a logo (including hatch logo and workpiece image logo).	
Target		PRG=0000 to 1999, BLK=000 to 255	
WX	Command	WX,PRG= 0000 ,BLK= 000 ,LogoSize= A,B [CR]	
	Response	WX,OK [CR]	
RX	Command	RX,PRG= 0000 ,BLK= 000 ,LogoSize [CR]	
	Response	RX,OK, A,B [CR]	
Parameter	A: Depends on the area size Normal(X):000.002 to 125.000 Other model: □"Logo height/width" of "Appendix-2 Model-Specific Input Value List" (Page49).	Logo height (mm) * Default value depends on the original DXF size	
	B: Depends on the area size Normal(X):000.002 to 125.000 Other model: □"Logo height/width" of "Appendix-2 Model-Specific Input Value List" (Page49).	Logo width (mm) * Default value depends on the original DXF size	

- Reference** • This command can be sent to a block No. having the block type (BlockType) of "-4: Hatch logo/-2: Workpiece image/-1: Logo".
- When the aspect ratio is maintained, the logo height is set automatically based on the value of the logo width.

7. String proportional setting (Change/Request)

Command		CharacterProportional	
Description		Changes/requests the enable/disable of the proportional function and the minimum character width of a string.	
Target		PRG=0000 to 1999, BLK=000 to 255	
WX	Command	WX,PRG= 0000 ,BLK= 000 ,CharacterProportional= A,B [CR]	
	Response	WX,OK [CR]	
RX	Command	RX,PRG= 0000 ,BLK= 000 ,CharacterProportional [CR]	
	Response	RX,OK, A,B [CR]	
Parameter	A: 0/1	Proportional setting 0: Disabled 1: Enabled * Default value "0"	
	B: 000 to 100	Minimum character width (%) * A: Fixed value of "20" when 0 * Default value "20"	

- Reference** • This command can be sent to a block No. having the block type (BlockType) of "00: Horizontal characters/02: Arc clockwise/03: Arc counterclockwise".

8. String ratio setting (Change/Request)

Command		CharacterRatio	
Description		Changes/requests the enable/disable of string ratio setting and the width and space ratios of a string.	
Target		PRG=0000 to 1999, BLK=000 to 255	
WX	Command	WX,PRG= 0000 ,BLK= 000 ,CharacterRatio= A,B,C [CR]	
	Response	WX,OK [CR]	
RX	Command	RX,PRG= 0000 ,BLK= 000 ,CharacterRatio [CR]	
	Response	RX,OK, A,B,C [CR]	
Parameter	A: 0/1	Ratio setting 0: Disabled 1: Enabled * Default value "0"	
	B: 020.00 to 500.00	Character width ratio (%) * A: Fixed value of "20" when 0 * Default value "66.67" if the character type is system font and "100" if it is a TrueType font	
	C: Depends on the block type Horizontal characters/Vertical characters: -100.00 to 1000.00 Arc (counter) clockwise string: 0000.00 to 1000.00	Character space ratio (%) * A: Fixed value of "0" when 0 * Default value "25" when the system font, circle layout, and character layout are "character spacing," and "0" for others.	

- Reference** • This command can be sent to a block No. having the block type (BlockType) of "00: Horizontal characters/01: Vertical characters/02: Arc clockwise/03: Arc counterclockwise".
- The ratio specification cannot be set in the case of TrueTypeFont.

9. Arc string character layout setting (Change/Request)

Command		ArcCharacter	
Description		Changes/request the character layout, radius, space, character angle space and open angle of an arc string.	
Target		PRG=0000 to 1999, BLK=000 to 255	
WX	Command	WX,PRG= 0000 ,BLK= 000 ,ArcCharacter= A,B,C,D,E [CR]	
	Response	WX,OK [CR]	
RX	Command	RX,PRG= 0000 ,BLK= 000 ,ArcCharacter [CR]	
	Response	RX,OK, A,B,C,D,E [CR]	
Parameter	A: 0 to 2	Arc character layout 0: Character space 1: Angular interval 2: Distribute angle * Default value "0"	
	B: 0000.001 to 9999.99	Arc radius (mm) * Default value "20"	
	C: Depends on the area size Normal(X):000.000 to 180.000 Other model: □"Arc character space" of "Appendix-2 Model-Specific Input Value List" (Page49).	Arc character space (mm) * A: Fixed value of "0" when other than 0 * Default value "0.5"	
	D: 000.000 to 359.999	Arc character angle space (°) * A: Fixed value of "0" when other than 1 * Default value "10"	
	E: 000.000 to 359.999	Arc open angle (°) * A: Fixed value of "0" when other than 2 * Default value "120"	

Reference • This command can be sent to a block No. having the block type (BlockType) of "02: Arc clockwise/03: Arc counterclockwise".

10. Barcode/2D code related (Change/Request)

Command		CodeSetting	
Description		Changes/requests the format, check digit setting, DataMatrix 06 macro setting, and QR Code error correction rate of a barcode/2D code.	
Target		PRG=0000 to 1999, BLK=000 to 255	
WX	Command	WX,PRG= 0000 ,BLK= 000 ,CodeSetting= A,B,C,D [CR]	
	Response	WX,OK [CR]	
RX	Command	RX,PRG= 0000 ,BLK= 000 ,CodeSetting [CR]	
	Response	RX,OK, A,B,C,D [CR]	
Parameter	A: 0/1/2	Format 0: Normal 1: Black/White inversion 2: Overprinting * Default value "0"	
	B: 0/1	Check Digit 0: No 1: Yes * Fixed value of "0" when the code type is other than CODE39/ITF/NW7 * Default value "0"	
	C: 0/1	DataMatrix 06 macro 0: No 1: Add * Fixed value of "0" when the code type is other than DataMatrix ECC200 * Default value "0"	
	D: 0/1/2/3	QR Code error correction rate 0: L (7%) 1: M(15%) 2: Q(25%) 3: H (30%) * Fixed value of "0" when the code type is other than QR Model 1/2 or Micro QR * Default value "3" when the code type is QR model 1/2, "2" when micro QR, and "0" for others.	

Reference • This command can be sent to a block No. having the block type (BlockType) of "09: Barcode/2D Code".

- If "Overprinting" is selected as the format, overprinting No.0 will be assigned to "Base" and overprinting No.1 will be assigned to "Code", respectively. Then, set the overprinting marking parameters (MultiPassMarkingParameter), overprinting pattern (MultiPassPattern), and overprinting fill parameters (MultiPassFillParameters).
- If you set the format to "Normal or Black/White Inversion", the parameters in all overprinting No. will be initialized.
- The format of "2: Overprinting" cannot be selected in the case of JAN/EAN/UPC/GS1 DataBar.
- The error correction proportion of a QR code cannot be set to H (30%) in the case of the micro QR.

11. Barcode size (Change/Request)

Command		BarcodeSize	
Description		Changes/requests the height, narrow bar, bar ratio and quiet zone width of a barcode.	
Target		PRG=0000 to 1999, BLK=000 to 255	
WX	Command	WX,PRG=0000,BLK=000,BarcodeSize=A,B,C,D [CR]	
	Response	WX,OK [CR]	
RX	Command	RX,PRG=0000,BLK=000,BarcodeSize [CR]	
	Response	RX,OK,A,B,C,D [CR]	
Parameter	A:	Depends on the area size Normal(X):000.200 to 125.000 Other model: □"Barcode height" of "Appendix-2 Model-Specific Input Value List" (Page49).	Barcode height (mm) * Default value "5"
	B:	00.010 to 10.000	Narrow bar (mm) * Default value "0.2"
	C:	002.0 to 004.0	Bar ratio (x) * Default value "2.5"
	D:	01 to 99	Quiet zone (x) * Default value "10"

- Reference** • This command can be sent to a block No. having the block type (BlockType) of "09: Barcode/2D Code" AND barcode type (CodeType) of "01: CODE39/02: ITF/03: 2of5/04: NW7/05: JAN/06: CODE128/18: CODE93".
- The bar ratio cannot be set in the case of JAN/EAN/UPC/CODE93/CODE128.
 - The quiet zone cannot be set when the format is "Normal."

12. GS1 DataBar size (Change/Request)

Command		GS1DataBarSize	
Description		Changes/requests the module width, linear code height, separator height, 2D module height, guard width and quiet zone width of GS1 DataBar.	
Target		PRG=0000 to 1999, BLK=000 to 255	
WX	Command	WX,PRG=0000,BLK=000,GS1DataBarSize=A,B,C,D,E,F [CR]	
	Response	WX,OK [CR]	
RX	Command	RX,PRG=0000,BLK=000,GS1DataBarSize [CR]	
	Response	RX,OK,A,B,C,D,E,F [CR]	
Parameter	A:	00.010 to 10.000	Module width (mm) * Default value 0.25
	B:	Depends on the area size Normal(X):000.200 to 125.000 Other model: □"Linear code height" of "Appendix-2 Model-Specific Input Value List" (Page49).	Linear code height (mm) * Default value "8.25" for GS1 DataBar Truncated, "3" for GS1 DataBar Stacked and "2.5" for GS1 DataBar Limited
	C:	0.010 to 5.000	Separator height (mm) * Fixed value of "0.25" when the barcode type is GS1 DataBar (Truncated) and GS1 DataBar Limited. * Default value "0.25"
	D:	0.010 to 5.000	2D module height (mm) * Fixed value of "0.5" when the barcode type is other than CC-A * Default value "0.5"
	E:	00 to 10	Guard (x) * Default value "0"
	F:	01 to 50	Quiet zone (x) * Default value "1"

- Reference** • This command can be sent to a block No. having the block type (BlockType) of "09: Barcode/2D Code" AND barcode type (CodeType) of "11 to 16: GS1 DataBar".
- The guard can be set when the format is "Black/white inversion."
 - The quiet zone can be set when CC-A and the format is "Black/white inversion."

13. DataMatrix size (Change/Request)

Command		DataMatrixSize	
Description		Changes/requests the symbol size, cell size and quiet zone width of DataMatrix.	
Target		PRG=0000 to 1999, BLK=000 to 255	
WX	Command	WX,PRG=0000,BLK=000,DataMatrixSize=A,B,C [CR]	
	Response	WX,OK [CR]	
RX	Command	RX,PRG=0000,BLK=000,DataMatrixSize [CR]	
	Response	RX,OK,A,B,C [CR]	
Parameter	A:	0001 to 0030	Symbol size 0001: 10x10/ 0002: 12x12/ 0003: 14x14/ 0004: 16x16/ 0005: 18x18/ 0006: 20x20/ 0007: 22x22/ 0008: 24x24/ 0009: 26x26/ 0010: 32x32/ 0011: 36x36/ 0012: 40x40/ 0013: 44x44/ 0014: 48x48/ 0015: 8x18/ 0016: 8x32/ 0017: 12x16/ 0018: 12x36/ 0019: 16x36/ 0020: 16x48/ 0021: 52x52/ 0022: 64x64/ 0023: 72x72/ 0024: 80x80/ 0025: 88x88/ 0026: 96x96/ 0027: 104x104/ 0028: 120x120/ 0029: 132x132/ 0030: 144x144
	B:	00.010 to 05.000	Cell size (mm) * Default value "0.2"
	C:	01~05	Quiet zone (x) * Default value "1"

- Reference** • This command can be sent to a block No. having the block type (BlockType) of "09: Barcode/2D Code" AND barcode type (CodeType) of "10: DataMatrix, 17: GS1 DataMatrix".
- The quiet zone cannot be set when the format is "Normal."

14. QR Code size (Change/Request)

Command		QRCodeSize	
Description		Changes/requests the version, cell size, and quiet zone width of QR Code.	
Target		PRG=0000 to 1999, BLK=000 to 255	
WX	Command	WX,PRG=0000,BLK=000,QRCodeSize=A,B,C,D [CR]	
	Response	WX,OK [CR]	
RX	Command	RX,PRG=0000,BLK=000,QRCodeSize [CR]	
	Response	RX,OK,A,B,C,D [CR]	
Parameter	A:	0001 to 0005	Version 1:1/M1 2:2/M2 3:3/M3 4:4/M4 5:5/M5 6: -/M6 7: -/M7 8: -/M8 9: -/M9 10: -/M10 11: -/M11 12: -/M12 13: -/M13 14: -/M14 15: -/M15 16: -/M16 17: -/M17 18: -/M18 19: -/M19 20: -/M20 21: -/M21 22: -/M22 23: -/M32 24: -/M24 25: -/M25 26: -/M26 27: -/M27 28: -/M28 29: -/M29 30: -/M30 * Default value "0" * The input range for Model 1 is "0 to 14" * The input range for Micro QR is "0 to 4"
	B:	00.010 to 05.000	Cell size (mm) * Default value "0.2"
	C:	0/1	Mode Auto 0: Disabled 1: Enabled * Default value "1"
	D:	01 to 05	Quiet zone (x) * Default value "4" for QR Code Model 1/2, "2" for Micro QR Code

- Reference** • This command can be sent to a block No. having the block type (BlockType) of "09: Barcode/2D Code" AND barcode type (CodeType) of "07: QR Model 1/08: QR Model 2/09: Micro QR".
- The mode AUTO cannot be set in the case of the micro QR.
 - The quiet zone can be set when the format is "Black/white inversion."

15. Block position (Change/Request)

Command	BlockPosition	
Description	Changes/requests the X/Y/Z coordinates and Z coordinate reference of the common parameters of a block.	
Target	PRG=0000 to 1999, BLK=000 to 255	
WX	Command	WX,PRG= 0000 ,BLK= 000 ,BlockPosition= A,B,C [CR]
	Response	WX,OK [CR]
RX	Command	RX,PRG= 0000 ,BLK= 000 ,BlockPosition [CR]
	Response	RX,OK, A,B,C [CR]
Parameter	A: Depends on the area size Normal(X):-062.500 to 0062.500 Other model: □"X coordinate" of "Appendix-2 Model-Specific Input Value List" (Page49).	X coordinate (mm) * Default value "0"
	B: Depends on the area size Normal(X):-062.500 to 0062.500 Other model: □"Y coordinate" of "Appendix-2 Model-Specific Input Value List" (Page49).	Y coordinate (mm) * Default value "0"
	C: Depends on the area size and 3D shape type - The 3D shape is XY plane Normal(X/F/U/Z)/Wide(X/F/U/Z): -021.000~0021.000 Small: -015.000~015.000(X), -002.000~002.000(Z) - The 3D shape is slope Normal: -083.500~0083.500 (X/F/U), -081.000~0081.000(Z) Wide: -186.000~0186.000(X/F/U), -171.000~0171.000(Z) Small: -040.000~0040.000(X), -027.000~0027.000(Z) - The 3D shape is cylinder, cone or sphere Normal(X/F/U/Z): -0261.000~0261.000 Wide(X/F/U/Z): -621.000~0621.000 Small: -115.000~0115.000(X), -102.000~0102.000(Z) - The 3D shape is Z-map Normal: -125.000~0125.000(X/F/U), -120.000~0120.000(Z) Wide: -330.000~0330.000(X/U), -300.000~0300.000(F/Z) Small(X/Z): -050.000~0050.000	Z coordinate (mm) * Fixed value of "9999.999" if the common block marking parameters are referenced * Default value "0"

16. Block layout (Change/Request)

Command	BlockLayout	
Description	Changes/requests the reference point, block angle, start angle and character angle of a block.	
Target	PRG=0000 to 1999, BLK=000 to 255	
WX	Command	WX,PRG= 0000 ,BLK= 000 ,BlockLayout= A,B,C,D,E [CR]
	Response	WX,OK [CR]
RX	Command	RX,PRG= 0000 ,BLK= 000 ,BlockLayout [CR]
	Response	RX,OK, A,B,C,D,E [CR]
Parameter	A: 0 to 8	Block reference point: 0: Left 1: Right 2: Center 3: Lower left 4: Lower right 5: Upper left 6: Upper right 7: Top 8: Bottom * Default value "3"
	B: -180.000 to 0180.000	Block angle (°) * Fixed value of "0" when the block type is arc character * Default value "0"
	C: -180.000 to 0180.000	Start angle (°) * Fixed value of "0" when the block type is other than arc character * Default value "90" for clockwise "-90" for counterclockwise
	D: 0/1	Set using character angle 0: Disabled 1: Enabled * Default value "0"
	E: -180.000 to 0180.000	Character angle (°) * Default value "0."

 • This command can be sent to a block No. having the block type (BlockType) of other than "04: Fixed point".

17. Fixed point emission time (Change/Request)

Command	FixedPointProcessingTime	
Description	Changes/requests the fixed point emission time.	
Target	PRG=0000 to 1999, BLK=000 to 255	
WX	Command	WX,PRG= 0000 ,BLK= 000 ,FixedPointProcessingTime= A [CR]
	Response	WX,OK [CR]
RX	Command	RX,PRG= 0000 ,BLK= 000 ,FixedPointProcessingTime [CR]
	Response	RX,OK, A [CR]
Parameter	A: 00000.1 to 65000.0	Emission time (ms) * Default value "1"

 • This command can be sent to a block No. having the block type (BlockType) of "04: Fixed point".

3-7 Marking parameters

1. Marking parameters (Change/Request)

Command	MarkingParameter
Description	Changes/requests the laser power, scan speed, pulse frequency, spot variable and marking count of a block.
Target	PRG=0000 to 1999, BLK=000 to 255
WX	Command WX,PRG= 0000 ,BLK= 000 ,MarkingParameter= A,B,C,D,E [CR]
	Response WX,OK [CR]
RX	Command RX,PRG= 0000 ,BLK= 000 ,MarkingParameter [CR]
	Response RX,OK, A,B,C,D,E [CR]
Parameter	A: 000.0~100.0 / 999.9 Laser power (%) * Fixed value of "999.9" if the common block marking parameter is referenced * Default value "0"
	B: Depends on the area size Normal(X):00001 to 12000 Other model: □"Scan speed" of "Appendix-2 Model-Specific Input Value List" (Page49). Scan speed (mm/s) * Fixed value of "99999" if the common block marking parameter is referenced * Default value "1000"
	C: Differs depending on the model Normal(X):000 to 400 Other model: □"Pulse frequency" of "Appendix-2 Model-Specific Input Value List" (Page49). Pulse frequency (kHz) * Fixed value of "999" if the common block marking parameter is referenced * Default value "100"
	D: Depends on the area size Normal(X):-210 to 0210 Other model: □"Spot variable" of "Appendix-2 Model-Specific Input Value List" (Page49). Spot variable * Fixed value of "9999" if the common block marking parameter is referenced * Default value "0"
	E: 001 to 100 / 999 Marking count (times) * Fixed value of "999" if the common block marking parameter is referenced * Default value "1"

2. Barcode/2D code pattern setting (Change/Request)

Command	CodePattern
Description	Changes/requests the various pattern settings, cell marking order and cell marking count of a barcode/2D code.
Target	PRG=0000 to 1999, BLK=000 to 255
WX	Command WX,PRG= 0000 ,BLK= 000 ,CodePattern= A,B,C,D,E,F [CR]
	Response WX,OK [CR]
RX	Command RX,PRG= 0000 ,BLK= 000 ,CodePattern [CR]
	Response RX,OK, A,B,C,D,E,F [CR]
Parameter	A: 000 to 011/254 Pattern (QR Code/DataMatrix/Bar Code) 000: -/-/Alternate 001: Pattern 1/A/Unidirectional 002: Pattern 2/B/- 003: Pattern 3/C/- 004: Pattern 4/D/- 005: Pattern 5/E/- 006: Pattern 6/F/- 007: Pattern 7/Entire pattern 1/- 008: Entire pattern 1/Entire pattern 2/- 009: Entire pattern 2/Entire pattern 3/- 010: Entire pattern 3/Entire pattern 4/- 011: Entire pattern 4/Entire pattern 5/- 012: Entire pattern 5/Entire pattern 6/- 013: Entire pattern 6/-/- 254: Individual/Individual/ - * Default value "9" for QR, DataMatrix, "0" for Bar Code * Entire pattern 5/6: Available on only MD-U1000 series
	B: 000 to 002/255 Finder 000: No 001: F1 002: F2 255: =Cell * Fixed value of "0" when other than QR Code AND B is 0 to 2 * Default value "1"
	C: 000 to 002/255 Alignment 000: No 001: A1 002: A2 255: =Cell * Fixed value of "0" when other than DataMatrix AND C is 0 to 2 * Default value "1"
	D: 000 to 008 Cell (QR Code/DataMatrix) 000: None/None 001: M1/C1 002: M2/C2 003: M3/C3 004: M4/C4 005: M5/C5 006: M6/C6 007: M7/C7 008: M8/C8 * Default value "1"
	E: 000 to 003 Cell marking order 0: None 1: Continuous 2: Skip 1 cell 3: Skip 2 cells *A: Fixed value of "0" when 8 to 11
	F: 001 to 100 Cell marking count (times) *A: Fixed value of "1" when 8 to 11 * Default value "1"

- Reference**
- This command can be sent to a block No. having the block type (BlockType) of "09: Barcode/2D Code".
 - "D: 0" cannot be set when "B: 0/255."
 - "D: 0" cannot be set when "C: 0/255."

3. Hatch logo pattern setting (Change/Request)

Command		HatchPattern	
Description		Changes/requests the fill type, pattern, fill direction, start position, fill angle, and fill cross angle of a hatch logo.	
Target		PRG=0000 to 1999, BLK=000 to 255	
WX	Command	WX,PRG= 0000 ,BLK= 000 ,HatchPattern= A,B,C,D,E,F,G _[CR]	
	Response	WX,OK _[CR]	
RX	Command	RX,PRG= 0000 ,BLK= 000 ,HatchPattern _[CR]	
	Response	RX,OK, A,B,C,D,E,F,G _[CR]	
Parameter		A: 0 to 2	Fill Type 0: Boundary + Fill 1: Fill 2: Boundary * Default value "0"
		B: 0 to 2	Pattern 0: Slant 1: Cross 2: Contour *A: Fixed value of "0" when 2 * Default value "0"
		C: 0 to 5	Slant/Cross direction 0: Right to left 1: Left to right 2: Left to right, Right to left 3: Right to left, Left to right 4: Left to right, Right to left (High Speed) 5: Right to left, Left to right (High Speed) * Fixed value of "2" when A is 0 or B is 2 * Default value "2" *4/5: Available on only MD-U1000 series
		D: 0 to 3	Contour direction 0: Clockwise 1: Counterclockwise 2: Clockwise to Counterclockwise 3: Counterclockwise to Clockwise * Fixed value of "0" when A is 2 or B is 0/1 * Default value "0"
		E: 0/1	Contour drawing start position 0: Inside 1: Outside * Fixed value of "1" when A is 2 or B is 0/1 * Default value "0"
		F: 000 to 359	Slant/Cross fill angle (°) * Fixed value of "0" when A is 2 or B is 2 * Default value "0"
		G: 000 to 359	Cross angle (°) * Fixed value of "0" when A is 2 or B is 0/2 * Default value "0"

 This command can be sent to a block No. having the block type (BlockType) of "-4: Hatch logo".

4. TrueType font pattern setting (Change/Request)

Command		TTFPattern	
Description		Changes/requests the fill type, pattern, fill direction, fill angle, and fill cross angle of a TrueType font.	
Target		PRG=0000 to 1999, BLK=000 to 255	
WX	Command	WX,PRG= 0000 ,BLK= 000 ,TTFPattern= A,B,C,D,E _[CR]	
	Response	WX,OK _[CR]	
RX	Command	RX,PRG= 0000 ,BLK= 000 ,TTFPattern _[CR]	
	Response	RX,OK, A,B,C,D,E _[CR]	
Parameter		A: 0 to 2	Fill Type 0: Boundary + Fill 1: Fill 2: Boundary * Default value "0"
		B: 0/1	Pattern 0: Slant 1: Cross *A: Fixed value of "0" when 2 * Default value "0"
		C: 0 to 3	Fill direction 0: Right to left 1: Left to right 2: Left to right, Right to left 3: Right to left, Left to right 4: Left to right, Right to left (High Speed) 5: Right to left, Left to right (High Speed) *A: Fixed value of "2" when 2/3 * Default value "2" *4/5: Available on only MD-U1000 series
		D: 000 to 359	Fill angle (°) * Fixed value of "0" when 2 * Default value "0"
		E: 000 to 359	Fill cross angle (°) * Fixed value of "0" when A is 2 or B is 0 * Default value "90"

 This command can be sent to a block No. having the block type (BlockType) of "00: Horizontal characters/01: Vertical characters/02: Arc clockwise/03: Arc counterclockwise" AND the font type of TrueType font.

5. Barcode/2D code fill marking parameters (Change/Request)

Command		CodeFillParameter	
Description		Changes/requests the fill interval and shrink fill of a barcode/2D code.	
Target		PRG=0000 to 1999, BLK=000 to 255	
WX	Command	WX,PRG= 0000 ,BLK= 000 ,CodeFillParameter= A,B _[CR]	
	Response	WX,OK _[CR]	
RX	Command	RX,PRG= 0000 ,BLK= 000 ,CodeFillParameter _[CR]	
	Response	RX,OK, A,B _[CR]	
Parameter		A: 0.000 to 1.000/9.999	Fill interval (mm) * Fixed value of "9.999" if the common block marking parameter is referenced * Default value "Normal: 0.06"/"Wide: 0.08"/"Small: 0.03"
		B: -Bar Code: -5.000 to 05.000, QR Code/DataMatrix: -2.500~02.500	Shrink fill (mm) * Default value "0"

 This command can be sent to a block No. having the block type (BlockType) of "09: Barcode/2D Code".

6. Hatch logo fill marking parameters

Command		HatchParameter	
Description		Changes/requests the fill interval, common line interval setting reference, shrink fill, no. of skipped fill lines, overprinting enable/disable, overprinting direction, overprinting count, shrink boundary, boundary fill setting, and printing order of a hatch logo.	
Target		PRG=0000 to 1999, BLK=000 to 255	
WX	Command	WX,PRG= 0000 ,BLK= 000 ,HatchParameter= A,B,C,D,E,F,G,H [CR]	
	Response	WX,OK [CR]	
RX	Command	RX,PRG= 0000 ,BLK= 000 ,HatchParameter [CR]	
	Response	RX,OK, A,B,C,D,E,F,G,H [CR]	
Parameter		A: 0.000 to 1.000 / 9.999	Fill interval (mm) * Fixed value of "9.999" if the common block marking parameter is referenced * Default value "Normal: 0.06"/"Wide: 0.08"/"Small: 0.03"
		B: 00.000 to 10.000	Shrink fill (mm) * Default value "0"
		C: 000 to 255	Skip line count (lines) * Default value "0"
		D: 0/1	Overprinting setting 0: Disabled 1: Enabled * Default value "0"
		E: 0/1	Overprinting direction 0: Alternate 1: Forward * Default value "0"
		F: 001 to 255	Overprinting count * Default value "1"
		G: 00.000 to 10.000	Shrink boundary (mm) * Default value "0"
		H: 0/1	Writing Order 0: Boundary -> Fill 1: Fill -> Boundary * Default value "1"

Reference

This command can be sent to a block No. having the block type (BlockType) of "-4: Hatch logo" and the fill type in hatch logo pattern setting (HatchPattern) of 0: Boundary + Fill/1: Fill".

7. TrueType font fill marking parameters (Change/Request)

Command		TTFParameter	
Description		Changes/requests the fill interval, common line interval setting reference, shrink fill, no. of skipped fill lines, overprinting enable/disable, overprinting direction, overprinting count, shrink boundary, and writing order of a TrueType font.	
Target		PRG=0000 to 1999, BLK=000 to 255	
WX	Command	WX,PRG= 0000 ,BLK= 000 ,TTFParameter= A,B,C,D,E,F,G,H [CR]	
	Response	WX,OK [CR]	
RX	Command	RX,PRG= 0000 ,BLK= 000 ,TTFParameter [CR]	
	Response	RX,OK, A,B,C,D,E,F,G,H [CR]	
Parameter		A: 0.000 to 1.000 / 9.999	Fill interval (mm) * Fixed value of "9.999" if the common block marking parameter is referenced * Default value "Normal: 0.06"/"Wide: 0.08"/"Small: 0.03"
		B: 00.000 to 10.000	Shrink fill * Default value "0"
		C: 000 to 255	Skip line count (lines) * Default value "0"
		D: 0/1	Overprinting setting 0: Disabled 1: Enabled * Default value "0"
		E: 0/1	Overprinting direction 0: Alternate 1: Forward * Default value "0"
		F: 001 to 255	Overprinting count * Default value "1"
		G: 00.000 to 10.000	Shrink boundary (mm) * Default value "0"
		H: 0/1	Writing order 0: Boundary -> Fill 1: Fill -> Boundary * Default value "1"

Reference

This command can be sent to a block No. having the block type (BlockType) of "00: Horizontal characters/01: Vertical characters/02: Arc clockwise/03: Arc counterclockwise" AND the font type of TrueType AND the fill type in the TrueType font patterning setting (TTFPattern) of "0: Boundary + Fill/1: Fill".

8. Photo setting (Change/Request)

Command		PhotoSetting	
Description		Changes/requests the gamma correction, contrast, contrast enhancement, brightness, skip dots and intensity of a photo.	
Target		PRG=0000 to 1999, BLK=000 to 255	
WX	Command	WX,PRG= 0000 ,BLK= 000 ,PhotoSetting= A,B,C,D,E,F [CR]	
	Response	WX,OK [CR]	
RX	Command	RX,PRG= 0000 ,BLK= 000 ,PhotoSetting [CR]	
	Response	RX,OK, A,B,C,D,E,F [CR]	
Parameter		A: 0.01 to 9.99 (High resolution only)	Gamma correction * Default value "0.6"
		B: -128 to 0127 (High resolution only)	Contrast * Default value "0"
		C: 0/1 (High resolution only)	Contrast enhancement 0: Disabled 1: Enabled * Default value "0"
		D: -128 to 0127 (High resolution only)	Brightness * Default value "0"
		E: 1 to 8 (Grayscale only)	Skip dots * Default value "1"
		F: 1 to 8 (Grayscale only)	Intensity Default value "3"

- Reference
- This command can be sent to a block No. having the block type (BlockType) of "-3: Photo".
 - You cannot use on the MD-F3200/5200 series.

9. Marking flag (Change)

Command		MarkingEnable	
Description		Changes the marking flag of a block.	
Target		PRG=0000 to 1999, BLK=000 to 255	
WX	Command	WX,PRG= 0000 ,BLK= 000 ,MarkingEnable= A,BBB--- [CR]	
	Response	WX,OK [CR]	
RX	Command	No	
	Response	No	
Parameter		A: 0/1/2	Reset the marking flag 0: Set the marking flag of all blocks to OFF 1: Set the marking flag of all blocks to ON 2: Do not change other than the specified block
		B: 0/1	Marking flag 0: Do not Mark 1: Mark * You can change the marking flag of continuous blocks in a batch by sending this parameter in multiple digits.

- Reference
- To change the marking flag of multiple blocks in a batch, send parameter B in multiple digits.
To set block No.10 to ON, No.11 to OFF, No.12 to ON and all other blocks to OFF, send the command as described below.
WX,PRG=0000,BLK=010,MarkingEnable=0,101 [CR]

10. Individual fill marking parameters (Change/Request)

Command		FillMarkingParameter	
Description		Changes/requests the enable/disable and the setting values of the individual fill parameters of a hatch logo.	
Target		PRG=0000 to 1999, BLK=000 to 255	
WX	Command	WX,PRG= 0000 ,BLK= 000 ,FillMarkingParameter= A,B,C,D,E,F [CR]	
	Response	WX,OK [CR]	
RX	Command	RX,PRG= 0000 ,BLK= 000 ,FillMarkingParameter [CR]	
	Response	RX,OK, A,B,C,D,E,F [CR]	
Parameter		A: 0/1	Individual fill parameters 0: Enabled 1: Disabled
		B: 000.0 to 100.0/9.999	Fill line laser power (%) * Fixed value of "999.9" if the common block marking parameter is referenced *A: Fixed value of "0" when 1 * Default value "0"
		C: Depends on the area size Normal(X):00001 to 12000 Other model: ☐"Scan speed" of "Appendix-2 Model-Specific Input Value List" (Page49).	Fill line scan speed (mm/s) * Fixed value of "99999" if the common block marking parameter is referenced *A: Fixed value of "1000" when 1 * Default value "1000"
		D: Differs depending on the model Normal(X):000 to 400 Other model: ☐"Pulse frequency" of "Appendix-2 Model-Specific Input Value List" (Page49).	Fill line pulse frequency (kHz) * Fixed value of "999" if the common block marking parameter is referenced *A: Fixed value of "100" when 1 * Default value "100"
		E: Depends on the area size Normal(X):-210 to 0210 Other model: ☐"Spot variable" of "Appendix-2 Model-Specific Input Value List" (Page49).	Fill spot variable * Fixed value of "9999" if the common block marking parameter is referenced * A: Fixed value of "0" when 1 * Default value "0"
		F: 001 to 100/999	Fill line marking count (times) * Fixed value of "999" if the common block marking parameter is referenced * A: Fixed value of "1" when 1 * Default value "1"

- Reference
- This command can be sent to a block No. having the block type (BlockType) of "-4: Hatch logo" or TrueTypeFont.

11. Jump Speed (Change/Request)

Command		JumpSpeed	
Description		Changes/requests the jump speed.	
Target		PRG=0000 to 1999, BLK=000 to 255	
WX	Command	WX,PRG= 0000 ,BLK= 000 ,JumpSpeed= A [CR]	
	Response	WX,OK [CR]	
RX	Command	RX,PRG= 0000 ,BLK= 000 ,JumpSpeed [CR]	
	Response	RX,OK, A [CR]	
Parameter		A: 0/1/2	Jump Speed 0: Top Speed 1: High Speed 2: Medium Speed * Default value "0"

- Reference
- This command is enabled when the quality level (MarkingQuality) is not "05: Customize".

12. Nudge marking quality setting (Change/Request)

Command		MarkingQuality	
Description		Changes/requests the skip cross, common skip cross setting reference, quality level, common quality level setting reference, and marking start wait time of a block.	
Target		PRG=0000 to 1999, BLK=000 to 255	
WX	Command	WX,PRG= 0000 ,BLK= 000 ,MarkingQuality= A,B,C [CR]	
	Response	WX,OK [CR]	
RX	Command	RX,PRG= 0000 ,BLK= 000 ,MarkingQuality [CR]	
	Response	RX,OK, A,B,C [CR]	
Parameter	A: 00.000 to 10.000 / 99.999	Skip cross (mm) * Fixed value of "99.999" if the common block marking parameter is referenced * Default value "0"	
	B: 00 to 06 / 99	Quality Level 00: Top speed 01: Speed priority 02: Standard 03: High quality 04: Top quality 05: Customize 06: Top speed 2 * Fixed value of "99" if the common block marking parameter is referenced * Default value "02"	
	C: 00000.0 to 65000.0	Wait time for start marking (ms) * Default value "0"	

-  • The top Speed 2 is used on MD-X1000/1500 series only.
• The skip cross can be set only for the character strings except TrueTypeFont.

13. Approach (Change/Request)

Command		Approach	
Description		Changes/requests the block approach.	
Target		PRG=0000 to 1999, BLK=000 to 255	
WX	Command	WX,PRG= 0000 ,BLK= 000 ,Approach= A [CR]	
	Response	WX,OK [CR]	
RX	Command	RX,PRG= 0000 ,BLK= 000 ,Approach [CR]	
	Response	RX,OK, A [CR]	
Parameter	A: Normal, Wide: 0.000 to 5.000, Small: 0.000 to 2.500	Approach (mm) * Default value "0.500"	

-  • This command is enabled when the quality level (MarkingQuality) is "05: Customize".

14. Space approach (Change/Request)

Command		SpaceApproach	
Description		Changes/requests the space approach.	
Target		PRG=0000 to 1999, BLK=000 to 255	
WX	Command	WX,PRG= 0000 ,BLK= 000 ,SpaceApproach= A [CR]	
	Response	WX,OK [CR]	
RX	Command	RX,PRG= 0000 ,BLK= 000 ,SpaceApproach [CR]	
	Response	RX,OK, A [CR]	
Parameter	A: 0.000 to 5.000	Space approach (mm) * Default value "0.250"	

-  • This command is enabled when the quality level (MarkingQuality) is "05: Customize".

15. Curve correction (Change/Request)

Command		CurveCorrection	
Description		Changes/requests the curve correction.	
Target		PRG=0000 to 1999, BLK=000 to 255	
WX	Command	WX,PRG= 0000 ,BLK= 000 ,CurveCorrection= A [CR]	
	Response	WX,OK [CR]	
RX	Command	RX,PRG= 0000 ,BLK= 000 ,CurveCorrection [CR]	
	Response	RX,OK, A [CR]	
Parameter	A: 0/1	Curve correction 0: Disabled 1: Enabled * Default value "1"	

-  • You cannot use Curve Correction on the MD-F3200/5200 series.

3-8 Code overprinting parameters

1. Barcode/2D code overprinting marking parameters (Change/Request)

Command		MultiPassMarkingParameter	
Description		Specifies the overprinting order in the barcode/2D code overprinting setting and changes/requests the marking parameters.	
Target		PRG=0000 to 1999,BLK=000 to 255,OLP=0 to 9	
WX	Command	WX,PRG= 0000 ,BLK= 000 ,OLP= 0 ,MultiPassMarkingParameter= A,B,C,D,E,F,G [CR]	
	Response	WX,OK [CR]	
RX	Command	RX,PRG= 0000 ,BLK= 000 ,OLP= 0 ,MultiPassMarkingParameter [CR]	
	Response	RX,OK, A,B,C,D,E,F,G [CR]	
Parameter		A: 0 to 2	Format 0: Code 1: Code (Black/white inversion) 2: Base * Default value "2"
		B: 000.0 to 100.0/999.9	Laser power (%) * Fixed value of "999.9" if the common block marking parameter is referenced * Default value "0"
		C: Depends on the area size Normal(X):00001 to 12000 Other model: □"Scan speed" of "Appendix-2 Model-Specific Input Value List" (Page49).	Scan speed (mm/s) * Fixed value of "99999" if the common block marking parameter is referenced * Default value "1000"
		D: Differs depending on the model Normal(X):000 to 400 Other model: □"Pulse frequency" of "Appendix-2 Model-Specific Input Value List" (Page49).	Pulse frequency (kHz) * Fixed value of "999" if the common block marking parameter is referenced * Default value "100"
		E: Depends on the area size Normal(X):-210 to 0210 Other model: □"Spot variable" of "Appendix-2 Model-Specific Input Value List" (Page49).	Spot variable * Fixed value of "9999.9" if the common block marking parameter is referenced * Default value "0"
		F: 001 to 100/999	Marking count (times) * Fixed value of "999" if the common block marking parameter is referenced * Default value "1"
		G: Depends on the area size Normal(X):00.000 to 42.000 Other model: □"Deep dig amount" of "Appendix-2 Model-Specific Input Value List" (Page49).	Deep dig amount (mm) * Default value "0"

- Reference** - This command can be sent when the type of block (BlockType) is "09: Barcode/2D code" and the format setting of the barcode or 2D code related settings (CodeSetting) is the block No. of "2: Overprinting."
- The overprinting can be added when inseting No. is specified so that it becomes consecutive number at OLP.

2. Barcode/2D code overprinting pattern setting (Change/Request)

Command		MultiPassPattern	
Description		Specifies the overprinting order in the barcode/2D code overprinting settings and changes/requests the various pattern settings, cell marking order and cell marking count.	
Target		PRG=0000 to 1999,BLK=000 to 255,OLP=0 to 9	
WX	Command	WX,PRG= 0000 ,BLK= 000 ,OLP= 0 ,MultiPassPattern= A,B,C,D,E,F [CR]	
	Response	WX,OK [CR]	
RX	Command	RX,PRG= 0000 ,BLK= 000 ,OLP= 0 ,MultiPassPattern [CR]	
	Response	RX,OK, A,B,C,D,E,F [CR]	
Parameter		A: 000 to 011/254	Pattern (QR Code/DataMatrix/2D Code base/Bar Code/Bar Code base) 000: -/-/-/Alternate/- 001: Pattern 1/A/B1/Unidirectional/Alternate 002: Pattern 2/B/B2-/Unidirectional 003: Pattern 3/C/B3-/Alternate (Horiz.) 004: Pattern 4/D/B4-/Unidirectional (Horiz.) 005: Pattern 5/E/B5-/Unidirectional 006: Pattern 6/F/B6-/Unidirectional 007: Pattern 7/Entire pattern 1/B7-/Unidirectional 008: Entire pattern 1/Entire pattern 2/B8-/Unidirectional 009: Entire pattern 2/Entire pattern 3/B9-/Unidirectional 010: Entire pattern 3/Entire pattern 4/-/-/-/Unidirectional 011: Entire pattern 4/Entire pattern 5/-/-/-/Unidirectional 012: Entire pattern 5/Entire pattern 6/-/-/-/Unidirectional 013: Entire pattern 6/-/-/-/Unidirectional 254: Individual/Individual/-/-/-/Unidirectional * Default value "0" for Bar Code, "9" for 2D Code * B7/8/9, Entire pattern 5/6: Available on only MD-U1000 series
		B: 000 to 002/255	Finder 000: No 001: F1 002: F2 255: =Cell * Fixed value of "0" when other than QR Code AND B is 0 to 2 * Default value "0"
		C: 000 to 002/255	Alignment 000: No 001: A1 002: A2 255: =Cell * Fixed value of "0" when other than DataMatrix AND C is 0 to 2 * Default value "0"
		D: 000 to 008	Cell (QR Code/DataMatrix) 000: None/None 001: M1/C1 002: M2/C2 003: M3/C3 004: M4/C4 005: M5/C5 006: M6/C6 007: M7/C7 008: M8/C8 * Default value "0"
		E: 001 to 003	Cell marking order 001: Continuous 002: Skip 1 cell 003: Skip 2 cells *A: Fixed value of "1" when 8 to 11
		F: 001 to 100	Cell marking count (times) *A: Fixed value of "1" when 8 to 11 * Default value "1"

- Reference** - This command can be sent when the type of block (BlockType) is "09: Barcode/2D code" and the format setting of the barcode or 2D code related settings (CodeSetting) is the block No. of "2: Overprinting."
- "D: 0" cannot be set when "B: 0/255."
 - "D: 0" cannot be set when "C: 0/255."

3. Barcode/2D code overprinting fill parameters (Change/Request)

Command		MultiPassFillParameters	
Description		Specifies the overprinting order in the barcode/2D code overprinting setting and changes/requests the fill interval, common line interval setting and shrink fill.	
Target		PRG=0000 to 1999, BLK=000 to 255, OLP=0 to 9	
WX	Command	WX, PRG= 0000 , BLK= 000 , OLP= 0 , MultiPassFillParameters= A, B [CR]	
	Response	WX, OK [CR]	
RX	Command	RX, PRG= 0000 , BLK= 000 , OLP= 0 , MultiPassFillParameters [CR]	
	Response	RX, OK, A, B [CR]	
Parameter		A: 0.000 to 1.000 /9.999	Fill interval (mm) * Fixed value of "9.999" if the common block marking parameter is referenced * Default value "Normal: 0.06"/"Wide: 0.08"/"Small: 0.03"
		B: 2D code: -2.500 to 02.500 Barcode: -5.000 to 05.000	Shrink fill (mm) * Default value "0"

 This command can be sent when the type of block (BlockType) is "09: Barcode/2D code" and the format setting of the barcode or 2D code related settings (CodeSetting) is the block No. of "2: Overprinting."

4. Quality level of barcode/2D code overprinting (Change/Request)

Command		MultiPassQualityLevel	
Description		In barcode/2D code overprinting settings, specify the overprinting order and change/request the quality level.	
Target		PRG=0000 to 1999, BLK=000 to 255, OLP=0 to 9	
WX	Command	WX, PRG= 0000 , BLK= 000 , OLP= 0 , MultiPassQualityLevel= A [CR]	
	Response	WX, OK [CR]	
RX	Command	RX, PRG= 0000 , BLK= 000 , OLP= 0 , MultiPassQualityLevel [CR]	
	Response	RX, OK, A [CR]	
Parameter		A: 00 to 06	Quality Level 00: Top speed 01: Speed priority 02: Standard 03: High quality 04: Top quality 05: Customize 06: Top speed 2 * Default value "02"

 The top Speed 2 is used on MD-X1000/1500 series only.

5. Approach of barcode/2D code overprinting (Change/Request)

Command		MultiPassApproach	
Description		In barcode/2D code overprinting settings, specify the overprinting order and change/request the approach.	
Target		PRG=0000 to 1999, BLK=000 to 255, OLP=0 to 9	
WX	Command	WX, PRG= 0000 , BLK= 000 , OLP= 0 , MultiPassApproach= A [CR]	
	Response	WX, OK [CR]	
RX	Command	RX, PRG= 0000 , BLK= 000 , OLP= 0 , MultiPassApproach [CR]	
	Response	RX, OK, A [CR]	
Parameter		A: Normal/Wide: 0.000 to 5.000, Small: 0.000 to 2.500	Approach (mm) * Default value "0.500"

 This command is enabled when the quality level of barcode/2D code overprinting (MultiPassQualityLevel) is "05: Customize".

6. Space approach of barcode/2D code overprinting (Change/Request)

Command		MultiPassSpaceApproach	
Description		In barcode/2D code overprinting settings, specify the overprinting order and change/request the space approach.	
Target		PRG=0000 to 1999, BLK=000 to 255, OLP=0 to 9	
WX	Command	WX, PRG= 0000 , BLK= 000 , OLP= 0 , MultiPassSpaceApproach= A [CR]	
	Response	WX, OK [CR]	
RX	Command	RX, PRG= 0000 , BLK= 000 , OLP= 0 , MultiPassSpaceApproach [CR]	
	Response	RX, OK, A [CR]	
Parameter		A: 0.000 to 5.000	Space approach (mm) * Default value "0.250"

 This command is enabled when the quality level of barcode/2D code overprinting (MultiPassQualityLevel) is "05: Customize".

7. Curve correction of barcode/2D code overprinting (Change/Request)

Command		MultiPassCurveCorrection	
Description		In barcode/2D code overprinting settings, specify the overprinting order and change/request the curve correction.	
Target		PRG=0000 to 1999, BLK=000 to 255, OLP=0 to 9	
WX	Command	WX, PRG= 0000 , BLK= 000 , OLP= 0 to 9 , MultiPassCurveCorrection= A [CR]	
	Response	WX, OK [CR]	
RX	Command	RX, PRG= 0000 , BLK= 000 , OLP= 0 to 9 , MultiPassCurveCorrection [CR]	
	Response	RX, OK, A [CR]	
Parameter		A: 0/1	Curve correction 0: Disabled 1: Enabled * Default value "0"

 It cannot be used on the MD-F3200/5200 series.

8. Jump speed of barcode/2D code overprinting (Change/Request)

Command		MultiPassJumpSpeed	
Description		In barcode/2D code overprinting settings, specify the overprinting order and change/request the jump speed.	
Target		PRG=0000 to 1999, BLK=000 to 255, OLP=0 to 9	
WX	Command	WX, PRG= 0000 , BLK= 000 , OLP= 0 to 9 , MultiPassJumpSpeed= A [CR]	
	Response	WX, OK [CR]	
RX	Command	RX, PRG= 0000 , BLK= 000 , OLP= 0 to 9 , MultiPassJumpSpeed [CR]	
	Response	RX, OK, A [CR]	
Parameter		A: 0/1/2	Jump speed 0: Top Speed 1: High Speed 2: Medium Speed * Default value "0"

 This command is enabled when the quality level of barcode/2D code overprinting (MultiPassQualityLevel) is not "05: Customize".

9. Wait time for start marking of barcode/2D code overprinting (Change/Request)

Command		MultiPassBlockMarkingDelayTime	
Description		In barcode/2D code overprinting settings, specify the overprinting order and change/request the wait time for start marking.	
Target		PRG=0000 to 1999, BLK=000 to 255, OLP=0 to 9	
WX	Command	WX, PRG= 0000 , BLK= 000 , OLP= 0 to 9 , MultiPassBlockMarkingDelayTime= A [CR]	
	Response	WX, OK [CR]	
RX	Command	RX, PRG= 0000 , BLK= 000 , OLP= 0 to 9 , MultiPassBlockMarkingDelayTime [CR]	
	Response	RX, OK, A [CR]	
Parameter		A: 00000.0 to 65000.0	Wait time for start marking (ms) * Default value "0"

3-9 3D shape setting

1. 3D shape setting (Change/Request)

Command		3DShape	
Description		Changes/requests the 3D shape setting enable/disable and the 3D shape No. to be pasted.	
Target		PRG=0000 to 1999, BLK=000 to 255	
WX	Command	WX, PRG= 0000 , BLK= 000 , 3DShape= A, B [CR]	
	Response	WX, OK [CR]	
RX	Command	RX, PRG= 0000 , BLK= 000 , 3DShape [CR]	
	Response	RX, OK, A, B [CR]	
Parameter		A: 0/1	3D shape setting 0: XY Plane 1: 3D Shape * Default value "0"
		B: 000 to 255	3D shape No. *A: Fixed value of "0" when 0 * Default value "0"

 • This command can be sent to a block No. having the block type (BlockType) of other than "04: Fixed point".

2. 3D shape type (Change/Request)

Command		3DShapeType	
Description		Specifies the 3D shape No. and creates a new or requests a 3D shape type.	
Target		PRG=0000 to 1999, 3DS=000 to 255	
WX	Command	WX, PRG= 0000 , 3DS= 000 , 3DShapeType= A [CR]	
	Response	WX, OK [CR]	
RX	Command	RX, PRG= 0000 , 3DS= 000 , 3DShapeType [CR]	
	Response	RX, OK, A [CR]	
Parameter		A: -01/000 to 006/020	3D Shape -01: Z map 000: Slope 001: Inside cylinder 002: Outside cylinder 003: Inside cone 004: Outside cone 005: Inside hemisphere 006: Outside hemisphere 020: XY Plane * Default value "20"

 • You cannot change a 3D shape No. for which a 3D shape has already been set. The 3D shape setting information is initialized when the block associated with the 3D shape No. is removed.

• Therefore, associate the block using the 3DShape command following the 3DShapeType.

3. 3D shape position (Change/Request)

Command		3DShapePosition	
Description		Specifies the 3D shape No. and changes/requests the X/Y/Z coordinates and X/Y/Z rotation angles.	
Target		PRG=0000 to 1999, 3DS=000 to 255	
WX	Command	WX,PRG= 0000 ,3DS= 000 ,3DShapePosition= A,B,C,D,E,F _[CR]	
	Response	WX,OK _[CR]	
RX	Command	RX,PRG= 0000 ,3DS= 000 ,3DShapePosition _[CR]	
	Response	RX,OK, A,B,C,D,E,F _[CR]	
Parameter		A: Depends on the area size and block type - The block type is other than arc character Normal(X):0000.200 to 0480.000 Other model: □"X coordinate" of "Appendix-2 Model-Specific Input Value List" (Page49). - The block type is arc character -9999.99 to 09999.99	X coordinate (mm) * Default value "0"
		B: Depends on the area size, block type and 3D shape type - The block type is other than arc character and 3D shape is other than cone Normal(X):0000.200 to 0480.000 Other model: □"Y coordinate" of "Appendix-2 Model-Specific Input Value List" (Page49). - The block type is other than arc character and 3D shape is cone Normal:0000.000 to 0062.500(X/F/U), 0000.000 to 0060.000(Z) Wide:0000.000 to 0165.000(X/U), 0000.000 to 0150.000(F/Z) Small:0000.000 to 0025.000 - The block type is arc character -9999.99 to 09999.99	Y coordinate (mm) * Default value "0"
		C: Depends on the area size and 3D shape type - The 3D shape is cylinder, cone or sphere Normal: -261.000 to 0261.000(X/F/U/Z) Wide: -621.000 to 0621.000 (X/F/U/Z) Small: -115.000 to 0115.000 (X/F/U), -102.000 to 0102.000(Z) - The 3D shape is slope Normal: -083.500 to 0083.500(X/F/U), -081.000 to 0081.000(Z) Wide: -186.000 to 0186.000(X/F/U), -171.000 to 0171.000(Z) Small: -040.000 to 0040.000(X/F/U), -027.000 to 0027.000(Z) - The 3D shape is Z-map Normal: -125.000 to 0125.000(X/F/U) -120.000 to 0120.000(Z) Wide: -330.000 to 0330.000(X/U) -300.000 to 0300.000(F/Z) Small: -050.000 to 0050.000	Z coordinate (mm) * Default value "0"
		D: -180.000 to 0180.000 E: -180.000 to 0180.000 F: -180.000 to 0180.000	X rotation angle (°) * Default value "0" Y rotation angle (°) * Default value "0" Z rotation angle (°) * Default value "0"

- Reference** • This command can be sent to a block No. having the 3D shape setting (3DShape) of "1: 3D Shapes".
- Specify the target specifier 3DS based on the 3D shape No. of the 3D shape setting (3DShape).

4. Diameter of cylinder shape (Change/Request)

Command		CylinderDiameter	
Description		Specifies the 3D shape No. and changes/requests the diameter of a cylinder shape.	
Target		PRG=0000 to 1999, 3DS=000 to 255	
WX	Command	WX,PRG= 0000 ,3DS= 000 ,CylinderDiameter= A _[CR]	
	Response	WX,OK _[CR]	
RX	Command	RX,PRG= 0000 ,3DS= 000 ,CylinderDiameter _[CR]	
	Response	RX,OK, A _[CR]	
Parameter		A: Depends on the area size Normal(X): 0000.200 to 0480.000 Other model: □"Cylinder diameter" of "Appendix-2 Model-Specific Input Value List" (Page49).	Cylinder diameter (mm) * Default value "Normal/Wide: 40"/"Small: 20"

- Reference** • This command can be sent to a block No. having the 3D shape setting (3DShape) of "1: 3D Shapes" AND the 3D shape type (3DShapeType) of "01/02: Cylinder".
- Specify the target specifier 3DS based on the 3D shape No. of the 3D shape setting (3DShape).

5. Cone shape size setting (Change/Request)

Command		ConeSize	
Description		Specifies the 3D shape No. and changes/requests the various sizes of a cone shape.	
Target		PRG=0000 to 1999, 3DS=000 to 255	
WX	Command	WX,PRG= 0000 ,3DS= 000 ,ConeSize= A,B,C,D,E _[CR]	
	Response	WX,OK _[CR]	
RX	Command	RX,PRG= 0000 ,3DS= 000 ,ConeSize _[CR]	
	Response	RX,OK, A,B,C,D,E _[CR]	
Parameter		A: Depends on the area size Normal(X): 0000.200 to 0480.000 Other model: □"Bottom diameter of cone" of "Appendix-2 Model-Specific Input Value List" (Page49).	Bottom diameter (mm) * Default value "Normal/Wide: 40"/"Small: 20"
		B: 0/1	Set with bus angle 0: Disabled 1: Enabled * Default value "0"
		C: Depends on the area size Normal(X):0000.200 to 0480.000 Other model: □"Top diameter of cone" of "Appendix-2 Model-Specific Input Value List" (Page49).	Top diameter (mm) * Default value "Normal/Wide: 20"/"Small: 10"
		D: Depends on the area size Normal(X):0000.100 to 125.000 Other model: □"Cone height" of "Appendix-2 Model-Specific Input Value List" (Page49).	Height (mm) * Default value "Normal/Wide: 20"/"Small: 10"
		E: -85.000 to 085.000	Bus angle (°) * Default value "0"

- Reference** • This command can be sent to a block No. having the 3D shape setting (3DShape) of "1: :3D shape" AND the 3D shape type (3DShapeType) of "3/4: Cone".
- Specify the target specifier 3DS based on the 3D shape No. of the 3D shape setting (3DShape).
 - The bus angle cannot be set when the specification is disabled at the bus angle. The top diameter and height cannot be set when the specification is enabled at the bus angle.

6. Diameter of sphere shape (Change/Request)

Command	SphereDiameter	
Description	Specifies the 3D shape No. and changes/requests the diameter of a sphere shape.	
Target	PRG=0000 to 1999, 3DS=000 to 255	
WX	Command	WX,PRG= 0000 ,3DS= 000 ,SphereDiameter= A [CR]
	Response	WX,OK [CR]
RX	Command	RX,PRG= 0000 ,3DS= 000 ,SphereDiameter [CR]
	Response	RX,OK, A [CR]
Parameter	A: Depends on the area size Normal(X): 0000.200 to 0480.000 Other model: □ "Sphere diameter" of "Appendix-2 Model-Specific Input Value List" (Page49).	Diameter (mm) * Default value "20"

- Reference** • This command can be sent to a block No. having the 3D shape setting (3DShape) of "1: 3D Shapes" AND the 3D shape type (3DShapeType) of "05/06: Sphere".
- Specify the target specifier 3DS based on the 3D shape No. of the 3D shape setting (3DShape).

7. Position on 3D shape (Change/Request)

Command	3DSurfacePosition	
Description	Changes/requests the X/Y/θ positions on the 3D shape.	
Target	PRG=0000 to 1999, BLK=000 to 255	
WX	Command	WX,PRG= 0000 ,BLK= 000 ,3DSurfacePosition= A,B,C [CR]
	Response	WX,OK [CR]
RX	Command	RX,PRG= 0000 ,BLK= 000 ,3DSurfacePosition [CR]
	Response	RX,OK, A,B,C [CR]
Parameter	A: Depends on the area size and block type - The block type is other than arc character Normal(X): -062.500 to 0062.500 Other model: □ "X coordinate" of "Appendix-2 Model-Specific Input Value List" (Page49). - The block type is arc character -9999.99 to 09999.99	X coordinate (mm) on 3D shape * Default value "0"
	B: Depends on the area size, block type and 3D shape type - The block type is other than arc character and 3D shape is other than cone Normal(X/F): -062.500 to 0062.500(X/F/U), -060.500 to 0060.500(Z) Wide(X): -165.000 to 0165.000(X/U), -150.000 to 0150.000(F/Z) Small: -025.000 to 0025.000(U/Z) - The block type is other than arc character and 3D shape is cone Normal: 0000.000 to 0062.500(X/F/U), 0000.000 to 0060.000(Z) Wide: 0000.000 to 0165.000(X/U), 0000.000 to 0150.000(F/Z) Small: 0000.000 to 0025.000(X/Z) - The block type is arc character -9999.99 to 09999.99	Y coordinate (mm) on 3D shape * Default value "0"
	C: -90.000 to 090.000	θ angle (°) on 3D shape * Default value "0"

- Reference** • This command can be sent to a block No. having the 3D shape setting (3DShape) of "01: 3D Shapes".
- When the type of 3D shape (3DShapeType) is a cylinder or cone (001 to 004), the X coordinate on the 3D shape cannot be set.
 - When the type of 3D shape (3DShapeType) is other than a cylinder or cone (001 to 004), the θ angle on the 3D shape cannot be set.

8. Cone setting (Change/Request)

Command	ConeSetting	
Description	Changes/requests how to paste, layout, set the character angle space and open angle of a cone.	
Target	PRG=0000 to 1999, BLK=000 to 255	
WX	Command	WX,PRG= 0000 ,BLK= 000 ,ConeSetting= A,B,C,D [CR]
	Response	WX,OK [CR]
RX	Command	RX,PRG= 0000 ,BLK= 000 ,ConeSetting [CR]
	Response	RX,OK, A,B,C,D [CR]
Parameter	A: 0/1	Char. Frame 0: Use fixed length 1: Use fixed angle * Default value "0"
	B: 1/2	Layout 1: Angular interval 2: Distribute angle 3: Character pitch * Default value "1"
	C: 000.000 to 180.000	Character angle space (°) * Fixed value of "10" when B is 2/3 * Default value "10"
	D: 000.000 to 180.000	Open angle (°) Fixed value of "120" when B is 1/3 * Default value "120"

- Reference** • This command can be sent to a block No. having the 3D shape setting (3DShape) of "01: 3D Shapes" AND the 3D shape type (3DShapeType) of "3/4: Cone".
- B: 3 (Character Pitch) can be set only in the case of TrueTypeFont.

3-10 Matrix setting

1. Matrix row & column setting (Change/Request)

Command	MatrixSetting	
Description	Changes/requests the number of rows/columns and marking direction of a matrix.	
Target	PRG=0000 to 1999	
WX	Command	WX,PRG= 0000 ,MatrixSetting= A,B,C [CR]
	Response	WX,OK [CR]
RX	Command	RX,PRG= 0000 ,MatrixSetting [CR]
	Response	RX,OK, A,B,C [CR]
Parameter	A: 001 to 255	Line count
	B: 001 to 255	Number of columns
	C: 1/2/4/5	Marking direction 1: Horizontal 2: Vertical 4: Horizontal (Alternate) 5: Vertical (Alternate) * Default value "1"

2. Matrix size setting (Change/Request)

Command	MatrixSize	
Description	Changes/requests the height, height specification method, width, and width specification method of a matrix.	
Target	PRG=0000 to 1999	
WX	Command	WX,PRG= 0000 ,MatrixSize= A,B,C [CR]
	Response	WX,OK [CR]
RX	Command	RX,PRG= 0000 ,MatrixSize [CR]
	Response	RX,OK, A,B,C [CR]
Parameter	A: 0/2/3	Height specification method 0: Cell height 2: Maximum distance 3: Matrix height * Default value "0"
	B: Depends on the area size Normal(X): 000.000 to 125.000 Other model: □"Matrix Height/Width" of "Appendix-2 Model-Specific Input Value List" (Page49).	Height (mm) * Default value "15" for Normal/Wide, and "5" for Small
	C: 0/2/3	Width specification method 0: Cell width 2: Maximum distance 3: Matrix width * Default value "0"
	D: Depends on the area size Normal(X): 000.000 to 125.000 Other model: □"Matrix Height/Width" of "Appendix-2 Model-Specific Input Value List" (Page49).	Width (mm) * Default value "15" for Normal/Wide, and "5" for Small

3. Matrix cell reference point (Change/Request)

Command	CellReferencePoint	
Description	Changes/requests the cell reference point of a matrix.	
Target	PRG=0000 to 1999	
WX	Command	WX,PRG= 0000 ,CellReferencePoint= A [CR]
	Response	WX,OK [CR]
RX	Command	RX,PRG= 0000 ,CellReferencePoint [CR]
	Response	RX,OK, A [CR]
Parameter	A: 02 to 06	Cell base point 02: Center 03: Lower left 04: Lower right 05: Upper left 06: Upper right * Default value "02"

 If you change the θ angle of the cell coordinates of the matrix (MatrixCell), it will rotate around this reference point.

4. Cell individual setting (Change/Request)

Command	MatrixCell	
Description	Specifies the matrix cell and changes/requests the marking enable/disable, X/Y/Z coordinate correction, θ angle correction and marking start wait time.	
Target	PRG=0000 to 1999,CEL=00001 to 65025	
WX	Command	WX,PRG= 0000 ,CEL= 00001 ,MatrixCell= A,B,C,D,E,F [CR]
	Response	WX,OK [CR]
RX	Command	RX,PRG= 0000 ,CEL= 00001 ,MatrixCell [CR]
	Response	RX,OK, A,B,C,D,E,F [CR]
Parameter	A: 0/1	Marking flag 0: Do not Mark 1: Mark * Default value "1"
	B: Depends on the area size Normal(X):-062.500 to 0062.500 Other model: □"X coordinate" of "Appendix-2 Model-Specific Input Value List" (Page49).	X coordinate (mm) Default value "0"
	C: Depends on the area size Normal(X):-062.500 to 0062.500 Other model: □"Y coordinate" of "Appendix-2 Model-Specific Input Value List" (Page49).	Y coordinate (mm) Default value "0"
	D: Depends on the area size Normal(X):-021.000 to 0021.000 Other model: □"Z coordinate" of "Appendix-2 Model-Specific Input Value List" (Page49).	Z coordinate (mm) Default value "0"
	E: -180.000 to 0180.000	θ angle (°) Default value "0"
	F: 00000.0 to 65000.0	Wait time for start marking (ms) * Default value "0"

5. Cell marking flag (Change)

Command		MatrixCellEnable	
Description		Changes the marking flag of matrix cells in binary.	
Target		PRG=0000 to 1999,CEL=00001 to 65025	
WX	Command	WX,PRG= 0000 ,CEL= 00001 ,MatrixCellEnable= A,BBB- -- [CR]	
	Response	WX,OK [CR]	
RX	Command	No	
	Response	No	
Parameter	A: 0/1/2	Reset the marking flag 0: Set the marking flag of all cells to OFF 1: Set the marking flag of all cells to ON 2: Do not change other than the specified cells	
	B: 0/1	Marking flag 0: Do not Mark 1: Mark * You can change the marking flag of continuous cells in a batch by sending this parameter in multiple digits.	

-  • To change the marking flag of multiple cells in a batch, send parameter B in multiple digits.
To set cell No.10 to ON, No.11 to OFF, No.12 to ON and all other cells to OFF, send the command as described below.
WX,PRG=0000,CEL=00010,MatrixCellEnable=0,101 [CR]

6. Matrix position setting (Change/Request)

Command		MatrixPosition	
Description		Changes/requests the reference point and X/Y coordinates of a matrix.	
Target		PRG=0000 to 1999	
WX	Command	WX,PRG= 0000 ,MatrixPosition= A,B,C [CR]	
	Response	WX,OK [CR]	
RX	Command	RX,PRG= 0000 ,MatrixPosition [CR]	
	Response	RX,OK, A,B,C [CR]	
Parameter	A: 00 to 08	Base point 00: Left edge 01: Right edge 02: Center 03: Lower left 04: Lower right 05: Upper left 06: Upper right 07: Top 08: Bottom * Default value "2"	
	B: Depends on the area size Normal(X):-062.500 to 0062.500 Other model: □"X coordinate" of "Appendix-2 Model-Specific Input Value List" (Page49).	X coordinate (mm) * Default value "0"	
	C: Depends on the area size Normal(X):-062.500 to 0062.500 Other model: □"Y coordinate" of "Appendix-2 Model-Specific Input Value List" (Page49).	Y coordinate (mm) * Default value "0"	

7. Count using invalid marking cells (Change/Request)

Command		InactiveCellCount	
Description		Changes/requests the setting of whether or not to count the invalid marking cells when marking a counter in a matrix.	
Target		PRG=0000 to 1999	
WX	Command	WX,PRG= 0000 ,InactiveCellCount= A [CR]	
	Response	WX,OK [CR]	
RX	Command	RX,PRG= 0000 ,InactiveCellCount [CR]	
	Response	RX,OK, A [CR]	
Parameter	A: 0/1	Count the invalid marking cells 0: Disabled 1: Enabled * Default value "0"	

3-11 Group/Counter setting

1. Group setting (Change/Request)

Command		GroupOffset	
Description		Specifies the group and changes/requests the X/Y coordinate correction, θ angle correction and marking enable/disable setting.	
Target		PRG=0000 to 1999,GRP=000 to 255	
WX	Command	WX,PRG= 0000 ,GRP= 000 ,GroupOffset= A,B,C,D [CR]	
	Response	WX,OK [CR]	
RX	Command	RX,PRG= 0000 ,GRP= 000 ,GroupOffset [CR]	
	Response	RX,OK, A,B,C,D [CR]	
Parameter	A: Depends on the area size Normal(X):-062.500 to 0062.500 Other model: □"X coordinate" of "Appendix-2 Model-Specific Input Value List" (Page49).		Shift X(mm) * Default value "0"
	B: Depends on the area size Normal(X):-062.500 to 0062.500 Other model: □"Y coordinate" of "Appendix-2 Model-Specific Input Value List" (Page49).		Shift Y(mm) * Default value "0"
	C: -180.000 to 0180.000		Shift θ (mm)
	D: 0/1		Marking flag 0: Disabled 1: Enabled

Reference • You can only create new groups using Marking Builder 3. The group number assigned when you created a group in Marking Builder 3 will be the number of the target specifier GRP.

2. Counter setting (Change/Request)

Command		CounterSetting	
Description		Specifies the counter No. and changes/requests the various counter settings.	
Target		PRG=0000 to 1999,CTR=0 to 9/A to J,	
WX	Command	WX,PRG= 0000 ,CTR= 0 ,CounterSetting= A,B,C,D,E,F,G,H,I [CR]	
	Response	WX,OK [CR]	
RX	Command	RX,PRG= 0000 ,CTR= 0 ,CounterSetting [CR]	
	Response	RX,OK, A,B,C,D,E,F,G,H,I [CR]	
Parameter	A: 00000 to 10000		Step * Default value "1"
	B: 0/1		Enabling the default value 0: Disabled 1: Enabled * Default value "0"
	C: 000000000 to 4294967295		Default value *B: Fixed value of "0" when 0 * Default value "0"
	D: 000000000 to 4294967295		Leading value * Default value "0"
	E: 000000000 to 4294967295		Final value * Default value "4294967295"
	F: 000000000 to 4294967295		Marking count * Default value "1"
	G: 0 to 4		Reset timing 0: Trigger 1: I/O 2: Power on 3: When switching the program No. 4: When the date changes 5: When the shift code is switched * Default value "1"
	H: 0/1		Count timing 0: Trigger 1: Each matrix cell/group/markings * Default value "0"
I: 2 to 36		Base * Default value "10"	

Reference • The target specifier PRG can be omitted if you are specifying a common counter.

3-12 Operation time

1. Request on controller operating time

Command		OperatingTime	
Description		Requests the operating time of the laser marker.	
Target		no	
WX	Command	no	
	Response	no	
RX	Command	RX,OperatingTime [CR]	
	Response	RX,OK,A [CR]	
Parameter		A:00000~99999	Cumulative operation time (h)

2. Request on laser exited time

Command		LaserOperatingTime	
Description		Requests the laser exited time. It is available on MD-U1000 and ML-Z9600 series only.	
Target		no	
WX	Command	no	
	Response	no	
RX	Command	RX,LaserOperatingTime [CR]	
	Response	RX,OK,A [CR]	
Parameter		A: 00000~99999	Laser exited time (h)

3. Request on scanner operating time

Command		ScannerOperatingTime	
Description		Requests the scanner operating time. It is available on MD-U1000 and ML-Z9600 series only.	
Target		no	
WX	Command	no	
	Response	no	
RX	Command	RX,ScannerOperatingTime [CR]	
	Response	RX,OK,A [CR]	
Parameter		A: 00000~99999	Scanner operating time (h)

4. Request on number of shutter operations

Command		ShutterOperatingCount	
Description		Requests the number of shutter operations. It is available on MD-U1000 and ML-Z9600 series only.	
Target		no	
WX	Command	no	
	Response	no	
RX	Command	RX,ShutterOperatingCount [CR]	
	Response	RX,OK,A [CR]	
Parameter		A:00000000~4294967295	Number of shutter operations (times)

5. Request on number of contactor operations

Command		ContactorOperatingCount	
Description		Requests the number of contactor operations. It is available on MD-U1000 series only.	
Target		no	
WX	Command	no	
	Response	no	
RX	Command	RX,ContactorOperatingCount [CR]	
	Response	RX,OK,A [CR]	
Parameter		A:00000000~4294967295	Number of contactor operations (times)

6. Request on head temperature

Command		MarkingUnitTemperature	
Description		Requests the head temperature. It is available on MD-U1000 series only.	
Target		no	
WX	Command	no	
	Response	no	
RX	Command	RX,MarkingUnitTemperature [CR]	
	Response	RX,OK,A [CR]	
Parameter		A:-999.9~0999.9	Head temperature (°C)

7. Request on controller temperature (°C)

Command		ControllerTemperature	
Description		Requests the controller temperature. It is available on MD-U1000 series only.	
Target		no	
WX	Command	no	
	Response	no	
RX	Command	RX,ControllerTemperature [CR]	
	Response	RX,OK,A [CR]	
Parameter		A:-999.9~0999.9	Controller temperature (°C)

8. Request on the result of laser power calibration

Command		LaserPowerCalibrationResult	
Description		Requests the result of laser power calibration. It is available on MD-U1000 series only.	
Target		no	
WX	Command	no	
	Response	no	
RX	Command	RX,LaserPowerCalibrationResult [CR]	
	Response	RX,OK,AB [CR]	
Parameter		A: 0/1	Existence of calibration execution 0: no 1: yes
		B: 000.00~999.99	Calibration result (W)

9. Cumulative marking count 1 and 2 (change/request)

Command		CumulativeMarkingCount	
Description		Changes and request the cumulative marking count 1 and 2.	
Target		no	
WX	Command	WX,CumulativeMarkingCount=A,B [CR]	
	Response	WX,OK [CR]	
RX	Command	RX,CumulativeMarkingCount [CR]	
	Response	RX,OK,A,B [CR]	
Parameter		A:00000000~4294967295	Cumulative marking count 1 (time)
		B:00000000~4294967295	Cumulative marking count 2 (times)

10. Request on replacing expiration of the dry agent for the head.

Command		DesiccantExpirationDate	
Description		Requests the replacing expiration of the dry agent for the head. It is available on MD-U1000 series only.	
Target		no	
WX	Command	no	
	Response	no	
RX	Command	RX,DesiccantExpirationDate [CR]	
	Response	RX,OK,A,B,C [CR]	
Parameter		A:0000~2099	Replacing expiration of the dry agent: year
		B:00~12	Replacing expiration of the dry agent: month
		C:00~31	Replacing expiration of the dry agent: date

3-13 Laser power measurement

11. Request on number of open/close of safety shutter A

Command	SafetyShutterAOperatingCount	
Description	Requests the number of open/close of safety shutter A. It is available on ML-Z9600 series only.	
Target	no	
WX	Command	no
	Response	
RX	Command	RX,SafetyShutterAOperatingCount [CR]
	Response	RX,OK,A [CR]
Parameter	A:00000000~4294967295	Number of operations of safety shutter A (times)

12. Request on number of open/close of safety shutter B

Command	SafetyShutterBOperatingCount	
Description	Requests the number of open/close of safety shutter B. It is available on ML-Z9600 series only.	
Target	no	
WX	Command	no
	Response	
RX	Command	RX,SafetyShutterBOperatingCount [CR]
	Response	RX,OK,A [CR]
Parameter	A:00000000~4294967295	Number of operations of safety shutter B (times)

13. Request on laser oscillating tube temperature

Command	MarkingLaserOscillatorTemperature	
Description	Requests the laser oscillating tube temperature. It is available on ML-Z9600 series only.	
Target	no	
WX	Command	no
	Response	
RX	Command	RX, MarkingLaserOscillatorTemperature [CR]
	Response	RX,OK,A [CR]
Parameter	A:-999.9~0999.9	Laser oscillating tube temperature (°C)

1. Laser power measurement

Command	LaserPowerCheck	
Description	Measures the laser power. It takes about 10 seconds for the measurement. The shutter closes, and the marking point is not irradiated. It is available on MD-U1000 series only.	
Target	no	
WX	Command	WX,LaserPowerCheck=A,B [CR]
	Response	WX,OK,C [CR]
RX	Command	no
	Response	
Parameter	A:000.0~100.0	Laser Power (%)
	B:000/040~400	Pulse frequency (kHz)
	C:000.00~999.99	Output power (W)

4. Applied Functions

This chapter provides information on omission of parameters, convenient command usages and how to create new settings using only commands.

4-1 Variable-length support

The unwanted "0" can be omitted when sending the setting values to the laser marker using the Write command.

■ Omission of the command for changing the currently running program No. to "1"

Command	WX,ProgramNo= 0001 [CR]
Response	WX,OK [CR]

Change the program No. to variable-length

Command	WX,ProgramNo= 1 [CR]
Response	WX,OK [CR]

Variable-length support complete

■ Omission of the command for changing the position correction values

Command	WX,AllPosition=-90.000,000.000,090.000,-062.500,0000.000, 21.000 [CR]
Response	WX,OK [CR]

Change the correction value to variable-length

Command	WX,AllPosition=- 90.0.90,-62.5.0.21 [CR]
Response	WX,OK [CR]

Variable-length support complete

4-2 Omission of target specifiers

In the following cases, you can send the command omitting the target specifier.

If the currently running program No. is the target

You can omit the target specifier if you are specifying the currently running program No. using the "PRG" target specifier.

■ Omission of the command for changing the title of the currently running program No.0001 to "ABC"

Command	WX, PRG=0001 ,Title=ABC [CR]
Response	WX,OK [CR]

You can omit "PRG" as this is a currently running program No.

Command	WX,Title=ABC [CR]
Response	WX,OK [CR]

Omission complete

If block No.000 is the target

You can omit the target specifier if you are specifying block No. 000 using the "BLK" target specifier.

■ Omission of the command for changing the block No.000 string of the currently running program No.0001 to "ABC"

Command	WX,PRG=0001, BLK=000 ,CharacterString=ABC [CR]
Response	WX,OK [CR]

You can omit "BLK" for block No.000.

Command	WX, PRG=0001 ,CharacterString=ABC [CR]
Response	WX,OK [CR]

You can omit "PRG" as this is a currently running program No.

Command	WX,CharacterString=ABC [CR]
Response	WX,OK [CR]

Omission complete

4-3 Omission of parameters

If you only wish to change some parameters using a command that have multiple parameters, you can send the command omitting those parameters you do not need to change.

■ Omission of the command changing only the C: Day setting value out of the six date/time setting parameters (A: Year, B: Month, C: Day, D: Hour, E: Minute, F: Second)

To change the current time setting of 2014/12/20/11: 38: 20 to 2014/12/**21**/11: 38: 20

Command	WX,TimeSetting= 2014.12.21,11.38.20 [CR]
Response	WX,OK [CR]

Omit the unwanted parameters

Command	WX,TimeSetting=., 21 ,., [CR]
Response	WX,OK [CR]

Omission complete

- Reference: • The omitted settings will retain their current status.
- The number of separator commas remain unchanged.

4-4 Sending of linked commands

You can link commands and send them together when sending commands to the same program No. for multiple times. Moreover, you can omit the already-specified target specifier when linking commands. Enter a target specifier only if you wish to re-specify the target in the middle of a command.

▶ Important

- You cannot link and send a command targeting two or more program No.
- You cannot link and send commands that are related to "Operation/Current Value" or "Status/Unit Setup".

For WX command

To send the command with a linked WX command, link the command by adding "WX" only to the first command and removing "WX" from the second and subsequent commands.

■ Omission of the command for changing the block No.1 string of the currently running program No.0001 to "ABC", and the block No.2 string to "123"

1. Command	WX,PRG=0001,BLK=001,CharacterString=ABC [CR]
2. Response	WX,OK [CR]
3. Command	WX,PRG=0001,BLK=002,CharacterString=123 [CR]
4. Response	WX,OK [CR]

You can link the commands as they are changes in the same program No.

Command	WX,PRG=0001,BLK=001,CharacterString=ABC,PRG=0001,BLK=002,CharacterString=123 [CR]
Response	WX,OK [CR]

You can omit the "PRG" on the end as the program No. are the same.

Command	WX,PRG=0001,BLK=001,CharacterString=ABC,BLK=002,CharacterString=123 [CR]
Response	WX,OK [CR]

You can omit "PRG" as this is a currently running program No.

Command	WX,BLK=001,CharacterString=ABC,BLK=002,CharacterString=123 [CR]
Response	WX,OK [CR]

You can omit "0s" as they are unnecessary for the parameters.

Command	WX,BLK=1,CharacterString=ABC,BLK=2,CharacterString=123 [CR]
Response	WX,OK [CR]

Omission complete

For RX command

To send the command with a linked RX command, link the command by adding "RX" only to the first command and removing "RX" from the second and subsequent commands. A response is returned in the order of the requesting commands.

■ Omission of the command for requesting the block No.1 (String: ABC) and No.2 (String: 123) string setting of the currently running program No. 0001

1. Command	RX,PRG=0001,BLK=001,CharacterString [CR]
2. Response	RX,OK,ABC [CR]
3. Command	RX,PRG=0001,BLK=002,CharacterString [CR]
4. Response	RX,OK,123 [CR]

You can link the commands as they are requests in the same program No.

Command	RX,PRG=0001,BLK=001,CharacterString,PRG=0001,BLK=002,CharacterString [CR]
Response	RX,OK,ABC,123 [CR]

You can omit the latter "PRG" as the program No. are the same.

Command	RX,PRG=0001,BLK=001,CharacterString,BLK=002,CharacterString [CR]
Response	RX,OK,ABC,123 [CR]

You can omit "PRG" as this is a currently running program No.

Command	RX,BLK=001,CharacterString,BLK=002,CharacterString [CR]
Response	RX,OK,ABC,123 [CR]

You can omit "0s" as they are unnecessary for the parameters.

Command	RX,BLK=1,CharacterString,BLK=2,CharacterString [CR]
Response	RX,OK,ABC,123 [CR]

Omission complete

Linking the communication command (WXC command)

You can link and send commands by using WXC command. Commands relating to operation can also be linked. The response will return when all the command processing has been completed. If an error occurs on a command, commands before the error are executed but commands after the error are not. In case of linking the commands, put "WXC," at the beginning and link the commands with ",%,".

■ In case of changing a character string and then continue the marking.

Command	WXC,WX,PRG=000,BLK=000,CharacterString=ABC,%,WX,StartMarking [CR]
Response	WXC,OK [CR]

▶ Important

- Up to 128 commands can be linked up.
- The request commands (RX commands) cannot be used. When the request commands are linked, no error will occur as long as the commands are processed correctly, but the results of the requests do not return as a response.

■ When an error occurs in halfway of linking commands.

The following linking command that switches the marking program to No.10 after the recent program's marking is finished. The error response below returns if there is no marking program in No.10.

Command	WXC,WX,StartMarking,%,WX,ProgramNo=10 [CR]
Response	WXC,NG,cmd_index=002,E015,No Program Error [CR]

cmd_index: No. of the linking commands on which an error occurs. 000 indicates errors occur on WXC command. 001 or the subsequent number indicates errors occur on the linking commands.

4-5 Creating new settings

Follow the workflow below if you are creating new settings using only a communication path.

- (1) Starting the creation of a new program
Declare a start of program creation on a non-registered program No. using the following command:

Command		CreateProgram
Description		Declares the start of program creation on a program No. The specified program No. will stop the expansion processing until "EndProgram" is input.
Target		No
WX	Command	WX.CreateProgram=A [CR]
	Response	WX.OK [CR]
RX	Command	No
	Response	No
Parameter		A: 0000 to 1999 Specifies the Program No.

- Reference**
- When you declare "CreateProgram" on a non-registered program No., a program will be created with all parameters in their default values.
 - By declaring "CreateProgram" on an existing program No., you can change the desired program parts using this program file as a base.
 - If you wish to initialize the program contents every time you create a program, insert "CreateProgramWithAllClear" into the command.

- (2) Setting the required program and block information
The command required to print a single block is described below.

- Head orientation □ "HeadDirection" (Page16)
- Block type □ "BlockType" (Page21)
- String setting □ "CharacterString" (Page21)
- Character size □ "CharacterSize" (Page23)
- Block position □ "BlockPosition" (Page26)
- Marking parameters □ "MarkingParameter" (Page27)

- Reference**
- Since all commands other than the string setting command have a default value, you can create new settings even if you omit these values.

- (3) Ending the program creation
You can finish editing the program using the command described below.

Command		EndProgram
Description		Declares the end of program editing.
Target		No
WX	Command	WX.EndProgram [CR]
	Response	WX.OK [CR]
RX	Command	No
	Response	No
Parameter		No

- Reference**
- If the settings are in their default values and the mark data is the "ABC" string, the program can be configured using just three commands as described below.
WX,CreateProgram=0001 [CR]
WX,PRG=0001,BLK=001,CharacterString=ABC [CR]
WX,EndProgram [CR]

MEMO

5. Communication Errors

5-1 Error response

An error response is returned if there is an error in the command format or data range. All error responses will have the error number "S****" and error code on the end of the command.

Send	WX,Command [CR]
Receive	Normal response: WX,OK [CR] Error response: WX,NG,S***,ErrCode [CR]

Reference • The "E****" type error may occur if you send "StartMarking" to start marking or "ProgramNo" to change the currently running program No. The "E****" error is not a communication error but is occurring on the controller side. Therefore, check the error details in the User's Manual of the laser marker.

5-2 Error list

There are following types of communication errors.

Error No.	Error name	Remedy
S000	Program incorrect error	Check whether the parameter is within the input range. Create the program again if no corrupt location can be found.
S001	Program memory full error	Remove the unwanted programs in the controller.
S002	Built-in memory card full error	Remove the unwanted logos, fonts, and Z-MAP data in the controller.
S003	USB flash drive full error	Remove any unwanted data from the USB flash drive.
S004	USB flash drive not inserted error	Perform the operation after inserting a USB flash drive.
S005	USB flash drive cannot be recognized error	Format the USB flash drive in FAT** format and try again. Try using a different USB flash drive if the error reoccurs.
S006	Priority error	The console and/or external communication has acquired communication priority. Check if the other devices are in test marking or finder mode, and perform the operation after exiting from these modes.
S008	No-File Error	Perform the communication again using an existing file as the target.
S009	Busy Error	Perform the operation while READY is in ON state.
S010	No marking block error	Set the marking flag to ON for one or more target blocks (palettes).
S011	Logos/custom characters over error	Reduce the number of files.
S012	Illegal optimization error	Reduce the line speed or adjust the character size, etc.
S013	Scan Optimize unexecutable error	Set the quality level of all blocks to [Customize].
S014	Program operation during execution error	A currently running program cannot be deleted.
S015	Logo/custom character file operation error	First remove the program that is using the logo or custom character you wish to delete.
S016	Test Mark Unexecutable Error	Start test marking after the device has gone into READY state.
S017	Fixed point marking parameter error	Modify the program to make sure that the fixed point and 3D shape blocks are not mixed.
S018	Barcode/2D code illegal setting error	Please enter an encoding string.
S019	All-setup restoration error	Make sure to use the backup data from the same model.
S020	Data Length Error	Noise may be entering the external communication cable if the error occurs in a sporadic manner.

Error No.	Error name	Remedy
S021	Program No. unregistration error	Transfer the program to the controller by following the procedure below. Select [LASER MARKER] - [File Operations] in the ribbon menu, and then transfer the program settings to the controller.
S022	Block# no registration error	Transfer the program to the controller by following the procedure below. Select [LASER MARKER] - [File Operations] in the ribbon menu, and then transfer the program settings to the controller.
S023	Status error	Reset the error and try marking again.
S024	Illegal Command Error	Acquire the communication history and check the parameter input range and block type.
S025	Checksum Error	Check if the checksum settings for the laser marker and external devices (PLC, etc.) are both ON. If there is no problem in the above, check if the checksum calculation method of the PLC is set to horizontal parity (Exclusive OR). Noise may be entering the external communication cable if the error occurs in a sporadic manner.
S026	Format error	Acquire the communication history and check the command details. If a comma (,) is used in the string, change it to "%044A" (special code representing a comma) before sending it.
S027	Command Unrecognizable Error	Acquire the communication history and check the command details.
S028	Response data length error	Modify the request command to reduce the response data length.
S029	Mark data request error	Send the command after the marking has completed.
S030	Group number unregistered error	Group the blocks in the program using MarkingBuilder 3. You can group blocks by following the procedure below. Select and right-click on a block to open the context menu, and then select [Grouping].
S050	Quick change of character setup error	Check the following when using the high speed character edit command. • Check if the block you wish to change is subject to high speed string editing. • Check that the string to be sent is registered as the character type that supports high speed string editing.
S051	Sample Marking Unexecutable Error	Commence sample marking in READY state.
S052	Laser inspection unexecutable error	Commence inspection laser in READY state.
S060	Block type incorrect setting error	Create the program again.
S061	Block assignment incorrect setting error	Create the program again.
S062	Character size incorrect setting error	Modify the blocks whose character aspect ratio is greater than 1:5 or 5:1.
S063	Character assignment incorrect setting error	Create the program again.
S064	Character advanced incorrect setting error	Create the program again.
S065	Marking condition incorrect setting error	Create the program again.

Error No.	Error name	Remedy
S066	Barcode/2D code illegal setting error	Create the program again.
S067	Continuous marking incorrect setting error	Create the program again.
S068	Movement/marking direction incorrect setting error	Create the program again.
S069	Program incorrect setting error	Create the program again.
S070	Matrix information incorrect setting error	Create the program again.
S071	Matrix cell information incorrect setting error	Create the program again.
S072	Character string incorrect setting error	Create the program again.
S073	Individual counter incorrect setting error	Create the program again.
S074	Common counter incorrect setting error	Configure the common counter settings again by following the procedure below. You can configure it by selecting [LASER MARKER] - [Marking Common] in the ribbon menu, followed by [Common Counter].
S075	Encoding information incorrect setting error	Configure the encoding setting again. You can configure it by selecting [LASER MARKER] - [Marking Common] in the ribbon menu, followed by [Encoding].
S076	System information incorrect setting error	Create the program again.
S077	Font replacement information incorrect setting error	Create the program again.
S078	Font scaling information incorrect setting error	Configure the character scaling settings again. You can configure it by selecting [LASER MARKER] - [Marking Common] in the ribbon menu, followed by [Character scaling].
S079	Font skip cross width information incorrect setting error	Configure the character skip cross settings again. You can configure it by selecting [LASER MARKER] - [Marking Common] in the ribbon menu, followed by [Character skip cross].
S080	Logo/custom character buffer information incorrect setting error	Create the program again.
S081	Current value incorrect setting error	Create the program again.
S082	3D system information incorrect setting error	Create the program again.
S083	3D information incorrect setting error	Create the program again.
S084	Operation limitation error	Delete the program that is using the [2D code reader function], or activate the [2D code reader function].
S085	Version of data outside support	The loaded program has been created in a higher version than the currently running MarkingBuilder 3. Upgrade the currently running Marking Builder 3 to the latest version, or downgrade the version of the loaded program.
S086	Wobble Incorrect Setting Error	Check if the marking line width, overlap rate and scan speed settings are within range.

Error No.	Error name	Remedy
S087	2D code reading error	Modify the program so that it is readable in test marking, and then run the program again.
S088	Working distance measurement error	Height measurement may be impossible in the following cases: <ul style="list-style-type: none"> Distance measuring light cannot be detected correctly because of the surface condition of the workpiece. Distance measuring light cannot be detected because the lighting in the rack is too bright.
S089	Working distance measurement limitation error	Measure the work distance in READY state.
S090	Registered barcode error	Change the barcode verification string.
S091	Barcode/2D code link setting error	Please check the following: <ul style="list-style-type: none"> Check if the 2D code overprinting setting is enabled for the target block. Check if the target overprinting No. exists.
S092	Barcode illegal registration state error	Configure it in either MarkingBuilder 3 or the console.
S093	Marking Confirmation Function Error	Check if the mark data exist in the field of view of the confirmation coordinates.
S094	TrueType font file size error	Reduce the number of TrueType font types being used.
S095	Model limitation error	Cannot be used.
S096	Open priority error	Restart the device.
S097	File Access Error	File may be read-only. Check the file attribute and try again.
S098	Serial No. error	Enter the correct serial No.
S099	Duplicate Serial No.	The serial code of the desiccant can only be used once. Purchase and replace with a new desiccant.

Appendix

Appendix-1 ASCII code list

		Upper 4 bits																
		0	1	2	3	4	5	6	7	8	9	A	B	C	D	E	F	
Lower 4 bits	0	NUL	DLE	SP	0	@	P	`	p				ー	タ	ミ			
	1	SOH	DC1	!	1	A	Q	a	q				。	ア	チ	ム		
	2	STX	DC2	"	2	B	R	b	r				「	イ	ツ	メ		
	3	ETX	DC3	#	3	C	S	c	s				」	ウ	テ	モ		
	4	EOT	DC4	\$	4	D	T	d	t				、	エ	ト	ヤ		
	5	ENQ	NAC	%	5	E	U	e	u				・	オ	ナ	ユ		
	6	ACK	SYN	&	6	F	V	f	v				ヲ	カ	ニ	ヨ		
	7	BEL	ETB	'	7	G	w	g	w				ア	キ	ヌ	ラ		
	8	BS	CAN	(8	H	X	h	x				イ	ク	ネ	リ		
	9	HT	EM)	9	I	Y	i	y				ウ	ケ	ノ	ル		
	A	LF	SUB	*	:	J	Z	j	z				エ	コ	ハ	レ		
	B	VT	ESC	+	;	K	[k	{				オ	サ	ヒ	ロ		
	C	FF	FS	,	<	L	¥	l	—				ヤ	シ	フ	ワ		
	D	CR	GS	-	=	M]	m	}				ユ	ス	ヘ	ン		
	E	SO	RS	.	>	N	^	n	to				ヨ	セ	ホ	°		
	F	SI	US	/	?	O	_	o	DEL				ッ	ソ	マ	°		

A

Appendix

Parameter	Unit	MD-X1000/1500 series			MD-F3200/5200 series		MD-U1000 series		ML-Z9600 series		
		Standard area	Wide area	Small spot	Standard area	Wide area	Standard area	Wide area	Standard area	Wide area	Small spot
		MD-X1000 /1500	MD-X1020 /1520	MD-X1050	MD-F3200 /5200	MD-F3220 /5220	MD-U1000	MD-U1020	ML-Z9610	ML-Z9620	ML-Z9650
Line width	mm	0.010 to 5.000	0.010 to 7.500	0.010 to 2.500	0.010 to 5.000	0.010 to 7.500	0.010 to 5.000	0.010 to 7.500	0.010 to 5.000	0.010 to 7.500	0.010 to 2.500
Height/Width	mm	000.100 to 125.000	000.100 to 330.000	000.001 to 050.000	000.100 to 125.000	000.100 to 300.000	000.010 to 125.000	000.010 to 330.000	000.100 to 125.000	000.100 to 300.000	000.100 to 050.000
Logo Height/Width	mm	000.002 to 125.000	000.005 to 330.000	000.001 to 50.000	000.002 to 125.000	000.002 to 300.000	000.002 to 125.000	000.005 to 330.000	000.002 to 120.000	000.005 to 300.000	000.001 to 050.000
Arc character space	mm	000.000 to 180.000	000.000 to 450.000	000.000 to 075.000	000.000 to 180.000	000.000 to 450.000	000.000 to 180.000	000.000 to 450.000	000.000 to 180.000	000.000 to 450.000	000.000 to 075.000
Character space	mm	000.000 to 180.000	000.000 to 450.000	000.000 to 075.000	000.000 to 180.000	000.000 to 450.000	000.000 to 180.000	000.000 to 450.000	000.000 to 180.000	000.000 to 450.000	000.000 to 075.000
Character full width/full height	mm	000.100 to 180.000	000.100 to 450.000	000.100 to 075.000	000.100 to 180.000	000.100 to 450.000	000.010 to 180.000	000.010 to 450.000	000.100 to 180.000	000.100 to 300.000	00.100 to 075.000
Character pitch	mm	-180.000 to 0180.000	-450.000 to 0450.000	-075.000 to 0075.000	-180.000 to 0180.000	-075.000 to 0075.000	-180.000 to 0180.000	-450.000 to 0450.000	-180.000 to 0180.000	-450.000 to 0450.000	-075.000 to 0075.000
Barcode height	mm	000.200 to 125.000	000.300 to 330.000	000.100 to 050.000	000.200 to 125.000	000.300 to 300.000	000.200 to 125.000	000.300 to 330.000	000.200 to 120.000	000.300 to 300.000	000.100 to 050.000
Linear code height	mm	000.200 to 125.000	000.500 to 330.000	000.100 to 050.000	000.200 to 125.000	000.500 to 300.000	000.200 to 125.000	000.500 to 330.000	000.200 to 120.000	000.500 to 300.000	000.100 to 050.000
X coordinate	mm	-062.500 to 0062.500	-165.000 to 0165.000	-025.000 to 0025.000	-062.500 to 0062.500	-150.000 to 0150.000	-062.500 to 0062.500	-165.000 to 0165.000	-060.000 to 0060.000	-150.000 to 0150.000	-025.000 to 0025.000
Y coordinate	mm	-062.500 to 0062.500	-165.000 to 0165.000	-025.000 to 0025.000	-062.500 to 0062.500	-150.000 to 0150.000	-062.500 to 0062.500	-165.000 to 0165.000	-060.000 to 0060.000	-150.000 to 0150.000	-025.000 to 0025.000
Z coordinate	mm	-021.000 to 0021.000	-021.000 to 0021.000	-015.000 to 0015.000	-021.000 to 0021.000	-021.000 to 0021.000	-021.000 to 0021.000	-021.000 to 0021.000	-021.000 to 0021.000	-021.000 to 0021.000	-002.000 to 0002.000
Sphere diameter, Cylinder diameter Bottom diameter of cone, Top diameter of cone	mm	0000.200 to 0480.000	0000.200 to 1200.000	0000.200 to 0200.000	0000.200 to 0480.000	0000.200 to 1200.000	0000.200 to 0480.000	0000.200 to 1200.000	0000.200 to 0480.000	0000.200 to 1200.000	0000.200 to 0200.000
Cone height	mm	000.100 to 125.000	000.100 to 330.000	000.100 to 050.000	000.100 to 125.000	000.100 to 300.000	000.100 to 125.000	000.100 to 330.000	000.100 to 120.000	000.100 to 300.000	000.100 to 050.000
Scan speed	mm/s	00001 to 12000	00001 to 08000	00001 to 06000	00001 to 12000	00001 to 08000	00001 to 12000	00001 to 08000	00001 to 12000	00001 to 06000	00001 to 03000
Approach scan speed	mm/s	0 to 04000	0 to 06000	0 to 02000	0 to 04000	0 to 06000	0 to 04000	0 to 06000	0 to 06000	0 to 09999	0 to 03000
Pulse frequency	kHz	000 to 400			060 to 120		000, 040 to 400		-		
Spot variable	-	-210 to 0210	-210 to 0210	-150 to 0150	-210 to 0210	-210 to 0210	-210 to 0210	-210 to 0210	-210 to 0210	-210 to 0210	-020 to 0020
Deep dig amount	mm	00.000 to 42.000	00.000 to 42.000	00.000 to 30.000	00.000 to 42.000		00.000 to 42.000		00.000 to 42.000	00.000 to 42.000	00.000 to 42.000
Matrix Height/Width	mm	000.000 to 125.000	000.000 to 330.000	000.000 to 050.000	000.000 to 125.000	000.000 to 300.000	000.000 to 125.000	000.000 to 330.000	000.000 to 120.000	000.000 to 300.000	000.000 to 050.000
Line speed	mm/s	0000.1 to 4000.0	0000.1 to 2000.0	0000.1 to 2000.0	0000.1 to 4000.0	0000.1 to 2000.0	0000.1 to 4000.0	0000.1 to 2000.0	0000.1 to 4000.0	0000.1 to 2000.0	0000.1 to 2000.0
Start Position	mm	-062.500 to 0062.500	-165.000 to 0165.000	-025.000 to 0025.000	-062.500 to 0062.500	-150.000 to 0150.000	-062.500 to 0062.500	-165.000 to 0165.000	-060.000 to 0060.000	-150.000 to 0150.000	-025.000 to 0025.000
End Position	mm	-062.500 to 0062.500	-165.000 to 0165.000	-025.000 to 0025.000	-062.500 to 0062.500	-150.000 to 0150.000	-062.500 to 0062.500	-165.000 to 0165.000	-060.000 to 0060.000	-150.000 to 0150.000	-025.000 to 0025.000
Z coordinate correction amount	mm	-42.000 to 042.000	-42.000 to 042.000	-30.000 to 030.000	-42.000 to 042.000	-42.000 to 042.000	-42.000 to 042.000	-42.000 to 042.000	-42.000 to 042.000	-42.000 to 042.000	-04.000 to 004.000
Upper tolerance limit	mm	-20.999 to 042.000	-20.999 to 042.000	-14.999 to 030.000	-20.999 to 042.000	-20.999 to 042.000	-20.999 to 042.000	-20.999 to 042.000	-20.999 to 042.000	-20.999 to 042.000	-01.999 to 004.000
Lower tolerance limit	mm	-42.000 to 020.999	-42.000 to 020.999	-30.000 to 014.999	-42.000 to 020.999	-42.000 to 020.999	-42.000 to 020.999	-42.000 to 020.999	-42.000 to 020.999	-42.000 to 020.999	-04.000 to 001.999
Movement reference point X/Y coordinates (Correct inside the horizontal plane)	mm	-062.500 to 0062.500	-165.000 to 0165.000	-025.000 to 0025.000	-060.000 to 0060.000	-150.000 to 0150.000	-062.500 to 0062.500	-165.000 to 0165.000	-060.000 to 0060.000	-150.000 to 0150.000	-025.000 to 0025.000
Correction amount X/Y (Correct inside the horizontal plane)	mm	-125.000 to 0125.000	-330.000 to 0330.000	-050.000 to 0050.000	-125.000 to 0125.000	-300.000 to 0300.000	-125.000 to 0125.000	-330.000 to 0330.000	-120.000 to 0120.000	-300.000 to 0300.000	-050.000 to 0050.000
X/Y coordinates position correction in the unit setup	mm	-062.500 to 0062.500	-165.000 to 0165.000	-025.000 to 0025.000	-062.500 to 0062.500	-150.000 to 0150.000	-062.500 to 0062.500	-165.000 to 0165.000	-060.000 to 0060.000	-150.000 to 0150.000	-025.000 to 0025.000
Z coordinate position correction in the unit setup	mm	-21.000 to 021.000	-21.000 to 021.000	-15.000 to 015.000	-21.000 to 021.000	-21.000 to 021.000	-21.000 to 021.000	-21.000 to 021.000	-21.000 to 021.000	-21.000 to 021.000	-02.000 to 002.000

Revision History

Date of printing	Version	Revision contents
April 2015	Official release	
September 2015	2nd edition	MARKING BUILDER 3 Ver 2.2 supported
September 2015	3rd edition	Variable Revisions
March 2016	4th edition	Correction
December 2016	5th edition	Added the MD-F3200/5200 series
January 2018	Revised 1st edition	Added the MD-U1000 and ML-Z9600 series
June 2018	2nd revision 1st edition	Add the counter reset timing.
January 2022	2nd revision 3rd edition	

Software License Agreement

NOTICE TO USER: PLEASE READ THIS SOFTWARE LICENSE AGREEMENT (THIS "AGREEMENT") CAREFULLY. BY USING ALL OR ANY PORTION OF THIS SOFTWARE, YOU ARE AGREEING TO BE BOUND BY ALL THE TERMS AND CONDITIONS OF THIS AGREEMENT. IF YOU DO NOT AGREE TO ANY TERMS OF THIS AGREEMENT, DO NOT USE THIS SOFTWARE.

1. Definition

1.1 "use" or "using" means to access, install, download, copy or otherwise benefit from using the functionality of this Software.

1.2 "This Software" means the software and all associated documentation provided by KEYENCE.

2. Grant of License.

Conditioned upon compliance with all of the terms and conditions of this Agreement, KEYENCE grants you a nonexclusive and nontransferable license to install this Software on all computers used by your entity in order to use the KEYENCE product. You may make one copy of this Software for backup or archive purposes only.

3. Restrictions.

3.1 Except for installation of updates or new functions provided by KEYENCE, you may not modify or add any function to this Software.

3.2 You may not reverse engineer, decompile or disassemble this Software.

3.3 You may not create derivative works based on this Software.

3.4 Other than expressly stated by KEYENCE, you may not resell, retransfer, rent or otherwise redistribute this Software to any third parties.

4. Intellectual Property Rights.

Except as expressly stated herein, KEYENCE reserves all right, title and interest in this Software, and all associated copyrights, trademarks, and other intellectual property rights therein.

5. Disclaimer.

Keyence is licensing this Software to you "AS IS" and without any warranty of any kind. In no event will KEYENCE or its suppliers be liable to you for any damages, claims, costs or any lost profits caused by using this Software.

6. Termination.

6.1 Your license under this Agreement will terminate automatically if you destroy this Software and the copy of this Software in your possession or voluntarily return this Software to us.

6.2 Your license under this Agreement will terminate automatically without any notice from KEYENCE if you fail to comply with any of the terms and conditions of this Agreement. Promptly upon termination, you shall cease all use of this Software and destroy all copies, full or partial, of this Software in your possession or control.

6.3 You will compensate KEYENCE for costs or any lost profits caused by your violation or breach of any term of this Agreement.

7. Governing Law.

7.1 This Agreement will be governed by and construed in accordance with the substantive laws of Japan without regards to the principles of conflicts of law.

7.2 If any part of this Agreement is found void and unenforceable, it will not affect the validity of the balance of this Agreement, which shall remain valid and enforceable according to its terms and conditions.

Warranties and Disclaimers

(1) KEYENCE warrants the Products to be free of defects in materials and workmanship for a period of one (1) year from the date of shipment. If any models or samples were shown to Buyer, such models or samples were used merely to illustrate the general type and quality of the Products and not to represent that the Products would necessarily conform to said models or samples. Any Products found to be defective must be shipped to KEYENCE with all shipping costs paid by Buyer or offered to KEYENCE for inspection and examination. Upon examination by KEYENCE, KEYENCE, at its sole option, will refund the purchase price of, or repair or replace at no charge any Products found to be defective. This warranty does not apply to any defects resulting from any action of Buyer, including but not limited to improper installation, improper interfacing, improper repair, unauthorized modification, misapplication and mishandling, such as exposure to excessive current, heat, coldness, moisture, vibration or outdoors air. Components which wear are not warranted.

(2) KEYENCE is pleased to offer suggestions on the use of its various Products. They are only suggestions, and it is Buyer's responsibility to ascertain the fitness of the Products for Buyer's intended use. KEYENCE will not be responsible for any damages that may result from the use of the Products.

(3) The Products and any samples ("Products/Samples") supplied to Buyer are not to be used internally in humans, for human transportation, as safety devices or fail-safe systems, unless their written specifications state otherwise. Should any Products/Samples be used in such a manner or misused in any way, KEYENCE assumes no responsibility, and additionally Buyer will indemnify KEYENCE and hold KEYENCE harmless from any liability or damage whatsoever arising out of any misuse of the Products/Samples.

(4) OTHER THAN AS STATED HEREIN, THE PRODUCTS/SAMPLES ARE PROVIDED WITH NO OTHER WARRANTIES WHATSOEVER. ALL EXPRESS, IMPLIED, AND STATUTORY WARRANTIES, INCLUDING, WITHOUT LIMITATION, THE WARRANTIES OF MERCHANTABILITY, FITNESS FOR A PARTICULAR PURPOSE, AND NON-INFRINGEMENT OF PROPRIETARY RIGHTS, ARE EXPRESSLY DISCLAIMED.

IN NO EVENT SHALL KEYENCE AND ITS AFFILIATED ENTITIES BE LIABLE TO ANY PERSON OR ENTITY FOR ANY DIRECT, INDIRECT, INCIDENTAL, PUNITIVE, SPECIAL OR CONSEQUENTIAL DAMAGES (INCLUDING, WITHOUT LIMITATION, ANY DAMAGES RESULTING FROM LOSS OF USE, BUSINESS INTERRUPTION, LOSS OF INFORMATION, LOSS OR INACCURACY OF DATA, LOSS OF PROFITS, LOSS OF SAVINGS, THE COST OF PROCUREMENT OF SUBSTITUTED GOODS, SERVICES OR TECHNOLOGIES, OR FOR ANY MATTER ARISING OUT OF OR IN CONNECTION WITH THE USE OR INABILITY TO USE THE PRODUCTS, EVEN IF KEYENCE OR ONE OF ITS AFFILIATED ENTITIES WAS ADVISED OF A POSSIBLE THIRD PARTY'S CLAIM FOR DAMAGES OR ANY OTHER CLAIM AGAINST BUYER. In some jurisdictions, some of the foregoing warranty disclaimers or damage limitations may not apply.

BUYER'S TRANSFER OBLIGATIONS:

If the Products/Samples purchased by Buyer are to be resold or delivered to a third party, Buyer must provide such third party with a copy of this document, all specifications, manuals, catalogs, leaflets and written information provided to Buyer pertaining to the Products/Samples.

Specifications are subject to change without notice.

KEYENCE CORPORATION

1-3-14, Higashi-Nakajima, Higashi-Yodogawa-ku, Osaka, 533-8555, Japan PHONE: +81-6-6379-2211

www.keyence.com/glb

AUSTRIA

Phone: +43 (0)2236 378266 0

BELGIUM

Phone: +32 (0)15 281 222

BRAZIL

Phone: +55-11-3045-4011

CANADA

Phone: +1-905-366-7655

CHINA

Phone: +86-21-3357-1001

CZECH REPUBLIC

Phone: +420 220 184 700

FRANCE

Phone: +33 1 56 37 78 00

GERMANY

Phone: +49-6102-3689-0

HONG KONG

Phone: +852-3104-1010

HUNGARY

Phone: +36 1 802 7360

INDIA

Phone: +91-44-4963-0900

INDONESIA

Phone: +62-21-2966-0120

ITALY

Phone: +39-02-6688220

KOREA

Phone: +82-31-789-4300

MALAYSIA

Phone: +60-3-7883-2211

MEXICO

Phone: +52-55-8850-0100

NETHERLANDS

Phone: +31 (0)40 206 6100

PHILIPPINES

Phone: +63-(0)2-8981-5000

POLAND

Phone: +48 71 368 61 60

ROMANIA

Phone: +40 (0)269 232 808

SINGAPORE

Phone: +65-6392-1011

SLOVAKIA

Phone: +421 (0)2 5939 6461

SLOVENIA

Phone: +386 (0)1 4701 666

SWITZERLAND

Phone: +41 (0)43 455 77 30

TAIWAN

Phone: +886-2-2721-8080

THAILAND

Phone: +66-2-078-1090

UK & IRELAND

Phone: +44 (0)1908-696-900

USA

Phone: +1-201-930-0100

VIETNAM

Phone: +84-24-3772-5555

