

CONVEY-ALL

INDUSTRIES INC.



TUBE CONVEYOR

Models:

TC-1000 Series, TC-1000-TED Series, TCGN-1000 Series,
TCH-1000 Series, TCH-1400 Series, TCSNH-1000 Series

OPERATOR'S MANUAL

LIMITED WARRANTY

Convey-All warrants to the buyer that the new machinery is free from defects in material and workmanship.

This warranty is only effective as to any new machinery which has not been altered, changed, repaired or treated since its delivery to the buyer, other than by Convey-All or its authorized dealers or employees, and does not apply to accessories, attachments, tools or parts, sold or operated with new machinery, if they have not been manufactured by Convey-All.

Convey-All shall only be liable for defects in the materials or workmanship attributable to faulty material or bad workmanship that can be proved by the buyer, and specifically excludes liability for repairs arising as a result of normal wear and tear of the new machinery or in any other manner whatsoever, and without limiting the generality of the foregoing, excludes application or installation of parts not completed in accordance with Convey-All operator's manual, specifications, or printed instructions.

Written notice shall be given by registered mail, to Convey-All within seven (7) days after the defect shall have become apparent or the repairs shall have become necessary, addressed as follows:

**Convey-All Industries Inc, Box 2008, 130 Canada Street
Winkler Manitoba R6W 4B7
Canada**

This warranty shall expire one (1) year after the date of delivery of the new machinery.

If these conditions are fulfilled, Convey-All shall at its own cost and at its own option either repair or replace any defective parts provided that the buyer shall be responsible for all expenses incurred as a result of repairs, labor, parts, transportation or any other work, unless Convey-All has authorized such expenses in advance.

The warranty shall not extend to any repairs, changes, alterations, or replacements made to the new equipment other than by Convey-All or its authorized dealers or employees.

This warranty extends only to the original owner of the new equipment.

This warranty is limited to the terms stated herein and is in lieu of any other warranties whether expressed or implied, and without limiting the generality of the foregoing, excluded all warranties, expressed or implied or conditions whether statutory or otherwise as to quality and fitness for any purpose of the new equipment. Convey-All disclaims all liability for incidental or consequential damages.

This machine is subject to design changes and Convey-All shall not be required to retrofit or exchange items on previously sold units except at its own option.

WARRANTY VOID IF NOT REGISTERED

**CONVEY-ALL
TUBE CONVEYOR**

WARRANTY REGISTRATION FORM & INSPECTION REPORT

WARRANTY REGISTRATION

This form must be filled out by the dealer and signed by both the dealer and the customer at the time of delivery.

Customer's Name _____	Dealer's Name _____
Address _____	Address _____
City _____	City _____
State/Prov, Code _____	State/Prov, Code _____
Phone Number (____) _____	
Tube Conveyor Model Number _____	Application:
Tube Conveyor Serial Number _____	<input type="checkbox"/> Private
Delivery Date _____	<input type="checkbox"/> Commercial

DEALER INSPECTION REPORT

- All Fasteners Tight
- Drive System Rotates Freely
- Drive Belts Aligned and Tensioned
- Driveline Secured to Machine
- Conveyor Belt Aligned and Tensioned
- All Belts Move Freely
- Hydraulic Hoses Free and Fittings Tight
- Checked Engine Fluid Levels
- Machine Lubricated
- Tire Pressure Checked

SAFETY INSPECTION REPORT

- All Guards, Shields Installed and Secured
- All Safety Decals Installed and Legible
- Reflectors and SMV Clean
- Reviewed Operating and Safety Instructions

I have thoroughly instructed the buyer on the above described equipment which review included the Operator's Manual content, equipment care, adjustments, safe operation and applicable warranty policy.

Date _____ Dealer's Rep. Signature _____

The above equipment and Operator's Manual have been received by me and I have been thoroughly instructed as to care, adjustments, safe operation and applicable warranty policy.

Date _____ Owner's Signature _____

WHITE	YELLOW	PINK
CONVEY-ALL	DEALER	CUSTOMER

This page intentionally left blank

PRODUCT INFORMATION

Always give your dealer the serial number of your Tube Conveyor when ordering parts or requesting service or other information.

The serial number for the conveyor is located on the left side above the transition between the hopper and the tube. Please mark the number in the space provided for easy reference.



Fig 1 - Serial Number Location

Tube Conveyor Model Number: _____

Tube Conveyor Serial Number: _____

Engine/Motor Model Number: _____

Engine/Motor Serial Number: _____

Production Year: _____

This page intentionally left blank

TABLE OF CONTENTS

DESCRIPTION	PAGE
Section 1: INTRODUCTION.....	1-1
Section 2: SAFETY.....	2-1
2.1 Safety Orientation.....	2-2
2.2 General Safety.....	2-2
2.3 Equipment Safety Guidelines.....	2-3
2.4 Safety Training.....	2-4
2.5 Safety Decals.....	2-4
2.5.1 How to Install Safety Decals.....	2-4
2.6 Work Preparation.....	2-5
2.7 Maintenance Safety.....	2-6
2.8 Electrical Safety.....	2-6
2.9 Tire Safety.....	2-6
2.10 Engine Safety.....	2-7
2.11 Workplace Hazard Area.....	2-8
2.12 Operating Safety.....	2-9
2.13 Lock-Out Tag-Out Safety.....	2-9
2.14 Transport Safety.....	2-10
2.15 Storage Safety.....	2-10
2.16 Safety Symbol Identification.....	2-11
Section 3: OPERATION.....	3-1
3.1 Machine Components.....	3-2
3.2 Machine Break-In.....	3-4
3.3 Pre-Operation Checklist.....	3-4
3.4 Components and Controls.....	3-5
3.5 - 10 Inch Swing Out Conveyor (Optional).....	3-12
3.6 - 14 Inch Swing Out Conveyor (Optional).....	3-15
3.7 - Pivot 14 Inch Swing Out Around Main Conveyor.....	3-17
3.8 Attaching to Tow Vehicle.....	3-19
3.8.1 Attach Unit with Hydraulic Lift.....	3-20
3.9 Conveyor Placement.....	3-21
3.10 Operating on Site.....	3-23
3.10.1 Attach PTO Driveline (If Equipped).....	3-23
3.10.2 Starting Conveyor.....	3-24
3.10.3 Stopping Conveyor.....	3-25
3.10.4 Emergency Stopping.....	3-26
3.10.5 Restarting after Emergency Stop.....	3-26
3.10.6 Unplugging.....	3-26
3.10.7 Hold Down Wheels on TCGN Models.....	3-27
3.11 Operating Hints.....	3-28
3.12 Transportation.....	3-29
3.13 Storage.....	3-31

TABLE OF CONTENTS cont'd

DESCRIPTION	PAGE
Section 4: SERVICE AND MAINTENANCE	4-1
4.1 Fluids and Lubricants	4-1
4.1.1 Greasing	4-2
4.2 Servicing Intervals	4-2
4.2.1 After 10 Hours or Daily	4-2
4.2.2 After 50 Hours or Weekly	4-5
4.2.3 After 200 Hours or Annually	4-7
4.3 Maintenance	4-8
4.3.1 Conveyor Belt Tension	4-8
4.3.2 Conveyor Belt Alignment	4-9
4.3.3 Conveyor Belt Replacement	4-10
4.3.4 Drive Belt Tension	4-11
4.3.5 Check Pulley Alignment	4-12
4.3.6 Drive Belt Replacement	4-12
4.3.7 TCGN Hold Down Wheels Replacement	4-13
4.3.8 Change Engine Oil and Filter	4-14
4.3.9 Change In-Line Fuel Filter	4-15
4.3.10 Clean/Change Air Filter	4-15
4.4 Service Record	4-17
4.5 Ordering Parts	4-18
Section 5: TROUBLE SHOOTING	5-1
Section 6: SIGN-OFF FORM	6-1
Section 7: REFERENCE	7-1
7.1 Specifications	7-2
7.2 Working Measurements	7-3
7.3 Bolt Torque	7-4

Section 1: INTRODUCTION

Congratulations on your choice of a Convey-All Tube Conveyor to complement the seed delivery system in your farming operation. This equipment has been designed and manufactured to meet the exacting standards for such equipment in the agricultural industry and will keep your seed delivery operation working at optimum efficiency.

This manual covers the Tube Conveyor manufactured by Convey-All Industries Inc.

Safe, efficient and trouble free operation of your tube conveyor system requires that you and anyone else who will be operating or maintaining the machine, read and understand the Safety, Operation, Maintenance and Trouble Shooting information contained within this Operator's Manual.

Use the Table of Contents as a guide to locate required information.

Keep this manual handy for frequent reference and to pass on to new operators or owners.

Call your Convey-All Industries Inc, dealer or distributor if you need assistance, information, additional/replacement copies or a digital copy of this manual.

OPERATOR ORIENTATION - The directions: left, right, as mentioned throughout this manual, are as seen from the hopper, facing the discharge spout.

This page intentionally left blank

Section 2: SAFETY

This Safety Alert symbol means:
ATTENTION! BECOME ALERT!
YOUR SAFETY IS INVOLVED!

Why is SAFETY important to you?

3 Big Reasons:

- Accidents Disable and Kill
- Accidents Cost
- Accidents Can Be Avoided



The Safety Alert symbol identifies important safety messages on the Convey-All Tube Conveyor and in this manual. When you see this symbol, be alert to the possibility of equipment damage, personal injury or death. Follow the instructions in the safety message.

SIGNAL WORDS:

Note the use of the signal words: DANGER, WARNING and CAUTION with the safety messages. The appropriate signal word for each message has been selected using the following guide-lines.

DANGER - Indicates an imminently hazardous situation that, if not avoided, will result in death or serious injury. This signal word is to be limited to the most extreme situations typically for machine components which, for functional purposes, cannot be guarded.

WARNING - Indicates a potentially hazardous situation that, if not avoided, could result in death or serious injury, and includes hazards that are exposed when guards are removed. It may also be used to alert against unsafe practices.

CAUTION - Indicates a potentially hazardous situation that, if not avoided, may result in minor or moderate injury. It may also be used to alert against unsafe practices.











2.1 SAFETY ORIENTATION

YOU are responsible for the SAFE operation and maintenance of your Convey-All tube conveyor. Ensure that you, and anyone else who will operate, maintain or work around the machine, be familiar with the safety, operating and maintenance procedures in this manual. This manual will take you step-by-step through your working day. It will alert you to all the safety practices that should be adhered to while operating the conveyor.

Remember, you are the key to safety. Good safety practices not only protect you but also the people around you. Make these practices a working part of your safety program. Be certain that everyone operating this equipment follows all the safety precautions. Most accidents can be prevented. Do not risk injury or death by ignoring good safety practices.

- Conveyor owners must give operating instructions to operators or employees before allowing them to operate the machine. Procedures must be reviewed annually thereafter, as per OSHA (Occupational Safety and Health Administration) regulation 1928.57.
- The most important safety device on this equipment is a SAFE operator. It is the operator's responsibility to read and understand all safety and operating instructions in this manual, and to follow them.
- A person who has not read and understood all operating and safety instructions is not qualified to operate the machine. An untrained operator exposes himself and bystanders to possible serious injury or death.
- Think SAFETY! Work SAFELY!

2.2 GENERAL SAFETY

1. Read and understand the Operator's Manual and all safety decals before operating, maintaining, adjusting or unplugging the conveyor. 
2. Only trained, competent persons shall operate the conveyor. An untrained operator is not qualified to operate the machine.
3. Have a first-aid kit available for use should the need arise and know how to use it. 
4. Provide a fire extinguisher for use in case of an accident. Store in a highly visible place. 
5. Do not allow riders.
6. Do not allow children, spectators or bystanders within hazard area around the machine.
7. Wear appropriate protective gear. This list may include but is not limited to:
 - Hard Hat 
 - Protective shoes with slip resistant soles 
 - Eye protection 
 - Heavy gloves 
 - Hearing protection 
 - Respirator or filter mask 
 - Hi-Visibility Safety Vest 
8. Review safety related items annually with all personnel who will be operating or maintaining the conveyor.

2.3 EQUIPMENT SAFETY GUIDELINES

1. Safety of the operator and bystanders is one of the main concerns in designing and developing this conveyor. However, every year many accidents occur which could have been avoided by a few seconds of thought and a more careful approach to handling equipment.

You, the operator, can avoid many accidents by observing the following precautions in this section. To avoid personal injury or death, study these precautions and insist those working with you, or for you, follow them also.

2. In order to provide a better view, certain photographs or illustrations in this manual may show an assembly with a safety guards removed. Equipment should never be operated in this condition. Keep all guards in place. If removal becomes necessary for repairs, replace the guard prior to use.



3. Replace any safety or instruction decal that is not readable or is missing.
4. Never use alcoholic beverages or drugs which can hinder alertness or coordination while operating this equipment.

Consult your doctor about operating this machine while taking prescription medications.

5. Do not allow persons to operate this unit until they have read this manual. They should have a thorough understanding of the safety precautions.

Review the safety instructions with all users annually.

6. This equipment is dangerous to children and persons unfamiliar with its operation. The operator should be a responsible, properly trained and physically able person familiar with farm machinery and trained in this equipment's operations.

If the elderly are assisting with farm work, their physical limitations need to be recognized and accommodated.

7. Never exceed the limits of a piece of machinery. If its ability to do a job, or to do so safely, is in question - DON'T TRY IT.
8. Do not modify the equipment in any way. Unauthorized modification result in serious injury or death and may impair the function and life of the equipment.
9. The design and configuration of this conveyor includes safety decals and equipment. They need to be clean, readable and in good condition.

2.4 SAFETY TRAINING

1. Safety is a primary concern in the design and manufacture of our products. Unfortunately, our efforts to provide safe equipment can be wiped out by a single careless act of an operator or bystander.
2. Hazard control and accident prevention are dependent upon the personnel operating and maintaining the conveyor. Their awareness, concern, prudence and proper training are crucial.
3. It has been said, "The best safety feature is an informed, careful operator." We ask you to be that kind of an operator. It is the operator's responsibility to read and understand all safety and operating instructions in this manual and to follow them. 
4. Working with unfamiliar equipment can lead to careless injuries. Read this manual before operating, to acquaint yourself with the machine. If this machine is used by any person other than yourself, or is loaned or rented, it is the machine owner's responsibility to make certain that the operator, prior to operating:
 - Reads and understands the operator's manuals.
 - Is instructed in safe and proper use.
5. Know your controls and how to stop the tractor, engine/motor, and conveyor quickly in an emergency. Read this manual and the one provided with your power unit.
6. Train all new personnel and review instructions frequently with existing workers. Be certain only a properly trained and physically able person will operate the machinery.

A person who has not read and understood all operating and safety instructions is not qualified to operate the machine. An untrained operator exposes himself and bystanders to possible serious injury or death.

If the elderly are assisting with farm work, their physical limitations need to be recognized and accommodated.



2.5 SAFETY DECALS

1. Keep safety decals clean and legible at all times.
2. Replace safety decals that are missing or have become illegible.
3. Replaced parts that displayed a safety decal should also display the current decal.
4. All safety decals have a part number in the lower right hand corner. Use this part number when ordering replacements.
5. Safety decals are available from your authorized distributor, dealer's parts department or from Convey-All Industries Inc.

2.5.1 How to Install Safety Decals:

1. Be sure that the installation area is clean and dry.
2. Ensure temperature is above 50°F (10°C).
3. Determine exact position before you remove the backing paper.
4. Remove the smallest portion of the split backing paper.
5. Align the decal over the specified area and carefully press the small portion with the exposed sticky backing in place.
6. Slowly peel back the remaining paper and carefully smooth the remaining portion of the decal in place.
7. Small air pockets can be pierced with a pin and smoothed out using the piece of decal backing paper.

2.6 WORK PREPARATION

1. Never operate the tractor, conveyor and its motor/engine until you have read and completely understand this manual. Also read the operator's manual for the power unit. Be familiar with the safety messages found on the decals around this unit.
2. Personal protection equipment including:
 - Hard Hat
 - Eye protection
 - Protective shoes
 - Heavy glovesare recommended during installation, placement, operation, adjustment, maintaining, repairing and removal of the implement.
3. Do not allow long hair, loose fitting clothing or jewelry to be around equipment.
4. **PROLONGED EXPOSURE TO LOUD NOISE MAY CAUSE PERMANENT HEARING LOSS!**
Agricultural equipment can often be noisy enough to cause permanent, partial hearing loss. We recommend that you wear hearing protection on a full-time basis if the noise in the Operator's position exceeds 80db.

Noise over 85db on a long-term basis can cause severe hearing loss.

Noise over 90db adjacent to the operator over a long-term basis may cause permanent, total hearing loss.

Note:

Hearing loss from loud noise (tractors, chain saws, radios, etc.) is cumulative over a lifetime without hope of natural recovery.

2.7 MAINTENANCE SAFETY

1. Review the Section 4: Service and Maintenance of this Manual before working with, maintaining or operating the conveyor.
2. Follow good shop practices:
 - Keep service area clean and dry.
 - Be sure electrical outlets and tools are properly grounded.
 - Use adequate light for the job.
3. Place all controls in neutral or off, stop engine/motor, remove ignition key or disable power source and wait for all moving parts to stop before servicing, adjusting, repairing.
4. Before applying pressure to a hydraulic system, make sure all components are tight and that hoses and couplings are in good condition.
5. Relieve pressure from hydraulic circuit before servicing or disconnecting from tractor.
6. Keep hands, feet, hair and clothing away from all moving and/or rotating parts.
7. Replace parts with genuine factory replacements parts to restore your equipment to original specifications. Convey-All Industries Inc. will not be responsible for injuries or damages caused by the use of unapproved parts and/or accessories.
8. Make sure there is plenty of ventilation. Never operate the engine in a closed building. The exhaust fumes may cause asphyxiation.
9. Clear the area of bystanders, especially children, when carrying out any maintenance and repairs or making any adjustments.
10. Place stands or blocks under the frame before working beneath the machine.
11. Before resuming work, install and secure all guards when maintenance work is completed.
12. Keep safety decals clean. Replace any decal that is damaged or not clearly visible.



2.8 ELECTRICAL SAFETY

1. Have only a qualified electrician supply power. All wiring should comply with the ANSI/NFPA 70 electrical requirements.
2. Make certain that the conveyor motor is properly grounded at the power source.
3. Ensure that all electrical switches are in the OFF position before plugging the conveyor in.
4. Turn machine OFF, shut down and lock out power supply (safety lock-out devices are available through your Convey-All dealer parts department) and wait for all moving parts to stop before assembling, servicing, adjusting, maintaining or repairing.
5. Disconnect power before resetting any motor.
6. Replace any damaged electrical plugs, cords, switches and components immediately.
7. Do not work on the conveyor's electrical system unless the power cord is unplugged or the power supply is locked out.



2.9 TIRE SAFETY

1. Failure to follow procedure when mounting a tire on a wheel or rim can produce an explosion and may result in serious injury or death.
2. Do not attempt to mount a tire unless you have the proper equipment and experience to do the job.
3. Have a qualified tire dealer or repair service perform required tire maintenance.
4. When replacing worn tires, make sure they meet the original tire specifications. Never undersize.



36-1000-0021

2.10 ENGINE SAFETY

Read and understand the operating manual provided with the engine.



1. Use proper tools to service engine.
2. Do not run engine in an enclosed area. Exhaust gases contain carbon monoxide, an odorless and deadly poison.
3. Store fuel in approved safety containers.
4. Do not store fuel near an open flame.
Appliances such as a stove, furnace, or water heater use a pilot light which can create a spark.
5. No smoking when filling fuel tank.
6. Do not remove fuel cap while engine is running.
7. Do not refuel indoors where area is not well ventilated. Outdoor refueling is preferred.
8. Do not refuel while engine is running. Allow engine to cool for 5 minutes before proceeding.
9. Use fresh fuel. Stale fuel can gum carburetor and cause leakage.
10. Check fuel lines and fittings frequently for cracks or leaks. Replace if necessary.
11. Do not operate engine if fuel has spilled. Move machine away. Avoid creating any ignition until the fuel has evaporated.
12. Do not run engine above rated speeds. This may result in damage and injury.
13. Do not tamper with the engine speed selected by the original equipment manufacturer.
14. Do not tamper with governor springs, governor links or other parts which may increase the governed engine speed.
15. Do not strike flywheel with a hard object or metal tool. This may cause it to shatter in operation.



16. Keep cylinder fins and governor parts free of grass and other debris which can affect engine speed.
17. Do not operate engine with grass, leaves, dirt or other combustible materials in muffler area.
18. Do not operate engine without muffler.



WARNING: Hot Equipment

Do not touch muffler, cylinder or fins while engine is running. Contact will cause burns.

19. Do not use this engine on any forest covered, brush covered, or grass covered unimproved land unless a spark arrester is installed on the muffler. The arrester must be maintained in effective working order by the operator.



In the State of California the above is required by law (Section 4442 of the California Public Resources Code). Other states may have similar laws. Federal laws apply on federal lands.

20. Inspect muffler periodically. Replace if necessary.
If engine is equipped with a muffler deflector, inspect periodically. Replace with correct part.
21. Do not check for spark, or crank engine with spark plug or spark plug wire removed.
22. Do not run engine with air filter or air it's cover removed.



WARNING: Possible Engine Damage

Decelerate engine slowly to stop. Avoid choking the carburetor to stop engine. Choke only for an emergency stop.

2.11 WORKPLACE HAZARD AREA

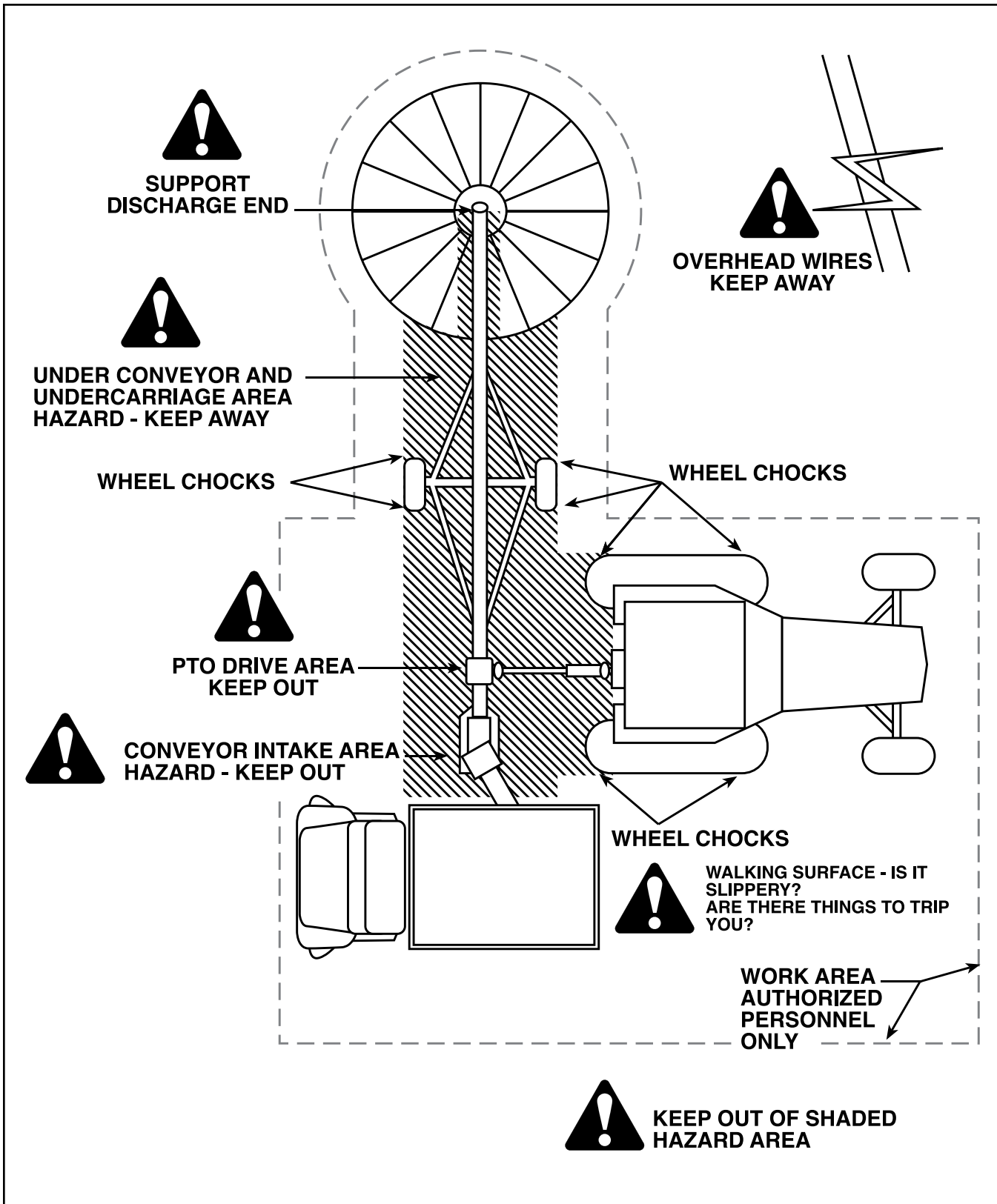

Fig 2 - Workplace Hazard Area

2.12 OPERATING SAFETY

1. Be sure that anyone who will be operating the machine or working on or around the unit reads and understands the operating, maintenance and safety information in this operator's manual.



Review the manual annually.

2. Clean or replace all safety decals if they cannot be clearly read and understood.
3. Stop the engine, place all controls in neutral, set park brake, remove ignition key and wait for all moving parts to stop before servicing, adjusting, repairing or unplugging.
4. Keep all bystanders, especially children, away from the machine when running, or when authorized personnel are carrying out maintenance work.
5. Establish a lock-out, tag-out policy for the work site. Be sure all personnel are trained in and follow all procedures. Lock-out, tag-out all power sources before servicing the unit or working around equipment.
6. Be familiar with machine hazard area. If anyone enters hazard areas, shut down machine immediately. Clear the area before restarting.

7. Keep hands, feet, hair and clothing away from all moving and/or rotating parts.



8. Do not allow riders on the conveyor when transporting.

9. Keep working area clean and free of debris to prevent slipping or tripping.



10. Stay away from overhead obstructions and power lines during operation and transporting. Electrocution can occur without direct contact.



11. Do not operate machine when any guards are removed.
12. Set park brake on tractor, chock wheels of conveyor before starting.
13. Be sure that conveyor is empty before raising or lowering.
14. Close valves in hydraulic line when machine positioned or before transporting.

2.13 LOCK-OUT TAG-OUT SAFETY

1. Establish a formal Lock-Out Tag-Out program for your operation.
2. Train all operators and service personnel before allowing them to work around the unloading system.
3. Provide tags on the machine and a sign-up sheet to record tag out details.

2.14 TRANSPORT SAFETY

1. Be sure that conveyor is empty before raising or lowering.
2. Always transport conveyor in collapsed position.
3. Comply with all local laws governing safety and transporting of equipment on public roads.
4. Check that all the lights, reflectors and other lighting requirements are installed and in good working condition.
5. Do not exceed a safe travel speed. Slow down for rough terrain and when cornering.
6. Stay away from overhead power lines. Electrocutation can occur without direct contact.
7. Plan your route to avoid heavy traffic.
8. Do not drink and drive.
9. Be a safe and courteous driver. Always yield to oncoming traffic in all situations, including narrow bridges, intersections, etc. Watch for traffic when operating near or crossing roadways.
10. Never allow riders on the conveyor.

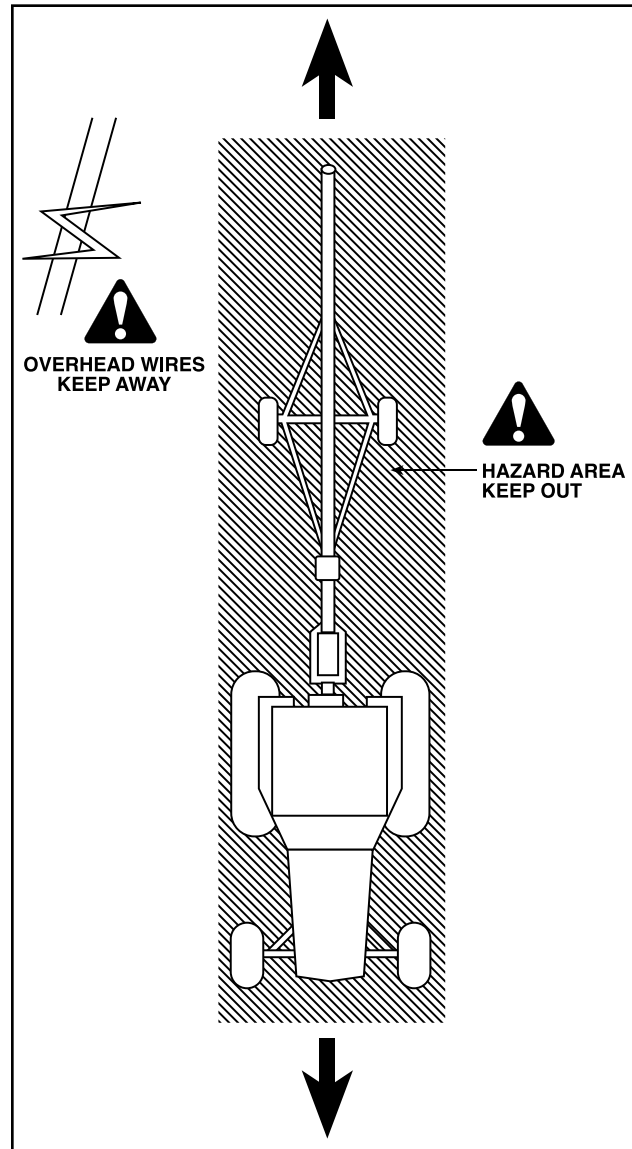

Fig 3 - Transporting Hazard Area

2.15 STORAGE SAFETY

1. Store the conveyor on a firm, level surface.
2. Store in an area away from human activity.
3. If required, make sure the unit is solidly blocked up.
4. Make certain all mechanical locks are safely and positively connected before storing.
5. Do not permit children to play on or around the stored machine.

2.16 SAFETY SYMBOL IDENTIFICATION

There are many types of safety symbols on decals placed in various locations on the tube conveyor. Good safety practices include being familiar with these signs, the type of warning, the area, and the particular function related to that area.

CAUTION

1. Read and understand the Operator's Manual before operating.
2. Keep all safety shields and devices in place and in good working order.
3. Make certain everyone is clear before operating or moving the machine. Keep children, visitors and untrained people away.
4. Keep hands, feet, hair and clothing away from moving parts.
5. Shut off and disable power source before adjusting, servicing, repairing or cleaning.
6. Disconnect power before resetting motor overload.
7. Be sure electric motors are grounded.
8. Support discharge end or anchor intake end to prevent upending.
9. Empty Conveyor before moving to prevent upending.
10. Lower Conveyor to its fully down position before moving or transporting. Use a tractor to move and transport.
11. Lower Conveyor well below level of power lines before moving or transporting. Electrocutation can occur without direct contact.
12. Keep away from intake. Keep others away.
13. Train operators annually.

36-1300-0001

36-1300-0001

DANGER



**ELECTROCUTION HAZARD
KEEP AWAY FROM POWER LINES**
To prevent serious injury or death from electrocution:

1. Stay well away from power lines. Electrocutation can occur without direct contact.
2. Lower Conveyor well below level of power line before moving or transporting.

HD11 36-1700-0002

36-1700-0002

WARNING



MOVING PART HAZARD
To prevent serious injury or death from falling:

1. Do not stand or climb on machine when operating. Keep others off.
2. Keep hands away from moving parts.
3. Wear tight clothing and safety gear.

36-3000-0010

36-3000-0010

WARNING





ROTATING PART HAZARD
To prevent serious injury or death from rotating parts:

1. Place all controls in neutral or off stop engine or motor, remove ignition key and wait for all moving parts to stop before servicing, adjusting, repairing or unplugging.
2. Install and secure all guards before operating.
3. Do not operate with rotating parts exposed.

36-3000-0004

36-3000-0004

DANGER



**FIRE HAZARD
NO SMOKING**
To prevent serious injury or death from fire:

1. Do not smoke when refueling.
2. Keep sparks, flames and hot material away from flammable substances.

36-1700-0004

36-1700-0004

DANGER





UPENDING HAZARD
To prevent serious injury or death from upending:

1. Support discharge end or anchor intake end before using.
2. Do not move Conveyor by hand.
3. Empty Conveyor before moving or transporting.
4. Do not hook or unhook unless hitch weight is down.

HD13 36-1700-0009

36-1700-0009

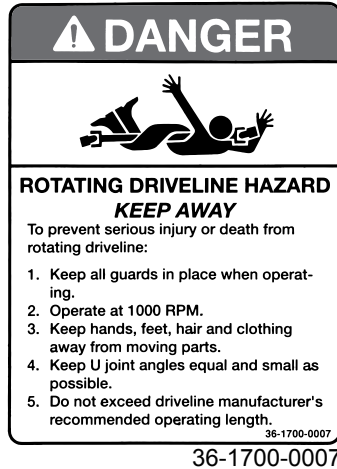
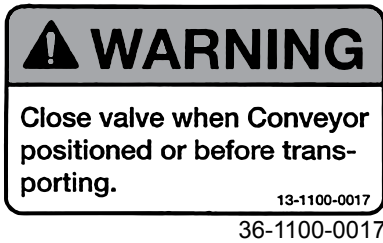
REMEMBER - If safety decals have been damaged, removed, become illegible, or parts were replaced without signage, new ones must be applied. New decals are available from your authorized dealer.



REMEMBER - If safety decals have been damaged, removed, become illegible or parts were replaced without decals, new decals must be applied. New decals are available from your authorized dealer.

Section 3: OPERATION



Operating Safety

- Read and understand the Operator's Manual, and all safety decals, before using.
- Stop the engine. Place all controls in neutral, remove ignition key and wait for all moving parts to stop before servicing, adjusting, or repairing or unplugging.
- Clear the area of bystanders, especially children, before starting.
- Be familiar with machine hazard area. If anyone enters hazard areas, shut down machine immediately. Clear the area before restarting.
- Keep hands, feet, hair and clothing away from all moving and/or rotating parts.
- Do not allow riders on the conveyor when transporting.
- Stay away from overhead obstructions and power lines during operation. Electrocutation can occur without direct contact.
- Do not operate machine when any guards are removed.
- Set park brake on tractor/truck, and chock wheels of conveyor before starting.
- Keep working area clean and free of debris to prevent slipping or tripping.
- Establish a lock-out, tag-out policy for the work site. Be sure all personnel are trained in and follow all procedures. Lock-out tag-out all power sources before servicing the unit or working around loading/unloading equipment.

The Convey-All Tube Conveyor is designed to efficiently move grain, pulse crops, or granular material from a truck or trailer, to a storage facility. Power is provided by an tractor PTO, electric motor, hydraulic motor, or a gas engine. Be familiar with the machine before starting.

It is the responsibility of the owner or operator to read this manual and to train all other operators before they start working with the machine. Follow all safety instructions exactly. It is everyone's business. By following recommended procedure, a safe working environment is provided for the operator, bystanders and the area around the work site.

The design and configuration of this conveyor includes safety decals and equipment. Hazard controls and accident prevention are dependent upon the personnel operating and maintaining it. Their awareness, concern, prudence and proper training are crucial.

Many features incorporated into this machine are the result of suggestions made by customers like you. Read this manual carefully to learn how to operate the machine safely. There are instructions on how to set it, to provide maximum efficiency. By following the operating instructions, in conjunction with a good maintenance program, your tube conveyor will provide many years of trouble free service.

3.1 MACHINE COMPONENTS

The tube conveyor is available in a variety of lengths for the most demanding needs.

A gas engine, electric or hydraulic motor, or a PTO can supply power to the conveyor belt.

A hand-operated winch or hydraulic cylinder is used to raise or lower the frame. A tractor supplies the hydraulic system.

Listed are of the main components and some of the options available on the various units.

* Their positions may vary depending on the model.

* Not all components appear on all conveyors:

- a. Main Tube
- b. Hopper
- c. Discharge Spout
- d. A-Frame Undercarriage

- e. Scissor Lift Undercarriage
- f. Swing Out Winch
- g. Hopper Winch
- h. Tube Lift Winch
- i. Conveyor Belt Wind Guard
- j. Conveyor Belt Tension Springs
- k. Gas Engine (Optional)
- l. Electric Motor Mount (Optional)
- m. Top End Drive (TED) (Optional)
- n. PTO (Optional)
- o. Cable Bridging
- p. Steel Bridging (Optional)
- q. Drive Box
- r. Swing Out Conveyor (Optional)
- s. Document Holder
- t. Hitch
- u. Jack

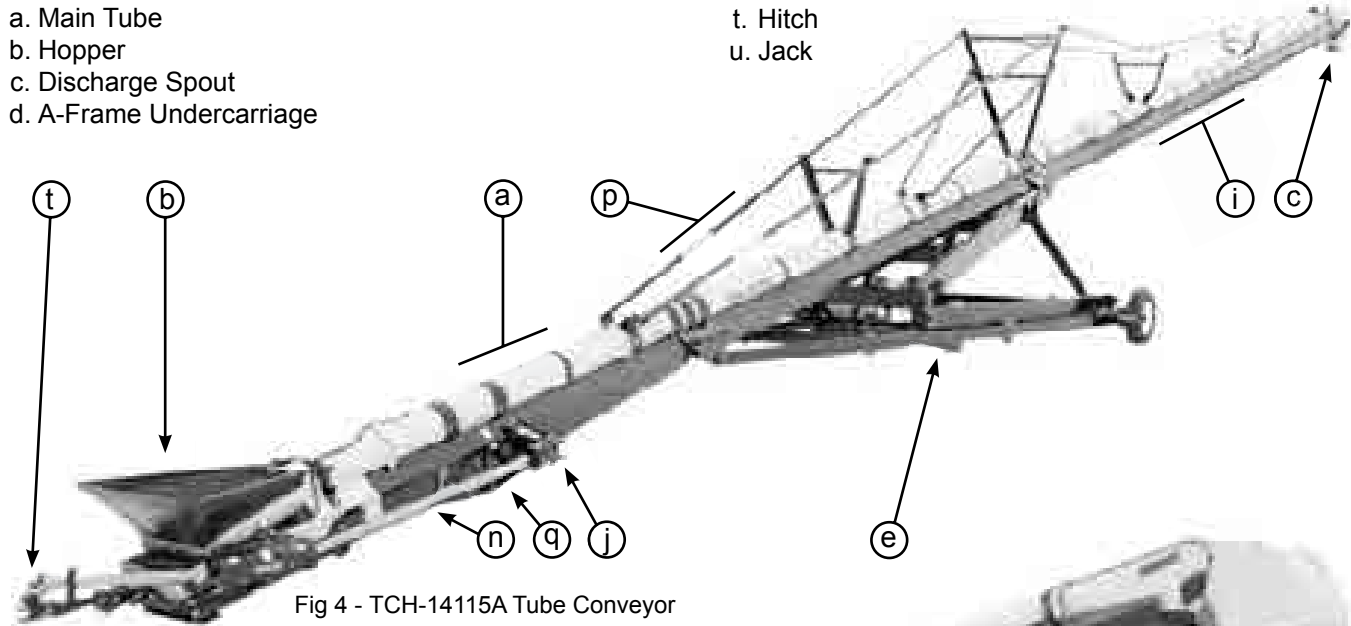

Fig 4 - TCH-14115A Tube Conveyor

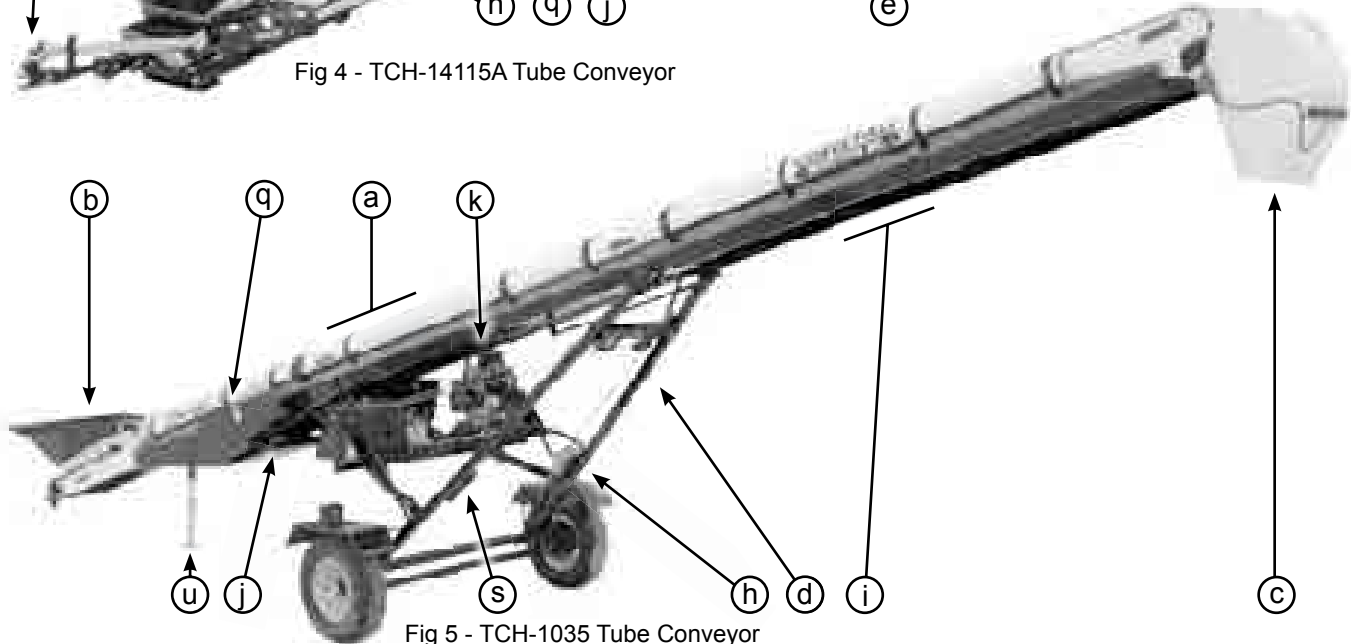

Fig 5 - TCH-1035 Tube Conveyor

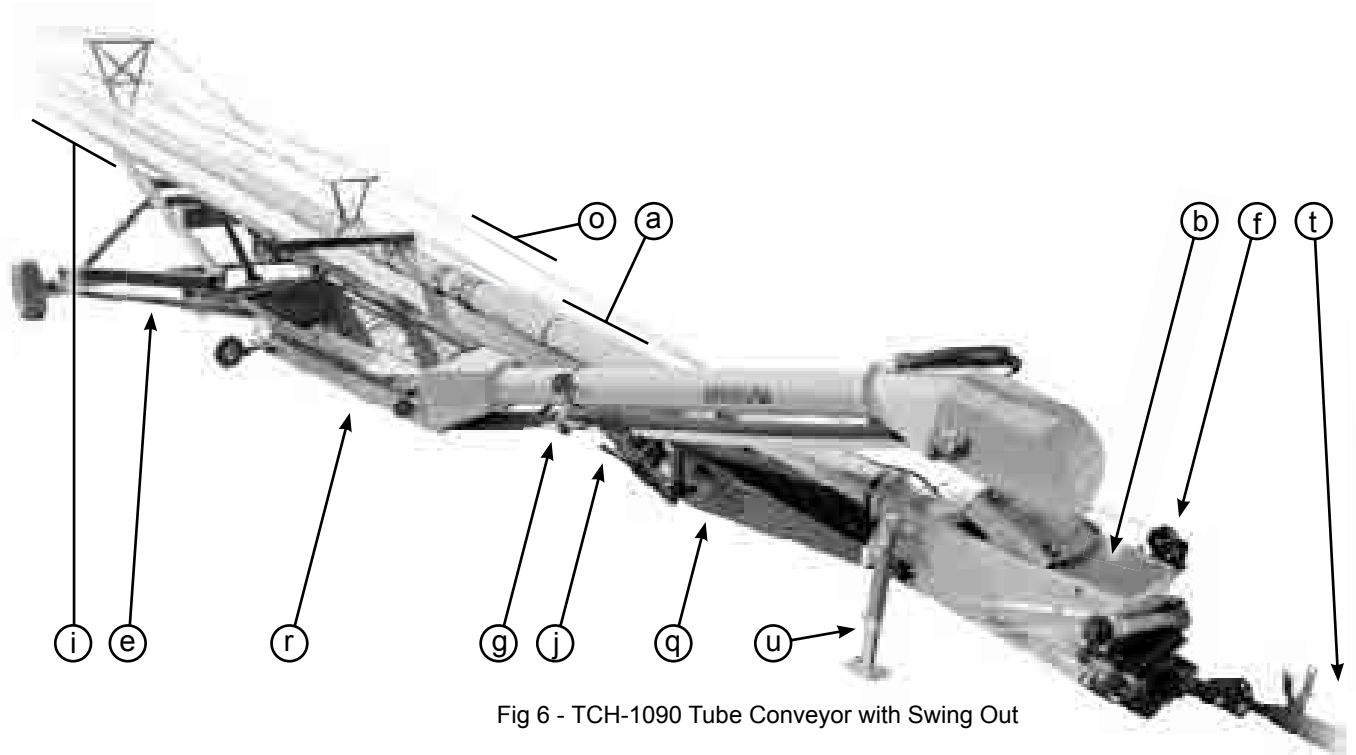

Fig 6 - TCH-1090 Tube Conveyor with Swing Out

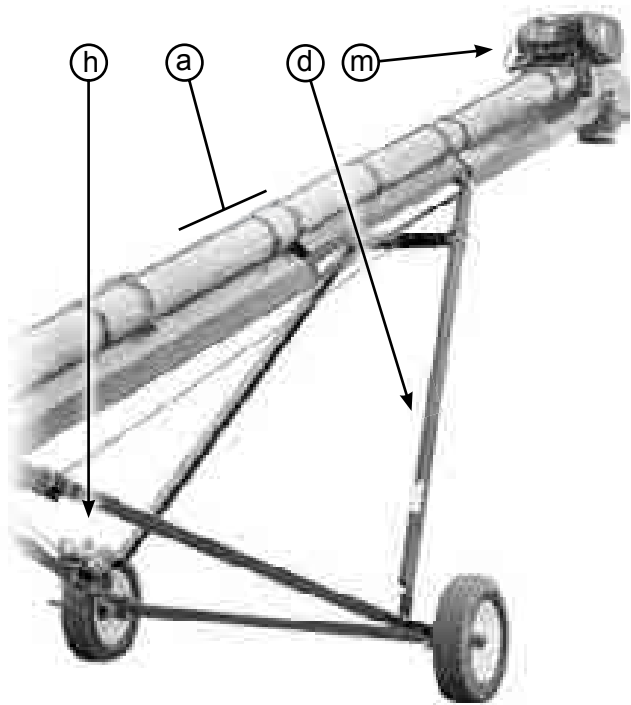

Fig 7 - TCH-1035-TED Tube Conveyor

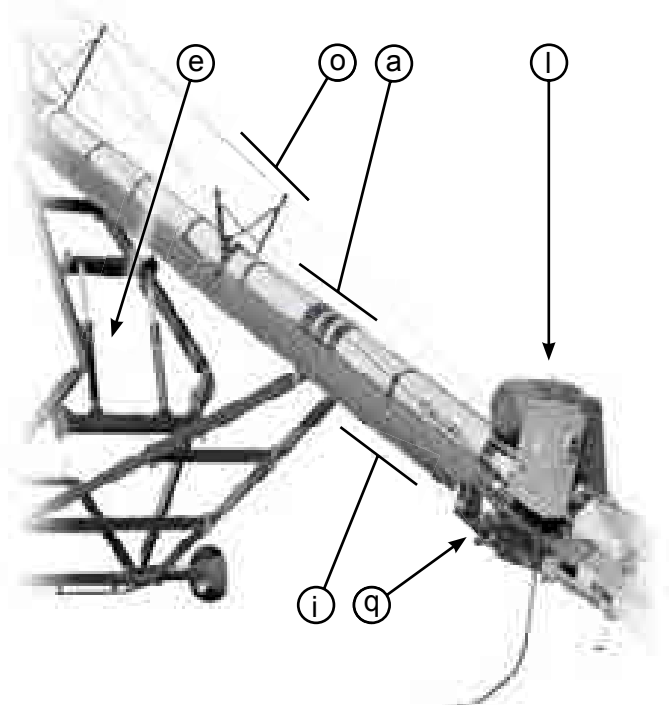

Fig 8 - TCH-1490 Tube Conveyor

3.2 MACHINE BREAK-IN

There are no operational restrictions on the conveyor when used for the first time. Even though, it is recommended that the following mechanical items be checked:

Before Starting Work:

1. Read the conveyor and power unit operator's manuals.
2. Run the unit for half an hour to seat the conveyor belt and flashing around the intake hopper. It is normal for rubber from the flashing to be expelled out the discharge and form a pattern on the belt.

After Operating or Transporting for 1/2 hour:

1. Re-torque all the wheel bolts fasteners and hardware.
2. Check the drive and conveyor belt tension and alignment. Tension or align as required.
3. During the conveyors first few minutes of operation, check belt alignment to ensure preset alignment and tension does not vary under loaded conditions.
4. Check the flashing seal on the input hopper. If any grain comes out of the hopper around the flashing, stop, loosen flashing mounting screws and adjust. Retighten anchor screws and try again. Repeat until no grain is lost.
5. Check condition of all hydraulic lines, hoses and connections. Repair or replace any damaged system components.
6. Check condition of all electrical lines, cords and connections. Repair or replace any damaged components.
7. Check that all guards are installed and working as intended.

After Operating For 5 Hours and 10 Hours:

Repeat steps 1 through 5 above.

Go to the normal servicing and maintenance schedule as defined in the Section 4: Service and Maintenance.

3.3 PRE-OPERATION CHECKLIST

Efficient and safe operation of the conveyor requires that each operator reads and understands the operating procedures and all related safety precautions outlined in this section. A pre-operation checklist is provided for the operator. It is important for both the personal safety and maintaining the good mechanical condition of the conveyor that this checklist is followed.

Before operating the conveyor and each time thereafter, the following areas should be checked off:

1. Service the machine as per the schedule outlined in the Section 4: Service and Maintenance.
2. Only use a tractor of adequate power to operate the conveyor.
3. Check that all guards are installed, secured and functioning as intended. Do not operate with missing or damaged shields.
4. Check worksite. Clean up working area to prevent slipping or tripping.
5. Check that conveyor belt is properly tensioned and aligned. Ensure it is not frayed or damaged. Refer to Section 4.3.1 and 4.3.2
6. Check the drive belt tension and alignment. Refer to Section 4.3.4 and 4.3.5
7. Be sure Conveyor wheels are chocked.
8. Check that discharge and intake areas are free of obstructions.



CAUTION: Upending Hazard

Anchoring or support conveyor during operation. When lower half of Conveyor empties of material, the weight balance transfers to the upper end of the machine, which can cause upending.

3.4 COMPONENTS AND CONTROLS

Before starting to work, all operators should familiarize themselves with the location and function of the controls. The location and functionality may vary depending on engine/motor model.

Gas Engine (Optional):

For units with a gas engine, below are a description of the controls:

- a. Ignition Switch:
This switch controls the electrical power to the engine electrical system. Turn clockwise to start, vertical position is ON.
Turn the key counterclockwise to turn OFF.
- b. Choke:
This lever controls the position of the choke. Slide the lever to the left to close the choke valve for starting when the engine is cold. Slide to the right to open the choke as the engine warms. Always open the choke fully when operating the machine.
- c. Throttle:
This lever controls the engine RPM. Move the lever left to increase the engine speed and right to decrease.

Engine should run slightly more than idle when drive belt is engaged.

IMPORTANT:

Do not engage clutch when at full RPM.

Always run at maximum engine RPM when operating the conveyor belt.

- d. Engine Position:
This lever sets the position of the engine base. Move the lever up to slide the engine base towards the drive pulley, disengaging the belt. Move lever downward to engage drive belt.

Always start or stop engine with drive belt disengaged. Set the belt tension so the belt does not slip during operation.

- e. Fuel Shut-Off Switch:
This switch controls the flow of fuel to the engine. Move the switch to the right to open the valve and start the flow of fuel. Move the switch left to close the valve and the engine will run.

Model	Electric HP	Gas HP	Diesel Drive	Belt Width	Tube Diameter
TC-1035	7.5	13	n/a	12	10
TC-1035-TED	5	n/a	n/a	12	10
TC-1040-TED	5	n/a	n/a	12	10
TC-1045	7.5	13	n/a	12	10
TC-1055	10	27	n/a	12	10
TC-1065	15	27	n/a	12	10
TC-1070	15	27	n/a	12	10
TC-1075	20	27	n/a	12	10
TC-1080	20	27	n/a	12	10
TC-1085	20	27	n/a	12	10
TCGN-1035	7.5	13	n/a	12	10
TCGN-1045	7.5	13	n/a	12	10
TCH-1035	7.5	27	n/a	16	10
TCH-1035-TED	7.5	n/a	n/a	16	10
TCH-1045	10	27	n/a	16	10
TCH-1055	15	n/a	n/a	16	10
TCH-1065	20	n/a	n/a	16	10
TCH-1070	20	n/a	40	16	10
TCH-1075	20	n/a	40	16	10
TCH-1080	20	n/a	40	16	10
TCH-1085	20	n/a	40	16	10
TCH-1090	20	n/a	40	16	10
TCH-1095	20	n/a	40	16	10
TCH-10100	20	n/a	40	16	10
TCH-1435	15	n/a	n/a	22	14
TCH-1445	15	n/a	n/a	22	14
TCH-1455	20	n/a	n/a	22	14
TCH-1465	25	n/a	n/a	22	14
TCH-1470	30	n/a	n/a	22	14
TCH-1475	30	n/a	n/a	22	14
TCH-1480	40	n/a	n/a	22	14
TCH-1485	40	n/a	n/a	22	14
TCH-1490	40	n/a	n/a	22	14
TCH-1495	40	n/a	n/a	22	14
TCH-14100	40	n/a	n/a	22	14
TCH-14105	40	n/a	n/a	22	14
TCH-14115A	50	n/a	n/a	22	14
TCH-14120	50	n/a	n/a	22	14
TCSNH-1035	15	27	n/a	16	10
TCSNH-1045	15	27	n/a	16	10

Table 1 - Power Requirements

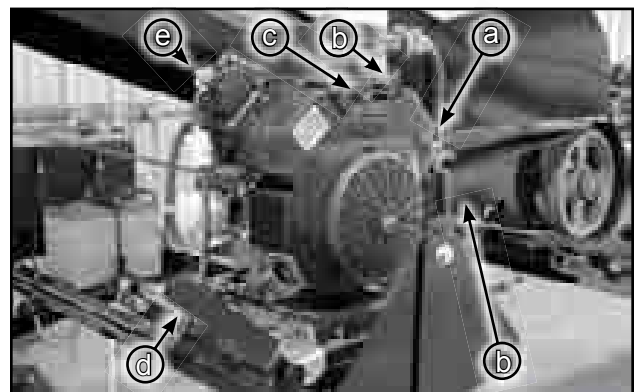

Fig 9 - Kohler Gas Engine

Electric Motor (Optional):

Conveyors with the electric power option rely on the dealer and customer to select a motor with the appropriate horsepower. Hire a licensed electrician to provide power.

A variety of switches can be used.

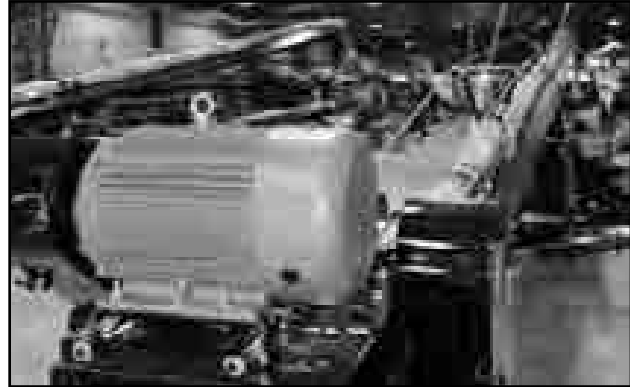

Fig 10 - Electric Motor

Electric to Hydraulic Power Pack (Optional):

This option includes an electric motor to drive the hydraulics, to raise and lower the conveyor tube. It could also be used to drive the conveyor on a rail. This creates a self-contained unit.



Fig 11 - Electric Motor to Hydraulics

Hydraulic Motor (Optional):

Position the power unit next to the conveyor, and connect hydraulic hoses to the couplers.



Fig 12 - Hydraulic Motor

Top End Drive (Optional):

Electric and Hydraulic drives are available on top end drive (TED) units.



Fig 13 - Top End Drive (TED)

PTO, Front or Side Driveline (Optional):

Machines with the PTO option, have the driveline connected to the unit's drive box.

IMPORTANT:

Do not move conveyor with PTO driveline attached. System is not designed with sufficient clearance for turning.

All PTO models are designed with a shear bolt in the driveline to protect the drive system components from an unexpected overload. If a bolt shears, remove the broken ends and replace with a genuine Convey-All replacement part.

Determine the cause of the overload and correct before resuming work.
read where the string is hanging.



Fig 16 - End PTO



Fig 17 - Side PTO

Conveyor Tube Lift Winch:

Conveyors that are less than 45 feet long are designed with a winch and cable pulley system to raise and lower the frame.

The tube conveyor can be set at any angle between 12° and 40° when operating.

Do not position at more than 45°.



Fig 14 - Tube Lift Winch

Hydraulic Valve to Conveyor Tube Cylinders:

This valve allows oil into or out of the hydraulic cylinder that raises/lowers the tube. Turn the handle parallel to hydraulic line to open the valve. Position at right angles to close valve. Run hydraulics from a tractor or external source.

IMPORTANT:

Hydraulic valve must be fully opened prior to lifting/lowering conveyor.
Valve must be closed fully when conveyor is to remain in fixed position, to prevent the ram from creeping downward during operation, transportation or storage.

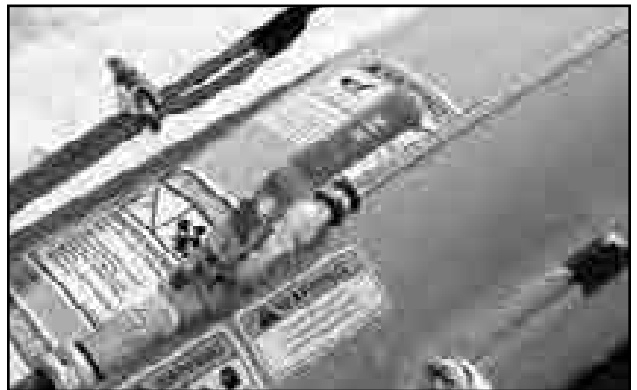

Fig 15 - Hydraulic Valve to Conveyor Tube Cylinders

Hopper:

Hoppers are designed with spring loaded hopper frames. This will allow the truck box to push the hopper edge down.

All hoppers have rubber flashing to seal the junction between the belt and the sides of the hopper.

Some hopper designs come with a clip on the frame to hold the canvas sides down when required.



Fig 18 - Collapsible Hopper

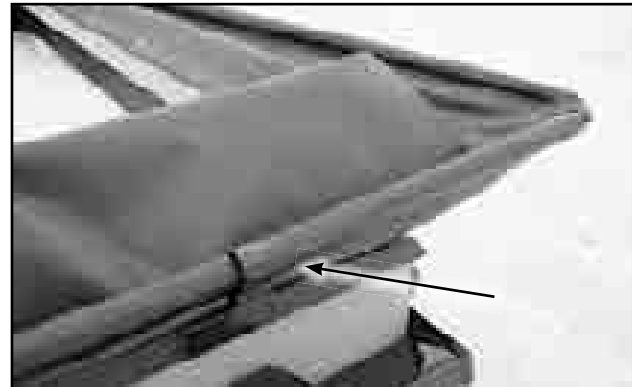

Fig 19 - Hopper Clip

Hopper Winch (Optional):

This winch is located on the side of the tube just above the hopper. It is used to lower the hopper frame.



WARNING: Unexpected Movement
 Do not release handle when ratchet lever is in unlocked position with load on winch. Handle could spin violently causing serious injury.

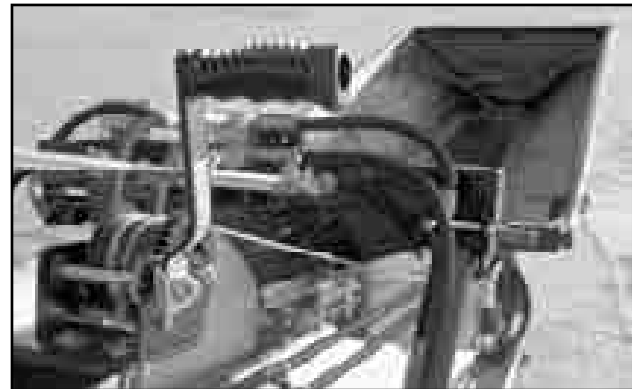

Fig 20 - Hopper Winch

Rail Car Hopper (Optional):

This hopper has a very low profile to allow for positioning under a rail car hopper. It come with a manual winch to raise and lower the hopper sides.



Fig 21 - Rail Car Hopper

Discharge Spout:

The discharge spout is designed with six settings to allow the customer to position the hood at the appropriate configuration for their application.

Move back into the one of the hole settings if the material needs to be directed further back rather than straight down.

Remove the position bracket and flip the hood back to throw the material as far as possible. This configuration works well when making piles or inside buildings.



Fig 22 - Discharge Spout

Discharge Spout with Electric Actuator (Optional):

On certain models, the discharge spout is available with 12 volt DC electric tilt control.



Fig 23 - Discharge Spout with Electric Actuator

Swing Out Conveyor (Optional):

A 10 inch or 14 inch swing out conveyor is available for convenient unloading. Refer to Section 3.5 and 3.6



Fig 24 - Swing Out Conveyor

Axle Adjustment (Optional).

On TCH-1400 series conveyors, an adjustable axle is available. They are designed with axles that are 12 feet wide, and have two extra settings; 14 feet and 16 feet.

Widen the wheels when the frame is positioned at a steep angle and retract when preparing to move or transport.



Fig 25 - Axle Adjustment

Working Lights Packages (Optional):

Working lights are available to illuminate the hopper and discharge ends of the machine. The 12 volt DC working lights make operating the conveyor at any time safe and convenient.



Fig 28 - Working Lights

Transport Light Packages (Optional):

On certain models, a 12 volt DC transport light package is available. The wiring harness would plug into a truck.

Angle of Operation Indicator:

On the drive box, is a decal to assist in calculation of operating angle.

Hold a weighted string against the arrow (above the Convey-All logo). Reference the graph and read where the string lies.

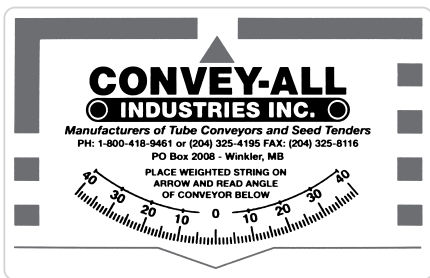

36-1800-0004



Fig 29 - Decal on Drive Box

Cable Bridging:

The standard bridging on most conveyors is cable bridging. Which needs to be adjusted periodically to ensure tube is straight. Refer to Section 4.2.3



Fig 26 - Cable Bridging

Steel Bridging (Optional):

On tube conveyors with a length of 85 feet or more, the bridging changes to steel. This gives a more heavy duty support, as well as requiring less maintenance.



Fig 27 - Steel Bridging

A-Frame Undercarriage:

This type of undercarriage uses a manual winch to raise and lower the tube.



Fig 30 - A-Frame Undercarriage

Scissor Lift Undercarriage:

This undercarriage uses hydraulics to raise and lower the tube. it is used on the longer conveyors.



Fig 31 - Scissor Lift Undercarriage

Goose Neck Transition (Optional):

Hold-down wheels are used to in this type of transition, between the hopper and incline portion of the machine.

A special undercarriage and rollers are used for this model.

It is necessary to regularly check the hold-down wheels for wear on their rubber wrap. Refer to Section 4.2.1, page 4-6

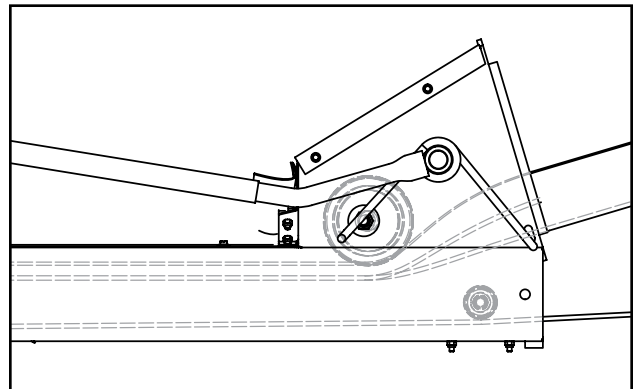

Fig 32 - Goose Neck Transition

S-Neck Transition (Optional):

The conveyor belt is threaded through an "S" pattern to transition between the hopper and incline portion of the unit.

A special undercarriage and rollers are used for this model.

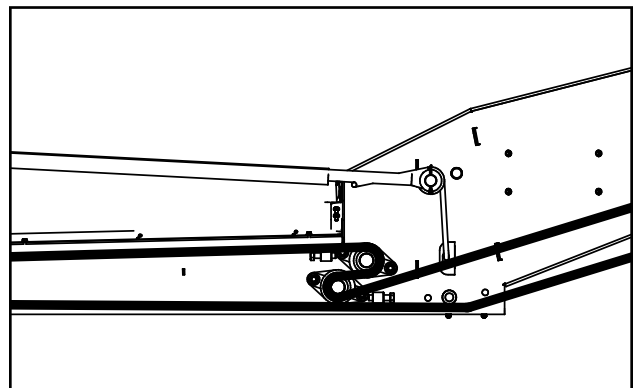

Fig 33 - S-Neck Transition

3.5 - 10 INCH SWING OUT CONVEYOR (OPTIONAL)

The swing out conveyor is an extension of the main tube conveyor. It is available for the TCH models (high capacity tube conveyors), which have a more substantial undercarriage.

The discharge spout of the swing out is attached to the main conveyor above the hopper. The Swing Out can swivel 270°, placing its hopper in a convenient position for unloading.

This swing out conveyor is available as:

- a manual drive unit, where it is pushed around the main conveyor.
- a hydraulic drive unit, which is driven by a mover kit.

Hopper:

The swing out is designed with a spring-loaded hopper frame. This will allow the truck box to push the hopper edge down when raising the hoist.

Hopper Frame Winch (Optional):

The hopper sides can be raised or lowered with a manual winch.

Hopper Wheels:

Manual drive units have a set of wheels under the rear end of the hopper. They are used to manually roll the hopper around the main conveyor.

Swing Out Mover Kit (Optional):

These wheels are attached below the transition between hopper and tube. The hydraulic bank controlling the mover kit is located on the swing out's tube, up from the hopper.



Fig 34 - 10 Inch Hydraulic Drive Swing Out (Optional)



Fig 35 - Hopper Winch



Fig 36 - Hopper Wheels



Fig 37 - Swing Out Mover Kit

Discharge Spout:

The discharge spout is attached to the main conveyor above its hopper. The spout can tilt and rotate as needed with the movement of the swing out. See Figure 34

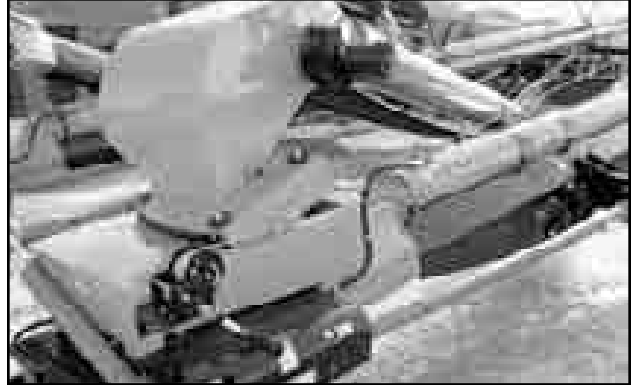
**Hydraulic Valve Bank:**

The set of 3 hydraulic valves located above the hopper of the swing out, operates the following movements:

- a. Drives the wheels, moving the swing out around the main conveyor.
- b. Raises/Lowers the swing out's mover kit wheels, lifting the hopper off the ground.
- c. Conveyor belt control. The belt rotates in only one direction.

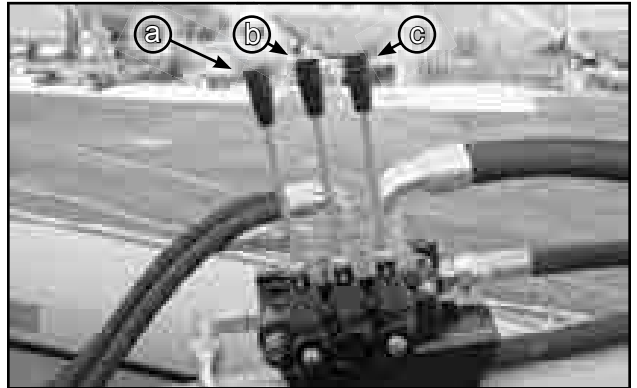

Fig 38 - Hydraulic Valves

Valve Adjustments:

The hydraulics on every tractor is set at a different flow rate or pressure. Therefore, the mover kit valve can be adjusted to run at the desired speed for the operator.

- a. The set screw with lock nut is the speed adjustment for the mover kit. There is another set screw on the back side of the valve bank, which must also be adjusted.
 - Twist set screw IN to slow the wheels
 - Twist it OUT to speed up the wheels
- b. **IMPORTANT:** This set screw needs no adjustment. It has been preset by the factory.

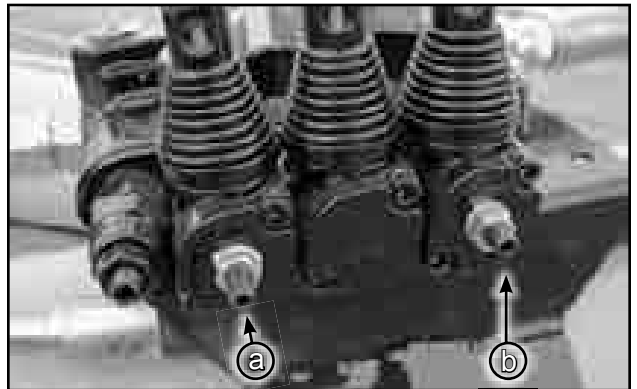

Fig 39 - Valve Adjustment



Fig 40 - Valve Adjustment, Rear of Bank

Swing Out Winch:

A winch is located on the side of the main conveyor tube. A cable is attached by a hook to the end of the hopper. It is used to raise and lower the swing out.

Remove the cable hook from the end of the hopper, when the swing out is sitting on the ground. Then, it can be pivoted into position.



Fig 41 - Swing Out Winch

Transport Hooks:

There are 2 hooks at the end of short chains.

When the swing out is raised off the ground, with the winch. Attach both hooks to the eyelets on either of the hopper frame.

This will relieve pressure from the winch. It will also secure the swing out for transportation or storage.

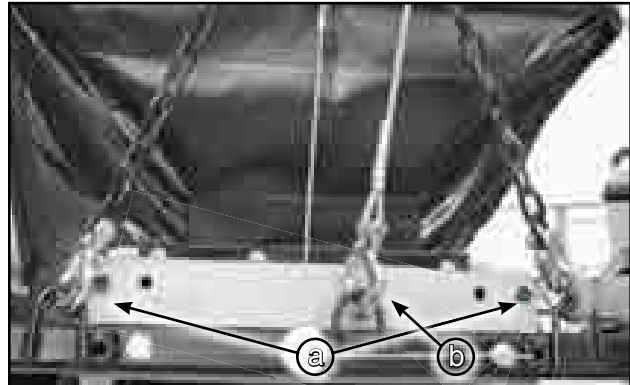

Fig 42 - Transport Hook (a), Winch Hook (b)

Hydraulic Motor:

The swing out conveyor belt is run by hydraulics. It needs to an external source, such as a tractor.



Fig 43 - Hopper Wheels

3.6 - 14 INCH SWING OUT CONVEYOR (OPTIONAL)

The swing out conveyor is an extension of the main tube conveyor. It is available for the TCH models (high capacity tube conveyors), which have a more substantial undercarriage.

2 support arms are used to hang the swing out from the main conveyor:

- The first support arm holds the swing out's hopper. A hook on a chain is used to secure the hopper when raised, for storage or transport.

A hydraulic winch is used to raise and lower the hopper. Detach the cable and hook from the hopper to drive it around into working position.

- The second is the swing lift arm. It is attached to the discharge hood. The arm uses a hydraulic cylinder to pivot from perpendicular to the main conveyor, to in-line, above the hopper. This will place the spout in position for unloading.

The swing out conveyor can be pivoted to the other side of the conveyor, and can be stored in that position.

For instructions, refer to Section 3.7

Hopper:

The swing out is designed with a spring-loaded hopper frame. This will allow the truck box to push the hopper edge down when raising the hoist.

Hopper Frame Winch (Optional):

The hopper frame can be raised or lowered with a manual winch.

Hydraulic Valves for Hopper Winch and Main Conveyor Hitch:

On the main conveyor, above the transition between the hopper and tube, are 2 valves.

- a. Works swing out conveyor's winch
- b. Raises/Lowers the hitch



Fig 44 - 14 Inch Swing Out Conveyor



Fig 45 - Hopper Support Frame



Fig 46 - Discharge Swing Lift Arm

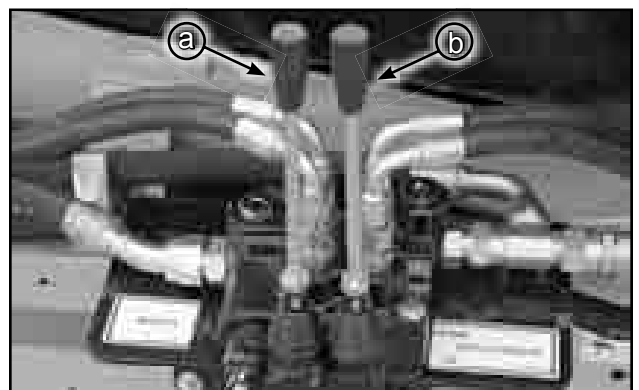

Fig 47 - Hydraulic Valves

Hydraulic Hopper Winch:

This is used to lower the hopper end of the swing out. Detach the hook and cable, and conveyor is free to swivel around the main conveyor.



Fig 48 - Swing Out Hydraulic Winch

Hopper Wheels:

There are a set of wheels under the end of the hopper. They are used to roll the swing out conveyor, when rotating the swing lift arm.

For transportation, strap the hopper to the main conveyor frame so it doesn't swing.



Fig 49 - Hopper Wheels

Swing Out Mover Kit:

These wheels are attached below the belt transition between hopper and tube. The hydraulic bank controlling the mover kit is located on the tube just above the hopper.



Fig 50 - Swing Out Mover Kit

Discharge Hood:

The swing out's hood has slotted brackets with adjustment bolts. The hood can be repositioned the angle at which it unloads into the main conveyor's hopper.

Swing Out Hydraulic Valves:

- Drives the wheels, moving the swing out conveyor along the ground around main conveyor.
- Raises/Lowers wheel hydraulics, to lift hopper off the ground, or lower it.
- Pivots the swing lift arm connected to the swing out conveyor's discharge hood.
- Conveyor belt control.

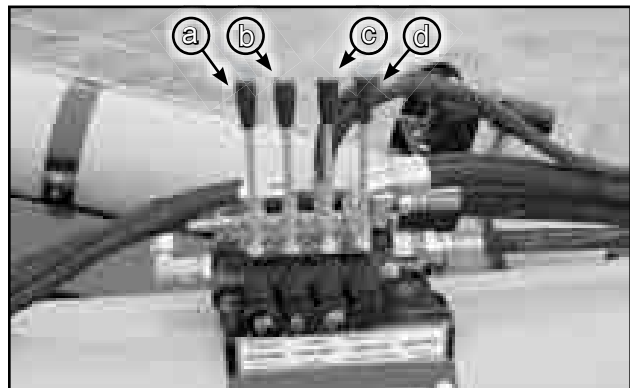

Fig 51 - Swing Out Hydraulic Valves

3.7 - PIVOT 14 INCH SWING OUT AROUND MAIN CONVEYOR

The 14 inch swing out conveyor can be moved from one side of the main conveyor to the other. It can be suspended, transported, or stored on either side.

Follow this procedure to make this change:

1. Remove the strap, which holds the swing out against the main frame for transportation.
2. Unhook safety chain from swing out conveyor's hopper.
3. Lower the hopper to the ground, using the hydraulic winch.
4. Disconnect the winch cable.

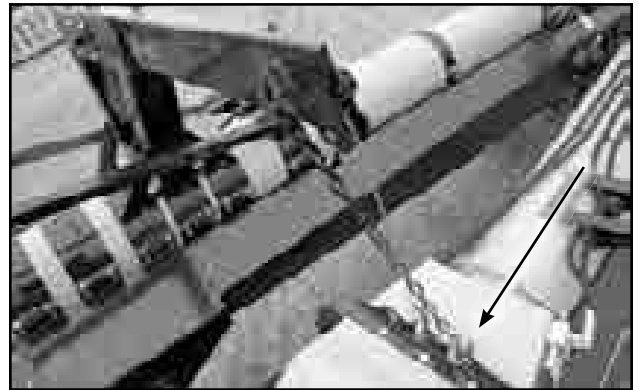

Fig 52 - Remove Safety Chain from Swing Out



Fig 53 - Hydraulic Lever for Swing Out Winch

5. Use the hydraulic valve for the swing lift arm, to move the arm from perpendicular to in-line with the main conveyor.

During this movement, the swing out conveyor is pulled along on it's rear hopper wheels.

6. When the lift arm is in-line, lower the mover kit wheels. This will lift the hopper off the ground.
7. Drive the swing out conveyor around until it is in-line with the main hopper.

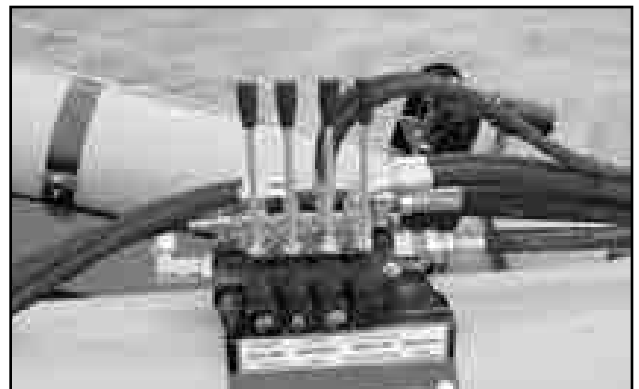

Fig 54 - Hydraulic Valve to Drive Swing Out



Fig 55 - Discharge Swing Lift Arm

8. Stop at the in-line position.

9. Remove the retainer clip, and disconnect the extended hydraulic cylinder from the wing on the swing lift arm.

10. Retract the cylinder. Then, move it past the lift arm's support frame to the other side.

11. Extend the cylinder again. Attach it to the wing on the other side of the arm. Fasten the retainer clip.

12. Raise the mover kit wheels, to lower the hopper so it rolls on it's rear wheels again.

13. Move the swing lift arm from in-line to perpendicular on the other side of the main conveyor.

14. Lower the mover kit wheels, so the hopper can be driven again.

15. Now the swing out conveyor can be driven around to the other side of the main conveyor.

16. Pivot the swing out, so the hopper is in a convenient working position.

When finished using the conveyor:

17. To store the conveyor on the other side of the main conveyor, flip the hopper support arm over to the other side.

18. Drive the swing out to sit below the repositioned support arm.

19. Hook the winch cable to the centre hole in the swing out's hopper frame.

20. Raise the hopper.

21. Hook the safety chain into place.

22. Strap the hopper to the main frame to secure it for storage or transportation.



Fig 56 - Hydraulic Valve on Discharge Swing Lift Arm



Fig 57 - Wings on Swing Lift Arm



Fig 58 - Attach Cylinder to Other Wing



Fig 59 - Hopper Support Arm

3.8 ATTACHING TO TOW VEHICLE

It is recommended that the conveyor be attached to a tractor whenever it is moved around a yard or into working position. It may be towed by a truck when transporting over long distances.

Follow this procedure when attaching to or unhooking from a tow unit:



WARNING: Electrocution Hazard
Ensure enough clearance from overhead obstructions, power lines or other equipment.

1. Clear the working area of bystanders, especially small children.
2. If the conveyor is above a storage facility, move the unit away, until the discharge spout clears the bin. Then lower the tube to its lowest position before attaching.
3. Ensure that there is sufficient room and clearance to back up to the conveyor.



CAUTION: Upending Hazard
The machine is closely balanced. Do not lift unless there is downward weight on the hopper end to prevent upending.

4. The hitch and jack are removable.
Install the jack.
5. Raise the hopper end of conveyor high enough to install the hitch.
Secure hitch with the anchor pin. Place the retainer before using hitch.
6. Align the tow vehicle's drawbar with the hitch of the conveyor while backing up.
7. Set the park brake before dismounting.



Fig 60 - Jack



Fig 61 - Hitch

8. Use the jack to raise the hopper and hitch to the drawbar height and install the pin with its retainer clip, to connect the tow vehicle.

Note:

If equipped with hydraulic lift, it may be necessary to connect hydraulic system to raise and lower machine.

9. Reverse the above procedure when unhooking.



Fig 62 - Attached to Tow Vehicle

3.8.1 Attach Unit with Hydraulic Lift:

1. Use a clean rag or paper towel to clean the dirt from around the coupler on the hose end and on the tractor.
 - Connect the hose to the tractor coupler. Be sure the coupler is securely seated.
 - Route the hose to prevent pinching rubbing or binding. Allow enough slack for raising and lowering. Keep the hose away from moving parts.
2. Open the valve in the hydraulic line and use the controls in the tractor to raise or lower the conveyor.
3. Close the valve when the machine is at its collapsed position.
4. Before transporting, refer to Section 3.11.
5. Reverse the above procedure when unhooking.



Fig 63 - Hydraulic Lift Valve

3.9 CONVEYOR PLACEMENT

Follow this procedure when placing the conveyor into its working position:

1. Clear the area of bystanders, especially small children, before starting.



WARNING: Electrocution Hazard
Ensure enough clearance from overhead obstructions, power lines or other equipment.

2. Attach conveyor to the tractor.
3. Back conveyor up to the storage facility while it is in its lowered configuration.
4. Set the park brake on the tractor before dismounting.
5. Use the tractor hydraulics or winch to raise the machine into position.
6. Slowly move the conveyor until the discharge spout is over the opening in the storage bin.
7. Place chocks around each wheel.
8. Unhook the unit from the tractor or towing vehicle and lower the hopper to the ground.
9. Remove the hitch from conveyor to prevent interfering and remove safety hazard.



Fig 64 - Hitch

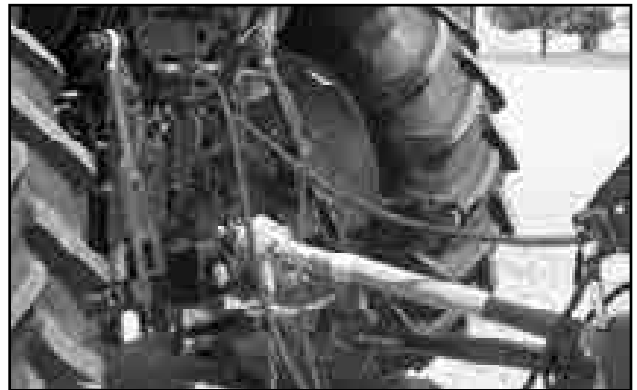

Fig 65 - Tractor Connections



Fig 66 - In Position to Unload



Fig 67 - Chocked Wheels

10. Use the hydraulics or winch to lower the discharge spout, until it is just over the opening.

Important:

To prevent damage to the conveyor tube and belt, be sure it does not rest on the any structure.



CAUTION: Upending Hazard
Always check the weight of the hopper end to prevent upending.

11. Stake or weigh down the hopper end to prevent upending when the machine is emptying.
12. Disconnect hydraulic hose and close valve (if equipped). to lock unit in position.
13. Reverse the above procedure to remove from location.



Fig 68 - Discharge Spout



Fig 69 - Motor Control Box

3.10 OPERATING ON SITE

When operating the conveyor, follow this procedure:

1. Clear the area of bystanders, especially small children, before starting.
2. Review the Pre-Operation Checklist before starting. Refer to Section 3.3
3. Review the Workplace Hazards schematic and use extra care when inside the hazard area. Keep all spectators and bystanders out of this area.

Should anyone enter this area, stop the machine immediately.

4. Check that all guards are in place and working as intended.

3.10.1 Attach PTO driveline (if equipped):

5. Position tractor at 10 to 12 feet from conveyor.

Important:

Position tractor to keep U joint angles equal and as small as possible.
15° or less is recommended.

6. Place chocks next to tractor tires and set the park brake.
7. Clean the splines on the shaft and in the yoke if required.
8. Check that the guard rotates freely and the driveline telescopes easily. If not, clean, lubricate or repair as required before installing.
9. Depress pin on yoke to retract lock pin. Slide the yoke over the tractor shaft. Stop when the lock pin clicks into position in the groove.
10. Pull on the yoke to be sure it is locked into the shaft.
11. Check that the yokes on the driveline are secured to their respective shafts.
12. Back the truck into position for unloading.

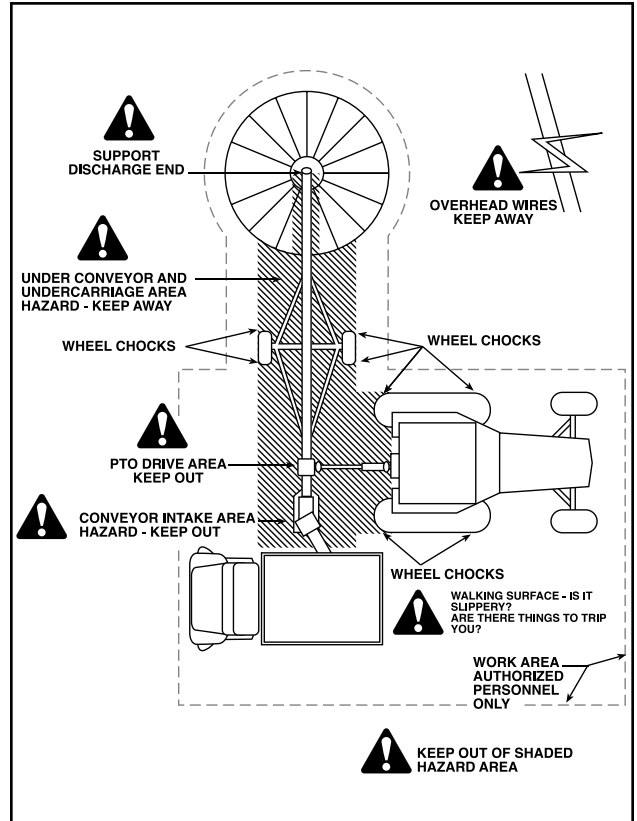

Fig 70 - Workplace Hazard Area

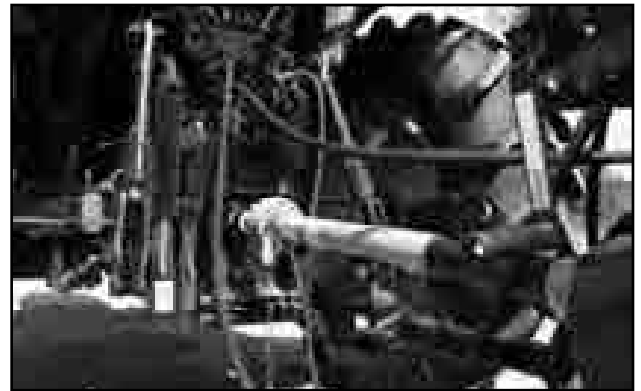

Fig 71 - Attach Tractor



Fig 72 - Wheel Chocks

3.10.2 Starting Conveyor:

PTO Drive Model:

1. Place all controls in neutral.
2. Start tractor and run at low idle.
3. Slowly engage the PTO clutch.
4. Start the flow of material and unload into hopper.
5. Increase engine speed to have a PTO speed of 300 or 350 RPM depending on model.



Fig 73 - PTO

Gas Engine Model:

1. Disengage belt drive.
2. Move throttle to its idle position.
3. Close the choke if the engine is cold or if the unit has not been run for a while.
4. Turn the ignition key clockwise to start the engine. Release the key when the engine starts.
5. Run for 2-3 minutes to allow the engine to warm.
6. Engage the belt drive when engine is running just above idle.



Fig 74 - Gas Engine, Engine Mount Handle

Note:

Do not engage drive belt when engine is at full RPM.

7. Now, increase engine speed to full throttle.
8. Start the flow of material and unload into hopper.



Fig 75 - Electric Motor

Electric Motor Model:

1. Have licenced electrician provide power to motor.
2. Plug power cord from master panel, into conveyor.
3. Turn power on at master control panel, at power source.
4. Turn conveyor motor on.

Hydraulic Motor Model:

1. Plug in hydraulic hoses.
2. Start hydraulic power source.
3. Turn on conveyor hydraulic system.



Fig 76 - Hydraulic Motor

3.10.3 Stopping Conveyor:**PTO model:**

1. Stop unloading. Wait for conveyor belt to run empty.
2. Reduce tractor engine speed to low idle.
3. Disengage PTO clutch.
4. Shut off tractor engine and remove ignition key.



Fig 77 - Working Conveyor

Gas Engine Model:

1. Stop unloading. Wait for conveyor belt to run empty.
2. Move the throttle to idle position.
3. Disengage belt drive.
4. Shut off engine and remove ignition key.

Electric Motor Model:

1. Stop unloading. Wait for conveyor belt to run empty.
2. Turn power off on conveyor.
3. Turn power off at main panel and unplug power cord.

Hydraulic Motor Model:

1. Stop unloading. Wait for conveyor belt to run empty.
2. Turn conveyor hydraulic system off.
3. Turn power source off.

3.10.4 Emergency Stopping:

Although it is recommended that the tube be emptied before stopping, in an emergency situation, stop or shut-down the power source immediately.

3.10.5 Restarting after Emergency Stop:

When the machine is shut down inadvertently or in an emergency, the conveyor belt will still be covered with material.

Since the start-up torque loads are much higher than normal when the belt is full, restart at a low speed.

Remove as much product from the hopper as possible.

It may be necessary to tighten the drive belt slightly to handle the heavier than normal loads.

3.10.6 Unplugging:

In unusual moisture, crop or material conditions, the machine can plug. When unplugging, follow this procedure:

1. Place all controls in neutral or off, stop engine or motors and disable power source. Wait for all belts to stop rotating.
2. Lock-out, tag-out the controls.
3. Remove the material from the discharge and the intake area.
4. Reposition unit if discharge area plugs due to lack of clearance.
5. Restart unit.



Fig 78 - Working Conveyor

3.10.7 Hold Down Wheels on TCGN models:

In situations where the conveyor belt jams or is overtightened, the belt can come out from under the hold down wheels at the transition point. To correct situation:

1. Run until machine is empty or remove all material from machine.
2. Turn engine or motors off and disable the power source.
3. Move conveyor belt into its loosest position.
Refer to Section 4.3.1
4. Remove transition cover.
5. Push conveyor belt under hold down wheels.
6. Set tension and alignment.
Refer to Section 4.3.1 and 4.3.2
7. Install and secure transition cover.

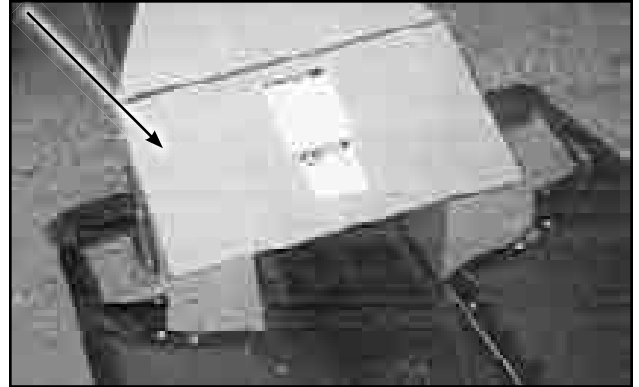

Fig 79 - Transition Cover



Fig 80 - Hold Down Wheel Location

3.11 OPERATING HINTS:

- Keep the hopper full for maximum capacity. Most efficient results will be obtained when flow of incoming material is directed to the front (closer to the tube) of the hopper.
- Always listen for any unusual sounds or noises. If any are heard, stop the machine and determine the source. Correct the problem before resuming work.
- Do not run the machine for long periods of time with no material on the belting. This increases the wear. Try to run only when moving material.
- Do not move the machine by hand. Always use a tractor.
- Do not support discharge end directly on the storage facility.
- Stake the hopper or weigh it down to prevent up ending.
- For better performance, use a transfer conveyor or drive over conveyor, to move product from the storage facility/truck to conveyor hopper.
- The hopper is designed with flashing to seal the junction of the belt with the sides of the hopper. It must be kept in good condition to prevent the material from "leaking" out of the hopper. Replace flashing if "leakage" occurs.
- Belt Speed:
The best results are obtained when the drive is set to provide a belt speed of 600 ft./min.

Count the number of belt revolutions per unit time to determine belt speed. Use the connector splice as a reference when counting belt revolutions.

Contact your dealer or the factory for the appropriate drive components to give the recommended belt speed.

- Belt Tension:
There may be a rapid decrease in belt tension during the first few hours of operation until the belt has worn in.

The correct operating tension is the lowest tension at which the belt will not slip under peak load conditions.

- Operating Angle:
The hydraulic lift can set the tube angle at any position between 12° and 35° when operating. Because the belt does not have roll-back barriers, the product will roll-back if the angle is too steep. Do not position at more than 35°.

Note:

The lower the angle,
the greater the capacity.

- On the PTO drive models, align the tractor axis with the conveyor input shaft to minimize the angles of the universal joints on the driveline.



Fig 81 - Using Drive Over Conveyor

3.12 TRANSPORTATION



Transporting Safety

- Read and understand ALL the information in the Operator's Manual regarding procedures and SAFETY when moving or transporting the conveyor.
- Check with local authorities regarding conveyor transport on public roads. Obey all applicable laws and regulations.
- Always travel at a safe speed. Use caution when making corners or meeting traffic.
- Make sure the SMV (Slow Moving Vehicle) emblem and all the lights and reflectors that are required by the local highway and transport authorities are in place, are clean and can be seen clearly by all overtaking and oncoming traffic.
- Keep to the right and yield the right-of-way to allow faster traffic to pass. Drive on the road shoulder, if permitted by law.
- Do not allow riders on the conveyor when transporting.
- Close valve in hydraulic line (if equipped).
- Lower conveyor to its lowest position for transporting.
- Attach conveyor to towing vehicle with a pin and retainer. Always attach the safety chain.
- Do not exceed 20 mph (32 km/h). Reduce speed on rough roads and surfaces.
- Stay away from overhead obstructions and power lines when transporting. Electrocution can occur without direct contact.
- Always use hazard warning flashers on tractor when transporting unless prohibited by law.

Convey-All Tube Conveyors are designed to be easily and conveniently moved from place to place. When transporting the unit, follow this procedure:

1. Refer to Section 3.7 to attach conveyor to tow vehicle.
2. Ensure the conveyor unit is ready for transport:
 - It is in fully collapsed position
 - Hydraulic line (if equipped) are closed
 - Hitch is attached using anchor pin, retainer and safety chain.
3. Be sure all bystanders are clear of the machine.
4. Raise the jack. Unpin anchor bracket. Rotate jack to lay horizontal along frame. Secure with anchor pin and retainer clip.
5. Remove PTO drive line (if equipped). Store in its cradle on the conveyor frame.

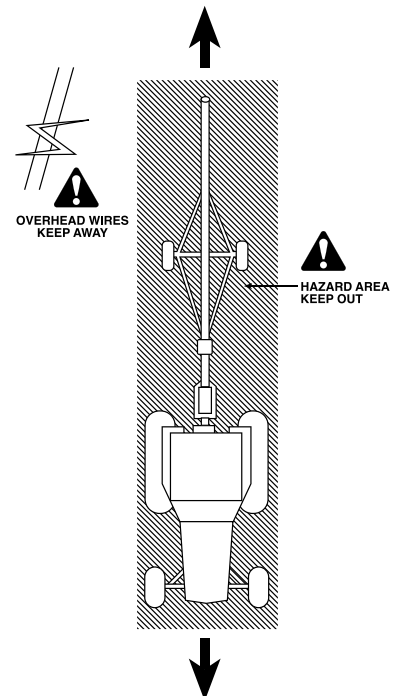

Fig 82 - Transporting Hazard Area

6. If equipped with lighting package, connect wiring harness to towing vehicle. Secure across the hitch with clips, tape or zip ties.
7. Remove chocks from the wheels.
8. Move axles into narrowest position (if equipped).
9. Slowly pull away from the working area. Be sure everything is connected, nothing is hanging.
10. Ensure the SMV (Slow Moving Vehicle) emblem, all lights and reflectors required by local highway and transport authorities are in place. They must be clean and clearly visible by all overtaking and oncoming traffic.
11. Keep to the right and yield the right-of-way to allow faster traffic to pass. Drive on the road shoulder, if permitted by law.
12. Never travel across slopes of more than 20°. It is better to go straight up and down.
13. It is not recommended that the machine be transported faster than 32km/h (20mph).

Road Speed	Weight of fully equipped or loaded implement(s) relative to weight of towing machine
up to 32km/h (20mph)	1 to 1, or less
up to 16km/h (10mph)	2 to 1, or less
Do not tow	More than 2 to 1

Table 2 - Road Speed

14. Do not allow riders on the conveyor.
15. During periods of limited visibility, use pilot vehicles or add extra lights to the machine.
16. Always use hazard flashers on the tractor when transporting unless prohibited by law.



Fig 83 - Stored Hitch

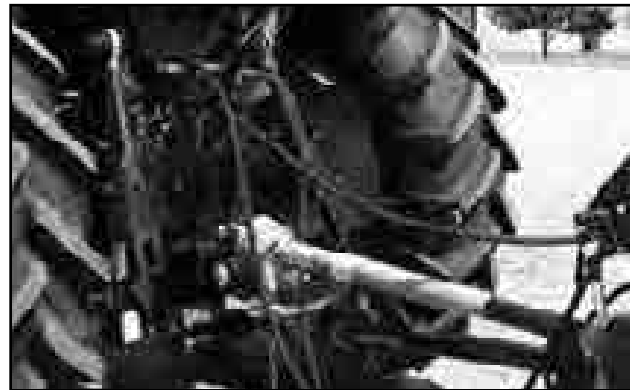

Fig 84 - Tractor Connections



Fig 85 - Transporting Conveyor



Fig 86 - Hitch

3.13 STORAGE



Storage Safety

- Store the unit in an area away from human activity.
- Do not permit children to play on or around the stored machine.
- Lower conveyor to its lowest position for storage unless supported by a storage facility.
- If required, make sure the unit is solidly blocked up.
- Make certain all mechanical locks are safely and positively connected before storing.

After the season's use, the conveyor should be thoroughly inspected and prepared for storage.

Repair or replace any worn or damaged components to prevent any unnecessary down time at the start of next season. To have a long, trouble free life, this procedure should be followed when preparing the unit for storage:

1. Remove all residual material from the hopper and the tube.
2. Inspect all moving or rotating parts to see if anything has become entangled in them. Remove the entangled material.
3. Wash the entire machine thoroughly using a water hose or pressure washer to remove all dirt, mud, debris or residue.
4. Inspect all hydraulic hoses, fittings, lines, couplers and valves. Tighten any loose fittings. Replace any hose that is badly cut, nicked or abraded or is separating from the crimped end of the fitting.
5. Touch up all paint nicks and scratches to prevent rusting.
6. Select an area that is dry, level and free of debris.



Fig 87 - Collapsed Position

This page intentionally left blank

Section 4: SERVICE AND MAINTENANCE



Servicing Safety

- Review the Operator's Manual and all safety items before working with, maintaining or operating the machine.
- Place all controls in neutral, stop engine/motor, unplug the cord. Wait for all moving parts to stop before servicing, adjusting, repairing or unplugging.
- Follow good shop practices:
 - Keep service area clean and dry.
 - Be sure electrical outlets and tools are properly grounded.
 - Use adequate light for the job at hand.
- Before applying pressure to a hydraulic system, make sure all components are tight and that hoses and couplings are in good condition.
- Relieve pressure from hydraulic circuit before servicing or disconnecting from tractor.
- Keep hands, feet, hair and clothing away from all moving and/or rotating parts.
- Make sure there is plenty of ventilation. Never operate the engine in a closed building. The exhaust fumes may cause asphyxiation.
- Place stands or blocks under frame before working beneath the unit.
- Clear the area of bystanders, especially children, when carrying out any maintenance and repairs or making any adjustments.
- Before resuming work, install and secure all guards when maintenance work is completed.
- Keep safety decals clean. Replace any decal that is damaged or not clearly visible.

By following the operating instructions, in conjunction with a good maintenance program, your tube conveyor will provide many years of trouble free service.

4.1 FLUIDS AND LUBRICANTS

Fuel & Engine Oil:

Refer to the operator's manual for the engine which is used on the conveyor, to find specific instructions.

Grease:

Use an SAE multipurpose high temperature grease with extreme pressure (EP) performance. Also acceptable, SAE multipurpose lithium based grease.

Storing Lubricants:

Your machine can operate at top efficiency only if clean lubricants are used. Use clean containers to handle all lubricants. Store them in an area protected from dust, moisture and other contaminants.

4.1.1 Greasing:

Use the Service Record provided on page 4-17, to keep a record of all scheduled maintenance.

1. Use a hand-held grease gun for all greasing.
2. Wipe grease fitting with a clean cloth before greasing, to avoid injecting dirt and grit.
3. All bearings are sealed and greasable. They require minimal grease.

Recommended greasing is 1 small stroke every 2 weeks. Be careful not to over grease as this may push the seal out.

4. Replace and repair broken fittings immediately.
5. If fittings will not take grease, remove and clean thoroughly. Also clean lubricant passageway. Replace fitting if necessary.

4.2 SERVICING INTERVALS

The conveyor belt alignment is preset to run true under a condition of no load. It is important to check alignment and make adjustments, if required, during the initial few minutes of loaded operation.

Check bearings for wear daily.

The periods recommended below are based on normal operating conditions. Severe or unusual conditions may require more frequent lubrication and oil changes.

4.2.1 After 10 Hours or Daily:

Gas Engine Units:

1. Check fuel level. Add as required.
2. Check engine oil level. Add as required.
3. Clean air filter.
4. Grease counter shaft bearings.

Electric Motor Units:

5. Grease counter shaft bearings.

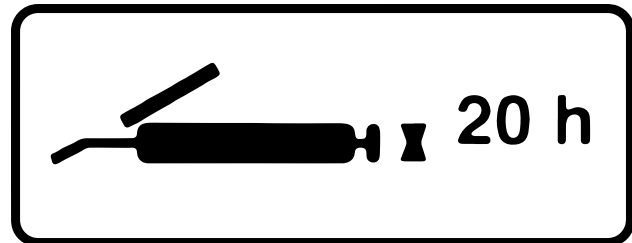

36-2200-0001



Fig 88 - Gas Engine



Fig 89 - Fuel Tank



Fig 90 - Counter Shaft (Motor not Installed)

PTO Drive Units:

6. Grease PTO shaft (5 locations).

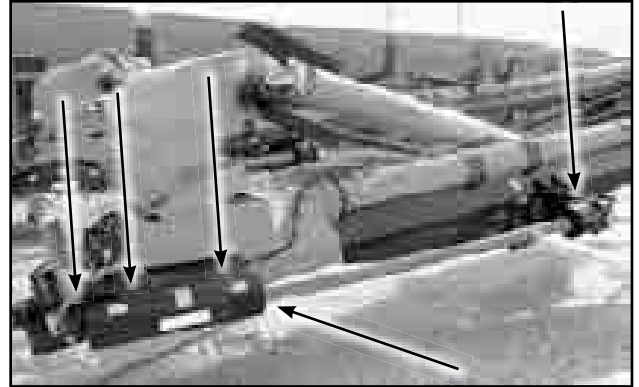

Fig 91 - PTO and Jack Shaft

7. Grease front PTO model longitudinal shaft (2 locations).



Fig 92 - Front PTO Model Longitudinal Shaft

Conveyor:

8. Grease hopper and transition roller bearings.

Also on the swing out conveyor (if equipped).



Fig 93 - Hopper Bearings



Fig 94 - Transition Roller Bearings

9. Grease discharge roller bearings.

Also on the swing out conveyor (if equipped).

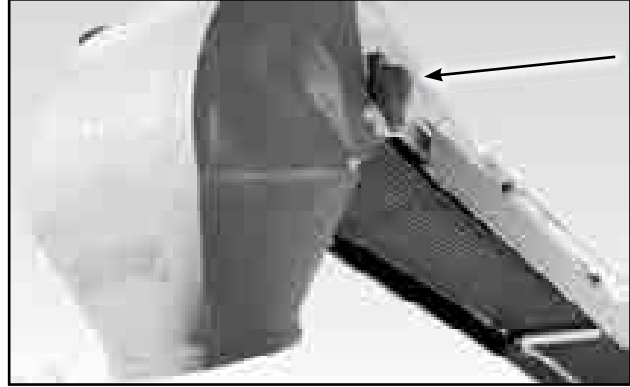

Fig 95 - Discharge Roller Bearings

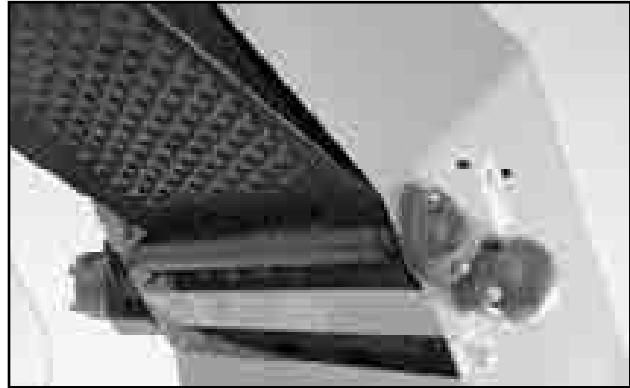

Fig 96 - Discharge Rollers on Swing Out

10. Grease drive box assembly bearings.

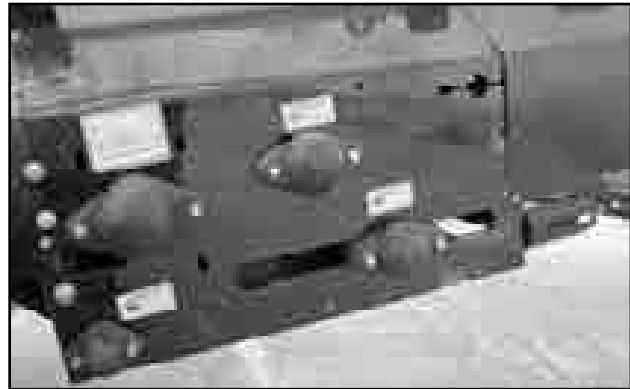

Fig 97 - Drive Box



Fig 98 - Positive Pinch Drive Box with PTO

4.2.2 After 50 Hours or Weekly:

11. Check the conveyor belt tension.
Refer to Section 4.3.1

Note:

A properly tensioned belt will not slip when in operation.

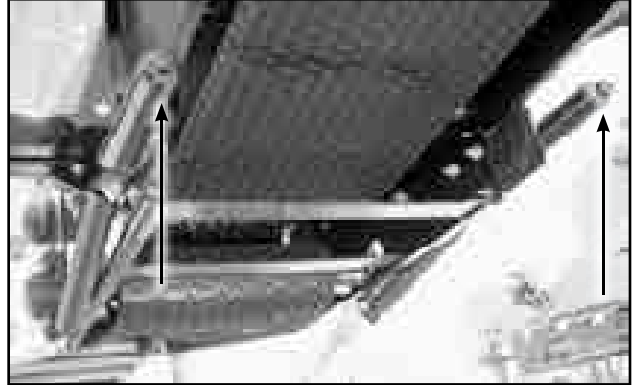

Fig 99 - Tension Bolts, Positive Pinch Drive

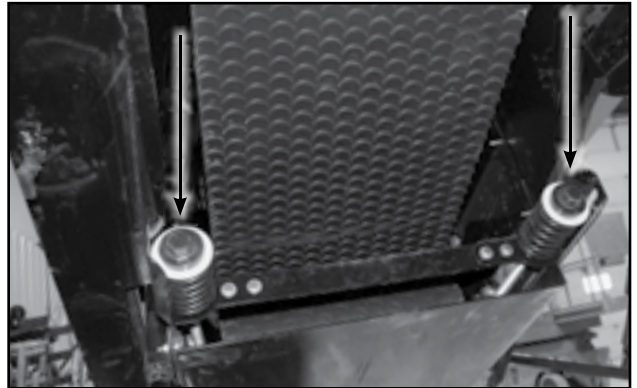

Fig 100 - Tension Bolts, S-Wrap Drive Box

12. Check conveyor belt alignment.
Refer to Section 4.3.2



Fig 101 - Adjustment Bolts on TCH

13. Check drive belt tension.
Refer to Section 4.3.4



Fig 102 - Drive Belt Tension Bolt

14. Check pulley alignment.
Refer to Section 4.3.5

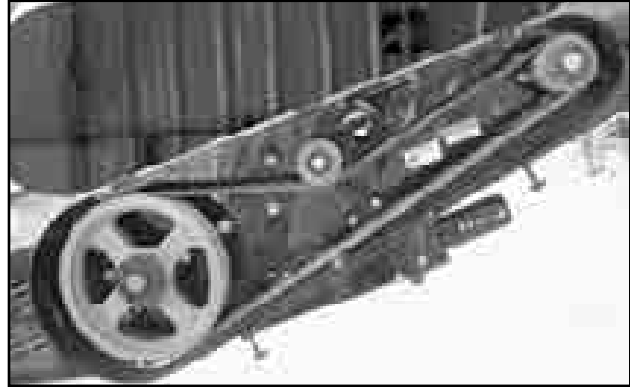

Fig 103 - Countershaft To Drive Roller Belt

15. Check the condition of rubber hopper flashing. Be sure it still seals the hopper to prevent leaking.

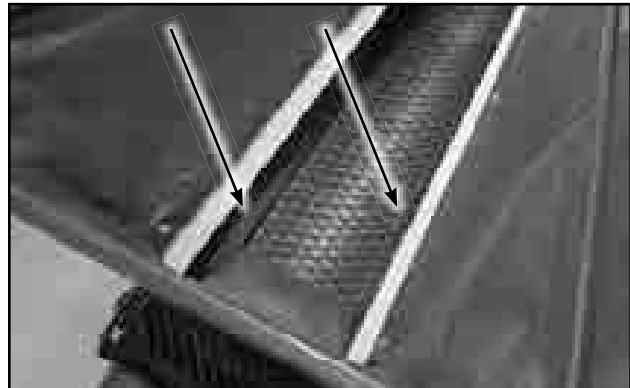

Fig 104 - Hopper Flashing

Hydraulic Motor Units:

16. Oil input drive coupler

Also on the Swing Out Conveyor (if equipped).



Fig 105 - Hydraulic Drive, Main Conveyor

TCGN Models:

17. Check hold down wheels for wear on rubber wrap. Replace if necessary. Refer to Section 4.3.7



Fig 106 - TCGN Model, Hold Down Wheel Location

4.2.3 After 200 hours or Annually:

Gas Engine Units:

- 18. Change engine oil and filter (a).
- 19. Change in-line fuel filter (b).
- 20. Change engine air filter (c).

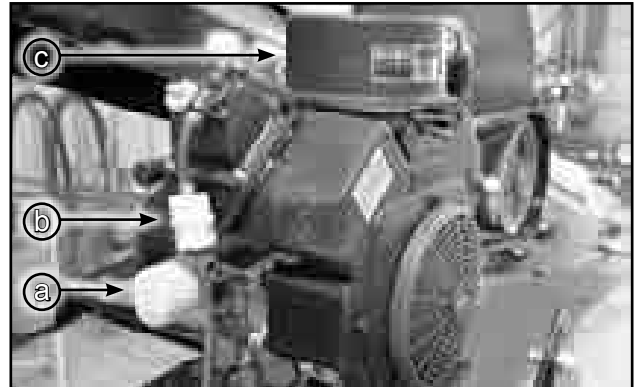

Fig 107 - Gas Engine

Conveyor:

- 21. Grease upper lift bearings (A-frame undercarriage).
- 22. Grease both ends of conveyor lift cylinder (scissor lift undercarriage).



Fig 108 - Upper Lift Bearings

- 23. Check for tube straightness. Adjust eyebolt if required.
- 24. Repack wheel bearings.
- 25. Wash the machine



Fig 109 - Tube Lift Cylinder



Fig 110 - Cable Bridging Eye Bolts

4.3 MAINTENANCE

By following a careful service and maintenance program for your machine, you will enjoy many years of trouble-free service.



WARNING: Rotating Part Hazard
Turn off engine/motor. Disconnect power source and wait for belts to stop moving.

4.3.1 Conveyor Belt Tension:

The tension of the belt should be checked weekly, or more often if required, to be sure that it does not slip. To maintain the belt, follow this procedure:

Use the drive box tension bolts to adjust the belt.

Positive Pinch Drive:

Longer tube conveyors have Positive Pinch Drive.

When loading on the belt gets heavier, the pinch roller tightens against the drive roller in proportion. This provides more torque

Tighten the tension bolts completely.

When the conveyor belt is tensioned correctly, the arm at the end of the spring should sit vertical. It can also be angled back, away from the tension bolt by as much as 2 inches. This indicates that the belt is a good length. See Figure 111

The arm should never be angled towards the tension bolt. This indicates the belt is too long. Measure the angle. If the belt angles 2 inches away from vertical, cut and re-lace the belt 4 inches shorter.

If the arm touches the far right edge, the belt is too short. Remove and replace with longer belt.

S-Wrap Drive:

Shorter tube conveyors, have yellow washers sandwiched between the tension bolt and spring.

Reference the tension indicator on the outside of each spring. Line up the yellow washer with the arrows. Using the indicator, the tension bolt springs will measure 3-3/4" (95 mm).

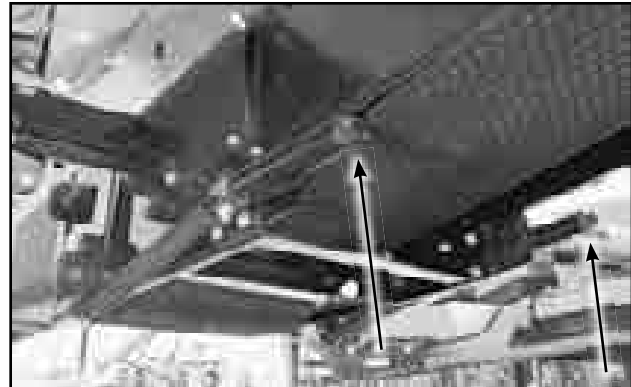

Fig 111 - Tension Bolt, Positive Pinch Drive

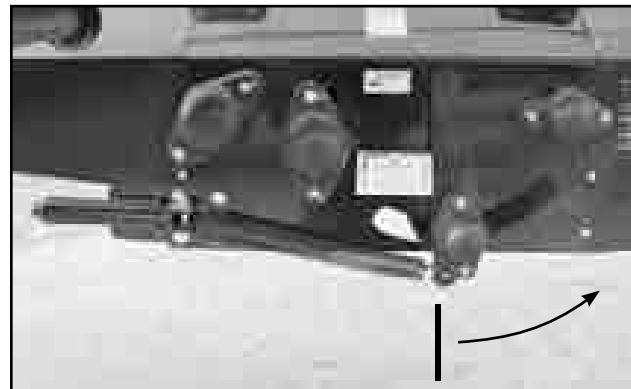

Fig 112 - Belt Length Indicator, Position Pinch Drive



Fig 113 - Tension Bolt, Spring Tension, S-Wrap Drive

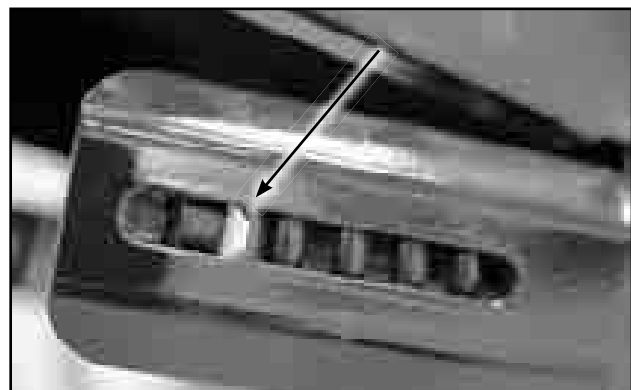

Fig 114 - Tension Indicator, S-Wrap Drive

4.3.2 Conveyor Belt Alignment:

The belt is properly aligned when it rotates in the centre of the rollers on both ends and in the drive box housing. As with tensioning, the alignment should be checked weekly, or as required.

1. Rotate the conveyor belt a half revolution when the belt is new and check the position of the belt on the drive, discharge and hopper rollers.

Note:

If belt is out of alignment,
it will move to the loose side.
Tighten loose side or loosen tight side.

2. Tighten or loosen the tensioning bolt by a 1/4 turn to 2 turns.
3. Run a couple of revolutions and check again.
4. Tighten the tension bolt lock nut.

Check frequently during the first few minutes of operation and then several times during the first 10 hours.

The belt normally seats itself during the first 10 hours of operation and can be checked weekly after that.

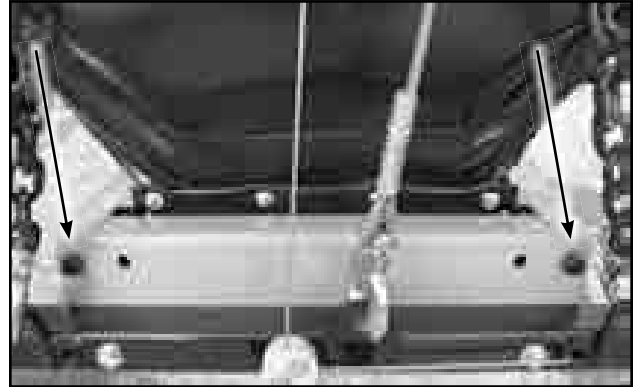

Fig 115 - Tension Bolts, Swing Out



Fig 116 - Adjustment Bolts on Hopper without Transition

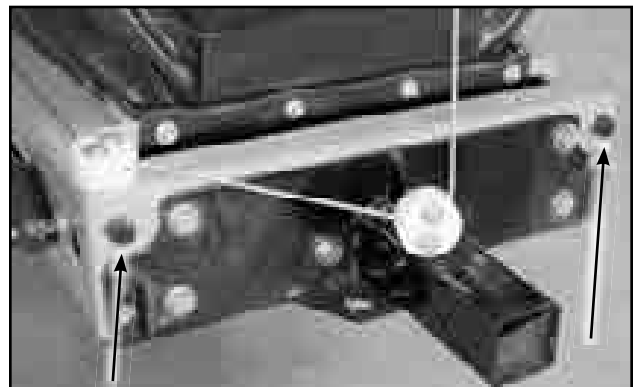

Fig 117 - Adjustment Bolts on Hopper with S-Neck Transition



Fig 118 - Inside Discharge Spout

4.3.3 Conveyor Belt Replacement:

1. Rotate the conveyor belt until the Alligator Lacing is positioned under the tube, inside the wind guard, and is accessible.
2. Rotate the tension bolt in the drive box to its loosest position. See Figure 110 or 112
3. Pull all the slack to the lacing area.
4. Remove the lacing pin and open the belt.
5. Attach one end of the replacement belt to the end of the belt (to be removed) which is hanging closest to the hopper.
6. Pull the end of the old belt which is coming from the direction of the discharge spout. The new belt will follow and be threaded into place.
7. Disconnect the old belt.
8. Connect the ends of the new belt. Place the pin in the Alligator Lacing. Crimp the ends of the pin.
9. Set the belt tension. Refer to Section 4.3.1
10. Set the belt alignment. Refer to Section 4.3.2.

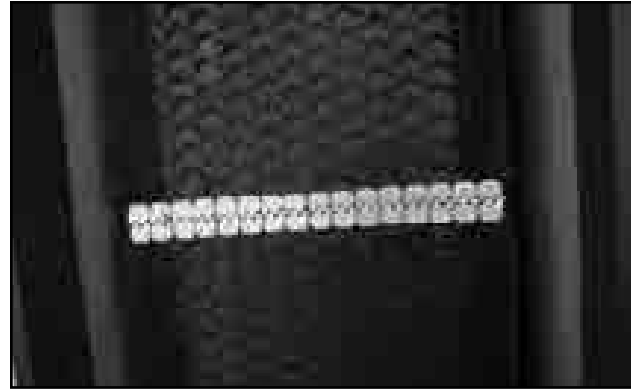

Fig 119 - Conveyor Belt Seam, as Seen in Hopper

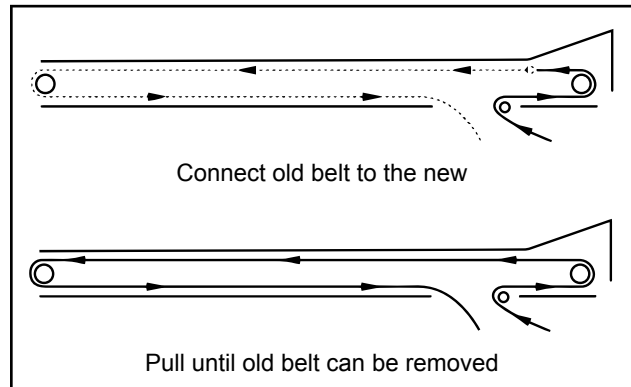

Fig 120 - Threading the Belt

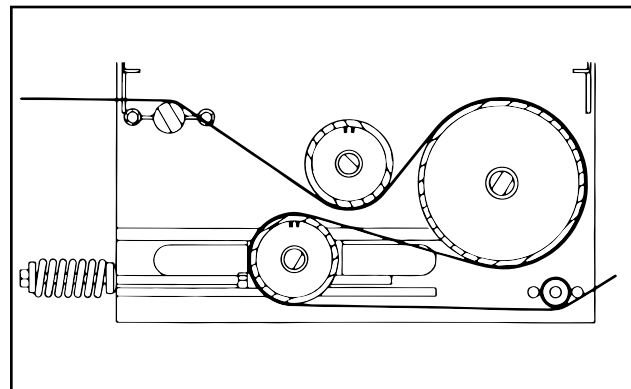

Fig 121 - Belt Path Through S-Wrap Drive Box

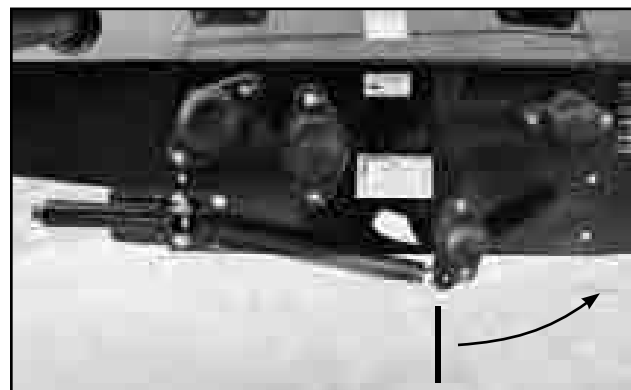

Fig 122 - Belt Length Indicator, Positive Pinch Drive

4.3.4 Drive Belt Tension:

To adjust the belt tension, follow this procedure:



WARNING: Rotating Part Hazard
Turn off engine/motor. Disconnect power source and wait for belts to stop moving.

First, set tension on "counter shaft to drive" belt.

1. Open the guard over the V-belt pulley.
2. Loosen counter shaft bearing mount anchor nuts and jam nuts.
3. Use bearing mount position bolts to set countershaft position and set belt tension.

Calculate the tension (See Figure 125):

- Measure the length of span between pulleys
- Allow 1/64" of deflection per inch of span

4. Tighten bearing mount anchor nuts.
5. Tighten adjusting bolt(s) and lock nut(s).
6. Close and secure guard over pulleys.

Second, set tension on "engine to counter shaft" belt.

7. Open the guard over the V-belt pulley.
8. Loosen engine/motor mount nuts and jam nuts.
9. Use motor mount nuts to set belt tension.

Calculate the tension (See Figure 125):

- Measure the length of span between pulleys
- Allow 1/64" of deflection per inch of span

10. Tighten motor mount anchor nuts.
11. Tighten adjusting bolt(s) and lock nut(s).
12. Close and secure guard over pulleys.

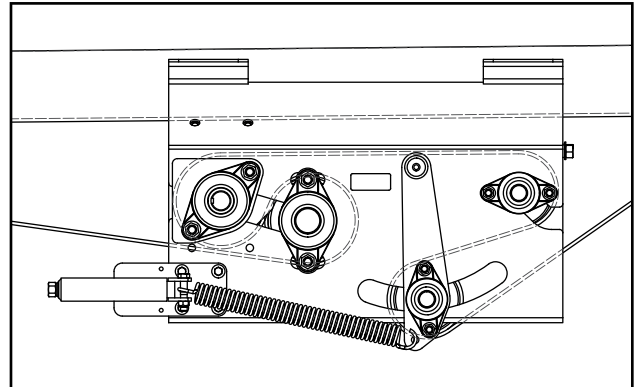

Fig 123 - Belt Path Through Positive Pinch Drive Box

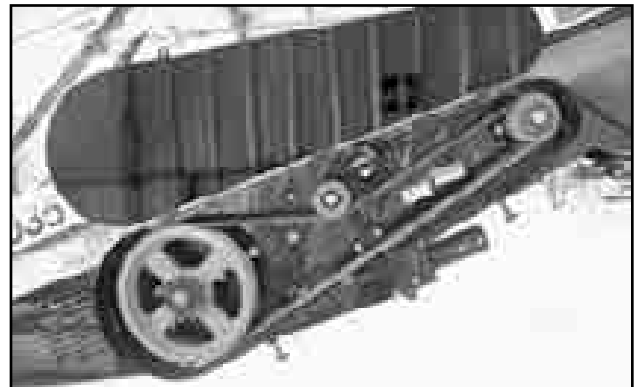

Fig 124 - Counter Shaft to Drive Belt with Guard Open



Fig 125 - Engine to Counter Shaft with Guard Open

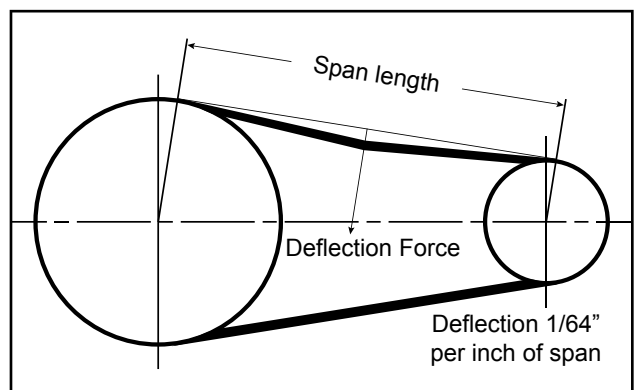

Fig 126 - Tension Calculation

4.3.5 Check Pulley Alignment:

1. Lay a straight edge across both drive and driven pulleys to check alignment.
2. Use the tapered lock hub in the center of the pulley to adjust the position of a pulley if required.
3. Move a pulley to align if there is more than a 1/32 inch gap between the edge of the pulley and the straight edge.

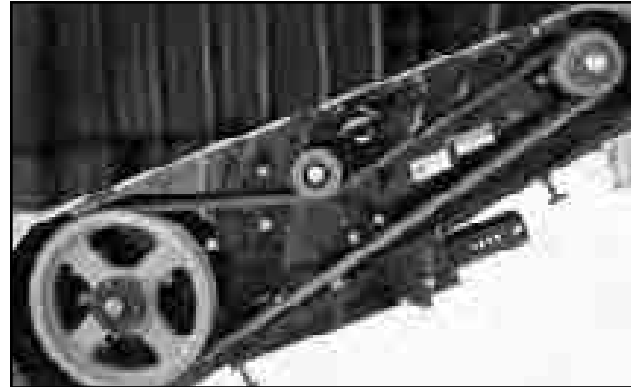

Fig 127 - In-Line Drive with Guard Opened

4.3.6 Drive Belt Replacement:

1. Place drive system into its loosest position.
2. Remove old belt.
3. Install replacement belt.
4. Set belt tension. Refer to Section 4.3.4
5. Check pulley alignment. Refer to Section 4.3.5

Cross Section	Smallest Sheave Diameter Range	RPM Range	Belt Deflection (Force Pounds)			
			Uncogged Hy-T® Belts and Uncogged Hy-T® Torque Team®		Cogged Torque Flex® and Machined Edge Torque Team® Belts	
			Used Belt	New Belt	Used Belt	New Belt
A, AX	3.0 - 3.6	1000-2500 2501-4000	3.7 2.8	5.5 4.2	4.1 3.4	6.1 5.0
	3.8 - 4.8	1000-2500 2501-4000	4.5 3.8	6.8 5.7	5.0 4.3	7.4 6.4
	5.0 - 7.0	1000-2500 2501-4000	5.4 4.7	8.0 7.0	5.7 5.1	9.4 7.6
B, BX	3.4 - 4.2	860-2500 2501-4000	n/a	n/a	4.9 4.2	7.2 6.2
	4.4 - 5.6	860-2500 2501-4000	5.3 4.5	7.9 6.7	7.1 6.2	10.5 9.1
	5.8 - 8.6	860-2500 2501-4000	6.3 6.0	9.4 8.9	8.5 7.3	12.6 10.9
C, CX	7.0 - 9.0	500-1740 1741-3000	11.5 9.4	17.0 13.8	14.7 11.9	21.8 17.5
	9.5 - 16.0	500-1740 1741-3000	14.1 12.5	21.0 18.5	15.9 14.6	23.5 21.6
D	12.0 - 16.0	200-850 851-1500	24.9 21.2	37.0 31.3	n/a	n/a
	18.0 - 20.0	200-850 851-1500	30.4 25.6	45.2 38.0	n/a	n/a
			Uncogged Hy-T® Wedge Belts and Uncogged Hy-T® Wedge Torque Team®		Cogged Hy-T® Wedge Belts and Hy-T® Wedge Machine Edge Torque Team®	
			Used Belt	New Belt	Used Belt	New Belt
5V	4.4 - 6.7	500-1749 1750-3000 3001-4000	n/a	n/a	10.2 8.8 5.6	15.2 13.2 8.5
	7.1 - 10.9	500-1740 1741-3000	12.7 11.2	18.9 16.7	14.8 13.7	22.1 20.1
	11.8 - 16.0	500-1740 1741-3000	15.5 14.6	23.4 21.8	17.1 16.8	25.5 25.0

Table 3 - Belt Deflection Force

4.3.7 TCGN Hold Down Wheels Replacement:

1. Remove transition cover.
2. Remove bolts which face the open hopper (a). There are 2 bolts on either side.
3. Remove bolts which are inside the tube (b). 1 on either side.
4. Now, these side brackets are loose, but still attached to the hopper flashing. Folded both sides out, to lay on hopper. This will give access to the wheels.
5. Remove the bolts, then remove worn wheels (c).
6. Insert the new wheels and tighten bolts.
7. Fold side brackets back into place. Bolt and tighten.
8. Secure transition cover to guard hopper transition.

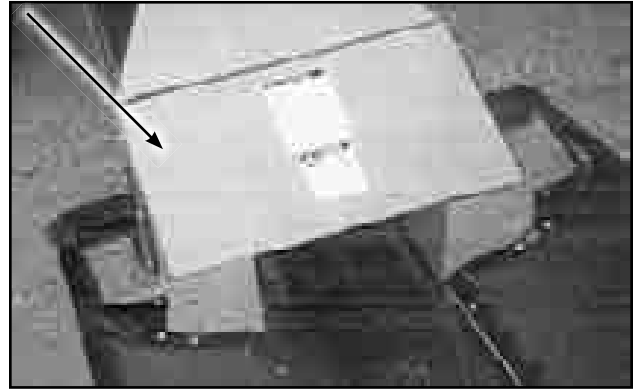

Fig 128 - Transition Cover

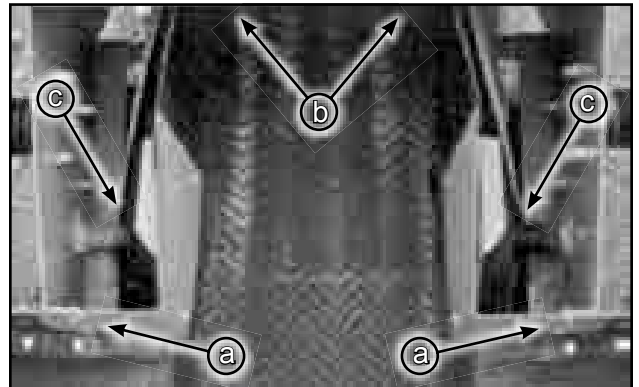

Fig 129 - Bolts Facing Hopper (a), Bolts Inside (b), Wheels (c)

4.3.8 Change Engine Oil and Filter

1. Review the operator's manual for the engine. Specific instructions may vary between engine models.



WARNING: Rotating Part Hazard
Turn off engine/motor. Disconnect power source and wait for belts to stop moving.



DANGER: Hot Components
Allow the engine to cool before changing the oil. Hot oil can cause burns if it contacts exposed skin.

Note:

It is best to change oil while engine is warm to keep contaminants in suspension.

2. Place a pan under the drain plug.
3. Remove the drain and allow the oil to drain for 10 minutes.
4. Install and tighten the drain plug.
5. Remove engine oil filter.
6. Dispose of the used oil in approved container.
7. Apply light coat of oil to the O-ring of new filter and install. Snug up by hand, then tighten another half turn.
8. Fill crankcase with specified oil.
9. Run the engine for 1-2 minutes and check for oil leaks.
10. If leaks are found, tighten drain plug slightly.
11. Check engine oil level. Top up as required.

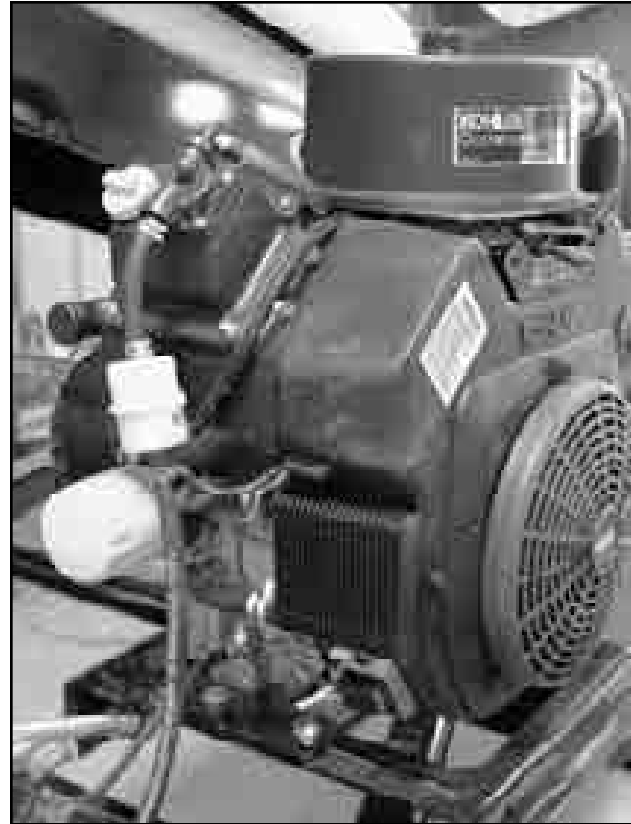

Fig 130 - In-Line Drive with Guard Opened

4.3.9 Change In-Line Fuel Filter:

1. Review the operator's manual for the engine. Specific instructions may vary between engine models.



WARNING: Rotating Part Hazard
Turn off engine/motor. Disconnect power source and wait for belts to stop moving.



DANGER: Hot Components
Allow the engine to cool before changing the oil. Hot oil can cause burns if it contacts exposed skin.

2. Place a pan under the filter to catch any spilled fuel.
3. Clamp off the line on each side of the filter to prevent the loss of any fuel.
4. Loosen the hose clamps on either side of the fuel filter.
5. Remove old fuel filter.
6. Install new filter and tighten hose clamps to their specified torque.
7. Remove catch pan and dispose of any spilled fuel in an environmentally safe manner.
8. Start engine and run for 1 to 2 minutes to check for leaks at the fuel filter. Re-tighten hose clamps if any leakage occurs.

4.3.10 Clean/Change Air Filter

1. Remove cover over the air filter.
2. Remove the foam from the engine.
3. Use an air hose to blow the dust and debris out of the foam.
4. Reinstall/Replace foam and secure the cover.



Fig 131 - In-Line Fuel Filter



Fig 132 - Air Filter

This page intentionally left blank

4.4 SERVICE RECORD

See Section 4.3 for details of maintenance. The Servicing Intervals section is only a guide under good conditions. Under extreme, or unusual circumstances adjust service timing accordingly. For a more detailed schedule pertaining to specific engine/motor models, consult it's operator's manual.

Copy this page to continue record.

Maintenance	Hours																		
	Serviced By																		
10 Hours or Daily																			
Check Fuel Level																			
Check Engine Oil Level																			
Clean Air Filter																			
Grease Counter Shaft Bearings																			
Grease PTO Shaft																			
Grease Front PTO Longitudinal Shaft																			
Grease Hopper Belt Roller Bearings																			
Grease Transition Roller Bearings																			
Grease Discharge Roller Bearings																			
Grease Drive Box Bearings																			
50 Hours, or Weekly																			
Check Conveyor Belt Tension																			
Check Conveyor Belt Alignment																			
Check Drive Belt Tension																			
Check Pulley Alignment																			
Check Hopper Flashing																			
Oil Input Drive Coupler																			
200 Hours or Annually																			
Change Engine Oil and Filter																			
Change In-Line Fuel Filter																			
Grease Conveyor Lift Cylinder (if equipped)																			
Check Tube Straightness																			
Grease Steering Axle Bushings (If equipped)																			
Repack Wheel Bearings																			
Change Engine Air Filter																			
Wash Machine																			

4.5 ORDERING PARTS

Always give the Model Number and Serial Number when ordering parts.

To get your parts promptly the following information will be required:

- The part name and number
- Your Name, Address, Town, Province/State, Country
- Complete information for shipping

Confirm all phoned in orders in writing. If Purchase Orders are required please note the number on the written order.

Unless claims for shortages or errors are made immediately upon receipt of goods, they will not be considered.

Inspect all goods received immediately upon receipt. When damaged goods are received, insist that a full description of the damage is made with the carrier against the freight bill. If this is insisted upon, full damage can be collected from the transport company.

No responsibility is assumed for delay or damage to merchandise while in transit. Dealers responsibility ceases upon delivery or pickup of shipment from or to the transportation company. Any freight damage claims must be made with the transportation company, not with the dealer.

Section 5: TROUBLE SHOOTING

In this section, many of the problems, causes and solutions which may be encounter, are listed.

If problems are confronted which are difficult to solve, even after having read through this section, please contact your authorized dealer, distributor or Convey-All Industries Inc. Before you call, please have this Operator's Manual and the unit's serial number ready.

Problem

Possible Cause	Possible Solution
----------------	-------------------

Electric motor labouring

Belt is sticky on the back side, because of oily product or wet/snowy conditions	Clean the belt
Hopper flashing too tight	Adjust to loosen the flashing

Engine won't start

Low battery	Recharge or replace
No fuel	Refuel
Cold engine	Open choke
Air filter dirty	Clean or replace the air filter

Conveyor belt doesn't turn or is slipping

Hopper flashing may be stuck to belt, because it is running dry and rubber is heating up	Turn off unit! Manually peel flashing up and off hopper. Then run dry product through to create barrier between flashing and belt
Conveyor belt loose	Tighten and align
Conveyor belt loose because it has stretched	Shorten belt
Conveyor belt frozen to tube from operating in high humidity conditions in extreme cold	Remove conveyor from area of high humidity and continue to run empty so the belt dries prior to freezing
Drive belt loose	Tighten drive belt
No power	Start engine, increase speed to maximum RPM
Electric/Gas system - drive roller slipping	Replace V-belt
Seized bearing	Check all bearings, Replace any that are rough or seized
Belt/roller is jammed	Check for sticks, stones, other objects jammed in belt drive area and remove

Problem - cont'd

Possible Cause	Possible Solution
----------------	-------------------

Conveyor belt won't align

Roller lagging may be worn	Replace roller or have it re-lagged
----------------------------	-------------------------------------

Conveyor Belt Fraying

Belt not aligned	Align and adjust tension
------------------	--------------------------

Product leakage

Product may be getting under the belt at the hopper, traveling up inside the belt and leaking off delivery end	Replace hopper flashing
--	-------------------------

Low capacity

Conveyor belt not tight enough	Tighten conveyor belt
Conveyor belt not pinched enough	Inside drive box there is a drive roller and pinch roller. Be sure the belt is snug between both rollers.
Electric/Gas system - drive roller is slipping or is worn out	Tighten or replace V-belt
Conveyor angle exceeds 30 degrees	Reposition with a lower tube slope

No hydraulic flow

Hydraulic valve closed or plugged	Open hydraulic valve
	Clean or replace hydraulic valve

10 inch Swing Out mover kit drives too fast/too slow

Hydraulic valve adjustment incorrectly set	Twist set screw IN to slow down wheels Twist set screw OUT to speed up
--	---

Section 6: SIGN-OFF FORM

Convey-All follows the general Safety Standards specified by the American Society of Agricultural Engineers (ASAE), and the Occupational Safety and Health Administration (OSHA). Anyone who will be operating and/or maintaining the unit must read and clearly understand all Safety, Operating and Maintenance information presented in this manual.

Do not operate, or allow anyone else to operate, this equipment until this document has been read. Review this information annually, before the season start-up.

Make periodic reviews of SAFETY and OPERATION a standard practice for all of your equipment.

The following Sign-Off Form is provided for your record keeping. Use it to show that all personnel who will be working with the equipment have read and understand the provided information. They also have been instructed in the operation of the equipment. Copy this page to continue the record.

DATE	EMPLOYEE'S SIGNATURE	EMPLOYER'S SIGNATURE

This page intentionally left blank

Section 7: REFERENCE

For information not included here, or for a digital copy of this manual, please call your dealer, or Convey-All Industries Inc. directly for assistance (1-800-418-9461).

See the next page for specifications table and working measurements.

7.1 SPECIFICATIONS

Model	Type of Under-Carriage	Tube Diameter	Belt Width	Axle Width	Transport Height	Transport Length
TC-1035	A-Frame	10"	12"	7' 11"	6' 10"	24' 4"
TC-1035-TED	A-Frame	10"	12"	7' 11"	11' 9"	37' 2"
TC-1040-TED	A-Frame	10"	12"	7' 11"	13' 10"	41' 9"
TC-1045	A-Frame	10"	12"	9' 2"	11' 2"	49' 2"
TC-1055	A-Frame	10"	12"	11'	11' 1"	59' 3"
TC-1065	A-Frame	10"	12"	12' 10"	10' 10"	69' 5"
TC-1070	Scissor Lift	10"	12"	12' 10"	11' 6"	74' 4"
TC-1075	Scissor Lift	10"	12"	12' 10"	12'	79' 4"
TC-1080	Scissor Lift	10"	12"	12' 10"	11'	84' 6"
TC-1085	Scissor Lift	10"	12"	12' 10"	11' 6"	89' 5"
TCGN-1035	A-Frame	10"	12"	7' 11"	8' 2"	39' 10"
TCGN-1045	A-Frame	10"	12"	8'	14' 2"	42' 3"
TCH-1035	A-Frame	10"	16"	8'	10' 11"	40' 8"
TCH-1035-TED	A-Frame	10"	16"	7' 11"	10' 1"	36' 6"
TCH-1045	A-Frame	10"	16"	9' 1"	11' 8"	50' 10"
TCH-1055	Scissor Lift	10"	16"	11' 4"	12' 6"	60' 8"
TCH-1065	Scissor Lift	10"	16"	11' 4"	11' 2"	70' 11"
TCH-1070	Scissor Lift	10"	16"	11' 4"	11' 10"	75' 11"
TCH-1075	Scissor Lift	10"	16"	11' 4"	12' 5"	80' 11"
TCH-1080	Scissor Lift	10"	16"			
TCH-1085	Scissor Lift	10"	16"	12' 6"	11' 7"	91' 1"
TCH-1090	Scissor Lift	10"	16"	12' 6"	12' 2"	96'
TCH-1095	Scissor Lift	10"	16"	12' 6"	12' 8"	100' 9"
TCH-10100	Scissor Lift	10"	16"	13' 6"	14' 7"	105' 10"
TCH-1435	A-Frame	14"	22"	8' 4"	10' 8"	38' 8"
TCH-1445	A-Frame	14"	22"	9' 1"	11' 3"	48' 9"
TCH-1455	Scissor Lift	14"	22"	9' 1"	9' 9"	59' 1"
TCH-1465	Scissor Lift	14"	22"	9' 1"	11' 5"	69'
TCH-1470	Scissor Lift	14"	22"	9' 1"	11' 7"	74'
TCH-1475	Scissor Lift	14"	22"	9' 1"	11' 2"	78' 11"
TCH-1480	Scissor Lift	14"	22"	13' 6"	11' 2"	86'
TCH-1485	Scissor Lift	14"	22"	13' 6"	12' 4"	89'
TCH-1490	Scissor Lift	14"	22"	13' 6"	13' 1"	93' 11"
TCH-1495	Scissor Lift	14"	22"	13' 6"	13' 8"	98' 11"
TCH-14100	Scissor Lift	14"	22"	13' 6"	14'	103' 11"
TCH-14105	Scissor Lift	14"	22"	13' 6"	14' 6"	108' 11"
TCH-14115A	Scissor Lift	14"	22"	13' 6"	15' 1"	113' 11"
TCH-14120	Scissor Lift	14"	22"	13' 11"	15'	124'
TCSNH-1035	A-Frame	10"	16"	7' 11"	10' 5"	43' 7"
TCSNH-1045	A-Frame	10"	16"	8' 4"	11' 5"	53' 7"

Table 4 - Specifications

Specifications subject to change without notice.

7.2 WORKING MEASUREMENTS

Model	15°		20°		25°		30°	
	Height	Length	Height	Length	Height	Length	Height	Length
TC-1035	n/a	n/a	11' 10"	34' 7"	14' 11"	33' 4"	17' 10"	32' 2"
TC-1035-TED	n/a	n/a	11' 1"	33' 10"	14'	32' 11"	16' 10"	31' 10"
TC-1040-TED	n/a	n/a	13' 11"	38' 7"	17' 11"	37' 6"	21' 2"	35' 11"
TC-1045	11' 5"	44' 7"	15' 5"	43' 7"	19' 3"	42' 4"	23'	40' 8"
TC-1055	14'	54' 2"	18' 10"	52' 11"	23' 6"	51' 4"	27' 11"	49' 4"
TC-1065	16' 7"	63' 10"	22' 8"	62' 4"	27' 8"	60' 5"	32' 11"	58'
TC-1070	17' 11"	68' 8"	23' 1"	67' 1"	29' 10"	64' 11"	35' 6"	62' 4"
TC-1075	19' 2"	73' 6"	25' 7"	71' 9"	31' 11"	69' 5"	37' 11"	66' 7"
TC-1080	20' 5"	78' 4"	27' 4"	76' 5"	34'	74'	40' 5"	71'
TC-1085	21' 8"	86' 4"	29' 1"	84' 1"	36' 2"	81' 1"	43' 1"	77' 8"
TCGN-1035	n/a	n/a	10' 3"	33' 11"	13' 5"	33'	16' 6"	31' 10"
TCGN-1045	n/a	n/a	n/a	n/a	18'	42' 3"	21' 10"	40' 8"
TCH-1035	n/a	n/a	12'	37' 1"	15' 1"	35' 10"	18' 1"	34' 5"
TCH-1035-TED	n/a	n/a	10' 5"	30' 7"	13' 3"	29' 10"	15' 11"	28' 10"
TCH-1045	10' 10"	45' 6"	14' 11"	44' 7"	18' 11"	43' 5"	22' 9"	41' 10"
TCH-1055	13' 5"	5' 2"	18' 4"	54'	23' 2"	52' 5"	27' 9"	50' 6"
TCH-1065	16'	65'	21' 10"	63' 6"	27' 4"	61' 6"	32' 8"	59'
TCH-1070	17' 4"	69' 8"	23' 6"	68' 1"	39' 6"	66' 1"	35' 3"	63' 6"
TCH-1075	18' 7"	74' 6"	25' 2"	72' 10"	31' 7"	70' 7"	37' 9"	67' 10"
TCH-1080	19' 11"	79' 4"	26' 11"	77' 6"	33' 8"	75' 1"	40' 3"	72' 2"
TCH-1085	21' 2"	84' 2"	28' 7"	82' 3"	35' 10"	79' 8"	42' 9"	76' 6"
TCH-1090	22' 6"	89'	30' 4"	86' 11"	37' 11"	84' 2"	45' 3"	80' 10"
TCH-1095	24' 1"	93' 8"	32' 4"	91' 5"	40' 4"	88' 6"	48'	84' 10"
TCH-10100	25' 1"	98' 8"	33' 9"	96' 4"	42' 2"	93' 3"	50' 3"	89' 6"
TCH-1435	n/a	n/a	10' 11"	33' 6"	13' 11"	32' 8"	16' 9"	31' 7"
TCH-1445	10' 5"	43' 8"	14' 3"	42' 10"	18' 1"	41' 8"	21' 9"	40' 2"
TCH-1455	12' 11"	53' 4"	17' 8"	52' 3"	22' 3"	50' 9"	26' 7"	48' 11"
TCH-1465	15' 6"	63'	21' 1"	61' 8"	26' 5"	59' 10"	31' 7"	57' 7"
TCH-1470	16' 10"	67' 10"	22' 9"	66' 4"	28' 6"	64' 4"	34' 1"	61' 11"
TCH-1475	18' 1"	72' 8"	24' 6"	71' 1"	30' 8"	68' 11"	36' 7"	66' 3"
TCH-1480	19' 10"	79' 4"	26' 10"	77' 6"	33' 8"	75' 2"	40' 3"	72' 2"
TCH-1485	20' 9"	82' 4"	28'	80' 5"	35'	77' 11"	41' 9"	74' 10"
TCH-1490	22' 7"	87' 2"	30' 1"	85' 2"	37' 5"	82' 5"	44' 6"	79' 2"
TCH-1495	23' 10"	92'	31' 10"	89' 10"	39' 6"	87'	47'	83' 6"
TCH-14100	25'	96' 10"	33' 6"	94' 6"	41' 8"	91' 6"	49' 6"	87' 10"
TCH-14105	26' 5"	101' 8"	35' 3"	99' 3"	43' 9"	96'	52'	92' 2"
TCH-14115A	27' 9"	106' 6"	36' 11"	103' 11"	45' 11"	100' 7"	54' 6"	96' 6"
TCH-14120	29' 10"	116' 2"	40'	113' 4"	49' 10"	109' 8"	59' 4"	105' 2"
TCSNH-1035	n/a	n/a	10' 7"	37' 2"	14' 1"	36' 2"	17' 5"	35'
TCSNH-1045	n/a	n/a	10' 5"	30' 7"	13' 3"	29' 10"	15' 11"	28' 10"

Table 5 - Working Measurements

Measurements subject to change without notice.

7.3 BOLT TORQUE

The tables shown below give correct torque values for various bolts and capscrews. Tighten all bolts to the torques specified in chart unless otherwise noted. Check tightness of bolts periodically, using bolt torque chart as a guide. Replace hardware with the same strength bolt.

ENGLISH TORQUE SPECIFICATIONS						
Bolt Diameter "A"	Bolt Torque*					
	SAE 2 (N.m) (lb-ft)		SAE 5 (N.m) (lb-ft)		SAE 8 (N.m) (lb-ft)	
	1/4"	8	6	12	9	17
5/16"	13	10	25	19	36	27
3/8"	27	20	45	33	63	45
7/16"	41	30	72	53	100	75
1/2"	61	45	110	80	155	115
9/16"	95	60	155	115	220	165
5/8"	128	95	215	160	305	220
3/4"	225	165	390	290	540	400
7/8"	230	170	570	420	880	650
1"	345	225	850	630	1320	970

Table 6 - English Torque

METRIC TORQUE SPECIFICATIONS				
Bolt Diameter "A"	Bolt Torque*			
	8.8 (N.m) (lb-ft)		10.9 (N.m) (lb-ft)	
	M3	0.5	0.4	1.8
M4	3	2.2	4.5	3.3
M5	6	4	9	7
M6	10	7	15	11
M8	25	18	35	26
M10	50	37	70	52
M12	90	66	125	92
M14	140	103	200	148
M16	225	166	310	229
M20	435	321	610	450
M24	750	553	1050	774
M30	1495	1103	2100	1550
M36	2600	1917	3675	2710

Table 7 - Metric Torque

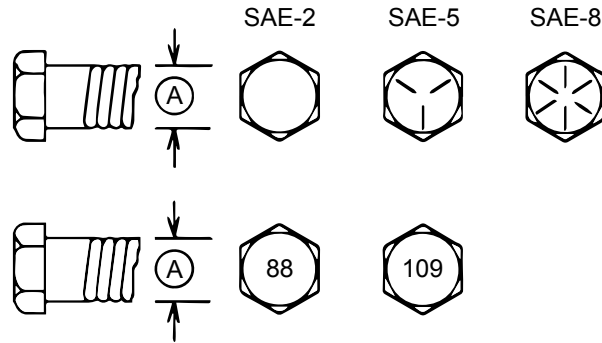

Torque figures indicated above are valid for non-greased or non-oiled threads and heads unless otherwise specified. Therefore, do not grease or oil bolts or capscrews unless otherwise specified in this manual. When using locking elements, increase torque values by 5%.

* Torque value for bolts and capscrews are identified by their head markings.

CONVEY-ALL
INDUSTRIES INC.

BOX 2008, 130 CANADA STREET
WINKLER MANITOBA R6W 4B7
CANADA

P: (204) 325-4195

F: (204) 325-8116

1-800-418-9461

PRINTED IN CANADA
ISSUE DATE: MARCH 2015
©2015 Convey-All Industries Inc. All Rights Reserved

PART NUMBER: 26-10TC-0004