

To Protect Your Warranty, Use Only ENERPAC Hydraulic Oil.

Enerpac recommends that all kit components be installed to insure optimum performance of the repaired product.

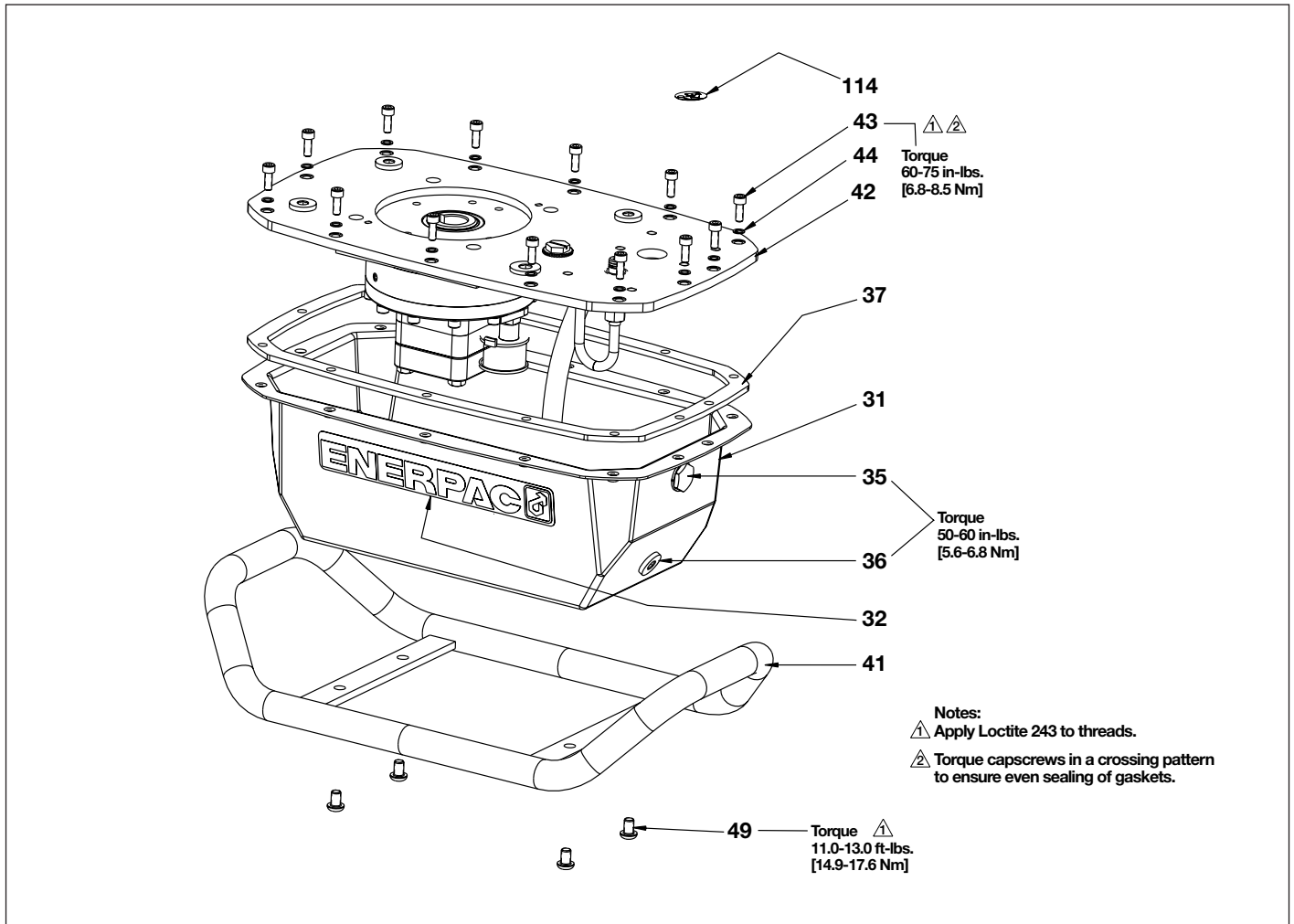

Figure 1, Reservoir Assembly

Repair Parts List for Figure 1

Item	Part Number	Qty.	Description	Item	Part Number	Qty.	Description
31	DC9379025SR	1	Reservoir, 4L (includes items 32, 35, 36 and 37)	41	◆ SBZ-4	1	Skid Bar w/o Heat Exch.
	DC8136025SR	1	Reservoir, 8L (includes items 32, 35, 36 and 37)		◆ SBZ-4L	1	Skid Bar w/ Heat Exch.
32	★ DC9596026	2	Decal, Enerpac	42	(See Figure 3)	1	Assembly, Pump
35	DC85900SR	1	Sight Glass, 4L and 8L	43	★ S3037	13	Gasket
36	DC8249006	1	Plug, Magnetic, SAE #8	44	CBE619028-1A	13	Screw, SHCS M6 x 16
37	★ DC9551920	1	Gasket, Reservoir	49	CBE817028-1E	4	BHCS M8 x 12 mm
				114	DC9920026	1	Decal, Read Instructions

★ Items included in and available only as part of Repair Kit ZU4TK.

◆ Skid bar includes screws, item 49.

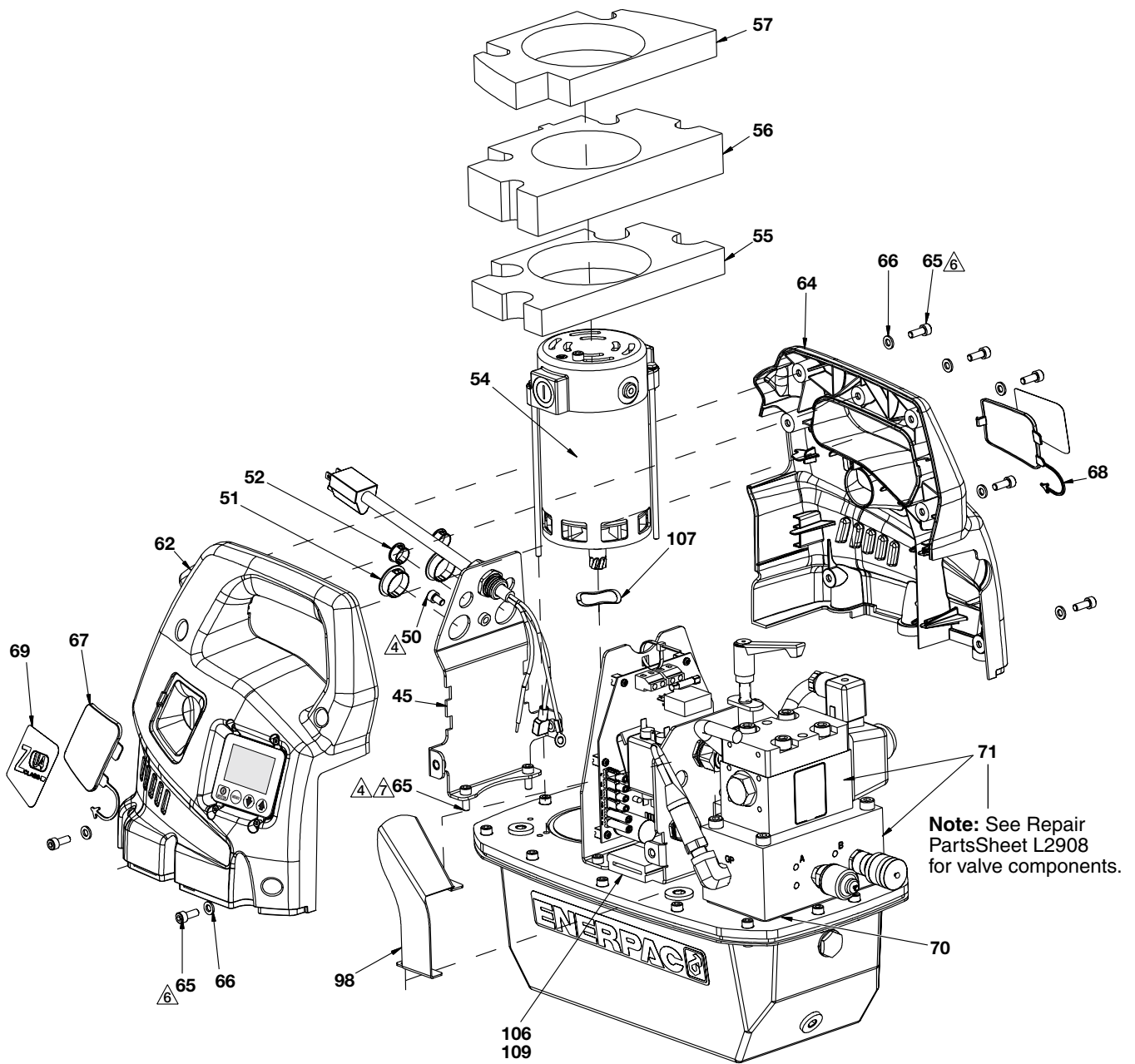

Repair Parts List for Figures 2A and 2B

Item	Part Number	Qty.	Description	Item	Part Number	Qty.	Description
45	DC9405111	1	Back Bracket	61	DC6876647	5	Cable Tie, Black
47	B1223503	1	O-Ring	60	(See Figure 6)	1	Assembly, Front Bracket
48	DC9538021	1	Lock Nut 20MM	62	(See Figure 7)	1	Enclosure, Left ZU4
50	CBE615028-1A	1	SHCS M6X10mm	64	DC9411424	1	Enclosure, Right ZU4, Yellow
51	DC9435009	2	Dome Plug 1"		DC9641424	1	Enclosure, Right ZU4, Black
52	DC9436009	3	Dome Plug 16mm	65	CBE619028-1A	6	SHCS M6X1X10
54	(See Figure 10)	1	Motor, 115V ZU4	66	CAE1060108-1A	6	6MM Washer
		1	Motor, 230V ZU4	67	DC9414424	1	Brush Cap, Left
55	DC9401298	1	Baffle, Lower ZU4	68	DC9413424	1	Brush Cap, Right
56	DC9400298	1	Baffle, Middle ZU4	69	★DC9598026	1	Decal, Brush Cap
57	DC9400298	1	Baffle, Upper ZU4	70	★DD1432037	1	Gasket, Valve
58	(See Figure 4)	1	Assembly, Middle Bracket	71	(see RPS L2908)	1	Valve, Torque Wrench
59	DC9444960	1	Power Cord - 115V 15 Amp	98	DD1474111	1	Guard, Transducer
	DC9445960	1	Power Cord - 230V w/ NEMA 5-15 plug	106	DC9740969	1	Ferrite
	DC8288960	1	Power Cord - 230V European plug, CE RF Compliant.	107	DC9661066	1	Washer, Wavy
	DD7819960	1	Power Cord - 230V Australian plug, AU/NZ only	108	DC9653028	1	Bolt, #10-32 x 6.5"
				109	DC9951405	1	Velcro, 2"
				115	B1080066	2	Washer, Lock

★ Items included in and available only as part of Repair Kit ZU4TK.

Note: Refer to Repair Parts Sheet L2908 for torque wrench valve (item 71) replacement parts.

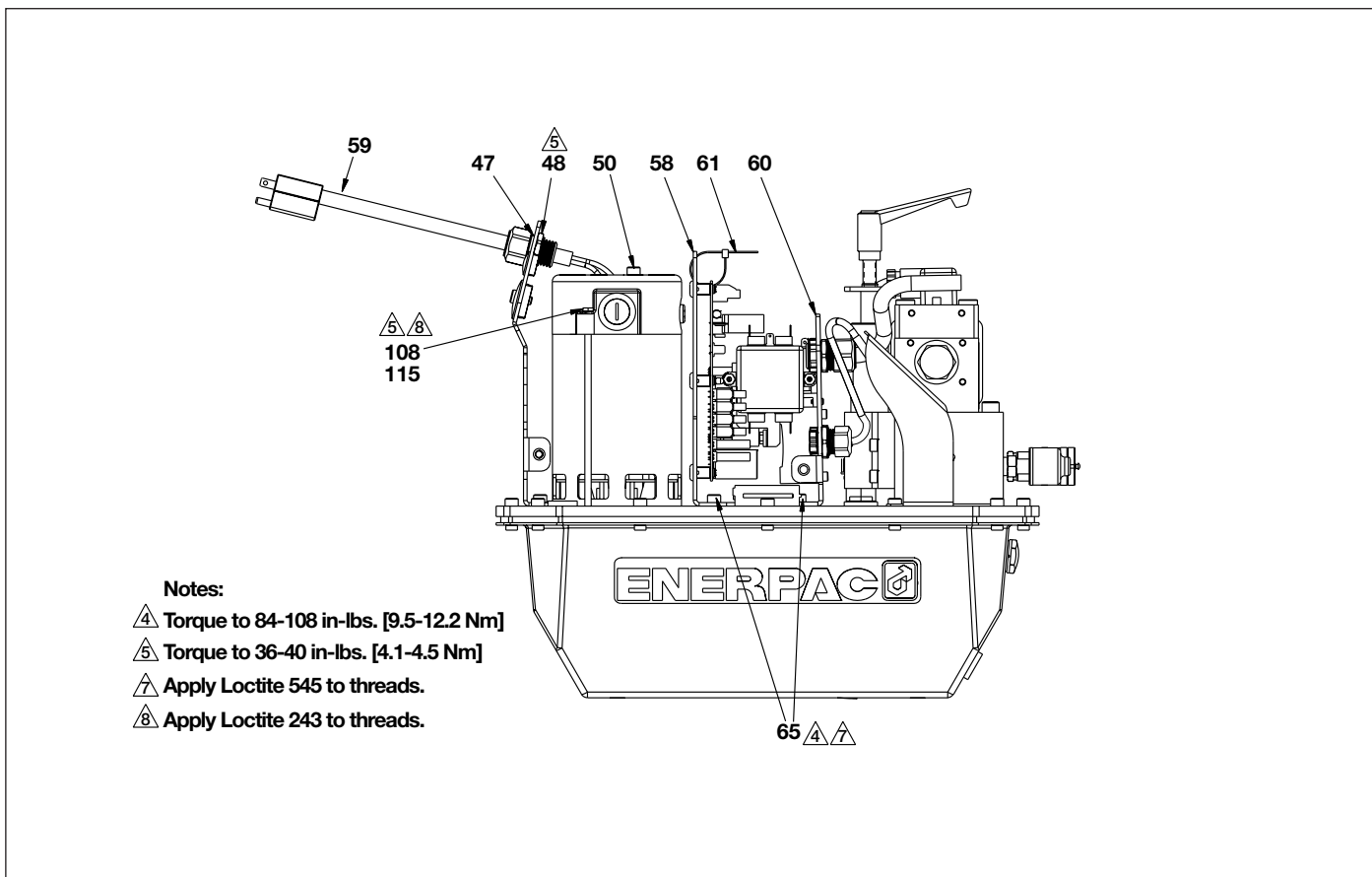

Figure 2B, Pump Assembly (side view)

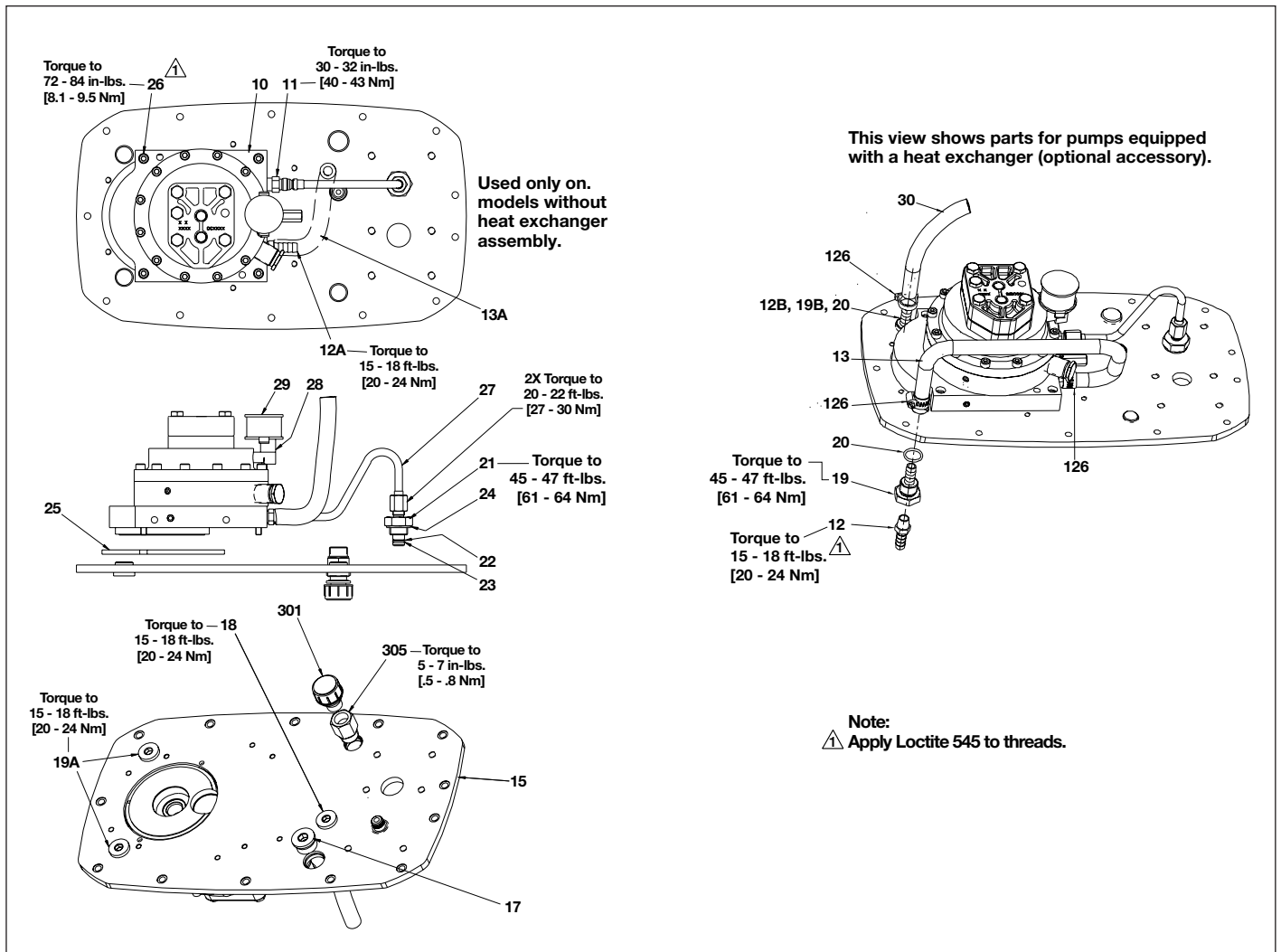

Figure 3, Pump Coverplate and Element Assembly

Repair Parts List for Figure 3

Item	Part Number	Qty.	Description	Item	Part Number	Qty.	Description
10	(See RPS L2596)	1	Pump Element Assy.	22	★ BSS0368D	1	Back-up
11	F100094-246	1	Fitting 5-4 FTX-S	23	★ B1012803	1	O-Ring
12A	F100097-16	1	Fitting, Standard Pump	24	★ DC9271167	1	Copper Gasket
12B	F100097-16	2	Fitting, Heat Exc. Pump	25	★ DC9551920	1	Gasket, Universal Pump
13A	DC9335646	1	Hose, Bypass 8"	26	CBE621028-1A	2	SHCS, M6 X 20
13B	DC9416646	1	Hose, Heat Exc. Pump 23"	27	DC9447920	1	Tube Assy, Steel, ZU
15	DC9407101	1	Cover Plate, Universal	28	DC9600268	1	Intake Tube, 1.6" 4L & 8L
17	B1007006	1	Plug SAE #10	29	DC9178118	1	Intake Filter
18	B1006006	1	Plug, Socket, SAE #8	30	DC9418646	1	Return Hose, Heat Exc.
19A	B1006006	2	Plug, SAE #8 Std. Pump	126	DC9639299	2	Clamp, Heat Exc. Pump
19B	DC9273097	2	Fitting, Heat Exc. Pump	301	DC8250006	1	Breather Assembly
20	★ B1908503	2	O-Ring, Heat Exc. Pump	305	F100096-38	1	Adapter Fitting
21	DC9173690	1	Connector Fitting				

★ Items included in Seal Kit ZU4TK.

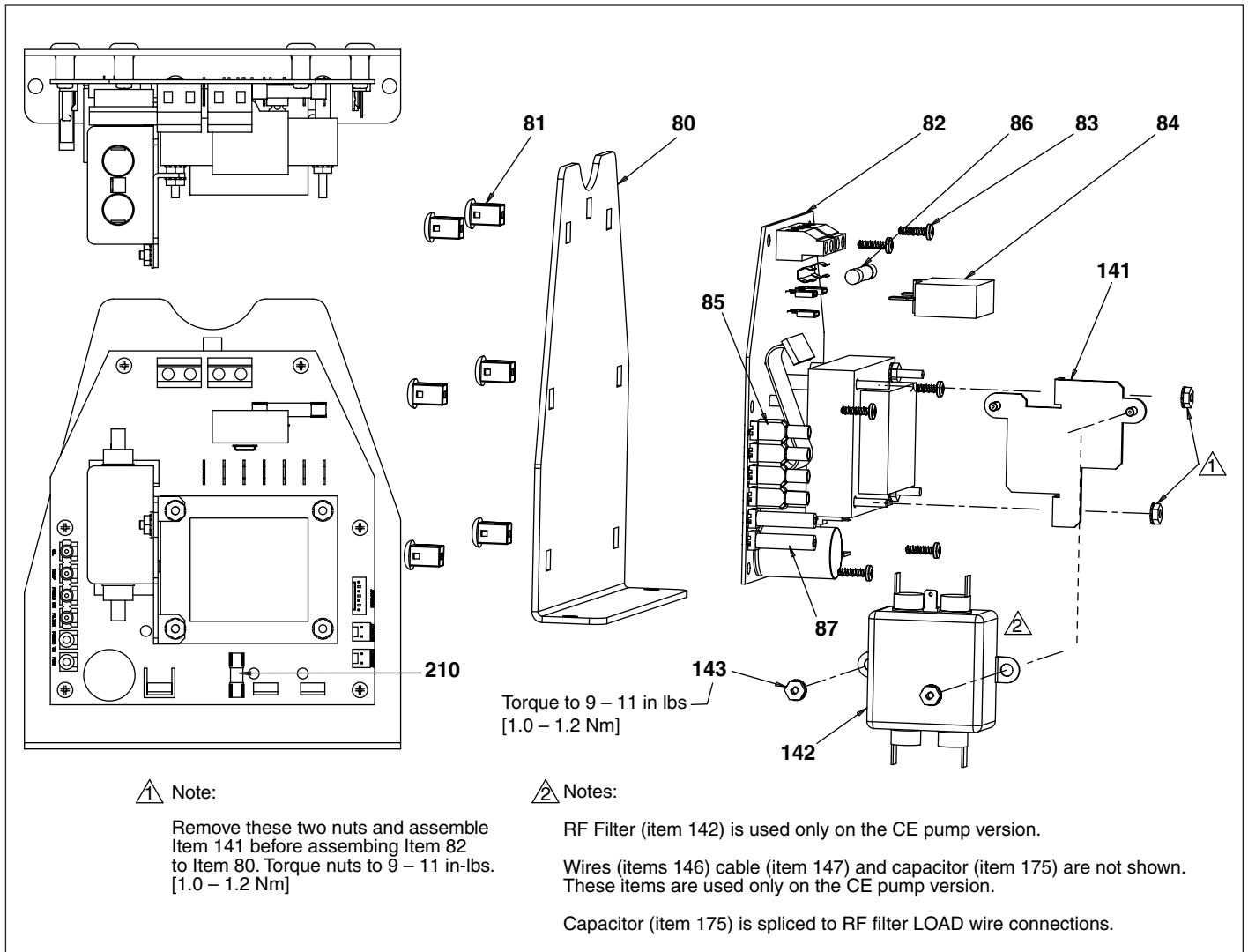

Figure 4, Middle Bracket Assembly, LCD Electric

Repair Parts List for Figure 4							
Item	Part Number	Qty.	Description	Item	Part Number	Qty.	Description
80	DC9404111	1	Middle Bracket	141	DC9916111	1	Bracket RF Filter 230V Eur CE
81	DC9429054	6	Standoff		†† DD7802111	1	Bracket RF Filter 230V AU/NZ
82	DC8181827	1	Power Board	142	† DC9580380	1	RF Filter 230V Eur CE
83	DC9428008	6	Screw Hi-Lo #8x1/2		†† DD7803380	1	RF Filter 230V AU/NZ
84	DC9536380	1	Circuit Breaker 25 Amp (115V)	143	† DC8006008	4	Lock Nut # 6-32 230V Eur CE
	DC9534380	1	Circuit Breaker 12 Amp (230V)	146	† DC9583960	2	Gnd. Wire 230V Eur CE (not shown)
85	E1001181	A/R	Jumper Connector	147	† DC9893960	1	Cable, TB600 to SSR (not shown)
86	DC9592378	1	Fuse 1.25A (115V)	174	† E10013528	1	1/4 Flag Connector (not shown)
	DC9591378	1	Fuse 0.75A (230V)	175	DC9579382	1	Capacitor, 1 µf x 2 (not shown)
87	DC9645268	A/R	Insulation Tube	210	DC8156378	1	Fuse, Secondary, F3, 3.5A, Slow B

† Used only on CE version.

†† Used only on Australian/New Zealand version.

A/R = As Required.

- Complete middle bracket assembly for 115V models: Order part number DC9993930SR.
- Complete middle bracket assembly for 230V models (except CE): Order part number DC9994930SR.
- Complete middle bracket assembly for 230V European CE models: Order part number DC9995930SR.
- Complete middle bracket assembly for 230V Australian and New Zealand models: Order part number DD7824900SR.

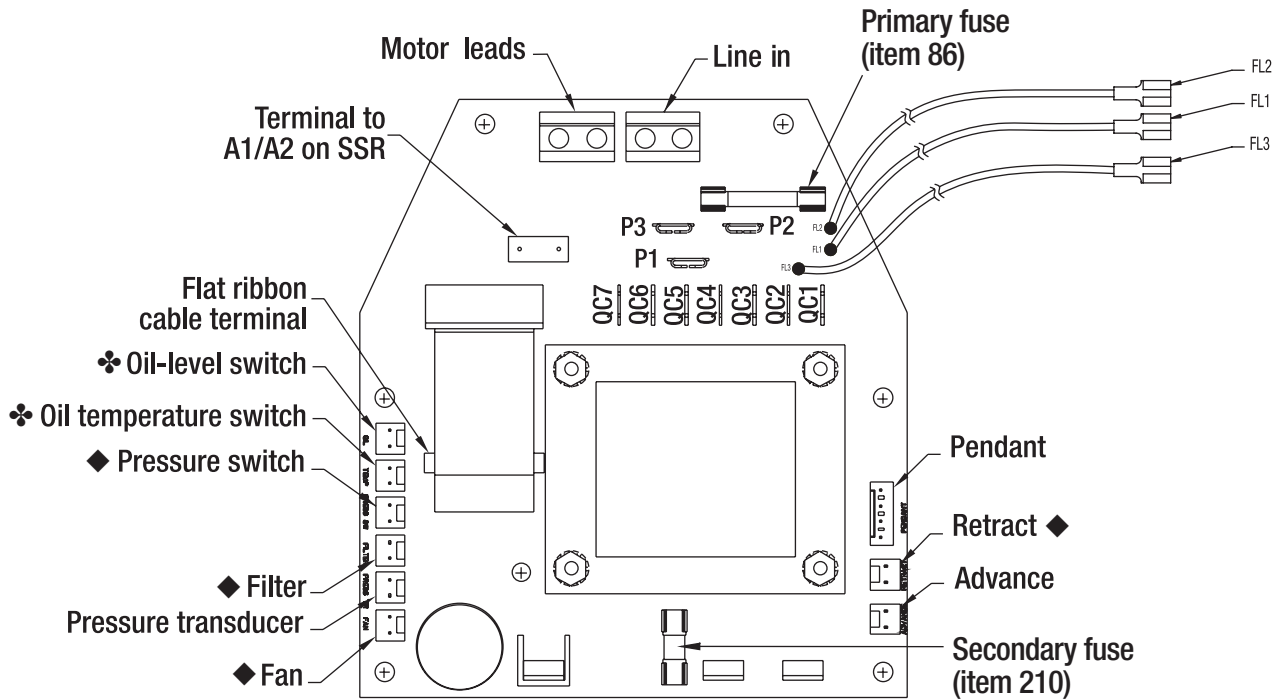

- ◆ Terminal not used on ZU4 Pro Series torque wrench pumps.
 - ❖ Terminal used only if optional level/temperature switch is installed.
- Note:** switch not available on pumps equipped with 1 or 2 gallon [4 or 8 liter] reservoirs.

Figure 5, Power Board, Single Phase SSR

Single Phase Transformer Tapping 100 to 120 Volts	
Lead	Connect to Terminal
FL 1	QC 3
FL 2	QC 6
FL 3	QC 7

Single Phase Transformer Tapping 200 to 240 Volts	
Lead	Connect to Terminal
FL 1	QC 1
FL 2	QC 2
FL 3	QC 5

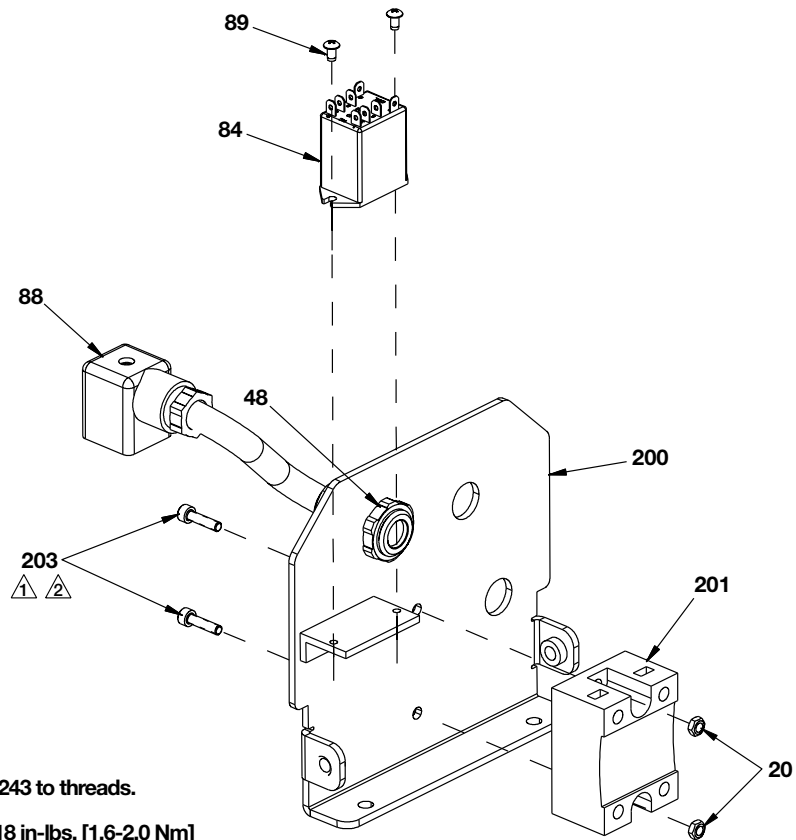

Notes:

⚠ Apply Loctite 243 to threads.

⚠ Torque to 14-18 in-lbs. [1.6-2.0 Nm]

Wire assembly items 221, 222 and 223 are not shown.

Figure 6, Front Bracket Assembly

Repair Parts List for Figure 6			
Item	Part Number	Qty.	Description
20	CBE1040120-1D	2	Nut, 4 mm
48	DC9538021	1	Nut, Locking, 20 mm
84	DD1342980	1	Relay, LY3F 24VDC Coil, 14 Amps DPDT
88	DD1420960	1	Cable Assembly, Solenoid Valve
89	DA3639028	1	Screw, Self Tapping
200	DD1417111	1	Bracket, Front Electrical
201	DC9919980	1	Relay, Solid State
203	CBE419028-1A	2	Screw, Socket Hd. Cap, M4.0 x 16 Zinc Plated
221	❖ DC9893960	1	Cable, Terminal Block to Solid State Relay
222	❖ DD1421960	1	Cable Assembly, Relay Coil
223	❖ DD1344960	1	Cable Assembly, Terminal Block to Relay
❖ Not Shown.			

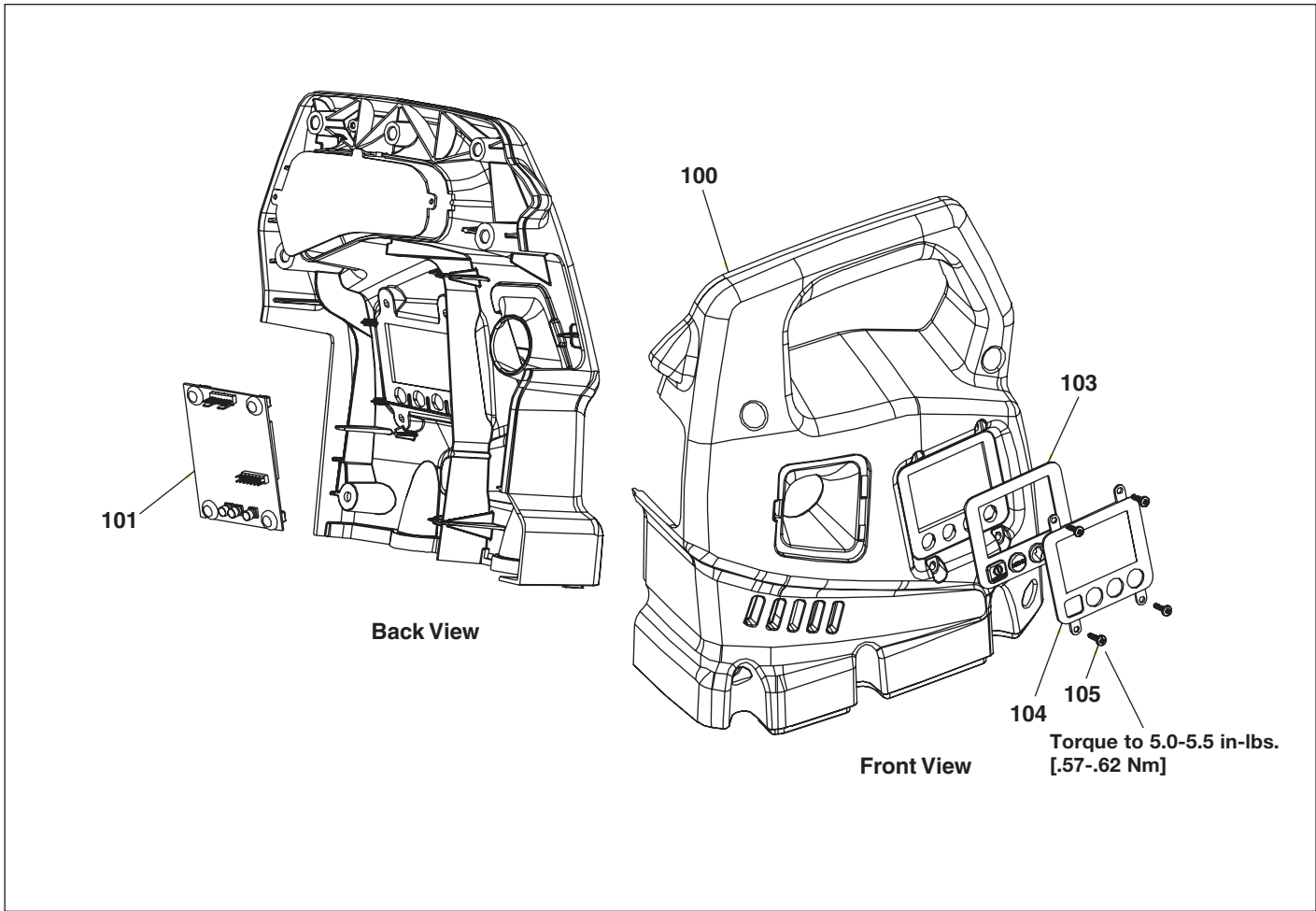

Figure 7, Enclosure Assembly (left side)

Repair Parts List for Figure 7			
Item	Part Number	Qty.	Description
100	DC9412424	1	Enclosure, Left, ZU4, Yellow
	DC9640424	1	Enclosure, Left, ZU4, Black
101	DC8178827	1	PCB LCD Control Board
103	* DC9560026	1	Keypad Shroud, LCD 4 Button
104	* DC9559026	1	Overlay Shroud, LCD 4 Button
105	* DA9428008	1	Screw, Hi-Lo #8 x 1/2
* Items included as part of Repair Kit DC9560900SR, Keypad Assembly (4 button).			

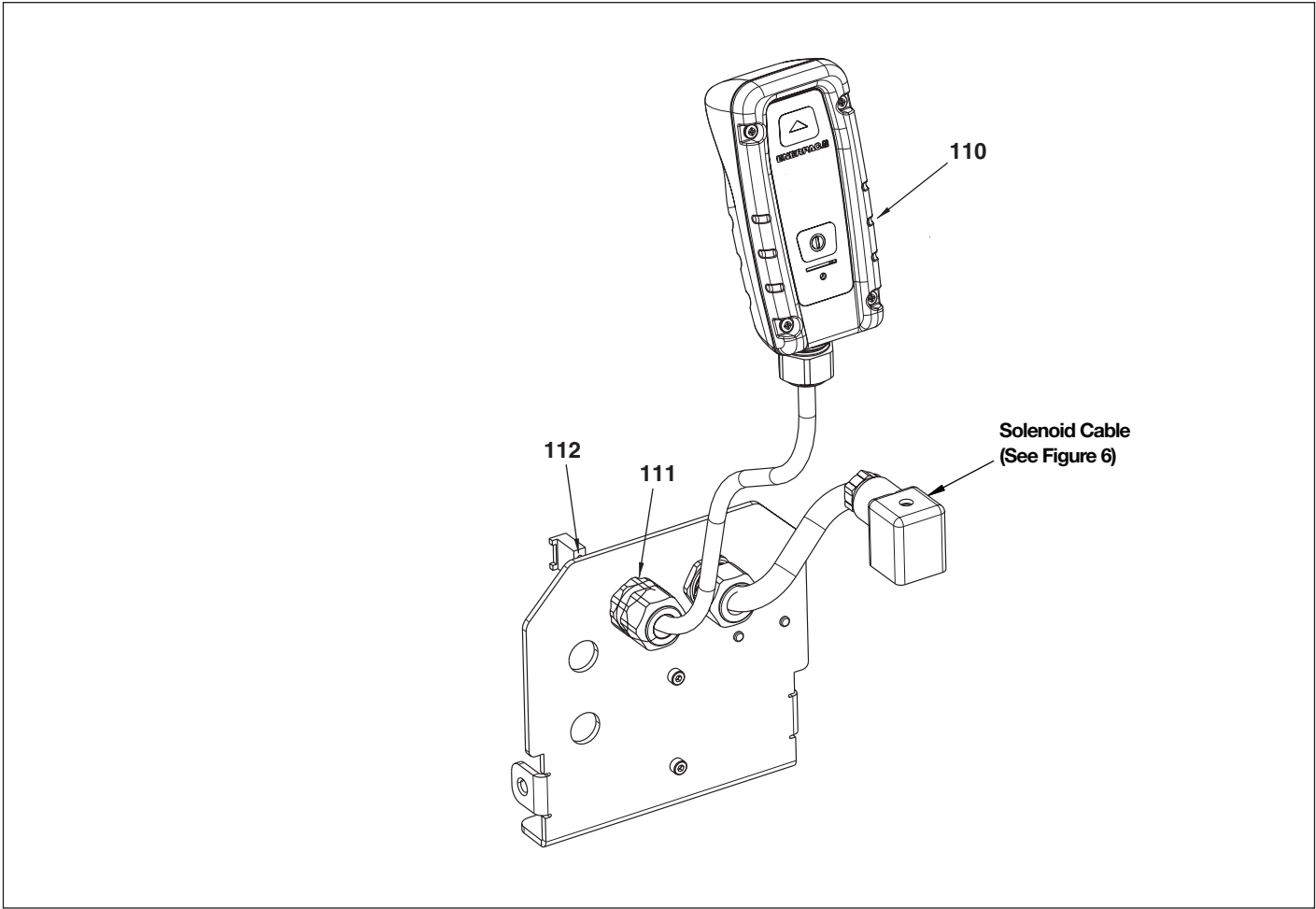

Figure 8, Pendant Assembly

Repair Parts List for Figure 8			
Item	Part Number	Qty.	Description
110	ZCP-220	1	Pendant Assy. 2 Button
111	* B1223503	1	O-ring
112	* DC9538021	1	Locking Nut 20 mm
* Items included with Pendant Assembly ZCP-220. See Repair Parts Sheet L2625 for pendant replacement parts.			

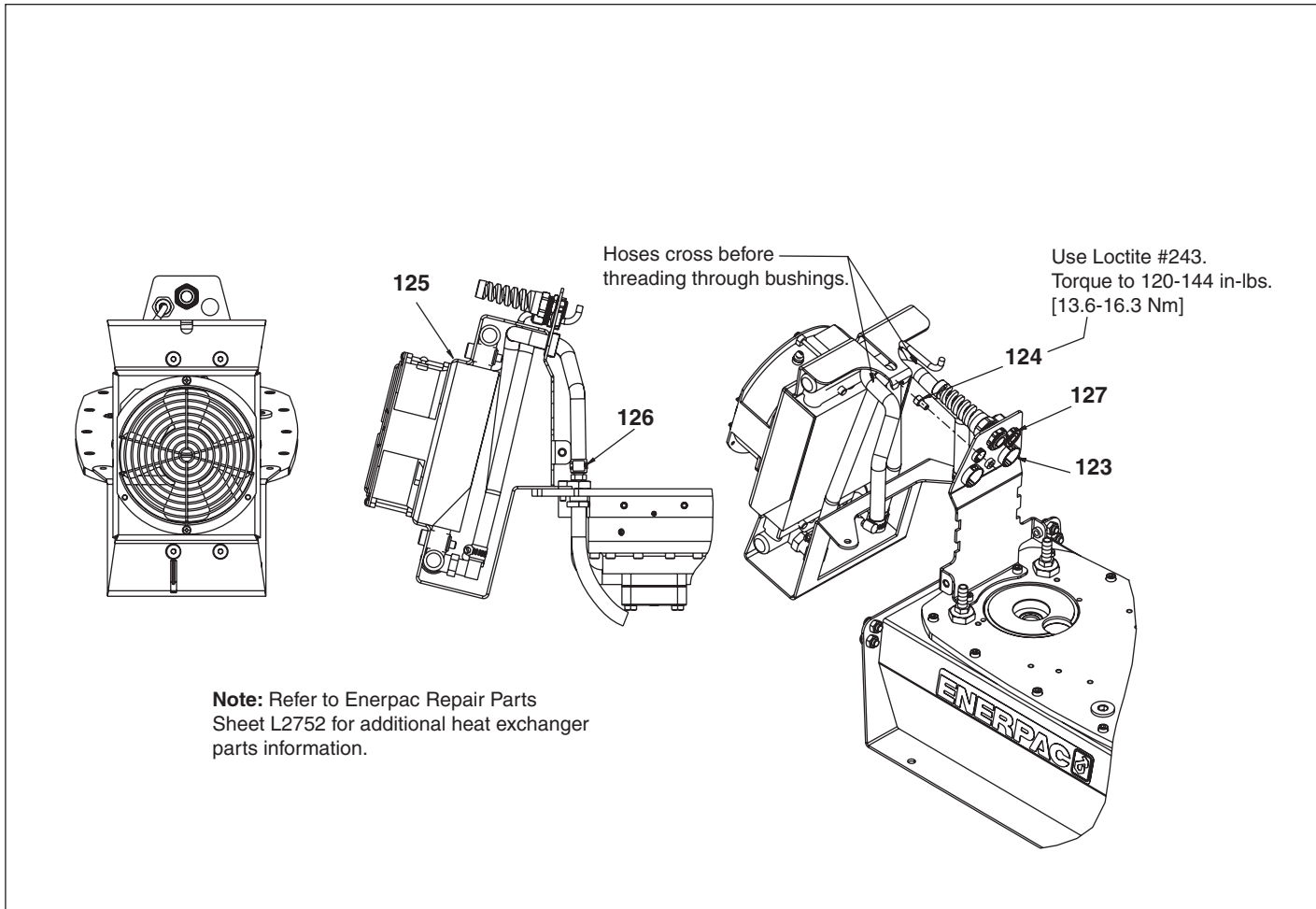

Figure 9, Heat Exchanger, 115 and 230 VAC Fan

Repair Parts List for Figure 9			
Item	Part Number	Qty.	Description
123	+* DC9690808	2	Grommet Rubber .69"-1"
124	+* CBE615028-1A	1	M6X10 SHCS
125	+ DC8375900	1	Heat Exch Assy, 115 VAC
	* DC8376900	1	Heat Exch Assy, 230 VAC
126	+* DC9639299	2	Hose Clamp, 3/8-7/8
127	+* DC9537021	1	Locking Nut, 16 mm
+ Items included as part of Heat Exchanger Kit ZHE-U115 (115V).			
* Items included as part of Heat Exchanger Kit ZHE-U230 (230V).			

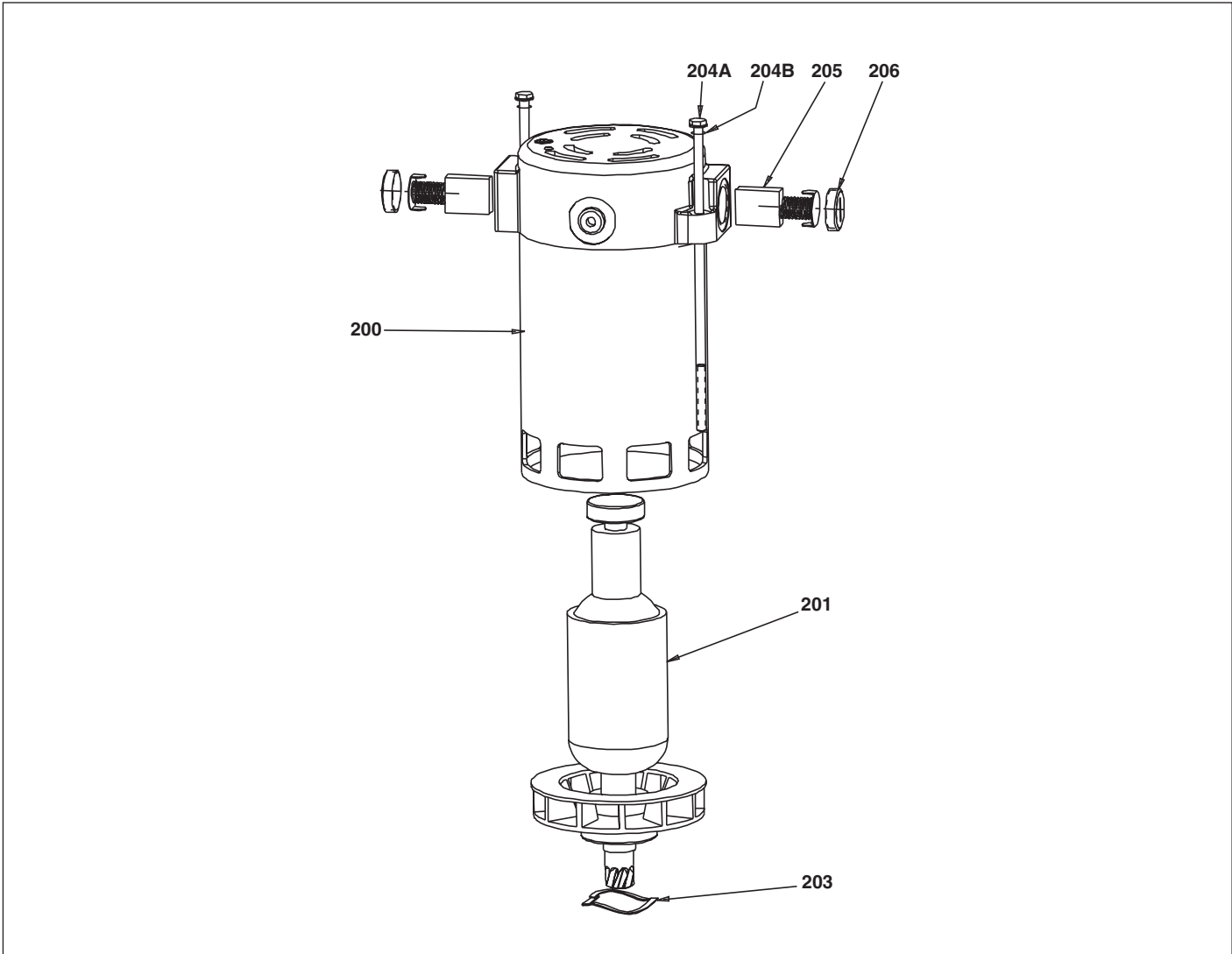

Figure 10, Motor Assembly

Repair Parts List for Figure 10			
Item	Part Number	Qty.	Description
85	▲ ▼ E1001181	2	Terminal, Flag (not shown)
200	Not available	-	Housing (order complete motor)
201	▲ DC8246736	1	Armature, 115V, ZU4
	▼ DC8247736	1	Armature, 230V, ZU4
203	▲ ▼ DC9661066	1	Spring Washer
204A	▲ ▼ DC9653028	2	Bolt #10-32 x 6.5"
204B	▲ ▼ B1080066	2	Washer, Lock
205	▲ ▼ DC9656259	2	Brush, ZU4
206	▲ ▼ DC9655020	2	Brush Cap, ZU4
▲ Items included as part of DC8244259SR Electric Motor Kit (115V).			
▼ Items included as part of DC8245259SR Electric Motor Kit (230V).			

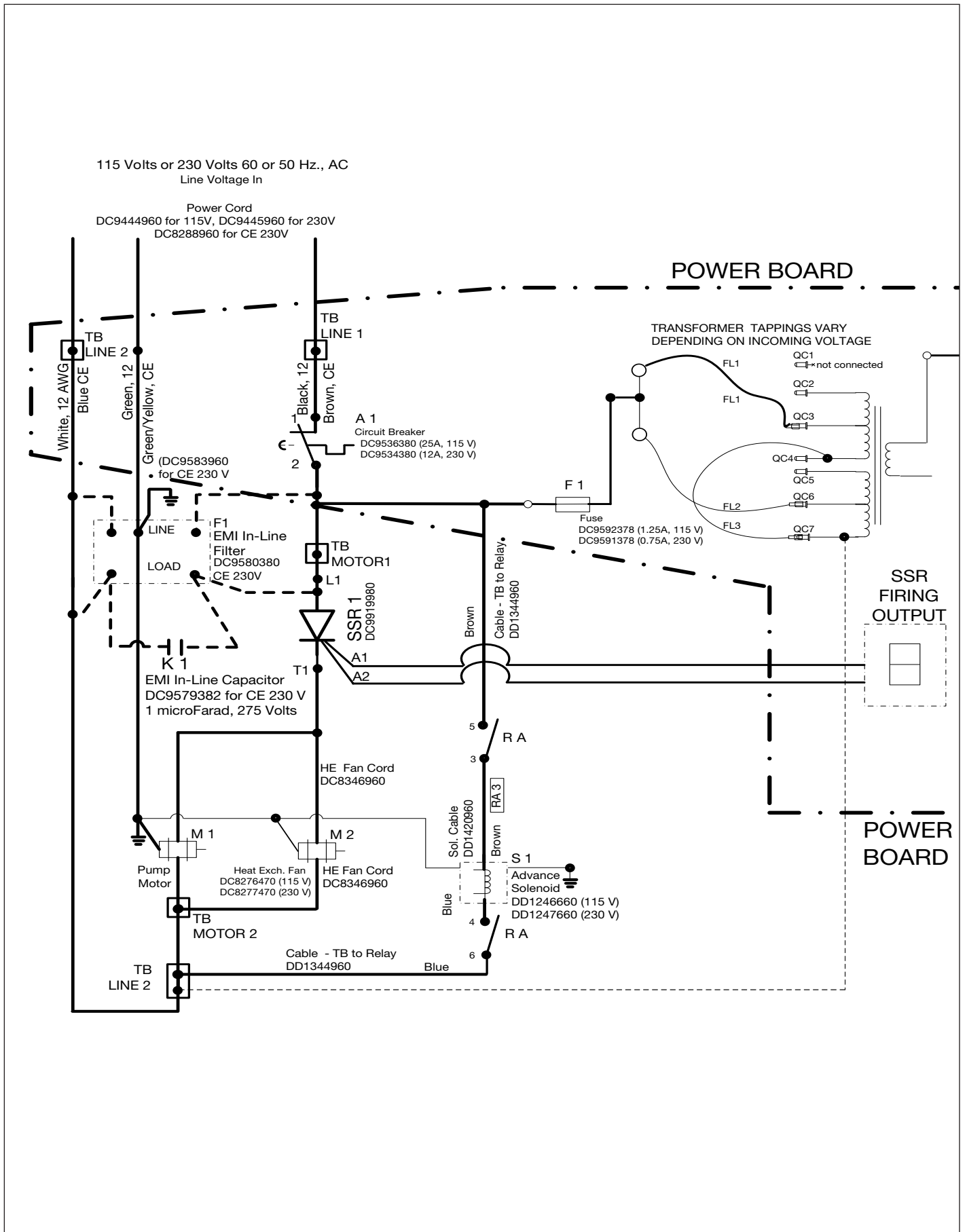

Figure 11, Electrical Diagram, ZU4 Pro Torque Wrench Pump (View 1 of 2)

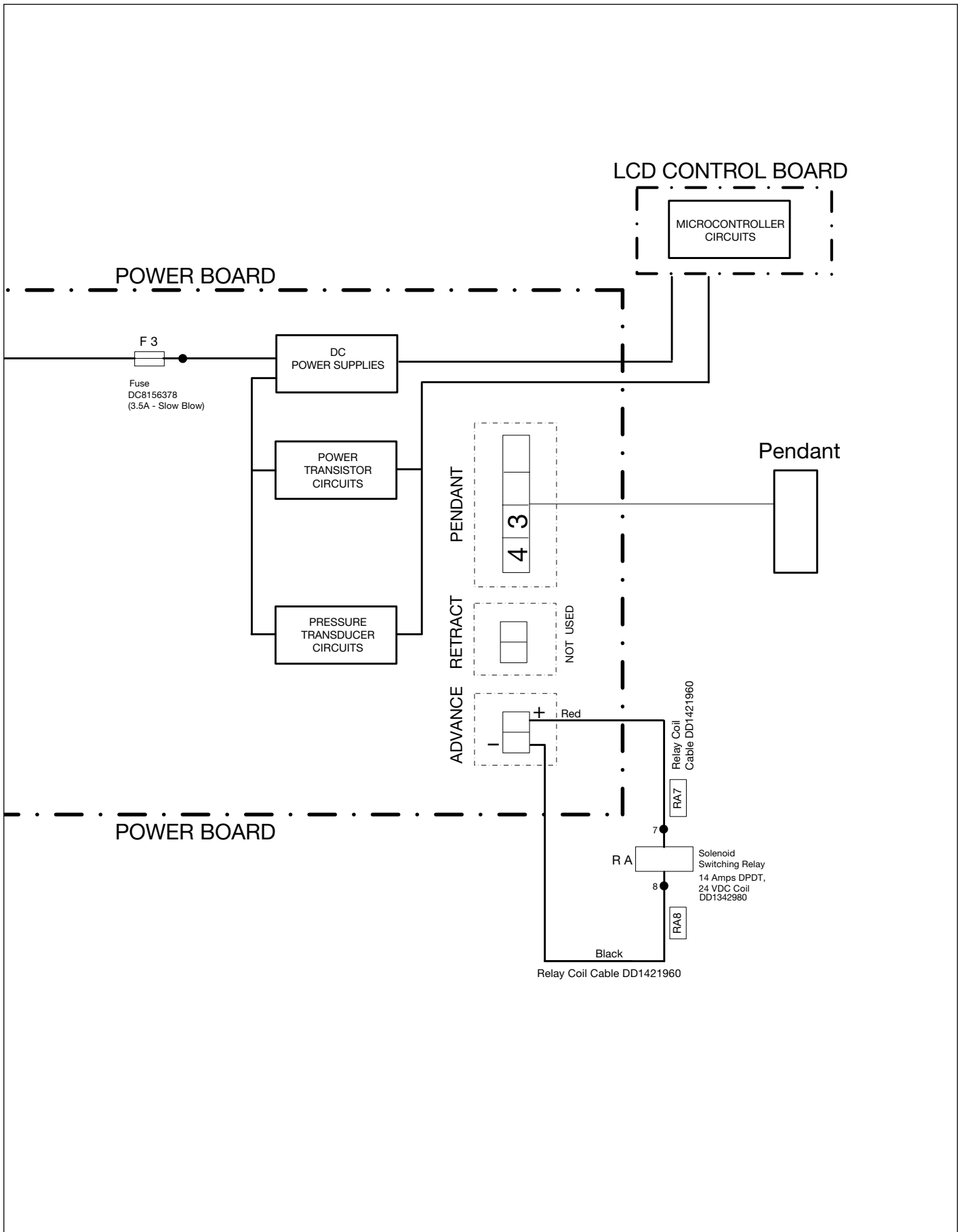

Figure 11, Electrical Diagram, ZU4 Pro Torque Wrench Pump (View 2 of 2)

