

# LINEAR GAGE

Catalog No. E4174-542/572/575



Linear displacement sensors offer superb durability and environmental resistance, resistance to suit production line applications

**Mitutoyo**

# Features

## 1. A range of models available

The gage heads described offer five measuring ranges (5, 10, 25, 50 and 100mm) and six resolution settings (0.01, 0.005, 0.001, 0.0005, 0.0001 and 0.00001mm) to enable the choice of gage to be closely matched to the application requirements. Various output modes are also available, including differential square-wave, Digimatic code (SPC) and sine wave.

## 2. Suitable for production line use

The gage heads offer superb durability and environmental resistance, making them ideal for in-line measurements. Durability is ensured by strong construction and linear ball bearings in the slider unit (except for models LGS and LGB), which are designed to last up to 10 million vertical spindle strokes (according to Mitutoyo's internal tests). Moreover, excellent dust/water protection (IP66) is provided for effective use in severe in-line environments (model LGF and others).

## 3. High-density design

The slender design of the standard gages enables installation in confined spaces or where the application demands close-pitched gaging. Slim-line models with outside diameters of 8mm are also available for measurements in spaces of 10mm or less. Gages come in two different cable arrangements — vertical and horizontal — to suit the type of fixture used.

## 4. Simple mounting

All gages can be mounted by the plain section of the stem using the split-clamp method. Alternatively, some gages are threaded at the bottom and so can also be installed simply by drilling a hole of the appropriate size in a fixture and clamping the gage with a plain nut or by using a thrust stem (see page 33). Gages with a stem threaded at the top can be mounted using a thrust stem as an alternative to the split clamp.

## 5. A choice of output format

The gage head display units offer a range of output formats to best match the application requirements: I/O, BCD, RS-232C and Digimatic code (SPC) types are available. The EH/EV counter has an RS link function to be connected with multiple counters for multi-gage measurement (see page 36).



Suitable for in-line use



Suitable for close-pitched applications

## Measurement principle

The gage heads mainly use transmission-type photoelectric linear encoders, as shown below. In this type, the light source (LED) and the detector element (photodiode) face each other with the main scale and index scale (20µm pitch) positioned between them.

As the scale moves with respect to the detector, the intensity of the light passing

through the window in the index scale varies constantly. At this time, two synchronized sine-wave signals having a relative 90-degree phase difference are output. These signals are then amplified and split electrically (with additional waveforms inserted) and output as 0.1µm, 0.5µm, 1µm or 5µm square-wave signals.

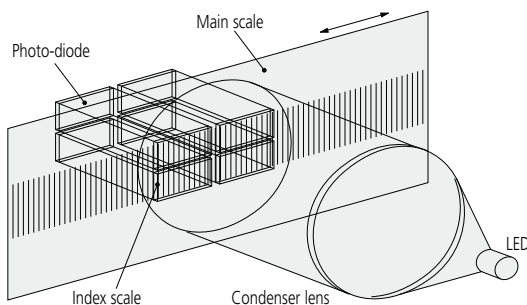

## Output

The gage head processes internally detected signals and outputs square-wave signals as shown below. These operating signals, which are square waves having a phase difference of 90 degrees, are equivalent to RS-422A signals, allowing for the independent use of the gage head. However, certain models (LGD and LGS), do not output square-wave signals but generate Digimatic code (SPC) output in order to identify the measurement position.

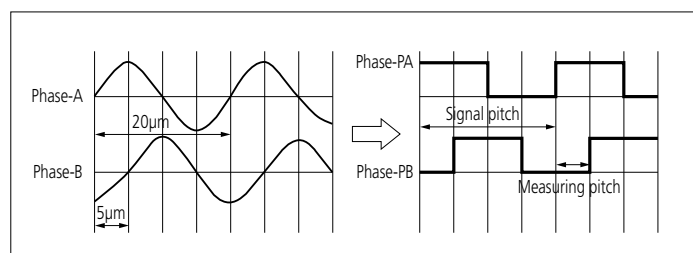

# Contents

Traceability System to National Standards		4 - 5
Applications		6 - 9
Gage Head Overview		10 - 12
Display Unit Overview		13
Gage Heads	LGK Slim Type	14
	LGF Standard Type	15
	LGF with Origin Point Mark	16
	LGF 0.1µm Resolution Type	17
	LGS Absolute Type	18
	LGD Absolute Type	19
	LGB Extremely Compact ø9.5mm Stem Type	20
	LGB Extremely Compact ø8mm Stem Type	21
	LG Long Stroke Type	22
	LGM Motor-drive, Long Stroke Type	23
	Laser Hologage High-resolution Type	24
	Litematic Head and Litematic	25
	Signal ID-C Absolute Type	26 - 27
	Output Signal Specifications	28 - 30
	Air Drive Unit	31
	Gage Head Mounting Fixtures	32 - 33
	Optional Accessories	34 - 36
Display Units	System Connection and Comparison of Counter Functions	37
	SENSORPAK	38
	EC Counter	39
	EG Counter	40 - 41
	EB Counter	42 - 45
	EH Counter	46 - 50
	D-EV Display Unit	50
	EV Counter	51 - 55
	Optional Accessories	56 - 57
	Quick Guide to Precision Measurement	58 - 61

# Traceability System to National Standards

## Traceability System of Length Standard

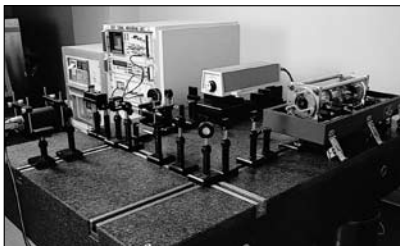
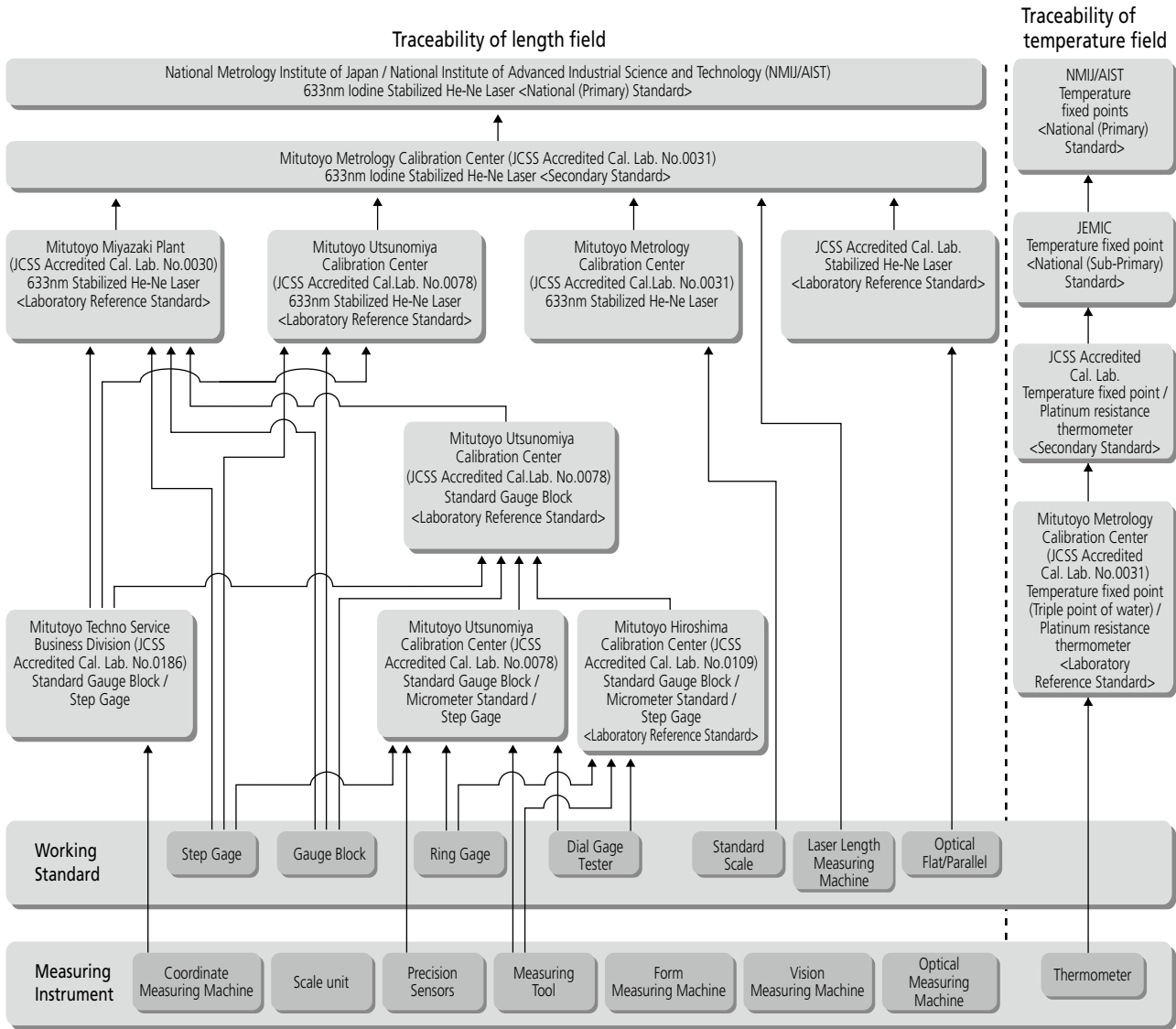

Iodine Absorption Stabilized He-Ne Laser used for calibrating length standards (Metrology Calibration Center)



Interferometer used for calibrating gauge blocks (Miyazaki Plant)

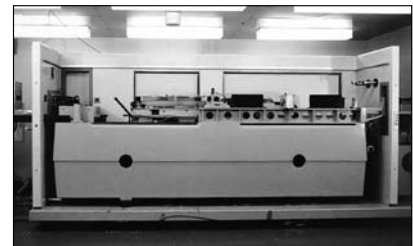

Interferometer used for calibrating linear scales (Metrology Calibration Center)

## Mitutoyo Group Accredited Calibration Laboratories

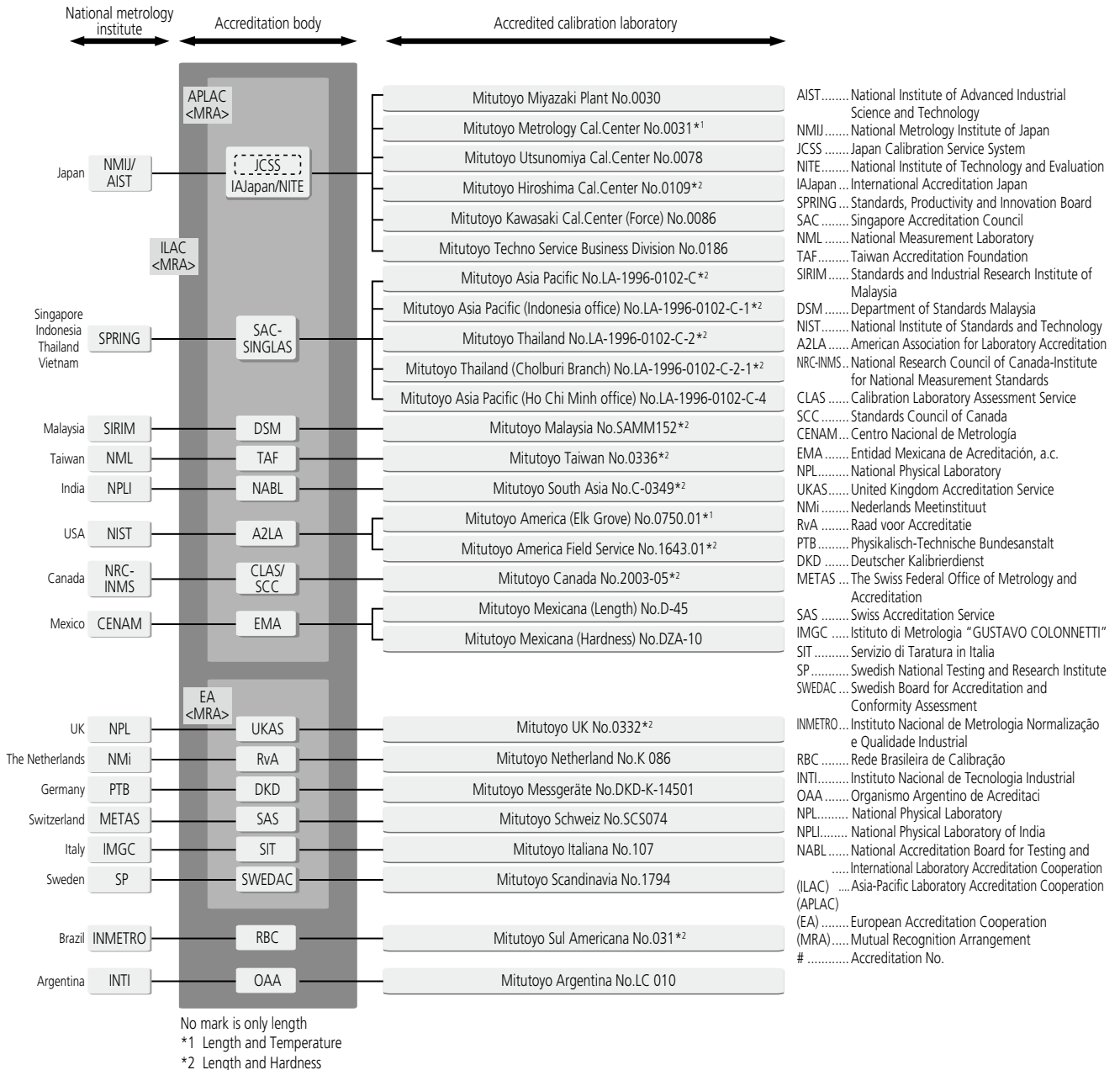

Mitutoyo has 27 accredited calibration laboratories posted worldwide as illustrated above, where each of the labs has established and implemented traceability of their reference standards through calibration to nationally or internationally recognized standards. It is this traceability system that enables Mitutoyo to contribute to industries worldwide in helping customers implement the base for their quality management and quality assurance program.

# Applications

## Multipoint measurement of automobile doors

Gage heads (LGS with EV counter) can be used to perform multi-point measurements for automobile doors and evaluate errors against the specified tolerances. When there are many points to measure, the use of the LGS gage provides higher cost-effectiveness.

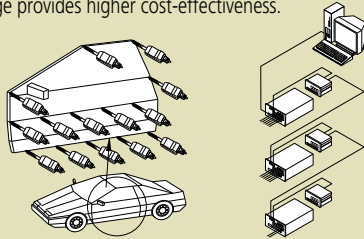

## Measurement of aircraft fuselage distortion

Gage heads (LGD with EV counter) can be used to help measure changes in stress generated in an aircraft fuselage. For the very large workpiece, the use of an absolute type gage head is recommended, since the master settings then need to be done just once.

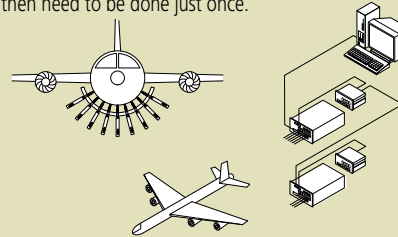

## Measurement of hydraulic coupling dimensions

Gage heads (LGF with EH counter) can be used to measure the outside diameters and thicknesses of hydraulic couplings used in mechanical diggers. The EH counter allows for the calculation of sums and differences between two gages.

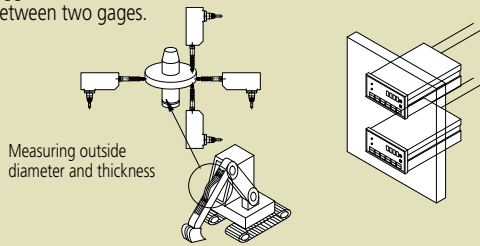

## Multipoint measurement of turbine blades

Gage heads (LGB with EV counter) can be used to perform multi-point measurements of gas turbine blades.

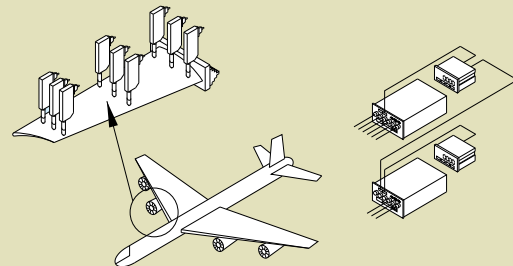

## Measurement of camshaft displacement

Gage heads (LGF with EH counter) can be used to measure camshaft lift. The EH counter is easily installed in the equipment panel.

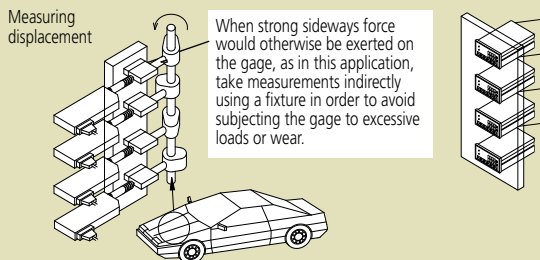

## Built-in sensor for inside diameter measurement tools

A gage head (LGF with EH counter) can be used to measure inside diameters.

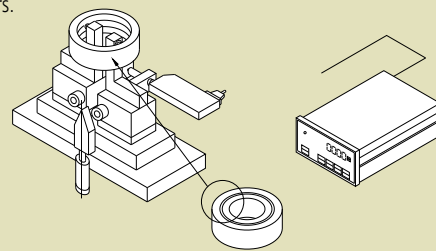

## Multipoint measurement of wheel hubs

Gage heads (LGF with EH counter) can be used to inspect a wheel hub for compliance with runout limits.

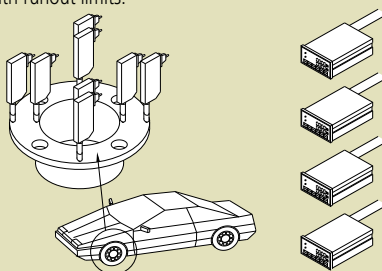

## Inspecting rivets

A gage head (LGD with EG counter) can be used to inspect the condition of fixing of a rivet or bolt. Inspection of parts press-fitted is also done in the same way.

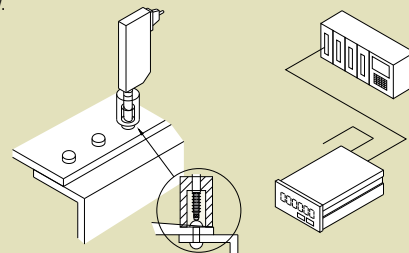

### Built-in sensor for machine tools

A gage head (LGM with EH counter) can be used to measure a workpiece which has been machined on a surface grinder.

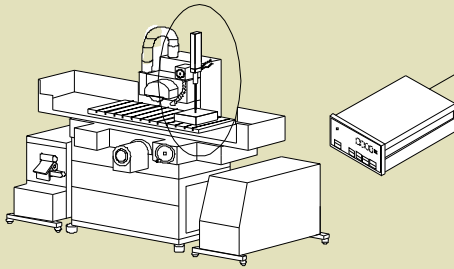

### Measurement of sash rail warp

Gage heads (LGF with EV counter) can be used to measure the warp of sash rails.

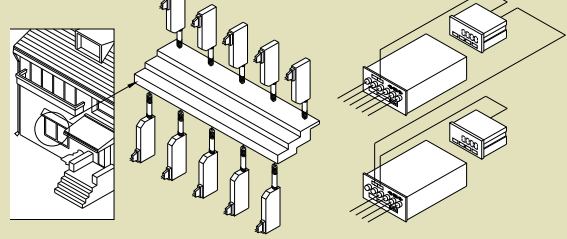

### Measurement of pipe wall thickness/outside diameter

A gage head (LGF with EH counter) can be used to measure the wall thickness or outside diameter of a pipe.

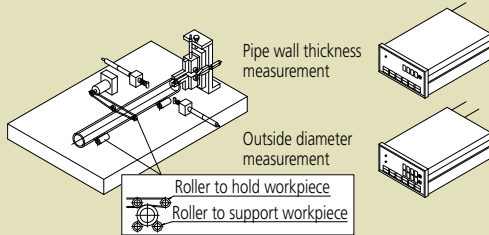

### Measurement of elevator drive-rail deflection

A gage head (LGF with EB counter) can be used to measure deflection in the drive rail of an elevator. Measured data can be output from the EB counter to a personal computer in order to plot the displacement.

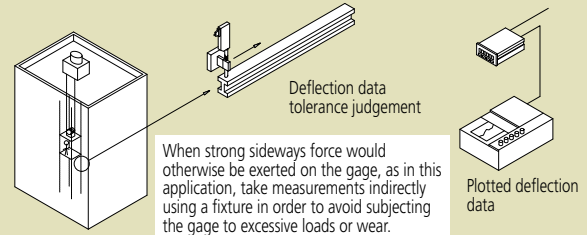

### Measurement of caulking height

A gage head (LGF with EB counter) can be used to measure the caulking height of a crimp contact, etc.

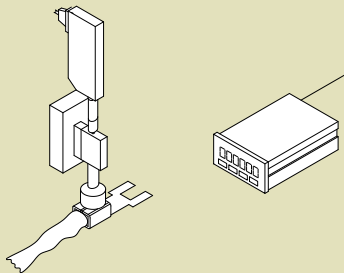

### Measurement of cylindrical pin displacement

Gage heads (LGB with EH counter) can be used to measure the displacement of tape-winding capstan pins in cassette recorders. The EH counter is capable of calculating sums and differences between two gages.

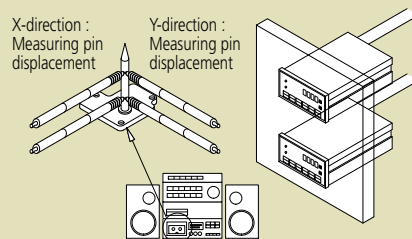

### Measurement of bridge-support joint

Gage heads (LGD with EG counter) can be used to measure the displacement of a bridge-support joint. Since this measurement is performed intermittently over a long period of time, use an absolute-type gage head that requires power only during measurement.

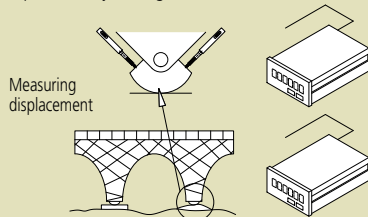

### Multipoint measurement on parabolic antenna

Gage heads (LGB with EV counter) can be used to perform multi-point measurements on a parabolic antenna surface.

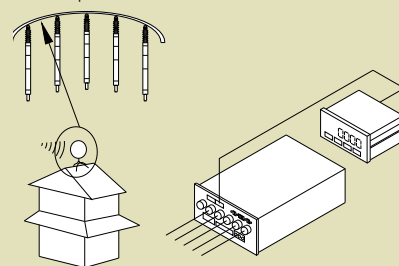

# Applications

## Multipoint measurement of VTR chassis

Gage heads (LGF with EV counter) can be used to measure VTR components at several points.

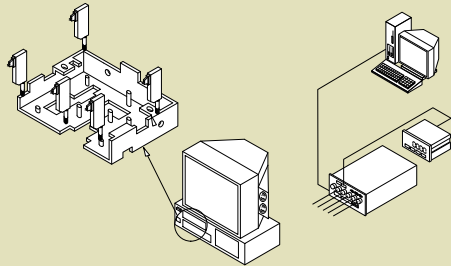

## Flatness measurement of tape cassette

Gage heads (LGK with EV counter) can be used to perform flatness measurement on a tape cassette surface.

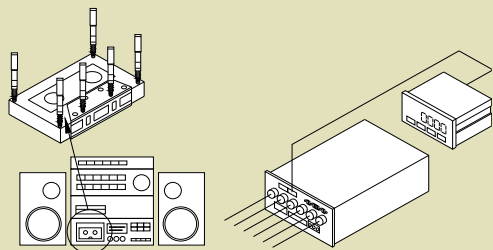

## Measurement of hub runout for floppy disks

The gage head (LGB with EH counter) can be used to measure the runout of the disk's hub.

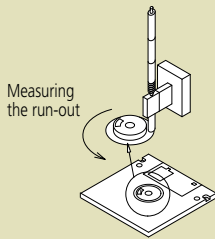

When strong sideways force would otherwise be exerted on the gage, as in this application, take measurements indirectly using a fixture in order to avoid subjecting the gage to excessive loads or wear.

## Contour measurement of CRT panel

Gage heads (LGS with EV counter) can be used to measure the surface contour of CRT panels.

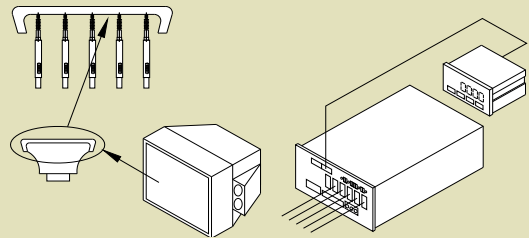

## Parallelism measurement of copying machine parts

Gage heads (LGD with EV counter) can be used to measure the parallelism of copying machine parts.

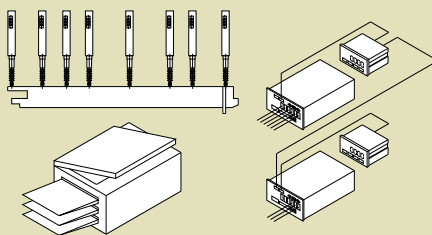

## Multipoint measurement on copying machine chassis

Gage heads (LGS with EV counter) can be used to perform multi-point measurement on a copying machine chassis. In the case of large workpieces an absolute type that eliminates the necessity of setting a master workpiece will be useful.

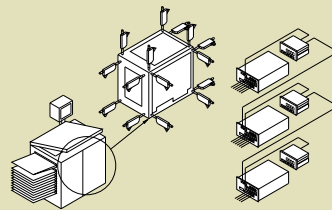

## Run-out measurement of motor shaft

Gage heads (LGF with EH counter) can be used to measure the radial and axial run-out of motor shafts. The EH counter can display both measurements simultaneously.

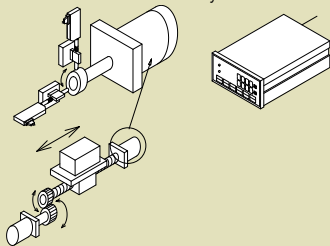

When strong sideways force would otherwise be exerted on the gage, as in this application, take measurements indirectly using a fixture in order to avoid subjecting the gage to excessive loads or wear.

## Sorting of parts

A gage head (LGF with EB counter) can be used to sort parts by size. The EB counter can divide the dimension into seven steps and output the signal for sorting.

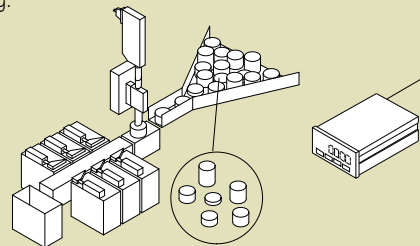



### Multipoint measurement of LCD panel

Gage heads (LGF with EH counter) can be used to measure distortion of LCD panels.

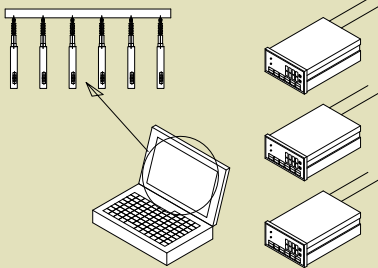

### X-Y stage positioning

Gage heads (LGF with EH counter) can be used to position a precision stage.

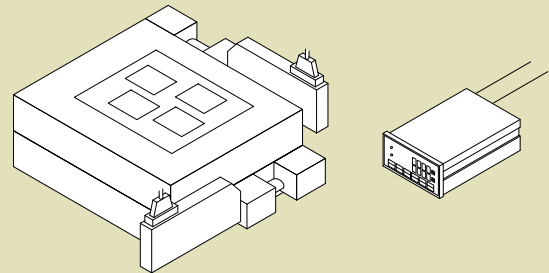

### Height measurement of cell

A gage head (LGF with EH counter) can be used to measure the height of built-in dry cells.

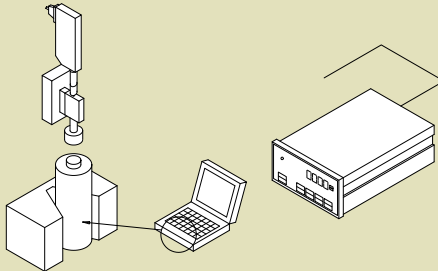

### Built-in sensor for material testing machines

A gage head (LGF with EH counter) can be used to measure the extension of a specimen during a tensile test.

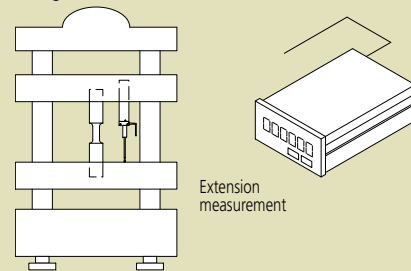

### Deformation measurement of bathtub

Gage heads (LGF with EV counter) can be used to measure the deformation of bathtubs. An origin setting when first mounting the gage head can eliminate the need for subsequent resetting with a standard.

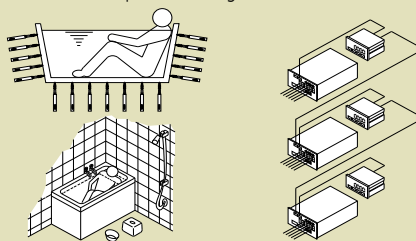

### Incorporation into auto-measurement machine

Gage heads (LGF with EH counter) can be incorporated into the auto-measurement unit for outside diameter and/or height measurement.

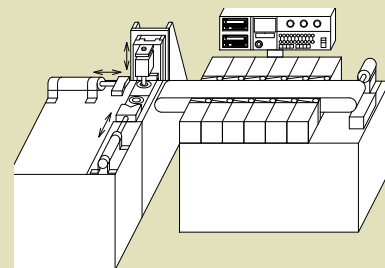

### Built-in sensor for tablet forming machine

A gage head (LGF with EH counter) can be used to measure the stroke of a tablet forming machine.

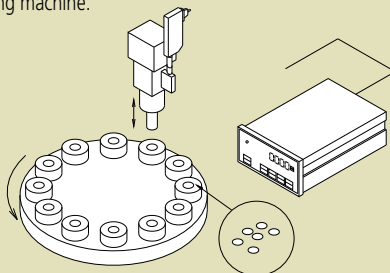

### Incorporation into vision measuring machine / microscope

A gage head (LGF with EH counter) can be incorporated into a measuring machine for height measurement.

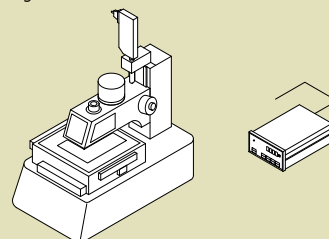

# Gage Head Overview

## Laser Hologage

Range: 10mm / .4"

- 0.01µm resolution
- Sine wave output
- ø15mm plain stem

Page 24

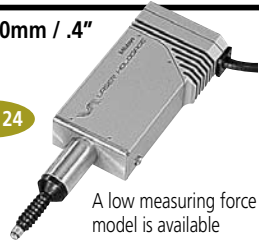

A low measuring force model is available

Compatible display unit

EH-102S

## Laser Hologage

Range: 10mm / .4"

- 0.1µm resolution
- Square wave output
- ø15mm plain stem

Page 24

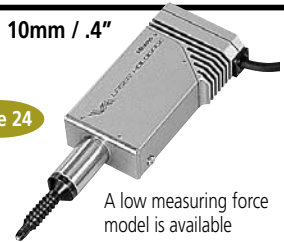

A low measuring force model is available

Compatible display unit

EG-101P EB-101P EH-102P

## LGB series

Range: 5mm / .2"

- 1µm resolution
- Square wave output
- ø9.5mm stem

Page 20



Compatible display unit

EG-101P EB-11P

EH-101P EH-102P

EV-16P

## LGB series

Range: 5mm / .2"

- 0.1 / 1µm resolution
- Square wave output
- ø9.5 / ø8mm stem

Page 20

Page 21



ø9.5mm stem  
With stem clamp nut



ø8mm stem

Compatible display unit

EG-101P EB-11P

EH-101P EH-102P

EV-16P

## LGB series

Range: 10mm / .4"

- 1µm resolution
- Square wave output
- ø9.5 / ø8mm stem

Page 20

Page 21

Page 20

Page 21



ø9.5mm stem  
With stem clamp nut



ø8mm stem



ø9.5mm stem  
With stem clamp nut



ø8mm stem

Compatible display unit

EG-101P EB-11P

EH-101P EH-102P

EV-16P

High accuracy, low measuring force and sine wave output models available

With pneumatic cylinder

## L GK series

Range: 10mm / .4"

- 0.1 / 0.5 / 1µm resolution
- Square wave output
- ø8mm stem

Page 14

Page 14

Page 14



0.1µm / 4µinch



0.5µm / .00002"



1µm / .00004"

Compatible display unit

EG-101P EB-11P

EH-101P EH-102P

EV-16P

## LG series

Range: 100mm / 4"

- 0.1 / 1µm resolution
- Square wave output
- ø20mm stem

Page 22

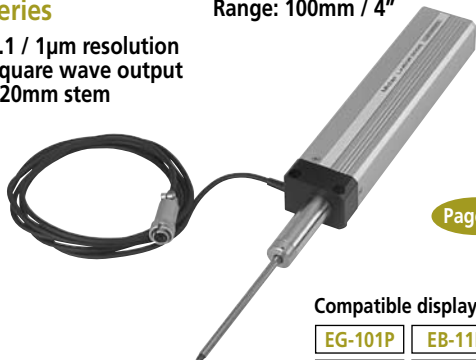

Compatible display unit

EG-101P EB-11P

EH-101P EH-102P

EV-16P

## LGM series

Range: 100mm / 4"

- 0.1 / 1µm resolution
- Square wave output
- ø20mm stem
- Motor-drive operation

Page 23

Motor-drive unit

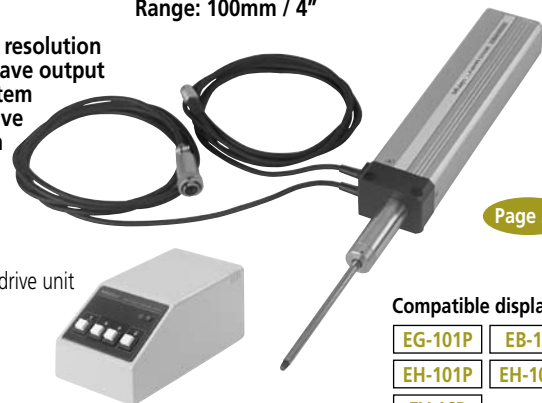

Compatible display unit

EG-101P EB-11P

EH-101P EH-102P

EV-16P

**LGF series**

- 0.5 / 1µm resolution
- Square wave output
- ø8mm / ø15mm stem

Compatible display unit

- |         |         |
|---------|---------|
| EG-101P | EB-11P  |
| EH-101P | EH-102P |
| EV-16P  |         |

Range: 10mm / .4"

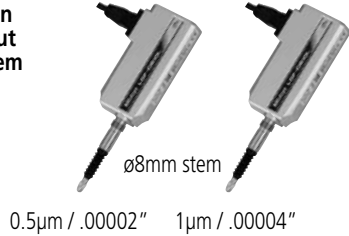

Page 15

Range: 25mm / 1"

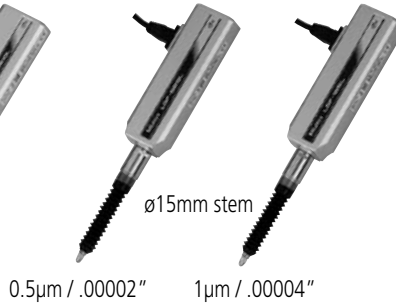

Page 15

Range: 50mm / 2"

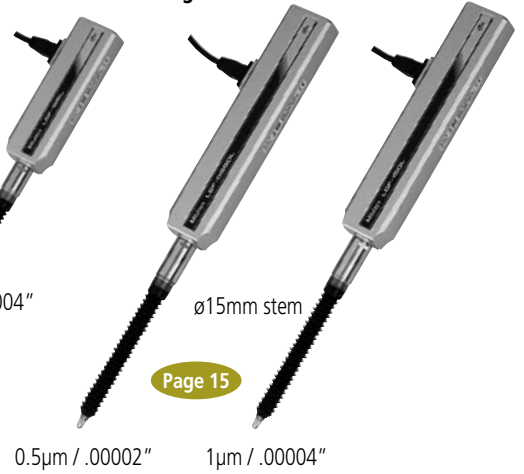

Page 15

**LGF series**

- 0.5 / 1µm resolution
- Square wave output
- ø8mm / ø15mm stem
- With origin point mark

Compatible display unit

- |         |        |
|---------|--------|
| EG-101Z | EB-11Z |
| EH-102Z | EV-16Z |

Range: 10mm / .4"

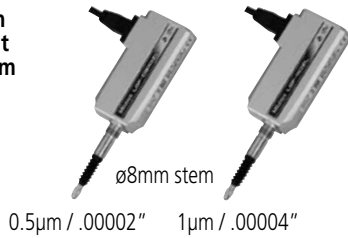

Page 16

Range: 25mm / 1"

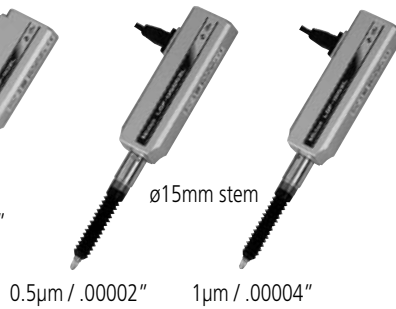

Page 16

Range: 50mm / 2"



Page 16

**LGF series**

- 0.1µm resolution
- Square wave output
- ø8mm / ø15mm stem

Compatible display unit

- |         |         |
|---------|---------|
| EG-101P | EB-11P  |
| EH-101P | EH-102P |
| EV-16P  |         |

Range: 10mm / .4"



Page 17

Range: 25mm / 1"



Page 17

0.5µm / .00002" 1µm / .00004"

**LGF series**

- 5µm resolution
- Square wave output
- ø15mm stem

Compatible display unit

- |         |         |
|---------|---------|
| EG-101P | EB-11P  |
| EH-101P | EH-102P |
| EV-16P  |         |

Range: 25mm / 1"



Page 15

Range: 50mm / 2"

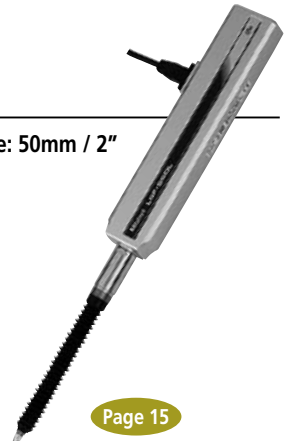

Page 15

# Gage Head Overview

## LGD series

- 0.01mm resolution
- Digimatic output
- Absolute linear encoder
- ø8mm / ø15mm stem

Compatible display unit

- EC-101D
- EG-101D
- EB-11D
- EH-102D
- EV-16D

Range: 10mm / .4"

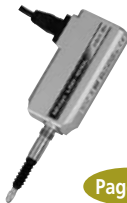

ø8mm stem

Page 19

Range: 25mm / 1"



ø15mm stem

Page 19

Range: 50mm / 2"



ø15mm stem

Page 19

## LGS series

- 0.01mm resolution
- Digimatic output
- Absolute linear encoder
- ø8mm stem

Compatible display unit

- EC-101D
- EG-101D
- EB-11D
- EH-102D
- EV-16D

Range: 12.7mm / .5"



Page 18

## Signal ID-C

- 0.001mm resolution
- Digimatic output
- Absolute linear encoder
- ø8mm stem

Compatible display unit

- EC-101D
- EG-101D
- EB-11D
- EH-102D
- EV-16D

Range: 12.7mm / .5"



Page 26

# System Connections

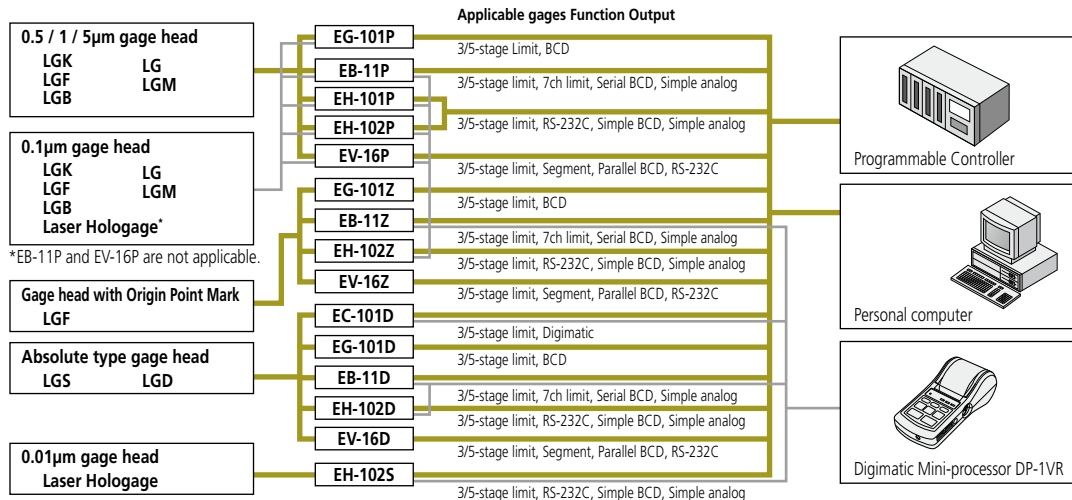

# Display Unit Overview

## EC counter

Single function type

Page 39

For Digimatic output gage heads



EC-101D

## EG counter

Single function type

Page 40

For Digimatic output gage heads



EG-101D

For square wave output gage heads



EG-101P

For square wave output gage heads with origin point mark



EG-101Z

## EB counter

Multi-function type

Page 42

For Digimatic output gage heads



EB-11D

For square wave output gage heads



EB-11P

For square wave output gage heads with origin point mark



EB-11Z

## EH counter

Multi-function type

Page 46

For Digimatic output gage heads



EH-102D

For square wave output gage heads (1-axis / 2-axis)



EH-101P

For square wave output gage heads with origin point mark



EH-102Z



EH-102P

For Sine wave output gage heads



EH-102S

## EV counter

Multi-function type for multi-gage system

Page 51

For Digimatic output gage heads



EV-16D

For square wave output gage heads



EV-16P

For square wave output gage heads with origin point mark



EV-16Z

Gage  
Heads**LGK Slim Type**

IP66

10mm range, 0.1 / 0.5 / 1µm resolution, Differential square-wave output

**FEATURES**

- A slim-body model which has succeeded the proven LGF series in terms of vibration- and impact-resistance. The sectional area is only a 1/5 compared to that of the LGF-110L model.
- Provides a resolution of 0.1 / 0.5 / 1µm, whichever is selectable.

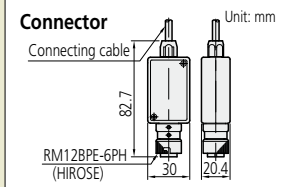
**Dimensions**

Unit: mm

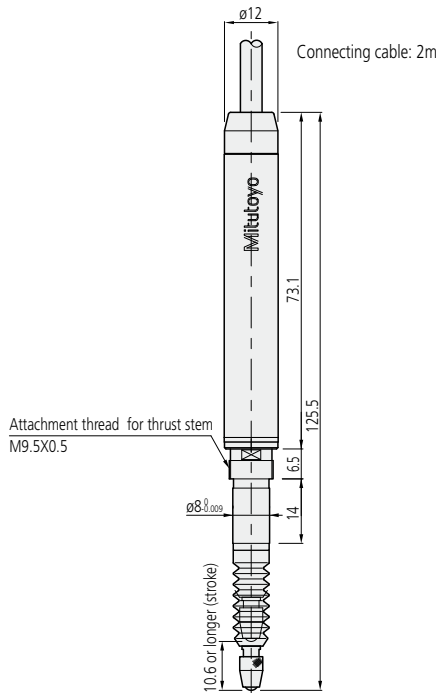
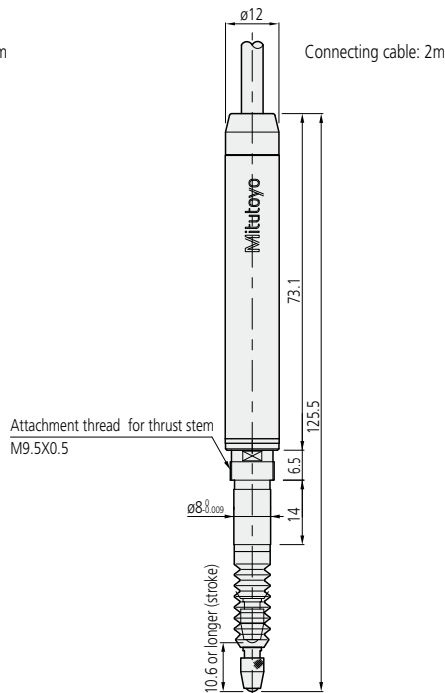
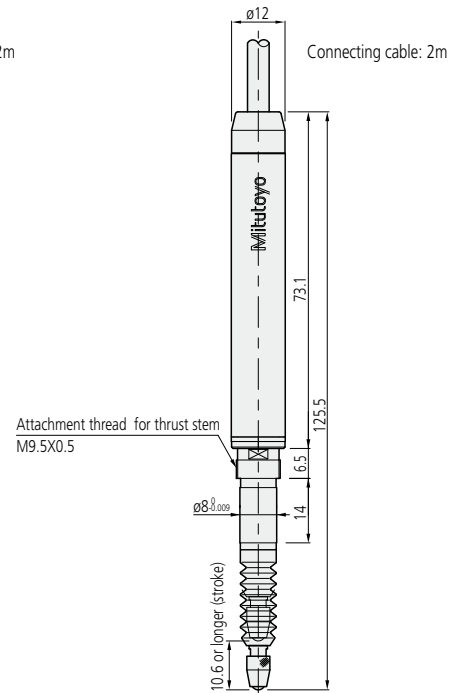
**542-158:** 0.1µm resolution model**542-157:** 0.5µm resolution model**542-156:** 1µm resolution model**SPECIFICATIONS**

Order No.	542-158	542-157	542-156
Measuring range		10mm	
Resolution	0.0001mm	0.0005mm	0.001mm
Accuracy (20°C)*1	(0.8+L/50)µm (L=mm)		(1.5+L/50)µm (L=mm)
Measuring force	Spindle DOWN	Approx. 0.8N or less	
	Horizontal	Approx. 0.75N or less	
	Spindle UP	Approx. 0.7N or less	
Position-detection sensor	Transmission-type photoelectric linear encoder*4		
Max. response speed*2	400mm/s	1500mm/sec	
Output signal	90° phase difference, differential square wave (RS-422A equivalent); minimum edge intervals 200ns for 0.1µm model, 250ns for 0.5µm model, and 500ns for 1µm model		
Signal pitch	0.4µm	2µm	4µm
Mass	250g		
Dust/Water protection level*3	IP66		
Contact point	ø3mm carbide (mounting: M2.5x0.45), <b>901312</b>		
Stem size	ø8mm		
Bearing type	Linear ball bearing*5		
Connecting cable length	2m		
Connector	Plug used: RM12BPE-6PH (HIROSE), Compatible socket: RM12BRD-6S (HIROSE)		
Operating environment	0°C to 40°C (20%RH to 80%RH, without condensation)		
Standard accessory	Wrench for contact point ( <b>538610</b> )		
Optional accessories	<b>238772:</b> 10mm rubber boot (spare)		
	<b>02ADB680:</b> Thrust stem and wrench set		
	<b>02ADB681:</b> Thrust stem		
	<b>02ADB683:</b> Thrust stem wrench		

\*1: Excluding quantizing error of ±1 count.

\*2: When the travel speed of spindle exceeds 1500mm/s (400mm/s for the case of 0.1µm model), an alarm signal will be output and an error display will result if any Mitutoyo counter is used. For the method of making use of alarm signals where any Mitutoyo counter is not used refer to Page 30. However, note that the spindle's free travel may exceed the given speed limit to cause an error if the contact point is released quickly after it has been pressed in, depending on the amount of over-travel produced.

\*3: IP level is the standard of protection against the ingress of solids/foreign matter and water. This may not be applicable for liquids other than water

\*4: Patent registered (Japan, U.S.A., Germany, U.K.)

\*5: Patent registered (Japan)

Gage Heads

# LGF Standard Type



10 / 25 / 50mm range, 0.5 / 1 / 5µm resolution, Differential square-wave output

## FEATURES

- Excellent protection against dust ingress and water splash (IP66) in harsh shop-floor environments.
- Uses linear stroke ball bearings on the spindle movement for resistance to external shock and vibration.
- Thrust Stem with a clamp nut is optional.

Connector

Unit: mm

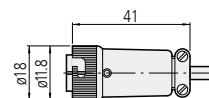

## Dimensions

Unit: mm

**542-171:** 0.5µm resolution, 10mm range model  
**542-161:** 1µm resolution, 10mm range model

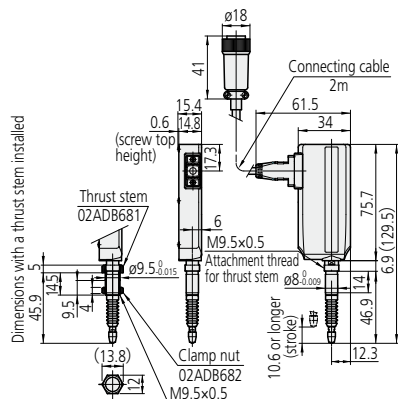

**542-172:** 0.5µm resolution, 25mm range model  
**542-162:** 1µm resolution, 25mm range model  
**542-612:** 5µm resolution, 25mm range model

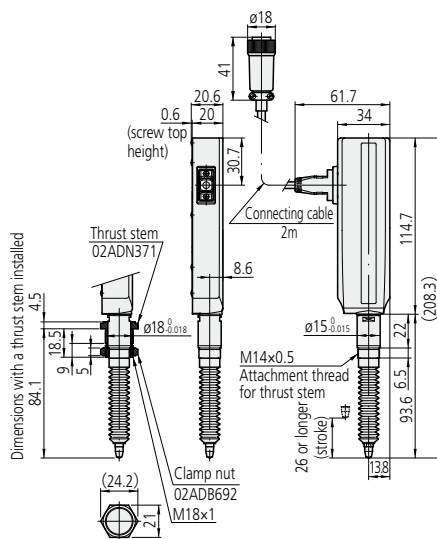

**542-173:** 0.5µm resolution, 50mm range model  
**542-163:** 1µm resolution, 50mm range model  
**542-613:** 5µm resolution, 50mm range model

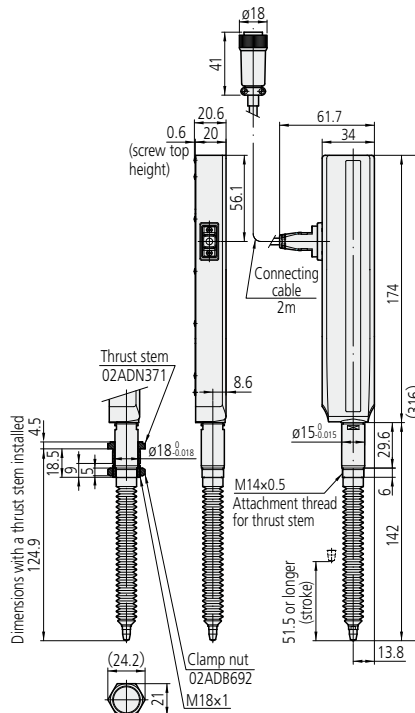

## SPECIFICATIONS

Order No.	542-171	542-161	542-172	542-162	542-612	542-173	542-163	542-613	
Measuring range	10mm			25mm			50mm		
Resolution	0.0005mm	0.001mm	0.0005mm	0.001mm	0.005mm	0.0005mm	0.001mm	0.005mm	
Accuracy (20°C)*1	(1.5+L/50)µm for 0.5µm / 1µm model, (7.5+L/50)µm for 5µm model (L=mm)								
Measuring force	Spindle DOWN		1.2N or less			4.6N or less		5.7N or less	
	Horizontal		1.1N or less			4.3N or less		5.3N or less	
	Spindle UP		1.0N or less			4.0N or less		4.9N or less	
Position-detection method	Transmission-type photoelectric linear encoder*4								
Max. response speed*2	1500mm/sec								
Output signal	90° phase difference, differential square wave (RS-422A equivalent); minimum edge intervals 250ns for 0.5µm model, 500ns for 1µm model, 1000ns for 5µm model,								
Signal pitch	4µm	2µm	4µm	2µm		4µm	2µm		
Mass	250g			300g			400g		
Dust/water protection*3	IP66								
Contact point	ø3mm carbide (mounting: M2.5x0.45) <b>901312</b>								
Stem size	ø8mm			ø15mm					
Bearing type	Linear ball bearing*5								
Connecting cable length	2m								
Connector	Plug used: RM12BPE-6PH (HIROSE), Compatible socket: RM12BRD-6S (HIROSE)								
Operating environment	0°C to 40°C (20%RH to 80%RH, without condensation)								
Standard accessory	Wrench for contact point ( <b>538610</b> )			Wrench for contact point ( <b>210187</b> )					
Optional accessories	<b>238772:</b> 10mm rubber boot (spare)		<b>962504</b> 25mm rubber boot (spare)			<b>962505</b> 50mm rubber boot (spare)			
	<b>02ADB680:</b> Thrust stem and wrench set <b>02ADB683:</b> Thrust stem rench		<b>02ADN370:</b> Thrust stem and wrench set <b>02ADB693:</b> Thrust stem wrench						

\*1: Excluding quantizing error of ±1 count.

\*2: When the travel speed of spindle exceeds 1500mm/s (400mm/s for the case of 0.1µm model), an alarm signal will be output and an error display will result if any Mitutoyo counter is used. For the method of making use of alarm signals where any Mitutoyo counter is not used refer to Page 30. However, note that the spindle's free travel may exceed the given speed limit to cause an error if the contact point is released quickly after it has been pressed in, depending on the amount of over-travel produced.

\*3: IP level is the standard of protection against the ingress of solids/foreign matter and water. This may not be applicable for liquids other than water

\*4: Patent registered (Japan, U.S.A., Germany, U.K.)

\*5: Patent registered (Japan)

Gage Heads

# LGF with Origin Point Mark



10 / 25 / 50mm range, 0.5 / 1μm resolution, Differential square-wave output

## FEATURES

- The origin point signal output function enables the measuring system to be reset easily when this gage is incorporated in a machine tool. This function helps boost productivity by drastically reducing reset time, since the origin position can be recaptured very easily even when lost due to over-speed errors, etc.

Connector Unit: mm

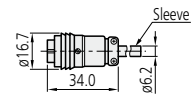

## Dimensions

Unit: mm

542-176: 0.5μm resolution, 50mm range model

542-166: 1μm resolution, 50mm range model

542-174: 0.5μm resolution, 10mm range model  
542-164: 1μm resolution, 10mm range model

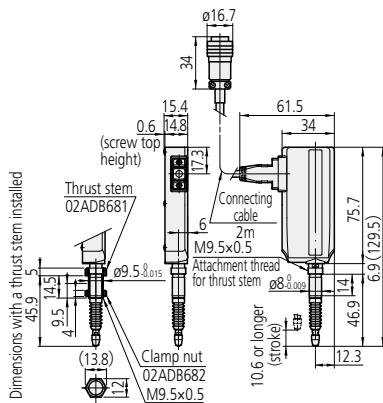

542-175: 0.5μm resolution, 25mm range model  
542-165: 1μm resolution, 25mm range model

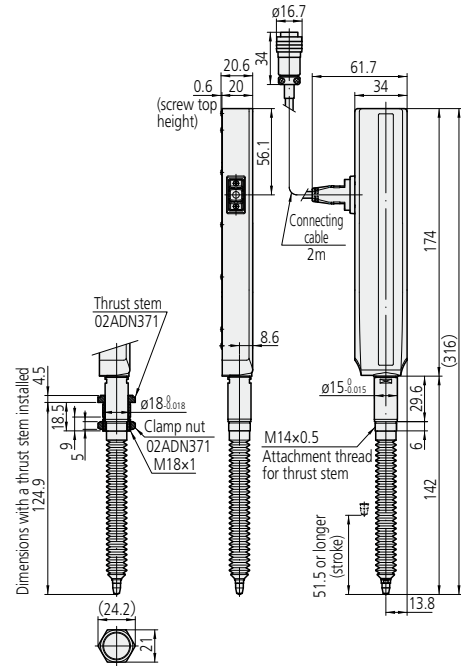
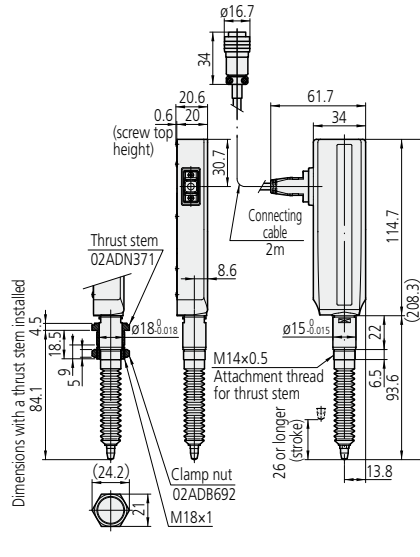

## SPECIFICATIONS

Order No.	542-174	542-164	542-175	542-165	542-176	542-166
Measuring range	10mm		25mm		50mm	
Resolution	0.0005mm	0.001mm	0.0005mm	0.001mm	0.0005mm	0.001mm
Accuracy (20°C)*1	(1.5+L/50)μm (L=mm)					
Measuring force	Spindle DOWN		4.6N or less		5.7N or less	
	Horizontal		4.3N or less		5.3N or less	
	Spindle UP		1.0N or less		4.9N or less	
Position-detection method	Transmission-type photoelectric linear encoder*4					
Origin point	Approx. 3mm from initial contact with tip			Approx. 5mm from initial contact with tip		
Repeatability of origin point (20°C)	≤0.5μm (passing speed less than 300mm/s in the same direction)					
Max. response speed*2	1500mm/s					
Output signal	90° phase difference, differential square wave (RS-422A equivalent); minimum edge intervals 500ns for 1μm model, 250ns for 0.5μm model					
Signal pitch	2μm	4μm	2μm	4μm	2μm	4μm
Mass	260g		300g		400g	
Dust/water protection*3	IP66					
Resistance to impact	1000m/s <sup>2</sup> , 11ms (IEC 68-2-27)					
Contact point	ø3mm carbide (mounting: M2.5x0.45), <b>901312</b>					
Stem size	ø8mm			ø15mm		
Bearing type	Linear ball bearing*3					
Connecting cable length	2m					
Connector	Plug used: PRC05-P8M (TAJIMI), Applicable receptacle: PRC05-R8F (TAJIMI)					
Operating environment	0°C to 40°C (20%RH to 80%RH, without condensation)					
Standard accessory	Wrench for contact point ( <b>538610</b> )			Wrench for contact point ( <b>210187</b> )		
Optional accessories	238772: 10mm rubber boot (spare) 02ADB680: Thrust stem and wrench set 02ADB683: Thrust stem wrench		962504: 25mm rubber boot (spare)		962505: 50mm rubber boot (spare) 02ADN370: Thrust stem and wrench set 02ADB693: Thrust stem wrench	

\*1: Excluding quantizing error of ±1 count.

\*2: When the travel speed of spindle exceeds 1500mm/s (400mm/s for the case of 0.1μm model), an alarm signal will be output and an error display will result if any Mitutoyo counter is used. For the method of making use of alarm signals where any Mitutoyo counter is not used refer to Page 30. However, note that the spindle's free travel may exceed the given speed limit to cause an error if the contact point is released quickly after it has been pressed in, depending on the amount of over-travel produced.

\*3: IP level is the standard of protection against the ingress of solids/foreign matter and water. This may not be applicable for liquids other than water

\*4: Patent registered (Japan, U.S.A., Germany, U.K.)

\*5: Patent registered (Japan)



10 / 25mm range, 0.1µm resolution, Differential square-wave output

**FEATURES**

- Excellent protection against dust ingress and water splash (IP66) in harsh shop-floor environments.
- Uses linear stroke ball bearings on the spindle movement for resistance to external shock and vibration.
- Thrust Stem with clamp nut is optional.

**Connector**

Unit: mm

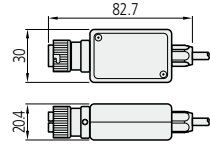
**Dimensions**

Unit: mm

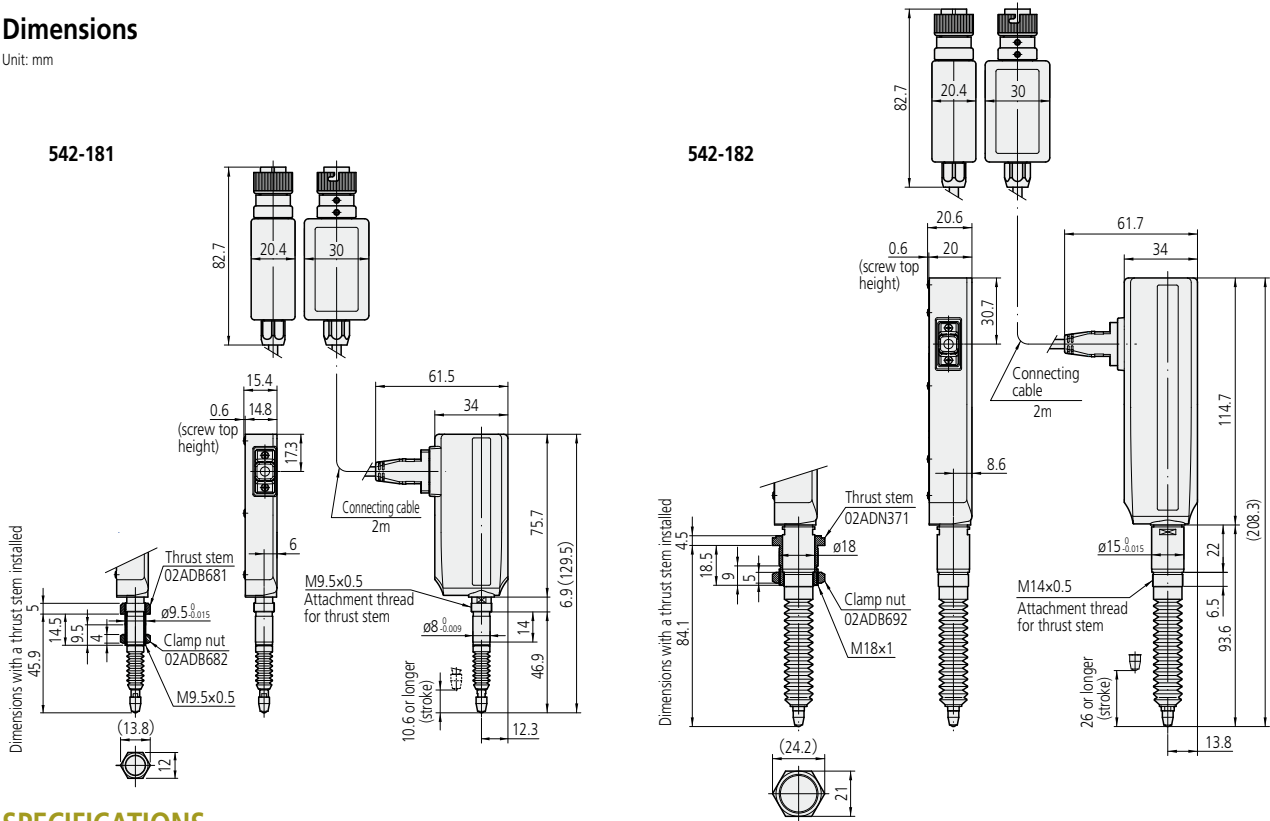
**SPECIFICATIONS**

Order No.	542-181	542-182
Measuring range	10mm	25mm
Resolution	0.0001mm	
Accuracy (20°C)* <sup>1</sup>	(0.8+L/50)µm (L=mm)	
Accuracy (20°C)	(0.8+L/50)µm (L=mm)	
Measuring force	Spindle DOWN	1.2N or less
	Horizontal	1.1N or less
	Spindle UP	1.0N or less
Position-detection method	Transmission-type photoelectric linear encoder* <sup>4</sup>	
Max. response speed* <sup>2</sup>	400mm/s	
Output signal	90° phase difference, differential square wave (RS-422A equivalent); minimum edge intervals 200ns	
Signal pitch	0.4µm	
Mass	310g	350g
Dust/water protection* <sup>3</sup>	IP66	
Contact point	ø3mm carbide (mounting: M2.5x0.45), <b>901312</b>	
Stem size	ø8mm	ø15mm
Bearing type	Linear ball bearing* <sup>5</sup>	
Connecting cable length	2m	
Connector	Plug used: RM12BPE-6PH (HIROSE), Applicable receptacle: RM12BRD-6S (HIROSE)	
Operating environment	0°C to 40°C (20%RH to 80%RH, without condensation)	
Standard accessory	Wrench for contact point ( <b>538610</b> )	Wrench for contact point ( <b>210187</b> )
Optional accessories	<b>238772</b> : 10mm rubber boot (spare) <b>02ADB680</b> : Thrust stem and wrench set <b>02ADB683</b> : Thrust stem wrench	<b>962504</b> : 25mm rubber boot (spare) <b>02ADB690</b> : Thrust stem and wrench set <b>02ADB693</b> : Thrust stem wrench

\*1: Excluding quantizing error of ±1 count.

\*2: When the travel speed of spindle exceeds 1500mm/s (400mm/s for the case of 0.1µm model), an alarm signal will be output and an error display will result if any Mitutoyo counter is used. For the method of making use of alarm signals where any Mitutoyo counter is not used refer to Page 30. However, note that the spindle's free travel may exceed the given speed limit to cause an error if the contact point is released quickly after it has been pressed in, depending on the amount of over-travel produced.

\*3: IP level is the standard of protection against the ingress of solids/foreign matter and water. This may not be applicable for liquids other than water.

\*4: Patent registered (Japan, U.S.A., Germany, U.K.)

\*5: Patent registered (Japan)

Gage Heads

# LGS Absolute Type

IP66

12.7mm range, 0.01 resolution, Digimatic code (SPC) output

## FEATURES

- Employing the ABSOLUTE linear encoder, the LGS always displays the position of the spindle relative to the current origin, previously set by the user, at power-on. The unlimited response speed of the gage eliminates over-speed errors.

Connector: LGS

Unit: mm

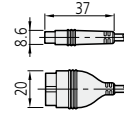

## Dimensions

Unit: mm



575-303

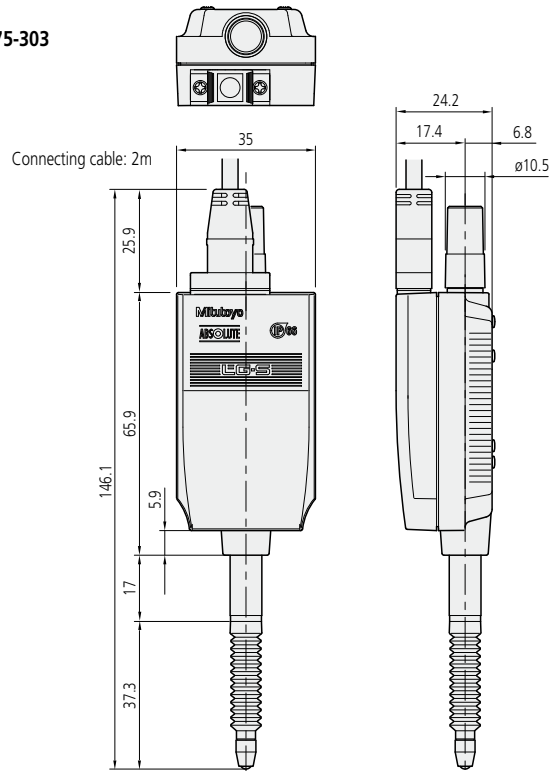

## SPECIFICATIONS

Order No.	575-303	575-313
Measuring range	12.7mm	.5"
Resolution	0.01mm	.0005"
Accuracy (20°C)* <sup>1</sup>	0.015mm	.0008"
Measuring force	Spindle DOWN	Approx. 2N or less
	Horizontal	Approx. 1.8N or less
	Spindle UP	Approx. 1.6N or less
Position-detection method	Capacitance-type absolute linear encoder* <sup>3</sup>	
Response speed	Unlimited; measurement by scanning cannot be performed	
Output signal	Digimatic	
External input	Origin-setting signal (ABS origin can be changed externally)* <sup>4</sup>	
Mass	190g (including cable)	
Dust/water protection* <sup>2</sup>	IP66	
Contact point (mounting threads)	ø3mm carbide (M2.5X0.45mm)	ø3mm carbide (#4-48unf)
Stem size	ø8mm	ø9.5mm
Bearing type	Slide-bearing type	
Connecting cable length	2m	
Operating environment	0°C to 40°C (20%RH to 80%RH, without condensation)	
Optional accessories	<b>238774:</b> Rubber boot (spare) <b>903594:</b> Air drive unit for 575-303, <b>903598:</b> Air drive unit for 575-313 <b>02ADF640:</b> Joint for extension SPC cable <b>02ADD950:</b> Extension SPC cable (0.5m), <b>936937:</b> Extension SPC cable (1m), <b>965014:</b> Extension SPC cable (2m)	

\*1: Excluding quantizing error of ±1 count.

\*2: IP level is the standard of protection against the ingress of solids/foreign matter and water. This may not be applicable for liquids other than water.

\*3: Patent registered (Japan, U.S.A., Germany, U.K., Switzerland, Sweden, China)

\*4: The ABS origin is user-settable anywhere within the measuring range and holds value through power interruptions.

Gage Heads

# LGD Absolute Type



10 / 25 / 50mm range, 0.01mm resolution, Digimatic code (SPC) output

## FEATURES

- The use of an Absolute scale in the gage head makes it possible to maintain the user-defined origin setting even when the power is switched off.
- Special linear ball bearings are used for the spindle guide to ensure a long service life.

Connector

Unit: mm

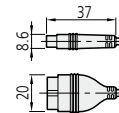

## Dimensions

Unit: mm



575-328: 50mm range model

575-326: 10mm range model

575-327: 25mm range model

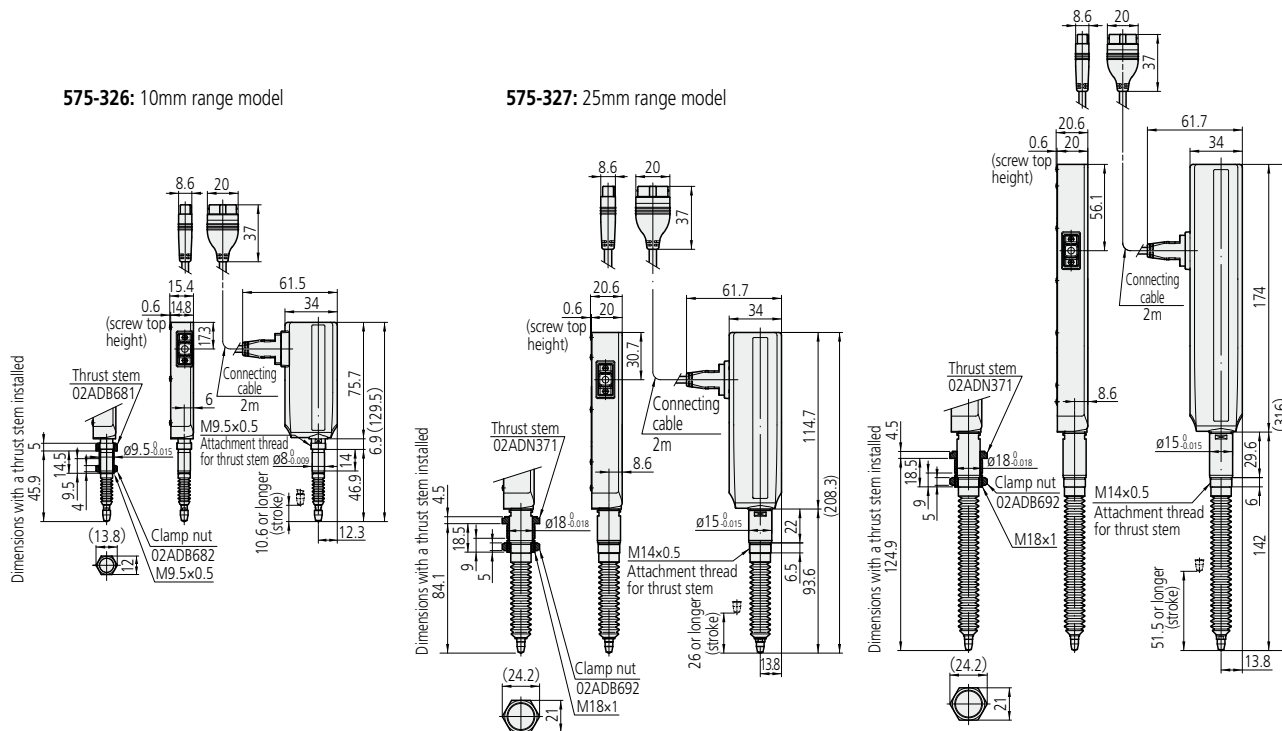

## SPECIFICATIONS

Order No.	575-326, 575-326-3, 575-326-5, 575-326-7	575-336, 575-336-3, 575-336-5, 575-336-7	575-327, 575-327-3, 575-327-5, 575-327-7	575-337, 575-337-3, 575-337-5, 575-337-7	575-328, 575-328-3, 575-328-5, 575-328-7	575-338, 575-338-3, 575-338-5, 575-338-7
Measuring range	10mm	.4"	25mm	1"	50mm	2"
Resolution	0.01mm	.0005"	0.01mm	.0005"	0.01mm	.0005"
Accuracy (20°C)*1	20µm	.001"	20µm	.001"	30µm	.001"
Measuring force	Spindle DOWN	Approx. 1.2N or less			Approx. 5.7N or less	
	Horizontal	Approx. 1.1N or less			Approx. 5.3N or less	
	Spindle UP	Approx. 1.0N or less			Approx. 4.9N or less	
Position-detection method	Capacitance-type absolute linear encoder*3					
Response speed	Unlimited; measurement by scanning cannot be performed					
Output signal	Digimatic					
External input	Origin-setting signal (ABS origin can be changed externally)*4					
Mass	260g		300g		400g	
Dust/water protection*2	IP-66 equivalent*2					
Contact point	ø3mm carbide (mounting: M2.5x0.45), <b>901312</b>					
Stem size	ø8mm			ø15mm		
Bearing type	Linear ball bearing*5					
Connecting cable length	2m (no suffix), 3m (suffix "-3"), 5m (suffix "-5"), 7m (suffix "-7")					
Operating environment	0°C to 40°C (20%RH to 80%RH, without condensation)					
Standard accessory	Wrench for contact point ( <b>538610</b> )			Wrench for contact point ( <b>210187</b> )		
Optional accessories	<b>238772</b> : 10mm rubber boot (spare)		<b>962504</b> : 25mm rubber boot (spare)		<b>962505</b> : 50mm rubber boot (spare)	
	<b>02ADB680</b> : Thrust stem and wrench set			<b>02ADN370</b> : Thrust stem and wrench set		
	<b>02ADB683</b> : Thrust stem wrench			<b>02ADB693</b> : Thrust stem wrench		

\*1: Excluding quantizing error of ±1 count.

\*2: IP level is the standard of protection against the ingress of solids/foreign matter and water. This may not be applicable for liquids other than water.

\*3: Patent registered (Japan, U.S.A., Germany, U.K., Switzerland, Sweden, China)

\*4: The ABS origin is user-settable anywhere within the measuring range and holds value through power interruptions.

\*5: Patent registered (Japan)

**LGB** Extremely Compact  $\phi 9.5\text{mm}$  Stem Type5 / 10mm range, 0.1 / 1 $\mu\text{m}$  resolution, Differential square-wave output\*

\*Sine-wave output: 542-421

**FEATURES**

- Extremely compact design.
- The small photoelectric linear encoder assures high precision over the entire stroke range.
- The ball bearings\* used in the spindle unit ensure superb durability. \*Patent registered (Japan)

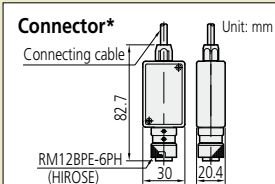

\*Differential square-wave output model

**Dimensions**

Unit: mm

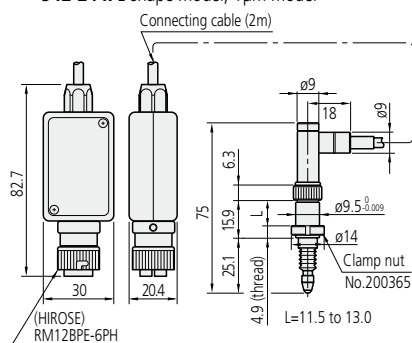
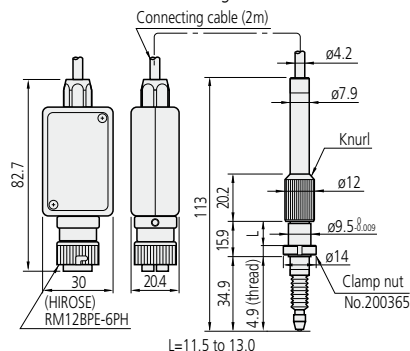
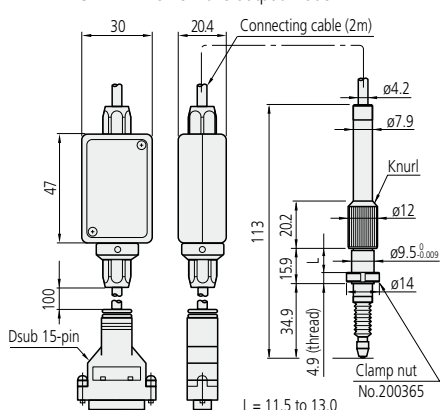
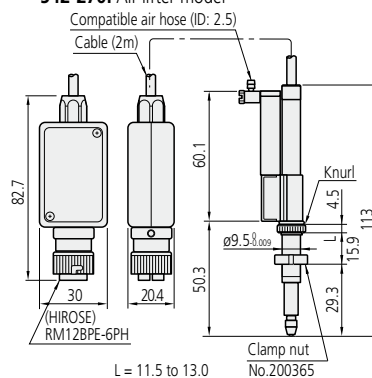
**542-246:** L-shape model, 0.1 $\mu\text{m}$  model**542-244:** L-shape model, 1 $\mu\text{m}$  model**542-262****542-262H:** High accuracy model**542-264:** Low measuring force model**542-421:** Sine-wave output model**542-270:** Air-lifter model**SPECIFICATIONS**

Order No.	542-246	542-244	542-262	542-262H	542-264	542-270	542-421
Measuring range	5mm (.2")		10mm (.4")				
Resolution	0.0001mm		0.001mm				
Accuracy (20°C)*1	0.8 $\mu\text{m}$	2 $\mu\text{m}$	2 $\mu\text{m}$	1 $\mu\text{m}$	2 $\mu\text{m}$	2 $\mu\text{m}$	2 $\mu\text{m}$
Measuring force	Spindle DOWN	0.65N or less		0.8N or less		0.8N or less	
	Horizontal	0.6N or less		0.75N or less		0.75N or less	
	Spindle UP	0.55N or less		0.7N or less		0.7N or less	
Position-detection method	Transmission-type photoelectric linear encoder						
Max. response speed	900mm/sec						
Output signal	90° phase difference, differential square wave (RS-422A equivalent)						Sine wave
Signal pitch	0.4 $\mu\text{m}$ pitch		4 $\mu\text{m}$ pitch				
Mass	160g		150g		170g		180g
Dust / water protection*2	IP54						
Contact point	$\phi 3\text{mm}$ carbide (mounting: M2.5x0.45), <b>901312</b>						
Stem size	$\phi 9.5\text{mm}$						
Bearing type	Linear ball bearing						
Connecting cable length	2m						
Connector	Plug used: RM12BPE-6PH (HIROSE), Compatible socket: RM12BRD-6S (HIROSE)						
Operating environment	0°C to 40°C (20%RH to 80%RH, without condensation)						
Spindle-drive method	None					Air lifter*3	
Standard accessory	Wrench for contact point ( <b>538610</b> )						
Optional accessory	<b>238773:</b> 5mm rubber boot (spare)		<b>238772:</b> 10mm rubber boot (spare)				

\*1: Excluding quantizing error of  $\pm 1$  count.

\*2: IP level is the standard of protection against the ingress of solids/foreign matters and water. This may not be applicable for liquids other than water.

\*3: Spindle extends when air is supplied. Required air-pressure range: 0.3 to 0.4 MPa

Gage Heads

# LGB Extremely Compact ø8mm Stem Type



5 / 10mm range, 1µm resolution, Differential square-wave output\*

\*Sine-wave output: 542-401

## FEATURES

- Extremely compact design. Available with an outside diameter as small as 8mm.
- The small photoelectric linear encoder assures high precision over the entire stroke range.
- The ball bearings\* used in the spindle unit ensure superb durability. \*Patent registered (Japan)

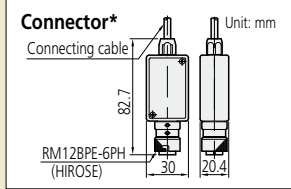

\*Differential square-wave output model

## Dimensions

Unit: mm

### 542-204: L-shape model

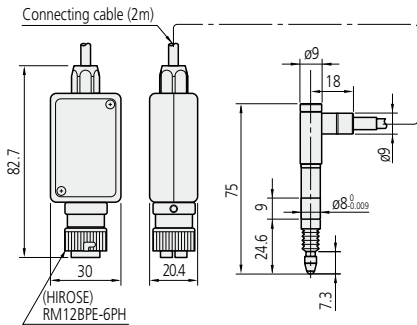

### 542-222

542-222H: High accuracy model

542-224: Low measuring force model

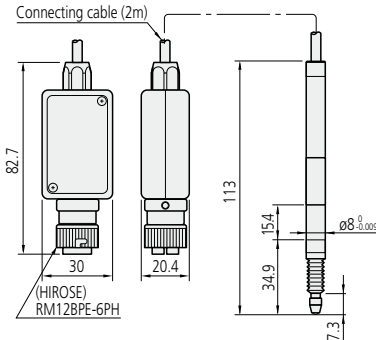

### 542-230: Air-lifter model

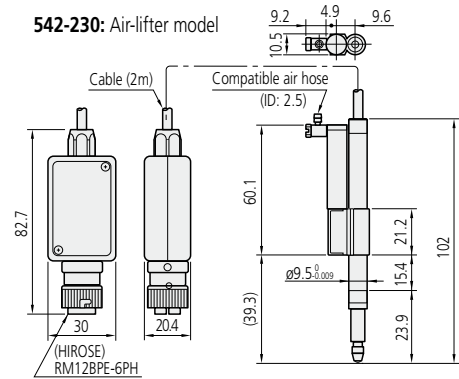

### 542-401: Sine-wave output model

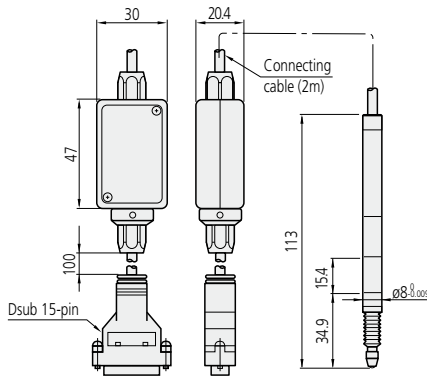

### 542-223: Air-lifter model

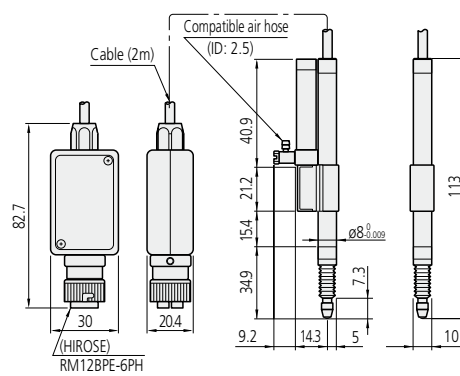

## SPECIFICATIONS

Order No.	542-204	542-222	542-222H	542-224	542-230	542-223	542-401	
Measuring range	5mm (.2")	10mm (.4")						
Resolution	0.001mm							
Accuracy (20°C)*1	2µm	2µm	1µm	2µm	2µm	2µm	2µm	
Measuring force	Spindle DOWN	0.65N or less	0.8N or less	0.6N or less	0.8N or less	0.8N or less	0.8N or less	
	Horizontal	0.6N or less	0.75N or less	0.55N or less	0.75N or less	0.75N or less	0.75N or less	
	Spindle UP	0.55N or less	0.7N or less	0.5N or less	0.7N or less	0.7N or less	0.7N or less	
Position-detection method	Transmission-type photoelectric linear encoder							
Response speed	900mm/sec							
Output signal	90° phase difference, differential square wave (RS-422A equivalent)						Sine wave	
Signal pitch	4µm pitch							
Mass	145g		140g			165g	160g	
Dust / water protection*2	IP54							
Contact point	ø3mm carbide (mounting: M2.5x0.45), <b>901312</b>							
Stem size	ø8mm							
Bearing type	Linear ball bearing							
Connecting cable length	2m							
Connector	Plug used: RM12BPE-6PH (HIROSE), Compatible socket: RM12BRD-6S (HIROSE)							
Operating environment	0°C to 40°C (20%RH to 80%RH, without condensation)							
Spindle-drive method		None			Air lifter*3	Air lifter*4	None	
Standard accessory	Wrench for contact point ( <b>538610</b> )							
Optional accessory	<b>238773</b> : 5mm rubber boot (spare)	<b>238772</b> : 10mm rubber boot (spare)						

\*1: Excluding quantizing error of ±1 count.

\*2: IP level is the standard of protection against the ingress of solids/foreign matter and water. This may not be applicable for liquids other than water.

\*3: Spindle extends when air is supplied. Required air-pressure range: 0.3 to 0.4 MPa

\*4: Spindle retracts when air is supplied. Required air-pressure range: 0.3 to 0.4 MPa

Gage Heads

# LG Long Stroke Type

IP54 IP66

100mm range, 0.1 / 1µm resolution, Differential square-wave output

## FEATURES

- There are three types including the standard model, low measuring force model, and rubber boot model ("made to order" basis) available.
- The resolution of each model can be selected to be 0.1µm or 1µm.

Connector

Unit: mm

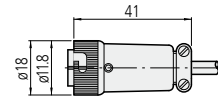

## Dimensions

Unit: mm

- 542-312: 0.1µm resolution model
- 542-316: 0.1µm resolution, low measuring force model
- 542-332: 1µm resolution model
- 542-336: 1µm resolution, low measuring force model

- 542-314: 0.1µm resolution, rubber boot model
- 542-334: 1µm resolution, rubber boot model

Lifting lever



IP54

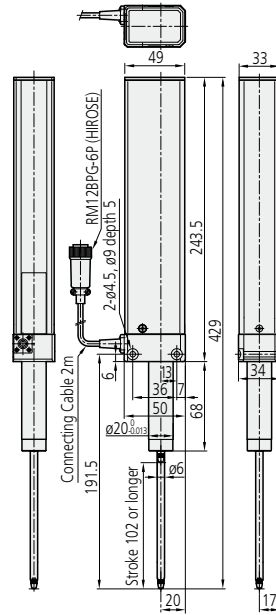

IP66

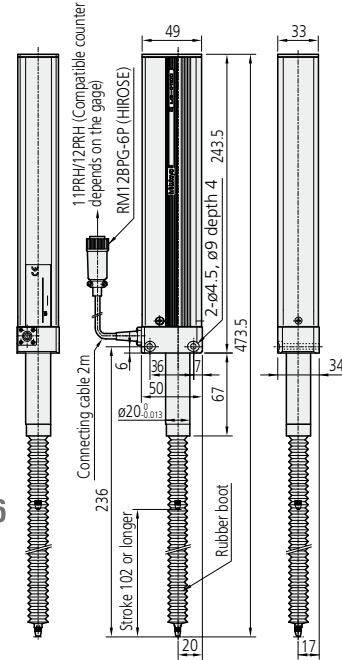

## SPECIFICATIONS

Order No.	542-312	542-316	542-314	542-332	542-336	542-334
Measuring range	100mm					
Resolution	0.0001mm			0.001mm		
Accuracy (20°C)*1	(2+L/100)µm ≤ 2.5µm (L=mm)			(2.5+L/100)µm ≤ 3µm (L=mm)		
Measuring force (Approx.)	Spindle DOWN	8.0N or less	3.0N or less	8.0N or less	8.0N or less	8.0N or less
	Horizontal	6.5N or less	Not available	6.5N or less	6.5N or less	6.5N or less
	Spindle UP	5.0N or less	Not available	5.0N or less	5.0N or less	5.0N or less
Position-detection method	Reflection-type photoelectric linear encoder					
Max. response speed*2	400mm/s			800mm/s		
Output signal	90° phase difference, differential square wave (RS-422A equivalent)					
Signal pitch	4µm					
Mass	Approx. 750g		Approx. 780g	Approx. 750g		Approx. 780g
Dust/water protection*3	IP54		IP66	IP54		IP66
Sealed-spindle method	Scraper type		Rubber boot type	Scraper type		Rubber boot type
Contact point	φ3mm carbide (mounting: M2.5x0.45), <b>901312</b>					
Stem size	φ20mm					
Bearing type	Linear ball bearing*4					
Resistance to impact	60g (According to Mitutoyo's internal tests)					
Connecting cable length	2m					
Connector	Plug used: RM12BPE-6PH (HIROSE), Compatible socket: RM12BRD-6S (HIROSE)					
Operating environment	0°C to 40°C (20%RH to 80%RH, without condensation)					
Standard accessories	Wrench for contact point ( <b>210187</b> ), hex-head bolt (M4x0.7x35, 2pcs.), washer (M4, 2pcs.), lifting lever ( <b>137693</b> ), lever holder ( <b>02ADG181</b> )					
Optional accessory	—		<b>02ADA004:</b> Rubber boot (spare)	—		<b>02ADA004:</b> Rubber boot (spare)

\*1: Excluding quantizing error of ±1 count.

\*2: Note that an over-speed error may occur if the contact point is released quickly after it has been pressed in, depending on the amount of over-travel produced.

\*3: IP level is the standard of protection against the ingress of solids/foreign matter and water. This may not be applicable for liquids other than water.

\*4: Patent pending (Japan)

Gage Heads

# LGM Motor-drive, Long Stroke Type

100mm range, 0.1 / 1µm resolution, Differential square-wave output

## FEATURES

- There are three types including the standard model, low measuring force model, and rubber boot model ("made to order" basis) available.
- The resolution of each model can be selected to be 0.1µm or 1µm.

IP54 IP66

Connector

Unit: mm

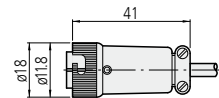

## Dimensions

Unit: mm

542-313: 0.1µm resolution model  
542-333: 1µm resolution model

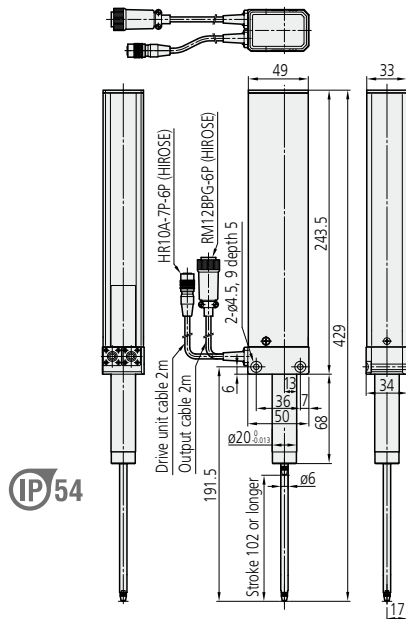

IP54

542-315: 0.1µm resolution, rubber boot model  
542-335: 1µm resolution, rubber boot model

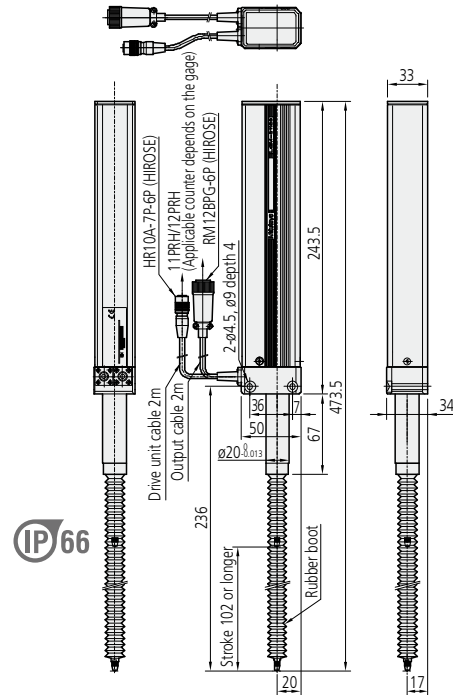

IP66

## SPECIFICATIONS

Order No.	542-313	542-315	542-333	542-335
Measuring range	100mm			
Resolution	0.0001mm		0.001mm	
Accuracy (20°C)*1	(2+L/100)µm ≤ 2.5µm (L=mm)		(2.5+L/100)µm ≤ 3µm (L=mm)	
Measuring force (Approx.)	Spindle DOWN	L3 (approx. 3.0N)	L4 (approx. 4.5N)	L4 (approx. 4.5N)
	Horizontal	L7 (approx. 6.5N)	Not available	L7 (approx. 6.5N)
	Spindle UP	H4 (approx. 9.5N)	L9 (approx. 6.0N)	H4 (approx. 9.5N)
Position-detection method	Reflection-type photoelectric linear encoder			
Response speed*2	400mm/s		800mm/s	
Output signal	90° phase difference, differential square wave (RS-422A equivalent)			
Signal pitch	4µm			
Mass	Approx. 940g	Approx. 970g	Approx. 940g	Approx. 970g
Dust/water protection*3	IP54	IP66	IP54	IP66
Spindle-sealing method	Scraper	Rubber boot	Scraper	Rubber boot
Contact point	Sø3mm carbide (mounting: M2.5x0.45), <b>901312</b>			
Stem size	ø20mm			
Spindle-drive method	Electric motor			
Bearing type	Linear ball bearing*4			
Resistance to impact	60g (According to Mitutoyo's internal tests)			
Connecting cable length	2m			
Connector types	Data output	Plug used: RM12BPE-6PH (HIROSE), Compatible socket: RM12BRD-6S (HIROSE)		
	Gage control	Plug used: HR10A-7P-6P (HIROSE), Compatible socket: HR10A-7P-6P (HIROSE)		
	External control	Plug used: HR10A-10R-10S (HIROSE), Compatible socket: HR10A-10R-10P (HIROSE)		
Operating environment	0°C to 40°C (20%RH to 80%RH, without condensation)			
Standard accessories	Wrench for contact point ( <b>210187</b> ), hex-head bolt (M4x0.7x35, 2pcs.), washer (M4, 2pcs.)			
Optional accessory	—	<b>02ADA004:</b> Rubber boot (spare)	—	<b>02ADA004:</b> Rubber boot (spare)

\*1: Excluding quantizing error of ±1 count.

\*2: Both the plunge speed and measuring force of the motor-driven type can be varied with the supplied motor drive unit.

\*3: IP level is the standard of protection against the ingress of solids/foreign matter and water. This may not be applicable depending on the kind of liquid.

\*4: Patent pending (Japan)

## Motor Drive Unit

(provided as standard)



## FEATURES

Controls spindle extension/retraction of motor-driven type gage heads.

- Measuring force: Can be set appropriately with the rotary switch on the main unit (to one of the combinations of H/L and a number between 0 and 9) depending on the mounting position.
- Dimensions (WxDxH): 90x175x74mm (without rubber boot)
- Input signal: Spindle extend / Spindle retract
- Output signal: Spindle stopped at upper limit of travel
- Mass: Approx. 830g
- Power supply: AC100 to 240V

# Laser Hologage High-resolution Type

10mm range, 0.1 / 0.01 $\mu$ m resolution, Sine-wave output

## FEATURES

- Excellent measuring stability — the design is also highly resistant to the unfavorable effects of environmental conditions such as air movement and atmospheric pressure changes.
- High-precision linear ball bearings are used in the guide for extremely smooth movement and exceptional durability.

The Mitutoyo Laser Hologage is a high-end digital gaging system that employs diffracted laser beam interference to make highly accurate and repeatable measurements. It features ultra-fine-pitch diffraction gratings on the scale.

## Dimensions

Unit: mm

**542-711-1:** 0.1 $\mu$ m model

**542-712-1:** 0.1 $\mu$ m and low measuring force model

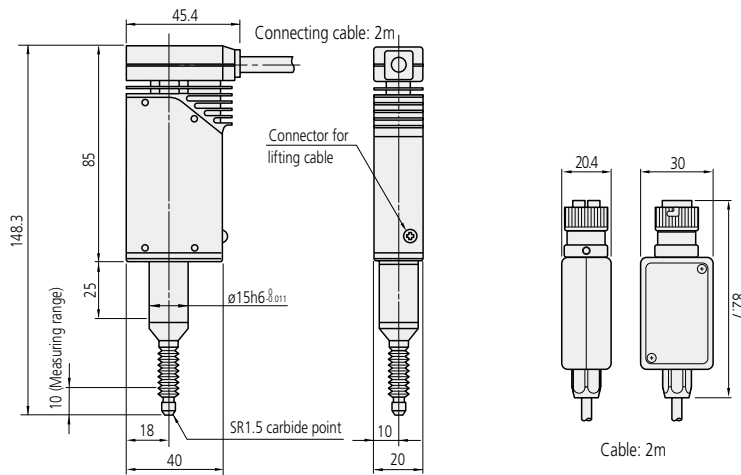

**542-925:** 0.01 $\mu$ m model with display unit

**542-926:** 0.01 $\mu$ m and low measuring force model with display unit

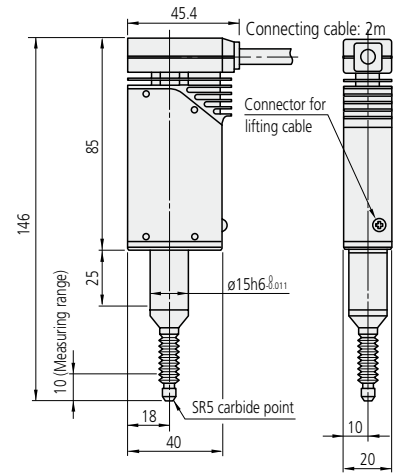

## Display Unit

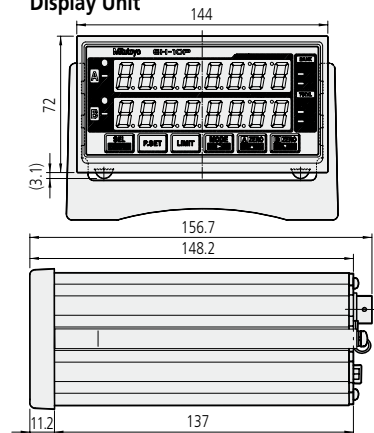

## SPECIFICATIONS: Gage head

Order No.	542-711-1	542-712-1	542-925■	542-926■
Measuring range	10mm		10mm	
Resolution	0.1 $\mu$ m		0.01 $\mu$ m	
Accuracy (20°C)*1	0.2 $\mu$ m		0.1 $\mu$ m	
Repeatability (2 $\sigma$ )	0.1 $\mu$ m		0.02 $\mu$ m	
Retrace error	0.1 $\mu$ m		0.05 $\mu$ m	
Measuring force	Spindle DOWN	0.55N or less	0.1N	0.55N or less
	Horizontal	0.45N or less	Not available	0.45N or less
	Spindle UP	0.35N or less	Not available	0.35N or less
Position-detection sensor	Laser-hologram measuring sensor			
Response speed	250mm/s			
Output signal	90° phase difference, two-phase sine wave			
Scale pitch	0.25 $\mu$ m			
Mass (gage head)	200g			
Dust/Water protection	Not specified			
Contact point	SR1.5mm carbide (mounting: M2.5x0.45)		SR5mm carbide (mounting: M2.5x0.45)	
Stem size	15mm			
Bearing type	High-precision linear ball bearing*2			
Connecting cable length	2m			
Connector types	Plug used: RM12BPE-6PH (HIROSE), Compatible socket: RM12BRD-6S (HIROSE)		—	
Display unit	Optional		Provided	
Standard accessory	Wrench for contact point (538610)			
Optional accessories	971751: Stem fixture A, 971752: Stem fixture B, 971753: Spindle lifting cable, 971750: Stand, 238772: 10mm rubber boot (spare)			

■ : Suffix A for 110V, D for 220/230V, E for 240V, DC for China, K for Korea or none for 100V, No Suffix is required for JIS/100V

\*1: Excluding quantizing error of  $\pm 1$  count.

\*2: Patent registered (Japan)

## SPECIFICATIONS: Display unit

Display	8-digit fluorescent tubes and a [-] sign
Range	$\pm 999.99999$ mm
Functions	Zero-set, preset, halved reading, double reading (diameter display), ABS/INC measurement switching, measurement direction switching, mm/inch display, linear error compensation, error alarm
Data output	Via RS-232C interface (provided)
Power supply	100-120V/200-240V AC, 50/60Hz
Power consumption	Approx. 30VA
Operating temperature	10°C to 30°C (20%RH to 80%RH, without condensation)
Mass	2kg



# Litematic Head and Litematic

High resolution and low measuring force

## Litematic Head



## Dimensions

Unit: mm

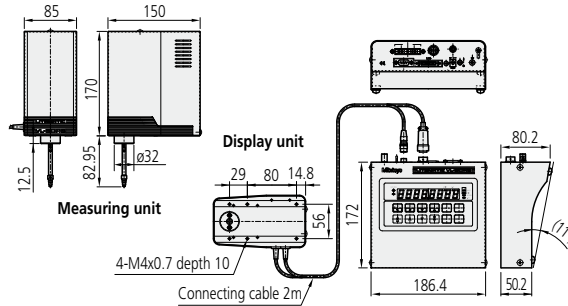

## Litematic

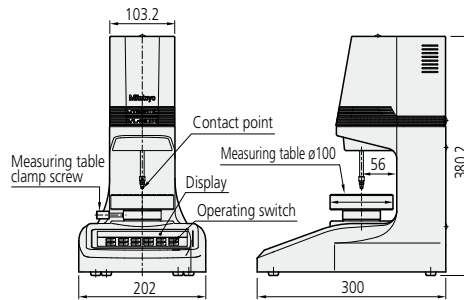

## Super Litematic

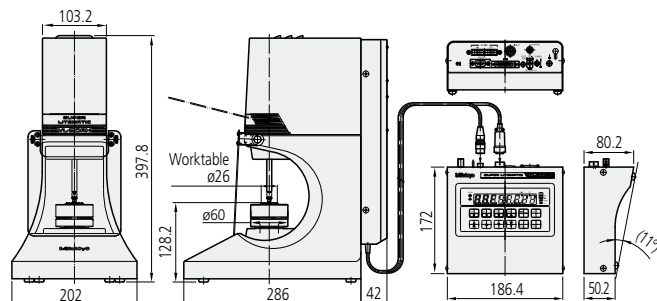

## FEATURES

- The Litematic is designed for measuring easily-deformed workpieces and high-precision parts such as pin gages, thin-wall bearings, plastic parts, and springs.
- Extra-low measuring force of 0.01N (1gf).
- Super Litematic employs an unique Laser Hologram as the length standard, ensuring excellent measuring accuracy and repeatability.

CLASS 1 LASER PRODUCT

- Ceramic anvil is free from corrosion and easy to maintain (Litematic and Super Litematic).
- The measuring unit can be mounted onto fixtures or an optional stand to allow great flexibility of use (Litematic Head).
- With SPC output.

## SPECIFICATIONS

Order No.	318-213■	318-211■	318-217■
Model name	Litematic Head	Litematic	Super Litematic
Measuring range	50mm		
Resolution	0.01μm / 0.1μm / 1μm switchable		
Accuracy (20°C)*1	(0.5+L/100)μm L=Measured length (mm)		0.15μm (0.25μm: 35 - 50mm)
Repeatability (S)	0.05μm		0.02μm
Measuring force	0.01N		
Contact point	SR1.5mm carbide (mounting threads: M2.5 (P=0.45)x5mm), <b>901312</b>		SR1.5mm carbide (mounting threads: M2.5 (P=0.45)x5mm)
Measuring table	—	φ100mm grooved ceramic anvil	φ26mm grooved ceramic anvil
Display	8 digits and 14mm character height		
Functions	Normal measurement, peak (maximum, minimum, runout) measurement, zero-set, preset, data hold, tolerance judgment		
Output signal	SPC output, RS-232C output		
External I/O	Input: Motor UP / DOWN, FAST / SLOW, Output: Workpiece detection		

■ To denote your AC line voltage add the following suffixes to the order No. (e.g. **318-217A**):  
**A** for U/USA, **D** for CEE, **E** for BS, **F** for SAA, **DC** for China, **K** for EK, **No suffix** is required for JIS/100V  
 \*1: Excluding quantizing error of ±1 count, 20°C±0.5°C for Super Litematic

## FEATURES

- Employing the ABSOLUTE linear encoder, the Signal ID-C always displays the true spindle position from the currently set origin at power on. Also, unlimited response speed eliminates over-speed errors.
- With the max./min. value holding function, the signal ID-C can output the GO/±NG judgment result against the peak values set. The judgment is carried out by calculation, within the gage, on the measurement data obtained. This provides high reliability with no concerns about deterioration of contact points as for electromechanical systems.
- The signal can be output to an external device, such as a sequencer, through the open-collector output.
- The GO/±NG judgment result is also indicated by a green/red LED and "<, O, >" symbols on the LCD.

## Dimensions

Unit: mm

543-280  
ISO/JIS type

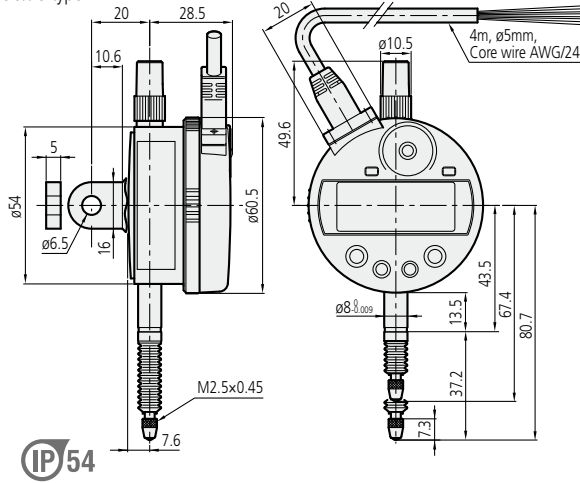

- Note 1: Dimensions of the inch (ANSI/AGD Type) dial indicator partly differ from those of the metric (ISO/JIS Type) indicator.
- Note 2: Inch (ANSI/AGD Type) dial indicator is provided with a stem of 3/8" dia. and #4-48UNF thread mount for the contact point.

## SPECIFICATIONS

Order No.	543-280	543-280B	543-281	543-281B	543-282	543-282B	543-283	543-283B
Measuring range	12.7mm		5"					
Resolution	0.001mm		.00005" / 0.001mm				.0005" / 0.01mm	
Accuracy (20°C)*1	0.003mm		.00012"					
Measuring force	2.0N or less							
Position-detection method	Capacitance-type absolute linear encoder*3							
Response speed	Infinite (scanning measurement is not available.)							
Output signal	NPN open collector							
External input	Remote control (hold-preset, preset-recall, zero-set)							
Mass	175g							
Dust/water protection*2	IP54							
Contact point (mounting threads)	SR1.5mm carbide (M2.5X0.45mm)			SR1.5mm carbide or steel (#4-48unf)				
Stem size	ø8mm			ø9.5mm				
Type of back	Lug	Flat	Lug	Flat	Lug	Flat	Lug	Flat
Connecting cable length	4m							
Operating environment	0°C to 40°C (20%RH to 80%RH, without condensation)							
Optional accessories	<b>902011</b> : Spindle lifting lever for mm model,		<b>125317</b> : Rubber boot (spare)		<b>902794</b> : Spindle lifting lever for inch/mm model,		<b>540774</b> : Spindle lifting cable	

\*1: Excluding quantizing error of ±1 count.

\*2: IP level is the standard of protection against the ingress of solids/foreign matter and water. This may not be applicable for liquids other than water.

\*3: Patent registered (Japan, U.S.A., Germany, U.K., Switzerland, Sweden, China)

## Tolerance judgment output signals

Wire	- NG	OK	+ NG	Error condition alert
Orange (- NG)	Low	High	High	High
Green (OK)	High	Low	High	High
Brown (+ NG)	High	High	Low	High
LED	Red	Green	Red	Red (blinking)
LCD	<	O	>	"x.xxE" indication

## I/O Specifications

Wire	Signal	I/O	Description
Black	- V (GND)	—	Power supply return
Red	+ V (GND)	I	Power supply (12 - 24VDC)
Orange	- NG	O	Tolerance judgment result output: The signal wire corresponding to a judgment result is set to the 'Low' level.
Green	OK	O	
Brown	+ NG	O	
Yellow	PRESET_RECALL ZERO	I	External input terminal: If the relevant terminal is set to the Low level, its signal becomes true.
Blue	HOLD_RESET	I	
Shield	FG	—	Connected to GND

# Digimatic Connection Example

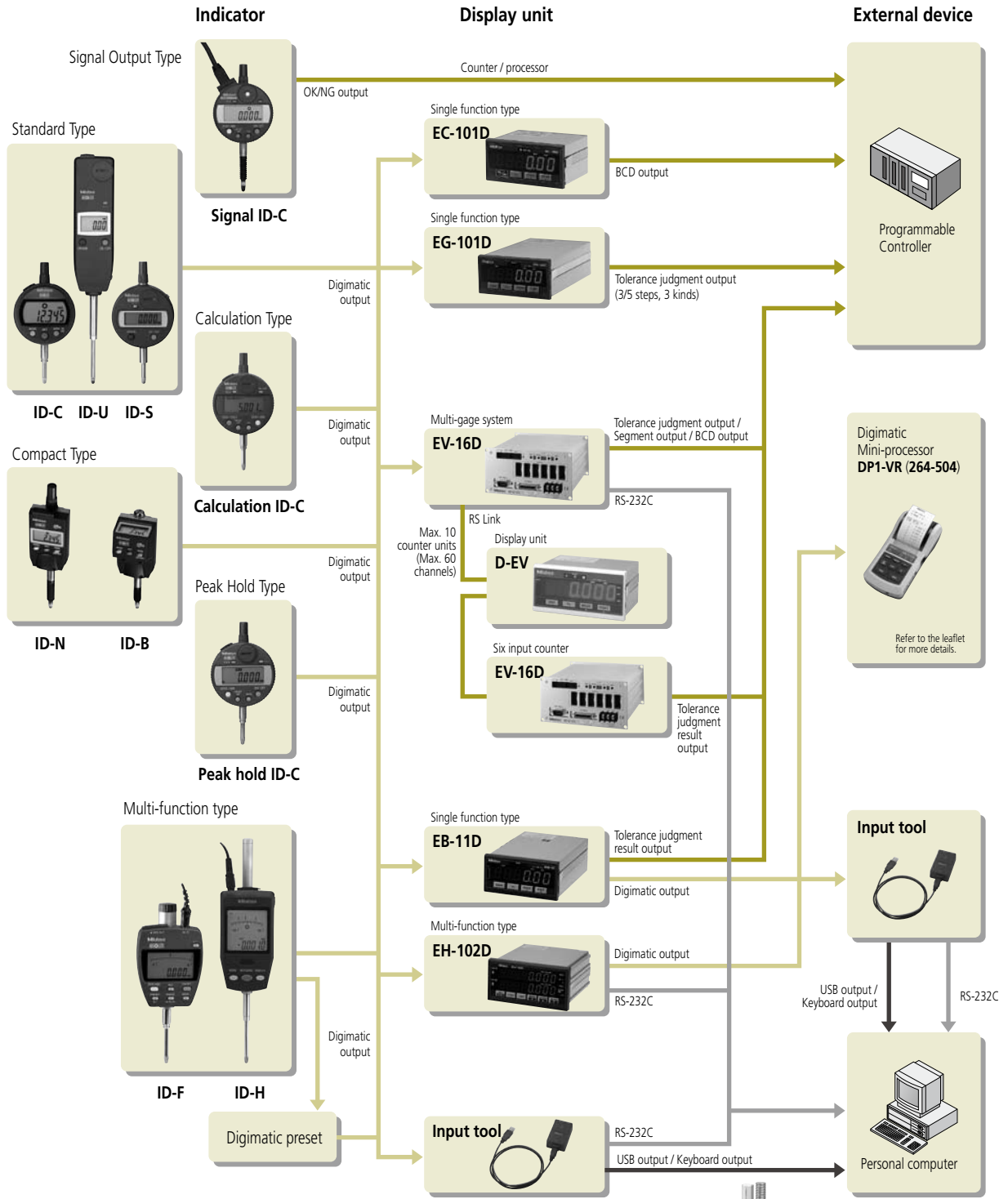

With an Input tool connected to the keyboard connector on a personal computer, measurement data from a measuring tool can be loaded directly into a spreadsheet such as Excel or Lotus 1-2-3.



# Output Signal Specifications

## Differential square-wave

	0.1µm LGB	0.1µm LGK/LGF	0.5µm LGK/LGF	1µm LG/LGB/LGF	5µm LGF
Output signal	90° phase difference, differential square wave (RS-422A equivalent)				
Signal pitch	0.4µm		2µm	4µm	20µm
Minimum edge interval	250nsec.	200nsec.	250nsec.	500nsec.	1000nsec.
Output signal level	+5V (4.8 to 5.2V, 80mA) øA, øB, øB̄: TTL output, line driver output, AM26LS31 or equivalent				
Plug type	RM12BPE-6PH (HIROSE)				
Compatible socket	RM12BRD-6S (HIROSE)				
Recommended receiver	Differential input, line receiver, AM26LS32 or equivalent				
Gage connecting cable length	2 m; directly connected to the gage				
Maximum extension cable length	20m (extension cables of 5, 10 and 20m in length are available)				
Alarm output*1	A special signal (see the chart below) is output when an alarm condition occurs				
Power supply	+5V (120mA), power supply ripple voltage 200mV p-p max.				

\*1: With an LGF gage, a seventh signal line may be provided to output the error alarm. (Factory option).

### 1) Pin assignment

RM12BPE-6PH (HIROSE)

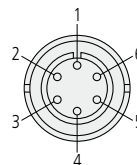

Pin No.	Assignment
1	+5V
2	øA
3	øB
4	øĀ
5	GND
6	øB̄

\*: Power supply (120mA) to a sensor (gage head)  
Power supply ripple voltage: 200mVp-p or less

### 2) Recommended processing circuit for received waveform

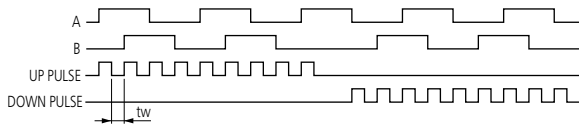
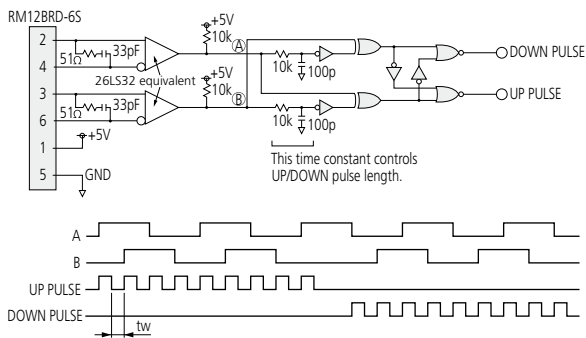

### 3) Timing chart (normal)

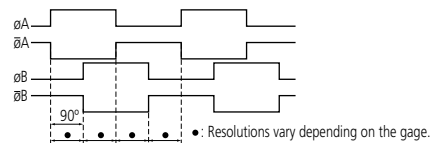

### 4) Timing chart (occurrence of gage alarm)

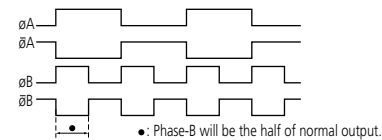

## Differential square-wave with Origin Point Mark

	0.5µm reading	1µm reading
Output signal	90° phase difference, differential square wave (RS-422A equivalent)	
Signal pitch	2µm	4µm
Minimum edge interval	250nsec.	500nsec.
Output signal level	+5V (4.8 to 5.2V, 120mA) øA, øĀ, øB, øB̄, øZ: TTL, line driver, AM26LS31 or equivalent	
Plug type	PRC05-P8M (TAJIMI)	
Compatible socket	PRC05-R8F (TAJIMI)	
Recommended receiver	Differential input, line receiver, AM26LS32 or equivalent	
Gage connecting cable length	2 m; directly connected to the gage	
Maximum extension cable length	20m (extension cables of 5, 10 and 20m in length are available)	
Alarm output	A special signal (see the chart below) is output when an alarm detection occurs	
Power supply	+5V (120mA), power supply ripple voltage 200mV p-p max.	

PRC05-P8M (TAJIMI)

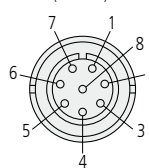

### 1) Pin assignment

Pin No.	Signal
1	+5V
2	GND
3	øA
4	øĀ
5	øB
6	øB̄
7	øZ
8	øB̄

\*: Power supply to a gage head  
Supply voltage: 5V (4.8-5.2V)  
Ripple voltage: 200mVp-p or less  
Current consumption: 120mA

### 2) Recommended processing circuit for received waveform

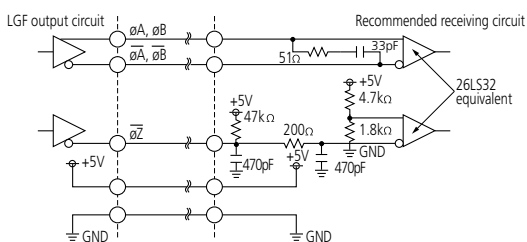

### 3) Timing chart (normal)

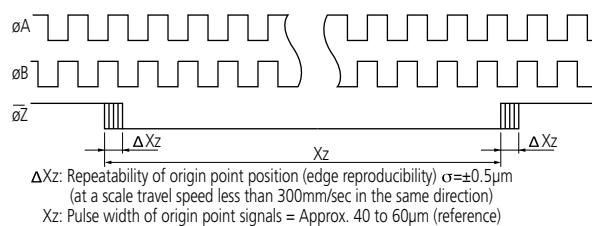

## Differential square-wave

### Data output timing: 1µm resolution LGB and 1µm / 0.5µm resolution LGF

The gages listed above use the following three output signal modes. Reception circuitry can be designed that includes an error detecting process making use of these mode patterns:

#### 1) Real-time pulse output (Phase-A wave advances when the spindle is retracted.)

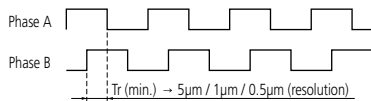

1. Output condition: Spindle speed  $\leq 250\text{mm/s}^{*2}$
2. Minimum edge-to-edge interval =  $T_r$
3. Output delay time<sup>\*1</sup>: Max. 1µs

#### 2) Burst mode output (Phase-A wave advances when the spindle is retracted.)

When the spindle speed reaches the limit of real-time pulse output, the gage head switches its signal output to burst mode. These pulse bursts are 2-phase square wave signals that are forcibly created from the internal clock with a minimum edge-to-edge interval smaller than the normal real-time pulse output. The bursts will not always be output to exactly reflect the actual spindle motion and the delay in signals also becomes larger, but the counting values will still be valid provided this output form continues.

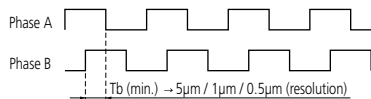

1. Output condition:  $250\text{mm/s}^{*2} < \text{Spindle speed} \leq \text{Gage response speed}^{*3}$
2. Minimum edge-to-edge interval =  $T_b$
3. Output delay time<sup>\*1</sup>:
  - At one-way displacement = Max. 5µs
  - At two-way displacement (including the reverse direction) = Max. 10µs

#### 3) Error output

The pulse generation circuit may sometimes overstep its response limit, if the output wave is subject to extreme disturbance due to vibration or impact on the gage head, or if the spindle moves faster than the output limit of burst mode. However, at this timing, as the gage head automatically switches its output signal from burst mode to error mode, in addition to synchronizing Phase A and Phase B of the 2-phase square wave signals, the user can make use of this facility for error detection.

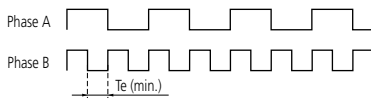

1. Output condition: LGB will identify an error under the following conditions and produce its output in one of the modes described above.
  - Gage response speed<sup>\*3</sup> < Spindle moving speed
  - At a disturbance such as interference, vibration, etc.
2. Minimum pulse width of output pulses =  $T_e$

### Data output timing: 0.1µm resolution LGB / LGF and 1µm / 0.1µm resolution LG / LGM

The gages listed above use the following two output signal modes. Reception circuitry can be designed that includes an error detecting process making use of these mode patterns:

#### 1) Real-time pulse output (Phase-A wave advances when the spindle is retracted.)

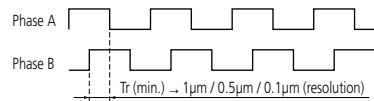

1. Output condition: Spindle speed  $\leq \text{Gage response speed}^{*3}$
2. Minimum edge-to-edge interval =  $T_r$
3. Output delay time<sup>\*1</sup>: Max. 2.5µs

#### 2) Error output

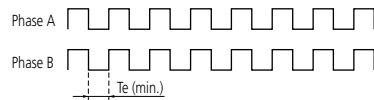

1. Output condition: Gage heads will identify an error under the following conditions and produce an output as described above.
  - Gage response speed<sup>\*3</sup> < Spindle speed
  - At a disturbance such as interference, vibration, etc.
2. Minimum width of output pulses =  $T_e$

### Minimum edge-to-edge interval / pulse width under each condition

Model	Resolution	$T_r$ (real-time output)	$T_b$ (burst output)	$T_e$ (error output)
LGB	1µm	1µs	0.5µs	0.2µs
LGF		0.4µs	—	0.4µs
LGK		0.2µs	—	0.2µs
LG / LGM	0.5µm	1µs	0.2µs	0.2µs
LGB		0.2µs	—	0.2µs
LGF	0.1µm	0.2µs	—	0.2µs
LGK				
LG / LGM				

[NOTE]

> Since any output during an error condition cannot be used as the attribute data, it is necessary to detect the error condition at the reception circuitry side.  
> It is recommended to design user circuitry based on an IC chip that is capable of counting at 5Mcps (equivalent to square wave of 1.25MHz) or greater.

- \*1 : Output delay time: Time until the counting pulse catches up to the spindle position.
- \*2 : The actual limit of real-time pulse output will be depreciated to this value. This is because actual detection signals unavoidably contain acceleration components in association with the spindle motion as well as error components from a little noise included in the signal itself. As a result, some burst pulses at a speed below the ideal conditions (i.e. ideal signal form at constant speed) may be generated.
- \*3 : Gage response speed: Refer to the specifications section in the User's Manual.

# Output Signal Specifications

## Digimatic code

### 1. Pin assignments and signals

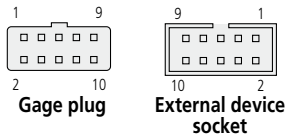

Compatible socket:  
Sumitomo 3M : V Low-Proheader  
Model: **7610-5002XX** or equivalent

Pin No.	Signal	I/O	Description
1	GND	—	Signal ground
2	DATA	Output	Measurement data-output terminal
3	CK	Output	Synchronized clock-output terminal
4*1	N.C.	—	Not used
5	REQ	Input	Input for data transmission request from external device
6*1	ORIG	Input	Input for absolute-origin setting signal
7*1	N.C.	—	Not used
8*1	N.C.	—	Not used
9*1	+5V	—	Power supply (+5V ±10%)*2
10*1	GND(F.G.)	—	Frame ground

\*1 : LGD, LGS uses a unique specification.  
All others use the common Digimatic output specification (10-pin, square).  
\*2 : Current consumption of LGD,LGS: Idd=20mA max.

### 2. I/O electrical specifications

- Output terminal format: CK, DATA  
N-channel open drain  
Maximum output current: 400µA max. (when Vol=0.4V)  
Output withstand voltage: -0.3V to 7V
- Input terminal format: REQ, ORIG  
Pull-up CMOS input  
Internal power supply voltage: Vdd= 1.35 to 1.65V  
Pull-up resistance: R1= 10 to 100KΩ  
"H" level input voltage: VIH= .1V min.:  
"L" level input voltage: VIL= 0.3V max.

#### Recommended receiving circuit

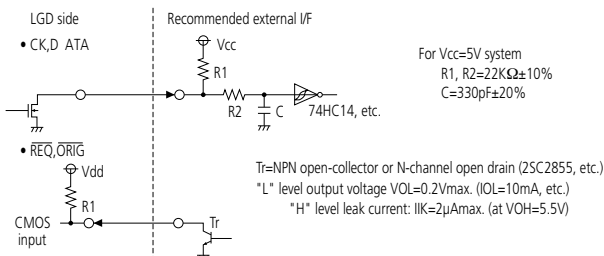

Note: Since the power supply voltages are different between the gage side and the external device side, be sure to use an open collector or open drain circuit. Do not use CMOS output or the like.

### 3. Data format

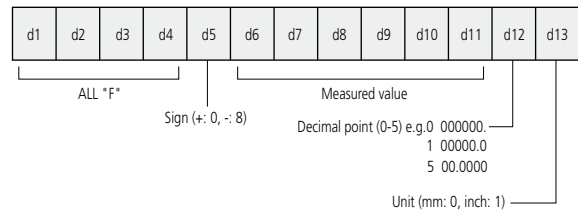

- Data is output as 13-digit (52-bit) based on 4 bits = 1 digit.
- Data is output in order from d1 to d13. Each digit is output in the order of LSB to MSB.
- Measurement data is output in the order of MSD to LSD.
- The sign, measurement data, decimal position and unit are output in BCD based on positive logic (0=L, 1=H).

### 4. Timing chart

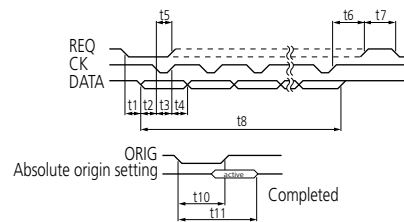

#### Standard (for reference)

Symbol	min.	max.
*t1	0µs	2sec
t2	15µs	—
t3	100µs	—
t4	100µs	—
t5	0µs	—
*t6	—	—
*t7	—	—
*t8	—	—

#### LGD

Symbol	min.	max.
*t1	30µs	95ms
t2	15µs	—
t3	100µs	—
t4	100µs	—
t5	0µs	—
*t6	—	100µs
*t7	100µs	—
*t8	—	30ms

#### LGS

Symbol	min.	max.
*t1	160µs	85ms
t2	150µs	180µs
t3	150µs	180µs
t4	300µs	330µs
t5	0µs	—
*t6	—	100µs
*t7	100µs	—
*t8	—	—

Symbol	min.	max.
*t10	1.5s	—
*t11	—	4s

- Note 1: The specifications indicated by an asterisk (\*) are applicable only to LGD, LGS. All other Digimatic output specifications are common to all models.  
 Note 2: Read data only when CK is at the "L" level.  
 Note 3: Do not input REQ signal (fixed at "H") while the absolute origin is being set (during t11).  
 Note 4: If t5, t6 and t7 are satisfied and REQ is continuously input, an output is obtained from LGD, LGS at intervals of approximately 95ms.  
 Note 5: Start inputting ORIG and REQ after two or three seconds have elapsed (the estimated time required for internal circuit/sensor to stabilize) following power-on.

# Air Drive Unit

## FEATURES

- Advances or retracts the spindle of a gage head by using a pneumatic cylinder.
- Spindle advance speed can be adjusted by using the speed controller of the drive unit.
- Automatic measurement is possible by using a solenoid valve.

### For LGS: 903594 (mm), 903598 (inch)



### For 10mm LGD / LGF / LGK: 02ADE230

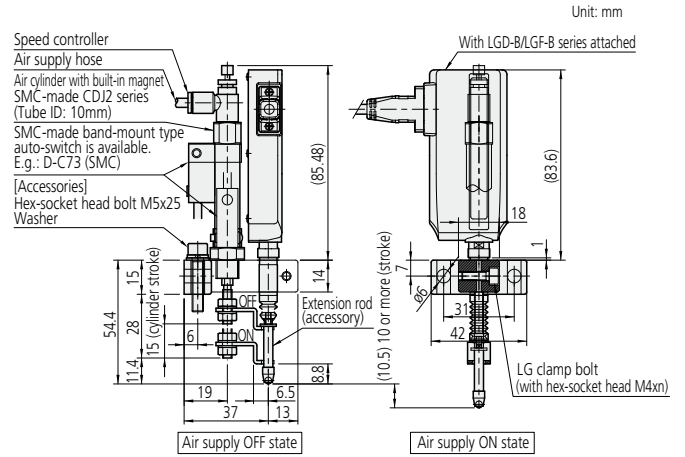

### For 25mm LGD / LGF: 02ADE250

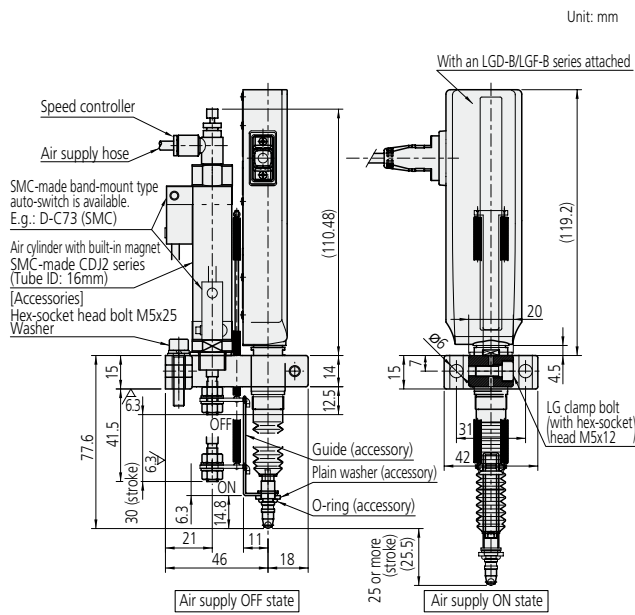

### For 50mm LGD / LGF: 02ADE270

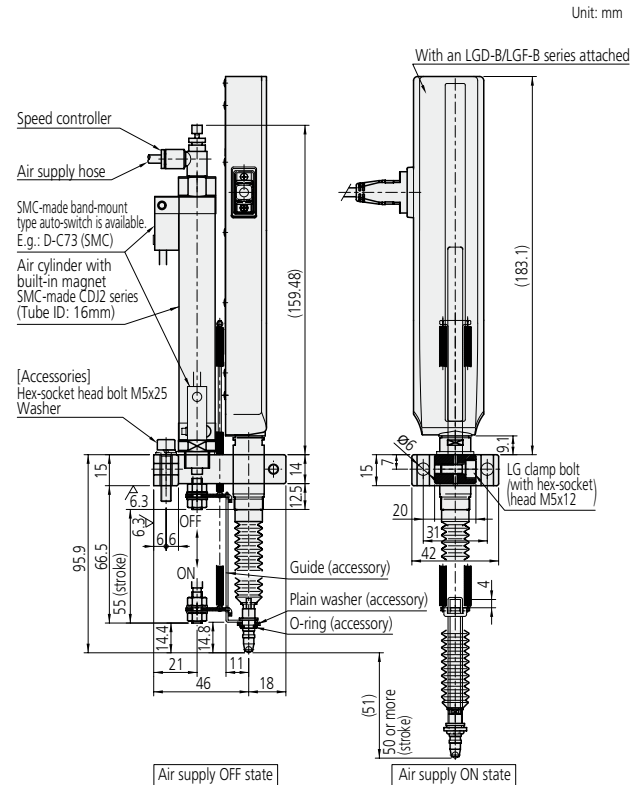

## SPECIFICATIONS

Order No.	903594	903598	02ADE230	02ADE250	02ADE270
Stroke	10mm	.4"	10mm	25mm	50mm
Compatible gage head	LGS		LGD, LGF		
Air supply	0.49MPa		0.2 to 0.4MPa		
Mass	60g		150g	250g	300g

# Gage Head Mounting Fixtures

Gage heads are mounted on a fixture or stand using the precision-machined cylindrical stem. Stems can be any one of several standard diameters and are either just plain or with a fixing thread at one end or the other. All gages can be mounted using the split-clamp method which is suitable for a range of applications, especially where small axial adjustments may be required. However, care is needed to avoid over-tightening the clamp, which could interfere with the spindle movement. Those stems with a thread at the spindle end can also be mounted just by using a nut to clamp them into a hole in a fixture. They can also use a 'thrust stem' (see page 33) that is clamped into a larger hole in a fixture and into which the gage is screwed. Stems with a thread at the body end can also use this method of mounting.

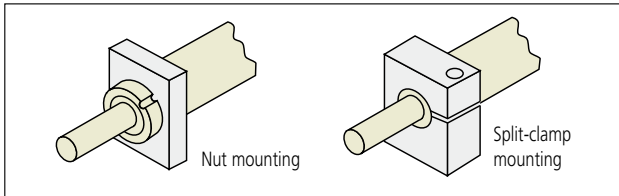

## Split-clamp mounting fixtures

- To mount a gage head with an 8mm diameter stem, use a 9.5mm diameter stem bushing.

**546288**  
ø9.5x15

**546343**  
ø9.5x8.5

Unit: mm

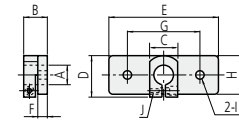
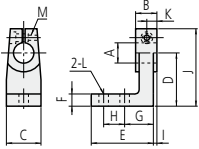

Part No.	303560	303569
A	ø9.5	ø9.5
B	9	14.5
C	15	20
D	20	30
E	23	35
F	5	7
G	11	16
H	8	12
I	1.5	3.25
J	32.5	42.5
K	4.5	7.25
L	ø3.4	ø4.5
M	M3x0.5	M3x0.5

Part No.	303560	303569
A	ø9.5	ø9.5
B	9	14.5
C	15	20
D	20	30
E	23	35
F	5	7
G	11	16
H	8	12
I	1.5	3.25
J	32.5	42.5

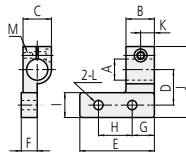
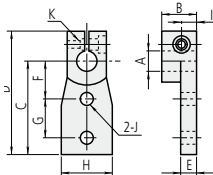

Part No.	303560	303569
A	ø9.5	ø9.5
B	9	14.5
C	15	20
D	20	30
E	23	35
F	5	7
G	11	16
H	8	12
I	1.5	3.25
J	32.5	42.5
K	4.5	7.25

Part No.	303560	303569
A	ø9.5	ø9.5
B	9	14.5
C	15	20
D	20	30
E	23	35
F	5	7
G	11	16
H	8	12
I	1.5	3.25
J	32.5	42.5
K	4.5	7.25
L	ø3.4	ø4.5
M	M3x0.5	M3x0.5

## Example of plain-stem mounting

The recommended clamping torque is 0.4 to 0.5Nm (LGB-0105L: 0.2 to 0.3Nm). Overly tightening the stem will prevent smooth movement of the spindle.

### Example 1

Split-clamp method

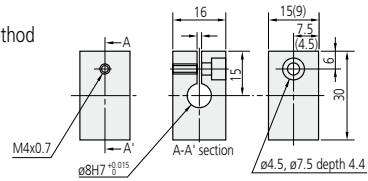

Unit: mm

### Example 2

Setscrew method

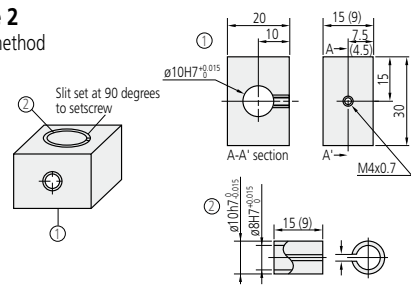

Unit: mm

## Nut-clamp mounting fixtures

- A gage head with a 9.5mm diameter stem threaded at the bottom can be installed without additional parts or machining.

Unit: mm

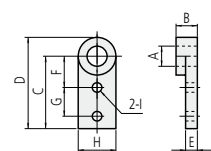
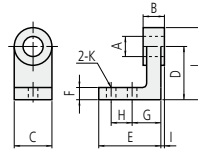

Part No.	303568
A	ø9.5
B	11.5
C	20
D	30
E	35
F	7
G	16
H	12
I	1.75
J	40
K	ø4.5

Part No.	303572
A	ø9.5
B	11.5
C	40
D	50
E	6.5
F	18
G	15
H	20
I	ø4.5

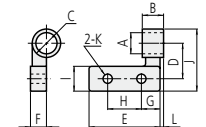
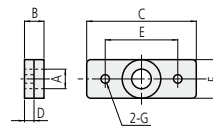

Part No.	303570
A	ø9.5
B	11.5
C	60
D	5.5
E	40
F	20
G	ø4.5

Part No.	303572
A	ø9.5
B	11.5
C	40
D	50
E	6.5
F	18
G	15
H	20
I	ø4.5



## Mounting with a thrust stem

A thrust stem is available as an option for the LGF, LGK, LGE and LGD gage heads. Installing a thrust stem on the stem allows direct mounting, simply by drilling a hole in a section of suitable thickness on the fixture.

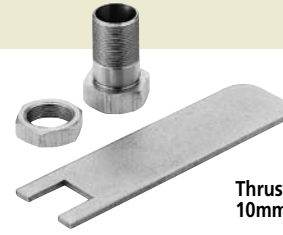

Thrust Stem for  
10mm LGD / LGF / LGK

### For 10mm LGD / LGF / LGK: 02ADB680

Unit: mm

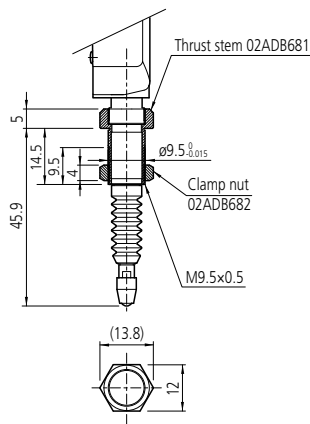

\* A mounting section with a thickness of 6 through 10.5mm is suitable.

With the use of a thrust stem and clamp nut, a gage fixture can be arranged simply by drilling a 9.5mm dia. hole. A gage can be secured firmly with ease with this arrangement.

#### IMPORTANT

In attaching a thrust stem, be sure to fix the stem first with a dedicated wrench (**02ADB683**). An excessive force applied between the gage main body and stem may cause damage to the gage.

#### NOTE

Both the dedicated wrench (**02ADB683**) and M9.5x0.5 threaded section are for mounting a thrust stem. Do not use them for other purpose than mounting a thrust stem.

### For 25mm LGD / LGF: 02ADN370

Unit: mm

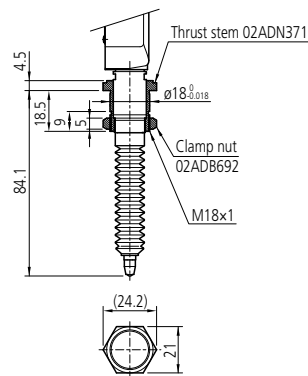

\* A mounting section with a thickness of 10 through 12mm is suitable.

With the use of a thrust stem and clamp nut, a gage fixture can be arranged simply by drilling an 18mm dia. hole. A gage can be secured firmly with ease with this arrangement.

#### IMPORTANT

In attaching a thrust stem, be sure to fix the stem first with a dedicated wrench (**02ADB693**). An excessive force applied between the gage main body and stem may cause damage to a gage.

#### NOTE

Both the dedicated wrench (**02ADB693**) and M14x0.5 threaded section are for mounting a thrust stem. Do not use them for other purpose than mounting a thrust stem.

### For 50mm LGD / LGF: 02ADN370

Unit: mm

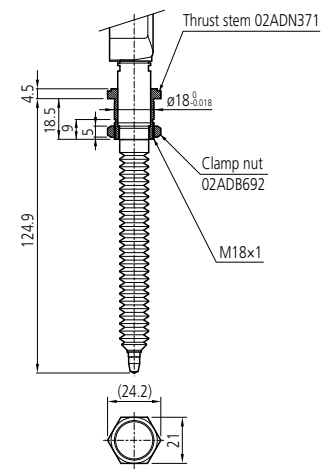

\* A mounting section with a thickness of 10 through 12mm is suitable.

With the use of a thrust stem and clamp nut, a gage fixture can be arranged simply by drilling an 18mm dia. hole. A gage can be secured firmly with ease with this arrangement.

#### IMPORTANT

In attaching a thrust stem, be sure to fix the stem first with a dedicated wrench (**02ADB693**). An excessive force applied between the gage main body and stem may cause damage to a gage.

#### NOTE

Both the dedicated wrench (**02ADB693**) and M14x0.5 threaded section are for mounting a thrust stem. Do not use them for other purpose than mounting a thrust stem.

## SPECIFICATIONS

Set order No.*	02ADB680	02ADN370
Compatible gage	10mm LGD / LGF / LGK	25 / 50mm LGD / LGF
Part No.	Thrust stem	02ADN371
	Clamp Nut	02ADN372
	Wrench	02ADB693
Gage mounting hole diameter (nominal)	$\varnothing 9.5\text{mm}$	$\varnothing 18\text{mm}$
Recommended plate thickness (mounting section)	6 to 10.5mm	10 to 12mm

\* A thrust stem set is comprised of a thrust stem and clamp nut. A dedicated wrench is required for tightening.

# Optional Accessories

## Spare rubber boot



Protects the spindle bearing of a gage head from dust.

### SPECIFICATIONS

Order No.	Compatible Gage head
238773	5mm LGB
238772	10mm LGB / LGD / LGF / LGK / Laser Hologage
962504	25mm LGD / LGE / LGF
962505	50mm LGD / LGE / LGF
02ADA004	LG / LGM
238774	LGS

## Output divider for multiple gage heads

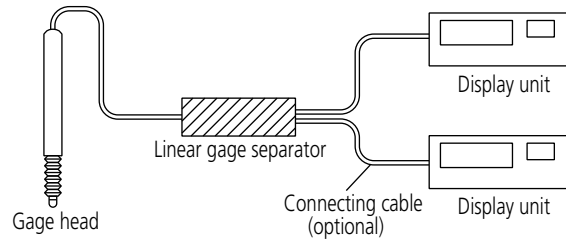

Enables the output from one gage head to be sent to multiple destinations.

### SPECIFICATIONS

Order No.	No. of output channels	Description
959458	2ch	"made to order" basis
958454	3ch	"made to order" basis
971790	4ch	"made to order" basis

\* For LG, LGB, LGF, and LGK models.  
(Excluding the LGB of sine-wave output, LGF with Origin Point Mark, Laser Hologages, LGS and LGD models)

## Extension signal cable



### SPECIFICATIONS

Order No.	Cable length
902434	5m
902433	10m
902432	20m

The distance between a gage head\* and display unit can be extended up to 20m by using these cables (max. 3 cables).

\*Not available for LGF with Origin Point Mark, LGS, LGD models, and Laser Hologage.

## Extension signal cable for gage head with Origin Point Mark



### SPECIFICATIONS

Order No.	Cable length
02ADF260	5m
02ADF280	10m
02ADF300	20m

- A signal cable from the head to the receiver circuitry can be extended.
- Maximum number of connectable cables is limited to 3, and the maximum total extension length is limited to 20m.

## Digimatic cable extension adapter: 02ADF640

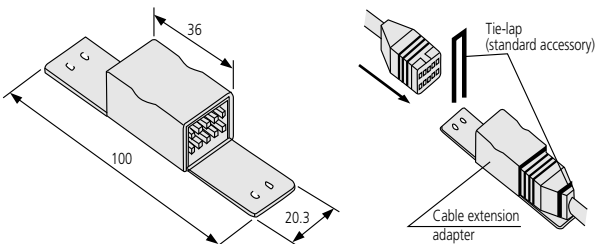

This adapter can be used when the LGS or LGD gage head is to be connected to a display unit where the provided cable length is not sufficient for this connection.

Do not joint more than one piece of this product together for use.

## Measuring stand

Useful for long-stroke LG / LGM models.

### Granite comparator stand



### SPECIFICATIONS

Order No.	215-156
Base material	Granite
Base size	W300 x D250 x H95
Base flatness	3.5µm
Fine adjustment	Square thread
Stem size	ø20, ø8

### Comparator stand



### SPECIFICATIONS

Order No.	215-505
Base material	Hardened steel
Base size	W150 x D150 x H64
Base flatness	2µm
Fine adjustment	Square thread
Stem size	ø20, ø8

## Measuring stand for Laser Hologage

Order No.: 971750

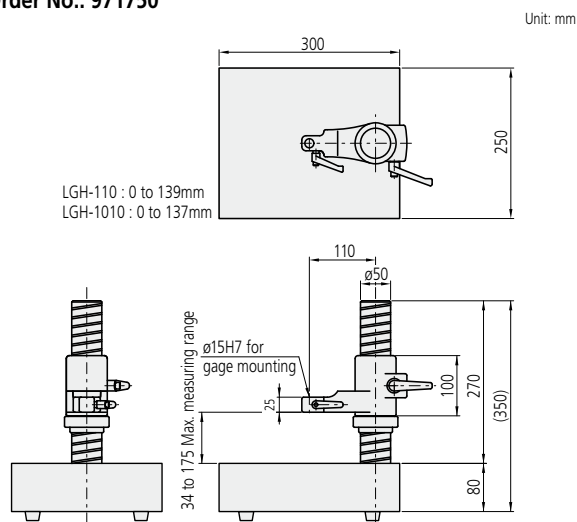

## Release with damper: 971753

Spindle-lift release for the Laser Hologage. A sudden drop of the spindle is prevented by the return-speed adjustment knob.

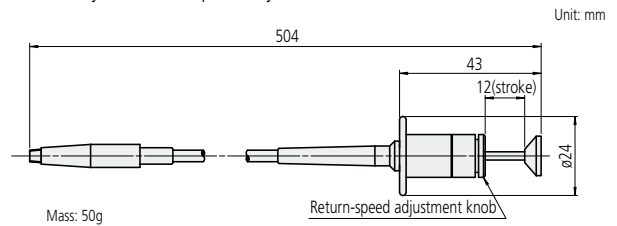

## Digimatic power supply unit

This is used to power the gage head (LGD or LGS model) when it is connected to an external device, except for a display unit (e.g. MUX-10F, DP1-VR).



### SPECIFICATIONS

Order No.	965275
Compatible gage head	LGD, LGS model
Function	External zero-set, data output,
Dimensions	W60 x D40 x H20

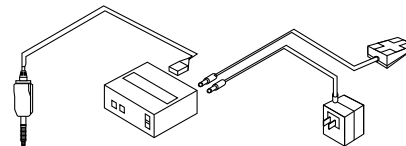

## Mounting holder A, B

Useful when the Laser Hologage is mounted on an alternate fixture rather than the regular measuring stand.

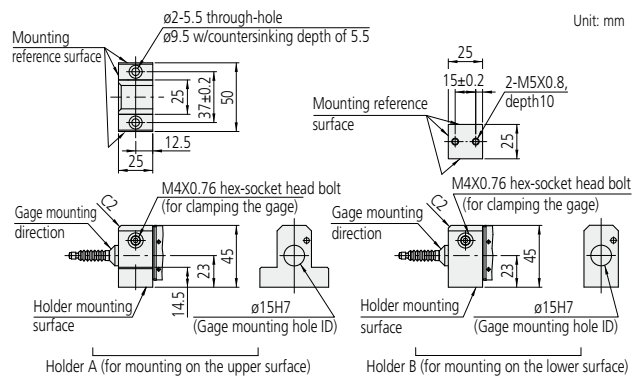

## Interchangeable contact points

- With all gage heads, the mounting-thread specification for the interchangeable contact points is M2.5x0.45x5mm, except for the inch versions of the LGS gages (**575-311** and **575-312**) which conform to the UNF thread specification (#4-48 UNF).

- After replacing a contact point, it should be tightened firmly so that it will not loosen during usage. (Recommended tightening torque=5N·cm)
- Ruby and carbide contact points show the best resistance to abrasion.

### ø3mm Ball Points

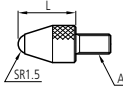

L	Material	Order No.	A
7.3	Carbide	901312	M2.5x0.45
		901454	#4-48UNF
	Steel	900030	M2.5x0.45
		901994	M2.5x0.45
		902018	#4-48UNF
15	Ruby	120047	M2.5x0.45
	Carbide	120049	M2.5x0.45
20	Ruby	120051	M2.5x0.45
	Carbide	137391	M2.5x0.45
25	Ruby	137392	M2.5x0.45
	Carbide	120053	M2.5x0.45
	Ruby	120055	M2.5x0.45

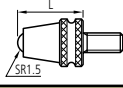

L	Material	Order No.	A
8.3*	Carbide	902119	M2.5x0.45
	Steel	900986	M2.5x0.45

\* For waterproof dial indicators.

### Flat Points\*

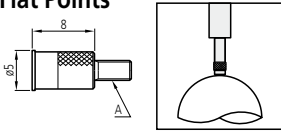

Order No.	A
131365	M2.5x0.45
133017	#4-48UNF

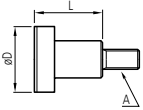

D	L	Order No.	A
10	10	101117	M2.5x0.45
12.7	9.53	101188	#4-48UNF
9.53	9.53	101189	#4-48UNF

### Flat Points (Carbide)\*

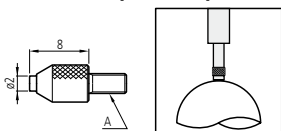

Order No.	A
120056	M2.5x0.45

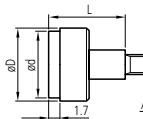

D	d	L	Order No.	A
5.2	4.3	5	120041	M2.5x0.45
7	6.5	10	120042	M2.5x0.45
10.5	9.5	10	120043	M2.5x0.45

### Ball Points

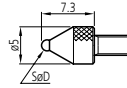

D	Order No.	A
1	21AAA349	M2.5x0.45
1.5	21AAA350	M2.5x0.45
1.8	101122	M2.5x0.45
2.5	21AAA351	M2.5x0.45
4	21AAA352	M2.5x0.45

### Shell Type Points

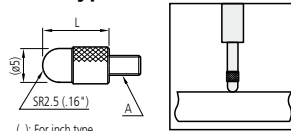

( ): For inch type

L	Order No.	A
3.97	101184	#4-48UNF
5	101386	M2.5x0.45
10	101118	M2.5x0.45
12.7	101185	#4-48UNF
15	137393	M2.5x0.45
19.05	101186	#4-48UNF
20	101387	M2.5x0.45
25	101388	M2.5x0.45
25.4	101187	#4-48UNF

### Spherical Points

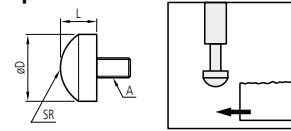

D	L	SR	Order No.	A
10	5	7	101119	M2.5x0.45
12.7	3.18	7	101205	#4-48UNF
9.53	2.38	9	101204	#4-48UNF

### Spherical Points (Carbide)

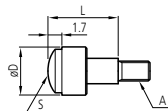

D	L	SR	Order No.	A
5.2	5	5	120058	M2.5x0.45
7.5	10	7	120059	M2.5x0.45
10.5	10	10	120060	M2.5x0.45

### Roller Points

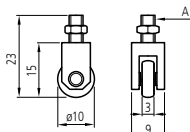

Order No.	A
901954	M2.5x0.45
901991	#4-48UNF

### 60° Conical Points

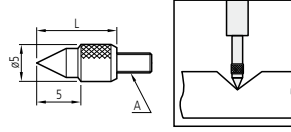

L	Order No.	A
10	101120	M2.5x0.45
12.7	101190	#4-48UNF

### 90° Conical Points

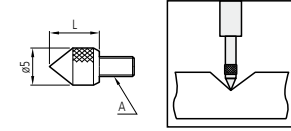

L	Order No.	A
5	101385	M2.5x0.45
7.14	101191	#4-48UNF

### 90° Conical Points (Carbide)

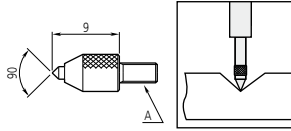

Order No.	A
120057	M2.5x0.45

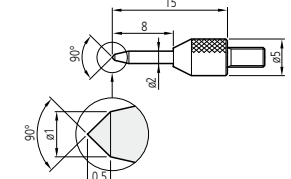

Order No.	A
120068	M2.5x0.45

### Extension Rods

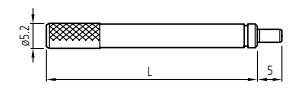

L	Order No.	L	Order No.
10	303611	55	21AAA259G
15	21AAA259A	60	304146
20	303612	65	21AAA259H
25	21AAA259B	70	21AAA259J
30	303613	75	21AAA259L
35	21AAA259C	80	21AAA259M
40	21AAA259D	90	304147
45	21AAA259E	100	303614
50	21AAA259F		

### Needle Points

Unit: mm

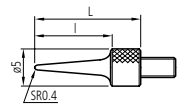

L	Order No.	A
11	101121	M2.5x0.45
21	21AAA255	M2.5x0.45
31	21AAA256	M2.5x0.45

### Needle Points (Carbide)

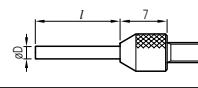

L	D	Order No.	A
3	0.45	120066	M2.5x0.45
3		120065	M2.5x0.45
5	0.45	21AAA329	M2.5x0.45
5		21AAA330	M2.5x0.45
5	1.5	21AAA335	M2.5x0.45
8		21AAA331	M2.5x0.45
8	2	127257	M2.5x0.45
10		21AAA332	M2.5x0.45
10	1.5	21AAA336	M2.5x0.45
13	1.5	120064	M2.5x0.45
18	2	21AAA257	M2.5x0.45
20		21AAA333	M2.5x0.45
20	1.5	21AAA337	M2.5x0.45
28	2	21AAA258	M2.5x0.45
40	1	21AAA334	M2.5x0.45
40	1.5	21AAA338	M2.5x0.45
40	2	21AAA339	M2.5x0.45

### Blade Points (Carbide)

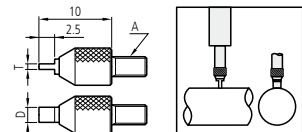

T	W	Order No.	A
0.4	2	120061	M2.5x0.45
0.6	2	120062	M2.5x0.45
1	4	120063	M2.5x0.45

### Knife Edge Point (Carbide)

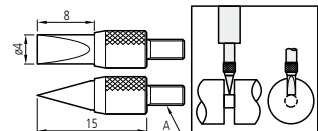

Order No.	A
120067	M2.5x0.45

\*Note: If the perpendicularity with the stem or parallelism with the reference surface is required when using Flat Points, it is necessary to use a custom-made indicator/contact-point assembly. Consult Mitutoyo for advice.

# System Connections and Comparison of Counter Functions

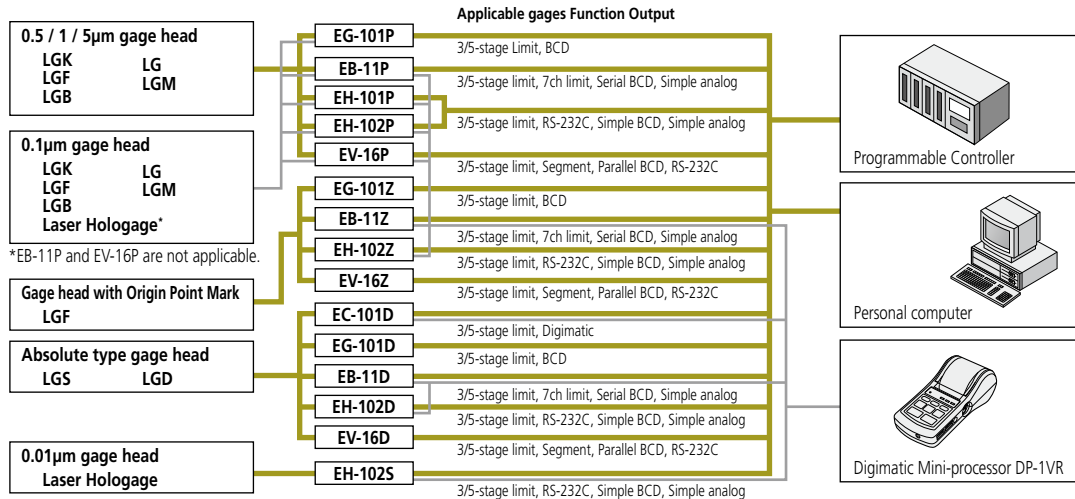

Display unit	EC Counter			EG Counter			EB Counter			EH Counter			EV Counter		
	EC-101D	EG-101P	EG-101Z	EG-101D	EB-11P	EB-11Z	EB-11D	EH-101P	EH-102P	EH-1002Z	EH-102S	EH-102D	EV-16P	EV-16D	EV-16Z
<b>Applicable gages</b>															
0.01µm Laser Hologage													✓		
0.1µm Laser Hologage		✓						✓	✓						
0.1µm LG / LGM		✓			✓			✓	✓					✓*1	
0.1µm LGK / LGB / LGF		✓			✓			✓	✓					✓*1	
0.5µm LGK / LGF		✓			✓			✓	✓					✓	
0.5µm LGF with Origin Point Mark				✓		✓				✓					✓
1µm LGF with Origin Point Mark				✓		✓				✓					✓
1µm LG / LGM		✓			✓			✓	✓					✓	
1µm LGK / LGB / LGF		✓			✓			✓	✓					✓	
5µm LGF		✓			✓			✓	✓					✓	
0.01mm LGD / LGS	✓			✓		✓						✓		✓	
<b>Functions</b>															
Number of connectable gages	1	1	1	1	1	1	1	1	2	2	2	2	6	6	6
Display	✓	✓	✓	✓	✓	✓	✓	✓	✓	✓	✓	✓	*1	*1	*1
Zero set	✓	✓	✓	✓	✓	✓	✓	✓	✓	✓	✓	✓	*1	*1	*1
Presetting	✓	✓	✓	✓	✓	✓	✓	✓	✓	✓	✓	✓	*1	*1	*1
Direction switch	✓	✓	✓	✓	✓	✓	✓	✓	✓	✓	✓	✓	✓	✓	✓
GO/NG indication	✓	✓	✓	✓	✓	✓	✓	✓	✓	✓	✓	✓	✓	✓	✓
GO/NG output	✓	✓	✓	✓	✓	✓	✓	✓	✓	✓	✓	✓	✓	✓	✓
5-stage tolerance display/output		✓	✓	✓	✓	✓	✓	✓	✓	✓	✓	✓	✓	✓	✓
3-stage tolerance display/output	✓	✓	✓	✓	✓	✓	✓	✓	✓	✓	✓	✓	✓	✓	✓
mm/inch switch	✓	✓	✓	✓	✓	✓	✓	✓	✓	✓	✓	✓	✓	✓	✓
ABS gage zero set	✓			✓										✓	✓
ABS/INC gage changeover	✓			✓										✓	✓
Peak (max / min) hold		✓	✓	✓	✓	✓	✓	✓	✓	✓	✓	✓	✓	✓	✓
Run out (TIR) measurement		✓	✓	✓	✓	✓	✓	✓	✓	✓	✓	✓	✓	✓	✓
Double count								✓	✓	✓	✓	✓			
Sum / difference calculation								✓	✓	✓	✓	✓			
Lower digit blank-out								✓	✓	✓	✓	✓			
External zero set	*2	*2	*2	*2	*2	*2	*2	✓	✓	✓	✓	✓	✓	✓	✓
External preset	✓	✓	✓	✓	✓	✓	✓	✓	✓	✓	✓	✓	✓	✓	✓
External hold	✓	✓	✓	✓	✓	✓	✓	✓	✓	✓	✓	✓	✓	✓	✓
External tolerance set (when a PC is used)								✓	✓	✓	✓	✓	✓	✓	✓
External tolerance memory switch (when I/O is used)		✓	✓	✓	✓	✓	✓	✓	✓	✓	✓	✓	✓	✓	✓
External peak-hold cancel		✓	✓	✓	✓	✓	✓	✓	✓	✓	✓	✓	✓	✓	✓
Inter-axial calculation function													✓	✓	✓
<b>Output</b>															
Power-supply voltage error	✓	✓	✓	✓	✓	✓	✓	✓	✓	✓	✓	✓	✓	✓	✓
Overspeed error	✓	✓	✓	✓	✓	✓	✓	✓	✓	✓	✓	✓	✓	✓	✓
Overflow error	✓	✓	✓	✓	✓	✓	✓	✓	✓	✓	✓	✓	✓	✓	✓
Gage error	✓	✓	✓	✓	✓	✓	✓	✓	✓	✓	✓	✓	✓	✓	✓
Tolerance setting error	✓	✓	✓	✓	✓	✓	✓	✓	✓	✓	✓	✓	✓	✓	✓
Communication error								✓	✓	✓	✓	✓	✓	✓	✓
Parallel BCD output		✓	✓	✓									✓	✓	✓
Serial BCD output					✓	✓	✓								
Simple BCD output								✓	✓	✓	✓	✓			
Simple analog output					✓	✓	✓	✓	✓	✓	✓	✓			
Tolerance judgment output	*3	✓	✓	✓	✓	✓	✓	✓	✓	✓	✓		✓	✓	✓
Limit output					✓	✓	✓								
Segment output													✓	✓	✓
RS-232C output								*3	*3	*3	*3	*3	✓	✓	✓
Digimatic output	*5					✓	✓	*4	*4	*4	*4	*4			
USB output for SESORPAK								✓	✓	✓	✓	✓			
RS link								*3	*3	*3	*3	*3	✓	✓	✓
RS link (maximum number of gages)								6	12	12	12	12	60	60	60

\*1: When an optional D-EV is connected. \*2: Enabled by setting "0" via external presetting. \*3: Switchable between the Digimatic output. \*4: Switchable between the RS-232C output. \*5: Switchable between the tolerance judgment output.

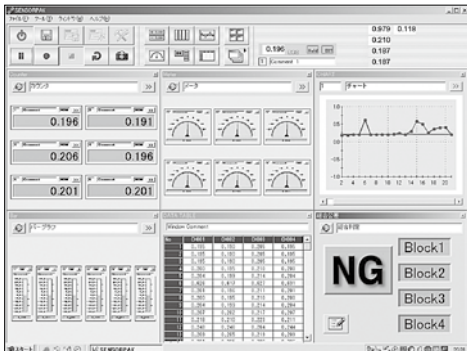

Measurement screen

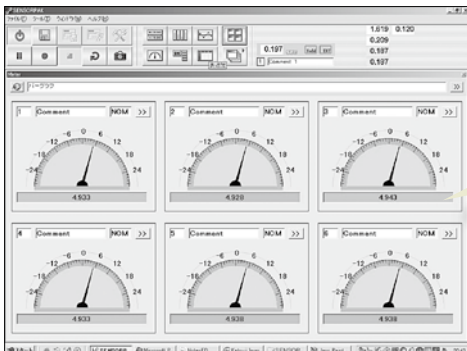

Meter screen

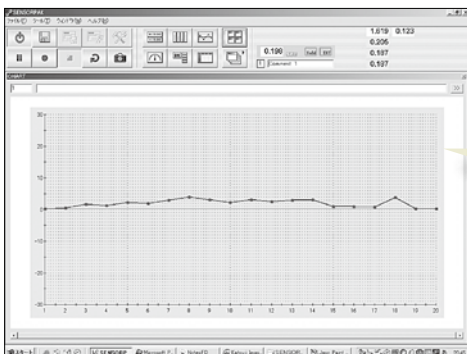

Chart screen

This software facilitates the loading of measurement data from the EH / EV counter or Litematic USB connection is possible with EH counter, too into user's personal computer.

### FEATURES

- Maximum 60 channels of measuring points can be processed.
- Arithmetical calculation and maximum width calculation using the measurement data.
- Export of measurement data into MS-Excel.
- Various graphic functions (numeric value display, meter display, bar-graph display, overall judgment display)
- Frequency of data loading: Max. 9999 times (60ch) to 60000 times (6CH)

### Real-time measurement data display

Measures the tilt of a pin in three directions to determine its reference position and inclination. With the real-time measurement data display, workpieces can be set up while positioning.

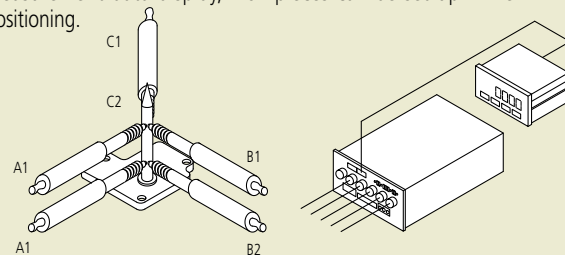

### Ongoing measurement data feedback monitoring

Monitors ongoing feedback of press work in progress. This allows confirmation of time series data.

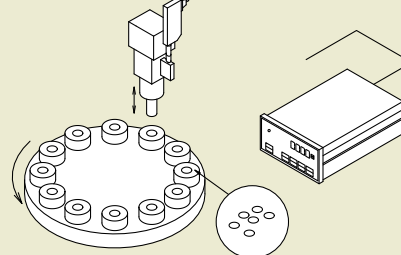

## SPECIFICATIONS

Order No.	02ADM260 (Software only)	02ADM270 (Software plus I/O cable)
Display function	Display type: Counter, bar graph, meter, chart (capable of simultaneous display) Tolerance judgment result: Color display (green/red) Connectable gages: Max. 60 gages	
Calculation function	Calculation items: Sum, difference, total, average, maximum, minimum, range (maximum-minimum), calculation with a constant Connectable gages: Max. 30 calculation items (between desired gages)	
Total tolerance judgment	GO/NG judgment (by specifying gages to be used for total tolerance judgment) GO/NG signal output with optional I/O cable	
Input function	Trigger function: by means of key, timer or external TRG (with optional I/O cable) Data input frequency: Max. 9999 times (with 60 gages connected) to 60000 times (with 6 gages connected)	
Output function	Direct output to EXCEL spreadsheet, CSV file output (compatible with MeasureLink)	
Connectable items	Various Mitutoyo counters (those compatible with RS_LINK)	
Product requirement	Recommendation: PC/AT compatible machine, CPU: Pentium4 2GHz or higher, Memory: 256MB or more Disk: 100MB or more OS: Windows ME, 2000, XP	

Display Units

# EC Counter

DIN size (96 x 48mm) assembly-type display unit

## FEATURES

- Employs the DIN size (96x48mm) and mount-on-panel configuration, which greatly facilitates incorporation into a system.
- Can either produce tolerance judgment output or Digimatic output.



## Dimensions

Unit: mm

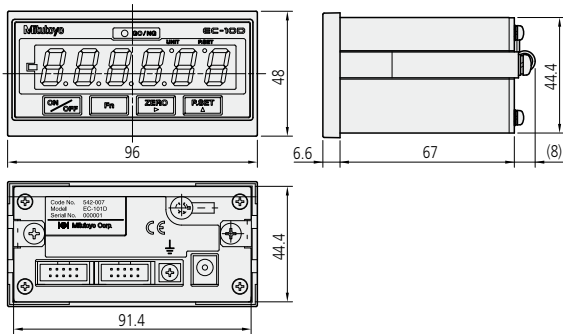

## Input / output specifications

### 1) Compatible plug

MIL type connector FAS-10-17 (YAMAICHI), XG4M-1030-T (OMRON)

### 2) Pin assignment

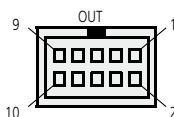

Pin No.	I/O	Description	Function	Optional I/O cable color
1		COM	Connected to the internal GND	Light brown/black
2	O	+NG	Tolerance output: The relevant output terminal falls to L.	Light brown/red
3	O	GO		Yellow/black
4	O	-NG	At an error display [+NG=-NG=L]	Yellow/red
5	I	HOLD	HOLD input	Bright green/black
6	I	P.SET	PRESET input (to cancel the error)	Bright green/red

Other than the above listed shall be unconnected.

- \* Output from each pin in the Digimatic output mode may differ from those which are described in the table above.
- \* One end of the I/O cable (2m, optional) consists of separate wires for connection as appropriate. The cable's F.G wire (with solderless terminal, green) should be connected to the grounding terminal of the main unit.

### 3) I/O circuit

#### 1. Output circuit (-NG, GO, +NG)

Transistor is "ON" when the open-collector output is "L".

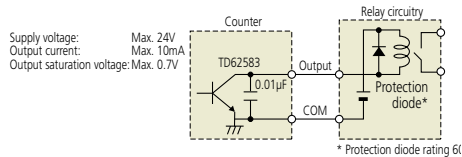

## SPECIFICATIONS

Order No.	542-007■
Model No.	EC-101D
Number of gage inputs	1
Maximum input frequency	Depends on the gage head connected
Resolution	0.01mm, 0.001mm (automatically set depending on the gage.)
Display	6-digit and a negative [-] sign LED (amber, green, red)
Function	Preset, GO/±NG judgment
Output (selectable)	Tolerance judgment: -NG, OK, +NG (open-collector) Data: Digimatic code
Input	Control signal: Preset, data hold
Power supply	Via AC adaptor
Operating temperature	0° to 40°
Dimensions	W96 x H48 x D156mm
Optional accessories	<b>936937</b> : SPC cable (1m) <b>965014</b> : SPC cable (2m) <b>214938</b> : DC plug PJ-2 <b>C162-155</b> : I/O cable
Compatible gage heads	LGD, LGS, ID-C
Mass	220g

■ (suffix): A for 110V, D for 220/230V, E for 240V, DC for China, K for Korea or no suffix for 100V.

### 2. Input circuit (PSET, HOLD)

Input is valid when the line is "L".

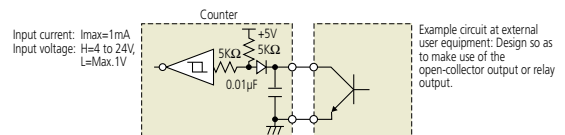

## 4) Timing chart

### 1. Tolerance judgment output

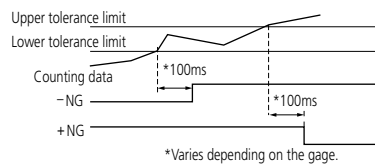

### 2. External preset/HOLD

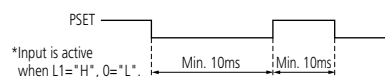

## 5) Optional I/O cable (2m)



# EG Counter

DIN size (96 x 48mm) assembly-type display unit

## FEATURES

- Possible to produce 3-step/5-step x 3 kinds of tolerance output and BCD output.
- Smoothing function can reduce fluctuation of display digits.
- Employs the DIN size (96x48mm) and mount-on-panel configuration, which greatly facilitates incorporation into a system.



542-015



542-017



542-016



For differential square-wave output gage head

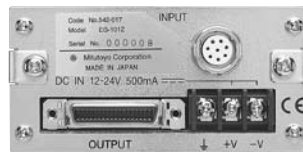

For differential square-wave output gage head with Origin Point Mark



For Digimatic code output gage head

## SPECIFICATIONS

Order No.	542-015	542-017	542-016
Model No.	EG-101P	EG-101Z	EG-101D
Number of gage inputs	1		
Maximum input frequency	1.25MHz*1 (differential square-wave)		Depends on the gage head connected
Resolution	0.01mm, 0.005mm, 0.001mm, 0.0005mm, 0.0001mm		0.01mm, 0.001mm
Tolerance judgment display	LED display (3 steps: amber, green, red / 5 steps: amber, amber flashing, green, red flashing, red)		
Function	Preset, direction switch, tolerance judgment (3/5-step, 3 kinds). peak (max., min., runout) measurement, calculation with a constant, smoothing, error display/output, protection over keys		
Output	L1 to L5 (Switchover between open-collector output and BCD output by means of parameter)		
Tolerance judgment	L1 to L5 (Switchover between open-collector output and BCD output by means of parameter)		
Control signal	NOM (normal signal) open-collector		
BCD	6-digit (positive/negative-true logic) open-collector (Switchover between tolerance judgment output by means of parameter)		
Input	Control signal		
Control signal	Preset, display hold, peak value clear, tolerance judgment BANK switch		
Power supply voltage	DC+12 to 24V		
Power consumption	6W (500mA) or less (Secure power supply more than 1A for each unit.)		
Operating temperature	0°C to 40°C (20%RH to 80%RH, without condensation)		
Dimensions	W96 x H48 x D156mm		
Optional accessories	<b>02ADB440:</b> Output connector with cover, <b>02ADN460:</b> AC adaptor, AC adaptor connecting cable, Connecting cable, <b>02ADF180: External switch box</b>		
Compatible gage heads	LGF, LGK, LGB, LGM, 0.1µm Laser Hologage	LGF with Origin Point Mark	LGD, LGS, ID-C
Mass	400g		

\*1: Depending on the gage head connected, \*2: Excluding Origin Point Mark and sine wave types

## Dimensions

Unit: mm

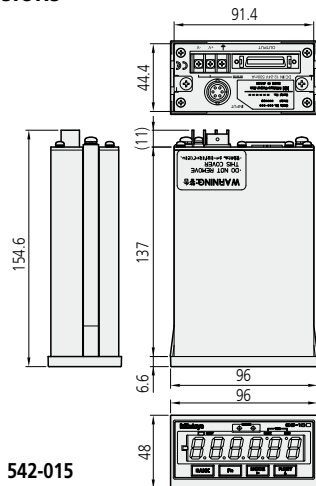

542-015

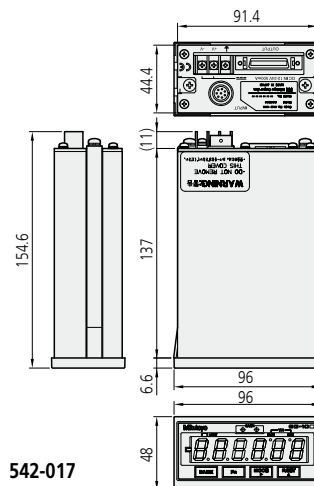

542-017

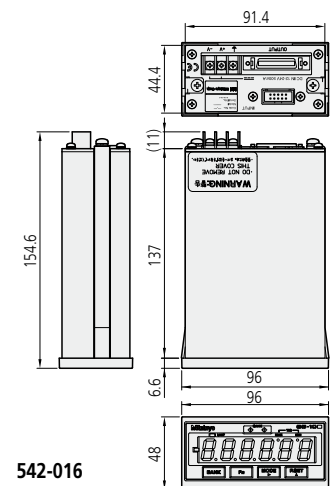

542-016



## Input / output specifications

### 1) Compatible plug: 02ADB440 (with cover)

### 2) Pin assignment

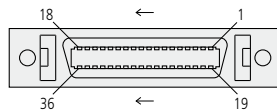

#### 1. In tolerance judgment mode

Pin No.	I/O	Description	Function
1, 2		COM	Connected to the internal GND
3	O	L1	
4	O	L2	Tolerance output: The relevant output terminal falls to L.
5	O	L3	
6	O	L4	At an error display [L1=L5=L]
7	O	L5	
10	O	NOM	Normal output
27	I	SET1	BANK, Peak mode setting: Enter the setting value with SET. Determines
28	I	SET2	the mode and bank to be used with MODE and BANK, respectively.
29	I	MODE	Determining the change of peak value: Combined operation with SET
34	I	HOLD	HOLD input
35	I	PSET	At normal measurement: Preset At peak value measurement: Peak clear
36	I	BANK	Determining the change of BANK: Combined operation with SET
		NC	Other than the above listed shall be unconnected.

#### 2. In BCD output mode

Pin No.	I/O	Description	Pin No.	I/O	Description	Pin No.	I/O	Description
1		COM	13	O	4X102	25	O	4X105
2		COM	14	O	8X102	26	O	8X105
3	O	1X100	15	O	1X103	27	I	SET1
4	O	2X100	16	O	2X103	28	I	SET2
5	O	4X100	17	O	4X103	29	I	MODE
6	O	8X100	18	O	8X103	30	—	NC
7	O	1X101	19	O	1X104	31	O	SIGN
8	O	2X101	20	O	2X104	32	O	NOM
9	O	4X101	21	O	4X104	33	O	READY
10	O	8X101	22	O	8X104	34	I	HOLD
11	O	1X102	23	O	1X105	35	I	PSET
12	O	2X102	24	O	2X105	36	I	INH

- \* Pin Nos. 3 to 26, and 31 can be logically inverted via the corresponding parameter.
- \* SIGN: Represents the sign of counting value as either "H" for positive value or "L" for negative value.
- \* READY: It will be "L" during the output data determination.
- \* INH: During input operation each output from Pin No. 3 to 26, and 31 will be "H".
- \* External output terminal is valid at "L".
- \* NOM, HOLD, and PSET function in the same way as in the tolerance judgment mode.
- \* External input uses negative true logic as "L" corresponding to "Valid".

### 3) I/O circuit

#### 1. Output circuit (NOM, L1 to L5)

Transistor is "ON" when the open-collector output is "L".

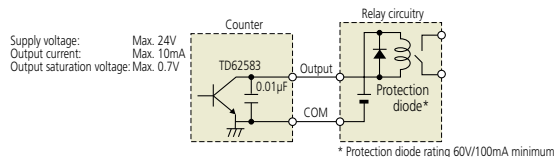

#### 2. Input circuit (SET, MODE, BANK, PSET, HOLD)

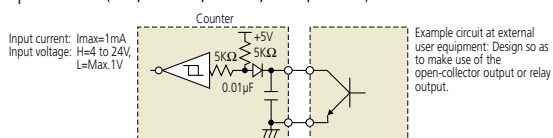

### 4) Timing chart

#### 1. Power ON characteristics

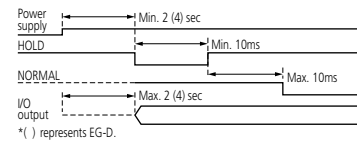

#### 2. Tolerance output

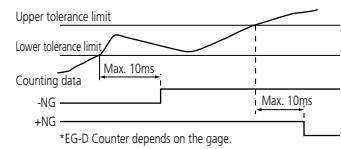

#### 3. External preset/ Peak clear

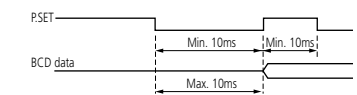

#### 4. Peak mode/BANK specification

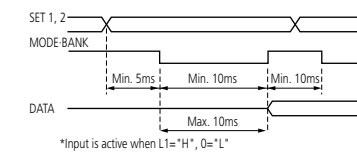

#### 5. HOLD timing

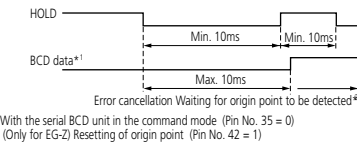

- \*1: With the serial BCD unit in the command mode (Pin No. 35 = 0)
- \*2: (Only for EG-Z) Resetting of origin point (Pin No. 42 = 1)

#### 6. Interval mode

The data will be continuously output according to the internal timing of the counter.

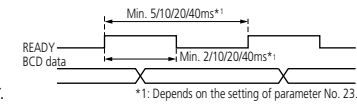

- \*1: Depends on the setting of parameter No. 23.

#### 7. Command mode

The data will be output with both the HOLD and READY lines being synchronized.

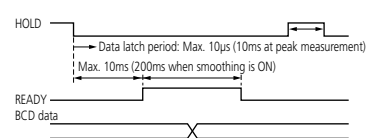

#### 8. INH input

BCD data output is OFF during the input of INH.

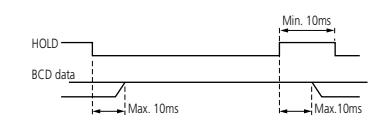

# EB Counter

DIN size (96 x 48mm) assembly-type display unit

## FEATURES

- Possible to produce 3-step/5-step x 7 kinds of tolerance output and limit value output independently for each of 7 channels.
- Provided with serial BCD output capability, which makes the connection to a programmable controller or personal computer, etc., possible with the minimum cabling requirement.
- Possible to perform dynamic measurement with the simplified analog output.



542-092-2



542-094-2



542-093-2



For differential square-wave output gage head



For differential square-wave output gage head with Origin Point Mark

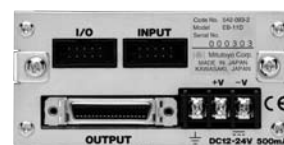

For Digimatic code output gage head

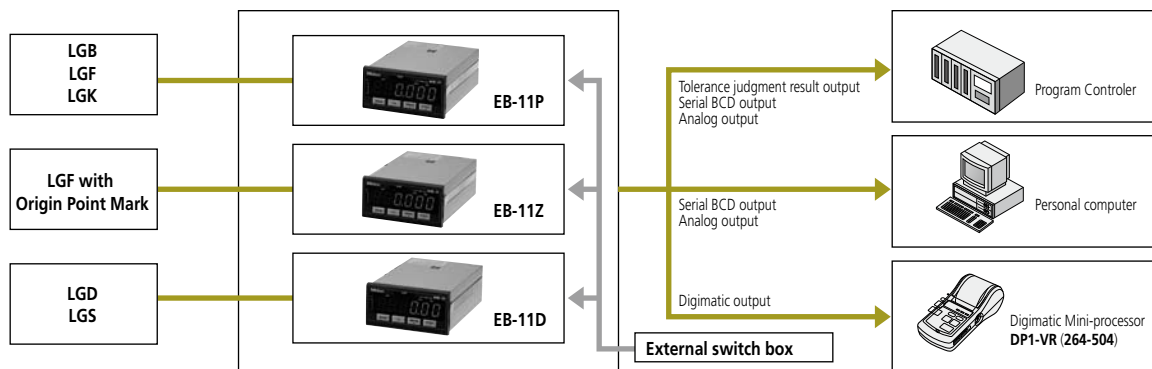

## SPECIFICATIONS

Order No.	542-092-2	542-094-2	542-093-2
Model No.	EB-11P	EB-11Z	EB-11D
Number of gage inputs	1		
Maximum input frequency	1.25MHz*1 (differential square-wave)		Depends on the gage head connected
Resolution	0.01mm, 0.005mm, 0.001mm, 0.0005mm, 0.0001mm		0.01mm, 0.001mm
Tolerance judgment display	LED display (3 steps: amber, green, red / 5 steps: amber, amber flashing, green, red flashing, red)		
Interface	Serial BCD	Bit-serial format, open-collector	
	Analog output	2.5V + Counting value X voltage resolution (25mV/2.5mV): Full-scale 0 to 5V	
	Digimatic input/output	<ul style="list-style-type: none"> <li>• Connecting to the external switch box (02ADF180) makes it easy to enter tolerance limits and preset values. Note) This cannot be used when the gage is connected to a Mitutoyo DP-1VR Digimatic Mini-Processor. <ul style="list-style-type: none"> <li>• Possible to connect to a Mitutoyo DP-1VR Digimatic Mini-Processor.</li> <li>• Number of tolerance steps can be expanded by using multiple EB-D counters.</li> </ul> </li> </ul>	
Output	Tolerance judgment	L1 to L5, open-collector	
	Control signal	Normal operation signal (NORMAL), open-collector	
Input	Control signal	Preset, display hold, peak value clear, tolerance judgment BANK switch, open-collector or no-voltage contact signal (with/without contact point)	
Power supply voltage	DC+12 to 24V		
Power consumption	6W (500mA) or less (Secure power supply more than 1A for each unit.)		
Operating temperature	0°C to 40°C (20%RH to 80%RH, without condensation)		
Dimensions	W96 x H48 x D156mm		
Optional accessories	02ADB440: Output connector with cover, 02ADN460: AC adapter, AC adaptor connecting cable, Connecting cable, 02ADF180: External switch box		
Compatible gage heads	LGK, LGB, LGF	LGF with Origin Point Mark	LGD, LGS, ID-C
Mass	400g	400g	400g

\*1: Depends on the gage head connected.

## Dimensions

Unit: mm

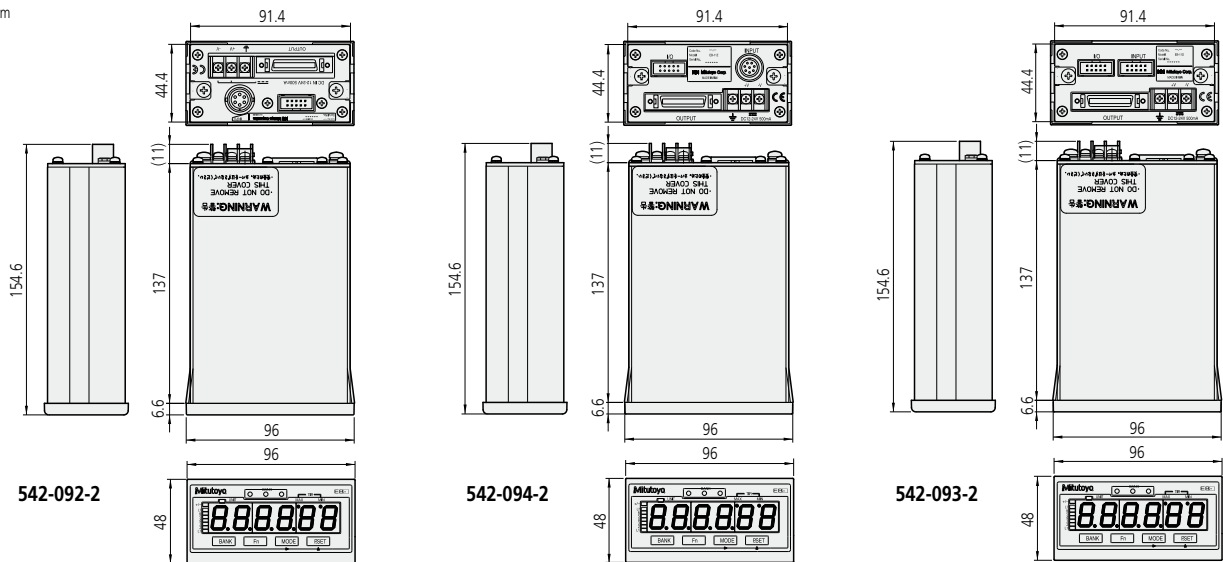

## Powerful tolerance judgment function

### 1) Keeps up to seven 3-step/5-step tolerance limits in memory.

It is possible to switch these tolerance limits with an appropriate button operation or external signal.

#### • Stop position adjustment

Adjust the stop position depending on the workpiece type. For this control use the tolerance judgment signals.

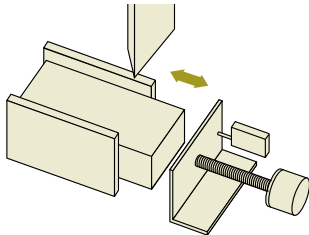

#### • Indicator display/output where 3 steps of tolerance limit are set

	GO/NG indicator	LIMIT indicator and I/O output
Measured value < S1	Amber ON	L1
S1 ≤ measured value ≤ S4	Green ON	L3
S4 ≤ measured value	Red ON	L5

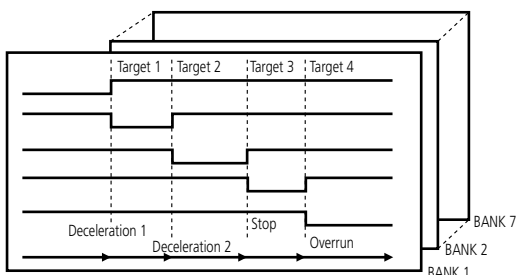

#### • Indicator display/output where 5 steps of tolerance limit are set

	GO/NG indicator	LIMIT indicator and I/O output
Measured value < S1	Amber ON	L1
S1 ≤ measured value ≤ S2	Amber flash	L2
S2 ≤ measured value ≤ S3	Green ON	L3
S3 ≤ measured value ≤ S4	Red flash	L4
S4 ≤ measured value	Red ON	L5

### 2) Possible to selectively keep two of the limit values for 7 channels.

It is possible to switch these tolerance limits with an appropriate button operation or external signal.

#### • Sorting workpieces by value

It is possible to sort workpieces according to user-defined value ranges.

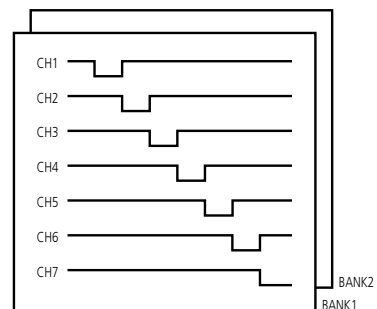

# EB Counter

DIN size (96 x 48mm) assembly-type display unit

## Input / output specifications

1) Suitable plug: 02ADB440 (with cover)

2) Pin assignment

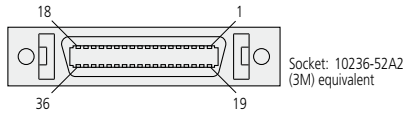

Pin No.	Description	I/O	Function
1	COM	—	Common terminal for input/output circuit (to be connected to the internal GND)
2	COM	—	Common terminal for input/output circuit (to be connected to the internal GND)
3	BANK1/L1	OUT	Tolerance judgment result output • At an error AL1, AL5= Output of "L" AL2, AL3, AL4 = Output of "H"
4	BANK2/L2	OUT	
5	BANK3/L3	OUT	
6	BANK4/L4	OUT	
7	BANK5/L5	OUT	
8	BANK6	OUT	
9	BANK7	OUT	
10	NOM	OUT	Outputs "L" where counting is possible.
11 - 20	N.C.	—	Unconnected terminal
21	BCD_CK	OUT	Serial BCD output
22	BCD_ST	OUT	
23	BCD_DT	OUT	
24	ANALG	OUT	Analog output
25	ANGND	OUT	
26	AREG	IN	Analog range changeover: Enter in combination with SET BANK: Sets the PSET tolerance to the specified bank. MODE: NOM, MAX, MIN, TIR settings AREG: Analog range specification
27	SET1	IN	
28	SET2	IN	
29	SET3	IN	
30	MODE	IN	Peak changeover: Enter in combination with SET.
31	N.C.	—	Unconnected terminal
32	BANK	IN	BANK changeover: Enter in combination with SET.
33	N.C.	—	Unconnected terminal
34	HOLD	IN	<ul style="list-style-type: none"> <li>The display value is held during input.</li> <li>Data output proceeds while the serial BCD interface is used.</li> <li>When an error has occurred, the error will be cleared at the rise of this signal.</li> <li>Perform presetting.</li> </ul>
35	PSET	IN	Peak clear: When entered during the peak mode, it serves as peak clear.
36	N.C.	—	Unconnected terminal

## 3) I/O circuit

1. Output circuit

Transistor is "ON" when the open-collector output is "L".

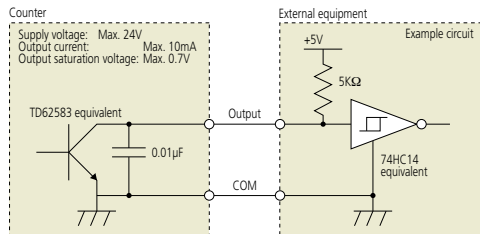

2. Input circuit (SET, MODE, BANK, PSET, HOLD)

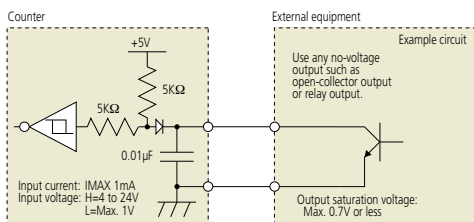

## Simple Analog Output

Output waveforms can be monitored with an analog recorder connected.

1) Output specifications

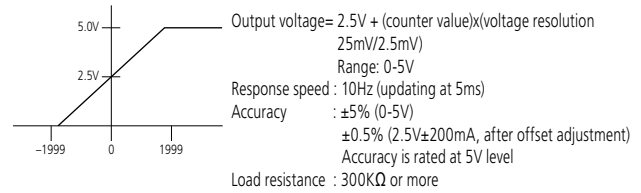

2) Measuring range

SET	Parameter	Measuring range (mm) / Resolution (mm)					Voltage		
3	2	1	No.30	10µm gage	5µm gage	1µm gage		0.5µm gage	0.1µm gage
0	0	0	0	±0.99 / 0.01	±0.095 / 0.005	±0.099 / 0.001	±0.0095 / 0.0005	±0.0099 / 0.0001	2.5mA
0	0	1	1	±9.99 / 0.01	±0.995 / 0.005	±0.999 / 0.001	±0.0995 / 0.0005	±0.099 / 0.0001	25mA
0	1	0	2	±99.90 / 0.1	±9.950 / 0.05	±9.990 / 0.01	±0.9950 / 0.005	±0.9990 / 0.001	25mA
0	1	1	3	±999.00 / 1	±99.500 / 0.5	±99.900 / 0.1	±9.9500 / 0.05	±9.9900 / 0.01	25mA
1	0	0	4	±9990.00 / 10	±995.000 / 5	±999.000 / 1	±99.500 / 0.5	±99.900 / 0.1	25mA

3) Example of connection to external equipment

This is a connection example to an external programmable controller.

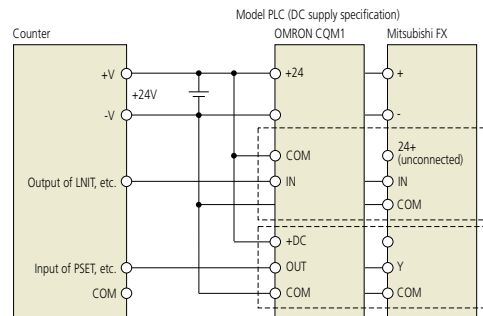

4) Sample program for collecting serial BCD outputs

For OMRON CQM1 (to connect one unit of counter)

LD NOT	0000		P0: Detecting if CK = "H".
AND	0002		
CLC (41)			P2(DATA) = L CY clear
LD NOT	0000		P0: Detecting if CK = "H".
AND NOT	0002		
STC (40)			P2(DATA) = H CY clear
LD NOT	0000		P0: Detecting the rise of CK.
@ROL (27)		DM0350	Left-rotate shift with carry
@ROL (27)		DM0351	Right-rotate shift with carry
LD NOT	0001		P1: Detecting if STB = H
@MOV (21)	DM0350	DM0360	Transfers the result.
@MOV (21)	DM0351	DM0361	Transfers the result.

## 6) Timing chart

### 1. Power ON characteristics

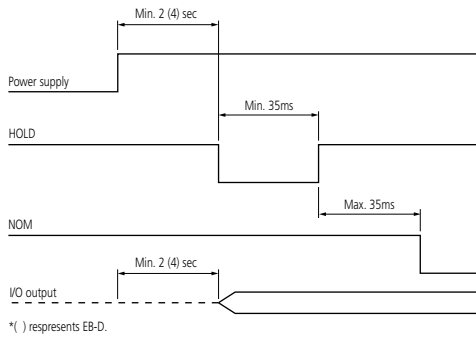

### 2. Tolerance judgment result output period

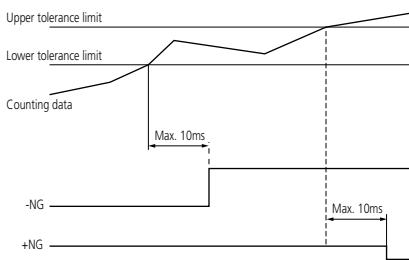

### 3. External preset/Peak clear

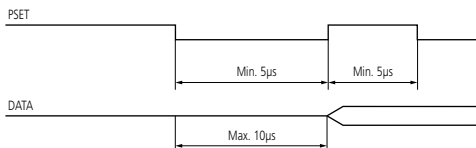

### 4. Peak mode/BANK specification

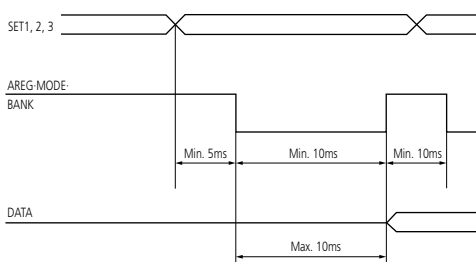

### 5. HOLD timing

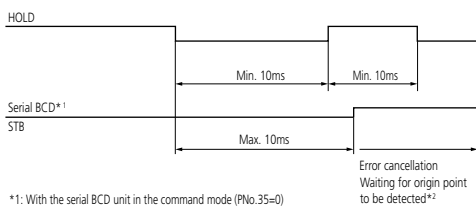

\*1: With the serial BCD unit in the command mode (PNo.35=0)  
\*2: (Only for EV-Z) Resetting of origin point (PNo.42=1)

## External switch box (optional)

Makes it easy to enter tolerance settings and preset values.  
**02ADF180** (with a 2m cable)



# EH Counter

DIN size (144 x 72mm) assembly-type display unit

## FEATURES

- Multi-functional counter with functions of zero-set, preset, and tolerance judgment
- Equipped with an RS-232C interface as standard. This allows data transfer to a personal computer, etc.
- A multi-point measuring system can easily be built up with the built-in networking function (RS link). (Max. 12 points)



542-075■  
542-075-1



542-071■  
542-071-1



542-073■  
542-073-1



For differential square-wave output gage head (single axis)



For differential square-wave output gage heads (2 axes)



For differential square-wave output gage heads with Origin Point Mark (2 axes)



542-074  
542-074-1



542-072  
542-072-1

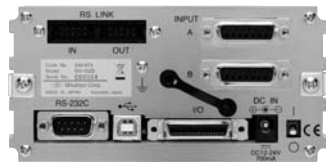

For differential sine-wave output gage heads (2 axes)



For Digimatic code output gage heads (2 axes)

## SPECIFICATIONS

Order No.	542-075■ 542-075-1*1	542-071■ 542-071-1*1	542-073■ 542-073-1*1	542-074■ 542-074-1*1	542-072■ 542-072-1*1
Model No.	EH-101P		EH-102P		EH-102Z
Number of gage inputs	1		2		
Maximum input frequency	1.25MHz*2 (differential square-wave)			1MHz*2 (differential sine-wave)	
Resolution	0.01mm, 0.001mm, 0.0001mm			0.01mm, 0.001mm, 0.0001mm	
Tolerance judgment display	LED display (3 steps: amber, green, red / 5 steps: amber, amber flashing, green, red flashing, red)				
Interface	RS-232C / USB / Digimatic code (parameter selectable), 3-step tolerance / 5-step tolerance / digit-BCD (parameter selectable), total tolerance judgment output, analog output (1V to 4V)				
Output	Control signal: Normal operation signal (NORMAL), open-collector				
Input	Control signal: Display BANK switch, peak mode, preset, display hold, individual axis hold: open-collector or no-voltage contact signal (with/without contact point)				
Power supply voltage	DC+12 to 24V (02ADN460: AC adaptor, AC adaptor connecting cable)				
Power consumption	8.4W (700mA) or less (Secure power supply more than 1A for each unit.)				
Operating temperature	0°C to 40°C (20%RH to 80%RH, without condensation)				
Dimensions	W144 x H72 x D156.7mm				
Optional accessory	02ADB440: Output plug with cover				
Compatible gage head	LG, LGB, LGF, LGK		LGF with Origin Point Mark	LGB with sine-wave output	LGD, LGS, ID-C
Mass	760g	800g	800g	900g	800g

■ (suffix): A for 110V, D for 220/230V, E for 240V, DC for China, K for Korea or no suffix for 100V. \*1: Without AC adapter. \*2: Depends on the gage head connected.

## Standard Accessories

- : Washer (M4, 6 pcs.)
- 02ADN460:** AC adaptor
- : AC adaptor connecting cable
- : DC plug
- 02ADC304:** Stand
- : Rubber foot

## Optional Accessories

- 02ADB440:** I/O output plug w/ cover
- 02ADD950:** RS Link connecting cable (0.5m)
- 936937:** RS Link / SPC connecting cable (1m)
- 965014:** RS Link / SPC connecting cable (2m)

## Dimensions

Unit: mm

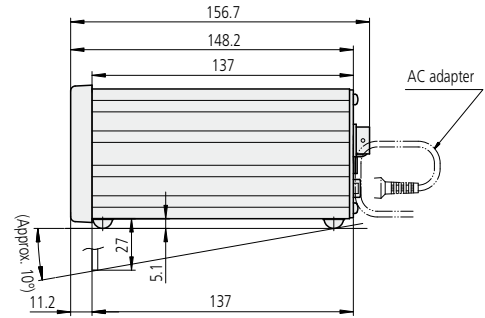
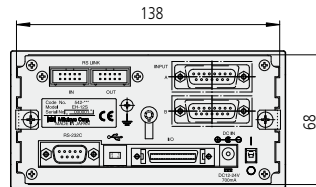
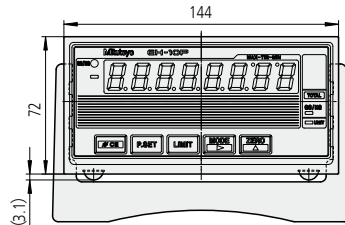

## Functions

### 1. Zero-set

Sets the displayed value to 0 at any position of the spindle.

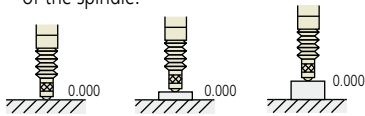

### 2. Tolerance judgment indication/output

Sets two (or four) desired tolerances for three (or five) stages. Judgment results can be output to an external device.

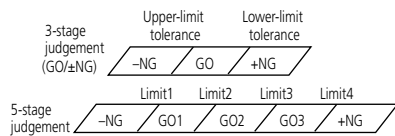

### 3. Peak hold/TIR measurement

Allows switching to the measurement mode for maximum value, minimum value, and run out value (maximum - minimum), in addition to the normal measurement mode.

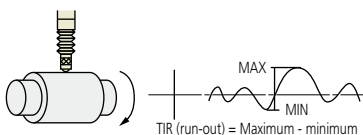

### 4. Digimatic output

Data can be output to various printers and statistical processing devices, such as DP-1VR and MUX-10LF, using Digimatic code (SPC) output.

### 5. Preset

Presets the display at any value. Counting begins at the preset value.

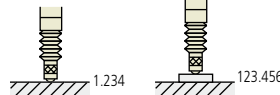

### 6. Segment output

The function used to divide the specified range into 21 equal segments and output where the measured value falls among the 23 segments, including the segments before and after the divided segments.

### 7. BCD output

The displayed value can be output as one of I/O signal to a sequence, etc.

### 8. Double count

Displays a value twice the actual count value. Allows the direct reading of diameter for cylindrical objects.

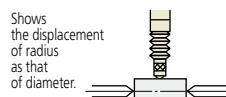

### 9. I/O output

For input/output of external control signals and tolerance judgment result to/from the PLCs or other external devices.

### 10. External control

Zero set, preset and display hold can be controlled from the I/O terminals.

### 11. Direction switch

Selects the counting direction of (+) or (-), whichever is convenient with a given direction of spindle movement.

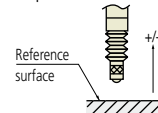

### 12. Inch/mm switch

Selects mm or inch as the unit of display, and enables the automatic conversion of displayed values according to the selected unit.

### 13. ABS gage zero set

Sets the absolute origin of an LGD gage from the counter side. Once set, the absolute origin will be maintained even during a power failure or when the counter is disconnected.

### 14. Sum/difference calculation

Enables measurement of thickness or step height using two gages.

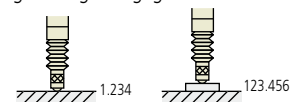

### 15. Communication via RS-232C interface

RS-232C allows communication with a personal computer. It allows not only the reading of measured values but also data transmission to the counter and remote operations, such as when changing various settings.

# EH Counter

DIN size (144 x 72mm) assembly-type display unit

## BCD Output

Simultaneously outputs at channels [A] and [B] in groups of 4 bits.

### 1) Timing chart

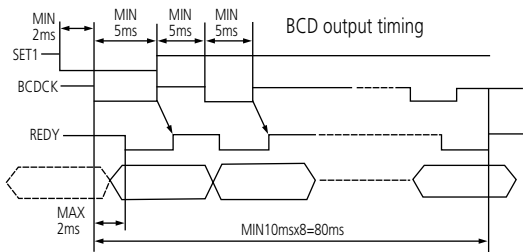

### 2) Data format

	LSD (Least significant digit)				MSD (Most significant digit)			
	D1	D2	D3	D4	D8			
A/B_bit0	1 x 10 <sup>0</sup>	1 x 10 <sup>0</sup>	.....	.....	1 x 10 <sup>7</sup>			
A/B_bit1	2 x 10 <sup>0</sup>	1 x 10 <sup>0</sup>	.....	.....	2 x 10 <sup>7</sup>			
A/B_bit2	4 x 10 <sup>0</sup>	1 x 10 <sup>0</sup>	.....	.....	4 x 10 <sup>7</sup>			
A/B_bit3	8 x 10 <sup>0</sup>	1 x 10 <sup>0</sup>	.....	.....	8 x 10 <sup>7</sup>			
A/B_bit4	SIGN	BANK	PEAK1	PEAK2				

+	H						
-	L						
		BANK1: L					
		BANK2: H					
			PEAK1	PEAK2			
			NOM	L	L		
			MAX	H	L		
			MIN	L	H		
			TIR	H	H		

Data output example

	D1	D2	D3	D4	D5	D6	D7	D8
Bits 0-3	1	0	6	5	4	3	2	1
SIGN	L							

▶ - 1 2 3 4 5 6 0 1

\* Negative logic output is possible for SIGN, BANK, PEAK, DATA (PNo.21=1).

## Simple analog output

Monitoring of output waveforms is possible with an analog recorder connected.

### 1) Output specification

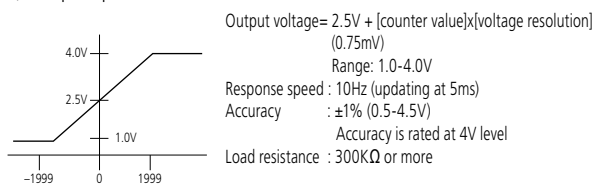

### 2) Measuring range

Parameter	Measuring range (mm) / Resolution (mm)		
No.30	10µm gage	5µm gage	1µm gage
0	±19.99(0.01)	±1.999(0.001)	±0.1999(0.0001)
1	±199.90(0.01)	±19.990(0.01)	±1.9990(0.001)
2	±1999.00(0.1)	±199.900(0.1)	±19.9900(0.01)

## RS Link\* Function

It is possible to connect a maximum of 10 counter units together to carry a maximum of 20 channels of multi-point measurement at a time.

For this connection use a dedicated RS link cable; **02ADD950** (0.5m), **936937** (1m) or **965014** (2m) (The maximum total length of RS link cables permitted for the entire system is 10m.)

\* Patent registered (Japan, U.S.), Patent pending (E.U.)

## RS-232C Communication Functions

Makes it possible not only to log measured values but also make various remote settings including the zero-setting of a counter, etc.

Command format	Corresponding output	Function
GA**CRLF	G#**, +01234.567CRLF	Outputs the [Displayed value] through RS-232C.
CN**CRLF	CH**CRLF	Switches the display to the [Current value].
CX**CRLF	CH**CRLF	Switches the display to the [Maximum value].
CM**CRLF	CH**CRLF	Switches the display to the [Minimum value].
CW**CRLF	CH**CRLF	Switches the display to the [TIR (runout)].
CR**CRLF	CH**CRLF	Zerose
CL**CRLF	CH**CRLF	Clears the peak value.
CP**, +01234567CRLF	CH**CRLF	Inputs the preset value.
CD**, +01234567CRLF	CH**CRLF	Inputs tolerance value S1.
CE**, +01234567CRLF	CH**CRLF	Inputs tolerance value S2.
CF**, +01234567CRLF	CH**CRLF	Inputs tolerance value S3.
CG**, +01234567CRLF	CH**CRLF	Inputs tolerance value S4.
CS**CRLF	CH**CRLF	Cancel the error.
CK**CRLF	CH**, \$CRLF (\$=0 or 1)	Checks the HOLD status.

\*\* : denotes a gage channel number between 01 and 99 ("00" means all channels).

# : denotes the type of data [N: Current value, X: Maximum value, M: Minimum value, W: TIR (runout)].

CRLF: CR (carriage return), LF (line feed).

Note 1: For presetting and tolerance limit setting, enter each value consisting of a sign and 8 digits of numeric value without a decimal point.

Note 2: Perform the tolerance limit setting in the order of CD and CG for the case of 3-step tolerance judgment, and in the order of CD, CE, CF, and CG for the case of 5-step tolerance judgment.

Note 3: The RS communication function will be suspended during key operation (e.g. setting parameters, preset values, or tolerance limits). It automatically resumes the command and data output operation when the gage is recovered to such a condition that the counting is possible.

Note 4: For canceling the counting-standby state, use CS00CRLF (specification of all channels).

## Digimatic Code Output Specifications

Possible to externally output the measured data and connect with a DP-1VR Digimatic Mini-Processor.

### 1) Socket to be used

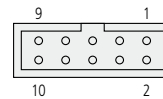

### 2) Data output format: A total of 13 digits will be output as follows.

Each digit is represented by a 4-bit binary, and will be output beginning with the LSB (least significant bit) of the least significant digit in the order of 20 - 21 - 22 - 23.

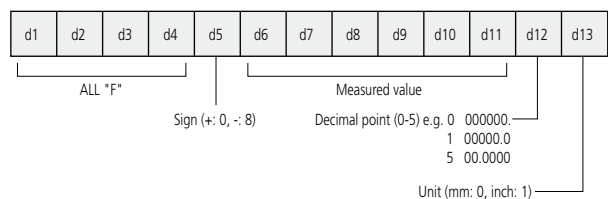



## Input / output specifications

### 1) Suitable plug: 02ADB440 (with cover)

### 2) Pin assignment

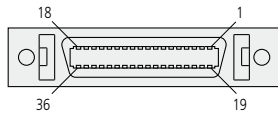

Socket: 10236-52A2 (3M) equivalent

Pin No.	Description	I/O	Function
1	COM	—	Common terminal for input/output circuit (to be connected to the internal GND)
2	COM	—	
3	AL1	OUT	A-axis tolerance judgment result output pin
4	AL2	OUT	> Only the pin that is involved in the judgment will output "L".
5	AL3	OUT	> At an error
6	AL4	OUT	AL1, AL5 = Output of "L"
7	AL5	OUT	AL2, AL3, AL4 = Output of "H"
8	N.C.	IN	Unconnected terminal
9	N.C.	IN	Unconnected terminal
10	NOM	OUT	Outputs "L" where counting is possible. "H" will be output when an error occurs on either of A and B axes.
11	BL1	OUT	B-axis tolerance judgment result output pin
12	BL2	OUT	> Only the pin that is involved in the judgment will output "L".
13	BL3	OUT	> At an error
14	BL4	OUT	BL1, BL5 = Output of "L" BL2, BL3, BL4 = Output of "H"
15	BL5	OUT	normally outputs "H".
16 - 33	N.C.	IN	Unconnected terminal
34	HOLD	OUT	> The display value is held during input. > When an error has occurred, the error will be cleared by this signal.
35	PA	OUT	> Perform presetting. > Peak clear: Entering a PA signal during input of HOLD signal in the peak mode serves as peak clear.
36	PB	IN	Presetting or peak clear on B-axis

### 3) I/O circuit

#### 1. Output circuit

NOM, AL1 to AL5, BL1 to BL5 Transistor is "ON" to drive the line to "L" (open-collector output).

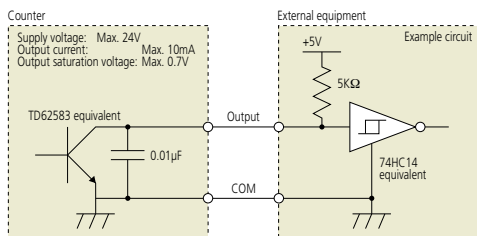

#### 2. Input circuit (SET, MODE, BANK, PSET, HOLD)

PA, PB (only with 542-062), HOLD Input is valid when the line is "L".

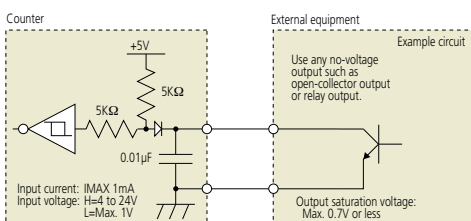

## 6) Timing chart

### 1. Power ON characteristics

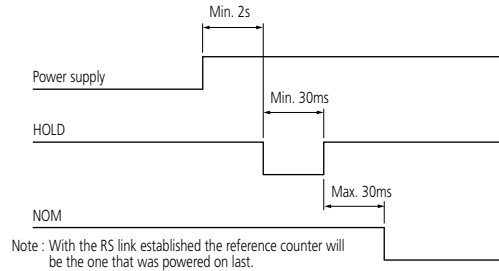

### 2. Tolerance judgment result output period

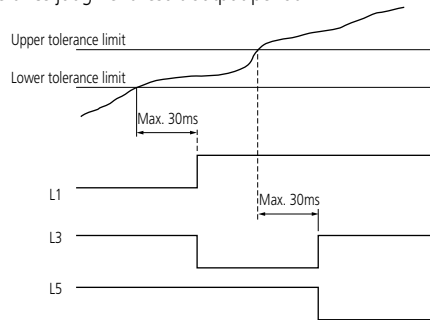

### 3. External preset (PA, PB) input

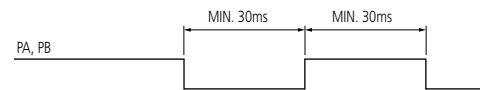

Note: Excluding the period during key input, RS-232C communication or Digimatic processing.

### 4. Peak clear input

(After inputting HOLD, or simultaneous input with the preset value)

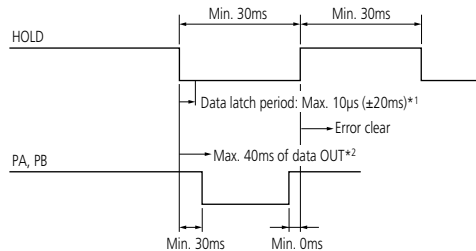

\*1: ( ) represents the case either in the peak mode or in such the mode that an input of HOLD triggers RS-232C output.  
\*2: Case in such the mode that input of HOLD triggers RS-232C output.  
\*3: The PRESET indicator will be flashing during the input operation of HOLD.

### 5. RS-232C command input and response output

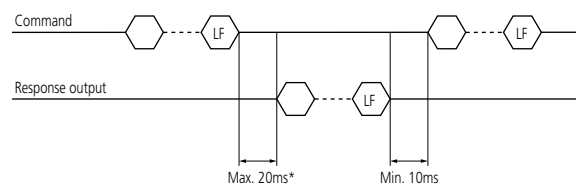

Note: Excluding the period during key input, RS-232C communication or Digimatic processing.

Display Units

# EH Counter

DIN size (144 x 72mm) assembly-type display unit

Display Units

# D-EV Display Unit

External display unit for EV counter

## RS-232C specifications

### 1) Compatible plug:

D-sub9 pin (female), inch thread specification

### 2) Pin assignment

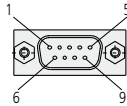

Pin No.	Description	I/O	Function
2	RXD	IN	Receive data
3	TXD	OUT	Send data
4	DTR	OUT	Data terminal ready
5	GND	—	Ground
6	DSR	IN	Data set ready
7	RTS	OUT	Request to send
8	CTS	IN	Clear to send
1, 9	N.C.	—	Connection impossible

### 3) Communication specifications (conforming to EIA RS-232C)

Home position	DTE (Data Terminal Equipment) Use a cross-type cable.
Communication method	Half-duplex, teletype protocol
Data transfer rate	4800, 9600, 19200bps
Bit configuration	Start bit: 1 Data bits: (7, 8) ASCII, upper-case characters Number of parity bits: None, even, odd Number of stop bits: 2
Setting the communication conditions	Set via parameters.

## FEATURES

- Display unit for the EV counter.
- Using this display allows various settings for the EV counter to be made without the need for a personal computer or other equipment.
- Able to display each axis measurement value and GO/NG judgment result, total GO/NG judgment result for all axes, setting details, and errors.
- DIN compatible compact panel-mounting - cutout dimensions 45<sup>+0.8</sup> x 92<sup>+0.8</sup>
- The required power supply is DC +12 to +24V, 200mA at the terminal block. (AC adaptor **02ADN460** is available.)



## SPECIFICATIONS

Order No.	<b>02ADD400</b>
Model No.	D-EV
Number of connectable units	One display unit allows external display and setting for one EV counter.
Displayed digits	It uses a single sign plus six digits (EV counter operates on eight-digit data internally but displays only the last six digits).
LED display	Channel display (also for display of judgment result) : 3 (three-color LED) Measurement mode display (current, maximum, minimum, runout) : 2 Status display : 1 (two-color)
Operating switches	4
Switches and their functions	Channel switching, measurement mode switching (current value, maximum value, minimum value and runout), parameter setting, preset, and tolerance setting
Input/output	RS Link connectors: 1 in and 1 out.
Error display	Overspeed, gage error and others.
Power supply	Terminal block (M3 screws), DC +12 to +24V, 200mA
Operating temperature (humidity) range	0°C to 40°C (20%RH to 80%RH, without condensation)

## Dimensions

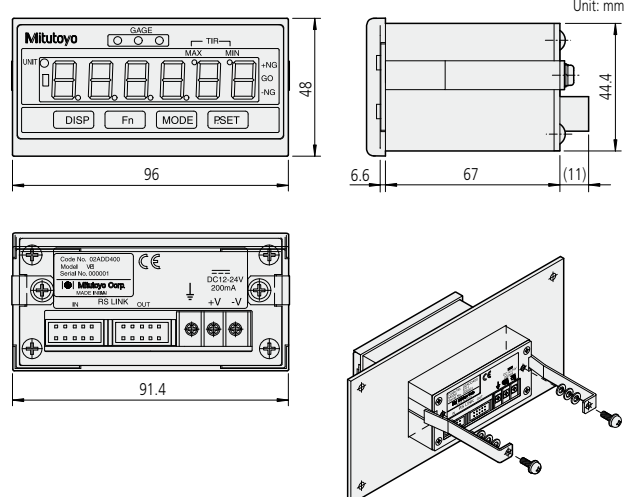

# EV Counter

DIN size (144 x 72mm) assembly-type unit for multi-gage systems

## FEATURES

- Able to connect up to 10 EV counters to one personal computer using the RS link function to facilitate the configuration of a multi-point measurement system comprising a maximum of 60 gages.
- A range of output modes to choose from; I/O output for tolerance judgment and segment output, BCD data output and RS-232 output are available.



For differential square-wave output gage heads (6 axes)

542-063

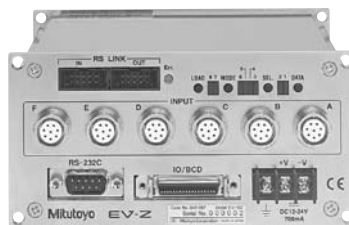

For differential square-wave output gage heads with Origin Point Mark (6 axes)

542-067



For Digimatic code output gage heads (6 axes)

542-064

## Dimensions

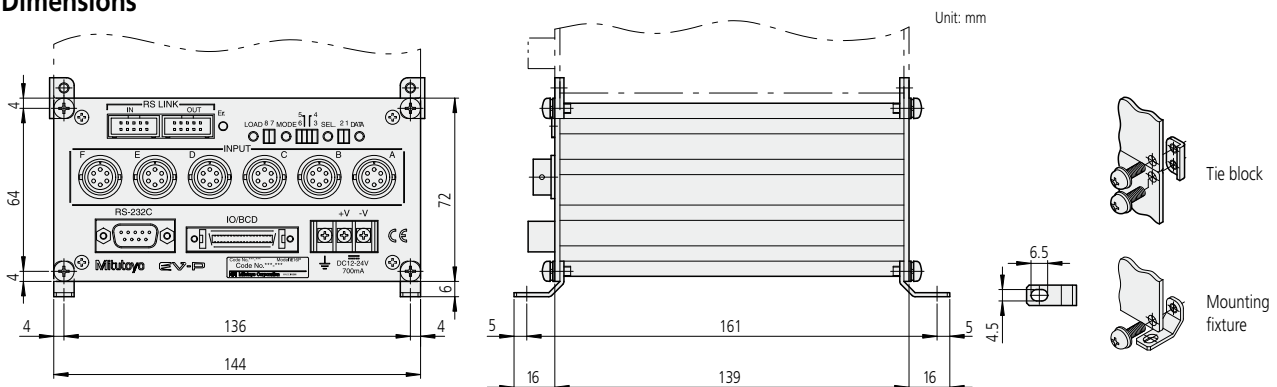

## SPECIFICATIONS

Order No.	542-063	542-067	542-064
Model No.	EV-16P	EV-16Z	EV-16D
Number of gage inputs	6		
Maximum input frequency	1.25MHz (differential square-wave): Max counting Speed: 5MHz		Depends on the gage head connected
Resolution	0.0005mm, 0.001mm, 0.005mm, 0.01mm		Depends on the gage head connected
LED indication	Parameter indication: 8, Error indication: 1		
Error indication	Overspeed, gage error		
Available external display	D-EV display unit (optional)		
No. of input switches	4		
Input switch functions	Measurement mode switching, parameter setting		
Interface	RS-232C	Measurement data and control signal, Conform to EIA RS-232C standard, Home position: DTE (Data Terminal Equipment), use a cross-type cable.	
	RS Link	Max. No. of connectable counters: 10 (6: EH counter is mixed.), Max. total length of RS link cable: 10m, Data transfer time: 1sec/60CH at 19200bps	
	Tolerance judgment	1 to 6-axis (L1, L2, L3), open-collector	
	BCD output	BCD parallel output (positive logic / negative logic), open-collector	
Input / output	Segment output	Turns ON the output terminal corresponding to the measurement value, open-collector	
	Control output	Normal operation signal (NORMAL), open-collector	
	Control input	Output channel designation (segment, BCD output modes), preset, peak value clear, range switching (segment output mode), data hold, open-collector or no-voltage contact signal (with/without contact point)	
Power supply	Terminal block (M3 screws), DC +12 to +24V, 700mA (max.)		
Power consumption	8.4W or less		
Operating temperature	0°C to 40°C (20%RH to 80%RH, without condensation)		
Dimensions	W144 x H72 x D156.7mm		
Standard accessories	Mounting fixture (4 pcs.), tie block (4 pcs.), screw M4 x 12 (8 pcs.)		
Optional accessories	02ADB440: Output plug with cover, 02ADD400: D-EV display unit, 02ADD950: RS Link / SPC connecting cable (0.5m), 936937: RS Link / SPC connecting cable (1m), 965014: RS Link / SPC connecting cable (2m), 02ADD930: Terminal connecting cable, 02ADN460: AC adaptor, AC adaptor connecting cable		
Compatible gage head	LGK, LGB (ex. 0.0001mm resolution), LGF	LGF with origin point mark	LGD, LGS
Mass (main unit only)	910g		830g

# EV Counter

DIN size (144 x 72mm) assembly-type unit for multi-gage systems

## System configuration

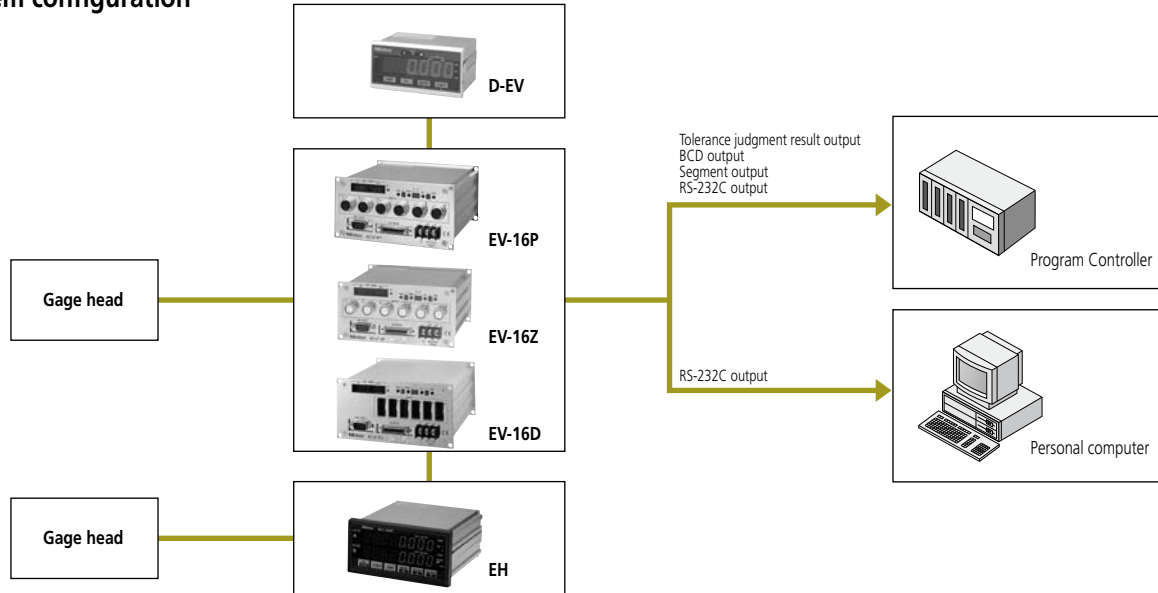

## Internal block diagram

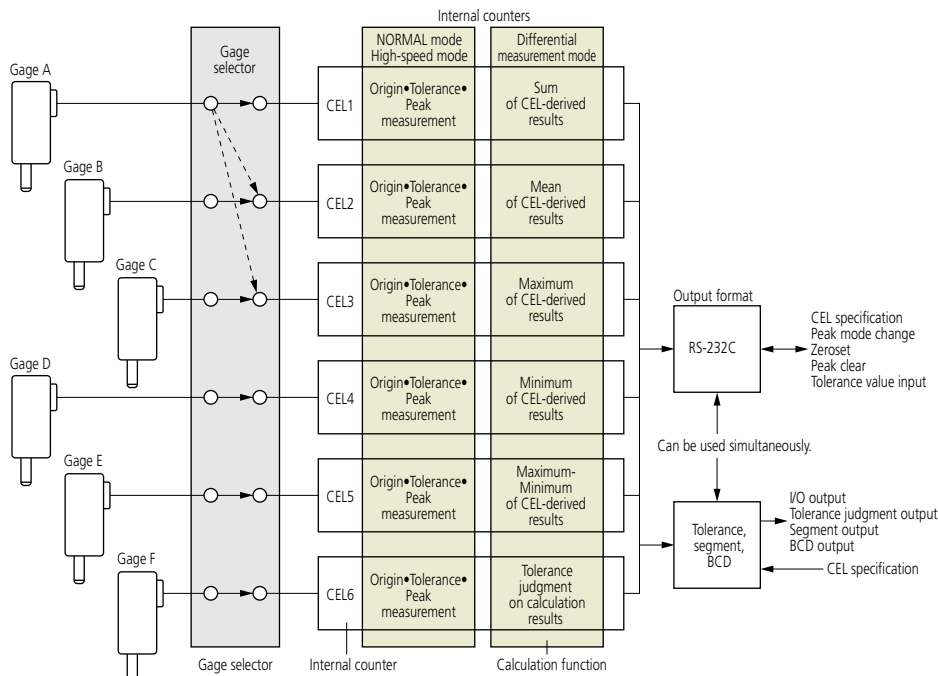

### Gage selector

It is possible to assign gage signals one-to-one or one-to-many to the internal counters through parameter settings. This allows the user to set more than one origin point and/or tolerance limit on one gage head.

### Internal counters

Using the 6 internal counters (CEL1-CEL6) it is possible to perform origin setting, peak measurement, and tolerance limit setting.

### Calculation function

Each of the internal counters is assigned a unique calculation function so that various kinds of calculation can be made between the internal counters specified with the parameters.

### Output function

The output format can be selected from among RS-232C, BCD, tolerance judgment result and segment output. The objective CEL of the output can be selected with an appropriate RS-232C command or SET signal.

## RS Link\* function

It is possible to connect a maximum of 10 counter units together to carry a maximum of 60 channels of multi-point measurement at a time.  
For this connection use the dedicated RS link cable; **02ADD950** (0.5m), **936937** (1m) or **965014** (2m) (The maximum total length of RS link cables permitted for the entire system is 10m.)

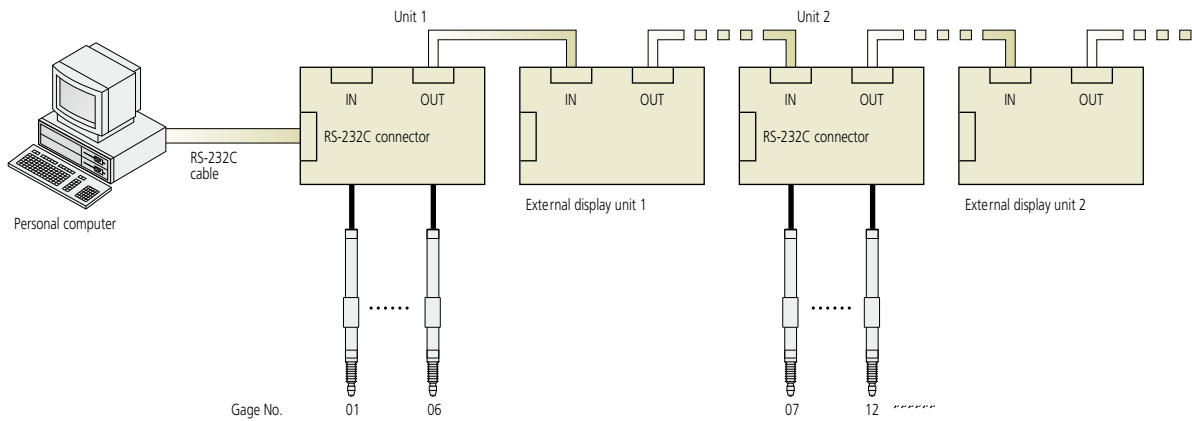

\*Patent registered (Japan, U.S.),  
Patent pending (E.U.)  
When used with an EH counter, up to 6 counter units can be connected.

## RS-232C Communication Functions

Makes it possible not only to log measured values but also make various remote settings including the zero-setting of a counter, etc.

Command format	Corresponding output	Function
GA**CRLF	G#**, +01234.567CRLF	Outputs the [Displayed value] through RS-232C.
CN**CRLF	CH**CRLF	Switches the display to the [Current value].
CX**CRLF	CH**CRLF	Switches the display to the [Maximum value].
CM**CRLF	CH**CRLF	Switches the display to the [Minimum value].
CW**CRLF	CH**CRLF	Switches the display to the [TIR (runout)].
CR**CRLF	CH**CRLF	Zerose
CL**CRLF	CH**CRLF	Clears the peak value.
CP**, +01234567CRLF	CH**CRLF	Inputs the preset value and performs presetting.
CD**, +01234567CRLF	CH**CRLF	Inputs tolerance value.
CG**, +01234567CRLF	CH**CRLF	Inputs tolerance value.
CS**CRLF	CH**CRLF	Cancels the error.
CK**CRLF	CH**, \$CRLF (\$=0 or 1)	Confirms the HOLD state.
CT**CRLF	CH**, +01234.567CRLF	Outputs the [Displayed value] through RS-232C.

\*\* : denotes a gage channel number between 01 and 99 ("00" means all channels).  
# : denotes the type of data [N: Current value, X: Maximum value, M: Minimum value, W: TIR (runout)].  
CRLF: CR (carriage return), LF (line feed).  
Note 1: For presetting and tolerance limit setting, enter each value consisting of a sign and 8 digits of numeric value without a decimal point.  
Note 2: Perform the tolerance limit setting in the order of CD and CG for the case of 3-step tolerance judgment, and in the order of CD, CE, CF, and CG for the case of 5-step tolerance judgment.  
Note 3: The RS communication function will be suspended during key operation (e.g. setting parameters, preset values, or tolerance limits). It automatically resumes the command and data output operation when the gage is recovered to such a condition that the counting is possible.  
Note 4: For canceling the counting-standby state, use CS00CRLF (specification of all channels).

## RS-232C specifications

- Compatible plug:**  
D-sub 9-pin (female), inch thread specification
- Pin assignment**

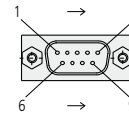

Pin No.	Description	I/O	Contents (application)
2	RXD	IN	Receive data
3	TXD	OUT	Send data
4	DTR	OUT	Data terminal ready
5	GND	—	Ground
6	DSR	IN	Data set ready
7	RTS	OUT	Request to send
8	CTS	IN	Clear to send
1, 9	N.C.	—	Connection impossible

## 3) Communication specifications (conforming to EIA RS-232C)

Home position	DTE (Data Terminal Equipment) Use a cross-type cable.
Communication method	Half-duplex, teletype protocol
Data transfer rate	4800, 9600, 19200bps
Bit configuration	Start bit: 1 Data bits: (7, 8) ASCII, upper-case characters Number of parity bits: None, even, odd Number of stop bits: 2
Setting the communication conditions	Set via parameters.

# EV Counter

DIN size (144 x 72mm) assembly-type unit for multi-gage systems

## Input / output specifications

1) Compatible plug: 02ADB440 (with cover)

2) Pin assignment

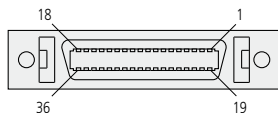

Socket: 10236-52A2 (3M) equivalent

## Output functions

Select either "Tolerance judgment result output", "Segment output", or "BCD output" depending on the application needs.

Tolerance judgment result output				Segment output				BCD output			
Pin No.	Description	Function	I/O	Description	Function	I/O	Description	Function	I/O		
1	COM	Common terminal for I/O circuit (to be connected to the internal GND)	—	COM	Common terminal for I/O circuit (to be connected to the internal GND)	—	COM	Common terminal for I/O circuit (to be connected to the internal GND)	—		
2	COM		—	COM		—	COM		—		
3	CEL1_-NG	Tolerance judgment result output pin (1CH)	O	-OVER	- over-range	O	1X100	BCD output will be made through the specified channel.	O		
4	CEL1_GO		O	-L10		O	2X100				
5	CEL1_+NG		O	-L9		O	4X100				
6	CEL1_NOM	Outputs "L" where counting is possible.	O	-L8	O	8X100					
7	CEL2_-NG	Tolerance judgment result output pin (2CH)	O	-L7	O	1X101					
8	CEL2_GO		O	-L6	O	2X101					
9	CEL2_+NG		O	-L5	O	4X101					
10	CEL2_-NOM	Outputs "L" where counting is possible.	O	-L4	O	8X101					
11	CEL3_-NG	Tolerance judgment result output pin (3CH)	O	-L3	With the specified channel ranges, make output from ±10 divisions.	O	1X102				
12	CEL3_-GO		O	-L2		O	2X102				
13	CEL3_+NG		O	-L1		O	4X102				
14	CEL3_NOM	Outputs "L" where counting is possible.	O	L0		O	8X102				
15	CEL4_-NG	Tolerance judgment result output pin (4CH)	O	+L1		O	1X103				
16	CEL4_GO		O	+L2		O	2X103				
17	CEL4_+NG		O	+L3		O	4X103				
18	CEL4_NOM	Outputs "L" where counting is possible.	O	+L4		O	8X103				
19	CEL5_-NG	Tolerance judgment result output pin (5CH)	O	+L5		+ over-range	O	1X104			
20	CEL5_GO		O	+L6			O	2X104			
21	CEL5_+NG		O	+L7	O		4X104				
22	CEL5_NOM	Outputs "L" where counting is possible.	O	+L8	O		8X104				
23	CEL6_-NG	Tolerance judgment result output pin (6CH)	O	+L9	O		1X105				
24	CEL6_GO		O	+L10	O		2X105				
25	CEL6_+NG		O	+OVER	O		4X105				
26	CEL6_NOM	Outputs "L" where counting is possible.	O	NOM (ANG)	Outputs "L" where counting is possible.		O	8X105			
27	EXTEND	Output "L" while the RS command is processed.	O	EXTEND	Output "L" while the RS command is processed.		O	SIGN	Sign of the counting value (+="H", -="L")	O	
28	READY	Data confirmation signal	O	READY	Data confirmation signal		O	READY	Data confirmation signal	O	
29	START	First CEL identification signal	O	START	First CEL identification signal	O	START	First CEL identification signal	O		
30	NORMAL	Normal signal	O	NORMAL	Normal signal	O	NORMAL	Normal signal	O		
31	P.SET	Preset	I	P.SET	Preset	I	P.SET	Preset	I		
32	OUTCEL	Set the objective CEL of output.	I	OUTCEL	Set the objective CEL of output.	I	OUTCEL	Set the objective CEL of output.	I		
33	SET1	CEL specification data or segment range data	I	SET1	CEL specification data or segment range data	I	SET1	CEL specification data or segment range data	I		
34	SET2	CEL specification data or segment range data	I	SET2	CEL specification data or segment range data	I	SET2	CEL specification data or segment range data	I		
35	SET3	CEL specification data or segment range data	I	SET3	CEL specification data or segment range data	I	SET3	CEL specification data or segment range data	I		
36	HOLD	Hold/Peak clear	I	HOLD	Hold/Peak clear	I	HOLD	Hold/Peak clear	I		

### 3) I/O circuit

#### 1. Output circuit:

Tolerance judgment result output, NOM, segment output, etc.  
Transistor is "ON" to drive the line to "L" (open-collector output).

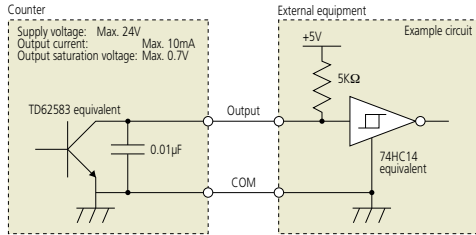

#### 2. Input circuit :

P.SET, HOLD, SET, etc. Input is valid when the line is "L".

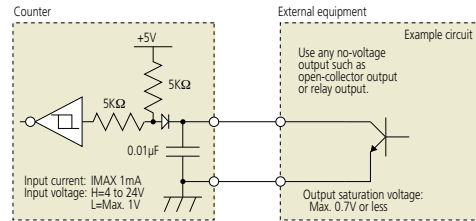

### 4) Timing chart

#### 1. Power ON characteristics

Where the RS link is established, the reference counter shall be the one that was powered last.

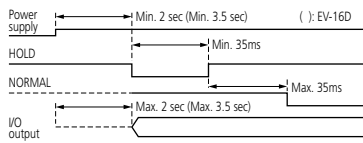

#### 2. Tolerance judgment result output period

All CELs will not output simultaneously.

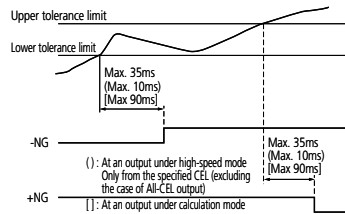

Note: The output period in the case of ED-V counter depends on the gage unit being connected.

#### 3. Data output

There are two data output methods; Command mode and Interval mode. Either of them can be set via the I/O output mode parameters.

##### a. Command mode (All-CEL output)

All-CEL data output (specified with SET1 through SET3) while the HOLD and READY lines are synchronously controlled.

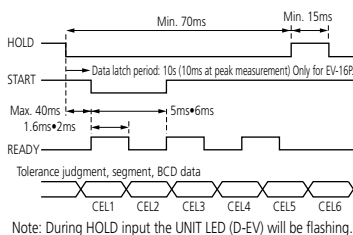

Note: During HOLD input the UNIT LED (D-EV) will be flashing.

##### b. Command mode (Individual CEL output)

Individual CEL data output (specified with SET1 through SET3) can be performed while the HOLD and READY lines are synchronously controlled.

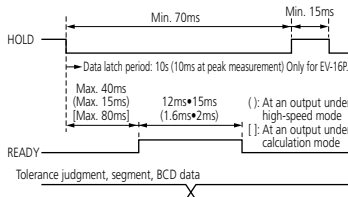

Note: When it is required to operate in the high-speed mode or All-CEL output mode, always use equipment whose input response time is 1ms or less.

##### c. Interval mode (All-CEL output)

All-CEL data (specified with SET1 through SET3) will be sequentially output according to the counter's internal timing.

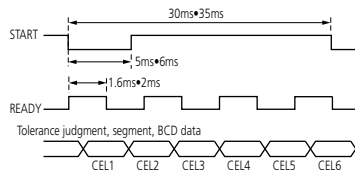

Note: When it is required to operate in the high-speed mode or All-CEL output mode, always use equipment whose input response time is 1ms or less.

##### d. Interval mode (Individual CEL output)

Individual CEL data (specified with SET1 through SET3) will be sequentially output according to the counter's internal timing.

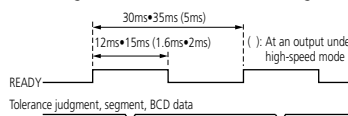

Note: The data update time in the case of 542-064 depends on the type of gage being connected. In addition, the same data may be output over multiple cycles.

#### 4. External presetting

Takes the current value of CEL (which has been specified with SET1 through SET3) as the preset value.

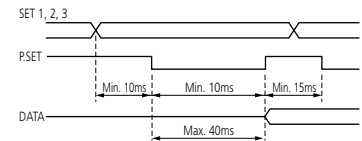

If presetting is executed, the peak value up until then will be cleared. (Max=Min=Current value, TIR=0)

#### 5. Specification of objective CEL of output/ Specification of calculation method

Assigns the CEL that has been specified with SET1 through SET3 to the data output CEL.

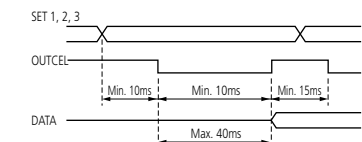

Input with SET3 through SET1 during segment output. This usually operates as the range specification data. (This acts as CEL specification when OUTCEL is input.)

- NORMAL, High-speed mode: Specification of the output CEL
- Differential calculation mode: Specification of the calculation method

#### 6. Peak clear

Clears the peak value.

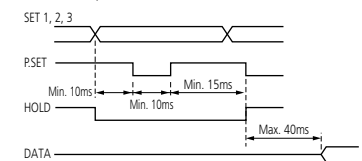

Note: Peak clear takes effect only in the peak mode. (In the case of a current value, this has the same effect as a presetting operation.)

# Optional Accessories

## Input / output connector



02ADB440

This plug fits the I/O output socket on EF/EV counters. Refer to the corresponding technical explanations (page 40 and 41) for pin assignments.

## AC adaptor / AC cable



Connected to the power supply terminal

Order No.	Description
02ADN460	AC adaptor
02ZAA000	AC code
02ADD930	Terminal connecting cable

## RS Link / SPC connecting cable



- Used to output the measured data from EC / EB / EH counters to Digimatic mini-processor DP-1VR.
- Used to interconnect EH/EV counters comprising an RS link. Same as the cable used for Digimatic code (SPC) output.

Order No.	Cable length
02ADD950	0.5m
936937	1m
965014	2m

## Connector compatibility

The connectors listed below are compatible with the specific models of counter shown for measurement, data output, and external control purposes.

Counter	Counter Order No.	Description	Connector Order No.
EC-101D	542-007	GO/NG judgment output	C162-155
EG-101P	542-015	BCD output, GO/NG judgment output	02ADB440
EG-101Z	542-017	BCD output, GO/NG judgment output	
EG-101D	542-016	BCD output, GO/NG judgment output	
EB-11P	542-092-2	GO/NG judgment output, serial BCD output, simple analog output	02ADB440
EB-11Z	542-094-2	GO/NG judgment output, serial BCD output, simple analog output	
EB-11D	542-093-2	GO/NG judgment output, serial BCD output, simple analog output	
EH-101P	542-075	Remote input, GO/NG judgment output RS-232C output	02ADB440
EH-102P	542-071	Remote input, GO/NG judgment output RS-232C output	02ADB440
EH-102Z	542-073	Remote input, GO/NG judgment output RS-232C output	02ADB440
EH-102S	542-074	Remote input, GO/NG judgment output RS-232C output	02ADB440
EH-102D	542-072	Remote input, GO/NG judgment output RS-232C output	02ADB440
EV-16P	542-063	Remote input, GO/NG judgment output Segment output, BCD output RS-232C output	02ADB440
EV-16D	542-064	Remote input, GO/NG judgment output Segment output, BCD output RS-232C output	02ADB440
EV-16Z	542-067	Remote input, GO/NG judgment output Segment output, BCD output RS-232C output	02ADB440
LG-DA1	542-003	Analog output Pulse output EXT.ZERO	965617 965606 271254A
LG-DF	572-041	Pulse output	965606



## D/A conversion unit LG-DA1: 542-003

### FEATURES

- This unit consists of the pulse control circuit, counting circuit, and D/A conversion circuit to output gage head displacement in the form of an analog voltage.



542-003

■ Suffix A for 110V, D for 220/230V, E for 240V

### SPECIFICATIONS

Output voltage	±10V / full-scale
Resolution of output voltage	±1000 steps of full-scale
Linearity of output voltage	1/2 LSB
Power supply	Via AC adaptor (DC9V, 500mA)
Dimensions (W x D x H)	236 x 160 x 44.2mm
Standard accessories	AC adaptor, analog output cable
Mass	1500g

### Measuring range / resolution

When connected to a 0.001mm gage head

Range	Resolution
±1mm	0.001mm
±2mm	0.002mm
±5mm	0.005mm
±10mm	0.01mm
±20mm	0.02mm
±50mm	0.05mm

When connected to a 0.01mm gage head

Range	Resolution
±5mm	0.005mm
±10mm	0.01mm
±25mm	0.025mm
±50mm	0.05mm
±100mm	0.1mm
±250mm	0.25mm

### Connection example

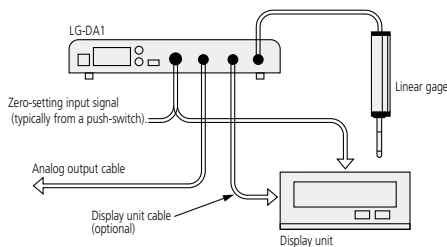

### Optional accessory

965606: Display unit connecting cable

## Difference / Sum unit LG-DF: 542-004

### FEATURES

- This unit serves to output a differential calculation result (A+B, A-B) or single value (A, B) of the counting values obtained from the gage heads\* with differential square-wave signal output that are connected to A and B input connectors, respectively.

\* The resolution of the gage heads that are connected to A and B input connectors should be identical.



542-004

### SPECIFICATIONS

Spindle speed limit	250mm/s when 5 / 10µm gage heads are connected 50mm/s when 1µm gage heads are connected
Power supply	Via AC adaptor (DC9V, 500mA)
Power consumption	4.5W
Dimensions (W x D x H)	236 x 160 x 44.2mm
Standard accessory	Display unit connecting cable
Mass	2000g

### Over-speed error output and the remedies

If either of the gage heads connected to the A and B input connectors is driven in excess of the spindle speed limit, as stated above, the counter will display an over-speed error.

### Connection example

Measurement of curved-plate thickness

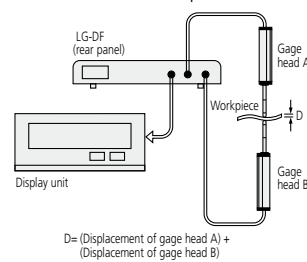

Step measurement

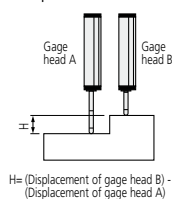

### Optional accessory

526688: AC adaptor

# Quick Guide to Precision Measurement

## Precision measuring terms

### Nut and split-clamp stem mounting

Gage heads are mounted on a fixture or stand using the precision-machined cylindrical stem. Stems can be any one of several standard diameters and are either just plain or with a fixing thread at one end or the other.

All gages can be mounted using the split-clamp method which is suitable for a range of applications, especially where small axial adjustments may be required. However, care is needed to avoid over-tightening the clamp, which could interfere with the spindle movement.

Those stems with a thread at the spindle end can also be mounted just by using a nut to clamp them into a hole in a fixture. They can also use a 'thrust stem' (see page 33) that is clamped into a larger hole in a fixture and into which the gage is screwed. Stems with a thread at the body end can also use this method of mounting.

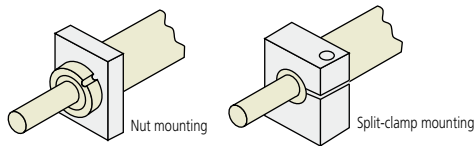

### Comparison measurement

When a measurement is required that is beyond the measuring range of a particular gage head, so that an 'absolute' measurement is impossible, a calibrated master gage (e.g. gage blocks) or master workpiece can be used to subtract the greater part of the distance involved so that the head only has to measure the difference between the workpiece and the master. This 'comparing' of the size of a workpiece with that of a master gives rise to the term 'comparison measurement'. (See page 59 for a detailed description.)

### Measuring force

A force is produced when a workpiece is brought into contact with the tip of a linear gage head and forces the spindle to retract against the action of the return spring. This is known as the measuring force and is specified in newtons (symbol N). As this force is spring-generated it increases with spindle retraction.

### IP Codes

#### IP54

Code digit	Type of protection	Degree of protection
5	Protected against dust	Ingress of dust is not totally prevented, but dust that does penetrate must not interfere with satisfactory operation of the apparatus or impair safety
4	Protected against splashing water	Water splashed against the enclosure from any direction shall have no harmful effects

#### IP66

Code digit	Type	Protection guarantee
6	Dust-proof	No ingress of dust allowed
6	Protected against powerful water jets	Water projected in powerful jets against the enclosure from any direction shall have no harmful effects

### Zero set

The action of setting the measurement display to zero at the current position of the spindle before making a measurement, which will then be made relative to zero. This function is used when making an absolute measurement relative to a reference surface, or when making a comparison measurement relative to a master gage (or workpiece), although in the latter case a calculation is necessary to add the size of the master to the displayed value to get the true measurement value.

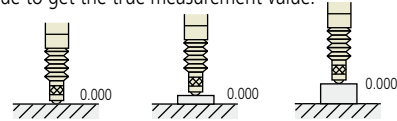

### Preset

The action of setting the measurement display to a non-zero value at the current position of the spindle before making a measurement, which will then be made relative to this 'preset' value. This function is useful in comparison measurement because it can be used to eliminate the need for calculation, which otherwise would be necessary, to get the true measurement value if the display was merely zeroed before measurement.



### Communication via RS-232C interface

RS-232C allows communication with a personal computer. It allows not only the reading of measured values but also data transmission to the counter and remote operations, such as when changing various settings.

### Direction switch

Selects the counting direction of (+) or (-), whichever is convenient with a given direction of spindle movement.

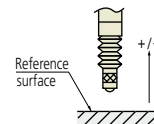

### Peak hold/TIR measurement

Allows switching to the measurement mode for maximum value, minimum value, and run out value (maximum - minimum), in addition to the normal measurement mode.

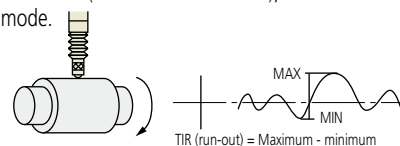

### Tolerance judgment indication/output

Sets two (or four) desired tolerances for three (or five) stages. Judgment results can be output to an external device.

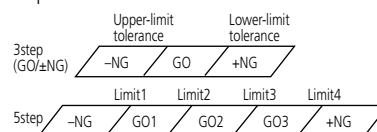

### BCD output

The displayed value can be output in Binary Coded Decimal format.

### Digimatic output

Data can be output to various printers and statistical processing devices, such as DP-1VR and MUX-10LF, using the Digimatic code (SPC) output format.

## Comparison measurements

The following is a description of the interactions that occur between Origin Point Mark detection, the Internal Counter, the Display and the Offset Register while setting up and making a comparison measurement with a linear gage head.

### The offset register

The purpose of the offset register is to supply a value to be added to the display so that it indicates the correct measurement value. When a preset value (the master gage dimension) is entered into the system the current internal counter value is subtracted from this value and the result is stored in the offset register. From then onward this resultant value is added to the internal counter to provide the display value, which then indicates the correct dimension relative to the datum surface.

$$12.000 - 4.000 = 8.000$$

To the timing when the spindle passes over the originpoint, the counter begins counting from the offset value.

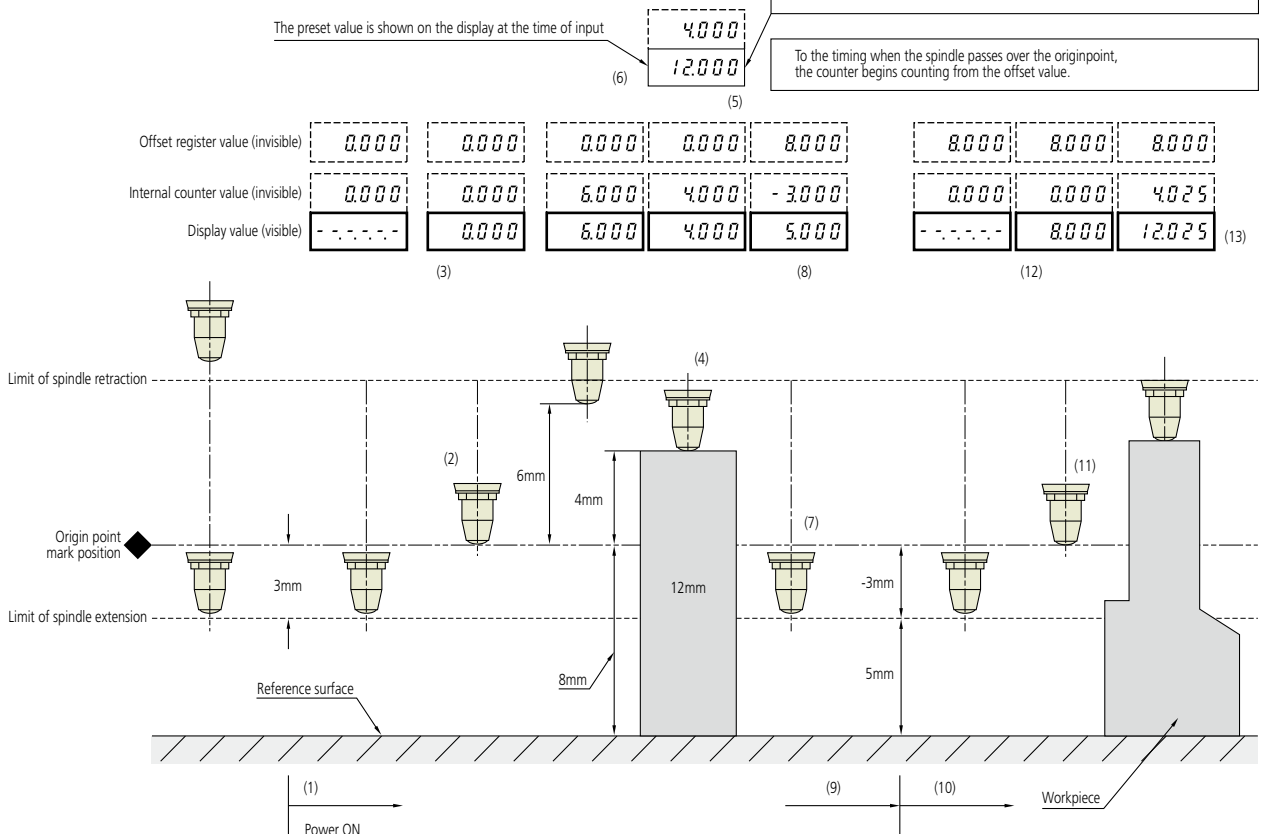

Note) The example linear gage used in the above explanation is LGF-0510 (110) ZL. This linear gage has its origin point marked at a position approximately 3mm from the limit of the spindle extension. In the case of 25/50mm-stroke types the origin point mark is positioned approximately 5mm from the spindle extension limit.

### Procedure

1. Turn the display unit connected to the gage head to ON. (The offset register is set to zero at this stage.)
2. Displace the gage head spindle approximately more than 3mm from the spindle extension limit position to make it pass over the origin point mark.
3. The display unit will automatically read the origin point and zero-set itself.
4. Bring the gage head contact point into contact with the master gage as shown.
5. The display unit indicates the displacement from the origin point position. (Offset register still contains zero.)
6. Input the preset value (the calibrated size of the master gage, 12.000).
7. Remove the master gage so that the spindle extends to its limit.
8. The display unit displays position of the contact point relative to the datum surface (-3.000 + 8.000 = 5.000)
9. Turn OFF the display unit.
10. Turn ON the display unit.
11. Displace the gage head spindle approximately more than 3mm from the spindle extension limit position to make it pass over the origin point mark.
12. The display unit will automatically read the origin point and the displayed value will effectively start from the stored offset register value (0.000 + 8.000 = 8.000).
13. The contact tip can now be brought into contact with the workpiece to make the measurement and the display will indicate the workpiece size (4.025 + 8.000 = 12.025).

# Quick Guide to Precision Measurement

## Before using the gage head

### About exporting

- Mitutoyo products are subject to Appended Table 1 of the Export Trade Control Ordinance. In order to export relevant products, an application may be required for an export license.

### Avoid installing the gage in locations where:

- The gage will be exposed to direct sunlight, or where the ambient temperature may drop below 0°C or exceed 40°C.
- The relative humidity may drop below 20%RH or exceed 80%RH, or where a sudden change in temperature may cause condensation.
- The gage would be subject to corrosive gas, or where combustible materials are placed nearby.
- The gage is subject to air containing significant amounts of dust, salt or iron powder.
- The gage is subject to direct vibration or shock.
- The gage may come in contact with splashed water, oil or chemicals. (The gage system components are not designed for protection against water, oil or chemical attack, except for the gage unit.)
- Electronic noise is likely to affect the gage.

### Conformance to EC Directive (89/336/EEC)

All Linear Gage series (gage head and display unit) conform to EN55011:1992, EN55082-2:1995, EN61000-4-2, ENV50140, ENV50204, ENV50141 and EN61000-4-4.

### Preventing electrical interference

- Bundling the sensor cable with high-voltage lines or power lines may cause the gage to malfunction. The sensor cable run should be completely separate.

### Power supply to the display unit

- If a generic switching regulator is used, provide grounding via the frame's ground terminal or ground terminal of the power supply.
- If a malfunction occurs due to superimposed noise on the power-supply line, use a DC-regulated power supply that incorporates an isolation transformer.

### About grounding

- Avoid sharing the frame ground (F.G.) terminal of this unit with the high-power line grounding but separately connect it to Class 3 Grounding.

### Handling precautions

- This product is a precision measuring instrument. Avoid dropping or otherwise subjecting it to impact.
- The spindle of the gage head is connected to the body via a spring. Be careful not to pull the spindle in the extending direction or rotate it with force. Doing so may cause permanent distortion and damage to the spring.
- The gage is shipped with a standard contact point (**901312** or **900032** for the inch version of the LGS) installed on the spindle. This contact point can be replaced with a different type that best suits the shape of workpiece. (See page 36.)

When installing or removing a contact point, place the wrench provided on the catch in order to keep the spindle from rotating. Then grip the contact point with pliers to install or remove it.

When gripping the contact point with pliers, insert a piece of felt or other soft packing between the jaws and the point to protect it from damage.

## Gage head mounting precautions

The illustrations below highlight the mounting precautions that should be observed when a gage head or counter is used.

### All models of gage head

- Mount the gage on a fixture or stand by using its stem only.
- Be careful not to over-tighten the stem. Doing so may cause problems in gage operation.
- Never fasten the gage by placing the tip of a screw directly against the stem.
- Never fasten the gage by any section other than its stem.
- Mount the gage in such a way that its stem is in line with the direction of measurement required. If installed at an angle to this direction, measurement errors will occur.
- Be careful not to exert force on the gage via the cables. Exercise due care especially when using an additional extension cable.

### Examples of the plain-stem mount

- The recommended clamping torque is 0.4 to 0.5Nm. Over-tightening the stem clamp will prevent smooth movement of the spindle. Ensure the spindle can move freely after clamping.

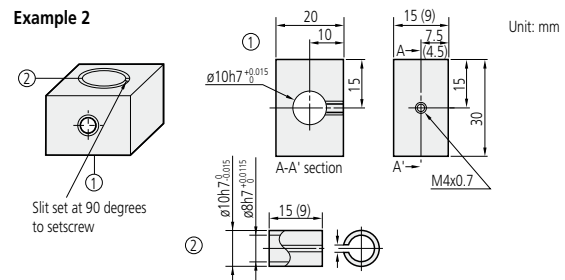
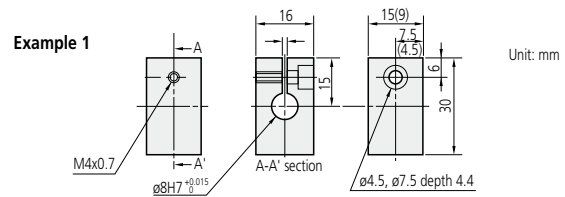

### LGK, LGF and LGD models

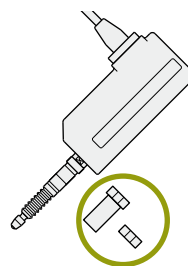

The use of a thrust stem allows a gage head to be mounted securely and easily just by drilling a  $\varnothing 9.5$ mm hole (or  $\varnothing 18$ mm for  $\varnothing 15$ mm stems) in a plate approximately 10mm thick (see page 33). A dedicated (optional) wrench is available that fits the wrench-seat at the top of the stem for holding the gage while the clamping nut is tightened with a spanner. Ensure that no force or torque is applied to the cable during this operation, otherwise damage may be caused.

### LGB model

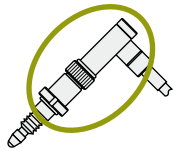

Insert a gage in the mounting hole (recommendation:  $\varnothing 9.5_{H6}$ ) and fix it with the clamp nut supplied. For this gage, be sure to hold the knurled section at the middle of the gage body by hand and tighten the clamp nut with the special wrench supplied. Ensure that no force or torque is applied to the cable during this operation, otherwise damage may be caused. Optional mounting brackets are available. Incidentally, when fabricating a mounting bracket, it is recommended that dimension 'B' (shown on page 32) is 11.5mm.

Gage heads have been widely introduced and accepted in various fields of industries. When it comes to the matter of mounting gage heads onto equipment, however, the problem encountered is a higher cost involved in fabricating mounting brackets. In order to avoid waste of this kind, Mitutoyo offers mounting brackets (material: cast iron, FC45, nickel plated) that have been fabricated with varieties of mounting methods taken into consideration in view of design and machining. (See page 32.)

### Air drive model

- Service air pressure: 0.3 to 0.4MPa
- Lubricating oil: Turbine oil class 1 (ISO VG32)
- Caution: Holding the air cylinder section while mounting gage will exert force on section A, causing a gage failure. For the same reason it is essential not to apply force to section A when connecting an air hose to the gage head.

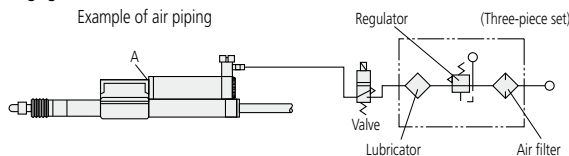

### Laser Hologage

A Laser Hologage can be mounted by inserting its stem in the mounting hole of a dedicated stand or other equipment.

Recommended mounting hole diameter in fixture:  $15\text{mm}^{+0.024}_{-0.006}$

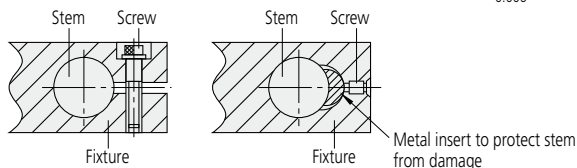

- The mounting hole shall be machined parallel with the direction of measurement. Cosine-effect measurement error will occur if the gage is misaligned with this direction.
- Excessive force in tightening the stem will affect smooth spindle motion and should be avoided.
- In applications where a Laser Hologage is subject to movement, ensure that the mounting is designed to avoid the cable being dragged when in motion.
- Precautions for measurement:
  - To help ensure accuracy, allow 30 minutes warm-up time for the system after powering ON.
  - Allow sufficient time for temperature stabilization for both the gage and workpieces to be measured.
  - Thoroughly clean the contact point and all surfaces to be measured before measurement to avoid accuracy degradation due to dust or grease.
  - Be aware of possible overspeed errors if the contact point is allowed to drop significantly from surface to surface on the workpiece. Appropriate measuring procedures should always be used with due consideration for the part features.

### Replacement of contact point

All models of gage head

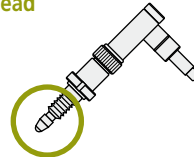

- Engage the key wrench (supplied) with the wrench-seat to prevent the spindle from rotating, grip the contact point with a pair of pliers, then loosen or tighten it as necessary. When gripping a contact point with a pair of pliers, insert a piece of felt or other soft packing between the jaws and the point to protect it from damage.
- Torque exerted via the spindle on the internal mechanism of a gage can cause damage to the gage. To avoid this problem, ensure that the spindle is firmly held with a key wrench before loosening/tightening the contact point.
- Contact points are interchangeable according to the required specification of the customer.

### Display unit mounting precautions

EC, EG, EB and EV counters

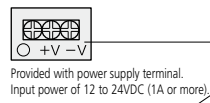

Only the optional I/O output connector **No.02ADB440** is available from Mitutoyo. This is because the number of pins and length of cable varies with application requirements and accordingly wiring is better left for customer's arrangement.

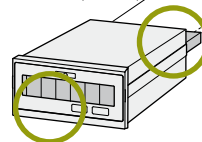

This counter is dedicated to panel-mount application and is not suited for direct bench-mount application. Choose an EH counter for bench-mount or carry-on application.

### About dust / water protection

All gage heads, excluding the LGH and 100mm gage heads, are protected to IP66 or IP54 (DIN40050/IEC529 standards).

- The preamplifiers and counters are not designed to provide dust or water protection. Install them in places where they will not come into direct contact with water or oil.
- When an extension cable is used, seal the preamplifier connection and connectors completely, making sure no portion is left exposed.
- If the cable cover is damaged, water or other liquids may enter the gage due to the capillary effect, causing gage failure. If the cable cover becomes damaged it should be repaired or replaced immediately.
- Handle the gage with due caution to make sure that the rubber boots will not be damaged by scuffing, etc. If the rubber boots are damaged, the gage can no longer be protected from dust or water. When damage is found, repair or replace the boots immediately.
- The rubber material used for the boots and seals does not provide complete protection against coolants and chemicals, which are becoming increasingly complex in composition. If rubber parts are found to have deteriorated significantly, contact your nearest Mitutoyo office.
- The gage must not be disassembled, since it will break the seals of various components. Never attempt to disassemble the gage. Doing so will prevent the gage from functioning to its original specifications.



**Low-cost type — LGS 1012P**



**A slim-body model — LGK series**

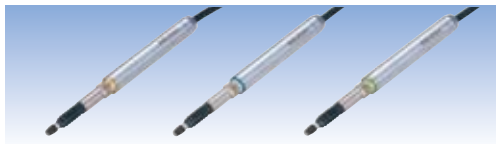

**Assembly type display unit — EG counter**



**Multi-gage system — EV counter**



Export permission by the Japanese government may be required for exporting our products according to the Foreign Exchange and Foreign Trade Law. Please consult our sales office near you before you export our products or you offer technical information to a nonresident.

- Coordinate Measuring Machines
- Vision Measuring Systems
- Form Measurement
- Optical Measuring
- Sensor Systems
- Test Equipment and Seismometers
- Digital Scale and DRO Systems
- Small Tool Instruments and Data Management



**Mitutoyo Corporation**

20-1, Sakado 1-Chome,  
 Takatsu-ku, Kawasaki-shi,  
 Kanagawa 213-8533, Japan  
 T +81 (0) 44 813-8230  
 F +81 (0) 44 813-8231  
<http://www.mitutoyo.co.jp>

Note: All information regarding our products, and in particular the illustrations, drawings, dimensional and performance data contained in this pamphlet, as well as other technical data are to be regarded as approximate average values. We therefore reserve the right to make changes to the corresponding designs, dimensions and weights. The stated standards, similar technical regulations, descriptions and illustrations of the products were valid at the time of printing. Only quotations submitted by ourselves may be regarded as definitive.

