

2/2 SOLENOID VALVES DIRECT AND PILOT OPERATED

Product Index

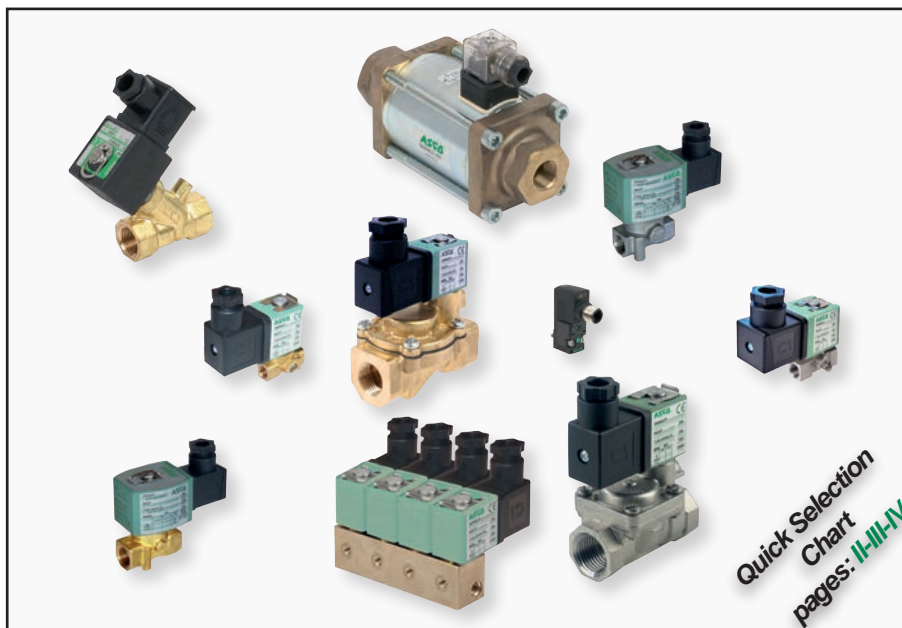

Function	Δ P		Temperature		Pipe connections	Series	page
	min. (bar)	max. (bar)	min. (°C)	max. (°C)			
BRASS BODY							
NC-NO	0	28	-10	+100	1/8 - 1/4	256	3
	0	103	-25	+80	1/8-1/4	262	5
	0	34	-25	+80	3/8	263	17
	0	1	-20	+90	3/8 .. 3/4	030	23
	0	40	-20	+100	Coaxial 3/8 .. 1	287	25
NC	0	20	-10	+100	Manifolds 1/8	256	35
NC-NO	0	103	-25	+80	pad mount (1/4-1/2)	262	37
NC	0	10	-20	+85	3/8 .. 1	238	43
NC-NO	0	9	-20	+85	3/8 .. 1 1/2	210	45
NC	0,3	16	-10	+85	3/8 .. 2	238	49
NC-NO	0,35	20	-20	+85	3/8 .. 2	210	53
NC	0,07	24	-20	+90	3/8 .. 1 1/2	210	59
	0,7	100	-20	+90	1/4 .. 3/4	223	63
STAINLESS STEEL BODY							
NC-NO	0	7	0	+60	M5 / pad mount	065	1
	0	28	-10	+100	1/8 - 1/4	256	3
	0	151	-25	+80	1/8-1/4	262	5
	0	150	-20	+90	1/4	262	15
	0	34	-25	+80	3/8	263	17
	0	40	-20	+100	Coaxial 3/8 .. 1	287	25
	0	9	-20	+85	3/8 .. 1 1/2	210	45
	0	12	0	+130	3/8 .. 1	238	51
	0,35	9	-20	+85	1 1/4 .. 2	210	53
	NC	0,07	9	-20	+90	3/8 - 1/2	210
1,8		100	-20	+90	1/2 - 3/4	223	63
ALUMINIUM BODY							
NC-NO	0	9	-20	+85	3/8 .. 3	215	65
SYNTHETIC BODY							
NC	0	10	-25	+40	CNOMO, size 15 pad mount (M5/instant fittings)	302	27
	0	16	-10	+80	pad mount (M5)	108	33

(Potentially explosive atmospheres, see pages: V - VI)

				group II																		
				dusts		gas / dusts																
				zone 22	zones 2 - 22	zones 1 - 21					zones 0 - 20											
				3 D Ex tc	3 G Ex nA 3 D Ex tc	2 G Ex db 2 D Ex tb					2 G Ex eb mb 2 D Ex tb	2 G Ex mb 2 D Ex mb	1G Ex ia 1D Ex ia									
				IIC T115°C Dc IP65X	IIC T6..T4 Gc/ IIC IP65 T85°C.. T135°C Dc	IIC T6..T4 Gb /IIC Db IP66/67					IIC T5..T3 Gb /IIC Db IP67	IIC T6..T4 Ga, IIC T85°C..T135°C Da										
page	series	power coil (W)		SG (XM5)	SG (C25)	SG (M6-II)	SG (MXX-II)	302	NF (MXX)	NF (M12)	WSNF (MXX)	WSNF (M12)	EM (M6)	EM (MXX)	EM (M12)	WSEM (M6)	WSEM (MXX)	WSEM (M12)	PV (EM5)	PV (EMXX)	302	
		AC (~)	DC (=)																			
3	256	4		⊕																		
		5	6,9	⊕																6,9		
5	262	8,1	-		⊕								9									
		-	10,6		⊕								15,3									
		11,1	-		⊕									15,3								
		-	18,6		⊕																	
		10,1	-		⊕				10,5	10,5				10,5								10,5
		-	11,6		⊕				11,2	11,2				11,2								11,2
15	262	6	9,7										⊕									
		9	-										⊕									
		-	15,3										12,5			⊕						
		10,5	11,2					⊕	⊕				⊕			⊕					⊕	
		16,7	-					⊕	⊕				⊕			⊕					⊕	
17	263	8,1	-		⊕								9									
		-	10,6		⊕								15,3									
		11,1	-		⊕								15,3									
		-	18,6		⊕																	
		10,1	-		⊕				10,5	10,5				10,5								10,5
		-	11,6		⊕				11,2	11,2				11,2								11,2
23	030	6	9,7										⊕									
		10,5	11,2					⊕	⊕				⊕			⊕						
		16,7	-					⊕	⊕				⊕			⊕						
		15,4	16,8					⊕	⊕				⊕			⊕						
		20	-					⊕	⊕				⊕			⊕						
27	302	-	-																	⊕		
33	108	2,5	3	⊕														⊕				
37	262	10,1	11,6		⊕																	
43	238	6	-																			
		9	-																			
45	210	-	15,3																			
		10,5	11,2					⊕	⊕				⊕			⊕					⊕	
		16,7	-					⊕	⊕				⊕			⊕						
		15,4	-					⊕	⊕				⊕			⊕						
		20	-					⊕	⊕				⊕			⊕						
-	23																					
-	30,6																					

00027GB-2019/R02 Availability, design and specifications are subject to change without notice. All rights reserved.

 		operators (See Explosionproof Solenoids section)		group II																
				dusts		gas / dusts														
				zone 22	zones 2 - 22	zones 1 - 21				zones 0 - 20										
				3 D Ex tc	3 G Ex nA 3 D Ex tc	2 G Ex db 2 D Ex tb		2 G Ex eb mb 2 D Ex tb		2 G Ex mb 2 D Ex mb		1G Ex ia 1D Ex ia								
power coil (W)	III C T115°C Dc IP65X	III C T6..T4 Gc / III C IP65 T85°C.. T135°C Dc	III C T6..T4 Gb /III C Db IP66/67	III C T6..T3 Gb /Ex tb III C Db IP66/67	III C T5..T3 Gb /III C Db IP67	III C T6..T4 Ga, III C T85°C..T135°C Da														
AC (~)	DC (=)	SG (XM5)	SG (C25)	SG (M6-II)	SG (MXX-II)	302	NE (MXX)	NE (M12)	WSNF (MXX)	WSNF (M12)	EM (M6)	EM (MXX)	EM (M12)	WSEM (M6)	WSEM (MXX)	WSEM (M12)	PV (EM5)	PV (EMXX)	302	
49	238	4	-	⊕														⊕		
		-	6,9	⊕														⊕		
		5	-	⊕														⊕		
		-	5	⊕														⊕		
		8	9																	
51	238	4	-	⊕														⊕		
		-	6,9	⊕														⊕		
		-	5	⊕														⊕		
53	210	6	-				⊕													
		-	11,2				⊕													
		16,7	-				⊕													
		15,4	16,8				⊕													
		8,1	-	⊕																
			11,6				⊕													
59	210	6	-				⊕													
		-	11,2				⊕													
		16,7	-				⊕													
		15,4	16,8				⊕													
		20	-				⊕													
			30,6				⊕													
63	223	10,5	11,2				⊕													
		16,7	-				⊕													
		-	19,7				⊕													
65	215	10,5	11,2				⊕													
		15,4	-				⊕													
		-	14,9				⊕													
		28,2	-				⊕													



SOLENOID VALVES

direct operated, quick switching
threaded or pad-mount body
M5

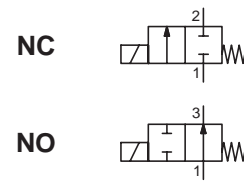

2/2
Series
065

FEATURES

- Miniature solenoid valve for medical analyzers, gas analyzers and leak detectors
- New flat-spring technology ensures no contamination of fluids (no friction)
- Suitable for the control of gases
- The valves have a service life of more than 1 billion cycles when used with inert gas
- Short response times
- Easy to integrate thanks to the valves' small size
- Available in a variety of versions for a wide range of applications: threaded connections or pad-mount for installation on multiple manifolds
- Vacuum application up to 0,1 bar abs. (0,6 mm and 1 mm dia. orifice sizes)

GENERAL

Differential pressure	See «SPECIFICATIONS» [1 bar =100 kPa]
Maximum viscosity	20 cSt (mm ² /s)
Response time	< 10 ms
Internal volume	≤ 350 µl (couplings not included)

fluids (*)	temperature range (TS)	seal materials (*)
air, inert gases (filtered 50 µm)	0°C to +60°C	FPM (fluoroelastomer) ⁽²⁾

MATERIALS IN CONTACT WITH FLUID

(*) Ensure that the compatibility of the fluids in contact with the materials is verified

Body	Stainless steel, AISI 303 (1.4305)
Plugnut	Stainless steel
Spring disc	Stainless steel
Seat	Stainless steel
Seals	FPM
Disc	FPM

ELECTRICAL CHARACTERISTICS

Coil insulation class	F
Connection	Cable leads (ETFE); 0,35 m length
Electrical safety	IEC 335
Electrical enclosure protection	IP40 (EN 60529)
Standard voltages	DC (=) : 6V - 12V - 24V

prefix option	power ratings			operator ambient temperature range (TS) (C°)	replacement coil	type ⁽¹⁾
	inrush ~ (VA)	holding ~ (W)	hot/cold = (W)			
L	-	-	-	2,1 / 2,1	-	01

⁽¹⁾ Refer to the dimensional drawings on the following page.

SPECIFICATIONS

pipe size	orifice size (mm)	flow coefficient Kv (m ³ /h) (l/min)		operating pressure differential (bar)		power coil (W)	catalogue number	
				min.	max. (PS)		threaded	pad-mount body
					air, inert gases (*)			
NC - Normally closed								
M5 ⁽³⁾	0,6	0,013	0,22	0	7	2,1	LE065A001V	LS065A001V
	1	0,025	0,43	0	5	2,1	LE065A002V	LS065A002V
	1,4	0,032	0,54	0	3	2,1	LE065A003V	LS065A003V
	2	0,057	0,95	0	1,5	2,1	LE065A004V	LS065A004V
NO - Normally open								
M5	0,6	0,013	0,22	0	7	2,1	LE065A005V	-
	1	0,025	0,43	0	5	2,1	LE065A006V	-
	1,4	0,032	0,54	0	3	2,1	LE065A007V	-
	2	0,057	0,95	0	1,5	2,1	LE065A008V	-

⁽²⁾ FFPM seals for corrosive fluids (Contact us).

⁽³⁾ External thread with pad-mount body.

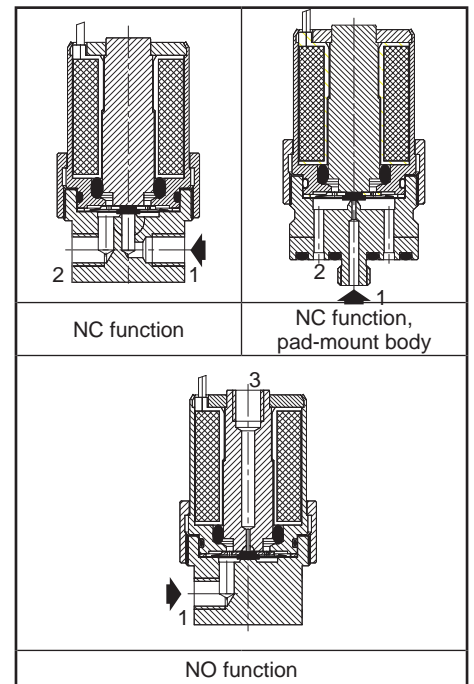

00157GB-2017/R01
Availability, design and specifications are subject to change without notice. All rights reserved.

OPTIONS (on request)

- Other seal materials
- Response time 2-3 ms
- Oxygen service
- Other pipe connections are available
- 0,7 W rated coil

INSTALLATION

- The solenoid valves can be mounted in any position without affecting operation
- Threaded solenoid valves have 2 mounting holes in body
- Pad-mount valves and o-ring seals for multiple manifolds

ORDERING EXAMPLES:

L	E	065	A	001	V	6V / DC
L	E	065	A	002	V	24V / DC
L	S	065	A	006	V	12V / DC
L	S	065	A	007	V	6V / DC

prefix ————
 pipe thread ————
 basic number ————
 voltage ————
 suffix ————

DIMENSIONS (mm), WEIGHT (kg)

TYPE 01
Prefix "L" Solenoid
Cable ends
IP40

LE065A001V/002V/003V/004V

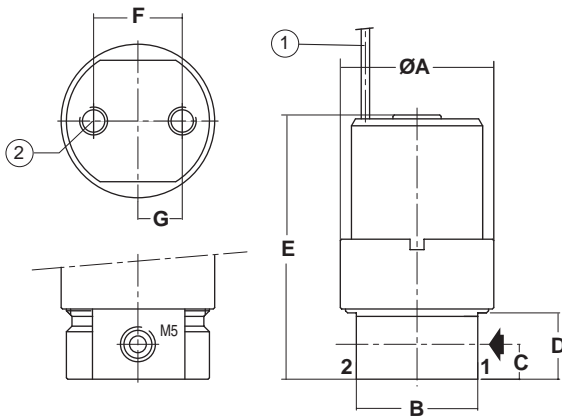

LS065A001V/002V/003V/004V

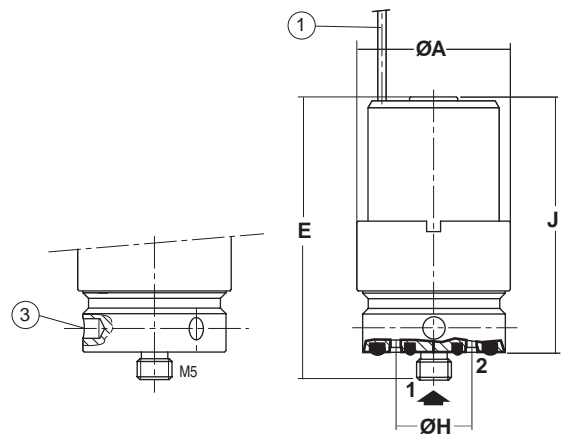

LE065A005V/006V/007V/008V

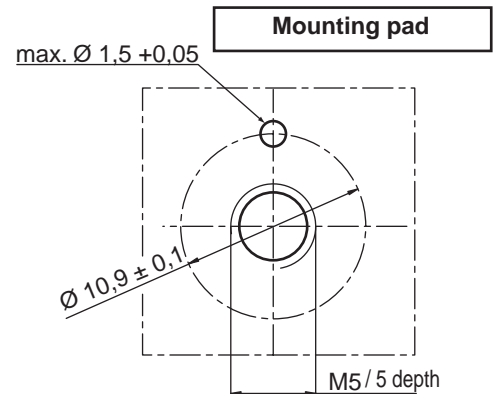
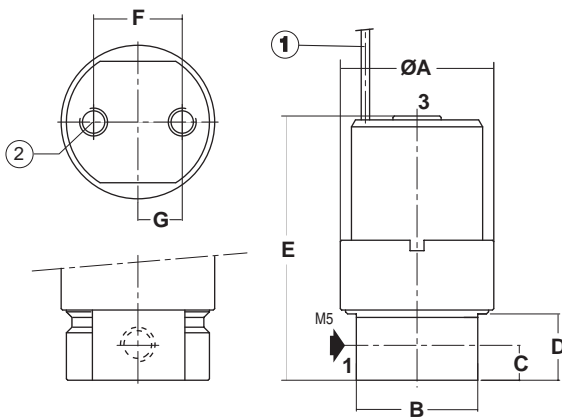

type	prefix option	catalogue number	A	B	C	D	E	F	G	H	J	weight ⁽¹⁾
01	L	LE065A001V/002V/003V/004V	22	17,4	5	9,5	38	12,7	6,35	-	-	0,074
		LS065A001V/002V/003V/004V	22	-	-	-	41	-	-	10,9	37	0,066
		LE065A005V/006V/007V/008V	22	17,4	5	9,5	38	12,7	6,35	-	-	0,071

⁽¹⁾ Including leads, length 0,35 m.

- ① 2 electrical supply wires, length: 0,35 m.
- ② 2 mounting holes Ø M4, depth 6 mm.
- ③ Mounting with hook spanner wrench DIN 1810B.

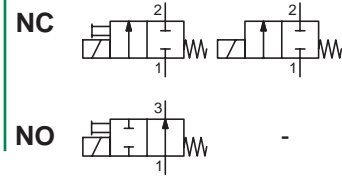

FEATURES

- Wide range of flow and pressure ratings
- Quick disassembly of core tube for easy maintenance of internal parts
- Standard disc seal made of FPM suitable for a wide range of operating temperatures and compatible with many fluids
- Standard manual operator allows an easy installation (Except 4 and 5 mm orifice sizes)
- AC/DC interchangeability of the solenoid without disassembly of the valve
- Compliance with UL and CSA standards (coil 4/6,9 W)
- Compact and low weight valve
- The solenoid valves satisfy all relevant EU directives

GENERAL

Differential pressure See «SPECIFICATIONS» [1 bar =100 kPa]
Maximum viscosity 40 cSt (mm²/s)
Response time 5 - 10 ms

fluids (*)	temperature range (TS)	seal materials (*)
air, inert gas, water, oil	-10°C to +100°C	FPM (fluoroelastomer)

MATERIALS IN CONTACT WITH FLUID

(*) Ensure that the compatibility of the fluids in contact with the materials is verified

	Brass body	Stainless steel body
Body	Brass	AISI 316
Core tube	Stainless steel	Stainless steel
Core and plugnut	Stainless steel	Stainless steel
Springs	Stainless steel	Stainless steel
Seat	Brass	Stainless steel
Seals	FPM	FPM
Disc	FPM	FPM
Shading coil	Copper	Copper

ELECTRICAL CHARACTERISTICS

Coil insulation class F
Connector Spade plug (cable Ø 6-8 mm or Ø 6-10 mm)
Connector specification DIN 43650, 11 mm, industry standard B (type 01) or ISO 4400 / EN 175301-803, form A (type 02)
Electrical safety IEC 335
Electrical enclosure protection Moulded IP65 (EN 60529)
Standard voltages DC (=) : 24V - 48V
 (Other voltages and 60 Hz on request) AC (~) : 24V - 48V - 115V - 230V / 50 Hz

prefix option	power ratings				operator ambient temperature range (TS) (C°)	replacement coil		type ⁽¹⁾
	inrush ~	holding ~	hot/cold =			~	=	
	(VA)	(VA)	(W)	(W)		230 V/50 Hz	24 V DC	
SC	12	6	4	5 / 6,9	-10 to +60	400127-197	400127-142	01
	15	7	5	4 / 5	-10 to +60	400727-117	400727-185	02

⁽¹⁾ Refer to the dimensional drawings on the following page.

SPECIFICATIONS

pipe size	orifice size	flow coefficient Kv		operating pressure differential (bar)								power coil (W)		catalogue number		options		
				min.	max. (PS)						EPDM					-	-	
					air (*)	water (*)	oil (*)	~	=	~								=
G	(mm)	(m ³ /h)	(l/min)		~	=	~	=	~	=	~	=	~/=	~/=				
NC - Normally closed																		
1/8	1,2	0,05	0,8	0	28	20	28	20	28	20	4	6,9	SCG256B001VMS	SCG256B013VMS	E	-	-	
	1,6	0,08	1,33	0	20	12	20	12	20	12	4	6,9	SCG256B002VMS	SCG256B014VMS	E	-	-	
	2,0	0,11	1,83	0	15	6	15	6	15	6	4	6,9	SCG256B003VMS	SCG256B015VMS	E	-	-	
	2,4	0,13	2,16	0	12	4	12	4	12	4	4	6,9	SCG256B004VMS	SCG256B016VMS	E	-	-	
1/4	1,6	0,08	1,33	0	20	12	20	12	20	12	4	6,9	SCG256B402VMS	SCG256B414VMS	-	-	-	
					20	15	20	15	20	15	5	5	SCG256B466VMS	SCG256B434VMS	-	-	-	
	2,4	0,16	2,67	0	12	4	12	4	12	4	4	6,9	SCG256B404VMS	SCG256B416VMS	-	-	-	
					15	8	15	8	15	8	5	5	SCG256B470VMS	SCG256B436VMS	-	-	-	
	4	0,33	5,5	0	5	2	5	2	5	2	5	5	SCG256B471V	-	-	-	-	
	5	0,45	7,5	0	3	1	3	1	3	1	5	5	SCG256B472V	-	-	-	-	
NO - Normally open																		
1/8	1,2	0,05	0,8	0	10	10	10	10	10	10	4	6,9	SCG256B006VMS	SCG256B018VMS	E	-	-	

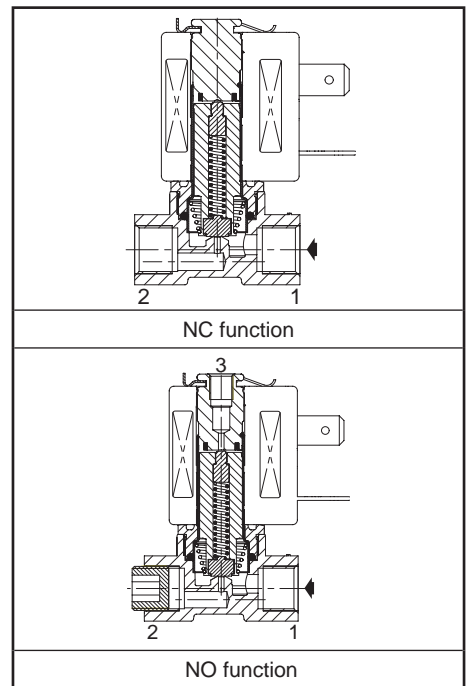

OPTIONS

- Valves can also be supplied with EPDM (ethylene-propylene) seals and discs. Use the appropriate optional suffix letter for identification (1/8 version only)
- Explosionproof enclosures for use in zones 1/21-2/22, categories 2-3 to ATEX Directive 2014/34/EU (www.asco.com)
- Flying leads coil, use prefix L (e.g.: LG256B001VMS) (4 W/6,9 W coil only)
- Oxygen service with seals and disc in FPM, suffix NV, example: SCG256B001NVMS
- Solenoid valves integrated on manifold, orifice sizes 1,2 - 1,6 - 2 - 2,4 mm (www.asco.com)
- Without manual operator, on request
- Other pipe connections are available on request
- Connector with visual indication and peak voltage suppression or with cable length of 2 m (www.asco.com)

INSTALLATION

- The solenoid valves can be mounted in any position without affecting operation
- Solenoid valves have 2 mounting holes in body
- Pipe connection identifier is G = G (ISO 228/1)
- Installation/maintenance instructions are included with each valve

ORDERING EXAMPLES:

SC	G	256	B 001	VMS	230V / 50 Hz
SC	G	256	B 002	EMS	115V / 50 Hz
SC	G	256	B 014	NVMS	24V / DC
SC	G	256	B 001	FWMS	24V / DC
SC	G	256	B 471	V	230V / 50 Hz
SC	G	256	B 006	VMS	230V / 50 Hz

prefix: SC
 pipe thread: G
 basic number: 256
 voltage: 230V / 50 Hz
 suffix: VMS

DIMENSIONS (mm), WEIGHT (kg)

TYPE 01
 Prefix "SC" Solenoid
 Epoxy moulded
 IEC 335 / DIN 43650
 IP65

NC (1/8): SCG256B001V/002V/003V/004V/013V/014V/015V/016V
 NO (1/8): SCG256B006V/018V

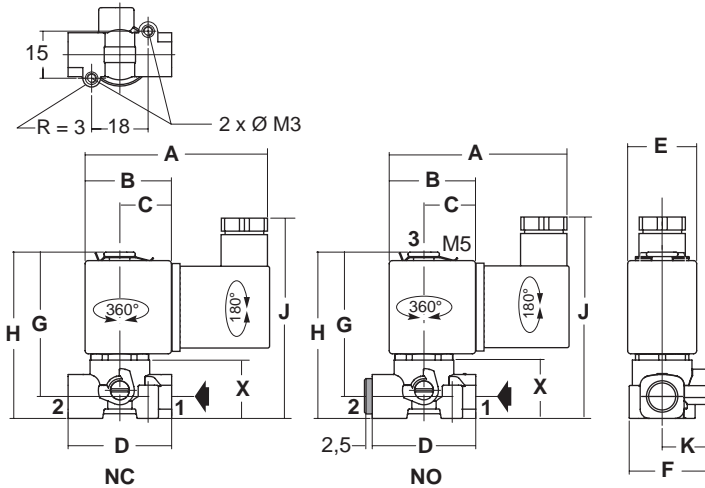

TYPE 02
 Prefix "SC" Solenoid
 Epoxy moulded
 IEC 335 / ISO 4400
 IP65

NC (1/4): SCG256B434VMS/436VMS/466VMS/470VMS/471V/472V

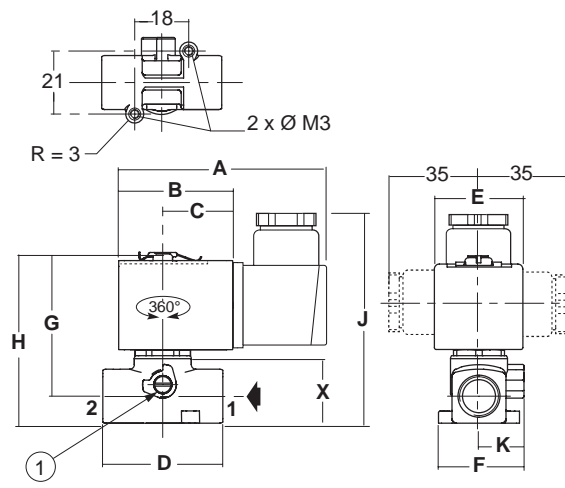

① Except catalogue numbers: SCG256B471V/472V

NC (1/4): SCG256B402VMS/404VMS/414VMS/416VMS

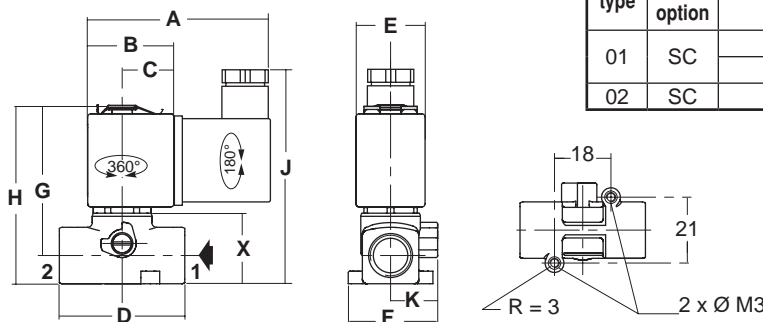

type	prefix option	pipe size	A	B	C	D	E	F	G	H	J	K	X
01	SC	1/8	60,5	27,5	16,5	33	22	25,5	46	53	69	15	18,6
		1/4	60,5	27,5	16,5	40	22	28,5	48	57	76	15	23,4
02	SC	1/4	76	38	23,3	40	29,7	28,5	48	57	78,5	15	23,4

type	prefix option	pipe size	weight ⁽²⁾	
			brass	stainless steel
01	SC	1/8	0,152	0,148
		1/4	0,180	0,177
02	SC	1/4	0,235	0,232

²⁾ Incl. coil(s) and connector(s).

ASCO™ Solenoid Valves

For High Pressure Fluids

Direct Operated, 1/8" or 1/4" tapped, 15 mm Compression Fittings

2/2 NC-NO

Series

262

- High operating pressure
- RoHS compliance
- AC/DC interchangeability of the coil possible only for NC (10,1 W/11,6 W and 17,1 W/22,6 W)
- Valves do not require a minimum operating pressure
- Large selection of seal materials providing wide chemical compatibility
- Compliance with UL and CSA standards
- The solenoid valves satisfy all relevant EU directives

General

Differential pressure See «SPECIFICATIONS» [1 bar = 100 kPa]
Maximum viscosity 65 cSt (mm²/s)
Response time 5 - 25 ms

fluids (*)	temperature range (TS)	seal materials (*)
air, inert gas, water, oil	-25°C to +80°C	NBR (nitrile)
	0°C to +60°C	UR (cast urethane)

Materials in contact with fluid

(*) Ensure that the compatibility of the fluids in contact with the materials is verified

Body Brass or Stainless steel, AISI 304
Shading coil Copper or Silver
Core tube Stainless steel, AISI 305
Core and plugnut Stainless steel, AISI 430F
Springs Stainless steel, AISI 302
Seal NBR
Disc NBR or UR
Disc holder (NO function) PA

Electrical characteristics

Coil insulation class F (AC) or H (DC)
Connector Spade plug (cable Ø 6-10 mm)
Connector specification ISO 4400 / EN 175301-803, form A
Electrical safety IEC 335
Electrical enclosure protection Moulded IP65 (EN 60529)
Standard voltages DC (=) : 24V - 48V
 (Other voltages and 60 Hz on request) AC (-) : 24V - 48V - 115V - 230V/50 Hz

operator ambient temperature range (TS) (°C)	power ratings				replacement coil ⁽¹⁾	
	inrush ~ (VA)	holding ~ (VA)	hot/cold = (W)	hot/cold = (W)	~ 230 V/50 Hz	= 24 V DC
-25 to +55	30	16	8,1	7,7/ 10,6	238213-059	238513-006
	45	20	11,1	12,5/18,6	238213-157	238513-106
	50	25	10,1	8,5/11,6	238613-059	238913-006
	70	40	17,1	15,1/22,6	238613-159	238913-106

⁽¹⁾ All 238 basic numbers are UL & CSA approved and marked with the UR (recognised component) & CSA logos.

Options

- Seals and disc (τ) ⁽²⁾ (fluid temperature range)
 - FPM (fluoroelastomer): -15°C to +100°C (coil class F), -15°C to +120°C (coil class H)
 - EPDM (ethylene-propylene), 0°C to +100°C
 - CR (chloroprene), 0°C to +80°C
 - PTFE: -15°C to +100°C (coil class F), -15°C to +120°C (coil class H)
- Oxygen service, FPM disc and seals, see "15-DIGIT PRODUCT CODE"
- WRAS approval, EPDM disc and seals, see "15-DIGIT PRODUCT CODE"
- Magnetic latching versions, reverse polarity DC voltages, see "15-DIGIT PRODUCT CODE FOR MAGNETIC LATCHING VERSION ONLY"
- 15 mm compression-fitting body, supplied with nut and olive, see "15-DIGIT PRODUCT CODE"
- Connector with visual indication and peak voltage suppression or with cable length of 2 m
- Explosionproof enclosures for use in zones 1/21-2/22, categories 2-3 to ATEX Directive 2014/34/EU (See page: 8)

(*) Ensure that the compatibility of the fluids in contact with the materials is verified.

⁽²⁾ The minimum ambient temperature of the solenoid valve is determined by the limitations of minimum temperature indicated.

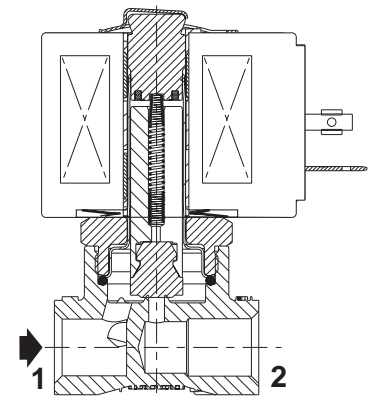
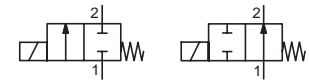

NC function

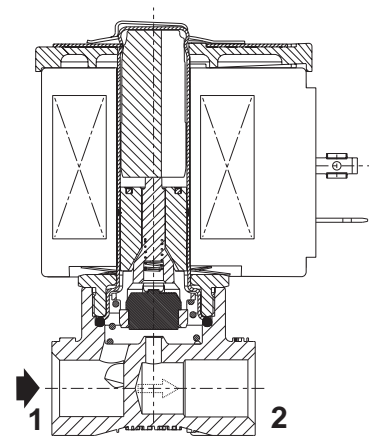

NO function

Specifications

															15-DIGIT PRODUCT CODE							
pipe size	orifice size	flow coefficient Kv			operating pressure differential (bar)						power coil (W)		thread type	dimensions / type ⁽¹⁾	brass	stainless steel	voltage code					
					max. (PS)												24 V/50 Hz	48 V/50 Hz	115 V/50 Hz	230 V/50 Hz	24 V/DC	48 V/DC
		min.	air (*)		water (*)		oil (*)		~	=	~	=										
(mm)	(m ³ /h)	(l/min)	~	=	~	=	~	=	~	=	~	=	~	=								
Without manual operator																						
NC - Normally closed, NBR seal and disc																						
1/8	1,2	0,05	0,8	0	51	51	51	41	50	34	8,1	10,6	G	01	G262K001S1N00	-	FL	FR	FT	F8	H1	H9
					NPT	01	-	8262K012S1N00														
	2,4	0,18	3	0	25	14	22	10	13	10	8,1	10,6	G	01	G262K014S1N00	-						
					NPT	01	-	8262K015S1N00														
	3,2	0,3	5	0	12	8	12	6,5	8	6	8,1	10,6	G	01	G262K002S1N00	-						
					NPT	01	-	8262K006S1N00														
1/4	1,2	0,05	0,8	0	103	68	103	66	103	58	10,1	11,6	G*	02	E262K200S1W00 ⁽²⁾	-						
					G*	02	-	E262K214S1W00 ⁽²⁾														
					NPT	02	-	8262K214S1W00 ⁽²⁾														
					G*	01	E262K019S1N00	-														
					NPT	01	-	8262K080S1N00														
					G*	01	E262K020S1N00	-														
	2,4	0,18	3	0	25	14	22	10	11	10	8,1	10,6	G*	01	E262K020S1N00	-						
					NPT	01	-	8262K086S1N00														
					G*	01	E262K021S1N00	-														
					G*	02	E262K108S1N00	E262K182S1N00														
					NPT	02	-	8262K182S1N00														
					G*	02	E262K109S1N00	E262K183S1N00														
3,2	0,3	5	0	12	8	12	6,5	6	5,5	8,1	10,6	G*	01	E262K022S1N00	-							
				NPT	01	-	8262K007S1N00															
				G*	01	E262K023S1N00	-															
				G*	02	E262K232S1N00	E262K184S1N00															
				NPT	02	-	8262K184S1N00															
				G*	02	E262K110S1N00	E262K185S1N00															
4	0,45	7,5	0	7	5	7	4	4	4	8,1	10,6	G	01	E262K111S1N00	E262K186S1N00							
				NPT	01	-	8262K186S1N00															
				G*	02	E262K202S1N00	E262K220S1N00															
				NPT	02	-	8262K220S1N00															
				G*	02	E262K112S1N00	E262K187S1N00															
				NPT	02	-	8262K187S1N00															
5,6	0,63	10,5	0	6,5	2	6,5	2	6,5	2	10,1	11,6	G*	02	E262K208S1N00	E262K226S1N00							
				NPT	02	-	8262K226S1N00															
				G*	02	E262K114S1N00	E262K188S1N00															
				NPT	02	-	8262K188S1N00															
				G*	01	E262K013S1N00	-															
				NPT	01	-	8262K036S1N00															
7,1	0,76	12,7	0	2	1,6	2	1,5	2	1,3	8,1	10,6	G*	01	E262K090S1N00	-							
				NPT	01	-	8262K038S1N00															
				G*	02	E262K210S1N00	E262K189S1N00															
				NPT	02	-	8262K189S1N00															
				G*	02	E262K212S1N00	E262K230S1N00															
				NPT	02	-	8262K230S1N00															

⁽¹⁾For dimensions, see drawing(s) for each construction type on the following page(s).
(*) Ensure that the compatibility of the fluids in contact with the materials is verified.

⁽²⁾ UR disc only, fluid temperature 0°C to +60°C, no other elastomer can be used.

Specifications

															15-DIGIT PRODUCT CODE							
pipe size	orifice size	flow coefficient Kv			operating pressure differential (bar)						power coil (W)		thread type	dimensions / type ⁽¹⁾	brass	stainless steel	voltage code					
					max. (PS)												24 V/50 Hz	48 V/50 Hz	115 V/50 Hz	230 V/50 Hz	24 V/DC	48 V/DC
					air (*)		water (*)		oil (*)													
(mm)	(m ³ /h)	(l/min)	min.	~	=	~	=	~	=	~	=	~	=	~	=	~	=					
Without manual operator																						
NO - Normally open, NBR seal and disc																						
1/8	1,2	0,05	0,8	0	79	44	62	33	55	22	10,1	11,6	G 02	G262K155S1W00 ⁽²⁾	G262K168S1W00 ⁽²⁾	FL	FR	FT	F8	H1	H9	
					51	44	51	38	51	27	10,1	11,6	NPT 02	-	8262K168S1W00 ⁽²⁾							
	2,4	0,18	3	0	18	11	15	9	12	6,5	10,1	11,6	G 02	G262K128S1N00	G262K236S1N00							
					NPT 02	-	8262K236S1N00															
	3,2	0,3	5	0	11	6,5	10	6,5	8,5	4,5	10,1	11,6	G 02	G262K129S1N00	G262K237S1N00							
					NPT 02	-	8262K237S1N00															
1/4	1,2	0,05	0,8	0	79	44	62	33	55	22	10,1	11,6	G* 02	E262K161S1W00 ⁽²⁾	E262K199S1W00 ⁽²⁾							
					51	44	51	38	51	27	10,1	11,6	NPT 02	-	8262K199S1W00 ⁽²⁾							
	2,4	0,18	3	0	18	11	15	9	12	6,5	10,1	11,6	G* 02	E262K260S1N00	E262K130S1N00							
					NPT 02	-	8262K130S1N00															
	3,2	0,3	5	0	11	6,5	10	6,5	8,5	4,5	10,1	11,6	G* 02	E262K261S1N00	E262K134S1N00							
					NPT 02	-	8262K134S1N00															
4	0,47	7,8	0	6	4	6	3,5	4,5	3	10,1	11,6	G* 02	E262K262S1N00	E262K138S1N00								
				NPT 02	-	8262K138S1N00																
5,6	0,72	12	0	3	2	3	1,7	2,5	1,7	10,1	11,6	G* 02	E262K263S1N00	E262K142S1N00								
				NPT 02	-	8262K142S1N00																
7,1	0,83	13,8	0	3	2	3	1,7	2,5	1,7	10,1	11,6	G* 02	E262K264S1N00	E262K148S1N00								
				NPT 02	-	8262K148S1N00																
7,1	0,83	13,8	0	2	1,3	2	1,1	2	1,1	10,1	11,6	G* 02	E262K265S1N00	E262K148S1N00								
				NPT 02	-	8262K152S1N00																
With maintained manual operator																						
NC - Normally closed, NBR seal and disc																						
1/4	2,4	0,18	3	0	40	16	28	16	28	15	10,1	11,6	G* 02	E262K108S1N01	E262K182S1N01	FL	FR	FT	F8	H1	H9	
					49	41	28	28	28	27	17,1	22,6	NPT 02	-	8262K182S1N01							
	3,2	0,3	5	0	23	7,5	20	7	14	6,5	10,1	11,6	G* 02	E262K109S1N01	E262K183S1N01							
					NPT 02	-	8262K183S1N01															
	3,2	0,3	5	0	23	7,5	20	7	14	6,5	10,1	11,6	G* 02	E262K232S1N01	E262K184S1N01							
					NPT 02	-	8262K184S1N01															
	4	0,45	7,5	0	34	17	26	17	24	15	17,1	22,6	G* 02	E262K110S1N01	E262K185S1N01							
					NPT 02	-	8262K185S1N01															
	4	0,45	7,5	0	14	3,5	13	3,5	10	3,5	10,1	11,6	G* 02	E262K202S1N01	E262K185S1N01							
					NPT 02	-	8262K220S1N01															
	4	0,45	7,5	0	14	3,5	13	3,5	10	3,5	10,1	11,6	G* 02	E262K202S1N01	E262K220S1N01							
					NPT 02	-	8262K220S1N01															
	5,6	0,63	10,5	0	6,5	2	6,5	2	6,5	2	10,1	11,6	G* 02	E262K112S1N01	E262K187S1N01							
					NPT 02	-	8262K187S1N01															
	5,6	0,63	10,5	0	6,5	2	6,5	2	6,5	2	10,1	11,6	G* 02	E262K208S1N01	E262K226S1N01							
					NPT 02	-	8262K226S1N01															
	5,6	0,63	10,5	0	8,5	4	8,5	4	8,5	4	17,1	22,6	G* 02	E262K114S1N01	E262K188S1N01							
					NPT 02	-	8262K188S1N01															
7,1	0,76	12,7	0	4	1,5	5	1,5	4	1,3	10,1	11,6	G* 02	E262K210S1N01	E262K189S1N01								
				NPT 02	-	8262K189S1N01																
7,1	0,76	12,7	0	6	3	6	3	6	3	17,1	22,6	G* 02	E262K212S1N01	E262K189S1N01								
				NPT 02	-	8262K230S1N01																

⁽¹⁾ For dimensions, see drawing(s) for each construction type on the following page(s).

(*) Ensure that the compatibility of the fluids in contact with the materials is verified.

⁽²⁾ UR disc only, fluid temperature 0°C to +60°C, no other elastomer can be used.

00167CB-2019/R02
Availability, design and specifications are subject to change without notice. All rights reserved.

Configurator - CAD Files

15-DIGIT PRODUCT CODE
- **262 K 001 S1 N00 H1**

Thread connection
G = ISO 228/1 (1/8)
E = ISO 228/1 & ISO 7/1 (combination thread, G*)
8 = NPT (SAE 71051)
H = 15 mm compression fittings⁽²⁾

Product series
262
Revision letter
K = Initial release

Valves version

Voltage - class
FL = 24 V / 50 Hz - class F
FR = 48 V / 50 Hz - class F
FT = 115 V / 50 Hz - class F
F8 = 230 V / 50 Hz - class F
H1 = 24 V DC - class H
H9 = 48 V DC - class H

Options
Without manual operator
N00 = NBR disc and seals
V00 = FPM disc and seals
VNO = FPM disc and seals for Oxygen service
EMO = EPDM disc and seals, WRAS approved⁽²⁾
E00 = EPDM disc and seals
J00 = CR disc and seals
T00 = PTFE disc and seals⁽¹⁾
With maintained manual operator
N01 = NBR disc and seals
V01 = FPM disc and seals
VN1 = FPM disc and seals for Oxygen service
E01 = EPDM disc and seals
J01 = CR disc and seals

Electrical interface & explosion proof options

- S1 = With spade plug connector
- FN = Aluminium enclosure, 1/2 NPT conduit, IECEx/ATEX
II 2G Ex db IIC Gb / II 2D Ex tb IIIC Db, zone 1-21 (equivalent to NF prefix)⁽³⁾
- FT = Aluminium enclosure, 20 mm conduit, IECEx/ATEX
II 2G Ex db IIC Gb / II 2D Ex tb IIIC Db, zone 1-21 (equivalent to NFET prefix)⁽³⁾
- FS = AISI 316L enclosure, 1/2 NPT conduit, IECEx/ATEX
II 2G Ex db IIC Gb / II 2D Ex tb IIIC Db, zone 1-21 (equivalent to WSNF prefix)⁽³⁾
- FU = AISI 316L enclosure, 20 mm conduit, IECEx/ATEX
II 2G Ex db IIC Gb / II 2D Ex tb IIIC Db, zone 1-21 (equivalent to WSNFET prefix)⁽³⁾
- MV = Steel enclosure, M20 cable gland, IECEx/ATEX
II 2G Ex eb mb IIC Gb / II 2D Ex tb IIIC Db, zone 1-21 (equivalent to EM prefix)⁽³⁾
- MT = Steel enclosure, 20 mm conduit, IECEx/ATEX
II 2G Ex eb mb IIC Gb / II 2D Ex tb IIIC Db, zone 1-21 (equivalent to EMET prefix)⁽³⁾
- MN = Steel enclosure, 1/2 NPT conduit, IECEx/ATEX
II 2G Ex eb mb IIC Gb / II 2D Ex tb IIIC Db, zone 1-21 (equivalent to EMT prefix)⁽³⁾
- MW = AISI 316 enclosure, M20 cable gland, IECEx/ATEX
II 2G Ex eb mb IIC Gb / II 2D Ex tb IIIC Db, zone 1-21 (equivalent to WSEM prefix)⁽³⁾
- MU = AISI 316 enclosure, 20 mm conduit, IECEx/ATEX
II 2G Ex eb mb IIC Gb / II 2D Ex tb IIIC Db, zone 1-21 (equivalent to WSEMET prefix)⁽³⁾
- MS = AISI 316 enclosure, 1/2 NPT conduit, IECEx/ATEX
II 2G Ex eb mb IIC Gb / II 2D Ex tb IIIC Db, zone 1-21 (equivalent to WSEMT prefix)⁽³⁾
- A7 = Moulded enclosure, epoxy encapsulated, integrated cable, IECEx/ATEX
II 2G Ex mb IIC Gb / II 2D Ex mb IIIC Db, zone 1-21 (equivalent to PV prefix)⁽³⁾
- SG = Moulded coil with connector, epoxy encapsulated, ATEX
II 3GD Ex ec IIC Gc / II 3GD Ex tc IIIC Dc, zone 22 (equivalent to SG prefix)⁽³⁾⁽⁴⁾

⁽¹⁾ Max. operating pressure limited to 75% of standard value.
⁽²⁾ Check the online configurator for available versions on Emerson.com/asco
⁽³⁾ Search prefix in Emerson.com/asco to get detailed technical information.
 Please note that the valve pressure ratings with some of the ATEX enclosures will be reduced.
 To obtain the correct pressure rating please check the landing pages of the "2-Way Solenoid Valve DIN Configurator".
⁽⁴⁾ Coils class F only.

00167GB-2019/R02
Availability, design and specifications are subject to change without notice. All rights reserved.

		Spare parts kits no. (*)																
		AC (~)								DC (=)								
		NBR	FPM	FPM (oxygen)	EPDM	EPDM (+WRAS)	CR	PTFE	NBR + UR	NBR	FPM	FPM (oxygen)	EPDM	EPDM (+WRAS)	CR	PTFE	NBR + UR	
E262K013/019/020/021/022/023/090	M200001	N00	V00	VN0	E00	EM0	J00	T00	-	M200005	N00	V00	VN0	E00	EM0	J00	T00	-
E262K08/109/110/112/114	M200007	N00	V00	VN0	E00	EM0	J00	T00	-	M200007	N00	V00	VN0	E00	EM0	J00	T00	-
E262K130	M200017	N00	V00	VN0	E00	EM0	J00	T00	-	M200033	N00	V00	VN0	E00	EM0	J00	T00	-
E262K134	M200018	N00	V00	VN0	E00	EM0	J00	T00	-	M200033	N00	V00	VN0	E00	EM0	J00	T00	-
E262K138/142/148/152	M200018	N00	V00	VN0	E00	EM0	J00	T00	-	M200034	N00	V00	VN0	E00	EM0	J00	T00	-
E262K161	M200021	-	-	-	-	-	-	-	W00	-	-	-	-	-	-	-	-	-
E262K182/183/184/185/187/188/189	M200008	N00	V00	VN0	E00	EM0	J00	-	-	M200008	N00	V00	VN0	E00	EM0	J00	-	-
E262K200	M200007	-	-	-	-	-	-	-	W00	M200007	-	-	-	-	-	-	-	W00
E262K202/208/210/212	M200007	N00	V00	VN0	E00	EM0	J00	T00	-	M200007	N00	V00	VN0	E00	EM0	J00	T00	-
E262K214	M200008	-	-	-	-	-	-	-	W00	M200008	-	-	-	-	-	-	-	W00
E262K220/226/230	M200008	N00	V00	VN0	E00	EM0	J00	-	-	M200008	N00	V00	VN0	E00	EM0	J00	-	-
E262K232	M200007	N00	V00	VN0	E00	EM0	J00	T00	-	M200007	N00	V00	VN0	E00	EM0	J00	T00	-
E262K260	M200015	N00	V00	VN0	E00	EM0	J00	T00	-	M200031	N00	V00	VN0	E00	EM0	J00	T00	-
E262K261	M200016	N00	V00	VN0	E00	EM0	J00	T00	-	M200031	-	-	-	-	-	-	-	W00
E262K262/263/264/265	M200016	N00	V00	VN0	E00	EM0	J00	T00	-	M200032	N00	V00	VN0	E00	EM0	J00	T00	-
G262K001/002/014/016	M200001	N00	V00	VN0	E00	EM0	J00	T00	-	M200005	N00	V00	VN0	E00	EM0	J00	T00	-
G262K128	M200016	N00	V00	VN0	E00	EM0	J00	T00	-	M200031	N00	V00	VN0	E00	EM0	J00	T00	-
G262K129	M200016	N00	V00	VN0	E00	EM0	J00	T00	-	M200032	N00	V00	VN0	E00	EM0	J00	T00	-
G262K155	M200021	-	-	-	-	-	-	-	W00	-	-	-	-	-	-	-	-	-
G262K156	M200015	N00	V00	VN0	E00	EM0	J00	T00	-	M200031	N00	V00	VN0	E00	EM0	J00	T00	-
G262K168	M200021	-	-	-	-	-	-	-	W00	-	-	-	-	-	-	-	-	-
G262K169	M200017	N00	V00	VN0	E00	EM0	J00	T00	-	M200033	N00	V00	VN0	E00	EM0	J00	T00	-
G262K199	M200021	-	-	-	-	-	-	-	W00	-	-	-	-	-	-	-	-	-
G262K236	M200018	N00	V00	VN0	E00	EM0	J00	T00	-	M200033	N00	V00	VN0	E00	EM0	J00	T00	-
G262K237	M200018	N00	V00	VN0	E00	EM0	J00	T00	-	M200034	N00	V00	VN0	E00	EM0	J00	T00	-
8262K006/007/012/015/036/038	M200003	N00	V00	VN0	E00	EM0	J00	T00	-	M200005	N00	V00	VN0	E00	EM0	J00	T00	-
8262K080/086	M200003	N00	V00	VN0	E00	EM0	J00	T00	-	M200005	N00	V00	VN0	E00	EM0	J00	T00	-
8262K130	M200017	N00	V00	VN0	E00	EM0	J00	T00	-	M200033	N00	V00	VN0	E00	EM0	J00	T00	-
8262K134	M200018	N00	V00	VN0	E00	EM0	J00	T00	-	M200033	N00	V00	VN0	E00	EM0	J00	T00	-
8262K138/142/148/152	M200018	N00	V00	VN0	E00	EM0	J00	T00	-	M200034	N00	V00	VN0	E00	EM0	J00	T00	-
8262K168	M200021	-	-	-	-	-	-	-	W00	-	-	-	-	-	-	-	-	-
8262K169	M200017	N00	V00	VN0	E00	EM0	J00	T00	-	M200033	N00	V00	VN0	E00	EM0	J00	T00	-
8262K182/183/184/185/187/188/189	M200008	N00	V00	VN0	E00	EM0	J00	-	-	M200008	N00	V00	VN0	E00	EM0	J00	-	-
8262K199	M200021	-	-	-	-	-	-	-	W00	-	-	-	-	-	-	-	-	-
8262K220/226/230	M200008	N00	V00	VN0	E00	EM0	J00	-	-	M200008	N00	V00	VN0	E00	EM0	J00	-	-
8262K236	M200018	N00	V00	VN0	E00	EM0	J00	T00	-	M200033	N00	V00	VN0	E00	EM0	J00	T00	-
8262K237	M200018	N00	V00	VN0	E00	EM0	J00	T00	-	M200034	N00	V00	VN0	E00	EM0	J00	T00	-

(*) Ensure that the compatibility of the fluids in contact with the materials is verified.

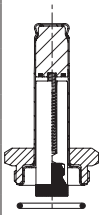

Magnetic latching version

fluids (*)	temperature range (TS)	seal materials (*)
water	0°C to +85°C	EPDM

Electrical characteristics

Coil insulation class

F (DC)

Standard voltages

DC (=) : 3V - 6V - 9V - 12V

operator ambient temperature range (TS) (°C)	power ratings		replacement coil (1)	
	hot/cold = (W)		=	
	640	641/642/643/644	6 V DC	12 V DC
0 to +40	2,5	-	400927-003	400927-005
	-	6	400927-007	400927-014

(1) All coils 400 series are not UL & CSA approved.



Specifications

pipe size	orifice size (mm)	flow coefficient Kv (m³/h) (l/min)	operating pressure differential (bar)		power coil (W)	thread type	dimensions / type (2)	15-DIGIT PRODUCT CODE						
			min.	max. (PS)				brass	voltage code					
				water (*)					3 V/DC	6 V/DC	9 V/DC	12 V/DC	24 V/DC	
Without manual operator														
EPDM seal and disc														
15 mm compression fittings	1,2	0,05	0,8	0	10	2,5	H	03	H262K640S1EM0	CD	E7	E8	F3	F1
	2,0	0,15	2,5	0	10	6	H	03	H262K641S1EM0					
	3,2	0,30	5,0	0	3	6	H	03	H262K642S1EM0					
	4	0,45	7,5	0	2	6	H	03	H262K643S1EM0					
	6,7	0,82	13,7	0	0,7	6	H	03	H262K644S1EM0					

(2) For dimensions, see drawing(s) for each construction type on the following page(s).

(*) Ensure that the compatibility of the fluids in contact with the materials is verified.

Configurator - CAD Files

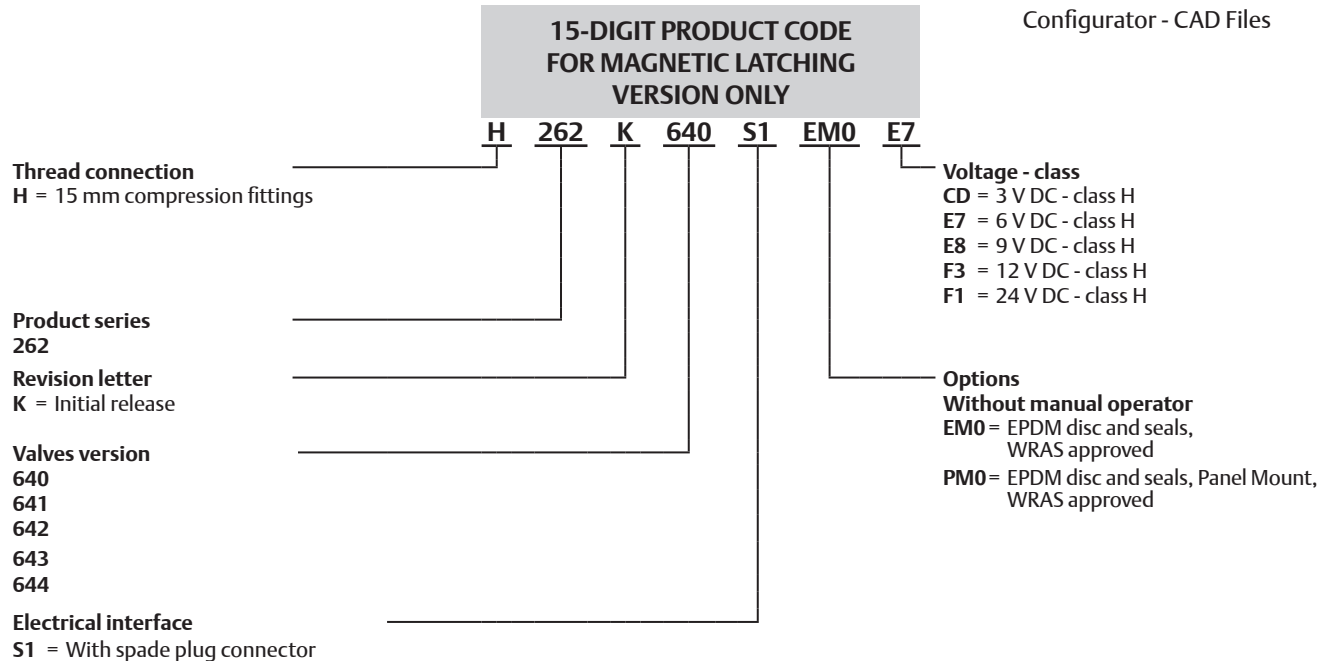

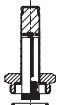
Spare parts kits no. (*)	
DC (=)	
EPDM (+ WRAS)	
 H262K640 / H262K641 H262K642 / H262K643 H262K644	M200001 EM0

(*) Ensure that the compatibility of the fluids in contact with the materials is verified.

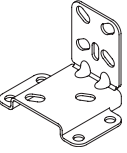
		Accessories code
	Mounting bracket Steel version (AISI 1010 / 1.1121)	M200094A00
	Mounting bracket Stainless steel version (AISI 304 / 1.4301)	M200095A00

Installation

- The solenoid valves can be mounted in any position without affecting operation
- Solenoid valves have 2 mounting holes in body
- Thread connection “E” applicable for 1/4 have standard thread according to ISO 228/1 and ISO 7/1. Thread connection “G” applicable for 1/8, have standard thread according to ISO 228/1
- Thread connection “8” have standard thread = NPT (SAE 71051)
- Thread connection “H” have 1/2” male ‘G’ thread according to BS 2779 plus cap-nut and olive
- Installation/maintenance instructions are included with each valve

Dimensions (mm), Weight (kg)

Configurator - CAD Files



TYPE 01
Electrical interface “S1”
Epoxy moulded
IEC 335 / ISO 4400
IP65

1/8, power coil 8,1 W / 10,6 W and 11,1 W / 18,6 W

1/4, power coil 8,1 W / 10,6 W and 11,1 W / 18,6 W

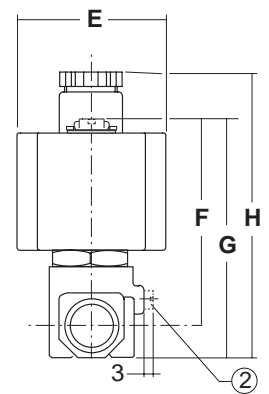
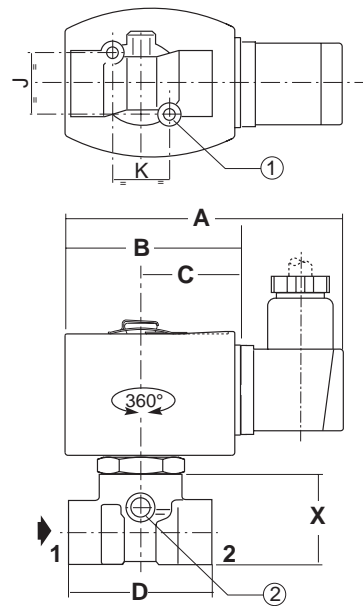
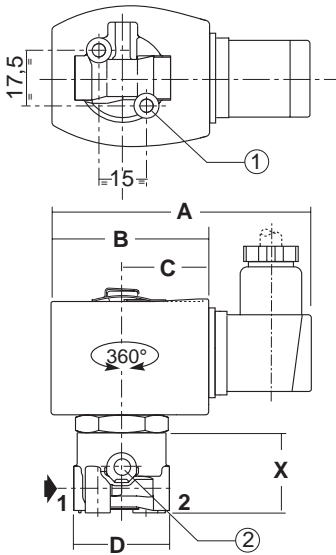

type	pipe size	A	B	C	D	E	F	G	H	X	weight ⁽¹⁾
01	1/8	88	51	30	30	43	62	71	88	26	0,30
	1/4	88	51	30	40	43	65	75	92	30	0,42

- ① 2 mounting holes:
M5 dia., depth 6,5 mm (1/8)
M5 dia., depth 7,5 mm (1/4)
- ② Manual operator location

⁽¹⁾ Incl. coil(s) and connector(s).

Dimensions (mm), Weight (kg) 

Configurator - CAD Files



TYPE 02
Electrical interface "S1"
Epoxy moulded
IEC 335 / ISO 4400
IP65

NC: 1/4, power coil 10,1 W / 11,6 W and 17,1 W / 22,6 W

NO: 1/8-1/4, power coil 10,1 W / 11,6 W

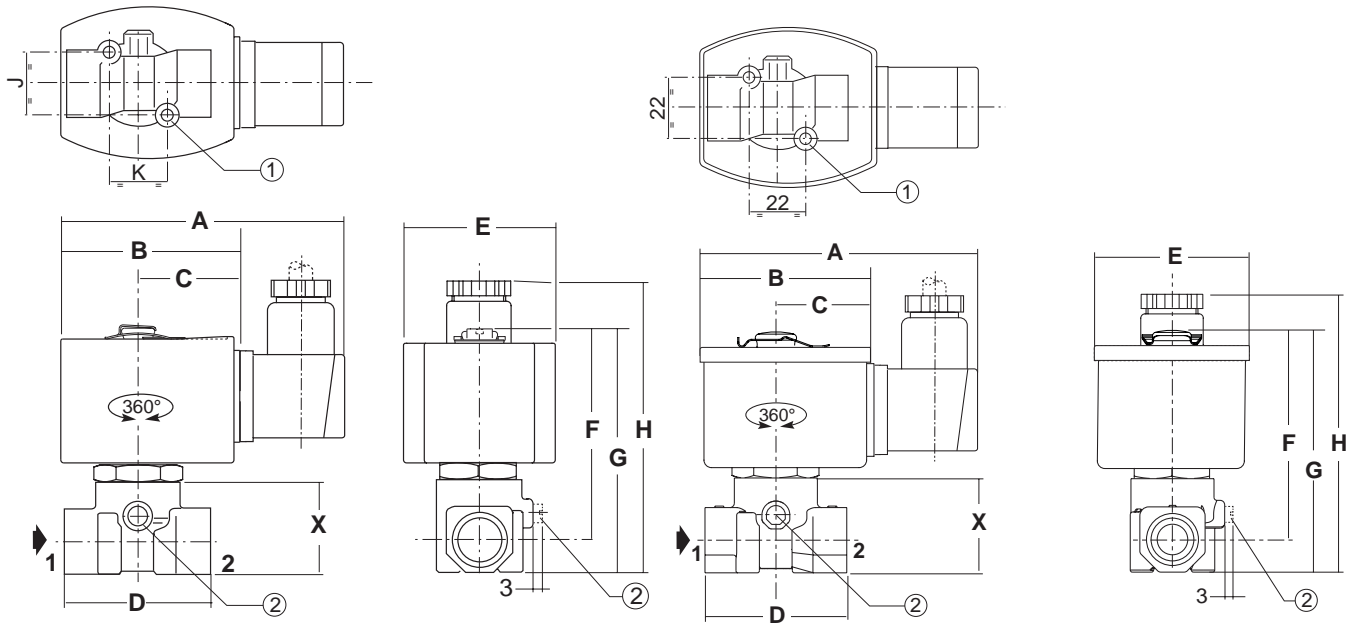

type	pipe size	A	B	C	D	E	F	G	H	J	K	X	weight ⁽¹⁾
02	1/8 (NO)	96	59	34	30	52	67	75	88	17,5	15	26	0,50
	1/4 (NC)	95	57	33	40	50	69	78	96	22	22	30	0,60
	1/4 (NO)	96	59	34	40	52	69	78	96	22	22	30	0,62

- ① 2 mounting holes:
M5 dia., depth 7,5 mm
(1/4)
- ② Manual operator location.

⁽¹⁾ Incl. coil(s) and connector(s).

Dimensions (mm), Weight (kg)



TYPE 03

Electrical interface "S1"
Epoxy moulded
IEC 335 / ISO 4400
IP65

Magnetic latching coil 2,5 W / 6 W

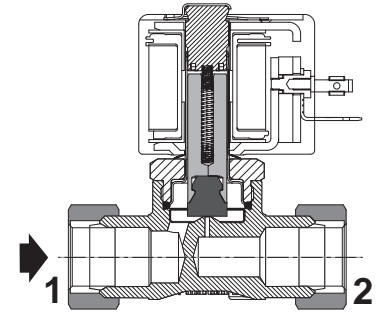
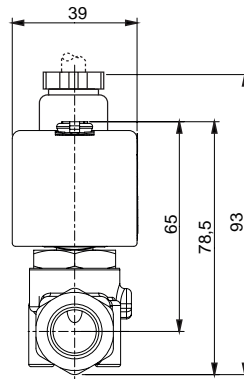
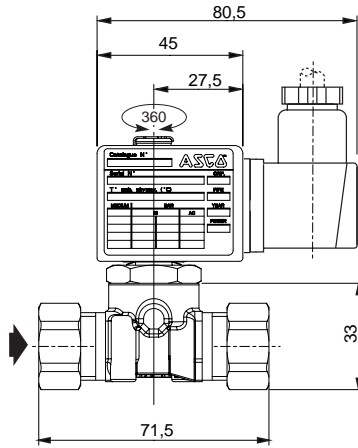
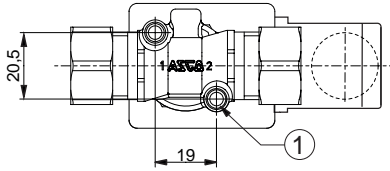

Magnetic Latching version

① 2 mounting holes:
190-24 UNC-2B, depth 6 mm

weight ⁽¹⁾
0,45

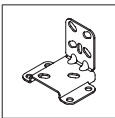

Mounting bracket

Steel or stainless steel

M200094A00 / M200095A00

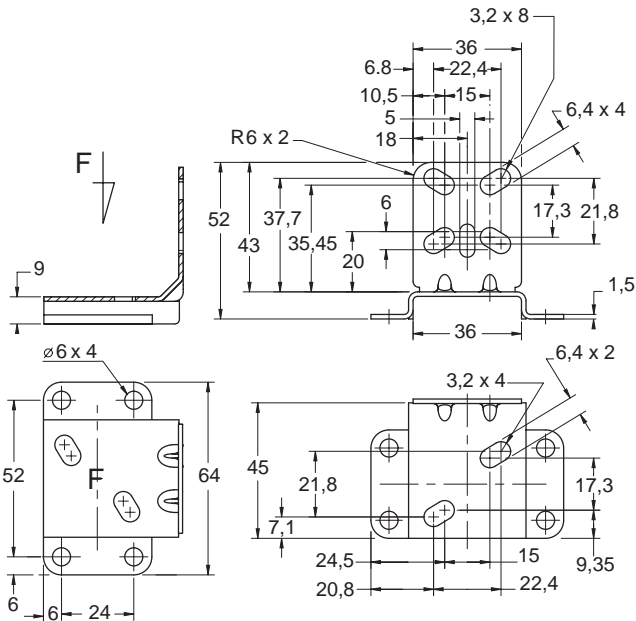

00167CB-2019/R02
Availability, design and specifications are subject to change without notice. All rights reserved.

00167 GB-2019/R02
Availability, design and specifications are subject to change without notice. All rights reserved.



SOLENOID VALVES

direct operated
for high pressure fluids
1/4

NC

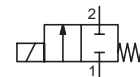

NO

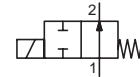

2/2
Series
262

FEATURES

- Valves do not require a minimum operating pressure and have a high operating pressure as indicated
- Valve operation is not affected by mounting position
- The solenoid valves satisfy all relevant EU directives

GENERAL

Differential pressure
Maximum viscosity
Response time

See «SPECIFICATIONS» [1 bar =100 kPa]
65 cSt (mm²/s)
5 - 25 ms

fluids (*)	temperature range (TS)	seal materials (*)
air, inert gas, water, oil	-20°C to +90°C -20°C to +40°C	NBR (nitrile) UR (cast urethane)

MATERIALS IN CONTACT WITH FLUID

(*) Ensure that the compatibility of the fluids in contact with the materials is verified

Body	Stainless steel, AISI 303 SS
Core tube	Stainless steel
Core and plugnut	Stainless steel
Springs	Stainless steel
Seat	Stainless steel
Seals	NBR
Disc	NBR or UR
Disc holder (NO function)	PA
Shading coil	Silver

ELECTRICAL CHARACTERISTICS

Coil insulation class	F
Connector	Spade plug (cable Ø 6-10 mm)
Connector specification	ISO 4400 / EN 175301-803, form A
Electrical safety	IEC 335
Electrical enclosure protection	Moulded IP65 (EN 60529)
Standard voltages	DC (=) : 24V - 48V AC (~) : 24V - 48V - 115V - 230V / 50 Hz
(Other voltages and 60 Hz on request)	

prefix option	power ratings				operator ambient temperature range (TS) (C°)	replacement coil		type ⁽¹⁾	
	inrush ~ (VA)	holding		230 V/50 Hz		24 V DC			
		~ (VA)	(W)				hot/cold = (W)		
SC	34	15,6	6	7 / 9,7	-20 to +75	400325-117	400325-142	01	
	30	22,5	9	9,5/15,3	-20 to +50	400325-217	400325-242	01	
	55	23	10,5	9/11,2	-20 to +75	400425-117	400425-142	02	
	78	35	16,7	-	-20 to +50	400425-217	-	02	
	-	-	-	14/19,7	-20 to +25	-	400425-342	-	02

⁽¹⁾ Refer to the dimensional drawings on the following page.

SPECIFICATIONS

pipe size	orifice size	flow coefficient Kv		operating pressure differential (bar)						power coil (W)		catalogue number	options						
				min.	max. (PS)			min.	max.				min.	max.	maintained man. operator	FPM	EPDM	CR	PTFE
					air (*)	water (*)	oil (*)												
NPT	(mm)	(m ³ /h)	(l/min)																
NC - Normally closed, NBR seals and disc																			
1/4	1,2	0,05	0,8	0	50	35	50	35	35	35	6	9,7	SCB262C080	-	V	E	J	T	
	2,4	0,15	2,8	0	25	10	23	8	11	8	6	9,7	SCB262C086	MO	V	E	J	T	
	3,2	0,3	5	0	9	4	11	4	8	4	6	9,7	SCB262C007	-	V	E	J	T	
	4	0,43	7,2	0	12	2,5	13	2,5	10	3	10,5	11,2	SCB262C220	-	V	E	J	T	
	5,6	0,62	10,3	0	6,5	1,7	6,5	1,7	6,5	1,7	10,5	11,2	SCB262C226	-	V	E	J	T	
		0,73	12,2	0	2,5	1,2	3	1,3	2,5	1,3	6	9,7	SCB262C036	MO	V	E	J	T	
	7,1	0,82	13,7	0	1,8	1	2,5	1	1,9	1	6	9,7	SCB262C038	MO	V	E	J	T	
0,75		12,5	0	6	1,7	6	1,3	6	1,3	16,7	19,7	SCB262B230	MO	V	E	J	T		
NC - Normally closed, NBR seals and UR disc																			
1/4	1,2	0,05	0,8	0	150	32	135	32	75	30	10,5	11,2	SCB262B214	-	-	-	-	-	T
NO - Normally open, NBR seals and disc																			
1/4	3,2	0,3	5	0	9	5,5	7	4	6,5	4	10,5	11,2	SCB262A138	-	V	E	J	T	
	4	0,43	7,2	0	5,5	3	5	2	4	2	10,5	11,2	SCB262A142	-	V	E	J	T	
	5,6	0,73	12,2	0	4,5	-	4,5	-	4	-	10,5	-	SCB262A148	-	V	E	J	T	
	7,1	0,82	13,7	0	3	-	2,5	-	2	-	10,5	-	SCB262A152	-	V	E	J	T	
NO - Normally open, NBR seals and UR disc																			
1/4	1,2	0,05	0,8	0	50	35	48	35	48	35	10,5	11,2	SCB262A130	-	-	-	-	-	T
	2,4	0,17	2,8	0	20	13	17	10	16	8	10,5	11,2	SCB262A134	-	-	-	-	-	T

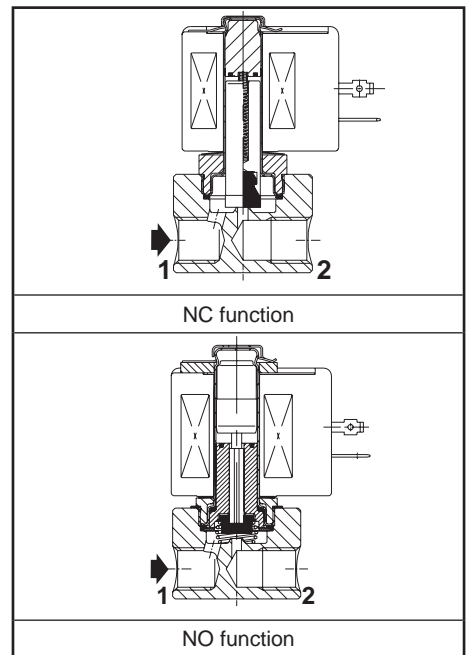

OPTIONS

- Valves can also be supplied with FPM (fluoroelastomer), EPDM (ethylene-propylene), CR (chloroprene) and PTFE seals and discs. Use the appropriate optional suffix letter for identification
- Waterproof enclosure with embedded screw terminal coil according to protection class IP67, CEE-10
- Explosionproof enclosures for use in zones 1/21-2/22, categories 2-3 to ATEX Directive 2014/34/EU (www.asco.com)
- Electrical enclosures according to "NEMA" standards are available
- Compliance with "UL", "CSA" and other local approvals available on request
- Other pipe connections are available on request
- Connector with visual indication and peak voltage suppression or with cable length of 2 m (www.asco.com)

INSTALLATION

- The solenoid valves can be mounted in any position without affecting operation
- Valves are standard supplied with mounting brackets
- Pipe connection identifier is B = NPT (ANSI 1.20.3)
- Installation/maintenance instructions are included with each valve

SPARE PARTS KIT & ACCESSORIES

catalogue number	spare parts kit no.		mounting bracket no.
	~	=	
SCB262C007/080/086	C302020	C302070	254573-001
SCB262C036/038	C302024	C302070	254573-001
SCB262C214	C304365	C304365	254573-001
SCB262C220/226/230	C304352	C304352	254573-001
SCB262A130/134	C302047	C302078	254573-001
SCB262A138/142	C302053	C302082	254573-001
SCB262A148/152	C302055	C302082	254573-001

⁽¹⁾ Standard prefixes/suffixes are also applicable to kits.

ORDERING EXAMPLES:

SC	B	262	C	080	230V / 50 Hz
SC	B	262	C	086	MO 115V / 50 Hz
SC	B	262	C	220	V 24V / DC
SC	B	262	A	130	T 230V / 50 Hz

prefix — pipe thread — basic number — voltage — suffix

ORDERING EXAMPLES KITS:

C302020 ⁽¹⁾	
C302024	V
C304365	T

basic number — suffix

DIMENSIONS (mm), WEIGHT (kg)



TYPE 01-02

Prefix "SC" Solenoid
Epoxy moulded
IEC 335 / ISO 4400
IP65

Type 01: SCB262C080/086/007/036/038

Type 02: SCB262C220/C226/B230/B214



TYPE 02

Prefix "SC" Solenoid
Epoxy moulded
IEC 335 / ISO 4400
IP65

SCG262A138/A142/A148/A152/A130/A134

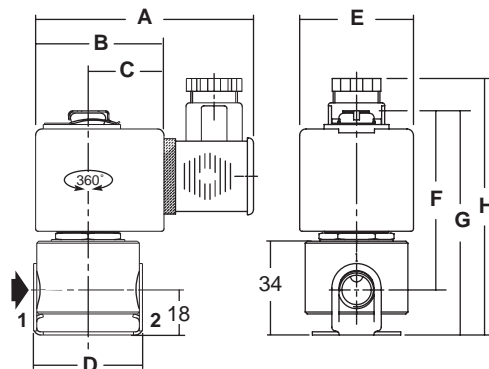
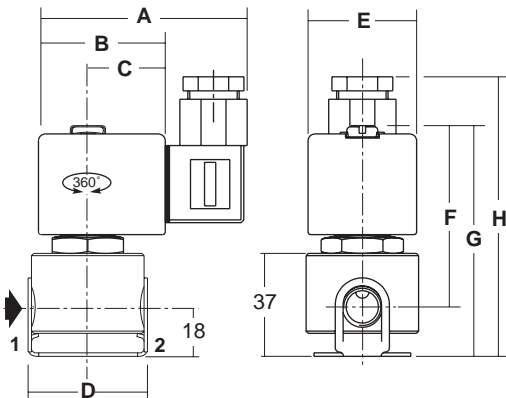

type	prefix option	A	B	C	D	E	F	G	H	weight ⁽²⁾	
										NC	NO
01	SC	75	45	27	40	39	65	85	102	0,35	-
02	SC	80	50	30	40	45	69	89	106	0,6	0,5

⁽²⁾ including coil and connector.

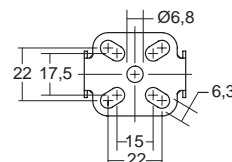

Bottom view of mounting bracket

All leaflets are available on: www.asco.com

ASCO™ Solenoid Valves

For High Pressure Fluids

Direct Operated, 3/8" tapped

2/2 NC-NO

Series

263

- High operating pressure
- RoHS compliance
- AC/DC interchangeability of the coil (10,1 W/11,6 W and 17,1 W/22,6 W)
- Valves do not require a minimum operating pressure
- Large selection of seal materials providing wide chemical compatibility
- Compliance with UL and CSA standards
- The solenoid valves satisfy all relevant EU directives

General

Differential pressure See «SPECIFICATIONS» [1 bar = 100 kPa]
Maximum viscosity 65 cSt (mm²/s)
Response time 5 - 25 ms

fluids (*)	temperature range (TS)	seal materials (*)
air, inert gas, water, oil	-25°C to +80°C	NBR (nitrile)

Materials in contact with fluid

(*) Ensure that the compatibility of the fluids in contact with the materials is verified

Body Brass or Stainless steel, AISI 304
Shading coil Copper or Silver
Core tube Stainless steel, AISI 305
Core and plugnut Stainless steel, AISI 430F
Springs Stainless steel, AISI 302
Seal NBR
Disc NBR
Core guide CA

Electrical characteristics

Coil insulation class F/H (AC) or H (DC)
Connector Spade plug (cable Ø 6-10 mm)
Connector specification ISO 4400 / EN 175301-803, form A
Electrical safety IEC 335
Electrical enclosure protection Moulded IP65 (EN 60529)
Standard voltages DC (=) : 24V - 48V
 (Other voltages and 60 Hz on request) AC (-) : 24V - 48V - 115V - 230V/50 Hz

operator ambient temperature range (TS) (°C)	power ratings				replacement coil ⁽¹⁾	
	inrush ~ (VA)	holding ~ (VA)	hot/cold = (W)	hot/cold = (W)	~	=
-25 to +55	30	16	8,1	7,7/ 10,6	238213-059	238513-006
	45	20	11,1	12,5/18,6	238213-157	238513-106
	50	25	10,1	8,5/11,6	238613-059	238913-006
	70	40	17,1	15,1/22,6	238613-159	-
	70	40	17,1	15,1/22,6	238813-159	238913-106

⁽¹⁾ All 238 basic numbers are UL & CSA approved and marked with the UR (recognised component) & CSA logos.

Options

- Seals and disc (τ) ⁽²⁾ (fluid temperature range)
 - FPM (fluoroelastomer): -15°C to +100°C (coil class F) -15°C to +120°C (coil class H)
 - EPDM (ethylene-propylene), 0°C to +100°C
 - CR (chloroprene), 0°C to +80°C
 - PTFE: -15°C to +100°C (coil class F) -15°C to +120°C (coil class H)
- Oxygen service, FPM disc and seals, see "15-DIGIT PRODUCT CODE"
- Connector with visual indication and peak voltage suppression or with cable length of 2 m
- Explosionproof enclosures for use in zones 1/21-2/22, categories 2-3 to ATEX Directive 2014/34/EU (See page: 19)

(*) Ensure that the compatibility of the fluids in contact with the materials is verified.

⁽²⁾ The minimum ambient temperature of the solenoid valve is determined by the limitations of minimum temperature indicated.

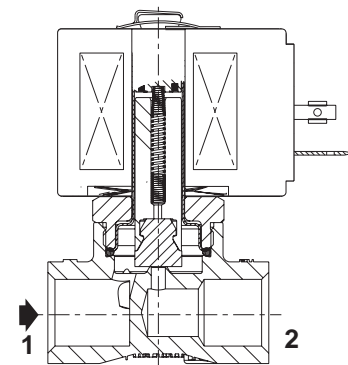

NC function

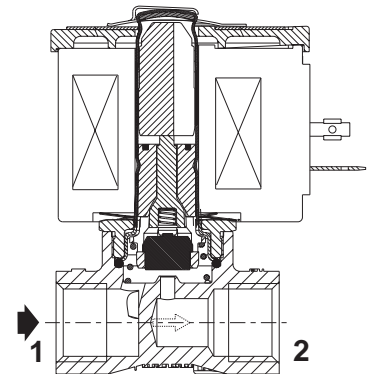

NO function

Specifications

pipe size	orifice size (mm)	flow coefficient Kv (m³/h) (l/min)		operating pressure differential (bar)						power coil (W)		thread type	dimensions / type ⁽¹⁾	15-DIGIT PRODUCT CODE							
				max. (PS)			brass	stainless steel	voltage code					24V/50 Hz	48V/50 Hz	115V/50 Hz	230V/50 Hz	24V/DC	48V/DC		
				air (*)	water (*)	oil (*)															
		min.	~	=	~	=	~	=	~	=											
Without manual operator																					
NC - Normally closed, NBR seal and disc																					
3/8	3,2	0,3	5	0	12	8	12	6,5	6	5	8,1	10,6	G* 01	E263K002S1N00	-	FL	FR	FT	F8	H1	H9
					18	10	17	8	9,5	7	11,1	18,6	G* 01	E263K003S1N00	-						
					23	7,5	20	7	14	5	10,1	11,6	G* 02	E263K232S1N00	E263K190S1N00						
					34	17	26	17	24	10	17,1	22,6	NPT 02	-	8263K190S1N00						
													G* 02	E263K115S1N00	E263K191S1N00						
									NPT 02	-	8263K191S1N00										
									G* 02	E263K200S1N00	E263K331S1N00										
									NPT 02	-	8263K331S1N00										
									G* 02	E263K118S1N00	E263K193S1N00										
									NPT 02	-	8263K193S1N00										
									G* 01	E263K119S1N00	-										
									G* 02	E263K124S1N00	E263K195S1N00										
									NPT 02	-	8263K195S1N00										
									G* 02	E263K206S1N00	E263K332S1N00										
									NPT 02	-	8263K332S1N00										
7,1	0,76	12,7	0	2	1,6	2	1,5	1,4	1,3	8,1	10,6	G* 01	E263K054S1N00	-							
				4	-	4	-	3	-	10,1	-	G* 02	E263K125S1N00	E263K197S1N00							
												NPT 02	-	8263K197S1N00							
								G* 02	E263K210S1N00	E263K333S1N00											
								NPT 02	-	8263K333S1N00											
NO - Normally open, NBR seal and disc																					
3/8	3,2	0,3	5	0	11	6,5	10	6,5	8,5	4,5	10,1	11,6	G* 02	E263K070S1N00	E263K080S1N00	FL	FR	FT	F8	H1	H9
					14	9	13	7,5	12	6,5	17,1	22,6	NPT 02	-	8263K080S1N00						
									G* 02	E263K100S1N00	E263K104S1N00										
									NPT 02	-	8263K104S1N00										
	4	0,47	7,8	0	6	4	6	3,5	4,5	3	10,1	11,6	G* 02	E263K071S1N00	E263K081S1N00						
					8	5	7,5	4	7	3,5	17,1	22,6	NPT 02	-	8263K081S1N00						
									G* 02	E263K101S1N00	E263K105S1N00										
									NPT 02	-	8263K105S1N00										
	5,6	0,72	12	0	3	2	3	1,7	2,5	1,7	10,1	11,6	G* 02	E263K072S1N00	E263K082S1N00						
					4	2	3,5	2	3,5	2,1	17,1	22,6	NPT 02	-	8263K082S1N00						
									G* 02	E263K102S1N00	E263K106S1N00										
									NPT 02	-	8263K106S1N00										
	7,1	0,83	13,8	0	2	1,3	2	1,1	2	1,1	10,1	11,6	G* 02	E263K073S1N00	E263K083S1N00						
													NPT 02	-	8263K083S1N00						
					2,5	1,3	2,5	1,1	2,5	1,1	17,1	22,6	G* 02	E263K103S1N00	E263K107S1N00						
								NPT 02	-	8263K107S1N00											
With maintained manual operator																					
NC - Normally closed, NBR seal and disc																					
3/8	3,2	0,3	5	0	23	7,5	20	7	14	5	10,1	11,6	G* 02	E263K232S1N01	E263K190S1N01	FL	FR	FT	F8	H1	H9
					34	17	26	17	24	10	17,1	22,6	NPT 02	-	8263K190S1N01						
													G* 02	E263K115S1N01	E263K191S1N01						
													NPT 02	-	8263K191S1N01						
													G* 02	E263K200S1N01	E263K331S1N01						
									NPT 02	-	8263K331S1N01										
									G* 02	E263K118S1N01	E263K193S1N01										
									NPT 02	-	8263K193S1N01										
									G* 02	E263K124S1N01	E263K195S1N01										
									NPT 02	-	8263K195S1N01										
									G* 02	E263K206S1N01	E263K332S1N01										
									NPT 02	-	8263K332S1N01										
	7,1	0,76	12,7	0	4	-	4	-	3	-	10,1	-	G* 02	E263K125S1N01	E263K197S1N01						
													NPT 02	-	8263K197S1N01						
					6,5	3	5,5	3	4,5	3	17,1	22,6	G* 02	E263K210S1N01	E263K333S1N01						
								NPT 02	-	8263K333S1N01											

⁽¹⁾For dimensions, see drawing(s) for each construction type on the following page(s).
(*) Ensure that the compatibility of the fluids in contact with the materials is verified.

Configurator - CAD Files

15-DIGIT PRODUCT CODE
E 263 K 002 S1 N00 H1

Thread connection

E = ISO 228/1 & ISO 7/1 (combination thread, G*)
8 = NPT (SAE 71051)

Product series

263

Revision letter

K = Initial release

Valves version

Electrical interface & explosion proof options

- S1** = With spade plug connector
- FN** = Aluminium enclosure, 1/2 NPT conduit, IECEx/ATEX
II 2G Ex db IIC Gb / II 2D Ex tb IIIC Db, zone 1-21 (equivalent to NF prefix)⁽²⁾
- FT** = Aluminium enclosure, 20 mm conduit, IECEx/ATEX
II 2G Ex db IIC Gb / II 2D Ex tb IIIC Db, zone 1-21 (equivalent to NFET prefix)⁽²⁾
- FS** = AISI 316L enclosure, 1/2 NPT conduit, IECEx/ATEX
II 2G Ex db IIC Gb / II 2D Ex tb IIIC Db, zone 1-21 (equivalent to WSNF prefix)⁽²⁾
- FU** = AISI 316L enclosure, 20 mm conduit, IECEx/ATEX
II 2G Ex db IIC Gb / II 2D Ex tb IIIC Db, zone 1-21 (equivalent to WSNFET prefix)⁽²⁾
- MV** = Steel enclosure, M20 cable gland, IECEx/ATEX
II 2G Ex eb mb IIC Gb / II 2D Ex tb IIIC Db, zone 1-21 (equivalent to EM prefix)⁽²⁾
- MT** = Steel enclosure, 20 mm conduit, IECEx/ATEX
II 2G Ex eb mb IIC Gb / II 2D Ex tb IIIC Db, zone 1-21 (equivalent to EMET prefix)⁽²⁾
- MN** = Steel enclosure, 1/2 NPT conduit, IECEx/ATEX
II 2G Ex eb mb IIC Gb / II 2D Ex tb IIIC Db, zone 1-21 (equivalent to EMT prefix)⁽²⁾
- MW** = AISI 316 enclosure, M20 cable gland, IECEx/ATEX
II 2G Ex eb mb IIC Gb / II 2D Ex tb IIIC Db, zone 1-21 (equivalent to WSEM prefix)⁽²⁾
- MU** = AISI 316 enclosure, 20 mm conduit, IECEx/ATEX
II 2G Ex eb mb IIC Gb / II 2D Ex tb IIIC Db, zone 1-21 (equivalent to WSEMET prefix)⁽²⁾
- MS** = AISI 316 enclosure, 1/2 NPT conduit, IECEx/ATEX
II 2G Ex eb mb IIC Gb / II 2D Ex tb IIIC Db, zone 1-21 (equivalent to WSEMT prefix)⁽²⁾
- A7** = Moulded enclosure, epoxy encapsulated, integrated cable, IECEx/ATEX
II 2G Ex mb IIC Gb / II 2D Ex mb IIIC Db, zone 1-21 (equivalent to PV prefix)⁽²⁾
- SG** = Moulded coil with connector, epoxy encapsulated, ATEX
II 3GD Ex ec IIC Gc / II 3GD Ex tc IIIC Dc, zone 22 (equivalent to SG prefix)⁽²⁾⁽³⁾

Voltage - class

- FL** = 24 V / 50 Hz - class F
- FR** = 48 V / 50 Hz - class F
- FT** = 115 V / 50 Hz - class F
- F8** = 230 V / 50 Hz - class F
- HL** = 24 V / 50 Hz - class H
- HR** = 48 V / 50 Hz - class H
- HT** = 115 V / 50 Hz - class H
- H8** = 230 V / 50 Hz - class H
- H1** = 24 V DC - class H
- H9** = 48 V DC - class H

Options

Without manual operator

- N00** = NBR disc and seals
- V00** = FPM disc and seals
- VN0** = FPM disc and seals for Oxygen service
- E00** = EPDM disc and seals
- J00** = CR disc and seals
- T00** = PTFE disc and seals ⁽¹⁾

With maintained manual operator

- N01** = NBR disc and seals
- V01** = FPM disc and seals
- VN1** = FPM disc and seals for Oxygen service
- E01** = EPDM disc and seals
- J01** = CR disc and seals

⁽¹⁾ Max. operating pressure limited to 75% of standard value.

⁽²⁾ Search prefix in Emerson.com/asco to get detailed technical information.

Please note that the valve pressure ratings with some of the ATEX enclosures will be reduced.

To obtain the correct pressure rating please check the landing pages of the "2-Way Solenoid Valve DIN Configurator".

⁽³⁾ Coils class F only.

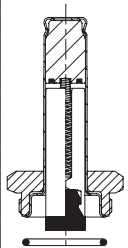
		Spare parts kits no. (*)													
		AC (~)							DC (=)						
		NBR	FPM	FPM (oxygen)	EPDM	CR	PTFE	NBR	FPM	FPM (oxygen)	EPDM	CR	PTFE		
	E263K002	M200001	N00	V00	VN0	E00	J00	T00	M200005	N00	V00	VN0	E00	J00	T00
	E263K003	M200001	N00	V00	VN0	E00	J00	T00	M200006	N00	V00	VN0	E00	J00	T00
	E263K054	M200020	N00	V00	VN0	E00	J00	T00	M200008	N00	V00	VN0	E00	J00	T00
	E263K070	M200016	N00	V00	VN0	E00	J00	T00	M200032	N00	V00	VN0	E00	J00	T00
	E263K071	M200017	N00	V00	VN0	E00	J00	T00	M200033	N00	V00	VN0	E00	J00	T00
	E263K072	M200018	N00	V00	VN0	E00	J00	T00	M200034	N00	V00	VN0	E00	J00	T00
	E263K073	M200019	N00	V00	VN0	E00	J00	T00	M200035	N00	V00	VN0	E00	J00	T00
	E263K080/081/082/083	M200018	N00	V00	VN0	E00	J00	T00	M200034	N00	V00	VN0	E00	J00	T00
	E263K100/101/102/103	M200022	N00	V00	VN0	E00	J00	T00	M200038	N00	V00	VN0	E00	J00	T00
	E263K104/105/106/107	M200040	N00	V00	VN0	E00	J00	T00	M200040	N00	V00	VN0	E00	J00	T00
	E263K115/118	M200007	N00	V00	VN0	E00	J00	T00	M200007	N00	V00	VN0	E00	J00	T00
	E263K119	M200001	N00	V00	VN0	E00	J00	T00	M200007	N00	V00	VN0	E00	J00	T00
	E263K124/125	M200007	N00	V00	VN0	E00	J00	T00	M200007	N00	V00	VN0	E00	J00	T00
	E263K190/191/193	M200008	N00	V00	VN0	E00	J00	T00	M200008	N00	V00	VN0	E00	J00	T00
	E263K195/197	M200008	N00	V00	VN0	E00	J00	T00	M200008	N00	V00	VN0	E00	J00	T00
	E263K197	M200008	N00	V00	VN0	E00	J00	T00	M200008	N00	V00	VN0	E00	J00	T00
	E263K200/206/210/232	M200007	N00	V00	VN0	E00	J00	T00	M200007	N00	V00	VN0	E00	J00	T00
	E263K331/332/333	M200008	N00	V00	VN0	E00	J00	T00	M200008	N00	V00	VN0	E00	J00	T00
	8263K080/081/082/083	M200018	N00	V00	VN0	E00	J00	T00	M200034	N00	V00	VN0	E00	J00	T00
	8263K104/105/106/107	M200040	N00	V00	VN0	E00	J00	T00	M200040	N00	V00	VN0	E00	J00	T00
8263K190/191/193	M200008	N00	V00	VN0	E00	J00	T00	M200008	N00	V00	VN0	E00	J00	T00	
8263K195/197	M200008	N00	V00	VN0	E00	J00	T00	M200008	N00	V00	VN0	E00	J00	T00	
8263K331/332/333	M200008	N00	V00	VN0	E00	J00	T00	M200008	N00	V00	VN0	E00	J00	T00	

(*) Ensure that the compatibility of the fluids in contact with the materials is verified.

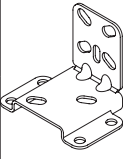
		Accessories code
	Mounting bracket Steel version (AISI 1010 / 1.1121)	M200094A00
	Mounting bracket Stainless steel version (AISI 304 / 1.4301)	M200095A00

Installation

- The solenoid valves can be mounted in any position without affecting operation
- Solenoid valves have 2 mounting holes in body
- Thread connection “E” have standard thread according to ISO 228/1 and ISO 7/1
- Thread connection “8” have standard thread = NPT (SAE 71051)
- Installation/maintenance instructions are included with each valve

Dimensions (mm), Weight (kg)



TYPE 01
Electrical interface "S1"
Epoxy moulded
IEC 335 / ISO 4400
IP65



TYPE 02
Electrical interface "S1"
Epoxy moulded
IEC 335 / ISO 4400
IP65

Configurator - CAD Files

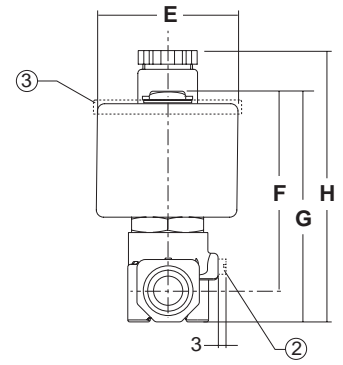
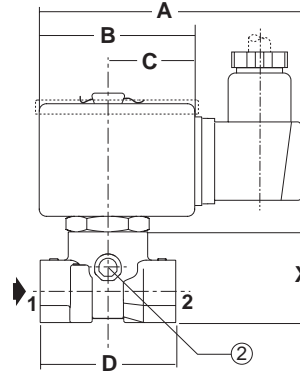
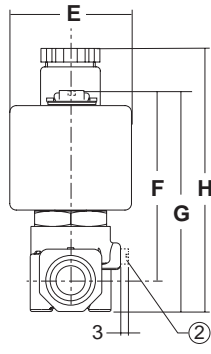
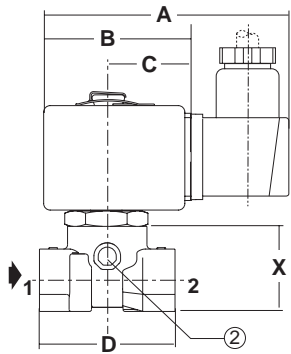
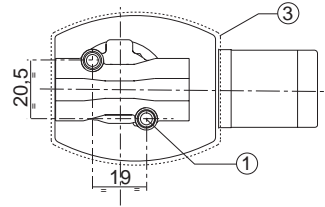
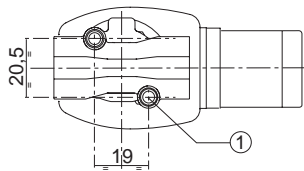

type	A	B	C	D	E	F	G	H	X	weight ⁽¹⁾
01 (NC)	91	51	30	48	43	65	76	104	32	0,5
02 (NC)	95	57	33	48	50	69	80	107	32	0,63
02 (NO)	96	59	34	48	52	69	80	107	32	0,65

- ① 2 mounting holes M5 dia., depth 6 mm.
- ② Manual operator location.
- ③ NO version only.

⁽¹⁾ Incl. coil(s) and connector(s).

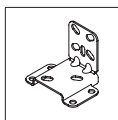

Mounting bracket
Steel or stainless steel

M200094A00 / M200095A00

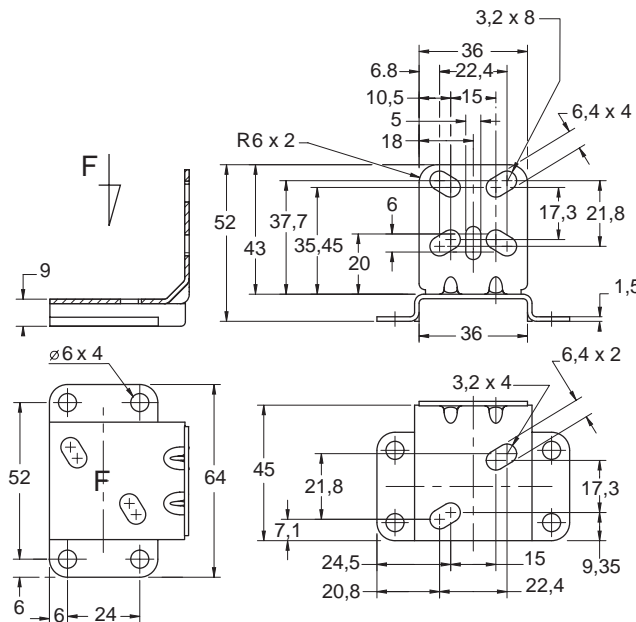

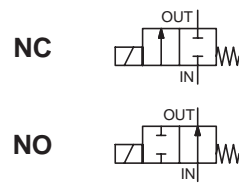

FEATURES

- For gas pilot control on industrial power boilers and low pressure gas control on gas-fired ovens and furnaces
- The normally open type is particularly suited for venting systems in gas installations
- Brass bodied low pressure valves designed to provide maximum flow
- Direct lift solenoid valves have a resilient soft seating for absolute tight shut-off on low pressures
- The solenoid valves do not require a minimum operating pressure
- The solenoid valves satisfy all relevant EU directives

GENERAL

Differential pressure See «SPECIFICATIONS» [1 bar =100 kPa]
Response time 5 - 40 ms

fluids (*)	temperature range (TS)	seal materials (*)
air, gas, water	-20°C to +90°C	NBR (nitrile)

MATERIALS IN CONTACT WITH FLUID

(*) Ensure that the compatibility of the fluids in contact with the materials is verified

Body	Brass
Core tube	Stainless steel
Core and plugnut	Stainless steel
Core spring	Stainless steel
Seat	Brass
Seals	NBR
Discs	NBR
Shading coil	Copper

ELECTRICAL CHARACTERISTICS

Coil insulation class F
Connector Spade plug (cable Ø 6-10 mm)
Connector specification ISO 4400 / EN 175301-803, form A
Electrical safety IEC 335
Electrical enclosure protection Moulded IP65 (EN 60529)
Standard voltages DC (=) : 24V - 48V
(Other voltages and 60 Hz on request) AC (-) : 24V - 48V - 115V - 230V / 50 Hz

prefix option	power ratings				operator ambient temperature range (TS) (C°)	replacement coil		type ⁽¹⁾
	inrush ~	holding ~	hot/cold =			~	=	
	(VA)	(VA)	(W)	(W)		230 V/50 Hz	24 V DC	
SC	34	15,6	6	7 / 9,7	-20 to +75	400325-117	400325-142	01
	55	23	10,5	9/11,2	-20 to +75	400425-117	400425-142	02
	78	35	16,7	-	-20 to +50	400425-217	-	02
	110	33,6	15,4	12/16,8	-20 to +75	400525-117	400625-142	03
	240	43	20	-	-20 to +50	400525-217	-	03

⁽¹⁾ Refer to the dimensional drawings on the following page.

SPECIFICATIONS

pipe size	orifice size	flow coefficient Kv		min.	operating pressure differential (bar)				power coil (W)		catalogue number	options			
					max. (PS)							maintained man. operator	FPM	EPDM	CR
					air/gas (*)		water (*)								
Rp	(mm)	(m³/h)	(l/min)		~	=	~	=	~	=	~/=				
NC - Normally closed															
3/8	9	1,5	25	0	0,5	0,2	0,35	0,2	6	9,7	SCE030B010	-	V	E	J
					1	0,25	1	0,25	10,5	11,2	SCE030B013	-	V	E	J
1/2	11	2,4	40	0	0,3	-	0,4	-	6	-	SCE030A016	-	V	E	J
					1	0,4	1	0,4	15,4	16,8	SCE030A017	-	V	E	J
3/4	19	4,3	71,7	0	0,15	0,07	0,15	0,07	10,5	11,2	SCE030B003	-	V	E	J
					0,3	-	0,3	-	16,7	-	SCE030B043	-	V	E	J
NO - Normally open															
3/8	9	1,4	23,3	0	1	0,17	1	0,15	15,4	16,8	SCE030A070	-	V	E	J
1/2	11	1,9	31,7	0	1	0,17	1	0,15	20	16,8	SCE030A071	-	V	E	J

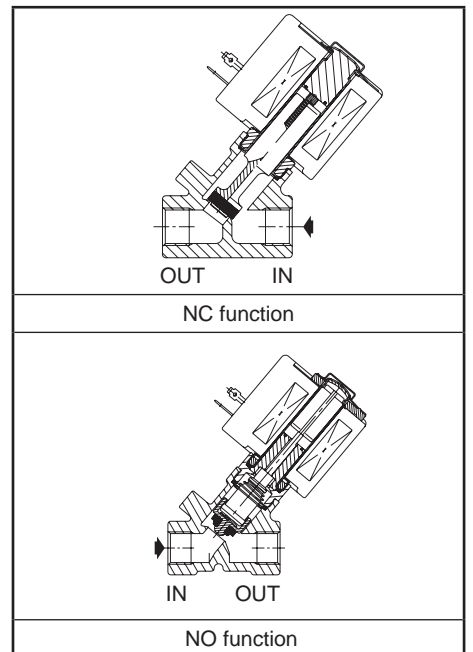

OPTIONS

- Valves can also be supplied with FPM (fluoroelastomer), EPDM (ethylene-propylene) and CR (chloroprene) seals and discs. Use the appropriate optional suffix letter for identification
- Several worldwide gas approvals, see combustible gas section
- Waterproof enclosure with embedded screw terminal coil according to protection class IP67, CEE-10
- Explosionproof enclosures for use in zones 1/21-2/22, categories 2-3 to ATEX Directive 2014/34/EU (www.asco.com)
- Electrical enclosures according to "NEMA" standards are available
- Compliance with "UL", "CSA" and other local approvals available on request
- Mounting brackets, suffix MB
- Other pipe connections are available on request
- Connector with visual indication and peak voltage suppression or with cable length of 2 m (www.asco.com)

INSTALLATION

- The solenoid valves can be mounted in any position without affecting operation
- Pipe connection identifier is E = Rp (ISO 7/1)
- Installation/maintenance instructions are included with each valve

SPARE PARTS KIT & ACCESSORIES

catalogue number	spare parts kit no.		mounting bracket no.
	~	=	
SCE030B003	C302791	C302818	038713-000
SCE030B010	C302787	C302815	093200-001
SCE030B013	C302788	C302816	093200-001
SCE030A016	C302789	-	093200-001
SCE030A017	C302790	C302817	093200-001
SCE030B043	C302791	-	038713-000
SCE030A070	C302797	C302824	093200-001
SCE030A071	C302798	C302824	093200-001

⁽¹⁾ Standard prefixes/suffixes are also applicable to kits.
- Not available

ORDERING EXAMPLES:

SC	E	030	B	003	230V / 50 Hz
SC	E	030	B	013	MO 115V / 50 Hz
SC	E	030	A	017	V 24V / DC
SC	E	030	A	071	230V / 50 Hz

prefix pipe thread basic number voltage suffix

ORDERING EXAMPLES KITS:

C302791 ⁽¹⁾	
C302816	V
C302817	E

basic number suffix

DIMENSIONS (mm), WEIGHT (kg)



TYPE 01-02-03

Prefix "SC" Solenoid
Epoxy moulded
IEC 335 / ISO 4400
IP65

Type 01: SCE030B010/A016

Type 02: SCE030B013

Type 03: SCE030A017/A070/A071



TYPE 02

Prefix "SC" Solenoid
Epoxy moulded
IEC 335 / ISO 4400
IP65

SCE030B003/B043

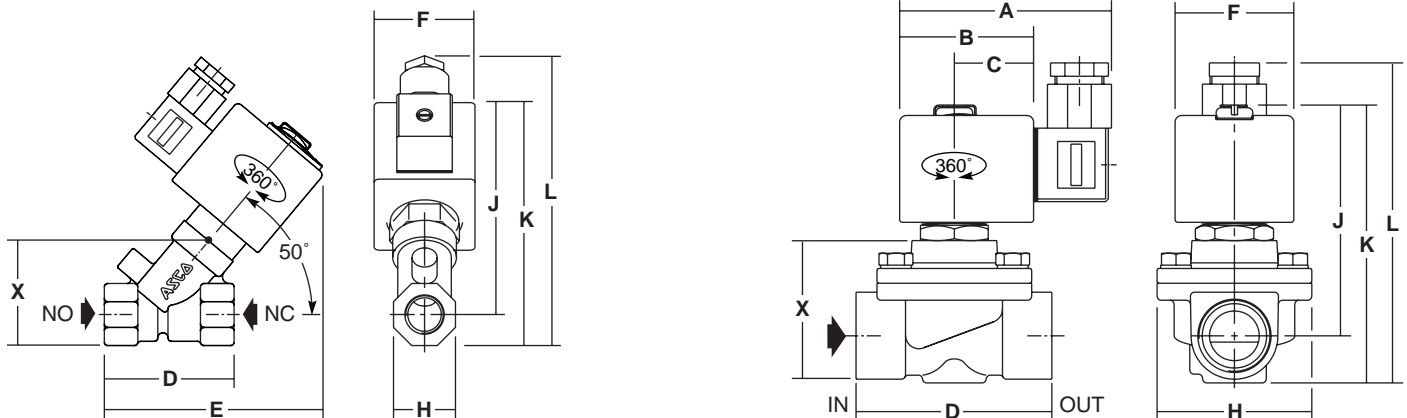

type	prefix option	catalogue number	A	B	C	D	E	F	H	J	K	L	X	weight ⁽²⁾
01	SC	SCE030B010	-	-	-	48	75	39	22	77	88	122	36	0,5
		SCE030A016	-	-	-	58	87	39	28	82	96	130	49	0,5
02	SC	SCE030B013	-	-	-	48	80	45	22	84	95	126	36	0,5
		SCE030B003 / B043	80	50	30	73	-	45	58	87	104	114	54	0,9
03	SC	SCE030A017	-	-	-	58	98	50	28	94	108	128	42	0,9
		SCE030A070	-	-	-	48	88	50	22	97	108	126	36	0,7
		SCE030A071	-	-	-	58	108	50	28	99	113	131	42	0,8

⁽²⁾ including coil and connector.

All leaflets are available on: www.asco.com

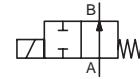
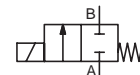

FEATURES

- Coaxial-type solenoid operated valve designed for high flow rates with low pressure loss
- Compatible with viscous or abrasive gases and liquids
- Suitable for high pressure applications
- Solenoid operated valve designed for long service life
- Vacuum operation up to 10^{-4} mbar
- The valves satisfy article 4.3 of Pressure Equipment Directive 2014/68/EU

GENERAL

Differential pressure	A → B : 40 bar, B → A : 12 bar [1 bar = 100 kPa]
Maximum viscosity	500 cSt (mm ² /s)
Response time (air operation ΔP = 4 bar)	3/8 1/2 3/4 1
opening time (ms)	45 60 105 150
closing time (ms)	70 130 150 190

fluids (*)	temperature range (TS)	seal materials (*)
air and gas groups 1 & 2 water, oil, liquids groups 1 & 2	-20°C to +100°C	FPM (fluoroelastomer) PTFE

MATERIALS IN CONTACT WITH FLUID

(*) Ensure that the compatibility of the fluids in contact with the materials is verified

	Brass body	Stainless steel body
Body	Brass	Stainless steel
Internal parts	Brass	Stainless steel
Tube	Stainless steel	Stainless steel
Seals	FPM /PTFE	FPM /PTFE
Disc seal	FPM	FPM

ELECTRICAL CHARACTERISTICS

Coil insulation class	H
Connector (rectifier for AC)	Spade plug (cable Ø 6-8 mm) with indicator LED
Connector specification	ISO 4400 / EN 175301-803, form A
Electrical safety	IEC 335
Electrical enclosure protection	IP65 (EN 60529)
Standard voltages	DC (=) : 24V AC (~) : 110V - 230V / 50 Hz

prefix option	pipe size	power ratings (integrated coil DC (=), cold)			operator ambient temperature range (TS) (C°)	replacement coil		type ⁽¹⁾
		110 V ~ (W)	230 V ~ (W)	24 V ~/= (W)		~	=	
SC	3/8	40	42	35	-20 to +60	-	-	01
	1/2	45	55	51				
	3/4	62	60	53				
	1	68	69	60				

⁽¹⁾ Refer to the dimensional drawings on the following page.

SPECIFICATIONS

pipe size	DN	flow coefficient Kv		operating pressure differential (bar)				power coil (W)		catalogue number		
				max. (PS)						brass	stainless steel	
				air/gas/water/oil (*)								
				min.		B → A		A → B		~/=	~/=	
G		(m ³ /h)	(l/min)	~	=	~	=	~	=			
NC - Normally closed												
3/8	10	2,2	36,6	0	12	12	40	40	42	35	SCG287A001	SCG287A009
1/2	15	5,2	86,6	0	12	12	40	40	55	51	SCG287A002	SCG287A010
3/4	20	7,5	125	0	12	12	40	40	60	53	SCG287A003	SCG287A011
1	25	12,2	203,3	0	12	12	40	40	69	60	SCG287A004	SCG287A012
NO - Normally open												
3/8	10	2,2	36,6	0	12	12	40	40	42	35	SCG287A005	SCG287A013
1/2	15	5,2	86,6	0	12	12	40	40	55	51	SCG287A006	SCG287A014
3/4	20	7,5	125	0	12	12	40	40	60	53	SCG287A007	SCG287A015
1	25	12,2	203,3	0	12	12	40	40	69	60	SCG287A008	SCG287A016

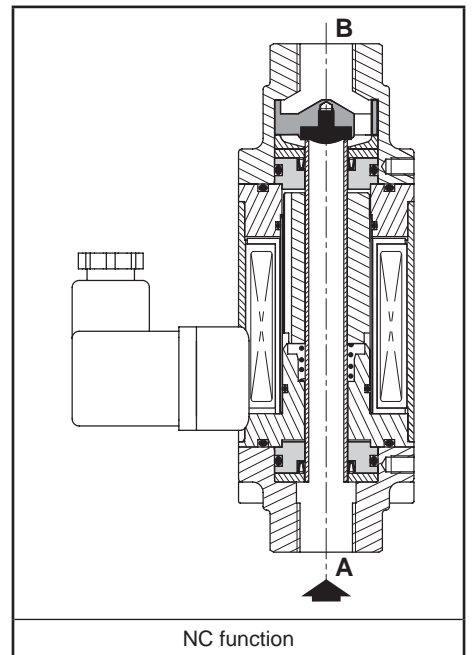

00036GE-2019/R01 Availability, design and specifications are subject to change without notice. All rights reserved.

OPTIONS

- Connector rectifier: 110 V AC, catalogue number: **88122635**; 230 V AC, catalogue number: **88122634**

INSTALLATION

- The solenoid valves can be mounted in any position without affecting operation
- Solenoid valves have 2 mounting holes in body
- Pipe connection identifier is G = G (ISO 228/1)
- Installation/maintenance instructions are included with each valve

SPARE PARTS KIT & ACCESSORIES

catalogue number	spare parts kit no.		mounting bracket no.
	brass	stainless steel	
SCG287A001/009/005/013	C140178	C140179	C140130
SCG287A002/010/006/014	C140182	C140183	C140131
SCG287A003/011/007/015	C140186	C140187	C140132
SCG287A004/012/008/016	C140190	C140191	C140133

ORDERING EXAMPLES:

SC	G	287	A	001	230V / 50 Hz
SC	G	287	A	005	110V / 50 Hz
SC	G	287	A	009	24V / DC

prefix — pipe thread — basic number — voltage — suffix

ORDERING EXAMPLES KITS:

C140179	C140183
---------	---------

basic number —

DIMENSIONS (mm), WEIGHT (kg)



TYPE 01

Prefix "SC" Solenoid
IEC 335 / ISO 4400
IP65

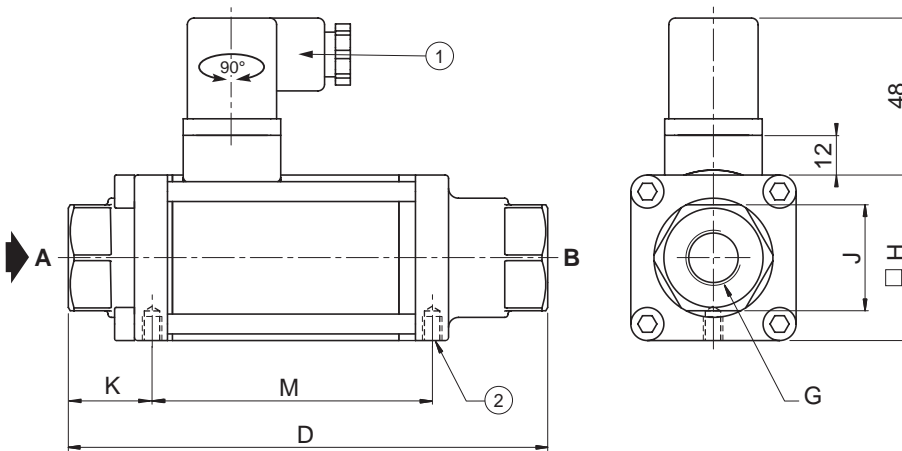

- ① Connector rectifier for AC (~)
- ② 2 mounting holes Ø M5, depth 7 mm

type	prefix option	G	D	H	J	K	M	X	Y	Z	weight ⁽¹⁾
01	SC	3/8	145	50	32	25	85	24	111	6	1,7
		1/2	173	70	41	31	103	38	136	6	3,7
		3/4	193	80	46	35	111	45	151	7	5,4
		1	212	90	55	36	121	50	165	7	7,1

⁽¹⁾ Including connector (without mounting brackets).

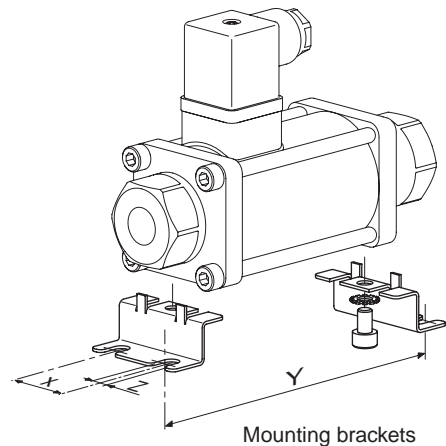



MINI-SOLENOID VALVES

ISO 15218 (CNOMO, size 15) interface
direct operated, pad mounting body
connector size 15

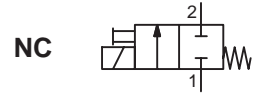

2/2
Series
302

FEATURES

- Compact, monobloc solenoid pilot valve with spade-plug connector type EN 175301-803, industry standard form C, with 9,4 mm spacing, or to EN 175301-803, form C, with 8 mm spacing
- Version with or without integrated LED and electrical protection
LED indicator visible from 3 sides
- The solenoid valves satisfy all relevant EU directives

GENERAL

Differential pressure See «SPECIFICATIONS» [1 bar = 100 kPa]
Pneumatic base ISO 15218 (CNOMO E06.36.120N, size 15)
Connection Subbase
Response time 8 - 15 ms

fluids (*)	temperature range (TS)	seal materials (*)
air or inert gas	-25°C to +60°C (LP2) ⁽¹⁾	NBR (nitrile)
filtered at 50 µm, lubricated or not	-25°C to +60°C / +50°C (LP3) ⁽¹⁾	FPM (fluoroelastomer)

⁽¹⁾ LP2, LP3: see "electrical characteristics" table

MATERIALS IN CONTACT WITH FLUID

(*) Ensure that the compatibility of the fluids in contact with the materials is verified

Body PARA
Internal parts POM, PET, stainless steel and brass
Seals NBR (disc), FPM (others)
Pneumatic interface seal TPE

OTHER MATERIALS

Coil Thermoplastic PET

ELECTRICAL CHARACTERISTICS

Coil insulation class F
Connector Spade plug (cable Ø 4-6 mm)
Connector specification EN 175301-803, industry standard form B (9,4 mm) or EN 175301-803, form C (8 mm)
IEC 335

Electrical safety
Electrical enclosure protection Moulded IP65 (EN 60529)
Standard voltages DC (=): 24V
(Other voltages on request) AC (-): 24V - 115V - 230V / 50-60 Hz

power ranges	coils		power ratings (↔)				operator ambient temperature range ⁽³⁾ (TS) (°C)	type ⁽²⁾
	voltages (V)		inrush ~	holding ~	hot/cold =			
	~	=	(VA)	(VA)	(W)	(W)		
LP2	24-115	24	1,4	1,2	1,1	1 / 1,2	-25 to +60	01
LP3	230	24	2,1	1,6	1,5	2 / 2,65	-25 to +60 (-)/+50 (=) ⁽³⁾	

⁽²⁾ Refer to the dimensional drawings on the following page.

⁽³⁾ With LED and joinable subbase mounting, see following pages

SPECIFICATIONS

orifice size (mm)	flow				operating pressure differential (bar)		power ranges	basic catalogue number					
	at 6 bar l/min (ANR)		coefficient Kv					manual operator		impulse		maintained	
	1 → 2	2 → 3	1 → 2	2 → 3				9,4 mm	8 mm	9,4 mm	8 mm		
	~	=			min.	max. (PS)	~	=	~	=	=		
NC - Normally closed (Without LED and protection)													
0,6	11	20	0,11	0,26	0	10	LP2	30211007	30210007	30211008	30210008		
0,8	17	28	0,22	0,35	0	8	LP2	30211010	30210010	30211011	30210011		
1,1	32	51	0,35	0,50	0	5	LP2	30211016	30210016	30211017	30210017		
					0	10	LP3	30211019	30210019	30211020	30210020		
1,5	39	53	0,50	0,56	0	3	LP2	30211022	30210022	30211023	30210023		
					0	6	LP3	30211025	30210025	30211026	30210026		
NC - Normally closed (With LED and protection) ⁽⁴⁾													
0,6	11	20	0,11	0,26	0	10	LP2	30215007	30214007	30215008	30214008		
0,8	17	28	0,22	0,35	0	8	LP2	30215010	30214010	30215011	30214011		
1,1	32	51	0,35	0,50	0	5	LP2	30215016	30214016	30215017	30214017		
					0	10	LP3	30215019	-	30215020	-		
1,5	39	53	0,50	0,56	0	3	LP2	30215022	30214022	30215023	30214023		
					0	6	LP3	30215025	-	30215026	-		

⁽⁴⁾ Only available in 24 V AC/DC and 115 V AC.

When ordering, please specify in addition to the basic catalogue number:

the type of current: voltage / frequency + the version: with or without connector

	~	=
with connector	--A	--D
without connector	--L	--P

to be inserted after
the basic catalogue number

Examples: • with connector 24V DC : 30211007--D 24V DC
• without connector 24V DC : 30211007--P 24V DC

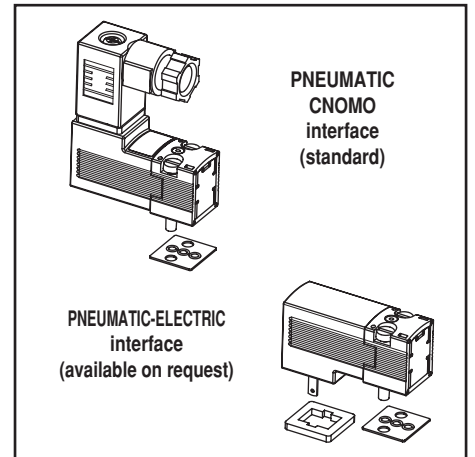

(↔) Nominal power ratings of versions without LED indicator and electrical protection.

For versions with LED indicator and electrical protection, add:
0,15 W with DC (=)
0,4 W / VA with AC (-)

OPTIONS AND ACCESSORIES

- Seals and disc made of FPM (fluoroelastomer)
- Versions without manual operator and NO (Normally Open): contact us
- Version with pneumatic-electric interface
- Version 12 V DC, LP2, connector EN 175301-803, industry standard form C (9,4 mm)
- Connector EN 175301-803, form C (8 mm): (www.asco.com)
 - standard: catalogue number **88130211**
 - with cable 2 m length: Contact us
- Connector EN 175301-803, industry standard form C (9,4 mm): (www.asco.com)
 - standard: catalogue number **88143581**
 - with cable 2 m length: catalogue number **88143567**
- Explosionproof enclosures for use in zones 0/20-1/21-2/22, categories 1-2-3 to ATEX-Directive 2014/34/EU (www.asco.com)

INSTALLATION

- The solenoid valves can be mounted in any position without affecting operation
- Solenoid valve supplied with mounting screws and mounting pad seal(s)
- Installation/maintenance instructions are included with each valve

DIMENSIONS (mm), WEIGHT (kg)



TYPE 01

IEC 335 / EN 175301-803
IP65

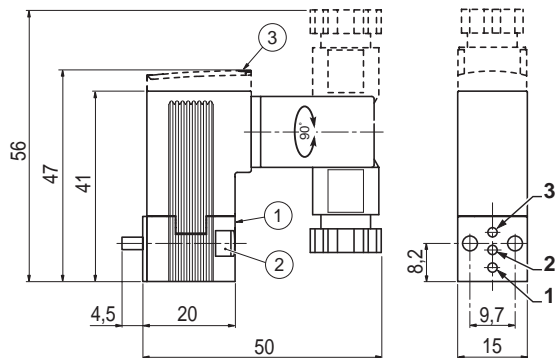

Subbase mounting surface: ISO 15218
(CNOMO E06.36.120N, size 15)

function	connection		
	1	2	3
NC	P	O	-

P: Pressure
O: Outlet

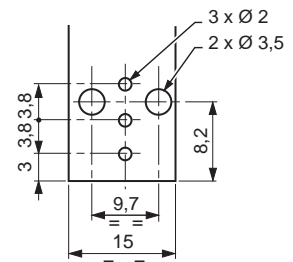

- ① Manual operator location
- ② 2 mounting screw M3 x 20
- ③ Version with LED and electrical protection

weight ⁽¹⁾
0,047

⁽¹⁾ with standard connector.

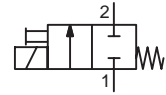

FEATURES

- Compact, monobloc solenoid pilot valve with M12 connector or cable ends
- Version with integrated LED indicator and electrical protection.
LED indicator visible from 3 sides
- The solenoid valves satisfy all relevant EU directives

GENERAL

Differential pressure	See «SPECIFICATIONS» [1 bar = 100 kPa]
Pneumatic base	ISO 15218 (CNOMO E06.36.120N, size 15)
Connection	Subbase
Response time	8 - 15 ms

fluids (*)	temperature range (TS)	seal materials (*)
air or inert gas filtered at 50 µm, lubricated or not	-25°C to +60°C (LP2) ⁽¹⁾	NBR (nitrile) FPM (fluoroelastomer)

⁽¹⁾ LP2: see "electrical characteristics" table

MATERIALS IN CONTACT WITH FLUID

(*) Ensure that the compatibility of the fluids in contact with the materials is verified

Body	PAA
Internal parts	POM, PET, stainless steel and brass
Pneumatic interface seal	TPE

OTHER MATERIALS

Coil	Thermoplastic PET
------	-------------------

ELECTRICAL CHARACTERISTICS

Coil insulation class	F
Connection	Connector M12 or cable ends
Electrical safety	IEC 335
	connector M12 cable ends
Electrical enclosure protection	CNOMO E03.62.520.N EN 60730
Standard voltages	Moulded IP67 (EN 60529) DC (=) : 24V

power ranges	coils		power ratings (⇧)			operator ambient temperature range ⁽³⁾ (TS) (°C)	type ⁽²⁾
	voltages (V)		inrush	holding	hot/cold		
LP2	~	=	(VA)	(VA) (W)	(W)	-25 to +60	01-02-03
	-	24	-	-	-		

⁽²⁾ Refer to the dimensional drawings on the following page. ⁽³⁾ For joinable subbase mounting, see pages suivantes.

SPECIFICATIONS

orifice size (mm)	flow				operating pressure differential (bar)		power ranges	basic catalogue number	
	at 6 bar l/min (ANR)		coefficient Kv		min.	max. (PS)		impulse	manual operator
	1 → 2	2 → 3	1 → 2	2 → 3					
NC - Normally closed, connection M12 + LED and protection									
1,5	39	53	0,50	0,56	0	3	LP2	30212022	30212023
NC - Normally closed, cable ends + LED and protection									
1,5	39	53	0,50	0,56	0	3	LP2	30213022	30213023

When ordering:

	M12	cable
with connector	--D	<input checked="" type="checkbox"/>
without connector	--P	<input checked="" type="checkbox"/>
complete	<input checked="" type="checkbox"/>	--D

} to be inserted after the basic catalogue number

- Examples:
- M12 with connector : **30212022--D**
 - M12 without connector : **30212022--P**
 - cable ends : **30213022--D**

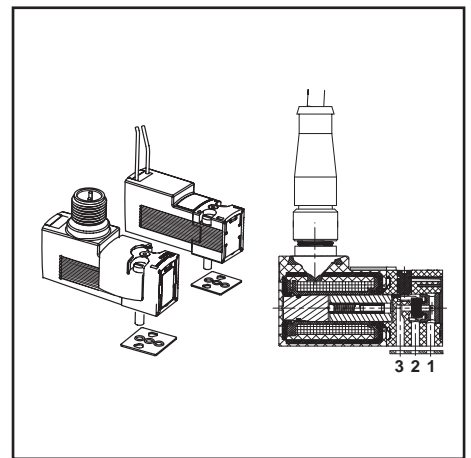

(⇧) Nominal power ratings of standard versions (with LED indicator and electrical protection)

OPTIONS AND ACCESSORIES

- Seals and disc made of FPM (fluoroelastomer)
- Versions without manual operator and NO (Normally Open): contact us
- Version with pneumatic-electric interface
- Straight M12 connector:
 - with 5 m cable length: catalogue number **88130212**
- Explosionproof enclosures for use in zones 0/20-1/21-2/22, categories 1-2-3 to ATEX-Directive 2014/34/EU (www.asco.com)

INSTALLATION

- The solenoid valves can be mounted in any position without affecting operation
- Solenoid valve supplied with mounting screws and mounting pad seal(s)
- Installation/maintenance instructions are included with each valve

DIMENSIONS (mm), WEIGHT (kg)



TYPE 01
IEC 335
Connection M12
IP67



TYPE 02
IEC 335
Straight M12 connector, 5 m cable length
IP67

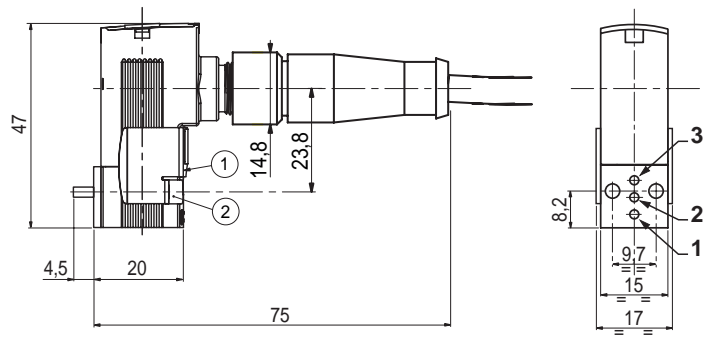
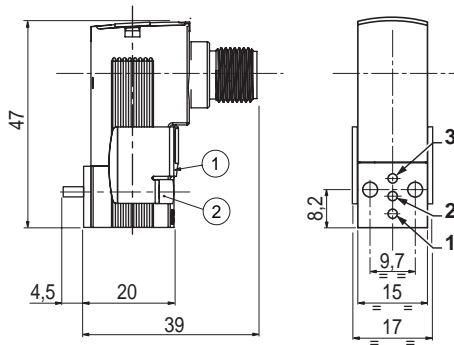

- ① Manual operator location.
- ② 2 mounting screw M3 x 20

M12 ⁽¹⁾		weight	cable ends
⁽¹⁾	⁽²⁾		
0,049	0,288		0,040

- ⁽¹⁾ Without connector
- ⁽²⁾ With connector

function	connection		
	1	2	3
NC	P	O	-

P: Pressure O: Outlet



TYPE 03
IEC 335
Cable ends 0,3 m length
IP67

Subbase mounting surface: ISO 15218
(CNOMO E06.36.120N, size 15)

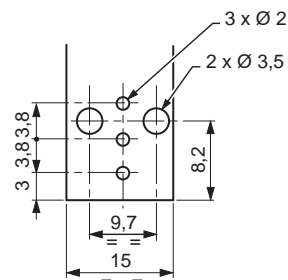
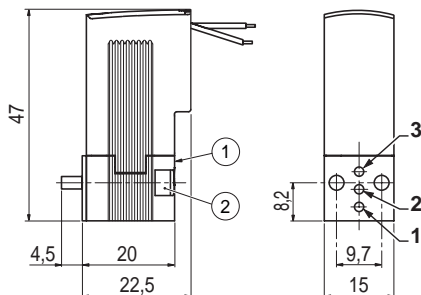

DIMENSIONS (mm), WEIGHT (kg)

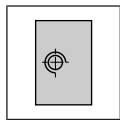

Single subbase Aluminium or brass

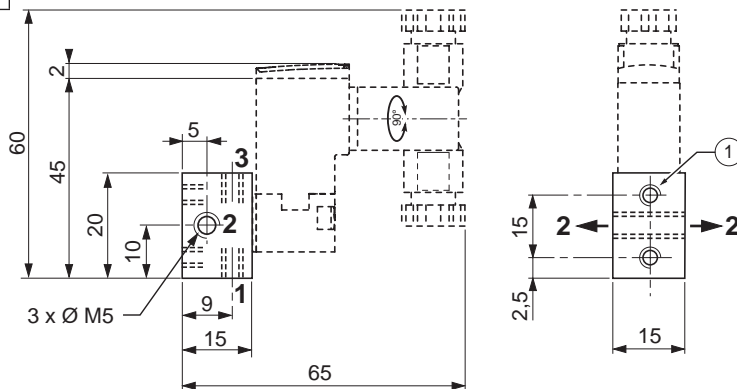

- ① Mounting: 2 holes M3, depth 4,5
Orifice (2) can be connected on the left or on the right of the subbase.

material	catalogue number	weight ⁽¹⁾
aluminium	88263002	0,011
brass	30300001	0,034

⁽¹⁾ subbase alone

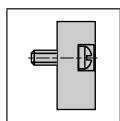

Adapter CNOMO size 30 (only for NC version) Aluminium

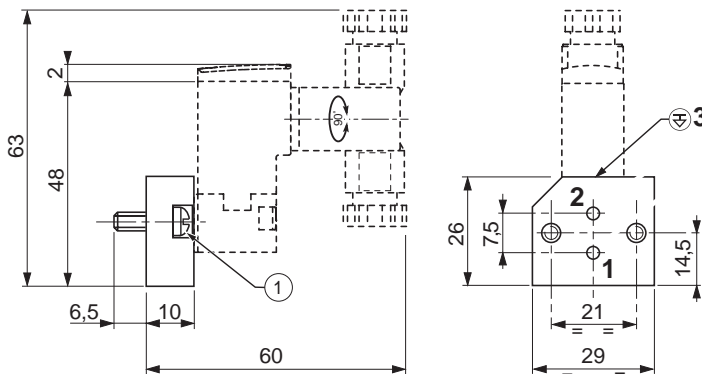

- ① Mounting: 2 screws M4 x 10 (supplied)

catalogue number	weight ⁽²⁾
88263001	0,018

⁽²⁾ adapter alone

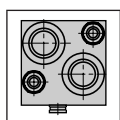

Joinable subbases Aluminium

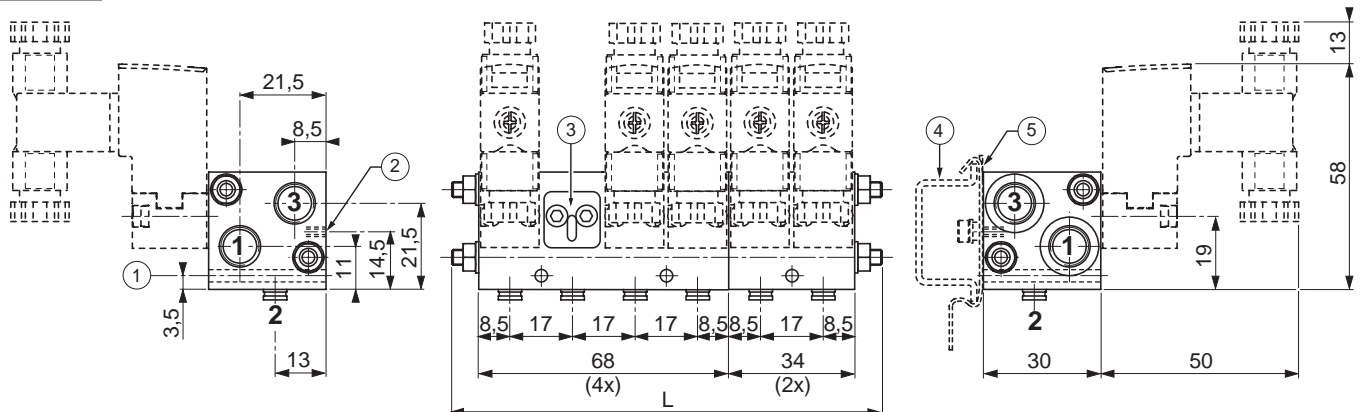

Ports 1 and 3: G1/8

Port 2: coupling for 4mm OD tube

- ① Fixing hole Ø 3,2 (2 for 4x ; 1 for 2x)
- ② Fixing hole M3, depth 8 (2 for 4x ; 1 for 2x)
- ③ Mating surface blanking plates (option)
- ④ TS35 DIN rail (not supplied)
- ⑤ Clip for DIN rail mounting (option)

catalogue number	x	subbases	L	weight ⁽³⁾
35500564	2	2x	-	0,076
35500565	4	4x	-	0,148
35500566	6	4x + 2x	114	0,236
35500567	8	4x + 4x	148	0,313
35500568	10	4x + 4x + 2x	182	0,389
35500569	12	4x + 4x + 4x	216	0,466

⁽³⁾ subbases alone
x = place for mini-solenoid valves.
2 plugs R1/8 supplied.

All leaflets are available on: www.asco.com

OPTIONS AND ACCESSORIES

- Additional subbase with 2 places (with seals): catalogue number **35500570**
- 2 tie-rods + nuts for a subbase with:
 4 places: catalogue number **88100752**
 6 places: catalogue number **88100753**
 8 places: catalogue number **88100754**
 10 places: catalogue number **88100755**
 12 places: catalogue number **88100756**
- Mounting kit for DIN rail (2 clips + screws + washers): catalogue number **88100757**
- Mating surface blanking plate: catalogue number **88130203**

AMBIENT TEMPERATURE RANGES

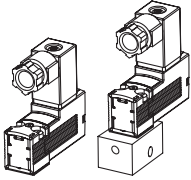
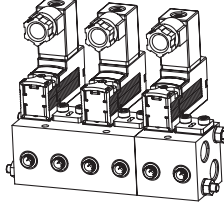
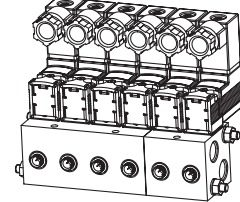
current type	power range	power coil		version				
		inrush/holding (VA) ~	hot/cold (W) =					
DC (=)	LP2 ⁽¹⁾	-	1/1,2	standard	-25°C ; +60°C	-25°C ; +60°C	-25°C ; +60°C	
		-	1,15/1,35	LED + protection			-25°C ; +40°C	
	LP3 ⁽²⁾	-	2/2,65	standard			-25°C ; +50°C	-25°C ; +40°C
		-	2,15/2,8	LED + protection			-25°C ; +40°C	-
AC (~)	LP2 ⁽²⁾	1,4/1,2	-	standard	-25°C ; +60°C	-25°C ; +40°C	-25°C ; +40°C	
		1,8/1,6	-	LED + protection			-25°C ; +60°C	-25°C ; +40°C
	LP3 ⁽²⁾	2,1/1,6	-	standard			-25°C ; +50°C	-
		2,5/2	-	LED + protection			-25°C ; +60°C	-25°C ; +40°C

⁽¹⁾ Voltage: -15% / +20%

⁽²⁾ Voltage: -15% / +10%

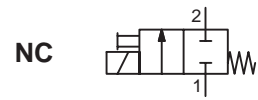

FEATURES

- Compact size and light weight simplify assembly on single or joinable subbases
- AC/DC interchangeability of the solenoid without disassembly of the valve
- Flexible installation on joinable subbases
- Manual operator allows an easy installation
- The solenoid valves satisfy all relevant EU directives

GENERAL

Differential pressure See «SPECIFICATIONS» [1 bar = 100 kPa]
Maximum viscosity 40 cSt (mm²/s)
Response time 5 - 10 ms

fluids (*)	temperature range (TS)	seal materials (*)
air, inert gas, water, oil	-10°C to +80°C	NBR (nitrile) FPM (fluoroelastomer)

MATERIALS IN CONTACT WITH FLUID

(*) Ensure that the compatibility of the fluids in contact with the materials is verified

Body and subbases PPS
Core tube Brass
Internal parts, springs Stainless steel
Seals NBR or FPM
Subbase seals FPM
Shading coil Copper

ELECTRICAL CHARACTERISTICS

Coil insulation class F
Connector Spade plug (cable Ø 6-8 mm)
Connector specification DIN 43650, 11 mm, industry standard B
Electrical safety IEC 335
Electrical enclosure protection Moulded IP65 (EN 60529)
Standard voltages DC (=) : 24V - 48V
 (Other voltages and 60 Hz on request) AC (~) : 24V - 48V - 115V - 230V / 50 Hz

power ratings				operator ambient temperature range (TS)	replacement coil		type ⁽¹⁾
inrush ~	holding ~	hot/cold =	~		=		
(VA)	(VA)	(W)	(W)	(C°)	230 V/50 Hz	24 V DC	
6	3,5	2,5	2,5 / 3	-10 to +60	400127-097	400904-142	01

⁽¹⁾ Refer to the dimensional drawings on the following page.

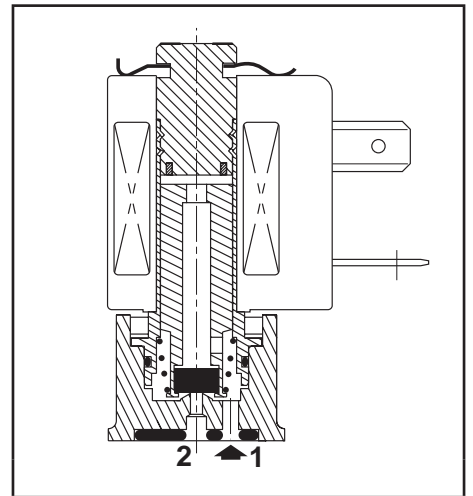
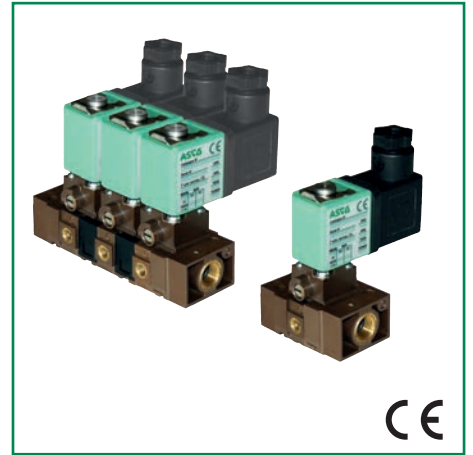

SPECIFICATIONS

pipe size	orifice size	flow coefficient Kv		operating pressure differential (bar)				power coil (W)		catalogue number		
				min.	max. (PS)		with maintained manual operator					
					air (*)	water/oil (*)	NBR			FPM		
	(mm)	(m ³ /h)	(l/min)		~	=	~	=	~/=	~/=		
NC - Normally closed												
pad mounting	1	0,02	0,4	0	16	16	16	16	2,5	3	10800001	10800004
	1,5	0,04	0,7	0	12	4	12	4	2,5	3	10800016	10800019
	2,5	0,06	1	0	4,5	2	4,5	2	2,5	3	10800003	10800006

SUBBASES ⁽²⁾

pipe size	mounting type	designation	composition	catalogue number
6/6 polyamide subbases				
M5 subbases G 1/8 ends	Individual mounting	Single subbase + two ends. Pressure to right, G 1/8		36100009
		1 joinable subbase		36100004
	Assembly of 2 to 10 joinable subbases ⁽⁴⁾	Set of 2 joinable subbases with ends. Pressure to right, G 1/8		36100005
		Set of 2 joinable subbases with ends. Pressure to right and/or left, G 1/8		36100032 ⁽³⁾

⁽²⁾ These subbases can be mounted on symmetrical rail to EN 50022, AFNOR NF C 63015, using 2 clips (clips: catalogue number 33400036, pack of 10).

⁽³⁾ Used for two different pressures, delivered with 1 plug to be put in the right place.

⁽⁴⁾ Maximum number of solenoid valves which can operate simultaneously on joinable subbases: Ø 1 mm: 10, Ø 1,5 mm: 5, Ø 2,5 mm: 3.

OPTIONS

- Explosionproof enclosures for use in zones 1/21-2/22, categories 2-3 to ATEX Directive 2014/34/EU (www.asco.com)
- Compliance with "UL", "CSA" standards are available
- Oxygen service, used option catalogue number: **970517**
- Connector with visual indication and peak voltage suppression or with cable length of 2 m (www.asco.com)

INSTALLATION

- The solenoid valves can be mounted in any position without affecting operation
- Mounting on single or joinable subbases
- ATEX 2014/34/EU versions can be installed on single subbases (all versions) or joinable zamak subbases ("SG" and "PV" series)
- Pipe connections 1/8 have standard thread according to ISO 228/1
- Installation/maintenance instructions are included with each valve

ORDERING EXAMPLES:

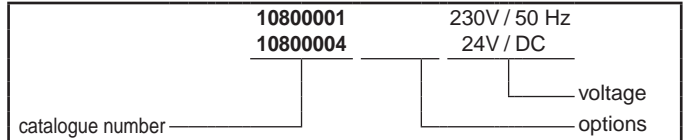

DIMENSIONS (mm), WEIGHT (kg)

TYPE 01
 Prefix "SC" Solenoid
 Epoxy moulded
 IEC 335 / DIN 43650 / IP65
 weight : 0,100
10800001 / 03 / 04 / 06 / 16 / 19

JOINABLE SUBBASE G 1/8
 PPS
36100005 / 36100032

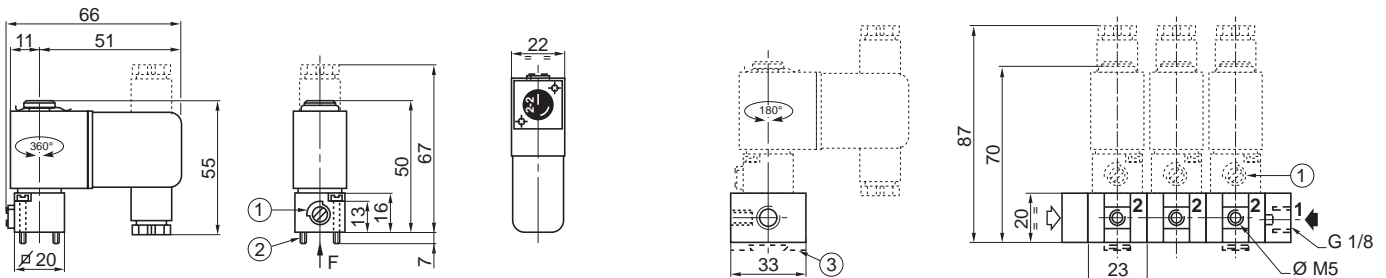

- ① Manual operator location
- ② 2 M3 x 20 screws
- ③ Clips

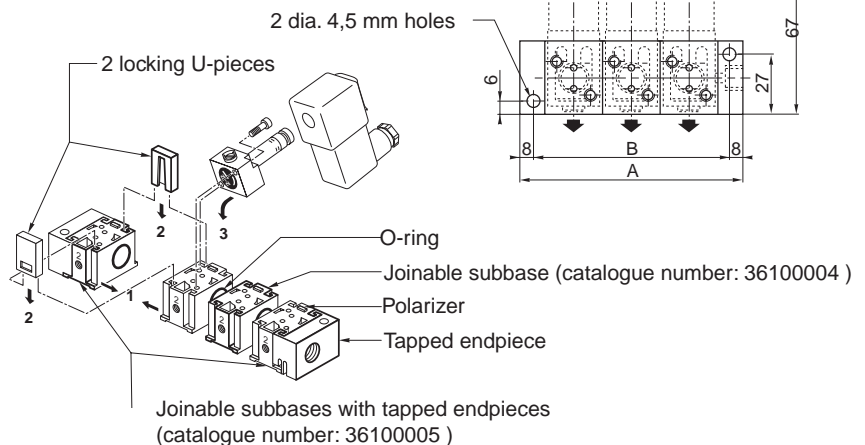
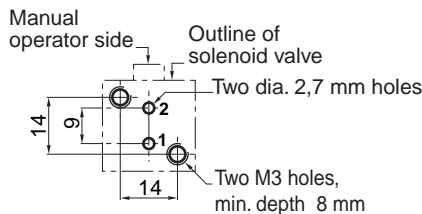

number of subbases	A	B	weight ⁽¹⁾
2	72	56	0,300
3	95	79	0,420
4	118	102	0,540
5	141	125	0,660
6	164	148	0,780
+1	+23	+23	+0,120

⁽¹⁾ including coils, connectors and joinable endpieces.



SOLENOID VALVES

direct operated
multiple manifold sub-bases
1/8

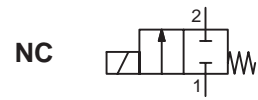

2/2
Series
256

FEATURES

- Very small size and easy assembly
- Mixing or distributing function
- AC/DC interchangeability of the solenoid without disassembling the valve
- Quick disassembly of core tube for easy maintenance of internal parts
- Standard disc seal made of FPM suitable for a wide range of operating temperatures and compatible with many fluids
- Compliance with UL and CSA standards
- The solenoid valves satisfy all relevant EU directives

GENERAL

Differential pressure See «SPECIFICATIONS» [1 bar =100 kPa]
Maximum viscosity 40 cSt (mm²/s)
Response time 5 - 10 ms

fluids (*)	temperature range (TS)	seal materials (*)
air, inert gas, water, oil	-10°C to +100°C	FPM (fluoroelastomer)

MATERIALS IN CONTACT WITH FLUID

(*) Ensure that the compatibility of the fluids in contact with the materials is verified

Manifold body	Brass
Core tube	Stainless steel
Core and plugnut	Stainless steel
Springs	Stainless steel
Seat	Brass
Seals	FPM
Disc	FPM
Shading coil	Copper

ELECTRICAL CHARACTERISTICS

Coil insulation class F
Connector Spade plug (cable Ø 6-8 mm)
Connector specification DIN 43650, 11 mm, norma industrial B
Electrical safety IEC 335
Electrical enclosure protection Moulded IP65 (EN 60529)
Standard voltages ⁽²⁾ DC (=) : 24V - 48V
(Other voltages and 60 Hz on request) AC (-) : 24V - 48V - 115V - 230V / 50 Hz

prefix option	power ratings			operator ambient temperature range (TS) (C°)	replacement coil		type ⁽¹⁾
	inrush ~	holding ~	hot/cold =		~	=	
	(VA)	(VA) (W)	(W)		230 V/50 Hz	24 V DC	
SC	12	6 4	5 / 6,9	-10 to +60	400127-197	400127-142	01

⁽¹⁾ Refer to the dimensional drawings on the following page.

⁽²⁾ Duty cycle: 50% (30 min)

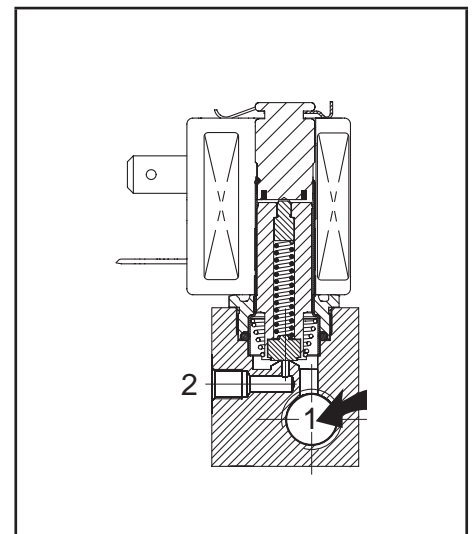

SPECIFICATIONS

pipe size	orifice size	flow coefficient Kv		operating pressure differential (bar)				power coil (W)		Number of valves	catalogue number	options				
				min.	max. (PS)		EPDM									
					air, water (*)	oil (*)										
G	(mm)	(m ³ /h)	(l/min)	~	=	~	=	~	=	~/=						
NC - Normally closed																
1/8 ⁽³⁾	1,6	0,08	1,33	0	20	12	20	12	4	6,9	2	SCG256B819V	E	-	-	
											3	SCG256B820V	E	-	-	
											4	SCG256B821V	E	-	-	
											5	SCG256B822V	E	-	-	
											6	SCG256B823V	E	-	-	
	2,4	0,13	2,16	0	12	4	12	4	4	4	6,9	2	SCG256B855V	E	-	-
												3	SCG256B856V	E	-	-
												4	SCG256B857V	E	-	-
												5	SCG256B858V	E	-	-
												6	SCG256B859V	E	-	-
											7	SCG256B860V	E	-	-	
											8	SCG256B861V	E	-	-	
											9	SCG256B862V	E	-	-	
											10	SCG256B863V	E	-	-	

⁽³⁾ Pipe size port 2: M5

OPTIONS

- Valves can also be supplied with EPDM (ethylene-propylene) seals and discs. Use the appropriate optional suffix letter for identification
- Flying leads coil, use prefix L (e.g.: LG256B822V)
- Oxygen service with seals and disc in FPM, suffix NV, example: SCG256B822NV
- NC, orifice sizes 1,2 mm and 2 mm
- NO, orifice size 1,6 mm
- Stainless steel manifold bodies, NC and NO, on request
- Other pipe connections are available on request
- Connector with visual indication and peak voltage suppression or with cable length of 2 m (www.asco.com)

INSTALLATION

- The solenoid valves can be mounted in any position without affecting operation
- Multiple manifold solenoid valves have 2 mounting holes in body
- Pipe connection identifier is G = G (ISO 228/1)
- Installation/maintenance instructions are included with each valve

SPARE PARTS KIT

catalogue number	spare parts kit no.	
	~	=
all	C140262V	C140262V

⁽¹⁾ Standard prefixes/suffixes are also applicable to kits.

ORDERING EXAMPLES:

SC	G	256	B	821	V	230V / 50 Hz
SC	G	256	B	826	E	115V / 50 Hz
SC	G	256	B	857	NV	24V / DC
SC	G	256	B	863	V	230V / 50 Hz

prefix: SC, pipe thread: G, basic number: 256 B, voltage: 230V / 50 Hz, suffix: V

ORDERING EXAMPLES KITS:

C140262	V⁽¹⁾
C140262	E

basic number: C140262, suffix: V, E

DIMENSIONS (mm), WEIGHT (kg)



TYPE 01

Prefix "SC" Solenoid
Epoxy moulded
Integrated in manifold
IEC 335 / DIN 43650, IP65

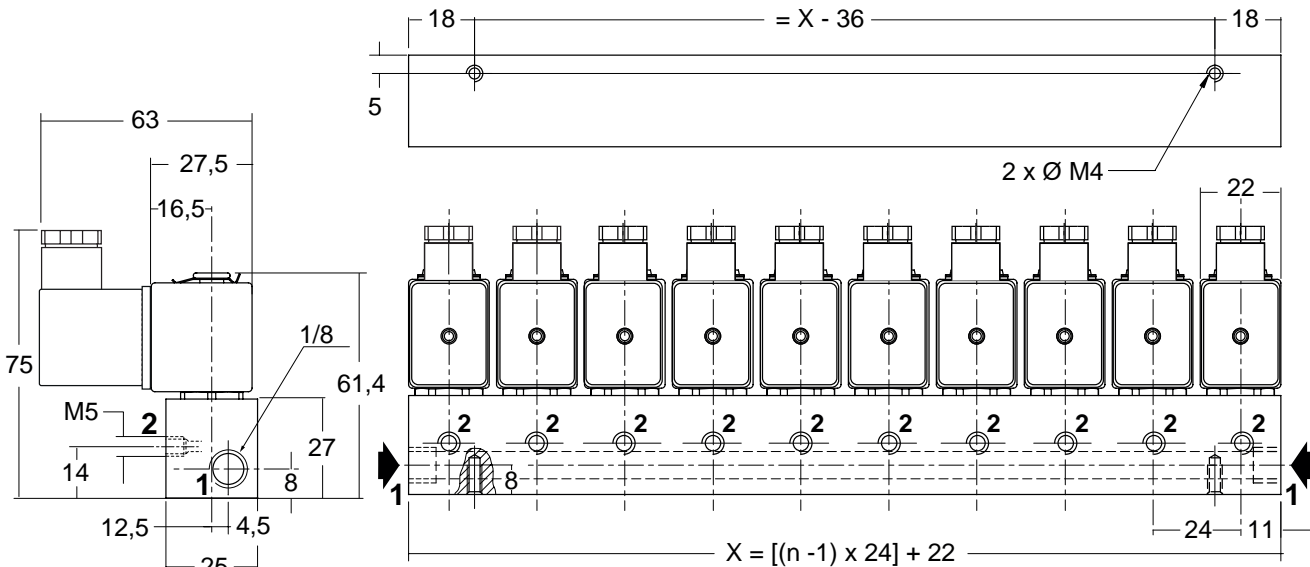

type	prefix option	weight ⁽²⁾								
		number of solenoid valves (n)								
		2	3	4	5	6	7	8	9	10
01	SC	0,321	0,426	0,531	0,636	0,741	0,846	0,951	1,056	1,161

⁽²⁾ Incl. coil(s) and connector(s)

All leaflets are available on: www.asco.com

ASCO™ Solenoid Valves

Pad Mounting Body

Direct Operated, For Subbase 1/4" or 1/2"

2/2 NC-NO

Series

262

- High operating pressure
- RoHS compliance
- AC/DC interchangeability of the coil possible only for NC version only
- Flexible installation on joinable subbases
- Large selection of seal materials providing wide chemical compatibility
- Compliance with UL and CSA standards
- The solenoid valves satisfy all relevant EU directives

General

Differential pressure See «SPECIFICATIONS» [1 bar = 100 kPa]

Maximum viscosity 65 cSt (mm²/s)

Response time 5 - 25 ms

fluids (*)	temperature range (TS)	seal materials (*)
air, inert gas, water, oil	-25°C to +80°C	NBR (nitrile)

Materials in contact with fluid

(*) Ensure that the compatibility of the fluids in contact with the materials is verified

Body	Brass
Shading coil	Copper
Core tube	Stainless steel
Core and plugnut	Stainless steel
Springs	Stainless steel
Seal	NBR
Disc	NBR
Disc holder (NO function)	PA

Electrical characteristics

Coil insulation class F (AC) or H (DC)

Connector Spade plug (cable Ø 6-10 mm)

Connector specification ISO 4400 / EN 175301-803, form A

Electrical safety IEC 335

Electrical enclosure protection Moulded IP65 (EN 60529)

Standard voltages DC (=) : 24V - 48V

(Other voltages and 60 Hz on request) AC (~) : 24V - 48V - 115V - 230V/50 Hz

operator ambient temperature range (TS) (°C)	power ratings				replacement coil ⁽¹⁾	
	inrush ~ (VA)	holding ~ (VA) (W)		hot/cold = (W)	~ 230 V/50 Hz	= 24 V DC
-25 to +55	50	25	10,1	8,5/11,6	238613-059	238913-006

⁽¹⁾ All 238 basic numbers are UL & CSA approved and marked with the UR (recognised component) & CSA logos.

Options

- **Seals and disc (*)** (fluid temperature range) ⁽²⁾
 - FPM (fluoroelastomer): -15°C to +100°C (coil class F)
 - 15°C to +120°C (coil class H)
 - EPDM (ethylene-propylene), 0°C to +100°C
 - CR (chloroprene), 0°C to +80°C
- Oxygen service, FPM disc and seals, see "15-DIGIT PRODUCT CODE"
- Connector with visual indication and peak voltage suppression or with cable length of 2 m
- Explosionproof enclosures for use in zones 1/21-2/22, categories 2-3 to ATEX Directive 2014/34/EU (See page: 40)

(*) Ensure that the compatibility of the fluids in contact with the materials is verified.

⁽²⁾ The minimum ambient temperature of the solenoid valve is determined by the limitations of minimum temperature indicated.



CE

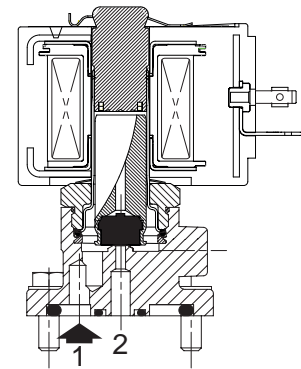

NC function

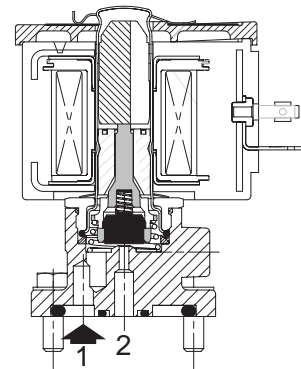

NO function

Specifications

													15-DIGIT PRODUCT CODE										
pipe size	orifice size (mm)	flow coefficient Kv (m ³ /h) (l/min)		operating pressure differential (bar)						power coil (W)		dimensions / type ⁽¹⁾	brass	voltage code									
				min.	max. (PS)			~	=					~	=	~	=	24 V/50 Hz	48 V/50 Hz	115 V/50 Hz	230 V/50 Hz	24 V/DC	48 V/DC
					air (*)	water (*)	oil (*)																
Without manual operator																							
NC - Normally closed, NBR seal and disc																							
pad mounting	1,2	0,05	0,8	0	103	68	103	66	103	58	10,1	11,6	01	R262K200S1W00 ⁽²⁾	FL	FR	FT	F8	H1	H9			
	2,4	0,18	3	0	40	16	28	16	28	15	10,1	11,6	01	R262K108S1N00									
	3,2	0,3	5	0	23	7,5	20	7	14	6,5	10,1	11,6	01	R262K232S1N00									
	4	0,45	7,5	0	14	3,5	13	3,5	10	3,5	10,1	11,6	01	R262K202S1N00									
	5,6	0,63	10,5	0	6,5	2	6,5	2	6,5	2	10,1	11,6	01	R262K208S1N00									
	7,1	0,76	12,7	0	4	1,5	5	1,5	4	1,3	10,1	11,6	01	R262K210S1N00									
NO - Normally open, NBR seal and disc																							
pad mounting	1,2	0,05	0,8	0	79	44	62	33	55	22	10,1	11,6	02	R262K161S1W00 ⁽²⁾	FL	FR	FT	F8	H1	H9			
	2,4	0,18	3	0	18	11	15	9	12	6,5	10,1	11,6	02	R262K260S1N00									
	3,2	0,3	5	0	11	6,5	10	6,5	8,5	4,5	10,1	11,6	02	R262K262S1N00									
	4	0,47	7,8	0	6	4	6	3,5	4,5	3	10,1	11,6	02	R262K263S1N00									
	5,6	0,72	12	0	3	2	3	1,7	2,5	1,7	10,1	11,6	02	R262K264S1N00									
	7,1	0,83	13,8	0	2	1,3	2	1,1	2	1,1	10,1	11,6	02	R262K265S1N00									
With maintained manual operator																							
NC - Normally closed, NBR seal and disc																							
pad mounting	2,4	0,18	3	0	40	16	28	16	28	15	10,1	11,6	01	R262K108S1N01	FL	FR	FT	F8	H1	H9			
	3,2	0,3	5	0	23	7,5	20	7	14	6,5	10,1	11,6	01	R262K232S1N01									
	4	0,45	7,5	0	14	3,5	13	3,5	10	3,5	10,1	11,6	01	R262K202S1N01									
	5,6	0,63	10,5	0	6,5	2	6,5	2	6,5	2	10,1	11,6	01	R262K208S1N01									
	7,1	0,76	12,7	0	4	1,5	5	1,5	4	1,3	10,1	11,6	01	R262K210S1N01									

⁽¹⁾ For dimensions, see drawing(s) for each construction type on the following page(s).

⁽²⁾ UR disc only, fluid temperature 0°C to +60°C, no other elastomer can be used.

(*) Ensure that the compatibility of the fluids in contact with the materials is verified.

Configurator - CAD Files

15-DIGIT PRODUCT CODE

Thread connection
R = Pad mounting

Product series
262

Revision letter
K = Initial release

Valves version

Voltage - class

- FL = 24 V / 50 Hz - class F
- FR = 48 V / 50 Hz - class F
- FT = 115 V / 50 Hz - class F
- F8 = 230 V / 50 Hz - class F
- H1 = 24 V DC - class H
- H9 = 48 V DC - class H

Options

Without manual operator

- N00 = NBR disc and seals
- V00 = FPM disc and seals
- VN0 = FPM disc and seals for Oxygen service
- E00 = EPDM disc and seals
- J00 = CR disc and seals

With maintained manual operator

- N01 = NBR disc and seals
- V01 = FPM disc and seals
- VN1 = FPM disc and seals for Oxygen service
- E01 = EPDM disc and seals
- J01 = CR disc and seals

Electrical interface & explosion proof options

- S1 = With spade plug connector
- FN = Aluminium enclosure, 1/2 NPT conduit, IECEx/ATEX
II 2G Ex db IIC Gb / II 2D Ex tb IIIC Db, zone 1-21 (equivalent to NF prefix)⁽¹⁾
- FT = Aluminium enclosure, 20 mm conduit, IECEx/ATEX
II 2G Ex db IIC Gb / II 2D Ex tb IIIC Db, zone 1-21 (equivalent to NFET prefix)⁽¹⁾
- FS = AISI 316L enclosure, 1/2 NPT conduit, IECEx/ATEX
II 2G Ex db IIC Gb / II 2D Ex tb IIIC Db, zone 1-21 (equivalent to WSNF prefix)⁽¹⁾
- FU = AISI 316L enclosure, 20 mm conduit, IECEx/ATEX
II 2G Ex db IIC Gb / II 2D Ex tb IIIC Db, zone 1-21 (equivalent to WSNFET prefix)⁽¹⁾
- MV = Steel enclosure, M20 cable gland, IECEx/ATEX
II 2G Ex eb mb IIC Gb / II 2D Ex tb IIIC Db, zone 1-21 (equivalent to EM prefix)⁽¹⁾
- MT = Steel enclosure, 20 mm conduit, IECEx/ATEX
II 2G Ex eb mb IIC Gb / II 2D Ex tb IIIC Db, zone 1-21 (equivalent to EMET prefix)⁽¹⁾
- MN = Steel enclosure, 1/2 NPT conduit, IECEx/ATEX
II 2G Ex eb mb IIC Gb / II 2D Ex tb IIIC Db, zone 1-21 (equivalent to EMT prefix)⁽¹⁾
- MW = AISI 316 enclosure, M20 cable gland, IECEx/ATEX
II 2G Ex eb mb IIC Gb / II 2D Ex tb IIIC Db, zone 1-21 (equivalent to WSEM prefix)⁽¹⁾
- MU = AISI 316 enclosure, 20 mm conduit, IECEx/ATEX
II 2G Ex eb mb IIC Gb / II 2D Ex tb IIIC Db, zone 1-21 (equivalent to WSEMET prefix)⁽¹⁾
- MS = AISI 316 enclosure, 1/2 NPT conduit, IECEx/ATEX
II 2G Ex eb mb IIC Gb / II 2D Ex tb IIIC Db, zone 1-21 (equivalent to WSEMT prefix)⁽¹⁾
- A7 = Moulded enclosure, epoxy encapsulated, integrated cable, IECEx/ATEX
II 2G Ex mb IIC Gb / II 2D Ex mb IIIC Db, zone 1-21 (equivalent to PV prefix)⁽¹⁾
- SG = Moulded coil with connector, epoxy encapsulated, ATEX
II 3GD Ex ec IIC Gc / II 3GD Ex tc IIIC Dc, zone 22 (equivalent to SG prefix)⁽¹⁾

⁽¹⁾ Search prefix in Emerson.com/asco to get detailed technical information.

Please note that the valve pressure ratings with some of the ATEX enclosures will be reduced.

To obtain the correct pressure rating please check the landing pages of the "2-Way Solenoid Valve DIN Configurator".

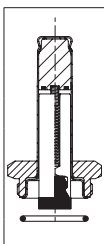

		Spare parts kits no. (*)												
		AC (~)					DC (=)							
		NBR	FPM	FPM (oxygen)	EPDM	CR	NBR + UR		NBR	FPM	FPM (oxygen)	EPDM	CR	NBR + UR
R262K108	M200007	N00	V00	VN0	E00	J00	-	M200007	N00	V00	VN0	E00	J00	-
R262K161	M200021	-	-	-	-	-	W00	-	-	-	-	-	-	-
R262K200	M200007	-	-	-	-	-	W00	M200007	-	-	-	-	-	W00
R262K202/208/210	M200007	N00	V00	VN0	E00	J00	-	M200007	N00	V00	VN0	E00	J00	-
R262K232	M200007	N00	V00	VN0	E00	J00	-	M200007	N00	V00	VN0	E00	J00	-
R262K260	M200015	N00	V00	VN0	E00	J00	-	M200031	N00	V00	VN0	E00	J00	-
R262K261	M200016	N00	V00	VN0	E00	J00	-	M200031	-	-	-	-	-	W00
R262K262/263/264/265	M200016	N00	V00	VN0	E00	J00	-	M200032	N00	V00	VN0	E00	J00	-

(*) Ensure that the compatibility of the fluids in contact with the materials is verified.

Installation

- The solenoid valves can be mounted in any position without affecting operation
- Mounting on single or joinable subbase or on supply rail, four mounting holes
- ATEX 2014/34/EU versions can be installed on single or joinable brass subbases
- 1/4 and 1/2 subbases pipe connections (G*) have standard combination thread according to ISO 228/1 and ISO 7/1
- Installation/maintenance instructions are included with each valve

Dimensions (mm), Weight (kg) 

Configurator - CAD Files



TYPE 01
Electrical interface "S1"
Epoxy moulded
IEC 335 / ISO 4400
IP65

NC: power coil, 10,1 W / 11,6 W

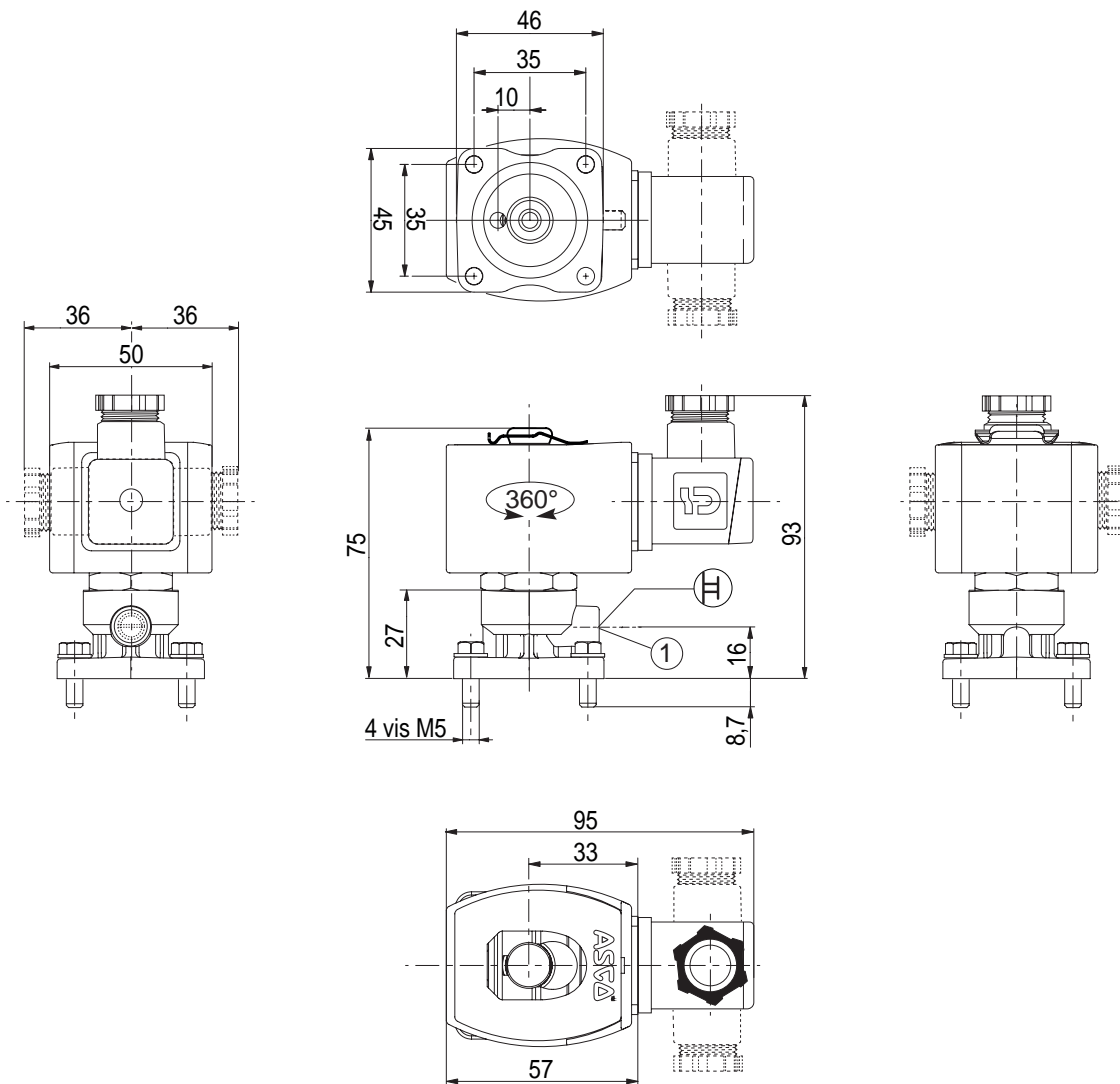

type	weight ⁽¹⁾
01	0,53

① Manual operator location

⁽¹⁾ Incl. coil(s) and connector(s).

Dimensions (mm), Weight (kg)

Configurator - CAD Files



TYPE 02

Electrical interface "S1"
Epoxy moulded
IEC 335 / ISO 4400
IP65

NO: power coil, 10,1 W / 11,6 W

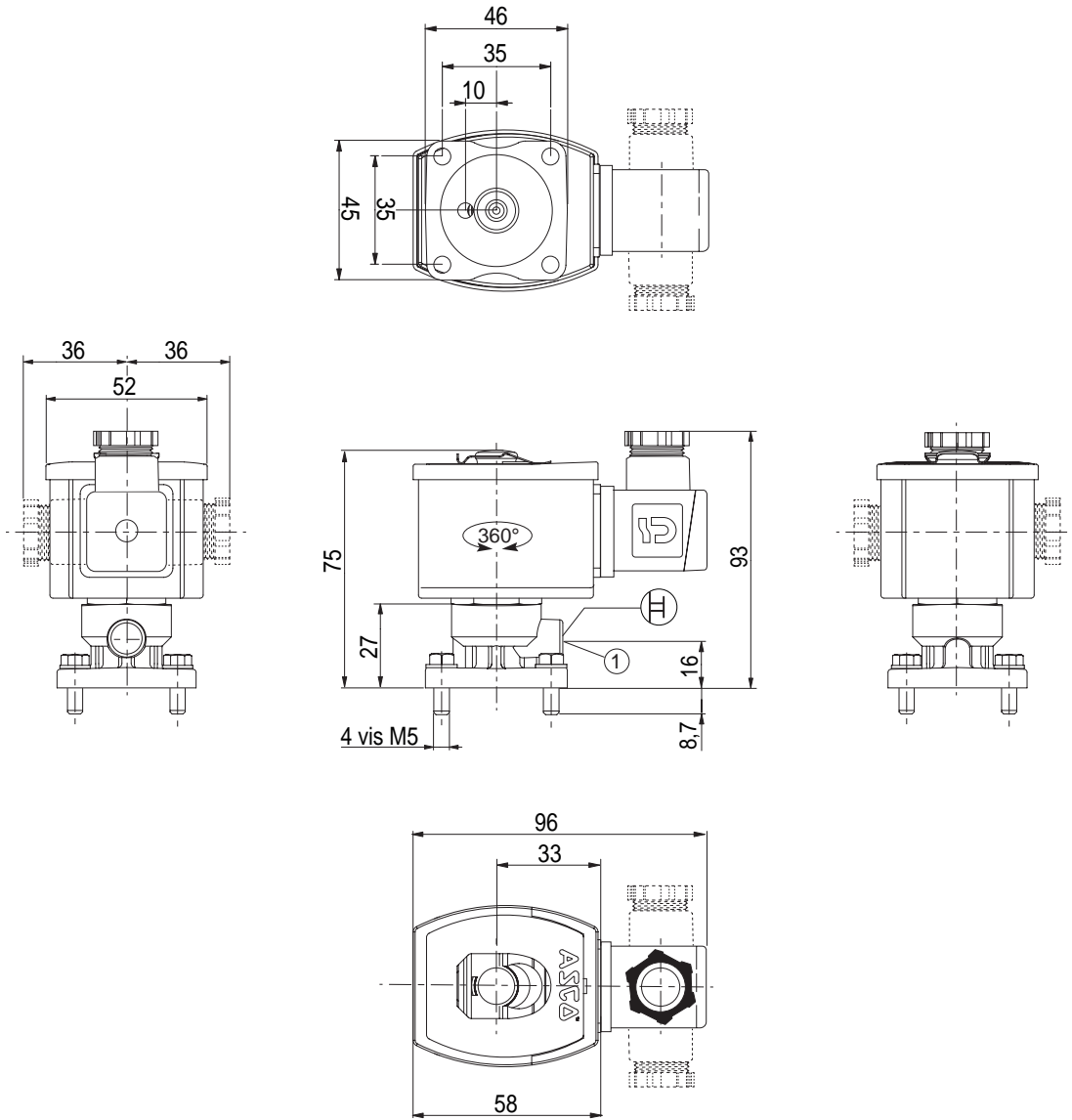

type	weight ⁽¹⁾
02	0,56

① Manual operator location

⁽¹⁾ Incl. coil(s) and connector(s).

Dimensions (mm), Weight (kg)

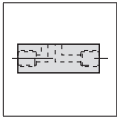

TYPE 03
Single brass subbase
Catalogue number: **36101001**
weight: 0,453

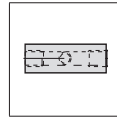

TYPE 04
Single aluminium subbase
Catalogue number: **36101029**
weight: 0,228

View F

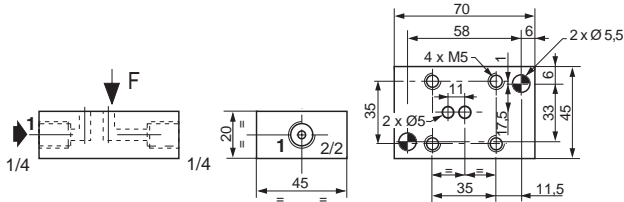

View F

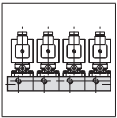
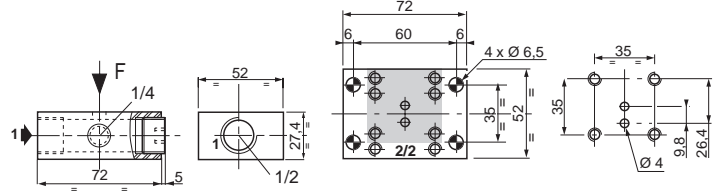

TYPE 05
Joinable brass subbases
Catalogue number: **36101027** (unit)
NC/NO 2/2-way can be combined with 3/2-way

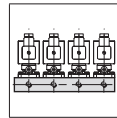

TYPE 06
Aluminium supply rails
Catalogue number: **36101030..1036**
NC/NO 2/2-way can be combined with 3/2-way

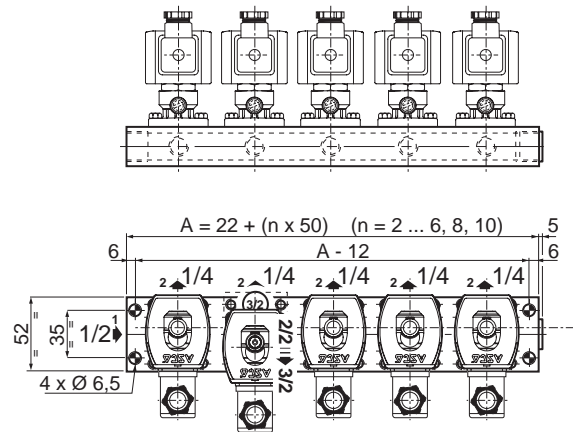
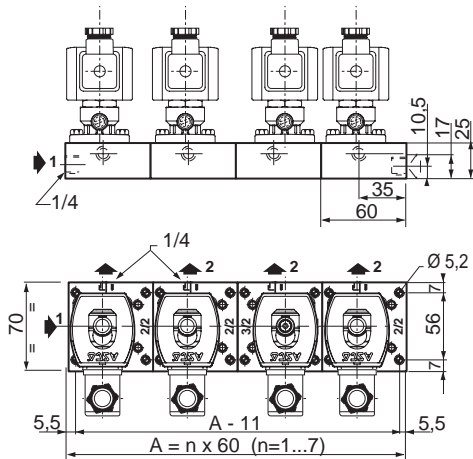

type	weight									
	number of valves									
	2	3	4	5	6	7	8	9	10	
joinable brass subbase	1,49	2,25	3,02	3,78	4,54	5,31	-	-	-	
joinable aluminium subbase	0,38	0,53	0,68	0,83	0,98	-	1,29	-	1,59	



SOLENOID VALVES

anti-waterhammer
pilot operated, hung diaphragm
3/8 to 1

NC

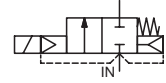

2/2
Series
238

FEATURES

- Two way shut-off valves for the control of cold and hot water
- Zero bar minimum operating pressure
- Valves are designed to reduce waterhammer
- Self-cleaning device located in the bleed orifice to guarantee an optimal performance
- The solenoid valves satisfy all relevant EU directives

GENERAL

Differential pressure 0 to 10 bar [1 bar =100 kPa]
Maximum viscosity 40 cSt (mm²/s)

fluids (*)	temperature range (TS)	seal materials (*)
water	-20°C to +85°C	NBR (nitrile)

CONSTRUCTION

Anti-waterhammer test EN 60730-2-8 (CENELEC)
FCI-82-1 (Fluid Controls Institute)

MATERIALS IN CONTACT WITH FLUID

(*) Ensure that the compatibility of the fluids in contact with the materials is verified

Body Brass
Internal parts Stainless steel
Springs Stainless steel
Seals, diaphragm and disc NBR
Shading coil Copper

ELECTRICAL CHARACTERISTICS

Coil insulation class F
Connector Spade plug (cable Ø 6-10 mm)
Connector specification ISO 4400 / EN 175301-803, form A
Electrical safety IEC 335
Electrical enclosure protection Moulded IP65 (EN 60529)
Standard voltages DC (=) : 24V - 48V
(Other voltages and 60 Hz on request) AC (-) : 24V - 48V - 115V - 230V / 50 Hz

prefix option	power ratings				operator ambient temperature range (TS) (C°)	replacement coil		type ⁽¹⁾
	inrush ~	holding ~	hot/cold =			~	=	
	(VA)	(VA)	(W)	(W)		230 V/50 Hz	24 V DC	
SC	34	15,6	6	-	-20 to +75	400325-117	-	01
	30	22,5	9	9,5/15,3	-20 to +50	400325-217	400325-242	

⁽¹⁾ Refer to the dimensional drawings on the following page.

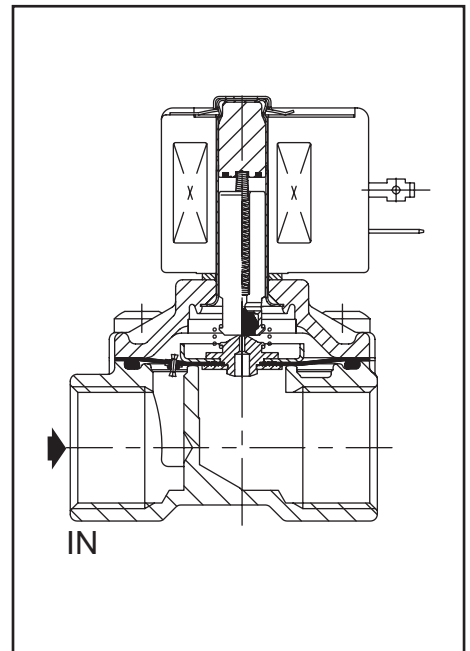

SPECIFICATIONS

pipe size	orifice size	flow coefficient Kv		operating pressure differential (bar)				power coil (W)		catalogue number	options		
				min.	max. (PS)		water (*)				EPDM		
					~	=							
G	(mm)	(m ³ /h)	(l/min)										
NC - Normally closed													
3/8	12,5	2,1	35	0	10	10	6	15,3	SCG238A044	E	-	-	
1/2	12,5	2,1	35	0	10	10	6	15,3	SCG238A046	E	-	-	
1/2	19	4,2	70	0	10	10	6	15,3	SCG238A047	E	-	-	
3/4	19	4,5	75	0	10	10	6	15,3	SCG238A048	E	-	-	
3/4	25	10	166	0	10	10	9	15,3	SCG238A049	-	-	-	
1	25	10	166	0	10	10	9	15,3	SCG238A050	-	-	-	

00039GB-2017/R01 Availability, design and specifications are subject to change without notice. All rights reserved.

OPTIONS

- Valves can also be supplied with EPDM (ethylene-propylene) seals and discs. Use the appropriate optional suffix letter for identification
- Explosionproof enclosures for use in zones 1/21-2/22, categories 2-3 to ATEX Directive 2014/34/EU (www.asco.com)
- WRAS approval
- Other pipe connections are available on request
- Connector with visual indication and peak voltage suppression or with cable length of 2 m (www.asco.com)

INSTALLATION

- The solenoid valves can be mounted in any position without affecting operation
- Threaded pipe connection is standard: G = G (ISO 228/1)
- Installation/maintenance instructions are included with each valve

SPARE PARTS KIT

catalogue number	spare parts kit no.	
	~	=
SCG238A044/046	C132486	C132487
SCG238A045/047/048	C132488	C132489
SCG238A049/050	C132490	C132491

ORDERING EXAMPLES:

SC	G	238	A	044	230V / 50 Hz
SC	G	238	A	046	E 115V / 50 Hz
SC	G	238	A	049	24V / DC
SC	G	238	A	050	48V / 50 Hz

prefix: SC, pipe thread: G, basic number: 238 A, voltage: 230V / 50 Hz, suffix: E

ORDERING EXAMPLES KITS:

C132486 ⁽¹⁾	E
C132489	
C132490	

basic number: C132486, C132489, C132490, suffix: E

DIMENSIONS (mm), WEIGHT (kg)



TYPE 01

Prefix "SC" Solenoid
Epoxy moulded
IEC 335 / ISO 4400
IP65

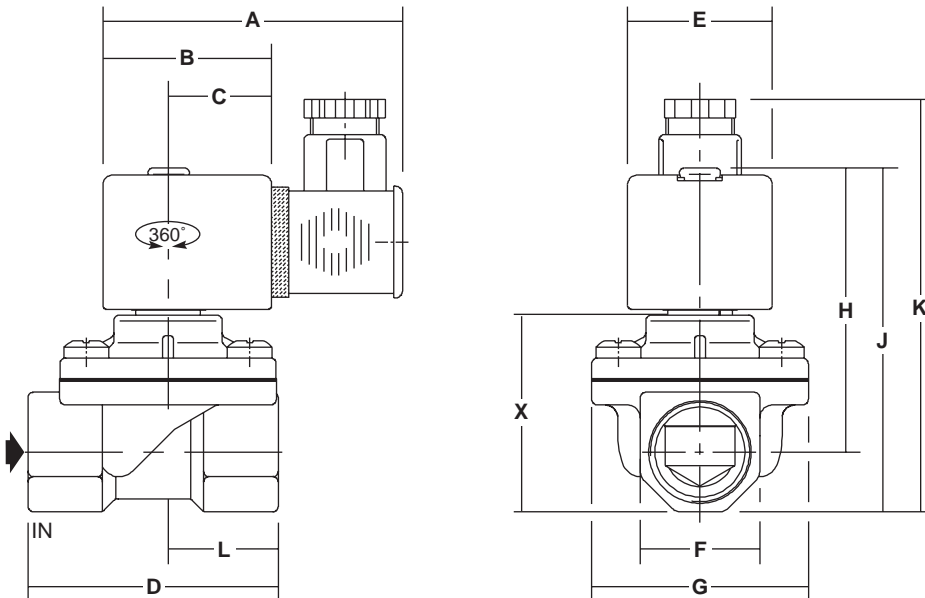

type	prefix option	catalogue number	A	B	C	D	E	F	G	H	J	K	L	X	weight ⁽¹⁾
01	SC	SCG238A044	80	45	27,5	52	39	27	37	72	85	104	23	40	0,55
		SCG238A046	80	45	27,5	52	39	27	37	72	85	104	23	40	0,50
		SCG238A047	80	45	27,5	65	39	27	58	74	87	106	29,5	42	0,75
		SCG238A048	80	45	27,5	67	39	32	58	76	92	111	29,5	47	0,70
		SCG238A049	80	45	27,5	86	39	41	73	92	112	131	37	67	1,30
		SCG238A050	80	45	27,5	86	39	41	73	92	112	131	37	67	1,20

⁽¹⁾ Incl. coil(s) and connector(s).

ASCO™ Solenoid Valves

Pilot Operated, Hung Diaphragm, 3/8" to 1" 1/2

- Two way shut-off valves for the control air, inert gas, water, oil and other gases/liquids compatible with the sealing material used
- Valves do not require a minimum operating pressure
- All products are covered by Pressure Equipment Directive 2014/68/EU and are suitable for group 1 and 2 fluids
- The solenoid valves satisfy all relevant EU directives

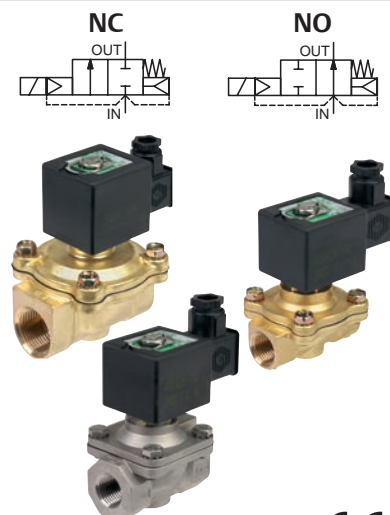

General

Differential pressure See «SPECIFICATIONS» [1 bar = 100 kPa]
Maximum viscosity 65 cSt (mm²/s)
Response time 15 - 120 ms

fluids (*)	temperature range (TS)	seal materials (*)
air, inert gas, water, oil	-20°C to +85°C	NBR (nitrile)

Materials in contact with fluid

(*) Ensure that the compatibility of the fluids in contact with the materials is verified

	Brass body	Stainless steel body
Body	Brass	AISI 304 SS
Core tube	Stainless steel	Stainless steel
Core and plugnut	Stainless steel	Stainless steel
Springs	Stainless steel	Stainless steel
Seat	Brass	Stainless steel
Seals, diaphragm & disc	NBR	NBR
Disc holder (NO function)	PA	PA
Shading coil	Copper	Silver



Electrical characteristics

Coil insulation class F or H
Connector Spade plug (cable Ø 6-10 mm)
Connector specification ISO 4400 / EN 175301-803, form A
Electrical safety IEC 335
Electrical enclosure protection Moulded IP65 (EN 60529)
Standard voltages DC (=): 24V - 48V
 (Other voltages and 60 Hz on request) AC (-): 24V - 48V - 115V - 230V / 50 Hz

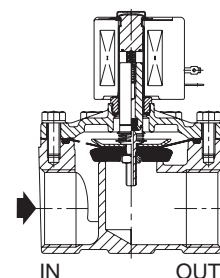

NC function

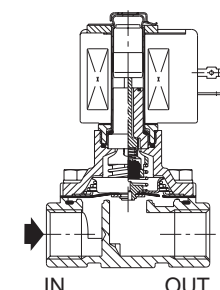

NO function

prefix option	power ratings				operator ambient temperature range (TS) (C°)	replacement coil		type ⁽¹⁾
	inrush		holding			hot/cold =	=	
	~	~	~	~				
SC	(VA)	(VA)	(W)	(W)	(C°)	230 V/50 Hz	24 V DC	
	55	23	10,5	9/ 11,2	-20 to +75	400425-117	400425-142	01
	78	35	16,7	-	-20 to +50	400425-217	-	01
	110	33,6	15,4	-	-20 to +75	400525-117	-	02
	240	43	20	16,8/23	-20 to +50	400525-217	400625-242	02

⁽¹⁾ Refer to the dimensional drawings on the following page.

Specifications

pipe size	orifice size	flow coefficient Kv		operating pressure differential (bar)						power coil (W)		Catalog number		options				
				min.	max. (PS)				brass					stainless steel	maintained man. operator	FPM	EPDM	CR
					air (*)	water (*)	oil (*)	air (*)										
	(mm)	(m ³ /h)	(l/min)	~	=	~	=	~	=	~	=							
NC - Normally closed																		
Rp 3/8	16	2,6	43	0	9	3	9	3	-	-	10,5	11,2	SCE210C093	-	MO	V	E	J
Rp 1/2	16	3,4	57	0	9	3	9	3	-	-	10,5	11,2	SCE210C094	-	MO	V	E	J
G 1/2													-	SCG210C087	MO	V	E	J
Rp 3/4	16	4,3	72	0	9	3	9	3	-	-	10,5	11,2	SCE210D095	-	MO	V	E	J
G 3/4													-	SCG210C088	MO	V	E	J
Rp 1	25	11,1	185	0	9	7	9	7	9	5	15,4	23	SCE210B154 ⁽²⁾	-	MO	V	E	J
G 1													-	SCG210D189	-	V	E	J
Rp 1 1/4	28	12,8	213	0	9	6	9	6	9	4	15,4	23	SCE210B155 ⁽²⁾	-	MO	V	E	J
Rp 1 1/2													-	SCE210B156 ⁽²⁾	-	MO	V	E

⁽²⁾ Mounting position, DC only: piping horizontal, solenoid upright.

Specifications

pipe size	orifice size (mm)	flow coefficient Kv (m ³ /h) (l/min)		operating pressure differential (bar)						power coil (W)		catalogue number brass stainless steel		options				
				min.	max. (PS)									maintained man. operator	FPM	EPDM	CR	
					air (*)	water (*)	oil (*)	~	=									~
NO - Normally open																		
Rp 3/8	16	2,6	43	0	9	9	9	9	9	5	10,5	11,2	SCE210C033	-	-	V	E	J
Rp 1/2	16	3,4	57	0	9	9	9	9	9	5	10,5	11,2	SCE210C034	-	-	V	E	J
NPT 1/2		2,6	43	0	9	9	9	9	9	7	5	10,5	11,2	-	SCB210B030	-	V	E
Rp 3/4	19	4,7	79	0	9	9	9	9	9	5	10,5	11,2	SCE210C035	-	-	V	E	J
NPT 3/4	16	2,6	43	0	9	9	9	9	7	5	10,5	11,2	-	SCB210B038	-	V	E	J
Rp 1	25	11,2	185	0	9	-	9	-	9	-	20	-	SCE210B057 ⁽¹⁾	-	-	V	E	J
Rp 1 1/4	28	12,8	213	0	9	-	9	-	9	-	20	-	SCE210B058 ⁽¹⁾	-	-	V	E	J
Rp 1 1/2	32	19,3	322	0	9	-	9	-	9	-	20	-	SCE210B059 ⁽¹⁾	-	-	V	E	J

⁽¹⁾ Mounting position: piping horizontal, solenoid upright.

Options

- Valves can also be supplied with FPM (fluoroelastomer), EPDM (ethylene-propylene) and CR (chloroprene) diaphragms, seals and discs. Use the appropriate optional suffix letter for identification
- Waterproof enclosure with embedded screw terminal coil according to protection class IP67, CEE-10
- Explosionproof enclosures for use in zones 1/21-2/22, categories 2-3 to ATEX Directive 2014/34/EU ⁽²⁾
- Electrical enclosures according to “NEMA” standards are available
- Compliance with “UL”, “CSA” and other local approvals available on request
- Mounting brackets for brass bodied valves, suffix MB (Except pipe size Rp 1, 1 1/4 and 1 1/2)
- For protection against corrosion caused by the environment or the fluid, contact us
- Other pipe connections are available on request
- Connector with visual indication and peak voltage suppression or with cable length of 2 m

⁽²⁾ Please consult the quick selection guide on potentially explosive atmospheres on Emerson.com/asco

Installation

- The solenoid valves can be mounted in any position without affecting operation, unless indicated otherwise in the specifications table.
- Stainless steel valves are standard supplied with mounting brackets
- Pipe connection identifiers are: G = G (ISO 228/1), E = Rp (ISO 7/1) or B = NPT (ANSI 1.20.3)
- Installation/maintenance instructions are included with each valve

Spare parts kit & Accessories

Catalog number	spare parts kit no.		mounting bracket
	~	=	
SCE210C093/C094	C302272	C302372	038713-000
SCE210D095	C302276	C302375	038713-000
SCE210B154	C302283	C133800	-
SCE210B155	C302283	C133801	-
SCE210B156	C302286	C133802	-
SCE210C033/C034	C302334	C302449	038713-000
SCE210C035	C302335	C302450	038713-000
SCE210B057	C302337	-	-
SCE210B058	C302339	-	-
SCE210B059	C302340	-	-
SCG210C087/C088	C302328	C302423	038713-000
SCB210B030/B038	C302347	C302447	-
SCG210D189	C302329	C133668	-

- Not available

Ordering examples:

SC	E	210	C	093	230V / 50 Hz
SC	E	210	C	094	MO 115V / 50 Hz
SC	B	210	C	087	V 24V / DC
SC	B	210	D	089	230V / 50 Hz

prefix — pipe thread — basic number — voltage — suffix

Ordering examples kits:

C302272 ⁽³⁾	
C302276	V
C302449	E

basic number — suffix

⁽³⁾ Standard prefixes/suffixes are also applicable to kits.

Dimensions (mm), Weight (kg)

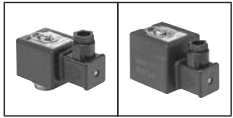

TYPE 01-02
Prefix "SC" Solenoid
Epoxy moulded
IEC 335 / ISO 4400
IP65

Type 01: SCE210C093/C094/D095
SCG210C087/C088

Type 02: SCE210B154/B155
SCG210D189

Type 02: SCE210B156

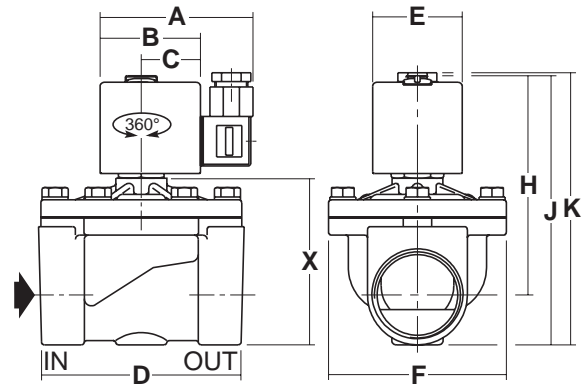
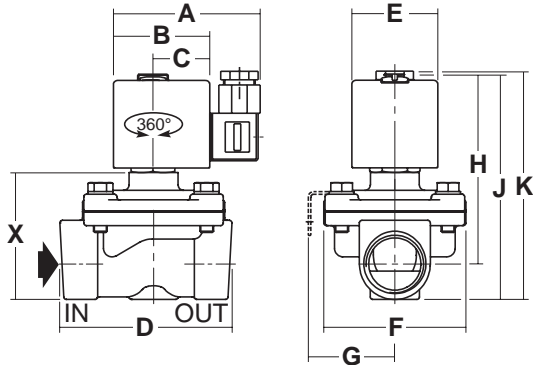

Type 01: SCE210C033/C034/C035
SCB210B030/B038

Type 02: SCB210B057/B058/B059

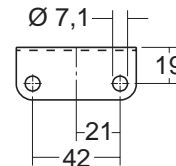
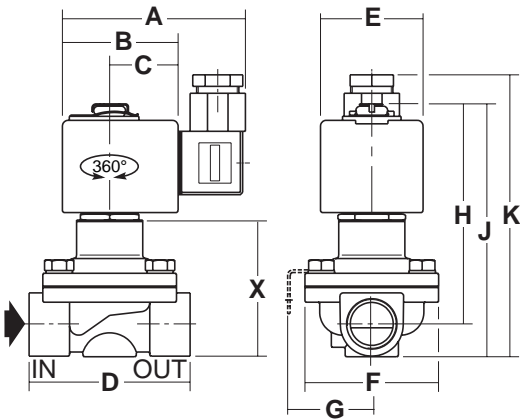

Mounting brackets for valves: (0,3 kg)
SCE210C093/C094/D095
SCG210C087/C088/D189
SCE210C033/C034/C035

type	prefix option	Catalog number	A	B	C	D	E	F	G	H	J	K	X	weight ⁽²⁾
01	SC	SCE210C093/C094	80	50	30	70	45	58	41	80	97	109	46	0,8
		SCE210D095	80	50	30	73	45	58	41	89	103	121	54	1,0
		SCG210C087/C088	80	50	30	71	45	61	41	87	105	122	55	1,0
		SCE210C033/C034	80	50	30	70	45	58	41	98	108	127	60	0,9
		SCE210C035	80	50	30	70	45	58	41	102	117	132	68	1,0
		SCB210B030/B038	80	50	30	71	45	59	41	100	116	133	67	1,0
02	SC	SCE210B156	86	56	33	111	50	99	-	125	153	158	96	2,8
		SCE210B154	86	56	33	95	50	83	-	112	129	137	75	2,0
		SCE210B155	86	56	33	95	50	83	-	112	143	148	86	2,0
		SCG210D189	86	56	33	95	50	99	56	113	133	132	77	2,2
		SCE210B057	86	56	33	95	50	83	-	155	172	157	98	2,0
		SCE210B058	86	56	33	95	50	83	-	161	187	187	130	2,0
		SCE210B059	86	56	33	111	50	99	-	167	194	194	137	2,5

⁽²⁾ Incl. coil(s) and connector(s)

00040CB-2019/R01
Availability, design and specifications are subject to change without notice. All rights reserved.



SOLENOID VALVES

pilot operated
built-in pilot, floating diaphragm
3/8 to 2

NC

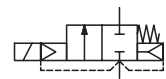

NO

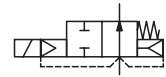

2/2
Series
238

FEATURES

- Minimum operating pressure differential ΔP 0,3/0,5 bar
- Two way valves for automatic control of water, air and inert gas and other gases/liquids compatible with the sealing materials used
- Interchangeability of magnetic heads, AC and DC
- The solenoid valves satisfy all relevant EU Directives

GENERAL

Differential pressure	See «SPECIFICATIONS» [1 bar =100 kPa]						
Ambient temperature range	-10°C to +60°C						
Maximum viscosity	40 cSt (mm ² /s)						
Response time	3/8	1/2	3/4	1	1 1/4	1 1/2	2
opening time (ms)	25	30	55	70	300	300	1500
closing time (ms)	40	90	110	200	1000	1000	2000

fluids (*)	temperature range (TS)	seal materials (*)
air, inert gas and water	-10°C to +85°C	NBR (nitrile) FPM (fluoroelastomer)

MATERIALS IN CONTACT WITH FLUID

(*) Ensure that the compatibility of the fluids in contact with the materials is verified

Body	Brass
Internal parts	Stainless steel and brass
Springs	Stainless steel
Diaphragm & valve disc	NBR
Seals and pilot disc	FPM
Shading coil	Copper

ELECTRICAL CHARACTERISTICS

Coil insulation class	F
Connector	Spade plug (cable Ø 6-8 mm or Ø 6-10 mm)
Connector specification	DIN 43650, 11 mm, industry standard B
for power coil: 4 W/6,9 W	ISO 4400 / EN 175301-803, form A
for power coil: 5/6,9W-8/9W-12,5/9W	IEC 335
Electrical safety	Moulded IP65 (EN 60529)
Electrical enclosure protection	DC (=) : 24V - 48V
Standard voltages	AC (~) : 24V - 48V - 115V - 230V / 50 Hz
(Other voltages and 60 Hz on request)	

prefix option	power ratings				operator ambient temperature range (TS) (C°)	replacement coil		type ⁽¹⁾
	inrush ~	holding ~	hot/cold =			~	=	
	(VA)	(VA)	(W)	(W)				
SC	12	6	4	5/6,9	-10 to +60	400127-197	400127-142	01 ⁽²⁾
	10,4	6	5	5/6,9	-10 to +60	400727-117	400727-185	02
	23	14	8	7,5/9	-10 to +50	511239-009	511239-002	03
	28	20	12,5	7,5/9	-10 to +50	511239-014	511239-002	03

⁽¹⁾ Refer to the dimensional drawings on the following page.

⁽²⁾ UL/CSA certified.

SPECIFICATIONS

pipe size	orifice size	flow coefficient Kv		operating pressure differential (bar)				power coil (W)		catalogue number	options			
				min.	max. (PS)		~				=	maintained man. operator	FPM	EPDM
					air / water (*)									
NC - Normally closed														
G* 3/8	12	2,4	40	0,3	10	10	4	6,9	SCE238D001	MO	V	E		
					16	16	5	6,9					SCE238D006	MO
G* 1/2	12	2,4	40	0,3	10	10	4	6,9	SCE238D002	MO	V	E		
					16	16	5	6,9	SCE238D007	MO	V	E		
	15	4,2	70	0,3	10	10	4	6,9	SCE238D003	MO	V	E		
					16	16	5	6,9	SCE238D008	MO	V	E		
G* 3/4	20	6,6	110	0,3	10	10	4	6,9	SCE238D004	MO	V	E		
					16	16	5	6,9	SCE238D009	MO	V	E		
G* 1	25	9,9	165	0,3	10	10	4	6,9	SCE238D005	MO	V	E		
					16	16	5	6,9	SCE238D010	MO	V	E		
G 1 1/4	30	15	250	0,5	10	10	8	9	SCG238E016	MO	V	-		
G 1 1/2	45	27	450	0,5	10	10	8	9	SCG238E017	MO	V	-		
G 2	45	34	566	0,5	10	10	8	9	SCG238E018	MO	V	-		
NO - Normally open														
G 1 1/4	30	15	250	0,5	10	10	12,5	9	SCG238E019	-	V	-		
G 1 1/2	45	27	450	0,5	9	9	12,5	9	SCG238E020	-	V	-		
G 2	45	34	566	0,5	9	9	12,5	9	SCG238E021	-	V	-		

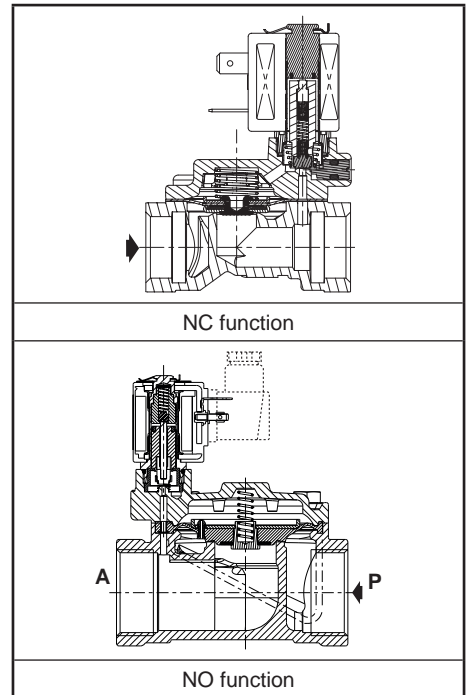

00041 GB-2017/R02
Availability, design and specifications are subject to change without notice. All rights reserved.

All leaflets are available on: www.asco.com

OPTIONS

- Valves can also be supplied with FPM (fluorelastomer), EPDM (ethylene-propylene) seals, diaphragm and disc. Use the appropriate optional suffix letter for identification
- Explosionproof enclosures for use in zones 1/21-2/22, categories 2-3 to ATEX Directive 2014/34/EU (www.asco.com)
- Oxygen service, suffix NV, example: SCE238D002NVMO (Except pipe size G 1 1/4, G 1 1/2 and G 2)
- Connector with visual indication and peak voltage suppression or with cable length of 2 m (www.asco.com)

INSTALLATION

- The solenoid valves can be mounted in any position without affecting operation
- Pipe connections (G*) have standard combination thread according to ISO 228/1 and ISO 7/1. Pipe connections (G) have standard combination thread according to ISO 228/1
- Installation/maintenance instructions are included with each valve

SPARE PARTS KIT

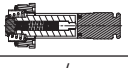
catalogue number	spare parts kit no. ⁽¹⁾	
		
	~/=	~/=
SCE238D001/002/006/007	C131600	C140262V
SCE238D003/D008	C131618	C140262V
SCE238D004/D009	C131606	C140262V
SCE238D005/D010	C131609	C140262V

⁽¹⁾ Standard suffixes are also applicable to kits.

ORDERING EXAMPLES:

SC	E	238	D	001	230V / 50 Hz
SC	E	238	D	008	V 115V / 50 Hz
SC	E	238	D	004	E 24V / DC
SC	G	238	E	016	230V / 50 Hz

prefix — pipe thread — basic number — voltage — suffix

ORDERING EXAMPLES KITS:

C131600 ⁽¹⁾	
C131618	V
C140262	E

basic number — suffix

DIMENSIONS (mm), WEIGHT (kg)



TYPE 01
Prefix "SC" Solenoid
Epoxy moulded
IEC 335 / DIN 43650
IP65

SCE238D001/002/004/005
SCE238D003



TYPE 02
Prefix "SC" Solenoid
Epoxy moulded
IEC 335 / ISO 4400
IP65

SCE238D006/007/009/010
SCE238D008



TYPE 03
Prefix "SC" Solenoid
Black PPS moulded
IEC 335 / ISO 4400
IP65

SCG238E016/017/018
SCG238E019/020/021

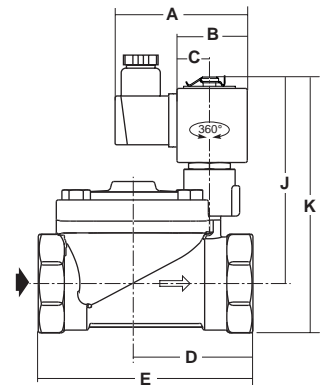
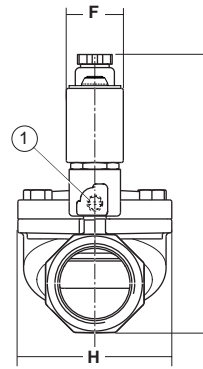
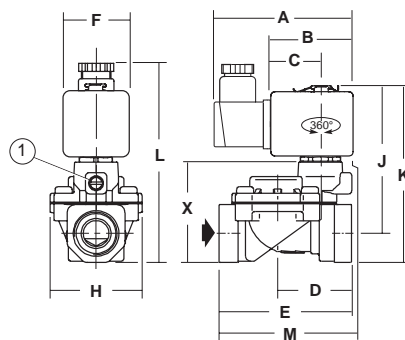
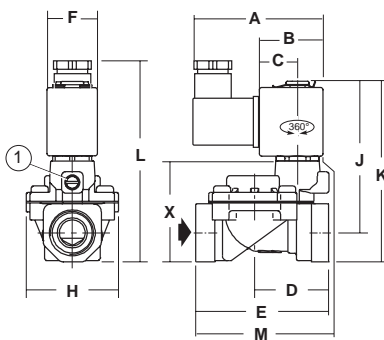

type	prefix option	catalogue number	A	B	C	D	E	F	H	J	K	L	M	X	weight ⁽²⁾
01	SC	SCE238D001/002	60,5	27,5	17	34,5	62	22	43	68,5	81	98	57,5	47	0,4
		SCE238D003	60,5	27,5	17	45,5	81,5	22	57	71	83,5	100	73,5	49,5	0,5
		SCE238D004	60,5	27,5	17	53	95	22	68	79,5	94,5	111	85,5	60,5	0,8
		SCE238D005	60,5	27,5	17	58	105,5	22	87	84,5	104	121	93	70	1,0
02	SC	SCE238D006/007	76	38	23	34,5	62	30	43	69,5	83	100,5	61,5	47	0,5
		SCE238D008	76	38	23	45,5	81,5	30	57	72	85,5	103	77,5	49,5	0,6
		SCE238D009	76	38	23	53	95	30	68	80,5	96,5	114	89,5	60,5	0,9
		SCE238D010	76	38	23	58	105,5	30	87	85,5	106	123,5	97	70	1,1
03	SC	SCG238E016/019	76	36,6	21,6	63	113	30	81	108	134	150	-	-	1,7
		SCG238E017/020	76	36,6	21,6	76	140	30	110	112	142	157	-	-	2,6
		SCG238E018/021	76	36,6	21,6	85	157	30	110	116	152	168	-	-	2,9

⁽¹⁾ Manual operator location

⁽²⁾ Incl. coil(s) and connector(s).



SOLENOID VALVES

pilot operated, built-in pilot
stainless steel body, floating diaphragm
3/8 to 1

NC

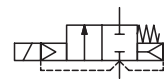

NO

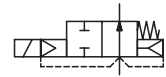

2/2
Series
238

FEATURES

- Minimum operating pressure differential ΔP 0,35 bar
- Two way valves for automatic control of water, air and inert gas and other gases/liquids compatible with the sealing materials used
- Stainless steel body for wide compatibility with environments and fluids
- Interchangeability of magnetic heads, AC and DC
- The solenoid valves satisfy all relevant EU Directives

GENERAL

Differential pressure	See «SPECIFICATIONS» [1 bar = 100 kPa]
Ambient temperature range	-10°C to +60°C
Maximum viscosity	37 cSt (mm ² /s)
Response time	3/8 1/2 3/4 1
opening time (ms)	300 300 300 1500
closing time (ms)	1000 1000 1000 2000

fluids (*)	temperature range (TS)	seal materials (*)
air, inert gas and water	0°C to +130°C	FPM (fluoroelastomer)

MATERIALS IN CONTACT WITH FLUID

(*) Ensure that the compatibility of the fluids in contact with the materials is verified

Body	Stainless steel, AISI 316L
Core tube	Stainless steel
Core and plugnut	Stainless steel
Springs	Stainless steel
Seat	Stainless steel, AISI 316L
Diaphragm & disc valve	FPM
Seals & disc pilot	FPM
Shading coil	Copper

ELECTRICAL CHARACTERISTICS

Coil insulation class	F
Connector	Spade plug (cable Ø 6-8 mm or Ø 6-10 mm)
Connector specification	
for power coil: 4 W/6,9 W	DIN 43650, 11 mm, industry standard B
for power coil: 6,9 W DC	ISO 4400 / EN 175301-803, form A
Electrical safety	IEC 335
Electrical enclosure protection	Moulded IP65 (EN 60529)
Standard voltages	DC (=) : 24V - 48V
(Other voltages and 60 Hz on request)	AC (-) : 24V - 48V - 115V - 230V / 50 Hz

prefix option	power ratings				operator ambient temperature range f (TS) (C°)	replacement coil		type ⁽¹⁾
	inrush ~	holding ~	hot/cold =	~		=		
	(VA)	(VA)	(W)					
SC	12 -	6 -	4 -	4 / 6,9 4 / 5	-10 to +60 -10 to +60	230 V/50 Hz -	400127-142 400727-185	01 ⁽²⁾ 02

⁽¹⁾ Refer to the dimensional drawings on the following page.

⁽²⁾ UL/CSA certified.

SPECIFICATIONS

pipe size	orifice size	flow coefficient Kv		operating pressure differential (bar)				power coil (W)		catalogue number	options			
				min.	max. (PS)		~				=	maintained man. operator	EPDM	
					air / water (*)									
G	(mm)	(m ³ /h)	(l/min)		~	=		~	=	~/=				
NC - Normally closed														
3/8	13,5	2,5	41,7	0,35	12	12	4	6,9		SCG238D101V	MO	E	-	
1/2	13,5	3,8	63,3	0,35	12	12	4	6,9		SCG238D102V	MO	E	-	
3/4	18	5	83,3	0,35	10	10	4	6,9		SCG238D103V	MO	E	-	
1	24	12	200	0,35	10	10	4	6,9		SCG238D104V	MO	E	-	
NO - Normally open														
3/8	13,5	2,5	41,7	0,35	12	12	4	5 ⁽²⁾		SCG238D105V	-	E	-	
1/2	13,5	3,8	63,3	0,35	12	12	4	5 ⁽²⁾		SCG238D106V	-	E	-	
3/4	18	5	83,3	0,35	10	10	4	5 ⁽²⁾		SCG238D107V	-	E	-	
1	24	12	200	0,35	10	10	4	5 ⁽²⁾		SCG238D108V	-	E	-	

⁽²⁾ Type 02.

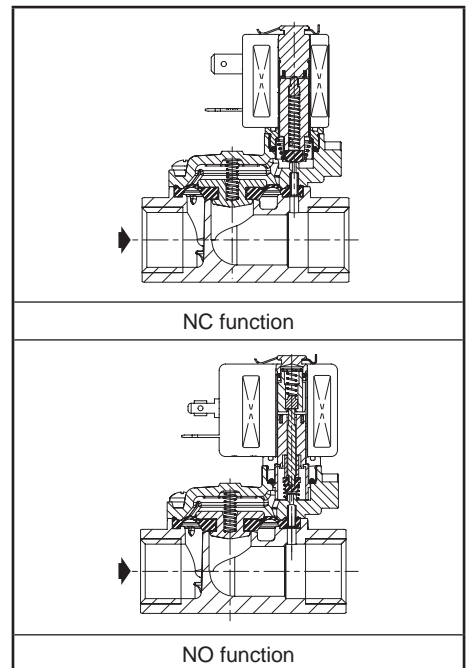



OPTIONS

- Valves can also be supplied with EPDM (ethylene-propylene) seals, diaphragm and disc. Use the appropriate optional suffix letter for identification
- Explosionproof enclosures for use in zones 1/21-2/22, categories 2-3 to ATEX Directive 2014/34/EU (www.asco.com)
- Oxygen service, suffix NV, example: SCG238D102NV
- Connector with visual indication and peak voltage suppression or with cable length of 2 m (www.asco.com)

INSTALLATION

- The solenoid valves can be mounted in any position without affecting operation
- Threaded pipe connection is standard: G = G (ISO 228/1)
- Installation/maintenance instructions are included with each valve

SPARE PARTS KIT

catalogue number	spare parts kit no. ⁽¹⁾	
	 ⁽¹⁾	
	~/=	~/=
SCG238D101V/102V	C131038V	C140267V
SCG238D103V	C131039V	C140267V
SCG238D104V	C131040V	C140267V
SCG238D105V/106V	C131041V	C140508V
SCG238D107V	C131042V	C140508V
SCG238D108V	C131043V	C140508V

⁽¹⁾ For EPDM version, replace "V" with "E".

ORDERING EXAMPLES:

SC	G	238	D	101	V	230V / 50 Hz
SC	G	238	D	104	E	24V / DC
SC	G	238	D	102	VMO	230V / 50 Hz

prefix — pipe thread — basic number — voltage — suffix

ORDERING EXAMPLES KITS:

C140267	V
C131038	E

basic number — suffix

DIMENSIONS (mm), WEIGHT (kg)



TYPE 01
Prefix "SC" Solenoid
Epoxy moulded
IEC 335 / DIN 43650
IP65

SCG238D101/102/103/104

AC (-): SCG238D105/106/107/108



TYPE 02
Prefix "SC" Solenoid
Epoxy moulded
IEC 335 / ISO 4400
IP65

DC (-): SCG238D105/106/107/108

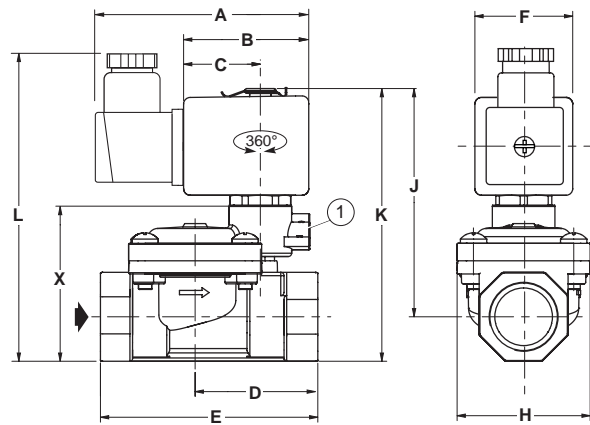
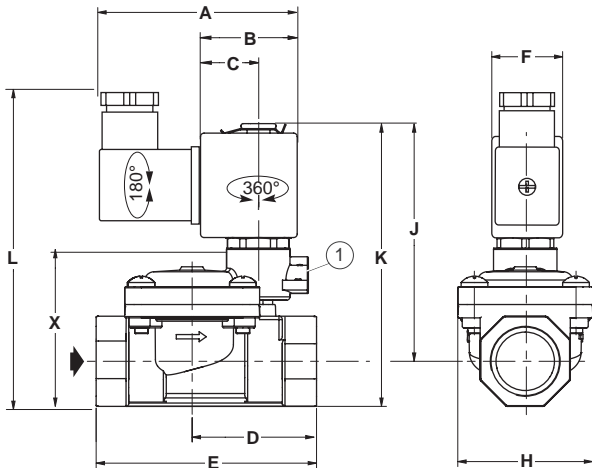

¹ Manual operator location.

type	prefix option	catalogue number	A	B	C	D	E	F	H	J	K	L	X	weight ⁽²⁾	
														NC	NO
01	SC	SCG238D101 / SCG238D105 (-)	60,5	27,5	17	34,5	60	22	40	67	78	95	42	0,33	0,35
		SCG238D102 / SCG238D106 (-)	60,5	27,5	17	37	66	22	40	69	83	100	47	0,45	0,41
		SCG238D103 / SCG238D107 (-)	60,5	27,5	17	43,5	79	22	50	73,5	90	107	54	0,52	0,55
		SCG238D104 / SCG238D108 (-)	60,5	27,5	17	59	105	22	71	85	106	123	70	1,08	1,11
02	SC	SCG238D105 (=)	76	38	23	34,5	60	30	40	67	78	95	42	-	0,35
		SCG238D106 (=)	76	38	23	37	66	30	40	69	83	83	47	-	0,41
		SCG238D107 (=)	76	38	23	43,5	79	30	50	73,5	90	90	54	-	0,55
		SCG238D108 (=)	76	38	23	59	105	30	71	85	106	106	70	-	1,11

⁽²⁾ Incl. coil(s) and connector(s).

All leaflets are available on: www.asco.com

ASCO™ Solenoid Valves

Pilot Operated, Floating Diaphragm/Piston, 3/8 to 2

- Two way shut-off valves for automatic control of air, inert gas, water, oil and other gases/liquids compatible with the seal materials used
- Valves require a minimum ΔP of 0,35 bar
- All products are covered by Pressure Equipment Directive 2014/68/EU and are suitable for group 1 and 2 fluids
- The solenoid valves satisfy all relevant EU Directives

General

Differential pressure See «SPECIFICATIONS» [1 bar = 100 kPa]
Maximum viscosity 65 cSt (mm²/s)
Response time 15 - 60 ms (3/8 to 3/4); 40 - 120 ms (1 to 2)

fluids (*)	temperature range (TS)	seal materials (*)
air, inert gas, water, oil	-20°C to +85°C	NBR (nitrile)

Materials in contact with fluid

(*) Ensure that the compatibility of the fluids in contact with the materials is verified

Body Brass / 316L Stainless steel
Shading coil Copper / Silver
Core tube Stainless steel
Core and plugnut Stainless steel
Springs Stainless steel
Seat Brass / 316L Stainless steel
Seal, diaphragm & disc NBR
Piston Brass / st. steel
Piston disc NBR
Disc holder (NO function) PA

Electrical characteristics

Coil insulation class F
Connector Spade plug (cable Ø 6-10 mm)
Connector specification ISO 4400 / EN 175301-803, form A
Electrical safety IEC 335
Electrical enclosure protection Moulded IP65 (EN 60529)
Standard voltages DC (=) : 24V - 48V
 (Other voltages and 60 Hz on request) AC (-) : 24V - 48V - 115V - 230V/50 Hz

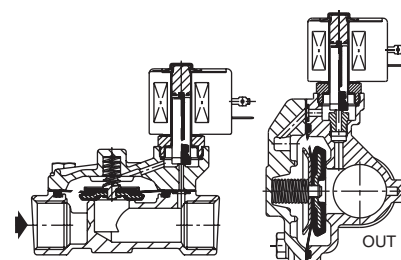

NC function

NO function

prefix option	power ratings				operator ambient temperature range (TS) (C°)	replacement coil		type ⁽¹⁾
	inrush ~		holding ~			~	=	
	(VA)	(VA)	(W)	(W)		230 V/50 Hz	24 V DC	
SC	34	15,6	6	-	-20 to +75	400325-117	-	01
	-	-	-	9/ 11,2	-20 to +75	-	400425-142	02
	78	35	16,7	-	-20 to +50	400425-217	-	02
	110	33,6	15,4	12/16,8	-20 to +75	400525-117	400625-142	03
	30	16	8,1	-	-25 to +55	238213-059	-	04
-	-	-	8,5/ 11,6	-25 to +55	-	238913-006	-	05

⁽¹⁾ Refer to the dimensional drawings on the following page.

Specifications

pipe size	orifice size	flow coefficient Kv	operating pressure differential (bar)								power coil (W)		Catalog number		options				
			min.	max. (PS)						maintained man. operator					FPM	EPDM	CR		
				air (*)	water (*)		oil (*)												
Rp	(mm)	(m ³ /h)(l/min)	~	=	~	=	~	=	~	=	~	=	brass	stainless steel					
NC - Normally closed																			
3/8	16	2,6	43	0,35	14	9	10	7	10	7	6	11,2	SCE210D001	-	MO	V	E	J	
					20	-	20	-	20	-	16,7	-	MO	V	E	J			
1/2	16	3,4	57	0,35	14	9	10	7	10	7	6	11,2	SCE210D002	-	MO	V	E	J	
					20	-	20	-	20	-	16,7	-	MO	V	E	J			
3/4	19	4,3	72	0,35	9	7	9	6	9	5	6	11,2	SCE210D009	-	MO	V	E	J	
		5,6	93	0,35	17	9	10	9	10	9	6	11,2	SCE210D003	-	MO	V	E	J	
1	25	11,1	185	0,35	9	9	9	9	9	9	6	11,2	SCE210D004	-	MO	V	E	J	
		28	12,8	213	0,35	9	9	9	9	9	6	11,2	SCE210D008	-	MO	V	E	J	
1 1/4	32	19,3	322	0,35	9	9	9	9	9	9	8,1	11,6	-	SCE210G125	MO	V	E	J	
		32	19,3	322	0,35	9	9	9	9	9	6	11,2	SCE210D022	-	MO	V	E	J	
1 1/2	32	19,3	322	0,35	9	9	9	9	9	9	6	11,2	SCE210D022	-	MO	V	E	J	
											8,1	11,6	-	SCE210G127	MO	V	E	J	
2	44	37	617	0,35	9	3	9	3	6	3	6	11,2	SCE210-100 ⁽²⁾	-	MO	V	E	J	
											8,1	11,6	-	SCE210G129 ⁽²⁾	MO	V	E	J	

⁽²⁾ Floating piston construction.

00042GB-2019/R02 Availability, design and specifications are subject to change without notice. All rights reserved.

Specifications

pipe size	orifice size	flow coefficient Kv		operating pressure differential (bar)								power coil (W)		Catalog number		options			
				min.	max. (PS)						brass					stainless steel	maintained man. operator	FPM	EPDM
					air (*)	water (*)	oil (*)	air (*)	water (*)	oil (*)									
Rp	(mm)	(m³/h)	(l/min)		~	=	~	=	~	=	~	=							
NO - Normally open																			
3/4	19	5,7	95	0,35	17	17	14	14	14	14	15,4	16,8	SCE210C013	-	MO	V	E	J	
1	25	11,1	185	0,35	9	9	9	9	9	9	15,4	16,8	SCE210D014	-	MO	V	E	J	
1 1/4	28	12,8	213	0,35	9	9	9	9	9	9	15,4	16,8	SCE210D018	-	MO	V	E	J	
	32	19,3	322								15,4	16,8	-	SCE210A131	MO	V	E	J	
1 1/2	32	19,3	322	0,35	9	9	9	9	9	9	15,4	16,8	SCE210D032	SCE210A132	-	V	E	J	
2	44	37	617	0,35	9	9	9	9	9	9	15,4	16,8	SCE210-103 ⁽¹⁾	SCE210A133 ⁽¹⁾	-	V	E	J	

⁽¹⁾ Floating piston construction.

Options

- Valves can also be supplied with FPM (fluoroelastomer), EPDM (ethylene-propylene), CR (chloroprene) and PTFE seals and discs. Use the appropriate optional suffix letter for identification.
- Waterproof enclosure with embedded screw terminal coil according to protection class IP67, CEE-10
- Explosionproof enclosures for use in zones 1/21-2/22, categories 2-3 to ATEX Directive 2014/34/EU ⁽²⁾
- Electrical enclosures according to "NEMA" standards are available
- Compliance with "UL", "CSA" and other local approvals available on request
- For protection against corrosion caused by the environment or the fluid, contact us
- Mounting brackets (3/8 to 3/4 solenoid valves)
- Other pipe connections are available on request
- Connector with visual indication and peak voltage suppression or with cable length of 2 m

⁽²⁾ Please consult the quick selection guide on potentially explosive atmospheres on Emerson.com/asco

Installation

- The solenoid valves can be mounted in any position without affecting operation
- Pipe connection identifier is E = Rp (ISO 7/1)
- Installation/maintenance instructions are included with each valve

Spare parts kit & Accessories

Catalog number	spare parts kit no.		mounting bracket
	~	=	
SCE210G125/G127	C325338	C325365	-
SCE210G129/A131	C325366	C325367	-
SCE210A132	C325368	C325368	-
SCE210A133	C325369	C325369	-
SCE210D001/D002	C302273	C302373	038713-000
SCE210D009	C302277	C302376	038713-000
SCE210C006/C007	C302274	-	038713-000
SCE210D003	C302279	C302378	038914
SCE210D004/D008	C302280	C302379	-
SCE210D022	C302284	C302383	-
SCE210C013	C302336	C302451	038914
SCE210D014/D018	C302338	C302452	-
SCE210D032	C302341	C302453	-
SCE210-100	C304355	C304359	-
SCE210-103	C304361	C304361	-

- Not available

Ordering examples:

SC	E	210	D	001	230V / 50 Hz
SC	E	210	C	007	MO 115V / 50 Hz
SC	E	210	D	022	V 24V / DC
SC	E	210	-	103	230V / 50 Hz

prefix — pipe thread — basic number — voltage — suffix

Ordering examples kits:

C302277 ⁽³⁾	
C302373	V
C302451	E

basic number — suffix

⁽³⁾ Standard prefixes/suffixes are also applicable to kits.

00042GB-2019/R03 Availability, design and specifications are subject to change without notice. All rights reserved.

Dimensions (mm), Weight (kg)



TYPE 01-02
Prefix "SC" Solenoid
Epoxy moulded
IEC 335 / ISO 4400
IP65

Type 01 (AC): SCE210D001/D002/D009
Type 02 (DC): SCE210D001/D002/D009
(AC): SCE210C006/C007

Type 01 (AC): SCE210D003
Type 02 (DC): SCE210D003

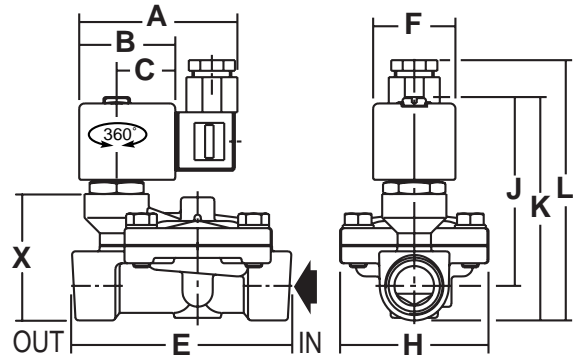
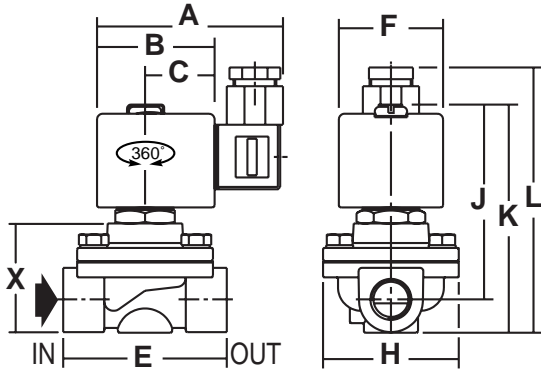

Type 01 (AC): SCE210D004/D008
Type 02 (DC): SCE210D004/D008

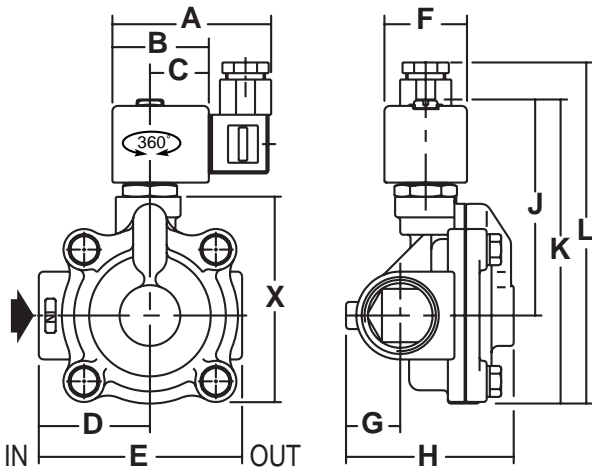

mounting brackets	for valves
	SCE210D001 SCE210D002 SCE210D009 SCE210C006 SCE210C007
	SCE210D003

type	prefix option	Catalog number	A	B	C	D	E	F	G	H	J	K	L	M	X	weight ⁽¹⁾
01	SC	SCE210D001/D002	75	45	27	-	70	39	-	58	72	86	103	-	46	0,8
		SCE210D009	75	45	27	-	71	39	-	58	76	92	109	-	47	0,8
		SCE210D003	75	45	27	-	100	39	-	70	90	105	122	-	60	1,3
		SCE210D004	75	45	27	52	95	39	25	75	101	143	160	-	98	1,8
		SCE210D008	75	45	27	58	115	39	33	99	105	155	172	-	109	2,0
02	SC	SCE210D001/D002	80	50	30	-	70	45	-	58	85	97	111	-	46	0,9
		SCE210D009	80	50	30	-	71	45	-	58	89	106	123	-	57	0,9
		SCE210D003	80	50	30	-	100	45	-	70	94	109	126	-	60	1,4
		SCE210C006/C007	80	50	30	-	70	45	-	58	85	99	116	-	50	0,9
		SCE210D004	80	50	30	52	95	45	25	75	105	147	164	-	98	2,0
SCE210D008	80	50	30	58	115	45	33	99	110	159	175	-	98	2,0		

⁽¹⁾ Incl. coil(s) and connector(s).

Dimensions (mm), Weight (kg)



TYPE 01-02
Prefix "SC" Solenoid
Epoxy moulded
IEC 335 / ISO 4400
IP65

Type 01 (AC): SCE210D022
Type 02 (DC): SCE210D022

Type 01, AC: SCE210-100
Type 02, DC: SCE210-100

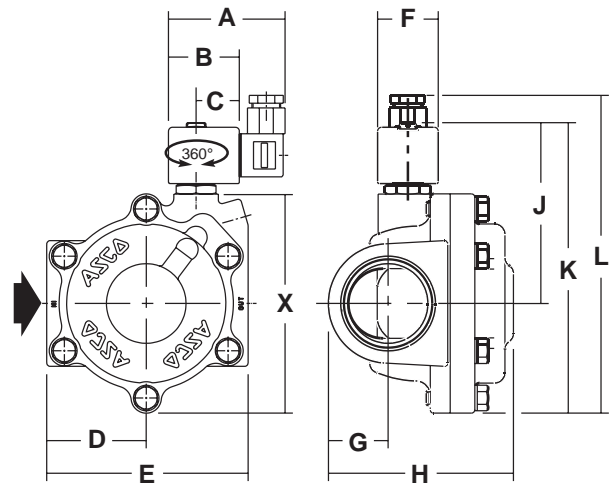
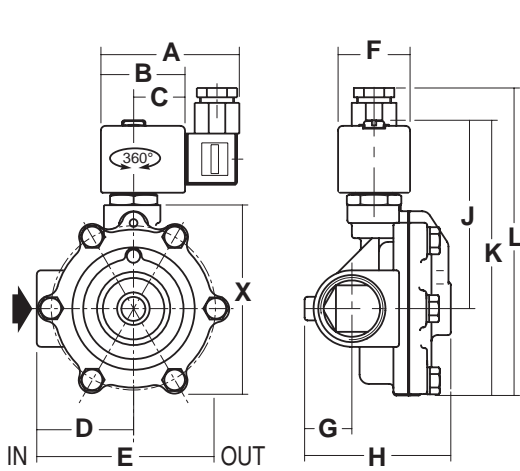

type	prefix option	Catalog number	A	B	C	D	E	F	G	H	J	K	L	M	X	weight ⁽¹⁾
01	SC	SCE210D022	75	45	27	58	115	39	33	99	105	155	172	-	109	2,5
		SCE210-100	75	45	27	64	129	39	39	117	116	186	203	32	140	5,5
02	SC	SCE210D022	80	50	30	58	115	45	33	99	110	159	175	-	109	2,6
		SCE210-100	80	50	30	64	129	45	39	117	120	190	206	32	140	5,5

⁽¹⁾ Incl. coil(s) and connector(s).



TYPE 03
Prefix "SC" Solenoid
Epoxy moulded
IEC 335 / ISO 4400
IP65

SCE210C013

SCE210A131/A132/D014/D018/D032

SCE210-103 / SCE210A133

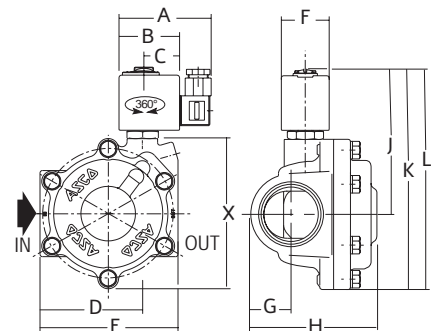
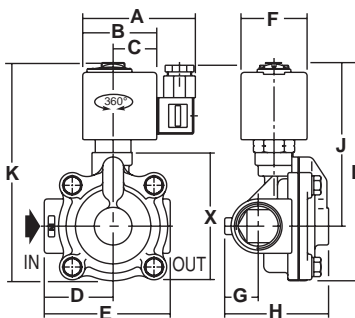
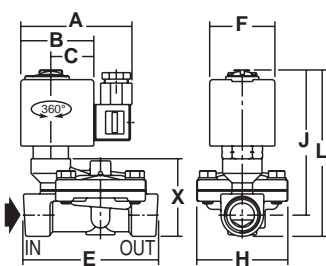

type	prefix option	Catalog number	A	B	C	D	E	F	G	H	J	K	L	M	X	weight ⁽²⁾
03	SC	SCE210C013	91	56	33	-	96	50	-	70	112	-	120	-	81	1,6
		SCE210D014	91	56	33	52	95	50	25	75	125	-	165	-	97	2,1
		SCE210D018	91	56	33	52	95	50	30	85	125	-	165	-	108	2,0
		SCE210D032	91	56	33	56	111	50	33	95	128	-	178	-	121	2,5
		SCE210A131/A132	91	56	33	58	115	50	33	99	128	177	174	-	109	2,7
		SCE210-103	91	56	33	64	129	50	39	117	120	208	205	32	140	4,6
		SCE210A133	91	56	33	64	129	50	39	117	138	208	205	32	140	4,3

⁽²⁾ Incl. coil(s) and connector(s).

mounting brackets	for valves
	SCE210C013

00042GB-2019 R02
Availability, design and specifications are subject to change without notice. All rights reserved.

Dimensions (mm), Weight (kg) 



TYPE 04-05
Prefix "SC" Solenoid
Epoxy moulded
IEC 335 / ISO 4400
IP65

Type 04 (AC): SCE210G125/127
Type 05 (DC): SCE210G125/127

Type 04 (AC): SCE210G129
Type 05 (DC): SCE210G129

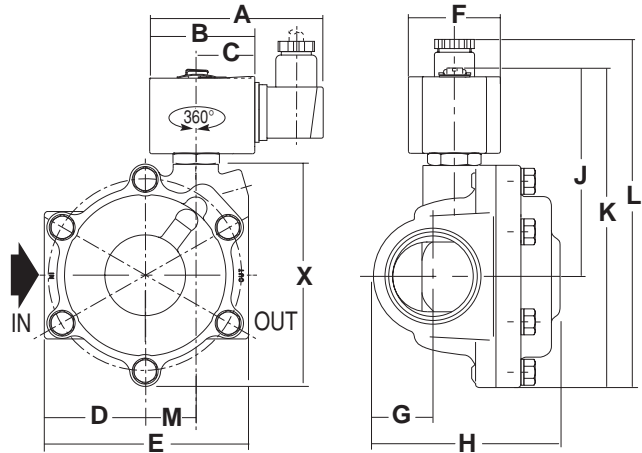
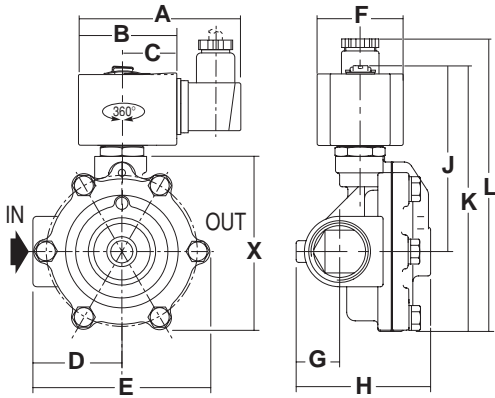

type	prefix option	Catalog number	A	B	C	D	E	F	G	H	J	K	L	M	X	weight ⁽¹⁾
04	SC	SCE210G125 / G127	80	45	28	58	115	39	33	99	105	155	172	-	109	2,4
		SCE210G129	80	45	28	64	129	39	39	117	116	186	203	32	140	4,0
05	SC	SCE210G125 / G127	85	50	30	58	115	45	33	99	110	159	175	-	109	2,6
		SCE210G129	85	50	30	64	129	45	39	117	120	190	206	32	140	4,2

⁽¹⁾ Incl. coil(s) and connector(s)

ASCO™ Solenoid Valves

Pilot Operated, Floating Diaphragm/Piston, 3/8" to 1" 1/2

Features

- Two way shut-off valves for automatic control of air, inert gas, water, oil and other gases/liquids compatible with the seal materials used
- Heavy duty piston design for severe applications
- All products are covered by Pressure Equipment Directive 2014/68/EU and are suitable for group 1 and 2 fluids
- The solenoid valves satisfy all relevant EU directives

General

Differential pressure See «SPECIFICATIONS» [1 bar = 100 kPa]
Maximum viscosity 65 cSt (mm²/s)
Response time 40 - 120 ms

fluids (*)	temperature range (TS)	seal materials (*)
air, inert gas, water, oil	-20°C to +90°C	NBR (nitrile) / PTFE

Materials in contact with fluid

(*) Ensure that the compatibility of the fluids in contact with the materials is verified

	Brass body	Stainless steel body
Body	Brass	AISI 304 SS
Shading coil	Copper	Silver
Core tube	Stainless steel	Stainless steel
Core and plugnut	Stainless steel	Stainless steel
Springs	Stainless steel	Stainless steel
Seat	Brass	Stainless steel
Seals and core disc	NBR	NBR
Piston	PPS / brass	PPS or brass
Piston disc	NBR or PTFE	NBR
Piston rings	PTFE (carbon filled)	PTFE (carbon filled)

Electrical characteristics

Coil insulation class F or H F
Connector Spade plug (cable Ø 6-10 mm) or cable leads, 0,35 m length (EF)
Connector specification ISO 4400 / EN 175301-803, form A
Electrical safety IEC 335
Electrical enclosure protection Moulded IP65 (EN 60529) or NEMA 3, 7, 9 (EF)
Standard voltages DC (=) : 24V - 48V
 (Other voltages and 60 Hz on request) AC (-) : 24V - 48V - 115V - 230V/50 Hz

prefix option	power ratings				operator ambient temperature range (TS) (°C)	replacement coil		type ⁽¹⁾
	inrush ~ (VA)	holding ~ (W)		hot/cold = (W)		~ 230 V/50 Hz	= 24 V DC	
		(VA)	(W)					
SC	34	15,6	6	-	-20 to +75	400325-117	-	01
	-	-	-	9/11,2	-20 to +75	-	400425-142	02
	78	35	16,7	-	-20 to +50	400425-217	-	02
	110	33,6	15,4	12/16,8	-20 to +75	400525-117	400625-142	03
	240	43	20	-	-20 to +50	400525-217	-	03
EF	-	-	-	21/30,6	-20 to +25	-	074073-005D	04

⁽¹⁾ Refer to the dimensional drawings on the following page.

Specifications

pipe size	orifice size (mm)	flow coefficient Kv (m ³ /h) (l/min)		operating pressure differential (bar)						power coil (W)		Catalog number		options					
		min.	max. (PS)	min.		max. (PS)		~	=	~	=	brass	stainless steel	maintained main operator	FPM	EPDM	CR	PTFE	
				air (*)	water (*)	oil (*)	air (*)												water (*)
NC - Normally closed, PPS piston, NBR seals and discs																			
Rp 3/8	9	1,3	21,7	0,35	9	3	-	-	-	-	6	11,2	SCE210C073	-	MO	V	E	J	-
NPT 3/8				0,07	9	3	9	3	-	-	-	-	6	11,2	-	SCB210A036	MO	V	E
Rp 1/2	11	1,9	31,6	0,35	9	3	-	-	-	-	6	11,2	SCE210A015	-	MO	V	E	J	-
NPT 1/2				0,07	9	3	9	3	-	-	-	-	6	11,2	-	SCB210A037	MO	V	E

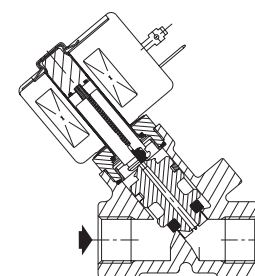

3/8 to 1

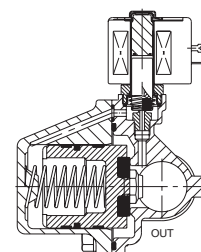

1 1/4 to 1 1/2

00043CB-2020/R01 Availability, design and specifications are subject to change without notice. All rights reserved.

Specifications

pipe size	orifice size	flow coefficient Kv		operating pressure differential (bar)						power coil (W)		Catalog number		options					
				min.	max. (PS)			brass	stainless steel					maintained man. operator	FPM	EPDM	CR	PTFE	
					air (*)	water (*)	oil (*)												
	(mm)	(m³/h)	(l/min)		~	=	~	=	~	=	~	=							
NC - Normally closed, brass piston, NBR seals and PTFE disc																			
Rp 3/4	19	5,2	86,7	0	24	14	14	12	14	12	15,4	-	SCE210B026	-	MO	V	E	J	T
											-	30,6	EFE210B026 ⁽¹⁾	-	MO	V	E	J	T
Rp 1	25	11,6	193	0,7	20	16	20	14	20	14	16,7	16,8	SCE210B078	-	MO	-	-	-	-
Rp 1 1/4	28	12,8	214	0,7	20	16	20	14	20	14	16,7	16,8	SCE210B080	-	MO	-	-	-	-
Rp 1 1/2	32	19,3	322	0,7	20	16	20	14	20	14	16,7	16,8	SCE210B082	-	MO	-	-	-	-
NC - Normally closed, brass piston, NBR seals and discs																			
Rp 1	25	11,6	193	0	20	-	8	-	8	-	20	-	SCE210B027	-	MO	V	E	J	T

⁽¹⁾ Valve to be mounted with solenoid vertical and upright for DC.

Options

- Valves can also be supplied with FPM (fluoroelastomer), EPDM (ethylene-propylene), CR (chloroprene) and PTFE seals and discs. Use the appropriate optional suffix letter for identification
- Waterproof enclosure with embedded screw terminal coil according to protection class IP67, CEE-10
- Explosionproof enclosures for use in zones 1/21-2/22, categories 2-3 to ATEX Directive 2014/34/EU ⁽²⁾
- Electrical enclosures according to “NEMA” standards are available
- Compliance with “UL”, “CSA” and other local approvals available on request
- Mounting brackets, suffix MB (Except for: SCE210B078/B080/B082/B027)
- Other pipe connections are available on request
- Connector with visual indication and peak voltage suppression or with cable length of 2 m

⁽²⁾ Please consult the quick selection guide on potentially explosive atmospheres on Emerson.com/asco

Installation

- The solenoid valves can be mounted in any position without affecting operation, unless indicated otherwise in the specifications table.
- Stainless steel valves are standard supplied with mounting brackets
- Pipe connection identifier is E = Rp (ISO 7/1) or B = NPT (ANSI 1.20.3)
- Installation/maintenance instructions are included with each valve

Spare parts kit & Accessories

Catalog number	spare parts kit no.		mounting bracket no.
	~	=	
SCE210C073	C302271	C302371	093200-001
SCB210A036	C302327	C302421	093200-001
SCE210A015	C302275	C302374	100835-001
SCB210A037	C302326	C302422	100835-001
SCE210B026	C302278	-	038713-000
EFE210B026	-	C302377	038713-000
SCE210B078	C302281	C302380	-
SCE210B080	C302281	C302380	-
SCE210B082	C302285	C302384	-
SCE210B027	C302282	-	-

- Not available

Ordering examples:

SC	E	210	A015	230V / 50 Hz
SC	E	210	B026	MO 115V / 50 Hz
SC	B	210	A037	V 24V / DC
SC	E	210	B027	230V / 50 Hz

prefix — pipe thread — basic number — voltage — suffix

Ordering examples kits:

C302271 ⁽³⁾	
C302374	V
C302278	E

basic number — suffix

⁽³⁾ Standard prefixes/suffixes are also applicable to kits.

00043GB-2020/R01 Availability, design and specifications are subject to change without notice. All rights reserved.

Dimensions (mm), Weight (kg)



TYPE 01-02
Prefix "SC" Solenoid
Epoxy moulded
IEC 335 / ISO 4400
IP65

Type 01, AC: SCE210C073/A015 - SCB210A036/037
Type 02, DC: SCE210C073/A015 - SCB210A036/037



TYPE 02-03
Prefix "SC" Solenoid
Epoxy moulded
IEC 335 / ISO 4400
IP65

Type 02, AC: SCE210B078/B080/B082
Type 03, DC: SCE210B078/B080/B082

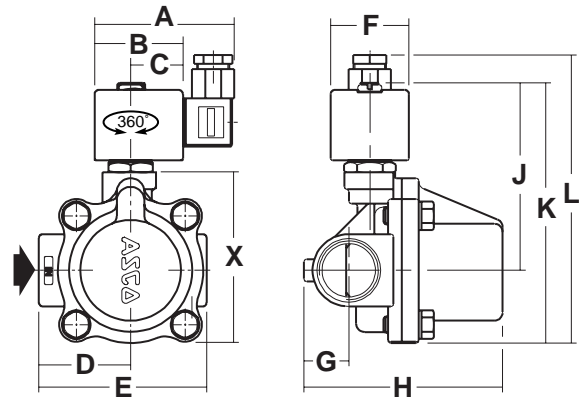
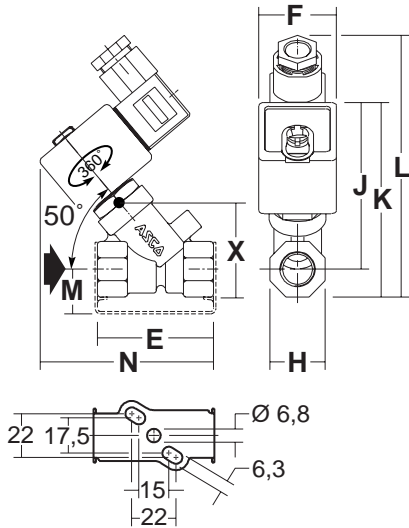

TYPE 03
Prefix "SC" Solenoid
Epoxy moulded
IEC 335 / ISO 4400
IP65

AC: SCE210B026/027

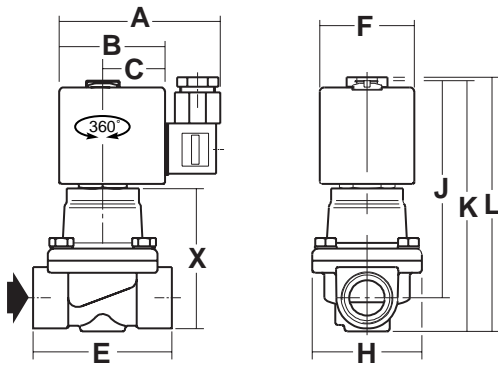

type	prefix option	Catalog number	A	B	C	D	E	F	G	H	J	K	L	M	N	X	weight ⁽¹⁾
01	SC	SCE210C073/A036	-	-	-	-	48	39	-	22	74	85	124	22	72	41	0,6
		SCE210A015/A037	-	-	-	-	58	39	-	28	82	95	128	22	89	47	0,6
02	SC	SCE210C073/A036	-	-	-	-	48	45	-	22	80	91	130	22	80	41	0,6
		SCE210A015/A037	-	-	-	-	58	45	-	28	82	95	128	22	93	47	0,6
		SCE210B078	80	50	30	55	95	45	45	108	55	154	149	-	-	95	2,8
		SCE210B080	80	50	30	52	95	45	30	119	108	149	166	-	-	117	3,0
03	SC	SCE210B082	80	50	30	52	111	45	33	148	112	162	179	-	-	108	4,2
		SCE210B078	86	56	33	55	95	50	50	108	55	154	152	-	-	95	2,8
		SCE210B080	86	56	33	52	95	50	30	119	114	156	156	-	-	97	3,0
		SCE210B082	86	56	33	52	111	50	33	148	118	165	165	-	-	110	4,2
		SCE210B026	86	56	33	-	74	50	-	59	117	133	135	-	-	76	1,3
		SCE210B027	86	56	33	-	100	50	-	33	50	83	143	-	-	84	2,5

⁽¹⁾ Incl. coil(s) and connector(s)

Dimensions (mm), Weight (kg) 



TYPE 04
Prefix "EF" Solenoid
Epoxy encapsulated
ICS-6 ANSI
NEMA type 3, 7, 9

DC: EFE210B026

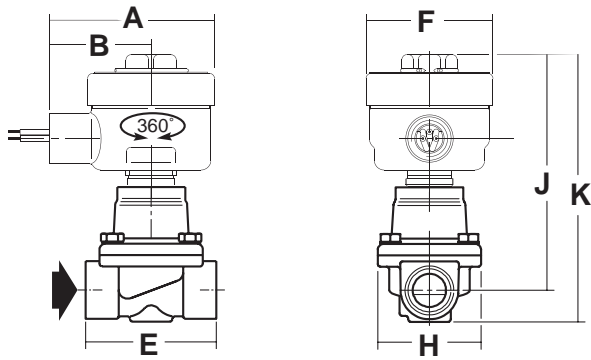

type	prefix option	Catalog number	A	B	C	D	E	F	G	H	J	K	weight ⁽¹⁾
04	EF	EFE210B026	83	51	-	-	74	64	-	59	117	133	1,3

⁽¹⁾ Incl. coil

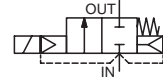

FEATURES

- Heavy duty two way shut-off solenoid valves for control of air, inert gas, water, oil and other gases/liquids compatible with the seal materials used
- Valves require a minimum operating pressure
- The solenoid valves satisfy all relevant EU directives

GENERAL

Differential pressure See «SPECIFICATIONS» [1 bar =100 kPa]
Maximum viscosity 65 cSt (mm²/s)
Response time 15 - 60 ms

fluids (*)	temperature range (TS)	seal materials (*)
air, inert gas, water, oil	-20°C to +90°C	PA (polyamide) PTFE

MATERIALS IN CONTACT WITH FLUID

(*) Ensure that the compatibility of the fluids in contact with the materials is verified

	Brass body	Stainless steel body
Body	Brass	AISI 304 SS
Core tube	Stainless steel	Stainless steel
Core and plugnut	Stainless steel	Stainless steel
Springs	Stainless steel	Stainless steel
Seat	Brass	Stainless steel
Core disc	UR	UR
Seals	NBR	NBR
Piston	Stainless steel	Stainless steel
Piston disc	PTFE	PTFE
Piston rings	PTFE (carbon filled)	PTFE (carbon filled)
Shading coil	Copper	Silver

ELECTRICAL CHARACTERISTICS

Coil insulation class F
Connector Spade plug (cable Ø 6-10 mm)
Connector specification ISO 4400 / EN 175301-803, form A
Electrical safety IEC 335
Electrical enclosure protection Moulded IP65 (EN 60529)
Standard voltages DC (=) : 24V - 48V
 (Other voltages and 60 Hz on request) AC (~) : 24V - 48V - 115V - 230V / 50 Hz

prefix option	power ratings				operator ambient temperature range (TS) (C°)	replacement coil		type ⁽¹⁾
	inrush ~	holding ~	hot/cold =			~	=	
	(VA)	(VA)	(W)	(W)		230 V/50 Hz	24 V DC	
SC	55	23	10,5	9/11,2	-20 to +75	400425-117	400425-142	01
	78	35	16,7	-	-20 to +50	400425-217	-	
	-	-	-	14/19,7	-20 to +25	-	400425-342	

⁽¹⁾ Refer to the dimensional drawings on the following page.

SPECIFICATIONS

pipe size	orifice size	flow coefficient Kv		operating pressure differential (bar)						power coil (W)		catalogue number		options				
				min.	max. (PS)							brass	stainless steel	FPM	EPDM	CR	PTFE	
					air (*)	water (*)	oil (*)		~									=
NPT	(mm)	(m ³ /h)	(l/min)		~	=	~	=	~	=	~	=	~/=	~/=				
NC - Normally closed																		
1/4	8	1,3	21,7	0,7	50	30	50	30	50	30	10,5	11,2	SCB223A121	-	V	E	-	T
				0,7	100	35	100	35	100	35	16,7	19,7	SCB223A125	-	V	E	-	T
3/8	8	1,3	21,7	0,7	50	30	50	30	50	30	10,5	11,2	SCB223A123	-	V	E	J	T
				0,7	100	35	100	35	100	35	16,7	19,7	SCB223A127	-	V	E	-	T
1/2	9	2,7	45	1,8	100	35	100	35	100	35	16,7	19,7	SCB223A103	-	V	E	-	T
				-	-	-	-	-	-	-	-	-	SCB223A010	-	V	E	-	T
3/4	19	6,7	112	1,8	50	20	50	20	50	20	16,7	11,2	SCB223B005 ⁽²⁾	-	V	-	-	T
				-	-	-	-	-	-	-	-	-	-	SCB223A012	-	V	E	-

⁽²⁾ PA piston.

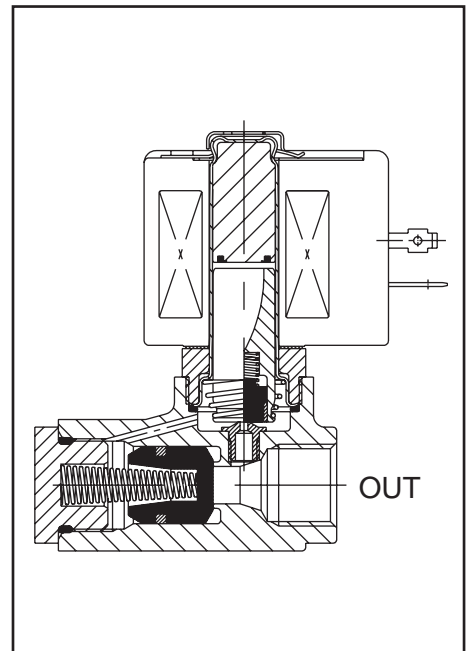

OPTIONS

- Valves can also be supplied with FPM (fluoroelastomer), EPDM (ethylene-propylene), CR (chloroprene) and PTFE seals and discs. Use the appropriate optional suffix letter for identification
- Waterproof enclosure with embedded screw terminal coil according to protection class IP67, CEE-10
- Explosionproof enclosures for use in zones 1/21-2/22, categories 2-3 to ATEX Directive 2014/34/EU (www.asco.com)
- Electrical enclosures according to "NEMA" standards are available
- Compliance with "UL", "CSA" and other local approvals available on request
- Normally Open constructions (NO)
- Other pipe connections are available on request
- Connector with visual indication and peak voltage suppression or with cable length of 2 m (www.asco.com)

INSTALLATION

- The solenoid valves can be mounted in any position without affecting operation
- Pipe connection identifier is B = NPT (ANSI 1.20.3)
- Installation/maintenance instructions are included with each valve

SPARE PARTS KIT

catalogue number	spare parts kit no.	
	~	=
SCB223A121	C133612	C133613
SCB223A125/A127	C133861	C133863
SCB223A123	C133612	C133613
SCB223A103	C133862	C133864
SCB223A010	C302322	C302417
SCB223B005	C302316	C302412
SCB223A012	C302323	C302418

⁽¹⁾ Standard prefixes/suffixes are also applicable to kits.

ORDERING EXAMPLES:

SC	B	223	A	125	230V / 50 Hz
SC	B	223	A	121	MO 115V / 50 Hz
SC	B	223	A	103	V 24V / DC
SC	B	223	A	012	230V / 50 Hz

prefix — pipe thread — basic number — voltage — suffix

ORDERING EXAMPLES KITS:

C302313 ⁽¹⁾	
C133864	V
C302322	E

basic number — suffix

DIMENSIONS (mm), WEIGHT (kg)

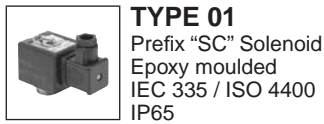

SCB223A121/A125/A123/A127

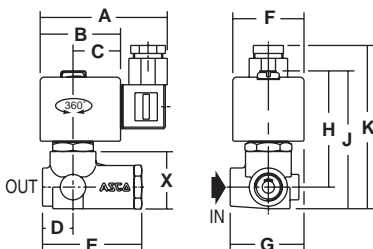

SCB223A103/A010

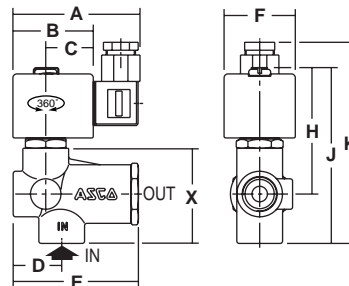

SCB223B005

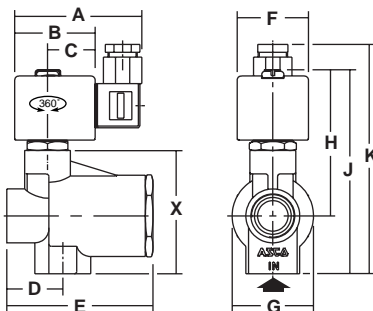

SCB223A012

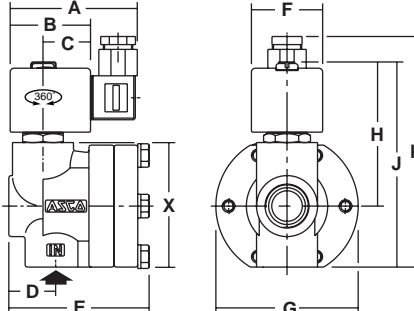

type	prefix option	catalogue number	A	B	C	D	E	F	G	H	J	K	X	weight ⁽²⁾
01	SC	SCB223A121/A125/A123/A127	80	50	30	20	65	45	46	72	86	103	37	0,7
		SCB223A103/A010	80	50	30	31	78	45	-	78	109	126	60	0,9
		SCB223B005	80	50	30	34	91	45	50	91	127	144	78	1,5
		SCB223A012	80	50	30	29	88	45	89	88	128	143	77	2,3

⁽²⁾ Incl. coil(s) and connector(s)

All leaflets are available on: www.asco.com



SOLENOID VALVES

pilot operated
hung diaphragm, gaseous fluids
3/8 to 3

NC

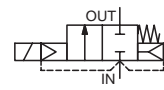

NO

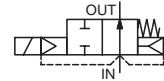

2/2
Series
215

FEATURES

- The valves are for the control of low pressure air and gases, compatible with the seal materials used
- Aluminium bodied valves designed to provide maximum flow
- The valve have a resilient soft seating for tight shut-off
- Valves do not require a minimum operating pressure
- All products are covered by Pressure Equipment Directive 2014/68/EU and are suitable for group 1 and 2 fluids
- The solenoid valves satisfy all relevant EU directives

GENERAL

Differential pressure See «SPECIFICATIONS» [1 bar =100 kPa]
Response time 25 - 120 ms

fluids (*)	temperature range (TS)	seal materials (*)
air, fuel gas NC: inert gas	-20°C to +85°C	NBR (nitrile)

MATERIALS IN CONTACT WITH FLUID

(*) Ensure that the compatibility of the fluids in contact with the materials is verified

Body	Aluminium
Core tube	Stainless steel
Core and plugnut	Stainless steel
Springs	Stainless steel
Seat	Aluminium or stainless steel
Seals, diaphragms & discs	NBR
Core guide	POM
Disc holder (NO function)	PA
Rider rings	PTFE
Shading coil	Copper

ELECTRICAL CHARACTERISTICS

Coil insulation class F
Connector Spade plug (cable Ø 6-10 mm) or cable leads, 0,35 m length (EF)

Connector specification ISO 4400 / EN 175301-803, form A
Electrical safety IEC 335
Electrical enclosure protection Moulded IP65 (EN 60529) or NEMA 3, 7, 9 (EF)
Standard voltages DC (=) : 24V - 48V
AC (~) : 24V - 48V - 115V - 230V / 50 Hz
(Other voltages and 60 Hz on request)

prefix option	power ratings				operator ambient temperature range (TS) (C°)	replacement coil		type ⁽¹⁾
	inrush ~	holding ~	hot/cold =			~	=	
	(VA)	(VA)	(W)	(W)		230 V/50 Hz	24 V DC	
SC	55	23	10,5	9/ 11,2	-20 to +75	400425-117	400425-142	01
	110	33,6	15,4	-	-20 to +75	400525-117	-	02
EF	385	50	28,2	11/14,9	-20 to +75	206409-035D	062691-002D	03

⁽¹⁾ Refer to the dimensional drawings on the following page.

SPECIFICATIONS

pipe size	orifice size	flow coefficient Kv		operating pressure differential (bar)				power coil (W)		catalogue number		options			
				min.	max. (PS)		FPM					CR			
					air (*)	fuel gas (*)									
Rp	(mm)	(m³/h)	(l/min)		~	=	~	=	~	=					
NC - Normally closed															
3/8	19	2,9	48,3	0	3,5	1,8	3,5	1,8	10,5	11,2	SCE215C010 ⁽⁴⁾	SCE215C010 ⁽⁴⁾	V	J	-
1/2	19	3,8	63,3	0	3,5	1,8	3,5	1,8	10,5	11,2	SCE215C020 ⁽⁴⁾	SCE215C020 ⁽⁴⁾	V	J	-
3/4	19	4,4	73,3	0	3,5	1,8	3,5	1,8	10,5	11,2	SCE215C030 ⁽⁴⁾	SCE215C030 ⁽⁴⁾	V	J	-
1	41	18	300	0	1,8	1,8	1,8	1,8	15,4	14,9	SCE215B050	EFE215B050 ⁽²⁾	V	J	-
1 1/4	41	27	450	0	1,8	1,8	1,8	1,8	15,4	14,9	SCE215B060	EFE215B060 ⁽²⁾	V	J	-
1 1/2	41	30	500	0	1,8	1	1,8	1	15,4	14,9	SCE215B070	EFE215B070 ⁽²⁾	V	J	-
2	53	50	833	0	1,8	1	1,8	1	15,4	14,9	SCE215B080	EFE215B080 ⁽²⁾	V	J	-
2 1/2	76	100	1667	0	0,35	-	0,35	-	28,2	-	EFE215A090 ⁽²⁾	-	V	J	-
3	76	118	1967	0	0,35	-	0,35	-	28,2	-	EFE215A040 ⁽²⁾	-	V	J	-
NO - Normally open															
3/8	19	2,7	45	0	9	9	9	9	10,5	11,2	SCE215A013	SCE215A013	V	J	-
1/2	19	3,4	56,7	0	9	9	9	9	10,5	11,2	SCE215A023	SCE215A023	V	J	-
3/4	19	3,9	65	0	9	9	9	9	10,5	11,2	SCE215A033	SCE215A033	V	J	-
1	41	18	300	0	1,8	1	1,8	1	15,4	14,9	SCE215C053	EFE215C053 ⁽³⁾	V	J	-
1 1/4	41	28	450	0	1,8	1	1,8	1	15,4	14,9	SCE215C063	EFE215C063 ⁽³⁾	V	J	-
1 1/2	41	31	500	0	1,8	1	1,8	1	15,4	14,9	SCE215C073	EFE215C073 ⁽³⁾	V	J	-
2	53	50	833	0	1,8	1	1,8	1	15,4	14,9	SCE215C083 ⁽²⁾	EFE215C083 ⁽²⁾⁽³⁾	V	-	-
2 1/2	76	100	1667	0	0,35	-	0,35	-	28,2	-	EFE215B093 ⁽²⁾	-	V	-	-

⁽²⁾ Mounting position: piping horizontal, solenoid upright.

⁽⁴⁾ Valves have stainless steel seat.

⁽³⁾ Lead connection coil on DC.

All leaflets are available on: www.asco.com

Solenoid Valves (2/2) - 65

OPTIONS

- Valves can also be supplied with FPM (fluoroelastomer) and CR (chloroprene) diaphragms, seals and discs. Use the appropriate optional suffix letter for identification
- Waterproof enclosure with embedded screw terminal coil according to protection class IP67, CEE-10
- Explosionproof enclosures for use in zones 1/21-2/22, categories 2-3 to ATEX Directive 2014/34/EU (www.asco.com)
- Electrical enclosures according to "NEMA" standards are available
- Compliance with "UL", "CSA" and other local approvals available on request
- Mounting brackets (3/8, 1/2 and 3/4 only), suffix MB
- Other pipe connections are available on request
- Connector with visual indication and peak voltage suppression or with cable length of 2 m (www.asco.com)

INSTALLATION

- The solenoid valves can be mounted in any position without affecting operation, unless indicated otherwise in the specifications table.
- Pipe connection identifier is E = Rp (ISO 7/1)
- Installation/maintenance instructions are included with each valve

SPARE PARTS KIT & ACCESSORIES

catalogue number	spare parts kit no.		mounting bracket no.
	~	=	
SCE215C010/C020/C030	C302350	C302430	038713-000
SCE215B050/B060/B070	C302352	-	-
EFE215B050/B060/B070	-	C302432	-
SCE215B080	C302353	-	-
EFE215B080	-	C302433	-
EFE215A090/A040	C302354	-	-
SCE215A013/A023/A033	C302361	C302439	038713-000
SCE215C053/C063/C073	C304691	-	-
EFE215C053/C063/C073	-	C304699	-
SCE215C083	C304692	-	-
EFE215C083	-	C304700	-
EFE215B093	C302365	-	-

(1) Standard prefixes/suffixes are also applicable to kits.
- Not available

ORDERING EXAMPLES:

SC	E	215	C	010	230V / 50 Hz
SC	E	215	C	020	MB 115V / 50 Hz
EF	E	215	A	090	V 230V / 50 Hz
EF	E	215	B	070	24V / DC

prefix — pipe thread — basic number — voltage — suffix

ORDERING EXAMPLES KITS:

C302350 ⁽¹⁾	
C302352	V
C302432	J

basic number — suffix

DIMENSIONS (mm), WEIGHT (kg)



TYPE 01

Prefix "SC" Solenoid
Epoxy moulded
IEC 335 / ISO 4400
IP65

SCE215C010/C020/C030



TYPE 02

Prefix "SC" Solenoid
Epoxy moulded
IEC 335 / ISO 4400
IP65

AC: SCE215B050/B060/B070/B080



TYPE 03

Prefix "EF" Solenoid
Epoxy encapsulated
ICS-6 ANSI
NEMA type 3-7-9

DC: EFE215B050/060/070/080
EFE215A090/A040

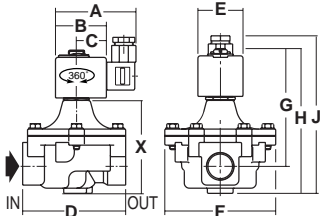

SCE215A013/A023/A033

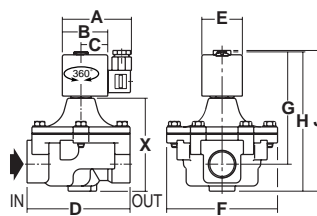
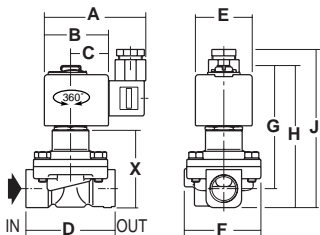

AC: SCE215C053/C063/C073/C083

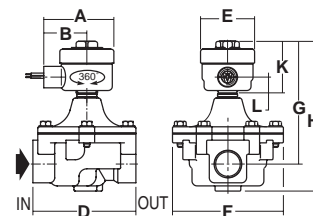
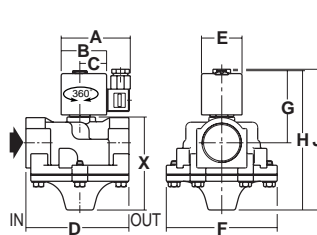

DC: EFE215C053/063/073/083
EFE215B093

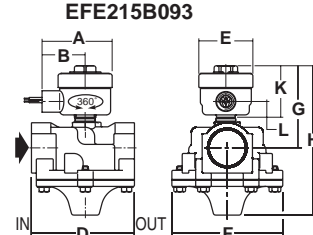

type	prefix option	catalogue number	A	B	C	D	E	F	G	H	J	K	L	X	weight ⁽²⁾
01	SC	SCE215C010/C020	80	50	30	70	45	60	88	102	119	-	-	53	0,6
		SCE215C030	80	50	30	84	45	60	93	113	130	-	-	59	0,7
		SCE215A013/A023	80	50	30	70	45	60	99	114	131	-	-	65	0,5
		SCE215A033	80	50	30	84	45	60	104	125	142	-	-	68	0,7
02	SC	SCE215B050/B060/B070	86	56	33	127	50	137	140	171	172	-	-	121	1,8
		SCE215B080	86	56	33	155	50	160	149	188	188	-	-	139	2,1
		SCE215C053/C063/C073	86	56	33	127	50	137	90	172	172	-	-	123	1,5
		SCE215C083	86	56	33	155	50	160	95	187	187	-	-	132	2,3
03	EF	EFE215B050/B060/B070	83	64	-	127	64	137	161	193	-	78	19	-	2,3
		EFE215B080	83	64	-	155	64	160	170	208	-	78	19	-	2,9
		EFE215C053/C063/C073	83	64	-	127	64	137	112	193	-	78	19	-	2,3
		EFE215C083	83	64	-	155	64	160	117	208	-	78	19	-	2,9
		EFE215A090/A040	83	64	-	198	64	202	194	253	-	78	19	-	5,0
		EFE215B093	83	64	-	198	64	202	125	255	-	78	19	-	5,0

(2) Incl. coil(s) and connector(s)

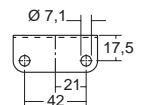

Mounting brackets for valves:

- SCE215C010
- SCE215C020
- SCE215C030
- SCE215A013
- SCE215A023
- SCE215A033

All leaflets are available on: www.asco.com