



EUROPEAN
TELECOMMUNICATION
STANDARD

ETS 300 324-1

February 1994

Source: ETSI TC-SPS

Reference: DE/SPS-03003.1

ICS: 33.080

Key words: V interface, V5 interface, LE, AN

**Signalling Protocols and Switching (SPS);
V interfaces at the digital Local Exchange (LE)
V5.1 interface for the support of Access Network (AN)
Part 1: V5.1 interface specification**

ETSI

European Telecommunications Standards Institute

ETSI Secretariat

Postal address: F-06921 Sophia Antipolis CEDEX - FRANCE

Office address: 650 Route des Lucioles - Sophia Antipolis - Valbonne - FRANCE

X.400: c=fr, a=atlas, p=etsi, s=secretariat - **Internet:** secretariat@etsi.fr

Tel.: +33 92 94 42 00 - Fax: +33 93 65 47 16

Copyright Notification: No part may be reproduced except as authorized by written permission. The copyright and the foregoing restriction extend to reproduction in all media.

© European Telecommunications Standards Institute 1994. All rights reserved.

Contents

Foreword	13
Introduction	13
1 Scope	15
2 Normative references	16
3 Definitions, symbols and abbreviations	16
3.1 Definitions	16
3.2 Symbols and abbreviations	19
4 Electrical and physical interface requirements	21
5 Procedural interface requirements	21
6 Services and architecture aspects and requirements	21
6.1 On-demand services	21
6.1.1 PSTN	21
6.1.2 ISDN basic access	22
6.2 Permanent Line (PL) capability	22
6.3 Semi-permanent leased line	22
6.4 Permanent leased line services	23
7 Control and provisioning	23
7.1 Control principles	23
7.1.1 General requirements and assumptions	23
7.1.2 Control of ISDN user port for the PL capability	25
7.1.2.1 Statements and assumptions	25
7.1.2.2 ISDN and PL capability	25
7.1.2.3 Decoupling of AN and LE FSM	26
7.2 Provisioning strategy and requirements	26
7.2.1 General	26
7.2.2 Provisioning requirements	26
8 Protocol architecture and multiplexing structure	27
8.1 Functional description	27
8.2 Protocol requirements for PSTN and ISDN	28
8.3 Time slots	29
8.4 Time slot allocation for communication channels	29
8.5 Layer 2 sublayering and multiplexing on communication channels	30
8.6 Layer 3 multiplexing	30
8.7 Congestion control	31
8.7.1 Flow control end to end	31
8.7.2 Congestion control on the V5.1 interface	31
8.7.3 Blocking of ISDN user ports at layer 2	31
9 Envelope Function sublayer of LAPV5 (LAPV5-EF)	31
9.1 Frame structure for peer-to-peer communication	31
9.1.1 General	31
9.1.2 Flag sequence	32
9.1.3 Interframe time fill	32
9.1.4 Envelope function address field	32
9.1.5 Envelope information field	32
9.1.6 Transparency	32
9.1.7 Frame Check Sequence (FCS)	32

9.1.8	Format convention	33
9.1.9	Invalid frames	33
9.1.10	Frame aborts	33
9.2	Format of fields for data link envelope peer-to-peer communication	33
9.2.1	Envelope function address field format	33
9.2.2	Address field variables.....	33
9.2.2.1	Address field extension bit	33
9.2.2.2	EFaddr	33
10	Data Link sublayer of LAPV5 (LAPV5-DL)	34
10.1	Frame structure for peer-to-peer communication	34
10.1.1	General	34
10.1.2	Link address field.....	34
10.1.3	Control field.....	34
10.1.4	Information field	34
10.1.5	Format convention	34
10.2	Invalid frames.....	34
10.3	Elements of procedures and formats of fields for data link sublayer peer-to-peer communication	35
10.3.1	Link address field format	35
10.3.2	Link address field variables	35
10.3.2.1	Address field extension (EA) bit.....	35
10.3.2.2	Command/response field bit	35
10.3.2.3	V5DLaddr	35
10.3.3	Control field formats	35
10.3.4	Control field parameters and associated state variables.....	36
10.3.5	Frame types.....	36
10.4	Definition of the peer-to-peer procedures of the data link sublayer	36
10.4.1	General	36
10.4.2	Procedure for the use of the Poll/Final (P/F) bit.....	37
10.4.3	Terminal Endpoint Identifier (TEI) management procedures	37
10.4.4	Automatic negotiation of data link layer parameters.....	37
10.4.5	Procedures for establishment and release of multiple frame operation	38
10.4.5.1	Establishment of multiple frame operation.....	38
10.4.5.1.1	General.....	38
10.4.5.1.2	Establishment procedures.....	38
10.4.5.1.3	Procedure on expiry of timer T200.....	39
10.4.5.2	Information transfer.....	39
10.4.5.3	Termination of multiple frame operation	39
10.4.5.4	Link-not-established state	39
10.4.5.5	Collision of unnumbered commands and responses.....	40
10.4.5.5.1	Identical transmitted and received commands.....	40
10.4.5.5.2	Different transmitted and received commands.....	40
10.4.5.6	Unsolicited DM response and SABME command.....	40
10.4.6	Procedures for information transfer in multiple frame operation	40
10.4.7	Re-establishment of multiple frame operation.....	40
10.4.7.1	Criteria for re-establishment.....	40
10.4.7.2	Procedures.....	41
10.4.8	Exception condition reporting and recovery.....	41
10.4.9	List of system parameters	41
10.4.10	Data link monitor function	41
10.4.10.1	General	41
10.4.10.2	Data link layer supervision in the multiple-frame-established state	41
10.4.10.3	Connection verification procedures.....	42
10.4.11	PSTN and control data link FSM and requirements	42
10.4.11.1	General	42
10.4.11.2	Data link FSM.....	43
11	AN frame relay sublayer	44
11.1	General.....	44

11.2	Invalid frames	44
11.3	Detailed description of the AN frame relay function.....	45
11.3.1	Frame received from LE.....	45
11.3.2	Frame received from ISDN user port	46
12	Sublayer-to-sublayer communication and mapping function	46
12.1	LAPV5-EF to LAPV5-DL communication.....	46
12.2	LAPV5-DL to LAPV5-EF communication.....	46
12.3	AN-FR to LAPV5-EF communication.....	46
12.4	LAPV5-EF to AN-FR communication.....	46
13	PSTN signalling protocol specification and layer 3 multiplexing	46
13.1	General	46
13.1.1	Introduction.....	46
13.1.2	Separation of responsibilities	47
13.1.3	National specific PSTN signal information elements.....	47
13.2	PSTN protocol entity definition.....	48
13.2.1	Definition of PSTN path states and explanation.....	48
13.2.1.1	Path states in the AN (AN(PSTN))	48
13.2.1.2	Path states in the LE (LE(PSTN)).....	49
13.2.2	Definition of PSTN protocol primitives, messages and timers	49
13.3	PSTN protocol message definition and content.....	52
13.3.1	ESTABLISH.....	52
13.3.2	ESTABLISH ACK	53
13.3.3	SIGNAL	53
13.3.4	SIGNAL ACK.....	54
13.3.5	STATUS	54
13.3.6	STATUS ENQUIRY	54
13.3.7	DISCONNECT.....	55
13.3.8	DISCONNECT COMPLETE.....	55
13.3.9	PROTOCOL PARAMETER.....	55
13.4	General message format and information element coding.....	56
13.4.1	Overview.....	56
13.4.2	Protocol discriminator.....	56
13.4.3	Layer 3 address.....	57
13.4.4	Message type	57
13.4.5	Coding of other information elements	58
13.4.6	Single octet information elements	58
13.4.6.1	Pulse notification.....	58
13.4.6.2	Line-information.....	59
13.4.6.3	State	59
13.4.6.4	Autonomous-signalling-sequence	60
13.4.6.5	Sequence-response	60
13.4.7	Information elements with variable length format.....	61
13.4.7.1	Sequence-number	61
13.4.7.2	Cadenced-ringing	61
13.4.7.3	Pulsed-signal	62
13.4.7.4	Steady-signal	63
13.4.7.5	Digit-signal.....	64
13.4.7.6	Recognition-time.....	65
13.4.7.7	Enable-autonomous-acknowledge	66
13.4.7.8	Disable-autonomous-acknowledge	67
13.4.7.9	Cause	67
13.4.7.10	Resource-unavailable.....	68
13.5	PSTN call control procedures	69
13.5.1	General.....	69
13.5.2	Handling of error conditions	70
13.5.2.1	Protocol discriminator error	71
13.5.2.2	L3 address error	71
13.5.2.3	Message type error.....	71
13.5.2.4	Information element out of sequence	72
13.5.2.5	Repeated information elements.....	72
13.5.2.6	Mandatory information element missing.....	72

	13.5.2.7	Unrecognized information element	73
	13.5.2.8	Content error of mandatory information element	73
	13.5.2.9	Content error of optional information element.....	73
	13.5.2.10	Unexpected message	74
	13.5.2.11	Optional information element not allowed	74
	13.5.2.12	Optional information element missing.....	74
	13.5.2.13	Status enquiry procedure	74
	13.5.2.14	Status procedure.....	76
13.5.3		Path related procedures	76
	13.5.3.1	Path initiation by AN.....	77
		13.5.3.1.1 Subscriber seizure request	77
		13.5.3.1.2 Subscriber seizure confirmation.....	78
	13.5.3.2	Path initiation by LE.....	79
		13.5.3.2.1 Establish request.....	79
		13.5.3.2.2 Establish acknowledge.....	80
	13.5.3.3	Path collision	80
		13.5.3.3.1 Originating call prevail	80
		13.5.3.3.2 Destination call prevail	81
	13.5.3.4	Path active	81
		13.5.3.4.1 Normal operation.....	81
		13.5.3.4.2 Exceptional procedures.....	82
	13.5.3.5	Disconnecting path.....	82
		13.5.3.5.1 Disconnect request	83
		13.5.3.5.2 Disconnect acknowledge	84
	13.5.3.6	Line information procedure	84
		13.5.3.6.1 Normal operation.....	84
		13.5.3.6.2 Exceptional procedures.....	85
13.5.4		Non-path related procedures	85
	13.5.4.1	Protocol parameter procedures	85
		13.5.4.1.1 Normal operation.....	85
		13.5.4.1.2 Exceptional procedures.....	86
	13.5.4.2	Port blocking procedures	86
	13.5.4.3	Restart procedure	86
13.5.5		Layer 3 error detection procedure	87
	13.5.5.1	Multiple SIGNAL message operation - variables, sequence numbers and timers	87
		13.5.5.1.1 Modulus.....	87
		13.5.5.1.2 Send sequence variable S(S).....	87
		13.5.5.1.3 Acknowledge sequence variable S(A) ..	87
		13.5.5.1.4 Send sequence number M(S)	88
		13.5.5.1.5 Receive sequence variable S(R).....	88
		13.5.5.1.6 Receive sequence number M(R)	88
		13.5.5.1.7 Timer Tt.....	88
		13.5.5.1.8 Timer Tr.....	88
	13.5.5.2	Multiple SIGNAL message operation - procedures.....	88
		13.5.5.2.1 Initialization.....	88
		13.5.5.2.2 Sending a SIGNAL message	88
		13.5.5.2.3 Sending a SIGNAL ACK message.....	88
		13.5.5.2.4 Receiving a SIGNAL message.....	89
		13.5.5.2.5 Receiving a SIGNAL ACK message	89
		13.5.5.2.6 Start of timer Tr	89
		13.5.5.2.7 Stop of timer Tr	89
		13.5.5.2.8 Timeout of timer Tr.....	89
		13.5.5.2.9 Start of timer Tt	89
		13.5.5.2.10 Stop of timer Tt.....	89
		13.5.5.2.11 Timeout of timer Tt.....	89
		13.5.5.2.12 Receiving a DISCONNECT message..	89
	13.5.5.3	Multiple SIGNAL message operation - values	90
		13.5.5.3.1 Number of outstanding SIGNAL messages.....	90
		13.5.5.3.2 Timer Tt.....	90
		13.5.5.3.3 Timer Tr.....	90
13.6		List of system parameters	90

13.7	AN and LE side state tables.....	91
14	Control requirements and protocol.....	97
14.1	ISDN user port status indication and control protocol.....	97
14.1.1	General aspects	97
14.1.2	Events and function elements relevant for the control of the state machines.....	98
14.1.3	ISDN user port FSMs, AN (ISDN port) and LE (ISDN port)	99
14.1.3.1	Description of the states	100
14.1.3.2	Definition of port control states.....	100
	14.1.3.2.1 ISDN user port FSM - AN(ISDN port) .	100
	14.1.3.2.2 ISDN User port FSM - LE (ISDN port)	101
14.1.3.3	Principles and procedures	102
	14.1.3.3.1 General	102
	14.1.3.3.2 Blocking	102
	14.1.3.3.3 Blocking request	102
	14.1.3.3.4 Coordinated unblocking	102
	14.1.3.3.5 Activation	103
	14.1.3.4 ISDN port FSM at the AN	104
	14.1.3.5 ISDN port FSM at the LE	106
14.1.4	Performance monitoring aspects	107
14.2	PSTN user port status indication and control protocol.....	107
14.2.1	General aspects	107
14.2.2	Events and function elements relevant for the control of the state machines.....	108
14.2.3	PSTN user port FSM, AN (PSTN port) and LE (PSTN port).....	108
14.2.3.1	Description of the states	108
14.2.3.2	Definition of port control states.....	109
	14.2.3.2.1 PSTN user port FSM - AN (PSTN port).....	109
	14.2.3.2.2 PSTN user port FSM - LE (PSTN port)	109
14.2.3.3	Principles and procedures	110
	14.2.3.3.1 General	110
	14.2.3.3.2 Blocking	110
	14.2.3.3.3 Blocking request	110
	14.2.3.3.4 Coordinated unblocking	110
	14.2.3.4 PSTN port FSM at the AN	111
	14.2.3.5 PSTN port FSM at the LE	111
14.3	Interface layer 1 maintenance requirements and protocol.....	112
14.3.1	Events and failure reports	112
14.3.2	Detection algorithm for events and signals	113
14.3.3	V5.1 interface layer 1 FSM.....	113
14.3.4	Requirements and procedures for the additional functions.....	114
14.4	Control protocol.....	115
14.4.1	Control protocol message definition and content	115
14.4.1.1	PORT CONTROL message	115
14.4.1.2	PORT CONTROL ACK message	116
14.4.1.3	COMMON CONTROL message	116
14.4.1.4	COMMON CONTROL ACK message	117
14.4.2	General message format and information element coding	117
14.4.2.1	Overview.....	117
14.4.2.2	Protocol discriminator information element	117
14.4.2.3	Layer 3 (L3) address information element.....	117
14.4.2.4	Message type information element.....	118
14.4.2.5	Other information elements	119
	14.4.2.5.1 Coding rules.....	119
	14.4.2.5.2 Performance grading information element	119
	14.4.2.5.3 Rejection cause information element .	120
	14.4.2.5.4 Control function element information element	120
	14.4.2.5.5 Control function ID information element	121

	14.4.2.5.6	Variant information element	121
	14.4.2.5.7	Interface ID information element	122
14.4.3		State definitions of the control protocol	122
	14.4.3.1	Port control protocol	122
	14.4.3.2	Common control protocol	123
14.4.4		Control protocol procedures	123
	14.4.4.1	General	123
	14.4.4.2	Handling of error conditions	124
	14.4.4.2.1	Protocol discriminator error	124
	14.4.4.2.2	L3 address error	124
	14.4.4.2.3	Message type error	124
	14.4.4.2.4	Repeated information elements	125
	14.4.4.2.5	Mandatory information element missing	125
	14.4.4.2.6	Unrecognized information element ...	125
	14.4.4.2.7	Content error of mandatory information elements	125
	14.4.4.2.8	Content error of optional information element	125
	14.4.4.2.9	Optional information element not allowed	126
	14.4.4.2.10	Optional information element missing	126
	14.4.4.3	Start traffic indication	126
	14.4.4.4	Stop traffic indication	126
	14.4.4.5	Port control protocol procedure	126
	14.4.4.6	Common control protocol procedure	127
	14.4.4.7	Timers for the control protocol	128
	14.4.4.8	AN and LE side state tables	128
14.5		V5.1 re-provisioning procedures	130
	14.5.1	General aspects	130
	14.5.2	Events and states	130
	14.5.2.1	Events	130
	14.5.2.2	Definition of the AN and LE states for the re-provisioning procedures	130
	14.5.3	Re-provisioning FSMs	131
	14.5.3.1	AN (variant&ID) and LE (variant&ID) state tables for the verification procedure	131
	14.5.3.2	AN (re-pro) and LE (re-pro) state tables for the re- provisioning synchronization procedure	132
	14.5.4	Procedures	133
	14.5.4.1	Request variant and ID	133
	14.5.4.2	Verify re-provisioning	133
	14.5.4.3	Re-provisioning synchronization	133
	14.5.4.4	Restart procedure	134
Annex A (normative):		Requirements for the support of the PL capability through an ISDN basic access	135
Annex B (normative):		Assumptions and requirements for the support of semi-permanent leased lines	136
B.1		General	136
B.2		Signalling associated to semi-permanent leased lines	136
B.3		User ports	136
B.4		Requirements for non-ISDN user ports for semi-permanent leased lines	137
Annex C (normative):		Basic requirements of the system management functions in AN and LE	138

Annex D (normative):	Use of the protocol information elements for national PSTN protocols.....	145
D.1	Introduction.....	145
D.2	The placement of information elements.....	146
D.2.1	Information elements within the ESTABLISH message	146
D.2.2	Information elements within the ESTABLISH-ACK message.....	146
D.2.3	Information elements within the SIGNAL message	147
D.2.4	Information elements within the DISCONNECT message	147
D.2.5	Information elements within the DISCONNECT-COMPLETE message	147
D.2.6	Information elements within the PROTOCOL-PARAMETER message	148
D.3	The information elements.....	148
D.3.1	Line-Information information elements	148
D.3.1.1	Impedance marker reset	148
D.3.1.2	Impedance marker set	148
D.3.1.3	Low loop impedance	149
D.3.1.4	Anomalous loop impedance.....	149
D.3.1.5	Anomalous line condition received.....	149
D.3.2	Pulse-notification information element.....	149
D.3.3	Autonomous-signalling-sequence information element.....	149
D.3.4	Sequence-response information element.....	149
D.3.5	Cadenced-ringing information element.....	150
D.3.6	Pulsed-signal information element.....	150
D.3.6.1	The pulse type	150
D.3.6.2	The suppression indicator	150
D.3.6.2.1	Suppression indicator value 00.....	151
D.3.6.2.2	Suppression indicator value 01.....	151
D.3.6.2.3	Suppression indicator value 10.....	151
D.3.6.2.4	Suppression indicator value 11.....	151
D.3.6.3	The pulse duration type	151
D.3.6.4	The acknowledgement request indicator	151
D.3.6.5	The number of pulses	151
D.3.7	Use of Pulsed-signals	152
D.3.7.1	Pulsed normal polarity	152
D.3.7.2	Pulsed reverse polarity	152
D.3.7.3	Pulsed battery on C-wire	152
D.3.7.4	Pulsed on-hook	152
D.3.7.5	Pulsed reduced battery.....	152
D.3.7.6	Pulsed no battery.....	152
D.3.7.7	Meter pulse.....	152
D.3.7.8	Initial ring	152
D.3.7.9	Pulsed off-hook	152
D.3.7.10	Pulsed b-wire connected to earth	152
D.3.7.11	Register recall (timed open loop)	152
D.3.7.12	Earth loop pulse	153
D.3.7.13	50 Hz pulse.....	153
D.3.7.14	Pulsed b-wire connected to battery	153
D.3.7.15	Pulsed a-wire connected to earth	153
D.3.7.16	Pulsed a-wire connected to battery	153
D.3.7.17	Pulsed c-wire connected to earth	153
D.3.7.18	Pulsed c-wire disconnected.....	153
D.3.7.19	Pulsed normal battery	153
D.3.7.20	Pulsed a-wire disconnected	153
D.3.7.21	Pulsed b-wire disconnected	153
D.3.8	Use of Steady-signals	153
D.3.8.1	Normal-polarity	153
D.3.8.2	Reversed-polarity	153
D.3.8.3	Battery on c-wire.....	154
D.3.8.4	No battery on c-wire	154
D.3.8.5	Off hook (loop closed)	154
D.3.8.6	On hook (loop open).....	154
D.3.8.7	Battery on a-wire	154

D.3.8.8	No battery on b-wire.....	154
D.3.8.9	Reduced battery.....	154
D.3.8.10	No battery	154
D.3.8.11	Alternate reduced power/no power	154
D.3.8.12	No battery on a-wire.....	154
D.3.8.13	Normal battery	154
D.3.8.14	Stop ringing.....	155
D.3.8.15	Start pilot frequency	155
D.3.8.16	Stop pilot frequency	155
D.3.8.17	A-wire on earth	155
D.3.8.18	Low impedance on b-wire	155
D.3.8.19	B-wire connected to earth.....	155
D.3.8.20	B-wire disconnected from earth.....	155
D.3.8.21	Battery on b-wire	155
D.3.8.22	Low loop impedance.....	155
D.3.8.23	High loop impedance	155
D.3.8.24	Anomalous loop impedance	155
D.3.8.25	A-wire disconnected from earth	155
D.3.8.26	C-wire on earth	156
D.3.8.27	C-wire disconnected from earth.....	156
D.3.9	Digit-signal information element.....	156
D.3.10	Recognition-time information element.....	156
D.3.11	Enable-autonomous-acknowledge information element	156
D.3.11.1	Suppression indicator value 00.....	157
D.3.11.2	Suppression indicator value 01.....	157
D.3.11.3	Suppression indicator value 10.....	157
D.3.11.4	Suppression indicator value 11.....	157
D.3.12	Default values for the Enable-autonomous-acknowledge information element.....	157
D.3.13	Use of the Autonomous-signalling-sequence.....	157
D.3.14	Disable-autonomous-acknowledge information element	157
D.4	Signalling sequences in the event of failure of a V5.1 interface to return a user port to the idle condition before releasing the signalling path.....	158
D.4.1	Protocol implications of going directly to the NULL state	158
D.4.2	Protocol implications of going to the BLOCKED state	158
D.5	Leaving the BLOCKED state	158
D.6	Pre-defined PSTN port states.....	159
D.7	The line parked condition.....	159
D.8	Information element meaning.....	159
D.9	Coding of pulse duration types	159
D.10	Ring signals and their placement in V5 messages.....	160
D.11	Resource unavailable	160
Annex E (informative):	Service scenarios, architecture and functional definition of access arrangements with AN at the LE	161
E.1	Conclusions on multiple V5 interface applications	161
E.2	Conclusions on architecture aspects.....	161
E.3	Implementation of Q _{AN}	162
Annex F (informative):	The concept and requirements for the upgrade of a V5.1 interface to a V5.2 interface	163

Annex G (informative):	Use of function element primitives in the V5 PSTN protocol.....	164
G.1	Introduction.....	164
G.2	FE primitives used in the PSTN protocol entity in the AN	164
G.2.1	FE-subscriber_seizure	164
G.2.2	FE-subscriber_release.....	164
G.2.3	FE-line_information.....	165
G.2.4	FE-line_signal	165
G.3	FE primitives used in the PSTN protocol entity in the LE.....	165
G.3.1	FE-establish_request.....	165
G.3.2	FE-establish_acknowledge_indication.....	165
G.3.3	FE-establish_indication.....	166
G.3.4	FE-establish_acknowledge.....	166
G.3.5	FE-disconnect_request.....	166
G.3.6	FE-disconnect_complete_request	166
G.3.7	FE-line_signal_request	167
G.3.8	FE-line_signal_indication	167
G.3.9	FE-protocol_parameter_request.....	167
G.3.10	FE-disconnect_complete_indication.....	167
Annex H (informative):	PSTN protocol; explanatory notes and information flow	168
H.1	Explanatory notes.....	168
H.2	Information flow diagrams.....	170
Annex J (informative):	AN requirement for pulse dialling	173
Annex K (informative):	Layer 3 error detection procedure	174
K.1	Variables and sequence numbers.....	174
K.2	Values of counters and timers.....	175
K.3	Procedures.....	175
K.4	Examples of the error detection mechanism.....	175
Annex L (informative):	SDL diagrams.....	178
L.1	SDL diagrams for the AN side.....	178
L.1.1	System description.....	178
L.1.2	Block descriptions.....	180
L.1.2.1	Block description of the PSTN protocol.....	180
L.1.2.2	Block description of the control protocol	181
L.1.2.3	Block description of the ISDN port status FSM	182
L.1.2.4	Block description of the PSTN port status FSM	182
L.1.2.5	Block description of the system management.....	183
L.1.3	Explanation of SDL symbols	184
L.1.4	PSTN protocol procedure	185
L.1.4.1	Scope	185
L.1.4.2	Path states	185
L.1.4.3	SDLs.....	185
L.1.5	Control protocol procedures	197
L.1.5.1	Scope	197
L.1.5.2	States	197
L.1.5.3	SDLs.....	197
L.1.5.3.1	Port control protocol.....	198
L.1.5.3.2	Common control protocol	200
L.1.6	Port status FSM control	202
L.1.6.1	Scope	202

L.1.6.2	States.....	202
L.1.6.3	SDLs.....	202
L.1.6.3.1	ISDN port status FSM control.....	203
L.1.6.3.2	PSTN port status FSM control.....	211
L.1.7	System management procedure.....	214
L.1.7.1	Scope.....	214
L.1.7.2	States.....	214
L.1.7.3	SDLs.....	214
L.2	SDL diagrams for the LE side.....	225
L.2.1	System description.....	225
L.2.2	Block descriptions.....	227
L.2.2.1	Block description of the PSTN protocol.....	227
L.2.2.2	Block description of the control protocol.....	228
L.2.2.3	Block description of the ISDN port status FSM.....	229
L.2.2.4	Block description of the PSTN port status FSM.....	229
L.2.2.5	Block description of the system management.....	230
L.2.3	Explanation of SDL symbols.....	231
L.2.4	PSTN protocol procedure.....	231
L.2.4.1	Scope.....	231
L.2.4.2	Path states.....	231
L.2.4.3	SDLs.....	231
L.2.5	Control protocol procedures.....	241
L.2.5.1	Scope.....	241
L.2.5.2	States.....	241
L.2.5.3	SDLs.....	241
L.2.5.3.1	Port control protocol.....	242
L.2.5.3.2	Common control protocol.....	244
L.2.6	Port status FSM control.....	246
L.2.6.1	Scope.....	246
L.2.6.2	States.....	246
L.2.6.3	SDLs.....	246
L.2.6.3.1	ISDN port status FSM control.....	247
L.2.6.3.2	PSTN port status FSM control.....	252
L.2.7	System management procedure.....	255
L.2.7.1	Scope.....	255
L.2.7.2	States.....	255
L.2.7.3	SDLs.....	255
Annex M (informative):	Structures used in the V5.1 interface.....	266
Annex N (informative):	Protocol architecture for PSTN and ISDN user port control.....	267
N.1	Scope.....	267
N.2	ISDN user port status control.....	267
N.2.1	Functional split between LE and AN.....	267
N.2.2	Information transfer between LE and AN.....	267
N.2.3	Activation/deactivation procedure.....	268
N.3	PSTN user port control - information transfer between LE and AN.....	269
Annex P (informative):	Items identified to be pre-defined or provisioned.....	270
Annex Q (informative):	Bibliography.....	271
Index.....		272
History.....		274

Foreword

This European Telecommunication Standard (ETS) has been produced by the Signalling Protocols and Switching (SPS) Technical Committee of the European Telecommunications Standards Institute (ETSI).

This ETS is part 1 of a multi-part standard covering the V5.1 interface specification as described below:

Part 1: V5.1 interface specification;

Part 2: Protocol Implementation Conformance Statement (PICS) proforma;

Part 3: Test Suite Structure and Test Purposes (TSS&TP).

NOTE: At the time of publication of this ETS, the final structure of further part(s) and/or separate ETS(s) containing the test specifications was still under study.

Introduction

The work on a new V interface concept was initiated by a request from the ETSI Technical Assembly (TA) to Technical Committee Network Aspects (TC NA), in particular Sub-Technical Committee (STC) NA4 to consider, in cooperation with other STCs involved, possible new structures and interfaces for the connection of new access arrangements to local exchanges. After two meetings (in January and May 1991) the work was terminated with some guidelines for further consideration.

The work was taken over by a Special Experts Group, set up by TC SPS, working under STC SPS3, with experts from several STCs, e.g. SPS5, TM3 and NA4. This was to avoid a split of the difficult task to several STCs requiring intensive cooperation and possibly may have caused significant delay of the standardization work.

TC SPS identified in the terms of reference two interface concepts, one based on a static multiplexer principle, now called V5.1 interface, and another based on a dynamic, concentrator type principle, now called V5.2 interface. It was requested that the overall concept should provide faculties for an evolution from V5.1 to V5.2.

This V5.1 interface standard, forming part of a number of standards of the V5 interface concept, has been developed by the Special Experts Group mentioned above. Due to the importance of this new V5 concept and the urgency identified by SPS the Special Experts Group met about every month over a time period of 17 months to fulfil this task in time.

Other STCs involved have been informed about the decisions made and the progress of work by distribution of the meeting reports and any other material in a regular way to the STC chairman or other involved persons. SPS3 and SPS5 were involved especially by distribution of advanced drafts for preparation of the discussion in these STCs and approval by SPS3.

The following set of standards and reports is expected to relate to the V5 interface concept:

ETS 300 324-1:	V5.1 interface to support the access network;
ETS 300 324-2:	Protocol implementation conformance statement for the V5.1 interface;
ETS 300 324-3:	Test suite structure and test purposes for the V5.1 interface;
ETS 300 347-1:	V5.2 interface to support the access network;
ETS 300 347-2:	Protocol implementation conformance statement for the V5.2 interface;
ETS 300 347-3:	Test suite structure and test purposes for the V5.2 interface;

- ETS 300 376-1: Q3 interface specification at the access network for the configuration management of V5 interfaces and associated user ports;
- ETS 300 376-2: Q3 interface specification at the access network; Managed object conformance statement for the configuration management;
- ETS 300 377-1: Q3 interface specification at the local exchange for the configuration management of V5 interfaces and associated customer profiles;
- ETS 300 377-2: Q3 interface specification at the local exchange; Managed object conformance statement for the configuration management;
- ETS 300 378-1: Q3 interface specification at the access network for the fault and performance management of V5 interfaces and associated user ports;
- ETS 300 378-2: Q3 interface specification at the access network; Managed object conformance statement for fault and performance management;
- ETS 300 379-1: Q3 interface specification at the local exchange for the fault and performance management of V5 interfaces and associated customer profiles;
- ETS 300 379-2: Q3 interface specification at local exchange; Managed object conformance statement for fault and performance management;
- ETR 150: V5 interface; PSTN protocol mapping examples.

1 Scope

This first part of ETS 300 324 specifies the electrical, physical, procedural and protocol requirements for the V5.1 interface between an Access Network (AN) and the Local Exchange (LE) for the support of the following access types:

- analogue telephone access;
- ISDN basic access with a line transmission system conforming to ETS 300 297 [4] for the case with a NT1 separate from the AN;
- ISDN basic access with a user network interface according to ETS 300 012 [3] at the user side of the AN (i.e. the interface at the T reference point);
- other analogue or digital accesses for semi-permanent connections without associated outband signalling information,

with flexible (provisioned) information channel (bearer channel) allocation but without concentration capability within the AN.

This ETS does not specify the implementation of the requirements within the AN and does not constrain any implementation alternative as long as the functionality at the V5.1 interface as specified in this ETS is met.

Protocol Implementation Conformance Statements (PICS) and the conformance test specification to the requirements of this ETS will be provided in other parts of this ETS.

This ETS identifies a number of functions, characteristics and procedures requiring either that they are pre-defined or provisioned via the relevant Q interface. Annex P lists references to those items in this ETS.

A complementary ETS specifies interface V5.2 which is based on the V5.1 interface. Interface V5.1 shall be upgradable to interface V5.2. The concept and the requirements for the upgrade are defined in Annex F.

Annex E provides an overview of the service scenarios and architecture taken as the conceptual basis for the specification of the V5.1 interface.

Annex H to this ETS provides additional notes and information flow diagrams to the PSTN protocol specification. The use of the protocol information elements for the definition of the national PSTN protocols is defined in Annex D.

Annex K provides the definition of the layer 3 PSTN protocol error detection.

The Specification and Description Language (SDL) diagrams for all the protocols and procedures are given in Annex L.

Permanent lines from an ISDN user port or from other types of customer access, which bypass the LE, are outside the scope of this specification. Requirements for the support of permanent lines in ISDN basic accesses, using one or both B-channels, are specified in Annex A.

Semi-permanent leased lines are supported. They are routed through the V5.1 interface by application of a provisioning procedure. The assumptions and requirements for this procedure are defined in Annex B.

Annex C specifies the basic requirements of the management function in the LE and the AN to support correct operation and control of the configuration.

Annex M provides an overview of frame formats used in the V5.1 interface.

Annex N describes the protocol architecture for the ISDN and PSTN user port status control information transfer.

Annex Q lists informative references.

Annex R provides an index list to this ETS.

2 Normative references

This ETS incorporates by dated or undated reference, provisions from other publications. These normative references are cited at the appropriate places in the text and the publications are listed hereafter. For dated references, subsequent amendments to or revisions of any of these publications apply to this ETS only when incorporated in it by amendment or revision. For undated references the latest edition of the publication referred to applies.

- [1] ETS 300 166 (1993): "Transmission and Multiplexing (TM); Physical and electrical characteristics of hierarchical digital interfaces for equipment using the 2 048 kbit/s-based plesiochronous or synchronous digital hierarchies".

NOTE 1: This ETS is based on CCITT Recommendation G.703 (1991).

- [2] ETS 300 167 (1993): "Transmission and Multiplexing (TM); Functional characteristics of 2 048 kbit/s interfaces".

NOTE 2: This ETS is based on CCITT Recommendations G.704 (1991) and G.706 (1991).

- [3] ETS 300 012 (1992): "Integrated Services Digital Network (ISDN); Basic user-network interface; Layer 1 specification and test principles".

- [4] ETS 300 297: "Integrated Services Digital Network (ISDN); Access digital section for ISDN basic rate".

NOTE 3: This ETS is based on ITU-T Recommendation G.960 (1993).

- [5] ETS 300 125 (1991): "Integrated Services Digital Network (ISDN); User-network interface data link layer specification; Application of CCITT Recommendations Q.920/I.440 and Q.921/I.441".

- [6] ETS 300 102 (1990): "Integrated Services Digital Network (ISDN); User-network interface layer 3; Specifications for the basic call control".

- [7] CCITT Recommendation G.823 (1988): "The control of jitter and wander within digital networks which are based on the 2 048 kbit/s hierarchy".

3 Definitions, symbols and abbreviations

3.1 Definitions

For the purposes of this ETS the following definitions apply, together with those given in the normative references:

Access Network (AN): a system implemented between the Local Exchange (LE) and user, replacing part or the whole of the local line distribution network.

The functions associated with the V5 interface(s) of an AN can be configured and operated flexibly via a management Q interface.

NOTE 1: An AN may consist of multiplexing, cross connect and transmission functions. The V5 interface ETS is independent of the transmission media used inside the AN. An AN may support services which are outside the scope of this ETS. Examples can be found in Clause 6. Additional information can be found in Annex E.

B-channel number: a B-channel number identifies a B-channel on the ISDN basic access subscribed to for connections on demand, i.e. 1, 2.

Bearer channel: a 64 kbit/s time slot in the V5.1 interface allocated for a B-channel of an ISDN user port or a PCM encoded 64 kbit/s channel from a PSTN user port.

Communication path (C-path): any one of the following information types:

- the layer 2 data link carrying the control protocol;
- the layer 2 data link carrying the PSTN signalling;
- all the ISDN Ds-data from one or more user ports;
- all the ISDN p-data from one or more user ports;
- all the ISDN f-data from one or more user ports.

NOTE 2: This definition includes the possibility that there is more than one C-path of the same information type each allocated to a different C-channel. Refer to subclause 8.4 for details about the different information types.

Communication channel (C-channel): a 64 kbit/s time slot on a V5.1 interface used to carry one or more communication paths all of different types.

Control: control is concerned with status and control of user ports; V5.1 interface layer 1 and 2 establishment and other common procedures.

Envelope Function address (EFaddr): an EFaddr is an address used in the LAPV5-EF frame to identify different V5 enveloping function sublayer connections, each of them used to support a relaying mechanism for the LAPD frames of each of the ISDN user port or messages corresponding to the V5.1 layer 3 protocols (e.g. PSTN protocol, control protocol). It shall be present in every LAPV5-EF and its purpose is to provide a common envelope both in frames in which the LAPV5-EF information field is terminated by the AN (e.g. LAPV5-DL frames used by the PSTN protocol and control protocol) and those where the payload is terminated outside the AN (ISDN LAPD frames from the ISDN user ports). It shall be a 13 bit number, binary coded.

Frame relay function: the statistical multiplexing in an AN of ISDN D-channel frames from an ISDN access layer 2 onto a V5 communication channel and demultiplexing for ISDN D-channel frames received on a V5 communication channel.

NOTE 3: Furthermore it indicates that ISDN D-channel frames are minimally processed, and that they in principle are just relayed from an input layer 2 to an output layer 2, without performing the complete set of layer 2 functions. The term "frame relay" should not be confused with the ISDN Frame Mode Bearer service, which is defined in e.g. CCITT Recommendations Q.922 and Q.933, nor should it be confused with dedicated packet networks for high speed data transfer, referred to as frame relay networks.

Interface ID: a unique number of a V5.1 interface of an AN which is labelled through the Q interfaces of the AN and LE. It shall be a 24 bit number.

LAPV5-frame: a LAPV5 frame is the frame format used within a V5.1 interface for all types of signalling, packetized data or control information.

Layer 3 address (L3addr): a L3addr is an address within layer 3 messages of EFaddr types PSTN signalling or control only. Its purpose is to uniquely reference a user port or a common control function. In the case of a PSTN user port, this shall be a 15 bit number. In the case of an ISDN user port or a common control function, this shall be a 13 bit number.

Line Circuit (LC): user port for the support of the PSTN access, or the analogue or digital access for the semi-permanent leased line.

Local Exchange (LE): an exchange on which user lines are terminated via an AN.

The functions associated with the V5 interface(s) on a LE can be configured and operated flexibly via a management Q interface.

NOTE 4: An LE may also directly terminate user lines but these are outside the scope of this ETS.

Permanent Line (PL): a permanently established connection provided between two ISDN user network interfaces routed through the transmission network bypassing network nodes of the switched digital network (see also Annex A). The PL reduces the access capability at the user network interface for switched services.

Pre-defined: when a parameter is stated as being pre-defined within a V5 interface, the parameter is not required to be presented to the equipment via the Q interface. Instead the parameter is either intrinsically provided within the equipment or is provided on installation or re-equipping of the equipment via a local interface. As a guide it can be assumed that a quantity that is pre-defined will be kept as a constant for the lifetime of the equipment. A pre-defined parameter may take on one of several values depending for example, upon the country of installation or the national PSTN protocol supported.

NOTE 5: Annex P gives references to aspects which should be pre-defined.

Provisioned: a parameter is said to be provisioned if the Q interface has the capability to verify and change it. Such a parameter may have a default value and/or may be altered by a local interface.

NOTE 6: Annex P gives references to aspects required to be provisioned by this ETS.

Provisioning variant: the provisioning variant is a unique label of a complete provisioning data set applied via the Q interfaces.

Semi-permanent leased line: a permanently established connection between two user network interfaces routed through the switched digital network (see also Annex B).

Time slot number: a time slot number identifies a time slot of 64 kbit/s within the 2 048 kbit/s V5.1 interface (see ETS 300 167 [2]). The range of time slot numbers shall be 0 to 31.

User port: the physical port implemented in the AN to provide the relevant interface functions towards the user. The user port is addressed by a logical address used in the relevant protocols on the V5 interface.

V5 Data Link address (V5DLaddr): a V5DLaddr is an address used in the LAPV5-DL frames to identify different V5 data link sublayer connections, each of them used to support a particular V5.1 layer 3 protocol (e.g. PSTN protocol, control protocol). It shall be present in every LAPV5-DL frame and shall be a direct copy of the EFaddr. It shall be a 13 bit number, binary coded.

NOTE 7: The V5DLaddr field has been included within the LAPV5 frames for structural compatibility with other protocols (e.g. ETS 300 125 [5]).

V5 interface: a general term for the family of V interfaces for connection of ANs to the LE, e.g. a V5.1 interface or a V5.2 interface.

3.2 Symbols and abbreviations

For the purposes of this ETS, the following symbols and abbreviations apply:

ac	alternate current
AI	Activate Indication
AIS	Alarm Indication Signal
AN	Access Network
AN-FR	AN Frame Relay function
BCC	Bearer Channel Connection
BECN	Backward Explicit Congestion Notification
C/R	Command/Response
C-channel	Communication channel
C-path	Communication path
C64	Communication channel 64 kbit/s
CRC	Cyclic Redundancy Check
CTRL	Control protocol message
Cx	Communication channel with index
D16	D-channel 16 kbit/s
dc	direct current
DDI	Direct Dialling In
DE	Discard Eligibility indicator
DI	Deactivate Indication
DISC	Disconnect
DL	primitive between layer 2 and layer 3
DLCI	Data Link Connection Identifier
DM	Disconnect Mode
Ds	D-channel signalling
DS	access Digital Section
DTMF	Dual Tone Multiple Frequency
EA	Address Extension
EF	Envelope Function
EFaddr	EF address
EI	Error Indication
ET	Exchange Termination
FCS	Frame Check Sequence
FE	Function Element
FECN	Forward Explicit Congestion Notification
FRI	Frame Relaying Information
FRMR	Frame Reject
FSM	Finite State Machine
ID	Identifier
ISDN	Integrated Services Digital Network
L1	Layer 1
L2	Layer 2
L3	Layer 3
L3addr	L3 address
LAPB	Link Access Protocol Balanced for X.25
LAPD	Link Access Protocol for ISDN D-channel
LAPF	Link Access Protocol for Frame mode
LAPV5	Link Access Protocol for V5 interface
LAPV5-DL	LAPV5 Data Link sublayer
LAPV5-EF	LAPV5 Envelope Function sublayer
LC	Line Circuit
LE	Local Exchange
LOF	Loss Of Frame alignment

LOS	Loss Of Signal
LT	Line Termination
MCID	Malicious Call Identification
MDL	primitive between layer 2 and layer 3 Management
MDU	Management Data Unit
MF	Mapping Function
MPH	primitive between Physical layer and layer 2 Management
NT1	Network Termination 1
NT2	Network Termination 2
P/F	Poll/Final
PABX	Private Automatic Branch eXchange
PCM	Pulse Code Modulation
PH	primitive between Physical layer and layer 2
PICS	Protocol Implementation Conformance Statement
PL	Permanent Line
PSTN	Public Switched Telephone Network
Q _{AN}	Q interface at the AN
Q _{LE}	Q interface at the LE
RAI	Remote Alarm Indication
REJ	Reject
RNR	Receive Not Ready
RR	Receive Ready
SABM	Set Asynchronous Balanced Mode
SABME	SABM Extended
SAPI	Service Access Point Identifier
SDL	Specification and Description Language
TE	Terminal Equipment (ISDN or PSTN)
TEI	Terminal Endpoint Identifier
TMN	Telecommunication Management Network
UA	Unnumbered Acknowledgement
UI	Unnumbered Information
V5DLaddr	V5 Data Link address

4 Electrical and physical interface requirements

The V5.1 interface consists of a single 2 048 kbit/s interface as defined in ETS 300 166 [1] and ETS 300 167 [2].

The electrical and physical characteristics of the interface shall conform to ETS 300 166 [1], 2 048 kbit/s case.

Two interface presentation alternatives are defined in ETS 300 166 [1], the balanced interface pair type and the coaxial type. According to the two alternatives of interface applications shown in figure 1, it is left to the network operator to request the interface presentation required.

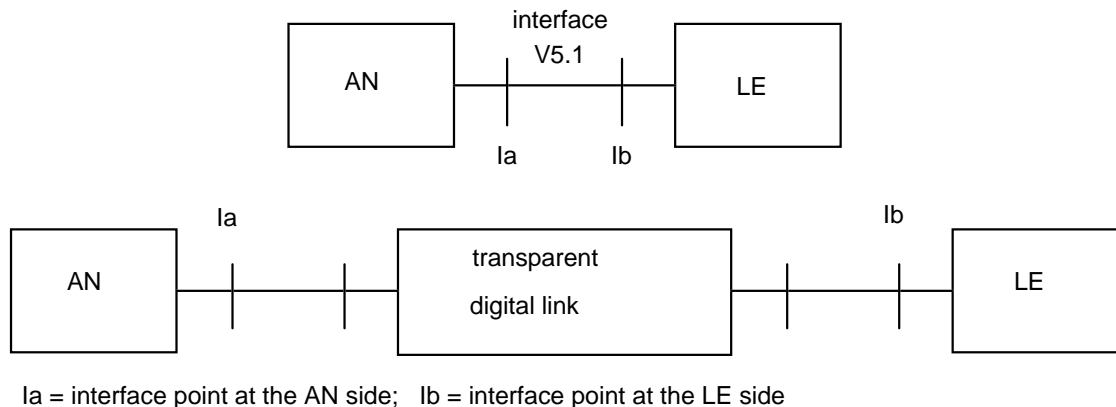

Figure 1: V5.1 application with and without transparent digital link

Concerning the jitter requirements the tolerance to jitter of interface inputs shall conform with the requirements for low-Q clock recovery according to CCITT Recommendation G.823 [7]. Interface outputs shall conform with the requirements for high-Q clock recovery according to CCITT Recommendation G.823 [7] even with tolerable input jitter according to low-Q clock recovery, i.e. a jitter reduction capability is required in the frequency area between high-Q and low-Q cut off frequencies for the jitter transfer. This requirement supports independency of the interface implementation from application in networks using different clock recovery Q factors as well as with an additional digital link to increase the range of the interface.

5 Procedural interface requirements

The functional and procedural requirements of the interface shall conform to ETS 300 167 [2], 2 048 kbit/s case. The CRC-4 procedure specified in ETS 300 167 [2] shall be applied including the Cyclic Redundancy Check (CRC) error reporting using bit E in the CRC-multi-frame.

6 Services and architecture aspects and requirements

The following services shall be supported by the V5.1 interface specification. It is however not intended by this specification to restrict any implementation of ANs or LEs supporting the full set or a subset of the services listed in this ETS.

6.1 On-demand services

On-demand services pass through the V5.1 interface. Two types of accesses are supported, as given in subclauses 6.1.1 and 6.1.2.

6.1.1 PSTN

a) Single customer:

- with Dual Tone Multiple Frequency (DTMF) or line state signalling;
- with or without supplementary services.

- b) PABXs:
- with or without Direct Dialling In (DDI);
 - with DTMF or line state signalling;
 - with or without supplementary services.

The protocol elements specified in this ETS can be combined in a flexible manner to support dedicated PSTN applications except those using data over voice methods.

6.1.2 ISDN basic access

With NT1 as integral part of the AN, or as a separate equipment supporting transmission systems described in ETR 080 and conforming to ETS 300 297 [4]:

- for the support of multipoint layer 1 passive bus configuration at the coincident S and T reference point;
- for the support of NT2 (e.g. ISDN PABX) connected at T reference point.

There shall be no restriction for teleservices or bearer services using B-channels as well as supplementary services for the ISDN access. Packet mode services through D-channel and Packet-data in B-channel shall also be supported.

Bit rates lower than 64 kbit/s are not supported directly. They are seen as user applications within a 64 kbit/s B-channel.

One or both B-channels may be used for the optional Permanent Line (PL) capability or semi-permanent leased line service, see subclauses 6.2 and 6.3.

6.2 Permanent Line (PL) capability

The PL capability uses one or both B-channels of an ISDN basic access. The PL B-channel bypasses the LE as shown in figure 2. For further information on their effect on the V5.1 interface see Annex A. Provisions have been made in the user port control procedure for the support of this capability (see subclause 14.1).

6.3 Semi-permanent leased line

Semi-permanent leased lines pass through the V5.1 interface. For further information on their effect on the V5.1 interface see Annex B.

Three types of semi-permanent leased line services are shown in figure 2:

- a) use of one or both B-channels of an ISDN basic access;
- b) analogue leased line without outband signalling;
- c) digital leased line(s) without outband signalling.

The requirements and procedures for the support of the semi-permanent leased lines are covered by the requirements and procedures defined in this ETS.

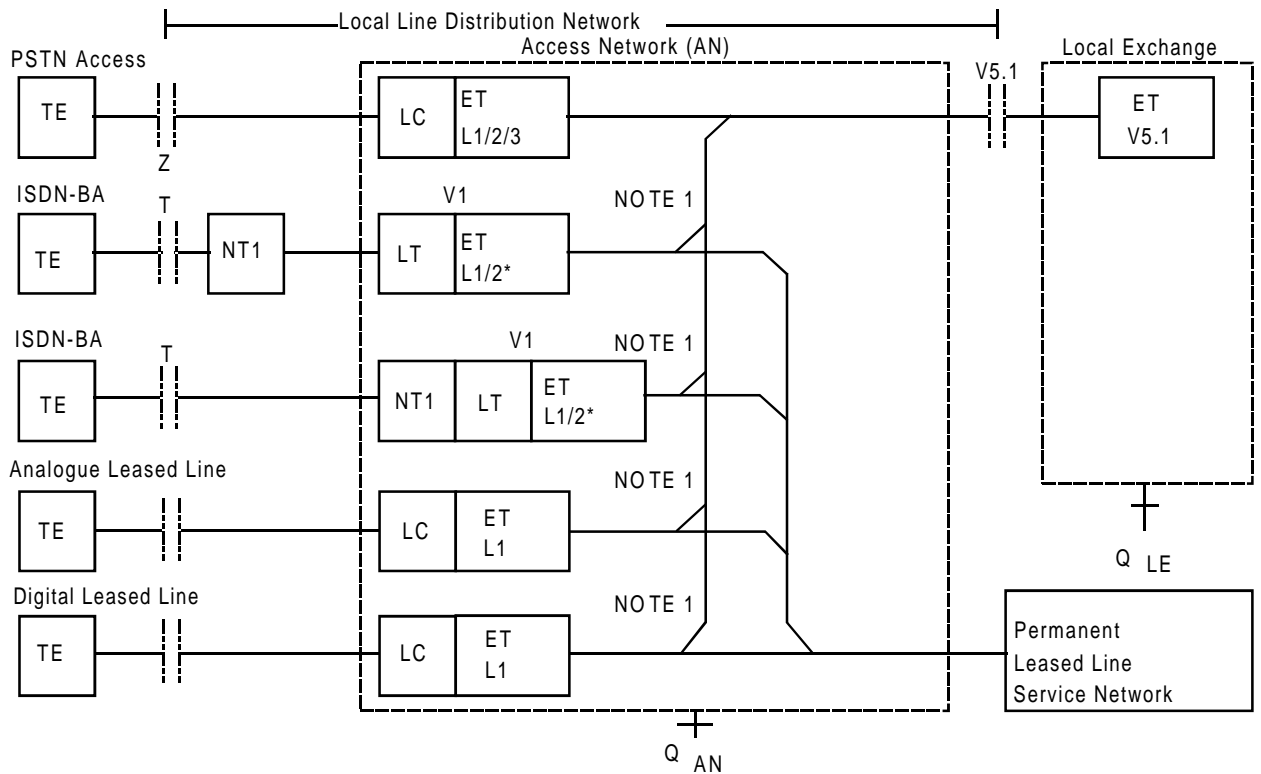

NOTE 1: The selection of channels and the service allocation are part of the provisioning.

NOTE 2: The asterisk indicates that layer 2 is only partially terminated in the AN.

Figure 2: Architecture of V5.1 interface from service point of view

6.4 Permanent leased line services

Permanent leased line services, provided by an AN, bypass the LE and have no effect on the V5.1 interface. The interfaces may be analogue or digital.

7 Control and provisioning

7.1 Control principles

7.1.1 General requirements and assumptions

Based on figure 3 the following general requirements have been identified for the ISDN basic access port. They shall be relevant for PSTN ports as well if not stated otherwise.

- 1) The responsibility for call control resides in the LE (i.e. the AN may have no knowledge of the call state during normal operation of the V5.1 interface).
- 2) The access management in the AN and the service management in the LE each maintain their Finite State Machines (FSMs) and protocol entities and communicate over the V5.1 interface.

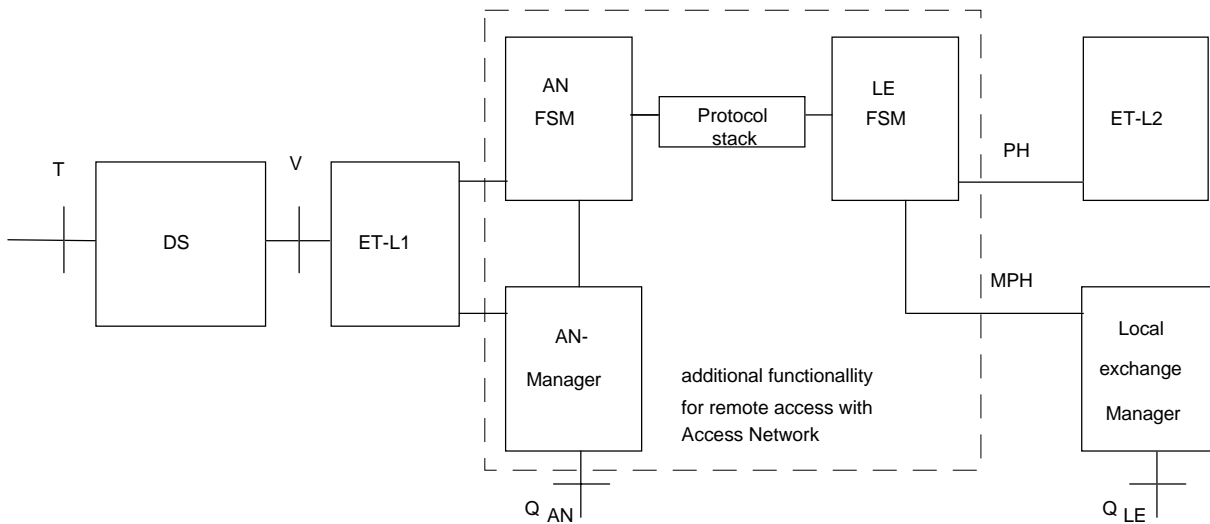
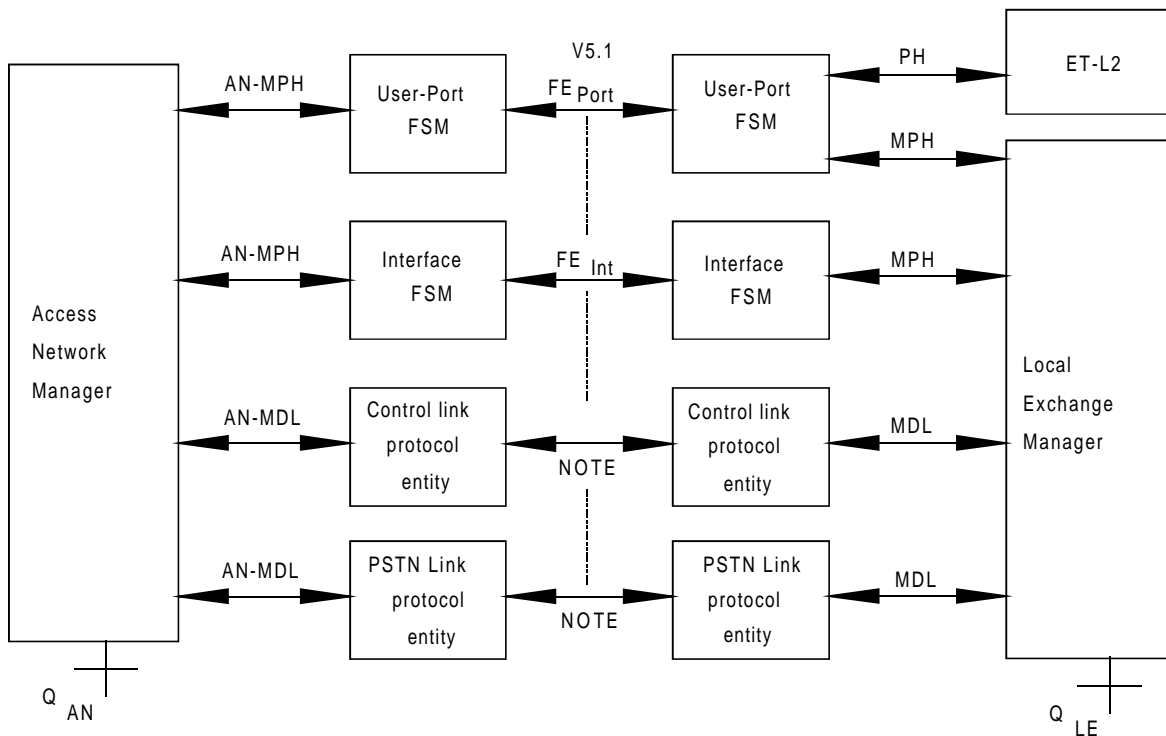

Figure 3: ISDN user port functional model

FSMs are required for each user port and for the 2 048 kbit/s interface as well as protocol entities for the layer 2 links, in both the AN and in the LE (see figure 4 for clarification and Clause 14 for the definition of the FSMs, protocol entities and the layer 3 protocol). The information provided from the individual FSM or protocol entity to the management shall be used to decide on the appropriate action towards other FSMs and protocol entities, the call control function and the operation system. For further information some basic assumptions are provided in Annex C.



NOTE: Refer to subclause 10.4.

Figure 4: Layer 1 and layer 2 FSM functional model

- 3) Port blocking request, for non-urgent port maintenance via the Q-interface of the AN, can only be granted by the LE (i.e. blocking request should not interfere with on-going calls, calls being set up or cleared down or semi-permanent connections).
- 4) Urgent port maintenance requested via the Q-interface of the AN shall be indicated to the LE irrespective of the state in the LE, (i.e. "immediate blocking" effective immediately, but new state to be synchronized with the LE).

- 5) Detected layer 1 failures related to a user port shall result in immediate blocking (for both ISDN and PSTN).

There may be anomalies and defects which may degrade the service but do not result in a total loss of service and thus do not result in the generation of an immediate blocking message. Such anomalies or defects affecting PSTN service may impact the PSTN protocol, for instance through the negative acknowledgement of a request message, but shall not affect the port FSM.

- 6) It is required that detected anomalies and other events are reported to the associated management and logged.
- 7) When a port is blocked originating calls are not possible and terminating calls shall be treated by the LE as if the port is out of service according to the national protocol.
- 8) The LE shall know the transmission quality level related to user ports via "grading" messages from the AN to the LE which do not affect the port status FSMs. These messages contain grading information to be registered by the LE. The LE may use this information to decide whether a requested service should be delivered or not.

This requirement is only relevant to an ISDN port with NT1 which lies outside the AN. The performance between user port and V5.1 interface shall not be impacted unduly by a reduced performance due to bit errors occurring on AN internal links. This shall be excluded by in-service monitoring and blocking of AN internal links from service in case of reduced error performance.

- 9) Loopback shall only be applied when a port is in the blocked state. This function is under the control of the AN.

The execution of failure localization within the AN and the user port is the responsibility of the AN. Active testing which interferes with the service under the responsibility of the LE shall not be carried out until the port is blocked (FSM in blocked condition) by the LE.

- 10) There shall be a mechanism to identify individual V5 interfaces, and the labels of their current and new provisioning variants. The provisioning variant is a unique label of a complete provisioning data set applied via the Q interfaces (see subclause 14.5).

7.1.2 Control of ISDN user port for the PL capability

7.1.2.1 Statements and assumptions

- 1) The PL capability supported by an AN in the V5.1 interface configuration is an additional feature at an ISDN user network interface which cannot be supported by an access connected directly to an LE.
- 2) The PL capability may as an option use one or both B-channels on a user port, that are not provisioned in the AN and LE to carry on-demand services. Permanent activation of the access is required.
- 3) The LE is responsible for on-demand services, as well as for the permanent activation of the access during normal operational conditions of the user port.

7.1.2.2 ISDN and PL capability

The PL service shall not use the D-channel.

The currently defined ISDN service over the basic access (ETS 300 297 [4]) delivered to an ISDN user port at an AN shall be the same as for direct access connections to the LE.

For an AN no impact on an ISDN on-demand service can be accepted from any service (e.g. PL service) that uses one or both of the B-channels for other than on-demand service. The definition of such a service shall accept any unavoidable impact due to the activation/deactivation control responsibility of the access by the LE.

The LE system management has the capability of overruling the permanent activation for the PL capability in case of fault occurrence and fault recovery, because in these conditions the responsibility for activation control changes from the LE to AN or vice-versa. Under operational conditions the PL capability will not be affected.

7.1.2.3 Decoupling of AN and LE FSM

As a consequence of the PL capability sharing the same user port with on-demand services, the two user port FSMs in the AN and LE need to be decoupled when in the "non-operational" states. This allows for the activation of the access under the control of the AN to maintain the PL capability until both sides change to an operational state and the LE takes over the responsibility for activation control (refer to subclause 14.1 which defines the relevant procedures in the AN).

7.2 Provisioning strategy and requirements

7.2.1 General

Provisioning is one of many aspects to control functions. It has been separated from the other control requirements because provisioning shall be performed through the Q interfaces of the AN and the LE and is therefore not directly relevant to the V5.1 interface specification. Only those provisioning aspects having at least conceptual or indirect implication to the interface definition are defined below.

7.2.2 Provisioning requirements

- 1) The association of bearer channels to user ports at the AN and LE shall be provisioned. In case where an AN equipment has only a single 2 048 kbit/s interface, the equipment may have a pre-defined association of bearer channels to user ports. As a principle the same applies to the allocation of an EFaddr to an ISDN user port or a L3addr to a PSTN user port. Further exceptions from this principle however may be defined in the AN specification.
- 2) All data for provisioning, including modification and cessation, shall be handled by the relevant Q-interface. Data for provisioning shall be consistent with the splitting of control functionality between the LE and the AN. This includes data related to the user interface (for example line circuit parameters) and the signalling protocol (for both the LE and the user interfaces);

The TMN function has the responsibility of ensuring that the configuration of the LE and of the AN are compatible, and there is no impact on the V5.1 interface specification. This includes provisioning of PL capability which are multiplexed onto an ISDN user port.
- 3) Changing the provisioning (re-provisioning) shall only be applied when the relevant user port is in the non-operational state in order not to interfere with on-going calls or calls being set-up or cleared down.
- 4) The AN may support ports and services which are not associated with the V5.1 interface. These ports or services shall not impact the operability of ports associated with the V5.1 interface.
- 5) A single AN may have multiple V5.1 interfaces. The association of user ports with different V5.1 interfaces shall be performed through provisioning. The V5.1 interface does not support a change of association between user ports and the V5.1 interfaces on a call-by-call basis;

The control of the association between user ports and V5.1 interfaces shall be performed via the Q-interface, not over the V5.1 interface.

- 6) Information flow for inventory and auditing functions shall be via the Q-interfaces, not the V5.1 interface.
- 7) AN shall be provisioned to support tributary line and user port testing in addition to the other related control functions which were previously LE functions.
- 8) Provisioning includes installation testing of the AN carried out prior to its connection to the LE. AN testing, including tributary line and user port tests, is initiated by the Q interface and can be used to check the AN during this phase.
- 9) Re-provisioning of a V5 interface can be synchronized by the use of the interface ID and the provisioning variant protocol elements of the control protocol. Fields shall be provided for this labelling by the V5 interface protocol, but the TMN function is responsible for the content of these fields and the consistency of the provisioning data set. Reference is made to subclause 14.5, describing the re-provisioning procedures, to the common control protocol specification in subclause 14.4 as well as to Annex C.
- 10) If there is no PSTN protocol provisioned all the requirements and procedures related to the PSTN protocol and PSTN data link are invalid.

Reference is made to Annexes A and B which describe the assumptions and requirements for the application of permanent and semi-permanent leased lines relevant to the V5.1 interface concept, as well as to Annex F concerning upgrading aspects.

8 Protocol architecture and multiplexing structure

8.1 Functional description

The functional description is illustrated in figure 5.

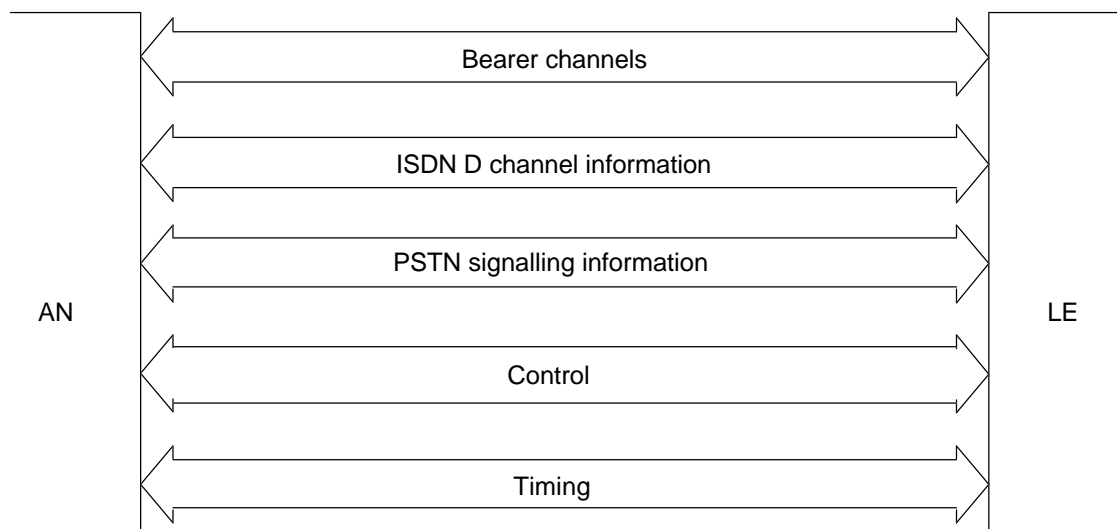

Figure 5: Functional description of the V5.1 interface

The following functional requirements are defined:

- bearer channels: to provide the bidirectional transmission capability for allocated B-channels from basic access user ports or PCM encoded 64 kbit/s channels from PSTN user ports;
- ISDN D-channel information: to provide the bidirectional transmission capability for D-channel information from basic access user ports (including Ds-, p- and f-type data);
- PSTN signalling information: to provide the bidirectional transmission capability for signalling information of PSTN user ports;

- control of user ports: to provide the bidirectional transmission capability to carry the status and control of each individual user port;
- control of the 2 048 kbit/s link: frame alignment, multiframe alignment, alarm indication and CRC information of the 2 048 kbit/s;
- control of layer 2 links: to provide bidirectional communication capability to carry control and PSTN signalling information;
- control for the support of common functions: to provide synchronized application of provisioning data and restart capability;
- timing: to provide the necessary timing information for bit transmission, octet identification and frame synchronization. This information may also be used for the synchronization of LE and AN for synchronous operation. There are however various other methods possible to establish synchronous operation therefore the method used for a particular network may depend on the network operator's requirement and is outside the scope of this ETS.

8.2 Protocol requirements for PSTN and ISDN

Figure 6 shows the protocol architecture in a simplified form. The functions specified in this ETS are shaded.

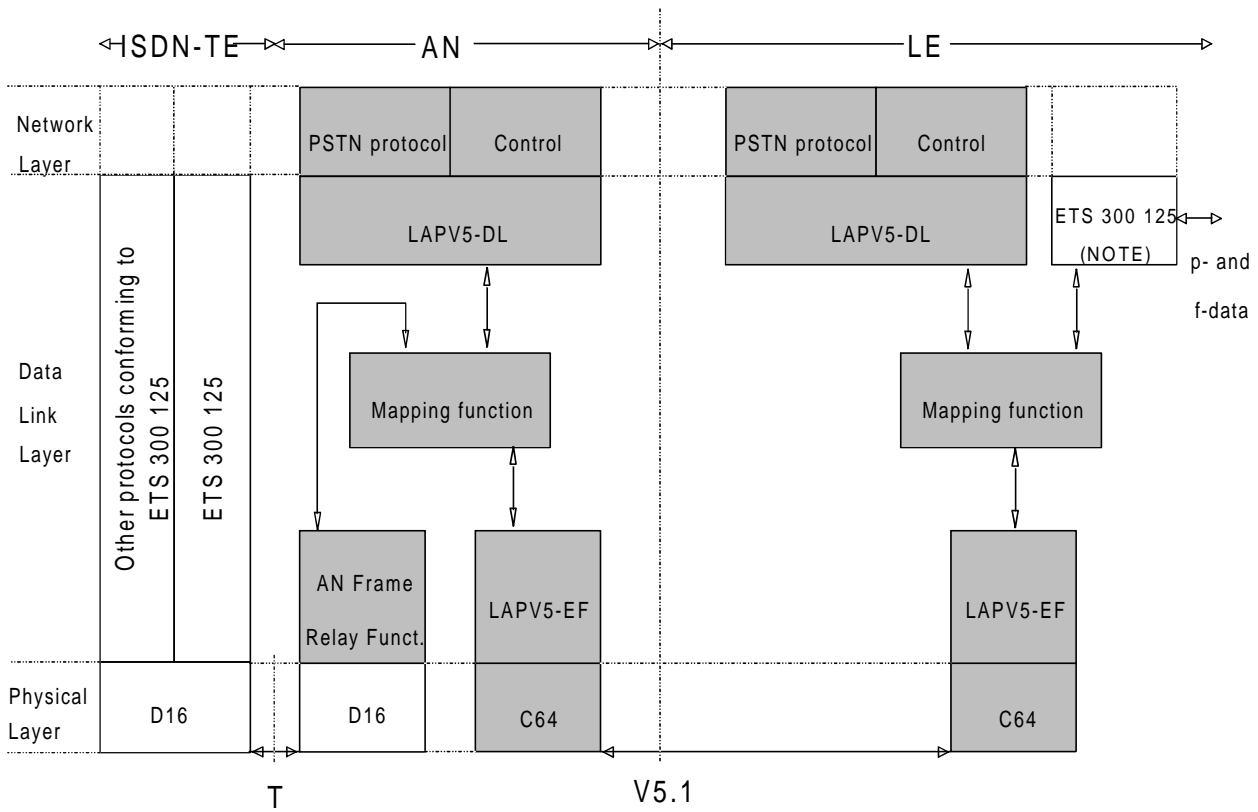

NOTE: Except those functions terminated in the AN Frame Relay function in the AN.

Figure 6: Protocol architecture

They are defined in the following Clauses:

- envelope function sublayer of LAPV5 (LAPV5-EF) Clause 9;
- data link sublayer of LAPV5 (LAPV5-DL) Clause 10;
- frame relaying sublayer of the AN (AN-FR) Clause 11;
- sublayer-to-sublayer communication and mapping function Clause 12;
- PSTN signalling protocol specification and layer 3 multiplexing Clause 13;
- control protocol Clause 14.

The ISDN D-channel information shall be multiplexed at layer 2 and frame relayed over the V5.1 interface. The capability to separate p-type and f-type data from s-type signalling data onto different communication channels shall be supported by the AN and the LE, but it shall be possible to carry them on a single communication channel as a traffic engineering option, which requires that this can be provisioned (see also subclause 8.4).

An overview of frame formats used in the V5.1 interface can be found in Annex M.

The protocol specification for PSTN ports is based on the following:

- the analogue PSTN signalling information shall be transported over the V5.1 interface using the layer 3 messages of the V5-PSTN protocol;
- signalling information shall be multiplexed at layer 3 and carried over a single layer 2 data link;
- only the LE shall have knowledge about the PSTN services under operational condition of the V5.1 interface;
- DTMF senders, receivers, tone generators and announcements shall be located in the LE.

NOTE: DTMF senders, receivers, tone generators and announcements may also be present in the AN e.g. for:

- line maintenance (via the Q interface);
- emergency call handling in case of V5.1 interface failures; the required facilities shall only be activated for long term failures. This function is optional.

Emergency call handling is outside the scope of this ETS.

8.3 Time slots

According to Clauses 4 and 5 there shall be only one 2 048 kbit/s link on a V5.1 interface and layer 1 of the V5.1 interface is structured according to ETS 300 167 [2]. Timeslots 1 to 31 of the 2 048 kbit/s link shall be used for channels allocated by provisioning:

- time slots which carry ISDN and PSTN bearer channels;
- communication channels which carry ISDN D-channel information, PSTN signalling information and control information.

8.4 Time slot allocation for communication channels

If only PSTN user ports are supported the capability for 2 communications channels shall be provided, assigned through provisioning.

If either ISDN user ports or ISDN and PSTN user ports are supported the capability for 3 communications channels shall be provided, assigned through provisioning.

If only one communication channel is allocated then it shall be timeslot 16 (C-channel 1).

If two communications channels are allocated then they shall be timeslots 15 and 16 (C-channels 2 and 1, respectively).

If all three communications channels are allocated then they shall be timeslots 15, 16 and 31 (C-channels 2, 1 and 3, respectively).

The following types of data have been defined which shall be conveyed over the V5.1 interface as communication paths:

- a) p-type data: This is ISDN D-channel data with SAPI 16;
- b) f-type data: This is ISDN D-channel data with SAPI = 32 to 62;
- c) Ds-type: This is ISDN D-channel signalling type data with SAPI not equal to any of those above;

NOTE 1: It has been identified that services using previously reserved SAPIs may be provided in the future. Giving a default allocation at least allows earlier implementations of V5.1 to transport these D-channel signalling types across the AN although their future data type allocation may be changed.

- d) PSTN: This is PSTN signalling information;
- e) Control: This is control information data.

The control communication path shall always be allocated to C-channel 1. The other communication paths shall be allocated to any C-channel by provisioning. Ds-type data shall be kept within a single C-channel. The same applies for PSTN.

p-type data from an ISDN user port shall be placed in a single C-channel. f-type data from an ISDN user port shall be placed in a single C-channel. Both p-type data and f-type data from an ISDN user port may be placed in the same C-channel or split over different C-channels. p-type and f-type data with different EFaddr may be split into different communication paths which shall be conveyed over different C-channels, following the rules above.

NOTE 2: p-type and f-type data may also be routed by the AN through the leased line service network by provisioning. There is no impact to the V5.1 interface specification.

8.5 Layer 2 sublayering and multiplexing on communication channels

The protocol specification and procedures are based upon the LAPD protocol and procedures defined in ETS 300 125 [5] to allow for flexibility in multiplexing the different information streams into the communication channels. This protocol is defined in Clauses 9, 10 and 11.

The LAPV5 is subdivided into an Envelope Function sublayer (LAPV5-EF) and a Data Link sublayer (LAPV5-DL).

The layer 2 function of the AN shall additionally contain the AN frame relay sublayer for the support of ISDN D-channel information.

The sublayer-to-sublayer communication within the layer 2 shall be controlled by the Mapping function which is defined in Clause 12.

8.6 Layer 3 multiplexing

The signalling information for PSTN user ports is multiplexed at layer 3 and carried via one layer 2 data link over the V5.1 interface. Similarly control information is multiplexed at layer 3 and carried via the control Layer 2 data link over the V5.1 interface. Address information of the individual ports is contained in the layer 3 messages of the PSTN and control protocols. The specification of the layer 3 protocol for PSTN signalling is given in Clause 13. The control protocol is defined in Clause 14.

8.7 Congestion control

Three mechanisms for congestion control are available but all are based on existing mechanisms or those required for control of the user port.

8.7.1 Flow control end to end

The LE shall utilize existing flow control procedures at layer 2 of the user network interface to regulate the traffic in the D-channel of the ISDN user port.

8.7.2 Congestion control on the V5.1 interface

No additional flow control procedure has been identified necessary in the V5.1 protocol. Overload should be prevented by traffic engineering.

8.7.3 Blocking of ISDN user ports at layer 2

Blocking for the ISDN D-channels may be required in case of a terminal failure causing overload in the protocol multiplexer and overflow of buffers. Control functionalities shall be used by the LE to request from the AN to discard all layer 2 frames from an individual ISDN user port (see also subclause 14.1, primitives MPH-DB and MPH-DU as well as FE207 and FE208). The user port stays operational and activated, to enable periodic D-channel unblocking by the LE management to verify the persistence of the problem.

9 Envelope Function sublayer of LAPV5 (LAPV5-EF)

9.1 Frame structure for peer-to-peer communication

9.1.1 General

All envelope function peer-to-peer exchanges of information between the AN and the LE shall be in frames conforming to the format shown in figure 7.

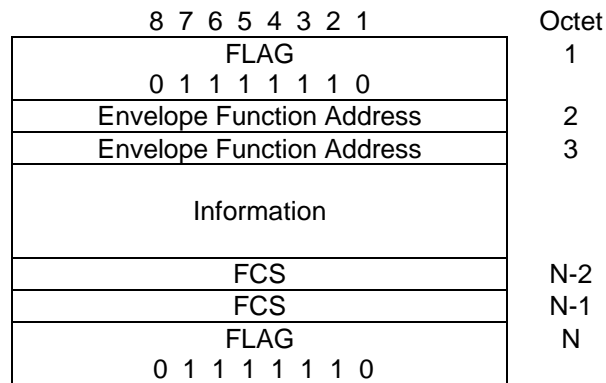

Figure 7: Frame structure supported by the envelope function

9.1.2 Flag sequence

The definition and use of the flags shall be as in ETS 300 125 [5] (Q.921), subclause 2.2.

9.1.3 Interframe time fill

Contiguous flags shall be transmitted when no layer 2 frames have to be sent. Flag monitoring is not required at the receiving side of the data link connection to detect an anomalous condition or failure.

NOTE: It is left to the implementor of the equipment to implement the flag monitoring for consistency reasons with the data link monitoring procedures defined for the communications channels in the V5.2 interface specification.

9.1.4 Envelope function address field

The envelope function address field consists of two octets. The format of the address field is defined in subclause 9.2.1.

9.1.5 Envelope information field

The envelope information field of a frame follows the envelope address field and precedes the frame check sequence field. The contents of the envelope information field shall consist of an integral number of octets.

The default value for the maximum number of octets in the envelope information field shall be 533 octets. The minimum envelope information field size shall be 3 octets.

NOTE: Because of the relaying provided by the LAPV5-EF, this function has to apply even to frames considered as "too long frames" but not to "unbounded frames" (frames which are not properly bounded by flags).

A layer 2 frame is considered unbounded if two times the longest permissible frame plus two octets are received without flag (closing flag) detection. So, an unbounded frame will consist of a sequence of 538 ($2 \times 268 + 2$) octets.

Unbounded frames are considered as invalid frames and discarded by LAPV5-EF (see subclause 9.1.9). Consequently, the maximum permissible size of a "too long frame" shall be 537 octets.

Considering that LAPV5-EF relays frames without the 4 octets corresponding to the opening flag, closing flag and FCS fields, the maximum sequence of octets to be accommodated by the envelope for relaying will be 533 ($537 - 4$) octets.

That leads to the conclusion that the default maximum value for the information field of the envelope is 533 octets (maximum size of the sequence of octets to be relayed by the V5.1 interface).

9.1.6 Transparency

The definition and use of transparency shall be as in ETS 300 125 [5] (Q.921), subclause 2.6.

9.1.7 Frame Check Sequence (FCS)

The definition and use of the FCS shall be as in ETS 300 125 [5] (Q.921), subclause 2.7.

9.1.8 Format convention

The definition of format and numbering conventions shall be as in ETS 300 125 [5] (Q.921), subclause 2.8.

9.1.9 Invalid frames

An invalid frame shall be a frame which:

- a) does not conform to subclause 9.1.5; or
- b) has fewer than five octets between the address field and the closing flag; or
- c) does not consist of an integral number of octets prior to ZERO bit insertion or following ZERO bit extraction; or
- d) contains a frame check sequence error; or
- e) contains an address field with size not equal to 2 octets; or
- f) contains an Envelope Function address (EFaddr) which is not supported by the receiver.

Invalid frames shall be discarded without notification to the sender. No action shall be taken on receipt of invalid frames.

9.1.10 Frame aborts

The definition of and the reaction to frame aborts shall be as in ETS 300 125 [5] (Q.921), subclause 2.10.

9.2 Format of fields for data link envelope peer-to-peer communication

9.2.1 Envelope function address field format

The length of the address field shall be 2 octets. The address field format is defined in figure 8. It contains the Address Extension bits (EA) and the EFaddr. The second bit of the first octet shall be set to ZERO and the receiving side shall treat it as don't care.

8	7	6	5	4	3	2	1	Octet
EFaddr						0	EA 0	1
EFaddr (lower)							EA 1	2

Figure 8: Envelope address field format

9.2.2 Address field variables

9.2.2.1 Address field extension bit

The definition and use of the EA shall be as in ETS 300 125 [5] (Q.921), subclause 3.3.1.

9.2.2.2 EFaddr

The EFaddr shall be a 13 bit number. The range from 0 to 8 175 shall be used to uniquely identify an ISDN user port within the V5 interface.

Values 8 176 up to 8 191 are reserved and shall be used to identify a point at which data link layer services are provided by the V5 layer 2 entity to a layer 3. These values of EFaddr shall be equal to the corresponding V5DLaddr as defined in subclause 10.3.2.3.

10 Data Link sublayer of LAPV5 (LAPV5-DL)

10.1 Frame structure for peer-to-peer communication

10.1.1 General

All data link sublayer peer-to-peer exchanges of information between the AN and the LE shall be in frames conforming to the formats defined in figure 9. Two format types are shown:

- format A for frames without information field; and
- format B for frames containing an information field.

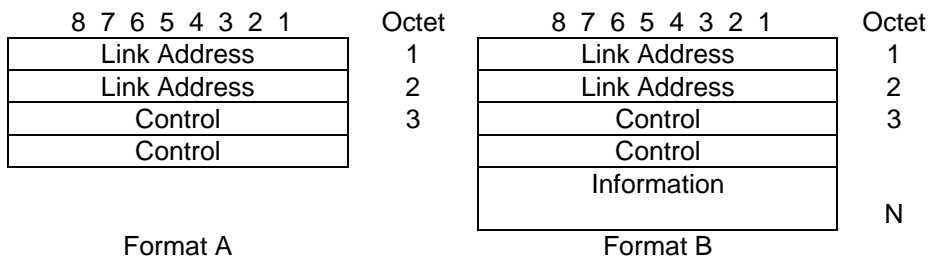

Figure 9: Data-link sublayer frame formats

10.1.2 Link address field

The link address field consists of two octets. The format of the link address field is defined in subclause 10.3.

10.1.3 Control field

The definition of the control field shall be as in ETS 300 125 [5] (Q.921), subclause 2.4.

10.1.4 Information field

The information field of a frame, when present, follows the control field. The contents of the information field shall consist of an integer number of octets. The maximum number of octets in the information field shall be 260.

10.1.5 Format convention

The definition of format and numbering conventions shall be as in ETS 300 125 [5] (Q.921), subclause 2.8.

10.2 Invalid frames

An invalid frame shall be a frame which:

- a) has fewer than four octets if it contains sequence numbers and fewer than three octets if it does not contain sequence numbers; or
- b) contains a Link address field whose size is not equal to two octets; or

c) contains a V5 Data Link address (V5DLaddr) which is not supported by the receiver.

Invalid frames shall be discarded without notification to the sender. No action shall be taken as the result of that frame.

10.3 Elements of procedures and formats of fields for data link sublayer peer-to-peer communication

10.3.1 Link address field format

The length of the address field shall be 2 octets. The link address field format is defined in figure 10. It contains extension bits, the Command/Response (C/R) bit and the V5DLaddr.

8	7	6	5	4	3	2	1	Octet	
V5DLaddr							C/R	EA 0	1
V5DLaddr (lower)								EA 1	2

Figure 10: Link address field format

10.3.2 Link address field variables

10.3.2.1 Address field extension (EA) bit

The definition and use of the EA bit shall be as in ETS 300 125 [5] (Q.921), subclause 3.3.1.

10.3.2.2 Command/response field bit

The definition and use of the C/R bit shall be as in ETS 300 125 [5] (Q.921), subclause 3.3.2.

10.3.2.3 V5DLaddr

The V5DLaddr shall be a 13 bit number. Values in the range of 0 up to 8 175 shall not be used to identify a layer 3 protocol entity, because that range is used for identifying ISDN user ports.

Defined values of the V5DLaddr are given in table 1.

Table 1: Coding of V5DL address values

Bits								
8	7	6	5	4	3	2	1	
1	1	1	1	1	1	C/R	EA	Octet 1
								Octet 2
1	1	1	0	0	0	0	EA	PSTN signalling (8 176 decimal)
1	1	1	0	0	0	1	EA	Control protocol (8 177 decimal)

10.3.3 Control field formats

The definition and use of the control field shall be as in ETS 300 125 [5] (Q.921), subclause 3.4.

10.3.4 Control field parameters and associated state variables

The definition and use shall be as in ETS 300 125 [5] (Q.921), subclause 3.5.

10.3.5 Frame types

The definition and use of frame types shall be as in ETS 300 125 [5] (Q.921), subclause 3.6.

10.4 Definition of the peer-to-peer procedures of the data link sublayer

10.4.1 General

The purpose of the Link Access Procedure for the Control-channel or PSTN-signalling-channel is to convey information between layer 3 in the LE and corresponding peer entities in the AN.

Communications between the data link layer and adjacent layers, and between the data link layer and the system management are accomplished by means of primitives.

Primitives represent, in an abstract way, the logical exchange of information and control between the data link layer and adjacent layers, and between the data link layer and the system management.

The Link Access Procedures for the Control-channel or PSTN-signalling-channel are based on the point-to-point Link Access Procedures on the D-channel (LAPD) specified in ETS 300 125 [5].

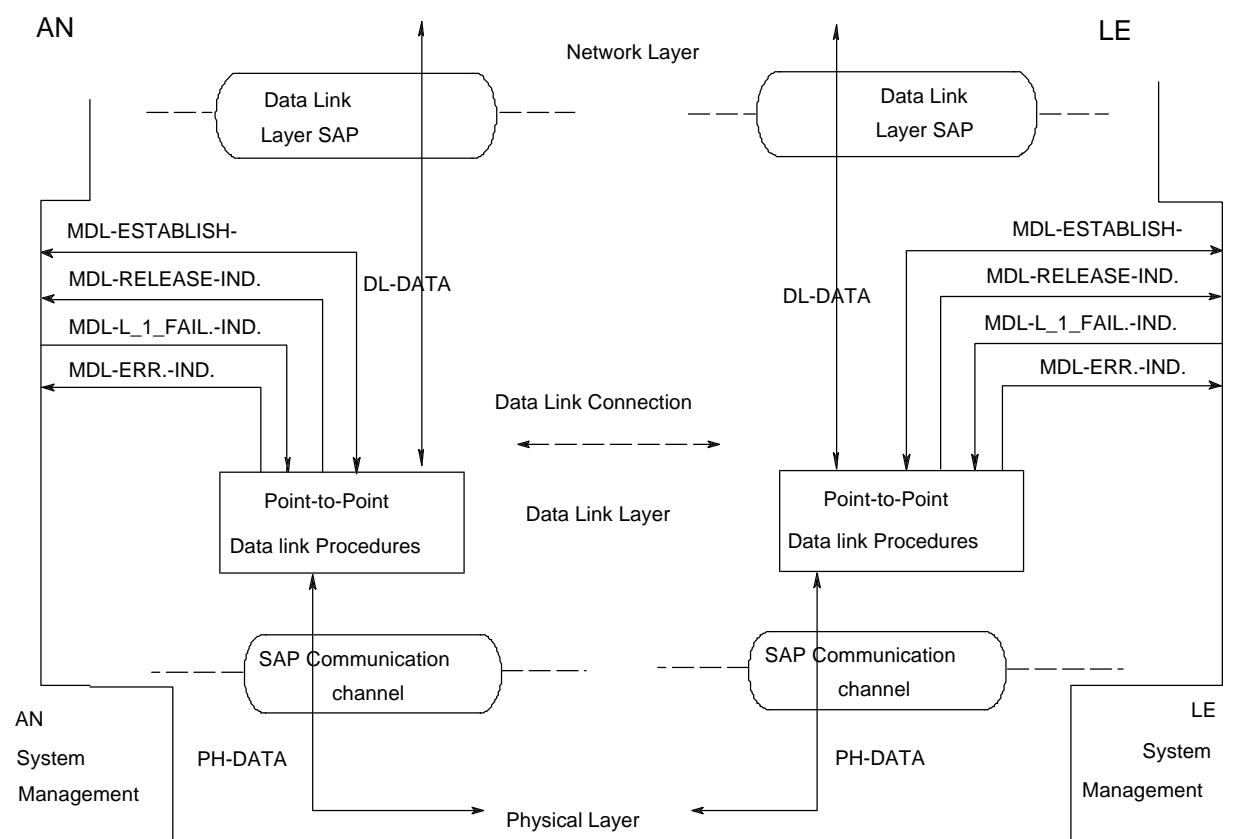

Figure 11: Functional model of the data link layer management

Figure 11 shows the functional model of the data link layer and the relevant primitives. From the repertoire of primitives defined in ETS 300 125 [5] (Q.921), subclause 4.1, the following subset shall also be used for the LAPV5-DL peer-to-peer communication procedures:

- PH-DATA-(REQUEST, INDICATION);
- MDL-ERROR-INDICATION;
- DL-DATA-(REQUEST, INDICATION).

The establishment and release of data links shall be the responsibility of the system management (see Annex C). Therefore in addition to the above listed primitives the following new primitives shall be used:

- MDL-ESTABLISH-(REQUEST, CONFIRMATION, INDICATION);
- MDL-RELEASE-INDICATION;
- MDL-LAYER_1_FAILURE-INDICATION.

The MDL-ESTABLISH primitives are used to request, indicate and confirm the outcome of the procedures for establishing multiple frame operation. The MDL-RELEASE primitives are used to indicate the outcome of the procedures for terminating multiple frame operation.

The information about the condition of the physical layer (MDL-LAYER_1_FAILURE-INDICATION) is provided by the FSM of the 2 048 kbit/s interface as defined in subclause 14.3 and is available for the system management in the LE and AN. Thus no activation/deactivation procedures or primitives are required. As a consequence, between layer 1 and layer 2 only PH-DATA primitives shall be issued. No MPH primitives are used (MPH-ACTIVATION, MPH-DEACTIVATION, MPH-INFORMATION). For system management procedures see Annex C.

Subclause 10.4.11 specifies the state transition tables related to the procedures defined in this subclause.

For the LAPV5-DL peer-to-peer communication procedures only the multi frame acknowledged information transfer shall be used. Unacknowledged information transfer and connection management entity information transfer as defined in ETS 300 125 [5] (Q.921) are not used.

The elements of procedure (frame types) which apply shall be:

- SABME-command;
- UA-response;
- DM-response;
- RR-command/response;
- RNR-command/response;
- REJ-command/response;
- I-command.

NOTE: The DISC-command as well as the FRMR-response is neither generated nor expected to be received.

10.4.2 Procedure for the use of the Poll/Final (P/F) bit

The procedure for the use shall be as defined in ETS 300 125 [5] (Q.921), subclause 5.1.

10.4.3 Terminal Endpoint Identifier (TEI) management procedures

Since the Data Link Connection Identifier (DLCI) for the Control- and PSTN-signalling-links are fixed no TEI management procedures shall be applied. Therefore, the states 1-4 in ETS 300 125 [5], Annex B (i.e. TEI unassigned, Establish awaiting TEI, Assign awaiting TEI and TEI assigned) shall be replaced by a single state called LINK-NOT-ESTABLISHED (state 9).

10.4.4 Automatic negotiation of data link layer parameters

Automatic negotiation of data link layer parameters shall not be used. The data link layer parameters as specified in subclause 10.4.9 shall be used.

10.4.5 Procedures for establishment and release of multiple frame operation

10.4.5.1 Establishment of multiple frame operation

Extended multiple frame operation (modulo 128 sequencing) shall be used.

10.4.5.1.1 General

These procedures shall be used to establish multiple frame operation between the LE and a corresponding entity in the AN.

The system management shall request establishment of the multiple frame operation by the use of the MDL-ESTABLISH-REQUEST primitive. This procedure shall also be applied after initialization of the interface or recovery of layer 1 from failure condition indicated by MPH-AI. Re-establishment shall also be initiated as a result of the data link layer procedures defined in subclause 10.4.7. All frames other than unnumbered frame formats received during the establishment procedures shall be ignored.

10.4.5.1.2 Establishment procedures

A data link entity shall initiate a request for the multiple frame operation to be set by transmitting the SABME command. All existing exception conditions shall be cleared, the retransmission counter shall be reset, and timer T200 shall then be started (timer T200 is defined in ETS 300 125 [5] (Q.921) subclause 5.9.1). All mode setting commands shall be transmitted with the P bit set to ONE.

System management initiated establishment procedures imply the discard of all outstanding DL-DATA-REQUEST primitives and all I frames in queue.

A data link layer entity receiving an SABME command, if it is able to enter the multiple-frame-established state, shall:

- respond with an UA response with the F bit set to the same binary value as the P bit in the received SABME command;
- set V(S), V(R) and V(A) to ZERO;
- enter the multiple-frame-established state and inform system management using the MDL-ESTABLISH-INDICATION primitive;
- clear all existing exception conditions;
- clear any existing peer receiver busy condition; and
- start timer T203 (timer T203 is defined in ETS 300 125 [5] (Q.921) subclause 5.9.8).

If the data link layer entity is unable to enter the multiple-frame-established state, it shall respond to the SABME command with a DM response with the F bit set to the same binary value as the P bit in the received SABME command.

Upon reception of the UA response with the F bit set to ONE, the originator of the SABME command shall:

- reset timer T200;
- start timer T203;
- set V(S), V(R), and V(A) to ZERO; and

- enter the multiple-frame-established state and inform system management using the MDL-ESTABLISH-CONFIRM primitive.

Upon reception of a DM response with the F bit set to ONE, the originator of the SABME command shall indicate this to system management by means of the MDL-RELEASE-INDICATION primitive, and reset timer T200. It shall then enter the link-not-established state. DM responses with the F bit set to ZERO shall be ignored in this case.

10.4.5.1.3 Procedure on expiry of timer T200

If timer T200 expires before the UA or DM response with F bit set to ONE is received, the data link layer entity shall:

- retransmit the SABME command as above;
- restart T200; and
- increment the retransmission counter.

After retransmission of the SABME command N200 times, the data link layer entity shall indicate this to system management by means of the MDL-RELEASE-INDICATION and MDL-ERROR-INDICATION primitives and enter the link-not-established state, after discarding all outstanding DL-DATA-REQUEST primitives and all I frames in queue.

The value of N200 is defined in ETS 300 125 [5] (Q.921), subclause 5.9.2.

10.4.5.2 Information transfer

Having either transmitted the UA response to a received SABME command or received the UA response to a transmitted SABME command, I frames and supervisory frames shall be transmitted and received according to the procedures described in ETS 300 125 [5] (Q.921), subclause 5.6.

If an SABME command is received while in the multiple-frame-established state, the data link layer entity shall invoke the re-establishment procedure described in ETS 300 125 [5] (Q.921), subclause 5.7.

10.4.5.3 Termination of multiple frame operation

In the case of persistent layer 1 failure the system management shall inform the data link layer entity by MDL-LAYER_1_FAILURE-INDICATION; which then shall discard all I queues and deliver to the system management an MDL-RELEASE-INDICATION primitive. If timers T200 or T203 are running, they shall be stopped.

10.4.5.4 Link-not-established state

While in the link-not-established state:

- on receipt of an SABME command, the procedures defined in subclause 10.4.5.1 shall be followed;
- on receipt of an unsolicited DM response with the F bit set to ZERO, the data link layer entity shall, if it is able to, initiate the establishment procedures by the transmission of the SABME (see subclause 10.4.5.1.2). Otherwise, the DM shall be ignored;
- on receipt of any unsolicited UA response an MDL-ERROR-INDICATION primitive shall be issued; and
- all other frame types shall be discarded.

10.4.5.5 Collision of unnumbered commands and responses

10.4.5.5.1 Identical transmitted and received commands

If the transmitted and received unnumbered commands (SABME) are the same, the data link layer entities shall send UA response at the earliest possible opportunity. The indicated state shall be entered after receiving the UA response. The data link layer entity shall notify system management by means of the appropriate confirm primitive.

10.4.5.5.2 Different transmitted and received commands

If the transmitted and received unnumbered commands (SABME) are different, the data link layer entities shall issue a DM response at the earliest possible opportunity. Upon receipt of a DM response with the F bit set to ONE, the data link layer shall enter the link-not-established state and notify system management by means of the appropriate primitive.

10.4.5.6 Unsolicited DM response and SABME command

When a DM response with the F bit set to ONE is received by a data link layer entity, a collision between a transmitted SABME command and the unsolicited DM response may have occurred.

In order to avoid misinterpretation of the DM response received, a data link layer entity shall always send its SABME command with the P bit set to ONE.

A DM response with the F bit set to ZERO colliding with an SABME command shall be ignored.

10.4.6 Procedures for information transfer in multiple frame operation

Procedures for information transfer in multiple frame operation shall be as defined in ETS 300 125 [5] (Q.921), subclause 5.6.

The DISC command shall neither be generated nor expected to be received.

10.4.7 Re-establishment of multiple frame operation

10.4.7.1 Criteria for re-establishment

The criteria for re-establishing the multiple frame mode of operation are defined in this subclause by the following conditions:

- the receipt, while in the multiple frame mode of operation, of an SABME;
- the receipt of an MDL-ESTABLISH-REQUEST primitive from the system management (see subclause 10.4.5.1.1);
- the occurrence of N200 retransmission failures while in the timer recovery condition (see ETS 300 125 [5] (Q.921), subclause 5.5.1.1);
- the occurrence of a frame rejection condition as identified in ETS 300 125 [5] (Q.921), subclause 5.8.5;
- the receipt, while in the multiple frame mode of operation, of an unsolicited DM response with the F bit set to ZERO (see ETS 300 125 [5] (Q.921), subclause 5.8.7);
- the receipt, while in the timer-recovery condition, of a DM response with the F bit set to ZERO.

10.4.7.2 Procedures

In all re-establishment situations, the data link layer entity shall follow the procedures defined in subclause 10.4.5.1. All locally generated conditions for re-establishment will cause the retransmission of the SABME.

In the case of data link layer and peer initiated re-establishment, the data link layer entity shall also:

- issue an MDL-ERROR-INDICATION primitive to the system management; and
- if $V(S) > V(A)$ prior to re-establishment, then issue an MDL-ESTABLISH-INDICATION primitive to the system management, and discard all I queues.

In case of system management initiated re-establishment, or if an MDL-ESTABLISH-REQUEST primitive occurs pending re-establishment, the MDL-ESTABLISH-CONFIRM primitive shall be used.

10.4.8 Exception condition reporting and recovery

Exception condition reporting and recovery shall be as defined in ETS 300 125 [5] (Q.921), subclause 5.8. The TEI-assigned state in ETS 300 125 [5] is replaced by the link-not-established state.

10.4.9 List of system parameters

The values of the following parameters, defined in ETS 300 125 [5] (Q.921) subclause 5.9, shall be:

- timer T200 (1 s);
- maximum number of retransmissions N200 (3);
- maximum number of octets in an information field N201 (260);
- timer T203 (10 s).

The maximum number (k) of sequentially numbered I frames that may be outstanding (that is unacknowledged) at any time shall be 7.

NOTE: This value of k is in line with the value for signalling data on a 64 kbit/s D-channel according to ETS 300 125 [5] (Q.921), subclause 5.9.

10.4.10 Data link monitor function

10.4.10.1 General

The procedural elements defined in subclause 10.4 allow for the supervision of the data link layer resource. This subclause defines the procedures which shall be used to provide this supervision function at the LE and AN side.

10.4.10.2 Data link layer supervision in the multiple-frame-established state

The procedure is based on supervisory command frames (RR command, RNR command) and timer T203, and operates in the multiple-frame-established state as follows.

If there are no frames being exchanged on the data link connection (neither new nor outstanding I-frames, nor supervisory frames with a P bit set to ONE), there is no means to detect a faulty data link connection condition. Timer T203 represents the maximum time allowed without frames being exchanged.

If timer T203 expires, a supervisory command with a P bit set to ONE is transmitted. Such a procedure is protected against transmission errors by making use of the normal timer T200 procedure including retransmission count and N200 attempts.

10.4.10.3 Connection verification procedures

The connection verification procedures shall be as defined in ETS 300 125 [5] (Q.921) subclause 5.10.3.

10.4.11 PSTN and control data link FSM and requirements

This subclause specifies the state transition table of the point-to-point procedures of the data link layer for the PSTN and control.

10.4.11.1 General

The state transition table defined in this subclause is based on the peer to peer procedures of the data link sublayer, as defined in subclauses 10.4.1 to 10.4.10, which result in the following four basic states and the related transmitter and receiver conditions:

- state 5: Awaiting-establishment;
- state 7: Multiple-frame-established;
- state 8: Timer-recovery;
- state 9: Link-not-established.

The state transition tables shall be derived from the existing LAPD state transition tables included in ETS 300 125 [5], Annex D. Thus the same numbering was used for states 5, 7 and 8. The new state defined in subclause 10.4.3 (Link-not-established) is state 9.

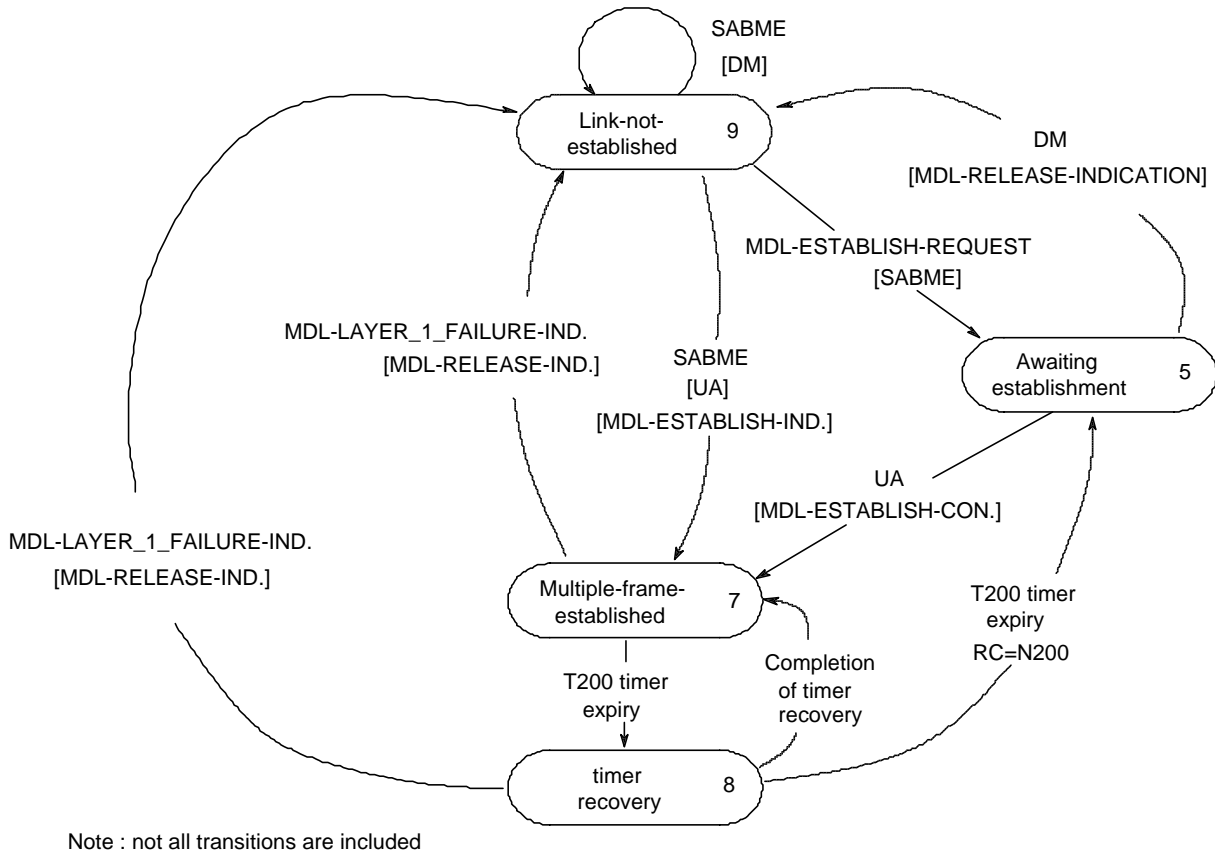

Figure 12: Overview of the states of the data link FSM

Figure 12 gives an overview of the states and the typical transitions. This overview is incomplete, and serves only as an introduction to the state transition tables.

10.4.11.2 Data link FSM

The requirements and specifications in this subclause are relevant for both the AN and LE because of the symmetry of the interface functions.

The state transition table relinquishes to any partitioning of the procedures. It is conceptual and does not prevent a designer from partitioning in his implementation. Moreover, all the processes related to primitive procedures, the management of queues and the exchange of information between adjacent layers are conceptual, not visible from outside of the system and would not impose any constraints on the implementation.

The four basic states apply to both the transmitter and the receiver within one data link layer entity. However, some of the conditions are confined to the transmitter (e.g. "peer receiver busy"), whilst some are confined to the receiver (e.g. "REJ recovery"). This implies, if the concept of non-partitioning is adopted, that each transmitter condition has to be combined with each receiver condition resulting in composite states. This state transition table comprises 19 composite states representing the 4 basic states and the related combinations of transmitter and receiver conditions.

Events are defined as follows:

- a) primitives;
- b) repertoire of frames to be received:
 - unnumbered frames (SABME, UA, DM);
 - supervisory frames (RR, REJ, RNR);
 - information frame (I),
- c) internal events (Servicing of queues, expiry of timers, receiver busy condition).

The actions to be taken when an event occurs whilst in a specific state comprise:

- 1) transition to another state;
- 2) peer-to-peer frame to be transmitted;
- 3) primitives to be issued;
- 4) timer actions;
- 5) retry counters;
- 6) state variables;
- 7) P/F bit setting;
- 8) discarding contents of queues.

Tables D-1, D-2 and D-3 of ETS 300 125 [5] define the data link layer FSM with the modifications given below.

Changes to tables D-1 to D-3 shall be as follows:

- replace the basic state name "TEI-ASSIGNED" (state 4) by "LINK-NOT-ESTABLISHED" (state 9);
- replace all the transitions to state 4 ("TEI-ASSIGNED state") by transitions to state 9 ("LINK-NOT-ESTABLISHED");
- replace the event "Persistent Deactivation" in table D-1.1, D-2.1, and D-3.1 by "MDL-LAYER_1_FAILURE-INDICATION";
- replace all "DL-ESTABLISH" and "DL-RELEASE" primitives by "MDL-ESTABLISH" and "MDL-RELEASE" primitives;

- delete the following event rows:
 - "DL-RELEASE-REQUEST";
 - "DL-UNIT DATA-REQUEST";
 - "UI FRAME IN QUEUE";
 - "MDL-ASSIGN-REQUEST";
 - "MDL-REMOVE-REQUEST";
 - "MDL-ERROR-RESPONSE";
 - "DISC P=1";
 - "DISC P=0";
 - "UI command";
 - all rows related to "FRMR response";
 - "DISC incorrect length";
 - "FRMR incorrect length",

- delete in tables D-1.1 to D-1.10 columns related to state numbers 1, 2, 3, 5.2 and 6.

11 AN frame relay sublayer

11.1 General

The AN executes an AN frame relay function, which means that the customer's D-channel data link layer protocol is not fully terminated. The AN only performs the following core procedures in its relay process:

- frame delimiting, alignment and transparency;
- frame multiplexing/demultiplexing using the ISDN layer 2 address field according to subclause 8.5;
- inspection of the frame to ensure that it consists of an integral number of octets prior to ZERO bit insertion or following ZERO bit extraction;
- inspection of the frame that it is neither unbounded nor too short;
- insertion of HDSL flags if no layer 2 frames have to be sent; and
- detection of transmission errors.

Valid frames incoming from an ISDN access, shall be multiplexed onto an allocated V5 communication channel on the basis of the ISDN layer 2 frame address, after adding the EFaddr related to the frame's user port of origin. The definition of invalid frames from the ISDN user port is given below.

Valid frames incoming from the LE, shall be demultiplexed and relayed to the relevant user port after EFaddr removal. Invalid frames shall be detected and handled by the LAPV5-EF function.

11.2 Invalid frames

The AN-FR shall discard, without notification to the sender, invalid frames received from an ISDN user port.

An invalid frame shall be a frame which:

- a) is not properly bounded by two flags, i.e. longer than 533 octets; or
- b) has fewer than 5 octets between flags; or
- c) does not consist of an integral number of octets prior to ZERO bit insertion or following ZERO bit extraction; or

- d) contains a frame check sequence error; or
- e) contains a single octet address field.

11.3 Detailed description of the AN frame relay function

The main function of the AN concerning ISDN protocol handling, is to add in the AN to LE direction the EFaddr and to remove this number in the AN to customer direction as defined in this subclause. Figure 13 shows the frame relaying function in the AN.

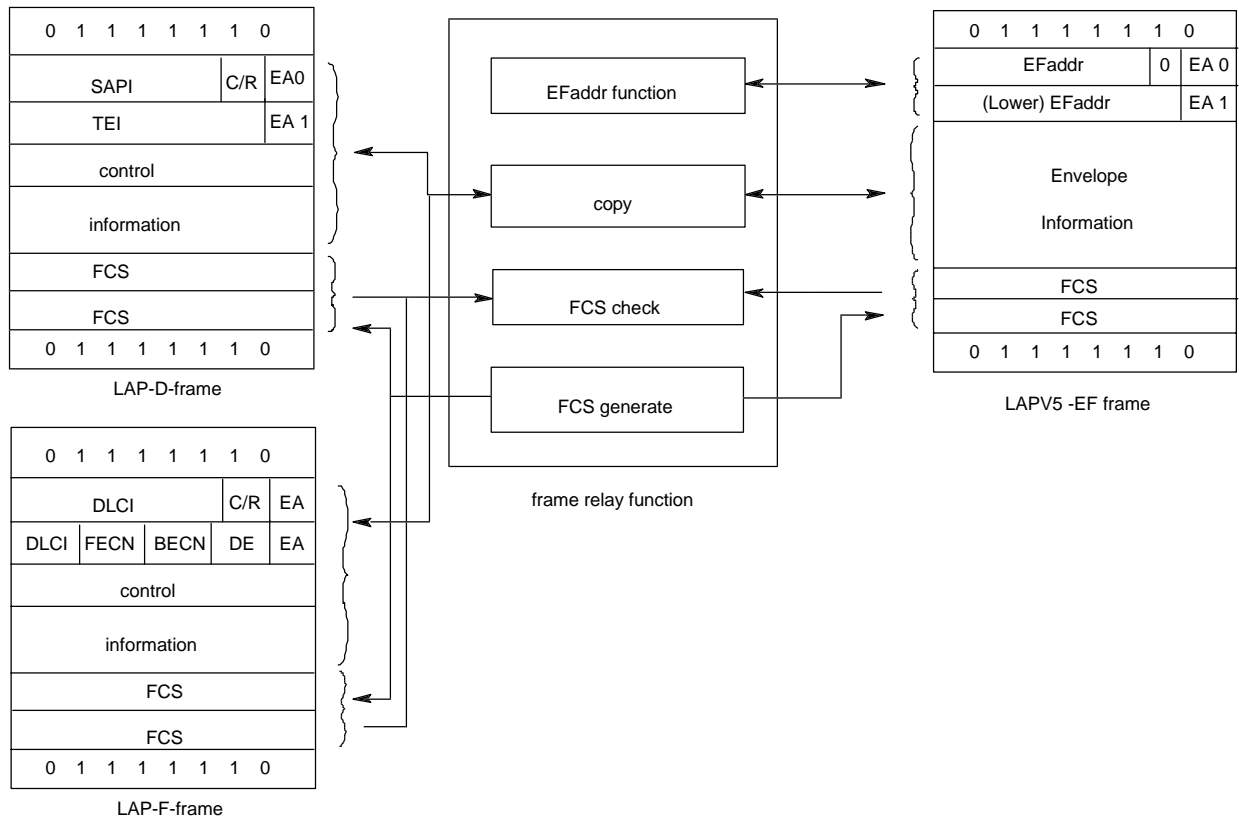

Figure 13: The frame relaying function in the AN

11.3.1 Frame received from LE

- Receive EFaddr and envelope information field from the mapping function in accordance with subclause 12.4;
- Determine ISDN user port with EFaddr using provisioning data;
- Create frame with opening flag;
- Copy the envelope information field after the flag;
- Generate the frame check sequence;
- Add closing flag.

11.3.2 Frame received from ISDN user port

- Check for valid frame;
- Remove flags and FCS;
- Retrieve allocated EFaddr from provisioning data;
- Pass EFaddr and processed frame to mapping function in accordance with subclause 12.3.

12 Sublayer-to-sublayer communication and mapping function

12.1 LAPV5-EF to LAPV5-DL communication

When frames are received by the LAPV5-EF sublayer from the LE, and if the V5DLaddr lies within the range reserved for sublayer peer-to-peer data as defined in subclause 10.3.2.3 the envelope information field shall be passed to the LAPV5-DL sublayer.

12.2 LAPV5-DL to LAPV5-EF communication

The data link sublayer requests the envelope function to transmit data link sublayer peer-to-peer data with a given EFaddr, which shall be set equal to the V5DLaddr. The data link sublayer frame (see figure 9) shall be mapped into the envelope information field of the Envelope function of the communications channel selected in accordance with subclause 8.4.

12.3 AN-FR to LAPV5-EF communication

D-channel frames received from ISDN user ports shall be passed after processing by the AN frame relay function of the AN (see Clause 11) to the Envelope function for transmission on the V5 interface. The EFaddr associated with the port is passed as a parameter. The processed frame shall be mapped into the envelope information field of the envelope function of the communications channel selected in accordance with subclause 8.4.

12.4 LAPV5-EF to AN-FR communication

When frames are received by the LAPV5-EF sublayer from the LE, and if the V5DLaddr lies within the range reserved for ISDN user port identification as defined in subclause 9.2.2.2, the envelope information field and the EFaddr shall be passed to the AN frame relay function for additional processing and transmission towards the ISDN user port.

13 PSTN signalling protocol specification and layer 3 multiplexing

13.1 General

13.1.1 Introduction

The PSTN protocol on the V5.1 interface is basically a stimulus protocol; i.e. it does not control the call procedures in the AN it rather transfers information about the analogue line state over the V5.1 interface. The V5.1 PSTN protocol shall be used in conjunction with the national protocol entity in the LE (see figure 14). The national protocol entity in the LE, which is used for customer lines which are connected directly to the LE, will also be used to control calls on customer lines which are connected via the V5.1 interface. For time critical sequences it is also required to extract certain signalling sequences (e.g. compelled sequences) from the national protocol entity into an "AN part" of the national protocol entity.

However, the V5.1 PSTN protocol has a relatively small functional part which is concerned with path setup, release of the path on the V5.1 interface, call collision resolution on the V5.1 interface and handling of new calls in case of overload conditions in the LE. The majority of line signals will not be interpreted by the V5.1 PSTN protocol, but simply transferred transparently between the user port in the AN and national protocol entity in the LE.

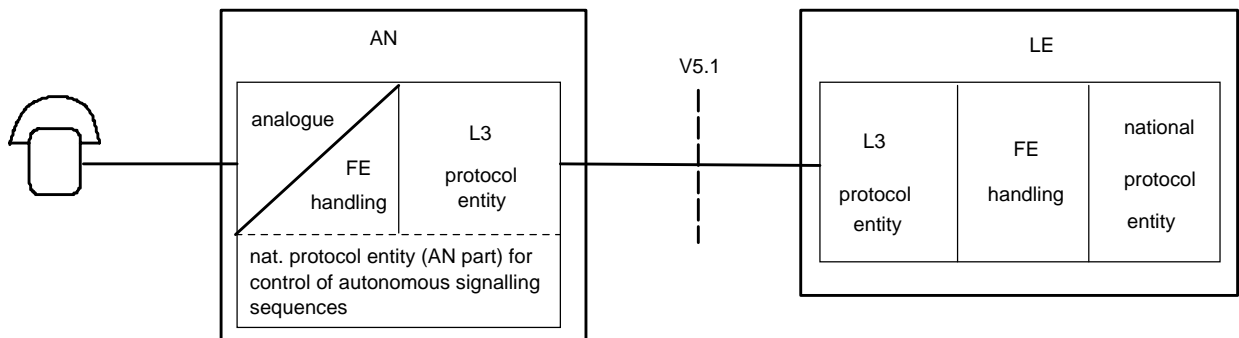

Figure 14: PSTN user port functional model

13.1.2 Separation of responsibilities

The LE shall be responsible for providing the service (call control, supplementary services). DTMF senders, receivers, tone generators and announcements shall be located in the LE. This implies that address information using DTMF shall be carried transparently between user port and LE whereas line state signalling shall be interpreted in the AN and then carried over the V5.1 interface by means of layer 3 messages.

It shall be the responsibility of the AN to handle access specific parameters related to the protocol such as recognition times of analogue signals, duration, voltage and frequency of meter pulses, ringing current or the specific details of a signalling sequence (AN part of the national protocol entity). These parameters shall be set either in hardware, software or in data. In the latter case this data shall be pre-defined but some of the data may be overruled by "protocol parameter" messages via the V5.1 interface for a call.

For time critical responses to customer signalling it is necessary for the AN to respond autonomously. This shall be explicitly required for ring trip and dial tone suppression. There may be other time critical responses required in national PSTN protocols which shall be defined in the national PSTN protocol mapping specification.

For time critical signalling sequences (e.g. autonomous seizure acknowledge for ground start PBXs) it shall also be necessary for the AN to control the time-critical part of the signalling sequence autonomously. In this case, the autonomous signalling sequence shall be triggered by the national protocol entity in the LE. After executing the autonomous signalling sequence, the AN may return a response to the LE.

The protocol definition is provided in this Clause. Background information and flow diagrams are provided in Annex H. The SDL diagrams are given in Annex L. Annex D provides additional information for the use of the information elements to define the national PSTN protocol mapping.

13.1.3 National specific PSTN signal information elements

The ETS gives the complete set of PSTN signalling information elements that may be sent over a V5.1 interface in order to cope with all the national PSTN protocols identified to date. It is unlikely that the full set of PSTN signal information elements will be required by any network provider and therefore it is not expected that the full set will be utilised over any individual V5.1 interface. Optionally an equipment may support more PSTN signal information elements than required by a particular network provider. In this case, only those PSTN signal information elements required in order to correctly support that particular national PSTN protocol shall appear on the interface.

It will be the responsibility of the individual equipment providers to ensure that their equipment contains at least the ability to recognize and utilize the correct PSTN signal information elements for the national PSTN protocols to be supported by the local network provider.

It shall be the responsibility of the equipment providers to ensure that the PSTN signal information elements are provided in accordance with the national PSTN protocols.

PSTN signal information elements not required for the required national PSTN protocol shall be treated as unrecognized information elements as specified under subclause 13.5.2.7, if they occur.

The full set of PSTN messages, information elements, and coding, may not be required to support a specific national protocol. Only those PSTN messages, information elements, and coding that apply to the protocol shall be used over the V5.1 interface.

13.2 PSTN protocol entity definition

13.2.1 Definition of PSTN path states and explanation

13.2.1.1 Path states in the AN (AN(PSTN))

Out of service state (AN0): this state shall be entered when the restart procedure has been initiated by the system management and is applicable to all PSTN ports simultaneously.

Null state (AN1): the port is inactive and there is no call in progress. This shall be the rest state for the port interface. When the PSTN protocol entity in the AN returns to the NULL state, it shall be capable to detect and report a (may be already present) subscriber seizure.

Path initiated by AN state (AN2): a seizure has been detected within the AN and an ESTABLISH message has been sent to the LE. The AN is now waiting for a ESTABLISH-ACK back from the LE. In the event of no response from the LE, for example in the case of an LE overload, the ESTABLISH message will be repeated at a low repetition rate (Timer T1).

Call collision resolution shall be achieved by the AN and LE during this phase of the call.

Path abort request state (AN3): ESTABLISH message was sent to the LE but no ESTABLISH-ACK has yet been received. The subscriber has released (e.g. on-hook). This state shall be used to regulate the number of ESTABLISH messages that may be sent to the possibly overloaded LE, if the port is seized again. After a guard period the AN will go back to the NULL state.

Line information state (AN4): this state shall only be entered into whilst a line information from the PSTN port is being processed by the LE. This state may only be entered or exited from/to the NULL state.

Path active (AN5): the active state shall be the state during which normal PSTN signalling functions are active for that port. During this state a user may proceed with call establishment, communication or call clearing.

Port blocked state (AN6): this state can be entered from any state. Once entered, the only state that the port may proceed to shall be the NULL state when the port is again available for service.

Once the blocked state has been entered all call activity for that port shall be halted and the port may be deactivated, e.g. power down.

Disconnect request state (AN7): the AN requests the LE to disconnect the path. This state shall be exited when the LE has successfully acknowledged the DISCONNECT. If this does not happen, the maintenance entity shall be informed.

13.2.1.2 Path states in the LE (LE(PSTN))

Out of service state (LE0): this state shall be entered when the restart procedure has been initiated by the system management and is applicable to all PSTN ports simultaneously.

Null state (LE1): the port is inactive and there is no call in progress. This shall be the rest state for the port interface.

Path initiated by LE state (LE2): the port is seized. The LE has sent an ESTABLISH message to the AN. Call collision resolution shall be achieved by the AN and the LE during this phase of the call.

Path initiated by AN state (LE3): the AN has sent an ESTABLISH message to the LE and is waiting for an ESTABLISH-ACK. Call collision resolution shall be achieved by the AN and the LE during this phase of the call.

Path active state (LE4): the active state shall be the state during which normal PSTN signalling functions are active for that port. During this state a user may proceed with call establishment, communication or call clearing.

Path disconnect request state (LE5): the LE requested the AN to release the path. This state shall be exited when the AN has successfully acknowledged the DISCONNECT. If this does not happen, the maintenance entity shall be informed.

Port blocked state (LE6): this state can be entered from any state. Once entered, the only state that the interface may proceed to shall be the NULL state when the port is again available for service.

Once the blocked state has been entered all call activity for that port shall be halted.

13.2.2 Definition of PSTN protocol primitives, messages and timers

Tables 2 and 3 define the primitives, messages and timers used for the PSTN state transitions in tables 29 and 30. The PSTN Function Element (FE) primitives are to be used either inside the AN between the PSTN protocol entity and the user port or inside the LE between the PSTN protocol entity and the National Protocol entity.

Table 2: Primitives, messages and timers used in the AN (PSTN) FSM

Name	Direction	Description
FE-line_information	PSTN_AN <-- SUB	The subscriber line status has changed.
FE-line_signal	PSTN_AN <-> SUB	The subscriber has applied an electrical condition to the port or change the electrical condition of the subscriber port.
FE-subscriber_release (e.g. on hook)	PSTN_AN <-- SUB	The subscriber indicates release during initiation of the PSTN path.
FE-subscriber_seizure (e.g. off hook)	PSTN_AN <-- SUB	Subscriber wishes to originate a PSTN path.
DISCONNECT	PSTN_AN <-> PSTN_LE	Initiation of clearing the path.
DISCONNECT COMPLETE	PSTN_AN <-> PSTN_LE	Positive response to path clearing.
ESTABLISH	PSTN_AN <-> PSTN_LE	Initiation of PSTN path.
ESTABLISH ACK	PSTN_AN <-> PSTN_LE	Positive response to PSTN path initiation.
PROTOCOL PARAMETER	PSTN_AN <-- PSTN_LE	A request to change a PSTN port parameter.
SIGNAL	PSTN_AN <-> PSTN_LE	An electrical condition described in a message.
SIGNAL ACK	PSTN_AN <-> PSTN_LE	Acknowledgement of sent/received signal messages.
STATUS ENQUIRY	PSTN_AN <-- PSTN_LE	Request of PSTN port status.
STATUS	PSTN_AN --> PSTN_LE	Report of PSTN port status.
timeout T1/T2	AN internal	Timer T1 or T2 has expired.
timeout T3	AN internal	Timer T3 has expired.
timeout Tr	AN internal	Timer Tr has expired
timeout Tt	AN internal	Timer Tt has expired
MDU-CONTROL (port blocked)	PSTN_AN <-- SYS	The AN system management indicates to block the subscriber port in the AN.
MDU-CONTROL (port unblocked)	PSTN_AN <-- SYS	The AN system management indicates to unblock the subscriber port in the AN.
MDU-CONTROL (restart request)	PSTN_AN <-- SYS	The AN system management requests a restart of the PSTN protocol entity.
MDU-CONTROL (restart complete)	PSTN_AN <-- SYS	The AN system management indicates that the restart procedure is completed.
MDU-CONTROL (restart ack)	PSTN_AN --> SYS	Positive response to restart request.
MDU_error_indication	PSTN_AN --> SYS	Indication of error condition in AN.
Notation:	SUB = subscriber port; SYS = AN system management; PSTN_AN = PSTN protocol entity in the AN; PSTN_LE = PSTN protocol entity in the LE.	

Table 3: Primitives, messages and timers used in the LE (PSTN) FSM

Name	Direction	Description
FE-disconnect_request	PSTN_LE <-- NAT	The national protocol requests clearing of the PSTN path.
FE-disconnect_complete_request	PSTN_LE <-- NAT	The national protocol requests that an acknowledgement of line-information is sent.
FE-establish_acknowledge	PSTN_LE <-- NAT	Positive response from the national protocol to request for a PSTN path.
FE-establish_request	PSTN_LE <-- NAT	The national protocol requests establishment of a PSTN path.
FE-line_signal_request	PSTN_LE <-- NAT	The national protocol requests an electrical condition to be applied to the subscriber's port in the AN.
FE-protocol_parameter_request	PSTN_LE <-- NAT	The national protocol requests that a PSTN protocol parameter is changed.
FE-disc._complete_ind.	PSTN_LE --> NAT	Indication that the PSTN path has been cleared completely.
FE-establish_indication	PSTN_LE --> NAT	Report of a request to initiate a PSTN path.
FE-establish_ack_ind.	PSTN_LE --> NAT	Positive response to a request to initiate a PSTN path.
FE-line_signal_indication	PSTN_LE --> NAT	Report that the electrical conditions have changed at the subscriber's port in the AN.
DISCONNECT	PSTN_LE <--> PSTN_AN	Initiation of clearing the PSTN path.
DISCONNECT COMPLETE	PSTN_LE <--> PSTN_AN	Positive response to a path clearing.
ESTABLISH	PSTN_LE <--> PSTN_AN	Initiation of PSTN path.
ESTABLISH ACK	PSTN_LE <--> PSTN_AN	Positive response to path initiation.
SIGNAL	PSTN_LE <--> PSTN_AN	An electrical condition described in a message.
SIGNAL ACK	PSTN_LE <--> PSTN_AN	Acknowledgement of sent/received signal messages.
STATUS	PSTN_LE <--> PSTN_AN	Report of PSTN status.
STATUS ENQUIRY	PSTN_LE --> PSTN_AN	A request for a report of PSTN port state.
PROTOCOL PARAMETER	PSTN_LE --> PSTN_AN	A request to change a PSTN port parameter.
timeout T1	LE internal	Timer T1 has expired.
timeout T3	LE internal	Timer T3 has expired.
timeout T4	LE internal	Timer T4 has expired.
timeout Tr	LE internal	Timer Tr has expired.
timeout Tt	LE internal	Timer Tt has expired.
MDU-CONTROL (port blocked)	PSTN_LE <-- SYS	The LE system management indicates to block a PSTN port in the LE.
MDU-CONTROL (port unblocked)	PSTN_LE <-- SYS	The LE system management indicates to unblock a PSTN port in the LE.
MDU-CONTROL (restart request)	PSTN_LE <-- SYS	The LE system management requests a restart of the PSTN protocol entity.
MDU-CONTROL (restart complete)	PSTN_LE <-- SYS	The LE system management indicates that the restart procedure is completed.
MDU-CONTROL (restart ack)	PSTN_LE --> SYS	Positive response to a restart request.
MDU-error_indication	PSTN_LE --> SYS	Indication of error condition at the LE.
Notation:	NAT = national Protocol; SYS = LE system management; PSTN_AN = PSTN protocol entity in the AN; PSTN_LE = PSTN protocol entity in the LE.	

13.3 PSTN protocol message definition and content

A complete set of messages for the PSTN protocol is given in table 4.

Table 4: Messages for PSTN protocol control

Message type	Reference
ESTABLISH	13.3.1
ESTABLISH ACK	13.3.2
SIGNAL	13.3.3
SIGNAL ACK	13.3.4
STATUS	13.3.5
STATUS ENQUIRY	13.3.6
DISCONNECT	13.3.7
DISCONNECT COMPLETE	13.3.8
PROTOCOL PARAMETER	13.3.9

In the following subclauses, the different messages are specified highlighting the functional definition and information content (i.e. semantics) of each message. Each definition includes:

- a) a brief description of the message, direction and use;
- b) a table listing the information elements in the order of their appearance in the message (same relative order for all message types). For each information element the table indicates:
 - 1) the subclause of this ETS describing the information element;
 - 2) the direction in which it may be sent; i.e. AN-to-LE, LE-to-AN, or both;
 - 3) whether inclusion is mandatory ("M") or optional ("O");
 - 4) the length of the information element in octets.

Refer to Annex G for further information about the FE primitives used in the AN and LE.

13.3.1 ESTABLISH

The ESTABLISH message shall be used as an indication of either an originating or terminating path request.

Table 5: ESTABLISH message content

Message Type: ESTABLISH
Direction: Both

Information element	Reference	Direction	Type	Length
Protocol discriminator	13.4.2	Both	M	1
L3 address	13.4.3	Both	M	2
Message type	13.4.4	Both	M	1
Line-information	13.4.6.2	AN to LE	O	1
Autonomous-signalling-sequence	13.4.6.4	LE to AN	O	1
Cadenced-ringing	13.4.7.2	LE to AN	O	3
Pulsed-signal	13.4.7.3	LE to AN	O	3 to 5
Steady-signal	13.4.7.4	Both	O	3

NOTE: Only one of the optional information elements may be contained in the message.

13.3.2 ESTABLISH ACK

The ESTABLISH ACK message shall be used to acknowledge that the requested action has been performed by the entity. Reference is made to Annex D, Clause D.10, concerning a special procedure for the cases where a signal information element was contained in the ESTABLISH message.

Table 6: ESTABLISH ACK message content

Message Type: ESTABLISH ACK
Direction: Both

Information element	Reference	Direction	Type	Length
Protocol discriminator	13.4.2	Both	M	1
L3 address	13.4.3	Both	M	2
Message type	13.4.4	Both	M	1
Autonomous-signalling-sequence	13.4.6.4	LE to AN	O	1
Pulsed-signal	13.4.7.3	Both	O	3 to 5
Steady-signal	13.4.7.4	Both	O	3

NOTE: Only one of the optional information elements may be contained in the message.

13.3.3 SIGNAL

The SIGNAL message shall be used to convey the PSTN line conditions to the LE, or to instruct the AN to establish specific line conditions.

Table 7: SIGNAL message content

Message Type: SIGNAL
Direction: Both

Information element	Reference	Direction	Type	Length
Protocol discriminator	13.4.2	Both	M	1
L3 address	13.4.3	Both	M	2
Message type	13.4.4	Both	M	1
Sequence-number	13.4.7.1	Both	M	3
Pulse notification	13.4.6.1	AN to LE	O	1
Autonomous-signalling-sequence	13.4.6.4	LE to AN	O	1
Sequence-response	13.4.6.5	AN to LE	O	1
Cadenced-ringing	13.4.7.2	LE to AN	O	3
Pulsed-signal	13.4.7.3	Both	O	3 to 5
Steady-signal	13.4.7.4	Both	O	3
Digit-signal	13.4.7.5	Both	O	3
Resource-unavailable	13.4.7.10	AN to LE	O	3 to 8

NOTE: Only one optional information element shall be contained in the message and shall be handled as mandatory information element.

13.3.4 SIGNAL ACK

The SIGNAL ACK message shall be used to acknowledge SIGNAL and PROTOCOL PARAMETER messages.

Table 8: SIGNAL ACK message content

Message Type: SIGNAL ACK
Direction: Both

Information element	Reference	Direction	Type	Length
Protocol discriminator	13.4.2	Both	M	1
L3 address	13.4.3	Both	M	2
Message type	13.4.4	Both	M	1
Sequence-number	13.4.7.1	Both	M	3

13.3.5 STATUS

The STATUS message shall be used to indicate the status of the V5 PSTN protocol entity in the AN. This message shall be sent either on request by a STATUS ENQUIRY message from the LE or when the AN receives an unexpected message from the LE.

Table 9: STATUS message content

Message Type: STATUS
Direction: AN to LE

Information element	Reference	Direction	Type	Length
Protocol discriminator	13.4.2	AN to LE	M	1
L3 address	13.4.3	AN to LE	M	2
Message type	13.4.4	AN to LE	M	1
State	13.4.6.3	AN to LE	M	1
Cause	13.4.7.9	AN to LE	M	3 to 5

13.3.6 STATUS ENQUIRY

The STATUS ENQUIRY message shall be used to request the status of the V5 PSTN protocol entity in the AN.

Table 10: STATUS ENQUIRY message content

Message Type: STATUS ENQUIRY
Direction: LE to AN

Information element	Reference	Direction	Type	Length
Protocol discriminator	13.4.2	LE to AN	M	1
L3 address	13.4.3	LE to AN	M	2
Message type	13.4.4	LE to AN	M	1

13.3.7 DISCONNECT

The DISCONNECT message shall be used to indicate that there is no call activity and that the protocol entity in the AN can return to the NULL state or it shall be used by the AN to indicate that the path shall be released.

Table 11: DISCONNECT message content

Message Type: DISCONNECT
Direction: Both

Information element	Reference	Direction	Type	Length
Protocol discriminator	13.4.2	Both	M	1
L3 address	13.4.3	Both	M	2
Message type	13.4.4	Both	M	1
Steady-signal	13.4.7.4	Both	O	3

13.3.8 DISCONNECT COMPLETE

This message shall be used to acknowledge that the requested action has been performed by the entity.

Table 12: DISCONNECT COMPLETE message content

Message Type: DISCONNECT COMPLETE
Direction: Both

Information element	Reference	Direction	Type	Length
Protocol discriminator	13.4.2	Both	M	1
L3 address	13.4.3	Both	M	2
Message type	13.4.4	Both	M	1
Steady-signal	13.4.7.4	LE to AN	O	3

13.3.9 PROTOCOL PARAMETER

The PROTOCOL PARAMETER message shall be used by the LE to change a protocol parameter in the AN.

Table 13: PROTOCOL PARAMETER message content

Message Type: PROTOCOL PARAMETER
Direction: LE to AN

Information element	Reference	Direction	Type	Length
Protocol discriminator	13.4.2	LE to AN	M	1
L3 address	13.4.3	LE to AN	M	2
Message type	13.4.4	LE to AN	M	1
Sequence-number	13.4.7.1	LE to AN	M	3
Recognition-time	13.4.7.6	LE to AN	O	4
Enable-autonomous-acknowledge	13.4.7.7	LE to AN	O	4 to 6
Disable-autonomous-acknowledge	13.4.7.8	LE to AN	O	3

NOTE: At least one optional information element shall be contained in the message. It is only allowed to have one of each information element in the message. When provided these information elements shall be handled as mandatory information elements.

13.4 General message format and information element coding

This subclause defines the message format and the coding of the information elements. For each of the information elements the coding of their different fields is provided. For some information elements (e.g. cadenced-ringing) the code points are not defined (e.g. cadence ringing type) and those code points are left to be nationally specified according to the requirements of the national PSTN protocols.

Within each octet, the bit designated "bit 1" shall be transmitted first, followed by bits 2, 3, 4, etc. Similarly, the octet shown at the top of each figure shall be sent first.

13.4.1 Overview

Within this protocol, every message shall consist of the following parts:

- a) protocol discriminator;
- b) L3 address;
- c) message type;
- d) other information elements, as required.

Information elements a), b) and c) are common to all the messages and shall always be present, while information element d) is specific to each message type.

This organization is illustrated in the example shown in figure 15.

8	7	6	5	4	3	2	1	Octet
Protocol discriminator								1
Layer 3 address							1	2
Layer 3 address (lower)								3
0	Message type							4
Other information element								etc.

Figure 15: General message organization example

A particular information element shall be present only once in a given message.

When a field extends over more than one octet, the order of bit values progressively decreases as the octet number increases. The least significant bit of the field shall be represented by the lowest numbered bit of the highest-numbered octet of the field.

13.4.2 Protocol discriminator

The purpose of the Protocol-discriminator information element is to distinguish messages corresponding to the protocols defined in this ETS from others corresponding to other protocols (not defined in this ETS) making use of the same data link connection.

NOTE: The Protocol-discriminator information element has been included within the protocol messages for structural compatibility with other protocols (e.g. with ETS 300 102 [6]). It provides a mechanism for being future proof, allowing the future use of the same data link connection for other layer 3 protocols not yet identified.

The protocol discriminator shall be the first element of every message.

The protocol discriminator shall be coded according to table 14.

Table 14: Protocol discriminator

Bits								Octet
8	7	6	5	4	3	2	1	
0	1	0	0	1	0	0	0	1
NOTE: All other values are reserved.								

13.4.3 Layer 3 address

The purpose of the L3 address is to identify the PSTN user port at the V5.1 interface to which the particular message applies. The format of the L3 address shall be according to figure 15. The L3 address shall be coded in binary and all values from 0 to 32 767 shall be valid.

13.4.4 Message type

The purpose of the message type is to identify both, the protocol the message belongs to and the function of the message being sent. Table 15 defines the coding rules for the various protocol message types required by this ETS.

Table 15: Protocol message types

Bits							Protocol message types	Reference
7	6	5	4	3	2	1		
0	0	0	-	-	-	-	PSTN protocol message types	13.3
0	0	1	0	-	-	-	Control protocol message types	14.4

The message type shall be the third part of every message. The PSTN protocol message types shall be coded as shown in table 16.

Table 16: PSTN protocol message types

Bits							Message type	Reference
7	6	5	4	3	2	1		
0	0	0	0	-	-	-	Path establishment messages	
0	0	0	0	0	0	0	ESTABLISH	13.3.1
0	0	0	0	0	0	1	ESTABLISH ACK	13.3.2
0	0	0	0	0	1	0	SIGNAL	13.3.3
0	0	0	0	0	1	1	SIGNAL ACK	13.3.4
0	0	0	1	0	-	-	Path clearing messages	
0	0	0	1	0	0	0	DISCONNECT	13.3.7
0	0	0	1	0	0	1	DISCONNECT COMPLETE	13.3.8
0	0	0	1	1	-	-	Other messages	
0	0	0	1	1	0	0	STATUS ENQUIRY	13.3.6
0	0	0	1	1	0	1	STATUS	13.3.5
0	0	0	1	1	1	0	PROTOCOL PARAMETER	13.3.9
NOTE: All other values of PSTN protocol message types are reserved.								

13.4.5 Coding of other information elements

For the coding of the information elements the same rules apply as defined in ETS 300 102-1 [6], subclause 4.5.1, without the functionality of the shift information element (there shall be only one codeset).

The information elements are defined in table 17, which also gives the coding of the information identifier bits.

Annex D provides guidelines how to interpret line signals used in a national PSTN protocol into the defined information elements and their coding.

Table 17: Information element identifier coding

Bits								Name	Reference	Length
8	7	6	5	4	3	2	1			
1	-	-	-	x	x	x	x	SINGLE OCTET		
1	1	0	0	0	0	0	0	Pulse-notification	13.4.6.1	1
1	0	0	0	x	x	x	x	Line-information	13.4.6.2	1
1	0	0	1	x	x	x	x	State	13.4.6.3	1
1	0	1	0	x	x	x	x	Autonomous-signalling-sequence	13.4.6.4	1
1	0	1	1	x	x	x	x	Sequence-response	13.4.6.5	1
0	-	-	-	-	-	-	-	VARIABLE LENGTH		
0	0	0	0	0	0	0	0	Sequence-number	13.4.7.1	3
0	0	0	0	0	0	0	1	Cadenced-ringing	13.4.7.2	3
0	0	0	0	0	0	1	0	Pulsed-signal	13.4.7.3	3 to 5
0	0	0	0	0	0	1	1	Steady-signal	13.4.7.4	3
0	0	0	0	0	1	0	0	Digit-signal	13.4.7.5	3
0	0	0	1	0	0	0	0	Recognition-time	13.4.7.6	4
0	0	0	1	0	0	0	1	Enable-autonomous-acknowledge	13.4.7.7	4 to 6
0	0	0	1	0	0	1	0	Disable-autonomous-acknowledge	13.4.7.8	3
0	0	0	1	0	0	1	1	Cause	13.4.7.9	3 to 5
0	0	0	1	0	1	0	0	Resource-unavailable	13.4.7.10	3 to 8

NOTE: All other values are reserved.

13.4.6 Single octet information elements

13.4.6.1 Pulse notification

The purpose of the Pulse-notification information element is to indicate to the LE that a certain pulse at the PSTN user port requested by the LE has finished.

The Pulse-notification information element does not contain any specific identification to indicate which pulse has finished.

It is understood that the transmission of this information element shall be the result of the last request in a Pulsed-signal information element or in a digit signal information element from the LE asking the AN for notification.

The Pulse-notification information element shall be coded according to table 18.

Table 18: Pulse-notification information element

Bits								Octet
8	7	6	5	4	3	2	1	
1	1	0	0	0	0	0	0	1

13.4.6.2 Line-information

The purpose of the Line-information information element is to transmit specific information on the subscriber line status from AN to LE whilst there is no signalling path.

The Line-information information element shall be coded according to figure 16 and table 19.

Bits								Octet
8	7	6	5	4	3	2	1	
1	0	0	0	Parameter				1

Figure 16: Line-information information element

Table 19: Coding of parameter

Bits				Meaning
4	3	2	1	
0	0	0	0	Impedance marker reset
0	0	0	1	Impedance marker set
0	0	1	0	Low loop impedance
0	0	1	1	Anomalous loop impedance
0	1	0	0	Anomalous line condition received

NOTE: All other values are reserved.

13.4.6.3 State

The purpose of the State information element is to indicate to the LE the state of the PSTN signalling protocol entity in the AN when requested by the LE.

The length of this information element shall be one octet.

The State information element shall be coded according to figure 17 and table 20.

Bits								Octet
8	7	6	5	4	3	2	1	
1	0	0	1	PSTN FSM state				1

Figure 17: State information element

Table 20: Coding of PSTN FSM state

Bits 4 3 2 1	Meaning
0 0 0 0	AN0
0 0 0 1	AN1
0 0 1 0	AN2
0 0 1 1	AN3
0 1 0 0	AN4
0 1 0 1	AN5
0 1 1 0	AN6
0 1 1 1	AN7
1 1 1 1	reserved

13.4.6.4 Autonomous-signalling-sequence

The purpose of the Autonomous-signalling-sequence information element is to indicate to the AN, that it has to start a particular (pre-defined) signalling sequence autonomously. The Autonomous-signalling-sequence information element shall be sent in messages from the LE to the AN only. The signalling sequence to be started shall be indicated by the sequence type. The Autonomous-signalling-sequence shall be coded according to figure 18.

The sequence type shall be coded in binary.

Bits							Octet
8	7	6	5	4	3	2	1
1	0	1	0	Sequence type			1

Figure 18: Autonomous-signalling-sequence information element

13.4.6.5 Sequence-response

The purpose of the Sequence-response information element is to give a response back to the LE about the result of the signalling sequence. The Sequence-response information element shall be sent in messages from the AN to the LE only. The Sequence-response type indicates a particular (pre-defined) response value. The Sequence-response type shall be coded in binary. The Sequence-response information element shall be coded according to figure 19.

Bits							Octet
8	7	6	5	4	3	2	1
1	0	1	1	Sequence-response type			1

Figure 19: Sequence-response information element

13.4.7 Information elements with variable length format

13.4.7.1 Sequence-number

The purpose of the Sequence-number information element is to communicate a sequence number to the peer entity. The procedures which use this sequence number are specified in subclause 13.5.5.

The Sequence-number information element may be sent in both directions, from the LE to the AN or vice-versa.

The Sequence-number information element shall be mandatory for SIGNAL, PROTOCOL PARAMETER and SIGNAL ACK messages and is not allowed in other messages.

The length of the Sequence-number information element shall always be 3 octets.

In SIGNAL and PROTOCOL PARAMETER messages the sequence number contains the send sequence number M(S) (see subclause 13.5.5.1.4) and in SIGNAL ACK messages the sequence number contains the receive sequence number M(R) (see subclause 13.5.5.1.6).

The sequence number shall be coded in binary.

The Sequence-number information element shall be coded according to figure 20.

Bits								Octet
8	7	6	5	4	3	2	1	
0	0	0	0	0	0	0	0	1
Length of Sequence-number content								2
1 ext.	Sequence number							3

Figure 20: Sequence-number information element

13.4.7.2 Cadenced-ringing

The purpose of the Cadenced-ringing information element is to indicate to the AN that ringing with a certain pre-defined cadenced-ringing type shall be started at the PSTN user port. The cadenced-ringing type shall be coded in binary.

The Cadence-ringing information element shall be sent in messages from the LE to the AN only.

The length of the Cadenced-ringing information element shall always be 3 octets.

The Cadence-ringing information element shall be coded according to figure 21.

Bits								Octet
8	7	6	5	4	3	2	1	
0	0	0	0	0	0	0	1	1
Length of Cadenced-ringing content								2
1 ext.	Cadenced-ringing type							3

Figure 21: Cadenced-ringing information element

13.4.7.3 Pulsed-signal

The purpose of the Pulsed-signal information element sent from LE to AN is to indicate to the AN that a certain pulsed signal shall be activated at the PSTN user port.

Table 21: Coding of pulse type (octet 3)

Bits 7 6 5 4 3 2 1	Meaning
1 1 1 1 1 1 1	Pulsed normal polarity
1 1 1 1 1 1 0	Pulsed reversed polarity
1 1 1 1 1 0 1	Pulsed battery on c-wire
1 1 1 1 1 0 0	Pulsed on hook
1 1 1 1 0 1 1	Pulsed reduced battery
1 1 1 1 0 1 0	Pulsed no battery
1 1 1 1 0 0 1	Initial ring
1 1 1 1 0 0 0	Meter pulse
1 1 1 0 1 1 1	50 Hz pulse
1 1 1 0 1 1 0	Register recall (timed loop open)
1 1 1 0 1 0 1	Pulsed off hook (pulsed loop closed)
1 1 1 0 1 0 0	Pulsed b-wire connected to earth
1 1 1 0 0 1 1	Earth loop pulse
1 1 1 0 0 1 0	Pulsed b-wire connected to battery
1 1 1 0 0 0 1	Pulsed a-wire connected to earth
1 1 1 0 0 0 0	Pulsed a-wire connected to battery
1 1 0 1 1 1 1	Pulsed c-wire connected to earth
1 1 0 1 1 1 0	Pulsed c-wire disconnected
1 1 0 1 1 0 1	Pulsed normal battery
1 1 0 1 1 0 0	Pulsed a-wire disconnected
1 1 0 1 0 1 1	Pulsed b-wire disconnected

The duration of that pulsed signal shall be indicated by pulse duration type. The pulse duration type points to a pre-defined description which e.g. consists of the time for the pulse in total and the duty cycle.

The suppression indicator (bit 6 and 7 in octet 4) allows the LE to indicate to the AN whether the ongoing pulsed signal shall be suppressed. See Annex D and table 22.

Table 22: Coding of suppression indicator (octet 4)

Bits 7 6	Meaning
0 0	No suppression
0 1	Suppression allowed by pre-defined V5.1 SIGNAL message from LE
1 0	Suppression allowed by pre-defined line signal from TE
1 1	Suppression allowed by pre-defined V5.1 SIGNAL message from LE or pre-defined line signal from TE

The acknowledge request indicator (bits 6 and 7 in octet 4a) allows the LE to request that the AN notify that a pulsed signal has either begun, ended or one of a sequence of pulses has ended, see table 23.

Table 23: Coding of acknowledge request indicator (octet 4a)

Bits 7 6	Meaning
0 0	No acknowledgement requested
0 1	Ending acknowledgement requested when finished each pulse
1 0	Ending acknowledgement requested when finished all pulses
1 1	Start of pulse acknowledgement requested

The Number of pulses field contains a number coded in binary which indicates "how many pulses" shall be sent. The value 0 is invalid.

The length of the Pulsed-signal information element may vary from 3 to 5 octets.

If the Pulsed-signal information element is sent from the AN to the LE it corresponds to a pulsed signal at the PSTN user port generated by the subscriber's equipment.

The Pulsed-signal information element shall be coded according to figure 22 and tables 21 to 23.

Bits							Octet
8	7	6	5	4	3	2 1	
0	0	0	0	0	0	1 0	1
Length of Pulsed-signal content							2
1 ext.	Pulse type						3
0/1 ext.	Suppression indicator		Pulse duration type				4
1 ext.	Acknowledge request indicator		Number of pulses				4a

Figure 22: Pulsed-signal information element

13.4.7.4 Steady-signal

The purpose of the Steady-signal information element is either to indicate to the AN that a certain steady signal shall be activated at the PSTN user port (generated by the AN) or that a particular steady signal transmitted by the subscriber's equipment has been detected at the PSTN user port which shall be reported to the LE.

The length of the Steady-signal information element shall always be 3 octets.

The Steady-signal information element shall be coded according to figure 23 and table 24.

Bits							Octet
8	7	6	5	4	3	2 1	
0	0	0	0	0	0	1 1	1
Length of Steady-signal content							2
1 ext.	Steady-signal type						3

Figure 23: Steady-signal information element

Table 24: Coding of Steady-signal type (octet 3)

Bits 7 6 5 4 3 2 1	Meaning
0 0 0 0 0 0 0	Normal polarity
0 0 0 0 0 0 1	Reversed polarity
0 0 0 0 0 1 0	Battery on c-wire
0 0 0 0 0 1 1	No battery on c-wire
0 0 0 0 1 0 0	Off hook (loop closed)
0 0 0 0 1 0 1	On hook (loop open)
0 0 0 0 1 1 0	Battery on a-wire
0 0 0 0 1 1 1	A-wire on earth
0 0 0 1 0 0 0	No battery on a-wire
0 0 0 1 0 0 1	No battery on b-wire
0 0 0 1 0 1 0	Reduced battery
0 0 0 1 0 1 1	No battery
0 0 0 1 1 0 0	Alternate reduced power / no power
0 0 0 1 1 0 1	Normal battery
0 0 0 1 1 1 0	Stop ringing
0 0 0 1 1 1 1	Start pilot frequency
0 0 1 0 0 0 0	Stop pilot frequency
0 0 1 0 0 0 1	Low impedance on b-wire
0 0 1 0 0 1 0	B-wire connected to earth
0 0 1 0 0 1 1	B-wire disconnected from earth
0 0 1 0 1 0 0	Battery on b-wire
0 0 1 0 1 0 1	Low loop impedance
0 0 1 0 1 1 0	High loop impedance
0 0 1 0 1 1 1	Anomalous loop impedance
0 0 1 1 0 0 0	A-wire disconnected from earth
0 0 1 1 0 0 1	C-wire on earth
0 0 1 1 0 1 0	C-wire disconnected from earth

13.4.7.5 Digit-signal

The purpose of the Digit-signal information element is either to indicate to the AN that a certain digit shall be sent to the subscribers equipment or that a particular digit transmitted by the subscribers equipment has been detected at the PSTN user port.

The length of the Digit-signal information element shall always be 3 octets.

Within the digit information field the number of pulses received by AN or required to be sent by AN, coded in binary, shall be transmitted. The code with bits 1 to 4 all set to ZERO is invalid.

The digit acknowledge request indicator field allows the LE to request the AN to indicate the ending of the transmission of a digit to the user port (see table 25 for coding). In the AN to LE direction this bit shall always be set to ZERO.

The Digit-signal information element shall be coded according to figure 24 and table 25.

Bits								Octet
8	7	6	5	4	3	2	1	
0	0	0	0	0	1	0	0	1
Length of Digit-signal content								2
1 ext.	Digit ack. req. ind.	Spare		Digit information				3

Figure 24: Digit-signal information element

Table 25: Coding of Digit acknowledge request indicator (octet 3)

Bit	Meaning
7	
0	No ending acknowledgement requested
1	Ending acknowledgement requested when digit transmission is finished

Bits 5 and 6 of the third octet shall be set to ZERO.

13.4.7.6 Recognition-time

The purpose of the Recognition-time information element is to indicate to the AN that the recognition time of a certain signal has to be updated.

The length of the Recognition-time information element shall always be 4 octets.

The Recognition-time information element shall be sent in messages from the LE to the AN only.

In the Signal field all codings of signals as specified in tables 21 and 24 shall be valid.

The duration type field contains an index into a pre-defined table within the AN. The table shall contain the actual value of the duration of the recognition time. The actual value shall be the time the signal shall stay active before being recognized.

The Recognition-time information element shall be coded according to figure 25.

Bit 7 of the fourth octet shall be set to ZERO.

Bits								Octet
8	7	6	5	4	3	2	1	
0	0	0	1	0	0	0	0	1
Length of Recognition-time content								2
1 ext.	Signal							3
1 ext.	Spare	Duration type						4

Figure 25: Recognition-time information element

13.4.7.7 Enable-autonomous-acknowledge

The purpose of the Enable-autonomous-acknowledge information element is to indicate to the AN that there shall be an autonomous response to a particular line signal produced by the subscribers equipment. This shall be done to ensure that the reaction to that signal will be in time.

The Enable-autonomous-acknowledge information element shall be sent in messages from the LE to the AN only.

The length of the Enable-autonomous-acknowledge information element shall be 4 octets for steady signals or 4 to 6 octets for pulsed signals.

For the Signal field all codings of signals as specified in tables 21 and 24 shall be valid.

For the Response field all codings of signals as specified in tables 21 and 24 shall be valid.

The Enable-autonomous-acknowledge information element shall be coded according to figure 26 for steady signal responses and figure 27 for pulsed signal responses.

Bits								Octet
8	7	6	5	4	3	2	1	
0	0	0	1	0	0	0	1	1
Length of Enable-autonomous-acknowledge content								2
1 ext.	Signal							3
1 ext.	Response							4

Figure 26: Enable-autonomous-acknowledge information element (response is a steady signal)

Bits								Octet
8	7	6	5	4	3	2	1	
0	0	0	1	0	0	0	1	1
Length of Enable-autonomous-acknowledge content								2
1 ext.	Signal							3
1 ext.	Response							4
0/1 ext.	Suppression indicator			Pulse duration type				5
1 ext.	Acknowledge request indicator			Number of pulses				5a

Figure 27: Enable-autonomous-acknowledge information element (response is a pulsed signal)

In case the response is a pulsed signal the same rules apply to the pulse duration type, suppression indicator, acknowledge request indicator and number of pulses field as specified for the Pulsed-signal information element in subclause 13.4.7.3.

13.4.7.8 Disable-autonomous-acknowledge

The purpose of the Disable-autonomous-acknowledge information element is to indicate to the AN that a previously enabled autonomous acknowledge has to be disabled.

The Disable-autonomous-acknowledge information element shall be sent in messages from the LE to the AN only.

The length of the Disable-autonomous-acknowledge information element shall always be 3 octets.

For the Signal field all codings of signals as specified in tables 21 and 24 shall be valid.

The Disable-autonomous-acknowledge information element shall be coded according to figure 28.

Bits								Octet
8	7	6	5	4	3	2	1	
0	0	0	1	0	0	1	0	1
Length of Disable-autonomous-acknowledge content								2
1 ext.	Signal							3

Figure 28: Disable-autonomous-acknowledge information element

13.4.7.9 Cause

The purpose of the Cause information element is to report to the LE the error condition in the AN.

The Cause information element shall be sent in messages from the AN to the LE only.

The Cause information element for some cause types shall include a diagnostic field in order to provide additional information related to these cause values. This diagnostic field shall consist of one or two octets, when present, shall be a copy of the received message type identifier that has triggered the sending of the message containing the cause and, when needed, the relevant information element identifier within that message.

The length of the Cause information element may be 3, 4 or 5 octets as indicated in table 26.

Table 26: Coding of cause type

Bits 7 6 5 4 3 2 1	Meaning	Length of inform. element
0 0 0 0 0 0 0	Response to STATUS ENQUIRY	3
0 0 0 0 0 0 1	Protocol discriminator error	3
0 0 0 0 0 1 1	L3 address error	3
0 0 0 0 1 0 0	Message type unrecognized	4
0 0 0 0 1 0 1	Out of sequence information element	5
0 0 0 0 1 1 0	Repeated optional information element	5
0 0 0 0 1 1 1	Mandatory information element missing	5 (4) (NOTE 2)
0 0 0 1 0 0 0	Unrecognized information element	5
0 0 0 1 0 0 1	Mandatory information element content error	5
0 0 0 1 0 1 0	Optional information element content error	5
0 0 0 1 0 1 1	Message not compatible with path state	4
0 0 0 1 1 0 0	Repeated mandatory information element	5
0 0 0 1 1 0 1	Too many information elements	4

NOTE 1: All other values reserved.
NOTE 2: If the missing information element is an optional one, refer to subclause 13.5.2.12, the information element identifier cannot be inserted into the diagnostics. In this case the length of the Cause information element shall be 4 octets.

When the length of the Cause information element is 3 octets, no diagnostic field shall be included.

When the length of the Cause information element is 4 octets, octet 4 of the Cause information element shall be present, as the diagnostic, specifying the message type identifier of the message triggering the cause.

When the length of the Cause information element is 5 octets, octets 4 and 4a of the Cause information element shall be present, as the diagnostic, specifying the message type identifier and the information element identifier triggering the cause.

The Cause information element shall be coded according to figure 29 and table 26.

Bits							Octet
8	7	6	5	4	3	2 1	
0	0	0	1	0	0	1 1	1
Length of Cause content							2
1 ext.	Cause type						3
0	Diagnostic (message type identifier)						4
Diagnostic (information element identifier)							4a

Figure 29: Cause information element

13.4.7.10 Resource-unavailable

The purpose of the Resource-unavailable information element is to indicate to the LE that the particular resource which had been requested by that information element copied into the returned Resource-unavailable information element is not available.

The Resource-unavailable information element shall be sent in SIGNAL messages from the AN to the LE only.

The length of the Resource-unavailable information element depends on the length of the information element returned. Therefore it may vary between 3 and 8 octets.

The copy field contains the copy of that information element for which the requested action could not be performed due to the unavailability of resources.

The Resource-unavailable information element shall be coded according to figure 30.

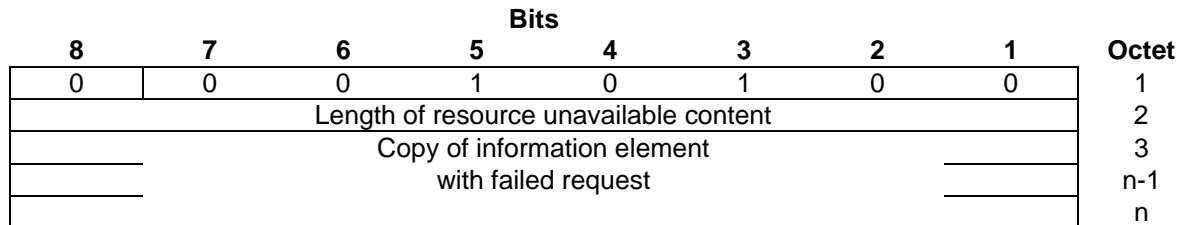

Figure 30: Resource-unavailable information element

13.5 PSTN call control procedures

The PSTN call control procedures described in this subclause are limited to protocol error handling and path control procedures. The path control procedures are based on the following FE-groups:

- FE-subscriber_seizure;
- FE-line_information;
- FE-subscriber_release; or
- FE-line_signal.

It is a requirement for the AN analogue signal detection and FE handling function to distinguish specific line conditions in a particular way and allocate them to one of the FE-group of function elements. The national protocol specification for the AN shall provide the relevant information and definition how any relevant line condition required by the national PSTN protocol in a specific AN state shall be presented to the FSM as one of the FE-group. This concerns states AN1, AN2, AN3 and AN5. The relevant procedures for this function is outside the scope of this ETS however, further information is provided in Annex G.

13.5.1 General

This subclause specifies procedures which shall be handled by the V5 protocol entities at each side of the V5 interface for the PSTN protocol application (see figure 14, PSTN functional user port model). Three types of procedures are specified:

- a) path-related procedures (see subclause 13.5.3);

The main purpose of these procedures shall be to establish a signalling path to ensure the transfer of line signals between the AN analog access port and the LE national PSTN protocol;

For this path establishment, functional procedures are used, this ensures the AN V5 protocol entity and the LE V5 protocol entity synchronization and allows the resolution of LE overload conditions and call collisions;

A FE-line_signal generated by an analog entity shall not be interpreted by V5 protocol entity, i.e. the corresponding information shall only be transported transparently via the V5 interface and retransmitted at the peer analog entity, by means of FE-line_signal primitives, when the path shall be established or in conjunction with the path establishment. Therefore, the LE national protocol shall be responsible for all call handling aspects; these aspects are outside the scope of this ETS;

- b) non-path-related procedures (see subclause 13.5.4);

Procedures not directly related to the path establishment allow the AN to:

- change some protocol parameters;
- block or unblock ports;
- act upon a restart request;

- c) layer 3 error detection procedure (see subclause 13.5.5);

This procedure allows the layer 3 to detect an error in transmission of layer 3 messages which are not protected by the functional part of the protocol.

In addition to the above procedures, each message received by a V5 protocol entity shall pass the error handling procedures specified in subclause 13.5.2 before being further processed.

Each PSTN layer 3 message contains a L3 address: the purpose of the L3 address is to identify the PSTN access port to which the particular message applies.

PSTN layer 3 messages shall be sent to the data link layer using a DL-DATA-REQUEST primitive; the data link service is specified in Clause 10.

Detailed SDL diagrams for the procedures specified in this subclause are contained in Annex L.

Some examples of these procedures are illustrated in Annex H by means of information flow diagrams.

13.5.2 Handling of error conditions

Before acting upon a message, the receiving entity, either the AN V5 Protocol entity or the LE V5 Protocol entity, shall perform the procedures specified in this subclause.

As a general rule, all messages shall contain, at least: the Protocol discriminator, the L3 address and the message type information elements. These information elements are specified in subclause 13.4. When receiving a message having less than 4 octets, the receiving protocol entity in the AN or LE shall generate a Protocol error indication to the system management and ignore the message.

If more than 3 optional information elements are detected within a message, then the message shall be considered as too long and shall be truncated after the third optional information element. All the truncated information is assumed to be repeated optional information elements. When doing the truncation, the entity shall react according to subclause 13.5.2.5 for repeated optional information elements.

Each receipt of message, using the valid protocol discriminator, shall activate the checks described in subclauses 13.5.2.1 through 13.5.2.12 by order of precedence. No state change occurs during these checks.

After the message has been checked using the error handling procedures following and if the message is not to be ignored, then either:

- path related procedures (see subclause 13.5.3); or
- non-path related procedures (see subclause 13.5.4),

shall follow.

Within this subclause the term "Ignore the message" means to do nothing with the message content, i.e. message header and information elements.

13.5.2.1 Protocol discriminator error

When a message is received in the L3 PSTN entity with a protocol discriminator coded different to the specification of the protocol discriminator in subclause 13.4.2:

the AN V5 Protocol entity: shall generate an internal error indication, ignore the message and send a STATUS message with the State information element indicating the current state and the Cause information element indicating Cause value No.1 "Protocol discriminator error";

the LE V5 Protocol entity: shall ignore the message and generate an internal error indication.

13.5.2.2 L3 address error

If the L3 address is:

- a) not coded as specified in subclause 13.4; or
- b) the value is not recognized or does not correspond to an existing PSTN access port,

then:

the AN V5 Protocol entity: shall ignore the message, generate an internal error indication and send a STATUS message with the L3 address received and the State information element indicating the current state (= not applicable) and the Cause information element indicating Cause "L3 address error";

the LE V5 Protocol entity: shall ignore the message and generate an internal error indication.

13.5.2.3 Message type error

Whenever an unrecognized message, either not implemented or non-existent, is received:

the AN V5 Protocol entity: shall ignore the message, generate an internal error indication and send a STATUS message with the State information element indicating the current state and the Cause information element indicating Cause "Message type unrecognized" and the corresponding diagnostic, as specified in subclause 13.4.7.9;

the LE V5 Protocol entity: shall ignore the message and generate an internal error indication.

13.5.2.4 Information element out of sequence

A variable length information element which has a code value lower than the code value of the variable information element preceding shall be considered as an out of sequence information element.

If this occurs:

the AN V5 Protocol entity: shall remove the information element and continue with the processing of the message. The AN shall also generate an internal error indication and send a STATUS message with the State information element indicating the current state and the Cause information element indicating Cause "out of sequence information element" and the corresponding diagnostic as specified in subclause 13.4.7.9;

the LE V5 Protocol entity: shall remove the information element and generate an internal error indication.

If the removed information element is mandatory, this shall be reflected in a mandatory information element missing error situation that shall be treated according to subclause 13.5.2.6.

13.5.2.5 Repeated information elements

If a mandatory information element is repeated in a message, the reaction of the receiving entity shall be as follows:

the AN V5 Protocol entity: shall ignore the message, generate an internal error indication and send a STATUS message with the Cause information indicating the current state and the Cause information element indicating Cause "Repeated mandatory information element" and the corresponding diagnostic as specified in subclause 13.4.7.9;

the LE V5 Protocol entity: shall ignore the message and generate an internal error indication.

If an optional information element is repeated in a message, the reaction of the receiving entity shall be as follows:

the AN V5 Protocol entity: shall remove the repeated optional information elements and continue with the processing of the message; it shall also generate an internal error indication and send a STATUS message with the Cause information indicating the current state and the Cause information element indicating Cause "Repeated optional information element" and the corresponding diagnostic as specified in subclause 13.4.7.9;

the LE V5 Protocol entity: shall remove the repeated optional information elements and continue with the processing of the message; it shall also generate an internal error indication.

13.5.2.6 Mandatory information element missing

When a message is received with a mandatory information element missing:

the AN V5 Protocol entity: shall ignore the message, generate an internal error indication and send a STATUS message with the Cause information indicating the current state and the Cause information element indicating Cause "Mandatory information element missing" and the corresponding diagnostic as specified in subclause 13.4.7.9;

the LE V5 Protocol entity: shall ignore the message and generate an internal error indication.

13.5.2.7 Unrecognized information element

When a message is received with one or more information elements unrecognized:

the AN V5 Protocol entity: shall remove all the unrecognized information elements and continue with the processing of the message; it shall also generate an internal error indication and send a STATUS message with the State information element indicating the current state and the Cause information element indicating Cause "Unrecognized Information element" and the corresponding diagnostic as specified in subclause 13.4.7.9;

the LE V5 Protocol entity: shall remove all the unrecognized information elements and continue with the processing of the message; it shall also generate an internal error indication.

For the purpose of the error handling procedures unrecognized information elements are those that are not defined within this ETS, or are not implemented in supporting the national PSTN protocol, i.e. not pre-defined.

13.5.2.8 Content error of mandatory information element

When a message is received with a mandatory information element having a content error either:

- a) the minimum or the maximum length does not conform to the length specified in subclause 13.4; or
- b) the content is not known and cannot be mapped to a line signal,

then:

the AN V5 Protocol entity: shall ignore the message, generate an internal error indication and send a STATUS message with the State information element indicating the current state and the Cause information element indicating Cause "Mandatory information element content error" and the corresponding diagnostic as specified in subclause 13.4.7.9;

the LE V5 Protocol entity: shall ignore the message and generate an internal error indication.

For the purpose of the error handling procedures information element content errors are codepoints included within a particular information element that are not defined within this ETS, or are not implemented in supporting the national PSTN protocol, i.e. not pre-defined.

13.5.2.9 Content error of optional information element

When a message is received with an optional information element having a content error either:

- a) the minimum or the maximum length does not conform to the length specified in subclause 13.4; or
- b) the content is not known and cannot be mapped to a line signal,

then:

the AN V5 Protocol entity: shall remove the information element and continue with the processing of the message; it shall also generate an internal error indication and send a STATUS message with the State information element indicating the current state and the Cause information element indicating Cause "Optional information element content error" and the corresponding diagnostic as specified in subclause 13.4.7.9;

the LE V5 Protocol entity: shall remove the information element content and continue with the processing of the message; it shall also generate an internal error indication.

For the purpose of the error handling procedures information element content errors are codepoints included within a particular information element that are not defined within this ETS, or are not implemented in supporting the national PSTN protocol, i.e. not pre-defined.

13.5.2.10 Unexpected message

A message sequence error occurs when an unexpected message is received. The unexpected messages are identified in subclause 13.5.3 exceptional procedures.

Whenever an unexpected message is received no state change occurs:

the AN V5 Protocol entity: shall ignore the message, generate an internal error indication and send a STATUS message with the State information element indicating the current state and the Cause information element indicating Cause "Message not compatible with path state" and the corresponding diagnostic as specified in subclause 13.4.7.9;

the LE V5 Protocol entity: shall ignore the message and generate an internal error indication, send a STATUS ENQUIRY message and apply the procedures specified in subclause 13.5.2.13.

13.5.2.11 Optional information element not allowed

When a SIGNAL, ESTABLISH or ESTABLISH ACK message is received containing more than one optional information element, the receiving entity shall react as follows:

the AN V5 protocol entity: shall ignore the message, generate an internal error indication and send a STATUS message with the State information element indicating the current state and the Cause information element indicating Cause "Too many information elements" and the corresponding diagnostic as specified in subclause 13.4.7.9;

the LE V5 protocol entity: shall ignore the message and generate an internal error indication.

13.5.2.12 Optional information element missing

When a message is received with optional information element(s) missing, the message shall be handled according to subclause 13.5.2.6 as if a mandatory information element is missing.

For the purpose of the error handling procedures the identification that an optional information element is missing in a particular message shall take into account the PSTN message definition of subclause 13.3 as well as the requirements defined in the relevant national PSTN protocol.

13.5.2.13 Status enquiry procedure

The Status enquiry procedure shall be initiated by the LE V5 Protocol entity only. This procedure applies when the LE V5 Protocol entity wants to check the correctness of the AN V5 call state; this occurs when the LE V5 Protocol entity receives:

- a) an internal status enquiry; or
- b) an unexpected message (see subclause 13.5.2.10).

The LE V5 Protocol entity shall, upon the sending of the STATUS ENQUIRY message, start timer T4.

When the AN V5 Protocol entity receives the STATUS ENQUIRY message, it shall send a STATUS message to the LE with the State information element indicating the current state and the Cause information element indicating Cause "Response to STATUS ENQUIRY".

The LE V5 Protocol entity having received the STATUS message shall stop timer T4, check if the state received is compatible with the current state (see table 27), and:

- if it is compatible, it shall report the result, and remain in the same state;
- else, it shall generate an error indication to the system management and if the LE PSTN protocol entity is not in the BLOCKED or OUT OF SERVICE state or the AN PSTN protocol entity has indicated that it is not in the BLOCKED or OUT OF SERVICE state it shall send a DISCONNECT message and apply the procedures specified in subclause 13.5.3.5.

Table 27: State map LE - AN for status enquiry procedure

LE state	OUT OF SERVICE	NULL	PATH INITIATED BY LE	PATH INITIATED BY AN	PATH ACTIVE	PATH DISC. REQ.	PORT BLOCKED
AN state	LE0	LE1	LE2	LE3	LE4	LE5	LE6
OUT OF SERVICE AN0	+	*	*	*	*	*	*
NULL AN1	*	+	+	-	-	/	*
PATH INITIATED BY AN AN2	*	+	+	+	-	/	*
PATH ABORT REQUEST AN3	*	+	-	+	-	/	*
LINE INFORMATION AN4	*	+	-	+	-	/	*
PATH ACTIVE AN5	*	-	-	-	+	/	*
PORT BLOCKED AN6	*	*	*	*	*	*	+
DISC. REQ. AN7	*	/	/	/	/	/	*
Notation:	<ul style="list-style-type: none"> - State synchronization required (DISCONNECT) * State synchronization required (error indication to system management) + No synchronization required / No further action required (Disconnect pending) 						

If timer T4 expires:

- the first and the second time, the STATUS ENQUIRY message shall be re-sent, and timer T4 shall be restarted;
- the third time when not in the BLOCKED or OUT OF SERVICE state, a DISCONNECT message shall be sent and an internal error indication shall be generated;
- the third time when in the BLOCKED or OUT OF SERVICE state, an internal error indication shall be generated.

13.5.2.14 Status procedure

The Status procedure shall only be initiated by the AN V5 Protocol entity. This occurs when:

- a) a STATUS ENQUIRY message is received (see subclause 13.5.2.13); or
- b) the Error handling procedures are not successful (see subclauses 13.5.2.1 through 13.5.2.12).

When the LE V5 Protocol entity receives in any state, except the PATH DISCONNECT REQUEST state (see subclause 13.5.3.5) a STATUS message with the Cause information element indicating a cause other than "Response to STATUS ENQUIRY", the LE V5 Protocol entity shall check if the state received is compatible with the current state and:

- if it is compatible, it shall generate an internal error indication;
- else, it shall generate an internal error indication, send a DISCONNECT message and apply procedures specified in subclause 13.5.3.5.

13.5.3 Path related procedures

The path related procedures specified in this subclause, apply when the following messages (which have succeeded to the error handling procedures) or events are received in V5 Protocol entity,

- a) Messages from LE or AN V5 Protocol entity:

ESTABLISH, ESTABLISH ACK, SIGNAL, DISCONNECT, DISCONNECT COMPLETE, SIGNAL ACK;

- b) Events:

from user port: FE-subscriber_seizure, FE-subscriber_release, FE-line_information, FE-line_signal;

from national protocol: FE-establish_request, FE-establish_acknowledge, FE-disconnect_request, FE-disconnect_complete_request, FE-line_signal_request;

internal: status enquiry, timeout of timers.

Any message, except the SIGNAL ACK message, may carry certain line signal information. When in the PATH ACTIVE state, the SIGNAL message shall be used to carry this information.

The DISCONNECT and DISCONNECT COMPLETE messages shall never be considered by the received entity as unexpected messages; if a V5 Protocol entity receives one of these messages, procedures specified in subclause 13.5.3.5 shall apply.

NOTE: The receipt of other messages than those identified above shall not be considered in this subclause; for STATUS and STATUS ENQUIRY messages see the error handling procedures specified in subclause 13.5.2 and for PROTOCOL PARAMETER messages and the restart procedure see non-path related procedures specified in subclause 13.5.4.

Therefore, depending on the particular message or event of the list of messages or events indicated above and the actual state of the V5 Protocol entity, one of the following procedures shall apply:

- path initiation by AN, see subclause 13.5.3.1;
- path initiation by LE, see subclause 13.5.3.2;

- path collision, see subclause 13.5.3.3;
- path active, see subclause 13.5.3.4;
- disconnect path, see subclause 13.5.3.5;
- line information, see subclause 13.5.3.6.

In these above subclauses, if the received message is:

- coherent with the state, normal operation applies. The result of this process shall be (except in case of call collision) the sending of a message and/or an internal indication (this shall lead to the path establishment);
- not coherent with the state, exceptional procedures apply. The result of this process shall be, either the handling of message sequence error or the ignorance of the message (this may lead to the path failure).

13.5.3.1 Path initiation by AN

13.5.3.1.1 Subscriber seizure request

The AN V5 Protocol entity and LE V5 Protocol entity are in the NULL state.

Normal operation: the AN V5 Protocol entity receives a FE-subscriber_seizure; the LE V5 Protocol entity receives an ESTABLISH message.

Exceptional procedures: any other event or message.

13.5.3.1.1.1 Normal operation

The AN V5 Protocol entity receiving in the NULL state a FE-subscriber_seizure, shall:

- if the autonomous seizure acknowledge option applies, return an acknowledge indication (FE-line_signal);
- else, no seizure acknowledge indication shall be returned;
- send an ESTABLISH message to the LE and start timer T1;
- interrupt the transmission path (bearer non-transparent);
- enter the PATH INITIATED BY AN state.

The LE V5 Protocol entity receiving in the NULL state an ESTABLISH message shall generate a FE-establish_indication and enter the PATH INITIATED BY AN state.

13.5.3.1.1.2 Exceptional procedures

If the AN V5 Protocol entity receives in the NULL state:

- a FE-line_signal, no action shall be taken;
- a FE-line_information, perform the procedure specified in subclause 13.5.3;
- a SIGNAL message, the AN V5 Protocol entity shall apply procedures specified in subclause 13.5.2.10;

- an ESTABLISH ACK message, the AN V5 Protocol entity shall apply procedures specified in subclause 13.5.2.10.

If the LE V5 Protocol entity receives in the NULL state:

- an ESTABLISH ACK or a SIGNAL message, the LE V5 Protocol entity shall apply procedures specified in subclause 13.5.2.10.

13.5.3.1.2 Subscriber seizure confirmation

The AN V5 Protocol entity and LE V5 Protocol entity are in the PATH INITIATED BY AN state.

Normal operation: the LE V5 Protocol entity receives a FE-establish_acknowledge request, the AN V5 Protocol entity receives an ESTABLISH ACK message.

Exceptional procedures: any other event or message.

13.5.3.1.2.1 Normal operation

The LE V5 Protocol entity receiving in the PATH INITIATED BY AN state a FE-establish_acknowledge request shall send an ESTABLISH ACK message to the AN apply the procedures described in subclause 13.5.5.2.1 and enter the PATH ACTIVE state.

The AN V5 Protocol entity receiving in the PATH INITIATED BY AN state an ESTABLISH ACK message shall stop timer T1 or T2, depending on which one is running, apply the procedures described in subclause 13.5.5.2.1, re-connect the transmission path (bearer transparent) and enter the PATH ACTIVE state.

13.5.3.1.2.2 Exceptional procedures

If the LE V5 Protocol entity receives in the PATH INITIATED BY AN state:

- an ESTABLISH message, the LE V5 Protocol entity shall ignore this message and remain in the PATH INITIATED BY AN state;
- an ESTABLISH ACK or SIGNAL message, the LE V5 Protocol entity shall apply procedures specified in subclause 13.5.2.10;
- a FE-establish_request, the LE V5 protocol entity shall send an ESTABLISH message, start timer T1 and enter the PATH INITIATED BY LE state.

If the AN V5 Protocol entity receives, in the PATH INITIATED BY AN state:

- a timeout of timers T1, the AN V5 Protocol entity shall re-send the ESTABLISH message to the LE, start timer T2 and remain in the PATH INITIATED BY AN state;
- a timeout of timer T2, the AN V5 protocol entity shall re-send the ESTABLISH message to the LE, restart timer T2 and remain in the PATH INITIATED BY AN state;
- a FE-line_signal other than the FE-subscriber_release, the AN V5 Protocol entity shall ignore the FE-line_signal and shall remain in the PATH INITIATED BY AN state;
- a SIGNAL message, the AN V5 Protocol entity shall apply procedures specified in subclause 13.5.2.10;
- a FE-subscriber_release, the AN V5 Protocol entity shall enter the PATH ABORT REQUEST state.

If the AN V5 Protocol entity receives, in the PATH ABORT REQUEST state:

- a timeout of timers T1 or T2, the AN V5 Protocol entity shall enter the NULL state;
- a FE-line_signal, the AN V5 Protocol entity shall ignore the FE-line_signal and shall remain in the PATH ABORT REQUEST state;
- a FE-line_information, this FE shall be saved and the AN V5 protocol entity shall remain in the PATH ABORT REQUEST state;
- an ESTABLISH ACK message, the AN V5 Protocol entity shall stop timer T1 or T2, depending on which one is running, send to the LE a DISCONNECT message and apply procedures specified in subclause 13.5.3.5;
- a SIGNAL message, the AN V5 Protocol entity shall apply procedures specified in subclause 13.5.2.10;
- a FE-subscriber_seizure, it shall:
 - if the autonomous seizure acknowledge option applies, return an acknowledge indication;
 - else, no seizure acknowledge indication shall be returned;
 - enter the PATH INITIATED BY AN state.

13.5.3.2 Path initiation by LE

13.5.3.2.1 Establish request

The LE V5 Protocol entity and the AN V5 Protocol entity are in the NULL state.

Normal operation: the LE V5 Protocol entity receives a FE-establish_request, the AN V5 Protocol entity receives an ESTABLISH message.

Exceptional procedures: any other event or message.

13.5.3.2.1.1 Normal operation

The LE V5 Protocol entity receiving in the NULL state a FE-establish_request shall send an ESTABLISH message to the AN, start timer T1 and enter the PATH INITIATED BY LE state.

The AN V5 Protocol entity receiving in the NULL state an ESTABLISH message shall:

- send a FE-line_signal to the subscriber port (if appropriate);
- return to the LE an ESTABLISH ACK message;
- enter the PATH ACTIVE state.

13.5.3.2.1.2 Exceptional procedures

If the LE V5 Protocol entity receives in the NULL state:

- an ESTABLISH ACK or a SIGNAL message, the LE V5 Protocol entity shall apply procedures specified in subclause 13.5.2.10;

- a FE-establish_acknowledge or a FE-line_signal, the LE V5 protocol entity shall ignore these FEs and shall remain in the NULL state.

13.5.3.2.2 Establish acknowledge

The LE V5 Protocol entity is in the PATH INITIATED BY LE state and the AN V5 Protocol entity is in the PATH ACTIVE state.

Normal operation: the LE V5 Protocol entity receives an ESTABLISH ACK message.

Exceptional procedures: any other event or message.

13.5.3.2.2.1 Normal operation

The LE V5 Protocol entity receiving in the PATH INITIATED BY LE state an ESTABLISH ACK message shall stop timer T1, generate a FE-establish_acknowledge_indication and enter the PATH ACTIVE state.

13.5.3.2.2.2 Exceptional procedures

If the LE V5 Protocol entity receives in the PATH INITIATED BY LE state:

- a FE-disconnect_request, the LE V5 Protocol entity shall stop timer T1, send a DISCONNECT message to the AN and apply procedures specified in subclause 13.5.3.5;
- a SIGNAL message, the LE V5 Protocol entity shall apply procedures specified in subclause 13.5.2.10;
- a timeout of timer T1 the LE V5 Protocol entity shall:
 - if it is the first expiry, send an ESTABLISH message to the AN, start timer T1 and remain in the PATH INITIATED BY LE state;
 - else, generate an internal error indication, send a DISCONNECT message to the AN and apply procedures specified in subclause 13.5.3.5.

13.5.3.3 Path collision

A path collision occurs when both the AN and the LE simultaneously transfer ESTABLISH messages specifying the same L3addr. In this protocol, priority between either the originating call or the terminating call shall be pre-defined and may differ from one national protocol to another. A protocol parameter in the AN and the LE indicates whether on the given PSTN access port an originating or terminating call shall prevail. If the collision occurs in the AN, call priority shall be given according to the pre-defined value. Collision occurring in the LE shall not be seen at the V5 interface.

13.5.3.3.1 Originating call prevail

The AN V5 Protocol entity, after having sent an ESTABLISH message, enters the PATH INITIATED BY AN state. If the AN V5 Protocol entity receives an ESTABLISH message in this state (or in the PATH ABORT REQUEST state), it shall remain in the same state.

The LE V5 Protocol entity, after having sent an ESTABLISH message, enters the PATH INITIATED BY LE state. If the LE V5 Protocol entity receives an ESTABLISH message in this state, it shall generate a FE-establish_indication and remain in the PATH INITIATED BY LE state. If the LE V5 Protocol entity receives a FE-establish_acknowledge request, it shall stop timer T1, send an ESTABLISH ACK message to the AN and enter the PATH ACTIVE state.

13.5.3.3.2 Destination call prevail

The AN V5 Protocol entity, after having sent an ESTABLISH message, enters the PATH INITIATED BY AN state. If the AN V5 Protocol entity receives an ESTABLISH message in this state or in the PATH ABORT request state, it shall stop timer T1 or T2, depending on which one is running, return an ESTABLISH ACK to the LE, re-connect the transmission path (bearer transparent) and enter the PATH ACTIVE state.

The LE V5 Protocol entity, after having sent an ESTABLISH message, enters the PATH INITIATED BY LE state. If the LE V5 Protocol entity receives an ESTABLISH message in this state, it shall generate a FE-establish_indication and remain in the PATH INITIATED BY LE state.

13.5.3.4 Path active

The path is active. Signals related to the call control (e.g. digits, pulse, etc.) shall be transferred in a transparent mode using the SIGNAL message. This information shall not be analyzed by the V5 Protocol entity.

If the loss of any SIGNAL message is detected by layer 3 detection procedure, the call and the path through the AN shall be released by the V5 Protocol entity detecting the loss (AN V5 Protocol entity or LE V5 Protocol entity) using DISCONNECT message.

Normal operation: the LE V5 Protocol entity or AN V5 Protocol entity receives a SIGNAL message or a FE-line_signal request;

 a FE-disconnect_request is received from the LE national protocol, a DISCONNECT message is received in the AN.

Exceptional procedures: any other event or message.

13.5.3.4.1 Normal operation

The LE V5 Protocol entity receiving in the PATH ACTIVE state:

- a FE-line_signal request, it shall apply the procedure specified in subclause 13.5.5 and if the procedure detects no error it shall send a SIGNAL message to the AN with the particular FE-line_signal information and remain in the PATH ACTIVE state.

If the procedure detects an error the state DISCONNECT REQUEST shall be entered.

NOTE: The FE-line_signal can be carried by one of the line signal information elements e.g. Digit signal, Cadence ringing, pulsed signal, steady signal information elements or as a result of the pulse-notification sent by AN, the Pulse-notification information element. For detailed description see subclause 13.3.3.

- a SIGNAL message with a particular FE-line_signal information, it shall apply the procedures specified in subclause 13.5.5 and if the procedures detect no error, it shall generate a FE-line_signal indication and remain in the PATH ACTIVE state. If the procedures detect an error, the state DISCONNECT REQUEST shall be entered;
- a SIGNAL ACK message, it shall apply the procedures specified in subclause 13.5.5. If the procedures detect no error, it shall remain in the PATH ACTIVE state, otherwise the state DISCONNECT REQUEST shall be entered;
- a FE-disconnect_request, shall apply procedures specified in subclause 13.5.3.5.

The AN V5 Protocol entity receiving in the PATH ACTIVE state:

- any FE-line_signal shall:
 - send a SIGNAL message to the LE with the corresponding FE-line_signal information; and
 - if the autonomous acknowledge option applies, generate the autonomous acknowledge indication (FE-line_signal);
 - else, no indication shall be generated; the procedures specified in subclause 13.5.5 shall be applied and if the procedure detects no error it shall remain in the PATH ACTIVE state;

If the procedure detects an error the state DISCONNECT REQUEST shall be entered.

- a SIGNAL message with a particular FE-line_signal information, it shall apply the procedures specified in subclause 13.5.5 and if the procedures detect no error, it shall generate a FE-line_signal indication and remain in the PATH ACTIVE state. If the procedures detect an error, the state DISCONNECT REQUEST shall be entered;
- a SIGNAL ACK message, it shall apply the procedures specified in subclause 13.5.5. If the procedures detect no error, it shall remain in the PATH ACTIVE state, otherwise the state DISCONNECT REQUEST shall be entered;
- a DISCONNECT or DISCONNECT COMPLETE message, shall apply procedures specified in subclause 13.5.3.5.

13.5.3.4.2 Exceptional procedures

If the LE V5 Protocol entity receives in the PATH ACTIVE state:

- an ESTABLISH or ESTABLISH ACK message, it shall apply procedures specified in subclause 13.5.2.10.

If the AN V5 Protocol entity receives in the PATH ACTIVE state:

- an ESTABLISH or ESTABLISH ACK message, it shall apply procedures specified in subclause 13.5.2.10.

13.5.3.5 Disconnecting path

In any state except the PORT BLOCKED state and the OUT OF SERVICE state, the LE V5 Protocol entity and the AN V5 Protocol entity receiving a DISCONNECT or DISCONNECT COMPLETE message shall react as specified in this subclause.

The AN V5 Protocol entity shall only:

- generate the DISCONNECT message, if being in the PATH ABORT REQUEST state and an ESTABLISH ACK message is received, or the layer 3 error detection mechanism (see subclause 13.5.5) detects a failure;
- generate the DISCONNECT COMPLETE message in response to a DISCONNECT message coming from the LE.

The LE V5 Protocol entity shall:

- generate the DISCONNECT message when a FE-disconnect_request is received, or the layer 3 error detection mechanism (see subclause 13.5.5) detects a failure;
- generate the DISCONNECT COMPLETE message when a DISCONNECT message or a FE-disconnect_complete_request is received (facility acknowledge).

NOTE: These above statements do not include error handling conditions which are specified in subclause 13.5.2.

Normal operation: the LE V5 Protocol entity or the AN V5 Protocol entity having sent a DISCONNECT message shall receive a DISCONNECT COMPLETE message.

Exceptional procedures: any other event or message.

13.5.3.5.1 Disconnect request

13.5.3.5.1.1 Normal operation

Except when the AN is in the PATH ABORT REQUEST state or the layer 3 error detection mechanism detects a failure, disconnection shall always be initiated by the national functional protocol which sends to the LE V5 Protocol entity a FE-disconnect_request or FE-disconnect_complete_request.

Disconnection initiated by LE:

The LE V5 Protocol entity receiving a FE-disconnect_request shall send a DISCONNECT message to the AN, stop all timers, start timer T3 and enter the PATH DISCONNECT REQUEST state.

The AN V5 Protocol entity receiving a DISCONNECT message shall stop all timers, generate a FE-line_signal indication if a steady signal information element is contained in the message, return a DISCONNECT COMPLETE message and reset all protocol parameters to its pre-defined values. Then the status of the subscriber line has to be monitored for a subscriber seizure or a line information condition and the NULL state shall be entered. If one of the above conditions exist, then the appropriate signal has to be generated by the user port.

Disconnection initiated by AN:

If the AN V5 Protocol entity receives in the PATH ABORT REQUEST state an ESTABLISH ACK or the layer 3 error detection mechanism detects a failure, it shall send a DISCONNECT message to the LE, start timer T3 and enter the DISCONNECT REQUEST state.

The AN V5 Protocol entity receiving a DISCONNECT COMPLETE message in the DISCONNECT REQUEST state shall stop all timers, and reset all protocol parameters to its pre-defined values. Then the status of the subscriber line has to be monitored for a subscriber seizure or a line information condition, and the NULL state shall be entered. If one of the above conditions exist, then the appropriate signal has to be generated by the user port.

The LE V5 Protocol entity receiving a DISCONNECT message shall stop all timers, generate a FE-disconnect_complete indication, return a DISCONNECT COMPLETE message and enter the NULL state.

13.5.3.5.1.2 **Exceptional procedures**

None identified.

13.5.3.5.2 **Disconnect acknowledge**

13.5.3.5.2.1 **Normal operation**

The LE V5 Protocol entity or the AN V5 Protocol entity receiving, in the PATH DISCONNECT REQUEST or the DISCONNECT REQUEST state respectively, a DISCONNECT COMPLETE or a DISCONNECT message shall stop timer T3, generate the corresponding indication and enter the NULL state.

13.5.3.5.2.2 **Exceptional procedures**

- a) if the LE V5 Protocol entity or the AN V5 Protocol entity receives in the PATH DISCONNECT REQUEST or DISCONNECT REQUEST state, respectively:
 - any message except a DISCONNECT COMPLETE or a DISCONNECT message, it shall ignore the message and remain in the same state;
 - a timeout of timer T3, it shall:
 - if it is not the third expiry, send a DISCONNECT message to the peer entity, start timer T3 and remain in the same state;
 - else, shall generate an internal error indication and enter the NULL state;
- b) if the LE V5 Protocol entity or the AN V5 Protocol entity receives in any state, except the PATH DISCONNECT REQUEST state a DISCONNECT COMPLETE message, it shall stop all timers, generate the FE-disconnect_complete_indication (except for the NULL state) and enter the NULL state;
- c) if the AN V5 protocol entity receives in the DISCONNECT REQUEST state any FE the FE shall be ignored and the AN V5 protocol entity shall remain in the DISCONNECT REQUEST state;
- d) if the LE V5 protocol entity receives in the PATH DISCONNECT REQUEST state a FE other than the FE-protocol_parameter_request the FE shall be ignored and the LE V5 protocol entity shall remain in the PATH DISCONNECT REQUEST state.

13.5.3.6 **Line information procedure**

13.5.3.6.1 **Normal operation**

The AN V5 Protocol entity receiving a FE-line_information in the NULL state shall send an ESTABLISH message to the LE with the Line-information information element start timer T1 and enter the LINE INFORMATION state.

The LE V5 Protocol entity receiving an ESTABLISH message with the Line-information information element in the NULL state shall generate a FE-establish_indication and enter the PATH INITIATED BY AN state.

The LE V5 Protocol entity receiving a FE-disconnect_complete_request in the PATH INITIATED BY AN state shall send a DISCONNECT COMPLETE message to the AN and return to the NULL state.

The AN V5 Protocol entity receiving a DISCONNECT COMPLETE message in the LINE INFORMATION state shall return to the NULL state.

13.5.3.6.2 Exceptional procedures

If the AN V5 Protocol entity receives in the LINE INFORMATION state:

- an ESTABLISH message or a FE other than the FE-protocol_parameter_request, no action shall be taken and the AN V5 Protocol entity shall remain in the LINE INFORMATION state;
- any message except the DISCONNECT or the DISCONNECT COMPLETE message, it shall apply procedures specified in subclause 13.5.2.10 and remain in the LINE INFORMATION state;
- a timeout of timer T1 or T2, it shall send an ESTABLISH message with the Line-information information element to the LE, start or restart timer T2 and remain in the LINE INFORMATION state.

13.5.4 Non-path related procedures

The non-path related procedures specified in this subclause, apply when the following messages (which have succeeded to the error handling procedures) or events are received in V5 Protocol entity:

- a) Messages: PROTOCOL PARAMETER;
- b) Events:
 - from analogue line: none identified;
 - from national protocol: FE-protocol_parameter_request;
 - from management entity: MDU-CTRL(port blocked), MDU-CTRL(port unblocked), MDU-CTRL(restart request), MDU-CTRL(restart complete).

NOTE: The receipt of other messages than those identified above shall not be considered in this subclause; for STATUS and STATUS ENQUIRY messages see the error handling procedures and for ESTABLISH, ESTABLISH ACK, DISCONNECT, SIGNAL and DISCONNECT COMPLETE see the path related procedures.

The protocol parameter procedure applies to the PATH ACTIVE state only. The other procedures are not related to a given state and they may be handled in any state. Depending on the message or the request received one of the following applies:

- protocol parameter, see subclause 13.5.4.1;
- port blocking, see subclause 13.5.4.2;
- restart procedure, see subclause 13.5.4.3.

13.5.4.1 Protocol parameter procedures

13.5.4.1.1 Normal operation

In general, parameters which are specific for a national protocol shall be pre-defined in the AN. However, some parameter may be changed by the LE during a call.

The LE V5 Protocol entity, being in the PATH ACTIVE state and receiving from the national protocol entity a FE-protocol_parameter_request shall send a PROTOCOL PARAMETER message to the AN with the change indication of signal or pulse and remain in the same state.

The AN V5 Protocol entity, being in the PATH ACTIVE state and receiving a PROTOCOL PARAMETER message shall update the protocol parameters. No state change occurs.

13.5.4.1.2 Exceptional procedures

The AN Protocol entity receiving a PROTOCOL PARAMETER message in any other than the PATH ACTIVE state shall apply procedures specified in subclause 13.5.2.10.

13.5.4.2 Port blocking procedures

These procedures are internally initiated by the management entity:

- any state:

if the AN V5 Protocol entity or the LE V5 Protocol entity receives from the management entity an MDU-CTRL(port blocked) request all timers shall be stopped, the port shall be cleared, a DISCONNECT COMPLETE message shall be sent and the corresponding port enters the a PORT BLOCKED state;
- PORT BLOCKED state:

any request or message received shall be ignored by the LE V5 Protocol entity or the AN V5 Protocol entity except the MDU-CTRL(port unblocked) request which is generated by the management entity and the corresponding port shall enter the NULL state. On receipt of a message the LE and AN shall apply the procedures for unexpected messages defined in subclause 13.5.2.10. All protocol parameters have to be reset in the AN Protocol entity to the pre-defined values, and the subscriber line has to be monitored for a subscriber seizure or line information condition, If this condition exists an appropriate event has to be generated in the NULL state.

13.5.4.3 Restart procedure

The restart procedure shall be used to return V5 PSTN protocol entities except those being in the PORT BLOCKED state via the OUT OF SERVICE state to the NULL state. The procedure shall be invoked by the System Management protocol entity (see Annex C) of the AN and/or the System Management of the LE.

The AN V5 protocol entity, receiving in any state except the PORT BLOCKED state an MDU-CTRL(restart request) from the System Management protocol entity, shall:

- clear the user port;
- send a DISCONNECT COMPLETE message;
- return a MDU-CTRL(restart ack) to the System Management protocol entity; and
- enter the OUT OF SERVICE state.

In the OUT OF SERVICE state, the AN V5 protocol entity shall ignore any other event except the MDU-CTRL(restart complete) indication and the MDU-CTRL(restart request) indication from the System Management protocol entity. On receipt of a message the AN shall apply the procedures for unexpected messages defined in subclause 13.5.2.10. When the AN V5 PSTN protocol entity receives the MDU-CTRL(restart complete) indication, it shall return to the NULL state. When the AN V5 PSTN protocol entity receives the MDU-CTRL(restart request) indication it shall send MDU-CTRL(restart ack).

The LE V5 protocol entity, receiving in any state except the PORT BLOCKED state an MDU-CTRL(restart request) from the System management protocol entity, shall:

- send FE-disconnect_complete_indication to the national protocol entity;
- send a DISCONNECT COMPLETE message;

- return a MDU-CTRL(restart ack) to the System Management protocol entity; and
- enter the OUT OF SERVICE state.

In the OUT OF SERVICE state, the LE V5 protocol entity shall ignore any other event except the MDU-CTRL(restart complete) indication and the MDU-CTRL(restart request) indication from the System Management protocol entity. On receipt of a message the LE shall apply the procedures for unexpected messages defined in subclause 13.5.2.10. When the LE V5 PSTN protocol entity receives the MDU-CTRL(restart complete) indication, it shall return to the NULL state. When the LE V5 PSTN protocol entity receives the MDU-CTRL(restart request) indication it shall send MDU-CTRL(restart ack).

13.5.5 Layer 3 error detection procedure

Path related messages are protected inherently within the PSTN Protocol entity by their functional procedures.

The PSTN SIGNAL messages and the PROTOCOL PARAMETER message containing FE-line_signal information and FE-protocol_parameter information respectively have not such a protection mechanism and are protected by the mechanism defined in this subclause.

In the following the procedure is described for SIGNAL messages only for simplification reasons.

Annex K provides further material for this procedure.

13.5.5.1 Multiple SIGNAL message operation - variables, sequence numbers and timers

13.5.5.1.1 Modulus

Each SIGNAL message shall be sequentially numbered and may have the value 0 through n minus 1 (where n is the modulus of the sequence number).

The modulus equals 128 and the sequence numbers cycle through the entire range, 0 through 127.

NOTE: All arithmetic operations on sequence variables and sequence numbers specified in subclauses 13.5.5.1.2 to 13.5.5.1.6 of this ETS shall be calculated by modulo 128.

13.5.5.1.2 Send sequence variable S(S)

Each point-to-point path connection endpoint shall have an associated S(S). S(S) denotes the number of the next message to be transmitted and may have a value in the range from 0 through n minus 1. The value of S(S) shall be incremented by 1 with each successive SIGNAL message to be sent and shall not exceed S(A) by more than the maximum number of outstanding SIGNAL messages.

13.5.5.1.3 Acknowledge sequence variable S(A)

Each point-to-point path connection endpoint shall have an associated S(A). S(A) identifies the last SIGNAL message that has been acknowledged by its peer entity (S(A) - 1 equals the M(S) of the last acknowledged SIGNAL message). S(A) can take on the value 0 through n minus 1. The value of S(A) shall be updated by the valid M(R) value received from its peer. A valid M(R) shall be in the range $(S(A) \leq M(R) \leq S(S))$.

13.5.5.1.4 Send sequence number M(S)

In every SIGNAL message there shall be a mandatory information element which contains the send sequence number M(S), which indicates the send sequence number of that transmitted message. At the time that an in-sequence SIGNAL message is designated for transmission, the value of the sequence number M(S) shall be set equal to S(S).

13.5.5.1.5 Receive sequence variable S(R)

Each point-to-point path connection endpoint shall have an associated S(R). S(R) denotes the sequence number of the next SIGNAL message expected to be received. S(R) can take on the value 0 through n minus 1. The value of S(R) shall be incremented by one with the receipt of a SIGNAL-message whose M(S) equals S(R).

13.5.5.1.6 Receive sequence number M(R)

In every SIGNAL ACK message there shall be a mandatory information element which contains the receive sequence number M(R), which indicates the number of the SIGNAL message to be received next. At the time that a SIGNAL ACK message is designated for transmission, the value of the sequence number M(R) shall be set equal to S(R). S(R) indicates that the layer 3 entity transmitting the M(R) has correctly received all SIGNAL messages numbered up to and including M(R) - 1.

13.5.5.1.7 Timer Tt

Each point-to-point path connection endpoint shall have an associated timer Tt. Timer Tt supervises the receipt of a SIGNAL ACK message after a SIGNAL message has been sent.

13.5.5.1.8 Timer Tr

Each point-to-point path connection endpoint shall have an associated timer Tr. Timer Tr supervises the maximum time which may pass until a SIGNAL ACK message shall be sent.

13.5.5.2 Multiple SIGNAL message operation - procedures

13.5.5.2.1 Initialization

When leaving the NULL state, the variables S(S), S(A) and S(R) shall be reset to ZERO.

13.5.5.2.2 Sending a SIGNAL message

Whenever layer 3 is going to transmit a SIGNAL message, the sequence number M(S) shall be set to S(S) and S(S) shall be incremented by 1.

If S(S) exceeds the maximum number, timer Tt and Tr shall be stopped, an error indication shall be issued to the management entity and a DISCONNECT message shall be sent.

If S(S) is valid and timer Tt is running, nothing shall happen.

If S(S) is valid and timer Tt is not running, timer Tt shall be started.

13.5.5.2.3 Sending a SIGNAL ACK message

Whenever layer 3 is going to transmit a SIGNAL ACK message, M(R) shall be set to S(R).

13.5.5.2.4 Receiving a SIGNAL message

Whenever layer 3 receives a SIGNAL message $M(S)$ shall be compared to $S(R)$. If $M(S)$ equals $S(R)$, the message shall be accepted and $S(R)$ shall be incremented by 1.

If $M(S)$ does not equal $S(R)$, timer T_t and T_r shall be stopped, an error indication shall be issued to the management entity and a DISCONNECT message shall be sent.

13.5.5.2.5 Receiving a SIGNAL ACK message

Whenever layer 3 receives a SIGNAL ACK message, $M(R)$ shall be checked.

If $M(R)$ is not valid (see subclause 13.5.5.1.3), timers T_t and T_r shall be stopped, an error indication shall be issued to the management entity and a DISCONNECT message shall be sent.

If $M(R)$ is valid, $S(A)$ shall be set to $M(R)$.

If $S(A)$ equals $S(S)$, timer T_t shall be stopped.

If $S(A)$ does not equal $S(S)$ and if $M(R)$ is valid (see subclause 13.5.5.1.3), timer T_t shall be re-started.

13.5.5.2.6 Start of timer T_r

Timer T_r shall be started whenever a new SIGNAL message is received and timer T_r is not running.

13.5.5.2.7 Stop of timer T_r

Timer T_r shall be stopped whenever a SIGNAL ACK message is sent.

13.5.5.2.8 Timeout of timer T_r

Whenever timer T_r expires, a SIGNAL ACK message shall be transmitted.

13.5.5.2.9 Start of timer T_t

If timer T_t is not running, it shall be started whenever a new SIGNAL message is sent.

Timer T_t shall be re-started whenever a SIGNAL ACK message arrives whose $M(R)$ does not equal $S(S)$ but is valid.

13.5.5.2.10 Stop of timer T_t

Timer T_t shall be stopped whenever a SIGNAL ACK message arrives whose $M(R)$ equals $S(S)$.

13.5.5.2.11 Timeout of timer T_t

Whenever timer T_t expires, timer T_r shall be stopped, an error indication shall be issued to the management entity, and a DISCONNECT message shall be sent to the peer entity.

13.5.5.2.12 Receiving a DISCONNECT message

Whenever a DISCONNECT message is received, timers T_t and T_r shall be stopped.

13.5.5.3 Multiple SIGNAL message operation - values

13.5.5.3.1 Number of outstanding SIGNAL messages

The value for the maximum number of outstanding SIGNAL messages shall be 127.

13.5.5.3.2 Timer Tt

The default value for timer Tt, at the end of which a DISCONNECT message shall be sent according to the procedures described in subclause 13.5.5.2.11, shall be 10 seconds.

13.5.5.3.3 Timer Tr

The default value for timer Tr, at the end of which a SIGNAL ACK message shall be sent according to the procedures described in subclause 13.5.5.2.7, shall be 5 seconds.

13.6 List of system parameters

The definition of timers is given in table 28. The specified timers shall be maintained in the AN V5 Protocol entity and the LE V5 Protocol entity. All the timers defined in table 28, except timer T2, shall have a maximum tolerance of $\pm 10\%$.

Table 28 defines the actions on expiry of the timers in normal procedures only. Actions for exceptional procedures are defined in the state tables.

Table 28: Timers in the AN and LE

Timer number	Timeout value	State	Cause for start	Normal stop	At the first expiry	At the second expiry	Cross reference
T1	4 s	AN1	Subscriber seizure/Line Info ESTABLISH sent	After reception of ESTABLISH ACK or DISCONNECT COMPLETE	Repeat ESTABLISH and start timer T2	---	13.5.3.1
T2	5-30 s	AN2 AN4	Time out T1 Time out T2	After reception of ESTABLISH ACK or DISCONNECT COMPLETE	Repeat ESTABLISH and restart timer T2	Continuously repeated until FE-subscriber release	13.5.3.1
T1	2 s	LE1 LE2 LE3	ESTABLISH sent	Reception of ESTABLISH ACK from AN or network	A new ESTABLISH sent to AN and a restart of timer T1	Start T3 and send DISCONNECT to AN; FE-disconnect indication to the national protocol	13.5.3.2
T3	2 s	LE2 LE3 LE4 LE5	DISCONNECT sent	DISCONNECT or DISCONNECT COMPLETE received	A new DISCONNECT sent to AN and restart of timer T3	Repeat DISCONNECT and restart of timer T3 (NOTE)	13.5.3.5
T3	2 s	AN3 AN5 AN7	DISCONNECT sent	DISCONNECT or DISCONNECT COMPLETE	Repeat DISCONNECT and restart of timer T3	Repeat DISCONNECT and restart of timer T3 (NOTE)	13.5.3.5
T4	2 s	LE1 LE2 LE3 LE4	STATUS ENQUIRY sent	Receiving of STATUS from AN indicating response to STATUS ENQUIRY	Repeat STATUS ENQUIRY and restart of timer T4	Repeat STATUS ENQUIRY and restart of timer T4 (NOTE)	13.5.2.13
Tr	5 s	AN5	SIGNAL or PROTOCOL PARAMETER received	Time out	send SIGNAL ACK	-	13.5.5
Tr	5 s	LE4	SIGNAL received	Time out	send SIGNAL ACK	-	13.5.5
Tt	10 s	AN5	SIGNAL sent	SIGNAL ACK received	send DISCONNECT	-	13.5.5
Tt	10 s	LE4	SIGNAL or PROTOCOL PARAMETER sent	SIGNAL ACK received	send DISCONNECT	-	13.5.5

NOTE: In case of the third expiry of timer T3 or timer T4 an error indication shall be issued to the management entity.

13.7 AN and LE side state tables

Table 29 defines the state transition table for the AN side of the V5.1 interface.

Table 30 defines the state transition table for the LE side of the V5.1 interface.

The notes below tables 29 and 30 apply for both tables.

The FSM for the AN requires that the AN analogue signal detection and FE handling function can distinguish specific line conditions in a particular way as specific function elements. This is for the support of the various procedures covered by this FSM which are required by some national PSTN protocols. This means that the same line condition may be interpreted by the FSM differently therefore, depending of the AN state, a line condition shall be allocated to one of the following FE-groups for the path control of the FSM:

- FE-subscriber_seizure;
- FE-line_information;
- FE-subscriber_release; or
- FE-line_signal.

It is, therefore, required that the national protocol specification for the AN provides the relevant information and definition how any relevant line condition required by the national PSTN protocol in a specific AN state shall be presented to the FSM. This concerns states AN1, AN2, AN3 and AN5.

This requirement shall be seen as the functional behaviour of the AN protocol entity and shall neither restrict nor force a specific implementation of these functions.

It should further be noted that the FSM shows for convenience of the reader the above listed FE-groups as the only input events and not the individual line signal. If however a specific AN design has implemented the analogue signal detection and FE handling function separate from the FSM then it is required to inform the FE handling function about the state the FSM is in for correct treatment of the analogue line conditions. This is outside the scope of this ETS.

Table 29: PSTN State Transition Table - AN (PSTN)

STATE	OUT OF SERVICE	NULL	PATH INITIATED BY AN	PATH ABORT REQUEST	LINE INFORMATION	PATH ACTIVE	PORT BLOCKED	DISCONNECT REQUEST
EVENT	AN0	AN1	AN2	AN3	AN4	AN5	AN6	AN7
FE-subscriber_seizure (e.g. off hook)	-	start T1, ESTABLISH, bearer non-transparent, FE-line_signal, (NOTE 1); AN2	/	FE-line_signal, (NOTE 1); AN2	-	/	-	-
FE-line_information	-	start T1, ESTABLISH; AN4	/	/	/	/	-	/
FE-subscriber_release (e.g. on hook)	-	-	AN3	/	-	/	-	-
ESTABLISH ACK	STATUS -	STATUS -	bearer transparent, stop T1/T2; AN5	stop T1/T2, DISCONNECT, start T3; AN7	STATUS -	STATUS -	STATUS -	-
ESTABLISH (NOTEs 2 and 13)	STATUS -	ESTABLISH ACK, (NOTE 3); AN5	ESTABLISH ACK, bearer transparent, stop T1/T2 (NOTE 3); AN5	ESTABLISH ACK, bearer transparent, stop T1/T2 (NOTE 3); AN5	-	STATUS -	STATUS -	-
DISCONNECT (NOTE 13)	STATUS -	DISCONNECT COMPLETE; -	DISCONNECT COMPLETE, stop timers; AN1 (NOTE 9)	DISCONNECT COMPLETE, stop timers; AN1 (NOTE 9)	stop T1/T2, DISCONNECT COMPLETE; AN1 (NOTE 9)	DISCONNECT COMPLETE, stop timers; AN1 (NOTE 9)	STATUS -	stop T3; AN1 (NOTE 9)
SIGNAL (NOTE 7)	STATUS -	STATUS -	STATUS -	STATUS -	STATUS -	FE-line_signal, start Tr (NOTE 6); - stop timers, MDU-error_indication, DISCONNECT, start T3; AN7	STATUS -	-
FE-line_signal (NOTE 8)	-	-	-	-	-	SIGNAL, FE-line_signal, (NOTE 1), start Tt; - SIGNAL, stop timers, MDU-error_indication, DISCONNECT, start T3; AN7	-	-
MDU-CTRL (port unblocked)	MDU-error_indication; -	-	-	-	-	-	AN1 (NOTE 9)	-
DISCONNECT COMPLETE	STATUS -	-	stop timers AN1 (NOTE 9)	stop timers AN1 (NOTE 9)	stop timers AN1 (NOTE 9)	stop timers AN1 (NOTE 9)	STATUS -	stop T3; AN1 (NOTE 9)

(continued)

Table 29 (concluded): PSTN State Transition Table - AN (PSTN)

STATE	OUT OF SERVICE	NULL	PATH INITIATED BY AN	PATH ABORT REQUEST	LINE INFORMATION	PATH ACTIVE	PORT BLOCKED	DISCONNECT REQUEST
EVENT	AN0	AN1	AN2	AN3	AN4	AN5	AN6	AN7
PROTOCOL PARAMETER (NOTE 7)	STATUS -	STATUS -	STATUS -	STATUS -	STATUS -	update protocol parameter, start Tr (NOTE 6); - stop timers, MDU-error_indication, DISCONNECT, start T3; AN7	STATUS -	STATUS -
MDU-CTRL (port blocked)	AN6	stop timers, clear port, DISCONNECT COMPLETE; AN6	stop timers, clear port, DISCONNECT COMPLETE; AN6	stop timers, clear port, DISCONNECT COMPLETE; AN6	stop timers, clear port, DISCONNECT COMPLETE; AN6	stop timers, clear port, DISCONNECT COMPLETE; AN6	-	stop timers, clear port, DISCONNECT COMPLETE; AN6
SIGNAL ACK (NOTE 7)	STATUS -	STATUS -	STATUS -	STATUS -	STATUS -	stop or restart Tt; - stop timers, MDU-error_indication, DISCONNECT, start T3; AN7	STATUS -	-
STATUS ENQUIRY	STATUS -	STATUS -	STATUS -	STATUS -	STATUS -	STATUS -	STATUS -	STATUS -
MDU-CTRL (restart request)	MDU-CTRL (restart ack); -	clear port, DISCONNECT COMPLETE, MDU-CTRL (restart ack); AN0	clear port, DISCONNECT COMPLETE, MDU-CTRL (restart ack); AN0	clear port, DISCONNECT COMPLETE, MDU-CTRL (restart ack); AN0	clear port, DISCONNECT COMPLETE, MDU-CTRL (restart ack); AN0	clear port, DISCONNECT COMPLETE, MDU-CTRL (restart ack); AN0	MDU-CTRL (restart ack) -	clear port, DISCONNECT COMPLETE, MDU-CTRL (restart ack); AN0
MDU-CTRL (restart complete)	AN1	/	/	/	/	/	-	-
timeout T1/T2	/	/	ESTABLISH, start T2; -	AN1 (NOTE 9)	ESTABLISH, start T2; -	/	/	/
timeout T3 (NOTE 4)	/	/	/	/	/	/	/	DISCONNECT, start T3; - AN1, MDU-error_indication (NOTE 9)
time out Tr	/	/	/	/	/	SIGNAL ACK; -	/	/
time out Tt	/	/	/	/	/	MDU-error_indication, DISCONNECT, stop timers, start T3; AN7	/	/
Notation: UPPER CASE = external message or event; lower case = internal message or event; - = no state change; / = unexpected event, no state change								

Table 30: PSTN State Transition Table - LE (PSTN)

STATE	OUT OF SERVICE	NULL	PATH INITIATED BY LE	PATH INITIATED BY AN	PATH ACTIVE	PATH DISCONNECT REQUEST	PORT BLOCKED
EVENT	LE0	LE1	LE2	LE3	LE4	LE5	LE6
FE-establish_request	-	ESTABLISH, start T1; LE2	/	ESTABLISH, start T1; LE2	/	/	-
ESTABLISH (NOTE 13)	STATUS ENQUIRY, start T4; -	FE-establish_ind.; LE3	FE-establish_ind.; -	-	STATUS ENQUIRY, start T4; -	-	STATUS ENQUIRY, start T4; -
DISCONNECT (NOTE 13)	STATUS ENQUIRY, start T4; -	DISC. COMPLETE; -	DISC. COMPLETE, FE-disc._complete_ind.; stop timers; LE1	DISC. COMPLETE, FE-disc._complete_ind.; stop timers; LE1	DISC. COMPLETE, FE-disc._complete_ind.; stop timers; LE1	stop T3, FE-disc._complete_ind.; LE1	STATUS ENQUIRY, start T4; -
DISCONNECT COMPLETE	STATUS ENQUIRY, start T4; -	/	FE-disc._complete_ind.; stop timers; LE1	FE-disc._complete_ind.; stop timers; LE1	FE-disc._complete_ind.; stop timers; LE1	stop T3, FE-disc._complete_ind.; LE1	STATUS ENQUIRY, start T4; -
FE-establish_acknowledge	-	/	stop T1, ESTABLISH ACK; LE4	ESTABLISH ACK; LE4	/	/	-
ESTABLISH ACK	STATUS ENQUIRY, start T4; -	STATUS ENQUIRY, start T4; -	stop T1, FE-establish_ack_ind.; LE4	STATUS ENQUIRY, start T4; -	STATUS ENQUIRY, start T4; -	-	STATUS ENQUIRY, start T4; -
SIGNAL (NOTE 7)	STATUS ENQUIRY, start T4; -	STATUS ENQUIRY, start T4; -	STATUS ENQUIRY, start T4; -	STATUS ENQUIRY, start T4; -	FE-line_signal_ind.; start Tr, (NOTE 6); - FE-line-signal_ind.; stop timers, MDU-error_ind.; DISC., start T3; LE5	-	STATUS ENQUIRY, start T4; -
SIGNAL ACK (NOTE 7)	STATUS ENQUIRY, start T4; -	STATUS ENQUIRY, start T4; -	STATUS ENQUIRY, start T4; -	STATUS ENQUIRY, start T4; -	stop or restart Tt; - MDU-error_ind.; stop timers, DISC., start T3; LE5	-	STATUS ENQUIRY, start T4; -
STATUS (NOTE 11)	stop T4 (NOTE 10), MDU-error_ind.; -	stop T4 (NOTE 10); - stop all timers, MDU-error_ind.; DISC., start T3; LE5	stop T4 (NOTE 10); - stop all timers, MDU-error_ind.; DISC., start T3; LE5	stop T4 (NOTE 10); - stop all timers, MDU-error_ind.; DISC., start T3; LE5	stop T4 (NOTE 10); - stop all timers, MDU-error_ind.; DISC., start T3; LE5	-	stop T4 (NOTE 10), MDU-error_ind.; -
FE-line_signal_request (NOTE 8)	/	/	/	/	SIGNAL, start Tt; - SIGNAL, stop timers, MDU-error_ind.; DISC., start T3; LE5	-	/

(continued)

Table 30 (concluded): PSTN State Transition Table - LE (PSTN)

STATE	OUT OF SERVICE	NULL	PATH INITIATED BY LE	PATH INITIATED BY AN	PATH ACTIVE	PATH DISCONNECT REQUEST	PORT BLOCKED
EVENT	LE0	LE1	LE2	LE3	LE4	LE5	LE6
FE-protocol_parameter_request (NOTE 8)	-	-	-	-	PROTOCOL PARAMETER, start Tt; - PROTOCOL PARAMETER, stop timers, MDU-error_ind.; DISC., start T3; LE5	-	/
FE-disconnect_request	-	/	stop timers, DISC., start T3; LE5	stop timers, DISC., start T3; LE5	stop timers, DISC., start T3; LE5	/	/
FE-disconnect_complete_request	/	/	/	DISC. COMPLETE; LE1	-	-	/
MDU-CTRL (port blocked)	LE6	stop timers, DISC. COMPLETE, FE-disc._complete_ind.; LE6	stop timers, DISC. COMPLETE, FE-disc._complete_ind.; LE6	stop timers, DISC. COMPLETE, FE-disc._complete_ind.; LE6	stop timers, DISC. COMPLETE, FE-disc._complete_ind.; LE6	stop timers, DISC. COMPLETE, FE-disc._complete_ind.; LE6	-
MDU-CTRL (port unblocked)	-	-	-	-	-	-	LE1
MDU-CTRL (restart request)	MDU-CTRL (restart ack); -	DISC. COMPLETE, FE-disc._complete, MDU-CTRL (restart ack); LE0	DISC. COMPLETE, FE-disc._complete, MDU-CTRL (restart ack); LE0	DISC. COMPLETE, FE-disc._complete, MDU-CTRL (restart ack); LE0	DISC. COMPLETE, FE-disc._complete, MDU-CTRL (restart ack); LE0	DISC. COMPLETE, FE-disc._complete, MDU-CTRL (restart ack); LE0	MDU-CTRL (restart ack) -
MDU-CTRL (restart complete)	LE1	/	-	-	-	-	-
timeout T1 (NOTE 5)	/	/	ESTABLISH, start T1; - start T3, DISC., MDU-error_ind.; LE5	/	/	/	/
timeout T3 (NOTE 4)	/	/	/	/	/	DISC., start T3; - MDU-error_ind.; LE1	/
timeout T4 (NOTE 12)	STATUS ENQUIRY, start T4; -	STATUS ENQUIRY, start T4; -	STATUS ENQUIRY, start T4; -	STATUS ENQUIRY, start T4; -	STATUS ENQUIRY, start T4; -	/	STATUS ENQUIRY, start T4; -
	MDU-error_ind.; -	stop all timers, MDU-error_ind.; DISC., start T3; LE5	stop all timers, MDU-error_ind.; DISC., start T3; LE5	stop all timers, MDU-error_ind.; DISC., start T3; LE5	stop all timers, MDU-error_ind.; DISC., start T3; LE5	/	MDU-error_ind.; -
time out Tr	/	/	/	/	SIGNAL ACK; -	/	/
time out Tt	/	/	/	/	stop timers, MDU-error_ind.; DISCONNECT, start T3; LE5	/	/

Notation: UPPER CASE = external message or event; lower case = internal message or event; - = no state change; / = unexpected event, no state change.

Notes to both PSTN state transition tables (tables 29 and 30), AN and LE side:

- NOTE 1: The "line signal" shall only be sent if the AN is configured for Autonomous Acknowledge.
- NOTE 2: The decision between the two options in AN2 or AN3 is made within the AN depending on whether the originating or terminating call has priority. This option shall be taken if the originating call has priority according to the provisioning data.
- NOTE 3: A "send signal" procedure may be carried out depending on a decision made within the AN. This procedure is specified in detail in the SDL diagrams contained in Annex L.
- NOTE 4: The decision between the two options in AN7 or LE5 shall be made depending on whether timer T3 has expired for the third time or not. On the third timeout of timer T3 the lower option shall be chosen.
- NOTE 5: The decision between the two options in LE2 shall be made within the LE depending on whether this event is caused by the first expiry of timer T1 or not. If it is the second timeout of timer T1 the lower option shall be chosen.
- NOTE 6: Timer Tr shall be started only if not running.
- NOTE 7: If the received Sequence-number is invalid (see subclause 13.5.5), the lower option shall be chosen.
- NOTE 8: If the next Sequence-number is unavailable (see subclause 13.5.5.2.2) the lower option shall be chosen.
- NOTE 9: Before entering the state AN1, all protocol parameter values shall be reset to the pre-defined values (see also subclause 13.5.3.5.1.1).
- NOTE 10: Timer T4 shall be stopped if the STATUS message is received indicating the response to a STATUS ENQUIRY.
- NOTE 11: If the states in the AN and LE protocol entity are compatible, the action shall be as defined in the upper row otherwise as defined in the lower row where applicable.
- NOTE 12: The action on receipt of this event shall be as defined in the upper row where applicable. If however timer T4 has expired the third time the action shall be as defined in the lower row where applicable.
- NOTE 13: If an ESTABLISH or a DISCONNECT message contains a signal information element, the acknowledgement with ESTABLISH ACK or DISCONNECT COMPLETE shall be sent after completion of the requested action. Refer to Clause D.10 for further information.

14 Control requirements and protocol

This Clause defines the control requirements, protocols and procedures in form of normative Finite State Machines (FSM) specification and supporting prose description of the procedures. The supplementary SDL diagrams are given in Annex L.

14.1 ISDN user port status indication and control protocol

14.1.1 General aspects

The ISDN user port status indication is based on the defined split of responsibilities between AN and LE. Only that status information of the user port having call control relevance shall influence the state machine in the LE via the V5.1 interface.

Port tests, e.g. loop back operation, shall be the responsibility of the AN. However, those tests which interfere with the service shall only be performed when the port is "Blocked", either due to failure or on request to and permission by the LE. This requires two groups of states, relevant to the V5.1 interface protocol, at both sides:

- operational state; and
- non-operational state.

In the operational state the activation/deactivation procedure, as defined in ETS 300 012 [3] shall be applied under the responsibility of the LE. Additional states are required in the AN for:

- activation for the support of the optional PL-capability;
- maintenance of the DS and the user port; and
- the optional partial activation as defined in ETS 300 297 [4].

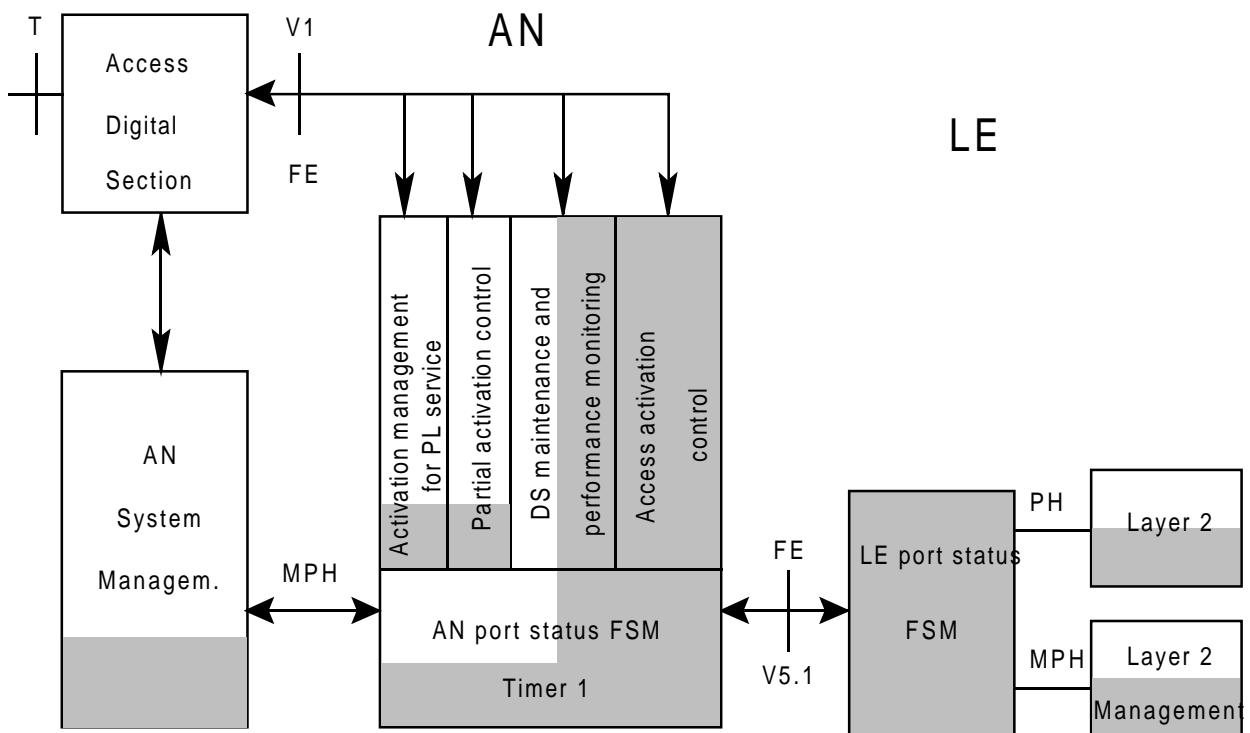

NOTE: The function elements, and primitives to this figure are defined in subclause 14.1.2 below.

Figure 31: Port control functional model

Figure 31 shows the functional model for control of the ISDN user port. The shading indicates the area defined in this ETS. The definition of the other functions and capabilities are outside the scope of this ETS. Reference is made to Annex C for further information about assumptions for the management functions in the AN and LE.

In the following only those functions and procedures are specified having relevance to the V5.1 interface.

14.1.2 Events and function elements relevant for the control of the state machines

Tables 31, 32, 33 and 34 give the set of FEs relevant for the V5.1 interface, the FEs defined in ETS 300 297 [4] for the support of the activation/deactivation procedure as well as the primitives (PH and MPH) towards layer 2 and the management function in AN or LE (see also figures 3 and 4).

Table 31: ETS 300 297 [4] set of function elements with relevance to interface V5.1

FE	Name	DS ET	Meaning at ET in LE
FE1	activate access	<--	PH/MPH-AR
FE2	access activation initiated by user	-->	MPH-AWI (awake indication)
FE3	DS activated	-->	MPH-DSAI
FE4	access activated	-->	PH/MPH-AI
FE5	deactivate access	<--	MPH-DR
FE6	access deactivated	-->	PH/MPH-DI
FE7	LOS/LFA on DS	failure in DS	not directly relevant
FE8	activate loopback 2	AN maintenance	not directly relevant
FE9	activate loopback 1	AN maintenance	not directly relevant
FE10	activate loopback 1A	AN maintenance	not directly relevant
FE11	activate partially the DS	AN management	not directly relevant
FE12	LOS/LFA at T	AN management information	not directly relevant
FE13	deactivate T whilst keeping DS partially activated	AN management	not directly relevant

Table 32: Set of function elements of interface V5.1

FE	Name	AN LE	Description
FE101	activate access	<--	request
FE102	activation initiated by user	-->	indication
FE103	DS activated	-->	indication
FE104	access activated	-->	indication
FE105	deactivate access	<--	request
FE106	access deactivated	-->	indication
FE201	unblock	<--	request or acknowledgement
FE202	unblock	-->	request or acknowledgement
FE203	block	<--	command
FE204	block	-->	command
FE205	block request	-->	request
FE206	grading	-->	performance information (NOTE 1)
FE207	D-channel block	<--	command (NOTE 2)
FE208	D-channel unblock	<--	command (NOTE 2)
NOTE 1:	The grading information may be sent from the AN management when being in state AN/LE2.2, see also subclause 14.1.4.		
NOTE 2:	The commands "D-channel block" and "D-channel unblock" are used to interrupt or resume the operation of the upstream D-channel of an individual ISDN user port according to the requirement in subclause 8.7.3. These commands may appear when being in state AN/LE2.2 without change of state.		
NOTE 3:	FE101 to FE106 have been derived from FE1 to FE6.		

Table 33: Set of primitives in the LE

Primitive	FSM L2/Management	Description
MPH-UBR	<--	unblock request
MPH-UBR	-->	unblock request
MPH-UBI	-->	unblock indication
MPH-BI	<--	block command
MPH-BI	-->	block command
MPH-BR	-->	incoming block request
PH/MPH-AR	<--	activate access
MPH-AWI	-->	access activation initiated by user
MPH-DSAI	-->	DS activated
PH/MPH-AI	-->	access activated
MPH-DR	<--	deactivate access
PH/MPH-DI	-->	access deactivated
MPH-GI	-->	grading information with parameter (NOTE 1)
MPH-DB	<--	block D-channel from user port (NOTE 2)
MPH-DU	<--	unblock D-channel from user port (NOTE 2)
NOTE 1:	The grading information may be sent from the AN management when being in state LE2.2, see also subclause 14.1.4.	
NOTE 2:	The commands "MPH-DB" and "MPH-DU" are used to interrupt or resume the operation of the upstream D-channel of an individual ISDN user port according to the requirement in subclause 8.7.3. These commands may appear when being in state LE2.2 without change of state.	

Table 34: Set of management primitives in the AN relevant to interface V5.1

Primitive	Management FSM	Description
MPH-UBR	-->	unblock request
MPH-UBR	<--	unblock request
MPH-UBI	<--	unblock indication
MPH-BI	-->	block command
MPH-BI	<--	block command
MPH-BR	-->	block request
MPH-T1	<--	indication of unsuccessful activation attempt
MPH-I1	<--	reception of FE101
MPH-AR	-->	activate access from AN
MPH-I2	<--	reception of FE2
MPH-DSAI	<--	DS active
MPH-AI	<--	access active under control of the LE
MPH-I5	<--	reception of FE105
MPH-DR	-->	deactivate access from AN
MPH-DI	<--	access deactivated
MPH-EI7	<--	indication of DS failure (FE7)
MPH-GI	-->	grading information with parameter (NOTE 2)
MPH-DB	<--	block D-channel from user port (NOTE 3)
MPH-DU	<--	unblock D-channel from user port (NOTE 3)
MPH-PAI	<--	access active under control of the AN
MPH-LxAR	-->	activate loopback
MPH-DSAR	-->	activate partially
MPH-DSDR	-->	deactivate T whilst keeping DS partially activated
MPH-EI12	<--	indication of LOS/LFA at T (FE12) (NOTE 4)
NOTE 1:	The last five primitives are not directly relevant for the interface V5.1 but given for information and complete description of the reaction in the FSM on receipt of those events even in states relevant to interface V5.1.	
NOTE 2:	The grading information may be sent from the AN management when being in state AN2.2, see also subclause 14.1.4.	
NOTE 3:	The commands "MPH-DB" and "MPH-DU" are used to interrupt or resume the operation of the upstream D-channel of an individual ISDN user port according to the requirement in subclause 8.7.3. These commands may appear when being in state AN2.2 without change of state.	
NOTE 4:	The meaning of this error indication is different in different states. In states AN2 it indicates that there is no layer 1 response from the terminal at the user network interface which may be due to application of the supplementary service "terminal portability", however if in parallel a PL service is offered at this user port the meaning for this service is as in states AN3. In states AN3 it indicates that the operation of the PL service is interrupted at the user network interface.	

14.1.3 ISDN user port FSMs, AN (ISDN port) and LE (ISDN port)

The primitives, function elements and the state tables are given for the definition of the functional behaviour and cooperation between the various functional blocks. There is no restriction for the implementation of these functions as long as the implementation is in conformance with the functionality defined in this ETS over the interface V5.1 and with the access digital section.

14.1.3.1 Description of the states

Activation and deactivation of the user port (access activation/deactivation) shall be under the control of the LE as long as the port is in the operational state. If the port is put into the non-operational state the control on activation and deactivation is given to the AN for any purpose e.g. port maintenance or maintaining the port active for the support of permanent PL. This is outside the scope of the V5.1 interface specification. Alignment of the two state machines is required when the port control responsibility shall be changed from "blocked" to the "operational" state in the LE.

The procedure for blocking and unblocking of the user port as specified in the port FSMs takes account of the principles given in subclause 7.1.

Blocking request shall be issued from the AN management only when being in the operational state. This request does not have any effect on the state unless the LE responds with FE203.

Immediate blocking indication has immediate effect in any relevant state in both FSMs. No specific confirmation of this indication is required.

Unblocking needs to be coordinated on both sides, therefore, an unblock request requires confirmation from the other side. The coordination is guaranteed through the two unblock states. If a block indication is received from the other side when being in local unblock state this shall only be interpreted as no confirmation and may be relevant only for the management system.

The unblock request may also be used by the management system to confirm the status of the layer 1 state machines.

The AN-FSM defined for the ISDN user port supports the optional PL-capability which requires that, if the LE is in state LE1, the activation of the DS and the user terminal may be under the responsibility of the AN. This procedure is defined in the optional states AN3.1 and AN3.2. The relevant deactivated state for this procedure is state AN1.0.

Maintenance of the DS and loopback tests (i.e. FE7 to FE10 and FE12 as given in table 33) may use the additional states AN4 which are outside the scope of this ETS. These states shall only be entered from the blocked state or the remote unblock state.

Cooperation of the optional function "partial activation", controlled by primitives MPH-DSAR and MPH-DSDR, as well as FE11 and FE13 respectively (see table 31), according to ETS 300 297 [4] with the "access activation" function is the responsibility of the AN and outside the scope of the V5.1 interface specification. The deactivation of the T interface by FE13, triggered by MPH-DSDR, can only occur from the required states AN5 which are not contained in this ETS.

States AN4 can only be entered from states AN1 and can only return to AN1.0. States AN5 can only be entered from states AN1 or AN2.0 and can return to AN1.0 or AN2.0 as appropriate to the port condition. If return to AN1.0 is required then, to align AN and LE FSM FE204 shall be sent to the LE and the unblock procedure may then be applied.

Permanent activation of the access shall be maintained by the LE if the user port is used for a permanent leased line as well. The indication required at the LE management is a provisioning requirement and outside the scope of this specification.

14.1.3.2 Definition of port control states

The user port FSMs reflect the AN and LE view of the layer 1 state of the ISDN port only. Call control is the responsibility of the ISDN protocol.

14.1.3.2.1 ISDN user port FSM - AN(ISDN port)

Non-operational (AN1 and AN3): Activation of the full basic access is not allowed. D-channel blocking has been applied to the port. Therefore, no layer 2 information shall be frame relayed to the LE, and the port cannot be used to originate or terminate calls.

Blocked (AN1.0): The port is in the non-operational state and neither side has initiated unblocking.

Local unblock (AN1.1): The AN has initiated unblocking (by sending FE202) and is awaiting confirmation from the LE.

NOTE 1: The DS may be activated from AN1.0 or AN1.1 for PL service.

Remote unblock (AN1.2): The LE has initiated unblocking (by sending FE201) and is awaiting confirmation from the AN.

NOTE 2: States AN1.1 and AN1.2 provide a mechanism for the synchronized unblocking of ports. The AN may remain in these states for an undetermined period of time.

PL states (AN3): The PL states shall be used for the PL capability, and allow the AN to activate the portion of the basic access between the AN and TE only, in the event of decoupling of the FSMs. In this case, the AN controls activation.

PL activation initiated (AN3.1): A transient state used to coordinate activation of the basic access between the AN and TE.

PL activated (AN3.2): Layer 1 of the basic access between the AN and TE is activated. The B-channel(s) provisioned for PL on the basic access can be used.

Operational (AN2): Activation of the basic access is allowed.

Operational deactivated (AN2.0): Activation may be requested by either end (FE101 from the LE; FE2 from the DS, initiated by the TE).

Activation Initiated (AN2.1): A transient state used to synchronize the FSMs in the LE and AN for activation of the basic access.

Access activated (AN2.2): Layer 1 of the basic access is activated. Layer 2 (and layer 3) links may (subsequently) be established.

14.1.3.2.2 ISDN User port FSM - LE (ISDN port)

Non-operational (LE1): Activation of the basic access shall not be allowed. No layer 2 information is expected at the LE, and the port cannot be used to originate or terminate calls.

Blocked (LE1.0): The port is in the non-operational state and neither side has initiated unblocking.

Local unblock (LE1.1): The LE has initiated unblocking (by sending FE201) and is awaiting confirmation from the AN.

Remote unblock (LE1.2): The AN has initiated unblocking (by sending FE202) and is awaiting confirmation from the LE.

NOTE: States LE1.1 and LE1.2 provide a mechanism for the synchronized unblocking of ports. The LE may remain in these states for an undetermined period of time.

Operational (LE2): Activation of the basic access is allowed.

Operational deactivated (LE2.0): Activation may be indicated by the AN (FE102) or requested by the LE (MPH/PH-AR).

Activation initiated (LE2.1): A transient state used to synchronize the FSMs in the LE and AN for activation of the basic access.

Access activated (LE2.2): Layer 1 of the basic access is activated. Layer 2 (and layer 3) links may (subsequently) be established.

14.1.3.3 Principles and procedures

14.1.3.3.1 General

Next subclauses describe the mechanism implemented in the FSMs in AN and LE for ISDN (basic access) ports, which are presented in the relevant State Transition tables 35 and 36.

The following mechanisms are described:

- blocking;
- blocking request;
- coordinated unblocking;
- activation:
 - user port;
 - permanent line;
 - digital section.

14.1.3.3.2 Blocking

A user port being in one of the operational substates can be blocked from both sides, however AN management has no knowledge about the call state of the port, hence shall only apply this procedure under failure and other conditions, that allow for affecting the service.

When AN-management issues MPH-BI, the FSM sends FE204 (Block Command) to the LE and goes to the Blocked state AN1.0. If the user port was (being) activated the port is now de-activated (with FE5 to the DS).

When LE-management issues MPH-BI, the FSM sends FE203 (Block Command) to the AN and goes to the Blocked state LE1.0. If the user port was (being) activated the port is now de-activated (with FE5 from AN-FSM to the DS).

14.1.3.3.3 Blocking request

The blocking request mechanism allows for non-urgent port blocking (e.g. deferrable maintenance). In this case AN-management issues a Blocking Request (MPH-BR) resulting in FE205 to the LE. This request shall be passed by the LE-FSM to LE-Management by MPH-BR.

LE-Management, knowing the call state, may grant the request by issuing MPH-BI, resulting in FE203 (Block Command) to the AN, then goes to Blocked state.

In case of a semi-permanent connection the LE-Management shall not grant this request but send MPH-UBR as a negative confirmation.

The AN management may cancel the blocking request by issuing MPH-UBR. The LE management may then receive MPH-UBI and cancel the blocking request (i.e. ignore the previously received request) if the port has not yet been blocked. In the latter case the LE may start the unblock procedure by issuing MPH-UBR.

14.1.3.3.4 Coordinated unblocking

Unblocking a port, needs to be coordinated at both sides. An Unblock Request requires confirmation from the other side. To guarantee this coordination there are two separate Unblock states (Local & Remote Unblock) in both FSMs. This procedure is fully symmetrical between AN and LE. If the LE wants to unblock, it issues MPH-UBR, sends FE201 (Unblock request) and goes to "Local Unblock" (LE1.1). The AN goes to "Remote Unblock" (AN1.2) and sends MPH-UBR to its management, which may agree, then responds with MPH-UBR (unblock acknowledge), sends FE202 and goes to "Operational Deactivated" state (AN2.0).

For the LE in "Local Unblock" and receiving this acknowledgement, the FSM goes to "Operational Deactivated" (LE2.0) and issues MPH-UBI to its management. The AN-Management may as well take the initiative, for which the same procedure applies.

For AN and LE, when in "Remote Unblock" state and receiving FE204 or FE203 respectively, the state shall be reset to Blocked, and an MPH-BI sent to management. This undoes a previous Unblock Request from the other side.

14.1.3.3.5 Activation

14.1.3.3.5.1 User port activation

Activation/deactivation of the user port (access) shall be under control of the LE, when the port is in the operational state. If the port is non-operational the control for activation/deactivation is given to the AN, for port maintenance or activation for the support of permanent lines.

a) **activation from user side** (from state AN2.0 "Operational Deactivated"):

The user activates the access, resulting in a FE2 to the AN-FSM, which issues MPH-I2 to management, sends FE102 to the LE, goes to state AN2.1 "Activation Initiated", and starts timer T1 for supervision of the activation process. The LE (on receipt of FE102 in LE2.0) shall issue MPH-AWI and goes to LE2.1 "Activation Initiated".

Before timer T1 expires (AN) a FE4 "Access Activated" is expected by the FSM, which issues MPH-AI to management, sends FE104 to the LE, goes to AN2.2 "Access Activated" and stops timer T1. The LE (on receipt of FE104 in LE2.1) shall issue PH/MPH-AI and goes to LE2.2 "Access Activated".

Timer T1 is defined in ETS 300 012 [3];

b) **activation from LE** (from state LE2.0 "Operational Deactivated):

LE-Management issues MPH-AR, goes to LE2.1 "Activation Initiated" and sends FE101 to AN.

The AN (on receipt of FE101 in AN2.0) issues MPH-I1 to management, FE1 to DS, goes to state AN2.1 "Activation Initiated", starts timer T1 for supervision. Before timer T1 expires a FE4 is expected, the same way as for user initiated activation;

c) **deactivation from LE (only)** (from state LE2.2 "Access Activated"):

The LE-Management issues MPH-DR, causing FE105 to the AN, PH-DI, new state LE2.0 "Operational Deactivated", The AN (on receipt of FE105 in state AN2.2), issues MPH-I5 to management, FE5 to the DS, goes to state AN2.0 "Operational Deactivated", sends FE106 back to the LE.

The LE just passes this confirmation to management (MPH-DI).

14.1.3.3.5.2 Permanent line activation

For the PL capability the LE has the responsibility for permanent activation of the user port. Once in state LE2.2 "Access Activated" LE-Management shall not issue MPH-DR for a user port with PL capability assigned, thus maintaining permanent activation.

When FSMs in AN/LE get decoupled, with AN-FSM in state AN1.0 "Blocked", AN-Management takes over the responsibility for the activation of the DS and the user terminal.

AN-Management then issues MPH-AR, resulting in a FE1 ("activate access"), goes to state AN3.1 "PL activation initiated", again guarded by timer T1.

Before timer T1 expires, a FE4 is expected, clearing the timer, but now issueing MPH-PAI to AN-management and goes to state AN3.2 "PL activated".

AN-Management can deactivate with MPH-DR, resulting in state AN1.0 "Blocked", and FE5 "deactivate access" to the user port.

LE can take over again (from AN3.2) by sending FE201 "Unblock request", confirmed by FE104 to LE "access activated" and moving to state AN2.2 "access activated".

From state AN3.1 "PL activation initiated" this FE201 would be confirmed by a FE102, simulating user-initiated access activation, with AN moving to state AN2.1 "activation initiated".

14.1.3.3.5.3 Access digital section partial activation

Partial activation of the Access Digital Section (DS) can be provided from states AN1.0, AN1.1 or AN2.0 by AN-Management issueing MPH-DSAR, resulting in FE11 "activate partially the DS" and moving to state AN5.

Deactivation from state AN5, back to AN1.0 or AN2.0 as appropriate, would result from MPH-DR from the AN management.

It is assumed that state AN5 has several substates similar at least to AN2 substates.

14.1.3.4 ISDN port FSM at the AN

The ISDN user port FSM is defined in table 35 in accordance with the assumptions in subclause 14.1.1 and figure 31.

Timer T1 is shown in this state table as being part of the FSM for convenience and clarification only but may be implemented elsewhere (e.g. in the AN system management). This timer shall be used to supervise the activation procedure to identify the successful or unsuccessful activation attempt. In case of expiry of T1 the activation attempt is deemed to be unsuccessful and the AN management may test the access. This condition may be taken to initiate the verification procedure as defined for the continuity test in ETS 300 297 [4]. Timer T1 is defined in ETS 300 012 [3].

The AN FSM provides a mechanism which allows the local manager of the AN to verify that the FSM is in the Operational state, without having to go through the sequence of blocking and unblocking. This mechanism is internal to the AN. To do so the AN management issues MPH-UBR and receives the information whether the FSM is in a non-operational state.

The state table shall be read as follows:

Assume to be in a state and an event is then detected. The relevant box in the state table defines the actions to be taken in this condition, e.g. in state AN2.1, FE4 detected: issue primitive MPH-AI to AN management, issue FE104 to LE FSM, stop and reset timer T1 and go to state AN2.2.

Table 35: AN (ISDN port) FSM for ISDN basic access user ports

State	AN 1.0	AN 1.1	AN 1.2	AN 2.0	AN 2.1	AN 2.2	AN 3.1	AN 3.2
State name	Blocked	Local unblock	Remote unblock	Operational deactivated	Activation initiated	Access activated	PL activation initiated	PL activated
FE2	MPH-I2 -	MPH-I2 -	MPH-I2 -	MPH-I2; FE102 start T1; 2.1	-	/	-	/
FE3	MPH-DSAI -	MPH-DSAI -	MPH-DSAI -	MPH-DSAI -	MPH-DSAI FE103; -	/	MPH-DSAI -	/
FE4	MPH-AI -	MPH-AI -	MPH-AI -	-	MPH-AI; FE104; stop T1; 2.2	-	MPH-PAI stop T1 3.2	-
FE6	MPH-DI -	MPH-DI -	MPH-DI -	-	MPH-DI; FE5 stop T1 FE106; 2.0	MPH-DI FE5; FE106 2.0	MPH-DI FE5; stop T1; FE204; 1.0	MPH-DI FE5; FE204; 1.0
FE7	MPH-EI7 -	MPH-EI7 -	MPH-EI7 -	/	MPH-EI7; FE5 stop T1 FE106; 2.0	MPH-EI7 FE5; FE106 2.0	MPH-EI7 FE5; stop T1; FE204; 1.0	MPH-EI7 FE5; FE204 1.0
FE12	MPH-EI12 -	MPH-EI12 -	MPH-EI12 -	/	/	MPH-EI12 -	MPH-EI12; -	MPH-EI12; -
FE201	MPH-UBR 1.2	MPH-UBI 2.0	MPH-UBR -	FE202; MPH-UBI; -	FE202; MPH-UBI; -	MPH-UBI; -	MPH-UBI FE102; 2.1	MPH-AI FE104; 2.2
FE203	-	MPH-BI 1.0	MPH-BI 1.0	MPH-BI 1.0	MPH-BI; FE5 stop T1; 1.0	MPH-BI FE5; 1.0	MPH-BI -	/
FE101	/	/	/	MPH-I1; FE1 start T1; 2.1	/	FE104 -	/	/
FE105	/	/	/	FE106 -	MPH-I5 FE5; FE106 stop T1; 2.0	MPH-I5 FE5; FE106 2.0	/	/
expiry of timer 1	/	/	/	/	MPH-T1 FE5; FE106 2.0	/	MPH-T1 FE5; FE204 1.0	/
MPH-UBR	FE202 1.1	FE202 -	FE202; MPH-UBI 2.0	MPH-UBI; FE202 -	MPH-UBI; FE202 -	MPH-AI; FE202 -	-	MPH-PAI -
MPH-BI	FE204 -	FE204 1.0	FE204 1.0	FE204 1.0	FE204; FE5 stop T1; 1.0	FE204 FE5; 1.0	n.r.	n.r.
MPH-BR	-	/	/	FE205 -	FE205 -	FE205 -	n.r.	n.r.
MPH-AR	FE1; start T1; 3.1	FE1; start T1; 3.1	/	/	/	/	-	/
MPH-DR	FE5; -	FE5; -	FE5; -	/	/	/	FE5; stop T1; FE204; 1.0	FE5; FE204; 1.0
MPH-LxAR (NOTE 1)	FEEx; start T1; 4.x	/	FEEx; start T1; 4.x	/	/	/	/	/
MPH-DSAR (NOTE 1)	FE11; start T1; 5.x	FE11; start T1; 5.x	/	FE11; start T1; 5.x	/	/	/	/
MPH-DSDR	-	-	-	-	-	-	-	-
MPH-GI	/	/	/	/	/	FE206	/	/
FE207	/	/	/	/	/	MPH-DB	/	/
FE208	/	/	/	/	/	MPH-DU	/	/

Notation: - no state change; / unexpected event, no state change; n.r. not relevant to this ETS;

NOTE 1: States AN4 and AN5 are not relevant to this ETS and not defined in this ETS.

NOTE 2: If D-channel blocking has been applied to a user port after receipt of FE207, when in state 2.2 and if the port FSM leaves state 2.2, then D-channel blocking shall be removed.

NOTE 3: The action "stop T1" includes the reset function.

14.1.3.5 ISDN port FSM at the LE

Table 36 gives the FSM of the LE.

Table 36: LE (ISDN port) FSM for ISDN basic access user ports

State	LE 1.0	LE 1.1	LE 1.2	LE 2.0	LE 2.1	LE 2.2
State name	Blocked	Local unblock	Remote unblock	Operational deactivated	Activation initiated	Access activated
PH/MPH-AR	/	/	/	FE101 2.1	-	/
FE102	-	MPH-AWI 2.1	/	MPH-AWI 2.1	-	/
FE103	-	-	-	-	MPH-DSAI -	/
FE104	-	PH/MPH-AI 2.2	/	PH/MPH-AI 2.2	PH/MPH-AI 2.2	-
MPH-DR (NOTE 1)	-	-	-	FE105 -	FE105; MPH-DI 2.0	FE105; PH-DI 2.0
FE106	-	-	-	MPH-DI; -	MPH-DI; 2.0	PH/MPH-DI; 2.0
MPH-UBR	FE201 1.1	FE201 -	MPH-UBI; FE201 2.0	FE201 -	FE201 -	PH/MPH-AI; FE201 -
MPH-BI	FE203 -	FE203 1.0	FE203 1.0	FE203 1.0	FE203 1.0	FE203 1.0
FE202	MPH-UBR 1.2	MPH-UBI 2.0	MPH-UBR -	MPH-UBI -	MPH-UBI -	MPH-UBI -
FE204	-	MPH-BI 1.0	MPH-BI 1.0	MPH-BI 1.0	MPH-BI; PH/MPH-DI 1.0	MPH-BI; PH/MPH-DI 1.0
FE205	-	-	-	MPH-BR -	MPH-BR -	MPH-BR -
FE206	/	/	/	/	/	MPH-GI -
MPH-DB (NOTE 2)	/	/	/	/	/	FE207 -
MPH-DU	/	/	/	/	/	FE208 -

Notation: - no state change; / unexpected event, no state change;

NOTE 1: MPH-DR shall not be issued when being in state LE2.2 if the access shall be maintained permanently active as a subscription option or for a permanent line service provided through this user port.

NOTE 2: If D-channel blocking has been applied to a user port when in state 2.2, by issuing the MPH-DB primitive, the system management shall be aware that D-channel blocking in the AN will be removed when the port FSM leaves state AN2.2.

The LE FSM provides a mechanism which allows the local manager of the LE to verify that the FSM is in the operational state by issuing MPH-UBR, without having to go through the sequence of blocking and unblocking.

Unlike the corresponding situation for the AN, this mechanism is not internal to the LE and requires the co-operation of the AN FSM, and confirms the alignment of both FSMs and the link between them.

The asymmetry here reflects the responsibility of the LE for supporting the service.

14.1.4 Performance monitoring aspects

The performance of the access digital section, if the NT1 is implemented separately from the AN, shall be monitored by the AN when the DS is in the activated state. The application of this mechanism is to be provisioned at the AN and LE on a per port basis.

As reflected in subclause 7.1.1, item 8), the working concept is that on the V5 interface there shall be no impact from any implementation of the user-port. The AN is supposed to monitor the performance of the access digital section. Parameters for validation algorithms and specific thresholds shall be pre-defined in the AN. Only passing the threshold shall be reported ("Grading" with parameter indicating which grade shall now be relevant) at most once a minute. The LE may use these reports to decide whether or not a requested service shall be delivered. This concept makes Performance Monitoring on V5 access-implementation independent, having no effect on the Port-Status FSM.

The persistent excess of bit error ratio shall be considered as a failure requiring maintenance (according to the CCITT M.series of Recommendations and CCITT Recommendation G.921), and therefore immediate blocking of the user port.

14.2 PSTN user port status indication and control protocol

14.2.1 General aspects

The PSTN user port status indication is based on the defined split of responsibilities between AN and LE. Only those status information of the user port having call control relevance shall influence the state machine in the LE via the V5.1 interface.

Port tests, e.g. line tests, shall be the responsibility of the AN. However, those tests which interfere with the service shall only be performed when the port is "Blocked", either due to failure or on request to and permission by the LE. This requires two main states, relevant to the V5.1 interface protocol, at both sides:

- operational; and
- non-operational.

Figure 32 shows the functional model for control of the PSTN user port. The shading indicates the area defined in this ETS. The definition of the other functions and capabilities are outside the scope of this ETS. Reference is made to Annex C for further information about assumptions for the management functions in the AN and LE.

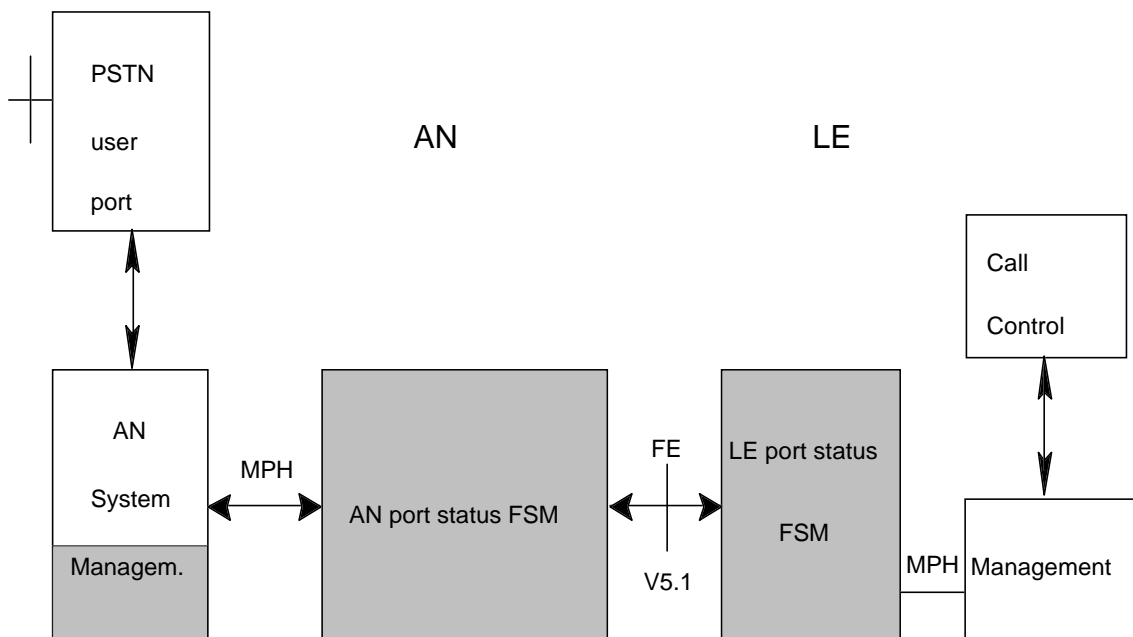

Figure 32: Port operation and maintenance functional model

The co-ordination of the different FSMs, for instance in the event of layer 1 or layer 2 failure and recovery, occurs through management intervention as described in Annex C using the primitives shown in tables 40 and 41.

In the following only those functions and procedures are specified having relevance to the V5.1 interface.

14.2.2 Events and function elements relevant for the control of the state machines

Tables 37, 38 and 39 give the set of FEs relevant for the V5.1 interface and the MPH-primitives towards the management function in AN or LE (see also figure 32).

Table 37: Set of function elements of interface V5.1

FE	Name	AN	LE	Description
FE201	unblock	<--		request or acknowledgement
FE202	unblock		-->	request or acknowledgement
FE203	block	<--		command
FE204	block		-->	command
FE205	block request		-->	request

Table 38: Set of primitives in the LE

Primitive	FSM Management	Description
MPH-UBR	<--	unblock request
MPH-UBR	-->	unblock request
MPH-UBI	-->	unblock indication
MPH-BI	<--	block command
MPH-BI	-->	block command
MPH-BR	-->	incoming block request

Table 39: Set of management primitives in the AN relevant to interface V5.1

Primitive	Management FSM	Description
MPH-UBR	-->	unblock request
MPH-UBR	<--	unblock request
MPH-UBI	<--	unblock indication
MPH-BI	-->	block command
MPH-BI	<--	block command
MPH-BR	-->	block request

14.2.3 PSTN user port FSM, AN (PSTN port) and LE (PSTN port)

The primitives, function elements and the state tables are given for the definition of the functional behaviour and cooperation between the various functional blocks. There shall be no restriction for the implementation of these functions as long as the implementation is in conformance with the functionality defined in this ETS over the interface V5.1 and with the access digital section.

14.2.3.1 Description of the states

The FSM in the AN and in the LE can both be regarded as being constructed from two fundamental states: Operational and Non-operational.

The Non-operational state is sub-divided into Blocked, Local Unblocked, and Remote Unblocked. This sub-division simplifies the co-ordination of both FSMs in the unblocking sequence and ensures that unblocking shall be acknowledged by both sides before going into the operational state.

The primitives MPH-UBI and MPH-BI shall be used by the both FSMs to notify their managers of a transition into and out of the operational state respectively.

The mechanism for Unblocking is acknowledged, as is the mechanism for deferrable blocking request. The mechanism for Immediate Blocking is unacknowledged.

The primitive MPH-BR, for deferrable blocking, shall only be issued in the Operational State.

14.2.3.2 Definition of port control states

The user port FSMs reflected the AN and LE view of the functional state of the PSTN port only. Call control shall be the responsibility of the PSTN protocol.

14.2.3.2.1 PSTN user port FSM - AN (PSTN port)

Non-operational (AN1): The PSTN protocol entity is forced into the blocked state (AN6 of PSTN protocol entity). Therefore, line signals shall not be passed to the LE, and the port cannot be used to originate or terminate calls.

Blocked (AN1.0): The port in the non-operational state and neither side has initiated unblocking.

Local unblock (AN1.1): The AN has initiated unblocking (by sending FE202) and is awaiting confirmation from the LE.

Remote unblock (AN1.2): The LE has initiated unblocking (by sending FE201) and is awaiting confirmation from the AN.

NOTE: States AN1.1 and AN1.2 provide a mechanism for the synchronized unblocking of ports. The AN may remain in these states for an undetermined period of time.

Operational (AN2.0): The PSTN port shall be ready to originate and terminate calls, under the control of the PSTN protocol.

14.2.3.2.2 PSTN user port FSM - LE (PSTN port)

Non-operational (LE1): The PSTN protocol entity is forced into the blocked state (LE6 of PSTN protocol entity). Therefore, the PSTN port cannot originate or terminate calls.

Blocked (LE1.0): The port is in the non-operational state and neither side has initiated unblocking.

Local unblock (LE1.1): The LE has initiated unblocking (by sending FE201) and is awaiting confirmation from the AN.

Remote unblock (LE1.2): The AN has initiated unblocking (by sending FE202) and is awaiting confirmation from the LE.

NOTE: States AN1.1 and AN1.2 provide a mechanism for the synchronized unblocking of ports. The LE may remain in these states for an undetermined period of time.

Operational (LE2.0): The PSTN port shall be ready to originate and terminate calls, according to the PSTN call control protocol.

14.2.3.3 Principles and procedures

14.2.3.3.1 General

Next subclauses describe the mechanism implemented in the FSMs in AN and LE for PSTN, which are presented in the relevant State Transition tables.

The following mechanisms are described:

- blocking;
- blocking request;
- coordinated unblocking.

14.2.3.3.2 Blocking

A user port can be blocked from both sides, however AN management has no knowledge about the call state of the port, hence shall only apply this procedure under failure and other conditions, that allow for affecting the service.

When AN-management issues MPH-BI, the FSM sends FE204 (Block Command) to the LE and goes to the Blocked state AN1.0. Both protocol entities, AN(PSTN) and LE(PSTN) shall be put into the Blocked state by the relevant management.

When LE-management issues MPH-BI, the FSM sends FE203 (Block Command) to the AN and goes to the Blocked state LE1.0.

14.2.3.3.3 Blocking request

The blocking request mechanism allows for non-urgent port blocking (e.g. deferrable maintenance). In this case AN-management issues a Blocking Request (MPH-BR) resulting in FE205 to the LE. This request shall be passed by the LE-FSM to LE-Management by MPH-BR.

LE-Management, knowing the call state, may grant the request by issuing MPH-BI, resulting in FE203 (Block Command) to the AN, then goes to Blocked state.

The AN management may cancel the blocking request by issueing MPH-UBR. The LE management may then receive MPH-UBI and cancel the blocking request (i.e. ignore the previously received request) if the port has not yet been blocked. In the latter case the LE may start the unblock procedure by issueing MPH-UBR.

14.2.3.3.4 Coordinated unblocking

Unblocking a port, needs to be coordinated at both sides. An Unblock Request requires confirmation from the other side. To guarantee this coordination there are two separate Unblock states (Local & Remote Unblock) in both FSMs. This procedure is fully symmetrical between AN and LE. If the LE wants to unblock, it issues MPH-UBR, sends FE201 (Unblock request) and goes to "Local Unblock" (LE1.1). The AN goes to "Remote Unblock" (AN1.2) and sends MPH-UBR to its management, which may agree, then responds with MPH-UBR (unblock acknowledge), sends FE202 and goes to "Operational" state (AN2).

For the LE in "Local Unblock" and receiving this acknowledgement, the FSM goes to "Operational" (LE2) and issues MPH-UBI to its management. The AN-Management may as well take the initiative, for which the same procedure applies.

For AN and LE, when in "Remote Unblock" state and receiving FE204 or FE203 respectively, the state shall be reset to Blocked, and an MPH-BI sent to management. This undoes a previous Unblock Request from the other side.

14.2.3.4 PSTN port FSM at the AN

The FSM defined in table 40 covers the shaded area of the AN given in figure 32.

Table 40: AN (PSTN port) FSM for PSTN user ports

State	AN1.0	AN1.1	AN1.2	AN2.0
State name	Blocked	Local unblock	Remote unblock	Operational
Event				
FE201	MPH-UBR; 1.2	MPH-UBI; 2.0	MPH-UBR; -	FE202; MPH-UBI; -
FE203	-	MPH-BI; 1.0	MPH-BI; 1.0	MPH-BI; 1.0
MPH-UBR	FE202; 1.1	FE202; -	FE202; MPH-UBI; 2.0	MPH-UBI; FE202; -
MPH-BI	FE204; -	FE204; 1.0	FE204; 1.0	FE204; 1.0
MPH-BR	-	/	/	FE205; -

Notation: - no state change; / unexpected event, no state change;

The AN FSM provides a mechanism which allows the local manager of the AN to verify that the FSM is in the Operational state, without having to go through the sequence of blocking and unblocking. This mechanism is internal to the AN. To do so the AN management issues MPH-UBR and receives the information whether the FSM is in a non-operational state.

14.2.3.5 PSTN port FSM at the LE

Table 41 gives the FSM of the LE.

The LE FSM provides a mechanism which allows the local manager of the LE to verify that the FSM is in the operational state by issuing MPH-UBR, without having to go through the sequence of blocking and unblocking.

Unlike the corresponding situation for the AN, this mechanism is not internal to the LE and requires the co-operation of the AN FSM, and confirms the alignment of both FSMs and the link between them.

The asymmetry here reflects the responsibility of the LE for supporting the service.

Table 41: LE (PSTN port) FSM for PSTN user ports

State	LE1.0	LE1.1	LE1.2	LE2.0
State name	Blocked	Local unblock	Remote unblock	Operational
Event				
MPH-UBR	FE201; 1.1	FE201; -	FE201; MPH-UBI; 2.0	FE201; -
MPH-BI	FE203; -	FE203; 1.0	FE203; 1.0	FE203; 1.0
FE202	MPH-UBR; 1.2	MPH-UBI; 2.0	MPH-UBR; -	MPH-UBI; -
FE204	-	MPH-BI; 1.0	MPH-BI; 1.0	MPH-BI; 1.0
FE205	-	-	-	MPH-BR; -

Notation: - no state change; / unexpected event, no state change;

14.3 Interface layer 1 maintenance requirements and protocol

14.3.1 Events and failure reports

The requirements and specifications in this subclause are relevant for both the AN and LE because of the symmetry of the interface functions.

Table 42 gives the identified events for the V5.1 interface layer 1 FSM.

Table 42: Events and primitives for the interface layer 1 FSM

Event (signal)	AN/LE Management	Primitive
operational signal (normal frames, not RAI)	-->	MPH-AI
non-operational condition	-->	MPH-DI
loss of signal	-->	MPH-EIa
loss of frame alignment	-->	MPH-EIa
reception of Remote Alarm Indication (RAI)	-->	MPH-EIb
reception of Alarm Indication Signal (AIS) (NOTE 1)	-->	MPH-EIc
internal failure	-->	MPH-EId
CRC block received in error	-->	MPH-EIe
CRC error information (i.e. E bit set to ZERO) (NOTE 3)	-->	MPH-EIf
request to stop with error report (NOTEs 2 and 3)	<--	MPH-stop
request to proceed with error report (NOTEs 2 and 3)	<--	MPH-proceed
NOTE 1: AIS may be generated by the V5.1 interface in case it has detected an internal failure preventing it from generating the normal output signal. The receiving side of the interface, however, shall detect this event because the application alternative with a transparent digital link between the LE and the AN AIS may be generated by this link according to CCITT Recommendations (see also Clause 4).		
NOTE 2: This function may have greater importance for the V5.2 interface but to facilitate a possible upgrade it should also be used in V5.1.		
NOTE 3: These events have relevance for the interface and the relation with the management system but do not have impact on the FSM.		

The FSMs AN(interface) and LE(interface) can both be regarded as being constructed from two fundamental states: Operational and Non-operational. The transition into these conditions shall be notified by MPH-AI or MPH-DI at the AN and MPH-AI or MPH-DI at the LE respectively.

The report mechanism available to the remote side of the interface is the RAI function and the CRC error report function (E-bit).

14.3.2 Detection algorithm for events and signals

The detection algorithm for events or signals is defined in table 43.

Table 43: Detection algorithm for layer 1 signals

Normal frames:	The algorithms shall be in accordance with those given in ETS 300 167 [2] (which refers to CCITT Recommendation G.706 (1991), §§ 4.1.2 and 4.2).
Loss of frame alignment:	The algorithm shall be in accordance with the one given in ETS 300 167 [2] (which refers to CCITT Recommendation G.706 (1991), § 4.1.1).
RAI:	RAI is detected when both of the two following conditions occur: - frame alignment condition; and - reception of one bit A with binary content ONE.
Loss of signal:	The equipment shall implement one or both of the following alternatives to detect "loss of signal". The detection of this event shall not inhibit the operation of the frame alignment procedure. a) The incoming signal amplitude is, for a time duration of at least 1 ms, more than 20 dB below the nominal output amplitude defined in ETS 300 166 [1] (which refers to CCITT Recommendation G.703). b) The input detects more than 10 consecutive HDB3 ZEROs.
AIS:	AIS is detected when both of the two following conditions occur: - loss of frame alignment; and - reception of 512 bit periods containing less than 3 binary ZEROs (this is based on CCITT Recommendation O.162, § 3.3.2).
CRC error information:	Reception of one E bit set to ZERO.

14.3.3 V5.1 interface layer 1 FSM

Three implementation alternatives have been identified concerning the reporting of detection of events from the FSM to the management and the decision on the consequent action with regard to service provision.

- 1) Immediate report of the detected event to the management for logging (MPH-EI) and processing to evaluate the interface status with regard to consequent actions on the service and the other FSMs. In this case the management shall perform the necessary persistence check of the reported events to identify the operational or non-operational status of the interface.
- 2) Immediate report of the detected event to the management for logging (MPH-EI). The layer 1 performs the persistence check to evaluate the interface status resulting in a status report to the management (i.e. MPH-AI, MPH-DI at the AN and LE).
- 3) A combination of both alternatives 1 and 2.

Table 44 gives the interface FSM in the LE and the AN, symmetrical approach. It should be noted that the FSM in table 44 allows all three approaches concerning the persistence check procedure implementation.

The persistency check timer(s) in AN and LE shall be pre-defined in steps of 100 ms, from 100 ms to 25 s. The persistency check timers shall have a tolerance of ± 50 ms for nominal values of 100 ms to 1 s and $\pm 10\%$ above 1 s. Further principles are given in NOTE 2 of table 44.

Table 44: V5.1 interface layer 1 FSM - AN(interface) and LE(interface)

State number	AN/LE1	AN/LE2	AN/LE3	AN/LE4
Condition	normal	locally detected failure	remotely detected failure	internal failure
signal sent to remote side	normal frames	RAI	normal frames	AIS
normal frames	-	start timer; 1	start timer; 1	/
Loss of signal or loss of frame alignment	start timer; MPH-EIa; 2	MPH-EIa; -	MPH-EIa; MPH-EIbr; 2	MPH-EIa; -
RAI	start timer; MPH-EIb; 3	MPH-EIbr; MPH-EIb; 3	-	-
AIS	start timer; MPH-EIc; 2	MPH-EIc; -	MPH-EIc; MPH-EIbr; 2	MPH-EIc; -
internal failure	MPH-DI; MPH-EId; 4	MPH-DI; MPH-EId; 4	MPH-DI; MPH-EId; 4	-
disappearance of internal failure	/	/	/	MPH-EIdr; 3
expiry of persistence check timer	MPH-AI; -	MPH-DI; -	MPH-DI; -	-
Notation:	- no state change; / unexpected event, no state change; MPH-EI error indication (the parameter "r" means recovery from a previously reported error condition)			
NOTE 1:	The generation of AIS may not be possible in all internal failure conditions.			
NOTE 2:	The persistence check timer shall be started upon reception of the appropriate event as indicated by "start timer". If, due to reception of another event another timer is started, a currently running timer is to be stopped and reset. The values for the timers, which may be specific for each event, shall be pre-defined. The timer values for the AN shall be: - greater for going into non-operational condition than for the LE; and - smaller for going into operational condition than for the LE.			

14.3.4 Requirements and procedures for the additional functions

CRC shall be operational in states AN/LE1 and AN/LE3 and detected CRC blocks in error shall be reported to both the remote end by setting bit E to ZERO and to the management by MPH-EIe. The management may process the CRC error information according to pre-defined thresholds and may react towards the operation system. This is outside the scope of the interface FSM. Persistent excess of error performance of 10^{-3} shall be considered as non-operational.

CRC error information may be received in states AN/LE1, AN/LE3 and AN/LE4. E bits set to ZERO, which may be received in state AN/LE1, shall be reported to the management by MPH-EIf. The management may process the CRC error information according to pre-defined thresholds and may react towards the operation system. This is outside the scope of the interface FSM. Persistent excess of error performance of 10^{-3} shall be considered as non-operational.

If the interface FSM receives the primitive MPH-Stop from the management the FSM continues to operate but shall not send the MPH-EI to the management. On receipt of the primitive MPH-Proceed it shall send the actual status (last generated MPH-EI to the management and any further one).

14.4 Control protocol

14.4.1 Control protocol message definition and content

Table 45 summarizes the messages for the ISDN and PSTN user port status and control protocol as well as the global control functions of the V5.1 interface. Reference is made to Annex C which gives requirements for the management of the AN and the LE.

Table 45: Messages for V5.1 control protocol

Message type	Reference
PORT CONTROL	14.4.1.1
PORT CONTROL ACK	14.4.1.2
COMMON CONTROL	14.4.1.3
COMMON CONTROL ACK	14.4.1.4

The different messages are specified highlighting the functional definition and information content (i.e. semantics) of each message. Each definition includes:

- a) a brief description of the message, direction and use;
- b) a table listing the information elements in the order of their appearance in the message (same relative order for all message types). For each information element the table indicates:
 - 1) the subclause of this ETS describing the information element;
 - 2) the direction which it may be sent, i.e. AN-to-LE, LE-to-AN, or both;
 - 3) whether inclusion is mandatory ("M") or optional ("O");
 - 4) the length of the information element in octets.

14.4.1.1 PORT CONTROL message

This message shall be sent by the AN or LE to convey an ISDN or PSTN user port Control-function-element information element.

Table 46: PORT CONTROL message content

Message Type: PORT CONTROL
Direction: both

Information element	Reference	Direction	Type	Length
Protocol discriminator	14.4.2.2	both	M	1
Layer 3 address	14.4.2.3	both	M	2
Message type	14.4.2.4	both	M	1
Control-function-element	14.4.2.5.4	both	M	3
Performance-grading	14.4.2.5.2	AN to LE	O (NOTE)	1

NOTE: The Performance-grading information element is included when the Control-function-element information element has value FE206.

14.4.1.2 PORT CONTROL ACK message

This message shall be sent by the AN or LE as an immediate acknowledgement of the receipt of a PORT CONTROL message and shall not be considered as a response to the control function provided.

Table 47: PORT CONTROL ACK message content

Message Type: PORT CONTROL ACK
Direction: both

Information element	Reference	Direction	Type	Length
Protocol discriminator	14.4.2.2	both	M	1
Layer 3 address	14.4.2.3	both	M	2
Message type	14.4.2.4	both	M	1
Control-function-element	14.4.2.5.4	both	M	3

14.4.1.3 COMMON CONTROL message

This message shall be sent by the AN or LE to convey information required for common, non-port specific, control functions.

Table 48: COMMON CONTROL message content

Message Type: COMMON CONTROL
Direction: both

Information element	Reference	Direction	Type	Length
Protocol discriminator	14.4.2.2	both	M	1
Layer 3 address	14.4.2.3	both	M	2
Message type	14.4.2.4	both	M	1
Control-function-ID	14.4.2.5.5	both	M	3
Variant	14.4.2.5.6	both	O (NOTE 3)	3
Rejection-cause	14.4.2.5.3	both	O (NOTE 1)	1
Interface-ID	14.4.2.5.7	both	O (NOTE 2)	5

NOTE 1: Included if Control-function-ID information element is "not ready for re-provisioning" or "cannot re-provision".

NOTE 2: Included if Control-function-ID information element is "variant and interface ID".

NOTE 3: Not included if Control-function-ID information element is "request variant and interface ID".

14.4.1.4 COMMON CONTROL ACK message

This message shall be sent by the AN or LE as an immediate acknowledgement of the receipt of a COMMON CONTROL message and shall not be considered as a response to the control function provided.

Table 49: COMMON CONTROL ACK message content

Message Type: COMMON CONTROL ACK
Direction: both

Information element	Reference	Direction	Type	Length
Protocol discriminator	14.4.2.2	both	M	1
Layer 3 address	14.4.2.3	both	M	2
Message type	14.4.2.4	both	M	1
Control-function-ID	14.4.2.5.5	both	M	3

14.4.2 General message format and information element coding

This subclause defines the message format and the coding of the information elements.

Within each octet, the bit designated "bit 1" shall be transmitted first, followed by bits 2, 3, 4, etc. Similarly, the octet shown at the top of each figure shall be sent first.

14.4.2.1 Overview

Within the V5.1 control protocol, every message shall consist of the following parts:

- a) protocol discriminator;
- b) L3 address;
- c) message type;
- d) other information elements, as required.

Information elements a), b) and c) are common to all the messages and shall always be present, while information element d) is specific to each message type.

This organization is illustrated in the example shown in figure 15.

A particular information element shall be present only once in a given message.

When a field extends over more than one octet, the order of bit values progressively decreases as the octet number increases. The least significant bit of the field shall be represented by the lowest numbered bit of the highest-numbered octet of the field.

14.4.2.2 Protocol discriminator information element

The Protocol-discriminator information element shall be as defined in subclause 13.4.2.

14.4.2.3 Layer 3 (L3) address information element

The purpose of the L3-address information element is to identify the ISDN or PSTN user port or indicate a common V5 control function.

The L3-address information element shall be the second part of every message and shall be coded as shown in figures 33 and 34. Bit 1 of octet 1 is used to differentiate between ISDN port addresses or common V5 control function and PSTN port addresses.

The L3 address value shall be coded in binary.

8	7	6	5	4	3	2	1	octet	
L3 address							0	0	1
L3 address (lower)								1	2

NOTE: The L3 address value shall be either:

- a copy of the EFaddr used for the D-channel signalling data of an ISDN user port for which the control information applies; or
- the address for the common control function which shall be as for the V5DLaddr for the control protocol and thus shall have the value 8 177.

Figure 33: Use of L3-address information element for ISDN port or common V5 control function identification

8	7	6	5	4	3	2	1	octet
L3 address							1	1
L3 address (lower)								2

NOTE: The L3 address value is a copy of the L3 address for the PSTN protocol data of the PSTN user port for which the control information applies.

Figure 34: Use of L3-address information element for PSTN port identification

14.4.2.4 Message type information element

The purpose of the Message-type information element is to identify both the protocol the message belongs to and the function of the message being sent. Table 15 defines the coding rules for the various protocol message types required in this ETS.

The Message-type information element shall be the third part of every message. The control protocol message types shall be coded as shown in figure 15 and table 50.

Table 50: Control protocol message types

Bits 7 6 5 4 3 2 1	Message type	Reference
0 0 1 0 0 0 0	PORT CONTROL	14.4.1.1
0 0 1 0 0 0 1	PORT CONTROL ACK	14.4.1.2
0 0 1 0 0 1 0	COMMON CONTROL	14.4.1.3
0 0 1 0 0 1 1	COMMON CONTROL ACK	14.4.1.4

NOTE: All other values of control protocol message types are reserved.

14.4.2.5 Other information elements

14.4.2.5.1 Coding rules

For the coding of the information elements, the same rules apply as defined in ETS 300 102-1 [6], Clause 4, without the functionality of the Shift information element. (there shall only be one code set).

The information elements are defined in the following subclauses and summarized in table 51, which also gives the coding of the information element identifier bits.

Table 51: Information element identifier coding

Bits								Name	Reference	Length
8	7	6	5	4	3	2	1			
1	-	-	-	x	x	x	x	SINGLE OCTET	---	-
1	1	1	0	x	x	x	x	Performance grading	14.4.2.5.2	1
1	1	1	1	x	x	x	x	Rejection cause	14.4.2.5.3	1
0	-	-	-	-	-	-	-	VARIABLE LENGTH	---	-
0	0	1	0	0	0	0	0	Control function element	14.4.2.5.4	3
0	00	1	0	0	0	0	1	Control function ID	14.4.2.5.5	3
0	0	1	0	0	0	1	0	Variant	14.4.2.5.6	3
0		1	0	0	0	1	1	Interface ID	14.4.2.5.7	5

NOTE: All other values are reserved.

14.4.2.5.2 Performance grading information element

This information element indicates the performance range currently being achieved. See figure 35 and table 52.

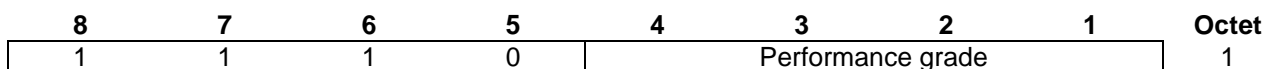

Figure 35: Performance-grading information element

Table 52: Coding of the performance grade

Bits				Performance grade
4	3	2	1	
0	0	0	0	normal grade
0	0	0	1	degraded
0	0	1	0	not used
"	"	"	"	"
1	1	1	1	not used

14.4.2.5.3 Rejection cause information element

This information element indicates the reason for rejecting a "VERIFY RE-PROVISIONING" or "SWITCH-OVER-TO-NEW-VARIANT" Control-function-ID value. See figure 36 and table 53.

8	7	6	5	4	3	2	1	Octet
1	1	1	1	Rejection cause				1

Figure 36: Rejection-cause information element

Table 53: Coding of rejection cause

Bits 4 3 2 1	Rejection cause
0 0 0 0	variant unknown
0 0 0 1	variant known, not ready
0 0 1 0	re-provisioning in progress (re-pro)
NOTE: All other values are reserved.	

14.4.2.5.4 Control function element information element

This information element identifies the ISDN or PSTN user port status and Control function element to be conveyed by the message. See figure 37 and table 54.

8	7	6	5	4	3	2	1	Octet
0	0	1	0	0	0	0	0	1
Length of control function element contents								2
1 ext.	Control function element							3

Figure 37: Control-function-element information element

Table 54: Coding of control function element

Bits (octet 3) 7 6 5 4 3 2 1	Control function element
0 0 0 0 0 0 1	FE101 (activate access)
0 0 0 0 0 1 0	FE102 (activation initiated by user)
0 0 0 0 0 1 1	FE103 (DS activated)
0 0 0 0 1 0 0	FE104 (access activated)
0 0 0 0 1 0 1	FE105 (deactivate access)
0 0 0 0 1 1 0	FE106 (access deactivated)
0 0 1 0 0 0 1	FE201/202 (unblock)
0 0 1 0 0 1 1	FE203/204 (block)
0 0 1 0 1 0 1	FE205 (block request)
0 0 1 0 1 1 0	FE206 (performance grading)
0 0 1 0 1 1 1	FE207 (D-channel block)
0 0 1 1 0 0 0	FE208 (D-channel unblock)
NOTE: All other values are reserved.	

14.4.2.5.5 Control function ID information element

This information element identifies the common control function identity to be conveyed by the message. See figure 38 and table 55.

8	7	6	5	4	3	2	1	Octet
0	0	1	0	0	0	0	1	1
Length of control function ID contents								2
1 ext.	Control function ID							3

Figure 38: Control-function-ID information element

Table 55: Coding of control function ID

Bits (octet 3) 7 6 5 4 3 2 1	Control function ID	Optional information element considered mandatory
0 0 0 0 0 0 0	Verify re-provisioning	Variant
0 0 0 0 0 0 1	Ready for re-provisioning	Variant
0 0 0 0 0 1 0	Not ready for re-provisioning	Variant, rejection cause
0 0 0 0 0 1 1	Switch-over to new variant	Variant
0 0 0 0 1 0 0	Re-provisioning started	Variant
0 0 0 0 1 0 1	Cannot re-provision	Variant, rejection cause
0 0 0 0 1 1 0	Request variant and interface ID	-
0 0 0 0 1 1 1	Variant and interface ID	Variant, interface ID
0 0 0 1 0 0 0	Blocking started	-
0 0 1 0 0 0 0	Restart request	-
0 0 1 0 0 0 1	Restart complete	-

NOTE: All other values are reserved.

14.4.2.5.6 Variant information element

This information element identifies the new provisioning variant when specifying the "VERIFY RE-PROVISIONING" value in the content of the Control-function-ID information element. This information element also identifies the variant of current provisioning data set when specifying the "VARIANT & INTERFACE ID" value in the content of the Control-function-ID information element. See figure 39 and table 56.

8	7	6	5	4	3	2	1	Octet
0	0	1	0	0	0	1	0	1
Length of variant contents								2
1 ext.	Variant							3

Figure 39: Variant information element

Table 56: Coding of variant

Bits (octet 3) 7 6 5 4 3 2 1	Variant
0 0 0 0 0 0 0	Variant 0
0 0 0 0 0 0 1	Variant 1
0 0 0 0 0 1 0	Variant 2
" " " " " " "	"
1 1 1 1 1 1 1	Variant 127

14.4.2.5.7 Interface ID information element

This information element identifies the specific V5.1 interface via which the "REQUEST VARIANT & INTERFACE ID" value within the Control-function-ID information element has been received. See figure 40 and table 57.

8	7	6	5	4	3	2	1	Octet
0	0	1	0	0	0	1	1	1
Length of interface ID contents								2
Interface ID (upper)								3
Interface ID								4
Interface ID (lower)								5

Figure 40: Interface ID information element

Table 57: Coding of interface ID

Octet	Bits								Interface ID
	8	7	6	5	4	3	2	1	
1	0	0	0	0	0	0	0	0	Interface 0
2	0	0	0	0	0	0	0	0	
3	0	0	0	0	0	0	0	0	
1	0	0	0	0	0	0	0	0	Interface 1
2	0	0	0	0	0	0	0	0	
3	0	0	0	0	0	0	0	1	
	"	"	"	"	"	"	"	"	"
1	1	1	1	1	1	1	1	1	Interface 2 ²⁴ -1
2	1	1	1	1	1	1	1	1	
3	1	1	1	1	1	1	1	1	

14.4.3 State definitions of the control protocol

14.4.3.1 Port control protocol

a) OUT OF SERVICE:

this state shall be entered when the system is started or MDU-stop_traffic is received from the system management and shall be applicable to all port-related control protocol entities simultaneously.

b) IN SERVICE:

this state shall be entered when the control protocol entity is in the OUT OF SERVICE state and receives an MDU-start_traffic from the system management.

c) AWAIT PORT ACK:

this state shall be entered when a PORT CONTROL message has been sent to the CONTROL-DL.

14.4.3.2 Common control protocol

a) OUT OF SERVICE:

this state shall be entered when the system is started or MDU-stop_traffic is received from the system management.

b) IN SERVICE:

this state shall be entered when the control protocol entity is in the OUT OF SERVICE state and receives an MDU-start_traffic from the system management.

c) AWAIT COMMON ACK:

this state shall be entered when a COMMON CONTROL message has been sent to the CONTROL-DL.

14.4.4 Control protocol procedures

14.4.4.1 General

This subclause specifies the procedures for the control protocol. The control protocol is symmetrical, i.e. that the procedures apply to both the AN and the LE side of the V5.1 interface. Two types of procedures are identified:

a) port-related control protocol procedures (see subclause 14.4.4.3):

a port-related control protocol entity exists for each PSTN and ISDN port;

b) common control protocol procedures (see subclause 14.4.4.4):

only one common protocol entity exists.

In addition to the above procedures, each message received by a control protocol entity shall pass the error handling procedures specified in subclause 14.4.4.2 before being further processed.

The description of the procedure is for a single event (FE or MDU-CTRL) only to be handled at the same point in time. There shall be a memory per port or protocol entity in the AN and LE to store further events to be transmitted in the order received from the FSM. The next event shall be transmitted when the relevant control protocol FSM has entered state 1.

Each control protocol message contains a layer 3 address to identify the particular PSTN or ISDN port or the common control protocol entity.

Control protocol messages shall be sent to the data link using a DL-Data-Request primitive; the data link service is specified in Clause 10.

Detailed SDL diagrams are contained in Annex L, subclauses L.1.5 and L.2.5.

14.4.4.2 Handling of error conditions

Before acting upon a message, the receiving entity, either the AN V5 Control Protocol entity or the LE V5 Control Protocol entity, shall perform the procedures specified in this subclause.

As a general rule, all messages shall contain, at least: the Protocol-discriminator, the L3-address and the Message-type information elements. These information elements are specified in subclause 14.4.2. When receiving a message having less than 4 octets, the receiving protocol entity in the AN or LE shall generate a Protocol error indication to the system management and ignore the message.

If more than 2 optional information elements are detected within a message, then the message shall be considered as too long and shall be truncated after the second optional information element. All the truncated information is assumed to be repeated optional information elements. When doing the truncation, the entity shall react according to subclause 14.4.4.2.4 for repeated optional information elements.

Each receipt of a control message shall activate the checks described in subclauses 14.4.4.2.1 through 14.4.4.2.10 by order of precedence. No state change occurs during these checks.

If an error is detected by the checks the relevant protocol entity (i.e. the LE V5 control protocol entity or the AN V5 control protocol entity) shall generate an internal error indication.

After the message has been checked using the error handling procedures following and if the message is not to be ignored, then either:

- port-related control protocol procedures (see subclause 14.4.4.5); or
- common control protocol procedures (see subclause 14.4.4.6) shall follow.

Within this subclause the term "Ignore the message" means to do nothing with the message content.

14.4.4.2.1 Protocol discriminator error

When a message is received in a L3 control protocol entity with a protocol discriminator coded different to the specification of the protocol discriminator in subclause 13.4.2, the V5 Control Protocol entity shall generate an internal error indication and ignore the message.

14.4.4.2.2 L3 address error

If the L3 address is:

- a) not coded as specified in subclause 14.4.2.3; or
- b) the value is not recognized or doesn't correspond to an existing PSTN or ISDN user port, then:
 - the V5 Control Protocol entity shall generate an internal error indication and ignore the message.

14.4.4.2.3 Message type error

Whenever an unrecognized message is received:

- the V5 Control Protocol entity shall generate an internal error indication and ignore the message.

14.4.4.2.4 Repeated information elements

If a mandatory information element is repeated in a message, the reaction of the receiving entity shall be as follows:

- the V5 Control Protocol entity shall generate an internal error indication and ignore the message.

If an optional information element is repeated in a message the reaction of the receiving entity shall be as follows:

- the V5 Control Protocol entity shall remove the repeated information elements and continue with the processing of the message; it shall also generate an internal error indication.

14.4.4.2.5 Mandatory information element missing

When a message is received with a mandatory information element missing, then:

- the V5 Control Protocol entity shall generate an internal error indication and ignore the message.

14.4.4.2.6 Unrecognized information element

When a message is received with one or more information elements unrecognized, then:

- the V5 Control Protocol entity shall remove all the unrecognized information elements and continue with the processing of the message; It shall also generate an internal error indication.

For the purpose of the error handling procedures unrecognized information elements shall be those that are not defined within this ETS.

14.4.4.2.7 Content error of mandatory information elements

When a message is received with a mandatory information element having a content error, either:

- a) the length is not conform to the length specified in subclause 14.4.2; or
- b) the content is not known, then:
 - the V5 Control Protocol entity shall generate an internal error indication and ignore the message.

For the purpose of the error handling procedures information element content errors are codepoints included within a particular information element that are not defined within this ETS.

14.4.4.2.8 Content error of optional information element

When a message is received with an optional information element having a content error, either:

- a) the length is not conform to the length specified in subclause 14.4.2; or
- b) the content is not known, then:
 - the V5 Control Protocol entity shall remove the information element and continue with the processing of the message; it shall also generate an internal error indication.

For the purpose of the error handling procedures information element content errors are codepoints included within a particular information element that are not defined within this ETS.

14.4.4.2.9 Optional information element not allowed

When a PORT CONTROL ACK or COMMON CONTROL ACK message is received containing an optional information element, a PORT CONTROL message is received by the AN V5 Control Protocol entity containing an optional information element, a PORT CONTROL message is received by the LE V5 Control Protocol entity containing more than one optional information element, or a COMMON CONTROL message is received containing more than two optional information elements, the receiving entity shall react as follows:

- the V5 Control Protocol entity shall generate an internal error indication and ignore the message.

14.4.4.2.10 Optional information element missing

When a COMMON CONTROL message is received not containing one of the optional information elements associated to the control function ID as specified in tables 50 and 57, the message shall be handled according to subclause 14.4.4.2.5 as if a mandatory information element is missing.

14.4.4.3 Start traffic indication

Normal operation:

If a port-related control protocol entity or common control protocol entity receiving in the OUT OF SERVICE state an MDU-start_traffic from the system management entity the IN SERVICE state shall be entered.

Exceptional procedures:

If a port-related control protocol entity receives in the OUT OF SERVICE state any PORT CONTROL message or any FE an MDU-error-indication shall be generated. No state change occurs.

If a common control protocol entity receives in the OUT OF SERVICE state any COMMON CONTROL message or any MDU-CTRL an MDU-error-indication shall be generated. No state change occurs.

14.4.4.4 Stop traffic indication

Normal operation:

If a port-related control protocol entity or common control protocol entity receiving in the IN SERVICE or the AWAIT PORT ACK/AWAIT COMMON ACK state an MDU-stop_traffic from the system management entity the OUT OF SERVICE state shall be entered.

Exceptional procedure:

None.

14.4.4.5 Port control protocol procedure

Normal operation:

When a port-related control protocol entity is in the IN SERVICE state and:

- receives a PORT CONTROL message, a PORT CONTROL ACK message with the same Control function element shall be sent and the FE contained in the message shall be sent to the associated port status FSM. The port-related control protocol entity shall remain in the IN SERVICE state;
- receives from the associated port status FSM a FE, or if there is any saved FE, a PORT CONTROL message containing the FE shall be sent, timer T01 shall be started and the state AWAIT PORT ACK shall be entered.

If a PORT CONTROL message is received in the AWAIT PORT ACK state a PORT CONTROL ACK message shall be sent and the FE contained in the message shall be sent to the associated port status FSM. The port-related control protocol entity shall remain in the AWAIT PORT ACK state.

If a FE is received in the AWAIT PORT ACK state from the associated port status FSM, the FE shall be saved and the port-related control protocol entity remains in the AWAIT PORT ACK state.

Upon reception of a PORT CONTROL ACK message in the AWAIT PORT ACK state, timer T01 shall be stopped and the IN SERVICE state shall be entered.

Exceptional procedures:

If a PORT CONTROL ACK message is received containing an unexpected Control function element, the message shall be treated as defined in subclause 14.4.4.2.7 (content error of mandatory information element).

If timer T01 expires the first time the PORT CONTROL message shall be repeated and timer T01 shall be started. No state change occurs.

If timer T01 expires the second time an error indication shall be sent to the management entity and the IN SERVICE state shall be entered.

14.4.4.6 Common control protocol procedure

Normal procedure:

When the common control protocol entity is in the IN SERVICE state and receives:

- a COMMON CONTROL message, a COMMON CONTROL ACK message with the same control function ID shall be sent and an MDU containing the control function ID and if received the variant, the rejection cause and the interface ID shall be sent to the system management entity. The common control protocol entity shall remain in the IN SERVICE state;
- from system management entity an MDU, or if there is any saved MDU, a COMMON CONTROL message containing the control function ID and if received the variant, the rejection cause and the interface ID shall be sent, timer T02 shall be started and the state AWAIT COMMON ACK shall be entered.

If a COMMON CONTROL message is received in the AWAIT COMMON ACK state a COMMON CONTROL ACK message shall be sent and an MDU containing the control function ID and if received the variant, the rejection cause and the interface ID shall be sent to the system management entity. The common control protocol entity shall remain in the AWAIT COMMON ACK state.

If an MDU is received in the AWAIT COMMON ACK state from the system management entity, the MDU shall be saved and the common control protocol entity shall remain in the AWAIT COMMON ACK state.

Upon reception of a COMMON CONTROL ACK message in the AWAIT COMMON ACK state, timer T02 shall be stopped and the IN SERVICE state shall be entered.

Exceptional procedures:

If a COMMON CONTROL ACK message is received containing an unexpected Control function id, the message shall be treated as defined in subclause 14.4.4.2.7 (content error of mandatory information elements).

If timer T02 expires the first time the COMMON CONTROL message shall be repeated and timer T02 shall be started. No state change occurs.

If timer T02 expires the second time an error indication shall be sent to the management entity and the IN SERVICE state shall be entered.

14.4.4.7 Timers for the control protocol

The timers for the control protocol in the AN and the LE are specified in table 58. All the timers defined in table 58 shall have a maximum tolerance of $\pm 10\%$.

Table 58: Timers for the control protocol

Timer number	Timeout value	State	Cause for start	Normal stop
T01	1 s	AN1(CTRL port) LE1(CTRL port)	PORT CONTROL message sent	PORT CONTROL ACK message received
T02	1 s	AN1(CTRL common) LE1(CTRL common)	COMMON CONTROL message sent	COMMON CONTROL ACK message received

14.4.4.8 AN and LE side state tables

Table 59 defines the state transition table of the port control protocol and table 60 defines the state transition table of the common control protocol for the AN side of the V5.1 interface. Table 61 defines the state transition table of the port control protocol and table 62 defines the state transition table of the common control protocol for the LE side of the V5.1 interface.

Table 59: Port control protocol state transition table - AN (CTRL port)

state event	OUT OF SERVICE AN0	IN SERVICE AN1	AWAIT PORT ACK AN2
MDU-start_traffic	AN1	-	-
MDU-stop_traffic	-	stop T01; AN0	stop T01; AN0
FE or saved FE	send MDU-error_indication; -	send PORT CONTROL; start T01; AN2	save new received FE; -
PORT CONTROL	send MDU-error_indication; -	send FE; send PORT CONTROL ACK; -	send FE; send PORT CONTROL ACK; -
PORT CONTROL ACK	send MDU-error_indication; -	/	stop T01; AN1
timeout T01	/	/	first expiry: repeat PORT CONTROL; start T01; - second expiry: send MDU-error_indication; AN1
Notation: UPPER CASE = external message or event; lower case = internal message or event; - = no state change; / = unexpected event, no state change;			

Table 60: Common control protocol state transition table - AN (CTRL common)

event	state	OUT OF SERVICE AN0	IN SERVICE AN1	AWAIT COMMON ACK AN2
MDU-start_traffic		AN1	-	-
MDU-stop_traffic		-	stop T02; AN0	stop T02; AN0
MDU-CTRL or saved MDU-CTRL		send MDU-error_indication; -	send COMMON CONTROL; start T02; AN2	save new received MDU-CTRL; -
COMMON CONTROL		send MDU-error_indication; -	send MDU-CTRL; send COMMON CONTROL ACK; -	send MDU-CTRL; send COMMON CONTROL ACK; -
COMMON CONTROL ACK		send MDU-error_indication; -	/	stop T02; AN1
timeout T02		/	/	first expiry: repeat COMMON CONTROL; start T02; - second expiry: send MDU-error_indication; AN1
Notation: UPPER CASE = external message or event; lower case = internal message or event; - = no state change; / = unexpected event, no state change				

Table 61: Port control protocol state transition table - LE (CTRL port)

event	state	OUT OF SERVICE LE0	IN SERVICE LE1	AWAIT PORT ACK LE2
MDU-start_traffic		LE1	-	-
MDU-stop_traffic		-	stop T01; LE0	stop T01; LE0
FE or saved FE		send MDU-error_indication; -	send PORT CONTROL; start T01; LE2	save new received FE; -
PORT CONTROL		send MDU-error_indication; -	send FE; send PORT CONTROL ACK; -	send FE; send PORT CONTROL ACK; -
PORT CONTROL ACK		send MDU-error_indication; -	/	stop T01; LE1
timeout T01		/	/	first expiry: repeat PORT CONTROL; start T01; - second expiry: send MDU-error_indication; LE1
Notation: UPPER CASE = external message or event; lower case = internal message or event; - = no state change; / = unexpected event, no state change				

Table 62: Common control protocol state transition table - LE (CTRL common)

event	state	OUT OF SERVICE LE0	IN SERVICE LE1	AWAIT COMMON ACK LE2
MDU-start_traffic		LE1	-	-
MDU-stop_traffic		-	stop T02; LE0	stop T02; LE0
MDU-CTRL or saved MDU-CTRL		send MDU-error_indication; -	send COMMON CONTROL; start T02; LE2	save new received MDU-CTRL; -
COMMON CONTROL		send MDU-error_indication; -	send MDU-CTRL; send COMMON CONTROL ACK; -	send MDU-CTRL; send COMMON CONTROL ACK; -
COMMON CONTROL ACK		send MDU-error_indication; -	/	stop T02; LE1
timeout T02		/	/	first expiry: repeat COMMON CONTROL; start T02; - second expiry: send MDU-error_indication; LE1
Notation: UPPER CASE = external message or event; lower case = internal message or event; - = no state change; / = unexpected event, no state change				

14.5 V5.1 re-provisioning procedures

14.5.1 General aspects

The re-provisioning procedures have been designed in order to check and if necessary to change the provisioning variant currently being used by a V5.1 interface.

It is essential that a network provider can tell the following information about a V5.1 interface:

- a) the unique number of the interface which has been currently assigned to it;
- b) the current provisioning variant of the interface;
- c) when the interface should be switched over to a new provisioning variant.

The main purpose of these procedures is to ensure that re-provisioning is achieved in a structured and synchronized manner.

The network provider may choose not to use the information or procedures on re-provisioning provided within this subclause.

14.5.2 Events and states

14.5.2.1 Events

Table 63 gives the events relevant for the re-provisioning state table. Events in capital letters used in the following tables are layer 3 messages of the common control protocol; events in small letters refer to internal events to the system management.

Table 63: Events for re-provisioning procedures

Messages and internal events	AN LE	Description
SONV	<->	SWITCH-OVER TO NEW VARIANT
BS	<--	BLOCKING STARTED
RS	-->	RE-PROVISIONING STARTED
CR	<->	CANNOT RE-PROVISION
REQUEST V&ID	<->	REQUEST VARIANT & INTERFACE ID
V&ID	<->	VARIANT & INTERFACE ID
VERIFY	<->	VERIFY RE-PROVISIONING
READY	<->	READY FOR RE-PROVISIONING
NOT READY	<->	NOT READY FOR RE-PROVISIONING
sonv		Switch-over to new variant
bs (LE)		Blocking started
rs (AN)		Re-provisioning started
cr		Cannot re-provision
request v&id		Request variant & ID
v&id		Variant & ID
verify		Verify re-provisioning
ready		Ready for re-provisioning
not ready		Not ready for re-provisioning

14.5.2.2 Definition of the AN and LE states for the re-provisioning procedures

The states are defined to illustrate the re-provisioning procedure. It is outside the scope of this ETS whether they are implemented in the relevant system management or in the operation system.

- AN0 Normal (Not ready for re-provisioning);
AN1 Ready for re-provisioning;
AN2 Re-provisioning in progress.

LE0	Normal (Not ready for re-provisioning);
LE1	Ready for re-provisioning; ports operational;
LE2	Ready for re-provisioning; ports blocked;
LE3	Re-provisioning in progress.

14.5.3 Re-provisioning FSMs

The state tables are given for the definition of the functional behaviour of the LE or AN including the system management and the operation system. There shall be no restriction for the implementation of these functions as long as the implementation is in conformance with the functionality defined in this ETS.

NOTE: For further information on the split of functionality between the relevant system management and the operation system refer to the Q3 interface specifications for the configuration management (see ETS 300 376 and ETS 300 377).

14.5.3.1 AN (variant&ID) and LE (variant&ID) state tables for the verification procedure

Tables 64 and 65 give the state tables for the AN (variant&ID) and LE (variant&ID) request variant & ID and verify re-provisioning procedures. The states in tables 64 and 65 shall be controlled by the state tables given in tables 66 and 67. Therefore the action done on receipt of an event does not cause a state change.

Table 64: AN (variant&ID) state table

event	state	AN0	AN1	AN2
request v&id		REQUEST V&ID	REQUEST V&ID	/
REQUEST V&ID		V&ID	V&ID	-
V&ID		v&id	v&id	-
verify		VERIFY	VERIFY	/
VERIFY		verify	verify	verify
ready		/	READY	/
READY		ready	ready	/
not ready (cause)		NOT READY (cause)	NOT READY (cause)	NOT READY (cause)
NOT READY		not ready	not ready	-
Notation: UPPER CASE = layer 3 messages; lower case = internal event; - = no action; / = unexpected event				

Table 65: LE (variant&ID) state table

event	state	LE0	LE1	LE2	LE3
request v&id		REQUEST V&ID	REQUEST V&ID	REQUEST V&ID	/
REQUEST V&ID		V&ID	V&ID	V&ID	-
V&ID		v&id	v&id	v&id	-
verify		VERIFY	VERIFY	VERIFY	/
VERIFY		verify	verify	verify	verify
ready		/	READY	READY	/
READY		ready	ready	ready	/
not ready (cause)		NOT READY (cause)	NOT READY (cause)	NOT READY (cause)	NOT READY (cause)
NOT READY		not ready	not ready	not ready	-
Notation: UPPER CASE = layer 3 messages; lower case = internal event; - = no action; / = unexpected event					

14.5.3.2 AN (re-pro) and LE (re-pro) state tables for the re-provisioning synchronization procedure

Tables 66 and 67 give the AN (re-pro) and the LE (re-pro) state tables for the re-provisioning synchronization procedure respectively.

Table 66: AN (re-pro) state table

event	state	AN0	AN1	AN2
SONV (variant known)		/	sonv; -	CR (re-pro); -
SONV (unknown)		CR (unknown); -	CR (unknown); -	CR (unknown); -
BS		/	bs; -	/
rs		/	RS; AN2	/
re-provisioning completed		/	/	AN0
CR		-	cr; -	/
cr		/	CR (cause); -	/
data set available		AN1	/	-
sonv		/	SONV; -	-
remove variant		-	AN0	/

Notation: - no state change; / unexpected event, to be reported to management, no state change

Table 67: LE (re-pro) state table

event	state	LE0	LE1	LE2	LE3
SONV (variant known)		/	sonv; -	/	CR (re-pro); -
SONV (unknown)		CR (unknown); -	CR (unknown); -	CR (unknown); -	CR (unknown); -
bs		/	BS; -	/	/
rs		/	/	SONV; -	/
re-provisioning completed		-	-	/	LE0
CR		-	-	cr; -	-
cr		/	/	CR (cause); -	/
data set available		LE1	/	/	-
sonv		/	SONV; -	/	-
remove variant		-	LE0	LE0	/
RS		/	/	rs; LE3	/
ports blocked		/	SONV; LE2	/	/
ports unblocked		-	-	LE0	/

Notation: - no state change; / unexpected event, to be reported to management, no state change

14.5.4 Procedures

This procedure describes the mechanism used to identify the individual V5.1 interfaces and the labels of their current and new provisioning variants (see subclause 7.1.1, item 10).

Re-provisioning shall only be applied when the relevant ports are in the blocked state (see subclause 7.2.2, item 3).

Changing the provisioning (re-provisioning) can be synchronized (see subclause 7.2.2, item 9) but the TMN function shall be responsible for applying the procedure and the consistency of the provisioning data set.

Table 55 shows the coding of the Control-function-ID information element, this information element shall be used for re-provisioning verification and synchronization. Annex C introduces these procedures from the AN and LE system management point of view.

Tables 64 to 67 give the state tables (AN (variant&ID), LE (variant&ID), AN (re-pro) and LE (re-pro)) for these procedures in a functional way, neither enforcing nor excluding any particular implementation. Some or all of the implicit functionality shown in the tables shall be system management or operation system functionality. Internal events may be regarded as information flow between the common control protocol entity and any other entity of the AN or LE.

14.5.4.1 Request variant and ID

Either side (AN or LE) can request the variant and interface ID from the opposing side using the "REQUEST VARIANT & INTERFACE ID" value within the Control-function-ID information element in a COMMON CONTROL message. The other side shall return the following information:

- a) the label of the current provisioning data set;
- b) the V5.1 interface ID.

In states AN2/LE3 (re-provisioning in progress) this sub-procedure is not applicable.

14.5.4.2 Verify re-provisioning

Either side (AN or LE) can request the other side to verify the label of a new provisioning data set. By means of the Control-function-ID information element, the response should either be:

- a) "READY FOR RE-PROVISIONING";
- b) "NOT READY FOR RE-PROVISIONING" (with cause).

In states AN0/LE0 the response shall always be "NOT READY FOR RE-PROVISIONING" with the cause value "unknown variant" because the new data set is unavailable.

In states AN2/LE3 the response shall always be "NOT READY FOR RE-PROVISIONING" with the cause value "re-provisioning in progress".

14.5.4.3 Re-provisioning synchronization

- a) The normal procedure, initiated by LE (see figure C.1)

The event "data set available" in LE0/AN0 results in states LE1/AN1.

After blocking of the relevant ports (LE2) using the event "switch-over to new variant" the LE sends "SWITCH-OVER TO NEW VARIANT" value of the Control-function-ID information element to the AN resulting in "RE-PROVISIONING STARTED" value of the Control-function-ID information element being sent to the LE and hence the new states AN2/LE3 (Re-provisioning in progress).

After receipt of the event "re-provisioning completed", the LE and AN shall return to LE0/AN0 respectively. Both sides should then unblock the relevant ports.

- b) The normal procedure, initiated by AN (see figure C.2)

The event "data set available" in LE0/AN0 results in states LE1/AN1.

The AN may initiate the re-provisioning by the event "switch-over to new variant" from AN management and sends "SWITCH-OVER TO NEW VARIANT" value of the Control-function-ID information element to the LE. The LE shall respond with either "BLOCKING STARTED" value of the Control-function-ID information element, if the relevant ports are still operational (LE1), or "SWITCH-OVER TO NEW VARIANT" value of the Control-function-ID information element, if the relevant ports are blocked (LE2). On receipt of "SWITCH-OVER TO NEW VARIANT" value of the Control-function-ID information element the AN may proceed with "RE-PROVISIONING STARTED" value of the Control-function-ID information element sent to the LE and hence the new states shall be AN2/LE3.

After receipt of the event "re-provisioning completed", the LE and AN shall return to LE0/AN0 respectively. Both sides should then unblock the relevant ports.

- c) The exception procedure initiated by AN or LE, but with invalid variant

The event "data set available" in LE0/AN0 results in states LE1/AN1.

Either using the event "switch-over to new variant" the AN sends "SWITCH-OVER TO NEW VARIANT" value of the Control-function-ID information element to the LE or, after blocking of the relevant ports the LE using the event "switch-over to new variant" the LE sends "SWITCH-OVER TO NEW VARIANT" value of the Control-function-ID information element to the AN. The response from either side shall be "CANNOT RE-PROVISION" value of the Control-function-ID information element with cause "unknown variant".

- d) The exception procedure initiated by LE, but with AN in state AN2

Sending "SWITCH-OVER TO NEW VARIANT" value of the Control-function-ID information element to the AN results in "CANNOT RE-PROVISION" value of the Control-function-ID information element with cause "re-provisioning in progress".

- e) The exception procedure ("Remove Variant")

The TMN can instruct either end to back out of re-provisioning. The state table assumes that LE management shall ensure that the "data set available" indication is not given to the state table until the management has received an outstanding "RE-PROVISIONING STARTED" value of the Control-function-ID information element.

14.5.4.4 Restart procedure

The restart procedure of the PSTN protocol shall be invoked by AN or LE system management, as defined in Annex C, item 14) and subclause 13.5.4.3.

There is no restart procedure defined for the control protocol because the port-related and common control procedures are defined in a way that re-alignment of the protocol entities and the FSMs is achieved by application of inherent procedures (e.g unblock procedure for ports). The control protocol however supports PSTN protocol restart through the transport the restart and restart acknowledge messages.

Annex A (normative): Requirements for the support of the PL capability through an ISDN basic access

Permanent lines bypass the LE and are outside the scope of the V5.1 interface specification with the exception that the information about the access capability of the ISDN basic access user ports of the AN for services under control of the LE needs to be available in the LE. This is a provisioning requirement and described in Clause 7. The necessary support from the control point of view is specified in subclause 14.1.

Annex B (normative): Assumptions and requirements for the support of semi-permanent leased lines

B.1 General

Semi-permanent leased lines pass through the V5.1 interface.

For the V5.1 interface, where the connection for all bearer channels is established between the user port of the AN and the LE as part of the provisioning of the V5.1 interface, no additional procedure between the LE and the AN is required for the support of semi-permanent leased lines.

Pre-defining the user port according to the requirements of the user is under the responsibility of the AN and therefore outside the scope of the V5.1 interface specification.

B.2 Signalling associated to semi-permanent leased lines

User to user signalling capability may be provided for example by:

- inband signalling (conversion of any outband signalling at the user port is subject of the AN) through the bearer channel;
- use of another connection available to the user which is seen from the network as a transparent bearer channel;
- for services via the ISDN basic access user to user signalling within the D-channel protocol as specified in ETS 300 102 [6] and the relevant supplementary service specification.

All these methods do not have any impact on the V5.1 interface specification.

B.3 User ports

The semi-permanent leased line may be provided to the user:

- 1) through an ISDN user port, in parallel to on-demand services;
- 2) through another (non-ISDN) user port, not provisioned for the support of on-demand services, either with an analogue or digital interface.

Case 1) is fully covered by the existing specification for the ISDN user port defined in this ETS.

For case 2) the user port control and associated requirements are defined below on the basis of the assumption made concerning the user port types. Two types of user port need to be distinguished:

- a) analogue port with single bearer channel (e.g. with a 2 wire or 4 wire interface), or digital port with single bearer channel, e.g. with an interface according to CCITT Recommendation G.703 (64 kbit/s or X type interface of the data networks);

NOTE: For the purposes of the definition of the V5 interface related requirements there is no need to distinguish between an analogue and a digital port providing a single bearer channel only, because all such ports look like digital ports at the V5 interface.

- b) digital port with multiple bearer channels of 64 kbit/s, e.g. with an interface according to CCITT Recommendations I.430, I.431, G.703/704 with 2 048 kbit/s or X type interface of the data networks. It is not required that all the bearer channels provided by this are provisioned for the support of semi-permanent leased lines. Those bearer channels not provisioned for semi-permanent leased lines may be provisioned for permanent leased lines under the responsibility of the AN or not used at all.

It shall be a requirement for the AN provisioning to configure the electrical and functional interface characteristics of those types of ports.

B.4 Requirements for non-ISDN user ports for semi-permanent leased lines

This Clause defines the requirements relevant to the V5 interface for non-ISDN ports for the support of semi-permanent leased lines.

The provisioning data for those types of user ports shall contain the information for the LE on the bearer capability supported by the user port, i.e. single bearer channel port or multiple bearer channel port and for the latter case the number of 64 kbit/s bearer channels for semi-permanent leased lines and the bearer channel identification.

For the control and status indication of user ports through the control protocol in AN and LE, an address shall be allocated to the semi-permanent leased line user port through provisioning.

Single bearer channel user ports shall use an address of the PSTN address range (L3addr). This address shall be used in PORT CONTROL messages of the control protocol as defined in subclause 14.4.2.3.

NOTE 1: The same address should be used in the V5.2 interface by the Bearer Channel Connection (BCC) protocol for connection control because there is no need for time slot identification in a single bearer channel user port.

Multiple bearer channel user ports shall use an address of the ISDN port address range (EFaddr). This address shall be used in PORT CONTROL messages of the control protocol as defined in subclause 14.4.2.3.

NOTE 2: The same address should be used in the V5.2 interface by the BCC protocol for connection control. This address provides the capability for time slot identification required for a multiple bearer channel user port in the V5.2 interface.

The user port control and status indication shall be as defined in subclause 14.2. A blocking request from the AN, however, shall be rejected by the LE system management if a semi-permanent leased line is currently established through this user port. For this, subclause 14.1.3.3.3, third paragraph, applies.

NOTE 3: There is only the need to identify at the LE whether the user port is out of service (blocked or in unblocking procedure) or in service (operational). Any other user port implementation related function shall be the AN responsibility and shall be taken into account in any necessary extension of the AN port control FSM required to maintain such type of user port. This is outside the scope of the V5 interface specification. One example is that there shall be no requirement to handle activation and deactivation by the LE for a user port implemented like an ISDN basic access port but not used for on demand services. The V5 interface shall not be concerned with any dedicated implementation aspect of such type of user port, e.g. permanently active by implementation or by AN control.

Any message received by the AN or LE PSTN protocol entity or by the AN frame relay function having an address, which has been allocated to a semi-permanent leased line user port, shall be considered invalid in those entities and discarded.

Annex C (normative): Basic requirements of the system management functions in AN and LE

- 1) Procedure for the ISDN basic access continuity test.

ETS 300 297 [4] defines a continuity test procedure for the verification of the status of the ISDN basic access for example a certain time without activity. The procedure is based on the requirements defined in ETR 001. The test uses the elements of the activation procedure and is to be initiated by the LE on the knowledge of the service activity and service provision. If the test fails the mechanism to verify the situation is the failure localization under the responsibility of the AN.

In order to support the split of control functions between LE and AN for the ISDN basic access the AN shall operate the timer T1 function as specified in subclause 14.1. Timer T1 is not required in the LE. The information about an unsuccessful activation, which is relevant for the identification of the appropriate cause to be sent to reject an incoming call, can be taken from the receipt of FE106 when being in state LE2.1.

Timer T1 is defined in ETS 300 012 [3].

MPH-T1 may be used in the AN to initiate the necessary verification tests which requires blocking of the user port. The AN does not know whether the activation attempt from the LE was initiated for delivery of an incoming call or for the continuity test. The LE considers the port operational even after unsuccessful activation and it shall be the responsibility of the AN to clarify the port status.

- 2) The AN management shall not send MPH-BR when the port is in one of the non-operational substates.

The LE management may respond with MPH-BI within an appropriate time frame according to the service conditions of this user port. See also subclause 7.1.1.3). In case of semi-permanent connections the LE-management shall issue MPH-UBI.

If the AN management has erroneously sent a blocking request to the LE the AN management may cancel the blocking request by issuing MPH-UBR. The LE management may then receive MPH-UBI and cancel the blocking request (i.e. ignore the previously received request) if the port has not yet been blocked. In the latter case the LE may start the unblock procedure by issuing MPH-UBR.

- 3) Collision between primitives sent from the FSM to the management and vice-versa at the same time are resolved in the relevant FSM.
- 4) PH-BI shall only be issued by the AN management in case of hard failure or unacceptable error performance in AN internal links used and affecting the service provision at the user port significantly. The MPH-BI will not be acknowledged and leads directly to the termination of calls in progress or in set up phase. It is required that the AN checks whether the situation persists longer than typical intermittent effects.
- 5) Unblocking of a port requires acknowledgement by the other side to establish coordinated transition to the operational state. If the reaction from the remote side on MPH-UBR is a MPH-BI this should be interpreted only as an indication that the other side does not agree currently to move to the operational state and the FSM has went back to the fully blocked state. No response to MPH-UBR shall be interpreted that the other side does not agree to go to the operational state at this point in time but may react later, the FSM remains in local unblock state.
- 6) Reference is made to subclause 7.1.1, items 2), 4), 6), 8) and 9).
- 7) Reference is made to subclauses 14.1.3.4 and 14.2.3.4 for the AN verification mechanism and to subclauses 14.1.3.5 and 14.2.3.5 for the LE verification mechanism using MPH-UBR.

- 8) Reference is made to NOTE 1 in table 36 concerning permanent activation of the ISDN access.
- 9) Communication of an FSM or layer 2 protocol entity is only towards the system management. Since there is no direct communication between the different FSMs or layer 2 protocol entity in the AN or the LE the system management shall coordinate the FSMs or layer 2 protocol entity by use of the appropriate primitives taking into account as well the information received from various functional blocks in the AN or LE about the status and failures.
- 10) Error performance in the access digital section below a certain minimum level over a period of time shall be considered as unacceptable from any service point of view. The AN management shall block the relevant user port if this condition has been detected.
- 11) Provisioning verification.

The procedure for provisioning verification uses the messages defined in subclause 14.5 and the protocol elements, coding and procedures are defined in subclauses 14.3 and 14.4.

Before re-provisioning, it is suggested that the verification mechanism be used to verify that the new provisioning variant is available in both the AN and LE. Subsequent modification of provisioning data may prevent a proper switch-over. The system management or Operation System shall ensure a timely execution of the switch-over procedure. To do so the side wishing to do re-provisioning issues the "VERIFY RE-PROVISIONING" value within the Control-function-ID information element and receives either:

- "READY FOR RE-PROVISIONING" value within the Control-function-ID information element;
or
- "NOT READY FOR RE-PROVISIONING" value within the Control-function-ID information element.

In the latter case it shall be the responsibility of the system management or Operation System to take any necessary action.

- 12) Re-provisioning synchronization.

The procedure for provisioning synchronization shall only be applied at the agreed re-provisioning time. The procedure uses the messages defined in subclauses 14.3 and 14.5.

Re-provisioning initiated from the LE management:

The procedure is shown in figure C.1.

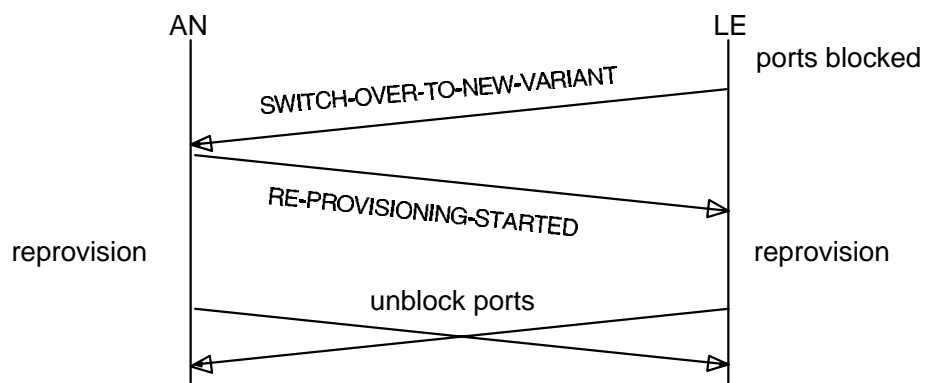

Figure C.1: Procedure for re-provisioning initiated from LE
(The figure shows the exchange of Control-function-ID information element values)

The LE blocks all relevant ports. The LE issues the "SWITCH-OVER TO NEW VARIANT" value within the Control-function-ID information element, and receives either:

- "RE-PROVISIONING STARTED" value within the Control-function-ID information element; or
- "CANNOT RE-PROVISION" value within the Control-function-ID information element with the proper cause value.

In the former case, the AN then begins re-provisioning upon sending the "RE-PROVISIONING STARTED" value within the Control-function-ID information element and the LE begins re-provisioning upon reception "RE-PROVISIONING STARTED" value within the Control-function-ID information element and both ends initiate unblocking of ports when ready using the defined unblocking mechanism. In the latter case, the LE only informs its management and may unblock the ports.

The AN and LE may delay the start of the re-provisioning to ensure the delivery of the "RE-PROVISIONING STARTED" value within the Control-function-ID information element to the AN.

In the latter case it shall be the responsibility of the management to take any necessary action.

Re-provisioning initiated by the AN management:

The procedure is shown in figure C.2.

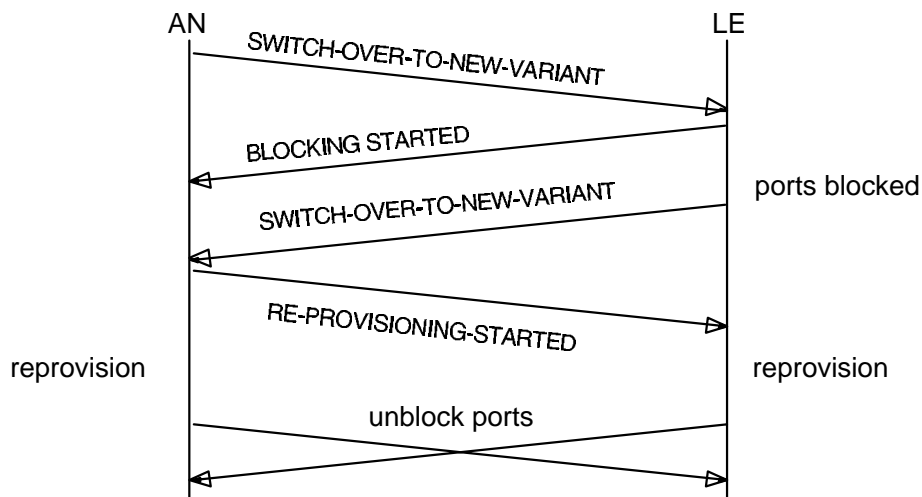

Figure C.2: Procedure for re-provisioning initiated from AN, showing the exchange of Control-function-ID information element values

The AN sends the "SWITCH-OVER-TO-NEW-VARIANT" value within the Control-function-ID information element. If the LE can support re-provisioning it starts blocking of the relevant ports and responds with "BLOCKING STARTED" value within the Control-function-ID information element. The procedure is then the same as for LE-initiated re-provisioning. If there are no ports to be blocked or blocked already the LE may proceed immediately with "SWITCH-OVER TO NEW VARIANT" value within the Control-function-ID information element.

If the LE cannot re-provision, it responds to the "SWITCH-OVER-TO-NEW-VARIANT" value within the Control-function-ID information element with the "CANNOT RE-PROVISION" value within the Control-function-ID information element. In this case no other action shall be taken at the LE.

Re-provisioning verification:

It may be required to request the variant & interface ID before starting to unblock the ports. This procedure avoids ports in operation but a mismatch of variant or interface after re-provisioning.

Fallback procedure:

It may be possible to "undo" the re-provisioning using the re-provisioning synchronization mechanism if the control protocol link is still active. In this case, the variant used would label a data set corresponding to the old data set.

13) System startup.

Within the system startup procedure the variant & interface ID shall be checked after establishing the data link for the control protocol. If the variant & interface ID corresponds to the own variant & interface ID the PSTN data link shall be activated and the restart procedure shall be invoked. If the C-path carrying the PSTN signalling is not provisioned there will be no PSTN data link. In this case the interface shall, during system startup, enter the IN SERVICE state immediately after successful interface ID verification.

Annex L, subclauses L.1.6 and L.2.6 provide the SDL description of the system startup procedure.

14) Restart procedure.

The restart procedure shall be invoked by the system management in the AN or the LE. Annex L, subclauses L.1.7 and L.2.7 provide the SDL description of the restart procedure. Restart shall be invoked after either PSTN-V5DL failure as described in item 17) or by system startup as described in item 13) of this annex. There is no specific restart procedure defined for the control protocol. The system management shall use the port individual blocking and unblocking procedure instead if required.

- a) within the **system startup procedure** an MDU-CTRL(restart request) shall be sent to the control protocol entity and to all PSTN protocol FSMs. Timers TR1 and TR2 shall be started and the state REST1 shall be entered.

Upon reception of the MDU-CTRL(restart complete) from the control protocol entity timer TR2 shall be stopped; upon reception of the MDU-CTRL(restart ack) indication from all state machines of the PSTN protocol entity timer TR1 shall be stopped. When the MDU-CTRL(restart complete) indication from the control protocol and the MDU-CTRL(restart ack) indications from all state machines of the PSTN protocol entity have been received an MDU-CTRL(restart complete) indication shall be sent to all state machines of the PSTN protocol entity.

Upon expiry of timer TR1 or TR2 a notification of the unsuccessful restart shall be given to the maintenance entity and the process shall be stopped. A system integrity process shall ensure that the system management is put into the SYSTEM STARTUP state repeatedly (e.g. every 5 minutes);

- b) if an MDU-CTRL(restart request) is received from the control protocol entity a restart request indication shall be sent to all PSTN protocol FSMs, timer TR1 shall be started and the state REST2 shall be entered.

Upon reception of the restart ack indication from all PSTN protocol FSMs timer TR1 shall be stopped and a restart complete indication shall be sent to the control protocol entity and to all PSTN protocol FSMs and the state IN SERVICE shall be entered.

Upon expiry of timer TR1 an error indication shall be sent to the maintenance entity and the IN SERVICE state shall be entered;

- c) if an MDU-CTRL(restart request) is generated internally an MDU-CTRL(restart request) shall be sent to the control protocol entity and to all PSTN protocol FSMs, timers TR1 and TR2 shall be started and the state REST3 shall be entered.

Upon reception of the MDU-CTRL(restart complete) indication from the control protocol entity timer TR2 shall be stopped; upon reception of the MDU-CTRL(restart ack) indication from all state machines of the PSTN protocol entity timer TR1 shall be stopped. When the MDU-CTRL(restart complete) indication from the control protocol and the MDU-CTRL(restart ack) indications from all state machines of the PSTN protocol entity have been received an MDU-CTRL(restart complete) indication shall be sent to all state machines of the PSTN protocol entity.

Upon expiry of timer TR1 or TR2 an error indication shall be sent to the maintenance entity and the IN SERVICE state shall be entered.

15) Data link activation procedure.

The system management requests during the system startup procedure the establishment of the CONTROL_DL and, if the c-path for the PSTN protocol is provisioned, the PSTN_DL by sending an MDL-Establish-Request to both data links.

When an MDL-Establish-Confirm or an MDL-Establish-Indication is received from the CONTROL_DL an MDU-start_traffic shall be sent to all control protocol entities.

The system startup was successful if the Control data link and, if provisioned, the PSTN protocol data link indicate the establishment by MDL-Establish-Confirm or an MDL-Establish-Indication.

16) Data link reset.

If an MDL-Establish-Indication is received from the CONTROL_DL after system initialization or in the SYSTEM STARTUP state the system management shall send an MDU-start_traffic to all control protocol entities, request the variant & interface ID and enter the WAIT FOR VARIANT&ID state.

If an MDL-Establish-Indication is received from the PSTN_DL in the WAIT FOR VARIANT&ID or ACTIVATE PSTN state the restart procedure shall be initiated.

In all other states a spontaneous data link layer reset indicated by an MDL-Establish-Indication shall be ignored.

17) Data link failure.

If an MDL-Release-Indication is received by the system management an MDL-Establish-Request shall be sent to the appropriate layer 2 entity (PSTN_DL or CONTROL_DL), timers TC1 or TC3 shall be started and an error indication shall be sent to the maintenance entity.

If no MDL-Establish-Confirm or MDL-Establish-Indication is received from the CONTROL_DL within 15 seconds (Timer TC1) an MDU-stop_traffic shall be sent to all control protocol entities, the blocking of the ISDN ports shall be invoked by the relevant system management and timer TC2 (1 minute) shall be started. Upon expiry of timer TC2 the system startup procedure shall be invoked.

If no MDL-Establish-Confirm or MDL-Establish-Indication is received from the PSTN_DL within 15 seconds (Timer TC3) the blocking of all PSTN ports shall be invoked by sending an MDU-CTRL(port blocked) to all PSTN protocol FSMs. An MDU-CTRL(port unblocked) shall be sent to the appropriate PSTN protocol FSM after the re-establishing of the PSTN_DL.

18) Control protocol layer 3 protection mechanism error.

On "error indication" from the layer 3 protection mechanism for the control protocol, the relevant user port FSMs in AN and LE may be misaligned. Following management actions may be required:

- flush queue of messages for this port;
- verify current (operational) state by sending "unblock";
- if not clarified, enforce re-alignment through "block/unblock" sequence.

19) States in the system management procedures.

The states listed hereafter are applicable in both the AN and the LE.

a) SYSTEM STARTUP (ANSY0; LESY0)

This state shall be entered when the system is started and an MDL-ESTABLISH-REQUEST has been used to the CONTROL-DL.

b) WAIT FOR VARIANT&ID (ANSY1; LESY1)

The variant and interface ID has been requested from the AN or LE respectively during the system startup procedure.

c) ACTIVATE PSTN (ANSY2; LESY2)

The activation of the PSTN-DL has been requested during the system startup procedure.

d) REST1 (ANSY3; LESY3)

The restart of the PSTN protocol entities has been requested during the system startup procedure.

e) IN SERVICE (ANSY4; LESY4)

The system has been started and the CONTROL-DL is established.

f) REST2 (ANSY5; LESY5)

This state shall be entered when the system management is in the IN SERVICE state and an MDU_CTRL(restart request) is received from the CONTROL-DL.

g) REST3 (ANSY6; LESY6)

This state shall be entered when the system management is in the IN SERVICE state and an internal restart request is generated.

h) SWITCH OVER (ANSY7; LESY7)

This state shall be entered when the system management is in the IN SERVICE state and an MDU_CTRL(switch over) is received from the CONTROL-DL and the V5.1 interface shall be restarted.

- j) AWAIT V5-INTERFACE INITIALIZATION (ANSY8; LESY8)

This state shall be entered when the system management is in the IN SERVICE state and a MDU-CTRL(switch over) is received from the CONTROL-DL and the V5.1 interface shall not be restarted.

- k) CONTROL DL RELEASED1,2,3 (ANSY9-1,-2,-3; LESY9-1,-2,-3)

These states shall be entered when the system management is in the IN SERVICE state and receives an MDL-RELEASE-INDICATION from the CONTROL-DL.

- 20) Timers in the system management entity.

The timers in the system management of the AN and the LE are specified in table C.1. All the timers defined in table C.1 shall have a maximum tolerance of $\pm 5\%$.

Table C.1: Timers in the system management entity

Timer number	Timeout value	State	Cause for start	Normal stop
TR1	100 s	ANSY2 LESY2	MDU-CTRL(restart request) to all PSTN protocol port states machines	MDU-CTRL(restart ack) from all PSTN protocol port state machines
TR2	2 min	ANSY2 LESY2	MDU-CTRL(restart request) to CONTROL-DL	MDU-CTRL(restart complete) from CONTROL-DL
TC1	15 s	ANSY9-1,-2,-3 LESY9-1,-2,-3	CONTROL-DL establishment requested	reception of MDL-ESTABLISH-CONFIRM or MDL-ESTABLISH-INDICATION from CONTROL-DL
TC2	1 min	ANSY9-1,-2,-3 LESY9-1,-2,-3	CONTROL-DL establishment requested	reception of MDL-ESTABLISH-CONFIRM or MDL-ESTABLISH-INDICATION from CONTROL-DL
TC3	15 s	any state except ANSY0, ANSY1 LESY0, LESY1	PSTN-DL establishment requested	reception of MDL-ESTABLISH-CONFIRM or MDL-ESTABLISH-INDICATION from PSTN-DL

- 21) If the V5 interface FSM indicates to the system management the persistent loss of layer 1 capability by MPH-DI or if an internal failure has been detected or in any other relevant condition requiring the release of the PSTN_DL and the CONTROL_DL the system management shall issue MDL-LAYER_1_FAILURE-INDICATION to the data link entities.

Annex D (normative): Use of the protocol information elements for national PSTN protocols

D.1 Introduction

This annex shows the use of the information elements shown in table 17 of this ETS. It does not show the use of the other information elements such as the protocol discriminator.

The PSTN protocol mapping of line signals at the PSTN user port to the protocol elements defined in this ETS as well as the definition of the national PSTN protocol entity is outside the scope of this ETS. The definition of these functions are the responsibility of the individual network operator.

NOTE: ETR 150 gives examples of PSTN protocol mappings for information.

All of the examples given in this annex are informative and not meant to constrain the use of information elements in any network's PSTN mapping.

The information elements are to be used within several different messages. The purpose of these information elements is to allow the national PSTN protocol(s) in the LE to adequately control the operation and responses of the line circuits over a common message based signalling channel.

It is the purpose of this annex to show how the national PSTN protocols will use the message sets provided by the V5.1 interface in order to control the remotely located line circuits.

These information elements may be used within different messages at different times depending upon time constraints imposed by the national PSTN protocols and the state of the signalling path at that time.

The use of some of the PSTN information elements included in the main body of this ETS have not yet been defined. Their inclusion should allow network operators to use them without having to request them, as additional code points, from ETSI. For a similar reason, the direction in which the PSTN signals can be used, has not been restricted. It is possible that some of the PSTN signals may only be used in one direction (e.g. AN to LE).

In the event of the PSTN stimulus signalling coming back to the national PSTN protocol being incorrect (whether because unexpected signals are received, or signals are not received within the expected period of time) it shall be the responsibility of the national PSTN protocol to be able to cope with the error and respond in a defined manner. An example of a signal not being received from the AN is when an acknowledgement request indicator is set for a pulsed signal and no such indication is received (see subclause D.3.6.4).

Only one of the optional information elements may be placed within any message except for the PROTOCOL PARAMETER message. These information elements will either immediately affect the PSTN port or will provision a port to respond in a predictable manner when the correct stimulus occurs. Signals can be programmed to either continue in the event of a response from the customer premises equipment or to change to another condition when an appropriate stimulus is received.

Associated with the information elements are several optional octets within the information elements that, when used, will change the way in which the information elements function.

The various information elements are presented in order to allow the national PSTN protocols to work correctly across the V5 interface. Although some of the information elements appear to have other uses, for example copper line testing, this is not their purpose. For this reason a full set of copper line messages is not defined by this ETS and its absence is not an oversight. According to subclause 7.1.1, item 9), testing of the user port and the copper line is to be achieved via the Q_{AN} interface whilst the port is blocked. Although it might even be possible to use some of the functions for control of the line to support port and line testing this is outside the scope of this ETS.

It shall be realized by the national PSTN protocol mapping specification that the common channel signalling approach used in the V5 interface will result in variable delays in the signalling paths from AN to LE and vice-versa. The consequence of this is that the mapping specification shall take care to ensure that maximum and minimum pulse durations, interdigit pauses etc. required for their PSTN protocols are not inadvertently violated.

D.2 The placement of information elements

It is permissible to place information elements within certain message types only. Furthermore, only a subset of the information elements are allowed within those messages.

Only one information element may be placed within any of the message types (except for the PROTOCOL PARAMETER message) in which information elements are allowed although the information elements themselves may be comprised of several parts, some of which may themselves be optional.

It is not permitted to define a default information element for ESTABLISH and/or DISCONNECT messages as part of the normal procedure, e.g. in a national PSTN protocol specification. However, reference is made to Clauses D.4 and D.10 which explain the behaviour in exceptional conditions.

D.2.1 Information elements within the ESTABLISH message

The following information element types are individually allowed to be placed within the ESTABLISH message:

- a) line-information information element;

NOTE 1: To allow the transport of certain signals to reach the LE without setting up a permanent path. This is useful for the line information elements which are liable to change infrequently (e.g. impedance marker condition or PBX is in non-operational condition).

- b) other information elements permitted:

NOTE 2: To enable a signal to be passed from/to the national PSTN protocol in the LE whilst a signalling path is being established.

- autonomous-signalling-sequence information element;
- cadenced-ringing information element;
- pulsed-signal information element;
- steady-signal information element.

D.2.2 Information elements within the ESTABLISH-ACK message

The following information element types are individually allowed to be placed within the ESTABLISH-ACK message:

- a) autonomous-signalling-sequence information element;
- b) pulsed-signal information element;
- c) steady-signal information element.

The purpose of allowing any of the above information elements within the ESTABLISH-ACK message is to enable a signal to be passed to/from the national PSTN protocol in the LE whilst a signalling path is being established.

D.2.3 Information elements within the SIGNAL message

The following information element types are individually allowed to be placed within the SIGNAL message:

- a) pulse-notification information element;
- b) autonomous-signalling-sequence information element;
- c) sequence-response information element;
- d) cadence-ringing information element;
- e) pulsed-signal information element;
- f) steady-signal information element;
- g) digit-signal information element;
- h) resource-unavailable information element.

The only type of information elements not in the above list is the Line-information information element as this is supposed to be handled without setting up a permanent path. All other information elements may be carried over the SIGNAL message. The SIGNAL message is the usual transporter of the information elements used in order to implement the national PSTN protocols over the V5.1 interface.

D.2.4 Information elements within the DISCONNECT message

Only the steady-signal information element is allowed to be placed within the DISCONNECT message.

The DISCONNECT message may be generated by either the LE or the AN. In either case, this message can contain a Steady-signal information element.

The Steady-signal information elements can be used in the direction LE to AN in order to deactivate the user ports from a service point of view. (It can do this by removing power from the user port for example).

In the direction AN to LE, the Steady-signal information elements are used in order to indicate the current status of a user port to the LE.

D.2.5 Information elements within the DISCONNECT-COMplete message

The Steady-signal information element is allowed to be placed within the DISCONNECT-COMplete message.

The DISCONNECT-COMplete message may be generated by the LE or the AN.

When the message is generated by the LE in the line information procedure, it can contain a Steady-signal information element to enforce the AN to apply the indicated signal to the analogue line.

D.2.6 Information elements within the PROTOCOL-PARAMETER message

The following information element types are allowed to be placed within the PROTOCOL-PARAMETER message:

- a) recognition-time information element;
- b) enable-autonomous-acknowledge information element;
- c) disable-autonomous-acknowledge information element.

This message is only allowed within the PATH ACTIVE state.

Care should be taken in the national PSTN protocol mapping specification that the PROTOCOL PARAMETER messages are only protected by the layer 3 error detection mechanism defined in subclause 13.5.5. There is no indication to the LE when this change has become active in the user port. In the event of the message being lost at layer 3, the loss will not become apparent until the layer 3 error detection mechanism reports back to the LE, when the call will be cleared.

D.3 The information elements

The information elements are used both to control the line circuits in the access network, to inform the LE about the condition of the customer's TE connected to that line, and to inform on aspects of the AN itself.

The overall aim of the information elements is to allow the LE to control the AN in order to minimize the effects caused by the common channel signalling channel placed between these two items. For this reason, some of the information elements do not have a one to one correspondence with the effect that they have but instead pre-arm the access network to respond in set ways.

Their function and an example of their use is given in the following subclauses.

D.3.1 Line-Information information elements

The Line-information information element may only have one of five parameters assigned to it. These and their uses are given below:

- a) impedance marker reset;
- b) impedance marker set;
- c) low loop impedance;
- d) anomalous loop impedance;
- e) anomalous line condition received.

D.3.1.1 Impedance marker reset

This shall be used to report that an impedance marker, previously detected and reported, has been removed from the line. It shows that a special marker condition has been removed from the line.

D.3.1.2 Impedance marker set

This shall be used to report that an impedance marker has been detected on a line. It shows that a special marker has been added to the line. This is normally used to provide call diversion on a PSTN line.

D.3.1.3 Low loop impedance

This is used in some networks to indicate that a PBX has returned to the idle state.

D.3.1.4 Anomalous loop impedance

This shall be used to report that an unusual loop impedance has been detected on a line. It is used to indicate an error condition on a PBX in some networks.

D.3.1.5 Anomalous line condition received

This shall be used to indicate to the LE that a port should be given a signalling path in order to bring the port back to an idle condition.

D.3.2 Pulse-notification information element

The Pulse-notification information element may take only one value. It is used to indicate that a pulsed signal to be sent to the TE from the user port has either begun, ended or one of a sequence of pulses has ended.

One of the uses of the Pulse-notification information element is in some networks to indicate that the initial ringing burst has finished.

If the LE does not receive the requested Pulse-notification information element from the AN in due time it is the responsibility of the national PSTN protocol entity to resolve this problem according to the definition in the relevant PSTN mapping specification.

D.3.3 Autonomous-signalling-sequence information element

The Autonomous-signalling-sequence information element shall be used to indicate to the AN that it has to start a particular (pre-defined) signalling sequence. The Autonomous-signalling-sequence information element shall be sent in messages from the LE to the AN only. The signalling sequence to be started shall be indicated by the sequence type. The sequence type shall be a four bit binary value.

Some networks use this information element for terminating calls onto certain types of PBX. Different responses from a PBX shall result in different actions by the AN/LE but as the signalling sequences are too fast, the AN shall perform these functions autonomously.

The Autonomous-signalling-sequence information field may not be used to pre-arm a line circuit to respond when the message path for that line is in the NULL state. It is assumed that pre-defined information would be used to control line circuit behaviour when the signalling path is in the NULL state.

D.3.4 Sequence-response information element

The purpose of the Sequence-response information element shall be to give back a response to the LE about the result of a signalling sequence. The Sequence-response information element shall be sent in messages from the AN to the LE only. The Sequence-response type indicates a particular (pre-defined) response value. The Sequence-response type shall be coded in binary.

This information element is not to be used in response to a Pulse-signal(s) information element.

D.3.5 Cadenced-ringing information element

The purpose of the Cadenced-ring information element shall be to start applying ringing current to a line circuit. A field within the Cadence-ringing information element allows one of up to 128 pre-defined types of ringing to be applied to the line. The value 0 is reserved for the default ring current.

Each type of ringing shall be defined as a particular combination of ac voltage, dc voltage, frequency and cadence.

D.3.6 Pulsed-signal information element

The Pulsed-signal information element has a number of uses, both in the direction LE to AN and vice-versa. It is envisaged that its most useful role is in the application of subscribers metering pulse and hence will be used in the direction LE to AN. There are several fields that may be used, as described in the following subclauses.

D.3.6.1 The pulse type

This shall be used to indicate which one of the pre-defined pulse types are to be applied to the line. In the example of subscribers private metering in some networks this could be used to differentiate between the application of 50 Hz or 16 kHz metering pulses.

D.3.6.2 The suppression indicator

The suppression indicator shall be used to indicate whether the pulse generation shall be stopped in a network if the line conditions change, if a new SIGNAL message is received from the LE or if either occurs. This is especially important for meter pulses in some networks, where metering pulses are not sent after the call is cleared, this could be used to suppress metering pulses after the call has been cleared.

In other networks it is essential that the meter pulses are sent out regardless of either a change in line state due to messages from the LE or changes due to the TE.

In the case of suppression being allowed, the specific, pre-defined behaviour at the user port is to be specified in the national PSTN protocol mapping. The possible alternatives are that suppression should take place:

- a) immediately during the sending of a pulse (single pulse or one pulse and further ones of a sequence of pulses); or
- b) after termination of the current pulse (being sent) but inhibiting further ones in that current sequence.

The specification of the pre-defined behaviour may allow that suppression shall take place if (a) specific message(s) or line state change(s) only occur(s) but not for any others.

NOTE: The suppression indicator has effect only for a pulse or a sequence of pulses being sent while the line state change occurs or a further message is received. It is to be pre-defined how to treat requests for sending of pulses after the detection of a specific line state condition because in this circumstances the suppression indicator does not apply, (i.e. autonomous action).

The default setting for this sub-element is to be that suppression is allowed either by messages being received from the LE or by new conditions from TE, i.e. suppression indicator value 11. This shall be the default condition and will be assumed if this sub-element is not present.

The suppression indicator may take the four following values.

D.3.6.2.1 Suppression indicator value 00

This suppression value means that no suppression is allowed. No matter what the line conditions change to on a user port or what message is received (except a blocking message), the pulses shall be sent out from a user port.

D.3.6.2.2 Suppression indicator value 01

This suppression value means that only a new message generated in the LE shall terminate the pulses being sent out from a user port.

D.3.6.2.3 Suppression indicator value 10

This suppression value means that only a new condition from TE shall terminate the pulses being sent out from a user port.

D.3.6.2.4 Suppression indicator value 11

This suppression value indicates that either messages received from the LE or a new condition from TE shall terminate the pulses being sent out from a user port.

D.3.6.3 The pulse duration type

The pulse duration type shall be used in the direction LE to AN to alter a pulse duration type from its default value to a number of pre-defined other values or to indicate from the AN to the LE the receipt of a pulse with a duration corresponding to one of a number of pre-defined duration values other than the default value. In the latter case the fields for the suppression indicator, the acknowledge request indicator and the number of pulses may have no meaning if not defined in the national PSTN protocol specification.

The default, which will be used when the pulse duration type sub-element is not present is to be the pulse duration type corresponding to a value of ZERO for this field.

D.3.6.4 The acknowledgement request indicator

The acknowledgement request indicator will be used to indicate that the entity receiving the information element shall respond after finishing the pulse application. This is essential for some networks that the metering pulses sent to a subscriber are accurate and a call cannot be cleared until the correct number have been sent to the subscriber. If this sub-element is not present, then the default shall be taken to be no acknowledgement required.

In the event of more than one pulse being requested in a message (see next subclause) then an acknowledgement shall be sent either after every pulse or after each of the pulses depending upon how the acknowledgement request indicator shall be set.

D.3.6.5 The number of pulses

There may be an occasion when it is required to send more than one pulse from a line circuit in a short period of time. An example of this is when it is necessary to send multiple metering pulses to a customer quickly due to a high rate of charging.

An optional field within the Pulsed-signal information element allows the number of pulses to be sent in response to one message to be altered.

The number of pulses shall be given within the number-of-pulses field. This may be any number between one and fifteen. If the number-of-pulses field is set to ZERO, this shall be taken as an error and the message shall be discarded without sending any pulses.

In the event of the octet not being present, only one pulse will be sent (the default).

D.3.7 Use of Pulsed-signals

D.3.7.1 Pulsed normal polarity

This Pulsed-signal can be used either to send a pulse out on a user port or to indicate that a pulse has been received at the user port. On finishing the pulse, the line will revert to the previously existing condition. The electrical condition for "normal polarity" shall be pre-defined according to the national PSTN protocol specification (e.g. as the a-wire being more positive than the b-wire).

D.3.7.2 Pulsed reverse polarity

This information element can be used to give a pulse of reverse polarity line voltage from the existing line condition. On finishing the pulse, the line will revert to the previously existing condition. The line condition shall be reversed from the one defined for normal polarity.

D.3.7.3 Pulsed battery on C-wire

This Pulsed-signal can be sent either in the direction LE to AN or vice-versa.

D.3.7.4 Pulsed on-hook

An example of this Pulsed-signal is that it may be used for specific PABX signalling.

D.3.7.5 Pulsed reduced battery

An example of this Pulsed-signal is that it may be used for specific PABX signalling.

D.3.7.6 Pulsed no battery

An example of this Pulsed-signal is that it may be used for specific PABX signalling.

D.3.7.7 Meter pulse

An example of this Pulsed-signal, in the direction LE to AN, is to initiate the sending of a meter pulse from the user port to equipment in the customer's premises. This shall be used to increment a meter in the customer's premises to give an indication of the cost of a call.

D.3.7.8 Initial ring

An example of this Pulsed-signal is in some networks where it is used as an indication that calling line identification will follow as in-band tones.

D.3.7.9 Pulsed off-hook

An example for a use of this Pulsed-signal has yet to be identified, see Clause D.1.

D.3.7.10 Pulsed b-wire connected to earth

An example for a use of this Pulsed-signal has yet to be identified, see Clause D.1.

D.3.7.11 Register recall (timed open loop)

An example of this Pulsed-signal is to report to the LE that a register-recall signal has been generated by customer equipment.

D.3.7.12 Earth loop pulse

An example for a use of this Pulsed-signal has yet to be identified, see Clause D.1.

D.3.7.13 50 Hz pulse

An example of this Pulsed-signal is to release the connection of some types of PBX.

D.3.7.14 Pulsed b-wire connected to battery

An example for a use of this Pulsed-signal has yet to be identified, see Clause D.1.

D.3.7.15 Pulsed a-wire connected to earth

An example for a use of this Pulsed-signal has yet to be identified, see Clause D.1.

D.3.7.16 Pulsed a-wire connected to battery

An example for a use of this Pulsed-signal has yet to be identified, see Clause D.1.

D.3.7.17 Pulsed c-wire connected to earth

An example for a use of this Pulsed-signal has yet to be identified, see Clause D.1.

D.3.7.18 Pulsed c-wire disconnected

An example for a use of this Pulsed-signal has yet to be identified, see Clause D.1.

D.3.7.19 Pulsed normal battery

An example for a use of this Pulsed-signal has yet to be identified, see Clause D.1.

D.3.7.20 Pulsed a-wire disconnected

An example for a use of this Pulsed-signal has yet to be identified, see Clause D.1.

D.3.7.21 Pulsed b-wire disconnected

An example for a use of this Pulsed-signal has yet to be identified, see Clause D.1.

D.3.8 Use of Steady-signals

D.3.8.1 Normal-polarity

This Steady-signal shall be used in the direction LE to AN to set a line to normal polarity or, in the direction AN to LE, to indicate the end of a line reversal for certain PBXs. The electrical condition for "normal polarity" shall be pre-defined according to the national PSTN protocol specification (e.g. as the a-wire being more positive than the b-wire).

D.3.8.2 Reversed-polarity

This Steady-signal shall be used in the direction LE to AN to set a line to reverse polarity or, in the direction AN to LE, to indicate a line reversal for certain PBXs. The line condition shall be reversed from the one defined for normal polarity.

D.3.8.3 Battery on c-wire

This Steady-signal shall be used in the direction LE to AN to set a battery on c-wire condition or, in the direction AN to LE, to indicate the condition of battery on the c-wire for certain PBXs.

D.3.8.4 No battery on c-wire

This Steady-signal shall be used in the direction LE to AN to remove a battery on c-wire condition or, in the direction AN to LE, to indicate the condition of battery removed from the c-wire for certain PBXs.

D.3.8.5 Off hook (loop closed)

This Steady-signal shall be used in the direction AN to LE to indicate a looped condition on a user port or, in the direction LE to AN, to indicate a looped condition by certain PBXs.

D.3.8.6 On hook (loop open)

This Steady-signal shall be used in the direction AN to LE to indicate an open-looped condition on a user port or, in the direction LE to AN, to indicate an open-looped condition by certain PBXs.

D.3.8.7 Battery on a-wire

This Steady-signal shall be used in the direction AN to LE and the direction LE to AN in order to control PBXs in some networks.

D.3.8.8 No battery on b-wire

An example of this Steady-signal is in some networks where it is used for the control of PBXs.

D.3.8.9 Reduced battery

An example of this Steady-signal shall be to reduce the battery voltage applied to certain types of PBXs or to park a line.

D.3.8.10 No battery

An example of this Steady-signal is to remove the battery voltage from the lines of certain types of PBXs.

D.3.8.11 Alternate reduced power/no power

An example of this Steady-signal is to alternately reduce/remove the power from certain types of PBXs or to park a line.

D.3.8.12 No battery on a-wire

An example of this Steady-signal is to remove the earth from a previously earthed a-wire, or to indicate this condition to the LE, which are used in certain types of PBXs.

D.3.8.13 Normal battery

A use for this Steady-signal has yet to be identified.

D.3.8.14 Stop ringing

An example of this Steady-signal is to remove the ringing voltage from most line ports in the event of subscriber B not answering the call and subscriber A terminating the call. This Steady-signal is not applicable for ring trip, refer to subclause 13.1.2.

D.3.8.15 Start pilot frequency

An example of this Steady-signal is to start sending a pilot tone to certain types of PBX in some networks.

D.3.8.16 Stop pilot frequency

An example of this Steady-signal is to stop a previously started pilot tone being sent to some PBXs.

D.3.8.17 A-wire on earth

An example of this Steady-signal is to earth the a-wire, or to indicate this condition to the LE. These are used for certain types of PBXs in some networks.

D.3.8.18 Low impedance on b-wire

An example of this Steady-signal is in some networks where it is used for the control of PBXs.

D.3.8.19 B-wire connected to earth

An example of this Steady-signal is to report to the LE that the b-wire on a PBX has been connected to earth.

D.3.8.20 B-wire disconnected from earth

An example of this Steady-signal is to report to the LE that the b-wire on a PBX has been disconnected from earth.

D.3.8.21 Battery on b-wire

An example of this Steady-signal is in some networks where it is used for the control of PBXs.

D.3.8.22 Low loop impedance

An example of this Steady-signal is to report that a low loop impedance has been detected on a line in some networks. This is used to indicate that a PBX is available for traffic or to communicate that the subscriber has answered.

D.3.8.23 High loop impedance

An example of this Steady-signal is to report that a high loop impedance has been detected on a line in some networks. This indicates either that the subscriber has cleared or that an address complete signal should be generated.

D.3.8.24 Anomalous loop impedance

An example of this Steady-signal is to report to the LE that an unusual loop impedance has been detected on a line in some networks. This is used to indicate an error condition on a PBX.

D.3.8.25 A-wire disconnected from earth

An example of the use of this Steady-signal in some networks is to control a PBX.

D.3.8.26 C-wire on earth

An example as to use this Steady-signal has yet to be identified, see Clause D.1.

D.3.8.27 C-wire disconnected from earth

An example as to use this Steady-signal has yet to be identified, see Clause D.1.

D.3.9 Digit-signal information element

An example in the direction AN to LE, it is used to pass customer premises equipment generated digit information to the LE.

Another example of the use of this signal in direction LE to AN is to provide digit information for a DDI PBX. In this case, the LE may request an acknowledgement from the AN when the digit has been pulsed out by the user port to the DDI PBX. This allows the LE in some networks to control the interdigit timing.

D.3.10 Recognition-time information element

The Recognition-time information element shall be used to change the time for which a signal from a user port has to be active before reporting the event to the AN. The message specifies the event to be measured and the duration type. The duration type shall be one of 128 pre-defined values already available in the access network. Should the duration-type not have been pre-defined, then the information element is deemed to have failed the consistency checks as detailed in subclause 13.5.2.

D.3.11 Enable-autonomous-acknowledge information element

The Enable-autonomous-acknowledge information element shall be used in order to respond quickly to events generated within user equipment. This information element may respond to these events by either providing a steady signal, a pulse or a series of pulses. The event that triggers the Autonomous-acknowledge information element is also specified in the enabling message.

The suppression indicator shall be used to indicate whether the pulse generation shall be stopped in a network if the line conditions change, if a new SIGNAL message is received from the LE or if either occurs.

In the case of suppression being allowed, the specific, pre-defined behaviour at the user port is to be specified in the national PSTN protocol mapping. The possible alternatives are that suppression should take place:

- a) immediately during the sending of a pulse (single pulse or one pulse and further ones of a sequence of pulses); or
- b) after termination of the current pulse (being sent) but inhibiting further ones in that current sequence.

The specification of the pre-defined behaviour may allow that suppression shall only take place if specific messages or line state changes occur, but not for any others.

NOTE: The suppression indicator has effect only for a pulse or a sequence of pulses being sent while the line state change occurs or a further message is received. It is to be pre-defined how to treat requests for sending of pulses after the detection of a specific line state condition because in this circumstances the suppression indicator does not apply, (i.e. autonomous action).

The suppression indicator may take the four following values.

D.3.11.1 Suppression indicator value 00

This suppression value means that no suppression is allowed. No matter what the line conditions change to on a user port or what message is received (except a blocking message), the pulses shall be sent out from a user port.

D.3.11.2 Suppression indicator value 01

This suppression value means that only a new message generated in the LE shall terminate the pulses being sent out from a user port.

D.3.11.3 Suppression indicator value 10

This suppression value means that only a new condition from TE shall terminate the pulses being sent out from a user port.

D.3.11.4 Suppression indicator value 11

This suppression value indicates that either messages received from the LE or a new condition from TE shall terminate the pulses being sent out from a user port.

D.3.12 Default values for the Enable-autonomous-acknowledge information element

In the case of pulses being sent to users equipment the following default conditions will apply in the absence of the sub-information fields being used:

The default pulse duration type shall be one corresponding to a pulse duration type of value 0.

That acknowledgements are not required by the LE.

Only one pulse will be sent.

D.3.13 Use of the Autonomous-signalling-sequence

One use of the Autonomous-signalling-sequence information element is in some networks where it is required to pre-arm a direct LE line in order that it may reverse the polarity of a line when a specific line state is detected without waiting for a message from the LE. Without the Autonomous-signalling sequence, the line circuit could not have put on the response condition without a message from the LE, which would have resulted in a line protocol failure to the excessive time needed to receive and action that message.

D.3.14 Disable-autonomous-acknowledge information element

This information element shall be used in order to cancel a previously sent Enable-autonomous-acknowledge message. In order to recognize the message that is to be cancelled, the trigger types of both the enable and the disable messages shall be identical.

A Disable-autonomous-acknowledge information element which cannot be matched to a previously received Enable-autonomous-acknowledge pulse is deemed to have failed the consistency checks as detailed in subclause 13.5.2.

D.4 Signalling sequences in the event of failure of a V5.1 interface to return a user port to the idle condition before releasing the signalling path

The cause of the user port not being returned to idle before the signalling path is removed may be due to failures associated with the V5.1 interface, blocking conditions, or other national-specific occurrences outside the scope of this ETS.

In the event of the user port not being returned to idle condition because of unspecified failures before the signalling path is removed, the V5.1 interface, the PSTN protocol entity, AN(PSTN) and LE(PSTN), may go either to the NULL state or the BLOCKED state. The implications for the user port are given in this clause.

D.4.1 Protocol implications of going directly to the NULL state

The effect on the PSTN protocol will depend upon the way the national PSTN protocol has been implemented and the way in which the V5.1 interface clears the signalling path.

There are many ways in which the user port can be put back into the idle condition:

- a) the user port can go directly to the pre-defined idle state;
- b) by using the Signal information element provided in the DISCONNECT message which will put the user port back into the idle condition if this is possible with only one Signal information element;
- c) by the AN sending an ESTABLISH message, with a Line-information information element set to anomalous line condition, to the LE. The LE will respond by sending a DISCONNECT COMPLETE message containing the Signal information element which will put the user port back into the idle condition if this is possible with only one Signal information element;
- d) the AN should use the PSTN protocol to send an ESTABLISH message with a Line-information information element set to anomalous line condition to the LE. The LE will respond by noting the error and sending back a DISCONNECT COMPLETE message. Once this has been done, the LE will set up another signalling path and recover the port back to the idle condition. The signalling path will then be released;
- e) the LE has the responsibility to identify the non-idle condition of the user port. In this case it shall automatically set up a path and bring the port back to the idle condition. The signalling path will then be released.

It is national PSTN specific as to which one, or more than one, method of returning a user port to the idle condition is selected.

D.4.2 Protocol implications of going to the BLOCKED state

In the event of failures on the layer 2 signalling link, it will sometimes be necessary for the signalling path to go directly to the BLOCKED state. Should this occur, it is the responsibility of the AN to ensure that the users equipment is taken back to a state where that equipment can recognize that the port is unavailable for traffic. This should be done as quickly as possible in a way that is consistent with the national PSTN protocol being supported on that port. This is to be a pre-defined state.

D.5 Leaving the BLOCKED state

It is not always easy to bring a port that was previously in the BLOCKED state, back into service.

Should the national PSTN protocol be a simple one, then it is likely that the port can be put back into the idle condition under the control of the AN without any intervention from the LE.

If the national PSTN protocol is one of the more complex ones, then the following paragraph should apply.

The AN should use the PSTN protocol to send an ESTABLISH message with a Line-information information element set to anomalous line condition to the LE. The LE will respond by noting the error and sending back a DISCONNECT-COMplete message. Once this is done, the LE will set up another signalling path and recover the port back to the idle condition.

D.6 Pre-defined PSTN port states

It is assumed that at least a minimum amount of information will be pre-defined within an AN in order to allow a national PSTN protocol to be initiated. It would be better if enough information were pre-defined in order to allow a national PSTN protocol to be followed with a minimum of re-defining information being passed either via the V5.1 interface or the Q interface (pre-provisioning).

Once a PSTN signalling path has been reset to the NULL state, then the pre-defined information is to be used and no re-defining of PSTN call parameters via the LE will be allowed until the signalling path has been taken out of the NULL state.

D.7 The line parked condition

The line parked condition is that condition which is used when a user port cannot be set back to the idle condition because of user behaviour which falls outside the normal ones expected. The usual example of this for a direct exchange line is when a user fails to release a line after a call has been terminated.

The signalling path is to be kept active whilst a line is in the parked condition and not released back to the NULL state.

The condition presented to the user whilst the line is in the parked state is national-specific but generally would result in no power or a low power condition being presented to the user.

D.8 Information element meaning

The Information elements have been given specific names in order that their function can be made clear. It has been noted that some of these elements could be given alternative meanings in order to re-use certain of the elements for purposes for which they were not defined. If this incorrect assignment were done, it would be difficult for manufacturers of V5.1 equipment to identify the correct code points for any implementation. For this reason it is essential to use the code points provided according to the strict guidelines of this ETS.

D.9 Coding of pulse duration types

It shall be the responsibilities of the national administrations to define both the static and dynamically assigned pre-defined pulse duration types. These types need not be assigned in a binary ascending sequence although the allowable types and meanings shall be unambiguously defined for each national PSTN protocol supported. Pre-defined values will be those coded as type 0 in the pre-defined tables.

At the end of a PSTN call, the signalling path should be removed and the PSTN protocol entities in the LE and the AN should be set back to the NULL state. When this happens, the recognition times etc. will be put back to their pre-defined values. This means that dynamically assigned values within any PSTN call will only last for the rest of the duration of that call.

The line signals will not be altered by the user ports once the signalling path has been removed unless failure conditions have occurred.

D.10 Ring signals and their placement in V5 messages

It is expected that many national PSTN implementations will require that the first message to be sent from the LE to the AN in order to indicate an incoming call will be the Cadenced-ring information element.

In order to allow the LE to signal a ring tone back to the calling subscriber knowing with a high degree of certainty that ringing has indeed been applied, the Cadenced-ring information element should be placed in the ESTABLISH message. By returning an ESTABLISH-ACK message, the AN is confirming both that it has received the ESTABLISH message and that it has the resources required in order to ring from the user port. This may only be achieved in this fashion if the Cadenced-ring signal is placed in, and hence protected by, the ESTABLISH/ESTABLISH-ACK message pair. Once the ESTABLISH-ACK message has been received by the LE it will send the ring tone but not before. In the event of no ESTABLISH-ACK message being received within the correct time, the LE may either re-try or clear the call depending upon the national PSTN protocol.

If the Cadenced-ring information element has to be placed in a SIGNAL message, it cannot be protected by the ESTABLISH/ESTABLISH-ACK message pair. If the requested resource is not available, in this case, it is the responsibility of the AN to return a Resource-unavailable information element by means of a SIGNAL message. As this message may take some time to reach the LE and as it will only be sent during overload or failure conditions, it is likely that the LE will already be returning ring tone to the calling subscriber. In this case it will be national-specific as to whether the ring tone is changed to busy tone or the call is immediately cleared.

The AN shall ensure that ringing is stopped whenever the path is cleared regardless of the reason for clearing.

D.11 Resource unavailable

This information element can only be generated by the AN. It shall be used to signal to the LE that a signal requested to be provided in the AN by the LE cannot in fact be sent due to a lack of resource in the AN. A cause value will be sent back to the LE with this steady signal which will be a direct copy of the information element causing the resource unavailable information element to be sent.

One specific example is that of ringing. The LE may request a line to have ringing applied although the ringer may be faulty or in danger of going into an overload condition.

Annex E (informative): Service scenarios, architecture and functional definition of access arrangements with AN at the LE

E.1 Conclusions on multiple V5 interface applications

- a) An access network (AN) may have one or a number of V5 (V5.1 and/or V5.2) interfaces.
- b) The V5 interfaces of an AN may all connect to one LE or to several LEs however, in the latter case any individual V5 interface is connected to only one LE (single homing principle).

Dual homing allows a user port to be associated, via a V5.1 interface, with an exchange, and alternately be associated, by re-provisioning or re-configuration, to another exchange via a V5.1 or V5.2 interface.

Implementation of the dual homing feature shall have no impact on the V5.1 interface.

The association of a user port to the V5.1 interface covers all channels of this port except those allocated for permanent leased lines, which are allocated to an interface to the leased line network.

NOTE 1: Dual homing may be applied for the support of service continuation even under LE failure condition. This should be performed by switching the V5 interface or an individual user port from the first host LE to the pre-allocated (and probably pre-provisioned and conditioned) second host LE.

- c) A user port at an AN is served by only one V5.1 interface; this includes all the channels of this user port allocated for on demand services or for leased lines established under the control of the LE.

NOTE 2: The PL service through this user port which bypasses the LE is not included since they are going through another type of interface and not another V5 interface.

- d) Different user ports belonging to the same customer may be provisioned for the same V5 interface or for different V5 interfaces.

NOTE 3: There is no restriction in the use of the principle described under item b).

- e) Stand-by 2 048 kbit/s digital links may be used for protection of V5.1 interfaces. Control of switching to stand-by digital link is not supported over the V5.1 interface.

These stand-by digital links may be used to connect the AN to the same LE, or a different LE in a dual homing configuration.

These stand-by digital links may be permanently active at layer 1.

E.2 Conclusions on architecture aspects

The V5.1 interface is limited to one physical 2 048 kbit/s link. The number of V5.1 links between the AN and the LE is unlimited.

The ET layer 1 functions, as defined in ETS 300 297 [4], are split amongst the AN and the LE (see figure 3).

Additional channel switching between the AN and the LE, e.g. by a separate cross connect, is allowed but without impacting the functionality of the V5.1 interface specified in this ETS. Cascading of ANs (i.e. by connecting them with a "V5 type" interface) shall not impact the functions of the V5.1 interface.

The scope of the V5 interface is not limited to ANs exclusively and is independent on their architecture. Cross connect(s) between an AN and the LE are seen from the V5 interface as being integral part of the AN.

The coexistence of interface V5.1, V5.2 and V3 within the AN or LE shall be possible.

E.3 Implementation of Q_{AN}

It is outside the scope of this ETS to define the Q_{AN} interface and its implementation or application. From the functional point of view a number of implementation alternatives are possible within this ETS:

- a) the use of AN capabilities:
 - a separate physical interface at the AN, which may include a remote application through a permanent leased line;
- b) the use of V5 interface capabilities and supported services:
 - b1) semi-permanent leased line;
 - b2) 64 kbit/s unrestricted bearer service through a B-channel from a virtual ISDN user port in AN;
 - b3) p-type data service from a virtual ISDN user port in AN;
 - b4) f-type data service from a virtual ISDN user port in AN.

NOTE: Attention should be paid to the fact that no communication capability through a V5 interface exists prior to provisioning of that V5 interface and bringing it into service. Therefore an additional functionality is required for the initialization of the V5 interface.

Annex F (informative): The concept and requirements for the upgrade of a V5.1 interface to a V5.2 interface

The upgrade of a V5.1 interface to a V5.2 interface can be achieved through the use of the provisioning capability on the control protocol defined in this ETS.

The existing provisioning variant and interface identifier (ID) on the V5.1 interface can be verified before the upgrade is initiated, if this is desired. The upgrade is initiated by requesting first a switch-over to a new provisioning variant for the new V5.2 configuration.

If the upgrade is not successful, the subsequent procedures are outside the scope of the V5 interface specification. For details of the procedure refer to Annex C, items 11 and 12).

Annex G (informative): Use of function element primitives in the V5 PSTN protocol

G.1 Introduction

This annex shows the use of PSTN FE primitives as given in tables 2 and 3 of Clause 13.

All of the given explanations in this annex are examples and do not constrain the use of FEs in any implementation as long as the functionality defined for the PSTN protocol in this ETS is met.

These primitives have been introduced within the PSTN protocol procedures for the path control related procedures. They may additionally carry line signal information which are not directly relevant for the V5.1 interface path control but are related to the call control procedures under the responsibility of the national PSTN protocol entity. The latter may be implemented according to the internal structures and the PSTN line signal and mapping requirements in the ANs or LEs. Any line signal at the user port belongs to one of the four FE groups according to the national protocol mapping specification. The FE will then be used in the path control for this user port or to convey an individual line signal information to or from the national PSTN protocol entity in the LE or AN for the control of the call procedures.

G.2 FE primitives used in the PSTN protocol entity in the AN

G.2.1 FE-subscriber_seizure

This primitive shall be used whenever a user's equipment indicates, by seizing the line, that a path shall be set up.

This primitive is valid only when sent from the user port to the PSTN protocol entity in the AN.

This primitive is valid only in cases where the PSTN protocol entity in the AN is in the NULL or PATH ABORT REQUEST state.

The AN has to make sure that predefined seizure conditions at the user port are translated into the FE-subscriber_seizure primitive whenever the PSTN protocol entity in the AN is in the NULL or PATH ABORT REQUEST state.

This primitive may carry additional information concerning the seizure condition.

G.2.2 FE-subscriber_release

This primitive shall be used whenever a user's equipment indicates release during initiation of the PSTN signalling path across the V5 interface.

This primitive is valid only when sent from the user port to the PSTN protocol entity in the AN.

This primitive is valid only in cases where the PSTN protocol entity in the AN is in the PATH INITIATED BY AN state.

The AN has to make sure that a predefined seizure release or idle condition at the user port is translated into the FE-subscriber_release primitive whenever the PSTN protocol entity in the AN is in the PATH INITIATED BY AN state.

This primitive shall not carry additional information.

G.2.3 FE-line_information

This primitive shall be used to inform the LE of changes of the line status invoked by the user's equipment which are used for services other than path initiation.

This primitive is valid only when sent from the user port to the PSTN protocol entity in the AN.

This primitive is valid only in cases where the PSTN protocol entity in the AN is in the NULL state.

The AN has to make sure that predefined changes of the line status different from those that indicate a seizure condition are translated into the FE-line_information primitive whenever the PSTN protocol entity in the AN is in the NULL state.

This primitive shall carry additional information concerning the user port status.

G.2.4 FE-line_signal

This primitive shall be used whenever either:

- a line status event detected at the user port shall be transmitted to the LE via the PSTN protocol entity in the AN; or
- the PSTN protocol entity in the AN wants to apply an (electrical) condition to the user port on request of the LE.

This primitive is valid in both directions, from the PSTN protocol entity in the AN towards the user port and vice-versa.

This primitive is valid only in cases where the PSTN protocol entity in the AN is in the PATH ACTIVE state.

This primitive shall carry additional information concerning the (electrical) event that is to be applied or has been detected.

G.3 FE primitives used in the PSTN protocol entity in the LE

G.3.1 FE-establish_request

This primitive shall be used whenever the National Protocol entity in the LE wishes to set up a call and, hence, to originate a PSTN signalling path across the V5 interface.

This primitive is valid only when sent from the National Protocol entity to the PSTN protocol entity in the LE.

This primitive is valid only in cases where the PSTN protocol entity in the LE is in the NULL or PATH INITIATED BY AN state.

This primitive may carry additional information concerning the desired signalling at the user port.

G.3.2 FE-establish_acknowledge_indication

This primitive shall be used whenever the PSTN protocol entity in the LE wishes to indicate to the National Protocol entity that it has received a positive response to a previously requested set-up of a PSTN signalling path across the V5 interface.

This is usually an acknowledgement to a previous FE-establish_request primitive.

This primitive is valid only when sent from the PSTN protocol entity in the LE to the National Protocol entity.

This primitive is valid only in cases where the PSTN protocol entity is in the PATH INITIATED BY LE state.

This primitive may carry additional information concerning the signalling at the user port.

G.3.3 FE-establish_indication

This primitive shall be used whenever the PSTN protocol entity in the LE wishes to indicate to the National Protocol entity that it has received a request to establish a PSTN signalling path across the V5 interface.

This primitive is valid only when sent from the PSTN protocol entity in the LE to the National Protocol entity.

This primitive is valid only in cases where the PSTN protocol entity is in the NULL or PATH INITIATED BY LE state.

This primitive may carry additional information concerning the signalling at the user port.

G.3.4 FE-establish_acknowledge

This primitive shall be used whenever the National Protocol entity in the LE wishes to confirm to the AN the set-up of a PSTN signalling path across the V5 interface.

This is usually a response to a previous FE-establish_indication primitive.

This primitive is valid only when sent from the National Protocol entity to the PSTN protocol entity in the LE.

This primitive is valid only in cases where the PSTN protocol entity in the LE is in the PATH INITIATED BY LE or PATH INITIATED BY AN state.

This primitive may carry additional information concerning the signalling at the user port.

G.3.5 FE-disconnect_request

This primitive shall be used whenever the National Protocol entity in the LE wishes to clear the PSTN signalling path across the V5 interface.

This primitive is valid only when sent from the National Protocol entity to the PSTN protocol entity in the LE.

This primitive is valid only in cases where the PSTN protocol entity in the LE is in the PATH INITIATED BY AN, PATH INITIATED BY LE or PATH ACTIVE state.

This primitive may carry additional information concerning the signalling to be left on the user port in the idle state. See Clause D.4 for further information.

G.3.6 FE-disconnect_complete_request

This primitive shall be used whenever the National Protocol entity wants the PSTN protocol entity in the LE to send an acknowledgement to previously received line_information to the AN.

This primitive is valid only when sent from the National Protocol entity to the PSTN protocol entity in the LE.

This primitive is valid only in cases where the PSTN protocol entity in the LE is in the PATH INITIATED BY AN state.

This primitive may carry additional information concerning the signalling at the user port.

G.3.7 FE-line_signal_request

This primitive shall be used whenever the National Protocol entity in the LE wishes to apply an (electrical) condition at the user port in the AN.

This primitive is valid only when sent from the National Protocol entity to the PSTN protocol entity in the LE.

This primitive is valid only in cases where the PSTN protocol entity in the LE is in the PATH ACTIVE state.

This primitive shall carry additional information concerning the signalling to be applied at the user port.

G.3.8 FE-line_signal_indication

This primitive shall be used whenever the PSTN protocol entity in the LE wishes to indicate to the National Protocol entity that an event concerning the user's port has been detected.

This primitive is valid only when sent from the PSTN protocol entity in the LE to the National Protocol entity.

This primitive is valid only in cases where the PSTN protocol entity is in the PATH ACTIVE state.

This primitive shall carry additional information concerning the event detected at the user port.

G.3.9 FE-protocol_parameter_request

This primitive shall be used whenever the National Protocol entity in the LE wishes to change a PSTN protocol parameter in the AN.

This primitive is valid only when sent from the National Protocol entity to the PSTN protocol entity in the LE.

This primitive is valid only in cases where the PSTN protocol entity in the LE is in the PATH ACTIVE state.

This primitive shall carry additional information concerning the protocol parameter to be changed.

G.3.10 FE-disconnect_complete_indication

This primitive shall be used whenever the PSTN protocol entity in the LE wishes to indicate to the National Protocol entity that the PSTN signalling path across the V5 interface has been cleared completely.

This is usually an acknowledgement to a previous FE-disconnect_request primitive.

This primitive is valid only when sent from the PSTN protocol entity in the LE to the National Protocol entity.

This primitive is always valid except when the PSTN protocol entity is in the OUT OF SERVICE or PORT BLOCKED state.

This primitive shall not carry additional information.

Annex H (informative): PSTN protocol; explanatory notes and information flow

H.1 Explanatory notes

1) Overload in the LE:

When the LE is in overload, the amount of signalling for PSTN should be reduced to a minimum. The protocol complies with the following requirements:

- existing calls shall continue;
- new call requests from customers connected via an AN to the overloaded LE, shall not be acknowledged by the LE until the overload condition has disappeared;
- a call request from a customer on the AN that is not acknowledged by the LE shall not result in a continuous blocking of the PSTN user port due to loss of the ESTABLISH request.

These requirements have been incorporated in the protocol in the following way: The AN sends an ESTABLISH message to the LE after detecting the customer seizure and starts the timer T1. This timer shall be stopped after the acknowledge of the ESTABLISH by the LE. If the acknowledge is not received, the timer will expire. At this time the customer may either be off hook in which case the ESTABLISH shall be repeated and the timer T2 shall be started or the customer is on hook in which case the PSTN protocol entity in the AN returns to the Null state.

2) Compelled signalling sequences:

Some national PSTN protocols have a compelled signalling sequence that requires a quick response (e.g. in the Dutch ALS-70 protocol a clear forward has to be acknowledged - depending on the call state - with a return to normal polarity within 100 ms). For customer lines connected directly to the switch, the switch is responsible for handling this compelled sequence. However, for customers connected via an AN the delays on the V5 interface require the handling of this signalling sequence to be done autonomously in the AN. Disable/enable of an autonomous handling of a compelled signalling sequence shall be under control of the finite state machine for the national PSTN protocol. For this purpose the "PROTOCOL PARAMETER" message is available.

3) Parked line:

When a customer fails to go on hook after all applicable timers have expired, the LE can request the AN to reduce battery or to remove battery from the customer line and periodically apply reduced battery to verify if the customer has replaced his handset. The signal commands "Reduced Battery" and "Alternate Reduced Power/No Power" are available for this purpose. Both protocol entities in the LE and AN shall remain in the PATH ACTIVE state while one of these signals is applied. When the subscriber release is finally reported in a SIGNAL message, the LE shall start the DISCONNECT procedure over the V5 interface.

4) Variable recognition time:

The recognition time of received signals may depend on the call state. In the Spanish PSTN protocol for example, the on hook recognition time is 150 ms but this may change to 1 100 ms for terminating calls with Malicious Call Identification (MCID) in order to discriminate between hook flash (used to activate MCID) and clear back. For this purpose the "PROTOCOL PARAMETER" message is available.

5) Non call related signals:

In some analogue PSTN protocols the customer can activate/deactivate certain services by setting an impedance marker (e.g. a 30 k Ω resistance over the loop). Changes of the impedance marker condition (e.g. from open loop to 30 k Ω loop and vice-versa) shall be reported only when there is no call active. A change is reported by means of a ESTABLISH message that contains the new impedance marker condition. The FSM in the AN then wait in the LINE INFORMATION state for an acknowledge (DISCONNECT COMPLETE) from the LE that it has received the impedance marker report. No calls shall be accepted by the AN during the period between the sending of the ESTABLISH and the reception of the DISCONNECT COMPLETE.

Another example of a non-call related signal is the blocking signal present in some PABX protocols.

6) Line seizure for terminating calls:

In the ESTABLISH message the LE can indicate what signal has to be applied to the customer line. This signal can be for example: normal polarity, reversed polarity, ringing. For some applications (on hook transmission) it may be required to activate the line without providing ringing current.

7) Deactivate a PSTN user port:

It may be necessary from a service point of view, to block a user port by removing the power from the line. Usually there will be no call active at the time the line is blocked. The procedure is as follows: The LE shall send an ESTABLISH to the AN with the indication that power should be removed. The AN shall remove the power from the line and acknowledge the ESTABLISH. The LE shall then send a DISCONNECT message with the indication that the battery should remain disconnected from the port while it is deactivated.

8) Report end of timed signal:

Due to variations in the delay of layer 3 messages over the V5 interface, the LE has no knowledge when a requested timed signal is completed in the AN. When the LE has to wait for the completion of a timed signal before it can proceed, it can indicate in the timed signal request that the AN has to report back the end of a timed signal. For some supplementary services, like calling line identification, a single burst of ringing current has to be given before the LE may send data to the terminal (using Multi Frequency signals). The end of the initial ring can be reported using the End-of-pulse information element within a SIGNAL message. After completion of the data exchange the LE may request cadenced ringing.

9) Interruption of pulsed signal:

Some pulsed signals must not be interrupted by a subsequent signal, others may indeed be overwritten (aborted) by a new signal before completion.

Therefore, additional information is required to indicate that the pulsed signal has to be completed, and subsequent signals delayed till after completion (e.g. metering pulses need to be completed).

10) Autonomous signalling sequences:

Some national PSTN protocols use a series of time-supervised compelled signalling sequences for certain functions (e.g. the seizure function of a PABX line in terminating calls in Austria). Due to the signalling delays in an AN and the very stringent timing requirements it is required to extract such a signalling sequence from the national protocol entity in LE and have it executed autonomously in the AN.

For this purpose the "Autonomous signalling sequence" and "Sequence response" information elements are available to carry this signalling information on a functional basis. It is the responsibility of the user port to execute correctly this message.

- 11) During PSTN signalling path establishment, initiated by the AN, the transmission path shall be non-transparent. Therefore the AN shall ensure that the transmission path is interrupted before sending the ESTABLISH message to the LE until receipt of the ESTABLISH ACK message from the LE. This procedure coordinates the reception of the dial tone at the PSTN terminal, generated by the LE, and the enabling of the dialling information receiver in the AN user port which will be enabled at receipt of the (possibly) delayed ESTABLISH ACK message.

H.2 Information flow diagrams

Figures H.1 to H.6 show the information flow diagrams.

Time is shown running top to bottom in the diagrams, with no scale. The vertical bars have the following meanings:

- Sub = Customer connected to the AN;
- AN = AN PSTN protocol entity;
- LE = LE PSTN protocol entity;
- NAT = National PSTN protocol entity implementation in the LE.

Signals, which are indicated by a 1 in a circle, in the following diagrams are passed transparently between the Sub and NAT. When a national specific sequence of messages clears the call within the NAT, the V5.1 PSTN protocol releases the link as a response to a "Disconnect Request" from the NAT.

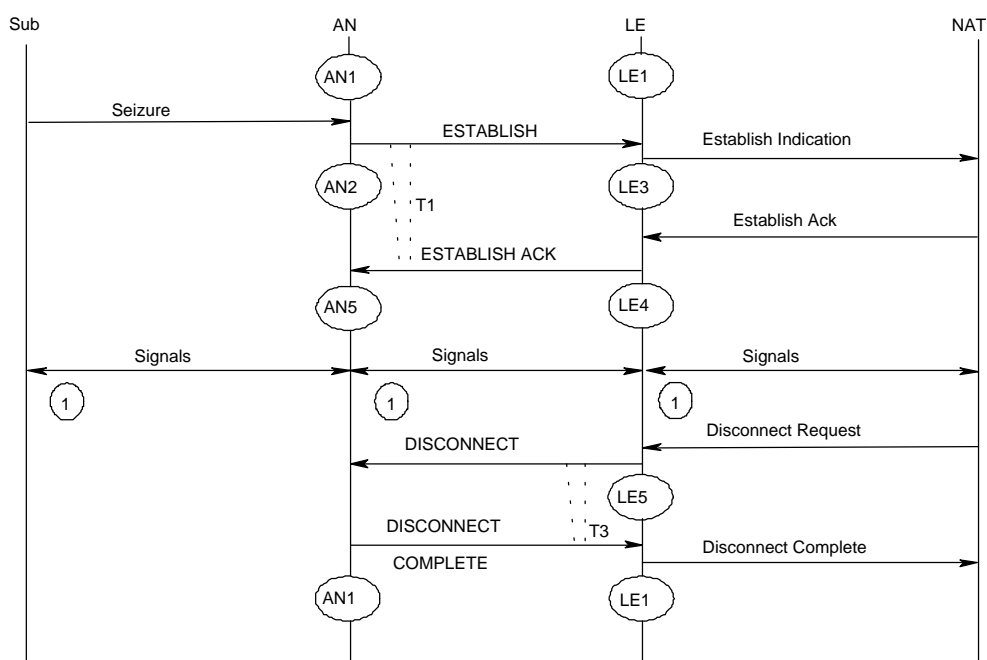

Figure H.1: Originating call

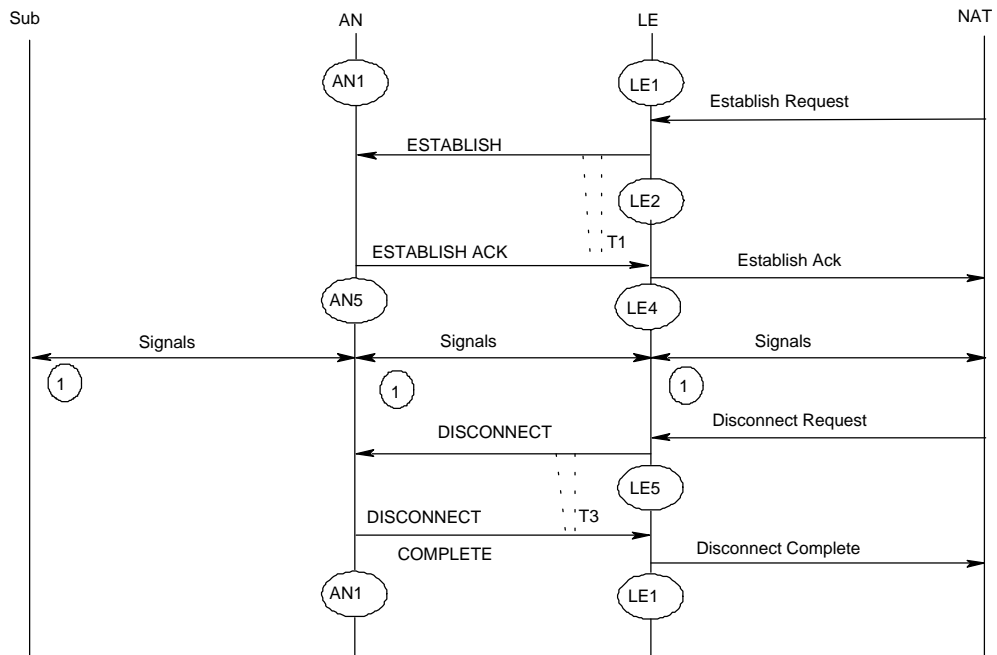

Figure H.2: Terminating call

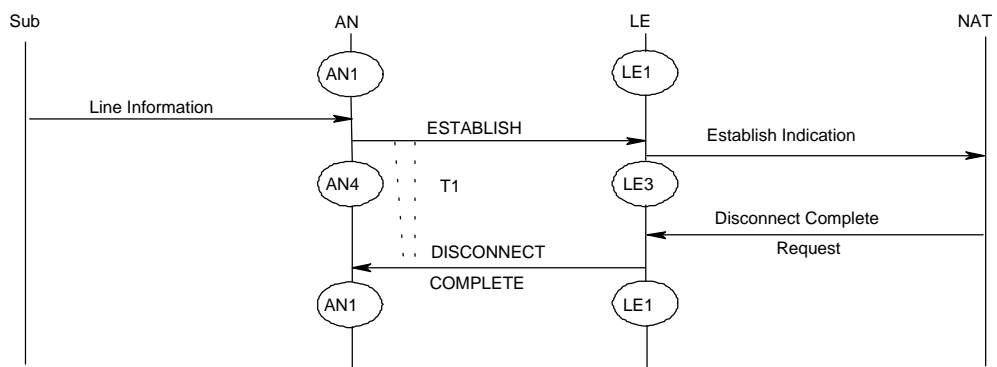

Figure H.3: Facility request

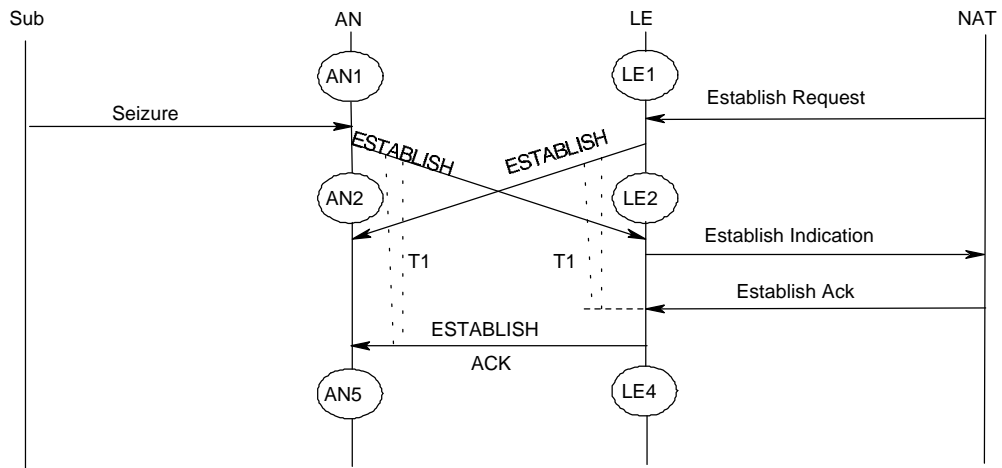

Figure H.4: Call collision; originating call has priority

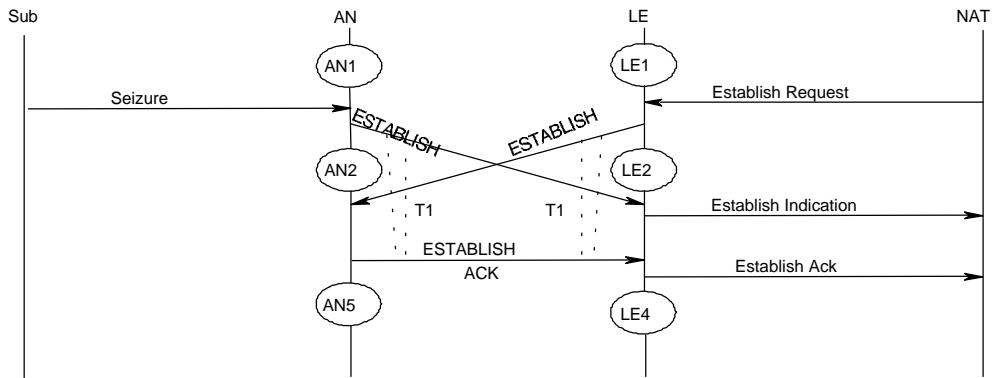

Figure H.5: Call collision; terminating call has priority

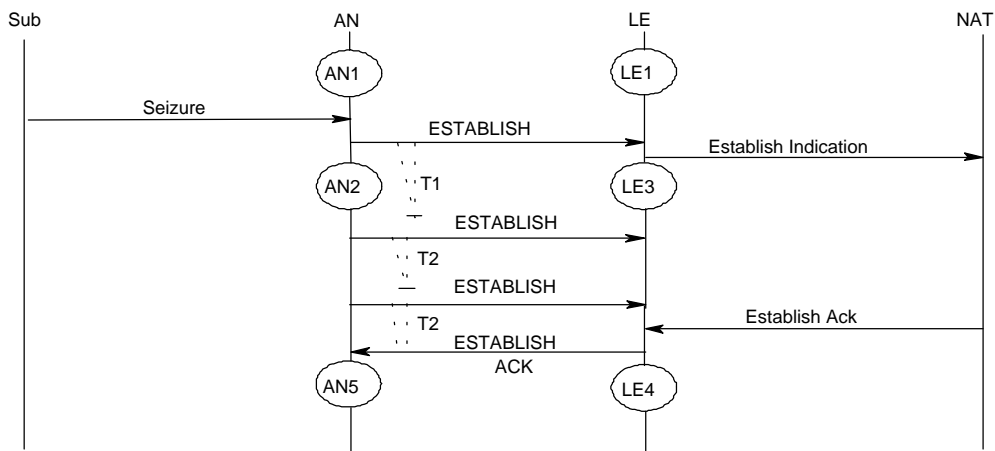

Figure H.6: Originating call; guard timer T1/T2 expire

Annex J (informative): AN requirement for pulse dialling

The AN has to interrupt the line transmission path at the beginning of a line state signal (e.g. digit or register recall). This is needed so that the dial-tone being generated by the LE is cut (by interrupting the transmission path) as soon as the subscriber starts dialling as opposed to after a short delay when the digit signal reaches the LE.

Every time the AN detects the first pulse of a line state signal, it interrupts the transmission path. Once it recognizes the end of the line state signal and sends the SIGNAL message to the LE, the AN starts a timer. Once the timer expires, the AN re-connects the transmission path (see figure J.1). This applies to all received line state signals.

The timer may be provisioned in the AN through the Q_{AN} interface. A recommended value for this timer is 200 ms. This procedure has no impact on the V5.1 interface.

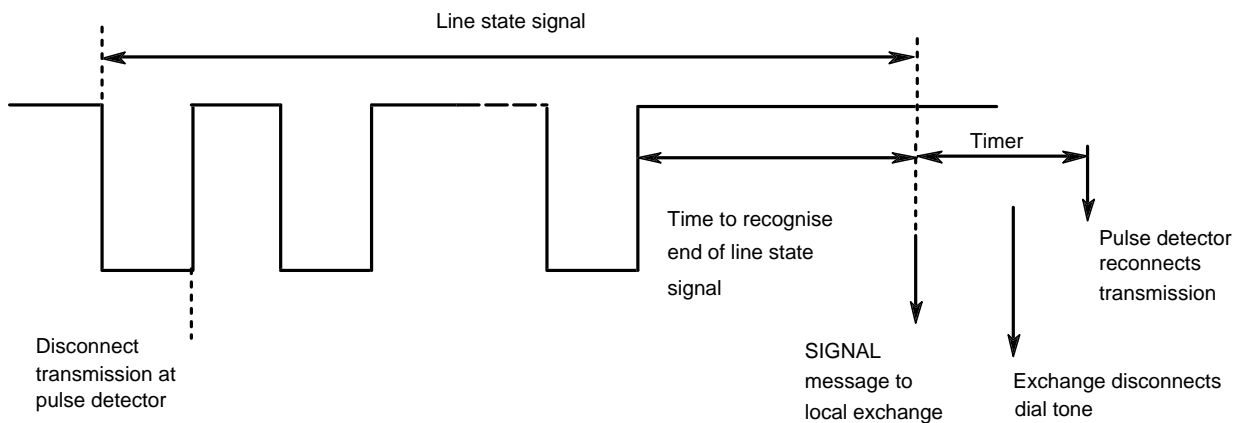

Figure J.1: AN pulse dialling requirement

Annex K (informative): Layer 3 error detection procedure

The V5.1 interface is provided with an error protection mechanism for PSTN messages at layer 3. Path related messages shall be protected within the PSTN protocol entity by their functional operation. The PSTN SIGNAL messages and the PROTOCOL PARAMETER message containing FE-line_signal information and FE-protocol_parameter information respectively do not have such a protection mechanism. An error detection mechanism is defined which allows for errors in such messages to be detected. The mechanism does not provide a means to guarantee secure transmission, hence no extra buffers are required. On detection of an error, that particular PSTN path shall be cleared down.

In the following the procedure is described for SIGNAL messages only for simplification reasons.

K.1 Variables and sequence numbers

Each SIGNAL message shall be sequentially numbered and may have the value 0 through n minus 1 (where n is the modulus of the sequence number).

The modulus equals 128 and the sequence numbers cycle through the entire range, 0 through 127.

There shall be three counters on either side (AN and LE) as follows:

- S(S) which is the Sequence Number next to be transmitted;
- S(A) which is the Sequence Number of the last acknowledged message;
- S(R) which is the Sequence Number next to be received.

These counters shall be set to 0 whenever an originating or terminating call is started in the NULL state.

In every SIGNAL message there shall be a counter M(S) which indicates the send sequence number of that transmitted message. At the time that an in-sequence SIGNAL message is designated for transmission, the value of M(S) shall be set equal to S(S).

Additionally to the existing messages there shall be a SIGNAL ACK message which contains a counter M(R) which indicates the number of the SIGNAL message to be received next. At the time that a SIGNAL ACK message is designated for transmission, the value of M(R) shall be set equal to S(R).

S(S) denotes the number of the next message to be transmitted and may have a value in the range from 0 through n minus 1. The value of S(S) shall be incremented by 1 with each successive SIGNAL message and shall not exceed S(A) by more than the maximum window size of 127.

S(A) identifies the last frame that has been acknowledged by its peer. S(A) can take on the value 0 through n minus 1. A valid S(A) shall be in the range $\text{MOD}(S(S)-127) \leq S(A) \leq S(S)$ (S(A) - 1 equals the M(S) of the last acknowledged message).

S(R) denotes the number of the SIGNAL message expected to be received.

S(R) can take on the value 0 through n minus 1.

S(R) shall be incremented by one with the receipt of a SIGNAL message whose M(S) equals S(R).

Timer Tt watches over the receipt of a SIGNAL ACK message after a SIGNAL message has been sent. Timer Tt shall be started whenever a new SIGNAL message is sent after all previous messages have been acknowledged. Timer Tt shall be re-started whenever a SIGNAL ACK message arrives which M(R) does not equal S(S). Whenever timer Tt expires the path shall be released.

Timer T_r watches over the maximum time which may pass until a SIGNAL ACK message shall be sent. Timer T_r shall be started whenever a new SIGNAL message is received. It is not re-started if already active. Whenever timer T_r expires a SIGNAL ACK message shall be sent.

K.2 Values of counters and timers

The window size of the transmitting peer shall be 127 to avoid the need of queueing at layer 3.

Timer T_t shall allow layer 2 to handle all means of recovery before clearing down the path by layer 3. If there is a DL-establish-indication during T_t running this indication can be ignored because message loss can be detected by the mechanism described above. Layer 2 may need up to 8 seconds to re-establish the layer 2 link. For those reasons T_t is fixed at 10 seconds.

Timer T_r should be much more less than the timer T_t to avoid queueing of frames at the transmitting peer but should not be too small to allow for acknowledge after a number of messages received. Therefore, timer T_r is fixed at 5 seconds.

K.3 Procedures

Due to the symmetry and the independency between sending and receiving part of the proposed mechanism only one direction of message transport is described.

Whenever layer 3 is going to transmit a SIGNAL message $M(S)$ shall be set to $S(S)$ and $S(S)$ shall be incremented by 1. If $S(S)$ exceeds the window size of 127 this is an indication for problems (e.g. overload) and the path shall be released. If $S(S)$ is valid and timer T_t is running nothing shall happen. If $S(S)$ is valid and timer T_t is not running timer T_t shall be started.

Whenever layer 3 is going to transmit a SIGNAL ACK message $M(R)$ shall be set to $S(R)$.

Whenever layer 3 receives a SIGNAL message $M(S)$ shall be compared to $S(R)$. If $M(S)$ equals $S(R)$ the message shall be accepted and counter $S(R)$ shall be incremented by 1. If $M(S)$ does not equal $S(R)$ a message was lost before and the path shall be released.

Whenever layer 3 receives a SIGNAL ACK message $S(A)$ shall be set to $M(R)$. If $S(A)$ equals $S(S)$ timer T_t shall be stopped. If $S(A)$ does not equal $S(S)$ and if $M(R)$ is valid timer T_t shall be re-started. If $S(A)$ is not valid the path shall be released.

Whenever timer T_r expires a SIGNAL ACK message shall be transmitted.

Whenever timer T_t expires the path shall be released due to missing SIGNAL ACK messages.

K.4 Examples of the error detection mechanism

A number of possible message flows are shown in the tables K.1 to K.5. Due to the symmetry and the independency between sending and receiving part only one direction of message transport is shown.

Time runs from the top to the bottom.

Table K.1: Start scenario

Tt	S(S)	S(A)	S(R)	Tr
	x	x	x	
			ESTABLISH → ESTABLISH ACK ←	
	0	0	0	
start	1	0	SIGNAL; M(S)=0 →	start
running	2	0	SIGNAL; M(S)=1 →	running

Table K.2: Time out Tr

Tt	S(S)	S(A)	S(R)	Tr
running	5	0	5	running
			SIGNAL; M(S)=5 →	
running	6	0	6	running
.
.	.	.	6	time out
			SIGNAL ACK; M(R)=6 ←	
running	6	6	6	running
stop			SIGNAL; M(S)=6 →	
start	7	6	7	start

Table K.3: Re-start Tt

Tt	S(S)	S(A)	S(R)	Tr
running	5	0	5	running
			SIGNAL; M(S)=5 →	
running	6	0	6	running
.
.	.	.	6	time out
			SIGNAL; M(S)=6 → SIGNAL ACK; M(R)=6 ←	
running	7	0	7	running
running	7	6	7	start
re-start			SIGNAL; M(S)=7 →	
running	8	6	8	running

Table K.4: Time out Tt

Tt	S(S)	S(A)	S(R)	Tr
running	5	0	5	running
			SIGNAL; M(S)=5 →	
running	6	0	6	running
.
.
.
time out				
stop Tr			DISCONNECT →	

Annex L (informative): SDL diagrams

L.1 SDL diagrams for the AN side

L.1.1 System description

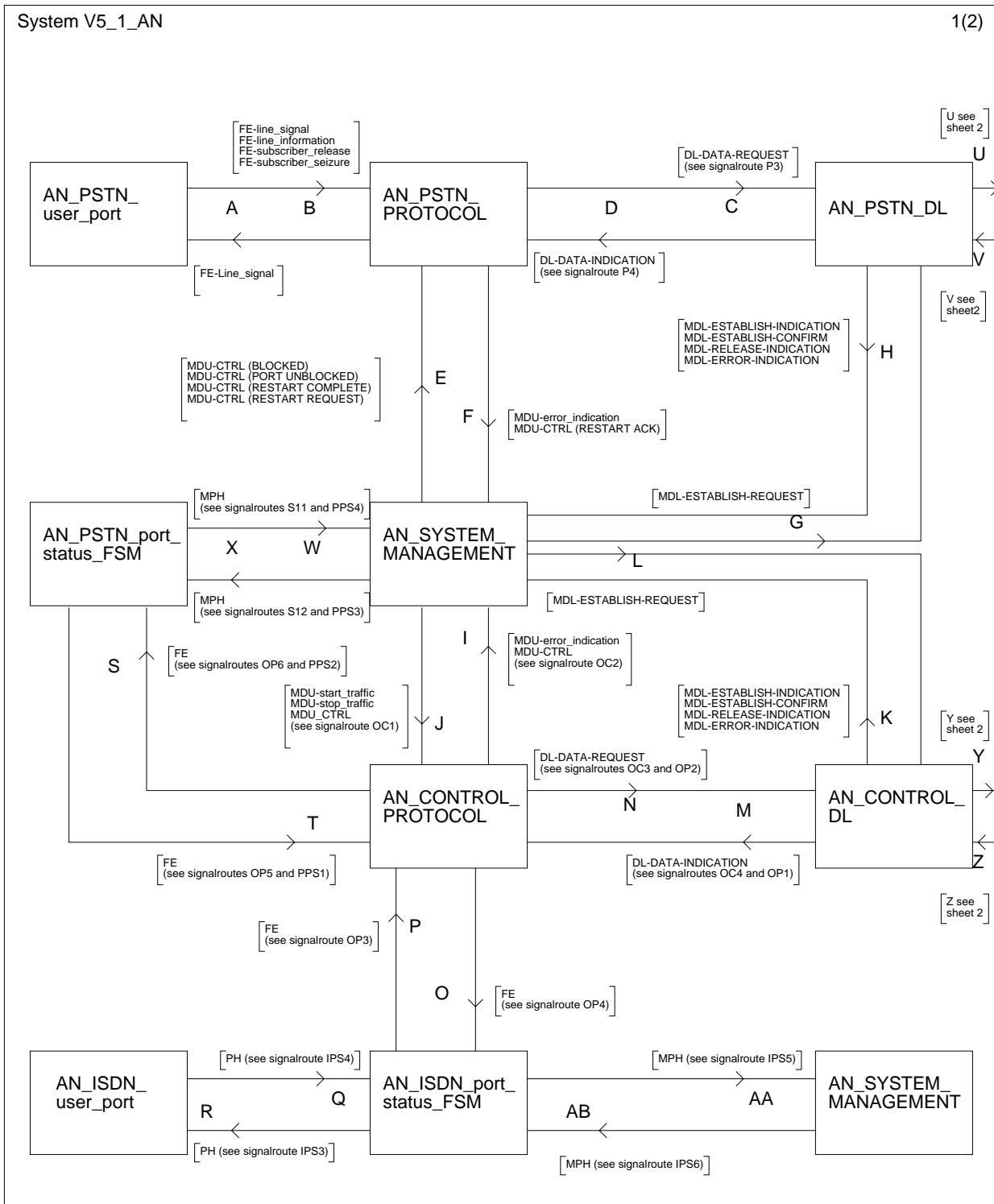

Figure L.1.1: V5.1 system overview AN-side (sheet 1 of 2)

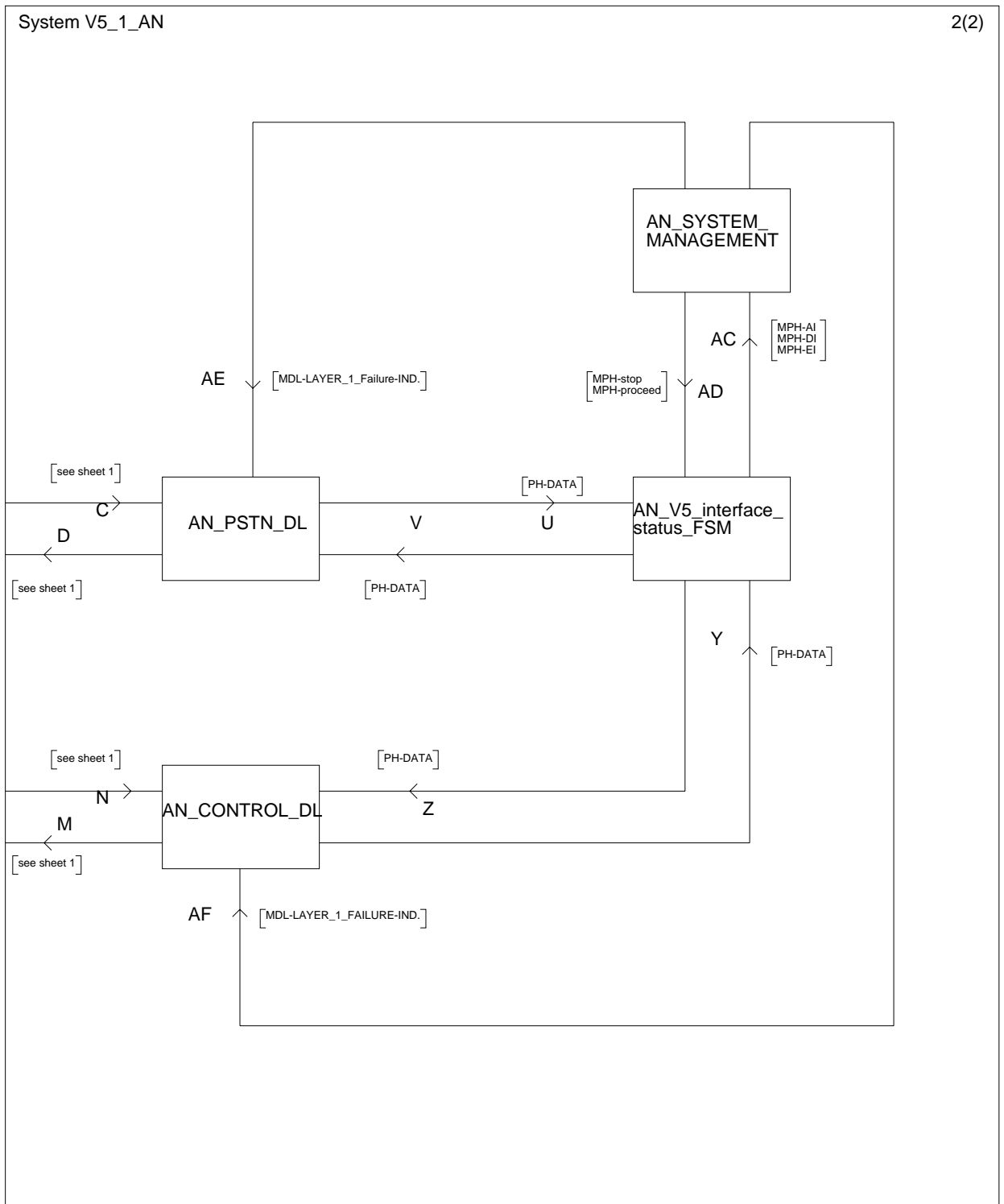

Figure L.1.2: V5.1 system overview AN-side (sheet 2 of 2)

L.1.2 Block descriptions

L.1.2.1 Block description of the PSTN protocol

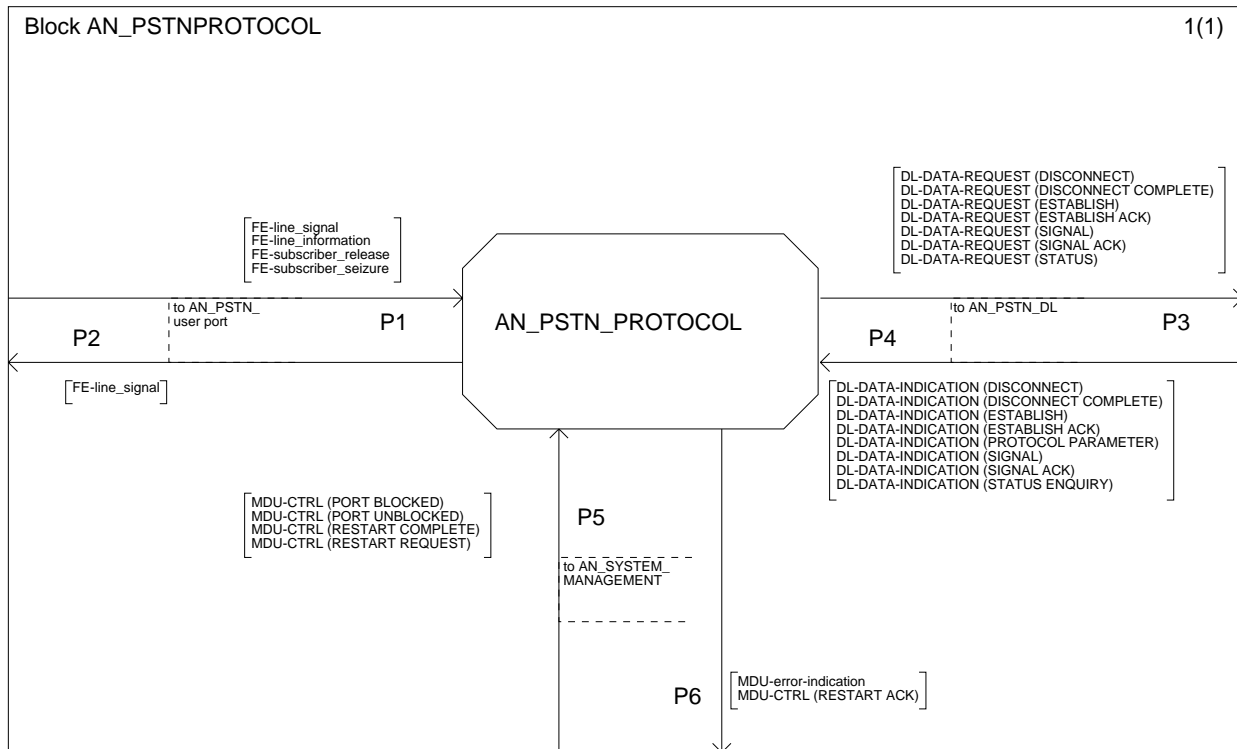

Figure L.2: PSTN protocol block description AN-side

L.1.2.2 Block description of the control protocol

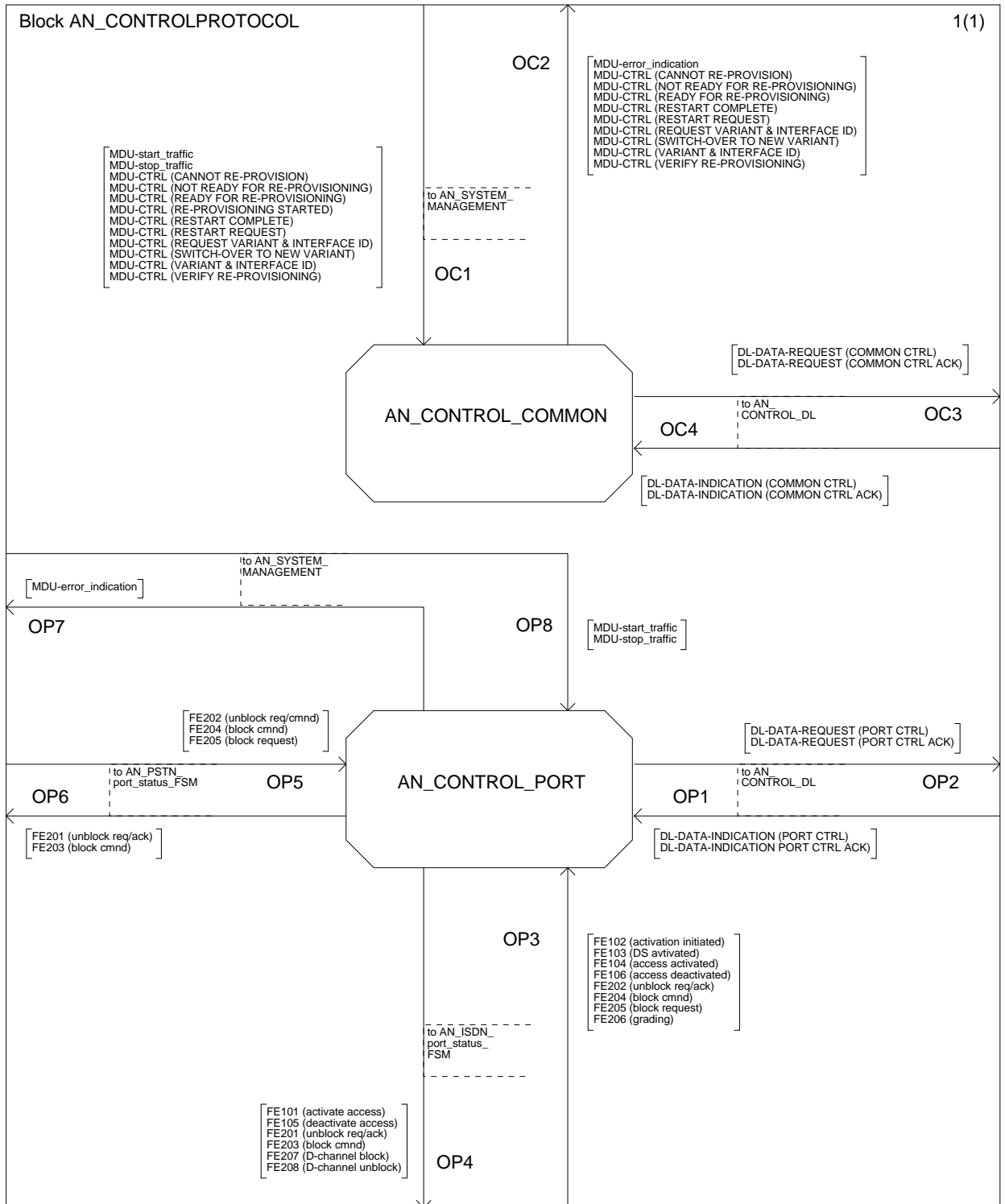

Figure L.3: Control protocol block description AN-side

L.1.2.3 Block description of the ISDN port status FSM

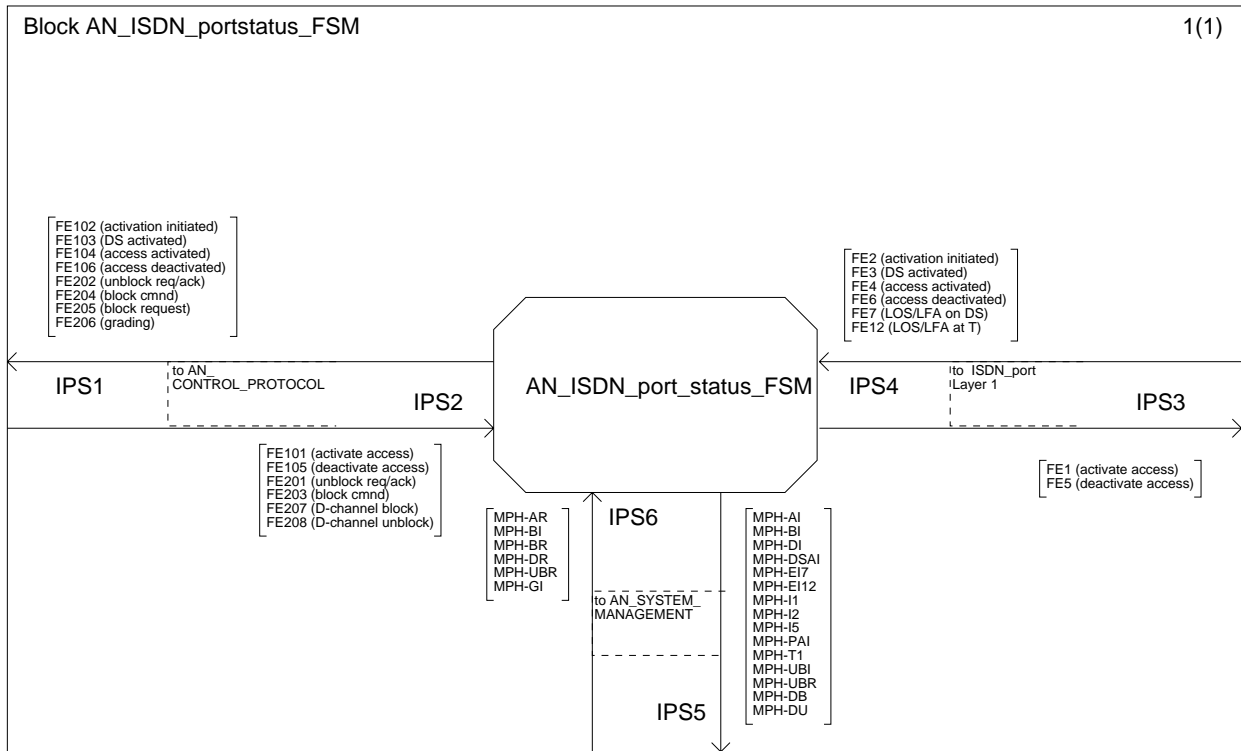

Figure L.4: ISDN port status FSM block description AN-side

L.1.2.4 Block description of the PSTN port status FSM

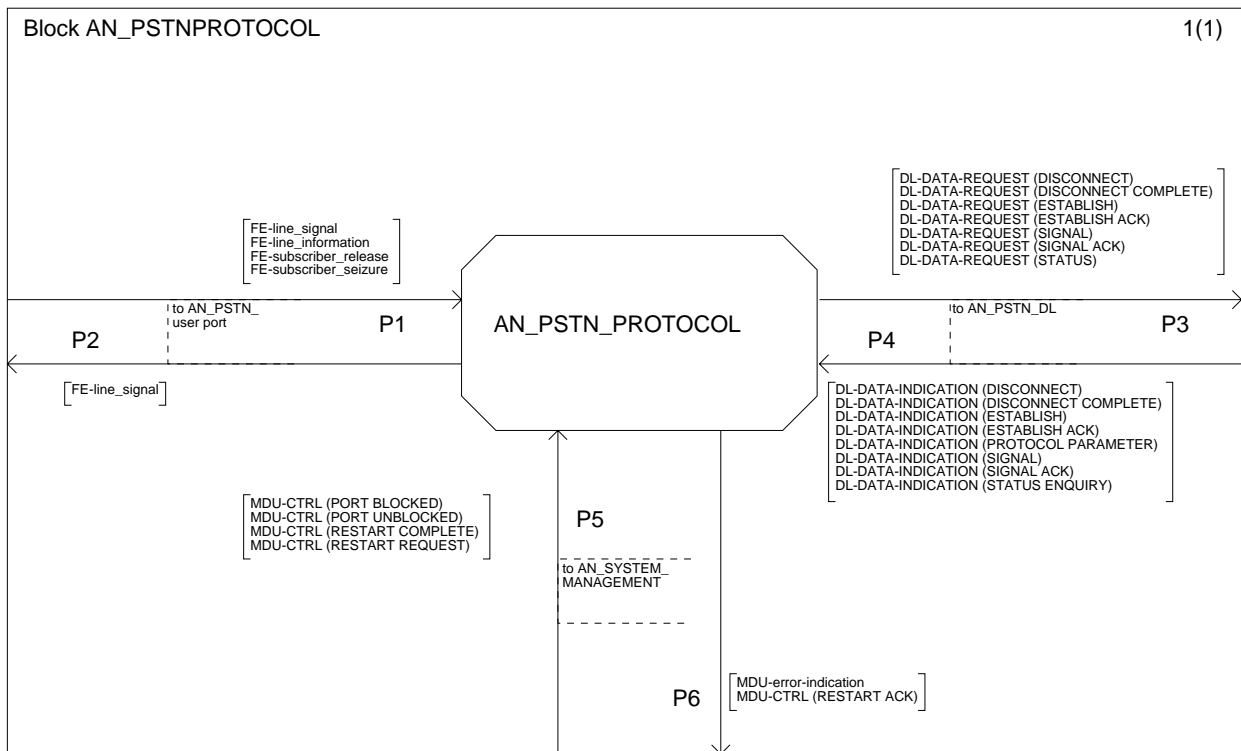

Figure L.5: PSTN port status FSM block description AN-side

L.1.2.5 Block description of the system management

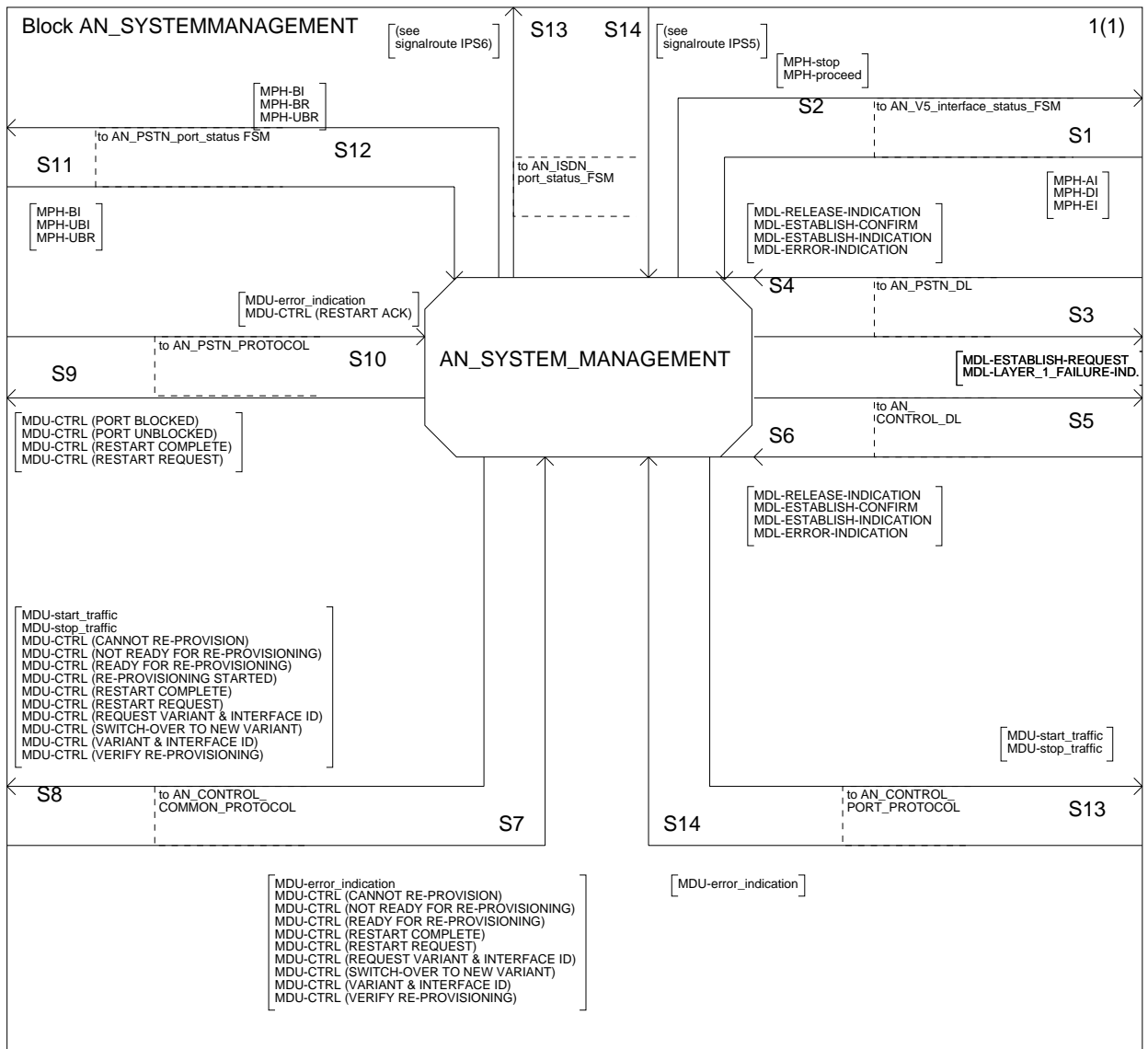

Figure L.6: System management block description AN-side

L.1.3 Explanation of SDL symbols

The symbols given in figure L.7 are used in the following. A full description of the symbols and their meaning and application is given in CCITT Recommendation Z.100.

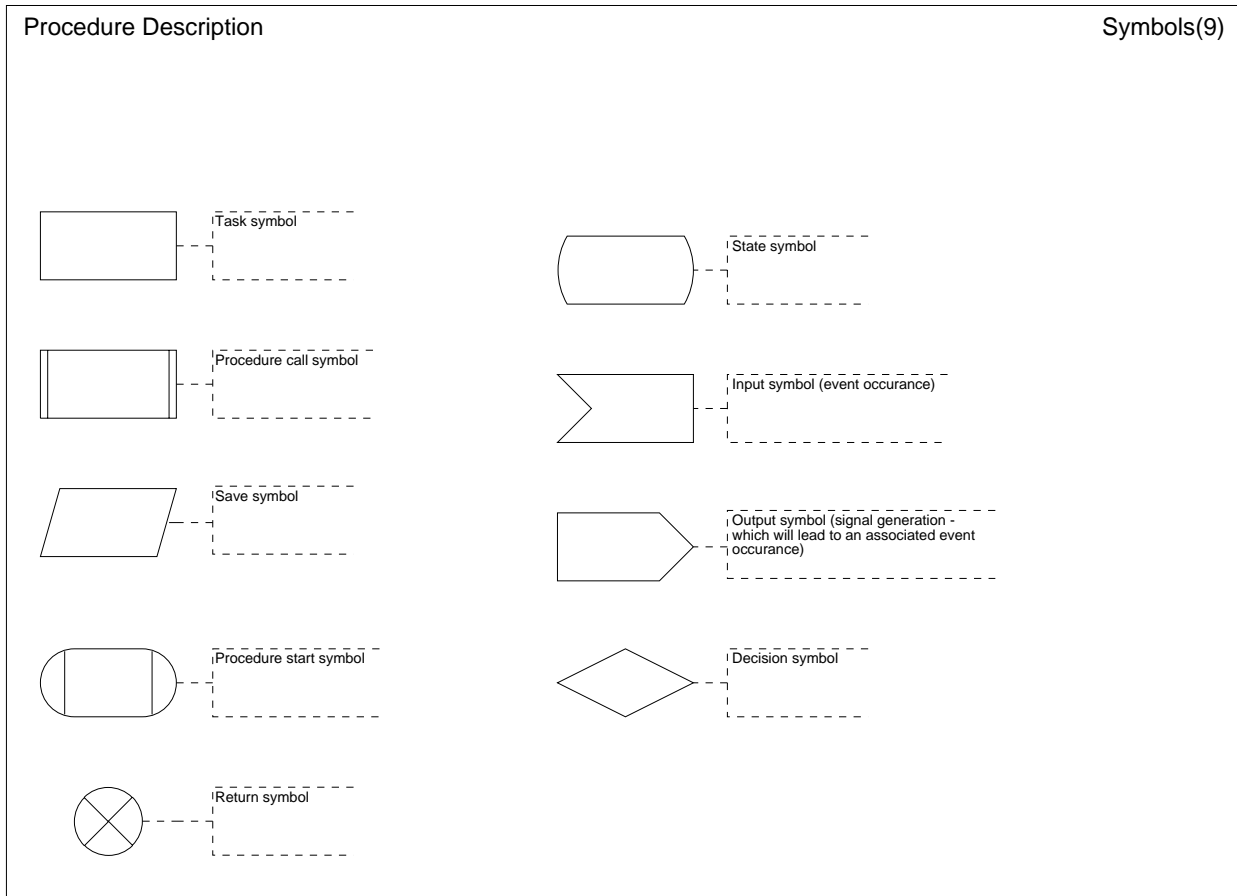

Figure L.7: List of SDL symbols

L.1.4 PSTN protocol procedure

L.1.4.1 Scope

This subclause shows the SDL representation according to the PSTN path control procedures specified in Clause 13.

L.1.4.2 Path states

The path states for the AN side are defined in subclause 13.2.1.

L.1.4.3 SDLs

The input and output symbols application in figure L.8 as well as the abbreviation are used in the following.

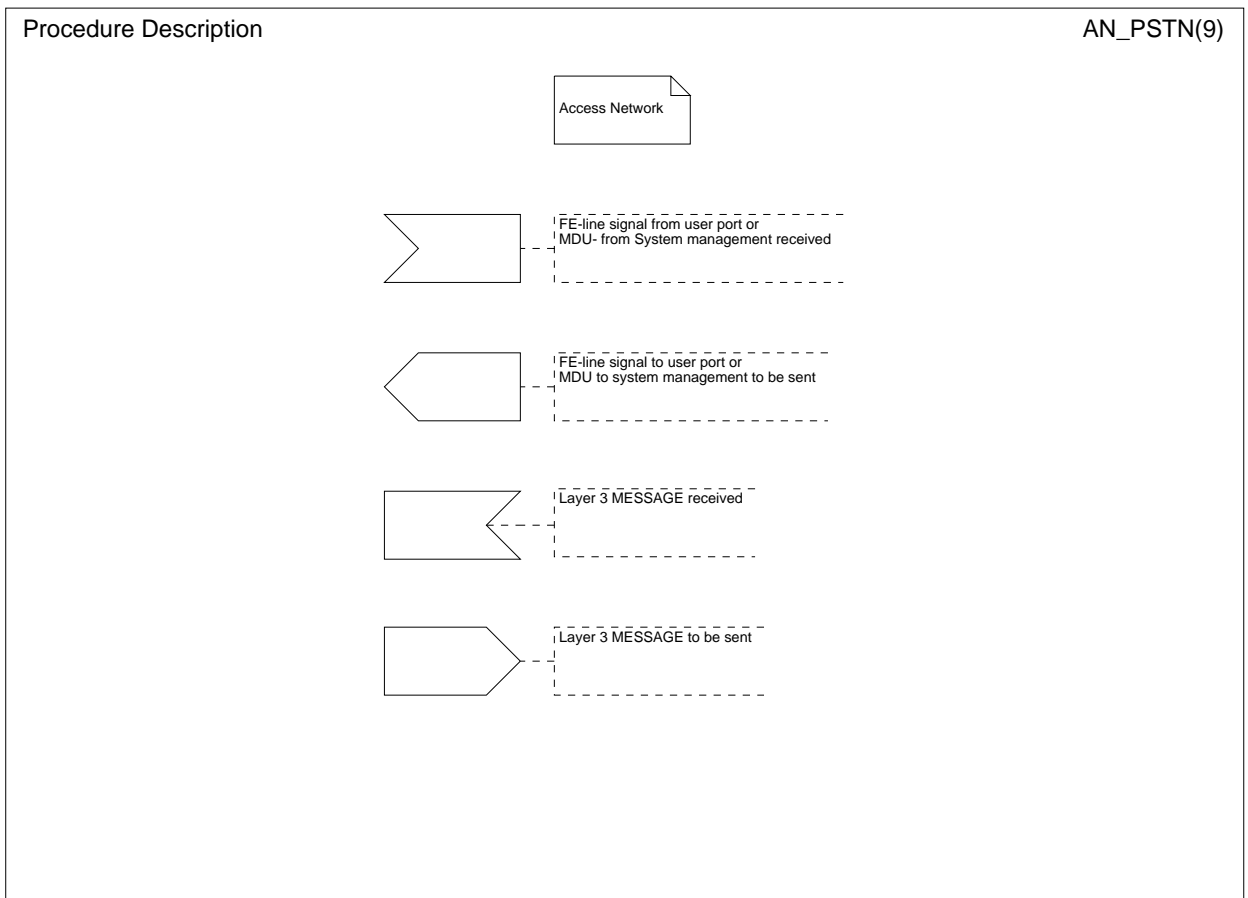

Figure L.8: Input and output symbols application - PSTN protocol (AN-side)

Process AN_PSTN_PROTOCOL

1(11)

State
 AN0(PSTN)

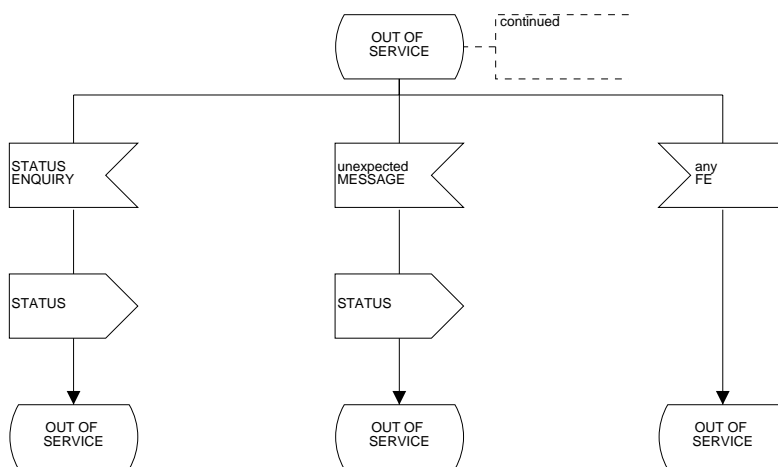
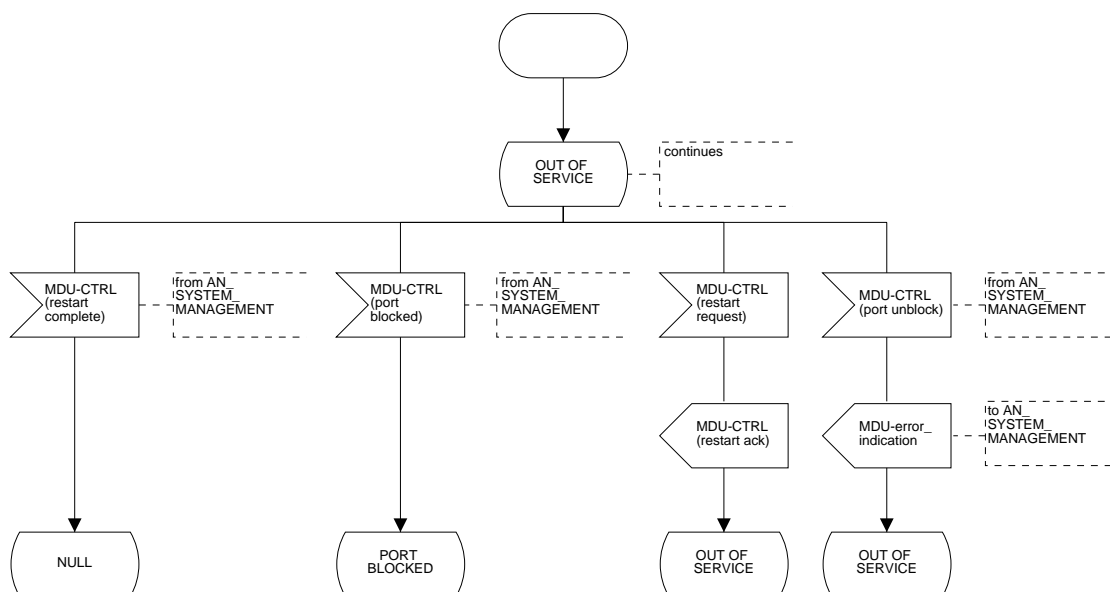

Figure L.9.1: PSTN protocol AN-side; state OUT OF SERVICE (AN0(PSTN))

Process AN_PSTN_PROTOCOL

2(11)

State
 AN1(PSTN)

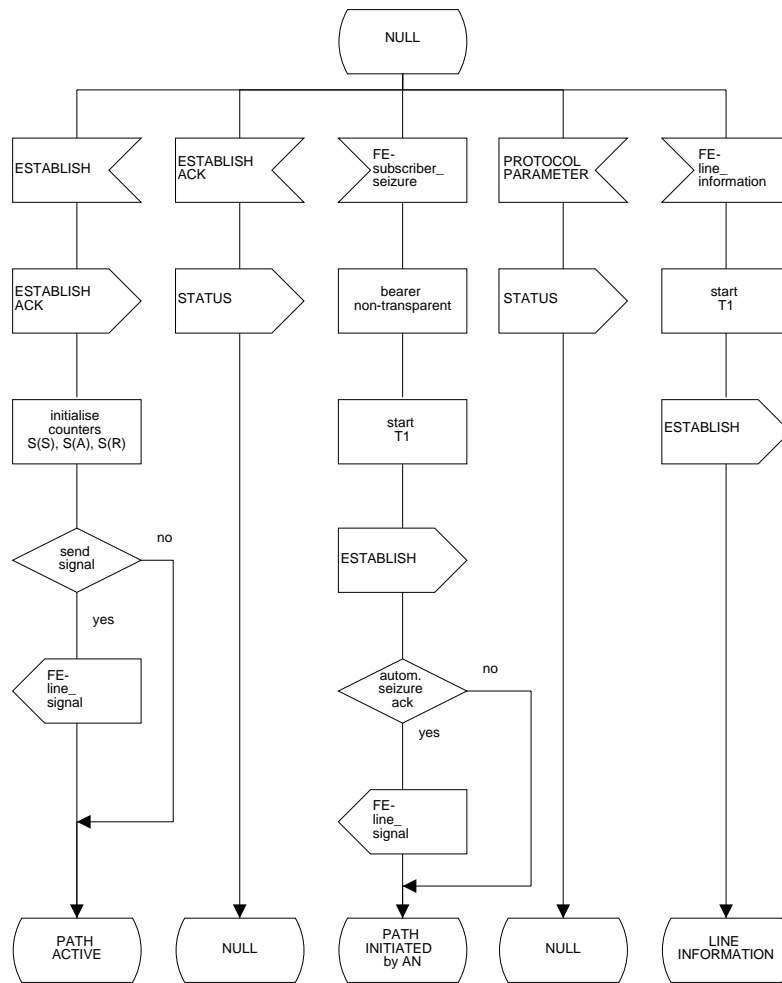

Figure L.9.2: PSTN protocol AN-side; state NULL (AN1(PSTN))

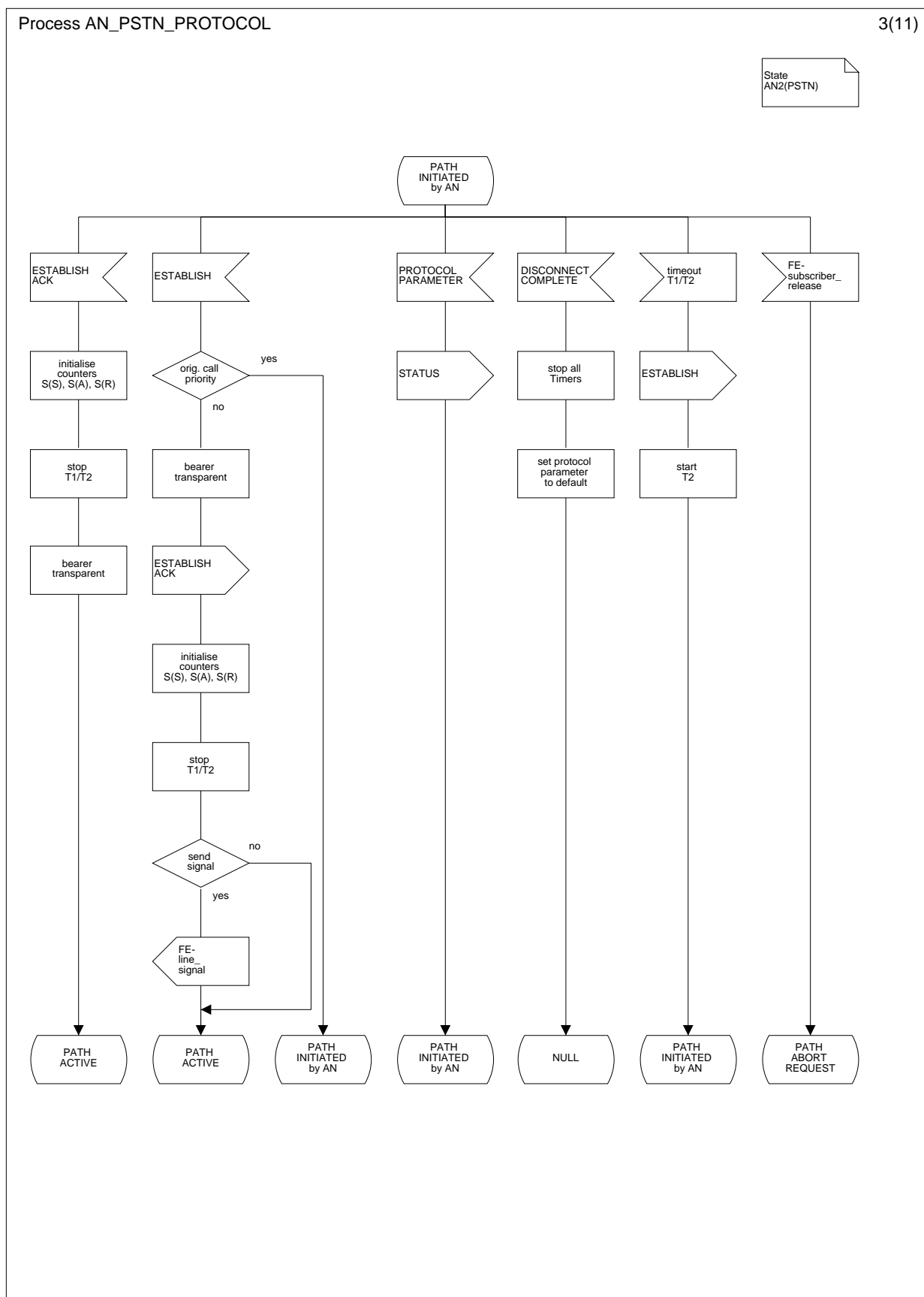

Figure L.9.3: PSTN protocol AN-side; state PATH INITIATED BY AN (AN2(PSTN))

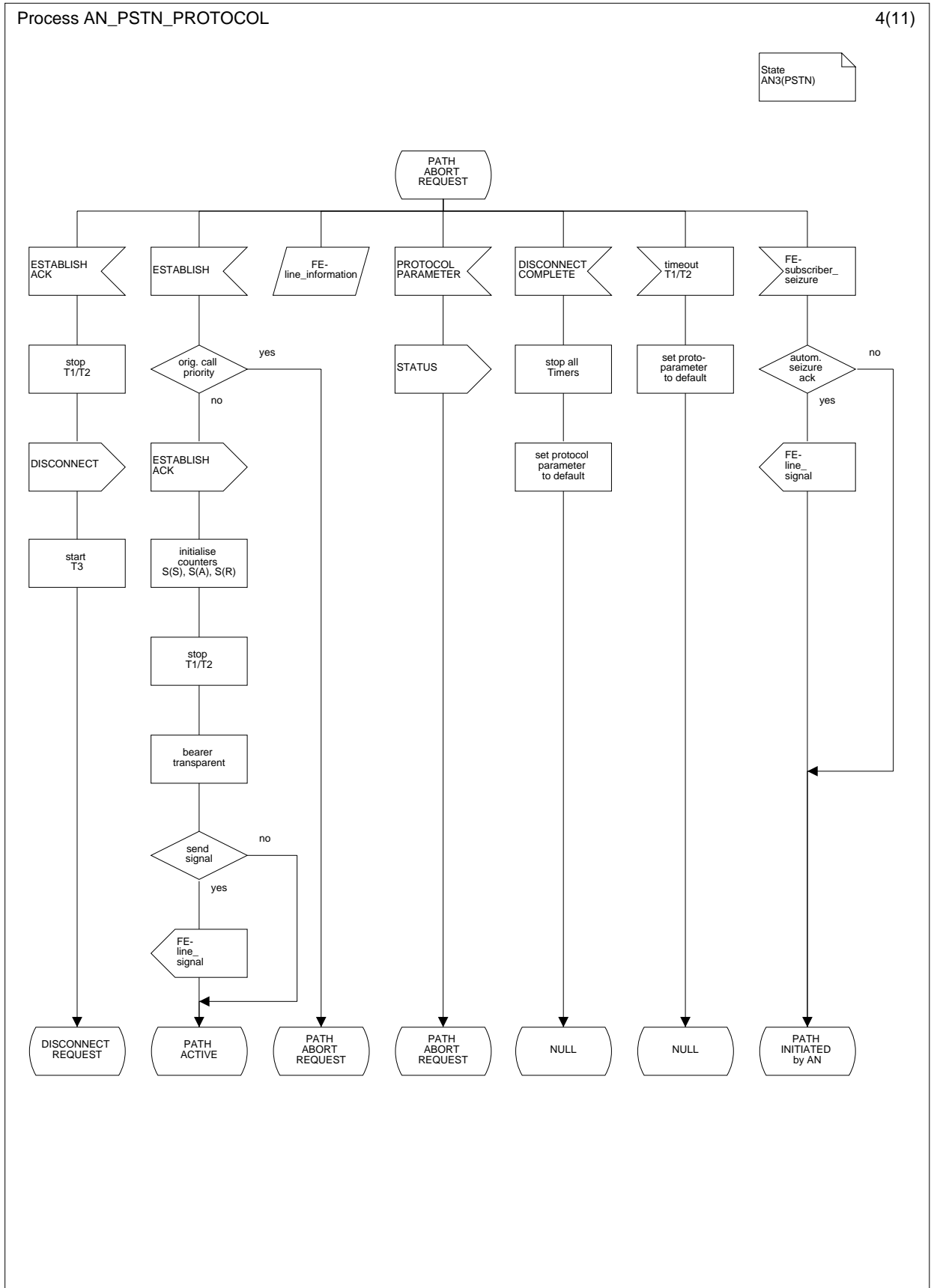

Figure L.9.4: PSTN protocol AN-side; state PATH ABORT REQUEST (AN3(PSTN))

Process AN_PSTN_PROTOCOL

State
AN4(PSTN)

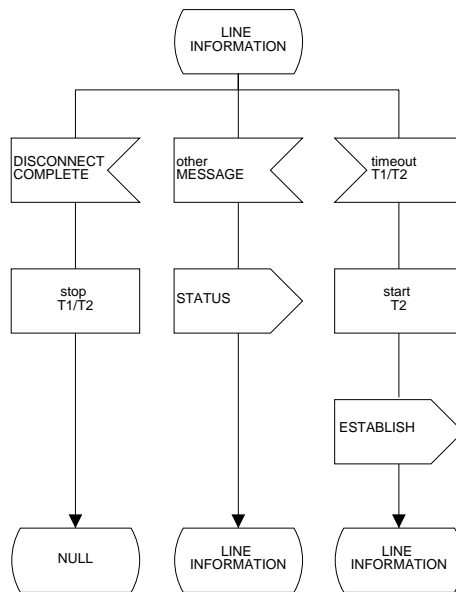

Figure L.9.5: PSTN protocol AN-side; state LINE INFORMATION (AN4(PSTN))

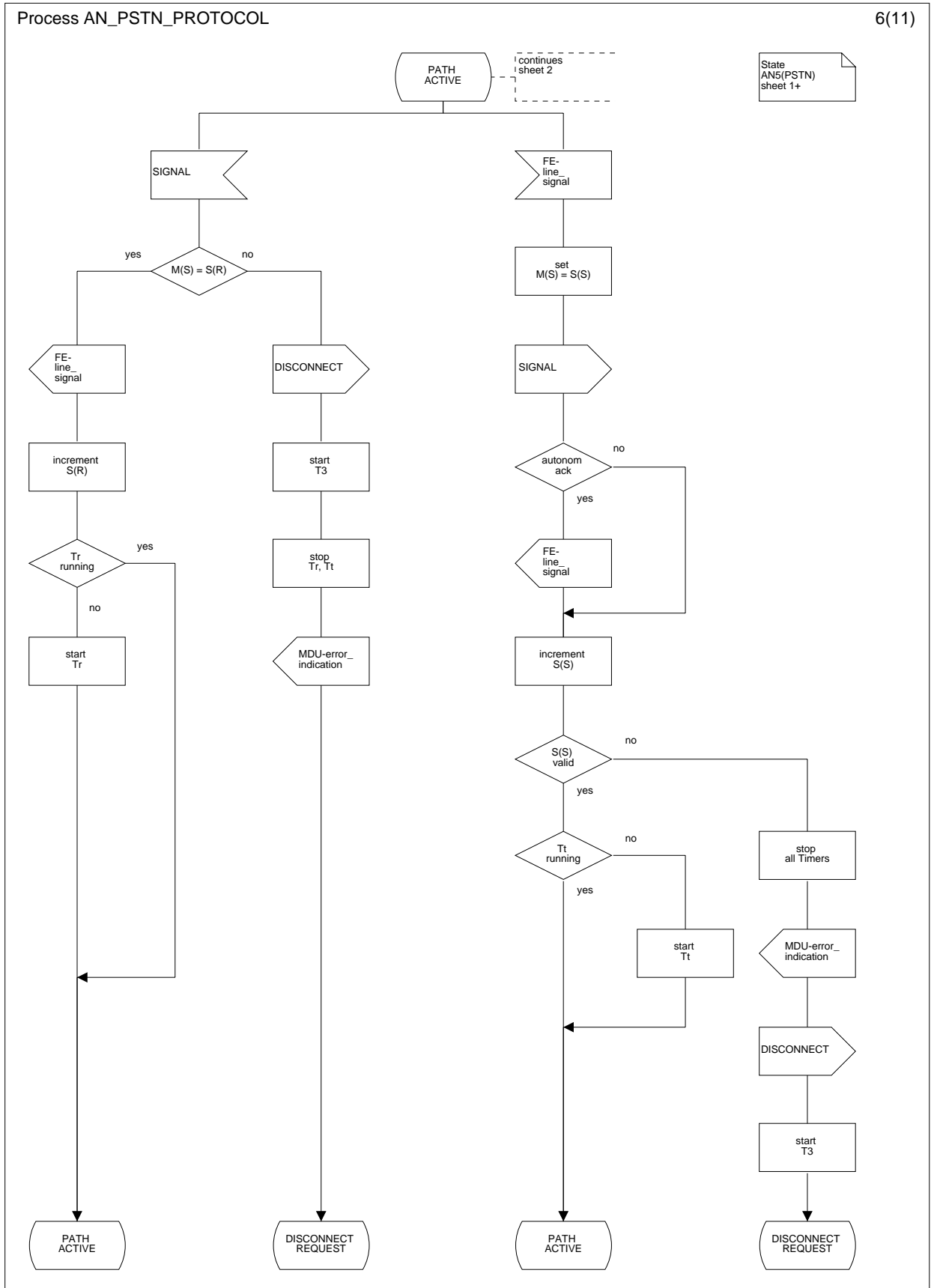

Figure L.9.6: PSTN protocol AN-side; state PATH ACTIVE (AN5(PSTN)) (sheet 1 of 3)

State
 AN5(PSTN)
 sheet 2-

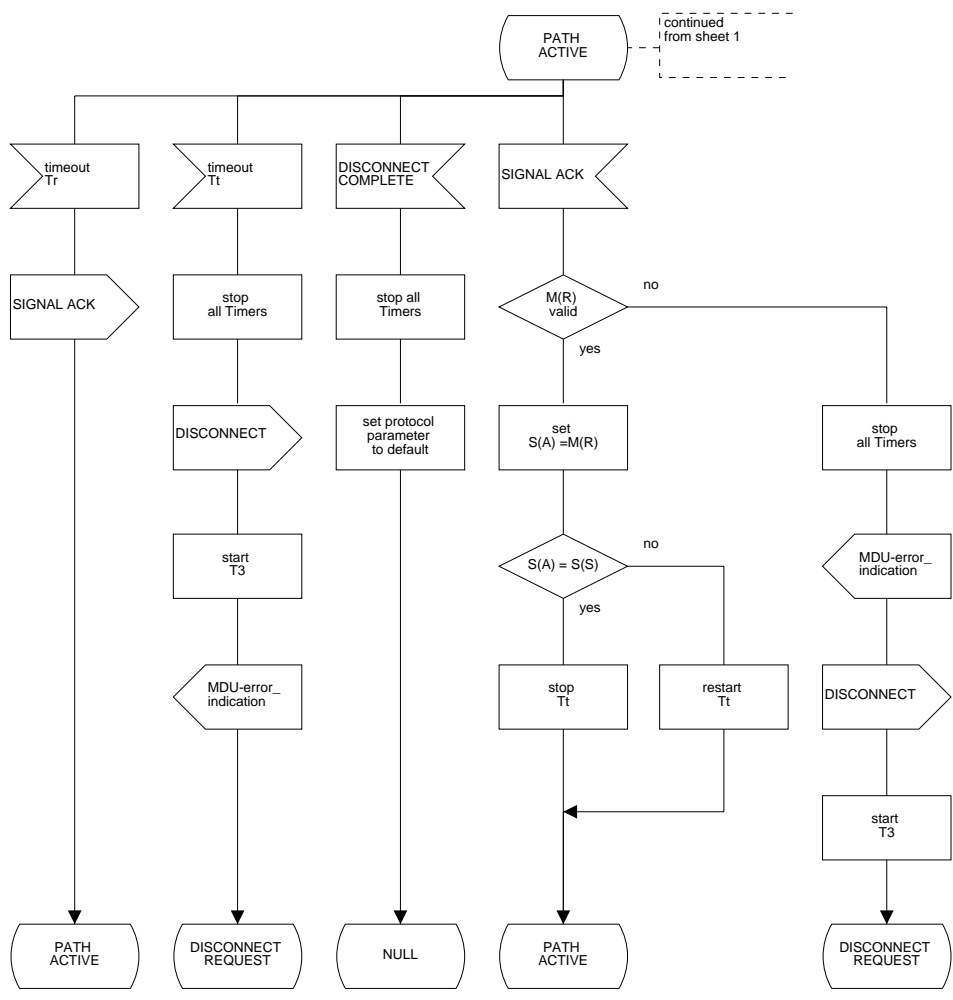

Figure L.9.7: PSTN protocol AN-side; state PATH ACTIVE (AN5(PSTN)) (sheet 2 of 3)

Process AN_PSTN_PROTOCOL

8(11)

State
AN5(PSTN)
sheet 3

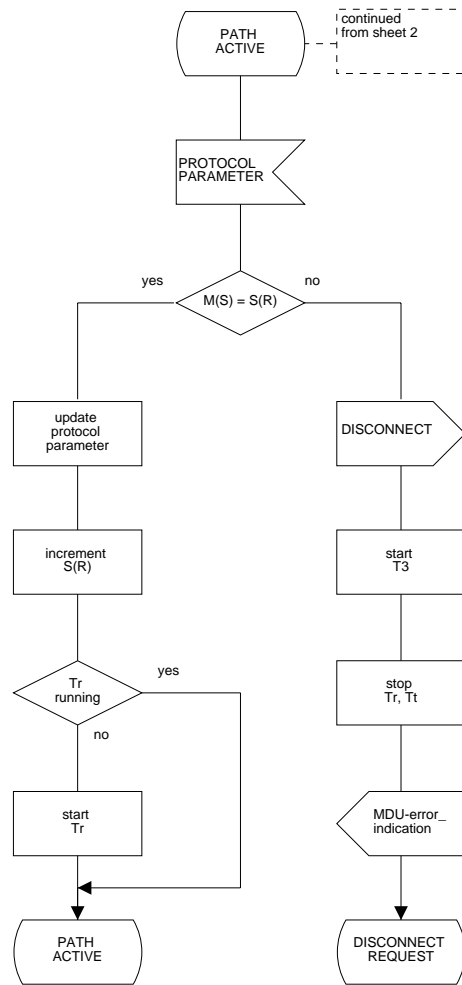

Figure L.9.8: PSTN protocol AN-side; state PATH ACTIVE (AN5(PSTN)) (sheet 3 of 3)

State
AN6(PSTN)

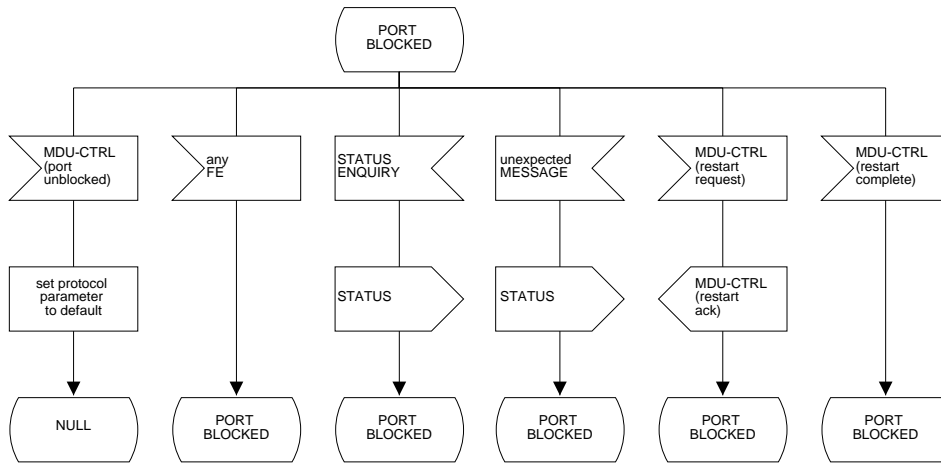

Figure L.9.9: PSTN protocol AN-side; state PORT BLOCKED (AN6(PSTN))

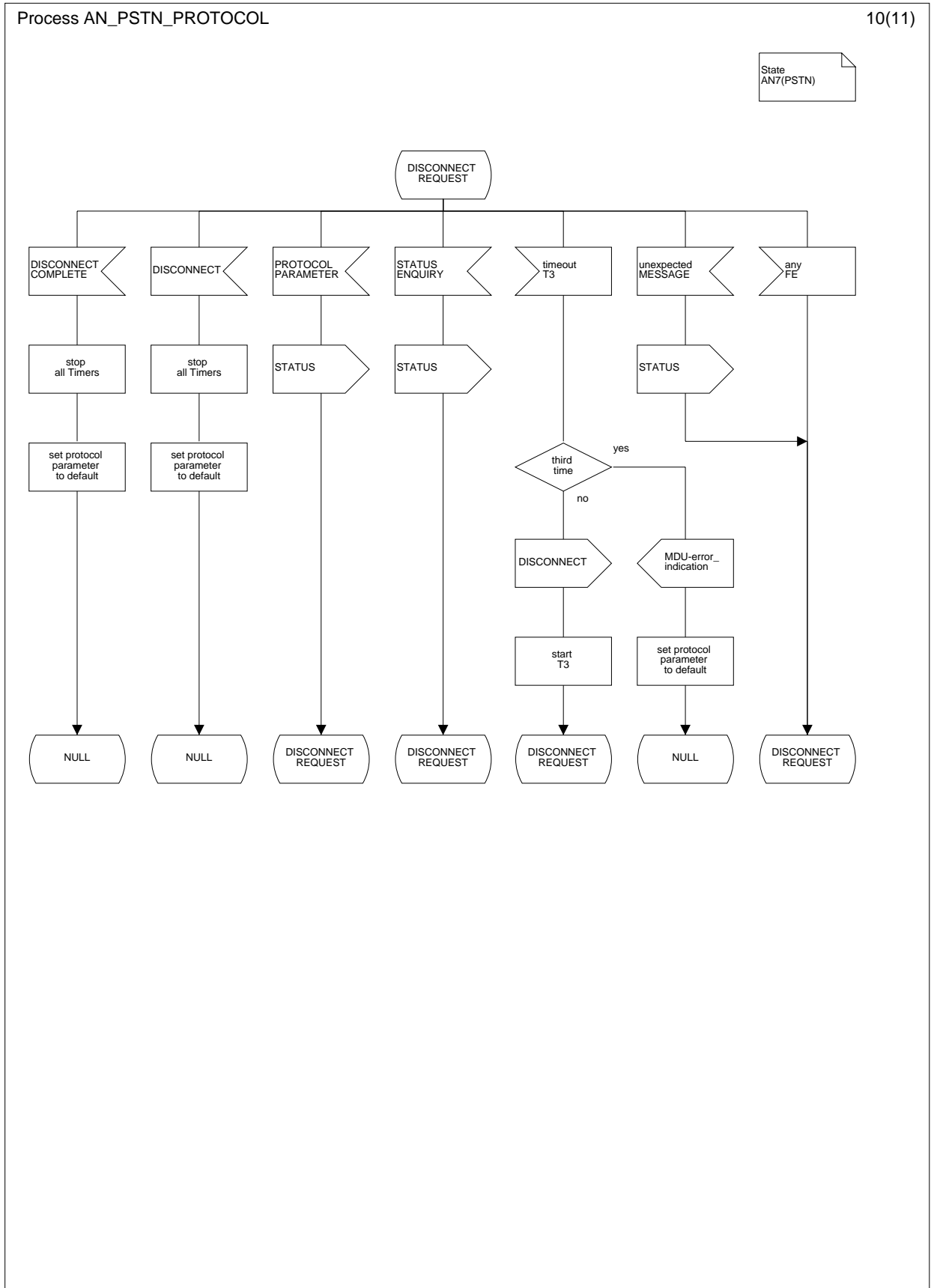

Figure L.9.10: PSTN protocol AN-side; state DISCONNECT REQUEST (AN7(PSTN))

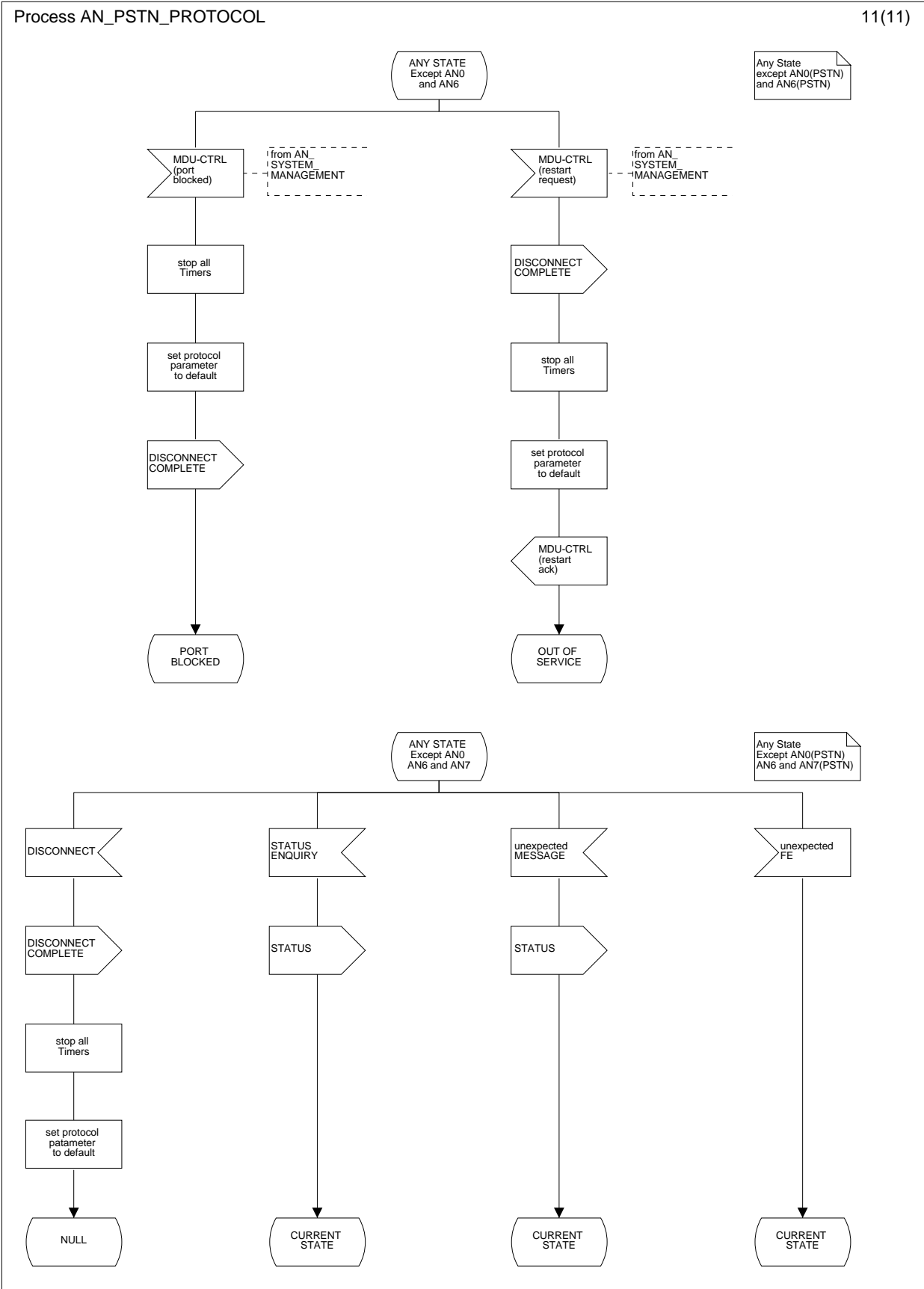

Figure L.9.11: PSTN protocol AN-side; any state except AN0(PSTN) and AN6(PSTN) and any state except AN0(PSTN) and AN7(PSTN)

L.1.5 Control protocol procedures

L.1.5.1 Scope

This subclause shows the SDL representation according to the port control procedure and the common control procedure specified in subclause 14.4.

L.1.5.2 States

The states for the AN side are defined in subclause 14.4.

L.1.5.3 SDLs

The input and output symbols application in figure L.10 as well as the abbreviation are used in the following.

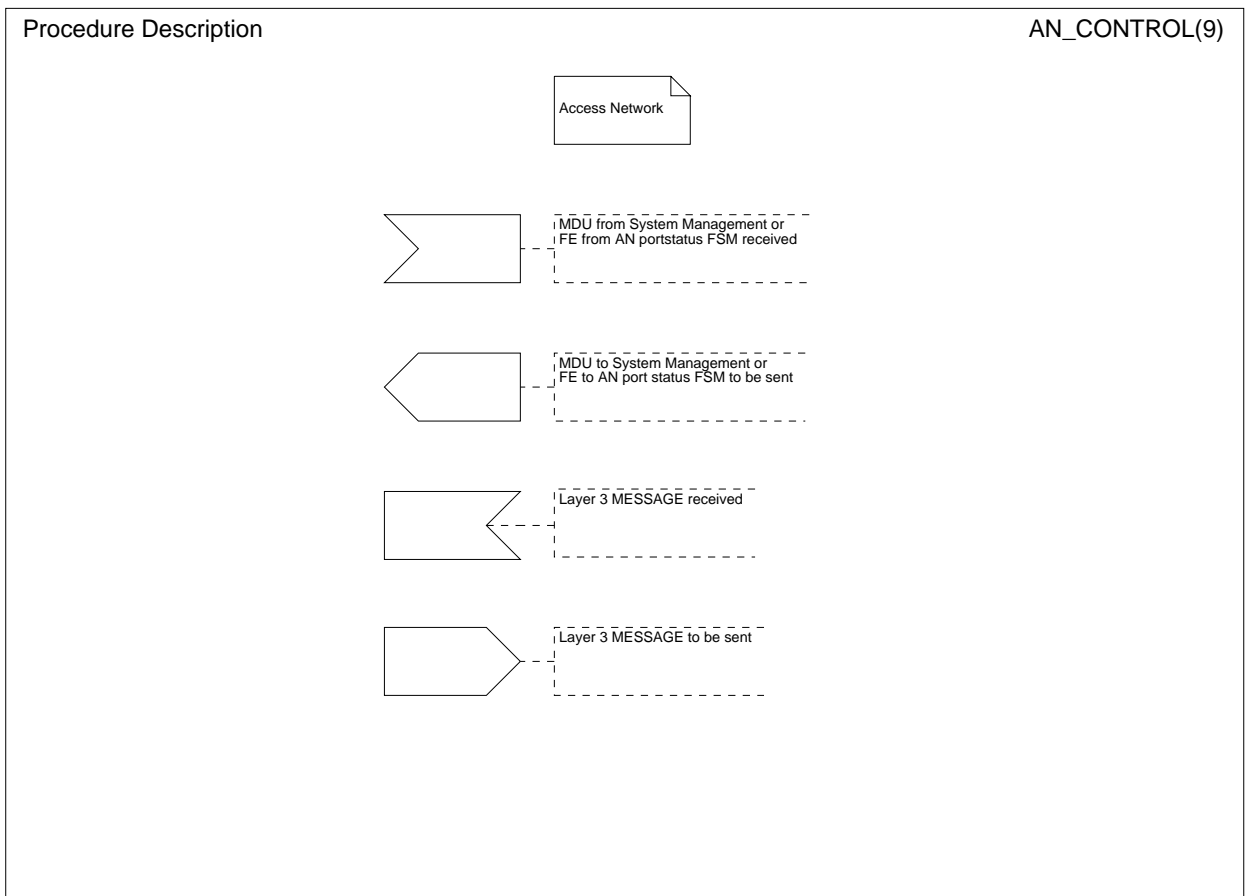

Figure L.10: Input and output symbols application - control protocol (AN-side)

L.1.5.3.1 Port control protocol

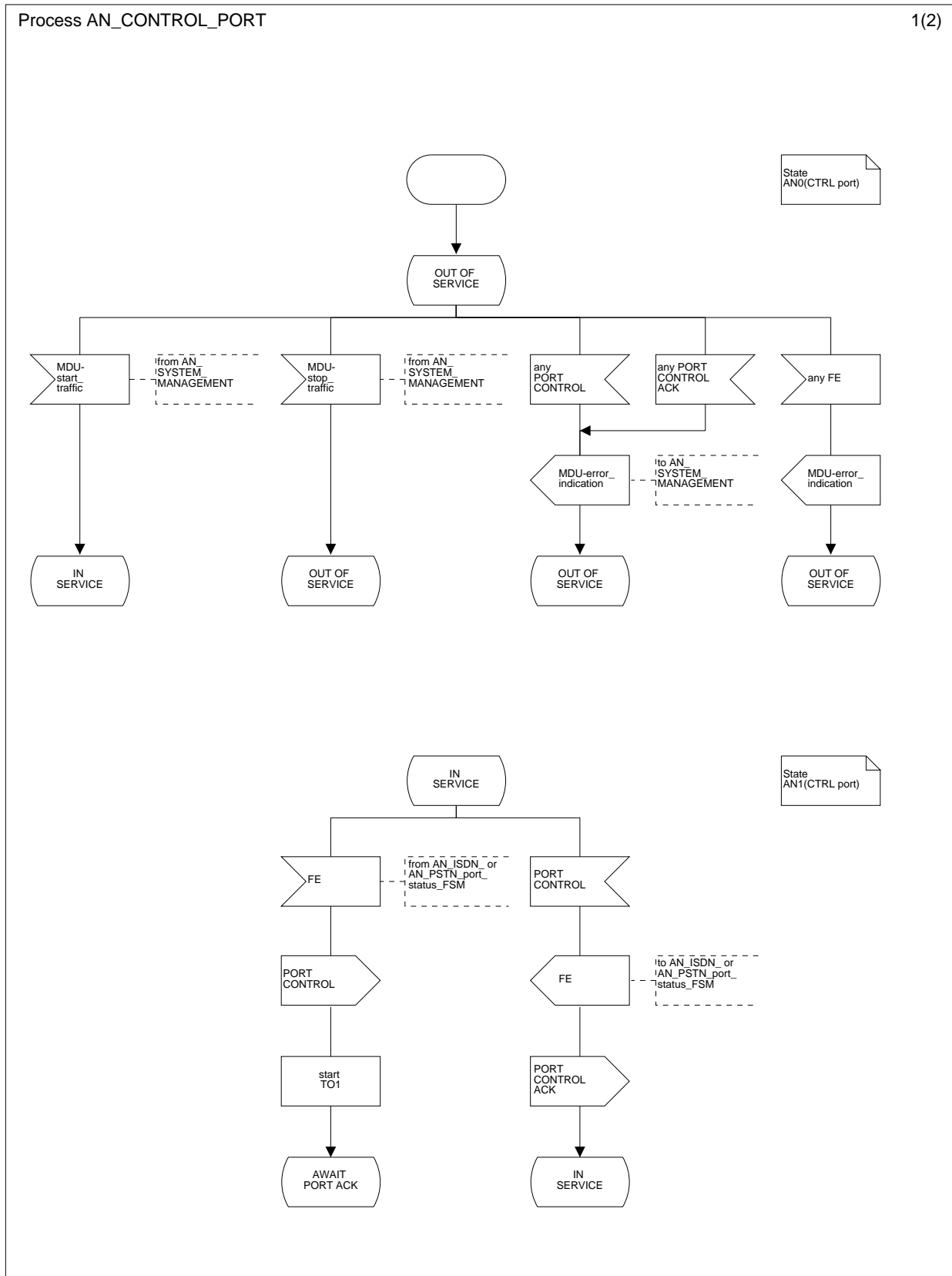

Figure L.11.1: Port control protocol AN-side; states OUT OF SERVICE (AN0(CTRL port)) and IN SERVICE (AN1(CTRL port))

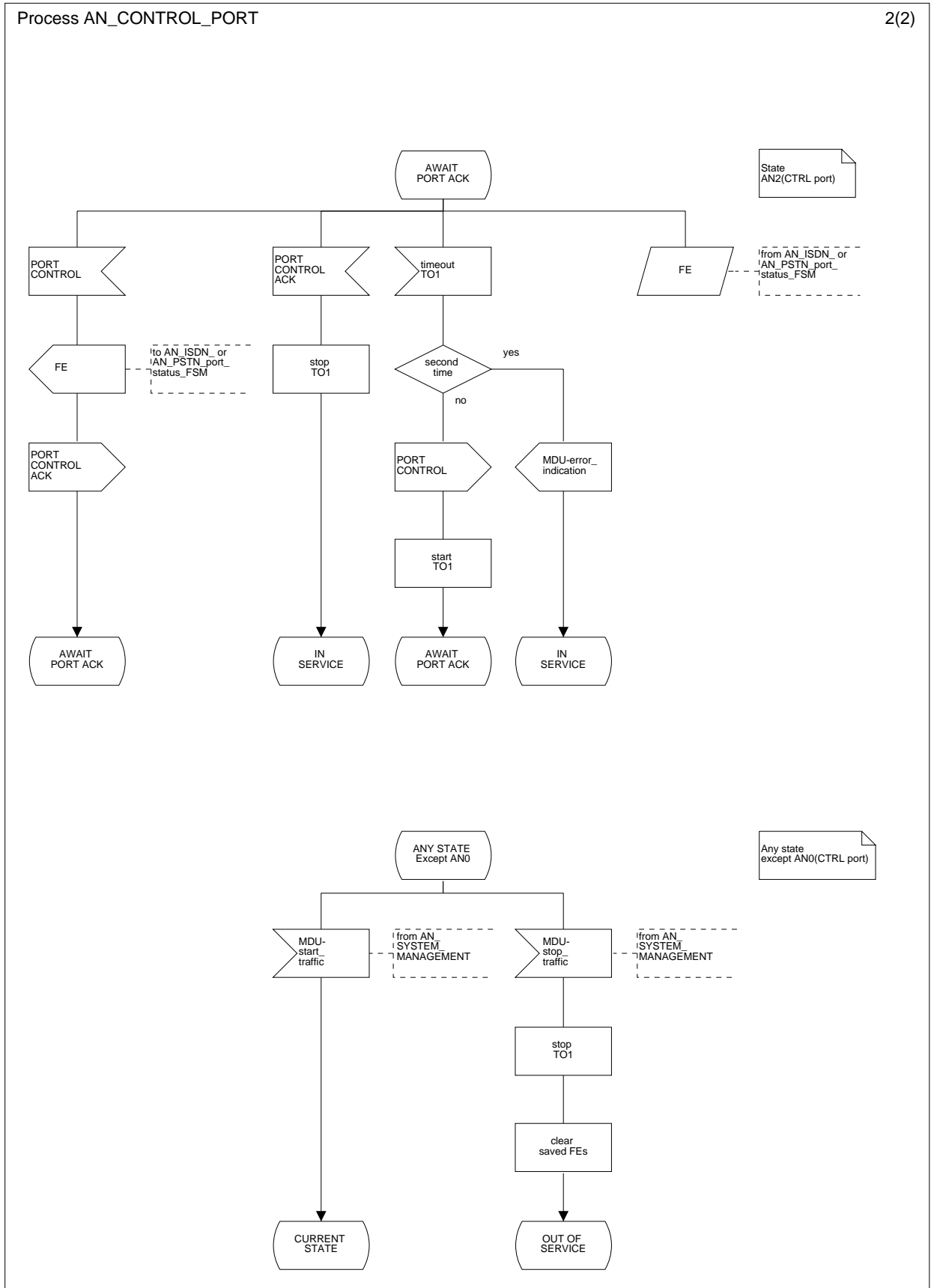

Figure L.11.2: Port control protocol AN-side; state AWAIT PORT ACK (AN2(CTRL port)) and any state except AN0(CTRL port)

L.1.5.3.2 Common control protocol

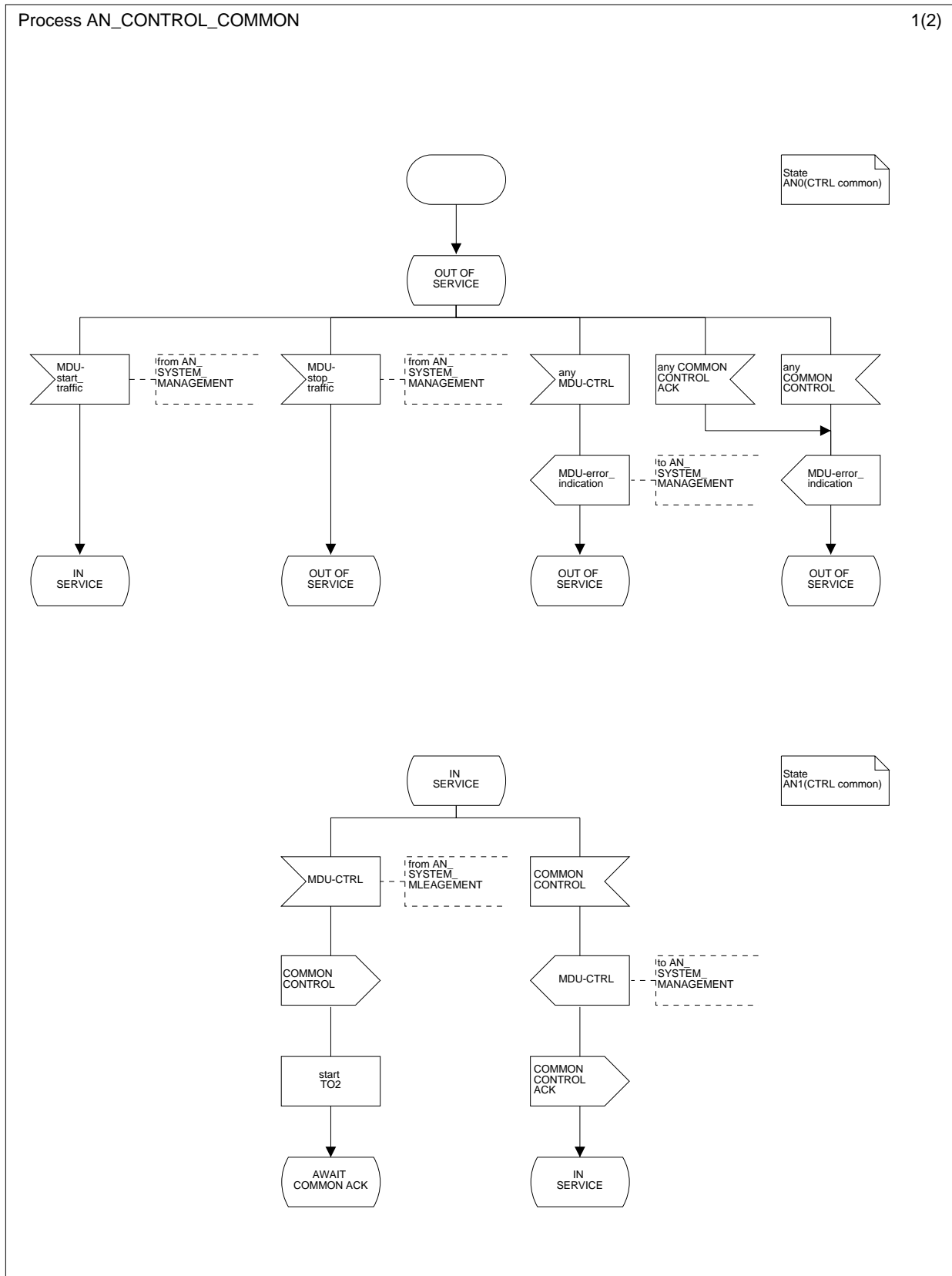

Figure L.12.1: Common control protocol AN-side; states OUT OF SERVICE (AN0(CTRL common)) and state IN SERVICE (AN1(CTRL common))

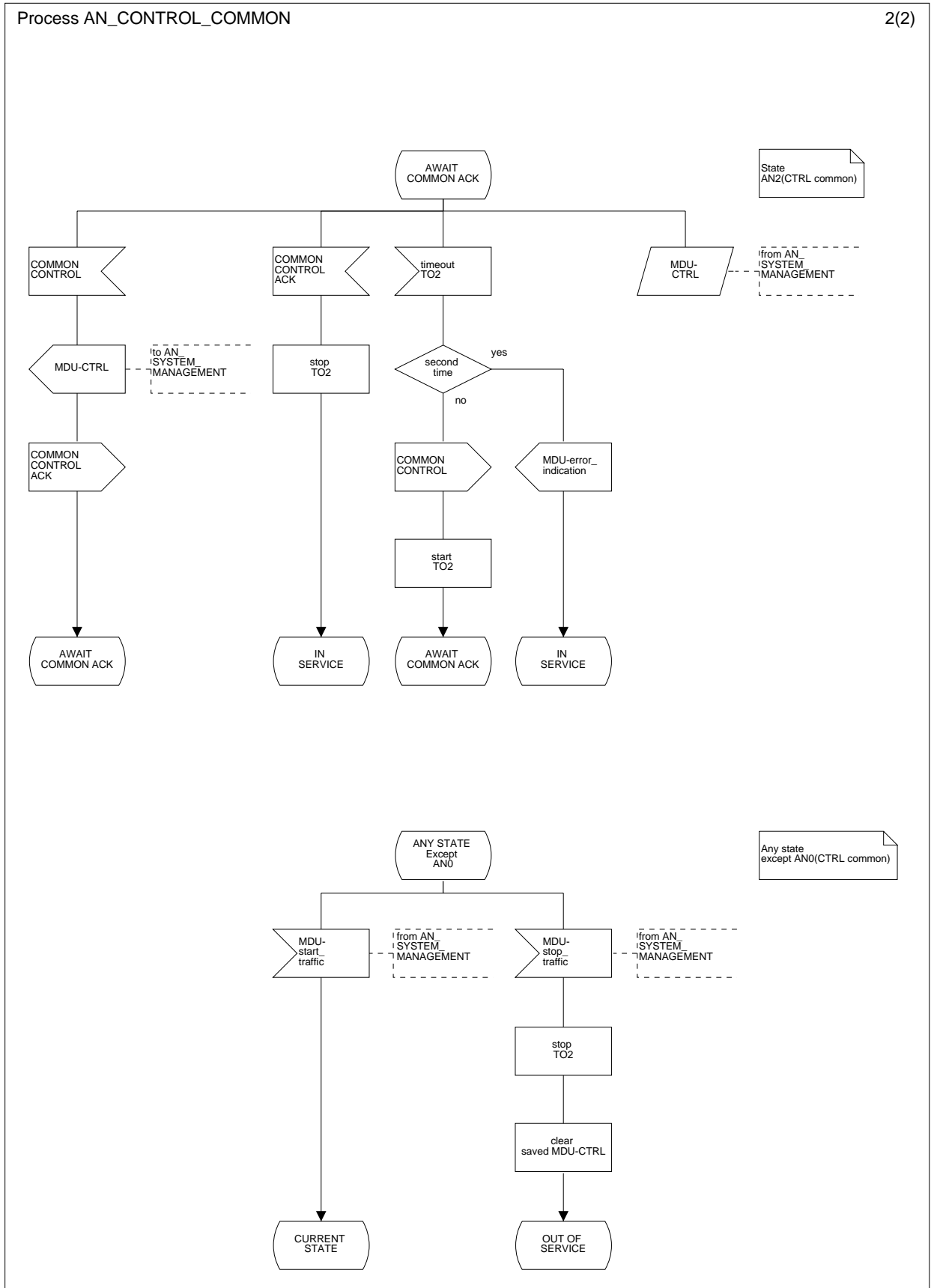

Figure L.12.2: Common control protocol AN-side; state AWAIT COMMON ACK (AN2(CTRL common)) and any state except AN0(CTRL common)

L.1.6 Port status FSM control

L.1.6.1 Scope

This subclause shows the SDL representation according to the port status FSM control for ISDN and PSTN ports specified in subclauses 14.1 and 14.2.

L.1.6.2 States

The states for the AN side are defined in subclauses 14.1.3.1 and 14.2.3.1.

L.1.6.3 SDLs

The input and output symbols application in figure L.13 as well as the abbreviation are used in the following.

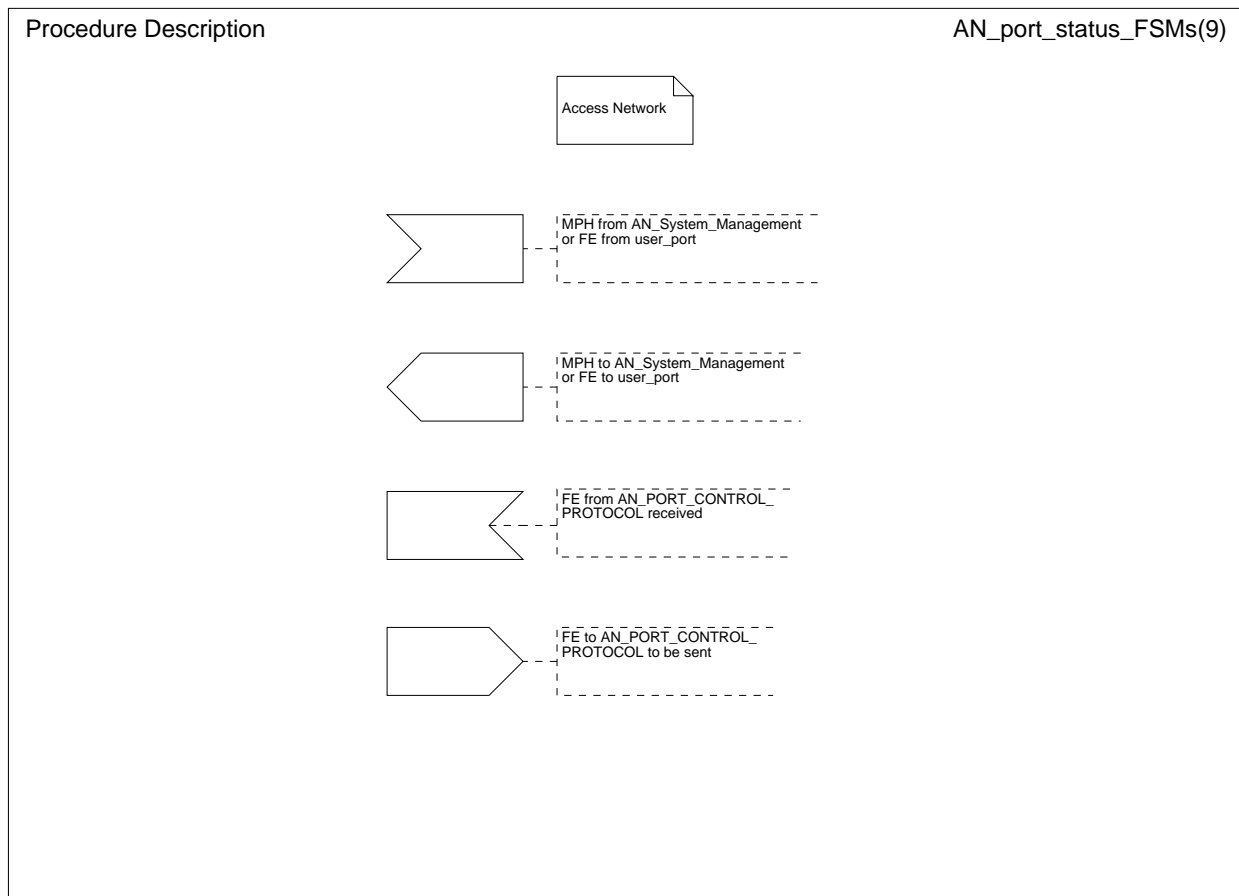

Figure L.13: Input and output symbols application - port status FSM control (AN-side)

L.1.6.3.1 ISDN port status FSM control

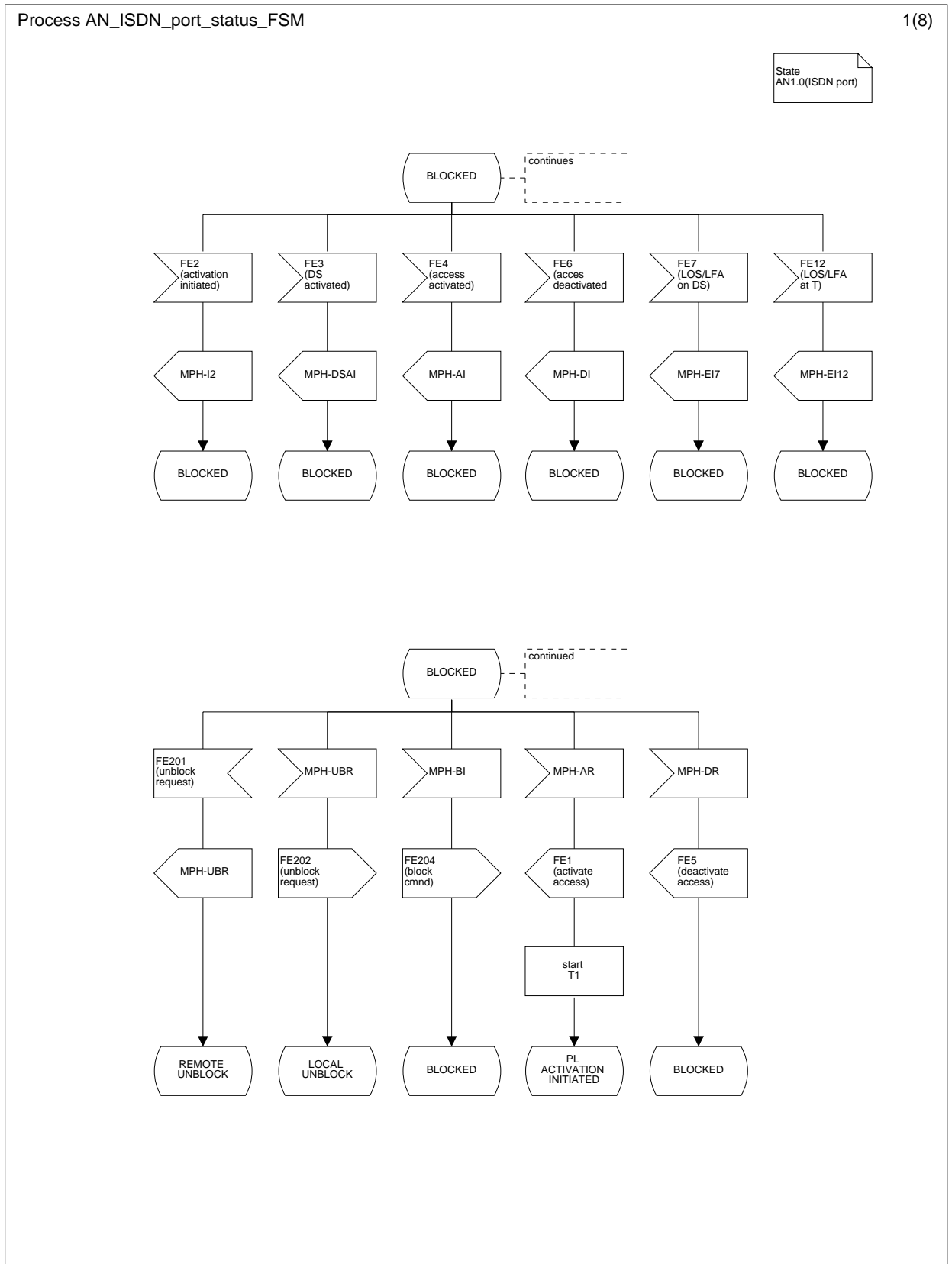

Figure L.14.1: ISDN port status FSM control AN-side; state BLOCKED (AN1.0(ISDN port))

State
 AN1.1 (ISDN port)

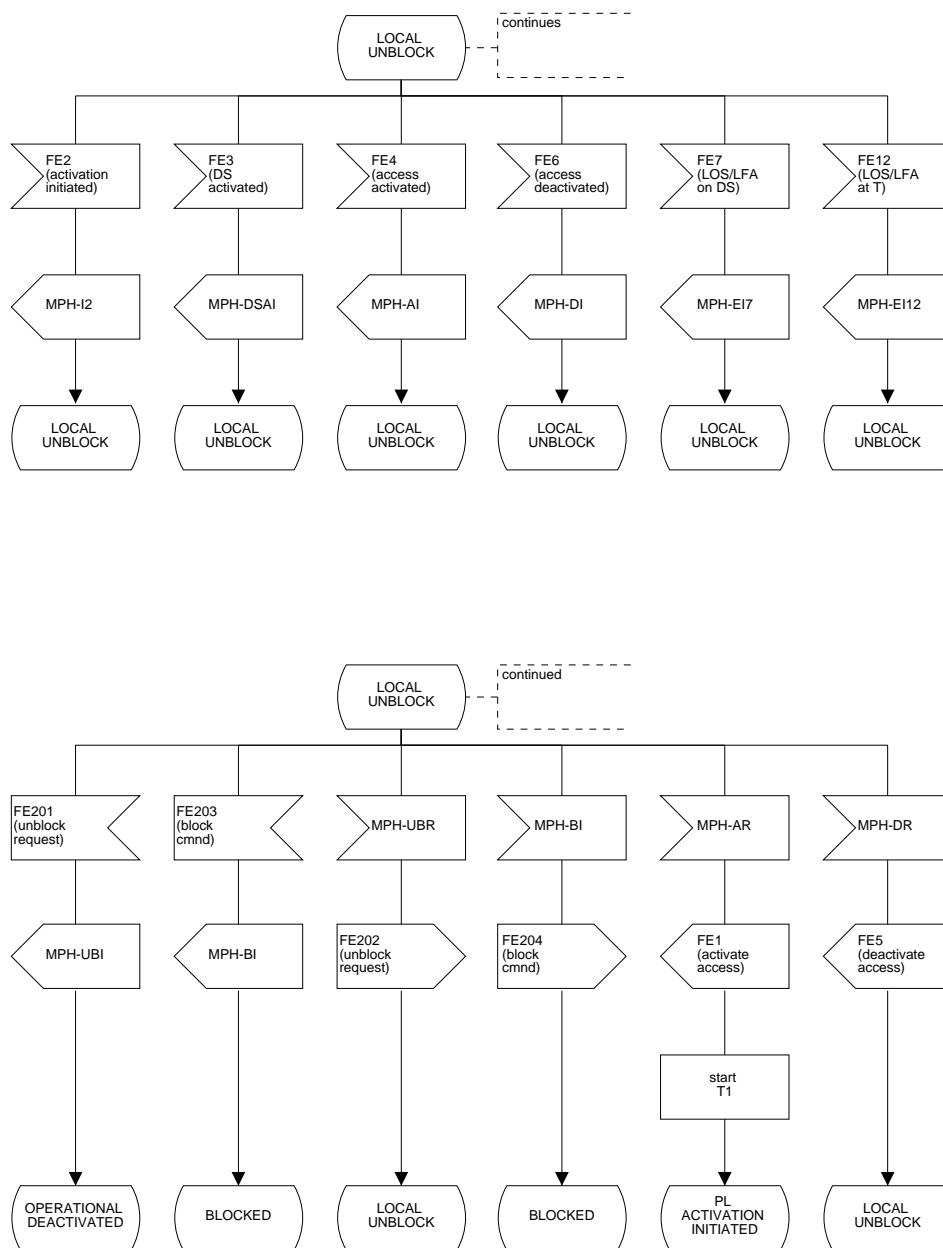

Figure L.14.2: ISDN port status FSM control AN-side; state LOCAL UNBLOCK (AN1.1 (ISDN port))

Process AN_ISDN_port_status_FSM

3(8)

State
 AN1.2(ISDN port)

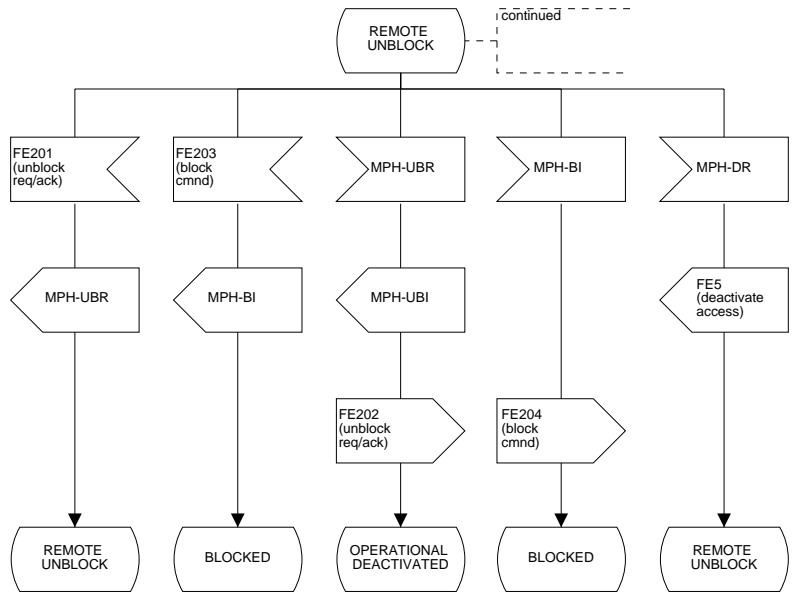
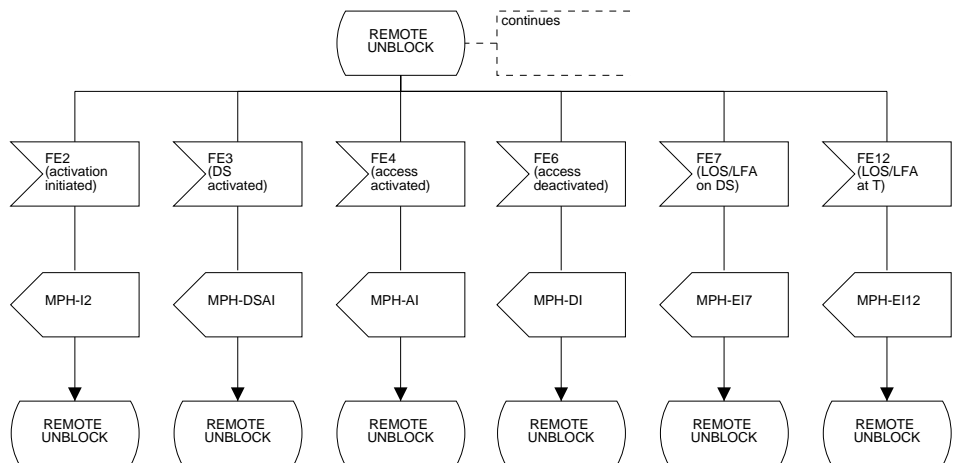

Figure L.14.3: ISDN port status FSM control AN-side; state REMOTE UNBLOCK (AN1.2(ISDN port))

unlockState
 AN2.0(ISDN port)

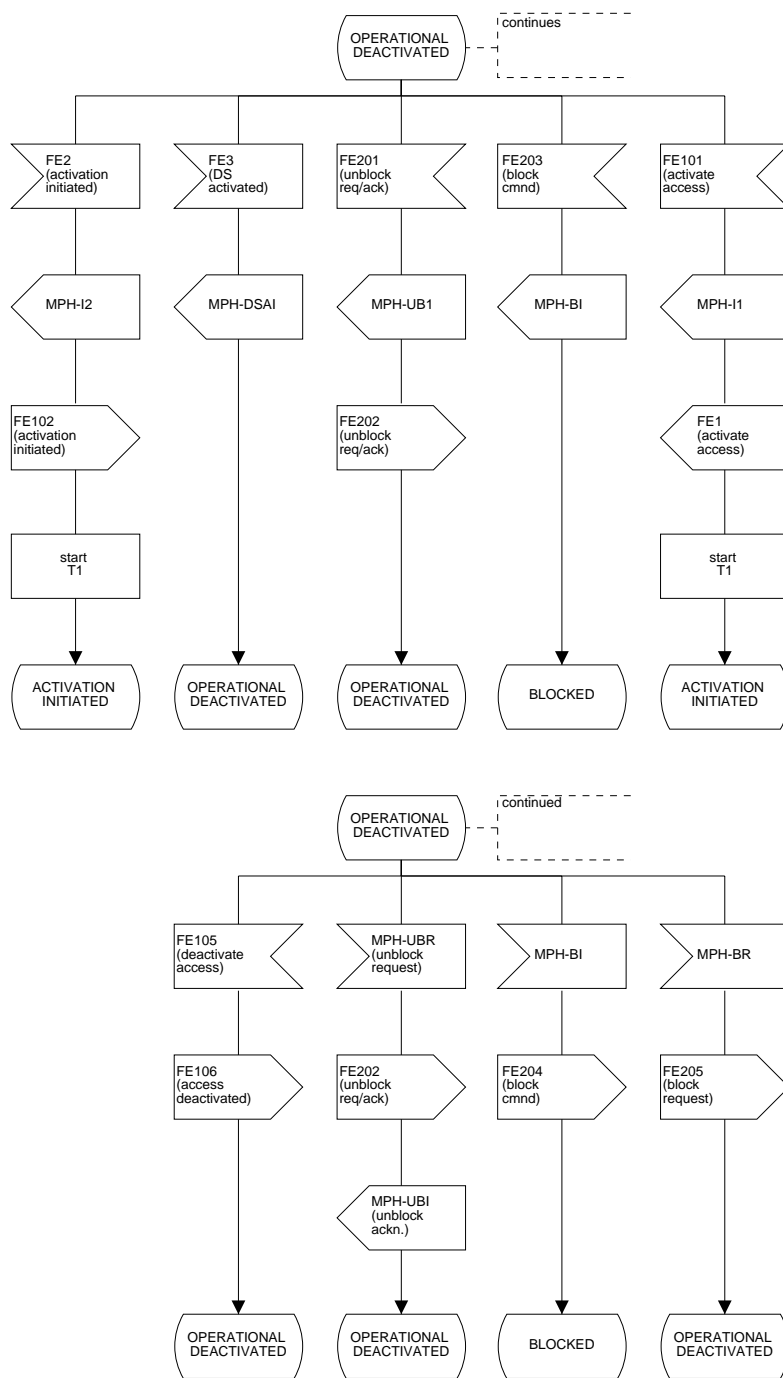

Figure L.14.4: ISDN port status FSM control AN-side; state OPERATIONAL DEACTIVATED (AN2.0(ISDN port))

Process AN_ISDN_port_status_FSM

5(8)

State
 AN2.1 (ISDN port)

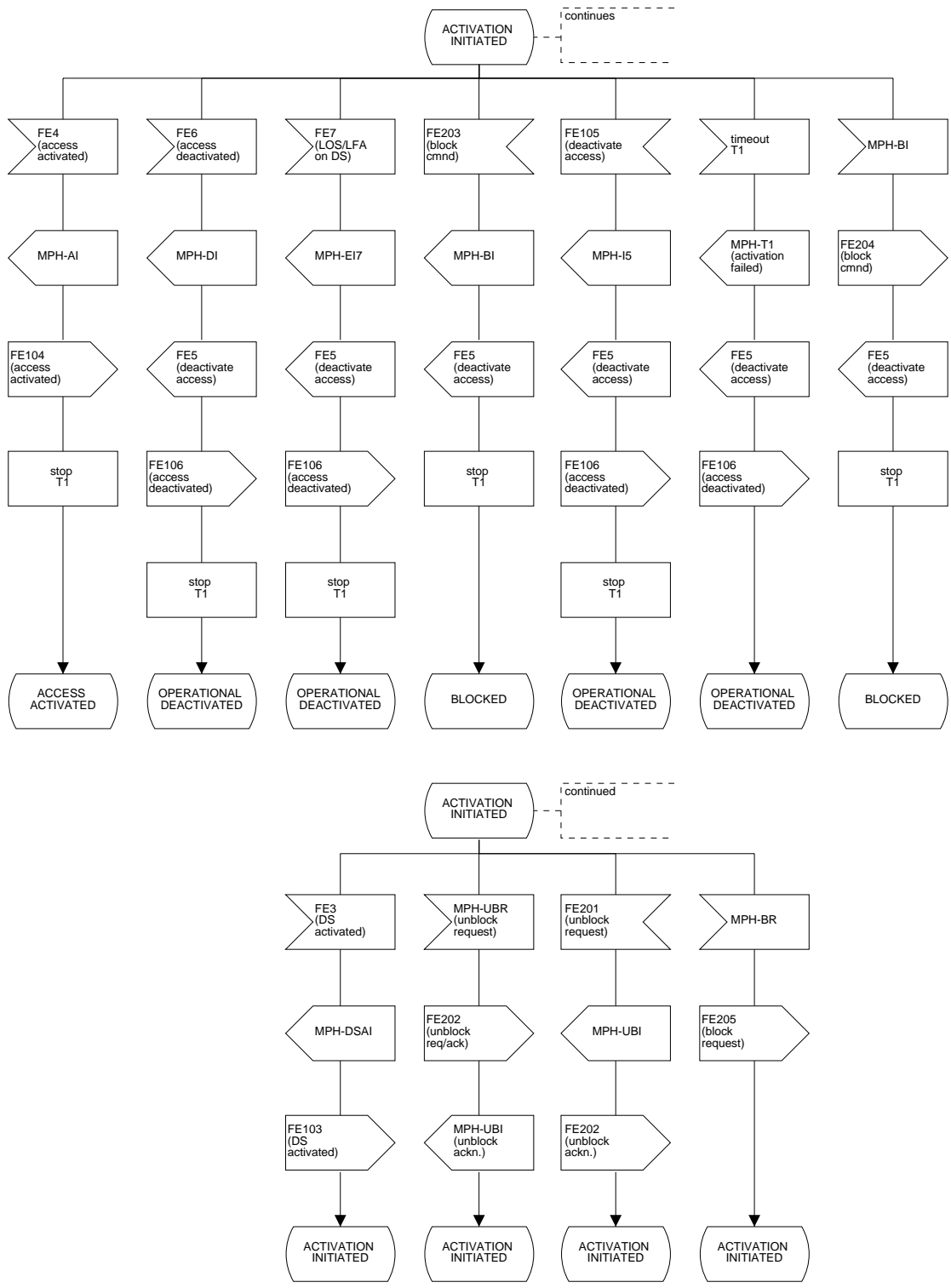

Figure L.14.5: ISDN port status FSM control AN-side; state ACTIVATION INITIATED (AN2.1 (ISDN port))

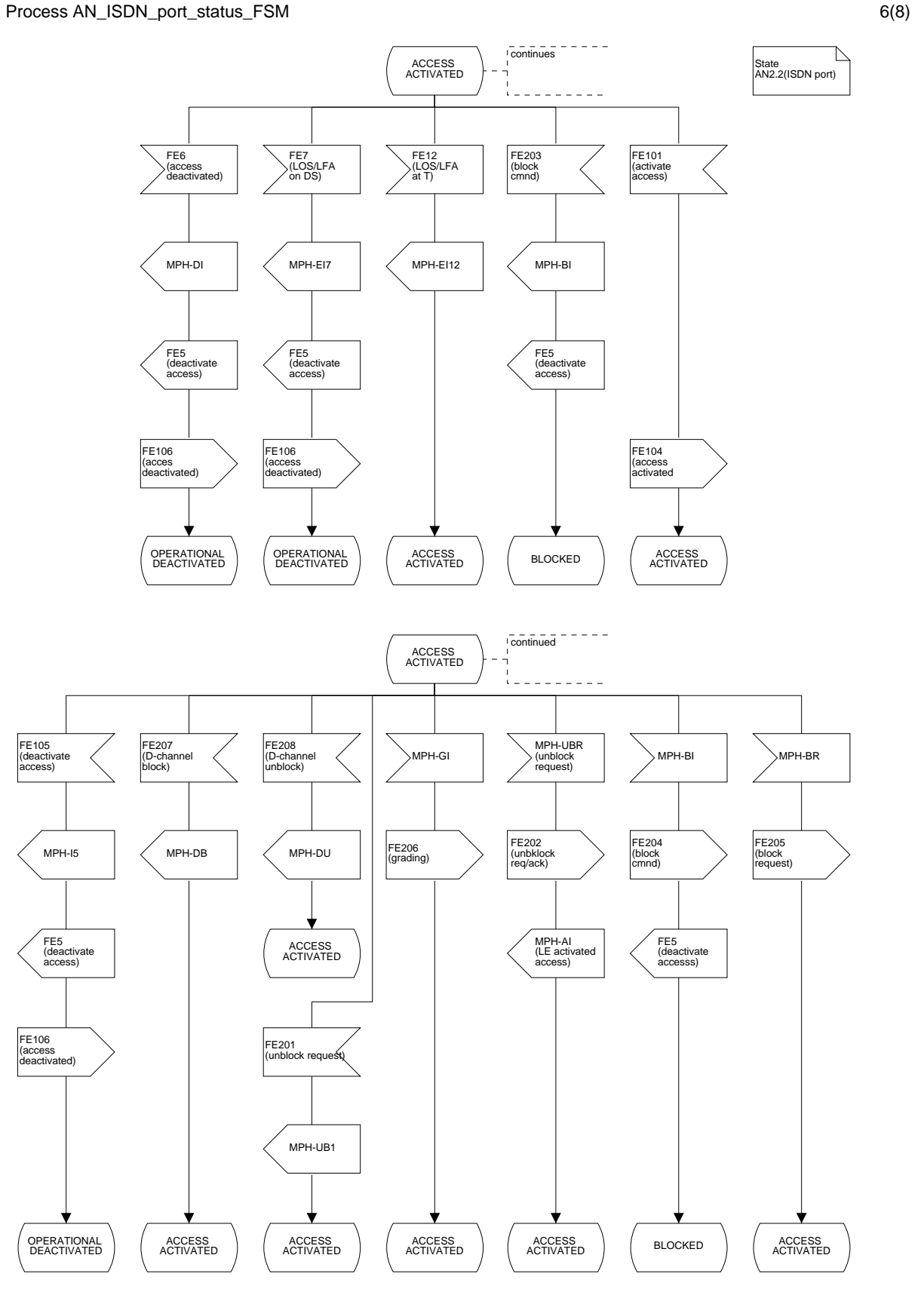

Figure L.14.6: ISDN port status FSM control AN-side; state ACCESS ACTIVATED (AN2.2(ISDN port))

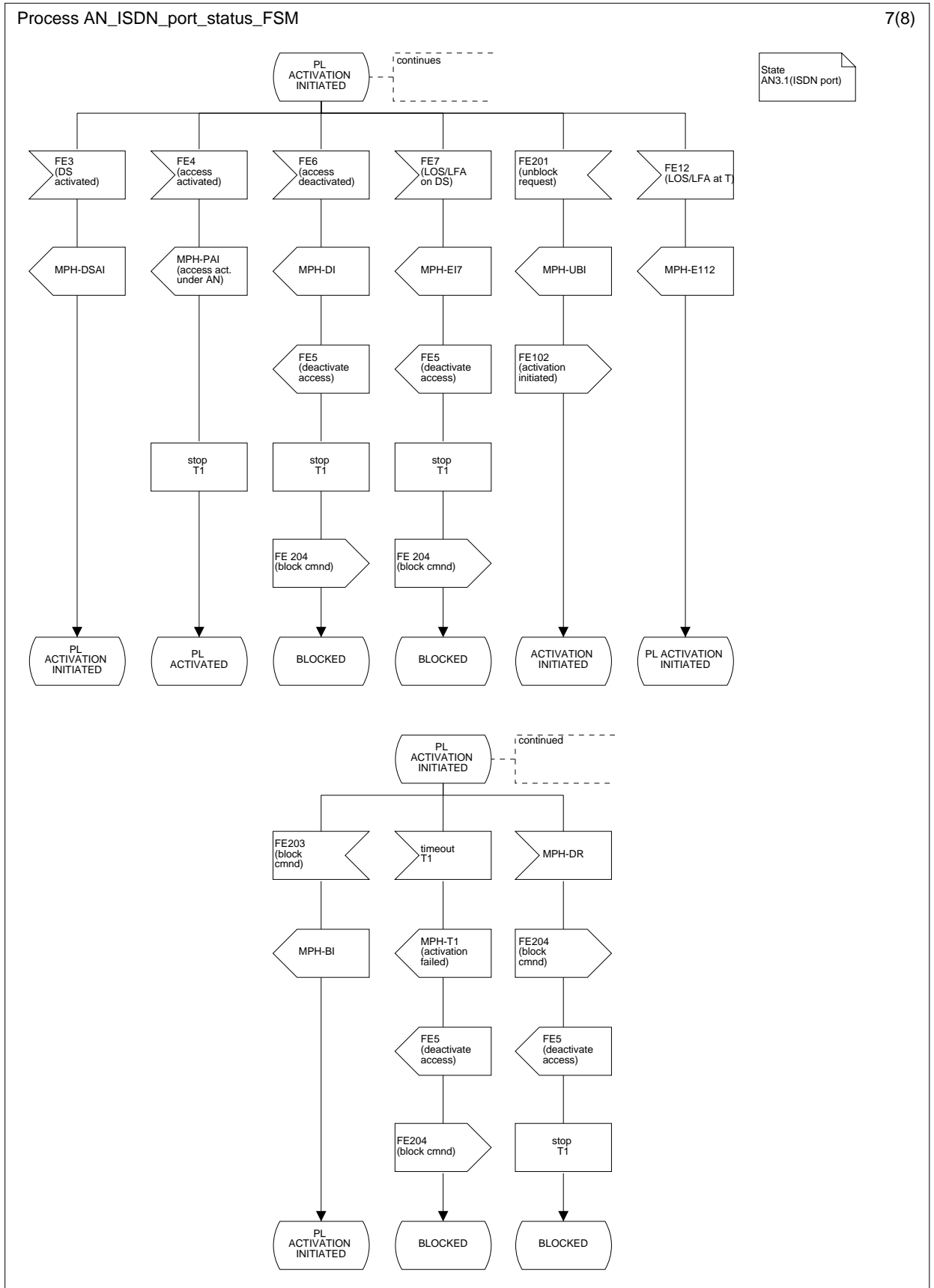
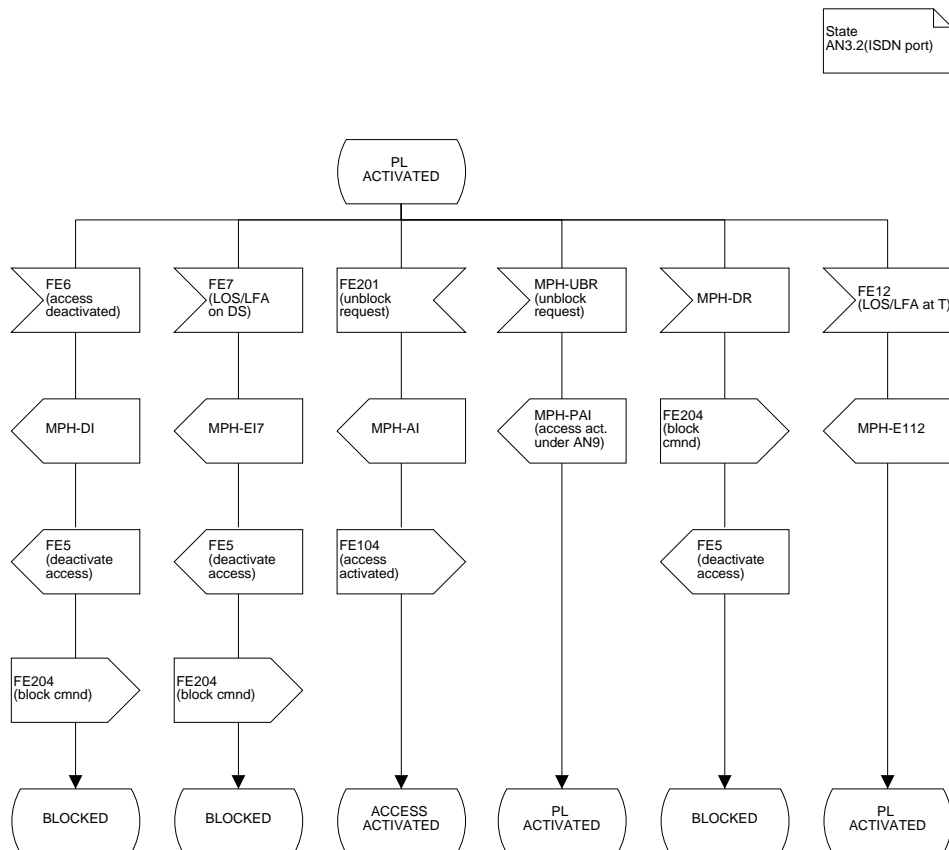
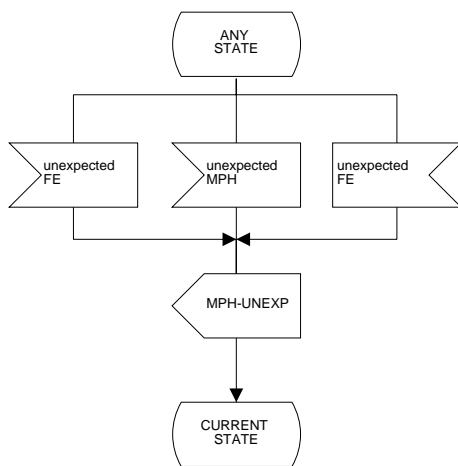

Figure L.14.7: ISDN port status FSM control AN-side; state PL ACTIVATION INITIATED (AN3.1 (ISDN port))



State AN3.2(ISDN port)



Any State AN(ISDN port)

Figure L.14.8: ISDN port status FSM control AN-side; state PL ACTIVATED (AN3.2(ISDN port)) and any AN(ISDN port) state

L.1.6.3.2 PSTN port status FSM control

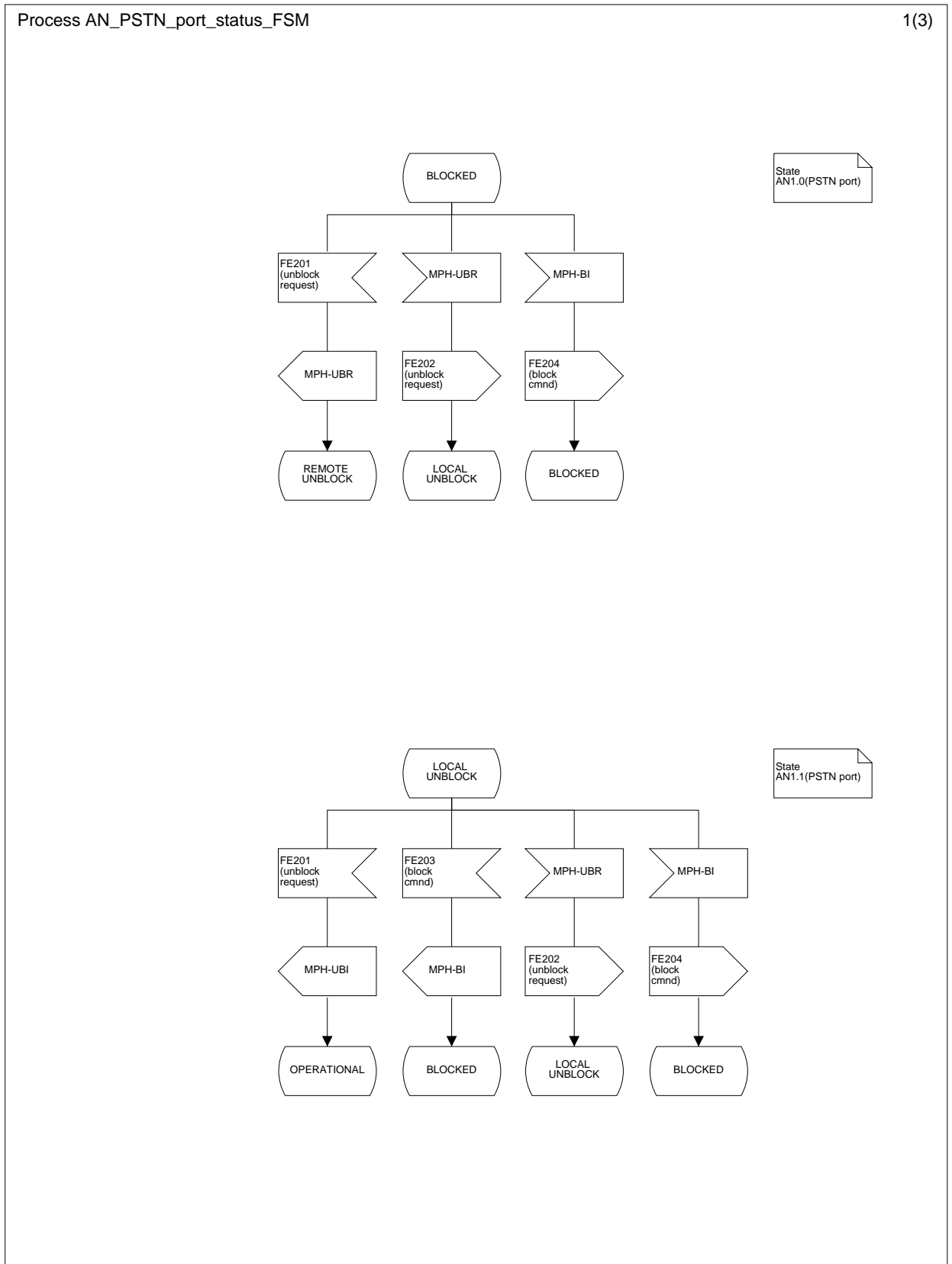

Figure L.15.1: PSTN port status FSM control AN-side; states BLOCKED (AN1.0(PSTN port)) and LOCAL UNBLOCK (AN1.1(PSTN port))

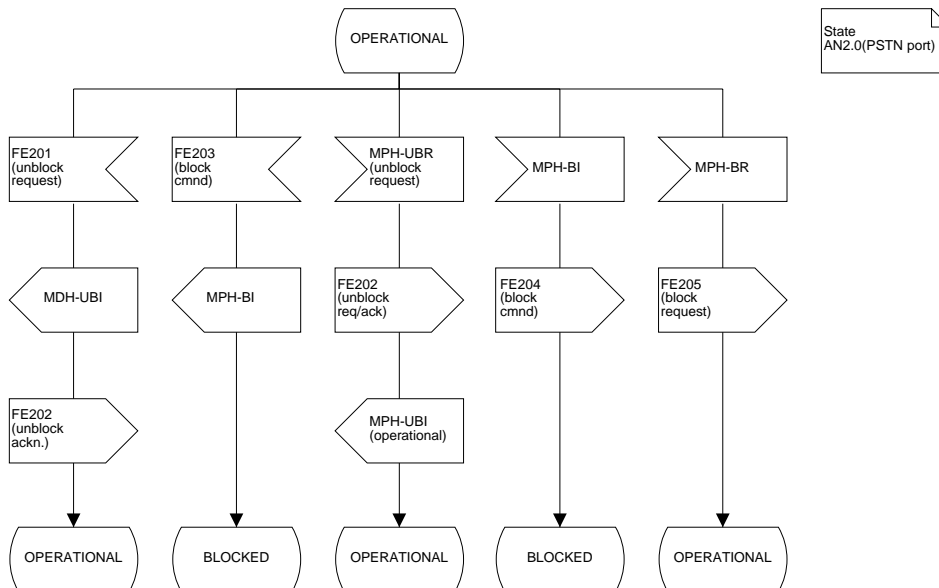
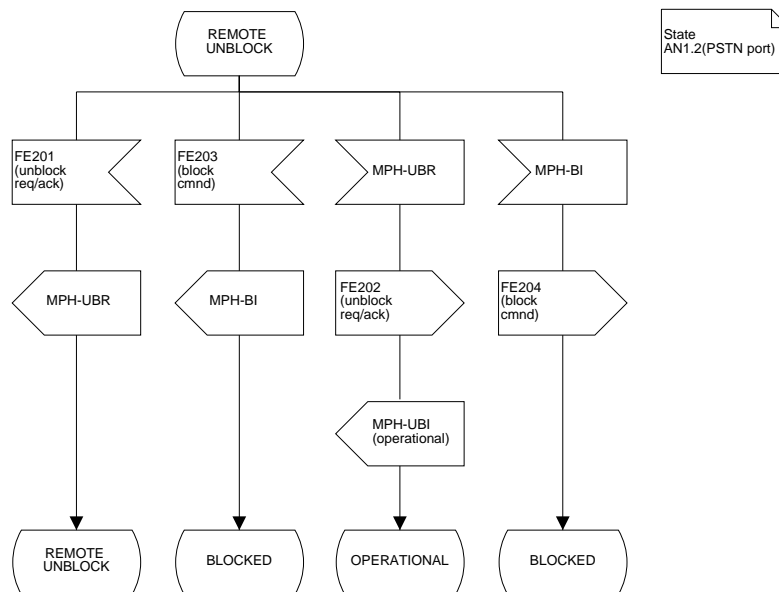

Figure L.15.2: PSTN port status FSM control AN-side; states REMOTE UNBLOCK (AN1.2(PSTN port)) and OPERATIONAL (AN2.0(PSTN port))

Process AN_PSTN_port_status_FSM

3(3)

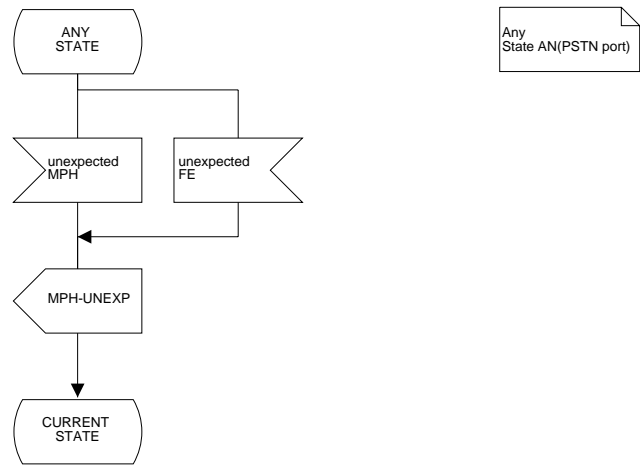

Figure L.15.3: PSTN port status FSM control AN-side; any AN(PSTN port) state

L.1.7 System management procedure

L.1.7.1 Scope

This subclause shows the SDL representation according to the procedures specified in subclause 14.5 and Annex C.

L.1.7.2 States

The states for the AN side are defined in Annex C.

L.1.7.3 SDLs

The input and output symbols application in figure L.16 as well as the abbreviation are used in the following.

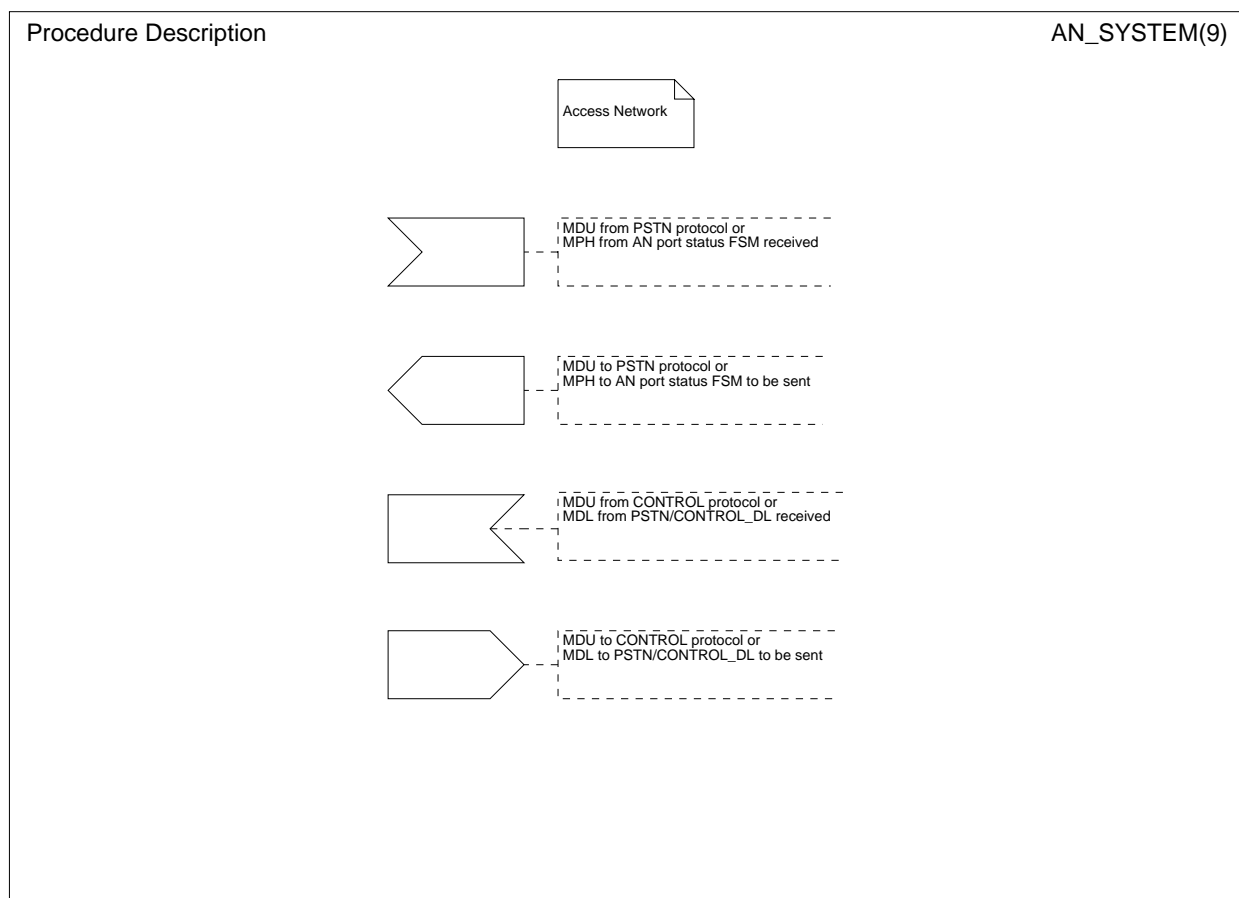

Figure L.16: Input and output symbols application - system management (AN-side)

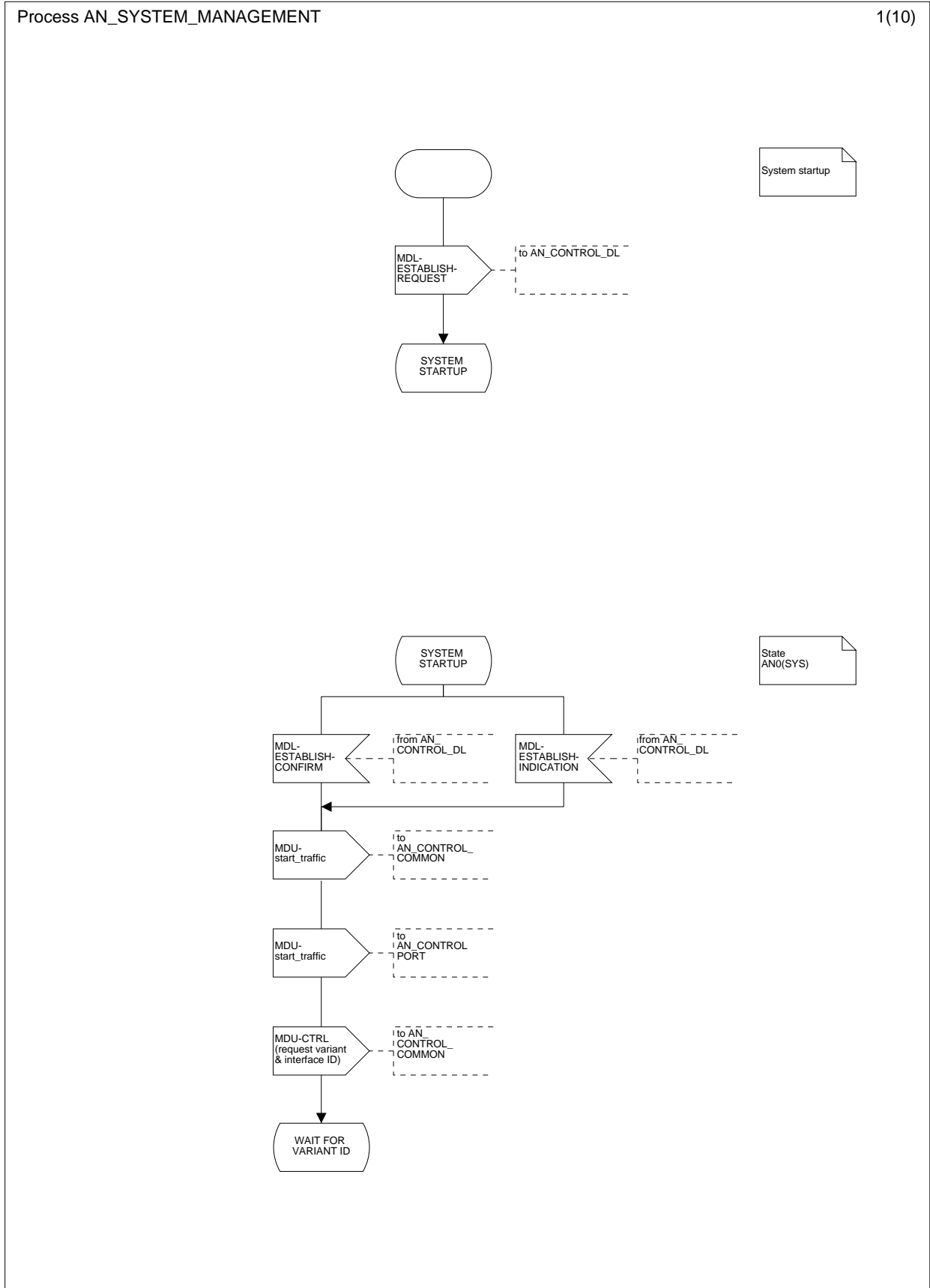

Figure L.17.1: System management AN-side; system startup and state OUT OF SERVICE (AN0(SYS))

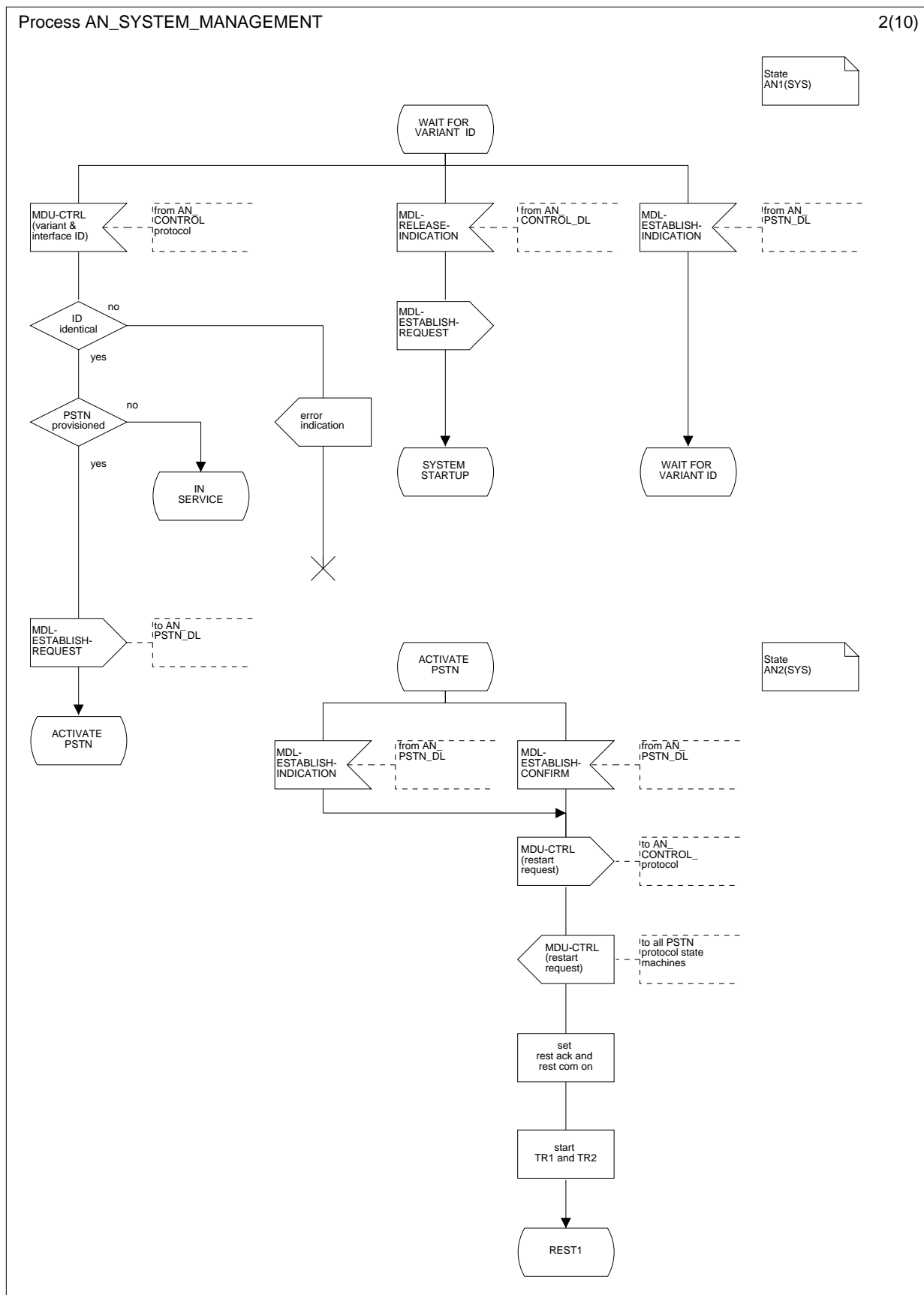

Figure L.17.2: System management AN-side; states WAIT FOR VARIANT ID (AN1(SYS)) and ACTIVATE PSTN (AN2(SYS))

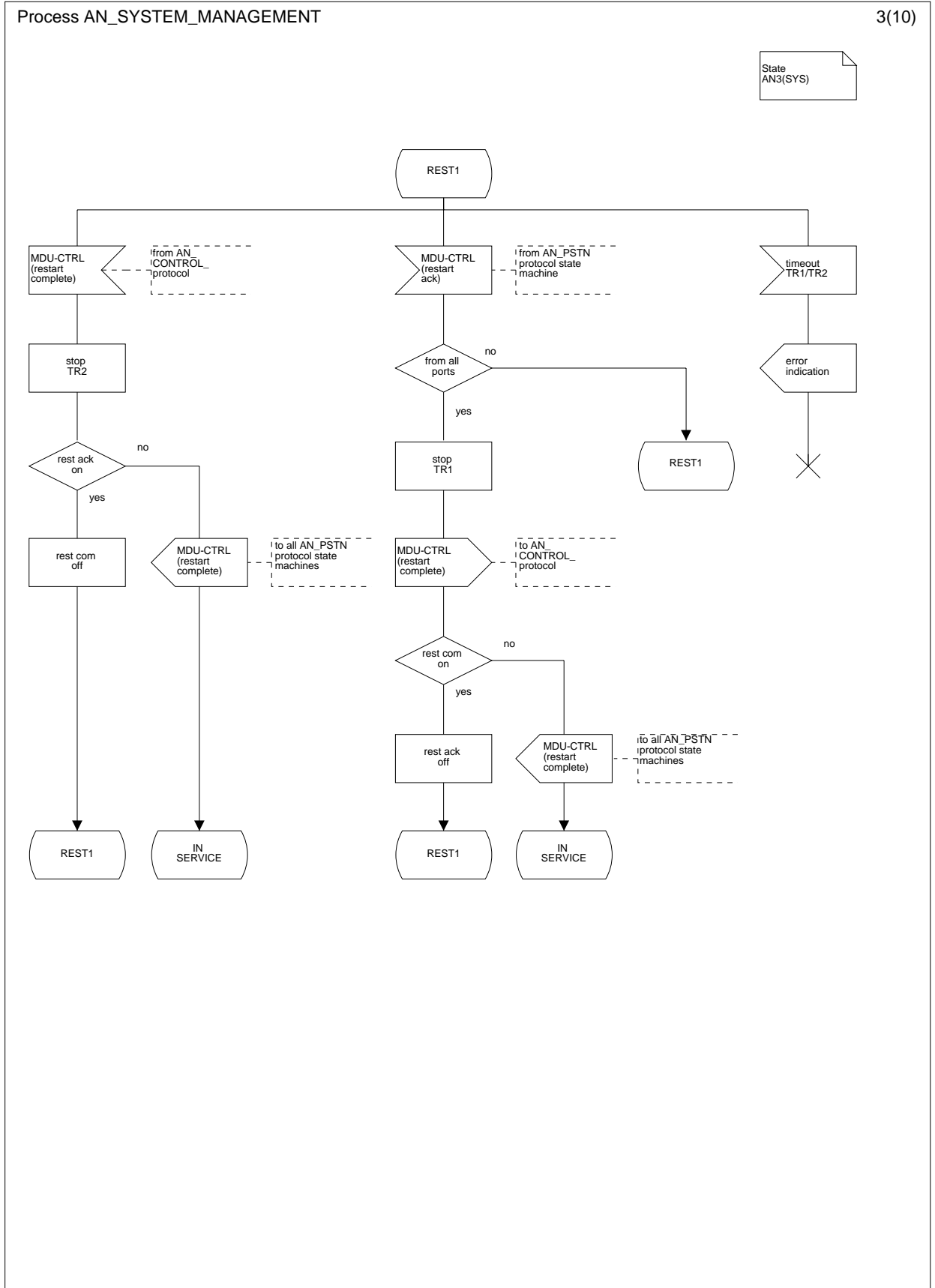

Figure L.17.3: System management AN-side; state REST1 (AN3(SYS))

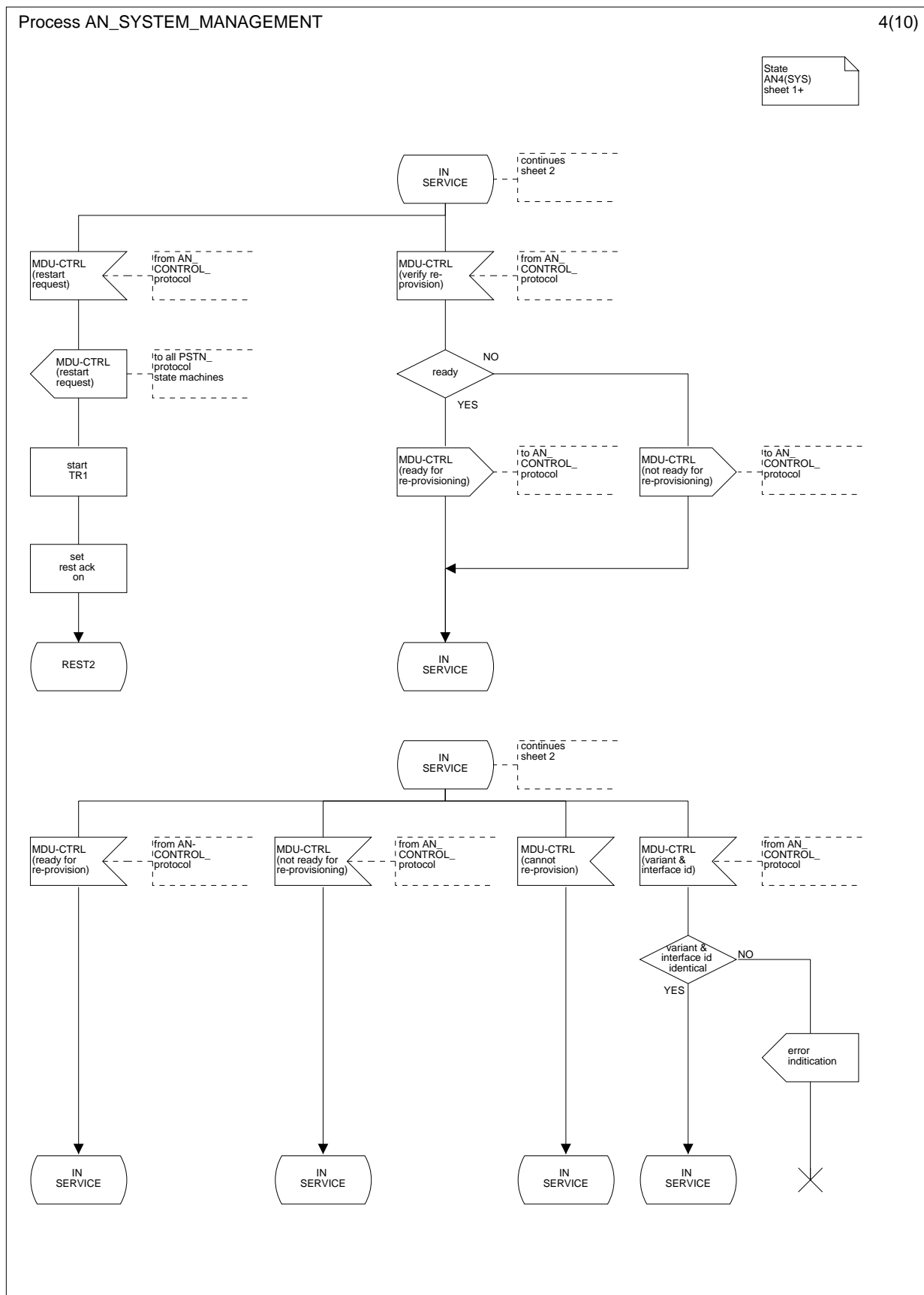

Figure L.17.4: System management AN-side; state IN SERVICE (AN4(SYS)) (sheet 1 of 3)

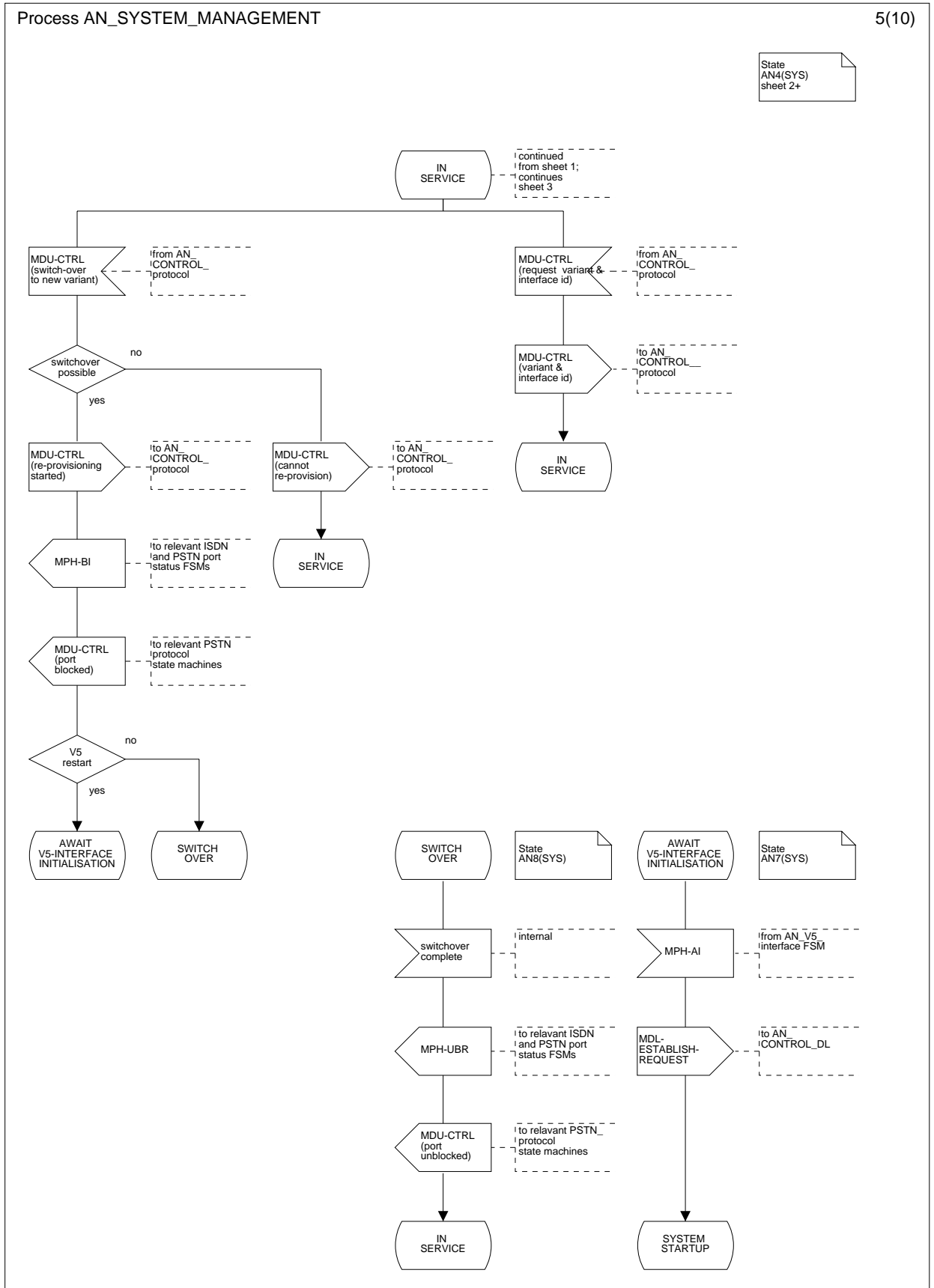

Figure L.17.5: System management An-side; state IN SERVICE (AN4(SYS)) (sheet 2 of 3), and states AWAIT V5-INTERFACE INITIALISATION (AN7(SYS)) and SWITCH OVER (AN8(SYS))

Process AN_SYSTEM_MANAGEMENT

6(10)

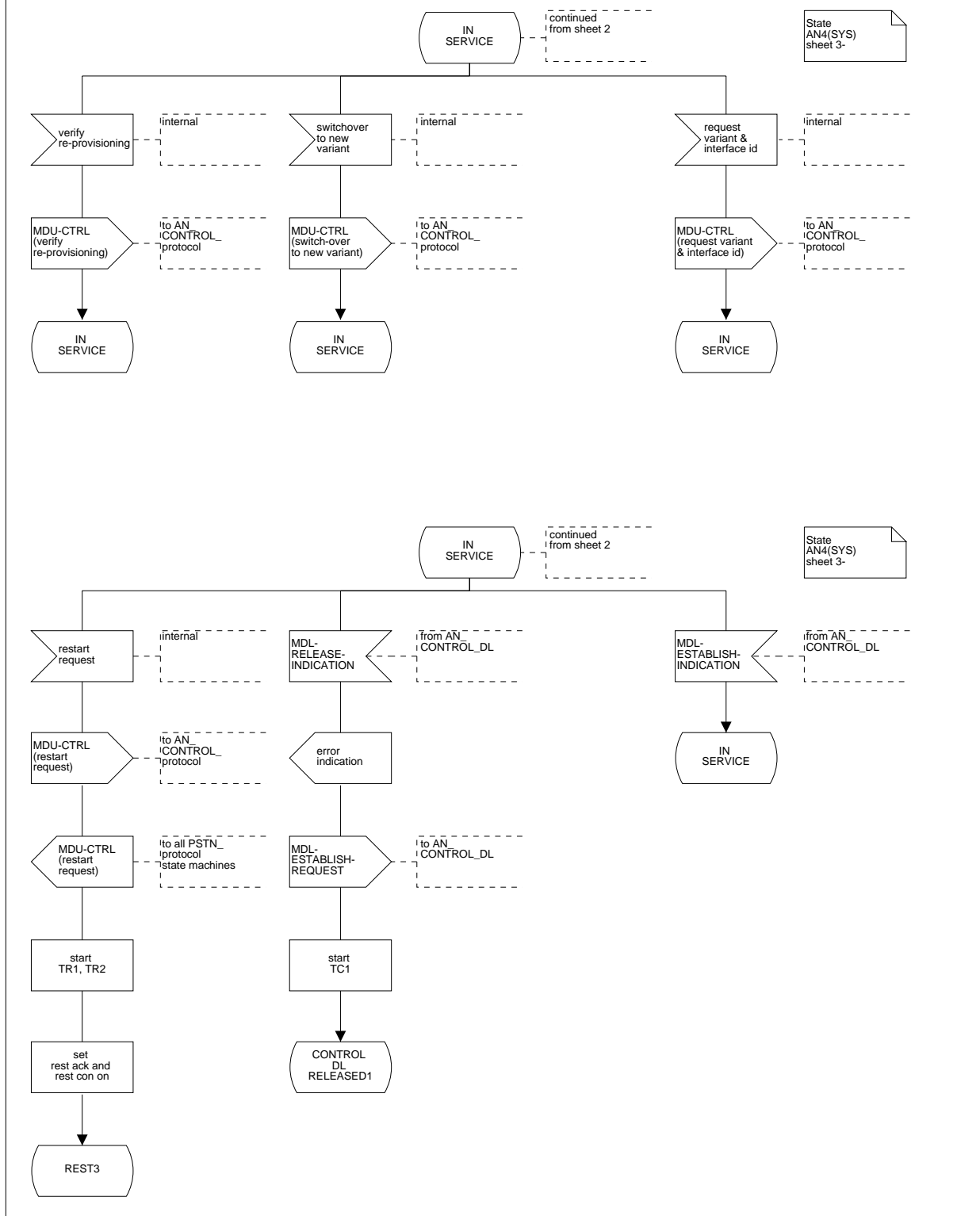

Figure L.17.6: System management AN-side; state IN SERVICE (AN4(SYS)) (sheet 3 of 3)

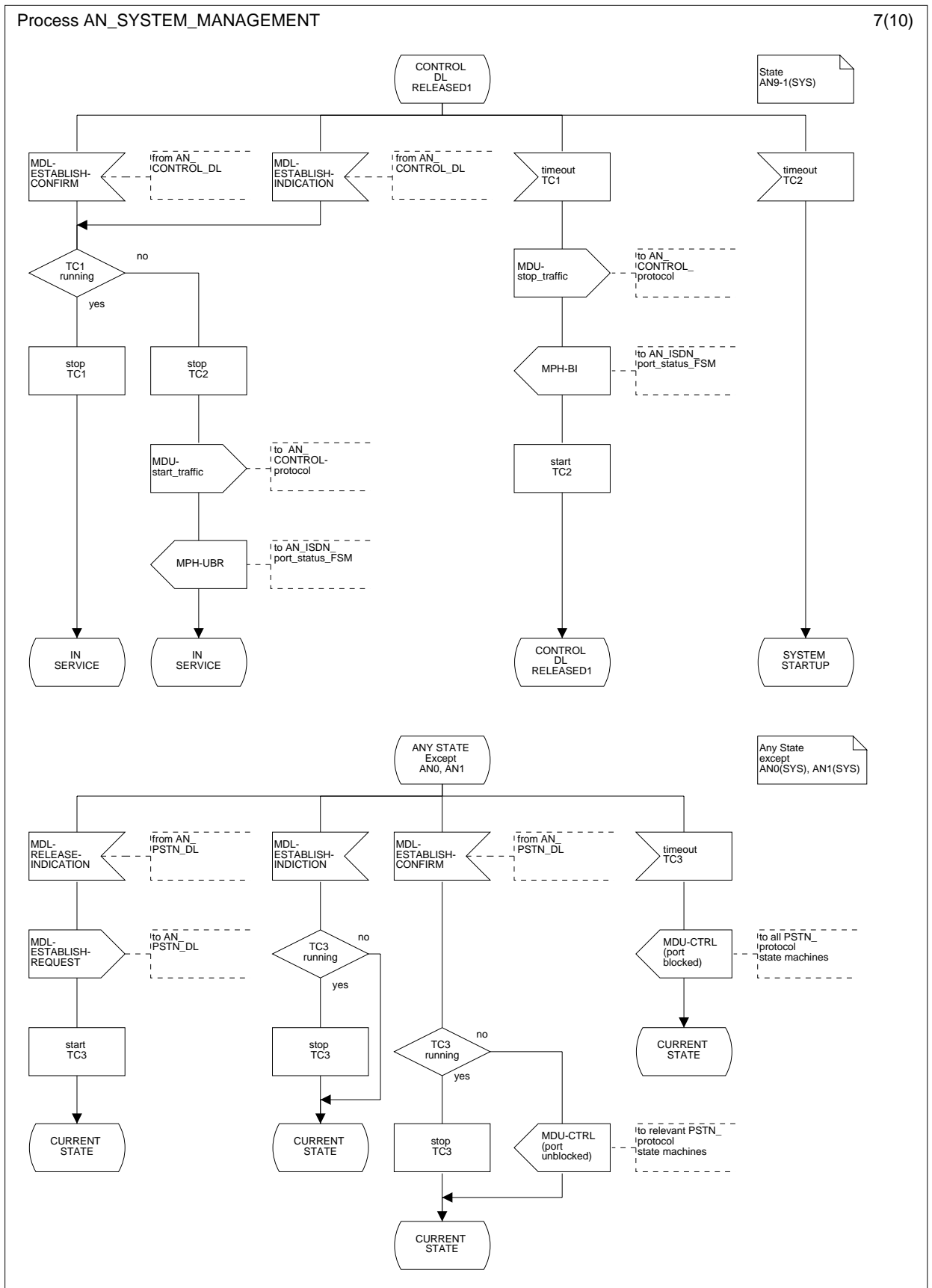

Figure L.17.7: System management AN-side; state CONTROL DL RELEASED1 (AN9-1(SYS)) and any state except AN0(SYS) and AN1(SYS)

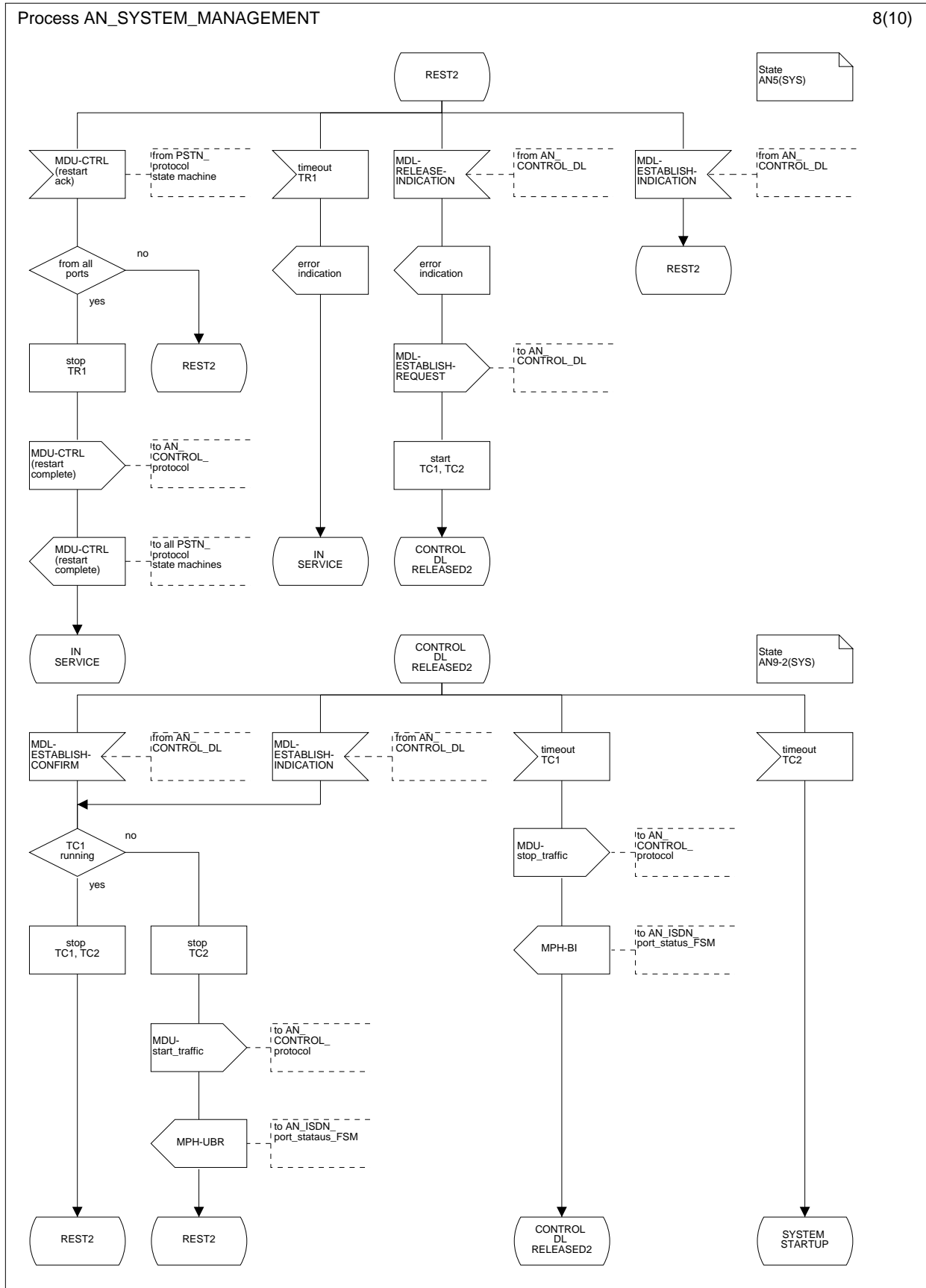

Figure L.17.8: System management AN-side; states REST2 (AN5(SYS)) and CONTROL DL RELEASED2 (AN9-2(SYS))

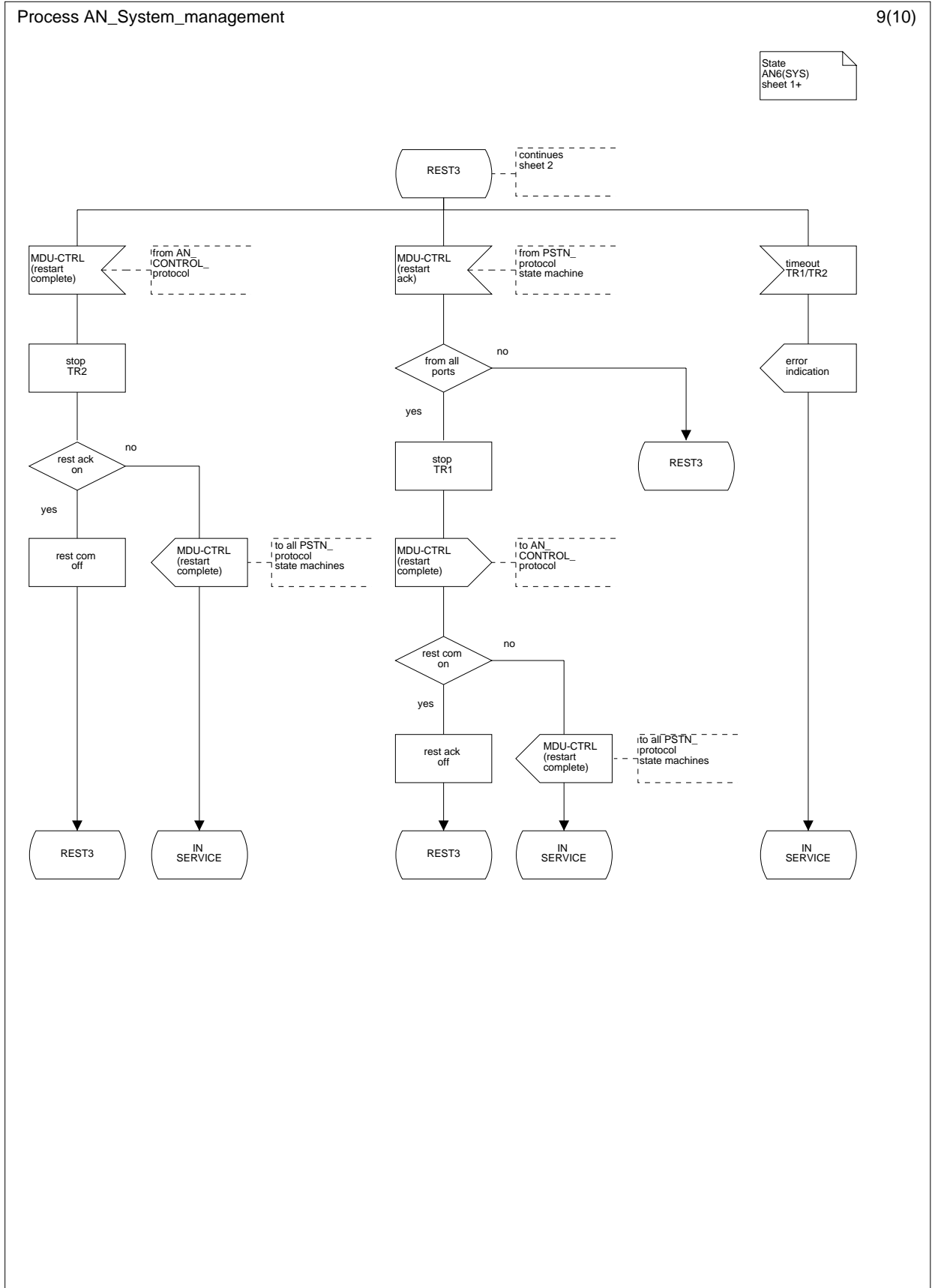

Figure L.17.9: System management AN-side; state REST3 (AN6(SYS)) (sheet 1)

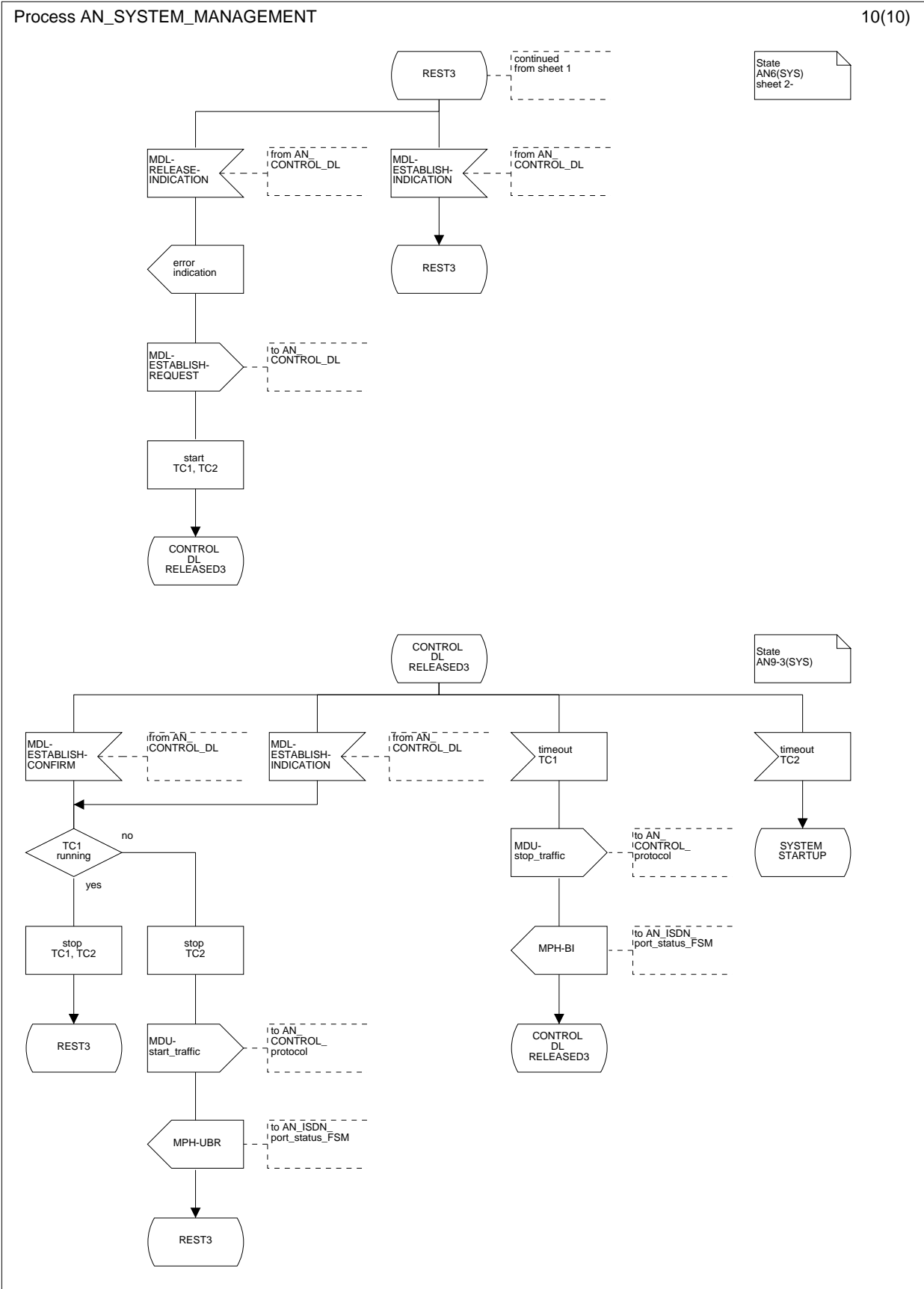

Figure L.17.10: System management AN-side; states CONTROL DL RELEASED3 (AN9-3(SYS)) and REST3 (AN6(SYS))

L.2 SDL diagrams for the LE side

L.2.1 System description

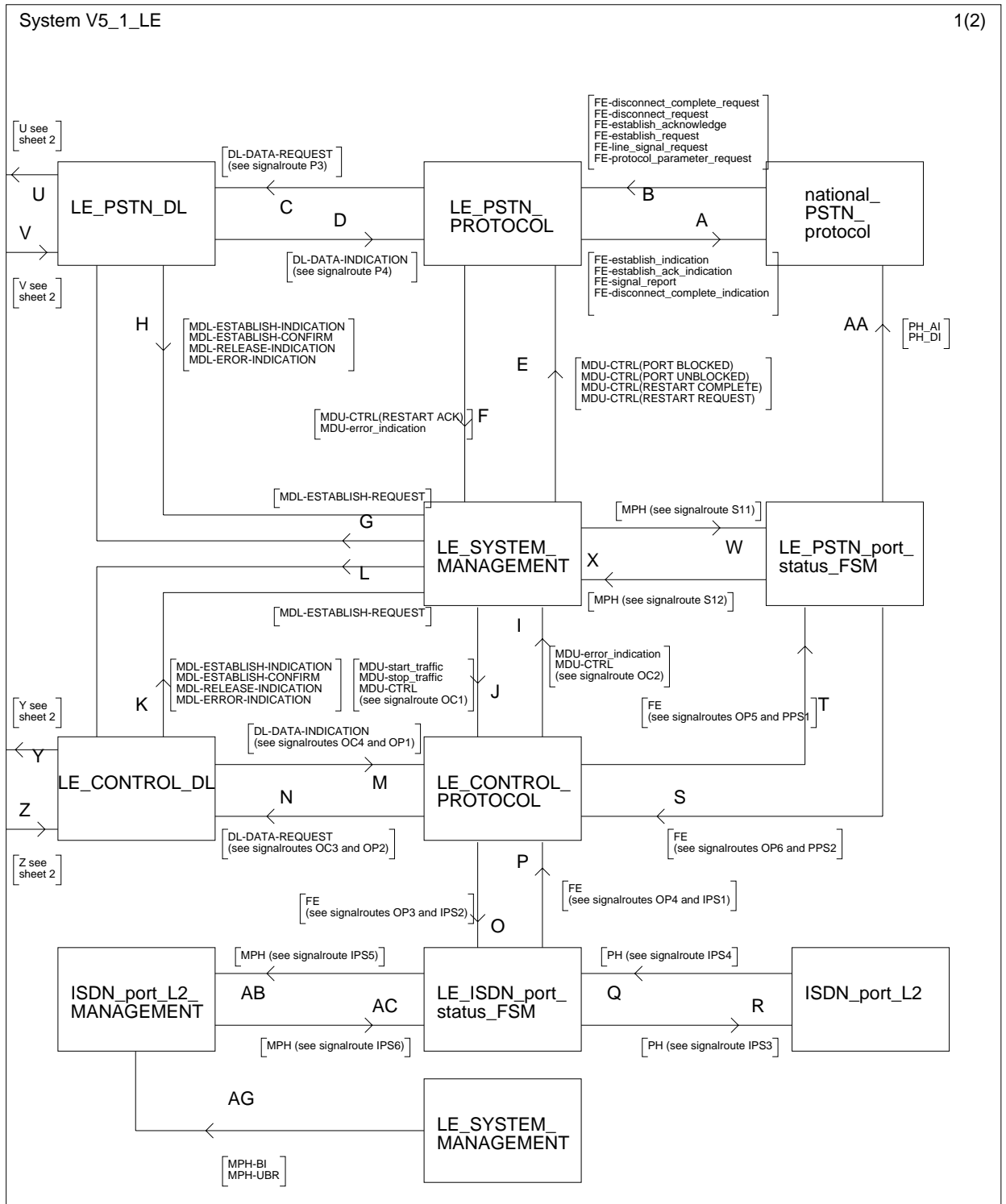

Figure L.18.1: V5.1 system overview LE-side (sheet 1)

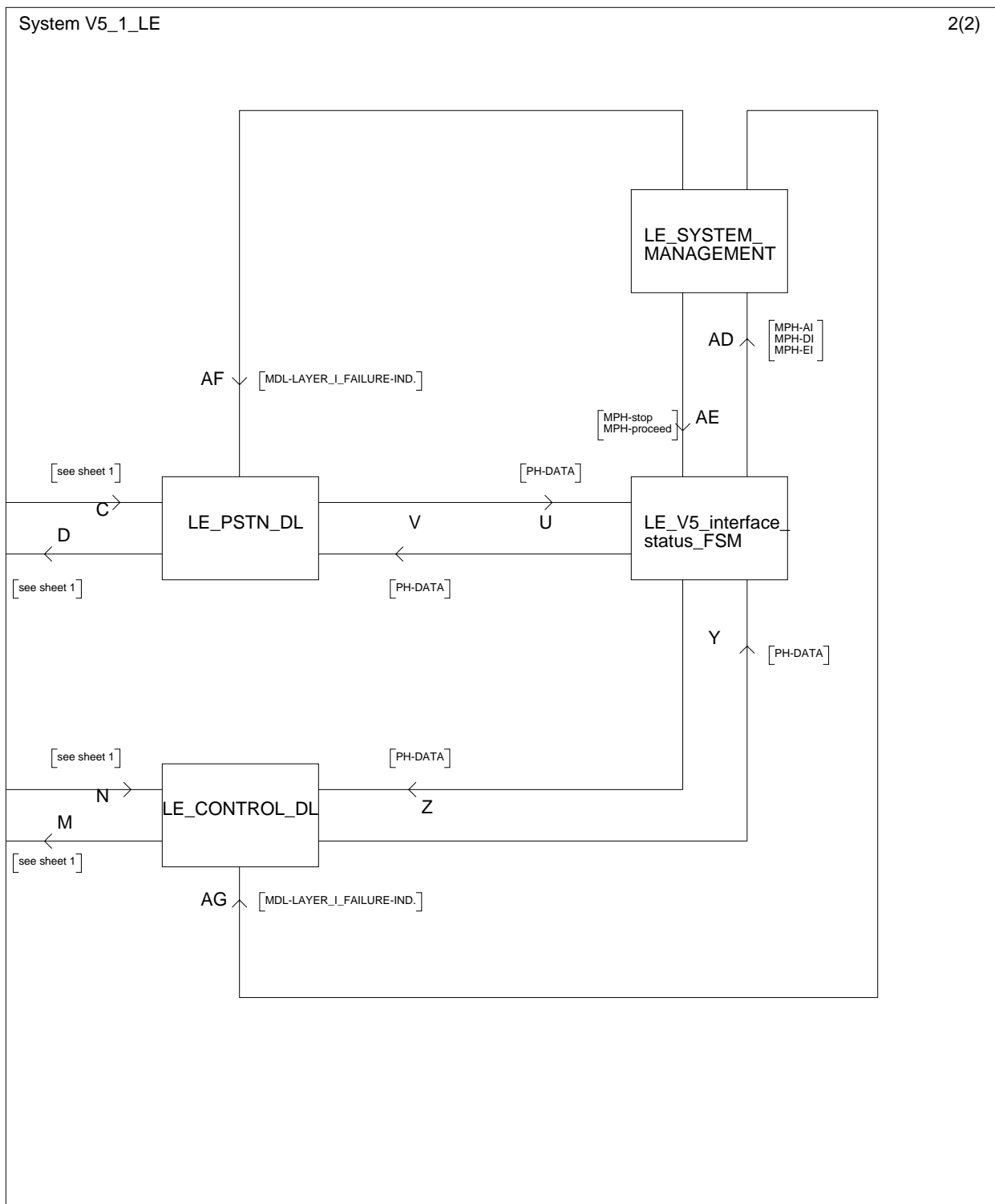

Figure L.18.2: V5.1 system overview LE-side (sheet 2)

L.2.2 Block descriptions

L.2.2.1 Block description of the PSTN protocol

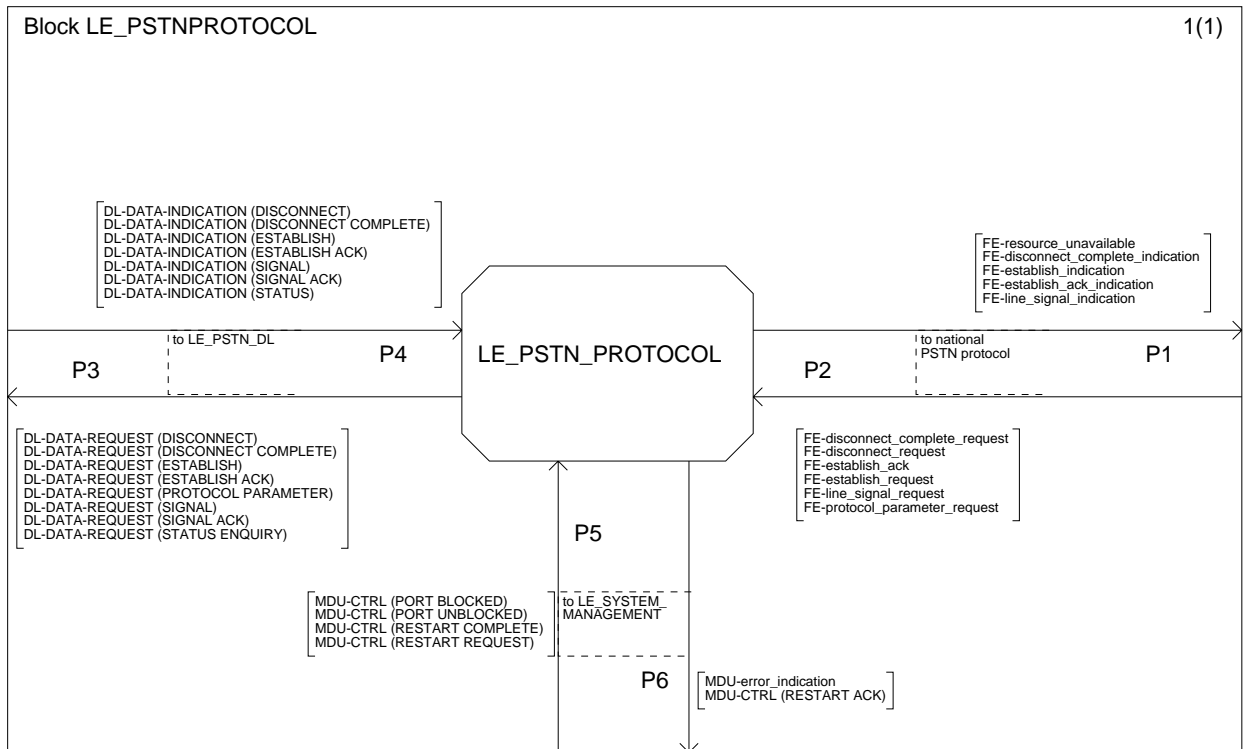

Figure L.19: PSTN protocol block description LE-side

L.2.2.2 Block description of the control protocol

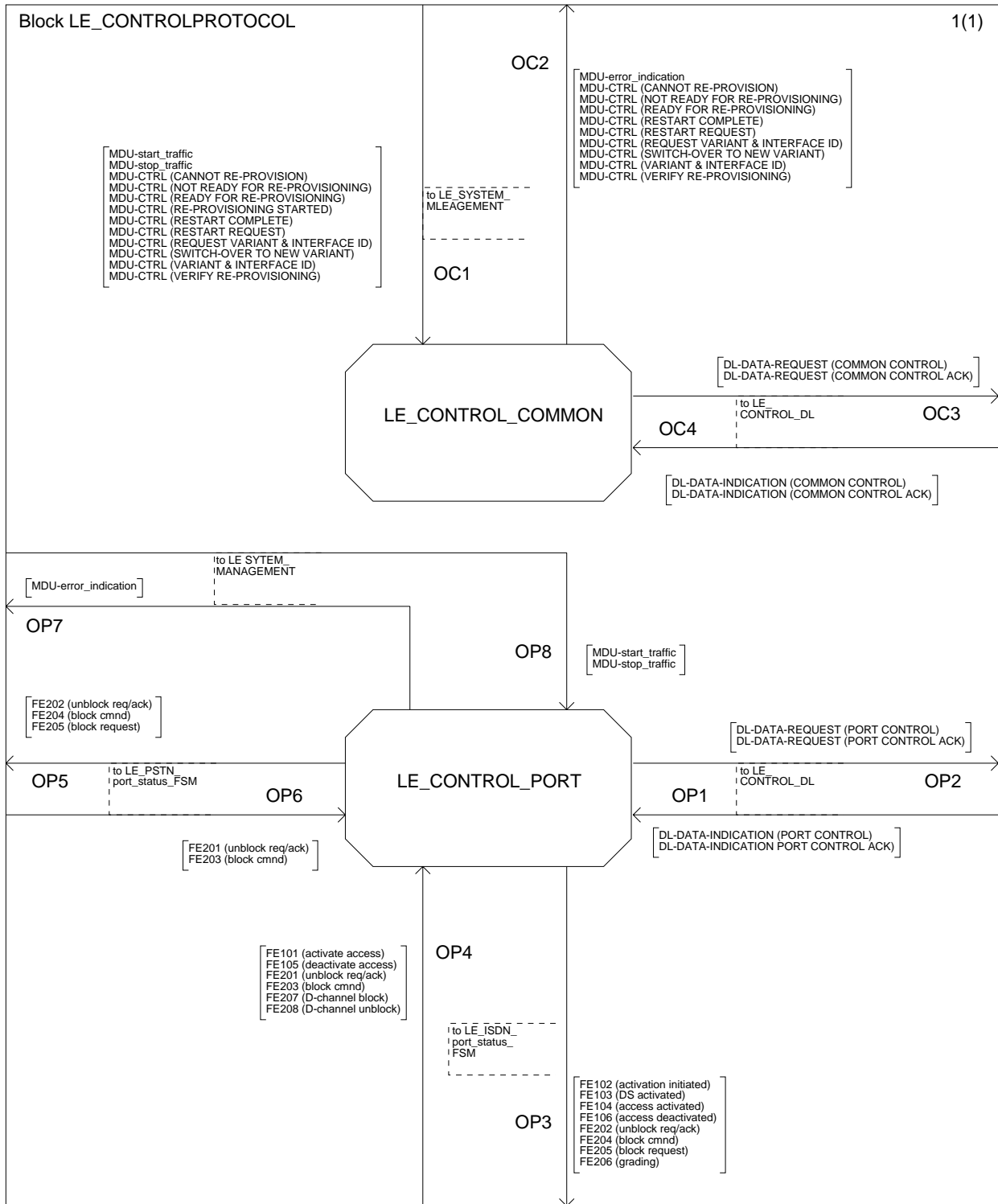

Figure L.20: Control protocol block description LE-side

L.2.2.3 Block description of the ISDN port status FSM

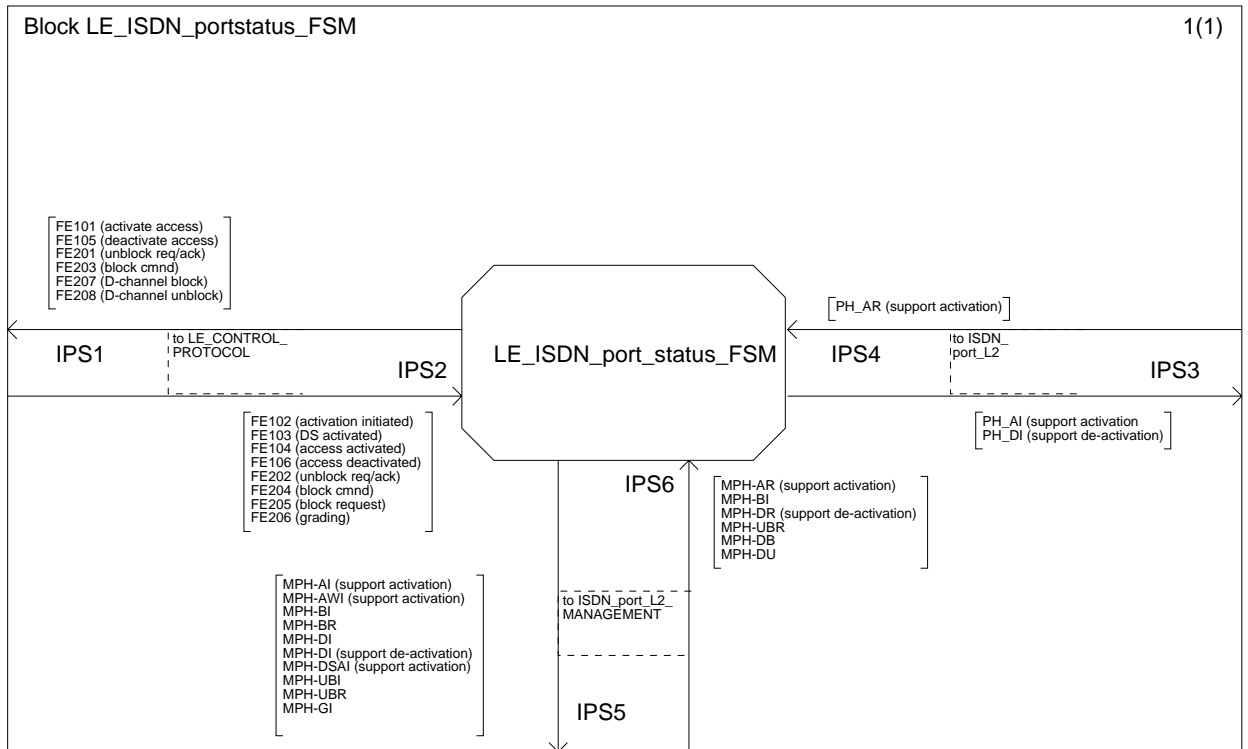

Figure L.21: ISDN port status FSM block description LE-side

L.2.2.4 Block description of the PSTN port status FSM

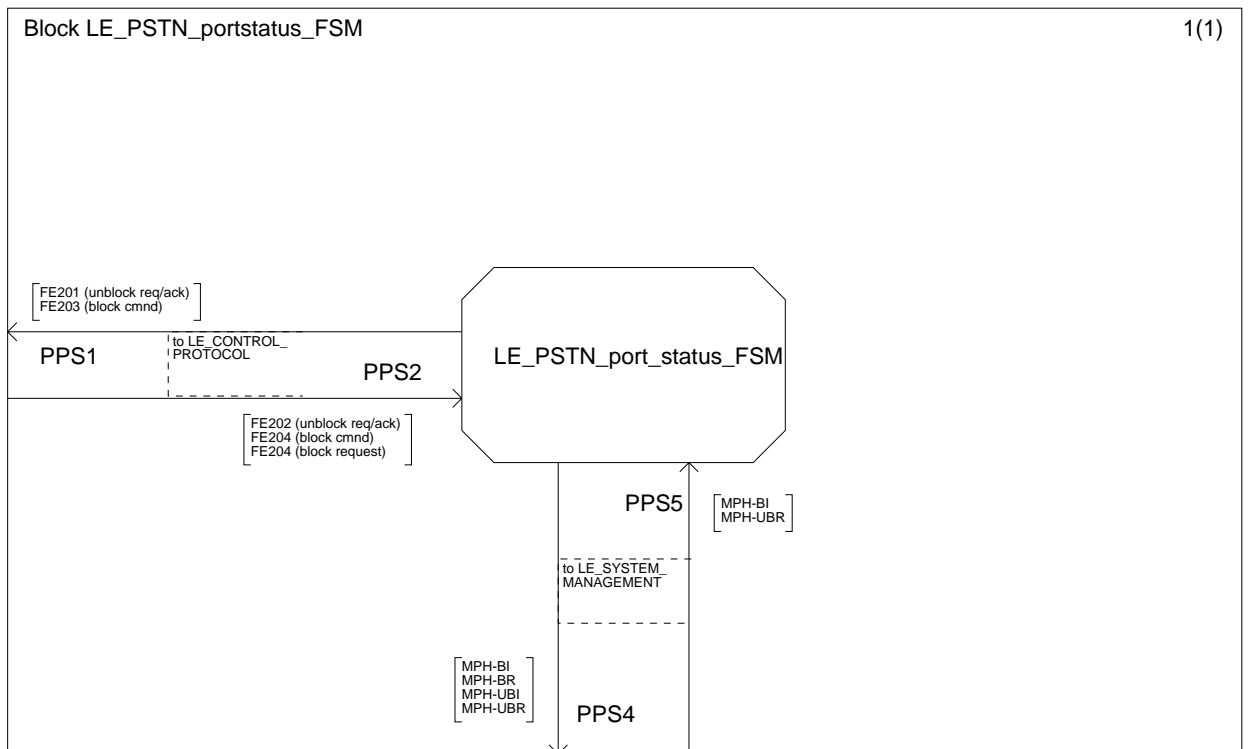

Figure L.22: PSTN port status FSM block description LE-side

L.2.2.5 Block description of the system management

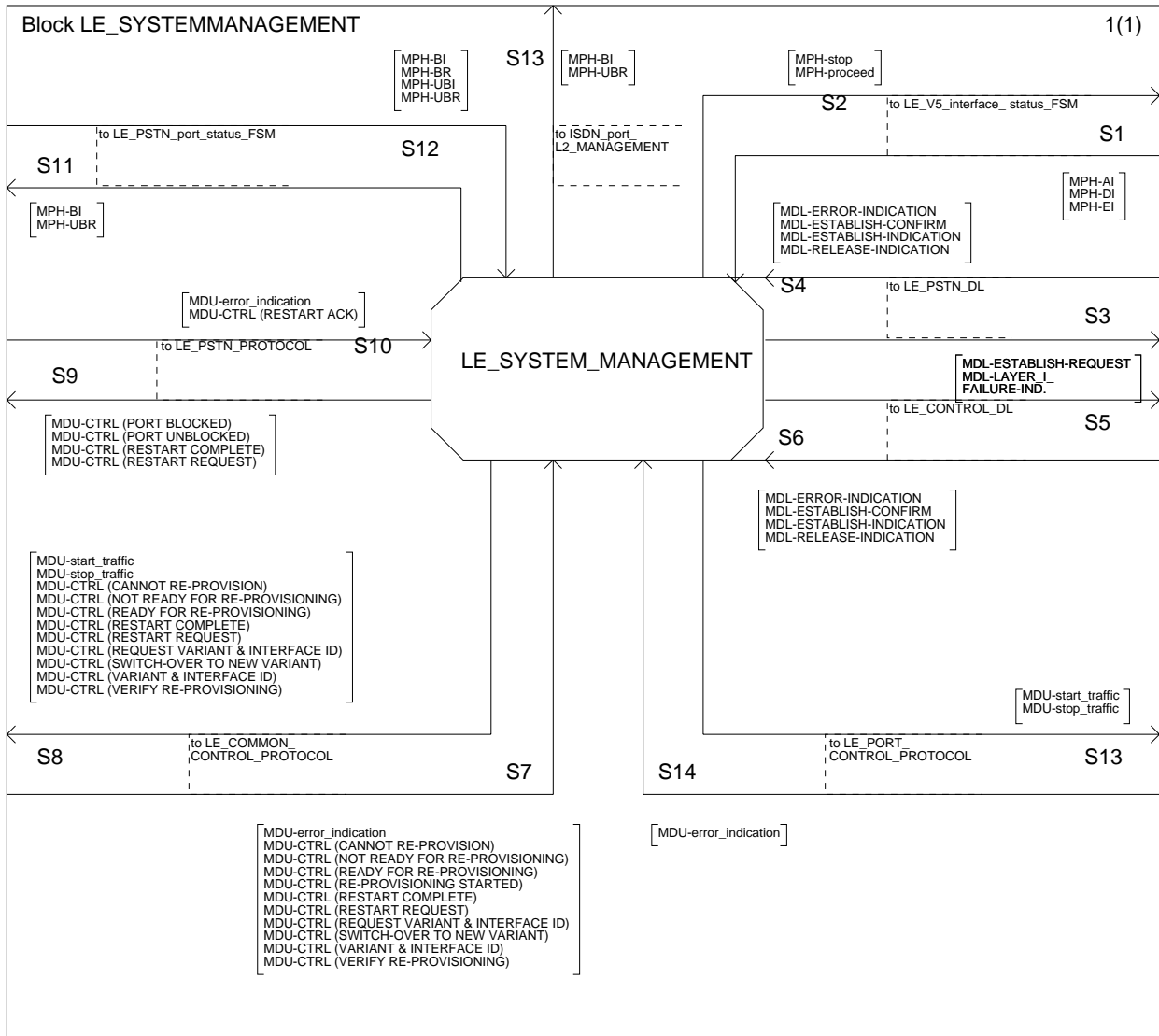

Figure L.23: System management block description LE-side

L.2.3 Explanation of SDL symbols

The symbols given in figure L.7 are used in the following. A full description of the symbols and their meaning and application is given in CCITT Recommendation Z.100.

L.2.4 PSTN protocol procedure

L.2.4.1 Scope

This subclause shows the SDL representation according to the PSTN path control procedures specified in Clause 13.

L.2.4.2 Path states

The path states for the AN side are defined in subclause 13.2.1.

L.2.4.3 SDLs

The input and output symbols in figure L.24 as well as the abbreviation are used in the following.

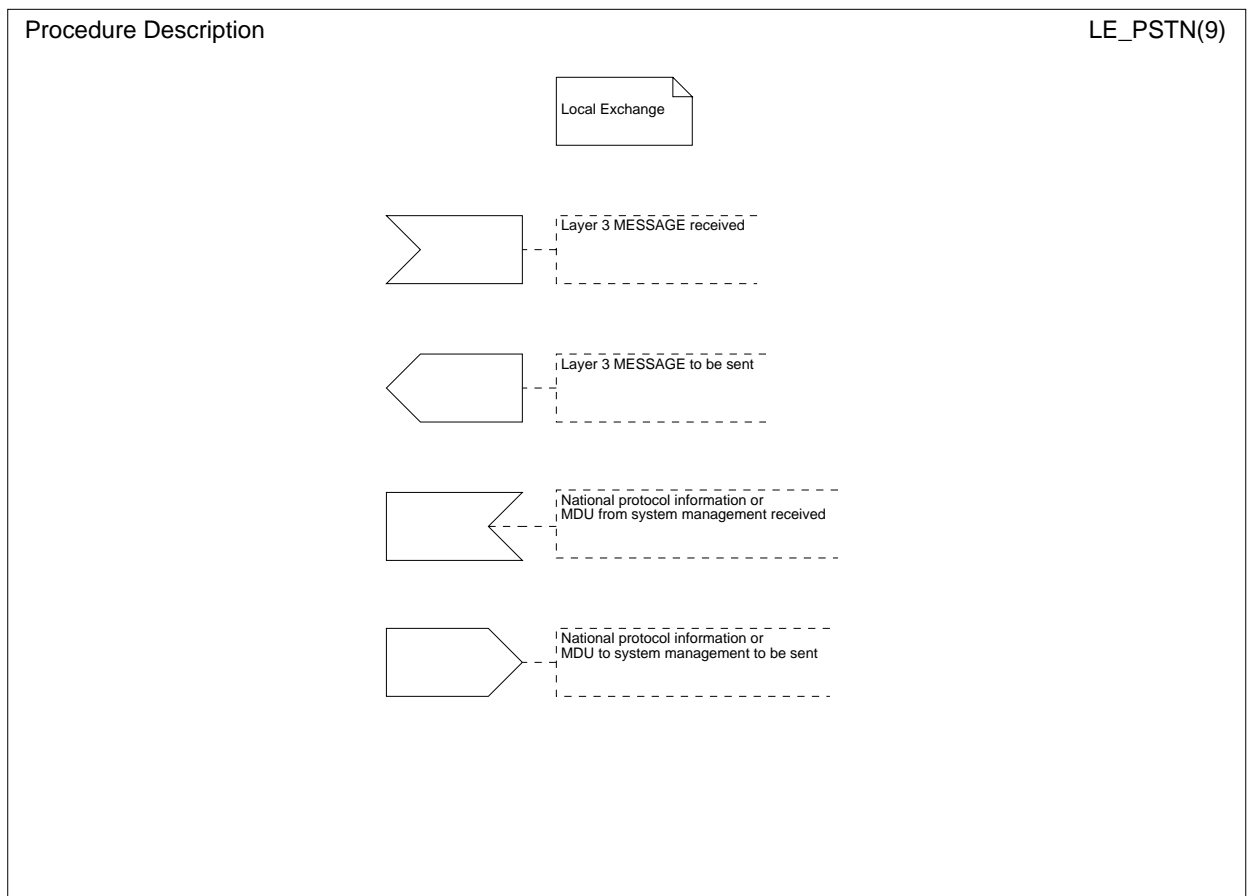

Figure L.24: Input and output symbols application - PSTN protocol (LE-side)

Process LE_PSTN_PROTOCOL

1(9)

State
LE0(PSTN)

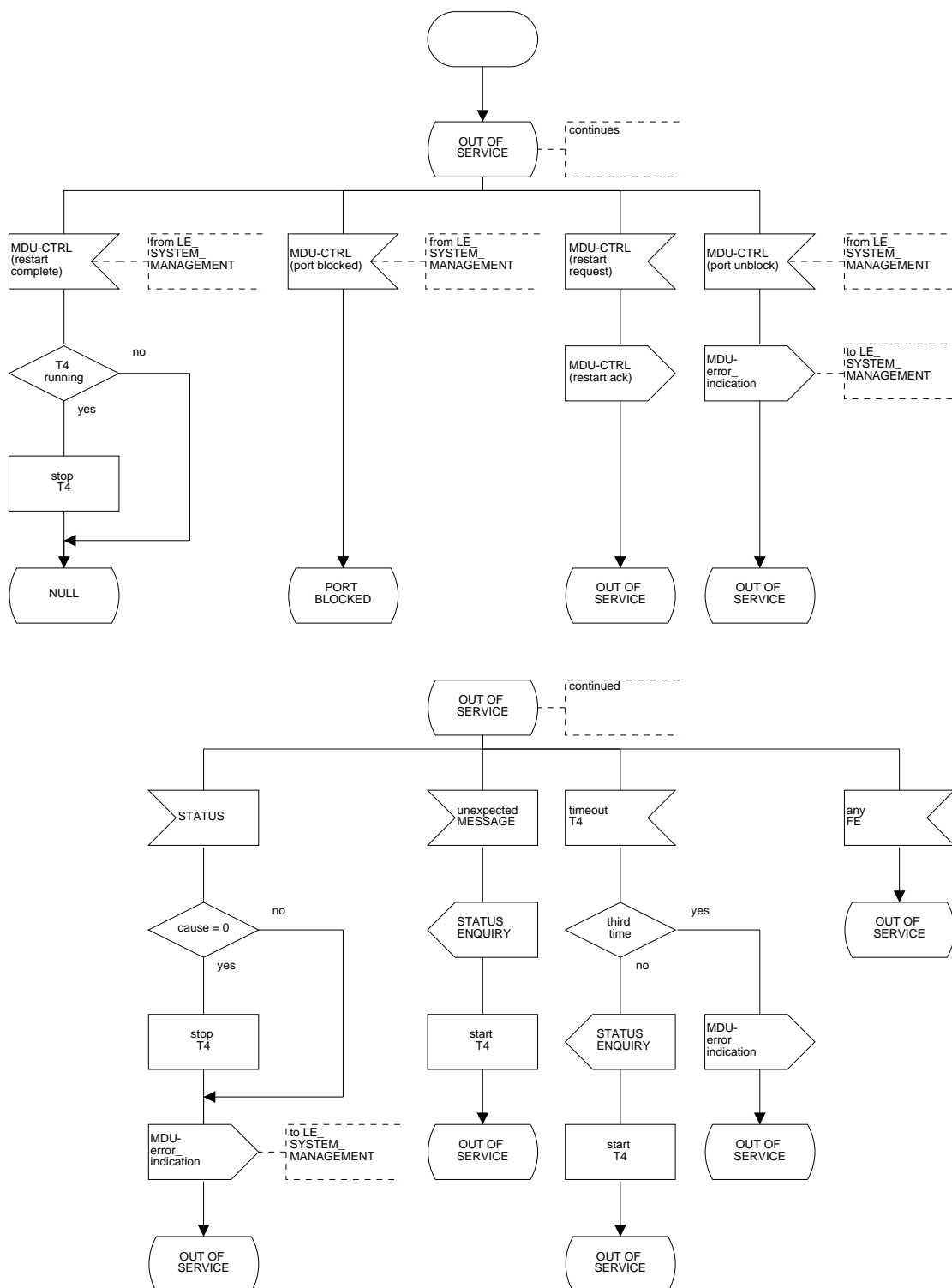

Figure L.25.1: PSTN protocol LE-side; state OUT OF SERVICE (LE0(PSTN))

Process LE_PSTN_PROTOCOL

2(9)

State
LE1(PSTN)

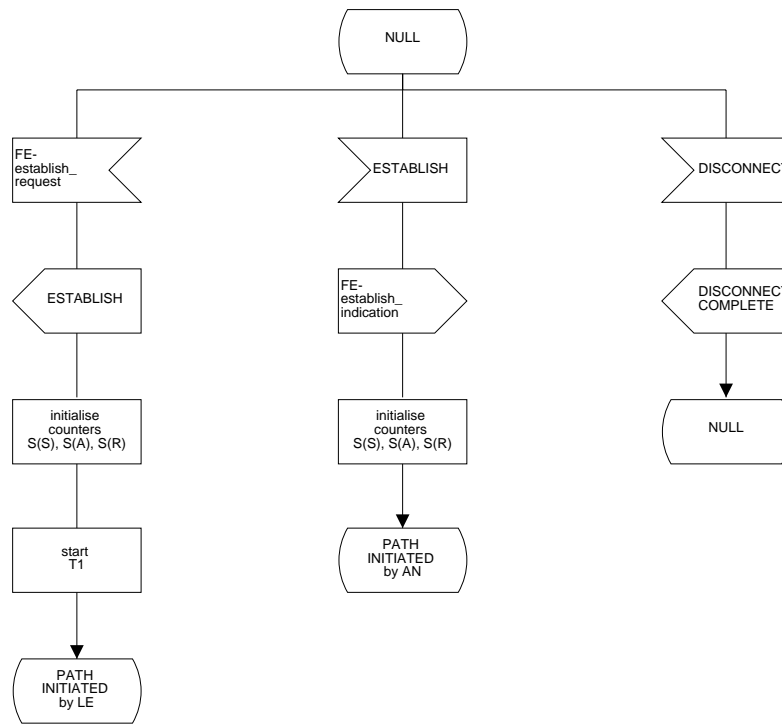
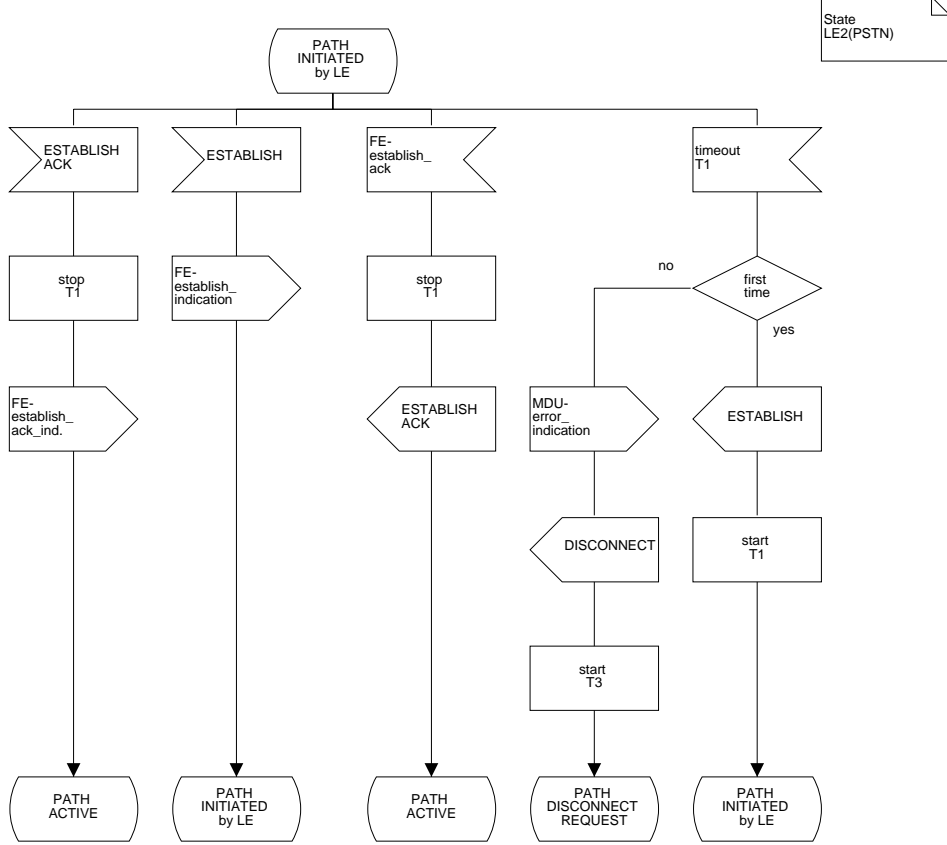

Figure L.25.2: PSTN protocol LE-side; state NULL (LE1(PSTN))

Process LE_PSTN_PROTOCOL

3(9)



State LE3(PSTN)

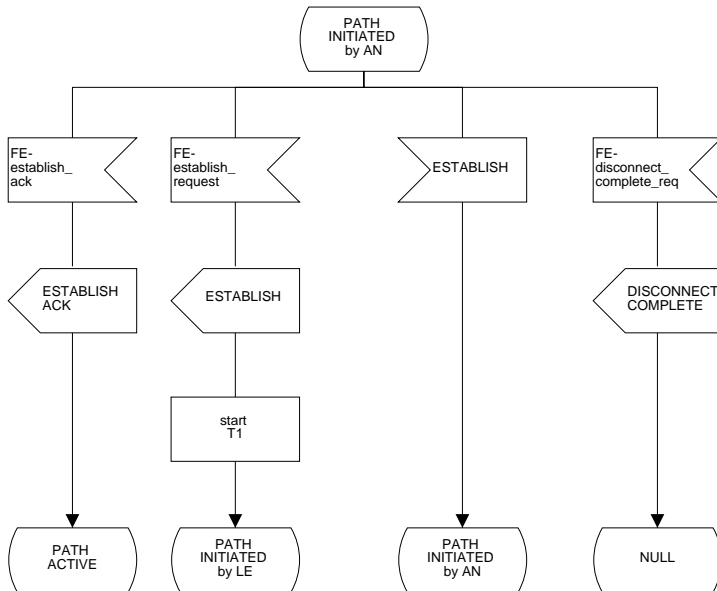

Figure L.25.3: PSTN protocol LE-side; states PATH INITIATED BY LE (LE2(PSTN)) and PATH INITIATED BY AN (LE3(PSTN))

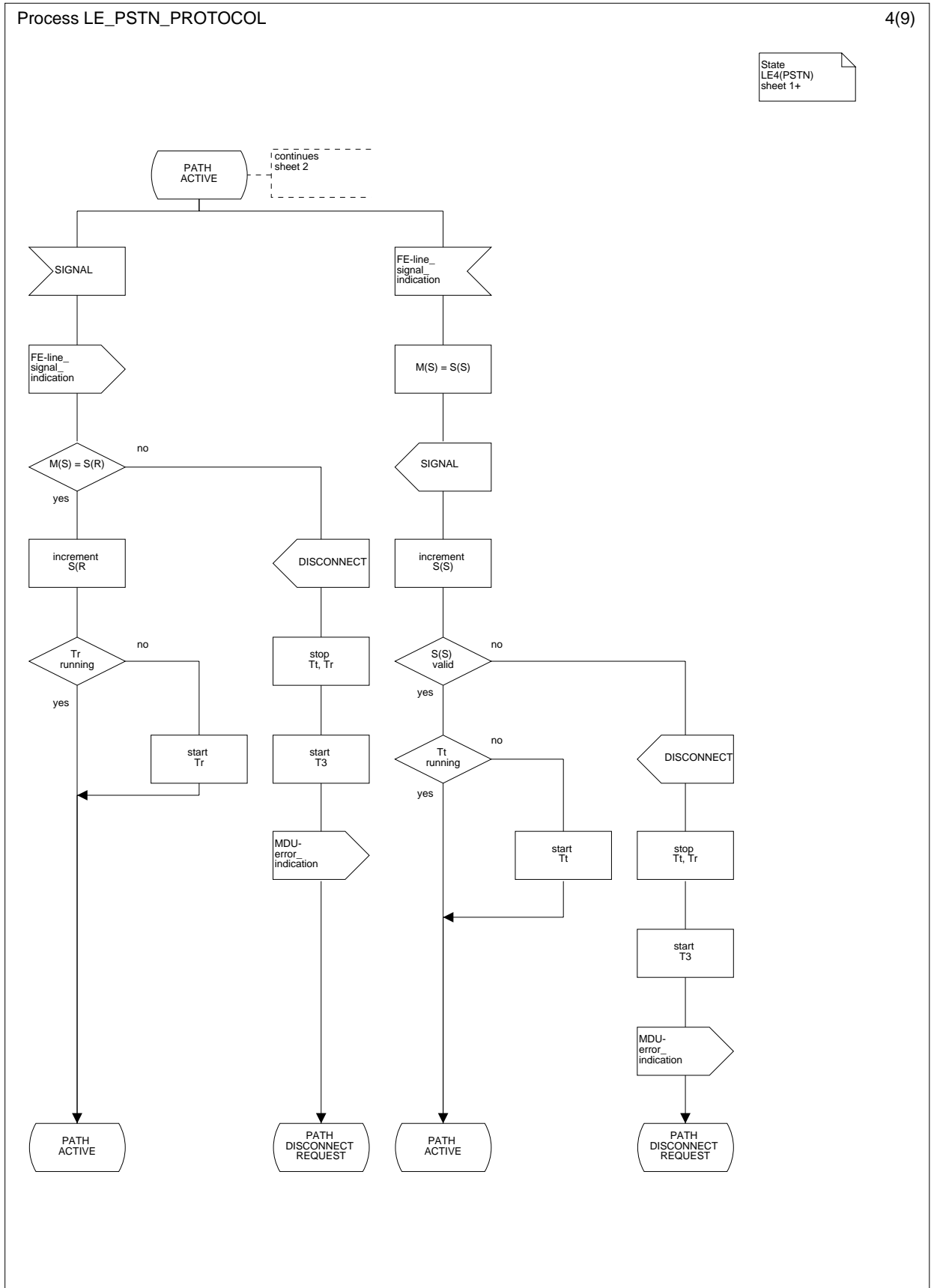

Figure L.25.4: PSTN protocol LE-side; state PATH ACTIVE (LE4(PSTN)) (sheet 1)

Process LE_PSTN_PROTOCOL

5(9)

State
 LE4(PSTN)
 sheet 2

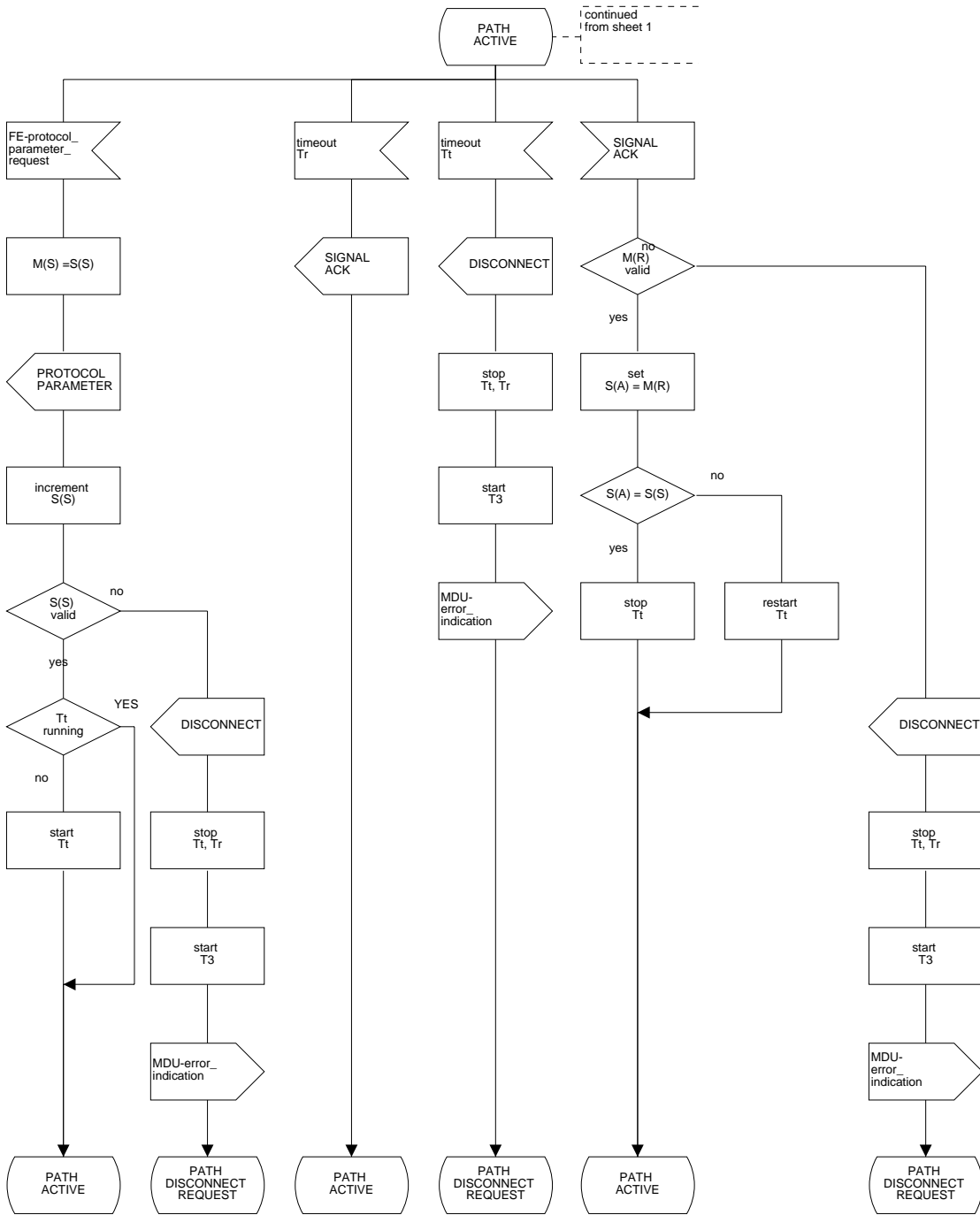

Figure L.25.5: PSTN protocol LE-side; state PATH ACTIVE (LE4(PSTN)) (sheet 2)

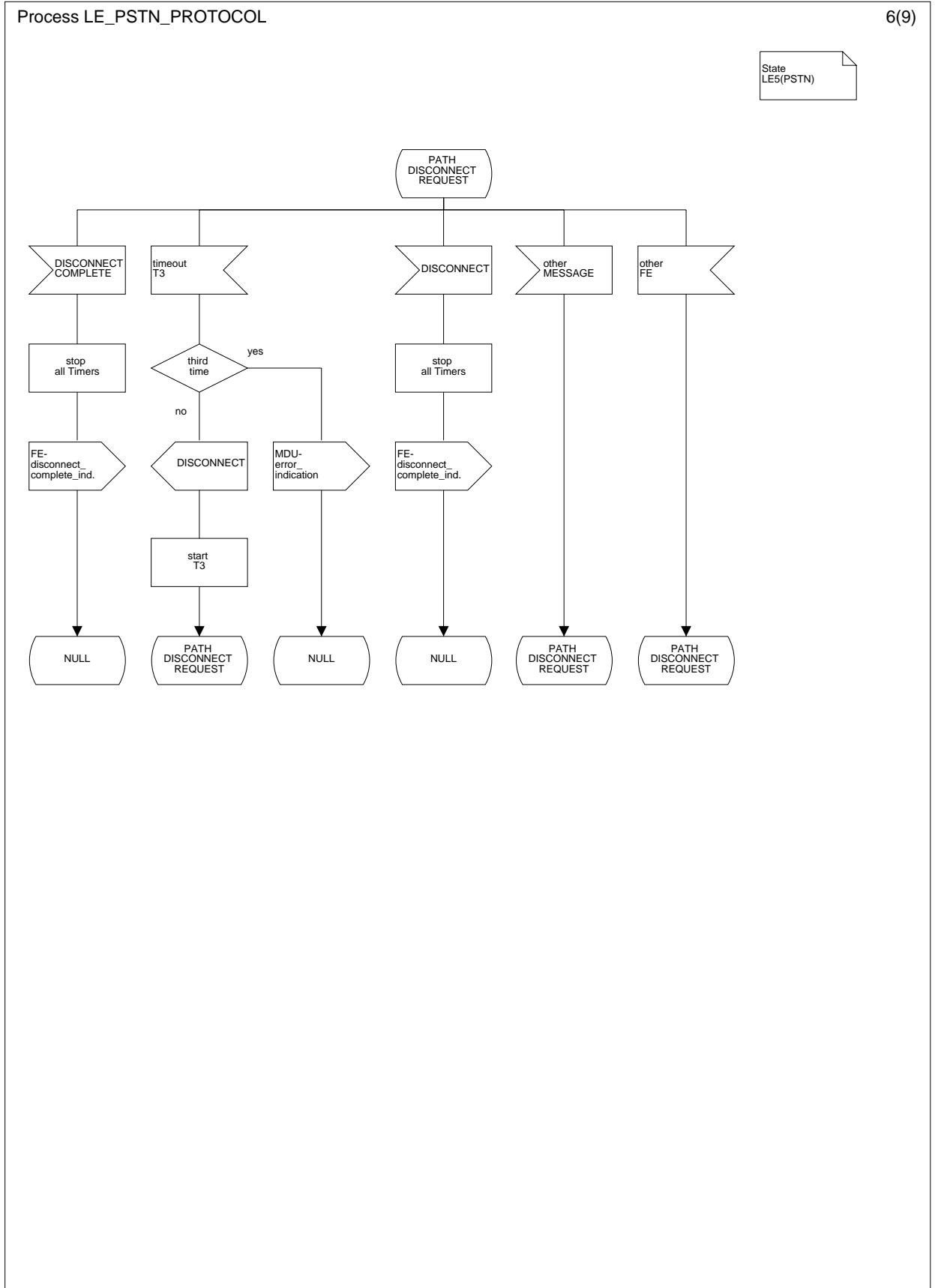

Figure L.25.6: PSTN protocol LE-side; state PATH DISCONNECT REQUEST (LE5(PSTN))

Process LE_PSTN_PROTOCOL

State
 LE6(PSTN)

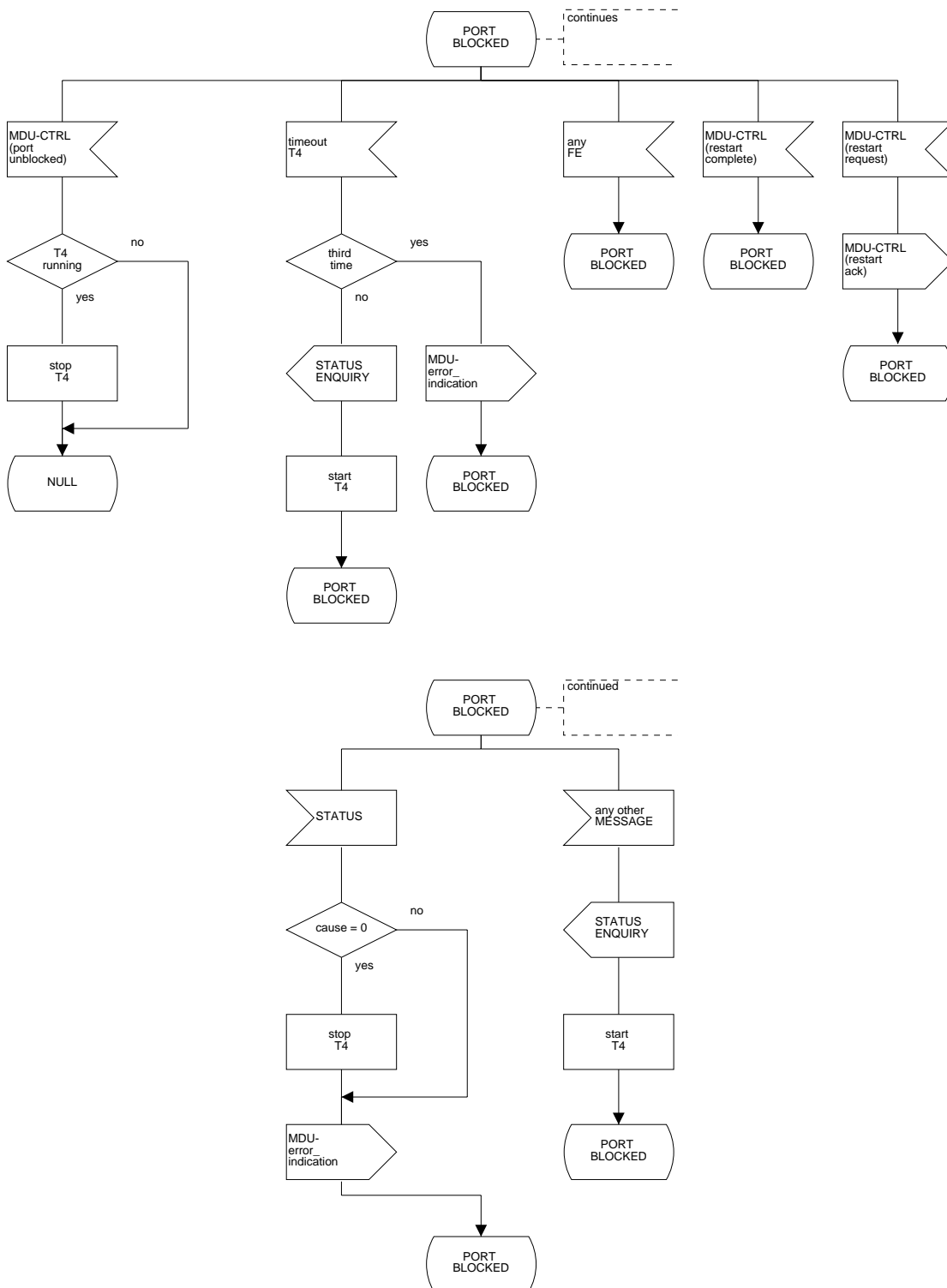

Figure L.25.7: PSTN protocol LE-side; state PORT BLOCKED (LE6(PSTN))

Process LE_PSTN_PROTOCOL

8(9)

Any State
 except LE0(PSTN),
 LE5(PSTN) and LE6(PSTN)
 sheet 1+

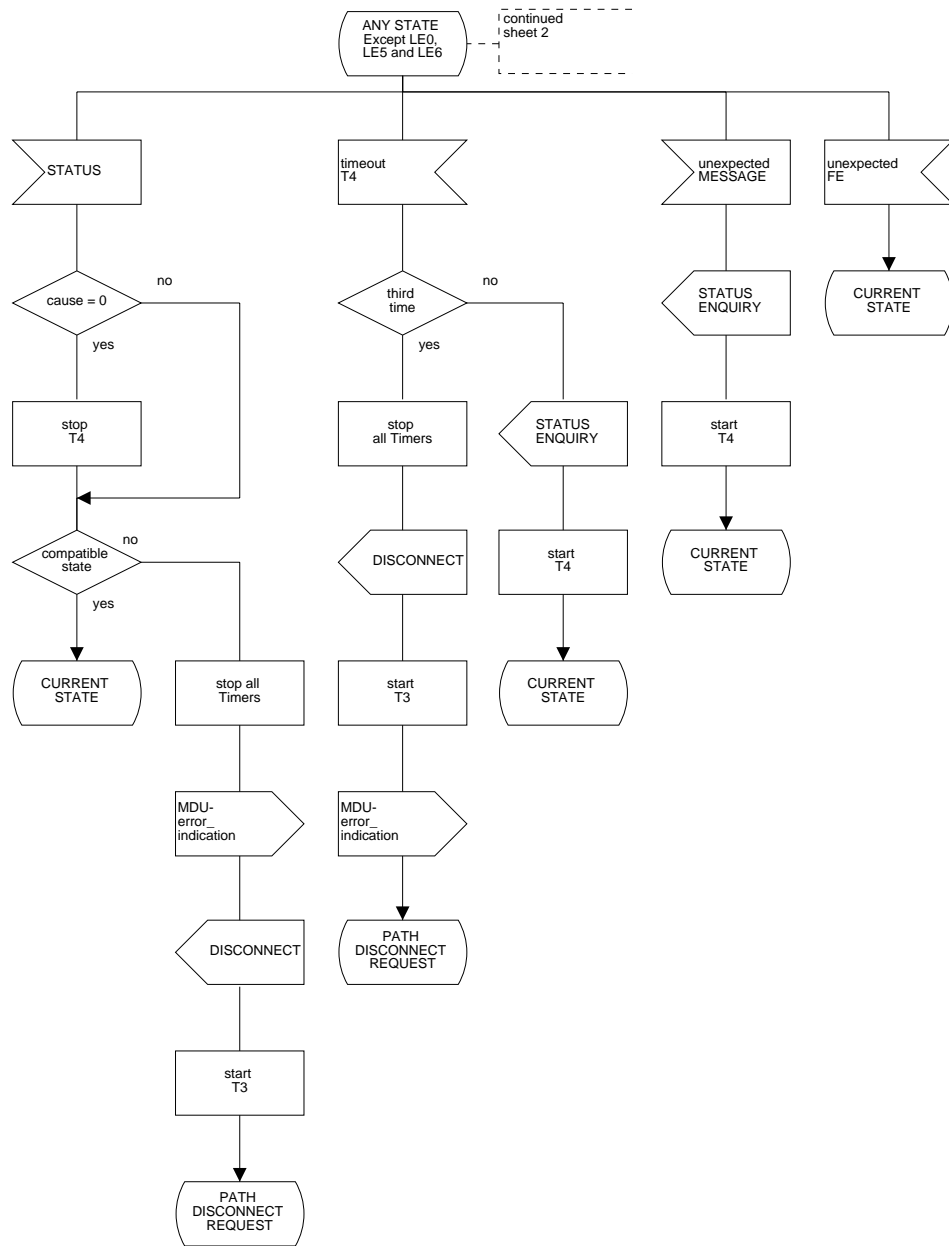

Figure L.25.8: PSTN protocol LE-side; any state except LE0(PSTN), LE5(PSTN) and LE6(PSTN) (sheet 1)

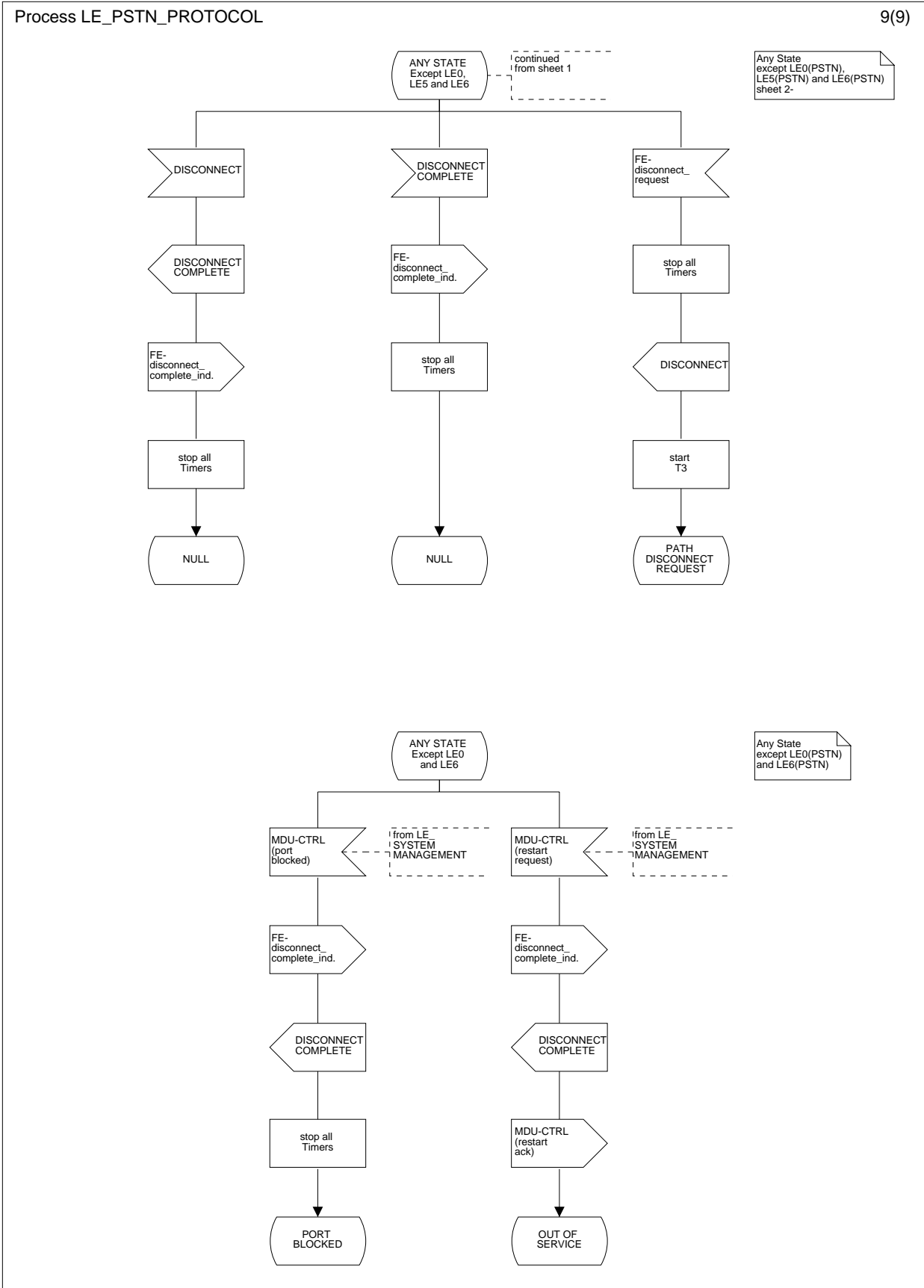

Figure L.25.9: PSTN protocol LE-side; any state except LE0(PSTN), LE5(PSTN) and LE6(PSTN) (sheet 2) and any state except LE0(PSTN) and LE6(PSTN)

L.2.5 Control protocol procedures

L.2.5.1 Scope

This subclause shows the SDL representation according to the port control and the common control procedures specified in subclause 14.4.

L.2.5.2 States

The states for the AN side are defined in subclause 14.4.

L.2.5.3 SDLs

The input and output symbols in figure L.26 as well as the abbreviation are used in the following.

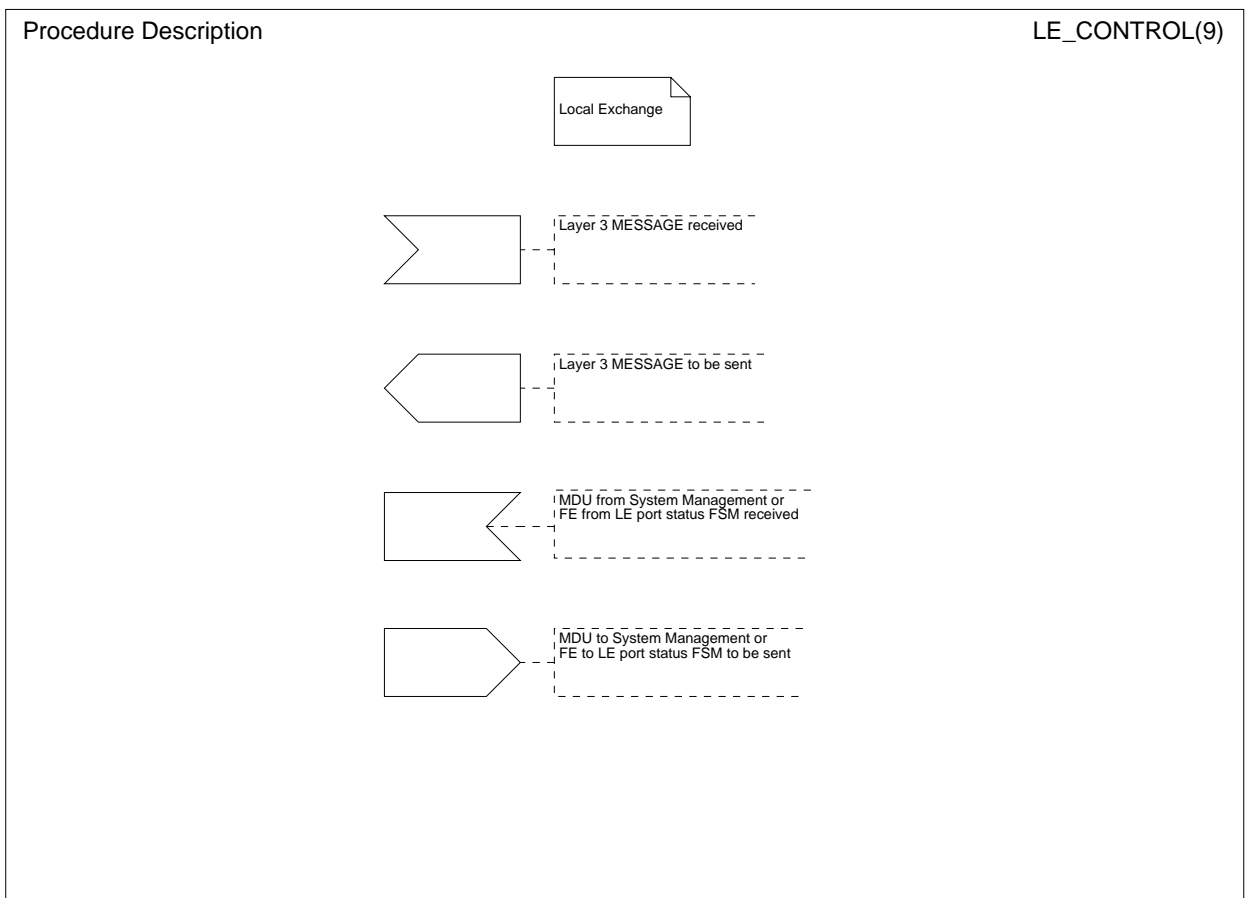

Figure L.26: Input and output symbols application - control protocol (LE-side)

L.2.5.3.1 Port control protocol

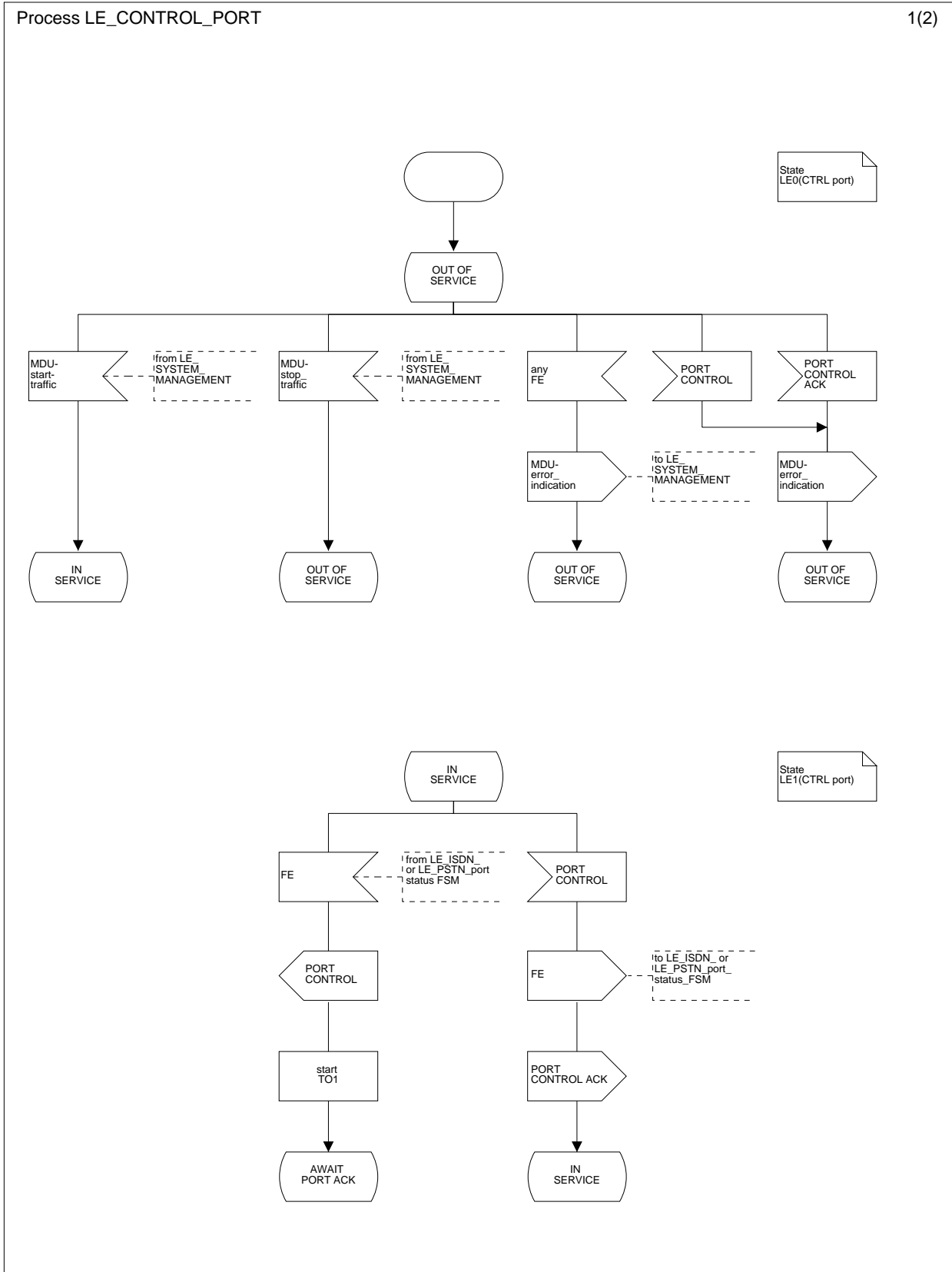

Figure L.27.1: Port control protocol LE-side; states **OUT OF SERVICE (LE0(CTRL port))** and **IN SERVICE (LE1(CTRL port))**

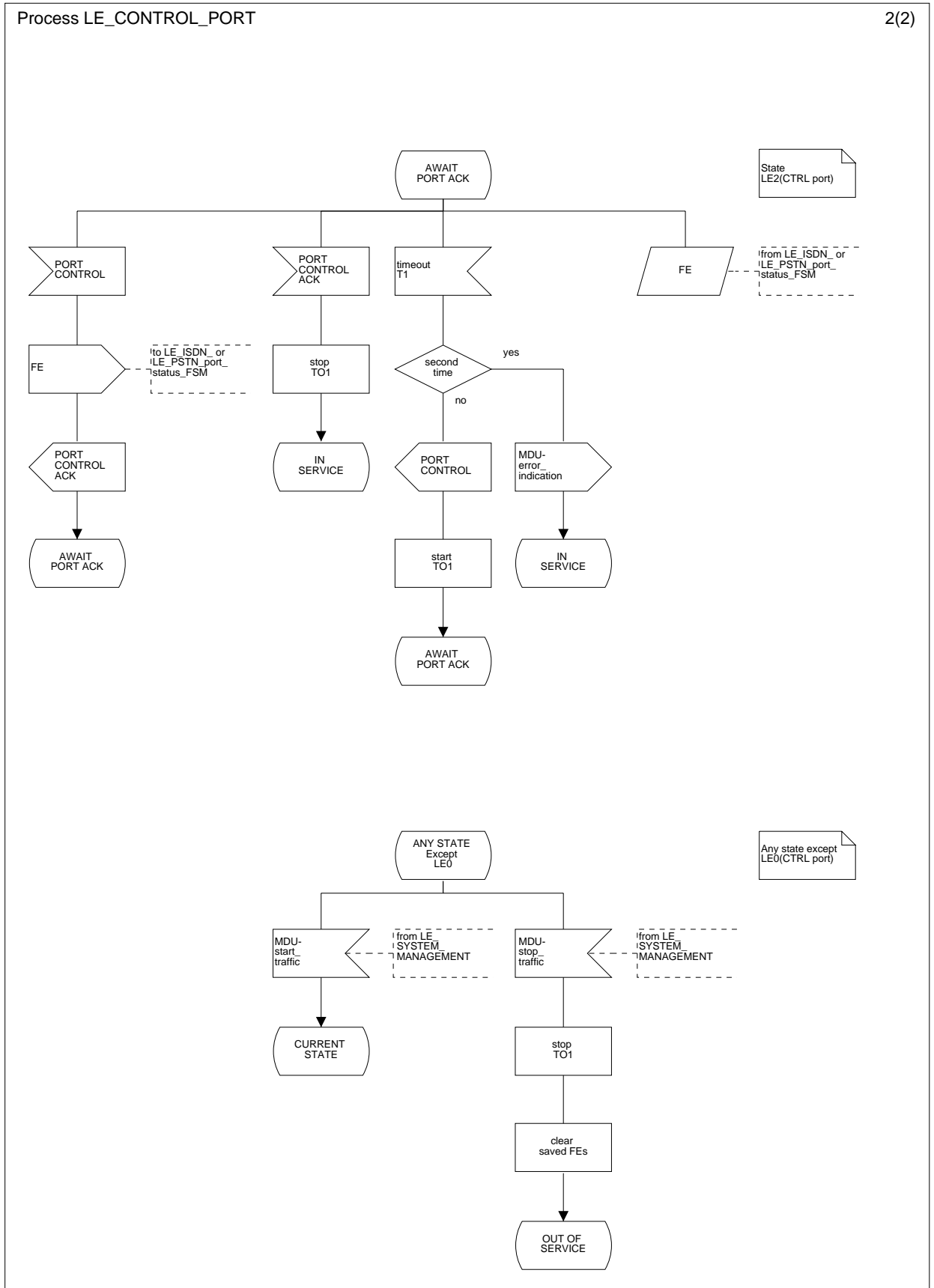

Figure L.27.2: Port control protocol LE-side; state AWAIT PORT ACK (LE2(CTRL port)) and any state except LE0(CTRL port)

L.2.5.3.2 Common control protocol

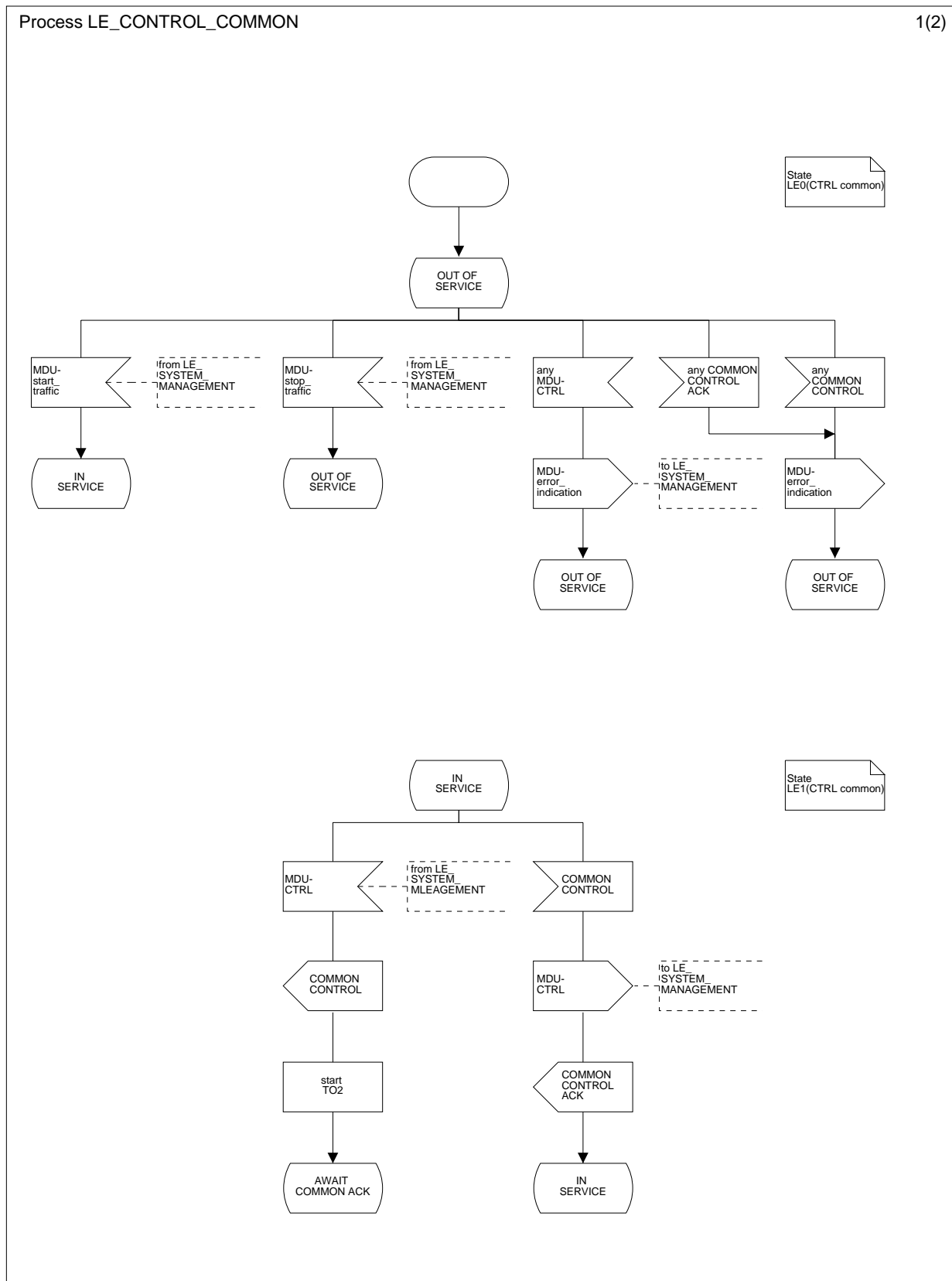

Figure L.28.1: Common control protocol LE-side; states OUT OF SERVICE (LE0(CTRL common)) and IN SERVICE (LE1(CTRL common))

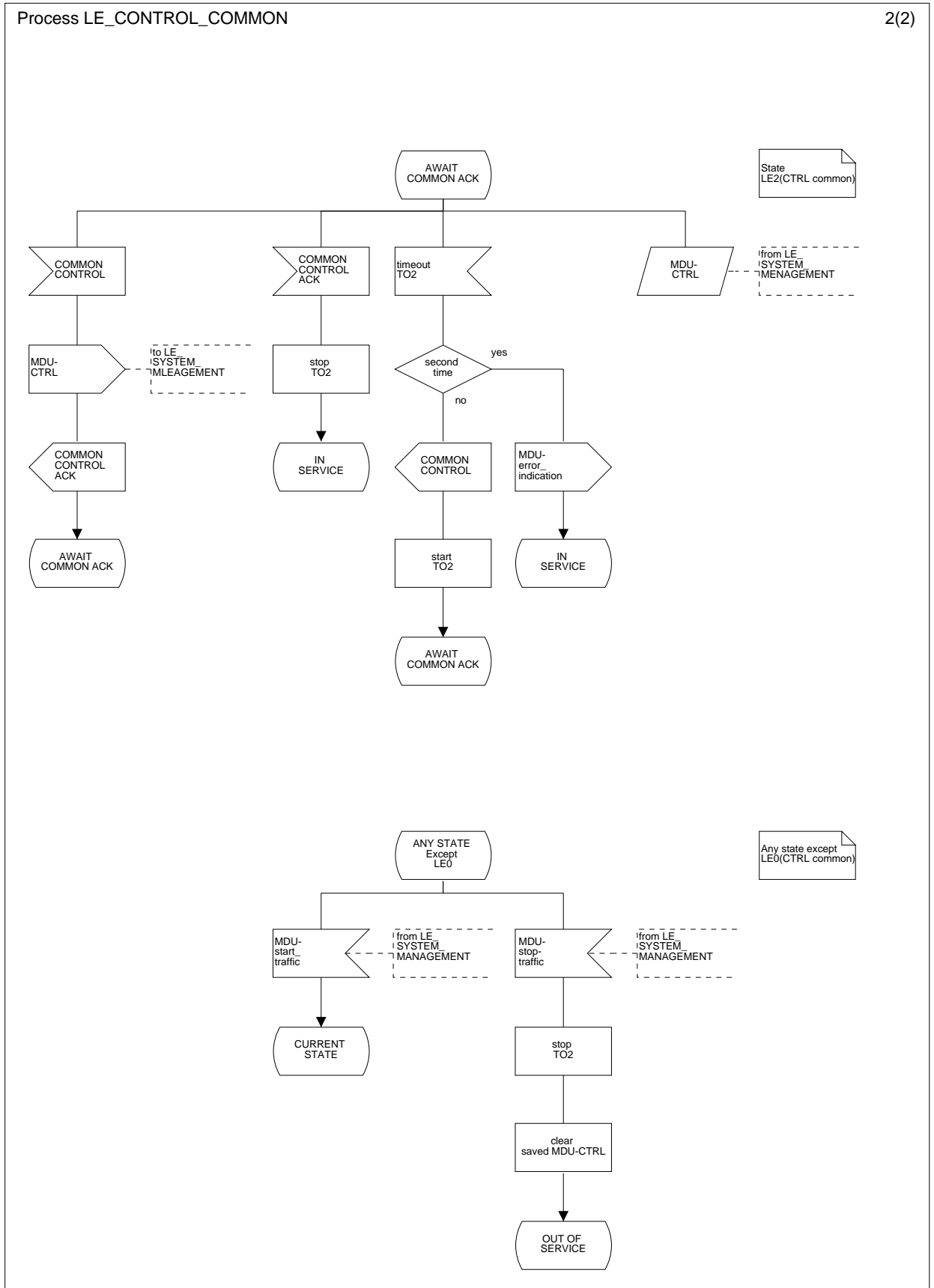

Figure L.28.2: Common control protocol LE-side; state AWAIT COMMON ACK (LE1(CTRL common)) and any state except LE0(CTRL common)

L.2.6 Port status FSM control

L.2.6.1 Scope

This subclause shows the SDL representation according to the port status FSM control for ISDN and PSTN ports specified in subclauses 14.1 and 14.2.

L.2.6.2 States

The states for the LE side are defined in subclauses 14.1.3.1 and 14.2.3.1.

L.2.6.3 SDLs

The input and output symbols application in figure L.29 as well as the abbreviation are used in the following.

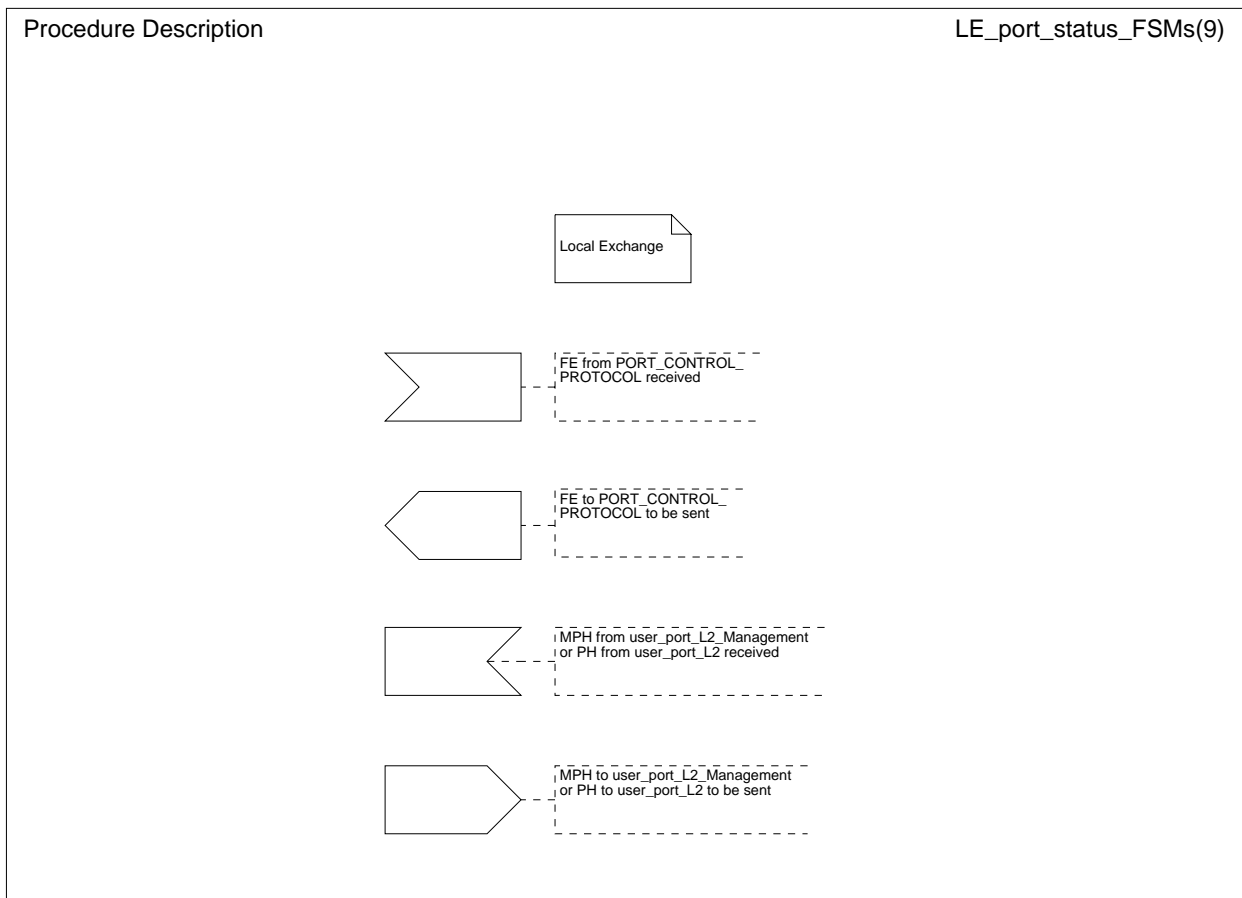

Figure L.29: Input and output symbols application - port status FSM control (LE-side)

L.2.6.3.1 ISDN port status FSM control

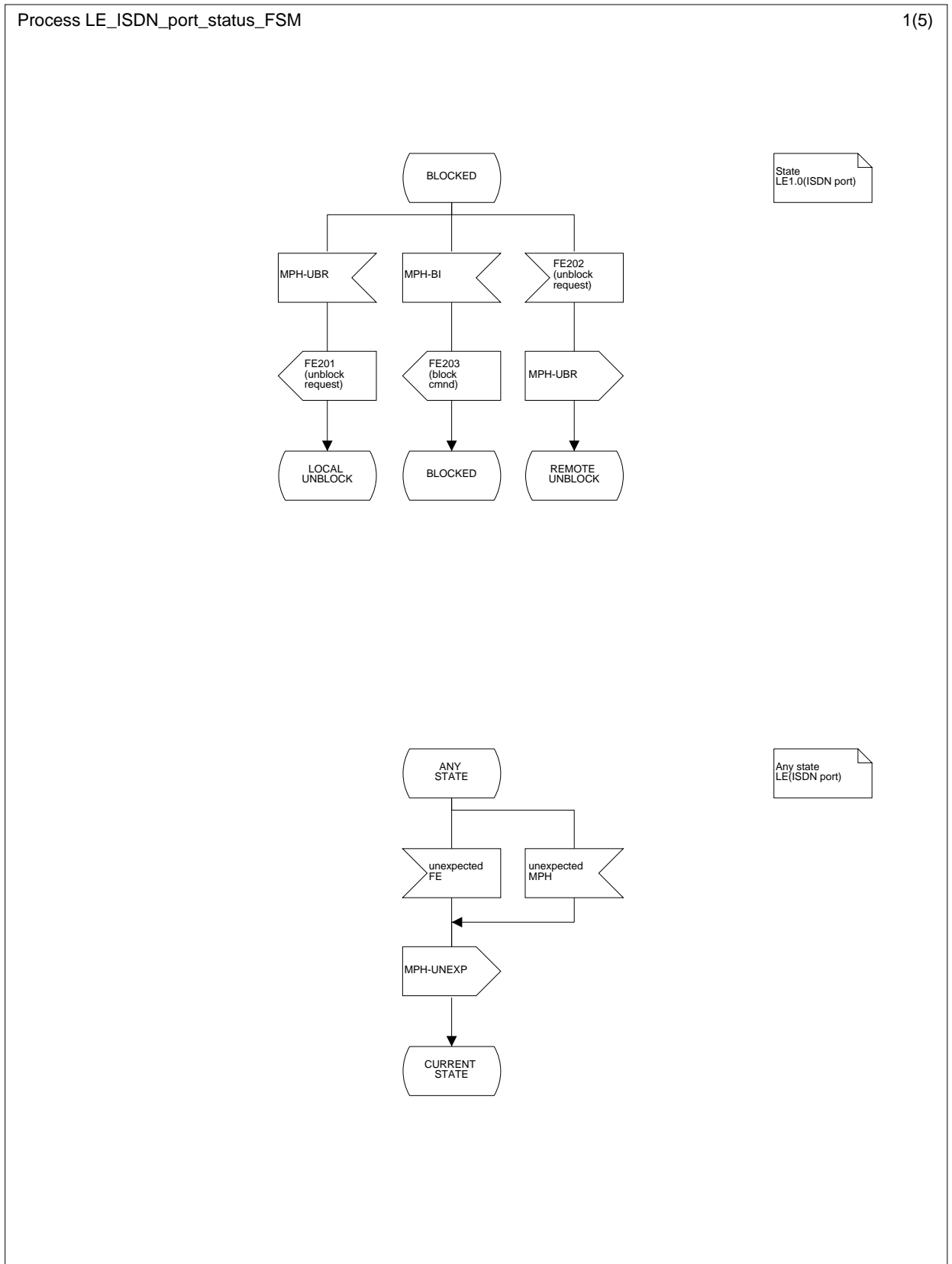
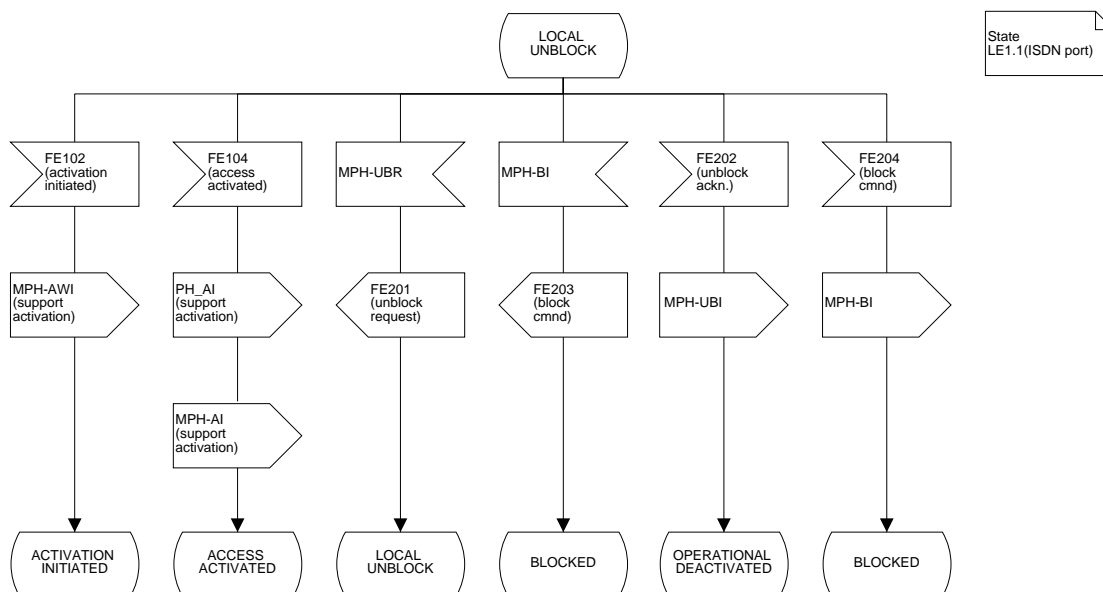

Figure L.30.1: ISDN port status FSM control LE-side; state BLOCKED (LE1.0(ISDN port)) and any LE(ISDN port) state

Process LE_ISDN_port_status_FSM

2(5)



State
LE1.1(ISDN port)

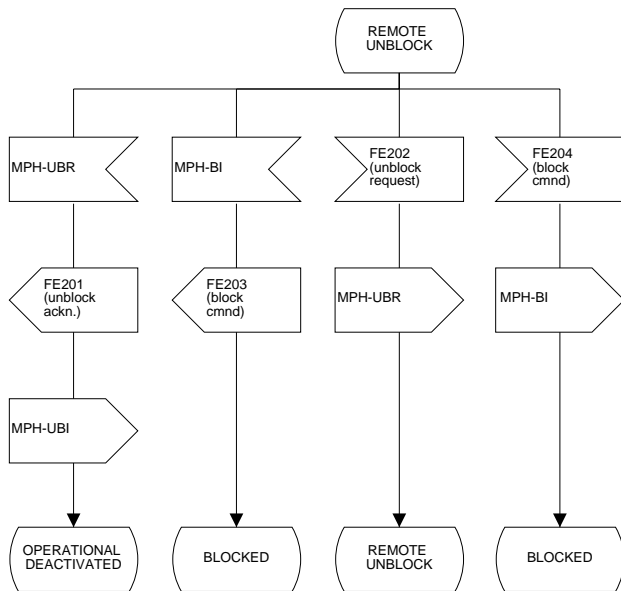

State
LE1.2(ISDN port)

Figure L.30.2: ISDN port status FSM control LE-side; states LOCAL UNBLOCK (LE1.1(ISDN port)) and REMOTE UNBLOCK (LE1.2(ISDN port))

Process LE_ISDN_port_status_FSM

3(5)

State
 LE2.0(ISDN port)

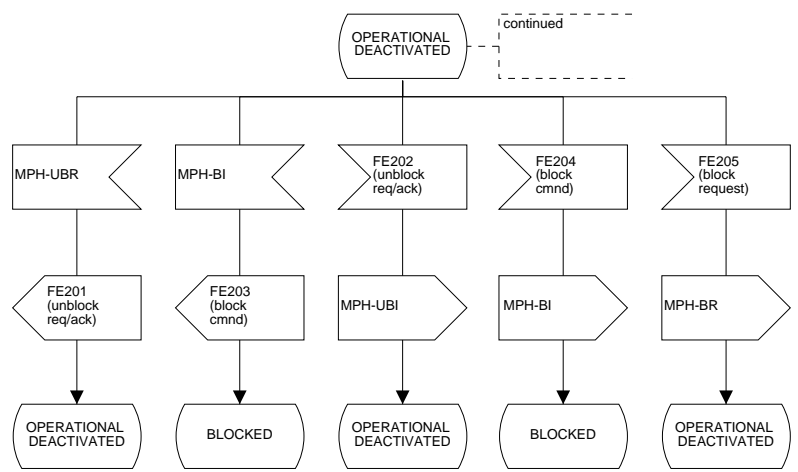
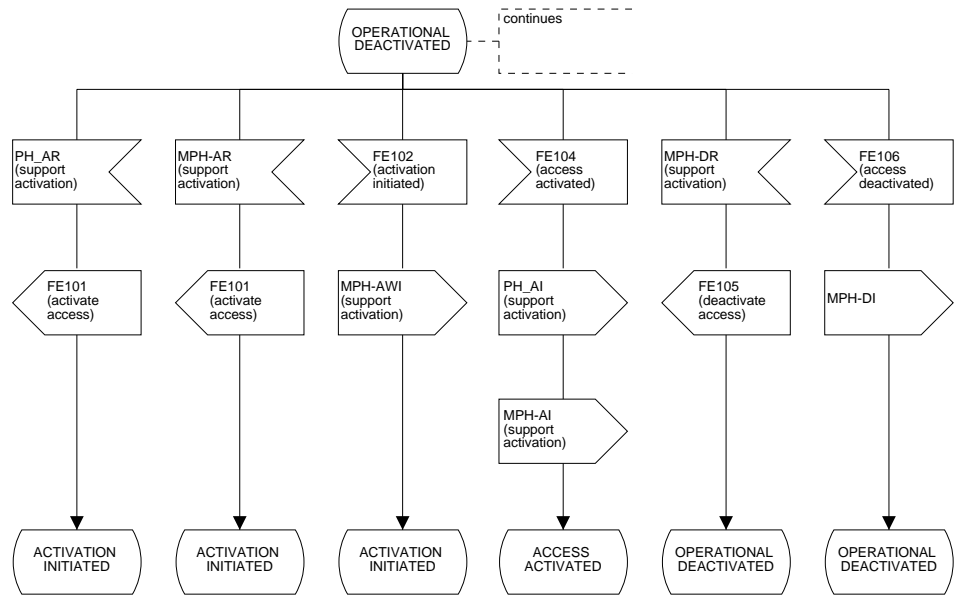

Figure L.30.3: ISDN port status FSM control LE-side; state OPERATIONAL DEACTIVATED (LE2.0(ISDN port))

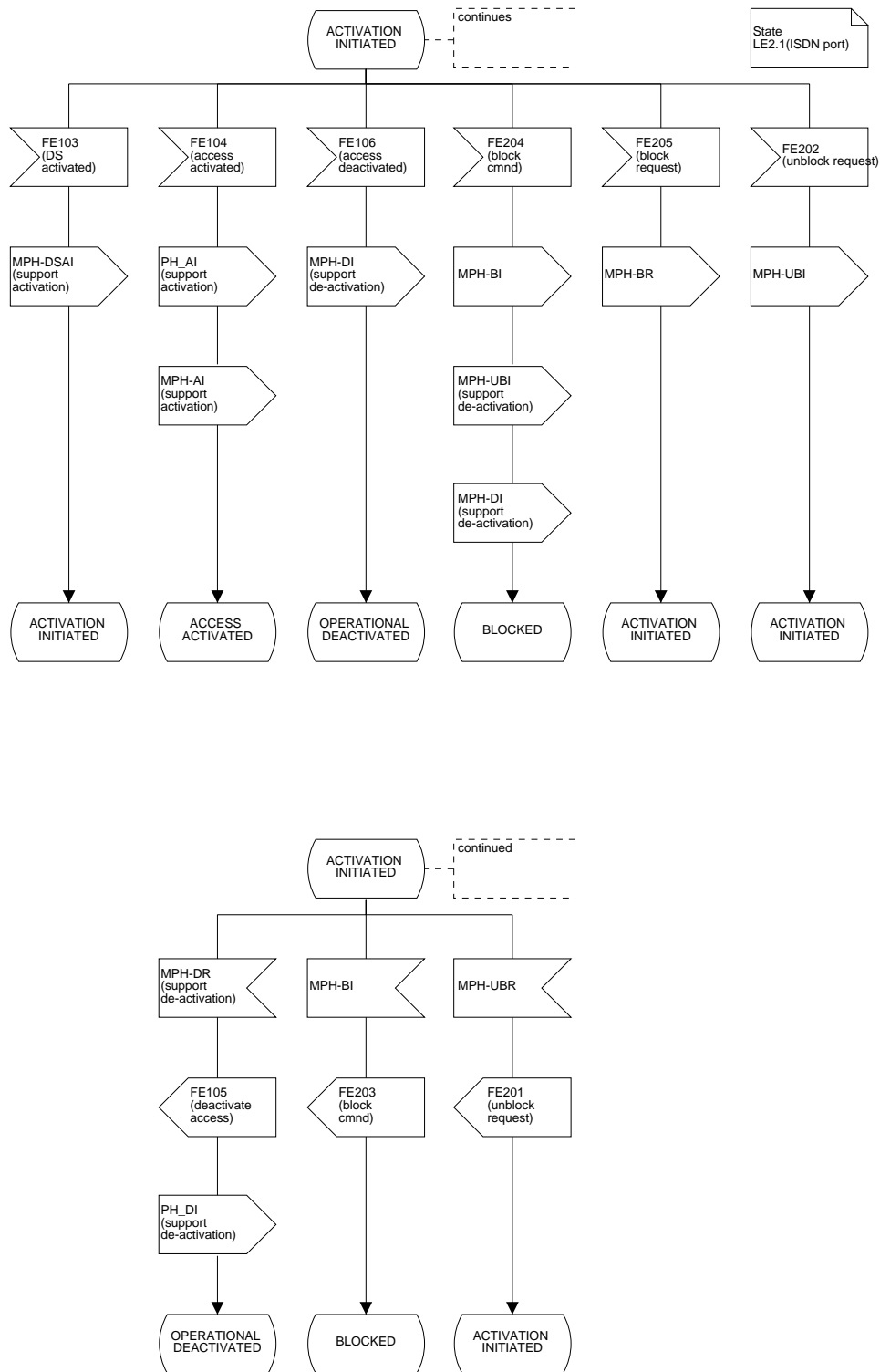

Figure L.30.4: ISDN port status FSM control LE-side; state ACTIVATION INITIATED (LE2.1(ISDN port))

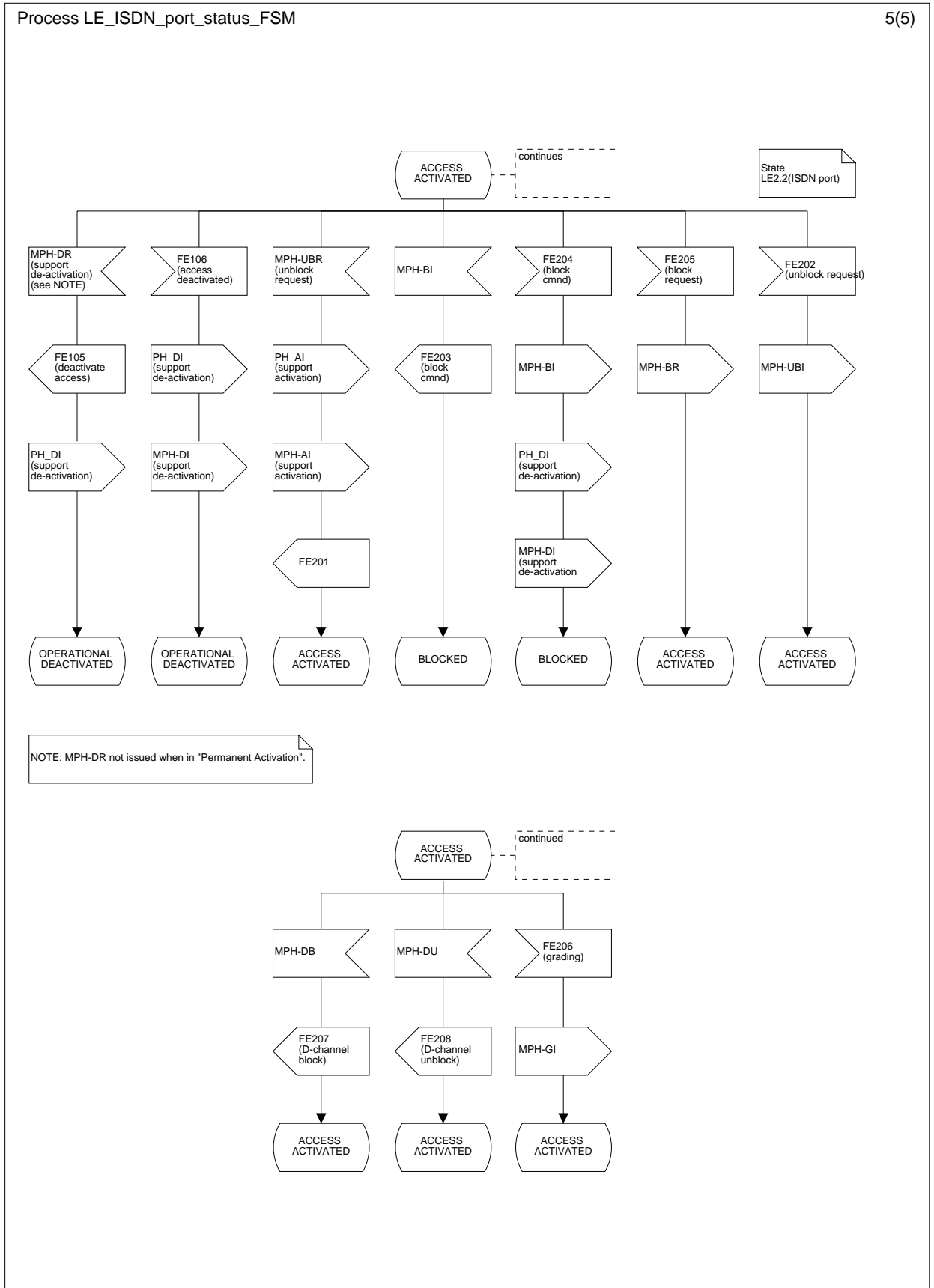

Figure L.30.5: ISDN port status FSM control LE-side; state ACCESS ACTIVATED (LE2.2(1SDN port))

L.2.6.3.2 PSTN port status FSM control

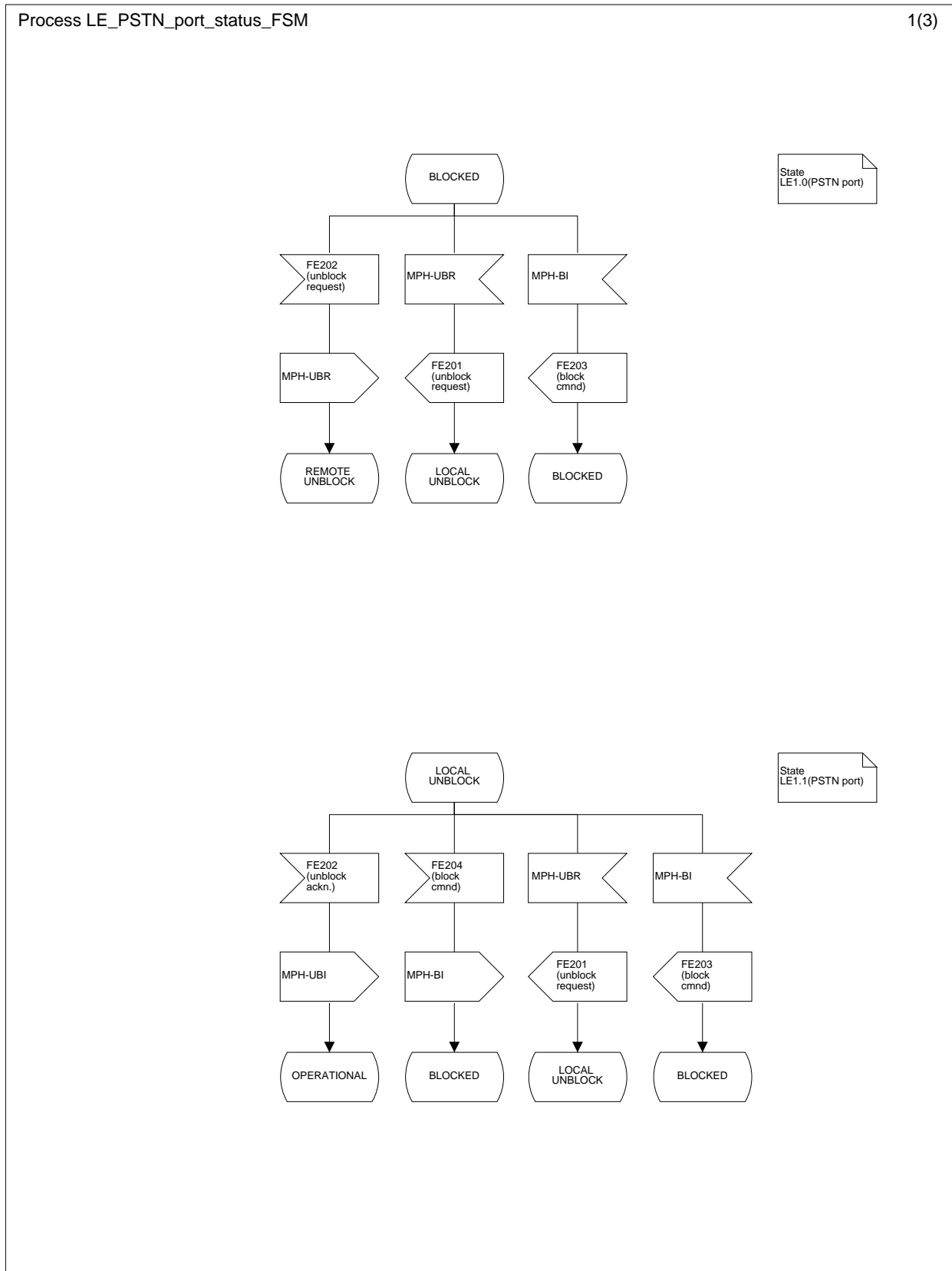

Figure L.31.1: PSTN port status FSM control LE-side; states **BLOCKED (LE1.0(PSTN port))** and **LOCAL UNBLOCK (LE1.1(PSTN port))**

Process LE_PSTN_port_status_FSM

2(3)

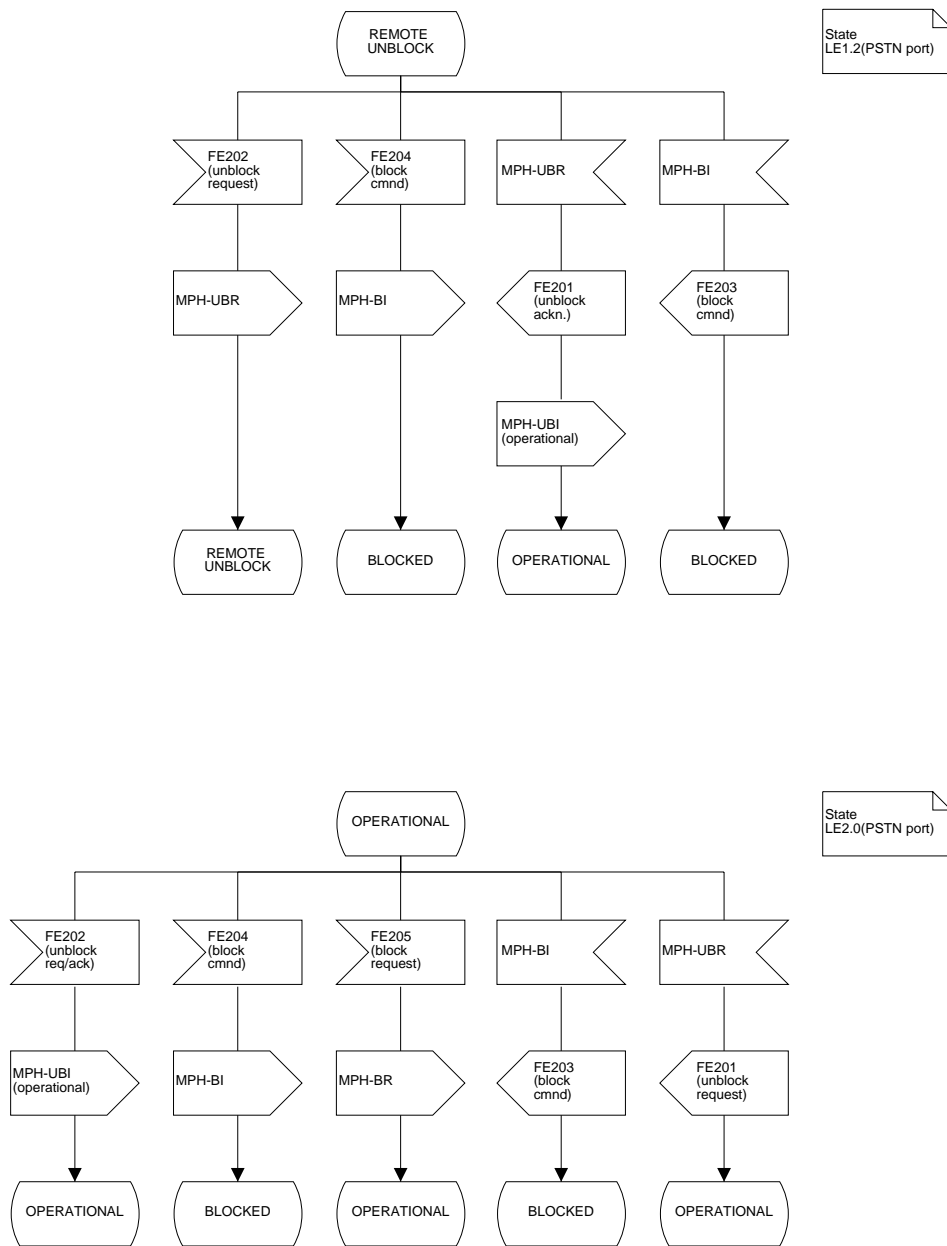

Figure L.31.2: PSTN port status FSM control LE-side; states REMOTE UNBLOCK (LE1.2(PSTN port)) and OPERATIONAL (LE2.0(PSTN port))

Process LE_PSTN_port_status_FSM

3(3)

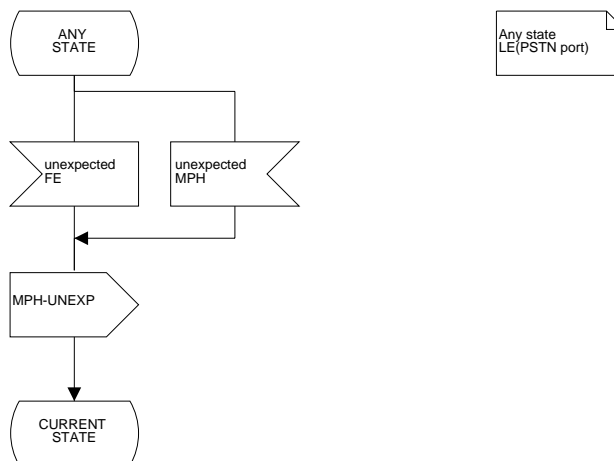

Figure L.31.3: PSTN port status FSM control LE-side; any LE(PSTN port) state

L.2.7 System management procedure

L.2.7.1 Scope

This subclause shows the SDL representation according to the procedures specified in subclause 14.5 and Annex C.

L.2.7.2 States

The states for the AN side are defined in Annex C.

L.2.7.3 SDLs

The input and output symbols application in figure L.32 as well as the abbreviation are used in the following.

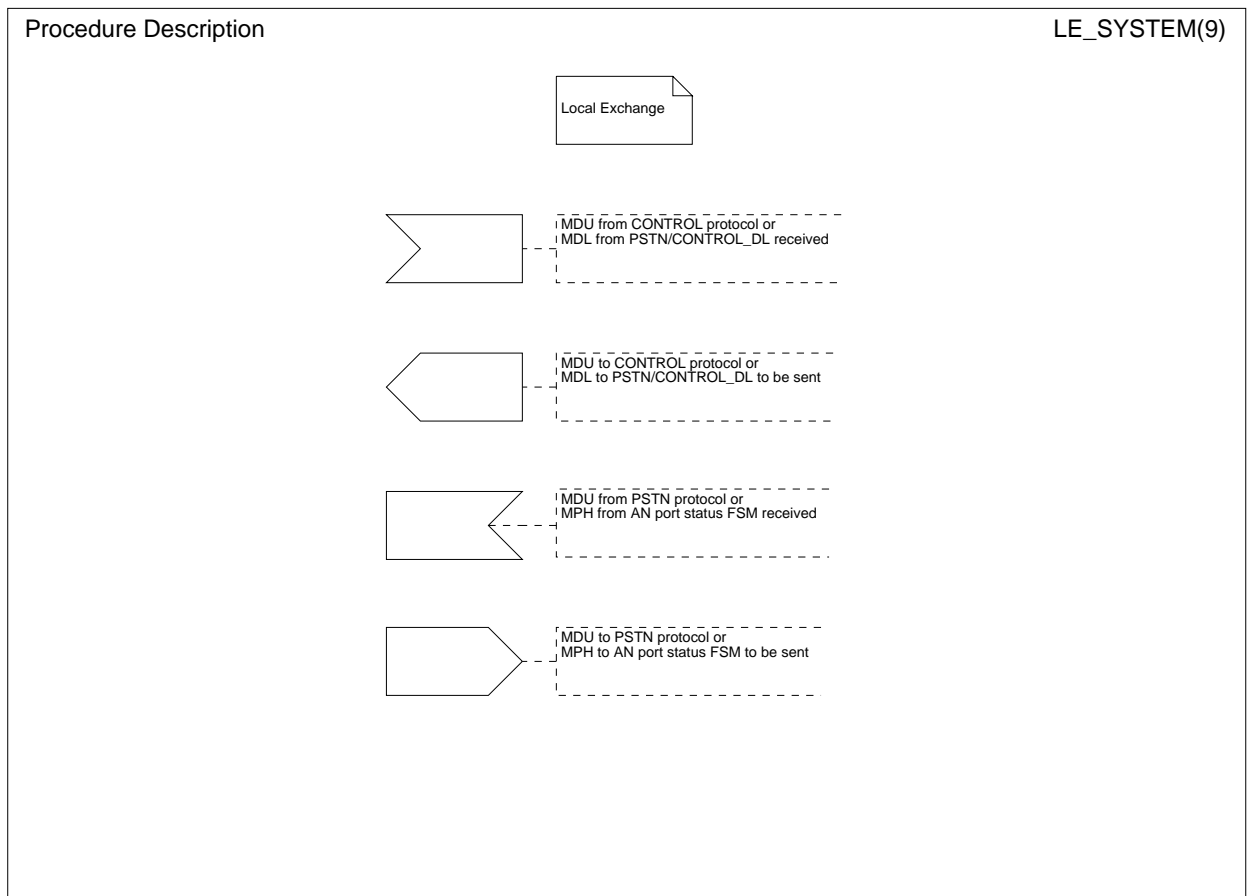

Figure L.32: Input and output symbols application - system management (LE-side)

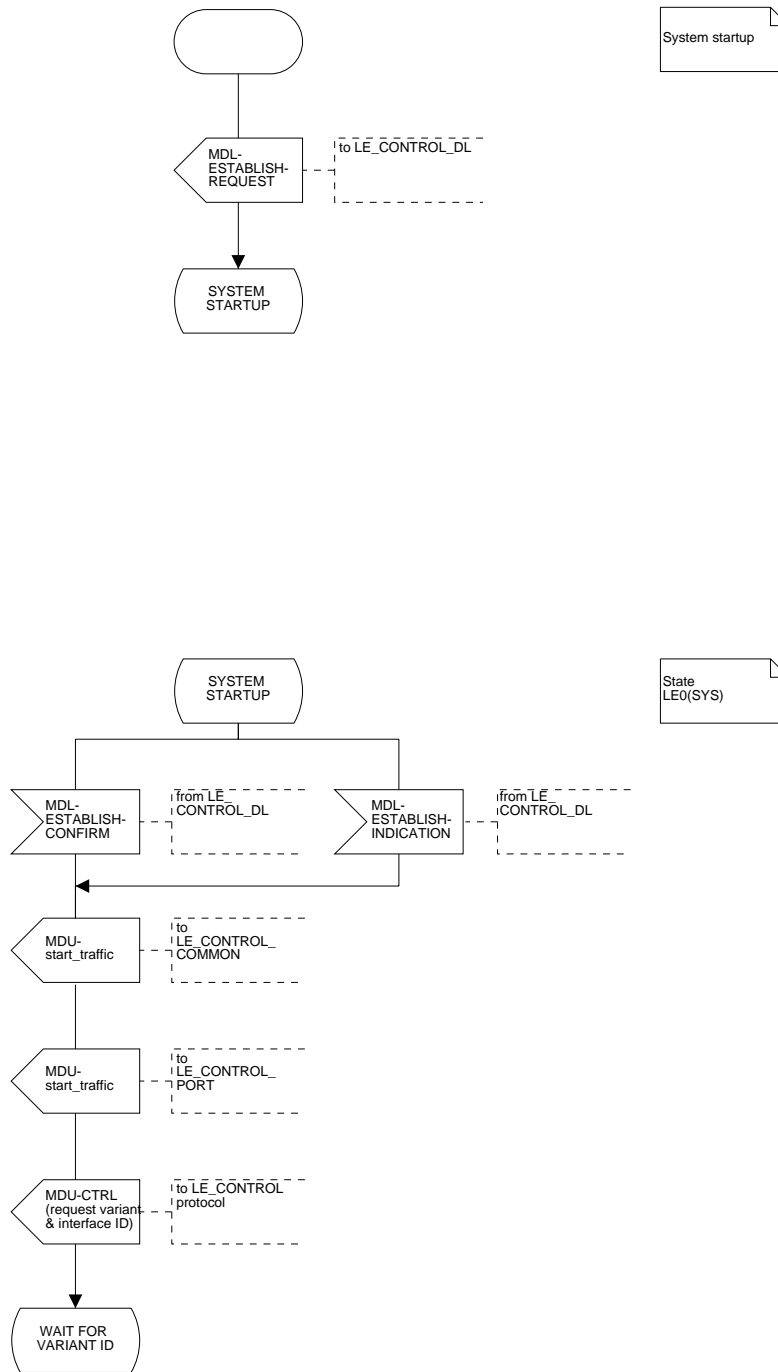

Figure L.33.1: System management LE-side; system startup and state OUT OF SERVICE (LE0(SYS))

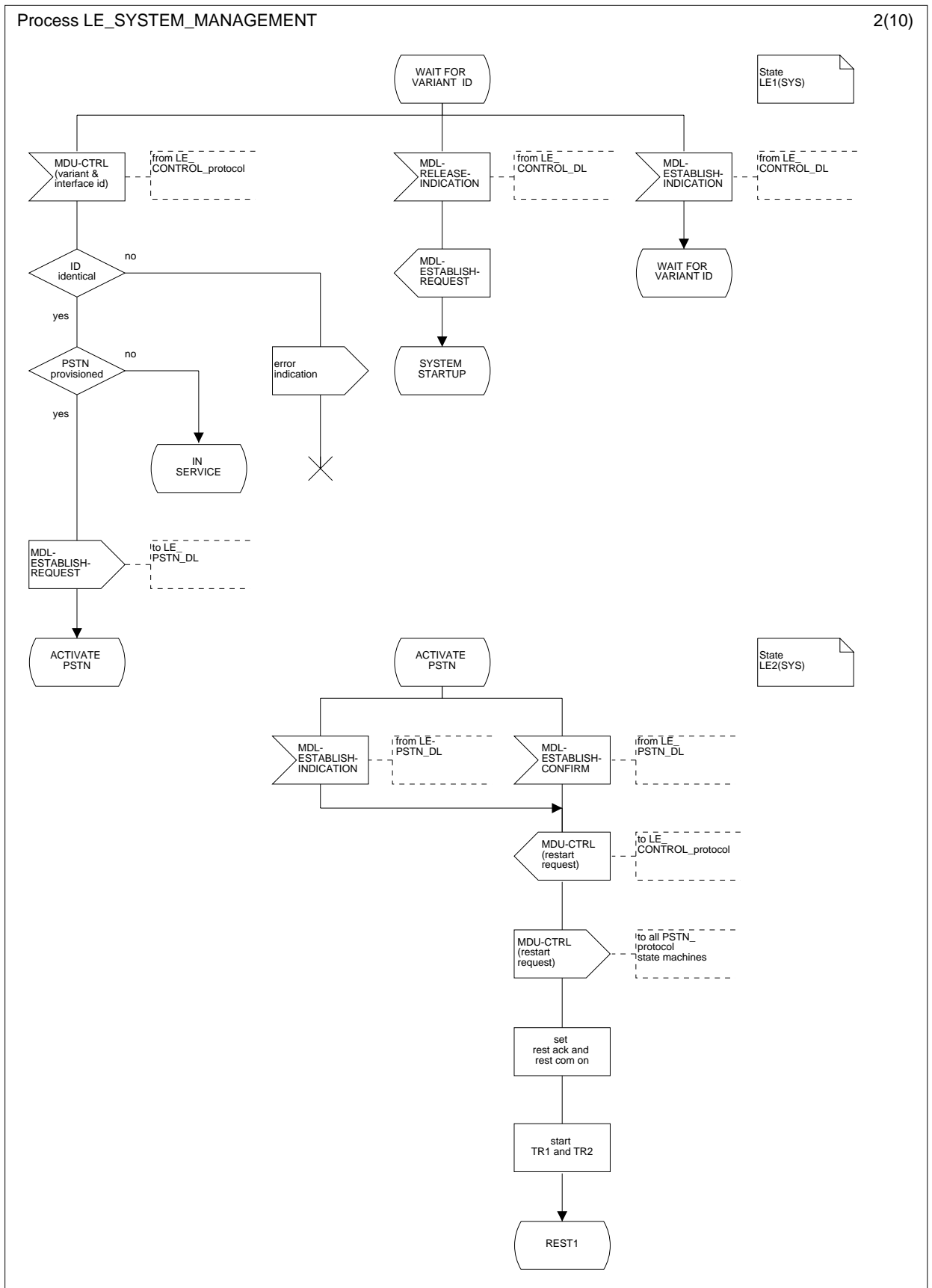

Figure L.33.2: System management LE-side; states WAIT FOR VARIANT ID (LE1(SYS)) and ACTIVATE PSTN (LE2(SYS))

Process LE_SYSTEM_MANAGEMENT

3(10)

State
 LE3(SYS)

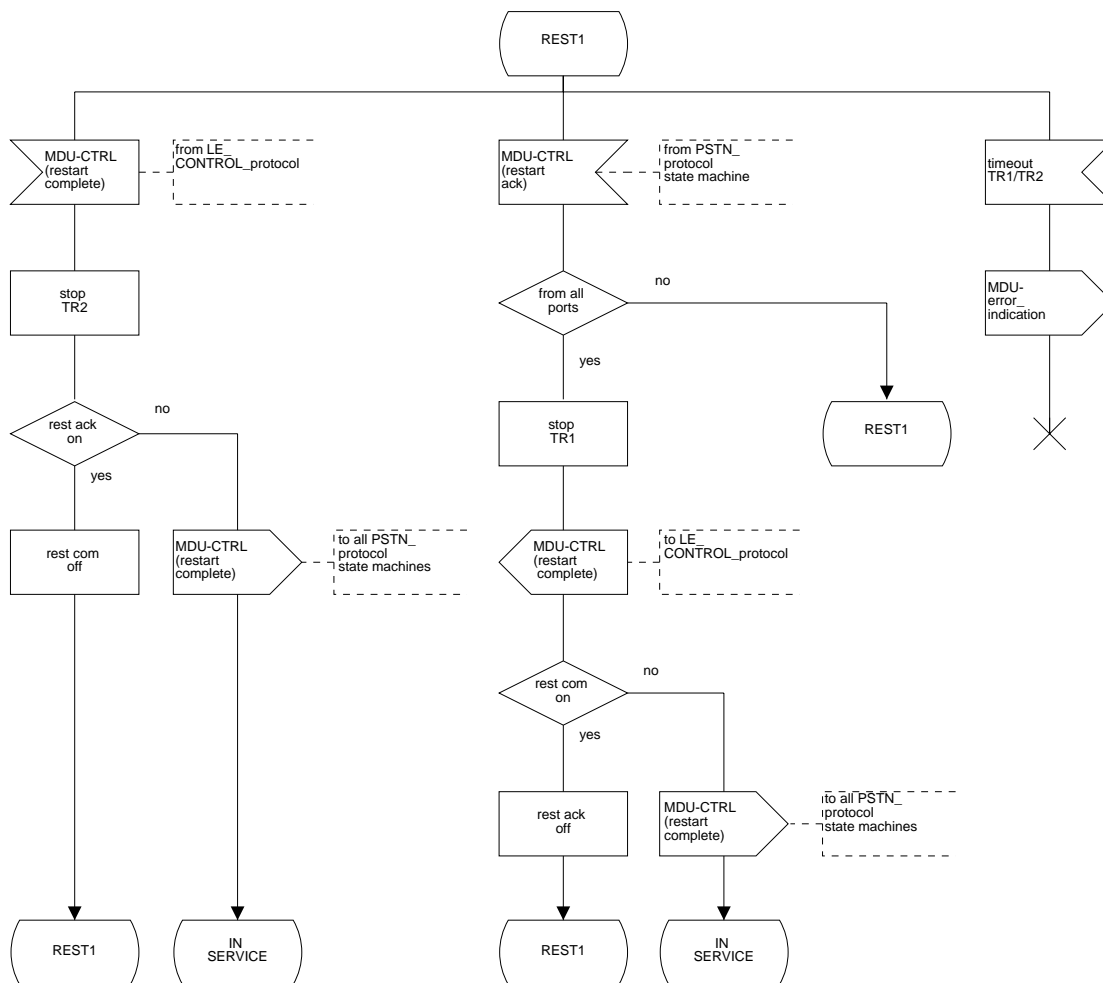

Figure L.33.3: System management LE-side; state REST1 (LE3(SYS))

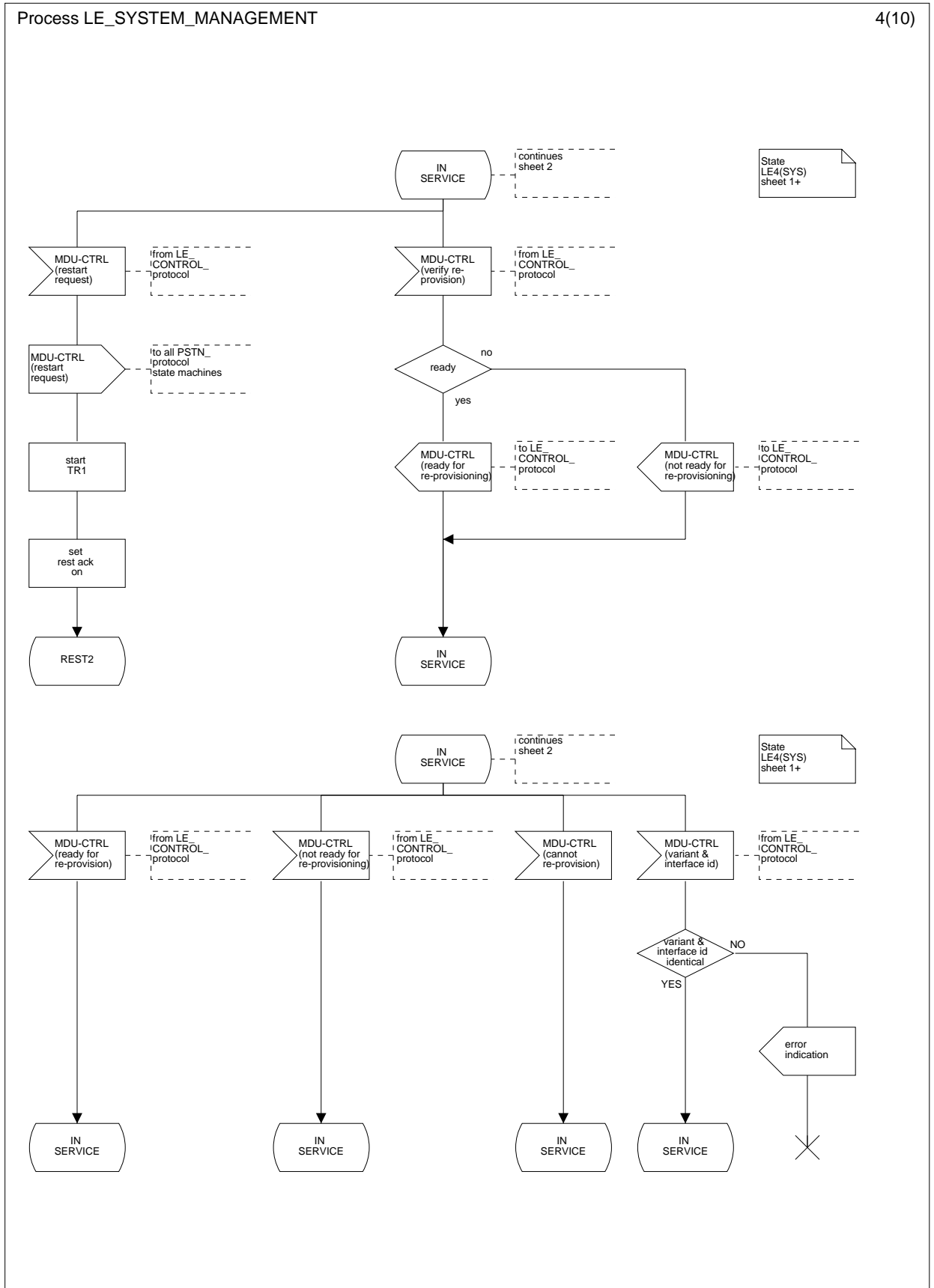

Figure L.33.4: System management LE-side; state IN SERVICE (LE4(SYS)) (sheet 1)

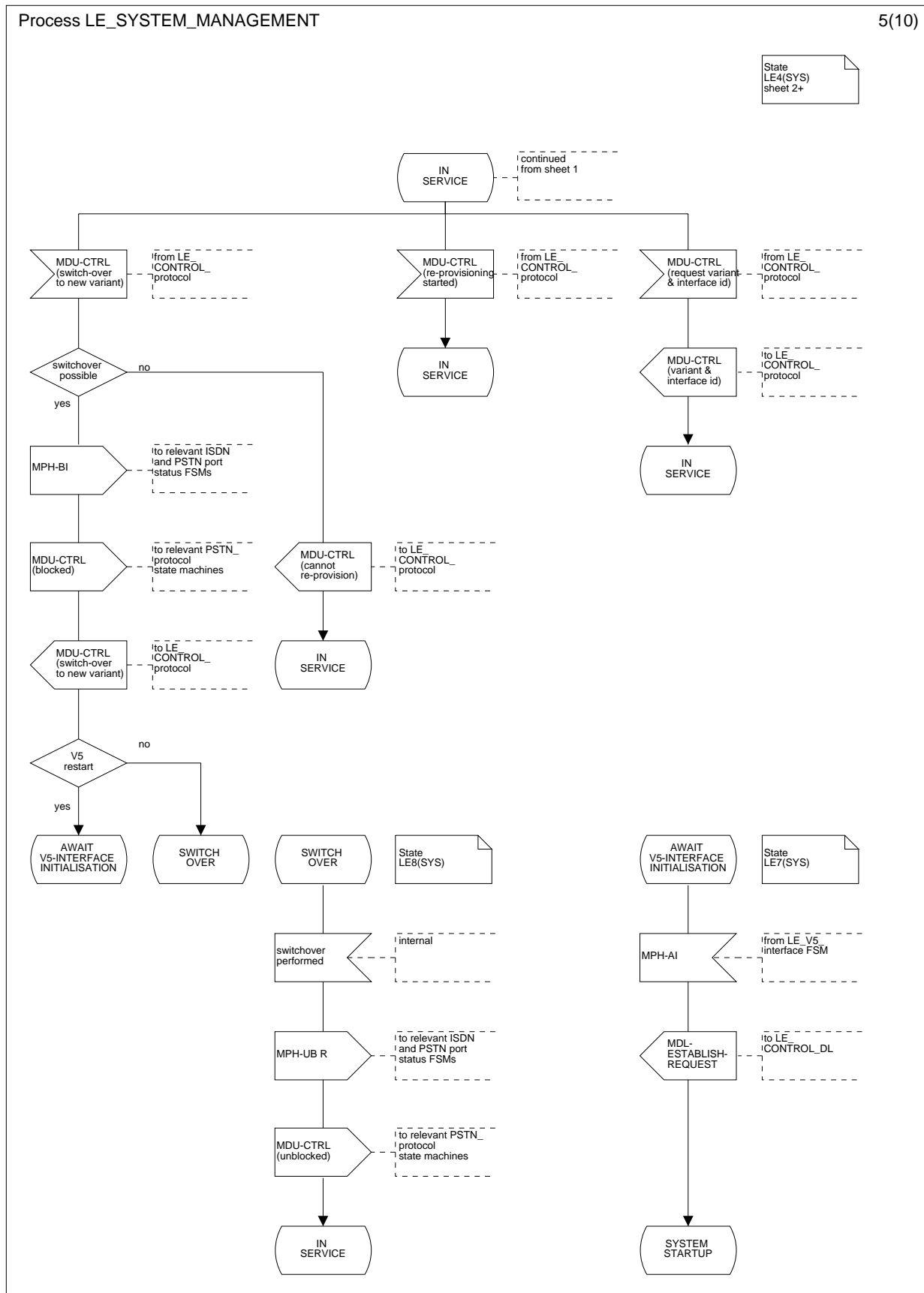

Figure L.33.5: System management LE-side; states IN SERVICE (LE4(SYS)) (sheet 2), AWAIT V5-INTERFACE INITIALISATION (LE7(SYS)) and SWITCH OVER (LE8(SYS))

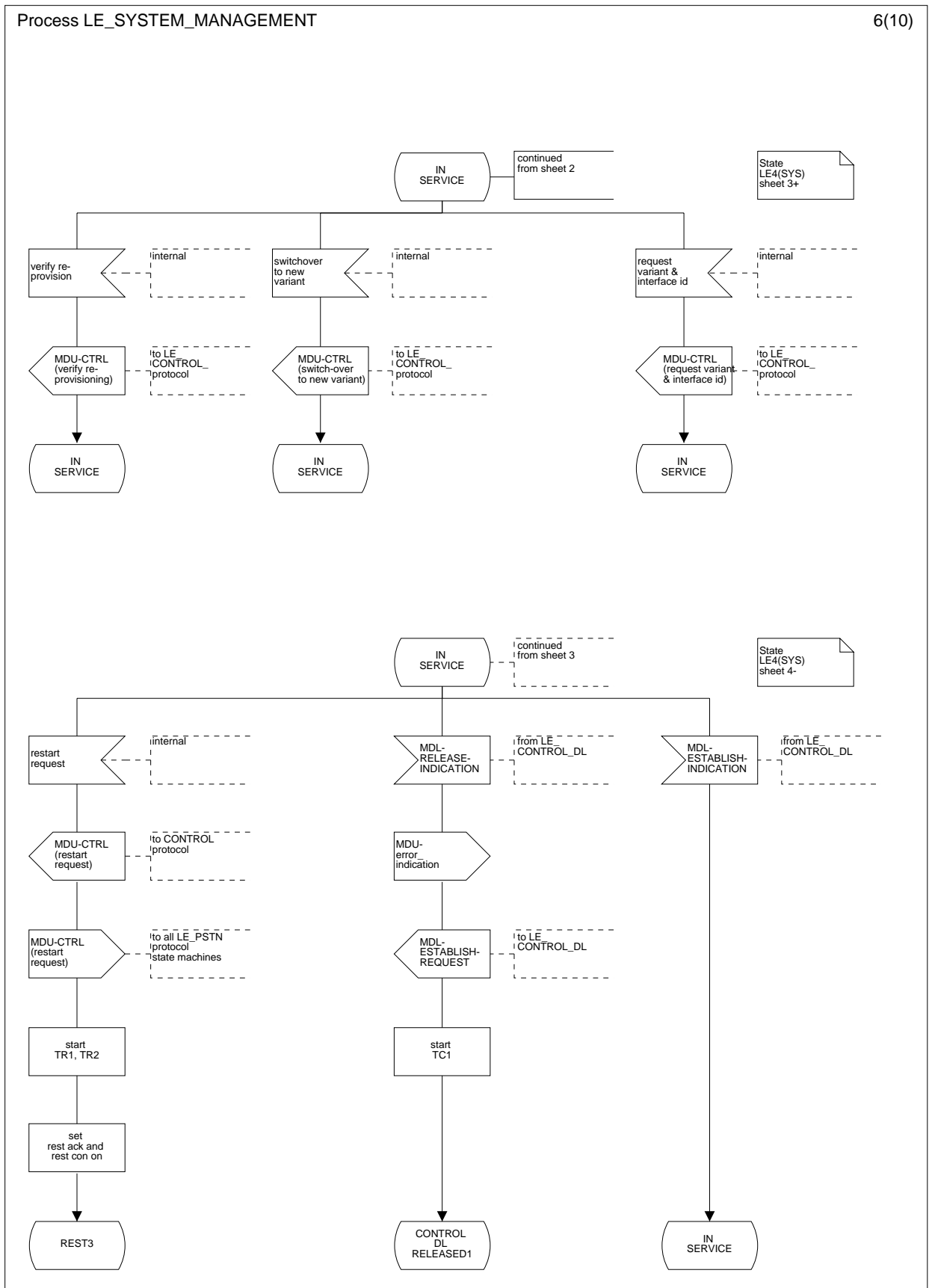

Figure L.33.6: System management LE-side; states IN SERVICE (LE4(SYS)) (sheet 3)

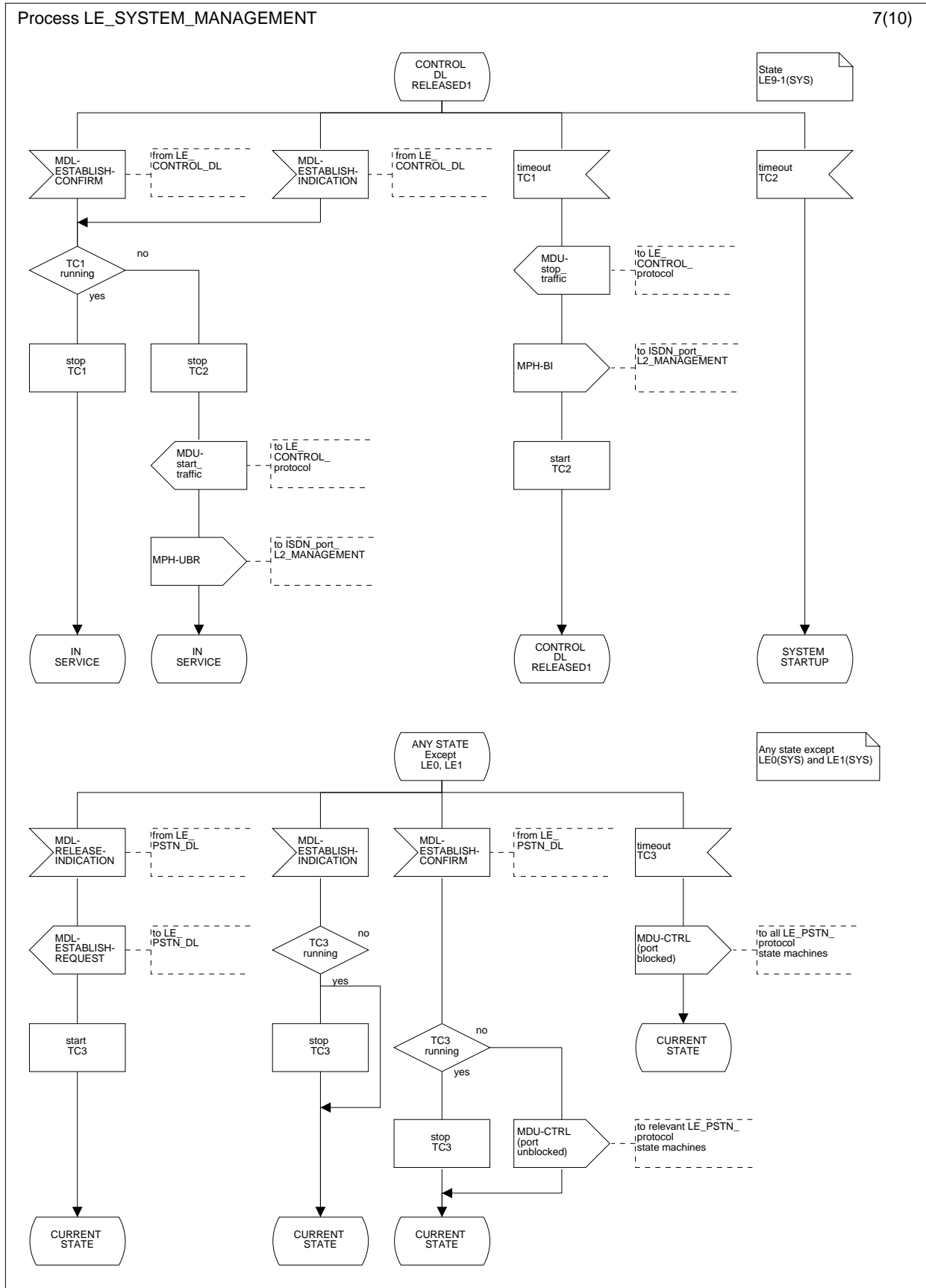

Figure L.33.7: System management LE-side; state CONTROL DL RELEASED1 (LE9-1(SYS)) and any state except LE0(SYS) and LE1(SYS)

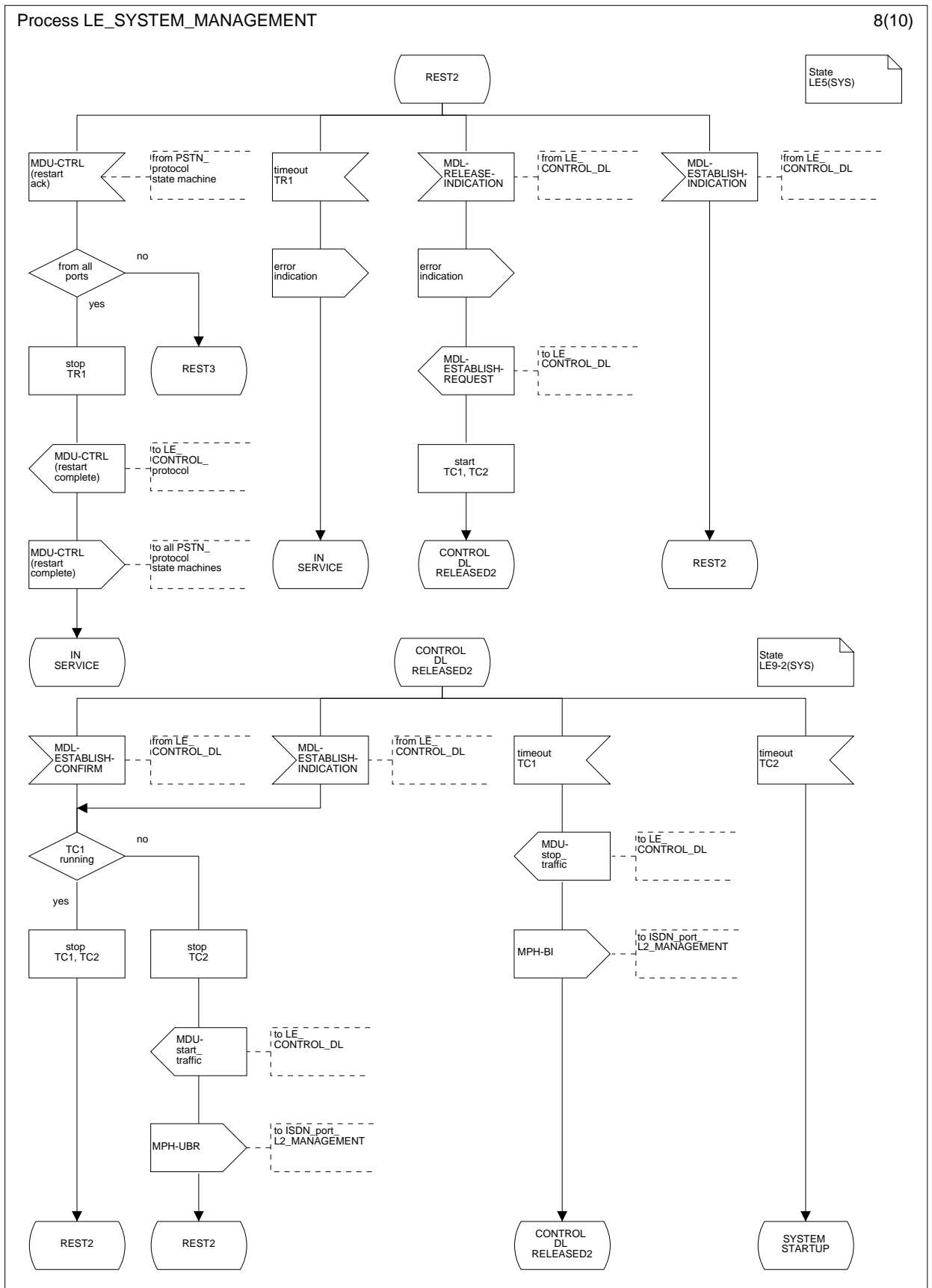

Figure L.33.8: System management LE-side; states REST2 (LE5(SYS)) and CONTROL DL RELEASED2 (LE9-2(SYS))

State
 LE6(SYS)
 sheet 1+

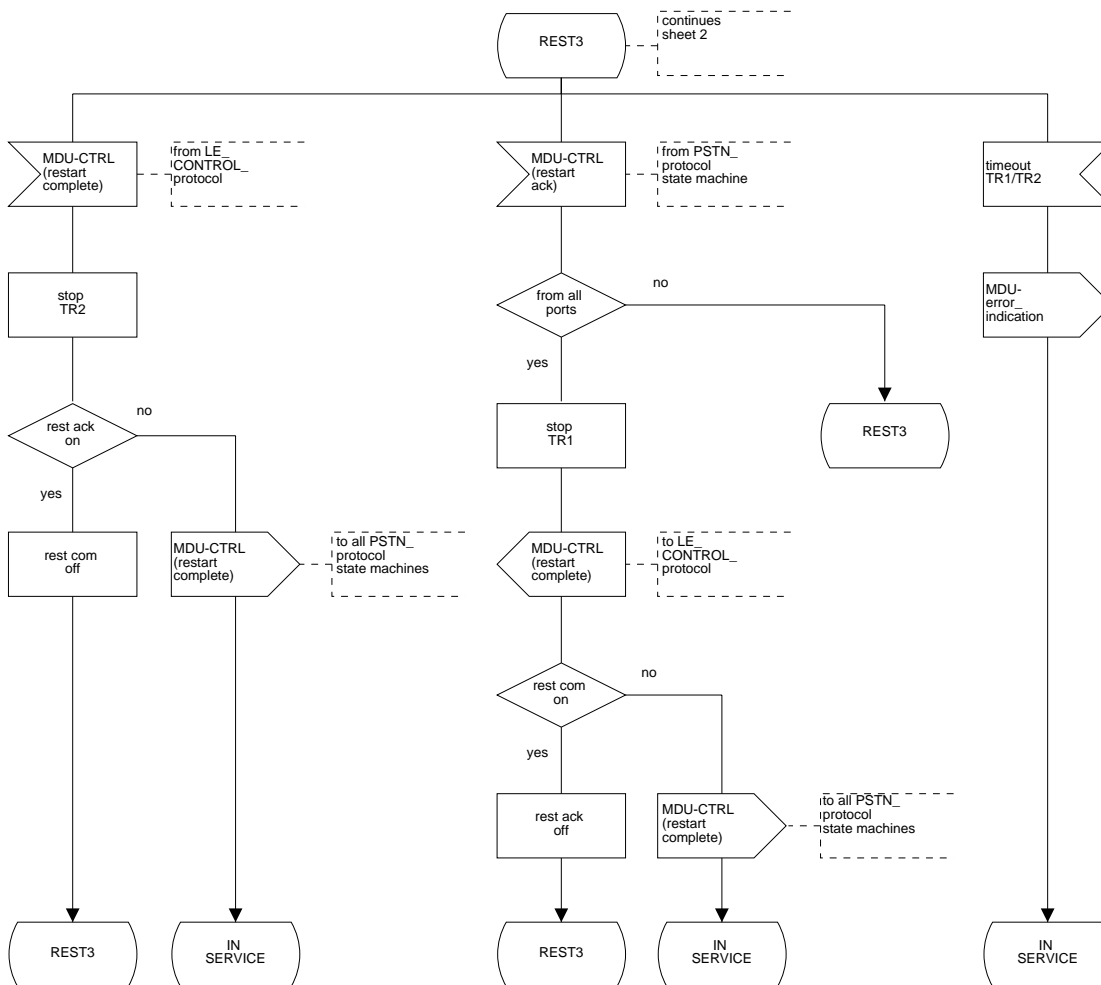

Figure L.33.9: System management LE-side; state REST3 (LE6(SYS)) (sheet 1)

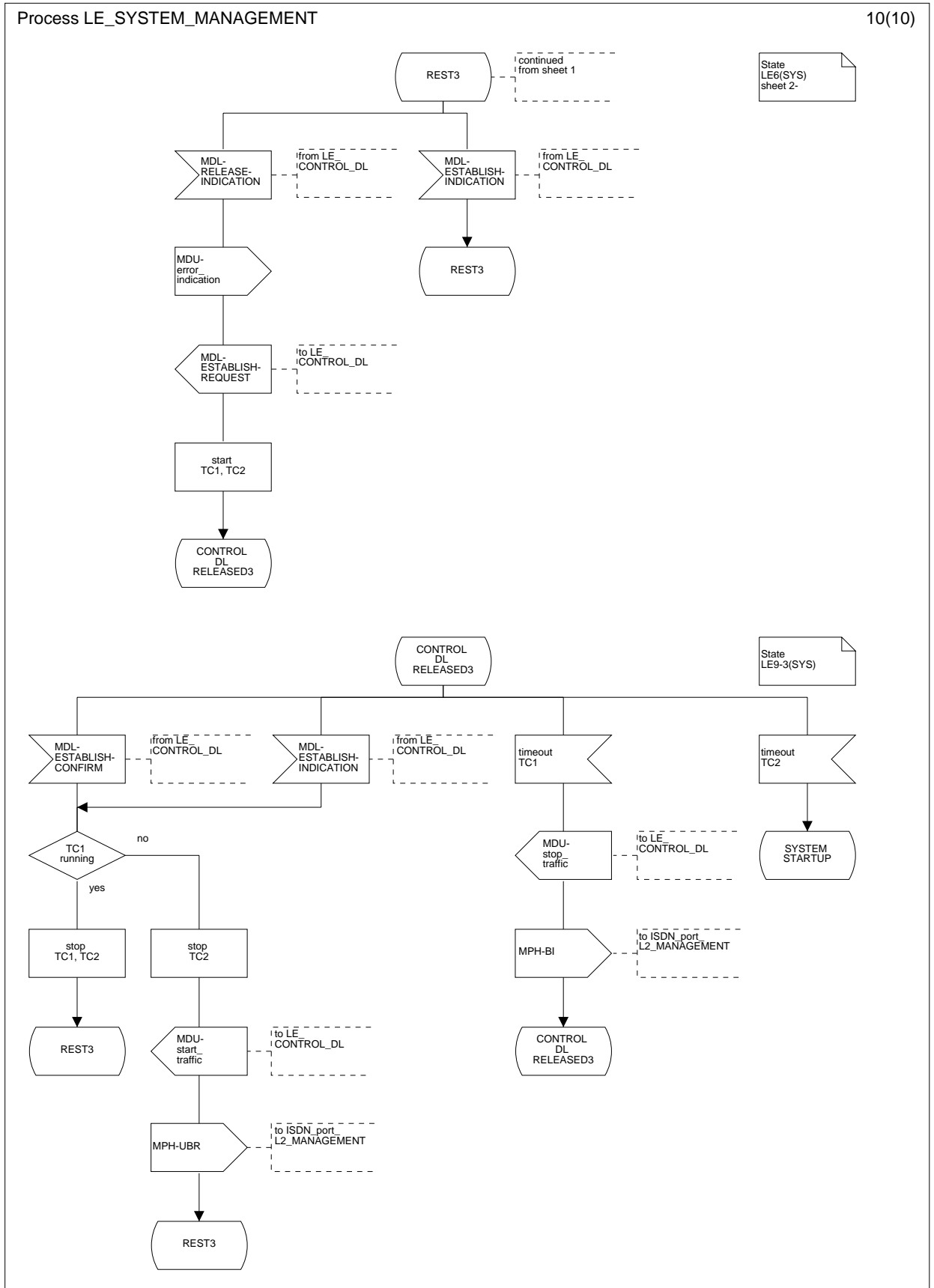
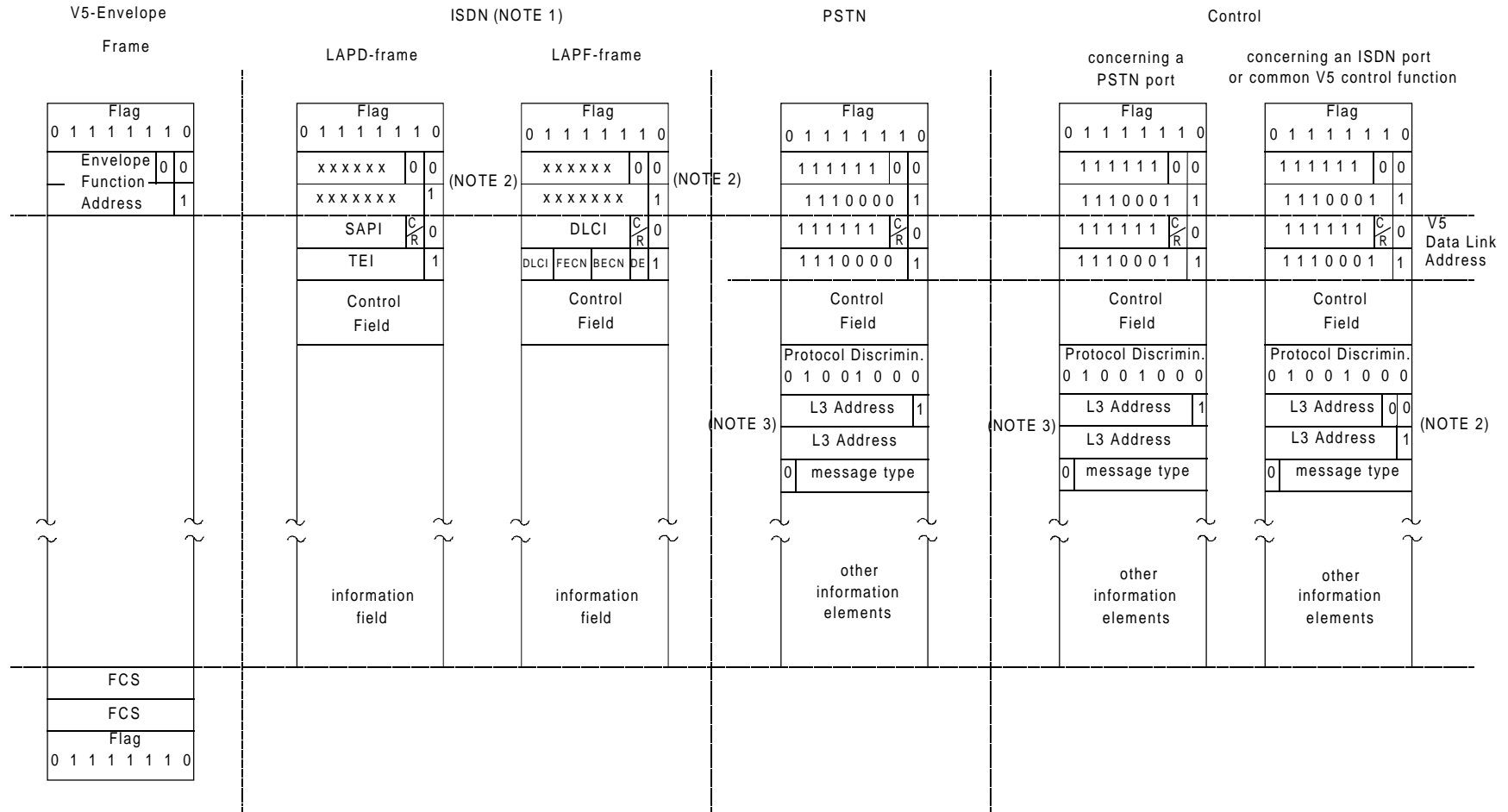

Figure L.33.10: System management LE-side; states CONTROL DL RELEASED3 (LE9-3(SYS)) and REST3 (LE6(SYS)) (sheet 2)

Annex M (informative): Structures used in the V5.1 interface

Figure M.1 shows the possible structures of frames carried in the various communication channels and protocols.



NOTE 1: For the ISDN case, the address, control and information fields of the ISDN layer 2 frames are not changed at the V5.1 interface.

NOTE 2: For a given ISDN port, these address fields have the same values.

NOTE 3: For a given PSTN port, these address fields have the same value.

Figure M.1: Frame formats used in the V5.1 interface

Annex N (informative): Protocol architecture for PSTN and ISDN user port control

N.1 Scope

This annex describes the protocol architecture for the ISDN and PSTN user port status control information transfer.

N.2 ISDN user port status control

N.2.1 Functional split between LE and AN

For those ISDN basic accesses which are not directly connected to the LE but remotely accessed via an AN, the ET layer 1 functionality is split between the LE and the AN.

In principle the LE will only be informed about the layer 1 availability of the user port (operational/non-operational). In addition, for ISDN basic accesses the activation/deactivation procedure has to be supported in the operational state. This procedure shall be controlled by the LE and relevant information has to be passed between the AN and the LE via the V5.1 interface.

Since maintenance of the Access Digital Section and customer lines is the responsibility of the AN the operation of loopbacks or activation/deactivation of the digital section only will be controlled by the AN. Thus no information related to these functions shall be transmitted to the LE (FE8 to FE13).

N.2.2 Information transfer between LE and AN

Figure N.1 shows the protocol architecture model for ISDN basic access port control functions.

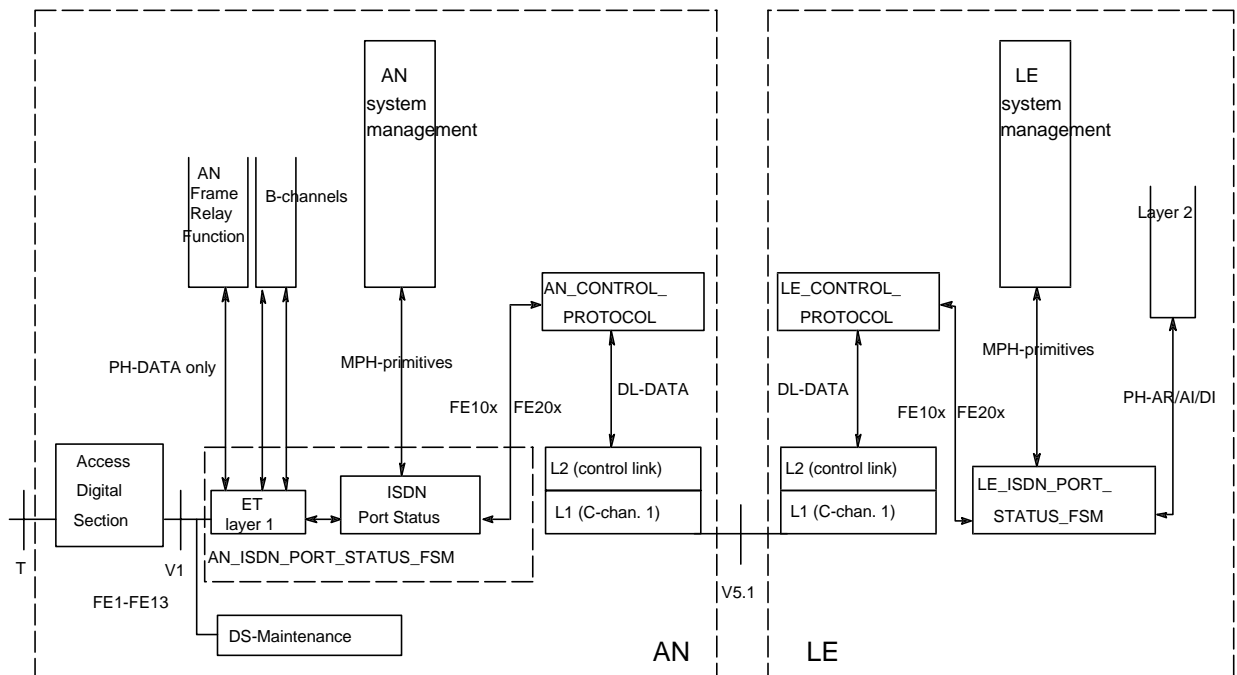

Figure N.1: Protocol architecture for ISDN basic access port control functions

For the bidirectional information transfer between the two user port FSMs, AN(ISDN port) and LE(ISDN port), function elements (FE10x for activation and deactivation procedures, FE20x for blocking and unblocking procedures) are used. They are carried on a layer 3 port control protocol. This protocol includes an acknowledgement procedure to protect against loss of individual frames.

N.2.3 Activation/deactivation procedure

In the LE activation or deactivation of an access may be initiated by the system management or layer 2 using MPH-primitives or PH-primitives, respectively. Only the following primitives are used in the LE:

- MPH-AWI;
- MPH-DSAI;
- MPH-AI;
- MPH-DI;
- MPH-DR;
- PH-AR;
- PH-AI;
- PH-DI.

Since the PH-primitives from layer 2 are handled directly in the LE(ISDN port)-FSM and are transferred via the port control protocol to the ET layer 1 function in the AN, no PH-primitives are used in the AN.

At the V1 reference point in the AN the existing function elements (FE1-FE13) according to ETS 300 297 [4] have to be supported, since no difference shall be made between directly or remotely connected ISDN basic accesses.

The function elements (FE2, FE3, FE4, FE6) received at the ET layer 1 function in the AN are passed to the AN(ISDN port) which then informs the AN system management and transmits the appropriate function elements (FE10x) to the LE. Those function elements on the V1 reference point related to the maintenance of the Access Digital Section only (e.g. loopback activation etc.) are handled in the DS-maintenance entity in the AN.

The LE(ISDN port) can initiate the transmission of function elements (FE1, FE5) by the ET layer 1 in the AN by sending the appropriate function element (FE10x) to the AN. The relevant procedures are defined in Clause 14.

Thus from the LE point of view the MPH- and PH-primitives for the activation and deactivation of an ISDN basic access is transparently handled between the LE system management and LE ET layer 2, and the remote ET layer 1 function in the AN.

N.3 PSTN user port control - information transfer between LE and AN

Figure N.2 shows the protocol architecture model for PSTN user port control functions.

For the bidirectional information transfer between the two user port FSMs AN(PSTN port) and LE(PSTN port) function elements (FE20x) are used. They are carried on a layer 3 port control protocol. This protocol includes an acknowledgement procedure to protect against loss of individual frames.

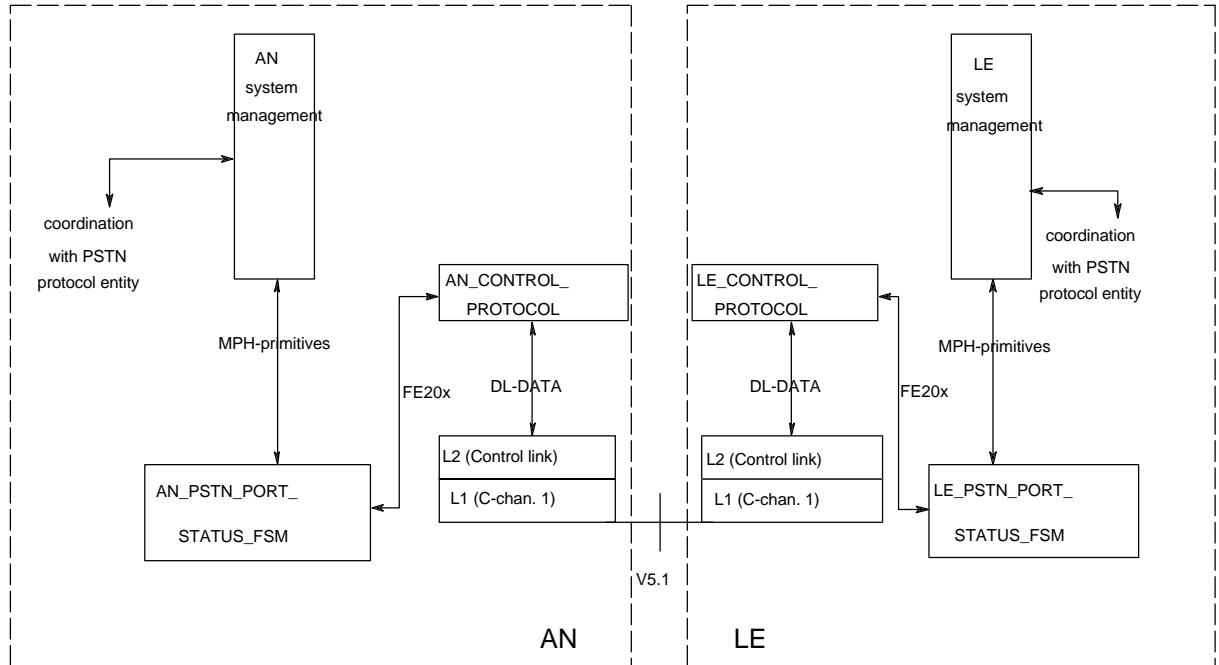

Figure N.2: Protocol architecture for PSTN port control functions

Annex P (informative): Items identified to be pre-defined or provisioned

This annex lists references to subclauses defining that functions, parameters or capabilities in the AN or LE shall either be pre-defined or provisioned as defined in Clause 2. There may be more than one occurrence of either term in a subclause referred to.

Reference is made to subclause 7.2 which explains the provisioning strategy and general requirements.

Table P.1 gives the references to items which shall be pre-defined.

Table P.1: References to pre-defined items

clause 1	13.5.2.7	14.3.3	D.3.7.1
7.2.2, item 1)	13.5.2.8	14.3.4	D.3.8.1
13.1.2	13.5.2.9	B.1	D.3.10
13.4.6.4	13.5.3.3	D.3.3	D.3.11
13.4.6.5	13.5.3.5.1.1	D.3.4	D.4.2
13.4.7.2	13.5.4.1.1	D.3.5	D.6
13.4.7.3	13.5.4.2	D.3.6.1	D.9
13.4.7.6	13.7	D.3.6.2	
13.4.7.7	14.1.4	D.3.6.3	

References to items requiring provisioning are listed in table P.2.

Table P.2: References to items to be provisioned

clause 1	7.2.2, item 7)	14.1.3.1	B.1
7.1.1, item 10)	7.2.2, item 8)	14.1.3.2.1	D.1
7.1.2.1, item 2)	7.2.2, item 9)	14.1.4	D.6
7.2.1	8.3	14.4.2.5.6	E.1
7.2.2	8.4	14.5.4	E.3
7.2.2, item 1)	11.3.1	14.5.4.1	Annex F
7.2.2, item 2)	11.3.2	14.5.4.2	Annex J
7.2.2, item 5)	13.7	Annex A	

Annex Q (informative): Bibliography

- 1) CCITT Recommendation G.703 (1991): "Physical/electrical characteristics of hierarchical digital interfaces".
- 2) CCITT Recommendation G.704 (1991): "Synchronous frame structures used at primary and secondary hierarchical levels".
- 3) CCITT Recommendation G.706 (1991): "Frame alignment and cyclic redundancy check (CRC) procedures relating to basic frame structure defined in Recommendation G.704".
- 4) CCITT Recommendation G.921 (1988): "Digital sections based on the 2 048 kbit/s hierarchy".
- 5) CCITT Recommendation O.162 (1992): "Equipment to perform in-service monitoring on 2 048, 8 448, 34 368 and 139 264 kbit/s signals".
- 6) CCITT Recommendation Q.922 (1992): "ISDN data link layer specification for frame mode bearer services".
- 7) ITU-T Recommendation Q.933 (1993): "Layer 3 signalling specification for frame mode bearer service".
- 8) CCITT Recommendation Z.100 (1988): "Specification and description language (SDL)".
- 9) ETS 300 376-1: "Signalling Protocols and Switching (SPS); Q3 interface at the Access Network (AN) for configuration management of V5 interfaces and associated user ports; Part 1: Q3 interface specification".
- 10) ETS 300 377-1: "Signalling Protocols and Switching (SPS); Q3 interface at the Local Exchange (LE) for configuration management of V5 interfaces and associated customer profiles; Part 1: Q3 interface specification".
- 11) ETR 001 (1990): "ISDN subscriber access and installation maintenance".
- 12) ETR 080 (1993): "Transmission and Multiplexing (TM); ISDN basic rate access, Digital transmission system on metallic local lines".
- 13) ETR 150 (1994): "Signalling Protocols and Switching (SPS); V5 PSTN protocol; Sample mappings of national PSTN protocols".

Index

A

Access digital section 16, 104, 107, 108, 139
Activation 25, 26, 37, 97-106, 120, 137-139, 142, 143, 267, 268
Analogue leased line 22
Anomalies 25
Auditing 27

B

Bearer channel 15, 17, 26, 27, 29, 136, 137
Bearer service 17, 22, 162, 271
Block 50, 51, 70, 98-100, 102, 108, 110, 112, 139, 143, 169, 180-183, 227-230
Blocking 24, 25, 31, 85, 86, 100, 102, 104-107, 109-111, 121, 130, 133, 134, 137, 138, 140-142, 151, 157, 158, 168, 169, 268

C

Call collision 47-49, 77, 171, 172
Communication channel 17, 19, 29, 30, 44, 266
Communication path 17, 19, 30
Continuity test 104, 138
Control 15-19, 22-31, 34-37, 42, 46, 47, 52, 57, 69, 81, 91, 97-100, 103, 107-109, 115-130, 133-143, 145, 148, 149, 154-156, 161, 163, 164, 168, 181, 185, 197-213, 228, 231, 241-254, 266-269
Control protocol 17-19, 27, 29, 35, 57, 97, 107, 115, 117, 118, 122-124, 126-130, 133, 134, 137, 141-143, 163, 181, 197-201, 228, 241-245, 268, 269
CRC 19, 21, 28, 112, 113, 114, 271

D

Data link 16, 17, 18, 27, 29, 30, 32-44, 46, 56, 70, 141, 142, 271
DDI 19, 22, 156
Deferrable blocking 109
Digital leased line 22
DS 19, 97-104, 107, 120, 268
DTMF 19, 21, 22, 29, 47
Dual homing 161

E

EFaddr 17-19, 26, 30, 33, 34, 44-46, 118, 137
Envelope function 29, 31-33, 46

F

Failure localization 25, 138
Fallback procedure 141
FCS 19, 31, 32, 46
Finite State Machine (FSM) 19, 23, 24, 25, 26, 37, 42, 43, 50, 51, 59, 60, 69, 91, 97, 99-114, 123, 126, 127, 137-139, 144, 168, 169, 182, 202-213, 229, 246-254, 268
Frame relay 17, 29, 30, 44-46
Function Element (FE) 19, 49, 69, 91, 97-99, 108, 119, 120, 126, 127, 164, 268, 269

G

Grading 25, 98, 99, 107, 119

I

Inband signalling 136
Interface ID 17, 27, 116, 119, 121, 122, 127, 133, 140-143
Invalid frames 32-35, 44

L

L3addr 19, 26, 80, 137
LAPV5 frame 17, 18
Leased line network 161
Line circuit 26, 145, 148, 149-151, 157
Line tests 107

M

Management 14-16, 18, 20, 23-26, 31, 36-41, 43, 48-51, 70, 75, 85-90, 98-100, 102-104, 106, 108, 110-115, 122-124, 126-128, 130-134, 137-144, 183, 214-224, 230, 255-265, 268, 271
Manager 104, 106, 111
Mapping function 29, 30, 45, 46
Message type 52-57, 67, 68, 70, 71, 115-118, 146
Monitoring 25, 32, 107, 271

N

National PSTN protocol 170
Network provider 47, 48, 130
Non-operational 100, 101, 109
NT1 15, 20, 22, 25, 107

O

Operational 25, 26, 29, 31, 97, 100-107, 109-114, 131, 134, 137, 138, 143, 146, 267
Outband signalling 15, 22, 136
Overload condition 47, 69, 160, 168

P

Partial activation 97, 100, 104
Permanent line 15, 102, 103, 106, 135
Persistency check 113
Physical layer 20, 37
Port maintenance 24, 100, 103
Port test 27, 97, 107
Primitive 19, 20, 38-41, 43, 70, 99, 106, 108, 109, 112, 114, 164, 165-167
Protocol discriminator 52-57, 68, 70, 71, 115-117, 124, 145
Provisioned 15, 18, 25, 26, 27, 101, 107, 136, 137, 141, 142, 161, 173, 270
Provisioning 15, 18, 23, 25-30, 45, 46, 96, 100, 116, 120, 121, 130-137, 139-141, 159, 161-163, 270

R

Restart 28, 39, 48-51, 70, 76, 78, 85-87, 90, 93-95,
121, 134, 141-144

S

Signal information element 47, 48, 53, 58, 62-65,
66, 81, 83, 96, 146, 147, 150, 151, 156, 158
Startup 141-143, 215, 256
State transition table 37, 42, 43, 91, 96, 128, 129
Stimulus protocol 46
Supplementary service 21, 22, 47, 99, 136, 169
System management 26, 36-41, 48-51, 70, 75, 86,
104, 106, 122-124, 126, 127, 130, 131, 133, 134,
137-139, 141-144, 183, 214-224, 230, 255-265,
268

T

Time slot 17, 18, 29, 137
Timer 38-43, 48, 50, 51, 75, 77-81, 83-85, 88-90,
96, 103-105, 113, 114, 127, 128, 138, 141, 142,
144, 168, 173-175
TMN 20, 26, 27, 133, 134
Tone generator 29, 47
Transmission error 42, 44
Transmission quality 25

U

Unacknowledged information 37
Unblock 50, 51, 70, 98-106, 108-111, 134, 138,
140, 143
Upgrade 15, 112, 163

V

V3 162
V5 data link 18
V5.2 13, 15, 32, 112, 137, 161-163
V5DLaddr 18, 34, 35, 46, 118
Variant 18, 25, 27, 116, 119-121, 127, 130-134,
139-143, 163

W

Window size 174, 175

History

Document history	
February 1994	First Edition
February 1996	Converted into Adobe Acrobat Portable Document Format (PDF)