

SSV SL-IZ

Safety Shut-off Valve

Features

- High accuracy shut-off
- Low pressure loss
- Operating temperature up to -20°C
- Easy maintenance
- DVGW approval



These shut-off valves are designed for transmission and distribution networks, as well as commercial and industrial use.

Description

These models, designed for high shut-off pressures, automatically interrupt the gas flow when the outlet pressure of the regulator is outside the range of acceptable values.

Operating Principle (see picture on page 2)

The SL-IZ type of safety shut-off valves are designed to automatically interrupt the gas flow in the gas pressure regulating systems as soon as the pressure in the system to be protected reaches an upper response pressure (over-pressure).

The devices consist of a control unit (1), which pneumatically controls a switching unit (2), and releases a flap valve (3). The switching unit and the control unit are mounted on the actuator body (4).

The pressure to be monitored is transmitted to a diaphragm measuring unit (5); connection "A" measures the connection.

The response pressure is controlled by the force of the setting spring (6) at the top of the measuring unit. Use the setting screw (7)

to adjust the response pressure.

Turn the setting screw (7) clockwise to increase the response pressure, or counter-clockwise to reduce it.

When the set response pressure is exceeded, the diaphragm unit (5) is raised and an overflow volume is released through the nozzle (8).

The resulting increase in pressure acts on the switching diaphragm (9).

The switching diaphragm acts against the force of a weak cylindrical coil spring (10), or against the friction force of a locking unit.

When pressure acts on the switching unit, the detent (11) is released and the flap valve (3) is closed by the force of one or more (ANSI 300 and higher) torsion springs (12)*

Tightness is guaranteed even at a very low operating pressure due to the dimensions of the closing springs. Use the manipulation valve (18) to compensate for the pressure at the valve flap.

* A special tool (spring tension spanner) is required to assemble the torsion spring (12)

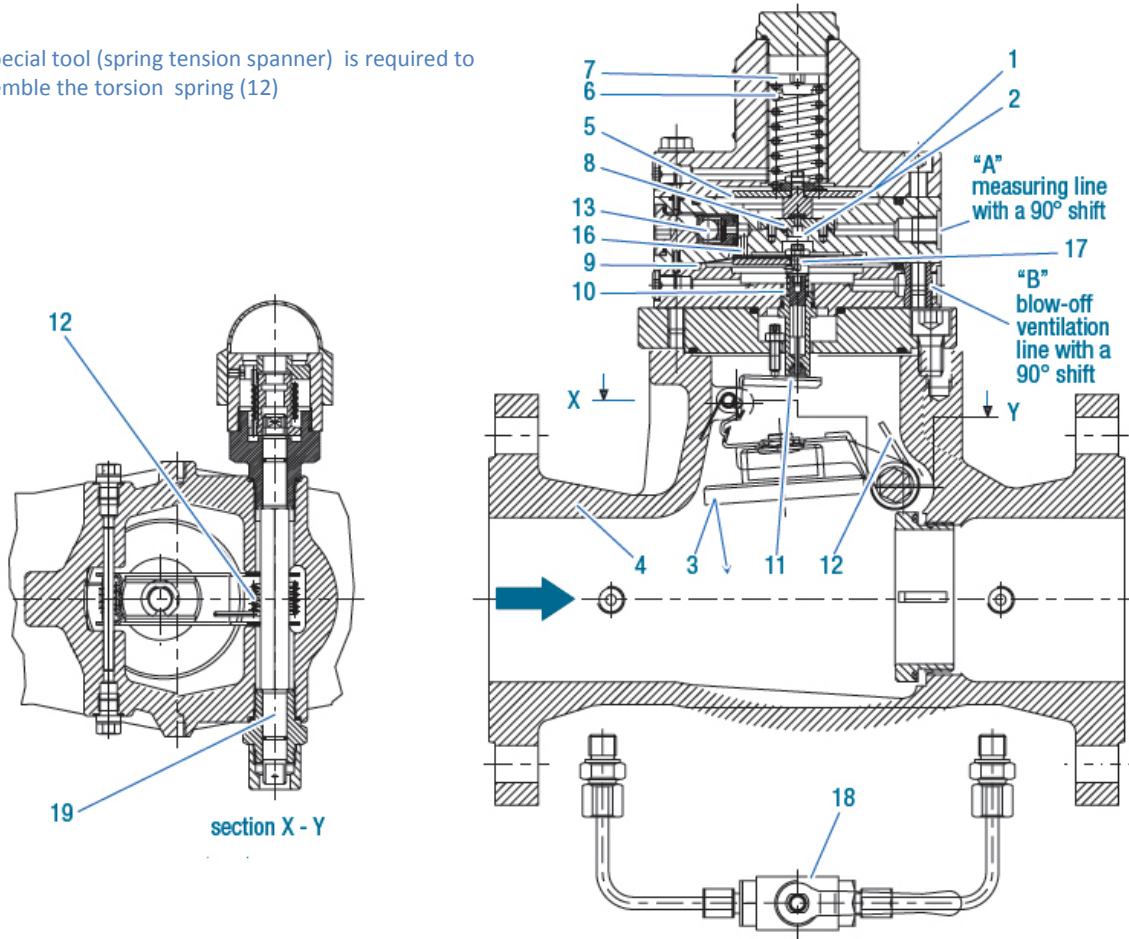

DIAPHRAGM BREAK PROTECTION

The safety shut-off valves meet all requirements of the EN14382 standard, April 2009 Edition. According to this standard, devices must have a unit that closes the SSV control unit (1) in case the diaphragm is damaged (5).

For this reason, these types of safety shut-off valves are equipped with an over-pressure valve (13) in the control unit (1). If the comparator diaphragm (5) is damaged, gas flows to the top of the diaphragm.

Pressure builds up, thereby opening the over- pressure valve (13). In addition, the switching process is triggered by the overflowing volume, which flows through the bore (16).

The pressure in the switching unit (2) is further decreased by means of a small bore (17), which is located in the switching unit. The gas is discharged through the blow-off/ ventilation connection "B".

This connection also carries gas if the existing control pressure (e.g., pressure test) is above the set response pressure.

Technical Features

Inlet pressure	Pu: up to 101,2 bar
OPSO* range	Pdso: 35,0 mbar – 60,0 bar
Accuracy class	AG 2,5 to AG 10
Operating temperature	-20 °C to +60 °C
Ambient temperature	-30 °C to +60 °C (body material)
Acceptabel gases	Natural gas, propane, butane, air, nitrogen and all non-corrosive gases

* OPSO: over-pressure shut off

Sizes & Connections

Sizes	DN25, DN50 and DN80
Orifice diameter (mm)	Ø 28, 40 and 65
Body lengths	See table
Flanges	PN16, 25 and 40 / ANSI 150, 300 and 600

Materials

Body	GGG40 / GS-C25N / GS-C45
Actuator SSV	Steel, zinc coated / Al Mg Si F 28
Internal parts	Brass, Steel zinc coated/Stainless steel
Seals / "O"-rings	NBR rubber/Viton
Diaphragm	NBR rubber, reinforced fabric
Orifice	Brass, Steel zinc coated/Stainless steel

Safety Shut-off valve type SL-IZ

SSV	Pu max / Orifice	Design
SL-IZN.1 SL-IZM.1 SL-IZH.1	101,2 bar	SSV for over-pressure shut off (command range Wdo 35 mbar – 60 bar)
DN25 DN50 DN80	Orifice ø 28 mm Orifice ø 40 mm Orifice ø 65 mm	Flange
PN16 PN25 PN40 ANSI 150 ANSI 300 ANSI 600		Flanges according to DIN, PN16, PN25 and PN40 with Form C seal Flanges according to ANSI 150, 300 and 600 RF

Device designation example: Safety shut-off valve
type SL-IZM.1, DN50, ANSI 300

Spring Range and Accuracy Class

Type	Spring Range Wdso (bar)	Spring Code	Colour	Wire ø (mm)	Accuracy Class	Range Wdso (bar)
SL-IZN.1	0.035 – 0.25	64146 (955-202-36)	red	1,8	AG10	0.035 – 0.1
	0.2 – 0.8	64147 (955-202-37)	green	2,5	AG5	>0.1 – 0.8
SL-IZM.1	0.6 – 6.6	64148 (955-202-38)	yellow	3,6	AG5	0.6 – 6.6
SL-IZH.1	3.5 – 10.5	64149 (955-201-68)	black	6,0	AG2.5	3.5 – 10.5
	10.5 – 21.0	64150 (955-201-69)	grey	7,0	AG1	>10.5 – 60.0
	18.0 – 60.0	64151 (955-202-84)	yellow	10,0		

Dimensions (mm)

DN	A		B		C	D		E		F		G	H	
Orifice	PN16, 25, 40 ANSI 150	ANSI 300, 600	SL-IZ N.1 M.1	SL-IZ H.1	> PN 40	PN16, 25, 40	ANSI 150	ANSI 300, 600	SL-IZ N.1 M.1 H.1	≤ PN 40	> PN 40			
25	28	160	230	240	280	105	57.5	54	62	140	170	150	105	135
50	40	230	300	245	285	110	82.5	76	82.5	140	110	110	108	135
80	65	310	380	285	330	145	100	95.5	105	155	145	145	154	181

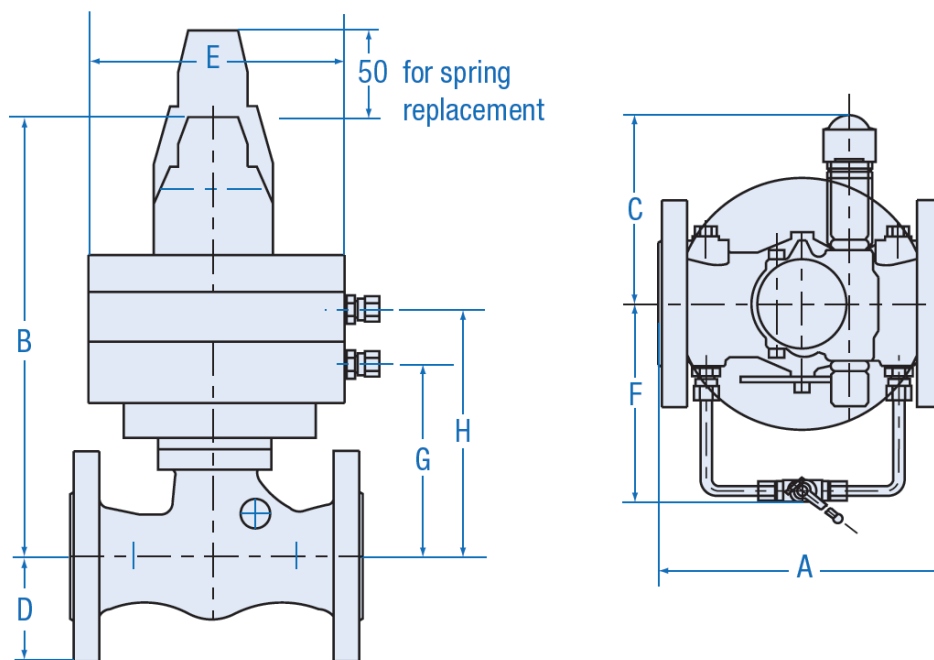

Installation Position

- DN 25 and DN 50 = no restriction.
- DN 80 ≤ PN 40 = for a vertical installation, the flow direction must be upwards (weight of the SSV flap has an opening effect), and an additional spring is required. DN 80 > PN 40 = no restriction

Pressure loss of the safety shut-off valve type SL-IZ

These types of safety shut-off valves have very low pressure loss. Use the following formula to calculate the pressure loss:

$$\Delta p (P \text{ inlet} - P \text{ outlet}) = \left(\frac{Q}{C_g}\right)^2 \times \frac{1}{P_i \text{ abs}} = [\text{bar}]$$

Q = Flow rate (m³/h Natural gas)

C_g = Flow constant (see table)

Note:

The max. velocity of SL-IZ is 70 m/s

Example

Type DN50

Inlet pressure P_u = 3,0 bar

Flow rate Q = 500 m³/h Natural gas

$$\Delta p = \left(\frac{500}{2600}\right)^2 \times \frac{1}{4} = 0.0092 \text{ bar}$$

DN	25	50	80
C _g	600	2600	5100

Information to be specified when ordering:

- ❖ SSV type code (N/M/H, DN, PN/ANSI)
- ❖ Shut-off pressure range
- ❖ Shut-off pressure setting
- ❖ Flow direction
- ❖ Kind of gas
- ❖ Finishing
- ❖ Accessories (i.e. position indicator)
- ❖ Certificates required
- ❖ Quantity required

