

*Parsons Brinckerhoff  
2010 William Barclay Parsons Fellowship  
Monograph 26*

# Pioneering the Application of High Speed Rail Express Trainsets in the United States



*Fellow: **Francis P. Banko**  
Professional Associate  
Principal Project Manager*

*Lead Investigator: **Jackson H. Xue**  
Rail Vehicle Engineer  
December 2012*



*Parsons Brinckerhoff  
2010 William Barclay Parsons Fellowship  
Monograph 26*

# Pioneering the Application of High Speed Rail Express Trainsets in the United States



*Fellow: **Francis P. Banko**  
Professional Associate  
Principal Project Manager*

*Lead Investigator: **Jackson H. Xue**  
Rail Vehicle Engineer  
December 2012*

First Printing 2013  
Copyright © 2013, Parsons Brinckerhoff Group Inc.

All rights reserved. No part of this work may be reproduced or used in any form or by any means—graphic, electronic, mechanical (including photocopying), recording, taping, or information or retrieval systems—without permission of the publisher.

Published by:  
Parsons Brinckerhoff Group Inc.  
One Penn Plaza  
New York, New York 10119

Graphics Database: V212



---

# CONTENTS

<b>FOREWORD</b> . . . . .	<b>xv</b>
<b>PREFACE</b> . . . . .	<b>xvii</b>
<b>PART 1: INTRODUCTION</b> . . . . .	<b>1</b>
<b>CHAPTER 1 INTRODUCTION TO THE RESEARCH</b> . . . . .	<b>3</b>
1.1 Unprecedented Support for High Speed Rail in the U.S. . . . .	3
1.2 Pioneering the Application of High Speed Rail Express Trainsets in the U.S. . . . .	4
1.3 Research Objectives . . . . .	6
1.4 William Barclay Parsons Fellowship Participants . . . . .	6
1.5 Host Manufacturers and Operators . . . . .	7
1.6 A Snapshot in Time . . . . .	10
<b>CHAPTER 2 HOST MANUFACTURERS AND OPERATORS, THEIR PRODUCTS AND SERVICES.</b> . . . . .	<b>11</b>
2.1 Overview . . . . .	11
2.2 Introduction to Host HSR Manufacturers . . . . .	11
2.3 Introduction to Host HSR Operators and Regulatory Agencies . . . . .	16
2.4 Existing/Emerging HSR Trainset Platforms . . . . .	25
2.5 Emerging HSR System Developments: 218 mph (350 km/h) Target Operational Speed . . . . .	40
2.6 Bi-Level Platform Development for HSR Greater than 218 mph (350 km/h) . . . . .	41
2.7 Production Facilities and Manufacturing Capacity. . . . .	42
<b>PART 2: TRAINSETS</b> . . . . .	<b>47</b>
<b>CHAPTER 3 CRASH ENERGY MANAGEMENT AND STRENGTH OF VEHICLES.</b> . . . . .	<b>49</b>
3.1 FRA's Developing Requirements for HSR Crash Energy Management and Strength of Vehicles . . . . .	49
3.2 Crash Energy Management . . . . .	50

---

3.3	Passive Safety . . . . .	58
3.4	Vehicle Structural Strength . . . . .	62
3.5	Attachments and Fittings. . . . .	71

**CHAPTER 4 EMERGENCY PREPAREDNESS (SYSTEM PROTECTION) . . . . . 75**

4.1	Fire Safety . . . . .	75
4.2	U.S. and International Fire Safety Standards . . . . .	80
4.3	Side-Facing Emergency Windows . . . . .	82
4.4	Driver's Cab Windows . . . . .	86
4.5	Emergency Side Door Releases . . . . .	86
4.6	Back-Up Power/Emergency Lighting . . . . .	87
4.7	Emergency Preparedness Plans and Procedures . . . . .	89

**CHAPTER 5 ENVIRONMENTAL CONDITIONS AND THEIR IMPACTS ON TRAINSETS AND INFRASTRUCTURE . . . . . 91**

5.1	Weather-Related Ballast Pickup . . . . .	91
5.2	Temperature Ranges and Cooling Air . . . . .	93
5.3	Aerodynamics and Running Resistance . . . . .	94
5.4	Aerodynamic Loads on Track Workers. . . . .	96
5.5	Aerodynamic Impacts of Trainsets Approaching Platforms . . . . .	98
5.6	Pressure Loads in Open Air . . . . .	98
5.7	Crosswind . . . . .	100
5.8	Exterior Noise. . . . .	102
5.9	Interior Noise . . . . .	106
5.10	Trainset Sealing . . . . .	108
5.11	Air Conditioning . . . . .	109

**CHAPTER 6 TRACTION AND ELECTRICAL SYSTEMS . . . . . 113**

6.1	Traction System Overviews. . . . .	113
6.2	Traction Wheel/Rail Adhesion Requirements. . . . .	119
6.3	Exterior Electromagnetic Interference . . . . .	119

---

**CHAPTER 7 BRAKE SYSTEMS . . . . . 121**

7.1 Operational Features of High Speed Trainset Brake Systems . . . . . 121

7.2 Failsafe Attributes of Electrodynamic Brakes . . . . . 124

7.3 Friction Brake System Duty Cycle . . . . . 124

7.4 Electromagnetic Rail Brake, and Eddy Current Track and Axle-Mounted Brake Systems. . . . . 125

7.5 Safe Braking Distances . . . . . 128

7.6 Passenger Alarm/Emergency Braking . . . . . 130

7.7 Brake System Response Time . . . . . 131

7.8 Runaway Acceleration during Braking . . . . . 131

7.9 Brake System Redundant Characteristics . . . . . 132

7.10 Reduced Wheel Adhesion . . . . . 132

7.11 Wheel Slide Protection and Wheel Rotation Monitoring Systems . . . . . 133

7.12 Brake Pipe Installations and Train Rescue . . . . . 134

7.13 Remote Monitoring of Brake Application Force. . . . . 134

7.14 FRA/ASME Requirements Relative to Brake Reservoirs . . . . . 135

7.15 Parking Brake/Hand Brake System . . . . . 135

**CHAPTER 8 BOGIES AND TILTING SYSTEMS . . . . . 137**

8.1 Articulated Trainset Architecture . . . . . 137

8.2 Bogie Design . . . . . 140

8.3 Tilting Systems . . . . . 142

**CHAPTER 9 TRAIN CONTROL AND SIGNALING SYSTEMS . . . 143**

9.1 Train-to-Wayside Communication Systems . . . . . 143

9.2 ATC Interface with Braking and Propulsion Systems . . . . . 155

9.3 ATC Interaction with Driver's Vigilance (Deadman) Device . . . . . 157

9.4 Design Headway for the ATC System and Minimum Headway Parameters . . . . . 158

9.5 Operation of Trainset after Isolation of ATC . . . . . 158

9.6 ATC Normal/Degraded/Bypass Operating Modes. . . . . 159

9.7 ATC Interface with Onboard Systems . . . . . 160

9.8 Automatic Train Operation . . . . . 161

9.9 Other Aspects of Train Control and Signaling Systems . . . . . 162

---

**CHAPTER 10 END-FACING, SIDE-FACING, AND INTERIOR  
GLAZINGS . . . . . 167**

10.1 End-Facing Glazings . . . . . 167  
10.2 Side-Facing Glazings . . . . . 170  
10.3 Interior Glazings . . . . . 175

**CHAPTER 11 EXTERIOR DOORS . . . . . 177**

11.1 Door Design and Control Systems . . . . . 177  
11.2 Detection of Obstructions when Closing . . . . . 179  
11.3 Opening the Doors . . . . . 179

**CHAPTER 12 EXTERIOR LIGHTING . . . . . 181**

12.1 Head Lights . . . . . 181  
12.2 Auxiliary Lights . . . . . 182  
12.3 Marker Lights (Tail Lamps) . . . . . 183  
12.4 Side Door Threshold Lights . . . . . 183

**CHAPTER 13 PASSENGER INFORMATION, COMMUNICATIONS,  
AND SERVICE SYSTEMS . . . . . 185**

13.1 Passenger Information Displays . . . . . 185  
13.2 Communication Systems . . . . . 186  
13.3 Onboard Passenger Service Systems (Internet, Ticketing, Vending,  
Entertainment) . . . . . 187

**CHAPTER 14 ACCESSIBILITY AND INTERIOR TRAINSET  
DESIGN . . . . . 191**

14.1 Level Boarding Requirements . . . . . 191  
14.2 Wheelchair Mobility and Accessibility . . . . . 192  
14.3 Toilet Rooms . . . . . 196  
14.4 Water Supply . . . . . 197  
14.5 Interior Furnishings . . . . . 198  
14.6 Interior Lighting . . . . . 202

---

**PART 3: HSR INFRASTRUCTURE . . . . . 203**

**CHAPTER 15 INFRASTRUCTURE INTERFACES AND VEHICLE/  
TRACK INTERACTION . . . . . 205**

15.1 Maximum Gradients of Alignment . . . . .205  
15.2 Minimum Curve Radius for Mainline, Stations, and Overnight Storage Tracks .206  
15.3 Widening of the Track Gauge . . . . .209  
15.4 Wheel/Rail Profile . . . . .209  
15.5 Kinematic Gauge . . . . .211  
15.6 Static Axle Load. . . . .212  
15.7 Axle Bearing Health Monitoring. . . . .213  
15.8 Derailment Detection/Mitigation. . . . .214  
15.9 Uncontrolled Lateral Motion. . . . .216  
15.10 Vehicle and Track Interaction (VTI) . . . . .217  
15.11 Friction Modifiers/Flange Lubrication . . . . .224

**CHAPTER 16 OVERHEAD CONTACT SYSTEMS . . . . . 225**

16.1 Pantographs Power Collection Overview . . . . .225  
16.2 Pantograph Operating Range . . . . .228  
16.3 Pantograph Collector Head Configuration . . . . .229  
16.4 Minimum/Maximum OCS Voltage . . . . .230  
16.5 Neutral Sections (Phase Breaks) . . . . .231

**CHAPTER 17 BRIDGES AND TUNNELS. . . . . 233**

17.1 Dynamic Effects on HSR Bridges. . . . .233  
17.2 Tunnel Cross-Sections, Blockage Ratios, and Pressure Waves . . . . .235

**CHAPTER 18 HIGH SPEED RAIL CORRIDORS AND WAYSIDE  
PROTECTION . . . . . 239**

18.1 Dedicated vs. Shared Track . . . . .239  
18.2 High Speed Rail Installation . . . . .239  
18.3 Wayside Protection Devices . . . . .241

---

**PART 4: MAINTENANCE AND OPERATIONS . . . . . 243**

**CHAPTER 19 TRAINSET INSPECTION AND MAINTENANCE. . . 245**

19.1 Inspection and Maintenance Overview . . . . . 245  
19.2 Maintenance Costs per Mile . . . . . 254  
19.3 Effect of Slab or Ballasted Track on Rolling Stock Maintenance Costs . . . . . 256  
19.4 Reliability, Availability, and Service Duty of Trainsets. . . . . 257  
19.5 Life Cycle of the Vehicle Structure . . . . . 261  
19.6 Frequencies of Inspection, Maintenance, and Light and Heavy Overhauls . . 261  
19.7 Trainset Reliability as a Function of Operator Entity . . . . . 271

**CHAPTER 20 OPERATIONS . . . . . 273**

20.1 Enforcement of Speed Restrictions . . . . . 273  
20.2 End Couplers/Decoupling Procedure. . . . . 275  
20.3 Speeds at Which Rescued Trains Travel . . . . . 276  
20.4 Train Turnaround Time . . . . . 276  
20.5 Drivers and Train Crews . . . . . 277

**CHAPTER 21 INTERNATIONAL HOSTS' PERSPECTIVES ON HSR SAFETY . . . . . 285**

21.1 Overview of HSR Safety and Experiences . . . . . 285  
21.2 TSI Development . . . . . 294  
21.3 Planned Trainset Safety Enhancements . . . . . 295  
21.4 Operators' Perspectives of Aspects Critical to the Success of HSR Projects in the U.S. . . . . 295

**AFTERWORD . . . . . 299**

Lessons Learned . . . . . 299  
Afterthoughts and Acknowledgements . . . . . 301

**GLOSSARY . . . . . 305**

---

**REFERENCES . . . . . 321**

**APPENDICES . . . . . 327**

Appendix A Trip Logs . . . . .327  
Appendix B Meeting Agenda . . . . .335

---

# LIST OF FIGURES

## Chapter 1

1.1 Ten Potential High Speed Rail Corridors . . . . .	3
1.2 Alstom's AGV as Delivered to NTV. . . . .	7
1.3 CSR's CRH380A . . . . .	8
1.4 Hyundai Rotem's KTX-II and HEMU-400X . . . . .	8
1.5 Shinkansen N700 Series and E5 Series . . . . .	9
1.6 Siemens' ICE/Velaro D Trainset . . . . .	9

## Chapter 2

2.1 700T High Speed Trainset . . . . .	14
2.2 Germany's HSR Network . . . . .	16
2.3 Korea's HSR Network . . . . .	17
2.4 Japan's HSR Network . . . . .	18
2.5 China's HSR Network. . . . .	20
2.6 Italy's HSR Network and NTV HSR Line . . . . .	21
2.7 Spain's HSR Network. . . . .	23
2.8 France's HSR Network . . . . .	24
2.9 TGV-R Pass-By at Champagne-Ardenne Station . . . . .	26
2.10 V150 World Speed Record Trainset . . . . .	28
2.11 CRH380A at Hangzhou Railway Station . . . . .	33
2.12 Hyundai Rotem's G7 Prototype Trainset . . . . .	35
2.13 E954 Fastech 360S Experimental Trainset . . . . .	38
2.14 Siemens' Velaro CN. . . . .	39
2.15 Alstom's La Rochelle Manufacturing Facility . . . . .	43

## Chapter 3

3.1 EN 15227 Collision Scenarios for C-I Category Rolling Stock (Locomotives, Coaches, and Fixed Train Units) . . . . .	50
3.2 Key Safety Parameters of Crashworthiness . . . . .	51
3.3 Articulated Architecture Featuring One Bogie Shared by Two Cars. . . . .	53
3.4 Alstom MEGA Unit Validation . . . . .	55
3.5 Siemens Velaro Intermediate Couplers . . . . .	57
3.6 Siemens Velaro Front Crumple Zone. . . . .	57
3.7 Alstom AGV Coupler Retreat System . . . . .	60



---

3.8 Alstom AGV Passive Safety Final Validation . . . . .	60
3.9 Alstom's Supplementary Protection of the Abdomen through Additional Airbag Chamber Deployment . . . . .	62
3.10 AGV MEGA with Integrated Coupler . . . . .	65
3.11 Siemens Velaro Depicting Locations for the Application of Compressive Loads . . . . .	65
3.12 CHR380A Obstacle Deflector . . . . .	67

## **Chapter 4**

4.1 Alstom's Five Stages of Fire Protection in Order of Importance . . . . .	75
4.2 Velaro E Fire Barrier Doors . . . . .	79
4.3 KTX-I Seat Fire Test. . . . .	81
4.4 Velaro E Emergency Side Glazing with Breakout Hammer . . . . .	82
4.5 Velaro E Cab Emergency Hatch . . . . .	86

## **Chapter 5**

5.1 Damage to the Velaro Underfloor from Ballast Pickup. . . . .	93
5.2 Two Alstom TER 2N-NG Trainsets Passing with 11.8-foot (3,6-m) Track Centers . . . . .	94
5.3 Distribution of Aerodynamic Drag . . . . .	96
5.4 Setup for Air Pressure Tests . . . . .	99
5.5 Pressures Resulting from the AGV Prototype Passing . . . . .	99
5.6 SNCF's Approach to Crosswinds . . . . .	101
5.7 TGV Duplex Interior Noise . . . . .	106
5.8 Velaro D HVAC Unit . . . . .	110

## **Chapter 6**

6.1 Evolution of Alstom's Very High Speed Train Traction Motors . . . . .	114
6.2 Distributed Traction Equipment on the Velaro E . . . . .	117

## **Chapter 7**

7.1 CRH380A Brake System . . . . .	122
7.2 Eddy Current Track Brake System on a Siemens ICE 3 Trainset . . . . .	123
7.3 Passenger Emergency Brake Device on ICE 3 . . . . .	130
7.4 Siemens Velaro E Disc Brake Arrangement . . . . .	136

---

## Chapter 8

8.1 Number of Bogies Required for 656-foot (200-m) Trainsets of Various Architectures . . . . .	137
8.2 TGV Derailments in France. . . . .	138
8.3 Energy Consumption of the Articulated AGV vs. Semi-Articulated Duplex and Non-Articulated Trainsets. . . . .	139
8.4 CRH380A Motor Bogie and Trailer Bogie . . . . .	140
8.5 Velaro SF 500 Bogie . . . . .	141

## Chapter 9

9.1 ETCS Levels 1 and 2. . . . .	144
9.2 European Signaling Systems by Country . . . . .	144
9.3 ATLAS Subsystems. . . . .	146
9.4 RGV 2N Onboard Signaling Equipment . . . . .	149
9.5 Trainguard 100 for ETCS Level 1. . . . .	151
9.6 Trainguard 200 for ETCS Level 2. . . . .	151
9.7 CTCS-3 GSM-R Redundant Coverage. . . . .	153
9.8 Example of a Safe Braking Curve . . . . .	155
9.9 CTCS-3 Driver-Machine Interface . . . . .	156
9.10 Alstom Functional Driver's Desk Simulator and DMI Prototype Screens . . . . .	163
9.11 UIC 612 Generic Layout of Driver's Desk and Actual Desk on Alstom PRIMA II Locomotive . . . . .	164

## Chapter 10

10.1 Alstom AGV Trainset Front Glazing Configuration . . . . .	168
10.2 CRH380A Windscreen Impact Test to 49 CFR §238.421 Criteria . . . . .	169
10.3 Velaro Side Glazing Pressure Test . . . . .	173

## Chapter 11

11.1 Velaro E Emergency Door Release . . . . .	178
--	-----

## Chapter 12

12.1 Comparison of TSI and CFR Exterior Lighting Intensity Requirements . . . . .	181
---	-----

---

## Chapter 13

13.1 Overhead Passenger Information Display on Velaro E . . . . .	185
---	-----

## Chapter 14

14.1 Alstom AGV Interior Layout with Universal Toilet . . . . .	193
14.2 Alstom AGV Gangway Clear Opening . . . . .	193
14.3 Siemens Velaro Exterior Door Opening . . . . .	195
14.4 Emergency Call Buttons at Wheelchair Seating Locations on the Velaro . . . . .	195
14.5 Emergency Call Buttons in the PRM Restroom on the Velaro . . . . .	196
14.6 Velaro D Cab with Electrical Lockers . . . . .	199
14.7 CRH380A First Class Seating and Second Class Seating . . . . .	200

## Chapter 15

15.1 Cologne-to-Frankfurt High Speed Line . . . . .	206
15.2 ICE 3 Approaching Cologne Main Station . . . . .	208
15.3 A Comparison of Wheel Profiles and Rail Profiles . . . . .	210
15.4 Velaro E Redundant Yaw Damper Configuration . . . . .	217
15.5 APTA Wheel Flange Angle Criteria . . . . .	221
15.6 Two Contact Areas between the Wheel Tread and Rails at a Switch . . . . .	223

## Chapter 16

16.1 Comparison of Actual Measurements and OSCAR Simulations for Contact Forces Encountered on Part of the LGV Atlantique with a TGV Operating at 186 mph (300 km/h) Using a CX Pantograph . . . . .	227
16.2 Comparison of Actual Measurements and OSCAR Simulations for Steady Arm Uplift Encountered on Part of the LGV Atlantique with a TGV Operating at 186 mph (300 km/h) Using a GPU Pantograph . . . . .	227
16.3 Monitoring of Pantograph and OCS Interaction . . . . .	228
16.4 Velaro E Pantograph Interface with Contact Rail at NERTUS Facility . . . . .	230

## Chapter 17

17.1 Periodic Loading of a Railway Deck . . . . .	233
17.2 SNCF Tunnel Aerodynamics Curve - Test/Simulation Validation . . . . .	237

---

## Chapter 18

18.1 Interior of the Slab Track Batch Plant . . . . .	.240
---	------

## Chapter 19

19.1 TrainTracer Remote Monitoring . . . . .	.247
19.2 Maintenance Management Systems for the Velaro. . . . .	.249
19.3 Trainset Lift Arrangement at SNCF Technicentre . . . . .	.251
19.4 CRH Maintenance Depot Showing Trainset Lift/Bogies Removed . . . . .	.253
19.5 CRH Maintenance Depot Showing Three-Layer Working Platform . . . . .	.254
19.6 TGV Undergoing Major Refurbishment is Prepped for Paint and Newly Painted . . . . .	.256
19.7 Real-Time Monitoring of AGV Trainset Status. . . . .	.258
19.8 Siemens Velaro Maintenance Regime Prepared for "Balanced Maintenance". .265	
19.9 Lacroix Interior for TGV Trainsets . . . . .	.268
19.10 Automated Wheelset and Pantograph Inspection Site . . . . .	.271

## Chapter 20

20.1 CRH EMU Car Wash Facility . . . . .	.274
20.2 NTV Simulator . . . . .	.280
20.3 TGV 2N2 Bar Car . . . . .	.282

## Chapter 21

21.1 Fatality Rates of the Three Primary Modes of Travel Showing Factors of Increase Compared with Train Travel. . . . .	.286
21.2 Types of Rail Accidents . . . . .	.286
21.3 Wind Barriers on the Cologne-to-Frankfurt Line . . . . .	.289
21.4 AGV Pegase Prototype Trainset . . . . .	.290

---

# LIST OF TABLES

## Chapter 2

2.1 Characteristics of 7-Car-to-14-Car AGVs . . . . .	31
---	----

## Chapter 4

4.1 NFF 31129 Fragmentation Criteria for Side-Facing Emergency Glazings. . . . .	85
--	----

## Chapter 5

5.1 Maximum Air Velocities Encountered by the 7-Car AGV Prototype . . . . .	97
5.2 Air Speeds for the AGV Travelling on the Paris-to-Strasbourg Line . . . . .	97
5.3 Pass-by Noise Generated by Various TGV Models . . . . .	103
5.4 Noise Performance of CRH380A Compared with International Standards . . . . .	105

## Chapter 6

6.1 Acceleration Rates of Hyundai Rotem's High Speed Trainsets . . . . .	116
--	-----

## Chapter 7

7.1 Emergency Stopping Distances in China . . . . .	128
7.2 Minimum Stopping Distances for Siemens High Speed Trains . . . . .	129

## Chapter 10

10.1 Alstom Configurations for Side-Facing Glazings from Exterior to Interior . . . . .	171
---	-----

## Chapter 15

15.1 Comparison of Chinese and European Wheel/Rail Profiles . . . . .	211
15.2 Limits of Alignment Design Parameters: 218 mph (350 km/h) . . . . .	218



---

## FOREWORD

When Frank Banko, Parsons Brinckerhoff rolling stock manager, invited me to join him and Jackson Xue on the William Barclay Parsons Fellowship trips, the California High Speed Train Project (CHSTP) was just gaining momentum. The Federal Railroad Administration (FRA) was participating in regular meetings with CHSTP staff to determine what kind of system requirements would be appropriate for 220 mph high speed rail operation. Many of our discussions on system requirements ended with questions such as, "I wonder how they handle this issue on Shinkansen?" or, "Does anyone know what they use on TGV?"

In the fall of 2009 Frank was awarded the 2010 William Barclay Parsons Fellowship to study the application of high speed rail express trainsets in the U.S. The fellowship program provided the opportunity to learn about international best practices used to design, manufacture, operate, and maintain high speed trainsets. The fellowship trips took place throughout 2010 and provided access to the world's high speed rail experts.

Our small team reviewed all the major trainset platforms and witnessed high speed rail operations in Germany, Spain, France, Italy, Japan, China, and Korea. Wherever we went, we asked as many questions as our patient hosts would tolerate. We wanted to know how experienced high speed rail operators addressed the many issues linked to high speed operation. We covered trainsets, train control, traction power, communications, track, infrastructure, operations, and maintenance. We were able to get real answers to our most difficult questions—from experts who had lived through the problems and developed the solutions.

The fellowship program provided our team with the unprecedented opportunity to update and fine tune our knowledge of high speed rail. The results of what we learned are already reflected in many aspects of California's high speed rail system requirements and in FRA's standards and regulatory initiatives. The fellowship program has led to a high level of collaboration and a productive partnership with CHSTP and influenced the direction of the Railroad Safety Advisory Committee Engineering Task Force, FRA's vehicle for developing requirements for the highest speed trainsets.

Personally, the input and perspective I gained through participating in the fellowship program prepared me for the profusion of high speed rail issues FRA is currently addressing. I am grateful to Parsons Brinckerhoff for sponsoring the fellowship and to FRA for funding my participation. I am especially grateful to Frank and Jackson, my constant companions throughout the fellowship trips, for including me on this great adventure.

The most valuable things we learned are captured in this document. The information is invaluable to any decision maker involved in a high speed rail program. The document lays out the international approach to high speed rail and—most importantly—answers the question, "How do they do it over there?"

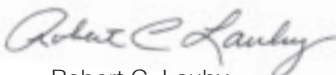

Robert C. Lauby  
Fellowship Participant





---

## **PREFACE**

Long distance train travel oftentimes elicits various emotions for passengers. Whether it is the anticipation associated with experiencing a new destination, uninterrupted periods of quiet time for reflection, or inspiration gained while witnessing the technological feats that enable train travel, most passengers complete each journey with a renewed sense of what is possible. These same emotions surfaced when I was selected as the 2010 William Barclay Parsons Fellow to study the successful application of high speed rail throughout the world.

I am grateful to the William Barclay Parsons Fellowship program for providing this exceptional opportunity. I am equally grateful to my family, Peggy, Kelly, and Patrick, for supporting me throughout this journey, and for appreciating the significant impact high speed train travel can have on a region.

I am hopeful that this monograph—a detailed account of our research—will elicit a sense of anticipation, encourage reflection, and inspire each of us as the U.S. embarks on the path of implementing a world-class high speed rail network.



Francis P. Banko



---

## **PART 1: INTRODUCTION**



---

# CHAPTER 1 INTRODUCTION TO THE RESEARCH

## 1.1 UNPRECEDENTED SUPPORT FOR HIGH SPEED RAIL IN THE U.S.

### 1.1.1 The President’s “Vision for High Speed Rail in America”

In April 2009 President Obama heralded a new era for high speed passenger trains when he shared his vision for high speed rail (HSR) in America. This vision called for a safe, reliable, clean, and energy-efficient option for travelers—one that reduced dependence on cars and planes and spurred economic development in key corridors across the country. The President’s plan identified an \$8 billion funding program under the American Recovery and Reinvestment Act (ARRA) that was to be used as a catalyst to establish a world-class passenger rail system.

President Obama’s plan identified the following ten potential HSR corridors (Figure 1.1):

- California
- Pacific Northwest
- South Central
- Gulf Coast
- Chicago Hub Network
- Florida
- Southeast
- Keystone
- Empire
- Northern New England

In addition, the Washington-to-Boston Northeast Corridor (NEC), where the U.S. has its only existing HSR service, would have the opportunity to compete for funds.

**Figure 1.1 Ten Potential High Speed Rail Corridors**

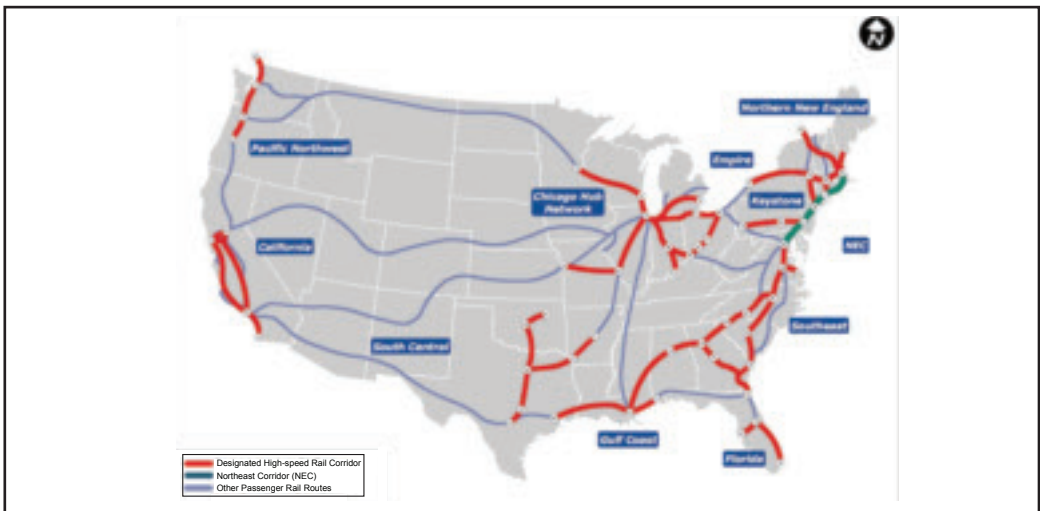

Source: Federal Railroad Administration

---

In June 2009 the Federal Railroad Administration (FRA) issued a notice of funding availability as provided under the ARRA program, and provided interim guidance for HSR and Intercity Passenger Rail Programs.

### **1.1.2 FRA's High Speed Passenger Rail Safety Strategy**

Following President Obama's announcement of a strategic plan for HSR, FRA published a draft document entitled *High Speed Passenger Rail Safety Strategy* in July 2009 wherein FRA committed to take on the challenge of working to make HSR a reality in the key corridors identified. FRA's draft strategy announced a process whereby FRA would develop additional and new safety guidance for the development of HSR systems. As stated in the draft strategy, "the hallmark of world-class, high speed rail is safety."

FRA's proposed safety strategy is based on a three-tier approach:

- Establish safety standards and program guidance for HSR
- Apply a system safety approach to address safety concerns on specific rail lines
- Ensure that railroad operators involved in passenger train service can manage train emergencies effectively and efficiently.

FRA endeavors to achieve safe rail passenger service regardless of speed, but noted that the severity of collisions and derailments increases with speed, and that safety performance targets may be issued in a tiered format that becomes more stringent as speed increases. One proposed tier would be for HSR express service applicable to HSR corridors where trains operate at speeds up to 220 mph (354 km/h).

### **1.1.3 Realistic and Viable Funding Sources Identified and Committed to High Speed Rail**

It is anticipated that the \$8 billion funding under ARRA would be augmented by state and local funding commitments. An example of such funding can be found in the California referendum (Proposition 1A) that was passed in November 2008 authorizing the sale of \$9.95 billion in bonds to support the development of the California High Speed Train Project (CHSTP).

Funding from private investors is critical as well. One can look to CHSTP to gauge the level of interest of private investment. In March 2011 more than 1,000 expressions of interest to assist with the construction of the HSR system were received by the California High Speed Rail Authority (CHSRA). These expressions of interest identified numerous California-based entities being established by potential concessionaires.

## **1.2 PIONEERING THE APPLICATION OF HIGH SPEED RAIL EXPRESS TRAINSETS IN THE U.S.**

Parsons Brinckerhoff (PB) is serving as the lead firm of the program management team for CHSTP and is charged with managing the design of what will become the first HSR express

---

system in America. PB also has the enviable position of being a leader in the emerging HSR market. In this role, PB has the potential to guide the establishment of new policies and requirements that will set the standard for CHSTP and for other potential HSR express systems in the U.S. To this end, the 2010 William Barclay Parsons Fellowship recipients focused on:

- International best practices that have been proven to provide safe HSR service
- Recent advancements in HSR trainset design, infrastructure, operations, and maintenance
- Advice from HSR manufacturers and operators about those factors important to establishing a successful HSR program in the U.S.

### **1.2.1 Carrying on the Heritage and Direction Set by William Barclay Parsons**

William Barclay Parsons and PB's leaders who followed him recognized the unquestioned need for engineering professionals to stay abreast of advancements made in their fields and of knowledge gained from engineering experience. Recognizing opportunities to apply such advancements is what distinguishes an engineer or an engineering firm as an industry leader.

In conducting research under the 2010 William Barclay Parsons Fellowship (Fellowship), the authors learned how advancements in technology, material sciences, and manufacturing techniques have been applied to trainset designs for HSR systems around the world, and how these advancements have contributed to improvements in safety, reliability, energy efficiency, and passenger comfort. Insight has been gained into the lessons learned and operating histories that were integral to the development of today's HSR systems. The authors also learned about those technologies that resulted in negligible or deleterious effects on design, as well as critical areas of risk and strategies for mitigating these risks. Throughout the research, the focus was to better understand the realistic applications of technologies proven by HSR operating histories.

### **1.2.2 Working from a Proven Platform**

Against the backdrop of potential requirements unique to U.S. HSR operations, the authors focused on how the trainset platforms and proven technologies implemented in Europe and Asia could be modified to comply with these requirements while proven safety attributes were preserved. The findings from the Fellowship are being used in a manner that will help to develop:

- Trainset designs that are commercially viable and meet U.S. program requirements
- Performance specifications and safety standards for HSR express trainsets.

In addition, the findings have been beneficial in guiding FRA's rule-making process as FRA establishes new safety regulations.

---

## **1.3 RESEARCH OBJECTIVES**

### **1.3.1 Identify High Speed Rail System Requirements**

Throughout the research, the authors evaluated European and Asian best practices while focusing on service-proven HSR technical and regulatory approaches. These approaches were compared with U.S. carbody strength and crashworthiness requirements as codified in FRA's Code of Federal Regulations (CFR), which was established to support train operations up to 150 mph (241 km/h). The authors also evaluated speed-independent U.S. rail safety regulations that might apply to HSR express programs. They identified areas where there is parity between U.S. and international approaches and areas where diverging viewpoints exist, and shared those findings with FRA.

Through this process, the authors developed a comprehensive set of system requirements for HSR trainsets using a safety strategy based on a holistic system-based approach. These system requirements were distributed to FRA for review and feedback, and they are now being incorporated into HSR express trainset performance specifications.

### **1.3.2 Gain Working Knowledge of European and Asian Best Practices and Approaches**

The Fellowship offered the authors the opportunity to become immersed in the processes used to develop HSR trainset designs around the world through interaction with vehicle engineers located at key international technical design centers. The research was augmented with interactive discussions about critical design and safety issues with international HSR trainset specialists and HSR operators. Through these discussions the authors gained:

- Working knowledge of international HSR trainset regulations and standards
- Understanding of HSR trainset cost drivers and risk elements
- Expertise in key phases of HSR trainset design, manufacturing, production oversight, and inspection
- Expertise in HSR trainset operations, testing, commissioning, and maintenance
- Understanding of ancillary system interfaces, including train control, traction power, track, stations, and other infrastructure.

## **1.4 WILLIAM BARCLAY PARSONS FELLOWSHIP PARTICIPANTS**

Participants in the 2010 William Barclay Parsons Fellowship research were:

- Frank Banko, 2010 Fellow (PB)
- Jackson Xue, Lead Investigator (PB)



- 
- Robert Lauby, Deputy Associate Administrator for the FRA Office of Safety, who participated in all Fellowship trips and currently heads the Railroad Safety Advisory Committee (RSAC) Engineering Task Force (ETF) for high speed rail regulatory planning
  - Ronald Mayville, Senior Principal of Simpson Gumpertz & Heger, who participated in the Siemens and Kawasaki portions of the program and is a key participant in the ETF.

## **1.5 HOST MANUFACTURERS AND OPERATORS**

Numerous HSR trainsets were suitable candidates for operation on America's HSR corridors. The Fellowship research focused on equipment that is or will be capable of operating in service at speeds of up to 220 mph (354 km/h), currently designated by FRA as HSR express trainsets. Five manufacturers and associated operating entities were selected that have in-service trainsets that are or may become capable of operating at this level of performance. The host manufacturers and operators are identified briefly below. Detailed discussions about their products and services are presented in Chapter 2.

### **1.5.1 Manufacturer: Alstom Transport Operators: Société Nationale des Chemins de fer Français (SNCF) Nuovo Trasporto Viaggiatori (NTV)**

Alstom developed the Automotrice à Grande Vitesse (AGV) HSR trainset platform with a maximum design speed of 224 mph (360 km/h). This trainset was developed in-house with the first procurement of AGV trainsets underway for delivery to NTV, a new private rail operator in Italy (Figure 1.2). The French national railways operator, SNCF, has been operating Alstom's Train à Grande Vitesse (TGV) HSR platform since 1981 in France and in neighboring countries.

**Figure 1.2 Alstom's AGV as Delivered to NTV**



Source: <http://www.theage.com.au/travel/travel-news/italy-unveils-new-ferrari-highspeed-trains-20111214-1ouj1.html>

---

**1.5.2 Manufacturer: CSR Qingdao Sifang Co., Ltd. (CSR Sifang)**  
**Regulatory Agency: State-Owned Assets Supervision and Administration Commission of the State Council (SASAC)**  
**Operator: Ministry of Railways of the People's Republic of China (MOR)**

CSR Sifang is a subsidiary of CSR Corporation, Ltd (CSR). Its manufacturing facility developed the CRH380A trainset platform (Figure 1.3). This trainset has a maximum design speed of 236 mph (380 km/h). It is used in 218 mph (350 km/h) operations on the Hangzhou-to-Shanghai high speed line.

**Figure 1.3 CSR's CRH380A**



Source: CSR Sifang Presentation, "Information about High Speed EMU," November 2010

**1.5.3 Manufacturer: Hyundai Rotem Company**  
**Operator: Korea Railroad Corporation (Korail)**

Hyundai Rotem developed the Korea Train eXpress (KTX)-II trainset platform, which has a maximum design speed of 205 mph (330 km/h) and is based on a concentrated power design. The Korean national operator, Korail, has been operating this trainset in Korea since 2010. Hyundai Rotem is also designing a new distributed power electric multiple unit (EMU) HSR trainset called the High Speed Electric Multiple Unit (HEMU)-400X. This trainset has a maximum design speed of 249 mph (400 km/h), and is scheduled to be ready for commissioning tests in 2012. Both models are shown in Figure 1.4.

**Figure 1.4 Hyundai Rotem's KTX-II (left) and HEMU-400X (right)**



Source: Hyundai Rotem Presentation, "High Speed Trains," November 2010

---

**1.5.4 Manufacturer: Kawasaki Heavy Industries**  
**Regulatory Agency: Ministry of Land, Infrastructure, Transport and Tourism (MLIT)**  
**Operators: Central Japan Railway Company (JR Central)**  
**East Japan Railway Company (JR East)**

HSR trainsets have been operating in Japan since 1964 on the Japanese high speed network called the Shinkansen. The Shinkansen N700 Series is the newest in-service trainset design and has a maximum design speed of 186 mph (300 km/h). A newer development, JR East's E5 Series platform, is designed to travel at 199 mph (320 km/h) and is scheduled to enter service in 2011. Both models are shown in Figure 1.5.

**Figure 1.5 Shinkansen N700 Series (left) and E5 Series (right)**

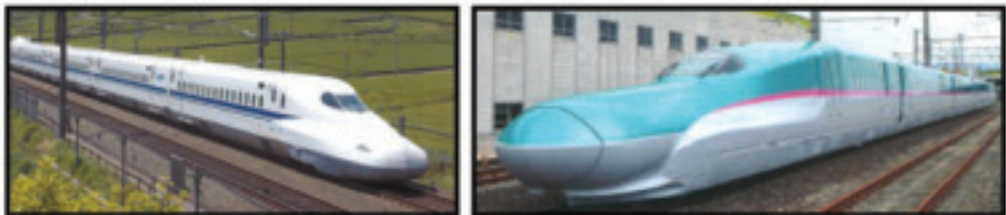

Sources: Left: *Japanese Railway Information*, Issue 111, February 2009  
Right: Kawasaki quarterly newsletter, *Scope*, Issue 82, February 2010

**1.5.5 Manufacturer: Siemens AG**  
**Operators: Deutsche Bahn Fernverkehr AG (DB)**  
**Renfe Operadora (Renfe)**

Siemens developed the Velaro HSR trainset platform with a maximum design speed of 236 mph (380 km/h). This trainset is in operation in Spain (Velaro E or AVE Class 103), Russia (Velaro RUS or Sapsan), and China (Velaro CN or CRH3) and will soon be in operation in Germany (Velaro D or DB Class 407 as shown in Figure 1.6). The predecessor for the Velaro platform is the InterCityExpress (ICE) 3 trainset that is currently operating in Germany and in neighboring countries.

**Figure 1.6 Siemens' ICE/Velaro D Trainset**



Source: Siemens, April 2010

---

## 1.6 A SNAPSHOT IN TIME

The Fellowship research team made four trips to Europe and Asia during 2010 to meet with many of the world's HSR experts, and to experience their trainsets and understand their operations.<sup>1</sup> One of the tangible elements of this program was the receipt and review of numerous technical presentations from the host manufacturers and operators. The presentations provided myriad details on HSR trainset design and operation. The technical findings presented in this monograph summarize the information discussed, while respecting the intent of the Non-Disclosure Agreements that were signed as a condition of receipt of this information.

On that note, Kawasaki Heavy Industries, MLIT, JR Central, and JR East were most generous with the information they provided. It was their wish, however, that their contributions to the technical discussions covered in Parts 2 through 4 of this monograph be withheld from publication.

Readers are advised to recognize that HSR technology is advancing rapidly throughout the world and circumstances change. The material presented herein was accurate at the time it was received, as recorded, and the perspective of this monograph is from the time of the presentations and meetings. This monograph does not reflect subsequent events or activities, unless specifically noted otherwise.

The general approach taken in preparing this monograph was to present manufacturer and operator discussions about a topic in alphabetical order. There are exceptions, however. For example, information might be presented according to the chronological order of the research trips.

The information presented is based on that offered by the manufacturers and the operators. Because some entities discussed various topics to a greater level of detail than others, there is not always an equal comparison of a topic for all participants.

The most valuable elements the authors learned in the Fellowship program are captured in this monograph. It is hoped that decision makers involved in HSR programs find this information beneficial to their tasks. The authors' intent was to lay out the international approaches to HSR and, most importantly, highlight best practices developed during decades of experience and shared so generously by our hosts.

---

<sup>1</sup> A detailed trip log is provided in Appendix A.

A sample agenda for the meetings with the manufacturers and operators is provided in Appendix B.

---

# CHAPTER 2 HOST MANUFACTURERS AND OPERATORS, THEIR PRODUCTS AND SERVICES

## 2.1 OVERVIEW

The 2010 William Barclay Parsons Fellowship focused on learning about international best practices that have been proven to provide safe HSR service. In addition, advice was sought from HSR operators regarding those factors important to establishing a successful HSR program in the U.S. This chapter provides:

- Introductory commentary from and overviews of HSR manufacturers and operators who were interviewed as part of this research
- Information about their existing and emerging HSR trainset platforms
- Discussion about emerging developments for HSR at speeds greater than 218 mph (350 km/h).

## 2.2 INTRODUCTION TO HOST HSR MANUFACTURERS

### 2.2.1 Alstom Transport

The Alstom Group has 81,500 employees across 70 countries. The company focused on providing equipment and services for two market sectors—rail transport and power generation—until recently, when it acquired a new subsidiary engaged in a third market, power transmission. The group's total sales for fiscal year 2008-2009 were \$24.3 billion<sup>1</sup> (€18,7 billion).

Alstom Transport accounts for approximately 33 percent of the group's sales and activities and has 26,665 employees engaged in more than 60 countries in Europe, Latin America, North America, and Asia Pacific. Its percentages of sales by product line in FY 2008-2009 were:

- 57 percent rolling stock
- 17 percent services
- 14 percent signaling
- 12 percent infrastructure.

Alstom stated that it is currently the number one manufacturer of very high speed trains and the number two manufacturer of urban transportation (e.g., metros, trams). Its products, ranging from low speed to very high speed rolling stock, and their maximum design speeds include:

- Light rail vehicles: 37 mph (60 km/h)
- Metros: 62 mph (100 km/h)
- Regional and suburban rail vehicles and locomotives: 87 mph (140 km/h)

---

<sup>1</sup> Based on conversion of €1 = \$1.30.

- 
- Interurban vehicles: 124 mph (200 km/h)
  - Pendolino high speed trains: 155 mph (250 km/h)
  - TGV very high speed trains: 199 mph (320 km/h)
  - AGV very high speed trains: 224 mph (360 km/h).

In addition to being a major purveyor of rolling stock to France and Italy, Alstom provides a variety of rolling stock products, rail infrastructure, signaling, and maintenance services to other rail operators. For example:

- **China:** Alstom will be supplying 500 locomotive units, each with 13,400 hp (10 MW).
- **Spain:** Between 2000 and 2004, Alstom designed, supplied, and installed eleven 2x25 kV substations.
- **Italy:** Alstom designed, supplied, and installed 25 kV overhead contact equipment between Torino and Milan (31 miles (49 km)), Milan and Bologna (50 miles (80 km)), and Florence and Bologna (25 miles (40 km)).
- **Channel Tunnel:** Alstom designed, procured, manufactured, installed, tested, and commissioned the track and overhead contact equipment for the second section of the rail link that comprises of 25 miles (40 km) of open track and 25 miles (40 km) of tunnel length.
- **Korea:** Alstom designed, installed, tested, and commissioned the overhead contact equipment for 296 miles (477 km) of single track, and developed two prototype trains and 44 production trains.

## 2.2.2 CSR

CSR advised that in the past all rolling stock manufacturers belonged to MOR; however, after the Chinese economic reform, the manufacturing capabilities were divided into two companies, CSR and CNR, both of which can bid for projects independently. CSR began manufacturing HSR trains in 2004. The first to be placed into service was the CRH2 (based on the Shinkansen E2 Series), which started service on April 18, 2007.

CSR advised that due to its willingness to learn from other countries, China has gathered extensive technical knowledge from HSR manufacturers worldwide (e.g., differences in technologies, protection of environment, etc.). CSR is now capable of designing and constructing HSR systems, designing and manufacturing high speed EMUs, and designing and implementing train control systems.

Over the past several years, China's HSR system has been the fastest in the world to develop. Fifteen high speed lines totaling 4,400 miles (7080 km) are currently in operation. An additional 8,080 miles (13 000 km) are under construction. By 2012, a total of 8,080 miles (13 000 km) will be in operation, and by 2020 that number is expected to increase to 9,950 miles (16 000 km). China's current HSR system is served by 418 high speed EMUs of 8-car and 16-car configurations. If considering only 8-car configurations, then there is a total of 480 trainsets.

By the end of October 2010, CSR had delivered 199 sets of high speed EMUs that can operate at speeds between 155 mph and 218 mph (250 km/h and 350 km/h). These include sleeper EMUs for long distances and intercity trains for short distances.

---

Before the development of the 819-mile (1318-km)-long Beijing-to-Shanghai high speed line, travel between the two cities took approximately 10 hours. Travel time is to be approximately 4 hours nonstop, with the CRH380A trainset traveling at an operating speed of 218 mph (350 km/h) and a maximum speed of 236 mph (380 km/h). CSR was the MOR-preferred company for exporting the CRH380A trainset.

### **2.2.3 Hyundai Rotem**

Hyundai Rotem began manufacturing rolling stock in 1964 and, soon after, delved into the defense and plant engineering businesses. The company's Research and Development (R&D) Center has four divisions and employs approximately 700 engineers. Its largest division, Railway Systems (located in Uiwang between Seoul and Busan), focuses on high speed trains, magnetic levitation (maglev) trains, EMUs, diesel multiple units (DMU), locomotives, electrical equipment, signaling, and systems engineering. This division accounts for 57 percent of Hyundai Rotem's R&D efforts. Its production record includes:

- High speed trains (KTX series): 1,160 cars
- EMUs (metro, commuter) and light rail vehicles: 11,528 cars
  - Korea: 9,987 cars
  - Export: 1,541 cars built to various standards, including U.S. and International Union of Railways (UIC) requirements
- DMUs (commuter, intercity): 1,469 cars
  - Korea: 999 cars
  - Export: 470 cars
- Locomotives (electric, diesel-electric): 668 cars
  - Korea: 617 cars
  - Export: 51 cars
- Coaches (first class, second class): 4,455 cars
  - Korea: 3,262 cars
  - Export: 1,193 cars
- Freight cars: 28,396 cars
  - Korea: 6,898 cars
  - Export: 21,498 cars.

Hyundai Rotem's U.S. clients include:

- Southeastern Pennsylvania Transportation Authority (SEPTA): 130 EMU cars that run at 99 mph (160 km/h) and are built to U.S. standards
- Southern California Regional Rail Authority (SCRRA): 131 coaches that run at 110 mph (177 km/h) and include crash energy management (CEM) designs
- Massachusetts Bay Transportation Authority (MBTA): 75 coaches that run at 103 mph (166 km/h).



---

Hyundai Rotem has been involved in the development of maglev solutions also. Basic technology research spanned from 1989 to 2001. The intention for the initial application of maglev technology was for use at a theme park; however, the technology is being further developed for a link between the Incheon International Airport and a leisure complex located approximately 3.7 miles (6 km) away. Expected to open in 2013, the rail will operate at a speed of 68 mph (110 km/h). Hyundai Rotem developed the practical model between 2003 and 2008. The technology is being implemented into a commercial operating design between 2007 and 2012.

The reasons for developing maglev for low speed operation include:

- Its suitability for operations in urban areas where noise from rolling steel-wheeled equipment was a concern
- Its grade climbing capability, which is superior to that of steel-wheeled equipment and an important feature in Korea because of the country's steep hilly topography
- The savings in operational costs due to less wear on the vehicle and rail, which outweigh the higher initial investment.

## **2.2.4 Kawasaki Heavy Industries**

Kawasaki was founded by Shozo Kawasaki in 1878 as the Kawasaki Tsukiji Shipyard. In 1896 the business was incorporated as the Kawasaki Dockyard Co., Ltd., with Kojiro Matsukata selected as the first president of the company. During his 32-year tenure, Matsukata expanded Kawasaki's business to include shipping, aircraft, and rolling stock.

Kawasaki's rolling stock profile ranges from subways to freight locomotives to high speed trainsets. Domestically, Kawasaki has provided various types of rolling stock for Japanese customers. Some of Kawasaki's exports to foreign markets include:

- R142A subway cars to New York City Transit (NYCT)
- 700T Series high speed trainsets (Figure 2.1) to Taiwan High Speed Rail Corporation (THSRC).

**Figure 2.1 700T High Speed Trainset**



Source: *Japanese Railway Information*, Issue 112, August 2009

Kawasaki has approximately 33,700 employees.



---

## 2.2.5 Siemens Mobility

Since its founding in 1847 by Werner von Siemens, Siemens has established a long history of setting milestones in rail car development:

- In 1879 Siemens became the first company to introduce the electric locomotive.
- In 1903 its three-phase voltage system permitted trains to travel up to 126 mph (203 km/h).
- In the 1930s Siemens' Flying Hamburg, a diesel-electric train, connected major cities in Germany at 99 mph (160 km/h).
- From 1970 to 1999 Siemens manufactured a six-axle locomotive for high-speed travel in Germany at speeds of up to 124 mph (200 km/h).
- In the 1980s, 1990s, and 2000s diesel-electric locomotives for freight operation in the U.S. were equipped with three-phase drives from Siemens. These AC traction systems provided increased levels of adhesion, improved reliability, and reduced maintenance requirements.

Siemens Mobility, which is Siemens' rail transport division, has 26,000 employees and revenue of \$7.5 billion (€5,84 billion) worldwide. Siemens' other divisions are involved in energy, healthcare, and other cross-sector industries.

Siemens rolling stock and infrastructure systems for public transit include:

- High-speed, intercity, commuter, and light rail vehicles.
- Electric and diesel locomotives and components (refurbishment and new).
- Rail automation (operation control systems and automatic train control (ATC) systems).
- Complete transport solutions. For example, in China, Siemens designed the train control system, the rolling stock, and the electrification system. The client was China's MOR, which served as the system integrator.

Siemens categorized the speeds for rail vehicle transport as follows:

- Velaro: greater than 149 mph (240 km/h)
- Locomotive hauled (Railjet): greater than 109 mph (175 km/h) and up to 149 mph (240 km/h)
- EMUs: greater than 90 mph (145 km/h) and up to 109 mph (175 km/h)
- DMUs: up to 90 mph (145 km/h).

Siemens has delivered more than 1,000 high speed train car bodies and more than 5,000 regional train car bodies. The company's success is attributed to ongoing comprehensive quality control, with workers performing self-verification of their activities.

---

## 2.3 INTRODUCTION TO HOST HSR OPERATORS AND REGULATORY AGENCIES

### 2.3.1 Germany: Deutsche Bahn (DB)

DB provided a chronology of HSR in Germany:

- 1991: The first high speed line was constructed between Hamburg and Munich.
- 1993: The high speed line from Berlin to Switzerland was constructed.
- 1998: The high speed network was expanded to Cologne.
- 2003: A high speed line was established between Cologne and Frankfurt. This line is 127 miles (204 km) long and has seven stations. Trains operate at a maximum speed of 186 mph (300 km/h) with headways of approximately eight trains per hour. The trip time is 55 minutes.
- 2006: DB upgraded the infrastructure between Cologne and Berlin to facilitate an increase in operating speed. The new Central Station in Berlin was opened and is considered Europe's largest two-level railway station.

Germany's HSR network is illustrated in Figure 2.2.

**Figure 2.2 Germany's HSR Network**

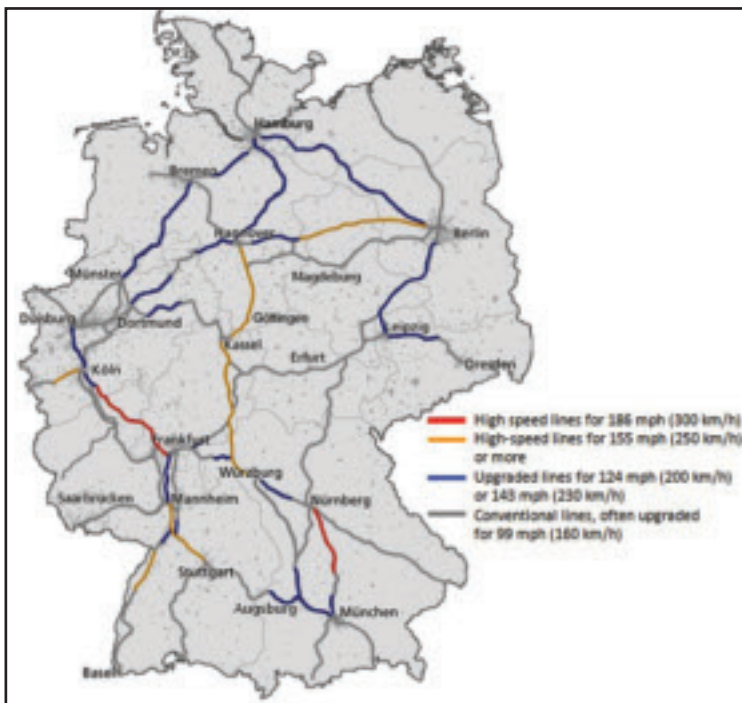

Source: *Wikimedia Commons*, a freely licensed media file repository

DB is an integrated provider of infrastructure and operations. It operates 27,000 trains per day and has a fleet of 242 Siemens ICE trainsets. Revenues are approximately \$47 billion (€36 billion), with \$3 billion (€2,4 billion) coming from the U.S.

DB currently has 6,000 employees in the U.S. The company expects its rail network (commuter, intercity, and freight services) to expand by 60 percent by 2025, with direct connections to 18 European cities.

### 2.3.2 Korea: Korea Railroad Corporation (Korail)

The Korean National Railroad (KNR) was in charge of railroad operations in South Korea from 1963 to 2005. In 2005, KNR split into two agencies: Korail, which is responsible for railroad operations, and the Korea Rail Network Authority, which is a railroad construction and management company. Korea's HSR network is shown in Figure 2.3.

**Figure 2.3 Korea's HSR Network**



Source: *Wikimedia Commons*, a freely licensed media file repository

---

## 2.3.3 Japan: Ministry of Land, Infrastructure, Transport and Tourism (MLIT), Central Japan Railway Company (JR Central), and East Japan Railway Company (JR East)

### 2.3.3.1 MLIT

MLIT advised that Japan began developing the world's first HSR system in 1964. The first line, called the Tokaido Shinkansen, operated from Tokyo to Shin-Osaka. This project was funded by the World Bank.

Japan's current HSR network comprises eight lines (Figure 2.4):

- Tokaido Shinkansen (1964)
- Sanyo Shinkansen (1972 from Shin-Osaka to Okayama and extended in 1975 to Hakata)
- Tohoku Shinkansen (1982)
- Joetsu Shinkansen (1982)
- Akita Shinkansen (1997)
- Yamagata Shinkansen (1999)
- Hokuriku Shinkansen (1997)
- Kyushu Shinkansen (2004).

**Figure 2.4 Japan's HSR Network**



Source: *Wikimedia Commons*, a freely licensed media file repository

---

Japan has 1,352 miles (2176 km) of HSR in operation, 394 miles (634 km) under construction, and 331 miles (533 km) in the planning stage. There have been no HSR collisions since the establishment of the Shinkansen.

MLIT emphasized the importance of enhancing the understanding of the American and Japanese railroad systems. Its primary interest lies in the technological standards to be developed for U.S. HSR because these standards will drive the types of technologies exported to that country.

### **2.3.3.2 JR Central**

JR Central operates the Tokaido Shinkansen and several conventional lines. The maximum speed on the Shinkansen recently increased from 137 mph to 168 mph (220 km/h to 270 km/h), so the trip from Tokyo to Shin-Osaka, a distance of approximately 344 miles (553 km) can now be made in approximately 2 hours 25 minutes.

JR Central is responsible for the overall system design. The detailed components are designed by the manufacturers.

### **2.3.3.3 JR East**

JR East operates the Akita, Joetsu, Nagano, Tohoku, and Yamagata Shinkansen and several conventional lines. The highest operating speed of 186 mph (300 km/h) is encountered on the Tohoku Shinkansen.

## **2.3.4 China: Ministry of Railways of the People's Republic of China (MOR), China Railway Highspeed (CRH), China Railway Construction Corporation (CRCC), Third Survey and Design Institute (TSDI), Fourth Survey and Design Institute (FSDI)**

### **2.3.4.1 MOR**

MOR has jurisdiction over the development and operation of railroads throughout China and is responsible for the final review of technical standards in China. Other institutes (e.g., China's four railway survey and design institutes) participate in the rulemaking process. MOR has two departments—a technical department and a policy and standards department. All of China's sixteen railway bureaus report to MOR (e.g., Beijing Railway Bureau, Shanghai Railway Bureau, etc.).

### **2.3.4.2 CRH**

CRH is the umbrella name for the HSR system in China (Figure 2.5). CRH is operated by China Railways under the jurisdiction of MOR through various sub-entities. Sub-entities that participated in the Fellowship research were the Beijing Railway Bureau, Guangzhou Railway Group, and Shanghai Railway Bureau.

**Figure 2.5 China's HSR Network**



Source: *Wikimedia Commons*, a freely licensed media file repository

### 2.3.4.3 CRCC

CRCC is China's largest construction contractor. It specializes in the survey, design, and construction of plateau railways, high speed railways, urban rail traffic, highways, bridges, and tunnels. CRCC advised that two-thirds of the HSR lines placed into service were designed and constructed by CRCC.

CRCC's work on the modernization of the large-scale HSR line construction in China includes the design and construction of the 664-mile (1069-km) Wuhan-to-Guangzhou line, which has a maximum operating speed of 218 mph (350 km/h). Total travel time from one terminal to the other is 3 hours. The Wuhan-to-Guangzhou line has 15 stations. The length of the arrival and departure track is 2,133 feet (650 m). Each station has its unique features that serve the combination of functional, system, cultural, and economic needs; and provide passengers with a comfortable traveling environment.

CRCC comprises several subsidiaries, including FSDI.

#### 2.3.4.4 TSDI

TSDI, established in 1953, is headquartered in Tianjin, a city located 81 miles (130 km) from Beijing. TSDI is the only large-scale multi-disciplinary survey and design institute directly subordinated to the MOR. TSDI is also one of the largest transportation and infrastructure design institutes. TSDI designed the first high speed railway line in China, the Beijing-to-Tianjin Intercity High Speed Railway; and the first EMU maintenance center in China, the Beijing EMU depot. TSDI is also the general designer of the Beijing-to-Shanghai High Speed Railway.

#### 2.3.4.5 FSDI

FSDI, established in 1953, is headquartered in Wuhan. FSDI is also one of the largest transportation and infrastructure design institutes. FSDI designed the Wuhan-to-Guangzhou High Speed Railway, and it is one of the designers of the Beijing-to-Shanghai High Speed Railway.

### 2.3.5 Italy: Nuovo Trasporto Viaggiatori (NTV)

NTV's mission is to provide high speed passenger service in Italy while assuring high quality at competitive prices. Its objectives are to serve the increasing demand for a more environment-friendly and energy-efficient mode of transportation and to take full advantage of the state's \$45.5 billion (€35 billion) investment in the high speed network (Figure 2.6). NTV will be Italy's first private operator of HSR.

**Figure 2.6 Italy's HSR Network (left), and NTV HSR Line (shared with other operators) (right)**

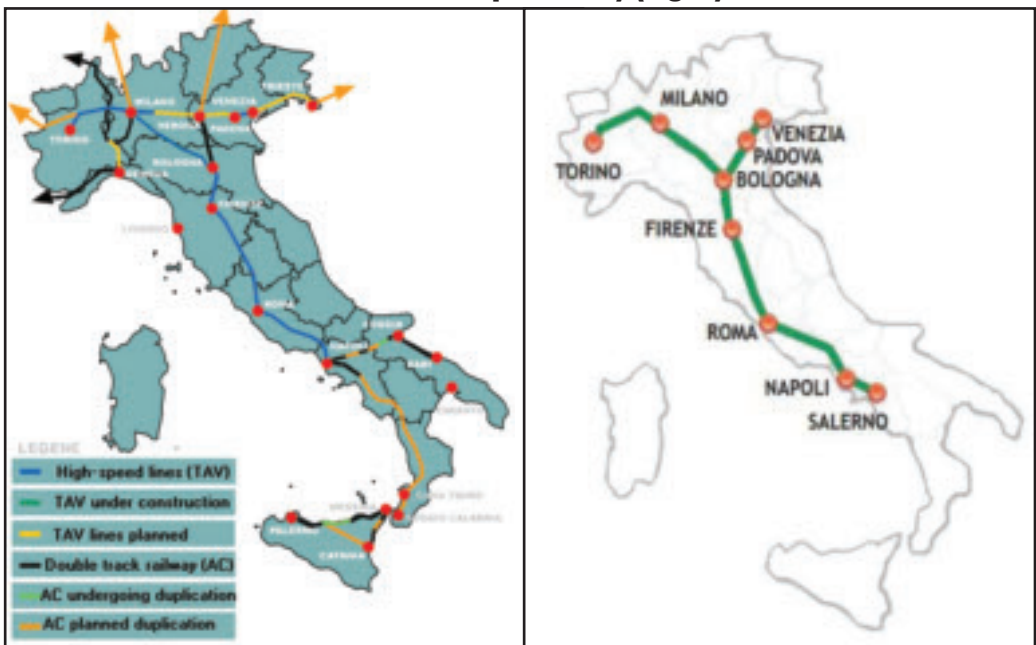

Sources: Left: *Wikimedia Commons*, a freely licensed media file repository  
Right: NTV Presentation, "NTV: The Company and its Italo Service," June 2010



---

NTV was founded in December 2006 by four private investors. In February 2007 it received its railway firm license, and in November 2007 NTV ordered 25 AGVs from Alstom. Other milestones leading up to NTV meeting its plans to begin operations in September 2011 include:

- Agreement was signed in January 2008 with Rete Ferroviaria Italiana (RFI), the infrastructure manager.
- The first AGV drivers were selected in September 2008.
- The first AGV coach was constructed in June 2009 in La Rochelle, France.
- The train simulator was activated in November 2009.
- An agreement was reached to create space for “Casa Italo” in the stations in December 2009.
- Later in December 2009, with the HSR network complete, NTV acquired certification for high speed operation.
- The first prototype trainset, the Pegase, arrived in Italy in January 2010.

NTV plans to operate 51 trips per day at the start of service with approximately 7.65 million miles (12,3 million km) traveled per year. It expects that by 2015 service will increase to 54 trips per day with approximately 8.39 million miles (13,5 million km) traveled per year. NTV estimated that its service will accommodate 30,000 travelers per day, equal to 10 million travelers per year. It expects to employ 1,000 people by 2011, of which 900 will handle operations and real-time service monitoring in the operations control center.

### **2.3.6 Spain: Renfe Operadora (Renfe)**

The Red Nacional de los Ferrocarriles Españoles (Renfe) was formed in 1941 with the nationalization of Spain’s railways. The entity was divided into two agencies in 2005:

- Renfe Operadora, which is in charge of railroad operations (intercity, commuter, and freight)
- Administrador de Infraestructuras Ferroviarias (ADIF), the administrator of rail infrastructure.

Spain’s HSR network is shown in Figure 2.7.



**Figure 2.7 Spain's HSR Network**



Source: *Wikimedia Commons*, a freely licensed media file repository

### **2.3.7 France: Société Nationale des Chemins de fer Français (SNCF)**

SNCF operates six HSR lines domestically (Figure 2.8), as well as HSR lines in the UK, Spain, Morocco, Taiwan, Italy, Belgium, Netherlands, and Portugal. Its domestic HSR lines, also known as Lignes à Grande Vitesse (LGV), are:

- East Line (LGV Est européenne) between Paris and Baudrecourt
- South-East Line (LGV Sud-Est) between Paris and Lyon
- Atlantic Line (LGV Atlantique) between Paris and Le Mans and Tours
- Rhône-Alpes Line (LGV Rhône-Alpes) between Lyon and Valence
- North Line (LGV Nord) between Paris, Lille, and the Channel Tunnel
- Mediterranean Line (LGV Méditerranée) between Valence and Marseille
- Rhin-Rhône Line (LGV Rhin-Rhône) between Dijon and Mulhouse, Dijon and Lyon, and joining the LGV Sud-Est Line.

These lines are owned by the infrastructure manager, Réseau Ferré des France (RFF).

**Figure 2.8 France's HSR Network**



Source: *Wikimedia Commons*, a freely licensed media file repository

SNCF practices conform to the requirements set forth in the European Directive 2008/57/EC.

SNCF comprises the following subsidiaries, which themselves include subsidiaries that are wholly or partially owned by SNCF:

- **SNCF Infra:** Engineering work for the design of HSR infrastructure for domestic and international applications.
- **SNCF Proximités:** Rail and bus operations in the UK, Sweden, Denmark, Canada, Belgium, Germany, and the Netherlands.
- **SNCF Voyages:** This division is involved in HSR operations, including the TGV, Eurostar International, and others.
- **SNCF Geodis:** This division is involved in freight operations.
- **Gares et Connexions:** A new division created in 2009 for the architectural designs of stations and the distribution of rail tickets.

The SNCF Engineering Department offers a full range of consulting and project expertise at the system and detailed levels. During the Fellowship research, this department provided the technical details in response to the agenda items and questions. The engineering depart-

---

ment assists SNCF in safety acceptance process management, various preliminary studies (e.g., technical feasibility studies, infrastructure capacity assessments, economic studies, safety assessments, etc.), and operation and maintenance particularities. It is also involved in:

- Railway system engineering (system integration, testing, and commissioning)
- Track alignment and design
- Civil and structural engineering (tunnels, bridges, and viaducts)
- Technical buildings and multimodal platforms
- Environmental studies
- Electrical engineering (overhead contact system (OCS), traction power, and signal measurement and testing)
- Telecommunications (telephony, transmission, radio, and GSM-R<sup>1</sup>).

SNCF's Engineering Department has its own product and system development division that provides general supervision on design and construction (e.g., homologation tests,<sup>2</sup> operations and management compliance, etc.).

## **2.4 EXISTING/EMERGING HSR TRAINSET PLATFORMS**

### **2.4.1 Alstom**

#### **2.4.1.1 Commercial High Speed Rail Fleet Development**

Alstom advised that prior to the 1970s, the fastest trains in Europe traveled at 124 mph (200 km/h). The Paris-to-Lyon line had become saturated by then, however, so it was necessary to create a new line dedicated to passenger traffic alone, giving France an opportunity to develop infrastructure for higher speed trains.

In 1969 Alstom launched the gas turbine TGV001 prototype. Completed in 1972, the TGV001 could travel at speeds greater than 186 mph (300 km/h). In 1973, the TGV001 broke the world record, traveling at 198 mph (318 km/h). The first TGVs were delivered in 1981.

Alstom now has one of the largest fleets of high speed trainsets. It has delivered 669 very high speed trainsets (speeds greater than 168 mph (270 km/h)), and has more than 560 trains operated at speeds between 186 mph and 199 mph (300 km/h and 320 km/h). The fleet is spread over the largest variety of networks throughout nine countries.

Since launching the TGV more than 30 years ago, Alstom's high speed rolling stock has been evolving continuously, and now spans four generations.

---

<sup>1</sup> GSM-R: Global system for mobile communications-railway, a wireless communications standard for communication between trains and railway regulation control centers.

<sup>2</sup> Homologation testing is a certification process during which a trainset (or other type of product) is evaluated against the requirements of a regulatory standard.

---

### Generation 1

- **1981: TGV Sud-Est (TGV-PSE).** 109 trainsets ordered, 112 trainsets delivered.

Commercial service of the TGV PSE began between Paris and Lyon in 1981 with a maximum speed of 168 mph (270 km/h). The commercial speed today is 186 mph (300 km/h). The TGV PSE consists of two power cars and eight trailer cars to accommodate 386 passengers within a 656-foot (200-m) trainset. It is powered by six motored bogies (first three bogies on each end) with DC motors rated at a total of 8,450 hp (6,3 MW). Three similar trainsets were used for the Postal Service in France.

### Generation 2: Domestic

- **1989: TGV Atlantique (TGV-A).** 105 trainsets ordered and delivered.

Commercial service began in 1989 with a maximum speed of 186 mph (300 km/h). The TGV-A consists of two power cars and ten trailer cars to accommodate 485 passengers within a 781-foot (238-m) trainset. It is powered by four motored bogies with AC synchronous motors rated at a total of 11,800 hp (8,8 MW).

- **1993: TGV Réseau (TGV-R).** 80 trainsets ordered, 61 trainsets delivered.

Commercial service began in 1993 with a maximum speed of 186 mph (300 km/h). The TGV-R (Figure 2.9) consists of two power cars and eight trailer cars to accommodate 377 passengers within a 656-foot (200-m) trainset. It is powered by four motored bogies with AC synchronous motors rated at a total of 11,800 hp (8,8 MW).

**Figure 2.9 TGV-R Pass-By at Champagne-Ardenne Station**



Source: WBPF Photograph, June 2010

### Generation 2: Export

- **1992: AVE Class 100.** 24 trainsets ordered and delivered.

Commercial service began in Spain (Renfe) in 1992 with a maximum speed of 186 mph (300 km/h). The Class 100 consists of two power cars and eight trailer cars to accommodate 329 passengers within a 656-foot (200-m) trainset. It is powered by four motored bogies with AC synchronous motors rated at a total of 11,800 hp (8,8 MW).

- **2004: KTX-I (TGV-K).** 46 trainsets ordered and delivered, 12 trainsets were manufactured in France.

Commercial service began in Korea (Korail) in 2004 with a maximum speed of 186

---

mph (300 km/h). The KTX-I consists of two power cars and eighteen trailer cars to accommodate 935 passengers within a 1,273-foot (388-m) trainset. It is powered by six motored bogies with AC synchronous motors rated at a total of 17,700 hp (13,2 MW).

### **Generation 2: Cross Border**

- **1994: TGV TransManche Super Train (TGV-TMST) Eurostar (British Rail Class 373).** 38 trainsets ordered and delivered.

Commercial service began in 1994 with a maximum speed of 186 mph (300 km/h). The TGV-TMST consists of two power cars and eighteen trailer cars to accommodate 794 passengers within a 1,047-foot (319-m) trainset. It is powered by six motored bogies with AC synchronous motors rated at a total of 16,360 hp (12,2 MW). The reason for the long trainset is that the train splits into two sections to service two lines in different directions. The traction motors for the Eurostar were developed in the UK.

- **1996: Thalys Paris-Brussels-Amsterdam (PBA) and Paris-Brussels-Cologne-Amsterdam (PBKA).** 27 trainsets ordered and delivered.

Commercial service for France (SNCF), Belgium (Société Nationale des Chemins de fer Belges (SNCB)), Netherlands (Nederlandse Spoorwegen (NS)), and Germany (DB) began in 1996 with a maximum speed of 186 mph (300 km/h). The Thalys PBA and PBKA consist of two power cars and eight trailer cars to accommodate 377 passengers within a 656-foot (200-m) trainset. They are powered by four motored bogies with AC synchronous motors rated at a total of 11,800 hp (8,8 MW). The uniqueness of these trainsets includes their ability to travel through four different line voltages.

### **Generation 3**

- **1996: TGV Duplex.** 124 trainsets ordered, 143 trainsets delivered; 69 additional trainsets to be delivered.

Commercial service began in 1996 with a maximum speed of 186 mph (300 km/h). The TGV Duplex consists of two power cars and eight trailer cars to accommodate 509 passengers within a 656-foot (200-m) trainset. It is powered by four motored bogies with AC synchronous motors rated at a total of 11,800 hp (8,8 MW).

- **2011: TGV 2N2 (RGV 2N).** 55 trainsets ordered and delivered, another 40 have been ordered.

Commercial service with the Rames à Grande Vitesse et à 2 Niveaux (RGV 2N) will begin in 2011 with a maximum speed of 199 mph (320 km/h). The RGV 2N consists of two power cars and eight trailer cars to accommodate 509 passengers within a 656-foot (200-m) trainset. It is powered by four motored bogies with AC asynchronous motors (ASM) rated at a total of 12,450 hp (9,28 MW). The RGV 2N is an improved version of the Duplex that is designed to comply with the requirements set forth in the European Technical Specification for Interoperability (TSI)<sup>1</sup>.

---

<sup>1</sup> TSI is a set of common standards being developed for interoperability of high speed and conventional trains across Europe. Alstom estimated that the TSI was 80 percent to 90 percent complete, and that all European countries were in transitioning phases to meet TSI requirements. [See Section 21.2 for more information about TSI development.]

---

### Generations 2 and 3 Combined

- **2007: TGV-POS.** 19 trainsets ordered and delivered.

Commercial service on the LGV Est line began in 2007 with a maximum speed of 199 mph (320 km/h). The TGV-POS consists of two duplex power cars and eight TGV-A trailer cars to accommodate 377 passengers within a 656-foot (200-m) trainset. It is powered by four motored bogies with AC ASMs rated at a total of 12,450 hp (9,28 MW).

### Generation 4

- **2011: AGV.** 25 trainsets ordered, to be delivered.

Developed without orders, the AGV was designed to be a generic platform capable of cross-border operations in Europe. NTV ordered 25 trainsets with an option for 10 more. Commercial service of the AGV is scheduled to start in 2011 with a maximum speed of 186 mph (300 km/h), although the trainset is capable of operating at speeds of up to 224 mph (360 km/h). The AGV consists of eleven cars with distributed power to accommodate 487 passengers within a 656-foot (200-m) trainset. It is powered by six motored bogies with permanent magnet motors (PMMs) rated at a total of 11,800 hp (8,8 MW). NTV will use five motored bogies rated at a total of 10,730 hp (8,0 MW).

#### 2.4.1.2 Very High Speed Train Tests

Alstom holds several world speed records, including:

- February 1981: 236 mph (380 km/h)
- May 1990: 318.9 mph (513,3 km/h)
- April 2007: 357.2 mph (574,8 km/h).

The April 2007 tests were conducted under real-life conditions at speeds beyond 311 mph (500 km/h) to measure and validate the aerodynamics, acoustics, dynamics, and vibratory phenomena on the TGV-POS power cars, the TGV Duplex coach cars, and the two AGV bogies Alstom had produced at the time. The world speed record five-car trainset, dubbed the V150 trainset, (Figure 2.10) consisted of two power cars and three Duplex trailer cars. The traction equipment used was the same as that now installed on the AGV trainsets. The total power of the five-car trainset was 26,820 hp (20 MW).

**Figure 2.10 V150 World Speed Record Trainset**



Source: Alstom Presentation, "TGV: 30 Years of Experience of High Speed," June 2010

---

The train was equipped with 350 sensors for safety and measurement purposes. The measurements included:

- Wheel/rail forces
- Dynamic stability (accelerations and comfort)
- Aerodynamic effects
- Acoustical effects
- Pantograph dynamics and electrical behaviors
- Traction chain control (TGV-POS's concentrated power and AGV's distributed power)
- Electrical measurements (voltage, power).

An instrumented pantograph and vertical and lateral accelerometers were installed on the first car. The first trailer car, a VIP coach, also had vertical and lateral accelerometers. Sensors were in place in the center car to measure exterior, interior, and surface noises. The third trailer car was the laboratory car. Between the laboratory car and the power car were sensors to check the bearing temperature, gearbox temperature, and brake disc temperature. The last power car contained vertical and lateral accelerometers for checks on stability.

Measurements at the track level were conducted to determine the dynamic and aerodynamic constraints of the track, the aerodynamics under the trainset, and the exterior pass-by noise of the trainset. These included the use of:

- Strain gauges on the rail to measure wheel load
- Pressure sensors between the rails
- Vertical accelerometers on the sleepers
- Vertical, lateral, and horizontal accelerometers on the sidelines
- Anemometers on the sidelines
- Camera and laser sensors for rail pad and sleeper displacements.

Other measurements included the dynamic behavior of structures (viaducts, bridges, etc.), vertical and twisting constraints, and aerodynamic constraints.

The testing permitted Alstom to witness the operation of the installed systems at a very high operating speed and provided valuable feedback that was used to develop improvements and system modifications for Alstom's high speed trainset product line.

### **2.4.1.3 Offerings for the U.S. Market**

Alstom has advertised two products for U.S. purposes, the TGV Duplex and the AGV.

- **The TGV Duplex** has a high density configuration of 1,100 seats over 1,312 feet (400 m). It is capable of operating at a commercial speed of 199 mph (320 km/h). The bar is located on the second floor of one coach, and the technical equipment (e.g., auxiliary cabling) is installed on the first floor of this same coach. Alstom stated that there are benefits of having concentrated power versus distributed power because of lower maintenance costs (concentration of equipment in the cab cars). Alstom also felt that the argument of needing distributed power for better adhesion was not valid.



- 
- **The AGV** is a flexible product capable of having seven to fourteen cars for diversified traffic. It is capable of operating up to 224 mph (360 km/h). Alstom advised that an AGV Duplex solution is not an option due to the lack of space available for equipment.

**The Duplex Platform.** By the end of the 1980s the Paris-to-Lyon line was saturated once again, after less than ten years of HSR operation. Several constraints prevented expansion, such as set platform lengths and the impossibility of increasing throughput, so SNCF determined that the only way to build was up. Alstom advised that designing and constructing a double-deck train to maintain the 18.7-ton (17-tonne) axle requirement set forth in TSI proved to be a great technical challenge, especially with its articulated architecture in which bogies are shared between two coaches, resulting in fewer bogies to accommodate the trainset weight.

Solutions included improved aerodynamics, an aluminum carbody, and lighter seats (26.5 lb<sub>m</sub> (12 kg) savings for every two-passenger seat assembly). The results of the process included:

- The same trainset length of 656 feet (200 m) and same platform height of 22 inches (550 mm)
- An optimized mass of 474 tons (430 tonnes)
- Same power of 11,800 hp (8,8 MW)
- Faster speeds of up to 199 mph (320 km/h) if 12,450 hp (9,28 MW) power is used
- Increased reliability and optimized operating costs
- Increased capacity by 35 percent (509 passengers with 30 percent first class as opposed to 377 passengers)
- Varying comfort levels (inclusive of passenger and business areas).

Alstom added that the TGV Duplex trainset was developed jointly with SNCF and that the design belongs to SNCF.

Alstom noted that a double-deck very high speed train has an optimized life-cycle cost combined with the largest capacity on the market. Along with its articulation benefits, lower maintenance costs, energy consumption, and cost per passenger can be achieved. The trainset itself is capable of operating at 199 mph (320 km/h) with a high level of reliability (fewer than eight delays of five minutes per 621,400 miles (1 million km)). The 9.5-foot (2,9-m) width of the trainset permits numerous interior design possibilities to suit the operator's needs.

According to Alstom, the maintenance concept of the double-deck very high speed train has been optimized by SNCF over the past 20 years. Concentrated power simplifies maintenance because all of the main components are located in the power car. Alstom advised that due to the optimization of aerodynamics and the low train weight (only 1,764 lb<sub>m</sub> (800 kg) per passenger), only 8,050 hp (6 MW) of power is needed to maintain a train speed of 199 mph (320 km/h) at grade. Alstom's new RGV 2N will be fitted with 12,450 hp (9,28 MW) of power, thereby giving the train a larger power margin for steep gradients and degraded modes.

**The AGV.** Alstom advised that the AGV trainset was built on Alstom's experiences in articulated trainsets, weight optimization, and safety. It offers a number of benefits, including more modularity, capacity, speed, comfort, and availability to the customer, and it is fully compliant with all TSI requirements.



---

The AGV is fitted with Alstom's ATLAS technology to accommodate the European Rail Traffic Management System (ERTMS) and the European Train Control System (ETCS) requirements. Its driver's desk is based on the recommendations of the European Driver's Desk plus (EUDD+) working group, a concept that was tested in a simulator by international drivers. The AGV also accounts for European interoperability crash standards. Its Module of Energy of Great Absorption (MEGA) CEM system includes a retractable coupler and is capable of absorbing 4.8 MJ. Alstom notes that the AGV was designed for energy savings as well. It uses 10 percent less energy when compared to competitors due to:

- Lower weight (77 tons (70 tonnes) less)
- Optimization of regenerative brakes (up to 8 MW of power feedback into the grid)
- 25 percent fewer bogies (lower effects of aerodynamic drag)
- High efficiency with PMMs
- Intensive work on the aerodynamic shape of the trainset.

In terms of lessening environmental impacts, the trainset:

- Is designed with 98 percent easily recyclable materials (e.g., aluminum, steel, copper, and glass)
- Produces the same exterior pass-by noise at 224 mph (360 km/h) as other competitors' trainsets do at 186 mph (300 km/h).

Operational cost reductions include:

- 15 percent reduction in maintenance due to fewer bogies than conventional trains
- 15 percent longer lifetime than other trains due to its specific wheel design
- Fine tuning for train circulation, train fleet, and railway hubs due to its modular design.

The interior width of the AGV is 8.9 feet (2,7 m), and the gangway width is 3.3 feet (1,0 m). The interior design of the trainset is flexible, and can be modified to suit the customer's requirements. The trainset also has 15 percent larger windows.

The AGV is designed in triplets with its traction systems distributed beneath the floor. When compared to a trainset led by a power car, 20 percent more space is available to passengers. The AGV can be designed to range from seven to fourteen cars, each having the characteristics shown in Table 2.1.

**Table 2.1**  
**Characteristics of 7-Car-to-14-Car AGVs**

Model	Maximum Speed mph (km/h)	Length feet (m)	Standard Passenger Capacity	High-Density Passenger Capacity
AGV 7	186 (300)	433 (132)	245	312
AGV 8	186 (300)	489 (149)	321	378
AGV 10	199 (320)	600 (183)	374	462
AGV 11	224 (360)	656 (200)	446	510
AGV 14	224 (360)	827 (252)	593	654

---

Alstom is capable of manufacturing a 1,312-foot (400-m) trainset; however, it could not be used in double traction.

#### **2.4.1.4 SNCF Comment on Trainset Length**

SNCF advised that the trainset length, defined in TSI, is related to the length of the station platforms. TSI calls for a maximum trainset length of 1,312 feet (400 m) and a minimum trainset length of 656 feet (200-m). The minimum length is specified due to the pantograph's interaction with the catenary. It takes into account catenary oscillations caused by increasing trainset speed and pantograph friction.

Each TGV has a trainset length of 656 feet (200-m). The platforms in France typically have a length of 1,312 feet (400 m), except those that accommodate the TGV-A, which are 1,640 feet (500 m) in length (the TGV-A consists of ten coaches). The Eurostar is a 1,312-foot (400-m)-long trainset because of the Channel Tunnel. There was a requirement that passengers must be able to pass through the cars of the train in the event of an emergency. This is not possible when two 656-foot (200-m) trainsets are coupled together.

### **2.4.2 CSR**

#### **2.4.2.1 High Speed Rail Fleet**

**CRH380A.** CSR's primary goals when designing the CRH380A trainset (Figure 2.11) included:

- **Operational speed:** China aimed for a normal operational speed of 218 mph (350 km/h) and a maximum operational speed of 236 mph (380 km/h). The maximum test speed was 249 mph (400 km/h); however, this speed was exceeded twice at 259 mph and 302 mph (416,6 km/h and 486,1 km/h).
- **Comfort:** China focused on providing good ride quality, convenient service facilities, and ergonomic designs.
- **Environmental friendliness:** China wanted to reduce running resistance, improve aerodynamics, mitigate noise (aerodynamic and vibrational), and improve utilization of regenerated energy.
- **Safety:** China focused on trainset safety and reliability during continuous operations at very high speeds.

---

**Figure 2.11 CRH380A at Hangzhou Railway Station**



Source: WBPF Photograph, November 2010

CSR advised that the length of the eight-car CRH380A trainset is 667 feet (203,4 m). This trainset also has six motor cars and two trailer cars.

**CRH2C.** The Shanghai Railway Bureau (SRB) advised that the CRH2C is designed to operate at 218 mph (350 km/h) along with multiple traction modes. It is used to operate on 124 mph to 186 mph (200 km/h to 300 km/h) passenger lines. The CRH2C trainset has six motor cars and two trailer cars, with the latter two representing the leading and trailing ends of the trainset. Two trainsets can be coupled together to meet operational needs.

#### **2.4.2.2 Trainset Design and Testing Processes**

CSR advised that the design process for the trainset includes:

- Communication with customers upon receiving the technical specification
- Production of a design plan
- Proposal of the design
- Simulation analyses
- Manufacture
- Static test verification
- Line test verification
- Optimization.

Simulations conducted include:

- Structure and mode analyses
- Crash deformation analyses
- Fatigue analyses
- Dynamic analyses
- Aerodynamics analyses
- Noise analyses
- Electromagnetic compatibility (EMC) analyses
- Welding analyses.

---

Research platforms were developed to test trainset vibration modes, air tightness, fatigue strength, train running/rolling, and trainset reliability. A product virtual reality center was also developed.

CSR advised that more than 200 type and research tests were conducted on the CRH2C trainset between January 2008 and June 2008. More than 2,000 conditions were evaluated throughout the 180-day period, and testing at 239 mph (385 km/h) proved the running safety and reliability of the trainsets at that speed. Between December 2008 and November 2009, line tests were conducted on the Wuhan-to-Guangzhou High Speed Railway. During this time, research tests, endurance tests, and traceability tests were conducted. The total accumulated test mileage was more than 249,000 miles (400 000 km).

Between June 2010 and October 2010, 16 tests were conducted with the CRH380A under thousands of working conditions on the Zhengzhou-to-Xian High Speed Railway. The total accumulated test mileage was 20,560 miles (33 075 km). The test data showed satisfactory performance of this new generation EMU.

### **2.4.2.3 Plans for Continuing Advancements in HSR**

To date, CSR Sifang has delivered more than 150 trainsets to upgraded existing lines and new lines for service speeds of up to 218 mph (350 km/h). As a result, CSR Sifang is currently the new R&D leader in HSR in China. By the end of 2010, with MOR approval, a new R&D center will be established.

On November 15, 2010, a task force from MOR was established to evaluate the R&D of HSR. This effort includes 1,000 engineers to conduct preliminary R&D and to develop a conceptual design. With the HSR lab and R&D center, along with the combination of all efforts in-state and abroad, China is looking to develop an innovative platform.

## **2.4.3 Hyundai Rotem**

### **2.4.3.1 HSR Fleet Development**

Hyundai Rotem's experience with high speed trains dates back to 1994, when the contract was signed with Alstom to deliver KTX-I trains. The KTX-I trainset is a push-pull configuration and operates at a maximum speed of 186 mph (300 km/h). This trainset has been in operation since 2004. Hyundai Rotem's products under consideration for export to the U.S. are the KTX-II and HEMU-400X.

**G7 and KTX-II.** From 1997 to 2007, Hyundai Rotem's R&D Center developed the seven-car G7 prototype trainset (Figure 2.12), a push-pull type that is capable of operating at speeds of up to 218 mph (350 km/h).

---

**Figure 2.12 Hyundai Rotem's G7 Prototype Trainset**



Source: Hyundai Rotem Presentation, "High Speed Trains," November 2010

The results from the G7 project were incorporated into the development of the ten-car KTX-II, which is manufactured by Hyundai Rotem. Currently, 100 KTX-II cars are in operation. The KTX-II is of the push-pull configuration. It operates at a maximum speed of 186 mph (300 km/h), although it has a design speed of 205 mph (330 km/h). The operating speed is restricted to 186 mph (300 km/h) as required by the customer because the KTX-II shares rail lines with the KTX-I. The KTX-II began service in 2010. The length of the KTX-II trainset is 660 feet (201 m).

**HEMU-400X.** In 2007 Hyundai Rotem began researching a high speed EMU trainset. Its six-car prototype, designated the HEMU-400X, is designed for a maximum operating speed of 230 mph (370 km/h), but can achieve a speed of 249 mph (400 km/h). Additional new technologies include upgraded communication systems and increased rider comfort via active vibration control. Hyundai Rotem is targeting TSI compliance with the HEMU-400X. This trainset is currently under construction. After testing, the findings will contribute to the development of the KTX-III, which will operate between Seoul and Mokpo. The length of the HEMU-400X trainset is 648 feet (197,6 m) for an eight-car trainset.

Hyundai Rotem is developing the distributed power EMU instead of advancing the G7 project to allow the total weight of the trainset to be distributed more evenly and to decrease the axle load. Korail, Hyundai Rotem's primary customer, is focused on decreasing maintenance due to fatigue on the rails. In addition, Korea has a high passenger capacity requirement. All of these factors render the EMU a more feasible solution for Korea.

#### **2.4.3.2 Design and Testing Processes**

Hyundai Rotem provided an overview of the design process at its R&D center:

- Conceptual design: definition of system requirements and planning
- Preliminary design: design, analyses and calculations, simulations, and digital mock-ups
- Final design: detailed design, validation and tests, detailed analyses, and physical mock-ups

- 
- Production
  - Testing and commissioning: type tests, routine tests, combined vehicle tests, performance tests, test runs in the depot, and test runs on the mainline.

Hyundai Rotem performs system integration between the carbody and the train control and monitoring systems, the passenger information and passenger announcement systems, the main propulsion systems, the auxiliary power supply systems, the traction motors, the bogies, and the brakes.

- **Design development:**

- Developments in the carbody include lightweight and modular designs and crashworthiness.
- For electrical equipment, simulations in Matlab/Simulink, PSPICE, PSIM, and OrCAD contribute to a high performance systems design. For the traction motor, programs such as MAGNET6 and ABAQUS, and I-DEAS contribute to its lightweight and compact size.
- The design of the bogie goes through a four-step process. The first step includes review of the specification and the conceptual design. The second step is 3D modeling, where a digital mock-up is developed in CATIA. The third step involves analyses and simulations where, for example, the structure and the dynamics are analyzed. The fourth step involves verification tests, which include static load tests, fatigue tests, roller-rig tests, sway tests, and ride comfort tests.
- Trainset interior designs include passenger doors; passenger seats and heaters; heating, ventilation and air conditioning (HVAC) systems; cab modules; interior paneling; etc.

- **Design validation:**

- A digital mock-up is used to check interference within components and/or systems. Examples include the review of cab equipment layout and interference checks of various bogie and underframe equipment.
- A partial- or full-scale physical mock-up is developed so interference can be verified and adjusted to design for optimum accessibility and maintainability. Examples include the ergonomic review of the driver's cab and the check for underfloor wiring maintainability.
- The carbody structure is analyzed for stress, deformation, and buckling using linear static analysis software, such as I-DEAS and MSC-NASTRAN. The structure then undergoes static and fatigue tests.
- Systems engineering (e.g., reliability, availability, maintainability, and safety (RAMS); EMC; electromagnetic interference (EMI); fire safety; etc.) is performed. Fire safety is done by applying Korean safety regulations via simulations.
- The crashworthiness of the carbody structure is analyzed via quasi-static tests and dynamic tests.

- **Testing and Commissioning:**

- Dynamic analyses and simulated trial runs are performed to evaluate the performance of the trainsets at high speeds. Parameters studied include the derailment coefficient and the wheel/rail forces.

- 
- Noise analyses are conducted by using the finite/boundary element method (Sysnoise), the ray tracing method (ExNoise, Raynoise) for external noise prediction, and the statistical energy analysis (AutoSEA) for internal noise prediction.

## **2.4.4 JR Central, JR East, and Kawasaki Heavy Industries**

### **2.4.4.1 Kawasaki**

In Japan's case, the manufacture of high speed trainsets is typically divided among a consortium of Japanese manufacturers. Kawasaki has an extensive history with various Shinkansen series trainsets, the most recent of which are the N700 Series and the E5 Series, as developed by JR Central and JR East, respectively. In addition to manufacturing for the domestic market, Kawasaki has experience exporting high speed trainsets, namely the 700T for Taiwan.

Kawasaki has begun to develop an in-house design to suit various high speed markets. This trainset, dubbed the environmentally-friendly Super Express Train (efSET), would consist of eight cars, have a maximum operating speed of 218 mph (350 km/h), and accommodate up to 600 passengers.

Kawasaki advised that the maximum Shinkansen train length is approximately 1,312 feet (400 m). Shinkansen trainsets that are 656 feet (200 m) long include:

- Railstar (JR West): eight cars
- E2 Series (Nagano Shinkansen): eight cars
- N700S (Sakura): eight cars
- E4 Series (JR East): eight cars.

### **2.4.4.2 JR Central**

**N700.** The N700 is a 16-car trainset with fourteen motored coaches and two trailer coaches. It can accommodate a capacity of 1,323 passengers. The maximum operating speed of the N700 is 186 mph (300 km/h) on the Sanyo Shinkansen, which is run by JR West. It is anticipated that the export trainset, the N700-International (N700-I), will be able to accommodate a maximum operating speed of 205 mph (330 km/h).

### **2.4.4.3 JR East**

**E5 Series.** The E5 is a ten-car trainset with eight motored coaches and two trailer coaches. It incorporates the results gathered from the Series E954 Fastech 360S experimental trainset (Figure 2.13), which Japan used to evaluate 224 mph (360 km/h) operational speeds. The E5 can accommodate a capacity of 731 passengers and has a maximum operating speed of 199 mph (320 km/h) on the Tohoku Shinkansen.

---

**Figure 2.13 E954 Fastech 360S Experimental Trainset**



Source: Kawasaki quarterly newsletter, *Scope*, Issue 82, February 2010

### 2.4.5 Siemens

Siemens' experience with HSR dates back to its ICE 1 and ICE 2, both of which use power cars for push-pull operations. The ICE 3 platform was the first generation of distributed traction power for Siemens' high speed trainsets. The second and third generations were developed as part of the Velaro family with the Velaro E, and the Velaro CN and Velaro RUS, respectively. The Velaro D is the latest platform being developed for DB.

Velaro trainsets can operate in two 8-car configurations. The typical carbody length is approximately 79 feet (24 m). The maximum weight of the 1,312-foot (400-m)-long coupled trainset is 1,102 tons (1000 tonnes). One 8-car trainset weighs approximately 496 tons (450 tonnes). When fully loaded and fully equipped for all European traction power and signal systems, the weight of the 16-car payload is approximately 110 tons (100 tonnes).

**ICE 1 and ICE 2.** The ICE 1 is a 1,312-foot (400-m)-long trainset with two power cars and fourteen intermediate coaches. It accommodates 700 to 800 passengers. The ICE 2 is a 656-foot (200-m) trainset with one power car, six intermediate coaches, and one cab car. A 1,312-foot (400-m) configuration is possible with two power cars and fourteen intermediate coaches.

**ICE 3.** The first generation ICE 3 trainset was considered the greatest challenge for Siemens in HSR trainset design because of the move to distributed traction, with which the propulsion equipment and, therefore the masses, are distributed throughout the trainset. With its successful development, however, Siemens has been able to offer greater passenger capacity in a comparable trainset length.

Siemens identified the following systems, which were introduced on the ICE 3 platform:

- Eddy current track brakes to save on brake pad replacement and associated maintenance costs
- An HVAC system that used an air machine concept (non-Freon based) as an environmentally-friendly solution to cooling the trainset interior



- 
- A new diagnostic system
  - New ETCS train control.

Since the contract signed with DB in 1995, the ICE 3 has become a stable platform that is still in revenue service. Its success is the basis for future Siemens high speed rolling stock developments.

**Velaro E.** The second generation distributed traction Velaro E trainset was a further development from the ICE 3 and Siemens' first train to meet TSI requirements. The Velaro E has a maximum speed of 218 mph (350 km/h), although it operates at a maximum speed of 186 mph (300 km/h) because it runs under ETCS Level 1 [see Section 9.1.1].

The carbody shells were manufactured in Uerdingen and transported to Spain along with various interior components for assembly. The interior assembly was completed by local partners of Renfe. Train commissioning and testing were performed in Spain. The end cars, complete with onboard Automatic Train Protection (ATP) systems, were assembled in Uerdingen. The transfer of technology in Spain spanned from 2001 to 2007.

**Velaro CN and Velaro RUS.** The third generation distributed traction Velaro CN (Figure 2.14) and Velaro RUS trainsets are not fully TSI compliant because China and Russia have their own regulations and norms. The Velaro CN has a maximum speed of 218 mph (350 km/h). The Velaro RUS has a maximum speed of 186 mph (300 km/h). Both trains are 1 foot (300 mm) wider than the Velaro E (the Velaro CN because of China's high capacity requirement necessitating 2 + 3 seating versus the 2 + 2 European seating, and Russia's cold environment necessitating thicker insulation in the walls to withstand -58°F (-50°C) temperatures. Seven Velaro CN trainsets were delivered for the Chinese Olympic Games in 2008. Three were built and assembled in Germany; two were built in Germany and delivered, along with components, to China for final assembly. All of the Velaro RUS trainsets were built and assembled in Germany.

**Figure 2.14 Siemens' Velaro CN**



Source: Siemens brochure, *High Speed Trainset Velaro CN*

**Velaro D.** Siemens had just begun production of the first Velaro D, the fourth generation distributed traction trainset, at the time of the Fellowship meetings. The Velaro D was designed for DB. It seats 460 passengers. In comparison, the first series of the ICE 3 seats 441 to 458

---

depending on the respective version. This capacity increase is due mainly to the redesign of the interior to relocate equipment lockers.

The Velaro D was built for all international routes and can operate at a maximum speed of 199 mph (320 km/h). Siemens stated that the length of the Velaro's intermediate cars is 79.3 feet (24.2 m), which offers flexibility to the customer relative to the amount of passengers the trainset can accommodate. Siemens identified a possibility to extend the 656-foot (200-m) trainset length criterion to 820 feet (250 m) for additional capacity. The Velaro D comes with full bogie cladding and intercar coverings for ballast protection. It has fully optimized higher roof shrouds to improve the aerodynamics of the trainset.

## **2.5 EMERGING HSR SYSTEM DEVELOPMENTS: 218 MPH (350 KM/H) TARGET OPERATIONAL SPEED**

### **2.5.1 China: CRCC, CSR, MOR, and SRB**

#### **2.5.1.1 CRCC**

CRCC advised that China has unique operating experiences from increasing speeds. The country currently operates several speed classes on its high speed network: 155 mph, 186 mph, and 218 mph (250 km/h, 300 km/h, and 350 km/h). For its approximately 1 year in operational service, China has not experienced any mechanical or operational issues running at 218 mph (350 km/h). Also, because its new HSR system has been in service for only 11 months, CRCC has not seen anything yet in terms of necessary maintenance increases for rolling stock or infrastructure.

Operating at 218 mph (350 km/h) is possible because of the design (e.g., wheel/rail interface). A small increase in speed is also possible. For operations at 249 mph (400 km/h), however, additional study is required. The technology is capable of this speed, but safety, reliability, and passenger comfort have to be reviewed. CRCC advised that the current 218 mph (350 km/h) maximum operating speed is determined largely by the market demands.

#### **2.5.1.2 CSR**

CSR advised that the optimal maximum speed for HSR trainsets should be based on market requirements. CSR has performed an analysis of speed versus cost, with cost including energy consumption, maintenance, etc. CSR has estimated the energy consumption of the CRH380A to be less than 6 kWh (per person, per 62 miles (100 km)) when operating at 218 mph (350 km/h).

#### **2.5.1.3 SRB**

SRB, which reports to MOR, advised that all new HSR lines are planned to be fully dedicated. Currently, existing stations are used; however, the dedicated passenger lines (DPL) will be fully dedicated to HSR when complete. DPLs will permit train travel at speeds of more than 155 mph (250 km/h).

---

SRB mentioned some concern that freight trains could possibly damage tracks, so the maximum speed of high speed trains on tracks shared with freight is less than 124 mph (200 km/h); this speed is also possible only on lines that have been upgraded. This mixed use can be found throughout China currently; however, the increase in DPLs will reduce the number of these lower speed mixed-use lines. China has dedicated trainsets for specific lines. For example, trainsets with a maximum speed of 155 mph (250 km/h) will travel only on 155 mph (250 km/h) lines.

## **2.5.2 Korea: Hyundai Rotem and Korail**

### **2.5.2.1 Hyundai Rotem**

Hyundai Rotem advised that the future lines in Korea will operate at 249 mph (400 km/h). Existing lines are limited to 205 mph (330 km/h). Hyundai Rotem advised that the OCS must be modified to operate at such high speeds, and that this is easier to do with the design of new lines. Two new lines are being constructed in Korea—the Honam Line between Seoul and Mokpo and the Gyeongbu Line between Seoul and Busan. Speed will be restricted to 199 mph (320 km/h) in the initial setup, but 218 mph (350 km/h) is a possibility soon after. Hyundai Rotem reported that from an economics standpoint, a maximum speed of 186 mph (300 km/h) is enough, however, and that it placed more emphasis on average speed. Higher speed trainsets are being developed mainly to remain competitive with outside competition.

### **2.5.2.2 Korail**

Korail advised that prior to the implementation of a speed-up program to 93 mph (150 km/h), speeds on KTX conventional lines were limited to 81 mph (130 km/h) with original rail and catenary. After the installation of new infrastructure, however, (e.g., straightened curves, new rail, new catenary), the speed was increased to 93 mph (150 km/h). Changes made to improve/ensure safety include:

- Changes in the train control system
- Different catenary heights
- Different signaling systems.

## **2.6 BI-LEVEL PLATFORM DEVELOPMENT FOR HSR GREATER THAN 218 MPH (350 KM/H)**

### **2.6.1 CSR**

CSR advised that developing a bi-level trainset capable of 218 mph (350 km/h) is not advantageous. It emphasized that there is no space in the underfloor area to place equipment. Furthermore, China is not interested in developing concentrated power trainsets.

---

## 2.6.2 Siemens

Siemens advised that it is not interested in investing in the HSR bi-level concept, stating that the efficiencies associated with a bi-level design are realized only in the push-pull concept, and that passenger comfort would be compromised in a number of ways (e.g., through narrow passageways). In addition, there are concerns for passengers with reduced mobility because of the stairs between the two seating levels. A point stressed was that if there is to be level boarding, it would be contradictory to have passengers climb stairs inside the vehicle. Siemens also stated that the bi-level design provides no space under the car to place electrical equipment, thereby reducing interior space available to the passengers.

## 2.7 PRODUCTION FACILITIES AND MANUFACTURING CAPACITY

### 2.7.1 Alstom

Alstom's plant in Belfort, France, has 700 employees capable of manufacturing 100 power cars/locomotives per year. In 2009 the plant had a turnover of \$11.6 million (€8,9 million) with \$8.6 million (€6,6 million) in R&D and \$3 million (€2,3 million) in manufacturing. The plant has a total surface area of 14.6 acres (5,9 ha), and it has produced 1,200 power cars. Alstom is currently filling an order of 300 Prima diesel locomotives for SNCF (France and Germany), 20 Prima electric locomotives for Office National des Chemins de Fer du Maroc (ONCF) (Morocco), and 500 12,880 hp (9,6 MW) triple-axle locomotives for MOR (China). For SNCF, the Belfort plant has manufactured 98 Duplex ASYNchronous ERTMS (DASYE) power cars and 111 RGV 2N power cars.

Alstom's plant in La Rochelle, France, (Figure 2.15) has 1,207 employees (27 percent production workers, 36 percent administrative employees and technicians, 37 percent engineers and managers). It is the largest private employer in the Poitou-Charentes region and has invested more than \$43 million (€33 million) over 3 years to reshape the site. The La Rochelle plant is capable of producing 15 TGV trainsets and 11 AGV trainsets per year. It is also capable of producing 100 tramway units per year. The plant has a 74-acre (30-ha) surface area. Key activities at the plant include:

- Sub-assembly machining
- Body shell production and painting
- Coach equipment assembly and wiring
- Carriage and train tests
- Climate and acoustic chamber tests.

Alstom advised that the La Rochelle plant serves as the Center of Excellence for the production and manufacture of high speed and very high speed trainsets, including the TGV Duplex and the AGV, and as the Center of Excellence in the areas of climate and acoustic chamber testing.

**Figure 2.15 Alstom's La Rochelle Manufacturing Facility**



Source: Alstom Presentation, "La Rochelle Plant," June 2010

Alstom's North American facility locations and their product/service lines include:

- **Hornell, New York:** The largest rolling stock manufacturing operation in the U.S., this facility has supplied more than 2,200 new cars and more than 5,000 refurbished cars. It is capable of producing more than 50 metro cars per month.
- **Rochester, New York:** A main North American manufacturer of signaling and train control equipment, this facility supplies equipment for traffic management, network communications, traction and energy control, and operations and incident management.
- **Montreal, Quebec:** This is a main North American facility for the manufacture of passenger information systems, video surveillance systems, and communications equipment.
- **Chicago, Illinois; New Castle, Delaware; San Francisco, California; and Calgary, Canada:** These facilities provide management and technical support, material supply, maintenance, and overhaul and modernization services.

In terms of environment and safety, Alstom's corporate objectives involve reducing greenhouse gas emissions, managing high-risk activities, improving Environmental Health Safety (EHS) management on site, maintaining zero accidents, and keeping an accident-frequency rate below 1.5. Contributions of the La Rochelle plant include zero waterborne emissions, a goal of reducing volatile organic compound (VOC) emissions by half in 2010, and an aim to reduce the accident-frequency rate by two-thirds from 2006 to 2008.

## 2.7.2 CSR

The CSR Sifang Qingdao facility has been producing rail equipment for more than 100 years. This facility is capable of producing 200 high speed trainsets (1,600 cars) per year. Annually, it can also manufacture 1,000 metro cars in parallel. Sifang is currently the largest HSR rolling stock manufacturer in China.

---

The total area of the facility is 321 acres (130 ha). The workshop has an area of 99 acres (40 ha). Construction of a new plant is currently underway and it will have an area of 131 acres (53 ha). CSR Sifang has two bases, one in downtown Sifang and the other in Jihongtan. Together they have 20 production lines capable of manufacturing 200 high speed EMU train-sets and 120 metro trainsets per year. Sifang runs one 8-hour shift per day.

CSR advised that the length of its test track is 12,123 feet (3695 m). The track gauge is 56.5 inches (1435 mm). The maximum gradient encountered is 4 percent. The electrification provided is 25 kV AC, 1.5 kV DC, and 750 V DC. The maximum speed permitted on the test track is 68 mph (110 km/h) on the straight section.

### **2.7.3 Hyundai Rotem**

Hyundai Rotem advised that its Changwon manufacturing plant has an area of 156 acres (63 ha). There is a 10,302-foot (3140-m)-long straight test track located in the plant grounds. The carbody shop has an area of 5.9 acres (2.4 ha). It has a capacity of 880 cars per year. There are 162 employees in the Changwon plant.

### **2.7.4 Kawasaki Heavy Industries**

Kawasaki advised that its Hyogo Works building area is approximately 33 acres (13.2 ha) in size. The South Factory produces the carbody shells and bogies. The North Factory is used for final assembly. There are approximately 3,000 employees at Hyogo Works, and the facility can produce 960 passenger cars and 72 locomotives per year.

Kawasaki has two manufacturing locations in the U.S.:

- Kawasaki Rail Car, Inc. in Yonkers, New York
- Kawasaki Motors Manufacturing Corp. in Lincoln, Nebraska.

### **2.7.5 Siemens**

Siemens advised that the total manufacturing time of a Velaro cab car is 133 days under the following scenario:

- 52 days (three shifts per day) from the start of the car manufacturing process to the end of the carbody painting process
- 81 days (one shift per day) from the beginning of preassembly of the car to the end of the testing process, or 51 days if running two shifts per day.

Siemens can deliver approximately 450 high speed coaches and 600 regional coaches per year. Siemens advised that customers do not usually have inspectors on-site during the entire production process. Customer personnel visit the plant typically at key milestones and prior to delivery.

---

Siemens main plant for manufacturing the Velaro trainsets is located in the Uerdingen District of Krefeld, Germany. This facility produced the Velaro E for Spain, Velaro CN for China, and Velaro RUS for Russia; and it currently produces the Velaro D for Germany. Depending on the extent of technology transfer, some trains could be manufactured and assembled in their respective countries.

Velaro trains for the U.S. would most likely be manufactured in Sacramento. Siemens established a factory there in 1984 for light rail vehicles. This facility currently employs approximately 700 workers. Siemens purchased a 22-acre (8,9-ha) lot adjacent to its existing facility in hopes of expanding its product line in the U.S. to include DMUs, locomotives, and high speed rolling stock. Siemens is developing an FRA-compliant DMU and hopes to be in a position to market this trainset to U.S. operators who are seeking DMU equipment. The company is currently awaiting new contracts to justify and begin the expansion.

A question was posed to Siemens about whether vehicle procurement and core-systems procurement (train control, communications, track, traction power, etc.) should be separate procurements. Siemens stated that if a client has a working environment with existing infrastructure, then trains would be built to fit that system (i.e., separate procurements). When a client is constructing an entirely new system, however, the entire system (new vehicles, track, and systems) should be taken into account to ensure that everything is fully integrated and compatible (i.e., single procurement). In China, Siemens designed the train control system, rolling stock, and electrification. MOR served as the system integrator.





---

## **PART 2: TRAINSETS**



---

## **CHAPTER 3 CRASH ENERGY MANAGEMENT AND STRENGTH OF VEHICLES**

### **3.1 FRA'S DEVELOPING REQUIREMENTS FOR HSR CRASH ENERGY MANAGEMENT AND STRENGTH OF VEHICLES**

In September 2009 the FRA RSAC's ETF Phase 1 (ETF I) convened to evaluate European and Asian rolling stock designs (i.e., non-FRA-compliant, alternatively-designed rolling stock) and to develop guidelines that U.S. railroads and rail industry could implement to support waiver petitions applicable to existing Tier I Code of Federal Regulations (CFRs) (Tier I being operations at speeds of up to 125 mph (201 km/h)). This effort resulted in *Technical Criteria and Procedures for Evaluating the Crashworthiness and Occupant Protection Performance of Alternately-Designed Passenger Rail Equipment for Use in Tier I Service*, a report issued in draft form in December 2010. These criteria and procedures (C&P) are based upon current domestic and international service-proven technologies in rail equipment crashworthiness and structural strength.

The C&P presented guidance on the crashworthiness and strength of trainset structural elements. This guidance departed from the requirements contained in the Tier I CFR. One example of such departure is the implementation of collision scenarios to determine minimum train-level design characteristics, which is a philosophy embraced in European rolling stock design. Using predefined collision scenarios, the C&P identified requirements that, if adopted, will provide an equivalent level of crashworthiness while allowing the use of service-proven lightweight and efficient rolling stock designed to international standards.

Neither Tier I nor Tier II regulations address rolling stock traveling at speeds greater than 150 mph (241 km/h). Tier II requirements were developed primarily for the Acela HSR service, which began operating between Boston and Washington, DC, in 2000 at speeds of up to 150 mph (241 km/h). Tier II regulations are not appropriate to 220 mph (354 km/h) trainsets because such trainsets will be subject to significant restrictions on weight and axle loading.

As the number of HSR projects and potential HSR corridors increased in the U.S., FRA convened a new ETF focused on developing guidelines for HSR trainsets capable of traveling at a revenue operating speed of up to 220 mph (354 km/h). These new regulations will be known as Tier III. The first meeting of ETF Phase 2 (ETF II) was held in Cambridge, Massachusetts, in October 2010. At this meeting, FRA presented an agenda composed of similar topics that were identified and evaluated during the Fellowship program.<sup>1</sup> As a result, the knowledge gained during this Fellowship has been applied to the ETF proceedings. The new Tier III regulations will augment and in some cases replace existing regulations and will apply to train service at speeds greater than 125 mph (201 km/h). Tier III regulations will reference, in large part, the C&P developed by ETF I for Tier I operations.

This chapter presents information relative to international best practices for crashworthiness and occupant protection. In most sections, the prevailing Tier II CFRs and related European or Asian regulations are cited. HSR train manufacturers were asked to respond by

---

<sup>1</sup> Update: As of October 2011, the ETF had reached consensus on 25 technical points and had begun discussions on brake system design and inspection requirements, and on vehicle/track interaction.

---

giving their opinions of the regulations or by explaining how their trainset designs under consideration for U.S. operations comply with or provide equivalent levels of safety.

The majority of the information presented in this chapter relates to the European TSI, a system-based compilation of directives developed to ensure continued and enhanced interoperability of train operations over the trans-European HSR system. In addition, the following European Norms (EN) provide the engineering criteria for designing TSI-compliant HSR rolling stock based on the four collision scenarios listed in Figure 3.1:

- **EN 15227:2008:** Railway Applications — Crashworthiness Requirements for Railway Vehicle Bodies
- **EN 12663:2000:** Railway Applications — Structural Requirements of Railway Vehicle Bodies.

**Figure 3.1 EN 15227 Collision Scenarios for C-I Category Rolling Stock (Locomotives, Coaches, and Fixed Train Units)**

**FOUR COLLISION SCENARIOS STIPULATED IN EN 15227 SECTION 5.**

1. Front-end impact between two identical train units at 22 mph (36 km/h).
2. Front-end impact with a different type of railway vehicle, such as an 88-ton (80-tonne) freight car/wagon at 22 mph (36 km/h).
3. Train unit front-end impact with a large road vehicle, such as a 16.5-ton (15-tonne) truck/deformable obstacle at an at-grade crossing at a maximum of 68 mph (110 km/h).
4. Train unit impact into a low obstacle, such as a car, animal, or rubbish, on an at-grade crossing to achieve obstacle deflector requirements.

Crashworthiness, and specifically crash energy management (CEM), is a design philosophy currently being evaluated in Asia. Historically, Asia has focused on accident prevention and the fail-safe separation of high speed trainsets operating over dedicated HSR corridors, whereas Europe has promoted crashworthiness to mitigate the effects of a collision occurring while operating in shared rail corridors that are used by high speed, commuter and freight rail operations, and traversed by automobiles and trucks at at-grade crossings. To remain cost effective, HSR operations in the U.S. may include operations over dedicated rail corridors in the higher speed sections, and over shared corridors in sections leading into and out of major urban centers.

## **3.2 CRASH ENERGY MANAGEMENT**

### **3.2.1 Crash Energy Management and Crashworthiness**

As stated above, HSR systems in Asia follow primarily an approach based on *active* safety (i.e., systems that reduce the probability of an accident occurring), whereas in Europe, in addition to active safety, *passive* safety elements (i.e., systems that reduce the consequences of an accident, should it occur) are incorporated into the system design. It is generally understood that passive safety systems are not used to compensate for a lack of active safety in the railway network, but are complementary to active safety to account for personal safety when all other measures have failed. This perspective is evident in the ENs, which require the crash-

---

worthiness design of the trainset to cater to a 22 mph (36 km/h) impact as opposed to a 218 mph (350 km/h) collision.

CEM and crashworthiness are design philosophies embraced in passive safety system design. CEM/crashworthiness designs provide a means of dissipating the energy produced during a collision to provide protection to the occupants. The key safety parameters addressed through crashworthiness are shown in Figure 3.2.

### **Figure 3.2 Key Safety Parameters of Crashworthiness**

#### **KEY SAFETY PARAMETERS OF CRASHWORTHINESS**

- Reduce the risk of overriding.
- Absorb collision energy in a controlled manner.
- Maintain survival space and structural integrity of the occupied areas.
- Limit the deceleration.
- Reduce the risk of derailment and limit the consequences of hitting a track obstruction.

CEM systems are designed so that deformation of the trainset during a collision is controlled to absorb the energy of the collision. The collapse zones are located in non-occupied areas, typically those close to the extremities of each vehicle, in front of the cab, or adjacent to intercar gangways.

#### **3.2.1.1 Alstom**

Alstom advised that it has embraced a CEM-based design philosophy beginning with the TGV Duplex in the 1990s. It mentioned that passive safety was triggered by a TGV accident. Other scenarios as identified in EN 15227 were developed from discussions of “feared events.”

### **3.2.2 Dissipation of Collision Energy via Crash Energy Management**

*In discussing their approaches to designing trains for crashworthiness, manufacturers were asked if evaluating kinetic energy<sup>1</sup> was the correct approach when determining the requirements for CEM.*

#### **3.2.2.1 Alstom**

Alstom advised that evaluating CEM designs relative to the dissipation of kinetic energy is a correct approach. The various input parameters, which are vital in determining the energy distribution and the shape and location of the CEM absorbers, typically include:

- A set of collision scenarios (e.g., EN 15227)
- A set of criteria related to the collision scenarios (deceleration, plastic strain, etc.)
- The train architecture.

---

<sup>1</sup> Energy due to the speed of the train, defined as one-half of the body's mass times the square of its speed.

---

### **3.2.3 Designing to European Standards (EN 12663 and EN 15227)**

#### **3.2.3.1 Alstom**

Alstom's high speed trainsets meet the requirements of EN 12663 and EN 15227.

#### **3.2.3.2 CSR**

The carbody strength of the CRH380A meets the requirements of EN 12663; category P-II requirements (e.g., fixed units and coaches) cover the leading and trailing cars. No CEM is incorporated on the CRH380A currently; however, the requirements identified in EN 15227 are under research for high speed applications [see also Section 3.2.7.2]. That standard is followed for metro cars.

#### **3.2.3.3 DB**

DB advised that it is implementing TSI guidance and the associated EN and International Union of Railways (UIC) requirements for CEM.

#### **3.2.3.4 Hyundai Rotem**

Hyundai Rotem advised that the crashworthiness design for the HEMU-400X trainset is in conformance with EN 15227.

#### **3.2.3.5 Siemens**

Siemens stated that the Velaro trainset conforms to the requirements of EN 12663 and EN 15227.

### **3.2.4 European and U.S. Collision Scenarios**

*EN 15227 Section 5 identifies the four collision scenarios shown in Figure 3.1. 49 CFR §238.403 Section (d) identifies the scenario of an identical trainset collision at 30 mph (48 km/h). Manufacturers were asked to discuss these and additional collision scenarios for which their HSR trainsets have been designed and tested.*

#### **3.2.4.1 Siemens**

Most accidents in Europe occur at grade crossings on non-dedicated corridors. The collision speed requirement of 68 mph (110 km/h) for a collision with a 16.5-ton (15-tonne) truck/deformable object is based on the assumption that the train will reduce its speed from 99 mph to 68 mph within 1,640 feet (160 km/h to 110 km/h within 500 m) after seeing a truck/object on the right-of-way. This scenario was incorporated into EN 15227 after a collision between a TGV and a truck. Siemens advised that most train-to-train accidents occur near stations. As a result, the speed assumed in Scenarios 1 and 2 is 22 mph (36 km/h).

Siemens advised that although some U.S. HSR systems may not have any at-grade crossings, it might still be necessary to design according to Scenario 3 of EN 15227 to account for a motor vehicle making its way onto the right-of-way. In Germany, alternate mitigation measures, such as intrusion barriers, intrusion detection, etc., are being investigated to mitigate this hazard.

---

### 3.2.5 CFR Crash Energy Management Requirements and International Best Practices

49 CFR §238.403 Section (c) identifies CEM requirements that stipulate the absorption of 13 MJ at the end of each identical trainset in a collision at 30 mph (48 km/h) through controlled crushing of unoccupied volumes as follows:

- 5 MJ absorbed ahead of the operator's cab
- 3 MJ by the power car structure between the cab and first passenger car
- 5 MJ by the end of that first passenger car.

Manufacturers were asked to compare these CFR values with international designs and to discuss best practices for determining minimum CEM requirements.

#### 3.2.5.1 Alstom

Alstom advised that the AGV is EN 15227 compliant with an impact energy resistance of approximately 4.8 MJ located entirely in the front of the trainset. It does not have intercar absorbers. Alstom's policy is to take a safe, conservative approach with regard to CEM and trainset stability. Alstom advised that if one were to design energy absorbers at the AGV's or TGV Duplex's articulated ends (Figure 3.3), and if crush stroke (i.e., length of the deformable section of a structural element) is necessary, stability could be compromised. Alstom advised that the articulated trainset design inherently provides resistance to trainset overriding vertically and laterally.

**Figure 3.3 Articulated Architecture Featuring One Bogie Shared by Two Cars**

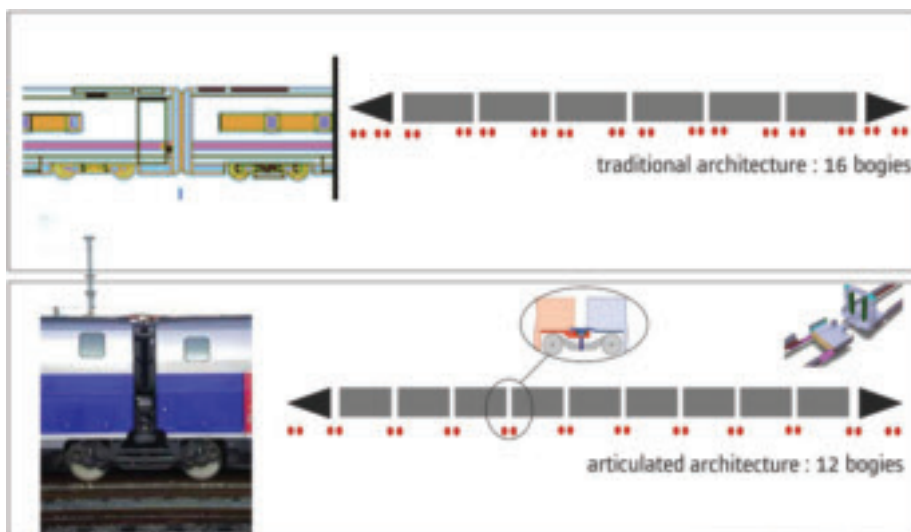

Source: Alstom Presentation, "Articulated/Conventional Architecture," June 2010

---

The TGV Duplex is fully compliant with EN 15227 and the 2002 and 2008 TSIs. The honeycomb structure of the Duplex CEM module can withstand 2 MJ. In addition, 5 MJ can be absorbed at the rear end of the power car, and another 5 MJ can be absorbed at the front of the first trailer car.

### **3.2.5.2 Hyundai Rotem**

Hyundai Rotem advised that the CEM module for the KTX-II trainset is a honeycomb apparatus. This device can absorb 2 MJ. There is no CEM system installed between cars.

## **3.2.6 TSI Requirements for Energy Dissipation**

*The 2002 TSI [2002 RST TSI Section 4.1.7 (b) and Annex A] identified a requirement for the dissipation of 6 MJ, with 4.5 MJ dissipated in front of the cab. This requirement was removed in the 2008 version of the TSI. The manufacturers were asked to discuss this change and to discuss the current criteria for CEM.*

### **3.2.6.1 Alstom**

Alstom advised that the 2002 TSI requirement was from an earlier requirement derived from a collision with a 16.5-ton (15-tonne) rigid plate (representative of a truck) at 69 mph (111 km/h). In the past, a minimum energy dissipation requirement was imposed because there were fewer possibilities for CEM systems. The 2008 TSI identifies collision scenarios and the truck model is now deformable, making this set of requirements more representative of an actual collision. Alstom advised that there are no longer minimum energy dissipation values identified in any European regulation or standard.

### **3.2.6.2 Siemens**

Siemens advised that the 4.5 MJ dissipation identified in the 2002 TSI was not relevant for design. The EN 15227 requirements have been implemented to focus on the preservation of the occupied volumes and the reduction of deceleration forces.

## **3.2.7 Crash Energy Management Energy Absorption Systems**

*The manufacturers were asked to discuss current designs of CEM systems and to identify performance characteristics and lessons learned. In addition, they were asked to discuss CEM design initiatives underway.*

### **3.2.7.1 Alstom**

Alstom's Module of Energy of Great Absorption (MEGA), the AGV CEM solution, absorbs 4.8 MJ of energy and has a crush stroke of 8.2 feet (2,5 m). MEGA's capacity is in addition to the energy absorption capacity of the fiberglass shroud, which Alstom stated is 500 kJ, although this value is not predictable.



---

Alstom advised that the key points linked to the CEM design validation are:

- Stability of the absorbers
- Quality of the calibration models
- Return on experience based on actual accidents.

Before and after photos taken from validation testing of the AGV MEGA unit are shown in Figure 3.4.

**Figure 3.4 Alstom MEGA Unit Validation**



Source: Alstom Presentation, "Passive Safety in Alstom High Speed Trains," June 2010

Alstom advised that the AGV and the TGV Duplex offer key advantages for safety. Articulation provides stability against derailments and rollovers and results in lower deceleration in the event of a collision because most of the mass is coupled, as opposed to conventional trainset architecture. For collisions of high speed trains on high radius curves, the collision angles are low and the effects of offset would be negligible. Alstom noted that the energy absorption capacity of MEGA would not be 100 percent in this type of collision, as it would in a head-on collision, but that MEGA would absorb a major portion of the impact. Alstom has not conducted any testing regarding lateral impacts.

Alstom advised that SNCF often specifies coupler performance parameters as follows:

- For the coupling unit at speeds up to 3.7 mph (6 km/h), devices are to be recoverable with no damage (cartridge is the expansion tube).
- For a collision at speeds between 3.7 mph and 9.3 mph (6 km/h and 15 km/h), the coupler retreat system will be replaced, with no damage to the structural absorber.

There are energy absorption elements in the intercar area for the TGV; there are no energy absorption elements in the intercar area for the AGV. This was a design choice by the Alstom engineers, who decided to bring all of the energy absorption capacity to the lead car. Alstom stated that by doing so, the deceleration felt by the first coach could be reduced. Thus, the long nose, rigid cab structure, electrical equipment and, finally, the first passenger seat are located between the impact point and the passenger area. For the TGV Duplex, the energy absorption elements between cars are negligible. The TGV buffers are each designed to withstand 250 kJ, which equates to a longitudinal deformation of 5 inches (125 mm) with a 220-ton (200-tonne) load applied.

---

### 3.2.7.2 CSR

CSR's development of a CEM system for the CRH380A trainset is progressing, although no CEM is incorporated currently. The initial design of the energy-absorbing device is complete, and simulations per EN 15227 have been performed and finished. ETF I's Tier I requirements are also under consideration/research, as China is looking to design the trainset to satisfy these criteria.

CSR has extensive experience researching and designing energy absorption elements for metro cars, which follow the criteria defined in EN 15227. The energy-absorbing elements are at the front and rear ends of the driver's cab and of the center car. These elements absorb energy sufficiently to preserve occupied space and, along with the anti-climber adopted in CSR Sifang's design of urban transit vehicles, guarantee the vehicles' safety in the event of a collision. The design requirements are usually specified by the operators.

CSR advised that the CRH380A trainset coupler buffer device can absorb the energy developed when two trainsets are coupled with a closing speed of 3.1 mph (5 km/h).

### 3.2.7.3 Siemens

Siemens' Velaro CEM systems are designed to absorb a substantial amount of the energy in train-to-train collisions. Couplers at the cab ends of the Velaro are positioned longitudinally during normal train operations. The composite end car mask has a mechanism that can be opened when the coupler is required. The coupler includes a recoverable energy absorber integral with the main shank and a deformation tube absorber at its inboard end that is approximately 9.8 inches (250 mm) long and 7.9 inches (200 mm) in diameter. The deformation tube is open on the inboard side and there is room for the end of the coupler to move rearward with additional stroke. Siemens advised, however, that there was probably not enough stroke to accommodate that needed for a collision with a rigid locomotive (as identified in the ETF I C&P document for alternatively-designed equipment). The coupler load drops to zero once the anti-climber absorbers come into contact in a conventional flat wall impact.

The intermediate cars on the Velaro are coupled using the equivalent of a special drawbar (Figure 3.5). This unit includes a deformation tube mechanism as its energy absorber and provides climbing resistance.

Characteristics of this unit include:

- Energy absorption of 1.2 MJ for the entire coupled connection (EN 15227 Scenario 1).
- Stroke of 31.5 inches (800 mm), although interference between car ends occurs at a stroke of approximately 23.6 inches (600 mm). The distance between main parts of the underframe is 31.5 inches (800 mm).
- Stepped load on push back with two levels: 270 kips and 540 kips (1200 kN and 2400 kN). It is noted, however, that energy absorption of 1.2 MJ in 23.6 inches (600 mm) implies a mean force of 450 kips (2000 kN). This load over 31.5 inches (800 mm) would provide 1.6 MJ of energy absorption.

---

**Figure 3.5 Siemens Velaro Intermediate Couplers**

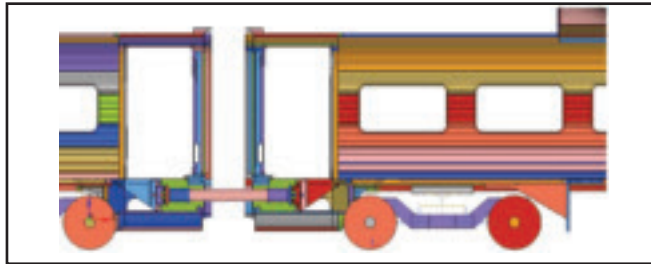

Source: Siemens Presentation, "Crashworthiness," January 2010

The Velaro's ability to satisfy EN 15227 Scenario 1 is independent of the total length of the trainset because each coupled connection is designed to absorb the energy of a single car colliding with another car at 22 mph (36 km/h).

Siemens' coupler elements include a mechanism that helps to resist catapulting (i.e., when the end of the coupler drops between the tracks and acts like a jack at the lead end of the trainset), which occurs when the coupler element rotates in the vertical plane about the end connected to the car. This mechanism features a flange-type element connected to the carbody that comes into contact with the rotating coupler, thereby inducing a resisting moment into the coupler. The energy of the coupled connection is exhausted under Scenario 1 conditions. Siemens' favored approach to achieving similar results at higher collision speeds would be to modify the coupled connection to permit more stroke. This might be achieved by increasing the distance between cars.

The crush zone design for the Velaro is illustrated in Figure 3.6. The total capacity of the front energy absorber is 3 MJ, which is required mainly for EN 15227 Scenario 3. Scenarios 1 and 2 require only 1.5 MJ. Siemens stated that Scenario 2 was the most challenging to meet for the Velaro. The length of the crush zone elements is approximately 3.3 feet (1 m).

**Figure 3.6 Siemens Velaro Front Crumple Zone**

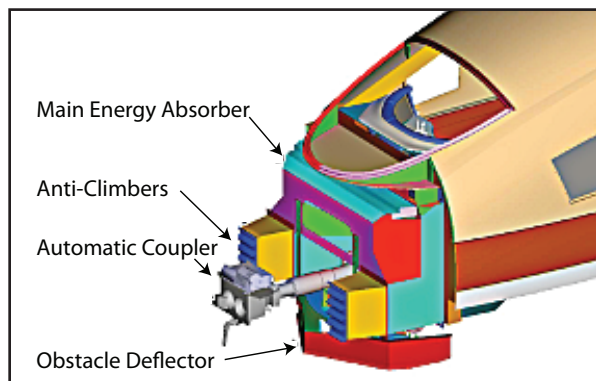

Source: Siemens Presentation, "Crashworthiness," January 2010

---

The energy absorbers work in two stages, the anti-climber absorbers and the main crush box. Both are fabricated from steel sheets approximately 0.25 inch (6,4 mm) thick with yield strength of approximately 46.4 ksi (320 MPa). The two anti-climber absorbers, one on each side to line up with European buffers (elements installed at each corner of the end of a rail vehicle), are bolted to and protrude from the crush box. They are approximately 13.8 inches (350 mm) in length. The absorbers are tapered and have ribs on their outboard faces except for an approximately 2-inch (50-mm)-long straight section on the outboard end of the absorber that helps to control collapse during the crush process.

The Velaro crush box consists of several flat plates welded together in a rectilinear fashion to form several large cells, two deep in the longitudinal direction. Some local reinforcement is used to facilitate collapse during crush. The crush box bolts directly onto the carbody. There is an additional plate on the inboard side of the crush box. The thickness/strength of this plate will not quite satisfy the CFR requirement (per 49 CFR §238.409 Section (d)), although a slight increase in thickness could be made. Siemens believes there is no need to modify the current crush box design, however, and that the steel it is made of is adequate. Siemens advised that some minor cracking of the absorbers occurs on crush, but that it does not affect performance. The longitudinal welds were placed to minimize cracking.

Siemens advised that as a result of the large surface of the CEM module on the Velaro, crash energy absorption is possible even with offset collisions. There is no explicit crushable structure at the coupled intercar ends of a Velaro trainset. The outer “skin” of the aluminum profile extends beyond the car ends at the coupled interface and would absorb some energy on crush. The ends themselves would also crush eventually. Siemens does not include the composite mask in crush calculations. It believes that these masks do not interfere with the crush zone operation. This view is supported by calculations and tests done on light rail vehicles in which the mask was included.

Siemens advised that dynamic crush testing for the lead end crushable structure of the Velaro (i.e., standard crash module) was conducted at Tuv-Sued (Technischer Ueberwachungs Verein) in Gorlitz, Germany. Only one dynamic test was conducted. This test did not provide the performance Siemens desired, so Siemens refined its model and material properties until agreement between the simulation and test observations was reached. Subsequent refinement of the crushable structure design was then performed through simulation.

## **3.3 PASSIVE SAFETY**

### **3.3.1 Trainset Design**

*Manufacturers of HSR trainsets for Europe have incorporated passive safety elements into the structural design to reduce the consequences of an accident should it occur. Alstom provided insight into the incorporation of passive safety into current HSR trainset designs.*

#### **3.3.1.1 Alstom**

Alstom advised that train systems must be secure from the perspectives of active safety—the prevention of accidents, and passive safety—the mitigation of consequences in the event of accidents. Active safety can be achieved through, for example, train control systems,

---

positioning systems, and the use of dedicated HSR lines. Alstom stated that passive safety is essential because accidents can be caused by unforeseen and non-HSR factors that active safety systems cannot guard against. These factors include but are not limited to visual driving (i.e., manual operation with the ATC system not functioning), grade crossings, and maintenance equipment on high speed right of ways.

Alstom advised that the passive safety design process in Europe includes the following steps:

- 1.** Identify and adhere to the passive safety performance requirements (e.g., collision scenarios).
- 2.** Develop passive safety specifications based on those scenarios (CEM system energy distribution performance requirements).
- 3.** Design passive safety components.
- 4.** Validate passive safety components (correlation with the specification of passive safety components).
- 5.** Validate passive safety performance through finite element analysis (FEA) (correlation with the collision scenarios).

Alstom explained how it applies this design process by using the AGV for illustration in most steps.

**Step 1.** The AGV is required to be compliant with the TSI and EN 15227.

**Step 2.** The form of energy distribution must be considered for each trainset design (i.e., bogie architecture). For the fully articulated AGV, the specification could reference typical calculations (i.e., single mass model). For conventional or partially articulated architecture, the specification must reference a lumped mass model.

**Step 3.** The passive safety design for the AGV takes into consideration the crash energy distribution provided by the obstacle deflector, the coupler retreat system, and the structural absorbers.

**Step 4.** Subcomponent validation is performed for passive safety elements. For example, with the coupler retreat system (Figure 3.7), the stroke of the pushback coupler is approximately 3.9 feet (1.2 m), as determined in a crash test. The system is a two-rod (aluminum) self-machining system. During a collision, the bolts break and the coupler pushes back. The AGV uses a hydraulic recoverable/replaceable coupler. Through pushback, the coupler can absorb approximately 1 MJ.

The entire MEGA system is placed onto a crash test bench and the test is conducted. After the coupler is pushed back, all compressible parts of the coupler enter into the absorber.

**Figure 3.7 Alstom AGV Coupler Retreat System**

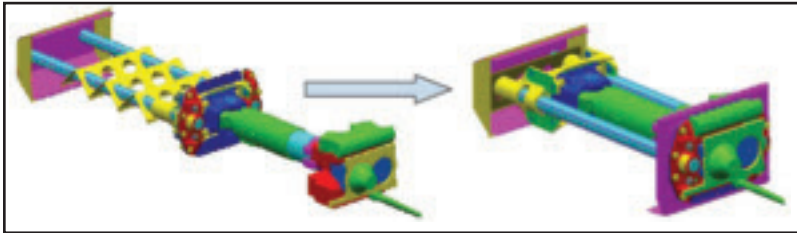

Source: Alstom Presentation, "Passive Safety in Alstom High Speed Trains," June 2010

**Step 5.** Alstom uses full finite element method (FEM) models that are properly calibrated from the actual testing to assess EN 15227 Scenarios 1, 2, and 3 (Figure 3.8). With these models, the criteria defined in EN 15227 can be checked (e.g., plastic strain, carbody length reduction, maximum deceleration, maximum wheel lift, etc.).

**Figure 3.8 Alstom AGV Passive Safety Final Validation**

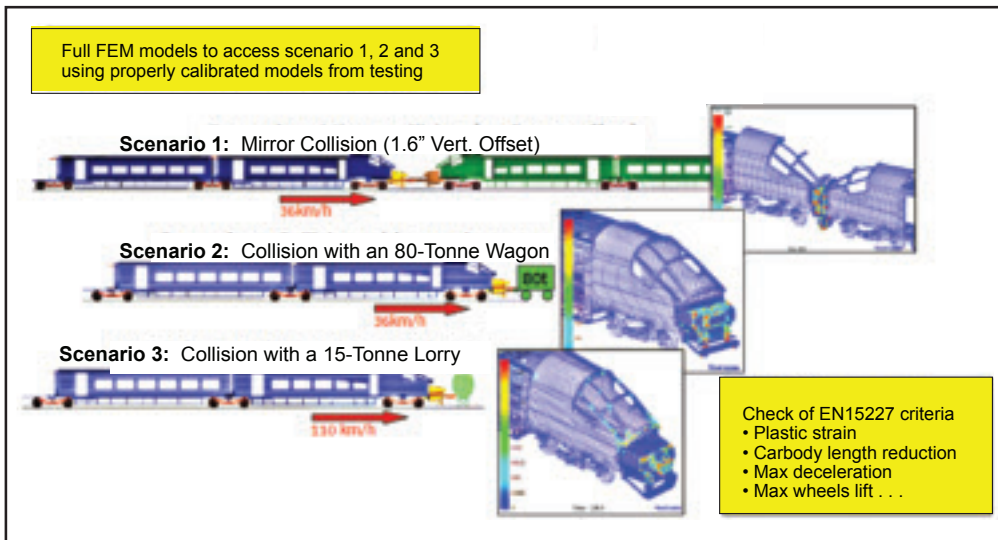

Source: Alstom Presentation, "Passive Safety in Alstom High Speed Trains," June 2010

### 3.3.2 Survival Space

*Manufacturers were asked to discuss the trainset structural elements needed to limit deformation and to discuss the crash energy pulse required to cause a reduction in the occupied volume of the driver's cab and in the passenger space in the leading car (e.g., post-collision).*

#### 3.3.2.1 Siemens

Siemens advised that the body shell hollow extrusions are stiff and provide excellent protection of occupied volumes. These extrusions are able to withstand more than 1,350 kips

---

(6000 kN) of uniform crush loading. Siemens confirmed that the vestibule area does not count as part of the occupied space as per EN 15227.

### **3.3.3 Post Collision Scenario and Passenger Impact Severity**

*CFR [49 CFR §238.403 Section (d)(2)] requirement of an 8 g maximum deceleration and TSI [2008 RST TSI Annex A.3.2] and EN [EN 15227 Section 6.4.1] requirements of a 5 g mean deceleration identify deceleration limits based on collision scenario speeds. The manufacturers were asked to discuss the maximum deceleration rate for their trainsets that are under consideration for the U.S. and to compare the maximum secondary impact velocity (SIV) of the 25 mph (40 km/h) collision scenario called out in 49 CFR §238.403 Section (d)(1).*

#### **3.3.3.1 Alstom**

Alstom advised that secondary impact management had not been taken into consideration previously in Europe at either the standard-making level or the regulation level. Alstom had participated in research that evaluated this concept, however. The research was performed under the SafelInterior project, a 3.5-year-long effort undertaken to guide the development of integrated safety systems (preventive, active, and passive) that are reliable and fault-tolerant, while taking into account human-machine interface (HMI) concepts and focusing on system integration. This project was funded in part by the European Commission (EC).

Alstom provided an overview of the SafelInterior project:

- All analyses were conducted with Hybrid III anthropomorphic test devices (crash-test dummies).
- The impact severity was defined in accordance with the scenarios defined in EN 15227 (5 g deceleration over 100 ms), resulting in a secondary impact velocity of 11.2 mph (5 m/s), and with the interior equipment strength defined in EN 12663.
- The layout included inline seating with tables and without tables, bay seating with a fixed table, a low backseat, and a grab pole.

Some of the outcomes of the test were as follows:

- SafelInterior determined that the lightest rolling stock in the EN 15227 Scenario 1 collision resulted in the worst case.
- SafelInterior will recommend adoption of moderate injury criteria (20 percent of risk of Abbreviated Injury Scale (AIS) Code 2). Other recommendations are ongoing. The SafelInterior recommendations were made to the EC on July 1, 2010. In approximately 6 months to 1 year, there will be an open discussion on the secondary impact management's relation to EN 15227. Two years afterwards, it is expected to be incorporated into a standard.

As a result of its research in support of the SafelInterior program, Alstom developed a patented system for driver protection that incorporates an airbag into the design of the driver's console (Figure 3.9). The airbag deploys near the driver's abdomen upon impact, thereby helping to divert impact to the chest.

---

**Figure 3.9 Alstom's Supplementary Protection of the Abdomen Through Additional Airbag Chamber Deployment**

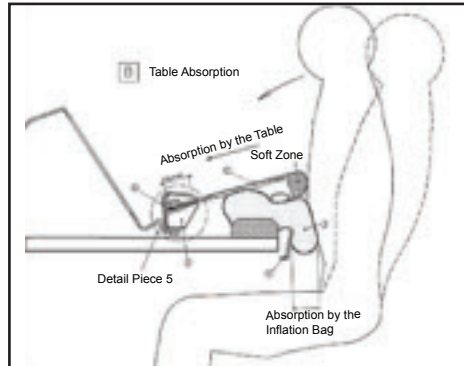

Source: Alstom Presentation, "Passive Safety in Alstom High Speed Trains," June 2010

### **3.3.3.2 Siemens**

Siemens advised that the deceleration rate is calculated from the beginning of the collision until the net force equals zero. This averages out to approximately 5 g. It is expected that the SIV will be slightly less than half of the closing speed in an identical trainset collision.

### **3.3.4 Overriding**

*CFR [49 CFR §238.403 Section (e)(1)] requires that all wheels of the trainset remain in contact with the rails during a collision. TSI [2008 RST TSI Annex A.3.1] and EN [EN 15227 Section 6.2.1] allow for an offset of 1.6 inches (40 mm) granted the criteria for survival space and deceleration are met and that at least one wheelset of each bogie remains in contact with the rail. This offset may be a cause for derailment. The manufacturers were asked to discuss each approach.*

### **3.3.4.1 Siemens**

Siemens stated that analysis conducted on the Velaro trainset showed that the flange of the wheel will not lift above the rail during any of the EN 15227 collision scenarios.

## **3.4 VEHICLE STRUCTURAL STRENGTH**

### **3.4.1 Vehicle Construction/Structural Strength**

#### **3.4.1.1 Alstom**

Alstom advised that its HSR trains under consideration for the U.S. adhere to requirements identified in EN 12663 and EN 15227. The AGV is designed to the passenger vehicle category of P-II requirements (as defined in EN 12663) for a fixed or semi-permanently coupled trainset, while the TGV is designed to the passenger vehicle category P-I requirements for a locomotive-led trainset.



---

### **3.4.1.2 CSR**

CSR advised that hollow, thin-wall, extruded aluminum alloy profiles are used for the side walls, roofs, and end walls of the CRH380A trainset. The cab is of the slab and girder type. The underframe is a monoblock bearing structure comprising the side and cross beams. The lead car of the trainset is of the cuneal structure type (wedge shaped) with parabolas. The carbody strength of the CRH380A meets the requirements of EN 12663. In addition, the fatigue strength of the carbody structure is tested to  $\pm 0.87$  psi ( $\pm 6$  kPa).

CSR advised that the design of the CRH380A lead car started with 20 models, 10 of which made it to the conceptual stage. During conceptual design, 32 variables and 200 model optimizations were evaluated. Of the ten models, five were selected to continue on to the design phase, during which 75 simulations and 10 wind tunnel tests were conducted. One model was then selected to continue on to the manufacture and verification stages. During manufacturing, 4 test verifications and 40 process verifications were conducted. During the verification stage, 22 ground tests and 6 line tests were conducted.

### **3.4.1.3 Hyundai Rotem**

Hyundai Rotem advised that aluminum alloy is used for construction of the KTX-II trainset trailer cars, and that steel is used for the power car. Aluminum extrusions are used for the HEMU-400X carbody.

### **3.4.1.4 Siemens**

Siemens advised that aluminum extrusion technology is used for the Velaro carbody shells. Aluminum is cost-efficient, lightweight, and capable of withstanding extraordinary loads. A stiff structure is necessary to meet the longitudinal static compressive force requirements and to deliver good ride comfort to the passengers. Siemens' design takes into consideration the distribution of longitudinal loads through the carbody shell. Aluminum carbodies are manufactured in Uerdingen. The aluminum extrusions used for the Velaro are manufactured by Alcan and are joined in a tongue and groove fashion. The extrusions are then MIG-welded together longitudinally. Flat sheets are formed to construct parts of the sides of the curved nose of the cab end. The portion of the leading end of the cab car that is not occupied by passengers depends on the specific Velaro model. The Velaro D has the leading one-third section of the lead car unoccupied by passengers. This area includes an equipment room located directly behind the cab.

## **3.4.2 Longitudinal Static Compressive Forces**

*There is a large difference between the longitudinal static compressive forces identified in EN standards (e.g., 337,000 lb<sub>f</sub> (1500 kN) in EN 12663 Section 4.2, Category P-II) and those identified in CFR (2,100,000 lb<sub>f</sub> (9342 kN) in 49 CFR §238.405 Section (a) and 800,000 lb<sub>f</sub> (3559 kN) in 49 CFR §238.405 Section (b)). The manufacturers provided feedback on the CFR and TSI/EN requirements, identifying how the TSI/EN compressive requirements were developed and identifying solutions available to mitigate potential hazards.*

### **3.4.2.1 Alstom**

Alstom advised that the compressive strength for the AGV is 330,700 lb<sub>m</sub> (150 tonnes), whereas the compressive strength for the TGV is 441,000 lb<sub>m</sub> (200 tonnes). The typical loco-

---

motive manufactured by Alstom complies with the 441,000-lb<sub>m</sub> (200-tonne) requirement (as defined in EN 12663). The static load of 441,000 lb<sub>m</sub> (200 tonnes) was intended to protect the carbody against light shocks.

The TGV Duplex cab structure is designed to withstand 1.1 million lb<sub>m</sub> (500 tonnes); the full body can withstand 441,000 lb<sub>m</sub> (200 tonnes) with no elastic deformation. The front of the TGV power car consists of a fiber shroud with steel construction.

Alstom advised that the collision scenarios and related requirements used to validate carbody designs were based on French and German collision experiences but were developed more than 15 years ago, before the release of EN 15227. The French had additional requirements for side collision tests and required that trainsets be able to withstand an impact with a wall. Although the earlier TGVs were not tested to EN 15227 because the standard did not exist then, they comply with it because they complied with the old, more stringent French standard. The requirements of EN 15227 were developed based on the criteria in UIC 566, which is consistent with older, superseded French standards.

Alstom stated that the required strengths for the TGVs are low when compared to the U.S. requirements because the weights of the trainsets are lower. Achieving 18.7 tons (17 tonnes) per axle for the TGV and the AGV was a challenge and, if the CFR criteria are adhered to, then the weights would increase and their impacts on speed and infrastructure would have to be considered.

Alstom advised that potential hazards are mitigated through compliance with the performance requirements associated with EN 15227's four collision scenarios. EN requirements are valid for the leading and trailing cars. On the TGV, 441,000 lb<sub>m</sub> (200 tonnes) are applied at the coupler attachment points. On the AGV there is a crash absorbing system, MEGA (Figure 3.10), that consists of an integrated coupler and crash box. This system meets the 330,700-lb<sub>m</sub> (150-tonne) requirement.

#### **3.4.2.2 CSR**

CSR advised that the value of the compressive strength should guarantee that the carbody structure cannot be destroyed with impacts sustained during coupling or small/medium type crashes. Therefore, the value of the compressive load is related to the coupling speed and the possibility of an accident. Accidents can be avoided by using dedicated high speed lines and advanced train control systems. CSR advised that the EN 12663 Category P-II requirements cover leading and trailing cars. The CRH380A trainset complies with the compressive load requirements of EN 12663.

#### **3.4.2.3 Siemens**

Siemens advised that the Velaro trainsets are designed according to the EN 12663 Category P-II requirements (Figure 3.11). They have a buff strength (i.e. static compressive load) of 337,300 lb<sub>m</sub> (153 tonnes); the buff tests are carried out in Uerdingen.

**Figure 3.10 AGV MEGA with Integrated Coupler**



Source: Alstom brochure, *AGV: Full Speed Ahead into the 21st Century*

**Figure 3.11 Siemens Velaro Depicting Locations for the Application of Compressive Loads**

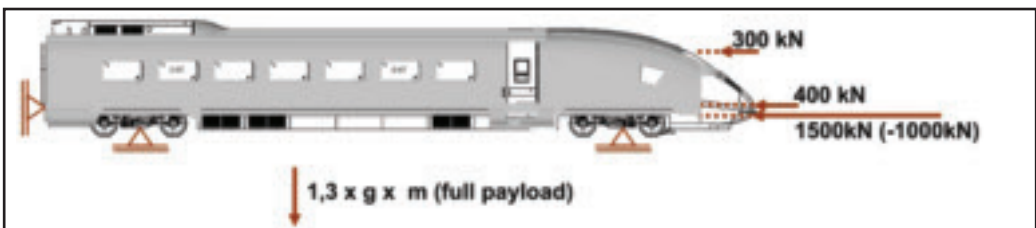

Source: Siemens Presentation, "Construction and Structural Requirements of Carbodies," January 2010

### 3.4.3 Vertical Static Loads: Anti-Climbers

*There is a difference between European and U.S. practices for the definition of vertical static loads. CFR [49 CFR §238.407] codifies structural requirements for anti-climbing mechanisms (e.g., forward end to resist an upward or downward static vertical force of 200,000 lbf (890 kN), and interior train coupling points to resist vertical force of 100,000 lbf (445 kN). TSI and the ENs are silent on these criteria. The manufacturers were asked to discuss how the anti-climbing design accounts for resistance to vertical forces.*

---

### **3.4.3.1 Alstom**

Alstom advised that EN 15227 Section 6 defines anti-climbing criteria. According to Alstom, the TGV and the AGV are safe in regard to overriding because of their articulated architecture. The TGV has a  $2 \times 38,220 \text{ lb}_f$  (170 kN) anti-climbing strength at the ends of the trainset (primarily because the intermediate/articulated ends do not require such strength) to meet an SNCF requirement.

Alstom advised that override can be prevented dramatically by using CEM systems because of the reduced effects of the collision. The front ends of the trainsets are designed with a combed system to prevent climbing; however, Alstom advised that it is primarily the vertical stability of the energy absorber (MEGA), as installed on the AGV, that will prevent override.

### **3.4.3.2 CSR**

CSR advised that an anti-climbing structure is under study for the CRH380A, although currently no anti-climbers are on the high speed EMUs. Anti-climbing devices are installed between the front cars and middle cars of metro/mass transit trains. The vertical force is resisted by the meshing of the anti-climbing teeth.

### **3.4.3.3 Siemens**

Siemens advised that lead cars have two ribbed anti-climbers at the buffer locations. The anti-climbers are pieces of steel (approximately three) welded to the end of the anti-climber absorbers. The approximate vertical resistance for the two anti-climbers is  $45,000 \text{ lb}_f$  (200 kN). Anti-climbing capability is evaluated using the entire train-to-train collision simulation in which wheel lift from the track is calculated.

Siemens stated that its anti-climber absorbers are designed to be short in length for better stability against overriding. Siemens also stated that the Velaro's design of coupled connection provides a high level of stability against override.

## **3.4.4 Vertical Static Loads: Coupler Arrangement**

*The manufacturers were asked what total vertical force their coupler arrangements were capable of resisting, and to compare the value of this force with the  $100,000 \text{ lb}_f$  (445 kN) identified in CFR [49 CFR §238.407 Section (c)].*

### **3.4.4.1 Alstom**

Alstom stated that resistance of vertical forces by a coupler is irrelevant because anti-climbing is accounted for by the energy absorber. The TGV is designed to prevent overriding where one coupler head is 2 inches (51 mm) above the other in an identical trainset collision. Alstom advised that ETF I modified this criterion for Tier I. Instead, the wording of EN 15227 was adopted to ensure that the anti-climbers are engaged throughout the collision.

### **3.4.4.2 Siemens**

Siemens advised that the front coupler is not intended to carry any vertical loads; however, if one lifts a car relative to another, the coupler can resist  $22,500 \text{ lb}_f$  (100 kN).

---

### 3.4.5 Obstacle Deflectors

EN 15227 Section 5 requires the obstacle deflector to withstand 67,500 lb<sub>f</sub> (300 kN) of load at the centerline and 56,200 lb<sub>f</sub> (250 kN) of load 29.5 inches (750 mm) from the centerline laterally. This requirement is specified for speeds greater than 99 mph (160 km/h). The manufacturers were asked to discuss the performance requirements for obstacle deflectors.

#### 3.4.5.1 Alstom

The TGV obstacle deflector meets the requirements for 99 mph (160 km/h) speeds and higher. Alstom feels that this criterion is sufficient for 218 mph (350 km/h) operations. Alstom also emphasized that the TGV corridor is fenced in to prevent animals and trespassers from entering the right of way. In addition, no at-grade crossings intersect the line.

#### 3.4.5.2 CSR

CSR advised that the CRH380A obstacle deflectors (Figure 3.12) installed at the front end will prevent derailment and reduce the consequences of impacting obstacles on the track. They can deflect obstacles that weigh up to 220 lb<sub>m</sub> (100 kg) and are located less than 15.8 inches (400 mm) above the track.

**Figure 3.12 CRH380A Obstacle Deflector**

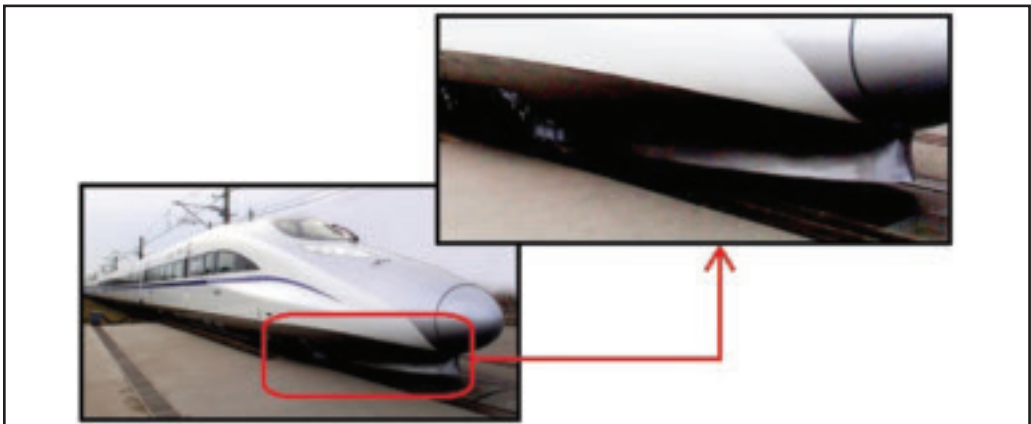

Source: CSR Sifang Presentation, "Information about High Speed EMU," November 2010

#### 3.4.5.3 Siemens

Siemens advised that the obstacle deflector for the Velaro trainset satisfies the requirements of EN 15227. This deflector pushes back as it absorbs energy rather than pushes down. Siemens also tested the obstacle deflector with a new, internally approved scenario in addition to the EN 15227 requirement. This scenario involves a collision at 68 mph (110 km/h) with a 4.4-cubic-foot (0,125-m<sup>3</sup>) rigid block weighing 551 lb<sub>m</sub> (250 kg) placed 3.9 inches (100 mm) above the top of rail.

---

### **3.4.6 End Structures of Power and Trailer Cars**

*CFR [49 CFR §238.409, 49 CFR §238.411, 49 CFR §238.413, 49 CFR §238.415, and 49 CFR §238.417] describes in detail the forces that each structural member at the ends of the vehicle (e.g., collision post, corner post, forward facing skin) is to resist upon an impact. Traditional U.S. rail car designs have incorporated these structural members to provide a means for withstanding compressive loads encountered during a collision. The manufacturers were asked to compare these loadings with the compressive loads identified by EN 12663 Section 4.2.2.*

#### **3.4.6.1 Alstom**

Alstom advised that no collision or corner posts are on the TGV or the AGV trainsets, adding that there was no need for such extensive requirements on the end structures because crashworthiness is verified by the collision scenarios, and there is coherence between the static requirements of EN 12663 and the collision requirements of EN 15227. In fact, EN 12663 was optimized based on EN 15227. Alstom advised that its current trainset designs are able to resist high loads.

#### **3.4.6.2 CSR**

CSR advised that the CRH380A trainset is designed to withstand compressive forces of:

- 88,200 lb<sub>m</sub> (40 tonnes) at the end wall structure at 5.9 inches (150 mm) from the floor
- 66,200 lb<sub>m</sub> (30 tonnes) on the belt rail of the carbody (window sill level on the side of the car)
- 66,200 lb<sub>m</sub> (30 tonnes) on the upper level of the side window.

#### **3.4.6.3 Siemens**

Siemens advised that the Velaro trainset does not have distinct collision and corner posts. The cab car end frame requirements specified in 49 CFR §238 Appendix F would be satisfied, as demonstrated by the analyses of the Railjet crush zone, which is essentially identical to that used on the Velaro. For coupled intercar ends, Siemens would rely on the CFR provision for semi-permanently coupled trains that allows for no collision posts. At the coupled ends, Siemens could add structure in front of the occupied volume to satisfy the CFR requirement. Siemens advised, however, that compliance with the U.S. corner post requirements would result in increased weight.

### **3.4.7 Rollover Strength**

*EN 15227 Section 6.3 states that 80 percent of the original ceiling-to-floor height in the cab shall be maintained when subjected to the collision scenarios. 49 CFR §238.415 requires that each car be able to rest on its side (uniformly supported at the roof rail and the side sill) and on its roof (damage limited to roof sheathing and framing, where deformation is permitted to the extent necessary to permit the vehicle to be supported directly on the top chords of the side and end frames). These requirements were reviewed by the manufacturers and their feedback is documented in this section.*

---

### **3.4.7.1 Alstom**

Alstom advised that there are no particular requirements for trainset rollover strength so it is not evaluated in simulations. Alstom stated that the articulated architecture of the AGV and the TGV Duplex trains precludes just one car from rolling over, the entire trainset must follow. Alstom is confident, however, that both trainsets meet current CFR requirements.

### **3.4.7.2 CSR**

CSR advised that based on its simulations, the CRH380A trainset can withstand the loadings when rolled over on its roof or its side. As a result, it complies with the requirements in EN 15227 Section 6.3 and in 49 CFR §238.415.

### **3.4.7.3 Siemens**

Siemens stated that the roof strength would be demonstrated by supporting the car on its sides at the elements corresponding to the car lines. The calculation has not yet been performed for the Velaro platform, however, because calculations for crippling loads are not a requirement in Europe. The language of the CFR permits deformation of certain roof structure members. Concern has been expressed by RSAC members that the aluminum extrusion roof could buckle inwards and consume a significant part of the occupied volume.

## **3.4.8 Side Loading**

*CFR [49 CFR §238.417] identifies resistance of 80,000 lb<sub>f</sub> (356 kN) at the side sill and 10,000 lb<sub>f</sub> (44,5 kN) at the belt rail. No European or Asian requirements are known to accommodate side impact criteria.*

### **3.4.8.1 Alstom**

Alstom advised that side loading is designed according to foreseeable aerodynamic loads and not to potential side impacts. Alstom does not believe that its side structures will be able to withstand large impacts or loadings.

### **3.4.8.2 CSR**

CSR advised that side loading is not taken into account in its designs; however, numerical simulations of the CRH380A trainset showed that the 49 CFR §238.417 criteria can be met.

### **3.4.8.3 Siemens**

Siemens stated that the Velaro should have no problems meeting the CFR requirements for side loading. It emphasized that side loading is not a function of the speed of the trainset.

## **3.4.9 Static Strength and Structural Stability and Stiffness**

*EN 12663 identifies requirements for structural stability and stiffness. The manufacturers were asked to discuss these requirements and compliance with them. In addition, the manufacturers were asked to identify additional requirements/standards for static strength, structural stability, and stiffness.*



---

### **3.4.9.1 CSR**

CSR advised that the CRH380A trainset meets the criteria identified in EN 12663. CSR recommended that the carbody bending vibration frequency be different from the vibration frequency of the bogie, and that this ratio (separation of excitation frequency between the bogie and the carbody) should be greater than 1.4. CSR stated that one needs to understand the characteristics of the track before conducting dynamic analyses of the rolling stock.

### **3.4.10 Superposition of Static Loads**

*EN 12663 identifies superposition load cases that include the combination of the longitudinal and vertical static load cases. The manufacturers were asked to compare the EN requirements to the CFR load requirements for end structures of power and trailer cars.*

#### **3.4.10.1 CSR**

CSR advised that the superposition conditions of vertical and torsional loadings are added into the design of the CRH380A trainset.

### **3.4.11 Demonstration of Fatigue Strength**

*EN 12663 identifies methods of assessing fatigue strength (e.g., endurance limit or cumulative damage). The manufacturers were asked to comment on how the limits for fatigue strength were derived.*

#### **3.4.11.1 Alstom**

Alstom follows the endurance limit approach to demonstrate fatigue strength. Accelerations of  $\pm 0.15$  g in vertical and transversal directions, etc., as defined in EN 12663, are applied for 10 million cycles.

#### **3.4.11.2 CSR**

CSR designed the CRH380A carbody for an infinite life, and its fatigue strength meets the requirements of EN 12663. CSR uses the endurance limit approach for fatigue. The effective load changing rate is  $\pm 0.1$ . The load and unload cycles are considered based on the actual working conditions. Track induced loading is considered as 2.8 kips/foot (40 kN/m). The g-loading of the carbody, the decoupling of vibrations, and track twist are also considered. The traction and braking loads are considered per acceleration and deceleration. The air tightness fatigue strength analysis of  $\pm 0.87$  psi ( $\pm 6$  kPa) is included on the basis of EN 12663. UIC 566 is also referenced to analyze fatigue loads.

#### **3.4.11.3 Siemens**

Siemens advised that the Velaro is tested to an aerodynamic load of 0.87 psi (6 kPa). EN 12663 does not define the approach on how to apply fatigue loads. Siemens advised that it was essential to optimize the attachments of heavy underfloor equipment to reduce vibrations. Lateral vibration of the carbody is sometimes limiting in design (this is the mode in which the car cross section deforms laterally as if in shear). Siemens conducts fatigue evaluations using DVS 1612, which defines vertical bending.



---

## **3.5 ATTACHMENTS AND FITTINGS**

### **3.5.1 Equipment Attachments**

*CFR [49 CFR §238.419] and EN 12663 Section 4.5 requirements for equipment attachment strength differ, with the CFR requirements being more stringent. The manufacturers were asked to discuss how the EN requirements were developed and how the EN loads compare with the requirements called out by CFR.*

#### **3.5.1.1 Alstom**

Alstom advised that CFR uses very high accelerations because it has no CEM considerations (i.e., collision scenarios). Energy absorbers are accounted for in the EN so there is no need for such high acceleration resistance. Alstom stated that the EN equipment attachment criteria were derived from UIC 566.

#### **3.5.1.2 CSR**

Equipment attachments for high speed trains are evaluated based on the dynamic stresses encountered throughout the lifetime of the trainset. China collects information regarding track excitation forces and develops an excitation spectrum.

### **3.5.2 Truck Attachment Strength**

*ETF I is proposing a truck attachment strength capable of resisting forces generated by accelerations of 5 g longitudinal, 1 g lateral, and 3 g vertical. This strength is equivalent to the truck-to-car-body attachment requirements under Category P-1 in EN 12663 Section 4.5. The manufacturers were asked to discuss limitations associated with truck attachment strength.*

#### **3.5.2.1 Alstom**

Alstom advised that the maximum truck acceleration in the horizontal direction, is  $\pm 3$  g, so the 250,000-lb<sub>f</sub> (1112-kN) force requirement 49 CFR §238.419 Section (a) is too high. Alstom advised that the fixed load for truck attachments was evaluated by the ETF.

Per the ETF proceedings, the truck attachment is linked to a collision scenario in which it will need to resist accelerations of 5 g longitudinal, 1 g lateral, and 3 g vertical as defined in the C&P.

#### **3.5.2.2 Siemens**

Siemens stated that the weight of its truck is 11 tons (10 tonnes), and that the attachment could sustain a 5 g ultimate load (3 g yield).

### **3.5.3 Interior Fittings and Surfaces**

*The acceleration requirements codified by CFR [49 CFR §238.435] are more stringent than those of EN [EN 61373 Section 10.5], being 8 g longitudinal for non-cab car or 12 g longitudinal for cab car, 4 g lateral, 4 g vertical, versus 5 g longitudinal, 3 g lateral, 3 g vertical. The manufacturers were asked to discuss how the EN requirements were developed.*

---

### 3.5.3.1 Alstom

The EN requirements for equipment attachments were brought over from UIC 566. According to the European experience, 5 g longitudinal, 1 g lateral, and 3 g vertical are sufficient.

All equipment attachments on the TGV Duplex meet the 5 g requirement. Alstom's main concerns were ensuring that equipment installed behind the back walls did not penetrate the passenger cabin. Alstom emphasized that while doing so is not required in TSI or EN, it designs the metal fastener attachments to accommodate equipment fixation failure. In addition, Alstom also uses safety pins to attach the equipment. This design, which was decided upon based on a fault analysis conducted jointly with SNCF, can accommodate accelerations greater than 5 g.

Alstom advised that applying the 8 g or 12 g requirement on a transformer unit or another large unit results in a weight increase issue. In addition, seeing a 12 g deceleration is not possible with an energy absorbing device. Alstom advised that the 8 g requirement might be too high for public address (PA) and emergency lighting attachments, especially with CEM-enhanced trainsets.

### 3.5.3.2 Siemens

Siemens stated that the Velaro can comply with CFR requirements. Seats are attached to the car at two points, the floor between a pair of seats and the wall. Siemens has designed an energy absorbing table for which the absorption system is integral with the table wall mount. The absorbers get deformed as the table swivels toward the wall. The weight of the table with all of its components is 79 lb<sub>m</sub> (36 kg). This table was not designed for the Velaro but could be adapted to it.

## 3.5.4 Interior Fittings for the Driver's Cab

*The acceleration requirements codified by CFR [49 CFR §238.447] are more stringent than those of EN [EN 12663 Section 4.5], being 12 g, 4 g, and 4 g versus 3 g, 1 g, and 3 g. The manufacturers were asked to discuss how the EN requirements were developed and to present their cab seat designs (e.g., mechanisms that permit push back).*

### 3.5.4.1 CSR

CSR advised that the cab seats' ability to withstand shock and vibrations complies with Chinese standard TB/T 3058, which is equivalent to EN 61373. Vibration tests carried out per Class 1 Grade A with a frequency range of 5 to 50 Hz and vibration accelerations of 0.5 m/s<sup>2</sup> longitudinal, 0.37 m/s<sup>2</sup> lateral, and 0.75 m/s<sup>2</sup> vertical showed no damage to the seats.

The strength of the cab seat complies with TB/T 2961:1999 Sections 5.1 through 5.3:

- Clause 5.1 specifies that the cushion and armrest must withstand a 397-lb<sub>m</sub> (180-kg) object along the plumb line direction. The cushion covering, bracket, and base should not be damaged by the load, and there should be no permanent deformation or welding cracks.
- Clause 5.2 requires that the backrest be struck by a 249-lb<sub>m</sub> (113-kg) test block to generate 373 lb<sub>f</sub> (1660 N) and 749 lb<sub>f</sub> (3330 N) forces. Under the first case, no per-

---

manent deformation or damage should occur. Under the second case, permanent deformation should be less than 2 inches (50 mm).

- Clause 5.3 defines the rotating stability of the seat. A torsional load of 160 lbf (710 N) applied to the seat should not result in any damage of the seat; however, permanent deformation is permitted on the lock pin.

#### **3.5.4.2 Siemens**

Siemens advised that the driver's cab is designed according to UIC 644, UIC 651, DIN 5566, EN 45542, DIN 5510, and EN 15152.

Siemens stated that it can comply with the CFR requirements. The Velaro cab covers the entire width of the car. The driver seat is in the center, it is rigidly attached, and there is no push-back mechanism. The volume/zone around the driver is preserved based on the dimensions outlined in the EN standard. As a result, there is no designated deformation zone around the driver that makes push-back necessary.



---

# CHAPTER 4 EMERGENCY PREPAREDNESS (SYSTEM PROTECTION)

## 4.1 FIRE SAFETY

A comparison of U.S. and international fire safety standards revealed many similarities in the approaches followed to maximize passenger and crew safety in the event of a fire. The standards address the safety of individual components and materials installed on the trainsets and the system-based approaches for eliminating fire hazards and mitigating the harmful effects of a fire. This chapter provides insights into international approaches to fire safety.

### 4.1.1 Alstom

Alstom has its own fire safety policy, the *ATSA Fire Safety Management Work Method Statement (ENG WMS 005)*, that serves as a guideline for the fire safety design of Alstom's entire product line, including rolling stock, infrastructure, signaling, etc. ENG WMS 005 covers all necessary fire safety recommendations and rules to reduce and eliminate fire ignition and propagation and assist in passenger evacuation. This policy is used primarily when there are no particular contractual or legal requirements regarding fire safety for the trainset. In such cases, the trainset-specific requirements are referenced and the final provisions are submitted to CCN Fire Safety Management (a management/specialty group internal to Alstom) for approval. CCN Fire Safety is always consulted first for the definition of the minimum level of requirements that need to be achieved. Alstom can then propose to its clients a trainset that incorporates the suggested fire safety protection.

Alstom develops a fire safety report that includes safety analyses, tests, and validations for each stage of a project. The report also fully describes TSI regulations and potential future European standards. It is followed and adhered to during the engineering process of the trainset.

In order of importance, Alstom sees the five stages of fire protection being prevention, attenuation, evacuation, help and rescue, and provisions for dealing with the remaining risks (Figure 4.1).

**Figure 4.1 Alstom's Five Stages of Fire Protection in Order of Importance**

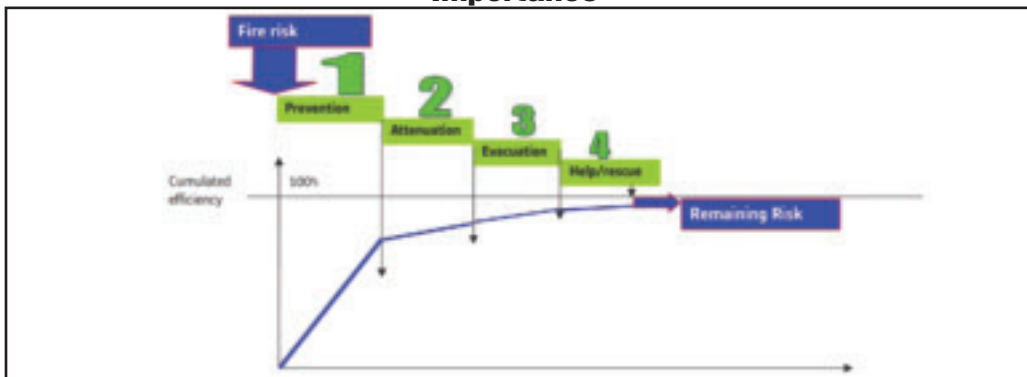

Source: Alstom Presentation, "ATSA Fire Safety Policy," June 2010

---

**Prevention.** Alstom advised that its requirements to prevent fire ignition and toxic smoke production cover components of train design and operation, including:

- Interior and exterior materials, their fire reaction properties, and their applications inside the trainset
- Potential ignition sources in the design of the trainset (e.g., electrical components)
- Various potentially dangerous substances that could be transported by the trainset or another trainset that shares the infrastructure (e.g., gas or flammable liquids).

As an example of interior materials, the AGV floor is fire resistant for up to 30 minutes as long as it is well protected. Alstom advised that there is a specific layer of fiberglass that increases the time it takes for the aluminum to melt. The aluminum floor itself is fire resistant for up to 15 minutes.

Alstom is currently working in France to demonstrate that there is no fire propagation after the ignition source is removed.

**Attenuation.** The requirements needed to mitigate the effects of fire spread include:

- Installation of fire barriers
- Installation of thermal and/or smoke detection alarms with the capability of remotely isolating the ignition sources
- Incorporation of firefighting equipment on the trainset.

The AGV trainset for NTV is equipped with an active fire suppression system, which was requested by NTV because of the numerous rail tunnels through which its trains will operate. This system, supplied by FOGTEC, is designed for a single application in one coach. Its two main components are:

- **A water-mist based system for the passenger areas.** This system is supplied by two 13-gallon (50-L) tanks of water, one installed at each end of the train behind the HVAC system on the roof. It works in conjunction with smoke detectors installed in the passenger areas. The placement of these detectors is modeled by the supplier.
- **A nitrogen-based system for the high voltage electrical compartments.** This system is supplied by two 6.6-gallon (25-L) tanks of nitrogen, one installed at each end of the train behind the HVAC system on the roof.

The water system weighs approximately 959 lb<sub>m</sub> (435 kg) per each end of the train, and the nitrogen system weighs approximately 115 lb<sub>m</sub> (52 kg). Piping throughout the trainset weighs approximately 110 lb<sub>m</sub> (50 kg). The fire suppression system for the entire train adds approximately 3,440 lb<sub>m</sub> (1560 kg) to the trainset weight.

The fire suppression system is pressurized to 2.9 ksi (200 bar) with high pressure pumps. The nitrogen piping is designed to withstand 100 times the normal pressure expected. The system itself is dry, with no fluids in the pipes until activation. The fire load for the AGV is 40 GJ per coach.

The addition of trainset fire suppression systems can reduce the costs of tunnel ventilation systems drastically; however, tunnel infrastructure still must be designed to be structur-

---

ally sound in the event of a fire. According to Alstom, the tunnel needs to withstand 1,832°F (1000°C) for 2 hours.

**Evacuation.** Alstom asserts that the potential effects of a fire for each risk area identified by the fire safety analysis must be evaluated to determine the time needed for the trainset to reach a place of safety for passenger evacuation. Vital functions of the trainset that need to be considered include the carbody shell and floor (structural resistance), underfloor equipment, and the trainline for traction and braking. Design considerations to facilitate passenger evacuation include emergency windows and doors, emergency lighting, and passenger alarm and communication systems.

Alstom uses LEGION software to simulate passenger evacuations and to analyze evacuation times based on the average walking speed of the passengers (a variable that is input to the program). Alstom advised that its simulations for the TGV Duplex showed the evacuation time to be 2.08 minutes. Alstom also conducts other simulations using FDS, Star CCM+, and ANSYS software packages, which can simulate the burning of a component installed in the trainset. Alstom suggested that these packages might assist in determining whether or not a particular CFR test is required.

Alstom discussed the rolling stock fire safety criteria for tunnels as defined in TSI. Fire safety criteria termed Category A are specified when the rolling stock is anticipated to travel through a tunnel for which the time to reach an area of safety is less than 4 minutes at 50 mph (80 km/h), which is typically a tunnel less than 3.1 miles (5 km) long. Fire safety criteria termed Category B are specified when the rolling stock is anticipated to travel through a tunnel for which the time to reach an area of safety is less than 15 minutes at 50 mph (80 km/h), which is typically a tunnel less than 12.4 miles (20 km) long. Alstom emphasized that the tunnel length is not as critical as the time needed to reach a safe area to evacuate the passengers.

Consideration must also be given to the scenario in which the trainset is unable to exit the tunnel (e.g., if a traction motor catches fire). While a fire suppression system can extinguish the fire, provisions still need to be made on the infrastructure side (e.g., walkways) to facilitate passenger evacuation from the trainset, if necessary.

**Rescue.** In the past, rescue efforts were planned with local authorities and documented by the operator. Alstom is preparing an internal document, *Rescue Technical Instruction in Case of Accident on the Rolling Stock*, to assist in this process. This document serves as a guideline that covers rescue efforts depending on the type of trainset. Alstom acknowledges that the fire might not originate from the trainset equipment itself (i.e., human negligence, vandalism, etc.), so the document is based on the worst-case scenario where fire and smoke have invaded a coach in which passengers are trapped. The various sections of the rescue instruction document are:

- **Train identification:** A general description of the train, including its configuration and dimensions, the number of cars and the approximate number of passengers and crew members
- **Hazards:** Internal and external hazards, such as embedded electrical, hydraulic, and mechanical energies, battery locations, air tank locations, high voltage areas, and electrical wiring
- **Access:** Locations for access into the trainset, including passenger and cab doors, emergency windows, etc.

- 
- **Evacuation:** Locations for evacuation means from the trainset, including coach doors, emergency windows, gangway doors, cab doors, etc.
  - **Traffic:** The traffic and routes to various areas of the trainset
  - **Firefighting provisions:** Locations of firefighting and fire suppression equipment, fire barriers, PA system, etc.

#### 4.1.2 CSR

**Materials.** A requirement for the CRH380A was that non-metallic materials not spread flame, so fireproof/flame retardant materials are used. These materials are low-smoke, non-/low-toxic and halogen-free. The requirements of DIN 5510-2 are followed for the CRH380A. With the exception of high voltage cables connecting to the input of the transformer, all wire and cables are halogen-free, flame-retardant, low-smoke, and non-toxic when burned.

**Fire Suppression.** MOR requires fire extinguishers onboard the trainsets as follows:

- One dry powder extinguisher in the driver's cab
- Two water extinguishers 11 lb<sub>m</sub> (5 kg) in each food preparation area
- One dry powder extinguisher and one water extinguisher 4.4 lb<sub>m</sub> (2 kg) at each end of each coach.

The MOR requirements are more stringent than, and therefore in compliance with:

- UIC 564-2, which stipulates one extinguisher in each passenger coach and two extinguishers in each sleeping car and dining car
- TSI, based on EN 3-3, EN 3-6, and EN 3-7, which stipulates that the trainset should be equipped with portable extinguishers, which includes water type extinguishers.

No high-pressure fire suppression systems are installed currently on the CRH380A.

**Emergency Communications.** TSDI advised that there are three levels of emergency communication:

- MOR is responsible for the overall state emergency plan.
- The railway bureaus are responsible for the emergency plans for the local governments.
- The stations and depots are responsible for interacting with emergency responders and providing emergency engineering assistance.

#### 4.1.3 Hyundai Rotem

Hyundai Rotem advised that monitoring systems are installed on its trains for smoke and heat. The fire safety methods used in Korea involve a two-step process:

- Use materials that mitigate fire spread
- Use portable extinguishers for fire suppression.



---

#### 4.1.4 Siemens

Siemens complies with German laws and European standards in addition to TSI for high speed rolling stock and safety in railway tunnels. Siemens stated:

- Its train systems must be able to function in the event of a fire, including traction control, brake control, train control, communication devices, door control, emergency exits, emergency lighting (which must function until the end of an evacuation), and fire detection systems.
- It is essential that the trainsets be designed to have no open hollow spaces or recesses, good visibility of the luggage racks, good views from car to car, and fire extinguishers.

**Materials.** Siemens uses various materials to cover critical metallic (e.g., aluminum) parts to meet certain fire safety requirements.

Siemens calculates the deflection of the structural members of the trainset as a result of heat effects on their material capabilities. For Germany, these calculations are based on defined scenarios. As an example, Siemens had to demonstrate the deformation of the car-body shell under fire conditions, a scenario defined in DIN 5510-4.

**Fuel Loads.** While it is common to calculate total fuel loads on trams (e.g., metros), Siemens advised that it is less common to calculate this value for HSR trainsets. Siemens has not performed this calculation for the Velaro platform.

**Fire Barrier Doors.** Velaro trainsets are designed with automatic (electrically-operated) fire barrier doors (Figure 4.2) that close via an electric door operator, but can be opened manually after they have been closed. All fire barrier doors on the Velaro are made of glass. Siemens developed intumescent<sup>1</sup> grids to close ventilated cabinets in the event of a fire.

**Figure 4.2 Velaro E Fire Barrier Doors**



Source: WBPF Photograph, February 2010

<sup>1</sup> Intumescent components swell when heated.

---

**Evacuation.** Siemens has performed calculations and simulations for emergency evacuations, but such planning is still a new concept.

**Fire Suppression.** A nitrogen-based fire suppression system for the high voltage cabinets was adopted for the Velaro RUS instead of a water-based system. Incidents had occurred in Europe where water-based systems were falsely triggered, causing extensive damage to the electrical equipment. Siemens advised that false indications can be caused by smoke coming from the exterior of the vehicle and not generated from within the trainset itself.

Siemens stated that it was not possible to sense for both heat and smoke for the Velaro RUS platform. The requirement for a fire suppression system on the Velaro RUS was a customer requirement; it was not required by standards or laws. The systems are supplied to high voltage lockers and to high power cabinets mounted on the underfloor. No high voltage equipment is located in the carbody itself. One bottle of nitrogen can supply two cabinets.

Siemens stated that fire suppression systems in the form of aqueous solutions will be available as an option for its DMUs. Siemens added that a fire suppression system is beneficial to a single traction system, but is not necessary for a multiple traction system because the redundancy will enable the driver to move the train to a safe location.

**Tunnel Fire.** NERTUS, a Siemens/Renfe joint venture formed in 2002 to provide trainset maintenance, advised that to meet the fire safety requirements of TSI, the Velaro E is capable of traveling at a speed of 50 mph (80 km/h) in degraded mode for 15 minutes, a distance of about 12.4 miles (20 km), to allow the trainset to exit a tunnel.

## **4.2 U.S. AND INTERNATIONAL FIRE SAFETY STANDARDS**

### **4.2.1 Alstom**

Alstom advised that current 49 CFR §238 standards for fire safety and the seven parts of EN 45545 standards illustrate requirements that focus on the rolling stock itself. TSI considers fire safety requirements on rolling stock and infrastructure. The approach is similar to that taken by NFPA 130 Section 8. Alstom stated that CFR requirements need to be assessed because the test methods are different.

Alstom advised that results of various tests have demonstrated the fire resistance capabilities of its trainsets, as have actual scenarios. For example:

- In November 1993 an attack was launched on a TGV-A trainset at Hendaye station in France. The perpetrator dumped 14.5 gallons (55 L) of petroleum in one coach and lit it on fire. The fire did not spread in the coach.
- In the 2005-2006 timeframe, Korea experienced a terrible fire on its metro. As a result, a fire test was conducted on the Korean TGV (Figure 4.3) and aired on national television. The fire burned the seat, but the seat did not ignite.

---

**Figure 4.3 KTX-I Seat Fire Test**

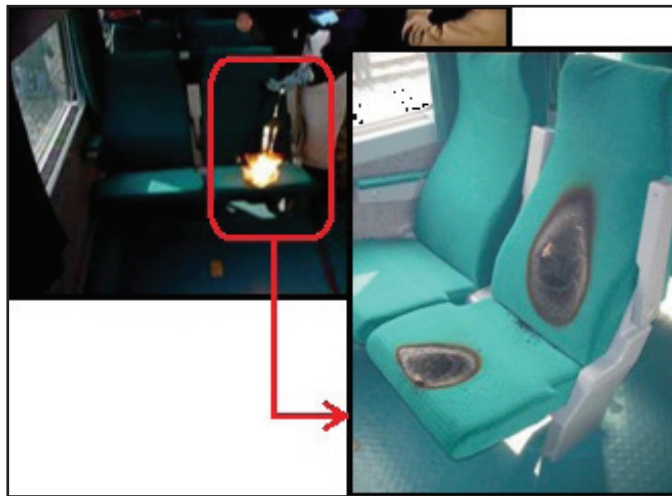

Source: Alstom Presentation, "Very High Speed Train and Safety," June 2010

Alstom's strategy towards fire safety is to apply EN 45545 to the extent possible. Some customers request compliance with EN and with national standards. Alstom feels, however, that there are still some risks associated with full compliance with EN, but that there are no risks with the national standards. EN 45545 is currently still a draft standard. The first six parts will be voted on in 2012. The seventh part, which details fire and smoke qualifications, is being finalized.

Standards that Alstom complies with are:

- Material safety requirements: BS 6853, NFF 16-101, NFF 16-102, DIN 5510-2, UNI CEI 11170-1/3, PNK-02511/02502, TS 45545-2, and ISO 834
- Fire extinguishing requirements: EN 3-3, EN 3-6, and EN 3-7.

#### **4.2.2 CSR**

CSR advised that the CRH380A design complies with BS 6853, DIN 5510-2, and NFF 16-101, which include tests for flammability, smoke, and toxicity. BS 6853 has the most severe requirements for the car structure, with the exception of parts and materials. DIN 5510-2 specifies not only flammability, smoke, and toxicity requirements, but also flame drip during burning. The testing requirements are categorized as follows:

- S: Flame spread and flame time, which are classified as S1-S5 grade
- SF: Heat radiation during burning, which is classified as SF1-SF3 grade
- ST: Flame/material drip, which is classified as ST1-ST2 grade
- SR: Smoke diffusion/flame extinction, which is classified as SR1-SR2 grade
- FED: Measurement of toxic gas according to a specified time (for 30 minutes,  $FED \leq 1$ ).

---

CSR stated that EN 45545-2 is equivalent to DIN 5510-2. EN 45545-2 is the amendment based on the DIN standard.

CSR recommended that fire extinguishers be used on U.S. high speed trainsets and not fire suppression systems. It also recommended limiting the use/reference of multiple standards, as this practice could result in testing difficulties and additional costs.

## **4.3 SIDE-FACING EMERGENCY WINDOWS**

*The U.S. approach to emergency windows typically incorporates the use of an elastomeric gasket that can be removed from the perimeter of the window to allow passengers to dislodge the window without the use of tools. The international approach is to have passengers use a hammer-type device to break a specially designed emergency window. Once the window is broken by the passenger, the entire unit can be pushed out of the trainset side wall. The merits of both approaches were discussed with the manufacturers.*

### **4.3.1 Impact Resistance**

*The authors discussed side-facing emergency glazing and the Tier II, Type IIIH impact requirements, under which current CFR regulations require side windows to withstand a large object impact of 122 J (e.g., a 12-lbm (5,4-kg) solid steel sphere traveling at 15 mph (24 km/h)), a small object impact of 127 J (e.g., a 0.5-lbm (0,23-g) granite ballast stone traveling at 75 mph (121 km/h)), and a ballistic impact of 359 J (e.g., a 0.35-in (9-mm) bullet traveling at 900 feet per second (274 m/s)).*

#### **4.3.1.1 Siemens**

Siemens advised that current emergency window designs can meet the CFR requirements for side facing glazing.

Figure 4.4 shows the emergency glazing and the accompanying hammer installed on the Velaro E.

**Figure 4.4 Velaro E Emergency Side Glazing with Breakout Hammer**



Source: WBPF Photograph, February 2010

---

## 4.3.2 Resistance to Pressure Pulses

HSR trainsets will encounter significant pressure pulses during operations that could impact side-facing windows. Such pulses are typically the most severe when two trainsets pass each other on closely spaced track centers or when a trainset enters and leaves a tunnel. Manufacturers were asked to discuss the pressure test requirements of NEA VWV 6.2 Section 3.5.2.2. The ICE 3 meets the  $\pm 1.2$  psi ( $\pm 8,1$  kPa) requirement defined in this standard.

### 4.3.2.1 Alstom

Alstom developed the pressure wave resistance requirements and the mounting designs for the AGV in-house. Alstom expressed two primary concerns with the pressure wave resistance of rubber gasketed side glazings:

- The deflections experienced may cause injury to passengers. In addition, there is the potential for the glazing to blow in or blow out.
- Today's side glazings for very high speed trains are mounted flush with the carbody. If rubber gasketing is used, aerodynamic drag will increase and parasitic noises will be generated.

Alstom advised that the pressure tightness for the AGV side-facing glazing is tested with the following simulations:

- **Fatigue from trains passing outdoors:** +0.20 psi (+1,4 kPa); -0.33 psi (-2,3 kPa) for 4 million cycles (with triangle signal of 17.41 psi/s (120 kPa/s))
- **Fatigue from trains running in tunnels:** +0.36 psi (+2,5 kPa); -0.80 psi (-5,5 kPa) for 1.2 million cycles (with triangle signal of 10.88 psi/s (75 kPa/s))
- **Exceptional fatigue load from trains passing in tunnels:** +0.36 psi (+2,5 kPa); -0.65 psi (-4,5 kPa) for 100,000 cycles (with triangle signal of 26.11 psi/s (180 kPa/s))
- **Exceptional stress load in tunnels:**  $\pm 1.0$  psi ( $\pm 7,0$  kPa) for 60,000 cycles (with square signal).

Pressure tightness for the TGV Duplex side-facing glazing is tested up to  $\pm 1.0$  psi ( $\pm 7,0$  kPa). Water tightness is achieved with the application of an ultraviolet (UV)-resistant sealant.

### 4.3.2.2 Siemens

The Velaro side-facing emergency glazings are tested to a pressure of  $\pm 0.87$  psi ( $\pm 6$  kPa).

Siemens stated that it is possible to retain the U.S. method of window removal. If the pressure deflects the pane inwards/outwards, however, it is possible for water to seep in at the location of the elastomeric gasketing. Water has been shown to deteriorate the adhesive that bonds the glass laminations, thereby degrading the safety aspects associated with laminated glass. If the U.S. method of removing emergency glazing is used, effective water drainage is necessary. Siemens advised that the methods for allowing drainage could impact trainset sealing. In addition, the performance of the gasketing needs to be verified periodically to provide assurance that the gasketing material remains pliable to serve the intended function. Siemens commented that this results in an increase in inspection and maintenance costs.

**Note:** Additional information about trainset sealing is provided in Section 5.10.

---

### **4.3.3 Side Glazing Passenger Containment**

*The manufacturers were asked to describe any passenger containment tests associated with side glazings. An example of such test can be found in GM/RT 2100 Section 5.3.*

#### **4.3.3.1 Alstom**

Alstom advised that passenger containment tests on the sided glazings are conducted according to NFF 01492 and NFP 08301. The purpose of this testing is to simulate a human body impact on the glass. The projectile, a 110-lbm (50-kg) bag filled with 0.12-inch (3-mm)-diameter glass balls, is swung from a height of 4.9 feet (1,5 m). Upon impact, the projectile speed is approximately 8.7 mph (14 km/h). The impact energy against the side glazing is 735 J. The passing criterion is that the projectile does not penetrate the glazing.

#### **4.3.3.2 Siemens**

Siemens stated that passenger containment tests can be conducted on Velaro side-facing emergency glazings with passing results.

### **4.3.4 Number of Emergency Glazings Required per Car**

#### **4.3.4.1 Alstom**

Alstom advised that France does not have standards that identify requirements regarding water tightness or mounting configurations for side-facing emergency glazings. TSI requires two emergency glazing exits for cars with seating for up to 40 passengers, and three emergency glazing exits for cars with seating for more than 40 passengers. UIC 660 also requires two emergency glazing exits for a car with seating for up to 40 passengers, but it requires four emergency glazing exits for cars with seating for more than 40 passengers. The AGV currently is designed to follow the UIC 660 requirements, and features four emergency glazing exits per coach.

### **4.3.5 Characteristics of Breakable Side-Facing Emergency Glazings**

#### **4.3.5.1 Alstom**

Side-facing emergency glazings comprise tempered glass on the interior and laminated glass on the exterior, with the lamination between the two panes. The interior tempered glass is thermally reinforced per NFF 31129. If broken, the fragmented particles will be dull, with dimensions and shape as defined in NFF 31129 Section 7.1.4 (Table 4.1). The external laminated glass is designed to break according to NFF 31250, whereby the fragmented particles remain on the polyvinyl butyral (PVB) film. These panes are also thermally reinforced in accordance with NFF 31129.

**Table 4.1**  
**NFF 31129 Fragmentation Criteria for Side-Facing**  
**Emergency Glazings**

Glass Thickness inches(mm)	Maximum Fragment Mass ounces (g)	Maximum Combined Mass of 10 Largest Fragments ounces (g)	Maximum Length of Fragments	
			Flat Glass inches(mm)	Curved Glass inches (mm)
0.20 (5)	0.14 (4)	0.67 (19)	1.6 (40)	1.8 (45)
0.24 (6)	0.18 (5)	0.81 (23)	1.2 (30)	1.8 (45)
0.32 (8)	0.21 (6)	1.06 (30)	0.8 (20)	1.8 (45)
0.39 (10)	0.28 (8)	1.34 (38)	0.8 (20)	1.8 (45)
0.47 (12)	0.35 (10)	1.62 (46)	0.8 (20)	1.8 (45)

Alstom advised that the exterior laminated glass panes offer several advantages:

- Removal of the glass from the trainset interior is facilitated.
- Glass particles are not expelled from the trainset, so passengers on the platform are not injured by glass when the train passes by.
- Fewer consequences result in terms of speed limitations and injury of passengers when evacuating to another vehicle.
- The greater resistance to potential impacts enables the optimization of glazing weight.

#### **4.3.5.2 Siemens**

Siemens stated that when the glass shatters, the edges of the remaining pieces are dull; however, there remains a small chance of a sharp edge.

### **4.3.6 Glazing Configurations**

#### **4.3.6.1 Alstom**

The emergency side-facing glazing on the AGV (from exterior to interior) consists of:

- Laminated glass: 0.24 inch/0.06 inch PVB film/0.16 inch (6 mm/1,52 mm PVB film/4 mm)
- Air gap: 0.87 inch (22 mm)
- Tempered glass: 0.20 inch (5 mm).

The emergency side-facing glazing on the TGV Duplex (exterior to interior) consists of:

- Laminated glass: 0.20 inch/0.03 inch PVB film/0.24 inch (5 mm/0,76 mm PVB film/6 mm)
- Air gap: 0.47 inch (12 mm)
- Tempered glass: 0.20 inch (5 mm).

The AGV and the TGV Duplex emergency glazings are designed to be breakable with a hammer, as specified in UIC 564-1, to permit egress within 30 seconds.

---

#### **4.3.6.2 Siemens**

Siemens uses laminated glass for its emergency windows. Two panes of toughened glass are separated by a film. In Germany, a hammer is used to destroy the glass. The entire configuration may then be pushed out of the opening.

### **4.4 DRIVER'S CAB WINDOWS**

#### **4.4.1 CSR**

CSR advised that the CRH380A trainset cab windows do not open.

#### **4.4.2 Siemens**

Siemens advised that the Velaro E trainset has two hatches in the driver's cab (Figure 4.5) for emergency egress, one on each side of the cab. The hatches can be pulled in via a door handle. They are designed to accommodate a stretcher. The cab is equipped with a rope ladder located beneath the seat, which the driver can use in case of an emergency.

**Figure 4.5 Velaro E Cab Emergency Hatch**



Source: WBPF Photograph, February 2010

### **4.5 EMERGENCY SIDE DOOR RELEASES**

#### **4.5.1 Emergency Power**

*U.S. regulations dictate that each powered exterior side door in a passenger car be connected to an emergency back-up power system. This feature of the door system design was discussed.*



---

#### **4.5.1.1 CSR**

CSR advised that emergency power is provided for up to 2 hours.

#### **4.5.1.2 Siemens**

Siemens advised that the exterior side doors are connected to the battery back-up system.

### **4.5.2 Emergency Opening Device**

*U.S. regulations (49 CFR §238.235 and 49 CFR §238.439) dictate that all coaches be equipped with manual override devices accessible from the interior and the exterior of the trainset. These devices must be installed adjacent to the doors that they control. The design and performance requirements for these devices, as identified in APTA SS-C&S-012-02 – Standard for Door Systems for New and Rebuilt Passenger Cars, include a prohibition against incorporating an interlock signal for actuation of door override devices. This information was discussed with the manufacturers and operators.*

#### **4.5.2.1 Alstom**

Alstom advised that emergency door opening devices cannot be activated unless the train is travelling at a speed of less than 6.2 mph (10 km/h). In addition, two actions are typically required to open the doors—raising a panel and moving a mechanism.

If any doors are not closed once the trainset reaches 6.2 mph (10 km/h), they will be closed automatically.

#### **4.5.2.2 CSR**

CSR advised that emergency door opening on the CRH380A is performed by a crew member with a key, and that this is not interlocked with speed. EN 14752 requires a 6.2 mph (10 km/h) interlock to provide tamper-proof protection of the emergency door opening device.

#### **4.5.2.3 Hyundai Rotem**

Hyundai Rotem advised that for emergency door operation, the door is interlocked to a speed signal. The door can open only when the speed is less than 9.3 mph (15 km/h).

#### **4.5.2.4 Renfe**

Renfe advised that in the future, trains will brake automatically when a passenger opens a door via the emergency door release. Renfe also believes that such an action should be difficult for passengers (to prevent unwarranted door openings) and that doors should not be allowed to open while the train is moving.

## **4.6 BACK-UP POWER/EMERGENCY LIGHTING**

*U.S. regulation 49 CFR §238.115 identifies design and performance requirements for emergency lighting systems, including minimum illumination requirements, back-up power requirements, and strength requirements to withstand the initial shock of a collision. This*

---

*information was discussed with the international HSR manufacturers and operators, and their insights are provided in this section.*

#### **4.6.1 Alstom**

Alstom uses light emitting diodes (LED) for emergency lighting to reduce power consumption. All emergency lights use a common battery source. Alstom advised that the load shedding profile for the low-voltage power supply depends on the operator's requirements. For example, some specifications require back-up to the ventilation system. Back-up power can be provided to other systems by providing additional batteries.

Alstom's NTV AGV trainset amenities operate as follows after the loss of power:

- 10 minutes: normal lighting is reduced
- 1 hour: backup ventilation starts
- 1.5 hours: toilets are locked
- 3 hours: PA and emergency lighting systems are turned off
- After 3 hours: there should still be enough energy to restart the train.

#### **4.6.2 CSR**

CSR advised that emergency power is provided for up to 2 hours on the CRH380A trainset.

#### **4.6.3 Siemens**

Siemens advised that the full auxiliary load of the Velaro is between 500 kW and 600 kW; however, this value is dependent on the outside temperature because of the power requirements for the HVAC system. There are four auxiliary control units per trainset. Even if one auxiliary control unit fails, the system can supply all auxiliary loads.

The load shedding profile of the Velaro auxiliary system provides 5 minutes of full power, after which several non-critical systems are disconnected. Siemens advised that the Velaro trainsets provide back-up power for 3 hours for emergency lighting, PA, door controls, HVAC, and ATP. The Siemens Velaro LED emergency lighting is powered by the main battery system.

The available voltage systems for the Velaro auxiliary system are as follows:

- 440 V AC, 60 Hz: HVAC
- 230 V AC, 60 Hz: various supplies
- 400 V AC, 50 Hz: small loads
- 110 V DC: control units, lighting.

Siemens advised that one battery charger will suffice for the entire train, but that two are provided for purposes of redundancy.

---

## **4.7 EMERGENCY PREPAREDNESS PLANS AND PROCEDURES**

### **4.7.1 DB**

DB advised that it has evacuation plans for every line on the network. The preparedness plans permit a train to be stopped within ten minutes following an incident. This timeframe allows the operator to select the safest place to stop the train and gives enough time for an emergency crew to be dispatched on-site.

DB provides automated external defibrillators (AED) onboard the train. In addition, DB is evaluating the potential of providing more sophisticated medical equipment onboard because there is usually a doctor (passenger) onboard who could assist during a medical emergency.

### **4.7.2 Korail**

Korail has plans and manuals in place for emergencies, and conducts drills on a regular basis. Korail has twelve local headquarters. Staff must participate in drills twice a year, and monthly drills are conducted for train crews and emergency crews for events such as derailments.

Korail advised that when high speed trains first started, there was only driver briefing. Currently, all KTX drivers must go through a 2-hour safety training course each month, as required by law. In addition, drivers must complete refreshment training for unexpected incidents or accidents every 2 years. This training typically lasts 24 hours. Every quarter, the drivers undergo a “check ride.”

### **4.7.3 Renfe**

Currently, Spain has no laws or standards that regulate the evacuation of a trainset in the event of an emergency. Renfe is developing such plans, however, through analyses of potential hazards. Such plans will include emergency procedures in the event of a fire or a derailment. Renfe's Madrid-to-Seville line features a 17.7-mile (28,5-km) tunnel, which is the fourth longest rail tunnel in Europe; hence, an important issue is moving a train out of the tunnel in the event of a fire.

Renfe advised that train drivers and crew receive regular training for the evacuation of passengers. This training includes moving passengers to separate trains via small portable bridges and addresses issues associated with passenger evacuations in tunnels or on viaducts. The training is coordinated with the police and fire departments. A report is written after each training course and the results are analyzed. The analysis is used to improve training and/or to recommend adoption of product improvements. The Renfe evacuation procedures are not made public. For new lines, Renfe and ADIF jointly evaluate the safety/security systems and evacuation plans.

Three levels of communication are required, depending on the severity of the emergency:

- 
- Renfe
  - Renfe + ADIF
  - Renfe + Police + Fire Department.

Spanish law recommends certain actions depending on the emergency scenario. For example, if a passenger sustains minor injuries or a fractured limb in an accident, Renfe is not required to call the police. If a passenger sustains major trauma, such as losing a limb, Renfe is required to call the police. If a train derails, Renfe is required to call the police and fire departments.

#### **4.7.4 SNCF**

Simulations and real exercises are conducted for the Eurostar annually in the Channel Tunnel to prepare the emergency responders for potential events. Currently no such exercises are conducted for the TGV.

SNCF's train crews are trained in first aid, evacuation, and response in the event a train is stopped. The last item—a stopped train—is extremely critical and it is important to protect trains against collisions. SNCF stated that even though the trains are protected by a block system, precautionary measures are still necessary, especially, for example, in the event of a derailment.

#### **4.7.5 SRB**

In China, emergency preparedness plans are necessary before each railway bureau takes over operation of a high speed line. Procedures are simulated before the takeover.

---

# **CHAPTER 5 ENVIRONMENTAL CONDITIONS AND THEIR IMPACTS ON TRAINSETS AND INFRASTRUCTURE**

*The authors explored the subject of environmental conditions during their Fellowship visits with manufacturers and operators of HSR equipment. Recognizing the lightweight designs of HSR trainsets and their very high operating speeds, the objectives were to learn about the effects of environmental factors on the trainsets and methods to mitigate related safety hazards and equipment degradation.*

## **5.1 WEATHER-RELATED BALLAST PICKUP**

*Ballast pickup is a phenomenon that is experienced across HSR systems throughout the world. TSI leaves ballast pickup requirements as an open point, so the authors wanted to hear what the main causes were and what mitigation measures manufacturers and operators use from the trainset and infrastructure standpoints, respectively.*

### **5.1.1 Alstom**

Alstom advised that winter weather has a significant impact on the rolling stock and infrastructure. Ballast pickup is caused by large pieces of ice dropping onto the ballast while the trainset is traveling at very high speeds. Ballast stones become airborne and can inflict great damage to the underside and the windows of a high speed trainset. Additional damage can also result from snow accumulating on the inner crevices of the trainset. These occurrences ultimately affect the availability of the equipment because the trainset would have to be removed from service for corrective maintenance. Mitigation for ballast pickup, as implemented by SNCF, includes speed reduction and anti- and de-icing actions.

### **5.1.2 SNCF**

SNCF confirmed that ballast pickup generally happens in snowy areas. The aerodynamics under the trainset along with the accumulation of snow and ice on the bogie and undercar regions are usually the main causes. SNCF imposes speed restrictions depending on the amount of snow. Upon indication of ballast pickup, speeds are reduced to 143 mph (230 km/h). SNCF advised that outside of the winter period, there are no concerns regarding ballast pickup when the trainset is traveling at 218 mph (350 km/h). SNCF advised that as long as the ballast is maintained to be at the same level as or below the top of the sleepers, ballast pickup is not a concern.

### **5.1.3 Siemens**

Siemens advised that the main cause of ballast pickup is ice blocks falling off the train and onto the track while the train is running at high speeds. Siemens is considering developing a ballast pickup alarm in the near future. Siemens advised that if ballasted track is used, it is essential that the ballast remains at least 1 inch to 1.5 inches (25,4 mm to 38,1 mm) below

---

the top of the sleepers to minimize ballast pickup. No ballast protection on the trainset is needed if slab track is used.

Current developments for ballast protection on the Velaro trainsets include:

- Reducing the gaps between cars
- Minimizing the cavities in the bogies and the underfloor antenna region
- Designing underfloor components with integrated armor
- Installing intercar deflectors and additional deflectors at the bogie cavities to improve underfloor aerodynamics and, thereby, reduce air turbulence.

Siemens added that the recent higher speeds achieved by HSR trainsets can also contribute to ballast pickup. Tests conducted when Siemens set a new world speed record run for production trains at 251 mph (404 km/h) on ballasted track showed that ballast pickup did occur.

Siemens strives to find the optimal balance between operating costs and maintenance costs for its trainsets. During periods of heavy snowstorms on the Madrid-to-Barcelona line, Renfe reduces its operating speed to prevent heavy maintenance costs incurred from ballast pickup. In Germany, prior to the discovery of ballast pickup, the ICE 3 trains would continue to travel at their normal speeds during snowy conditions, something that caused extensive damage to the trains. The phenomenon of falling ice affecting ballast pickup was seen at speeds greater than 124 mph (200 km/h). Currently, DB reduces the speed from 186 mph to 124 mph (300 km/h to 200 km/h) during periods of snow to minimize the impact.

#### **5.1.4 Renfe**

When Renfe was asked if any design changes are planned to the infrastructure to mitigate ballast pickup, its representatives responded that Renfe prefers to have slab track in tunnels. Renfe advised of the budgeting challenges associated with different agencies responsible for rolling stock and the track/infrastructure. In Spain, ADIF is responsible for managing Spain's railway track, signaling, and stations. Renfe and ADIF are peer agencies. Renfe commented that if ADIF spends less on infrastructure (e.g., installation of ballasted versus slab track), then Renfe could expect to spend more on maintaining rolling stock (e.g., repairs from ballast impacts).

#### **5.1.5 NERTUS**

NERTUS advised of the potential for trainset damage caused by airborne ballast, adding that significant damage has been witnessed during the winter when snow and ice buildup occurs under the trainset (Figure 5.1). As the blocks of snow/ice fall to the track, the ballast is dislodged and picked up by the turbulent air currents. Ballast impacts have been reduced when operating at 186 mph (300 km/h) without snow. NERTUS is waiting to see what will happen when speeds are increased to 218 mph (350 km/h). The cost of ballast impacts on the trainsets is usually paid for by the operator, Renfe, if it is determined that the infrastructure is the cause.

---

**Figure 5.1 Damage to the Velaro Underfloor from Ballast Pickup**



Source: NERTUS Presentation, February 2010

NERTUS advised of one incident in the tunnels where ballast flew from the track, hit against the tunnel walls, and struck the side of the train. The train was badly damaged and had to be taken out of service. As a result of the incident, Renfe reduces the maximum speed from 186 mph to either 143 mph or 99 mph (300 km/h to either 230 km/h or 160 km/h), depending on the snow conditions. NERTUS advised that ballast damage is typically more severe on the trailing trainset of a 1,312-foot (400-m)-long train.

## **5.2 TEMPERATURE RANGES AND COOLING AIR**

*Manufacturers and operators were asked to discuss the temperature ranges HSR trainsets are currently designed to, and to identify specific design attributes used to mitigate the results of high/low ambient temperatures. In addition, lessons learned regarding maintaining a clean supply of cooling air were discussed.*

### **5.2.1 Alstom**

Alstom is focusing currently on enhancing protection against the ingress of sand into the traction equipment cooling-air stream, a design improvement that could also help to protect against snow ingestion and ice accumulation. Alstom emphasized that the design solution for the TGV was straightforward because the power is concentrated at the end cars. The AGV solution has not been designed yet; however, Alstom was considering using both media and cyclonic filters.

### **5.2.2 CSR**

CSR advised that the design temperature for the CRH380A is -13°F to 104°F (-25°C to 40°C).

### **5.2.3 Siemens**

Siemens advised that the temperature ranges accommodated by its Velaro models are:

- Velaro E: -4°F to 122°F (-20°C to 50°C)

- Velaro CN: -31°F to 104°F (-35°C to 40°C)
- Velaro RUS: -58°F to 104°F (-50°C to 40°C)
- Velaro D: -22°F to 113°F (-30°C to 45°C).

#### 5.2.4 SNCF

SNCF advised that the TGV is designed to the EN 50125 T3 classification for:

- Outdoor operational temperatures of -13°F to 113°F (-25°C to 45°C)
- Inside vehicle compartment temperatures of -13°F to 131°F (-25°C to 55°C)
- Inside equipment cabinet (i.e., cubicle) temperatures of -13°F to 149°F (-25°C to 65°C).

### 5.3 AERODYNAMICS AND RUNNING RESISTANCE

*The HSR manufacturers and operators advised of the importance of designing trainsets with good aerodynamic properties. Optimized aerodynamics can have beneficial impacts on the pressure pulses caused by passing trains and trains entering/exiting tunnels, energy efficiency (as a function of reduced running resistance), and exterior noise. This section provides information on the key role aerodynamics plays in an efficient HSR operation.*

#### 5.3.1 Alstom

Alstom advised that the carbody strength of its trainset designs is based on environmental conditions associated with the pressure pulses encountered when trains pass (Figure 5.2), and when they travel through tunnels.

**Figure 5.2 Two Alstom TER 2N-NG Trainsets Passing with 11.8-foot (3,6-m) Track Centers**

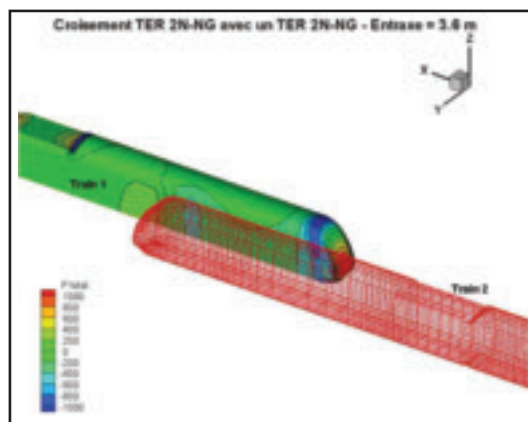

Source: Alstom Presentation, "VHST Aerodynamics," June 2010



---

### 5.3.2 CSR

CSR advised that the aerodynamic performance parameters and the air tightness fatigue strength of the CRH380A trainset meet the MOR purchasing technical conditions. There are no related requirements in EN 12663. MOR required testing to a pressure fluctuation of  $\pm 0.87$  psi ( $\pm 6$  kPa). This criterion is based on test results where a 0.58 psi (4 kPa) pressure pulse was measured when two trains passed traveling at speeds of 218 mph (350 km/h).

### 5.3.3 Siemens

Siemens advised that the effects of aerodynamics on open track are defined in EN 14067-2. Running resistance (R) =  $A + Bv + Cv^2$

Where:

- A: dependent on the friction between the wheel and the surface of the rail and the bearing resistance
- B: dependent on the impact of cooling air and air conditioning systems, which vary with speed
- C: air resistance dependent on the cross-sectional area; length and shape varies with the square of the speed.

Siemens advised that the values/range of the factors A, B, and C are:

- A: 0.0074 N/kg. This value is to be multiplied by the mass of the train.
- B: 50 kg/s to 100 kg/s. This value is dependent on the necessary air for the cooling unit and the air conditioning system.
- C: 5.5 kg/m to 10 kg/m. This value is dependent on the specific train layout (e.g., gauge, position of the pantograph and bogie equipment, etc.).

Siemens noted that at 218 mph (350 km/h), the greatest train resistance and, thus, impact on energy consumption, results from the train aerodynamics (C) in addition to resistances due to cooling air (B) and rolling resistance (A). The distribution of aerodynamic drag is in accordance with Figure 5.3.<sup>1</sup>

Siemens made some observations related to aerodynamics:

- Accurate sizing of the air intake fans is critical to ensure that air intake volume is optimized to the level required. Excessive air intake levels could adversely impact aerodynamics.
- Siemens is currently investigating methods to reduce the gap between cars (in the gangways) to reduce drag.
- It is preferable from an aerodynamic perspective to have 13.1-foot to 16.4-foot (4-m to 5-m) track centers.
- The head pressure pulse, boundary layer, and wake are less critical factors, but they are restricted by TSI and customer specifications. These aerodynamic factors also have to be taken into consideration in the vehicle strength analysis.

---

<sup>1</sup> Siemens dedicates significant effort to improving aerodynamics, which contribute most to the running resistance of trainsets and affect overall energy consumption. In addition, Siemens believes that proper driver training will save more energy than will reducing the overall weight of trainsets. Siemens has a plan in place with DB whereby drivers are analyzed on their performance and ability to conserve energy during operations.

**Figure 5.3 Distribution of Aerodynamic Drag**

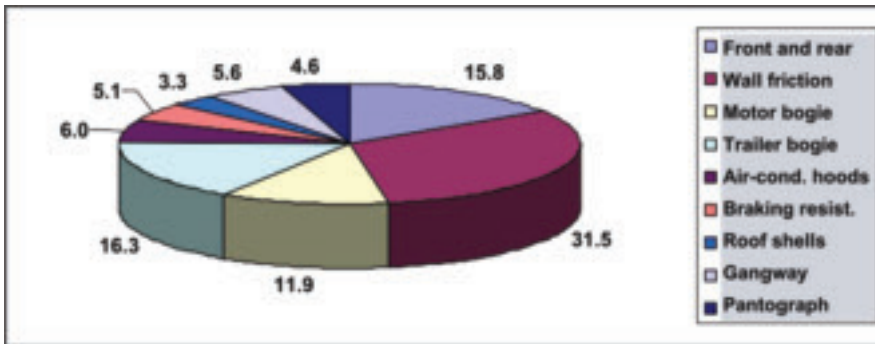

Source: Siemens Presentation, "Train Aerodynamics," January 2010

Siemens advised that Germany has no problems regarding pressures, fatigue, and strength of high speed rolling stock. Ever since the ICE trains, Siemens learned of the potential of such issues from other railways; as a result, it tackled and solved the problems during the design process. DB has never had a problem with these issues. The latest design of extruded aluminum with hollow profiles accounts for such factors. Siemens has conducted tests on the design, but because the stresses are so low, the issues are irrelevant.

### **5.3.4 SNCF**

SNCF confirmed that in Europe, TSI and EN 14067 standards are used to define aerodynamic requirements. Parameters that affect aerodynamic characteristics include train speed, train length, train head shape, and distance between the train and obstacle (e.g., track centers for passing trains).

## **5.4 AERODYNAMIC LOADS ON TRACK WORKERS**

### **5.4.1 Alstom**

Alstom advised that the aerodynamic effects of passing trains are evaluated based on pressure loads developed and air flow velocities induced. Air flow velocities are measured by five anemometers spaced every 65.6 feet (20 m) longitudinally. The anemometers are located 9.8 feet (3 m) from the track centerline at a height of 7.9 inches (200 mm) from the top of rail. Measurements are taken on calm days with wind speeds of less than 6.6 feet per second (2 m/s). An average of 20 measurements and two standard deviations are needed.

Alstom provided air velocity test results for the 7-car AGV prototype passing at 187 mph and 221 mph (301 km/h and 356 km/h). The maximum velocities encountered are shown in Table 5.1.

**Table 5.1**  
**Maximum Air Velocities Encountered by the 7-Car AGV Prototype**

<b>Air Velocities</b>	<b>187 mph (301 km/h) Test Speed feet per second (m/s)</b>	<b>221 mph (356 km/h) Test Speed feet per second (m/s)</b>
Longitudinal Direction	25.59 (7,80)	28.45 (8,67)
Transverse Direction	6.99 (2,13)	10.56 (3,22)
Overall Maximum	25.85 (7,88)	28.48 (8,68)

Alstom advised that TSI developed limits of the maximum induced trackside air speed to protect track workers from high air velocities. This limit is 72 feet per second (22 m/s) and includes the average of the wind speed measurements plus two standard deviations. Induced trackside air speeds for the AGV traveling on the Paris-to-Strasbourg line at speeds of 186 mph and 199 mph (300 km/h and 320 km/h) are shown in Table 5.2.

**Table 5.2**  
**Air Speeds for the AGV Travelling on the Paris-to-Strasbourg Line**

<b>Speed mph (km/h)</b>	<b>Average Wind Velocity feet per second (m/s)</b>	<b>Standard Deviation feet per second (m/s)</b>	<b>Induced Trackside Air Speed feet per second (m/s)</b>
186 (300) <sup>1</sup>	25.26 (7,70)	3.84 (1,17)	32.94 (10,04)
186 (300) <sup>2</sup>	25.98 (7,92)	4.63 (1,41)	35.24 (10,74)
199 (320) <sup>1</sup>	26.61 (8,11)	4.07 (1,24)	34.74 (10,59)
199 (320) <sup>2</sup>	26.74 (8,15)	5.05 (1,54)	36.84 (11,23)

<sup>1</sup> Paris to Strasbourg

<sup>2</sup> Strasbourg to Paris

Alstom advised that the length of the trainset affects the air velocity generated. Longer trainsets tend to generate higher air velocities. As seen on conventional trains, however, the difference in velocities will not be great. The air velocity is highest in the wake of the trainset.

#### **5.4.2 DB**

DB advised that the pressure waves created by the trains are correlated with the minimum distance to the track workers as specified in TSI. DB stated that TSI guidance for the protection of track workers is appropriate.

#### **5.4.3 Siemens**

Siemens stated that the trackside maximum permissible air speed is 20 percent higher for 186 mph to 218 mph (300 km/h to 350 km/h) operations than what is defined in TSI for 155 mph to 186 mph (250 km/h to 300 km/h) operations.

---

#### **5.4.4 SNCF**

SNCF advised that aerodynamics become a safety concern for track workers, passengers on platforms, any equipment placed in the vicinity of the tracks, and passing trains (loading on the train structure, windows, doors, etc.); and that the effects of aerodynamics impact comfort issues and, ultimately, maintenance requirements.

### **5.5 AERODYNAMIC IMPACTS OF TRAINSETS APPROACHING PLATFORMS**

#### **5.5.1 Alstom**

Alstom advised that TSI requires that the maximum induced air speed at a height of 4 feet (1,2 m) above the platform and at a distance of 6.6 feet (2 m) from the track centerline not exceed 51 feet per second (15,5 m/s). This requirement is in line with the 72 feet per second (22 m/s) required for trackside workers. As a result, the same tests are conducted. In Europe, trains typically pass small platforms at 124 mph (200 km/h). At large stations, the passing speed adjacent to a platform is usually limited to 99 mph (160 km/h), whereas trains on the center track normally pass at maximum speed.

#### **5.5.2 SNCF**

SNCF advised that walls/gates are installed at TGV stations to protect passengers from very high speed tracks. The TGV is permitted to operate at maximum speed through the station if it is traveling on the center track. On the tracks next to the platform, the speed is limited to 137 mph (220 km/h); however, SNCF advised that center track configurations are preferable for new lines. For conventional lines, the maximum permissible speed next to a platform is 124 mph (200 km/h).

### **5.6 PRESSURE LOADS IN OPEN AIR**

#### **5.6.1 Alstom**

Alstom advised that air pressures in open air are measured via pitot tubes located every 1 foot (0,3 m) vertically from a height of 4.9 feet to 10.8 feet (1,5 m to 3,3 m) and a distance of 8.2 feet (2,5 m) from the track centerline (Figure 5.4). The measurements are conducted on a calm day with wind speed of less than 6.6 feet per second (2 m/s). An average of ten measurements and two standard deviations are needed.

Alstom provided air pressure test results for the AGV prototype passing at 150 mph (241,9 km/h). Referring to Figure 5.5:

- At 150 mph (241,9 km/h), the peak-to-peak pressures are less than 0.12 psi (795 Pa).
- The first peak-to-peak measurement represents the pressure loads generated from the passing of the leading end of the trainset.

- The second peak-to-peak measurement represents the pressure loads generated from the passing of the tail end of the trainset. This value is usually two-thirds of the peak-to-peak value of the leading end.
- The large distance between the evenly-spaced peaks represents the passing of each axle of the 7-car AGV prototype.

**Figure 5.4 Setup for Air Pressure Tests**



Source: Alstom Presentation, "VHST Aerodynamics," June 2010

**Figure 5.5 Pressures Resulting from the AGV Prototype Passing**

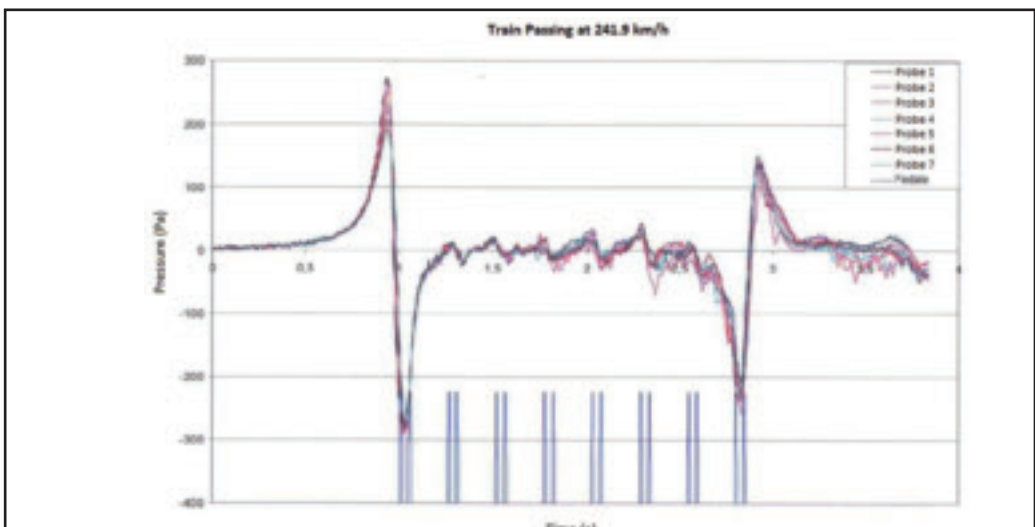

Source: Alstom Presentation, "VHST Aerodynamics," June 2010

---

## 5.7 CROSSWIND

### 5.7.1 Alstom

Alstom stated that the most wind-sensitive car in a trainset is the one with the axle that first reaches 90 percent unloading during high crosswinds. According to TSI, this is usually one of the two leading cars.

Alstom advised that TSI requires the characteristic wind curves of the most wind sensitive car in a trainset to be equivalent to or greater than the reference characteristic wind curves that it defines. Alstom raised a concern regarding the reference characteristic wind curves developed for TSI. It stated that the curves were overly optimistic because they were based on initially flawed assumptions in trainset suspension models. Alstom recommended that TSI criteria could still be followed, but that it was necessary also to be aware of other standards (e.g., EN or ISO), namely EN 14067-1 through EN 14067-6. Currently, new crosswind reference curves are being studied and developed by the Transport Research Knowledge Centre (TRKC)<sup>1</sup> in the AEROdynamics Total Regulatory Acceptance for the Interoperable Network (AEROTRAIN) project and will be adopted in the TSI when the results are released. The technical committee in the European Committee for Standardization (CEN) working on the new aerodynamics requirements is CEN/TC 256/WG 6. In the future, all crosswind tests will be conducted on single-track ballasted rail as opposed to the “floating train” concept used to develop current TSI requirements.

### 5.7.2 CSR

CSR advised that it increased the roof radius of the CRH380A to make the train more aerodynamically sound against crosswind. The roof radius for the CRH380A is 27.6 inches (700 mm), whereas that for the CRH2 is 15.7 inches (400 mm).

### 5.7.3 SNCF

SNCF advised that the Mediterranean and East European lines are among the newer HSR lines that are exposed to high crosswinds. Crosswind-related accidents occurred in Japan and Belgium in 1996 and in Switzerland in 2007. One of the key parameters involving crosswind resistance is the weight of the leading cars.

SNCF's approach to dealing with crosswinds involves three main steps (also refer to Figure 5.6):

- **Line characteristics are defined and then used in two analyses.** The line characteristics are:
  - Line orientations
  - Cants
  - Curve radii

---

<sup>1</sup> The Transport Research Knowledge Centre is funded by the EC's Directorate General for Mobility and Transport under the Seventh Framework Programme for Research and Technological Development (FP7).

- Platform types and required speeds.

The two analyses are:

- Train sensitivity, which involves studying aerodynamic coefficients, vehicle models, wind models, and safety criteria

- Meteorological analysis, which involves analyzing meteorological data, orography (characteristics of any nearby mountains), and rail roughness.

- **Analyses results are then used to determine the line's sensitivity to crosswind and to assist in a risk analysis.** The various inputs to the risk analysis include:
  - Rolling stock sensitivity data based on manufacturers' and operators' experiences
  - Rolling stock characteristic wind curves (uses 90 percent unloading)
  - Characteristic wind curves for all sites
  - Determination of critical sites based on existing meteorological data
  - Potential fencing of various sites.
- **A protection strategy for the line is then developed.** Protection methods could include fixed fences, which could also act as noise barriers, and wind alarm systems.

**Figure 5.6 SNCF's Approach to Crosswinds**

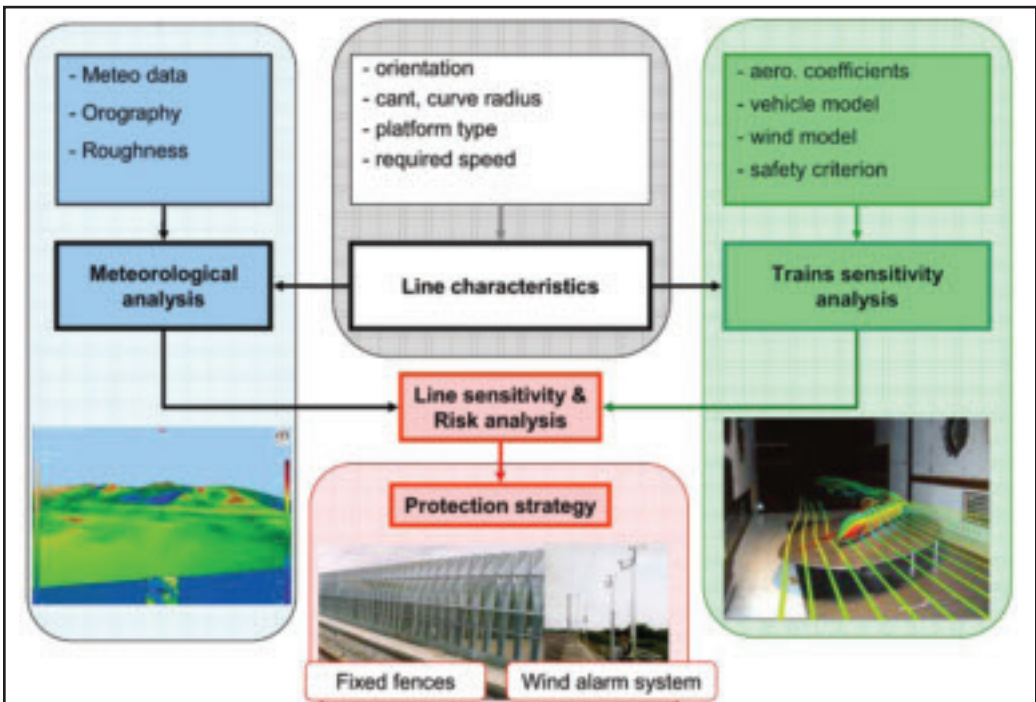

Source: SNCF Presentation, "Aerodynamic Effects," June 2010

---

The SNCF wind alarm system design consists of dividing operating lines into different zones, each of which is monitored by an anemometric station where wind speed, duration and direction are recorded. The settings of the wind curve limits for each zone are geared toward one accident every 200 years. The information in TSI is based on the TGV Duplex, ICE 3, and Elettro Treno Rapido (ETR) 500. SNCF states that the values for 218 mph (350 km/h) are appropriate.

SNCF advised that vehicle speeds for the TGV are enforced via the ERTMS Level 2 train control system, which stipulates the following speed reductions when high crosswinds are detected:

- Trains traveling at 199 mph (320 km/h) reduce their speed immediately to 143 mph (230 km/h).
- Trains traveling at 143 mph (230 km/h) reduce their speed immediately to 106 mph (170 km/h).
- Trains traveling at 106 mph (170 km/h) reduce their speed immediately to 50 mph (80 km/h).

SNCF advised that the HSR lines with anemometric stations are the Mediterranean, which is completely covered, and the East European, which is partially covered. The Rhin-Rhône line is being studied. On the Mediterranean line, speed reductions are even more stringent than those mentioned above, going from 186 mph to 106 mph (300 km/h to 170 km/h) when high crosswinds are detected. SNCF relies on the wind alarm system to implement speed restrictions. The wind curve limits are based on the TGV design, but are also applicable to TSI-compliant trainsets. During operation, the driver has to respect the speed restrictions caused by wind, which are imposed by the signaling system.

SNCF emphasized the importance of calculating for crosswinds for all sections of a high speed line, especially on embankments due to the high acceleration of wind over embankment tops.

#### **5.7.4 Siemens**

Siemens advised that roof edge curvature is critical to reducing the forces from crosswind, and that the Velaro trainset roof edge curvature radius is greater than or equal to 5.9 inches (150 mm). It is safe to operate the Velaro at 218 mph (350 km/h) through crosswinds of up to 92 feet per second (28 m/s). To protect against high winds, wind protection walls are installed adjacent to the right of way. If high winds are measured/detected along the right of way, then a warning is transmitted to the train. For DB, the operational speed is reduced once high winds are detected. Regardless of the factors affecting the trainset, the Velaro design maintains a 10 percent margin to ensure adequate wheel loading on the rail.

### **5.8 EXTERIOR NOISE**

*The authors discussed pass-by exterior noise values for HSR trainsets traveling at 218 mph (350 km/h). The limit for pass-by noise stated in 40 CFR §201.12 is 90 dB(A) measured*



at a distance of 100 feet (30,5 m) from the centerline of the track and at a height of 4 feet (1,2 m) above the top of the rail. This requirement was discussed relative to actual exterior noise test results.

## 5.8.1 Trainset Noise Emissions

### 5.8.1.1 Alstom

Alstom advised that pass-by noises for its various TGV trainsets, as measured according to the TSI criteria of 82 feet (25 m) from the track centerline, are as shown in Table 5.3.

**Table 5.3**  
**Pass-by Noise Generated by Various TGV Models**

TGV Model	Sound Level at 185 mph (300 km/h) dB(A)	Sound Level at 168 mph (270 km/h) dB(A)	Sound Level at 155 mph (250 km/h) dB(A)	Sound Level at 124 mph (200 km/h) dB(A)	Sound Level at 93 mph (150 km/h) dB(A)
PSE Orange	n/a	99.5	98.5	95.6	91.8
PSE Modified	94.5	93.1	92.1	89.2	85.5
Atlantique	94.0	92.6	91.6	88.7	85.0
Réseau	93.0	91.6	90.6	87.7	84.0
Duplex	92.0	90.6	89.6	86.7	83.0

Alstom advised that the progressive decrease in the TGV noise levels resulted from:

- **Brake shoes:** Brake shoes on the older TGVs are made of cast iron, but newer models feature composite brake shoes.
- **Aerodynamics:** The aerodynamic designs of the trainsets have been improved progressively.

The external noise level for the AGV prototype measured at the TSI criteria was 97 dB(A) at 218 mph (350 km/h). These measurements were taken during braking tests, however, and the wheels did not have the correct surface quality.

Alstom stated that the dominant source of noise at speeds of up to 186 mph (300 km/h) is rolling noise. Between 186 mph and 218 mph (300 km/h and 350 km/h), rolling noise would be dominant if the wheels are worn and wheel and rail interaction is poor; otherwise, aerodynamic noise prevails.

Alstom stated that the difference in sound level between ballasted and slab tracks is approximately +3 dB(A) for slab track. The method of track fixation must also be taken into account; while it is not as significant a contributor to noise as rail roughness is, it still needs to be considered.

Alstom commented that the main difference between CFR regulations and the TSI standard is the lack of a track quality definition in the former. In addition, the distance of measurement is different. Alstom follows the criteria set forth in ISO 3095 for exterior noise, in which the condition of the measurements is established (e.g., the quality of the track is defined with criteria that can be measured).

---

Alstom proposed keeping the TSI requirements for pass-by noise with the following measurement criteria defined for higher speeds (these include the 1 dB(A) margin permitted in TSI):

- 155 mph (250 km/h): 88 dB(A)
- 186 mph (300 km/h): 92 dB(A)
- 199 mph (320 km/h): 93 dB(A)
- 218 mph (350 km/h): 96 dB(A).

Alstom proposed keeping the exterior standstill noise limit at 68 dB(A).

In Europe, the requirements for noise is an average of 60 dB(A) during the day and an average of 55 dB(A) during the night. If needed, various mitigation solutions can be implemented to meet environmental noise level criteria, such as operating trains at a slower speed and/or installing sound barriers.

### **5.8.1.2 SNCF**

SNCF advised that TSI has noise standards for two cases: high speed operations (greater than or equal to 124 mph (200 km/h)) and conventional rail operations. For HSR, TSI calls for a maximum of:

- 68 dB(A) for stationary noise
- 85 dB(A) for startup noise from 0 mph to 19 mph (0 km/h to 30 km/h)
- 91 dB(A) for pass-by noise at 186 mph (300 km/h) and 92 dB(A) at 199 mph (320 km/h).

SNCF advised that rolling noise increases with speed by a factor of 3, while aerodynamic noise increases with speed by a factor of 6 to 8. As a result, aerodynamic noise tends to be the largest component of pass-by noise at high speeds. SNCF added two comments in reference to Alstom's response:

- The TGV pass-by noise is measured on slab track.
- The +3 dB(A) difference for slab track at 186 mph (300 km/h) affects interior noise as well as exterior.

SNCF noted that at 186 mph (300 km/h), the quality of the rail is still significant to rolling noise. At 218 mph (350 km/h), aerodynamic noise prevails. SNCF advised that 95 dB(A) at 218 mph (350 km/h) can be achieved.

The SNCF network noise (not for rolling stock; similar to U.S. Environmental Protection Agency (EPA) requirements) is established as follows:

- French Regulation Law 92-1444 of December 31, 1992 and Regulation of November 8, 1999 Railway network:
  - Two indicators are to be placed 6.6 feet (2 m) in front of houses. The equivalent sound pressure level,  $L_{pAeq}$ , is then measured for two time frames: 6 a.m. to 10 p.m. and 10 p.m. to 6 a.m. The measurements must be taken for areas close to TGV tracks, where the speed is greater than 155 mph (250 km/h), and near other railway networks.

- European regulation 2002/49/CE of June 25, 2002:
  - Acoustical maps for each of the big cities, industrial areas, and areas with large transportation structures were developed.
  - Two indicators are required:  $L_{den}^1$  and  $L_{night}^1$ .
    - The sound levels,  $L_{den}$ , for the country<sup>2</sup> are measured during the day from 6 a.m. to 6 p.m., the evening from 6 p.m. to 10 p.m., and the night from 10 p.m. to 6 a.m.
    - The sound levels,  $L_{night}$ , are measured from 10 p.m. to 6 a.m.

SNCF stated that there is no major difference between the French regulations and EPA requirements. RFF is currently conducting studies for potential improvements in achieving regulation requirements. These include studies for new tracks, track modifications, significant modifications of traffic, and individual and global protections.

### 5.8.1.3 CSR and CRCC

CSR mentioned various criteria and how the CRH380A performs in comparison. These are summarized in Table 5.4.

**Table 5.4  
Noise Performance of the CRH380A Compared with  
International Standards**

	<b>CRH380A</b>	<b>TSI Section 4.2.6.5</b>	<b>UIC 660</b>
<b>Standing Noise, dB(A)</b>	<b>65</b>	<b>68</b>	<b>65</b>
From Track Centerline, feet (m)	24.6 (7,5)	24.6 (7,5)	24.6 (7,5)
From Top of Rail, feet (m)	3.9 (1,2)	3.9 (1,2)	3.9 (1,2)
<b>Starting Noise, dB(A)</b>	<b>75</b>	<b>85</b>	<b>80</b>
From Track Centerline, feet (m)	82.0 (25)	24.6 (7,5)	82.0 (25)
From Top of Rail, feet (m)	11.5 (3,5)	3.9 (1,2)	11.5 (3,5)
<b>Rolling Noise / Speed, dB(A)</b>	<b>95 at 218 mph (350 km/h)</b>	<b>92 at 199 mph (320 km/h)</b>	<b>91 at 186 mph (300 km/h)</b>
From Track Centerline, feet (m)	82.0 (25)	82.0 (25)	82.0 (25)
From Top of Rail, feet (m)	11.5 (3,5)	11.5 (3,5)	11.5 (3,5)

CRCC advised that noise barriers comprised of metal plates are installed along the line to reduce noise impacts on the environment.

<sup>1</sup>  $L_{den}$  (day-evening-night) refers to the noise indicator for overall annoyance.  $L_{night}$  (nighttime) refers to the noise indicator for sleep disturbance.

<sup>2</sup> Country refers to a quiet area in open country that is undisturbed by noise from traffic, industry, or recreational activities.

---

#### 5.8.1.4 Siemens

Siemens advised that the equipment that influences airborne and structure-borne noise include:

- Pantographs
- Wheel/rail contact
- Motors and gears
- Transformers/rectifiers
- Fans
- Air compressors
- Battery chargers
- Air conditioning system.

Siemens stated that TSI requires a stationary noise measurement 24.6 feet (7,5 m) from the centerline of the track at a height of 3.9 feet (1,2 m). This value is not permitted to exceed 68 dB(A); the average value for the Velaro is approximately 65.4 dB(A) (not localized). The exterior pass-by noise for the Velaro at 218 mph (350 km/h) is 95 dB(A) on ballasted track with good wheel/rail condition. It is approximately 3 dB(A) higher on slab track. Noise mitigation measures can be installed between the rails for slab track installations. Siemens recommended defining the minimum wheel/rail quality to achieve the desired noise level.

## 5.9 INTERIOR NOISE

### 5.9.1 Alstom

Alstom advised that the following interior measurements were observed for the TGV Duplex operating at 218 mph (350 km/h):

- 71 dB(A) on the lower level at the center of the coach
- 72 dB(A) on the lower level at the side of the coach
- 79 dB(A) in the vestibule area
- 70 dB(A) on the upper level at one side of the coach
- 73 dB(A) on the upper level at the other side of the coach
- 82 dB(A) in the intercar area.

Figure 5.7 illustrates this distribution.

**Figure 5.7 TGV Duplex Interior Noise**

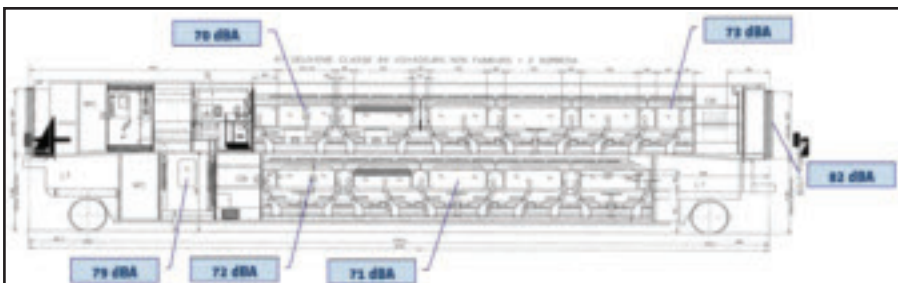

Source: Alstom Presentation, "America Referential for High Speed," June 2010

---

Alstom follows the criteria set forth in ISO 3381 for interior noise. In this standard, the condition of the measurements is fixed (the quality of the track is defined with criteria that can be measured).

Alstom proposed keeping the TSI requirements for cab interior noise with the following measurement criteria defined for higher speeds:

- At standstill (during external acoustical warning): 95 dB(A) for 3 seconds
- At 186 mph (300 km/h) (open country without interior or exterior warnings): 80 dB(A) for 60 seconds
- At 218 mph (350 km/h) (open country without interior or exterior warnings): 84 dB(A) for 60 seconds.

Alstom advised that 80 dB(A) for the driver's cab interior noise is achievable at 218 mph (350 km/h).

### **5.9.2 SNCF**

SNCF advised that the noise level inside the driver's cab cannot exceed 80 dB(A) when the trainset is traveling at maximum speed. At standstill, this noise level cannot exceed 95 dB(A) with the horn blowing. There are no requirements for the passenger areas.

### **5.9.3 CSR**

CSR advised that the interior noise is tested according to ISO 3381. At 218 mph (350 km/h), the noise level of the CRH380A is 79 dB(A) in the driver's cab and 68 dB(A) in the first class car. UIC 660 specifies that at 186 mph (300 km/h), the noise level in the center of the first class coach should be a maximum of 68 dB(A). For 218 mph (350 km/h), there are no related regulations for the noise limits for the train.

### **5.9.4 Hyundai Rotem**

Hyundai Rotem advised that the cab of the HEMU-400X has a maximum noise limit of 80 dB(A). For the passenger salon, the maximum limit is 71 dB(A).

### **5.9.5 Siemens**

Siemens advised that sounds transmit through the side walls, floors, windows, coves, roofs, and partitions. The sound reduction indices are as follows:

- Side walls: 43 dB(A)
- Floors: 48 dB(A)
- Windows: 43 dB(A)
- Roofs: 46 dB(A)
- Double-layer bellows: 38 dB(A).

Thermal insulation is provided in the cavities to limit the transfer of acoustic energy and to assist in energy dissipation.

---

For the Velaro interior with the trainset stopped, the range of measured noise levels in all measure points inside the passenger compartment is 51 dB(A) to 59 dB(A). On average, the level is 55 dB(A). At a speed of 218 mph (350 km/h), the range of measured noise levels in the middle of the passenger compartment is 65 dB(A) to 71 dB(A). On average, the level is 69 dB(A). At all measure points inside the compartment, the range of noise levels is 64 dB(A) to 74 dB(A). On average, the level is 70 dB(A).

## 5.10 TRAINSET SEALING

### 5.10.1 Overview

*HSR trainsets are typically sealed to ensure aural comfort for passengers when the trainsets are entering and leaving tunnels. Several approaches are used for sealing the trainsets, including the installation of mechanized flaps that seal the HVAC fresh air intakes, pneumatic seals around the perimeter of the access doors, and devices that seal penetrations through the carbody (bellows, valves, gaskets, etc.).*

#### 5.10.1.1 Alstom

Alstom advised that it was easier to seal trains that incorporate articulated bogie architecture [refer to Chapter 8 regarding the different architectures] because the motion between two adjacent coaches is limited to a hinged or rotating motion, as opposed to conventional bogie architecture where adjacent coaches also encounter lateral motion (e.g., a sliding motion).

#### 5.10.1.2 Siemens

Siemens advised that the dynamic pressure tightness coefficient ( $\tau_{dyn}$ ) is more dependent on pressure loading than speed. Siemens uses Quest, a 1D tunnel pressure calculation program, to determine this value. The Velaro's  $\tau_{dyn}$  is approximately 22 to 25 on average. A low pressure difference would be  $\tau_{dyn}$  of approximately 4 to 8, while a high pressure difference would be  $\tau_{dyn}$  of approximately 40. The higher the value of  $\tau_{dyn}$ , the better the trainset is sealed. Siemens stated that a  $\tau_{dyn}$  greater than 20 represents a very well-sealed trainset, and that it equates to an unsealed area of only about 1 square inch (645 mm<sup>2</sup>). A  $\tau_{dyn}$  greater than 25 is considered impressive.

#### 5.10.1.3 SNCF

SNCF advised that the first high speed line in France had no tunnels, so there was no need to seal the trains. The second line had tunnels; however, no specific parameters for passenger comfort were stipulated at the time. When the TGV-A first entered tunnels at 124 mph (200 km/h), passengers complained about aural discomfort. SNCF then reduced the speed to 112 mph (180 km/h) and the responses were better. All TGVs developed after the TGV-A are sealed.

### 5.10.2 Instantaneous Pressure Change

*TSI references "Medical Health Criteria," which restrict the maximum allowable instantaneous pressure change on a person's ear to 1.45 psi (10 kPa). Such a change could occur*

---

when a HSR train enters or leaves a tunnel. Manufacturers and operators were asked to discuss current “state of the art” methods for trainset sealing.

### **5.10.2.1 Alstom**

Alstom advised that typical tunnel cross-sectional areas of tunnels in France are 678 square feet (63 m<sup>2</sup>). Trains enter the tunnels at 155 mph (250 km/h). To ensure the aerodynamic safety of the passengers, the peak-to-peak pressure variation in tunnels must be less than or equal to 1.45 psi (10 kPa). Moving model rigs and computational fluid dynamics are used to simulate the pressures generated by two trains passing each other and by one train entering a tunnel. These simulations are used to predict the behavior of the trainsets to optimize the aerodynamic design of the trainset. Alstom uses a 1:25 model of the AGV traveling at 168 mph (270 km/h) for the moving model simulation.

### **5.10.2.2 SNCF**

SNCF confirmed that the aural safety criterion specified in TSI is 1.45 psi (10 kPa) peak-to-peak. The aural comfort criterion is defined by each operator, however, based on its individual perception of comfort. The two train types considered are sealed or unsealed:

- **Sealed trains.** A pressure sealing coefficient,  $\tau$ , defines the criteria for sealed trains. SNCF requires a change in pressure of not more than 0.15 psi (1 kPa) in 10 seconds and a change in pressure over time of less than 0.07 psi/s (0,5 kPa/s). Alstom tests pressure sealing by pressurizing the car up to 0.44 psi (3 kPa).
- **Unsealed trains.** The internal pressure of an unsealed train is equivalent to the external pressure. UIC 779-11 recommends a change in pressure of not more than 0.44 psi (3 kPa) in 4 seconds in a single track tunnel and not more than 0.65 psi (4,5 kPa) in 4 seconds in a double track tunnel.

### **5.10.2.3 CSR**

China’s maximum pressure variation inside the tunnels is 0.73 psi (5 kPa). CSR advised that the pressure sealing criterion used in China is a maximum pressure change of 0.12 psi (0,8 kPa) within 3 seconds. The CRH380A performance is less than this value. CSR stated that it has tested the use of opening/closing mechanical flaps; however, it discovered that such use cannot be controlled well. Instead, it uses a continuous supply of fresh air for the CRH380A.

### **5.10.2.4 Siemens**

Siemens advised that the criteria in Spain for comfort are pressure changes of 0.03 psi (0,2 kPa) over a 1-second period and 0.15 psi (1 kPa) over a 10-second period.

## **5.11 AIR CONDITIONING**

### **5.11.1 Alstom**

Alstom advised that the HVAC modules for the AGV are provided by Mitsubishi.

---

### 5.11.2 DB

DB advised that its ICE 3 high speed trains use an air-cycle air conditioning system. An ongoing discussion within DB focuses on the ecological concerns about using the environmentally-friendly air-cycle system, which does not require the use of Freon, but has higher energy consumption than conventional HVAC systems. DB made a point that conventional Freon-based HVAC systems take longer to maintain due to the complexity of the system and the need to evacuate and capture Freon during maintenance activities. The latest Velaro D high speed train being developed for Germany will have a Freon-based air conditioning system, selected solely for commercial reasons.

### 5.11.3 Siemens

Siemens advised that the Velaro HVAC system consists of the HVAC compressor/condenser unit, the air distribution system, the exhaust air system, and the HVAC control system. Each end car has a separate HVAC system for the driver's cab and the passenger compartment. The driver's cab HVAC module is mounted at a location of approximately one-third the length of the lead unit away from the cab. The system for the passenger compartment is designed according to EN 14813-1; the system for the passenger compartment is designed according to EN 13129-1. Figure 5.8 shows the mounting of the HVAC unit above the passenger saloon of the Velaro D.

**Figure 5.8 Velaro D HVAC Unit**

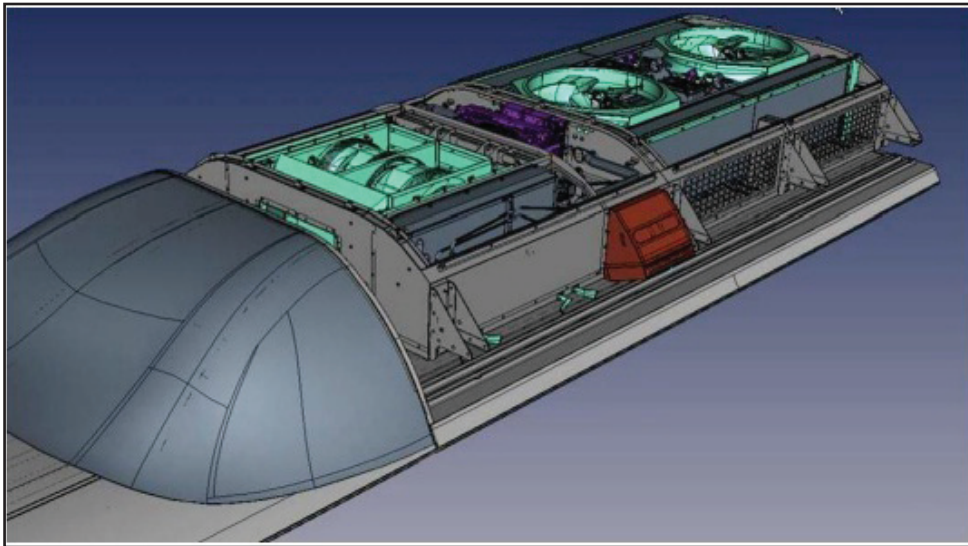

Source: Siemens Presentation, "Interior Design," January 2010

The HVAC system is designed to accommodate a maximum of 76 persons per car:

- The system is designed to provide a fresh air flow of 70.6 cfm (120 m<sup>3</sup>/h).
- The supply air flows for the passenger area are:
  - Cooling: maximum of 2,295 cfm (3900 m<sup>3</sup>/h)
  - Heating: maximum of 1,648 cfm (2800 m<sup>3</sup>/h).



- 
- The supply air flow for the driver's cab is a maximum of 412 cfm (700 m<sup>3</sup>/h).
  - The effects of solar radiation are 254 Btu/hr-ft<sup>2</sup> (800 W/m<sup>2</sup>) for climate Zone 1 (maximum exterior temperature of 104°F (40°C) in the summer) and 222 Btu/hr-ft<sup>2</sup> (700 W/m<sup>2</sup>) for climate Zone 2 (maximum exterior temperature of 95°F (35°C) in the summer), per EN 13129.
  - The interior temperature provided is 72°F (22°C), based on:
    - Winter: Outside temperature of -4°F (-20°C) and 79°F (26°C)
    - Summer: Outside temperature of 95°F (35°C) with a relative humidity of 50 percent.

The Velaro D has a cooling capacity of 116 kBtu/hr (34 kW).

The Velaro system uses reciprocating compressors and R-134A refrigerant. China's Velaro CN uses scroll compressors and a system based on R-407C refrigerant, which could be used to improve cooling performance.

All heating is by forced hot air; there is no radiant heating. The ceiling center duct is for cold air distribution; the ceiling side ducts are for hot air. In addition, hot air is ducted through the side walls. If the HVAC system fails, it is possible to still have ventilation running. The ventilation system is powered by the battery supply, which keeps the system operational for up to 90 minutes.

Siemens advised that there are several modes of HVAC operation:

- Automatic Mode
- Standby Mode
- Emergency Off
- Wash-Run
- HVAC Off.



---

# CHAPTER 6 TRACTION AND ELECTRICAL SYSTEMS

*The two classifications of traction power configurations for high speed trainsets are concentrated and distributed. A concentrated-power configuration has a power car on each end of the trainset and non-powered intermediate coaches. Examples include Alstom's TGV single-level and Duplex trainsets and Hyundai-Rotem's KTX-II trainsets. Benefits of concentrated power include the simplified design of the traction systems and improved maintainability because the traction equipment is contained in the end units of the trainset.*

*A distributed-power configuration spreads the traction equipment throughout the trainset. Examples include Alstom's AGV trainsets, China's CRH trainsets, Siemens' ICE and Velaro trainsets, and Japan's Shinkansen trainsets. Benefits of distributed power include better performance in terms of adhesion and acceleration, improved weight distribution, and increased capacity because passengers can occupy the end cars.*

## 6.1 TRACTION SYSTEM OVERVIEWS

### 6.1.1 Alstom

Alstom's portfolio of very high speed trains includes the concentrated-power TGV single-level and Duplex trainsets, and the distributed-power AGV. The trainsets are based on a 656-foot (200-m) length configured as follows:

- **TGV (concentrated):** The main transformer and two traction units are located in each power car. Each traction unit drives two asynchronous motors (ASM). There are eight motors per train. Each power car has one auxiliary block that supplies power to a battery charger and a three-phase inverter via a 530 V DC trainline. The inverter outputs three-phase 380 V AC, 50 Hz.
- **AGV (distributed):** A 656-foot (200-m) AGV trainset has three triplets, each comprised of a lead car and two trailer cars. One main transformer is located in each leading car. Each of the second and third trailer cars has one traction unit. Each traction unit drives two permanent magnet motors (PMM), with there being twelve motors per train.<sup>1</sup> The AGV has six auxiliary units, each feeding a 300 kVA auxiliary network. In the event that one inverter fails, that inverter can be isolated and the train can continue with the remaining units.

**Traction Motors.** Alstom has developed four generations of traction motors (Figure 6.1). The fourth, the PMM, has resulted in significant weight savings. It has a rated power of 1,073 hp (800 kW), a weight of 1,693 lb<sub>m</sub> (768 kg), and a maximum rotational frequency of 4,570 rpm.

The PMM consists of glued magnets on the rotor and a wound stator. The motor is completely sealed and is autoventilated. The cooling air ducts are designed into the stator.

---

<sup>1</sup> A variation of this configuration was designed for the AGV trainsets being delivered to NTV, which have only five traction units and ten PMMs because of a 186 mph (300 km/h) maximum operating speed limit.

Alstom advised that thermal image monitoring of the PMM has indicated no issues regarding the blockage of the air ducts in the motor. The AGV is the first HSR application of PMM in the world.

**Figure 6.1 Evolution of Alstom’s Very High Speed Train Traction Motors**

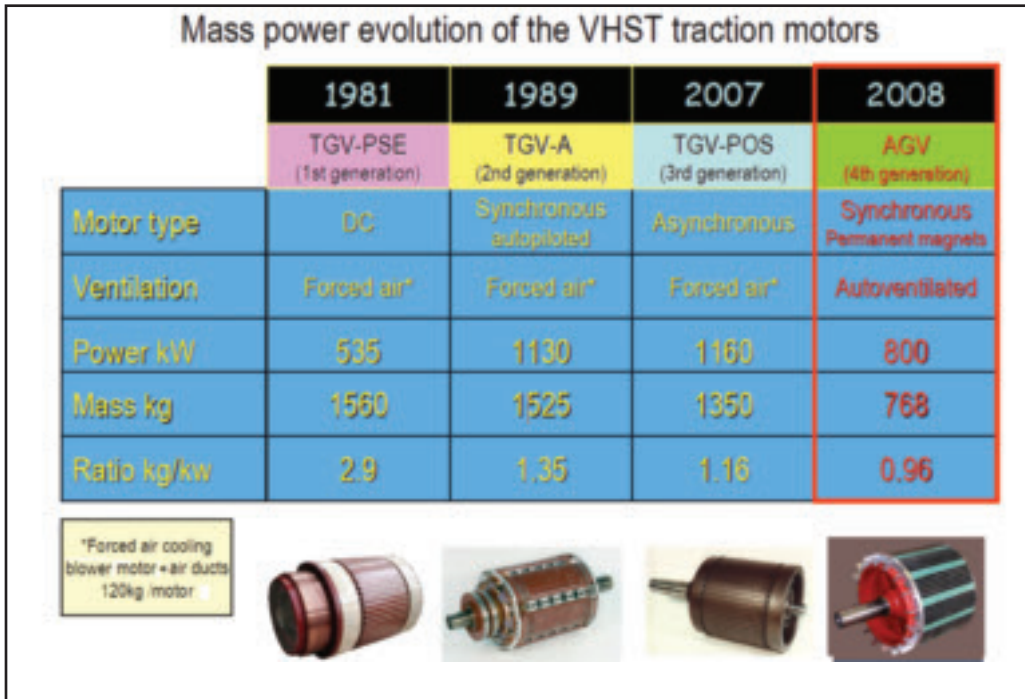

Source: Alstom Presentation, "Traction Drive," June 2010

Alstom provided information on the pros and cons of ASMs and the synchronous PMMs as follows:

- **Cost:** 20 percent more for PMMs; however, this does not include the cost for the ASM's cooling system.
- **Weight:** 25 percent less for PMMs. Alstom noted that the weight of the AGV bogie with the PMM traction motor is the same as the weight of the TGV bogie minus the traction motor.
- **Volume:** 25 percent less for PMMs.
- **Efficiency:** 3 percent more for PMMs (98 percent efficient) due to low losses at the rotor side. The ASM (95 percent efficient) has significant losses in the rotor.
- **Supply:**
  - **ASM:** It is possible to supply several motors with one inverter. For a typical configuration, the motor torque is not the same if there is more than 1 percent difference in wheel diameter.
  - **PMM:** One inverter supplies one motor. There is no wheel diameter constraint.

- 
- **Protection:**
    - **ASM:** There is inverter pulsing inhibition.
    - **PMM:** There is a three-phase contactor to disconnect the motor from the inverter in case of a fault.
  - **Installation:**
    - **ASM:** Forced-air cooling must be installed.
    - **PMM:** The system is autoventilated and closed.
  - **Integration with bogie:** This is simplified with the PMM because of the motor's compactness.
  - **Noise:** Both motors produce approximately the same amount of noise, but in effect, the PPM is quieter because it is a closed system. The noise generated by the ASM fans is the dominant source of noise.

**Sensors and Transformers.** Alstom's traction design incorporates sensors that measure speed and direction. When the train begins to roll back, the sensor detects the wrong direction and the motor can provide a high torque in the right direction.

All transformers on Alstom trainsets are oil cooled by either ester or silicone oil. The traction converter units (e.g., ONIX 233 modules) are equipped with insulated gate bipolar transistor (IGBT) modules that are cooled by a glycol and water solution:

- The TGV-POS uses 3.3 kV, 1,200 A IGBT modules. One power module needs six IGBTs.
- The AGV uses 6.5 kV, 600 A IGBT modules.
- IGBT modules are provided by manufacturers such as Mitsubishi, Hitachi, etc.

### 6.1.2 CSR

The principle behind the CRH380A distributed-power traction system is to provide sufficient power for the trainset, guarantee high speed running, and provide for regeneration. The power from the catenary provides the working voltage for the traction motor after transformation, rectification, and inversion. The traction system includes the pantograph, transformer, converter, traction motor, driving device, etc. The rated power of the trainset is 12,880 hp (9.6 MW).

**OCS Power.** For the CRH380A trainset, 25 kV AC, 50 Hz power from the catenary is transformed to 1.5 kV AC to 2 kV AC. The voltage is then rectified, in the case of 1.5 kV AC, to provide stable 3 kV DC power. The inverter takes the DC power and changes it into 3-phase AC via variable voltage variable frequency (VVVF), which is then supplied to the traction motor.

**Facilitating High Speed Operations.** CSR advised that overcoming resistance to high speed running was key. This was accomplished by using lightweight shell-type transformers; lightweight traction motors and gear boxes; high-power, compact converters; and high-power IGBT modules.

---

**Shock and Vibration.** CRH380A traction equipment meets the TB/T 3058 (the Chinese equivalent of EN 61373) shock and vibration requirements, which are:

- Shock: Impact three times in both the positive and negative directions of each three orthogonal planes to satisfy  $\pm 5$  g longitudinal,  $\pm 3$  g lateral, and  $\pm 3$  g vertical
- Vibration: Vibrate for 5 hours in each of three orthogonal directions (total 15 hours) to satisfy:
  - Class A:  $\pm 0.39$  g longitudinal,  $\pm 0.29$  g lateral, and  $\pm 0.59$  g vertical
  - Class B:  $\pm 0.55$  g longitudinal,  $\pm 0.35$  g lateral, and  $\pm 0.79$  g vertical.

**Acceleration Rates.** The CRH380A's average acceleration from 0 mph to 124 mph (0 km/h to 200 km/h) is  $\geq 0.895$  mphps (0,40 m/s<sup>2</sup>). The residual acceleration when the train is running on level track is:

- At 186 mph (300 km/h):  $\geq 0.112$  mphps (0,05 m/s<sup>2</sup>)
- At 218 mph (350 km/h): 0.078 mphps (0,035 m/s<sup>2</sup>)
- At 236 mph (380 km/h):  $\geq 0.045$  mphps (0,02 m/s<sup>2</sup>).

In comparison, for TSI Section 4.2.8.1 type cars, the average accelerations are:

- 0 mph to 25 mph (0 km/h to 40 km/h):  $\geq 0.895$  mphps (0,40 m/s<sup>2</sup>)
- 0 mph to 75 mph (0 km/h to 120 km/h):  $\geq 0.716$  mphps (0,32 m/s<sup>2</sup>)
- 0 mph to 99 mph (0 km/h to 160 km/h):  $\geq 0.380$  mphps (0,17 m/s<sup>2</sup>).

**Energy Consumption.** CSR has energy consumption data collected from actual operations at 218 mph (350 km/h). CSR stated that it was possible to estimate energy consumption for 249 mph (400 km/h) based on the data; however, one must also consider the performance of regenerative braking at higher speeds. At 236 mph (380 km/h), the performance of the regenerative brake is 133 percent of the traction performance. At 218 mph (350 km/h) and less, the performance of the regenerative brake is 150 percent of the traction performance. CSR advised that there are better efficiencies at lower speeds. All tests are performed on level tracks, and different trains have different regenerative performances. CSR stated that speed curves are calculated for one specific train on one specific line; they cannot be compared to other trains or other lines.

### 6.1.3 Hyundai Rotem

Hyundai Rotem provided the maximum acceleration of its HSR trainsets, as shown in Table 6.1.

**Table 6.1**  
**Acceleration Rates of Hyundai Rotem's High Speed Trainsets**

Model	Speed Range mph (km/h)	Acceleration Rate mphps (m/s <sup>2</sup> )
KTX-II	0 to 37 (0 to 60)	1.007 (0,45)
HEMU-400X	0 to 93 (0 to 150)	1.119 (0,50)

The acceleration of the HEMU-400X trainset is 30 percent to 40 percent faster than that of the KTX-II. The time necessary for the HEMU-400X to accelerate to various speeds and the total distance needed are:

- 0 mph to 186 mph (0 km/h to 300 km/h): 230 seconds, 7.25 miles (11,67 km)
- 0 mph to 218 mph (0 km/h to 350 km/h): 346 seconds, 13.84 miles (22,27 km)
- 0 mph to 249 mph (0 km/h to 400 km/h): 673 seconds, 35.41 miles (56,98 km).

**Traction System/Power Overview.** Hyundai Rotem advised that the tractive effort for the KTX-II is 47.2 kips (210 kN) (ten cars with four motor blocks). The KTX-II trainset uses 1,475 hp (1,1 MW) ASMs. The total power of the HEMU-400X trainset is 13,200 hp (9,84 MW) for an eight-car configuration. The power supply for KTX-II and HEMU-400X is 25 kV, 60 Hz.

Hyundai Rotem advised that the main electrical equipment of the KTX-II concentrated-power trainset includes the cab cubicle, motor block, main transformer, pantograph, traction motor, and auxiliary block. The HEMU-400X distributed-power configuration comprises three main transformers, six converter/inverters, and twenty-four traction motors on an eight-car trainset.

### 6.1.4 Siemens

Siemens' Velaro trainsets have distributed-power configurations (Figure 6.2) with 16 traction motors mounted on bogie frames. In addition, each 656-foot (200-m) trainset has:

- 16 powered axles
- 16 non-powered axles
- 2 main circuit breakers
- 2 pantographs
- 2 main transformers
- 4 auxiliary control units
- 4 independent traction converter units
- 8 pulse width modulated inverters
- 2 battery chargers.

**Figure 6.2 Distributed Traction Equipment on the Velaro E**

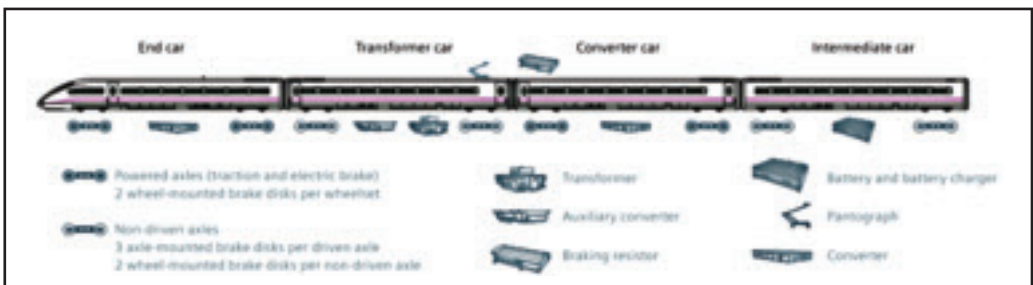

Source: Siemens brochure, *High Speed Trainset Velaro E*

---

**Motors.** The Velaro uses ASMs that are force ventilated. There are eight fans, each of which cools two motors. Inertial filters are used. Motors are rated at between 671 hp to 805 hp (500 kW to 600 kW). Siemens is investigating a synchronous PMM design and has a prototype motor operating in a metro car. Siemens advised that self ventilation of the PMM traction motors results in increased noise, especially at 5,700 rpm at maximum speed with worn wheels.

**Transformer/Converter.** Siemens advised that the transformers are oil cooled. The cooling medium is ester, which is nonflammable. The rated power of the transformer is approximately 5.6 MW. Protection systems for the transformers include an oil flow detector, a temperature sensor, an oil level indication, an overpressure valve, and differential current protection.

The Velaro D platform provides two transformer oil pumps for redundancy. The traction converter units are equipped with IGBT modules. The cooling medium for the traction converter units is glycol.

The cooling air for the Velaro RUS propulsion equipment is ducted from the top of the train to prevent the intake of snow. A similar cooling air system may be appropriate for dusty areas that may be found along the future CHSTP route.

**Power.** The Velaro traction equipment is designed to work continuously, developing 12,340 hp (9,2 MW) of power. Siemens advised that the amount of power installed on a trainset should be based on the operational requirements. Excessively higher installed power typically results in a minimal decrease of travel time. It results also in higher power losses and, therefore, an unnecessary increase in energy consumption.

Siemens reported that the Velaro E and Velaro CN have 11,800 hp (8,8 MW) of power, and the Velaro RUS and Velaro D have 10,730 hp (8 MW) of power. The continuous power per wheelset of the Velaro's SF 500 bogie is 671 hp (500 kW) with a maximum starting tractive effort of 4.3 kips (19 kN) per wheelset. The Velaro E and Velaro CN operate on 25 kV AC, 50 Hz. The Velaro RUS operates on 25 kV AC, 50 Hz and 3 kV DC. The Velaro D operates on 15 kV AC, 25 kV AC, 1.5 kV DC, and 3 kV DC.

When the catenary voltage is zero and there is no voltage in the DC link, the inverter can receive energy from the battery to feed into the DC link. Once the magnetic flux has been restored in the traction motor, the motors will serve as generators to feed energy back into the link.

**Power Consumption.** Siemens was asked to calculate the distance required to reach 242 mph (390 km/h) with 12,340 hp (9,2 MW) of power. This is the speed at which a trainset capable of operating at 220 mph (354 km/h) will be tested. Siemens responded that the distance is 26.1 miles (42 km). For testing purposes, the trainset will need to travel an additional 11.2 miles (18 km) at maximum speed (traveling at speed for approximately 2.5 minutes), and will need another 12.4 miles (20 km) for braking. Therefore, the minimum total length of test track needed is 49.7 miles (80 km).

Siemens was asked to evaluate three grade scenarios typical of what could be encountered when operating over/through California's Tehachapi Mountains. Assuming the train travelled at maximum speed prior to entering the grade, the time required to travel 77.7 miles (125 km) was as follows:



- 
- 3.3% gradient: 1,603 seconds
  - 2.8% gradient: 1,600 seconds
  - 2.5% gradient: 1,598 seconds.

Siemens found that electrical consumption among the three scenarios was nearly the same, with only about a 1 percent difference. Siemens advised, therefore, that the Velaro trainset can operate over the gradients identified above. Siemens illustrated that the difference in time between using a 12,340 hp (9,2 MW) power rating and a 14,750 hp (11 MW) power rating is negligible (2 minutes), but that the difference in energy consumption is significant.

Siemens advised that equilibrium is reached (no power/no brakes) with a Velaro trainset traveling at 220 mph (354 km/h) on a 1.7 percent down gradient.

## **6.2 TRACTION WHEEL/RAIL ADHESION REQUIREMENTS**

### **6.2.1 Siemens**

Siemens advised that a high number of driven axles are advantageous to account for bad adhesion coefficients and gradients. Siemens advised that regenerative braking is maximized by staying under TSI limits for adhesion.

## **6.3 EXTERIOR ELECTROMAGNETIC INTERFERENCE**

### **6.3.1 CSR**

CSR advised that EMC for the CRH380A trainset follows GB/T 17626.4, which is equivalent to IEC 61000-4.

CSR performs electrical fast transient burst immunity tests as follows:

- Output voltage: 4 kV
- Pulse rise time: 5 ns
- Pulse width: 50 ns
- Pulse frequency: 5 kHz.

Voltage surge immunity tests are conducted by CSR using a 4 kV wave form. Immunity to conducted disturbances, which can be induced by radio frequency fields, are conducted with a 10 V RMS carrier voltage, 150 kHz to 80 MHz, 80 percent AM (1 kHz), and a source impedance of 150  $\Omega$ .

---

### 6.3.2 SNCF

SNCF advised that the exterior EMI section of TSI is an open point because the specifications regarding EMI are so different from country to country. EMI requirements are currently being defined in an EN.

SNCF advised that EMI needs to be considered to optimize infrastructure costs. EMI is present from electrical currents in the catenary, rails, and earth. The factors that influence EMI and rail/earth conduction include:

- AC current
- Distance between substations
- Traction return current.

SNCF also advised that EM induction, rail/earth voltages, and infrastructure/earth voltages affect signaling, neighboring networks (e.g., telecommunications), and people's safety.

SNCF currently lends its expertise in normalization committees such as ITU-T, CENELEC, and UTE. Its experts have developed models and calculations specific to EMC software that take into account the traction power supply design. The modeling and calculations include:

- Relative geographical position studies of the inducing system (railway vs. signaling and telecommunication)
- Electrical parameters of the line, such as current and voltage in the conductors (overhead and in rails)
- Studies of harmonic frequencies.

SNCF conducted EMI studies for several lines, including:

- Channel Tunnel Rail Link
- High Speed Link South in The Netherlands
- Metro lines in Montreal and New Delhi.

### 6.3.3 Siemens

Siemens advised that the Velaro trainset components are compliant with EN 50155.

**Note:** Additional information about some topics discussed in this chapter is available as follows:

- Traction performance on gradients: Chapter 15.
- Overhead contact system infrastructure: Chapter 16.

---

## CHAPTER 7 BRAKE SYSTEMS

*HSR trainsets incorporate the use of electric, electrodynamic, and mechanical friction-based braking systems to stop safely and reliably within the required distances. Equipment manufacturers have refined their systems to accommodate the mechanical and thermal stresses associated with stopping trainsets from very high speeds. HSR operators have evaluated the performance aspects of the braking systems to determine the most reliable and cost-effective approaches. This chapter provides insight into HSR brake systems from the perspectives of system design and operations.*

### 7.1 OPERATIONAL FEATURES OF HIGH SPEED TRAINSET BRAKE SYSTEMS

#### 7.1.1 Alstom

Alstom advised that there were several constraints to address when designing the TGV brake system, including the following:

- The semi-articulated trainset architecture and resultant reduced number of bogies meant a reduction in friction braking capacity to achieve the required braking performances on high speed and conventional lines.
- Large gradients of up to 3.5 percent for long distances can be found on the infrastructure side (a feature that helped to keep down the cost of constructing high speed lines).
- Trainsets must maintain a high operational availability, so the brake system had to be highly reliable and require minimal time for repairs or maintenance.
- No speed restrictions should need to be imposed for up to two major brake failures (two bogies isolated).

In addition to addressing these constraints, high levels of braking forces had to be possible and the associated energies dissipated. Alstom determined that electrodynamic braking must assist friction braking in all situations, including emergency braking. Therefore, the basis for the TGV brake design required fail-safe electrodynamic brakes. Mechanical brakes are reserved for emergency braking and to stop the train at low speeds. The use of mechanical brakes starts at 44 mph (70 km/h) for the TGV and at 19 mph (30 km/h) for the AGV.

A high level of operational availability is maintained through the use of conventional automatic pneumatically-operated friction brakes with electro-pneumatic assist via a charged brake pipe throughout the trainset to decrease the response time. In addition, each motor bogie is independent of the others.

#### 7.1.2 CSR

The CRH380A braking system comprises the brake control unit, main air supply unit, auxiliary air supply unit, and brake calipers (Figure 7.1). There are seven levels of service braking.

**Figure 7.1 CRH380A Brake System**

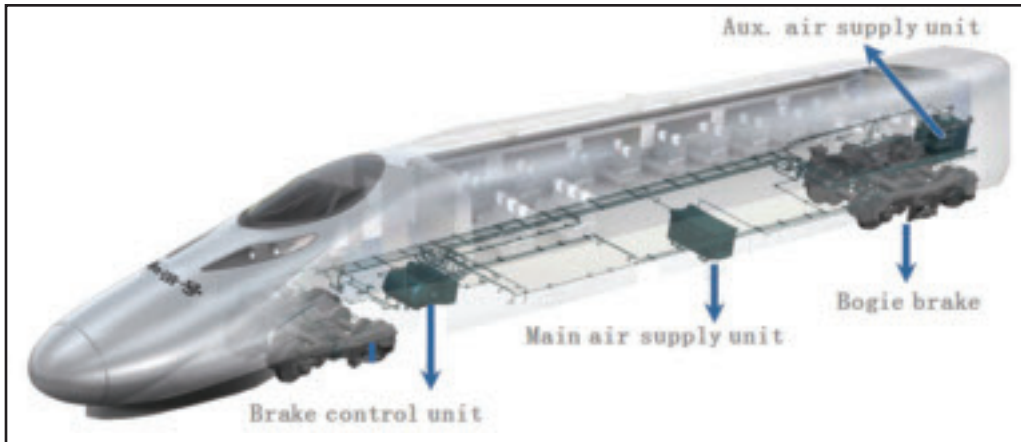

Source: CSR Presentation, "Information about High Speed EMU," November 2010

Four brake control units are on the trainset. The first controls the leading trailer car and the two following motor cars. The second and third brake units control the next two cars' braking capabilities, respectively. The last brake unit controls the brakes of the last two motor cars and the last trailer car. The braking system on the CRH380A has undergone sixteen component-level tests, seven system-level tests, and nine line tests (six anti-skid tests, two brake distance tests, and one long-term operational test).

The CRH380A braking system is designed to UIC 540, UIC 541-1, UIC 541-05, UIC 541-5, UIC 543, UIC 660, EN 13452-1, EN 13452-2, and TSI standards. Many of the UIC standards are based on the automatic air brake, and many of the clauses are not applicable to HSR. In addition, because the brake command for the automatic brake is transmitted via the trainline, transmission and brake responses are slow. The system is complicated and the control is complex. This type of system is usually used only as a backup braking system. In the EN and UIC standards, the brake instructions are transmitted via the train communication network. China felt that the EN-/UIC-specified process was not optimal, and has adopted the Attached Resource Computer Network (ARCNET) transmission, a type of local area network (LAN) protocol that is reliable and occurs in real-time.

### **7.1.3 Siemens**

The Siemens Velaro brake system is managed by brake control units, with one unit in each car. The brake control unit in the leading car serves as the master for the entire train. The Velaro has 50 percent of its axles driven. On the driven axles, the brakes are mounted on the wheels (cheek brakes). On the non-driven axles, three brake discs are mounted on each axle. Tread brakes are not installed on the Velaro platform.

Two reciprocating air compressors are installed on each 656-foot (200-m) trainset. One air compressor is capable of maintaining the required volume of air for the trainset. Beginning with the Velaro RUS trainset oil-free compressors are used. Prior to this design, the oil and water mixture of the compressor had to be collected.

---

Siemens recommended the use of eddy current brakes for new systems. Eddy current brake systems produce a retarding force by creating eddy currents through electromagnetic induction. These eddy currents create resistance to forward motion. The main advantage of such brakes is that they are contactless and, therefore, “wearless.” In addition, the use of pneumatic brakes and the resulting wear of brake pads and rotors are reduced. Siemens began using eddy current track brakes on its ICE platform with the ICE 3 (Figure 7.2).

**Figure 7.2 Eddy Current Track Brake System on a Siemens ICE 3 Trainset**



Source: Siemens Presentation, "Braking Operation High Speed Trains," January 2010

The rail is heated during the use of these brakes, however, so the operator must take into consideration how long/how many times the brakes can be applied through the length of track (i.e., application of eddy current track brakes should factor into the headways). Siemens stated that the use of eddy current brakes at switches and at stations, where the train is typically braking, requires careful consideration.

Siemens recommended a meeting with industry professionals (e.g., Siemens, Knorr-Bremse, etc.) to discuss the possibility of implementing eddy current brakes on new trains for the U.S. Siemens does not foresee a problem with infrastructure; however, the brakes might interfere with the signaling system. Siemens stated that the designers should understand the magnetic fields and the electrical interferences imparted by eddy current braking.

Siemens discussed an incident where eddy current brakes interfered with the axle counters. Both the axles and the magnetic fields generated by the eddy current brake were counted (as if they were axles) at the first signal block when the eddy current brakes were applied. When the train entered the second signal block and the eddy current brakes were not applied, only the axles were counted. The difference between axle counts caused the signaling system to issue a stop command. Siemens developed a solution with Knorr-Bremse to shield the cables and to install coils to resolve this interference. Siemens also recommended providing protection of the eddy current brake equipment and associated cabling to shield the equipment from debris damage.

---

## **7.2 FAILSAFE ATTRIBUTES OF ELECTRODYNAMIC BRAKES**

### **7.2.1 Alstom**

Alstom advised that the electrodynamic braking function is independent of the catenary.

### **7.2.2 CSR**

The brake system of the CRH380A supports 90 percent feedback to the OCS. The CRH380A does not use brake resistor grids (resistive elements that convert the power generated by electrodynamic braking into heat).

### **7.2.3 Siemens**

Siemens advised that electrodynamic brakes that feed back into the catenary should not be included in the emergency brake calculation because there can be faults exterior to the train (e.g., occurrences at substations). Brake energy developed by the traction motors and dissipated through the use of brake resistors can be included in the calculations because they are independent of the infrastructure. The use of resistor grids is included in the brake performance calculations for the Velaro. Siemens advised that the Velaro D trainset will not have braking resistors, and that electric energy is fed back to the catenary.

Siemens stated that regeneration requires that the infrastructure be capable of receiving energy back from the train. Conventional braking from 99 mph (160 km/h) in 3,281 feet (1000 m) results in regeneration of approximately 10 percent of the energy, with 3,000 kW/h being fed by the catenary and 300 kW/h being returned.

Siemens advised that if electrodynamic braking fails, the ratio of pneumatic braking increases and full pneumatic braking is possible. This is accomplished via the ATC system, which can sense degraded braking performance.

## **7.3 FRICTION BRAKE SYSTEM DUTY CYCLE**

### **7.3.1 Alstom**

Alstom advised that the AGV is at the limits of TSI stopping distance criteria. It does not have enough friction braking power to fully stop a train from high speeds, especially on the motor bogies, and the energy constraints are high, especially on high gradients. If additional braking performances are required, other braking systems (e.g., eddy current brakes) will need to be considered.

Three consecutive emergency braking applications can be performed without exceeding the thermal limits of the brake components from 186 mph (300 km/h) when the train is running on flat ground with normal operating load.

---

In France, SNCF imposed operational margins within which a trainset must still brake normally with two bogies isolated:

- On 1.6 percent grade, the train must still be able to operate at and stop from 199 mph (320 km/h).
- On 1.6 percent to 2.2 percent grade, the train must be able to operate at and stop from 186 mph (300 km/h).
- On 2.2 percent to 3 percent grade, the train must be able to operate at and stop from 168 mph (270 km/h).
- On 3 percent to 3.5 percent grade, the train must be able to operate at and stop from 143 mph (230 km/h).

The old TGVs used solid brake discs. Thermal capabilities were not a concern on conventional lines because the speeds were lower. Prior to the introduction of the TGV-A, the routes trains traversed were one-third high speed and two-thirds conventional. Ventilated discs are used today, however, so the number of brake discs could be reduced from four to three, depending on the operational requirements.

### **7.3.2 CSR**

CSR stated that the CRH380A's braking system is designed with high thermal capacities. The friction brakes alone are able to stop the trainset within the stopping distances specified in China.

### **7.3.3 Siemens**

Siemens advised that the brake pads will heat to up to 1,652°F (900°C) after two consecutive emergency brake applications from 218 mph to 0 mph (350 km/h to 0 km/h) at a -3.5 percent grade. Any additional applications would require the changing of brake pads. Siemens stated that neither one nor two emergency applications on -3.5 percent grades will deteriorate the equipment. Siemens stated that it aims to reach the stopping distances of the TSI solely with the pneumatic brake because of this brake's high reliability. Normally, the pneumatic brakes are able to stop the train within the given distances.

## **7.4 ELECTROMAGNETIC RAIL BRAKE, AND EDDY CURRENT TRACK AND AXLE-MOUNTED BRAKE SYSTEMS**

### **7.4.1 DB**

DB is currently studying the development and application of eddy current track braking. In particular, it is studying the feasibility of using:

- Electrodynamic brakes via the traction motors
- Eddy current track brakes for all service braking requirements
- Pneumatic brakes only during slow speeds and emergency brake applications.

---

This study includes investigations on the electromagnetic influence of the eddy current brakes with the signaling system components.

DB advised that eddy current track brakes are not recommended for ballasted track, especially on a busy line, because they heat the rail when applied. Intense heating of the rail can cause sudden lateral movements, something that is especially problematic in areas with high ambient temperatures. DB stated that a review of a ballasted track installation would be needed to confirm the track's ability to react acceptably to such heating. Eddy current brakes can be used on ballasted track for an emergency brake application, which would result in a 7°F to 9°F (4°C to 5°C) increase in rail temperature for a 1,312-foot (400-m) trainset.

The ICE 3 has three braking systems:

- Regenerative dynamic braking, which is used to feed energy back to the catenary
- Eddy current track braking, which is typically used on slab tracks
- Conventional pneumatic friction braking.

DB uses dynamic braking first, eddy current track braking second, and pneumatic braking third when operating over slab track. DB anticipates reducing costs associated with brake pad maintenance and replacement.

#### **7.4.2 Siemens**

Siemens advised that eddy current track braking can be provided on the Velaro trainsets for the U.S., but that it would be used only for the high speed network. Eddy current braking is currently used in Germany and France, but not in Spain or Russia where brake resistors are installed to accommodate electrodynamic braking. The eddy current brakes used in Germany (i.e., eddy current track brakes) are different from the type used in Japan, which are axle-mounted eddy current brakes.

The Velaro has four traction inverters. Each inverter supplies two bogies that are equipped with eddy current track brakes. The brakes use 3 kV of the DC link. The brake effort is controlled by the IGBT switch, which is installed on the inverter. If a serious fault occurs in the inverter, 25 percent of the dynamic and eddy current brake power in the trainset is lost. It is not necessary to reduce speed, however, because by design, 75 percent braking capacity is sufficient to achieve 100 percent performance.

The main difference between the eddy current track brake and the electromagnetic rail brake is that the former does not have any contact with the rail; however, there is energy input into the rail in the form of heat. The electromagnetic brake is based on the principle that the brake is pressed magnetically on the rail, providing friction to reduce the speed of the trainset.

Electromagnetic rail brakes can be used for HSR applications; however, the maintenance costs are high because their use requires contact with the track, sometimes at speeds as high as 174 mph (280 km/h). In addition, using such brakes leaves magnetic dust on the tracks. The point was made, however, that U.S. tracks are usually more robust than European tracks because of the higher axle loadings in the U.S. In reduced adhesion conditions (e.g., wet rail), electromagnetic style track brakes actually clean the rail; hence, while there is low braking effort for the first car, the level of adhesion increases for the trailing cars. The use of eddy current brakes is independent of rail conditions.



---

Siemens advised that there are maintenance requirements unique to eddy current track brakes. During the first year of operating eddy current brakes, DB maintenance workers did not realize that this was a contact-free brake system. Siemens stated that the height of the eddy current brakes must be accounted for when reprofiling the wheels. The minimum and maximum air gaps at which the units will operate effectively under normal conditions are 0.24 inch and 0.28 inch (6 mm and 7 mm), respectively. Braking power is reduced with greater gap sizes. Eddy current brake heights are adjusted during wheel reprofiling, which is typically done every 125,000 miles to 155,000 miles (200 000 km to 250 000 km). The normal wheel wear for this distance is normally below the gap tolerance specified by Siemens.

The eddy current brake system provides additional braking power, especially at speeds over 174 mph (280 km/h). It greatly helps to reduce the speed of the trainset without relying on the coefficient of friction of the rail. Siemens advised that if old infrastructure is used, it must first be proven that the infrastructure can accept the use of eddy current brakes, (e.g., the interference with existing ATP systems, and the capability of the rail to accept the additional heat generated).

In Germany, eddy current brakes are used typically on slab-track portions of the line, and used only minimally on existing ballasted tracks (i.e., for an emergency). DB uses dynamic and eddy current braking only between Cologne and Frankfurt. Siemens advised that eddy current braking could be used effectively on newly constructed ballasted track (those that are TSI-compliant), as that track can tolerate the effects of eddy current braking.

Eddy current brakes are not permitted in Belgium on either old or new systems. They are used on various systems in France; however, the maximum brake force of eddy current brakes was reduced to between 50 and 60 percent. In addition, the use of eddy current brakes is forbidden on conventional tracks for speeds greater than 99 mph (160 km/h).

As summarized later in Table 7.2, braking for the ICE 3 trainset is accomplished mainly with a combination of dynamic, eddy current, and pneumatic brakes. Dynamic braking is typically used down to 44 mph (70 km/h) to allow enough reaction time for pneumatic brakes to operate in the event of a catenary failure. Eddy current brakes are used during high speeds and should be cut out at 31 mph (50 km/h). Otherwise, strong deceleration forces can be felt by the passengers.

Siemens is currently working on developing axle-mounted eddy current brake systems. It stated, however, that the system is not ready for installation on high speed trains.

### **7.4.3 Alstom**

In 1995 to 1996, one TGV (TGV-001) had eddy current brakes mounted on the wheels. Alstom noted that these brakes affected the train's stability because of the intense heating of the wheels.

Alstom advised that eddy current brakes are costly and heavy, even though their use lowered maintenance costs for the friction brake pads. Alstom added that these brakes are expensive because currently only one supplier provides them. Alstom's experience with eddy current track brakes through tests found an increase of up to 59°F (15°C) in rail temperature.

---

#### 7.4.4 SNCF

SNCF advised that eddy current brakes could be used in France if the line speeds are increased to 224 mph (360 km/h); however, the intense heating of the rail must be considered. The electromagnetic track brakes currently installed are used only in Germany when traveling on conventional lines.

### 7.5 SAFE BRAKING DISTANCES

#### 7.5.1 Alstom

Alstom advised that the braking system for the TGV was designed taking into consideration the normal load.<sup>1</sup> The deceleration rates are:

- From a top speed of 199 mph to 137 mph (320 km/h to 220 km/h): 2.01 mphps (0,9 m/s<sup>2</sup>)
- From 137 mph to 0 mph (220 km/h to 0 km/h): 2.91 mphps to 3.13 mphps (1,3 m/s<sup>2</sup> to 1,4 m/s<sup>2</sup>).

The emergency braking distances are:

- From 186 mph (300 km/h): approximately 2.1 miles (3,3 km)
- From 199 mph (320 km/h): approximately 2.4 miles (3,8 km), reached in approximately 90 to 100 seconds.

Full service braking is similar to emergency braking except that the response time in emergency braking is slightly lower. Alstom advised that the braking rates were the same whether the trainset was in single or double traction.

#### 7.5.2 CSR

CSR discussed emergency stopping distances required in China. These criteria are summarized in Table 7.1.

**Table 7.1  
Emergency Stopping Distances in China**

Speed mph (km/h)	TB Standard miles (km)
186 (300)	Maximum of 2.4 (3,8)
218 (350)	Maximum of 4.0 (6,5)
236 (380)	Under amendment, the maximum specified stopping distance could be greater than 5.3 (8,5)

---

<sup>1</sup> There was not a big difference between normal and tare loads.

CSR stated that because France uses powerful traction motors with a concentrated-power design, the wheels tend to skid/lose adhesion more readily during startup. In addition, it was better to calculate braking distances based on train headways (with larger headways, there was no need to tighten braking distances). The use of frictionless braking is also an option. CSR does not recommend using sand to increase friction between the wheel and the rail. Sifang is currently studying the use of aerodynamic brakes.

### 7.5.3 Hyundai Rotem

Hyundai Rotem advised that the full service deceleration rate for the KTX-II is 2.37 mphps (1,06 m/s<sup>2</sup>). The emergency deceleration rate for the KTX-II is 2.46 mphps (1,10 m/s<sup>2</sup>).

### 7.5.4 Siemens

The minimum stopping distances for the ICE 3 and the Velaro D trainsets are shown in Table 7.2.

**Table 7.2  
Minimum Stopping Distances for Siemens High Speed Trains**

Model	Braking Configuration	Speed mph (km/h)	Minimum Stopping Distance miles (km)
Velaro D	Single traction, full pneumatic brake capacity, and 75% eddy current brake capacity	218 (350)	3.39 (5,45)
ICE 3	Single traction and full pneumatic brake capacity	174 (280)	1.93 (3,10)
ICE 3	Single traction, full pneumatic brake capacity, and 75% eddy current brake capacity	174 (280)	1.49 (2,40)
ICE 3	Double traction and full pneumatic brake capacity	205 (330)	2.73 (4,40)
ICE 3	Double traction, full pneumatic brake capacity, and 75% eddy current brake capacity	205 (330)	2.24 (3,60)
ICE 3	Double traction, full pneumatic brake capacity, and full dynamic brake capacity	205 (330)	2.30 (3,70)
ICE 3	Double traction, full pneumatic brake capacity, full dynamic brake capacity, and 75% eddy current brake capacity	205 (330)	1.99 (3,20)

The nominal emergency brake rate is 4.03 mphps (1,8 m/s<sup>2</sup>). This is based on an initial velocity of 205 mph (330 km/h) and a braking force of approximately 180 kips (800 kN).

---

## 7.6 PASSENGER ALARM/EMERGENCY BRAKING

### 7.6.1 Alstom

Alstom advised that service braking is initiated when the passenger alarm is pulled (half of the full service braking capacity with 11.6 psi (0,8 bar) of pressure in the brake pipe). This braking application can be interrupted by the driver to allow him or her to select the appropriate location to stop the train. An emergency brake cock that is linked directly to the brake pipe is located in the crew compartment. This application is irretrievable until the cock is reset. There is one crew compartment per trainset.

### 7.6.2 CSR

CSR advised that activation of the passenger alarm will not initiate braking. Once the alarm is pushed, a signal appears in the driver's cab indicating where the alarm was activated. The driver will then ask the engineer to check the situation.<sup>1</sup> Communication is directly between the driver and the engineer. The driver selects the appropriate location to stop the train.

Emergency brake valve handles are located in the crew rooms. Emergency brake applications via these handles are irretrievable, and the driver cannot override such a braking command. All crew members are trained, however, and must follow the process that is in place before pulling the emergency handle.

### 7.6.3 Siemens

Siemens advised that emergency brake devices (Figure 7.3) are provided for crew member and passenger use. The driver can override the emergency brake command to stop the train at an authorized stopping location. For example, if there is a fire onboard the train and a passenger pulls the emergency brake while the train is in a tunnel, a retrievable application will allow the driver to control the train and exit the tunnel.

**Figure 7.3 Passenger Emergency Brake Device on ICE 3**



Source: WBPF Photograph, January 2010

<sup>1</sup> In China, each train has a mechanical technician/engineer onboard to check faults/events.

---

## **7.7 BRAKE SYSTEM RESPONSE TIME**

### **7.7.1 Alstom**

Alstom advised there is a 3-second equivalent response time from when the driver presses the brake button to when pressure is applied in all of the bogies. This includes a 1-second dead time and 4-second buildup time. Because the buildup time is a step function, there is a step at 2 seconds. Jerk limiting is consistent with the TSI standard of 2.7 mphpsps (1,2 m/s<sup>3</sup>).

### **7.7.2 SNCF**

SNCF advised that the buildup time for the TGV brakes is 3.5 seconds; it is 20 seconds for freight trains.

The TGV must be able to fully control its brakes upon system startup. The onboard monitoring system reports to the driver if there are bogies isolated. The driver will then enter the number of operational bogies/brakes into the system, and the system will then check to see if the driver is correct. If the driver isolates the brakes on bogies, operating rules mandate that the train must operate at a reduced speed.

### **7.7.3 CSR**

The response time for the emergency brake on the CRH380A trainset is less than 0.4 second. A pressurization time of 3.5 seconds then follows.

### **7.7.4 Siemens**

The response time for pneumatic brakes on the Velaro D is 2.5 seconds. The dead time is 0.5 second and it takes 2 seconds for buildup.

## **7.8 RUNAWAY ACCELERATION DURING BRAKING**

### **7.8.1 Alstom**

Alstom advised that it uses a double interlock system to prevent the risk of having traction power during emergency braking. On the TGV, at the train level the system opens the main circuit breaker (which can be operated by the driver as well). In addition, traction is cut off once each bogie senses decreased pressure in the brake pipe (monitored by two sensors). On the AGV, the driver initiates the opening of the main circuit breaker.

### **7.8.2 Siemens**

Siemens stated that, by design, it is impossible to have traction power and a brake application at the same time.

---

## **7.9 BRAKE SYSTEM REDUNDANT CHARACTERISTICS**

### **7.9.1 Alstom**

Alstom advised that each motor bogie is independent of the others. The only common link is the control. The brake system has three levels of redundancy with two wheel slide protection (WSP) and one wheel rotation monitoring (WRM) devices [discussed in more detail in Section 7.11]. The electric command to the system that generates the pressure needed in the brake pipe has dual routes.

The main computer in the cab monitors the status of all bogies and the redundancy in the WSP. Once the driver is advised of any potential brake failures, the driver has to stop and manually isolate braking capabilities of the bogie.

### **7.9.2 Siemens**

Siemens advised that the signal from the brake lever to the brake control unit is both electric and pneumatic, thereby allowing for a minimum of two ways of communication. The signal is electric for normal operations. Both signals are in effect for emergency brake applications.

## **7.10 REDUCED WHEEL ADHESION**

### **7.10.1 Alstom**

Alstom advised that the brake system design is based on adhesion values that are compliant with TSI. Alstom considers the average weight per axle. To achieve the 0.15 adhesion limit, some axles may have 0.145 adhesion and others may have 0.155 adhesion.

### **7.10.2 CSR**

CSR advised that sanding is not used on high speed lines. It is difficult to direct sand onto the railhead when operating at speeds above 149 mph (240 km/h) because of the eddies/turbulences generated around the bogies. CSR's high speed trainsets are equipped with tread cleaning shoes to increase adhesion. Even when applying sand in metro service at speeds of around 50 mph (80 km/h), only a small amount of sand makes it onto the rail surface.

### **7.10.3 Siemens**

Siemens advised that TSI specifies a normal adhesion limit of 0.15. The average adhesion for wet rail is 0.12. According to TSI, tests are conducted by placing a soap-water mixture on the first wheelset, which will reduce the wheelset's adhesion value to 0.08. Although

---

the first wheelsets have a low adhesion value, they are “cleaning” the rails for the latter ones, and the adhesion value rises to 0.15 toward the middle of the trainset.

#### **7.10.4 SNCF**

SNCF advised that sand is used only for anti-slip. It is provided on each side of each motored bogie. SNCF does not use sand at high speeds, however, due to the nature of the sand spraying everywhere and the potential to adversely affect track circuits.

### **7.11 WHEEL SLIDE PROTECTION AND WHEEL ROTATION MONITORING SYSTEMS**

#### **7.11.1 Alstom**

Alstom advised that the braking forces on an articulated trainset are concentrated on a reduced number of axles, so there is higher sensitivity to wheel/rail adhesion when compared to the TSI limitation. As a result, it is necessary to integrate high-performance WSP and WRM devices. Without these devices, braking performance is reduced and stopping distances will increase due to poor wheel/rail adhesion.

The WSP system limits increases in stopping distance during degraded conditions to approximately 10 percent to 15 percent. In addition, the WSP and the WRM devices act as a protection against locked axles, which can cause derailments. WSP and WRM devices are microprocessor-controlled with high redundancy levels and are UIC-certified.

The WSP system is available during electrodynamic, friction braking and emergency braking. It is axle-controlled and is independent for each bogie. In addition, cross monitoring is available.

#### **7.11.2 CSR**

The CRH380A implements axle rotation monitoring in addition to WSP. Through its anti-skid tests, CSR has found no defects in the form of flat spots on its wheelsets. The brake control system on the CRH380A can recover adhesion on the skidding axle in a reasonable time.

#### **7.11.3 Siemens**

The Siemens Velaro design respects TSI and the UIC leaflet 541-05 for WSP. WSP provides controlled wheel slide in the event of low wheel/rail adhesion to minimize any increase in stopping distances. It is active during emergency braking and during rescue operation.

The Velaro's rotation monitoring system is independent of the slip/slide control system and is designed to be highly redundant.

---

## **7.12 BRAKE PIPE INSTALLATIONS AND TRAIN RESCUE**

### **7.12.1 Alstom**

It is typical for rescue trains in Europe to connect with disabled trains via brake pipes. Typically the brake pipe is trainlined and uses a flexible hose between cars that can be disconnected only in maintenance shops.

### **7.12.2 CSR**

There is no brake pipe on the CRH380A. Rescue is accomplished by either a rescue trainset or locomotive.

### **7.12.3 Siemens**

The latest Velaro platform incorporates the use of a brake pipe to transmit pneumatic signals to the brake system. The ICE 3 trainset uses an electric brake signal to command pneumatic braking; however, the Velaro platform has been changed back to using an electro-pneumatic signal. The brake pipe is also used for rescue services. The rescue unit must be able to control the brakes through the main brake pipe.

<p><b>Note:</b> Additional information about the speeds that operators allow for rescued trains is provided in Section 20.3.</p>
--

## **7.13 REMOTE MONITORING OF BRAKE APPLICATION FORCE**

### **7.13.1 Alstom**

Alstom advised that each motored bogie has a system in place to detect pressure in the brake pipe. Remote monitoring of the brake application force is done via an open loop. The pressure in the brake cylinder activates or deactivates a pressure switch/sensor. Green/red (released/pressurized) indicators on the outside of the trainset are tied to the sensor, and show whether or not the brakes are released.

### **7.13.2 CSR**

The brake force in each CRH380A car can be monitored via cylinder pressure. In regards to monitoring the actual brake force, CSR stated that the brake force in each car changes with loads, so it is not used.

### **7.13.3 Siemens**

There are two types of automatic brake testing that ensures for the driver that the brakes are operating correctly:



- 
- **Automatic Night Test.** The driver inputs the time the train is to leave the yard. The train will then calculate when to begin complete checks of the brake system. During this time, the train will also calculate when to turn on the HVAC system, etc. The brake tests last approximately 1 hour.
  - **Manual Brake Test.** The driver can start the manual brake test after receiving notification that everything is operational from the night tests. Doing so will give the driver information about the braking capability of the train. The tests are conducted based on the pressure developed in the cylinders and not the force from the pads to the discs.

## **7.14 FRA/ASME REQUIREMENTS RELATIVE TO BRAKE RESERVOIRS**

### **7.14.1 Alstom**

Alstom had no concerns about using ASME-certified brake reservoirs on HSR trainsets.

### **7.14.2 CSR**

CRH380A brake reservoirs are made of carbon steel.

### **7.14.3 Siemens**

The brake reservoirs on the Velaro are aluminum; however, Siemens stated that the reservoirs can be manufactured from either aluminum or stainless steel.

## **7.15 PARKING BRAKE/HAND BRAKE SYSTEM**

### **7.15.1 Alstom**

Alstom advised that the parking brakes are spring applied and released manually. There is an indication to ensure that all of the brakes are released. With a manual release system, the driver would be alerted if the brakes are applied. For an automatic release system, the quick venting of the parking brake cylinder can be accomplished once a specific pressure value is reached. There is no monitoring of the parking brake with the automatic function; however, this would put the responsibility on proper maintenance. Alstom advised that automatic parking brake systems have higher purchase prices and maintenance costs.

External means, such as wheel chocks, can be provided to hold the train on a grade if the train is to keep the parking brake deployed beyond 2 hours, which is the limit parking brakes are required to be effective as defined in TSI. Alstom noted that it is expected that the train would be rescued within the 2-hour limit. It is interesting to note that measurements taken by SNCF found that the train was able to hold for 8 to 10 hours. Alstom advised that the braking

---

system must be designed in consideration of both technical and operational requirements.

### 7.15.2 CSR

There are no parking brakes on the CRH380A. Instead, wheel chocks are used.

### 7.15.3 Siemens

Parking brakes are applied via a pushbutton located in the driver's desk. The spring brake is released pneumatically and can also be operated manually from the exterior of the trainset. There is a mechanical disconnect between the brake caliper and the spring. The Velaro has 24 spring brakes—three are mounted on discs on each of the eight trailer bogies (Figure 7.4). Each trailer bogie has six discs distributed among the axles to maximize adhesion. Siemens stated that this system is sufficient to give holding capacity on a 4 percent grade. (TSI requires 3.5 percent).

**Figure 7.4: Siemens Velaro E Disc Brake Arrangement**

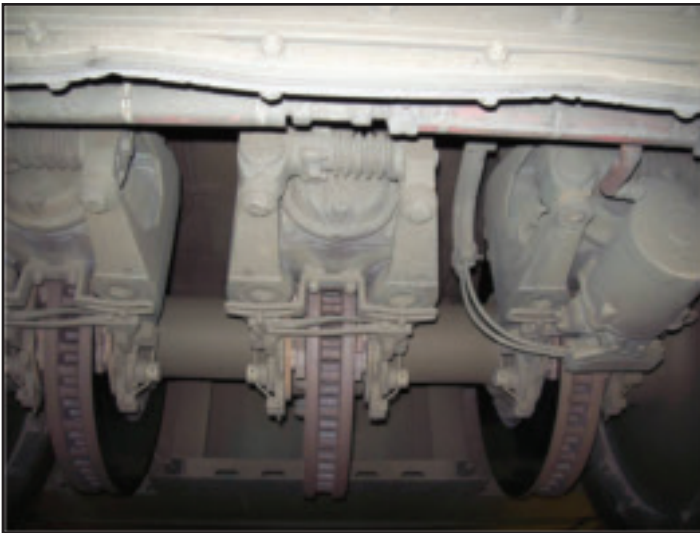

Source: WBPF Photograph, February 2010

**Note:** Additional information about issues related to braking is provided in:

- Section 9.2, ATC Interface with Braking and Propulsion Systems
- Chapter 15, Infrastructure Interfaces and Vehicle/Track Interaction.

---

# CHAPTER 8 BOGIES AND TILTING SYSTEMS

## 8.1 ARTICULATED TRAINSET ARCHITECTURE

### 8.1.1 Alstom

Alstom discussed the design attributes of articulated trainset architecture, which is defined as having a single bogie between two cars, as opposed to placing one bogie directly underneath each end of each car. In comparing the number of bogies required for various architectures of a 656-foot (200-m) trainset, Alstom provided the following, which is also illustrated in Figure 8.1:

- **Traditional/conventional architectures**, such as those used on the Velaro, Shinkansen, ETR 450, and the new Pendolino, require two bogies per car, for a total of 16.
- **Semi-articulated trains**, such as the TGV-PSE, TGV-R, and TGV Duplex, are not articulated between the two end cars and the adjacent trailer cars, but all intermediate cars are articulated. The total number of bogies is 13 (19 percent fewer than conventional architectures).
- **Fully articulated trains**, such as the AGV, have only 12 bogies (25 percent fewer than conventional architectures).

The length of coaches of the articulated AGV trainsets is 55.8 feet (17 m) compared to 60.4 feet (18,4 m) for the semi-articulated TGV and 82.0 feet (25 m) for conventional trains.

**Figure 8.1 Number of Bogies Required for 656-foot (200-m) Trainsets of Various Architectures**

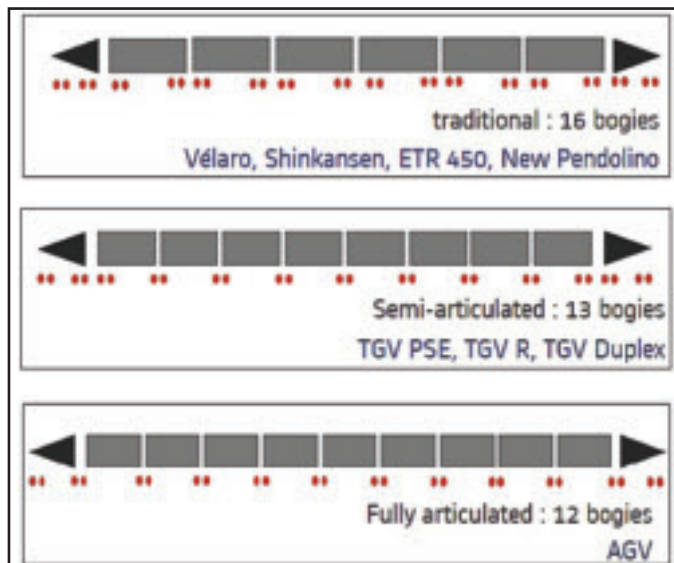

Source: Alstom Presentation, "Articulated Architecture," June 2010

---

Alstom advised that each trainset has one key car that has two bogies attached; all other cars have one. During attachment, each car is mounted on the bogie of the adjacent car. Alstom's axles on each bogie are typically spaced 9.8 feet (3 m) apart. The benefits of articulated architecture include improved safety, additional comfort, less energy consumption, and lower operational costs.

**Safety.** Alstom advised that two of the most feared scenarios for railway accidents are the accordion effect and overturn. Alstom has experienced three accidents on its very high speed lines in 30 years of operation:

- The first happened on December 14, 1992, in Macon on a first generation TGV traveling from Paris to Lyon at a speed of 168 mph (270 km/h). Due to a failure in the WSP device, WSP was not working properly. One wheel locked and developed a flat when the driver initiated braking, leading to an eventual derailment. Since this incident, two independent WSP devices are installed.
- The second incident happened on December 21, 1993, at the Haute-Picardie Station with the train traveling at 183 mph (294 km/h). Excessive rain led to a large hole developing underneath the track, which led to a derailment.
- The third incident happened on June 5, 2000, at Croisilles with the Eurostar train traveling at 180 mph (290 km/h). The gearbox had not been properly lubricated during maintenance. As a result, the shaft failed while the train was in operation and the train derailed.

The articulated architecture of the trainsets prevented the cars from serious damage in all three incidents, as illustrated in Figure 8.2. Articulated architecture inherently provides resistance to trainset overriding both vertically and laterally, so the accordion effect or overturn was never observed on the TGV. To date, there have been no fatalities on the very high speed lines in France.

**Figure 8.2 TGV Derailments in France**



Source: Alstom Presentation, "Articulated Architecture," June 2010

---

**Comfort.** Alstom advised that the articulated architecture also leads to increased comfort in terms of:

- **Reduced noise:** The bogies are located between the cars and not directly underneath them, so the sources of noise are located away from the passengers. In addition, the fewer bogies with articulated architecture result in less exterior noise.
- **Fewer vibrations:** Vibrations are dampened by having the dampers between the coaches; none are transferred from the bogie to the carbody. As a result, vibrations felt by the passengers are limited.

**Energy.** Having fewer bogies reduces the trainset weight drastically (77 tons per 656-foot trainset (70 tonnes per 200-m trainset)). In addition, aerodynamic drag, to which bogies typically contribute up to 40 percent, is reduced. Based on Alstom's simulations for the Paris-to-Lyon line, this reduced drag reduces energy consumption by 10 percent (Figure 8.3).

**Cost.** Maintenance costs are reduced by approximately 15 percent to 20 percent of the trainset purchase price over 30 years.

**Figure 8.3 Energy Consumption of the Articulated AGV vs. Semi-Articulated Duplex and Non-Articulated Trainsets**

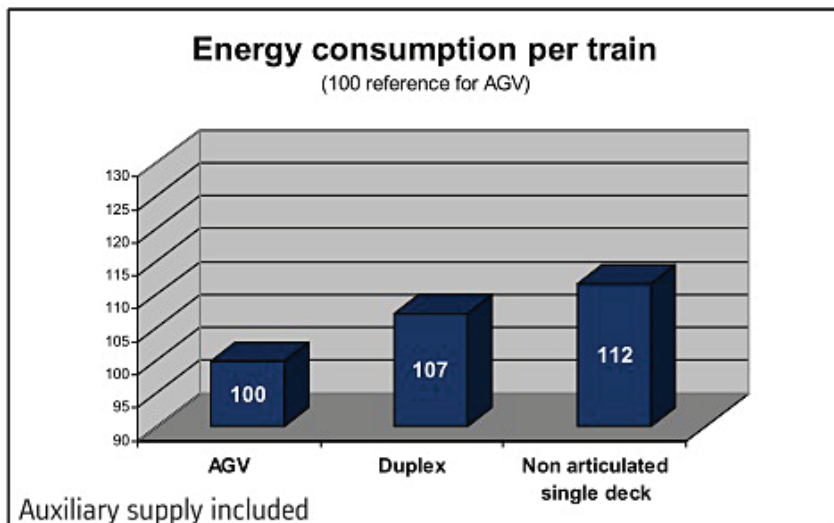

Source: Alstom Presentation, "Articulated Architecture," June 2010

### 8.1.2 SNCF

SNCF advised that its choice to use an articulated design was governed first by the lower aerodynamic drag, and second by its lower noise emissions and increased passenger comfort. The safety aspect of articulation was not realized until later, after a derailment at 186 mph (300 km/h) on the North Line. In this incident, the train managed to stop after 3,281 feet (1000 m). There were no injuries to the passengers or the crew.

---

## 8.2 BOGIE DESIGN

### 8.2.1 CSR

CSR advised that the CRH380A trainset uses a lightweight, bolsterless bogie (Figure 8.4). The bogie is designed for a continuous operational speed of 218 mph (350 km/h), a maximum operational speed of 236 mph (380 km/h), and a maximum test speed of more than 249 mph (400 km/h). The CRH380A journal center distance is 6.6 feet (2 m), the wheelbase is 8.2 feet (2,5 m), and the distance between bogie centers is 57.4 feet (17,5 m). The wheel diameters for new and worn wheels are 33.9 inches and 31.1 inches respectively (860 mm and 790 mm). The bogie suspension comprises a primary steel spring system and a secondary air spring system.

**Figure 8.4 CRH380A Motor Bogie (left) and Trailer Bogie (right)**



Source: CSR Presentation, "Information about High Speed EMU," November 2010

CSR advised that the bogies are designed according to the following standards:

- UIC 518 for the testing and approval of railway vehicles from their dynamic behavior perspectives (e.g., safety, track fatigue, ride quality, etc.)
- UIC 513 for guidelines in evaluating passenger comfort relative to vehicle vibration
- UIC 615-4 for the structural strengths of the bogie frames for motored bogies
- UIC 515-4 for the structural strengths of the bogie frames for trailer bogies
- Technical Regulation from MOR with Reference No. 2008-28 named "Chinese Test Specification Standard for High Speed EMUs"
- EN 13749, which includes methods of specifying structural requirements of bogie frames (resistance to forces generated from  $\pm 5$  g longitudinal,  $\pm 1$  g lateral, and  $(1 \pm 2)$  g vertical accelerations)
- Interim MOR regulations that identify requirements for the strength design and test evaluation for rolling stock that operate at speeds greater than 124 mph (200 km/h), and identify rigidity tests that are not seen in UIC 615 and EN 13749.

---

Factors in the bogie analyses include:

- Aerodynamic forces
- Hunting/self-excitation vibration
- Track irregularities
- Changes in track rigidity
- Changes in wheel/rail interaction
- Primary and secondary suspension parameters
- Wheel/rail interaction.

CSR advised that the structural strength of the wheelsets is designed according to EN 13260 for wheelset requirements, EN 13261 for axle requirements, and EN 13262 for wheel requirements. Analyses are conducted according to EN 13103 for non-powered axles and EN 13104 for powered axles.

CSR advised that bogie frames of all high speed EMUs are welded robotically.

### **8.2.2 Hyundai Rotem**

Hyundai Rotem advised that the HEMU-400X trainset will have an active suspension system<sup>1</sup> to improve trainset stability. According to Hyundai Rotem, while the cost of an active suspension system is greater than that of a passive system<sup>2</sup>, the safety, stability, and passenger comfort outweigh the increase in cost.

### **8.2.3 Siemens**

Siemens uses SF 500 bogies (Figure 8.5) for the Velaro trainset. The Velaro design incorporates two air springs and two anti-roll bars per bogie. Auxiliary springs are provided inside the air springs to account for air spring failure. The bogie is a self-steering design. It can accommodate operational speeds of up to 218 mph (350 km/h) plus 10 percent (for testing).

**Figure 8.5 Velaro SF 500 Bogie**



Source: Siemens Presentation, "Running Dynamics and Gauging," January 2010

---

<sup>1</sup> An active suspension system uses an onboard system (via accelerometers and actuators) to automatically detect and electronically mitigate carbody lateral vibration and roll.

<sup>2</sup> A passive suspension system uses traditional dampers, coil and air springs to physically mitigate the effects of carbody lateral vibrations and roll.

---

The typical wheelbase for the Velaro SF 500 bogie is 8.2 feet (2,5 m); however, the wheelbase of the Velaro RUS is 8.5 feet (2,6 m). The maximum distance between bogies is 57.0 feet (17,4 m). The diameters for new and worn motored wheels are 36.2 inches and 32.7 inches respectively (920 mm and 830 mm). The diameters for new and worn trailing wheels are 36.2 inches and 33.9 inches respectively (920 mm and 860 mm).

**Note:** Related information is provided in Section 15.7, Axle Bearing Health Monitoring.

## **8.3 TILTING SYSTEMS**

### **8.3.1 Alstom**

Alstom advised that no active tilting is used. A solution is available for speeds of up to 168 mph (270 km/h).

### **8.3.2 CSR**

CSR advised that although China has a solution for active tilting systems for HSR trainsets, the system is not installed on the CRH380A. Tilting is used only on existing lines that contain small curves.

### **8.3.3 Siemens**

Siemens does not use active or passive tilt mechanisms on the Velaro platform.



---

# CHAPTER 9 TRAIN CONTROL AND SIGNALING SYSTEMS

*The attributes of international HSR ATC and signaling systems were discussed with the equipment manufacturers and operators. ATC, also referred to as ATP, is a train protection system that ensures safe operations by keeping trains a safe distance apart. The information presented in this chapter identifies the similarities and differences between the U.S., Asian, and European requirements for ATC systems.*

## 9.1 TRAIN-TO-WAYSIDE COMMUNICATION SYSTEMS

### 9.1.1 Alstom and Siemens Overview of European Rail Traffic Management System (ERTMS)

*Representatives of Alstom and Siemens provided overview information about ERTMS, its main components, and industry standard guidelines during their separate interviews. Because much of the information provided by Alstom and Siemens was similar, their combined comments follow.*

Europe initiated ERTMS to consolidate and integrate national ATC/ATP systems within an integrated corridor solution and thereby increase interoperability, safety, and competitiveness among railways in Europe. ERTMS is a global system that encompasses ETCS as its safety element.

ETCS is the link between the interlocking and the vehicle. It currently covers two levels of communications (Figure 9.1), with a third level under development.

- **Level 1** covers coded signals transmitted through the rails and communications sent via balises (transponders) installed in the tracks. Transponder signals are picked up by onboard antennas when trains pass over the balises. Level 1 can be superimposed on existing signaling systems via lineside electronic unit (LEU) encoders and switchable (variable-data) balises. Continuous supervision is provided by the balises with spot transmission. There is also detection for occupied/unoccupied tracks.
- **Level 2** is a digital radio-based or cellular signal-based train protection system that transmits and receives all pertinent data via GSM-R. Complete supervision is provided with continuous transmission. While trains continue to operate in a fixed-block principle,<sup>1</sup> continuous transmission permits greater line throughput. The balises are used at this level as passive positioning beacons or “electronic milestones.” Balises are used also for position calibration (e.g., after slip/slide conditions), and are spaced depending on the operation (for long tracks, approximately 62 miles (100 km) apart). The track vacancy detection indications (TVDIs) at the interlockings send signals to the radio block center (RBC), which then sends a signal to the train via GSM-R.
- **Level 3** is intended to permit trains to operate under a moving block principle,<sup>2</sup> allowing even greater line throughput.

---

<sup>1</sup> Fixed blocks are sections of track between two fixed points.

<sup>2</sup> A moving block is the calculated safe zone required for the train to stop safely.

**Figure 9.1 ETCS Levels 1 and 2**

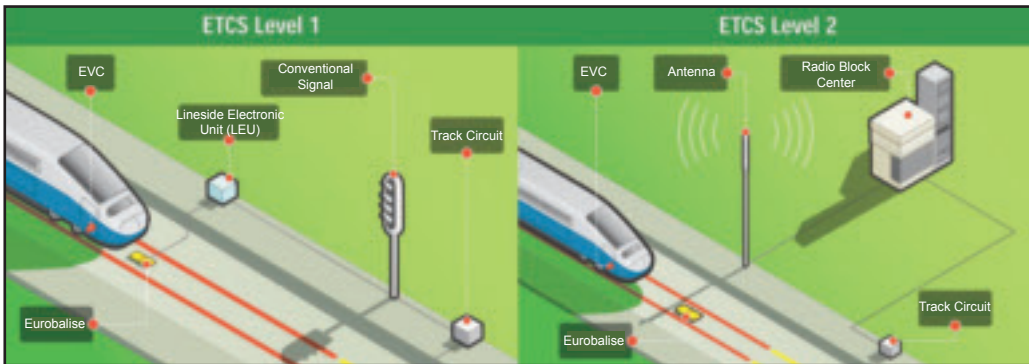

Source: Alstom brochure, *Seamless Interoperability*

The overall goal is for all rail lines in Europe to be compatible with all ERTMS levels and with various national systems (i.e., freight). As of September 2009 more than 3,700 miles (6000 km) of track had been equipped with ETCS. Since September 2009 all EU-funded projects (six corridors) were required to be equipped with ETCS. In addition, after 2012 all new locomotives, railcars, and vehicles must be equipped with ETCS technology. Currently, most countries in Europe are transitioning to ETCS Level 1; some are transitioning to ETCS Level 2.

### 9.1.2 SNCF

SNCF concurred with Alstom's and Siemens' description of ERTMS, adding that TSI is aiming to consolidate the signaling systems for European high speed rail. The results will better accommodate interoperability and permit a more open market. The goal of ERTMS is to replace the existing national systems used currently in Europe, including KVB/TVM for France and LZB for Germany (Figure 9.2). Currently, ERTMS is used in Spain, Italy, Belgium, and the Netherlands.

**Figure 9.2 European Signaling Systems by Country**

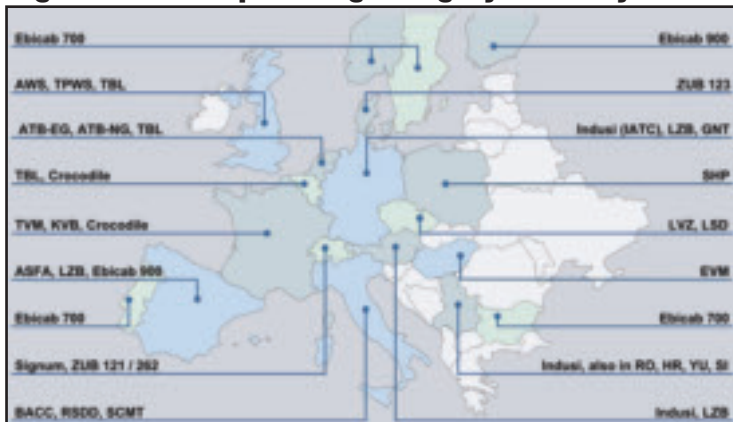

Source: Siemens Presentation, "High Speed Signalling ETCS," February 2010

---

SNCF stated that it was significant to have both safety and speed control. ERTMS is necessary because, for example, in France a flashing green light tells the driver to reduce speed to 99 mph (160 km/h); whereas in the Netherlands, a flashing green light tells the driver to reduce speed to 25 mph (40 km/h). Another benefit of ERTMS is that the trainset knows its own braking performance and constantly checks its braking curve. All of the trains running on HSR lines in France are TGVs, so the signaling system was designed around them taking into consideration the safety margin of the safe braking distance plus 656 feet (200 m) as required by the Ministry of Transport. With ERTMS, however, it is possible to optimize the performance between the trainset and the infrastructure. All ERTMS systems are designed to Safety Integrity Level (SIL)-4<sup>1</sup>.

SNCF stated that ETCS Level 2 (with GSM-R) performs well at 199 mph (320 km/h) and was tested to 218 mph (350 km/h).

### 9.1.3 Alstom

Alstom developed a configurable, modular, and user-friendly solution that integrates current ERTMS and legacy ATP systems. Alstom advised that 53 percent of the HSR trains in Europe contracted for onboard ERTMS equipment are/will be supervised by Alstom's ATLAS signaling system (ATLAS 100 for Level 1 and ATLAS 200 for Level 2). Alstom has been responsible for onboard ERTMS projects in Spain, Germany, the Czech Republic, Switzerland, and Italy. It has also been responsible for wayside ERTMS projects in Belgium, Switzerland, and Italy.

Alstom stated that 89 percent of its high speed trains are equipped with the ATLAS 200 system, and 74 percent of the total kilometers equipped with ERTMS Level 2 run on infrastructure provided by Alstom. As an example, the ATLAS 200 system is installed on Italy's 137-mile (220-km) double-track Rome-to-Naples line and 95-mile (152-km) double-track Bologna-to-Florence line for Trenitalia. These lines have been in commercial service since December 2005. ERTMS Level 2 is installed with no other backup signaling system. The system characteristics include:

- 186 mph (300 km/h) maximum operating speed
- 25 kV AC, 50 Hz OCS
- 5-minute headways
- 33 circulations per day
- 30 trains inclusive of four different train types.

**ATLAS Systems.** ATLAS 100 and ATLAS 200 are supported by a number of individual subsystems and integrated systems (Figure 9.3). Among these are:

- **ADVANTI<sup>K</sup> ATC**, which integrates onboard and wayside modules from Alstom or other suppliers via either antennas and in-track balises for ETCS Level 1 or bidirectional GSM-R transmission for ETCS Level 2.

**Onboard equipment**, which has at least two channels to provide information in case of failure, includes:

---

<sup>1</sup> Per EN 50129, the SIL is a number that indicates the required degree of confidence with which a system will meet its specified safety functions in the event of systematic failures.

- European vital computer (EVC), which consists of three computers. If two of the three computers are in agreement, then the command is validated. The EVC serves as the core of the onboard ERTMS system.
- Juridical recorder unit (JRU), which is the trainset's black box. In addition to meeting European requirements, Alstom included an additional function to store maintenance information, which can then be transmitted to the maintenance center via radio.
- Cab radio.
- Driver machine interface (DMI), which provides typical real-time and advanced information to the driver [Section 9.9.3].
- Balise antenna.
- Radar transceivers, which are used to monitor wheel slip.
- Wheel sensors.

**Wayside equipment** includes:

- LEU
- GSM-R antenna
- RBC
- Maintenance staff protection terminal.
- Eurobalise

**Figure 9.3 ATLAS Subsystems**



Source: Alstom Presentation, "High Speed Signalling ERTMS: The Present and the Future," June 2010

- **ICONIS**, which integrates information, supervision, and control for the entire railway network.  
**Control levels:** ICONIS can operate at three control levels:
  - Manual: operators can track trains and control railway signals.
  - Automatic: trains are matched with a timetable and tools are provided to set routes automatically.
  - Optimization and decision making: trains are monitored constantly and the network

---

is optimized. Any potential issues can be detected and suggestions will be provided on how to resolve them.

**Functions:** ICONIS modules cover two primary functions: operations and onboard communications and monitoring.

- Operations: ICONIS provides modules for:
  - Advanced scheduling functions
  - Dark territory control
  - Conflict detection/resolution.
- Onboard communications and monitoring: ICONIS provides optional modules for:
  - Passenger information systems to coordinate announcements to passengers through either a PA system or visual display
  - Supervisory control and data acquisition (SCADA) to monitor all fixed equipment and railway electrical power supply to lines and stations
  - Security to monitor video cameras, access control, fire detection, etc.
  - Maintenance supervision to detect failures in wayside equipment and to provide remote diagnostics.
- **SMARTLOCK**, which controls conventional wayside signaling equipment and its interfaces with ADVANTIK. SMARTLOCK is designed to SIL-4 and is redundant to ensure high availability and to not jeopardize railway safety.
- **SMARTWAY**, which comprises products such as track circuits and axle counters for train detection, switches, level crossing equipment, derailment detectors, hotbox detectors, etc.

Alstom advised that the ATLAS system integrates all critical subsystems and equipment through a synchronous digital hierarchy (SDH) railway backbone. Trains can also be equipped with an onboard Ethernet network that permits integration of various functions, such as security, passenger information, and train monitoring systems. Modular integration of older systems is done through specific transmission modules (i.e., pre-existing national signaling systems).

**Key Issues.** Alstom suggested that the following issues are key to centralized operations:

- **Diagnostic data collection and GSM-R monitoring.** ATLAS uses diagnostic data collection tools to investigate the global performance of the GSM-R system for ERTMS/ETCS Level 2 to:
  - Identify and correct potential issues or weaknesses prior to those issues affecting operations
  - Support investigations in the event of communication problems
  - Assist in identifying potential connection issues of onboard devices
  - Monitor correct train identification.
- **Key management center (KMC) solutions.** Keys are used to authenticate connections between the RBC and the EVC or between the radio infill unit (RIU) and the EVC. These keys are shared between the two devices in sync and must be updated.

---

ed periodically for safety purposes. The KMC solution provides a tool to download authentication keys in the RBCs, EVCs, and RIUs; it also provides a tool to manage key exchange requests with foreign KMCs.

- **Handheld terminals (HHTs).** HHTs are used to liaise with the RBC via GSM or GSM-R and to perform various maintenance activities. HHTs are lightweight, wireless, and robust in that they are designed for outdoor use with resistance to cold and hot temperatures, dust, rain, etc. An RBC with HHT and interlocking functions can use the terminals in lieu of switch boxes. This option reduces costs because no cables, switches, or installation are required. HHTs can also be used by staff members to, for example, impose speed restrictions.

**Signaling Performance.** SNCF specifies that the signaling equipment for Alstom's RGV 2N Duplex trainset include:

- JRU, which provides the functions required (record signaling information, train information, driver's actions, etc.), and offers options to include voice recording and data transmission via GSM
- Automatic and dynamic signaling transitions at the borders (managed by ERTMS balises)
- Deadman system, or driver's vigilance system [Section 9.3]
- Sound generator for different signaling systems
- Voice radio (both analog and GSM-R)
- Train technical functions: automatic transition for neutral sections (e.g., phase brakes) via balises or TVM loop, managed by the train control and monitoring system (TCMS).

Alstom is evaluating performance improvements for ETCS. Called Boosted ERTMS, this enhanced system is defined as ERTMS signaling with boosted braking performance. Boosted ERTMS follows from ERTMS Level 3, and enables even smaller headways without any infrastructure changes by displaying the information (e.g., speed, location) on the leading train, thereby allowing a precise calculation of safe zones between trains. Boosted ERTMS takes into account increasing service capacities and improves performances for very high speed lines (even with mixed traffic).

Alstom illustrated the importance of establishing a common approach to ATC throughout Europe (i.e., ERTMS) by identifying the many signaling systems currently in use:

- **France:** RPS (punctual signaling repetition) + KVB (speed control with balises) + TVM430 (high speed line signaling) + ERTMS Level 2
- **Germany:** PZB (speed control with balises) + LZB (speed control with continuous transmission) + ERTMS Level 2 (end of 2011)
- **Switzerland:** SIGMUM/INTEGRA (punctual signaling repetition) + ZUB (speed control with balises) + ERTMS Level 2.

Each signaling system has its own antenna, tachometer, and display. Alstom is working to:

- Consolidate all displays into one monitor on the ERTMS DMI
- Provide functional interfaces between ERTMS and the national signaling equipment (for transitions)
- Integrate all antennas and speed sensors.

Figure 9.4 offers an example of the equipment currently installed on the RGV 2N trainset to accommodate the different signaling systems.

**Figure 9.4 RGV 2N Onboard Signaling Equipment**

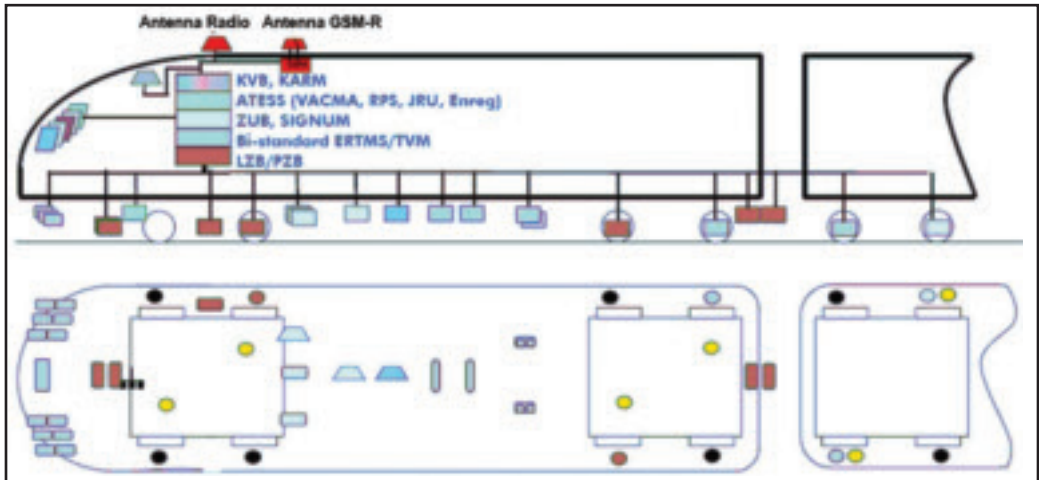

Source: Alstom Presentation, "Signalling Equipments Integration," June 2010

Signaling validation will be performed via a type test in a laboratory per EN 50155 (class T3 for temperature). An integration test will be conducted in an ERTMS laboratory to validate interfaces with the national signaling equipment. Another integration test will be conducted in a TCMS laboratory to validate the interfaces between the signaling equipment and the TCMS. Commissioning will then take place on the first train with the suppliers. Functional validation of the train's technical aspects will then be performed, after which a certificate will be issued.

The use of GPS to pinpoint the exact location of a train is currently being studied. The verification of the precise location of the trainset will ensure that the correct signal is working and displayed. If GPS is shown to be viable, a verification and validation program will be conducted prior to implementation.

**U.S. Requirements.** Alstom recognized that the U.S. is looking for suppliers to provide a system based on ERTMS (potential use of radio and wayside signals) that complies with FRA's new Positive Train Control (PTC) requirements.<sup>1</sup> The functionality of an FRA-compliant PTC system includes the prevention of train-to-train collisions, over-speed derailments, incursion into established work zones without appropriate authorization, and movement of a train through a mainline switch in an improper position.

Alstom stated that the several challenges to meeting the U.S. PTC requirements include those related to interoperability and the radio transmission used. Alstom recognized the benefits of having a standardized ATC system in the U.S. (e.g., PTC) that is implemented by freight,

<sup>1</sup> Positive train control (PTC) systems are integrated command, control, communications, and information systems for controlling train movements. Efforts to deploy PTC on various railroads in the U.S. have accelerated since 2008.



---

commuter, intercity, and high speed trains, but commented that when speed increases on HSR lines, the train control technology should be evaluated to ensure the level of safety remains the same.

#### 9.1.4 Siemens

Siemens advised that ETCS systems can provide several benefits for U.S. HSR projects in that such systems:

- Are designed for top speeds of 300 mph (483 km/h) and for high density traffic (approximately 3-minute headways)
- Can be integrated with U.S. PTC systems to access the entire railway network
- Reduce infrastructure requirements (i.e., signals); however, wayside signals can still be used as fallback systems for redundancy.

Siemens said that it is advisable to have an open transition rulebook, defined by the operator, for each manufacturer to prove interoperability in the U.S. FRA has stipulated that all commuter railroads must be interoperable with PTC systems that the trainsets might come across. Wabtec's Electronic Train Management System (ETMS) uses GPS technology and is designed primarily for large freight trains operating over non-electrified territory. The ETMS PTC system has FRA approval. In San Jose and San Francisco, the Communication-Based Operating Signal System (CBOSS) PTC System initiative is underway. Siemens suggested ETCS can overlay any existing U.S. system.

In addition to Siemens producing 80 percent of today's Eurobalises, its Trainguard 100 and Trainguard 200 systems for ETCS Level 1 and Level 2, respectively (Figures 9.5 and 9.6) are currently used on many high speed lines, including those in the Netherlands, China, and Spain.

- **Netherlands:** Trainguard 100 and 200 are used on HSL-Zuid, the Netherlands' first high speed project with an approximate speed of 124 mph (200 km/h). The line uses ETCS Levels 1 and 2, whereas the ATB signalling system is used on other networks. HSL-Zuid is Europe's first cross border project with a transition between the Netherlands and Belgium.
- **China:** Trainguard 100 and the Chinese Train Control System (CTCS) are used on the Beijing-to-Tianjin line. Approximately 70 miles (113 km) long, it is China's first railway line to travel at speeds greater than 200 mph (approximately 220 mph) (322 km/h, or approximately 354 km/h). Also, as the first ETCS project in China, it features interfaces between Siemens and Chinese technology.
- **Spain:** Trainguard 100 and 200 are used on the La Sagra-to-Toledo line, Spain's first high speed ETCS project. The trains are equipped with ETCS Level 2 and the onboard units are designed to run on tracks equipped with ETCS systems. There is also an interface to ASFA, the Spanish train control system similar to LZB.

Siemens also developed Trainguard MT, a system based on ETCS but with reduced modes and operations. This system is adopted mainly for mass transit.

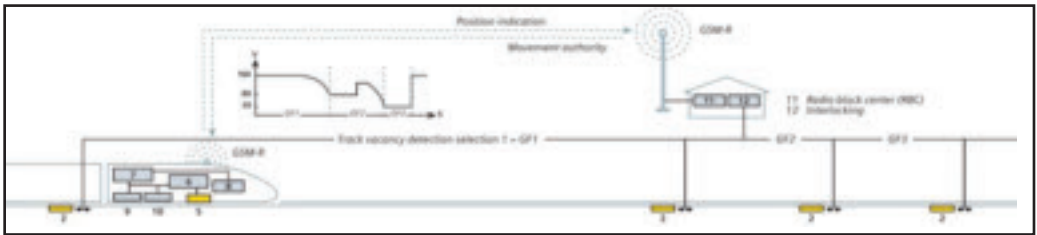

**Figure 9.5 Trainguard 100 for ETCS Level 1**



Source: Siemens brochure, *Trainguard – Full Interoperability for European Railways*

**Figure 9.6 Trainguard 200 for ETCS Level 2**



Source: Siemens brochure, *Trainguard – Full Interoperability for European Railways*

Siemens discussed the Velaro train control system, advising that it includes the propulsion and brake control for optimization of energy consumption and ride performance, and the driver advisory system for verification of driver operations. Siemens advised that its train control system includes the auxiliary power supply control that provides redundancy and power management control. It supports emergency running by ensuring all safety functions, such as brakes, are working properly and diagnostics by displaying train status/faults. The central control unit (CCU) forwards commands from the cab to the various control units (e.g., traction, brakes, etc.). In addition, the CCU receives feedback signals from other peripheral units and subsystems. Siemens provides four CCUs for each 656-foot (200-m) trainset to provide a high level of redundancy.

### 9.1.5 Hyundai Rotem

Korea uses ERTMS for train control. Motorola is the service provider for the GSM-R network. Korea has had no issues at test speeds of up to 230 mph (370 km/h). ATC on conventional lines uses ultra high frequency (UHF)-based communication.

### 9.1.6 TSDI

China uses CTCS Levels 0 through 3 for train control as follows:

- CTCS-0: existing conventional lines
- CTCS-1: interim system for lines operating at speeds of less than 99 mph (160 km/h)
- CTCS-2: dedicated passenger lines with speeds of 155 mph (250 km/h) and on upgraded existing lines

- 
- CTCS-3: dedicated passenger lines with operating speeds of 186 mph (300 km/h) and higher.

TSDI advised that CTCS-3, similar to ETCS-2, is a train control system that is based on bi-directional information transmission between the trainset and the wayside. The main characteristics of CTCS-3 are:

- Continuous bidirectional transmission of trainset information
- Interoperability with CTCS-2, which serves as the degraded train control mode
- Real-time information about train status
- Flexibility in setting temporary speed restrictions.

In addition, CTCS-3 permits 3-minute headways under 218 mph (350 km/h) operations.

The onboard equipment for CTCS-3 includes:

- Redundant DMI connected by the multifunction vehicle bus (MVB).
- JRU.
- Redundant vital computers, each with two control units. Each vital computer is connected to a balise transmission module and a track circuit receiving module.
- Redundant speed units and speed sensors.
- Secure digital interface for emergency braking.
- Communication interface unit and general encryption unit for wireless communication through GSM-R.

Wayside equipment for CTCS-3 includes:

- Station interlocking
- LEU
- Train control center
- Computer supervision and monitoring system
- ZPW-2000 track circuit
- Temporary speed restriction server connected to the centralized traffic control
- RBC
- GSM-R infrastructure (e.g., base transmission stations and optical transmission equipment).

The RBC transmits movement authorities to the onboard ATC system via the GSM-R network. Track circuits are used to detect track vacancies, and fixed balises spaced 0.6 mile (1 km) apart are used to provide trainset positioning information. The track circuits interface with the train control center, which communicates with the RBC and centralized traffic control.

- Train position and speed information is transmitted from the train via GSM-R to the RBC.
- The RBC transmits this information to the centralized traffic control. Any temporary speed restrictions are sent from centralized traffic control to the RBC.

- Track occupation information is sent to the computer-based interlocking and the route information is transmitted to the RBC.
- The RBC will generate a movement authority and transmit this information back to the train.

TSDI advised that the communication between the GSM-R network and the trainset is protected by a key to authenticate transmissions. This key is generated by the KMC and goes through an encryption process prior to entering the GSM-R communication network. CTCS-3 key management is in accordance with EN 50159-2.

TSDI advised that the CTCS-3 communication system is redundant (Figure 9.7):

- The GSM-R system provides redundant radio coverage through an interlace structure. When one base station fails, the others will meet the field coverage requirements.
- Two fiber optic lines are installed along the right of way (one on each side).
- The dispatching communication system is configured with independent and redundant networks. Communication is with the dispatching centers of the MOR, the railway bureau, and various sub-centers of the bureau.

**Figure 9.7 CTCS-3 GSM-R Redundant Coverage**

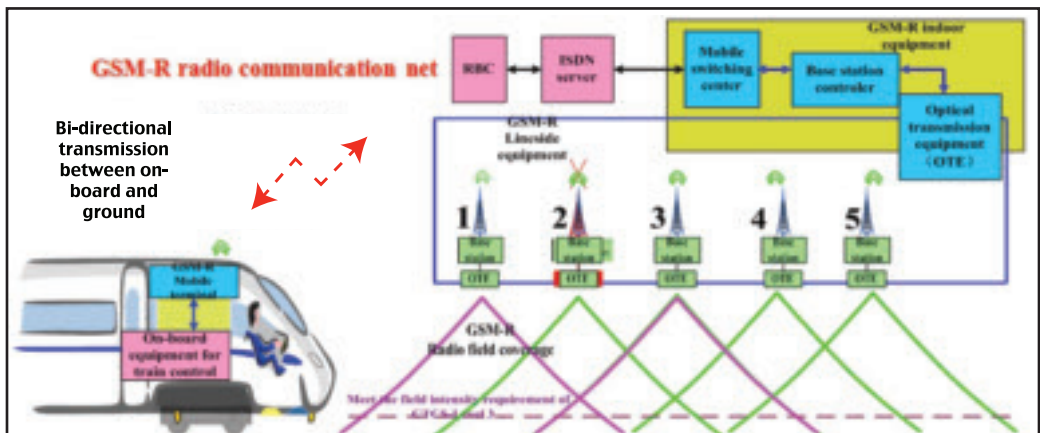

Source: TSDI Presentation, "Brief Introduction of CTCS-3: Communication and Disaster Prevention Monitoring System," November 2010

TSDI advised that CTCS-3 was simulated in a lab to verify its functions and interoperability. It was then validated on-site through a static test. Dynamic integration and validation were performed with other systems under an actual operating environment. TSDI stated that the CTCS-3 system design complies with failsafe principles. By applying such a system with movement authority control, one can avoid collisions to ensure operational safety. The functional safety of electrical and programmable electronics complies with IEC 61508. The specification and demonstration of RAMS is in accordance with IEC 62278 and EN 50126. Communication, signaling, and processing systems requirements are in accordance with IEC 62280 and EN 50159. CTCS-3 is SIL-4 certified.

---

TSDI advised that CTCS-3 is now used on 1,290 miles (2076 km) of HSR lines and will be used on another 3,169 miles (5100 km) of HSR lines that are being constructed and commissioned. CTCS-3 is installed on 120 trainsets that are currently in use; another 200 trainsets with CTCS-3 are undergoing tests, and an additional 1,800 trainsets are in planning.

Radio communications at speeds greater than 218 mph (350 km/h) will first be tested at higher speeds on the Beijing-to-Shanghai line because of potential 236 mph (380 km/h) operations. Testing speed will be greater than 249 mph (400 km/h).

CTCS-3 also interfaces with falling object detection and the rain and wind monitoring systems. The former system will inform CTCS-3 in the event of falling objects from an overpass through employment of a double-metallic mesh to catch the object. If one mesh breaks, an alarm is sent to the dispatcher. If both meshes break, CTCS-3 will automatically stop the train. The rain and wind monitoring systems also send information about dangerous conditions to the dispatcher, who will command the train to decelerate or stop. Video monitoring is used along the lines, with cameras installed at bridges, viaducts, tunnel entrances, GSM-R towers, station waiting, and ticketing areas.

### **9.1.7 CSR**

CSR advised that the following parameters are monitored on the CRH380A trainset:

- Traction transformer temperature
- Current in the primary and secondary coils of the main transformer
- Grounding of the main circuit
- DC voltage of the traction converter
- Operation of the traction converter and ventilation of the traction converter
- Ventilation of the traction motor and temperature of the traction motor
- Current in the traction motor
- Speed generator
- Brake cylinder pressure sensor
- Main reservoir pressure sensor
- Regenerative braking and emergency braking
- Service braking power
- Release of brakes
- Bogie bearing health
- Axle rotation
- Operation of pantograph
- Oil temperature in the air compressor
- Smoke/fire alarm detector
- Operation of the car doors
- Transmission between the trainset and the infrastructure network.

---

### 9.1.8 SRB

SRB advised that trains can be monitored in real-time in the control center of each bureau in China (e.g., SRB, Guangzhou Railway Group, etc.).

## 9.2 ATC INTERFACE WITH BRAKING AND PROPULSION SYSTEMS

### 9.2.1 SNCF

SNCF presented an example of a safe braking curve (Figure 9.8):

- The yellow (intervention) curve advises the driver that he or she is close to the permitted speed and needs to react (apply brakes).
- Between the yellow and pink curves is the permitted driver's reaction time.
- Between the pink and blue curves the trainset begins to build up brake application force.
- The blue curve to the orange curve illustrates the reaction time of the automatic brake system.
- The orange curve represents the safe braking constraints based on the performance of the trainset.

**Figure 9.8 Example of a Safe Braking Curve**

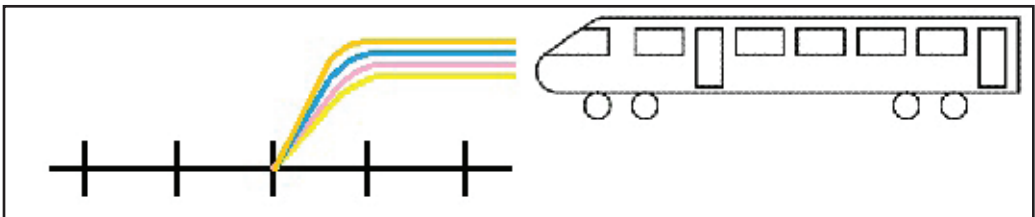

Source: SNCF Presentation, "Control Command and Signalling: ERTMS," June 2010

The rule is to not overpass the pink curve. If this curve is passed, a warning will sound in the cab. If the driver reacts too late or fails to react, the train will pass the blue curve, the circuit breaker will trip the propulsion system and the train will automatically decelerate. When the train reaches 19 mph (30 km/h), the emergency brake will be applied and the train will stop before the danger point.

### 9.2.2 TSDI

TSDI provided a graphic of the CTCS-3 DMI (Figure 9.9). The yellow curve represents the permitted speed. The orange point represents the actual speed, which is also indicated in the center orange circle. The blue curve is the speed curve. The green circle represents cab signals and shows the minimum number of open blocks in front of the train.

**Figure 9.9 CTCS-3 Driver-Machine Interface**



Source: TSDI Presentation, "Brief Introduction of CTCS-3: Communication and Disaster Prevention Monitoring System," November, 2010

### 9.2.3 Siemens

Siemens advised that the ATP system interfaces with the propulsion/braking systems and, depending on the vehicle speed and the operator-issued commands, it can switch between different outputs. The driver is responsible for respecting the maximum allowable speed, but the ATP system removes traction power and initiates a braking command if this speed is exceeded. The ATP system also supervises the automatic train operation (ATO) system, which is focused on optimizing the application of traction power and braking commands in an effort to maximize efficiency (e.g., energy consumption, trip times, passenger comfort, etc.). ATO interfaces with propulsion and braking during normal service operations [Section 9.8].

Siemens advised that its train communication network is designed according to IEC 61375-1. This network comprises two systems, the wired train bus (WTB) and the MVB. Both systems are wired redundantly. This redundancy can be seen on the dual thin film transistor (TFT) displays at the driver's desk; if one MVB fails, the second MVB provides the information. The MVB connects all control units in a car (e.g., traction, brake, door, etc.). There is one MVB per four cars, or two per trainset. Both are connected with a WTB.

Siemens advised that it is possible to interface control units from other suppliers, and that Siemens provides instructions on how those units will interface with the MVB. As an example, in the case of an overhaul, the operator is the system integrator, but the subcomponent overhauls can be subcontracted out. The equipment provided by the subcontractors interfaces with the MVB via a Siemens "PC-104" interface card. The software used is designed in compliance with EN 50128.

---

## **9.3 ATC INTERACTION WITH DRIVER'S VIGILANCE (DEADMAN) DEVICE**

### **9.3.1 Alstom**

Alstom provides a deadman device on the TGV that the driver needs to push. It is a button on either the floor or the handle of the master controller. The TGV deadman system checks for driver activity or acknowledgement every 55 seconds.

### **9.3.2 Siemens**

Siemens stated that the driver vigilance device need not be active while operating under ATP because this system is designed to be fail-safe to SIL-4 requirements. This feature is dependent on the rail operator's requirements. In areas where ATO is not permitted or the ATP system is cut out, the responsibility falls back to the driver and the driver's vigilance device is active.

### **9.3.3 SNCF**

SNCF emphasized the differing philosophies of HSR, saying that in Japan, the safety system has priority over the driver, but in Europe, the safety system only monitors the driver.

### **9.3.4 TSDI**

In China there is no driver's vigilance device. Overspeed is monitored via the ATP system. Drivers must communicate with the dispatching center every few minutes and when entering or leaving stations.

The CRH380A trainset ATP system provides an indication of overspeed conditions to the driver as follows:

- Overspeed by 1.2 mph (2 km/h) will provide a warning sign to the driver.
- Overspeed by 3.1 mph (5 km/h) will request the driver to implement a service brake.
- Overspeed by 6.2 mph (10 km/h) will result in an emergency brake application if the train speed is less than 155 mph (250 km/h).
- Overspeed by 9.3 mph (15 km/h) will result in an emergency brake application if the train speed is 155 mph (250 km/h) or more.

---

## 9.4 DESIGN HEADWAY FOR THE ATC SYSTEM AND MINIMUM HEADWAY PARAMETERS

### 9.4.1 Siemens

Siemens advised that the minimum design headway, or train-to-train distance in time, is approximately 3 minutes. Headway is related to the safety offset of the braking curve calculation, and equals:

$$[\text{train-to-train distance} \times 3600(\text{s/hr})] / \text{maximum train speed.}$$

For example:

- 218 mph (350 km/h) and 7.8 miles (12,5 km) between trains: Headway = 130 seconds
- 186 mph (300 km/h) and 5.6 miles (9 km) between trains: Headway = 110 seconds
- 174 mph (280 km/h) and 4.7 miles (7,5 km) between trains: Headway = 100 seconds
- 162 mph (260 km/h) and 3.7 miles (6 km) between trains: Headway = 85 seconds.

### 9.4.2 TSDI

TSDI advised that the minimum headway in China is 3 minutes for HSR operations.

## 9.5 OPERATION OF TRAINSET AFTER ISOLATION OF ATC

*The HSR manufacturers and operators were asked to identify the prerequisites for moving the trainset and for restricting maximum operating speed after isolation of the ATC system.*

### 9.5.1 SNCF

SNCF stated that a driver must stop the train if the ATC system is isolated because of a failure. Then upon the driver receiving orders from the signalmen, the train may continue (e.g., under staff-responsible mode), but may not exceed 19 mph (30 km/h) until authorizations for higher speeds are given.

### 9.5.2 Siemens

Siemens advised that DB decided to have a fallback solution for its new fleet in case the ATP system fails or is isolated. Thus, when the driver isolates the ETCS system, he or she can operate under a Class B (LZB, PZB) ATP legacy system up to 99 mph (160 km/h).

The Velaro train control system provides a means for isolation. When ETCS fails, the system can revert to a block signaling system. In the event of total system failure, the operator could rely on a second fallback system or operate under maximum speed supervision.



---

Siemens advised that it is possible to revert back to a block signaling system as long as balises are installed. It is appropriate to have balises installed every 3.1 miles (5 km) to allow the ETCS system to receive a new movement authority. Siemens advised that the greater the distance is between balises, the more restrictive the system becomes from an operational perspective.

In the event of failure of the infrastructure-based system, the emergency brakes are applied. If the driver isolates the onboard equipment, then the driver can reactivate the equipment provided he or she has verified proper operation of the system.

### **9.5.3 TSDI**

TSDI discussed the various failure modes of the CTCS-3 system and resulting operational restrictions, which include the following:

- Failure of radio communication will result in the train decelerating to less than 186 mph (300 km/h). The train control system will automatically switch to the CTCS-2 system.
- If a train's CTCS-3 system fails in a station, a movement authority will be given to the train via a code in the track circuit.
- If the train's CTCS-3 system fails between stations, the train will operate at slower speeds (maximum 75 mph (120 km/h) at the driver's discretion), and communication will be via signal blocks.

China had never seen failures of the two latter types.

## **9.6 ATC NORMAL/DEGRADED/BYPASS OPERATING MODES**

### **9.6.1 Renfe**

Renfe decided to have two EVCs on the Velaro E to provide redundancy and assurance that the timetable could be met if one EVC failed. While the Velaro E trainsets in Spain are equipped with ETCS Level 2, the high speed line between Barcelona and Madrid employs ETCS Level 1. If something failed on the wayside, then trains would revert back to ASFA.

Each EVC is equipped with a set of national values (Level 0). The EVC can then operate over the route made for those values, providing maximum speed supervision. In degraded mode, the EVC can provide guidance, but the driver is responsible for compliance.

### **9.6.2 SNCF**

SNCF advised that one of two modes is possible for degraded operation (i.e., ATC not operating at 100 percent capability):

- ON SIGHT. The train is controlled in terms of speed and distance, but the driver must watch the track. This mode is activated based on a decision from signalmen. Radio block control (used in ERTMS Level 2) is still operating.

- 
- STAFF RESPONSIBLE. The radio block control is cut out, so the driver and crew are responsible for speed and distance and for watching the track.

SNCF stated that ON SIGHT operation may be possible for ERTMS Level 1; however, the radio system for ERTMS Level 1 is not completely specified.

### **9.6.3 TSDI**

TSDI identified nine main modes of operation for onboard ATC equipment as follows:

- Full supervision: Used for normal operations, all information is complete (e.g., track circuit, balise), and the RBC and the GSM-R are under normal operation.
- Partial supervision: Used for CTCS-2.
- On sight: In effect under either of two circumstances:
  - When CTCS-3 is isolated but not necessarily cut out (e.g., when the RBC does not know the position of the train and cannot issue a movement authority)
  - During startup, until the RBC picks up the location of the train via balise. After the balise picks up the location, the mode is switched to full supervision.
- Calling on.
- Shunting: Used mainly in the depots. The maximum speed is 25 mph (40 km/h) when under traction and 19 mph (30 km/h) when being pushed. If coupling two train-sets, the maximum speed is 1.9 mph (3 km/h).
- Standby.
- Isolation.
- Cab signal: Used for CTCS-2.
- Sleeping.

## **9.7 ATC INTERFACE WITH ONBOARD SYSTEMS**

### **9.7.1 Siemens**

Siemens advised that ATC fully supports door operations (e.g., door interlocks, right side door operations, etc.). The EVC module will advise the driver when it is appropriate to open the door.

### **9.7.2 TSDI**

China is currently investigating ATP interaction with doors and platform screen doors. ATP also interacts with the brake system.

---

## **9.8 AUTOMATIC TRAIN OPERATION**

### **9.8.1 Overview**

#### **9.8.1.1 Alstom**

Alstom advised that SNCF prefers that drivers operate trains manually. ATO is available to the driver; however, the decision of whether or not to use it is up to the driver. ATO is used only for speed regulation.

#### **9.8.1.2 Siemens**

Siemens advised that the simplest ATO function used is autopilot, which is normally implemented through the master controller. ATP gives the master controller the speed limit of the supervised area. ATO systems can perform all required functions between station stops. The ATO system can be interfaced with a timetable. If there are service delays, the system can try to recover and get the train back to schedule, which is preferable for the mainline. The ATO system can also maximize energy efficiency, linking the train performance with the timetable requirement. The ATS system will set the regulations/requirements for operation during bad weather.

#### **9.8.1.3 TSDI**

China is currently investigating the possibility for ATO and is expecting to test it on intercity trains at 131 mph to 155 mph (210 km/h to 250 km/h) by the second half of 2011. ATO's main benefits include reduction of energy use and improvement of overall train performance. China feels that drivers must focus on punctuality. ATO is used on metro trains to test the effectiveness of keeping with the timetable. ATO is most effective in systems with short headways, as the optimal train performance can be obtained. China stated that the benefits associated with ATO systems are reduced in systems with large headways.

TSDI advised that CTCS-3 and CTCS-2 implements ATO to some level via automatic speed control (e.g., automatic braking and traction). The next step for China is to implement ATO from station to station (full operation). If ATO is adopted on HSR trainsets, then changes in the performance of the EMUs will need to be evaluated—something that is still in the research stage. With the implementation of ATO, the driver's main focus would be for emergency situations only.

### **9.8.2 Enabling and Disabling ATO**

#### **9.8.2.1 Siemens**

Siemens trains have a button for enabling ATO operation. ATO is disabled if the driver touches the brake/propulsion levers during ATO operation. To resume operation, the driver presses the ATO button.

---

### **9.8.3 ATO Interaction with Driver's Vigilance Device**

#### **9.8.3.1 Siemens**

Siemens advised that the ATO system can have complete control. If the driver moves the brake/propulsion lever then ATO will stop, and the driver's vigilance system will become active.

### **9.8.4 ATO into Stations**

#### **9.8.4.1 Siemens**

Siemens advised that ATO will regulate the speed to the stopping point. This action is supervised by ATC.

### **9.8.5 ATO Interface with the Door Control System**

#### **9.8.5.1 Siemens**

Siemens advised that if a train enters a station with a short platform, ATO will identify the number of doors that are permitted to be opened. ATO will also know on which side of the vehicle the doors should open. ATO will give a signal to the driver to let the driver know when to open and close the doors.

## **9.9 OTHER ASPECTS OF TRAIN CONTROL AND SIGNALING SYSTEMS**

### **9.9.1 Wheel/Rail Interface**

#### **9.9.1.1 Siemens**

Siemens advised that there is direct contact from wheel to wheel, stating that the resistance value for the Velaro trainset is less than 0.006  $\Omega$ .

### **9.9.2 Monitoring and Diagnostic Concepts: Event Recorder**

#### **9.9.2.1 Alstom**

Alstom's TGV Duplex trainset includes the juridicial data recorder that provides the functions required by the railways (signaling information, train information, driver's actions, etc.). Options are available to add other functions, such as voice recording and data transmission via GSM.

#### **9.9.2.2 Siemens**

Siemens Velaro trainsets incorporate a juridicial data recorder. Siemens advised that interior/exterior cameras can be integrated into the system.

---

### 9.9.2.3 TSDI

China currently uses real time monitoring to transfer information about the health of onboard systems to the wayside via public network/train radio, and to the MOR dispatching center. GSM-R will be implemented for this purpose in early 2011. The CRH380A trainsets use a juridicial data recorder.

## 9.9.3 Driver Machine Interface/Driver's Desk

### 9.9.3.1 Alstom

Alstom has designed driver desks for various countries and cultures (Figure 9.10). Its goal is to improve the working environment while maximizing work efficiency and comfort, and its approach is to involve the trainset drivers in the design and validation phases. For each new project or modification of an existing design, Alstom:

- Asks the driver what is good or bad about a design so its design team can decide what elements to keep
- Reviews the driver's anthropometric data
- Lists and characterizes the driver's tasks (e.g., driving, frequent movements, urgent movements, etc.)
- Develops an initial mockup that is reviewed and assessed with the drivers
- Develops a (functional) mockup that is integrated with a simulator and then reviewed and assessed with drivers.

Alstom emphasized that ergonomics must be taken into account as early in the design phase as possible.

**Figure 9.10 Alstom Functional Driver's Desk Simulator and DMI Prototype Screens**

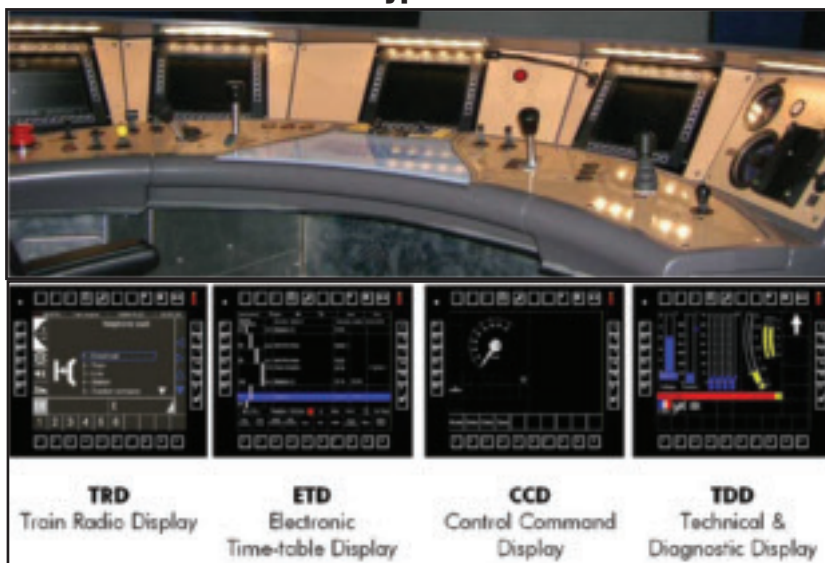

Source: Alstom Presentation, "Driver's Desk," June 2010

---

Alstom has participated in several research projects undertaken in Europe that were dedicated to development of the driver's desk:

- From January 2001 to December 2003 the EUDD project entailed a functional demonstrator that was verified with virtual reality tests in a simulator. This demonstrator was promoted by various manufacturers.
- From February 2004 to April 2008 the MODTRAIN/EUCAB entailed a functional demonstrator that was verified with virtual reality tests at the SIMUFER simulator in Lille. More than 40 drivers took part in this project, giving operators more say in what they needed.
- From July 2006 to January 2010 the EUDD+ entailed a multisystem demonstration and field test verification at the Wegberth-Wildenrath Test Validation Center. This event also gave operators additional say regarding their needs, with 70 drivers from 12 countries taking part.

Alstom advised that the main objectives of the EUDD+ project were to:

- Implement the concept already tested in the SNCF simulator in Lille
- Provide input for future European standards
- Raise all issues (hardware and software) regarding the implementation of the desk on one side.

The result of these three research programs resulted in UIC 612, the standard issued at the end of 2009 that describes the generic layout of the desk (Figure 9.11), including the set of displays that show, from left to right, radio, timetable, signaling information, and the TCMS. A keyboard sits on the desk directly in front of the driver. This keyboard is used to interface with all of the displays.

**Figure 9.11 UIC 612 Generic Layout of Driver's Desk and Actual Desk on Alstom PRIMA II Locomotive**



Source: Alstom Presentation, "Driver's Desk," June 2010

---

Alstom stated that the AGV has a very similar layout; however, such layout has been tested only on the Prima II locomotive. It advised that all new designs will now follow this new layout, although retrofits might not.

In discussing its design process for the AGV driver's desk, Alstom stated that the assessment process was done with Laboratoire d'Anthropologie Appliquee of PARIS V. Several reports issued included the driver's task analysis, ergonomic studies of the desk, master controller, and displays.

During Phase I a mockup of the desk was manufactured in collaboration with experts in the ergonomics field, SNCF traction managers, and six SNCF drivers. Locations of the equipment to be moved were marked. During Phase II a functional desk based on the drivers' recommendations was integrated into a training simulator with 5 degrees of freedom of motion.

Alstom advised that currently, the normative environment in Europe consists of:

- Compulsory: TSI regarding visibility of signals and the few elements on ergonomics
- Voluntary: EN standards, the UIC leaflets, and UIC-UNIFE TecRec.

### **9.9.3.2 Siemens**

Siemens advised that the complexity of the train control instrumentation in the driver's cab is the concern for rolling stock for cross-border traffic. Siemens advised that the DMI for the Velaro trainset follows the requirements set forth in UIC 612.

### **9.9.3.3 TSDI**

China follows European DMI standards and adheres to several Chinese requirements.





---

# CHAPTER 10 END-FACING, SIDE-FACING, AND INTERIOR GLAZINGS

*FRA has established safety regulations codified in 49 CFR §238 that pertain to end- and side-facing glazings. Historically, U.S. trainsets have been designed to withstand impacts from large and small objects and ballistic impacts. International HSR manufacturers have also addressed impact resistant requirements in their designs of glazings for conventional and HSR trainsets. In this chapter the attributes of the CFR are evaluated and compared to international best practices.*

*For reference, windscreens in Europe and Asia are of the monolithic curve-paned configuration, while the windscreens for U.S. rolling stock are typically of the flat-paned configuration. Also, for side-facing emergency glazings, typical mounting practice in the U.S. uses an elastomeric gasket, whereas such glazings in Europe are fastened to the carbody mechanically and require the use of hammer-like devices to break the glazing for emergency egress.*

## 10.1 END-FACING GLAZINGS

### 10.1.1 Configuration of Windscreen

#### 10.1.1.1 Alstom

The TGV windscreen is 1.26 inches (32 mm) thick. The Acela windscreen is 1.81 inches (46 mm) thick.

The AGV windscreen is 1.34 inches (34 mm) thick. The weight of the glass is 14.03 lb<sub>m</sub>/ft<sup>2</sup> (68,5 kg/m<sup>2</sup>), making the weight of the total windscreen 419 lb<sub>m</sub> (190 kg). The AGV windscreen has an anti-spall layer located on the inside face of the glazing. The AGV glazing is adhered to a frame that is fastened mechanically to the carbody.

#### 10.1.1.2 Siemens

Siemens' windscreen consists of panes of clear, multi-layer, high-strength, laminated safety glass. The glass is electrically heated (defroster). In addition, there is sufficient exchange of air at the windscreen via air ducts to reduce the formation of condensate. The windscreen on the Velaro D is supplied by Glas Trösch.

### 10.1.2 FRA and International Impact Requirements

#### 10.1.2.1 Alstom and SNCF

The AGV windscreen (Figure 10.1) is tested at an impact angle of 30 degrees with respect to the horizontal, in accordance with TSI criteria. The impact velocity is 323 mph (520 km/h), resulting in impact energy of 10.8 kJ. Alstom advised that it had not performed testing in accordance with CFR Tier II requirements, and was unsure as to whether the AGV front glazing satisfies CFR criteria. A proposal is in place between Alstom and St. Gobain to test the AGV windscreen to current CFR requirements and to determine what impact velocity/energy the glass could withstand.

---

Alstom noted that an impact test of the Acela glazing was conducted by St. Gobain with an 11.9-lb<sub>m</sub> (5,4-kg) steel ball projected towards the glazing at 155 mph (250 km/h). The resulting impact energy was 14 kJ.

**Figure 10.1 Alstom AGV Trainset Front Glazing Configuration**

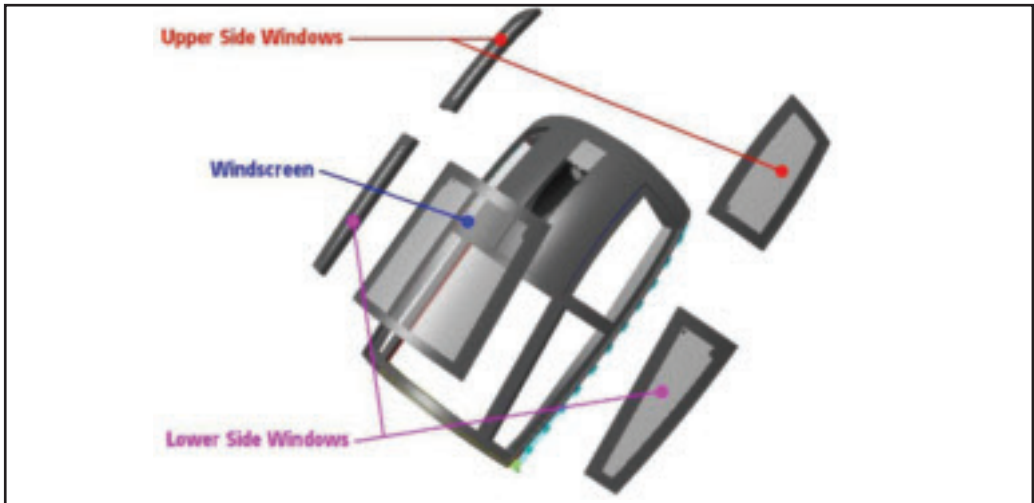

Source: Alstom Presentation, "Front Glazing," June 2010

SNCF added that it was very rare to have the need for a windscreen change. Those events usually happen in the winter and result from ballast or ice projections. The TGV windscreens are tested at a shooting center in Toulouse.

#### **10.1.2.2 CSR**

The CRH380A windscreen meets the requirements of EN 15152. CSR advised that the CRH380A windscreen can resist impact energies of more than 10 kJ. At 360 mph (580 km/h), which is equal to a test speed of 261 mph plus 99 mph (420 km/h plus 160 km/h) per EN 15152 criteria, the windscreen can withstand 13 kJ. During the test, the windscreen was mounted at a 21 degree angle, the same angle at which it is mounted on the trainset.

A recent test of a sample CRH380A windscreen was conducted to the 12-lb<sub>m</sub> (5,4 kg) 49 CFR §238.421 requirement. The test was performed in a lab in a 68°F (20°C), 50 percent relative humidity environment. A 12-lb<sub>m</sub> (5,4-kg) steel ball was projected at 224 mph (360 km/h) at the windscreen, which was mounted at an angle of 21 degrees. The ball did not penetrate the windscreen and there was no spalling from the opposite face (Figure 10.2).

Electric elements are integrated with the windscreen to provide capability for demisting/defogging. CSR stated that it has never had any incidents of broken windscreens.

---

**Figure 10.2 CRH380A Windscreen Impact Test to 49 CFR §238.421 Criteria**

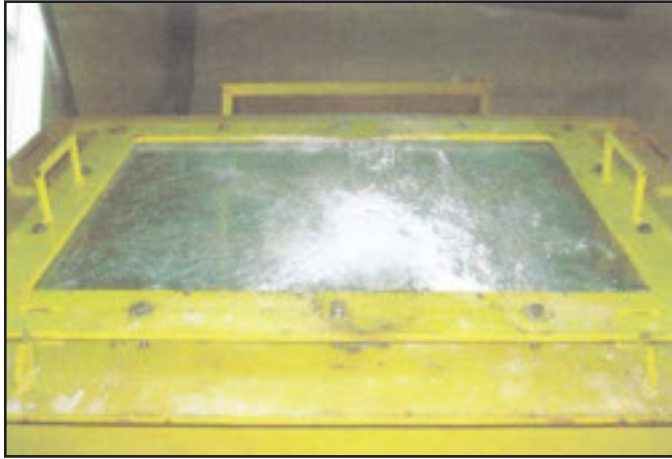

Source: CSR Presentation, December 2010

### **10.1.2.3 Siemens, DB, and Renfe**

**Siemens** advised that the Velaro windscreen is designed to withstand forces impacting at a speed of 323 mph (224 mph plus 99 mph) (520 km/h (360 km/h plus 160 km/h)), in accordance with UIC 651 and EN 15152. This speed is higher than the maximum operational speed to account for a passenger throwing an object at a passing train. Siemens stated that its windscreen might meet the CFR Tier II requirements for 26 kJ if the windscreen is tested at the mounted angle, which is approximately 32 degrees from horizontal. Its windscreen will not withstand an impact energy of 26 kJ if tested at right angles. Siemens advised that its supplier, TROESCH of Switzerland, was not equipped to do such testing in Europe and that Siemens would investigate performing such testing in the U.S.

**DB** added that it has never had an object penetrate the windscreen of a high speed train. DB has experienced cracked windscreens. In the most severe case the driver was hit by spall.

**Renfe** is in the process of developing new regulations that specify additional tests for the front windscreen to account for possible vandalism while the train is in operation. There is a history of people dropping stones or metal objects onto trains from overpasses, some of which were so large that they penetrated the front windscreen. Incidents in which people dangled stones and blocks on ropes over the right of way and in the path of an oncoming train have also occurred. Although this latter act has not occurred in the past two years, Renfe anticipates an increase in vandals hurling stones against the side windows. Renfe advised that no crew injuries due to objects penetrating the windscreens on the Velaro trainsets have been reported.

---

### 10.1.3 Impact Resistance versus Optical Clarity

#### 10.1.3.1 Alstom

Alstom advised that it is possible to use a flat-paned configuration similar to the Acela's, but that it would not be aerodynamically efficient. Alstom stated further that having a thicker monolithic curved-pane windscreen will adversely affect optical clarity.

#### 10.1.3.2 Siemens

Siemens stated that increasing the thickness of the windscreen adversely affects the clarity of the curved pane. The thickness and curvature have been optimized to meet the impact and clarity requirements of TSI and to improve aerodynamics of the trainset.

Siemens recommended respecting the overall thickness of the front windscreen, adding that it might be possible to increase impact resistance by reducing the thickness of the outer pane and increasing the thickness of the inner panes.

### 10.1.4 Performance Requirements Contained In National Standards

#### 10.1.4.1 Alstom

The AGV windscreen adheres to the requirements of NFF 15818 and EN 15152. Pressure tightness for the AGV front-facing glazing is tested with the following simulations:

- **Fatigue from trains passing outdoors:** +0.20 psi (+1,4 kPa); -0.33 psi (-2,3 kPa) for 4 million cycles (with triangle signal of 17.41 psi/s (120 kPa/s))
- **Fatigue from trains passing in tunnels:** +0.36 psi (+2,5 kPa); -0.80 psi (-5,5 kPa) for 1.2 million cycles (with triangle signal of 10.88 psi/s (75 kPa/s))
- **Exceptional fatigue load from trains passing in tunnels:** +0.36 psi (+2,5 kPa); -0.65 psi (-4,5 kPa) for 100,000 cycles (with triangle signal of 26.11 psi/s (180 kPa/s))
- **Exceptional stress load in tunnels:**  $\pm 1.02$  psi ( $\pm 7,0$  kPa) for 60,000 cycles (with square signal).

## 10.2 SIDE-FACING GLAZINGS

*This section provides insight into international best practices that guide the design of side-facing glazing. [Readers can reference Section 4.3 also for details pertaining to side-facing emergency glazing (i.e., breakable by a passenger or crew member)].*

### 10.2.1 Configuration of the Glazing

#### 10.2.1.1 Alstom

Alstom's information about the side-facing glazing of the AGV and TGV is summarized in Table 10.1.

**Table 10.1**  
**Alstom Configurations for Side-Facing Glazings from Exterior to Interior**

<b>Trainset</b>	<b>Laminated Glass Exterior Layer inch (mm)</b>	<b>Air Gap inch (mm)</b>	<b>Tempered Glass Interior Layer inch (mm)</b>
<b>AGV</b>	0.24/0.06 PVB film/0.16 (6/1,52/4)	0.87 (22)	0.20 (5)
<b>TGV</b>	0.20/0.03 PVB film/0.24 (5/0,76/6)	0.47 (12)	0.20 (5)

Alstom advised that a 0.04-inch (1-mm) increase in the glazing thickness will result in a 5.5-lbm (2,5-kg) increase in the weight of each window.

### 10.2.1.2 Siemens

The side glazing consists of an inner pane of laminated safety glass and an outer pane of hardened glass. Siemens advised that an outer pane of hardened glass is more resistant to damage from ballast strikes. This configuration is also lightweight.

## 10.2.2 FRA and International Impact Requirements

### 10.2.2.1 Alstom

The side-facing glazings for the AGV and the TGV Duplex are tested according to NFF 31314 and NFF 31250. Parameters in this test include the following:

- **Projectile composition:** Weighs 0.7 ounce (20 g), is made of aluminum alloy designation 2017A, has a diameter of 0.77 inch (19,5 mm) and length of 0.83 inch (21 mm).
- **Projectile speed:** 87 mph (140,5 km/h) for the AGV glazing and 134 mph (216 km/h) for the TGV Duplex glazing. This difference is due mainly to the Duplex lower side glazing being mounted closer to the track level—61.4 inches (1560 mm) from the center of the glazing to top of rail as opposed to 85.2 inches (2165 mm) for the AGV.
- **Passing criterion:** The glazing does not break.

The results of NFF 31250 showed that the energies are 15.2 J for the AGV and 36 J for the TGV Duplex. As a result, the laminated glass for the Duplex is designed to be more resistant to ballast impacts. There is a 5.5-lbm (2,5-kg) weight increase per pane of glass for the Duplex when compared to the AGV.

The side-facing glazing for the AGV must also pass an additional ballistics test according to NFF 15818. The AGV is tested to withstand the impact of a .22 caliber long rifle bullet at 649 mph (1044 km/h). The passing criterion is that the projectile does not penetrate the glazing. For a 0.1-ounce (2,6-g) bullet, the impact energy against the side glazing is 109 J.

### 10.2.2.2 Siemens

Siemens advised that its current designs can meet CFR requirements for side-facing glazing.

---

## 10.2.3 Pressure Test Requirements

*During operations, HSR trainsets will encounter significant pressure pulses that impact side-facing glazings. Such pulses are the most severe typically when two trainsets pass each other on closely spaced track centers or when a trainset enters and leaves a tunnel. Manufacturers were asked to discuss the pressure test requirements of NEA VWV 6.2 Section 3.5.2.2.*

### 10.2.3.1 Alstom

Alstom expressed two primary concerns with the pressure wave resistance of rubber gasketed side glazings:

- The deflections experienced may cause injury to passengers, and there is the potential for the glazing to blow in or blow out.
- Today's side glazings for very high speed trains are mounted flush with the carbody. If rubber gasketing is used, aerodynamic drag will increase and parasitic noises will be generated.

Alstom advised that pressure tightness for the AGV side-facing glazing is tested with the following simulations:

- **Fatigue from trains passing outdoors:** +0.20 psi (+1,4 kPa); -0.33 psi (-2,3 kPa) for 4 million cycles (with triangle signal of 17.41 psi/s (120 kPa/s))
- **Fatigue from trains passing in tunnels:** +0.36 psi (+2,5 kPa); -0.80 psi (-5,5 kPa) for 1.2 million cycles (with triangle signal of 10.88 psi/s (75 kPa/s))
- **Exceptional fatigue load from trains passing in tunnels:** +0.36 psi (+2,5 kPa); -0.65 psi (-4,5 kPa) for 100,000 cycles (with triangle signal of 26.11 psi/s (180 kPa/s))
- **Exceptional stress load in tunnels:**  $\pm 1.02$  psi ( $\pm 7,0$  kPa) for 60,000 cycles (with square signal).

Alstom advised that pressure tightness for the TGV Duplex side-facing glazing is tested up to  $\pm 1.0$  psi ( $\pm 7,0$  kPa). Water tightness is achieved with the application of a UV-resistant sealant.

### 10.2.3.2 CSR

The side-facing glazings are designed to resist pressure fluctuations of  $\pm 0.87$  psi ( $\pm 6$  kPa). CSR stated that the CRH380A side-facing glazing must continue to resist pressure even when there are cracks on the glazing exterior.

### 10.2.3.3 Siemens

The Velaro side-facing glazings are tested to a pressure of  $\pm 0.87$  psi ( $\pm 6$  kPa) (Figure 10.3).

**Figure 10.3 Velaro Side Glazing Pressure Test**

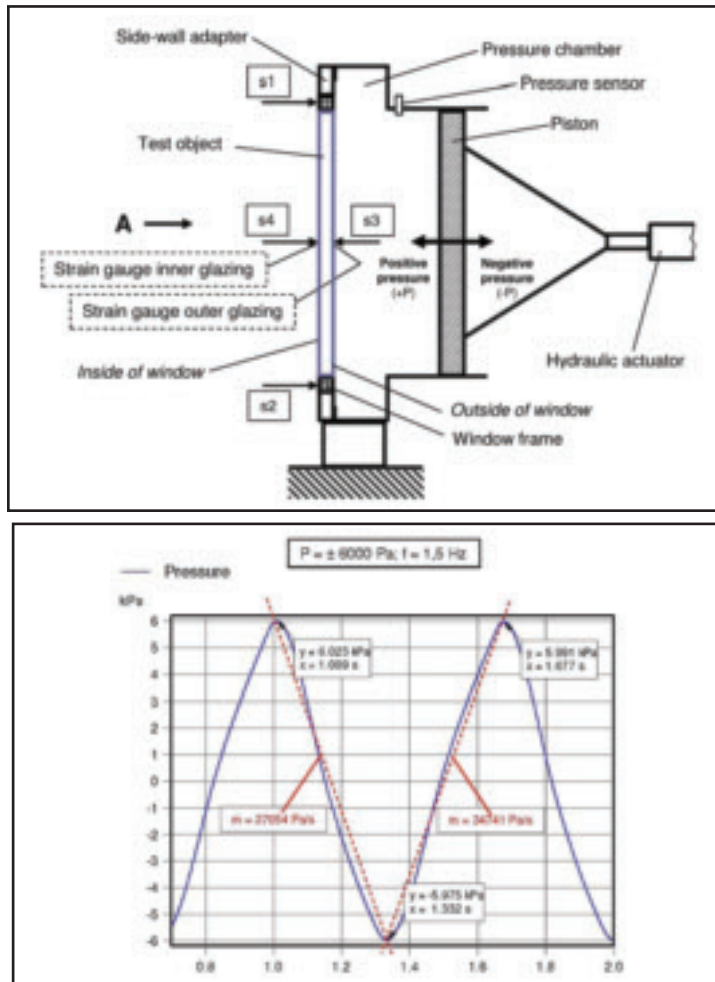

Source: Siemens Presentation, "Interior Design," January 2010

Siemens stated that it is possible to retain the U.S. method of window removal. If the pressure deflects the pane inwards/outwards, however, it is possible for water to seep in at the location of the elastomeric gasketing. Water has been shown to deteriorate the adhesive that bonds the glass laminations, thereby degrading the safety aspects associated with laminated glass. If the U.S. method of removing glazing is used, effective water drainage is necessary. Siemens advised that the methods for allowing drainage could impact trainset sealing. In addition, the performance of the gasketing needs to be verified periodically to provide assurance that the gasketing material remains pliable to serve the intended function. Siemens commented that this results in an increase in inspection and maintenance costs.

The ICE 3 meets the  $\pm 1.2 \text{ psi}$  ( $\pm 8.1 \text{ kPa}$ ) requirement defined in NEA VVW 6.2 Section 3.5.2.2.

---

## **10.2.4 Passenger Containment Testing**

### **10.2.4.1 Alstom**

Passenger containment tests on the side glazings are conducted according to NFF 01492 and NFP 08301. The purpose of this test is to simulate a human body impact on the glass. The projectile, a 110-lb<sub>m</sub> (50-kg) bag filled with 0.12-inch (3-mm) diameter glass balls is swung from a height of 4.9 feet (1,5 m). The projectile speed upon impact is approximately 8.7 mph (14 km/h). The impact energy against the side glazing is 735 J. The passing criterion is such that the projectile does not penetrate the glazing.

### **10.2.4.2 Siemens**

Siemens stated that passenger containment tests have been conducted on their side-facing glazings with successful results.

## **10.2.5 Performance Requirements Contained in National Standards**

### **10.2.5.1 Alstom**

The side-facing glazings of the AGV satisfy the thermal properties of EN 673 and the light and energy properties of EN 410 and ISO 9050. The main standards used for the AGV and TGV Duplex side glazings are:

- NFF 31129 for reinforced glass
- NFF 31250 for laminated glass
- NFF 31314 for insulated glazing
- NFF 01492 for windows
- NFF 01492-1 Section 11.7 for water tightness.

Other standards used for the AGV and TGV Duplex side glazings include:

- NFEN 410 for solar factor and light transmission
- NFEN 673 for thermal insulation
- NFF 31314 Section 7.1.1 for ballast impacts
- NFF 15818 Section 18.5.2.4.1 for ballistic impacts (AGV only)
- NFF 01492-1 Section 11.8 for passenger containment
- NFENISO 12543-2 for UV resistance.

## **10.2.6 Installation Methods**

### **10.2.6.1 Alstom**

During the initial installation phase, the AGV passenger window glass is mounted to a secondary frame using adhesive. The primary frame is fastened mechanically and adhered to the carbody. Then the secondary frame/glazing assembly is fastened to the primary frame



---

mechanically and a UV-resistant sealant is applied. The frames themselves are not visible from the outside, and the glass is mounted flush with the exterior of the carbody. This design has been proven to be effective on the Pendolino trainsets.

Replacement of AGV side glazing is performed from the exterior of the coach. The UV-resistant sealant is removed and the secondary frame is replaced. No action is required on the interior fittings for the primary frame. Once the secondary frame is reattached, new sealant is applied.

The TGV Duplex passenger window glass is mounted to a frame using adhesive. This frame/glazing assembly is then fastened to the carbody mechanically. As with the AGV, the frame is not visible from the outside and the glass is mounted flush with the exterior of the carbody. This design has been proven on the TGV Duplex. Replacement of Duplex side glazing is conducted from the inside, however. The UV-resistant sealant and the interior fittings need to be removed. A new frame is then reattached and the sealant is reapplied.

#### **10.2.6.2 CSR**

CRH380A side glazings are installed with an airtight arrangement. The glazing is installed from the interior and pressed against the interior of the side wall with a frame. CSR's reason for this type of mounting is similar to that for the doors, which are sliding pocket doors with an airtight seal made by pressing the door against the interior of the side wall. CSR feels that this method provides the best protection/safety.

### **10.3 INTERIOR GLAZINGS**

#### **10.3.1 Alstom**

Interior glazings in compartments and vestibule doors are designed to NFF 31129, a standard dedicated to reinforced tempered glass. Interior glazings on the AGV are 0.20 inch (5 mm) thick. They are tested with a 1.1 lb<sub>m</sub> (0,5-kg) ball dropped from a height of 4.4 feet (1,35 m). The resulting impact energy is 6.6 J.

#### **10.3.2 CSR**

The interior glazings of the CRH380A comply with the criteria identified in GB 10845.

#### **10.3.3 Siemens**

Interior glazing (e.g., compartment and vestibule doors) is made of toughened glass. In the event of an emergency, hammers that can be used to destroy the glass are provided adjacent to the glass.

---

---

# CHAPTER 11 EXTERIOR DOORS

## 11.1 DOOR DESIGN AND CONTROL SYSTEMS

### 11.1.1 Alstom

Alstom advised that the door signal for the Korea KTX trainsets is interlocked with a speed signal. The doors can be opened once the speed of the trainset falls below 1.9 mph (3 km/h). When the doors are open, the trainset does not take traction power. All doors are closed from the interior of the trainset. The train crew uses a key to close all doors except the local door. The local door is then closed afterwards.

Alstom advised that it was required for the AGV in Italy that all doors be closed at the same time.

### 11.1.2 CSR

The CRH380A trainset has pocket sliding doors for the coach cars, with the doors kept within the side walls of the carbody when open. This concept provides an airtight structure complemented with sound insulation. It does not comply with EN 14752 because the doors are not flush with the carbody. Although this design increases the level of aerodynamic noise, it was selected because CSR believes that pocket sliding doors are safer than the plug door design. CSR stated that in Europe on April 27, 2010, a door that complied with EN 14752 was ejected from a passenger coach due to the negative pressure generated at high speeds. Similarities between the door system of the CRH380A and EN 14752 include fault isolation, compliance with EN 61373, and an interlock speed of 3.1 mph (5 km/h). The trainline status of air tightness and the opening/closing of doors are monitored by the train control system.

CSR advised that the structure of the door must comply with the structure of the carbody and the air tightness of the train. The action of the door must guarantee fail-safe operation. In the event of a failed door, it must be guaranteed that the door will remain closed. Doors are interlocked to prevent opening at high speeds.

CSR advised that the following actions occur before a train departs a station:

- A "door close" signal from the door controller is received and then the doors begin to close.
- Any door that remains open will close automatically when the train reaches 3.1 mph (5 km/h).
- When all doors are fully closed, the circuit is closed.

All doors are sealed when the train reaches 19 mph (30 km/h) (e.g., force is applied, mechanically pressing the door to the frame). The doors are kept closed and sealed when the train is running. When slowing for a station stop, the doors are sent a signal when the speed falls below 3.1 mph (5 km/h). The doors remain closed, but are unsealed. The doors open once the train is fully stopped.

---

### 11.1.3 Siemens

Siemens advised that the door system on the Velaro is electric mainly to decrease maintenance costs. The door controls are tied to a zero speed command. A concern was expressed that in the event of an accident, if the zero speed command was prevented from functioning properly then the doors would not open. Siemens advised that the door interlock circuit must be designed as a vital (fail-safe) safety circuit. Siemens advised also that the option to release the doors for opening during normal operations should be available only to the driver. Once the doors are released, they can be opened either by the trainmaster (for the entire train) or by the passengers (for the local door via the green and red pushbuttons shown in Figure 11.1). The opening of doors at any other time by any other person should result in the removal of traction power.

Siemens advised that the door interlock signal could be transmitted by the brake control unit to the doors. The brake control unit would receive the speed signal from the train control unit and would conduct a real-time control check of every element of the train bus. The emergency door release mechanisms could be interlocked with a speed signal of less than 6.2 mph (10 km/h); however, this interlock must be vital.

Figure 11.1 also depicts the emergency release mechanism installed adjacent to a Velaro E door.

**Figure 11.1 Velaro E Emergency Door Release**



Source: WBPF Photograph, February 2010

---

#### **11.1.4 DB**

DB advised of its operational requirements prior to leaving the station:

- All doors close except the local door where the conductor activates the door controller.
- The conductor checks the platform to ensure it is clear and then closes the local door.
- A message appears on the operator's console indicating that the last door has been closed. The operator then locks the doors.
- If a door detects an obstacle while closing, then it will reopen and close again 10 seconds later. This reclosing is allowed to happen two to three times before the door will stay open until the conductor closes all doors again.
- If the driver begins to drive with any of the doors open, the doors will close automatically once a speed of 3.1 mph (5 km/h) is reached.

### **11.2 DETECTION OF OBSTRUCTIONS WHEN CLOSING**

#### **11.2.1 Alstom**

Alstom advised that all doors have a sensitive edge that monitors the amount of current consumed by the motor. An increase in the level of current draw is indicative of a locked rotor caused by an obstruction.

#### **11.2.2 CSR**

CRH380A has a jogging cylinder to reduce the closing force of the door. In compliance with EN 14752, the door-closing action stops if an obstacle is detected and the door reopens.

#### **11.2.3 Siemens**

Siemens advised that there are two sensitive edges and additional motor current control provided for obstacle detection. The Velaro trainset uses pressure-sealed sliding plug doors, which operate electrically. There are no pneumatic components. The operational software is designed according to EN 50128.

### **11.3 OPENING THE DOORS**

#### **11.3.1 Alstom**

Alstom advised that a door release command (left or right) is issued by the driver. Passengers can then open the doors by pressing a button from the interior or exterior of the train. An emergency device is also provided to open the door from the exterior of the trainset.

---

### **11.3.2 CSR**

CSR advised that a locked cover protects the emergency handle at every door. This cover can be unlocked only by a crew key, at which time the emergency door release can be activated.

## CHAPTER 12 EXTERIOR LIGHTING

U.S. requirements for exterior and interior lighting and exterior warning devices vary significantly from international HSR requirements. As an example, U.S. requirements for exterior lighting focus on improving drivers' ability to detect obstructions in the right of way and on improving trainset conspicuity. International best practices focus on trainset conspicuity because it is recognized that driver reaction time at high speeds is insufficient to prevent a collision with an obstruction in the right of way. In this chapter, manufacturers discuss U.S. and international best practices associated with interior and exterior lighting and warning devices.

### 12.1 HEAD LIGHTS

The luminosity values of the international and U.S. requirements for headlights are quite different (Figure 12.1). 49 CFR §238.443 Section (a) requires each headlight to produce at least 200,000 cd (peak), whereas 2008 RST TSI Annex H.2 (a) calls for at least 40,000 cd (peak) and at least 10,000 cd (peak) at all angles within 5 degrees on either side of the center line in the horizontal plane.

**Figure 12.1 Comparison of TSI and CFR Exterior Lighting Intensity Requirements**

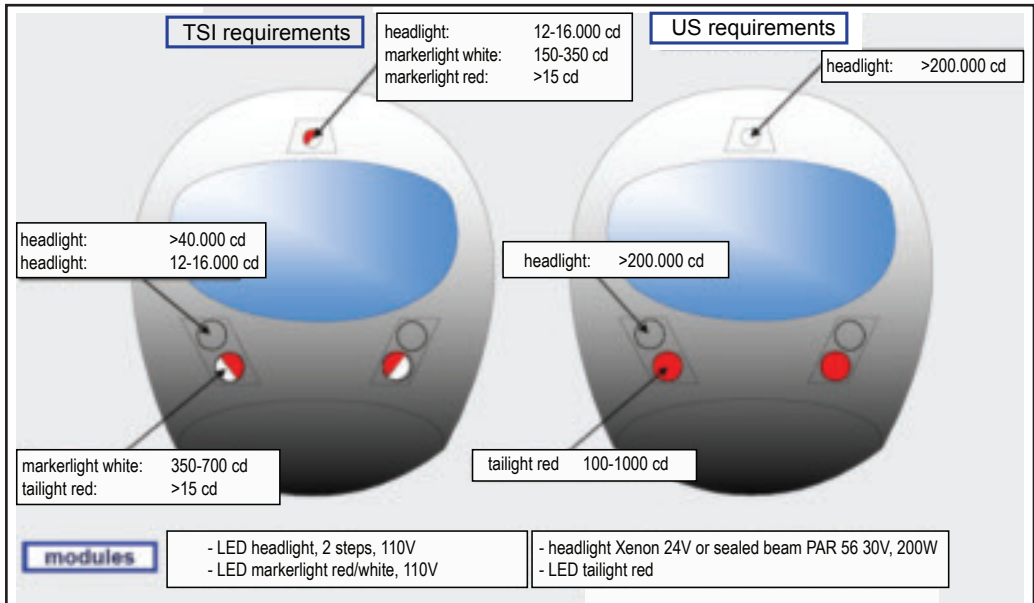

Source: Siemens Presentation, "Interior Design," January 2010

---

### **12.1.1 Alstom**

Alstom advised that the purpose of headlights on HSR trains in Europe is for people to see the train, not for the driver to see the track. Drivers of trains traveling at 186 mph (300 km/h) have no time to react if they see an object ahead. Alstom advised that by using LEDs instead of incandescent bulbs, there should be no issue with increasing power for higher intensities. Regarding obstructions in the right of way, on each HSR line in France, one train leaves at 4 a.m. every morning to ensure that the track is clear and safe. These trains travel at 99 mph (160 km/h).

### **12.1.2 CSR**

The luminous intensity of the CRH380A headlights at the reference axis is greater than 500,000 cd, and the illuminated distance is greater than 1,476 feet (450 m). At  $\pm 5$  degrees from the reference axis, it is greater than 20,000 cd. The high luminous intensity for the headlights is on high speed trains only. The CRH380A headlights feature xenon high intensity discharge (HID) bulbs. These headlights meet the requirements of TB/T 2325.

### **12.1.3 Siemens**

Siemens stated that either 24 V Xenon lights or sealed-beam 30 V, 200 W parabolic aluminized reflector (PAR) 56 units lights can be provided to meet the CFR candela requirement. The LED lights currently installed on the Velaro trainsets (LED-Scheinwerfer ST 189V) meet TSI requirements but will not meet CFR requirements. They are provided by Helmholz & Pauli GmbH.

The dimensions of the headlight installations on the Velaro are:

- 78.4 inches (1990 mm) from top of rail to the headlights
- 53.0 inches (1345 mm) between headlights
- 132.8 inches (3374 mm) from top of rail to the top headlight.

## **12.2 AUXILIARY LIGHTS**

*The luminosity values for international and U.S. requirements for auxiliary lights are also quite different. 49 CFR §229.125 Section (d)(2) requires each auxiliary light to produce at least 200,000 cd (peak), or at least 3,000 cd at 7.5 degrees from the centerline of the train when the light is aimed parallel to tracks, and at least 400 cd at 20 degrees from the same place and under the same conditions. The 2008 RST TSI Annex H.2 (b) calls for lower auxiliary lights to produce 300 cd to 700 cd (peak) and 20 cd to 40 cd (peak) at 45 degrees on either side of the center line in the horizontal plane, and for upper auxiliary lights to produce 150 cd to 350 cd (peak).*

### **12.2.1 CSR**

CSR advised that the luminous intensity of the CRH380A auxiliary lights at the reference



---

axis is greater than 170,000 cd, and that it is greater than 6,000 cd at  $\pm 4$  degrees from the reference axis.

### **12.2.2 Siemens**

The dimensions of the auxiliary light installations on the Velaro are:

- 73.0 inches (1855 mm) from top of rail to the auxiliary lights
- 50.4 inches (1280 mm) between auxiliary lights.

## **12.3 MARKER LIGHTS (TAIL LAMPS)**

*The luminosity values for the international and the U.S. requirements for marker lights are quite different. 49 CFR §229.14 Section (a)(1) requires each marker light to produce 100 cd to 1,000 cd, whereas 2008 RST TSI Annex H.3 (b) calls for 15 cd to 40 cd and a minimum of 10 cd at 7.5 degrees on either side of the center line in a horizontal plane, and 10 cd at 2.5 degrees on either side of the center line in a vertical plane.*

### **12.3.1 CSR**

The luminous intensity of the CRH380A marker lights at the reference axis is greater than 25 cd, and it is greater than 7 cd at  $\pm 4$  degrees from the reference axis.

### **12.3.2 Siemens**

Siemens stated that red LED lights can be provided that meet the CFR candela requirement for marker lights.

## **12.4 SIDE DOOR THRESHOLD LIGHTS**

### **12.4.1 Alstom**

Alstom recognized that CFR requires doorways or stepwells to have at least 1.2 footcandles (21,5 lx) of illumination when doors are open, as measured on the door threshold, step tread, ramp, bridge plate, or lift platform. TSI requires that the vehicle access steps be illuminated to a minimum of 7.0 footcandles (75 lx) across 80 percent of the width of each step by a light placed within or immediately adjacent to it. Alstom stated that the AGV design complies with CFR requirements. The lighting requirements do not apply to the Duplex because these trainsets do not have access steps. Internal steps at the access door level are illuminated, however.



---

# CHAPTER 13 PASSENGER INFORMATION, COMMUNICATIONS, AND SERVICE SYSTEMS

## 13.1 PASSENGER INFORMATION DISPLAYS

### 13.1.1 Alstom

Alstom advised that passenger information displays are located onboard in the overhead areas and on doors. They are provided by Alstom or other suppliers (as is the case for NTV's AGVs).

### 13.1.2 Siemens

The Siemens Velaro platform features a variety of LED and thin film transistor (TFT) passenger information displays. Flat screens are suspended from the ceiling for station stop announcements and information about train route identification, stations, speed, time, etc. (Figure 13.1). The passenger information system could display a welcome message or other operator-requested information. Siemens advised that if video is to be broadcast throughout the trainset, the signal must be synchronous.

**Figure 13.1 Overhead Passenger Information Display on Velaro E**



Source: WBPF Photograph, February 2010

---

## **13.2 COMMUNICATION SYSTEMS**

### **13.2.1 Intercom Systems**

#### **13.2.1.1 Alstom**

Alstom advised that an intercom is provided for communication between the driver and the crew. There is also a connection between the train control system and the intercom system. For example, if a passenger tries to open a door, the train control system generates a signal to the intercom system to alert the driver and the crew of the issue.

A communication system is also provided to passengers as part of the passenger alarm system. At a location inside the passenger coach, a passenger can push a button to notify the crew of a problem. When the system is activated, a communication link is established between the passenger and a crew member.

#### **13.2.1.2 Siemens**

Passengers alert the train crew of an emergency via the passenger alarm system.

### **13.2.2 Redundancy of the Public Address (PA) System**

#### **13.2.2.1 Alstom**

Alstom's PA system is designed to be redundant:

- One of every two speakers is connected to an amplifier. Two amplifiers are provided in each trainset.
- The software is designed to be fault tolerant.

Alstom recognized that CFR requires each car to be equipped with a PA system that transportation system personnel can use to announce stations and provide other passenger information. Alstom states that the AGV and the TGV Duplex comply with this requirement.

#### **13.2.2.2 CSR**

CSR advised that its PA system is redundant. All loudspeakers and amplifiers are arranged in pairs, one on each end of the trainset.

#### **13.2.2.3 Siemens**

Siemens advised that in accordance with TSI, at least half of the PA loudspeakers must function in the event of a failure of a transmission element. Two lines are provided to ensure this functionality, one in the ceiling and one under the floor. Two amplifiers are also provided per trainset. The cables and the hub are fire-resistant.

---

## **13.3 ONBOARD PASSENGER SERVICE SYSTEMS (INTERNET, TICKETING, VENDING, ENTERTAINMENT)**

### **13.3.1 Alstom**

Alstom advised that Internet access is provided for the TGV East and Thalys service via Wi-Fi. NTV service in Italy provides Internet access and entertainment via satellite. The satellite connection has not been tested at extreme speeds; however, live streaming on the AGV prototype was possible at 186 mph (300 km/h).

### **13.3.2 CSR**

CSR advised that it is continuing developments for improving passenger information on HSR. News, weather, etc. are provided on the metro system, but to date, they are not provided on intercity or high speed trains.

### **13.3.3 NTV**

NTV advised that the telematics<sup>1</sup> design of its AGV trainsets is provided through a partnership of 21Net and Alstom. 21Net delivers all telematic equipment, and Alstom installs the equipment during the manufacturing process. (The telematics contract is between NTV and 21Net.) The trainline telematics design is separated physically from trainline safety systems and logistics. A network operations center supervises the connectivity over the AGV fleet.

NTV's AGV trainsets will be equipped with:

- Fiber optics for good bandwidth (independent of infrastructure)
- Four terabytes of storage space on the server
- Bidirectional satellite disk (maximization of connectivity performance along the corridor independent of infrastructure)
- Near-live television (1 to 2 minutes delay)
- Web portal with multimedia content available via Wi-Fi (music, films, games)
- Individual touch screens in select coaches
- Cinema coach with high-definition screens, multilingual audio, and noise suppression
- Camera car with view from the driver's cab.

The train-to-ground connectivity includes satellite and universal mobile telecommunications system (UMTS)/Wi-Fi, with the latter multiband connectivity used as a backup link. Continuous connectivity and high speed navigation is available at 186 mph (300 km/h). In tunnels, the performance of the antenna permits a fast link upon exit. NTV advised that mobile coverage is provided inside tunnels, even though the bandwidth is lower. A 3.5G network is available from Telecom Italia's agreement with Trenitalia.

---

<sup>1</sup> Long distance transmission of computerized information.

---

NTV advised that telematics have been installed on three coaches of the Pegase for the following:

- Hardware and software tuning
- Validation of the telematics equipment:
  - Train-to-ground connectivity with satellite and UMTS/Wi-Fi
  - In coach access to Wi-Fi
  - Cinema car screens, audio devices, individual touch screens
  - Backbone and intercar cables
  - Software and Web portal
  - Near-live television
- Measurement of system performances.

NTV's plan is to adopt leading edge technology and standards to implement a HSR information and communication technologies platform capable of sustaining innovations in business and operational effectiveness.

NTV uses a service-oriented architecture (SOA) to provide timely and personalized service to customers, maintain real-time control of rail operations, and reduce time-to-market and development costs. As an example of why using SOA is beneficial, prior to having it:

- The marketing line was responsible for customer relationship management.
- The service line was responsible for enterprise resource planning.
- The operations line was responsible for all operations-relevant aspects, such as circulating data, interfacing with the infrastructure manager, RFI, and scheduling.
- The three lines then communicated with each other.

SOA provides an integration layer that combines customer relations management, enterprise resource planning, and operations.

NTV will use multiple customer-oriented sales and service channels to maximize operating revenue:

- Internet: customer Web portal, control room information management, and partner services
- Messaging platform: customer messages via email, text messaging
- Mobile workforce: personal digital assistant (PDA), smartphone applications
- Ticket vending machine (TVM) server: station TVMs.

Web access for passengers is included in the price of tickets currently; however, it can be a separate charge in the future.

---

#### **13.3.4 Siemens**

Siemens advised that the Ethernet backbone on the Velaro is currently 100 Mbit/s. Its next step is to upgrade to a gigabyte Ethernet (GbE) network using shielded twisted pair CAT-6 cable. Additional audio upgrade concepts include using sound exciters instead of speakers. Exciters can be installed behind virtually any solid object and will function as a traditional speaker. Installation techniques and placement are simplified using this type of technology. Exciters use the same operational power as do speakers.

A passenger counting system can be provided on the Velaro trainset.





---

## CHAPTER 14 ACCESSIBILITY AND INTERIOR TRAINSET DESIGN

*HSR manufacturers and operators were asked to share lessons learned when developing trainset interiors, with a focus on enhancing accessibility. In the U.S., passenger rail systems are obligated to conform to the accessibility requirements contained in 49 CFR §38 – Americans with Disability Act (ADA) Accessibility Specifications for Transportation Vehicles. In Europe, TSI identifies requirements relating to persons with reduced mobility (PRM). For Asian countries, such criteria are usually defined by the operator. Accessibility requirements address issues such as platform height, door and aisle widths, toilet room layouts, hand rails, priority seating locations, passenger communications, and signage. A key difference in philosophy is that the U.S. ADA regulations pertain to every car in a train, whereas international requirements apply typically to one car per train. This chapter provides information on different approaches that have been implemented on HSR trainsets to enhance accessibility.*

### 14.1 LEVEL BOARDING REQUIREMENTS

#### 14.1.1 Alstom

Alstom advised that the floor height of the AGV is 45.7 inches (1160 mm) from the top of the rail, while that of the TGV single level is 49.2 inches (1250 mm) and that of the TGV Duplex is 21.7 inches (550 mm). However, all TSI compliant trainsets can accommodate platform heights that range from 21.7 inches to 29.9 inches (550 mm to 760 mm).

Alstom recognized that CFR ADA criteria call for a maximum horizontal gap between the train and the platform of 3.0 inches (76 mm) and a maximum vertical difference of 0.625 inch (16 mm). The vertical alignment can be accomplished by using the car suspension or other suitable means (e.g., shimming of the bogie suspension, thereby raising the door threshold height).

In comparison, while TSI criteria call for a maximum horizontal gap of just about 3.0 inches (75 mm), the maximum vertical difference is 2.0 inches (50 mm). A lift is used for the AGV and single-level TGV trainsets to assist wheelchair users getting on and off the train. This lift could be located onboard, in the vestibule area, or on the platform, as is the case for NTV. For the TGV Duplex, a portable access ramp is used to help wheelchair passengers traverse the horizontal and vertical offsets.

#### 14.1.2 CSR

China advised that the height from the top of rail to the train floor is 51.2 inches (1300 mm). The CRH380A platform height is 49.2 inches (1250 mm). The height difference can be controlled within a certain range by adding a shim to the bogie suspension when the wheel tread has been worn, adding that a certain limit to the height of the shim would apply. In addition, the secondary air suspension can maintain the height difference between the floor and the platform within a range of passenger loading using a leveling valve.

---

### 14.1.3 Hyundai Rotem

Hyundai Rotem has begun developing an adjustable height system (i.e., active suspension system) that will ensure the floor height is level with the platform. Information about this system is proprietary.

### 14.1.4 Siemens

Siemens advised that the platform height for the Velaro CN is 49.2 inches (1250 mm), while the platform height for the Velaro RUS is 53.5 inches (1360 mm). The varying heights of these platforms are due to customer requirements. The floor height of the Velaro is approximately 48.8 inches (1240 mm) above the top of rail. This height meets TSI requirements for the height of the single steps and for European PRM requirements. Siemens believes that a Velaro floor height of between 48.8 inches and 49.6 inches (1240 mm and 1260 mm) above the top of rail will work well in the U.S. without the need for any major modifications.

## 14.2 WHEELCHAIR MOBILITY AND ACCESSIBILITY

### 14.2.1 Alstom

Alstom was asked to evaluate potential trainset floor plans taking into consideration the requirements needed to comply with ADA criteria. Alstom provided an in-depth presentation of the accessibility features required by TSI for PRM, and how the Alstom trainsets (TGV Duplex and AGV) accommodated these requirements.

**Doorways.** CFR requires that at least one doorway on each side of the car be wheelchair accessible and at least one adjacent doorway into coach passenger compartments have a minimum clear opening of 32.0 inches (815 mm). TSI requires all exterior passenger doorways to have a minimum clear useable width of 31.5 inches (800 mm) when open. Alstom stated that the AGV is compliant with CFR requirements. The clear opening width of the access door is 35.4 inches (900 mm) and that of the gangway door between coaches is 37.8 inches (960 mm). Alstom stated that the clear opening width of the TGV Duplex access door is 41.3 inches (1050 mm).

**Passage Clearways.** CFR requires access to and from wheelchair accessible areas (e.g., seating, café, and toilet areas) to have a minimum clearway width of 32.0 inches (815 mm). If passage through a vestibule is necessitated, CFR requires that the vestibule width be a minimum of 42.0 inches (1065 mm). TSI requires a minimum clearway width between these areas of 31.5 inches (800 mm) up to a minimum height of 57.1 inches (1450 mm) at any point. The AGV does not meet all CFR requirements. The interior door providing access to the wheelchair spaces is 33.5 inches (850 mm) wide, but the vestibule clearway is reduced to 32.1 inches (815 mm) in width between the toilet room and the sidewall (Figure 14.1). The gangway (bellows area) has a clear opening of 38.4 inches (975 mm) except at the floor level, which is 31.7 inches (804 mm), as shown in Figure 14.2.

**Figure 14.1 Alstom AGV Interior Layout with Universal Toilet (Dimensions in mm)**

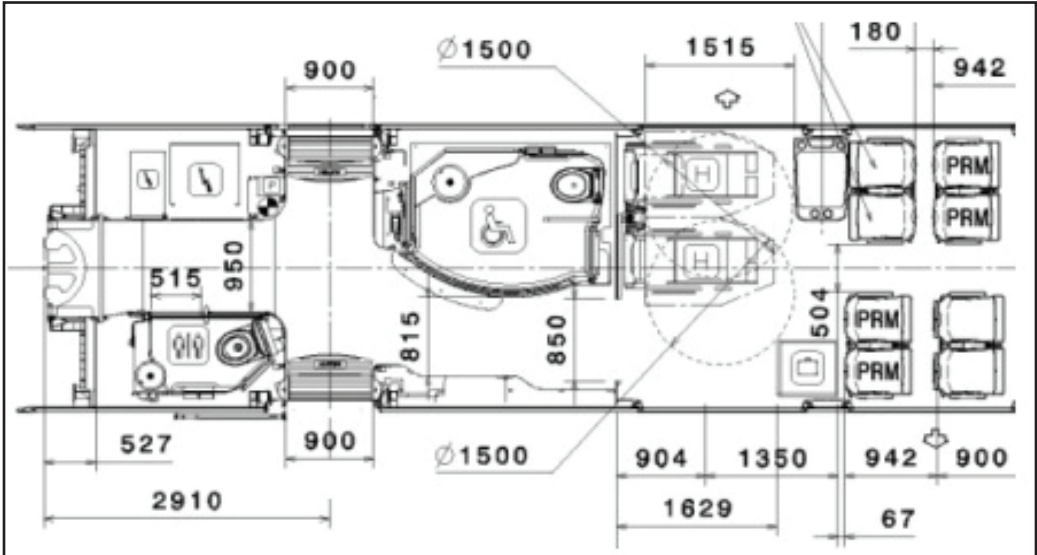

Source: Alstom Presentation, "Persons with Reduced Mobility," June 2010

**Figure 14.2 Alstom AGV Gangway Clear Opening (Dimensions in mm)**

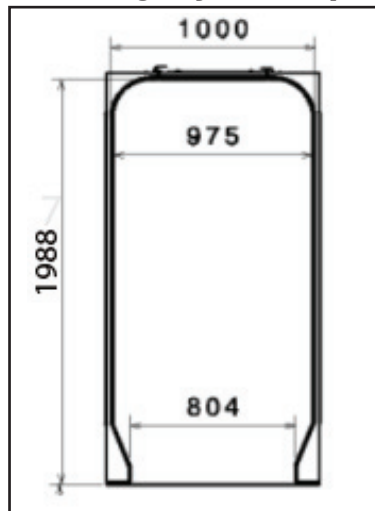

Source: Alstom Presentation, "Persons with Reduced Mobility," June 2010

The TGV Duplex does not meet all CFR requirements. The vestibule area clearance is in compliance, but the interior door with access to the wheelchair spaces is 31.5 inches (800 mm) wide. It was noted that the dining area is on the upper level, with the wheelchair spaces on the lower level.

---

**Wheelchair Spaces.** CFR requires that each car have at least one but not more than two mobility aid seating locations that comply with spacing requirements, and at least one but not more than two seating locations that comply with “other spaces” requirements. The TGV Duplex and the AGV for NTV do not meet this CFR requirement. TSI requirements are quite different, stipulating the number of wheelchair spaces required per trainset, with that number depending on trainset length, as follows:

- Trainsets less than 672.6 feet (205 m) in length must have two wheelchair spaces.
- Trainsets from 672.6 feet to 984.3 feet (205 m to 300 m) in length must have three wheelchair spaces.
- Trainsets greater than 984.3 feet (300 m) in length must have four wheelchair spaces.

**Wheelchair Floor Space.** CFR requires that wheelchair floor spaces have minimum dimensions of 48.0 inches by 30.0 inches (1220 mm by 760 mm), while TSI requires minimum dimensions of 51.2 inches by 27.6 inches (1300 mm by 700 mm). Alstom stated that the wheelchair spaces for the TGV Duplex satisfy CFR requirements, but that those of the AGV spaces do not. TSI also requires minimum wheelchair space requirements for two adjacent wheelchairs to be 51.2 inches by 57.1 inches (1300 mm by 1450 mm).

**Foldable Seats.** Alstom stated that the TGV Duplex and the AGV satisfy CFR clearance criteria for the use of foldable seats (no obstruction into the 48-inch by 30-inch (1220-mm by 760-mm) space when folded).

The Duplex has locations where a wheelchair can be stored if the passenger wants to transfer to a regular coach seat or the dining car. The AGV does not have such provisions, but Alstom advised that they are possible.

**Floors, Steps, and Thresholds.** CFR requires floor surfaces be slip-resistant in the aisles, on step treads, and in areas where wheelchair users are accommodated; it also requires that all step edges and thresholds have a band of contrasting color running the full width of the step or threshold or length of aisle. Alstom stated that the AGV and the TGV Duplex comply with these requirements.

## 14.2.2 CSR

CSR advised that the door opening height for the CRH380A is a minimum of 72.8 inches (1850 mm), but less than or equal to 74.8 inches (1900 mm) as required by EN 14752. The CRH380A currently has one seat per trainset for a wheelchair passenger.

## 14.2.3 Renfe

Renfe advised that EN 14752 describes the requirements for door systems for PRM. This EN is not required currently, but Renfe will adopt it for all new trainsets.

## 14.2.4 Siemens

**Doorways.** Siemens advised that the exterior (Figure 14.3) and interior door widths and the passageways of the Velaro comply with CFR requirements.

**Figure 14.3 Siemens Velaro Exterior Door Opening (Dimensions in mm)**

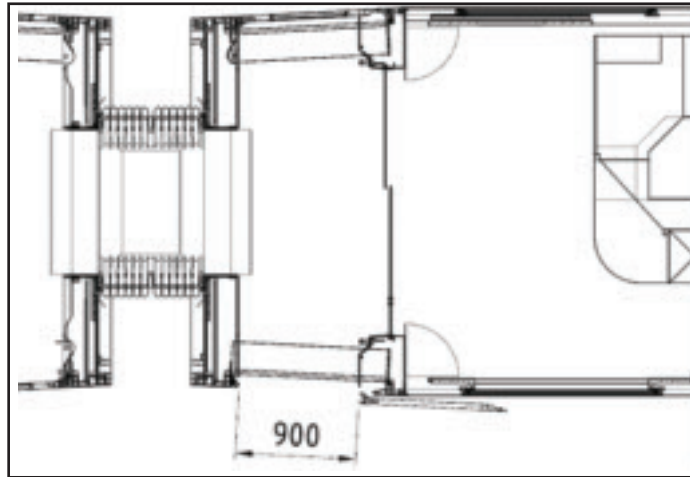

Source: Siemens Presentation, "Interior Design," January 2010

**Wheelchair Spaces.** Siemens developed a potential layout for a U.S. HSR trainset that would feature two wheelchair spaces in each car. The spaces are 63.0 inches (1600 mm) from the wall to the front of the seat for the passenger who accompanies the wheelchair passenger. Siemens advised that the exterior and interior door widths and the passageways will comply with CFR requirements. Two emergency call buttons are provided for PRM, one at the regular wheelchair seating height and one at the floor level. These buttons are installed in the coach at the wheelchair seating locations (Figure 14.4) and in the PRM restrooms (Figure 14.5).

**Figure 14.4 Emergency Call Buttons at Wheelchair Seating Locations on the Velaro**

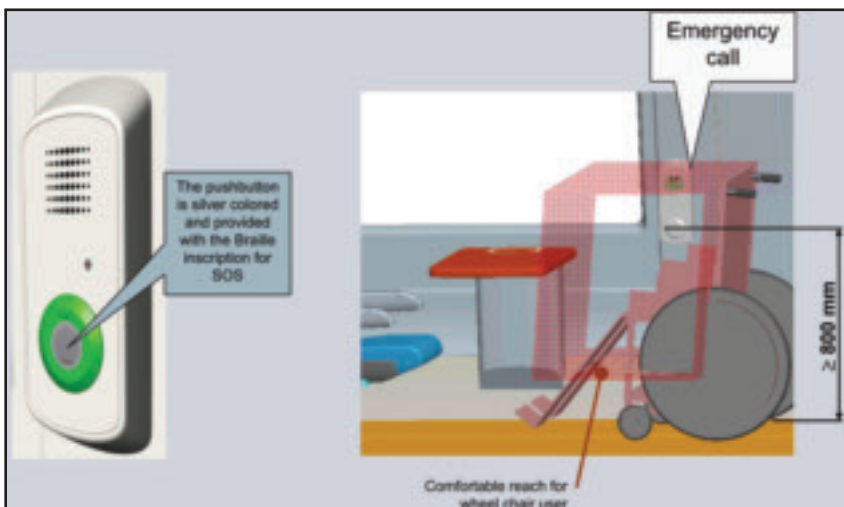

Source: Siemens Presentation, "Interior Design," January 2010

**Figure 14.5 Emergency Call Buttons in the PRM Restroom on the Velaro**

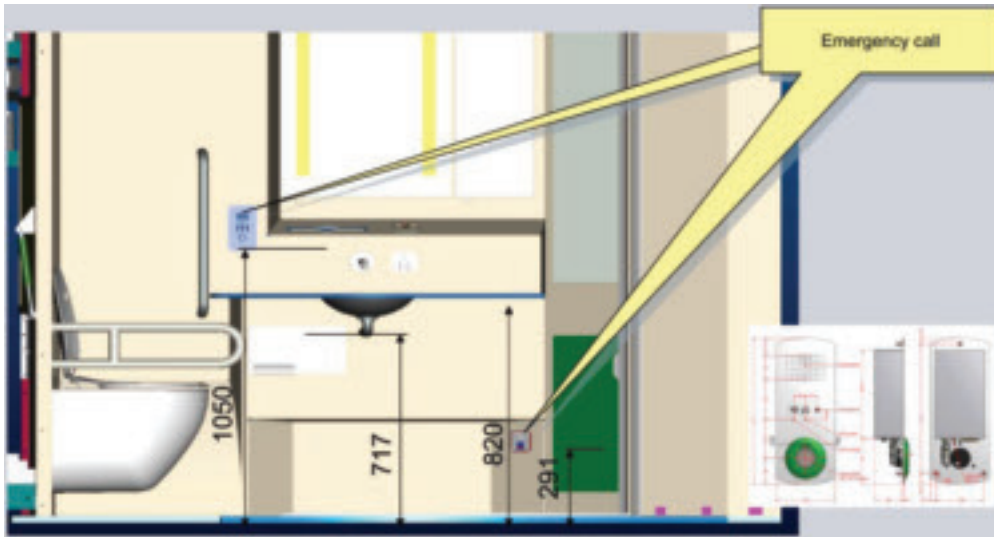

Source: Siemens Presentation, "Interior Design," January 2010

## 14.3 TOILET ROOMS

### 14.3.1 Alstom

Alstom advised that one toilet room serves 45 to 50 passengers. On the AGV, there are ten toilet rooms on an eleven-car trainset. The AGV for NTV accommodates 460 passengers.

CFR states that if a restroom is provided to passengers, a wheelchair-accessible restroom must be provided also. Alstom reviewed the following requirements for ADA accessible toilet rooms based on 49 CFR §38:

- **Floor area.** CFR requires a minimum clear floor area of 60.0 inches by 35.0 inches (1525 mm by 890 mm). Alstom's AGV universal (ADA accessible) toilet is compliant with the TSI PRM requirement and meets the CFR ADA requirement.
- **Toilet height.** CFR requires the distance from the toilet room floor to the top of the toilet seat to be 17.0 inches to 19.0 inches (432 mm to 483 mm). TSI stipulates that this distance be 17.7 inches to 19.7 inches (450 mm to 500 mm). Alstom states that the AGV water closet satisfies the CFR requirement.
- **Grab bar.** CFR requires that a grab bar 24.0 inches (610 mm) long be mounted behind the toilet and a horizontal grab bar 40.0 inches (1015 mm) long be mounted on the side wall with one end not more than 12.0 inches (305 mm) from the back wall. The height of this grab bar should be between 33.0 inches and 36.0 inches (838 mm and 915 mm) above the floor. TSI requires a fixed vertical and/or horizontal handrail adjacent to the toilet and the wash basin and a horizontal handrail on each side of the toilet seat. The handrail on the wheelchair accessible side has to be hinged so as to

---

enable an unobstructed transfer between the wheelchair and the toilet seat. Alstom stated that the AGV is not compliant with CFR criteria for handrails.

- **Faucets and flush controls.** CFR requires faucets and flush controls to be operable with one hand without the need for tight grasping, pinching, or twisting of the wrist. In addition, the force needed to activate the controls should not be greater than 5 lbf (22,2 N). The controls for the flush valves should be mounted no more than 44.0 inches (1118 mm) above the floor level. TSI requires that any door control device and other equipment inside the toilet room be operable by exerting a force not exceeding 4.5 lbf (20 N). Alstom states that the AGV meets CFR requirements except for the height of the flush valve, which can be moved.
- **Doorways.** CFR requires that a doorway opposite the toilet should have a minimum clear opening width of 32.0 inches (815 mm), and that a doorway on the side wall should have a minimum clear opening width of 39.0 inches (991 mm). TSI requires the toilet access door to provide a minimum clear useable width of 31.5 inches (800 mm). Alstom states that the AGV is not compliant with CFR criteria.
- **Location.** CFR requires the accessible restroom to be in close proximity of the wheelchair storage space and to have an unobstructed path with a minimum width of 32.0 inches (815 mm). Alstom states that the AGV complies with this requirement.

### 14.3.2 CSR

CSR advised that the CRH380A trainset currently has one wheelchair accessible toilet. As mentioned earlier, the CRH380A has only one seat per trainset for a wheelchair passenger.

### 14.3.3 Siemens

UIC provides standards identifying the number of restrooms needed on a trainset based on the number of passengers accommodated. Siemens typically provides one toilet for every 40 passengers. It is a requirement in Germany to have a wheelchair turning radius of 2.5 feet (0,75 m) for restrooms on the trainset. Siemens advised that providing an additional standard toilet would reduce capacity by approximately eight seats.

## 14.4 WATER SUPPLY

### 14.4.1 CSR

CSR advised that the water supply system includes a roof water tank, pump box, control box, electrically heated water boiler, electric hot water device, and water tap. The sanitation system includes a water pressurizer, transfer tank, wastewater tank, pneumatic panel, and water level meters. The CRH380A trainset complies with UIC 563, which identifies fittings provided in train coaches in the interest of hygiene and cleanliness. It also follows TB/T 3125 for electric hot water devices for rail vehicles. CSR stated that water from the washing basin of the CRH380A is discharged to the ground. The wastewater tank is discharged in the depots. The capacity of the water tank is sufficient for 21 hours. Actual usage is estimated to be approximately 16 hours per day.

---

## **14.4.2 Siemens**

Siemens advised that the freshwater tank has a capacity of 84.5 gallons (320 L). Freshwater is normally filled daily; however, it can be filled after the second day of operation. The wastewater tank capacity of 277 gallons (1050 L) permits 3 days of operation prior to emptying the tank.

For ventilation purposes, the air from the restrooms enters the exhaust air system of the coach.

## **14.5 INTERIOR FURNISHINGS**

### **14.5.1 Seating**

#### **14.5.1.1 SNCF**

SNCF advised that there is no set ratio of first class seats to second class seats. That ratio is determined by the market and readjusted accordingly during Level 4 maintenance (not easy to adjust otherwise).

#### **14.5.1.2 Siemens**

Siemens stated that longer coaches offer more flexibility to accommodate any additional seating arrangements. The Velaro platform provides 92 percent of the coach length for passengers. Siemens advised that the wider Velaro CN carbody design (approximately 11 feet (3.35 m)) would be most appropriate for U.S. HSR programs. This wider carbody allows a 2 + 2 first class seating arrangement. The Velaro CN does not have a tapered carbody at the ends of the coaches, as does the Velaro E trainset.

The cab on the Velaro D was redesigned to eliminate the passenger viewing area by installing an equipment room behind the driver's cab (Figure 14.6) so as to:

- Offer more privacy for the driver
- Co-locate the electrical lockers in the area behind the cab
- Decrease design costs associated with providing a passenger seating compartment directly behind the cab.



---

**Figure 14.6 Velaro D Cab with Electrical Lockers**

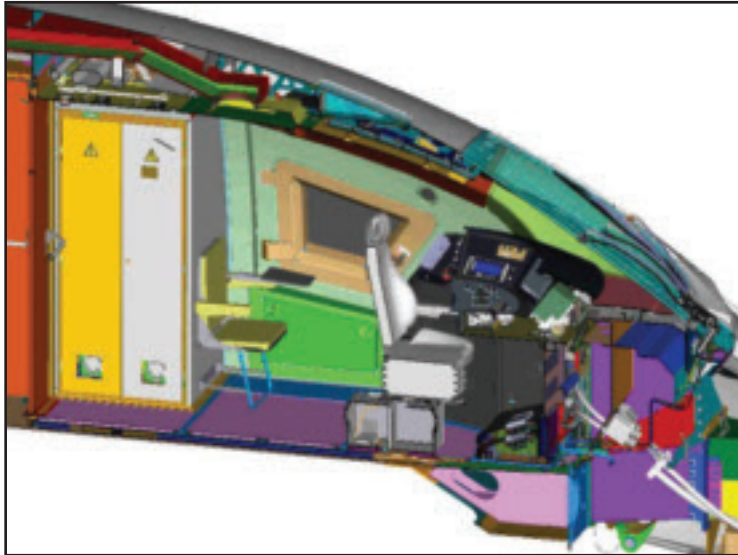

Source: Siemens Presentation, "Interior Design," January 2010

#### **14.5.1.3 NERTUS**

NERTUS advised that the Velaro E has 405 seats total and three seating classes, Club, Preferente, and Tourista. The Velaro D has 480 seats in two classes (first and second class).

### **14.5.2 Seat Pitch**

#### **14.5.2.1 Alstom**

Alstom advised that the seat pitch of the AGV is 39.0 inches (990 mm) for first class and 36.2 inches (920 mm) for second class. The second class seat pitch for high-density capacity is 35.4 inches (900 mm).

#### **14.5.2.2 CSR**

CSR advised that the seat pitch on the CRH380A is 47.2 inches (1200 mm) for first class and 39.4 inches (1000 mm) for second class. The width of the first class seat is 18.7 inches (475 mm); the width of the second class seat is 17.5 inches (445 mm).

Figure 14.7 depicts the interior of the CRH380A first and second class seating areas.

---

**Figure 14.7 CRH380A First Class Seating (left) and Second Class Seating (right)**



Source: CSR Presentation, "Information about High Speed EMU," November 2010

### **14.5.2.3 Hyundai Rotem**

In Korea, the seat pitches for the KTX-II are 44.1 inches (1120 mm) for first class and 38.6 inches (980 mm) for second class.

## **14.5.3 Mechanized Rotating Seats**

### **14.5.3.1 DB**

DB had rotating passenger seats on its trains in the 1960s and 1970s, and the ICE 1 had rotating seats. These seats were eliminated soon after, however. DB has many lines on which its trains change directions, and stated that having to rotate the seats increased turnaround times and maintenance costs. DB also pointed out that not everyone prefers to sit in the direction of travel.

### **14.5.3.2 Hyundai Rotem**

Hyundai Rotem advised that the seats on the KTX-II are rotatable.

### **14.5.3.3 Renfe**

Renfe advised that rotating seats and removable tables are currently installed on the Velaro E, but that it will not specify rotating seats for its trainsets in the future.

### **14.5.3.4 Siemens**

Siemens advised that rotatable seats do not decrease seating capacity, and that issues to consider include the:

- Need to remove tables to allow seats to rotate
- Potential for malfunction
- Increased weight

- 
- Need for staff to rotate seats
  - Increased in-station dwell time.

#### **14.5.3.5 SRB**

The seats on the CRH380A can be rotated 180 degrees so that passengers can face the direction of travel.

### **14.5.4 Tables**

#### **14.5.4.1 Siemens**

Siemens developed crushable tables for Great Britain. Crushable elements in the sidewall mounting of the table absorb energy upon impact. One of the goals of this component is to prevent the opposite end of the table from impacting passengers.

### **14.5.5 Luggage Racks**

#### **14.5.5.1 Siemens**

Siemens advised that each car has room for luggage accommodations (either overhead racks or shelf racks). For security reasons, European trainsets do not have enclosed luggage compartments or overhead racks. The luggage racks incorporate semi-transparent materials that allow train crew to readily detect packages left behind. The overhead racks for first class seating are adjusted to provide a minimum headroom of 6.6 inches (168 mm). Polycarbonate material is used for the luggage racks instead of glass for weight reduction. The distance between luggage barriers is 6.6 feet (2 m).

### **14.5.6 Hand Rails**

#### **14.5.6.1 Alstom**

Alstom recognized that CFR requires the diameter or the width of the gripping surface of interior handrails and stanchions to be 1.3 inches to 1.5 inches (32 mm to 38 mm) with a minimum knuckle clearance of 1.5 inches (38 mm) from the adjacent surface. TSI requires the diameter to be 1.2 inches to 1.6 inches (30 mm to 40 mm) with a minimum clear distance of 1.8 inches (45 mm) to any adjacent surface. Alstom states that AGV handrails are not completely compliant with CFR criteria (e.g., 1.6 inches (40 mm) for handrails in ADA toilets).

### **14.5.7 Materials**

#### **14.5.7.1 CSR**

CSR follows TB/T 3139 for the environmental standard relevant to interior decoration material and indoor air. This standard identifies the limits for harmful substances.

---

## **14.6 INTERIOR LIGHTING**

### **14.6.1 Siemens**

Velaro main interior lighting fixtures are located at the sides of the coach and above the luggage racks. Unlike the LED emergency lights and reading lights, the main interior lights are fluorescent tubes. LED lights have a luminous efficacy of 60 lm/W, while fluorescent lights have a luminous efficacy of 80 lm/W. Siemens stated that LED technology is improving, however, and a luminous efficacy of 260 lm/W is projected for the near future.

---

**PART 3: HSR INFRASTRUCTURE**

---

---

## **CHAPTER 15 INFRASTRUCTURE INTERFACES AND VEHICLE/TRACK INTERACTION**

*During the Fellowship, manufacturers and operators discussed the unique characteristics of a HSR alignment and provided the authors with information about best practices relative to safety and passenger comfort. The findings are summarized in this chapter.*

### **15.1 MAXIMUM GRADIENTS OF ALIGNMENT**

*Manufacturers discussed the effects of maximum gradients on operating performance (propulsion/braking) and potential impacts if the track alignment exceeds the TSI maximum gradient criteria of 2.5 percent average grade over 6.2 miles (10 km).*

#### **15.1.1 Alstom**

Alstom advised that more traction equipment may be needed if the slope is greater than 2.5 percent. Alstom used Brazil as a reference, where 3.5 percent to 4 percent grades are encountered for distances of 15 miles to 17 miles (24 km to 27 km). Alstom added that using more traction equipment could adversely affect capacity.

As is, the traction equipment on the AGV could cope with slopes of up to 4 percent. Alstom emphasized, however, that the route profile must be defined as clearly as possible to ensure appropriate design and integration of the traction power equipment.

#### **15.1.2 CSR**

CSR advised that the CRH380A was required by procurers to be capable of operating at 3 percent grade. CSR advised that the CRH380A can accommodate 3.5 percent to 4.5 percent grades.

#### **15.1.3 MOR**

MOR advised that the maximum grade experienced on the Wuhan-to-Guangzhou line is 2 percent.

#### **15.1.4 Hyundai Rotem**

Hyundai Rotem advised that the maximum gradient currently encountered in Korea is 3.5 percent.

---

### 15.1.5 Siemens

Siemens advised that the first high speed line gradient was 1.25 percent. This line was shared with freight traffic. The maximum gradient on the Cologne-to-Frankfurt line is 4 percent sustained over a length of approximately 2 miles (3 km) (Figure 15.1). This line is fully dedicated to high speed traffic. The Velaro is designed to operate on a 4 percent grade with 75 percent traction power, and on a 5 percent grade with 100 percent traction power.

**Figure 15.1 Cologne-to-Frankfurt High Speed Line**

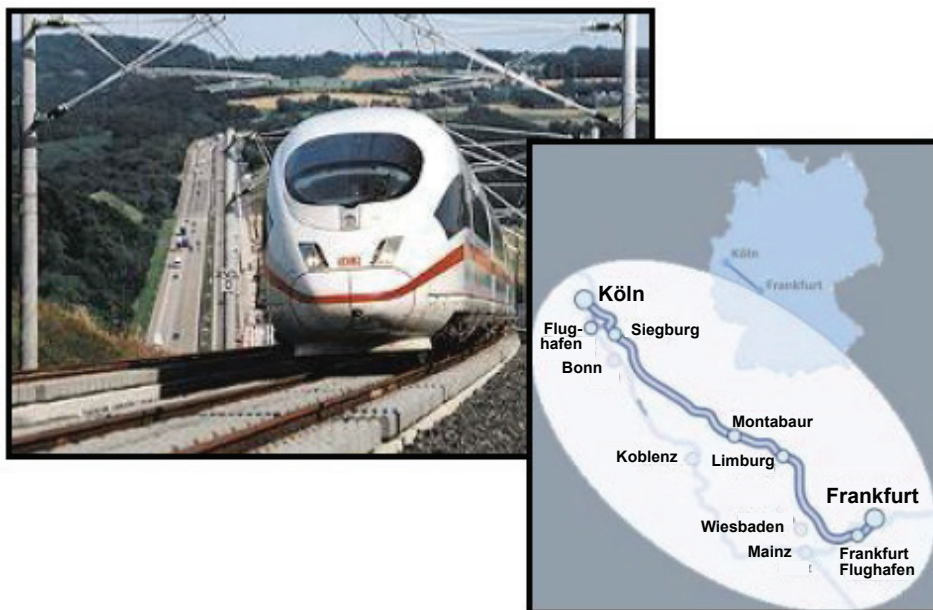

Source: Siemens Presentation, "Traction and Auxiliary System," February 2010

## 15.2 MINIMUM CURVE RADIUS FOR MAINLINE, STATIONS, AND OVERNIGHT STORAGE TRACKS

*A common attribute of successful HSR programs is long lengths of straight track connected by curves with generous curve radii because such an alignment maximizes the amount of time a trainset can remain at a desired speed. U.S. HSR projects might be required to operate over existing and potentially shared railroad infrastructure to gain access into urban centers, yards, and depots. Although such programs might wish to upgrade existing infrastructure to better accommodate trainset performance and passenger comfort, spatial constraints could dictate that sections of track alignments have small curve radii. The topics of preferred mainline curve radii and minimum curve radii were discussed with international HSR manufacturers and operators.*



---

### 15.2.1 Alstom

Alstom advised that very low curve radii exist in SNCF yards, with the lowest being 410 feet (125 m). Taking into consideration Alstom's trainset capabilities due to the articulated architecture, Alstom recommends the following minimum curve radii:

- Depot (absolute minimum): 328 feet (100 m)
- Depot (preferred minimum—train speed of not more than 15 mph (24 km/h)): 410 feet (125 m).

Alstom advised that one must take into consideration the wheel/rail interaction at tight curves, and that wayside lubrication might be needed.<sup>1</sup> Alstom has not experienced any issues regarding wheel lift on tight radii curves.

### 15.2.2 SNCF

SNCF advised that 19,357 feet and 18,242 feet (5900 m and 5560 m) are the normal and exceptional curve radii respectively for 218 mph (350 km/h) operations. SNCF advised that 13,123 feet (4000 m) is the minimum curve radius on its existing high speed lines.

Vertical curve radius parameters for 218 mph (350 km/h) operation are:

- Desirable minimum: 82,021 feet (25 000 m)
- Acceptable minimum: 68,898 feet (21 000 m)
- Absolute minimums (crest and sag): 59,055 feet and 54,134 feet (18 000 m and 16 500 m) respectively.

The above vertical curve radius values are derived from the following vertical acceleration limits for comfort, which are higher than those for conventional lines:

- Maximum for repeated curves: 0.045 g
- Single value for crest and sag: 0.05 g
- Maximum limit for sag: 0.06 g.

### 15.2.3 CSR

CSR advised that the minimum curve radius that a single car can traverse is 492 feet (150 m). The minimum curve radius that the CRH380A trainset can traverse is 591 feet (180 m) for an S-curve with a 32.8-foot (10-m) transitional section and 656 feet (200 m) for a single curve.

### 15.2.4 MOR

MOR advised that the standard minimum curve radius on the Wuhan-to-Guangzhou main-line is 29,528 feet (9000 m). In areas where tighter curves are necessary, the absolute minimum is 22,966 feet (7000 m).

---

<sup>1</sup> Please see Section 15.11 for additional information on lubrication.

---

### 15.2.5 SRB

For SRB, the minimum curve radius for the depot in Shanghai is 820 feet (250 m).

### 15.2.6 Hyundai Rotem

Hyundai Rotem advised that the minimum curve radius is 492 feet (150 m) in the depots and 1,969 feet (600 m) on the mainline. Speed through the latter curve is limited to approximately 62 mph (100 km/h). An absolute minimum of 1,312 feet (400 m) is present on the system in conventional passenger service areas, where train speed is limited to 50 mph (80 km/h).

### 15.2.7 Siemens

Siemens advised that a minimum curve radius of 492 feet (150 m) is acceptable; however, speed would be limited to 25 mph (40 km/h). The minimum curve radius encountered in HSR is the 623-foot (190-m) entry into Cologne station (Figure 15.2). The smallest curves in Cologne station have radii of 525 feet (160 m); however, these curves are traversed predominantly by regional trains.

**Figure 15.2 ICE 3 Approaching Cologne Main Station**



Source: Siemens Presentation, April 2010

Siemens representatives were asked if they knew of any issues with traversing 650-foot (198-m) curves, as this could be the minimum curve radius seen in U.S. applications. They stated that increased wheel wear (and associated maintenance costs) due to periodic passing on curves of 650-foot (198-m) radius would not be expected based on Siemens' experiences with the ICE 3 on the approach to Cologne station. Every hour from 6 a.m. to 10 p.m. a minimum of four ICE 3 trainsets, some in double traction, arrive at and depart from Cologne through the 623-foot (190-m) curves.

The maximum speed through a 650-foot (198-m) curve is 22 mph (36 km/h) without superelevation and 34 mph (54 km/h) with a superelevation of 3.9 inches (100 mm). The reason for such excellent behavior of the trainset is the specific design of the Velaro bogies with an 8.2-foot (2.5-m) wheelbase that, in connection with the particular design of the guidance of the wheelsets, permits good running through curves with little wear. The guidance of the wheelsets contributes to ensuring stable and comfortable running behavior at speeds of up to 250 mph (403 km/h).

---

The minimum curve radius in workshops (for single, uncoupled coaches) is 394 feet (120 m). The minimum recommended curve radius is 492 feet (150 m) per consist and 394 feet (120 m) per car. Siemens stated that wheel lift is not a concern for curves with radii greater than or equal to 492 feet (150 m).

## **15.3 WIDENING OF THE TRACK GAUGE**

*International HSR operators and infrastructure managers may specify an increase in the nominal track gauge dimension in locations where there are small curve radii. This is done typically to mitigate the potential of a wheel flange “climbing” up the rail head. The practice of widening the gauge in these locations needs to be analyzed carefully to prevent unintended consequences associated with low-speed derailments.*

### **15.3.1 Alstom**

Alstom advised that the track gauge in France is widened only on tight radii curves. The average gauge ranges from 56.5 inches to 56.8 inches (1435 mm to 1442 mm) averaged over a section of 328 feet (100 m). The gauge widening criteria provided in SNCF’s technical specification for new trains are as follows:

- For radii less than 656 feet (200 m), the gauge is 57.1 inches (1450 mm).
- For radii greater than or equal to 656 feet (200 m), the gauge is 56.6 inches (1437 mm).
- For radii greater than 984 feet (300 m), the gauge is 56.5 inches (1435 mm).

### **15.3.2 CSR**

CSR advised that gauge widening is not done in China because there are no tight curves.

### **15.3.3 Siemens**

Siemens advised that the track gauge is widened in Germany only on curves with radii of 820 feet (250 m) or less.

## **15.4 WHEEL/RAIL PROFILE**

*This section provides a summary of international HSR best practices relative to establishing the optimal interface between the wheel tread and the rail, which is critical to providing a stable, safe, and comfortable ride. The level of stability required at the highest operating speeds needs to be considered when determining this interface, as does the resistance to derailment at low speeds. Complexity is added when the trainset is operated over both dedicated and shared corridors because the rail profiles and maintenance programs may differ. A key lesson learned was that the wheel/rail interface needs to be approached from an overall systems perspective.*

---

### 15.4.1 Alstom

Alstom advised that the 1:40 inclination and GV 1/40 wheel profile are used in France, while in Germany, the 1:20 inclination and S1002 wheel profile are used (refer to EN 13715 for requirements pertaining to these profiles). Currently, the proposed wheel profile for Alstom's new high speed trains is per EN 13715 – 1/40/h28/e32/15% (meaning the profile is derived from the 1:40 reference profile, with a flange 1.1 inches (28 mm) high, 1.3 inches (32 mm) thick, and a 15 percent reverse slope). The rail profile is 60E1, also known as UIC60.

### 15.4.2 Siemens

Siemens advised that 1:20 inclination is the most common profile used in Europe (e.g., Germany, Spain), and that 1:40 is used in France, Russia, and China. The S1002 wheel profile is normally used with UIC60 (60E1) rails. Siemens stated that a 1:20 inclination is preferred for stability and comfort and that it provides the best level of stability and ride quality over the widest range of wheel wear.

Siemens advised that the Velaro's SF 500 bogies can accommodate a track gauge of 56.5 inches (1435 mm) and wheel/rail profiles of 1:20 and 1:40.

### 15.4.3 CSR

China uses the LM<sub>A</sub> wheel profile and the CHN60 rail profile. CSR advised that maintaining the interaction between wheels and track—both the existing and the upgraded/dedicated track—is of the utmost importance. In China, the rail profile for existing and dedicated lines is the same. The difference lies in maintenance, which China has regulations for, due to the lower operational speeds on existing general service routes. The frequencies of inspections are increased for the dedicated HSR lines and the rail defect tolerances are decreased. CSR advised against having one wheel profile meet different rail profiles. CSR provided Figure 15.3 and Table 15.1 to illustrate the differences between the wheel and rail profiles used in China, Europe, and Japan.

**Figure 15.3 A Comparison of Wheel Profiles (China's LM<sub>A</sub>, Europe's S1002, and Japan's JP-ARC) and Rail Profiles (China's CHN60, Europe's UIC60, and Japan's JIS60)**

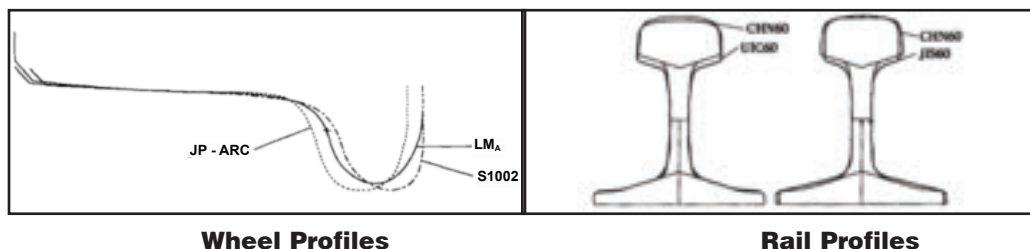

Source: CSR Presentation, "Information about High Speed EMU," November 2010

**Table 15.1**  
**Comparison of Chinese and European Wheel/Rail Profiles**

	China's Wheel/Rail Profiles LM <sub>a</sub> /CHN60	Europe's Wheel/Rail Profiles S1002/UIC60 (60E1)
Rail cant	1:40	1:40
Track gauge inches (mm)	56.5 (1435)	56.5 (1435)
Circle radius at the middle of rail top inches (mm)	11.8 (300)	11.8 (300)
Circle radius at the middle of wheel tread inches (mm)	3.5 / 17.7 (90 / 450)	3.9 / 13.0 (100 / 330)
Distance between backs of wheel flanges inches (mm)	53.3 (1353)	53.5 (1360)
Diameter of nominal rolling circle of wheelset inches (mm)	33.9 (860)	36.2 (920)
Space between nominal rolling circles of wheelset inches (mm)	58.8 (1493)	59.1 (1500)
Initial contact angle of wheel-rail radians	0.10145	0.10344

#### **15.4.4 Korail**

Korail advised that different rail profiles are used for conventional and high speed lines:

- High speed lines use the UIC60 (60E1) (weight = 121 lb<sub>m</sub>/yd (60 kg/m)) rail section.
- Conventional lines use a lighter weight UIC50 (50E1) (weight = 101 lb<sub>m</sub>/yd (50 kg/m)) rail section.

## **15.5 KINEMATIC GAUGE**

*Kinematic gauge is an outline drawing that represents the maximum size of the rolling stock (e.g., trainset height and width), taking into consideration factors such as suspension travel, overhang on curves, and lateral motion relative to the track. The kinematic gauge provides crucial information about the overall size envelope for particular trainsets. This information is used to develop the structure gauge.*

### **15.5.1 CSR**

CSR advised that the CRH380A trainset satisfies the Chinese “Interim Rules about Rolling Stock Gauge on Passenger Special Line.” These rules are related to TSI Section 4.2.3.1 on dynamic gauge and UIC 505-1 on rolling stock construction gauge. The height of the CRH380A trainset is 12.1 feet (3,7 m); its width is 11.1 feet (3,38 m).

---

### **15.5.2 Hyundai Rotem**

Hyundai Rotem advised that the HEMU-400X trainset has a width of 10.2 feet (3,1 m). This width was selected to maintain interoperability with existing lines (KTX-I and KTX-II, both of which are 9.8 feet (3 m) wide). The height of the trainset is 12.2 feet (3,72 m).

### **15.5.3 Siemens**

Siemens advised that the Velaro CN and the Velaro RUS have widths of 10.7 feet (3,27 m), and that there are no tapers on these trainsets. Siemens designs the Velaro per UIC 505-1, which is equivalent to TSI requirements.

## **15.6 STATIC AXLE LOAD**

*International HSR trainset manufacturers have stressed the importance of developing lightweight trainset designs to maximize operational efficiency and minimize maintenance costs associated with the trainset and the infrastructure. TSI identifies a maximum static axle load of 18.7 tons (17 tonnes). This section provides insight into the development of this criterion and of the importance of respecting the lightweight characteristics of trainset designs being contemplated for U.S. HSR systems.*

### **15.6.1 Alstom**

Alstom advised that the 18.7-ton (17-tonne) maximum static axle load criterion identified in TSI was based on discussions among SNCF's infrastructure engineers at the very beginning of HSR. The engineers compared dynamic loads and determined that 22-ton (20-tonne) axle loads at 124 mph (200 km/h) enabled them to maintain the track economically. The axle load was 22 tons (20 tonnes) when the concentrated power ICE 1 was placed into service.

The 18.7-ton (17-tonne) requirement was imposed eventually, starting with TGV-PSE: 18.7 tons (17 tonnes) at 162 mph (260 km/h). Alstom stated that thanks to the operating experience gained and the increased quality of ballast, it is possible to stay at 18.7 tons (17 tonnes) per axle for 186 mph (300 km/h) operation.

### **15.6.2 SNCF**

SNCF advised that when it designed high speed trains in the 1970s, it was critical to control the dynamics of the vertical forces and keep them at the same level as those of conventional trains. In addition, it was essential to be careful with unsprung masses (i.e., trainset masses that are not supported by the bogie suspension) because of their potential to generate high forces at high frequencies. As a result, the specification was set to limit/reduce the effects of those forces, keeping their magnitude comparable to those of a freight wagon running at 62 mph (100 km/h) or a locomotive at 124 mph (200 km/h).

For a locomotive with a 23.2-ton (21-tonne) axle load, the sleeper vertical acceleration was 0.8 g. With a 1.4 g limit for the TGV when operating at 186 mph (300 km/h), the maximum axle

---

load was decided to be 18.7 tons (17 tonnes). This choice was a compromise between the vehicle design and the track behavior. The durability of the track was attributed to the use of 60E1 (UIC60) rails, twin block sleepers, minimum ballast depth of 13.8 inches (350 mm), and optimization of sub-grade stiffness—too soft will lead to track instability; too hard will lead to generation of high forces. The TGV has an axle load of 18.7 tons (17 tonnes). This is exceptional because of the articulated design of the trainset (i.e., fewer axles per trainset).

### **15.6.3 NTV**

NTV advised that the static axle load of the NTV AGV trainset is 18.7 tons (17 tonnes).

### **15.6.4 CSR**

CSR advised that the CRH380A has an axle load of 16.5 tons (15 tonnes).

### **15.6.5 Hyundai Rotem**

Hyundai Rotem advised that the KTX-II trainset has an 18.7-ton (17-tonne) axle load. Its total weight is 478.4 tons (434 tonnes). The HEMU-400X trainset will have a 15.4-ton (14-tonne) axle load.

### **15.6.6 Siemens**

Siemens advised that the maximum static axle load for the Velaro is 18.7 tons (17 tonnes). The average Velaro carbody weight, per axle, is 14.3 tons (13 tonnes).

## **15.7 AXLE BEARING HEALTH MONITORING**

*North America's rail operations typically use ground-based axle bearing health monitoring systems (e.g., hot box detectors) to monitor the temperature of a bearing passing above the sensor. An elevated temperature reading results in notification to the operator that an overheated bearing condition may exist. Manufacturers and operators discussed the different systems currently in service to support the operation of HSR trainsets.*

### **15.7.1 Alstom and SNCF**

Alstom advised that axle bearing temperature detectors are installed onboard the AGV trainset. SNCF added that some systems use accelerometers to detect abnormal vibrations generated by an axle bearing, but that SNCF has not incorporated this technology to date.

### **15.7.2 Hyundai Rotem**

Hyundai Rotem advised that axle temperature monitoring is performed on the wayside. There are also sensors for falling objects and dragging objects on the right of way.

---

### 15.7.3 Siemens

Siemens advised that bogie health monitoring systems are mounted on the trainsets. It is possible to install bearing temperature monitors on the infrastructure side, but Siemens developed the Velaro platform to have bearing temperature monitoring systems onboard. Different alarm levels notify the operator as to when to reduce speed or stop the vehicle for visual inspection. All controls and wiring are installed with a high level of redundancy to reduce the potential for false alarms. Siemens advised that when a bearing temperature reaches 284°F (140°C), the operator is required to reduce speed to 31 mph (50 km/h) and seek inspection/maintenance intervention. Such delays are rare. For example, in Spain in 2008, Renfe experienced only two delays of more than 10 minutes on trains operating more than 3.1 million miles (5 million km). Siemens stressed the importance of designing a highly reliable bogie monitoring system.

### 15.7.4 DB

A question was posed to DB about which bogie components are deemed a risk to high speed operation. DB stated that the main risks are the bearings and axles. DB advised that there are two ways to monitor the bearings—either while the train is stationary or while it is running. In Europe, it is recommended to monitor the bearings onboard while the train is in operation to ensure that the overall system is performing as intended.

Two technologies are used for monitoring bearing health:

- **Temperature:** Elevated temperature readings must be reacted to immediately. DB stated that the bearing health monitoring equipment must provide reliable information because false indications will have severe impacts on operations.
- **Oscillation accelerations:** This predictive evaluation process characterizes the health of the bearing based on the measurement of vibrations. This approach permits the train to operate while bearing maintenance is being planned.

DB has conducted several tests on bearing failures and recommends monitoring the oscillation accelerations.

DB stated that its new trainsets will have continuous bogie monitoring. The technology is available and it improves the level of safety. In the past, DB changed the bogie dampers on its vehicles only when they were broken. With a distance-based maintenance program, the practice is to change the dampers after a certain number of kilometers. Continuous bogie monitoring checks the performance of the dampers, among other attributes, allowing maintenance to be performed on the dampers only when their performance deteriorates.

## 15.8 DERAILMENT DETECTION/MITIGATION

*The manufacturers were asked to discuss approaches to maintaining train alignment during a derailment (e.g., bogie-mounted devices that interact with the rail during a derailment). Several approaches are presented in this section, including the use of derailment detection systems and mechanical derailment mitigation appurtenances.*



---

### **15.8.1 Alstom**

Alstom advised that derailment detectors are not installed on the TGV, and that there are no developments underway to install such detectors. Accelerometers installed onboard are used to detect bogie instability (e.g., hunting). The goal is to stop the train when instability is detected.

Alstom's articulated trainset architecture would help to keep a trainset in alignment if there were a derailment. The four disc brakes on the non-powered bogie would also provide a guidance effect (with the rail) during derailment. In addition to onboard mitigation, guide rails are installed in derailment sensitive areas, such as bridges. These areas are usually evaluated on a case-by-case basis.

### **15.8.2 SNCF**

SNCF advised that as defined in TSI, four parameters that need to be considered to account for derailment issues and trainset safety are:

- Wheel climbing (Y/Q ratio where Y equals the lateral guiding force of the wheel exerted on the rail and Q equals the vertical force of the wheel on the rail)
- Track deformation limit (Prud'homme's Law:  $\Sigma Y = 10 + P/3$  where  $\Sigma Y$  equals the sum of the guiding forces of a wheelset and P equals the static axle load)
- Bogie instability
- Vehicle rollover.

SNCF advised that the TGV has bogie-mounted accelerometers that monitor bogie stability. These are installed primarily for safety reasons and not for passenger comfort. The TGV does not have any accelerometers mounted on car bodies.

### **15.8.3 CSR**

CSR advised that protection against derailment is provided by:

- Matching wheel/rail profiles and suspension parameters
- Implementing more stringent rail maintenance programs
- Using bogie instability detection devices.

### **15.8.4 Hyundai Rotem**

Hyundai Rotem advised that its onboard system includes monitoring and diagnostics to detect, for example, bogie hunting, loss of propulsion or braking, and driver impairment (in which case an alarm will sound and, if no response is given by the driver, the train will stop automatically).

### **15.8.5 Siemens**

Siemens advised that Japan's Shinkansen trainsets incorporate a bogie-mounted structural component that interfaces with the rail in the event of a derailment. Siemens does not have

---

such a design for the Velaro trainsets; however, onboard derailment detection via a bogie monitoring system is possible for future high speed trainsets. These systems are installed on commuter trains and can be adopted for high speed applications.

Siemens added that derailment detection requires the installation of accelerometers that are tied to indicators located in the cab. The installation of these accelerometers has been tested on the Velaro D platform. It was found that the most reliable location for the accelerometers was on the bogie frame 7.1 inches (180 mm) above the rail. Siemens stated that the addition of a ballast pickup alarm might also be possible.

Bogie monitoring is provided via instability detectors/alarms. Train speed is slowed automatically when instability is detected. Operators typically define safe operating rules when instability is detected (e.g., speed reduction to 124 mph (200 km/h) until the issue is resolved). The bogie monitoring system can also be used for preventative maintenance by providing notification of damper failure, poor bearing health, or wheel defects.

## **15.9 UNCONTROLLED LATERAL MOTION**

*Controlling lateral motion in a high speed trainset is essential to trainset stability and passenger comfort. This is done typically through trainset design or by limiting infrastructure irregularities. Various practices in accommodating lateral motions are detailed below.*

### **15.9.1 MOR**

MOR advised that construction of the track with tight tolerances is key to ensuring the safety, smoothness, and passenger comfort of HSR operations. Detailed control values for the Wuhan-to-Guangzhou line include:

- 0.04 inch (1 mm) in the horizontal direction
- 1.2 inches (30 mm) in elevation and track alignment
- 0.04 inch (1 mm) for short wavelength track defects
- 0.4 inch (10 mm) for 984-foot (300-m) long wavelength track defects.

### **15.9.2 Siemens**

Siemens advised that rotational stiffness of the bogie is necessary for high speed trainset stability, and that there needs to be compromise between stiffness and flexibility, which is essential to negotiating tight turn radii. Most curves in Germany have large radii, however, so bogie stiffness is not a major issue.

The Velaro incorporates passive dampening, but has no active dampener systems or active/passive tilting mechanisms. Two yaw dampers are provided on each bogie side to aid with stability (Figure 15.4). One yaw damper per side is sufficient; however, two are installed for reliability.

---

**Figure 15.4 Velaro E Redundant Yaw Damper Configuration**

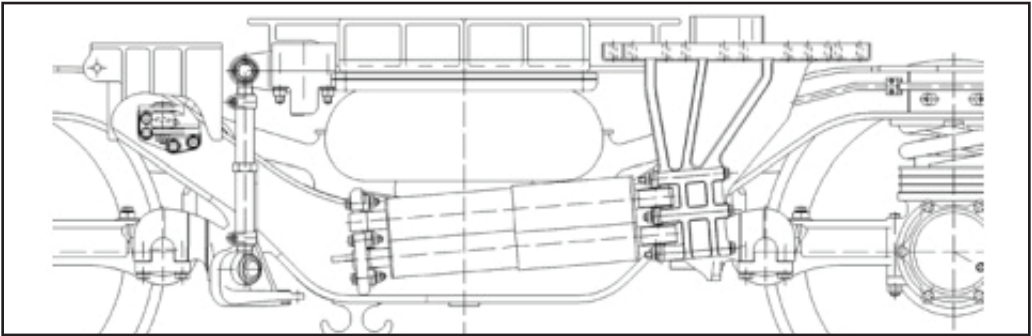

Source: Siemens Presentation, "Running Dynamics and Gauging," January 2010

The permitted uncontrolled lateral motion in the bogie prior to dampening via elastomeric bushings is 0.7 inch to 0.8 inch (18 mm to 20 mm), with a maximum 3.5 inches (90 mm) to the hard stop.

## **15.10 VEHICLE AND TRACK INTERACTION (VTI)**

*As stated in FRA's Vehicle Track Interaction Notice of Proposed Rulemaking (VTI NPRM), FRA is proposing to amend the Track Safety Standards and Passenger Equipment Safety Standards applicable to high speed and high cant deficiency train operations to promote the safe interaction of rail vehicles with the track over which they operate. The information contained in the proposed rulemaking document was forwarded to international HSR manufacturers and operators, whose comments are summarized in this section.*

### **15.10.1 Cant Deficiency**

#### **15.10.1.1 Alstom**

Alstom commented that FRA's Class 9 track standards were revised in VTI NPRM to adopt 220 mph (354 km/h) operations, which is consistent with Europe's 218 mph to 224 mph (350 km/h to 360 km/h) limits for very high speed tracks.<sup>1</sup> Overspeed limits defined in VTI NPRM, listed in the *Federal Register*, Vol. 75, No. 89 / Monday, May 10, 2010 / Proposed Rules are limited to 5 mph (8 km/h). Alstom recommended that FRA adopt a "maximum speed plus 10 percent" limit.

Cant deficiency in Europe is limited to 5.0 inches (127 mm) on high speed lines. The steady-state lateral carbody acceleration of 0.15 g, as stated in VTI NPRM, is equivalent to the UIC requirement. It permits a non-compensated acceleration of up to 0.12 g at the track level (cant deficiency of 7.0 inches (178 mm) for a flexibility coefficient of 0.25). Alstom stated that a flexibility coefficient of 0.25 is appropriate for high speed trains because it does not result in a stiff suspension. Locomotives tend to have a suspension coefficient of 0.15, whereas non-powered vehicles tend to have a coefficient of 0.4. Alstom advised that VTI NPRM requirements for

---

<sup>1</sup> Refer to FRA CFR section 49 CFR §213 for Track Class designations and associated requirements.

cant deficiency would be unlikely to impact very high speed lines because the trains usually travel with low cant deficiency values (less than 5 inches (127 mm)). With regards to the VTI NPRM safety limits, the carbody acceleration limits are higher than European limits by a factor of two.

### 15.10.1.2 SNCF

SNCF emphasized the importance of keeping passenger comfort and safety in mind when developing the alignment of HSR lines. Cant deficiency values for high speed lines are lower than those for conventional lines. For comfort purposes, cant deficiency is usually limited to 1.6 inches to 2.0 inches (40 mm to 50 mm). The maximum value for cant is 7.1 inches (180 mm).

SNCF advised that the normal and exceptional limits for alignment design parameters for 218 mph (350 km/h) operation are as shown in Table 15.2.

**Table 15.2**  
**Limits of Alignment Design Parameters: 218 mph (350 km/h)**

Parameter	Normal Limit	Exceptional Limit
Cant deficiency inches (mm)	2.6 (65)	3.2 (80)
Minimum radius feet (m)	19,357 (5900)	18,242 (5560)
Maximum gradient cant inches/foot (mm/m)	43.3 (0,52)	51.7 (0,62)
Maximum cant deficiency variation inches/second (mm/s)	1.2 (30)	2.0 (50)
Minimum length between curves <sup>1</sup> feet (m)	820 (250)	656 (200)

<sup>1</sup> To avoid carbody oscillations from being repetitively excited by succession of curves.

## 15.10.2 Stability/Truck Hunting

### 15.10.2.1 Alstom

Alstom advised that the truck hunting limit of 0.3 g RMS (linear trend removed) as stated in VTI NPRM seems to be tightened from the original FRA value of 0.4 g RMS, pending on the definition of "RMS (linear trend removed)." Europe's truck hunting limit with the TGV bogie mass is 0.42 g. A typical locomotive has a limit of 0.35 g. A value of 0.5 g is appropriate for hunting detection, although that value depends on the condition of the track. TSI specifies a hunting detection limit of 0.8 g. Alstom stated that it would be beneficial to link the truck hunting RMS limit to the bogie mass, as is done in EN 14363 Section 5.3.2.2 (f)(2), because lighter bogies are safer than heavier bogies for the same level of lateral acceleration and axle load.

### 15.10.2.2 CSR

CSR advised that the vibration comfort in the passenger area is less than 1.5 while running at 236 mph (380 km/h), per UIC 513. Wheel load reduction is less than 0.8. The CRH380A complies with Prud'homme criteria for the maximum wheel lateral force =  $10 + P_0/3$  kN. From a stability perspective, the vertical and lateral stability is less than or equal to 2.5, and the vibra-

---

tion comfort is less than or equal to 2.0. Filtering is performed at 10 Hz when the peak acceleration value reaches or exceeds the limit of 0.8 g to 1 g for more than six cycles.

### **15.10.2.3 Hyundai Rotem**

The KTX-II uses passive dampers and has had no issues operating at speeds of more than 205 mph (330 km/h). For speeds above 249 mph (400 km/h), however, Korea is studying the use of active dampers to maintain stability because issues were found when two high speed trains passed each other. Hyundai Rotem's R&D center is focused on 249 mph (400 km/h). Hyundai Rotem added that it was very challenging to maintain stability on tracks that see mixed traffic.

## **15.10.3 Train Qualification**

### **15.10.3.1 Alstom**

Alstom feels that the newly proposed train qualification process described in the VTI NPRM is an improvement. This new process uses minimally compliant analytical track (MCAT) to test a vehicle's performance in response to various types of perturbations (e.g., hunting, gauge narrowing and widening, etc.). It is useful because it combines the defects and tolerances of the track. Alstom advised that a 151-foot (46-m) defect wavelength should be used to evaluate high speed train performance. The European qualification tests are based on a network approach, and are conducted on the worst part of the trans-European system. Results are then evaluated to ensure that running on other portions of the network is possible. In the U.S., the qualification tests are performed on the route on which the trainset will travel.

## **15.10.4 Alignment Defects**

### **15.10.4.1 Alstom**

Alstom analyzed SNCF and VTI NPRM rules for alignment defects and derived a ratio defining the lateral and vertical comparisons. For lateral defects (defect wavelength ( $\lambda$ ) = 325 feet (99 m)):

- Class 8/9 track: the ratio is fairly close to unity (1.2 times the UIC value).
- Class 7 track: the ratio is approximately 1.6 times the UIC value.
- Class 6 track: the ratio is approximately 1.9 times the UIC value.

For vertical defects (defect wavelength ( $\lambda$ ) = 325 feet (99 m)):

- Class 7/8/9 track: the ratio is fairly close to unity (1.1 times the UIC value).
- Class 6 track: the ratio is fairly close to unity (1.2 times the UIC value).

Alstom emphasized that the larger defects could have a negative impact on passenger comfort levels, which are expected to be excellent on high speed services, especially in the lateral sense. The VTI NPRM irregularity limits permit high g loadings that will adversely affect passenger comfort. Alstom considers it imperative to keep the average values well below the limits via maintenance requirements so as to not jeopardize passenger comfort, especially for higher track classes.

---

#### **15.10.4.2 Korail**

Korail advised that VTI tests are conducted at night.

#### **15.10.4.3 Siemens**

Siemens advised that monitoring of the track is completed with an ICE 2 test train.

### **15.10.5 Vehicle Monitoring**

#### **15.10.5.1 Alstom**

Alstom advised that the vehicle monitoring procedures as defined in VTI NPRM are not required by European standards because vehicle behavior is controlled primarily through track inspections. The vehicle safety criteria are checked upon delivery of the trains and then rechecked when the wheel profiles reach their worn-condition levels. Alstom feels that it would be interesting to link the vehicle monitoring frequency to the safety margin shown during the qualification testing, as compared to the safety criteria limits. Trains with larger safety margins could have the benefit of lower inspection frequencies. From FRA's perspective, carbody acceleration and monitoring is a safety requirement. Alstom stated that if carbody monitoring is to be installed permanently on the trainsets, these systems will need to be calibrated regularly.

### **15.10.6 Track Gauge**

#### **15.10.6.1 Alstom**

While the gauge proposed for Class 9 track is consistent with the EU value, Alstom expressed concern over the minimum gauges proposed by FRA for Class 7 and 8 tracks, which are lower than what are seen typically in Europe. Alstom advised that the minimum values for Class 7 and Class 8 tracks could result in an increased equivalent conicity and increased wheel maintenance when operating at very high speeds. Equivalent conicity must be kept within a reasonable range to ensure a longer life for the rail profile. Alstom is currently following TSI criteria for gauge and wheel requirements.

Alstom stated that in Europe, the track gauge evolution along the track is controlled by measuring the average gauge over a specific track length, usually 328 feet (100 m). An isolated incident of a low gauge value should not be enough to create a sustained excitation that would degrade the stability performance of the trainset. If an exceptionally low gauge value is continued over a long distance, however, a sustained situation of high equivalent conicities could be created, which would lead to the degradation of trainset stability.

In Europe, the average gauge over a 328-foot (100-m) length of track must be a minimum of 56.5 inches (1435 mm). Introduction of this type of track gauge control would be essential in assuring the good running behavior of trains, especially in the higher track classes where the trains are more sensitive to variations in equivalent conicity (refer to EN 14363 Section 5.4.4.5 for European requirements for equivalent conicity). Alstom stated that there are no stability issues up to 342 mph (550 km/h) with an equivalent conicity of 0.25 to 0.3 and with new wheels and new rail. With wheel wear, there are no stability issues up to 211 mph to 218 mph (340 km/h to 350 km/h).

---

### 15.10.6.2 Siemens

Siemens advised that the conicity for new wheels with a 1:20 profile is typically around 0.2. Worn wheels will approach a conicity of 0.45; however, European regulations and standards set the limit at 0.3. While a higher conicity is preferred, it can lead to greater instability. At the same time, if there is no conicity, ride comfort is negatively affected. Siemens recommended that the conicity should be greater than or equal to 0.1. Ride comfort is evaluated according to EN 12299. Siemens advised that the Velaro can achieve a normal mean value for ride comfort of 1.6. A maximum level of 1.8 is permitted, but generally depends on the alignment.

The assumptions for determining the aforementioned ride comfort include:

- Velocity of 218 mph (350 km/h)
- Maximum lateral acceleration at 218 mph (350 km/h) of 0.045 g
- UIC60 rail section and an inclination of 1:20
- Track geometry level QN2 as per EN 14363 (this level necessitates taking short-term maintenance measures).

### 15.10.7 Wheel Flange Angle

#### 15.10.7.1 Alstom

Alstom confirmed that TSI limits the wheel flange angle to 67 degrees. Alstom stated that in Europe the flange angle is maintained to 70 degrees. Alstom emphasized that the flange angle requirement is not so much for instability as it is for low speed derailments. Regarding the 72-degree flange angle limit defined in APTA SS-M-15-06 (Figure 15.5), Alstom stated that it should not be an issue, but that the wheel and rail profile should be considered together. Europeans have taken a systems approach regarding HSR wheel and rail profiles.

**Figure 15.5 APTA Wheel Flange Angle Criteria**

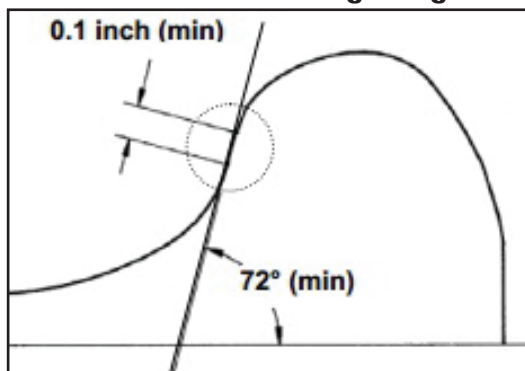

Source: APTA SS-M-15-06

#### 15.10.7.2 SNCF

Carbody acceleration needs to be considered for passenger comfort. Durability of track components is a major factor to the vertical forces generated. One needs to account for fatigue from the rail level down to the sub-grade area.

- 
- TSI calls for a minimum wheel flange angle of 67 degrees.
  - UIC/EN calls for a minimum angle of 70 degrees.
  - APTA calls for a minimum of 72 degrees.

SNCF advised that a 72-degree angle is possible. It emphasized that the flange angle requirement is not so much for instability as it is for low speed derailments.

## **15.10.8 Wheel Load Equalization**

### **15.10.8.1 Alstom**

Alstom stated that the Class G passenger equipment suspension system classification of APTA SS-M-14-06 is similar to TSI's Classes 1 and 2. Alstom emphasized that it is very rare to find a defect of 2 inches (50 mm) or more on very high speed lines. (APTA calls for a limit of 3 inches (76 mm) within any 62-foot (19-m) stretch of track.) These lines tend to have very tough criteria that would otherwise sacrifice passenger comfort. Such defects are more likely to occur in shop/yard locations where track maintenance requirements are not as stringent.

Alstom feels that a 70 percent to 75 percent wheel unloading requirement should be appropriate.

Alstom advised that the current reference in Europe for track twist (warp) is defined in EN 13848-5. The criteria includes up to 0.08 inch/foot (7 mm/m) for short warp (usually for bogies with wheelbases of approximately 9.8 feet (3 m)). This corresponds to 0.8 inch (21 mm). Per EN 13848-1, twist measurements should be taken simultaneously at a fixed distance (e.g., equivalent to the wheelbase) or be computed from consecutive cross-level measurements.

According to the twist limit formula  $20 \text{ mm/L} + 3 \text{ mm/m}$  (as defined in EN 13848-5), where L is the twist base-length in meters and could be considered as the distance between pivots, a distance of 62 feet (19 m) permits 3 inches (76 mm). This corresponds to the APTA reference for long warp. However, there is a difference in terms of short warp between the two criteria: 2.25 inches (57 mm) versus 0.8 inch (21 mm).

Alstom advised that European vehicles in normal service conditions are designed typically to respect the 40 percent wheel unloading criteria with margin. Depending on this margin and the exact trainset configuration, APTA Class R criteria could be respected, but might require some modifications at the primary suspension level for lighter trains. For a Class R vehicle, with 2 inches (50 mm) of wheel vertical displacement, the wheel unloading should be lower than 65 percent. With 2.5 inches (63,5 mm) of wheel vertical displacement, the wheel unloading should be lower than 100 percent. Class R trucks operate over tracks with a difference in cross-level upper limit of 2.25 inches over 10 feet, and 3 inches over 62 feet (57 mm over 3 m, and 76 mm over 19 m). The trainset should be in the normal service condition.

Alstom is curious about the test values specified for Class R vehicles and their applicability for a high speed trainset. It suggested that test results could indicate a need for modifications that could impact the functional characteristics of the trainset. Alstom also suggested that derailment risk be assessed in a more accurate way (e.g., as defined in EN 14363 where wheel unloading is analyzed in conjunction with lateral loads in a tight curve with a determined track warp). The idea behind this approach is that the Y/Q ratio on the leading wheel is usually a better indicator for derailment than wheel unloading.



---

### 15.10.8.2 Siemens

Siemens advised that wheel unloading is exacerbated by high crosswinds, sway dynamics, and acceleration through curves. Regardless of the type of disturbances, however, the Velaro design maintains a 10 percent margin for ensuring adequate wheel loading. Siemens advised that the crosswind disturbance has the most effect on the leading car. Siemens also stated that a distributed EMU trainset typically has a lower center of gravity than with a power car trainset configuration.

### 15.10.9 Wheel Tread Chamfer

#### 15.10.9.1 Alstom

Alstom stated that European wheel designs incorporate a chamfer at the edge of the running tread to improve passage at switches. It emphasized that there is no drawback to including such a chamfer; the only limitations may be because of conventional lines.

In clarifying how the chamfer comes into play, Alstom noted that the tapered zone on the outer part of the wheel profile running tread is effective mainly during switching, and typically it is not in contact with the rail during normal operations. It might contact the rail in very sharp yard curves where there is gauge opening, however, these cases are extremely rare.

The dimensional criteria of the tapered area are based on minimizing perturbations created when passing over switches. When the trainsets go through switches, there is a time when two areas on the wheel profile contact the rail, one near the wheel flange where the new rail path begins, and the second near the outer area where the old rail path is followed prior to the switch (Figure 15.6). When the two paths diverge, there is a weight transfer between the old and new paths that is minimized with this taper by reducing the effects of the over-elevated external rail. This taper allows a smooth transition from the dual contact area back to a single contact area. According to the UIC's Office for Research and Experiments, a 1/15 taper did not create any discontinuity during the passage of the wheelset over switches.

**Figure 15.6 Two Contact Areas between the Wheel Tread and Rails at a Switch**

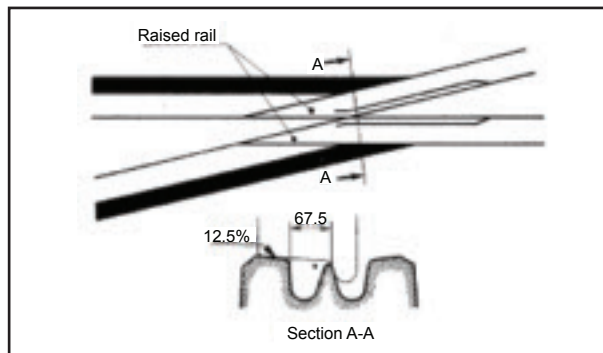

Source: Alstom Presentation, June 2010

---

## **15.11 FRICTION MODIFIERS/FLANGE LUBRICATION**

### **15.11.1 CSR**

CSR advised that flange lubrication is not needed. For existing lines, the radii are greater than 6,562 feet (2000 m), and for passenger dedicated lines, the minimum radius is 22,966 feet (7000 m).

### **15.11.2 Hyundai Rotem**

Hyundai Rotem advised that flange lubrication was not considered initially. After Korea opened its high speed lines, however, many issues related to the lack of flange lubrication were discovered, such as accelerated wheel wear. Currently, flange lubrication is used.

### **15.11.3 Siemens**

Siemens advised that friction modifiers are implemented onboard the trainsets, typically with a lubricant sprayed on the wheel.

### **15.11.4 SNCF**

SNCF advised that flange lubrication is provided on the first trailer bogie on each end of the trainset. Lubrication is used only for the TGV on conventional lines. SNCF advised that for radii less than 3,281 feet (1000 m), rails can wear easily without the presence of lubrication.

---

# CHAPTER 16 OVERHEAD CONTACT SYSTEMS

*The interactions of high speed trainsets with traction power and OCS are critical to ensuring stable power supplies to the trainsets and the overall safety and reliability of the HSR system. Trainset-to-OCS interfaces become somewhat complicated when trains travel at very high speeds. The associated issues were discussed with HSR equipment manufacturers and operators, and their perspectives are presented in this chapter.*

## 16.1 PANTOGRAPHS POWER COLLECTION OVERVIEW

### 16.1.1 CSR

CSR advised that the pantograph-to-OCS interaction was significant to guaranteeing stable current collection. Several technical challenges associated with this interface include:

- Vertical displacement of the pantograph from the OCS
- Stability of current collection with double pantographs
- Effects of aerodynamics and noise
- Use under multi-line conditions and voltages.

CSR found that the contact force becomes greater as the speed of the trainset increases. The uplift force is also increased proportionally to speed due to aerodynamics. CSR added an air deflector near the pantograph to help mitigate this effect and has implemented the use of semi-active control. During testing to verify proper characteristics of aerodynamics, noise, and resistance, CSR discovered that a single-arm pantograph performs much better than a double-arm pantograph.

The standards used in the design of CRH380A pantographs include EN 50367, EN 50126, and IEC 60077. While the supply of the pantograph is outsourced, CSR emphasized that the design of the pantograph must be developed while taking into consideration the OCS characteristics (e.g., tension of the overhead wire) when operating in China's environment.

### 16.1.2 CRCC

CRCC confirmed CSR's statements, saying that the pantograph-to-OCS relation is one of the key technical conditions in HSR operations. The contact wire used is of the magnesium-copper alloy type with a cross-sectional area of 0.23 square inch (150 mm<sup>2</sup>). The system is of the balance-weight type for auto-tensioning. The tension in the contact wire is 6.7 kips (30 kN).

### 16.1.3 Siemens

When in double traction, pantograph spacing on the Velaro is approximately 656 feet (200 m), or one trainset long. One pantograph is used for normal 8-car operations; however, two

---

are used for coupled trainsets. Siemens stated that it is not necessary to isolate the pantographs because there is only one pantograph used for each trainset. The pantograph contact force depends on the speed of the vehicle. This force is adjusted by fins or by a control unit. The pantographs on the Velaro trainsets are designed by Siemens.

#### **16.1.4 SNCF**

SNCF conducts OCS simulations for studying nominal and perturbed situations and for researching potential optimization techniques. Studying nominal situations enables SNCF to understand better the physics behind HSR operations, and the effects that the trainset pantographs have on the OCS and vice versa. This information is useful in forecasting potential speed increases on the lines. Studying perturbed situations enables SNCF to understand better the defect signatures along with extreme climatic effects. With a prospective viewpoint, SNCF can optimize the catenary system for potential higher speed operations. For example, during the world record run SNCF knew that the pantograph uplift should not exceed 9.8 inches (250 mm) at 357 mph (575 km/h).

SNCF uses the program, OSCAR, to evaluate catenary and pantograph contact. This program can simulate the effects of pantograph and OCS contact under a variety of different scenarios, including:

- Broken hangers
- Pantograph wear
- Contact wire wear
- Defective pantograph suspension
- Ice and crosswind effects
- Vehicle motion.

The output from this program includes pantograph position (longitudinal, transverse, and vertical), velocity, and contact force as a function of time.

Finite element analysis is used for catenary modeling. Numerical modeling is used for pantograph modeling because of the several levels of complexity and the different applications. OSCAR performs simulations from a 3D perspective. Figures 16.1 and 16.2 show that the results from the OSCAR analyses for contact forces and steady arm uplifts, as encountered by the TGV at 186 mph (300 km/h) on the LGV Atlantique line are close to the measured results. Figure 16.3 illustrates monitoring of pantograph and OCS interaction.

**Figure 16.1 Comparison of Actual Measurements and OSCAR Simulations for Contact Forces Encountered on Part of the LGV Atlantique with a TGV Operating at 186 mph (300 km/h) Using a CX Pantograph**

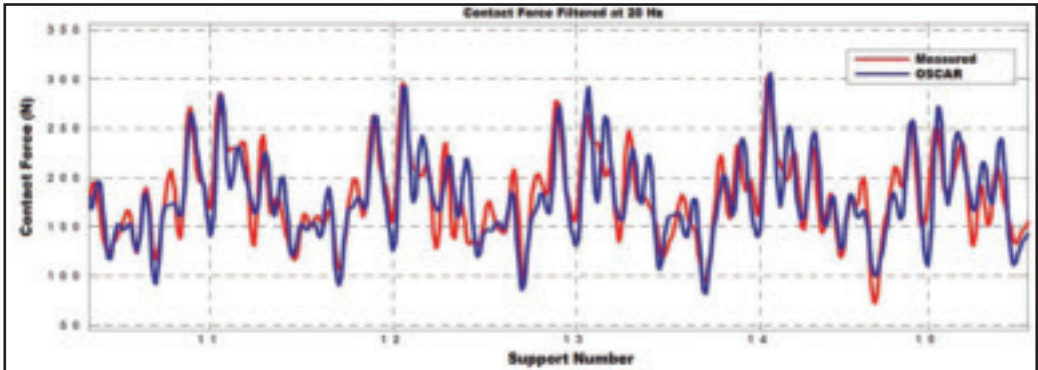

Source: SNCF Presentation, "Electric Traction Interfaces," June 2010

**Figure 16.2 Comparison of Actual Measurements and OSCAR Simulations for Steady Arm Uplift Encountered on Part of the LGV Atlantique with a TGV Operating at 186 mph (300 km/h) Using a GPU Pantograph**

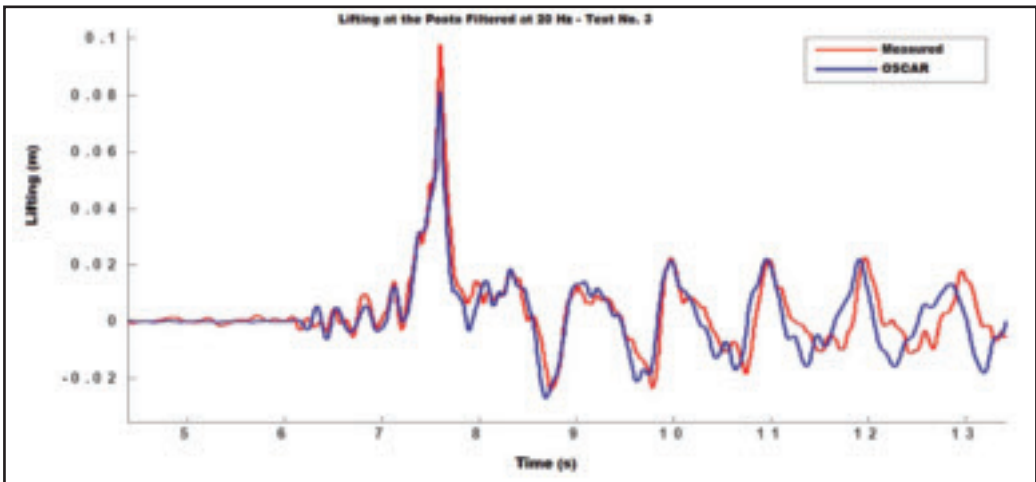

Source: SNCF Presentation, "Electric Traction Interfaces," June 2010

---

**Figure 16.3 Monitoring of Pantograph and OCS Interaction**



Source: SNCF Presentation, "Electric Traction Interfaces," June 2010

OSCAR is certified up to a speed of 242 mph (390 km/h) in accordance with EN 50318, and it can be used for catenary systems with or without stitch wiring. SNCF advised that stitch wiring is no longer used in France for maintenance reasons. It is also possible to use the software to simulate the effects of using multiple pantographs when in double traction.

OSCAR can be used also to simulate interoperability (i.e., trainsets running in environments present in other countries, including different power systems and catenary setups). This capability enables SNCF to evaluate its pantograph performances while operating trainsets in those countries.

### **16.1.5 Alstom**

Alstom advised that each pantograph is independent of the other when in double traction.

## **16.2 PANTOGRAPH OPERATING RANGE**

### **16.2.1 CSR**

CSR advised that the working range of the pantographs is:

- 43 inches to 63 inches when the trainsets are operating at speeds of 124 mph to 249 mph (1100 mm to 1600 mm at speeds of 200 km/h to 400 km/h)

- 
- 35 inches to 102 inches when the trainsets are operating at speeds of less than 124 mph (900 mm to 2600 mm at less than 200 km/h).

The maximum reach of the pantograph from the top of rail ranges from 17.4 feet to 21.3 feet (5,3 m to 6,5 m).

### **16.2.2 Hyundai Rotem**

Hyundai Rotem advised that the catenary height is 16.7 feet on conventional lines and 15.1 feet on high speed lines (5,1 m and 4,6 m respectively).

### **16.2.3 Siemens**

The working range of the pantograph on the Velaro extends to 21.3 feet (6,5 m) (maximum 22.3 feet (6,8 m)) above the top of rail. A contact height of 23.0 feet (7,0 m) is possible; however, Siemens made the point that a higher pantograph will adversely affect the aerodynamics of the trainset.

## **16.3 PANTOGRAPH COLLECTOR HEAD CONFIGURATION**

### **16.3.1 Alstom**

In France, a 57.1-inch (1450-mm)-wide collector head is used for lines with 25 kV AC, and a 76.8-inch (1950-mm)-wide head is used for 1.5 kV DC and 3 kV DC. Alstom recommended using a 63.0-inch (1600-mm)-wide collector head. Alstom added that it is always better to have a lighter pantograph because of its dynamic effects on the catenary, such as the waves generated in the overhead wire.

### **16.3.2 CSR**

CSR advised that pantograph collector head widths of 76.8 inches and 78.0 inches (1950 mm and 1980 mm) can operate normally at 249 mph (400 km/h) and can conform to the L2 envelope criteria specified in EN 50367.

### **16.3.3 Siemens**

Pantograph collector heads in Germany are 76.8 inches (1950 mm) wide, while in the rest of Europe they are 77.2 inches (1960 mm) wide. Siemens advised that the pantograph head and the contact strip designs are project-specific; however, the pantographs are generally designed for speeds of up to 249 mph (400 km/h). The Velaro pantograph head meets the L2 envelope criteria specified in EN 50367. The Velaro pantograph (Figure 16.4) uses contact strips that have a small channel filled with air pressure. When the strip is damaged, the air is lost and the pantograph drops via a spring. The pantograph contact strips are designed for approximately 62,000 miles (100 000 km). The pantographs are inspected during the 5,000-mile (8000-km) bogie inspection.

---

**Figure 16.4 Velaro E Pantograph Interface with Contact Rail at NERTUS Facility**



Source: WBPF Photograph, February 2010

## **16.4 MINIMUM/MAXIMUM OCS VOLTAGE**

### **16.4.1 Alstom**

Alstom advised that very high speed trains in Europe draw four different line voltages:

- 15 kV, 16.7 Hz
- 25 kV, 50/60 Hz
- 3 kV DC
- 1.5 kV DC.

### **16.4.2 CSR**

CSR advised that the optimal performance voltage of the OCS is 22.5 kV to 27.5 kV.



---

### **16.4.3 Siemens**

Siemens advised that a nominal line voltage of 25 kV, 60 Hz is the preferred voltage/frequency. The minimum OCS voltage for 90 percent performance is 22.5 kV. The maximum OCS voltage for full performance is 30 kV.

## **16.5 NEUTRAL SECTIONS (PHASE BREAKS)**

### **16.5.1 Alstom**

Alstom advised that when an AGV trainset enters a neutral section—an insulated section located typically between two separate electric lines fed from separate sources to prevent the mixing of out-of-phase supplies (also known as a phase break)—the PMMs go into a regenerative mode automatically to supply the DC bus. With ASMs, it is possible to reenergize the motor with the battery. [PMMs are discussed in more detail in Section 6.1.]

### **16.5.2 Siemens**

Siemens advised that when the main circuit breaker is open, the batteries will supply enough power for the motors to regenerate the energy necessary for the auxiliary systems.



---

# CHAPTER 17 BRIDGES AND TUNNELS

## 17.1 DYNAMIC EFFECTS ON HSR BRIDGES

### 17.1.1 SNCF

SNCF advised that HSR bridges are designed to:

- Tolerate minor deformations and vibrations caused by passing trains
- Accommodate resonance
- Require little maintenance
- Exhibit good behavior in fatigue.

**Deformation and Vibration.** SNCF advised that the static load model (UIC 71 as defined in EN 1991-2), which has been used since the 1970s, consists of one to four pairs of wheels, each spaced 5.3 feet (1,6 m) apart and producing a downwards vertical force of 56.2 kips (250 kN). A distributed load of 5.5 kips/foot (80 kN/m) is applied 2.6 feet (0,8 m) from each side of the first and last pair of wheels.

The loads applied to the bridge by the successive axes of the trainset, which can be described as periodic loading, initiate a forced periodic vibration of the deck (Figure 17.1). SNCF advised that the effects of the resulting dynamic excitations must be accounted for in the design of railway bridges. The frequency of the resulting excitation is 4.62 Hz at 186 mph (300 km/h) and 5.2 Hz at 218 mph (350 km/h), values not normally seen on bridges on conventional rail lines. These values also reflect the fact that the amplitude of the vibrations depends on the speed of the train, which factors into the maximum deflection—the higher the velocity of the train, the greater the deflection.

**Figure 17.1 Periodic Loading of a Railway Deck**

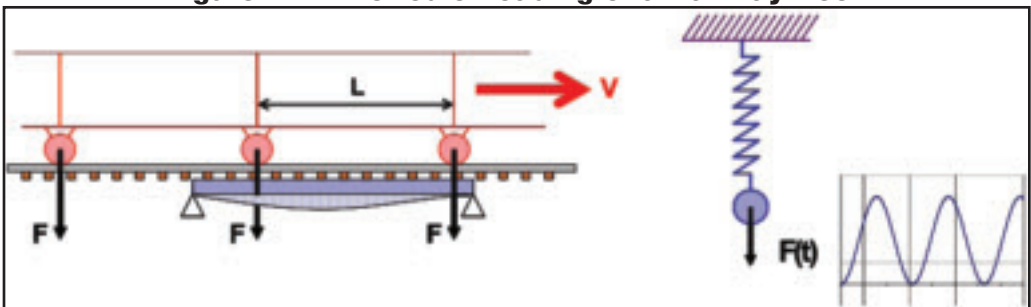

Source: SNCF Presentation, "Interfaces Infrastructure/Rolling Stock," June 2010

**Resonance.** Resonance on the bridge is a function of the loading frequency and the natural frequencies of the bridge. Risks of resonance include the following three:

- Loss of contact between the wheel and the rail (if maximum acceleration in the deck is approximately 1 g)
- Loss of transverse resistance in the case of ballasted track (if maximum acceleration is greater than 0.7 g)

- 
- Amplification of forces and stresses in the bridge.

For bridges with spans of less than 98.4 feet (30 m), the interaction of the trainset and the bridge will reduce the effects of resonance.

**Dynamic Effects.** SNCF advised that the aggressiveness of each train/load model is estimated by plotting the Fourier transformation of the exciting force (signature) as a function of speed and frequency. The standards used to account for the dynamic effects are EN 1991-2 Section 6.4 and EN 1990-A1, which provide the criteria to determine whether a dynamic analysis is necessary. If required, the standards provide a hypothesis on the method to go about conducting such an analysis and define the acceptance criteria regarding the bridge's dynamic behavior for the analysis. Such criteria include the fixing of:

- The maximum acceptable peak acceleration of the deck
- The maximum deformation of the deck
- Enhanced static loads and fatigue effects.

For the high speed load model:

- According to EN 1991-2 Annex D, for speeds under 124 mph (200 km/h), 12 real trains have to be considered. For speeds over 124 mph (200 km/h), two universal train designations with variable coach lengths have been developed to account for all existing and future trains:
  - High Speed Load Model A: for small contiguous bridges or bridges with spans of more than 23.0 feet (7 m), the model involves a 10-car trainset with its bogies, separated by their wheelbase, generating specific downward forces
  - High Speed Load Model B: for simple bridges with spans of less than 23.0 feet (7 m), the model involves the bogies, separated by their wheelbase, generating a downward load of 38.2 kips (170 kN) per bogie
- With each load model, the maximum limits that the deck could resist are:
  - Acceleration: 0.35 g for ballasted track and 0.5 g for others
  - Twist: 0.06 inch per 9.8 feet (1,5 mm per 3 m) for a trainset velocity greater than 124 mph (200 km/h)
  - Rotation: limited by a 0.4-inch (10-mm) maximum horizontal movement between the deck and the abutment.

One must also consider the influences of track defects and vehicle imperfections.

**Variation of Stresses.** SNCF advised that with the dynamic effects of passing trains, the variation of stresses incurred on the structure is greater than that those expected from static calculations, giving rise to the fact that additional fatigue damage may occur. The fatigue analysis takes into consideration the time history of the stresses, corresponding stress cycles, traffic hypothesis for the bridge, and global amount of damage (via the Palmgren-Miner method). Using the case of the new Perpignan-to-Figueres high speed line as an example, the following factors are considered for HSR lines:

- Bridge design life: 100 years
- Trains encountered: TGV (double traction)

- 
- 75 trains per day per direction
  - 5 percent of the time with trains passing on the bridge
  - 50 percent of the time running at the commercial speed and 50 percent at the nearest critical speed.

SNCF advised that the new developments on the dynamics of railway bridges consider very high trainset speeds (greater than 199 mph (320 km/h)). On the 357 mph (574 km/h) world record run, the train operated over various bridge types that were designed to accommodate 261 mph (420 km/h) runs. The following observations were made:

- The bridges exhibited good behavior; thus, the trainset speeds for normal operation could be increased.
- The models used for dynamic calculations gave results that were comparative with actual measurements.

SNCF stated that the stiffness of the viaduct differs from the stiffness of the land that track is laid on, so a transition between the track on land and the track on bridges must be carefully integrated.

## **17.2 TUNNEL CROSS-SECTIONS, BLOCKAGE RATIOS, AND PRESSURE WAVES**

*The design of tunnels, especially the cross-sectional area of tunnels, is a key point for integration with the trainset, the operating plan, and the surrounding environment. The tunnel cross-sectional area needs to take into consideration the tunnel length, maximum operating speed through the tunnel, and trainset aerodynamic characteristics. The pressure waves generated by a trainset traveling into and out of a tunnel can adversely affect the trainset carbody in the form of fatigue cracking and may result in a sound wave (i.e., sonic boom) being generated. The high cost of tunnels needs to be balanced with the operating plan so that an efficient solution can be realized.*

### **17.2.1 MOR**

MOR advised that bridges and tunnels make up 67 percent of the 664-mile (1069-km)-long Wuhan-to-Guangzhou High Speed Railway. All tunnel engineering for this line was completed in 3.5 years. Tunnel cross-sections on the line are typically 1,722 square feet (160 m<sup>2</sup>) or more. The effective cross section area after lining is up to 1,076 square feet (100 m<sup>2</sup>), which is larger than the standard 754-square-foot (70-m<sup>2</sup>) area for conventional railway tunnels. Trains are capable of passing each other in the tunnels at 218 mph (350 km/h).

### **17.2.2 Hyundai Rotem**

Hyundai Rotem advised that the bridge/tunnel-to-mainline ratio on Korea's new Gyeongbu Line is 70 percent. The single-bore, double-track tunnels for the Gyeongbu and the new Honam Lines were designed initially to have a cross-sectional area of 1,152 square feet (107

---

m<sup>2</sup>). The cross-sectional area of these tunnels will be decreased to 1,023 square feet (95 m<sup>2</sup>), however, because of the requirement for more economic construction.

### **17.2.3 Siemens**

Siemens advised that single track, single bore tunnels are usually 27.9 feet to 29.5 feet (8.5 m to 9 m) in diameter and 1.2 miles to 1.9 miles (2 km to 3 km) in length. The blockage ratio is the cross-sectional blockage of the tunnel by the train. There are two methods of reducing the pressure variation inside tunnels:

- Operate at lower speeds inside the tunnels.
- Increase tunnel cross-sectional area.

Siemens advised that tunnel cross-sectional areas can be as large as 1,238 square feet to 1,292 square feet (115 m<sup>2</sup> to 120 m<sup>2</sup>) when close to the critical tunnel length (i.e., the tunnel length that produces the highest train-induced pressure variation, dependent on train speed and train length for a given trainset and tunnel cross-sectional area). Siemens recommended using only single-track tunnels because of the pressure pulses developed by high speed trains. An incident occurred in Germany when high speed trains were first developed and shared tunnels with freight trains, in which the pressure pulses generated by the high speed trains shifted the containers on the freight trains.

### **17.2.4 SNCF**

SNCF noted that the main factors to consider when designing HSR tunnels include:

- Tunnel length, portal configuration, geometry
- Train speed, profile, and sealing characteristics
- Tunnel and train interaction, or blockage ratio, which is defined as the train cross-sectional area divided by the tunnel cross-sectional area.

SNCF advised that tunnel pressure waves consist of the following (also illustrated in Figure 17.2):

- Compression wave, caused by the train head's entry into the tunnel
- Expansion wave, caused by the remaining train's entry into the tunnel
- Depression, caused by wave reflections at the portals.

**Figure 17.2 SNCF Tunnel Aerodynamics Curve – Test/Simulation Validation**

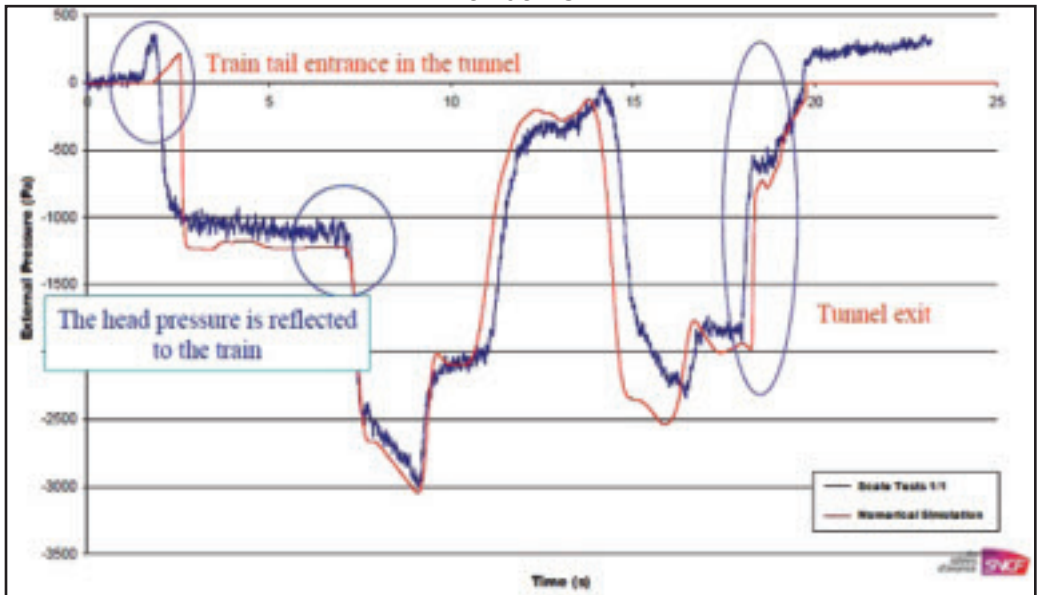

Source: SNCF Presentation, "Tunnel Aerodynamics," June 2010

SNCF advised that the air flow inside the tunnel involves the acceleration of the air column (piston effect) when the train enters and travels through the tunnel. The induced high air speed around the train has an influence on rolling stock and tunnel equipment (e.g., doors, cable supports, signals, etc.). When the train first enters the tunnel, energy is emitted at the tunnel exit as a pressure microwave. There is a risk of a sonic boom if the microwave amplitude is greater than 0.004 psi (25 Pa). This wave is dependent on the roughness of the tunnel, which is also influenced by the use of slab or ballasted track. SNCF advised that the risks of a sonic boom are higher with slab track. Mitigation techniques involve considerations for the portal and track designs, and installation of potential absorbers.





---

# CHAPTER 18 HIGH SPEED RAIL CORRIDORS AND WAYSIDE PROTECTION

## 18.1 DEDICATED VS. SHARED TRACK

### 18.1.1 Hyundai Rotem

Hyundai Rotem advised that the KTX system was intended to be fully dedicated since the beginning of HSR in Korea. A new Seoul station was located 12.4 miles (20 km) south of the old station for this reason. Because Korea had an economic crisis, however, its high speed lines were developed together with conventional lines to save the cost of constructing new tunnels. HSR trains operate at a limited speed of 93 mph (150 km/h). Korea encountered several challenges to making the existing lines interoperable between high speed trains and conventional trains. Two such challenges were associated with the signaling system and the OCS. Solutions were developed to design these systems to be compatible with both types of rail operations. Between Daejeon and Daegu are 12.4 miles to 18.6 miles (20 km to 30 km) of shared track.

### 18.1.2 Korail

In Korea, the authors witnessed operations of mixed traffic operating over shared track while at the Busan station platform, including:

- Electrical locomotive hauled coaches
- Diesel locomotive hauled coaches
- Electrical locomotive hauled freight
- KTX-I high speed trains.

This can be considered one of the most diverse shared-track operations currently in service with HSR trainsets.

## 18.2 HIGH SPEED RAIL INSTALLATION

### 18.2.1 MOR

MOR advised that continuously welded rail (CWR) is installed over the entire HSR mainline. Double block, non-ballasted track is used for the mainline. Each CWR section for the Wuhan-to-Guangzhou line is 1,640 feet (500 m) long. Length, precision, and quality of long welded rail and turnouts are factors critical to ensuring smooth running of high speed trains.

MOR advised that there is one temporary slab track batch plant (Figure 18.1) every 50 miles to 62 miles (80 km to 100 km) for a section of a HSR line. The location of these plants limits transport to approximately 25 miles to 31 miles (40 km to 50 km) in each direction. Once

---

the section is done, the plant is moved further down the line. The plant is capable of producing 80 plates every 24 hours. Each plate's rail seat is ground at the batch plant to suit the profile of the section of line that it will be used on.

**Figure 18.1 Interior of the Slab Track Batch Plant**

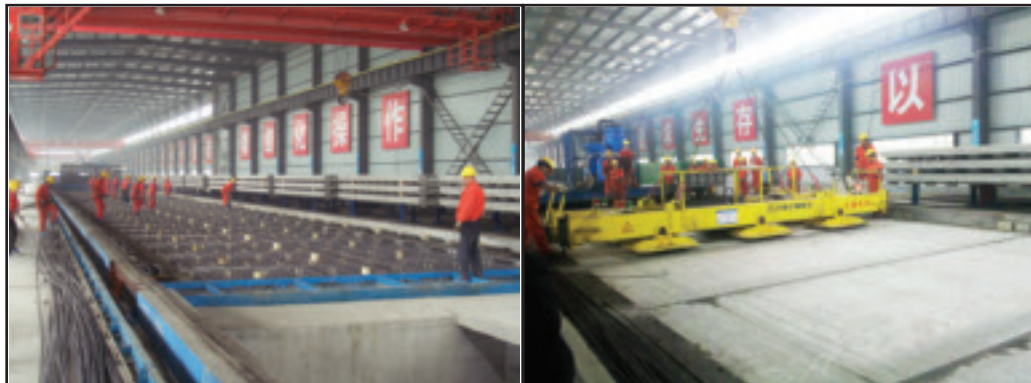

Source: WBPF Photographs, November 2010

### **18.2.2 CRCC**

CRCC advised that sub-grade settlement control techniques were key to construction of the Wuhan-to-Guangzhou line. CRCC created a series of scientific design and construction measures to ensure that sub-grade settlement after construction is less than 0.2 inch (5 mm) and uneven settlement in the transition sections is less than 0.08 inch (2 mm). These measures surpass the requirements of 0.6 inch and 0.2 inch (15 mm and 5 mm) respectively in the design standards.

The Wuhan-to-Guangzhou line runs through complex terrains and topographies with numerous geological conditions. It features 169 groups of non-ballasted turnouts. CRCC applied two types of track turnout technologies, slab, non-ballasted; and long sleeper buried, non-ballasted.

### **18.2.3 Hyundai Rotem**

Hyundai Rotem advised that the rail sections used in Korea for high speed are 984 feet (300 m) long and continuously welded.

---

## **18.3 WAYSIDE PROTECTION DEVICES**

### **18.3.1 Alstom**

Alstom advised that wayside safety measures for the new TGV high speed lines (above 125 mph (201 km/h)) include:

- Access controlled right of way
- Catch nets and detectors for falling objects from overpasses and bridges
- Intrusion detection
- No at-grade crossings
- Crosswind monitoring [see Alstom's and SNCF's discussions in Section 5.7] and earthquake monitoring.



---

## **PART 4: MAINTENANCE AND OPERATIONS**

---

---

# CHAPTER 19 TRAINSET INSPECTION AND MAINTENANCE

*A comprehensive and effective inspection and maintenance program is critical to the safe and efficient delivery of HSR service. Such a program will provide assurance that trainsets are maintained to a high standard of readiness and compliance with U.S. federal regulations. A common theme emphasized by operators of HSR systems was that the safety of the system relies upon proper maintenance. Otherwise stated, if one forgets about maintenance, there is no safety.*

*In the U.S., it is typical to establish inspection and maintenance programs using calendar-based milestones. The authors met with manufacturers and operators to gain insights on this approach and other recommended milestones, such as mileage and operating hours, inspection and maintenance activities, and preventative maintenance regimes, and on those attributes that are specific to HSR operation.*

## 19.1 INSPECTION AND MAINTENANCE OVERVIEW

### 19.1.1 Alstom

Alstom implements an integrated logistic support (ILS) process, and advised that ILS is a key contributor to the trainset system performance. As a result, ILS is an integral part of the trainset specification.

Alstom has more than 15 years of experience in rail system maintenance and is comfortable in committing to up to 30 years of total train life management. For example:

- In 1992, Alstom agreed to full maintenance of AVE trains in Spain for 24 years. These trainsets include:
  - 18 AVE TGV-A high speed trains that operate between Madrid and Seville at 186 mph (300 km/h)
  - 6 Euromed high speed trains that operate between Valencia and Barcelona at 137 mph (220 km/h)
  - 20 Siemens locomotives S/252
  - 1 wreck train
  - 1 control measuring car.

The scope includes:

- Comprehensive maintenance and cleaning of the rolling stock
- Mid-life overhaul
- Components repair and replacement
- Management of three depots
- 100 percent availability.

- 
- In 2004, Alstom agreed to full maintenance of 53 Pendolino trains in the UK for 22 years. The scope includes:
    - Comprehensive maintenance of the rolling stock.
    - Maintenance and technical support for all rolling stock on the West Coast Line.
    - Availability of 47 trains daily and 48 trains on weekends.
    - Reliability of approximately 9,900 miles (16 000 km) per 5-minute delay required and achieved. This was increased to approximately 25,000 miles (40 000 km) per 5-minute delay in 2008.
  - In 2006, Alstom agreed to full material management of 20 Acela trains for 10 years.
  - In 2008, Alstom agreed to full maintenance of the 25 AGV trains in Italy for 30 years.
  - In 2010, Alstom agreed to the interior and exterior modernization of 18 AVE trains.

The various themes in the ILS process include:

- Maintenance engineering:
  - Breakdown into line-replaceable units
  - Design for serviceability
  - Life cycle cost
  - Maintenance plan
- Support system deliverables:
  - Maintenance documentation
  - Spares and inventory procurement and management
  - Test equipment and tool specification and validation
  - Training and technical assistance
  - Workshops (facilities, networks, tools).

Alstom's approach to designing for serviceability is to give easy access to trainset components so less time is needed to remove and refit them. For example, for the AGV the traction motor can be dropped without the need to drop the entire bogie. In addition, by using integrated traction components (e.g., electrical and hydraulic connectors), maintenance workers can access the respective components from the exterior of the train. Additional benefits include reductions in weight and volume.

Life cycle cost is the forecast of all the current and future costs incurred during the life cycle of the product. Alstom explained that buyers seeking to purchase a trainset are usually thinking foremost about the acquisition cost. This cost is only a small portion of the costs that will be incurred over the trainset's lifetime, however, and the cost of operation, maintenance, unavailability, and discarding should also be considered.

Alstom currently uses condition-based maintenance and remote train monitoring (with TrainTracer) to assist in advancing HSR maintenance approaches. An example of condition-based maintenance is the overhead monitoring system, which includes laser interferometry, laser flight time, and linear opto-sensor systems that help to obtain information on the panto-



---

graph life and the behavior of the OCS. The overhead monitoring system includes a dynamic model of the catenary system; however, it does not monitor, for example, the thickness of the carbon strip.

TrainTracer (Figure 19.1) supports various activities spanning through operations, maintenance, train validation and commissioning, and warranty and reliability growth. With TrainTracer, real-time data can be transmitted for monitoring and maintenance planning purposes to improve the overall fleet performance. Key benefits include:

- Monitoring key train components and alerting of potential faults
- Early warnings on critical onboard events
- Fleet management and arbitration support
- Increase in maintenance operation productivity
- Monitoring of dynamic commercial service events
- Anticipation of corrective maintenance
- Increase in reliability through analysis of historical and current data.

**Figure 19.1 TrainTracer Remote Monitoring**

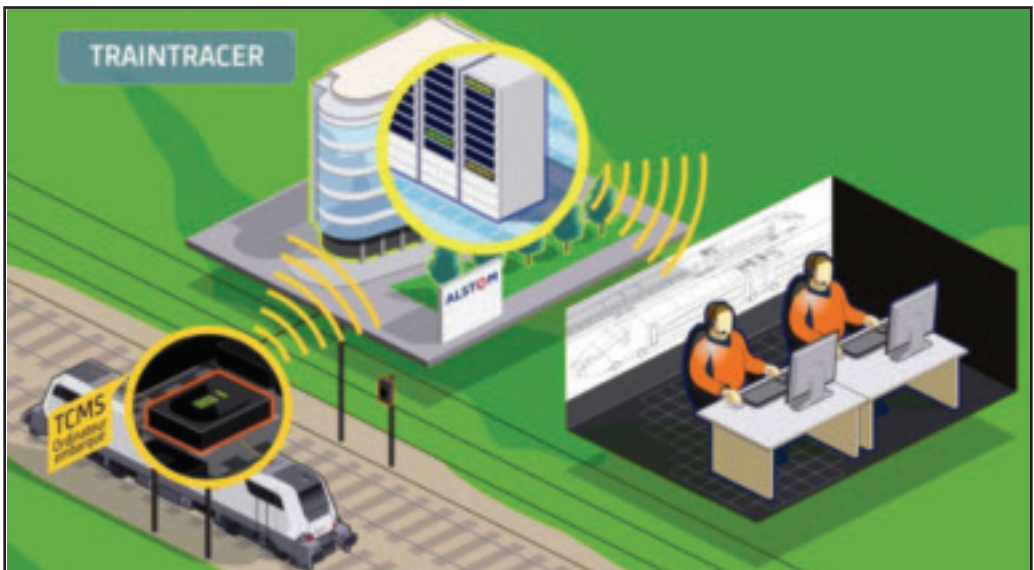

Source: Alstom Presentation, "Train Life Services – Integrated Logistic Support: Contributions to Operators' Performance," June 2010

Alstom advised that using TrainTracer helps to improve the availability of the trainset and reduce the downtime for maintenance. As an example, on the UK's West Coast Main Line:

- At 6 a.m. Train 023 leaves Carlisle with tilt failure.
- At 8 a.m. the train monitoring log is downloaded and the tilt failure is diagnosed. The information is then transmitted to the Wembley Depot.

- 
- At 11 a.m. the maintenance crew has the necessary tools and parts and is waiting at the depot for the train's arrival.
  - At 12 p.m. the train is placed back into service.

Alstom introduced the 30-year global service contract that it has with NTV. Alstom will conduct all NTV rolling stock maintenance services. These services include preventative maintenance, corrective maintenance, development of a maintenance plan, repair and modification of train components, spare parts management, train assistance along the network, and management of the Nola maintenance depot. NTV personnel will perform quality assurance and will audit Alstom's maintenance practices.

### **19.1.2 Korail**

Korail advised that its main maintenance facility, the Goyang Maintenance Depot, is 321.2 acres (130 ha) in area. There is a total of 24.9 miles (40 km) of rail length in the depot.

### **19.1.3 NTV**

NTV's \$117-million (€90-million) Nola maintenance facility was designed by Alstom, who was also responsible for overseeing/supervising construction of the depot to ensure compliance with the original design. NTV stated that its goal is to focus on providing service for its customers. While NTV owns the facility and pays for the construction costs, Alstom manages the facility during operations and provides the 220 employees who work there. The total area of the facility is 34.6 acres (14 ha) and it has 3.7 miles (6 km) of track. The five main sections and two specialized plants are as follows:

- F1: Train wash, emptying of toilets, sand refill, and wheel diagnostics
- F2: Inspection and maintenance
- F3: Warehouse
- F4: Maintenance garage for components removed from the trains
- F5: Lathe for wheel reprofiling
- Track building
- Substation.

### **19.1.4 Siemens**

Siemens emphasized that the operators invest in trainsets to have them in operation and not in maintenance and depots. Therefore, a highly optimized maintenance system is needed to realize the true value of HSR.

The diagnostic systems for Siemens' high speed trains greatly enhance the availability of the fleet by reducing the maintenance effort and ensuring a short maintenance standstill time (Figure 19.2). These systems continuously monitor the train's functions and immediately identify any deviation from normal operation. Siemens advised that those parts that are not monitored automatically (pantographs, brake shoes, etc.) are included in the inspection process via

programmed maintenance schedules. The system is standardized for the operator independent of the vehicle type. There is a difference in the information that is displayed to the driver and the maintenance worker. For example, the driver will get a message if a door fails to close; the maintenance worker will get a message detailing the sensors that failed. The diagnostic system is also designed for manual fault inputs (e.g., entered by the train manager). The faults are radioed ahead to the maintenance facility so that all parts can be readied prior to the train's arrival. The driver receives a report every morning on the results of all the tests conducted by the train during warm stabling at night.

**Figure 19.2 Maintenance Management Systems for the Velaro**

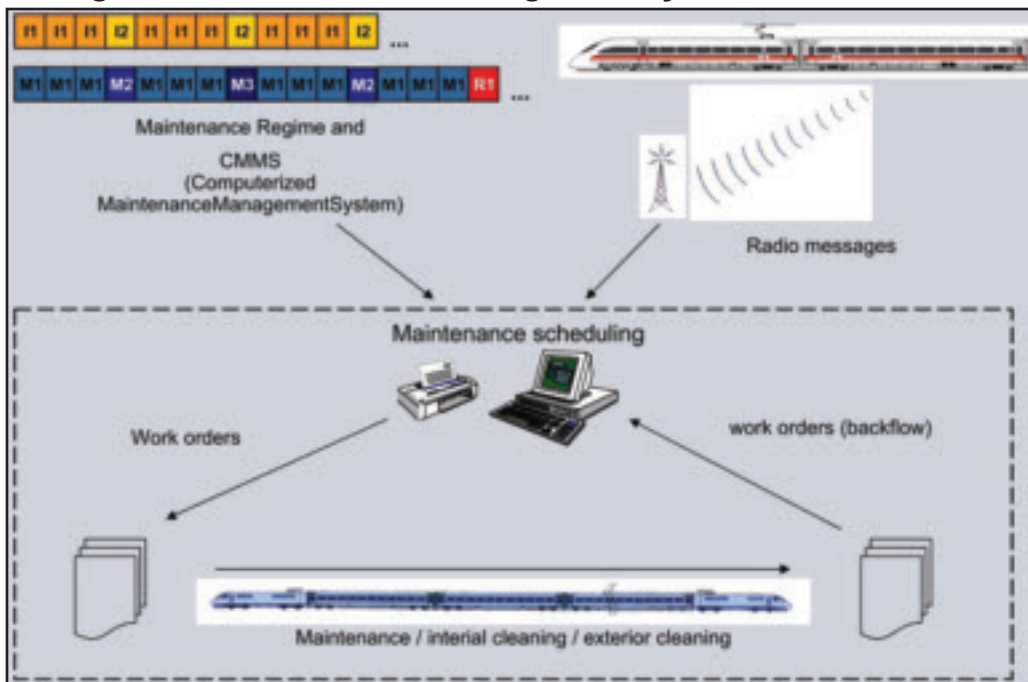

Source: Siemens Presentation, "Velaro Maintenance," February 2010

Siemens advised that the most critical elements (e.g., hollow axle monitoring) are inspected and tested during regularly scheduled maintenance intervals, and the results are recorded. DB had an accident two years ago in Cologne due to a cracked axle. The speed of crack propagation within an axle is currently under scientific study. When there is a bogie overhaul, the wheelset is replaced and the axle is tested with magnetic particle equipment. Ultrasonic tests on the axles are also completed and recorded with automatic equipment. DB has established specific checks for inspecting wheelsets.

Siemens is continually improving the diagnostic/feedback capability for its current operating trainsets to improve their reliability. Its project maintenance and design engineering teams are working together to deliver a diagnostic solution with high performance. It also holds discussions with operators to ensure that the new diagnostic platform caters to all of the operator's needs.

---

### 19.1.5 NERTUS

Representatives of Siemens and NERTUS introduced the Santa Catalina, Spain Maintenance Facility. NERTUS's customer is Renfe Operadora AVE. The scope of the NERTUS contract is to provide complete maintenance of the trainsets for a 15-year period. The NERTUS operation started in June 2007 and is expected to continue through May 2022. NERTUS uses maintenance management systems based on the Maximo and SAP platforms.

The first units of the Velaro E trainsets reached the end of their 3-year/621,000-mile (1-million-km) warranty in January 2010. An extended warranty for 4 years/932,000 miles (1,5-million km) is provided for HVAC and bogie components.

### 19.1.6 SNCF

SNCF advised that the main objective of maintenance is to support business by providing passenger comfort and safety, train availability and punctuality, and optimized costs. In 1980 the TGV-PSE only had one maintenance depot. New, additional depots were constructed as the fleet and the high speed system grew. SNCF currently has four depots in Paris and one in Lyon that are specialized for the TGV. In addition, other depots that were used to perform services on conventional trains were transformed in the early 2000s to accommodate TGVs as well. Although one fleet was specialized to one depot initially, today maintenance can be conducted at any facility in the country. SNCF believes this type of maintenance system helps to optimize trainset availability.

Among the new depots was the TGV Technicentre located 3.1 miles (5 km) from Paris' Gare de l'Est. It began operation in 2007 after the LGV Est line was constructed to accommodate travel between Paris and Strasbourg. Since then, 52 TGV-R trainsets have been renovated at this Technicentre (19 international and 33 domestic). Each has been outfitted with the new Christian Lacroix interior [Section 19.6.7] and each has been upgraded to accommodate 199 mph (320 km/h) operation. The trainsets are also equipped with ERTMS Level 2, which is currently an overlay over the existing train control system. This Technicentre contributed to the AGV trials on the LGV Est line at 218 mph (350 km/h) and trials for the TGV Duplex at 224 mph (360 km/h).

A similar facility was constructed in Lyon in 2006. SNCF advised that the four tracks installed initially in the Gare de Lyon station to provide maintenance after the Lyon-Paris trip are no longer needed, and that maintenance is now done in the depot after approximately every 3,100 miles (5000 km). SNCF pointed out that it had been expensive to provide maintenance staff at the station.

SNCF advised that there are jacks in the depot to lift the entire trainset. SNCF emphasized that the capability to lift the entire trainset is more efficient when removing multiple pieces of equipment at one time (Figure 19.3).

The two main goals of the TGV Technicentre are:

- **Adherence to travel schedule.** Availability of trainsets is optimized through an analysis of maintenance requirements for forecasted service rosters of trains depart-

---

ing from Gare de l'Est, and adaptations needed during exceptional peak periods. SNCF advised that it is essential to always have a trainset available for service when needed.

- **Performance of maintenance.** Maintenance operations include preventative operations (e.g., examinations, inspections, cleaning) and corrective actions (e.g., breakdown and accident repairs). SNCF strives to maintain a 50/50 ratio of preventative-to-corrective maintenance. SNCF also emphasized the need to have redundancy, adding that train service cannot be delivered reliably without a prescribed level of redundancy built into the operating plan. If the level of redundancy was insufficient, an unscheduled maintenance incident could affect the maintenance strategy because the trainset would have to be taken out of service.

**Figure 19.3 Trainset Lift Arrangement at SNCF Technicentre**



Source: SNCF Presentation, "Rolling Stock Maintenance Policy," June 2010

SNCF prides itself on its incorporation of feedback based on maintenance experience and the resulting improvements in maintenance rules and technical upgrades. A technical report is generated for every maintenance operation that is performed. This report is a legal requirement by the French Railway Safety Authority (EPSF) and, in the event of an accident, SNCF must be able to provide proof that the maintenance was performed correctly. SNCF states that there can be differences between the manufacturer's recommendations, which set out the basis for the maintenance required, and SNCF's experiences. SNCF has found that actions outside of the manufacturer's maintenance scheme might be required to either increase a trainset's availability throughout its life cycle or to meet legal requirements. Furthermore, SNCF strives to perform inspection and maintenance activities early to prevent bottlenecks in its schedule. Inspectors from the safety department check on whether or not the maintenance rules are followed.

SNCF has metrics in place that help its staff determine whether or not a trainset is suitable for service. For example, if there is an air conditioning defect in the cab or in a coach and the train is full, the train will not run. (If there is such a defect in a coach and the train is not full, the train master will have the passengers move to different cars.) These metrics are linked to reports by crew members who discover the faults. SNCF stated that improvements in reliability are developed based on the feedback from operations personnel.

---

SNCF advised that the train driver is never in direct communication with the maintenance center. In fact, in France, drivers are forbidden to communicate with anyone other than the train crew and the operations control center. If a technical failure is detected, notification can be forwarded to the depot in advance of the train's arrival via the train control GSM-R radio. The requirement that drivers communicate with the operations control center was established because those who are in charge of maintenance are not trained to drive the trainset, so they might lead the driver to perform an unsafe action. SNCF emphasized that solutions used in the depot might not work when the trainset is in operation. If a failure occurs en route, the driver can consult a maintenance guide on the monitor to determine how to continue forward (e.g., impose a speed restriction). If necessary, a team of specialists located in the operations control center can assist the driver with any troubleshooting needs.

The staff in the depot can view faults in real time while the trainset is in operation. This provision of continuous data enables them to determine the seriousness of the fault and when the maintenance should be made, and to schedule the needed maintenance. Information of any faults is stored in the onboard computer and can be viewed by the driver before starting the train. The GSM-R-based train control radio used to forward information to the maintenance depot can also locate the train to check for potential delays and forward speed restrictions to the driver in real time.

### **19.1.7 SRB**

SRB advised that four main EMU maintenance centers are located in China (Beijing, Shanghai, Guangzhou, and Wuhan). Each maintenance center has its own characteristics; however, the maintenance standards followed are the same. The Beijing EMU Maintenance Center has an area of 296.5 acres (120 ha). SRB has 126 EMU trainsets (168 8-car trainsets in all), 69 218-mph (350-km/h) trainsets, and 7 types of trains (CRH1B, CRH1E, CRH2A, CRH2B, CRH2C, CRH3C, and CRH380A). Daily operations include 182 round trips.

SRB advised that in addition to the four EMU centers, trains are serviced in seven work-shops (Shanghai South, Nanxiang, Nanjing, Hangzhou, Hongqiao, Nanjing South, and Hefei South) and one heavy maintenance center in Nanxiang. The Nanxiang facility features a storage yard, the operations and inspections yard, and the advanced maintenance yard. It has:

- 4 lines in the inspection shop
- 8 lines in the maintenance shop
- 1 line in the dynamic testing zone.

The heavy maintenance facility has a debug shop, three-layer inspection shop, bogie shops, assembly and disassembly shops, carbody inspection shop, and painting shop:

- The debug shop can hold two trainsets per track.
- After an entire trainset is lifted, the bogies are removed and pushed out from underneath (Figure 19.4). This is performed approximately every 373,000 miles (600 000 km). The height of the lifting can be adjusted based on various requirements.



- 
- The bogie line permits dismantling of the bogies, cleaning, and inspection. Robotic stations also assist in conducting the maintenance.
  - The inspection line for the wheelsets permits gearbox inspections, bearing inspections, ultrasonic inspection, magnetic particle inspection, and cleaning.

**Figure 19.4 CRH Maintenance Depot Showing Trainset Lift/Bogies Removed**



Source: CRH Presentation, "Introduction of SR EMU Operation and Maintenance," November 2010

The other workshops have temporary and permanent inspection shops and storage yards. They undertake mainly Levels 1 and 2 maintenance and small/temporary repair works [Section 19.6.8]. Other facilities at these workshops include:

- Wheelset tread and pantograph inspection devices. Wheelset tread measurements/dimensions are conducted by a camera. The data is collected and transmitted to the depot. Another camera measures the thickness of the pantograph contact strips.
- Carwash facility.
- Three-layer working platforms that permit simultaneous inspections of the underfloor; windows, doors and interiors; and roofs (Figure 19.5).
- Ultrasonic inspection equipment for wheels.
- Hollow axle inspection devices.
- Underfloor wheel lathes.
- Ground power supplies. (The driver's cab is inspected and the trainset interior is cleaned when the power is on.)

---

The goal of the maintenance program is to effectively predict/prevent defects from occurring while the trainset is in service.

SRB advised that trainset errors are forwarded to the depot in real time. The information can also be downloaded once the train enters the depot. Parts are stored and obtained by an automated system.

**Figure 19.5 CRH Maintenance Depot Showing Three-Layer Working Platform**



Source: CRH Presentation, "Introduction of SR EMU Operation and Maintenance," November 2010

## **19.2 MAINTENANCE COSTS PER MILE**

### **19.2.1 Alstom**

Alstom advised that trainset maintenance usually costs \$3.90 to \$6.50 per mile (€3 to €5 per km) per train. These values stem from the trainset life cycle costs and include, for example, the maintenance of the depot. Alstom advised that the maintenance costs of a trainset during its life cycle is about 1.8 times that of the purchase cost. Bogie maintenance represents approximately 30 percent to 40 percent of the trainset maintenance cost.



---

Alstom advised against specifying different units (imperial and metric) of fasteners on a trainset. This type of configuration would require two sets of tools in the depot and lead to inefficiencies and increased maintenance costs.

### **19.2.2 Siemens**

Siemens advised that DB keeps its cost of maintenance confidential. However, an investigation of the costs of maintenance of high speed systems (e.g., TGV, ICE 3) including servicing, cleaning, etc. is covered in the report, *Some Stylized Facts about High Speed Rail around the World: an Empirical Approach*. The information presented is based on UIC data. In Spain, NERTUS gets paid per kilometer. Additional costs to NERTUS are possible depending on the reliability of the trainsets.

### **19.2.3 SNCF**

SNCF stated that the daily, weekly, and monthly maintenance represents half of the total maintenance costs. SNCF advised that the annual cost of spares used are inclusive in the maintenance costs, and that they represent approximately 50 percent to 60 percent of the total maintenance cost.

The SNCF rolling stock fleet includes:

- 467 very high speed trains with 1,162 miles (1870 km) of high speed lines
- 1,081 EMUs
- 981 DMUs
- 1,644 electric locomotives
- 1,342 diesel locomotives
- 1,015 shunting locomotives
- 6,275 coaches
- 53,000 freight cars.

Maintenance has \$3.1 billion (€2.4 billion) turnover (annual expenditure) with 28 maintenance depots, 70 production sites, and 24,000 staff members. SNCF also has a highly qualified technical center and a testing and commissioning center.

The fleet life-cycle cost includes:

- Specification for the trainsets
- Tender for the trainsets
- Development of the trainsets
- Testing and commissioning
- Fleet introduction
- Engineering (\$67.6 million (€52 million) per year)

- Light maintenance (\$1,551 million (€1193 million) per year)
- Spares, overhaul, and repair (\$429 million (€330 million) per year)
- Overhaul (\$152 million (€117 million) per year)
- Transformation, illustrated in Figure 19.6 (\$416 million (€320 million) per year)
- Scrapping and recycling.

**Figure 19.6 TGV Undergoing Major Refurbishment is Prepped for Paint (left) and Newly Painted (right)**



Source: SNCF Presentation, "Rolling Stock Maintenance Policy," June 2010

Key figures for SNCF's very high speed train fleet are as follows:

- 92 percent availability for peak hours
- More than 800 train trips traveled per day
- Approximately 323,000 miles (520 000 km) traveled per day
- Approximately 118 million miles (190 million km) traveled per year
- Average travel of approximately 255,000 miles (410 000 km) per trainset per year
- Maintenance cost of \$650 million (€500 million) for its 467 very high speed trains.

Engineering involves studying technical failures and R&D (e.g., to implement the new ERTMS system or to increase line speed). Between the tender and scrapping phases, there is a return on experience from internal and external operations, the safety authority (EPSF), and the infrastructure provider. Interaction also occurs between the operator and the trainset and component suppliers.

## **19.3 EFFECT OF SLAB OR BALLASTED TRACK ON ROLLING STOCK MAINTENANCE COSTS**

### **19.3.1 Alstom**

Alstom does not have experience operating high speed trains on slab track, so its repre-

---

sentatives did not know how slab track would affect rolling stock maintenance costs. It advised that maintenance costs are incurred due to ballast impacts, but that this issue would be more relevant to track maintenance costs than to rolling stock costs.

### **19.3.2 Korail**

All new HSR projects in Korea will use slab track. Hyundai Rotem stated that this decision was made due largely to the decrease in track maintenance costs.

### **19.3.3 Siemens**

Siemens advised that the information is not readily available because all trainsets in Germany operate on both ballasted and slab tracks. In snow conditions, however, ballast pickup becomes an issue and can lead to vehicle damage.

### **19.3.4 SNCF**

SNCF operates mostly on ballasted track; therefore, it does not have enough experience in operating over slab track to comment on the difference. SNCF is preparing to launch a study regarding the use of slab track; however, it does not anticipate much impact on the rolling stock itself. SNCF stated that, as a party to a public-private partnership, it will be operating on a new line that includes 43.5 miles (70 km) of slab track. From its experience, SNCF found the investment in slab track to be 1.6 times that for ballasted track.

## **19.4 RELIABILITY, AVAILABILITY, AND SERVICE DUTY OF TRAINSETS**

### **19.4.1 Alstom**

A train's availability will be affected by the major overhaul performed at its midlife; however, Alstom stated that an average availability of 97 percent can be expected over the entire life of a train. Of the 25 AGVs ordered by NTV, two to three trainsets are spares. (Alstom stated that 95 percent availability is acceptable with a larger fleet of trainsets.) A 97 percent intrinsic technical availability of the trainsets is required (based on a 124 mph (200 km/h) commercial speed), with intrinsic technical availability being equal to:

$$\text{operating time} / (\text{operating time} + \text{maintenance time}).$$

Alstom advised that intrinsic availability depends on the train design, maintenance preparation, depot equipment, and the workforce present. Operational availability is dependent on intrinsic availability, shift patterns, and the supply chain performance.

---

## 19.4.2 NTV

The status of the NTV fleet will be monitored continuously by onboard crew and the NTV control room (Figure 19.7). Any irregularities will be forwarded wirelessly to the Nola depot. Alstom advised that by using a telematic system it can also monitor in real time the status/diagnostics of items that are not monitored automatically by the train. The availability of the trainsets per day can be seen on a panel in the control room. The functionality of various car systems, including climate control, illumination, communication, etc. can also be viewed. For the onboard system, items such as door failures can be monitored.

**Figure 19.7 Real-Time Monitoring of AGV Trainset Status**



Source: NTV Presentation, "NTV: The Company and its Italo Service," June 2010

## 19.4.3 SNCF

SNCF advised that the close relationship between operations and maintenance includes determining whether it is more efficient to offer fewer trainsets for the same amount of service or to offer the same number of trainsets with increased service. A goal of the engineering department is to develop a modular maintenance plan, while a goal for the SNCF Centers for Excellence is to provide methods on how to go about and adhere to the plan. Rolling stock operators are responsible for co-designing the plans with the engineering department and the Centers for Excellence.

SNCF's technical studies include continuous research into maintenance improvements that will enhance performance with the potential to decrease costs. The process begins with maintenance rule design, which consists of analyses on technical aspects, costs, safety, customer needs, and return on experience. The rule is then applied and the depots monitor the return

---

on experience. Based on this experience, new practices evolve and new rules are explored. Safety and quality audits and standards are in place to prevent decreases in performance or increases in costs.

SNCF emphasized that the supply chain is a key component for operations and maintenance. A constant supply of spare parts is essential for effective and efficient maintenance because it eliminates time lost for lack of spares and enables operators to increase the availability of its fleets. SNCF currently has 108,000 part references in stock valued at \$455 million (€350 million). Approximately 2,800 transfers of spare parts occur each day (\$2.6 million (€2 million)), and 275,580 tons (250 000 tonnes) of spare parts are transported each year. In 2008, support and logistics for the transport and movement of spares cost \$148 million (€114 million). SNCF emphasized that it is also necessary to account for and provide spares for future use because some could become harder to find or might no longer be available.

Several key stakeholders can impact the efficient supply chain and sufficient spare pool as follows:

- Industrial organizations, engineers, and logistics specialists conduct statistical analyses and forecast the amount of spares needed.
- Logistics specialists focus on the correct amount of stock and find methods to improve their transfer.
- Industrial organizations continually search for improvements.

Staff size must be considered also. It is important to optimize the use of staff against potential revenue lost, and increase staff size if needed.

SNCF strives for 92 percent peak availability and 85 percent off-peak availability. Current availability is 83 percent during weekday periods and 92.3 percent during weekends. SNCF stated that Friday to Sunday is considered peak, and that during this time only four to five trainsets are unavailable. During the week, nine trainsets are unavailable. Trainset availability is maximized by the majority of the maintenance being done at night at a depot that takes into consideration the location and time of the following morning's departure.

The 2010 targets for reliability per 621,000 miles (1 million km) are 9 failures for domestic operations and 20 failures for international operations (more complications with newer equipment and different international systems). SNCF defines failures as those that result in more than 5 minutes of delay. SNCF advised that there must be a balance between reliability, cost of maintenance, and availability while maintaining safety.

SNCF stated that there is no real limit regarding the number of annual miles to be traveled for each trainset. This criterion depends on the operational constraints. For example, in France, the TGV is not always on high speed lines. On average, however, each trainset travels approximately 255,000 miles (410 000 km) per year.

#### **19.4.4 Siemens**

In typical high-speed operations, Siemens' trainsets travel approximately 249,000 miles to 311,000 miles (400 000 km to 500 000 km) per year. Each Velaro E trainset has an annual

---

mileage of 311,000 miles (500 000 km). Increases to annual mileage of, for example, 435,000 miles (700 000 km) is possible, but the trainsets would require additional inspections and/or maintenance operations. Siemens calculated that the ICE 3 runs for 311,000 miles (500 000 km) per year on both slab and ballasted track. Siemens advised that the maintenance schedule is based on experience depending on the conditions of the line. Siemens stated that the goal of maintenance is to ensure maximum availability of the trainsets for daily operation. As a result, most of the maintenance is completed overnight.

Siemens advised that equipping trains with intelligent diagnostic systems to support the computerized maintenance management system greatly reduces time for failure identification and reduces the downtime for corrective maintenance. This advantage includes radio messaging, which is part of an optimized material management system. Information about the failure is radioed to the maintenance shop so that parts can be organized and available prior to the train's arrival. The failure messages can be relayed by the driver manually via the train radio, or automatically by a predetermined milestone, such as train location. Typically, the manufacturer clarifies with the customer what the best fault message trigger conditions are.

#### **19.4.5 NERTUS**

Typically, four trainsets are out for maintenance at any time. Two are usually at the maintenance facility in Santa Catalina and two at the facility in La Sagra. In addition, Renfe keeps two trains reserved for operational availability partly because, in accordance with the NERTUS joint venture terms, the entire fleet must be available (i.e., 100 percent availability) for service a minimum of 29 days each year (i.e., 8 percent of the time). NERTUS commented that the larger the fleet, the smaller the spare ratio, as there is more opportunity to spread inspection and maintenance intervals. The NERTUS fleet has accumulated approximately 14.6 million miles (23,5 million km) since June 2007. It makes 54 service runs per day with 20 trainsets typically in service at any time. On the Madrid-to-Barcelona line, 26 trainsets travel 606,000 miles (975 000 km) per month (equivalent to 280,000 miles (450 000 km) per train per year). NERTUS anticipates that the usage will increase to 342,000 miles (550 000 km) per train per year.

NERTUS aims to increase reliability to 684,000 miles (1,1 million km) between service delays. A question was posed to NERTUS as to whether or not reliability is monitored based on subsystem performance (i.e., failure of a subsystem that may not result in a service delay). NERTUS responded that if the train runs but not all systems are working (e.g., door control issue, toilet malfunction, HVAC malfunction), Renfe will consider the train unavailable for service and a financial penalty will result. A second question posed to NERTUS was about how Renfe will know when a failure occurs en route. NERTUS responded that the train crew, who are Renfe employees, keep track of any failures and report them to maintenance personnel.

#### **19.4.6 SRB**

SRB advised that trainsets typically run 373,000 miles (600 000 km) per year at speeds of 124 mph to 155 mph (200 km/h to 250 km/h) and 186 mph to 218 mph (300 km/h to 350 km/h).

---

## **19.5 LIFE CYCLE OF THE VEHICLE STRUCTURE**

### **19.5.1 Alstom**

Alstom advised that the TGV Duplex for the LGV Sud-Est has a 30-year life cycle, but that the trainsets can last for up to 40 years.

### **19.5.2 SNCF**

The calculated life cycle of the vehicle structure is 30 years. SNCF checks the structure during every mid-life overhaul at 15 years.

### **19.5.3 CSR**

CSR advised that the life of the trainset is 20 years, citing that the short life cycle is due mainly to fatigue. The 20-year life is based on operational service experience from all (comprehensive) high speed lines in China. For a life of 30 years for the CRH380A, China advised that one must consider the conditions for a specific line to verify that the design could accommodate that particular line.

### **19.5.4 SRB**

The life cycle of the CRH380A is 20 years.

### **19.5.5 Siemens**

The calculated life cycle of the Siemens' Velaro D vehicle structure is 30 years  $\pm$ 10 percent depending on mileage.

## **19.6 FREQUENCIES OF INSPECTION, MAINTENANCE, AND LIGHT AND HEAVY OVERHAULS**

*Manufacturers and operators were asked to identify the frequencies of inspections, maintenance, and light and heavy overhauls. It is noted that the mileage equivalents identified in this section are approximations.*

### **19.6.1 Alstom**

Alstom advised that the recommended inspection, maintenance, light and heavy overhaul frequencies are dependent on the design for serviceability. By using a "component-based maintenance" process, downtimes can be reduced and trainset availability can be increased.

---

The maintenance plan for the TGV Duplex includes the following tasks and associated down times:

- Servicing:
  - Servicing every 3,100 miles (5000 km): 1 hour
  - Toilet dumping every 3 days: 1 hour
- Preventative maintenance:
  - Service exam every 3,100 miles (5000 km): 3 hours
  - Trainset vitals visit (i.e., inspection and test protocol) every 37,000 miles (60 000 km): 8 hours
  - Limited visits every 233,000 miles (375 000 km): 32 hours
  - General visits every 466,000 miles (750 000 km): 64 hours
  - In depth general visit every 932,000 miles (1,5 million km): 80 hours
- Mid life overhaul:
  - Mid life overhaul every 5.1 million miles (8,25 million km) or 15 years: 3 weeks to 1 month depending on customer's needs
- Wheels and brakes:
  - Truing for the motor bogie wheels every 93,000 miles (150 000 km): 6.7 hours
  - Truing for the trailer bogie wheels every 217,000 miles (350 000 km): 9.3 hours
  - Wheel replacements for the motor bogies every 932,000 miles (1,5 million km): 4.8 hours
  - Wheel replacements for the trailer bogies every 932,000 miles (1,5 million km): 6.7 hours
  - Brake pad replacements every 109,000 miles (175 000 km)
- Corrective maintenance:
  - After the third year of the trainset life, corrective maintenance is conducted every 3,100 miles (5000 km)
  - For failures that affect the operation of the trainset, corrective maintenance is performed every 621,000 miles (1 million km): 4 hours down time.

Alstom added that hollow axle inspections are conducted every 19,000 miles (30 000 km) for the AGV primarily to gain experience in determining the appropriate mileage-based inspection interval.

Alstom advised that the pantograph contact strip thickness is inspected every 3,100 miles (5000 km) during the general service. Alstom is looking into the possibility of conducting this inspection every 4,700 miles (7500 km), but noted that the 3,100-mile (5000-km) interval will most likely remain unchanged to avoid introducing an additional maintenance cycle. In-service pantograph monitoring is done via an air pressure signal in place to detect breakage of the pantograph carbon strip.



---

## 19.6.2 NTV

NTV advised that it will implement five levels of inspection/maintenance:

- Level 1: Conducted by the driver during service through automated equipment status inquiries
- Level 2: Operational inspection every 4,700 miles (7500 km), which is every 4 days and takes 3 hours  
Inspection of mechanical components every 19,000 miles (30 000 km)
- Level 3: Reduced general inspection every 233,000 miles (375 000 km)  
General inspection every 466,000 miles (750 000 km)  
More in-depth general inspection every 932,000 miles (1,5 million km)
- Level 4: Limited replacements/modifications every 1.9 million miles (3 million km)  
General replacements/modifications every 3.7 million miles (6 million km)
- Level 5: Overhaul.

NTV advised that cleaning is one of the most important aspects of train maintenance, adding that according to market research, passengers consider trainset cleanliness to be as important as punctuality. Cleaning of NTV's trainset interiors is subcontracted out, while that of trainset exteriors is performed by Alstom. The NTV model target for cleaning is based on SNCF experiences and Japanese philosophies. The cleanliness of the trainset is controlled by:

- Sample controls
- Unannounced visits onboard the trains by NTV representatives
- Customer satisfaction inquiries
- Technical controls (visual and instrumented inspections)
- Certification of process and products used by the cleaning providers
- Surveillance of the trains during stabling.

NTV has implemented six levels of cleaning:

- L1: Cleaning during commercial service on the Florence-to-Bologna line
- L2: Cleaning in stations at the start and end of each trip, or in terminal stations twice a day
- L3: End of the day cleaning in the terminal stations or in the maintenance depot
- L4L: Cleaning in the maintenance depot every 4 to 6 days
- L4H: Cleaning in the maintenance depot every 30 to 60 days
- L5: Deep cleaning in the maintenance depot every 1 to 1.5 years.

The inspection/maintenance plan recommended by Alstom for the NTV service is conservative because of the unknowns of Italian conditions. For example, if wheels/rails are subjected to less-wearing conditions, then the frequency for wheel reprofiling can be reduced.

---

### 19.6.3 Korail

Korail advised that every night there is a check-in process for each HSR trainset. Wheels are inspected automatically and reprofiled if necessary. For inspections and repairs, fault codes can be downloaded. Toilet and interior cleaning is conducted at the depot. Braking and function tests are performed prior to departure.

Korail has four levels of maintenance:

- Daily
- Periodic: 2 weeks, 1 month, 3 months, 6 months, 1 year
- Component replacement
- Overhaul: beginning at 8 years.

### 19.6.4 Siemens

Siemens provided an overview of its maintenance program as follows:

- **Inspections:** Visual inspections of bogies, brake systems, pantographs, heat exchangers of cooling systems, etc., are completed during the normal overnight downtime of the trainset. They last approximately 1 to 2 hours.
- **Scheduled (Preventative) Maintenance:** Mileage-based or time-based maintenance intervals for changing oil in the gearboxes, replacing filter pads in cooling systems, bearings or other components, etc. as mentioned and required in the maintenance documentation. Siemens advised that the best approach is to perform preventative activities overnight, and that such activities take approximately 6 to 8 hours.
- **Unscheduled (Corrective) Maintenance:** Unplanned maintenance resulting from a failed door, broken component, etc. is typically performed while the trainset is out of operation during the night. Siemens advised that it is prudent to use this time for all scheduled and corrective maintenance activities.
- **Overhauls:** Intervals of "heavy maintenance" for replacement and refurbishment of bogie components, brake systems, air conditioning, etc. Depending on the boundary conditions (i.e., fleet size), Siemens recommended a balanced maintenance approach under which a scheduled overhaul program is divided into several activities instead of one large activity. This approach prevents the need to remove trainsets from service for extended periods of time. In addition are redesigns/overhauls of trainset interiors, which most operators do after 15 years.

Siemens advised that DB has depots in Hamburg, Frankfurt, and Munich to maintain the ICE 1, ICE 3, and ICE T trainsets. A depot in Leidschendam also maintains the ICE 3, and a depot in Berlin maintains the ICE 2.

The maintenance plan for the Velaro D, without implementation of balanced maintenance methods (Figure 19.8), is as follows:

- I1: Every 5,000 miles (8000 km) or every 2.5 to 5 days; lasts less than or equal to 1.5 hours

- I2: Every 15,000 miles (24 000 km) or every 2 weeks; lasts less than or equal to 5 hours
- M1: Every 62,000 miles (100 000 km) or every 2.5 months; lasts less than or equal to 14 hours
- M2: Every 249,000 miles (400 000 km) or every 9 months; lasts less than or equal to 20 hours (components)
- M3: Every 497,000 miles (800 000 km) or every 1.5 years; lasts less than or equal to 22 hours (toilet system)
- R1: Every 994,000 miles (1,6 million km); lasts greater than or equal to 1 day and includes changing several parts of the bogie, overhauling the brake systems, overhauling the ATP system (e.g., antennas), overhauling the gearboxes and wheel bearings, etc.
- R2: Every 2 million miles (3,2 million km); lasts 4 to 5 days, and includes overhauling the entire bogie, decoupling the entire trainset to change coupler components, etc.
- R3: Every 3 million miles (4,8 million km), a special kind of R1 that includes the door systems.

**Figure 19.8 Siemens Velaro Maintenance Regime Prepared for "Balanced Maintenance"**

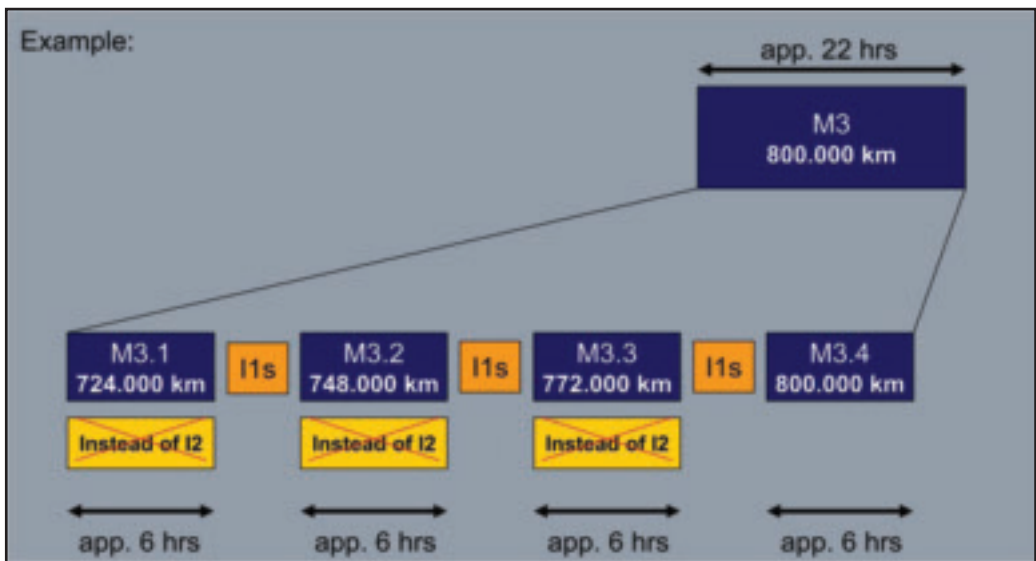

Source: Siemens Presentation, "Velaro Maintenance," February 2010

Using a balanced maintenance approach, maintenance activities are divided into smaller work packages, with these work packages performed at a greater frequency. Siemens advised that the philosophy in Europe is to check the bogies every 5,000 miles (8000 km). During these inspections, the maintenance workers check the brakes, gearboxes, traction motors, discs, wheels, and axles for damages. Typically, wheel reprofiling is done every 124,000 miles

---

to 155,000 miles (200 000 km to 250 000 km). All dimensions of reprofiled wheelsets are cataloged and stored. This information enables the maintenance staff to quickly identify for rapid change out a wheelset having the required (i.e., compatible) wheel diameters versus delaying the trainset for wheel reprofiling. Siemens uses hollow axles for weight reduction and cost control purposes. Ultrasonic tests are conducted to inspect the condition of the axles without removing the wheelsets from the bogies.

Siemens added that pantograph contact strips are designed for 62,000 miles (100 000 km), depending on weather conditions. The contact strip design incorporates a small channel that is pressurized. When the strip is damaged, the air pressure is lost and the pantograph retracts. In addition, the contact strips are checked during running gear inspection at every 5,000 miles (8000 km). To facilitate pantograph inspections, DB shops can move the OCS away from the trainset to provide clear, safe access to the roof mounted equipment. In its Berlin facility, the OCS is mounted on movable rails.

Daily cleaning normally takes 1 hour. A more in-depth cleaning done every 3 months involves closer looks at the seats, changing of pillows, etc., and takes up to 6 hours. An even more in-depth cleaning takes place once a year at 249,000 miles (400 000 km). This cleaning, which includes special carpet cleaning, is usually integrated with the associated maintenance activities.

### **19.6.5 DB**

DB advised that trains go back to a maintenance facility every 3 days for inspections/maintenance. DB harmonizes the schedule for wastewater evacuation with the 3-day inspection cycle, so it advised of the importance of sizing the freshwater/wastewater tanks accordingly. DB added that trash is collected en route.

### **19.6.6 NERTUS**

NERTUS's maintenance facility in Santa Catalina is used primarily for periodic inspections and running maintenance. Its La Sagra facility is used typically for heavy maintenance (levels M1 through M3). As Renfe expands its facilities, it is expected that some of the M1 maintenance will be performed in Santa Catalina as well. NERTUS has a team of 230 people supporting the high speed maintenance operations at these two facilities and in various stations. They perform eight to nine I1 activities each night in Santa Catalina. A total of 10 M1 activities can be performed per month in La Sagra. The work orders for the maintenance are allocated based on the analyses of the trainset systems.

Levels of inspection and running maintenance include the following:

- I1: Every 3,100 miles (5000 km), (2 to 3 days); takes approximately 4 to 6 hours
- I2: Every 12,000 miles (20 000 km); takes approximately 8 to 10 hours
- M1: Every 62,000 miles (100 000 km); usually takes 3 days
- M2: Every 249,000 miles (400 000 km)
- M3: Every 497,000 miles (800 000 km)
- R1: Every 746,000 miles (1,2 million km).

---

I1 inspection/maintenance was done every 2,500 miles (4000 km) in the first year. This interval was selected to develop a baseline of performance. It was increased to every 3,100 miles (5000 km) in the second year. NERTUS is seeking to increase the I1 interval to every 5,000 miles (8000 km). If this is achieved, NERTUS would have two additional trainsets available for service. These step-by-step increases in the distances traveled between inspection/maintenance are based on operating experience with the line. Several Velaro E trainsets are finishing their first cycle of M3 maintenance and are starting the initial key systems overhaul phase (R1).

Wheel changes are expected at 994,000 miles to 1.2 million miles (1,6 million km to 2 million km); bearing changes are expected at 746,000 miles (1,2 million km). Wheel reprofiling normally takes 48 hours per trainset. NERTUS's equipment reprofiles one wheelset at a time, but NERTUS advised that a dual wheelset reprofiling operation is highly desirable.

Toilet dumping is done during each I1 maintenance. Water filling is done in the station every time a train enters Barcelona. Sand refilling is done in Santa Catalina.

## 19.6.7 SNCF

SNCF advised that its two principles to maintenance are preventative and curative (corrective). Preventative maintenance involves several operations completed systematically based on mileage or time. The goal of preventative maintenance is to prevent any major issues on the lines. Curative maintenance involves technical faults or failures encountered by the trainset during revenue service. SNCF stated that it was important to find the correct balance between preventative and curative maintenances.

SNCF implements five main levels of maintenance:

- **Level 1:** Basic service performed prior to trainset operations. This service includes daily checks (e.g., brakes, etc.) by the driver, who has a checklist to go through during train preparation for departure. This routine takes approximately 10 minutes, and the train is included in the train roster (trainsets available for service) during this type of maintenance.
- **Level 2:** Checks and maintenance performed at maintenance depots. In the service exam, faults or failures are examined and corrected and the trainset is cleaned. These activities are completed by the maintenance staff, and the train is included in the train roster for this type of maintenance.
- **Level 3:** Periodic activities performed on the trainsets. The train is taken out of commercial service and the maintenance work is performed by the depot staff. The train is removed from the train roster for this type of maintenance.
- **Level 4:** Mid-life trainset and components overhaul. This type of maintenance is performed at an SNCF Technicentre every 15 years. During this overhaul, the entire carbody structure is checked. SNCF focuses also on installing modular elements during overhauls because of the overhauls' effects on revenue service. For example, it is less costly to replace fabrics than to wash them continually.
- **Level 5:** Modernization or refurbishment of the trainset. Level 5 includes implementation of ERTMS for Thalys trainsets. This type of maintenance is also performed at an SNCF Technicentre.

---

SNCF stated that approximately 180 TGV trainsets were refurbished over a 6-year period. Recent refurbishments include redesign by the firm of renowned French designer, Christian Lacroix, along with technical studies and industrial work performed by SNCF. Customer feedback on the Lacroix refurbishments was very positive, with passengers stating that it provided a new image for very high speed trains (Figure 19.9). They felt that comfort was greatly increased with larger interior spaces. SNCF feedback on the Lacroix refurbishment was that the trainset looked brand new. SNCF advised that it is now willing to perform such maintenance every 5 to 10 years instead of every 15 years.

The last refurbishment of the Eurostar was done in 2005. It took 1 year to complete, and SNCF was actively involved. The next refurbishment is scheduled to be conducted in 2012. SNCF stated that refurbishments were needed to offset competition from airlines and other rolling stock operators. During the last refurbishment, the Eurostar trainsets were modified to provide hot meals.

**Figure 19.9 Lacroix Interior for TGV Trainsets**



Source: SNCF Presentation, "Rolling Stock Maintenance Policy," June 2010

The development of the maintenance plan changes based on the operator's experience. SNCF stated that every year, a 2 percent increase in productivity was gained with 40-year-old rolling stock. The following information provides a comparison between SNCF's maintenance plan during 1999 and 2009:

- Every 3,100 miles (5000 km) the train returns to the depot for an ES (service exam), a Level 2 operation. This generally involves a visual inspection of the top and sides of the vehicle.
- After 8 days the train returns to the depot for an ECC (comfort examination: seats, air conditioning, etc.), a Level 2 operation.
- After 18 days (1999) the train returns to the depot for an ATS (systematic work involving other components), a Level 2 operation. This interval was extended to after 22 days by 2009.
- After 37 days the train returns to the depot for an ECF/EMN (comfort and mechanical examination—bogies, pantographs, etc.), a Level 2 operation.
- After 52 days the train returns to the depot for an ATS1, a Level 2 operation.
- After 104 days (1999) the train returns to the depot for an ATS2, a Level 2 operation. This interval was extended to after 168 days or 140,000 miles (225 000 km) by 2009.
- After 7 months or 149,000 miles (240 000 km) (1999) the train returns to the depot for a VL (limited visit). This interval was extended to after 10 months or 280,000 miles (450 000 km) by 2009.

- 
- After 13 months or 267,000 miles (430 000 km) (1999) the train returns to the depot for a VG (general visit). This interval was extended to after 19 months or 559,000 miles (900 000 km) by 2009.
  - After 25 months or 597,000 miles (960 000 km) (1999) the train returns to the depot for a GVG (in-depth general visit). This interval was extended to after 37 months or 1.1 million miles (1,8 million km) by 2009.

Wheel reprofiling is conducted every 311,000 miles (500 000 km) (this interval used to be every 62,000 miles (100 000 km)). SNCF stressed the importance of vehicle track interaction and the bogie design for stability and preventative maintenance. The linkages in the trailer bogies are replaced every 5 years or 1.2 million miles (2 million km).

Every 2 days (maximum 3 days), the toilets are discharged and refilled. Eurostar has a requirement that if the two PRM toilets are disabled, the trainset cannot be used in service.

SNCF advised that cleaning represents 30 percent of the total maintenance costs and that this job is outsourced.

The deputy manager at the Technicentre is in charge of quality, safety (legal implications), and overall management. The Technicentre staff includes:

- 100 employees in logistics support
- 100 employees in train products
- 400 employees in production
- 120 employees in cleaning.

### **19.6.8 SRB**

SRB advised that preventative maintenance on the EMUs is divided into five levels, and that Levels 1 and 2 are performed in the workshop when the trains are stabled overnight. These levels include visual inspections, ground equipment tests, and onboard system tests, and are when most faults are repaired and eliminated to ensure reliability and safety of the trainset.

- **Level 1:** Non-powered and powered inspections. Non-powered inspection includes inspections and repairs of the roof, carbody side, and underframe. Powered inspections include test of onboard facilities, cab tests, train control management system, and other functions. Each type of inspection takes approximately 40 minutes, and it takes approximately 50 minutes to troubleshoot any issues. The entire maintenance is completed in approximately 2.5 hours.
- **Level 2:** Maintenance of parts and components. This maintenance is performed every 2 weeks and is completed in approximately 4 hours. SRB has established dedicated teams to perform Level 2 maintenance:
  - Cab team inspects the cab and car end wiring, dispatches work to other teams, and manages the maintenance process to improve efficiency.

- 
- Bogie team inspects the traction motors, wheelsets, and springs.
  - HVAC team inspects the HVAC system and distribution box.
  - Pipe/water team inspects the water supply.
  - Electrical team inspects the power supply and auxiliary electrical wires.
  - Doors and windows team inspects doors, chairs, and windows.
  - Non-destructive testing team performs nondestructive testing of bearings.
  - Assistance team assists in changing filters, inspects underframe, and performs side maintenance.
- **Level 3:** The bogies are dismantled, inspected and maintained, and the entire trainset is inspected and maintained. Level 3 takes approximately 25 days and is conducted in the maintenance center.
  - **Level 4:** This level includes disassembly of major trainset components for inspection, testing, and debugging. It takes approximately 35 days. Level 4 differs from Level 3 in that the entire trainset is disassembled. In addition, depending on the condition of the exterior, the trainset may be repainted.
  - **Level 5:** This level includes disassembly of the entire trainset. All components are inspected, tested, and replaced, if necessary. The carbody is also repainted. Most of the heavy maintenance occurs during this stage. The train structure is inspected and the seats are replaced.

The intervals of service depend on the speeds at which the trainsets operate. The CRH2C maintenance cycle based on 155 mph (250 km/h) normal operation includes:

- Level 1: Every 2,500 miles (4000 km) or 48 hours
- Level 2: Every 19,000 miles (30 000 km) or 30 days
- Level 3: Every 373,000 miles (600 000 km) or 1.5 years
- Level 4: Every 746,000 miles (1,2 million km) or 3 years
- Level 5: Every 1.5 million miles (2,4 million km) or 6 years.

The 218 mph (350 km/h) operation maintenance cycle includes:

- Level 1: Every 2,500 miles (4000 km) or 48 hours
- Level 2: Every 19,000 miles (30 000 km) or 30 days
- Level 3: Every 280,000 miles (450 000 km) or 1 year
- Level 4: Every 559,000 miles (900 000 km) or 3 years
- Level 5: Every 1.1 million miles (1,8 million km) or 6 years.

SRB advised that when a train first arrives at the workshop every other day, the wheelsets are inspected automatically, the pantographs are inspected automatically via a camera-based monitoring system and tested via an air pressure signal (Figure 19.10), and the carbody is washed. If the pantograph fails, the driver is notified via a diagnostics monitor in the cab that displays the condition of the pantograph, and the unit is scheduled for maintenance. The train then proceeds to Level 1 and Level 2 inspections. Once these inspections are completed, the train is stored until it returns to service. At the inspection center, the teams and equipment are readied and work is delegated.



---

**Figure 19.10 Automated Wheelset and Pantograph Inspection Site**



Source: CRH Presentation, "Introduction of SR EMU Operation and Maintenance," November 2010

SRB advised that automated pantograph inspection is done when the train passes through the wheel tread and pantograph inspection area. The pantograph is also monitored in-service.

Levels 3, 4, and 5 maintenance procedures are performed at EMU maintenance centers; these include disassembly and exchange of parts. After the items are reinstalled onto the trainset, the equipment on the trainset will be tested in the center. After the debugging process, the trainset will be tested dynamically. After the dynamic test, the trainset is placed into storage prior to departure.

The hollow axles are inspected every 37,000 miles (60 000 km). Typically, bearings are cleaned every 746,000 miles (1,2 million km) and replaced every 1.5 million miles (2,4 million km). The wheelsets are reprofiled every 174,000 miles (280 000 km). The service life of a wheel is anticipated to be 559,000 miles (900 000 km). In addition:

- Every 2 months the wheelsets are inspected with mobile ultrasonic inspection equipment that can detect cracks of less than 0.4 inch (10 mm). This machine is placed on the lower level of the three-layer platforms, from where it is used to inspect the wheel rims and webs. This process takes approximately 30 minutes for each wheelset.
- Every 8 months the wheelsets are inspected by a stationary ultrasonic inspection machine. A prototype wheelset (standard) that contains 32 cracks is used to calibrate the stationary machine.

## **19.7 TRAINSET RELIABILITY AS A FUNCTION OF OPERATOR ENTITY**

*The authors participated in discussions with HSR equipment manufacturers and operators to evaluate impacts to trainset reliability attributed to the structure of the operating organization (e.g., railroad owned/operated, contracted operation, equipment supplier owned/operated).*

---

### **19.7.1 Alstom**

Alstom emphasized that the manufacturer is usually in the best position to sustain trainset reliability in the long term.

### **19.7.2 Siemens**

Siemens advised that modification to its HSR trainset design were based upon operational/maintenance feedback provided by DB.

### **19.7.3 SNCF**

SNCF stated that supplier owned/operated maintenance is not an issue but that the organization responsible for maintenance might not benefit from the operator's experience. SNCF advised that since it started maintaining its own vehicles, productivity has increased by 20 percent. France has in place strong safety regulations pertaining to contracting out the maintenance operation and assuring that compliance to these regulations typically represents half of the total maintenance costs. Adherence to these regulations is more flexible, however, when all of the responsibility is in the hands of one entity (e.g., the operator).

---

## CHAPTER 20 OPERATIONS

### 20.1 ENFORCEMENT OF SPEED RESTRICTIONS

#### 20.1.1 Temporary Speed Restrictions

##### 20.1.1.1 Hyundai Rotem

Hyundai Rotem advised that monitoring systems are located onboard and in the wayside. Information about all abnormal conditions, such as hot rails during summers or inclement weather, is forwarded to the operations control center, which sends a signal to the ATC system. ATC then automatically implements a speed restriction. Voice notification of speed restrictions is used also as a backup.

##### 20.1.1.2 Korail

Korail advised that speed restrictions are implemented typically when there is bad weather or high winds. In the case of wind, for example, wind velocity and direction are measured, and the information is given to the operations control center. The controller evaluates the weather data and identifies the appropriate speed restriction. This speed restriction information is transmitted to the train via the ATC system.

##### 20.1.1.3 Siemens

Siemens advised that temporary speed limits are enforced depending on the operational requirements. These temporary restrictions are communicated via radio for ETCS Level 2 systems or via a signal aspect for ETCS Level 1 systems. When operating from one block to the next, a new movement authority can be given showing the new speed. A new movement authority can also be communicated via the LEU that is connected to the signal aspect. Additional input could be provided by central control, which informs the ATP system of a new speed requirement.

Depending on the operational concept, if the temporary speed restrictions are required for a longer term, then operations personnel can install additional, temporary balises on the track that are programmed with the speed restrictions. These balises will then be removed when the temporary speed restriction is lifted.

##### 20.1.1.4 SNCF

SNCF advised that temporary speed limits are enforced via instructions issued by the operations control center. With ETCS Level 1, temporary speed limits can be enforced by using temporarily-installed balises. With ETCS Level 2, temporary speed limits can be enforced via the RBC. For HSR lines, the operations control center is equipped with a specific tool that feeds speed limit requirements to the RBC, which then transmits the information to the train.

---

## **20.1.2 Maximum Speeds for “Safe” Movement in Yards**

### **20.1.2.1 Alstom**

Alstom advised that an ERTMS Level 1 system is used in the yards.

### **20.1.2.2 DB**

DB stated that shunting in yards is limited to 16 mph (25 km/h). Movements in the yards are also highly dependent on the train protection systems.

### **20.1.2.3 Siemens**

Siemens stated that it is difficult to implement train control rules in yard areas. Speed can be controlled by installing balises (e.g., for wash mode). ATO can also be used in the yards. ATC could be used for speed control within the yard through balises.

### **20.1.2.4 SNCF**

SNCF advised that the maximum speed permitted inside yards is 8.1 mph (13 km/h). Train wash speed is 1.9 mph (3 km/h), and movement inside the shops is limited to 4.4 mph (7 km/h). There is no mode in the train control system for these limits. Drivers control the speed while inside the shops. There are audits to check the train speed during movements inside the depot. For passage through the car wash, the speed is preset and trains travel through on their own power.

### **20.1.2.5 SRB**

In China, train speeds inside the yards are limited to a maximum of 9.3 mph (15 km/h); however, the actual speed is dependent on the tracks in the yard. A 28 mph (45 km/h) limit is imposed for shunting. Train movement through the car wash facility is limited to 1.9 mph (3 km/h) (Figure 20.1). Train movement through the wheelset tread and pantograph inspection facility is limited to 6.2 mph (10 km/h).

**Figure 20.1 CRH EMU Car Wash Facility**



Source: CRH Presentation, "Introduction of SR EMU Operation and Maintenance," June 2010

---

### **20.1.2.6 TSDI**

Drivers operate trains in the yards for SRB. The maximum permitted speed is 25 mph (40 km/h). ATP is present in the yard for the test track. There is no ATP functionality for controlling speed while operating through the train wash facility or for shunting equipment.

## **20.1.3 Roadway Worker Protection**

### **20.1.3.1 Alstom**

Alstom advised that speed is reduced from 199 mph to 186 mph (320 km/h to 300 km/h) in areas where track workers are present on the right of way. When workers are conducting required services on a specific track, no rail traffic is permitted on that track and the speed on the opposite track is reduced to 106 mph (170 km/h).

### **20.1.3.2 TSDI**

When track work is to take place in China, the constructor sends a request to the operations control center, which will send a temporary speed restriction to the RBC. The RBC will then send a movement authority to the vehicles. Also, a lower speed limit can be sent manually from the dispatching center.

Normal track maintenance of HSR passenger dedicated lines takes place between 12:00 a.m. and 5:00 a.m. Shortly after 5:00 a.m. an inspection train is sent onto the mainline to ensure that maintenance activities have concluded and the mainline can be operated normally. Notification of any potential issues is sent to CTCS and the dispatching system. TSDI stated that trains can be diverted to another line, but that doing so affects the normal operations of that line.

## **20.2 END COUPLERS/DECOUPLING PROCEDURE**

### **20.2.1 CSR**

CSR advised that coupling of trainsets is fully automatic. Coupling of the trainsets occurs with one trainset stationary and the other traveling at a maximum of 3.1 mph (5 km/h).

### **20.2.2 Siemens**

Siemens advised that it is possible to disengage the coupler manually by using a handle provided near the coupler head.

---

## **20.3 SPEEDS AT WHICH RESCUED TRAINS TRAVEL**

### **20.3.1 Alstom**

Alstom advised that there is a 62 mph (100 km/h) speed restriction for rescue.

### **20.3.2 CSR**

CSR advised that rescued trains can travel up to 124 mph to 155 mph (200 km/h to 250 km/h) on shared lines and up to 218 mph to 236 mph (350 km/h to 380 km/h) on dedicated lines. Both types of lines can support operation of coupled trainsets depending on passengers and peak times.

### **20.3.3 SRB**

SRB has two methods for rescuing trains:

- It will first use the disabled trainset EMU's redundant power.
- It will use an EMU train to rescue the disabled trainset. Depending on the rescue train's maximum operable speed, rescue can occur at 218 mph (350 km/h). If there is no braking ability on the disabled trainset, speed will be reduced from 218 mph to 99 mph (350 km/h to 160 km/h).

## **20.4 TRAIN TURNAROUND TIME**

### **20.4.1 DB**

DB advised that the shortest turnaround time at a terminal station is 4 minutes. When a train pulls into the station, the next driver is already waiting at the other end of the platform. The turnaround time at a terminal station when maintenance services are provided (e.g., adding water, cleaning trains, etc.) is approximately 2 hours, with 30 minutes provided for equipment transfer time and 1 hour provided for servicing the trainset. This turnaround time does not include time for inspections.

### **20.4.2 Renfe**

Renfe advised that the average turnaround time at a terminal station is approximately 1 hour. The first 10 minutes are for passenger egress. The next 30 minutes is allotted for an 11-person crew to clean a 656-foot (200-m) train and rotate the seats. Approximately 10 minutes are provided for passenger boarding.

### **20.4.3 SNCF**

SNCF advised that the minimum turnaround time at Gare de Lyon is 25 to 30 minutes.

---

SNCF advised that the platform width should be designed to accommodate efficient passenger inflow and outflow within a maximum of 11 to 12 minutes of turnaround time. Eurostar's minimum turnaround time is approximately 55 minutes. At times, SNCF sends trains to depots just to clear the stations. SNCF conducts cleaning onboard the trainset during revenue service to reduce turnaround time.

#### **20.4.4 SRB**

In China, the turnaround time for a 656-foot (200-m) trainset is typically 20 minutes. This includes 4 minutes for passenger egress, 6 minutes for cleaning, and 10 minutes for passenger boarding. While the train is enroute, there are normally two people already aboard each car to assist with collecting garbage. These people also serve as service attendants. At terminal stations, a cleaning crew of three to four people per 8 cars (656-foot (200-m) trainsets) awaits the arrival of the train.

## **20.5 DRIVERS AND TRAIN CREWS**

### **20.5.1 Work Schedules for Train Operators**

#### **20.5.1.1 DB**

DB advised that normally train operators can drive up to a maximum of 4 hours uninterrupted, and that in any day they are permitted to drive a maximum of 10 hours.

#### **20.5.1.2 Renfe**

Renfe advised that drivers operate for 5 to 6 hours per day (e.g., the Barcelona-Madrid-Barcelona run). Drivers can operate for 5 hours, rest for 45 minutes, and then operate for an additional 2.5 hours. Renfe advised that these "hours of duty" are closely tied to the time required to travel between the major termini.

#### **20.5.1.3 SNCF**

SNCF advised that drivers are not permitted to be in the cab for more than 8 hours on any given day. After drivers put in 8 hours, they go home to rest for approximately 10 hours. When they are on the road and away from home, they rest for 9 hours normally, but might be allowed to rest for only 8 hours approximately twice a week. On average, train drivers stay aboard one train for 3.5 hours. On the TGV, however, the time spent onboard typically does not exceed 4 hours to 5 hours.

#### **20.5.1.4 SRB**

China has labor rules by MOR that permit drivers and crew to work a maximum of 167 hours per month. Every bureau can follow this requirement, but can also change it slightly to optimize operation. Drivers typically work no more than 8 hours per day including the time they are in the cab and the time needed to prepare the trainset.

---

## **20.5.2 Work Schedules for Train Crew**

### **20.5.2.1 DB**

DB advised that the length of time that train crews are permitted to stay onboard the train is dependent on German law. Crew members can rest during the train ride in designated resting rooms, so the set of operating rules for them is different from that for drivers.

### **20.5.2.2 Renfe**

Renfe advised that train crews normally work 8 hours per day. Train crews normally arrive 30 minutes before the driver to prepare the trainset (e.g., load/prepare galleys).

### **20.5.2.3 SNCF**

SNCF advised that there is one train manager per train, although sometimes two are onboard for safety and revenue protection reasons. One is always the chief train manager in charge of security onboard the train; the second is an assistant manager, similar to conductors and assistant conductors in the U.S. On the Eurostar, the chief train manager is also capable of operating the train. On sleeping cars, there is usually one train manager for every two coaches and an additional manager for overall security. Train crews work the same hours as the drivers. Train managers, on the other hand, tend to stay longer onboard the trains.

### **20.5.2.4 SRB**

In China, the train crews work the same hours as the drivers.

## **20.5.3 Train Crew Facilities**

### **20.5.3.1 DB**

DB advised that crew members are sometimes permitted to stay overnight at hotels. The lodging expenses are covered by a DB service contract. Crew members are reimbursed for actual costs.

### **20.5.3.2 Renfe**

Renfe tries to return the driver and the crew home. If this is not possible, Renfe has agreements/accounts with various hotels in which the driver and the crew stay at Renfe's expense.

### **20.5.3.3 SNCF**

SNCF advised that typically drivers and conductors do not return home overnight. Labor rules stipulate that drivers and conductors cannot stay on the road longer than they stay at home; however, so they tend to spend one day on the road and one day at home. In the past, each depot had rooms for drivers to rest overnight. Today, SNCF has an account set up with Accor hotels for its crews. This account is billed directly to SNCF.

### **20.5.3.4 SRB**

In China, each railway bureau has dedicated hotels for the drivers and crew members.



---

The bureaus want to ensure that their crews rest well prior to the next day of work. The expenses for the hotels are covered by the bureaus.

## **20.5.4 Driver/Train Crew Training**

### **20.5.4.1 Korail**

In Korea, one must go through 12 weeks of training and have at least 6,210 miles (10 000 km) of driving experience to become a HSR train driver. In the past, one needed 5 years of experience operating conventional trains before being qualified to train as a high speed driver. This requirement was reduced to 3 years; however, the average years of experience remains at five.

### **20.5.4.2 SRB**

In China, typically two drivers are in the cab when a new line is opened. One is the instructor and the other is the trainee.

### **20.5.4.3 NTV**

NTV stated that its HSR service is a new venture, so it was essential to have a fresh start. NTV prefers to train young drivers as opposed to expert drivers to establish a new mentality. NTV needed 15 drivers for its initial startup service and a total of 106 drivers for its entire 25-trainset fleet. NTV received approximately 13,000 applications for these positions. At the time of Fellowship research, 42 drivers had been licensed and training was either underway or planned for the others who had been selected.

NTV advised that candidates needed to meet the following requirements prior to becoming a high speed train driver:

- Complete at least 18 months of driving training on traditional lines with an expert driver, during which time candidates:
  - Become qualified as a second tier driver on traditional lines within 8 months from the start of training
  - Become qualified as a first tier driver on traditional lines within the next 12 months of training.
- Successfully complete 1 month of training in the traditional courses to study and understand the signaling system. At this point, the candidates become second tier high speed drivers.
- Successfully complete 1 more month of practical training, after which candidates can become NTV drivers.

NTV purchased a train simulator in 2009 to assist in driver training (Figure 20.2). There are two phases to the simulation:

- Phase 1 focuses on signaling aspects (reproduced using a simulated electric locomotive).
- Phase 2 focuses on simulating failures on the train. This phase is also relevant to the training of the train manager. It was designed by Alstom because of the need to resemble AGV characteristics.

---

**Figure 20.2 NTV Simulator**



Source: Source: NTV Presentation, "NTV: The Company and Its Italo Service," June 2010

NTV stated that candidates train on the simulator and on real trains in the field; however, every day on the simulator equates to five days on real lines.

NTV advised that its training on conventional lines was not coordinated with Trenitalia, its competitor. Instead, a contract was established with other railway agencies (e.g., freight) for NTV to train its candidates. NTV felt that this process was more beneficial because it gave candidates the opportunity to train for various actions and procedures not encountered normally on the passenger route and helped them prepare for potential interactions with freight traffic.

NTV advised that training requirements are not standardized in Europe, and each country has its own training rules and program for certification. NTV's rules and program are not inclusive of SNCF's. SNCF did provide the driving program for the AGV trainset prototype (Pegase), however, which is being used for homologation testing in Italy.

#### **20.5.4.4 SNCF**

SNCF has 10,140 train managers, of which about 20 percent are women and nearly 35 percent are high school graduates. The average age of train managers is 40.6. Train managers report to the train crew managers. In SNCF, 22 train managers report to one train crew manager.

SNCF advised that in the past 5 years, 42 percent of the new train managers were recruited internally, mostly from commercial posts. Recruitment involves a series of psycho-technical tests to evaluate the candidate's ability to perform railway service and safety functions. The role of the train manager revolves around:

- Greeting and assisting passengers, and providing them with all information relevant to their travel experience

- 
- Ensuring passenger safety, security, and comfort during normal travel, delays, or emergencies
  - Checking travel documents, rectifying situations where passengers do not have valid tickets, and selling tickets onboard
  - Containing damage affecting passengers
  - Coordinating the actions of people called upon to intervene in issues onboard the train
  - Checking the condition of the rolling stock and preventing unnecessary damage.

SNCF train managers' tools include handheld devices that perform many interactive functions now considered standard, such as reading and checking radio frequency identification (RFID) tickets and barcodes, or providing real-time communication with the office to report on staff activities. Several more advanced functions have been added recently, however. These include general packet radio service (GPRS), which gives real time access to information and seat reservation data, and the direct transfer of data regarding travel documents issued onboard the trainset.

SNCF is aiming to transform train crew methods to accommodate customer requirements in relation to each market segment. This involves encouraging the train manager and the train crew manager for potential changes in roles and ensuring that they can work as an interchangeable team. SNCF is also looking to apply a specialization rationale by dedicating specific train managers to specific types of trains and services.

SNCF is also looking to improve the process of managing staff being presented with changes in job responsibilities. This is accomplished by moving away from an approach based on systematic training for all disciplines, which have proved costly and at times unproductive. SNCF is now targeting training that will clearly define the train manager and train crew manager specializations.

SNCF is also simplifying its training courses. The course for train managers, which used to be 110 days, is now 76 days typically. SNCF advised that this course could be reduced further to 40 to 50 days.

SNCF is also redefining new career profiles for train managers and train crew managers. As part of this effort, SNCF:

- Keeps staff apprised of the potential for mobility between the different types of train manager and train crew manager positions
- Provides training to enable its staff to progress professionally by obtaining the skills necessary to become train crew managers.

SNCF is looking to promote its own staff members in other sectors that are seemingly less prestigious (e.g., TER regional trains).

Enhanced training techniques currently being used for drivers have potential for saving time. For example, when using the simulator, drivers can learn how to react to potential failures and flaws so that related problems can be prevented in the future on the mainline.

TGV drivers are also trained to operate on conventional lines.

---

## 20.5.5 Catering Crew

### 20.5.5.1 SNCF

SNCF emphasized that onboard catering is part of the HSR travel experience, with its level of catering varying by market segment:

- TGV: Bar service (hot meals, snacks, and drinks) is provided (Figure 20.3).
- Thalys and Eurostar trains: Bar service and at-seat services. At-seat meal service is included in the price of a first class ticket.
- TGV North: Vending machines are provided.
- iDTGV: Bar and trolley service are provided.
- AGV: Trolley and at-seat services are provided. There is no bar service on the train.

**Figure 20.3 TGV 2N2 Bar Car**



Source: SNCF Presentation, "Catering," June 2010

A staff of 1,200 provides catering service onboard SNCF's 800 TGV trains, while a staff of 250 provides catering onboard SNCF's 60 Thalys trains, which offer at-seat meal service at the first-class seats. Each Thalys trainset has three first-class coaches. There is one staff member for each coach and one at the bar.

Catering for SNCF is a tripartite relationship. SNCF defines and funds the level of catering service to be provided and employs the onboard catering staff. The service provider defines the products to be offered according to SNCF's specifications, and negotiates prices and places orders with the caterer. (The service provider can also act as a concessionaire with its investment.) The caterer supplies the products to the trains and manages the waste from its catering centers at the origin and destination stations.

---

SNCF states that, from a business perspective, one must find the correct balance between defining the service needed and profitability. An operator could also consider ancillary revenues from services such as onboard entertainment, taxis, car rentals, etc.



---

## CHAPTER 21 INTERNATIONAL HOSTS' PERSPECTIVES ON HSR SAFETY

*The safety records of the European and Asian HSR systems are outstanding, making travel by high speed train among the safest modes of passenger transportation in the world. When the authors evaluated HSR systems worldwide, they recognized the importance of implementing a system-based approach to safety that embraces the tenets of fail-safe train separation, CEM technology appropriate to the trainsets purchased, and the development of safe and effective procedures for operation of the railroad, including the efficient implementation of these procedures by well-trained staff. The perspectives of several operators and manufacturers relative to the safe operation of a HSR system are documented in this chapter. In their discussions, they emphasize the importance of many points made in the preceding chapters.*

### 21.1 OVERVIEW OF HSR SAFETY AND EXPERIENCES

#### 21.1.1 Alstom

Alstom provided a presentation on railway safety, advising that trains are one of the safest modes of transportation and that in Europe, automobile accidents claim 97 percent of travel-related fatalities. Alstom provided the following statistics for all rail transport in Europe. These are illustrated in Figures 21.1 and 21.2:

- Fatality rates per 62 million person miles (100 million person km) are:
  - Trains: 0.035
  - Airplanes: 0.035
  - Cars: 0.95
- Fatality rates per 100 million person hours are:
  - Trains: 2
  - Airplanes: 16
  - Cars: 28
- More than 80 percent of rail accidents result from external causes (e.g., trespassers in the right of way, vehicles at at-grade crossings), and only 4 percent of associated fatalities were rail passengers. Alstom reported that the TGV service has been in high speed operation for 30 years with no major passenger injuries. Of the various rail accidents:
  - 58.7% involved injury or death caused by trainset in motion
  - 27.9% occurred at at-grade crossings
  - 5.7% were train collisions
  - 4.7% were train derailments
  - 1.6% were train fires.

**Figure 21.1 Fatality Rates of the Three Primary Modes of Travel Showing Factors of Increase Compared with Train Travel**

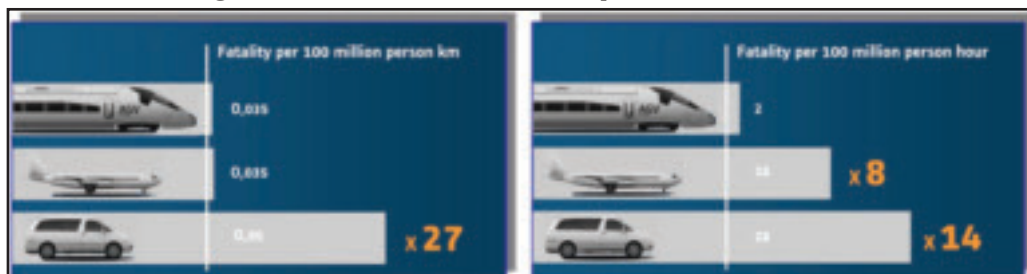

Source: Alstom Presentation, "Very High Speed Train & Safety," June 2010

**Figure 21.2 Types of Rail Accidents**

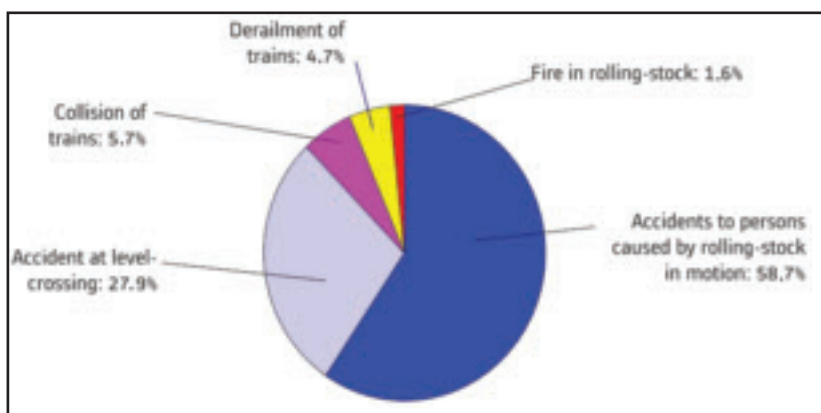

Source: Alstom Presentation, "Very High Speed Train & Safety," June 2010 / UIC, 2006

Alstom advised that the railway is a complex system (i.e., operation in an open environment, impacts from human factors). Risks exist, therefore, and must be managed via:

- Active safety (part of the railway system)
- Passive safety (part of the trainset)
- The integration of standards
- Having safety assurance<sup>1</sup> and a safety management system<sup>2</sup> in place to effectively manage potential rolling stock incidents.

Alstom discussed the merits of active safety, stating that it is essential to first prevent accidents by doing all that is possible within reasonable limits and within the limits of existing technologies. Alstom uses its ATLAS signaling system for ETCS Levels 1 and 2. ATLAS integrates ETCS to prevent conflicts of routes at interlockings and to control the speeds of its trains.

<sup>1</sup> Safety assurance is the reduction of hazard risks to an acceptable level of safety.

<sup>2</sup> A safety management system is the planning, organizing, directing, and controlling of those activities necessary to achieving an organization's loss-prevention and loss-control objectives.



---

All high speed lines in France are fenced and detectors are installed to sense falling objects (from overpasses) via nets. These nets automatically signal the ATC system to stop the train if an object is detected. The brakes on the high speed trainsets must undergo simulations and tests to ensure their operation during actual emergencies. Electrical and friction braking are UIC-compliant, and the anti-sliding devices are designed with failsafe principles. Alstom stressed the importance for very high speed trains to have a safe and reliable wheel slide protection device. Alstom also emphasized that safety does not always mean that the train must stop (e.g., incidents within a tunnel).

Bogie and track monitoring must also be performed to ensure safe high speed travel. This is accomplished on the wayside by:

- Detection of broken rails by track circuits
- Switch point control
- Crosswind speed monitoring
- Earthquake detection
- Overspeed protection and control.

The target speed for the May 1990 world record run with the test TGV 117 was 261 mph (420 km/h); however, effective bogie and track monitoring meant that the train was able to travel up to 320 mph (515,3 km/h).

Alstom advised that passive safety must also be considered to limit the consequences of potential accidents. Passive safety includes, for example, crashworthiness and fire safety. Alstom advised of three derailment incidents in which articulated configurations prevented serious injury to the passengers and crew and minimized damage to the trainsets:

- December 14, 1992: A TGV train derailed at 168 mph (270 km/h) at Mâcon-Loché Station because of a wheel flat. This flat resulted from a prior emergency stop.
- December 21, 1993: A TGV train derailed at 183 mph (294 km/h) near Haute-Picardie Station after a rainstorm produced a void underneath the track. Only the cab car remained on the track. There were no injuries.
- June 5, 2000: A Eurostar train derailed at 180 mph (290 km/h) near Croisilles. This derailment resulted from a defect of maintenance. The gearbox did not contain oil and the shaft failed. The motored bogie derailed, but there were no injuries.

Alstom also advised of two collisions that occurred with the TGV in the earlier years with the first and second generation trainsets. The first collision took place at a grade crossing on a conventional line with the train traveling at 62 mph (100 km/h). The train struck a truck carrying an 88-ton (80-tonne) transformer. There were no major passenger injuries, but unfortunately the driver of the train did not survive. This collision triggered the development of the first generation of energy absorbers for the TGVs. The second collision also took place at a grade crossing with the train traveling at 62 mph (100 km/h). The train struck a 44-ton (40-tonne) vehicle. In this accident, the train driver sustained minor injuries.

Alstom performs crashworthiness tests at its Center of Excellence in Reichshoffen, France, to ensure compliance with TSI collision scenarios. In addition, the development of crashworthiness solutions is ongoing continually at this R&D facility. Fire and smoke simulations (SIRENE) are conducted at Alstom's Center of Excellence in Valenciennes, France. Alstom follows regulations for tunnel safety that include compliance with fire and smoke standards; evacuation

---

and ventilation strategies; and energy, communication, and signaling management. Alstom also incorporates vehicle fire protection into its trainset designs. The Valenciennes Center of Excellence also maintains the material and certificate database, MARIE.

Alstom discussed its Railway Safety Policy, whereby Alstom developed a voluntary safety management system as a response to changes in the European market and as a provision of safety assurance to potential customers. Alstom Transport Safety is compliant with EN 50126. The firm is also familiar with MIL-STD-882 and 49 CFR §238.

Alstom stated that in the U.S. the certification/homologation process involves clients, consultants, and the industry. In France, there is an additional fourth body for independent assessments, EPSF, the French public railway safety authority.

### **21.1.2 DB**

DB advised that the key to crew and passenger safety is compliance with TSI and the German national standards, and that it is moving towards TSI as Germany's national standards become incorporated. Vehicle characteristics can be found in TSI, which codifies the minimum requirements of the vehicle. DB stated that the UIC leaflets comprise one of the most important sets of documents currently, and that a process is underway whereby the information contained in the leaflets is being incorporated in TSI. Currently in Europe, each country complies with TSI and a set of national standards. It is DB's hope that within the next 10 years Europe will have consolidated all of the national standards into TSI.

DB stated that the hierarchy of regulations/standards in Germany is as follows:

- European Commission laws (EU)
- Mandatory European regulations (TSI)
- European standards (EN, UIC)
- National standards (NEA).

DB uses a hazard analysis process to assess the level of risk/hazard severity associated with each 164-foot (50-m) section of infrastructure. For example, if the track runs at-grade, a lower risk is assigned; whereas if the track runs on an aerial structure, a higher level of risk is assigned. DB also analyzes the risk curve for each particular line and vehicle and determines the operational characteristics appropriate for that line. For example, in areas of high crosswinds, DB reduces the speed limit of the line or constructs wind barriers (Figure 21.3). In the end, the risk must be within the limit of the curve developed. The operational characteristics are documented in DB's internal regulations.

DB advised that there is no automated link between measured wind speed and the train control system. The line operator has the authority to slow down trains when strong winds are in the area based on local operational rules. If the strong winds blow near bridges, the operators are advised to reduce speed. Today, speed is reduced mainly to limit the effects of flying ballast—a concern was expressed about the possibility of ballast destroying the LZB ATC antenna.

DB prefers to have the right of way fenced in with controlled access. The goal is to keep trespassers and animals away from oncoming trains. DB recounted an accident in which sheep had made their way into one of the tunnels.

---

**Figure 21.3 Wind Barriers on the Cologne-to-Frankfurt Line**



Source: Siemens Presentation, "Train Aerodynamics," January 2010

### **21.1.3 Korail**

There have been no recorded HSR accidents in Korea and no injuries to crew or passengers. In its 5 to 6 years of operation on conventional lines, Korail has had no HSR derailments due to its trains staying within the speed limits of 81 mph to 93 mph (130 km/h to 150 km/h).

### **21.1.4 NTV**

NTV advised that Italy's national safety authority, ANSF, was founded to ensure compliance with all safety standards and to continually improve those standards in relation to technical and scientific developments. ANSF is independent of Italy's national infrastructure manager, RFI. The Ministry of Transport has direct supervision over ANSF. The main objectives of ANSF include:

- Checking for the proper application of norms
- Defining the safety rules for railway operations
- Conducting the final assessment on the homologation and authorization process for rolling stock and the relevant subsystems and components
- Releasing the "safety certificate" to railway undertakings (e.g., Alstom) and the "safety clearance" to RFI.

ANSF uses independent safety assessors (ISA) to conduct a detailed assessment of the homologation process. ISAs have the role of checking the major subsystems and components for compliance with applicable national standards and TSI. ANSF uses notified bodies for the homologation process of interoperable trainsets. The notified bodies assess compliance of the rolling stock with the TSI.

---

NTV provided an overview of the ANSF homologation process for the Italo AGV trainset. Participants include:

- Alstom: Dossier (technical documentation) preparation
- Rina (ISA): Dossier validation
- NTV: Monitoring of processes and tests
- Alstom: Responsible for the train (requests authorization to run train)
- Rina: Responsible for the tests
- EurailTest: Test laboratory
- RFI: Schedule available time slots for tests.

NTV advised that the homologation testing was initiated using the Pegase trainset, which is the 7-car Alstom AGV prototype (Figure 21.4). Homologation tests for running behavior can be conducted at speeds of up to 205 mph (330 km/h):

- Between December 27, 2009, and January 7, 2010, the Pegase was transferred to Italy.
- The first phase of homologation tests, the speed increase tests, was conducted between February 9, 2010, and March 19, 2010. By March, the Pegase was reaching speeds of 186 mph (300 km/h).
- The second phase of homologation tests, the signal system tests, was conducted between March 22, 2010, and July 31, 2010.
- The third phase of homologation tests, the running dynamics/behavior tests, was conducted between May 24, 2010, and September 30, 2010. The signal tests and the dynamic tests were conducted in parallel between May 24, 2010, and July 31, 2010.

**Figure 21.4 AGV Pegase Prototype Trainset**



Source: Alstom brochure, *AGV: Full Speed Ahead into the 21st Century*

---

During testing, twenty people from Alstom were aboard the Pegase, eighteen from NTV, and one or two from other entities.

Two full-size trainsets are needed to complete the homologation tests because of the amount of equipment needed to test running behavior. NTV expects its first full-size AGV trainset for homologation testing in October 2010. It will be a lab train with no fitted interiors, and will be used to complete all tests except those for vibration and acoustics. Tests will include EMC, braking curves, etc., and are scheduled for completion by April 2011. NTV expects to receive the second full-length AGV trainset in December 2010. This train will have the configuration of a commercial train and will be used for the comfort tests (vibration, acoustics, etc.), which are scheduled for completion by May 2011.

### 21.1.5 SNCF

SNCF provided an overview of the safety certification process and advised that EPSF was set up because the limits of operator and infrastructure responsibilities were not yet defined. It was essential for an operable railway network to have authorized infrastructure systems, authorized rolling stock, safety requirements, and regulations, along with potential users.

SNCF advised that the main safety stakeholder entities are:

- **EPSF**, the French public railway safety authority, which authorizes new systems, delivers safety authorizations and certificates, controls the correct use of the authorizations issued, and publishes technical recommendations.
- **The applicant**, which is usually the infrastructure manager, the railway undertaking, or the trainset manufacturer that is asking for permission to operate a service or place a trainset into service.
- **The French Ministry of Transport**, which is in charge of transportation, defines policies and publishes safety regulations.
- **The railway undertakings**, or the operators, which operate a set of services on the French railway network. The railway undertakings respect national rules along with safety rules set by the infrastructure managers.
- **The infrastructure managers**, which design, develop and maintain the railway network, manage train traffic, and enforce the safety rules.
- **The notified bodies**, which control the enforcement of European technical and safety rules during a new system authorization assessment.
- **The designated bodies**, which control the enforcement of national technical and safety rules during a new system authorization assessment.

SNCF advised that certain authorizations are needed to operate on the French railway network:

- **The railway undertakings must have their safety certificates.** The safety certificate for a railway undertaking is granted when it has set up:
  - A safety management system that will be able to maintain the operational organization of all of the railway undertaking's services. The system ensures control over all risks associated with the railway undertaking's activities (Part A).

- 
- An operational organization that considers the safety requirements and regulations necessary to manage the services.
  - An operational organization to manage its activities' risks (Part B).

The assessment procedure for the safety certificate first involves the railway undertaking providing a safety dossier and filing an application (Parts A and B) prior to submittal to EPSF. During the assessment, the French infrastructure manager, RFF, reviews Part B of the application. The entire process is completed within a maximum of 4 months. Upon completion, the safety certificate is issued.

- **The infrastructure managers must have their safety authorizations.**

The safety authorization for the infrastructure manager consists of:

- Confirmation of acceptance of the infrastructure manager's safety management system
- Confirmation of acceptance of the provisions for the infrastructure manager to meet and comply with specific requirements necessary for the safe design, maintenance, and operation of the railway infrastructure, including the maintenance and operation of the traffic control and signaling systems.

The assessment procedure for the safety authorization involves the infrastructure manager providing a safety dossier and filing an application prior to submittal to EPSF. During the assessment, RFF reviews the application and provides its opinion (if the applicant is not itself). The entire process is completed within a maximum of 4 months. Upon completion, the safety authorization is issued.

- **Authorizations must be in place** before new or modified systems (rolling stock, infrastructure, etc.) are put into service. Several stakeholders are involved when placing new or modified systems into service, including EPSF, the applicant, RFF, the notified bodies, the designated bodies, and the French Ministry for civil safety:

- During the initial phase of the project, a definition safety dossier must be defined. This dossier is completed by the applicant at the end of the definition phase of the project. It details the project's main technical and practical characteristics, and it introduces the main safety stakes and the elements that will enable safety targets and TSI requirements to be reached and complied with.

The applicant supplies EPSF with the definition safety dossier. EPSF reviews it and refers to RFF (if the applicant is not itself) and the French Interior Ministry for their feedback. EPSF then provides its feedback to the applicant, taking into consideration the feedback from RFF and the Interior Ministry.

- At the end of the conceptual studies, a preliminary safety dossier is produced by the applicant. This dossier:
  - Specifies safety targets and the methods to be used to achieve them
  - Provides the demonstration methods and rules to be used to maintain the safety level of the system during its operating life
  - Describes the applicant's safety management system via a risk assessment and

---

analysis, a preliminary hazard analysis, a reliability, availability, maintainability and safety (RAMS) analysis, foreseeable safety studies, tests, etc.

- Contains a project organization presentation that identifies the safety role of each stakeholder
- Contains a safety report generated by a designated body.

The applicant supplies EPSF with the preliminary safety dossier. EPSF reviews it and refers to RFF (if the applicant is not itself) and the French Interior Ministry for their feedback. EPSF then provides the application for authorization to the applicant, and construction works for the new or modified service can then begin.

- At the end of the construction phase, the applicant completes the safety dossier. This document describes the performed system or subsystem and reports that all of the safety targets have been fulfilled. It also demonstrates that such safety level will be maintained during the operating life of the system, and it shows compliance with TSI requirements.

A designated body generates a safety report and a notified body generates a European conformity declaration that the applicant supplies with its safety dossier. EPSF then reviews the documents and refers to RFF (if the applicant is not itself) and the French Interior Ministry for their feedback. Afterwards, the EPSF provides the authorization for placing the system into service.

The time from the initial phase to the time the system is placed into service is approximately 4 months under what has been the typical process. New lines tend to follow the progress of the project, however, so when the final file is updated, authorization could be granted within 1 week.

SNCF advised that TSI was developed primarily for interoperability and the possibility of keeping an open market. While European norms are not requirements or regulations that must be followed, their marriage with TSI provides for a safe system. SNCF went on to emphasize that safety is not only relevant prior to service, but is also essential during service (e.g., maintenance practices).

SNCF advised that there have been no injuries on the high speed lines with the TGV. There was one train driver fatality with the TGV on a conventional line where the train collided with a truck carrying an 88-ton (80-tonne) transformer.

### **21.1.6 SRB**

The railway bureaus in China report to the MOR. The bureaus are responsible for daily operations. All bureaus are trained in and use standardized MOR rules. The bureaus maintain documents detailing the record of passenger safety/passenger injury. To date, there have been no recorded incidents of driver injury since the beginning of high speed operation 2 years ago, and no recorded incidents of passenger injury. The development of the bureau's operational model mandates safety first.



---

### **21.1.7 Renfe**

Renfe advised that past incidents involving derailments of high speed trains occurred during commissioning and shunting activities, both at low speeds. There have been no train derailments on the high speed network. Renfe maintains records of every crew and passenger injury.

Renfe discussed safety issues associated with door systems and front windscreens. Renfe has concerns relating to opening exterior doors (emergency release) while the train is in operation. Renfe advised that a passenger committed suicide by opening the door of a trainset while the train was moving at a high speed. Renfe prefers the trainsets to apply the brake automatically when a passenger opens the door via the emergency door release. Renfe also believes that such an action should be difficult for passengers (to prevent unwarranted door openings), and that the doors should not be allowed to open while the train is moving. Renfe advised that the “sensitive edges” of the doors do not provide sufficient obstacle detection, especially for thin objects that could be clamped by the doors (e.g., hands, luggage straps, etc.). Renfe is in the process of developing new internal standards to address this issue.

EN 14742 describes the requirements for door systems for persons with reduced mobility (PRM). This EN is not required currently, but Renfe will adopt it for all new trainsets.

## **21.2 TSI DEVELOPMENT**

### **21.2.1 NTV**

NTV advised that on July 23, 1996, the European Parliament decided to establish guidelines for the development of a trans-European transport network. This network comprised roads, railways, waterways, ports, airports, etc., and the services required for the safe operation of these infrastructures. The Technical Specification for Interoperability for high speed and conventional trains stemmed from this decision. Currently, all European countries are in a transitioning phase to meet TSI requirements. National safety agencies were developed to harmonize TSI with national laws. The goal was to establish one common standard. As a result, the development of TSI is an ongoing process. NTV feels that TSI is 80 percent to 90 percent complete.

### **21.2.2 SNCF**

SNCF advised that it has always been interested in engineering and operating know-how. SNCF has been involved, along with the manufacturers, since the beginning of TSI's development, sharing its operator's perspectives for consideration as TSI requirements are developed. It was believed that an optimum interoperability standard could stem only from considering viewpoints of both the trainset suppliers and the trainset operators. The development of TSI is still an ongoing process, as time is needed for feedback from various entities. The criteria for ERTMS Level 1 are complete, while those for ERTMS Level 2 are still ongoing, and the requirements for ERTMS Level 3 are in their initial stages of development. SNCF stated that TSIs for HSR are already quite mature, whereas TSIs for conventional rail are still being worked on.



---

## **21.3 PLANNED TRAINSET SAFETY ENHANCEMENTS**

### **21.3.1 SNCF**

SNCF believes that the crash absorption capabilities of the TGV have been greatly improved with the addition of energy absorption elements in the intercar areas. It also believes that ERTMS needs to be implemented to protect the trainset and its occupants.

### **21.3.2 Renfe**

Renfe expressed concern regarding protection of the right of way and protection of the train from small animals. Renfe trains have been damaged when impacting animals at high speed. It feels that the trains could be improved for the future to minimize the amount of damage sustained.

Renfe advised that it will be installing security cameras inside and outside of the trainsets to monitor crime, thefts, terrorist activities, etc. Renfe prefers to have cameras installed during the manufacturing process of future trainsets. Preferably, cameras will provide three types of surveillance:

- Monitoring the interior of the passenger train
- Recording pictures of all passengers boarding the train (cameras to be located at a lower position than the roof because typical entry into train is with head down)
- Monitoring the cameras used for surveillance to deter vandals from disabling cameras.

Renfe would like to cross-reference the photographs of passengers with the police department to identify potential threats.

## **21.4 OPERATORS' PERSPECTIVES OF ASPECTS CRITICAL TO THE SUCCESS OF HSR PROJECTS IN THE U.S.**

### **21.4.1 DB**

DB highly recommends using ballast-less track construction (e.g., slab track). Although slab track is more expensive initially, operators prefer it over ballasted track because of the high risk of flying ballast, especially in snowy conditions, and the significant damage to train and infrastructure that can result. DB advised that pieces of ice/snow falling from the bogies impact the ballast and increase the likelihood of ballast being lifted by a passing train. DB added that from its experience, slab track offers other advantages in addition to precluding ballast pickup. For example:

- There is less movement of the tracks.
- Smaller curve radii are possible because slab track can better resist the centrifugal forces. For example, at 186 mph (300 km/h), it is possible to have 10,830-foot (3300-

---

m) curves with slab track, but the minimum curve radius for the same speed on ballasted track is 16,730 feet (5100 m).

Another issue is braking. If eddy current brakes are to be used on ballasted track, a full investigation/analysis should be completed. Such brakes should be used only in emergency service cases over ballasted tracks.

DB raised concerns about the noise barriers' resistance to pressure waves generated by a passing train. It emphasized the need to accommodate the pressure waves (sonic boom) into the design of the barriers if they are to be used.

DB stated that it is important for the train to have a long nose shape at its ends to maximize aerodynamics and energy efficiency.

DB advised that it is necessary to protect the crew and passengers against pressures in the tunnels. To that end, it is essential to have a good trainset sealing system onboard the train. In Germany, three types of technologies are used:

- Systems that stop airflow into and out of the train when entering a tunnel and allow airflow after leaving the tunnel
- Fans with specific design characteristics
- The combination of these two technologies.

The ventilation system needs to be balanced carefully to provide an adequate level of trainset sealing while minimizing the accumulation of carbon dioxide.

#### **21.4.2 Korail**

Korail advised that the rolling stock must be designed for the conditions of high speed lines and of conventional lines. The trainsets in Korea are designed to operate on both.

#### **21.4.3 MOR**

MOR stated that the purpose for train operation is the same in China as it is in the U.S.—provide safety and comfort to the passengers and allow them to reach their destinations. China's HSR system is constructed under the guidance and regulations of MOR. It is very reliable, safe, and comfortable. China believes that the U.S. should follow the same approach.

The maximum speed on the Beijing-to-Tianjin line is 218 mph (350 km/h). From Tianjin-to-Qingdao, on existing tracks, the maximum speed is 155 mph (250 km/h). Since April 2007 there have been six speed increases on existing lines.

As of July 2011, China will be reducing the operating speeds of its HSR fleet, however. Trains that currently operate at speeds of 218 mph (350 km/h) will now operate at 186 mph (300 km/h), and many intercity trains will operate between 124 mph and 155 mph (200 km/h and 250 km/h). Reducing operating speeds when launching HSR would leave larger safety redundancy for better man-machine running-in periods. In addition, efforts to lower ticket prices would draw more passengers to travel by HSR—a greener, low-carbon transportation mode. MOR advised that trains operating at 218 mph (350 km/h) require twice the energy of those operating at 124 mph (200 km/h).

---

MOR stated it is knowledgeable in various safety aspects (e.g., wheel/rail interaction, train control, etc.). It is willing to share technology and help to develop high speed regulations.

MOR stated that anti-collision technology (e.g., energy absorbing device, pushback couplers) could be incorporated into existing HSR trainset designs, so it would not be an issue with the TSI or U.S. requirements. Current Chinese standards mandate that trains withstand train-to-train collisions at 19 mph (30 km/h) with no damage. In addition, there are requirements governing acceptable damage for collisions with an 88-ton (80-tonne) truck at 22 mph (36 km/h) and a 16.5-ton (15-tonne) lorry at 68 mph (110 km/h). The latter two scenarios were used to test individual trainset components and not the actual vehicle. In 2011, China is planning to test with the complete front end of the train.

According to China's statistics, most accidents occur at grade crossings. In China, lines with speeds greater than 75 mph (120 km/h) are fenced. China stated that the primary goal should be to avoid accidents.

MOR emphasized that its trains are 10.8 feet (3,3 m) wide, while the train width in Europe is 9.5 feet (2,9 m). China's wider trainsets are able to operate at 218 mph (350 km/h) in tunnels. As a result of many tests performed with trains passing in tunnels, MOR suggested that the requirements for trainset width and maximum operating speed in tunnels be placed into the performance specification of the trainset. When evaluating trains, it recommended including provisions for high speed trains to have been service-proven to operate in tunnels at 205 mph to 218 mph (330 km/h to 350 km/h).

MOR stated that every process from the planning, surveying, manufacturing, and operating stages should be monitored. In China, newly built track and existing track are interoperable. They also have to meet all potential weather conditions.

China is focused on safety and reliability, as well as passenger and crew comfort. MOR believes that China's requirements for the latter are more stringent than Japan's or Europe's. It emphasized also that China's infrastructure has needed less maintenance because of the use of slab track. China advised that a reduced need for maintenance equates to a safer environment.

#### **21.4.4 SRB**

SRB stated that the three main components that contribute to the safety of a HSR system and that are essential to protect against natural disasters and obstacles infringing on the right of way are:

- Trainsets
- Track/infrastructure
- Traction power supply system.

SRB added that operating safe trains depends not only on the operator, but also on the train control design, the trainset design, and the infrastructure design. Regarding infrastructure, the concept implemented in China was to build elevated lines to eliminate at-grade crossings. Further, all tracks are fenced to protect against pedestrians accidentally entering the

---

right of way. SRB also stressed the importance of having good track quality, and that track quality needs to be closely monitored during the manufacturing stage.

SRB stated that manufacturing, operations, and maintenance must be well organized. It operates three types of HSR equipment, but has unified procedures for maintenance along with strict regulations and rules to ensure the quality of maintenance and safety.

The maintenance cycle must be kept short in China because of its very high ridership levels (i.e., train availability needs to remain high). Regarding efficient track maintenance, it is critical to separate mixed traffic, if possible.

It is also essential to have a good maintenance model and qualified staff. In China, all inspection and maintenance depend on state-of-the-art equipment and facilities. Track checks are conducted whereby data are collected for the maintenance center via devices on the ground. This method also assists in scheduling maintenance for the trainsets. Monitoring systems are also used in the workshops/maintenance center. All workers and staff technicians are selected based on age, education, background, and expertise, which are important to ensuring maintenance quality.

SRB stated also that it is essential for the U.S. to have methods to handle emergency cases. It is also essential to have a good organization and rescue system with full equipment and spares. For example, in accordance with requirements, China has trains on standby in Nanjing and Shanghai for use in the event of a trainset failure. Passenger volume could reach 8,500 during peak times, so a trainset failure would result in large problems.

#### **21.4.5 Renfe**

Renfe mentioned that a comprehensive risk analysis is critical and suggested that potential risks be identified and evaluated early in the planning/design process. In addition, it mentioned that it would be helpful to consult with agencies that have actual operating experience.

#### **21.4.6 SNCF**

SNCF advised that it was preferable to have all entities involved in the early phases of the design of rolling stock, infrastructure, etc., but noted that doing so depends on the type of tender. SNCF stressed that system integration is absolutely necessary, however, and emphasized a systems-based approach. Alstom and SNCF believe that Korea set a good example. The rolling stock contract was signed in 1994, but studies had begun in 1988. When the tender for rolling stock was issued, almost the entire infrastructure was completely designed.

### LESSONS LEARNED

The U.S. has been very keen in the past on developing requirements that concentrate on the passive safety aspects of the trainset. This practice has been driven by learning from past injuries and accidents, and by viewing the trainset as a standalone system. As a result, U.S. trainsets are designed to withstand greater loads to offer protection for the passengers and crewmembers in the event of a collision. Doing so comes at a price, however—increased weight and noise, decreased energy efficiency, increased wear on the trainset and on the infrastructure, etc. Now, with the advent of the need for new regulations to govern rail travel up to 220 mph (354 km/h), the U.S. rail industry has the opportunity to develop criteria that not only adopt the latest technological and operational innovations, but also provide equivalent or enhanced safety to train passengers and crew.

While each manufacturer and operator interviewed during this Fellowship has its unique opinions about the advantages of, for example, its trainset design or its train control system, one prominent theme that we heard throughout all our visits was the need to focus on an integrated systems safety approach. Implementing automatic train control, having dedicated passenger lines, installing right of way intrusion detection, or optimizing operations and maintenance (to name just a few), allow us to shift the focus for safety from solely the trainset towards the elements of safety provided by other interfaces. When that happens, trainsets can be built to lower structural requirements without compromising passenger safety or affecting ride quality, thereby permitting trainsets to be lighter and more aerodynamically sound.

We have also seen greater concentration on the relationship between operations and maintenance. Much effort is being placed on optimizing the balance between the two in order to provide safe, fast, and efficient service. For example, in Japan maintenance of the track is conducted at night between 12 a.m., when Shinkansen service ends, and 6 a.m. We have seen China invest in state-of-the-art equipment, such as automatic storage and retrieval of parts to decrease downtime. In France, feedback from daily operations is reported back to maintenance to optimize preventative measures and decrease corrective activities to sustain high availability. Meanwhile, Germany made the point that operators invest in trainsets to have them in operation and not in the depots or maintenance facilities. One operator told us, "Safety includes maintenance. It is our perspective that if one forgets about maintenance, there is no safety." This comment was later affirmed by a trainset manufacturer.

It is without doubt that there is much we can learn from our overseas counterparts and their decades of high speed rail design and operations experience—the success of which can be found in the continual upgrades that are performed on their trains and infrastructure. The underlying thought that is mirrored throughout every country, including the U.S., is the focus on safety. Japan has invested in what is the world's most advanced earthquake detection and protection system and the results speak for themselves with zero passenger injuries since the inception of the Tokaido Shinkansen in 1964. Europe has adopted ERTMS and ETCS to support interoperability and the safe passage of trains from one country to another. China has begun

---

to upgrade its lower speed lines to accommodate higher speed services while implementing CTCS.

It is essential for the U.S. to take the best practices found around the world and to implement them, as appropriate, in our development of a high speed rail system so as to not "reinvent the wheel." It is also essential, however, to consider our own practices and history while doing so. It has been emphasized that while most, if not all, countries have had the benefit of seeing an incremental growth and expansion of dedicated high speed rail systems, the U.S. does not have this luxury. For example, we have witnessed the challenges associated with having completely dedicated high speed passenger lines (e.g., real estate acquisition issues, urban density). In Japan, the philosophy of collision avoidance is embraced; however, the value and appropriateness of crashworthiness is recognized in the U.S. We must be able to develop a trainset that realizes the benefits of improved energy efficiency, decreased noise, latest technological innovations, etc., while still providing an equivalent level of safety for the public. It is with this mentality that, if we are to ever have high speed rail service in the U.S., we must depart from the philosophy of viewing the trainset as a standalone system and begin to view the trainset as a part of a larger system.

With the guidance of the high speed rail manufacturing and operating community, FRA has been open to adopting a systems-based approach to safety as long as it can be proven that such approach offers equal or better safety than the approach provided by the current Code of Federal Regulations. This willingness to reconsider established regulations can be seen through the FRA/RSAC Engineering Task Force meetings held with the attendance of worldwide industry professionals. The results of the initial effort to develop alternative guidelines for Tier I service (speeds up to 125 mph (201 km/h)) can be found in the Railroad Safety Advisory Committee report, *Technical Criteria and Procedures for Evaluating the Crashworthiness and Occupant Protection Performance of Alternatively-Designed Passenger Rail Equipment for Use in Tier I Service*, the language of which will eventually be adopted into the Code of Federal Regulations. The industry is currently evaluating and deciding upon the requirements for Tier III operations, in hopes of what will eventually evolve into the guiding principles behind 220 mph (354 km/h) rail travel.

---

## **AFTERTHOUGHTS AND ACKNOWLEDGEMENTS**

The main purpose of the Fellowship was to research and study industry best practices in high speed rail. With the firm support of the Obama administration in upgrading our rail infrastructure along with the onset of various high speed rail projects in the U.S., we decided that it was a timely moment to undertake such an effort. The opportunity that was afforded to us not only gave us the chance to learn about the theories and reasoning behind each practice, but also permitted us to witness firsthand the design of trainsets, the manufacturing process, and eventually, trainset operation and maintenance. In addition, the mutual interactions with manufacturers and operators gave them a better understanding of our direction and thought process towards implementing high speed rail in our country.

Our approach during the Fellowship was to learn about past mistakes in addition to the current innovations. This knowledge would help us to better understand what to avoid doing so that we don't make similar errors with U.S. programs. With every entity that we met, we requested their advice on the aspects most critical to the success of high speed rail in the U.S. France emphasized the importance of understanding the systems perspective. China and Japan stressed the importance of passenger comfort in addition to trainset safety and reliability. Germany pointed out the need to find the optimal balance between trainset operating costs and maintenance costs. The list continues; however, there was not a single host who devalued the importance of systems integration.

This significance was easily appreciated by witnessing their daily operations. The moment we arrived in Germany for the first leg of the trip, we were impressed by the smoothness in ride quality while traveling from Frankfurt to Cologne. This attribute was echoed throughout all subsequent high speed rail travels that we experienced, and it showed the benefits of maintaining good wheel and rail interaction. The punctuality of the Shinkansen system illustrated the competence of the Japanese drivers in addition to the operators' focus on infrastructure and trainset maintenance. France showed us the various roles of the operator (design, operations, maintenance) during the life cycle of the trainset. In China, we witnessed the investment that was placed into high speed rail (e.g., ballastless track construction, state-of-the-art trainset manufacturing equipment, depots and yards), which helped us understand how they were able to have the fastest growing network in the last few years (with many more miles to come).

As evidenced by the wealth of information that was provided, every entity that we had met with was open about sharing their knowledge and expertise. We went to them with the same agenda on each leg of the trip and essentially, after all the trips, came back with what is now this monograph. Unsurprisingly, our hosts were welcoming and gracious. We have no doubt that our research could not have been conducted without the generosity and receptiveness of everyone we met with. We are greatly indebted to the time and dedication provided by the manufacturers, the operators, and the governmental agencies during not only the sessions, but also during the planning stages of the Fellowship. We would like to take this opportunity to give credit where credit is due. Unfortunately, while we cannot name every engineer, systems expert, or project manager who had contributed to the development of this monograph (frankly, it's a long list and we would probably leave someone out), you know who you are, and we extend to you our deepest gratitude.

---

We thank the following manufacturers and their respective representative(s) for dedicating their time and effort to make our Fellowship possible:

- Alstom Transportation, Inc. and Mr. Charles Wochele, Vice President of Industry and Government Relations, and Mr. Dave Ward, Engineering and Bids Director
- CSR Qingdao Sifang Co., Ltd./GE Transportation and Mr. Gagan Sood, Senior Project Manager for Government
- Hyundai Rotem Co. and Mr. Doug Dan, Senior Vice President of Sales and Marketing
- Kawasaki Heavy Industries, Ltd. and Mr. Takahiro Sato, Deputy Senior Manager for the Overseas Marketing Department (Rolling Stock Company)
- Siemens Industry, Inc. and Mr. Armin Kick, Director of High Speed Rail Development (Rolling Stock).

We also express our thanks to the following companies, which offered their expertise on infrastructure, train control, maintenance, and operations practices:

- Beijing Railway Bureau
- Central Japan Railway Co. (JR Central)
- China Railway Construction Corp., Ltd. (CRCC)
- China Railway Siyuan Survey and Design Group Co., Ltd. (FSDI)
- Deutsche Bahn Fernverkehr AG (DB)
- East Japan Railway Co. (JR East)
- Guangzhou Railway Group Corp.
- Japan Railway Construction, Transport and Technology Agency (JRTT)
- Korea Railroad Corp. (Korail)
- NERTUS Mantenimiento Ferroviario, SA (NERTUS)
- Nuovo Trasporto Viaggiatori, S.p.a. (NTV)
- Renfe Operadora (Renfe)
- Shanghai Railway Bureau (SRB)
- Société Nationale des Chemins de fer Français (SNCF)
- Third Railway Survey and Design Institute Group Corp. (TSDI).

Our gratitude extends also to the governmental agencies that shared with us their knowledge on high speed rail and assisted in organizing our sessions:

- Federal Railroad Administration (FRA) and Mr. Robert Lauby, Deputy Associate Administrator for Regulatory and Legislative Operations
- Ministry of Land, Infrastructure, Transport and Tourism (MLIT) and Mr. Fujio Kitamura, Director of the Engineering Planning Division (Railway Bureau)
- Ministry of Railways (MOR) and Mr. Liu Lianqing, Director-General and Senior Engineer.



---

Finally, we thank Parsons Brinckerhoff, the William Barclay Parsons Fellowship program, and the California High Speed Train Project for granting us the opportunity to embark on this endeavor to further our expertise on high speed rail; our mentors Mr. Bruce Pohlot, Mr. George Pristach, Mr. Joseph Silien, Mr. Clive Thornes, and Mr. Anthony Daniels for their continuous support and guidance throughout the program; and our editor, Ms. Lorraine Anderson, and graphic designer, Mr. Pedro Silva, for lending their expertise to this publication.

The information gathered from the trips has already proved to be a great return on investment as we continue to support the FRA and the U.S. rail industry in developing high speed rail regulations and guidelines. For PB, this knowledge has already been applied to various high-speed rail programs throughout the U.S. For us, we view the experience as a baseline for further education, as technology and practices evolve, and as a stepping stone towards pioneering the application of high speed rail express trainsets in the U.S.



Francis P. Banko  
Fellow  
Professional Associate  
Principal Project Manager



Jackson H. Xue  
Lead Investigator  
Rail Vehicle Engineer



---

## GLOSSARY

### DEFINITIONS, ABBREVIATIONS, ACRONYMS, AND STANDARDS

#### A

<b>Active safety</b>	Measures to reduce the probability of an accident occurring, such as dedicated high speed rail corridors and wayside protection
<b>ADA</b>	Americans with Disabilities Act
<b>ADIF</b>	Administrador de Infraestructuras Ferroviarias, Spain's national infrastructure manager
<b>Aerodynamic brakes</b>	A type of braking system whereby the braking force results from the use of components protruding from the exterior of the vehicle, providing an increase in drag
<b>AFNOR</b>	Association Française de Normalization (French Norm), standard abbreviation is NF
<b>AGV</b>	Automotrice à Grande Vitesse, Alstom's newest distributed-power high speed platform
<b>AIS</b>	Abbreviated Injury Scale
<b>ANSF</b>	Agenzia Nazionale per la Sicurezza delle Ferrovie, the Italian National Safety Authority
<b>ANSI/SAE Z26.1</b>	Safety Glazing Materials for Glazing Motor Vehicles and Motor Vehicle Equipment Operating on Land Highways – Safety Standard
<b>Anti-climbers</b>	Structural members that interlock with the same members on a colliding vehicle to prevent overriding
<b>APTA SS-C&amp;S-012-02</b>	Standard for Door Systems for New and Rebuilt Passenger Cars
<b>APTA SS-M-14-06</b>	Standard for Wheel Load Equalization of Passenger Railroad Rolling Stock
<b>APTA SS-M-15-06</b>	Standard for Wheel Flange Angle for Passenger Equipment
<b>ARRA</b>	American Recovery and Reinvestment Act
<b>Articulated design</b>	A trainset configuration whereby a single bogie is shared by two adjacent coaches (as used on Alstom's TGV trainsets)
<b>ASFA</b>	Anuncio de Señales y Frenado Automático, Spain's cab signaling train protection system
<b>ASM</b>	Asynchronous motor
<b>ASME</b>	American Society of Mechanical Engineers
<b>ATB</b>	Automatische TrainBeïnvloeding, Netherland's train protection system
<b>ATC</b>	Automatic train control
<b>ATO</b>	Automatic train operation

---

<b>ATP</b>	Automatic train protection
<b>ATS</b>	Automatic train supervision
<b>B</b>	
<b>Balise</b>	Transponder
<b>Bogie</b>	Also known as a truck, a bogie is a component comprised of a frame and wheelsets, and is attached to a rail vehicle
<b>Bogie hunting</b>	The side-to-side oscillation of the bogie relative to the running rails (typically caused by uncontrolled self-steering along tangent track)
<b>Brake calipers</b>	A subcomponent of the brake system that imparts mechanical force to the brake pad/brake rotor
<b>Brake pipe</b>	A system of piping used for connecting vehicles in a consist for the passage of compressed air
<b>Brake reservoir</b>	A volume of compressed air that is used to actuate the brake system
<b>BS 6853</b>	Code of Practice for Fire Precautions in the Design and Construction of Passenger Carrying Trains
<b>BSI</b>	British Standard Institute (British Norm) – standard abbreviation is BS
<b>Buffers</b>	Elements installed at each corner of the end of a rail vehicle as part of a buffer-and-chain coupling system
<b>C</b>	
<b>C&amp;P</b>	Criteria and Procedures
<b>Cant</b>	Also known as superelevation, cant is the difference in elevation between the two rails. Cant is not to be confused with the North American terminology of “rail cant,” which is defined as the vertical inclination of the rails
<b>Cant deficiency</b>	In curves, cant deficiency is the difference between the applied cant on the track and the equilibrium cant for the vehicle at the particular stated speed
<b>Cant rail</b>	Longitudinal carbody member where the side wall and roof panel meet
<b>CEM</b>	Crash energy management
<b>CEN</b>	Comité Européen de Normalisation, European committee for standardization
<b>CFR</b>	Code of Federal Regulations, as issued by the FRA
<b>CHSRA</b>	California High Speed Rail Authority
<b>CHSTP</b>	California High Speed Train Project

---

<b>Class 1 to Class 9 Track</b>	Refer to FRA CFR section 49 CFR §213 for track class designations and associated requirements
<b>Class G/Class R Passenger Equipment</b>	Passenger equipment suspension classification as defined in APTA SS-M-14-06
<b>Concentrated power</b>	Configuration where all of the traction equipment needed to propel the trainset is located at the leading and trailing ends of the equipment
<b>Conicity</b>	The decimal equivalent of wheel tread taper or inclination
<b>Construction gauge</b>	Also known as the structure gauge, the construction gauge is an outline drawing that identifies the minimum clearance to surrounding infrastructure elements based on the dynamic gauge of the rolling stock
<b>Couplers</b>	Devices used to connect two adjacent coaches (i.e., intercar couplers) or two trainsets (i.e., end couplers)
<b>CRCC</b>	China Railway Construction Corporation
<b>CRH</b>	China Railway Highspeed
<b>CSR</b>	CSR Corporation, Ltd.
<b>CTCS</b>	Chinese Train Control System
<b>CTCS Level 0</b>	CTCS used for existing conventional lines
<b>CTCS Level 1</b>	CTCS used as an interim system for lines with operating speeds of less than 99 mph (160 km/h)
<b>CTCS Level 2</b>	Equivalent to ETCS Level 1 – CTCS used on dedicated passenger lines with operating speeds up to 155 mph (250 km/h) and on upgraded existing lines
<b>CTCS Level 3</b>	Equivalent to ETCS Level 2 – CTCS used on dedicated passenger lines with operating speeds of 186 mph (300 km/h) and higher
<b>CWR</b>	Continuously Welded Rail
<b>D</b>	
<b>DB</b>	Deutsche Bahn, Germany's national railway operator
<b>Dead heading</b>	An operation whereby a trainset is moved from one location to another in a non-revenue capacity (i.e., no passengers onboard)
<b>Design crush stroke</b>	The length of the predetermined deformable section of a structural element that is part of a crash energy management system
<b>DIN</b>	Deutsches Institut für Normung (German Norm) – standard abbreviation is DIN
<b>DIN 5510-2</b>	Preventive Fire Protection in Railway Vehicles – Part 2: Fire Behaviour and Fire Side Effects of Materials and Parts – Classification, Requirements and Test Methods

---

---

<b>DIN 5510-4</b>	Preventive Fire Protection in Railway Vehicles – Part 4: Vehicle Design – Safety Requirements
<b>DIN 5566</b>	Railway Vehicles – Drivers Cabs
<b>Disc brakes</b>	Rotors that are slowed down by the mechanical force imparted by the brake calipers to reduce the velocity of the trainset
<b>Distributed power</b>	Configuration where all of the traction equipment needed to propel the trainset is distributed on the coaches throughout the trainset
<b>DMI</b>	Driver-machine interface
<b>DMU</b>	Diesel multiple unit, or a train consisting of self-propelled cars powered by diesel fuel
<b>Double traction</b>	Operation of two trainsets coupled together
<b>DPL</b>	Dedicated passenger line
<b>Dynamic gauge</b>	Also known as the kinematic gauge, the dynamic gauge is an outline drawing that represents the maximum size of rolling stock taking into consideration factors such as suspension travel, overhang on curves, and lateral motion relative to the track
<b>E</b>	
<b>EC</b>	European Commission
<b>efSet</b>	environmentally friendly Super Express Train, the new high speed trainset that Kawasaki is developing for the global export market
<b>EHS</b>	Environmental Health Safety
<b>EMC</b>	Electromagnetic compatibility
<b>EMI</b>	Electromagnetic interference
<b>EMU</b>	Electric multiple unit, or a train consisting of self-propelled cars powered by electricity
<b>EN</b>	European Norm
<b>EN 3-3</b>	Portable Fire Extinguishers – Part 3: Construction, Resistance to Pressure, Mechanical Tests
<b>EN 3-4</b>	Portable Fire Extinguishers – Part 4: Charges, Minimum Required Fire
<b>EN 3-6</b>	Portable Fire Extinguishers – Part 6: Provisions for the Attestation of Conformity of Portable Fire Extinguishers in Accordance with EN 3 Part 1 to Part 5
<b>EN 3-7</b>	Portable Fire Extinguishers – Part 7: Characteristics, Performance Requirements and Test Methods
<b>EN 410</b>	Glass in Building – Determination of Luminous and Solar Characteristics of Glazing
<b>EN 673</b>	Glass in Building – Determination of Thermal Transmittance (U Value) – Calculation Method

---

---

<b>EN 1990/A1</b>	Eurocode – Basis of Structural Design
<b>EN 1991-2</b>	Eurocode 1 – Actions on Structures – Part 2: Traffic Loads on Bridges
<b>EN 12299</b>	Railway Applications – Ride Comfort for Passengers – Measurement and Evaluation
<b>EN 12663</b>	Railway Applications – Structural Requirements of Railway Vehicle Bodies
<b>EN 13103</b>	Railway Applications – Wheelsets and Bogies – Non-Powered Axles – Design Method
<b>EN 13104</b>	Railway Applications – Wheelsets and Bogies – Powered Axles – Design Method
<b>EN 13129-1</b>	Railway Applications – Air Conditioning for Main Line Rolling Stock – Part 1: Comfort Parameters
<b>EN 13260</b>	Railway Applications – Wheelsets and Bogies – Wheelsets – Product Requirements
<b>EN 13261</b>	Railway Applications – Wheelsets and Bogies – Axles – Product Requirements
<b>EN 13262</b>	Railway Applications – Wheelsets and Bogies – Wheels – Product Requirements
<b>EN 13452-1</b>	Railway Applications – Braking – Mass Transit Brake Systems – Part 1: Performance Requirements
<b>EN 13452-2</b>	Railway Applications – Braking – Mass Transit Brake Systems – Part 2: Methods of Test
<b>EN 13715</b>	Railway Applications – Wheelsets and Bogies – Wheels – Tread Profile
<b>EN 13749</b>	Railway Applications – Wheelsets and Bogies – Method of Specifying the Structural Requirements of Bogie Frames
<b>EN 13848-1</b>	Railway Applications – Track – Track Geometry Quality – Part 1: Characterization of Track Geometry
<b>EN 13848-5</b>	Railway Applications – Track – Track Geometry Quality – Part 5: Geometric Quality Levels – Plain Line
<b>EN 14067-1</b>	Railway Applications – Aerodynamics – Part 1: Symbols and Units
<b>EN 14067-2</b>	Railway Applications – Aerodynamics – Part 2: Aerodynamics on Open Track
<b>EN 14067-3</b>	Railway Applications – Aerodynamics – Part 3: Aerodynamics in Tunnels
<b>EN 14067-4</b>	Railway Applications – Aerodynamics – Part 4: Requirements and Test Procedures for Aerodynamics on Open Track
<b>EN 14067-5</b>	Railway Applications – Aerodynamics – Part 5: Requirements and Test Procedures for Aerodynamics in Tunnels
<b>EN 14067-6</b>	Railway Applications – Aerodynamics – Part 6: Requirements and Test Procedures for Cross Wind Assessment

---

---

<b>EN 14363</b>	Railway Applications – Testing for the Acceptance of Running Characteristics of Railway Vehicles – Testing of Running Behaviour and Stationary Tests
<b>EN 14752</b>	Railway Applications – Bodyside Entrance Systems
<b>EN 14813-1</b>	Railway Applications – Air Conditioning for Driving Cabs – Part 1: Comfort Parameters
<b>EN 15152</b>	Railway Applications – Front Windscreens for Train Cabs
<b>EN 15227</b>	Railway Applications — Crashworthiness Requirements for Railway Vehicle Bodies
<b>EN 50125-1</b>	Railway Applications – Environmental Conditions for Equipment – Part 1: Equipment Onboard Rolling Stock
<b>EN 50125-2</b>	Railway Applications – Environmental Conditions for Equipment – Part 2: Fixed Electrical Installations
<b>EN 50125-3</b>	Railway Applications – Environmental Conditions for Equipment – Part 3: Equipment for Signalling and Telecommunications
<b>EN 50126</b>	Railway Applications – The Specification and Demonstration of Reliability, Availability, Maintainability and Safety (RAMS)
<b>EN 50128</b>	Railway Applications – Communication, Signalling and Processing Systems – Software for Railway Control and Protection Systems
<b>EN 50129</b>	Railway Applications – Communication, Signalling and Processing Systems – Safety Related Electronic Systems for Signalling
<b>EN 50155</b>	Railway Applications – Electronic Equipment Used on Rolling Stock
<b>EN 50159-1</b>	Railway Applications – Communication, Signalling and Processing Systems – Part 1: Safety-Related Communication in Closed Transmission Systems
<b>EN 50159-2</b>	Railway Applications – Communication, Signalling and Processing Systems – Part 2: Safety-Related Communication in Open Transmission Systems
<b>EN 50318</b>	Railway Applications – Current Collection Systems – Validation of Simulation of the Dynamic Interaction between Pantograph and Overhead Contact Line
<b>EN 50367</b>	Railway Applications – Current Collection Systems – Technical Criteria for the Interaction between Pantograph and Overhead Line (to Achieve Free Access)
<b>EN 61673</b>	Railway Applications – Rolling Stock Equipment – Shock and Vibration Tests
<b>EN ISO 12543-2</b>	Glass in Building – Laminated Glass and Laminated Safety Glass – Part 2: Laminated Safety Glass
<b>EPA</b>	Environmental Protection Agency
<b>EPSF</b>	Établissement Public de Sécurité Ferroviaire, the French public railway safety authority

---



---

<b>Equivalent conicity</b>	Also known as the stability taper, equivalent conicity is the tangent of the cone angle of a wheelset with coned wheels whose lateral movement has the same kinematic wavelength as the given wheelset on straight track and large-radius curves
<b>ERTMS</b>	European Rail Traffic Management System
<b>ETCS</b>	European Train Control System, the train control component of ERTMS
<b>ETCS Level 1</b>	Communication via transponder-based systems (for spot transmission) incorporated as an overlay to existing rail-based systems
<b>ETCS Level 2</b>	Communication via digital radio-based or cellular signal systems (for continuous transmission), while maintaining the fixed block principle seen in ETCS Level 1
<b>ETCS Level 3</b>	New ETCS level under development to permit moving blocks vs. fixed blocks
<b>ETF</b>	Engineering Task Force, as part of the FRA's Railroad Safety and Advisory Committee
<b>ETMS</b>	Electronic Train Management System, Wabtec's solution for positive train control
<b>ETR</b>	Eletto Treno Rapido, a series of high speed trains operated by Trenitalia
<b>EU</b>	European Union
<b>EVC</b>	European vital computer
<b>F</b>	
<b>FEA</b>	Finite element analysis
<b>FEM</b>	Finite element model
<b>Fixed block</b>	A fixed operating distance between two signaling points
<b>FRA</b>	Federal Railroad Administration
<b>FSDI</b>	Fourth Survey and Design Institute of China Railways
<b>G</b>	
<b>g</b>	G force (also used for acceleration due to gravity)
<b>gal</b>	Measure of peak ground acceleration
<b>GB</b>	Chinese Norm, standard abbreviation is GB
<b>GB/T 17626.4</b>	Electromagnetic Compatibility – Testing and Measurement – Techniques – Electrical Fast Transient Burst Immunity Test
<b>GbE</b>	Gigabyte Ethernet

---

---

<b>GM/RT</b>	UK Railway Group Standard
<b>GM/RT 2100</b>	Requirements for Rail Vehicle Structures
<b>GPRS</b>	General Packet Radio Service
<b>GPS</b>	Global Positioning System
<b>GSM</b>	Global System for Mobile Communications
<b>GSM-R</b>	Global System for Mobile Communications –Railway, a wireless communications standard for communication between trains and railway regulation control center
<b>H</b>	
<b>Headway</b>	Train-to-train interval measured in units of time
<b>HEMU</b>	Highspeed Electric Multiple Unit, the designation for Hyundai Rotem's new distributed power high speed trainsets
<b>HHT</b>	Handheld terminal
<b>HID</b>	High intensity discharge
<b>HMI</b>	Human-machine interface
<b>Homologation</b>	A certification process during which a trainset (or other product) is evaluated against the requirements of a regulatory standard
<b>HSR</b>	High speed rail
<b>HVAC</b>	Heating, ventilation, and air conditioning
<b>I</b>	
<b>ICE</b>	InterCityExpress
<b>IEC</b>	Commission Électrotechnique Internationale, the International Electrotechnical Commission
<b>IEC 61000</b>	Electromagnetic Compatibility
<b>IEC 60077</b>	Railway Applications – Electric Equipment for Rolling Stock
<b>IEC 61375-1</b>	Electronic Railway Equipment – Train Communication Network – Part 1: General Architecture
<b>IEC 61508</b>	Functional Safety of Electrical/Electronic/Programmable Electronic Safety-Related Systems
<b>IEC 62278</b>	Railway Applications – Specification and Demonstration of Reliability, Availability, Maintainability and Safety (RAMS)
<b>IEC 62280</b>	Railway Applications – Communication, Signalling and Processing Systems
<b>IGBT</b>	Insulated gate bipolar transistor

---

---

<b>ILS</b>	Integrated logistics support
<b>Inclination</b>	Also known as wheel taper, inclination is the slope of the wheel tread (e.g., 1:20 or 1:40) relative to the axis of the wheelset
<b>Intumescent</b>	Intumescent elements swell when heated
<b>ISA</b>	Independent safety assessors
<b>ISO</b>	Organisation Internationale de Normalisation, the International Organization for Standardization
<b>ISO 834</b>	Fire Resistance Tests – Elements of Building Construction
<b>ISO 3095</b>	Railway Applications – Acoustics – Measurement of Noise Emitted by Railbound Vehicles
<b>ISO 3381</b>	Railway Applications – Acoustics – Measurement of Noise Inside Railbound Vehicles
<b>ISO 9050</b>	Glass in Building – Determination of Light Transmittance, Solar Direct Transmittance, Total Solar Energy Transmittance, Ultraviolet Transmittance and Related Glazing Factors
<b>J</b>	
<b>JR</b>	Japan Railway Company
<b>JRU</b>	Juridical recorder unit
<b>K</b>	
<b>Kinematic gauge</b>	Also known as the dynamic gauge, an outline drawing that represents the maximum size of rolling stock taking into consideration factors such as suspension travel, overhang on curves, and lateral motion relative to the track
<b>KMC</b>	Key management center
<b>Korail</b>	Korea Railroad Corporation, Korea's national railway operator
<b>KTX</b>	Korea Train eXpress, the designation for Korail's high speed trainsets
<b>KVB</b>	Contrôle de Vitesse par Balises – France's cab signaling/train protection system (with speed control via balises) used on conventional lines
<b>L</b>	
<b>LED</b>	Light emitting diode
<b>LEU</b>	Lineside electronic unit
<b>LGV</b>	Lignes à Grande Vitesse, France's high speed lines

---

---

<b>Locomotive</b>	Power car within a trainset
<b>Lorry</b>	A vehicular truck
<b>LZB</b>	Linienzugbeeinflussung, Germany's cab signaling/train protection system (with speed control via continuous transmission)
<b>M</b>	
<b>MEGA</b>	Module of Energy of Great Absorption, Alstom's CEM system for the AGV trainset
<b>MLIT</b>	Japan's Ministry of Land, Infrastructure, Transport and Tourism
<b>MOR</b>	Ministry of Railways of the People's Republic of China
<b>Moving block</b>	A signaling block designed as a protective safe zone of the trainset while it is in operation
<b>MVB</b>	Multifunction vehicle bus
<b>N</b>	
<b>NEA</b>	German Federal Railway Administrative Regulation
<b>NEA VVW 6.2</b>	Administrative Order for Examining Emergency Exit Windows and Emergency Units in Rail
<b>NERTUS</b>	A Siemens and Renfe joint venture to provide trainset maintenance
<b>NFF 01-492</b>	Railway Rolling Stock – Glass Bays (Windows and Other)
<b>NFF 15-818</b>	Railway Rolling Stock – Frontal Windscreens
<b>NFF 16-101</b>	Rolling Stock – Fire Behaviour – Materials Choosing
<b>NFF 16-102</b>	Rolling Stock – Fire Behaviour – Materials Choosing – Application for Electric Equipments
<b>NFF 31-129</b>	Railway Rolling Stock – Toughened Safety Glass Panels
<b>NFF 31-250</b>	Railway Rolling Stock – Laminated Glass
<b>NFF 31-314</b>	Railway Rolling Stock – Insulating Glass Units
<b>NFP 08-301</b>	Vertical Building Elements – Impact Resistance Tests – Impact Bodies – Principle and General Test Procedures
<b>NFPA</b>	National Fire Protection Association
<b>NFPA 130</b>	Standard for Fixed Guideway Transit and Passenger Rail Systems
<b>Nominal wheel load</b>	The vertical load of the wheel on the rail when measured on level tangent track. This measurement is conducted with all wheels on the same plane and the vehicle stationary
<b>NPRM</b>	Notice of Proposed Rulemaking

---

<b>NS</b>	Nederlandse Spoorwegen, Netherland's national railway operator
<b>NTV</b>	Nuovo Trasporto Viaggiatori, a private high speed rail operator in Italy
<b>O</b>	
<b>OCS</b>	Overhead contact system
<b>P</b>	
<b>PA</b>	Public address
<b>PAR</b>	Parabolic aluminized reflector
<b>Passive safety</b>	Measures incorporated into the trainset design to mitigate the consequences of an accident, should one occur
<b>PB</b>	Parsons Brinckerhoff
<b>PNK</b>	Polski Komitet Normalizacyjny (Polish Norm) – standard abbreviation is PN
<b>PMM</b>	Permanent magnet motor
<b>PN-K-02502</b>	Railway Rolling Stock – Susceptibility of Seats to Inflammability – Requirements and Tests
<b>PN-K-02511</b>	Rolling Stock – Fire Safety of Materials – Requirements
<b>PRM</b>	Persons with Reduced Mobility
<b>PVB</b>	Polyvinyl butyral
<b>PZB</b>	Punktförmige Zugbeeinflussung – Germany's cab signaling/train protection system (with speed control via balises)
<b>R</b>	
<b>R&amp;D</b>	Research and development
<b>RAMS</b>	Reliability, availability, maintainability, and safety
<b>RBC</b>	Radio block control
<b>Renfe</b>	Red Nacional de los Ferrocarriles Españoles , or Renfe Operadora, Spain's national railway operator
<b>RFF</b>	Réseau Ferré de France, France's national infrastructure manager
<b>RFI</b>	Rete Ferroviaria Italiana, Italy's national infrastructure manager
<b>RFID</b>	Radio frequency identification
<b>RGV 2N</b>	Rames à Grande Vitesse et à 2 Niveaux, SNCF's designation for the new TGV Duplex trainsets

---

---

<b>RIU</b>	Radio infill unit
<b>RPS</b>	Répétition Ponctuelle des Signaux – France's punctual signaling repetition system
<b>RSAC</b>	Railroad Safety and Advisory Committee
<b>S</b>	
<b>Salon (or saloon)</b>	Passenger seating compartment
<b>SASAC</b>	State-Owned Assets Supervision and Administration Commission of the State Council, China's regulatory agency for rail operations
<b>SDH</b>	Synchronous digital hierarchy
<b>Shunting</b>	Coupling
<b>SIL</b>	Safety integrity level
<b>SIV</b>	Secondary impact velocity
<b>Sleepers</b>	Rail ties
<b>SNCB</b>	Société Nationale des Chemins de fer Belges, Belgium's national railway operator
<b>SNCF</b>	Société Nationale des Chemins de fer Français, France's national railway operator
<b>SOA</b>	Service-oriented architecture
<b>Spall</b>	Glass shatter
<b>SRB</b>	Shanghai Railway Bureau
<b>Static gauge</b>	An outline drawing that represents the maximum size of the rolling stock in a stationary position
<b>Stitch wiring</b>	A method used in catenary design to accommodate higher speeds than does simple catenary by allowing a greater contact force between the pantograph and the OCS
<b>Stroke</b>	The length of a deformed section of a structural element
<b>Suspension coefficient</b>	Value that identifies a stiff or flexible suspension
<b>T</b>	
<b>TB</b>	Chinese Norm, standard abbreviation is TB
<b>TB/T 2325</b>	Technical Specifications for Front Illuminators, Auxiliary Illuminators, and Lighting Marks Used for Locomotive and Multiple Units
<b>TB/T 2961</b>	Locomotive Cab Seats

---

---

<b>TB/T 3058</b>	Railway Applications – Rolling Stock Equipment Shock and Vibration Tests
<b>TB/T 3125</b>	Electric Hot Water Device for Railway Passenger Car
<b>TB/T 3139</b>	Decorating Materials and Indoor Air Limit of Harmful Substance for Railway Locomotive and Vehicle
<b>TCMS</b>	Train control and monitoring system
<b>TFT</b>	Thin film transistor
<b>TGV</b>	Train à Grande Vitesse, the designation for high speed trainsets currently operating in France
<b>Tier I</b>	FRA CFRs applying to trains traveling at speeds up to 125 mph (201 km/h)
<b>Tier II</b>	FRA CFRs applying to trains traveling at speeds from 125 mph to 150 mph (201 km/h to 241 km/h)
<b>Tier III</b>	FRA CFRs under development for application to trains traveling at speeds greater than 125 mph (201 km/h) and up to 220 mph (354 km/h)
<b>Track brakes</b>	A type of brake system whereby the braking force results from the application of a brake shoe directly onto the running rail
<b>Track gauge</b>	Dimension between the inside surfaces of the rail heads of two rails
<b>Train manager</b>	Member of the train crew analogous to conductors on U.S. trains
<b>Trainline</b>	An electric, pneumatic, or hydraulic line that runs the length of a trainset, and is used to transmit control signals
<b>Trenitalia</b>	Italy's national railway operator
<b>TRKC</b>	Transport Research Knowledge Centre
<b>Truck</b>	Bogie
<b>TS 45545</b>	Railway Applications – Fire Protection on Railway Vehicles
<b>TSDI</b>	Third Survey and Design Institute of China Railways
<b>TSI</b>	European Technical Standards for Interoperability
<b>TVDI</b>	Track vacancy detection indication
<b>TVM</b>	Ticket vending machine
<b>Twist</b>	The algebraic difference between two cross levels taken at a defined distance apart (usually expressed as a gradient between the two points of measurement in % or in/ft (mm/m))
 <b>U</b>	
<b>UHF</b>	Ultra high frequency
<b>UIC</b>	Union Internationale des Chemins de Fer, the International Union of Railways

---

---

<b>UIC 505-1</b>	Railway Transport Stock – Rolling Stock Construction Gauge
<b>UIC 513</b>	Guidelines for Evaluating Passenger Comfort in Relation to Vibration in Railway Vehicles
<b>UIC 515-4</b>	Passenger Rolling Stock – Trailer Bogies – Running Gear – Bogie Frame Structure Strength Tests
<b>UIC 518</b>	Testing and Approval of Railway Vehicles from the Point of View of Their Dynamic Behaviour – Safety – Track Fatigue – Ride Quality
<b>UIC 540</b>	Brakes – Air Brakes for Freight Trains and Passenger Trains
<b>UIC 541-05</b>	Brakes – Specifications for the Construction of Various Brake Parts – Wheel Slide Protection Device (WSP)
<b>UIC 541-1</b>	Brakes – Regulations Concerning the Design of Brake Components
<b>UIC 541-5</b>	Brakes – Electropneumatic Brake (EP Brake) – Electropneumatic Brake Override (EBO)
<b>UIC 543</b>	Brakes – Regulations Governing the Equipment of Trailing Stock
<b>UIC 563</b>	Fittings Provided in Coaches in the Interests of Hygiene and Cleanliness
<b>UIC 564-1</b>	Coaches – Windows Made from Safety Glass
<b>UIC 564-2</b>	Regulations Relating to Fire Protection and Firefighting Measures in Passenger Carrying Railway Vehicles or Assimilated Vehicles Used on International Services
<b>UIC 566</b>	Loadings of Coach Bodies and Their Components
<b>UIC 612</b>	Driver Machine Interfaces for EMU/DMU Locomotives and Driving Coaches
<b>UIC 615-0</b>	Tractive Units – Bogies and Running Gear – General Provisions
<b>UIC 615-4</b>	Motive Power Units – Bogies and Running Gear – Bogie Frame Structure Strength Tests
<b>UIC 644</b>	Warning Devices Used on Tractive Units Employed on International Services
<b>UIC 651</b>	Layout of Driver's Cabs in Locomotives, Railcars, Multiple-Unit Trains and Driving Trailers
<b>UIC 660</b>	Measures to Ensure the Technical Compatibility of High-Speed Trains
<b>UIC 779-11</b>	Determination of Railway Tunnel Cross-Sectional Areas on the Basis of Aerodynamic Considerations
<b>UMTS</b>	Universal mobile telecommunications system
<b>UNI</b>	Ente Nazionale Italiano di Unificazione (Italian Norm) – standard abbreviation is UNI
<b>UNI CEI 11170</b>	Railway and Tramway Vehicles – Guidelines for Fire Protection of Railway, Tramway and Guided Path Vehicles – General Principles
<b>Unsprung mass</b>	Sum of the masses of bogie components that are not supported by the suspension (e.g., wheels, axles)

---



---

**UV** Ultraviolet

**V**

**Vestibule area** Area linking two passenger compartments

**VIP** Very important person

**VOC** Volatile organic compound

**VTI** Vehicle-track interaction

**VVVF** Variable voltage variable frequency

**W**

**Wagon** Freight car

**Wheel load** The vertical load of the wheel on the rail

**Wheel unloading** Wheel unloading occurs when one wheel is lifted or dropped (with respect to other wheels) due to the difference in cross level (twist). Wheel unloading is expressed in percentage as the ratio of the difference between the nominal wheel load and the wheel load to the nominal wheel load

**Wi-Fi** Wireless fidelity

**Windscreen** The end-facing, or forward-facing window on the driver's cab

**WRM** Wheel rotation monitoring

**WSP** Wheel slide protection

**WTB** Wired train bus

**Z**

**ZUB** Zugbeeinflussung, Switzerland's train control system (with speed control via balises)



---

## REFERENCES

### ALSTOM

- Avril, E. "Articulated/Conventional Architecture." La Rochelle, France, June 2010.
- Avril, E. "TGV: 30 Years of Experience of High Speed." La Rochelle, France, June 2010.
- Brisou, F. "High Speed in the USA: Braking Stakes." La Rochelle, France, June 2010.
- Cuny, N. "America Referential for High Speed." La Rochelle, France, June 2010.
- Debruyne, M. "Traction Drives for Very High Speed Trains." La Rochelle, France, June 2010.
- Dindeleux, J. "ATSA Fire Safety Policy." La Rochelle, France, June 2010.
- Douce, M., N. Flix, and C. Ponticelli. "Train Life Services – Integrated Logistic Support: Contributions to Operators' Performance." La Rochelle, France, June 2010.
- Drouin, D., L. Finet, and J. Lehmann. "Strength of Vehicle Structure." Belfort, France, June 2010.
- Durand, J. "Safety Approval Process for VHST Trains in USA." Belfort, France, 2010.
- Gregoire, R. "VHST Aerodynamics: TSI/CEN Documents & Discussions." La Rochelle, France, June 2010.
- Lacote, F. "Very High Speed Train and Safety." Paris, France, June 2010.
- Le Chatelier, N., and S. Geraud. "Signalling Equipments Integration." Belfort, France, June 2010.
- Le Corre, D. "Passive Safety in Alstom High Speed Trains." Reichshoffen, France, June 2010.
- Miglianico, D. "Driver's Desk." Belfort, France, June 2010.
- Pailler, C. "ADA Accessibility Requirements for Rolling Stock." La Rochelle, France, June 2010.
- Pailler, C. "Front Glazing." La Rochelle, France, June 2010.
- Pailler, C. "Side Glazing for Very High Speed Trains: AGV & RGV." La Rochelle, France, June 2010.
- Passau, V. "High Speed Signalling ERTMS: The Present and the Future." Paris, France, June 2010.
- Peille, B. "La Rochelle Plant." La Rochelle, France, June 2010.
- Perez, S. "FRA Vehicle/Track Interaction: Safety." Paris, France, June 2010.
- Sol Rolland, B. "The Alstom Group." Paris, France, June 2010.

### CSR

- Li, Y., et al. "Information about High Speed EMU." Qingdao, China, November 2010.
- CSR Qingdao Sifang Company. "Propulsion Curve." Personal Communication, January 2011.

---

CSR Qingdao Sifang Company. "Layout of Emergency Window." Personal Communication, January 2011.

CSR Qingdao Sifang Company. "Fire Proof Advice." Personal Communication, January 2011.

CSR Qingdao Sifang Company. "Trainset of CRH380A." Personal Communication, January 2011.

CSR Qingdao Sifang Company. "Composition Proposal of EMU for California." Personal Communication, January 2011.

CSR Qingdao Sifang Company. "The Health System on the CRH380A." Personal Communication, January 2011.

CSR Qingdao Sifang Company. "Energy Consumption Curve." Personal Communication, January 2011.

CSR Qingdao Sifang Company. "Inspection Report of Windscreen." Personal Communication, January 2011.

## **FRA**

<http://www.fra.dot.gov> accessed on October 18, 2011.

## **HYUNDAI-ROTEM**

Choi, J. "High Speed Trains." Seoul, Korea, November 2010.

Lee, B., and W. Na. "Welcome to Hyundai Rotem R&D Center." Uiwang, Korea, November 2010.

## **NERTUS**

López, J. "AVE S103/Velaro E Maintenance." Madrid, Spain, February 2010.

## **NTV**

Agrillo, M., P. Belforte, R. Raspanti, F. Sgroi, P. Vignes. "NTV: The Company and Its Italo Service." Rome, Italy, June 2010.

---

## **SIEMENS**

- Beller, R. "Velaro Maintenance." Erlangen, Germany, February 2010.
- Cuylen, J. "Interior Design." Krefeld–Uerdingen, Germany, January 2010.
- Cuylen, J. "Train Layout Velaro USA." Krefeld–Uerdingen, Germany, January 2010.
- Duesing, C., O. Kemmann, and H. Waldeck. "Fire Safety." Krefeld–Uerdingen, Germany, January 2010.
- Filz, K. "Welcome to Wegberg-Wildenrath: Siemens' Test Center for Railway Systems." Wegberg-Wildenrath, Germany, January 2010.
- Fritzsich, G, and T. Schoeggel. "High Speed Signalling ETCS." Erlangen, Germany, February 2010.
- Grießinger, J., and N. Straub. "Passenger Information Systems." Erlangen, Germany, February 2010.
- Kasper, M. "Welcome at Uerdingen Plant." Krefeld–Uerdingen, Germany, January 2010.
- Kick, A. "Introduction to Siemens Sacramento." Krefeld–Uerdingen, Germany, January 2010.
- Kistner, M. "Traction and Auxiliary System." Erlangen, Germany, February 2010.
- Knoernschild, U. "Diagnostic System." Erlangen, Germany, February 2010.
- Knoernschild, U. "Train Control System." Erlangen, Germany, February 2010.
- Koschnitzke, A., J. Schüler, and H. Waldeck. "Acoustics." Krefeld–Uerdingen, Germany, January 2010.
- Maier, M. "Complete Mobility: Integrated Solutions for Efficient People and Freight Transport." Krefeld–Uerdingen, Germany, January 2010.
- Maier, M. "Velaro E: 26 High Speed Train Sets for the Spanish National Railways (RENFE)." Madrid, Spain, February 2010.
- May, B., and H. Waldeck. "Construction and Structural Requirements of Carbodies." Krefeld–Uerdingen, Germany, January 2010.
- Rüter, A., and H. Waldeck. "Train Aerodynamics." Krefeld–Uerdingen, Germany, January 2010.
- Schmidt, G., and H. Waldeck. "Crashworthiness." Krefeld–Uerdingen, Germany, January 2010.
- Schroeder-Bodenstein, K. "Running Dynamics and Gauging." Krefeld–Uerdingen, Germany, January 2010.
- Steuger, M. "Braking Operation High Speed Trains." Erlangen, Germany, February 2010.
- Steuger, M. "The Velaro Success Story." Krefeld–Uerdingen, Germany, January 2010.

---

## **SNCF**

Bobillot, A. "Electric Traction Interfaces: Electromagnetism Interference." Paris, France, June 2010.

Bouhadana, J. "Interfaces Infrastructure/Rolling Stock Part 2: Rolling Stock." Paris, France, June 2010.

Bouhadana, J. "Rolling Stock Maintenance Policy." Paris, France, June 2010.

Bouhadana, J., and J. Valdes. "High Speed Lines Tunnel Aerodynamics." Paris, France, June 2010.

Bouhadana, J., and J. Valdes. "Involvement in European Norms and Technical Requirements." Paris, France, June 2010.

Chevol, S. Train Servicing: "On-Board Staff Recruiting, Training and Management." Paris, France, June 2010.

Coudert, F., and P. Schmitt. "Interfaces Infrastructure/Rolling Stock Part 1: Infrastructure." Paris, France, June 2010.

Damas, G. "Safety and Interoperability: The French Plan." Paris, France, June 2010.

Gallou, J. "SNCF Engineering Department Domestic and International Experiences." Paris, France, June 2010.

Le Caignec, H. "SNCF Worldwide Involvements in HST Design and Operations." Paris, France, June 2010.

Loizeau, T. "Environmental Aspect: Noise." Paris, France, June 2010.

Paradot, N. "Aerodynamic Effects." Paris, France, June 2010.

Pignal, O. "Control Command and Signaling: ERTMS." Paris, France, June 2010.

Zekri, S. "Catering." Paris, France, June 2010.

## **SRB**

Shanghai Railway Bureau. "Introduction of SR EMU Operation and Maintenance." Beijing, China, November 2010.

## **TSDI**

He, S., et al. "Brief Introduction of CTCS-3: Communication and Disaster Prevention Monitoring System." Beijing, China, November 2010.

---

## **UIC**

[www.uic.org/reunion.php/20819/18\\_safetydatabase.pdf](http://www.uic.org/reunion.php/20819/18_safetydatabase.pdf).





## APPENDIX A TRIP LOGS

The Fellowship research team made four trips to Europe and Asia during 2010. The countries visited, dates of travel, companies and agencies whose representatives participated, and topics discussed are presented in Tables A.1, A.3, A.5, and A.7. While abroad, the team also traveled on HSR trainsets and lines manufactured and operated by their hosts. These trips are summarized in Tables A.2, A.4, A.6, and A.8.

**Table A.1 Research Trip Log: Germany and Spain 1/25/10 thru 2/5/10**

<b>Date</b>	<b>Entities Met</b>	<b>Topics for Discussion</b>
1/25/10	Siemens	<b>Program level</b> (schedule, milestones) <b>CEM</b> (strength of vehicle structure) <b>Vehicle structural strength</b> (RSAC ETF activities, static loads, end structures, fatigue loads, equipment attachments) <b>Passive safety</b> (survival space, deceleration limit, overriding)
1/26/10	Siemens	<b>Environmental conditions</b> (aerodynamics, exterior noise) <b>Infrastructure</b> (sealing, "medical health criteria," pressure curve, maximum pressures/fatigue/strength of rolling stock/trainset) <b>Fire safety</b> (fire safety testing)
1/26/10	Siemens	<b>Visit to Uerdingen Plant</b> (manufacturing facility)
1/27/10	Siemens	<b>Glazing safety</b> (glazings, emergency exits) <b>Exterior lights and horn</b> (headlights, auxiliary lights, marker lights, horn) <b>General</b> (design of trains) <b>Structure and mechanical parts</b> (safety appliances, end couplers, toilets, driver's cab) <b>System protection</b> (emergency exit, fire safety, electric shock protection, lifting rescue procedures, air conditioning, driver's vigilance device, software, particular specification for tunnels, emergency lighting, vehicle identification) <b>Mobility</b> (level boarding, ADA accessibility, trainset floor plans)
1/28/10	Siemens	<b>Track interaction and gauging</b> (kinematic gauge, static axle load, rolling stock parameters, design) <b>Interface issues</b> (AREMA 141, max/min criteria)
1/28/10	Siemens	<b>Visit to Wegberg Wildenrath Test Center</b> (testing facility)
1/29/10	DB	<b>Operator HSR safety and experience</b> (crew and passenger safety, injury data, trainset hazard reporting, emergency preparedness, safety enhancements) <b>Operations</b> (speeds, seats, train crews, turnaround times)

**Table A.1 Research Trip Log: Germany and Spain 1/25/10 thru 2/5/10 (cont'd)**

<b>Date</b>	<b>Entities Met</b>	<b>Topics for Discussion</b>
2/1/10	Siemens	<b>Traction requirements</b> (traction and electrical equipment, traction performance requirements, traction wheel/rail adhesion requirements, electric power supply) <b>Energy requirements</b> (running resistance, tractive effort/braking curves, pantograph) <b>Propulsion design</b> (superconductor advancements and applications) <b>Braking</b> (braking performance, brake system) <b>Health monitoring</b> (tests) <b>Truck stability monitoring</b> (inspections)
2/2/10	Siemens	<b>Monitoring and diagnostic concepts</b> (diagnostic systems, reports) <b>Passenger alarm</b> (function) <b>Passenger information and communication</b> (PA system, information signs, functionality)
2/3/10	Siemens	<b>ATC/ATO</b> (requirements, functionality) <b>Exterior EMI</b> (measures) <b>Control and command</b> (requirements, facilities) <b>Monitoring and diagnostic concepts</b> (equipment) <b>Maintenance</b> (protocols, costs, efficiency, cycles)
2/4/10	Renfe	<b>Operations</b> (seats, train crews, turnaround times)
2/5/10	NERTUS	<b>Visit to NERTUS Santa Catalina Maintenance Facility</b>

**Table A.2 HSR Travel in Germany and Spain**

<b>Date</b>	<b>Operator</b>	<b>Trainset</b>	<b>High Speed Rail Line</b>
1/23/10	DB	ICE 3	Frankfurt – Cologne – Krefeld
1/29/10	DB	ICE	Krefeld – Cologne – Frankfurt
1/29/10	DB	ICE	Frankfurt – Nuremburg
2/4/10	Renfe	Velaro E	Barcelona to Madrid, Atocha Train Station

**Table A.3 Research Trip Log: Japan 4/5/10 thru 4/16/10**

<b>Date</b>	<b>Entities Met</b>	<b>Topics for Discussion</b>
4/5/10	MLIT, JR East, JR Central, Japan Railway Construction, Transport, and Technology Agency	<b>Program level</b> (HSR express project, future plans, HSR system developments, bi-level platform, perspective of critical aspects) <b>Infrastructure</b> (curve radii, gauge, friction modifiers, AREMA 141, sealing, rolling stock) <b>Maintenance</b> (protocols, costs, efficiency, cycles, inspections) <b>Operations</b> (scheduling, seats, turnaround time)
4/6/10	JR East	<b>Operator HSR safety and experience</b> (injury data, safety enhancements, rolling stock, perspective of critical aspects)
4/6/10	JR East	<b>Visit to JR East Sendai Shinkansen General Rolling Stock Center</b> (maintenance facility)
4/7/10	JR Central	<b>Operator HSR safety and experience</b> (injury data, emergency preparedness, safety enhancements, rolling stock, perspective of critical aspects)
4/7/10	JR Central	<b>Visit to JR Central's Operations Control Center</b> (operations facility) <b>Visit to JR Central's Komaki Research and Development Center</b>
4/8/10	Kawasaki	<b>Glazing safety</b> (end-facing glazings, screen configuration, side-facing glazings, emergency glazings, interior glazings)
4/8/10	Kawasaki	<b>Visit to Hyogo Works Factory</b> (manufacturing facility)
4/9/10	Kawasaki	<b>ATC/ATO</b> (signaling, driver's vigilance device, headway, prerequisites, performance, scheduling) <b>Exterior lights and horn</b> (headlights, auxiliary lights, marker lights, horn) <b>Braking</b> (performance, features, design, system requirements)
4/12/10	Kawasaki	<b>Fatal flaw analysis</b> (design, structure, mechanical parts, end couplers, access, toilets, driver's cab, storage, steps, kinematic gauge, static axle load, rolling stock, stability, length, gradients, curve radii, flange lubrication, suspension, sanding, aerodynamics, braking, PA system, passenger alarms, environmental conditions, loads, crosswinds, exterior noise, exterior EMI, protection, fire safety, procedures, interior noise, air conditioning, driver's vigilance device, signaling, diagnostics, lighting, software, interface identification, traction and electrical equipment, power supply) <b>Energy requirements</b> (running resistance, braking curves, pantographs, voltage)
4/13/10	Kawasaki	<b>CEM</b> (strength of vehicle structure, requirements, energy absorption) <b>Passive safety</b> (survival space, deceleration limit, overriding) <b>Vehicle structural strength</b> (strength of vehicle structure, RSAC ETF activities, loads, end structures, rollover strength, stability)

**Table A.3 Research Trip Log: Japan 4/5/10 thru 4/16/10 (cont'd)**

<b>Date</b>	<b>Entities Met</b>	<b>Topics for Discussion</b>
4/14/10	Kawasaki	<b>Vehicle structural strength</b> (strength of vehicle structure, fatigue, loads, crashworthiness validation, equipment attachments, driver's cab, PA system, emergency lighting) <b>Fire safety</b> (testing)
4/15/10	Kawasaki	<b>Fatal flaw analysis</b> (servicing, cleaning facilities, toilet discharge system, interior cleaning, water restocking, sand restocking, stabling, refueling, equipment) <b>Mobility</b> (floor plans) <b>Program level</b> (scheduling, forecast, inspections, production, testing, design, commissioning)
4/16/10	MLIT	<b>Meeting with MLIT</b> (closeout)

**Table A.4 HSR Travel in Japan**

<b>Date</b>	<b>Operator</b>	<b>Trainset</b>	<b>High Speed Rail Line</b>
4/6/10	JR East	E2/E4	Tokyo – Sendai
4/7/10	JR Central	N700	Tokyo – Nagoya – Kobe
4/15/10	JR Central	N700	Kobe – Tokyo

**Table A.5 Research Trip Log: France and Italy 6/14/10 thru 6/26/10**

<b>Date</b>	<b>Entities Met</b>	<b>Topics for Discussion</b>
6/14/10	Alstom, SNCF	<b>System requirements</b> (environmental conditions) <b>Infrastructure</b> (sealing, pressure curves, aerodynamic drag) <b>System requirements</b> (EMI) <b>System requirements</b> (track interaction and gauging) <b>Infrastructure</b> (AREMA 141, Class 2 track standards)
6/15/10	SNCF	<b>ATC/ATO</b> (control-command and signaling system, requirements) <b>System requirements</b> (system protection) <b>System requirements</b> (aerodynamics, ballast pickup) <b>System requirements</b> (exterior noise, interior noise) <b>Operations</b> (scheduling, turnaround times) <b>Maintenance</b> (protocols, costs, cycles, efficiency) <b>Operator HSR safety and experience</b> (passenger and rolling stock safety)
6/16/10	SNCF	<b>Operations</b> (maximum speeds) <b>System requirements</b> (track interaction and gauging)
6/16/10	SNCF	<b>Visit to SNCF TGV East Technical Maintenance Center</b>
6/17/10	Alstom	<b>Vehicle structural strength</b> (loads, structural stability)
6/17/10	Alstom	<b>Visit Alstom's Belfort Plant</b> (manufacturing facility)
6/18/10	Alstom	<b>Passive safety</b> <b>CEM</b> (strength of vehicle structure)
6/18/10	Alstom	<b>Visit Alstom's Reichschoffen Plant</b> (manufacturing and testing facility)
6/21/10	Alstom	<b>Braking system requirements</b> (braking performance) <b>Traction requirements</b> (traction and electrical equipment) <b>Energy requirements</b> (pantograph)
6/21/10	Alstom	<b>Visit to Bellevue Test Track</b> (testing facility)
6/22/10	Alstom	<b>System requirements</b> (exterior noise) <b>System requirements</b> (interior noise) <b>Glazing safety</b> (windscreen and front of train) <b>System requirements</b> (aerodynamics) <b>Mobility</b> (PRM/ADA system requirement for rolling stock) <b>Maintenance</b> (protocols, costs, cycles, efficiency) <b>Fire safety</b> (fire safety testing)
6/22/10	Alstom	<b>Visit to La Rochelle Plant</b> (manufacturing facility)
6/23/10	Alstom	<b>Exterior lights and horn</b> (headlights, auxiliary lights, marker lights, horn) <b>System requirements</b> (general, structure and mechanical parts) <b>Critical system interfaces</b> (tunnel safety, other inquiries) <b>Program level</b>
6/24/10	Alstom, SNCF	<b>System requirements</b> (rolling stock dynamic behavior) <b>Closeout</b>
6/25/10	NTV, SNCF	<b>Introduction to NTV</b>

---

**Table A.6 HSR Travel in France and Italy**

<b>Date</b>	<b>Operator</b>	<b>Trainset</b>	<b>High Speed Rail Line</b>
6/16/10	SNCF	TGV	Paris – Strasbourg
6/18/10	SNCF	TGV	Strasbourg – Paris
6/20/10	SNCF	TGV	Paris – La Rochelle
6/23/10	SNCF	TGV	La Rochelle – Paris
6/26/10	Trenitalia	ETR500/ ETR600	Rome – Florence

**Table A.7 Research Trip Log: China and Korea 10/30/10 thru 11/12/10**

<b>Date</b>	<b>Entities Met</b>	<b>Topics for Discussion</b>
10/30/10	MOR	<b>Meet with MOR</b>
11/1/10	CRCC	<b>Program level</b> (system developments)
11/2/10	SRB, MOR	<b>HSR operator safety and experience</b> (crew/passenger safety, rolling stock safety, reporting) <b>Operations</b> (maximum safe speeds, rotating seats, scheduling, turnaround times)
11/2/10	MOR	<b>Visit to Hangzhou Slab Track Manufacturing Plant</b>
11/3/10	CSR	<b>Program level</b> (multi-level trainset development)
11/3/10	CSR	<b>Visit to CSR Manufacturing Facility</b>
11/4/10	CSR	<b>System requirements</b> (aerodynamics, crosswind, exterior noise, exterior EMI, kinematic gauge, rolling stock, maximum gradients, curve radii, flange lubrication, sanding, design, structure, mechanical parts, end couplers, PA system, passenger alarm, emergency exit) <b>Infrastructure</b> (rolling stock, AREMA 141) <b>CEM</b> (strength of vehicle structure) <b>Passive safety</b> (survival space, deceleration limit, overriding) <b>Vehicle structural strength</b> (strength of vehicle structure, longitudinal and vertical loads, forces, crashworthiness validation, equipment attachments, driver's cab) <b>Traction requirements</b> (traction and electrical equipment, performance requirements) <b>Energy requirements</b> (pantographs, voltage) <b>Exterior lights and horn</b> (headlights, auxiliary lights, marker lights, horn) <b>Operations</b> (braking curves) <b>Braking</b> (performance, rescue purposes) <b>Program level</b> (HSR system developments)
11/5/10	CSR	<b>System requirements</b> (structure, mechanical parts, interior noise, system protection, toilets) <b>Glazing safety</b> (end-facing glazings, side-facing glazings, emergency exits, interior glazings) <b>Fire safety</b> (testing) <b>Mobility</b> (PRM/ADA system, level boarding, toilets, floor plans) <b>Critical system interfaces</b> (health monitoring)
11/6/10	SRB, CRCC	<b>Maintenance</b> (protocols, costs, efficiency, cycles)
11/6/10	MOR	<b>Visit to Beijing EMU Maintenance Center</b>
11/8/10	TSDI, CRCC	<b>ATC/ATO</b> (requirements, driver's vigilance devices, headway, prerequisites, protection, operations, signaling) <b>System requirements</b> (signaling, diagnostics, interfaces)

**Table A.7 Research Trip Log: China and Korea 10/30/10 thru 11/12/10 (cont'd)**

<b>Date</b>	<b>Entities Met</b>	<b>Topics for Discussion</b>
11/9/10	MOR	<b>Program level/all systems, closeout meeting with MOR</b> (perspective on critical aspects)
11/11/10	Korail	<b>Operator safety and experience</b> (injury data, preparedness, procedures, rolling stock safety, perspectives on critical aspects) <b>Maintenance</b> (protocols, costs)
11/11/10	Hyundai Rotem	<b>Visit to Hyundai Rotem's Research and Development Center</b>
11/11/10	Korail	<b>Visit Goyang Maintenance Depot</b>
11/12/10	Hyundai Rotem	<b>Visit to Hyundai Rotem's Changwon Plant</b> (manufacturing facility)

**Table A.8 HSR Travel in China and Korea**

<b>Date</b>	<b>Operator</b>	<b>Trainset</b>	<b>High Speed Rail Line</b>
11/1/10	CRH	CRH3	Wuhan – Guangzhou
11/2/10	CRH	CRH380A	Hangzhou – Shanghai
11/8/10	CRH	CRH3	Beijing – Tianjin
11/12/10	Korail	KTX-I	Busan – Seoul



---

## **APPENDIX B MEETING AGENDA**

The goal of the 2010 William Barclay Parsons Fellowship was to investigate and disseminate proven European and Asian best practices in the realm of HSR. The knowledge gathered will be essential to advancing the application of HSR express trainsets in the U.S. The following agenda summarizes the topics planned for discussion during the research team's meetings with HSR trainset manufacturers and operators.

### **1. INTRODUCTION TO THE 2010 WILLIAM BARCLAY PARSONS FELLOWSHIP PROGRAM**

- Overview of the Fellowship
- Review of the proposal
- Intent of the program
- Discussion of the monograph
- Concentration on the safety of rolling stock.

### **2. PROGRAM LEVEL (FOR HSR $\geq$ 218 MPH (350 KM/H))**

- Introduction of program level issues for HSR express projects
- Current/future HSR plans
  - U.S. (California, Texas, and Florida)
  - International
- Emerging HSR system developments
- Emerging trainset platforms
- HSR bi-level platform development for  $\geq$ 218 mph (350 km/h)
- Production schedule and forecast
  - Discuss key phases and associated schedule durations of trainset production process, including design, production, inspection, testing, and commissioning
- Procurement process and key milestones
  - Discuss cost drivers and risk elements associated with HSR trainset procurements
- Manufacturer's/operator's perspective of aspects critical to the success of U.S. HSR express projects.

---

### 3. INTRODUCTION TO ISSUES REGARDING CEM/ PROBLEM STATEMENT

- Strength of vehicle structure – CEM
  - Discuss the approach to crashworthiness.
    - Is evaluation of kinetic energy the correct approach towards determining the requirements for CEM? Discuss minimizing kinetic energy developed during collision and on the ratio of dissipation of collision energy via CEM.
      - > What deviations, if any, from the current international standards (EN 12663 and EN 15227) are embodied in the design of the trainset (e.g., different collision speed)?
      - > Discuss international and U.S. collision scenarios. EN 15227 Section 5 calls for an identical trainset collision at 22 mph (36 km/h), a collision with an 88-ton (80-tonne) wagon at 22 mph (36 km/h), and a collision with a 16.5-ton (15-tonne) deformable obstacle at 68 mph (110 km/h). 49 CFR §238.403 Section (d) calls for an identical trainset collision at 30 mph (48 km/h). Discuss any additional collision scenarios that the manufacturer has designed and tested to.
      - > Discuss the U.S. CEM requirements as per 49 CFR §238.403 Section (c) (13 MJ at each end through controlled crushing of unoccupied volumes—5 MJ ahead of operator’s cab, 3 MJ by the power car structure between cab and first trailer car, and 5 MJ by the end of the first trailer car adjacent to the power car). From analysis, it is seen that these values result from the 49 CFR §238.403 Section (d) requirement of an identical trainset collision at 30 mph (48 km/h). How do these values compare with the trainset design and international minimum requirements? Discuss the best method for determining minimum CEM requirements.
      - > Why was the original 2002 TSI [2002 RST TSI Section 4.1.7 (b) and Annex A] requirement of the dissipation of 6 MJ (4,5 MJ in the front of the first car) removed in the 2008 TSI? Discuss the current criteria for CEM.
      - > Calculations show that a collision between two identical Acelas, at 30 mph (48 km/h), will dissipate 25.5 MJ of crash energy. This conforms to the 26 MJ called out in 49 CFR §238.403 Section (c). Discuss this analysis.
      - > Discuss the energy absorption system (i.e., overall energy absorption capacity, type and number of absorbers, etc.).
      - > What other considerations/standards are taken into account when determining the CEM requirements of trainsets?
      - > What can be done system-wide to adopt a TSI-compliant CEM requirement for the U.S.? What solutions will mitigate potential hazards?
- Discuss how the trainset meets/exceeds the requirements.
- Discussion of action items to close CEM topics/resolution of topic.

---

## **4. INTRODUCTION TO ISSUES REGARDING PASSIVE SAFETY/PROBLEM STATEMENT**

- Strength of vehicle structure – passive safety
  - Discuss the approach to passive safety
    - Survival Space
      - > How were the TSI limits of deformation of occupied spaces [2008 RST TSI Annex A.3.3 and EN 15227 Section 6.3.1] determined and achieved (i.e., dependent on CEM, structural strength, etc.)? What are the features necessary to limit deformation? How are these limits met? Discuss the crash energy pulse required to cause a reduction in the occupied volume of the driver's cab. Discuss the crash energy pulse required to cause a reduction in the occupied volume of the passenger space in the leading car.
    - Deceleration Limit
      - > Both the CFR [49 CFR §238.403 Section (d)(2)] requirement of an 8 g maximum deceleration] and the TSI [2008 RST TSI Annex A.3.2 and EN 15227 Section 6.4.1] requirement of a 5 g mean deceleration] call out deceleration limits based on collision scenario speeds. What maximum deceleration rate is the trainset designed to? How does the maximum SIV of 25 mph (40 km/h) called out in 49 CFR §238.403 Section (d)(1) translate to an international equivalent? How is the deceleration limit affected at collisions greater than the collision scenario speeds?
    - Overriding
      - > Discuss the approach to ensuring override protection. It is required by the CFR [49 CFR §238.403 Section (e)(1)] that all wheels of the trainset remain in contact with the rails during a collision. The TSI [2008 RST TSI Annex A.3.1 and EN 15227 Section 6.2.1] identifies an offset of 1.6 in (40 mm) granted the criteria for survival space and deceleration are met and that at least one wheelset of each bogie remains in contact with the rail; this offset may be a cause for derailment. Discussion of each approach and opportunity to comply with CFR requirements.
  - Discuss how the trainset meets/exceeds the requirements.
  - Discussion of action items to close passive safety topics/resolution of topic.

## **5. INTRODUCTION TO ISSUES REGARDING VEHICLE STRUCTURAL STRENGTH/PROBLEM STATEMENT**

- Strength of vehicle structure – structural strength
  - Discuss the approach to structural strength
    - RSAC ETF Activities
      - > Discuss the current RSAC ETF activities and the implications on whether the trainset will meet the requirements.
      - Discuss the U.S. locomotive impact test (20 mph (32 km/h) – cab forward structure into locomotive).

- 
- Longitudinal and Vertical Static Loads
    - > Discuss the differences between the international and U.S. requirements
      - What deviations, if any, from the current international standards (EN 12663 and EN 15227) are embodied in the design of the trainset (e.g., category P-1 carbody strength requirements)?
      - There exists a large difference in the longitudinal static compressive forces (337,000 lbf (1500 kN) [EN 12663 Section 4.2] vs. 2,100,000 lbf (9342 kN) and 800,000 lbf (3559 kN) [49 CFR §238.405 Section (a) and 49 CFR §238.405 Section (b)]). Discuss the CFR requirements and the TSI approach. How were the TSI compressive requirements developed? What solutions are available to mitigate potential hazards? Do the EN requirements cover both leading and trailing cars? Define trainset compressive requirements. Discuss buff strength tests conducted.
      - A difference also lies between the international and U.S. practice for the definition of vertical static loads. The CFR [49 CFR §238.407] codifies structural requirements for anti-climbing mechanisms, the TSI and the ENs are silent on these criteria. How does the international anti-climbing design account for resistance to these vertical forces? Description on lead end and coupled/articulated end anticlimbers.
      - What vertical force is the trainset's coupler arrangement capable of resisting? How does this compare with the 100,000 lbf (445 kN) identified by the CFR [49 CFR §238.407 Section (c)]?
      - EN 15227 Section 5 calls for the obstacle deflector to withstand 67,500 lbf (300 kN) of load at the centerline and 56,200 lbf (250 kN) of load at 29.5 in (750 mm) from the centerline laterally. This requirement is called out for speeds greater than 99 mph (160 km/h); however, the trainset will be travelling at more than twice that speed 218 mph (350 km/h). How does this affect the design of the deflector?
      - What other static load requirements/standards are the trainsets designed and tested to?
    - End Structures of Power and Trailer Cars
      - > Discuss the differences between the international and U.S. requirements
        - The CFR [49 CFR §238.409, 49 CFR §238.411, 49 CFR §238.413, 49 CFR §238.415, and 49 CFR §238.417] describes in great detail the forces that each end member of the vehicle is to resist at specific locations. How do these loadings compare with the compressive loads identified by the EN [EN 12663 Section 4.2.2]? Discuss the compressive loadings. What do the CFR requirements translate to in international terms?
        - How is rollover strength taken into account? EN 15227 Section 6.3 states that 80% of the original ceiling to floor height shall be maintained. 49 CFR §238.415 requires that each car be able to rest on its side (uniformly supported at the roof rail and the side sill) and on its roof (damage limited to roof sheathing and framing, where deformation is permitted to the extent necessary to permit the vehicle to be supported directly on the top chords of the side and end frames). Discuss.
        - How is side loading taken into account? 49 CFR §238.417 identifies resistance of 80,000 lbf (356 kN) at the side sill and 10,000 lbf (44,5 kN) at the belt rail. However, there are no EN requirements known to accommodate side impact criteria. Discuss.
        - What solutions are present to mitigate the risks?

- 
- What other requirements/standards are the end structures designed and tested to?
  - Demonstration of Static Strength and Structural Stability and Stiffness
    - > Discuss the international requirements
      - How can these EN [EN 12663 Section 3.4 and EN 12663 Section 3.5] requirements be correlated to U.S. standards?
      - Are there any additional requirements/standards for static strength, structural stability, and stiffness?
  - Superposition of Static Loads
    - > Discuss the international requirements
      - The EN [EN 12663 Section 4.4] superposition load cases include the combinations of both the longitudinal and vertical static load cases. How do these compare to the individual callouts codified by the CFR (see “end structures of power and trailer cars”)?
      - Are there any other superposition requirements?
  - Demonstration of Fatigue Strength
    - > Discuss the international requirements
      - Which approach for calculating fatigue resistance, as defined in EN 12663 Section 3.6, (endurance limit or cumulative damage) does the manufacturer use for its fatigue analyses? Discuss.
      - Are there any additional standards that are followed?
  - Fatigue Loads
    - > Discuss the international requirements
      - How does the manufacturer simulate payload changes, load/unload cycles, track induced loading, aerodynamic loads, and traction and braking (as defined in EN 12663 Section 4.6)?
      - Are there any additional requirements for fatigue resistance?
      - What additional standards are relevant in analyzing fatigue loads?
  - Crashworthiness Validation
    - > Discuss the international and U.S. requirements
      - Can the manufacturer provide a copy of a crashworthiness validation report which details all analyses and testing (e.g., 3D dynamic FEA, trainset simulations, etc.) done on a trainset?
  - Equipment Attachments
    - > Discuss the differences between international and U.S. requirements for truck-to-carbody and truck component attachments
      - The U.S. [49 CFR §238.419] and the international [EN 12663 Section 4.5] acceleration requirements differ from each other; dependent on the direction of the force, one can be more stringent than the other. How were the EN acceleration requirements developed? How does the superposition of these loads compare with the singular requirements called out by the CFR?
      - 49 CFR §238.419 Section (a) calls for a horizontal force of 250,000 lbf (1112 kN) acting in any horizontal direction. How does this translate to the trainset design?
      - The RSAC ETF is proposing a truck attachment strength capable of resisting forces generated by 5 g longitudinal, 1 g lateral, and 3 g vertical accelerations. This is equivalent to the truck-to-carbody attachment requirements under Category P-1 in EN 12663 Section 4.5. Discuss.
      - What additional standards are adhered to when designing truck-to-carbody and truck component attachments?
-

- 
- > Discuss the differences between international and U.S. requirements for interior fittings and surfaces
    - The acceleration requirements codified by the CFR are more stringent than those of the EN (8 g or 12 g, 4 g, 4 g [49 CFR §238.435] vs. 5 g, 3 g, 3 g [EN 61373 Section 10.5]). How were the EN requirements developed?
    - What solutions are present to mitigate the risks involved with proceeding with the EN requirements?
    - What additional standards are adhered to when designing interior attachments?
  - > Driver's Cab
    - The acceleration requirements codified by the CFR are more stringent than those of the EN (12 g, 4 g, 4 g [49 CFR §238.447] vs. 3 g, 1 g, 3 g [EN 12663 Section 4.5]). How were the EN requirements developed? Discuss seat design (e.g., mechanism that permits push back).
    - What solutions are present to mitigate the risks involved with proceeding with the EN requirements?
    - What additional standards are adhered to when designing the driver's seat attachment?
  - > PA System
    - The acceleration requirements codified by the CFR are more stringent than those of the EN (8 g, 4 g, 4 g [49 CFR §238.121] vs. 5 g, 3 g, 3 g [EN 61373 Section 10.5]). How were the EN requirements developed?
    - What solutions are present to mitigate the risks involved with proceeding with the EN requirements?
    - What additional standards are adhered to when accounting for shock resistance for the PA system?
  - > Emergency Lighting System
    - The acceleration requirements codified by the CFR are more stringent than those of the EN (8 g, 4 g, 4 g [49 CFR §238.115] vs. 5 g, 3 g, 3 g [EN 61373 Section 10.5]). How were the EN requirements developed?
    - What solutions are present to mitigate the risks involved with proceeding with the EN requirements?
    - What additional standards are adhered to when accounting for shock resistance for the emergency lighting system?
  - Discuss how the trainset meets/exceeds the requirements.
  - Discussion of action items to close structural strength topics/resolution of topic.

## **6. INTRODUCTION TO ISSUES REGARDING GLAZING SAFETY/PROBLEM STATEMENT**

- Windscreen and front of train
  - End-Facing Glazings
    - Explanation of current Tier II impact requirements [49 CFR §238.421 Section (b) and potentially 49 CFR §238.421 Section (c)(1)] for trainsets with operational speeds up to 150 mph (214 km/h) (Tier II, Type IHP)
    - Discuss the differences between the international and U.S. requirements
      - > The TSI [2008 RST TSI Annex J.2.1 and EN 15152 Section 6.2.6.1] requires resistance to 10 kJ of impact energy. Discuss. Are there any negative effects to designing a windscreen to accept 26 kJ [49 CFR §238.421

- 
- Section (b)(1)]? What are the trainset's end-facing glazings designed to resist?
- > Does designing a windscreen to accept 26 kJ greatly affect the optical clarity of the windscreen? What are the pros and cons of having a flat-paned configuration (like Acela)? What are the pros and cons of having a monolithic curve-paned configuration? Can there be a curved windscreen that dissipates 26 kJ and still maintains optical clarity?
  - > What solutions are present to mitigate a requirement of 26 kJ?
  - > What other impact/optical requirements does the manufacturer follow (other national standards)?
  - Discuss configuration of windscreen
    - > What is the current end-facing glazing layering configuration on the trainset? What are the pros and cons of having this type of configuration? Discuss injury and safety history.
    - > Can the manufacturer provide drawings of this configuration?
    - > What are the installation methods?
  - Side-Facing Glazings
    - Explanation of current Tier II impact requirements [49 CFR §238.421 Section (a), 49 CFR §223 Appendix A Section (b)(11), and potentially, 49 CFR §238.421 Section (c)(2) and 49 CFR §238.421 Section (c)(3)] for trainsets with operational speeds up to 150 mph (241 km/h) (Tier I, Type II and potentially Tier II, Type IIIH)
    - Discuss the differences between the international and U.S. requirements
      - > Can the trainset side-facing glazings meet the Tier II, Type IIIH impact requirements (large object impact of 122 J, small object impact of 127 J and a ballistic impact of 359 J)?
      - > Are they designed to meet all stages of the pressure test requirements of NEA VVV 6.2 Section 3.5.2.2 ( $\pm 1.2$  psi ( $\pm 8,1$  kPa) meets operational requirements for German National Standard)?
      - > Have passenger containment tests been conducted on those glazings (for example, as per requirements set forth in GM/RT 2100 Section 5.3)?
      - > What other requirements are the side-facing glazings designed and tested to?
      - > Does the manufacturer have any experience pressure testing current FRA compliant side-facing glazings?
    - Discuss configuration of the glazing
      - > What is the current side-facing glazing layering configuration on the trainset? What are the pros and cons of having this type of configuration? Discuss injury and safety history.
      - > Can the manufacturer provide drawings of this configuration?
      - > What are the installation methods?
  - Side-Facing Emergency Glazings
    - Discuss the differences between the international and U.S. requirements
      - > Can the trainset side-facing emergency glazing meet the Tier II, Type IIIH impact requirements (large object impact of 122 J, small object impact of 127 J and a ballistic impact of 359 J)?
      - > Are they designed to meet all stages of the pressure test requirements of NEA VVV 6.2 Section 3.5.2.2 ( $\pm 1.2$  psi ( $\pm 8,1$  kPa) meets operational requirements for German National Standard)?

- 
- > Have passenger containment tests been conducted on those glazings (for example, as per requirements set forth in GM/RT 2100 Section 5.3)?
  - > What other requirements are the side-facing emergency glazings designed and tested to?
  - > Does the manufacturer have any experience pressure testing current FRA compliant side-facing emergency glazings?
  - Discuss configuration of the glazing
    - > What are the pros and cons of having a breakable glazing? Discuss injury and safety history.
    - > What potential hazards are encountered in egress via this method (i.e., breakable glazing)? How are these hazards accounted for (e.g., tempering level, particle test, etc.)?
    - > What is the current side-facing emergency glazing layering configuration on the trainset? What are the pros and cons of having this type of configuration? Can the manufacturer provide drawings of this configuration?
    - > What are the installation methods? What are the differences in performance/safety when placing tempered in and laminated out and vice versa?
    - > Is there a way to accommodate resistance to potential blow-in/blow-out and still retain the U.S. method of window removal (i.e., without breaking the glazing)?
  - Interior glazings
    - Discuss the differences between the international and U.S. requirements
      - > What level of impact resistance are interior glazings designed to? Discuss injury and safety history.
      - > What standards are followed [GM/RT 2100 Section 6.5.2, ANSI/SAE Z26.1 Section 5.9, ANSI/SAE Z26.1 Section 5.12, ANSI/SAE Z26.1 Section 5.26, etc.]?
- Discuss how the trainset meets/exceeds the requirements.
  - Discussion of action items to close glazing topics/resolution of topic.

## **7. INTRODUCTION TO ISSUES REGARDING BRAKING PROBLEM STATEMENT**

- Minimum braking performance
  - Braking Performance
    - Discuss the U.S. requirements
      - > Can the manufacturer provide documentation on the trainset's brake system configuration?
      - > Discuss the anticipated operational features of the proposed system, and identify concerns relative to the operational limits of current braking technology.
      - > What components of the vehicle performance are included in the safe braking model to assure safe stopping:
        - Nominal emergency brake rate
        - Brake system failure effects on nominal rate



- 
- Other system failures that affect nominal brake rate (e.g., load weight)
  - Effects on runaway acceleration (if considered a possible failure at all)
  - Other safe braking model impacts
  - > Discuss braking related details for passenger alarm devices.
  - > Discuss the dead time/buildup time for service and emergency brake application for the trainset. Verify that response times include dynamic braking, and that jerk limiting is not initiated for emergency braking applications.
  - > Discuss the redundant characteristics of the braking system (e.g., number of independent brake subsystems).
  - > Discuss design values for reduced wheel adhesion, minimum deceleration rates (emergency and service) based on these adhesion values, and measures for ensuring stop distances.
  - > Discuss FRA requirement that the friction brake system shall be designed to safely stop the train under all operating conditions.
    - The braking system shall not exceed the thermal duty cycle of the brake components under any braking scenario, while respecting the maximum stop distance identified for safe operation. Discuss.
  - > Discuss requirements to implement (or not) track brakes to achieve stop distances.
  - > Discuss requirements for the WSP system, and the effect that the WSP system has relative to respecting maximum stop distances.
  - > Discuss requirements for brake pipe installations.
  - > Discuss requirements for the axle rotation monitoring system. Information on system dependency and component redundancy shall be elicited.
  - > Discuss the FRA/ASME requirements relative to reservoirs.
  - > Discuss requirements for the irretrievable emergency brake applications. Identify instances when this is not desirable.
  - > Discuss axle mounted eddy current brake systems that may be utilized.
  - > Verify the dynamic brakes are independent of the catenary voltage. If so, is their contribution to emergency braking considered in the calculation of braking performance?
  - > Discuss remote monitoring of brake application force.
  - > Discuss emergency brake valve that is accessible to another crew member in the passenger compartment or vestibule.
  - > Description of parking brake/hand brake system.
  - Brake wheel/rail adhesion
  - Brake system requirements
  - Service braking performance
  - Eddy current brakes
  - Protection of an immobilized train
  - Brake performance on steep gradients
  - Brake requirements for rescue purposes
  - Discuss how the trainset meets/exceeds the requirements.
  - Discussion of action items to close braking topics/resolution of topic.

---

## **8. INTRODUCTION TO ISSUES REGARDING TRACTION/ PROBLEM STATEMENT**

- Traction and electrical equipment
  - Traction performance requirements
  - Traction wheel rail adhesion requirements
  - Electric power supply
    - The nominal line voltage will be 25 kV, 60 Hz. Discuss.
- Discuss how the trainset meets/exceeds the requirements.
- Discussion of action items to close traction topics/resolution of topic.

## **9. INTRODUCTION TO ISSUES REGARDING AUTOMATIC TRAIN CONTROL/AUTOMATIC TRAIN OPERATION PROBLEM STATEMENT**

- Control-command and signaling system
  - ATC
    - Discuss the differences between the international and U.S. requirements
      - > Discuss the purpose/requirements for ATC systems.
      - > How does ATC interface with braking and propulsion systems?
      - > ATP overspeed interventions
      - > ATO operation
      - > How does ATC interact with the driver's vigilance device?
      - > What is the design headway for the ATC system and what is considered the practical minimum headway for scheduling?
      - > What prerequisite conditions are required for enabling and disabling ATC operation? Discuss. What are the prerequisites for moving the trainset after isolation of the ATC system? Discuss maximum speed enforcement after isolation of the ATC system based on FRA PTC rulemaking 59 mph to 79 mph (95 km/h to 127 km/h). Is there any secondary system for enforcing signals when the onboard ATC is bypassed or operating in another degraded mode?
      - > What are the operating modes of the ATC system, including degraded modes and system bypass?
      - > How can fail-safe train control be maintained after isolation of the ATC system? Discuss.
      - > How are temporary speed limits enforced?
      - > If the ATC system is used to modify temporarily the speed limit, are other means used to identify longer lasting temporary limits including signs and flags?
      - > How does ATC interface with the central control system (e.g., civil restrictions/roadway worker protection)?
      - > How does ATC protect on-track workers? Do on-track workers carry devices that interact with the ATC system?
      - > What other interfaces are there onboard and to what extent does ATC enhance system safety:
        - Door interlocks

- 
- - Platform berthing and right-side door operations
    - PA announcement triggers from central control
    - Onboard systems diagnostics communicated to central control
    - Traction power switching to facility phase brakes and other power control issue.
  - > What form of signal system is used in the yards?
    - Are speed and signals enforced in any way other than by procedure?
    - What operating sub-modes are available in the yards – ATO, wash mode, etc.?
  - > Is onboard ATC equipment maintained by the same group that maintains the rest of the rolling stock? If not, which group is responsible?
  - > What availability are the train-to-wayside radio communications subsystems specified to; how is this performance met for 250 mph (402 km/h) operation?
  - > Discuss system requirements/descriptions for onboard/wayside elements.
  - o ATO
    - Discuss the international requirements
    - > Discuss the purpose/requirements for ATO systems.
    - > To what extent is ATO deployed, is it platform stop only, full station stop to station stop ATC, is a restart command required from the driver when starting from stations only, and when starting from a signal/train ahead stop?
    - > What are the full list of prerequisites for enabling and disabling ATO?
    - > Can ATO be enabled and disabled while the train is moving, if so how?
    - > How does ATO interact with the driver's vigilance device? Are there differences in this interface between manual driving and ATO?
    - > What is the headway differential allowed between manual driving and ATO operation? How is speed regulated during transitions from high speed zones into stations? Discussion of potential sub-modes of operation (e.g., full ATO versus programmed station stops only, yard/train wash modes).
    - > How does ATO interface with the door control system to enable a door opening command when correctly positioned at a platform?
    - > How does ATO interface with the central control system?
      - Civil restrictions/roadway worker protection
      - Recovery from service delays
      - Performance levels of acceleration, braking, cruise speed etc.
      - Automatic schedule regulation
      - Optimization of trains through merges and other junctions and terminal approaches
      - Adjustment of ATO performance during poor adhesion conditions such as light rain, leaves, and other rail contaminants.
    - > Discuss system requirements/descriptions for onboard/wayside elements.
  - Discuss how the trainset meets/exceeds the requirements.
  - Discussion of action items to close ATC/ATO topics/resolution of topic.

---

## **10. INTRODUCTION TO ISSUES REGARDING EXTERIOR LIGHTS/PROBLEM STATEMENT**

- External lights and horn
  - Head Lights
    - Discuss the differences between the international and U.S. requirements
      - > The values for the international and the U.S. requirements for headlights are greatly different. 49 CFR §238.443 Section (a) requires each headlight to produce at least 200,000 cd (peak) whereas the 2008 RST TSI Annex H.2 (a) calls for at least 40,000 cd (peak) and at least 10,000 cd (peak) at all angles within 5° on either side of the center line in the horizontal plane. Discuss the development and pros and cons of both approaches (including safety history). What solutions are present to mitigate the risks? Discuss compliance with 49 CFR §238.443.
  - Auxiliary Lights (Marker Lamps)
    - Discuss the differences between the international and U.S. requirements
      - > The values for the international and the U.S. requirements for auxiliary lights are greatly different. 49 CFR §229.125 Section (d)(2) requires each auxiliary light to produce at least 200,000 cd (peak), or at least 3,000 cd at 7.5° and at least 400 cd 20° from the centerline of the train when the light is aimed parallel to tracks, whereas the 2008 RST TSI Annex H.2 (b) calls for (for lower auxiliary lights) 300-700 cd (peak) and 20-40 cd (peak) at 45° on either side of the center line in the horizontal plane and for (for upper auxiliary lights) 150-350 cd (peak). Discuss the development and pros and cons of both approaches (including safety history). What solutions are present to mitigate the risks? Discuss compliance with 49 CFR §229.125 and 49 CFR §229.133.
  - Marker Lights (Tail Lamps)
    - Discuss the differences between the international and U.S. requirements
      - > The values for the international and the U.S. requirements for marker lights are greatly different. 49 CFR §229.14 Section (a)(1) requires each marker light to produce 100-1000 cd, whereas the 2008 RST TSI Annex H.3 (b) calls for 15-40 cd and a minimum of 10 cd at 7.5° on either side of the centerline in a horizontal plane and a minimum of 10 cd at 2.5° on either side of the centerline in a vertical plane. Discuss the development and pros and cons of both approaches (including safety history). What solutions are present to mitigate the risks? Discuss compliance with 49 CFR §229.14.
- Discuss how the trainset meets/exceeds the requirements.
- Discussion of action items to close exterior light topics/resolution of topic.

## **11. INTRODUCTION TO ISSUES REGARDING FIRE SAFETY/PROBLEM STATEMENT**

- Fire safety
  - Fire Safety Testing
    - Discuss the differences between the international and U.S. requirements
      - > An analysis was completed to determine the similarities and differences

---

between the international and U.S. fire safety requirements. The conclusion drawn was that, while some of the test methods were similar, the criteria for each method were different. To be discussed.

- > Discuss international and U.S. approach to fire safety (testing of materials – component/floor testing (Discuss floor fire test per ASTM E 119/EN 1363-1); measures to prevent fire and fire spread; fire safety analysis; emergency response plans; onboard emergency equipment).
  - > Discuss invoking requirements of 49 CFR §238 Appendix B/NFPA 130 ASTM E 1354/BSS 7239/EN 45545-2/ISO 5658-2/ISO 5660-1 for HSR Express trainsets.
  - > Materials utilized in the construction of the trainset shall meet the fire safety requirements identified in Appendix B of 49 CFR §238.
  - > Adoption of all CFR requirements relative to fire safety and emergency preparedness.
- Discuss how the trainset meets/exceeds the requirements.
  - Discussion of action items to close fire safety topics/resolution of topic.

## **12. MAINTENANCE – INTERFACE ISSUES**

- Overview of maintenance protocols. Programs based on mileage, operating hours, preventative maintenance regimes.
- What is the ratio of operating time to maintenance time?
- What is the cost per mile of operation per trainset?
- Does slab or ballasted track affect rolling stock maintenance costs?
- In a typical HSR operation, how many days is the train in service? What is the practical limit of annual miles per trainset?
- How many days out of service for: maintenance, inspections, cleaning, repair, etc.?
- What is calculated life cycle of the vehicle structure?
- What are the recommended inspection, maintenance, light and heavy overhaul frequencies?
- Discuss trainset reliability as a function of operating entity (e.g., railroad owned/operated, contracted operation, supplier owned/operated).
- Discuss elements of pantograph inspections
  - Frequency of inspection
  - Detailed inspection
  - Inspection protocol
  - Pantograph monitoring.

## **13. OPERATIONS – INTERFACE ISSUES**

- Running resistance – Davis formula
- Tractive effort/braking curves – degraded mode
- Maximum speeds for “safe” movement both in yards (during inspection, maintenance layover, etc.) and in terminals (revenue service carrying passengers)
- Mechanized rotating seats
- How long are train drivers scheduled to be in the cab of a high speed train?

- 
- How long are train crews scheduled to be onboard a high speed train?
  - Are train crews housed in hotels or other facilities or do they deadhead back to their home station? If housed at hotels or other facilities do they get expenses/per diem for their time away from home?
  - What is the shortest time a train can be turned around at a terminal station?
  - What is the average time it takes to turn a train around at a terminal station?

## 14. INFRASTRUCTURE – INTERFACE ISSUES

- Discuss the use of AREMA 141 RE rail
  - Wheel profile = 1:40
- Discuss Class 2 track standards for yards and compatibility with the manufacturer's trainsets.
- Sealing of high speed rolling stock to ensure aural comfort for passengers represented by the dynamic pressure tightness coefficient " $\tau_{dyn}$ " at operating speeds of 218 mph (350 km/h) to 249 mph (400 km/h).
  - Excellently sealed trains ( $\tau_{dyn} \geq 10$  seconds).
  - "Medical Health Criteria" which restricts the maximum allowable instantaneous pressure change on a person's ear to 1.5 psi (10 kPa) (in the event of sudden loss of sealing/window breaking).
- Current "state of the art" for trainset sealing
  - Performance criteria to quantify "excellent" sealed trainsets
- Pressure signature/envelope curve of high speed rolling stock for operating speeds of up to 250 mph (402 km/h) and minimum tunnel cross-sections/blockage ratios.
- Calculations for theoretical and full scale test results of aerodynamic drag in open air and in tunnels (including tunnel length and tunnel free cross-sectional areas) for the manufacturer's high speed rolling stock (656 foot (200 m) and 1,312 foot (400 m) configurations).
- Maximum allowable pressures/fatigue/strength of rolling stock/trainset and number of cycles for current high speed rolling stock.

## 15. ENERGY – INTERFACE ISSUES

- Please provide information on the types of pantographs used. Are they necessarily supplied by the train manufacturer? Or can a specific pantograph be required?
- Pantograph operating range
  - Provision for secondary pantograph for heights in excess of TSI range
  - Any problems in using 76.8 in (1950 mm) or even 80.0 in (1980 mm) pantograph for 250 mph (402 km/h) operation? Can that still meet the L2 envelope of EN 50367?
  - What is the maximum pantograph reach? Related to this, what is the maximum wire height used in yard and maintenance facility areas?
  - Does the manufacturer's kinematic pantograph envelope meet the L2 value calculated based on the formula shown in EN 50367 Annex A.3?
  - If the manufacturers' static pantograph is larger than what is specified in EN 50367 Annex A.2, does the formula L2 still work? Or will there be any modifications to the formula?

- 
- Please kindly provide the kinematic pantograph envelope based on the maximum superelevation and curve data.
  - Minimum/maximum OCS voltage for full performance
  - Pantograph head dimensions
    - What is the pantograph profile? Dimensions? Does that match EN 50367 Annex A.2?
    - What is the distance from the pantograph to the wheel axis?
      - If the pantograph is away from the wheel axis, what is the additional pantograph displacement on curve?
    - What is the range of pantograph spacings used on high speed trainset configurations?
  - Discuss pantograph advancements relative to the interface with the OCS
  - Discuss vehicle operating characteristics over extended down grades
    - Confirm status of propulsion/braking on down grades
  - Electrically connecting the pantographs would help minimize the arcing caused by contact loss. Is it necessary to isolate all the pantographs in use per RST TSI Section 4.2.8.3.6.2 or do those only need to be isolated when passing the short phase breaks less than 1,319 feet (402 m)?
  - How is hotel power kept alive through phase breaks? Is it through use of dynamic braking? Batteries?

## **16. MOBILITY – INTERFACE ISSUES**

- Review PRM/ADA system requirement for rolling stock.
- How is level boarding maintained based on wheel wear, passenger loading, etc. (e.g., active suspension)?
- Toilets to be ADA accessible
- Evaluate potential trainset floor plans
  - 450 people minimum per 656 foot (200 m) trainset.

## **17. CRITICAL SYSTEM INTERFACES**

- Safety in Tunnels
- Other trainset related inquiries
  - Advancements in propulsion design
    - Silicon carbide IGBT
    - Super conductor advancements and applications
  - Health monitoring
  - Truck stability monitoring
  - Active dampener systems (yaw, lateral, and vertical).

## **18. REVIEW OF SYSTEM REQUIREMENTS**

- Discuss how the trainset meets/exceeds the requirements
  - General
    - Introduction
      - > The manufacturer shall describe and list in a document the various

- 
- reasonably foreseeable degraded modes and the related acceptable limits and operating conditions of the rolling stock subsystem that can be experienced.
- Design of trains
    - > Discuss proposed tilt systems to be utilized.
    - > Discuss the promotion and use of recycled materials for the manufacturing of new trainsets.
  - Structure and mechanical parts
    - Discuss safety appliance mechanical strength and fasteners, handrails and handholds, and sill steps.
    - General
    - End couplers
      - > Discuss the decoupling procedure when the automatic uncoupling mechanism is disabled.
      - > Identify speeds at which rescued trains travel (with/without passengers).
    - Access
      - > The door opening signal shall be interlocked with a zero speed command. Discuss.
      - > The door control circuit to prevent the trainset from taking traction power in the event that an exterior door/hatch is not closed. Discuss.
      - > Discuss means to detect obstructions preventing door closure.
      - > A crew key, or other secure method, shall be utilized to enable the panel in order to prevent misuse or unauthorized use. The key shall be captive while the panel is activated. Discuss.
      - > Each door shall be provided with an individual internal emergency-opening device, accessible to passengers, which shall allow the door only to be opened at speeds below 6.2 mph (10 km/h). Discuss appropriate maximum speed.
    - Toilets
    - Driver's cab
      - > Discuss opening side windows in driver's cab.
      - > Discuss means utilized for side/rear view.
      - > Discuss driver's seat structural attachment strength (12 g, 4 g, 4 g).
    - Storage facilities for use by staff
    - External steps for use by shunting staff
  - Track interaction and gauging
    - Kinematic gauge
    - Static axle load
    - Rolling stock parameters which influence ground based train monitoring systems
    - Rolling stock dynamic behavior
      - > Discuss approaches to maintain train alignment during a derailment (e.g., truck mounted devices that interact with the rail during a derailment).
      - > Discuss total uncontrolled lateral motion.
      - > Identify specific requirements for vehicles with independently rotating wheels.
    - Maximum train length
    - Maximum gradients
      - > Discuss effects of maximum gradients on operating performance (propulsion/braking).



- 
- > Discuss maximum gradient criteria
    - Potential to exceed the TSI maximum gradient criteria of 2.5% average grade over any 6.2 miles (10 km).
    - Grades up to 3.3% for as much as 7 miles to 8 miles (11 km to 13 km)
    - Grades of 2.7% to 2.8% for approximately 10 miles (16 km).
    - Can the trainsets accommodate these grades over a long sustained service life?
    - Discuss maintenance, reliability concerns.
  - Minimum curve radius
    - > Approximately 240 train movements per day
      - Minimum radius of 500 feet (152 m) at 5 mph (8 km/h).
      - Minimum radius of 650 feet (198 m) at 15 mph (24 km/h).
    - > Maximum distance between axles/bogies
    - > Wheel/track/train dynamics influencing “wheel lift” under certain conditions with tight radii curves (i.e., immediately following wheel reprofiling)
    - > Opening the gauge (how often, where and how do you do it?)
    - > Use of friction modifiers
    - > Minimum curve radius for overnight storage tracks?
    - > What is the minimum recommended mainline curve radius and why?
    - > What long term concerns or considerations should be made for operations and maintenance for mainline curves of 492 feet to 525 feet (150 m to 160 m)
  - Flange lubrication
    - > Discuss methods for flange lubrication.
  - Suspension coefficient
  - Sanding
  - Ballast pick up
    - > Discuss aerodynamic performance of the exterior of the carbody to mitigate ballast pickup.
  - Passenger information and communication
    - PA system
      - > Define redundancy of the PA system.
      - > Discuss requirements for passenger accessible intercom system.
    - Passenger information signs
    - Passenger alarm
      - > Discuss system functionality.
      - > Discuss interface with the braking system.
      - > Backup power for a minimum period of 90 minutes shall be available in case of an emergency.
  - Environmental
    - Environmental conditions
    - Aerodynamics
    - Aerodynamic loads on track workers
    - Aerodynamic loads on passengers
      - > Identify maximum speed for a trainset approaching a platform.
    - Pressure loads in open air
    - Crosswind
      - > Identify crosswind issues traveling at 220 mph and 250 mph (354 km/h and 402 km/h).
    - Maximum pressure variations in tunnels
-

- 
- Exterior noise
    - > Passby noise values to be identified for Class 1 electric trainsets traveling at 218 mph (350 km/h). 40 CFR §201.12 states that the limit for passby noise shall be 90 dB(A) measured at a distance of 100 feet (30,5 m) from the centerline of the track, 4 feet (1,2 m) above top of rail. Discuss.
  - Exterior EMI
    - > Discuss EMI generated on the signaling system and the telecommunications network, and measures being taken to mitigate this issue. This is an open point in the TSI.
  - System protection
    - Emergency exit
      - > Discuss low location exit path markings.
      - > Each emergency window exit in a passenger car shall have an unobstructed opening with minimum dimensions of 26 inches (660 mm) horizontally by 24 inches (610 mm) vertically. A seatback is not an obstruction if it can be moved away from the window opening without using a tool or other implement. Discuss.
      - > Each powered, exterior side door in a passenger car shall be connected to an emergency backup power system. Discuss.
    - Protection against electric shock
    - Lifting rescue procedures
    - Interior noise
    - Air conditioning
    - Driver's vigilance device
    - Control-command and signaling system
      - > Discuss requirement of 0.006-Ω maximum resistance between wheels on the same axle.
      - > What facilities are provided onboard for the customers to enhance internet access, direct ticket vending, other vending, other entertainment? How are reliable data connections made with the wayside/satellite?
    - Monitoring and diagnostic concepts
      - > Each train shall be equipped with an event recorder with a certified crashworthy event recorder memory module that meets the requirements of Appendix D of 49 CFR §229. Discuss.
    - Particular specification for tunnels
    - Emergency lighting system
      - > Per 49 CFR §238.115, the emergency lighting system shall be capable of operating after the initial shock of a collision or derailment resulting in the following individually applied accelerations: longitudinal: 8 g; lateral: 4 g; and vertical: 4 g. Discuss.
    - Software
    - DMI
      - > The DMI remains an open point in the TSI. Please provide a system description for the proposed interface.
    - Vehicle identification
  - Servicing
    - General
    - Train external cleaning facilities
    - Toilet discharge system

- 
- Train interior cleaning
    - Water restocking equipment
    - Sand restocking equipment
    - Special requirements for stabling of trains
    - Refueling equipment
  - Maintenance
    - Responsibilities
    - The maintenance file
    - Management of the maintenance file
    - Management of the maintenance information
    - Implementation of the maintenance
  - Request manufacturer's system description of the trainset platform.

## **19. PROGRAM LEVEL/ALL SYSTEMS**

- Resolve outstanding issues.

## **20. MEET WITH MANUFACTURER AND OPERATOR FOR CLOSEOUT MEETING**

- Perspective of aspects critical to the success of U.S. HSR express projects.





