

E S S E X

Instruction Book



APRIL  
1930

SERIAL NUMBER 116567  
AND UPWARD

HUDSON MOTOR CAR COMPANY  
DETROIT, MICHIGAN, U. S. A.

# INDEX

## General

	Page
ACCESSORY MANUFACTURERS .....	9
BREAKING IN INSTRUCTIONS .....	11
CARE OF THE FINISH .....	29
LICENSE DATA AND TECHNICAL INFORMATION .....	7
OPERATION .....	10
STARTING THE ENGINE .....	11

## Lubrication

BRAKE CROSS Shaft .....	19
CHASSIS LUBRICATION CHART .....	13
CLUTCH .....	16
DISTRIBUTOR .....	15
ENGINE .....	14
FRONT WHEEL BEARING .....	18
GENERATOR .....	15
HOOD LEDGE LACINGS .....	18
HOOD LOCKS .....	18
HORN .....	14
REAR AXLE .....	17
REAR WHEEL BEARINGS .....	18
STARTING MOTOR .....	15
STEERING GEAR .....	19
THROTTLE CONTROL RODS AND LEVERS .....	19
TRANSMISSION .....	16
UNIVERSAL JOINTS .....	17

## Tuning and Inspection

BATTERY .....	24
BRAKES .....	26
CARBURETOR .....	22
CLUTCH PEDAL .....	23
FAN BELT .....	22
FRONT WHEEL ALIGNMENT .....	26
FRONT WHEEL BEARINGS .....	25
HEADLAMPS .....	29
HORN .....	27
IGNITION TIMING .....	20
RADIATOR .....	27
REAR WHEEL BEARINGS .....	25
SPARK PLUGS .....	20
SPRING MOUNTING .....	28
STEERING GEAR .....	24
TAPPETS .....	21
TIMING CHAIN .....	21
TIRES .....	25
VACUUM TANK .....	23
WIRING DIAGRAM .....	30

# Warranty

The factory obligation with respect to replacement of alleged defective parts is fully covered by our warranty as follows:

“We warrant each new vehicle manufactured by us, whether passenger car or commercial vehicle, to be free from defects in material under normal use and service, our obligation under this warranty being limited to making good any part or parts thereof which shall, within ninety (90) days after delivery of such vehicle to the original purchaser, be returned to us with transportation charges prepaid, and which our examination shall disclose to our satisfaction to have been thus defective.

“This warranty is expressly in lieu of all other warranties expressed or implied, and of all other obligations or liabilities on our part, and we neither assume nor authorize any other person to assume for us any other liability in connection with the sale of our vehicles.

“This warranty shall not apply to any Essex automobile which shall have been repaired or altered outside of our factory in any way so as, in our judgment, to affect its stability or reliability, or which has been subject to misuse, negligence, or accident.

“We make no warranty whatsoever in respect to tires, rims, ignition apparatus, tops, upholstery, horns or other signaling devices, batteries, speedometers, or other trade accessories.”

HUDSON MOTOR CAR COMPANY  
Detroit, Michigan

*The factory does not participate in any labor costs incident to the replacement of parts under the warranty. The warranty under which Essex motor cars are sold will be interpreted by the distributor or dealer from whom the car was purchased. If you are touring and require service, be sure to get in touch with your nearest authorized Essex distributor or dealer.*

## License Data

CAR SERIAL NUMBER — On plate on dash under hood  
 ENGINE SERIAL NUMBER — Stamped on left side of cylinder block opposite  
 cylinder No. 3  
 CYLINDER BORE — 2-3/4"  
 PISTON STROKE — 4 1/2"  
 NUMBER OF CYLINDERS — 6  
 N. A. C. C. HORSEPOWER RATING — 18.2  
 PISTON DISPLACEMENT 160.38

### Weights

Roadster	2550	Sunsedan	2760
Phaeton (5-Pass.)	2620	Standard Sedan	2805
Coupe (2-Pass.)	2660	Brougham	2850
Coupe (Rumble)	2700	Touring Sedan	2850
Coach	2730		

## Technical Information

### Engine

TYPE--6 cylinders	CAMSHAFT DRIVE — Adjustable Silent Chain
ACTUAL DEVELOPED H. P — 60 at 3600 R. P. M.	CONNECTING ROD LOWER BEARING CLEARANCE — .001"-.0015"; Side Clearance, .006", .010"
COMPRESSION RATIO 5.8 to 1	PISTON MATERIAL — Aluminum Alloy
FIRING ORDER — 1-5-3-6-2-4	PISTON TYPE — Tapered Slotted Skirt
NUMBER MAIN BEARINGS — 3	PISTON WEIGHT — 8 ounces
TYPE OF CRANKSHAFT — Fully counter balanced with Lanchester Torsional Vibration Dampener	SKIRT CLEARANCE — Top, .002"-.0025"; Bottom, .001"-.0015"
MAIN BEARING CLEARANCE — .001"-.0015"	NUMBER OF PISTON RINGS — Compression, 2; Oil Control, 2
MAIN BEARING END PLAY — .006"-.012"	PISTON RING GAP — .007"-.009"
VALVE MATERIAL — Silicon Steel	LUBRICATION — Double Flow Circulating Splash
VALVE HEAD DIAMPTER — Intake, 1 3/8" Exhaust, 1 3/8"	OIL Pump TYPE — Oscillating Plunger
VALVE TAPPET CLEARANCE — Intake, .003-.005"; Exhaust, .005"-.007"	

### Cooling System

RADIATOR TYPE — Ribbon Cellular	RADIATOR SHUTTTR-Vertical Manually Controlled
COOLING SYSTEM CAPACITY — 4 3/4 gals.	
FAN BELT — "V" Type	

Fuel System

CARBURETOR — 1¼" Marvel Air Valve Type  
 AIR CLEANER — A. C.

FUEL FEED — Stewart Vacuum System with Vacuum Booster  
 GASOLINE TANK CAPACITY — 11½ gals.

Starting and Ignition

MAKE — Auto-Lite  
 SPARK CONTROL — Full Automatic  
 TIMING — Dead Center  
 FIRING ORDER - 1-5-3-6-4  
 DISTRIBUTOR POINT GAP — .020"  
 SPARK PLUG MAKE — A. C.  
 SPARK PLUG TYPE — G10 - Metric

SPARK PLUG GAP .022"  
 GENERATOR REGULATION  
 Third Brush  
 GENERATOR NORMAL CHARGING RATE  
 — Cold, 13.5 amps.; Hot, 10 amps.  
 GENERATOR FUSE SIZE — 5 amps.

Lamp Bulb Specifications

	C.P.	Base	Voltage		C.P.	Base	Voltage
Head	21-21	D.C	6-8	Dash	3	S.C.	6-8
Side	3	S.C	6-8	Stop	15	S.C.	6-8
Tail	3	S.C	6-8	Dome	3	S.C.	6-8

Lighting Circuit Fuse Size — 30 amps

Clutch

TYPE — Single plate, cork insert type, in oil

CLUTCH PEDAL CLEARANCE AT FLOOR BOARD — ¾"

Transmission

TYPE — Selective  
 SPEEDS — 3 forward, 1 reverse

GEAR RATIO — Low, 3.244 to 1; Second, 1.961 to 1; High, 1 to 1; Reverse, 4.170 to 1

Rear Axle

TYPE — Semi-floating  
 GEAR RATIO — Roadster, Phaeton, Coupe — 5-1/10 to 1

Coach, Standard Sedan, Sunsedan, Brougham, Touring Sedan — 5-4/10 to 1

Front Axle

TYPE — I-beam, Reverse Elliott with Inclined Spindle Pins  
 SPINDLE PIN THRUST BEARING TYPE — Radial Thrust Ball Bearing

Toe IN Zero to 1/8"  
 CASTOR ANGLE — Zero to 1° backward  
 CAMBER — 1°

### Brakes

TYPE—4 Wheel Mechanical  
 SIZE—11" Diameter Lining Width,  
 1½"; Thickness, 5/32"

CLEARANCE BETWEEN LINING AND  
 DRUM—.010"

### Steering Gear

TYPE—Variable Pitch Worm and Sector  
 GEAR REDUCTION—15 to 1  
 STEERING COLUMN HEIGHT—Adjustable  
 TIRES—19 x 5.00

TIRES—19 x 5.00  
 PRESSURE - Average Driving, 32  
 Front and Rear; High-  
 Speed Driving, 40 pounds, Front  
 and Rear

### Chassis and General Dimensions

WHEELBASE—113"  
 TURNING RADIUS—20'  
 OVERALL LENGTH (including bumpers)  
 —14½'  
 OVERALL WIDTH—65"  
 OVERALL HEIGHT Closed Models  
 71"; Open Models, 69"

FLOOR TO HEADLINING—Closed  
 Models, 47"; Open Models, 46"  
 FRONT SEAT WIDTH — Coupe and  
 Roadster, 46½"; Coach, Sedans,  
 Brougham, 42½"  
 REAR SEAT WIDTH—Coupe, Roadster,  
 43½"; All Others, 49"

### Keys

Keys are numbered to correspond to the lock. Since it is necessary to conceal the number on the lock for theft protection, the key number should be noted on your title or some other accessible place. Keys can be supplied only by number. For your own protection in case of loss of keys, record the numbers.

### Accessory Manufacturers

The following is a list of manufacturers of accessories used on Essex cars, with whom all matters pertaining to repairs or replacements should be taken up:

SPEEDOMETER—Stewart-Warner Corp.,  
 Chicago, Illinois.

STARTING MOTOR, GENERATOR, DIS-  
 TRIBUTOR AND IGNITION COIL—

BATTERY—The Electric Storage Bat-  
 tery Co., Philadelphia, Pa.

The Electric Auto-Lite Co., Toledo, Ohio.

HORN—E. A. Laboratories, Inc.,  
 Brooklyn, N. Y.

VACUUM TANK — Stewart Warner  
 Corp., Chicago, Illinois.

SHOCK ABSORBERS—Monroe Auto  
 Equipment Co., Monroe, Mich.

WINDSHIELD CLEANER—Trico  
 Products Corp., Buffalo, New York

TIRES—Goodyear Tire & Rubber Co.,  
 Akron, Ohio.

## Operation

The operation of the Essex Super Six follows standard practice in most respects; however, even those accustomed to Hudson products may refresh their memory on some of the details by reading the following paragraphs:

The clutch is operated in the conventional manner by depressing the left-hand foot pedal to disengage the engine from the transmission to permit shifting of gears. It is not considered good practice to disengage the clutch except to permit shifting of gears or when coming to a complete stop. Disengagement of the clutch at speeds of over ten miles per hour while the brakes are being applied may cause the car to skid on slippery roads. Form the habit of keeping the foot off the clutch except when shifting gears, and when stopping only after the car has been brought to a speed of ten miles an hour by application of the brakes.

The transmission operation conforms to the standard shift, but cannot be shifted into or out of high or intermediate speeds without first completely disengaging the clutch.

The brakes are operated either by the right-hand foot pedal or the hand lever located on the driver's left just ahead of the front door.

The engine speed can be controlled either by the foot accelerator located to the right of the brake pedal, or by the hand throttle disc located on the steering wheel. This is the outer disc at the hub of the steering wheel. Turning clockwise opens the throttle.

The light control is the smaller disc at the hub of the steering wheel, while the horn button is in the center. Turning the light control through the extreme limit of its travel in a clockwise direction the contacts are lights off, side lights on, headlight driving beam, headlight low beam.

The starter control is located on the extreme left of the dash panel.

The radiator shutter control is located to the right of the starter button. Pull out to open shutters. Proper regulation of engine temperature will increase the life and efficiency of the engine.

The carburetor choke control button is located below the instrument group, and the ignition switch lock to the right of it.

Form the habit of glancing at the instruments occasionally while driving. After you have become accustomed to the normal position of the hands on the various instruments, a glance will be enough to tell if everything is operating properly. All the instruments give information on vital parts, and attention to the readings may prevent damage to the car. The correct readings of the various instruments are given under the proper headings in later parts of this book.

## Starting the Engine

The proper procedure in starting a cold engine is as follows: Insert key in ignition electrolock and turn it  $\frac{1}{4}$  turn clockwise. Close throttle to idling position. Pull choke control button out as far as it will go. Pull out starter button. Release the starter button immediately when engine starts and push choke button in as far as possible without stalling engine. If engine is cold, the choke can be returned only about  $\frac{1}{2}$  inch, but as the engine warms up the choke can be pushed in gradually until it is all the way in.

Confine the use of the choke to starting a cold or partially cold motor, pushing it all the way in as soon as possible and keeping it in this position for all driving.

To obtain maximum performance and efficiency, the radiator shutters should be closed when the engine is stopped and should not be opened after starting until the heat indicator on the instrument panel shows that the engine has reached the proper operating temperature. The shutters should then be opened just enough to maintain this temperature.

## Breaking-in Instructions

Keep Radiator Full

Keep Oil Reservoir Full

Heat is a major consideration in a new engine. Do not allow the engine to overheat. Although the heat indicator on the instrument panel shows the general temperature of the engine, it will not show a sudden rise in temperature of an individual part.

The pressure imposed on parts such as bearings and pistons due to rapid acceleration or hard pulling will cause them to overheat if the car has not been driven sufficiently to wear them in to proper clearances. Avoid fast acceleration and hard pulling while breaking in.

High speed also develops higher operating temperatures and to avoid damage the car speed should be kept within the following recommendations:

0-150 MILES

Do not exceed 30 m. p. h. in high gear or 15 m. p. h. in second. Do not accelerate rapidly. Use second gear on steep grades. Keep motor temperature at 160°-180°.



150-500 MILES

Steady driving speed not over 35 m. p. h. Allow car to accelerate slowly to 40 m. p. h. on level or down grade. As soon as car has reached this speed slow down to 30 to 35 m. p. h. Repeat this frequently, but not at less than five-minute intervals.

500-1000 MILES

Steady driving speed not over 40 m. p. h. Allow car to accelerate to 50 m. p. h. at not less than five-minute intervals as suggested above.

1000-1500 MILES

Steady driving speed not over 45 in. p. h. Allow car to accelerate to 55 m. p. h. at not less than three-minute intervals.

1500-2000 MILES

Steady driving speed not over 50 in. p. h. Allow car to accelerate to 60 m. p. h. at not less than three-minute intervals.

## IMPORTANT

Do not UNDER ANY CONSIDERATION attempt to maintain a high rate of speed until the engine is thoroughly warmed up and you are sure the crankcase is full of good oil, with oil gauge on instrument panel showing proper pressure. Cold oil is not able to flow freely into the small clearances between working parts, so that damage may occur if SUFFICIENT time is not allowed for warming up before attempting high speeds.

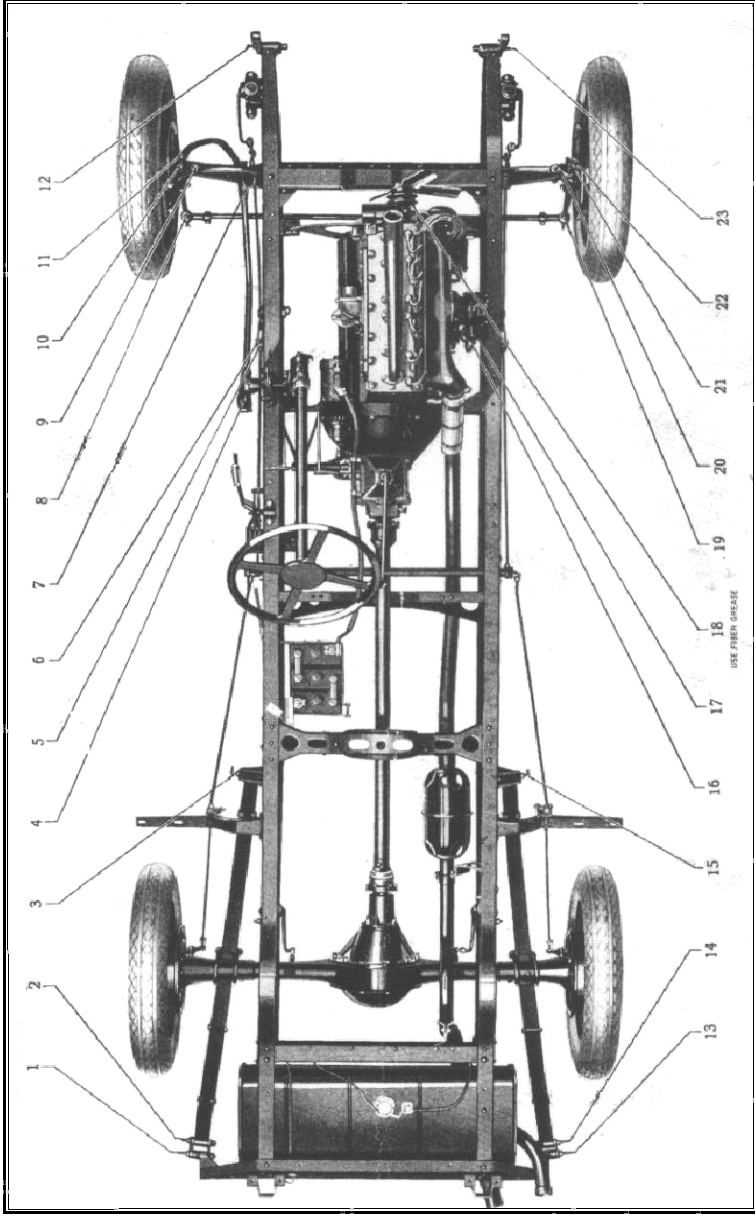

### CHASSIS LUBRICATION CHART

Once a week fill the oil gun furnished with the car and lubricate at all 23 points shown in the illustration. Count them as you go to eliminate chances of missing

## Engine

### Use High-Grade Oil-Medium Heavy Body



Consult your dealer if you are in doubt as to what oil to use

The oil pressure gauge on the instrument panel must always register when the engine is running. The pressure should be from three to four pounds.

The amount of oil in the reservoir is shown on the gauge on the instrument panel marked "Gasoline or Oil" when the ignition electrolock is turned "on" and the button between the ignition electrolock and the choke control button is pushed in.

A bayonet gauge is also provided at the oil filler. See illustration.

Add sufficient oil at the filler shown in the illustration every 250 miles to bring the level to the full mark. Drain and refill the reservoir every 500 miles, using five quarts of medium heavy body oil.

To drain the reservoir raise the front end of the car at least seven inches and remove the plug from the rear of the oil reservoir. Be sure the drain plug is tightened securely when replaced.

## Horn

### Use Light Motor Oil

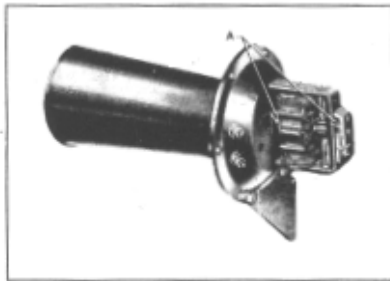

The horn should be lubricated every 2000 miles.

Remove the upper screw in the rear of the cover and withdraw cover.

Saturate the wicks indicated by "A" in the illustration. Do not overlubricate. Wipe off excess oil from all parts and see that commutator is clean.

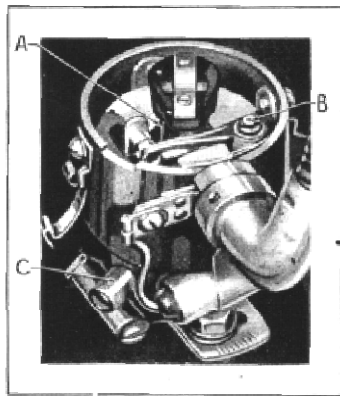

## Distributor

Use Motor Oil

Fill distributor base to the level of the oil cup "C" with motor oil every 2000 miles.

Coat rotor cam "A" lightly with vaseline or light cup grease every 2000 miles.

Apply a few drops of oil at breaker arm pivot "B" every 2000 miles. Do not overlubricate points "A" and "B". Wipe excess oil from all parts.

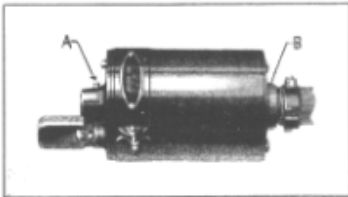

## Generator

Use Motor Oil

Three or four drops of light motor oil at points "A" and "B" in the illustration every 1000 miles.

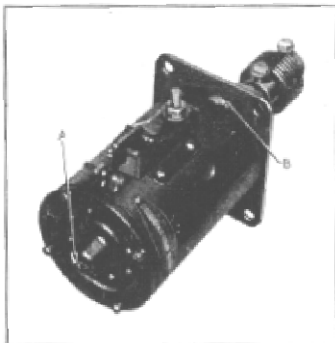

## Starting Motor

Use Motor Oil

Three or four drops of light motor oil at points "A" and "B" in the illustration every 1000 miles.

The oil cups on the starting motor have been made small to prevent over lubrication, which might find its way to the windings or commutator and eventually cause failure of the unit. Do not attempt to supply more oil than is required to fill the cups once.

## Transmission

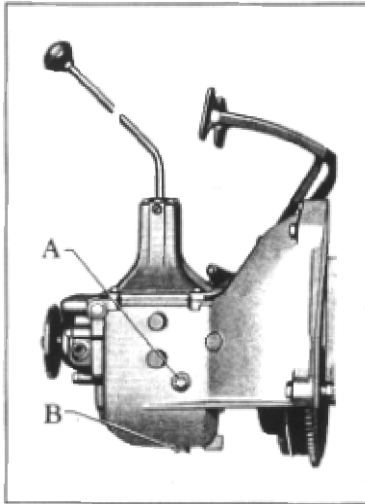

### Use Transmission Oil

The transmission oil should be kept to the level of the filler plug "A." The transmission should be drained every 500 miles by removing the drain plug "B." Replace the plug and fill with one pint of kerosene. Run engine with transmission in neutral and clutch engaged for one minute. Drain kerosene, replace drain plug, and fill with transmission oil to level of plug "A."

If the oil used in the transmission is too light in summer, it will permit the gears to spin when the clutch is disengaged, and require a slight hesitation in shifting. This condition can be overcome by draining and replacing with a heavier lubricant.

If the oil used is too heavy it will cause hard shifting. This can be overcome by adding medium body motor oil until shifting can be handled readily when lubricant is cold.

## Clutch

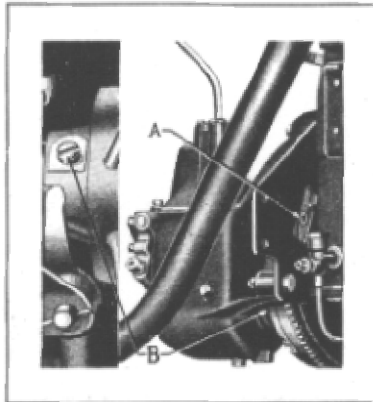

### Use 1/8 Pint Light Motor Oil and 1/8 Pint Kerosene

Clutch lubricant should be changed every 1500 miles.

To drain: Crank engine by hand until oil filler plug "A" on front side of flywheel is visible through inspection hole. Remove plug. Crank engine slowly, allowing clutch to drain while flywheel makes one revolution. When filler plug opening is again in view, refill as stated above and replace plug.

The clutch throwout bearing plug shown at "B" in illustration should be removed and bearing packed with fibre grease every 5000 miles. A grease gun is necessary for this operation.

## Universal Joints

Use Fibre Grease

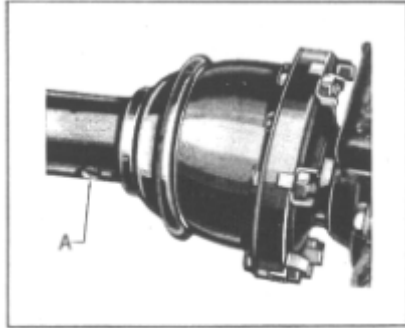

Remove the plug "A," shown in the illustration, of the rear universal joint and fill with good fibre grease. There is a plug similarly located just back of the front universal joint for filling.

The use of a proper grease at these points is very important in order to insure lubrication. These units should be filled every 1000 miles.

The universal joints are often neglected until wear has occurred to such an extent that replacement is necessary. Wear at these points throws the propeller shaft out of balance, causing vibration, and thus offsets the care taken in manufacture to obtain accurate balance which is necessary for smooth operation at high speeds.

## Rear Axle

Use High-Grade Differential Oil  
-Heavy Body

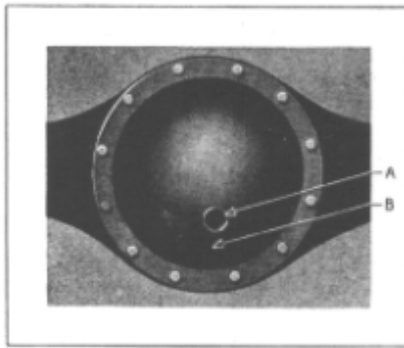

The oil supply in the axle housing should be kept level with the lower edge of the filler plug opening "A."

Every 5000 miles drain, flush out with kerosene and refill.

Housing may be drained by removing cover "B".

## Front Wheel Bearings



### Use Cup Grease

The front wheel should be removed by jacking up front of car, unscrewing the hub cap, withdrawing the cotter key in the end of the spindle, removing nut and washer. The wheel can then be pulled off. Wash out bearings and hubs with gasoline; pack bearings and hub with grease. See that felt washer at inner end of hub is in good condition and that there is no grease in the brake drum, brake shoe, or any other brake part. If necessary, wash these parts with gasoline.

line. Replace wheel. Fill hub cap with grease and replace. See page 25 for bearing adjustment.

## Rear Wheel Bearings

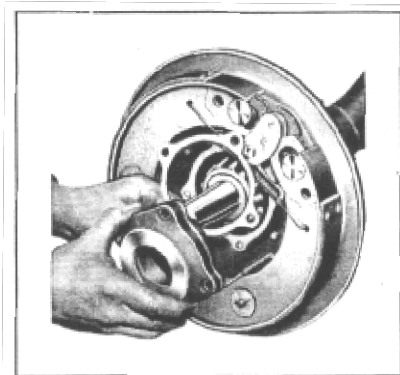

### Use Cup Grease

Jack up rear wheel, remove hub cap, remove cotter key in end of axle shaft, remove nut and washer, and withdraw wheel.

Remove four screws holding bearing cap. Remove bearing cap and bearing. Wash cap and bearing with gasoline and see that felt washer in cap is in good condition. Insert three ounces of grease in housing back of bearing. Rick bearing and cap with grease and replace. See page 25 for bearing adjustment.

Wash all brake parts including shoe and drum if any grease is found on them. Replace wheel.

HOOD LEDGE LACINGS-Use motor oil. Saturate with motor oil frequently to remove squeaks and preserve lacing.

HOOD LOCKS-Use motor oil. Lubricate occasionally by injecting a few drops of oil through hole in handle.

## Steering Gear

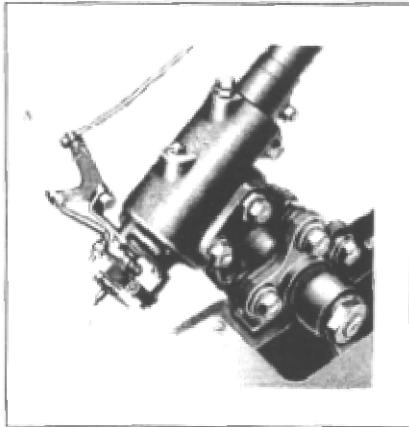

Use High-Grade Gear Oil

-Heavy Body

The steering gear case should be kept filled to the level of the filler plug "A." The use of a good-grade heavy gear oil is necessary to provide free operation under all climatic conditions.

If the steering becomes stiff and complete lubrication of the unit and the attached parts connecting with the front wheels does not correct the condition, follow the instructions on page 24 for adjustment and alignment of steering gear.

Noise in the unit may be due to the use of oil of insufficient body. If change of lubricant does not quiet operation, follow instructions for adjustment. page 24

## Throttle Control Rods and Levers

Oil or grease all accelerator connections. Throttle linkage should work with a snap. Grease choke wire occasionally to eliminate sticking.

## Brake Cross Shaft

Coat brake cross shaft rollers with light cup grease every 1000 miles. Do not oil or grease inside of brake drum.



## Ignition Timing

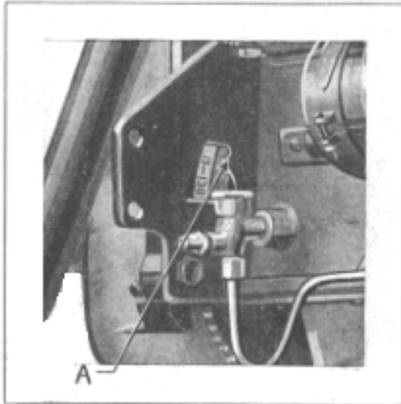

Remove distributor cap and inspect points and clean if necessary. Place breaker point file between points and let them close against file under their normal spring pressure. Move file straight up and down, dressing both points at the same time.

Crank engine with the hand crank until the breaker arm fibre block is on the highest point of the cam, giving the points their maximum opening. If necessary adjust, loosen lock nut "D" and turn screw "E" until the gap is .020". Tighten lock nut.

Remove the spark plug from number one cylinder. Crank the engine slowly by hand until air is forced out through the spark plug hole. Continue turning the engine slowly until the D. C. 1 and 6 mark is exactly in line with the pointer as shown at "A."

Loosen clamp screw "B" and turn ignition "on." Turn distributor clockwise to the full limit permitted by the slot in the clamping plate "C." The ammeter on the instrument panel should show a discharge.

Turn the distributor counter-clockwise until the hand on the ammeter falls to zero. This indicates that the points have just begun to open. Turn off ignition and tighten lockscrew "B."

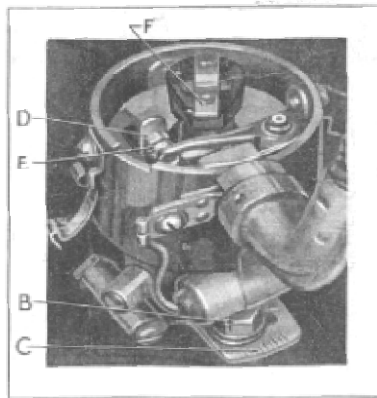

When the engine is in this position the rotor arm "F" will point directly to the sector in the distributor cap to which number one spark plug cable is connected. Following around the cap clockwise from this point the spark plug wires should be in the following order: 1-5-3-6-2-4.

## Spark Plugs

Remove spark plugs, clean and reset spark gaps to .022" every 3000 miles. Do not alter central electrode. Bend outer one to change gap.

## Tappets

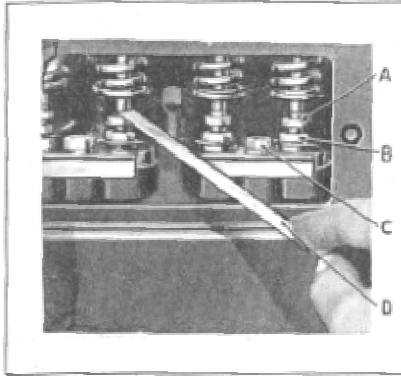

Before adjusting tappets see that the tappet clamp cap screw "C" is tight. Adjust tappet by loosening lock nut "B" and turning adjusting screw "A." Lock adjustment by tightening lock nut "B" while holding screw. Measure clearance between adjusting screw and end of valve stem with a feeler gauge as shown at "D" in the illustration. This measurement should be made while the engine is at its normal operating temperature. Adjust exhaust valve tappets to .006" clearance and intake tappets to .004" clearance.

Counting from the front the exhaust tappets are 1-3-6-7-10-12 and the intake tappets are 2-4-5-8-9-11.

Always adjust tappets after grinding valves.

## Timing Chain

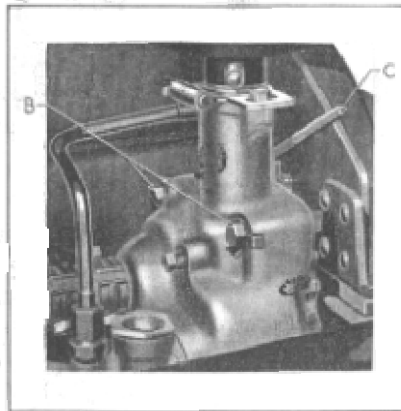

The timing chain should be checked at the expiration of the first 1000 miles and at intervals of 4000 thereafter.

A to and fro movement of approximately  $\frac{1}{8}$ " on the circumference of the coupling "A" (after the slack around the coupling bolt is taken up) should be maintained.

To adjust, loosen the three retaining bolts "B" (the inside top bolt and the bottom bolt, not shown, pass through the notches in the eccentric, necessitating their removal). Insert special tool "C" in notch and turn toward you until only the required movement is present.

If trouble is experienced in replacing the bolts, back off the adjustment slightly, allowing them to slide into place.

One-half pint of motor oil should be introduced through the pipe plug opening whenever the distributor support housing has been removed.

## Fan Belt



The fan belt must be kept at the proper tension to prevent slippage on the pulleys; however, an excessively tight belt will throw a heavy load on the fan bearings and cause rapid wear.

To adjust the belt, loosen the nut "A" and raise or lower the fan as necessary until the two sides of the belt can be drawn within  $\frac{3}{4}$ " of each other, as shown at "B." Tighten lock nut "A" securely.

When adjusting the fan see that the fan pulley is in line with the crankshaft pulley so that the belt runs straight in the pulley grooves. Proper alignment can be obtained by sliding the fan support arm backward or forward on the supporting stud.

## Carburetor

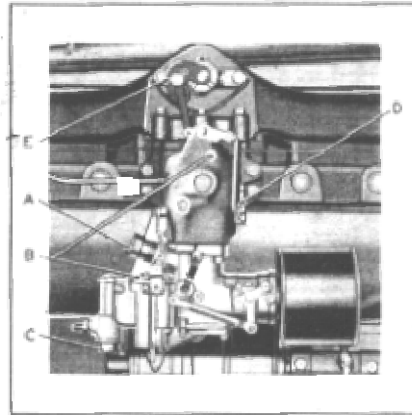

Spark plugs and breaker points should be cleaned, spark gaps properly spaced and all residue in gasoline passages removed before adjusting the carburetor.

Clean carburetor filter screen "C."

Note: Remove filter glass on vacuum tank to stop flow of gasoline to carburetor while cleaning. See illustration, page 23.

Adjust set screw "D" for faster or slower idling speed.

Adjust Air screw "A" to change mixture for smoother idling. Turn air screw until the end is flush with

the end of the ratchet spring bearing against it. Warm engine to proper operating temperature. Turn air screw counterclockwise until the engine hesitates, then clockwise two or three notches at a time until the engine runs smoothly.

The indicator "B" should be set at "winter" for all driving except in extremely hot weather, when it should be turned to the "summer" position.

The heat control adjustment "E" should be set in the WARM position for all driving conditions when the atmospheric temperature is less than 90° F. From 90° to 100° F. the MED. position may be used while temperatures above 100° F. will require the use of the COOL position.

## Vacuum Tank

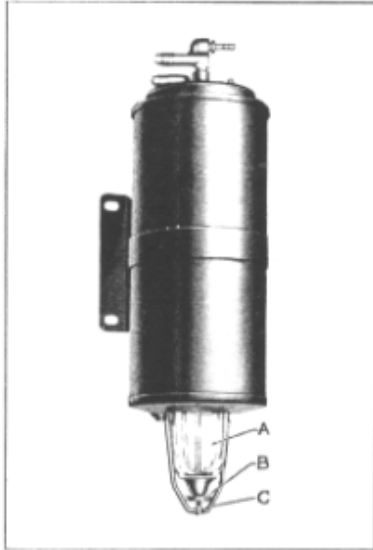

The glass sediment chamber at the bottom of the vacuum tank should be removed and cleaned whenever its contents show an accumulation of water or dirt. The water, due to the fact that it is heavier than gasoline, settles to the bottom of the glass and is easily distinguished.

The flow of gasoline is automatically shut off as soon as the glass is removed, so that it is only necessary to hold the glass "A" in one hand, loosen the thumbscrew "B," and swing the bracket "C" to one side to empty the glass.

## Clutch Pedal

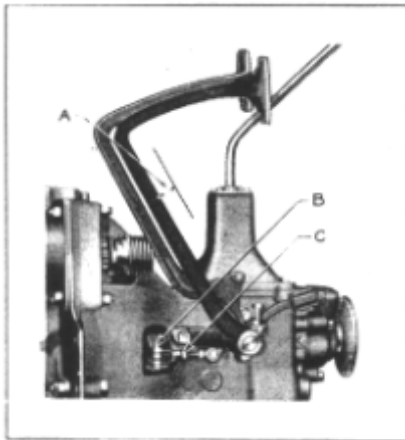

A clearance of  $\frac{3}{4}$ " must be maintained between the clutch pedal shank and the toe board, as shown in the illustration at "A."

To adjust, remove the clevis pin "B" and loosen the lock nut "C." Turn the yoke on the link to obtain proper length. Lengthening the link increases the clearance between the clutch pedal shank and the toe board, while shortening the link reduces it.

## Steering Gear

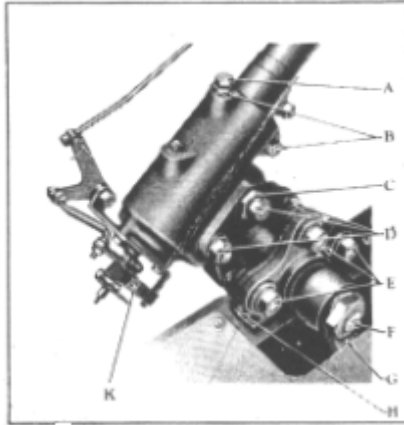

*To remove end play from main column:* Loosen nuts "B" one-half turn and turn adjusting screw "A" down as far as possible without stiffening the action of the steering wheel when turned through its entire movement.

Use care when doing this to turn screw "A" downward only, as it must be in positive contact with the bushing sleeve when the adjustment is completed. The nuts "B" should then be tightened securely.

*To remove side play in cross shaft:* The adjustment for cross shaft "F" is on the opposite end to that

shown in the illustration. Loosen the lock nut and with a screwdriver turn the adjusting screw down as tightly as possible, then back up slightly. Tighten lock nut.

*To remove play in mesh of worm and cross shaft sector:* Locate wheels in straight-ahead position, disconnect drag link from steering arm and shake arm to determine the amount of play. Loosen four stud nuts "D" ( $\frac{1}{4}$  turn only). Turn eccentric sleeve "C" to right or clockwise direction only in gradual stages, noting result by shaking steering arm at each step and using care at last stage to turn sleeve just sufficiently to remove play and no further. Securely tighten cover stud nuts "D."

*To change position of steering wheel to suit requirements of driver:* It is necessary to loosen frame bracket stud nuts "E," as well as cowl bracket nut under cowl then set steering wheel at desired position.

Keep steering column to dash clamp bolt and frame bolts "H" tight.

Tighten screw "K" to increase friction on hand throttle control disc and loosen to let disc turn free.

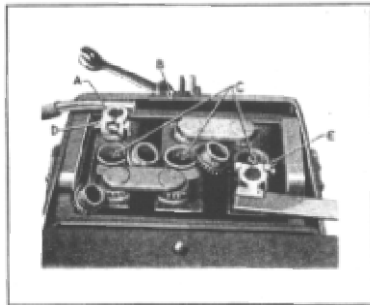

## Battery

Disconnect terminal "A" from the battery. Clean thoroughly, coat with vaseline, replace and tighten securely.

Battery must be kept securely fastened in tray. Tighten at "B."

Keep plates covered. Add distilled water monthly. Fill at "C."

Keep clamp bolts "D" and "E" tight at all times.

## Front Wheel Bearings



The adjustment of the front wheel bearings is important, as it affects braking and steering, as well as the free running of the car.

To adjust the front wheel bearings, jack up the front wheel, remove the hub cap, remove cotter key from end of spindle. Tighten spindle nut until a slight drag is felt when turning the wheel slowly by hand. Loosen spindle nut until wheel turns freely, insert cotter key and replace hub cap.

## Rear Wheel Bearings

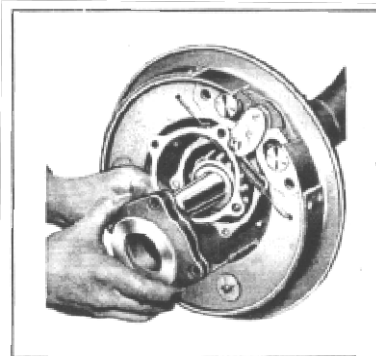

To adjust rear wheel bearings, jack up both rear wheels. Remove hub cap, cotter key, shaft nut and with-draw wheel.

Remove four cap screws and with-draw bearing cap. Remove shims from under bearing cap to decrease end play or install extra shims to increase play.

End play should be from .005" to .010", which amount is perceptible when pulling the axle shaft in and out.

Be sure that approximately the same thickness of shims is used at each rear wheel hearing so that brake drums will

be evenly spaced from brake dust shields.

## Tires

Check tires once a week and keep inflated to 32 pounds pressure. For fast driving inflate tires to 40 pounds.

## Brakes.

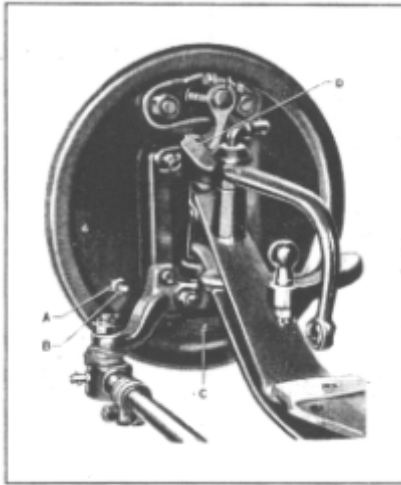

All linkage must work freely and brakes be fully released before an accurate adjustment can be made.

Jack up all four wheels and make the following adjustment at each:

Loosen lock nut "A" and turn eccentric "B" in the direction the wheel revolves when the car moves forward until a slight drag can be felt when turning the wheel by hand. Tighten lock nut sufficiently to hold the eccentric in that position temporarily.

Remove cover plate "C" and with a screwdriver turn the adjusting screw wheel toward the rim of the

backing plate until the pressure exerted against the drum is such that the wheel can just be turned by hand. Back off the adjustment screw wheel until only a slight drag is noticeable. Centralize the brake shoes in the drum by loosening the lock nut "A" and turning the eccentric "B" until the wheel is just free of brake drag. Hold the eccentric in that position and tighten the lock nut.

With the vehicle still jacked up, depress the brake pedal about two inches and test for equalization by turning the wheels by hand. The pressure on each front wheel should be equal and in a similar manner the pressure on each rear wheel should balance.

A maximum of clearance should be allowed at "D" to permit a slight amount of backlash.

## Front Wheel Alignment

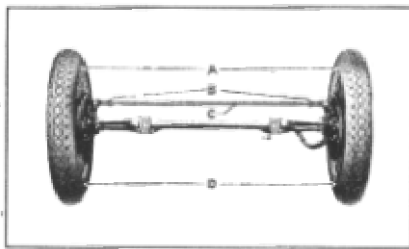

Measure the distances "A" and "D" as shown in the illustration. The distance "A" should be the same as "D" or not over  $\frac{1}{8}$ " longer - never shorter.

A special tool should be used for this purpose and the measurement taken between the rims at a height about even with the hubs. Loosen clamp bolts "B" and turn tie rod "C" clockwise, as viewed from the right, to increase "A" and counterclockwise to decrease "A."

## Radiator

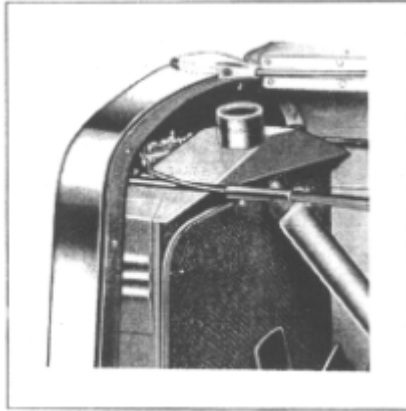

*Drain, flush out and refill frequently.*

Filler is located under the hood to eliminate possibility of anti-freeze ruining the finish on bonnet.

Each season after removing the anti-freeze, and about every four months thereafter, a solution consisting of one pound of washing soda to four gallons of water should be poured into the radiator and allowed to slowly circulate through the system by running the engine at idling speed. Leave drain cock open and thoroughly flush out after cleaning.

See that hose is in good condition and all hose clamps are tight.

Do not allow mud, etc., to clog air passages through radiator. Repair dents and leaks when they occur. Add an anti-freeze solution to the radiator in cold weather.

Drain enough water from the radiator so that after the anti-freeze has been added there will still be room for a slight expansion of the liquid without its running, over the overflow pipe.

### Add Anti-Freeze as Follows:

<i>For</i>	<i>Prestone</i>	<i>Alcohol</i>	<i>Radiator Glycerine</i>
32° to 10° above 0°	5½ qts.	6-2/3 qts.	11½ qts.
10° to 0°	7 qts.	8-2/3 qts.	14 qts.
0° to 10° below 0°	8-1/3 qts.	10 qts.	16-2/3 qts.
10° to 20° below 0°	9½ qts.	11¼ qts.	18¾ qts.

## Horn

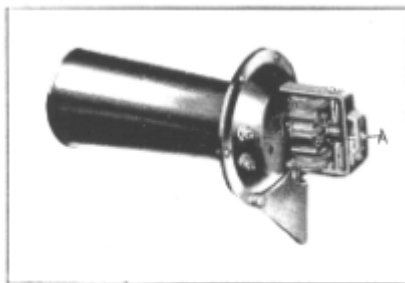

A weak or spasmodic tone, or a complete failure of the horn to respond, may be due to adjustment, lubrication, wiring, weak battery, or dirt on the commutator of the horn armature.

Should an adjustment be required to obtain the proper horn tone, turn the adjusting screw "A," noting the variation in the horn, until proper adjustment is obtained.



## Spring Mounting

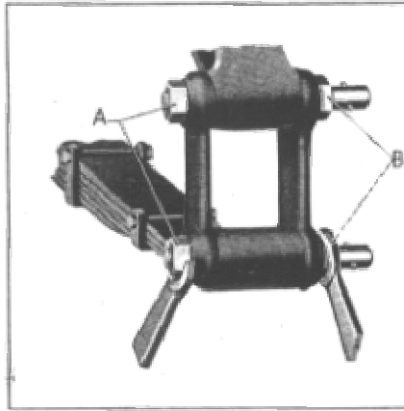

Chassis noise, erratic spring action and wandering of the car on the road can often be attributed to spring mountings.

Adjust the spring shackles to re-move end play of spring on shackle bolt by loosening the locking nut "A" and turning the bolt "B" until tight, then turn hack one-sixth turn and tighten nut "A."

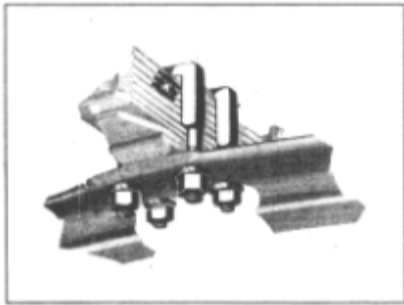

This operation should be performed every 5000 miles on both upper and lower shackle bolts at the rear of both the front and rear springs and on the anchor bolts (not illustrated), holding the front ends of front and rear springs to the frame brackets.

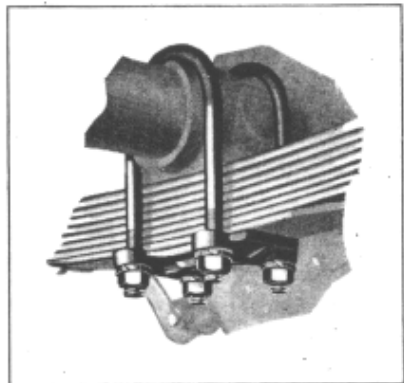

The spring clip nuts (front and rear) shown in the illustration should be tightened every 5000 miles.

When making the above adjustments the body hold-down bolts should also be tightened. There are eight of these, four on each side, located just outside the frame side members and under the body sills. Draw the nuts tight after the first 1000 miles and every 5000 miles thereafter.

## Headlamps

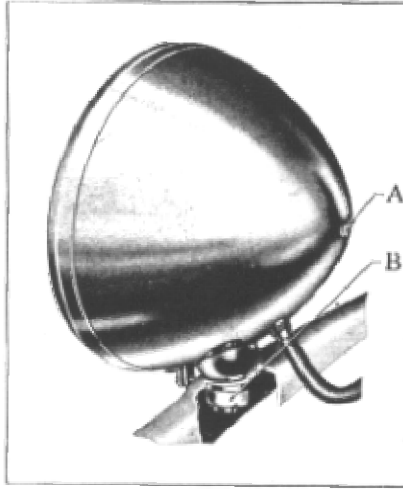

Place the vehicle under normal load on a level floor squarely facing a smooth wall 25 feet from the headlamps.

Measure the height of the lamp bulbs from the ground and draw a horizontal line on the wall at the same height as the bulbs.

Sight through windshield along hood rod and radiator cap to determine the center line of the vehicle. Locate center lines of lamps on the wall from this line.

Place the light lever in the position throwing the light beam farthest from the vehicle. Cover left lamp to obscure the light beam. Turn the adjusting screw "A" on the right lamp until the

light beam has a high intensity at the top and is as narrow as possible measured from top to bottom.

Loosen the adjusting nut "B" and aim the lamp so that the top of the beam is just even with the horizontal line and equal portions on each side of the center line of right lamp.

Repeat operations with the left lamp and the headlamps will be properly focused,

## Care of the Finish

The same care should be exercised in washing and cleaning cars finished in lacquer or enamel as is employed in the handling of varnished surfaces. Dry dirt accumulations should not be wiped off but should be softened and removed by thoroughly soaking the body with flowing water, applied under light pressure.

Careful washing of the car, followed by the use of a polish especially prepared for lacquer or enamel finishes, will maintain a high luster and preserve the finish. The use of polishes containing strong abrasives should be avoided, as they are particularly destructive to the striping employed. Anti-freeze solutions containing alcohol when accidentally spilled on the finish should be immediately washed off with clear water to prevent spotting, as alcohol is a solvent of lacquer.

It is recommended that every new car purchaser apply a coat of wax while lacquer is still clean and unmarked. If this is done and the application periodically renewed, it will be an important factor in the life of the finish.

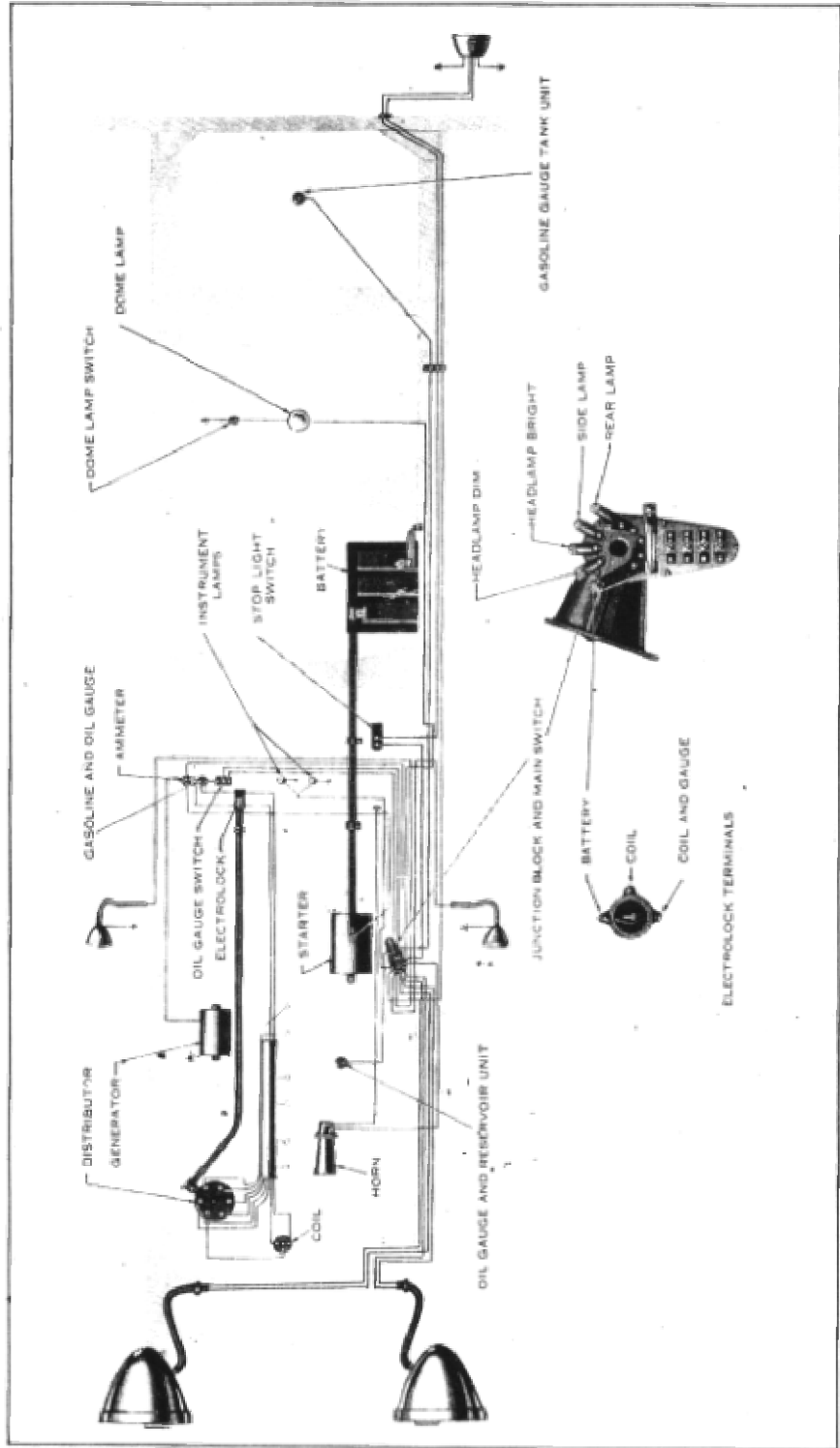

WIRING DIAGRAM