

*Hudson*



**OWNER  
MANUAL**

**HUDSON MOTOR CAR COMPANY**

DETROIT 14, MICH., U.S.A.

# *Welcome*

Your selection of a new Hudson Motor car is gratifying to us and we are happy to welcome you to the ever growing family of Hudson owners.

We share in your pride of ownership and are sure you will derive the many miles of enjoyable service to which you looked forward when purchasing it.

Your new Hudson has been carefully engineered and built and naturally, you will want to keep it trouble free and protect the investment in your purchase to the utmost.

With this thought in mind, we have prepared this Owner's Manual which contains comprehensive information to assist in giving this fine piece of mechanism the care and attention it deserves. In its pages you will find many suggestions to acquaint you with its construction, operating features and maintenance requirements.

Take a few minutes to study this manual at your early convenience. It contains a wealth of information—just the things you will want to know. Then place it in the locker box where it will be available for future reference.

**HUDSON MOTOR CAR COMPANY**  
Service Department

## WARRANTY

"We warrant each new car manufactured by us to be free from defects in material and workmanship under normal use and service, our obligation under this warranty being limited to making good at our factory any part or parts thereof, including all equipment or trade accessories (except tires) supplied by the Car Manufacturer, which shall, within ninety (90) days after making delivery of such vehicle to the original purchaser, or before such vehicle has been driven 4,000 miles, whichever event shall first occur, be returned to us with transportation charges prepaid, and which our examination shall disclose to our satisfaction to have been thus defective; this warranty being expressly in lieu of all other warranties expressed or implied, and of all other obligations or liabilities on our part, and we neither assume nor authorize any other person to assume for us any other liability in connection with the sale of our vehicles.

"This warranty shall not apply to any vehicle which shall have been repaired or altered by other than an Authorized Hudson Dealer in any way so as, in the judgment of the Manufacturer, to affect its stability or reliability, nor which has been subject to misuse, negligence or accident."

HUDSON MOTOR CAR COMPANY

Detroit, Michigan, U. S. A.

*The Hudson Motor Car Company reserves the right to make any changes in or improvements on its products without incurring any liability or obligation whatever, and without being required to make any corresponding changes or improvements on products theretofore manufactured or sold.*

## OWNER'S SERVICE POLICY

When you purchased your new Hudson, the Distributor or Dealer from whom you bought the car presented you with your Hudson Owner's Service Policy. We cannot too greatly impress you with the need for reading it fully and becoming acquainted with its provisions.

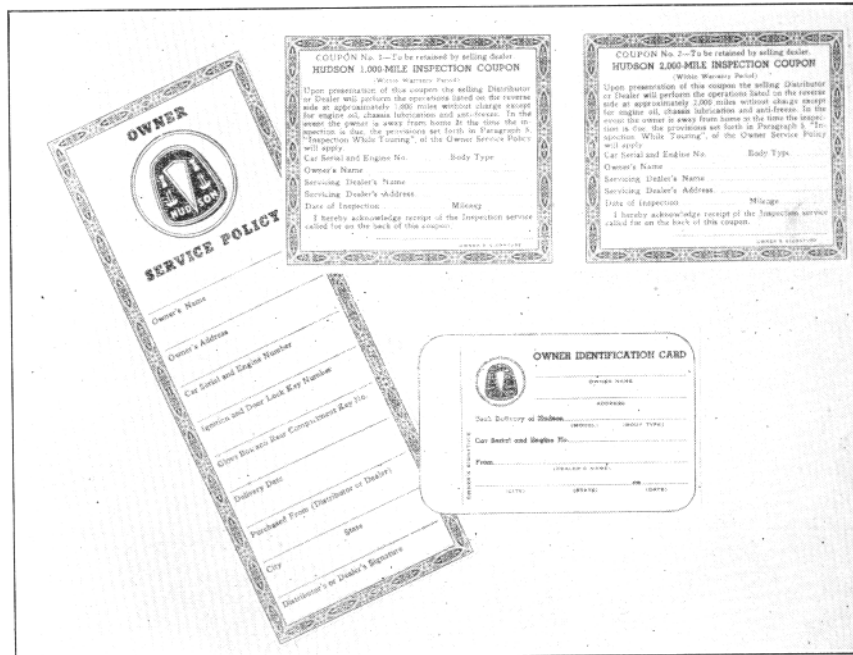

This policy includes two coupons which entitles you to the 1000 and 2000 Mile Inspections without charge and outlines our obligations as Manufacturer as well as those of the Car Dealer and the Owner. It also contains other pertinent information regarding the new car inspections and fully explains the provisions of the new car warranty concerning the replacement of parts.

A full knowledge of its contents will preclude the possibility of misunderstandings should it be necessary to consult your own or some other Hudson Dealer in regard to the provisions outlined.

# AUTHORIZED HUDSON SERVICE STATIONS

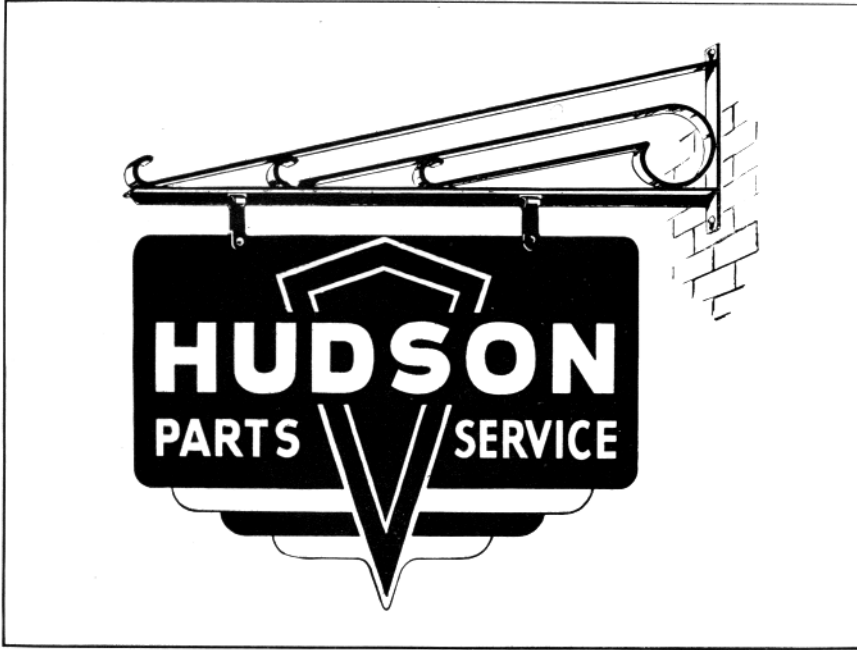

Your Authorized Hudson Dealer is the logical place to visit for the best available service on your new Hudson car. It is to his best interests to keep your car in good operating condition at the lowest possible cost.

In event the need for service arises when touring or away from home, look for the Authorized Hudson Dealer service sign illustrated above. The Hudson Dealer displaying this sign is your assurance of the same efficient, friendly service you receive at home. It is your further assurance that his Service Department handles genuine Hudson parts, uses factory approved methods and tools and employs capable and courteous mechanics.

## FIRST THINGS TO DO

When your new Hudson is delivered to you, make sure that:

1. Owner's Service Policy has been properly filled in and its provisions fully explained to you.
2. Identification Card is completely filled in on both sides and key numbers recorded.
3. Radio Warranty Registration Card is filled in and attached to radio.
4. Battery is properly registered with a National Battery Dealer.

## INSPECTION AND ADJUSTMENT SERVICE

Your Hudson Owner's Service Policy entitles you to inspection and adjustment service, which will be performed by the Hudson Dealer who sold the car, without charge, except for supplies and lubricants used. These inspections will be made at the expiration of 1,000 miles and again after 2,000 miles of driving.

If these services become due while you are touring or away from home, they may be performed by any authorized Hudson Dealer, who will make a charge of not more than \$6.00 for the 1,000 mile inspection and \$12.00 for the 2,000 mile inspection. The dealer who made the inspection will furnish you with a receipted bill and sign the inspection coupon attached to your Warranty, which should then be presented to the dealer (who sold the car) on your return. Your dealer will then credit your account in the above amount for each inspection performed. We suggest that you carefully read the Owner's Service Policy so that you may become fully acquainted with this and its other provisions.

The inspection and adjustment service consists of the following:

### 1,000 Mile Inspection

1. Check Operation of All Locks.
2. Check Signals and Instruments.
3. Check Operation of Lights.
4. Check Battery and Connections.
5. Tighten Cylinder Head Stud Nuts.
6. Tighten Manifolds.
7. Check Cooling System and Coolant.
8. Check Clutch Pedal Clearance.
9. Check Rear Wheel Hub Tightness.
10. Check Wheel Hub Bolts.
11. Check Rear Spring Mounting Clips.
12. Check Hand and Foot Brakes.
13. Check Drive-Master.
14. Road Test Car.

### 2,000 Mile Inspection

1. Check Operation of Signals and Instruments.
2. Check Operation of All Lights.
3. Check Operation of Windshield Wipers.
4. Check Cooling System and Coolant.
5. Check Battery and Connections.
6. Adjust Tappets—Engine Hot.
7. Tune Up Engine.
8. Check Generator Charging Rate.
9. Check Wheel Hub Bolts.
10. Check Hand and Foot Brakes.
11. Check Drive-Master.
12. Road Test Car.

## MODEL DESIGNATIONS AND SERIAL NUMBERS

The new Hudson models are produced in the Super and Commodore Series and carry the following designations:

Hudson Super Six Series.....	Model 491
Hudson Commodore Six Series.....	Model 492
Hudson Super Eight Series.....	Model 493
Hudson Commodore Eight Series.....	Model 494

### LICENSE INFORMATION

#### HUDSON SUPER SIX SERIES—MODEL 491

Body Types	Wheel- base	Starting Serial No.	No. of Cyls.	Bore	Stroke	A. M. A. H.P. Rating	Dry Weight Pounds
Brougham .....	124"	491101	6	3-9/16"	4-3/8"	30.4	3515
4 Door Sedan .....	124"	and up	6	3-9/16"	4-3/8"	30.4	3555
3 Pass. Coupe .....	124"		6	3-9/16"	4-3/8"	30.4	3485
Club Coupe .....	124"		6	3-9/16"	4-3/8"	30.4	3480
Convertible Brougham	124"		6	3-9/16"	4-3/8"	30.4	3750

#### HUDSON COMMODORE SIX SERIES—MODEL 492

4 Door Sedan .....	124"	492101	6	3-9/16"	4-3/8"	30.4	3625
Club Coupe .....	124"	and up	6	3-9/16"	4-3/8"	30.4	3585
Convertible Brougham	124"		6	3-9/16"	4-3/8"	30.4	3780

#### HUDSON SUPER EIGHT SERIES—MODEL 493

4 Door Sedan .....	124"	493101	8	3"	4-1/2"	28.8	3565
Club Coupe .....	124"	and up	8	3"	4-1/2"	28.8	3550

#### HUDSON COMMODORE EIGHT SERIES—MODEL 494

4 Door Sedan .....	124"	494101	8	3"	4-1/2"	28.8	3650
Club Coupe .....	124"	and up	8	3"	4-1/2"	28.8	3600
Convertible Brougham	124"		8	3"	4-1/2"	28.8	3800

The car serial number which is also the engine number, is stamped on a metal plate attached to the right front door hinge pillar post. In the car numbering system, the first three digits of the serial number indicate the series and model, while the remaining digits represent the actual car number. As the cars leave the production line, they are numbered in consecutive order, regardless of series or model. As an example, the car built after 491999 would be numbered 4911000, 4921000, 4931000 or 4941000 instead of 492000.

The engine number is stamped on the top of the cylinder between Nos. 1 and 2 exhaust manifold flanges on eight cylinder engines and on the right side of the cylinder at the upper front end, stamped vertically, on six cylinder engines.

**NOTE:** Do not confuse engine number with casting or other numbers appearing at different locations on the engine. Be sure this number corresponds with the one shown on your Owner Policy and Identification Card.

A code letter or letters indicating the car paint color option is stamped on the upper hinge of the right front door.

## TECHNICAL INFORMATION

### ENGINE

	Super Six and Commodore Six	Super Eight and Commodore Eight
Series .....	491 — 492 — 6 Cylinder	493 — 494 8 Cylinder
Arrangement .....	L Head	L Head
Bore and Stroke .....	3-9/16 x 4-3/8	3 x 4-1/2
Piston Displacement .....	262 Cu. In.	254 Cu. In.
Horsepower—Taxable .....	30.4	28.8
Actual .....	121 at 4000 RPM	128 at 4200 RPM
Compression Ratio—Std. ....	6.50:1	6.50:1
Engine Mounting .....	3 — Rubber	3 — Rubber
Camshaft Drive .....	Morse Chain	Gears
Number bearings .....	4 — Steel backed babbitt	5 — Steel backed babbitt
Crankshaft—Type .....	Compensated	Compensated
Type and number bearings .....	4 — Steel backed babbitt lined	5 — Bronze backed babbitt lined
Connecting Rods—		
Length—Center to Center .....	8-1/8"	8-3/16"
Lower End Bearing .....	Replaceable	Integral
Type and Material .....	Precision — Babbitt steel back	Spun — Babbitt
Upper End Bearing—		
Material .....	1 pc. steel back babbitt	1 pc. bronze
Diameter and Length .....	31/32 x 1-1/8"	3/4 x 29/32"
Pistons—Type .....	Cam ground	Cam ground
Material .....	Aluminum Alloy	Aluminum Alloy
Clearance .....	.0015" to .002"	.0015" to .002"
Piston Pin—Type and Length .....	Floating — 2-15/16"	Floating — 2-7/16"
Diameter .....	31/32"	3/4"
Piston Rings—Material .....	4—Cast iron—Pinned	4—Cast iron—Pinned
Compression Rings .....	2	2
Oil Rings .....	2 — 1 Below pin	2 — 1 Below pin
Gap Clearance—All Rings .....	.007 to .012	.004 to .009
Valves—		
Intake—		
Head Outside Diameter .....	1-53/64"	1-1/2"
Lift .....	11/32"	11/32"
Operating Clearance—Hot .....	.008	.006
Exhaust—		
Head Outside Diameter .....	1-9/16"	1-3/8"
Lift .....	11/32"	11/32"
* Operating Clearance—Hot .....	.010	.008
Lubricating Method .....	Full Pressure	Duo-Flo
Pump Type .....	Rotor	Oscillating Plunger
Oil Capacity—Qts. ....	Dry 7-1/2 Qts. Refill 7 Qts.	Dry 9 Qts. Refill 7 Qts.

### CLUTCH

Type .....	10" single plate in oil	10" single plate in oil
Facing .....	Cork Inserts	Cork Inserts
Pilot Bearing .....	Ball	Ball
Throw-out Bearing .....	Ball	Ball
Pedal Lash .....	1-1/2"	1-1/2"
Clutch Lubricant .....	1/3 Pt. Hudsonite	1/3 Pt. Hudsonite



### TRANSMISSION

	Super Six and Commodore Six	Super Eight and Commodore Eight
Type .....	Synchro-Mesh	Synchro-Mesh
Speeds .....	3 Forward — 1 Reverse	3 Forward — 1 Reverse
Gears .....	All Helical	All Helical
Gear Ratios—Without HDM—Low .....	2.61:1	2.61:1
Second .....	1.65:1	1.65:1
High .....	1:1	1:1
Reverse .....	3.17:1	3.17:1
Gear Ratios—With HDM—Low .....	2.88:1	2.88:1
Second .....	1.82:1	1.82:1
High .....	1:1	1:1
Reverse .....	3.5:1	3.5:1
Lubrication—Summer .....	90 E.P. — Mild	90 E.P. — Mild
Winter .....	80 E.P. — Mild	80 E.P. — Mild
Capacity—Without Overdrive .....	2 Pts.	2 Pts.
With Overdrive .....	3-1/4 Pts.	3-1/4 Pts.

### PROPELLER SHAFT

Front Shaft—Universals .....	1	1
Rear Shaft—Universals .....	2	2
Center Bearing .....	Annular Ball	Annular Ball
Bearing Lubrication .....	Prelubricated and Sealed	Prelubricated and Sealed
Spline Lubrication .....	Zerk Fitting	Zerk Fitting
Universal Lubrication .....	Zerk Fitting	Zerk Fitting

### REAR AXLE

Type .....	Semi-floating	Semi-floating
Gear Type .....	Hypoid	Hypoid
Ratios .....	4.1 and 4-5/9	4.1 and 4-5/9
Pinion Bearings .....	Taper Roller	Taper Roller
Adjustment .....	Shim	Shim
Differential Bearings .....	Taper Roller	Taper Roller
Wheel Bearings .....	Taper Roller	Taper Roller
Adjustment .....	Shim	Shim
Pinion and Gear Back Lash .....	.004 to .006	.004 to .006
Lubricant .....	S.A.E. 90 Multi Purpose Gear Lubricant 3-1/2 Pints	S.A.E. 90 Multi Pur- pose Gear Lubricant 3-1/2 Pints

### FRONT SUSPENSION

Type .....	Independent Coil Spring	Independent Coil Spring
Camber .....	1/2° to 1-1/2°	1/2° to 1-1/2°
Caster .....	1/2° to 1-1/2°	1/2° to 1-1/2°
Toe-in .....	1/32 plus or minus 1/32	1/32 plus or minus 1/32
Spindle Pin Inclination .....	3° — 36'	3° — 36'
Wheel Bearing—Type .....	Adj. Tapered Roller	Adj. Tapered Roller

### SPRINGS

Rear—Type .....	Semi-elliptic	Semi-elliptic
Length and Width .....	54" — 1-3/4"	54" — 1-3/4"
Shackles .....	Silent "U" Threaded	Silent "U" Threaded
Lubricant—Shackles and Leaves .....	Viscous Chassis Lub.	Viscous Chassis Lub.

**STEERING GEAR**

	Super Six and Commodore Six	Super Eight and Commodore Eight
Type .....	Worm and Triple Tooth Roller	Worm and Triple Tooth Roller
Ratio .....	20.4:1	20.4:1
Steering Wheel Diameter .....	17" and 18"	17" and 18"
Lubricant—Summer and Winter .....	S.A.E. 90 E.P.	S.A.E. 90 E.P.

**BRAKES**

Type .....	Bendix — Duo- Automatic	Bendix — Duo- Automatic
Drum Diameter .....	11"	11"
Lining—Type .....	Moulded	Moulded
Width .....	Front — 2-1/4" Rear — 1-3/4"	Front — 2-1/4" Rear — 1-3/4"
Clearance—Both Ends of Shoe .....	.010	.010
Pedal to Floor Board .....	1/4"	1/4"

**TIRES**

Make .....	Goodyear Super Cushion	Goodyear Super Cushion
Standard Size .....	7.10 x 15.00—4 Ply	7.10 x 15.00 — 4 Ply
Std. Wheel Rim .....	5.00 x 15.00	5.00 x 15.00
Optional Tire .....	7.60 x 15.00—4 Ply	7.60 x 15.00 — 4 Ply
Optional Wheel .....	5.50 x 15.00	5.50 x 15.00
Inflation Pressure .....	24 Lbs. Front and Rear—Cold	24 Lbs. Front and Rear—Cold

**COOLING SYSTEM**

Capacity in Quarts .....	19 Qts.*	17 Qts.*
Circulation .....	6 Vane Impeller Pump	6 Vane Impeller Pump
Temperature Control .....	Thermostat— By Pass	Thermostat— By Pass
Pump and Fan Drive .....	V Belt	V Belt
Fan .....	4 Blade	4 Blade
Belt Adjustment .....	Generator Mounting	Generator Mounting
Pump Bearing .....	2 Sealed Ball — Pre-lubricated	2 Sealed Ball — Pre-lubricated

**FUEL SYSTEM**

Carburetor—Make .....	Carter WDO 647-S	Carter WDO 648-S
Type .....	Dual Down-Draft 1-1/4"	Dual Down-Draft 1-1/4"
Choke and Heat Control .....	Automatic— Thermostatic	Automatic — Thermostatic
Fuel Delivery .....	Pressure Pump	Pressure Pump
Air Cleaner and Silencer .....	Dry Std. Oil Bath Optional	Dry Std. Oil Bath Optional
Fuel Tank Capacity .....	20 U.S. Gallons	20 U.S. Gallons

**ELECTRICAL EQUIPMENT**

Make .....	Auto-Lite	Auto-Lite
Distributor—Rotation .....	Clockwise	Clockwise
Drive .....	Camshaft	Camshaft
Advance .....	Automatic — Vacuum	Automatic — Vacuum
Point Gap .....	.020	.017
Breaker Points Open .....	T.D.C.	T.D.C.
Firing Order .....	1-5-3-6-2-4	1-6-2-5-8-3-7-4

\*Cars equipped with heater require one additional quart.

## ELECTRICAL EQUIPMENT (CONT'D.)

	Super Six and Commodore Six	Super Eight and Commodore Eight
Generator—Type .....	Third Brush Volt.	Third Brush Volt.
	Reg.	Reg.
Drive .....	V Belt	V Belt
Charging Rate—Cold .....	43 Amperes at 8 Volts	43 Amperes at 8 Volts
Charging Rate—Hot .....	37 Amperes at 8 Volts	37 Amperes at 8 Volts
Starting Motor—Drive .....	Bendix	Bendix
Control Switch .....	Solenoid	Solenoid
Battery—Make .....	National 6 Volt	National 6 Volt
Plates and Capacity .....	51—120 Amp. @ 20 Hr. Rate	51—120 Amp. @ 20 Hr. Rate
Dimensions .....	W—7-1/8", L—10-9/16", H—9-1/16"	W—7-1/8", L—10-9/16", H—9-1/16"
Terminal Grounded .....	Positive	Positive
Location .....	Under Bonnet Left Side	Under Bonnet Left Side
Spark Plugs—Cast Iron Head ..	Champion J-7 14 M.M.	Champion J-7 14 M.M.
Spark Plugs—Aluminum Head ..	Champion H-10	Champion H-10
Gap .....	.032	.032

## LAMP BULBS

	No.	C. P.	Base
Headlight (Sealed Beam Type) ..	4030	Sealed	Sealed
Bonnet Light .....	55	2	Single
Parking Light with Direction Indicator .....	1154	21-3	Double
Tail and Stop Light .....	1154	21-3	Double
License Light .....	63	3	Single
Dome Light—Front .....	87	15	Single
Rear Quarter Lights (2) .....	81	6	Single
Clock .....	55	2	Single
Speedometer .....	55	2	Single
Instrument Cluster .....	55	2	Single
Direction Indicator .....	55	2	Single
Radio .....	55	2	Single
Headlight Beam Indicator .....	55	2	Single
Ignition Lock .....	55	2	Single
Courtesy Light .....	87	15	Single
Fog Light—Sealed Beam .....	4015A	Sealed	Sealed
Spot Light—Sealed Beam .....	4535	Sealed	Sealed
Parking Light .....	63	3	Single
Generator and Oil Indicator .....	55	2	Single

## CAPACITIES

Cooling System .....	U.S.—19 Quarts*	17 Quarts*
	Imperial—15-1/4 Qts.	14 Quarts
	Metric—17-3/4 Liters	16 Liters
Gasoline Tank .....	U.S.—20 Gallons	20 Gallons
	Imperial—16-2/3 Gal.	16-2/3 Gallons
	Metric—75-3/4 Liters	75-3/4 Liters
Engine Oil—Dry .....	U.S.—7-1/2 Quarts	8 Quarts
	Imperial—6-1/2 Quarts	6-2/3 Quarts
	Metric—7 Liters	7-1/2 Liters
Engine Oil—Refill .....	U.S.—7 Quarts	7 Quarts
	Imperial—6 Quarts	6 Quarts
	Metric—6-1/2 Liters	6-1/2 Liters

\*Cars equipped with heater require one additional quart.

## CAPACITIES (CONT.)

	Super Six and Commodore Six	Super Eight and Commodore Eight
Clutch -----	U.S. — 1/3 Pint Imperial — 1/4 Pint Metric — 160 C.C.	1/3 Pint 1/4 Pint 160 C.C.
Transmission -----	U.S. — 2 Lbs. Imperial — 2 Lbs. Metric — .91 Kgs.	2 Lbs. 2 Lbs. .91 Kgs.
Transmission and Overdrive -----	U.S. — 3-1/4 Lbs. Imperial — 3-1/4 Lbs. Metric — 1.47 Kgs.	3-1/4 Lbs. 3-1/4 Lbs. 1.47 Kgs.
Rear Axle -----	U.S. — 3-1/2 Lbs. Imperial — 3 Lbs. Metric — 1.6 Kgs.	3-1/2 Lbs. 3 Lbs. 1.6 Kgs.

## DIMENSIONS

Overall Length—Including Bumpers	207-1/2"	207-1/2"
Overall Width -----	77-1/16"	77-1/16"
Overall Height -----	60"	60"
Road Clearance—Front -----	8"	8"
Road Clearance—Rear -----	8"	8"
Turning Radius -----	Right 21' 2" Left 20' 5"	Right 21' 2" Left 20' 5"

## LUBRICATION

Present day high speed driving, fast acceleration and closely fitted precision machined parts, place engine and chassis lubrication in the category of highly specialized services. A definite plan of application is necessary to provide the various working surfaces with the right amount of the correct lubricant at the proper time. Contrary to general belief, one lubricant will not suffice for all parts of the chassis. The varying load demands and operating conditions which the various parts are subjected to, call for different types of lubricants to minimize friction and reduce wear.

Your Authorized Hudson Dealer has been provided with the correct factory lubrication specifications for your car, as well as the definite plan of application. This is your assurance that the lubrication requirements of your car will be met with the greatest care. Be sure to consult him on this most important matter.

For your guidance, a copy of the Lubrication Chart is attached to the front cover of this manual. Additional information regarding the lubrication requirements of your car are given in the Lubrication Schedule shown below and elsewhere in this manual, under the description of the various units.

The lubricants placed in your car at the time of assembly are of the best quality and need not be changed until the recommended change period shown in the Lubrication Schedule has been reached.

## LUBRICATION SCHEDULE

## 500 MILES

Drain engine oil reservoir and refill with new oil of good quality. See "The Proper Engine Oil to Use," Page 14.

## 1,000 MILES

## Viscous Chassis Lubricant

	Points		Points
Drag Link .....	2	Tie Rod End .....	4
Upper Support Arm Eccentric Bushing .....	2	Steering Spindle Pivot Pins .....	2
Upper Support Arm Pivot Bushing .....	4	Gear Shift Bell Crank Pivot .....	1
Lower Support Arm Pivot Bushing .....	4	Clutch Pedal Bearing .....	1
Lower Support Arm Support Bushing .....	2	Clutch Throwout Bearing .....	1
Center Steering Arm Pivot Bearing .....	1	Universal Joint Spline .....	1
		Universal Joint Needle Rollers .....	3
		Rear Spring Shackle Bushing .....	4

## Engine Oil

	Points		Points
Engine .....	Check Oil Level	Rear Compartment Door Striker .....	4
Door Hinge .....	4 or 8	Rear Compartment Latch Rod .....	2
Gasoline Tank Filler Door Hinge and Spring .....	3	Hood Hinge .....	8
		Windshield Wiper Pulleys .....	4

## Water Resistant Lubricant

	Points		Points
Windshield Cables at Pulleys .....	4	Rear Compartment Door Clamping Lever .....	2
Door Check Arms .....	2 or 4	Hood Prop .....	2
Courtesy Light Switch .....	2 or 4	Hood Upper Lock .....	1
Door Lock Bolt and Slide .....	2 or 4	Hood Lower Lock .....	1
Door Striker .....	2 or 4	Hood Lower Lock and Control Wire .....	2
Rear Compartment Door Hinge .....	2		

## E. P. Gear Lubricant—S.A.E. 80 Winter, S.A.E. 90 Summer

Transmission .....	Check Level	Steering Gear .....	Check Level
Overdrive .....	Check Level		

## Multi Purpose Gear Lubricant—S.A.E. 90

Rear Axle .....

## Distilled Water

Check Battery Electrolyte level and gravity.

## Water or Anti-Freeze

Check Coolant level and Anti-Freeze strength.

## Hudson Hydraulic Brake Fluid

Check Brake Master Cylinder fluid level.

## 2,000 MILES

Perform operations included in 1,000 mile lubrication, in addition to the following:

## Engine Oil

Engine—Drain Oil Reservoir and refill. See "Proper Oil to Use," Page 14	Oil Filler Pipe Cap .....	Wash and re-oil
Generator .....	Throttle Operating Linkage .....	All Joints
Starting Motor .....	Brake Operating Linkage .....	All Joints
Distributor .....	Drive-Master Operating Linkage .....	All Joints
Air Cleaner—Standard .....		All Joints
Air Cleaner—Oil Bath .....	Vacumotive Drive Operating Linkage .....	All Joints
--Remove, wash and add new oil		All Joints

**5,000 MILES**

Perform operations included in 1,000 mile and 2,000 mile lubrications, in addition to the following:

	Hudsonite Clutch Compound	
Clutch.....	Drain and Refill	
	E. P. Gear Lubricant—S.A.E. 80 Winter. S.A.E. 90 Summer	
Transmission.....	Drain and Refill	Overdrive..... Drain and Refill
	Multi Purpose Gear Lubricant—S.A.E. 90	
Rear Axle.....	Drain and Refill	
	Viscous Chassis Lubricant	
Brake Cables.....	Clean and Lubricate	Oil Filter..... Renew Cartridge

**10,000 MILES**

Perform operations included in 1,000 mile, 2,000 mile and 5,000 mile lubrications, in addition to the following:

	Viscous Chassis Lubricant	
Rear Spring Covers.....	Inject lubricant with special lubricating clamp	
	Sodium Soap Base Lubricant	
Front Wheel Bearings.....	Remove, clean and repack	
Rear Wheel Bearings.....	Remove, clean and repack	
	Hudson Shock Absorber Oil	
Vacumotive Drive Cylinder.....	Remove plug and inject 1 ounce oil	
Drive-Master Power Cylinder.....	Disconnect elbow and inject 1 ounce oil	

**IMPORTANT:** When checking the level of the lubricant in the rear axle and transmission, make sure that the lubricant has stopped foaming. If the car has been run for a considerable length of time, it should be permitted to stand long enough to allow the oil to reach the true level before checking.

**BREAK-IN OIL**

Special compounds or so-called "break-in" oils are not necessary in Hudson engines. In the event it is decided to use them, make sure the supplier guarantees that they contain no harmful ingredients.

**ENGINE OIL CAPACITIES**

The total engine oil capacity is 7½ quarts for six cylinder and 8 quarts for eight cylinder engines. When the oil is drained in the conventional manner, the refilling quantity is 7 quarts for both six and eight cylinder engines.

When the oil reservoir is removed for cleaning or during service work, two quarts should be placed in the oil reservoir tray of eight cylinder engines before the reservoir is installed. The remaining seven quarts should then be placed in the reservoir through the crankcase filler opening. In six cylinder engines, the entire quantity is poured through the crankcase oil filler pipe.

**CHECKING ENGINE OIL LEVEL**

An engine in normal operating condition is expected to use some oil and it is, therefore, not unusual to add oil between change periods. Its rate of usage is governed by the individual engine and is dependent on operating speeds, temperatures and the viscosity and quality of the oil used.

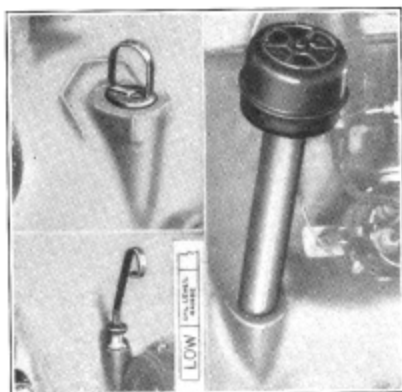

Figure 1

Approximately three and one-half quarts of oil are required to bring the level from low to full in both six and eight cylinder engines. If the level happens to be low and the speedometer indicates that the oil change period is near at hand, it is more economical to have the oil changed at that time.

#### WHEN TO CHANGE ENGINE OIL

The oil which is placed in the engine at the factory is satisfactory for the first 500 miles of operation.

Thereafter, at intervals of 2,000 miles, the reservoir should be drained and refilled with new oil of good quality. If the car is operated constantly in dusty areas or for short distances at low speeds during cold weather, which permits foreign matter and sludge to accumulate, it should be changed more frequently. However, the actual change period is largely dependent on the individual driving circumstances.

The oil is drained by removing the plug at the rear of the oil reservoir. To insure complete draining, it is important that the operation be performed while the engine is warm.

It is good practice to remove the oil reservoir at least twice a year, preferably in the spring and fall, to permit thorough cleaning of the screens and pan.

*Caution: The use of flushing oil or compounds is not recommended. However, in the event they are used, it will be necessary to remove the oil reservoir and thoroughly clean it out before installing the new oil.*

#### THE PROPER ENGINE OIL TO USE

The use of high-grade engine oil of the correct type is of great importance in obtaining maximum performance and satisfaction from your car. Select oils from well-known and dependable brands, of which there are many on the market, and of the proper viscosity to suit your seasonal and driving requirements.

The level should be checked each time fuel is added. The oil level gauge is located on the left side of the engine and is divided at its lower end to show the "Oil Level Range" and the "Low Range."

For normal operation, the oil level is satisfactory when it is within the "Oil Level Range." For high speed operation, the level should be maintained at the full mark, which is the top line on the "Oil Level Range."

To make an accurate check, it is best to wait a minute or two after shutting off the engine to permit the oil to drain back into the reservoir.

The oil refiners or marketers supplying oils are responsible for the quality of their product and their reputation is the car owner's best assurance of receiving high-grade lubricants.

**TYPES OF OIL**

The various types of oil marketed for engine lubrication has been defined by the American Petroleum Institute, as follows:

**REGULAR MOTOR OIL** — This term is used to designate a straight mineral oil. Oils of this type are generally suitable under moderate driving conditions.

**PREMIUM MOTOR OIL** — This term is used to designate an oil having proved oxidation, stability and bearing corrosion preventative properties. Oils of this type are generally suitable for use where operating conditions are such that regular oils do not give satisfactory service.

**HEAVY-DUTY MOTOR OIL** — This term is used to designate an oil having proved oxidation, stability, bearing corrosion preventative properties and detergent-dispersent characteristics. Oils of this type are generally suitable for use in both high-speed diesel and gasoline engines under heavy-duty service conditions.

It is most important that the oil should have the ability to flow at low temperatures to permit easy starting and at the same time, afford adequate lubrication when the engine is at normal operating temperatures. The oil selected should be based on its ability to perform these two functions at the lowest anticipated temperatures expected before the next oil change period. The following table will be helpful in making this selection.

FOR	USE
90° Average temperature.....	S.A.E. 30
32° Minimum temperature....	S.A.E. 20
10° Minimum temperature.....	20 W.
—10° Minimum temperature.....	10 W.
Below —10° temperature.....	10 W. plus 10% Kerosene

**NOTE:** *Kerosene should be added only when temperatures below —10° are expected for long periods.*

Your Authorized Hudson Dealer, who has had long experience with the brands of oil available in your locality, will be glad to help you with your lubrication problems.

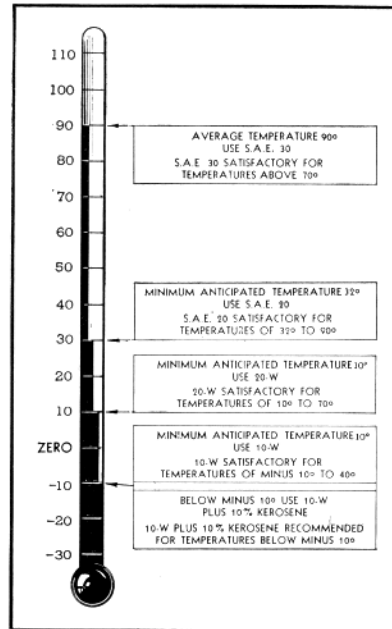

Figure 2



### OIL FILTER

A Hudson Oil Filter is available through your Authorized Hudson Dealer and its installation will assist in removing foreign matter and impurities from the oil, and at the same time, permit a normal oil flow through the engine. This filter will keep the oil cleaner for longer periods and help minimize wear on engine parts.

The cartridge should be replaced at approximately 5,000 mile intervals or when the oil shows definite evidence of becoming dirty. Replacement cartridges can be secured from your Hudson Dealer. When replacing the cartridge, be sure to use the new cover gasket furnished and see that it sets correctly on the filter body to prevent oil leaks.

### OPERATING CONTROLS

Arrangement and functions of the instruments and controls of your new Hudson have been planned for maximum convenience and comfort of the driver, as well as for safety. If you have driven Hudsons previously or are a first time Hudson owner, you will want to know all about the newer controls before driving your new car. We, accordingly, recommend that you read the following instructions carefully.

#### (1) SEAT ADJUSTING LEVER

—Raising the lever on the left side of the front seat permits the seat to be moved forward or backward to the position most convenient for the driver. As the seat moves forward, it rises, permitting short persons to sit higher; thus making for better vision. Seat locks in position when lever is released.

#### (2) DIRECTION INDICATOR LEVER

—Push lever upward for right turn and downward for left turn. Lever returns to OFF position automatically when turn is completed. Direction Indicator Light (1) on instrument panel flashes with front and rear indicator signal.

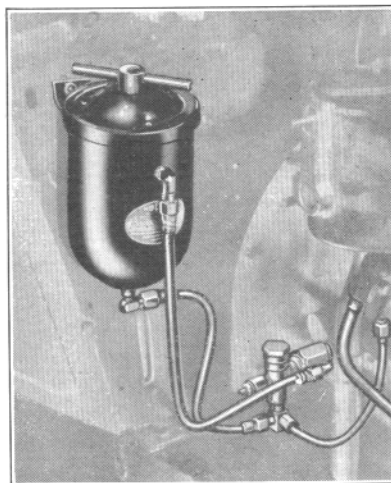

Figure 3

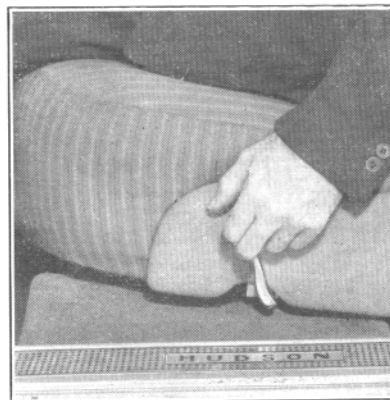

Figure 4

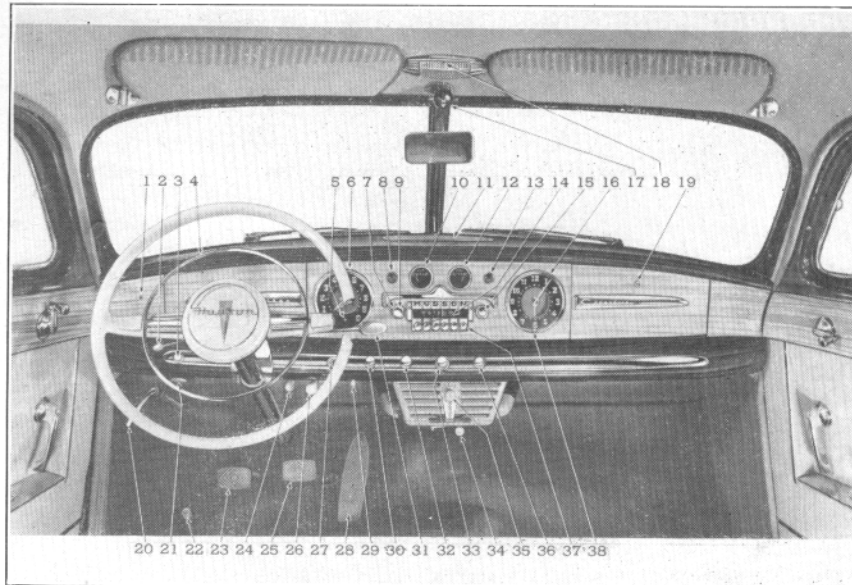

Figure 5

- (3) **STARTER BUTTON** — Pressing button in with ignition switch turned on operates the starter. On cars equipped with Drive-Master, the clutch pedal must be pushed down before the starter will operate. Do not press button when engine is running or car is in gear. Starter will not operate unless ignition is turned on.
- (4) **HORN OPERATING RING** — Press down from any position to operate horns.
- (5) **HEADLIGHT BEAM INDICATOR** — Incorporated in speedometer — shows red when headlight beam is in upper or country driving position.
- (6) **SPEEDOMETER** — Includes mileage indicator showing accumulated mileage.
- (7) **RADIO TONE CONTROL RING** — Turning to right from mid-position brings out the high notes and to left emphasizes the bass notes. See Radio Owner's Manual.
- (8) **OIL PRESSURE INDICATOR** — Shows red when ignition is turned on and engine not running. Light should go out when engine is started. Should the light flash or stay on when the engine is running, it indicates lack of oil in the reservoir, or some disarrangement in the oiling system. The engine should be shut off at once and the cause of the difficulty determined.
- (9) **RADIO ON AND OFF AND VOLUME CONTROL KNOB** — Off in extreme left position. Turning knob to right turns on radio and regulates volume.

- (10) **FUEL GAUGE** — Indicates the level of the fuel in the gasoline tank when the ignition switch is turned on. When needle reaches "empty" mark, approximately 1½ gallons of fuel remains in reserve.
- (11) **RADIO SPEAKER GRILLE** — Located at top of instrument panel.
- (12) **TEMPERATURE GAUGE** — Indicates temperature of water or anti-freeze when ignition is turned on. When ignition is turned off, the pointer returns to the "H" position at the right side of the dial.
- (13) **GENERATOR CHARGE INDICATOR** — Shows red when ignition is turned on and when engine is running at low speed. Light should go out as speed is increased. If electrical difficulty is encountered or the generator is not charging, the light will either flash or stay on as a warning. In this case, have the electrical system checked by an Authorized Hudson Dealer.
- (15) **RADIO MANUAL TUNING KNOB** — Turn knob to tune in stations manually. Tuning position shown on Station Dial (14).
- (16) **CLOCK** — Mechanical clock requires winding every day. Turn knob clockwise to wind. Electric clock requires no winding and is protected by a fuse at the back. On both types, hands are set by pulling out and turning knob (38).
- (17) **RADIO ANTENNA OPERATING KNOB** — To raise antenna, press in knob slightly and turn to right or left-half turn. To extend antenna, turn knob one-quarter turn, pull out inner or telescopic section of antenna and turn knob until antenna is in upright position.
- (18) **DOME LIGHT SWITCH** — Sliding switch operates front dome light. Rear compartment dome lights operated by sliding switch on right door pillar.
- (19) **LOCKER BOX LOCK** — Press in to open door. Lock by inserting key and turning one-quarter turn to left.
- (20) **PARKING BRAKE LEVER** — Apply brakes by pulling lever backward and pressing down brake pedal at the same time. Release brakes by turning handle to right and pushing it down as far as it will go.
- (21) **HOOD UNLOCKING HANDLE** — Pull handle to release lock. Then release safety catch by reaching finger under louver at front of car and pulling lever forward. Grasp hood at front end and raise. To lock, lower hood and press down on front end.
- (22) **HEADLIGHT FOOT SWITCH** — Controls country (upper) and traffic (lower) beams. When meeting oncoming traffic and beam indicator shows red, depress foot switch once and release for passing beam. Pressing and releasing switch the second time restores light beams to upper or country driving position.
- (23) **CLUTCH PEDAL** — Should be depressed fully to floorboard when shifting gears. On cars equipped with Hudson Drive-Master, this must be done before pressing the starter button or the starter will not operate. When starting the engine, particularly in cold weather, depressing the clutch pedal manually will eliminate transmission gear drag and facilitate starting.

(24) **OVERDRIVE CONTROL KNOB** — Push knob all the way in for operation in Overdrive. This may be done with the car standing or at any ordinary driving speed. Overdrive becomes operative at speeds above approximately 22 miles per hour and the shift is made by removing the foot from the accelerator momentarily. Upon again depressing the accelerator the car will operate in Overdrive and continue to do so until the speed drops to about 19 miles per hour. Overdrive will then automatically disengage, reverting to direct drive through free wheeling.

As operation in Overdrive does not provide best acceleration for passing other cars or give the necessary power to climb steep grades, it is occasionally necessary to revert temporarily to direct drive at speeds higher than 19 miles per hour. This can be accomplished by depressing the accelerator pedal fully beyond the wide open throttle position.

To re-engage Overdrive, momentarily release the accelerator pedal (at speeds above 22 miles per hour) and resume normal operation in Overdrive.

When Overdrive and free wheeling is not desired, as in heavy traffic, on icy and slippery pavements or on steep grades, simply pull the control knob out while the car is standing or moving at less than 19 miles per hour. If a clicking sound is heard after pulling the knob out, depress the accelerator pedal slightly to bring the engine up to the car speed and the shift will be completed.

When driving at speeds above 19 miles per hour, it is necessary to depress the accelerator pedal fully beyond full throttle to revert to direct drive and then pull out the control knob.

(25) **BRAKE PEDAL** — Controls hydraulic operation of brakes on all wheels. Also operates reserve mechanical system on rear wheels in event of disablement of hydraulic system.

(26) **COWL VENTILATOR HANDLE** — Should be pushed forward to open cowl ventilator and pulled back to close it. When Hudson Weather-Control is installed, follow instructions on page 63.

(27) **IGNITION LOCK** — Inserting and turning key to right turns ignition on. When lights are turned on, lock is illuminated.

(28) **ACCELERATOR PEDAL** — Controls the speed of the engine and car. Never pump the accelerator when starting the engine as it will result in flooding. When starting a cold engine, the accelerator pedal should be pressed half way and released slowly before cranking. (See "To Start Engine.") The accelerator controls the operation of the clutch on cars equipped with Drive-Master and Vacumotive Drive, as well as the engagement of Overdrive on cars fitted with this device.

(29) **INSTRUMENT LIGHT RHEOSTAT** — Controls the brilliance of the instrument lights. Turning knob to right decreases and to left increases amount of light. Turning knob to extreme left turns out lights entirely.

(30) **DRIVE-MASTER AND VACUMOTIVE DRIVE SWITCH**

**DRIVE-MASTER SWITCH** — Turn knob right for automatic opera-

tion of clutch and gear shifting. Left position provides automatic clutch operation and manual gear shifting. Center or off position permits conventional operation of clutch and gear shifting.

**DRIVE-MASTER OPERATION** — To start in forward speeds under normal conditions, place gear shift lever in high gear position. Depress accelerator and car will move in second gear. When accelerator is released above "shifting speed," high gear will be automatically engaged. It is possible to accelerate to any speed in second gear before shifting into high by keeping the accelerator depressed.

When slowing down for a stop upon releasing the accelerator, the transmission will shift into second when the "shifting speed" is reached and the car is ready for a new start.

To start in low gear, move the gear shift lever to the neutral position, hesitate momentarily and then move it into low gear. After starting, release the accelerator and shift into second or high position. If second speed is selected, it will be necessary to shift into high in the conventional manner. If the lever is moved to the high gear position and the accelerator released, the shift is made automatically into either second or high gear, depending upon the car speed.

Shift into reverse in the conventional manner by lifting the foot from the accelerator and moving the gear shift lever into neutral and then into reverse.

**MOUNTAIN DRIVING** — If it is desired to go into second gear when ascending or descending a steep grade, above the "shifting speed" momentarily release the accelerator, disengage the clutch manually and move gear shift lever into second position.

**VACUMOTIVE DRIVE SWITCH** — Turning knob to right provides automatic clutch operation. For manual clutch operation, turn knob to left or off position.

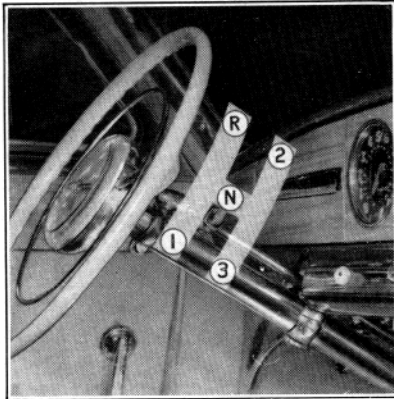

Figure 6

**(31) GEAR SHIFT LEVER** — Should always be placed in neutral position before starting engine. Raise knob and move lever forward for reverse gear and rearward for low gear. Move lever to neutral, depress and slide forward for second gear and rearward for high gear. If car is equipped with Hudson Drive-Master, follow instructions shown under "Drive-Master."

**(32) LIGHTING SWITCH** — Controls instrument lights, headlights, hood light, parking lights, license light and tail lights. Turning knob to first position at right, gives

parking lights, hood light, instrument lights, license light and tail lights. Moving knob to second position to right, turns on the headlights in addition to other lights. Turning knob to extreme left position, turns off all lights.

(33) **CIGARETTE LIGHTER**—Press in to operate. Automatically pushes out when proper temperature has been reached.

(34) **WEATHER-CONTROL HEAT REGULATOR LEVER**—Controls water circulating through heater. Moving lever to right increases and to left decreases temperature. At extreme left position, water is entirely shut off.

(35) **WEATHER-CONTROL SWITCH**—Controls operation of fans for defrosting windshield and circulating air when car is standing. Extreme left position of knob "OFF." First position to right provides low speed and extreme right position high speed operation of fans.

(36) **WINDSHIELD WIPER CONTROL KNOB**—Center position "OFF." Turning knob to right turns on and regulates speed of windshield wipers. When car is equipped with windshield washer as an accessory, turning knob to left and then to right causes wiper to wash windshield.

(37) **RADIO AUTOMATIC TUNING BUTTONS**—Press in button for automatic tuning of station desired.

### DRIVING YOUR NEW CAR

Before your new Hudson automobile was delivered to you, your Dealer checked it over thoroughly to be sure that all adjustments were in order; that all lubrication fittings and units of the car were properly lubricated; that the cooling system was filled to the proper level, and that the tires were inflated to the proper pressures.

When starting with a cold engine, always keep the speed near 30 until the engine reaches normal operating temperature. This is good practice at any time but especially necessary when the engine is new and the moving parts not worn in. For the first 250 miles keep the speed under 40 but drive as little as possible under 25. Between 250 miles and 500 miles the top limit may be increased to 50 and between 500 and 1000 miles to 60.

At least a third of the mileage of each period should be driven at or near the maximum speed recommended. Do not drive at constant speed for any length of time but vary the speed within the recommended limits. At no time during the first 1000 miles should the throttle be opened fully for quick acceleration or hill climbing.

The first 1000 miles are very important to your new engine and a little care during this time will pay off in added economy throughout a longer life.

After the first 500 miles of driving return your car to your Dealer to have the oil changed, as it is good practice to have fresh clean oil in the engine before starting to drive at the increased speeds permissible during the second 500 miles of the break-in.

### STARTING THE ENGINE

The carburetor is fitted with an automatic choke which correctly proportions the fuel mixture during the starting and warm-up period.

1. Place gear shift lever in neutral position.
2. Depress clutch pedal.
3. Turn on ignition switch.
4. If engine is completely cold from standing for several hours or overnight, depress the accelerator pedal at least one-half way and release slowly, then press starter button.

**ON CARS EQUIPPED WITH DRIVE-MASTER, THE CLUTCH PEDAL MUST BE DEPRESSED OR THE STARTER WILL NOT OPERATE.** After engine has started, it will run at high idle speed for warm-up. When the engine is warm, a slight depression and release of the accelerator pedal will permit the throttle to return to normal idle.

5. If engine is warm from previous running and has not been standing long enough to become completely cold, depress the accelerator pedal one-quarter to one-half way and hold in this position while cranking.

### TO START CAR

After the engine has been started and the clutch pedal depressed, raise transmission control lever and move it forward for reverse gear, or rearward for low gear. Move lever to neutral, depress and slide it forward for second gear, or rearward for high gear.

If car is equipped with Hudson Drive-Master or Vacuumotive Drive, see Special Operating Instructions, number (30) listed under "Operating Controls."

If car is equipped with Overdrive, follow Special Operating Instructions, number (24) listed under "Operating Controls."

### CARBON MONOXIDE GAS

**CARBON MONOXIDE, A DEADLY, COLORLESS, ODORLESS GAS IS ALWAYS PRESENT IN THE EXHAUST OF THE INTERNAL COMBUSTION ENGINE. GARAGE DOORS SHOULD ALWAYS BE FULLY OPENED WHEN STARTING OR RUNNING THE ENGINE.**

### LOCKING YOUR CAR

When your car was delivered to you, it was provided with two sets of keys. The keys with round handles fit the ignition and both front door outside locks. The keys with the octagonal shaped handles fit the locker box door and rear compartment locks.

All keys are numbered and these numbers should be registered on your Owner Identification Card, as well as some other suitable place where they will be available should the keys become lost. As insurance regula-

tions prohibit the stamping of key numbers on lock cylinders, misplaced or lost keys can be obtained from your Hudson Dealer only by referring to key change number.

Many cars are driven away by unscrupulous persons simply because the ignition key was left in the lock. Make it a practice to remove the key from the lock if the car is to be left unattended even for a few minutes.

## DOOR LOCK OPERATION

### TO OPEN DOORS

**FROM OUTSIDE**—Outside door handles are of the stationary type, fitted with a push button at the end. To open the door, grasp the handle and press in the push button with the heel of the hand or the thumb. Push door to close.

*Caution: Door will not close if latch bolt has been moved upward from lower end of curved slot in door. To return latch bolt to lower end of slot, lift inside safety button to "up" position, then operate outside or inside door handle.*

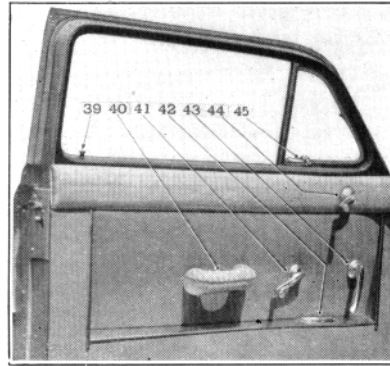

Figure 7

**FROM INSIDE**—Front doors—rotate inside handle (43) by pulling backward. Rear doors—rotate inside handle by pressing down.

Doors cannot be opened from inside or outside unless inside safety buttons in garnish mouldings are in the "up" position.

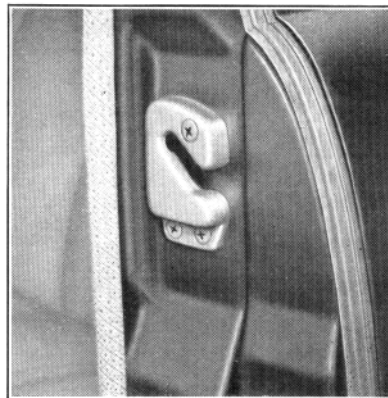
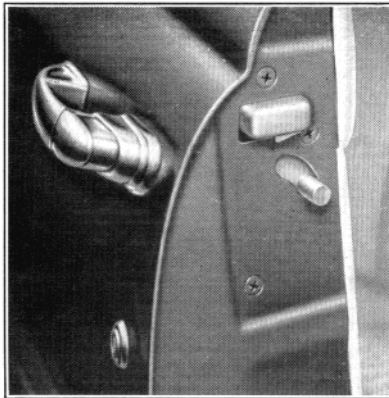

Figure 8



### TO LOCK DOORS

**FROM INSIDE** — Push down inside safety buttons (39) in garnish moulding.

**WHEN LEAVING CAR** — Close windows with doors *closed*. Push down inside safety buttons on all doors except the front one from which you are leaving. Close front door and turn lock with key until inside safety button is "Down." Turn key back to vertical position and remove.

### LOCKER BOX DOOR

To lock the door, turn key one-quarter turn clockwise and remove. To unlock door, turn key one-quarter turn counter-clockwise and remove.

When door is unlocked, it can be opened by pressing in on lock cylinder face.

### REAR COMPARTMENT DOOR

To safeguard the spare tire, tools and any luggage you may be carrying, always lock the rear compartment door. Turning the key one-half turn counter-clockwise unlocks the lock. To lock it, turn the key one-half turn in a clockwise direction. To open, lift the door with the left handle after raising the right handle to release the catches. To close, lower the door, then raise and lower the right handle to engage the catches.

### LOCKING THE HOOD

The hood of your Hudson car is designed to open at the front and is provided with a locking arrangement to prevent the battery, engine and accessories from being tampered with.

The hood lock is controlled by a handle located under the instrument panel on the left side. Pulling out the handle releases the lock and raises the front end of the hood slightly to the safety catch position.



Figure 9



Figure 10

The safety catch can then be released by reaching under the louver at the front of the car and pulling the catch forward and raising the front end of the hood at the same time. Spring loaded hinges assist in raising the hood and strong, self-locking supports hold it up.

To lock, lower the hood and press down at the front end to engage the safety catch and lock.

## TIRES

### INFLATION PRESSURES

Maintaining proper tire pressure is the most important factor in obtaining maximum tire life, proper car handling, and best riding qualities.

Because tires get hot due to road contact and internal friction, the air pressure may increase considerably after hard driving during hot weather. For this reason, tire inflation and pressure checking should always be done when the tires are cold. Do not reduce pressure when tires are hot.

Ordinarily tire pressure should be checked at least once a week. However, when touring, or if the car is driven extensively, they should be checked every morning before starting out.

Tire valve caps should be finger tight to prevent loss of air which may be escaping from a leaky valve and also precludes the possibility of dust and dirt getting into the valve. Replace missing valve caps promptly.

Keep tires inflated to the following pressures:

<i>Size</i>	<i>Front</i>	<i>Rear</i>
7.10 x 15 ( <i>Standard</i> )	24 Pounds Cold	24 Pounds Cold
7.60 x 15 ( <i>Optional</i> )	24 Pounds Cold	24 Pounds Cold

### MINIMIZING TIRE WEAR

By changing the position of the tires every 2500 to 3000 miles, they will last much longer. It is not necessary to remove the tires from the wheels but simply switch the complete wheel and tire so as to change the direction of rotation.

To avoid having more than one wheel jacked up at a time, always start, by installing the spare wheel and tire first, then follow through as shown in Figure 11.

### TIRE AND WHEEL BALANCE

Proper tire and wheel balance is essential to prevent undue tire wear and high speed wheel tramp, both

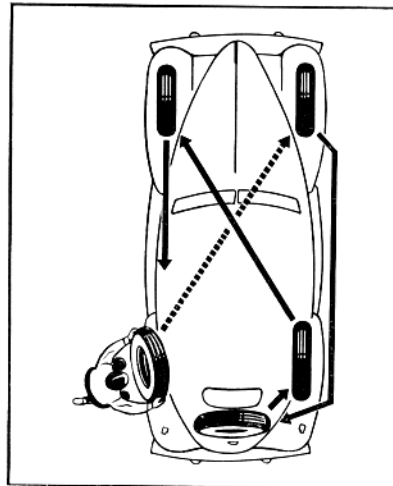

Figure 11

of which contribute to poor handling, certain riding discomforts and excessive wear of front end parts. Tires and tubes are balanced at the time of assembly at the factory. The balancing marks are indicated on the tire by a small red mark. Whenever a tire is removed from the wheel, it should always be reinstalled with the red mark aligned with the valve stem.

Although tires and wheels are balanced when they leave the factory, subsequent tire wear causes them to go out of balance. To maintain proper balance and assist in prolonging tire life, it is the tire manufacturers' recommendation that the wheel and tire assemblies be checked for balance every 2,500 miles and whenever a tire is repaired or recapped. Your Authorized Hudson Dealer has the necessary equipment to perform this work.

#### **DISMOUNTING AND REMOUNTING TIRES**

**TO DISMOUNT** — Deflate the tube completely. Stand on the tire with both feet to force the bead away from the rim. Push the valve stem back into the tire. With two tire tools inserted about eight inches apart between the bead and the rim, raise the bead over the rim. **BE CAREFUL NOT TO PINCH THE TUBE WITH THE TOOLS.** With one tool in position, move the other tool around the rim and remove the remainder of the bead. Then remove the tube.

Stand wheel in upright position with inner bead in rim well. Apply liquid soap around both sides of rim. Insert both tire tools between bead and rim and pry tire out of rim.

**TO REMOUNT TIRE** — Coat both beads of tire with liquid soap to help slide them over the rim. Inflate tube just enough to round it out, then insert it in the tire, placing the valve stem directly in line with the red balancing mark on the tire. Place the tire on the wheel, carefully guiding valve stem into the hole in the rim. Push the inner bead over the rim and into well at valve stem and force balance of bead over the rim. It may be necessary to force a small remaining portion of the bead over the rim with the tire tool.

Insert the tire tool between outer bead and rim at a point opposite the valve stem and work bead over the rim. Leave tool in place and work other tool around bead and force remainder of the bead over the rim. **BE CAREFUL NOT TO DAMAGE THE TUBE WITH THE TOOL.**

Inflate tire slowly, carefully checking beads to see that they both are seating properly on the rim. The tire may be centered by bouncing it a few times. Inflate tire to recommended pressure.

#### **TOOL KIT**

The tool kit is stored in the rear compartment. It contains a wheel hub bolt wrench (which is also used as a jack handle), pliers, screw driver, and a ratchet-type bumper jack and base.

#### **SPARE TIRE AND WHEEL**

To remove the spare tire and wheel mounted in the rear compartment, take out the clamp bolt and plate, using the wheel hub bolt wrench.

### USING THE BUMPER JACK

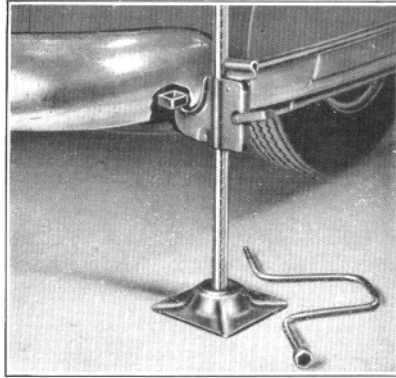

Figure 12

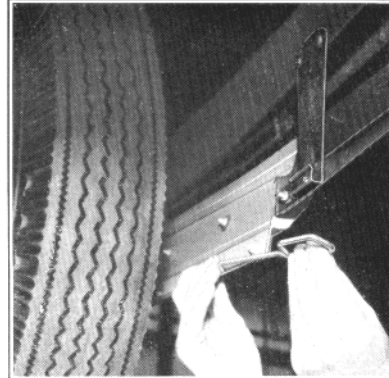

Figure 14

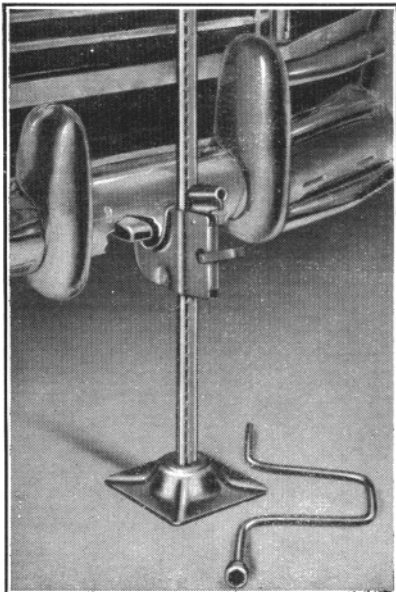

Figure 13

ing under and raising up the loop at each end of the attaching rod until it is clear of its hook, as shown.

Your New Hudson is provided with special jack lifting pads built into the frame at the front and at the sides near the rear, which assure maximum lifting efficiency and safety and prevents the possibility of springing the bumpers.

Set the parking brake securely and block the wheel opposite the one being changed to prevent any movement of the car. Set the jack base on a level and solid footing and engage the lifting lug of the jack in the socket of the frame pad, as shown. The wheel bolt wrench is designed for use as a handle to operate the jack.

When removing a rear wheel, it is necessary to take off the wheel cover which is a part of the rocker panel opposite the rear wheel (Figure 14). This can best be done after the car is jacked up, by reach-

### CHANGING THE WHEEL AND TIRE

Before raising the car, remove the hub cap with a screw driver and with the hub bolt wrench (jack wrench) loosen the hub bolts one turn. Raise

the car sufficiently to clear the ground and then remove all hub bolts and take off tire and wheel.

When installing the spare, be sure the pilot stud in the hub is in the top position, then slide wheel onto hub using pilot stud as a guide. After wheel has been installed and car lowered, again check tightness of hub bolts and replace hub cap.

## ENGINES

### ENGINE FEATURES—SUPER SIX

Hudson Super Six engines are of "L" head design, mounted at three points in live rubber cushions to prevent sound or vibration being transmitted to the body.

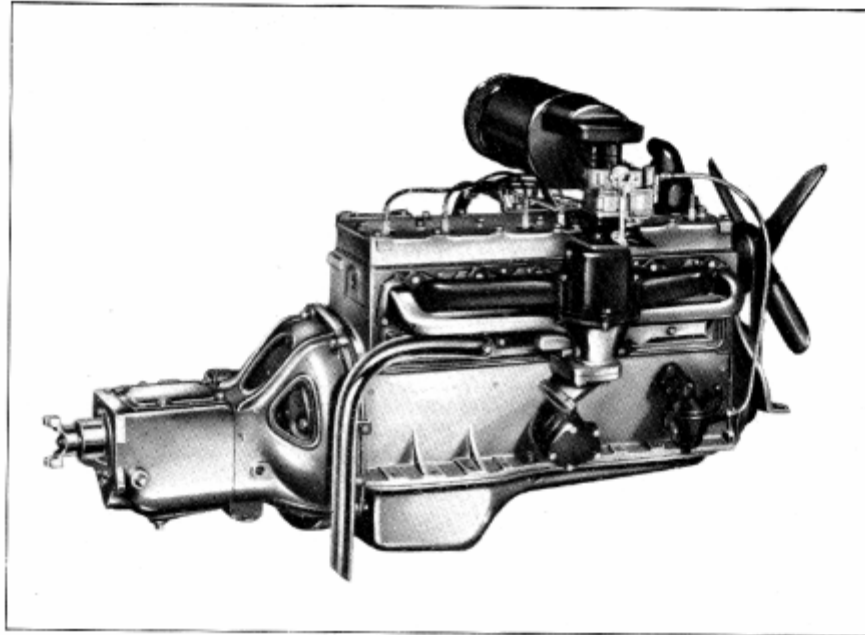

Figure 15

**CYLINDER HEAD**—High turbulence type for better fuel combustion.

**CRANKSHAFT**—Drop forged steel, fully compensated and equipped with rubber-insulated vibration damper, balanced at rest and in motion; four precision type, steel-backed, babbitt-lined main bearings.

**PISTONS**—T-slot, cam ground, aluminum alloy, fitted with four pinned, plated piston rings.

**CONNECTING RODS**—Drop-forged, high manganese alloy, with replaceable, steel-backed, babbitt-lined precision type bearings.

**CAMSHAFT** — Nickel-chrome-molybdenum-iron alloy, with angular ground cams for positive rotation of tappet. Heat treated for extreme hardness. Phosphate coated for better lubrication. Bearings pressure lubricated.

**TAPPETS** — Rotating mushroom type with special self-locking adjusting screw. Pressure lubricated.

**VALVES** — Special alloy. Installed at angle for faster intake and exhaust flow. Grooved for conical spring seat retainer. Valve seats integral with cylinder block, cooled around entire surfaces. Exhaust valves are of high nickel-chrome alloy.

**CYLINDER BLOCK** — High chrome alloy, entire block as hard as ordinary valve seat inserts. Water jackets full length of cylinders and all around each cylinder.

**CARBURETION** — Direct passage of fuel through radial manifold to combustion chamber. Dual down-draft type. Automatic choke. Climatic control. Anti-percolator valve.

**LUBRICATION** — Full pressure lubrication to 34 points. Float type oil intake draws clean oil from point just below top level in oil pan.

### ENGINE FEATURES—SUPER EIGHT

Hudson Super Eight engines are of "L" head design, mounted at three points in live rubber cushions to prevent sound or vibration being transmitted to the body.

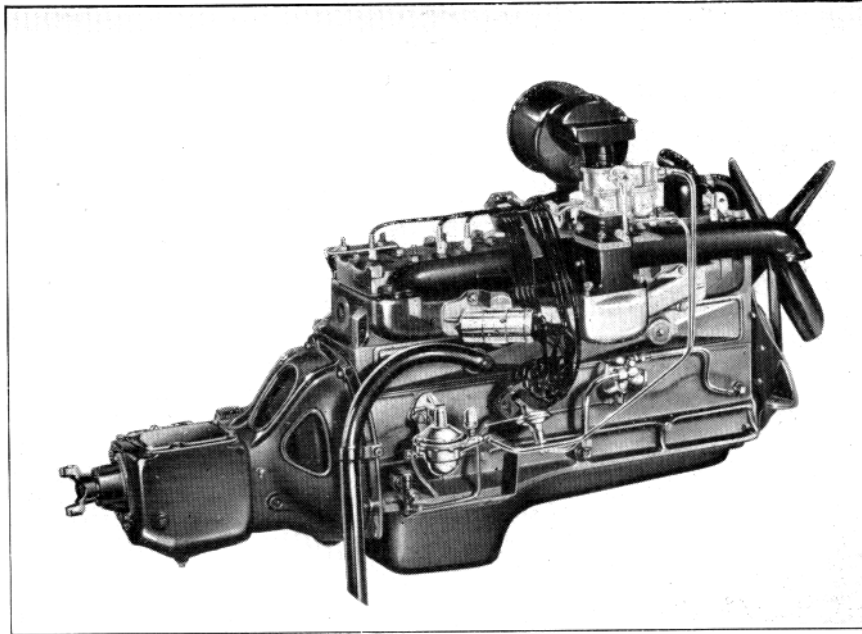

Figure 16

**CYLINDER HEAD**—High turbulence type for better fuel combustion.

**CRANKSHAFT** — Drop-forged, fully compensated and equipped with rubber-insulated damper, balanced at rest and in motion; five long-wearing, bronze-backed main bearings.

**PISTONS** — T-slot, cam ground, aluminum alloy, fitted with four pinned, plated piston rings.

**CONNECTING RODS** — Drop-forged, high manganese alloy for greater strength, dowel-fitted caps assure perfect alignment. Bearings with centrifugally installed babbitt metal.

**CAMSHAFT**— Nickel-chrome-molybdenum-iron alloy, heat treated for maximum hardness, specially treated for smooth finish. Large babbitt bearings.

**TAPPETS** — Exclusive roller cam design. Rotating cam lobe maintains constant contact, requires less adjustment, wears longer.

**VALVES** — Special alloy steel. Exhaust valves have high chrome content to resist high temperatures.

**CYLINDER BLOCK**—Super-hard chrome alloy. Provides wear resisting cylinder bores, eliminates need for special valve seat inserts. Entire block is as hard as ordinary valve seat inserts.

**CARBURETION** — Down-draft type. Dual flow to combustion chambers for more complete combustion. Radial intake manifold provides direct, free flow passages for fuel mixture. Automatic choke. Climatic control. Anti-percolator valve. Air cleaner.

**LUBRICATION** — Exclusive Duo-Flo supplies oil in direct ratio to engine speed. Lubricates every part at first turn of crankshaft. Float type oil intake draws clean oil from point just below surface of oil in pan.

### VALVE TAPPET ADJUSTMENT

Correct valve tappet adjustment is vital to good engine operation and it is important, therefore, that the specified clearance between the adjusting screws and valve stems be maintained at all times. These are as follows:

	Six Cylinder Engine	Eight Cylinder Engine
Intake Valves	.008"	.006"
Exhaust Valves	.010"	.008"

Tappets checked and adjusted only after the engine has been run long enough to attain normal operating temperature. Be sure to use an accurate feeler gauge.

The valve locations, counting from the front of the engine, are as follows:

	Six Cylinder Engine	Eight Cylinder Engine
Intake Valves	2-4-5-8-9-11	2-3-6-7-10-11-14-15
Exhaust Valves	1-3-6-7-10-12	1-4-5-8-9-12-13-16

## COOLING SYSTEM

The cooling system is of the pressure type, employing a cellular, tubular radiator, centrifugal pump and four blade fan.

The water pump has a large six vane impeller and the shaft is mounted on a double row ball bearing with grease sealed in and requiring no lubrication attention. A new type spring loaded bellows seal and composition thrust washers prevent leakage around the shaft.

By-pass type thermostats are used which permit quick engine warm-up by restricting the coolant circulation through the radiator and by-pass it around the cylinder block. The thermostat begins to open at temperatures of from 150 to 155 degrees and is wide open at 185 degrees.

A large 4 blade fan, with blades unevenly spaced to minimize sound, is used.

**COOLING SYSTEM CAPACITY**—6 Cylinder Models — 19 Qts.  
8 Cylinder Models — 17 Qts.

Cars equipped with heater require one additional quart.

**TO DRAIN** the radiator only, turn handle of the drain cock located at the lower right corner of the radiator, counter-clockwise. To drain the complete cooling system, also remove the pipe plug located at the left rear corner of the cylinder block.

**NOTE:** *If it becomes necessary to drain the radiator when it contains anti-freeze and it is desired to save it, a piece of hose may be fitted over the end of the drain cock and the loose end placed in a container.*

**PROPER CARE** of the cooling system is highly essential to maintain efficient engine operation. Rust and scale in the cylinder block is a natural product of water and iron. Therefore, unless the necessary precautions are taken to prevent this accumulation, which acts as an insulator, so-called "hot spots" may result through the inability of the water to cool the cylinders and the area adjacent to the valve seats.

The use of Hudson Rust and Corrosion Inhibitor in the cooling system prior to adding anti-freeze in the fall and after draining in the spring will assist to a large measure in keeping the system clean and permit efficient circulation. This product is available through all Authorized Hudson Dealers.

### FAN BELT

The fan belt is of the "V" type and drives the water pump and generator through the vibration dampener pulley.

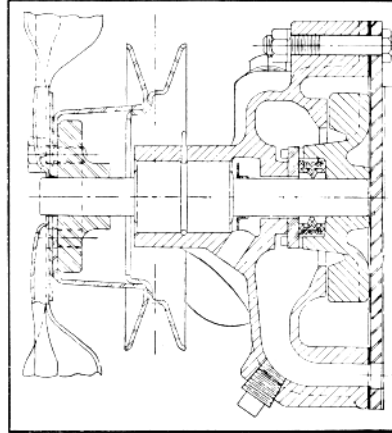

Figure 17



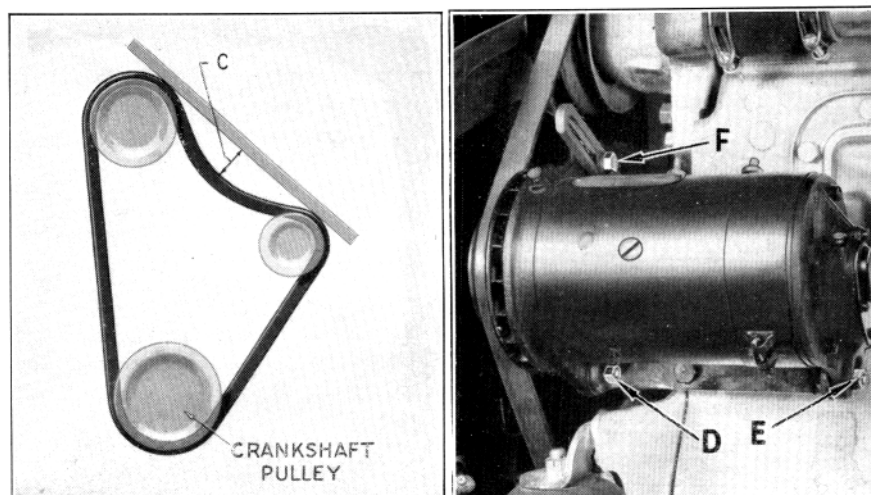

Figure 18

The belt is adjustable by means of a swinging generator mounting. Moving the generator away from the engine increases the belt tension while moving it towards the engine decreases its tension. Belt adjustment is correct when it is possible to depress the belt approximately  $\frac{3}{4}$ " , as shown in the illustration.

Adjustment is made by loosening cap screws and nuts (D), (E) and (F). When proper position has been obtained, be sure to tighten screws and nuts securely.

#### ANTI-FREEZE

Before installing any anti-freeze when preparing for winter operation, it is good practice to always drain and flush the cooling system to insure unrestricted circulation. Also carefully check all hoses and gaskets for leaks or signs of deterioration.

Avoid the use of anti-freeze solutions containing calcium salts, or other ingredients which promote electrolytic action. Glucose and honey clog the radiator; kerosene and fuel oil when hot, expel inflammable vapors and, therefore, solutions containing these ingredients should never be used. **NOTE:** Do not mix permanent and temporary anti-freeze solution.

The following anti-freeze table will be helpful in determining the quantity of anti-freeze for proper protection with Weather-Control:

Freezing Point Temperature	Hudson Anti-Freeze		Methanol or Denatured Alcohol		Ethylene Glycol (Prestone or Equivalent)	
	Qts.	Qts.	Qts.	Qts.	Qts.	Qts.
	6 cyl.	8 cyl.	6 cyl.	8 cyl.	6 cyl.	8 cyl.
10	5-3/4	5-1/4	6	5-1/2	5	4-1/2
0	7	6-1/2	7-1/4	6-3/4	6-1/2	6
-10	8-1/2	7-3/4	8-3/4	8	7-1/2	7
-20	9-3/4	9	10	9-1/4	8-3/4	8
-30	11-1/2	10-1/2	11-3/4	10-3/4	9-3/4	9

## CARBURETOR AND FUEL SYSTEM

### FUEL RECOMMENDATIONS

The engine of your Hudson car is designed to give good performance and economy with regular grades of gasoline. One of the most important factors in getting the most out of the fuels available, is correct ignition timing.

The lower grades of gasoline should be avoided in the present day high compression engines, as they tend to cause "pinging" under normal load conditions, which requires that the spark be retarded for quieter operation. Retarding the spark naturally affects the performance of the car, as well as economy of operation and, therefore, no saving in operation is obtained. Also avoid the use of fuels which tend to gum up quickly as they materially affect the operation of the engine.

Premium grades of fuel, such as Ethyl, which have a higher octane rating, permit the use of a more advanced spark timing without knock or "pinging." This will result in improved performance and economy. It should be remembered, however, that these extra advantages cannot be obtained from this type of fuel unless the spark timing is advanced.

For information on "Ignition Timing" see pages 39 and 40.

### FUEL ECONOMY

Gasoline mileage is the subject of considerable discussion among motorists. We hear a good deal about the results obtained by certain owners which may cause others to wonder how the claims are substantiated. Unless we understand the conditions under which the figures were obtained, they mean very little to us.

There are many factors governing gasoline mileage, such as car speed, road conditions, varying wind velocity, temperature changes, heavy traffic and frequent stops. All of these conditions have a direct bearing on the gasoline mileage your car can give. There are, however, a number of things you can do in driving to improve your gasoline mileage.

1. Avoid unnecessary acceleration of the engine.
2. Warm up the engine by letting it run idle for a few minutes when starting, to permit the oil to circulate properly. This is especially important in cold weather.

**CAUTION:** Avoid racing the engine during the warm-up period.

3. Accelerate slowly.
4. Do not drive in low or second speed gears unnecessarily.
5. Maintain as nearly uniform speed as possible when driving in city traffic.
6. Avoid sudden and unnecessary stops.
7. Keep tires inflated to the recommended pressure.
8. Do not idle the engine unnecessarily.
9. Use engine oil of the proper viscosity.
10. Keep your car properly lubricated.

11. Have the engine of your car tuned up by your Authorized Hudson Dealer each 5,000 miles. He will check its operation and make any necessary adjustments, including ignition timing, contact points, spark plugs, valve adjustment and other important details which have a direct bearing on operating economy.

### CARBURETORS

The carburetors are of the dual down-draft, automatic choke type, incorporating vacuum controlled metering rods, anti-percolator valve, accelerating pump, and fast idle features. A filter screen is also incorporated at the fuel inlet to prevent the entrance of foreign particles which would otherwise clog the small drilled passages and jets in the carburetor.

**ADJUSTMENTS**—There are no adjustments on the carburetor that will affect high speed operation. Therefore, any servicing the carburetor may require, other than minor adjustments that affect operation at idle speed only, should be performed by your Authorized Hudson Dealer who has the special tools and gauges required to service these units.

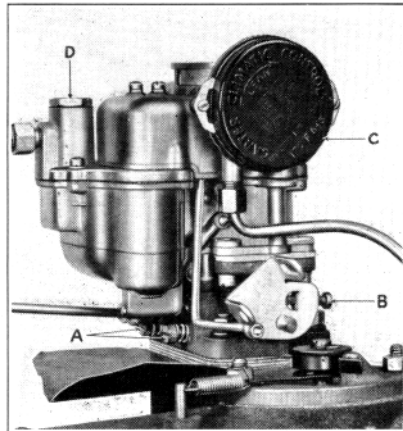

Figure 19

**IDLE MIXTURE ADJUSTMENT**— This adjustment is made by turning both idle adjusting screws (A). The normal position of these screws is  $\frac{1}{4}$  to 1 turn off their seats. To adjust them, turn both screws into their seats and then out exactly  $\frac{3}{4}$  of turn. Readjust for smooth idling. Turning the screws in a clockwise direction produces a leaner mixture and turning them in a counter-clockwise direction results in a richer mixture.

**THROTTLE ADJUSTING SCREW (B)**— controls the engine idle speed. This screw should be adjusted to give a speed of  $7\frac{1}{2}$  to 8 miles per hour in high gear.

**NOTE:** Before making the idle Mixture and Throttle Adjusting Screw Adjustments, be sure the engine has been run long enough to reach normal operating temperature. Never make these adjustments when engine is cold.

If these adjustments do not produce satisfactory results, the engine may require an Engine Tune-up and you should consult your Authorized Hudson Dealer.

**AUTOMATIC CHOKE CONTROL**— Automatically proportions the fuel and air requirements for both starting and engine warm-up.

The thermostatic housing spring which is contained within the thermostat housing (C), is calibrated to hold the choke valve closed at a temperature of  $75^{\circ}$  F. when it is set at the factory. As the engine warms up

the hot air drawn into the thermostat housing through a pipe passing through the exhaust manifold, causes the thermostatic coil spring to release its tension on the choke valve, permitting it to open gradually. Thus as the engine temperature increases, the choke valve gradually opens, resulting in a leaner mixture being fed into the engine to meet operating requirements.

Any service required on the Automatic Choke should be referred to your Authorized Hudson Dealer.

**MANIFOLD HEAT CONTROL VALVE**—is automatic and requires no adjustment.

**FILTER SCREEN CAP (D)**—should be removed and the screen cleaned every 2,000 miles.

#### CARBURETOR AIR CLEANERS

**THE OIL WETTED** type air cleaner is used as standard equipment on all models. In this type cleaner the wire gauze is oil soaked and as the air passes through it, foreign particles are removed, thereby permitting only clean air to enter the carburetor.

At periods of 2,000 miles, or oftener if local conditions warrant, the filter unit should be taken out by removing wing nut and lifting off cover. Clean off old oil and dirt by dipping it in kerosene. Blow it dry and re-oil by dipping it in engine oil, using the same grade as used in the engine. Permit excess oil to drain off and reinstall it in the cleaner.

The **OIL BATH** air cleaner is available as an option or may be installed by your Authorized Hudson Dealer. In this unit, dirt is washed out of the air by the oil spray created as the incoming air strikes the oil in the sump.

The oil bath type air cleaners should be serviced at 2,000 mile intervals or more frequently during severe dust conditions, as follows:

#### SIX CYLINDER ENGINES

1. Loosen long clamp screw at base, lift up and take off cleaner.
2. Remove wing nut at top of cleaner, take out upper section and wash filter element in gasoline. Do not oil.
3. Remove old oil, wash out cleaner base and refill to level indicated with one pint of S.A.E. 50 oil at temperatures above 32 degrees and S.A.E. 20 oil at temperatures below 32 degrees.

**CAUTION:** Do not fill above level mark.

4. Install upper section of cleaner and tighten wing nut.
5. Install cleaner on carburetor horn and turn clamping screw up moderately tight to avoid distorting carburetor air horn.

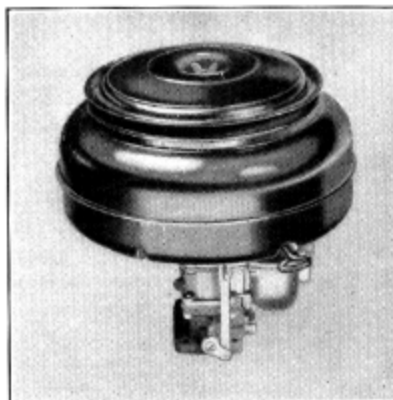

Figure 20

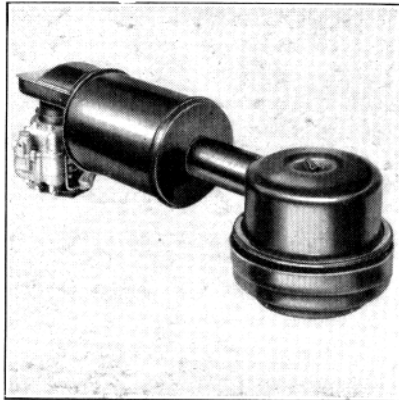

Figure 21

### EIGHT CYLINDER ENGINES

1. Unscrew and remove wing bolt at top of cleaner.
2. Remove lower section of cleaner.
3. Lift out filter element, clean in gasoline and drain.
4. Remove old oil, wash out base and refill to level indicated with one pint of new oil of the following body: S.A.E. 50 oil at temperatures above 32 degrees and S.A.E. 20 oil at temperatures below 32 degrees. **CAUTION:** Do not fill above level mark.
5. Place filter element and container in position without oiling and install lower section of cleaner with the dirt shield facing the front of the car.
6. Install and tighten wing bolt.

### FUEL PUMPS

The standard fuel pump is of the mechanically operated diaphragm type and should be serviced at 2,000 mile intervals by cleaning the bowl and screen.

This is done by removing the bowl screw "A," which in turn permits the removal of the bowl "B,"

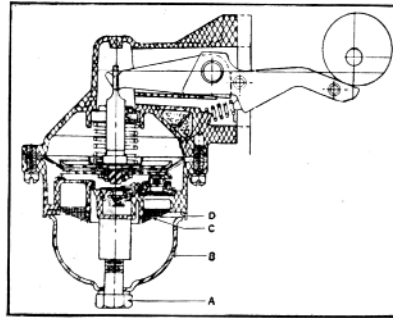

Figure 22

screen "C" and gasket "D." Clean and carefully inspect screen and gasket and replace them if necessary before reassembling.

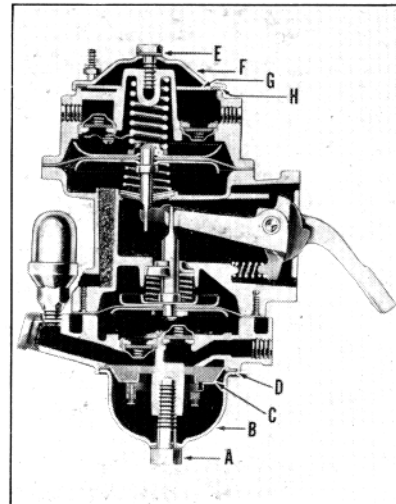

Figure 23

### COMBINATION FUEL AND VACUUM PUMP

To clean the gasoline filter screen, which is recommended every 2,000 miles, remove the lower cap screw (A) and bowl (B). Before replacing screen (C) and bowl gasket (D), carefully examine them and renew if necessary.

The air filter screen should also be cleaned at 2,000 mile intervals. This is accomplished by removing top cover screw (E) and cover (F). Before replacing the screen and cover, carefully examine screen (G) and gasket (H) and renew if necessary.

## STARTING, LIGHTING AND IGNITION

### BATTERY

The battery is located in the front left corner of the engine compartment where it is easily accessible for servicing. It is of the 51 plate type, 120 ampere hour capacity and has the positive post grounded.

The service you receive from your battery depends on the care it is given. The following suggestions will help you get the most out of your battery:

Only a fully charged battery (1.280 specific gravity) will perform efficiently. Have your battery checked at frequent intervals by your dealer to insure the best performance.

Low water level causes the plates to dry out resulting in premature battery failure.

Keep the cells filled to the square with distilled water.

Keep terminal connections tight and free from corrosion and top of the battery clean and dry. Be sure the battery is properly secured in the carrier.

Winter driving conditions create a heavier demand on the battery. When adding water in cold weather do so immediately before driving the car, or run the engine for a short time to insure the water mixing properly with the battery solution. Unless this precaution is taken freezing and battery damage may be experienced.

### GENERATORS

The generators used on all models are of the fully ventilated, high output type with third brush adjustment and voltage regulation. The generator is driven from the crankshaft through a "V" type, adjustable fan belt which also operates the water pump.

The maximum output on all models is 44 amperes cold and 38 amperes hot.

The term "hot" means after the engine has been run about 15 minutes at a speed corresponding to 20 miles per hour.

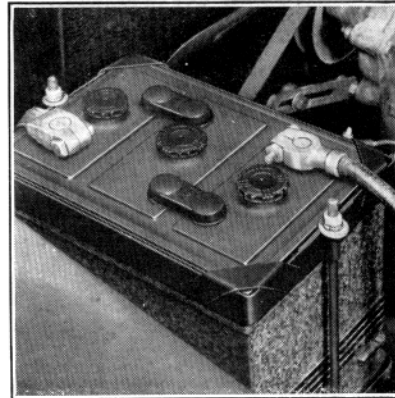

Figure 24

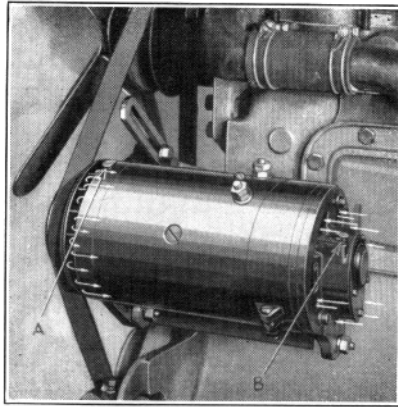

Figure 25

Maximum output is reached at a car speed of about 35 miles per hour. Adjustment of the output is dependent on battery voltage and, therefore, any adjustments required should be made by your Authorized Hudson Dealer, who has the proper checking equipment.

**LUBRICATION** — The front and rear armature bearings should be lubricated every 2,000 miles by applying a few drops of light engine oil to oilers (A) and (B). *Avoid over-oiling.*

#### VOLTAGE REGULATOR

This highly sensitive device automatically increases the amount of current flowing into the battery when it is low due to heavy electrical loads and reduces the current flow when the battery voltage reaches a predetermined value. This prevents damage to battery and other electrical units from excessively high voltage.

As special equipment is required to test this unit, and as the cover is sealed in place, the regulator should never be tampered with. See your Authorized Hudson Dealer if it requires checking.

#### STARTING MOTOR

The starting motor is located at the rear left corner of the engine and is operated by a separate solenoid switch. Control of the starting motor is by means of a push button located on the instrument panel to the left of the steering column. The starter control is operative only when the ignition switch is turned on.

A small button located at the rear end of the solenoid switch is exposed by unscrewing a cap and may be used to permit cranking the engine when checking ignition timing or changing clutch compound.

**LUBRICATION** — The front and rear armature bearings should be lubricated every 2,000 miles by applying a few drops of light engine oil to oilers (A) and (B). *Avoid over-oiling.*

The Bendix drive pinion threads should be cleaned occasionally with a brush dipped in kerosene to remove gum and dirt. Do not oil the threads as the kerosene will provide all the lubrication required.

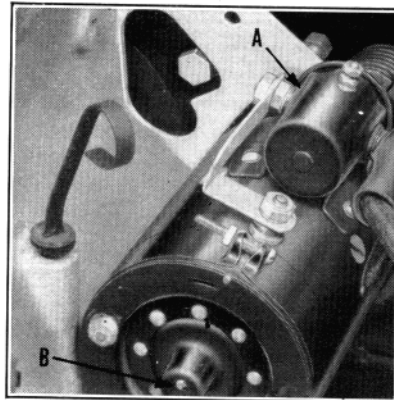

Figure 26

## DISTRIBUTOR

The distributor incorporates an automatic governor advance and in addition, a diaphragm advance control (A), operated by engine vacuum.

The automatic governor advance provides the proper ignition timing in direct proportion to engine speed.

The diaphragm advance control provides additional spark advance over the governor advance, through engine vacuum, for maximum fuel economy. When the engine is running under light load and engine vacuum is high, the distributor is rotated to the maximum advanced position. However, under heavy load conditions, as when the throttle is opened for additional acceleration or hill climbing, and engine vacuum is low, the distributor is rotated to the retarded position to prevent fuel detonation or pinging.

## LUBRICATION

Place a few drops of light engine oil in the oil cup (B) every 2,000 miles. At the same time, apply a few drops of oil to wick (E) at the top of the distributor shaft, to the contact arm pivot (G) and to the lobes of the cam (C). **CAUTION:** Do not over-oil.

## CONTACT POINT ADJUSTMENT

The distributor contact points should be clean, smooth and make full contact. The proper gap adjustment is .020" for the six cylinder and .017" for eight cylinder distributor. The points are adjusted by removing the distributor cap and rotor and cranking the engine until the fiber block on the contact arm rests on the highest point of the cam lobe (C). Then loosen lock screw (F) and turn adjusting screw (D) until the correct gap is obtained. Tighten lock screw and recheck the gap.

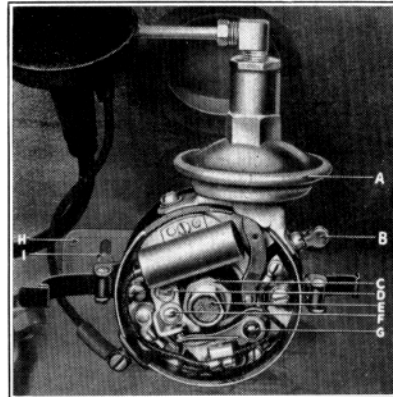

Figure 27

## IGNITION TIMING

Remove spark plug from No. 1 (front cylinder), place finger over spark plug hole and crank the engine until air pressure against the finger indicates that the piston is coming up on the compression stroke. Then continue cranking slowly until the mark "U.D.C. 1-6" (six cylinder engines) or "U.D.C. 1-8" (eight cylinder engines) lines up with opening in the rear engine support plate, as shown.



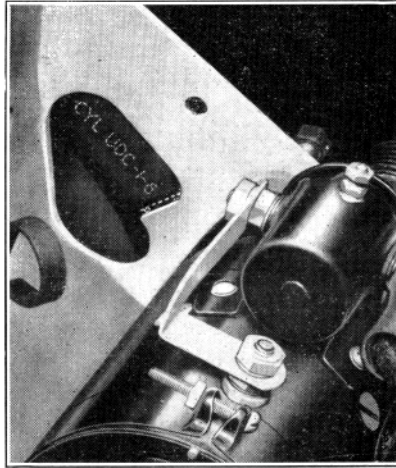

Figure 28

The engine can be cranked by removing the knurled cap on the starting motor solenoid and pressing the button in quick succession.

The distributor rotation is clockwise. Loosen the distributor advance arm screw (I) and rotate the distributor housing clockwise to the limit of the slot in quadrant. Take off the distributor cap and remove the central wire from the cap. Place the bare end  $\frac{1}{8}$ " from the cylinder head. Turn on the ignition and rotate the distributor body counter-clockwise slowly just until a spark jumps from the high tension wire to the cylinder head. Tighten screw (I), replace central cable in cap, and clamp cap on distributor.

With the distributor cap in position, the metal strip on the rotor should be directly in line with No. 1 terminal. The cables should be in the cap terminals in the order, 1-5-3-6-2-4 or 1-6-2-5-8-3-7-4, following in a clockwise rotation.

The foregoing is approximate normal timing for regular or non-premium fuels at or near sea level. For final setting see "Fuel and Altitude Compensation."

### FUEL AND ALTITUDE COMPENSATION

When Ethyl or premium fuels are used in place of the regular or non-premium grades, a more advanced spark timing should be used and final tests should be made on the road. Also when operating a car at high altitudes, it will be found that a more advanced spark timing can be used than at or near sea level.

To determine proper spark timing for these conditions, with engine at normal operating temperature, accelerate at full throttle from 10 miles per hour in high gear. A "ping" should be noted at approximately 15 miles per hour. If no "ping" is heard, loosen the distributor quadrant screw (I), and rotate distributor body in a counter-clockwise direction one graduation mark at a time until the "ping" is heard. Under no circumstances, however, should the pointer on the rear engine support be more than 1 inch (on 1st short mark) before the U.D.C. 1-6 or U.D.C. 1-8 mark on flywheels.

If the "pinging" is heard at speeds above those previously mentioned, retard the spark timing by loosening the clamp screw and rotate distributor body in opposite direction, one graduation mark at a time until the proper setting is obtained.

## HEADLAMPS

Hudson cars employ the headlighting system known as "Sealed Beam" in which the light source, the reflector, the lens, and the gasket are all assembled in one securely sealed unit. When the filament burns out or the lens break, the entire unit is discarded and a new one installed, thereby assuring maximum lighting efficiency throughout the life of the car. "Sealed Beam" headlamps provide two separate and distinct beams.

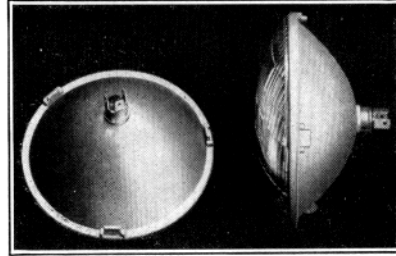

Figure 29

1. A country (upper) beam is provided to illuminate evenly for a considerable distance ahead of the car. This beam is for use on the open highway when no other vehicles are approaching.

2. A traffic (lower) beam is also provided and is low enough on the left side to avoid glare in the eyes of oncoming drivers. It should always be used when meeting other vehicles. This beam is designed so that it does not throw any dazzling light into the eyes of the approaching driver under any condition of car loading. At the same time distribution of light is such that the right side of the road is illuminated as far ahead as is practical without causing glare on curves.

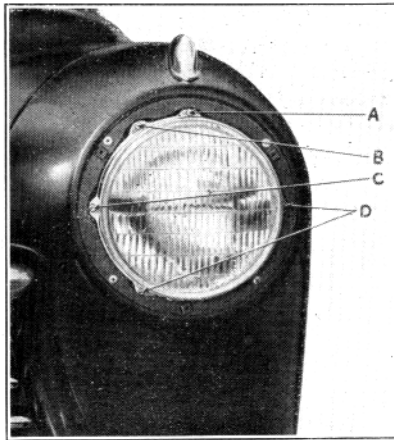

Figure 30

By turning the lighting switch knob on instrument panel to first position, the parking lights, instrument lights, bonnet light, license light and tail lights are turned on. Turning the knob to the second position turns on these lights in addition to the headlights. The country (upper) or traffic (lower) headlight beams are obtained by pressing the foot switch.

When the country (upper) beams are lighted, a red pilot bulb in the speedometer dial will be illuminated, making it convenient for the driver to determine when this beam is in use. Always use the traffic (lower) beam when meeting oncoming traffic.

**To Service Unit:**

1. Remove headlamp lens rim by taking out the three screws.
2. Loosen, but do not remove, the three screws (B) holding the retaining ring. (Do not disturb the aiming screws (A and C) at the top and left side of the unit.)
3. Remove retaining ring by rotating counter-clockwise, allowing the reflector unit to be removed.
4. Remove the reflector plug from the reflector unit.
5. Install new unit by reversing above operations.



Figure 31

**"SEALED BEAM" HEADLAMP AIMING ADJUSTMENT**

To obtain the maximum results in road illumination and the safety that has been built into the headlighting equipment, the headlamps must be properly aimed.

Place the car on a level position with a light-colored vertical screen 25 feet ahead. For best road lighting results, draw a horizontal line (A-A) on this surface at a level of a point three inches below the headlamp center.

If, however, your state requires a loading allowance, draw this horizontal line below the above mentioned line by the amount required by your particular state. Sight through the center of the rear window to the right and left of the windshield center bar and mark two points on the

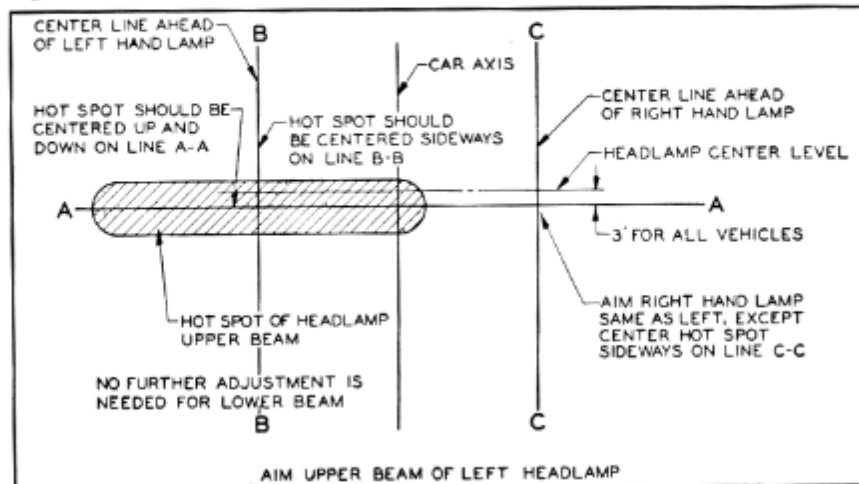

Figure 32

horizontal line. A point midway between these points represents the center line (car axis) on the screen. Next draw vertical lines (B-B) and (C-C) on the screen to the right and left of the center line at a distance equal to one-half of the center-to-center distance between the two headlamps.

Place lighting switch in the position which produces the country (upper) beam (bright light). When the country (upper) beam is lighted the lower filaments on both lamps are illuminated.

Independent adjustment of both horizontal and vertical aim is provided in "Sealed Beam" headlamps, with the adjustment screws accessible from the front of the lamp after first removing lens rim. The vertical adjustment screw is shown at (A) and the horizontal adjusting screw at (C). The light beam is moved to the right or left by tightening or loosening the horizontal adjusting screw (C). The beam may be raised or lowered by turning the vertical adjusting screw (A).

Cover one lamp to obscure the beam of light and then adjust the beam from the other lamp so that the center of the zone of highest intensity falls on the intersection of the horizontal line (A-A) three inches below the lamp center and the vertical line directly ahead of the lamp. Repeat the operation for the other lamp. No further adjustment is needed for the traffic (lower) beam.

### CIRCUIT BREAKERS AND FUSES

A circuit breaker incorporated in the lighting switch and an auxiliary circuit breaker mounted on the instrument panel protects the lighting and other circuits against damage in the event of a short or other derangement in the electrical system. Separate fuses are also employed for the protection of optional equipment and accessory items, as follows:

*The Electric Clock* — has a 3 ampere fuse contained in the fuse case located at the back of the clock.

*Weather-Control* — is protected by a 14 ampere fuse located in a fuse case on the left side of the heater housing.

*Radio* — includes a 14 ampere fuse contained in the fuse case incorporated in the "A" lead wire.

*Drive-Master* — is protected by a 10 ampere fuse located in the Drive-Master control switch on the instrument panel.

*Overdrive Circuit* — is protected by a 30 ampere fuse fitted in a bayonet socket holder near the "B" terminal of the voltage regulator.

*Direction Indicator* — has a fuse of 10 ampere capacity located in a fuse case attached to the flasher unit lead wire.

### CLUTCH

A Fluid Cushioned Clutch incorporating a single cork-insert disc, is used exclusively in Hudson cars to assure smooth engagement. Long life is assured through triple sealing the unit against fluid loss. Heat developed within the clutch is kept at a minimum through proper ventilation and the constant bath of fluid within the housing.

The only attention required is lubrication and a periodic check of the pedal-to-floor board clearance to insure full travel of the clutch pedal.

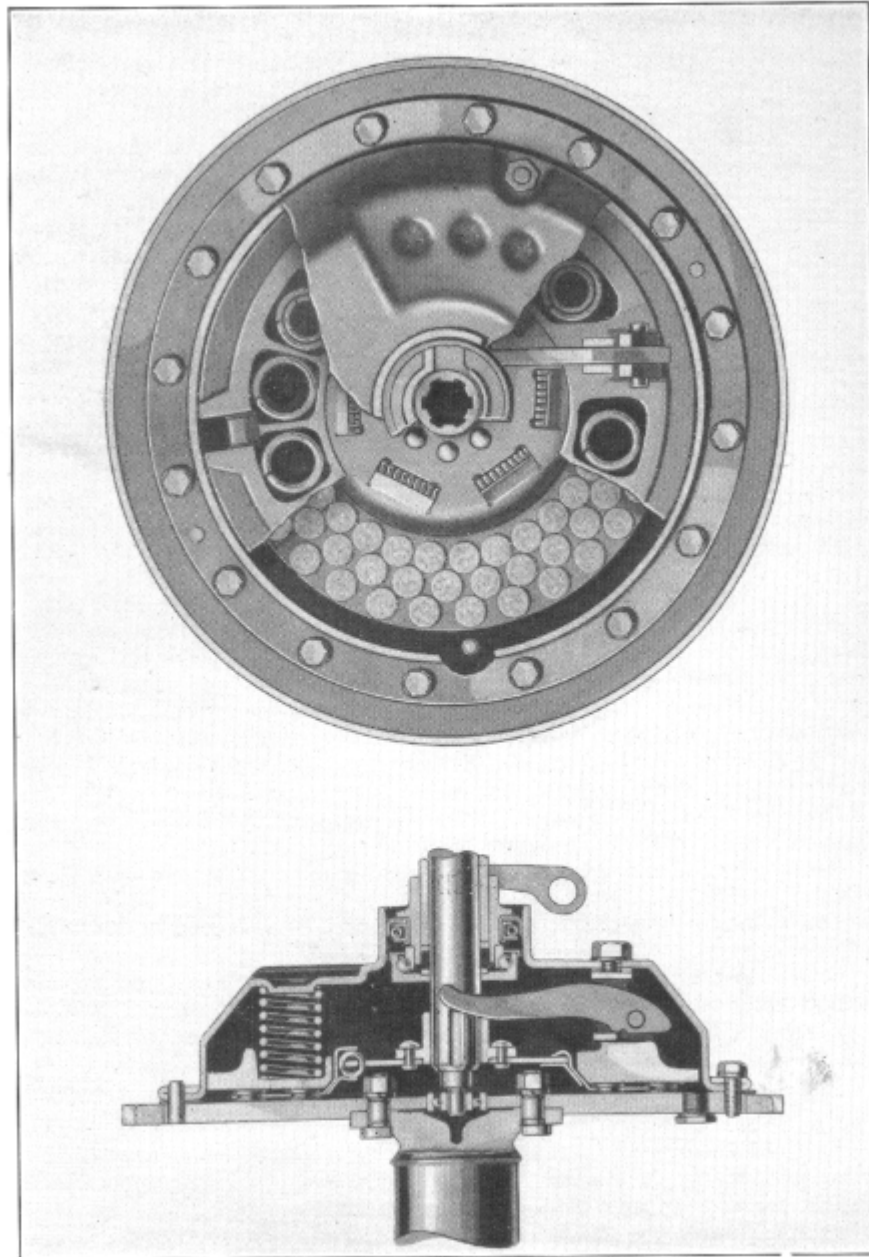

Figure 33

### CLUTCH PEDAL ADJUSTMENT

To assure full disengagement of the clutch to prevent clashing when shifting gears and also to prevent the clutch pedal from riding against the floor board,  $1\frac{1}{2}$ " clearance must be maintained between the floor board and rear face of pedal.

This can be adjusted by loosening lock nut (A), removing cotter pin and clevis pin (C), and turning yoke (B) to increase or decrease the clearance as required. Replace clevis pin and cotter pin and tighten lock nut securely.

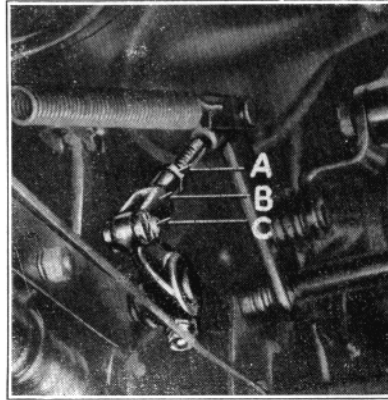

Figure 34

### LUBRICATION

The clutch throwout bearing should be lubricated every 1,000 miles, using viscous chassis lubricant applied through the grease fitting on the right side of the clutch housing.

The clutch pedal shaft bushings should also be lubricated at intervals of 1,000 miles, using viscous chassis lubricant applied through the grease fitting on the bottom of the pedal, reached from underneath the car.

Every 5,000 miles the clutch should be drained and refilled with HUDSONITE CLUTCH COMPOUND, which is produced in the Hudson Engineering Laboratories, and is available through all Authorized Hudson Dealers. The exclusive use of this compound is your assurance of obtaining smooth, even clutch action.

The clutch is drained without disturbing the flywheel guard by removing hex plug (A) in the front face of the flywheel. Then rotate the flywheel until the first star stamped on the flywheel face appears in inspection hole over starter motor and allow the old fluid to drain out. Turn flywheel until filler hole re-appears and refill with  $\frac{1}{3}$  pint of HUDSONITE CLUTCH COMPOUND. Replace plug and tighten securely.

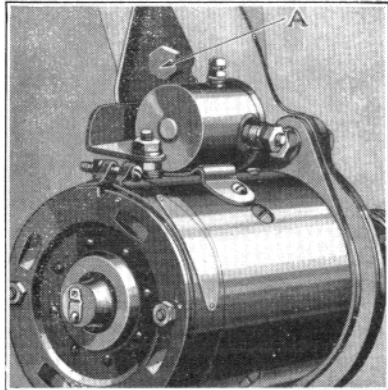

Figure 35

### VACUMOTIVE DRIVE

(Optional Equipment)

Vacumotive Drive, which is available as a factory installed op-

tion, or may be installed by your Authorized Hudson Dealer, provides a means of engaging and disengaging the clutch automatically without using the foot. It utilizes the engine vacuum and is operated by momentarily lifting the foot from the accelerator pedal to disengage the clutch and depressing the accelerator pedal to engage the clutch.

A control switch mounted on the instrument panel, permits the driver to change from conventional clutch operation to automatic operation by merely turning the knob to the right. To revert to conventional drive, turn knob to left. This can be done at any time.

A centrifugal governor switch prevents free wheeling or coasting in high gear at speeds above 19 miles per hour. Under certain conditions, such as when driving on icy or slippery pavements, or when descending steep grades when free wheeling may not be desired, the driver may revert to manual clutch control by turning knob to left.

### OPERATION

Turn control knob to right. Depress the clutch pedal manually, as Vacumotive Drive is operative only when the engine is running. Place the Gear Shift lever in neutral position and start the engine. Move the lever to the desired gear position and depress the accelerator pedal.

When moving in low gear, accelerate to the desired speed for shift into second gear. Lift the foot from the accelerator pedal, move the gear shift lever into second gear position and then depress the accelerator pedal. Repeat this operation for the shift into high gear.

### LUBRICATION

Vacumotive Drive linkage connections should be lubricated every 1,000 miles with a few drops of light engine oil.

At intervals of 10,000 miles, the vacuum power cylinder should be lubricated by removing pipe plug and injecting one ounce of HUDSON SHOCK ABSORBER FLUID. The piston rod end to bellcrank bolt and the valve rod to lever link should be removed and the piston rod rotated with an in-and-out movement to thoroughly distribute the oil over the piston and oil wick.

## TRANSMISSION

The transmission is of the synchronized design, incorporating the "blocker type" synchronizing unit, which assures an absence of gear clashing when shifting. It provides three speeds forward and one reverse. All gears are of helical cut tooth design for quiet operation in all speeds.

Gear shifting is accomplished by a steering column gear shift lever. The four speeds are in the conventional "H" plate order. When in neutral the shift lever is in a horizontal position in the second and high rail. To shift into reverse gear, the lever must be raised and moved forward. Movement to low gear is by pulling the lever backward in the same rail. The shift into second gear is forward to neutral position, then press lever down and move forward. Moving the lever backward gives high gear position.

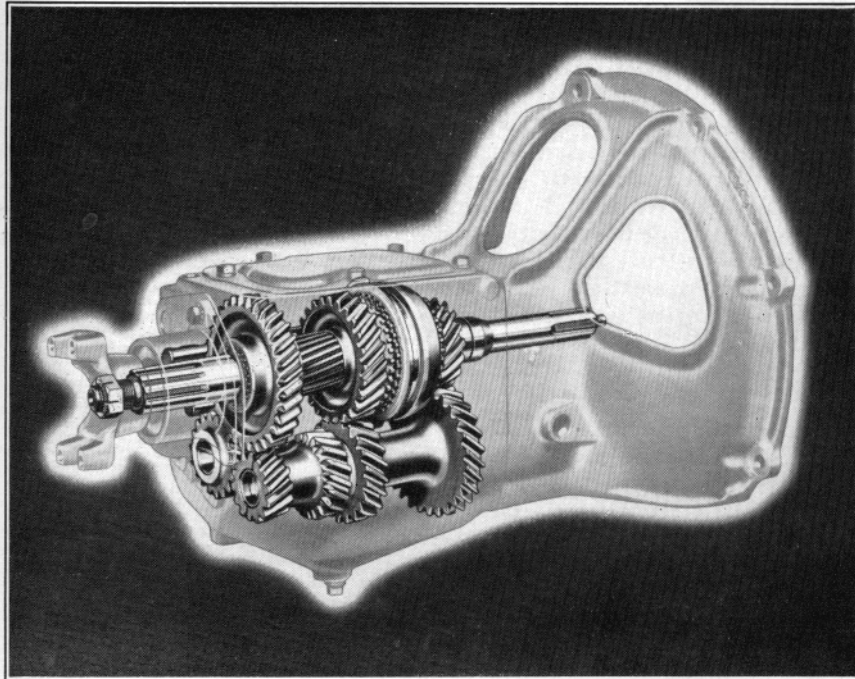

Figure 36

#### LUBRICATION—STANDARD TRANSMISSION

The transmission is fitted with one drain plug located at the bottom of the case and one filler plug on the right side.

Remove the filler plug every 1,000 miles and check fluid level. Permit car to stand idle a few minutes before checking the level. This will allow the foam to subside and assure a check of the actual oil level.

At intervals of 5,000 miles the oil should be drained and the transmission refilled with new lubricant. In summer use 2 pounds of S.A.E. 90 E.P. gear oil and in winter use an S.A.E. 80 E.P. grade. If the unit is flushed out, it should be refilled with 2¼ pounds of the proper lubricant.

Should hard shifting be encountered in extremely cold weather, drain out 2 ounces of transmission oil, add 2 ounces of kerosene and refill to proper level with oil.

#### LUBRICATION—TRANSMISSION WITH OVERDRIVE

As the same grades of gear oil recommended for the transmission are used in the Overdrive, communicating passages are provided between the two units. Separate drain and filler plugs are also provided in the Overdrive housing. The drain plug is located on the bottom and the filler plug is on the right side of the housing.



To check fluid level, first remove Overdrive filler plug and determine level, which should be even with lower edge of hole. If level is low, refill to correct level. Then check oil level in transmission and refill as required.

*To drain and refill*, first be sure lubricant is warm as it will flow more freely. Remove both drain plugs and drain all old lubricant. Replace plugs. Refill Overdrive first, permitting level to come up to bottom of filler plug hole. Next refill transmission to bottom of level of the filler plug hole. Replace both plugs.

Should it be necessary to thin the lubricant to facilitate shifting in extremely cold weather, drain out 2½ ounces of lubricant, add 2½ ounces of kerosene and then refill to proper level with oil.

## TRANSMISSION OVERDRIVE

(Optional Equipment)

Transmission Overdrive is available on all models as a factory installed option only. It is not available for field installation. This unit provides fourth speed operation at approximately 22 miles per hour and also permits free wheeling on deceleration below about 19 miles per hour. It reduces engine speed 28 per cent in relation to car speed and contributes to smoother operation and greater gasoline and oil economy at high speeds.

The speeds at which overdrive becomes operative on acceleration and when free wheeling becomes effective on deceleration are controlled by a centrifugal governor switch mounted on the Overdrive housing. Engagement and disengagement of Overdrive is controlled through the accelerator pedal when the Overdrive control knob, located on the instrument panel, is pushed out. Conventional operation is obtained when the knob is pulled out.

## OPERATION

Push the control knob all the way in for operation in Overdrive. This may be done with the car standing or at any ordinary driving speed. Overdrive becomes operative at speeds above approximately 22 miles per hour and the shift is made by removing the foot from the accelerator momentarily. Upon again depressing the accelerator, the car will operate in Overdrive and continue to do so until the speed drops to about 19 miles per hour. Overdrive will then automatically disengage, reverting to direct drive through free wheeling.

As operation in Overdrive does not provide best acceleration for passing other cars or give the necessary power to climb steep grades, it is occasionally necessary to revert temporarily to direct drive at speeds higher than 19 miles per hour. This can be accomplished by depressing the accelerator pedal fully beyond the wide open throttle position.

To re-engage Overdrive, momentarily release the accelerator pedal (at speeds above 22 miles per hour) and resume normal operation in Overdrive.

When Overdrive and free wheeling is not desired, as in heavy traffic, on icy and slippery pavements or on steep grades, simply pull the control

knob out while the car is standing or moving at less than 19 miles per hour. If a clicking sound is heard after pulling the knob out, depress the accelerator pedal slightly to bring the engine speed up to the car speed and the shift will be completed.

When driving at speeds above 19 miles per hour, it is necessary to depress the accelerator pedal fully beyond full throttle to revert to direct drive and then pull out the control knob.

### HUDSON DRIVE-MASTER

(Optional Equipment)

Hudson Drive-Master, which is available as a factory installed option only, provides automatic gear shifting in forward speeds under normal conditions, yet permits shifting in the conventional manner at ANY time. Hudson Drive-Master allows the driver to have COMPLETE CONTROL of the transmission in every speed at all times.

When the Drive-Master switch knob on the instrument panel is turned to the right, the operation of the clutch and gear shifting in forward speeds is automatic. When the switch is turned to the left, the clutch is operated automatically, but the transmission gears must be shifted in the conventional manner. When the knob is in the center or "Off" position, both transmission and clutch are operated manually.

**NOTE:** *The clutch pedal MUST be depressed before the starter will operate on cars equipped with Hudson Drive-Master.*

### OPERATION

To start in forward speeds under normal conditions, place gear shift lever in high gear position. Depress accelerator and car will move in second gear. When accelerator is released above "shifting speed," high gear will be automatically engaged. It is possible to accelerate to any speed in second gear before shifting into high by keeping the accelerator depressed.

When slowing down for a stop upon releasing the accelerator, the transmission will shift into second when the "shifting speed" is reached and the car is ready for a new start.

To start in low gear, move the gear shift lever to the neutral position, hesitate momentarily and then move it into low gear. After starting, release the accelerator and shift into second or high position. If second speed is selected, it will be necessary to shift into high in the conventional manner. If the lever is moved to the high gear position and the accelerator released, the shift is made automatically into either second or high gear, depending upon the car speed.

Shift into reverse in the conventional manner by lifting the foot from the accelerator and moving the gear shift lever into neutral and then into reverse.

**Mountain Driving**—If it is desired to go into second gear when ascending or descending a steep grade, above the "shifting speed," momentarily release the accelerator, disengage the clutch manually and move gear shift lever into second speed position.

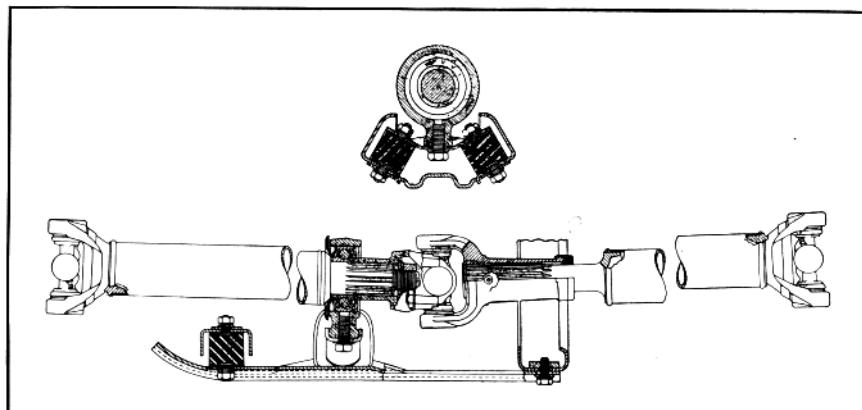

Figure 37

### PROPELLER SHAFT AND UNIVERSAL JOINTS

The engine power is transmitted to the rear axle through two tubular propeller shafts, which permits low center of gravity and smooth operation. The front propeller shaft is supported near the rear end in an annular ball bearing mounted in rubber to absorb any vibration and noise. Three universal joints of the needle roller bearing type are employed, one at the front end of the front shaft, one between the front and rear shafts and another at the rear end of the rear shaft.

### LUBRICATION

Each universal joint is provided with means of lubricating the needle rollers through drilled passages and pressure type grease fittings. The splined sleeve of the middle joint is also lubricated through a pressure fitting. Viscous chassis lubricant should be applied to these fittings each 1,000 miles, using a hand gun or a special adapter on the lubricating hose nozzle, to guard against excessive pressures.

### REAR AXLE

The rear axle is of the semi-floating type employing hypoid gears having teeth cut so that the driving pinion meshes with the ring gear considerably below the center line of the differential. This design provides quieter operation, increased gear tooth strength and a lower car floor with minimum raised section for the propeller shaft. High grade alloy steel is used throughout for gears and shafts and tapered adjustable roller bearings support the differential assembly, drive pinion and the outer ends of the axle drive shafts.

As the axle bearings are accurately adjusted under load at the factory, no further attention should be required. Special equipment is necessary to properly service this unit; therefore, any adjustments or repairs required should be referred to your **Authorized Hudson Dealer**.

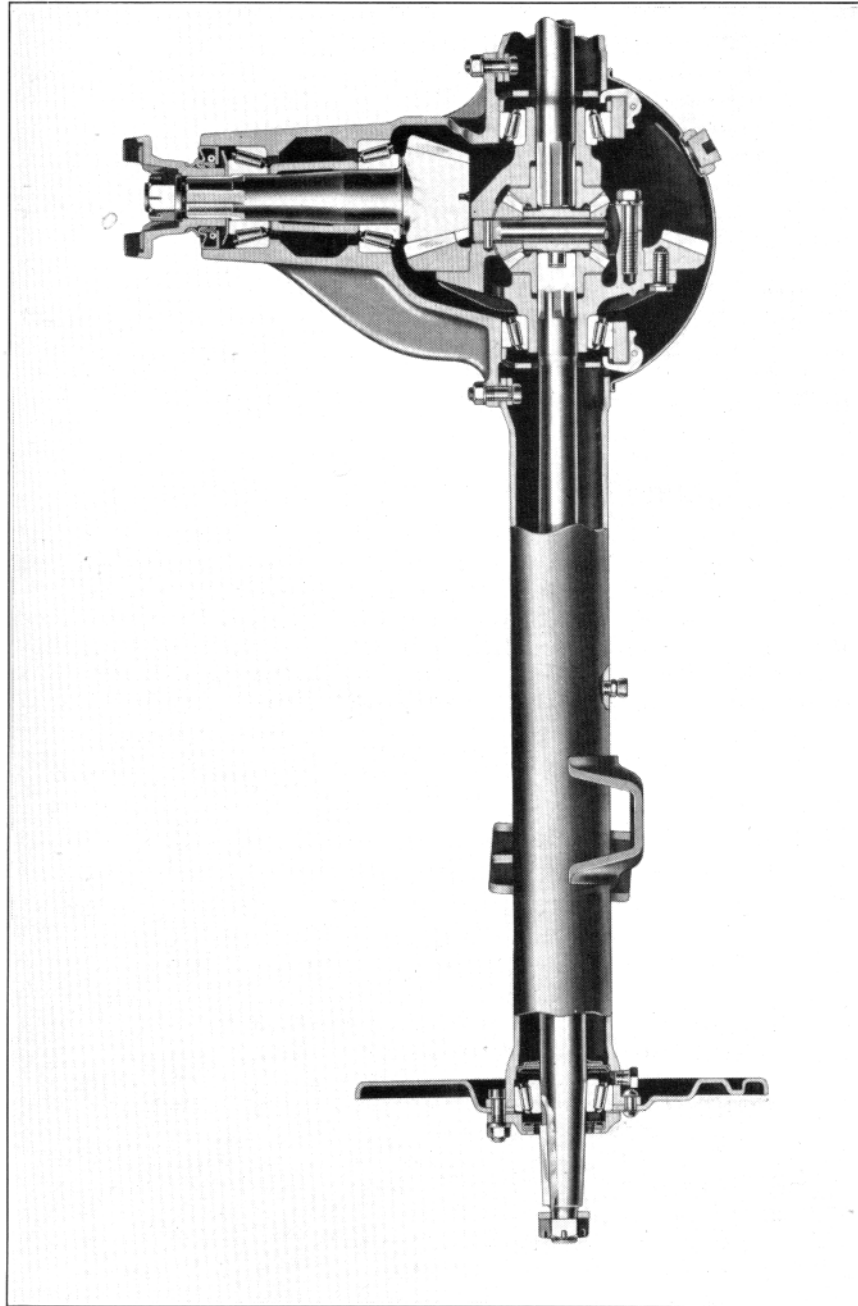

Figure 38

## LUBRICATION

The lubricant with which the axle is filled at the factory is especially suited for protection of the gears during the break-in period. This lubricant should be left in the axle for at least the first 10,000 miles.

The level of the oil in the axle housing should be checked every 1,000 miles and if low, brought up to the level of the filler plug by adding a S.A.E. 90 Multi-Purpose Gear Lubricant which has been qualified under U.S. Army Specification 2-105B.

As all gear oils have a tendency to foam due to agitation, the car should be permitted to stand about fifteen minutes to allow foam to subside before checking the level.

Although seasonal changes are not required it is recommended that the lubricant be removed from the axle housing and 3½ lbs. (1.5 kgs.) of new Multi-Purpose Gear Lubricant be installed at least once a year or every 10,000 miles.

Rear wheel bearings should be removed, cleaned, and repacked every 10,000 miles with 1½ ounces of milled sodium soap base lubricant. A special puller is required to remove the hubs; therefore, this operation should be performed by your Authorized Hudson Dealer.

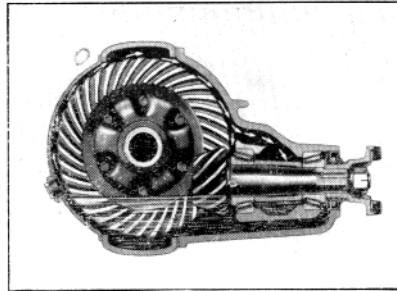

Figure 39

## BRAKE SYSTEM

### BRAKES

Patented Double-Safe Hydraulic Brakes employing a reserve mechanical system operating from the same brake pedal, are used.

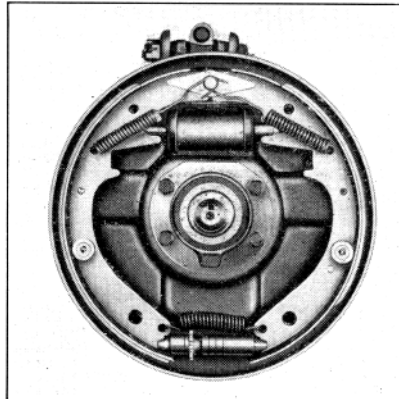

Figure 40

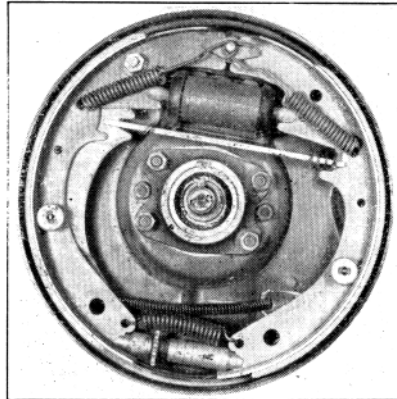

Figure 41

The brakes are of the Bendix Duo-Servo single anchor type, employing wider shoes and larger wheel cylinders at the front than at the rear for maximum brake efficiency and smooth stopping. The shoes are expanded at the top or anchor end by the wheel cylinders, which are actuated by hydraulic pressure exerted by the master cylinder through foot pressure applied to the brake pedal.

If at any time, the hydraulic system should fail due to an accident or some other cause, continued pressure on the foot pedal automatically applies the mechanical reserve system on the rear wheels.

### BRAKE FLUID

Numerous rubber parts are used in the hydraulic system which makes necessary the use of brake fluids that are entirely free of mineral oil and other ingredients which are detrimental to the rubber and may cause swelling and early deterioration. Hudson Hydraulic Brake Fluid meets these requirements.

The master cylinder is self-compensating and should be kept at least half full at all times. Always wipe off the master cylinder at the filler plug before removing plug to check the fluid level.

The hydraulic system must be bled if air enters the system. A spongy feeling pedal is usually an indication that bleeding is necessary.

Have your Authorized Hudson Dealer inspect your brakes and check the fluid level periodically, to insure proper operation. This should include a check of the mechanical follow-up linkage.

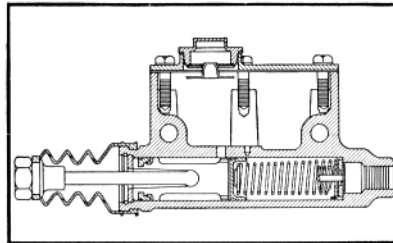

Figure 42

### ADJUSTMENTS

To insure proper functioning of the mechanical reserve brake, it is very important that the clevis at the front end of the pull rod attached to the brake pedal be adjusted to maintain a clearance of  $1\frac{1}{4}$ " between the rear end of the slot and the clevis pin at all times.

Brake adjustments should be performed by your Authorized Hudson Dealer. However, if an emergency arises where the brakes must be adjusted before you can reach an Authorized Hudson Dealer, the following adjustment procedure to compensate for lining wear can be used.

1. Jack up all wheels clear of the floor.
2. Be sure hand brake is fully released.
3. Remove wheel backing plate adjusting screw hole covers.
4. At each wheel, with a screw driver or suitable tool inserted through the slot in the brake backing plate, expand shoes against drum with adjusting screw by moving outer end of tool toward center of backing plate until a heavy drag is noted when wheel is turned by hand.

5. Back off screw exactly 14 notches at each wheel by moving tool toward outer edge of backing plate.

6. Replace hole covers and lower car to floor.

Test car for brake balance. If one wheel skids before the others, loosen the adjustment rather than tighten the other screws.

A major brake adjustment involves a complete inspection of the braking system — shoe linings, mechanical follow-up, anchor adjustment, and the hydraulic system. This should be necessary only in the event that an adjustment for normal lining wear does not produce satisfactory braking results.

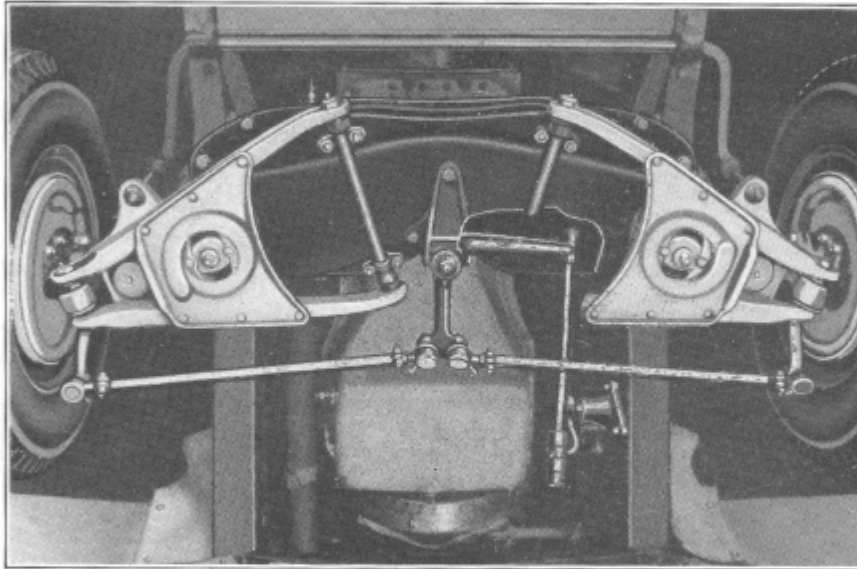

Figure 44

## FRONT SUSPENSION

Hudson Individual Front Wheel Suspension is of the angularly set "wish-bone" type, employing large diameter, soft acting coil springs of alloy steel.

The upper and lower control arms are pivoted at their inner ends to permit each wheel to move vertically independently of the other as they pass over road irregularities. They are mounted in threaded bushings adjustable for wear and fitted with rubber sleeves for protection against dirt and water.

### LUBRICATION

All front suspension joint grease fittings should be lubricated every 1,000 miles with viscous chassis lubricant. For the various fitting locations see the "Lubrication Chart" at the front of this book.

### MAINTAINING PROPER FRONT END ALIGNMENT

To prolong tire life, and assure easy car handling and maximum safety, it is essential that proper front end alignment be maintained. Unintentionally striking the curb a severe blow when turning, parking, or skidding may not cause enough damage to make it visible to the eye, but will be reflected in the handling of the car at high speeds, or in abnormal tire wear.

Proper front end alignment is dependent on proper adjustment of these three factors:

**CAMBER**, the outward tilt of the front wheels at the top.

**CASTER**, the backward or forward tilt of the spindle pins at the top.

**WHEEL TOE-IN**, the setting of the front wheels closer together at the front than at the rear.

Accurate gauges and carefully calibrated equipment are necessary to check and correct alignment. Therefore, it is suggested that any service requirements be referred to your Authorized Hudson Dealer who is best qualified to do this type of work.

### FRONT WHEEL BEARINGS

The front wheel bearings are of the tapered roller type, adjustable to compensate for wear and are adequately sealed against lubricant loss.

**ADJUSTMENT** — To check for looseness, raise the front end of the car, place one hand on the top of the tire and the other hand on the bottom of the tire and alternately pull with one hand while pushing with the other. If there is excessive looseness, adjustment should be made as follows:

Remove outer and inner hub caps (A) and (B), using a pry. Remove cotter pin holding nut (C). Turn nut to the right until a slight drag is felt when turning the wheel by hand. Loosen nut just sufficiently to permit wheel to turn freely. Insert cotter pin, replace hub caps and lower car to floor.

**LUBRICATION**—Every 10,000 miles, the bearings should be removed, cleaned and repacked with four ounces of milled sodium soap base lubricant. Adjust bearings as instructed under "Adjustment."

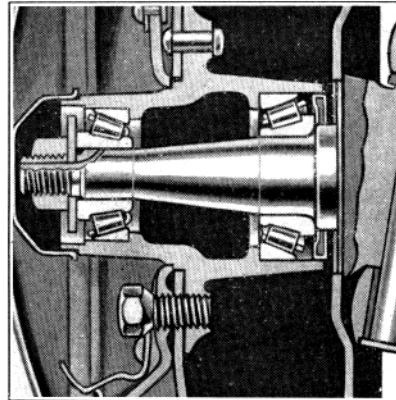

Figure 45

### STEERING GEAR

The steering gear is of the worm and triple roller tooth design. The worm revolves in two adjustable tapered roller bearings. The roller tooth shaft rotates in two bronze bushings.

This design provides ease of steering with freedom from frequent



adjustments. Provisions for adjustments are, however, incorporated, should they be required after extensive service.

As special equipment is needed to properly service this unit, all operations or adjustments required should be referred to your Authorized Hudson Dealer.

**LUBRICATION** — Every 1,000 miles, the oil level in the steering gear housing should be checked by removing plug. If level is low, refill to bottom of hole with S.A.E. 90 E.P. gear oil, summer or winter. Be sure plug is securely tightened.

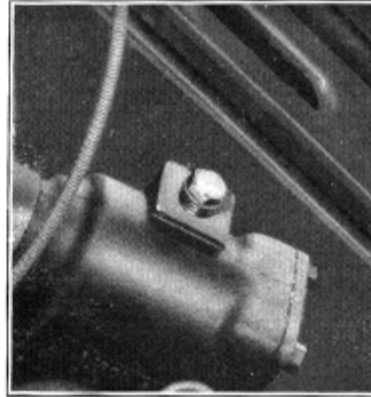

Figure 46

#### **DRAG LINK**

The drag link is fitted with adjustable bearings at the front and rear ends. Adjustments are required only in the event that excessive clearance is felt in the bearings and when steering adjustments are made. As special equipment is required to adjust the drag link to its proper relationship to the steering gear, all operations should be performed by your Authorized Hudson Dealer.

**LUBRICATION** — Grease fittings are provided at the front and rear ends and these should be lubricated every 1,000 miles with viscous chassis lubricant.

#### **FRONT LATERAL STABILIZER**

The front stabilizer is of the dual acting type, connected to each front suspension lower control arm near the steering spindle end and is com-

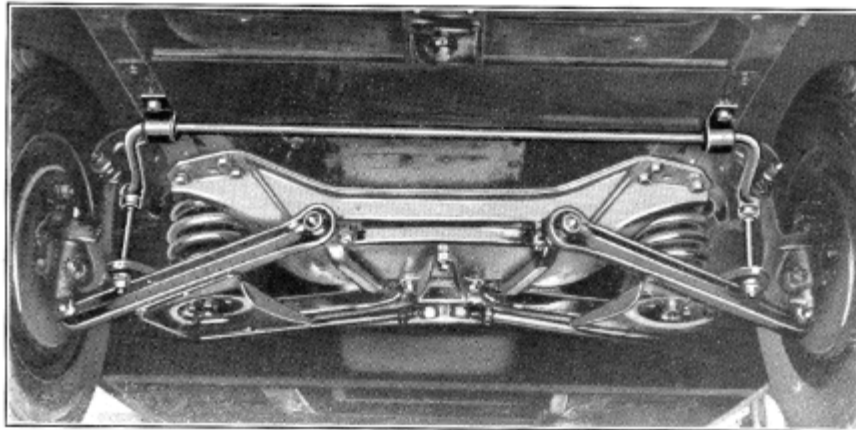

Figure 47

pletely mounted in rubber. It eliminates front end sway and stabilizes ride on rough roads, in heavy winds and when making sharp turns.

No service attention is required except to see that the connecting link nuts are properly tightened.

### REAR LATERAL STABILIZER

A rear lateral stabilizer is used as standard equipment. One end of this device is assembled to the frame side member and the other end to the rear axle housing. Its purpose is to control the horizontal movement

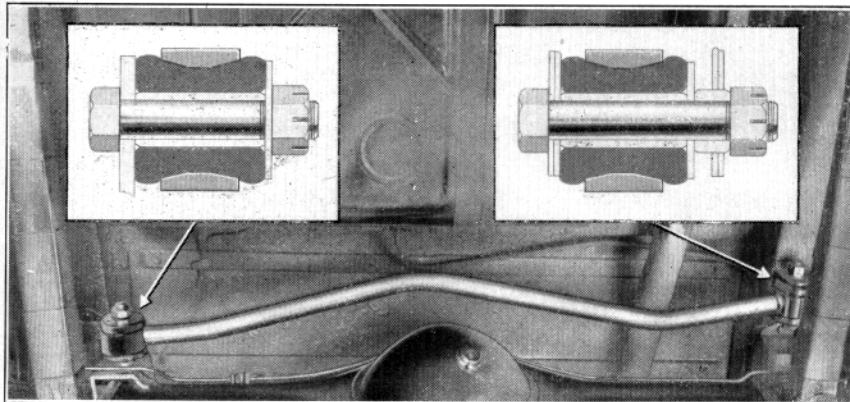

Figure 48

of the body and car. It also prevents lateral shake of the axle under the car on rough roads.

The ends of the steel bar are cushioned in rubber and no lubrication should be applied to these points.

### REAR SPRINGS

Rear springs are of long leaf, semi-elliptical design. The front ends are attached to frame brackets with pivot bolts cushioned in rubber. The rear ends are attached to the frame through threaded, self-adjusting "U" type shackles operating in hardened steel, threaded bushings. The bushing threads are protected from road splash and dirt by rubber seals. The rear springs of passenger models are fitted with metal covers.

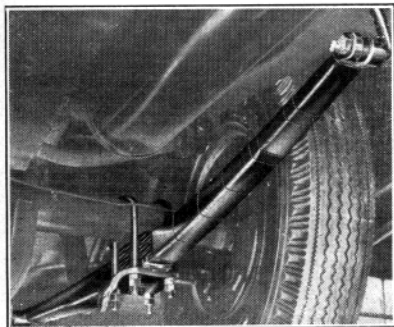

Figure 49

**LUBRICATION** — Use Viscous Chassis lubricant at 10,000 miles.

**Metal Covers** — Lubricate through holes in bottom of cover using special tool for this purpose.

Rear shackle bushings are provided with grease fittings and these should be lubricated with viscous chassis lubricant every 1,000 miles.

Rear spring front pivot bolt bushings require no lubrication.

### SHOCK ABSORBERS

Direct double acting hydraulic type shock absorbers are used at the front and rear. The front shock absorbers are mounted axially within the front coil springs and are cushioned at the upper and lower ends in rubber grommets.

The rear units are identical in construction to the front units, except that eyes are fitted at the upper and lower ends instead of studs and are also cushioned in rubber. At the upper end they are attached to the frame cross member, while at the lower end they are assembled to the rear spring clip plates.

The fluid is sealed in the shock absorbers and they require no further attention, unless a leak should develop. In this event, the faulty unit should be removed for repair or replacement. As special tools are required to service these shock absorbers, all shock absorber work should be performed by your Authorized Hudson Dealer.



Figure 50

## BODY AND FRAME

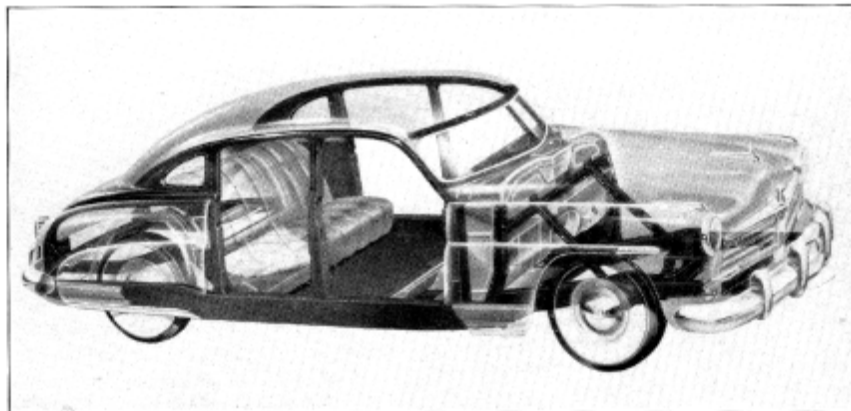

Figure 51

## BODY AND FRAME

The Hudson ALL STEEL Monobilt BODY-AND-FRAME includes box-type foundation frame of sturdy steel girders with all structural members of body-and-frame welded together into a single unit. The strength of steel and the permanence of welding make for rigidity and safety with minimum weight. Outside girders give bumper protection at rear and at both sides, even outside the rear wheels. Lowered floors contribute to a low center of gravity, provide ample head room and maintain road clearance.

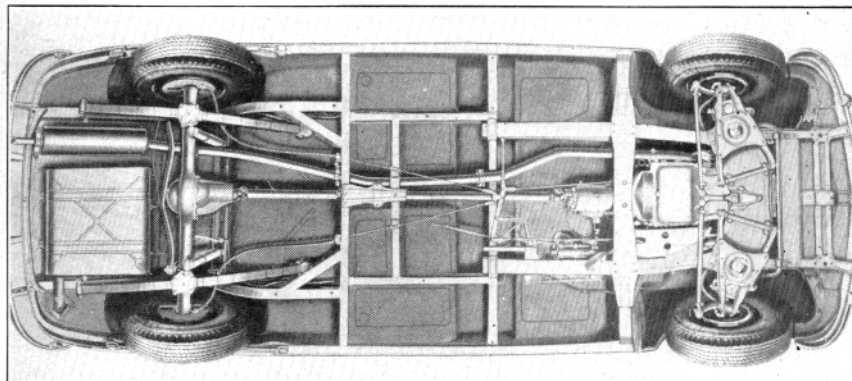

Figure 52

## DOOR LOCKS

Rotary door locks of a new design are used and all doors are fitted with stationary type outside handles. A push button at the end of the handle operates the lock and opens the door. When doors are locked, the handle push button moves in and out freely without actuating the lock.

*The Inside Safety Button 39 in the garnish molding, must be in the "up" position before the door can be opened by either the inside or outside handles.*

*To Open Door from Outside, grasp handle and push button either with the heel of the hand or the thumb. Push door to close.*

**CAUTION:** *Door will not close if latch bolt has been moved upward from lower end of curved slot in door. To return latch to lower end of slot, lift inside safety button to "up" position, then operate inside or outside door handle.*

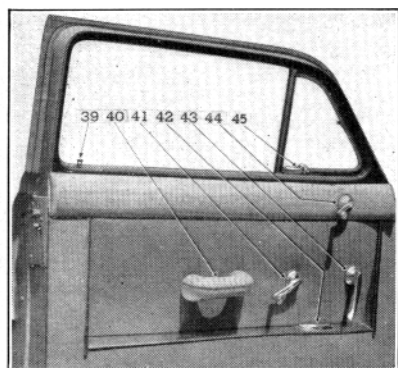

Figure 53

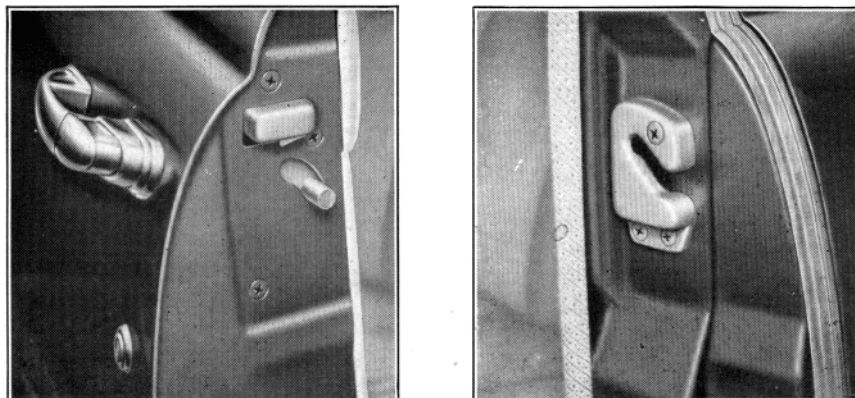

Figure 54 (two views)

*To Open Door from Inside—*

Front Door—Rotate inside (43) handle by pulling it backward.

Rear Door—Rotate inside handle by pressing it down.

*To Lock Car When Leaving—*

(1) Close windows. With doors closed, push inside safety buttons down on all doors except the front one from which you are leaving.

(2) Close front door and turn lock with key until inside safety button is “down.” Turn key back to vertical position and remove.

Doors must be closed before they can be locked either by the inside safety buttons or key.

*Door Adjustment—*

Door hinges and strikers are adjustable in both horizontal and vertical positions to insure proper door operation. The striker must be adjusted to permit the door to close easily but firmly against the door rubber weatherstrips with the lock fully engaged. When adjusting the striker, it is important that the lower edge of the opening in which the latch bolt operates is 1/16 inch above the bottom of the latch bolt. This provides a slight interference, which is necessary to insure proper engagement of the latch bolt in the slot.

### VENTILATOR WINGS

Friction type ventilator wings are employed on Super Six and Super Eight models and crank operated type wings on the Commodore Six and Eight models. The friction type wing is operated by pressing in the button and turning the handle (45) upward. The crank type wing is operated by a regulator controlled by a handle (44).

### DOOR WINDOWS

The door windows on all models are opened and closed by operating the handle (41).

### QUARTER WINDOWS

The quarter windows on Brougham and Coupe models are operated by crank handles. On Sedans, the windows are pivoted and friction controlled.

### LUBRICATION

See Body Lubrication Chart on inside of cover for body parts requiring lubrication attention.

### CARE OF THE FINISH

Your car is finished with high grade hand rubbed lacquer and with a reasonable amount of care, it should be possible to maintain its original luster for a long time. Constant exposure to the elements—strong sunlight, rain, snow and dust will cause the finish to become dull. If at all possible, it is good practice to park the car in the shade if it is to remain in one place for any great length of time.

To remove grime and dirt the finish should be washed frequently and occasionally it should also be polished.

**WASHING** the car should never be done when car is warm from standing in the sun. Always wait until the metal has cooled off. If dirt is heavily caked, soak it off first with cold water, using an ordinary garden hose. Apply Hudson Hurricane Auto Shampoo, as outlined in directions on container.

**POLISHING** the car is necessary at intervals to provide the finish with a protective coat. If ordinary washing does not remove the road grime use Hudson Polish and Cleaner.

A more durable, long lasting, high luster finish can be obtained by cleaning the surface with Hudson Liquid Glaze Cleaner and then applying Hudson Liquid Glaze Sealer.

**NEVER** polish the car in the sunlight or when the metal is warm. Let it cool first. When cleaning the surface, a slight amount of the color will be seen on the cloth. This, however, should be no cause for alarm as it is merely the loose pigment being cleaned off.

These cleaners and polishes may be purchased from your Authorized Hudson Dealer.

### CARE OF CHROMIUM PLATED PARTS

Ordinary chromium plated parts require no other attention than the cleaning they receive when the car is washed.

However, in the winter, when many municipalities use salt or calcium chloride to melt ice and snow on the pavements, these parts require a great deal more attention to prevent the finish becoming pitted and corroded. These melting agents are highly destructive to this type of finish and it is important that all trace of the salt be washed off each day.

An application of Hudson Chromium Polish after washing will assist in preserving the finish and provide added protection to the surfaces.

Bumper impact bars that are scratched through the finish should be sprayed with a coating of clear lacquer or have an application of Hudson Chromium Polish to prevent corrosion lifting off the plating.

Hudson Chromium Polish can be purchased from Authorized Hudson Dealers.

### CLEANING FABRIC TOPS

Soiled fabric tops used on Convertible models can be cleaned quite satisfactorily if proper instructions are followed.

Hudson Fabric Cleaner, which is available through your Authorized Hudson Dealer, should be used. Select an area slightly larger than the soiled portion and with a soft, clean cloth or sponge moistened with Hudson Fabric Cleaner, rub it in light successive strokes and work toward the center of the soiled area.

### CARE OF THE UPHOLSTERY

The same careful attention that you give the upholstered furniture in your home should be accorded the upholstery cloth of your automobile. Dust and dirt blown into the car when the windows are open settles in the fibres of the cloth and its abrasive action tends to wear the cloth and cause an unsightly appearance.

Once a month, it is good practice to brush the upholstery with a whisk broom or better still, use the portable attachments usually supplied with most household vacuum cleaners.

### CLEANING THE UPHOLSTERY

Spots on the cushions can easily be cleaned off by using the following instructions.

**AVOID** using hot water and soap unless specifically called for. **NEVER** use gasoline, as most brands contain tetraethyl of lead or coloring which is harmful to cloth, and it is also highly inflammable.

**NOTE:** When using cleaning fluid to remove spots, use it sparingly. Just dampen a clean cloth or a sponge with the fluid and select an area slightly larger than the soiled portion and rub from outside in toward the center in successive strokes. This will avoid forming a ring and prevent the spot from spreading.

Hudson Fabric Cleaner referred to herein, is available at all Authorized Hudson Dealers.

#### GREASE SPOTS AND OIL

Scrape off all excess grease with a dull knife. Moisten a cloth or sponge with Hudson Fabric Cleaner and rub spot as directed above.

#### CHEWING GUM AND TAR

First moisten lightly with Hudson Fabric Cleaner, then scrape off with a dull knife.

#### CANDY (Except Chocolate)

Moisten a clean cloth in very hot water, rinse out and rub lightly as directed above. If an oily spot remains after drying, rub it lightly with a cloth moistened with Hudson Fabric Cleaner.

#### CHOCOLATE CANDY

Sponge lightly with **LUKEWARM** water. After drying, rub lightly as directed above with a cloth moistened with Hudson Fabric Cleaner.

#### ICE CREAM

Sponge lightly with **LUKEWARM** soapsuds, using a neutral soap. Rinse with cold water and allow to dry. If an oily spot remains, rub it lightly as directed above with a cloth moistened with Hudson Fabric Cleaner.

**BLOOD**

Sponge lightly with **COLD** water. Apply a few drops of household ammonia, then sponge again with **COLD** water.

**CAUTION:** Never use warm water as it will set the stain.

**FRUIT AND WINE**

Apply a little hot water to the stain. Rub lightly with a cloth moistened with hot water. Allow it to dry, then rub lightly as directed above with a cloth moistened with Hudson Fabric Cleaner.

**CAUTION:** Soap or heat applied to a fruit or wine stain will cause it to set.

**COSMETICS**

Lipstick and creams may be removed by applying a few drops of Hudson Fabric Cleaner to the stain and absorbing it quickly with a blotter. Repeat as necessary until the spot is removed.

**SHOE POLISH**

Black and tan polish can be removed by rubbing it with a cloth moistened with Hudson Fabric Cleaner.

White polish can usually be removed by brushing with a whisk broom. If this does not remove it, moisten the spot with cold water, let it dry, then brush it again.

**URINE**

Sponge the spot lightly with a cloth dipped in lukewarm soapsuds (neutral soap) and then rinse well with a clean cloth rinsed in cold water. Next rub the spot with a clean cloth moistened in a solution of one part of household ammonia and five parts of water. After a minute, rinse it off with a clean moist cloth.

**DOG AND CAT HAIR**

Gather the hair together by rubbing the upholstery with a stiff sponge moistened with water. The hair can then be easily picked off.

**RUST SPOTS**

Clean these spots by sponging with a cloth moistened with lukewarm soapsuds (neutral soap).

**LEATHER AND IMITATION LEATHER**

Clean with lukewarm water and any mild soap, such as Castile. Work up a thin suds on a piece of cheese-cloth and rub over the surface. Wipe off the surface the second time, using a piece of cheese-cloth dampened with water. Finish by wiping with a dry cloth.

## HUDSON WEATHER-CONTROL

(Optional Equipment)

The Hudson Weather-Control, designed and built into the body structure as a combined ventilating and heating unit, gives maximum comfort with minimum adjustment of controls.

Fresh air is brought into the car through the cowl ventilator which is located high, out of the zone of splash, heavy gas fumes and dust con-



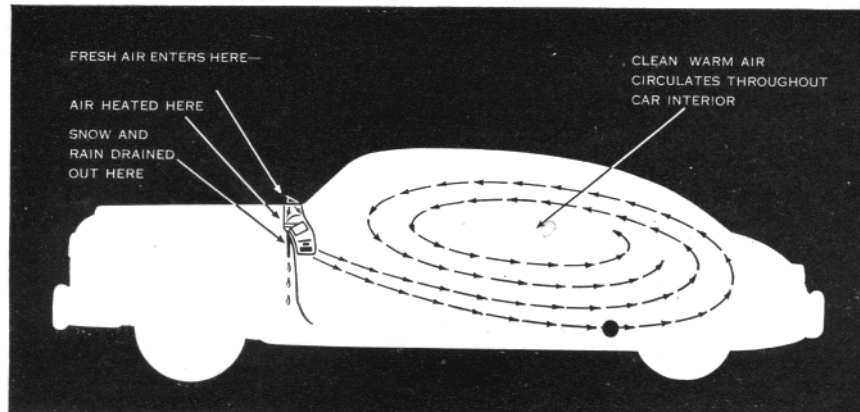

Figure 55

centration from preceding or passing traffic and gives the cleanest air available for passengers inside the car.

#### *Cold Weather Driving*

- (1) As soon as engine temperature gauge hand begins to move to the right (usually less than one mile after a cold start) open the cowl ventilator. (26—Fig. 5—Page 17.)
- (2) The automatic temperature control (34—Fig. 5—Page 17) should be set slightly to the right of center. Move to right to increase heat—to left to decrease heat.
- (3) If car is standing or being driven at slow or intermittent traffic speeds, turn blower control (35—Fig. 5—Page 17) clockwise — first position for high or second position for low.
- (4) If fogging or frosting of windshield and windows occurs when passengers enter a cold car, turn the blower control to the first position until cleared.
- (5) If icing occurs on the outside of the windshield, due to snow or rain, turn blower control clockwise to first position. For severe icing it is helpful to move the automatic temperature control to the extreme right. If the inside temperature becomes too high, open front door ventilating wings or lower windows slightly.

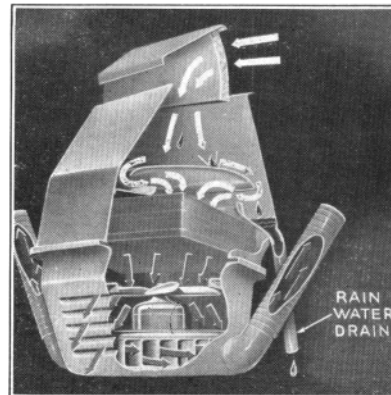

Figure 56

- A—The cowl ventilator should be kept fully open, after the engine warm-up period, except when driving at high speeds in extremely cold weather when partial closing of the ventilator will increase the temperature of the air entering the car. Water or snow entering the ventilator while driving is trapped and drained off. The ventilator should, however, be closed when the car is left standing outside for long periods while snow is falling.
- B—Ventilating wings and windows should be fully closed. Open windows or wings cause loss of heat and prevent normal circulation of air and heat in the passenger compartment. For example, opening a left front door ventilating wing will cause the heated air to flow from the heater outlet directly past the driver and out the ventilating wing. Little or no heat will reach the other passengers.
- C—The temperature control is automatic and once set to the desired temperature requires infrequent adjustment. It is not necessary to move temperature control further to the right for quick heat during engine warm-up. The thermostat automatically opens the control valve wide until the selected temperature in the car is reached, then closes as required to maintain that temperature.
- D—Heat is distributed from the front, back and both sides of the heater case so that a large volume of air can be supplied to adequately heat or cool the entire car interior without an excessive amount of air being directed on any of the front seat passengers. A knob located on the left side of the heater case controls the amount of air directed on the driver's feet. The maximum is obtained when the knob is in the up position.

#### *Warm Weather Driving*

- (1) Keep cowl ventilator (26—Fig. 5—Page 17) open at all times to get the cleanest air.
- (2) Keep automatic temperature control at extreme left.
- (3) *At low speeds* windows and ventilating wings can be opened as desired. For maximum air intake swing front door ventilating wings out until the desired amount of air is blown across the front compartment. By closing windows and opening rear quarter wings on sedans the full flow of air is directed through the entire passenger compartment.
- (4) *At high speeds* close windows and ventilating wings for minimum wind noise and wind burn. **Opening rear quarter ventilating wings**

slightly on sedans will help maintain full flow of air throughout passenger compartment.

- (5) *When driving on dusty roads* keep the cowl ventilator fully open to bring in the cleanest air possible and keep all windows and ventilating wings closed. This maintains a slight air pressure in the passenger compartment preventing dust from entering.

Opening ventilating wings even slightly at medium or high speeds causes an ejector action drawing air out of the passenger compartment so fast that even with the cowl ventilator open, additional air is drawn into the passenger and luggage compartment, bringing dust with it.

THE COWL VENTILATOR IS LOCATED TO GIVE THE CLEANEST AIR AVAILABLE FOR CAR VENTILATION.

## CONVERTIBLE BROUGHAM TOP

The raising and lowering of the top on the Convertible Brougham model is accomplished by power applied through double acting hydraulic cylinders located within the body structure. Power is furnished by a hydraulic pump, electrically driven, mounted behind the rear seat. This unit should be serviced twice a year, adding fluid if necessary to bring level to mark. Use only Hudson Hydraulic Brake Fluid for this purpose. Access to the power unit for servicing is had by removing the cover from the body underpanel.

To insure the top mechanism remaining in good condition, the top should be operated at least once a month.

Power operation of the top is controlled by a two-way switch fitted with a knob located on the instrument panel to the left of the steering column.

### TO LOWER TOP:

1. Stop car. Do not attempt to lower or raise top while car is in motion.
2. Release clamps at header on right and left sides.

**CAUTION:** *Make sure clamps are completely free from the windshield header.*

3. Raise top header slightly by hand and *pull out* control knob on instrument panel until top is fully lowered. This may be done with the door and quarter windows in either the up or down position. The rear window may also be in either the up or down position.
4. Tuck in surplus material at sides and install top boot.

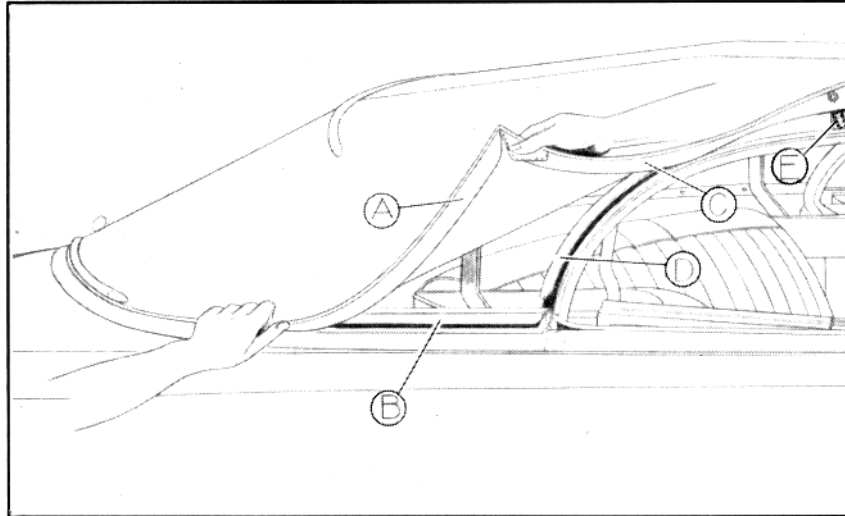

Figure 57

**TO RAISE TOP:**

1. Stop car.
2. Remove top boot.
3. Push top control knob *forward* until top is fully raised.
4. Pull down top header over windshield and attach and fasten clamps at each side.
5. Fasten side quarters of top by engaging flap "A" (Illustration No. 57) under channel "B," starting at the rear end. Continuing forward, enter flap "C" under curved channel "D" and work upward until flap is in place for its full length.
6. Engage the fasteners "E" in the slides on the bow above the doors.

## POWER OPERATED WINDOWS

The electrically operated hydraulic pump also furnishes power for raising and lowering the door and quarter windows. Each window is operated by a hydraulic cylinder arrangement and may be raised or lowered to any position by its own control button. Buttons located at each window are operated by pressing down to lower and up to raise the windows.

A group of 4 control buttons is mounted on the left door which permits the driver to operate all windows from a position convenient to the left hand. Counting from the front, buttons Nos. 1 and 2 control the left and right door windows respectively, while buttons Nos. 3 and 4 operate the left and right quarter windows.

## RADIO OPERATING INSTRUCTIONS

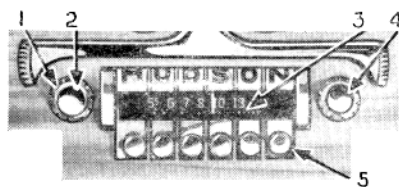

Figure 58

### OFF-ON SWITCH AND VOLUME CONTROL

To turn the receiver on, turn the volume control knob (2) to the right until it clicks and the dial is illuminated. Allow the receiver to reach operating temperature. (Approximately 20 seconds.) To in-

crease the volume, continue to turn this control knob to the right. To turn the receiver off turn the volume control knob to the left until it clicks.

### TONE CONTROL

The tone control ring (1) is located directly behind the volume control knob (Figure 58). Rotating this control to the right or left will change the tone of the receiver. The treble position is useful in overcoming wind, noise, etc., when driving, while the bass position brings out the full mellow tones of musical programs. With the tone control set midway, the full tonal range is obtained. Turning to the right will emphasize the high notes, while turning to left will emphasize the bass notes.

### MANUAL TUNING

To tune manually it is only necessary to turn the manual tuning knob (4). Tune to exact frequency for the best tone quality. This can be done at any time without disturbing the automatic-setting.

### AUTOMATIC TUNING

There are six automatic tuning positions (5), each of which may be adjusted to any desired station. In order to simplify the identification of the stations, it is advisable to set the automatic tuning mechanism in sequence according to frequencies of the stations, beginning with the station broadcasting on the lowest frequency, and progressing to the station broadcasting on the highest frequency. If the positions have not been previously adjusted, proceed as follows:

1. Loosen the first push button by turning it counter clockwise with your fingers.
2. Turn the manual tuning control knob (4) to tune in the desired station. Carefully tune to the middle of the signal for clearest reception.

3. Push the first push button in as far as it will go. Release the button, and tighten securely by turning it clockwise with the fingers.
4. Repeat the above procedure for the remaining five push buttons.

## HUDSON APPROVED ACCESSORIES

Your Authorized Hudson Dealer has available for installation on your car, a complete line of Factory Approved Accessories. The addition of these items will greatly enhance the appearance of the car, improve comfort and provide greater safety. Accessories available are:

Ash Tray—Instrument Panel	Mirror — Vanity
Ash Tray—Front Seat Back	Oil Filter
Back-Up Light	Oil Filter Cartridge
Battery Filler — Automatic	Pocket Molding Kit
Battery Charger — Home Type	Radiator Grille Guard
Cigar Lighter	Radio
Clock—Electric	Radio Antenna
Direction Indicator	Rear Bumper Guard
Electric Shaver—Auto Home	Rear Compartment Light
Combination	Rear Seat Radio Speaker
Emergency Trouble Light	Rear Window Wiper
Exhaust Deflector	Seat Covers — Custom Matting
Fire Extinguisher	Seat Covers — Deluxe Matting
Floor Mat—Auxiliary	Seat Covers—Rayon Tackle Twill
Fog Lamps	Spare Tire Valve Extension
Front Door Ventilator Wing Shield	Spotlight
Gasoline Filter	Steering Wheel Kit—18"
Gas Tank Locking Cap	Thermaster 8-hr. Bottle
Gas Tank Locking Cap — Electric	Thermaster Portable Refrigerator
Glove Box Light—Automatic	Trunk Light—Automatic
Hub Cap Kit—Large	Underseat Heater
Hydraulic Jack	Under Hood Light — Automatic
Karvisor	Vacumotive Drive
Kleenex Tissue Dispenser	Venetian Sun Shade—Rear Window
License Plate Frame	Weather Control—Automatic
Locker Box Light	Thermostat
Mirror — Outside Rear View	Wheel Trim Ring
Mirror — Large Oval	Window Ventshades
Mirror — Glare Proof	Windshield Washer — Automatic
	Assist Strap Kit—Gray or Russet

## GENUINE HUDSON SUPPLIES

A complete line of high quality supplies, bearing approval of the Hudson Laboratories, is available. These supplies enable the owner to preserve the finish and undercar parts of his car as well as clean interiors and chromium plated parts.

Essential items for the proper maintenance of your car are included in this group. Items stocked by Hudson Dealers are:

Anti-Freeze	PiB — Ignition Insulation
Black Rubber Finish	Polish and Cleaner
Brake Fluid	Polishing Cloth
Car Washing Chamois	Pre Wax Cleaner
Car Washing Sponge	Radiator Flush
Chromium Polish	Radiator Rust Preventive
Combination Cleaner and Wax	Radiator Stop Leak
Convertible Top Dressing	Rubber Lubricant
Door Ease	Rust Dissolve
Fabric Cleaner	Shock Absorber Fluid
Gasket Cement	Spot Remover
General Use Oil	Tar and Road Oil Remover
Glass Cleaner	Tire Pressure Gauge
Glass Sealer—Sealzit	Touch-Up Lacquer
High Gloss Wax	Undercoating
Hudsonite Clutch Compound	White Sidewall Cleaner
Hurricane Auto Shampoo	Windshield Cleaner Blade
Liquid Glaze Cleaner and Sealer	Windshield Washer Solvent
Penetrating Oil	

## INDEX

<b>A</b>		Carburetors .....	34
Accelerator Pedal .....	19	Carburetor Air Cleaner .....	35
Accessories .....	69	Carburetor and Fuel System .....	33
Air Cleaner Carburetor .....	35	Care of Chromium Plated Parts .....	61
Air Cleaner (Dry) Type .....	35	Care of Finish .....	61
(Oil Bath) Type .....	35	Care of Upholstery .....	62
Ammeter (See Generator Charge) ..	18	Caster .....	55
Anti-Freeze and Capacities .....	32	Changing Tires .....	27
Authorized Hudson Service Stations	4	Chassis Dimensions .....	6
Axle Front (See "Front Suspension")	55	Chassis Underview .....	59
Axle, Rear .....	50	Cigarette Lighter .....	21
		Circuit Breakers .....	43
<b>B</b>		Cleaning Fabric Tops .....	62
Battery .....	37	Cleaning Upholstery .....	62
Battery Registration .....	37	Clock .....	18
Beam Indicator .....	17	Clutch .....	7-43
Body Serial Number .....	6	Clutch Pedal .....	18
Brake Adjustment .....	53	Clutch Pedal Adjustment .....	45
Brakes .....	9-52	Combination Fuel and Vacuum Pump	36
Brake Fluid .....	53	Convertible Brougham Top .....	66
Brake Pedal Free Travel .....	19-53	Cooling System Capacities .....	9-10
"Breaking In" .....	21	Cooling System, Draining of .....	31
Break-in Oils .....	13-21	Corrosion Preventive .....	31
Breaker Point Adjustment .....	39	Cowl Ventilator Handle .....	19
		Crankcase Capacities .....	10-13
<b>C</b>		Cranking Engine Manually .....	38
Camber .....	55		
Capacities, Table of .....	10	<b>D</b>	
Car and Serial Numbers .....	6	Dealer Service Policy, Your .....	3
Carbon Monoxide Gas .....	22	Defroster, Operation .....	21-63
		Dimensions .....	11
		Direction Indicator .....	16

Distributor ..... 39  
 Dome Lamp Switch ..... 18  
 Door Lock Operation ..... 23-59  
 Drag Link ..... 56  
 Draining the Cooling System ..... 31  
 Drive-Master ..... 19-49  
 Driving Your New Car ..... 21

**E**

Electrical System Equipment ..... 9  
 Engine—6 Cylinder ..... 28  
 Engine—8 Cylinder ..... 29  
 Engine Oil—Checking Level of ..... 13  
 Engine Oil Capacity ..... 10-13  
 Engine Oil—Proper Kind to Use ..... 14  
 Engine Oil—When to Change ..... 14  
 Engine Lubrication ..... 10-13  
 Engine Specifications ..... 7

**F**

Fan ..... 31  
 Fan Belt—Adjustment of ..... 32  
 Finish, Care of Car ..... 61  
 Firing Order ..... 40  
 Front Lateral Stabilizer ..... 56  
 Front Seat Adjustment ..... 16  
 Front Suspension ..... 54  
 Front Wheel Bearings ..... 55  
 Fuel and Altitude Compensation ..... 40  
 Fuel Economy ..... 33  
 Fuel Gauge ..... 18  
 Fuel Pump ..... 36  
 Fuel Recommendations ..... 33  
 Fuses ..... 43

**G**

Gasoline Tank Capacity ..... 10  
 Gear Shifting ..... 20  
 Generator ..... 37  
 Generator Voltage Regulator ..... 38  
 Generator Charging Indicator ..... 18  
 Glove Compartment ..... 18

**H**

Hand Brake Lever ..... 18-53  
 Headlamps ..... 41  
 Headlamp Aiming Adjustment ..... 42  
 Headlamp Beam Indicator ..... 17  
 Headlight Beam Control Foot Switch ..... 18  
 Heat Indicator ..... 18

Hood Lock Handle ..... 18-24  
 Hood Unlocking Handle ..... 18-24  
 Horn Operating Ring ..... 17  
 Horsepower (AMA Rating) ..... 6  
 Hudson Drive-Master ..... 19-49

**I**

Identification Card ..... 4  
 Ignition, Breaker Point Gap ..... 39  
 Ignition Lock and Switch ..... 19  
 Ignition Timing ..... 39  
 Inflation Pressures, Tires ..... 25  
 Inspection and Adjustment Service ..... 5  
 Instrument Panel and Controls ..... 17

**J**

Jack, Use of ..... 27

**K**

Keys ..... 22

**L**

Lamp Bulb Specifications ..... 10  
 Lamps (Sealed Beam) ..... 42  
 License Information ..... 6  
 Lighting Switch ..... 20  
 Locker Box Lock ..... 18-24  
 Locking the Hood ..... 18-24  
 Locking your Car ..... 24  
 Locks ..... 24-59  
 Lubrication ..... 11  
     Body ..... 12  
     Brake Master Cylinder ..... 53  
     Carburetor Air Cleaner ..... 35-36  
     Chart ..... Inside Cover  
     Clutch ..... 11-43  
     Clutch Pedal ..... 45  
     Distributor ..... 39  
     Drag Link ..... 56  
     Drive-Master—See Chart Inside Cover  
     Engine—6 Cylinder ..... 10-13  
     Engine—8 Cylinder ..... 10-13  
     Front Suspension ..... 54  
     Front Wheel Bearings ..... 55  
     Generator ..... 37  
     Overdrive-Transmission ..... 11-47  
     Rear Axle ..... 11-50  
     Rear Springs ..... 57  
     Schedule ..... 12  
     Steering Gear ..... 55



Transmission .....	11-47	Specifications .....	7
Universal Joints .....	50	Speedometer .....	17
Vacumotive Drive .....	45	Springs—Rear .....	8-57
<b>M</b>			
Master Cylinder .....	53	Starter Button .....	17
Model Designation .....	6	Starting, Lighting and Ignition .....	37
Mountain Driving .....	20	Starting Motor .....	38
<b>O</b>			
Oil Dilution and Sludge .....	14	Starting the Engine .....	22
Oil, During Run-in Period .....	14	Steering Gear .....	55
Oil Filter .....	16	Supplies .....	69
Oil Pressure Indicator .....	17	<b>T</b>	
Oil Specification Chart .....	15	Tappet Clearance, Valves .....	30
Operating Controls .....	16	Technical Information .....	7
Overdrive—Transmission .....	48	Temperature Gauge .....	18
Overdrive—Control Knob .....	19	Thermostat .....	31
Owner's Service Policy .....	3	Tires .....	9-25
<b>P</b>			
Paint, Care of Finish .....	61	Tire and Wheel Balance .....	25
Parking Brake Lever .....	18	Tires—Changing .....	26
Polish, Application of .....	61	Tires—Dismounting and Remounting .....	26
Power Operated Windows .....	67	Tire Inflation Pressures .....	25
Propeller Shaft and Universal Joints .....	50	Tire Wear—Minimizing .....	25
<b>R</b>			
Radio Antenna .....	18	Tire Switching .....	25
Radio Control .....	17	Tool Kit .....	26
Radio Operating Instructions .....	68	Transmission .....	46
Rear Axle .....	50	Transmission Overdrive .....	11-48
Rear Compartment Door .....	24	<b>U</b>	
Rear Lateral Stabilizer .....	57	Universal Joints .....	50
Rear Springs .....	8-57	Upholstery, Care of .....	62
Rheostat .....	19	<b>V</b>	
Run-In Period .....	21	Vacumotive Drive .....	19-45
Rust and Corrosion Inhibitor .....	31	Vacuum Pump .....	36
<b>S</b>			
Seal Beam Replacing .....	42	Valve Tappet Adjustment .....	30
Seat Adjusting Lever .....	16	Ventilator Wings .....	60
Seat Covers .....	69	Voltage Regulator .....	38
Serial Number .....	6	<b>W</b>	
Service .....	4	Warming up the Engine .....	22
Service Policy .....	3	Warranty .....	2
Shifting Gears .....	20	Washing the Car .....	61
Shock Absorbers .....	58	Water Drain .....	31
Spare Tire and Wheel .....	26	Water Temperature Gauge .....	18
<b>T</b>			
<b>U</b>			
<b>V</b>			
<b>W</b>			
<b>X</b>			
<b>Y</b>			
<b>Z</b>			