

# 2018 MASTER CATALOGUE

MOTORCYCLE AND SCOOTER BRAKE SYSTEM COMPONENTS  
 COMPONENTES DEL SISTEMA DE FRENO PARA MOTOCICLETAS Y VESPAS - COMPONENTI DI SISTEMI DI FRENO PER MOTO E MOTORINI



HI-TECH BRAKE SOLUTIONS  
 MADE IN EUROPE



## CHOICE OF CHAMPIONS



**MICHAEL DUNLOP**  
 WINNER  
 SENIOR  
 TT  
 2017

ISLE OF MAN TT  
 Best lap  
 132.903 mph  
 214 km/h



**MICHAEL DUNLOP**  
 WINNER  
 SUPERSPORT  
 TT 1  
 2017



**IAN HUTCHINSON**  
 WINNER  
 SUPERBIKE  
 TT  
 2017



**IAN HUTCHINSON**  
 WINNER  
 SUPERSTOCK  
 TT  
 2017



|  |   |  |   |
|--|---|--|---|
| <b>SCOOTER</b><br>Sinter<br>Ceramic<br>Carbon Tech | <b>STREET</b><br>Sinter<br>Ceramic<br>Carbon Tech | <b>OFF-ROAD</b><br>Sinter<br>Ceramic<br>Carbon | <b>RACING</b><br>Sinter<br>Dual Sinter<br>Dual Carbon |
|--|---|--|---|

**sbs**  
 THE POWER TO STOP YOU®

sbs.dk

# HOW TO CHOOSE YOUR BRAKE PADS



## THE RIGHT CHOICE FOR YOUR MOTORCYCLE AND YOUR RIDING STYLE.

1. Choose your motorcycle type "Street Motorcycles", "American Motorcycles", "Scooter", "Road Racing", "Off Road", "ATV".
2. Find your "Type of use" in the matching diagram.
3. Pick the compound matching your needs and requirements.
4. Go to the "Motorcycle Model Applications" section to find your bike and matching SBS brake pad numbers.

### STREET MOTORCYCLES

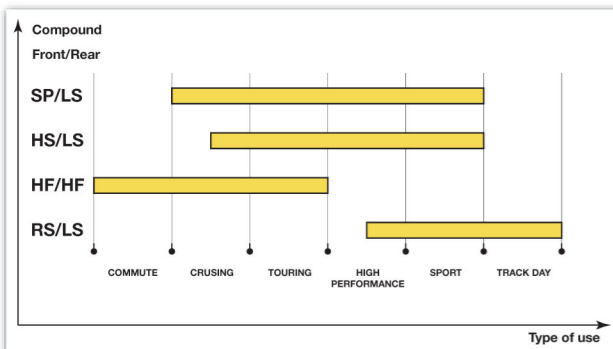

### AMERICAN MOTORCYCLES

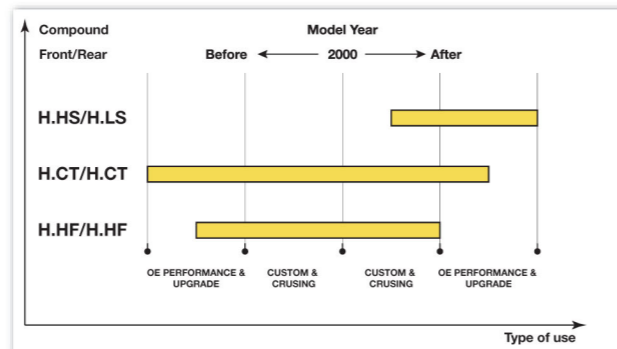

### SCOOTER

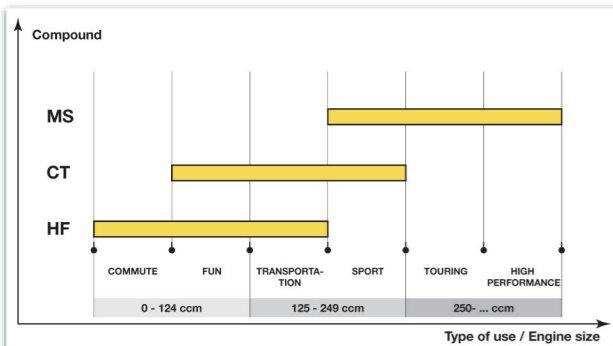

### ROAD RACING

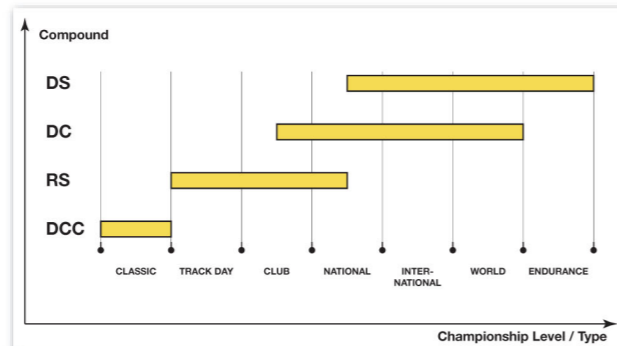

### OFF ROAD

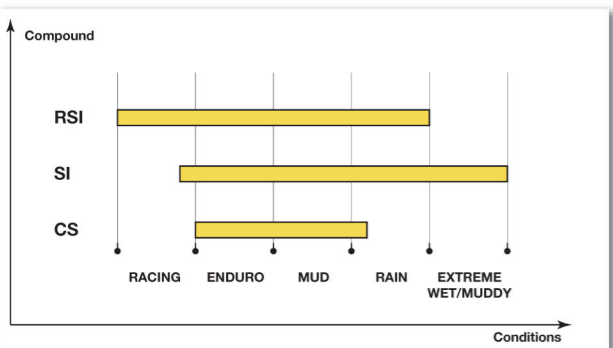

### ATV

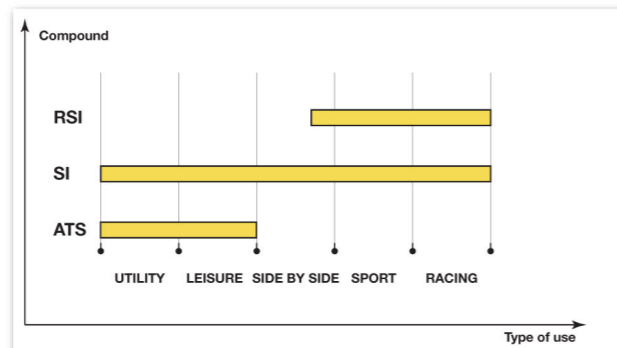

Choose ATS compound for older Arctic Cat and Polaris with plain steel discs.

RACING SUCCESS MORE THAN 25 YEARS

Persistence  
Passion &  
Performance



Chris Vermeulen

Kenan Sofuoglu

Carlos Checa

Sébastien Charpentier

Aaron Gobert • Aaron Slight • Aaron Yates • Adrian Nestrovic • Aiden Wagner • Akira Yanagawa • Alessandro Polita • Alessandro Tonucci • Alessio Corradi • Alex Barros • Alex Cudlin • Alex De Angelis • Alex Gobert • Alex Gramigni • Alex Hoffmann • Alex Schacht • Alexander Lundh • Alvaro Molina • Ana Carasco • Andi Notman • Andrew Irwin • Andrew Pitt • Andrew Stroud • Anthony Gobert • Anthony West • Arie Vos • Arne Tode • Axel Maurin • Ayrtton Badovini • Barry Veneman • Ben Bostrom • Ben Spies • Borja Sánchez • Brad Binder • Britt Turkington • Broc Parkes • Bruce Anstey • Bruno Bonhuil • Bryan Schouten • Cal Crutchlow • Cameron Beaubier • Cameron Donald • Cameron Petersen • Carl Fogarty • Carlos Checa • Chaz Davies • Chris Peris • Chris Ulrich • Chris Vermeulen • Chris Walker • Christer Lindholm • Christer Miniin • Christian Gamarino • Christian Iddon • Christian Kellner • Christian Zaiser • Christoffer Bergman • Christophe Ponsson • Claudio Corti • Colin Edwards • Conor Cummins • Cory West • Craig Coxhell • Damian Cudlin • Dan Linfoot • Daniilo Petrucci • Danny De Boer • Danny Eslick • Danny Webb • David Checa • David De Gea • David Jeffries • David McFadden • David Morillon • David Salom • Davide Giugliano • Dean Ellison • Dean Harrison • Denis Sacchetti • Didier van Keymeulen • Dominique Aegerter • Doug Chandler • Doug Polen • Doug Toland • Eddi La Marra • Elena Myers • Enrique Rocamora • Eric Bostrom • Erwan Nigon • Fabien Foret • Fabio Massei • Fabio Menghi • Fabrizio Piovano • Federico Cariasulo • Filip Backlund • Filip Altendorfer • Florian Alt • Florian Marino • Fonsi Nieto • Fred Merkel • Freddy Foray • Gabriel Rodrigo • Gareth Jones • Gary Johnson • Gary Mason • Gary McCoy • Gary Nixon • Geoff May • Giancarlo Falappa • Gianluca Nanelli • Gianluca Vizziello • Gino Borsoi • Gino Rea • Giovanni Bussei • Glen Richards • Glenn Allerton • Glenn Irwin • Glenn Scott • Graeme Gowland • Gregorio Lavilla • Grégory Fastré • Guy Martin • Hannes Soomer • Henk van der Mark • Hikari Okubo • Hiroshi Aoyama • Hitoyasu Izutsu • Horst Saiger • Iain MacPherson • Ian Hutchinson • Ian Lougher • Ian Simpson • Igor Jerman • Iker Lecuono • Ilario Dionisi • Illia Mykhalchuk • Ivan Clementi • Ivan Goi • Jack Kennedy • Jacob Smrz • Jaimie Van Sikkelerus • Jake Gagne • Jake Zemke • James Ellison • James Haydon • James Hillier • James Rispoli • James Toseland • James Witham • Jamie Hacking • Jamie James • Jamie Robinson • Jan Hanson • Jason Pridmore • Jasper Iwema • Javier Fores • Jay Springsteen • Jed Metcher • Jeremy Guarnoni • Jeremy McWilliams • Jesco Raffin • Jim Moodie • Jimmy Filice • Jimmy Lindström • Joan Lascorz • Joe Francis • Johan Stigefelt • John Crawford • John Crookford • John Hopkins • John Laverty • John McGuinness • John Reynolds • Jonas Folger • Jonathan Rea • Jordi Torres • Josh Brookes • Josh Hayes • Josh Waters • Joshua Day • Juan Borja • Juanfran Guevara • Jules Cluzel • Julian Puffe • Julian Simon • Julien da Costa • Julien Enjolras • Jürgen Van der Goorberg • Jörg Teuchert • Kai Børre Andersen • Karl Harris • Katsuki Fujiwara • Keith Amor • Kenan Sofuoglu • Kenny Foray • Kenny Noyes • Kevin Coghlan • Kevin Curtain • Kevin Valk • Kevin Wahr • Koen Meuffels • Kurtis Roberts • Kyle Ryde • Kyle Smith • Kyle Wyman • Leandro Mercado • Lee Johnston • Leon Camier • Leon Haslam • Livio Loi • Lorenzo Lanzi • Lorenzo Zanetti • Loris Baz • Luca Marconi • Luca Scassa • Lucas Mahias • Luis Salom • Lukas Pezsek • Lukas Trautmann • Marc Moser • Marcel Kellenberger • Marco Faccani • Maria Herrera • Mark Aitchinson • Mark Heckles • Markus Reiterberger • Martin Cardenas • Martin Jessor • Marvin Fritz • Massimo Roccoli • Mat Miladin • Matej Smrz • Mathew Scholtz • Mathieu Gines • Matteo Baiocco • Matthieu Lagrive • Mauro Sanchini • Maverick Vinales • Max Neukirchner • Maxime Berger • Melissa Paris • Michael Barnes • Michael Canducci • Michael Dunlop • Michael Laverty • Michael Rutter • Michael Savary • Michael Schulten • Michael van der Mark • Michel Fabrizio • Michele Pirro • Michelle Malatesta • Miguel Duhamel • Miguel Praia • Mika Kallio • Mika Pérez • Mike Di Meglio • Mike Edwards • Mike Hale • Mike Smith • Nacho Calero • Neil Hodgson • Nial McKenzie • Niccolò Canepa • Nicky Hayden • Niki Tuuli • Nina Prinz • Norick Abe • Ondrej Jezek • Jonas Folger • Paul Young • Pedro Vallsneras • Pere Riba • Peter Goddard • Peter Linden • Peter Oettl • Philipp Hafenegger • Philipp Oettl • Pier Francesco Chili • Piergiorgio Bontempi • P.J. Jacobsen • Raffaele De Rosa • Ralf Waldmann • Randy Krummenacher • Rattthapark Wilairot • Raymond Roche • Remy Gardner • Ricardo Chiarello • Riccardo Russo • Richard Cooper • Rob Hartog • Rob McElnea • Robbin Harms • Robert Schotman • Robert Ulm • Roberto Rolfo • Roberto Tamburini • Robin Mulhauser • Roger Lee Hayden • Roman Stamm • Ronald Ter Brake • Roy Ten Napel • Ruben Xaus • Michael Vos • Ryuichi Kiyonari • Sam Lowes • Sandro Cortese • Santiago Barragan • Scott Deroue • Scott Redding • Scott Russell • Sean Emmet • Sebastien LeGrelle • Sebastian Scarnato • Sébastien Gimbert • Sébastien Suchet • Shane Byrne • Sheridan Morais • Shinichi Nakatomi • Shinya Nakano • Simon Crafar • Simone Sanna • Stefan Bradl • Stefan Kerschbaumer • Stefan Nebel • Stephane Chambon • Stephane Mertens • Steve Hislop • Steve Martin • Steve Mercer • Steve Plater • Steve Rapp • Stuart Easton • Sylvain Barrier • Sylvain Guintoli • Tage Solberg • Tarran Mackenzie • Tatsuki Suzuki • Tatu Lauslehto • Taylor Mackenzie • Terry Rymer • Thomas Stevens • Tito Rabat • Tom Kipp • Tom Luthi • Tom Sykes • Tom Tunstall • Tommy Bridewell • Tommy Hayden • Tommy Hill • Toni Finsterbusch • Toni Sharpless • Toni Covena • Toprak Razgatlioglu • Travis Wyman • Troy Bayliss • Troy Corser • Vesa Kallio • Vincent Haskovec • Vincent Lonbois • Vittorio Iannuzzo • Walter Tortoroglio • Warwick Nowland • Warwick Maxwell • Wayne Tessesels • Werner Daemen • Wes Cooley • William De Angelis • William Dunlop • Xavier Simeon • Yoann Tiberio • Yonny Hernandez • Yukio Kagayama • Zulfahmi Khairuddin ...and many more.





# CONTENT

|         |  |
|---------|--|
| 2 – 3   | <b>WELCOME TO OUR UNIVERSE</b>                                   |
| 4 – 6   | <b>UNIQUE TECHNOLOGY FEATURES</b>                                |
| 7 – 9   | <b>STREET BRAKE PADS</b>   |
| 8       | HS/LS – <i>Street Performance</i>                                |
| 9       | SP – <i>Street Upgrade</i>                                       |
| 9       | HF – <i>Street Standard</i>                                      |
| 11 – 13 | <b>AMERICAN BRAKE PADS</b>                                       |
| 12      | H.HS/H.LS – <i>High Performance &amp; No Dust</i>                |
| 13      | H.CT – <i>High Power &amp; Noise Reduction Formula</i>           |
| 13      | H.HF – <i>Ultra Quiet &amp; Low Dust</i>                         |
| 15 – 17 | <b>SCOOTER BRAKE PADS</b>  |
| 16      | MS – <i>Maxi Sinter</i>  |
| 16      | CT – <i>Standard &amp; Maxi</i>                                  |
| 17      | HF – <i>Standard &amp; Maxi</i>                                  |
| 19 – 22 | <b>RACING BRAKE PADS</b>   |
| 20      | DS – <i>Road Racing &amp; Endurance</i>                          |
| 20      | DC – <i>Endurance, Classic &amp; Road Racing</i>                 |
| 21      | DCC – <i>Endurance, Classic &amp; Road Racing</i>                |
| 21      | RS – <i>Road Racing &amp; Track Days</i>                         |
| 22      | RQ – <i>Endurance, Classic &amp; Road Racing</i>                 |
| 22      | LS – <i>Endurance, Classic &amp; Road Racing</i>                 |
| 23 – 25 | <b>OFF ROAD &amp; ATV BRAKE PADS</b>                             |
| 24      | RSI – <i>Racing</i>  |
| 24      | SI – <i>Club, Trails &amp; Leisure</i>                           |
| 25      | CS – <i>Club, Trails &amp; Leisure</i>                           |
| 25      | ATS – <i>Club, Trails &amp; Leisure</i>                          |
| 26      | <b>BRAKE SHOES WITH SPRINGS</b>                                  |
| 27      | <b>STAINLESS BRAKE PINS</b>                                      |
| 28      | <b>ACCESSORIES – BRAKE SYSTEM BLEEDER &amp; ANTI-NOISE SHIMS</b> |
| 29 – 31 | <b>MERCHANDISE</b>   |
| 32      | <b>SALES &amp; POS MATERIAL</b>                                  |
| 33      | <b>MOTORCYCLE MODEL APPLICATIONS</b>                             |
| 34      | <i>Motorcycles, Off Road, ATV, Scooters</i>                      |
| 95      | <i>Motocross</i>   |
| 99      | <i>Racing</i>  |
| 105     | <i>Calipers</i>  |
| 109     | <b>BRAKE PAD 1:1 DRAWINGS, COMPOUNDS, FITMENTS</b>               |
| 621     | <b>CROSSLIST BRAKE PADS: SAME SHAPE – DIFFERENT THICKNESS</b>    |
| 625     | <b>BRAKE SHOE DRAWINGS, FITMENTS</b>                             |
| 677     | <b>CROSS REFERENCE LIST – OTHER BRANDS</b>                       |
| 689     | <b>BRAKE PIN FITMENTS, DRAWINGS</b>                              |

No se permite la copia total o parcial del catálogo sin el permiso de SBS Friction A/S. La empresa se reserva el derecho a realizar modificaciones en el diseño o aplicaciones para determinados modelos.  
Se ha realizado un gran esfuerzo para garantizar la exactitud de la información que se incluye en este catálogo. Sin embargo, no nos responsabilizaremos de las pérdidas ocasionadas por errores u omisiones.

Copie complete o parti di questo catalogo sono ammesse soltanto su autorizzazione della SBS Friction A/S. Sono riservati tutti i diritti inerenti a modifiche di disegno o di modelli di applicazione.  
È stato esperito ogni sforzo possibile per garantire la correttezza delle informazioni contenute nel presente catalogo. Tuttavia non risponderemo di eventuali perdite derivanti da errori od omissioni.

## BIENVENIDO A NUESTRO UNIVERSO



SBS Friction A/S es una empresa danesa que desarrolla, fabrica y comercializa pastillas de freno y soluciones de fricción para motocicletas, scooter, ATV/UTV, coches especiales y aplicaciones industriales, incluidos generadores eólicos.

Nuestra gama de productos incluye también componentes como discos de freno, zapatas de freno y otros accesorios (por ejemplo, tornillos de freno).

Nuestra historia se remonta a 1964. En la década de 1970 fuimos los primeros en introducir las pastillas de freno de disco en el mercado de piezas de repuesto para motocicletas. Desde entonces hemos seguido ampliando nuestra gama de productos hasta cubrir la práctica totalidad del mercado, con independencia de la marca, el modelo o el año de fabricación. Somos los primeros en ofrecer las novedades y los últimos en retirar los productos más antiguos.

Además de ser líderes en el mercado europeo de piezas de repuesto para pastillas de freno de motocicletas, SBS es sinónimo de excelencia en sistemas de frenado en todo el mundo. Nuestra red de distribución se extiende por unos 50 países de todo el mundo, entre ellos Estados Unidos, Canadá, Japón, Australia y la Unión Europea.

Nuestra cartera de clientes incluye tanto fabricantes de sistemas de frenado de equipos originales para motocicletas como fabricantes de vehículos, además de empresas de otros sectores de la industria, como fabricantes de generadores eólicos, gracias a nuestros conocimientos en materia de fricción.

En nuestra sede de Svendborg (Dinamarca), se encuentran los departamentos de I+D, producción y ventas. Nuestra planta de cerca de 12 000 m<sup>2</sup> incorpora líneas de producción de componentes de material cerámico, sinterizado y carbono.

Nuestra plantilla está integrada por unos 200 empleados y nuestra facturación ha aumentado de manera constante desde que presentamos nuestra primera pastilla de freno.

## BENVENUTI NEL NOSTRO UNIVERSO



La SBS Friction A/S è una società danese che sviluppa, produce e commercializza pastiglie freno e soluzioni di attrito per moto, ciclomotori, quad e UTV, vetture speciali e applicazioni industriali, comprese le turbine eoliche.

Inoltre, la nostra gamma di prodotti comprende altri componenti per freni quali i dischi freno, le ganasce per freno e accessori quali i perni per freno.

La nostra storia risale al 1964. Negli anni '70 siamo stati i primi ad introdurre le pastiglie per i freni a disco dei motocicli nel mercato aftermarket. Da allora abbiamo continuamente espanso la nostra gamma di prodotti e attualmente copriamo tutti i segmenti del mercato, indipendentemente da marca, modello o anno di costruzione. Siamo i primi ad avere i prodotti più nuovi e gli ultimi con i prodotti meno recenti.

Siamo il numero 1 sul mercato europeo aftermarket per le pastiglie freno delle moto; in tutto il globo il nome SBS è rinomato per l'eccellenza nella frenata. In totale, la nostra rete di distribuzione è sparsa in quasi 50 paesi del mondo compresi Stati Uniti, Canada, Giappone Australia e l'Unione Europea.

Il nostro portafoglio di clienti comprende gli OEM per l'industria motociclistica quali i prodotti di impianti frenanti e di veicoli; grazie alla nostra esperienza sull'attrito copriamo anche il settore dei produttori di turbine eoliche.

La nostra sede centrale, il reparto di R&S, la produzione e le vendite si trovano a Svendborg, in Danimarca. Il nostro stabilimento di produzione copre circa 12.000 m<sup>2</sup> con linee di produzione per componenti in ceramica, materiali sinterizzati e al carbonio.

Abbiamo circa 200 dipendenti e il nostro fatturato è aumentato costantemente da quando abbiamo introdotto la prima pastiglia freno.



## BIENVENIDO A NUESTRO UNIVERSO



### LA FRICCIÓN ES DEMASIADO IMPORTANTE PARA CONFIÁRSELA A OTROS

Por eso gestionamos internamente todos los procesos cruciales, como el desarrollo de productos, los ensayos, las mezclas, el prensado, los controles, el empaquetado, etc.

Consideramos que la innovación, la productividad y el control de calidad son fundamentales.

Trabajamos constantemente en el desarrollo de nuevos materiales para fricción, productos nuevos, métodos de producción novedosos y tecnología de procesos avanzada. Contamos con líneas de producción de última generación y sistemas altamente automatizados.

Todos los flujos de trabajo se basan en principios de producción ajustada y se centran estrictamente en las necesidades de nuestros clientes, que exigen un nivel de calidad elevado y constante, una total flexibilidad y un excelente grado de cumplimiento con los plazos de entrega. Nuestro personal, que tiene gran experiencia y formación, garantiza una alta eficiencia en todos los procesos, desde la mezcla de componentes hasta el empaquetado.

Nuestro departamento de I+D innova continuamente en tecnologías y materiales para ofrecer las máximas prestaciones, mayor durabilidad y comodidad y productos de frenado más respetuosos con el medio ambiente.

Además de satisfacer los requisitos del mercado de repuestos y de los clientes fabricantes de equipos originales, nuestros productos están homologados.

#### Nuestra misión es clara:

Desarrollar componentes de frenos de última generación para las necesidades actuales del mercado y marcar tendencia de cara al futuro en tecnología de frenos.

## BENVENUTI NEL NOSTRO UNIVERSO



### L'ATTRITO È TROPPO IMPORTANTE PER LASCIARLO AGLI ALTRI

Per questo gestiamo internamente tutti i processi cruciali, quali lo sviluppo del prodotto, le prove, la miscelazione, la pressatura, il controllo, il confezionamento, ecc...

Consideriamo competenze cruciali l'innovazione, la produttività e l'assicurazione qualità.

Sviluppiamo continuamente nuovi materiali di attrito, nuovi prodotti, nuovi metodi produttivi e tecnologie di processo avanzate. Le nostre linee di produzione sono all'avanguardia e funzionano con un'elevata automazione.

Tutti i flussi di lavoro sono su base SNELLA, si focalizzano unicamente sulle necessità dei nostri clienti per una qualità elevata e costante, per una completa flessibilità ed eccellenti prestazioni di consegna. Il nostro personale esperto e ben addestrato garantisce un'elevata efficienza in tutti i processi, dalla miscelazione dei composti al confezionamento.

Il nostro reparto R&S persegue continuamente innovazioni con nuovi materiali e tecnologie per ottenere le massime prestazioni, una durata maggiore, un comfort assoluto e prodotti per freno più rispettosi dell'ambiente.

Rispettiamo i requisiti di clienti OE e aftermarket e i nostri prodotti sono tutti approvati conseguentemente.

#### La nostra missione è chiara:

Sviluppare componenti per freni super moderni e creare gli standard per la tecnologia dei freni del futuro.



## CARACTERÍSTICAS TECNOLÓGICAS ÚNICAS

## CARATTERISTICHE DI UNA TECNOLOGIA ESCLUSIVA



### TECNOLOGÍA NRS (NUCAP RETENTION SYSTEM)

Para acoplar un material de fricción cerámico/orgánico a la placa posterior, suele utilizarse un tipo de adhesivo. Como la temperatura que alcanza el sistema de frenos es elevada, la temperatura de este adhesivo debe mantenerse muy estable. Además, la aplicación del adhesivo debe controlarse de forma meticulosa para garantizar una resistencia uniforme al corte. Sin embargo, por bien que se hagan las cosas, siempre existe un límite máximo de temperatura a partir del cual el adhesivo empieza a descomponerse, con lo que aumenta de manera considerable el riesgo de que se produzca delaminación entre la placa posterior y el material de fricción.

Como en SBS no queremos poner en riesgo la seguridad del piloto, utilizamos la tecnología NRS con todos los materiales de fricción de cerámica/orgánicos actuales de SBS, incluidos compuestos para motocicletas de calle, fuera de carretera y de carreras.

Este método también se utiliza en determinados tipos de pastillas sinterizadas (véase "sinterizado conductivo").

La Tecnología NRS se basa en una matriz de ganchos elevados en la placa posterior que se acopla al material de fricción y crea una adherencia mecánica indestructible sin adhesivos. En comparación con los métodos convencionales, la tecnología NRS ofrece las siguientes ventajas:

- // Ausencia de separación entre la placa posterior y el material de fricción
- // Ausencia de deformación de los bordes del material de fricción que proporciona sensación de firmeza
- // Ausencia de vibración entre el material de fricción y la placa posterior

### TECNOLOGÍA DE FABRICACIÓN DE MATERIAL CERÁMICO/ORGÁNICO

Aunque el material cerámico/orgánico se utiliza principalmente en motocicletas de menor tamaño y scooters, antes era el tipo de material más empleado en los frenos.

El polvo del material de fricción de material cerámico/orgánico se introduce en una cavidad caliente y se aplica presión junto con la placa posterior con tecnología de retención NRS. La cola que incluye el polvo de fricción provoca una reacción y de esta manera se crea el material de fricción. Tras un cierto intervalo de tiempo en la cavidad caliente, la pastilla (incluida la placa posterior) se expulsa y se transfiere a una estación de polimerización, en la que se endurece el material de fricción.



### TECNOLOGIA NRS (SISTEMA DI FISSAGGIO NUCAP)

Per collegare il materiale di attrito in ceramica/organico alla piastra posteriore, si utilizza uno specifico tipo di adesivo. Questo adesivo deve essere molto stabile alle temperature, considerando l'elevata temperatura che si raggiunge all'interno dell'impianto frenante. Inoltre, l'applicazione dell'adesivo deve essere controllata con la massima attenzione per accertarsi di ottenere una resistenza costante al taglio. Tuttavia, indipendentemente dalla qualità di questa operazione, ci sarà sempre un limite di temperatura superiore dove l'adesivo inizierà a decomporsi, il rischio di una delaminazione tra piastra posteriore e materiale di attrito aumenterà in modo significativo.

Considerando che SBS non vuole compromettere la sicurezza dei piloti, l'NRS è utilizzato per tutti i materiali di attrito in ceramica/organici prodotti attualmente da SBS compresi i composti per marcia su strada, fuoristrada e corse.

Anche per alcuni tipi di pastiglie sinterizzate si utilizza questo metodo (vedere "sinterizzazione conduttiva").

La tecnologia NRS è basata su una matrice di ganchi sollevati sulla piastra posteriore che si fondono nel materiale di attrito, creando un legame meccanico indestructibile senza l'utilizzo di adesivi. I vantaggi principali della tecnologia NRS rispetto a quelli tradizionali sono:

- // Nessuna separazione tra piastra posteriore e materiale di attrito
- // Nessuno spigolo sollevato nel materiale di attrito, con conseguente sensazione di una leva solida
- // Nessuna vibrazione tra materiale di attrito e piastra posteriore

### TECNOLOGIA DI PRODUZIONE CERAMICA/ORGANICA

I materiali ceramici/organici sono utilizzati principalmente per moto e ciclomotori, ma in precedenza erano il materiale predominante per i dischi freno.

La polvere del materiale di attrito ceramico/organico viene alimentata in uno stampo caldo e viene pressata insieme alla piastra posteriore, tramite la tecnologia di fissaggio NRS. Grazie alla interposizione di collante nella polvere di attrito, questa reagisce e crea il materiale di attrito. Dopo un dato periodo di tempo nello stampo caldo la pastiglia, inclusa la piastra posteriore, viene espulsa e inviata ad una stazione di indurimento, dove avviene l'indurimento definitivo del materiale di attrito.

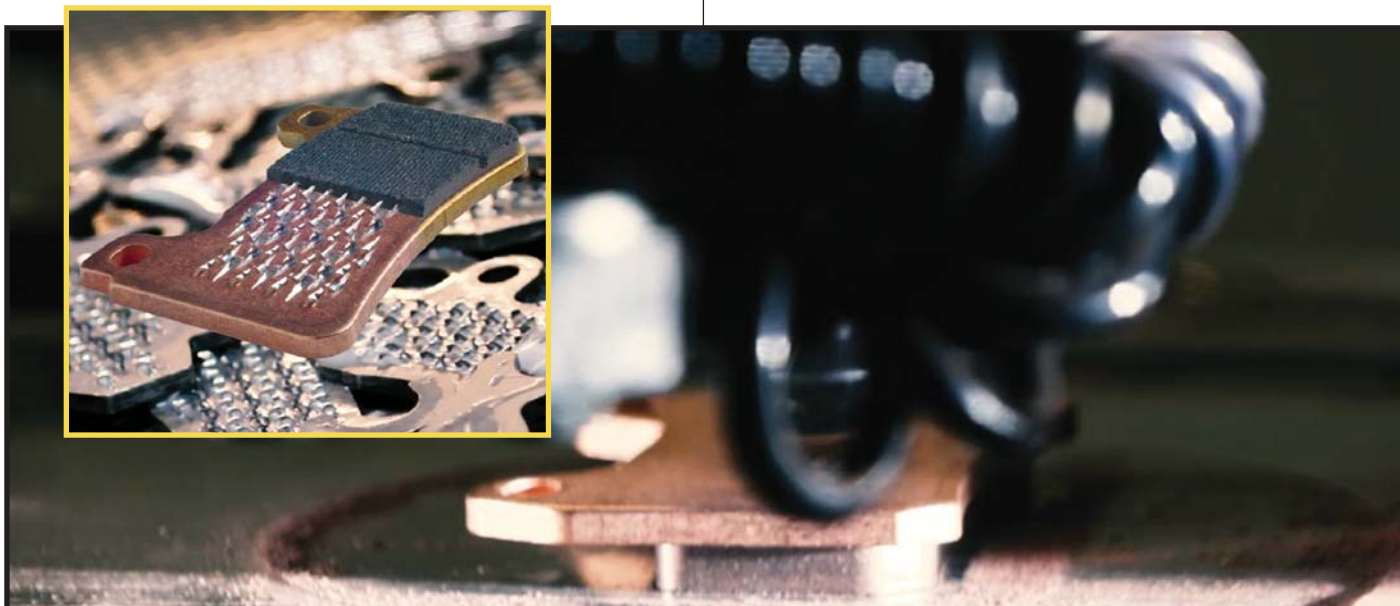

## CARACTERÍSTICAS TECNOLÓGICAS ÚNICAS

## CARATTERISTICHE DI UNA TECNOLOGIA ESCLUSIVA



### TECNOLOGÍA DE SINTERIZADO

Muchas motocicletas recientes llevan pastillas de freno sinterizadas.

SBS emplea dos métodos básicos para sinterizar los materiales de fricción:

#### Sinterizado en horno de cinta abierto

El proceso de sinterizado de los materiales de fricción es muy distinto del moldeo en caliente de los materiales de fricción de material cerámico/orgánico. En comparación con los materiales de fricción de material cerámico/orgánico, los materiales de fricción sinterizados se suelen someter a una presión 10 veces mayor.

En el proceso de sinterizado, el material de fricción se desplaza lentamente por un horno de cinta abierto, en el que se calienta a 800 °C o más. Durante el tiempo que transcurre en el horno, las partículas metálicas se funden y crean una matriz metálica. Este proceso se conoce como "sinterizado". Esta matriz metálica incluye partículas abrasivas o lubricantes que eventualmente hacen posible que se cree el material de fricción. Las pastillas de freno de SBS que se fabrican en el horno de cinta abierto se sueldan a la placa posterior o bien están diseñadas con la tecnología de adhesión NRS.

#### Sinterizado conductivo

El sinterizado conductivo o moldeo en caliente directo es una tecnología basada en el principio de calentar el material mediante el uso de corriente eléctrica. La ventaja de este método radica en la facilidad con que se controla el proceso de sinterizado, con lo que se obtiene un material de calidad excelente y homogénea para las pastillas de freno.

La tecnología de retención NRS se utiliza con los productos sinterizados por el método conductivo.



### TECNOLOGIA DI PRODUZIONE PER SINTERIZZAZIONE

Molte delle nuove moto sono dotate di pastiglie freno sinterizzate.

SBS utilizza due metodi basilari per la sinterizzazione dei materiali di attrito:

#### Sinterizzazione in fornace a cinghia aperta

La sinterizzazione del materiale di attrito è molto diversa rispetto alla pressatura a caldo di materiali di attrito ceramici/organici. Solitamente la pressione utilizzata per i materiali di attrito sinterizzati è superiore di 10 volte rispetto ai materiali di attrito ceramici/organici.

Nel processo di sinterizzazione il materiale di attrito si muove lentamente attraverso una fornace a cinghia aperta dove viene riscaldato ad una temperatura di 800° (o superiore). Durante il tempo trascorso nella fornace, le particelle di metallo si fondono insieme e creano una matrice metallica nota come sinterizzazione. All'interno di questa matrice metallica sono presenti inclusioni di particelle abrasive o lubrificanti, che alla fine costituiscono il materiale di attrito. Le pastiglie freno SBS prodotte all'interno di una fornace a cinghia aperta sono saldate a mezzo brasatura sulla piastra posteriore oppure utilizzano la tecnologia NRS per il fissaggio.

#### Sinterizzazione a conducibilità

La sinterizzazione a conducibilità, o stampaggio a caldo diretto, è una tecnologia basata sul principio del riscaldamento di un materiale tramite corrente elettrica. Il vantaggio di questo metodo è che il processo di sinterizzazione è facilmente controllabile, per ottenere una qualità eccellente ed omogenea del materiale delle pastiglie

Per prodotti ottenuti tramite sinterizzazione conduttiva, si utilizza il fissaggio NRS.

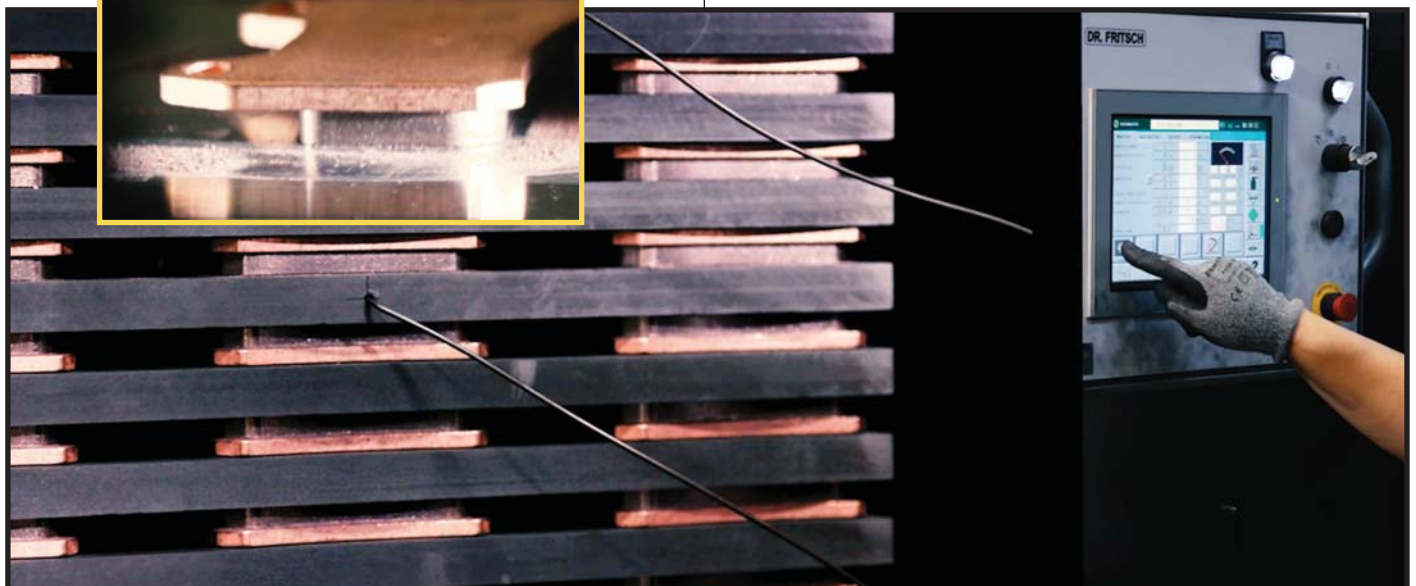
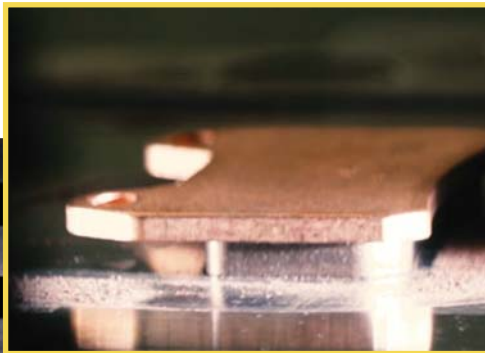

## CARACTERÍSTICAS TECNOLÓGICAS ÚNICAS



### DEST

DEST son las siglas en inglés de la tecnología de tratamiento de superficie de energía dinámica. Se utiliza en los compuestos DC para motocicletas de carreras con el fin de garantizar la regularidad de la calidad en la fabricación de frenos resistentes al desgaste en la línea de producción de SBS. Gracias al proceso DEST, no se requiere asentamiento térmico, ya que queda garantizada la desgasificación del material para evitar que se cree una película gaseosa entre el disco y la superficie de la pastilla que pueda provocar la pérdida de potencia de frenado (desgaste).

Durante el proceso de prevulcanización DEST, la superficie del material de fricción alcanza una temperatura de cerca de 700 °C (1292 °F). Esto significa que parte de la pastilla se descompone hasta una cierta profundidad y que la cantidad de gases que desprende la superficie de fricción se reduce de manera considerable.

### RECUBRIMIENTO

SBS solo emplea materiales y métodos de recubrimiento que ofrecen una protección óptima de las pastillas de freno frente a la corrosión.

#### Pastillas de material cerámico/orgánico:

Recubrimiento en polvo con estabilidad de temperatura de hasta 200-300 °C

#### Pastillas de carbono/sinterizadas:

Cobre, estabilidad de temperatura de 900 °C

Cromo-níquel, estabilidad de temperatura de 900 °C

El recubrimiento metálico suele tener un grosor de 10-15 µm. La prueba de corrosión se realiza conforme a lo establecido en la norma ISO 9227 (NSS).

## CARATTERISTICHE DI UNA TECNOLOGIA ESCLUSIVA



### DEST

Nella tecnologia DEST, DEST sta per Dynamic Energy Surface Treatment (Trattamento Superficiale a Energia Dinamica). Utilizzata per i composti da corsa DC garantisce prestazioni senza fade dalla linea di produzione SBS. Non è necessario nessun assestamento termico grazie al processo DEST che garantisce il degassaggio del materiale così da prevenire la creazione della pellicola gassosa tra il disco e la superficie della pastiglia che provoca una perdita di potenza frenante (fade).

Durante il processo di bruciatura superficiale DEST la superficie del materiale di attrito è riscaldata fino a circa 700°C (1292°F). Ciò significa che una parte della pastiglia si decompone fino ad una data profondità ed il quantitativo di gas che fuoriescono dalla superficie di attrito si riduce notevolmente.

### RIVESTIMENTO

SBS utilizza unicamente metodi e materiali di rivestimento che proteggono in modo ottimale le pastiglie freni contro la corrosione.

#### Pastiglie ceramiche/organiche:

Rivestimento a polvere con stabilità di temperatura fino a 200-300°C

#### Pastiglie al carbonio/sinterizzate:

Rame - stabilità di temperatura 900°C

Cromo-nichel- stabilità di temperatura 900°C.

Lo spessore dei rivestimenti metallici corrisponde solitamente a 10-15 µm. La prova di corrosione si effettua in accordo con la norma ISO 9227 NSS.

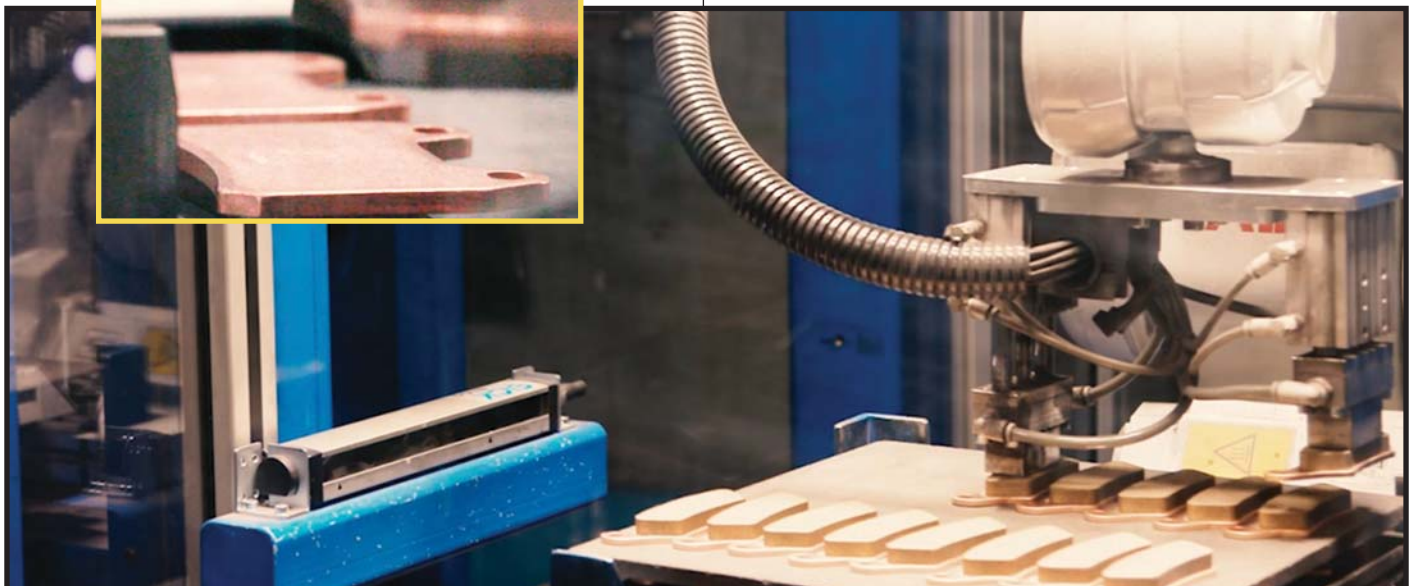



# LICENSE TO ADVENTURE



Si su pertenencia más preciada es una motocicleta de calle. Si reserva los fines de semana y las vacaciones para el turismo y la aventura. Si disfruta de la libertad que da pilotar una motocicleta. O si utiliza la motocicleta a diario.

Entonces, las pastillas de freno SBS STREET son perfectas para usted. Nuestros compuestos STREET se adecuan a motocicletas de calle de todas las marcas, modelos y años que hay en el mercado, sin excepción.

Ofrecen el rendimiento, la duración y el confort que necesita para SEGUIR ADELANTE.

Puede elegir entre:  
// PERFORMANCE – HS / LS  
// UPGRADE – SP  
// STANDARD – HF

Para acertar con las pastillas de su motocicleta, siga nuestras recomendaciones.



Se una moto da strada è il meglio che possiedi. Se ami le gite e le avventure durante i weekend e le vacanze. Se adori la libertà del viaggiare in moto, o se usi la moto ogni giorno per andare al lavoro.

Allora le pastiglie dei freni STREET SBS sono la scelta giusta per te. I nostri composti STREET sono sviluppati per tutte le marche, i modelli e gli anni di fabbricazione delle moto da strada presenti sul mercato – sia per pastiglie anteriori e posteriori.

Ti garantiscono le prestazioni, la durata ed il confort che ti servono per partire.

Scegli tra:  
// PERFORMANCE – HS / LS  
// UPGRADE – SP  
// STANDARD – HF

Segui i nostri consigli sulle pastiglie ideali per la tua moto.

**sbs**<sup>®</sup>  
GO AHEAD



# PERFORMANCE



## HS - SINTER

DELANTE / ANTERIORI



- // Compuesto de recambio original y mejorado para motocicletas con pastillas sinterizadas
- // Diseñado para utilizarse en motocicletas modernas de altas prestaciones, deportivas, gran turismo y adventure
- // Compuesto sinterizado formulado para garantizar poco desgaste, alta estabilidad térmica, excelente sensación de frenado y fácil modulación
- // Líder en el sector y alto rendimiento, desarrollado en competición y adaptado para el uso en la calle
- // Excelente para rotores/discos de freno de acero inoxidable o hierro fundido
- // Compuestos delantero (HS) y trasero (LS) que permiten un reparto de la frenada perfecto para evitar el bloqueo de la rueda trasera



- // Composto per migliorare e sostituire il prodotto OE per moto con pastiglie sinterizzate
- // Studiato per moto moderne ad alte prestazioni, sport, touring e adventure
- // Composto sinterizzato formulato per una usura ridotta, elevata stabilità termica, sensazione di frenata eccellente e modulazione facile
- // Prodotto leader nella categoria e ad elevate prestazioni, sviluppato nelle competizioni e messo a punto per l'uso su strada
- // Eccellente per rotori/dischi freni in acciaio inox o ghisa
- // Composti per freni anteriori (HS) e posteriori (LS) per un bilanciamento ideale e per evitare il bloccaggio della ruota posteriore

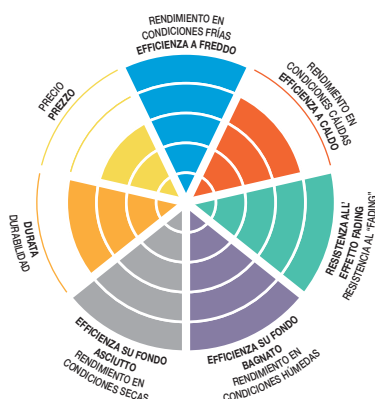

Diagramas de potencia de freno para comparar de forma individual los compuestos de STREET exclusivamente.



## LS - SINTER

POSTERIOR / POSTERIORI



- // Compuesto de recambio original para motocicletas con pastillas sinterizadas
- // Diseñado para utilizarse en motocicletas modernas de altas prestaciones, motocicletas deportivas y gran turismo
- // Compuesto sinterizado que ofrece resultados predecibles y controlables en la rueda trasera
- // Exclusivo compuesto para la rueda trasera formulado según el concepto del fabricante original, que ofrece un perfecto reparto de la frenada entre la parte delantera y la trasera para evitar frenadas bruscas y el bloqueo de la rueda trasera



- // Composto per sostituire il prodotto OE per moto con pastiglie sinterizzate
- // Studiato per moto moderne ad alte prestazioni, sport, touring grandi
- // Composto sinterizzato che offre prestazioni prevedibili e controllabili, per la ruota posteriore
- // Composto esclusivo per ruota posteriore formulato secondo un concetto OEM che offre un bilanciamento ideale dei freni anteriori / posteriori, per evitare frenate eccessive ed il bloccaggio della ruota posteriore

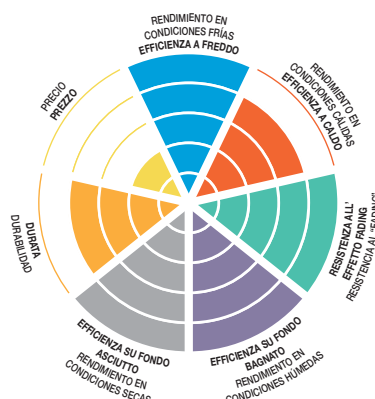

Diagrammi di prestazione dei freni da confrontare singolarmente con le sole mescole STREET.



STREET BRAKE PADS



GO AHEAD

## UPGRADE / STANDARD



### SP - EVO SINTER

DELANTE / ANTERIORI



- // Compuesto de recambio original y mejorado para motocicletas modernas adventure y cruisers, de altas prestaciones, para carretera, deportivas y de turismo
- // Compuesto EVO con sinterizado conductivo de vanguardia, formulado para lograr una mordida inicial enérgica con sensación inmediata de frenado, fácil modulación y altas prestaciones en las paradas
- // Resistente al desgaste con rendimiento constante y fiable en condiciones de conducción extremas y durante toda la vida útil de la pastilla de freno
- // Alta estabilidad térmica junto con larga duración de la pastilla y desgaste del disco de freno muy reducido
- // Tecnología NUCAP NRS que garantiza una adherencia mecánica e indestructible del compuesto
- // Compuestos delantero (SP) y trasero (LS) que permiten un reparto de la frenada perfecto para evitar el bloqueo de la rueda trasera



- // Composto per migliorare e sostituire il prodotto OE per moto moderne adventure e cruiser, ad alte prestazioni, roadster, sport e touring
- // Avanzato composto sinterizzato con riscaldamento diretto a resistenza/EVO formulato per una presa iniziale decisa con una sensazione di frenata istantanea, modulazione facile e arresto efficace
- // Prestazioni affidabili, costanti e senza fade in condizioni di guida estreme e per tutta la durata utile delle pastiglie dei freni
- // Elevata stabilità termica insieme ad una lunga durata delle pastiglie ed a un'usura dei dischi dei freni molto ridotta
- // La tecnologia NRS NUCAP garantisce un fissaggio meccanico ed indestructibile del composto
- // Composti per freni anteriori (SP) e posteriori (LS) per un bilanciamento ideale e per evitare il bloccaggio della ruota posteriore



Diagramas de potencia de freno para comparar de forma individual los compuestos de STREET exclusivamente.



### HF - CERAMIC

DELANTE / ANTERIORI • POSTERIOR / POSTERIORI



- // Compuesto de recambio original para motocicletas con pastillas no sinterizadas
- // Diseñado para motocicletas urbanas, motocicletas de calle polivalentes y cruisers,
- // Compuesto cerámico que garantiza una larga duración de la pastilla, poco polvo y un menor desgaste del rotor/disco de freno
- // Prestaciones excelentes y uniformes tanto en seco como en mojado
- // Tecnología NUCAP NRS que garantiza una adherencia mecánica e indestructible del compuesto
- // Innovadora tecnología de reducción del ruido que mejora el confort y reduce la emisión de ruido



- // Composto per sostituire il prodotto OE per moto con pastiglie non sinterizzate
- // Studiato per moto cruiser, per uso generico su strada e per andare al lavoro
- // Il composto ceramico offre una lunga durata delle pastiglie, bassa polverosità e una ridotta usura del rotore/disco freni
- // Prestazioni eccellenti e costanti in condizioni di asciutto e bagnato
- // La tecnologia NRS NUCAP garantisce un fissaggio meccanico ed indestructibile del composto
- // Tecnologia per la riduzione della rumorosità; per il massimo comfort e la minima generazione di rumore

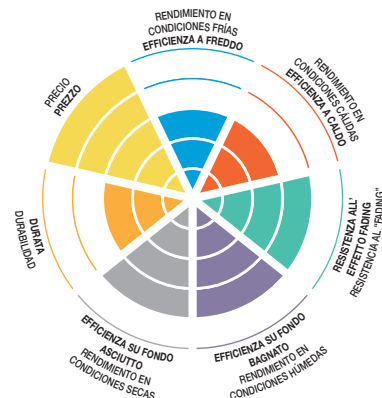

Diagrammi di prestazione dei freni da confrontare singolarmente con le sole mescole STREET.





## LICENSE TO FREEDOM



Si le apasiona el estilo de vida americano y el diseño y las características exclusivas de marcas de motocicletas tan legendarias como Harley Davidson, Buell e Indian, SBS tiene los frenos que necesita.

Nuestra gama de pastillas de freno creada especialmente para las motocicletas americanas incorpora compuestos que combinan alta potencia con poco ruido y larga vida útil. Nuestra gama abarca tanto los modelos clásicos de la década de 1980 como los modelos más modernos de motocicletas americanas.

Puede elegir entre:

- // HIGH PERFORMANCE & NO DUST – H.HS / H.LS
- // HIGH POWER & NOISE REDUCTION FORMULA – H.CT
- // ULTRA QUIET & LOW DUST – H.HF

Para acertar con las pastillas de su motocicleta, siga nuestras recomendaciones.



Se sei appassionato dello stile di vita americano, e del design e delle caratteristiche esclusive di famose marche di moto americane come Harley Davidson, Buell e Indian, allora SBS ha la risposta per le tue esigenze di freni.

La nostra gamma di pastiglie dei freni studiate appositamente per moto americane è caratterizzata da composti che uniscono elevata potenza con bassa rumorosità e lunga durata. La nostra gamma è completa - sia per modelli vintage risalenti agli anni '80 che per moto americane di produzione attuale.

Scegli tra:

- // HIGH PERFORMANCE & NO DUST – H.HS / H.LS
- // HIGH POWER & NOISE REDUCTION FORMULA – H.CT
- // ULTRA QUIET & LOW DUST – H.HF

Segui i nostri consigli sulle pastiglie ideali per la tua moto.





AMERICAN BRAKE PADS



GO AHEAD

## HIGH PERFORMANCE & NO DUST



### H.HS - SINTER

DELANTE / ANTERIORI



- // Compuesto de recambio original y mejorado para motocicletas con pastillas sinterizadas
- // Diseñado para utilizarse en motocicletas modernas de altas prestaciones, motocicletas deportivas y gran turismo
- // Compuesto sinterizado formulado para garantizar poco desgaste, alta estabilidad térmica y excelente sensación de frenado
- // Líder en el sector y alto rendimiento, desarrollado en competición y adaptado para el uso en la calle
- // Excelente para rotores/discos de freno de acero inoxidable o hierro fundido
- // Compuestos delantero (H.HS) y trasero (H.LS) que permiten un reparto de la frenada perfecto para evitar el bloqueo de la rueda trasera



- // Composto per migliorare e sostituire il prodotto OE per moto con pastiglie sinterizzate
- // Studiato per moto moderne ad alte prestazioni, sport, touring grandi
- // Composto sinterizzato formulato per una usura ridotta, elevata stabilità termica e sensazione di frenata eccellente
- // Prodotto leader nella categoria, ad elevate prestazioni, sviluppato nelle competizioni e messo a punto per l'uso su strada
- // Eccellente per rotori/dischi freni in acciaio inox o ghisa
- // Composti per freni anteriori (H.HS) e posteriori (H.LS) per un bilanciamento ideale e per evitare il bloccaggio della ruota posteriore

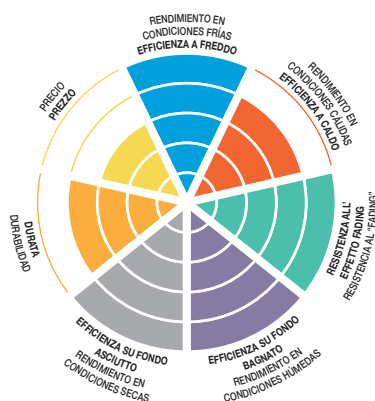

Diagramas de potencia de freno para comparar de forma individual los compuestos de AMERICAN exclusivamente.



### H.LS - SINTER

POSTERIOR/ POSTERIOR



- // Compuesto de recambio original para motocicletas con pastillas sinterizadas
- // Diseñado para utilizarse en motocicletas modernas de altas prestaciones, motocicletas deportivas y gran turismo
- // Compuesto sinterizado que ofrece resultados predecibles y controlables en la rueda trasera
- // Exclusivo compuesto para la rueda trasera formulado según el concepto del fabricante original, que ofrece un perfecto reparto de la frenada entre la parte delantera y la trasera para evitar frenadas bruscas y el bloqueo de la rueda trasera



- // Composto per sostituire il prodotto OE per moto con pastiglie sinterizzate
- // Studiato per moto moderne ad alte prestazioni, sport, touring grandi
- // Composto sinterizzato che offre prestazioni prevedibili e controllabili, per la ruota posteriore
- // Composto esclusivo per ruota posteriore formulato secondo un concetto OEM, per offrire un bilanciamento ideale dei freni anteriori / posteriori, evitare frenate eccessive ed il bloccaggio della ruota posteriore

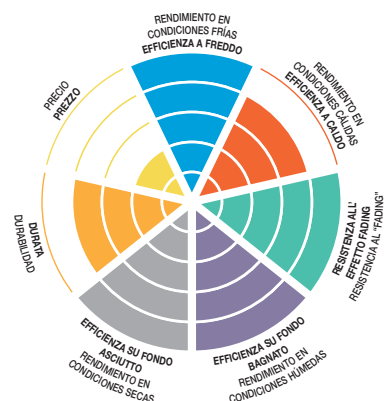

Diagrammi di prestazione dei freni da confrontare singolarmente con le sole mescole AMERICAN.



AMERICAN BRAKE PADS



GO AHEAD

## HIGH POWER & NOISE REDUCTION FORMULA / ULTRA QUIET & LOW DUST



### H.CT - CARBON

DELANTE / ANTERIORI • POSTERIOR / POSTERIORI



- // Compuesto con mejora de rendimiento, excelente para motocicletas con discos y sistemas de frenos personalizados
- // Compatible con discos de freno de acero inoxidable, hierro fundido, cromados y pulidos
- // Prestaciones HH, desarrollado en competición y adaptado para el uso en la calle
- // Sensación y control inigualables en la maneta de freno tanto en seco como en mojado
- // Tecnología NUCAP NRS que garantiza una adherencia mecánica e indestructible del compuesto



- // Composto per il miglioramento delle prestazioni, eccellente per moto con dischi e impianto freni personalizzato
- // Compatible con dischi freni in acciaio inox, ghisa, cromati e bruniti
- // Prodotto classificato HH, sviluppato nelle competizioni e messo a punto per l'uso su strada
- // Controllo e sensazione ineguagliabili nella leva del freno in condizioni di asciutto e bagnato
- // La tecnologia NRS NUCAP garantisce un fissaggio meccanico ed indistruttibile del composto

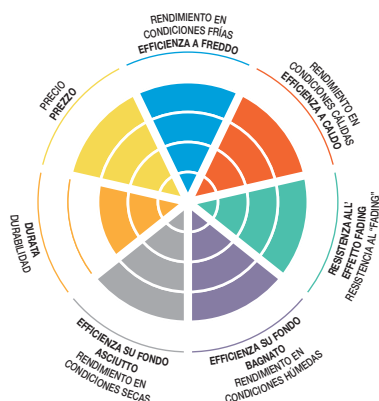

Diagramas de potencia de freno para comparar de forma individual los compuestos de AMERICAN exclusivamente.



### H.HF - CERAMIC

DELANTE / ANTERIORI • POSTERIOR / POSTERIORI



- // Compuesto de recambio original para motocicletas con pastillas no sinterizadas
- // Diseñado para motocicletas urbanas, motocicletas de calle polivalentes y cruisers
- // Compuesto cerámico que garantiza una larga duración de la pastilla, poco polvo y un menor desgaste del rotor/disco de freno
- // Prestaciones excelentes y uniformes tanto en seco como en mojado
- // Tecnología NUCAP NRS que garantiza una adherencia mecánica e indestructible del compuesto
- // Innovadora tecnología de reducción del ruido que mejora el confort y reduce la emisión de ruido



- // Composto per sostituire il prodotto OE per moto con pastiglie non sinterizzate
- // Studiato per moto cruiser, per uso generico su strada e per andare al lavoro
- // Il composto ceramico offre una lunga durata delle pastiglie, bassa polverosità e una ridotta usura del rotore/disco freni
- // Prestazioni eccellenti e costanti in condizioni di asciutto e bagnato
- // La tecnologia NRS NUCAP garantisce un fissaggio meccanico ed indistruttibile del composto
- // Tecnologia per la riduzione della rumorosità; per il massimo comfort e la minima generazione di rumore

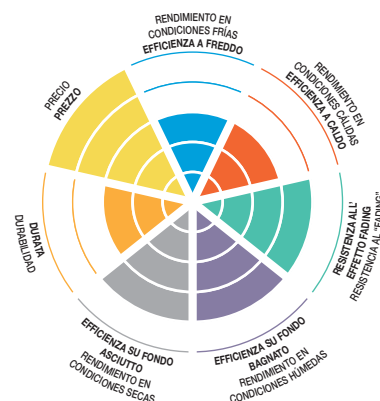

Diagrammi di prestazione dei freni da confrontare singolarmente con le sole mescole AMERICAN.



48



# LICENSE TO FUN



El scooter suele ser el vehículo perfecto para desplazarse por la ciudad. Con tráfico denso, es esencial disponer de unos frenos fiables. Las pastillas de freno para scooter de SBS ofrecen unas prestaciones de frenado y una durabilidad perfectas en ciudad.

Ofrecemos compuestos diferentes que se adecuan a distintos tipos de scooter y necesidades de conducción. Tenemos una oferta comercial amplia que incluye pastillas y compuestos para diferentes modelos, desde scooters pequeños de 50 cc hasta maxi scooters modernos de altas prestaciones.

Puede elegir entre:

- // MAXI SINTER – MS
- // STANDARD & MAXI – CT
- // STANDARD & MAXI – HF

Para acertar con las pastillas de su scooter, siga nuestras recomendaciones.



Spesso uno scooter è l'ideale quando ci si deve spostare in città. Ma in mezzo al traffico, devi poterti fidare dei tuoi freni. Le pastiglie dei freni Scooter SBS offrono le prestazioni di frenata e durata ideali per queste condizioni.

Offriamo vari composti per i diversi tipi di scooter ed esigenze di guida. La nostra gamma è ampia con pastiglie e composti per i modelli piccoli da 50 cc<sup>3</sup> fino agli scooter maxi ad alte prestazioni.

Scegli tra:

- // MAXI SINTER – MS
- // STANDARD & MAXI – CT
- // STANDARD & MAXI – HF

Segui i nostri consigli sulle pastiglie ideali per la tua moto.

**sbs**<sup>®</sup>  
GO AHEAD



SCOOTER BRAKE PADS



GO AHEAD

## MAXI SINTER / STANDARD & MAXI



### MS - SINTER

DELANTE / ANTERIORI • POSTERIOR / POSTERIORI



- // Compuesto sinterizado mejorado de alto rendimiento para maxi scooters (de 250 cc en adelante)
- // Recomendado para maxi scooters con tecnología de motocicleta
- // Compuesto sinterizado de vanguardia formulado para garantizar poco desgaste, alta estabilidad térmica y excelente sensación de frenado



- // Composto sinterizzato migliorato ad alte prestazioni per maxi scooter a partire da 250 cc<sup>3</sup>
- // Consigliato per maxi scooter con tecnologia da moto
- // Composto sinterizzato avanzato formulato per una usura ridotta, elevata stabilità termica e sensazione di frenata eccellente

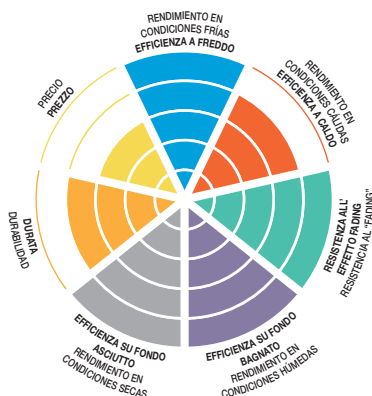

Diagramas de potencia de freno para comparar de forma individual los compuestos de SCOOTER exclusivamente.



### CT - CARBON

DELANTE / ANTERIORI • POSTERIOR / POSTERIORI



- // Compuesto de carbono con mejora de rendimiento para scooters de tamaño mediano (125-249 cc)
- // Recomendado para pilotaje deportivo, transporte diario y entretenimiento
- // Tecnología NUCAP NRS que garantiza una adherencia mecánica e indestructible del compuesto



- // Composto al carbonio per migliorare le prestazioni per scooter medi da 125-249 cc<sup>3</sup>
- // Consigliato per la guida sportiva, il trasporto di tutti i giorni ed il divertimento
- // La tecnologia NRS NUCAP garantisce un fissaggio meccanico ed indistruttibile del composto



Diagrammi di prestazione dei freni da confrontare singolarmente con le sole mescole SCOOTER.



SCOOTER BRAKE PADS



GO AHEAD

## STANDARD & MAXI



### HF - CERAMIC

DELANTE / ANTERIORI • POSTERIOR / POSTERIORI



- // Compuesto cerámico de recambio original para scooters de tamaño pequeño y mediano (50-124 cc)
- // Recomendado para pilotar motocicletas urbanas y motocicletas de calle polivalentes
- // Tecnología NUCAP NRS que garantiza una adherencia mecánica e indestructible del compuesto



- // Composto ceramico per sostituire il prodotto OE per scooter piccoli e medi da 50-124 cc<sup>3</sup>
- // Consigliato per uso generico su strada e per andare al lavoro
- // La tecnologia NRS NUCAP garantisce un fissaggio meccanico ed indistruttibile del composto

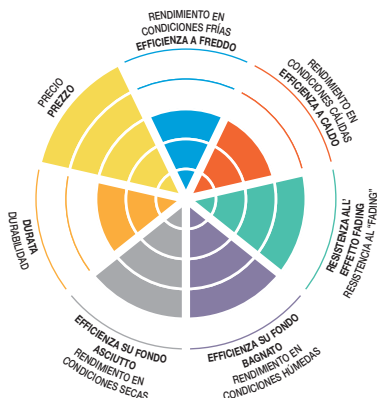

Diagramas de potencia de freno para comparar de forma individual los compuestos de SCOOTER exclusivamente.

Diagrammi di prestazione dei freni da confrontare singolarmente con le sole mescole SCOOTER.

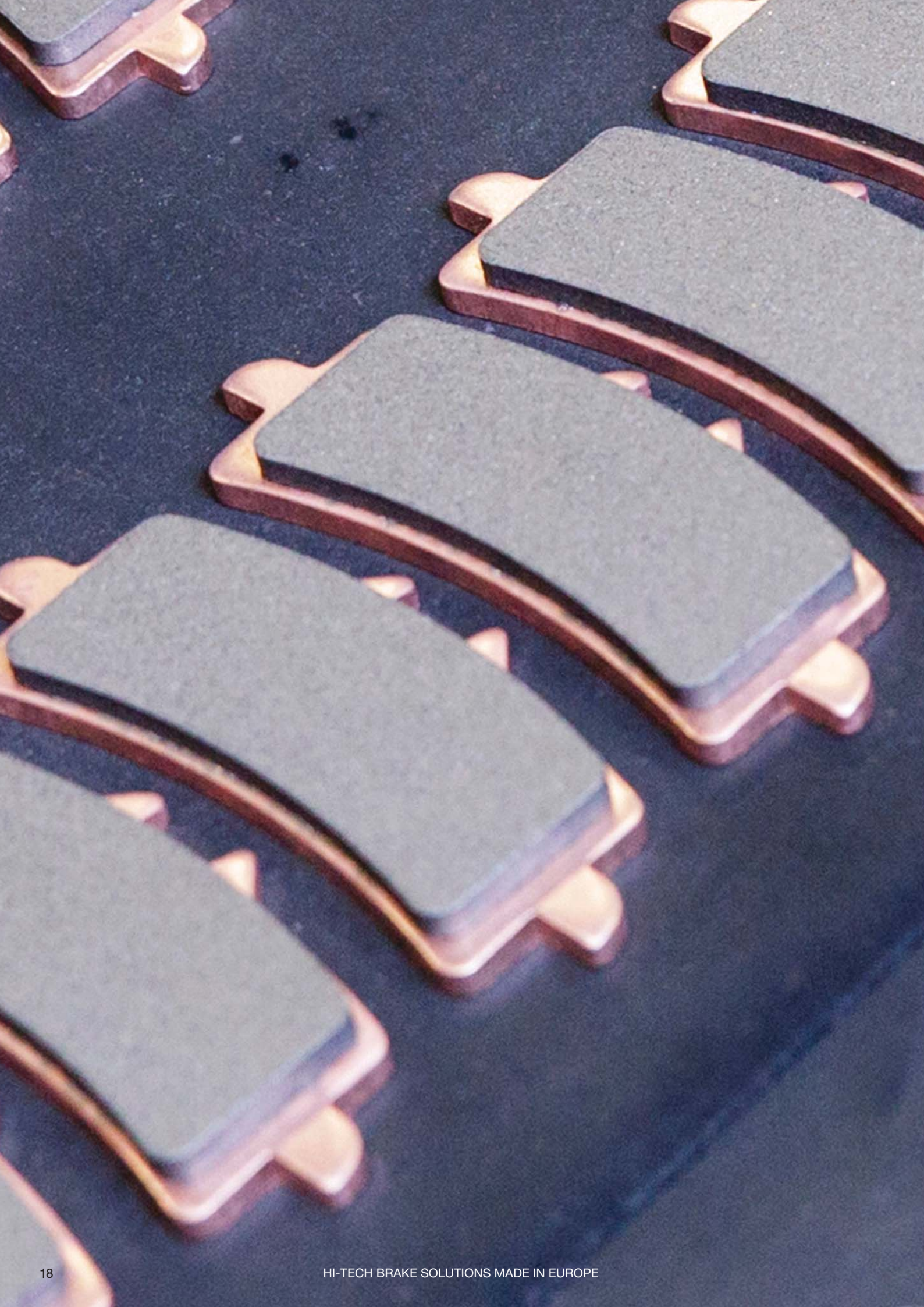

# LICENSE TO WIN



KENAN SOFUOGLU



Las carreras forman parte de nuestro ADN desde hace más de 25 años.

A través de nuestros colaboradores, en las carreras, ofrecemos potencia de frenado a los mejores del mundo de la competición. Se trate de carreras internacionales de primer nivel, como Superbike, Supersport o Resistencia, competiciones nacionales, tandas en circuito o carreras clásicas en carretera, SBS ofrece pastillas de freno con las que se pueden ganar centésimas de segundo importantes durante la frenada. Nuestros compuestos de carreras se han desarrollado especialmente para el uso en competición y en circuitos de carreras. Han sido probados y aprobados por destacados pilotos que participan en el Campeonato del Mundo.

Puede elegir entre:

- // ROAD RACING & ENDURANCE – DS
- // ROAD RACING & CLASSIC RACING – DC / DCC
- // ROAD RACING & TRACK DAYS – RS
- // RACING REAR – RQ / LS

Para acertar con las pastillas de su motocicleta, siga nuestras recomendaciones.



Le competizioni fanno parte del nostro DNA da oltre 25 anni.

Tramite i nostri Partner in questo settore forniamo la potenza di frenata per lo sport a due ruote. Che si tratti di competizioni su strada ad alto livello internazionale come Superbike, Supersport o Endurance, o di competizioni nazionali, di giornate in pista o di corse classiche su strada, SBS ti offre le pastiglie dei freni che ti servono per guadagnare quei centesimi di secondo fondamentali in frenata. I nostri composti per competizioni sono sviluppati specificatamente per l'uso in pista e in gara - testati ed approvati da alcuni dei principali piloti a livello mondiale.

Scegli tra:

- // ROAD RACING & ENDURANCE – DS
- // ROAD RACING & CLASSIC RACING – DC / DCC
- // ROAD RACING & TRACK DAYS – RS
- // RACING REAR – RQ / LS

Segui i nostri consigli sulle pastiglie ideali per la tua moto.

**sbs**<sup>®</sup>  
GO AHEAD



# ROAD RACING & ENDURANCE / ENDURANCE, CLASSIC RACING & ROAD RACING



## DS - DUAL SINTER

DELANTE / ANTERIORI - SÓLO PARA USO EN CIRCUITO



- // La alternativa elegida por numerosos campeones del mundo de Superbike, Supersport, Moto2 y Resistencia
- // Compuesto sinterizado de alta tecnología disponible para sistemas de frenos de carreras y convencionales que se usan en competición
- // Gran mordida inicial, prestaciones en parada graduales y potentes, resultados constantes con sensación y control de frenado excelentes
- // Excelente duración de las pastillas en carreras de resistencia
- // Tecnología NUCAP NRS que garantiza una adherencia mecánica e indestructible del compuesto



- // La scelta di numerosi campioni mondiali di Superbike, Supersport, Moto2 ed Endurance
- // Composto sinterizzato ad elevata tecnologia disponibile per impianti freni standard e da gara usati in competizioni
- // Presa iniziale elevata, prestazioni di arresto lineari, decise e costanti, con una sensazione e controllo di frenata eccellenti
- // Durata ottimale delle pastiglie per competizioni Endurance
- // La tecnologia NRS NUCAP garantisce un fissaggio meccanico ed indistruttibile del composto



Diagramas de potencia de freno para comparar de forma individual los compuestos de RACING exclusivamente.



## DC - DUAL CARBON

DELANTE / ANTERIORI - SÓLO PARA USO EN CIRCUITO



- // La alternativa mejorada para pilotos de Superbike, Supersport y Superstock que corren en campeonatos nacionales así como para las tandas en circuitos
- // Compuesto de carbono de alta tecnología desarrollado para sistemas de frenos de carreras y convencionales que se utilizan en motocicletas de carreras y deportivas
- // Bajo coeficiente de transferencia de calor que protege el sistema de frenos y el líquido de frenos frente a las temperaturas extremas
- // Mordida inicial suave y rendimiento en parada progresivo con modulación y sensibilidad excelentes en la maneta de freno
- // Uso de la tecnología DEST para lograr el preasentamiento del componente con el fin de evitar el desgaste y garantizar un rendimiento constante
- // Tecnología NUCAP NRS que garantiza una adherencia mecánica e indestructible del compuesto



- // La scelta più avanzata per piloti nei campionati nazionali Superbike, Supersport e Superstock e per piloti nei Track Day
- // Composto al carbonio ad elevata tecnologia disponibile per impianti freni standard e da gara usato per moto da competizione e sportive
- // Il tasso ridotto di trasferimento termico protegge l'impianto freni ed il liquido freni dalle temperature estreme
- // Presa iniziale fluida, prestazioni di arresto graduati, con una sensazione e modulazione di frenata eccellenti
- // La tecnologia DEST utilizzata per il pre-asestamento del composto elimina il fade ed assicura prestazioni costanti
- // La tecnologia NRS NUCAP garantisce un fissaggio meccanico ed indistruttibile del composto

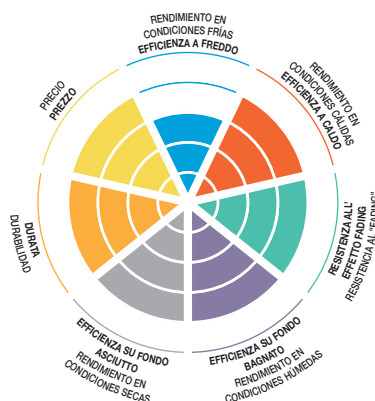

Diagrammi di prestazione dei freni da confrontare singolarmente con le sole mescole RACING.



RACING BRAKE PADS



GO AHEAD

## ENDURANCE, CLASSIC RACING & ROAD RACING / ROAD RACING & TRACKDAYS



### DCC - DUAL CARBON

DELANTE / ANTERIORI - SÓLO PARA USO EN CIRCUITO



- // La elección para carreras clásicas en carretera gracias a los más de 25 años de experiencia en el Campeonato del Mundo e inspirada en nuestro material DC (Dual Carbon), ganador del mundial
- // Mordida inicial suave, ideal para la configuración clásica de horquilla delantera y las llantas. Prestaciones de frenado progresivas con mayor potencia y mejor tacto en la rueda delantera
- // Estabilidad térmica, adecuada para la configuración de 1 y 2 discos. Compatible con discos de freno de hierro fundido y acero inoxidable
- // Escasa conductividad térmica que reduce la carga térmica en las juntas, el líquido de frenos y las pinzas de freno
- // Uso de la tecnología DEST para lograr el preasentamiento del componente con el fin de evitar el desgaste y garantizar un rendimiento constante
- // Tecnología NUCAP NRS que garantiza una adherencia mecánica e indestructible del compuesto



- // La scelta per le competizioni su strada classiche deriva da oltre 25 anni di esperienza nei Campionati mondiali e si ispira al nostro materiale DC Dual Carbon vincente in questi campionati
- // Presa iniziale morbida, ideale per strutture di forcelle anteriori e pneumatici classici. Prestazioni graduali dei freni che offrono potenza superiore e controllo del frontale
- // Stabilità termica, adatta per schema dischi 1 e 2. Compatibile con dischi freni in acciaio inox e ghisa
- // La ridotta conduttività termica riduce il carico termico alle guarnizioni, al liquido freni ed ai componenti delle pinze
- // La tecnologia DEST utilizzata per il pre-assettamento del composto elimina il fade ed assicura prestazioni costanti
- // La tecnologia NRS NUCAP garantisce un fissaggio meccanico ed indistruttibile del composto



El carácter singular del compuesto DCC no permite compararlo con otros productos, ya que se trata de un compuesto formulado especialmente para coches clásicos de carreras.



Vista la natura unica del composto DCC, formulato specificamente per le corse di veicoli d'epoca, non è possibile paragonarlo ad altri prodotti.

Diagramas de potencia de freno para comparar de forma individual los compuestos de RACING exclusivamente.



### RS - SINTER

DELANTE / ANTERIORI



- // La elección perfecta y económica para las tandas en circuito y para motocicletas mixtas para circuito y carretera
- // Compuesto sinterizado disponible para los modernos sistemas de frenos convencionales de las motocicletas de competición y deportivas
- // Excelente para rotores/discos de freno de acero inoxidable o hierro fundido
- // Mordida inicial enérgica y rendimiento en parada gradual con buena sensación y control de frenado



- // La scelta ideale e conveniente per le giornate in pista e per le moto combinate da strada e pista
- // Composto sinterizzato disponibile per impianti freni standard moderni per moto sportive
- // Eccellente per rotori/dischi freni in acciaio inox o ghisa
- // Presa iniziale decisa, prestazioni di arresto lineari, con una buona sensazione e controllo di frenata

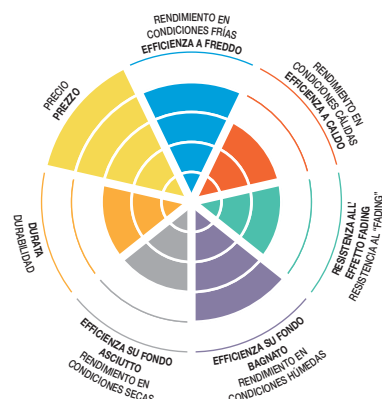

Diagrammi di prestazione dei freni da confrontare singolarmente con le sole mescole RACING.



## ENDURANCE, CLASSIC RACING & ROAD RACING



### RQ - CARBON TECH

POSTERIOR / POSTERIORI



- // Compuesto de carbono para el freno trasero con altas prestaciones de frenado
- // Sensación y control excelentes para gestionar la frenada en curvas



- // Composto al carbonio per freni posteriori con elevate prestazioni di frenata
- // Sensazione e controllo di frenata eccellenti nell'uso del freno posteriore in ingresso ed in uscita dalle curve



### LS - SINTER

POSTERIOR / POSTERIORI



- // Compuesto sinterizado para el freno trasero con prestaciones de frenado de nivel medio y larga duración de la pastilla
- // Recomendado para pilotos que utilizan el freno trasero de manera esporádica o ligeramente al entrar en curvas



- // Composto sinterizzato per freni posteriori con prestazioni di frenata media e lunga durata delle pastiglie
- // Consigliato per motociclisti che usano il freno posteriore occasionalmente e solo leggermente in ingresso alle curve



# LICENSE TO ACTION



Disfrutar de la libertad en el desierto. Conquistar colinas y montañas. Recorrer pistas de tierra a gran velocidad para llegar a lo más alto en las competiciones.

Si su pasión es el off-road, SBS ofrece el compuesto de freno ideal para entornos agresivos con gran cantidad de arena, polvo, barro y agua. En motocicleta, ATV o UTV.

Puede elegir pastillas de carreras para competir a todos los niveles o bien pastillas alternativas para salidas de ocio. Nuestra gama cubre todas las marcas y modelos todoterreno, así como las aplicaciones delantera y trasera.

Puede elegir entre:

// RACING – RSI

// CLUB, TRAILS & LEISURE – SI / CS / ATS

Para acertar con las pastillas de su motocicleta, siga nuestras recomendaciones.



Godersi la libertà del deserto. Conquistare rocce e montagne. Correre su strade sterrate per arrivare sul podio.

Se la guida off road è la tua passione, SBS ti offre il composto ideale per i freni per ambienti aggressivi con sabbia, polvere, fango e acqua. Su moto, ATV o UTV.

Scegli tra le nostre pastiglie per competizioni a tutti i livelli o le alternative quando fai fuoristrada semplicemente per divertirti. La nostra gamma spazia tra tutte le marche ed i modelli off road, ovviamente per applicazioni sia anteriori sia posteriori.

Scegli tra:

// RACING – RSI

// CLUB, TRAILS & LEISURE – SI / CS / ATS

Segui i nostri consigli sulle pastiglie ideali per la tua moto.

**sbs**<sup>®</sup>  
GO AHEAD



OFF ROAD & ATV BRAKE PADS

**sbs**

GO AHEAD

## RACING / CLUB, TRAILS & LEISURE

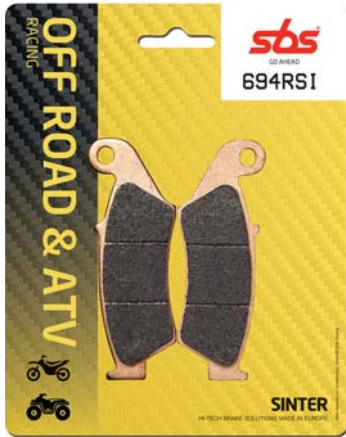

### RSI - SINTER

DELANTE / ANTERIORI • POSTERIOR / POSTERIORI



- // Alternativa con mejora de prestaciones elegida por equipos y pilotos del Campeonato del Mundo de MX GP y MX2
- // Compuesto sinterizado formulado para ofrecer alta estabilidad térmica, potencia y resultados predecibles sin desgaste
- // Compatible con discos de frenos estándar originales y discos para frenos de carreras con diseño especial



- // La scelta dei piloti e dei team MX GP ed MX2 nel Campionato Mondiale MX GP
- // Composto sinterizzato formulato per un'elevata stabilità termica, prestazioni potenti e prevedibili senza fade
- // Compatibile con dischi freni standard OE e con dischi da competizione speciali



Diagramas de potencia de freno para comparar de forma individual los compuestos de OFF ROAD exclusivamente.

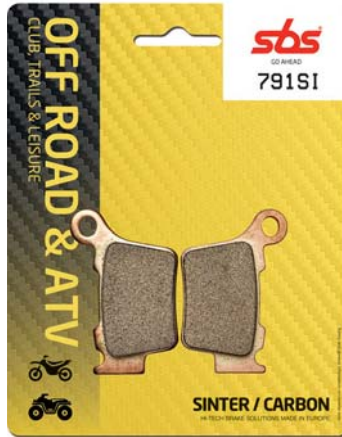

### SI - SINTER

DELANTE / ANTERIORI • POSTERIOR / POSTERIORI



- // La alternativa moderna para lugares con mucho barro, humedad o arena
- // Compuesto sinterizado formulado para ofrecer largos periodos de vida útil, alto rendimiento y fácil modulación
- // Rendimiento estable de primer nivel desarrollado en carrera en condiciones rigurosas



- // La scelta ottimale su fango, bagnato o sabbia
- // Composto sinterizzato formulato per manutenzione ridotta, prestazioni elevate e facile modulazione
- // Prestazioni fluide leader nella categoria, sviluppate nelle competizioni in condizioni difficili



Diagrammi di prestazione dei freni da confrontare singolarmente con le sole mescole OFF ROAD.



OFF ROAD & ATV BRAKE PADS

sbs

GO AHEAD

## CLUB, TRAILS & LEISURE

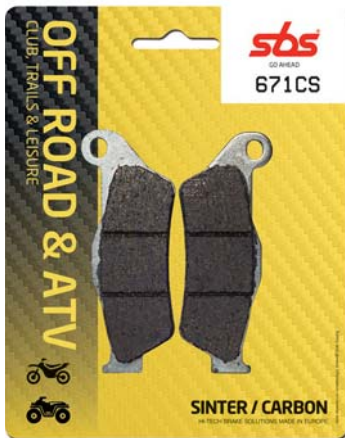

### CS - CARBON

DELANTE / ANTERIORI • POSTERIOR / POSTERIORI



- // Alternativa de recambio económica para competición y aficionados al motocross
- // Compuesto de carbono con funcionamiento suave, silencioso y sin agarrotamiento
- // Tecnología NUCAP NRS que garantiza una adherencia mecánica e indestructible del compuesto



- // Ricambi convenienti per motocross amatoriale e agonistico
- // Composto al carbonio che offre prestazioni fluide, silenziose e senza scatti
- // La tecnologia NRS NUCAP garantisce un fissaggio meccanico ed indistruttibile del composto

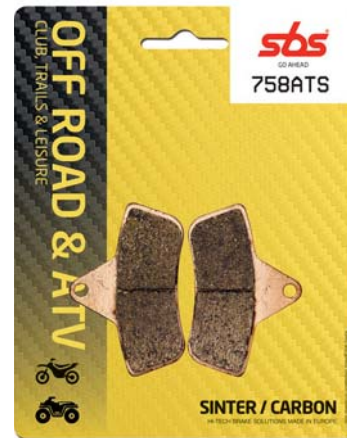

### ATS - SINTER

DELANTE / ANTERIORI • POSTERIOR / POSTERIORI



- // Compuesto de recambio original para combinar con discos de freno de acero normales
- // Compuesto sinterizado compatible con modelos originales de discos de freno de acero normales, como los que se emplean en los modelos ATV Arctic Cat y Polaris ATV



- // Composto per sostituire il prodotto OE in abbinamento con dischi freni in acciaio semplice
- // Composto sinterizzato compatibile con dischi freni in acciaio semplice standard OE come quelli utilizzati nei modelli ATV Arctic Cat e Polaris meno recenti



Diagramas de potencia de freno para comparar de forma individual los compuestos de OFF ROAD exclusivamente.



ATS supone una mejora de rendimiento para el uso con los discos de freno de acero normal de determinados modelos Polaris y Arctic Cat, por lo que su fórmula no puede compararse con la de otros compuestos.



ATS migliora le caratteristiche prestazionali dei dischi freno in acciaio pieno di determinati modelli Polaris e Arctic Cat, quindi la sua speciale formula non può essere paragonata a nessun altro composto.

Diagrammi di prestazione dei freni da confrontare singolarmente con le sole mescole OFF ROAD.



## ZAPATAS DE FRENO CON MUELLES

## MOLLE RICHIAMO GANASCE FRENI



Guarnición de freno sin amianto que ofrece un resultado y una durabilidad superiores en cualquier clima. Aleación de aluminio de alta calidad con resistencia superior. Superficie con tratamiento anticorrosión. Muelles realizados con alambre de acero de alta calidad conforme con las especificaciones DIN 17223 para una flexibilidad máxima.



Rivestimento freno privo di amianto per prestazioni eccellenti e durata in tutte le condizioni climatiche. Lega di qualità superiore per maggiore resistenza. Superficie trattata contro la corrosione. Molle di richiamo ganasce freno con filo di acciaio di alta qualità, secondo le specifiche DIN 17223 per ottenere la massima flessibilità.



**BRAKE PINS**

**sbs**  
GO AHEAD

## TORNILLOS DE FRENO INOXIDABLES

## PERNI IN ACCIAIO INOSSIDABILE

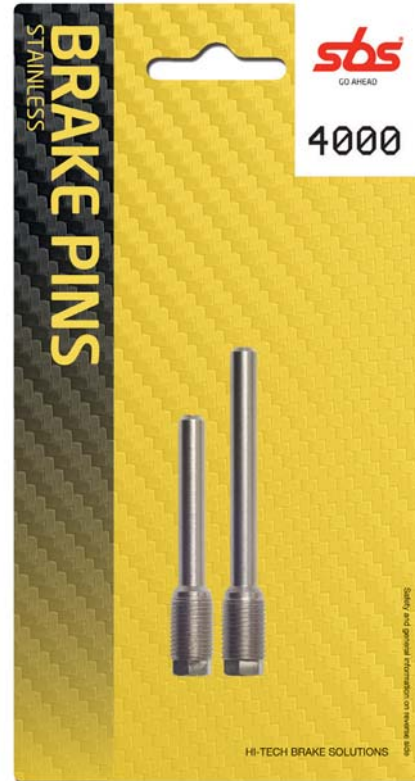

La serie de tornillos de freno inoxidable de SBS cubre las gamas de motocicletas MX y Enduro más comunes que aparecieron en la década de 1990 y que siguen existiendo en la actualidad.

La gama incluye 5 juegos completos de tornillos delanteros y traseros, pero también hay disponibles paquetes individuales (solo con tornillos delanteros o solo con traseros) específicos para cada modelo. Los tornillos de las zapatas de los frenos presentan grietas de desgaste después de un tiempo, por lo que se recomienda sustituirlos de forma periódica para evitar problemas de fricción estática y escaso rendimiento.

- // Realizados en acero inoxidable 304 de alta calidad
- // Cabeza hexagonal de 8 mm para un cambio rápido y fácil de la zapata del freno (excl. ref 4003)
- // Anticorrosión
- // Acoplamiento suave entre tornillos y zapatas de freno



La gamma di perni delle pinze dei freni in acciaio inossidabile SBS comprende prodotti per le moto MX ed Enduro più diffuse dall'inizio del 1990 ad oggi.

La gamma comprende 5 set completi, per anteriore e posteriore, ma sono disponibili anche confezioni singole con solo l'anteriore o il posteriore del relativo modello. Dopo un certo periodo di tempo, sui perni delle pastiglie dei freni si creano dei solchi dovuti all'usura, si consiglia pertanto di sostituirli con regolarità per prevenirne il distacco o le scarse prestazioni.

- // In acciaio inossidabile 304 di alta qualità
- // Testa esagonale da 8 mm per sostituzione delle pastiglie freni semplice e veloce (escluso il part. rif. 4003)
- // Inossidabile
- // Elevata scorrevolezza tra perno e pastiglie freni



BRAKE SYSTEM BLEEDER & ANTI-NOISE SHIMS

**sbs**<sup>®</sup>

GO AHEAD

## ACCESORIOS

## ACCESSORI



### PURGADOR DE FRENOS

Purgador del sistema de frenos de la motocicleta que permite cambiar el líquido de freno de forma rápida, limpia y segura. Se requiere una presión del aire mínima de 6 bar. El purgador de frenos está realizado con los materiales mejores y más resistentes al líquido de freno: el líquido, que es muy corrosivo, se mantiene en un circuito cerrado. Una válvula de seguridad especial y "antivuelco" impide la pulverización del líquido cuando el recipiente está lleno.

- // Válvula "antivuelco" incorporada
- // Llave giratoria
- // Conducto adicional de doble boquilla incluido
- // Manual en 12 idiomas

N.º de pieza 3908  
Unidades de caucho EPDM  
N.º art. 3916.10 (10 uds.)



### SFIATO FRENO

Sfiato dell'impianto frenante delle moto che permette una sostituzione rapida, sicura e pulita del liquido freni. È necessario avere a disposizione una pressione minima di 6 bar. Lo sfiato è formato dai migliori materiali, più resistenti al liquido freni, permettendo così di gestire il liquido freni altamente corrosivo all'interno di un circuito chiuso. Una speciale valvola di sicurezza di non ritorno evita che il flusso si atomizzi quando il contenitore è pieno.

- // Valvola di non ritorno incorporata
- // Raccordo per tubazione girevole
- // Tubazione aggiuntiva con 2 ingrassatori compresa
- // Manuale in 12 lingue

Numero di part. 3908  
Unità in gomma EPDM  
Numero art. 3916.10 (10 pezzi)

28



### CUÑAS DE PASTILLAS DE FRENO

- // Resistente a vibraciones/ruídos
- // Resistente a la transferencia del calor
- // Ideal para proteger el pistón
- // Mejor sensación de frenado
- // No utilizar en carreras

N.º de pieza 9500 (uds.)



### SPESSORI PER PASTIGLIE FRENI

- // Resistenti al rumore/alle vibrazioni
- // Resistenti al passaggio di temperatura
- // Protezione per i pistoni
- // Miglior sensazione di frenata
- // Da non utilizzare per le corse

Numero part. 9500 (pezzi)



MERCHANDISE

**sbs**<sup>®</sup>

GO AHEAD

**ARTÍCULOS PROMOCIONALES**

**MERCHANDISING**



**T-SHIRT VINTAGE**

| Art. no. | Size |
|----------|------|
| 982711   | M    |
| 982712   | L    |
| 982713   | XL   |
| 982714   | XXL  |



**JACKET - DOWN&FEATHER**

| Art. no. | Size |
|----------|------|
| 984111   | M    |
| 984112   | L    |
| 984113   | XL   |



**T-SHIRT**

| Art. no. | Size  |
|----------|-------|
| 991411   | M     |
| 991412   | L     |
| 991413   | XL    |
| 991414   | XXL   |
| 991415   | XXXL  |
| 991416   | XXXXL |



**POLO-SHIRT**

| Art. no. | Size |
|----------|------|
| 996911   | M    |
| 996912   | L    |
| 996913   | XL   |



**BEANIE - 10 pcs**

| Art. no. | Size |
|----------|------|
| 991811   | M    |
| 991812   | L    |



**SOCKS**

| Art. no. | Size  |
|----------|-------|
| 980101   | 39-42 |
| 980102   | 43-45 |



**GO AHEAD CAP**

| Art. no. |
|----------|
| 9808     |



**CAP**

| Art. no. |
|----------|
| 9995     |



**GLOVES**

| Art. no. | Size |
|----------|------|
| 981211   | M    |
| 981212   | L    |
| 981213   | XL   |

**ARTÍCULOS PROMOCIONALES**

**MERCHANDISING**



**NON-WOWEN GO AHEAD BAG – 100 pcs**

Art. no.  
9803



**NON WOVEN BAG  
– 100 pcs**

Art. no.  
9959



**SBS PAPER GIFT BAG**

Art. no.  
9802

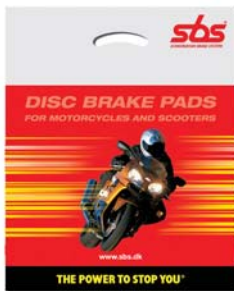

**PLASTIC BAG – 500 pcs  
45 x 35 cm**

Art. no.  
9930



**FLUID CAP – 10 pcs**

Art. no.  
9800



**COFFEE MUG**

Art. no.  
9974



**MUESLIBARS**

Art. no.  
9805



**BRAKE PAD MINTS  
– 20 pcs**

Art. no.  
9806



**SWEETS – 5 kg.**

Art. no.  
9842



**EARPLUGS**

Art. no.  
9815



**UMBRELLA – ø100 cm**

Art. no.  
983510



**ARTÍCULOS PROMOCIONALES**

**MERCHANDISING**



**PERSONAL NOTEBOOK**

Art. no.  
9816



**PENS – 50 pcs**

Art. no.  
9804



**POWERBANK – KEYHOLDER**

Art. no.  
9807



**PC MINI-MUS**

Art. no.  
9922



**KEYHANGER**

Art. no.  
9942



**SUNGLASSES**

|          |        |
|----------|--------|
| Art. no. | Colour |
| 9828     | RED    |
| 9831     | BLUE   |



**BANNER 8 X 0.8 M – 4 LOGOS**

Art. no.  
9825



**BUNTING 10 M**

Art. no.  
9826



**FLAG**

Art. no.  
9875



SALES & POS MATERIAL

## MATERIAL DE VENTAS Y PARA PDV

### DISPLAYS



SBS ofrece expositores prácticos y resistentes para exhibir el material de promoción de los productos SBS en el punto de venta. Puede elegir entre:



SBS offre espositori di vendita pratici e robusti per la promozione dei prodotti SBS sul punto di vendita. Scegli tra:



#### DISPLAY FOR WALL OR DESK MOUNTING

Art. no. 9899

Wall mountings and instruction 6 screws with raw plugs 12 hooks, 20 ref. cards. Width 57.2 cm, high 86.5 cm.



#### DISPLAY FOR WALL MOUNTING

Art. no. 9832

Complete with: Wall mountings and instruction 6 screws with raw plugs 36 hooks, 40 ref. cards. Width 40 cm, depth 30 cm, high 229 cm.



10 HOOKS FOR  
DISPLAY RACK  
Art. no. 9833



10 REF. CARDS FOR  
DISPLAY RACK  
Art. no. 9834

## MATERIALE COMMERCIALE & DEL PUNTO DI VENDITA

### PRINT MATERIALS

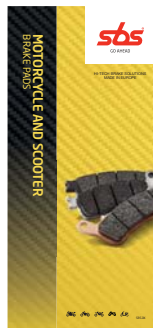

Booklet:  
**MOTORCYCLE AND SCOOTER BRAKE PADS**  
English: Art. no. 99110101

Other languages on request.



Flyer:  
**STREET UPGRADE**  
English: Art. no. 997001

Other languages on request.



Flyer:  
**CLASSIC ROAD RACING**  
English: Art. no. 996801

Other languages on request.



Flyer:  
**BRAKE PINS  
STAINLESS**  
English: Art. no. 997101

Other languages on request.

# MOTORCYCLE SCOOTER OFF-ROAD ATV



**RECOMMENDED**1xx = Scooter Pads  
5xx = Street, Off Road & Racing Pads  
2xxx = Brake Shoes

| ADLY |                            |         |         |        |
|------|----------------------------|---------|---------|--------|
|      | 25 Silver Fox              | 00 - 05 | 111 HF  | 2028   |
|      | 50 Cat                     | 01 - 08 | 111 HF  |        |
|      | 50 Cosy                    | 01 - 08 | 111 HF  |        |
|      | 50 Fox                     | 00 - 09 | 111 HF  | 2028   |
|      | 50 Fox Plus                | 01 - 09 | 111 HF  |        |
|      | 50 Jet                     | 96 - 99 | 111 HF  | 2028   |
|      | 50 Panther                 | 01 - 09 | 102 HF  |        |
|      | 50 Pista, Pista Twin Light | 96 - 99 | 111 HF  | 2028   |
|      | 50 Silver Fox              | 00 - 05 | 111 HF  | 2028   |
|      | 50 Silver Fox              | 06 - 09 | 102 HF  | 2028   |
|      | 50 Super Sonic             | 00 - 05 | 102 HF* |        |
|      | 50 Thunderbike             | 97 - 09 | 102 HF  |        |
| RS   | 50 Super Sonic             | 06 - 08 | 102 HF  | 102 HF |
| RT   | 50 Road Tracer             | 02 - 06 | 111 HF  |        |
|      | 70 Fox Plus                | 01 - 05 | 111 HF  |        |
|      | 70 Pista, Pista Twin Light | 01 - 05 | 111 HF  |        |
|      | 80 Cosy                    | 01 - 06 | 111 HF  |        |
| RT   | 90 Road Tracer             | 02 - 06 | 111 HF  |        |
|      | 100 Cat                    | 01 - 08 | 111 HF  |        |
|      | 100 Jet                    | 96 - 99 | 111 HF  | 2028   |
|      | 100 Panther                | 01 - 06 | 102 HF  |        |
|      | 100 Silver Fox             | 01 - 05 | 111 HF  |        |
|      | 100 Silver Fox             | 06      | 102 HF  | 2028   |
|      | 100 Super Sonic            | 01 - 05 | 102 HF* |        |
|      | 100 Thunderbike            | 01 - 04 | 102 HF* | 102 HF |
| RT   | 100 Road Tracer            | 02 - 06 | 111 HF  |        |
|      | 125 Cat                    | 01 - 04 | 111 CT  |        |
|      | 125 Super Sonic            | 01 - 05 | 102 CT* |        |
|      | 125 Thunderbike            | 01 - 04 | 102 CT* | 102 CT |
|      | 150 ATV                    | 05 - 07 | 544 SI* | 544 SI |
|      | 150 Interceptor            | 05 - 07 | 544 SI* | 544 SI |
|      | 300 ATV                    | 05 - 11 | 544 SI* | 544 SI |
|      | 300 Cross X Over           | 07 - 11 | 810 SI* |        |
|      | 300 Cross X Road           | 07 - 11 | 810 SI* |        |
| ATV  | 300 Sport                  | 07 - 13 | 810 SI* | 848 SI |
|      | 320 S                      | 07 - 13 | 810 SI* |        |
|      | 320 U                      | 07 - 13 | 810 SI* |        |
| AEON |                            |         |         |        |
|      | 50 Aero                    | 06      | 101 HF  |        |
|      | 50 Regal                   | 06      | 101 HF  |        |
|      | 50 Torch                   | 06 - 09 | 101 HF  |        |
|      | 90 Regal                   | 06      | 101 HF  |        |
|      | 100 Pulsar                 | 06      | 101 HF  |        |
|      | 100 Revo 2                 | 04 - 06 | 2043    | 544 SI |
|      | 110 Aero                   | 06      | 101 HF  |        |
|      | 110 Pulsar                 | 06      | 101 HF  |        |
|      | 125 Co-In                  | 14      | 101 CT  |        |
|      | 125 Elite                  | 13 - 14 | 163 CT  | 101 CT |
|      | 125 Overland               | 02 - 11 |         | 638 SI |
|      | 125 Oz                     | 14      | 119 CT  |        |
|      | 125 Pulsar                 | 06      | 544 HF  |        |
|      | 125 Urban                  | 11 - 13 | 163 CT  | 101 CT |
|      | 125 Urban                  | 14      | 119 CT  |        |
|      | 150 Pulsar                 | 06      | 101 CT  |        |
|      | 180 Overland               | 02 - 11 |         | 638 SI |
|      | 180 Roadster               | 02 - 09 |         | 638 SI |
|      | 250 Elite                  | 11 - 14 | 163 CT  | 101 CT |
|      | 350 Urban                  | 11 - 13 | 163 CT  | 101 CT |
|      | 400 Elite                  | 13 - 18 | 163 CT  | 101 CT |
| AJP  |                            |         |         |        |
| PR3  | 125 Enduro                 | 08 - 12 | 774 HF  | 802 HF |
| PR3  | 125 Enduro                 | 13 - 15 | 859 HF  |        |
| PR3  | 125 Enduro Pro             | 13 - 15 | 859 HF  |        |
| PR3  | 125 Extreme                | 13 - 15 | 859 HF  |        |
| PR3  | 125 Supermotard            | 08 - 12 | 774 HF  | 802 HF |
| PR3  | 125 Supermoto              | 13 - 15 | 859 HF  |        |
| PR4  | 125 Enduro                 | 04 - 12 | 817 HF  | 802 HF |
| PR4  | 125 Enduro                 | 13 - 15 | 859 HF  |        |
| PR4  | 125 Enduro Pro             | 13 - 15 | 859 HF  |        |
| PR4  | 125 Supermotard            | 04 - 09 | 817 HF  | 802 HF |

**RECOMMENDED**1xx = Scooter Pads  
5xx = Street, Off Road & Racing Pads  
2xxx = Brake Shoes

| AJP     |                          |         |         |         |
|---------|--------------------------|---------|---------|---------|
| PR4     | 125 Supermoto            | 13 - 15 | 859 HF  |         |
| PR4     | 125 Trail                | 13 - 15 | 859 HF  |         |
| MX      | 200                      | 09 - 11 | 774 HF  | 559 HF  |
| PR3     | 200 Enduro               | 08 - 12 | 774 HF  | 802 HF  |
| PR3     | 200 Supermotard          | 08 - 12 | 774 HF  | 802 HF  |
| PR4     | 200 Enduro               | 04      | 817 HF  | 802 HF  |
| PR4     | 200 Supermotard          | 04      | 817 HF  | 802 HF  |
| PR3     | 240 MX                   | 13 - 15 | 859 SI  |         |
| PR5     | 250 Enduro               | 09      | 694 SI  | 604 SI  |
| PR5     | 250 Enduro               | 10 - 15 | 859 HF  |         |
| PR5     | 250 Extreme              | 12 - 15 | 859 HF  |         |
| PR5     | 250 Supermotard          | 09      | 694 SI  | 604 SI  |
| PR5     | 250 Supermoto            | 10 - 15 | 859 HF  |         |
| PR7     | 650 Adventure            | 17      | 859 HF  | 604 HF  |
| ALFER   |                          |         |         |         |
| MC      | 80                       | 87      | 519 HF  | 559 HF  |
| MC      | 125                      | 87      | 519 HF  |         |
| MC      | 125                      | 88      | 601 HF  | 519 HF  |
| VRE     | 125 4-stroke             | 00      | 671 SI  | 675 SI  |
| GR      | 250 Enduro               | 85      | 519 HF  |         |
| GR      | 250 Enduro               | 88      | 601 HF  | 519 HF  |
| MC      | 250                      | 85      | 519 HF  |         |
| MC      | 250                      | 87      | 519 HF  | 519 HF  |
| MC      | 250                      | 88      | 601 HF  | 519 HF  |
| VR      | 250 Cross                | 99      | 671 RSI | 675 RSI |
| VR      | 250 Enduro               | 99      | 671 SI  | 675 SI  |
| VR      | 250 No Limit             | 99      | 671 RSI | 675 RSI |
| VR      | 250 Supermotard          | 99      | 671 RSI | 675 RSI |
| GR      | 300                      | 85      | 519 HF  |         |
| GR      | 300 Enduro               | 88      | 601 HF  | 519 HF  |
| APRILIA |                          |         |         |         |
|         | 50 Amico, Scooter        | 92      | 123 HF  | 2050    |
|         | 50 Amico, GL, GLE        | 93 - 98 | 123 HF  | 2012    |
|         | 50 Area 51               | 99 - 02 | 143 HF  | 143 HF  |
|         | 50 Classic               | 96 - 99 | 123 HF  |         |
|         | 50 Compay                | 09 - 13 | 143 HF  | 2201    |
|         | 50 Gulliver              | 96 - 00 | 123 HF  | 2012    |
|         | 50 Habana/Custom         | 99 - 02 | 143 HF  | 2201    |
|         | 50 McGulliver            | 00      | 123 HF  |         |
|         | 50 Mojito Retro          | 99 - 03 | 143 HF  | 2201    |
|         | 50 Mojito, Mojito Custom | 99 - 03 | 143 HF  | 2201    |
|         | 50 Mojito, Mojito Custom | 04 - 12 | 143 HF  |         |
|         | 50 Rally                 | 95 - 01 | 123 HF  | 2012    |
|         | 50 Scarabeo Ditech       | 02 - 06 | 123 HF  | 152 HF  |
|         | 50 Scarabeo, 2nd series  | 94 - 99 | 123 HF  | 2012    |
|         | 50 Sonic, GP             | 99 - 09 | 123 HF  | 2012    |
|         | 50 Sport City One        | 08 - 12 | 177 HF  |         |
|         | 50 Amico                 | 90 - 91 | 2012    | 2012    |
|         | 50 Business              | 97 - 98 | 123 HF  |         |
|         | 50 Club                  | 97 - 99 | 123 HF  |         |
|         | 50 Mini RX               | 04      | 803 RSI |         |
|         | 50 Red Rose              | 88 - 89 | 132 HF  |         |
|         | 50 Red Rose              | 90 - 94 | 109 HF  |         |
|         | 50 Red Rose Classic      | 92 - 94 | 607 HF  |         |
|         | 50 Scarabeo 4T           | 04 - 09 | 153 HF  |         |
|         | 50 Scarabeo Street       | 00 - 06 | 123 HF  | 2012    |
|         | 50 Tuareg                | 85      | 519 HF  |         |
|         | 50 Tuareg                | 86 - 96 | 607 HF  | 574 HF  |
|         | 50 Tuareg Rally          | 90 - 96 | 607 HF  | 574 HF  |
|         | 50 Tuono                 | 04 - 07 | 168 HF  | 138 HF  |
|         | 50 Younger               | 97      | 123 HF  |         |
| AC      | 50 Rally                 | 95 - 02 | 123 HF  | 2012    |
| AF1     | 50 AE                    | 86 - 96 | 109 HF  | 106 HF  |
| AF1     | 50 Europa, Futura        | 90 - 92 | 109 HF  | 106 HF  |
| ET      | 50                       | 85 - 90 | 138 HF  |         |
| LC      | 50 Rally                 | 96 - 01 | 123 HF  | 123 HF  |
| LX      | 50 Amico, Sport          | 92 - 97 | 114 HF  | 2012    |
| MX      | 50                       | 03 - 10 | 120 HF  | 106 HF  |
| RS      | 50 , Replica             | 00 - 05 | 120 HF  | 106 HF  |
| RS      | 50                       | 93 - 95 | 138 HF  | 138 HF  |

\* = 2 sets required / 2 jeux pour l'Avant.



**RECOMMENDED**

1xx = Scooter Pads  
5xx = Street, Off Road & Racing Pads  
2xxx = Brake Shoes



| APRILIA |                             |         |        |        |  |
|---------|-----------------------------|---------|--------|--------|--|
| RS      | 50                          | 96 - 99 | 138 HF | 106 HF |  |
| RS      | 50                          | 06 - 11 | 157 HF | 105 HF |  |
| RS-4    | 50                          | 12 - 18 | 189 MS | 101 HF |  |
| RS-4    | 50 Replica                  | 16 - 17 | 189 MS | 101 HF |  |
| RX      | 50 Racing                   | 04 - 06 | 120 HF | 106 HF |  |
| RX      | 50                          | 90 - 14 | 120 HF | 106 HF |  |
| RX      | 50                          | 06 - 14 | 186 HF | 105 HF |  |
| SR      | 50 Ditech                   | 01 - 06 | 123 HF | 152 HF |  |
| SR      | 50 Racing                   | 00 - 04 | 123 HF | 152 HF |  |
| SR      | 50 Replica (Liquid Cooled)  | 96      | 123 HF | 2012   |  |
| SR      | 50 Stealth, Racing          | 97 - 00 | 123 HF | 123 HF |  |
| SR      | 50 Street                   | 05 - 12 | 123 HF | 152 HF |  |
| SR      | 50 WWW, Netscaper           | 97 - 99 | 149 HF | 2012   |  |
| SR      | 50 Europa                   | 93 - 94 | 114 HF | 2012   |  |
| SR      | 50 Replica                  | 94 - 96 | 117 HF | 2012   |  |
| SR      | 50 Urban Kid                | 93 - 07 | 114 HF | 2012   |  |
| SR      | 50 Viper                    | 93 - 94 | 114 HF | 2012   |  |
| SX      | 50                          | 06 - 13 | 186 HF |        |  |
| SX      | 50 Ltd.                     | 07 - 15 | 197 CT | 101 CT |  |
|         | 100 Scarabeo                | 00 - 06 | 153 HF |        |  |
|         | 100 Scarabeo 4T             | 03 - 11 | 153 HF |        |  |
|         | 100 Scarabeo Net            | 10 - 14 | 153 HF |        |  |
|         | 125 Tuono ABS               | 17 - 18 | 821 HS | 544 HF |  |
|         | 125 Atlantic                | 03 - 14 | 159 CT | 152 CT |  |
|         | 125 Classic                 | 96 - 03 | 652 HF | 519 HF |  |
|         | 125 Habana/Custom           | 00 - 02 | 153 CT | 2205   |  |
|         | 125 Leonardo                | 96      | 123 CT | 106 CT |  |
|         | 125 Leonardo                | 97 - 98 | 149 CT | 143 CT |  |
|         | 125 Leonardo                | 99 - 06 | 153 CT | 153 CT |  |
|         | 125 Leonardo (Grimeca cal.) | 99 - 06 | 108 CT | 153 CT |  |
|         | 125 Mojito, Mojito Custom   | 02 - 12 | 153 CT | 2205   |  |
|         | 125 Pegaso                  | 90 - 91 | 652 HF | 692 HF |  |
|         | 125 Pegaso                  | 92 - 99 | 689 HF | 651 HF |  |
|         | 125 Red Rose                | 89      | 588 HF | 519 HF |  |
|         | 125 Red Rose                | 90 - 97 | 652 HF | 519 HF |  |
|         | 125 Scarabeo, Scarabeo GT   | 99 - 03 | 108 CT | 152 CT |  |
|         | 125 Sportcity               | 04 - 12 | 108 CT | 152 CT |  |
|         | 125 Tuono                   | 04 - 07 | 601 HF | 519 HF |  |
|         | 125 Scarabeo, Scarabeo GT   | 04 - 10 | 159 CT | 152 CT |  |
|         | 125 Sport Pro.              | 92      | 601 HF | 519 HF |  |
|         | 125 Strada                  | 85      | 574 HF |        |  |
|         | 125 Tuareg                  | 86      | 588 HF |        |  |
|         | 125 Tuareg                  | 87 - 92 | 605 HF | 519 HF |  |
|         | 125 Tuareg AS               | 86      | 605 HF | 519 HF |  |
|         | 125 Tuareg Rally            | 86 - 93 | 588 HF |        |  |
|         | 125 Tuareg Rally            | 89      | 588 HF | 519 HF |  |
|         | 125 Tuareg Rally            | 90 - 94 | 641 HF | 519 HF |  |
|         | 125 Tuareg Rally            | 92      | 652 HF | 651 HF |  |
|         | 125 Tuareg Wind             | 88      | 607 HF | 574 HF |  |
|         | 125 Tuareg Wind             | 90 - 94 | 652 HF | 692 HF |  |
| AF1     | 125                         | 87 - 88 | 608 HF | 519 HF |  |
| AF1     | 125 Europa, Futura          | 90 - 92 | 601 HF | 519 HF |  |
| AF1     | 125 Replica, Sintesi        | 89 - 91 | 601 HF | 519 HF |  |
| AF-1    | 125                         | 88      | 608 HF | 574 HF |  |
| ETX     | 125                         | 99 - 92 | 120 CT |        |  |
| ETX     | 125                         | 84 - 86 | 588 HF |        |  |
| ETX     | 125 PV                      | 86 - 02 | 606 HF |        |  |
| ETX     | 125 Tuareg                  | 86 - 87 | 588 HF | 519 HF |  |
| MX      | 125                         | 04 - 07 | 671 HF | 651 HF |  |
| MX      | 125 Supermoto               | 07      | 671 HF | 651 HF |  |
| MX      | 125 Cross                   | 85      | 588 HF |        |  |
| RS      | 125 , Extrema               | 93 - 98 | 601 HF | 824 HF |  |
| RS      | 125                         | 99 - 05 | 601 HF | 824 HF |  |
| RS      | 125                         | 06 - 12 | 844 HF | 747 HF |  |
| RS      | 125 Pista                   | 05 - 07 | 601 HF | 824 HF |  |
| RS-4    | 125 (AJP cal.)              | 11 - 18 | 821 HS | 585 HF |  |
| RS-4    | 125 (J.Juan cal.)           | 11 - 18 | 566 HS | 544 HF |  |
| RS-4    | 125 Replica, ABS            | 16 - 18 | 821 HS | 544 HF |  |
| RX      | 125                         | 97 - 99 | 671 HF | 692 HF |  |
| RX      | 125                         | 86 - 89 | 606 HF |        |  |
| RX      | 125                         | 90      | 641 HF | 586 HF |  |
| RX      | 125                         | 91      | 641 HF | 692 HF |  |



**RECOMMENDED**

1xx = Scooter Pads  
5xx = Street, Off Road & Racing Pads  
2xxx = Brake Shoes



| APRILIA |                             |         |         |         |  |
|---------|-----------------------------|---------|---------|---------|--|
| RX      | 125                         | 91 - 92 | 641 HF  | 684 HF  |  |
| RX      | 125                         | 92      | 120 CT  | 113 CT  |  |
| RX      | 125 Enduro                  | 08 - 12 | 671 HF  | 544 HF  |  |
| RX      | 125 Supermotard             | 08 - 12 | 671 HF  | 544 HF  |  |
| SR      | 125                         | 99 - 03 | 153 CT  | 2205    |  |
| SR      | 125 Max                     | 12 - 17 | 177 CT  | 177 CT  |  |
| SR      | 125 Sport City One          | 12      | 177 CT  |         |  |
| STX     | 125                         | 84      | 605 HF  |         |  |
| SX      | 125                         | 08 - 13 | 671 HF  | 651 HF  |  |
| TX      | 125                         | 86      | 606 HF  |         |  |
|         | 150 Leonardo                | 97 - 98 | 149 CT  | 143 CT  |  |
|         | 150 Leonardo                | 99 - 05 | 153 CT  | 153 CT  |  |
|         | 150 Leonardo (Grimeca cal.) | 99 - 05 | 108 CT  | 153 CT  |  |
|         | 150 Scarabeo                | 99 - 04 | 108 CT  | 152 CT  |  |
|         | 150 Scarabeo, Scarabeo GT   | 04 - 05 | 159 CT  | 152 CT  |  |
| SR      | 150                         | 00 - 03 | 153 CT  | 2205    |  |
|         | 200 Atlantic                | 03 - 06 | 159 CT  | 152 CT  |  |
|         | 200 Scarabeo, Scarabeo GT   | 02 - 03 | 108 CT  | 152 CT  |  |
|         | 200 Sportcity               | 04 - 08 | 108 CT  | 152 CT  |  |
|         | 200 Climber                 | 93 - 95 | 519 RSI | 519 RSI |  |
|         | 200 Scarabeo                | 07 - 09 | 159 CT  | 152 CT  |  |
|         | 200 Scarabeo Class          | 10 - 12 | 159 CT  | 152 CT  |  |
|         | 200 Scarabeo ie             | 12      | 159 CT  | 152 CT  |  |
|         | 240 Climber                 | 89 - 90 | 607 HF  | 574 HF  |  |
| TX      | 240                         | 86 - 88 | 559 RSI |         |  |
|         | 250 Leonardo                | 99 - 05 | 153 MS  | 152 MS  |  |
|         | 250 Leonardo (Grimeca cal.) | 99 - 05 | 108 MS  | 152 MS  |  |
|         | 250 Atlantic ie             | 07 - 12 | 159 MS  | 152 MS  |  |
|         | 250 Scarabeo, Scarabeo ie   | 06 - 11 | 159 MS  | 152 MS  |  |
|         | 250 Sportcity ie            | 06 - 08 | 108 MS* | 152 MS  |  |
|         | 250 Tuareg Rally            | 86      | 588 HF  | 519 HF  |  |
| AF1     | 250 Replica                 | 90      | 601 HF  | 506 HF  |  |
| MX      | 250 Cross                   | 85      | 519 SI  |         |  |
| RS      | 250                         | 95 - 96 | 566 HF  | 519 HF  |  |
| RS      | 250                         | 97 - 02 | 706 HF* | 519 HF  |  |
| RS      | 250 Pista                   | 04      | 706 HF* | 519 HF  |  |
| RX      | 250                         | 86      | 519 HF  |         |  |
|         | 275 Climber                 | 89 - 90 | 607 HF  | 574 HF  |  |
|         | 280 R, Climber              | 92      | 559 RSI | 559 RSI |  |
|         | 300 Leonardo (Grimeca cal.) | 05 - 06 | 108 MS  | 153 MS  |  |
|         | 300 Scarabeo Special        | 10 - 11 | 159 MS  | 152 MS  |  |
| SR      | 300 Max                     | 12 - 18 | 177 MS  | 177 MS  |  |
| TX      | 311                         | 86      | 559 RSI |         |  |
| TX      | 312 M                       | 88      | 559 RSI | 559 RSI |  |
| TXR     | 312 M                       | 88      | 559 RSI | 559 RSI |  |
|         | 350 Tuareg                  | 86      | 588 HF  | 519 HF  |  |
|         | 350 Tuareg                  | 88 - 89 | 641 HF  | 519 HF  |  |
|         | 350 Tuareg Wind             | 87      | 588 HF  | 519 HF  |  |
|         | 350 Tuareg Wind             | 88      | 594 HF  | 519 HF  |  |
|         | 350 Tuareg Wind             | 90 - 94 | 641 HF  | 586 HF  |  |
| ETX     | 350                         | 85 - 86 | 588 HF  | 519 HF  |  |
| ETX     | 350                         | 86 - 92 | 605 HF  | 519 SI  |  |
|         | 400 Scarabeo ie             | 07 - 08 | 108 MS* | 152 MS  |  |
| MXV     | 450                         | 09 - 13 | 694 RSI | 790 RSI |  |
| RXV     | 450                         | 06 - 13 | 694 SI  | 790 SI  |  |
| SXV     | 450                         | 06 - 13 | 842 RSI | 790 RSI |  |
| SXV     | 450 Van den Bosch Rep.      | 08 - 10 | 695 RS  | 790 RSI |  |
|         | 500 Atlantic Left/Rear      | 02 - 05 | 108 MS  | 152 MS  |  |
|         | 500 Atlantic Right          | 02 - 05 | 179 MS  |         |  |
|         | 500 Atlantic Sprint         | 06 - 10 | 159 MS  | 152 MS  |  |
|         | 500 Scarabeo                | 03 - 06 | 108 MS* | 152 MS  |  |
|         | 500 Scarabeo Class          | 10 - 11 | 108 MS* | 152 MS  |  |
|         | 500 Scarabeo ie             | 07 - 11 | 108 MS* | 152 MS  |  |
| RXV     | 550                         | 06 - 13 | 694 SI  | 790 SI  |  |
| SXV     | 550                         | 06 - 13 | 842 RSI | 790 RSI |  |
| SXV     | 550 Van den Bosch Rep.      | 08 - 10 | 695 RS  | 790 RSI |  |
|         | 600 Pegaso                  | 90 - 92 | 641 HF  | 651 HF  |  |
|         | 600 Tuareg                  | 86 - 87 | 588 HF  | 519 HF  |  |
|         | 600 Tuareg                  | 88 - 89 | 641 HF  | 692 HF  |  |
|         | 600 Tuareg Wind             | 88      | 594 HF  | 519 HF  |  |
|         | 600 Tuareg Wind             | 90 - 94 | 641 HF  | 692 HF  |  |
| ETX     | 600                         | 86 - 92 | 588 HF  | 519 HF  |  |

\* = 2 sets required / 2 jeux pour l'Avant.

Full compound selection, see under "Brake pad 1:1 Drawings" / Sélection complète de composés, voir "1:1 Schémas Plaquettes de frein".

**RECOMMENDED**1xx = Scooter Pads  
5xx = Street, Off Road & Racing Pads  
2xxx = Brake Shoes

| APRILIA                                |         |          |         |  |
|--|---------|----------|---------|--|
| 650 Moto                               | 95 - 03 | 674 HF   | 692 HF  |  |
| 650 Pegaso                             | 92 - 94 | 681 HF   | 651 HF  |  |
| 650 Pegaso                             | 95 - 00 | 674 HS   | 692 HF  |  |
| 650 Pegaso Factory                     | 07 - 09 | 842 HS   | 675 LS  |  |
| 650 Pegaso i.e.                        | 01 - 04 | 674 HS   | 675 LS  |  |
| 650 Pegaso i.e.                        |         |          |         |  |
| Tuscany Tibet Raid                     | 04      | 674 HS   | 675 LS  |  |
| 650 Pegaso Strada                      | 05 - 09 | 706 HS   | 675 LS  |  |
| 650 Pegaso Trail                       | 06 - 08 | 674 HS   | 675 LS  |  |
| 650 Starck                             | 96 - 01 | 674 HF   | 692 HF  |  |
| 750 Dorsoduro Factory                  | 12 - 13 | 706 HS*  | 675 LS  |  |
| SL 750 Shiver, ABS                     | 07 - 18 | 844 HS*  | 675 LS  |  |
| SL 750 Shiver GT, ABS                  | 09 - 12 | 844 HS*  | 675 LS  |  |
| SMV 750 Dorsoduro                      | 08      | 706 HS*  | 675 LS  |  |
| SMV 750 Dorsoduro                      | 09 - 18 | 844 HS*  | 675 LS  |  |
| NA 850 Mana                            | 07      | 844 HS*  | 675 LS  |  |
| NA 850 Mana GT, ABS                    | 09 - 13 | 844 HS*  | 588 HF  |  |
| NA 850 Mana GT, ABS<br>(Parking Brake) | 09 - 13 |          | 879 HF  |  |
| NA 850 Mana, ABS                       | 08 - 11 | 844 HS*  | 588 HF  |  |
| SRV 850 (Parking Brake)                | 12 - 18 |          | 209 HF  |  |
| SRV 850                                | 12 - 18 | 151 MS*  | 177 MS  |  |
| 900 Dorsoduro                          | 18 -    | 844 HS*  | 675 LS  |  |
| 900 Shiver                             | 18 -    | 844 HS*  | 675 LS  |  |
| 1000 Blue Marlin                       | 02      | 706 HS*  | 730 LS  |  |
| ETV 1000 Caponord                      | 01 - 08 | 674 HS*  | 730 LS  |  |
| ETV 1000 Caponord Rally Raid           | 04 - 08 | 674 HS*  | 730 LS  |  |
| RST 1000 Futura                        | 01 - 03 | 706 HS*  | 671 LS  |  |
| RSV 1000 Factory Pista                 | 04      | 762 HS*  | 730 LS  |  |
| RSV 1000 Falco SL, R                   | 00 - 04 | 706 HS*  | 730 LS  |  |
| RSV 1000 Mille                         | 97 - 01 | 706 HS*  | 730 LS  |  |
| RSV 1000 Mille                         | 02 - 03 | 762 HS*  | 730 LS  |  |
| RSV 1000 Mille Nera                    | 04      | 762 HS*  | 730 LS  |  |
| RSV 1000 Mille R                       | 00      | 706 HS*  | 730 LS  |  |
| RSV 1000 Mille R                       | 01 - 02 | 762 HS*  | 730 LS  |  |
| RSV 1000 Mille R                       | 04      | 762 HS*  | 730 LS  |  |
| RSV 1000 Mille R                       | 03      | 762 HS*  | 730 LS  |  |
| RSV 1000 Mille R                       | 05 - 07 | 762 HS*  | 730 LS  |  |
| RSV 1000 Mille R Factory               | 04 - 05 | 762 HS*  | 730 LS  |  |
| RSV 1000 Mille SP                      | 00      | 706 HS*  | 730 LS  |  |
| RSV 1000 Tuono Fighter                 | 03 - 05 | 706 HS*  | 730 LS  |  |
| RSV 1000 Tuono R                       | 03      | 762 HS*  | 730 LS  |  |
| RSV 1000 Tuono R, ABS                  | 04 - 12 | 706 HS*  | 730 LS  |  |
| RSV 1000 Tuono R Factory, ABS          | 06 - 12 | 762 HS*  | 730 LS  |  |
| RSV 1000 Tuono V4 R                    | 11 - 13 | 706 HS*  | 730 LS  |  |
| RSV 1000 Tuono V4 R                    | 14      | 900 HS*  | 730 LS  |  |
| RSV4 1000 , ABS                        | 09 - 13 | 841 SP*  | 730 LS  |  |
| RSV4-R 1000 , ABS APRC                 | 10      | 841 SP*  | 730 LS  |  |
| RSV4-RF 1000                           | 15 - 18 | 901 SP*  | 730 LS  |  |
| RSV4-RR 1000                           | 15 - 18 | 901 SP*  | 730 LS  |  |
| RSV 1100 Tuono V4                      | 15      | 900 HS*  | 730 LS  |  |
| RSV 1100 Tuono V4 Factory              | 16 - 18 | 900 HS*  | 730 LS  |  |
| RSV 1100 Tuono V4 RR                   | 15 - 18 | 900 HS*  | 730 LS  |  |
| 1200 Caponord                          | 13 - 18 | 900 SP*  | 675 LS  |  |
| 1200 Caponord Rally                    | 15 - 18 | 900 SP*  | 675 LS  |  |
| 1200 Caponord Travel Pack              | 16 - 18 | 900 SP*  | 675 LS  |  |
| 1200 Dorsoduro, ABS                    | 11 - 14 | 706 HS*  | 675 LS  |  |
|  |         |          |         |  |
| ARCTIC CAT                             |         |          |         |  |
| 50 2WD                                 | 04 - 06 | 2048     |         |  |
| 50 DVX                                 | 06 - 08 | 2048     | 638 SI  |  |
| 90 2WD                                 | 02 - 04 | 2048     |         |  |
| 90 DVX                                 | 06 - 14 | 2048     | 638 SI  |  |
| 250 2x4                                | 05 - 06 | 822 ATS* | 822 ATS |  |
| 250 2x4 (Man. Hand Brake)              | 99 - 04 |          | 827 ATS |  |
| 250 2x4/4x4                            | 99 - 04 | 758 ATS* | 758 ATS |  |
| 250 4x4 (Man. Hand Brake)              | 00 - 04 |          | 827 ATS |  |
| 250 DVX                                | 06 - 09 | 810 SI*  | 775 SI  |  |
| 300 2x4                                | 10 - 13 | 822 ATS* | 822 ATS |  |
| 300 2x4 (Man. Hand Brake)              | 98 - 04 |          | 827 ATS |  |
| 300 2x4/4x4                            | 98 - 04 | 758 ATS* | 758 ATS |  |
| 300 4x4                                | 05      | 822 ATS* | 822 ATS |  |

**RECOMMENDED**1xx = Scooter Pads  
5xx = Street, Off Road & Racing Pads  
2xxx = Brake Shoes

| ARCTIC CAT                                  |         |          |  |         |
|---|---------|----------|--|---------|
| 300 4x4 (Man. Hand Brake)                   | 98 - 05 |          |  | 827 ATS |
| 300 DVX                                     | 09 - 16 | 810 SI*  |  | 775 SI  |
| 375 2x4/4x4                                 | 02      | 758 ATS* |  | 758 ATS |
| 375 2x4/4x4<br>(Man. Hand Brake)            | 02      |          |  | 827 ATS |
| 400 2x4 (Man. Hand Brake)                   | 98 - 02 |          |  | 827 ATS |
| 400 2x4/4x4                                 | 98 - 04 | 758 ATS* |  | 758 ATS |
| 400 2x4/4x4 (FIS)                           | 02 - 04 | 758 ATS* |  | 758 ATS |
| 400 2x4/4x4 (FIS)                           | 05 - 07 | 822 ATS* |  | 822 ATS |
| 400 2x4/4x4 (FIS) Aut.<br>(Man. Hand Brake) | 03 - 04 |          |  | 827 ATS |
| 400 2x4/4x4 (FIS)<br>(Man. Hand Brake)      | 02 - 04 |          |  | 827 ATS |
| 400 2x4/4x4 (FIS)<br>(Man. Hand Brake)      | 05 - 08 |          |  | 758 ATS |
| 400 4x4 (Man. Hand Brake)                   | 98 - 04 |          |  | 827 ATS |
| 400 DVX                                     | 04 - 08 | 592 SI*  |  | 649 SI  |
| 400 TBX 4x4                                 | 04      | 758 ATS* |  | 758 ATS |
| 400 TBX 4x4<br>(Man. Hand Brake)            | 04      |          |  | 827 ATS |
| TRV 400                                     | 09 - 13 | 822 ATS* |  | 822 ATS |
| 440 Bear Cat                                | 96 - 97 |          |  | 758 ATS |
| 450 H1                                      | 10      | 822 ATS* |  | 822 ATS |
| XC 450                                      | 11 - 14 | 822 ATS* |  | 822 ATS |
| 454 Arctic Cat 4x4                          | 98      | 758 ATS* |  | 758 ATS |
| 454 Bear Cat 2x4/4x4                        | 96 - 98 | 758 ATS* |  | 758 ATS |
| 454 Bear Cat 2x4/4x4<br>(Man. Hand Brake)   | 98      |          |  | 827 ATS |
| 500 2x4 (FIS)<br>(Man. Hand Brake)          | 02      |          |  | 827 ATS |
| 500 2x4 (Man. Hand Brake)                   | 02      |          |  | 827 ATS |
| 500 2x4/4x4                                 | 98 - 04 | 758 ATS* |  | 758 ATS |
| 500 2x4/4x4 (FIS)                           | 02 - 04 | 758 ATS* |  | 758 ATS |
| 500 2x4/4x4 (FIS)                           | 05 - 09 | 822 ATS* |  | 822 ATS |
| 500 4x4 (FIS) Aut.<br>(Man. Hand Brake)     | 02 - 03 |          |  | 827 ATS |
| 500 4x4 (FIS)<br>(Man. Hand Brake)          | 02 - 03 |          |  | 827 ATS |
| 500 4x4 (Man. Hand Brake)                   | 98 - 02 |          |  | 827 ATS |
| 500 TBX 4x4                                 | 02 - 04 | 758 ATS* |  | 758 ATS |
| 500 TBX 4x4                                 | 05 - 06 | 822 ATS* |  | 822 ATS |
| 500 TBX 4x4<br>(Man. Hand Brake)            | 03 - 04 |          |  | 827 ATS |
| 500 TBX 4x4 Aut.<br>(Man. Hand Brake)       | 02      |          |  | 827 ATS |
| 500 TRV 4x4                                 | 03 - 04 | 758 ATS* |  | 758 ATS |
| 500 TRV 4x4                                 | 05 - 06 | 822 ATS* |  | 822 ATS |
| 500 TRV 4x4<br>(Man. Hand Brake)            | 03 - 04 |          |  | 827 ATS |
| 550 H1                                      | 09 - 13 | 822 ATS* |  | 822 ATS |
| 550 LTD                                     | 09 - 12 | 822 ATS* |  | 822 ATS |
| 550 Prowler                                 | 09 - 14 | 822 ATS* |  | 822 ATS |
| TRV 550                                     | 09 - 14 | 822 ATS* |  | 822 ATS |
| 650 H1 4x4 Aut.                             | 05 - 11 | 822 ATS* |  | 822 ATS |
| 650 Prowler                                 | 06 - 08 | 822 ATS* |  | 822 ATS |
| 650 V2 4x4 Aut.                             | 05 - 06 | 822 ATS* |  | 822 ATS |
| 650 V2 4x4 Aut. LE                          | 05 - 06 | 822 ATS* |  | 822 ATS |
| 700 Wildcat Sport                           | 15 - 16 | 946 ATS* |  | 822 ATS |
| 700 Wildcat Sport LTD.                      | 16      | 946 ATS* |  | 822 ATS |
| 700 Wildcat Sport LTD. EPS                  | 17      | 946 ATS* |  | 822 ATS |
| 700 Wildcat Sport XT                        | 15      | 946 ATS* |  | 822 ATS |
| 700 Wildcat Sport XT EPS                    | 16 - 17 | 946 ATS* |  | 822 ATS |
| 700 Diesel                                  | 06 - 14 | 822 ATS* |  | 822 ATS |
| 700 H1                                      | 09 - 10 | 822 ATS* |  | 822 ATS |
| 700 Prowler                                 | 08      | 822 ATS* |  | 822 ATS |
| TBX 700                                     | 12 - 14 | 822 ATS* |  | 822 ATS |
| TRV 700                                     | 09 - 12 | 822 ATS* |  | 822 ATS |
| 1000 Wildcat 4X                             | 16      | 912 ATS* |  | 822 ATS |
| 1000 Wildcat X                              | 16      | 912 ATS* |  | 822 ATS |
| 1000 Wildcat X Ltd.                         | 17      | 912 ATS* |  | 822 ATS |
| 1000 Wildcat X SE                           | 17      | 912 ATS* |  | 822 ATS |
| 1000 Prowler                                | 09      | 822 ATS* |  | 822 ATS |

\* = 2 sets required / 2 jeux pour l'Avant.

**RECOMMENDED**

1xx = Scooter Pads  
5xx = Street, Off Road & Racing Pads  
2xxx = Brake Shoes



| ARCTIC CAT |                            |         |          |         |
|------------|----------------------------|---------|----------|---------|
|            | 1000 Thundercat            | 09 - 14 | 822 ATS* | 822 ATS |
| TRV        | 1000                       | 09 - 14 | 822 ATS* | 822 ATS |
| ARMSTRONG  |                            |         |          |         |
| MX         | 500                        | 86      | 519 SI   |         |
| MX         | 600                        | 86      | 519 SI   |         |
| ASPES      |                            |         |          |         |
|            | 125 Sintesi                | 88      | 601 HF   | 519 HF  |
|            | 125 Yuma                   | 76 - 79 | 560 HF   |         |
| ATALA      |                            |         |          |         |
|            | 25 Carosello               | 97      | 123 HF   |         |
| AT10       | 25                         | 97      | 114 HF   |         |
|            | 50 Carosello               | 97 - 01 | 123 HF   |         |
|            | 50 Hacker                  | 95 - 00 | 123 HF   | 2181    |
|            | 50 Skeggia                 | 98 - 00 | 114 HF   |         |
| AT10       | 50                         | 97      | 114 HF   |         |
|            | 125 Hacker                 | 98      | 123 CT   |         |
| ATK        |                            |         |          |         |
|            | all models                 | 94      | 611 SI   | 611 SI  |
| ATK        | 250 CC,MX                  | 91 - 92 | 601 HF   | 519 SI* |
| ATK        | 350 ES CC,MX,STD           | 91 - 92 | 601 HF   | 519 SI* |
| ATK        | 350 GS                     | 93      | 519 SI   | 519 SI* |
| ATK        | 406 CC,MX                  | 91 - 92 | 601 HF   | 519 SI  |
| ATK        | 560                        | 84 - 85 | 519 SI   | 2122    |
| ATK        | 560                        | 86      | 519 SI   | 532 HF  |
| ATK        | 560                        | 87 - 88 | 519 SI   | 559 HF  |
| ATK        | 560                        | 89 - 91 | 601 HF   | 607 HF  |
| ATK        | 604                        | 91      | 601 HF   | 607 HF  |
| ATK        | 604 ES CC,MX,STD           | 91 - 92 | 601 HF   | 519 SI  |
| ATK        | 604 Quadracer              | 90      | 601 HF   | 607 HF  |
| ATK        | 640                        | 93      | 519 SI   | 519 SI* |
| BAOXIN     |                            |         |          |         |
| BX         | 125 L                      | 97      | 691 HF   |         |
| BARIGO     |                            |         |          |         |
|            | Scooter electric           | 97      | 105 HF   | 2028    |
| BATAVUS    |                            |         |          |         |
|            | 50 Grand Prix              | 80      | 546 HF   |         |
| BENELLI    |                            |         |          |         |
|            | 50 Pepe                    | 99 - 11 | 123 HF   | 2012    |
|            | 50 49X (Quattro Nove)      | 08 - 13 | 141 HF   |         |
|            | 50 Chrono                  | 92 - 93 | 109 HF   | 2012    |
|            | 50 Chrono                  | 94      | 123 HF   | 2012    |
|            | 50 Devil                   | 92      | 601 HF   | 595 HF  |
|            | 50 Naked                   | 02      | 143 HF   | 2028    |
|            | 50 Nemo, Quadra            | 94      | 123 HF   | 2012    |
|            | 50 Spring                  | 92      | 601 HF   | 595 HF  |
| 491        | 50 GT, Sport               | 98 - 99 | 123 HF   | 2012    |
| 491        | 50 Naked                   | 99 - 02 | 123 HF   | 2012    |
| 491        | 50 Racing                  | 99 - 04 | 123 HF   | 123 HF  |
| 491        | 50 RR, -GP                 | 00 - 02 | 123 HF   | 123 HF  |
| 491        | 50 ST                      | 01 - 02 | 123 HF   | 2012    |
| 491        | 50 Superbike               | 99 - 04 | 123 HF   | 123 HF  |
| K2         | 50 Air                     | 98 - 01 | 123 HF   | 123 HF  |
| K2         | 50 LC                      | 99 - 01 | 123 HF   | 123 HF  |
| K2         | 50 Namur                   | 99      | 123 HF   | 123 HF  |
| KB-X       | 50 Race                    | 14      | 619 HF   |         |
|            | 100 Naked                  | 02 - 03 | 123 HF   |         |
| K2         | 100 Biposto                | 99 - 01 | 123 HF   |         |
| LX         | 100 Pepe                   | 02 - 06 | 123 HF   | 2028    |
|            | 124 T                      | 83 - 85 | 519 HF   |         |
|            | 125 2CE                    | 76 - 78 | 519 HF   |         |
|            | 125 Adiva                  | 00 - 05 | 123 CT   | 166 CT  |
|            | 125 Velvet, Velvet Touring | 99      | 123 CT   | 164 CT  |
|            | 125 Caffenero Left/Rear    | 08 - 11 | 197 CT   | 197 CT  |
|            | 125 Caffenero Right        | 08 - 11 | 134 CT   |         |

**RECOMMENDED**

1xx = Scooter Pads  
5xx = Street, Off Road & Racing Pads  
2xxx = Brake Shoes



| BENELLI |                            |         |         |         |
|---------|----------------------------|---------|---------|---------|
|         | 125 Custom                 | 85      | 519 HF  |         |
|         | 125 Jarno                  | 89      | 601 HF* | 519 HF  |
|         | 125 MJ                     | 10      | 197 CT  | 197 CT  |
|         | 125 Sport                  | 82 - 89 | 519 HF  |         |
|         | 125 T                      | 76      | 519 HF  |         |
|         | 125 TT                     | 86      | 519 HF  |         |
| 666     | 125 Born in Hell           | 98      | 706 HF  | 697 HF  |
| BX      | 125                        | 89      | 601 HF  | 519 SI  |
| BXK     | 125                        | 88      | 519 HF  | 559 HF  |
| E       | 125 L.C.                   | 85      | 519 HF  |         |
| TNT     | 125                        | 17      | 558 HF  |         |
|         | 150 Adiva                  | 00 - 05 | 123 CT  | 166 CT  |
|         | 150 MJ                     | 10      | 197 CT  | 197 CT  |
|         | 150 Velvet, Velvet Touring | 00 - 12 | 123 CT  | 164 CT  |
|         | 250 2CE                    | 76      | 519 HF  |         |
|         | 250 Velvet, Velvet Touring | 99 - 08 | 123 CT  | 164 CT  |
|         | 250 Caffenero Left/Rear    | 08 - 14 | 197 MS  | 196 MS  |
|         | 250 Caffenero Right        | 08 - 14 | 134 MS  |         |
|         | 250 Disc                   | 76      | 519 HF  |         |
|         | 250 Leoncino               | 18 -    | 933 HS* | 832 LS  |
| BN      | 251                        | 15      | 933 HS  |         |
|         | 254                        | 83      | 532 HF  |         |
| BN      | 302                        | 14      | 706 HS* | 730 LS  |
| BN      | 302                        | 15      | 933 HS* | 832 LS  |
| BN      | 302 Tornado                | 16      | 933 HS* | 832 LS  |
|         | 304                        | 83      | 519 HF  |         |
|         | 350 4T Turismo             | 80      | 519 HF  | 506 HF  |
|         | 350 Zenzero                | 12 - 15 | 163 CT  | 101 CT  |
|         | 354                        | 78 - 82 | 519 HF* | 506 HF  |
|         | 354 Sport                  | 83 - 85 | 519 HF* | 519 HF  |
|         | 400 Velvet Dusk            | 03 - 04 | 120 CT  | 123 CT  |
|         | 402 S                      | 18 -    | 706 HS* | 832 LS  |
| BX      | 449 Cross                  | 07 - 09 | 671 RSI | 675 RSI |
| BX      | 449 Supermotard            | 08 - 10 | 762 RS  | 675 RSI |
|         | 500 -4                     | 76      | 519 HF* |         |
|         | 500 4T                     | 76      | 519 HF  | 506 HF  |
|         | 500 Leoncino               | 16 - 17 | 706 HS* | 730 LS  |
|         | 500 Leoncino Cinquecento   | 18 -    | 762 HS* | 832 LS  |
|         | 500 Leoncino Trail         | 18 -    | 674 HS* | 832 LS  |
| TRK     | 502                        | 18 -    | 762 HS* | 832 LS  |
| TRK     | 502                        | 16 - 17 | 706 HS* | 730 LS  |
| BX      | 505 Enduro                 | 08      | 671 SI  | 675 SI  |
| BN      | 600                        | 12 - 13 | 706 HS* | 730 LS  |
| BN      | 600                        | 14 - 17 | 762 HS* | 730 LS  |
| BN      | 600 GT                     | 14 - 15 | 762 HS* | 730 LS  |
|         | 654 Sport                  | 83      | 519 HF* | 519 HF  |
|         | 750 Sei                    | 75 - 78 | 506 HF* |         |
|         | 752 S                      | 18 -    | 762 HS* | 832 LS  |
|         | 756 Cue                    | 07 - 09 | 762 HS* | 730 LS  |
|         | 756 Cue                    | 10 - 12 | 706 HS* | 730 LS  |
|         | 899 Trek                   | 07 - 12 | 706 HS* | 730 LS  |
| TnT     | 899                        | 07 - 15 | 706 HS* | 730 LS  |
| TnT     | 899 Century Racer          | 11      | 762 HS* | 730 LS  |
|         | 900 Tornado TRE            | 03 - 06 | 762 HS* | 730 LS  |
|         | 900 Tornado TRE RS         | 04 - 06 | 762 HS* | 730 LS  |
|         | 900 Sei                    | 81 - 83 | 554 HF* |         |
|         | 900 Sei                    | 84      | 506 HF* | 506 HF  |
|         | 900 Tornado 3              | 00 - 06 | 706 HS* | 519 LS  |
| TnT     | 1100                       | 04      | 706 HS* | 519 LS  |
| TnT     | 1130                       | 05 - 14 | 706 HS* | 730 LS  |
| TnT     | 1130 Cafe Racer            | 05 - 13 | 762 HS* | 730 LS  |
| TnT     | 1130 Officine              | 07      | 762 HS* | 730 LS  |
| TnT     | 1130 Sport                 | 05 - 08 | 762 HS* | 730 LS  |
| TnT     | 1130 Titanium              | 05 - 08 | 762 HS* | 730 LS  |
| TnT     | 1130 Trek                  | 06 - 12 | 706 SP* | 730 LS  |
| TnT     | 1130 Trek Amazonas         | 07 - 15 | 706 SP* | 730 LS  |
| TnT     | 1130 Century Racer         | 11 - 12 | 762 HS* | 730 LS  |
| TnT     | 1130 R                     | 17      | 841 HS* | 730 LS  |
| BETA    |                            |         |         |         |
|         | 50 Ark AirCooled           | 99 - 12 | 123 HF  |         |
|         | 50 Ark K Series            | 97 - 05 | 123 HF  | 123 HF  |

\* = 2 sets required / 2 jeux pour l'Avant.

Full compound selection, see under "Brake pad 1:1 Drawings" / Sélection complète de composés, voir "1:1 Schémas Plaquettes de frein".

**RECOMMENDED**1xx = Scooter Pads  
5xx = Street, Off Road & Racing Pads  
2xxx = Brake Shoes

| BETA  |                                    |         |         |         |  |
|-------|------------------------------------|---------|---------|---------|--|
|       | 50 Ark LC                          | 99 - 12 | 123 HF  | 123 HF  |  |
|       | 50 Crono 502                       | 97 - 02 | 138 HF  |         |  |
|       | 50 Eikon                           | 99 - 03 | 105 HF  | 105 HF  |  |
|       | 50 Quadra                          | 95 - 96 | 123 HF  | 2012    |  |
|       | 50 Quadra                          | 97 - 00 | 138 HF  |         |  |
|       | 50 Tempo                           | 97 - 98 | 138 HF  |         |  |
|       | 50 AJP Caliper<br>incl. pin/spring | 90 - 18 | 188 HF  |         |  |
|       | 50 Chrono 13                       | 94 - 99 | 123 HF  | 2012    |  |
|       | 50 Eikon                           | 04 - 07 | 123 HF  | 152 HF  |  |
|       | 50 ProRace 12/10                   | 04      | 803 RSI | 803 RSI |  |
|       | 50 Rev                             | 00 - 09 | 559 HF  | 559 HF  |  |
|       | 50 Squirrel                        | 83      | 532 HF  |         |  |
|       | 50 Super Trial                     | 92      | 559 HF  | 636 HF  |  |
|       | 50 Techno                          | 96      | 105 HF  | 105 HF  |  |
|       | 50 Tempo                           | 92 - 96 | 105 HF  | 2012    |  |
|       | 50 Tempo                           | 99      | 123 HF  |         |  |
|       | 50 Tempo (13" wheels)              | 00 - 02 | 123 HF  |         |  |
|       | 50 Tempo (16" wheels)              | 00 - 02 | 123 HF  |         |  |
| AE    | 50 Four Twin                       | 88      | 595 HF  |         |  |
| ALP   | 50                                 | 91 - 00 | 595 HF  | 607 HF  |  |
| KR    | 50                                 | 86 - 87 | 519 HF  |         |  |
| KR    | 50 Twin                            | 88      | 519 HF  | 519 HF  |  |
| MX    | 50 Enduro                          | 92      | 607 HF  | 636 HF  |  |
| RR    | 50 Enduro                          | 99 - 09 | 148 HF  | 105 HF  |  |
| RR    | 50 Enduro                          | 10 - 18 | 168 HF  | 199 HF  |  |
| RR    | 50 Enduro Alu                      | 04 - 07 | 120 HF  |         |  |
| RR    | 50 Pro Race                        | 98      | 148 HF  | 105 HF  |  |
| RR    | 50 Standard                        | 99 - 08 | 148 HF  | 105 HF  |  |
| RR    | 50 Supermotard                     | 99 - 03 | 148 HF  | 105 HF  |  |
| RR    | 50 Supermotard                     | 04 - 07 | 105 HF  | 105 HF  |  |
| RR    | 50 Supermotard                     | 08 - 13 | 168 HF  | 199 HF  |  |
| RR    | 50 Supermotard Alu                 | 04 - 05 | 120 HF  |         |  |
| RV    | 50                                 | 88      | 595 HF  |         |  |
| RX    | 50                                 | 84      | 605 HF  |         |  |
| ST    | 50                                 | 97      | 559 HF  | 559 HF  |  |
| VRS   | 50                                 | 86      | 595 HF  |         |  |
|       | 80 EVO                             | 09 - 10 | 802 RSI |         |  |
|       | 80 EVO Junior                      | 10 - 11 | 559 HF  | 559 HF  |  |
|       | 80 Rev                             | 00 - 07 | 559 HF  | 559 HF  |  |
|       | 80 Rev                             | 08 - 10 | 802 RSI | 896 RSI |  |
|       | 125 Eikon                          | 99 - 03 | 105 CT  | 105 CT  |  |
|       | 125 M4                             | 06      | 774 HF  | 861 HF  |  |
|       | 125 Eikon                          | 04 - 06 | 123 CT  | 152 CT  |  |
|       | 125 EVO                            | 09 - 14 | 802 RSI | 895 RSI |  |
|       | 125 Jonathan                       | 99 - 05 | 566 HF  | 675 HF  |  |
|       | 125 Rev 3                          | 00 - 05 | 802 RSI | 802 RSI |  |
|       | 125 Rev 3                          | 06 - 08 | 802 RSI | 896 RSI |  |
|       | 125 TS, Custom                     | 83      | 560 HF  |         |  |
|       | 125 Urban                          | 10 - 15 | 774 HF  | 861 HF  |  |
| ALP   | 125                                | 99 - 09 | 559 RSI | 559 RSI |  |
| ALP   | 125 4-stroke                       | 00 - 05 | 559 RSI | 559 RSI |  |
| ALP   | 125 4-stroke                       | 06 - 09 | 774 HF  | 861 HF  |  |
| ALP   | 125                                | 90      | 595 HF  | 607 HF  |  |
| MG    | 125                                | 83      | 532 HF  |         |  |
| RR    | 125                                | 18 -    | 694 SI  | 790 SI  |  |
| RR    | 125 Enduro 4T                      | 10 - 15 | 774 HF  | 861 HF  |  |
| RR    | 125 Supermotard                    | 08 - 09 | 774 HF  | 861 HF  |  |
| RX    | 125                                | 84      | 605 HF  |         |  |
| SR    | 125 34                             | 89      | 559 HF  | 636 HF  |  |
| TR    | 125 32,33                          | 86 - 87 | 595 HF  |         |  |
| TR    | 125 34                             | 88      | 595 HF  | 607 HF  |  |
| TR    | 125 34                             | 92      | 672 HF  | 636 HF  |  |
| TR    | 125 34,35                          | 89 - 90 | 559 RSI | 559 RSI |  |
| TR    | 125 36                             | 92      | 672 HF  | 636 HF  |  |
| TRIAL | 125                                | 97      | 559 RSI | 636 HF  |  |
|       | 150 Eikon                          | 99 - 03 | 105 CT  | 105 CT  |  |
|       | 150 Eikon                          | 04      | 123 CT  | 152 CT  |  |
| R     | 150                                | 10 - 13 | 814 HF  |         |  |
|       | 200 EVO                            | 09 - 14 | 802 RSI | 895 RSI |  |
|       | 200 Rev 3                          | 06 - 08 | 802 RSI | 896 RSI |  |
|       | 200 Urban                          | 10      | 774 HF  | 861 HF  |  |

**RECOMMENDED**1xx = Scooter Pads  
5xx = Street, Off Road & Racing Pads  
2xxx = Brake Shoes

| BETA          |                      |         |         |         |  |
|---------------|----------------------|---------|---------|---------|--|
| ALP           | 200 4-stroke         | 00 - 05 | 559 RSI | 559 RSI |  |
| ALP           | 200 4-stroke         | 06      | 774 HF  | 861 HF  |  |
|               | 240 Super Trial      | 92      | 559 RSI | 636 HF  |  |
| ALP           | 240                  | 92      | 559 RSI | 636 HF  |  |
| ALP           | 240                  | 96      | 559 RSI | 519 RSI |  |
| TR            | 240 33               | 86 - 88 | 595 HF  |         |  |
|               | 250 4-T Rev 3        | 07 - 11 | 802 RSI | 896 RSI |  |
|               | 250 Eikon            | 99 - 10 | 105 CT  | 105 CT  |  |
|               | 250 EVO (2-T / 4-T)  | 09 - 14 | 802 RSI | 895 RSI |  |
|               | 250 Rev 3            | 00 - 04 | 802 RSI | 802 RSI |  |
|               | 250 Rev 3            | 05 - 09 | 802 RSI | 896 RSI |  |
|               | 250 Techno           | 96      | 559 RSI | 559 RSI |  |
|               | 250 Zero             | 91      | 559 RSI | 636 HF  |  |
| ALP           | 250                  | 92      | 559 RSI | 636 HF  |  |
| ALP           | 250                  | 97 - 03 | 559 RSI | 559 RSI |  |
| CR            | 250                  | 83      | 519 SI  |         |  |
| RR            | 250                  | 05 - 09 | 694 SI  | 790 SI  |  |
|               | 260 Synt             | 92      | 595 HF  | 636 HF  |  |
|               | 260 Zero             | 91      | 559 RSI | 636 HF  |  |
| ALP           | 260                  | 96      | 559 RSI | 519 RSI |  |
| TR            | 260 34               | 86 - 88 | 595 HF  | 607 HF  |  |
| TR            | 260 34,35,ZERO       | 89 - 92 | 559 RSI | 636 HF  |  |
|               | 270 Rev 3            | 00 - 04 | 802 RSI | 802 RSI |  |
|               | 270 Rev 3            | 05 - 08 | 802 RSI | 896 RSI |  |
|               | 290 EVO              | 09 - 13 | 802 RSI | 895 RSI |  |
|               | 300 Crosstrainer     | 15      | 694 SI  | 790 SI  |  |
|               | 300 EVO              | 09 - 15 | 802 RSI | 895 RSI |  |
| RR            | 300                  | 13 - 18 | 694 SI  | 790 SI  |  |
|               | 350 M4 (Brembo cal.) | 06 - 07 | 566 HF  | 861 HF  |  |
|               | 350 4.0 Motard       | 04 - 06 | 566 RSI | 574 RSI |  |
|               | 350 Euro             | 99 - 03 | 566 HF  | 675 HF  |  |
|               | 350 Jonathan         | 02 - 03 | 566 HF  | 675 HF  |  |
| ALP           | 350 4.0              | 04 - 05 | 774 HF  | 574 RSI |  |
| ALP           | 350 4.0              | 06      | 774 HF  | 861 HF  |  |
| RR            | 350 Efi              | 15      | 694 SI  | 790 SI  |  |
| RR            | 350 Efi Racing       | 15      | 694 SI  | 790 SI  |  |
| RR            | 350 Enduro           | 12 - 14 | 694 SI  | 790 SI  |  |
| RR            | 390                  | 15 - 18 | 694 SI  | 790 SI  |  |
| RR            | 400 Enduro           | 05      | 694 SI  | 790 SI  |  |
| RR            | 430                  | 15 - 18 | 694 SI  | 790 SI  |  |
| RR            | 430 Racing           | 15 - 18 | 694 SI  | 790 SI  |  |
| RR            | 450 Enduro           | 05 - 07 | 694 SI  | 790 SI  |  |
| RR            | 450 Cross Country    | 12      | 694 SI  | 790 SI  |  |
| RR            | 480                  | 15 - 18 | 694 SI  | 790 SI  |  |
| RR            | 480 Racing           | 15 - 18 | 694 SI  | 790 SI  |  |
| RR            | 498 Enduro           | 12 - 14 | 694 SI  | 790 SI  |  |
|               | 500 GS, RV           | 84      | 519 HF  |         |  |
| RR            | 525 Enduro           | 05 - 13 | 694 SI  | 790 SI  |  |
| <b>BIMOTA</b> |                      |         |         |         |  |
|               | all models           | 82 - 88 | 506 HF* | 506 HF  |  |
| BBX           | 300 Enduro           | 12      | 694 SI  | 790 SI  |  |
| YB7           | 400                  | 89      | 566 HF* | 519 HF  |  |
|               | 500 Vdue             | 97 - 00 | 566 HF* | 519 HF  |  |
| BBX           | 508 Enduro           | 12      | 694 SI  | 604 SI  |  |
|               | 600 Bellaria         | 91      | 566 HF* | 519 HF  |  |
| YB9           | 600 SRI              | 97      | 566 HF* | 519 HF  |  |
| BB1           | 650 Supermono        | 97 - 00 | 566 HF* | 519 HF  |  |
| SB7           | 750                  | 96 - 88 | 566 HF* | 519 HF  |  |
| YB4           | 750                  | 89      | 566 HF* | 519 HF  |  |
| 3D            | 800 Tesi             | 16      | 841 HS* | 730 LS  |  |
| 1D            | 851 Tesi             | 91      | 566 HF* | 519 HF  |  |
| 1D            | 900 Tesi             | 93      | 566 HF* | 519 HF  |  |
| DB2           | 900                  | 92 - 00 | 566 HF* | 519 HF  |  |
| DB3           | 900 Mantra           | 97 - 00 | 566 HF* | 519 HF  |  |
| DB4           | 900                  | 99 - 00 | 706 HS* | 519 LS  |  |
| 1D            | 906 Tesi             | 91      | 566 HF* | 519 HF  |  |
|               | 1000 Furano          | 92 - 93 | 566 HF* | 519 HF  |  |
| 2D            | 1000 Tesi            | 04 - 06 | 566 HS* | 519 LS  |  |
| BB3           | 1000                 | 14 - 18 | 901 SP* | 730 LS  |  |
| DB5           | 1000 Mille           | 05 - 11 | 762 SP* | 730 LS  |  |
| DB5           | 1000 S               | 07 - 11 | 762 SP* | 730 LS  |  |

\* = 2 sets required / 2 jeux pour l'Avant.





**RECOMMENDED**

1xx = Scooter Pads  
5xx = Street, Off Road & Racing Pads  
2xxx = Brake Shoes



**BIMOTA**

|      |      |             |         |         |        |
|------|------|-------------|---------|---------|--------|
| DB6  | 1000 | Delirio     | 07 - 09 | 762 HS* | 730 LS |
| SB3  | 1000 | D           | 83      | 506 HF* | 506 HF |
| SB8  | 1000 | R           | 98 - 00 | 706 HS* | 519 LS |
| SB8K | 1000 |             | 06      | 706 HS* | 519 LS |
| SB8K | 1000 | Santamonica | 07 - 09 | 762 HS* | 519 LS |
| YB11 | 1000 |             | 97 - 00 | 566 HF* | 519 HF |
| YB6  | 1000 |             | 89      | 566 HF* | 519 HF |
| YB8  | 1000 |             | 90      | 566 HF* | 519 HF |
|      | 1002 | Dieci       | 91      | 566 HF* | 519 HF |
| DB10 | 1078 | Bimotard    | 12      | 762 HS* | 730 LS |
| DB5  | 1078 | RE          | 12      | 762 HS* | 730 LS |
| DB7  | 1098 |             | 08      | 762 HS* | 730 LS |
| DB7  | 1099 |             | 09      | 901 HS* | 519 LS |
| 3D   | 1100 | Tesi        | 07 - 11 | 762 SP* | 730 LS |
| DB6R | 1100 | Delirio     | 08 - 09 | 762 HS* | 730 LS |
| DBX  | 1100 |             | 13 - 18 | 674 HS* | 671 LS |
| SB6  | 1100 |             | 97 - 00 | 566 HF* | 519 HF |
| DB8  | 1198 |             | 10 - 14 | 901 SP* | 730 LS |
|      | 1200 | Impeto      | 16 - 17 | 841 HS* | 730 LS |
| DB11 | 1200 | VLX         | 13      | 901 HS* | 730 LS |
| DB12 | 1200 |             | 12      | 762 HS* | 730 LS |
| DB9  | 1200 | Brivido     | 12 - 18 | 762 HS* | 730 LS |

**BLATA**

|  |     |        |         |        |        |
|--|-----|--------|---------|--------|--------|
|  | 125 | Enduro | 07 - 08 | 821 HS | 559 HF |
|  | 125 | Motard | 07 - 08 | 821 HS | 559 HF |

**BMW**

|       |     |                           |         |         |         |
|-------|-----|---------------------------|---------|---------|---------|
|       | 125 | C1                        | 00 - 03 | 176 CT  | 175 CT  |
|       | 200 | C1                        | 02 - 04 | 176 CT  | 175 CT  |
| G     | 310 | GS                        | 17 - 18 | 877 HS  | 675 LS  |
| G     | 310 | R                         | 16 - 18 | 877 HS  | 675 LS  |
| C     | 400 | X                         | 18 -    | 231 MS* | 175 MS  |
| G     | 450 | SMR                       | 09 - 10 | 762 RS  | 791 RSI |
| G     | 450 | X                         | 08 - 10 | 671 SI  | 791 SI  |
| R45   | 450 |                           | 78 - 80 | 527 HF* | 2139    |
| R45   | 450 |                           | 80 - 85 | 527 HF* | 2140    |
| C     | 600 | Evolution                 | 12 - 18 | 183 MS* | 183 MS  |
| C     | 600 | Evolution (Parking Brake) | 12 - 18 |         | 209 HF  |
| C     | 600 | Sport                     | 12 - 15 | 183 MS* | 183 MS  |
| C     | 600 | Sport (Parking Brake)     | 12 - 15 |         | 209 HF  |
| R60   | 600 | Series                    | 74 - 80 |         | 2139    |
| R60/7 | 600 |                           | 76 - 77 | 520 HF  | 2139    |
| C     | 650 | GT                        | 12 - 18 | 183 MS* | 183 MS  |
| C     | 650 | GT (Parking Brake)        | 12 - 15 |         | 209 HF  |
| C     | 650 | Sport                     | 16 - 18 | 183 MS* | 183 MS  |
| F     | 650 | , ST                      | 94 - 00 | 674 HF  | 675 HF  |
| F     | 650 | CS Scarver                | 02 - 06 | 674 HS  | 675 LS  |
| F     | 650 | GS                        | 08 - 12 | 674 HS  | 675 LS  |
| F     | 650 | GS ABS                    | 01 - 07 | 674 HF  | 675 HF  |
| F     | 650 | GS ABS                    | 08 - 12 | 674 HS  | 675 LS  |
| F     | 650 | GS Dakar                  | 01 - 07 | 674 HF  | 675 HF  |
| F     | 650 | GS, Rallye                | 01 - 07 | 674 HF  | 675 HF  |
| F     | 650 | ST Strada                 | 97 - 01 | 674 HF  | 675 HF  |
| G     | 650 | GS                        | 09 - 15 | 674 HS  | 675 LS  |
| G     | 650 | GS Sertao                 | 12 - 14 | 674 HS  | 675 LS  |
| G     | 650 | Xchallenge                | 06 - 07 | 674 HS  | 675 LS  |
| G     | 650 | Xcountry                  | 06 - 09 | 674 HS  | 675 LS  |
| G     | 650 | Xmoto                     | 06 - 07 | 706 HS  | 675 LS  |
| R65   | 650 |                           | 78 - 80 | 527 HF  | 2139    |
| R65   | 650 |                           | 80      |         | 2140    |
| R65   | 650 | GS                        | 87 - 92 | 506 HF  | 2140    |
| R65   | 650 | GS                        | 91 - 92 | 506 HS  |         |
| R65   | 650 | LS                        | 82 - 85 | 506 HF* | 2141    |
| R65/1 | 650 |                           | 86      | 554 HF* | 506 HF  |
| F     | 700 | GS                        | 13 - 16 | 674 HS* | 675 LS  |
| R70   | 700 | Series                    | 74 - 80 |         | 2139    |
| F     | 750 | GS                        | 18 -    | 674 HS* | 675 LS  |
| K75   | 750 |                           | 90      | 640 HS  | 506 LS  |
| K75   | 750 | C                         | 85 - 88 | 506 HF* | 2140    |
| K75   | 750 | RT                        | 91 - 96 | 640 HS* | 506 LS  |
| K75   | 750 | S, C                      | 85 - 95 | 506 HF* | 506 HF  |



**RECOMMENDED**

1xx = Scooter Pads  
5xx = Street, Off Road & Racing Pads  
2xxx = Brake Shoes



**BMW**

|        |      |                        |         |         |        |
|--------|------|------------------------|---------|---------|--------|
| R75    | 750  |                        | 86      |         | 2140   |
| R75/6  | 750  |                        | 74 - 76 | 520 HF  | 2139   |
| R75/7  | 750  |                        | 76 - 77 | 520 HF  | 2139   |
|        | 800  | Touring                | 87      |         | 2140   |
| F      | 800  | GS                     | 08 - 18 | 674 HS* | 675 LS |
| F      | 800  | GT                     | 13 - 18 | 706 HS* | 675 LS |
| F      | 800  | R                      | 09 - 14 | 706 HS* | 675 LS |
| F      | 800  | R                      | 15 - 18 | 900 HS* | 675 LS |
| F      | 800  | S                      | 06 - 10 | 706 HS* | 675 LS |
| F      | 800  | ST                     | 06 - 12 | 706 HS* | 675 LS |
| F      | 800  | ST Touring             | 11 - 12 | 706 HS* | 675 LS |
| R80    | 800  |                        | 77 - 85 | 506 HF  | 2140   |
| R80    | 800  |                        | 81      |         | 2139   |
| R80    | 800  |                        | 86 - 88 | 554 HF  | 2140   |
| R80    | 800  | G/S P.-D.              | 86      | 506 HF  | 2140   |
| R80    | 800  | GS                     | 81 - 87 | 506 HF  | 2140   |
| R80    | 800  | GS                     | 91 - 92 | 506 HS  | 2140   |
| R80    | 800  | GS Mystic              | 91 - 95 | 554 HS* | 2140   |
| R80    | 800  | GS Paris Dakar         | 88 - 94 | 554 HS  |        |
| R80    | 800  | R                      | 91 - 95 | 644 HS* | 506 LS |
| R80    | 800  | R                      | 93 - 94 | 640 HS  | 2143   |
| R80    | 800  | RT                     | 83      | 506 HF* | 2140   |
| R80    | 800  | RT                     | 85      | 554 HF* | 2140   |
| R80/7  | 800  |                        | 77 - 78 | 520 HF  | 2139   |
| R80/7  | 800  |                        | 79 - 81 | 520 HF  | 506 HF |
| F      | 850  | GS                     | 18 -    | 674 HS* | 675 LS |
| R      | 850  | C                      | 99 - 01 | 703 HS* | 742 LS |
| R      | 850  | GS                     | 99 - 07 | 703 HS* | 742 LS |
| R      | 850  | R                      | 96 - 02 | 703 HS* | 742 LS |
| R      | 850  | R                      | 03 - 07 | 778 HS* | 742 LS |
| R      | 850  | RT                     | 96 - 01 | 703 HS* | 675 LS |
| R      | 850  | RT With Integral ABS   | 01 - 06 | 796 HS* | 742 LS |
| R90    | 900  | S                      | 73 - 76 | 520 HF* | 2139   |
| R90    | 900  | Series                 | 74 - 80 |         | 2139   |
| R90/6  | 900  |                        | 73 - 76 | 520 HF  | 2139   |
| K1     | 1000 |                        | 89      | 644 HS* | 506 LS |
| K100   | 1000 | LT                     | 87      | 506 HF* | 506 HF |
| K100   | 1000 | LT                     | 92 - 94 | 644 HS* | 506 LS |
| K100   | 1000 | LT ABS                 | 89      | 640 HS* | 506 LS |
| K100   | 1000 | RS                     | 90 - 92 | 644 HS* | 506 LS |
| K100   | 1000 | RS ABS                 | 88 - 89 | 640 HS* | 506 LS |
| K100   | 1000 | RS, RT                 | 83 - 89 | 506 HF* | 506 HF |
| R100   | 1000 |                        | 79 - 81 |         | 2139   |
| R100   | 1000 |                        | 81 - 84 | 506 HF* | 506 HF |
| R100   | 1000 | all models             | 81 - 84 |         | 2140   |
| R100   | 1000 | CS,RS, RT              | 81 - 84 | 506 HF* | 506 HF |
| R100   | 1000 | GS                     | 87 - 94 | 554 HF  | 2140   |
| R100   | 1000 | GS Mystic              | 91 - 94 | 554 HS* | 2140   |
| R100   | 1000 | R                      | 91 - 95 | 644 HS* | 506 LS |
| R100   | 1000 | R                      | 92 - 95 | 644 HS* | 2143   |
| R100   | 1000 | RS                     | 76 - 80 | 520 HF* | 506 HF |
| R100   | 1000 | RS                     | 93 - 95 | 640 HS* | 506 LS |
| R100   | 1000 | RT                     | 91 - 95 | 554 HS* | 2143   |
| R100   | 1000 | S                      | 76 - 77 | 520 HF* | 2139   |
| R100   | 1000 | S                      | 78 - 80 | 520 HF* | 506 HF |
| R100   | 1000 | T                      | 79 - 84 | 520 HF* | 506 HF |
| R100/7 | 1000 |                        | 78 - 80 | 520 HF  | 2139   |
| S      | 1000 | R                      | 13 - 18 | 870 HS* | 675 LS |
| S      | 1000 | RR                     | 09 - 18 | 870 SP* | 675 LS |
| S      | 1000 | RR HP4                 | 12 - 14 | 901 SP* | 675 LS |
| S      | 1000 | XR                     | 15 - 18 | 900 SP* | 742 LS |
| K1100  | 1100 | LT/SE                  | 92 - 00 | 644 HS* | 506 LS |
| K1100  | 1100 | RS                     | 93 - 96 | 644 HS* | 506 LS |
| R      | 1100 | GS                     | 99      | 703 HS* | 742 LS |
| R      | 1100 | R Cast wheels          | 99 - 01 | 703 HS* | 742 LS |
| R      | 1100 | R Spoke wheels         | 99 - 06 | 703 HS* | 742 LS |
| R      | 1100 | RT Cast wheels         | 95 - 01 | 703 HS* | 742 LS |
| R      | 1100 | RT Spoke wheels        | 95 - 01 | 703 HS* | 742 LS |
| R      | 1100 | S                      | 99 - 00 | 703 HS* | 742 LS |
| R      | 1100 | S With Integral ABS    | 01 - 05 | 778 HS* | 742 LS |
| R      | 1100 | S Without Integral ABS | 01 - 05 | 796 HS* | 742 LS |
| R1100  | 1100 | GS                     | 94 - 01 | 703 HS* | 742 LS |

\* = 2 sets required / 2 jeux pour l'Avant.

Full compound selection, see under "Brake pad 1:1 Drawings" / Sélection complète de composés, voir "1:1 Schémas Plaquettes de frein".

**RECOMMENDED**

1xx = Scooter Pads  
5xx = Street, Off Road & Racing Pads  
2xxx = Brake Shoes



| BMW   |                                     |         |         |        |  |
|-------|-------------------------------------|---------|---------|--------|--|
| R1100 | 1100 RS                             | 93      | 644 HS* | 506 LS |  |
| R1100 | 1100 RS                             | 94 - 01 | 703 HS* | 506 LS |  |
| R     | 1150 GS                             | 00 - 01 | 703 HS* | 742 LS |  |
| R     | 1150 GS (Brembo cal.)               | 02 - 05 | 778 HS* | 742 LS |  |
| R     | 1150 GS Adventurer<br>(Tokico cal.) | 02 - 05 | 796 HS* | 742 LS |  |
| R     | 1150 R                              | 01 - 06 | 778 HS* | 742 LS |  |
| R     | 1150 R Rockster                     | 03 - 05 | 778 HS* | 742 LS |  |
| R     | 1150 RS                             | 01 - 04 | 778 HS* | 742 LS |  |
| R     | 1150 RT With Integral ABS           | 01 - 06 | 796 HS* | 742 LS |  |
|       | 1200 HP2 Enduro                     | 04 - 06 | 674 HS* | 671 LS |  |
|       | 1200 HP2 Megamoto                   | 06 - 08 | 796 HS* | 742 LS |  |
|       | 1200 HP2 Sport                      | 08 - 10 | 901 SP* | 671 LS |  |
| K     | 1200 GT (K41)                       |         |         |        |  |
|       | With Integral ABS                   | 02 - 05 | 796 HS* | 506 LS |  |
| K     | 1200 GT (K44)                       |         |         |        |  |
|       | With Integral ABS                   | 04 - 08 | 796 HS* | 671 LS |  |
| K     | 1200 LT                             | 99 - 00 | 703 HS* | 746 HF |  |
| K     | 1200 LT With Integral ABS           | 01 - 08 | 778 HS* | 746 HF |  |
| K     | 1200 R                              | 05 - 08 | 778 HS* | 742 LS |  |
| K     | 1200 R Sport                        | 05 - 07 | 778 HS* | 742 LS |  |
| K     | 1200 RS                             | 97 - 00 | 703 HS* | 506 LS |  |
| K     | 1200 RS                             | 01 - 05 | 796 HS* | 506 LS |  |
| K     | 1200 S                              | 05 - 08 | 796 HS* | 742 LS |  |
| R     | 1200 C                              | 98 - 02 | 703 HS* | 742 LS |  |
| R     | 1200 C Classic                      | 03 - 04 | 778 HS* | 742 LS |  |
| R     | 1200 C Independent                  | 03 - 04 | 778 HS* | 742 LS |  |
| R     | 1200 C Montauk                      | 02 - 04 | 778 HS* | 742 LS |  |
| R     | 1200 CL                             | 03 - 04 | 778 HS* | 746 HF |  |
| R     | 1200 GS                             | 04 - 12 | 796 SP* | 742 LS |  |
| R     | 1200 GS                             | 13 - 18 | 900 SP* | 674 LS |  |
| R     | 1200 GS Adventure                   | 14 - 16 | 900 SP* | 674 LS |  |
| R     | 1200 GS Tripple Black               | 11 - 16 | 796 SP* | 742 LS |  |
| R     | 1200 Nine-T                         | 14 - 18 | 900 HS* | 671 LS |  |
| R     | 1200 Nine-T Pure                    | 17 - 18 | 706 HS* | 671 LS |  |
| R     | 1200 Nine-T Racer                   | 17 - 18 | 706 HS* | 671 LS |  |
| R     | 1200 Nine-T Scrambler               | 16 - 18 | 706 HS* | 671 LS |  |
| R     | 1200 Nine-T Urban GS                | 17 - 18 | 706 SP* | 671 LS |  |
| R     | 1200 R                              | 07 - 14 | 778 HS* | 742 LS |  |
| R     | 1200 R                              | 15 - 18 | 900 HS* | 674 LS |  |
| R     | 1200 RS                             | 14 - 18 | 900 HS* | 674 LS |  |
| R     | 1200 RT                             | 06 - 13 | 796 HS* | 742 LS |  |
| R     | 1200 RT                             | 14 - 18 | 900 HS* | 674 LS |  |
| R     | 1200 S                              | 06 - 07 | 796 HS* | 742 LS |  |
| R     | 1200 ST                             | 06 - 07 | 796 HS* | 742 LS |  |
| K     | 1300 GT                             | 09 - 10 | 796 HS* | 671 LS |  |
| K     | 1300 R                              | 09 - 15 | 778 SP* | 742 LS |  |
| K     | 1300 R Dynamic                      | 11 - 15 | 778 SP* | 742 LS |  |
| K     | 1300 S                              | 09 - 15 | 796 HS* | 742 LS |  |
| K     | 1600 B                              | 17 - 18 | 778 HS* | 674 LS |  |
| K     | 1600 Grand America                  | 18 -    | 778 HS* | 674 LS |  |
| K     | 1600 GT                             | 11 - 18 | 778 HS* | 674 LS |  |
| K     | 1600 GTL                            | 11 - 18 | 778 HS* | 674 LS |  |

**BOMBARDIER**

|    |                             |         |         |        |  |
|----|-----------------------------|---------|---------|--------|--|
|    | 50 Quest                    | 03 - 04 | 2048    | 2041   |  |
| DS | 50                          | 02 - 06 | 2048    | 2041   |  |
|    | 90 Quest                    | 03 - 04 | 2048    | 2041   |  |
| DS | 90                          | 02 - 06 | 2048    | 2041   |  |
|    | 200 Rally 2x4               | 03 - 04 | 544 SI* |        |  |
|    | 200 Rally 2x4               | 05 - 06 | 544 SI* | 546 SI |  |
| DS | 250 Left/Rear               | 06      | 754 SI  | 754 SI |  |
| DS | 250 Right                   | 06      | 767 SI  |        |  |
|    | 330 Outlander Left/Rear     | 03 - 06 | 754 SI  | 754 SI |  |
|    | 330 Outlander Right         | 03 - 06 | 767 SI  |        |  |
|    | 400 Outlander Left/Rear     | 03 - 06 | 754 SI  | 754 SI |  |
|    | 400 Outlander Max Left/Rear | 03 - 06 | 754 SI  | 754 SI |  |
|    | 400 Outlander Max Right     | 03 - 06 | 767 SI  |        |  |
|    | 400 Outlander Right         | 03 - 06 | 767 SI  |        |  |
|    | 500 Quest Left/Rear         | 02 - 06 | 754 SI  | 754 SI |  |
|    | 500 Quest Right             | 02 - 06 | 767 SI  |        |  |
|    | 500 Traxter 4x4             | 99 - 00 | 730 HF* | 730 HF |  |

**BOMBARDIER**

|    |                            |         |        |        |  |
|----|----------------------------|---------|--------|--------|--|
|    | 500 Traxter 4x4 Left/Rear  | 01 - 06 | 754 SI | 767 SI |  |
|    | 500 Traxter 4x4 Right      | 01 - 06 | 767 SI |        |  |
|    | 500 Traxter Max Left/Rear  | 03 - 05 | 754 SI | 767 SI |  |
|    | 500 Traxter Max Right      | 03 - 05 | 767 SI |        |  |
|    | 650 Quest Left/Rear        | 02 - 06 | 754 SI | 754 SI |  |
|    | 650 Quest Max Left/Rear    | 03 - 06 | 754 SI | 767 SI |  |
|    | 650 Quest Max Right        | 03 - 06 | 767 SI |        |  |
|    | 650 Quest Right            | 02 - 06 | 767 SI |        |  |
|    | 650 Traxter Max Left/Rear  | 03 - 05 | 754 SI | 767 SI |  |
|    | 650 Traxter Max Right      | 03 - 05 | 767 SI |        |  |
| DS | 650 Left/Rear              | 01 - 06 | 754 SI | 754 SI |  |
| DS | 650 Right                  | 01 - 06 | 767 SI |        |  |
|    | 800 Outlander Left/Rear    | 06      | 754 SI | 754 SI |  |
|    | 800 Outlander Right        | 06      | 767 SI |        |  |
|    | 800 Outlander XT Left/Rear | 06      | 754 SI | 754 SI |  |
|    | 800 Outlander XT Right     | 06      | 767 SI |        |  |

**BORILE**

|   |            |         |        |        |  |
|---|------------|---------|--------|--------|--|
| B | 500 CR, MT | 02 - 04 | 566 HF | 675 HF |  |
|---|------------|---------|--------|--------|--|

**BRAMMO**

|  |         |         |         |        |  |
|--|---------|---------|---------|--------|--|
|  | Empulse | 14 - 16 | 706 HS* | 730 LS |  |
|--|---------|---------|---------|--------|--|

**BS VILLA**

|    |    |    |        |      |  |
|----|----|----|--------|------|--|
| AX | 50 | 93 | 111 HF | 2012 |  |
| GZ | 50 | 93 | 111 HF | 2012 |  |
| ZX | 50 | 93 | 115 HF | 2057 |  |

**BUELL**

|         |                     |         |        |        |  |
|---------|---------------------|---------|--------|--------|--|
|         | all models          | 94 - 97 | 658 HF | 692 HF |  |
|         | 500 Blast           | 01 - 09 | 627 HF | 614 HF |  |
| XB9R    | 984 Firebolt        | 02 - 10 | 795 HS | 614 LS |  |
| XB9S    | 984 Lightning       | 03 - 10 | 795 HS | 614 LS |  |
| XB9SX   | 984 CityX           | 05 - 10 | 795 HS | 614 LS |  |
|         | 1125 CR             | 09 - 10 | 856 HS | 857 LS |  |
|         | 1125 R              | 08 - 10 | 856 HS | 857 LS |  |
| M2      | 1200 Cyclone        | 98 - 02 | 676 HS | 614 LS |  |
| RS      | 1200                | 12      | 658 HF | 692 HF |  |
| S1      | 1200 Lightning      | 98 - 02 | 676 HS | 614 LS |  |
| S1      | 1200 Whitelightning | 98 - 02 | 676 HS | 614 LS |  |
| S3      | 1200 Thunderbolt    | 98 - 02 | 676 HS | 614 LS |  |
| X1      | 1200 Lightning      | 01 - 02 | 676 HS | 614 LS |  |
| XB12R   | 1200 Firebolt       | 04 - 08 | 795 HS | 614 LS |  |
| XB12R   | 1200 Firebolt       | 09 - 10 | 856 HS | 614 LS |  |
| XB12S   | 1200 Lightning      | 04 - 08 | 795 HS | 614 LS |  |
| XB12Scg | 1200 Lightning      | 06 - 08 | 795 HS | 614 LS |  |
| XB12Scg | 1200 Lightning      | 09 - 10 | 856 HS | 614 LS |  |
| XB12Ss  | 1200 Lightning Long | 06 - 08 | 795 HS | 614 LS |  |
| XB12Ss  | 1200 Lightning Long | 09 - 10 | 856 HS | 614 LS |  |
| XB12STT | 1200 Super TT       | 07 - 10 | 795 HS | 614 LS |  |
| XB12X   | 1200 Ulysses        | 06 - 10 | 795 HS | 614 LS |  |

**BULTACO**

|  |           |         |        |        |  |
|--|-----------|---------|--------|--------|--|
|  | 50 Astro  | 01 - 06 | 148 HF | 105 HF |  |
|  | 50 Lobito | 99 - 06 | 148 HF | 105 HF |  |

**CAGIVA**

|  |                   |         |        |        |  |
|--|-------------------|---------|--------|--------|--|
|  | 50 City           | 95 - 97 | 140 HF | 2012   |  |
|  | 50 Lucky Explorer | 88 - 02 | 519 HF | 574 HF |  |
|  | 50 AJP Caliper    |         |        |        |  |
|  | incl. pin/spring  | 90 - 18 | 188 HF |        |  |
|  | 50 Blues          | 89      | 108 HF | 106 HF |  |
|  | 50 City           | 92 - 94 | 115 HF | 2012   |  |
|  | 50 City           | 08      | 111 HF |        |  |
|  | 50 Cocis          | 88      | 138 HF | 106 HF |  |
|  | 50 Cocis          | 89      | 519 HF | 519 HF |  |
|  | 50 Corsa          | 98      | 105 HF |        |  |
|  | 50 Cucciolo       | 97 - 99 | 138 HF |        |  |
|  | 50 Mantis         | 99      | 105 HF | 2181   |  |
|  | 50 Mito           | 99 - 06 | 103 HF | 105 HF |  |
|  | 50 Nag            | 08      | 141 HF |        |  |
|  | 50 Nuvola         | 00      | 138 HF |        |  |

\* = 2 sets required / 2 jeux pour l'Avant.



**RECOMMENDED**

1xx = Scooter Pads  
5xx = Street, Off Road & Racing Pads  
2xxx = Brake Shoes



| CAGIVA |                       |         |         |        |
|--------|-----------------------|---------|---------|--------|
|        | 50 Prima              | 92      | 519 HF  | 519 HF |
|        | 50 Prima              | 93 - 94 | 672 HF  | 680 HF |
|        | 50 Progress           | 98 - 99 | 105 HF  |        |
|        | 50 Super City         | 93 - 95 | 641 HF  | 519 HF |
|        | 50 Supercity          | 92      | 519 HF  | 519 HF |
|        | 50 W 4                | 92      | 519 HF  | 519 HF |
| WMX    | 50                    | 89      | 608 HF  | 651 HF |
|        | 80 City               | 93 - 95 | 126 HF  | 117 HF |
|        | 80 Cocis              | 91      | 519 HF  | 574 HF |
|        | 80 Prima              | 92      | 672 HF  | 680 HF |
|        | 80 Super City         | 94 - 84 | 641 HF  | 519 HF |
|        | 80 Supercity          | 92 - 93 | 519 HF  | 519 HF |
|        | 80 W 4                | 92      | 519 HF  | 519 HF |
| LR     | 80                    | 83      | 519 HF  |        |
| SST    | 80                    | 83      | 519 HF  |        |
| SXT    | 80                    | 83      | 519 HF  |        |
|        | 110 Passing           | 94      | 611 HF  |        |
|        | 125 Cross             | 86      | 608 SI  | 692 SI |
|        | 125 Dakar             | 86      | 519 HF  |        |
|        | 125 Elefantre         | 87 - 88 | 519 HF  |        |
|        | 125 Enduro            | 86      | 519 HF  |        |
|        | 125 Planet            | 97 - 07 | 566 HF  | 519 HF |
|        | 125 W 8               | 96 - 01 | 641 HF  | 692 HF |
|        | 125 Aletta Electra    | 83 - 86 | 574 HF  |        |
|        | 125 Aletta Electra    | 87      | 519 HF  |        |
|        | 125 Aletta Oro        | 85 - 89 | 574 HF  | 574 HF |
|        | 125 Aletta Oro        | 86 - 89 | 519 HF* | 519 HF |
|        | 125 Blues             | 87 - 85 | 588 HF  | 519 HF |
|        | 125 Blues             | 93      | 519 HF  | 519 HF |
|        | 125 Brillo            | 08      | 723 HF  |        |
|        | 125 Cruiser           | 88 - 89 | 594 HF  | 519 HF |
|        | 125 Cruiser           | 89      | 608 HF  | 574 HF |
|        | 125 Cucciolo          | 00 - 01 | 138 CT  |        |
|        | 125 E2                | 86      | 574 HF  |        |
|        | 125 Elefant           | 81 - 88 | 574 HF  |        |
|        | 125 Freccia           | 89      | 608 HF  | 519 HF |
|        | 125 Freccia C 12 R    | 91      | 641 HF  | 519 HF |
|        | 125 Mito              | 91 - 92 | 641 HF  | 519 HF |
|        | 125 Mito              | 93 - 07 | 566 HF  | 519 HF |
|        | 125 Nuvola            | 00      | 138 CT  |        |
|        | 125 Raptor            | 03 - 10 | 566 HF  | 519 HF |
|        | 125 Roadster          | 94 - 97 | 588 HF  |        |
|        | 125 SST               | 81      | 574 HF  |        |
|        | 125 Stella            | 97 - 08 | 103 CT  |        |
|        | 125 Supercity         | 92 - 00 | 608 HF  | 519 HF |
|        | 125 Tamanaco          | 87 - 92 | 608 HF  | 574 HF |
|        | 125 Tamanaco          | 89      | 608 HF  | 519 HF |
|        | 125 W 8               | 92 - 95 | 519 HF  | 519 HF |
|        | 125 WSTX Aletta Rossa | 83 - 84 | 574 HF  |        |
| K7     | 125                   | 91 - 94 | 641 HF  | 519 HF |
| N1     | 125                   | 96 - 99 | 641 HF  | 519 HF |
| N90    | 125                   | 91 - 98 | 641 HF  | 574 HF |
| WMX    | 125                   | 88      | 608 SI  |        |
| WMX    | 125                   | 89 - 90 | 608 SI  | 692 SI |
| WMX    | 125 GP-Replica        | 86 - 89 | 519 SI  |        |
| WRX    | 125                   | 85      | 519 HF  |        |
|        | 200 Elefant           | 86      | 519 HF  |        |
|        | 200 Aletta Electra    | 83      | 574 HF  |        |
|        | 200 Cross             | 83 - 86 | 574 HF  |        |
|        | 200 Roadster          | 96 - 01 | 588 HF  |        |
|        | 250 Cross             | 86      | 608 SI  |        |
| MXR    | 250                   | 82      | 519 HF  |        |
| SST    | 250 Ala Verde         | 81 - 82 | 519 HF  |        |
| WMX    | 250                   | 88      | 608 SI  |        |
| WMX    | 250                   | 89 - 90 | 608 SI  | 692 SI |
| WMX    | 250 GP                | 82      | 519 SI  |        |
|        | 350 Alazzurra         | 85 - 86 | 519 HF  | 519 HF |
|        | 350 Alazzurra         | 87      | 519 HF* | 519 HF |
|        | 350 Elefant           | 86 - 89 | 594 HF  | 519 HF |
|        | 350 W 12              | 92 - 95 | 641 HF  | 519 HF |
| SST    | 350                   | 83      | 519 HF  |        |
| SST    | 350 Ala Verde         | 81 - 82 | 519 HF  |        |



**RECOMMENDED**

1xx = Scooter Pads  
5xx = Street, Off Road & Racing Pads  
2xxx = Brake Shoes



| CAGIVA        |                             |         |         |        |
|---------------|-----------------------------|---------|---------|--------|
| SXT           | 350 Ala Rosa                | 82      | 519 HF  |        |
| T4            | 350 E                       | 87 - 91 | 519 HF  |        |
| T4            | 350 R                       | 87 - 99 | 519 HF  | 2026   |
| MXR           | 400                         | 82      | 519 HF  |        |
|               | 500 Canyon                  | 99 - 01 | 647 HS  | 638 LS |
|               | 500 Mito                    | 07      | 566 HS  | 519 LS |
|               | 500 River                   | 00 - 01 | 566 HF  | 519 HF |
| MXR           | 500                         | 82      | 519 HF  |        |
| T4            | 500 E                       | 87 - 90 | 519 HF  | 2026   |
| WMX           | 500                         | 85 - 86 | 519 SI  |        |
| WMX           | 500 Cross                   | 87      | 519 SI  | 519 SI |
| SP            | 525 Mito                    | 08 - 10 | 566 HS  | 519 LS |
|               | 600 Canyon                  | 95 - 99 | 611 HS  | 638 LS |
|               | 600 River                   | 94 - 99 | 566 HF  | 519 HF |
|               | 600 W 16                    | 95 - 97 | 641 HF  | 692 HF |
|               | 650 Alazzurra               | 84      | 519 HF  | 519 HF |
|               | 650 Alazzurra               | 85 - 88 | 560 HF* | 560 HF |
|               | 650 Elefant                 | 86 - 87 | 594 HF  | 519 HF |
|               | 650 Raptor                  | 01 - 08 | 706 HS* | 730 LS |
|               | 650 V-Raptor                | 01 - 08 | 706 HS* | 730 LS |
|               | 750 Elefant                 | 88      | 519 HF  | 519 HF |
|               | 750 Elefant                 | 93 - 95 | 647 HS  | 671 LS |
|               | 750 Elefant Bifaro          | 90      | 594 HF  | 641 HF |
|               | 750 Lucky Explorer          | 88      | 594 HF  | 519 HF |
|               | 900 Canyon I.E.             | 97      | 647 HS  | 638 LS |
|               | 900 Elefant                 | 93 - 97 | 671 HF* | 671 HF |
|               | 900 Elefant I.E.            | 91 - 92 | 647 HS  | 638 LS |
|               | 900 Gran Canyon             | 99 - 04 | 627 HS* | 638 LS |
|               | 1000 Navigator, T           | 00 - 05 | 627 HS* | 638 LS |
|               | 1000 Raptor                 | 00 - 08 | 706 HS* | 730 LS |
|               | 1000 V-Raptor               | 00 - 08 | 706 HS* | 730 LS |
|               | 1000 X3 Raptor              | 04      | 762 HS* | 730 LS |
|               | 1000 X-Raptor               | 03 - 04 | 762 HS* | 730 LS |
|               | 1000 Xtra Raptor            | 02 - 06 | 706 HS* | 730 LS |
| <b>CAN-AM</b> |                             |         |         |        |
| DS            | 50                          | 07 - 11 | 2048    | 2041   |
| DS            | 70                          | 08 - 14 | 2048    | 2041   |
| DS            | 90                          | 07 - 17 | 2048    | 2041   |
| DS            | 90 X                        | 08 - 17 | 544 SI* | 544 SI |
|               | 200 ASE                     | 86      | 519 SI  |        |
|               | 250 ASE                     | 86      | 519 SI  |        |
|               | 250 MX LC                   | 86      | 519 SI  |        |
| DS            | 250                         | 08 - 16 | 810 SI* | 810 SI |
|               | 350 ASE                     | 86      | 519 SI  |        |
|               | 400 Outlander EFi           |         |         |        |
|               | Left/Rear                   | 09 - 14 | 754 SI  | 754 SI |
|               | 400 Outlander EFi Right     | 09 - 14 | 767 SI  |        |
|               | 400 Outlander MAX STD       |         |         |        |
|               | Left/Rear                   | 07 - 13 | 754 SI  | 754 SI |
|               | 400 Outlander MAX STD       |         |         |        |
|               | Right                       | 07 - 13 | 767 SI  |        |
|               | 400 Outlander MAX XT        |         |         |        |
|               | Left/Rear                   | 07 - 13 | 754 SI  | 754 SI |
|               | 400 Outlander MAX XT Right  | 07 - 13 | 767 SI  |        |
|               | 400 Outlander STD Left/Rear | 07 - 14 | 754 SI  | 754 SI |
|               | 400 Outlander STD Right     | 07 - 14 | 767 SI  |        |
|               | 400 Outlander XT Left/Rear  | 07 - 14 | 754 SI  | 754 SI |
|               | 400 Outlander XT Right      | 07 - 14 | 767 SI  |        |
|               | 406 ASE                     | 87      | 519 SI  |        |
|               | 450 Outlander Left          | 15 - 17 | 911 SI  |        |
|               | 450 Outlander Right/Rear    | 15 - 17 | 910 SI  | 910 SI |
|               | 450 Outlander MAX Left      | 15 - 17 | 911 SI  |        |
|               | 450 Outlander MAX           |         |         |        |
|               | Right/Rear                  | 15 - 17 | 910 SI  | 910 SI |
| DS            | 450                         | 08 - 12 | 907 SI* | 908 SI |
|               | 500 ASE                     | 86      | 519 SI  |        |
|               | 500 MX                      | 86      | 519 SI  |        |
|               | 500 Outlander MAX STD       |         |         |        |
|               | Left/Rear                   | 07 - 12 | 754 SI  | 754 SI |
|               | 500 Outlander MAX STD       |         |         |        |
|               | Right                       | 07 - 12 | 767 SI  |        |

\* = 2 sets required / 2 jeux pour l'Avant.

Full compound selection, see under "Brake pad 1:1 Drawings" / Sélection complète de composés, voir "1:1 Schémas Plaquettes de frein".

**RECOMMENDED**1xx = Scooter Pads  
5xx = Street, Off Road & Racing Pads  
2xxx = Brake Shoes**CAN-AM**

|      |                         |         |        |        |  |
|------|-------------------------|---------|--------|--------|--|
| 500  | Outlander MAX XT        |         |        |        |  |
|      | Left/Rear               | 07 - 12 | 754 SI | 754 SI |  |
| 500  | Outlander MAX XT Right  | 07 - 12 | 767 SI |        |  |
| 500  | Outlander STD Left/Rear | 07 - 12 | 754 SI | 754 SI |  |
| 500  | Outlander STD Right     | 07 - 12 | 767 SI |        |  |
| 500  | Outlander XT Left/Rear  | 07 - 12 | 754 SI | 754 SI |  |
| 500  | Outlander XT Right      | 07 - 12 | 767 SI |        |  |
| 500  | Outlander Left          | 13 - 14 | 911 SI |        |  |
| 500  | Outlander Right/Rear    | 13 - 14 | 910 SI | 910 SI |  |
| 500  | Outlander MAX Left      | 13 - 14 | 911 SI |        |  |
| 500  | Outlander MAX           |         |        |        |  |
|      | Right/Rear              | 13 - 14 | 910 SI | 910 SI |  |
| 500  | Renegade Left/Rear      | 08 - 11 | 754 SI | 754 SI |  |
| 500  | Renegade Right          | 08 - 11 | 767 SI |        |  |
| 500  | Renegade Left           | 12 - 13 | 911 SI |        |  |
| 500  | Renegade Right/Rear     | 12 - 13 | 910 SI | 910 SI |  |
| 500  | Renegade Left/Rear      | 14      | 911 SI | 911 SI |  |
| 500  | Renegade Right/Rear     | 14      | 910 SI | 910 SI |  |
| 560  | Sonic                   | 86 - 14 | 519 SI |        |  |
| 650  | Outlander MAX STD       |         |        |        |  |
|      | Left/Rear               | 07 - 12 | 754 SI | 754 SI |  |
| 650  | Outlander MAX STD       |         |        |        |  |
|      | Right                   | 07 - 12 | 767 SI |        |  |
| 650  | Outlander MAX XT        |         |        |        |  |
|      | Left/Rear               | 07 - 12 | 754 SI | 754 SI |  |
| 650  | Outlander MAX XT Right  | 07 - 12 | 767 SI |        |  |
| 650  | Outlander STD Left/Rear | 07 - 12 | 754 SI | 754 SI |  |
| 650  | Outlander STD Right     | 07 - 12 | 767 SI |        |  |
| 650  | Outlander XT Left/Rear  | 07 - 12 | 754 SI | 754 SI |  |
| 650  | Outlander XT Right      | 07 - 12 | 767 SI |        |  |
| 650  | Outlander Left          | 13 - 15 | 911 SI |        |  |
| 650  | Outlander Right/Rear    | 13 - 15 | 910 SI | 910 SI |  |
| 650  | Outlander MAX Left      | 13 - 15 | 911 SI |        |  |
| 650  | Outlander MAX           |         |        |        |  |
|      | Right/Rear              | 13 - 15 | 910 SI | 910 SI |  |
| 800  | Commander Left/Rear     | 11 - 14 | 638 SI | 611 SI |  |
| 800  | Commander Right         | 11 - 14 | 611 SI |        |  |
| 800  | Outlander MAX LTD       |         |        |        |  |
|      | Left/Rear               | 07 - 11 | 754 SI | 754 SI |  |
| 800  | Outlander MAX LTD       |         |        |        |  |
|      | Right                   | 07 - 11 | 767 SI |        |  |
| 800  | Outlander MAX STD       |         |        |        |  |
|      | Left/Rear               | 07 - 11 | 754 SI | 754 SI |  |
| 800  | Outlander MAX STD       |         |        |        |  |
|      | Right                   | 07 - 11 | 767 SI |        |  |
| 800  | Outlander MAX XT        |         |        |        |  |
|      | Left/Rear               | 07 - 11 | 754 SI | 754 SI |  |
| 800  | Outlander MAX XT Right  | 07 - 11 | 767 SI |        |  |
| 800  | Outlander STD Left/Rear | 07 - 11 | 754 SI | 754 SI |  |
| 800  | Outlander STD Right     | 07 - 11 | 767 SI |        |  |
| 800  | Outlander XT Left/Rear  | 07 - 11 | 754 SI | 754 SI |  |
| 800  | Outlander XT Right      | 07 - 11 | 767 SI |        |  |
| 800  | Outlander Left          | 12 - 15 | 911 SI |        |  |
| 800  | Outlander Right/Rear    | 12 - 15 | 910 SI | 910 SI |  |
| 800  | Outlander MAX Left      | 13 - 14 | 911 SI |        |  |
| 800  | Outlander MAX           |         |        |        |  |
|      | Right/Rear              | 13 - 14 | 910 SI | 910 SI |  |
| 800  | Renegade EFi Left/Rear  | 07 - 11 | 754 SI | 754 SI |  |
| 800  | Renegade EFi Right      | 07 - 11 | 767 SI |        |  |
| 800  | Renegade Left/Rear      | 08 - 11 | 754 SI | 754 SI |  |
| 800  | Renegade Right          | 08 - 11 | 767 SI |        |  |
| 800  | Renegade X Left/Rear    | 08 - 11 | 754 SI | 754 SI |  |
| 800  | Renegade X Right        | 08 - 11 | 767 SI |        |  |
| 800  | Renegade Left           | 12 - 13 | 911 SI |        |  |
| 800  | Renegade Right/Rear     | 12 - 13 | 910 SI | 910 SI |  |
| 800  | Renegade Left/Rear      | 14 - 15 | 911 SI | 911 SI |  |
| 800  | Renegade Right/Rear     | 14 - 15 | 910 SI | 910 SI |  |
| 1000 | Commander Left/Rear     | 11 - 14 | 638 SI | 611 SI |  |
| 1000 | Commander Right         | 11 - 14 | 611 SI |        |  |
| 1000 | Commander MAX Left      | 14 - 16 | 638 SI | 754 SI |  |
| 1000 | Commander MAX Right     | 14 - 16 | 611 SI | 767 SI |  |
| 1000 | Maverick Left           | 13 - 17 | 638 SI | 754 SI |  |

**RECOMMENDED**1xx = Scooter Pads  
5xx = Street, Off Road & Racing Pads  
2xxx = Brake Shoes**CAN-AM**

|                   |                        |         |         |         |  |
|-------------------|------------------------|---------|---------|---------|--|
| 1000              | Maverick Right         | 13 - 17 | 611 SI  | 767 SI  |  |
| 1000              | Outlander Left         | 12 - 15 | 911 SI  |         |  |
| 1000              | Outlander Right/Rear   | 12 - 15 | 910 SI  | 910 SI  |  |
| 1000              | Outlander MAX Left     | 12 - 16 | 911 SI  |         |  |
| 1000              | Outlander MAX          |         |         |         |  |
|                   | Right/Rear             | 12 - 16 | 910 SI  | 910 SI  |  |
| 1000              | Renegade Left          | 12 - 13 | 911 SI  |         |  |
| 1000              | Renegade Right/Rear    | 12 - 13 | 910 SI  | 910 SI  |  |
| 1000              | Renegade Left/Rear     | 14 - 16 | 911 SI  | 911 SI  |  |
| 1000              | Renegade Right/Rear    | 14 - 16 | 910 SI  | 910 SI  |  |
| 1330              | Spyder RS              | 14 - 16 | 900 HS* | 948 HS  |  |
| 1330              | Spyder RS RSS          | 13      | 900 HS* | 948 HS  |  |
| 1330              | Spyder RSS             | 14 - 15 | 900 HS* | 948 HS  |  |
|                   | Special Series         | 15      | 900 HS* | 948 HS  |  |
| 1330              | Spyder RT              | 14 - 18 | 900 HS* | 948 HS  |  |
| 1330              | Spyder RT Limited      | 13 - 18 | 900 HS* | 948 HS  |  |
| 1330              | Spyder RT RTS          | 13      | 900 HS* | 948 HS  |  |
| 1330              | Spyder RTS             | 14 - 15 | 900 HS* | 948 HS  |  |
| 1330              | Spyder RTS             |         |         |         |  |
|                   | Special Series         | 15      | 900 HS* | 948 HS  |  |
| 1330              | Spyder F3              | 15 - 18 | 900 HS* | 948 HS  |  |
| 1330              | Spyder F3 Limited      | 16 - 18 | 900 HS* | 948 HS  |  |
| 1330              | Spyder F3-S            | 15 - 18 | 900 HS* | 948 HS  |  |
| 1330              | Spyder F3-T            | 16 - 18 | 900 HS* | 948 HS  |  |
| 1330              | Spyder ST              | 14 - 16 | 900 HS* | 948 HS  |  |
| 1330              | Spyder ST Limited      | 13 - 15 | 900 HS* | 948 HS  |  |
| 1330              | Spyder ST STS          | 13      | 900 HS* | 948 HS  |  |
| 1330              | Spyder STS             | 14 - 15 | 900 HS* | 948 HS  |  |
| 1330              | Spyder STS             |         |         |         |  |
|                   | Special Series         | 15      | 900 HS* | 948 HS  |  |
| <b>CANNONDALE</b> |                        |         |         |         |  |
| MX                | 400                    | 00 - 03 | 694 RSI | 632 RSI |  |
|                   | 440 Blaze Left/Rear    | 03      | 754 SI  | 754 SI  |  |
|                   | 440 Blaze Right        | 03      | 767 SI  |         |  |
|                   | 440 Cannibal Left/Rear | 03      | 754 SI  | 754 SI  |  |
|                   | 440 Cannibal Right     | 03      | 767 SI  |         |  |
|                   | 440 Glamis Left/Rear   | 03      | 754 SI  | 754 SI  |  |
|                   | 440 Glamis Right       | 03      | 767 SI  |         |  |
|                   | 440 Moto Left/Rear     | 03      | 754 SI  | 754 SI  |  |
|                   | 440 Moto Right         | 03      | 767 SI  |         |  |
|                   | 440 Speed Left/Rear    | 03      | 754 SI  | 754 SI  |  |
|                   | 440 Speed Right        | 03      | 767 SI  |         |  |
| C                 | 440 R                  | 03      | 694 RSI | 632 RSI |  |
| E                 | 440 , A, R             | 03      | 694 RSI | 632 RSI |  |
| S                 | 440                    | 03      | 566 HF  | 632 HF  |  |
| X                 | 440                    | 03      | 694 RSI | 632 RSI |  |
| <b>CASAL</b>      |                        |         |         |         |  |
| RZ                | 50                     | 82      | 532 HF  |         |  |
| <b>CCM</b>        |                        |         |         |         |  |
|                   | 450 MX                 | 08 - 10 | 671 RSI | 790 RSI |  |
| GP                | 450                    | 16      | 671 SI  | 675 SI  |  |
| 604               | 600 RS                 | 01      | 671 HF  | 675 HF  |  |
| 604E              | 600 Sport              | 99 - 01 | 671 SI  | 675 SI  |  |
| 604E              | 600 Supermoto          | 99 - 01 | 671 SI  | 675 SI  |  |
| C25               | 600                    | 96 - 98 | 671 SI  | 675 SI  |  |
|                   | 644 DS                 | 03 - 06 | 671 HF  | 675 HF  |  |
|                   | 644 R30                | 02 - 06 | 671 HF  | 675 HF  |  |
| <b>CECTEK</b>     |                        |         |         |         |  |
|                   | 500 EFI Gladiator      | 09 - 13 | 810 HF* | 544 HF  |  |
|                   | 500 EFI King Cobra     | 09 - 13 | 878 HF* | 544 HF  |  |
|                   | 500 EFI Quadrift       | 09 - 11 | 878 HF* | 544 HF  |  |
|                   | 500 i Estoc            | 10      | 878 HF* | 544 HF  |  |
| <b>CF MOTO</b>    |                        |         |         |         |  |
|                   | 125 Papio              | 17      | 688 HF  | 784 HF  |  |
|                   | 400 NK Efi             | 17      | 674 HS* | 675 LS  |  |
|                   | 450 C-Force L          | 16 - 17 | 914 SI* | 799 SI  |  |

\* = 2 sets required / 2 jeux pour l'Avant.

**RECOMMENDED**

 1xx = Scooter Pads  
 5xx = Street, Off Road & Racing Pads  
 2xxx = Brake Shoes

**CF MOTO**

|    |                      |         |         |        |
|----|----------------------|---------|---------|--------|
|    | 450 G-Force L        | 16 - 17 | 914 SI* | 799 SI |
| CF | 500 Terralander      | 13 - 15 | 914 SI* | 799 SI |
|    | 550 C-Force          | 16 - 17 | 914 SI* | 799 SI |
|    | 550 U-Force Left     | 15 - 16 | 638 SI  |        |
|    | 550 U-Force Right    | 15 - 16 | 611 SI  |        |
|    | 550 Z-Force Left     | 15 - 16 | 638 SI  |        |
|    | 550 Z-Force Right    | 15 - 16 | 611 SI  |        |
| CF | 625 Terralander      | 11 - 15 | 914 SI* | 799 SI |
|    | 650 NK               | 14 - 16 | 674 HS* | 675 LS |
|    | 650 NK Efi           | 17      | 674 HS* | 675 LS |
|    | 650 TK               | 14 - 15 | 674 HS* | 675 LS |
|    | 800 Z-Force EX Left  | 15      | 638 SI  |        |
|    | 800 Z-Force EX Right | 15      | 611 SI  |        |
| CF | 800 Terralander      | 12 - 14 | 914 SI* | 799 SI |

**CIMATTI**

|  |           |    |        |  |
|--|-----------|----|--------|--|
|  | 50 Gringo | 85 | 532 HF |  |
|--|-----------|----|--------|--|

**COBRA**

|    |              |         |         |         |
|----|--------------|---------|---------|---------|
| CX | 50 Big Wheel | 10 - 14 | 794 RSI | 794 RSI |
| CX | 50 Junior    | 07 - 10 | 794 RSI |         |
| CX | 50 Junior    | 11 - 13 | 794 RSI | 794 RSI |
| CX | 50 Senior    | 07 - 13 | 794 RSI | 794 RSI |

**CPI**

|    |                          |         |         |        |
|----|--------------------------|---------|---------|--------|
|    | 50 Aragon Club           | 07 - 09 | 141 HF  |        |
|    | 50 Aragon GP             | 06 - 09 | 141 HF  |        |
|    | 50 Aragon SP             | 07 - 09 | 141 HF  |        |
|    | 50 Baby                  | 02      | 101 HF  | 2028   |
|    | 50 Freaky                | 07      | 141 HF  |        |
|    | 50 GTR                   | 02      | 120 HF  |        |
|    | 50 GTR                   | 03 - 09 | 157 HF  | 123 HF |
|    | 50 GTS                   | 02 - 03 | 120 HF  | 145 HF |
|    | 50 Hussar                | 01 - 02 | 101 HF  | 2028   |
|    | 50 Hussar                | 03 - 06 | 141 HF  | 2028   |
|    | 50 Mars                  | 01 - 02 | 101 HF  | 2028   |
|    | 50 Oliver                | 03 - 12 | 141 HF  | 2028   |
|    | 50 Oliver City           | 03 - 12 | 141 HF  | 2028   |
|    | 50 Oliver Sport          | 03 - 12 | 141 HF  | 2028   |
|    | 50 Popcorn               | 01 - 02 | 101 HF  | 2028   |
|    | 50 Popcorn               | 03 - 06 | 141 HF  | 2032   |
|    | 50 Supermoto, Supercross | 03 - 09 | 105 HF  | 105 HF |
|    | 125 Aragon GP            | 07 - 12 | 141 CT  |        |
|    | 125 GTR, GTS             | 02 - 03 | 120 CT  | 143 CT |
|    | 125 Sahel                | 02      | 694 HF  | 604 HF |
|    | 125 Supermoto            | 07 - 12 | 559 HF  |        |
|    | 125 X-Large              | 02 - 03 | 157 CT* | 157 CT |
|    | 200 GTR, GTS             | 02 - 03 | 120 CT  | 143 CT |
|    | 200 X-Large              | 02 - 03 | 157 CT* | 157 CT |
|    | 250 XS ATV               | 07 - 08 | 810 SI* |        |
| XS | 250 Quad                 | 06 - 08 | 544 SI* | 848 SI |

**CZ**

|    |     |    |        |  |
|----|-----|----|--------|--|
| CZ | 180 | 93 | 506 HF |  |
|----|-----|----|--------|--|

**DAELIM**

|    |                    |         |        |        |
|----|--------------------|---------|--------|--------|
|    | 50 a Four          | 06 - 12 | 163 HF |        |
|    | 50 Besbi           | 07      | 121 HF |        |
|    | 50 Bonita          | 09 - 12 | 115 HF |        |
|    | 50 Delfino         | 99      | 100 HF | 2069   |
|    | 50 E-Five          | 03 - 08 | 100 HF |        |
|    | 50 History, S-Five | 01      | 100 HF | 100 HF |
|    | 50 Message II      | 02      | 100 HF |        |
|    | 50 Tapo            | 99 - 04 | 100 HF | 2069   |
|    | 50 Vivo            | 99      | 100 HF | 2069   |
| GZ | 50 G Message       | 98 - 01 | 115 HF |        |
| SE | 50 Cordi           | 06 - 12 | 100 HF |        |
| SJ | 50 S-Five          | 06 - 12 | 115 HF |        |
|    | 100 Altino         | 99 - 03 | 536 HF |        |
|    | 100 Delfino        | 99 - 04 | 100 HF | 2069   |
|    | 110 City Ace       | 03 - 07 | 103 HF |        |
|    | 125 Altino         | 02 - 04 | 100 CT |        |

**RECOMMENDED**

 1xx = Scooter Pads  
 5xx = Street, Off Road & Racing Pads  
 2xxx = Brake Shoes

**DAELIM**

|    |                        |         |         |        |
|----|------------------------|---------|---------|--------|
|    | 125 Delfino            | 08 - 11 | 163 CT  |        |
|    | 125 DLX, Otello DLX    | 01 - 02 | 100 CT  | 100 CT |
|    | 125 History            | 01 - 06 | 100 CT  | 100 CT |
|    | 125 Message II         | 00      | 100 CT  |        |
|    | 125 Otello             | 99 - 00 | 100 CT  |        |
|    | 125 Otello             | 08      | 146 CT  | 100 CT |
|    | 125 Roadwin            | 04 - 12 | 630 HF  | 688 HF |
|    | 125 Rocket             | 99 - 01 | 630 HF  | 2069   |
|    | 125 S2                 | 06 - 08 | 183 CT  | 100 CT |
|    | 125 S2 FI              | 07 - 15 | 146 CT  | 100 CT |
| NF | 125                    | 03      | 536 HF  |        |
| NS | 125 II                 | 00      | 100 CT  | 2069   |
| QL | 125 Steezer            | 17 - 18 | 146 CT  | 119 CT |
| S  | 125 from VIN SDC007441 | 17 - 18 | 146 CT  | 201 CT |
| S  | 125 to VIN SDC007440   | 17 - 18 | 146 CT  | 119 CT |
| SC | 125 Besbi              | 08 - 13 | 144 CT  |        |
| SL | 125 U3 FI              | 07 - 09 | 146 CT  | 100 CT |
| SV | 125 S3                 | 11 - 15 | 146 CT  | 119 CT |
| VL | 125 Daystar            | 00 - 12 | 630 HF  |        |
| VS | 125 , Evolution        | 95 - 08 | 536 HF  |        |
| VT | 125 Evolution          | 00 - 03 | 630 HF  | 2069   |
| VT | 125 Magna              | 97 - 99 | 630 HF  |        |
|    | 250 Roadwin            | 08 - 12 | 630 HF  | 688 HF |
|    | 250 S2                 | 06 - 10 | 183 CT  | 100 CT |
| ST | 250 Sector Quad        | 05 - 06 | 544 SI* | 847 SI |
| S  | 300                    | 17 - 18 | 146 MS  | 201 MS |

**DB MOTORS**

|    |          |         |        |        |
|----|----------|---------|--------|--------|
| ZZ | 50 Pirat | 00 - 05 | 519 HF | 519 HF |
| ZZ | 50 Sport | 00 - 05 | 519 HF |        |

**DERBI**

|  |                          |         |         |        |
|--|--------------------------|---------|---------|--------|
|  | 50 AJP Caliper           |         |         |        |
|  | incl. pin/spring         | 90 - 18 | 188 HF  |        |
|  | 50 Atlantis              | 99 - 08 | 105 HF  | 2181   |
|  | 50 Atlantis 4T           | 04 - 10 | 105 HF  |        |
|  | 50 Atlantis Bullet       | 04 - 05 | 105 HF  |        |
|  | 50 Atlantis H2O          | 01      | 105 HF  |        |
|  | 50 Atlantis H2O Wave     | 01      | 105 HF  |        |
|  | 50 Atlantis Wave         | 01 - 02 | 105 HF  |        |
|  | 50 Aventura              | 96      | 105 HF  | 2206   |
|  | 50 Black Devil           | 04      | 168 HF  | 105 HF |
|  | 50 Boulevard             | 09 - 13 | 177 HF  |        |
|  | 50 DRD Pro corse         | 06 - 08 | 189 MS  | 105 HF |
|  | 50 DRD Racing R          | 05 - 10 | 168 HF  | 105 HF |
|  | 50 DRD Racing R Ltd.     | 05      | 168 HF  | 105 HF |
|  | 50 DRD Racing SM         | 05      | 168 HF  | 105 HF |
|  | 50 DRD Racing SM Ltd.    | 05      | 168 HF  | 105 HF |
|  | 50 Easy                  | 96 - 98 | 138 HF  | 2181   |
|  | 50 Fenix                 | 94 - 07 | 105 HF  | 105 HF |
|  | 50 Furax                 | 96 - 98 | 105 HF  | 105 HF |
|  | 50 Hunter                | 97 - 99 | 105 HF  | 2181   |
|  | 50 Manhattan             | 99      | 105 HF  | 2181   |
|  | 50 Predator LC           | 99 - 02 | 105 HF  | 105 HF |
|  | 50 Predator O2           | 00 - 02 | 105 HF  | 105 HF |
|  | 50 Rambla                | 06      | 105 HF  | 105 HF |
|  | 50 Savannah              | 91 - 97 | 105 HF  |        |
|  | 50 Senda DRD Pro SM      | 05 - 11 | 157 HF  | 167 HF |
|  | 50 Senda L               | 99 - 01 | 105 HF  | 105 HF |
|  | 50 Senda R DRD           | 03 - 04 | 148 HF* | 105 HF |
|  | 50 Senda R, X-Treme      | 94 - 04 | 105 HF  | 105 HF |
|  | 50 Senda SM DRD          | 03 - 04 | 105 HF* | 105 HF |
|  | 50 Senda SM DRD          |         |         |        |
|  | Black Edition            | 03 - 04 | 168 HF  | 105 HF |
|  | 50 Senda SM, X-Treme     | 99 - 06 | 105 HF  | 105 HF |
|  | 50 Sonar                 | 10 - 11 | 142 HF  |        |
|  | 50 Stinger               | 96      | 105 HF  |        |
|  | 50 Vamos FL              | 95 - 99 | 105 HF  | 2181   |
|  | 50 Vamos L               | 95      | 105 HF  | 2181   |
|  | 50 Vamos R (A.J.P. cal.) | 95      | 105 HF  | 2206   |
|  | 50 Vamos R (Brembo cal.) | 95      | 123 HF  | 2206   |
|  | 50 Variant Sport-R       | 01 - 13 | 105 HF  | 2206   |

\* = 2 sets required / 2 jeux pour l'Avant.

Full compound selection, see under "Brake pad 1:1 Drawings" / Sélection complète de composés, voir "1:1 Schémas Plaquettes de frein".

**RECOMMENDED**

1xx = Scooter Pads  
5xx = Street, Off Road & Racing Pads  
2xxx = Brake Shoes



| DERBI         |                         |         |         |         |  |
|---------------|-------------------------|---------|---------|---------|--|
|               | 50 X-Race R             | 05 - 09 | 105 HF  | 105 HF  |  |
|               | 50 X-Treme R            | 05      | 105 HF  | 105 HF  |  |
| DS            | 50                      | 88      | 559 HF  |         |  |
| FD            | 50 Yumbo                | 84      | 559 HF  |         |  |
| FD            | 50 Yumbo                | 84      | 625 HF  |         |  |
| FD            | 50 Yumbo Extra          | 84      | 625 HF  |         |  |
| FD            | 50 Yumbo Extra          | 87      | 559 HF  |         |  |
| FDS           | 50                      | 84      | 625 HF  |         |  |
| FDS           | 50                      | 87      | 559 HF  |         |  |
| FDT           | 50                      | 84      | 625 HF  |         |  |
| FDT           | 50                      | 87 - 85 | 559 HF  |         |  |
| FDT           | 50 Coppa                | 85      | 559 HF  |         |  |
| FDX           | 50                      | 89      | 559 HF  |         |  |
| GP            | 50                      | 01      | 105 HF  |         |  |
| GP1           | 50                      | 01 - 03 | 105 HF  | 105 HF  |  |
| GP1           | 50                      | 05      | 730 HF  | 559 HF  |  |
| GPR           | 50 Nude                 | 04 - 10 | 730 HF  | 559 HF  |  |
| GPR           | 50 R                    | 98 - 03 | 148 HF  | 105 HF  |  |
| GPR           | 50 Racing               | 04 - 13 | 730 HF  | 559 HF  |  |
| GPX1          | 50                      | 06      | 189 MS  | 105 HF  |  |
| ST            | 50 Paddock              | 96 - 99 | 105 HF  | 2181    |  |
|               | 75 1001, 1002           | 81      | 625 HF  | 625 HF  |  |
|               | 75 GPR                  | 89      | 607 HF  | 559 HF  |  |
|               | 75 Sport, Coppa         | 84      | 559 HF  |         |  |
|               | 75 Sport, Coppa         | 84      | 625 HF  |         |  |
| GPR           | 75 Sport                | 92      | 607 HF  | 559 HF  |  |
| GPR           | 80 Cup                  | 04 - 05 | 821 HS  | 559 HF* |  |
|               | 100 Atlantis 4T         | 04 - 06 | 105 HF  |         |  |
|               | 100 Atlantis O2/H2O     | 01      | 105 HF  |         |  |
|               | 125 Atmosphere          | 99      | 148 CT  |         |  |
|               | 125 Boulevard           | 03 - 07 | 167 CT  | 2205    |  |
|               | 125 Mulhacen            | 07      | 774 HF  | 519 HF  |  |
|               | 125 Mulhacen            | 08 - 11 | 859 HF  | 585 HF  |  |
|               | 125 Predator            | 99      | 105 CT  |         |  |
|               | 125 Rambla              | 08 - 14 | 108 CT  | 152 CT  |  |
|               | 125 Senda Baja          | 06 - 12 | 168 HF  | 167 CT  |  |
|               | 125 Senda DRD SM        | 10 - 14 | 157 HF  | 203 HF  |  |
|               | 125 Senda R 4T          | 04 - 12 | 774 HF  | 559 HF  |  |
|               | 125 Senda X-Treme SM 4T | 04 - 05 | 774 HF  | 559 HF  |  |
|               | 125 Terra               | 07      | 559 HF  | 519 HF  |  |
|               | 125 Terra               | 08 - 13 | 859 HF  | 585 HF  |  |
|               | 125 Terra Adventure     | 08 - 14 | 859 HF  | 585 HF  |  |
| GP1           | 125                     | 05 - 06 | 730 HF  | 559 HF  |  |
| GPR           | 125                     | 05 - 06 | 821 HS  | 559 HF* |  |
| GPR           | 125 Nude                | 05 - 08 | 821 HS  | 559 HF* |  |
| GPR           | 125 Racing              | 09      | 821 HS  | 559 HF* |  |
|               | 150 Boulevard           | 03 - 09 | 167 CT  | 2205    |  |
|               | 180 Predator            | 99      | 148 CT  |         |  |
| DXR           | 200 Quad (Front disc)   | 04 - 07 | 544 SI* | 586 SI  |  |
| DXR           | 200 Quad (Front drum)   | 04 - 05 | 2028    | 586 SI  |  |
| DXR           | 200 Quad (Front drum)   | 04 - 05 | 2028    | 611 SI  |  |
|               | 250 RC                  | 85      | 519 HF  |         |  |
|               | 250 T                   | 82      | 625 HF  |         |  |
| DXR           | 250 Quad (Front disc)   | 04 - 07 | 544 SI* | 586 SI  |  |
| DXR           | 250 Quad (Front drum)   | 04 - 05 | 2028    | 586 SI  |  |
| DXR           | 250 Quad (Front drum)   | 04 - 05 | 2028    | 611 SI  |  |
| GP1           | 250                     | 05 - 09 | 730 HF  | 772 HF  |  |
|               | 300 Rambla              | 08 - 12 | 108 MS  | 152 MS  |  |
|               | 659 Mulhacen            | 05      | 788 HS  | 730 LS  |  |
|               | 659 Mulhacen            | 06 - 07 | 762 HS  | 730 LS  |  |
|               | 659 Mulhacen Cafe       | 08      | 762 HS  | 730 LS  |  |
| <b>DUCATI</b> |                         |         |         |         |  |
|               | 250 Desmo               | 70 - 77 | 506 HF  |         |  |
|               | 350                     | 75 - 78 | 519 HF  |         |  |
|               | 350 Desmo               | 70 - 77 | 506 HF  |         |  |
|               | 350 F3                  | 86 - 89 | 506 HF* | 506 HF  |  |
|               | 350 F3                  | 86 - 90 | 519 HF* | 519 HF  |  |
|               | 350 GTV                 | 77      | 519 HF  | 519 HF  |  |
|               | 350 Indiana             | 86 - 91 | 594 HF  | 519 HF  |  |
|               | 350 Paso                | 86      | 519 HF* | 519 HF  |  |
|               | 350 Sport               | 77 - 80 | 519 HF* | 519 HF  |  |

**RECOMMENDED**

1xx = Scooter Pads  
5xx = Street, Off Road & Racing Pads  
2xxx = Brake Shoes



| DUCATI |                               |         |         |        |  |
|--------|-------------------------------|---------|---------|--------|--|
|        | 400 Monster (Japan)           | 01 - 06 | 706 HS  | 519 LS |  |
|        | 400 Scrambler Sixty Two       | 16 - 18 | 674 HS  | 675 LS |  |
|        | 400 SS, Junior                | 92 - 97 | 566 HF* | 519 HF |  |
|        | 400 SS, Nuda                  | 92 - 96 | 566 HF  | 519 HF |  |
|        | 500 GTV                       | 77 - 82 | 519 HF* | 519 HF |  |
|        | 500 Pantah                    | 85 - 89 | 519 HF* | 519 HF |  |
|        | 500 Sport                     | 77 - 82 | 506 HF* | 506 HF |  |
|        | 500 Sport Desmo               | 77 - 82 | 519 HF* |        |  |
|        | 500 Twin GTL                  | 75 - 80 | 519 HF  |        |  |
|        | 502 Single                    | 93      | 566 HF* | 519 HF |  |
|        | 502 Supermono                 | 93      | 566 HF* | 519 HF |  |
|        | 600 Monster                   | 00 - 01 | 706 HS  | 519 LS |  |
|        | 600 Pantah TL, SL             | 78 - 89 | 506 HF* | 506 HF |  |
|        | 600 SL, TL Pantah             | 76 - 89 | 506 HF* | 519 HF |  |
|        | 600 SS Supersport             | 95 - 00 | 566 HF  | 519 HF |  |
| M      | 600 Monster                   | 94 - 99 | 566 HF  | 519 HF |  |
|        | 620 Monster Dark i.e.         | 02 - 06 | 706 HS  | 519 LS |  |
|        | 620 Monster i.e., s i.e.      | 02 - 06 | 706 HS* | 519 LS |  |
|        | 620 Multistrada               | 05 - 06 | 671 HS* | 730 LS |  |
|        | 620 Multistrada Dark          | 05 - 06 | 706 HS  | 730 LS |  |
|        | 620 Sport                     | 03 - 06 | 706 HS* | 730 LS |  |
|        | 650 Indiana                   | 86 - 89 | 594 HF  | 519 HF |  |
|        | 650 Pantah                    | 84 - 89 | 506 HF* | 506 HF |  |
|        | 695 Monster                   | 07 - 12 | 671 HS* | 519 LS |  |
|        | 696 Monster                   | 08 - 12 | 706 HS* | 730 LS |  |
|        | 748 , S                       | 99 - 02 | 706 HS* | 519 LS |  |
|        | 748 Biposto                   | 95 - 98 | 566 HF* | 519 HF |  |
|        | 748 R                         | 00      | 706 HS* | 519 LS |  |
|        | 748 R                         | 01 - 02 | 762 HS* | 519 LS |  |
|        | 748 SP                        | 95 - 97 | 566 HF* | 519 HF |  |
|        | 748 SPS                       | 98 - 99 | 706 HS* | 519 LS |  |
|        | 749 , S                       | 03 - 07 | 762 HS* | 730 LS |  |
|        | 749 R                         | 04 - 07 | 762 HS* | 730 LS |  |
|        | 750 F1                        | 86 - 98 | 506 HF* | 506 HF |  |
|        | 750 GT                        | 74 - 76 | 506 HF* |        |  |
|        | 750 Indiana                   | 85 - 86 | 594 HF  | 519 HF |  |
|        | 750 Monster                   | 96 - 99 | 566 HF* | 519 HF |  |
|        | 750 Monster                   | 00 - 01 | 706 HS* | 519 LS |  |
|        | 750 Monster i.e.              | 02      | 706 HS* | 519 LS |  |
|        | 750 Paso                      | 86      | 519 HF* | 519 HF |  |
|        | 750 Paso                      | 87      | 506 HF* | 519 HF |  |
|        | 750 Paso                      | 88      | 519 HF* | 519 HF |  |
|        | 750 Sport                     | 74 - 76 | 523 HF* |        |  |
|        | 750 Sport                     | 90      | 506 HS* | 506 LS |  |
|        | 750 Sport                     | 00 - 02 | 706 HS  | 730 LS |  |
|        | 750 SS                        | 74 - 76 | 506 HF* | 506 HF |  |
|        | 750 SS                        | 91 - 98 | 566 HF  | 506 HF |  |
|        | 750 SS Supersport             | 95 - 99 | 566 HF  | 519 HF |  |
|        | 750 SS, Carenara              | 92 - 98 | 566 HF  | 519 HF |  |
|        | 750 SS, Nuda                  | 92      | 566 HF  | 519 HF |  |
|        | 750 Super Sport               | 92 - 94 | 566 HF* | 519 HF |  |
|        | 750 Super Sport               | 00 - 02 | 706 HS* | 730 LS |  |
|        | 795 Monster                   | 12      | 706 HS* | 730 LS |  |
|        | 796 Hypermotard ABS           | 10 - 12 | 706 HS* | 730 LS |  |
|        | 796 Monster                   | 11 - 14 | 706 HS* | 730 LS |  |
|        | 796 Monster ABS               | 11 - 14 | 706 HS* | 730 LS |  |
|        | 797 Monster                   | 17 - 18 | 900 HS  | 675 LS |  |
|        | 797 Monster+                  | 17 - 18 | 900 HS  | 675 LS |  |
|        | 800 Hypermotard               | 13 - 15 | 900 HS* | 730 LS |  |
|        | 800 Hypermotard ABS           | 13 - 15 | 900 HS* | 730 LS |  |
|        | 800 Hypermotard SP            | 13 - 15 | 900 HS* | 730 LS |  |
|        | 800 Hypermotard SP ABS        | 13 - 15 | 900 HS* | 730 LS |  |
|        | 800 Hyperstrada               | 13 - 15 | 900 HS* | 730 LS |  |
|        | 800 Hyperstrada ABS           | 13 - 15 | 900 HS* | 730 LS |  |
|        | 800 Monster Dark i.e., s i.e. | 03 - 07 | 706 HS* | 519 LS |  |
|        | 800 Monster i.e., s i.e.      | 03 - 07 | 706 HS* | 519 LS |  |
|        | 800 Monster S2R               | 05 - 07 | 671 HS* | 519 LS |  |
|        | 800 Monster S2R ABS           | 05 - 07 | 671 HS* | 519 LS |  |
|        | 800 Scrambler                 | 17 - 18 | 900 HS  | 675 LS |  |
|        | 800 Scrambler Classic         | 15 - 18 | 900 HS  | 675 LS |  |
|        | 800 Scrambler CR              | 17 - 18 | 900 HS  | 675 LS |  |
|        | 800 Scrambler CR Cafe Racer   | 17 - 18 | 900 HS  | 675 LS |  |

\* = 2 sets required / 2 jeux pour l'Avant.



**RECOMMENDED**

1xx = Scooter Pads  
 5xx = Street, Off Road & Racing Pads  
 2xxx = Brake Shoes



**DUCATI**

|       |                              |         |         |        |
|-------|------------------------------|---------|---------|--------|
|       | 800 Scrambler Enduro         | 15 - 16 | 900 HS  | 675 LS |
|       | 800 Scrambler Flat Track Pro | 16      | 900 HS  | 675 LS |
|       | 800 Scrambler Full Throttle  | 15 - 18 | 900 HS  | 675 LS |
|       | 800 Scrambler Icon           | 15 - 18 | 900 HS  | 675 LS |
|       | 800 Scrambler Mach 2.0       | 18 -    | 900 HS  | 675 LS |
|       | 800 Scrambler Street Classic | 17 - 18 | 900 HS  | 675 LS |
|       | 800 Scrambler Urban Enduro   | 16      | 900 HS  | 675 LS |
|       | 800 Scrambler-X DS           |         |         |        |
|       | Desert Sled                  | 17 - 18 | 900 HS  | 675 LS |
|       | 800 Sport                    | 03 - 06 | 706 HS* | 730 LS |
|       | 800 Supersport               | 03 - 06 | 706 HS* | 730 LS |
|       | 821 Monster                  | 14 - 18 | 900 HS* | 730 LS |
|       | 821 Monster Dark             | 15 - 16 | 900 HS* | 730 LS |
|       | 848                          | 08 - 10 | 706 HS* | 730 LS |
|       | 848 EVO                      | 11 - 12 | 841 HS* | 730 LS |
|       | 848 Streetfighter            | 12 - 15 | 706 HS* | 730 LS |
|       | 848 Streetfighter S          | 12 - 15 | 841 HS* | 730 LS |
|       | 851 Strada                   | 89      | 566 HF* | 519 HF |
|       | 851 Strada                   | 91 - 92 | 566 HF* | 506 HF |
|       | 851 Superbike                | 90      | 566 HF* | 519 HF |
|       | 860 GT                       | 75 - 77 | 506 HF  |        |
|       | 860 GT                       | 85      | 506 HF  | 506 HF |
|       | 888 Roche Replica            | 91      | 566 HF* | 506 HF |
|       | 888 SP V                     | 93      | 566 HF* | 519 HF |
|       | 888 SP4                      | 92 - 95 | 566 HF* | 519 HF |
|       | 888 SPO                      | 93      | 566 HF* | 519 HF |
|       | 888 SPS                      | 92 - 95 | 566 HF* | 519 HF |
|       | 888 Strada                   | 93      | 566 HF* | 519 HF |
|       | 888 Superbike                | 93      | 566 HF* | 519 HF |
|       | 899 Panigale                 | 14 - 15 | 900 HS* | 730 LS |
|       | 900 FE                       | 97 - 98 | 566 HF* | 519 HF |
|       | 900 GTS                      | 77 - 79 | 506 HF  |        |
|       | 900 M, IL Monster            | 93 - 99 | 566 HF* | 519 HF |
|       | 900 Mike Hailwood Replica    | 85 - 86 | 506 HF* | 506 HF |
|       | 900 Monster                  | 00 - 01 | 706 HS* | 519 LS |
|       | 900 Monster i.e.             | 02      | 706 HS* | 519 LS |
|       | 900 S2 Desmo                 | 85      | 506 HF* | 506 HF |
|       | 900 SL                       | 92 - 97 | 566 HF* | 519 HF |
|       | 900 Sport                    | 77 - 78 | 506 HF* | 506 HF |
|       | 900 SS                       | 78 - 89 | 506 HF* | 506 HF |
|       | 900 SS                       | 90 - 94 | 566 HF* | 519 HF |
|       | 900 SS Supersport            | 95 - 97 | 566 HF  | 519 HF |
|       | 900 SSR                      | 92      | 566 HF* | 519 HF |
|       | 900 Super Sport              | 98 - 02 | 706 HS* | 730 LS |
| 906   | 900 Paso                     | 89      | 506 HF* | 519 HF |
| 907   | 900 I. E.                    | 90 - 93 | 566 HF* | 519 HF |
| M     | 900 Street Monster           | 94 - 99 | 566 HF* | 519 HF |
| MH    | 900                          | 00 - 01 | 706 HS* | 519 LS |
|       | 916 Biposto                  | 94      | 566 HF* | 519 HF |
|       | 916 Monster S4               | 01 - 03 | 706 HS* | 519 LS |
|       | 916 Sport Touring 4          | 99 - 01 | 706 HS* | 730 LS |
|       | 916 SPS                      | 97 - 98 | 706 HS* | 519 LS |
|       | 939 Hypermotard              | 16 - 18 | 900 HS* | 730 LS |
|       | 939 Hypermotard SP           | 16 - 18 | 900 HS* | 730 LS |
|       | 939 Hyperstrada              | 16      | 900 HS* | 730 LS |
|       | 939 SuperSport               | 17 - 18 | 900 HS* | 730 LS |
|       | 939 SuperSport S             | 17 - 18 | 900 HS* | 730 LS |
|       | 944 Sport Touring            | 98 - 03 | 706 HS* | 730 LS |
|       | 944 ST2                      | 97 - 03 | 706 HS* | 730 LS |
|       | 950 Multistrada              | 17 - 18 | 900 HS  | 671 LS |
|       | 959 Panigale                 | 16 - 18 | 900 HS* | 730 LS |
|       | 959 Panigale Corse           | 18 -    | 900 HS* | 730 LS |
| D16RR | 990 Desmosedici RR           | 07 - 08 | 841 HS* | 730 LS |
|       | 992 ST3                      | 04 - 07 | 706 HS* | 730 LS |
|       | 992 ST3s ABS                 | 06 - 07 | 706 HS* | 730 LS |
|       | 996 , SPS                    | 99 - 01 | 706 HS* | 519 LS |
|       | 996 Monster S4R              | 04 - 06 | 706 HS* | 519 LS |
|       | 996 R                        | 01      | 762 HS* | 519 LS |
|       | 996 ST4s                     | 02 - 06 | 706 HS* | 730 LS |
|       | 996 ST4s ABS                 | 03 - 06 | 706 HS* | 730 LS |
|       | 998 , S                      | 02      | 706 HS* | 519 LS |
|       | 998 Monster S4Rs             | 06      | 762 HS* | 730 LS |



**RECOMMENDED**

1xx = Scooter Pads  
 5xx = Street, Off Road & Racing Pads  
 2xxx = Brake Shoes



**DUCATI**

|  |                                |         |         |        |
|--|--------------------------------|---------|---------|--------|
|  | 998 R                          | 02      | 762 HS* | 519 LS |
|  | 999 , S                        | 03 - 07 | 762 HS* | 730 LS |
|  | 999 Monster S4R                | 07 - 08 | 762 HS* | 730 LS |
|  | 999 Monster S4RS               | 07 - 08 | 762 HS* | 730 LS |
|  | 999 R                          | 03 - 07 | 762 HS* | 730 LS |
|  | 1000 /6 Mike Hailwood Replica  | 85      | 506 HF* | 506 HF |
|  | 1000 Biposto                   | 07 - 08 | 674 HS* | 675 LS |
|  | 1000 GT                        | 05 - 10 | 674 HS* | 675 LS |
|  | 1000 GT Touring                | 09 - 10 | 674 HS* | 675 LS |
|  | 1000 Hypermotard               | 06      | 762 HS* | 730 LS |
|  | 1000 Mille Replica             | 84 - 85 | 506 HF* | 506 HF |
|  | 1000 Monster Dark i.e., s i.e. | 03 - 06 | 706 HS* | 519 LS |
|  | 1000 Monster i.e., s i.e.      | 03 - 06 | 706 HS* | 519 LS |
|  | 1000 Monster S2R               | 06 - 07 | 706 HS* | 730 LS |
|  | 1000 Multistrada               | 07      | 706 HS* | 730 LS |
|  | 1000 Multistrada DS            | 03 - 06 | 706 HS* | 730 LS |
|  | 1000 Multistrada S DS          | 05 - 06 | 706 HS* | 730 LS |
|  | 1000 Paul Smart                | 05 - 08 | 674 HS* | 675 LS |
|  | 1000 S2 Desmo                  | 85      | 506 HF* | 506 HF |
|  | 1000 Sport, Sport S            | 05 - 09 | 674 HS* | 675 LS |
|  | 1000 Supersport DS             | 03 - 06 | 706 HS* | 730 LS |
|  | 1098                           | 07 - 08 | 841 HS* | 730 LS |
|  | 1098 R                         | 08 - 10 | 841 SP* | 730 LS |
|  | 1098 R Bayliss LE              | 09 - 10 | 841 SP* | 730 LS |
|  | 1098 S                         | 07 - 08 | 841 HS* | 730 LS |
|  | 1098 Streetfighter             | 09 - 14 | 841 HS* | 730 LS |
|  | 1098 Streetfighter S           | 09 - 13 | 841 HS* | 730 LS |
|  | 1100 Hypermotard               | 07 - 13 | 841 HS* | 730 LS |
|  | 1100 Hypermotard EVO           | 10 - 13 | 706 HS* | 730 LS |
|  | 1100 Hypermotard EVO SP        | 10 - 12 | 841 HS* | 730 LS |
|  | 1100 Monster                   | 09 - 13 | 706 HS* | 730 LS |
|  | 1100 Monster ABS               | 09 - 10 | 706 HS* | 730 LS |
|  | 1100 Monster EVO               | 11 - 13 | 706 HS* | 730 LS |
|  | 1100 Monster EVO ABS           | 11 - 13 | 706 HS* | 730 LS |
|  | 1100 Monster S                 | 09 - 13 | 706 HS* | 730 LS |
|  | 1100 Monster S ABS             | 09 - 10 | 706 HS* | 730 LS |
|  | 1100 Multistrada               | 07 - 09 | 706 HS* | 730 LS |
|  | 1100 Multistrada S             | 07 - 09 | 706 HS* | 730 LS |
|  | 1100 Panigale V4               | 18 -    | 841 SP* | 730 LS |
|  | 1100 Panigale V4 S             | 18 -    | 841 SP* | 730 LS |
|  | 1100 Panigale V4 Speciale      | 18 -    | 841 SP* | 730 LS |
|  | 1100 Scrambler                 | 18 -    | 900 HS* | 675 LS |
|  | 1100 Scrambler Special         | 18 -    | 900 HS* | 675 LS |
|  | 1100 Scrambler Sport           | 18 -    | 900 HS* | 675 LS |
|  | 1198                           | 09 - 13 | 841 SP* | 730 LS |
|  | 1198 S                         | 09 - 12 | 841 SP* | 730 LS |
|  | 1198 SP                        | 11 - 12 | 841 SP* | 730 LS |
|  | 1199 Panigale                  | 12 - 14 | 841 SP* | 730 LS |
|  | 1199 Panigale R                | 13 - 15 | 841 SP* | 730 LS |
|  | 1199 Panigale S                | 12 - 14 | 841 SP* | 730 LS |
|  | 1199 Superleggera              | 14      | 841 SP* | 730 LS |
|  | 1200 Multistrada Enduro        | 16 - 18 | 900 SP* | 671 LS |
|  | 1200 Multistrada Enduro Pro    | 18 -    | 900 SP* | 671 LS |
|  | 1200 Diavel                    | 11 - 18 | 901 HS* | 674 LS |
|  | 1200 Diavel Strada             | 11 - 14 | 901 HS* | 674 LS |
|  | 1200 Monster                   | 14 - 18 | 900 HS* | 730 LS |
|  | 1200 Monster R                 | 16 - 18 | 841 HS* | 730 LS |
|  | 1200 Monster S                 | 14 - 18 | 841 HS* | 730 LS |
|  | 1200 Multistrada               | 10 - 14 | 706 SP* | 730 LS |
|  | 1200 Multistrada               | 15 - 16 | 900 SP* | 671 LS |
|  | 1200 Multistrada S             | 15 - 17 | 841 SP* | 671 LS |
|  | 1200 Multistrada S D-air       | 15 - 17 | 841 SP* | 671 LS |
|  | 1200 Multistrada S GT          | 12 - 14 | 706 SP* | 730 LS |
|  | 1200 Multistrada S Pikes Peak  | 11 - 14 | 706 SP* | 730 LS |
|  | 1200 Multistrada S Pikes Peak  | 16 - 17 | 841 SP* | 671 LS |
|  | 1200 Multistrada S Sport       | 10 - 14 | 706 SP* | 730 LS |
|  | 1200 Multistrada S Touring     | 10 - 14 | 706 SP* | 730 LS |
|  | 1200 Xdiavel                   | 16 - 18 | 901 HS* | 674 LS |
|  | 1200 Xdiavel S                 | 16 - 18 | 901 HS* | 674 LS |
|  | 1260 Multistrada               | 18 -    | 841 SP* | 671 LS |
|  | 1260 Multistrada S             | 18 -    | 841 SP* | 671 LS |
|  | 1260 Multistrada S D-air       | 18 -    | 841 SP* | 671 LS |

\* = 2 sets required / 2 jeux pour l'Avant.

Full compound selection, see under "Brake pad 1:1 Drawings" / Sélection complète de composés, voir "1:1 Schémas Plaquettes de frein".

**RECOMMENDED**1xx = Scooter Pads  
5xx = Street, Off Road & Racing Pads  
2xxx = Brake Shoes

| DUCATI              |                           |         |          |          |  |
|---------------------|---------------------------|---------|----------|----------|--|
| 1260                | Multistrada S Pikes Peak  | 18 -    | 841 SP*  | 671 LS   |  |
| 1299                | Panigale                  | 15 - 17 | 841 SP*  | 730 LS   |  |
| 1299                | Panigale R                | 15 - 17 | 841 SP*  | 730 LS   |  |
| 1299                | Panigale R Final Edition  | 17 - 18 | 841 SP*  | 730 LS   |  |
| 1299                | Panigale S                | 15 - 17 | 841 SP*  | 730 LS   |  |
| 1299                | Panigale S Anniversario   | 17      | 841 SP*  | 730 LS   |  |
| 1299                | Superleggera              | 17      | 841 SP*  | 730 LS   |  |
| EASY RIDER          |                           |         |          |          |  |
| 50                  | Easy Rider                | 99      | 102 HF   | 2028     |  |
| EBR                 |                           |         |          |          |  |
| 1190                | RS                        | 12 - 15 | 856 HS   | 857 LS   |  |
| 1190                | RX                        | 14 - 15 | 856 HS   | 857 LS   |  |
| 1190                | SX                        | 14 - 15 | 856 HS   | 857 LS   |  |
| ELSTARS             |                           |         |          |          |  |
| 125                 | Blade S                   | 10 - 11 | 211 HF   | 211 HF   |  |
| ENDRESS             |                           |         |          |          |  |
| EMR                 | 50                        | 95      | 121 HF   |          |  |
| E-TON               |                           |         |          |          |  |
| RXL                 | 150 Viper                 | 07      | 2012     | 847 SI   |  |
| VXL                 | 250 Vector, ST Vector     | 06 - 07 | 544 SI*  | 847 SI   |  |
| VTX                 | 300 Vortex, ST Vortex     | 07      | 544 SI*  | 847 SI   |  |
| VXL                 | 300 Vector, ST Vector     | 07 - 13 | 544 SI*  | 847 SI   |  |
| EXCELSIOR-HENDERSON |                           |         |          |          |  |
| 1386                | Deadwood Special          | 00      | 739 H.HS | 739 H.LS |  |
| 1386                | Super X all models        | 99      | 739 H.HS | 739 H.LS |  |
| FACTORY             |                           |         |          |          |  |
| 50                  | Helix                     | 04 - 06 |          | 544 SI   |  |
| 50                  | Rex                       | 04 - 06 |          | 544 SI   |  |
| R12                 | 50 Phantom Agua           | 06      | 803 RSI  | 559 RSI  |  |
| R14                 | 50 Phantom Agua           | 04      | 803 RSI  | 559 RSI  |  |
| R14                 | 50 Phantom Aire           | 03      | 559 RSI  |          |  |
| RP                  | 50 Desert                 | 04      | 120 HF   | 105 HF   |  |
| SM                  | 50 Chrono                 | 04      | 120 HF   | 105 HF   |  |
| SP                  | 50 Chrono                 | 04      | 120 HF   | 105 HF   |  |
| YR                  | 50 Desert                 | 04      | 120 HF   | 105 HF   |  |
| R2                  | 65 Phantom                | 04      | 803 RSI  | 559 RSI  |  |
| 100                 | Helix                     | 04 - 06 |          | 544 SI   |  |
| 100                 | Rex                       | 04 - 06 |          | 544 SI   |  |
| YR                  | 125                       | 06      | 551 HF   | 559 HF   |  |
| YR                  | 250                       | 99 - 03 | 671 SI   | 675 SI   |  |
| FANTIC              |                           |         |          |          |  |
| 50                  | Caballero Motard          | 10      | 217 HF   | 220 HF   |  |
| 50                  | Caballero Regularita      | 10      | 217 HF   | 220 HF   |  |
| 50                  | .1 Oasis                  | 87      | 574 HF   | 574 HF   |  |
| 50                  | .1 Raider                 | 87      | 692 HF   |          |  |
| 50                  | .1 Raider Rally           | 87      | 574 HF   |          |  |
| 50                  | Big Wheel                 | 93      | 111 HF   | 118 HF   |  |
| 50                  | Fast                      | 88      | 607 HF   |          |  |
| 50                  | Grinta                    | 95 - 96 | 111 HF   | 118 HF   |  |
| 50                  | Koala                     | 88 - 89 | 519 HF   | 519 HF   |  |
| 50                  | Koala                     | 90      | 574 HF   | 574 HF   |  |
| 50                  | Leader                    | 95      | 111 HF   | 118 HF   |  |
| 50                  | Oasis                     | 90      | 607 HF   | 574 HF   |  |
| 50                  | Pony                      | 93 - 96 | 2028     | 2028     |  |
| 50                  | Pony SR                   | 93 - 95 | 111 HF   | 2028     |  |
| 50                  | Queenie                   | 95 - 96 | 111 HF   | 2028     |  |
| 50                  | Regolarna Casa            | 08 - 09 | 168 HF   | 101 HF   |  |
| 50                  | Regolarna Competizione    | 08 - 09 | 694 HF   | 604 HF   |  |
| 50                  | Strada                    | 83      | 692 HF   |          |  |
| 50                  | Super SIX                 | 83      | 532 HF   |          |  |
| 50                  | Supersei Motard           | 08 - 09 | 168 HF   | 101 HF   |  |
| 50                  | Trial                     | 83      | 595 HF   |          |  |
| 50                  | Trial .5 .7 .9            | 89 - 91 | 105 HF   | 105 HF   |  |
| MX                  | 50 Regolarna Competizione | 08      | 694 RSI  | 604 RSI  |  |

**RECOMMENDED**1xx = Scooter Pads  
5xx = Street, Off Road & Racing Pads  
2xxx = Brake Shoes

| FANTIC  |                             |         |         |         |  |
|---------|-----------------------------|---------|---------|---------|--|
| RC      | 50 Caballero                | 91      | 519 HF  | 519 HF  |  |
| RS      | 50 Caballero                | 91      | 519 HF  | 519 HF  |  |
| MX      | 65 Regolarna Competizione   | 08      | 694 RSI | 604 RSI |  |
|         | 75 Oasis                    | 89      | 607 HF  | 574 HF  |  |
|         | 80 Regolarna Competizione   | 08      | 694 HF  | 604 HF  |  |
| MX      | 85 Regolarna Competizione   | 08      | 694 RSI | 604 RSI |  |
|         | 125 Caballero Motard 2T     | 10      | 694 HF  | 777 HF  |  |
|         | 125 Caballero Regularita 4T | 10      | 926 HF  | 777 HF  |  |
|         | 125 Caballero Flat Track    | 17      | 877 HS  | 675 LS  |  |
|         | 125 Caballero Enduro 2T     | 12 - 10 | 694 HF  | 777 HF  |  |
|         | 125 Caballero Motard 4T     | 10      | 926 HF  | 777 HF  |  |
|         | 125 Raider                  | 83 - 85 | 574 HF  |         |  |
|         | 125 Regolarna Casa          | 08      | 774 HF  | 544 HF  |  |
|         | 125 Regolarna Competizione  | 08      | 694 HF  | 604 HF  |  |
|         | 125 Strada                  | 83 - 85 | 560 HF  |         |  |
|         | 125 Supersei Motard         | 08      | 774 HF  | 544 HF  |  |
|         | 125 Trial                   | 78 - 84 | 595 HF  |         |  |
|         | 125 Trial Professional      | 87      | 595 HF  | 595 HF  |  |
|         | 125 Trial Progress 1        | 87      | 595 HF  |         |  |
| HP1     | 125 Sport                   | 86      | 560 HF* |         |  |
| HP1     | 125 Sport                   | 87      | 574 HF* |         |  |
| HP1     | 125 Strada                  | 85      | 595 HF  |         |  |
| TZ      | 125 SM                      | 12      | 566 HF  |         |  |
|         | 200 Caballero Motard 4T     | 10      | 926 HF  | 777 HF  |  |
|         | 200 Caballero Regularita 4T | 10      | 926 HF  | 777 HF  |  |
|         | 201 Trial                   | 85 - 91 | 595 HF  |         |  |
|         | 201 Trial Progress 2        | 87      | 595 HF  |         |  |
|         | 241 Trial Progress 2        | 87      | 595 HF  |         |  |
|         | 243 Trial                   | 87 - 90 | 595 HF  | 595 HF  |  |
|         | 250 Coach                   | 91 - 98 | 519 HF  |         |  |
|         | 250 Enduro 4T               | 16 - 17 | 926 HF  | 777 HF  |  |
|         | 250 K-Roo                   | 93 - 95 | 559 RSI | 559 RSI |  |
|         | 250 Raider                  | 85      | 588 HF  |         |  |
|         | 301 Trial                   | 85 - 91 | 595 HF  |         |  |
|         | 301 Trial Progress 2        | 87      | 595 HF  |         |  |
|         | 303 Trial Professional      | 87      | 595 HF  | 595 HF  |  |
|         | 305                         | 89 - 90 | 559 RSI | 559 RSI |  |
|         | 307 Trial                   | 91 - 94 | 559 RSI | 559 RSI |  |
|         | 343 Trial Progress 2        | 87      | 595 HF  | 595 HF  |  |
|         | 500 Caballero               | 17      | 900 HS  | 675 LS  |  |
| GAC     |                             |         |         |         |  |
|         | 50 New T.T.                 | 87      | 559 HF  |         |  |
| GARELLI |                             |         |         |         |  |
|         | Xo Electric                 | 12      | 200 HF  | 107 HF  |  |
|         | 50 Ciclone LC, SM           | 86      | 559 HF  |         |  |
|         | 50 Flexi                    | 12      | 141 HF  |         |  |
|         | 50 Flo'                     | 00 - 02 | 123 HF  |         |  |
|         | 50 S, Sport 40              | 80      | 532 HF  |         |  |
|         | 50 Sahel                    | 91      | 607 HF  | 559 HF  |  |
|         | 50 Starter                  | 02      | 111 HF  |         |  |
|         | 50 Tiger XLE                | 86      | 519 HF  | 519 HF  |  |
|         | 50 Urka                     | 91      | 519 HF  |         |  |
|         | 50 Xo                       | 12      | 141 HF  | 105 HF  |  |
| CPR     | 50                          | 02      | 111 HF  |         |  |
| FX      | 50                          | 02 - 06 | 111 HF  |         |  |
| GSP     | 50                          | 12      | 141 HF  | 105 HF  |  |
| KRS     | 50                          | 02      | 140 HF  |         |  |
| PMX     | 50 Rally                    | 00      | 111 HF  |         |  |
| PMX     | 50 Sport                    | 00      | 140 HF  |         |  |
| SR      | 50 Pony                     | 95 - 02 | 111 HF  | 2032    |  |
|         | 80 Sport                    | 83      | 532 HF  |         |  |
|         | 125 Flexi                   | 12      | 200 HF  |         |  |
|         | 125 Freeland                | 02      | 140 CT  |         |  |
|         | 125 Joker 2                 | 02      | 103 CT  |         |  |
|         | 125 Panther                 | 02      | 115 CT  | 123 CT  |  |
|         | 125 Raider                  | 02      | 101 CT  |         |  |
|         | 125 Tiger XLE               | 86      | 588 HF  | 574 HF  |  |
|         | 125 T-Rex                   | 00      | 140 CT  |         |  |
|         | 125 Xo                      | 12      | 200 CT  | 107 CT  |  |
| GTA     | 125                         | 80 - 82 | 519 HF* | 519 HF  |  |

\* = 2 sets required / 2 jeux pour l'Avant.



**RECOMMENDED**1xx = Scooter Pads  
5xx = Street, Off Road & Racing Pads  
2xxx = Brake Shoes**GARELLI**

|     |               |         |         |        |
|-----|---------------|---------|---------|--------|
| GTA | 125           | 83 - 85 | 519 HF  |        |
| GTA | 125           | 86      | 560 HF* |        |
| TSR | 125           | 83      | 560 HF  |        |
| XR  | 125 Tiger XRD | 85      | 519 HF  |        |
|     | 150 Freeland  | 02      | 140 CT  |        |
|     | 150 Joker 2   | 02      | 103 CT  |        |
|     | 150 Panther   | 02      | 115 CT  | 123 CT |
|     | 150 Xo        | 12      | 200 CT  | 107 CT |
|     | 200 Xo        | 12      | 197 CT  | 107 CT |
|     | 250 Panther   | 02      | 115 CT  | 123 CT |
|     | 323 Trial     | 86      | 595 HF  |        |

**GAS GAS**

|     |                    |         |         |         |
|-----|--------------------|---------|---------|---------|
|     | 50 Wild HP         | 04 - 07 | 671 SI* | 671 SI  |
| EC  | 50 Boy             | 01 - 04 | 815 HF  | 815 HF  |
| EC  | 50 Rookie          | 01 - 04 | 148 HF  |         |
| EC  | 50 Rookie          | 05      | 168 HF  |         |
| SM  | 50 Rookie          | 01 - 02 | 148 HF  |         |
| TXT | 50 Boy             | 01      | 815 HF  | 815 HF  |
| TXT | 50 Boy             | 04      | 559 RSI | 559 RSI |
| TXT | 50 Rookie          | 02 - 03 | 815 HF  | 815 HF  |
| MC  | 65                 | 05 - 06 | 815 HF  | 815 HF  |
| TXT | 80 Rookie          | 02 - 03 | 815 HF  | 815 HF  |
|     | 125 Delta          | 91      | 559 HF  |         |
|     | 125 Enducross      | 93      | 694 SI  | 586 SI  |
|     | 125 Pampera        | 96 - 03 | 559 RSI | 559 RSI |
|     | 125 Pampera        | 04 - 13 | 774 HF  | 815 HF  |
|     | 125 Trial          | 91      | 559 RSI |         |
| EC  | 125                | 97 - 99 | 671 SI  | 675 SI  |
| EC  | 125                | 00 - 06 | 694 SI  | 604 SI  |
| MC  | 125                | 03 - 13 | 694 RSI | 604 RSI |
| SM  | 125                | 02 - 13 | 566 HF  | 604 HF  |
| TX  | 125 Randone        | 12 - 13 | 802 RSI | 803 RSI |
| TXT | 125 (Formula cal.) | 12 - 13 | 885 RSI | 803 RSI |
| TXT | 125                | 04 - 13 | 802 RSI | 803 RSI |
| TXT | 125 Pro Racing     | 14      | 939 RSI | 803 RSI |
| TXT | 125 Pro Replica    | 13      | 939 RSI | 803 RSI |
|     | 200 Pampera        | 99 - 08 | 559 RSI | 559 RSI |
|     | 200 Wild HP        | 08 - 09 | 671 SI* | 671 SI  |
| EC  | 200                | 99      | 671 SI  | 675 SI  |
| EC  | 200                | 00 - 09 | 694 SI  | 604 SI  |
| EC  | 200                | 17      | 694 SI  | 790 SI  |
| EC  | 200 Hobby          | 07 - 16 | 694 SI  | 604 SI  |
| TX  | 200                | 97 - 98 | 559 RSI | 559 RSI |
| TXT | 200                | 04 - 10 | 802 RSI | 803 RSI |
| XC  | 200                | 18 -    | 694 SI  | 790 SI  |
|     | 240 Wild HP        | 04 - 06 | 671 SI* | 671 SI  |
|     | 250 Pampera        | 96 - 99 | 559 RSI | 559 RSI |
|     | 250 Pampera        | 02 - 13 | 774 HF  | 815 HF  |
|     | 250 Trial          | 89 - 96 | 559 RSI | 559 RSI |
|     | 250 Wild HP        | 08      | 671 SI* | 671 SI  |
| EC  | 250                | 97 - 99 | 671 SI  | 675 SI  |
| EC  | 250                | 00 - 11 | 694 SI  | 604 SI  |
| EC  | 250                | 12 - 18 | 694 SI  | 790 SI  |
| EC  | 250 Enduro GP 18   | 18 -    | 694 SI  | 790 SI  |
| EC  | 250 fse            | 02 - 11 | 694 SI  | 604 SI  |
| GT  | 250 Contact        | 92 - 93 | 559 RSI | 559 RSI |
| MC  | 250                | 97 - 99 | 671 RSI | 675 RSI |
| MC  | 250                | 00 - 13 | 694 SI  | 604 SI  |
| SM  | 250                | 02 - 13 | 566 HF  | 604 HF  |
| TXT | 250 (Formula cal.) | 12 - 13 | 885 RSI | 803 RSI |
| TXT | 250                | 04 - 07 | 802 RSI | 803 RSI |
| TXT | 250 Pro Racing     | 14 - 18 | 939 RSI | 803 RSI |
| TXT | 250 Pro Replica    | 13 - 14 | 939 RSI | 803 RSI |
| XC  | 250                | 17      | 694 SI  | 790 SI  |
| TX  | 270                | 97 - 98 | 559 RSI | 559 RSI |
|     | 280 Pampera        | 04 - 08 | 774 HF  | 815 HF  |
| TXT | 280 (Formula cal.) | 12      | 885 RSI | 803 RSI |
| TXT | 280                | 04      | 802 RSI | 803 RSI |
| TXT | 280 Pro Racing     | 14 - 18 | 939 RSI | 803 RSI |
| TXT | 280 Pro Replica    | 13      | 939 RSI | 803 RSI |
|     | 300 Wild HP        | 03 - 05 | 671 SI* | 671 SI  |

**RECOMMENDED**1xx = Scooter Pads  
5xx = Street, Off Road & Racing Pads  
2xxx = Brake Shoes**GAS GAS**

|     |                    |         |         |         |
|-----|--------------------|---------|---------|---------|
| EC  | 300                | 99      | 671 SI  | 675 SI  |
| EC  | 300                | 00 - 11 | 694 SI  | 604 SI  |
| EC  | 300                | 12 - 18 | 694 SI  | 790 SI  |
| EC  | 300 Enduro GP 18   | 18 -    | 694 SI  | 790 SI  |
| TXT | 300 (Formula cal.) | 12      | 885 RSI | 803 RSI |
| TXT | 300                | 04 - 06 | 802 RSI | 803 RSI |
| TXT | 300 Pro            | 07 - 11 | 802 RSI | 803 RSI |
| TXT | 300 Pro Racing     | 14 - 18 | 939 RSI | 803 RSI |
| TXT | 300 Pro Replica    | 13      | 939 RSI | 803 RSI |
| XC  | 300                | 18 -    | 694 SI  | 790 SI  |
| TX  | 320                | 97 - 99 | 559 RSI | 559 RSI |
|     | 325 Halley PXC     | 86      | 559 RSI | 559 RSI |
|     | 327 Trial          | 89 - 90 | 559 RSI | 559 RSI |
| GT  | 327 Contact        | 89 - 90 | 559 RSI | 559 RSI |
|     | 370 Pampera        | 96 - 00 | 559 RSI | 559 RSI |
|     | 400 Pampera        | 06 - 09 | 694 SI  | 604 SI  |
| EC  | 400 fse            | 02      | 694 SI  | 604 SI  |
| SM  | 400 fse            | 02      | 566 HF  | 604 HF  |
|     | 450 Wild HP        | 03 - 09 | 671 SI* | 671 SI  |
| EC  | 450 fse            | 03 - 15 | 694 SI  | 604 SI  |
| EC  | 450 FSR            | 07 - 16 | 694 SI  | 604 SI  |
| SM  | 450 fse            | 03 - 06 | 566 HF  | 604 HF  |
| SM  | 450 FSR            | 07 - 13 | 566 HF  | 604 HF  |
|     | 515 Wild HP        | 09      | 671 SI* | 671 SI  |
| EC  | 515 fsr            | 08 - 16 | 694 SI  | 604 SI  |

**GENERIC**

|    |                           |         |        |        |
|----|---------------------------|---------|--------|--------|
|    | 50 Ideo                   | 06 - 13 | 141 HF | 2028   |
|    | 50 ROC                    | 08 - 11 | 141 HF |        |
|    | 50 Stroke                 | 08 - 12 | 141 HF |        |
|    | 50 Toxic                  | 07 - 16 | 168 HF | 123 HF |
|    | 50 Trigger SM             | 06 - 14 | 168 HF | 123 HF |
|    | 50 Trigger SM Competition | 08 - 14 | 168 HF | 123 HF |
|    | 50 Trigger X              | 06 - 14 | 168 HF | 123 HF |
|    | 50 Trigger X Competition  | 08 - 12 | 168 HF | 123 HF |
|    | 50 XOR                    | 06 - 13 | 141 HF | 2028   |
| SM | 50 Mini Trigger           | 08 - 09 | 211 HF | 211 HF |
| X  | 50 Mini Trigger           | 08 - 09 | 211 HF | 211 HF |
|    | 125 Soho                  | 07 - 16 | 141 CT |        |
|    | 125 Stroke                | 08 - 15 | 141 CT |        |
|    | 125 XOR                   | 07 - 11 | 141 CT |        |
|    | 125 Zion                  | 08 - 15 | 163 CT |        |

**GILERA**

|     |                                    |         |        |        |
|-----|------------------------------------|---------|--------|--------|
| SP  | 01                                 | 90      | 601 HF | 519 HF |
|     | 50 503                             | 91 - 94 | 132 HF | 132 HF |
|     | 50 AJP Caliper<br>incl. pin/spring | 90 - 18 | 188 HF |        |
|     | 50 Bullit                          | 90 - 97 | 595 HF |        |
|     | 50 DNA                             | 01 - 07 | 120 HF | 143 HF |
|     | 50 Eaglet                          | 96      | 131 HF | 2195   |
|     | 50 Eaglet                          | 97 - 99 | 123 HF | 102 HF |
|     | 50 Easy Moving                     | 96 - 11 | 130 HF | 2187   |
|     | 50 H@k                             | 99 - 02 | 105 HF | 105 HF |
|     | 50 Ice                             | 02 - 05 | 123 HF |        |
|     | 50 Rally                           | 87      | 131 HF |        |
|     | 50 Rally, R1                       | 92 - 96 | 519 HF |        |
|     | 50 Runner                          | 97 - 05 | 143 HF | 2195   |
|     | 50 Runner PJ                       | 06 - 11 | 177 HF | 202 HF |
|     | 50 Runner SP                       | 06 - 12 | 177 HF | 202 HF |
|     | 50 Runner SP, Purejet              | 98 - 05 | 143 HF | 202 HF |
|     | 50 Sioux                           | 92      | 519 HF | 519 HF |
|     | 50 Stalker                         | 97 - 01 | 123 HF | 202 HF |
|     | 50 Storm                           | 94 - 98 | 143 HF | 2187   |
|     | 50 Typhoon                         | 93 - 95 | 143 HF | 2187   |
|     | 50 Typhoon                         | 96 - 01 | 130 HF | 2200   |
|     | 50 Zulu                            | 01 - 03 | 105 HF | 105 HF |
| DT  | 50 Stalker                         | 01 - 05 | 123 HF | 202 HF |
| GSM | 50 Supermotard                     | 01 - 13 | 105 HF | 105 HF |
| NRG | 50                                 | 94 - 95 | 123 HF | 2187   |
| R   | 50                                 | 96      | 132 HF |        |
| RC  | 50 Top Rally                       | 90      | 519 HF | 519 HF |

\* = 2 sets required / 2 jeux pour l'Avant.

Full compound selection, see under "Brake pad 1:1 Drawings" / Sélection complète de composés, voir "1:1 Schémas Plaquettes de frein".

**RECOMMENDED**1xx = Scooter Pads  
5xx = Street, Off Road & Racing Pads  
2xxx = Brake Shoes

| GILERA |     |                           |         |               |
|--------|-----|---------------------------|---------|---------------|
| RCR    | 50  | 04 - 13                   | 105 HF  | 105 HF        |
| RI     | 50  | 91                        | 131 HF  |               |
| SMT    | 50  | 04 - 13                   | 105 HF  | 105 HF        |
|        | 70  | Runner Malossi            | 98      | 123 HF        |
|        | 80  | TG 1, 2, 3                | 77 - 82 | 560 HF        |
|        | 80  | Typhoon                   | 95 - 99 | 143 HF 2187   |
|        | 125 | Apache                    | 91 - 94 | 608 HF 575 HF |
|        | 125 | Arizona Hawk              | 86 - 89 | 519 HF        |
|        | 125 | Cougar                    | 99 - 02 | 108 CT        |
|        | 125 | Crono                     | 92 - 95 | 601 HF 519 HF |
|        | 125 | DNA                       | 01 - 03 | 120 CT 143 CT |
|        | 125 | Fast Bike                 | 88 - 89 | 588 HF        |
|        | 125 | Freestyle                 | 92 - 95 | 601 HF 519 HF |
|        | 125 | GSM                       | 00      | 105 CT 105 CT |
|        | 125 | HX, HE                    | 83      | 519 HF        |
|        | 125 | KK, KR, KZ                | 86 - 91 | 588 HF 519 HF |
|        | 125 | MX1, MRX, SP01            | 89 - 93 | 601 HF 519 HF |
|        | 125 | Nexus                     | 07 - 12 | 177 CT 177 CT |
|        | 125 | R1, R1S                   | 90 - 92 | 588 HF 519 HF |
|        | 125 | SP02                      | 90 - 94 | 601 HF 519 HF |
|        | 125 | Surfer                    | 00      | 559 HF 559 HF |
|        | 125 | TG 1, 2, 3 (alu wheels)   | 77 - 85 | 560 HF        |
|        | 125 | TG1, GR1, RTX             | 77 - 85 | 560 HF        |
|        | 125 | Typhoon                   | 96 - 00 | 130 CT 2195   |
| CX     | 125 |                           | 91 - 95 | 601 HF 519 HF |
| ER     | 125 | Rally                     | 87      | 588 HF        |
| FX     | 125 | Runner                    | 97 - 99 | 148 CT 2205   |
| FX     | 125 | Runner (Grimeca cal.)     | 00 - 05 | 120 CT 202 CT |
| FX     | 125 | Runner (Hengtong cal.)    | 00 - 05 | 177 CT 202 CT |
| FX     | 125 | Runner SP (Grimeca cal.)  | 00 - 03 | 120 CT 202 CT |
| FX     | 125 | Runner SP (Hengtong cal.) | 00 - 03 | 177 CT 202 CT |
| MXR    | 125 |                           | 90      | 588 HF 519 HF |
| RC     | 125 | Top Rally                 | 90 - 93 | 608 HF 575 HF |
| RRT    | 125 | Nebraska                  | 87      | 588 HF        |
| RTX    | 125 |                           | 86      | 588 HF        |
| RV     | 125 |                           | 86 - 88 | 560 HF*       |
| RX     | 125 |                           | 83      | 519 HF        |
| RX     | 125 | Arizona Hawk              | 85      | 588 HF        |
| SC     | 125 |                           | 06 - 07 | 189 MS 105 CT |
| ST     | 125 | Runner                    | 08 - 11 | 177 CT 166 CT |
| ST     | 125 | Runner                    | 12 - 13 | 177 CT 202 CT |
| VX     | 125 | Runner 4T (Grimeca cal.)  | 01 - 12 | 120 CT 166 CT |
| VX     | 125 | Runner 4T (Hengtong cal.) | 01 - 12 | 177 CT 166 CT |
| X1     | 125 |                           | 89      | 588 HF 574 HF |
| XR2    | 125 |                           | 90      | 588 HF 519 HF |
| FX     | 150 | Runner                    | 97 - 01 | 148 CT 2205   |
|        | 175 | Mad Mud                   | 02      | 120 CT 143 CT |
|        | 180 | DNA                       | 01 - 03 | 120 CT 143 CT |
| FXR    | 180 | Runner                    | 97      | 148 CT        |
| FXR    | 180 | Runner                    | 98 - 99 | 120 CT        |
| FXR    | 180 | Runner (Grimeca cal.)     | 00 - 03 | 120 CT 202 CT |
| FXR    | 180 | Runner (Hengtong cal.)    | 00 - 03 | 177 CT 202 CT |
| FXR    | 180 | Runner SP (Grimeca cal.)  | 00      | 120 CT 202 CT |
| FXR    | 180 | Runner SP (Hengtong cal.) | 00      | 177 CT 202 CT |
| VXR    | 180 | Runner                    | 01 - 08 | 177 CT        |
| VXR    | 180 | Runner 4T (Grimeca cal.)  | 01 - 08 | 120 CT 166 CT |
| VXR    | 180 | Runner 4T (Hengtong cal.) | 01 - 08 | 177 CT 166 CT |
|        | 200 | Arizona Hawk              | 85      | 588 HF        |
|        | 200 | ER                        | 87      | 588 HF        |
|        | 200 | Fast Bike                 | 87      | 588 HF 519 HF |
|        | 200 | RX                        | 83      | 519 HF        |
|        | 200 | Stalker                   | 97 - 01 | 123 CT 202 CT |
|        | 200 | T4, T4C, T4S              | 79 - 82 | 560 HF        |
| FX     | 200 | Runner                    | 97 - 98 | 148 CT 2205   |
| FX     | 200 | Runner SP                 | 98 - 01 | 120 CT 202 CT |
| RV     | 200 |                           | 85 - 86 | 560 HF*       |
| RV     | 200 |                           | 85 - 86 | 605 HF*       |
| ST     | 200 | Runner                    | 08 - 11 | 177 CT 166 CT |

**RECOMMENDED**1xx = Scooter Pads  
5xx = Street, Off Road & Racing Pads  
2xxx = Brake Shoes

| GILERA |     |                           |                        |
|--------|-----|---------------------------|------------------------|
| VXR    | 200 | Runner 4T (Grimeca cal.)  | 01 - 09 120 CT 166 CT  |
| VXR    | 200 | Runner 4T (Hengtong cal.) | 01 - 09 177 CT 166 CT  |
|        | 250 | Arizona Hawk              | 86 - 91 519 HF         |
|        | 250 | Arizona Rally             | 86 - 91 519 HF         |
|        | 250 | Arizona Rally             | 08 588 HF 519 HF       |
|        | 250 | Nexus                     | 07 - 08 177 MS 177 MS  |
|        | 250 | Oregon Quad               | 07 - 11 575 SI* 775 SI |
| NGR    | 250 |                           | 85 574 HF* 519 HF      |
|        | 350 | Dakota                    | 85 588 HF              |
|        | 350 | Dakota                    | 86 - 89 594 HF         |
|        | 350 | Saturno Bialbero          | 90 566 HF 519 HF       |
| XRT    | 350 |                           | 90 588 HF 519 HF       |
|        | 500 | Dakota                    | 86 588 HF              |
|        | 500 | Nexus                     | 04 - 12 151 MS* 157 MS |
|        | 500 | Saturno Bialbero          | 90 566 HF 519 HF       |
|        | 500 | Saturno Piuma             | 90 - 94 566 HF 519 HF  |
| RC     | 500 | Fuoco ie                  | 08 - 17 202 MS* 191 MS |
| RC     | 500 | Fuoco ie (Parking Brake)  | 08 - 17 209 HF         |
|        | 600 | Nordwest                  | 91 - 94 601 HF* 519 HF |
|        | 600 | Supersport                | 02 762 HS* 730 LS      |
| RC     | 600 |                           | 88 588 HF 519 HF       |
| RC     | 600 | Top Rally                 | 90 - 94 608 HF 575 HF  |
| XRT    | 600 |                           | 89 588 HF 519 HF       |
| GP     | 800 | (Parking Brake)           | 08 - 15 209 HF         |
| GP     | 800 |                           | 08 - 15 151 MS* 177 MS |

| GOES |     |     |                        |
|------|-----|-----|------------------------|
|      | 360 | Max | 08 - 14 914 SI*        |
|      | 520 | Max | 07 - 12 914 SI* 799 SI |
| G    | 520 |     | 07 - 12 914 SI* 799 SI |
| G    | 525 |     | 12 - 14 914 SI* 799 SI |
| G    | 620 |     | 11 - 14 914 SI* 799 SI |
| G    | 625 | A   | 12 - 14 914 SI* 799 SI |

| HAO-QING |     |    |           |
|----------|-----|----|-----------|
|          | 125 | 2C | 02 585 HF |

| HARLEY DAVIDSON |      |                    |                            |
|-----------------|------|--------------------|----------------------------|
| XG              | 500  | Street             | 14 - 15 924 H.HF 924 H.HF  |
| XG              | 500  | Street             | 16 - 18 674 H.HF 671 H.HF  |
| XG              | 750  | Street             | 14 - 15 924 H.HF 924 H.HF  |
| XG              | 750  | Street             | 16 - 17 674 H.HF 671 H.HF  |
| XG              | 750  | Street Rod         | 18 - 674 H.HF* 671 H.HF    |
| XL              | 883  | C Sportster Custom | 04 - 13 807 H.HS 808 H.LS  |
| XL              | 883  | L Sportster Low    | 06 - 13 807 H.HS 808 H.LS  |
| XL              | 883  | L Super Low        | 11 - 13 807 H.HS 808 H.LS  |
| XL              | 883  | L Super Low        | 14 - 18 934 H.HS 715 H.LS  |
| XL              | 883  | N Iron             | 13 807 H.HS 808 H.LS       |
| XL              | 883  | N Iron             | 14 - 18 934 H.HS 715 H.LS  |
| XL              | 883  | R Roadster         | 10 - 13 807 H.HS* 808 H.LS |
| XL              | 883  | R Roadster         | 14 - 15 934 H.HS 715 H.LS  |
| XL              | 883  | R Sportster        | 00 - 03 826 H.HS 826 H.LS  |
| XL              | 883  | Series             | 74 - 77 679 H.HF           |
| XL              | 883  | Sportster          | 04 - 13 807 H.HS 808 H.LS  |
| XL              | 883  | Sportster Custom   | 00 - 03 826 H.HS 826 H.LS  |
| XL              | 883  | Sportster R        | 05 - 13 807 H.HS* 808 H.LS |
| XLH             | 883  |                    | 70 - 83 537 H.HF           |
| XLH             | 883  | Series             | 88 - 99 579 H.HS* 669 H.LS |
| XLH             | 883  | Sportster          | 85 - 86 579 H.HF 549 H.HF  |
| XLH             | 883  | Sportster          | 87 - 99 579 H.HF 669 H.HF  |
| XLH             | 883  | Sportster          | 00 - 03 826 H.HS 826 H.LS  |
| XLH             | 883  | Sportster Hugger   | 00 - 03 826 H.HS 826 H.LS  |
| XL              | 1000 |                    | 78 537 H.HF 543 H.HF       |
| XLCH            | 1000 |                    | 73 513 H.HF                |
| XLCH            | 1000 |                    | 78 - 80 537 H.HF 543 H.HF  |
| XLH             | 1000 | Sportster          | 79 - 82 537 H.HF* 543 H.HF |
| XLH             | 1000 | Sportster          | 83 - 85 537 H.HF* 549 H.HF |
| XLS             | 1000 | Anniversary        | 82 537 H.HF* 549 H.HF      |
| XLS             | 1000 | Roadster           | 79 - 82 537 H.HF* 543 H.HF |
| XLS             | 1000 | Sportster          | 83 537 H.HF* 549 H.HF      |
| XLX             | 1000 | 61                 | 83 537 H.HF* 549 H.HF      |

\* = 2 sets required / 2 jeux pour l'Avant.

**RECOMMENDED**1xx = Scooter Pads  
5xx = Street, Off Road & Racing Pads  
2xxx = Brake Shoes**HARLEY DAVIDSON**

|        |      |                        |         |           |          |
|--------|------|------------------------|---------|-----------|----------|
| XLX    | 1000 | 61                     | 84      | 537 H.HF  | 549 H.HF |
| XR     | 1000 |                        | 85      | 537 H.HF* | 549 H.HF |
| XLH    | 1100 |                        | 87 - 88 | 579 H.HS  | 669 H.LS |
| XLH    | 1100 | Sportster              | 85 - 86 | 579 H.HF  | 549 H.HF |
| XLX    | 1100 |                        | 86      | 579 H.HF  | 549 H.HF |
| VRSCA  | 1130 | V-Rod                  | 02 - 05 | 826 H.HS* | 826 H.LS |
| VRSCA  | 1130 | V-Rod                  | 06 - 10 | 830 H.HS* | 830 H.LS |
| VRSCB  | 1130 | V-Rod                  | 04      | 826 H.HS* | 826 H.LS |
| VRSCD  | 1130 | Night Rod              | 06 - 08 | 830 H.HS* | 830 H.LS |
| VRSCR  | 1130 | Street Rod             | 06 - 07 | 830 H.HS* | 830 H.LS |
| FL     | 1200 | FLH Police             | 75 - 79 | 513 H.HF  | 513 H.HF |
| FLH    | 1200 |                        | 74 - 76 | 513 H.HF  | 513 H.HF |
| FLH    | 1200 |                        | 80      | 513 H.HF  | 553 H.HF |
| FLH    | 1200 | Anniversary            | 78      | 513 H.HF  | 513 H.HF |
| FLH    | 1200 | Touring                | 77 - 78 | 513 H.HF  | 513 H.HF |
| FLHS   | 1200 |                        | 77 - 80 | 513 H.HF  | 513 H.HF |
| FX     | 1200 |                        | 74 - 80 | 537 H.HF  | 513 H.HF |
| FXE    | 1200 |                        | 74 - 80 | 537 H.HF  | 513 H.HF |
| FXS    | 1200 |                        | 78 - 79 | 537 H.HF  | 513 H.HF |
| XL     | 1200 | C Sportster Custom     | 04 - 13 | 807 H.HS  | 808 H.LS |
| XL     | 1200 | C, CA, CB, CP Custom   | 14 - 18 | 934 H.HS  | 715 H.LS |
| XL     | 1200 | CX                     | 17      | 934 H.HS* | 715 H.LS |
| XL     | 1200 | L Sportster Low        | 07 - 10 | 807 H.HS  | 808 H.LS |
| XL     | 1200 | N Nightster            | 07 - 12 | 807 H.HS  | 808 H.LS |
| XL     | 1200 | R Sportster Roadster   | 04 - 09 | 807 H.HS* | 808 H.LS |
| XL     | 1200 | Roadster               | 18 -    | 934 H.HS* | 715 H.LS |
| XL     | 1200 | Sportster Custom       | 00 - 03 | 826 H.HS  | 826 H.LS |
| XL     | 1200 | Sportster Sport        | 00 - 03 | 826 H.HS* | 826 H.LS |
| XL     | 1200 | T Super Low            | 15 - 17 | 934 H.HS  | 715 H.LS |
| XL     | 1200 | V Seventy-Two          | 11 - 13 | 807 H.HS  | 808 H.LS |
| XL     | 1200 | V Seventy-Two          | 14 - 16 | 934 H.HS  | 715 H.LS |
| XL     | 1200 | X Forty-Eight          | 11 - 13 | 807 H.HS  | 808 H.LS |
| XL     | 1200 | X Forty-Eight          | 14 - 18 | 934 H.HS  | 715 H.LS |
| XLH    | 1200 | Sportster              | 90 - 99 | 579 H.HS  | 669 H.LS |
| XLH    | 1200 | Sportster              | 00 - 03 | 826 H.HS  | 826 H.LS |
| XR     | 1200 |                        | 08 - 10 | 860 H.HS* | 808 H.LS |
| XR     | 1200 | X                      | 10 - 13 | 860 H.HS* | 808 H.LS |
| VRSCAW | 1250 | V-Rod                  | 08 - 10 | 830 H.HS* | 830 H.LS |
| VRSCDX | 1250 | Night Rod Special      | 08 - 17 | 830 H.HS* | 830 H.LS |
| VRSCF  | 1250 | Muscle                 | 09 - 17 | 830 H.HS  | 830 H.LS |
| VRSCX  | 1250 | V-Rod                  | 08 - 10 | 830 H.HS* | 830 H.LS |
| FLH    | 1340 | 80                     | 78 - 80 | 513 H.HF  | 513 H.HF |
| FLH    | 1340 | 80                     | 81      | 513 H.HF  | 553 H.HF |
| FLH    | 1340 | Classic                | 82 - 83 | 543 H.HF* | 553 H.HF |
| FLH    | 1340 | Electra Glide          | 82 - 83 | 543 H.HF* | 513 H.HF |
| FLH    | 1340 | Electra Glide Spec.    | 84      | 513 H.HF  | 553 H.HF |
| FLH    | 1340 | Heritage               | 81      | 543 H.HF* | 553 H.HF |
| FLHS   | 1340 | Electra Glide Sport    | 90      | 579 H.HS* | 668 H.LS |
| FLHT   | 1340 | Electra Glide          | 85 - 86 | 579 H.HF* | 549 H.HF |
| FLHT   | 1340 | Electra Glide Classic  | 87 - 99 | 579 H.HS* | 669 H.LS |
| FLHT   | 1340 | Tour Glide             | 84      | 537 H.HF* | 553 H.HF |
| FLHTC  | 1340 | Electra Glide Classic  | 85 - 86 | 579 H.HF* | 549 H.HF |
| FLHTC  | 1340 | Electra Glide Classic  | 90 - 99 | 579 H.HS* | 668 H.LS |
| FLHTC  | 1340 | Electra Glide Classic  | 93      | 579 H.HS* | 669 H.LS |
| FLHTC  | 1340 | Ultra Classic          | 90 - 99 | 579 H.HS* | 668 H.LS |
| FLST   | 1340 | Heritage Softail       | 86 - 87 | 579 H.HF  | 549 H.HF |
| FLST   | 1340 | Heritage Softail       | 88 - 99 | 579 H.HS  | 668 H.LS |
| FLSTC  | 1340 | Heritage Softail Cl.   | 90 - 99 | 579 H.HS  | 669 H.LS |
| FLSTF  | 1340 | Fat Boy                | 90 - 99 | 579 H.HS  | 669 H.LS |
| FLSTN  | 1340 | Heritage Softail Nost. | 93 - 99 | 579 H.HS* | 669 H.LS |
| FLT    | 1340 |                        | 84 - 85 | 579 H.HF  | 553 H.HF |
| FLT    | 1340 | 80                     | 80 - 81 | 543 H.HF* | 553 H.HF |
| FLT    | 1340 | 80 Classic             | 81      | 543 H.HF* | 553 H.HF |
| FLT    | 1340 | Classic                | 82 - 83 | 543 H.HF* | 553 H.HF |
| FLT    | 1340 | Tour Glide             | 82      | 543 H.HF* | 553 H.HF |
| FLT/H  | 1340 | Series                 | 86 - 87 | 579 H.HS* | 668 H.LS |
| FLTC   | 1340 | Tour Glide Classic     | 85 - 86 | 579 H.HF  | 549 H.HF |
| FLTC   | 1340 | Tour Glide Classic     | 90      | 579 H.HS* | 668 H.LS |
| FXB    | 1340 | 80                     | 80 - 81 | 537 H.HF  | 513 H.HF |
| FXB    | 1340 | Sturgis                | 82      | 537 H.HF* | 513 H.HF |
| FXDB   | 1340 | Dyna Glide Daytona     | 91 - 99 | 579 H.HS* | 669 H.LS |
| FXDB   | 1340 | Dyna Glide Sturgis     | 91 - 99 | 579 H.HF  | 669 H.HF |

**HARLEY DAVIDSON**

|          |      |                                 |         |           |          |
|----------|------|---------------------------------|---------|-----------|----------|
| XDB      | 1340 | Sturgis                         | 91 - 99 | 579 H.HS  | 669 H.LS |
| FXDL     | 1340 | Dyna Low Rider                  | 93 - 99 | 579 H.HS* | 669 H.LS |
| FXDWG    | 1340 | Dyna Wide Glide                 | 93 - 99 | 579 H.HS  | 669 H.LS |
| FXE      | 1340 |                                 | 82      | 537 H.HF  | 669 H.HF |
| FXE      | 1340 |                                 | 85 - 86 | 579 H.HF  | 549 H.HF |
| FXE      | 1340 | 80                              | 78 - 81 | 537 H.HF  | 513 H.HF |
| FXE      | 1340 | Super Glide                     | 83 - 84 | 537 H.HF* | 513 H.HF |
| FXEF     | 1340 | 80 Fat Bob                      | 79 - 81 | 537 H.HF  | 513 H.HF |
| FXLR     | 1340 | Low Rider Custom                | 87 - 88 | 579 H.HS  | 669 H.LS |
| FXLR     | 1340 | Low Rider Custom                | 93 - 99 | 579 H.HS  | 669 H.LS |
| FXR      | 1340 |                                 | 78 - 81 | 537 H.HF  | 513 H.HF |
| FXR      | 1340 |                                 | 87 - 88 | 579 H.HS  | 669 H.LS |
| FXR      | 1340 | Super Glide                     | 82 - 83 | 537 H.HF  | 549 H.HF |
| FXR      | 1340 | Super Glide                     | 85 - 86 | 579 H.HF  | 549 H.HF |
| FXR      | 1340 | Super Glide                     | 90 - 99 | 579 H.HS  | 669 H.LS |
| FXRD     | 1340 | Sport Glide GTE                 | 85 - 86 | 579 H.HF* | 549 H.HF |
| FXRS     | 1340 | Low Glide                       | 82 - 84 | 537 H.HF* | 549 H.HF |
| FXRS     | 1340 | Low Rider                       | 85 - 86 | 579 H.HF* | 549 H.HF |
| FXRS     | 1340 | Low Rider Sport                 | 87 - 99 | 579 H.HS* | 669 H.LS |
| FXRS     | 1340 | Low Rider Sport Ed.             | 90 - 99 | 579 H.HS* | 669 H.LS |
| FXRS     | 1340 | Low Rider, Convert.             | 90 - 99 | 579 H.HS* | 669 H.LS |
| FXRS     | 1340 | Super Glide II                  | 82 - 83 | 537 H.HF* | 549 H.HF |
| FXRT     | 1340 | Sport Glide                     | 85 - 86 | 579 H.HF* | 549 H.HF |
| FXRT     | 1340 | Sport Glide                     | 90 - 99 | 579 H.HS* | 669 H.LS |
| FXRT     | 1340 | Super Glide II                  | 83      | 537 H.HF  | 549 H.HF |
| FXS      | 1340 | 80                              | 79 - 81 | 537 H.HF  | 513 H.HF |
| FXS      | 1340 | Low Rider                       | 82      | 537 H.HF* | 513 H.HF |
| FXSB     | 1340 | Low Rider                       | 83      | 537 H.HF* | 549 H.HF |
| FXST     | 1340 | Softail                         | 84 - 86 | 579 H.HF  | 549 H.HF |
| FXSTC    | 1340 | Softail Custom                  | 85 - 86 | 579 H.HF  | 549 H.HF |
| FXSTC    | 1340 | Softail Custom                  | 88 - 99 | 579 H.HS  | 669 H.LS |
| FXSTS    | 1340 | Springer Softail                | 90 - 99 | 579 H.HS  | 669 H.LS |
| FXWG     | 1340 |                                 | 87 - 88 | 579 H.HS  | 669 H.LS |
| FXWG     | 1340 | 80                              | 80 - 81 | 537 H.HF  | 513 H.HF |
| FXWG     | 1340 | Wide Glide                      | 82      | 537 H.HF* | 513 H.HF |
| FXWG     | 1340 | Wide Glide                      | 83      | 537 H.HF* | 549 H.HF |
| FXWG     | 1340 | Wide Glide                      | 84      | 537 H.HF  | 549 H.HF |
| FXWG     | 1340 | Wide Glide                      | 85 - 86 | 579 H.HF  | 549 H.HF |
| FLHR/I   | 1450 | Road King                       | 00 - 06 | 826 H.HS* | 826 H.LS |
| FLHR/I   | 1450 | Road King Classic               | 00 - 06 | 826 H.HS* | 826 H.LS |
| FLHR/I   | 1450 | Road King Custom                | 04 - 06 | 826 H.HS* | 826 H.LS |
| FLHT/I   | 1450 | Electra Glide Standard          | 00 - 06 | 826 H.HS* | 826 H.LS |
| FLHTC/I  | 1450 | Electra Glide Classic           | 00 - 06 | 826 H.HS* | 826 H.LS |
| FLHTCUI  | 1450 | Ultra Classic Electra<br>Glide  | 00 - 06 | 826 H.HS* | 826 H.LS |
| FLHXI    | 1450 | Street Glide                    | 06      | 826 H.HS* | 826 H.LS |
| FLSTC    | 1450 | Softail                         | 06 - 07 | 826 H.HS  | 826 H.LS |
| FLSTC/I  | 1450 | Heritage Softail Classic        | 00 - 04 | 826 H.HS  | 826 H.LS |
| FLSTC/I  | 1450 | Softail                         | 06      | 826 H.HS  | 826 H.LS |
| FLSTF    | 1450 | Fat Boy                         | 06 - 07 | 826 H.HS  | 826 H.LS |
| FLSTF/I  | 1450 | Fat Boy                         | 00 - 04 | 826 H.HS  | 826 H.LS |
| FLSTF/I  | 1450 | Fat Boy                         | 06      | 826 H.HS  | 826 H.LS |
| FLSTI    | 1450 | Heritage Softail                | 06      | 826 H.HS  | 846 H.LS |
| FLSTN/I  | 1450 | Softail Deluxe                  | 06      | 826 H.HS  | 826 H.LS |
| FLSTN/I  | 1450 | Heritage Springer               | 00 - 03 | 579 H.HS  | 826 H.LS |
| FLSTSC/I | 1450 | Springer Softail Classic        | 06      | 579 H.HS  | 826 H.LS |
| FLT      | 1450 | Series                          | 88 - 99 | 579 H.HS* | 668 H.LS |
| FLTR/I   | 1450 | Road Glide Classic              | 00 - 06 | 826 H.HS* | 826 H.LS |
| FXB      | 1450 | Series                          | 74 - 77 | 679 H.HF  |          |
| FXD      | 1450 | Dyna Super Glide                | 00 - 03 | 826 H.HS  | 826 H.LS |
| FXDBI    | 1450 | Dyna Street Bob                 | 06      | 826 H.HS  | 826 H.LS |
| FXDC/I   | 1450 | Dyna Super Glide<br>Custom      | 05 - 06 | 826 H.HS  | 826 H.LS |
| FXDI     | 1450 | 35th Anniversary<br>Super Glide | 06      | 826 H.HS  | 846 H.LS |
| FXDI     | 1450 | Dyna Super Glide                | 04 - 07 | 826 H.HS  | 826 H.LS |
| FXDL     | 1450 | Dyna Low Rider                  | 00 - 03 | 826 H.HS* | 826 H.LS |
| FXDLI    | 1450 | Dyna Low Rider                  | 04 - 06 | 826 H.HS  | 826 H.LS |
| FXDS     | 1450 | Dyna Convertible                | 00 - 02 | 826 H.HS* | 826 H.LS |
| FXDWG    | 1450 | Dyna Wide Glide                 | 00 - 03 | 826 H.HS  | 826 H.LS |
| FXDWGI   | 1450 | Dyna Wide Glide                 | 04 - 06 | 826 H.HS  | 826 H.LS |
| FXDX     | 1450 | Dyna Super Glide Sport          | 00 - 03 | 826 H.HS* | 826 H.LS |

\* = 2 sets required / 2 jeux pour l'Avant.

Full compound selection, see under "Brake pad 1:1 Drawings" / Sélection complète de composés, voir "1:1 Schémas Plaquettes de frein".

**RECOMMENDED**

1xx = Scooter Pads  
 5xx = Street, Off Road & Racing Pads  
 2xxx = Brake Shoes



| <b>HARLEY DAVIDSON</b> |      |                        |         |           |          |
|------------------------|------|------------------------|---------|-----------|----------|
| FXDXI                  | 1450 | Dyna Super Glide Sport | 04 - 06 | 826 H.HS  | 826 H.LS |
| FXDXT                  | 1450 | Dyna Super Glide       |         |           |          |
|                        |      | T-Sport                | 00 - 03 | 826 H.HS* | 826 H.LS |
| FXE                    | 1450 | Series                 | 74 - 77 | 679 H.HF  | 513 H.HF |
| FXST/I                 | 1450 | Softail Standard       | 00 - 05 | 826 H.HS  | 826 H.LS |
| FXST/I                 | 1450 | Softail Standard       | 06      | 826 H.HS  | 846 H.LS |
| FXSTB/I                | 1450 | Night Train            | 00 - 05 | 826 H.HS  | 826 H.LS |
| FXSTB/I                | 1450 | Night Train            | 06      | 826 H.HS  | 846 H.LS |
| FXSTD/I                | 1450 | Softail Deuce          | 00 - 05 | 826 H.HS  | 826 H.LS |
| FXSTD/I                | 1450 | Softail Deuce          | 06      | 826 H.HS  | 846 H.LS |
| FXSTS/I                | 1450 | Softail                | 05      | 579 H.HS  | 826 H.LS |
| FXSTS/I                | 1450 | Softail                | 06      | 579 H.HS  | 846 H.LS |
| FXSTS/I                | 1450 | Springer Softail       | 00 - 04 | 579 H.HS  | 826 H.LS |
| FLHR                   | 1584 | Road King              | 07      | 826 H.HS* | 826 H.LS |
| FLHR                   | 1584 | Road King              | 08 - 10 | 830 H.HS* | 830 H.LS |
| FLHRC                  | 1584 | Road King Classic      | 07      | 826 H.HS* | 826 H.LS |
| FLHRC                  | 1584 | Road King Classic      | 08 - 10 | 830 H.HS* | 830 H.LS |
| FLHRS                  | 1584 | Road King Custom       | 07      | 826 H.HS* | 826 H.LS |
| FLHT                   | 1584 | Electra Glide Standard | 07      | 826 H.HS* | 826 H.LS |
| FLHT                   | 1584 | Electra Glide Standard | 08 - 10 | 830 H.HS* | 830 H.LS |
| FLHTC                  | 1584 | Electra Glide Classic  | 07      | 826 H.HS* | 826 H.LS |
| FLHTC                  | 1584 | Electra Glide Classic  | 08 - 10 | 830 H.HS* | 830 H.LS |
| FLHTCi                 | 1584 | Ultra Electra Glide    |         |           |          |
|                        |      | Classic                | 08 - 10 | 830 H.HS* | 830 H.LS |
| FLHTCU                 | 1584 | Ultra Classic          |         |           |          |
|                        |      | Electra Glide          | 07 - 08 | 826 H.HS* | 826 H.LS |
| FLHTCU                 | 1584 | Ultra Classic          |         |           |          |
|                        |      | Electra Glide          | 09 - 10 | 830 H.HS* | 830 H.LS |
| FLHTK                  | 1584 | Electra Glide Ultra    |         |           |          |
|                        |      | LTD                    | 10      | 830 H.HS* | 830 H.LS |
| FLHX                   | 1584 | Street Glide           | 07      | 826 H.HS* | 826 H.LS |
| FLHX                   | 1584 | Street Glide           | 08 - 10 | 830 H.HS* | 830 H.LS |
| FLSTC                  | 1584 | Heritage Softail       |         |           |          |
|                        |      | Classic                | 07      | 826 H.HS  | 846 H.LS |
| FLSTC                  | 1584 | Heritage Softail       |         |           |          |
|                        |      | Classic                | 08 - 11 | 853 H.HS  | 854 H.LS |
| FLSTF                  | 1584 | Fat Boy                | 07      | 826 H.HS  | 846 H.LS |
| FLSTF                  | 1584 | Fat Boy                | 08 - 11 | 853 H.HS  | 854 H.LS |
| FLSTFB                 | 1584 | Fat Boy Special        | 10 - 11 | 853 H.HS  | 854 H.LS |
| FLSTN                  | 1584 | Softail Deluxe         | 07      | 826 H.HS  | 846 H.LS |
| FLSTN                  | 1584 | Softail Deluxe         | 08 - 11 | 853 H.HS  | 854 H.LS |
| FLSTSC/I               | 1584 | Softail                | 07      | 579 H.HS  | 846 H.LS |
| FLTR                   | 1584 | Road Glide             | 08 - 10 | 830 H.HS* | 830 H.LS |
| FLTRU                  | 1584 | Road Glide Ultra       | 11 - 16 | 830 H.HS* | 830 H.LS |
| FLTRX                  | 1584 | Road Glide Custom      | 10      | 830 H.HS* | 830 H.LS |
| FXCW                   | 1584 | Rocker                 | 08 - 09 | 853 H.HS  | 854 H.LS |
| FXCWC                  | 1584 | Rocker C               | 08 - 13 | 853 H.HS  | 854 H.LS |
| FXD                    | 1584 | Dyna Super Glide       | 07      | 826 H.HS  | 826 H.LS |
| FXD                    | 1584 | Dyna Super Glide       | 08 - 10 | 853 H.HS  | 854 H.LS |
| FXDB                   | 1584 | Dyna Street Bob        | 07      | 826 H.HS  | 826 H.LS |
| FXDB                   | 1584 | Dyna Street Bob        | 08 - 13 | 853 H.HS  | 854 H.LS |
| FXDC                   | 1584 | Dyna Super             |         |           |          |
|                        |      | Glide Custom           | 07      | 826 H.HS  | 826 H.LS |
| FXDC                   | 1584 | Dyna Super             |         |           |          |
|                        |      | Glide Custom           | 08 - 13 | 853 H.HS  | 854 H.LS |
| FXDF                   | 1584 | Fat Bob                | 08 - 11 | 853 H.HS  | 854 H.LS |
| FXDL                   | 1584 | Dyna Low Rider         | 07      | 826 H.HS  | 826 H.LS |
| FXDL                   | 1584 | Dyna Low Rider         | 08 - 13 | 853 H.HS  | 854 H.LS |
| FXDWG                  | 1584 | Dyna Wide Glide        | 07      | 826 H.HS  | 826 H.LS |
| FXDWG                  | 1584 | Dyna Wide Glide        | 08 - 10 | 853 H.HS  | 854 H.LS |
| FXST                   | 1584 | Softail Standard       | 07      | 826 H.HS  | 846 H.LS |
| FXST                   | 1584 | Softail Standard       | 08 - 14 | 853 H.HS  | 854 H.LS |
| FXST                   | 1584 | Softail Standard       | 15 - 17 | 860 H.HS  | 854 H.LS |
| FXSTB                  | 1584 | Night Train            | 07      | 826 H.HS  | 846 H.LS |
| FXSTB                  | 1584 | Night Train            | 08 - 09 | 853 H.HS  | 854 H.LS |
| FXSTC                  | 1584 | Softail Custom         | 07      | 826 H.HS  | 846 H.LS |
| FXSTC                  | 1584 | Softail Custom         | 08 - 10 | 853 H.HS  | 854 H.LS |
| FXSTD                  | 1584 | Softail Deuce          | 07      | 826 H.HS  | 846 H.LS |
| FLD                    | 1690 | Switchback             | 12 - 16 | 853 H.HS  | 854 H.LS |
| FLHR                   | 1690 | Road King              | 11 - 16 | 830 H.HS* | 830 H.LS |
| FLHRC                  | 1690 | Road King Classic      | 11 - 16 | 853 H.HS  | 854 H.LS |
| FLHTC                  | 1690 | Electra Glide Classic  | 11 - 16 | 853 H.HS  | 854 H.LS |

**RECOMMENDED**

1xx = Scooter Pads  
 5xx = Street, Off Road & Racing Pads  
 2xxx = Brake Shoes



| <b>HARLEY DAVIDSON</b> |      |                       |         |           |          |
|------------------------|------|-----------------------|---------|-----------|----------|
| FLHTCU                 | 1690 | Ultra Classic Electra |         |           |          |
|                        |      | Glide                 | 11 - 16 | 830 H.HS* | 830 H.LS |
| FLHTCUL                | 1690 | Electra Glide Ultra   |         |           |          |
|                        |      | Classic Low           | 15 - 16 | 830 H.HS* | 830 H.LS |
| FLHTCUTG               | 1690 | Tri Glide Ultra       | 14 - 16 | 922 H.HS* | 923 H.LS |
| FLHTCUTG               | 1690 | Tri Glide Ultra       |         |           |          |
|                        |      | Classic Trike         | 09 - 13 | 830 H.HS* | 904 H.LS |
| FLHTK                  | 1690 | Ultra Classic         |         |           |          |
|                        |      | Electra Glide         | 10 - 16 | 830 H.HS* | 830 H.LS |
| FLHTK                  | 1690 | Ultra Electra Glide   | 11 - 16 | 853 H.HS  | 854 H.LS |
| FLHTKL                 | 1690 | Ultra Limited Low     | 15 - 16 | 830 H.HS* | 830 H.LS |
| FLHX                   | 1690 | Street Glide          | 11 - 16 | 830 H.HS* | 830 H.LS |
| FLHXS                  | 1690 | Street Glide Special  | 14 - 16 | 830 H.HS* | 830 H.LS |
| FLHXXX                 | 1690 | Street Glide Trike    | 10 - 11 | 830 H.HS* | 904 H.LS |
| FLRT                   | 1690 | Freewheeler           | 15 - 16 | 922 H.HS* | 923 H.LS |
| FLS                    | 1690 | Softail Slim          | 12 - 14 | 853 H.HS  | 854 H.LS |
| FLS                    | 1690 | Softail Slim          | 15 - 17 | 860 H.HS  | 854 H.LS |
| FLSTC                  | 1690 | Heritage Softail      |         |           |          |
|                        |      | Classic               | 12 - 14 | 853 H.HS  | 854 H.LS |
| FLSTC                  | 1690 | Heritage Softail      |         |           |          |
|                        |      | Classic               | 15 - 17 | 860 H.HS  | 854 H.LS |
| FLSTF                  | 1690 | Fat Boy               | 12 - 14 | 853 H.HS  | 854 H.LS |
| FLSTF                  | 1690 | Fat Boy               | 15 - 17 | 860 H.HS  | 854 H.LS |
| FLSTF                  | 1690 | Fat Boy Special       | 12 - 14 | 853 H.HS  | 854 H.LS |
| FLSTFB                 | 1690 | Fat Boy               | 12 - 14 | 853 H.HS  | 854 H.LS |
| FLSTFB                 | 1690 | Fat Boy               | 15 - 17 | 860 H.HS  | 854 H.LS |
| FLSTN                  | 1690 | Softail Deluxe        | 12 - 14 | 853 H.HS  | 854 H.LS |
| FLSTN                  | 1690 | Softail Deluxe        | 15 - 17 | 860 H.HS  | 854 H.LS |
| FLTRX                  | 1690 | Road Glide            | 15 - 16 | 830 H.HS* | 830 H.LS |
| FLTRXS                 | 1690 | Road Glide Special    | 15 - 16 | 830 H.HS* | 830 H.LS |
| FXDB                   | 1690 | Dyna Street Bob       | 14 - 17 | 853 H.HS  | 854 H.LS |
| FXDBA                  | 1690 | Dyna Street Bob       | 13 - 17 | 853 H.HS  | 854 H.LS |
| FXDBB                  | 1690 | Dyna Street Bob       | 14 - 17 | 853 H.HS  | 854 H.LS |
| FXDBP                  | 1690 | Dyna Street Bob       | 13 - 17 | 853 H.HS  | 854 H.LS |
| FXDC                   | 1690 | Dyna Super Glide      |         |           |          |
|                        |      | Custom                | 14      | 853 H.HS  | 854 H.LS |
| FXDF                   | 1690 | Dyna Wide Glide       | 12 - 17 | 853 H.HS  | 854 H.LS |
| FXDF                   | 1690 | Fat Bob               | 12 - 17 | 853 H.HS* | 854 H.LS |
| FXDL                   | 1690 | Dyna Low Rider        | 14 - 17 | 853 H.HS* | 854 H.LS |
| FXDLS                  | 1690 | Dyna Low Rider S      | 17      | 853 H.HS* | 854 H.LS |
| FXS                    | 1690 | Blackline             | 13 - 17 | 853 H.HS  | 854 H.LS |
| FXSB                   | 1690 | Breakout              | 14      | 853 H.HS  | 854 H.LS |
| FXSB                   | 1690 | Breakout              | 15 - 17 | 860 H.HS  | 854 H.LS |
| FLDE                   | 1750 | Softail Deluxe        | 18 -    | 860 H.HS  | 949 H.LS |
| FLFB                   | 1750 | Fat Boy               | 18 -    | 860 H.HS  | 949 H.LS |
| FLHC                   | 1750 | Heritage Classic      | 18 -    | 860 H.HS  | 949 H.LS |
| FLHR                   | 1750 | Road King             | 17 - 18 | 830 H.HS* | 830 H.LS |
| FLHRC                  | 1750 | Road King Classic     | 17      | 830 H.HS* | 830 H.LS |
| FLHRXS                 | 1750 | Road King Special     | 18 -    | 830 H.HS  | 949 H.LS |
| FLHTCU                 | 1750 | Ultra Classic         |         |           |          |
|                        |      | Electra Glide         | 17 - 18 | 830 H.HS* | 830 H.LS |
| FLHTCUTG               | 1750 | Tri Glide Ultra       | 17 - 18 | 922 H.HS* | 923 H.LS |
| FLHTK                  | 1750 | Ultra Limited         | 17 - 18 | 830 H.HS* | 830 H.LS |
| FLHTKL                 | 1750 | Ultra Limited Low     | 17 - 18 | 830 H.HS* | 830 H.LS |
| FLHX                   | 1750 | Street Glide          | 17 - 18 | 830 H.HS* | 830 H.LS |
| FLHX                   | 1750 | Street Glide Special  | 17 - 18 | 830 H.HS* | 830 H.LS |
| FLHXS                  | 1750 | Street Glide Special  | 17 - 18 | 830 H.HS* | 830 H.LS |
| FLRT                   | 1750 | Freewheeler           | 17 - 18 | 922 H.HS* | 923 H.LS |
| FLSL                   | 1750 | Softail Slim          | 18 -    | 860 H.HS  | 949 H.LS |
| FLTRU                  | 1750 | Road Glide Ultra      | 17 - 18 | 830 H.HS* | 830 H.LS |
| FLTRX                  | 1750 | Road Glide            | 17 - 18 | 830 H.HS* | 830 H.LS |
| FLTRXS                 | 1750 | Road Glide Special    | 17 - 18 | 830 H.HS* | 830 H.LS |
| FXBB                   | 1750 | Street Bob            | 18 -    | 860 H.HS  | 949 H.LS |
| FXBR                   | 1750 | Breakout              | 18 -    | 860 H.HS  | 949 H.LS |
| FXFB                   | 1750 | Fat Bob               | 18 -    | 860 H.HS  | 949 H.LS |
| FCLR                   | 1750 | Low Rider             | 18 -    | 860 H.HS  | 949 H.LS |
| FLHRSE5                | 1802 | CVO Road King         | 14 - 15 | 830 H.HS* | 830 H.LS |
| FLHTKSE                | 1802 | CVO Limited           | 14 - 16 | 830 H.HS* | 830 H.LS |
| FLHXSE                 | 1802 | CVO Street Glide      | 10 - 16 | 830 H.HS* | 830 H.LS |
| FLSS                   | 1802 | Softail Slim S        | 16 - 17 | 860 H.HS  | 854 H.LS |
| FLSTFBS                | 1802 | Fat Boy S             | 16 - 17 | 860 H.HS  | 854 H.LS |
| FLSTNSE                | 1802 | CVO Softail Deluxe    | 14      | 853 H.HS* | 854 H.LS |

\* = 2 sets required / 2 jeux pour l'Avant.

**RECOMMENDED**

1xx = Scooter Pads  
 5xx = Street, Off Road & Racing Pads  
 2xxx = Brake Shoes

**HARLEY DAVIDSON**

|         |      |                    |         |           |          |
|---------|------|--------------------|---------|-----------|----------|
| FLSTNSE | 1802 | CVO Softail Deluxe | 15 - 17 | 860 H.HS* | 854 H.LS |
| FLTRUSE | 1802 | CVO Road Glide     |         |           |          |
|         |      | Ultra              | 11 - 16 | 830 H.HS  | 830 H.LS |
| FXSBSE  | 1802 | CVO Breakout       | 13 - 14 | 853 H.HS  | 854 H.LS |
| FLFBS   | 1870 | Fat Boy            | 18 -    | 860 H.HS  | 949 H.LS |
| FLHCS   | 1870 | Heritage Classic   | 18 -    | 860 H.HS  | 949 H.LS |
| FLHTKSE | 1870 | CVO Limited        | 17      | 830 H.HS* | 830 H.LS |
| FLHXSE  | 1870 | CVO Street Glide   | 17      | 830 H.HS* | 830 H.LS |
| FXBRS   | 1870 | Breakout           | 18 -    | 860 H.HS  | 949 H.LS |
| FLHTKSE | 1917 | CVO Limited        | 18 -    | 830 H.HS* | 830 H.LS |
| FLHXSE  | 1917 | CVO Street Glide   | 18 -    | 830 H.HS* | 830 H.LS |
| FLTRXSE | 1917 | CVO Road Glide     | 18 -    | 830 H.HS* | 830 H.LS |

**HERCULES**

|      |     |                     |         |         |      |
|------|-----|---------------------|---------|---------|------|
|      | 50  | Gipsy, Splinter,    |         |         |      |
|      |     | Reggae              | 95      | 123 HF  | 2012 |
|      | 50  | Limbo               | 95      | 2011    | 2012 |
|      | 50  | Ultra               | 79 - 83 | 532 HF* |      |
| RS   | 50  |                     | 79 - 83 | 532 HF* |      |
| SR   | 50  | Samba               | 93      | 2012    | 2012 |
|      | 80  | Ultra AC            | 81      | 532 HF* |      |
|      | 80  | Ultra AC Ch.        | 81 - 83 | 532 HF* |      |
|      | 80  | Ultra Chopper       | 81 - 83 | 532 HF* |      |
| RX-9 | 80  |                     | 82 - 83 | 532 HF  |      |
| RX-9 | 80  | Aircooled           | 82 - 83 | 532 HF  |      |
| SR   | 80  | Samba               | 93      | 2012    | 2012 |
|      | 125 | Silver Star Classic | 93      | 506 HF  |      |
| GP   | 125 | Supra               | 80      | 541 HF  |      |
| KX-5 | 125 |                     | 87      | 532 HF  |      |
| ZX   | 125 |                     | 86      | 519 HF  |      |
|      | 280 | ATV                 | 07      | 810 SI* |      |
|      | 300 | ATV Sport           | 07      | 810 SI* |      |

**HERO ENVOY**

|  |    |  |    |        |  |
|--|----|--|----|--------|--|
|  | 50 |  | 99 | 105 HF |  |
|--|----|--|----|--------|--|

**HIGHLAND**

|  |     |            |         |         |         |
|--|-----|------------|---------|---------|---------|
|  | 450 | MX         | 06 - 09 | 671 RSI | 675 RSI |
|  | 950 | V2 Motard  | 00 - 08 | 671 HF  | 675 HF  |
|  | 950 | V2 Outback | 99 - 08 | 671 HF  | 675 HF  |

**HM**

|     |     |                   |         |         |         |
|-----|-----|-------------------|---------|---------|---------|
| CRE | 50  |                   | 98 - 01 | 608 HF  | 548 HF  |
| CRE | 50  |                   | 06 - 13 | 774 HF  | 604 HF  |
| CRE | 50  | Baja              | 97 - 01 | 548 HF  | 548 HF  |
| CRE | 50  | Six Comp.         | 07 - 12 | 928 HF  | 790 HF  |
| CRM | 50  | Derapage Comp.    | 07 - 12 | 928 HF  | 790 HF  |
|     | 125 | Supermotard       | 00 - 02 | 694 HF  | 604 HF  |
| CR  | 125 | Supermotard       | 04 - 06 | 694 RSI | 777 RSI |
| CRE | 125 | Enduro            | 95 - 01 | 694 SI  | 604 SI  |
| CRE | 125 | Enduro            | 02 - 06 | 694 SI  | 777 SI  |
| CRE | 125 | Six Comp.         | 10 - 11 | 928 HF  | 790 HF  |
| CRE | 125 | Supermotard       | 03      | 694 HF  | 604 HF  |
| CRM | 125 | Derapage Comp. 2T | 11 - 12 | 928 HF  | 790 HF  |
| CRM | 125 | Derapage Comp. 4T | 11 - 12 | 928 HF  | 790 HF  |
| CRM | 125 | X Supermotard     | 07      | 843 RSI | 777 RSI |
|     | 250 | Supermotard       | 00 - 02 | 694 HF  | 604 HF  |
| CRE | 250 | Enduro            | 95 - 01 | 694 SI  | 604 SI  |
| CRE | 250 | Enduro            | 02 - 03 | 694 SI  | 777 SI  |
| CRE | 250 | F Enduro          | 04 - 13 | 694 SI  | 777 SI  |
| CRE | 250 | Supermotard       | 03      | 694 HF  | 604 HF  |
| CRE | 250 | Supermotard       | 04 - 07 | 694 RSI | 777 RSI |
| CRE | 250 | X Enduro          | 04 - 13 | 694 SI  | 777 SI  |
| CRF | 250 | Supermotard       | 04 - 06 | 694 RSI | 777 RSI |
| CRM | 250 | X Supermotard     | 07 - 13 | 843 RSI | 777 RSI |
| CRE | 450 | F Enduro          | 02 - 13 | 694 SI  | 777 SI  |
| CRE | 450 | X Enduro          | 04 - 13 | 694 SI  | 777 SI  |
| CRF | 450 | Supermotard       | 02 - 06 | 694 RSI | 777 RSI |
| CRM | 450 | X Supermotard     | 07 - 13 | 843 RSI | 777 RSI |
| CRM | 500 | X Supermotard     | 07 - 13 | 843 RSI | 777 RSI |

**RECOMMENDED**

1xx = Scooter Pads  
 5xx = Street, Off Road & Racing Pads  
 2xxx = Brake Shoes

**HONDA**

|      |    |                     |         |        |        |
|------|----|---------------------|---------|--------|--------|
|      | 50 | Dio, Life           | 94 - 96 | 2057   | 2057   |
|      | 50 | Formula             | 94 - 98 | 123 HF |        |
|      | 50 | Giorno              | 92 - 94 | 670 HF |        |
|      | 50 | Jazz                | 92      | 670 HF |        |
|      | 50 | Sky Classic         | 00 - 03 | 123 HF | 2012   |
|      | 50 | Sky Vetro           | 00 - 02 | 123 HF | 2012   |
|      | 50 | Super Dio (Japan)   | 94 - 96 | 2057   | 2057   |
| C    | 50 | all models          | 75 - 93 | 2012   | 2012   |
| CB   | 50 | all models          | 80 - 81 | 100 HF | 2013   |
| CB   | 50 | all models          | 81      | 2013   | 2013   |
| CB   | 50 | J, K1               | 75 - 79 | 525 HF | 2013   |
| CB   | 50 | Replica             | 99 - 00 |        | 144 HF |
| CF   | 50 | Chaly               | 79      | 2012   | 2012   |
| CR   | 50 | RE, RF              | 84 - 85 | 2057   | 2057   |
| CRF  | 50 | F                   | 04 - 18 | 2010   | 2010   |
| CRM  | 50 | (Made in Spain)     | 93 - 96 | 139 HF |        |
| CRM  | 50 |                     | 88 - 92 | 100 HF | 121 HF |
| CRM  | 50 |                     | 93 - 96 | 115 HF | 121 HF |
| GP   | 50 | Dio                 | 89 - 90 | 670 HF | 2011   |
| GP   | 50 | Dio                 | 91      | 115 HF | 2057   |
| HSC  | 50 | ZR, 01 Scooter      | 92 - 95 | 115 HF | 2057   |
| MB   | 50 | S                   | 80 - 82 | 100 HF | 2013   |
| MBX  | 50 |                     | 80 - 82 | 100 HF | 2013   |
| MBX  | 50 | S                   | 83 - 85 | 103 HF | 2013   |
| MRX  | 50 |                     | 88 - 92 | 100 HF | 2013   |
| MT   | 50 | S                   | 80 - 93 | 2013   | 2013   |
| MTX  | 50 | SC-SD               | 83 - 84 | 2013   | 2013   |
| NA   | 50 | Express             | 79 - 81 | 2010   | 2011   |
| NB   | 50 | ME, Aero            | 83 - 87 | 2010   | 2011   |
| NC   | 50 | Express             | 77 - 80 | 2010   | 2010   |
| NC   | 50 | Express             | 81 - 83 | 2010   | 2011   |
| ND   | 50 | C, ML Melody        | 82 - 85 | 2010   | 2011   |
| NE   | 50 | MF, MG, TH Vision   | 85 - 87 | 2010   | 2011   |
| NH   | 50 | Lead                | 83      | 2012   | 2011   |
| NH   | 50 | Lead                | 86 - 93 | 110 HF | 2011   |
| NH   | 50 | Lead                | 94      | 121 HF | 2011   |
| NH   | 50 | Lead (Drum vers.)   | 94      | 2012   | 2011   |
| NH   | 50 | Lead SS,MR,MSE      | 84 - 85 | 112 HF | 2011   |
| NN   | 50 | MD Gyro             | 84      | 2010   | 2010   |
| NP   | 50 | Melody D Mini       | 83 - 87 | 2010   | 2011   |
| NPS  | 50 | Zoomer              | 01 - 12 | 2057   | 2057   |
| NQ   | 50 | D, Spree            | 84 - 87 | 2010   | 2010   |
| NS   | 50 | F, Aero             | 88 - 91 | 103 HF | 2011   |
| NS-1 | 50 |                     | 91 - 94 | 103 HF | 2011   |
| NSC  | 50 | Vision              | 10 - 18 | 205 HF |        |
| NSR  | 50 |                     | 89 - 90 | 103 HF | 2013   |
| NT   | 50 | F, G, H Melody Mini | 85 - 87 | 2010   | 2010   |
| NU   | 50 | MC Runaway, Express | 82 - 83 | 2057   | 2011   |
| NV   | 50 | MSD Stream          | 84 - 86 | 2011   | 2011   |
| NX   | 50 | A, B, MC Caren      | 82      | 2010   | 2011   |
| OR   | 50 |                     | 93      | 2010   | 2011   |
| PA   | 50 |                     | 78 - 81 | 2010   | 2074   |
| PA   | 50 |                     | 82 - 83 | 2010   | 2010   |
| PA   | 50 | Camino              | 80 - 86 | 2074   | 2074   |
| PC   | 50 | K1                  | 79      | 2010   | 2010   |
| PF   | 50 | M Nocio             | 75 - 80 | 2074   | 2074   |
| PK   | 50 | Walaroo DX-STD      | 90 - 01 | 2057   | 2012   |
| PX   | 50 |                     | 82 - 83 | 2074   | 2011   |
| PX   | 50 |                     | 84      | 2074   |        |
| PXR  | 50 | all models          | 85 - 02 | 2193   | 2194   |
| QA   | 50 | K1-K3               | 87 - 89 | 2074   | 2074   |
| QR   | 50 |                     | 93 - 03 | 2010   | 2057   |
| QR   | 50 | ED, EF              | 82 - 92 | 2010   | 2011   |
| R    | 50 | Monkey              | 88      | 618 HF | 2012   |
| SA   | 50 | Elite LX, SR        | 88 - 93 | 2010   | 2011   |
| SA   | 50 | J Vision            | 88 - 94 | 2057   | 2057   |
| SB   | 50 |                     | 88 - 89 | 2010   | 2010   |
| SC   | 50 | 1-ZX                | 92 - 95 | 670 HF |        |
| SFX  | 50 | Sport               | 96 - 04 | 123 HF | 2012   |
| SGX  | 50 | Sky DX              | 97 - 03 | 123 HF | 2012   |
| SH   | 50 | City Express        | 84 - 96 | 2080   | 2012   |
| SH   | 50 | City Express        | 85 - 96 |        | 2012   |

\* = 2 sets required / 2 jeux pour l'Avant.

Full compound selection, see under "Brake pad 1:1 Drawings" / Sélection complète de composés, voir "1:1 Schémas Plaquettes de frein".

**RECOMMENDED**

1xx = Scooter Pads  
5xx = Street, Off Road & Racing Pads  
2xxx = Brake Shoes

**HONDA**

|      |    |               |        |         |         |
|------|----|---------------|--------|---------|---------|
| SH   | 50 | Fifty, Scoopy | 00 -03 | 123 HF  |         |
| SH   | 50 | Scoopy        | 88 -04 | 2012    | 2080    |
| SH   | 50 | T             | 97     | 123 HF  | 2012    |
| SJ   | 50 | Bali          | 93 -98 | 124 HF  | 2012    |
| SP   | 50 |               | 91     | 100 HF  |         |
| SP   | 50 |               | 92     | 670 HF  |         |
| SR   | 50 | Dio           | 93     | 115 HF  | 2057    |
| SR   | 50 | Super Dio     | 91 -92 | 115 HF  | 2057    |
| SRX  | 50 | Shadow        | 98 -99 | 144 HF  |         |
| SS   | 50 | K2            | 75 -77 | 2012    | 2012    |
| SS   | 50 | ZB2           | 75 -80 | 525 HF  | 2012    |
| ST   | 50 | Dax           | 78 -93 | 2012    | 2012    |
| SXR  | 50 |               | 98 -00 | 123 HF  |         |
| SZ   | 50 | Tact S        | 93 -96 | 115 HF  | 2057    |
| SZX  | 50 | X8R-S         | 98 -04 | 123 HF  | 129 HF  |
| SZX  | 50 | X8R-X         | 98 -01 | 123 HF  | 129 HF  |
| TG   | 50 | M Gyro S      | 85 -86 | 2010    | 2010    |
| TLM  | 50 | F             | 85     | 2057    | 2057    |
| XL   | 50 |               | 77 -82 | 2013    | 2013    |
| XR   | 50 | R             | 00 -03 | 2010    | 2010    |
| Z    | 50 | R, RD         | 80 -99 | 2010    | 2010    |
| ZX   | 50 | Super Dio     | 92 -01 | 115 HF  | 2057    |
| CR   | 60 | RF, RG        | 85 -86 | 2057    | 2057    |
| ATC  | 70 | all models    | 78 -85 |         | 2069    |
| C    | 70 | all models    | 75 -83 | 2012    | 2012    |
| CF   | 70 | K2, C         | 78     | 2012    | 2012    |
| CRF  | 70 | F             | 04 -14 | 2057    | 2057    |
| CT   | 70 |               | 91 -94 | 2010    | 2010    |
| ST   | 70 | Dax           | 78 -93 | 2012    | 2012    |
| TRX  | 70 |               | 86 -87 | 2048    | 2041    |
| XR   | 70 |               | 97 -12 | 2057    | 2057    |
|      | 75 | Yupy          | 90 -95 | 121 HF  | 2012    |
| CRM  | 75 | R             | 90 -94 | 603 HF  | 604 HF  |
| NF   | 75 |               | 79     | 2012    | 2012    |
| NS-1 | 75 |               | 92 -00 | 119 HF  | 121 HF  |
| NSR  | 75 | FII           | 88 -00 | 103 HF  | 2013    |
| SA   | 75 | Vision        | 89 -92 | 2012    | 2057    |
| SH   | 75 | Scoopy        | 88 -95 | 2012    | 2080    |
| XR   | 75 | K4            | 75 -79 | 2013    | 2013    |
| XR   | 75 | K5            | 79     | 2012    | 2013    |
| CB   | 80 |               | 80 -81 | 100 HF  |         |
| CH   | 80 | Elite         | 85 -88 | 2012    | 2057    |
| CR   | 80 | R             | 86 -91 | 584 SI  | 2043    |
| CR   | 80 | R, RB         | 92 -02 | 584 RSI | 604 RSI |
| CR   | 80 | R2            | 85     | 2013    | 2013    |
| CR   | 80 | RA, RB        | 80 -81 | 2013    | 2013    |
| CR   | 80 | RC            | 82     | 2013    | 2057    |
| CR   | 80 | RD, RE        | 83 -84 | 2057    | 2057    |
| CR   | 80 | RF            | 85     | 2057    | 2043    |
| CRF  | 80 | F             | 04 -14 | 2057    | 2057    |
| CRM  | 80 |               | 89 -92 | 584 HF  | 604 HF  |
| Lead | 80 | SS            | 85     | 628 HF  | 2011    |
| MB   | 80 |               | 80 -83 | 548 HF  | 2043    |
| MBX  | 80 |               | 83 -86 | 551 HF  | 2013    |
| MBX  | 80 |               | 86 -87 | 558 HF  | 2013    |
| MBX  | 80 | DX            | 82 -86 | 551 HF  | 2013    |
| MBX  | 80 | FWD           | 83 -86 | 536 HF* | 2013    |
| MBX  | 80 | SW, SWD       | 83     | 551 HF  | 2013    |
| MCX  | 80 |               | 82 -85 | 548 HF  | 2013    |
| MTX  | 80 | R             | 87     | 558 HF  | 2013    |
| MTX  | 80 | RF            | 83 -84 | 2013    | 2013    |
| NH   | 80 | Aero          | 85     | 2012    | 2057    |
| NH   | 80 | Lead Scooter  | 85     | 112 HF  | 2011    |
| NH   | 80 | Lead Scooter  | 86 -95 | 110 HF  | 2011    |
| NH   | 80 | MD Lead, Aero | 83 -84 | 2012    | 2011    |
| NSR  | 80 | R             | 87 -92 | 103 HF  | 121 HF  |
| NSR  | 80 | R             | 93 -95 | 119 HF  | 121 HF  |
| R    | 80 | Lead          | 88 -95 | 618 HF  | 2011    |
| SH   | 80 | Scoopy        | 88 -93 | 2012    | 2080    |
| XR   | 80 |               | 79 -84 | 2013    | 2013    |
| XR   | 80 | R             | 85 -88 | 2057    | 2057    |
| CR   | 85 | R, R Expert   | 03 -12 | 592 RSI | 604 RSI |

**RECOMMENDED**

1xx = Scooter Pads  
5xx = Street, Off Road & Racing Pads  
2xxx = Brake Shoes

**HONDA**

|     |     |                    |        |         |         |
|-----|-----|--------------------|--------|---------|---------|
| C   | 90  |                    | 93 -02 | 2013    | 2013    |
| C   | 90  | all models         | 75 -92 | 2012    | 2012    |
| CB  | 90  |                    | 79 -84 | 525 HF  |         |
| EZ  | 90  | Cub                | 90 -95 | 2012    | 2012    |
| NH  | 90  | Yupy               | 90 -94 | 121 HF  | 2013    |
| SRX | 90  | Shadow             | 99     | 144 HF  |         |
|     | 100 | Lead               | 00 -08 | 104 HF  |         |
| CB  | 100 | N                  | 79 -80 | 529 HF  | 2013    |
| CRF | 100 | F                  | 04 -14 | 2057    | 2057    |
| EX  | 100 | Bali               | 96 -03 | 124 HF  |         |
| H   | 100 | A, SD, SG, SJ      | 82 -92 | 2012    | 2012    |
| NSF | 100 |                    | 06     | 688 RS  | 604 HF  |
| SJ  | 100 | Bali               | 97 -03 | 124 HF  | 2012    |
| XL  | 100 | all models         | 78 -85 | 2013    | 2013    |
| XR  | 100 |                    | 81 -84 | 2013    | 2013    |
| XR  | 100 | R                  | 85 -03 | 2057    | 2057    |
| AFS | 110 | Wave               | 12 -18 | 216 HF  |         |
| ATC | 110 | all models         | 79 -85 |         | 2019    |
| CG  | 110 |                    | 77 -79 | 525 HF  |         |
| CRF | 110 | F                  | 13 -18 | 2057    | 2057    |
| NHX | 110 |                    | 08 -09 | 125 HF  |         |
| NHX | 110 |                    | 10 -12 | 104 CT  |         |
| NSC | 110 | Vision             | 10 -12 | 205 HF  |         |
| SCV | 110 | Lead               | 08 -09 | 125 HF  |         |
| SCV | 110 | Lead               | 10 -12 | 205 HF  |         |
| ANF | 125 | i Innova           | 07 -11 | 180 CT  | 2012    |
| ANF | 125 | Innova             | 03 -06 | 180 CT  | 2012    |
| ATC | 125 | ME, MF, MG, MH     | 84 -87 | 2012    | 2019    |
| CA  | 125 | Rebel              | 95 -96 | 713 HF  | 2026    |
| CA  | 125 | Rebel              | 97 -00 | 588 HF  | 2026    |
| CB  | 125 |                    | 72 -74 | 2012    | 2012    |
| CB  | 125 | F                  | 15 -18 | 638 HF  |         |
| CB  | 125 | J                  | 79     | 525 HF  | 2013    |
| CB  | 125 | R                  | 18 -   | 940 HS  | 915 HF  |
| CB  | 125 | RS                 | 83     | 536 HF  | 2069    |
| CB  | 125 | S                  | 76 -78 | 525 HF  | 2013    |
| CB  | 125 | S                  | 79 -82 | 2013    | 2013    |
| CB  | 125 | S                  | 84 -85 | 2041    | 2012    |
| CB  | 125 | T                  | 85     | 529 HF  | 2069    |
| CB  | 125 | T, Superdream      | 82 -83 | 572 HF  | 2069    |
| CB  | 125 | T, T1, T2, TZ      | 77 -81 | 529 HF  | 2069    |
| CB  | 125 | TDC                | 83 -89 | 542 HF  | 2069    |
| CB  | 125 | TT                 | 90     | 647 HF  | 2069    |
| CBF | 125 |                    | 09 -18 | 797 HF  |         |
| CBR | 125 | R                  | 03 -10 | 797 HF  | 784 HF  |
| CBR | 125 | R                  | 11 -18 | 797 HF  | 915 HF  |
| CBX | 125 | Custom             | 88     | 551 HF  | 2013    |
| CBX | 125 | F                  | 84 -88 | 572 HF  | 2020    |
| CD  | 125 |                    | 82     | 2023    | 2069    |
| CG  | 125 |                    | 04 -08 | 536 HF  |         |
| CG  | 125 | A, B, C            | 77 -84 | 2012    | 2012    |
| CG  | 125 | E, F, J            | 85 -91 | 2041    | 2012    |
| CH  | 125 | D, E, Spacy, Elite | 83 -84 | 2012    | 2012    |
| CH  | 125 | Spacy              | 94 -01 | 125 CT  | 2041    |
| CLR | 125 | Cityfly            | 99 -03 | 588 HF  |         |
| CM  | 125 |                    | 82 -85 | 2023    | 2069    |
| CR  | 125 | M2, M3, M4         | 76 -78 | 2013    | 2013    |
| CR  | 125 | R                  | 79 -81 | 2031    | 2041    |
| CR  | 125 | R                  | 95 -01 | 694 RSI | 604 RSI |
| CR  | 125 | R                  | 02 -07 | 694 RSI | 777 RSI |
| CR  | 125 | RC                 | 82     | 2041    | 2041    |
| CR  | 125 | RD                 | 83     | 2042    | 2042    |
| CR  | 125 | RE, RF             | 84 -85 | 558 SI  | 2042    |
| CR  | 125 | RG                 | 86     | 558 SI  | 2047    |
| CR  | 125 | RH, RJ, RK         | 87 -94 | 603 RSI | 604 RSI |
| CRE | 125 |                    | 02 -07 | 694 SI  | 777 SI  |
| CRE | 125 | RR                 | 11     | 859 SI  | 777 SI  |
| CRF | 125 | F                  | 14 -18 | 694 SI  | 2057    |
| CRM | 125 | , R                | 90 -98 | 588 HF  | 646 HF  |
| CT  | 125 | C                  | 85     | 2013    | 2013    |
| FES | 125 | Pantheon           | 98 -02 | 147 CT  | 2198    |
| FES | 125 | Pantheon           | 03 -06 | 147 CT  | 161 CT  |

\* = 2 sets required / 2 jeux pour l'Avant.

**RECOMMENDED**1xx = Scooter Pads  
5xx = Street, Off Road & Racing Pads  
2xxx = Brake Shoes**HONDA**

|     |                        |         |         |         |
|-----|------------------------|---------|---------|---------|
| FES | 125 S-Wing             | 07 - 11 | 192 CT  | 193 CT  |
| FS  | 125 Sonic              | 03 - 04 | 551 HF  |         |
| MBX | 125 RWB                | 84 - 86 | 551 HF  | 2042    |
| MSX | 125                    | 14 - 18 | 797 HF  | 915 HF  |
| MT  | 125 R                  | 77      | 525 HF  | 2013    |
| MT  | 125 R                  | 78      | 517 HF  | 2013    |
| MTX | 125 Camel, Italy       | 88 - 98 | 588 HF  | 2012    |
| MTX | 125 R                  | 84 - 95 | 558 HF  | 2013    |
| MTX | 125 R, Italy           | 86      | 588 HF  | 2013    |
| MTX | 125 RWD                | 83 - 84 | 2013    | 2013    |
| NES | 125 @                  | 01 - 06 | 104 CT  | 2208    |
| NH  | 125 Lead Scooter       | 86 - 87 | 112 CT  | 2012    |
| NH  | 125 Lead, Aero         | 83 - 84 | 2012    | 2012    |
| NS  | 125                    | 89      | 622 HF  | 618 HF  |
| NS  | 125 Italy              | 85 - 88 | 588 HF  | 2012    |
| NSR | 125 F                  | 88 - 89 | 558 HF  | 2012    |
| NSR | 125 F, R               | 90 - 92 | 588 HF  | 646 HF  |
| NSR | 125 R, Italy           | 89 - 01 | 588 HF  | 646 HF  |
| NSS | 125 Forza              | 15 - 18 | 183 CT  | 193 CT  |
| NX  | 125 , Transcity        | 90 - 98 | 588 HF  | 2013    |
| PCX | 125                    | 09 - 18 | 205 MS  | 2208    |
| PS  | 125 i                  | 07 - 13 | 125 CT  | 2208    |
| R   | 125 Lead               | 88      | 618 HF  | 2013    |
| RS  | 125                    | 95 - 03 | 566 DC  | 618 RQ  |
| RS  | 125 R                  | 91 - 94 | 627 HF* | 618 HF  |
| RTV | 125 NRS, Italy         | 87      | 588 HF  | 2012    |
| SES | 125 Dylan              | 02 - 07 | 125 CT  | 2208    |
| SH  | 125                    | 02 - 08 | 125 CT  | 2208    |
| SH  | 125                    | 13 - 18 | 183 CT  | 193 HF  |
| SH  | 125 i                  | 09 - 12 | 192 HF  | 193 HF  |
| SL  | 125 K1A                | 76      | 2012    | 2012    |
| SL  | 125 K1D, E, F, G, K2A  | 76 - 80 | 2013    | 2013    |
| TL  | 125                    | 76      | 2013    | 2013    |
| TRX | 125                    | 85 - 88 | 2012    | 2019    |
| VT  | 125 C1 Shadow          | 99 - 08 | 688 HF  | 2026    |
| VT  | 125 C2 Shadow          | 99 - 08 | 688 HF  | 2026    |
| XL  | 125 K2                 | 78      | 2013    | 2013    |
| XL  | 125 K3                 | 79      | 2012    | 2013    |
| XL  | 125 R                  | 86      | 558 HF  | 2013    |
| XL  | 125 R, P.D., Italy     | 85      | 588 HF  | 2013    |
| XL  | 125 R, P.D., Italy, EX | 87      | 588 HF  | 2013    |
| XL  | 125 S                  | 79 - 84 | 2013    | 2013    |
| XLR | 125 R                  | 98 - 01 | 694 HF  | 2013    |
| XLV | 125 Varadero           | 01 - 11 | 688 HF  | 784 HF  |
| XR  | 125 L                  | 03 - 07 | 694 HF  | 2013    |
| CBR | 150 R                  | 00 - 10 | 797 HF  | 784 HF  |
| CG  | 150                    | 04 - 05 | 536 HF  |         |
| CH  | 150 D Elite            | 85 - 87 | 2012    | 2012    |
| CRF | 150 F                  | 03 - 06 | 694 SI  | 2013    |
| CRF | 150 R                  | 07 - 18 | 592 RSI | 777 RSI |
| FES | 150 Pantheon           | 99 - 02 | 147 CT  | 2198    |
| FES | 150 Pantheon           | 03 - 06 | 147 CT  | 161 CT  |
| FES | 150 S-Wing             | 07 - 11 | 192 CT  | 193 CT  |
| NES | 150 @                  | 01 - 06 | 104 CT  | 2208    |
| NS  | 150                    | 92 - 95 | 121 HF  |         |
| NSR | 150                    | 02      | 688 HF  | 611 HF  |
| PCX | 150                    | 12 - 18 | 205 MS  | 2208    |
| PS  | 150 i                  | 07 - 11 | 125 CT  | 2208    |
| SES | 150 Dylan              | 02 - 06 | 125 CT  | 2208    |
| SH  | 150                    | 02 - 08 | 125 CT  | 2208    |
| SH  | 150                    | 13 - 18 | 183 CT  | 193 HF  |
| SH  | 150 i                  | 09 - 12 | 192 HF  | 193 HF  |
| CB  | 175 K3-K7              | 74 - 76 |         | 2068    |
| CD  | 175 all models         | 71 - 78 | 2019    |         |
| ATC | 185 A, S, SB           | 80 - 83 | 2012    | 2019    |
| CBX | 185 Custom             | 88      |         | 2013    |
| CBX | 185 F                  | 84      |         | 2026    |
| CD  | 185 T                  | 78 - 82 | 2023    | 2069    |
| CM  | 185 T                  | 78 - 79 | 2023    | 2069    |
| XL  | 185 S                  | 79 - 83 | 2013    | 2013    |
| ATC | 200                    | 81 - 83 | 2012    | 2019    |
| ATC | 200 X                  | 83 - 85 | 592 SI  | 562 SI  |

**RECOMMENDED**1xx = Scooter Pads  
5xx = Street, Off Road & Racing Pads  
2xxx = Brake Shoes**HONDA**

|      |                           |         |         |         |
|------|---------------------------|---------|---------|---------|
| CD   | 200 T                     | 79      | 2023    | 2069    |
| CM   | 200 TA, TB                | 80 - 82 | 2023    | 2069    |
| CTX  | 200                       | 04 - 06 | 694 SI  | 2013    |
| MTX  | 200 R                     | 85 - 86 | 558 HF  | 2013    |
| MTX  | 200 RWD                   | 83 - 84 | 2013    | 2013    |
| TL   | 200 J, Y                  | 76 - 78 | 2013    | 2013    |
| TLR  | 200 D, E, F               | 83 - 85 | 2057    | 2057    |
| TLR  | 200 G, H                  | 86 - 87 | 2013    | 2057    |
| TRX  | 200                       | 84      | 2044    | 2019    |
| TRX  | 200                       | 90 - 91 | 2083    | 2019    |
| TRX  | 200 D Type II             | 91 - 97 | 2083    | 2019    |
| TRX  | 200 SX                    | 86 - 88 | 2083    | 2019    |
| XL   | 200 R                     | 83 - 84 | 2013    | 2013    |
| XL   | 200 R, P.D., Italy        | 85      | 588 HF  | 2012    |
| XR   | 200                       | 80 - 84 | 2013    | 2013    |
| XR   | 200 R                     | 84 - 02 | 2013    | 2013    |
| XR   | 200 R, Pro Link           | 81 - 83 | 2013    | 2013    |
| TLM  | 220                       | 89 - 91 | 664 HF  | 629 HF  |
| CRF  | 230                       | 04 - 09 | 694 SI  | 2013    |
| CRF  | 230 L                     | 08 - 10 | 694 SI  | 604 SI  |
| CRF  | 230 M                     | 09 - 12 | 694 SI  | 604 SI  |
| SL   | 230                       | 97 - 01 | 694 HF  | 604 HF  |
|      | 250 Cota 4RT              | 04 - 16 | 802 RSI | 803 RSI |
|      | 250 Steed                 | 93 - 96 | 627 HF  |         |
| ATC  | 250 ES, SX                | 85 - 87 | 2019    | 2024    |
| ATC  | 250 R                     | 81      | 536 SI  | 2014    |
| ATC  | 250 R                     | 82 - 84 | 584 SI  | 562 SI  |
| ATC  | 250 R                     | 85 - 86 | 558 SI  | 558 SI  |
| ATC  | 250 X                     | 85      | 558 SI  | 562 SI  |
| AX-1 | 250                       | 90      | 603 HF  | 629 HF  |
| CA   | 250 Rebel                 | 90 - 95 | 638 HF  | 2058    |
| CB   | 250                       | 88 - 98 | 600 HF  | 2058    |
| CB   | 250                       | 92 - 05 | 627 HF  | 2058    |
| CB   | 250 G, T                  | 74 - 76 | 501 HF  | 2024    |
| CB   | 250 K3-K5                 | 73 - 75 | 2071    | 2024    |
| CB   | 250 N                     | 78 - 81 | 526 HF  | 2058    |
| CB   | 250 NA, NB, T, TZ         | 77 - 81 | 526 HF  | 2058    |
| CB   | 250 Nighthawk             | 91 - 02 | 2023    | 2069    |
| CB   | 250 Rebel                 | 86 - 96 | 551 HF  |         |
| CB   | 250 RS                    | 80 - 84 | 526 HF  | 2068    |
| CB   | 250 RS                    | 85      | 558 HF  | 2068    |
| CBF  | 250                       | 04 - 08 | 688 HF  |         |
| CBR  | 250 F                     | 86      | 593 HF* |         |
| CBR  | 250 Hurricane             | 87      | 593 HF* | 614 HF  |
| CBR  | 250 Nighthawk             | 92 - 95 | 627 HF  |         |
| CBR  | 250 R (Bybre cal)         | 11      | 674 HS  | 675 LS  |
| CBR  | 250 R (Nissin cal)        | 11 - 13 | 627 HS  | 881 LS  |
| CBR  | 250 R ABS (Nissin cal)    | 11 - 13 | 828 HS  | 881 LS  |
| CBR  | 250 R, RR                 | 90      | 627 HF* | 614 HF  |
| CBR  | 250 RJ                    | 88      | 627 HF* | 614 HF  |
| CBR  | 250 RR                    | 17 - 18 | 700 HS  | 881 LS  |
| CBX  | 250 RSE                   | 84 - 85 | 542 HF  | 2026    |
| CBX  | 250 S                     | 88      | 572 HF  |         |
| CD   | 250 UJ                    | 88 - 92 | 600 HF  | 2069    |
| CH   | 250 Elite                 | 85 - 86 | 2041    | 2082    |
| CH   | 250 Elite                 | 87 - 90 | 2041    | 2041    |
| CH   | 250 Spacy                 | 85 - 86 | 558 HF  | 2082    |
| CH   | 250 Spacy, Freeway Fusion | 88 - 93 | 104 MS  | 2041    |
| CJ   | 250 T                     | 76 - 78 | 501 HF  | 2024    |
| CL   | 250 SC                    | 81      | 2023    | 2068    |
| CM   | 250 C                     | 82 - 83 | 2023    | 2069    |
| CM   | 250 TB                    | 81      | 526 HF  | 2058    |
| CMX  | 250 C Rebel               | 96 - 00 | 713 HF  | 2069    |
| CMX  | 250 Rebel                 | 85 - 12 | 551 HF  | 2069    |
| CN   | 250                       | 93 - 04 | 127 CT  | 2041    |
| CN   | 250 Helix                 | 86 - 87 | 160 CT  | 2189    |
| CN   | 250 Helix (Fusion)        | 92      | 127 CT  | 2082    |
| CN   | 250 Helix (Fusion)        | 93 - 03 | 183 MS  | 2082    |
| CN   | 250 Scooter               | 88 - 92 | 127 CT  | 2189    |
| CN   | 250 Spazio                | 88 - 89 | 558 HF  | 2041    |
| CN   | 250 Spazio                | 88 - 92 | 572 HF  | 2189    |
| CR   | 250 R                     | 81 - 82 | 2030    | 2041    |

Applications  
Motorcycles, Off Road, ATV, Scooters

\* = 2 sets required / 2 jeux pour l'Avant.

Full compound selection, see under "Brake pad 1:1 Drawings" / Sélection complète de composés, voir "1:1 Schémas Plaquettes de frein".



**RECOMMENDED**

1xx = Scooter Pads  
5xx = Street, Off Road & Racing Pads  
2xxx = Brake Shoes



| HONDA |                 |         |         |         |
|-------|-----------------|---------|---------|---------|
| CR    | 250 R           | 83      |         | 2042    |
| CR    | 250 R           | 87 - 94 | 603 RSI | 604 RSI |
| CR    | 250 R           | 95 - 01 | 694 RSI | 604 RSI |
| CR    | 250 R           | 02 - 07 | 694 RSI | 777 RSI |
| CR    | 250 RE, RF      | 84 - 85 | 558 SI  | 2042    |
| CR    | 250 RG          | 86      | 558 SI  | 2047    |
| CR    | 250 RZ, RA      | 79 - 80 | 2031    | 2075    |
| CRE   | 250             | 02 - 07 | 694 SI  | 777 SI  |
| CRE   | 250 F           | 04      | 694 SI  | 777 SI  |
| CRF   | 250 L           | 13 - 15 | 859 SI  | 915 SI  |
| CRF   | 250 L ABS       | 17 - 18 | 859 SI  | 915 SI  |
| CRF   | 250 M           | 14 - 18 | 859 SI  | 915 SI  |
| CRF   | 250 R           | 04 - 09 | 694 RSI | 777 RSI |
| CRF   | 250 R Efi       | 10 - 17 | 694 RSI | 777 RSI |
| CRF   | 250 R Efi       | 18 -    | 694 RSI | 777 RSI |
| CRF   | 250 Rally       | 17 - 18 | 859 SI  | 915 SI  |
| CRF   | 250 X           | 04 - 14 | 694 SI  | 777 SI  |
| CRM   | 250 R           | 90      | 603 HF  | 629 HF  |
| FES   | 250 Foresight   | 98 - 99 | 156 MS  | 2198    |
| FES   | 250 Foresight   | 00 - 07 | 156 MS  | 161 MS  |
| FL    | 250 Odyssey     | 77 - 84 | 525 HF  | 2019    |
| FTR   | 250             | 86      | 558 HF  | 558 HF  |
| GB    | 250 Clubman     | 88 - 97 | 542 HF  |         |
| NS    | 250             | 89      | 622 HF  | 618 HF  |
| NS    | 250 R           | 85      | 572 HF* | 542 HF  |
| NSR   | 250 R           | 87      | 593 HF* | 542 HF  |
| NSR   | 250 R, SP       | 90      | 622 HS* | 614 LS  |
| NSR   | 250 RJ          | 88 - 89 | 622 HF* | 614 HF  |
| NSS   | 250             | 00 - 04 | 156 MS  | 158 MS  |
| NSS   | 250             | 05 - 13 | 192 MS  | 193 MS  |
| NSS   | 250 Forza       | 00 - 04 | 156 MS  | 158 MS  |
| NSS   | 250 Forza       | 05 - 13 | 192 MS  | 193 MS  |
| NSS   | 250 Jazz        | 01 - 04 | 156 MS  | 158 MS  |
| NX    | 250             | 88 - 90 | 603 HF  | 2029    |
| PS    | 250             | 05 - 06 | 192 MS  |         |
| RS    | 250 R           | 91 - 92 | 622 DC* | 614 HF  |
| RS    | 250 R           | 93      | 566 DC* | 618 RQ  |
| RTL   | 250 SG          | 86      | 2013    | 2013    |
| TL    | 250 K1          | 79      | 2013    | 2013    |
| TLM   | 250 RJ          | 89      | 2013    | 2013    |
| TLR   | 250 R           | 85 - 87 | 2013    | 2013    |
| TRX   | 250             | 85 - 87 | 2044    | 2024    |
| TRX   | 250 EX Sportrax | 01 - 08 | 592 SI* | 2055    |
| TRX   | 250 R           | 86 - 89 | 603 SI* | 558 SI  |
| TRX   | 250 Recon       | 97 - 14 | 2083    | 2055    |
| TRX   | 250 X           | 08 - 13 | 592 SI* | 2055    |
| TRX   | 250 X Fourtrax  | 87      | 603 SI* | 558 SI  |
| VT    | 250 F           | 83 - 87 | 552 HF  | 2068    |
| VT    | 250 F           | 88 - 90 | 593 HF  | 2068    |
| VT    | 250 Spada       | 89      | 627 HF  | 614 HF  |
| VTR   | 250             | 88 - 89 | 552 HF  | 2068    |
| VTR   | 250             | 90      | 593 HS  | 2068    |
| VTR   | 250             | 98 - 02 | 654 HF  | 614 HF  |
| VTZ   | 250             | 88 - 99 | 593 HF  | 2068    |
| XL    | 250             | 78 - 79 | 2070    | 2023    |
| XL    | 250 Degree      | 91      | 603 HF  | 2029    |
| XL    | 250 R           | 82 - 83 | 2041    | 2029    |
| XL    | 250 R           | 84 - 87 | 558 HF  | 2013    |
| XL    | 250 S           | 78 - 80 | 2023    | 2029    |
| XL    | 250 S           | 81      | 2023    | 2026    |
| XLR   | 250 R           | 88 - 89 | 558 SI  | 2013    |
| XLR   | 250 R Baja      | 88 - 90 | 603 SI  | 629 SI  |
| XLR   | 250 R SPL       | 94      | 694 SI  | 604 SI  |
| XR    | 250             | 79 - 80 | 2023    | 2029    |
| XR    | 250 L           | 91 - 92 | 603 HF  | 604 HF  |
| XR    | 250 L           | 93 - 97 | 694 HF  | 604 HF  |
| XR    | 250 R           | 81 - 83 | 2030    | 2029    |
| XR    | 250 R           | 84 - 87 | 558 SI  | 2013    |
| XR    | 250 R           | 88 - 89 | 603 SI  | 2013    |
| XR    | 250 R           | 90 - 95 | 603 SI  | 604 SI  |
| XR    | 250 S, R        | 96 - 00 | 694 HF  | 604 HF  |
| Cota  | 260 4Ride       | 16 - 18 | 939 RSI | 803 RSI |



**RECOMMENDED**

1xx = Scooter Pads  
5xx = Street, Off Road & Racing Pads  
2xxx = Brake Shoes



| HONDA |                                |         |         |         |
|-------|--------------------------------|---------|---------|---------|
| Cota  | 260 4RT                        | 04 - 16 | 802 RSI | 803 RSI |
| Cota  | 260 4RT Race Replica           | 15 - 18 | 939 RSI | 803 RSI |
| TLM   | 260 R                          | 90      | 664 HF  | 629 HF  |
| CB    | 300                            | 10      | 688 HF  |         |
| CB    | 300 R                          | 18 -    | 940 HS  | 915 HF  |
| CBR   | 300 F                          | 14 - 16 | 700 HS  | 881 LS  |
| CBR   | 300 F ABS                      | 14 - 17 | 700 HS  | 881 LS  |
| CBR   | 300 R                          | 14 - 18 | 700 HS  | 881 LS  |
| CMX   | 300 Rebel                      | 17      | 700 HS  | 881 LS  |
| Cota  | 300 RR                         | 16 - 18 | 939 RSI | 803 RSI |
| NSS   | 300 Forza                      | 14 - 18 | 192 MS  | 193 MS  |
| SH    | 300 i                          | 07 - 18 | 192 MS  | 193 HF  |
| SH    | 300 i SH30                     | 15 - 18 | 183 MS  | 193 MS  |
| TRX   | 300                            | 88 - 00 |         | 2024    |
| TRX   | 300 EX Sportrax                | 01 - 08 | 592 SI* | 592 SI  |
| TRX   | 300 X                          | 09      | 592 SI* | 592 SI  |
| XR    | 300                            | 10 - 12 | 694 HF  | 604 HF  |
| ATC   | 350 X                          | 85      | 558 SI  | 562 SI  |
| ATC   | 350 X                          | 86 - 89 | 603 SI  | 562 SI  |
| CB    | 350 F, F1                      | 73 - 76 | 501 HF  | 2024    |
| CB    | 350 K4                         | 74      | 2071    | 2024    |
| CB    | 350 S.G. (U.K. only)           | 87 - 90 | 593 HF* | 2058    |
| FL    | 350 R Odyssey                  | 85 - 87 | 2044    | 610 HF  |
| NX    | 350                            | 88 - 99 | 593 HF  | 2013    |
| TRX   | 350 all models                 | 86 - 89 | 2045    | 2046    |
| TRX   | 350 Rancher /ES 2x4, 4x4       | 00 - 09 | 2085    | 2207    |
| XL    | 350                            | 76 - 78 | 2070    | 2023    |
| XL    | 350 R                          | 84 - 87 | 558 HF  | 2029    |
| XR    | 350 R                          | 83      | 2042    | 2013    |
| XR    | 350 R                          | 84 - 85 | 558 SI  | 2013    |
| CB    | 360 G, T                       | 73 - 76 | 501 HF  | 2024    |
| CJ    | 360 T                          | 76 - 78 | 501 HF  | 2024    |
| CL    | 360                            | 74 - 77 | 501 HF  | 2024    |
|       | 400 Xelvis                     | 93      | 542 HF  | 542 HF  |
| CB    | 400                            | 81 - 82 | 542 HF  | 542 HF  |
| CB    | 400 A                          | 77 - 81 | 526 HF  | 2058    |
| CB    | 400 F, F1, F2                  | 75 - 79 | 501 HF  | 2024    |
| CB    | 400 Four                       | 81 - 85 | 542 HF* | 2058    |
| CB    | 400 Hawk                       | 81 - 85 | 542 HF  | 542 HF  |
| CB    | 400 N                          | 78 - 82 | 517 HF  | 2058    |
| CB    | 400 N                          | 82 - 85 | 542 HF* | 2058    |
| CB    | 400 N                          | 86      | 593 HF  | 2058    |
| CB    | 400 N, T, Hawk                 | 78 - 82 | 526 HF  | 2058    |
| CB    | 400 NZ                         | 79      | 517 HF* | 2024    |
| CB    | 400 Super Four                 | 92 - 95 | 654 HS* | 614 LS  |
| CB    | 400 Super Four S               | 97 - 02 | 727 HS* |         |
| CB    | 400 T1, T2                     | 77 - 78 | 526 HF  | 2058    |
| CB    | 400 Twin                       | 82 - 86 | 542 HF  | 2058    |
| CB-1  | 400 (CB 400 F)                 | 89 - 90 | 627 HS  | 614 LS  |
| CBR   | 400 F                          | 92 - 96 | 593 HS* | 657 LS  |
| CBR   | 400 F, FII                     | 85      | 542 HF* | 542 HF  |
| CBR   | 400 R                          | 87      | 593 HF* | 542 HF  |
| CBR   | 400 RR                         | 87 - 89 | 627 HS* | 614 LS  |
| CBX   | 400 Custom                     | 88      | 571 HF  | 571 HF  |
| CBX   | 400 F                          | 85 - 86 | 571 HF  | 571 HF  |
| CBX   | 400 F, F2, F2C                 | 82 - 84 | 552 HF  | 571 HF  |
| CM    | 400 A, T, TZ                   | 79      | 526 HF  | 2058    |
| CM    | 400 C                          | 81      | 572 HF  | 2058    |
| CM    | 400 E                          | 80 - 81 | 2071    | 2058    |
| CM    | 400 T                          | 79 - 81 | 526 HF  | 2058    |
| CM    | 400 T                          | 82 - 84 | 542 HF  | 2058    |
| CX    | 400                            | 81      | 517 HF  |         |
| FJS   | 400 Silverwing                 | 06 - 08 | 156 MS  | 184 MS  |
| FJS   | 400 Silverwing (Parking Brake) | 06 - 08 |         | 209 HF  |
| FL    | 400 R Pilot                    | 89 - 90 | 2044    | 610 HF  |
| GB    | 400 T.T.                       | 88 - 92 | 542 HF  | 2058    |
| GL    | 400                            | 77 - 80 | 517 HF* |         |
| NS    | 400 R                          | 85 - 87 | 572 HS* | 542 LS  |
| NTV   | 400 Bros II                    | 88      | 622 HF  | 614 HF  |
| NV    | 400 Custom                     | 88      | 571 HF  | 542 HF  |
| NV    | 400 Steed                      | 88      | 600 HF  |         |

\* = 2 sets required / 2 jeux pour l'Avant.





**RECOMMENDED**

1xx = Scooter Pads  
5xx = Street, Off Road & Racing Pads  
2xxx = Brake Shoes



| HONDA |                           |         |         |         |  |
|-------|---------------------------|---------|---------|---------|--|
| NV    | 400 Steed                 | 92 - 93 | 627 HS  |         |  |
| RVF   | 400 RR (NC35)             | 90 - 96 | 622 HF* | 623 HF  |  |
| SW-T  | 400                       | 09 - 13 | 192 MS  | 184 MS  |  |
| SW-T  | 400 ABS                   | 09 - 14 | 192 MS  | 184 MS  |  |
| TRX   | 400 AT                    | 04 - 11 | 2085    | 2207    |  |
| TRX   | 400 EX Sportrax           | 01 - 08 | 592 SI* | 592 SI  |  |
| TRX   | 400 Fourtrax EX           | 99 - 00 | 592 SI* | 592 SI  |  |
| TRX   | 400 FW Fourtrax Foreman   | 95 - 02 | 2085    | 2207    |  |
| TRX   | 400 X                     | 09 - 12 | 592 SI* | 592 SI  |  |
| VF    | 400 F                     | 85 - 86 | 552 HF  | 571 HF  |  |
| VF    | 400 FD                    | 83 - 85 | 552 HF* | 571 HF  |  |
| VF    | 400 Integra               | 86 - 88 | 572 HF  | 572 HF  |  |
| VFR   | 400 R                     | 86 - 87 | 593 HF* | 593 HF  |  |
| VFR   | 400 R                     | 87 - 88 | 593 HS* | 614 LS  |  |
| VFR   | 400 R                     | 89 - 92 | 622 HS* | 623 LS  |  |
| VRX   | 400 T Roadstar            | 95 - 99 | 630 HS  | 614 LS  |  |
| VT    | 400 E                     | 83 - 86 | 552 HF  | 571 HF  |  |
| VTR   | 400 R (NC 30)             | 90      | 622 HS* | 623 LS  |  |
| XLR   | 400                       | 83      | 2077    | 2026    |  |
| XR    | 400 R                     | 96 - 04 | 694 SI  | 604 SI  |  |
| XR    | 400 Supermotard           | 00 - 03 | 694 RSI | 604 RSI |  |
| TRX   | 420 FA / FPA              | 09 - 13 | 592 SI* | 813 SI  |  |
| TRX   | 420 FPE / FPM 4x4         | 09 - 14 | 592 SI* |         |  |
| XR    | 440 R                     | 00 - 03 | 694 SI  | 604 SI  |  |
| CB    | 450 DX                    | 89 - 92 | 598 HF  | 598 HF  |  |
| CB    | 450 K5, K6, K7            | 72 - 77 | 501 HF  | 2072    |  |
| CB    | 450 N                     | 84 - 85 | 561 HF  | 2058    |  |
| CB    | 450 N                     | 86 - 89 | 598 HF  | 2058    |  |
| CB    | 450 S                     | 86 - 88 | 593 HF* | 2058    |  |
| CB    | 450 SC Nighthawk          | 82      | 561 HF  | 2058    |  |
| CB    | 450 SC Nighthawk          | 83 - 86 | 572 HF  | 2058    |  |
| CB    | 450 T                     | 82 - 86 | 542 HF  | 2058    |  |
| CM    | 450 A, C                  | 82 - 86 | 542 HF  | 2058    |  |
| CMX   | 450 Rebel                 | 86 - 88 | 542 HF  | 2058    |  |
| CR    | 450 R                     | 81      | 2030    |         |  |
| CRE   | 450 F                     | 02 - 06 | 694 SI  | 777 SI  |  |
| CRF   | 450 Efi                   | 09 - 12 | 694 RSI | 777 RSI |  |
| CRF   | 450 R                     | 02 - 08 | 694 RSI | 777 RSI |  |
| CRF   | 450 R Efi                 | 13 - 18 | 694 RSI | 777 RSI |  |
| CRF   | 450 RX Efi                | 17 - 18 | 694 SI  | 777 SI  |  |
| CRF   | 450 X                     | 05 - 18 | 694 SI  | 777 SI  |  |
| TRX   | 450 EX Sportrax           | 01 - 05 | 592 SI* | 592 SI  |  |
| TRX   | 450 Foreman ES, Foreman S | 98 - 04 | 2085    | 2207    |  |
| TRX   | 450 R                     | 04 - 09 | 694 SI* | 813 SI  |  |
| CR    | 480 R                     | 82      | 2030    | 2041    |  |
| CR    | 480 R                     | 83      |         | 2042    |  |
| CB    | 500                       | 94 - 96 | 627 HS  | 2059    |  |
| CB    | 500                       | 97 - 05 | 674 HS  | 675 LS  |  |
| CB    | 500 F                     | 72 - 75 | 501 HF  | 2072    |  |
| CB    | 500 F                     | 13 - 18 | 700 HS  | 881 LS  |  |
| CB    | 500 S                     | 98 - 03 | 674 HS  | 675 LS  |  |
| CB    | 500 T                     | 75 - 78 | 501 HF  | 2072    |  |
| CB    | 500 X                     | 13 - 18 | 700 HS  | 881 LS  |  |
| CBF   | 500                       | 04 - 08 | 700 HS  | 657 LS  |  |
| CBF   | 500 ABS                   | 04 - 08 | 828 HS  | 657 LS  |  |
| CBR   | 500 F (Austria)           | 87 - 90 | 593 HS* | 542 LS  |  |
| CBR   | 500 R                     | 13 - 18 | 700 HS  | 881 LS  |  |
| CMX   | 500 Rebel                 | 17 - 18 | 700 HS  | 881 LS  |  |
| CR    | 500 R                     | 87 - 94 | 603 RSI | 604 RSI |  |
| CR    | 500 R                     | 95 - 01 | 694 RSI | 604 RSI |  |
| CR    | 500 RE, RF                | 84 - 85 | 558 SI  | 2042    |  |
| CR    | 500 RG                    | 86      | 558 SI  | 2047    |  |
| CX    | 500                       | 78 - 80 | 517 HF* | 2059    |  |
| CX    | 500                       | 81      | 572 HF* |         |  |
| CX    | 500 C                     | 81 - 82 | 542 HF* | 2059    |  |
| CX    | 500 Euro                  | 82 - 84 | 572 HF* | 572 HF  |  |
| CX    | 500 Silver W., Turbo      | 83 - 85 | 542 HF* | 542 HF  |  |
| CX    | 500 Turbo                 | 82 - 83 | 542 HF* | 572 HF  |  |
| CX    | 500 Z, A, B               | 79 - 81 |         | 2059    |  |
| FT    | 500                       | 82 - 84 | 542 HF* | 542 HF  |  |
| GB    | 500 T.T.                  | 88 - 92 | 542 HF  | 2059    |  |
| GL    | 500                       | 82      | 572 HF* | 542 HF  |  |



**RECOMMENDED**

1xx = Scooter Pads  
5xx = Street, Off Road & Racing Pads  
2xxx = Brake Shoes



| HONDA |                                   |         |         |        |  |
|-------|-----------------------------------|---------|---------|--------|--|
| GL    | 500 D                             | 81 - 82 | 542 HF* | 2059   |  |
| GL    | 500 I                             | 81 - 82 | 572 HF* | 2059   |  |
| NS    | 500 R                             | 85      | 542 HS* | 542 LS |  |
| NX    | 500 Dominator (Austria)           | 88 - 92 | 647 HS  | 614 LS |  |
| NX    | 500 Dominator (Austria)           | 93 - 96 | 600 HS  | 614 LS |  |
| NX    | 500 Dominator (Austria)           | 97 - 99 | 671 HS  | 675 LS |  |
| TRX   | 500 all models                    | 05 - 14 | 829 SI* | 2046   |  |
| TRX   | 500 Foreman, Rubicon              | 00 - 09 | 2085    | 2072   |  |
| VF    | 500 F, FII                        | 84 - 86 | 542 HF* | 542 HF |  |
| VT    | 500 C Shadow                      | 83 - 86 | 542 HF  | 2058   |  |
| VT    | 500 E                             | 83 - 85 | 552 HF* | 2058   |  |
| VT    | 500 ED                            | 82      | 552 HF  | 2058   |  |
| XBR   | 500 S                             | 85 - 89 | 542 HF  | 2055   |  |
| XL    | 500 R                             | 83 - 87 | 558 HF  | 2026   |  |
| XL    | 500 RC                            | 82      | 2077    | 2026   |  |
| XL    | 500 SB                            | 81      | 2075    | 2068   |  |
| XL    | 500 SZ                            | 80      | 2023    | 2026   |  |
| XR    | 500 R                             | 86      | 558 SI  | 2026   |  |
| XR    | 500 R Pro Link                    | 81 - 82 | 2030    | 2026   |  |
| XR    | 500 R, Pro Link                   | 83 - 84 | 558 HF  | 2013   |  |
| XR    | 500 SZ, SA                        | 79 - 80 | 2031    | 2026   |  |
| CB    | 550 F                             | 75 - 79 | 501 HF  | 2072   |  |
| CB    | 550 K                             | 74 - 78 | 501 HF  | 2072   |  |
| CB    | 550 SC                            | 83 - 84 | 542 HF  | 2058   |  |
| CBX   | 550 F, F2                         | 82 - 86 | 552 HF* | 571 HF |  |
|       | 600 Steed                         | 88 - 91 | 600 HS  |        |  |
|       | 600 Steed                         | 92 - 02 | 627 HS  |        |  |
| CB    | 600 Hornet                        | 98 - 06 | 627 HS* | 657 LS |  |
| CB    | 600 Hornet                        | 07 - 12 | 627 HS* | 834 LS |  |
| CB    | 600 Hornet (Japan)                | 98 - 99 | 734 HS* | 657 LS |  |
| CB    | 600 Hornet ABS                    | 07 - 12 | 828 HS* | 657 LS |  |
| CB    | 600 Hornet, S                     | 00 - 03 | 627 HS* | 657 LS |  |
| CBF   | 600 N                             | 04 - 11 | 627 HS* | 657 LS |  |
| CBF   | 600 N ABS                         | 08 - 11 | 828 HS* | 657 LS |  |
| CBF   | 600 S                             | 04 - 11 | 627 HS* | 657 LS |  |
| CBF   | 600 S ABS                         | 08 - 11 | 828 HS* | 657 LS |  |
| CBR   | 600 F                             | 11 - 13 | 627 HS* | 834 LS |  |
| CBR   | 600 F ABS                         | 11 - 13 | 828 HS* | 657 LS |  |
| CBR   | 600 F Hurricane                   | 87 - 90 | 593 HS* | 542 LS |  |
| CBR   | 600 F, Super Sport                | 91 - 94 | 593 HS* | 657 LS |  |
| CBR   | 600 F3                            | 95 - 98 | 627 HS* | 657 LS |  |
| CBR   | 600 F4, F4 Sport                  | 99 - 06 | 734 HS* | 657 LS |  |
| CBR   | 600 RR                            | 03 - 04 | 734 HS* | 657 LS |  |
| CBR   | 600 RR                            | 05 - 06 | 809 HS* | 657 LS |  |
| CBR   | 600 RR                            | 07 - 08 | 809 HS* | 834 LS |  |
| CBR   | 600 RR ABS                        | 09 - 18 | 809 HS* | 834 LS |  |
| CBX   | 600 E                             | 85      | 542 HF* |        |  |
| FJS   | 600 Silverwing                    | 01 - 08 | 156 MS  | 184 MS |  |
| FJS   | 600 Silverwing<br>(Parking Brake) | 01 - 08 |         | 209 HF |  |
| FJS   | 600 Silverwing                    | 09 - 18 | 192 MS  | 184 MS |  |
| FJS   | 600 Silverwing<br>(Parking Brake) | 09 - 18 |         | 209 HF |  |
| NTV   | 600 Bros I                        | 88 - 93 | 622 HF  | 614 HF |  |
| NTV   | 600 Revere                        | 88 - 92 | 593 HF  | 614 HF |  |
| NV    | 600 C                             | 88 - 96 | 600 HF  | 2059   |  |
| SW-T  | 600                               | 11 - 13 | 192 MS  | 184 MS |  |
| VT    | 600 C, Shadow                     | 88 - 93 | 647 HS  | 2059   |  |
| VT    | 600 C, Shadow                     | 94 - 00 | 627 HS* | 2059   |  |
| VT    | 600 CD Shadow VLX                 | 94 - 00 | 627 HS* | 2059   |  |
| XL    | 600 LM, RM                        | 85 - 87 | 542 HF  | 2026   |  |
| XL    | 600 R                             | 83 - 86 | 558 HF  | 2026   |  |
| XL    | 600 V, Transalp                   | 87 - 90 | 542 HS  | 2026   |  |
| XL    | 600 V, Transalpino                | 91 - 93 | 647 HS  | 614 LS |  |
| XL    | 600 V, Transalpino                | 94 - 96 | 700 HS  | 614 LS |  |
| XL    | 600 V, Transalpino                | 97 - 99 | 694 HS* | 614 LS |  |
| XLM   | 600 LM                            | 87 - 91 | 558 HF  | 2026   |  |
| XR    | 600 R                             | 83 - 87 | 558 SI  | 2013   |  |
| XR    | 600 R                             | 88 - 90 | 603 SI  | 2013   |  |
| XR    | 600 R                             | 91 - 92 | 603 SI  | 604 SI |  |
| XR    | 600 R                             | 93 - 00 | 694 SI  | 604 SI |  |
| CB    | 650                               | 79 - 81 | 526 HF  | 2027   |  |

Applications  
Motorcycles, Off Road, ATV, Scooters

\* = 2 sets required / 2 jeux pour l'Avant.

Full compound selection, see under "Brake pad 1:1 Drawings" / Sélection complète de composés, voir "1:1 Schémas Plaquettes de frein".

**RECOMMENDED**

1xx = Scooter Pads  
5xx = Street, Off Road & Racing Pads  
2xxx = Brake Shoes



| HONDA |  |         |         |        |
|-------|--|---------|---------|--------|
| CB    | 650                                    | 85      | 542 HF* |        |
| CB    | 650 C                                  | 80 - 85 | 526 HF  | 2027   |
| CB    | 650 F                                  | 14 - 18 | 700 HS* | 881 LS |
| CB    | 650 SC Nighthawk                       | 83 - 85 | 542 HF* | 2059   |
| CB    | 650 SCC Nighthawk                      | 82      | 561 HF* | 2027   |
| CB    | 650 Z                                  | 78 - 81 | 526 HF* | 2027   |
| CBR   | 650 F                                  | 14 - 18 | 700 HS* | 881 LS |
| CBR   | 650 F ABS                              | 14 - 18 | 700 HS* | 881 LS |
| CBX   | 650 E                                  | 83 - 90 | 552 HF* | 2059   |
| CBX   | 650 ED, SC, SCD                        | 83      | 542 HF* | 2059   |
| CX    | 650 C                                  | 83 - 86 | 542 HF* | 2059   |
| CX    | 650 E                                  | 83 - 86 | 572 HF* | 542 HF |
| CX    | 650 Turbo                              | 83 - 86 | 542 HF* | 542 HF |
| FMX   | 650                                    | 05 - 08 | 627 HS  | 657 LS |
| FX    | 650 Vigor                              | 99 - 02 | 674 HS  | 675 LS |
| GL    | 650 D                                  | 83 - 84 | 542 HF* | 2059   |
| NT    | 650 Hawk GT                            | 88 - 91 | 627 HS  | 614 LS |
| NT    | 650 V Deauville                        | 98 - 00 | 674 HS* | 614 LS |
| NT    | 650 V Deauville                        | 01      | 674 HS* | 657 LS |
| NT    | 650 V Deauville                        | 02 - 05 | 735 HS* | 736 LS |
| NTV   | 650                                    | 94 - 97 | 654 HS* | 614 LS |
| NTV   | 650 Bros                               | 88 - 97 | 622 HS* | 614 LS |
| NTV   | 650 Revere                             | 88 - 93 | 627 HS  | 614 LS |
| NX    | 650 Dominator                          | 93 - 96 | 600 HS  | 614 LS |
| NX    | 650 Dominator                          | 97 - 99 | 674 HS  | 675 LS |
| NX    | 650 Dominator J-K                      | 88 - 92 | 647 HS  | 614 LS |
| SLR   | 650                                    | 97 - 99 | 674 HS  | 675 LS |
| TRX   | 650 FA Rincon                          | 03 - 05 | 2085    | 813 SI |
| TRX   | 650 FGA Rincon                         | 04 - 05 | 2085    | 813 SI |
| XL    | 650 V Transalp                         | 00 - 07 | 694 HS* | 614 LS |
| XR    | 650 L                                  | 93 - 12 | 694 HF  | 604 HF |
| XR    | 650 R                                  | 00 - 11 | 694 SI  | 604 SI |
| XRV   | 650 Africa Twin                        | 88 - 89 | 647 HS  | 614 LS |
| DN-01 | 680 (Parking Brake)                    | 08 - 11 |         | 209 HF |
| DN-01 | 680                                    | 08 - 11 | 828 HS* | 630 LS |
| TRX   | 680 FA6 Rincon                         | 06 - 15 | 829 SI* | 813 SI |
| TRX   | 680 FGA6 Rincon                        | 06 - 15 | 829 SI* | 813 SI |
| CB    | 700 SC                                 | 84 - 86 | 542 HF* | 2046   |
| CTX   | 700                                    | 14 - 18 | 700 HS  | 881 LS |
| CTX   | 700 D ABS w/DCT                        | 13 - 15 | 700 HS  | 881 LS |
| CTX   | 700 D ABS w/DCT<br>(Parking Brake)     | 13 - 15 |         | 879 HF |
| CTX   | 700 N                                  | 14 - 18 | 700 HS  | 881 LS |
| CTX   | 700 ND ABS w/DCT                       | 14 - 15 | 700 HS  | 881 LS |
| CTX   | 700 ND ABS w/DCT<br>(Parking Brake)    | 14 - 15 |         | 879 HF |
| NC    | 700 D Integra                          | 12 - 13 | 828 HS  | 657 LS |
| NC    | 700 D Integra w/DCT<br>(Parking Brake) | 12 - 13 |         | 879 HF |
| NC    | 700 S                                  | 12 - 13 | 627 HS  | 614 LS |
| NC    | 700 SA ABS                             | 12 - 13 | 828 HS  | 657 LS |
| NC    | 700 SD ABS                             | 12 - 13 | 828 HS  | 657 LS |
| NC    | 700 SD ABS w/DCT<br>(Parking Brake)    | 12 - 13 |         | 879 HF |
| NC    | 700 X                                  | 12 - 13 | 627 HS  | 614 LS |
| NC    | 700 XA ABS                             | 12 - 13 | 828 HS  | 657 LS |
| NC    | 700 XD ABS                             | 12 - 13 | 828 HS  | 657 LS |
| NC    | 700 XD ABS w/DCT<br>(Parking Brake)    | 12 - 13 |         | 879 HF |
| NT    | 700 Deauville ABS                      | 06 - 12 | 828 HS* | 736 LS |
| NT    | 700 V Varadero, ABS                    | 10 - 13 | 828 HS* | 736 LS |
| TRX   | 700 XX                                 | 08 - 12 | 694 SI* | 829 SI |
| VF    | 700 C Magna                            | 84      | 542 HF* | 2059   |
| VF    | 700 C Magna                            | 85 - 86 | 572 HF* | 2046   |
| VF    | 700 C Magna                            | 87      | 542 HF  | 2046   |
| VF    | 700 F Interceptor                      | 84 - 85 | 572 HF* | 542 HF |
| VF    | 700 S                                  | 84 - 85 | 542 HF* | 2059   |
| VFR   | 700 F Interceptor                      | 88 - 89 | 627 HS* | 614 LS |
| VFR   | 700 F, F2                              | 86 - 87 | 600 HS* | 542 LS |
| VT    | 700 C Shadow                           | 84 - 85 | 561 HF* | 2059   |
| VT    | 700 C Shadow                           | 86      | 561 HF* | 2046   |
| VT    | 700 C, Shadow                          | 87      | 542 HF  | 2046   |

**RECOMMENDED**

1xx = Scooter Pads  
5xx = Street, Off Road & Racing Pads  
2xxx = Brake Shoes



| HONDA |   |         |         |        |
|-------|---|---------|---------|--------|
| XL    | 700 Transalp                            | 08 - 11 | 694 HS* | 614 LS |
| XL    | 700 Transalp ABS                        | 08 - 12 | 828 HS* | 657 LS |
|       | 750 X-ADV                               | 17 - 18 | 940 HS* | 881 LS |
|       | 750 X-ADV (Parking Brake)               | 17 - 18 |         | 879 HF |
| CB    | 750 A                                   | 76 - 78 | 501 HF  | 2027   |
| CB    | 750 C                                   | 80 - 81 | 526 HF* | 2027   |
| CB    | 750 C                                   | 82 - 84 | 542 HF* | 2027   |
| CB    | 750 C, F, Fil, K                        | 85 - 86 | 542 HF* | 2027   |
| CB    | 750 F                                   | 77 - 80 | 517 HF* | 517 HF |
| CB    | 750 F                                   | 81 - 82 | 542 HF* | 542 HF |
| CB    | 750 F1                                  | 75 - 76 | 501 HF  | 509 HF |
| CB    | 750 K                                   | 81 - 82 | 542 HF* | 542 HF |
| CB    | 750 K Four                              | 77 - 78 | 501 HF  | 2027   |
| CB    | 750 K, L                                | 79 - 80 | 526 HF* | 2027   |
| CB    | 750 K0-K6 Four                          | 70 - 76 | 502 HF  | 2027   |
| CB    | 750 KZ                                  | 82      | 542 HF  | 2027   |
| CB    | 750 N, F, Seven Fifty                   | 92 - 95 | 627 HS* | 657 LS |
| CB    | 750 PZ                                  | 81 - 84 | 526 HF  | 2027   |
| CB    | 750 SC                                  | 82 - 83 | 572 HF* | 2027   |
| CB    | 750 SS                                  | 77 - 79 | 508 HF* | 517 HF |
| CBR   | 750 Hurricane                           | 87 - 00 | 600 HS* | 542 LS |
| CBX   | 750                                     | 84 - 88 | 542 HF* | 542 HF |
| CBX   | 750 F                                   | 84 - 88 | 542 HF* | 542 HF |
| NC    | 750 D Integra                           | 14 - 18 | 700 HS  | 881 LS |
| NC    | 750 D Integra w/DCT<br>(Parking Brake)  | 14 - 18 |         | 879 HF |
| NC    | 750 S w/DCT                             | 14 - 18 | 700 HS  | 881 LS |
| NC    | 750 S w/DCT (Parking Brake)             | 14 - 18 |         | 879 HF |
| NC    | 750 X w/DCT                             | 14 - 18 | 700 HS  | 881 LS |
| NC    | 750 X w/DCT (Parking Brake)             | 14 - 18 |         | 879 HF |
| NM4   | 750 Vultus ABS w/DCT                    | 15 - 18 | 700 HS  | 881 LS |
| NM4   | 750 Vultus ABS w/DCT<br>(Parking Brake) | 15 - 18 |         | 879 HF |
| NR    | 750                                     | 92      | 622 HS* | 657 LS |
| NV    | 750 CG Shadow                           | 86 - 89 | 542 HF  |        |
| RVF   | 750 RR (RC-45)                          | 94 - 98 | 622 HS* | 623 LS |
| VF    | 750 C                                   | 82 - 84 | 542 HF* | 2059   |
| VF    | 750 C, CD Magna                         | 94 - 98 | 630 HS  | 2046   |
| VF    | 750 C, Magna                            | 88 - 93 | 542 HF  | 2046   |
| VF    | 750 F                                   | 83 - 84 | 542 HF* | 542 HF |
| VF    | 750 S                                   | 85      | 542 HF* | 2059   |
| VF    | 750 Sport                               | 82 - 83 | 542 HF* | 2059   |
| VFR   | 750 F                                   | 86 - 87 | 600 HS* | 542 LS |
| VFR   | 750 F                                   | 88 - 98 | 627 HS* | 630 LS |
| VFR   | 750 R                                   | 88 - 93 | 622 HS* | 623 LS |
| VP    | 750 CH, Custom                          | 87      | 542 HF  | 2046   |
| VT    | 750 Black Widow                         | 01 - 03 | 700 HS  | 2046   |
| VT    | 750 C                                   | 83 - 85 | 561 HF  | 2059   |
| VT    | 750 C, Shadow                           | 86 - 96 | 542 HF  | 2046   |
| VT    | 750 C2 Shadow A.C.E.                    | 97 - 03 | 700 HS  | 2046   |
| VT    | 750 C2 Shadow Spirit                    | 07 - 11 | 700 HS  | 2046   |
| VT    | 750 C2B                                 | 11 - 18 | 700 HS  |        |
| VT    | 750 C2S ABS                             | 13 - 14 | 828 HS  | 715 LS |
| VT    | 750 C4 Shadow                           | 04 - 05 | 700 HS  | 2046   |
| VT    | 750 CS ABS                              | 13 - 14 | 828 HS  | 715 LS |
| VT    | 750 RS                                  | 11 - 13 | 700 HS  |        |
| VT    | 750 S                                   | 11 - 12 | 700 HS  |        |
| XLV   | 750 R                                   | 83 - 85 | 542 HF  | 2055   |
| XLV   | 750 R                                   | 86 - 88 | 572 HF  | 2055   |
| XRV   | 750 Africa Twin                         | 90 - 92 | 593 HS  | 614 LS |
| XRV   | 750 Africa Twin                         | 93 - 03 | 694 HS* | 614 LS |
| PC    | 800 Pacific Coast                       | 89 - 97 | 627 HS* | 2046   |
| VFR   | 800                                     | 06 - 13 | 828 HS* | 736 LS |
| VFR   | 800 ABS                                 | 06 - 13 | 828 HS* | 736 LS |
| VFR   | 800 Crossrunner                         | 11 - 13 | 828 HS* | 862 LS |
| VFR   | 800 F                                   | 14 - 18 | 809 HS* | 862 LS |
| VFR   | 800 FI                                  | 98 - 01 | 735 HS* | 736 LS |
| VFR   | 800 V-TEC, ABS                          | 02 - 05 | 735 HS* | 736 LS |
| VFR   | 800 X Crossrunner                       | 15 - 18 | 809 HS* | 862 LS |
| VT    | 800 C                                   | 88 - 94 | 542 HF  | 2046   |
| CB    | 900 C                                   | 82      | 542 HF* | 542 HF |
| CB    | 900 F                                   | 78 - 80 | 517 HF* | 517 HF |

\* = 2 sets required / 2 jeux pour l'Avant.

**RECOMMENDED**1xx = Scooter Pads  
5xx = Street, Off Road & Racing Pads  
2xxx = Brake Shoes**HONDA**

|          |      |  |         |         |        |
|----------|------|--|---------|---------|--------|
| CB       | 900  | F, F2  | 81 - 84 | 572 HF* | 542 HF |
| CB       | 900  | Hornet   | 02 - 07 | 622 HS* | 657 LS |
| CBR      | 900  | RR Fireblade   | 92 - 97 | 622 HS* | 657 LS |
| CBR      | 900  | RR Fireblade   | 98 - 03 | 734 HS* | 657 LS |
| VFR      | 950  | F, Carat   | 92      | 627 HS* | 630 LS |
| CB       | 1000 | C  | 83 - 84 | 542 HF* | 542 HF |
| CB       | 1000 | F (Big One)  | 93 - 97 | 622 HS* | 657 LS |
| CB       | 1000 | R  | 18 -    | 947 HS* | 862 LS |
| CB       | 1000 | R  | 08 - 16 | 809 HS* | 862 LS |
| CB       | 1000 | R ABS  | 08 - 16 | 828 HS* | 862 LS |
| CB       | 1000 | R+   | 18 -    | 947 HS* | 862 LS |
| CBF      | 1000 |  | 06 - 11 | 700 HS* | 657 LS |
| CBF      | 1000 | ABS  | 06 - 11 | 828 HS* | 828 LS |
| CBF      | 1000 | F ABS  | 15 - 18 | 828 HS* | 657 LS |
| CBF      | 1000 | Limited Edition                                      | 09 - 14 | 700 HS* | 657 LS |
| CBF      | 1000 | Limited Edition<br>ABS                               | 09 - 14 | 828 HS* | 828 LS |
| CBR      | 1000 | F  | 87 - 88 | 600 HS* | 542 LS |
| CBR      | 1000 | F  | 89 - 92 | 627 HS* | 630 LS |
| CBR      | 1000 | F, FP  | 93 - 99 | 685 HS* | 685 LS |
| CBR      | 1000 | RR Fireblade   | 04 - 05 | 809 HS* | 657 LS |
| CBR      | 1000 | RR Fireblade   | 06 - 08 | 809 HS* | 834 LS |
| CBR      | 1000 | RR Fireblade ABS                                     | 09 - 16 | 809 SP* | 834 LS |
| CBR      | 1000 | RR Fireblade   | 17 - 18 | 947 SP* | 834 LS |
| CBR      | 1000 | RR SP  | 14 - 18 | 901 SP* | 834 LS |
| CBR      | 1000 | RR SP2   | 17 - 18 | 901 SP* | 834 LS |
| CBX      | 1000 |  | 78 - 80 | 517 HF* | 517 HF |
| CBX      | 1000 |  | 81 - 82 | 572 HF* | 542 HF |
| CRF      | 1000 | L Africa Twin  | 16 - 18 | 940 HS* | 657 LS |
| CRF      | 1000 | L Africa Twin<br>(Parking Brake)                     | 16 - 18 |         | 879 HF |
| CRF      | 1000 | L Africa Twin<br>Adventure Sports                    | 18 -    | 940 HS* | 657 LS |
| CRF      | 1000 | L Africa Twin<br>Adventure Sports<br>(Parking Brake) | 18 -    |         | 879 HF |
| GL       | 1000 | Gold Wing  | 81      | 517 HF* | 517 HF |
| GL       | 1000 | Gr. Tour. Gold Wing                                  | 81 - 82 | 517 HF* | 517 HF |
| GL       | 1000 | K1, K2 Gold Wing                                     | 75 - 77 | 508 HF* | 509 HF |
| GL       | 1000 | K3 Gold Wing   | 78 - 79 | 517 HF* | 509 HF |
| RC213V-S | 1000 |  | 16 - 18 | 901 SP* | 730 LS |
| VF       | 1000 | F, Fil   | 84 - 86 | 542 HF* | 542 HF |
| VF       | 1000 | Fil Bol d'Or   | 85      | 542 HF* | 542 HF |
| VF       | 1000 | R  | 84 - 87 | 542 HF* | 542 HF |
| VF       | 1000 | R  | 86      | 542 HF* | 542 HF |
| VFR      | 1000 |  | 89      | 627 HS* | 630 LS |
| VT       | 1000 | C  | 88      | 542 HF  | 2046   |
| VTR      | 1000 | F Firestorm  | 97 - 07 | 622 HS* | 657 LS |
| VTR      | 1000 | SP-1, SP-2   | 00 - 06 | 734 HS* | 657 LS |
| XL       | 1000 | Varadero   | 99      | 735 HS* | 736 LS |
| XL       | 1000 | Varadero   | 07 - 13 | 828 SP* | 736 LS |
| XL       | 1000 | Varadero<br>(Linked brake system)                    | 00 - 06 | 735 HS* | 736 LS |
| XL       | 1000 | Varadero ABS   | 04 - 13 | 828 HS* | 736 LS |
| CB       | 1100 | , EX   | 14 - 18 | 734 HS* | 657 LS |
| CB       | 1100 |  | 13      | 828 HS* | 657 LS |
| CB       | 1100 | EX ABS   | 17 - 18 | 734 HS* | 657 LS |
| CB       | 1100 | F  | 83 - 85 | 542 HF* | 542 HF |
| CB       | 1100 | Hornet   | 99      | 735 HS* | 736 LS |
| CB       | 1100 | R, RD  | 81 - 83 | 542 HF* | 542 HF |
| CB       | 1100 | RS ABS   | 17 - 18 | 947 HS* | 657 LS |
| CB       | 1100 | X-11   | 00 - 03 | 735 HS* | 736 LS |
| CBR      | 1100 | XX Super Blackbird                                   | 96 - 07 | 735 HS* | 736 LS |
| GL       | 1100 | -1, DLX Gold Wing                                    | 81 - 87 | 542 HF* | 542 HF |
| GL       | 1100 | A Gold Wing  | 79 - 83 | 517 HF* | 517 HF |
| GL       | 1100 | Gold Wing  | 82 - 83 | 572 HF* | 542 HF |
| ST       | 1100 |  | 90 - 02 | 627 HS* | 654 LS |
| ST       | 1100 | A6 ABS-TCS-CBS                                       | 96 - 01 | 721 HS* | 722 LS |
| ST       | 1100 | ABS-TCS  | 92 - 95 | 627 HS* | 654 LS |
| VF       | 1100 | C  | 83 - 86 | 572 HF* | 542 HF |
| VF       | 1100 | S  | 84 - 85 | 572 HF* | 542 HF |
| VT       | 1100 | C Shadow   | 87 - 93 | 542 HF  | 2046   |

**RECOMMENDED**1xx = Scooter Pads  
5xx = Street, Off Road & Racing Pads  
2xxx = Brake Shoes**HONDA**

|     |      |  |         |         |        |
|-----|------|--|---------|---------|--------|
| VT  | 1100 | C Shadow                                 | 94 - 96 | 627 HS* | 2046   |
| VT  | 1100 | C2 Shadow A.C.E.                         | 95 - 04 | 627 HS  | 657 LS |
| VT  | 1100 | C2 Y                                     | 00 - 05 | 627 HS  | 657 LS |
| VT  | 1100 | C3 Shadow Aero                           | 98 - 04 | 627 HS  | 657 LS |
| VT  | 1100 | T Shadow                                 | 98 - 04 | 627 HS* | 657 LS |
| GL  | 1200 | A, I Gold Wing                           | 84 - 86 | 572 HF* | 542 HF |
| GL  | 1200 | DX Gold Wing                             | 86 - 87 | 572 HF* | 542 HF |
| GL  | 1200 | Gold Wing                                | 84 - 86 | 572 HF* | 542 HF |
| VFR | 1200 | F  | 10 - 18 | 869 HS* | 862 LS |
| VFR | 1200 | F w/DCT                                  | 10 - 18 | 869 HS* | 892 LS |
| VFR | 1200 | F w/DCT (Parking Brake)                  | 10 - 18 |         | 879 HF |
| VFR | 1200 | XC Crosstourer                           | 12 - 18 | 828 SP* | 892 LS |
| VFR | 1200 | XDC Crosstourer w/DCT                    | 12 - 18 | 828 SP* | 892 LS |
| VFR | 1200 | XDC Crosstourer w/DCT<br>(Parking Brake) | 12 - 18 |         | 879 HF |
| CB  | 1300 |  | 05 - 13 | 734 HS* | 657 LS |
| CB  | 1300 | R  | 02 - 04 | 734 HS* | 715 LS |
| CB  | 1300 | S  | 11 - 15 | 828 HS* | 657 LS |
| CB  | 1300 | SF                                       | 98 - 00 | 676 HS* | 715 LS |
| CB  | 1300 | X-4                                      | 97 - 03 | 622 HS* | 715 LS |
| CTX | 1300 |  | 14 - 18 | 828 HS* | 630 LS |
| ST  | 1300 | Pan European, ABS                        | 02 - 07 | 735 HS* | 722 LS |
| ST  | 1300 | Pan European, ABS                        | 08 - 18 | 828 HS* | 722 LS |
| VT  | 1300 | CX A Fury                                | 10 - 18 | 627 HS  | 657 LS |
| VT  | 1300 | CXA A Fury ABS                           | 10 - 18 | 828 HS  | 736 LS |
| VTX | 1300 | C  | 04 - 09 | 627 HS  | 657 LS |
| VTX | 1300 | S  | 03 - 07 | 627 HS  | 657 LS |
| GL  | 1500 | A, SE, I Gold Wing                       | 94 - 99 | 647 HS* | 542 LS |
| GL  | 1500 | F6 C Valkyrie                            | 96 - 02 | 627 HS* | 630 LS |
| GL  | 1500 | Gold Wing,<br>Gold Wing SE               | 88 - 99 | 647 HS* | 542 LS |
| GLX | 1500 |  | 88 - 99 | 647 HF* | 542 HF |
| GL  | 1800 | Gold Wing                                | 01 - 16 | 735 HS* | 880 LS |
| GL  | 1800 | Gold Wing F6B                            | 13 - 16 | 735 HS* | 880 LS |
| VTX | 1800 |  | 01 - 12 | 735 HS* | 736 LS |

**HOREX**

|     |      |            |         |         |        |
|-----|------|------------|---------|---------|--------|
|     | 80   | Rebell N   | 83      | 532 HF  |        |
|     | 80   | Rebell T   | 86      | 506 HF* | 506 HF |
|     | 80   | Sport L    | 86      | 506 HF* | 506 HF |
|     | 125  | Imperator  | 96      | 506 HF  |        |
|     | 125  | Regent     | 96      | 506 HF  |        |
|     | 560  | E          | 86 - 88 | 506 HF* | 506 HF |
|     | 600  | Columbus   | 87 - 88 | 506 HF* | 506 HF |
| VR6 | 1200 |            | 11 - 16 | 706 HS* | 611 LS |
| VR6 | 1200 | Cafe Racer | 17      | 841 HS* | 730 LS |
| VR6 | 1200 | Classic    | 17      | 841 HS* | 730 LS |

**HRD**

|  |     |                     |         |        |        |
|--|-----|---------------------|---------|--------|--------|
|  | 50  | GS Enduro           | 00 - 02 | 652 HF | 675 HF |
|  | 50  | Sonic 2 Supermotard | 00 - 02 | 148 HF | 105 HF |
|  | 50  | Sonic 2 Trail       | 00 - 02 | 148 HF | 105 HF |
|  | 125 | Supermotard         | 00 - 02 | 652 HF | 559 HF |
|  | 125 | Trail               | 00 - 02 | 652 HF | 559 HF |

**HUSABERG**

|    |     |            |         |         |         |
|----|-----|------------|---------|---------|---------|
|    |     | all models | 89 - 92 | 608 SI  | 586 SI  |
|    |     | all models | 93 - 98 | 671 SI  | 586 SI  |
| TE | 125 |            | 13      | 671 SI  | 791 SI  |
| FE | 250 |            | 13      | 671 SI  | 791 SI  |
| TE | 250 |            | 11 - 13 | 671 SI  | 791 SI  |
| TE | 300 |            | 11 - 13 | 671 SI  | 791 SI  |
|    | 350 |            | 91 - 92 | 608 SI  | 586 SI  |
| FE | 350 |            | 13      | 671 SI  | 791 SI  |
| FE | 390 |            | 10 - 13 | 671 SI  | 791 SI  |
| FC | 400 |            | 99 - 02 | 671 RSI | 675 RSI |
| FE | 400 | ,S,E       | 99 - 03 | 671 SI  | 675 SI  |
| FS | 400 | e, c       | 01 - 03 | 631 RSI | 675 RSI |
| FC | 450 |            | 03 - 08 | 671 RSI | 675 RSI |
| FE | 450 |            | 09 - 13 | 671 SI  | 791 SI  |
| FE | 450 | e          | 04 - 08 | 671 SI  | 675 SI  |
| FS | 450 | c          | 06 - 08 | 842 RSI | 675 RSI |

\* = 2 sets required / 2 jeux pour l'Avant.

Full compound selection, see under "Brake pad 1:1 Drawings" / Sélection complète de composés, voir "1:1 Schémas Plaquettes de frein".

**RECOMMENDED**

1xx = Scooter Pads  
5xx = Street, Off Road & Racing Pads  
2xxx = Brake Shoes



| HUSABERG |            |         |         |         |
|----------|------------|---------|---------|---------|
| FS       | 450 e, c   | 03 - 05 | 631 RSI | 675 RSI |
| FX       | 450 e      | 03 - 08 | 671 RSI | 675 RSI |
| FC       | 470 , e    | 01 - 02 | 671 RSI | 675 RSI |
| FX       | 470 e      | 01 - 02 | 671 RSI | 675 RSI |
|          | 500        | 91 - 98 | 608 SI  | 586 SI  |
|          | 501 Enduro | 91 - 94 | 608 SI  | 586 SI  |
| FC       | 501        | 99 - 01 | 671 RSI | 675 RSI |
| FE       | 501 ,S,E   | 99 - 04 | 671 SI  | 675 SI  |
| FE       | 501        | 13      | 671 SI  | 791 SI  |
| FC       | 550        | 01 - 05 | 671 RSI | 675 RSI |
| FE       | 550 e      | 04 - 08 | 671 SI  | 675 SI  |
| FE       | 570        | 09 - 13 | 671 SI  | 791 SI  |
|          | 600 Enduro | 91 - 94 | 608 SI  | 586 SI  |
| FC       | 600        | 99 - 01 | 671 RSI | 675 RSI |
| FE       | 600 ,S,E   | 99 - 02 | 671 SI  | 675 SI  |
| FE       | 650 e      | 01 - 08 | 671 SI  | 675 SI  |
| FS       | 650 e, c   | 01 - 05 | 631 RSI | 675 RSI |
| FS       | 650 e, c   | 06 - 08 | 842 RSI | 675 RSI |
| FX       | 650 e      | 01 - 05 | 671 RSI | 675 RSI |

| HUSQVARNA |                               |         |         |         |
|-----------|-------------------------------|---------|---------|---------|
|           | all models                    | 72 - 79 | 2116    | 2116    |
|           | all models                    | 87 - 88 |         | 2116    |
|           | all models CR,TC,TE,WR        | 92 - 94 | 611 SI  | 536 SI  |
|           | all models TE,TC,WR,<br>CR,AE | 89      | 608 SI  | 2116    |
|           | all rear drum models          | 86      |         | 2117    |
|           | 50 Husky Boy J, R, S          | 01 - 10 | 559 RSI |         |
|           | 50 Racing                     | 98      | 105 HF  |         |
| CR        | 50 Junior                     | 06      | 803 RSI |         |
| CR        | 50 Pro Senior                 | 06      | 803 RSI | 794 RSI |
| CR        | 50 Senior                     | 06      | 803 RSI | 794 RSI |
| SM        | 50                            | 02      | 148 HF  | 105 HF  |
| SM        | 50                            | 10 - 12 | 803 HF  | 794 RSI |
| TC        | 50                            | 17 - 18 | 794 RSI | 794 RSI |
| WR        | 50                            | 02      | 148 HF  | 105 HF  |
| WRS       | 50                            | 98      | 105 HF  | 2181    |
| CR        | 65                            | 12 - 13 | 783 RSI | 872 RSI |
| TC        | 65                            | 17 - 18 | 783 RSI | 783 RSI |
| TC        | 85                            | 14 - 18 | 885 RSI | 872 RSI |
| CR        | 125                           | 83 - 84 | 2118    | 2116    |
| CR        | 125                           | 85 - 90 | 519 SI  | 2117    |
| CR        | 125                           | 96 - 04 | 671 RSI | 675 RSI |
| CR        | 125                           | 05 - 13 | 671 RSI | 791 RSI |
| CR/RL     | 125                           | 81 - 82 | 2117    | 2116    |
| CR/WR     | 125                           | 91      | 608 SI  | 692 SI  |
| CX        | 125                           | 84 - 85 | 519 SI  |         |
| SM        | 125 S                         | 09 - 13 | 671 HF  | 675 HF  |
| SM        | 125 S 4T                      | 11 - 13 | 671 HF  | 675 HF  |
| SM        | 125 Supermotard, S            | 99 - 13 | 671 HF  | 675 HF  |
| TC        | 125                           | 14 - 18 | 671 RSI | 791 RSI |
| TE        | 125                           | 14 - 16 | 671 SI  | 791 SI  |
| TE        | 125 4T                        | 11 - 13 | 671 HF  | 675 HF  |
| TX        | 125                           | 17 - 18 | 671 SI  | 791 SI  |
| WR        | 125                           | 80      | 2117    | 2116    |
| WR        | 125                           | 85 - 90 | 608 SI  | 2117    |
| WR        | 125                           | 96 - 13 | 671 SI  | 675 SI  |
| WR/XC     | 125                           | 82      | 2117    | 2117    |
| WR/XC     | 125                           | 83 - 84 | 2118    | 2117    |
| WRE       | 125                           | 96 - 13 | 671 SI  | 675 SI  |
| WRK       | 125                           | 90      | 608 SI  | 586 SI  |
| XC        | 125                           | 85      |         | 2116    |
|           | 200 Prof                      | 86      | 519 SI* | 519 SI  |
| CR        | 240                           | 84 - 85 | 519 SI  |         |
| WR        | 240                           | 87 - 90 | 608 SI  |         |
| WR        | 240                           | 91      | 608 SI  | 692 SI  |
| WRK       | 240                           | 90      | 608 SI  | 586 SI  |
| CR        | 250                           | 81 - 82 | 2117    | 2116    |
| CR        | 250                           | 83 - 84 | 2118    | 2116    |
| CR        | 250                           | 85 - 87 | 519 SI  | 2117    |
| CR        | 250                           | 91      | 608 SI  | 692 SI  |
| CR        | 250                           | 96 - 04 | 671 RSI | 675 RSI |

**RECOMMENDED**

1xx = Scooter Pads  
5xx = Street, Off Road & Racing Pads  
2xxx = Brake Shoes



| HUSQVARNA |                |         |         |         |
|-----------|----------------|---------|---------|---------|
| CR        | 250            | 05      | 671 RSI | 791 RSI |
| CX        | 250            | 84 - 85 | 519 SI  |         |
| FC        | 250            | 14 - 18 | 671 RSI | 791 RSI |
| FE        | 250            | 14 - 18 | 671 SI  | 791 SI  |
| TC        | 250            | 02 - 03 | 671 RSI | 675 RSI |
| TC        | 250            | 04 - 13 | 671 RSI | 791 RSI |
| TC        | 250            | 14 - 18 | 671 RSI | 791 RSI |
| TE        | 250            | 02 - 13 | 671 SI  | 675 SI  |
| TE        | 250            | 14 - 18 | 671 SI  | 791 SI  |
| TE        | 250 4T         | 10 - 13 | 671 SI  | 791 SI  |
| WR        | 250            | 96 - 13 | 671 SI  | 675 SI  |
| WR/OR     | 250            | 80      | 2117    | 2116    |
| WR/XC     | 250            | 81 - 82 | 2117    | 2117    |
| WR/XC     | 250            | 83 - 84 | 2118    | 2117    |
| WR/XC     | 250            | 87 - 90 | 608 SI  |         |
| WR        | 260            | 90 - 93 | 608 SI  | 692 SI  |
| TC        | 300            | 14 - 15 | 671 RSI | 791 RSI |
| TE        | 300            | 14 - 18 | 671 SI  | 791 SI  |
| WR        | 300            | 09 - 13 | 671 SI  | 791 SI  |
| TE        | 310 4T         | 10 - 13 | 671 SI  | 791 SI  |
| FC        | 350            | 14 - 18 | 671 RSI | 791 RSI |
| FE        | 350            | 14 - 18 | 671 SI  | 791 SI  |
| TE        | 350            | 96 - 13 | 671 SI  | 675 SI  |
| TE        | 350 Enduro     | 90      | 608 SI  | 586 SI  |
| WR        | 360            | 98 - 13 | 671 SI  | 675 SI  |
| WR/OR     | 390            | 80      | 2117    | 2116    |
| WR/XC     | 390            | 82      | 2117    | 2117    |
|           | 400 Enduro     | 85 - 88 | 519 SI  | 2117    |
| SM        | 400 R          | 02      | 566 HF  | 675 HF  |
| TE        | 400            | 01 - 13 | 671 SI  | 675 SI  |
| WR        | 400            | 87 - 88 | 608 SI  | 2117    |
| WRX       | 400            | 85      | 2118    | 2116    |
|           | 401 Svartpilen | 17 - 18 | 877 HS  | 675 LS  |
|           | 401 Vitpilen   | 17 - 18 | 877 HS  | 675 LS  |
| TE        | 410            | 96 - 13 | 671 SI  | 675 SI  |
|           | 430 Auto       | 87      | 608 SI  | 2117    |
|           | 430 Enduro     | 85 - 88 | 519 SI  | 2116    |
| CR        | 430            | 82      | 2117    | 2116    |
| CR        | 430            | 87 - 89 | 608 SI  | 2117    |
| CR/WR/CS  | 430            | 81      | 2117    | 2117    |
| WR        | 430            | 87 - 89 | 608 SI  | 2116    |
| XC        | 430            | 87 - 88 | 608 SI  | 2117    |
| SMR       | 449            | 11 - 13 | 762 RS  | 791 RSI |
| TC        | 449            | 11 - 13 | 671 RSI | 791 RSI |
| TE        | 449            | 11 - 13 | 671 SI  | 791 SI  |
| FC        | 450            | 14 - 18 | 671 RSI | 791 RSI |
| FE        | 450            | 14 - 18 | 671 SI  | 791 SI  |
| FS        | 450            | 15 - 18 | 841 RS  | 791 RSI |
| SM        | 450 R          | 03 - 04 | 566 HF  | 675 HF  |
| SM        | 450 R          | 05      | 762 RS  | 675 RSI |
| SM        | 450 R          | 06 - 13 | 762 RS  | 791 RSI |
| SM        | 450 RR         | 06 - 10 | 762 RS  | 791 RSI |
| TC        | 450            | 02 - 03 | 671 RSI | 675 RSI |
| TC        | 450            | 04 - 10 | 671 RSI | 791 RSI |
| TE        | 450            | 02 - 10 | 671 SI  | 675 SI  |
| TE        | 450            | 14      | 671 SI  | 791 SI  |
| CR        | 500            | 83 - 84 | 2118    | 2116    |
| CR        | 500            | 86 - 87 | 519 SI  | 2117    |
| CX/CR     | 500            | 84 - 85 | 519 SI  | 2116    |
| TC        | 500            | 86      | 519 SI  | 2117    |
| WR/XC/AE  | 500            | 83 - 84 | 2118    | 2117    |
| XC        | 500            | 87 - 88 | 608 SI  | 2117    |
| FE        | 501            | 14 - 18 | 671 SI  | 791 SI  |
|           | 504            | 83      | 519 SI  | 2117    |
|           | 510            | 87 - 89 | 608 SI  | 2117    |
|           | 510            | 90      | 608 SI  | 586 SI  |
| SM        | 510 Centennial | 06      | 762 RS  | 791 RSI |
| SM        | 510 R          | 05      | 762 RS  | 675 RSI |
| SM        | 510 R          | 06 - 10 | 762 RS  | 791 RSI |
| TC        | 510            | 02 - 03 | 671 RSI | 675 RSI |
| TC        | 510            | 04 - 10 | 671 RSI | 791 RSI |
| TE        | 510            | 86 - 87 | 519 SI  | 2117    |

\* = 2 sets required / 2 jeux pour l'Avant.



**RECOMMENDED**

1xx = Scooter Pads  
5xx = Street, Off Road & Racing Pads  
2xxx = Brake Shoes



| HUSQVARNA |                     |         |         |         |  |
|-----------|---------------------|---------|---------|---------|--|
| TE        | 510                 | 02 - 10 | 671 SI  | 675 SI  |  |
| TE        | 510 Centennial      | 04 - 05 | 671 SI  | 675 SI  |  |
| SMR       | 511                 | 11 - 13 | 762 RS  | 791 RSI |  |
| TE        | 511                 | 11 - 14 | 671 SI  | 791 SI  |  |
|           | 570 Nox             | 01 - 03 | 706 HF  | 675 HF  |  |
| SM        | 570 R               | 01 - 08 | 566 HF  | 675 HF  |  |
| TC        | 570                 | 01 - 13 | 671 RSI | 675 RSI |  |
| TE        | 570                 | 01 - 13 | 671 SI  | 675 SI  |  |
| LT        | 610                 | 00 - 02 | 706 HF  | 675 HF  |  |
| SM        | 610 ie              | 07 - 10 | 762 RS  | 791 RSI |  |
| SM        | 610 Super Motard, S | 98 - 00 | 706 HF  | 675 HF  |  |
| TC        | 610                 | 96 - 13 | 671 RSI | 675 RSI |  |
| TC        | 610 Cross           | 91      | 608 SI  | 692 SI  |  |
| TE        | 610                 | 91 - 95 | 608 SI  | 692 SI  |  |
| TE        | 610 Rallye          | 96 - 13 | 671 RSI | 675 RSI |  |
| SM        | 630                 | 10      | 762 HS  | 791 HF  |  |
| SMR       | 630                 | 04 - 08 | 706 RS  | 675 RSI |  |
| TE        | 630                 | 10 - 13 | 671 HS  | 791 HF  |  |
| TE        | 630                 | 14      | 671 SI  | 791 SI  |  |
| STR       | 650 CRC             | 07      | 762 HF  | 791 HF  |  |
| TR        | 650 Strada          | 13      | 674 HS  | 675 LS  |  |
| TR        | 650 Terra           | 13      | 674 HS  | 675 LS  |  |
|           | 701 Svartpilen      | 18 -    | 706 HS  | 675 LS  |  |
|           | 701 Vitpilen        | 18 -    | 706 HS  | 675 LS  |  |
| FE        | 701 Enduro          | 17      | 674 HS  | 675 LS  |  |
| SM        | 701 Supermoto       | 15 - 18 | 762 HS  | 675 LS  |  |
|           | 900 Nuda            | 12 - 13 | 706 HS* | 675 LS  |  |
|           | 900 Nuda R, ABS     | 12 - 13 | 841 HS* | 675 LS  |  |

| HYOSUNG |                       |         |         |        |  |
|---------|-----------------------|---------|---------|--------|--|
|         | 50 Avanti             | 99 - 02 | 101 HF  |        |  |
|         | 50 Rush               | 97 - 01 | 101 HF  |        |  |
|         | 50 Sense              | 98 - 07 | 101 HF  |        |  |
|         | 50 Super Cab          | 95 - 98 | 101 HF  |        |  |
|         | 50 Super Cab Plus     | 98      | 101 HF  |        |  |
| SB      | 50                    | 00 - 03 | 101 HF  |        |  |
| SB      | 50 P                  | 00 - 03 | 101 HF  |        |  |
| SD      | 50                    | 00 - 06 | 101 HF  |        |  |
| SF      | 50                    | 99 - 06 | 101 HF  |        |  |
|         | 100 Cab               | 98 - 01 | 101 HF  |        |  |
| EZ      | 100                   | 00 - 05 | 101 HF  |        |  |
|         | 110 Midas Plus        | 98 - 04 | 101 HF  | 2015   |  |
| FX      | 110 110               | 02 - 04 | 101 HF  | 2015   |  |
| KR      | 110 Master            | 04 - 05 | 101 HF  | 2015   |  |
|         | 125 Aquila            | 00 - 04 | 611 HF  |        |  |
|         | 125 Boomer            | 03      | 123 CT  | 103 CT |  |
|         | 125 Cruise II         | 99 - 06 | 524 HF  |        |  |
|         | 125 Cruise II Classic | 99 - 06 | 524 HF  |        |  |
|         | 125 Cruiser           | 92 - 06 | 524 HF  |        |  |
|         | 125 Exceed            | 02 - 06 | 123 CT  | 103 CT |  |
|         | 125 GA-4              | 99      | 557 HF  |        |  |
|         | 125 Grand Prix        | 98 - 04 | 123 CT  |        |  |
|         | 125 Grand Prix Plus   | 02 - 05 | 551 HF  |        |  |
|         | 125 Hyper             | 99 - 09 | 123 CT  |        |  |
|         | 125 V2                | 99 - 11 | 627 HF  |        |  |
| GA      | 125                   | 98 - 06 | 524 HF  |        |  |
| GA      | 125 F                 | 00 - 06 | 524 HF  |        |  |
| GD      | 125 EXIV              | 12 - 16 | 734 HF  | 544 HF |  |
| GF      | 125                   | 98 - 04 | 524 HF  |        |  |
| GPS     | 125 D                 | 00 - 03 | 123 CT  |        |  |
| GS      | 125                   | 99      | 524 HF  |        |  |
| GT      | 125                   | 07 - 10 | 814 HF* | 814 HF |  |
| GT      | 125 Comet             | 02 - 03 | 551 HF  |        |  |
| GT      | 125 Comet             | 04 - 06 | 814 HF  | 814 HF |  |
| GT      | 125 Naked             | 13      | 814 HF* | 814 HF |  |
| GT      | 125 R Supersport      | 07 - 16 | 814 HF* | 814 HF |  |
| GV      | 125 Aquila            | 02 - 04 | 551 HF  |        |  |
| GV      | 125 Aquila            | 05 - 11 | 814 HF  |        |  |
| RT      | 125 Karion            | 02 - 06 | 551 HF  |        |  |
| RT      | 125 Karion            | 07 - 09 | 814 HF* | 814 HF |  |
| RX      | 125                   | 00 - 07 | 551 HF  |        |  |
| RX      | 125 SM                | 07 - 11 | 814 HF* | 814 HF |  |



**RECOMMENDED**

1xx = Scooter Pads  
5xx = Street, Off Road & Racing Pads  
2xxx = Brake Shoes



| HYOSUNG |                    |         |         |        |  |
|---------|--------------------|---------|---------|--------|--|
| TN      | 125                | 92 - 95 | 524 HF  |        |  |
| XRX     | 125                | 07 - 09 | 814 HF* | 814 HF |  |
| XRX     | 125 Offroad        | 99 - 06 | 551 HF  |        |  |
|         | 150 Exceed         | 02 - 04 | 123 CT  | 103 CT |  |
|         | 150 Grand Prix     | 98 - 01 | 123 CT  |        |  |
|         | 250 Aquila         | 00 - 09 | 627 HF  |        |  |
| GD      | 250 EXIV-R         | 15 - 17 | 734 HS  | 747 HF |  |
| GT      | 250 Comet          | 02      | 597 HS  | 556 LS |  |
| GT      | 250 Comet          | 03 - 08 | 814 HF  | 814 HF |  |
| GT      | 250 iR             | 13 - 14 | 814 HS* | 814 LS |  |
| GT      | 250 iR             | 15      | 734 HS* | 747 HF |  |
| GT      | 250 P              | 13      | 814 HF  | 814 HF |  |
| GT      | 250 R              | 07 - 12 | 814 HF* | 814 HF |  |
| GV      | 250                | 02 - 09 | 551 HF  | 2014   |  |
| GV      | 250                | 17 - 18 | 734 HS  | 638 HF |  |
| GA      | 300                | 98 - 01 | 557 HF  |        |  |
| GT      | 300 R              | 16 - 17 | 734 HS  | 747 HF |  |
| GV      | 300                | 16 - 17 | 734 HS  | 638 HF |  |
| TE      | 400                | 05 - 06 | 536 SI* | 649 SI |  |
| XRX     | 400                | 05 - 08 | 551 HF  | 604 HF |  |
| RX      | 450 SM             | 08 - 11 | 762 HS  | 675 LS |  |
| TE      | 450                | 07 - 11 | 536 SI* | 649 SI |  |
|         | 600 Comet          | 02      | 597 HS  | 556 LS |  |
|         | 600 Comet          | 03      | 551 HF* |        |  |
| GT      | 650                | 04 - 12 | 814 HS* | 814 LS |  |
| GT      | 650 i              | 13      | 734 HS* | 814 LS |  |
| GT      | 650 i Naked        | 15      | 734 HS* | 814 LS |  |
| GT      | 650 iR             | 13 - 14 | 734 HS* | 814 LS |  |
| GT      | 650 iR             | 15      | 734 HS* | 747 HF |  |
| GT      | 650 P              | 16      | 814 HS* | 814 LS |  |
| GT      | 650 R              | 05 - 13 | 814 HS* | 814 LS |  |
| GT      | 650 S              | 05 - 13 | 814 HS* | 814 LS |  |
| GT      | 650 TTC            | 07 - 11 | 814 HS* | 814 LS |  |
| GT      | 650 TTC /          |         |         |        |  |
|         | Custom Trendkiller | 07 - 11 | 814 HS* | 814 LS |  |
| GT      | 650 X              | 07 - 11 | 814 HS* | 814 LS |  |
| GV      | 650 Aquila         | 04 - 05 | 551 HF* | 769 HF |  |
| GV      | 650 Aquila         | 06 - 11 | 814 HS* | 814 LS |  |
| ST      | 700                | 11 - 13 | 734 HS  | 814 LS |  |
| ST      | 700 i Deluxe       | 13      | 734 HS  | 814 LS |  |

| INDIAN |                             |         |           |          |  |
|--------|-----------------------------|---------|-----------|----------|--|
|        | 1000 Scout Sixty            | 16      | 929 H.HS  | 930 H.LS |  |
|        | 1000 Scout Sixty            | 17 - 18 | 674 H.HS  | 675 H.LS |  |
|        | 1130 Scout                  | 01 - 08 | 678 H.HS  | 678 H.LS |  |
|        | 1130 Scout                  | 15 - 16 | 929 H.HS  | 930 H.LS |  |
|        | 1200 Scout                  | 17 - 18 | 674 H.HS  | 675 H.LS |  |
|        | 1200 Scout Bobber           | 17 - 18 | 674 H.HS  | 675 H.LS |  |
|        | 1700 Chief Blackhawk        | 11 - 13 | 566 H.HS* | 506 H.LS |  |
|        | 1700 Chief Bomber           | 10 - 13 | 566 H.HS* | 506 H.LS |  |
|        | 1700 Chief Classic          | 10 - 13 | 566 H.HS* | 506 H.LS |  |
|        | 1700 Chief Dark Horse       | 10 - 13 | 566 H.HS* | 506 H.LS |  |
|        | 1700 Chief Deluxe           | 09 - 13 | 566 H.HS* | 506 H.LS |  |
|        | 1700 Chief Roadmaster       | 09 - 13 | 566 H.HS* | 506 H.LS |  |
|        | 1700 Chief Standard         | 09 - 13 | 566 H.HS* | 506 H.LS |  |
|        | 1700 Chief Vintage          | 09 - 13 | 566 H.HS* | 506 H.LS |  |
|        | 1800 Chief                  | 01 - 08 | 678 H.HS  | 678 H.LS |  |
|        | 1800 Chief                  | 15 - 18 | 782 H.HS* | 630 H.LS |  |
|        | 1800 Chief Classic          | 14 - 18 | 782 H.HS* | 630 H.LS |  |
|        | 1800 Chief Dark Horse       | 15 - 18 | 782 H.HS* | 630 H.LS |  |
|        | 1800 Chief Vintage          | 14 - 18 | 782 H.HS* | 630 H.LS |  |
|        | 1800 Chieftain              | 14 - 18 | 782 H.HS* | 630 H.LS |  |
|        | 1800 Chieftain Classic      | 15 - 18 | 782 H.HS* | 630 H.LS |  |
|        | 1800 Chieftain Dark Horse   | 15 - 18 | 782 H.HS* | 630 H.LS |  |
|        | 1800 Chieftain Limited      | 15 - 18 | 782 H.HS* | 630 H.LS |  |
|        | 1800 Dark Horse             | 16 - 18 | 782 H.HS* | 630 H.LS |  |
|        | 1800 Roadmaster             | 15 - 18 | 782 H.HS* | 630 H.LS |  |
|        | 1800 Roadmaster Classic     | 15 - 18 | 782 H.HS* | 630 H.LS |  |
|        | 1800 Roadmaster Elite       | 15 - 18 | 782 H.HS* | 630 H.LS |  |
|        | 1800 Springfield            | 16 - 18 | 782 H.HS* | 630 H.LS |  |
|        | 1800 Springfield Dark Horse | 15 - 18 | 782 H.HS* | 630 H.LS |  |

\* = 2 sets required / 2 jeux pour l'Avant.

**RECOMMENDED**

1xx = Scooter Pads  
5xx = Street, Off Road & Racing Pads  
2xxx = Brake Shoes



| ITALJET     |                   |         |         |         |
|-------------|-------------------|---------|---------|---------|
| 50          | AJP Caliper       |         |         |         |
|             | incl. pin/spring  | 90 - 18 | 188 HF  |         |
| 50          | Bazooka           | 93 - 02 | 111 HF  |         |
| 50          | Cruise            | 95 - 97 | 111 HF  |         |
| 50          | Dragster          | 99 - 06 | 105 HF  | 105 HF  |
| 50          | Formula           | 94 - 00 | 117 HF  | 123 HF  |
| 50          | Formula Air       | 99 - 00 | 105 HF  |         |
| 50          | Formula L.C.      | 98 - 00 | 105 HF  | 105 HF  |
| 50          | Jet-Set           | 02 - 03 | 167 HF  |         |
| 50          | Pista 2           | 92 - 97 | 111 HF  |         |
| 50          | Pit Jet           | 07 - 09 | 211 HF  | 211 HF  |
| 50          | Rollercraft       | 08 - 12 | 200 HF  | 119 HF  |
| 50          | Scoop             | 93 - 97 | 111 HF  |         |
| 50          | Torpedo           | 98 - 99 | 105 HF  |         |
| 50          | Torpedo 4T        | 01 - 03 | 105 HF  |         |
| 50          | Yankee 8          | 94 - 02 | 111 HF  | 111 HF  |
| SM          | 50                | 02 - 05 | 148 HF  |         |
| SX1         | 50                | 08 - 10 | 141 HF  |         |
|             | 80 Formula        | 94 - 97 | 117 HF  | 123 HF  |
|             | 100 Millennium 2T | 01      | 101 HF  |         |
|             | 100 Millennium 2T | 01      | 167 HF  |         |
|             | 125 Amarcord      | 08 - 16 | 121 HF  |         |
|             | 125 Dragster      | 99 - 03 | 105 CT  | 105 CT  |
|             | 125 Formula       | 94 - 03 | 117 CT  | 123 CT  |
|             | 125 Formula L.C.  | 99 - 03 | 105 CT  | 105 CT  |
|             | 125 Jet-Set       | 02 - 03 | 167 CT  |         |
|             | 125 Jupiter       | 02 - 03 | 128 CT  | 105 CT  |
|             | 125 Millennium    | 00 - 03 | 101 CT  |         |
|             | 125 Millennium    | 00 - 03 | 167 CT  |         |
|             | 125 Pit Jet       | 07 - 09 | 211 HF  | 211 HF  |
|             | 125 Torpedo       | 99 - 06 | 105 CT  |         |
|             | 125 Torpedo       | 08 - 11 | 200 CT  | 119 CT  |
|             | 125 Twin          | 98 - 01 | 105 CT  | 105 CT  |
| SM          | 125               | 02 - 05 | 652 HF  |         |
|             | 150 Jet-Set       | 02 - 03 | 167 CT  |         |
|             | 150 Jupiter       | 02 - 03 | 128 CT  | 105 CT  |
|             | 150 Millennium    | 00 - 03 | 101 CT  |         |
|             | 150 Millennium    | 00 - 03 | 167 CT  |         |
|             | 150 Torpedo       | 08 - 12 | 200 CT  | 119 CT  |
|             | 150 Torpedo 4T    | 01      | 105 CT  |         |
|             | 180 Dragster      | 99 - 03 | 105 CT  | 105 CT  |
|             | 250 Jupiter       | 01 - 03 | 128 CT  | 173 CT  |
|             | 350               | 83      | 519 HF* |         |
|             | 650 Bazooka       | 06      | 814 HS* | 814 LS  |
|             | 650 Grifon        | 06 - 07 | 814 HS* | 814 LS  |
|             | 900 Grifon        | 00      | 566 HF  |         |
| J. J. COBAS |                   |         |         |         |
| TR1         | 250               | 85      | 566 HF  | 559 HF  |
| Trial       | 250               | 85      | 559 RSI |         |
| JAWA        |                   |         |         |         |
| CZ          | 125 2T            | 95 - 00 | 506 HF  |         |
| CZ          | 125 MX            | 95 - 00 | 506 HF  |         |
| CZ          | 180               | 92      | 506 HF  |         |
|             | 300 Trail         | 93      | 506 HF  |         |
|             | 350               | 93 - 95 | 699 HF  |         |
| JCM         |                   |         |         |         |
|             | 125 Europa        | 89      | 559 RSI | 559 RSI |
|             | 125 Oxygene       | 89      | 595 HF  |         |
|             | 125 SR            | 89      | 559 RSI | 559 RSI |
|             | 125 Week-End      | 89      | 595 HF  |         |
|             | 233 Vega          | 88      | 595 HF  | 574 HF  |
|             | 240 Enduro        | 91      | 595 HF  |         |
|             | 240 Europa        | 89      | 559 RSI | 559 RSI |
|             | 240 Oxygene       | 89      | 595 HF  |         |
|             | 240 SR            | 89      | 559 RSI | 559 RSI |
|             | 240 Week-End      | 89      | 595 HF  |         |
|             | 250 Trial         | 87      | 595 HF  |         |
|             | 250 Week-End      | 91      | 595 HF  |         |
|             | 325 Europa        | 89      | 559 RSI | 574 RSI |

**RECOMMENDED**

1xx = Scooter Pads  
5xx = Street, Off Road & Racing Pads  
2xxx = Brake Shoes



| JCM        |                                  |         |          |         |  |
|------------|----------------------------------|---------|----------|---------|--|
|            | 325 Oxygene                      | 89      | 595 HF   |         |  |
|            | 325 SR                           | 89      | 559 RSI  | 559 RSI |  |
|            | 325 Week-End                     | 89      | 595 HF   |         |  |
|            | 333 Vega                         | 87      | 595 HF   |         |  |
|            | 333 Vega                         | 88      | 595 HF   | 574 HF  |  |
| JIANSHE    |                                  |         |          |         |  |
| JS         | 125 3                            | 02      | 691 HF   |         |  |
| JINCHENG   |                                  |         |          |         |  |
| JC         | 125 2A/3A                        | 97      | 638 HF   |         |  |
| JC         | 125 2B                           | 97      | 690 HF   |         |  |
| JC         | 125 7B                           | 97      | 585 HF   |         |  |
| JC         | 150 T-D                          | 06 - 09 | 691 HF   |         |  |
| JC         | 250                              | 06 - 09 | 713 HF   |         |  |
| JOHN DEERE |                                  |         |          |         |  |
| HPX        | 350 Gator                        | 10 - 14 | 908 SI*  | 908 SI* |  |
|            | 500 Buck EX, EXT Left/Rear       | 05      | 754 SI   | 767 SI  |  |
|            | 500 Buck EX, EXT Right           | 05      | 767 SI   |         |  |
|            | 500 Buck Left/Rear               | 05      | 754 SI   | 767 SI  |  |
|            | 500 Buck Right                   | 05      | 767 SI   |         |  |
|            | 500 Trail Buck Left/Rear         | 05      | 754 SI   | 767 SI  |  |
|            | 500 Trail Buck Right             | 05      | 767 SI   |         |  |
| XUV        | 625 Gator                        | 11      | 912 ATS* |         |  |
|            | 650 Trail Buck EX, EXT Left/Rear | 05      | 754 SI   | 767 SI  |  |
|            | 650 Trail Buck EX, EXT Right     | 05      | 767 SI   |         |  |
|            | 650 Trail Buck Left/Rear         | 05      | 754 SI   | 767 SI  |  |
|            | 650 Trail Buck Right             | 05      | 767 SI   |         |  |
| XUV        | 825 Gator                        | 11      | 912 ATS* |         |  |
| XUV        | 855 D Gator                      | 11      | 912 ATS* |         |  |
| JOTAGAS    |                                  |         |          |         |  |
| JT         | 125                              | 14 - 18 | 939 RSI  | 803 RSI |  |
| JT         | 250                              | 14 - 18 | 939 RSI  | 803 RSI |  |
| JT         | 280                              | 14 - 18 | 939 RSI  | 803 RSI |  |
| JT         | 300                              | 14 - 18 | 939 RSI  | 803 RSI |  |
| KAWASAKI   |                                  |         |          |         |  |
| AE         | 50                               | 81 - 82 | 2015     | 2015    |  |
| AR         | 50                               | 81 - 82 | 544 HF   | 2015    |  |
| KMX        | 50                               | 88 - 93 | 544 HF   | 2015    |  |
| KSR        | 50 I (50)                        | 90 - 91 | 544 HF   | 544 HF  |  |
| KX         | 60                               | 83 - 03 | 2093     | 2093    |  |
| KX         | 65                               | 00 - 15 | 752 RSI  | 536 RSI |  |
| AE         | 80                               | 81 - 86 | 2015     | 2015    |  |
| AR         | 80                               | 81 - 82 | 544 HF   | 2015    |  |
| KD         | 80                               | 80 - 87 | 2015     | 2015    |  |
| KD         | 80                               | 88 - 90 | 544 HF   | 2015    |  |
| KMX        | 80                               | 87 - 92 | 548 HF   | 2015    |  |
| KSR        | 80 II (80)                       | 90 - 91 | 544 HF   | 544 HF  |  |
| KX         | 80                               | 79 - 82 | 2087     | 2087    |  |
| KX         | 80                               | 83      | 2092     | 2093    |  |
| KX         | 80                               | 84 - 87 | 544 SI   | 2093    |  |
| KX         | 80                               | 88 - 96 | 544 RSI  | 592 RSI |  |
| KX         | 80                               | 97 - 00 | 726 RSI  | 592 RSI |  |
| KX         | 85                               | 01 - 18 | 726 RSI  | 592 RSI |  |
| KX         | 85 II                            | 01 - 13 | 726 RSI  | 592 RSI |  |
| KH         | 90                               | 78 - 83 | 522 HF   |         |  |
| KC         | 100                              | 80 - 83 | 2015     | 2015    |  |
| KE         | 100                              | 79 - 97 | 2015     | 2015    |  |
| KH         | 100                              | 76 - 77 | 2015     | 2015    |  |
| KH         | 100                              | 78 - 81 | 2014     | 2015    |  |
| KH         | 100 EX                           | 88 - 93 | 546 HF   | 2014    |  |
| KH         | 100 EX, G                        | 81 - 82 | 522 HF   | 2015    |  |
| KH         | 100 GH                           | 83 - 87 | 546 HF   | 2015    |  |
| KM         | 100                              | 78 - 81 | 2015     | 2015    |  |
| KX         | 100                              | 88 - 96 | 544 RSI  | 592 RSI |  |
| KX         | 100                              | 97 - 18 | 726 RSI  | 592 RSI |  |
| KLF        | 110 Mojave                       | 87 - 88 | 2015     | 2183    |  |
| KLX        | 110                              | 02 - 18 | 2093     | 2015    |  |

\* = 2 sets required / 2 jeux pour l'Avant.

**RECOMMENDED**

1xx = Scooter Pads  
 5xx = Street, Off Road & Racing Pads  
 2xxx = Brake Shoes

**KAWASAKI**

|      |                   |         |         |         |
|------|-------------------|---------|---------|---------|
| AR   | 125               | 82 - 94 | 546 HF  | 2183    |
| BN   | 125 Eliminator    | 98 - 99 | 536 HF  | 2183    |
| BN   | 125 Eliminator A3 | 00 - 07 | 638 HF  | 2183    |
| J    | 125               | 15 - 18 | 183 CT  | 204 CT  |
| KDX  | 125               | 90 - 94 | 544 SI  | 632 SI  |
| KE   | 125               | 76 - 85 | 2039    | 2183    |
| KE   | 125               | 86 - 91 | 546 HF  | 2014    |
| KH   | 125               | 77 - 80 | 516 HF  | 2025    |
| KH   | 125               | 82 - 98 | 546 HF  | 2014    |
| KLX  | 125               | 10 - 14 | 611 HF  | 536 HF  |
| KLX  | 125 D-Tracker     | 10 - 14 | 611 HF  | 536 HF  |
| KMX  | 125               | 86      | 544 HF  | 586 HF  |
| KMX  | 125               | 87 - 02 | 548 HF  | 586 HF  |
| KX   | 125               | 74 - 81 | 2039    | 2183    |
| KX   | 125               | 82      | 544 SI  | 2183    |
| KX   | 125               | 83 - 85 | 546 SI  | 2025    |
| KX   | 125               | 86      | 546 RSI | 586 RSI |
| KX   | 125               | 87 - 88 | 602 HF  | 586 SI  |
| KX   | 125               | 89 - 93 | 611 RSI | 632 RSI |
| KX   | 125               | 94      | 694 RSI | 632 RSI |
| KX   | 125               | 95 - 08 | 694 RSI | 604 RSI |
| Z    | 125 Pro           | 17 - 18 | 925 HF  | 536 HF  |
| ZL   | 125 Eliminator    | 97 - 99 | 544 HF  |         |
| KLX  | 140 , L           | 08 - 18 | 611 SI  | 592 SI  |
| KLX  | 150 D-Tracker     | 16 - 18 | 611 HF  | 536 HF  |
| KLX  | 150 L             | 14 - 15 | 611 HF  | 536 HF  |
| KDX  | 175               | 80 - 82 | 2039    | 2183    |
| KE   | 175               | 76 - 78 | 2039    | 2183    |
| KE   | 175               | 79 - 83 | 2039    | 2056    |
| KLF  | 185 Bayou         | 85      |         | 2038    |
| KLF  | 185 Bayou         | 86 - 88 | 2040    | 2038    |
| KDX  | 200               | 83 - 85 | 2056    | 2025    |
| KDX  | 200               | 93      | 611 SI  | 632 SI  |
| KDX  | 200               | 94 - 99 | 694 SI  | 632 SI  |
| KDX  | 200 C             | 86 - 88 | 546 SI  | 2025    |
| KDX  | 200 SR            | 89 - 92 | 546 SI  | 632 SI  |
| KMX  | 200               | 88 - 90 | 544 HF  | 586 HF  |
| Z    | 200               | 77 - 81 | 516 HF  | 2014    |
| Z    | 200               | 83 - 85 | 546 HF  | 2014    |
| KDX  | 220 R             | 97 - 05 | 694 SI  | 632 SI  |
| KLF  | 220 Bayou         | 88 - 02 | 2040    | 2038    |
|      | 250 Estrella      | 92 - 99 | 546 HF  | 586 HF  |
| BR   | 250               | 86 - 90 | 557 HF  | 2038    |
| CS   | 250               | 86 - 90 | 557 HF  |         |
| EL   | 250               | 91 - 94 | 557 HF  | 2038    |
| EL   | 250               | 93 - 94 | 557 HS  | 2038    |
| EL   | 250 Eliminator    | 88 - 89 | 557 HF  | 2038    |
| EX   | 250 R Ninja       | 86 - 87 | 557 HF  | 557 HF  |
| EX   | 250 R Ninja       | 88 - 07 | 597 HF  | 615 HF  |
| EX   | 250 R Ninja       | 08 - 12 | 638 HF  | 638 HF  |
| EX   | 250 SL Ninja      | 15 - 17 | 638 HS  | 638 LS  |
| GPX  | 250 R             | 88 - 91 | 597 HF* | 615 HF  |
| GPZ  | 250               | 83 - 85 | 557 HF* | 2038    |
| GPZ  | 250 Belt Drive    | 83 - 84 | 546 HF  | 2038    |
| GPZ  | 250 R             | 86 - 87 | 557 HF  | 557 HF  |
| KDX  | 250               | 80 - 82 | 2040    | 2016    |
| KDX  | 250               | 83 - 84 | 2040    | 2183    |
| KDX  | 250 SR            | 91 - 94 | 611 SI  | 632 SI  |
| KH   | 250               | 76 - 80 | 510 HF  | 2088    |
| KL   | 250 (KLR 250)     | 85 - 97 | 546 HF  | 2056    |
| KL   | 250               | 78 - 80 | 2040    | 2016    |
| KL   | 250               | 80 - 84 | 2039    | 2056    |
| KL   | 250 Super Sherpa  | 00 - 02 | 726 SI  | 586 SI  |
| KLT  | 250 Prairie       | 83 - 85 | 2015    | 2040    |
| KLX  | 250               | 79 - 80 | 2039    | 2183    |
| KLX  | 250               | 93 - 96 | 694 SI  | 632 SI  |
| KLX  | 250               | 98 - 07 | 694 SI  | 604 SI  |
| KLX  | 250               | 14 - 16 | 611 HF  | 604 HF  |
| KLX  | 250 S             | 09 - 14 | 611 HF  | 604 HF  |
| KLX  | 250 SF            | 09 - 10 | 611 HF  | 604 HF  |
| KR   | 250               | 85      | 546 HF* | 557 HF  |
| KR-1 | 250 S             | 89      | 615 HF* | 615 HF  |

**RECOMMENDED**

1xx = Scooter Pads  
 5xx = Street, Off Road & Racing Pads  
 2xxx = Brake Shoes

**KAWASAKI**

|      |                       |         |         |         |
|------|-----------------------|---------|---------|---------|
| KR-1 | 250 S                 | 90      | 631 HF* | 615 HF  |
| KSF  | 250 Mojave            | 87 - 02 | 591 SI* | 592 SI  |
| KT   | 250 all models        | 75 - 80 | 2039    | 2183    |
| KX   | 250                   | 75 - 81 | 2040    | 2016    |
| KX   | 250                   | 82      | 544 SI  | 2183    |
| KX   | 250                   | 83 - 85 | 546 SI  | 2183    |
| KX   | 250                   | 86      | 546 RSI | 586 RSI |
| KX   | 250                   | 87 - 88 | 602 HF  | 586 SI  |
| KX   | 250                   | 89 - 93 | 611 RSI | 632 RSI |
| KX   | 250                   | 94      | 694 RSI | 632 RSI |
| KX   | 250                   | 95 - 08 | 694 RSI | 604 RSI |
| KXF  | 250 Tecate            | 87 - 88 | 591 SI* | 592 SI  |
| KX-F | 250                   | 04 - 10 | 694 RSI | 790 RSI |
| KX-F | 250 DFI               | 11 - 18 | 694 RSI | 790 RSI |
| KXT  | 250 Tecate            | 84      | 2040    | 544 HF  |
| KXT  | 250 Tecate            | 85 - 86 | 546 SI  | 586 SI  |
| KXT  | 250 Tecate            | 87 - 88 | 591 SI  | 592 SI  |
| LX   | 250 Eliminator, SE    | 90 - 95 | 557 HS  |         |
| SC   | 250 Epsilon           | 02 - 06 | 146 MS* | 174 MS  |
| Z    | 250                   | 78 - 80 | 510 HF  | 556 HF  |
| Z    | 250                   | 80 - 83 |         | 2038    |
| Z    | 250                   | 81 - 83 |         | 2183    |
| Z    | 250 Eliminator        | 88      | 557 HF  | 2183    |
| Z    | 250 J                 | 81 - 85 | 540 HF* | 556 HF  |
| Z    | 250 SL                | 15 - 17 | 638 HF  | 638 HF  |
| Z    | 250 T, Scorpion       | 89      | 546 HF  | 2038    |
| ZR   | 250 Balius            | 91 - 95 | 597 HF  | 586 HF  |
| ZXR  | 250                   | 90      | 615 HS* | 615 LS  |
| ZXR  | 250 R                 | 89      | 615 HS* | 615 LS  |
| ZZR  | 250                   | 90 - 01 | 597 HS  | 586 LS  |
| EL   | 252                   | 97 - 00 | 557 HS  | 2038    |
| EL   | 252                   | 01 - 03 | 611 HS  | 2038    |
| EX   | 300 R Ninja, ABS      | 13 - 17 | 638 HS  | 638 LS  |
| J    | 300                   | 14 - 18 | 183 MS  | 204 MS  |
| KAF  | 300 Mule 500          | 92 - 95 | 2053    |         |
| KAF  | 300 Mule 550          | 03 - 05 | 2053    |         |
| KEF  | 300 Lakota            | 95 - 04 | 591 SI* | 592 SI  |
| KLE  | 300 Versys-X          | 17 - 18 | 627 HS  | 638 LS  |
| KLF  | 300 A1, A2 Bayou      | 86 - 87 | 2054    | 2038    |
| KLF  | 300 Bayou             | 88 - 04 | 546 SI* | 2038    |
| KLF  | 300 Bayou Left/Rear   | 89 - 05 | 611 SI  | 2197    |
| KLF  | 300 Bayou Right       | 89 - 05 | 638 SI  |         |
| KLX  | 300 R                 | 97 - 07 | 694 SI  | 604 SI  |
| KVF  | 300 Brute Force       | 13 - 17 | 536 SI* | 810 SI  |
| Z    | 300                   | 15 - 16 | 638 HS  | 638 LS  |
| EX   | 305                   | 83      | 557 HF  | 2038    |
| GPZ  | 305                   | 81 - 96 | 546 HF* | 2038    |
| GPZ  | 305                   | 83 - 96 | 557 HF* | 2038    |
| Z    | 305                   | 81 - 82 | 540 HF  | 2038    |
| Z    | 305                   | 87 - 88 | 540 HF  |         |
| KLR  | 350                   | 85      | 546 HF  |         |
| S2A  | 350                   | 73      | 503 HF  | 2088    |
| KVF  | 360 Prairie 2x4, 4x4  | 03 - 08 | 536 SI* |         |
|      | 400 Eliminator        | 94 - 95 | 597 HS  | 557 LS  |
|      | 400 Ninja R Left/Rear | 11      | 705 HS  | 687 LS  |
|      | 400 Ninja R Right     | 11      | 704 HS  |         |
| EN   | 400 Twin              | 85 - 89 | 557 HF  | 2060    |
| EX-4 | 400                   | 95      | 597 HF  | 586 HF  |
| FX   | 400 R                 | 86 - 88 | 546 HF* | 557 HF  |
| GPX  | 400                   | 87      | 615 HF* | 597 HF  |
| GPZ  | 400                   | 83 - 84 | 539 HF* | 540 HF  |
| GPZ  | 400                   | 85 - 87 | 546 HF* | 557 HF  |
| GPZ  | 400 R                 | 89      | 615 HS* | 597 LS  |
| GPZ  | 400 S                 | 88 - 90 | 597 HF  | 2038    |
| KFX  | 400                   | 02 - 05 | 592 SI* | 649 SI  |
| KH   | 400                   | 76 - 78 | 510 HF  | 2088    |
| KLE  | 400                   | 91 - 94 | 597 HS  | 586 LS  |
| KLE  | 400 Vulcan            | 90      | 557 HS  |         |
| KLF  | 400 Bayou Left        | 93 - 99 | 611 SI  | 2197    |
| KLF  | 400 Bayou Right       | 93 - 99 | 638 SI  |         |
| KLX  | 400 R                 | 03 - 04 | 694 SI  | 604 SI  |
| KLX  | 400 SR                | 03 - 04 | 694 HF  | 604 HF  |

\* = 2 sets required / 2 jeux pour l'Avant.

Full compound selection, see under "Brake pad 1:1 Drawings" / Sélection complète de composés, voir "1:1 Schémas Plaquettes de frein".

**RECOMMENDED**
 1xx = Scooter Pads  
 5xx = Street, Off Road & Racing Pads  
 2xxx = Brake Shoes

| KAWASAKI |     |                    |         |
|----------|-----|--------------------|---------|
| KVF      | 400 | Prairie            | 97 - 98 |
| KVF      | 400 | Prairie 2x4        | 99 - 01 |
| KVF      | 400 | Prairie 4x4        | 99 - 02 |
| LX       | 400 | Eliminator, SE     | 90      |
| S3       | 400 |                    | 74 - 75 |
| S3A      | 400 |                    | 74 - 75 |
| Z        | 400 |                    | 78 - 79 |
| Z        | 400 |                    | 79      |
| Z        | 400 | C1                 | 80 - 85 |
| Z        | 400 | D, S               | 76 - 77 |
| Z        | 400 | Eliminator         | 88      |
| Z        | 400 | F                  | 84 - 86 |
| Z        | 400 | J                  | 80 - 85 |
| Z        | 400 | Ninja              | 18 -    |
| Z        | 400 | T (Belt Drive)     | 83 - 85 |
| ZR       | 400 | F                  | 83 - 84 |
| ZR       | 400 | Xanthus (ZR 400D1) | 92 - 95 |
| ZRX      | 400 |                    | 98 - 01 |
| ZX       | 400 |                    | 85      |
| ZX       | 400 |                    | 86 - 87 |
| ZX-4     | 400 |                    | 88 - 89 |
| ZX-4     | 400 |                    | 90      |
| ZXR      | 400 |                    | 89 - 90 |
| ZXR      | 400 |                    | 91 - 02 |
| ZZR      | 400 |                    | 90 - 94 |
| KX       | 420 |                    | 80 - 81 |
| Z        | 440 | C                  | 80 - 81 |
| Z        | 440 | C, Twin            | 81 - 83 |
| Z        | 440 | H                  | 82 - 83 |
| Z        | 440 | LTD                | 80 - 82 |
| Z        | 440 | LTD                | 83 - 84 |
| EN       | 450 |                    | 85 - 90 |
| KFX      | 450 | Left/Rear          | 07 - 15 |
| KFX      | 450 | Right              | 07 - 15 |
| KLX      | 450 | R                  | 07 - 12 |
| KX-F     | 450 |                    | 06 - 08 |
| KX-F     | 450 | DFI                | 09 - 18 |
| Z        | 450 | LTD                | 84 - 89 |
| EN       | 500 |                    | 90 - 96 |
| EN       | 500 |                    | 98 - 04 |
| EN       | 500 | Vulcan             | 96 - 97 |
| ER-5     | 500 |                    | 97 - 00 |
| ER-5     | 500 |                    | 01 - 07 |
| EX       | 500 |                    | 87 - 89 |
| EX       | 500 |                    | 90 - 93 |
| EX       | 500 |                    | 94 - 96 |
| EX       | 500 | Ninja              | 94 - 97 |
| GPX      | 500 | R (Austria)        | 88 - 93 |
| GPZ      | 500 |                    | 93 - 95 |
| GPZ      | 500 |                    | 95 - 96 |
| GPZ      | 500 |                    | 97 - 04 |
| GPZ      | 500 | R (Austria)        | 85 - 87 |
| GPZ      | 500 | S                  | 87      |
| GPZ      | 500 | S                  | 88      |
| GPZ      | 500 | S                  | 89 - 92 |
| GPZ      | 500 | S (Austria)        | 87 - 93 |
| GPZ      | 500 | S (Austria)        | 94 - 96 |
| GPZ      | 500 | S (Austria)        | 97 - 01 |
| KH       | 500 |                    | 76 - 79 |
| KH       | 500 | H1                 | 74 - 75 |
| KL       | 500 | Tengai (Austria)   | 89 - 91 |
| KLE      | 500 |                    | 91 - 07 |
| KLR      | 500 | (Austria)          | 87 - 88 |
| KX       | 500 |                    | 83 - 85 |
| KX       | 500 |                    | 86      |
| KX       | 500 |                    | 87 - 88 |
| KX       | 500 |                    | 89 - 93 |
| KX       | 500 |                    | 94 - 95 |
| KX       | 500 |                    | 96 - 04 |
| Z        | 500 |                    | 79 - 80 |
| Z        | 500 |                    | 81 - 83 |
| ZL       | 500 | (Austria)          | 85 - 90 |
| 536 SI*  |     |                    | 2197    |
| 536 SI*  |     |                    |         |
| 536 SI*  |     |                    |         |
| 546 HF*  |     |                    |         |
| 503 HF   |     |                    |         |
| 503 HF   |     |                    |         |
| 522 HF   |     |                    | 2038    |
| 510 HF   |     |                    | 2038    |
| 510 HF   |     |                    |         |
| 518 HF   |     |                    | 2038    |
| 557 HF   |     |                    | 557 HF  |
| 546 HF   |     |                    | 2038    |
| 539 HF*  |     |                    | 2060    |
| 638 HS*  |     |                    | 638 LS  |
| 539 HF   |     |                    | 2060    |
| 546 HF   |     |                    | 2038    |
| 615 HS*  |     |                    | 586 LS  |
| 743 HS   |     |                    |         |
| 546 HF   |     |                    | 557 HF  |
| 557 HF*  |     |                    | 557 HF  |
| 615 HF*  |     |                    | 515 HF  |
| 631 HS*  |     |                    | 556 LS  |
| 631 HF*  |     |                    | 556 HF  |
| 666 HS*  |     |                    | 556 LS  |
| 631 HS*  |     |                    | 597 LS  |
| 2040     |     |                    | 2016    |
| 510 HF   |     |                    | 2038    |
| 540 HF   |     |                    | 2038    |
| 539 HF   |     |                    | 540 HF  |
| 510 HF   |     |                    | 2038    |
| 540 HF   |     |                    | 2038    |
| 557 HF   |     |                    | 2060    |
| 801 SI   |     |                    | 592 SI  |
| 798 SI   |     |                    |         |
| 694 SI   |     |                    | 790 SI  |
| 694 RSI  |     |                    | 790 RSI |
| 694 RSI  |     |                    | 790 RSI |
| 557 HF   |     |                    | 2060    |
| 557 HS   |     |                    | 2060    |
| 557 HS   |     |                    | 2060    |
| 557 HS   |     |                    | 2060    |
| 597 HS   |     |                    | 2038    |
| 597 HS   |     |                    | 2038    |
| 597 HF   |     |                    | 2038    |
| 597 HS   |     |                    | 2038    |
| 615 HS   |     |                    | 586 LS  |
| 597 HS   |     |                    | 586 LS  |
| 597 HF*  |     |                    | 597 HF  |
| 631 HS   |     |                    | 2038    |
| 546 HF*  |     |                    | 586 HF  |
| 615 HS*  |     |                    | 586 LS  |
| 557 HF*  |     |                    | 557 HF  |
| 557 HF   |     |                    | 2038    |
| 546 HF   |     |                    | 2038    |
| 546 HS*  |     |                    | 557 LS  |
| 597 HF   |     |                    | 2038    |
| 615 HS   |     |                    | 586 LS  |
| 615 HS*  |     |                    | 586 LS  |
| 510 HF   |     |                    |         |
| 503 HF   |     |                    |         |
| 597 HS   |     |                    | 586 LS  |
| 597 HS   |     |                    | 586 LS  |
| 602 HF   |     |                    | 586 HF  |
| 546 SI   |     |                    | 2183    |
| 546 RSI  |     |                    | 586 RSI |
| 602 HF   |     |                    | 586 SI  |
| 611 RSI  |     |                    | 632 RSI |
| 694 RSI  |     |                    | 632 RSI |
| 694 RSI  |     |                    | 604 RSI |
| 510 HF*  |     |                    | 512 HF  |
| 539 HF   |     |                    | 540 HF  |
| 557 HF   |     |                    | 2060    |

**RECOMMENDED**
 1xx = Scooter Pads  
 5xx = Street, Off Road & Racing Pads  
 2xxx = Brake Shoes

| KAWASAKI |     |                        |         |
|----------|-----|------------------------|---------|
| ZR       | 500 | (Z 500 F)              | 83 - 87 |
| ZZR      | 500 | (Austria)              | 90 - 92 |
| ZZR      | 500 | (Austria)              | 93 - 98 |
| GPZ      | 550 |                        | 84 - 87 |
| GT       | 550 |                        | 85 - 01 |
| KX       | 550 | A                      | 83      |
| Z        | 550 |                        | 80 - 85 |
| Z        | 550 |                        | 80 - 85 |
| Z        | 550 |                        | 81 - 84 |
| Z        | 550 | C3, LTD                | 82 - 84 |
| Z        | 550 | E, LTD                 | 81 - 84 |
| Z        | 550 | F                      | 83 - 84 |
| Z        | 550 | F                      | 85 - 88 |
| Z        | 550 | GP                     | 81 - 83 |
| Z        | 550 | GT                     | 83 - 01 |
| Z        | 550 | GT, LTD                | 82 - 85 |
| Z        | 550 | LTD                    | 81 - 85 |
| Z        | 550 | M1, LTD                | 83 - 86 |
| ZR       | 550 | A1, GP                 | 83 - 84 |
| ZR       | 550 | Zephyr                 | 90 - 92 |
| ZR       | 550 | Zephyr                 | 93 - 99 |
| ZR       | 550 | Zephyr (D)             |         |
|          |     | from VIN B024010-      | 93 - 01 |
| ZX       | 550 |                        | 84 - 89 |
|          | 600 | R, Ninja               | 89 - 96 |
| GPX      | 600 | R                      | 88 - 93 |
| GPX      | 600 | R                      | 94 - 96 |
| GPZ      | 600 | R                      | 85 - 89 |
| GPZ      | 600 | R                      | 94      |
| KL       | 600 |                        | 84 - 86 |
| KLR      | 600 |                        | 84 - 86 |
| KLR      | 600 | E                      | 85 - 94 |
| Z        | 600 | GP                     | 83 - 89 |
| ZL       | 600 |                        | 85 - 91 |
| ZL       | 600 | B2 Eliminator          | 95 - 98 |
| ZX       | 600 | Ninja                  | 85 - 87 |
| ZX       | 600 | Ninja R                | 88 - 97 |
| ZX-6R    | 600 | (Ninja ZX6)            | 93 - 97 |
| ZX-6R    | 600 | (Ninja ZX6R)           | 95 - 97 |
| ZX-6R    | 600 | (ZX6)                  | 90 - 93 |
| ZX-6R    | 600 | Ninja                  | 98 - 01 |
| ZX-6R    | 600 | Ninja                  | 07 - 17 |
| ZX-6RR   | 600 | Ninja                  | 03 - 06 |
| ZZR      | 600 |                        | 90 - 92 |
| ZZR      | 600 |                        | 93 - 05 |
| ZX-6R    | 636 | Ninja                  | 02      |
| ZX-6R    | 636 | Ninja                  | 03 - 06 |
| ZX-6R    | 636 | Ninja                  | 13 - 16 |
| ZX-6R    | 636 | Ninja ABS              | 13 - 16 |
| EN       | 650 | Vulcan S               | 15 - 18 |
| EN       | 650 | Vulcan S Cafe          | 17 - 18 |
| EN       | 650 | Vulcan S SE            | 17 - 18 |
| ER-6f    | 650 | Left/Rear              | 06 - 16 |
| ER-6f    | 650 | Right                  | 06 - 16 |
| ER-6n    | 650 | Left/Rear              | 06 - 16 |
| ER-6n    | 650 | Right                  | 06 - 16 |
| EX       | 650 | Ninja ABS              | 17 - 18 |
| KLE      | 650 | Versys Left/Rear       | 07 - 14 |
| KLE      | 650 | Versys Right           | 07 - 14 |
| KLE      | 650 | Versys                 | 15 - 18 |
| KLE      | 650 | Versys LT              | 15 - 16 |
| KLR      | 650 |                        | 87 - 07 |
| KLR      | 650 |                        | 95 - 04 |
| KLR      | 650 |                        | 08 - 10 |
| KLR      | 650 | Tengai                 | 89 - 92 |
| KLX      | 650 |                        | 93 - 96 |
| KLX      | 650 | R                      | 93 - 95 |
| KLX      | 650 | R D1                   | 96      |
| KVF      | 650 | Brute Force 4x4 Left   | 05 - 11 |
| KVF      | 650 | Brute Force 4x4 Right  | 05 - 11 |
| KVF      | 650 | Brute Force 4x4i Left  | 05 - 11 |
| KVF      | 650 | Brute Force 4x4i Right | 05 - 11 |
| 546 HF   |     |                        | 2038    |
| 631 HS*  |     |                        | 597 LS  |
| 631 HS*  |     |                        | 687 LS  |
| 557 HF*  |     |                        | 557 HF  |
| 557 HF*  |     |                        | 2060    |
| 546 SI   |     |                        |         |
| 510 HF   |     |                        | 2060    |
| 539 HF   |     |                        | 2060    |
| 540 HF   |     |                        | 2060    |
| 540 HF   |     |                        | 2060    |
| 539 HF*  |     |                        | 540 HF  |
| 546 HF*  |     |                        | 2038    |
| 557 HF*  |     |                        | 2038    |
| 539 HF   |     |                        | 540 HF  |
| 546 HF*  |     |                        | 2038    |
| 557 HF*  |     |                        | 2038    |
| 539 HF   |     |                        | 2060    |
| 540 HF   |     |                        | 2060    |
| 540 HF   |     |                        | 2060    |
| 546 HF*  |     |                        | 2038    |
| 597 HS*  |     |                        | 615 LS  |
| 597 HS*  |     |                        | 687 LS  |
| 615 HS*  |     |                        | 687 LS  |
| 557 HF*  |     |                        | 557 HF  |
| 631 HF*  |     |                        | 556 HF  |
| 597 HF*  |     |                        | 597 HF  |
| 597 HS*  |     |                        | 597 LS  |
| 557 HF*  |     |                        | 557 HF  |
| 597 HS*  |     |                        | 597 LS  |
| 546 HF   |     |                        | 2183    |
| 546 HF   |     |                        | 2183    |
| 546 HF   |     |                        | 2183    |
| 557 HF*  |     |                        | 557 HF  |
| 597 HS*  |     |                        | 597 LS  |
| 631 HS*  |     |                        | 687 LS  |
| 631 HS*  |     |                        | 687 LS  |
| 631 HS*  |     |                        | 597 LS  |
| 686 HS*  |     |                        | 687 LS  |
| 838 HS*  |     |                        | 687 LS  |
| 788 HS*  |     |                        | 687 LS  |
| 631 HS*  |     |                        | 597 LS  |
| 631 HS*  |     |                        | 687 LS  |
| 686 HS*  |     |                        | 687 LS  |
| 788 HS*  |     |                        | 687 LS  |
| 894 HS*  |     |                        | 834 LS  |
| 894 HS*  |     |                        | 834 LS  |
| 735 HS   |     |                        | 657 LS  |
| 735 HS   |     |                        | 657 LS  |
| 735 HS   |     |                        | 657 LS  |
| 705 HS   |     |                        | 687 LS  |
| 704 HS   |     |                        |         |
| 705 HS   |     |                        | 687 LS  |
| 704 HS   |     |                        |         |
| 735 HS   |     |                        | 657 LS  |
| 705 HS   |     |                        | 687 LS  |
| 705 HS   |     |                        | 687 LS  |
| 735 HS   |     |                        | 657 LS  |
| 705 HS   |     |                        | 687 LS  |
| 704 HS   |     |                        |         |
| 627 HS*  |     |                        | 881 LS  |
| 627 HS*  |     |                        | 881 LS  |
| 602 HF   |     |                        | 586 SI  |
| 705 HS   |     |                        | 586 LS  |
| 611 HS   |     |                        | 638 LS  |
| 597 HS   |     |                        | 586 LS  |
| 694 SI   |     |                        | 632 SI  |
| 694 SI   |     |                        | 632 SI  |
| 694 SI   |     |                        | 604 SI  |
| 801 SI   |     |                        |         |
| 798 SI   |     |                        |         |
| 611 SI   |     |                        |         |
| 638 SI   |     |                        |         |

\* = 2 sets required / 2 jeux pour l'Avant.





**RECOMMENDED**

1xx = Scooter Pads  
 5xx = Street, Off Road & Racing Pads  
 2xxx = Brake Shoes



| KAWASAKI |     |                        |         |         |        |
|----------|-----|------------------------|---------|---------|--------|
| KVF      | 650 | Prairie Left           | 01 - 03 | 801 SI  |        |
| KVF      | 650 | Prairie Right          | 01 - 03 | 798 SI  |        |
| W        | 650 |                        | 99 - 05 | 704 HF  | 2038   |
| Z        | 650 |                        | 77 - 79 | 510 HF* | 2060   |
| Z        | 650 |                        | 78 - 79 | 510 HF* | 514 HF |
| Z        | 650 |                        | 78 - 82 | 510 HF* | 512 HF |
| Z        | 650 |                        | 80      | 510 HF  | 2060   |
| Z        | 650 |                        | 81 - 84 | 539 HF  | 2060   |
| Z        | 650 | ABS                    | 17 - 18 | 627 HS* | 657 LS |
| Z        | 650 | CSR                    | 81 - 82 | 540 HF  |        |
| Z        | 650 | F                      | 81 - 84 | 539 HF* | 2060   |
| KFX      | 700 | V-Force Left           | 04 - 13 | 801 SI  |        |
| KFX      | 700 | V-Force Right          | 04 - 13 | 798 SI  |        |
| KSV      | 700 | V-Force Left           | 04 - 11 | 801 SI  |        |
| KSV      | 700 | V-Force Right          | 04 - 11 | 798 SI  |        |
| KVF      | 700 | Prairie Left           | 04 - 13 | 801 SI  |        |
| KVF      | 700 | Prairie Right          | 04 - 13 | 798 SI  |        |
| VN       | 700 | Vulcan                 | 85      | 557 HF* | 2060   |
| Z        | 700 |                        | 83 - 88 | 539 HF* | 540 HF |
| ZN       | 700 |                        | 84 - 89 | 557 HF* | 557 HF |
|          | 750 | Vulcan                 | 93 - 94 | 557 HF  | 2060   |
| GPX      | 750 | R                      | 87 - 89 | 597 HF* | 597 HF |
| GPZ      | 750 |                        | 82      | 539 HF  | 540 HF |
| GPZ      | 750 |                        | 83 - 87 | 557 HF* | 557 HF |
| GPZ      | 750 | R                      | 85 - 86 | 557 HF* | 557 HF |
| GPZ      | 750 | T                      | 83 - 85 | 557 HF* | 557 HF |
| GT       | 750 |                        | 86 - 91 | 557 HF* | 557 HF |
| KRF      | 750 | Teryx 4x4 Left         | 08 - 13 | 611 SI  |        |
| KRF      | 750 | Teryx 4x4 Right        | 08 - 13 | 638 SI  |        |
| KVF      | 750 | Brute Force 4x4i Left  | 05 - 15 | 611 SI  |        |
| KVF      | 750 | Brute Force 4x4i Right | 05 - 15 | 638 SI  |        |
| VN       | 750 | Vulcan                 | 86 - 94 | 557 HF* | 2060   |
| VZ       | 750 | Twin                   | 88      | 557 HF  | 2060   |
| Z        | 750 | , ABS                  | 07 - 12 | 627 HS* | 657 LS |
| Z        | 750 |                        | 83      | 557 HF* | 2060   |
| Z        | 750 |                        | 83 - 86 | 540 HF* | 540 HF |
| Z        | 750 |                        | 84 - 86 | 539 HF* | 540 HF |
| Z        | 750 | B                      | 76 - 79 | 510 HF  | 514 HF |
| Z        | 750 | E                      | 80 - 81 | 539 HF* | 540 HF |
| Z        | 750 | Eliminator             | 88      | 557 HF* | 557 HF |
| Z        | 750 | GT                     | 82 - 85 | 539 HF* | 540 HF |
| Z        | 750 | H                      | 72 - 75 | 503 HF  | 2091   |
| Z        | 750 | L                      | 80 - 83 | 539 HF* | 540 HF |
| Z        | 750 | L                      | 84 - 87 | 540 HF* | 540 HF |
| Z        | 750 | Left/Rear              | 04 - 06 | 705 HS  | 687 LS |
| Z        | 750 | LTD                    | 80      | 510 HF* | 2060   |
| Z        | 750 | LTD                    | 80 - 81 | 539 HF* | 540 HF |
| Z        | 750 | LTD Belt Drive         | 83 - 85 | 539 HF* | 540 HF |
| Z        | 750 | LTD Twin               | 82      | 539 HF* | 540 HF |
| Z        | 750 | LTD Twin               | 83 - 85 | 557 HF  | 557 HF |
| Z        | 750 | M1                     | 82 - 85 | 540 HF  | 2060   |
| Z        | 750 | N, LTD                 | 82 - 85 | 539 HF* | 540 HF |
| Z        | 750 | R                      | 11 - 12 | 838 HS* | 881 LS |
| Z        | 750 | R1                     | 82      | 540 HF* | 540 HF |
| Z        | 750 | Right                  | 04 - 06 | 704 HS  |        |
| Z        | 750 | S Left/Rear            | 05 - 06 | 705 HS  | 687 LS |
| Z        | 750 | S Right                | 05 - 06 | 704 HS  |        |
| Z        | 750 | Sp.                    | 83 - 84 | 539 HF* | 540 HF |
| Z        | 750 | Turbo                  | 84 - 86 | 557 HF* | 557 HF |
| ZR       | 750 | Zephyr                 | 91 - 95 | 597 HS* | 597 LS |
| ZR       | 750 | Zephyr Left/Rear       | 96 - 97 | 705 HS  | 597 LS |
| ZR       | 750 | Zephyr Right           | 96 - 98 | 704 HS  |        |
| ZR-7     | 750 | Left/Rear              | 99 - 04 | 705 HS  | 704 LS |
| ZR-7     | 750 | Right                  | 99 - 04 | 704 HS  |        |
| ZR-7S    | 750 | Left/Rear              | 01 - 04 | 705 HS  | 704 LS |
| ZR-7S    | 750 | Right                  | 01 - 04 | 704 HS  |        |
| ZX       | 750 | E, GP                  | 83 - 85 | 557 HF* | 557 HF |
| ZX-7R    | 750 | Ninja                  | 89 - 95 | 631 HS* | 556 LS |
| ZX-7R    | 750 | Ninja                  | 96 - 03 | 686 HS* | 556 LS |
| ZX-7RR   | 750 | Ninja                  | 96 - 02 | 676 HS* | 715 LS |
| ZXR      | 750 | R                      | 89 - 95 | 631 HS* | 556 LS |
|          | 800 | Mule Pro FX Left       | 15 - 17 | 611 SI  |        |



**RECOMMENDED**

1xx = Scooter Pads  
 5xx = Street, Off Road & Racing Pads  
 2xxx = Brake Shoes



| KAWASAKI |      |                         |         |         |        |
|----------|------|-------------------------|---------|---------|--------|
|          | 800  | Mule Pro FX Right       | 15 - 17 | 638 SI  |        |
| KRF      | 800  | Teryx BEF/CEF/DEF Left  | 14 - 17 | 611 SI  |        |
| KRF      | 800  | Teryx BEF/CEF/DEF Right | 14 - 17 | 638 SI  |        |
| KRT      | 800  | Teryx 4 BEF/CEF/DEF     |         |         |        |
|          |      | Left                    | 14 - 17 | 611 SI  |        |
| KRT      | 800  | Teryx 4 BEF/CEF/DEF     |         |         |        |
|          |      | Right                   | 14 - 17 | 638 SI  |        |
| VN       | 800  | Classic                 | 98 - 99 | 705 HS  | 2060   |
| VN       | 800  | Drifter                 | 99 - 02 | 705 HS  | 704 LS |
| VN       | 800  | Vulcan, Classic         | 95 - 97 | 557 HS  | 2060   |
| W        | 800  |                         | 11 - 16 | 704 HS  |        |
| Z        | 800  |                         | 13 - 16 | 782 HS* | 881 LS |
| Z        | 800  | ABS                     | 13 - 16 | 782 HS* | 881 LS |
| Z        | 800  | e                       | 13 - 16 | 627 HS* | 881 LS |
| Z        | 800  | e ABS                   | 13 - 16 | 782 HS* | 881 LS |
| GPZ      | 900  | R                       | 84 - 89 | 557 HF* | 557 HF |
| GPZ      | 900  | R                       | 90 - 96 | 631 HS* | 597 LS |
| VN       | 900  | Classic                 | 06 - 16 | 705 HS  | 886 LS |
| VN       | 900  | Classic SE              | 11 - 16 | 705 HS  | 886 LS |
| VN       | 900  | Custom                  | 07 - 16 | 705 HS  | 886 LS |
| Z        | 900  |                         | 17 - 18 | 782 HS* | 881 LS |
| Z        | 900  | A                       | 76 - 77 | 510 HF* | 2091   |
| Z        | 900  | RS                      | 18 -    | 806 HS* | 657 LS |
| Z        | 900  | RS Cafe                 | 18 -    | 806 HS* | 657 LS |
| Z1       | 900  | Z1 A, Z1 B              | 73 - 75 | 503 HF  | 2091   |
| ZL       | 900  | Eliminator              | 85 - 86 | 557 HF* | 557 HF |
| ZX       | 900  |                         | 83 - 84 | 557 HF* | 557 HF |
| ZX-9R    | 900  | Ninja                   | 94 - 95 | 631 HS* | 687 LS |
| ZX-9R    | 900  | Ninja                   | 96 - 01 | 686 HS* | 687 LS |
| ZX-9R    | 900  | Ninja                   | 02 - 03 | 782 HS* | 687 LS |
| GPZ      | 1000 | RX                      | 86 - 88 | 557 HS* | 557 LS |
| GTR      | 1000 |                         | 86 - 93 | 557 HS* | 557 LS |
| GTR      | 1000 |                         | 94 - 06 | 597 HS* | 557 LS |
| KLE      | 1000 | Versys                  | 12 - 18 | 631 SP* | 657 LS |
| KLE      | 1000 | Versys ABS              | 15 - 16 | 631 SP* | 657 LS |
| KLE      | 1000 | Versys LT               | 15 - 16 | 631 SP* | 657 LS |
| KLK      | 1000 | Left/Rear               | 04 - 07 | 705 HS  | 657 LS |
| KLK      | 1000 | Right                   | 04 - 07 | 704 HS  |        |
| KZ       | 1000 |                         | 87 - 01 | 539 HF* | 540 HF |
| Z        | 1000 |                         | 10 - 16 | 806 HS* | 687 LS |
| Z        | 1000 | ABS                     | 15 - 18 | 806 HS* | 687 LS |
| Z        | 1000 |                         | 76 - 81 | 510 HF* | 512 HF |
| Z        | 1000 |                         | 03 - 06 | 782 HS* | 687 LS |
| Z        | 1000 |                         | 07 - 09 | 838 HS* | 657 LS |
| Z        | 1000 | F1                      | 80 - 82 | 539 HF* | 512 HF |
| Z        | 1000 | GL                      | 80 - 82 | 510 HF* | 512 HF |
| Z        | 1000 | H1                      | 80 - 83 | 510 HF* | 512 HF |
| Z        | 1000 | J                       | 79 - 83 | 539 HF* | 540 HF |
| Z        | 1000 | K, M, CSR               | 81 - 84 | 539 HF* | 540 HF |
| Z        | 1000 | LTD                     | 77 - 79 | 510 HF* | 514 HF |
| Z        | 1000 | LTD                     | 81 - 84 | 539 HF* | 540 HF |
| Z        | 1000 | MKII                    | 79 - 80 | 539 HF* | 512 HF |
| Z        | 1000 | Police                  | 82 - 84 | 539 HF* | 540 HF |
| Z        | 1000 | R                       | 78 - 79 | 510 HF* | 512 HF |
| Z        | 1000 | R                       | 17 - 18 | 841 HS* | 687 LS |
| Z        | 1000 | R Ninja                 | 86 - 88 | 557 HF* | 557 HF |
| Z        | 1000 | RE1, R2                 | 82 - 84 | 540 HF* | 540 HF |
| Z        | 1000 | SE                      | 14 - 16 | 806 HS* | 687 LS |
| Z        | 1000 | ST                      | 79 - 81 | 539 HF* | 512 HF |
| Z        | 1000 | SX                      | 11 - 18 | 806 HS* | 687 LS |
| ZL       | 1000 |                         | 86 - 87 | 557 HF* | 557 HF |
| ZX       | 1000 | H2 Carbon Ninja         | 17 - 18 | 841 SP* | 730 LS |
| ZX       | 1000 | H2 Ninja                | 15 - 18 | 841 SP* | 730 LS |
| ZX       | 1000 | H2 SX                   | 18 -    | 806 HS* |        |
| ZX       | 1000 | H2R Ninja               | 15 - 18 | 841 SP* | 730 LS |
| ZX-10    | 1000 |                         | 88 - 90 | 597 HS* | 597 LS |
| ZX-10R   | 1000 | Ninja                   | 04 - 07 | 788 HS* | 687 LS |
| ZX-10R   | 1000 | Ninja                   | 08 - 10 | 806 SP* | 687 LS |
| ZX-10R   | 1000 | Ninja                   | 11 - 15 | 806 SP* | 834 LS |
| ZX-10R   | 1000 | Ninja                   | 16 - 18 | 841 SP* | 834 LS |
| ZX-10R   | 1000 | Ninja ABS               | 12 - 15 | 806 SP* | 834 LS |
| ZX-10R   | 1000 | Ninja SE                | 18 -    | 841 SP* | 834 LS |

\* = 2 sets required / 2 jeux pour l'Avant.

Full compound selection, see under "Brake pad 1:1 Drawings" / Sélection complète de composés, voir "1:1 Schémas Plaquettes de frein".

**RECOMMENDED**

1xx = Scooter Pads  
5xx = Street, Off Road & Racing Pads  
2xxx = Brake Shoes



**RECOMMENDED**

1xx = Scooter Pads  
5xx = Street, Off Road & Racing Pads  
2xxx = Brake Shoes



| KAWASAKI |                                     |         |         |        |
|----------|-------------------------------------|---------|---------|--------|
| ZX-10RR  | 1000 Ninja                          | 17 - 18 | 841 SP* | 834 LS |
|          | 1100 Zephyr Left/Rear               | 97 - 02 | 705 HS  | 597 LS |
|          | 1100 Zephyr Right                   | 97 - 02 | 704 HS  |        |
| GPZ      | 1100 (ZX 1100) Left/Rear            | 95 - 99 | 705 HS  | 687 LS |
| GPZ      | 1100 (ZX 1100) Right                | 95 - 99 | 704 HS  |        |
| GPZ      | 1100                                | 81 - 82 | 539 HF* | 540 HF |
| GPZ      | 1100                                | 83 - 86 | 557 HF* | 557 HF |
| GPZ      | 1100 ABS, Horizont<br>Left/Rear     | 97 - 99 | 705 HS  | 687 LS |
| GPZ      | 1100 ABS, Horizont Right            | 97 - 99 | 704 HS  |        |
| Z        | 1100 GP                             | 81      | 539 HF  | 540 HF |
| Z        | 1100 GP                             | 82      | 540 HF  | 540 HF |
| Z        | 1100 GP                             | 83 - 86 | 557 HF* | 557 HF |
| Z        | 1100 L1, LTD                        | 83      | 539 HF* | 540 HF |
| Z        | 1100 LTD                            | 85 - 87 | 557 HF* | 557 HF |
| Z        | 1100 R, LTD                         | 84      | 557 HF* | 557 HF |
| Z        | 1100 Spectre                        | 82 - 83 | 539 HF* | 540 HF |
| Z        | 1100 ST                             | 81 - 83 | 539 HF  | 512 HF |
| ZN       | 1100 LTD                            | 84      | 557 HF* | 557 HF |
| ZR       | 1100 Zephyr                         | 92 - 95 | 631 HS* | 597 LS |
| ZRX      | 1100                                | 96 - 00 | 686 HS* | 556 LS |
| ZX       | 1100                                | 93 - 97 | 631 HS* | 556 LS |
| ZX       | 1100 GP                             | 83      | 557 HF* | 557 HF |
| ZZR      | 1100                                | 90 - 93 | 631 HS* | 597 LS |
| ZZR      | 1100                                | 94 - 01 | 631 HS* | 556 LS |
| ZG       | 1200 Voyager XII                    | 86 - 93 | 557 HS* | 557 LS |
| ZRX      | 1200                                | 01 - 04 | 686 HS* | 556 LS |
| ZRX      | 1200 R                              | 01 - 08 | 686 HS* | 556 LS |
| ZRX      | 1200 S                              | 01 - 07 | 686 HS* | 556 LS |
| ZX-12R   | 1200 Ninja                          | 00 - 03 | 686 HS* | 556 LS |
| ZX-12R   | 1200 Ninja                          | 04 - 06 | 788 HS* | 556 LS |
| ZZR      | 1200                                | 02 - 04 | 631 HS* | 556 LS |
| Z        | 1300 , Sports                       | 79 - 83 | 539 HF* | 540 HF |
| Z        | 1300                                | 79 - 81 | 530 HF* | 512 HF |
| Z        | 1300                                | 85      | 557 HF* | 557 HF |
| Z        | 1300 DF1                            | 84      | 530 HF* | 512 HF |
| ZN       | 1300                                | 83 - 84 | 557 HF* | 557 HF |
| ZN       | 1300 Voy.                           | 85 - 86 | 557 HF* | 557 HF |
| GTR      | 1400                                | 07 - 16 | 838 HS* | 715 LS |
| GTR      | 1400 ABS                            | 07 - 16 | 838 HS* | 715 LS |
| ZZR      | 1400                                | 06 - 14 | 838 HS* | 715 LS |
| ZZR      | 1400 ABS                            | 06 - 14 | 838 HS* | 715 LS |
| ZZR      | 1400 Performance Sport              | 17 - 18 | 901 HS* | 715 LS |
| ZZR      | 1400 SE                             | 16 - 18 | 901 HS* | 715 LS |
| VN       | 1500 Classic                        | 97 - 04 | 705 HS  | 557 LS |
| VN       | 1500 Classic Fi                     | 00 - 04 | 705 HS  | 886 LS |
| VN       | 1500 Classic Tourer Fi<br>Left/Rear | 00 - 04 | 705 HS  | 886 LS |
| VN       | 1500 Classic Tourer Fi Right        | 00 - 04 | 704 HS  |        |
| VN       | 1500 Classic Tourer<br>Left/Rear    | 98 - 01 | 705 HS  | 557 LS |
| VN       | 1500 Classic Tourer Right           | 98 - 01 | 704 HS  |        |
| VN       | 1500 Drifter                        | 99 - 02 | 705 HS  | 704 LS |
| VN       | 1500 Mean Streak                    | 02 - 03 | 686 HS  | 886 LS |
| VN       | 1500 Sumo                           | 88 - 92 | 557 HF* | 557 HF |
| VN       | 1500 Vulcan                         | 87 - 92 | 557 HS  | 557 LS |
| VN       | 1500 Vulcan, SE                     | 87 - 92 | 557 HS  | 557 LS |
| VN       | 1600 Classic Left/Rear              | 03 - 08 | 705 HS  | 886 LS |
| VN       | 1600 Classic Right                  | 03 - 08 | 704 HS  |        |
| VN       | 1600 Mean Streak                    | 04      | 686 HS* | 886 LS |
| VN       | 1600 Mean Streak                    | 05      | 788 HS* | 886 LS |
| VN       | 1700 Classic Left/Rear              | 09 - 14 | 705 HS  | 886 LS |
| VN       | 1700 Classic Right                  | 09 - 14 | 704 HS  |        |
| VN       | 1700 Classic Tourer<br>Left/Rear    | 09 - 14 | 705 HS  | 886 LS |
| VN       | 1700 Classic Tourer Right           | 09 - 14 | 704 HS  |        |
| VN       | 1700 Voyager                        | 09 - 16 | 631 HS* | 886 LS |
| VN       | 2000                                | 04 - 10 | 631 HS* | 886 LS |
| KEEWAY   |                                     |         |         |        |
|          | 50 Flash                            | 07 - 12 | 101 HF  | 2028   |
|          | 50 Flash Electric                   | 10 - 12 | 141 HF  | 2028   |

| KEEWAY   |                                   |               |                   |                   |
|----------|-----------------------------------|---------------|-------------------|-------------------|
|          | 50 Focus                          | 06 - 15       | 141 HF            |                   |
|          | 50 Hurricane                      | 06 - 16       | 101 HF            | 2028              |
|          | 50 Matrix                         | 06 - 15       | 141 HF            | 2028              |
|          | 50 Matrix Electric                | 10 - 15       | 141 HF            |                   |
|          | 50 Matrix Racing Sport            | 10 - 16       | 141 HF            |                   |
| F-NKD    | 50                                | 10 - 11       | 141 HF            | 2028              |
| RY8      | 50                                | 07 - 09       | 141 HF            | 2028              |
| RY8      | 50                                | 10 - 16       | 141 HF            | 200 HF            |
| TX       | 50 SM                             | 10 - 12       | 173 HF            |                   |
|          | 90 Hurricane                      | 06 - 09       | 101 HF            |                   |
|          | 100 Partner                       | 06 - 10       | 119 HF            |                   |
|          | 110 Partner                       | 06 - 07       | 119 HF            |                   |
|          | 125 Arn                           | 06 - 08       | 123 CT            |                   |
|          | 125 Enduro                        | 07 - 08       | 774 HF            | 519 HF            |
|          | 125 Focus                         | 06 - 08       | 141 CT            |                   |
|          | 125 Matrix                        | 06 - 08       | 141 CT            |                   |
|          | 125 Matrix Racing Sport           | 10 - 16       | 141 CT            |                   |
|          | 125 Speed                         | 06 - 12       | 132 CT            | 119 CT            |
|          | 125 Superlight                    | 06 - 16       | 713 HF            |                   |
|          | 125 X-Ray                         | 07 - 08       | 774 HF            | 519 HF            |
| TX       | 125 SM                            | 10 - 16       | 780 HF            |                   |
|          | 150 Arn                           | 06 - 08       | 123 CT            |                   |
|          | 150 Focus                         | 06 - 09       | 141 CT            |                   |
|          | 150 Matrix                        | 06 - 08       | 141 CT            |                   |
|          | 150 Matrix Racing Sport           | 10 - 12       | 141 CT            |                   |
|          | 150 Speed                         | 06 - 09       | 132 CT            | 119 CT            |
|          | 150 Superlight                    | 06 - 16       | 713 HF            |                   |
|          | 250 Land Cruiser                  | 06 - 14       | 713 HF            |                   |
|          | 250 Supershadow                   | 06 - 09       | 691 HF            |                   |
| KOTIR    |                                   |               |                   |                   |
| RS       | 50                                | 90            | 2028              | 2028              |
| KRAM-IT  |                                   |               |                   |                   |
|          | 50 Scrambler                      | 90            |                   | 692 HF            |
| ER       | 125                               | 89 - 93       | 608 SI            | 692 SI            |
|          | 250 SMR                           | 00            |                   | 675 RSI           |
| GS       | 250                               | 97 - 00       | 671 SI            | 675 SI            |
| MC       | 250                               | 89            | 608 SI            | 692 SI            |
| MX       | 250                               | 97 - 00       | 671 SI            | 675 SI            |
| SM       | 250                               | 97 - 00       | 671 SI            | 675 SI            |
| ER       | 300                               | 89            | 608 SI            | 692 SI            |
| KREIDLER |                                   |               |                   |                   |
|          | 50 Florett                        | 81 - 82       | 524 HF            |                   |
|          | 50 Florett                        | 99 - 06       | 102 HF            | 2028              |
|          | 50 Florett XL                     | 99 - 06       | 102 HF            |                   |
|          | 125 Enduro                        | 07 - 08       | 713 HF            |                   |
|          | 125 Florett D                     | 07 - 08       | 638 HF            |                   |
|          | 125 Florett RMC-F                 | 07 - 08       | 638 HF            |                   |
|          | 125 Mustang                       | 83 - 87       | 560 HF            | 519 HF            |
|          | 125 Supermoto                     | 07 - 08       | 713 HF            |                   |
|          | 200 Enduro                        | 07 - 08       | 713 HF            |                   |
| KTM      |                                   |               |                   |                   |
|          | Freeride Electric<br>most models  | 12 - 14<br>94 | 885 RSI<br>671 SI | 872 RSI<br>675 SI |
| E-SM     | Freeride                          | 15 - 16       | 885 RSI           | 872 RSI           |
| E-SX     | Freeride                          | 15 - 16       | 885 RSI           | 872 RSI           |
| E-XC     | Freeride                          | 15 - 18       | 885 RSI           | 872 RSI           |
| MX       | 125 - 600 ccm.                    | 91            | 546 SI            | 586 SI            |
|          | 40 Comet                          | 91 - 95       | 2120              | 2120              |
|          | 50 Comet PL, TS, RLW,<br>RS, RS4L | 86 - 91       | 138 HF            |                   |
| GO       | 50                                | 94 - 97       | 109 HF            | 2012              |
| GP       | 50 DXL, RS1                       | 76 - 79       | 138 HF            |                   |
| GXE      | 50                                | 87 - 88       | 519 HF            |                   |
| GXE      | 50                                | 89 - 92       | 131 HF*           |                   |
| GXR      | 50                                | 89 - 91       | 131 HF*           |                   |
| MX       | 50                                | 87 - 90       | 519 SI            |                   |
| MX       | 50                                | 91            | 131 HF            |                   |
| RSV      | 50                                | 86 - 89       | 519 SI            |                   |

\* = 2 sets required / 2 jeux pour l'Avant.



**RECOMMENDED**

1xx = Scooter Pads  
5xx = Street, Off Road & Racing Pads  
2xxx = Brake Shoes



| KTM   |     |                       |         |                  |
|-------|-----|-----------------------|---------|------------------|
| SXC   | 400 | Tiainen Replica       | 99 - 00 | 671 SI 675 SI    |
| GS    | 420 |                       | 84 - 87 | 2122 2122        |
| XC    | 420 | , MC                  | 81 - 83 | 519 SI           |
|       | 450 | Rally                 | 11 - 16 | 674 SI 675 SI    |
| EXC-F | 450 | Racing                | 04 - 18 | 671 SI 791 SI    |
| SX    | 450 | ATV                   | 08 - 10 | 866 RSI* 867 RSI |
| SX    | 450 | SM Factory Replica    | 04 - 07 | 566 RSI 791 RSI  |
| SX    | 450 | SMR                   | 04 - 06 | 842 RSI 791 RSI  |
| SX    | 450 | SMR                   | 07 - 12 | 843 RSI 791 RSI  |
| SX    | 450 | SMR                   | 13 - 15 | 841 RS 791 RSI   |
| SX-F  | 450 |                       | 03 - 18 | 671 RSI 791 RSI  |
| XC    | 450 | ATV                   | 08 - 10 | 866 SI* 867 SI   |
| XC-F  | 450 |                       | 06 - 17 | 671 RSI 791 RSI  |
| MC    | 495 | Leleu                 | 82 - 83 | 519 SI 2121      |
| MX    | 495 |                       | 84      | 2122 2122        |
| MX    | 495 | Leleu                 | 82 - 83 | 519 SI 2121      |
|       | 500 | Cross                 | 82      | 2118 2121        |
| EXC-F | 500 |                       | 12 - 18 | 671 SI 791 SI    |
| GS    | 500 | 500 K4 Enduro         | 83      | 519 SI 2121      |
| LC    | 500 |                       | 85      | 519 SI 2122      |
| LC    | 500 |                       | 86 - 89 | 519 SI 519 SI    |
| MX    | 500 |                       | 83 - 84 | 2122 2122        |
| MX    | 500 |                       | 85      | 519 SI 2122      |
| MX    | 500 |                       | 86      | 519 SI 519 SI    |
| MX    | 500 |                       | 87      | 601 HF 601 HF    |
| MX    | 500 |                       | 88      | 621 HF 621 HF    |
| MX    | 500 |                       | 89 - 91 | 546 SI 692 SI    |
| MX    | 500 |                       | 92 - 93 | 671 SI 692 SI    |
| XC    | 500 | , MC                  | 81 - 83 | 519 SI           |
| SX    | 505 | ATV                   | 08 - 12 | 866 RSI* 867 RSI |
| SX    | 505 | Racing                | 07 - 09 | 671 RSI 791 RSI  |
| XC    | 505 | ATV                   | 08 - 12 | 866 SI* 867 SI   |
| XC-F  | 505 |                       | 08 - 09 | 671 RSI 791 RSI  |
| EXC   | 520 | Racing                | 00 - 02 | 671 SI 675 SI    |
| SX-F  | 520 | Racing                | 00 - 02 | 671 RSI 675 RSI  |
| EXC   | 525 | Racing                | 03      | 671 SI 675 SI    |
| EXC   | 525 | Racing                | 04 - 06 | 671 SI 791 SI    |
| SX    | 525 | SMR                   | 04 - 07 | 842 RSI 791 RSI  |
| SX-F  | 525 | Racing                | 03      | 671 RSI 675 RSI  |
| SX-F  | 525 | Racing                | 04 - 06 | 671 RSI 791 RSI  |
| EXC   | 530 | Racing                | 08 - 11 | 671 SI 791 SI    |
| SXC   | 540 | Tiainen Replica       | 99 - 00 | 671 SI 675 SI    |
| LC4   | 550 |                       | 87 - 89 | 601 HF 601 HF    |
| MX    | 550 |                       | 87 - 90 | 601 HF 601 HF    |
| SX    | 560 | SMR                   | 06 - 07 | 843 RSI 791 RSI  |
|       | 600 | Duke                  | 93 - 94 | 566 HF           |
| 4T    | 600 | Enduro                | 84 - 86 | 519 SI           |
| EXC   | 600 |                       | 87      | 601 HF 601 HF    |
| EXC   | 600 |                       | 88      | 621 HF 621 HF    |
| GS    | 600 |                       | 84      | 2122 2122        |
| GS    | 600 |                       | 85      | 519 SI 2122      |
| LC4   | 600 |                       | 88 - 91 | 601 HF 601 HF    |
| LC4   | 600 | Enduro                | 88 - 91 | 601 HF 601 HF    |
| LC4   | 600 | Six Days              | 92      | 671 SI 586 SI    |
| MC    | 600 |                       | 88      | 601 HF 601 HF    |
| MX    | 600 |                       | 87      | 601 HF 601 HF    |
| MX    | 600 |                       | 88 - 89 | 621 HF 621 HF    |
| XC    | 600 | Cross                 | 85      | 519 SI           |
| XCE   | 600 | Cross                 | 85      | 519 SI           |
|       | 620 | Duke                  | 96 - 98 | 566 HF 519 HF    |
| LC4   | 620 | Competition           | 99 - 02 | 671 SI 675 SI    |
| LC4   | 620 | Competition SuperMoto | 00 - 01 | 671 HF 675 HF    |
| LC4   | 620 | RXC                   | 95      | 671 SI 675 SI    |
| LC4   | 620 | Supercompetition      | 01      | 671 HF 675 HF    |
| SC    | 620 |                       | 99 - 00 | 671 SI 675 SI    |
| SX    | 620 |                       | 95 - 99 | 671 RSI 675 RSI  |
| LC4   | 625 | SC Supermoto          | 02 - 04 | 671 HF 675 HF    |
| SMC   | 625 |                       | 05 - 06 | 706 HF 675 HF    |
| SXC   | 625 |                       | 03 - 04 | 671 HF 675 HF    |
|       | 640 | Duke                  | 99 - 02 | 566 HF 519 HF    |
|       | 640 | Duke                  | 03 - 06 | 706 HF 675 HF    |
| LC4   | 640 | Adventure             | 99 - 04 | 671 HF 675 HF    |

**RECOMMENDED**

1xx = Scooter Pads  
5xx = Street, Off Road & Racing Pads  
2xxx = Brake Shoes



| KTM   |      |                             |         |                 |
|-------|------|-----------------------------|---------|-----------------|
| LC4   | 640  | Adventure                   | 05 - 07 | 674 HF 675 HF   |
| LC4   | 640  | Supermoto                   | 03      | 566 HF 675 HF   |
| LC4   | 640  | Supermoto                   | 04      | 706 HF 675 HF   |
| LC4-E | 640  | Enduro                      | 99 - 04 | 671 HF 675 HF   |
| LC4-E | 640  | Supermoto                   | 99 - 02 | 671 HF 675 HF   |
| LC4   | 660  | Rallye                      | 01 - 03 | 671 HF 675 HF   |
| LC4   | 660  | SM Factory Replica          | 02      | 566 RSI 675 RSI |
| SMC   | 660  | Supermoto                   | 03      | 566 HF 675 HF   |
| SMC   | 660  | Supermoto                   | 04 - 07 | 706 HF 675 HF   |
|       | 690  | Duke                        | 08 - 11 | 762 HS 675 LS   |
|       | 690  | Duke ABS                    | 12 - 18 | 706 HS 675 LS   |
|       | 690  | Duke R                      | 10 - 11 | 762 HS 675 LS   |
|       | 690  | Duke R                      | 14 - 17 | 841 HS* 675 LS  |
|       | 690  | Enduro                      | 08 - 14 | 674 HS 675 LS   |
|       | 690  | Enduro R                    | 09 - 17 | 674 HS 675 LS   |
|       | 690  | SM                          | 07 - 11 | 762 HS 675 LS   |
|       | 690  | SMC                         | 08 - 10 | 762 HS 675 LS   |
|       | 690  | Supermoto R                 | 08 - 09 | 762 HS 675 LS   |
|       | 790  | Duke                        | 18 -    | 671 HS* 675 LS  |
|       | 950  | R Superenduro               | 06 - 08 | 674 HS 671 LS   |
|       | 950  | SM                          | 05 - 07 | 762 HS* 671 LS  |
|       | 950  | SM R                        | 07 - 09 | 762 HS* 671 LS  |
| LC8   | 950  | Adventure                   | 02 - 07 | 674 HS* 675 LS  |
|       | 990  | Adventure R                 | 10 - 12 | 674 HS* 671 LS  |
|       | 990  | Adventure, Adventure S, ABS | 06 - 11 | 674 HS* 671 LS  |
|       | 990  | Super Duke                  | 04 - 13 | 762 HS* 675 LS  |
|       | 990  | Super Duke R                | 09 - 13 | 762 HS* 675 LS  |
|       | 990  | Supermoto                   | 07 - 11 | 762 HS* 671 LS  |
|       | 990  | Supermoto R                 | 10      | 841 HS* 671 LS  |
|       | 990  | Supermoto T                 | 09 - 13 | 762 HS* 671 LS  |
|       | 1050 | Adventure                   | 15 - 16 | 706 SP* 671 LS  |
|       | 1090 | Super Adventure             | 17 - 18 | 706 SP* 671 LS  |
|       | 1090 | Super Adventure R           | 17 - 18 | 706 SP* 671 LS  |
|       | 1190 | Adventure                   | 13 - 16 | 706 SP* 671 LS  |
| RC8   | 1190 |                             | 08 - 11 | 841 SP* 730 LS  |
| RC8   | 1190 | R                           | 09 - 15 | 841 SP* 730 LS  |
| RC8   | 1190 | R Track                     | 11 - 15 | 841 SP* 730 LS  |
|       | 1290 | Super Adventure             | 15 - 18 | 706 SP* 671 LS  |
|       | 1290 | Super Adventure R           | 17 - 18 | 706 SP* 671 LS  |
|       | 1290 | Super Adventure S           | 17 - 18 | 706 SP* 671 LS  |
|       | 1290 | Super Adventure T           | 17 - 18 | 706 SP* 671 LS  |
|       | 1290 | Super Duke GT               | 16 - 18 | 901 HS* 730 LS  |
|       | 1290 | Super Duke R                | 14 - 18 | 841 HS* 730 LS  |

| KYMCO |    |                       |         |               |
|-------|----|-----------------------|---------|---------------|
|       | 50 | Agility               | 05 - 08 | 163 HF 2012   |
|       | 50 | Agility (4T) R10      | 06 - 14 | 163 HF 2012   |
|       | 50 | Agility (4T) R12      | 06 - 15 | 163 HF 2012   |
|       | 50 | Agility (4T) R16      | 06 - 15 | 154 HF 2203   |
|       | 50 | Agility Basic         | 07      | 2012 2012     |
|       | 50 | B&W                   | 04 - 06 | 119 HF        |
|       | 50 | Calypso               | 97 - 99 | 141 HF 2012   |
|       | 50 | Cobra Cross           | 99 - 00 | 144 HF 2012   |
|       | 50 | Cobra Cross           | 01 - 06 | 121 HF 2012   |
|       | 50 | Cobra Exclusive       | 01 - 04 | 121 HF 2012   |
|       | 50 | Cobra Racer           | 99 - 00 | 144 HF 2012   |
|       | 50 | Cobra Racer           | 01 - 04 | 121 HF 2012   |
|       | 50 | Dink, Dink Sport, B&W | 99 - 02 | 119 HF 2012   |
|       | 50 | Easy                  | 01      | 121 HF 2012   |
|       | 50 | Filly                 | 99 - 03 | 2012 2012     |
|       | 50 | Filly LX              | 01      | 121 HF 2012   |
|       | 50 | Filly LX              | 02 - 06 | 163 HF        |
|       | 50 | Heroism               | 95 - 96 | 121 HF 2012   |
|       | 50 | Heroism               | 97 - 99 | 141 HF 2012   |
|       | 50 | K-Pipe                | 12 - 13 | 119 HF        |
|       | 50 | Manboy                | 95 - 00 | 110 HF 2012   |
|       | 50 | MXer                  | 03 - 07 | 2012 749 HF   |
|       | 50 | MXU                   | 05 - 10 | 2012 749 HF   |
|       | 50 | New Dink              | 08 - 13 | 119 HF        |
|       | 50 | New Sento             | 11 - 15 | 163 HF        |
|       | 50 | Nexxon                | 08 - 12 | 200 HF 200 HF |

\* = 2 sets required / 2 jeux pour l'Avant.



**RECOMMENDED**

1xx = Scooter Pads  
5xx = Street, Off Road & Racing Pads  
2xxx = Brake Shoes



| KYMCO |                          |         |        |        |
|-------|--------------------------|---------|--------|--------|
| 50    | People                   | 99 - 06 | 154 HF | 2203   |
| 50    | Refined                  | 94 - 98 | 2012   | 2012   |
| 50    | Scout                    | 95 - 00 | 121 HF | 2012   |
| 50    | Sento                    | 08 - 10 | 163 HF | 2012   |
| 50    | Spacer                   | 99 - 06 | 119 HF | 2012   |
| 50    | Super-8                  | 08 - 16 | 154 HF | 2203   |
| 50    | Super-9                  | 00 - 01 | 144 HF |        |
| 50    | Super-9 A/C              | 02 - 07 | 119 HF |        |
| 50    | Super-9 L/C              | 02 - 07 | 119 HF | 154 HF |
| 50    | Topboy on/off road       | 96 - 05 | 121 HF | 2012   |
| 50    | Topboy Racer/Cross       | 01 - 05 | 121 HF | 2012   |
| 50    | Vitality                 | 04 - 09 | 163 HF |        |
| 50    | Yager                    | 01 - 07 | 119 HF | 2012   |
| 50    | Yup                      | 01      | 121 HF | 2012   |
| 50    | Yup SP/AL                | 02 - 09 | 163 HF |        |
| 50    | Zap (Disc Brake version) | 95 - 00 | 110 HF |        |
| 50    | ZX 12                    | 06      | 144 HF |        |
| CX    | 50                       | 94 - 97 | 2012   | 2057   |
| CX    | 50 Curio Super           | 94 - 97 | 121 HF | 2057   |
| DD    | 50 Sniper                | 94 - 96 | 121 HF | 129 HF |
| DJ    | 50                       | 99 - 02 | 2012   | 2057   |
| DJ    | 50 Refined               | 99 - 02 | 2012   | 2057   |
| DJW   | 50                       | 94 - 97 | 2012   | 2057   |
| DJX   | 50                       | 91 - 92 | 2012   | 2057   |
| DJY   | 50                       | 93 - 06 | 2012   | 2057   |
| K12   | 50                       | 95 - 00 | 121 HF | 2012   |
| KB    | 50                       | 95 - 00 | 121 HF | 2012   |
| RS    | 50 Agility Naked         | 10 - 15 | 163 HF |        |
| ZX    | 50 Fever                 | 96 - 01 | 121 HF | 2057   |
| ZX    | 50 Super Fever           | 02 - 06 | 144 HF |        |
|       | 80 Filly                 | 99 - 02 | 2012   | 2012   |
|       | 90 Manboy                | 96 - 01 | 144 HF | 2012   |
| SP    | 90 Yup                   | 95 - 99 | 110 HF |        |
|       | 100 Cobra Racer          | 99 - 03 | 119 HF | 2012   |
|       | 100 Spike                | 02 - 06 | 103 HF |        |
|       | 100 Topboy on/off road   | 99 - 00 | 121 HF | 2012   |
| KB    | 100                      | 99 - 00 | 121 HF | 2012   |
|       | 110 Spike                | 03 - 06 | 103 HF |        |
|       | 125 Agility              | 06 - 11 | 163 CT | 2012   |
|       | 125 Agility 16+          | 14 - 16 | 154 CT | 119 CT |
|       | 125 Agility City         | 11 - 17 | 163 CT | 113 CT |
|       | 125 B&W, Dink Sport      | 99 - 06 | 119 CT | 119 CT |
|       | 125 Calypso              | 99      | 141 CT | 2012   |
|       | 125 Cruiser              | 99      | 119 CT |        |
|       | 125 Dink                 | 96 - 09 | 119 CT | 119 CT |
|       | 125 Downtown i           | 10 - 14 | 183 CT | 204 CT |
|       | 125 Grand Dink           | 02 - 07 | 119 CT | 119 CT |
|       | 125 Heroism              | 95 - 97 | 141 CT | 2012   |
|       | 125 Hipster              | 01 - 06 | 688 HF |        |
|       | 125 Jetix                | 08 - 15 | 103 CT |        |
|       | 125 K-Pipe               | 13 - 15 | 688 HF |        |
|       | 125 K-XCTi               | 14      | 159 CT | 195 MS |
|       | 125 Like                 | 11 - 16 | 163 CT |        |
|       | 125 Movie                | 99 - 08 | 119 CT | 2203   |
|       | 125 Movie XL             | 01 - 09 | 119 CT |        |
|       | 125 MXer                 | 03 - 07 | 2012   | 749 HF |
|       | 125 New Dink             | 08 - 10 | 119 CT | 119 CT |
|       | 125 New Downtown         | 16 - 17 | 159 CT | 204 CT |
|       | 125 New G-Dink           | 12 - 14 | 183 CT | 195 CT |
|       | 125 Nexxon               | 08 - 12 | 200 CT | 200 CT |
|       | 125 People               | 01 - 09 | 154 CT | 2203   |
|       | 125 People GTi           | 12 - 15 | 159 CT | 204 CT |
|       | 125 People One i         | 14 - 16 | 154 CT |        |
|       | 125 Pulsar               | 01 - 13 | 688 HF |        |
|       | 125 Quannon              | 08 - 12 | 119 CT | 119 CT |
|       | 125 Spacer               | 99 - 03 | 119 CT | 119 CT |
|       | 125 Spike                | 02 - 06 | 103 CT |        |
|       | 125 Stryker on/off       | 99 - 06 | 163 CT |        |
|       | 125 Super Dink           | 10 - 15 | 183 CT | 204 CT |
|       | 125 Super-8              | 08 - 15 | 154 CT |        |
|       | 125 Super-9              | 00 - 01 | 144 CT | 154 CT |
|       | 125 Techno GT            | 06 - 10 | 119 CT |        |



**RECOMMENDED**

1xx = Scooter Pads  
5xx = Street, Off Road & Racing Pads  
2xxx = Brake Shoes



| KYMCO |                              |         |          |         |
|-------|------------------------------|---------|----------|---------|
|       | 125 Vivio                    | 01 - 03 | 163 CT   |         |
|       | 125 X-Town                   | 16 - 17 | 159 MS   | 204 MS  |
|       | 125 Yager                    | 01 - 07 | 119 CT   | 119 CT  |
|       | 125 Yager GT                 | 09      | 119 CT   |         |
|       | 125 Zing                     | 96 - 14 | 688 HF   |         |
| B     | 125 Freeway                  | 93 - 95 | 106 CT   | 2012    |
| CK    | 125                          | 04 - 13 | 551 HF   |         |
| CK-1  | 125                          | 14 - 16 | 688 HF   |         |
| D2    | 125 Freeway                  | 95 - 92 | 2012     | 2012    |
| S     | 125 People                   | 05 - 08 | 154 CT   | 195 CT  |
|       | 150 B&W                      | 01 - 05 | 119 CT   | 119 CT  |
|       | 150 Dink                     | 99 - 04 | 119 CT   | 119 CT  |
|       | 150 Freeway                  | 95 - 00 | 121 HF   | 2012    |
|       | 150 Grand Dink               | 02 - 11 | 119 CT   | 119 CT  |
|       | 150 Heroism                  | 95 - 97 | 141 CT   | 129 CT  |
|       | 150 Hipster                  | 01 - 06 | 688 HF   |         |
|       | 150 Movie XL                 | 01 - 09 | 119 CT   |         |
|       | 150 MXer                     | 03 - 13 | 2012     | 749 HF  |
|       | 150 MXU                      | 05 - 17 | 2012     | 749 HF  |
|       | 150 People                   | 01 - 06 | 154 CT   | 2203    |
|       | 150 Quannon                  | 10 - 14 | 119 CT   | 119 CT  |
|       | 150 Spacer                   | 99 - 04 | 119 CT   | 119 CT  |
|       | 150 Straight                 | 08 - 11 | 200 CT   | 200 CT  |
|       | 150 Stryker Off              | 01 - 06 | 163 CT   |         |
|       | 150 Vivio                    | 01 - 02 | 163 CT   |         |
|       | 150 Yager                    | 01 - 05 | 119 CT   | 119 CT  |
|       | 150 Zing                     | 99 - 13 | 119 CT   |         |
| DX    | 150 Custom                   | 93 - 96 | 551 HF   |         |
| NSR   | 150                          | 93      | 551 HF   |         |
|       | 200 Agility 16+              | 14 - 17 | 154 CT   | 119 CT  |
|       | 200 Agility R16              | 11 - 15 | 154 CT   | 119 CT  |
|       | 200 Dink                     | 04 - 12 | 119 CT   | 119 CT  |
|       | 200 Downtown i               | 10 - 15 | 183 CT   | 204 CT  |
|       | 200 i New Dink               | 08 - 12 | 119 CT   | 119 CT  |
|       | 200 Like i                   | 10 - 16 | 119 CT   | 119 CT  |
|       | 200 People GTi               | 12 - 15 | 159 CT   | 204 CT  |
|       | 200 Yager                    | 04 - 13 | 119 CT   | 119 CT  |
| S     | 200 People                   | 05 - 07 | 154 CT   | 195 CT  |
|       | 250 B&W, Dink Sport          | 01 - 06 | 119 MS   | 119 MS  |
|       | 250 Grand Dink               | 01 - 10 | 171 MS   | 172 MS  |
|       | 250 MXU                      | 06 - 14 | 810 SI*  | 775 SI  |
|       | 250 People                   | 03 - 12 | 119 MS   |         |
|       | 250 Super-9                  | 00 - 05 | 144 CT   | 154 CT  |
|       | 250 Urban Quad               | 06      | 810 SI*  | 775 SI  |
|       | 250 Venox                    | 01 - 14 | 627 HF   | 627 HF  |
|       | 250 Xciting                  | 04 - 05 | 183 MS   | 183 MS  |
|       | 250 Xciting                  | 06 - 09 | 183 MS   | 195 MS  |
|       | 250 Yup                      | 03 - 05 | 119 MS   | 119 MS  |
| KXR   | 250                          | 04 - 14 | 810 SI*  | 775 SI  |
| S     | 250 People Left/Rear         | 06 - 08 | 197 MS   | 195 MS  |
| S     | 250 People Right             | 06 - 08 | 134 MS   |         |
|       | 300 Downtown i               | 10 - 15 | 183 MS   | 204 MS  |
|       | 300 K-XCTi                   | 12 - 15 | 159 MS   | 195 MS  |
|       | 300 Maxxer                   | 06 - 13 | 810 SI*  | 775 SI  |
|       | 300 Maxxer Supermoto         | 15      | 810 SI*  | 775 SI  |
|       | 300 MXU                      | 06 - 17 | 810 SI*  | 810 SI* |
|       | 300 New G-Dink               | 12 - 16 | 183 MS   | 195 MS  |
|       | 300 People Gti               | 10 - 13 | 183 MS   |         |
|       | 300 People GTi               | 12 - 15 | 159 MS   | 204 MS  |
|       | 300 People Si Left/Rear      | 08 - 10 | 163 CT   | 195 CT  |
|       | 300 People Si Right          | 08 - 10 | 119 CT   |         |
|       | 300 Xciting Ri               | 08 - 14 | 183 MS*  | 195 MS  |
|       | 300 X-Town                   | 16 - 17 | 159 MS   | 204 MS  |
|       | 350 New Downtown             | 16 - 17 | 159 MS   | 204 MS  |
|       | 400 Maxxer                   | 08 - 10 | 822 ATS* | 822 ATS |
|       | 400 Maxxer (Parking Brake)   | 08 - 10 |          | 921 HF  |
|       | 400 MXU                      | 08 - 11 | 822 ATS* | 822 ATS |
|       | 400 MXU (Parking Brake)      | 08 - 11 |          | 921 HF  |
|       | 400 Xciting i                | 12 - 14 | 214 MS*  | 212 MS  |
|       | 450 i Maxxer                 | 10 - 14 | 822 ATS* | 822 ATS |
|       | 450 i Maxxer (Parking Brake) | 10 - 14 |          | 921 HF  |
|       | 450 i MXU                    | 11 - 14 | 822 ATS* | 822 ATS |

Applications  
Motorcycles, Off Road, ATV, Scooters

\* = 2 sets required / 2 jeux pour l'Avant.

Full compound selection, see under "Brake pad 1:1 Drawings" / Sélection complète de composés, voir "1:1 Schémas Plaquettes de frein".

**RECOMMENDED**1xx = Scooter Pads  
5xx = Street, Off Road & Racing Pads  
2xxx = Brake Shoes

| KYMCO     |                           |         |          |         |
|-----------|---------------------------|---------|----------|---------|
|           | 450 i MXU (Parking Brake) | 11 - 14 |          | 921 HF  |
|           | 500 MXU                   | 06 - 08 | 810 SI*  | 810 SI* |
|           | 500 MXU                   | 09 - 14 | 945 SI*  |         |
|           | 500 MXU DX                | 11 - 13 | 945 SI*  |         |
|           | 500 UXV 4x4               | 08 - 14 | 810 SI*  | 810 SI  |
|           | 500 Xciting               | 04 - 15 | 183 MS*  | 212 MS  |
|           | 500 Xciting i Evo ABS     | 11 - 13 | 183 MS*  | 212 MS  |
|           | 500 Xciting R ABS         | 09 - 13 | 183 MS*  | 212 MS  |
|           | 550 MXU                   | 12 - 15 | 945 SI*  |         |
| AK        | 550                       | 17      | 900 HS*  |         |
|           | 700 MXU                   | 13 - 15 | 945 SI*  |         |
|           | 700 MyRoad, ABS           | 09 - 15 | 183 MS*  | 212 MS  |
| UXV       | 700                       | 14 - 16 | 945 SI*  |         |
| LAMBRETTA |                           |         |          |         |
|           | 50 Pato                   | 08 - 09 | 211 HF   |         |
| LAVERDA   |                           |         |          |         |
|           | 50 Gaucho                 | 92      | 519 HF   | 519 HF  |
| OR        | 50 Atlas                  | 86      | 519 HF   | 519 HF  |
| OR        | 50 Atlas                  | 90 - 92 | 519 HF   | 519 HF  |
|           | 125 Custom                | 86 - 99 | 519 HF   |         |
|           | 125 Formula               | 86 - 89 | 574 HF   |         |
|           | 125 Phoenix               | 01 - 04 | 178 CT   | 154 CT  |
| CU        | 125 Ride                  | 86 - 99 | 519 HF   |         |
| GS        | 125 Lesmo                 | 86 - 94 | 574 HF   | 574 HF  |
| HP        | 125 Quasar                | 04      |          | 758 ATS |
| LB        | 125 Strada, Sport         | 85      | 574 HF   |         |
| LB        | 125 Uno                   | 85 - 89 | 519 HF   |         |
|           | 150 Phoenix               | 01 - 04 | 178 CT   | 154 CT  |
| HP        | 180 Quasar                | 04      |          | 758 ATS |
|           | 200 Phoenix               | 01 - 04 | 178 CT   | 154 CT  |
| GS        | 350 Lesmo                 | 86 - 89 | 519 HF*  | 519 HF  |
| PF        | 350 Alpino                | 77 - 83 | 519 HF*  | 519 HF  |
| RS        | 350 Alpino                | 77 - 83 | 519 HF*  | 519 HF  |
|           | 400 Quasar 4x4            | 04      | 758 ATS* | 758 ATS |
|           | 500 Alpino, S             | 77 - 83 | 519 HF*  | 519 HF  |
|           | 500 Quasar 4x4            | 04      | 758 ATS* | 758 ATS |
|           | 500 Quasar 4x4 C          | 04      | 758 ATS* | 758 ATS |
| SFC       | 500                       | 81 - 83 | 506 HF*  | 506 HF  |
| OR        | 600 Atlas                 | 86 - 90 | 594 HF   | 519 HF  |
| SFC       | 600                       | 86 - 89 | 506 HF*  | 506 HF  |
|           | 650                       | 92      | 566 HF*  | 519 HF  |
|           | 650 V-Six                 | 93      | 506 HS*  | 506 LS  |
|           | 668 668                   | 96 - 97 | 566 HF   | 519 HF  |
|           | 668 Ghost, Diamante       | 97      | 566 HF*  | 519 HF  |
|           | 700 El Cid                | 90      | 546 HF   | 586 HF  |
|           | 750 Cup                   | 98 - 01 | 566 HF*  | 519 HF  |
|           | 750 Diamante              | 97 - 01 | 566 HF*  | 519 HF  |
|           | 750 Ghost Strike          | 97 - 01 | 566 HF*  | 519 HF  |
|           | 750 S Formula             | 97 - 01 | 566 HF*  | 519 HF  |
|           | 750 S, S Carenata         | 97 - 01 | 566 HF*  | 519 HF  |
|           | 750 Sport                 | 99 - 01 | 566 HF*  | 519 HF  |
|           | 750 Strike/Black Strike   | 99 - 01 | 566 HF*  | 519 HF  |
|           | 750 T8                    | 98 - 01 | 566 HF*  | 519 HF  |
| SF2       | 750                       | 74 - 78 | 506 HF*  |         |
| SF3       | 750                       | 74 - 78 | 506 HF*  |         |
| SF3       | 750 RGS Corsa, Executive  | 77 - 79 | 506 HF*  | 506 HF  |
| TTS       | 800                       | 99      | 566 HF*  | 730 HF  |
|           | 1000 Jota                 | 76 - 79 | 506 HF*  | 506 HF  |
| 3C        | 1000 3CE, 3CL             | 74 - 75 | 506 HF*  | 506 HF  |
| JOTA      | 1000                      | 95      | 566 HF   | 519 HF  |
| RGS       | 1000                      | 83      | 506 HF*  | 506 HF  |
| RGS       | 1000 Jota                 | 86      | 506 HF*  | 506 HF  |
| SFC       | 1000                      | 04      | 762 HS*  | 730 LS  |
| SFC       | 1000                      | 85 - 86 | 506 HF*  | 506 HF  |
| TGA       | 1000 Executive            | 84      | 506 HF*  | 506 HF  |
|           | 1200 Mirage               | 78 - 80 | 506 HF*  | 506 HF  |
| LEM       |                           |         |          |         |
|           | 50 CX2, CX3, RX2, RX3     | 03 - 06 | 794 RSI  | 794 RSI |
|           | 50 Flash                  | 94 - 98 | 111 HF   | 2028    |

**RECOMMENDED**1xx = Scooter Pads  
5xx = Street, Off Road & Racing Pads  
2xxx = Brake Shoes

| LEM      |                                    |         |         |         |
|----------|------------------------------------|---------|---------|---------|
|          | 50 Ghibli                          | 90 - 95 | 2028    | 2028    |
|          | 50 R2, R3, R3 XC                   | 03 - 06 | 794 RSI | 794 RSI |
| RX       | 65                                 | 05 - 10 | 794 RSI | 794 RSI |
| RX       | 150                                | 11      |         | 794 RSI |
| LIFAN    |                                    |         |         |         |
| LF       | 125 Off Road                       | 07      | 211 HF  | 213 HF  |
| LONCIN   |                                    |         |         |         |
| LX       | 110 4                              | 02      | 688 HF  |         |
| LX       | 125                                | 02      | 688 HF  |         |
| LX       | 150 6                              | 02      | 691 HF  |         |
| MACAL    |                                    |         |         |         |
|          | 50 Flash                           | 99      | 123 HF  |         |
| AM5/6    | 50 Trophy                          | 99      | 105 HF  |         |
| AM5/6    | 50 Trophy H2O                      | 99      | 105 HF  |         |
| MACBOR   |                                    |         |         |         |
| XC       | 50 510 Racing                      | 04      | 803 RSI | 559 RSI |
| XC       | 50 512 Pro                         | 04      | 803 RSI |         |
| XC       | 50 512 Racing                      | 04      | 803 RSI | 559 RSI |
| XC       | 50 512 T                           | 04      | 803 RSI |         |
| XC       | 50 515 R 6V                        | 04      | 803 RSI | 559 RSI |
| MAICO    |                                    |         |         |         |
|          | all models                         | 89      | 621 HF  | 621 HF  |
|          | all models                         | 91      | 621 HF  | 586 SI  |
|          | 50 Classic                         | 99      | 2028    | 2028    |
|          | 50 Cruiser                         | 99      | 101 HF  | 2028    |
|          | 50 Thunderbike I                   | 99      | 101 HF  | 2028    |
|          | 50 Thunderbike II                  | 99      | 101 HF* | 2028    |
|          | 50 Trafficjammer                   | 99      | 2028    | 2028    |
| C-1      | 50 Hard Enduro                     | 99      | 101 HF  | 2028    |
| R-1      | 50 Superbike                       | 99      | 101 HF  | 2028    |
| X-1      | 50 SuperCross                      | 99      | 101 HF  | 2028    |
|          | 250 Motocross/Enduro               | 99 - 01 | 671 SI  | 675 SI  |
| GM       | 250 LC                             | 85      | 519 SI  |         |
| GM       | 250 Star                           | 86      | 581 HF  | 581 HF  |
| GP       | 250 all models                     | 89      | 621 HF  | 621 HF  |
| GP       | 250 E                              | 87      | 581 HF  | 581 HF  |
| GP       | 250 Motocross                      | 87      | 581 HF  | 581 HF  |
| MD       | 250                                | 83 - 85 | 519 SI  | 519 SI  |
|          | 350                                | 93 - 95 | 621 HF  | 621 HF  |
| GP       | 400 all models                     | 89      | 621 HF  | 621 HF  |
| GP       | 400 E                              | 87 - 88 | 581 HF  | 581 HF  |
| GP       | 400 Motocross                      | 87 - 88 | 581 HF  | 581 HF  |
|          | 500                                | 93 - 94 | 621 HF  | 621 HF  |
|          | 500 Motocross/Enduro               | 99      | 671 SI  | 675 SI  |
|          | 500 Supermotard                    | 99      | 671 HF  | 675 HF  |
| GM       | 500 LC                             | 85 - 86 | 519 SI  |         |
| GM       | 500 Star                           | 86      | 581 HF  | 581 HF  |
| GP       | 500 all models                     | 89      | 621 HF  | 621 HF  |
| GP       | 500 E                              | 87      | 581 HF  | 581 HF  |
| GP       | 500 Motocross                      | 87      | 581 HF  | 581 HF  |
| GP       | 550                                | 87      | 581 HF  | 581 HF  |
| MALAGUTI |                                    |         |         |         |
|          | 50 AJP Caliper<br>incl. pin/spring | 91 - 18 | 188 HF  |         |
|          | 50 Centro                          | 93 - 96 | 109 HF  | 2012    |
|          | 50 Chopper 25, 40, 80, Fifty       | 83      | 532 HF  |         |
|          | 50 Chopper HF,<br>Watercooled      | 83      | 532 HF  |         |
|          | 50 Ciak                            | 00 - 09 | 123 HF  | 2012    |
|          | 50 Ciak Twin Disk                  | 02 - 09 | 123 HF  | 123 HF  |
|          | 50 Enduro                          | 85 - 87 | 519 HF  |         |
|          | 50 Enduro Dune                     | 87 - 88 | 132 HF  | 132 HF  |
|          | 50 Evolution                       | 91      | 574 HF  |         |
|          | 50 Fifty                           | 04      | 168 HF  | 105 HF  |
|          | 50 Fifty Evolution                 | 91      | 559 HF  |         |
|          | 50 Fifty Full, CX, Top             | 85      | 595 HF  |         |

\* = 2 sets required / 2 jeux pour l'Avant.



**RECOMMENDED**

1xx = Scooter Pads  
5xx = Street, Off Road & Racing Pads  
2xxx = Brake Shoes



| MALAGUTI |                       |         |         |        |
|----------|-----------------------|---------|---------|--------|
|          | 50 Fifty Mistral      | 90 - 95 | 595 HF  |        |
|          | 50 Yesterday          | 97 - 02 | 123 HF  | 2012   |
| CH       | 50                    | 86      | 595 HF  |        |
| CR-1     | 50 Crosser            | 95 - 96 | 132 HF  |        |
| EL       | 50 Crosser            | 97 - 00 | 123 HF  |        |
| ES       | 50 Dune               | 89      | 574 HF  | 574 HF |
| F-10     | 50                    | 92 - 93 | 113 HF  | 2012   |
| F-10     | 50 Jet-Line           | 94 - 98 | 123 HF  | 2012   |
| F-10     | 50 Timemachine        | 03 - 09 | 123 HF  |        |
| F-10     | 50 WAP                | 02 - 09 | 123 HF  |        |
| F-12     | 50 Phantom            | 94 - 98 | 132 HF  | 2012   |
| F-12     | 50 Phantom A.C.       | 99 - 03 | 123 HF  | 2012   |
| F-12     | 50 Phantom Digit      | 02 - 10 | 123 HF  | 123 HF |
| F-12     | 50 Phantom L.C.       | 94 - 98 | 109 HF  | 2012   |
| F-12     | 50 Phantom L.C. dd    | 99 - 09 | 123 HF  | 123 HF |
| F-12     | 50 Racing Life        | 03 - 09 | 123 HF  | 123 HF |
| F-12     | 50 Tyre Track         | 03 - 09 | 123 HF  | 123 HF |
| F-15     | 50 Fire Fox           | 96 - 08 | 132 HF  | 2012   |
| F-15     | 50 Fire Fox L.C.      | 96 - 08 | 109 HF  | 2012   |
| F-15     | 50 Mechatronic        | 03 - 08 | 123 HF  | 123 HF |
| MDX      | 50                    | 86 - 87 | 574 HF  |        |
| MDX      | 50 Gold Enduro        | 87      | 607 HF  | 596 HF |
| MEX      | 50                    | 86 - 87 | 541 HF  |        |
| MFX      | 50                    | 86 - 87 | 541 HF  |        |
| MLX      | 50 Enduro             | 87      | 607 HF  | 596 HF |
| MRX      | 50                    | 89      | 519 HF  |        |
| NKD      | 50                    | 04 - 09 | 168 HF  | 105 HF |
| NKD      | 50 Dragon             | 06 - 09 | 821 HS  | 559 HF |
| RCW      | 50 Ronco              | 83      | 532 HF  |        |
| RST      | 50                    | 90      | 519 HF  | 519 HF |
| RST      | 50 Sport              | 87      | 132 HF  | 132 HF |
| RST      | 50 Sport              | 87      | 574 HF  | 574 HF |
| SL       | 50 Centro             | 96 - 00 | 123 HF  | 2012   |
| V4       | 50 Olympique          | 83      | 532 HF  |        |
| XL       | 50 Sport              | 83 - 85 | 532 HF  |        |
| XSM      | 50                    | 03 - 14 | 120 HF  | 105 HF |
| XTM      | 50                    | 03 - 11 | 105 HF  | 105 HF |
|          | 100 Ciak              | 00 - 01 | 123 HF  | 123 HF |
| F-12     | 100 Phantom A.C.      | 00 - 03 | 123 HF  |        |
| F-12     | 100 Phantom Twin Disk | 02 - 03 | 123 HF  | 123 HF |
|          | 125 Blog              | 10      | 163 CT  | 102 CT |
|          | 125 Centro ie         | 08 - 11 | 163 CT  | 107 CT |
|          | 125 Ciak, Ciak Master | 02 - 06 | 123 CT  |        |
|          | 125 Madison 3         | 08 - 09 | 176 CT  | 157 CT |
|          | 125 Phantom Max       | 04 - 08 | 168 CT  | 152 CT |
|          | 125 Runner            | 86      | 532 HF  |        |
|          | 125 Runner            | 87      | 108 CT  |        |
|          | 125 Sport City Cube   | 08      | 108 CT  | 152 CT |
| F-18     | 125 , Warrior         | 00 - 02 | 123 CT  | 152 CT |
| R        | 125 Madison           | 99 - 09 | 120 CT  | 152 CT |
|          | 150 Ciak, Ciak Master | 02 - 08 | 123 CT  |        |
|          | 150 Madison           | 99 - 03 | 120 CT  | 152 CT |
| F-18     | 150                   | 00 - 03 | 123 CT  | 123 CT |
|          | 160 Blog              | 10 - 11 | 163 CT  | 102 CT |
|          | 160 Centro ie         | 08 - 11 | 163 CT  | 107 CT |
|          | 180 Madison           | 02      | 120 CT  | 152 CT |
|          | 200 Phantom Max       | 04 - 05 | 168 CT  | 152 CT |
|          | 200 Sport City Cube   | 08      | 108 CT  | 152 CT |
| S        | 200 Madison           | 03 - 06 | 120 CT  | 152 CT |
|          | 250 Madison           | 99 - 04 | 159 MS  | 152 MS |
|          | 250 Madison 3 ie      | 08 - 11 | 176 CT  | 157 CT |
|          | 250 Password          | 06 - 08 | 168 CT  | 152 CT |
|          | 250 Phantom Max       | 05 - 08 | 168 CT  | 152 CT |
|          | 250 Sport City Cube   | 08      | 108 MS* | 152 MS |
| RS       | 250 Madison           | 05 - 11 | 168 CT  | 152 CT |
|          | 300 Sport City Cube   | 08      | 108 MS* | 152 MS |
| K        | 400 Madison           | 02 - 11 | 159 MS  | 152 MS |
| MGX      | 425 Ronco             | 87 - 11 | 541 HF  |        |
| MGX      | 450 Ronco             | 87 - 11 | 595 HF  |        |
| GT       | 500 Spidermax         | 04 - 10 | 108 MS* | 157 MS |
| RS       | 500 Spidermax         | 09 - 11 | 108 MS* | 157 MS |



**RECOMMENDED**

1xx = Scooter Pads  
5xx = Street, Off Road & Racing Pads  
2xxx = Brake Shoes



| MALANCA |                             |         |         |        |
|---------|-----------------------------|---------|---------|--------|
|         | 50 Mozzi Motor              | 82      | 625 HF  |        |
| E2      | 80 C80                      | 80      | 574 HF* | 574 HF |
| GTI     | 80                          | 80      | 574 HF* | 574 HF |
|         | 125 Enduro Mark ST 54,      |         |         |        |
|         | GT55                        | 79 - 83 | 532 HF  |        |
|         | 125 Mark                    | 85      | 519 HF  |        |
| E2      | 125 125                     | 80 - 84 | 574 HF* | 574 HF |
| E2      | 125 CS ob one 5N, 6N,       |         |         |        |
|         | Racing                      | 80      | 574 HF* | 574 HF |
| E2      | 125 Sport                   | 80      | 574 HF* | 574 HF |
| GTI     | 125                         | 80      | 574 HF* | 574 HF |
| MASH    |                             |         |         |        |
|         | 125 Cafe Racer              | 14 - 16 | 814 HF  | 536 HF |
|         | 125 Scrambler               | 13 - 17 | 585 HF  |        |
|         | 125 Seventy                 | 13 - 17 | 585 HF  |        |
|         | 125 Seventy Five            | 14 - 17 | 814 HF  | 536 HF |
|         | 250 Cafe Racer              | 14 - 16 | 814 HF  | 536 HF |
|         | 250 Two Fifty               | 14 - 17 | 814 HF  | 536 HF |
|         | 400 Scrambler               | 13 - 17 | 627 HS  |        |
|         | 500 Five Hundred            | 13 - 16 | 627 HS  |        |
| MBK     |                             |         |         |        |
|         | 50 Active                   | 89      | 2021    | 2021   |
|         | 50 AJP Caliper              |         |         |        |
|         | incl. pin/spring            | 89 - 18 | 188 HF  |        |
|         | 50 Booster                  | 90 - 94 | 2050    | 2050   |
|         | 50 Booster 12"              | 03 - 10 | 123 HF  |        |
|         | 50 Booster Naked            | 04 - 16 | 123 HF  |        |
|         | 50 Booster Next Gen.        | 97 - 06 | 114 HF  | 2050   |
|         | 50 Booster Rocket           | 95 - 02 | 114 HF  | 2050   |
|         | 50 Booster Spirit           | 00 - 16 | 123 HF  | 2050   |
|         | 50 Booster Track            | 97 - 02 | 114 HF  | 2050   |
|         | 50 Champ                    | 91      | 2112    | 2112   |
|         | 50 Equalis                  | 96 - 98 | 114 HF  | 2028   |
|         | 50 Evasion straight wheels  | 01      | 2194    | 2194   |
|         | 50 Evolis                   | 92 - 98 | 114 HF  | 2050   |
|         | 50 Fizz                     | 93 - 00 | 114 HF  | 2028   |
|         | 50 Flipper                  | 99 - 04 | 123 HF  | 2050   |
|         | 50 Forte                    | 94 - 98 | 114 HF  | 2028   |
|         | 50 Hardrock straight wheels | 01      | 2194    | 2194   |
|         | 50 Hot Champ                | 91 - 97 | 2021    | 2050   |
|         | 50 Mach G                   | 02 - 03 | 123 HF  |        |
|         | 50 Magnum straight wheels   | 01      | 2194    | 2194   |
|         | 50 Nitro                    | 97 - 10 | 114 HF  | 145 HF |
|         | 50 Ovetto                   | 97 - 10 | 114 HF  | 2050   |
|         | 50 Passion straight wheels  | 01      | 2194    | 2194   |
|         | 50 Sorriso                  | 92 - 95 | 2028    | 2028   |
|         | 50 Stunt                    | 00 - 10 | 145 HF  |        |
|         | 50 Target                   | 92 - 95 | 111 HF  | 2028   |
|         | 50 X-Limit                  | 04 - 16 | 105 HF  | 105 HF |
|         | 50 X-Power                  | 04 - 13 | 168 HF  | 105 HF |
|         | 75 Active                   | 90      | 2050    | 2021   |
|         | 80 Active                   | 89      | 2021    | 2021   |
|         | 80 Evolis                   | 94 - 98 | 114 HF  | 2028   |
|         | 100 Booster                 | 99 - 02 | 111 HF  |        |
|         | 100 Nitro                   | 00 - 03 | 123 HF  |        |
| YN      | 100 Ovetto                  | 00 - 02 | 123 HF  |        |
|         | 125 Dodo                    | 01 - 05 | 123 CT  |        |
|         | 125 Flame R/F               | 95 - 03 | 107 CT  | 2028   |
|         | 125 Skycruiser              | 06 - 14 | 194 CT  | 157 CT |
| XC      | 125 Waap                    | 08 - 12 | 858 HF  |        |
| XQ      | 125 Thunder                 | 01 - 04 | 151 CT  | 157 CT |
| YP      | 125 Flame X                 | 05 - 12 | 190 CT  |        |
| YP      | 125 Skyliner                | 99 - 00 | 151 CT  | 2199   |
| YP      | 125 Skyliner                | 01 - 12 | 151 CT  | 157 CT |
| YW      | 125 Z                       | 10      | 208 CT  |        |
|         | 150 Dodo                    | 01      | 123 CT  |        |
|         | 150 Skyliner                | 01 - 03 | 151 CT  | 157 CT |
|         | 150 Vertex                  | 97      | 107 CT  |        |
| XQ      | 150 Thunder                 | 02 - 03 | 151 CT  | 157 CT |
|         | 180 Skyliner                | 04 - 07 | 151 CT  | 157 CT |

Applications  
Motorcycles, Off Road, ATV, Scooters

\* = 2 sets required / 2 jeux pour l'Avant.

Full compound selection, see under "Brake pad 1:1 Drawings" / Sélection complète de composés, voir "1:1 Schémas Plaquettes de frein".

**RECOMMENDED**

1xx = Scooter Pads  
5xx = Street, Off Road & Racing Pads  
2xxx = Brake Shoes



| MBK        |                          |         |         |         |  |
|------------|--------------------------|---------|---------|---------|--|
|            | 250 Skyliner             | 00 - 02 | 128 MS  | 155 MS  |  |
|            | 300 Kilibre              | 03 - 08 | 151 MS  | 151 MS  |  |
|            | 400 Skyliner             | 04      | 128 MS  |         |  |
| MEGELLI    |                          |         |         |         |  |
|            | 125 M, R, S              | 08 - 10 | 814 HF  | 777 HF  |  |
| MINARELLI  |                          |         |         |         |  |
| MR         | 80                       | 96      | 105 HF  |         |  |
| MONDIAL    |                          |         |         |         |  |
|            | 1000 EVO                 | 04      | 762 HS* | 730 LS  |  |
|            | 1000 Plega               | 03 - 04 | 762 HS* | 730 LS  |  |
|            | 1000 RZ Nuda             | 04      | 762 HS* | 730 LS  |  |
|            | 1000 Starfighter         | 04      | 762 HS* | 730 LS  |  |
| MONTESA    |                          |         |         |         |  |
|            | 125 Cota                 | 88      | 559 RSI | 559 RSI |  |
|            | 250 Cota 4RT             | 04 - 16 | 802 RSI | 803 RSI |  |
|            | 260 Evasion              | 92      | 559 RSI | 519 RSI |  |
|            | 260 4Ride                | 16 - 18 | 939 RSI | 803 RSI |  |
| Cota       | 260 4RT                  | 04 - 16 | 802 RSI | 803 RSI |  |
| Cota       | 260 4RT Race Replica     | 15 - 18 | 939 RSI | 803 RSI |  |
| Cota       | 300 RR                   | 16 - 18 | 939 RSI | 803 RSI |  |
|            | 304 Cota                 | 88      | 559 RSI | 559 RSI |  |
|            | 307 Cota                 | 89      | 559 RSI | 559 RSI |  |
|            | 307 Cota Trial           | 88 - 89 | 559 RSI | 559 RSI |  |
|            | 309 Cota                 | 89 - 90 | 559 RSI | 519 RSI |  |
|            | 310 Cota                 | 89 - 92 | 559 RSI | 519 RSI |  |
|            | 311 Cota Trial           | 92      | 559 RSI | 519 RSI |  |
|            | 315 Cota R               | 97 - 04 | 559 RSI | 559 RSI |  |
|            | 335 Cota                 | 87 - 91 | 559 RSI | 559 RSI |  |
|            | 360 315R                 | 01 - 04 | 802 RSI | 803 RSI |  |
| H7         | 360 Enduro               | 86      | 595 HF  |         |  |
| M7         | 360 Enduro               | 85      | 559 HF  |         |  |
| MORBIDELLI |                          |         |         |         |  |
|            | 125 cc                   | 76      | 559 HF* | 559 HF  |  |
| MORIWAKI   |                          |         |         |         |  |
| MD         | 250                      | 09      | 782 DC  | 618 RQ  |  |
| MOTOBECANE |                          |         |         |         |  |
|            | 50 all models            | 88 - 89 | 2074    |         |  |
| MOTO-GUZZI |                          |         |         |         |  |
|            | 125 Custom               | 85      | 519 HF  |         |  |
|            | 125 Enduro TT            | 85      | 519 HF  |         |  |
| BX         | 125                      | 92      | 519 HF  | 519 HF  |  |
|            | 240 /4                   | 77      | 519 HF  |         |  |
|            | 250 TS                   | 75 - 76 | 519 HF  |         |  |
|            | 350                      | 77 - 81 | 519 HF* | 519 HF  |  |
|            | 350 Falco                | 88      | 519 HF  | 519 HF  |  |
|            | 350 Imola                | 78 - 84 | 519 HF* | 519 HF  |  |
|            | 350 Nevada               | 92 - 97 | 519 HF* |         |  |
| NTX        | 350                      | 88      | 519 HF  | 519 HF  |  |
| NTX        | 350                      | 90      | 519 HF  | 506 HF  |  |
| V35        | 350 C                    | 82 - 86 | 506 HF* | 519 HF  |  |
| V35        | 350 Florida              | 85 - 86 | 506 HF* | 519 HF  |  |
| V35        | 350 GT                   | 77      | 519 HF  |         |  |
| V35        | 350 GT                   | 90      | 506 HF  | 519 HF  |  |
| V35        | 350 II, Imola, Imola II  | 77      | 519 HF* | 519 HF  |  |
| V35        | 350 III                  | 87      | 506 HF* | 506 HF  |  |
| V35        | 350 TT                   | 86      | 506 HF* | 506 HF  |  |
|            | 400                      | 77 - 84 | 519 HF* | 519 HF  |  |
|            | 500                      | 77 - 80 | 519 HF* | 519 HF  |  |
|            | 500 Monza                | 78 - 85 | 519 HF* | 519 HF  |  |
| V50        | 500 1,2,3, Monza Chopper | 77      | 519 HF* | 519 HF  |  |
|            | 650                      | 80 - 84 | 519 HF* | 519 HF  |  |
|            | 650 Florida              | 85 - 84 | 519 HF* | 519 HF  |  |
| GT         | 650 Sessantacinque       | 89      | 519 HF* | 519 HF  |  |
| NTX        | 650                      | 90 - 02 | 519 HF  | 506 HF  |  |

**RECOMMENDED**

1xx = Scooter Pads  
5xx = Street, Off Road & Racing Pads  
2xxx = Brake Shoes



| MOTO-GUZZI |                                     |         |         |        |  |
|------------|-------------------------------------|---------|---------|--------|--|
| V65        | 650 Florida                         | 86 - 94 | 506 HF* | 506 HF |  |
| V65        | 650 GT                              | 90 - 94 | 506 HF  | 598 HF |  |
| V65        | 650 Lario                           | 86 - 94 | 519 HF* | 519 HF |  |
| V65        | 650 NTX                             | 87 - 02 | 519 HF  | 519 HF |  |
| V65        | 650 SP, Chopper                     | 80 - 84 | 519 HF* | 519 HF |  |
| V65        | 650 TT                              | 86 - 94 | 519 HF* | 519 HF |  |
|            | 750 Brevia                          | 03 - 09 | 706 HS  | 730 LS |  |
|            | 750 Ippogrifo                       | 97      | 566 HF  | 519 HF |  |
|            | 750 Nevada                          | 92 - 96 | 519 HF* |        |  |
|            | 750 Nevada Classic ie               | 06 - 11 | 706 HF  | 730 HF |  |
|            | 750 Nevada, Club/Base               | 97 - 02 | 519 HF* | 519 HF |  |
|            | 750 Nevada, Nevada Club             | 03 - 16 | 706 HF  | 730 HF |  |
|            | 750 Targa                           | 89      | 519 HF* | 519 HF |  |
| NTX        | 750                                 | 89      | 519 HF  | 519 HF |  |
| NTX        | 750                                 | 90 - 93 | 596 HS  | 506 LS |  |
| S3         | 750 Left                            | 75 - 76 | 506 HF  |        |  |
| S3         | 750 Right                           | 75 - 76 | 506 HF  |        |  |
| SP         | 750                                 | 91 - 92 | 506 HS  | 506 LS |  |
| V7         | 750 Cafe Classic                    | 10 - 13 | 706 HS  | 730 LS |  |
| V7         | 750 Classic                         | 09 - 12 | 706 HS* | 730 LS |  |
| V7         | 750 Clubman Racer                   | 10      | 706 HS* | 730 LS |  |
| V7         | 750 Racer                           | 11      | 706 HS  | 730 LS |  |
| V7         | 750 Racer                           | 12 - 14 | 706 HS  | 588 HF |  |
| V7         | 750 Stone                           | 12 - 14 | 706 HS  | 588 HF |  |
| V7 II      | 750 Racer                           | 15 - 16 | 706 HS  | 588 HF |  |
| V7 II      | 750 Scrambler                       | 16      | 706 HS  | 588 HF |  |
| V7 II      | 750 Special                         | 15 - 16 | 706 HS  | 588 HF |  |
| V7 II      | 750 Stone                           | 15 - 16 | 706 HS  | 588 HF |  |
| V7 II      | 750 Stornello                       | 16      | 706 HS  | 588 HF |  |
| V7 II      | 750 Stornello Ltd. Edition          | 17 - 18 | 706 HS  | 588 HF |  |
| V7 III     | 750 Anniversario                    | 17 - 18 | 706 HS  | 588 HF |  |
| V7 III     | 750 Carbon                          | 18 -    | 706 HS  | 588 HF |  |
| V7 III     | 750 Euro 4                          | 17 - 18 | 706 HS  | 588 HF |  |
| V7 III     | 750 Milano                          | 18 -    | 706 HS  | 588 HF |  |
| V7 III     | 750 Racer                           | 17 - 18 | 706 HS  | 588 HF |  |
| V7 III     | 750 Rough                           | 18 -    | 706 HS  | 588 HF |  |
| V7 III     | 750 Special                         | 17 - 18 | 706 HS  | 588 HF |  |
| V7 III     | 750 Stone                           | 17 - 18 | 706 HS  | 588 HF |  |
| V75        | 750                                 | 86 - 88 | 506 HF* | 506 HF |  |
| V75        | 750 Duna                            | 86 - 90 | 506 HF  | 506 HF |  |
| V75        | 750 TT Paris-Dakar                  | 86      | 506 HF  | 506 HF |  |
|            | 850 Le Mans                         | 76 - 79 | 506 HF* | 506 HF |  |
| T          | 850                                 | 74 - 76 | 506 HF  |        |  |
| T3         | 850                                 | 75 - 80 | 506 HF* | 506 HF |  |
| T4         | 850                                 | 75 - 82 | 506 HF* | 506 HF |  |
| T5         | 850                                 | 75 - 88 | 506 HF* | 506 HF |  |
| T5         | 850 N.T.                            | 86 - 88 | 506 HF* | 506 HF |  |
| V9         | 850 Bobber                          | 16 - 17 | 706 HS  | 588 HF |  |
| V9         | 850 Roamer                          | 16 - 17 | 706 HS  | 588 HF |  |
| V9         | 850 X-Track                         | 17      | 706 HS  | 588 HF |  |
|            | 940 Custom                          | 07      | 706 HS* | 674 LS |  |
|            | 1000                                | 81 - 83 | 554 HF* | 554 HF |  |
|            | 1000 California II                  | 85 - 88 | 506 HF* | 506 HF |  |
|            | 1000 California III C               | 91 - 95 | 506 HS* | 506 LS |  |
|            | 1000 California III, Fuel Injection | 89      | 506 HF* | 506 HF |  |
|            | 1000 Daytona                        | 91 - 02 | 566 HF* | 506 HF |  |
|            | 1000 Le Mans IV                     | 85 - 89 | 506 HF* | 506 HF |  |
|            | 1000 Le Mans, V                     | 90 - 98 | 506 HS* | 506 LS |  |
|            | 1000 Quota                          | 92      | 566 HF* | 614 HF |  |
| GT         | 1000 V                              | 91      | 506 HS* | 506 LS |  |
| RS         | 1000 Daytona                        | 97 - 00 | 566 HF* | 519 HF |  |
| S          | 1000                                | 90      | 506 HS* | 506 LS |  |
| SP         | 1000 III                            | 91 - 94 | 506 HS* | 506 LS |  |
| SP         | 1000 Le Mans Left/Rear              | 79 - 83 | 506 HF  | 554 HF |  |
| SP         | 1000 Le Mans Right                  | 79 - 83 | 506 HF  |        |  |
| V          | 1000 Strada                         | 93 - 94 | 506 HF* | 519 HF |  |
| V10        | 1000 Centauro                       | 96 - 00 | 566 HF* | 519 HF |  |
|            | 1100 California                     | 96 - 99 | 506 HS* | 506 LS |  |
|            | 1100 California EV                  | 06      | 706 HS  | 674 LS |  |
|            | 1100 California EV Touring          | 06      | 706 HS  | 674 LS |  |
|            | 1100 California Jackal              | 00      | 566 HF* | 674 HF |  |

\* = 2 sets required / 2 jeux pour l'Avant.





**RECOMMENDED**

1xx = Scooter Pads  
5xx = Street, Off Road & Racing Pads  
2xxx = Brake Shoes



**MOTO-GUZZI**

|        |                              |         |         |        |
|--------|------------------------------|---------|---------|--------|
| 1100   | California Jackal            | 01 - 06 | 706 HS* | 674 LS |
| 1100   | California Jackal Basic      | 00      | 566 HF  | 674 HF |
| 1100   | California Jackal Basic      | 01 - 06 | 706 HS  | 674 LS |
| 1100   | California Special           | 99 - 00 | 566 HF* | 674 HF |
| 1100   | California Special           | 01      | 706 HS* | 674 LS |
| 1100   | California Special           |         |         |        |
|        | Sport Alloy                  | 02 - 06 | 706 HS* | 674 LS |
| 1100   | California Stone Metal       | 02 - 03 | 706 HS  | 674 LS |
| 1100   | California Stone,            |         |         |        |
|        | Stone Touring                | 02 - 05 | 706 HS  | 674 LS |
| 1100   | California Titanium          | 03 - 05 | 706 HS* | 674 LS |
| 1100   | California Vintage           | 06 - 13 | 706 HS* | 674 LS |
| 1100   | Griso                        | 05 - 10 | 706 HS  | 674 LS |
| 1100   | Sport                        | 96 - 04 | 566 HF* | 519 HF |
| ES     | 1100 Quota                   | 99 - 03 | 674 HF* | 519 HF |
| EV     | 1100 California              | 97 - 00 | 566 HF* | 519 HF |
| EV     | 1100 California, 80, Touring | 01      | 706 HS* | 519 LS |
| V      | 1100 Brevia                  | 04      | 706 HS  | 730 LS |
| V      | 1100 Brevia, ABS             | 05 - 07 | 706 HS  | 671 LS |
| V11    | 1100 , Scura, Sport Scura    | 02 - 05 | 706 HS* | 519 LS |
| V11    | 1100 Lemans, Lemans Tenni,   |         |         |        |
|        | Lemans Rosso Corsa           | 01 - 06 | 706 HS* | 519 LS |
| V11    | 1100 Sport                   | 97 - 00 | 566 HF* | 519 HF |
| V11    | 1100 Sport Rosso Mandell     | 01 - 06 | 706 HS* | 519 LS |
| V11    | 1100 Sport, Sport Naked      | 01 - 05 | 706 HS* | 519 LS |
| 1200   | Griso 8V                     | 07 - 13 | 706 HS* | 671 LS |
| 1200   | MGS-01 Corsa                 | 05 - 13 | 762 SP* | 730 LS |
| 1200   | Norge                        | 06 - 14 | 706 HS* | 671 LS |
| 1200   | Norge GT 8V                  | 10 - 13 | 706 HS* | 671 LS |
| 1200   | Sport                        | 07 - 08 | 706 HS* | 671 LS |
| 1200   | Sport 4V                     | 09 - 11 | 706 HS* | 730 LS |
| 1200   | Sport 8V                     | 12 - 13 | 706 HS* | 671 LS |
| 1200   | Sport 8V SE                  | 12 - 15 | 706 HS* | 671 LS |
| 1200   | Stelvio                      | 08 - 11 | 706 SP* | 671 LS |
| 1200   | Stelvio 8V SE                | 12 - 16 | 706 SP* | 671 LS |
| 1200   | Stelvio NTX                  | 09 - 11 | 706 SP* | 671 LS |
| V      | 1200 Brevia                  | 08 - 13 | 706 HS  | 671 LS |
| 1400   | Audace                       | 15 - 17 | 706 HS* | 674 LS |
| 1400   | California Custom            | 13 - 15 | 706 HS* | 674 LS |
| 1400   | California Touring           | 13 - 15 | 706 HS* | 674 LS |
| 1400   | California Touring SE        | 16 - 17 | 706 HS* | 674 LS |
| 1400   | Eldorado                     | 15 - 17 | 706 HS* | 674 LS |
| MGX-21 | 1400 Flying Fortress         | 15 - 17 | 706 HS* | 674 LS |

**MOTOM**

|    |        |         |        |  |
|----|--------|---------|--------|--|
| 50 | Spasso | 08 - 09 | 211 HF |  |
|----|--------|---------|--------|--|

**MOTO-MORINI**

|     |                    |         |         |        |
|-----|--------------------|---------|---------|--------|
| 125 | KJ                 | 84 - 88 | 606 HF  |        |
| 125 | Strada             | 80      | 560 HF  |        |
| 250 | Strada             | 80      | 560 HF  |        |
| XE  | 250 Country        | 88      | 519 HF  |        |
| 350 | Coguardo           | 90 - 95 | 608 HF  | 519 HF |
| 350 | Coguardo, New York | 90 - 94 | 608 HF  | 519 HF |
| 350 | Dart               | 88      | 608 HF  | 519 HF |
| 350 | Dart               | 90 - 92 | 641 HF  | 519 HF |
| 350 | Excalibur          | 86      | 594 HF  | 594 HF |
| 350 | Excalibur          | 87 - 89 | 588 HF  | 606 HF |
| 350 | Indiana            | 88      | 594 HF  | 519 HF |
| 350 | K2                 | 84 - 87 | 560 HF  | 606 HF |
| 350 | Kanguro            | 88      | 588 HF  | 519 HF |
| 350 | Strada             | 76 - 81 | 560 HF  |        |
| RLX | 350 Excalibur      | 90 - 92 | 608 HF  | 519 HF |
| 400 | Dart               | 89      | 608 HF  | 519 HF |
| 400 | Dart               | 90 - 92 | 641 HF  | 519 HF |
| 400 | S                  | 82      | 519 HF* | 519 HF |
| 500 | Sei V Classic      | 89      | 519 HF* |        |
| 500 | Strada             | 80 - 82 | 560 HF  |        |
| 501 | Camel              | 88      | 588 HF  | 519 HF |
| 501 | Coguardo           | 89      | 608 HF  | 519 HF |
| 501 | Excalibur          | 86 - 91 | 594 HF  | 594 HF |
| 501 | Excalibur          | 87      | 588 HF  | 606 HF |



**RECOMMENDED**

1xx = Scooter Pads  
5xx = Street, Off Road & Racing Pads  
2xxx = Brake Shoes



**MOTO-MORINI**

|      |               |         |         |        |
|------|---------------|---------|---------|--------|
| 501  | Excalibur     | 89      | 594 HF  | 519 HF |
| 501  | New York      | 89      | 594 HF  | 519 HF |
| RLX  | 501 Excalibur | 90      | 608 HF  | 519 HF |
| 650  | Indiana       | 88      | 594 HF  | 519 HF |
| 750  | Indiana       | 88      | 594 HF  | 519 HF |
| 1200 | 11 1/2        | 18 -    | 706 HS* | 730 LS |
| 1200 | 9 1/2         | 06 - 09 | 706 HS* | 730 LS |
| 1200 | Corsaro       | 06 - 13 | 706 HS* | 730 LS |
| 1200 | Corsaro ZZ    | 18 -    | 901 HS* | 730 LS |
| 1200 | Granferro     | 10      | 762 HS* | 671 LS |
| 1200 | Granpasso     | 08 - 13 | 674 HS* | 671 LS |
| 1200 | GT            | 10      | 674 HS* | 671 LS |
| 1200 | Milano        | 18 -    | 901 HS* | 730 LS |
| 1200 | Scrambler     | 09 - 10 | 674 HS* | 671 LS |
| 1200 | Scrambler     | 18 -    | 901 HS* | 730 LS |
| 1200 | Sport         | 08 - 13 | 706 HS* | 730 LS |

**MOTOR UNION**

|    |             |         |        |  |
|----|-------------|---------|--------|--|
| JC | 125 2B Deer | 98 - 99 | 690 HF |  |
| HK | 250 Haoke   | 97 - 99 | 638 HF |  |

**MOTORHISPANIA**

|     |                  |         |        |        |
|-----|------------------|---------|--------|--------|
| 50  | AJP Caliper      |         |        |        |
|     | incl. pin/spring | 89 - 18 | 188 HF |        |
| MH  | 50 Furia 6v      | 99      | 105 HF | 105 HF |
| MH  | 50 Furia Max     | 06 - 10 | 105 HF | 105 HF |
| MH  | 50 Urban Bike    | 06 - 10 | 168 HF | 105 HF |
| RX  | 50 R             | 08 - 14 | 189 MS | 203 HF |
| RX  | 50 Racing        | 00 - 05 | 148 HF | 105 HF |
| RYZ | 50 Enduro        | 05 - 13 | 105 HF | 105 HF |
| RYZ | 50 Supermotard   | 05 - 10 | 186 HF | 105 HF |
| MH7 | 125 Naked        | 08 - 14 | 821 HS | 585 HF |
| RX  | 125 R            | 08 - 14 | 821 HS | 585 HF |
| RYZ | 125 Arena Enduro | 05 - 07 | 559 HF | 559 HF |

**MOTRON**

|     |                   |         |        |  |
|-----|-------------------|---------|--------|--|
| 50  | Spike             | 97 - 98 | 123 HF |  |
| 50  | Sting             | 95 - 98 | 123 HF |  |
| 50  | Syncro            | 97 - 98 | 123 HF |  |
| 50  | Thunder           | 95 - 98 | 123 HF |  |
| GL4 | 50 ID Flash       | 92      | 532 HF |  |
| GTD | 50 Italian Max, 2 | 92      | 532 HF |  |
| RZ1 | 50 Compact        | 92      | 532 HF |  |

**MV AGUSTA**

|     |                      |         |         |        |
|-----|----------------------|---------|---------|--------|
|     | all models           | 01      | 506 HF* | 506 HF |
| 675 | Brutale              | 12 - 15 | 706 HS* | 730 LS |
| 675 | F3                   | 11 - 12 | 706 HS* | 763 LS |
| 675 | F3                   | 13 - 14 | 706 HS* | 730 LS |
| 675 | F3                   | 15 - 17 | 901 HS* | 730 LS |
| 675 | F3 RC                | 16 - 17 | 901 HS* | 730 LS |
| 750 | Brutale, Brutale S   | 01 - 05 | 676 HS* | 763 LS |
| 750 | F4 SPR               | 01 - 03 | 676 HS* | 763 LS |
| 750 | F4/F4S               | 99 - 02 | 676 HS* | 763 LS |
| 800 | Brutale              | 13 - 17 | 706 HS* | 730 LS |
| 800 | Brutale Dragster     | 15 - 18 | 706 HS* | 730 LS |
| 800 | Brutale Dragster RC  | 17 - 18 | 706 HS* | 730 LS |
| 800 | Brutale Dragster RR  | 15 - 18 | 706 HS* | 730 LS |
| 800 | Brutale Dragster RR  |         |         |        |
|     | LH44                 | 18 -    | 706 HS* | 730 LS |
| 800 | Brutale Dragster RR  |         |         |        |
|     | Pirelli              | 18 -    | 706 HS* | 730 LS |
| 800 | Brutale RC           | 18 -    | 706 HS* | 730 LS |
| 800 | Brutale RR           | 16 - 17 | 706 HS* | 730 LS |
| 800 | F3                   | 14 - 17 | 901 HS* | 763 LS |
| 800 | F3 RC                | 16 - 17 | 901 HS* | 730 LS |
| 800 | Rivale               | 13 - 17 | 900 HS* | 730 LS |
| 800 | RVSΔ1                | 18 -    | 706 HS* | 730 LS |
| 800 | Stradale             | 15 - 16 | 900 HS* | 730 LS |
| 800 | Turismo Veloce       | 14 - 16 | 900 HS* | 730 LS |
| 800 | Turismo Veloce Lusso | 14 - 16 | 900 HS* | 730 LS |
| 800 | Turismo Veloce RC    | 17 - 18 | 900 HS* | 730 LS |

\* = 2 sets required / 2 jeux pour l'Avant.

Full compound selection, see under "Brake pad 1:1 Drawings" / Sélection complète de composés, voir "1:1 Schémas Plaquettes de frein".

**RECOMMENDED**1xx = Scooter Pads  
5xx = Street, Off Road & Racing Pads  
2xxx = Brake Shoes

| MV AGUSTA                    |         |         |        |  |
|------------------------------|---------|---------|--------|--|
| 910 Brutale                  | 06 - 08 | 676 HS* | 763 LS |  |
| 910 Brutale R                | 06 - 08 | 676 HS* | 763 LS |  |
| 910 Brutale S                | 06 - 08 | 676 HS* | 763 LS |  |
| 920 Brutale                  | 12 - 14 | 706 HS* | 763 LS |  |
| 989 Brutale R                | 09      | 706 HS* | 763 LS |  |
| 990 Brutale R                | 10 - 11 | 706 HS* | 763 LS |  |
| 1000 F4 LH44                 | 18 -    | 841 SP* | 763 LS |  |
| 1000 F4 Mamba                | 04 - 06 | 676 HS* | 763 LS |  |
| 1000 F4 R                    | 06 - 07 | 762 HS* | 763 LS |  |
| 1000 F4 R                    | 12 - 15 | 841 SP* | 763 LS |  |
| 1000 F4 RC                   | 15 - 18 | 841 SP* | 763 LS |  |
| 1000 F4 RR                   | 12 - 17 | 841 SP* | 763 LS |  |
| 1000 F4 Tamburini            | 04 - 06 | 676 HS* | 763 LS |  |
| 1000 F4S                     | 04 - 06 | 676 HS* | 763 LS |  |
| 1078 Brutale RR              | 09      | 841 HS* | 763 LS |  |
| 1078 F4 CC                   | 08 - 11 | 841 SP* | 763 LS |  |
| 1078 F4 RR                   | 08 - 11 | 841 SP* | 763 LS |  |
| 1090 Brutale Corse           | 14 - 16 | 841 HS* | 763 LS |  |
| 1090 Brutale R               | 12 - 15 | 706 HS* | 763 LS |  |
| 1090 Brutale RR              | 10 - 17 | 841 HS* | 763 LS |  |
| MZ                           |         |         |        |  |
| 50 (MUZ) Moskito             | 99 - 02 | 111 HF  |        |  |
| 50 (MUZ) Moskito SX          | 00 - 02 | 101 HF  |        |  |
| 125 (MUZ) Moskito            | 99 - 02 | 111 CT  |        |  |
| 125 Mantizz S                | 07      | 103 CT  |        |  |
| 125 Roadstar                 | 92 - 94 | 506 HF  |        |  |
| 125 SM, SX                   | 99 - 01 | 681 HF  | 633 HF |  |
| 125 SM, SX                   | 02 - 08 | 713 HF  | 633 HF |  |
| 125 Sportstar                | 93 - 98 | 506 HF  |        |  |
| ETZ 125                      | 82 - 84 | 506 HF  | 2172   |  |
| ETZ 125                      | 85 - 92 | 2172    | 2172   |  |
| ETZ 125                      | 85 - 92 | 506 HF  |        |  |
| RT 125                       | 06 - 08 | 633 HF  | 633 HF |  |
| TS 125                       | 73 - 85 | 2171    | 2172   |  |
| ETZ 150                      | 82 - 84 | 506 HF  | 2172   |  |
| ETZ 150                      | 85 - 92 | 2172    | 2172   |  |
| ETZ 150                      | 85 - 95 | 506 HF  |        |  |
| TS 150                       | 73 - 85 | 2171    | 2172   |  |
| ETZ 250                      | 82 - 84 | 506 HF  | 2171   |  |
| ETZ 250                      | 85 - 92 | 2171    | 2171   |  |
| TS 250                       | 73 - 81 | 2171    | 2171   |  |
| 251 (MUZ) Sportstar          | 96 - 98 | 506 HF  |        |  |
| 251 Saxon Tour               | 93 - 98 | 506 HF  |        |  |
| ETZ 251                      | 89      | 506 HF  |        |  |
| ETZ 300 LUX                  | 90      | 506 HF  |        |  |
| ETZ 300 X                    | 88      | 506 HF  |        |  |
| 301 (MUZ) Sportstar          | 96 - 98 | 506 HF  |        |  |
| 301 Saxon Tour               | 93 - 98 | 506 HF  |        |  |
| ETZ 301                      | 90 - 92 | 506 HF  |        |  |
| 500 Saxon Country            | 92 - 98 | 506 HF  |        |  |
| 500 Saxon Fun                | 92 - 98 | 506 HF  |        |  |
| 500 Saxon Voyager            | 93 - 98 | 506 HF  |        |  |
| 500 Silver Star Classic      | 93 - 98 | 506 HF  |        |  |
| 660 (MUZ) Baghira            | 96 - 00 | 681 HF  | 684 HF |  |
| 660 (MUZ) Black Panther      | 00 - 06 | 681 HF  | 684 HF |  |
| 660 (MUZ) Mastiff            | 96 - 06 | 681 HF  | 684 HF |  |
| 660 (MUZ) Skorpion Cup       | 99      | 566 HF  | 519 HF |  |
| 660 (MUZ) Skorpion Replica   | 97 - 99 | 566 HF* | 519 HF |  |
| 660 (MUZ) Skorpion Sport     | 95 - 99 | 566 HF  | 519 HF |  |
| 660 (MUZ) Skorpion Tour      | 95 - 00 | 566 HF  | 519 HF |  |
| 660 (MUZ) Skorpion Traveller | 99 - 00 | 566 HF  | 519 HF |  |
| 660 (MUZ) Street Moto        | 00 - 06 | 681 HF  | 684 HF |  |
| 660 (MUZ) Super Moto         | 07      | 681 HF  | 684 HF |  |
| 1000 (MUZ) S                 | 01 - 02 | 706 HS* | 691 HF |  |
| 1000 (MUZ) S                 | 03 - 10 | 624 HS* | 715 LS |  |
| 1000 (MUZ) SF                | 05 - 10 | 624 HS* | 715 LS |  |
| 1000 (MUZ) SFX               | 07      | 624 HS* | 715 LS |  |
| 1000 (MUZ) SN                | 05      | 624 HS* | 715 LS |  |
| 1000 (MUZ) ST                | 07 - 10 | 624 HS* | 715 LS |  |
| NORTON                       |         |         |        |  |

**RECOMMENDED**1xx = Scooter Pads  
5xx = Street, Off Road & Racing Pads  
2xxx = Brake Shoes

| MZ                          |         |         |         |  |
|-----------------------------|---------|---------|---------|--|
| 600 Commander               | 90      | 506 HF* | 506 HF  |  |
| 600 Interpol                | 83 - 88 | 506 HF* | 506 HF  |  |
| 600 Wankel Classic          | 88 - 89 | 506 HF* | 506 HF  |  |
| F-1 600                     | 90      | 566 HF* | 506 HF  |  |
| TT 600                      | 92      | 566 HF* |         |  |
| MK2 850 Commando            | 73 - 75 | 505 HF  |         |  |
| MK3 850 Commando            | 75 - 77 | 505 HF  | 505 HF  |  |
| 961 Commando Cafe Racer     | 11 - 14 | 762 HS* | 730 LS  |  |
| 961 Commando Cafe Racer     |         |         |         |  |
| MKII                        | 18 -    | 900 HS* | 730 LS  |  |
| 961 Commando SE             | 10 - 11 | 706 HS* | 730 LS  |  |
| 961 Commando SE             | 12 - 14 | 762 HS* | 730 LS  |  |
| 961 Commando SF             | 13 - 15 | 762 HS* | 730 LS  |  |
| 961 Commando SF Sport       | 11 - 15 | 706 HS* | 730 LS  |  |
| 961 Commando Sport          | 18 -    | 900 HS* | 730 LS  |  |
| 961 Dominator Naked         | 17 - 18 | 900 HS* | 730 LS  |  |
| 1200 V4 RR                  | 18 -    | 841 HS* | 730 LS  |  |
| OSSA                        |         |         |         |  |
| TR 125 i                    | 15      | 802 RSI | 803 RSI |  |
| TR 250 i                    | 15      | 802 RSI | 803 RSI |  |
| TR 280 i                    | 10 - 15 | 802 RSI | 803 RSI |  |
| TR 280 i Explorer           | 12 - 15 | 802 RSI | 803 RSI |  |
| TR 300 Factory R            | 15      | 939 RSI | 803 RSI |  |
| TR 300 i                    | 15      | 802 RSI | 803 RSI |  |
| 350 TU-YO                   | 82      | 532 HF  |         |  |
| 500 Yanqee                  | 78      | 506 HF  | 519 HF  |  |
| PETERSON                    |         |         |         |  |
| 50 Hurricane                | 95      | 111 HF  | 101 HF  |  |
| SR 50 Racing                | 95      | 111 HF  | 101 HF  |  |
| 80 Hurricane                | 95      | 111 HF  | 101 HF  |  |
| SR 80 Racing                | 95      | 111 HF  | 101 HF  |  |
| PEUGEOT                     |         |         |         |  |
| e-Vivacity                  | 11 - 15 | 141 HF  | 2012    |  |
| 50 103                      | 71 - 75 | 2074    | 2074    |  |
| 50 104                      | 76      | 2074    | 2074    |  |
| 50 105                      | 82      | 2074    | 2074    |  |
| 50 AJP Caliper              |         |         |         |  |
| incl. pin/spring            | 89 - 18 | 188 HF  |         |  |
| 50 Blaster                  | 09 - 12 | 105 HF  |         |  |
| 50 Blaster Furios           | 11 - 12 | 105 HF  | 105 HF  |  |
| 50 Blaster RS12             | 09 - 12 | 105 HF  |         |  |
| 50 Buxy (A.J.P. cal.)       | 94 - 97 | 105 HF  | 2012    |  |
| 50 Buxy (Brembo cal.)       | 94 - 97 | 123 HF  | 2012    |  |
| 50 Buxy (Hengtong cal.)     | 94 - 97 | 102 HF  | 2012    |  |
| 50 CityStar                 | 14 - 16 | 177 HF  | 157 HF  |  |
| 50 Django Allure            | 14 - 16 | 205 HF  |         |  |
| 50 Django Evasion           | 14 - 16 | 205 HF  |         |  |
| 50 Django Heritage          | 14 - 16 | 197 HF  |         |  |
| 50 Django Sport             | 14 - 16 | 205 HF  |         |  |
| 50 Elyseo                   | 02 - 05 | 105 HF  | 105 HF  |  |
| 50 Elyseo (A.J.P. cal.)     | 99 - 01 | 105 HF  | 2012    |  |
| 50 Elystar                  | 03 - 05 | 105 HF  | 167 HF* |  |
| 50 Jet C-Tech               | 09      | 105 HF  | 105 HF  |  |
| 50 Jet-Force                | 03 - 10 | 105 HF  | 105 HF  |  |
| 50 Kisbee                   | 10 - 14 | 102 HF  |         |  |
| 50 Kisbee RS                | 11 - 17 | 102 HF  |         |  |
| 50 Looxor                   | 02 - 05 | 105 HF  | 2012    |  |
| 50 Looxor                   | 06      | 105 HF  | 105 HF  |  |
| 50 Ludix                    | 04 - 08 | 105 HF  | 2012    |  |
| 50 Ludix (Drum front)       | 04 - 05 | 2012    | 2012    |  |
| 50 Metropolis               | 85 - 90 | 2012    | 2011    |  |
| 50 Rapido                   | 85 - 93 |         | 2011    |  |
| 50 Speedake (A.J.P. cal)    | 94 - 01 | 105 HF  | 2012    |  |
| 50 Speedake (Brembo cal.)   | 94 - 01 | 123 HF  | 2012    |  |
| 50 Speedake (Hengtong cal.) | 94 - 01 | 102 HF  | 2012    |  |
| 50 Speedfight 2 A/C         | 01 - 08 | 105 HF  |         |  |
| 50 Speedfight 2 L/C         | 01 - 08 | 105 HF  | 105 HF  |  |
| 50 Speedfight 2 X-Race,     |         |         |         |  |
| Furious, 206 WRC            | 01 - 02 | 105 HF  | 105 HF  |  |

\* = 2 sets required / 2 jeux pour l'Avant.



**RECOMMENDED**

1xx = Scooter Pads  
5xx = Street, Off Road & Racing Pads  
2xxx = Brake Shoes



| PEUGEOT |                                   |         |        |        |
|---------|-----------------------------------|---------|--------|--------|
| 50      | Speedfight 3 (AC)                 | 10 - 16 | 200 HF | 2012   |
| 50      | Speedfight 3 (LC)                 | 10 - 16 | 200 HF | 157 HF |
| 50      | Speedfight 3 RS (LC)              | 10 - 16 | 200 HF | 157 HF |
| 50      | Speedfight 4 (AC)                 | 15 - 16 | 200 HF |        |
| 50      | Speedfight 4 (LC)                 | 15 - 16 | 200 HF | 157 HF |
| 50      | Speedfight LBD/LBDP               | 00      | 105 HF | 105 HF |
| 50      | Speedfight LC,<br>(A.J.P. cal.)   | 96 - 15 | 105 HF | 2012   |
| 50      | Speedfight LC,<br>(Brembo cal.)   | 96 - 15 | 123 HF | 2012   |
| 50      | Speedfight LC,<br>(Hengtong cal.) | 96 - 15 | 102 HF | 2012   |
| 50      | Speedfight Lemans                 | 11      | 105 HF | 105 HF |
| 50      | Squab (A.J.P. cal.)               | 94 - 04 | 105 HF | 2012   |
| 50      | Squab (Hengtong cal.)             | 94 - 04 | 102 HF | 2012   |
| 50      | TKR Furious                       | 05 - 10 | 105 HF |        |
| 50      | TKR WRC                           | 05 - 10 | 105 HF |        |
| 50      | Trekker Metal-X                   | 01 - 08 | 105 HF |        |
| 50      | Trekker Offroad                   | 99 - 01 | 102 HF |        |
| 50      | Trekker Road                      | 99 - 00 | 105 HF | 2012   |
| 50      | Trekker Streetboard               | 00 - 02 | 105 HF |        |
| 50      | Trekker Urban Black               | 00      | 105 HF |        |
| 50      | Tweet                             | 10 - 13 | 140 HF | 2012   |
| 50      | Tweet Evo                         | 14 - 15 | 140 HF |        |
| 50      | Tweet Evo RS                      | 14 - 17 | 140 HF | 202 HF |
| 50      | Tweet RS                          | 10 - 13 | 140 HF | 202 HF |
| 50      | V-Clic                            | 08 - 13 | 111 HF | 2012   |
| 50      | Vivacity                          | 08 - 14 | 100 HF |        |
| 50      | Vivacity (A.J.P. cal.)            | 99 - 07 | 105 HF |        |
| 50      | Vivacity (Hengtong cal.)          | 05 - 07 | 102 HF |        |
| 50      | Vivacity Sportline                | 11      | 141 HF |        |
| 50      | Zenith                            | 94 - 01 | 2011   | 2012   |
| 50      | Zenith Luxe                       | 94 - 00 | 123 HF | 2012   |
| SC      | 50                                | 85 - 90 | 2012   | 2011   |
| ST      | 50                                | 98 - 99 | 2010   | 2011   |
| STL 2   | 50                                | 90 - 94 | 2010   | 2011   |
| SV      | 50 APS                            | 91      | 2012   | 2012   |
| SV      | 50 Geo                            | 91      | 2012   | 2012   |
| SV      | 50 Geo                            | 92      | 116 HF | 2012   |
| SV      | 50 Geo                            | 93 - 99 | 121 HF | 2012   |
| SV      | 50 J,Junior                       | 93 - 97 | 2012   | 2012   |
| SV      | 50 L                              | 93      | 121 HF | 2012   |
| SV      | 50 Roland Garros                  | 93      | 113 HF | 2012   |
| SV      | 50 Sport                          | 93      | 113 HF | 2012   |
| SX      | 50                                | 75 - 80 | 2012   |        |
| XP 6    | 50 Enduro                         | 06 - 12 | 105 HF | 105 HF |
| XP 6    | 50 Supermotard                    | 06 - 12 | 105 HF | 105 HF |
| XP 6    | 50 Trail                          | 04 - 05 | 105 HF | 105 HF |
| XP S-6  | 50 Enduro                         | 02 - 05 | 105 HF | 105 HF |
| XP S-6  | 50 Supermotard                    | 04 - 05 | 168 HF | 105 HF |
| XPLD    | 50 AV                             | 90      | 607 HF |        |
| XR 6    | 50 Race Spec                      | 02 - 07 | 148 HF | 105 HF |
| XR 7    | 50                                | 08 - 10 | 189 MS | 105 HF |
| SC      | 75                                | 74 - 77 | 2012   | 2011   |
| SX      | 75                                | 74 - 77 | 2012   | 2011   |
| 80      | Metropolis                        | 80      | 2012   | 2011   |
| SC      | 80                                | 76 - 79 | 2012   | 2012   |
| SV      | 80                                | 96 - 98 | 141 HF |        |
| SV      | 80 Geo                            | 91 - 92 | 116 HF | 2012   |
| SV      | 80 Geo                            | 93 - 98 | 121 HF | 2012   |
| SX      | 80                                | 85 - 94 | 2012   | 2011   |
| SX      | 80 Pro                            | 85 - 94 | 2012   | 2011   |
| 100     | Elyseo                            | 02 - 05 | 105 HF | 105 HF |
| 100     | Elyseo (A.J.P. cal.)              | 99 - 01 | 105 HF | 2012   |
| 100     | Looxor                            | 02 - 07 | 105 HF | 105 HF |
| 100     | Speedfight                        | 00 - 07 | 105 HF | 105 HF |
| 100     | Speedfight 2, X-Race              | 01 - 07 | 105 HF | 105 HF |
| 100     | Trekker Road                      | 99 - 04 | 105 HF |        |
| 100     | Vivacity (A.J.P. cal.)            | 99 - 07 | 105 HF |        |
| 100     | Vivacity (Hengtong cal.)          | 05 - 07 | 102 HF |        |
| 125     | Active                            | 13      | 177 CT | 157 CT |
| 125     | CityStar                          | 11 - 15 | 177 CT | 157 CT |



**RECOMMENDED**

1xx = Scooter Pads  
5xx = Street, Off Road & Racing Pads  
2xxx = Brake Shoes



| PEUGEOT |                                   |         |         |        |
|---------|-----------------------------------|---------|---------|--------|
| 125     | Django Allure                     | 14 - 16 | 205 CT  | 135 CT |
| 125     | Django Evasion                    | 14 - 16 | 205 CT  | 135 CT |
| 125     | Django Heritage                   | 14 - 16 | 197 CT  | 157 CT |
| 125     | Django Sport                      | 14 - 16 | 205 CT  | 135 CT |
| 125     | Elyseo                            | 00 - 07 | 168 CT  | 167 CT |
| 125     | Elyseo (A.J.P. cal.)              | 99      | 105 CT  |        |
| 125     | Elystar                           | 03 - 07 | 168 CT  | 167 CT |
| 125     | Geopolis                          | 06 - 09 | 177 CT  | 167 CT |
| 125     | Geopolis (Nissin cal.)            | 07 - 09 | 197 CT  | 197 CT |
| 125     | Jet-Force Compressor              | 03 - 04 | 168 CT  | 167 CT |
| 125     | Looxor                            | 03 - 07 | 156 CT  | 167 CT |
| 125     | Ludix                             | 04 - 05 | 105 CT  | 2012   |
| 125     | Satelis                           | 04 - 05 | 105 CT  | 167 CT |
| 125     | Satelis                           | 06 - 16 | 168 CT  | 167 CT |
| 125     | Satelis ABS                       | 04 - 08 | 183 CT  | 167 CT |
| 125     | Satelis Black Ed.                 | 17      | 205 CT  |        |
| 125     | Tweet                             | 10 - 13 | 140 CT  | 2034   |
| 125     | Tweet Evo                         | 14 - 17 | 140 HF  | 202 HF |
| 125     | Tweet Evo RS                      | 14 - 16 | 140 HF  | 202 HF |
| 125     | Tweet RS                          | 10 - 13 | 140 CT  | 202 CT |
| 125     | Vivacity                          | 10 - 16 | 197 CT  |        |
| GT      | 125 Satelis Sport                 | 11 - 12 | 197 CT  | 197 CT |
| LXR     | 125                               | 10 - 13 | 140 CT  | 201 CT |
| RS      | 125 Geopolis                      | 10 - 13 | 177 CT  | 167 CT |
| SV      | 125 C Executive                   | 96 - 98 | 121 HF  | 2012   |
| SV      | 125 Executive                     | 94 - 95 | 121 HF  | 2012   |
| SV      | 125 Geo                           | 91 - 92 | 116 CT  | 2012   |
| SV      | 125 Geo                           | 93 - 98 | 121 HF  | 2012   |
| XPS     | 125 CT                            | 06 - 07 | 559 HF  | 559 HF |
| 150     | Django Allure                     | 14 - 15 | 205 CT  | 135 CT |
| 150     | Django Evasion                    | 14 - 15 | 205 CT  | 135 CT |
| 150     | Django Heritage                   | 14 - 15 | 197 CT  | 157 CT |
| 150     | Django Sport                      | 14 - 15 | 205 CT  | 135 CT |
| 150     | Elyseo                            | 00 - 04 | 168 CT  | 167 CT |
| 150     | Elystar                           | 03 - 04 | 168 CT  | 167 CT |
| 150     | Tweet                             | 10 - 13 | 140 CT  | 2034   |
| 150     | Tweet RS                          | 10 - 13 | 140 CT  | 202 CT |
| 200     | CityStar                          | 13 - 16 | 177 CT  | 157 CT |
| LXR     | 200                               | 10 - 11 | 140 CT  | 201 CT |
| 250     | Geopolis                          | 06 - 11 | 177 MS  | 177 MS |
| 250     | Satelis                           | 06 - 11 | 177 MS  | 177 MS |
| 300     | Geopolis GT                       | 14 - 16 | 183 MS* | 197 MS |
| 300     | Geopolis Premium<br>(Nissin cal.) | 10 - 13 | 197 MS  | 197 MS |
| 300     | Geopolis RS (Nissin cal.)         | 10 - 14 | 197 MS  | 197 MS |
| 300     | Geostyle (Nissin cal.)            | 10 - 12 | 197 MS  | 197 MS |
| 300     | Satelis                           | 13 - 16 | 197 MS  | 197 MS |
| 400     | Geopolis (AJP cal.)               | 07 - 12 | 168 CT  | 167 CT |
| 400     | Geopolis (Nissin cal.)            | 07 - 12 | 197 MS  | 197 MS |
| 400     | Geopolis GT                       | 14 - 15 | 183 MS* | 197 MS |
| 400     | Geopolis RS                       | 08 - 16 | 183 MS  | 197 MS |
| 400     | Metropolis                        | 15 - 16 | 219 MS* | 219 MS |
| 400     | Satelis i                         | 14 - 16 | 183 MS* | 197 MS |
| 500     | Satelis                           | 06      | 157 MS* | 157 MS |
| 500     | Satelis                           | 07 - 11 | 183 MS* | 197 MS |
| 600     | Satelis ABS                       | 04 - 12 | 183 CT  | 167 CT |
| PGO     |                                   |         |         |        |
|         | i-Dep                             | 09      | 140 HF  |        |
| 50      | Big Max                           | 94 - 02 | 111 HF  | 2188   |
| 50      | Big Max                           | 03 - 17 | 101 HF  |        |
| 50      | Big Max Sport                     | 96 - 04 | 111 HF  | 2188   |
| 50      | Bugrider                          | 06      | 855 HF* | 536 HF |
| 50      | Comet                             | 91 - 92 | 101 HF  | 2188   |
| 50      | Comet                             | 93 - 97 | 111 HF  | 2188   |
| 50      | Dr. Big                           | 01 - 06 | 140 HF  |        |
| 50      | EPS                               | 96 - 97 | 111 HF  |        |
| 50      | Galaxy                            | 91 - 97 | 101 HF  | 2188   |
| 50      | G-Max                             | 06 - 17 | 140 HF  |        |
| 50      | G-Max Doppler                     | 06      | 138 HF  |        |
| 50      | Hot                               | 97 - 09 | 111 HF  |        |
| 50      | Libra                             | 10      | 140 HF  |        |

\* = 2 sets required / 2 jeux pour l'Avant.

Full compound selection, see under "Brake pad 1:1 Drawings" / Sélection complète de composés, voir "1:1 Schémas Plaquettes de frein".

**RECOMMENDED**1xx = Scooter Pads  
5xx = Street, Off Road & Racing Pads  
2xxx = Brake Shoes

| PGO                          |         |         |        |  |
|------------------------------|---------|---------|--------|--|
| 50 Ligero                    | 06 - 11 | 140 HF  |        |  |
| 50 Mega                      | 96 - 99 | 111 HF  |        |  |
| 50 Road 66                   | 95      | 101 HF  |        |  |
| 50 Rodoshow                  | 01 - 09 | 114 HF  |        |  |
| 50 Star                      | 91 - 93 | 2012    | 2011   |  |
| 50 Tornado                   | 96 - 02 | 111 HF  |        |  |
| 50 T-Rex                     | 99 - 06 | 140 HF  |        |  |
| 50 T-Rex 3 (TR3-50)          | 02 - 16 | 104 HF  |        |  |
| 50 X-Rider                   | 03 - 10 |         | 544 SI |  |
| PMS 50                       | 99 - 03 | 140 HF  |        |  |
| PMX 50                       | 97 - 03 | 111 HF  |        |  |
| PMX 50 Naked                 | 06 - 08 | 140 HF  |        |  |
| PMX 50 Sport                 | 01 - 08 | 140 HF  |        |  |
| PS 50                        | 93      | 101 HF  | 2188   |  |
| 80 Big Max                   | 94 - 98 | 111 HF  |        |  |
| 80 Star                      | 91 - 95 | 2012    | 2011   |  |
| 90 Big Max                   | 97 - 06 | 111 HF  |        |  |
| 90 Galaxy                    | 92 - 94 | 101 HF  | 2188   |  |
| 90 Rodoshow                  | 02 - 06 | 114 HF  |        |  |
| 90 Tornado                   | 00      | 111 HF  |        |  |
| 100 Big Max                  | 96 - 99 | 111 HF  | 2188   |  |
| 100 My Bubu                  | 02 - 05 | 140 HF  |        |  |
| 110 T-Rex                    | 99 - 07 | 140 HF  |        |  |
| PMX 110                      | 00 - 01 | 111 HF  |        |  |
| 125 Charge A, B              | 02      | 140 CT  |        |  |
| 125 I-Charge Fuel Injection  | 03 - 08 | 163 CT  |        |  |
| 125 Kung Fu                  | 00      |         | 111 CT |  |
| 125 Libra                    | 10 - 12 | 197 CT  |        |  |
| 125 Ligero                   | 06 - 11 | 140 CT  |        |  |
| 125 My Bubu, Young Bubu      | 02 - 05 | 140 CT  |        |  |
| 125 Tornado                  | 96 - 97 | 111 CT  |        |  |
| 125 T-Rex (2 stroke)         | 99 - 16 | 140 CT  |        |  |
| 125 T-Rex (4 stroke)         | 99 - 02 | 140 CT  |        |  |
| 125 X-Hot                    | 10 - 11 | 197 CT  |        |  |
| 125 X-Rider                  | 03 - 10 |         | 544 SI |  |
| 150 TR3                      | 02 - 04 | 140 CT  |        |  |
| 150 T-Rex                    | 01 - 06 | 140 CT  | 2181   |  |
| 150 X-Rider                  | 03 - 10 |         | 544 SI |  |
| BR 150 Bugxter               | 05 - 07 | 855 HF* | 536 HF |  |
| BR 200 Bugrider              | 07      | 855 HF* | 848 HF |  |
| 250 G-Max                    | 06 - 07 | 566 HF  |        |  |
| BR 250 Bugrider              | 05 - 12 | 855 HF* | 848 HF |  |
| 500 Bug                      | 08 - 14 | 878 HF* | 810 HF |  |
| BR 500 i Racer               | 07 - 08 | 878 HF* | 810 HF |  |
| PIAGGIO VESPA                |         |         |        |  |
| 25 Zip II Cat DT             | 01      | 130 HF  | 2195   |  |
| 50 AJP Caliper               |         |         |        |  |
| incl. pin/spring             | 91 - 18 | 188 HF  |        |  |
| 50 Diesis                    | 02 - 05 | 105 HF  |        |  |
| 50 Fly                       | 05 - 17 | 177 HF  | 2205   |  |
| 50 Free (Disc Brake version) | 93 - 96 | 130 HF  |        |  |
| 50 Free (Disc Brake version) | 97 - 99 | 143 HF  | 2196   |  |
| 50 HP                        | 92 - 97 | 2146    | 2146   |  |
| 50 Liberty                   | 97 - 14 | 202 HF  | 2205   |  |
| 50 Liberty 4T                | 00 - 12 | 202 HF  | 2205   |  |
| 50 New Liberty S             | 16 - 18 | 101 HF  |        |  |
| 50 Primavera                 | 14 - 17 | 177 HF  |        |  |
| 50 Quartz                    | 92 - 96 | 117 HF  | 2187   |  |
| 50 Sfera                     | 91 - 99 | 2186    | 2187   |  |
| 50 Sprint                    | 15 - 17 | 177 HF  |        |  |
| 50 Storm                     | 94 - 95 | 143 HF  | 2187   |  |
| 50 Storm                     | 96 - 97 | 130 HF  | 2187   |  |
| 50 Typhoon                   | 94 - 95 | 143 HF  | 2187   |  |
| 50 Typhoon                   | 96 - 09 | 130 HF  |        |  |
| 50 Typhoon                   | 06 - 14 | 101 HF  |        |  |
| 50 Typhoon Catalyzed         | 02 - 08 | 143 HF  | 143 HF |  |
| 50 V FL2                     | 90      | 2146    | 2146   |  |
| 50 Zip                       | 92 - 93 | 2196    | 2187   |  |
| 50 Zip & Zip                 | 94 - 97 | 114 HF  | 2187   |  |
| 50 Zip Disco                 | 96 - 99 | 202 HF  | 2195   |  |
| 50 Zip Fast Rider            | 93 - 95 | 143 HF  | 2200   |  |

**RECOMMENDED**1xx = Scooter Pads  
5xx = Street, Off Road & Racing Pads  
2xxx = Brake Shoes

| PIAGGIO VESPA               |         |         |        |  |
|-----------------------------|---------|---------|--------|--|
| 50 Zip Fast Rider           | 96 - 97 | 202 HF  | 2195   |  |
| 50 Zip II                   | 01 - 15 | 130 HF  | 2195   |  |
| 50 Zip II Cat DT            | 01 - 12 | 130 HF  | 2195   |  |
| 50 Zip RST                  | 96 - 97 | 142 HF  |        |  |
| 50 Zip RST                  | 98 - 99 | 202 HF  |        |  |
| 50 Zip Sport Production     | 96 - 99 | 202 HF  |        |  |
| ET2 50                      | 97 - 06 | 202 HF  | 2195   |  |
| ET4 50                      | 00 - 05 | 202 HF  | 2195   |  |
| LX 50 2T/4T                 | 05 - 12 | 202 HF  | 2195   |  |
| LXV 50                      | 08      | 143 HF  |        |  |
| NRG 50                      | 96 - 00 | 130 HF  | 2200   |  |
| NRG 50 Extreme              | 01      | 143 HF  |        |  |
| NRG 50 mc2                  | 97 - 99 | 143 HF  | 2200   |  |
| NRG 50 mc3 DD               | 02 - 05 | 143 HF  | 143 HF |  |
| NRG 50 mc3 DT               | 02 - 05 | 143 HF  |        |  |
| NRG 50 Power DD             | 05      | 143 HF  | 143 HF |  |
| NRG 50 Power DD             | 06 - 16 | 101 HF  | 143 HF |  |
| NRG 50 Purejet              | 05      | 143 HF  | 143 HF |  |
| NRG 50 Purejet              | 06 - 07 | 101 HF  | 143 HF |  |
| NRG.1 50                    | 94 - 95 | 143 HF  | 2187   |  |
| NTT 50                      | 96      | 130 HF  | 2200   |  |
| PK 50                       | 83 - 98 |         | 2146   |  |
| PK 50 Special               | 83 - 98 |         | 2146   |  |
| PK 50 XL                    | 86 - 98 |         | 2146   |  |
| PK 50 XL 2                  | 86 - 98 | 2146    | 2146   |  |
| RST 50 Sfera                | 95 - 99 | 130 HF  | 2200   |  |
| S 50 2T                     | 07 - 14 | 202 HF  |        |  |
| S 50 4T                     | 09 - 14 | 202 HF  |        |  |
| S 50 College 4T             | 11 - 14 | 143 HF  |        |  |
| TPH 50                      | 93 - 95 | 143 HF  | 2187   |  |
| TPH 50                      | 96 - 97 | 130 HF  | 2200   |  |
| TPH 50 2T                   | 11 - 17 | 177 HF  |        |  |
| 80 Sfera                    | 94 - 99 | 2186    | 2187   |  |
| 80 Skipper                  | 93 - 95 | 117 HF  |        |  |
| 80 Skipper                  | 96 - 94 | 130 HF  |        |  |
| 80 Typhoon                  | 96 - 99 | 130 HF  |        |  |
| 100 Diesis                  | 02 - 03 | 105 HF  |        |  |
| 100 Fly                     | 07 - 15 | 177 HF  | 2205   |  |
| 100 Free                    | 02 - 03 | 143 HF  |        |  |
| 100 Zip                     | 07 - 10 | 177 HF  | 2205   |  |
| 125 946                     | 14 - 16 | 177 CT  | 166 CT |  |
| 125 Beverly                 | 02 - 09 | 177 CT  | 177 CT |  |
| 125 Carnaby                 | 08 - 11 | 177 CT  | 177 CT |  |
| 125 Cosa                    | 89 - 91 | 2184    | 2185   |  |
| 125 Cosa 2                  | 92 - 97 | 2184    | 2185   |  |
| 125 Fly                     | 05 - 13 | 177 CT  | 2205   |  |
| 125 Hexagon                 | 94 - 95 | 143 CT  | 2195   |  |
| 125 Liberty iGet 4T 3V      | 17 - 18 | 228 CT  |        |  |
| 125 Medley                  | 16 - 18 | 228 CT  | 187 CT |  |
| 125 Medley S                | 17 - 18 | 228 CT  | 187 CT |  |
| 125 MP3                     | 06 - 07 | 202 CT* | 191 CT |  |
| 125 MP3 (Parking Brake)     | 06 - 07 |         | 209 HF |  |
| 125 MP3 Efi                 | 08 - 11 | 202 CT* | 187 CT |  |
| 125 MP3 Efi (Parking Brake) | 08 - 11 |         | 209 HF |  |
| 125 MP3 Hybrid              | 09 - 12 | 202 CT* | 187 CT |  |
| 125 MP3 Hybrid              |         |         |        |  |
| (Parking Brake)             | 09 - 12 |         | 209 HF |  |
| 125 MP3 Yourban             | 11 - 12 | 202 CT* | 187 CT |  |
| 125 MP3 Yourban             |         |         |        |  |
| (Parking Brake)             | 11 - 12 |         | 209 HF |  |
| 125 New Liberty             | 16 - 18 | 228 CT  |        |  |
| 125 Primavera               | 14 - 16 | 177 CT  |        |  |
| 125 Primavera 70            | 16      | 177 CT  |        |  |
| 125 Sfera                   | 95 - 01 | 202 CT  | 2195   |  |
| 125 Skipper                 | 93 - 95 | 117 CT  | 2195   |  |
| 125 Skipper                 | 96 - 98 | 130 CT  |        |  |
| 125 Sprint                  | 16 - 17 | 177 CT  |        |  |
| 125 Sprint S                | 17      | 177 CT  |        |  |
| 125 Sprint Sport            | 17      | 177 CT  |        |  |
| 125 Typhoon                 | 96 - 03 | 130 CT  |        |  |
| 125 Typhoon Catalyzed       | 02 - 11 | 143 CT  | 143 CT |  |
| 125 X10 Executive Left/Rear | 13 - 15 | 177 MS  | 187 MS |  |

\* = 2 sets required / 2 jeux pour l'Avant.



**RECOMMENDED**

1xx = Scooter Pads  
5xx = Street, Off Road & Racing Pads  
2xxx = Brake Shoes



**PIAGGIO VESPA**

|     |   |         |         |        |
|-----|---|---------|---------|--------|
|     | 125 X10 Executive Right                             | 13 - 15 | 187 MS  |        |
|     | 125 X7  | 08 - 12 | 177 CT  | 187 CT |
|     | 125 X8  | 04      | 177 CT* | 157 CT |
|     | 125 X8  | 05 - 10 | 177 CT* | 191 CT |
|     | 125 X9  | 01 - 03 | 157 CT* | 157 CT |
|     | 125 X9 Evolution Left/Rear                          | 06 - 11 | 177 CT  | 157 CT |
|     | 125 X9 Evolution Right                              | 06 - 11 | 187 CT  |        |
|     | 125 X9 Left/Rear                                    | 04 - 11 | 177 CT  | 157 CT |
|     | 125 X9 Right  | 04 - 11 | 187 CT  |        |
|     | 125 Xevo  | 08 - 13 | 177 CT  | 187 CT |
|     | 125 Zip II 4T                                       | 00 - 08 | 202 CT  | 2195   |
| ET4 | 125   | 96 - 10 | 202 CT  | 2195   |
| GT  | 125 L   | 04 - 09 | 177 CT  | 166 CT |
| GTS | 125   | 07 - 10 | 177 CT  | 166 CT |
| GTS | 125 Super   | 10 - 13 | 177 CT  | 166 CT |
| GTS | 125 Super i.e.                                      | 15 - 16 | 177 CT  | 166 CT |
| GTS | 125 Supersport                                      | 13      | 177 CT  | 166 CT |
| GTS | 125 Touring   | 18 -    | 177 CT  | 166 CT |
| GTV | 125   | 08 - 09 | 177 CT  | 166 CT |
| GTX | 125 SuperHexagon<br>(Grimeca cal.)<br>(11" wheels)  | 00      | 120 CT  | 166 CT |
| GTX | 125 SuperHexagon<br>(Hengtong cal.)<br>(11" wheels) | 00      | 177 CT  | 166 CT |
| GTX | 125 SuperHexagon<br>(Hengtong cal.)<br>(12" wheels) | 01 - 03 | 177 CT  | 166 CT |
| LE  | 125 Liberty   | 99 - 03 | 202 CT  | 2205   |
| LX  | 125 4T  | 05 - 13 | 202 CT  |        |
| LX  | 125 Hexagon   | 99 - 00 | 120 CT  | 2205   |
| LX  | 125 Skipper, ST                                     | 99 - 04 | 120 CT  | 2205   |
| LX4 | 125 Hexagon   | 99 - 07 | 120 CT  | 2195   |
| LXV | 125   | 08 - 11 | 143 CT  |        |
| PK  | 125   | 83 - 89 | 2146    | 2146   |
| PK  | 125 Automatica                                      | 84 - 89 | 2146    |        |
| PK  | 125 Special   | 83 - 89 | 2146    | 2146   |
| PK  | 125 XL  | 86 - 89 | 2146    | 2146   |
| PX  | 125   | 78 - 89 | 2146    | 2146   |
| PX  | 125   | 02 - 11 | 202 CT  |        |
| PX  | 125 70  | 16      | 202 CT  |        |
| PX  | 125 Arcobalenco                                     | 83 - 89 | 2146    | 2146   |
| S   | 125 4T  | 07 - 10 | 202 CT  |        |
| SKR | 125   | 94 - 03 | 143 CT  |        |
| TPH | 125   | 96 - 03 | 130 CT  | 2195   |
|     | 150 Cosa  | 89 - 91 | 2184    | 2185   |
|     | 150 Fly   | 06 - 07 | 177 CT  | 2205   |
|     | 150 Hexagon   | 94 - 97 | 143 CT  | 2195   |
|     | 150 Liberty   | 99 - 03 | 202 CT  | 2205   |
|     | 150 Medley  | 16 - 18 | 228 CT  | 187 CT |
|     | 150 Primavera                                       | 14 - 17 | 177 CT  |        |
|     | 150 Skipper   | 93 - 03 | 117 CT  |        |
|     | 150 Sprint Veloce                                   | 75 - 80 |         | 2146   |
|     | 150 X8 Street                                       | 06 - 08 | 177 CT  |        |
| ET4 | 150   | 02 - 06 | 202 CT  |        |
| LX  | 150   | 08 - 11 | 143 CT  |        |
| PX  | 150   | 78 - 82 | 2146    | 2146   |
| PX  | 150   | 02 - 06 | 202 CT  |        |
| PX  | 150 Arcobalenco                                     | 83 - 88 | 2146    | 2146   |
| GS  | 160   | 75 - 80 |         | 2146   |
|     | 180 X9  | 02 - 06 | 157 CT* | 157 CT |
| GTX | 180 SuperHexagon<br>(Grimeca cal.)<br>(11" wheels)  | 00      | 120 CT  | 166 CT |
| GTX | 180 SuperHexagon<br>(Hengtong cal.)<br>(11" wheels) | 00      | 177 CT  | 166 CT |
| GTX | 180 SuperHexagon<br>(Hengtong cal.)<br>(12" wheels) | 01 - 03 | 177 CT  | 166 CT |
| LXT | 180 Hexagon   | 99 - 00 | 120 CT  | 2205   |
| SS  | 180   | 75 - 80 |         | 2146   |



**RECOMMENDED**

1xx = Scooter Pads  
5xx = Street, Off Road & Racing Pads  
2xxx = Brake Shoes



**PIAGGIO VESPA**

|     |   |         |         |        |
|-----|---|---------|---------|--------|
|     | 200 Beverly                             | 02 - 03 | 177 CT  | 177 CT |
|     | 200 Carnaby                             | 08 - 12 | 177 CT  | 177 CT |
|     | 200 Cosa                                | 89 - 91 | 2184    | 2185   |
|     | 200 Cosa 2                              | 92 - 97 | 2184    | 2185   |
|     | 200 Liberty                             | 06 - 13 | 202 CT  |        |
|     | 200 Rally                               | 75 - 80 |         | 2146   |
|     | 200 X8                                  | 04      | 177 CT* | 157 CT |
|     | 200 X8                                  | 05      | 177 CT* | 191 CT |
|     | 200 X9                                  | 03 - 11 | 157 CT* | 157 CT |
| BV  | 200                                     | 02 - 04 | 177 CT  | 177 CT |
| BV  | 200                                     | 05      | 177 CT  | 168 CT |
| GT  | 200 L                                   | 04 - 09 | 177 CT  | 166 CT |
| PE  | 200                                     | 83 - 88 | 2146    | 2146   |
| PX  | 200                                     | 02 - 07 | 202 CT  |        |
| PX  | 200 Arcobalenco                         | 83 - 85 | 2146    | 2146   |
| PX  | 200 E                                   | 78 - 85 | 2146    | 2146   |
|     | 250 Beverly                             | 07 - 08 | 177 MS  | 177 MS |
|     | 250 GT 60                               | 06 - 07 | 177 MS  | 166 MS |
|     | 250 LX 60                               | 06 - 10 | 202 MS  |        |
|     | 250 MP3                                 | 06 - 07 | 202 MS* | 191 MS |
|     | 250 MP3 (Parking Brake)                 | 06 - 07 |         | 209 HF |
|     | 250 MP3 Efi                             | 08 - 09 | 202 MS* | 187 MS |
|     | 250 MP3 Efi (Parking Brake)             | 08 - 09 |         | 209 HF |
|     | 250 MP3 LT iE                           | 09      | 202 MS* | 187 MS |
|     | 250 MP3 LT iE<br>(Parking Brake)        | 09      |         | 209 HF |
|     | 250 X7                                  | 08 - 09 | 177 MS  | 187 MS |
|     | 250 X8                                  | 06 - 09 | 177 MS* | 191 MS |
|     | 250 X9                                  | 00 - 04 | 157 MS* | 157 MS |
|     | 250 X9 Left/Rear                        | 05 - 10 | 177 MS  | 191 MS |
|     | 250 X9 Right                            | 05 - 10 | 187 MS  |        |
|     | 250 Xevo                                | 08 - 11 | 177 MS  | 187 MS |
| BV  | 250                                     | 06      | 177 MS  | 177 MS |
| GT  | 250 Hexagon                             | 99 - 03 | 120 MS  |        |
| GTS | 250 ABS                                 | 06 - 07 | 177 MS  | 166 MS |
| GTV | 250                                     | 08 - 10 | 177 MS  | 166 MS |
| GTX | 250 Super Hexagon                       | 01 - 02 | 120 MS  | 166 MS |
|     | 300 Beverly i.e.                        | 11 - 18 | 177 MS  | 187 MS |
|     | 300 Beverly Tourer                      | 07 - 08 | 177 MS  | 177 MS |
|     | 300 Carnaby Cruiser                     | 10 - 13 | 177 MS  | 177 MS |
|     | 300 MP3 Hybrid                          | 11 - 12 | 202 MS* | 187 MS |
|     | 300 MP3 Hybrid<br>(Parking Brake)       | 11 - 12 |         | 209 HF |
|     | 300 MP3 Hybrid iE                       | 11 - 18 | 202 MS* | 187 MS |
|     | 300 MP3 Hybrid iE<br>(Parking Brake)    | 11 - 18 |         | 209 HF |
|     | 300 MP3 iE                              | 10 - 18 | 202 MS* | 187 MS |
|     | 300 MP3 iE (Parking Brake)              | 10 - 18 |         | 209 HF |
|     | 300 MP3 LT                              | 13 - 18 | 202 MS* | 187 MS |
|     | 300 MP3 LT (Parking Brake)              | 13 - 18 |         | 209 HF |
|     | 300 MP3 LT Business                     | 13 - 18 | 202 MS* | 187 MS |
|     | 300 MP3 LT Business<br>(Parking Brake)  | 13 - 18 |         | 209 HF |
|     | 300 MP3 LT iE ABS                       | 14 - 18 | 224 MS* | 187 MS |
|     | 300 MP3 LT iE ABS<br>(Parking Brake)    | 14 - 18 |         | 209 HF |
|     | 300 MP3 LT Sport ABS                    | 14 - 18 | 224 MS* | 187 MS |
|     | 300 MP3 LT Sport ABS<br>(Parking Brake) | 14 - 18 |         | 209 HF |
|     | 300 MP3 LT Touring                      | 11 - 12 | 202 MS* | 187 MS |
|     | 300 MP3 LT Touring<br>(Parking Brake)   | 11 - 12 |         | 209 HF |
|     | 300 MP3 Touring                         | 11 - 12 | 202 MS* | 187 MS |
|     | 300 MP3 Touring<br>(Parking Brake)      | 11 - 12 |         | 209 HF |
|     | 300 MP3 Yourban iE                      | 11 - 18 | 202 MS* | 187 MS |
|     | 300 MP3 Yourban iE<br>(Parking Brake)   | 11 - 18 |         | 209 HF |
|     | 300 Sei Giorni                          | 18 -    | 177 MS  | 166 MS |
|     | 300 X7 Evo i.e.                         | 11 - 13 | 177 MS  | 187 MS |
| GTS | 300 i.e.                                | 12 - 15 | 177 MS  | 166 MS |
| GTS | 300 Super                               | 09 - 12 | 177 MS  | 166 MS |

\* = 2 sets required / 2 jeux pour l'Avant.

Full compound selection, see under "Brake pad 1:1 Drawings" / Sélection complète de composés, voir "1:1 Schémas Plaquettes de frein".

**RECOMMENDED**

1xx = Scooter Pads  
5xx = Street, Off Road & Racing Pads  
2xxx = Brake Shoes



| PIAGGIO VESPA  |   |         |          |         |  |
|----------------|---|---------|----------|---------|--|
| GTS            | 300 Super Sport i.e.                            | 11 - 15 | 177 MS   | 166 MS  |  |
| GTS            | 300 Touring ABS                                 | 17      | 177 MS   | 166 MS  |  |
| GTS            | 300 Touring i.e.                                | 11 - 12 | 177 MS   | 166 MS  |  |
| GTS            | 300 Yacht Club                                  | 18 -    | 177 MS   | 166 MS  |  |
| GTV            | 300 i.e.  | 11 - 15 | 177 MS   | 166 MS  |  |
|                | 350 Beverly S                                   | 14 - 18 | 177 MS   | 187 MS  |  |
|                | 350 Beverly Sport Touring ie                    | 12 - 18 | 159 MS   | 187 MS  |  |
|                | 350 Beverly Sport Touring ie ABS                | 12 - 18 | 177 MS   | 187 MS  |  |
|                | 350 X10 Executive (Parking Brake)               | 13 - 16 |          | 209 HF  |  |
|                | 350 X10 Executive Left/Rear                     | 13 - 16 | 177 MS   | 187 MS  |  |
|                | 350 X10 Executive Right                         | 13 - 16 | 187 MS   |         |  |
| BV             | 350   | 12 - 17 | 177 MS   | 187 MS  |  |
|                | 400 MP3 iE                                      | 07 - 10 | 202 MS*  | 177 MS  |  |
|                | 400 MP3 iE (Parking Brake)                      | 07 - 10 |          | 209 HF  |  |
|                | 400 MP3 LT iE                                   | 09 - 10 | 202 MS*  | 177 MS  |  |
|                | 400 MP3 LT iE (Parking Brake)                   | 09 - 10 |          | 209 HF  |  |
|                | 400 MP3 LT Touring                              | 11 - 12 | 202 MS*  | 177 MS  |  |
|                | 400 MP3 LT Touring (Parking Brake)              | 11 - 12 |          | 209 HF  |  |
|                | 400 MP3 Touring                                 | 11 - 12 | 202 MS*  | 177 MS  |  |
|                | 400 MP3 Touring (Parking Brake)                 | 11 - 12 |          | 209 HF  |  |
|                | 400 X8 Left/Rear                                | 07 - 08 | 177 MS   | 177 MS  |  |
|                | 400 X8 Right                                    | 07 - 08 | 187 MS   |         |  |
|                | 400 Xevo Left/Rear                              | 08 - 11 | 177 MS   | 177 MS  |  |
|                | 400 Xevo Right                                  | 08 - 11 | 187 MS   |         |  |
|                | 500 Beverly Cruiser                             | 08 - 12 | 157 MS*  | 157 MS  |  |
|                | 500 MP3   | 10      | 202 MS*  | 177 MS  |  |
|                | 500 MP3 (Parking Brake)                         | 10      |          | 209 HF  |  |
|                | 500 MP3 LT Touring Business                     | 11 - 13 | 202 MS*  | 177 MS  |  |
|                | 500 MP3 LT Touring Business (Parking Brake)     | 11 - 13 |          | 209 HF  |  |
|                | 500 MP3 LT Touring Business ABS                 | 14 - 15 | 224 MS*  | 177 MS  |  |
|                | 500 MP3 LT Touring Business ABS (Parking Brake) | 14 - 15 |          | 209 HF  |  |
|                | 500 MP3 LT Touring Sport                        | 11 - 13 | 202 MS*  | 177 MS  |  |
|                | 500 MP3 LT Touring Sport (Parking Brake)        | 11 - 13 |          | 209 HF  |  |
|                | 500 MP3 LT Touring Sport ABS                    | 14 - 15 | 224 MS*  | 177 MS  |  |
|                | 500 MP3 LT Touring Sport ABS (Parking Brake)    | 14 - 15 |          | 209 HF  |  |
|                | 500 MP3 Touring Business                        | 11 - 12 | 202 MS*  | 177 MS  |  |
|                | 500 MP3 Touring Business (Parking Brake)        | 11 - 12 |          | 209 HF  |  |
|                | 500 MP3 Touring Sport                           | 11 - 12 | 202 MS*  | 177 MS  |  |
|                | 500 MP3 Touring Sport (Parking Brake)           | 11 - 12 |          | 209 HF  |  |
|                | 500 X10 Executive (Parking Brake)               | 13 - 15 |          | 209 HF  |  |
|                | 500 X10 Executive Left/Rear                     | 13 - 15 | 177 MS   | 187 MS  |  |
|                | 500 X10 Executive Right                         | 13 - 15 | 187 MS   |         |  |
|                | 500 X9  | 01 - 03 | 157 MS*  | 157 MS  |  |
|                | 500 X9 Evolution                                | 04 - 07 | 151 MS*  | 157 MS  |  |
|                | 500 X9 Evolution ABS                            | 04 - 07 | 151 MS   | 157 MS  |  |
| BV             | 500   | 06 - 08 | 157 MS*  | 157 MS  |  |
| <b>POLARIS</b> |   |         |          |         |  |
|                | EV-LSV  | 10 - 11 | 897 ATS* | 800 ATS |  |
|                | LSV 4x4   | 11 - 12 | 897 ATS* | 800 ATS |  |
|                | Ranger 48v EV                                   | 13 - 16 | 897 ATS* | 800 ATS |  |
|                | 50 Predator                                     | 04 - 14 | 2048     |         |  |
|                | 50 Scrambler                                    | 01 - 03 | 2048     |         |  |
|                | 90 Predator                                     | 03 - 14 | 2043     |         |  |
|                | 90 Scrambler                                    | 01 - 03 | 2048     |         |  |
|                | 90 Sportsman                                    | 01 - 15 | 2048     |         |  |
|                | 170 Ranger RZR                                  | 09 - 16 | 905 SI*  | 906 SI  |  |
|                | 200 Phoenix                                     | 05 - 09 | 544 ATS* | 546 SI  |  |
|                | 200 Phoenix                                     | 10 - 14 | 905 SI*  | 546 SI  |  |

**RECOMMENDED**

1xx = Scooter Pads  
5xx = Street, Off Road & Racing Pads  
2xxx = Brake Shoes



| POLARIS |   |         |          |          |  |
|---------|---|---------|----------|----------|--|
|         | 200 Sawtooth                            | 06 - 07 | 544 ATS* | 544 ATS  |  |
|         | 250 2x4, 4x4                            | 90 - 93 | 716 ATS* | 717 ATS  |  |
|         | 250 Big Boss 4x6, 6x6                   | 89 - 93 | 716 ATS* | 717 ATS  |  |
|         | 250 Big Boss 4x6, 6x6 Middle Axle Brake | 89 - 93 | 717 ATS  |          |  |
|         | 250 Cyclone                             | 87      | 2028     | 643 HF   |  |
|         | 250 Trail Blazer                        | 90 - 98 | 716 ATS* | 717 ATS  |  |
|         | 250 Trail Blazer                        | 99 - 07 | 716 ATS* | 755 ATS  |  |
|         | 250 Trail Boss                          | 88 - 90 | 642 ATS* | 643 HF   |  |
|         | 250 Trail Boss                          | 91 - 99 | 716 ATS* | 717 ATS  |  |
|         | 250 Trail Boss 2x4, 4x4                 | 91 - 92 | 716 ATS* | 717 ATS  |  |
|         | 250 Xplorer 4x4                         | 00 - 02 | 716 ATS* | 755 ATS  |  |
|         | 300 2x4, 4x4                            | 94 - 95 | 716 ATS* | 717 ATS  |  |
|         | 300 Big Boss 6x6                        | 94      | 716 ATS* | 717 ATS  |  |
|         | 300 Big Boss 6x6 Middle Axle Brake      | 94      | 717 ATS  |          |  |
|         | 300 Hawkeye 2x4, 4x4                    | 06      | 822 ATS* | 822 ATS  |  |
|         | 300 Hawkeye 2x4, 4x4                    | 07 - 11 | 716 ATS* | 716 ATS  |  |
|         | 300 Sportsman 4x4                       | 08 - 11 | 642 ATS* | 642 ATS  |  |
|         | 300 Xplorer 4x4                         | 96 - 99 | 716 ATS* | 717 ATS  |  |
|         | 300 Xpress 2x4                          | 98 - 99 | 716 ATS* | 717 ATS  |  |
|         | 300 Xpress L                            | 96 - 97 | 716 ATS* | 717 ATS  |  |
|         | 325 Magnum 2x4, 4x4                     | 00 - 02 | 716 ATS* | 755 ATS  |  |
|         | 325 Trail Boss                          | 00 - 02 | 716 ATS* | 755 ATS  |  |
|         | 325 Xpedition                           | 00 - 01 | 642 ATS* | 755 ATS  |  |
|         | 325 Xpedition                           | 02      | 642 ATS* | 787 ATS  |  |
|         | 330 ATP                                 | 04 - 05 | 716 ATS* | 716 ATS* |  |
|         | 330 ATP                                 | 06 - 05 | 716 ATS* | 787 ATS  |  |
|         | 330 E Trail Blazer                      | 08 - 12 | 642 ATS* | 787 ATS  |  |
|         | 330 Magnum 2x4, 4x4                     | 03 - 13 | 716 ATS* | 787 ATS  |  |
|         | 330 Trail Boss                          | 03 - 14 | 716 ATS* | 755 ATS  |  |
|         | 335 Sportsman 4x4                       | 99 - 02 | 716 ATS* | 755 ATS  |  |
|         | 350 Big Boss                            | 93      | 716 ATS* | 717 ATS  |  |
|         | 350 Big Boss Middle Axle Brake          | 93      | 717 ATS  |          |  |
|         | 350 L 2x4, 4x4                          | 90      | 716 ATS* | 717 ATS  |  |
|         | 350 L 4x4                               | 93      | 716 ATS* | 717 ATS  |  |
|         | 350 Sportsman 4x4                       | 93      | 716 ATS* | 717 ATS  |  |
|         | 350 Trail Boss 2x4                      | 85 - 87 | 2028     |          |  |
|         | 350 Trail Boss 2x4, 4x4                 | 88 - 89 | 716 ATS* | 717 ATS  |  |
|         | 350 Trail Boss L 2x4                    | 91 - 93 | 716 ATS* | 717 ATS  |  |
|         | 350 Trail Boss L 4x4                    | 91      | 716 ATS* | 717 ATS  |  |
|         | 400 Big Boss L 6x6                      | 96      | 716 ATS* | 717 ATS  |  |
|         | 400 Big Boss L 6x6 Middle Axle Brake    | 96      | 756 ATS  |          |  |
|         | 400 L 2x4                               | 94 - 95 | 716 ATS* | 717 ATS  |  |
|         | 400 L 4x4                               | 94      | 716 ATS* | 717 ATS  |  |
|         | 400 Scrambler 2x4, 4x4                  | 00 - 03 | 716 ATS* | 755 ATS  |  |
|         | 400 Scrambler 4x4                       | 98      | 716 ATS* | 717 ATS  |  |
|         | 400 Scrambler 4x4                       | 99 - 03 | 716 ATS* | 755 ATS  |  |
|         | 400 Scrambler L 4x4                     | 95 - 97 | 716 ATS* | 717 ATS  |  |
|         | 400 Sport                               | 99 - 00 | 716 ATS* | 755 ATS  |  |
|         | 400 Sport L                             | 94 - 98 | 716 ATS* | 717 ATS  |  |
|         | 400 Sportsman                           | 01 - 13 | 716 ATS* | 755 ATS  |  |
|         | 400 Sportsman L 4x4                     | 94 - 97 | 716 ATS* | 717 ATS  |  |
|         | 400 Trail Blazer                        | 03 - 04 | 716 ATS* | 755 ATS  |  |
|         | 400 Xplorer L 4x4                       | 95 - 99 | 716 ATS* | 717 ATS  |  |
|         | 400 Xplorer L 4x4                       | 00 - 02 | 716 ATS* | 755 ATS  |  |
|         | 400 Xpress L                            | 96 - 97 | 716 ATS* | 717 ATS  |  |
|         | 425 2x4, 4x4 Magnum                     | 95 - 98 | 716 ATS* | 717 ATS  |  |
|         | 425 Magnum 6x6                          | 96      | 716 ATS* | 717 ATS  |  |
|         | 425 Magnum 6x6 Middle Axle Brake        | 96      | 756 ATS  |          |  |
|         | 425 Xpedition 4x4                       | 00 - 03 | 716 ATS* | 755 ATS  |  |
|         | 450 Outlaw MXR                          | 09 - 11 | 898 ATS* | 642 ATS  |  |
|         | 450 Outlaw S                            | 08      | 898 ATS* | 642 ATS  |  |
|         | 450 Sportsman                           | 06 - 09 | 716 ATS* | 787 ATS  |  |
|         | 455 Diesel EBS 4x4                      | 99 - 01 | 716 ATS* | 755 ATS  |  |
|         | 500 ATP HO                              | 04 - 05 | 716 ATS* | 716 ATS* |  |
|         | 500 Big Boss 6x6                        | 98 - 99 | 716 ATS* | 717 ATS  |  |
|         | 500 Big Boss 6x6 Middle Axle Brake      | 98 - 99 | 717 ATS  |          |  |

\* = 2 sets required / 2 jeux pour l'Avant.



**RECOMMENDED**

1xx = Scooter Pads  
 5xx = Street, Off Road & Racing Pads  
 2xxx = Brake Shoes



**POLARIS**

|                                       |         |          |          |
|---------------------------------------|---------|----------|----------|
| 500 E Scrambler 2x4, 4x4              | 08 - 11 | 642 ATS* | 787 ATS  |
| 500 Magnum 2x4, 4x4                   | 02 - 07 | 716 ATS* | 787 ATS  |
| 500 Magnum 4x4                        | 00 - 01 | 716 ATS* | 755 ATS  |
| 500 Outlaw                            | 06 - 09 | 716 ATS* | 716 ATS  |
| 500 Predator                          | 03 - 13 | 716 ATS* | 716 ATS  |
| 500 Predator e                        | 06 - 13 | 716 ATS* | 787 ATS  |
| 500 Ranger 2x4                        | 08 - 07 | 897 ATS* | 800 ATS  |
| 500 Ranger 2x4 EFi                    | 08 - 13 | 897 ATS* | 800 ATS  |
| 500 Ranger 2x4, 4x4, 6x6              | 02 - 13 | 800 ATS* | 800 ATS* |
| 500 Ranger 4x4                        | 12 - 13 | 897 ATS* | 800 ATS  |
| 500 Ranger 6x6                        | 00 - 02 | 716 ATS* |          |
| 500 Ranger XP                         | 06 - 09 | 800 ATS* | 800 ATS  |
| 500 Revolver                          | 06      | 642 ATS* | 642 ATS  |
| 500 Scrambler 2x4                     | 01 - 02 | 716 ATS* | 755 ATS  |
| 500 Scrambler 4x4                     | 97      | 716 ATS* | 717 ATS  |
| 500 Scrambler 4x4                     | 98 - 13 | 716 ATS* | 755 ATS  |
| 500 Sportsman 4x4                     | 96 - 14 | 716 ATS* | 717 ATS  |
| 500 Sportsman 6x6                     | 00 - 11 | 716 ATS* | 757 ATS  |
| 500 Sportsman EBS 4x4                 | 98 - 02 | 716 ATS* | 755 ATS  |
| 500 Sportsman HO<br>(from 16.12.2008) | 09 - 14 | 642 ATS* | 899 ATS  |
| 500 Sportsman HO<br>(to 15.12.2008)   | 03 - 08 | 642 ATS* | 787 ATS  |
| 500 Xplorer 4x4                       | 97      | 716 ATS* | 717 ATS  |
| 525 Outlaw                            | 07 - 13 | 898 ATS* | 642 ATS  |
| 525 Outlaw IRS                        | 08 - 13 | 898 ATS* | 642 ATS  |
| 525 Outlaw S                          | 08 - 11 | 898 ATS* | 642 ATS  |
| 550 Sportsman                         | 11 - 14 | 899 ATS* | 899 ATS  |
| 550 Sportsman EPS                     | 10 - 14 | 899 ATS* | 899 ATS  |
| 550 Sportsman EPS X2                  | 14      | 899 ATS* | 899 ATS  |
| 550 Sportsman Touring EPS             | 10 - 12 | 899 ATS* | 899 ATS  |
| 550 Sportsman X2                      | 10 - 14 | 899 ATS* | 899 ATS  |
| 550 Sportsman XP                      | 09 - 12 | 899 ATS* | 899 ATS  |
| 550 Sportsman XP EPS                  | 09 - 14 | 899 ATS* | 899 ATS  |
| 550 Sportsman XP Touring<br>EPS       | 12 - 14 | 899 ATS* | 899 ATS  |
| 570 Ranger RZR EFi                    | 12 - 13 | 898 ATS* | 642 ATS  |
| 600 Sportsman                         | 03 - 06 | 642 ATS* | 787 ATS* |
| 700 MVRS 4x4                          | 08      | 897 ATS* | 897 ATS  |
| 700 Ranger 4x4 EFi                    | 08      | 897 ATS* | 800 ATS  |
| 700 Ranger 6x6 EFi                    | 12 - 13 | 897 ATS* | 800 ATS  |
| 700 Sportsman                         | 02 - 09 | 642 ATS* | 787 ATS* |
| 700 Sportsman MV 700                  | 05 - 06 | 642 ATS* | 787 ATS  |
| 800 MVRS 4x4                          | 08      | 897 ATS* | 897 ATS  |
| 800 Ranger 4x4 EFi                    | 10      | 897 ATS* | 897 ATS  |
| 800 Ranger 6x6 EFi                    | 12 - 15 | 897 ATS* | 897 ATS  |
| 800 Ranger Crew                       | 12 - 15 | 897 ATS* | 897 ATS  |
| 800 Ranger RZR EFi                    | 08 - 14 | 898 ATS* | 642 ATS  |
| 800 Ranger RZR S EFi                  | 09 - 15 | 898 ATS* | 642 ATS  |
| 800 Ranger RZR4 EFi                   | 12 - 14 | 897 ATS* | 800 ATS  |
| 800 Ranger XP                         | 12 - 13 | 897 ATS* | 800 ATS  |
| 800 RZR                               | 08 - 15 | 898 ATS* | 642 ATS  |
| 800 RZR-4                             | 10 - 14 | 897 ATS* | 800 ATS  |
| 800 Sportsman<br>(from 16.12.2008)    | 09 - 14 | 642 ATS* | 899 ATS  |
| 800 Sportsman<br>(to 15.12.2008)      | 05 - 08 | 642 ATS* | 787 ATS  |
| 850 Forest                            | 15      | 899 ATS* | 899 ATS  |
| 850 Scrambler                         | 15      | 899 ATS* | 899 ATS  |
| 850 Scrambler HO EPS                  | 13 - 15 | 899 ATS* | 899 ATS  |
| 850 Scrambler MD                      | 15      | 899 ATS* | 899 ATS  |
| 850 Scrambler XP HO EPS               | 14 - 15 | 899 ATS* | 899 ATS  |
| 850 Sportsman                         | 11 - 13 | 899 ATS* | 899 ATS  |
| 850 Sportsman MV                      | 12      | 899 ATS* | 899 ATS  |
| 850 Sportsman Touring                 | 14 - 15 | 899 ATS* | 899 ATS  |
| 850 Sportsman Touring EPS             | 10 - 13 | 899 ATS* | 899 ATS  |
| 850 Sportsman Touring HO<br>EPS       | 13 - 14 | 899 ATS* | 899 ATS  |
| 850 Sportsman Touring MD              | 15      | 899 ATS* | 899 ATS  |
| 850 Sportsman X2                      | 11      | 899 ATS* | 899 ATS  |
| 850 Sportsman XP                      | 09 - 14 | 899 ATS* | 899 ATS  |
| 850 Sportsman XP EPS                  | 09 - 14 | 899 ATS* | 899 ATS  |



**RECOMMENDED**

1xx = Scooter Pads  
 5xx = Street, Off Road & Racing Pads  
 2xxx = Brake Shoes



**POLARIS**

|                                 |         |          |         |
|---------------------------------|---------|----------|---------|
| 850 Sportsman XP HO EPS         | 13 - 14 | 899 ATS* | 899 ATS |
| 850 Sportsman XP HO EPS<br>MD   | 15      | 899 ATS* | 899 ATS |
| 850 Sportsman XP Touring<br>EPS | 15      | 899 ATS* | 899 ATS |
| 900 Ranger 4x4 Diesel           | 10 - 14 | 897 ATS* | 897 ATS |
| 900 Ranger RZR4 XP EFi          | 12 - 15 | 897 ATS* | 897 ATS |
| 900 Ranger RZR4 XP4 EFi         | 12 - 14 | 897 ATS* | 897 ATS |
| 1000 Forest                     | 15      | 899 ATS* | 899 ATS |
| 1000 General EPS                | 16 - 17 | 897 ATS* | 898 ATS |
| 1000 Ranger RZR XP              | 14      | 897 ATS* | 897 ATS |
| 1000 Scrambler MD               | 15 - 16 | 899 ATS* | 899 ATS |
| 1000 Scrambler XP               | 15 - 17 | 899 ATS* | 899 ATS |
| 1000 Scrambler XP HO EPS        | 14      | 899 ATS* | 899 ATS |
| 1000 Sportsman MD               | 15 - 16 | 899 ATS* | 899 ATS |
| 1000 Sportsman Touring          | 15 - 17 | 899 ATS* | 899 ATS |
| 1000 Sportsman XP               | 15 - 17 | 899 ATS* | 899 ATS |
| 1050 MV Diesel Crew             | 13 - 17 | 897 ATS* | 897 ATS |

**POLINI**

|          |         |         |         |
|----------|---------|---------|---------|
| X1 50 R  | 04 - 06 | 794 RSI | 794 RSI |
| X3 50 R  | 04 - 06 | 794 RSI | 794 RSI |
| X5 65 RP | 05 - 06 | 794 RSI | 794 RSI |

**PRAGA**

|        |         |        |        |
|--------|---------|--------|--------|
| ED 250 | 99 - 03 | 671 SI | 675 SI |
| CD 610 | 99 - 03 | 671 SI | 675 SI |

**PROTOS**

|                       |    |        |  |
|-----------------------|----|--------|--|
| 50 Ellisse Scootercar | 98 | 123 HF |  |
|-----------------------|----|--------|--|

**PUCH**

|  |         |        |        |
|--|---------|--------|--------|
| 50 all models                          | 86      | 532 HF |        |
| 50 Cobra 6 GT, GTL                     | 80 - 84 | 532 HF | 2074   |
| 50 Condor                              | 90      | 559 HF |        |
| 50 Maxi 30 all models<br>(excl. Spain) | 69 - 80 | 2074   | 2074   |
| 50 Maxi 40 all models                  | 69 - 80 | 2074   | 2074   |
| 50 Monza 4 GP, all models              | 79 - 83 | 2074   | 2074   |
| 50 Monza 4 SL                          | 79      | 2074   | 2074   |
| 50 Monza 4 SL, GSL                     | 80 - 83 | 532 HF | 2074   |
| 50 Monza Lujo                          | 79 - 85 | 625 HF |        |
| 50 Storm (Austria)                     | 78 - 83 | 143 HF | 2187   |
| 50 Typhoon (Austria)                   | 95      | 143 HF | 2187   |
| 50 Typhoon (Austria)                   | 96      | 130 HF | 2200   |
| AP 50                                  | 71 - 80 | 2015   | 2015   |
| M82 50 Cobra                           | 78 - 85 | 625 HF |        |
| TZX 50                                 | 92      | 559 HF |        |
| 75 Cobra                               | 85      | 559 HF |        |
| MAXI 80                                | 88      | 133 HF | 138 HF |
| 125 Typhoon (Austria)                  | 82      | 130 CT |        |

**QUADRO**

|       |         |         |         |
|-------|---------|---------|---------|
| 350 3 | 16      | 145 MS* | 101 MS  |
| 350 4 | 16      | 145 MS* | 101 MS* |
| D 350 | 11 - 15 | 123 CT* | 101 CT  |

**QUADZILLA**

|             |         |         |        |
|-------------|---------|---------|--------|
| WK 140      | 06 - 08 | 211 HF  | 213 HF |
| XRV 250 , E | 06 - 07 | 855 HF* | 848 HF |

**QUINGOI**

|           |         |        |  |
|-----------|---------|--------|--|
| QM 125 2V | 02 - 05 | 691 HF |  |
| QM 125 GY | 02 - 05 | 713 HF |  |

**RBS CARS**

|               |         |         |  |
|---------------|---------|---------|--|
| 900 Adventure | 15 - 16 | 944 HS* |  |
|---------------|---------|---------|--|

**REAL**

|                 |    |        |  |
|-----------------|----|--------|--|
| 80 Nevada Sport | 00 | 532 HF |  |
|-----------------|----|--------|--|

\* = 2 sets required / 2 jeux pour l'Avant.

Full compound selection, see under "Brake pad 1:1 Drawings" / Sélection complète de composés, voir "1:1 Schémas Plaquettes de frein".

**RECOMMENDED**

1xx = Scooter Pads  
5xx = Street, Off Road & Racing Pads  
2xxx = Brake Shoes



| REWACO |                         |         |        |        |
|--------|-------------------------|---------|--------|--------|
|        | FX4                     | 07      | 519 HF |        |
|        | FX5                     | 07      | 519 HF |        |
|        | FX6                     | 07      | 519 HF |        |
|        | HS4                     | 01      | 519 HF |        |
|        | HS5                     | 01      | 519 HF |        |
|        | HS6                     | 01      | 519 HF |        |
|        | RF1                     | 07 - 14 | 519 HF |        |
| RIEJU  |                         |         |        |        |
|        | 50 AJP Caliper          |         |        |        |
|        | incl. pin/spring        | 91 - 18 | 188 HF |        |
|        | 50 Drac                 | 97      | 559 HF | 559 HF |
|        | 50 Drag                 | 92      | 595 HF |        |
|        | 50 FD4 Super Marathon   | 85      | 559 HF |        |
|        | 50 First, H2O           | 97 - 99 | 105 HF |        |
|        | 50 Racing Spec. Edition | 01      | 148 HF | 105 HF |
|        | 50 Spike Racing         | 02 - 06 | 105 HF | 105 HF |
|        | 50 Spike Racing         | 02 - 06 | 148 HF | 105 HF |
|        | 50 Spike X              | 08 - 09 | 585 HF | 585 HF |
|        | 50 Tango                | 08 - 12 | 157 HF | 105 HF |
|        | 50 Tango                | 10 - 12 | 730 HF | 559 HF |
|        | 50 Windy                | 97      | 105 HF |        |
| MRT    | 50                      | 09 - 15 | 203 HF | 203 HF |
| MRT    | 50 Pro                  | 09 - 14 | 157 HF | 157 HF |
| MRT    | 50 Pro Supermotard      | 09 - 17 | 157 HF | 157 HF |
| MRT    | 50 Supermotard          | 09 - 17 | 203 HF | 203 HF |
| MRX    | 50 , Racing             | 02 - 09 | 105 HF | 105 HF |
| MRX    | 50 Pro                  | 05 - 09 | 148 HF | 105 HF |
| NKD    | 50                      | 04 - 07 | 173 HF | 105 HF |
| RR     | 50 , Supermotard        | 96 - 05 | 559 HF | 559 HF |
| RRX    | 50                      | 08      | 203 HF | 203 HF |
| RRX    | 50                      | 08      | 105 HF | 105 HF |
| RRX    | 50 Spike                | 08      | 105 HF | 105 HF |
| RS1    | 50 , Castrol            | 01 - 03 | 120 HF | 105 HF |
| RS1    | 50                      | 92 - 05 | 595 HF | 559 HF |
| RS1    | 50 Evolution            | 96 - 00 | 105 HF | 105 HF |
| RS2    | 50 Matrix               | 03 - 09 | 173 HF | 167 HF |
| RS2    | 50 NKD                  | 06 - 10 | 180 HF | 101 HF |
| RS3    | 50                      | 12 - 17 | 173 HF | 101 HF |
| RS3    | 50 Pro                  | 12 - 17 | 189 MS | 105 HF |
| RV     | 50                      | 80      | 559 HF |        |
| SMX    | 50                      | 02 - 09 | 105 HF | 105 HF |
| SMX    | 50                      | 02 - 09 | 148 HF | 105 HF |
| SMX    | 50 Pro                  | 08 - 09 | 157 HF | 105 HF |
|        | 75 K6, LC Strada        | 87      | 559 HF |        |
|        | 75 P6, LC Strada        | 87      | 559 HF |        |
| MR     | 80 C, E                 | 88 - 90 | 559 HF |        |
| MR     | 80 Cross                | 87      | 559 HF |        |
| MR     | 80 Enduro               | 87      | 559 HF |        |
| RST    | 80                      | 91 - 93 | 559 HF | 559 HF |
|        | 125 Marathon Pro        | 09 - 14 | 730 HF | 585 HF |
|        | 125 Marathon Pro        |         |        |        |
|        | Supermotard             | 09 - 15 | 730 HF | 585 HF |
|        | 125 Tango               | 06 - 07 | 821 HS | 559 HF |
|        | 125 Tango               | 08 - 12 | 730 HF | 559 HF |
|        | 125 Tango Pro           | 08      | 730 HF | 559 HF |
| MRX    | 125                     | 03 - 08 | 559 HF | 559 HF |
| MRX    | 125                     | 03 - 08 | 652 HF | 559 HF |
| RR     | 125                     | 97 - 99 | 559 HF | 559 HF |
| RS2    | 125 NKD                 | 06 - 07 | 797 HF | 544 HF |
| RS2    | 125 Pro                 | 08 - 12 | 792 HF | 544 HF |
| RS3    | 125                     | 10 - 13 | 821 HS | 559 HF |
| SMX    | 125                     | 03 - 07 | 559 HF | 559 HF |
| SMX    | 125                     | 03 - 07 | 652 HF | 559 HF |
|        | 250 Tango               | 08 - 15 | 730 HF | 559 HF |
| MRX    | 250 Marathon            | 10 - 12 | 671 SI | 791 SI |
| MRX    | 450 Marathon            | 08 - 12 | 671 SI | 791 SI |
| RIXE   |                         |         |        |        |
| RS     | 80 W                    | 82      | 532 HF |        |

**RECOMMENDED**

1xx = Scooter Pads  
5xx = Street, Off Road & Racing Pads  
2xxx = Brake Shoes



| ROXON         |                         |         |         |         |
|---------------|-------------------------|---------|---------|---------|
|               | 50 Duel SM              | 06      | 105 HF  | 105 HF  |
|               | 50 Duel TT              | 06      | 105 HF  | 105 HF  |
|               | 150 Quad Sport Spirit   | 06      |         | 544 SI  |
| ROYAL ENFIELD |                         |         |         |         |
|               | 535 Continental GT      | 14 - 17 | 674 HS  | 675 LS  |
| SACHS         |                         |         |         |         |
|               | 50 MadAss               | 04 - 05 | 200 HF  |         |
|               | 50 MadAss 4T            | 05 - 09 | 200 HF  | 100 HF  |
| SA            | 80 Lotus                | 80 - 81 | 532 HF  |         |
| SW            | 80 Lotus                | 82      | 519 HF* |         |
|               | 125 MadAss              | 09      | 200 HF  | 100 HF  |
|               | 125 Roadster V2         | 01      | 588 HF  |         |
|               | 125 X-Road              | 05 - 07 | 566 HF  | 684 HF  |
| XTC           | 125                     | 99 - 07 | 566 HF  | 684 HF  |
| XTC-N         | 125                     | 99 - 07 | 566 HF  | 684 HF  |
| ZX            | 125                     | 99 - 02 | 588 HF  | 684 HF  |
| ZZ            | 125                     | 99 - 02 | 588 HF  | 684 HF  |
|               | 500 MadAss              | 05 - 08 | 566 HF* | 684 HF  |
|               | 650 Roadster V1.6       | 01 - 05 | 566 HF  | 684 HF  |
|               | 800 B-805               | 02 - 04 | 566 HS* |         |
|               | 800 Roadster V2         | 00 - 05 | 566 HF* | 684 HF  |
|               | 800 S-805               | 03 - 04 | 566 HS* |         |
| SANGLAS       |                         |         |         |         |
|               | 400 Y                   | 79 - 80 | 519 HF* | 519 HF  |
|               | 500 S2                  | 79 - 80 | 519 HF* | 519 HF  |
| SCORPA        |                         |         |         |         |
| SY            | 115 F Trial             | 06      | 802 RSI | 803 RSI |
| TY-S          | 115 F Trial             | 06      | 559 HF  | 803 RSI |
|               | 125 Twenty Trial        | 16 - 18 | 802 RSI | 803 RSI |
| SY            | 125 F Trial             | 06 - 11 | 802 RSI | 803 RSI |
| TY-S          | 125 F Trial             | 06 - 08 | 559 HF  | 803 RSI |
|               | 250 T-Ride              | 08 - 11 | 859 HF  | 773 HF  |
|               | 250 Twenty Trial        | 16 - 18 | 802 RSI | 803 RSI |
| SY            | 250 F Trial             | 06 - 11 | 802 RSI | 803 RSI |
| SY            | 250 Trial               | 00 - 01 | 802 RSI | 803 RSI |
|               | 300 Twenty Trial        | 16 - 18 | 802 RSI | 803 RSI |
| SHE-LUNG      |                         |         |         |         |
|               | 50 Falcon               | 97      | 111 HF  |         |
|               | 50 Racer                | 96      | 114 HF  |         |
|               | 125 Mars                | 97      | 111 CT  |         |
| SHERCO        |                         |         |         |         |
|               | 50 AJP Caliper          |         |         |         |
|               | incl. pin/spring        | 91 - 18 | 188 HF  |         |
|               | 50 Supermotard, Enduro  | 02 - 06 | 148 HF  | 105 HF  |
| SE            | 50 Enduro               | 07      | 168 HF  | 167 HF  |
| SM            | 50 Supermotard          | 07 - 13 | 168 HF  | 167 HF  |
|               | 80 0.8                  | 01 - 03 | 559 HF  | 559 HF  |
| ST            | 80 (Formula cal.)       | 13 - 14 | 885 RSI | 803 RSI |
|               | 125                     | 02      | 817 HF  | 559 HF  |
|               | 125 City Corp 4T Enduro | 03 - 07 | 817 HF  | 559 HF  |
|               | 125 City Corp 4T SM     | 03 - 07 | 817 HF  | 559 HF  |
| SE            | 125 1.25F               | 10 - 12 | 774 HF  | 773 HF  |
| SE-R          | 125                     | 17      | 671 SI  | 791 SI  |
| ST            | 125 (Formula cal.)      | 13 - 14 | 885 RSI | 803 RSI |
| ST            | 125 1.25                | 01 - 05 | 559 HF  | 559 HF  |
| ST            | 125 1.25                | 06 - 11 | 802 RSI | 803 RSI |
| ST            | 200 2.0                 | 01      | 559 HF  | 559 HF  |
| SE            | 250 , R                 | 14      | 671 SI  | 791 SI  |
| SE            | 250 2.5i Enduro         | 06 - 11 | 671 SI  | 790 SI  |
| SE            | 250 F, F-R              | 14 - 18 | 671 SI  | 791 SI  |
| SE            | 250 i/iR                | 12 - 13 | 671 SI  | 791 SI  |
| SE            | 250 i-F                 | 13      | 671 SI  | 791 SI  |
| ST            | 250 (Formula cal.)      | 13 - 14 | 885 RSI | 803 RSI |
| ST            | 250                     | 99 - 00 | 559 RSI | 559 RSI |
| ST            | 250 2.5                 | 01      | 802 RSI | 803 RSI |
| SX            | 250 2.5i-F              | 09 - 11 | 671 RSI | 790 RSI |

\* = 2 sets required / 2 jeux pour l'Avant.





**RECOMMENDED**

1xx = Scooter Pads  
5xx = Street, Off Road & Racing Pads  
2xxx = Brake Shoes



**SHERCO**

|       |                      |         |         |         |
|-------|----------------------|---------|---------|---------|
| ST    | 290 (Formula cal.)   | 13 - 14 | 885 RSI | 803 RSI |
| ST    | 290 2.9              | 01      | 802 RSI | 803 RSI |
| SCF-R | 300                  | 16 - 18 | 671 SI  | 791 SI  |
| SE    | 300 , R              | 14 - 18 | 671 SI  | 791 SI  |
| SE    | 300 3.0i-F           | 10 - 11 | 671 SI  | 790 SI  |
| SE    | 300 F, F-R           | 14 - 18 | 671 SI  | 791 SI  |
| SE    | 300 i/R              | 12 - 13 | 671 SI  | 791 SI  |
| SE    | 300 i-F              | 13      | 671 SI  | 791 SI  |
| ST    | 300                  | 16 - 18 | 802 RSI | 803 RSI |
| ST    | 305 (Formula cal.)   | 13 - 14 | 885 RSI | 803 RSI |
| ST    | 320 3.2F             | 05      | 802 RSI | 803 RSI |
| SE    | 450 4.5i Enduro      | 04      | 671 SI  | 604 SI  |
| SE    | 450 4.5i Enduro      | 05 - 11 | 671 SI  | 790 SI  |
| SE    | 450 F, F-R           | 14 - 18 | 671 SI  | 791 SI  |
| SE    | 450 iR               | 12 - 13 | 671 SI  | 791 SI  |
| SM    | 450 4.5i Supermotard | 06      | 762 RS  | 790 RSI |
| SE    | 510 5.1i Enduro      | 06 - 11 | 671 SI  | 790 SI  |
| SE    | 510 iR               | 12 - 13 | 671 SI  | 791 SI  |

**SIAM**

|  |           |    |        |  |
|--|-----------|----|--------|--|
|  | 50 Falcon | 97 | 123 HF |  |
|  | 50 Mat    | 97 | 102 HF |  |
|  | 50 Scross | 97 | 123 HF |  |
|  | 100 Mat   | 97 | 102 HF |  |

**SIAMOTO**

|  |            |         |        |  |
|--|------------|---------|--------|--|
|  | 50 Birdie  | 02 - 04 | 111 HF |  |
|  | 125 BD, KD | 02 - 04 | 148 CT |  |

**SIMSON**

|    |              |         |        |        |
|----|--------------|---------|--------|--------|
|    | 50 Habict CX | 01 - 99 | 519 HF |        |
|    | 50 Spatz     | 99      | 138 HF |        |
|    | 50 Sperber   | 99      | 138 HF |        |
|    | 50 Star      | 99      | 138 HF |        |
|    | 80 IFA       | 89      | 519 HF |        |
| SR | 80 -2 CE     | 87      | 519 HF |        |
| S  | 83 CX        | 93      | 519 HF |        |
| S  | 83 OR        | 83      | 519 HF |        |
|    | 125          | 01      | 588 HF | 684 HF |
|    | 125 RS       | 01      | 588 HF | 684 HF |
|    | 125 Schikra  | 99      | 108 CT | 138 CT |
|    | 125 SM       | 01      | 652 HF | 559 HF |
|    | 125 Star     | 99      | 105 CT |        |

**SMC**

|  |               |    |        |      |
|--|---------------|----|--------|------|
|  | 50 Easy Rider | 97 | 102 HF | 2028 |
|--|---------------|----|--------|------|

**STOMP**

|  |           |         |        |        |
|--|-----------|---------|--------|--------|
|  | 125 Elite | 07 - 09 | 211 HF | 213 HF |
|--|-----------|---------|--------|--------|

**SULA**

|  |                  |    |         |      |
|--|------------------|----|---------|------|
|  | 50 City Bird     | 99 | 111 HF  | 2028 |
|  | 50 Thunder Bird  | 99 | 101 HF* | 2028 |
|  | 100 Thunder Bird | 99 | 101 HF* | 2028 |
|  | 125 Thunder Bird | 99 | 101 CT  | 2028 |

**SUZUKI**

|    |                  |         |        |      |
|----|------------------|---------|--------|------|
| RE | 5M, A            | 75 - 77 | 503 HF | 2098 |
|    | 50 AJP Caliper   |         |        |      |
|    | incl. pin/spring | 91 - 18 | 188 HF |      |
|    | 50 Lido Scooter  | 89 - 94 | 2181   | 2181 |
|    | 50 Wolf          | 89 - 94 | 546 HF | 2103 |
| A  | 50               | 71 - 76 | 2015   | 2015 |
| AC | 50 DX            | 81 - 86 | 516 HF | 2015 |
| AC | 50 RG, ZR, Z1    | 79 - 84 | 516 HF | 2015 |
| AE | 50 R/L           | 88 - 93 | 101 HF |      |
| AH | 50 Adress        | 92 - 95 | 101 HF | 2181 |
| AJ | 50 Sepia         | 92 - 96 | 102 HF | 2181 |
| AN | 50               | 95      | 122 HF |      |
| AP | 50               | 75 - 78 | 2015   | 2015 |
| AP | 50               | 95 - 02 | 114 HF | 2015 |
| AY | 50 , Katana      | 96 - 04 | 114 HF | 2181 |



**RECOMMENDED**

1xx = Scooter Pads  
5xx = Street, Off Road & Racing Pads  
2xxx = Brake Shoes



**SUZUKI**

|      |                    |         |         |         |
|------|--------------------|---------|---------|---------|
| AY   | 50 , Katana        | 96 - 08 | 105 HF  | 2181    |
| AY   | 50 W               | 00 - 04 | 123 HF  | 105 HF  |
| AY   | 50 WR              | 00 - 05 | 123 HF  | 105 HF  |
| CC   | 50 Tune            | 92 - 97 | 544 HF  |         |
| CL   | 50 D, Suzi, Love   | 83      | 2101    | 2020    |
| CP   | 50                 | 85 - 90 | 101 HF  |         |
| CP   | 50 CHF             | 85      | 2181    | 2181    |
| CR   | 50 DC              | 87      | 101 HF  |         |
| CS   | 50 Roadie          | 83      | 2020    | 2020    |
| DR   | 50 Big             | 89 - 02 | 559 HF  |         |
| F    | 50                 | 71 - 73 | 2015    | 2015    |
| FA   | 50                 | 80 - 91 | 2101    | 2101    |
| FR   | 50                 | 74 - 81 | 2015    | 2015    |
| FS   | 50 Snip            | 80 - 81 | 2101    | 2101    |
| FZ   | 50                 | 79 - 83 | 2094    | 2094    |
| GSXR | 50                 | 87      | 135 HF  | 2017    |
| GT   | 50                 | 77 - 80 | 516 HF  | 2015    |
| JR   | 50                 | 89 - 07 | 2020    | 2020    |
| LT   | 50                 | 84 - 02 |         | 2020    |
| LT-A | 50 Quadmaster      | 01 - 05 | 2101    | 2017    |
| LT-Z | 50 Quadspout       | 06 - 17 | 2101    | 2017    |
| OR   | 50                 | 79      | 2015    | 2015    |
| OR   | 50                 | 80      | 2017    | 2017    |
| OR   | 50 E               | 80      | 135 HF  | 2017    |
| PV   | 50                 | 82 - 97 | 2014    | 2014    |
| RB   | 50                 | 87      | 546 HF  | 2015    |
| RG   | 50 GAG             | 87 - 92 | 135 HF  | 2103    |
| RG   | 50 Gamma           | 90 - 96 | 135 HF  | 2103    |
| RM   | 50                 | 75 - 76 | 503 HF  | 2015    |
| RM   | 50                 | 78 - 80 | 2015    | 2015    |
| RM   | 50                 | 81 - 82 | 2017    | 2017    |
| RME  | 50                 | 10      |         | 777 HF  |
| RMX  | 50                 | 00 - 02 | 105 HF  | 105 HF  |
| RV   | 50                 | 72 - 82 | 2015    | 2015    |
| S    | 50 K               | 93      | 2103    | 2094    |
| SMX  | 50 Super Motard    | 00 - 02 | 105 HF  | 105 HF  |
| TR   | 50 Street Magic    | 97 - 00 | 122 HF  | 2188    |
| TS   | 50                 | 80 - 83 | 2015    | 2017    |
| TS   | 50                 | 84 - 02 | 2103    | 2094    |
| TS   | 50 ERA             | 80      | 2015    | 2015    |
| TS   | 50 ERZ1            | 80 - 83 | 2017    | 2017    |
| TS   | 50 KN              | 79      | 2015    | 2015    |
| TSW  | 50                 | 91      | 2103    | 2094    |
| TV   | 50 Wolf            | 89 - 91 | 135 HF  | 2103    |
| UF   | 50 Estilete        | 00 - 02 | 105 HF  | 2181    |
| UX   | 50 W Zillion       | 99 - 02 | 105 HF  | 2181    |
| X-1  | 50                 | 79      | 516 HF  | 2015    |
| ZR   | 50                 | 81 - 87 | 135 HF  | 2017    |
| ZZ   | 50 Scooter         | 92      | 101 HF  | 2181    |
| RM   | 60                 | 03      | 2093    | 2093    |
| RM   | 65                 | 03 - 06 | 752 RSI | 536 RSI |
| DR-Z | 70                 | 08 - 18 | 2010    | 2010    |
| FR   | 70                 | 74 - 76 | 2015    | 2015    |
| LIDO | 75 Style           | 84 - 94 | 544 HF  | 2181    |
| AH   | 80 Adress, V, Tune | 88 - 91 | 101 HF  | 2181    |
| AH   | 80 Scooter         | 92 - 94 | 102 HF  | 2181    |
| CP   | 80                 | 85 - 93 | 2181    | 2181    |
| CS   | 80 CD              | 83 - 85 | 2094    | 2094    |
| DS   | 80                 | 80 - 96 | 2017    | 2017    |
| FR   | 80                 | 76 - 83 | 2015    | 2015    |
| GT   | 80 L/C             | 81      | 546 HF  | 2015    |
| JR   | 80                 | 01 - 07 | 2017    | 2017    |
| LT   | 80                 | 87 - 06 | 2101    | 2104    |
| RG   | 80                 | 85 - 87 | 587 HF  | 2014    |
| RG   | 80 Gamma           | 85 - 87 | 546 HF  |         |
| RG   | 80 Gamma           | 88 - 93 | 587 HF  | 2014    |
| RM   | 80                 | 77 - 79 | 2015    | 2015    |
| RM   | 80                 | 80 - 81 | 2017    | 2017    |
| RM   | 80                 | 82 - 85 | 2022    | 2182    |
| RM   | 80                 | 83 - 85 | 2014    | 2017    |
| RM   | 80                 | 86 - 89 | 548 HF  | 2182    |
| RM   | 80                 | 90 - 95 | 548 HF  | 544 SI  |

\* = 2 sets required / 2 jeux pour l'Avant.

**RECOMMENDED**  
1xx = Scooter Pads  
5xx = Street, Off Road & Racing Pads  
2xxx = Brake Shoes



| SUZUKI |                   |         |         |         |  |
|--------|-------------------|---------|---------|---------|--|
| RM     | 80                | 96 - 01 | 702 RSI | 544 RSI |  |
| RT     | 80                | 81 - 82 | 2015    | 2015    |  |
| TS     | 80                | 81 - 82 |         | 2017    |  |
| TS     | 80 X              | 84 - 87 | 2103    | 2094    |  |
| ZZ     | 80 Sepia          | 90 - 92 | 544 HF  |         |  |
| RM     | 85 , L            | 02 - 04 | 702 RSI | 544 RSI |  |
| RM     | 85 , L            | 05 - 18 | 726 RSI | 820 RSI |  |
| LT-Z   | 90 QuadSport      | 07 - 14 | 2017    | 2104    |  |
| RV     | 90                | 73 - 81 | 2015    | 2015    |  |
| TS     | 90                | 71 - 73 | 2015    | 2014    |  |
| A      | 100 all models    | 74 - 80 | 2014    | 2015    |  |
| ACC    | 100               | 70 - 72 | 2014    | 2014    |  |
| AH     | 100 V Adress      | 91 - 94 | 101 HF  | 2181    |  |
| AH     | 100 V Adress      | 95 - 96 | 122 HF  |         |  |
| ASS    | 100               | 69 - 71 | 2014    | 2015    |  |
| GP     | 100               | 78 - 81 | 538 HF  | 2015    |  |
| GP     | 100               | 79 - 92 | 2014    | 2015    |  |
| GT     | 100               | 78      | 503 HF  |         |  |
| RM     | 100               | 76 - 78 | 2015    | 2014    |  |
| RM     | 100               | 79 - 81 | 2015    | 2103    |  |
| RM     | 100               | 03      | 726 RSI | 592 RSI |  |
| TS     | 100               | 73 - 75 | 2015    | 2014    |  |
| TS     | 100               | 75 - 81 | 2014    | 2014    |  |
| TS     | 100 E             | 82 - 87 | 2014    | 2017    |  |
|        | 110 Smash         | 03 - 06 | 2015    | 2015    |  |
| DR-Z   | 110               | 02 - 06 | 2093    | 2015    |  |
| FX     | 110 Shogun        | 98 - 02 | 2015    | 2015    |  |
| UG     | 110 Hokuto        | 00 - 02 | 122 HF  | 2188    |  |
| UK     | 110 Adress        | 15 - 18 | 101 HF  |         |  |
| TRS    | 118               | 82 - 83 | 546 HF  |         |  |
| B      | 120               | 71 - 77 | 2014    | 2014    |  |
|        | 125 Vecstar       | 94 - 97 | 122 CT  | 2181    |  |
| AH     | 125 V Adress      | 95      | 122 HF  |         |  |
| AN     | 125               | 06 - 08 | 101 CT  | 2181    |  |
| AN     | 125 R             | 94 - 05 | 122 CT  | 2181    |  |
| CS     | 125 D             | 83 - 85 | 2015    | 2015    |  |
| DR     | 125               | 82 - 84 | 2014    | 2014    |  |
| DR     | 125               | 86 - 02 | 536 HF  | 2014    |  |
| DR     | 125 SM            | 08 - 12 | 694 HF  | 604 HF  |  |
| DR-Z   | 125 K             | 03 - 12 | 2017    | 2017    |  |
| DR-Z   | 125 L             | 03 - 18 | 702 SI  | 2017    |  |
| EN     | 125               | 05 - 09 | 611 HF  | 2014    |  |
| GN     | 125               | 82 - 90 | 585 HF  | 2014    |  |
| GN     | 125               | 91 - 04 | 546 HF  | 2014    |  |
| GN     | 125               | 05 - 10 | 585 HF  | 2014    |  |
| GP     | 125 all models    | 77 - 84 | 524 HF  | 2014    |  |
| GP     | 125 C (Norway)    | 78      | 538 HF  | 2014    |  |
| GS     | 125               | 82 - 84 | 2014    | 2014    |  |
| GS     | 125 E, Katana     | 90 - 94 | 585 HF  | 2014    |  |
| GS     | 125 ESD           | 83 - 94 | 585 HF  | 2014    |  |
| GS     | 125 ESZ           | 82      | 546 HF  | 2014    |  |
| GT     | 125               | 75 - 78 | 503 HF  | 2014    |  |
| GT     | 125               | 78 - 82 | 515 HF  | 2014    |  |
| GT     | 125               | 80 - 82 | 546 HF  | 2014    |  |
| GX     | 125 R             | 88 - 03 | 536 HF  | 2014    |  |
| GZ     | 125 Marauder      | 00 - 11 | 581 HF  | 2014    |  |
| LIDO   | 125 Vario Scooter | 90 - 93 | 101 CT  | 2181    |  |
| LT     | 125 D             | 83      |         | 2107    |  |
| LT     | 125 E-H           | 84 - 87 |         | 2016    |  |
| RG     | 125               | 79 - 80 | 515 HF  | 2014    |  |
| RG     | 125 F, Gamma      | 92 - 96 | 631 HF  | 635 HF  |  |
| RG     | 125 Gamma         | 85 - 90 | 587 HF  | 2014    |  |
| RG     | 125 Wolf          | 92 - 94 | 597 HF  | 556 HF  |  |
| RH     | 125 X             | 87      | 536 HF  |         |  |
| RM     | 125               | 75 - 78 | 2014    | 2014    |  |
| RM     | 125               | 79 - 80 | 2014    | 2103    |  |
| RM     | 125               | 81 - 83 | 2014    | 2102    |  |
| RM     | 125               | 84      | 2108    | 2102    |  |
| RM     | 125               | 85 - 86 | 581 HF  | 2102    |  |
| RM     | 125               | 87      | 611 SI  | 2102    |  |
| RM     | 125               | 88      | 611 RSI | 584 RSI |  |
| RM     | 125               | 89 - 90 | 611 RSI | 632 RSI |  |

**RECOMMENDED**  
1xx = Scooter Pads  
5xx = Street, Off Road & Racing Pads  
2xxx = Brake Shoes



| SUZUKI |                      |         |         |         |  |
|--------|----------------------|---------|---------|---------|--|
| RM     | 125                  | 91 - 95 | 611 RSI | 648 RSI |  |
| RM     | 125                  | 96 - 09 | 694 RSI | 604 RSI |  |
| RV     | 125 VanVan           | 03 - 18 | 704 HF  |         |  |
| SP     | 125                  | 82 - 83 | 2014    | 2014    |  |
| SP     | 125                  | 86 - 88 | 536 HF  | 2014    |  |
| SX     | 125                  | 85 - 86 | 536 HF  |         |  |
| TR     | 125                  | 83 - 86 | 546 HF  |         |  |
| TS     | 125                  | 72      | 2015    | 2014    |  |
| TS     | 125                  | 73 - 81 | 2014    | 2014    |  |
| TS     | 125                  | 82      | 2014    | 2017    |  |
| TS     | 125                  | 84      | 2014    |         |  |
| TS     | 125                  | 84      | 2014    | 2014    |  |
| TS     | 125                  | 85 - 89 | 536 HF  | 2103    |  |
| TS     | 125                  | 89 - 96 | 611 HF  | 632 HF  |  |
| TU     | 125 XT               | 99      | 546 HF  | 2183    |  |
| UC     | 125 Epicuro          | 99 - 02 | 122 CT  | 2202    |  |
| UE     | 125                  | 01 - 03 | 101 CT  |         |  |
| UH     | 125 Burgman          | 02 - 06 | 151 CT  | 157 CT  |  |
| UH     | 125 Burgman          | 07 - 18 | 192 CT  | 196 CT  |  |
| UX     | 125 SIXteen          | 08 - 12 | 192 CT  | 196 CT  |  |
| VL     | 125 Intruder LC      | 00 - 08 | 581 HF  |         |  |
| X4     | 125 , X3E            | 78 - 80 | 546 HF  | 2014    |  |
| AN     | 150                  | 98 - 01 | 122 CT  | 2181    |  |
| UC     | 150 Epicuro          | 99 - 02 | 122 CT  | 2202    |  |
| UE     | 150 CT               | 02 - 03 | 101 CT  |         |  |
| UH     | 150 Burgman          | 04 - 06 | 151 CT  | 157 CT  |  |
| UX     | 150 SIXteen          | 08 - 16 | 192 CT  | 196 CT  |  |
| LT     | 160                  | 89 - 92 | 2181    | 2016    |  |
| PE     | 175                  | 82      | 2104    |         |  |
| GT     | 185                  | 75 - 77 | 503 HF  | 2014    |  |
| LT     | 185                  | 84 - 87 |         | 2016    |  |
| RG     | 185                  | 75 - 77 | 503 HF  |         |  |
| TS     | 185                  | 74 - 81 | 2014    | 2014    |  |
|        | 200 Wolf             | 92 - 96 | 597 HF  | 635 HF  |  |
| DR     | 200                  | 86 - 88 | 536 SI  | 2014    |  |
| DR     | 200 S                | 15 - 17 | 536 SI  | 2014    |  |
| DR     | 200 SE               | 96 - 13 | 536 SI  | 2014    |  |
| DR     | 200 T                | 96      | 536 SI  | 2014    |  |
| GT     | 200 X5 (Nien)        | 79 - 82 | 515 HF  | 2014    |  |
| RG     | 200 Gamma            | 91 - 94 | 631 HS  | 635 LS  |  |
| RV     | 200 VanVan           | 16 - 18 | 704 HF  |         |  |
| SB     | 200                  | 79 - 81 | 2016    | 2014    |  |
| SP     | 200                  | 86 - 88 | 536 HF  | 2014    |  |
| SX     | 200 R                | 85 - 89 | 536 HF  | 2014    |  |
| TS     | 200 R                | 90 - 94 | 611 HF  | 632 HF  |  |
| UH     | 200                  | 07      | 192 CT  |         |  |
| UH     | 200 Burgman          | 07 - 13 | 192 CT  | 196 CT  |  |
| UH     | 200 Burgman          | 14 - 18 | 134 CT  | 196 CT  |  |
| XS     | 200                  | 79      | 515 HF  | 2014    |  |
| LT     | 230                  | 85 - 86 | 2051    | 2016    |  |
| LT     | 230                  | 85 - 88 | 591 SI* | 584 SI  |  |
| LT     | 230                  | 86 - 93 | 591 SI* | 592 SI  |  |
| LT-F   | 230                  | 86 - 87 | 2051    | 2016    |  |
| ET     | 240                  | 86      | 546 HF  |         |  |
| RH     | 240 X                | 87      | 536 HF  |         |  |
| TS     | 240 X                | 85 - 90 | 536 HF  | 2103    |  |
|        | 250 Across           | 90 - 99 | 597 HF  | 556 HF  |  |
|        | 250 Bandit           | 90 - 96 | 597 HS  | 556 LS  |  |
|        | 250 Cobra            | 90 - 92 | 631 HS  | 556 LS  |  |
|        | 250 Djebel           | 93 - 95 | 597 HF  | 632 HF  |  |
|        | 250 Impulse          | 95      | 627 HS* |         |  |
|        | 250 Sky Wave Type II | 98 - 01 | 146 MS* | 125 MS  |  |
|        | 250 Vecstar          | 94      | 122 CT  | 2181    |  |
|        | 250 Wolf             | 90 - 92 | 631 HS  | 556 LS  |  |
| AN     | 250 Burgman          | 98 - 03 | 146 MS  | 125 MS  |  |
| AN     | 250 Burgman          | 04 - 06 | 146 MS  | 174 MS  |  |
| DL     | 250 V-Strom          | 17 - 18 | 627 HF  | 657 HF  |  |
| DR     | 250                  | 82 - 83 | 2014    | 2014    |  |
| DR     | 250                  | 85 - 89 | 536 HF  | 2014    |  |
| DR     | 250                  | 90 - 95 | 611 HF  | 632 HF  |  |
| DR-Z   | 250                  | 01 - 07 | 694 SI  | 648 SI  |  |
| GF     | 250                  | 88      | 578 HF* | 556 HF  |  |

\* = 2 sets required / 2 jeux pour l'Avant.



**RECOMMENDED**

1xx = Scooter Pads  
5xx = Street, Off Road & Racing Pads  
2xxx = Brake Shoes



**SUZUKI**

|       |                         |         |         |         |
|-------|-------------------------|---------|---------|---------|
| GN    | 250                     | 86 - 97 | 533 HF  | 2014    |
| GNX   | 250                     | 82 - 84 | 533 HF  | 2018    |
| GS    | 250                     | 80 - 82 | 533 HF  | 2018    |
| GSF   | 250 VS, S Bandit        | 95 - 00 | 705 HS  |         |
| GSX   | 250                     | 80 - 81 | 533 HF  | 2018    |
| GSX   | 250                     | 81 - 82 | 533 HF  | 512 HF  |
| GSX   | 250                     | 85      | 534 HF  | 2018    |
| GSX   | 250                     | 86 - 87 | 534 HF* | 512 HF  |
| GSX   | 250 S, Katana           | 91      | 597 HS  | 556 LS  |
| GSX-R | 250                     | 88 - 89 | 577 HF* | 556 HF  |
| GSX-R | 250                     | 17 - 18 | 627 HF  | 657 HF  |
| GSX-R | 250 R                   | 89 - 91 | 631 HS* | 556 LS  |
| GT    | 250                     | 73 - 78 | 503 HF  | 2097    |
| GT    | 250                     | 78 - 81 | 515 HF  | 2018    |
| GW    | 250 Inazuma             | 12 - 18 | 627 HS  | 657 LS  |
| GW    | 250 Inazuma F           | 15 - 18 | 627 HS  | 657 LS  |
| GZ    | 250 Marauder            | 00 - 08 | 581 HF  | 2014    |
| LT    | 250                     | 85 - 86 | 2051    | 2098    |
| LT    | 250                     | 85 - 87 | 591 SI* | 584 SI  |
| LT    | 250                     | 88 - 94 | 591 SI* | 649 SI  |
| LT    | 250                     | 89 - 90 | 591 SI* | 592 SI  |
| LT-F  | 250                     | 88 - 01 | 2053    | 2110    |
| LT-F  | 250 4WD V, W Quadrunner | 97 - 98 | 2053    | 2098    |
| LT-F  | 250 Ozark               | 03 - 13 | 536 SI* |         |
| LT-Z  | 250 Quad Sport          | 04 - 11 | 536 SI* |         |
| NZ    | 250                     | 86 - 91 | 546 HF  | 2183    |
| RG    | 250                     | 78 - 82 | 515 HF  |         |
| RG    | 250                     | 83 - 84 | 556 HF  | 556 HF  |
| RG    | 250 Gamma               | 84 - 88 | 578 HF* | 556 HF  |
| RGV   | 250                     | 88      | 624 HS* | 556 LS  |
| RGV   | 250                     | 89 - 90 | 631 HF* | 556 HF  |
| RGV   | 250                     | 93 - 95 | 631 HF* | 615 HF  |
| RGV   | 250 Gamma               | 91 - 92 | 631 HF* | 615 HF  |
| RH    | 250                     | 85 - 87 | 536 HF  |         |
| RM    | 250                     | 76 - 78 | 2014    | 2016    |
| RM    | 250                     | 79      | 2016    |         |
| RM    | 250                     | 80      | 2104    |         |
| RM    | 250                     | 81 - 82 | 2107    | 2102    |
| RM    | 250                     | 83      | 2108    | 2102    |
| RM    | 250                     | 84      | 2108    | 2104    |
| RM    | 250                     | 85      | 581 HF  | 2104    |
| RM    | 250                     | 86      | 582 HF  | 2104    |
| RM    | 250                     | 87 - 88 | 611 RSI | 584 RSI |
| RM    | 250                     | 89 - 90 | 611 RSI | 632 RSI |
| RM    | 250                     | 91 - 95 | 611 RSI | 648 RSI |
| RM    | 250                     | 96 - 09 | 694 RSI | 604 RSI |
| RMX   | 250                     | 89 - 95 | 611 RSI | 648 RSI |
| RMX   | 250                     | 96 - 98 | 694 RSI | 648 RSI |
| RMX   | 250 X-K1                | 99      | 694 SI  | 604 SI  |
| RM-Z  | 250                     | 04 - 09 | 694 RSI | 790 RSI |
| RM-Z  | 250 Efi                 | 10 - 18 | 694 RSI | 790 RSI |
| SP    | 250                     | 85      | 536 HF  | 2014    |
| SW1   | 250                     | 92 - 95 | 597 HS  | 2018    |
| TS    | 250                     | 74 - 82 | 2016    | 2016    |
| TS    | 250 X                   | 85 - 89 | 536 HF  | 2016    |
| TU    | 250 X                   | 09 - 18 | 705 HF  |         |
| TU    | 250 X Super Classic     | 97 - 00 | 581 HF  | 2014    |
| TV    | 250                     | 88      | 631 HF  | 556 HF  |
| VL    | 250 Intruder            | 00 - 07 | 581 HF  | 2014    |
| GS    | 300                     | 82 - 85 |         | 2018    |
| LT    | 300                     | 87 - 89 | 2051    | 2098    |
| LT-F  | 300                     | 88 - 90 | 2051    | 2052    |
| LT-F  | 300 King Quad           | 91 - 01 |         | 2052    |
| LT-F  | 300 King Quad Left/Rear | 02      | 611 SI  | 2052    |
| LT-F  | 300 King Quad Right     | 02      | 638 SI  |         |
| RL    | 325                     | 80 - 82 | 2015    | 2014    |
|       | 350 Goose               | 92 - 99 | 631 HF  | 556 HF  |
| DR    | 350                     | 90 - 99 | 611 HF  | 648 HF  |
| DR    | 350 V, W, X             | 97 - 99 | 694 SI  | 648 SI  |
| SP    | 370                     | 77 - 79 | 2016    | 2016    |
| GT    | 380                     | 73 - 77 | 503 HF  | 2097    |
| GT    | 380 Asco                | 77      | 515 HF  | 2097    |



**RECOMMENDED**

1xx = Scooter Pads  
5xx = Street, Off Road & Racing Pads  
2xxx = Brake Shoes



**SUZUKI**

|       |                       |         |         |         |
|-------|-----------------------|---------|---------|---------|
| AN    | 400 Burgman           | 99 - 00 | 146 MS  | 125 MS  |
| AN    | 400 Burgman           | 01 - 06 | 146 MS  | 174 MS  |
| AN    | 400 Burgman Left/Rear | 07 - 18 | 197 MS  | 182 MS  |
| AN    | 400 Burgman Right     | 07 - 18 | 134 MS  |         |
| DR    | 400                   | 79 - 81 | 2016    | 2016    |
| DR-Z  | 400 S/E               | 00 - 12 | 694 HF  | 604 HF  |
| DR-Z  | 400 SM                | 05 - 10 | 694 RSI | 604 RSI |
| GN    | 400                   | 80      | 533 HF  | 2018    |
| GS    | 400                   | 77 - 78 | 511 HF  | 2097    |
| GS    | 400                   | 78 - 82 | 515 HF  | 2097    |
| GSF   | 400 Bandit            | 91 - 92 | 597 HS* | 556 LS  |
| GSF   | 400 Bandit            | 93 - 97 | 631 HS* | 556 LS  |
| GSX   | 400                   | 80 - 83 | 533 HF  | 2018    |
| GSX   | 400                   | 81 - 83 | 533 HF  | 2097    |
| GSX   | 400 E, S              | 85 - 86 | 534 HF  | 2018    |
| GSX   | 400 EFX               | 82      | 546 HF  | 2018    |
| GSX   | 400 F                 | 81 - 84 | 533 HF* | 512 HF  |
| GSX   | 400 F                 | 89 - 92 | 620 HF* | 556 HF  |
| GSX   | 400 FD                | 83      | 546 HF  | 512 HF  |
| GSX   | 400 FWS               | 83      | 556 HF* | 556 HF  |
| GSX   | 400 FWS               | 86 - 87 | 534 HF* | 512 HF  |
| GSX   | 400 FX, FZ            | 81 - 82 | 546 HF  | 512 HF  |
| GSX   | 400 Impulse           | 94 - 96 | 627 HS* | 556 LS  |
| GSX   | 400 S, Katana         | 83 - 86 | 546 HF  | 2097    |
| GSX   | 400 S, Katana         | 92      | 631 HS* | 556 LS  |
| GSX   | 400 X                 | 86 - 89 | 577 HF* | 556 HF  |
| GSX-R | 400                   | 87      | 577 HF* | 556 HF  |
| GSX-R | 400                   | 88 - 89 | 631 HF* | 556 HF  |
| GSX-R | 400 F                 | 85 - 86 | 578 HF* | 556 HF  |
| GSX-R | 400 R                 | 90 - 95 | 624 HS* | 556 LS  |
| KLT-A | 400 King Quad Left    | 08 - 14 | 835 SI  |         |
| KLT-A | 400 King Quad Right   | 08 - 14 | 836 SI  |         |
| KLT-F | 400 King Quad Left    | 08 - 14 | 835 SI  |         |
| KLT-F | 400 King Quad Right   | 08 - 14 | 836 SI  |         |
| LS    | 400 Savage            | 87 - 91 | 581 HF  | 2018    |
| LT-A  | 400 Eiger 2WD/4WD     | 02 - 07 | 536 SI* | 2018    |
| LT-A  | 400 King Quad Left    | 08 - 14 | 835 SI  |         |
| LT-A  | 400 King Quad Right   | 08 - 14 | 836 SI  |         |
| LT-F  | 400 Eiger 2WD/4WD     | 02 - 07 | 536 SI* | 2018    |
| LT-F  | 400 King Quad Left    | 08 - 14 | 835 SI  |         |
| LT-F  | 400 King Quad Right   | 08 - 14 | 836 SI  |         |
| LT-Z  | 400 Quad Sport        | 02 - 15 | 592 SI* | 649 SI  |
| PE    | 400                   | 79 - 81 | 2016    | 2016    |
| RF    | 400 RVC               | 93 - 97 | 627 HS  | 556 LS  |
| RM    | 400                   | 78      | 2014    | 2016    |
| RM    | 400                   | 79      | 2016    |         |
| RM    | 400                   | 80      | 2104    |         |
| SP    | 400                   | 80 - 82 | 2016    | 2016    |
| GS    | 425                   | 79      | 511 HF  | 2018    |
| GS    | 425                   | 80      | 515 HF  | 2018    |
| GS    | 450                   | 80 - 83 | 533 HF  | 2018    |
| GS    | 450                   | 85      | 534 HF  | 2018    |
| GS    | 450                   | 86      | 546 HF* | 512 HF  |
| GS    | 450                   | 90      | 597 HS  | 597 LS  |
| LT-A  | 450 King Quad Left    | 08 - 14 | 835 SI  |         |
| LT-A  | 450 King Quad Right   | 08 - 14 | 836 SI  |         |
| LT-R  | 450 Left/Rear         | 06 - 12 | 611 SI  | 649 SI  |
| LT-R  | 450 Right             | 06 - 12 | 638 SI  |         |
| RMX   | 450 Z Efi             | 10      | 694 SI  | 790 SI  |
| RMX   | 450 Z Efi             | 17 - 18 | 694 SI  | 790 SI  |
| RM-Z  | 450                   | 05 - 07 | 694 RSI | 790 RSI |
| RM-Z  | 450 Efi               | 08 - 17 | 694 RSI | 790 RSI |
| RM-Z  | 450 Efi               | 18 -    | 694 RSI | 790 RSI |
| RM    | 465                   | 81 - 82 | 2107    | 2014    |
| DR    | 500                   | 83 - 88 | 2016    | 2016    |
| DR    | 500                   | 89      | 582 HF  | 2014    |
| GS    | 500                   | 80 - 81 | 515 HF  | 512 HF  |
| GS    | 500                   | 81 - 85 | 534 HF* | 512 HF  |
| GS    | 500                   | 89 - 95 | 597 HS  | 556 LS  |
| GS    | 500                   | 96 - 03 | 704 HS  | 556 LS  |
| GS    | 500                   | 04 - 08 | 704 HS  | 556 HF  |
| GS    | 500 E (Austria)       | 78 - 79 | 515 HF* | 512 HF  |

Applications  
Motorcycles, Off Road, ATV, Scooters

\* = 2 sets required / 2 jeux pour l'Avant.

Full compound selection, see under "Brake pad 1:1 Drawings" / Sélection complète de composés, voir "1:1 Schémas Plaquettes de frein".

**RECOMMENDED**

1xx = Scooter Pads  
5xx = Street, Off Road & Racing Pads  
2xxx = Brake Shoes



| SUZUKI |                             |         |         |         |  |
|--------|-----------------------------|---------|---------|---------|--|
| GS     | 500 E (Austria)             | 81 - 82 | 534 HF* | 512 HF  |  |
| GS     | 500 F                       | 04 - 08 | 704 HS  | 556 HF  |  |
| GSX    | 500                         | 83 - 85 | 556 HF* | 556 HF  |  |
| GT     | 500                         | 73 - 75 | 515 HF  | 2098    |  |
| GT     | 500                         | 75 - 77 | 503 HF  | 2098    |  |
| LT     | 500                         | 87 - 95 | 591 SI* | 649 SI  |  |
| LT-A   | 500 F Vinson                | 02      | 536 SI* |         |  |
| LT-A   | 500 FY Quadmaster Left      | 00 - 08 | 611 SI  |         |  |
| LT-A   | 500 FY Quadmaster Right     | 00 - 08 | 638 SI  |         |  |
| LT-A   | 500 King Quad Left          | 11 - 14 | 835 SI  |         |  |
| LT-A   | 500 King Quad Right         | 11 - 14 | 836 SI  |         |  |
| LT-F   | 500 F Left                  | 98 - 07 | 638 SI  |         |  |
| LT-F   | 500 F Right                 | 98 - 07 | 611 SI  |         |  |
| RG     | 500                         | 85 - 87 | 577 HF* | 556 HF  |  |
| RG     | 500 Gamma                   | 85 - 86 | 577 HF* | 556 HF  |  |
| RM     | 500                         | 83 - 84 | 2108    | 2014    |  |
| RM     | 500                         | 85 - 87 | 581 HF  | 2014    |  |
| RM     | 500                         | 87 - 89 | 611 RSI | 592 RSI |  |
| GS     | 550                         | 77      | 515 HF* | 2099    |  |
| GS     | 550                         | 77 - 79 | 515 HF* | 512 HF  |  |
| GS     | 550                         | 80 - 84 | 534 HF* | 512 HF  |  |
| GS     | 550                         | 83 - 86 | 556 HF  | 556 HF  |  |
| GSX    | 550                         | 83 - 87 | 556 HF* | 556 HF  |  |
| GT     | 550                         | 73 - 77 | 503 HF  | 2098    |  |
| GT     | 550                         | 78      | 515 HF  | 2099    |  |
| DR     | 600 Djebel                  | 86 - 88 | 582 HF  | 2014    |  |
| DR     | 600 Djebel                  | 89      | 626 HF  | 635 HF  |  |
| DR     | 600 S Dakar                 | 85 - 87 | 582 HF  | 2014    |  |
| GSF    | 600 Bandit                  | 95 - 99 | 627 HS* | 556 LS  |  |
| GSF    | 600 Bandit / S Bandit       |         |         |         |  |
|        | Left/Rear                   | 00 - 04 | 705 HS  | 556 LS  |  |
| GSF    | 600 Bandit / S Bandit Right | 00 - 04 | 704 HS  |         |  |
| GSR    | 600                         | 06 - 10 | 631 HS* | 833 LS  |  |
| GSX    | 600 FW Left                 | 98 - 04 | 705 HS  | 556 LS  |  |
| GSX    | 600 FW Right                | 98 - 04 | 704 HS  |         |  |
| GSX    | 600 Katana                  | 88 - 89 | 620 HF* | 556 HF  |  |
| GSX    | 600 Katana                  | 90 - 97 | 620 HS* | 556 LS  |  |
| GSX-R  | 600                         | 04 - 05 | 806 HS* | 765 LS  |  |
| GSX-R  | 600                         | 06 - 10 | 806 HS* | 833 LS  |  |
| GSX-R  | 600                         | 11 - 18 | 841 HS* | 834 LS  |  |
| GSX-R  | 600                         | 92 - 93 | 624 HS* | 556 LS  |  |
| GSX-R  | 600                         | 97 - 03 | 631 HS* | 556 LS  |  |
| RF     | 600 R                       | 93 - 96 | 627 HS* | 556 LS  |  |
| SP     | 600 F                       | 85 - 87 | 582 HF  | 2014    |  |
| VS     | 600 GL Intruder             | 97      | 577 HS  | 2052    |  |
| AN     | 650 A Burgman Executive     | 04 - 12 | 183 MS* | 182 MS  |  |
| AN     | 650 Burgman                 | 02 - 15 | 183 MS* | 182 MS  |  |
| AN     | 650 Z Burgman Executive     | 13 - 18 | 183 MS* | 182 MS  |  |
| DL     | 650 V-Strom Left/Rear       | 04 - 18 | 705 HS  | 657 LS  |  |
| DL     | 650 V-Strom Right           | 04 - 18 | 704 HS  |         |  |
| DL     | 650 V-Strom XT Left/Rear    | 15 - 18 | 705 HS  | 657 LS  |  |
| DL     | 650 V-Strom XT Right        | 15 - 18 | 704 HS  |         |  |
| DR     | 650                         | 90 - 95 | 626 HS  | 635 LS  |  |
| DR     | 650 R                       | 92      | 626 HS  | 635 LS  |  |
| DR     | 650 SE T-W                  | 96 - 99 | 694 HF  | 648 HF  |  |
| GR     | 650                         | 83 - 84 | 534 HF* | 512 HF  |  |
| GR     | 650 X                       | 83 - 84 | 534 HF  | 2018    |  |
| GS     | 650                         | 81 - 83 | 534 HF* | 512 HF  |  |
| GS     | 650 G                       | 83 - 87 | 534 HF* | 512 HF  |  |
| GS     | 650 Turbo, XN               | 83 - 85 | 534 HF* | 512 HF  |  |
| GSF    | 650 Bandit                  | 07 - 11 | 631 HS* | 657 LS  |  |
| GSF    | 650 Bandit / S Bandit       |         |         |         |  |
|        | Left/Rear                   | 05      | 705 HS  | 765 LS  |  |
| GSF    | 650 Bandit / S Bandit       |         |         |         |  |
|        | Left/Rear ABS               | 06      | 705 HS  | 657 LS  |  |
| GSF    | 650 Bandit / S Bandit Right | 05      | 704 HS  |         |  |
| GSF    | 650 Bandit / S Bandit Right |         |         |         |  |
|        | ABS                         | 06      | 704 HS  |         |  |
| GSF    | 650 Bandit ABS              | 07 - 12 | 631 HS* | 657 LS  |  |
| GSF    | 650 S Bandit                | 07 - 11 | 631 HS* | 657 LS  |  |
| GSF    | 650 S Bandit ABS            | 07 - 13 | 631 HS* | 657 LS  |  |
| GSX    | 650 F                       | 08 - 18 | 631 HS* | 657 HF  |  |

**RECOMMENDED**

1xx = Scooter Pads  
5xx = Street, Off Road & Racing Pads  
2xxx = Brake Shoes



| SUZUKI |                           |         |         |        |  |
|--------|---------------------------|---------|---------|--------|--|
| GSX    | 650 GT                    | 86      | 534 HF* | 577 HF |  |
| LS     | 650                       | 05      | 581 HF  | 2018   |  |
| LS     | 650 P                     | 86 - 88 | 581 HF  | 2018   |  |
| LS     | 650 P Savage              | 95 - 04 | 581 HF  | 2018   |  |
| SFV    | 650 Gladius Left/Rear     | 09 - 16 | 705 HS  | 881 LS |  |
| SFV    | 650 Gladius Right         | 09 - 16 | 704 HS  |        |  |
| SV     | 650 ,S Left/Rear          | 99 - 02 | 705 HS  | 556 LS |  |
| SV     | 650 ,S Right              | 99 - 02 | 704 HS  |        |  |
| SV     | 650 ,S Left/Rear          | 03 - 12 | 705 HS  | 657 LS |  |
| SV     | 650 ,S Right              | 03 - 12 | 704 HS  |        |  |
| SV     | 650 ,S ABS                | 07 - 10 | 705 HS  | 657 LS |  |
| SV     | 650 ,S ABS                | 15 - 18 | 705 HS  | 657 LS |  |
| SV     | 650 Left/Rear             | 16 - 18 | 705 HS  | 881 LS |  |
| SV     | 650 Right                 | 16 - 18 | 704 HS  |        |  |
| SV     | 650 X Left/Rear           | 18 -    | 705 HS  | 881 LS |  |
| SV     | 650 X Right               | 18 -    | 704 HS  |        |  |
| XF     | 650 Freewind              | 97 - 02 | 704 HS  | 614 LS |  |
| GS     | 700                       | 85      | 533 HF* | 512 HF |  |
| GV     | 700 GLG Madura            | 86      | 533 HF* | 2052   |  |
| LT-A   | 700 King Quad Left        | 05 - 11 | 835 SI  |        |  |
| LT-A   | 700 King Quad Right       | 05 - 11 | 836 SI  |        |  |
| LT-V   | 700 Quadrunner Twin Peaks |         |         |        |  |
|        | Left                      | 04 - 06 | 801 SI  |        |  |
| LT-V   | 700 Quadrunner Twin Peaks |         |         |        |  |
|        | Right                     | 04 - 06 | 798 SI  |        |  |
| VS     | 700 GLFG                  | 86 - 87 | 577 HF  | 2052   |  |
| DR     | 750 Big                   | 89 - 90 | 626 HS  | 635 LS |  |
| DR     | 750 S, Big                | 88      | 626 HF  | 2111   |  |
| GS     | 750                       | 76 - 77 | 511 HF  | 512 HF |  |
| GS     | 750                       | 78 - 79 | 515 HF* | 512 HF |  |
| GS     | 750 D                     | 77 - 79 | 511 HF* | 512 HF |  |
| GS     | 750 E                     | 77 - 79 | 511 HF* | 512 HF |  |
| GS     | 750 Katana                | 85 - 86 | 556 HF* | 556 HF |  |
| GS     | 750 RF                    | 85      | 577 HF* | 556 HF |  |
| GS     | 750 SD                    | 83      | 534 HF* | 512 HF |  |
| GSR    | 750 Left/Rear             | 11 - 16 | 705 HS  | 657 LS |  |
| GSR    | 750 Right                 | 11 - 14 | 704 HS  |        |  |
| GSX    | 750 E                     | 82 - 83 | 533 HF* | 512 HF |  |
| GSX    | 750 EF                    | 80 - 86 | 533 HF* | 512 HF |  |
| GSX    | 750 ES                    | 83 - 85 | 533 HF* | 512 HF |  |
| GSX    | 750 ES                    | 84 - 85 | 556 HF* | 556 HF |  |
| GSX    | 750 ES, EF, STS           | 86 - 88 | 534 HF* | 512 HF |  |
| GSX    | 750 FW Left/Rear          | 98 - 02 | 705 HS  | 556 LS |  |
| GSX    | 750 FW Right              | 98 - 02 | 704 HS  |        |  |
| GSX    | 750 Katana                | 89 - 96 | 620 HS* | 556 LS |  |
| GSX    | 750 L                     | 80 - 82 | 533 HF* | 512 HF |  |
| GSX    | 750 Left/Rear             | 98 - 08 | 705 HS  | 556 LS |  |
| GSX    | 750 Right                 | 98 - 08 | 704 HS  |        |  |
| GSX    | 750 S                     | 82      | 533 HF* | 512 HF |  |
| GSX    | 750 S, Katana             | 85 - 86 | 534 HF* | 512 HF |  |
| GSX-R  | 750                       | 04 - 05 | 806 HS* | 765 LS |  |
| GSX-R  | 750                       | 06 - 10 | 806 HS* | 833 LS |  |
| GSX-R  | 750                       | 11 - 18 | 841 HS* | 834 LS |  |
| GSX-R  | 750                       | 85 - 87 | 577 HF* | 556 HF |  |
| GSX-R  | 750                       | 88 - 93 | 624 HS* | 556 LS |  |
| GSX-R  | 750                       | 94 - 99 | 686 HS* | 556 LS |  |
| GSX-R  | 750 Y                     | 00 - 03 | 631 HS* | 556 LS |  |
| GSX-S  | 750                       | 17 - 18 | 782 HS* | 657 LS |  |
| GSX-S  | 750 Left/Rear             | 15 - 16 | 705 HS  | 657 LS |  |
| GSX-S  | 750 Right                 | 15 - 16 | 704 HS  |        |  |
| GSX-S  | 750 Z Left/Rear           | 15 - 16 | 705 HS  | 657 LS |  |
| GSX-S  | 750 Z Right               | 15 - 16 | 704 HS  |        |  |
| GT     | 750                       | 73 - 77 | 503 HF* | 2098   |  |
| LT-A   | 750 King Quad Left        | 08 - 14 | 835 SI  |        |  |
| LT-A   | 750 King Quad Right       | 08 - 14 | 836 SI  |        |  |
| VS     | 750 Intruder              | 86 - 91 | 577 HF* | 2052   |  |
| C      | 800 Intruder              | 05 - 18 | 704 HS  | 2052   |  |
| DR     | 800 S, Big                | 90      | 626 HS  | 635 LS |  |
| DR     | 800 S, Big                | 91 - 95 | 597 HS  | 638 LS |  |
| DR     | 800 ST Big                | 96 - 98 | 705 HS  | 638 LS |  |
| DR-Z   | 800                       | 88 - 90 | 626 HS  | 592 LS |  |
| M      | 800 Intruder              | 05 - 18 | 704 HS  | 2052   |  |

\* = 2 sets required / 2 jeux pour l'Avant.



**RECOMMENDED**

1xx = Scooter Pads  
 5xx = Street, Off Road & Racing Pads  
 2xxx = Brake Shoes



**SUZUKI**

|       |      |                     |         |         |        |
|-------|------|---------------------|---------|---------|--------|
| VL    | 800  | Intruder LC Volusia | 01 - 04 | 704 HS  | 2052   |
| VS    | 800  | Intruder            | 91 - 99 | 577 HS  | 2052   |
| VX    | 800  | L-P                 | 90 - 93 | 597 HS  | 620 LS |
| VZ    | 800  | Marauder            | 97 - 04 | 704 HS  | 2052   |
| GS    | 850  |                     | 79 - 81 | 511 HF* | 512 HF |
| GS    | 850  |                     | 80 - 82 | 533 HF  | 512 HF |
| GS    | 850  |                     | 80 - 82 | 533 HF* | 512 HF |
| GS    | 850  | G                   | 83 - 86 | 533 HF* | 512 HF |
| GSX   | 850  | G                   | 83 - 85 | 533 HF  | 512 HF |
| XN    | 850  |                     | 83 - 85 | 534 HF* | 512 HF |
| RF    | 900  | RR,RS,RS2,T,V       | 94 - 97 | 714 HS* | 701 LS |
| DL    | 1000 | V-Strom Left/Rear   | 02 - 13 | 705 HS  | 657 LS |
| DL    | 1000 | V-Strom Right       | 02 - 13 | 704 HS  |        |
| DL    | 1000 | V-Strom             | 14 - 18 | 806 SP* | 833 LS |
| DL    | 1000 | V-Strom XT          | 17 - 18 | 806 SP* | 833 LS |
| G     | 1000 | SZ                  | 82      | 534 HF* | 512 HF |
| GS    | 1000 |                     | 78 - 80 | 515 HF* | 512 HF |
| GS    | 1000 |                     | 80 - 81 | 533 HF* | 512 HF |
| GS    | 1000 | ET                  | 81      | 534 HF* | 512 HF |
| GS    | 1000 | EX                  | 81      | 534 HF* | 512 HF |
| GSX   | 1000 | S, Katana           | 82 - 84 | 534 HF* | 512 HF |
| GSX-R | 1000 |                     | 03      | 788 HS* | 765 LS |
| GSX-R | 1000 |                     | 04 - 06 | 806 HS* | 765 LS |
| GSX-R | 1000 |                     | 07 - 08 | 806 HS* | 833 LS |
| GSX-R | 1000 |                     | 09 - 11 | 806 SP* | 834 LS |
| GSX-R | 1000 |                     | 12 - 18 | 841 SP* | 834 LS |
| GSX-R | 1000 |                     | 01 - 02 | 686 HS* | 765 LS |
| GSX-R | 1000 | R                   | 17 - 18 | 841 SP* | 834 LS |
| GSX-S | 1000 |                     | 15 - 18 | 841 HS* | 657 LS |
| GSX-S | 1000 | F                   | 15 - 18 | 841 HS* | 657 LS |
| SV    | 1000 | , S                 | 03 - 07 | 631 HS* | 657 LS |
| TL    | 1000 | RW                  | 98 - 02 | 686 HS* | 556 LS |
| TL    | 1000 | S V-Twin            | 97 - 01 | 631 HS* | 556 LS |
| GS    | 1100 |                     | 81      | 534 HF* | 512 HF |
| GS    | 1100 |                     | 82 - 83 | 533 HF  | 512 HF |
| GS    | 1100 | ED, ESD, GD         | 83      | 534 HF* | 512 HF |
| GS    | 1100 | G                   | 86 - 88 | 534 HF* | 512 HF |
| GS    | 1100 | GKD, SD, GLD        | 83      | 534 HF* | 512 HF |
| GS    | 1100 | L                   | 79      | 534 HF* | 512 HF |
| GSX   | 1100 |                     | 85      | 577 HF* | 577 HF |
| GSX   | 1100 |                     | 86      | 534 HF* | 512 HF |
| GSX   | 1100 |                     | 86 - 87 | 556 HF* | 556 HF |
| GSX   | 1100 |                     | 88 - 89 | 620 HF* | 577 HF |
| GSX   | 1100 |                     | 90 - 93 | 620 HS* | 577 LS |
| GSX   | 1100 |                     | 91 - 93 | 597 HS* | 620 LS |
| GSX   | 1100 | E                   | 82 - 84 | 534 HF* | 512 HF |
| GSX   | 1100 | E, L                | 79 - 81 | 534 HF  | 512 HF |
| GSX   | 1100 | F                   | 93 - 96 | 620 HS* | 556 LS |
| GSX   | 1100 | G                   | 94 - 95 | 597 HS* | 615 LS |
| GSX   | 1100 | G Left/Rear         | 96 - 98 | 705 HS  | 556 LS |
| GSX   | 1100 | G Right             | 96 - 98 | 704 HS  |        |
| GSX   | 1100 | Katana              | 93      | 624 HS* | 556 LS |
| GSX   | 1100 | S                   | 82 - 83 | 534 HF* | 512 HF |
| GSX-R | 1100 |                     | 86 - 88 | 577 HF* | 556 HF |
| GSX-R | 1100 |                     | 89 - 92 | 624 HS* | 556 LS |
| GSX-R | 1100 |                     | 93 - 97 | 686 HS* | 556 LS |
| GT    | 1100 |                     | 80      | 534 HF* | 512 HF |
| GS    | 1150 | EG                  | 86 - 87 | 577 HF* | 577 HF |
| GS    | 1150 | ES                  | 84 - 85 | 577 HF* | 577 HF |
| GSF   | 1200 | Bandit              | 95 - 96 | 624 HS* | 556 LS |
| GSF   | 1200 | Bandit              | 97 - 00 | 714 HS* | 556 LS |
| GSF   | 1200 | Bandit              | 01 - 05 | 686 HS* | 556 LS |
| GSF   | 1200 | Bandit              | 06      | 631 HS* | 657 LS |
| GSF   | 1200 | S Bandit            | 01 - 05 | 686 HS* | 556 LS |
| GSF   | 1200 | S Bandit            | 06      | 631 HS* | 657 LS |
| GSX   | 1200 |                     | 99 - 01 | 706 HS* | 556 LS |
| GV    | 1200 | GLG Madura          | 86      | 533 HF* | 512 HF |
| GSF   | 1250 | A Bandit            | 07 - 18 | 631 HS* | 657 LS |
| GSF   | 1250 | Bandit              | 06 - 18 | 631 HS* | 657 LS |
| GSF   | 1250 | F Bandit            | 12 - 18 | 631 HS* | 657 LS |
| GSF   | 1250 | S Bandit            | 06 - 18 | 631 HS* | 657 LS |
| GSF   | 1250 | SA Bandit           | 07 - 18 | 631 HS* | 657 LS |



**RECOMMENDED**

1xx = Scooter Pads  
 5xx = Street, Off Road & Racing Pads  
 2xxx = Brake Shoes



**SUZUKI**

|       |      |                       |         |         |        |
|-------|------|-----------------------|---------|---------|--------|
| GSX   | 1250 | FA Bandit             | 16 - 18 | 631 HS* | 657 LS |
| GSX   | 1250 | FA Traveller          | 15 - 16 | 631 HS* | 657 LS |
|       |      | 1300 B-King           | 07      | 838 HS* | 657 LS |
| GSX-R | 1300 | Hayabusa              | 99 - 07 | 686 HS* | 556 LS |
| GSX-R | 1300 | Hayabusa              | 08 - 12 | 806 HS* | 833 LS |
| GSX-R | 1300 | Hayabusa              | 13 - 18 | 841 HS* | 833 LS |
|       |      | 1340 B-King           | 08 - 14 | 782 HS* | 833 LS |
| GL    | 1400 | Cavalcade             | 87 - 88 | 620 HF* | 577 HF |
| GSX   | 1400 |                       | 02 - 07 | 686 HS* | 765 LS |
| GV    | 1400 | Cavalcade             | 85 - 86 | 534 HF* | 512 HF |
| GV    | 1400 | Cavalcade LXE         | 87 - 90 | 577 HS* | 577 LS |
| VS    | 1400 | GL Intruder           | 87 - 04 | 577 HS  | 577 LS |
| C     | 1500 | Intruder Left/Rear    | 05 - 10 | 705 HS  | 789 LS |
| C     | 1500 | Intruder Right        | 05 - 10 | 704 HS  |        |
| C     | 1500 | T Intruder            | 13 - 18 | 627 HS  | 886 LS |
| M     | 1500 | Intruder Left/Rear    | 09 - 18 | 705 HS* | 886 LS |
| M     | 1500 | Intruder Right        | 09 - 18 | 704 HS* |        |
| VL    | 1500 | Intruder LC           | 98 - 01 | 577 HS  | 577 LS |
| VL    | 1500 | Intruder LC Left/Rear | 02      | 705 HS  | 789 LS |
| VL    | 1500 | Intruder LC Right     | 02      | 704 HS  |        |
| M     | 1600 | Intruder              | 05 - 07 | 788 HS* | 886 LS |
| VZ    | 1600 | Marauder              | 04      | 686 HS* | 886 LS |
| C     | 1800 | R Intruder            | 08 - 11 | 828 HS* | 920 LS |
| M     | 1800 | R Intruder            | 06 - 16 | 806 HS* | 920 LS |
| M     | 1800 | R2 Intruder           | 08 - 10 | 806 HS* | 920 LS |
| M     | 1800 | RBZ Intruder          | 16 - 17 | 806 HS* | 920 LS |

**SWM**

|     |     |                   |         |         |        |
|-----|-----|-------------------|---------|---------|--------|
|     | 125 | GP                | 86      | 519 HF* | 519 HF |
|     | 125 | S1-S2             | 83      | 519 HF  |        |
|     | 250 | Explorer          | 86      | 519 SI  | 519 SI |
|     | 250 | Pioner            | 86      | 519 SI  | 519 SI |
|     | 250 | S1-S2             | 83      | 519 HF  |        |
| RS  | 300 | R                 | 15 - 18 | 671 SI  | 791 SI |
| TRL | 329 | MJ                | 86      | 519 RSI |        |
| XP  | 350 | Sahara            | 83      | 506 HF  |        |
|     | 440 | Gran Milano       | 15 - 17 | 627 HS  |        |
|     | 440 | Gran Milano       | 18 -    | 762 HS  |        |
|     | 440 | Gran Turismo      | 15 - 18 | 627 HS  |        |
|     | 440 | Silver Vase       | 15 - 18 | 627 HS  |        |
|     | 440 | Six Days          | 18 -    | 627 HS  |        |
| SM  | 450 | R                 | 15 - 17 | 762 HS  | 791 HF |
| RS  | 500 | R                 | 15 - 18 | 671 SI  | 791 SI |
| SM  | 500 | R                 | 18 -    | 762 HS  | 791 HF |
|     | 600 | Superdual GT Pack | 18 -    | 674 HS  | 675 LS |
|     | 600 | Superdual T       | 18 -    | 674 HS  | 675 LS |
|     | 600 | Superdual X       | 18 -    | 674 HS  | 675 LS |
|     | 650 | Superdual         | 15 - 18 | 762 HS  | 675 LS |

**SYM**

|  |    |                |         |        |        |
|--|----|----------------|---------|--------|--------|
|  | 50 | Allo           | 11 - 15 | 140 HF |        |
|  | 50 | Bullet         | 93      | 110 HF |        |
|  | 50 | Cinderella     | 01 - 00 | 110 HF |        |
|  | 50 | Crox           | 14 - 15 | 140 CT |        |
|  | 50 | Feel-big       | 98      | 618 HF |        |
|  | 50 | Fiddle         | 09 - 14 | 140 HF | 2012   |
|  | 50 | Fiddle III     | 16 - 18 | 140 CT | 202 CT |
|  | 50 | Jet 4 Naked    | 11 - 13 | 140 HF |        |
|  | 50 | Jet 4 R        | 11 - 13 | 140 HF |        |
|  | 50 | Jet BasiX      | 07 - 09 | 140 HF |        |
|  | 50 | Jet Euro X     | 05 - 12 | 140 HF |        |
|  | 50 | Jet Sport X    | 06 - 14 | 140 HF |        |
|  | 50 | Jet Sport X SR | 06 - 14 | 140 HF | 129 HF |
|  | 50 | Jet, Alpha     | 95 - 97 | 140 HF | 2012   |
|  | 50 | Jungle         | 96 - 02 | 140 HF | 2012   |
|  | 50 | Mask           | 00 - 05 | 140 HF | 2012   |
|  | 50 | Mask LC        | 00 - 05 | 140 HF | 2012   |
|  | 50 | Mio            | 05 - 16 | 110 HF | 2057   |
|  | 50 | Orbit II       | 12 - 13 | 140 HF |        |
|  | 50 | Pure           | 98      | 618 HF |        |
|  | 50 | Red Devil      | 97 - 09 | 140 HF | 2012   |
|  | 50 | Super Fancy    | 95 - 97 | 140 HF | 2012   |

\* = 2 sets required / 2 jeux pour l'Avant.

Full compound selection, see under "Brake pad 1:1 Drawings" / Sélection complète de composés, voir "1:1 Schémas Plaquettes de frein".

**RECOMMENDED**  
1xx = Scooter Pads  
5xx = Street, Off Road & Racing Pads  
2xxx = Brake Shoes



| SYM  |                  |         |        |        |  |
|------|------------------|---------|--------|--------|--|
|      | 50 Super Fancy   | 98 - 06 | 115 HF |        |  |
|      | 50 Symphony      | 09 - 15 | 140 HF |        |  |
|      | 50 Symphony SR   | 11 - 15 | 140 HF |        |  |
|      | 50 Symphony ST   | 15      | 140 CT |        |  |
|      | 50 Symply        | 08 - 14 | 140 HF |        |  |
|      | 50 X'Pro         | 13 - 17 | 140 HF |        |  |
| DD   | 50               | 02 - 12 | 110 HF | 2057   |  |
| RS   | 50               | 05 - 09 | 178 HF | 2012   |  |
| RS21 | 50               | 02 - 09 | 178 HF |        |  |
|      | 100 Cinderella   | 01      | 110 HF |        |  |
|      | 100 Jet          | 00      | 140 HF |        |  |
|      | 100 Jet Euro X   | 05      | 140 HF |        |  |
|      | 100 Jet Sport X  | 05      | 140 HF |        |  |
|      | 100 Mio          | 05 - 16 | 110 HF |        |  |
|      | 100 Party        | 97 - 00 | 140 HF |        |  |
|      | 100 Super Fancy  | 95 - 00 | 140 HF | 2012   |  |
|      | 110 Bullet       | 93      | 542 HF |        |  |
|      | 110 Star         | 03      | 140 HF |        |  |
|      | 125 Aero Wolf    | 02      | 542 HF |        |  |
|      | 125 Allo         | 11 - 15 | 140 CT |        |  |
|      | 125 Attila       | 95 - 02 | 708 HF | 2012   |  |
|      | 125 Citycom      | 09 - 14 | 140 CT |        |  |
|      | 125 Crox         | 14 - 15 | 140 CT |        |  |
|      | 125 Euro MX      | 03 - 04 | 178 CT |        |  |
|      | 125 Fiddle       | 09 - 16 | 140 CT |        |  |
|      | 125 Fiddle III   | 16 - 18 | 140 CT | 202 CT |  |
|      | 125 GTS          | 07 - 11 | 146 CT |        |  |
|      | 125 Husky        | 96 - 98 | 135 CT | 2188   |  |
|      | 125 Husky        | 99 - 05 | 150 CT |        |  |
|      | 125 Jet 14       | 17 - 18 | 140 CT | 202 CT |  |
|      | 125 Jet 4        | 11 - 13 | 140 HF |        |  |
|      | 125 Joymax Sport | 16      | 146 CT | 201 CT |  |
|      | 125 Joyride      | 01 - 06 | 178 CT | 154 CT |  |
|      | 125 Joyride      | 07 - 09 | 178 CT | 201 CT |  |
|      | 125 Joyride Evo  | 10 - 12 | 178 CT | 201 CT |  |
|      | 125 Joyride S    | 16 - 17 | 178 CT | 201 CT |  |
|      | 125 Megalo       | 02 - 05 | 140 CT |        |  |
|      | 125 New Duke     | 02 - 07 | 140 CT |        |  |
|      | 125 Super Duke   | 95 - 01 | 140 CT | 2188   |  |
|      | 125 Symphony     | 09 - 15 | 140 CT |        |  |
|      | 125 Symphony EX  | 17      | 140 CT |        |  |
|      | 125 Symphony S   | 11 - 17 | 140 CT | 202 CT |  |
|      | 125 Symphony SR  | 11 - 17 | 140 CT | 202 CT |  |
|      | 125 Symphony ST  | 15 - 18 | 140 CT | 202 CT |  |
|      | 125 Symply       | 08 - 14 | 140 CT |        |  |
|      | 125 Voyager      | 05      | 171 CT |        |  |
|      | 125 Wolf Classic | 05      | 551 HF |        |  |
|      | 125 Wolf Legend  | 02 - 05 | 103 CT |        |  |
|      | 125 X'Pro        | 14 - 16 | 140 CT |        |  |
| HD   | 125              | 04 - 10 | 154 CT |        |  |
| HD   | 125 Evo DT       | 10      | 140 CT | 201 CT |  |
| HD2  | 125 Evo          | 14      | 140 CT | 201 CT |  |
| RS   | 125              | 05 - 06 | 178 CT | 119 CT |  |
| RS21 | 125 , R          | 02      | 178 CT |        |  |
| SB   | 125 Wolf Ni      | 11 - 13 | 847 HF | 810 HF |  |
| VS   | 125              | 07 - 13 | 792 HF |        |  |
| VS   | 125              | 09 - 13 | 178 CT |        |  |
|      | 150 Attila       | 00 - 03 | 140 CT |        |  |
|      | 150 Crox         | 14 - 16 | 140 CT |        |  |
|      | 150 Euro MX      | 03 - 06 | 178 CT |        |  |
|      | 150 Husky        | 99 - 02 | 150 CT | 2188   |  |
|      | 150 Jet 4        | 11 - 14 | 140 HF |        |  |
|      | 150 Joyride      | 01 - 06 | 178 CT | 154 CT |  |
|      | 150 Super Duke   | 96 - 01 | 140 CT | 2012   |  |
|      | 150 Symphony S   | 11 - 15 | 140 CT | 202 CT |  |
|      | 150 Symphony SR  | 11 - 15 | 140 CT | 202 CT |  |
| H01  | 150              | 95 - 00 | 708 HF |        |  |
| RS   | 150              | 05 - 06 | 178 CT | 119 CT |  |
| VS   | 150              | 07 - 15 | 792 HF |        |  |
| MF   | 180              | 03      | 551 HF |        |  |
|      | 200 Fiddle II    | 11 - 13 | 140 CT |        |  |
|      | 200 Fiddle III   | 16 - 18 | 140 CT | 202 CT |  |

**RECOMMENDED**  
1xx = Scooter Pads  
5xx = Street, Off Road & Racing Pads  
2xxx = Brake Shoes



| SYM        |                     |         |         |        |  |
|------------|---------------------|---------|---------|--------|--|
|            | 200 Joyride         | 01 - 08 | 178 CT  | 154 CT |  |
|            | 200 Joyride Evo     | 09 - 15 | 140 CT  |        |  |
|            | 200 Joyride S       | 16 - 17 | 178 CT  | 201 CT |  |
|            | 200 Quadlander      | 12 - 13 | 810 SI* | 847 SI |  |
|            | 200 Trackrunner     | 05 - 08 | 810 SI* | 847 SI |  |
| HD         | 200                 | 04 - 06 | 154 CT  |        |  |
| HD         | 200 Evo             | 07 - 13 | 140 CT  | 201 CT |  |
| HD2        | 200 Evo             | 14      | 140 CT  | 201 CT |  |
|            | 250 GTS             | 07 - 11 | 146 MS  | 201 MS |  |
|            | 250 Joymax          | 07 - 10 | 171 MS  | 201 MS |  |
|            | 250 Joymax Sport    | 16 - 17 | 146 MS  | 201 MS |  |
|            | 250 Quadlander      | 06 - 07 | 810 SI* | 847 SI |  |
|            | 250 Voyager         | 05      | 171 MS  |        |  |
| RV         | 250 Efi             | 10      | 171 MS  | 201 MS |  |
| SN         | 250 Ni Wolf         | 14 - 15 | 893 HF  | 810 HF |  |
| SN         | 250 T2 Wolf         | 12 - 15 | 893 HF  |        |  |
|            | 300 City Max        | 06 - 07 | 810 SI* | 847 SI |  |
|            | 300 Citycom         | 09 - 15 | 140 CT  | 140 CT |  |
|            | 300 Citycom S       | 15 - 17 | 140 CT  | 140 CT |  |
|            | 300 Cruisym         | 17      | 215 MS  | 201 MS |  |
|            | 300 Joymax Evo      | 10 - 12 | 146 MS  | 201 MS |  |
|            | 300 Joymax Sport    | 16 - 17 | 146 MS  | 201 MS |  |
|            | 300 Joyride Evo i   | 10      | 146 MS  | 201 MS |  |
|            | 300 Quadlander      | 06 - 13 | 810 SI* | 810 SI |  |
|            | 300 Wolf Cafe Racer | 15      | 893 HF  | 810 HF |  |
|            | 300 Wolf Classic    | 15      | 893 HF  | 810 HF |  |
| GTS        | 300                 | 09 - 13 | 171 MS  | 201 MS |  |
| GTS        | 300 Evo i           | 11 - 15 | 146 MS  | 201 MS |  |
| SB         | 300 Cafe Racer      | 16 - 17 | 893 HF  | 810 HF |  |
|            | 400 i Maxsym        | 11      | 214 MS* | 218 MS |  |
|            | 400 i Maxsym        | 12 - 17 | 215 MS* | 218 MS |  |
|            | 500 GT              | 07 - 04 | 146 MS  | 154 MS |  |
|            | 600 i Maxsym        | 14 - 18 | 215 MS* | 218 MS |  |
|            | 600 i Maxsym Sport  | 18 -    | 215 MS* | 218 MS |  |
|            | 600 Quad Raider     | 08 - 15 | 810 SI* | 810 SI |  |
| <b>TGB</b> |                     |         |         |        |  |
|            | 50 101R             | 05 - 09 | 101 HF  |        |  |
|            | 50 101S             | 99 - 02 | 101 HF  |        |  |
|            | 50 202T             | 99 - 02 | 101 HF  | 2188   |  |
|            | 50 203              | 05 - 08 | 163 HF  |        |  |
|            | 50 303R             | 99 - 14 | 101 HF  |        |  |
|            | 50 309 Racing       | 05      | 101 HF  |        |  |
|            | 50 507              | 05      | 101 HF  |        |  |
|            | 50 Akros            | 99 - 04 | 101 HF  |        |  |
|            | 50 Akros tec 5      | 99 - 04 | 163 HF  |        |  |
|            | 50 Apollo           | 99 - 03 | 163 HF  |        |  |
|            | 50 Buffalo          | 03      |         | 688 HF |  |
|            | 50 Bull&t RS/RR     | 11 - 17 | 203 HF  | 101 HF |  |
|            | 50 Bullet           | 09      | 101 HF  | 101 HF |  |
|            | 50 Bullet           | 10 - 12 | 203 HF  |        |  |
|            | 50 Bunny            | 97 - 00 | 101 HF  |        |  |
|            | 50 Corona           | 03 - 05 | 132 HF  |        |  |
|            | 50 Double X         | 05      | 101 HF  |        |  |
|            | 50 Ergon            | 96 - 00 | 101 HF  |        |  |
|            | 50 Fire, Sky        | 03 - 05 | 163 HF  |        |  |
|            | 50 Hawk             | 09 - 14 | 101 HF  |        |  |
|            | 50 Hiw's            | 99      | 101 HF  |        |  |
|            | 50 Hook             | 10 - 12 | 101 HF  |        |  |
|            | 50 J409             | 00 - 03 | 101 HF  |        |  |
|            | 50 Tapo RS          | 11 - 12 | 101 HF  |        |  |
|            | 50 Trigger          | 99 - 03 | 101 HF  |        |  |
| GT         | 50 Veloce           | 09 - 12 | 141 HF  |        |  |
| R          | 50 X                | 06 - 14 | 132 HF  | 101 HF |  |
|            | 90 101S             | 99 - 02 | 101 HF  |        |  |
|            | 90 202T             | 99 - 02 | 101 HF  |        |  |
|            | 90 Akros            | 99      | 101 HF  |        |  |
|            | 90 Apollo           | 99 - 02 | 163 HF  |        |  |
|            | 90 Ergon            | 99 - 02 | 101 HF  |        |  |
|            | 90 Hiw's            | 99      | 101 HF  |        |  |
|            | 90 Trigger          | 99 - 02 | 101 HF  |        |  |
|            | 125 101S            | 99 - 03 | 101 CT  |        |  |

\* = 2 sets required / 2 jeux pour l'Avant.



**RECOMMENDED**

1xx = Scooter Pads  
5xx = Street, Off Road & Racing Pads  
2xxx = Brake Shoes



| TGB              |         |         |         |  |
|------------------|---------|---------|---------|--|
| 125 202T         | 99      | 101 CT  |         |  |
| 125 303R         | 99 - 08 | 101 CT  |         |  |
| 125 309 RS       | 00      | 101 HF  |         |  |
| 125 Bull&t RS/RR | 11 - 14 | 203 HF  | 101 HF  |  |
| 125 Hook         | 10      | 101 HF  |         |  |
| 125 X-Large      | 11      | 210 CT  | 201 CT  |  |
| 125 X-Motion     | 08 - 12 | 210 CT  | 201 CT  |  |
| 250 Dynasty      | 06      | 163 CT  | 111 CT  |  |
| 250 X-Motion     | 08 - 09 | 210 MS  | 201 CT  |  |
| 300 X-Motion     | 10 - 12 | 210 MS  | 201 CT  |  |
| TM               |         |         |         |  |
| 80 Cross         | 96 - 00 | 671 RSI | 675 RSI |  |
| 80 Junior        | 96 - 00 | 544 RSI | 592 RSI |  |
| MX 85            | 01 - 12 | 671 RSI | 604 RSI |  |
| MX 85            | 13 - 18 | 777 RSI | 777 RSI |  |
| SM 85            | 18 -    | 777 RSI | 777 RSI |  |
| 125              | 96 - 00 | 671 RSI | 675 RSI |  |
| 125              | 01 - 04 | 671 RSI | 604 RSI |  |
| 125              | 05 - 18 | 671 RSI | 790 RSI |  |
| 125 Enduro       | 01 - 04 | 671 SI  | 604 SI  |  |
| 125 Enduro       | 05 - 17 | 671 SI  | 790 SI  |  |
| SMR 125          | 05      | 566 RSI | 604 RSI |  |
| 250              | 01 - 04 | 671 RSI | 604 RSI |  |
| 250              | 05      | 671 RSI | 790 RSI |  |
| 250 E            | 95 - 00 | 671 RSI | 675 RSI |  |
| 250 Enduro       | 01 - 04 | 671 SI  | 604 SI  |  |
| 250 Enduro       | 05 - 15 | 671 SI  | 790 SI  |  |
| 250 F            | 01 - 04 | 671 RSI | 604 RSI |  |
| 250 F            | 05 - 17 | 671 RSI | 790 RSI |  |
| 250 F Enduro     | 00      | 671 SI  | 675 SI  |  |
| 250 F Enduro     | 01 - 04 | 671 SI  | 604 SI  |  |
| 250 F Enduro     | 05 - 17 | 671 SI  | 790 SI  |  |
| 300              | 98 - 00 | 671 RSI | 675 RSI |  |
| 300              | 01 - 04 | 671 RSI | 604 RSI |  |
| 300              | 05      | 671 RSI | 790 RSI |  |
| 300 Enduro       | 01 - 04 | 671 SI  | 604 SI  |  |
| 300 Enduro       | 05      | 671 SI  | 790 SI  |  |
| 320              | 96 - 97 | 671 RSI | 675 RSI |  |
| 400 F            | 00      | 671 RSI | 675 RSI |  |
| 400 F            | 01      | 671 RSI | 604 RSI |  |
| 400 F Enduro     | 01      | 671 SI  | 604 SI  |  |
| SMF 400 F        | 02      | 566 RSI | 604 RSI |  |
| SMR 400 F        | 03      | 566 RSI | 604 RSI |  |
| 450 F            | 02 - 04 | 671 RSI | 604 RSI |  |
| 450 F            | 05 - 17 | 671 RSI | 790 RSI |  |
| 450 F Enduro     | 02 - 04 | 671 SI  | 604 SI  |  |
| 450 F Enduro     | 05 - 17 | 671 SI  | 790 SI  |  |
| FT 450 Fi        | 17      | 671 RSI | 790 RSI |  |
| SMR 450 F        | 04      | 566 RSI | 604 RSI |  |
| SMX 450 F        | 03      | 566 RSI | 604 RSI |  |
| SMX 450 F        | 04      | 762 RS  | 604 RSI |  |
| 530 F            | 01 - 04 | 671 RSI | 604 RSI |  |
| 530 F            | 05      | 671 RSI | 790 RSI |  |
| 530 F Enduro     | 01 - 04 | 671 SI  | 604 SI  |  |
| 530 F Enduro     | 05      | 671 SI  | 790 SI  |  |
| SMR 530 F        | 03      | 566 RSI | 604 RSI |  |
| SMX 600 F        | 03      | 566 RSI | 604 RSI |  |
| SMX 660 F        | 04      | 762 RS  | 604 RSI |  |
| TOMOS            |         |         |         |  |
| 50 Hip Hop       | 06 - 08 | 105 HF  |         |  |
| 50 Racing        | 06 - 08 | 105 HF  |         |  |
| 50 Revival       | 02 - 04 | 123 HF  |         |  |
| 50 Street Soul   | 06 - 08 | 105 HF  |         |  |
| 50 Streetmate    | 03 - 05 | 123 HF  |         |  |
| 50 Youngst'r     | 06 - 08 | 105 HF  |         |  |
| BT 50 S          | 89      | 595 HF  |         |  |
| MC 50 Senior Pro | 04 - 06 | 667 HF  | 667 HF  |  |
| N 50 AT, BT      | 91 - 95 | 595 HF  |         |  |
| SE 50            | 05 - 06 | 148 HF  | 105 HF  |  |
| CTX 80           | 89      | 595 HF  |         |  |



**RECOMMENDED**

1xx = Scooter Pads  
5xx = Street, Off Road & Racing Pads  
2xxx = Brake Shoes



| TOMOS                       |         |         |        |  |
|-----------------------------|---------|---------|--------|--|
| MC 125 T                    | 06 - 08 | 817 HF  | 559 HF |  |
| SE 125                      | 05 - 08 | 817 HF  | 559 HF |  |
| SM 125 F                    | 06 - 08 | 821 HS  | 559 HF |  |
| TORNAX                      |         |         |        |  |
| RX 80                       | 83      | 519 HF  |        |  |
| TRIUMPH                     |         |         |        |  |
| 600 Daytona                 | 03 - 04 | 624 HS* | 614 LS |  |
| 600 Speed Four              | 03 - 06 | 624 HS* | 614 LS |  |
| TT 600                      | 00 - 03 | 624 HS* | 614 LS |  |
| 650 Daytona                 | 05 - 06 | 624 HS* | 614 LS |  |
| 660 Street Triple S A2      | 17 - 18 | 627 HS* | 675 LS |  |
| 675 Daytona                 | 06 - 08 | 782 HS* | 614 LS |  |
| 675 Daytona R Triple        | 11 - 12 | 901 HS* | 614 LS |  |
| 675 Daytona R Triple        | 13 - 18 | 901 HS* | 675 LS |  |
| 675 Daytona Triple          | 09 - 12 | 864 HS* | 614 LS |  |
| 675 Daytona Triple          | 13 - 18 | 864 HS* | 675 LS |  |
| 675 Street Triple           | 08 - 12 | 627 HS* | 614 LS |  |
| 675 Street Triple           | 13 - 17 | 627 HS* | 675 LS |  |
| 675 Street Triple R         | 09 - 12 | 782 HS* | 614 LS |  |
| 675 Street Triple R         | 13 - 17 | 782 HS* | 675 LS |  |
| 675 Street Triple RX        | 15 - 16 | 782 HS* | 675 LS |  |
| 750 Bonneville              | 84      | 554 HF  |        |  |
| 750 Bonneville U.K.         | 87      | 506 HF* | 506 HF |  |
| 750 Daytona                 | 91 - 92 | 624 HS* | 633 LS |  |
| 750 Trident Left/Rear       | 91 - 98 | 611 HS  | 611 LS |  |
| 750 Trident Right           | 91 - 98 | 638 HS  |        |  |
| 750 Trident T160V           | 75 - 77 | 523 HF  | 523 HF |  |
| T140 750 D,E,F,V Bonneville | 76 - 81 | 523 HF  | 523 HF |  |
| T140 750 ES Bonneville      | 81 - 83 | 523 HF* | 523 HF |  |
| TR65 750 Thunderbird        | 81 - 83 | 523 HF  |        |  |
| TR7T 750 Tiger Trail        | 81 - 83 | 523 HF  |        |  |
| TR7V 750 Tiger              | 73 - 81 | 523 HF  | 523 HF |  |
| TSS 750                     | 83      | 523 HF* | 523 HF |  |
| TSS 750 Electro Eight Valve | 84      | 523 HF  |        |  |
| TSX 750                     | 83      | 523 HF  | 523 HF |  |
| 765 Street Triple R         | 17 - 18 | 900 HS* | 675 LS |  |
| 765 Street Triple R Low     | 17 - 18 | 900 HS* | 675 LS |  |
| 765 Street Triple RS        | 17 - 18 | 901 HS* | 675 LS |  |
| 765 Street Triple S         | 17 - 18 | 627 HS* | 675 LS |  |
| 800 America                 | 03 - 06 | 627 HS  | 611 LS |  |
| 800 Bonneville              | 01 - 04 | 627 HS  | 611 LS |  |
| 800 Bonneville America      | 02 - 06 | 627 HS  | 611 LS |  |
| 800 Bonneville T100         |         |         |        |  |
| Centennial Edition          | 02 - 04 | 627 HS  | 611 LS |  |
| 800 Bonneville T100         |         |         |        |  |
| Paul Smith                  | 06 - 08 | 627 HS  | 611 LS |  |
| 800 Speedmaster             | 03 - 04 | 627 HS* | 611 LS |  |
| 800 Tiger                   | 11 - 14 | 627 HS* | 614 LS |  |
| 800 Tiger XC                | 11 - 17 | 627 HS* | 614 LS |  |
| 800 Tiger XC ABS            | 12 - 14 | 627 HS* | 614 LS |  |
| 800 Tiger XCA               | 15 - 17 | 627 HS* | 614 LS |  |
| 800 Tiger XCA               | 18 -    | 671 HS* | 614 LS |  |
| 800 Tiger XCR               | 15 - 17 | 627 HS* | 614 LS |  |
| 800 Tiger XCX               | 18 -    | 671 HS* | 614 LS |  |
| 800 Tiger XR                | 15 - 17 | 627 HS* | 614 LS |  |
| 800 Tiger XR                | 18 -    | 627 HS* | 614 LS |  |
| 800 Tiger XRT               | 15 - 17 | 627 HS* | 614 LS |  |
| 800 Tiger XRT               | 18 -    | 671 HS* | 614 LS |  |
| 800 Tiger XRX               | 15 - 17 | 627 HS* | 614 LS |  |
| 800 Tiger XRX               | 18 -    | 671 HS* | 614 LS |  |
| 800 Tiger XRX Low           | 18 -    | 671 HS* | 614 LS |  |
| 900 Adventurer              | 96 - 02 | 627 HS  | 630 LS |  |
| 900 America                 | 07 - 16 | 627 HS  | 611 LS |  |
| 900 Bonneville              | 05 - 08 | 627 HS  | 638 LS |  |
| 900 Bonneville              | 09 - 11 | 627 HS  | 611 LS |  |
| 900 Bonneville Newchurch    | 15      | 627 HS  | 611 LS |  |
| 900 Bonneville SE           | 09 - 13 | 627 HS  | 611 LS |  |
| 900 Bonneville Spirit       | 15      | 627 HS  | 611 LS |  |
| 900 Bonneville Street Cup   | 17 - 18 | 627 HS  | 611 LS |  |
| 900 Bonneville T100         | 05 - 18 | 627 HS  | 611 LS |  |

Applications  
Motorcycles, Off Road, ATV, Scooters

\* = 2 sets required / 2 jeux pour l'Avant.

Full compound selection, see under "Brake pad 1:1 Drawings" / Sélection complète de composés, voir "1:1 Schémas Plaquettes de frein".

**RECOMMENDED**1xx = Scooter Pads  
5xx = Street, Off Road & Racing Pads  
2xxx = Brake Shoes**TRIUMPH**

|      |                              |         |         |        |
|------|------------------------------|---------|---------|--------|
|      | 900 Bonneville T100 Black    | 16 - 18 | 627 HS  | 611 LS |
|      | 900 Bonneville T214          | 15      | 627 HS  | 611 LS |
|      | 900 Daytona                  | 91 - 94 | 624 HS* | 633 LS |
|      | 900 Daytona                  | 94 - 98 | 624 HS* | 638 LS |
|      | 900 Daytona Super III        | 94 - 98 | 683 HS* | 633 LS |
|      | 900 Daytona, Sprint          |         |         |        |
|      | Left/Rear                    | 93      | 611 HS  | 611 LS |
|      | 900 Daytona, Sprint Right    | 93      | 638 HS  |        |
|      | 900 Legend TT                | 99 - 01 | 627 HS  | 630 LS |
|      | 900 Scrambler                | 06 - 16 | 627 HS  | 611 LS |
|      | 900 Speed Triple             | 94 - 96 | 624 HS* | 638 LS |
|      | 900 Speedmaster              | 05 - 15 | 627 HS* | 611 LS |
|      | 900 Sprint                   | 94 - 98 | 624 HS* | 638 LS |
|      | 900 Street Scrambler         | 17 - 18 | 627 HS  | 611 LS |
|      | 900 Street Twin              | 16 - 18 | 627 HS  | 611 LS |
|      | 900 Thruxton                 | 04 - 05 | 627 HS  | 611 LS |
|      | 900 Thruxton Ace             | 15      | 627 HS  | 611 LS |
|      | 900 Thunderbird              | 96 - 05 | 627 HS  | 630 LS |
|      | 900 Thunderbird Sport        | 03 - 04 | 627 HS* | 630 LS |
|      | 900 Tiger                    | 99 - 00 | 627 HS* | 630 LS |
|      | 900 Tiger Left/Rear          | 93 - 98 | 611 HS  | 611 LS |
|      | 900 Tiger Right              | 93 - 98 | 638 HS  |        |
|      | 900 Trident Left/Rear        | 91 - 98 | 611 HS  | 611 LS |
|      | 900 Trident Right            | 91 - 98 | 638 HS  |        |
|      | 900 Trophy                   | 96 - 03 | 624 HS* | 633 LS |
|      | 900 Trophy Left/Rear         | 91 - 95 | 611 HS  | 611 LS |
|      | 900 Trophy Right             | 91 - 95 | 638 HS  |        |
| T509 | 900 Speed Triple             | 97 - 01 | 624 HS* | 611 LS |
| T595 | 950 Daytona                  | 96 - 98 | 624 HS* | 611 LS |
|      | 955 Daytona Centennial       | 02 - 04 | 624 HS* | 611 LS |
|      | 955 Daytona                  |         |         |        |
|      | from VIN 132513              | 99 - 01 | 624 HS* | 614 LS |
|      | 955 Daytona to VIN 132512    | 99 - 06 | 624 HS* | 611 LS |
|      | 955 Speed Triple             | 99 - 06 | 624 HS* | 611 LS |
|      | 955 Sprint RS                | 00 - 05 | 624 HS* | 611 LS |
|      | 955 Sprint ST                | 99 - 04 | 624 HS* | 611 LS |
|      | 955 Tiger                    | 01 - 04 | 627 HS* | 627 HF |
|      | 955 Tiger                    | 04 - 06 | 627 HS* | 638 LS |
|      | 1000 Daytona                 | 92      | 624 HS* | 633 LS |
|      | 1000 Trophy Left/Rear        | 91 - 95 | 611 HS  | 611 LS |
|      | 1000 Trophy Right            | 91 - 95 | 638 HS  |        |
|      | 1050 Speed 94                | 15 - 16 | 762 HS* | 611 LS |
|      | 1050 Speed 94R               | 15 - 16 | 901 HS* | 611 LS |
|      | 1050 Speed Triple            | 16 - 17 | 901 HS* | 611 LS |
|      | 1050 Speed Triple            | 05 - 07 | 782 HS* | 611 LS |
|      | 1050 Speed Triple            | 08 - 15 | 762 HS* | 611 LS |
|      | 1050 Speed Triple R          | 12 - 18 | 901 HS* | 611 LS |
|      | 1050 Speed Triple S          | 16 - 18 | 901 HS* | 611 LS |
|      | 1050 Sprint GT ABS           | 10 - 15 | 624 HS* | 611 LS |
|      | 1050 Sprint GT SE ABS        | 10 - 15 | 624 HS* | 611 LS |
|      | 1050 Sprint ST               | 05 - 11 | 624 HS* | 611 LS |
|      | 1050 Tiger                   | 07 - 13 | 782 HS* | 638 LS |
|      | 1050 Tiger SE                | 09 - 13 | 782 HS* | 638 LS |
|      | 1050 Tiger Sport             | 15 - 18 | 782 HS* | 611 LS |
|      | 1200 Bonneville Bobber       | 17      | 627 HS  | 614 LS |
|      | 1200 Bonneville Bobber Black | 18 -    | 671 HS* | 614 LS |
|      | 1200 Bonneville T120         | 16 - 18 | 627 HS  | 611 LS |
|      | 1200 Bonneville T120 Black   | 16 - 18 | 627 HS  | 611 LS |
|      | 1200 Daytona                 | 91 - 97 | 624 HS* | 633 LS |
|      | 1200 Speedmaster             | 18 -    | 671 HS* | 614 LS |
|      | 1200 Thruxton                | 16 - 18 | 627 HS* | 611 LS |
|      | 1200 Thruxton R              | 16 - 18 | 901 HS* | 611 LS |
|      | 1200 Tiger Explorer          | 12 - 15 | 624 SP* | 611 LS |
|      | 1200 Tiger Explorer          | 16 - 17 | 900 SP* | 611 LS |
|      | 1200 Tiger XCA               | 18 -    | 900 SP* | 611 LS |
|      | 1200 Tiger XCX               | 18 -    | 900 SP* | 611 LS |
|      | 1200 Tiger XR                | 18 -    | 900 SP* | 611 LS |
|      | 1200 Tiger XRT               | 18 -    | 900 SP* | 611 LS |
|      | 1200 Tiger XRX               | 18 -    | 900 SP* | 611 LS |
|      | 1200 Tiger XRX Low           | 18 -    | 900 SP* | 611 LS |
|      | 1200 Trophy                  | 96 - 03 | 624 HS* | 633 LS |
|      | 1200 Trophy Left/Rear        | 91 - 95 | 611 HS  | 611 LS |

**RECOMMENDED**1xx = Scooter Pads  
5xx = Street, Off Road & Racing Pads  
2xxx = Brake Shoes**TRIUMPH**

|  |                             |         |         |        |
|--|-----------------------------|---------|---------|--------|
|  | 1200 Trophy Right           | 91 - 95 | 638 HS  |        |
|  | 1200 Trophy SE              | 13 - 18 | 740 HS* | 611 LS |
|  | 1600 Thunderbird            | 09 - 18 | 624 HS* | 674 LS |
|  | 1700 Thunderbird Commander  | 14 - 18 | 624 HS* | 674 LS |
|  | 1700 Thunderbird LT         | 14 - 18 | 624 HS* | 674 LS |
|  | 1700 Thunderbird Nightstorm | 14 - 18 | 624 HS* | 674 LS |
|  | 1700 Thunderbird Storm      | 11 - 18 | 624 HS* | 674 LS |
|  | 2300 Rocket III             | 04 - 13 | 624 HS* | 674 LS |
|  | 2300 Rocket III Classic     | 07 - 13 | 624 HS* | 674 LS |
|  | 2300 Rocket III Roadster    | 10 - 18 | 624 HS* | 674 LS |
|  | 2300 Rocket III Touring     | 13 - 14 | 624 HS* | 674 LS |
|  | 2300 Rocket X               | 15      | 624 HS* | 674 LS |

**TRS**

|  |         |         |         |         |
|--|---------|---------|---------|---------|
|  | 250 ONE | 16 - 18 | 802 RSI | 803 RSI |
|  | 280 ONE | 16 - 18 | 802 RSI | 803 RSI |
|  | 300 ONE | 16 - 18 | 802 RSI | 803 RSI |

**UVM**

|  |             |    |        |  |
|--|-------------|----|--------|--|
|  | 50 BeThere  | 99 | 101 HF |  |
|  | 50 Bingo    | 99 | 101 HF |  |
|  | 125 BeThere | 99 | 101 CT |  |
|  | 125 Bingo   | 99 | 101 CT |  |
|  | 125 Paragon | 99 | 101 CT |  |

**VELOCIFERO**

|  |               |    |      |      |
|--|---------------|----|------|------|
|  | 50 Velocifero | 94 | 2189 | 2181 |
|--|---------------|----|------|------|

**VERTEMATI**

|   |                 |         |         |         |
|---|-----------------|---------|---------|---------|
| C | 500 Cross       | 02 - 04 | 671 RSI | 675 RSI |
| E | 501 Enduro      | 02 - 04 | 671 SI  | 675 SI  |
| S | 501 Supermotard | 02 - 04 | 671 HF  | 675 HF  |

**VERTIGO**

|  |                       |         |         |         |
|--|-----------------------|---------|---------|---------|
|  | 300 Combat Camo Works | 15 - 18 | 939 RSI | 803 RSI |
|  | 300 Combat Ice Hell   | 15 - 18 | 939 RSI | 803 RSI |
|  | 300 Combat RR         | 15 - 18 | 939 RSI | 803 RSI |

**VICTORY**

|  |                           |         |           |          |
|--|---------------------------|---------|-----------|----------|
|  | Empulse TT                | 16 - 17 | 706 H.HS* | 730 H.LS |
|  | 1200 Octane               | 17      | 674 H.HS  | 675 H.LS |
|  | 1500 Kingpin              | 04 - 05 | 706 H.HS  | 674 H.LS |
|  | 1500 Touring Cruiser      | 03 - 06 | 706 H.HS* | 674 H.LS |
|  | 1500 V92C Cruiser         | 98 - 02 | 706 H.HS  | 674 H.LS |
|  | 1500 V92C Deluxe          | 01 - 02 | 706 H.HS  | 674 H.LS |
|  | 1500 V92SC Sport Cruiser  | 00 - 02 | 706 H.HS* | 674 H.LS |
|  | 1500 Vegas                | 03 - 05 | 706 H.HS  | 674 H.LS |
|  | 1500 Vegas 8-Ball         | 05      | 706 H.HS  | 674 H.LS |
|  | 1634 Hammer               | 05 - 07 | 706 H.HS  | 674 H.LS |
|  | 1634 Hammer               | 08      | 782 H.HS* | 630 H.LS |
|  | 1634 Hammer S             | 06 - 08 | 706 H.HS  | 674 H.LS |
|  | 1634 Kingpin              | 06 - 07 | 706 H.HS  | 674 H.LS |
|  | 1634 Kingpin all models   | 08 - 12 | 782 H.HS  | 630 H.LS |
|  | 1634 Kingpin Tour         | 06 - 07 | 706 H.HS  | 674 H.LS |
|  | 1634 Vegas                | 06 - 07 | 706 H.HS  | 674 H.LS |
|  | 1634 Vegas                | 08 - 17 | 782 H.HS  | 630 H.LS |
|  | 1634 Vegas 8-Ball         | 06 - 07 | 706 H.HS  | 674 H.LS |
|  | 1634 Vegas 8-Ball         | 08 - 17 | 782 H.HS  | 630 H.LS |
|  | 1634 Vegas Jackpot        | 06 - 07 | 706 H.HS  | 674 H.LS |
|  | 1634 Vegas Jackpot        | 08      | 782 H.HS  | 630 H.LS |
|  | 1731 Boardwalk            | 13 - 15 | 782 H.HS  | 630 H.LS |
|  | 1731 Cross Country        | 10 - 17 | 782 H.HS* | 630 H.LS |
|  | 1731 Cross Country 8-Ball | 14 - 16 | 782 H.HS* | 630 H.LS |
|  | 1731 Cross Country Tour   | 12 - 17 | 782 H.HS* | 630 H.LS |
|  | 1731 Cross Roads          | 10 - 12 | 782 H.HS* | 630 H.LS |
|  | 1731 Cross Roads 8-Ball   | 14      | 782 H.HS* | 630 H.LS |
|  | 1731 Cross Roads Classic  | 14      | 782 H.HS* | 630 H.LS |
|  | 1731 Gunner               | 15 - 17 | 782 H.HS  | 630 H.LS |
|  | 1731 Hammer               | 09 - 11 | 782 H.HS* | 630 H.LS |
|  | 1731 Hammer 8-Ball        | 10 - 16 | 782 H.HS* | 630 H.LS |
|  | 1731 Hammer S             | 09 - 17 | 782 H.HS* | 630 H.LS |
|  | 1731 Hard-Ball            | 12 - 13 | 782 H.HS* | 630 H.LS |

\* = 2 sets required / 2 jeux pour l'Avant.





**RECOMMENDED**

1xx = Scooter Pads  
5xx = Street, Off Road & Racing Pads  
2xxx = Brake Shoes



**VICTORY**

|      |                   |         |           |          |
|------|-------------------|---------|-----------|----------|
| 1731 | High-Ball         | 12 - 17 | 782 H.HS  | 630 H.LS |
| 1731 | Jackpot           | 10 - 16 | 782 H.HS  | 630 H.LS |
| 1731 | Judge             | 13 - 17 | 782 H.HS  | 630 H.LS |
| 1731 | Kingpin           | 10 - 12 | 782 H.HS  | 630 H.LS |
| 1731 | Kingpin 8-Ball    | 10 - 11 | 782 H.HS  | 630 H.LS |
| 1731 | Magnum            | 15 - 17 | 782 H.HS* | 630 H.LS |
| 1731 | Magnum X-1        | 15 - 17 | 782 H.HS* | 630 H.LS |
| 1731 | Vegas             | 10 - 17 | 782 H.HS  | 630 H.LS |
| 1731 | Vegas 8-Ball      | 10 - 17 | 782 H.HS  | 630 H.LS |
| 1731 | Vegas Jackpot     | 09      | 782 H.HS  | 630 H.LS |
| 1731 | Vision all models | 08 - 17 | 735 H.HS* | 630 H.LS |

**VOR**

|     |                      |         |         |         |
|-----|----------------------|---------|---------|---------|
| 400 | Cross                | 00 - 01 | 671 RSI | 675 RSI |
| 400 | Enduro               | 00 - 01 | 671 SI  | 675 SI  |
| EN  | 400                  | 02 - 03 | 671 SI  | 675 SI  |
| MX  | 400                  | 02      | 671 RSI | 675 RSI |
| SM  | 400                  | 02      | 566 RSI | 675 RSI |
| EN  | 450                  | 02 - 04 | 671 SI  | 675 SI  |
| MX  | 450                  | 02 - 04 | 671 RSI | 675 RSI |
| SM  | 450                  | 02 - 04 | 566 RSI | 675 RSI |
|     | 500 492 Enduro       | 99      | 671 SI  | 675 SI  |
|     | 500 492 Super Motard | 00 - 01 | 566 HF  | 675 HF  |
|     | 500 495 Cross        | 99      | 671 RSI | 675 RSI |
| EN  | 530                  | 02 - 04 | 671 SI  | 675 SI  |
| MX  | 530                  | 02 - 04 | 671 RSI | 675 RSI |
| SM  | 530                  | 02 - 04 | 566 RSI | 675 RSI |

**VOXAN**

|      |            |         |         |        |
|------|------------|---------|---------|--------|
| 1000 | Cafe Racer | 01 - 06 | 566 HS* | 730 LS |
| 1000 | Roadster   | 01 - 06 | 566 HS* | 730 LS |
| 1000 | Scrambler  | 01 - 03 | 627 HF* | 633 HF |
| VB1  | 1000 EVO   | 04 - 06 | 706 HS* | 730 LS |

**WRM**

|     |    |         |         |         |
|-----|----|---------|---------|---------|
| 450 | MX | 06 - 08 | 671 RSI | 791 RSI |
|-----|----|---------|---------|---------|

**XINGFU**

|    |       |    |        |  |
|----|-------|----|--------|--|
| XF | 150 A | 97 | 572 HF |  |
|----|-------|----|--------|--|

**YAMAHA**

|    |                    |         |        |        |
|----|--------------------|---------|--------|--------|
| 50 | AJP Caliper        |         |        |        |
|    | incl. pin/spring   | 91 - 18 | 188 HF |        |
| 50 | Axis Pro Foot      | 92 - 99 | 111 HF | 2012   |
| 50 | Beluga             | 88 - 89 | 2021   | 2021   |
| 50 | Beluga             | 90 - 92 | 2050   | 2050   |
| 50 | Cygnus             | 96 - 01 | 107 HF |        |
| 50 | Jog R/RR           | 02 - 18 | 123 HF |        |
| 50 | Neo's 4            | 09 - 18 | 123 HF |        |
| 50 | Slider             | 00 - 05 | 145 HF |        |
| 50 | Why                | 99 - 07 | 123 HF | 2050   |
| BW | 50                 | 91 - 94 | 2050   | 2050   |
| BW | 50 Bump            | 97 - 02 | 123 HF | 2050   |
| BW | 50 Next Generation | 96 - 07 | 123 HF | 2050   |
| BW | 50 Sports Spec R   | 02 - 06 | 123 HF |        |
| BW | 50 Spy             | 95 - 03 | 123 HF | 2050   |
| CA | 50 Riva Salient    | 83 - 86 | 2112   | 2021   |
| CG | 50 A, B Riva Jog   | 90 - 91 | 2112   | 2021   |
| CR | 50 Target          | 91 - 95 | 111 HF | 2028   |
| CR | 50 Z               | 91 - 95 | 111 HF | 2050   |
| CV | 50 A/R Jog         | 03 - 08 | 206 HF |        |
| CV | 50 Jog, Jog ZR     | 01 - 06 | 165 HF |        |
| CW | 50 TA Zuma         | 90      | 2050   | 2050   |
| CX | 50                 | 88 - 93 | 2028   | 2028   |
| CY | 50 F Jog           | 94      | 2021   | 2028   |
| DT | 50 LCD             | 98 - 01 | 136 HF | 2028   |
| DT | 50 M, MX           | 78 - 86 | 2032   | 2032   |
| DT | 50 MX              | 87 - 90 | 2050   | 2050   |
| DT | 50 R               | 89 - 95 | 575 HF | 2050   |
| DT | 50 R               | 96 - 97 | 107 HF | 2050   |
| DT | 50 R               | 98 - 03 | 109 HF | 2028   |
| DT | 50 R               | 04 - 08 | 105 HF | 167 HF |



**RECOMMENDED**

1xx = Scooter Pads  
5xx = Street, Off Road & Racing Pads  
2xxx = Brake Shoes



**YAMAHA**

|        |                                 |         |        |        |
|--------|---------------------------------|---------|--------|--------|
| DT     | 50 X Supermotard                | 04 - 08 | 168 HF | 167 HF |
| FS     | 50 DX                           | 75 - 79 | 500 HF | 2032   |
| FS1    | 50 DX                           | 77 - 78 | 500 HF | 2032   |
| FS1    | 50 DX                           | 79 - 81 | 531 HF | 2032   |
| FS1    | 50 E                            | 74 - 76 | 2032   | 2032   |
| FS1    | 50 SE                           | 81 - 82 | 2032   | 2032   |
| FZR    | 50                              | 90 - 91 | 638 HF | 570 HF |
| FZR    | 50                              | 92      | 611 HF | 632 HF |
| JOG    | 50 (Spain)                      | 88      | 111 HF | 2021   |
| JOG    | 50 CY                           | 90 - 92 | 2021   | 2050   |
| JOG    | 50 E                            | 88 - 90 | 2112   | 2021   |
| JOG    | 50 R                            | 02 - 07 | 111 HF | 2050   |
| JOG-Z  | 50                              | 88 - 89 | 619 HF | 2182   |
| JOG-Z  | 50                              | 90 - 91 | 114 HF | 2021   |
| LB     | 50 Chappy                       | 80 - 83 | 2032   | 2032   |
| LC     | 50 M, Bop, G,H Champ            | 80 - 81 | 2021   | 2021   |
| MA     | 50 M, QT 50                     | 80 - 86 | 2112   | 2112   |
| MJ     | 50 J,M Towny                    | 82      | 2112   | 2112   |
| MJ     | 50 M Towny                      | 81 - 93 | 2112   | 2112   |
| MS     | 50                              | 85 - 86 | 2112   | 2021   |
| NS     | 50 Aerox                        | 13 - 18 | 114 HF | 145 HF |
| PW     | 50                              | 80 - 87 | 2112   | 2112   |
| PW     | 50                              | 90 - 95 | 2112   | 2112   |
| PW     | 50 H1                           | 96 - 18 | 2112   | 2112   |
| QA     | 50 Pocke                        | 83 - 85 | 2112   | 2112   |
| QB     | 50 Vogel                        | 83 - 85 | 2112   | 2112   |
| QT     | 50 Yamahopper                   | 79 - 87 | 2112   | 2112   |
| RD     | 50                              | 76 - 78 | 500 HF | 2032   |
| RD     | 50 M                            | 79 - 80 | 531 HF | 2032   |
| RD     | 50 MX                           | 81 - 87 | 547 HF | 2032   |
| RS     | 50 Champ                        | 88 - 93 | 111 HF | 2021   |
| RX     | 50 K                            | 83 - 85 | 547 HF | 2032   |
| SA     | 50 M, ME Passola                | 80 - 84 | 2112   | 2021   |
| SG     | 50 Sting                        | 84 - 91 | 2021   | 2021   |
| SH     | 50 E, F Razz                    | 93 - 95 | 2112   | 2021   |
| SH     | 50 Mint                         | 93 - 96 | 2112   | 2021   |
| SH     | 50 T,EMT,U,MU,W,MW,A, MA,B,D,MD | 87 - 93 | 2112   | 2021   |
| T      | 50                              | 86 - 89 | 2050   | 2050   |
| TDR    | 50                              | 90 - 92 | 107 HF | 107 HF |
| TRAFIC | 50 M                            | 83      | 2050   | 2050   |
| TT-R   | 50                              | 06 - 18 | 2010   | 2010   |
| TY     | 50 , M                          | 77 - 80 | 2032   | 2032   |
| TZM    | 50 R                            | 94 - 97 | 134 HF | 107 HF |
| TZR    | 50                              | 90 - 92 | 134 HF | 107 HF |
| TZR    | 50                              | 93 - 02 | 134 HF | 137 HF |
| TZR    | 50                              | 03 - 04 | 168 HF | 105 HF |
| V      | 50 M                            | 83      | 2050   | 2050   |
| V      | 50 M, P                         | 74 - 82 | 2032   | 2032   |
| YA     | 50 Axis Mofa                    | 97 - 02 | 123 HF | 2050   |
| YE     | 50 Zest (Italy)                 | 92 - 95 | 114 HF | 2028   |
| YE     | 50 Zest (Japan)                 | 92 - 95 | 111 HF | 2021   |
| YFM    | 50 Raptor                       | 04 - 11 | 2028   | 2034   |
| YH     | 50                              | 98 - 07 | 114 HF |        |
| YM     | 50 Breeze, Fizz                 | 95      | 114 HF | 2050   |
| YN     | 50 Neo's, LC                    | 97 - 16 | 123 HF | 2050   |
| YQ     | 50 Aerox                        | 97 - 12 | 114 HF | 145 HF |
| YSR    | 50                              | 87 - 91 | 575 HF | 2028   |
| YSR    | 50                              | 92      | 575 HF | 2032   |
| YZ     | 50                              | 80 - 83 | 2182   | 2182   |
| RD     | 60                              | 73 - 75 | 2032   | 2032   |
| YF     | 60 S Moto 4                     | 86      |        | 2050   |
| YT     | 60 Tri Zinger                   | 84 - 85 |        | 2050   |
| YZ     | 60                              | 85      | 2182   | 2182   |
| V      | 70 A                            | 76      | 2032   | 2032   |
| V      | 75 A                            | 77      | 2032   | 2032   |
|        | 80 Beluga                       | 81 - 89 | 2028   | 2028   |
| BW     | 80                              | 86 - 90 | 2182   | 2182   |
| CH     | 80 Beluga (CH 80)               | 90      | 2050   | 2021   |
| CJ     | 80                              | 86 - 88 | 2182   | 2182   |
| CV     | 80 Riva                         | 83 - 87 | 2028   | 2028   |
| CW     | 80 Beluga                       | 81 - 83 | 2028   | 2028   |

\* = 2 sets required / 2 jeux pour l'Avant.

Full compound selection, see under "Brake pad 1:1 Drawings" / Sélection complète de composés, voir "1:1 Schémas Plaquettes de frein".

**RECOMMENDED**

1xx = Scooter Pads  
5xx = Street, Off Road & Racing Pads  
2xxx = Brake Shoes



| YAMAHA |                  |        |         |         |  |
|--------|------------------|--------|---------|---------|--|
| DT     | 80 LC            | 81 -84 | 550 HF  | 2034    |  |
| DT     | 80 LC-2          | 85 -92 | 575 HF  | 2034    |  |
| DT     | 80 MX            | 81 -83 | 2032    | 2032    |  |
| DT     | 80 MX, MXS       | 84 -85 | 2050    | 2050    |  |
| LB2    | 80 Bop 2         | 80     | 2032    | 2032    |  |
| PW     | 80               | 83 -85 | 2182    | 2050    |  |
| PW     | 80               | 91 -08 | 2182    | 2028    |  |
| RD     | 80 LC            | 81 -82 | 550 HF  | 2032    |  |
| RD     | 80 LC            | 83 -85 | 575 HF  | 2032    |  |
| RD     | 80 MX            | 81 -86 | 547 HF  | 2032    |  |
| RX     | 80 SE            | 82 -84 | 547 HF  | 2032    |  |
| T      | 80 Townmate      | 83 -97 | 2050    | 2050    |  |
| TDR    | 80               | 89     | 575 HF  | 575 HF  |  |
| TY     | 80               | 77 -82 | 2182    | 2032    |  |
| TY     | 80               | 83 -84 | 2182    | 2028    |  |
| TZR    | 80               | 89 -91 | 570 HF  | 2034    |  |
| TZR    | 80               | 92 -95 | 619 HF  | 575 HF  |  |
| V      | 80               | 79 -82 | 2032    | 2032    |  |
| V      | 80 DL            | 83     | 2050    | 2050    |  |
| VN     | 80 NW            | 88     | 2034    | 2034    |  |
| YD     | 80               | 89     | 611 HF  | 632 HF  |  |
| YE     | 80 Zest (Italy)  | 93 -94 | 114 HF  |         |  |
| YE     | 80 Zest (Japan)  | 93 -95 | 111 HF  | 2021    |  |
| YFM    | 80               | 87 -88 | 2050    | 2034    |  |
| YFM    | 80 Badger        | 95 -07 | 2028    | 2034    |  |
| YFM    | 80 Grizzly       | 05 -08 | 2028    | 2034    |  |
| YFM    | 80 Raptor        | 02 -08 | 2028    | 2034    |  |
| YSR    | 80               | 86 -92 | 575 HF  | 2028    |  |
| YZ     | 80               | 74 -79 | 2182    | 2032    |  |
| YZ     | 80               | 80 -85 | 2182    | 2182    |  |
| YZ     | 80               | 86 -92 | 589 SI  | 2182    |  |
| YZ     | 80               | 93 -01 | 589 RSI | 592 RSI |  |
| YZ     | 85 , LW          | 02 -18 | 589 RSI | 592 RSI |  |
|        | 90 Axis Pro Foot | 94     | 111 HF  |         |  |
| CR     | 90 Target        | 91 -94 | 111 HF  | 2028    |  |
| JOG    | 90               | 90 -91 | 111 HF  | 2021    |  |
| RD     | 90               | 76 -79 | 500 HF  |         |  |
| TT-R   | 90               | 00 -10 | 2182    | 2028    |  |
| V      | 90               | 78     | 2032    | 2032    |  |
| YA     | 90 Axis          | 90 -93 | 111 HF  | 2032    |  |
| YFM    | 90 RY Raptor     | 09 -15 | 2028    | 586 SI  |  |
|        | 100 Aerox        | 00 -06 | 123 HF  | 2034    |  |
|        | 100 Neo's        | 00 -02 | 123 HF  | 2034    |  |
| AG     | 100 Farmbike     | 80 -91 | 2032    | 2034    |  |
| AG     | 100 Farmbike     | 92 -93 | 2050    | 2034    |  |
| DT     | 100              | 76 -80 | 2032    | 2034    |  |
| FJ     | 100 L, LC        | 84     | 555 HF  | 555 HF  |  |
| RD     | 100              | 80 -82 | 531 HF  |         |  |
| RD     | 100 D            | 76 -79 | 500 HF  |         |  |
| RS     | 100              | 75 -80 | 2032    | 2032    |  |
| RS     | 100 DX           | 77 -79 | 500 HF  | 2028    |  |
| RS     | 100 DX           | 80 -82 | 531 HF  | 2028    |  |
| RT     | 100 A-H          | 90 -96 | 2028    | 2028    |  |
| RX     | 100              | 76 -79 | 500 HF  | 2032    |  |
| RX     | 100              | 84 -87 | 550 HF  | 2032    |  |
| RXS    | 100              | 83 -97 | 2050    | 2050    |  |
| YB     | 100              | 78 -81 | 2032    | 2032    |  |
| YB     | 100              | 82 -86 | 2032    | 2028    |  |
| YB     | 100              | 87 -92 | 2028    | 2028    |  |
| YW     | 100 Booster      | 99 -02 | 111 HF  |         |  |
| YZ     | 100              | 78 -81 | 2032    | 2034    |  |
| YZ     | 100              | 82 -83 | 2028    | 2034    |  |
|        | 105 Crypton      | 98 -04 | 107 HF  | 2050    |  |
|        | 110 Mio          | 05 -07 | 165 HF  |         |  |
|        | 110 Mio Sporty   | 05 -07 | 165 HF  |         |  |
|        | 110 Nouvo        | 06 -07 | 165 HF  |         |  |
| TT-R   | 110              | 08 -18 | 2182    | 2028    |  |
|        | 115 D'elight     | 14 -18 | 858 HF  |         |  |
| RX     | 115 S            | 82 -85 | 550 HF  | 2032    |  |
|        | 125 Xenter       | 12 -18 | 208 CT  | 2209    |  |
| BL     | 125 Beluga       | 85 -87 | 2034    | 2034    |  |
| BL     | 125 Beluga       | 88 -93 | 2115    | 2034    |  |

**RECOMMENDED**

1xx = Scooter Pads  
5xx = Street, Off Road & Racing Pads  
2xxx = Brake Shoes



| YAMAHA |                        |        |         |        |  |
|--------|------------------------|--------|---------|--------|--|
| BWs    | 125                    | 10 -11 | 208 CT  | 2209   |  |
| DT     | 125 E, MX, LC          | 74 -85 | 2034    | 2034   |  |
| DT     | 125 LC                 | 85 -87 | 575 HF  | 2034   |  |
| DT     | 125 MX                 | 90 -93 | 2034    | 2034   |  |
| DT     | 125 R                  | 96 -07 | 107 CT  | 107 CT |  |
| DT     | 125 R, Electric        | 88 -03 | 575 HF  | 575 HF |  |
| DT     | 125 Tenere             | 89 -90 | 608 HF  | 2034   |  |
| DT     | 125 Tenere Scout       | 90 -94 | 653 HF  | 635 HF |  |
| DT     | 125 X Supermotard      | 05 -08 | 674 HF  | 632 HF |  |
| DTZ    | 125 Tenere             | 90 -94 | 653 HF  | 635 HF |  |
| GPD    | 125 N-Max              | 15 -18 | 226 CT  | 227 CT |  |
| IT     | 125 G, H, J            | 80 -82 | 2032    | 2034   |  |
| MT     | 125                    | 14 -18 | 844 HF  | 810 HF |  |
| MW     | 125 Tricity Left/Rear  | 14 -18 | 222 CT  | 225 CT |  |
| MW     | 125 Tricity Right      | 14 -18 | 223 CT  |        |  |
| NXC    | 125 Cygnus             | 10 -11 | 207 CT  | 2209   |  |
| NXC    | 125 Cygnus X           | 05 -09 | 190 CT  | 2209   |  |
| RD     | 125 DX                 | 75 -77 | 500 HF  | 2034   |  |
| RD     | 125 DX                 | 78 -81 | 531 HF  | 2037   |  |
| RD     | 125 LC                 | 82 -84 | 550 HF* | 2034   |  |
| RD     | 125 LC                 | 85 -87 | 570 HF  | 2034   |  |
| RS     | 125 DX                 | 76 -79 | 500 HF  | 2034   |  |
| RS     | 125 DX                 | 80 -86 | 531 HF  | 2034   |  |
| SR     | 125                    | 92 -96 | 550 HF  | 2050   |  |
| SR     | 125                    | 97 -02 | 691 HF  | 2050   |  |
| SR     | 125 Flame              | 96     | 575 HF  |        |  |
| SR     | 125 SE                 | 82     | 2034    | 2028   |  |
| SX     | 125 R                  | 88     | 536 HF  |        |  |
| TDR    | 125 (Italy)            | 90 -93 | 608 SI  | 692 SI |  |
| TDR    | 125 R                  | 93 -03 | 691 HS  | 575 LS |  |
| TT-R   | 125                    | 00 -13 | 2028    | 2028   |  |
| TT-R   | 125 LW                 | 00 -18 | 589 SI  | 2028   |  |
| TW     | 125                    | 99 -07 | 728 HF  | 2028   |  |
| TY     | 125                    | 80 -82 | 2032    | 2034   |  |
| TZ     | 125                    | 97 -00 | 624 DC  | 659 RQ |  |
| TZR    | 125                    | 87 -88 | 570 HF  | 2034   |  |
| TZR    | 125                    | 89 -92 | 555 HF  | 570 HF |  |
| TZR    | 125                    | 93     | 691 HF  | 555 HF |  |
| TZR    | 125                    | 94     | 634 HF  | 555 HF |  |
| TZR    | 125 R                  | 94 -04 | 634 HF  | 570 HF |  |
| VP     | 125 X-City             | 08 -13 | 181 CT  | 157 CT |  |
| WR     | 125                    | 91 -97 | 611 SI  | 632 SI |  |
| WR     | 125                    | 98 -02 | 694 SI  | 604 SI |  |
| WR     | 125 R, XY              | 09 -16 | 627 HF  | 675 HF |  |
| XC     | 125 Beluga             | 85     | 2034    | 2034   |  |
| XC     | 125 Beluga, Riva       | 87 -92 | 2115    | 2034   |  |
| XC     | 125 Cygnus F           | 00 -08 | 107 CT  | 2034   |  |
| XC     | 125 E, F Riva          | 93 -95 | 2115    | 2034   |  |
| XC     | 125 F                  | 00 -08 | 107 CT  | 2034   |  |
| XC     | 125 TR Cygnus, R       | 96 -98 | 107 CT  | 2034   |  |
| XC     | 125 Vity               | 08 -13 | 858 HF  |        |  |
| XN     | 125 Teos               | 01 -04 | 123 CT  | 2199   |  |
| XQ     | 125 Maxter             | 01 -05 | 151 CT* | 157 CT |  |
| XT     | 125                    | 82 -86 | 2034    | 2028   |  |
| XT     | 125 R                  | 05 -13 | 773 HF  | 559 HF |  |
| XT     | 125 X Supermotard      | 05 -13 | 774 HF  | 559 HF |  |
| XTZ    | 125                    | 05 -08 | 611 HF  |        |  |
| XV     | 125 Virago             | 97 -00 | 691 HF  | 2034   |  |
| XVS    | 125 Drag Star          | 00 -06 | 691 HF  | 2199   |  |
| Y      | 125 Fair Breeze        | 92 -95 | 2050    |        |  |
| YBR    | 125                    | 06 -16 | 575 HF  | 2034   |  |
| YFA    | 125 1 G-M Breeze       | 95 -07 | 2028    | 2034   |  |
| YFM    | 125 Grizzly            | 04 -13 | 2028    | 2034   |  |
| YP     | 125                    | 89     | 2037    | 2034   |  |
| YP     | 125 Majesty            | 01 -11 | 151 CT  | 157 CT |  |
| YP     | 125 R Majesty          | 99 -00 | 151 CT  | 2199   |  |
| YP     | 125 X-Max              | 06 -09 | 194 CT  | 157 CT |  |
| YP     | 125 X-Max              | 10 -18 | 181 CT  | 157 CT |  |
| YP     | 125 X-Max ABS          | 11 -16 | 181 CT  | 155 CT |  |
| YP     | 125 X-Max Business ABS | 11 -13 | 181 CT  | 155 CT |  |
| YP     | 125 X-Max Sport Ed.    | 11 -13 | 181 CT  | 157 CT |  |
| YS     | 125                    | 17 -18 | 858 HF  |        |  |

\* = 2 sets required / 2 jeux pour l'Avant.



**RECOMMENDED**

1xx = Scooter Pads  
5xx = Street, Off Road & Racing Pads  
2xxx = Brake Shoes



**YAMAHA**

|       |                       |         |         |         |
|-------|-----------------------|---------|---------|---------|
| YT    | 125 Tri Moto          | 80 - 81 |         | 617 HF  |
| YW    | 125 Z                 | 10 - 11 | 208 CT  | 2209    |
| YZ    | 125                   | 74 - 75 | 2032    | 2034    |
| YZ    | 125                   | 76 - 82 | 2033    | 2034    |
| YZ    | 125                   | 83      | 2033    | 2049    |
| YZ    | 125                   | 84      | 2036    | 2049    |
| YZ    | 125                   | 85 - 87 | 580 SI  | 2049    |
| YZ    | 125                   | 88      | 580 RSI | 575 RSI |
| YZ    | 125                   | 89      | 611 RSI | 584 RSI |
| YZ    | 125                   | 90 - 95 | 611 RSI | 632 RSI |
| YZ    | 125                   | 96 - 97 | 611 RSI | 648 RSI |
| YZ    | 125                   | 98 - 02 | 694 RSI | 604 RSI |
| YZ    | 125                   | 03 - 07 | 694 RSI | 790 RSI |
| YZ    | 125                   | 08 - 18 | 840 RSI | 790 RSI |
| YZF   | 125 R                 | 08 - 13 | 671 HF  | 810 HF  |
| YZF   | 125 R                 | 14 - 18 | 844 HF  | 810 HF  |
|       | 135 Crypton X         | 08 - 14 | 858 HF  | 2034    |
|       | 150 Teos              | 02 - 05 | 123 CT  | 2199    |
|       | 150 Xenter            | 12 - 18 | 208 CT  | 2209    |
| FZH   | 150 Fazer             | 11 - 14 | 671 HF  |         |
| XC    | 150 Fly One           | 92 - 99 | 575 HF  | 2012    |
| XC    | 150 Fly One R         | 98 - 02 | 107 CT  | 2028    |
| XQ    | 150 Maxter            | 01 - 02 | 151 CT* | 157 CT  |
| YP    | 150 Majesty           | 01 - 02 | 151 CT  | 157 CT  |
| YZF   | 150 R15               | 14      | 858 HF  | 784 HF  |
| GPD   | 155 N-Max             | 15 - 18 | 226 CT  | 227 CT  |
| DT    | 175                   | 95 - 99 | 2034    | 2034    |
| DT    | 175                   | 00      | 728 HF  | 2034    |
| DT    | 175 all models        | 74 - 83 | 2034    | 2034    |
| IT    | 175                   | 80 - 82 | 2033    | 2034    |
| TY    | 175                   | 77 - 80 | 2032    | 2034    |
| YT    | 175 Tri Moto          | 82 - 83 | 2028    | 576 HF  |
| RT    | 180                   | 90 - 93 | 596 HF  | 2034    |
| RT    | 180                   | 95 - 96 | 575 SI  | 2034    |
| XC    | 180 Cygnus, Riva      | 83 - 85 | 2115    | 2037    |
| YP    | 180 R Majesty         | 03      | 151 CT  | 2199    |
| YP    | 180 R Majesty         | 04 - 06 | 151 CT  | 157 CT  |
| SR    | 185 Exiter, H, J      | 81 - 82 | 2034    | 2028    |
| BW    | 200                   | 85 - 88 | 2028    | 2028    |
| DT    | 200                   | 85 - 87 | 575 HF  | 2034    |
| DT    | 200                   | 89      | 575 HF  | 575 HF  |
| DT    | 200 WR                | 91 - 93 | 611 HF  | 632 HF  |
| IT    | 200                   | 84 - 85 | 2049    | 2049    |
| IT    | 200                   | 85 - 86 | 575 SI  | 2049    |
| IT    | 200                   | 86      | 580 HF  | 2049    |
| RD    | 200 A, B              | 74 - 75 | 2113    | 2037    |
| RD    | 200 DX                | 76 - 78 | 500 HF  | 2037    |
| RD    | 200 DX                | 78 - 81 | 531 HF  | 2037    |
| RS    | 200                   | 79      | 2037    | 2037    |
| SDR   | 200                   | 88 - 89 | 570 HF  | 570 HF  |
| SX    | 200 R                 | 88 - 98 | 536 HF  |         |
| TT    | 200                   | 86 - 89 | 575 HF  | 2028    |
| TW    | 200                   | 87 - 00 | 2034    | 2028    |
| TW    | 200                   | 01 - 15 | 728 HF  | 2028    |
| WR    | 200                   | 91 - 92 | 611 SI  | 632 SI  |
| XC    | 200 Riva              | 87 - 91 | 2115    | 2034    |
| XT    | 200                   | 85 - 95 | 2034    | 2028    |
| YDS-7 | 200                   | 73 - 75 | 2113    | 2064    |
| YFM   | 200 DXS-DXW Moto 4    | 86 - 87 | 2028    | 576 HF  |
| YFM   | 200 N Moto 4          | 85 - 89 | 2028    | 576 HF  |
| YFS   | 200 R Blaster         | 03 - 06 | 536 SI* | 592 SI  |
| YFS   | 200 U-P Blaster       | 88 - 02 | 2028    | 637 SI  |
| YTM   | 200 K-N Tri Moto      | 83 - 85 | 2028    | 576 HF  |
|       | 225 Bronco, Cellow    | 97 - 02 | 728 HF  |         |
|       | 225 Serow             | 85 - 87 | 575 HF  | 2014    |
| TT    | 225 S,T               | 86 - 00 | 575 HF  | 2028    |
| TTR   | 225                   | 01 - 04 | 575 SI  | 2028    |
| XT    | 225                   | 92 - 00 | 575 HF  | 2028    |
| XT    | 225                   | 01      | 728 HF  | 2028    |
| XT    | 225 Serow             | 86      | 575 HF  | 2028    |
| YFM   | 225 Moto 4            | 86 - 88 | 2028    | 576 HF  |
| YTM   | 225 DRN, DRS Tri Moto | 85 - 86 | 2028    | 576 HF  |



**RECOMMENDED**

1xx = Scooter Pads  
5xx = Street, Off Road & Racing Pads  
2xxx = Brake Shoes



**YAMAHA**

|       |                       |         |         |         |
|-------|-----------------------|---------|---------|---------|
| YTM   | 225 DXK, DXN Tri Moto | 83 - 85 | 2028    | 576 HF  |
| TT-R  | 230                   | 05      | 611 SI  | 2034    |
| XV    | 240 Virago            | 92 - 98 | 550 HF  |         |
| DT    | 250 all models        | 75 - 80 | 2035    | 2037    |
| FZ    | 250 Phazer N, S       | 85 - 86 | 555 HF* | 2034    |
| FZ    | 250 R                 | 85      | 570 HF  |         |
| FZR   | 250                   | 87 - 88 | 590 HF* | 570 HF  |
| FZR   | 250 R                 | 89 - 99 | 639 HF* | 570 HF  |
| FZX   | 250 Zeal              | 91 - 92 | 663 HS  | 570 LS  |
| GX    | 250 Left              | 80 - 85 | 545 HF  |         |
| GX    | 250 Right             | 80 - 85 | 528 HF  |         |
| IT    | 250                   | 80 - 82 | 2033    | 2037    |
| IT    | 250                   | 84      | 2036    | 2037    |
| IT    | 250                   | 85 - 86 | 575 SI  | 2037    |
| MT-25 | 250                   | 16 - 17 | 931 HS  | 932 HF  |
| NX    | 250                   | 88      | 580 HF  |         |
| R1-Z  | 250                   | 90 - 92 | 639 HF  | 570 HF  |
| RD    | 250                   | 73 - 77 | 504 HF  | 2064    |
| RD    | 250                   | 77      | 504 HF  | 504 HF  |
| RD    | 250                   | 78 - 79 | 528 HF  | 528 HF  |
| RD    | 250 DX Left/Rear      | 80      | 545 HF  | 2064    |
| RD    | 250 DX Right          | 80      | 528 HF  |         |
| RD    | 250 LC                | 80      | 535 HF  | 2064    |
| RD    | 250 LC                | 81 - 82 | 547 HF  | 2064    |
| RD    | 250 LC                | 83 - 84 | 550 HF  | 555 HF  |
| RZ    | 250 RR                | 88      | 570 HS* | 570 LS  |
| RZR   | 250                   | 90      | 570 HS* | 570 LS  |
| SR    | 250                   | 90 - 93 | 2192    | 2034    |
| SR    | 250 SE                | 80 - 82 | 2035    | 2034    |
| SRV   | 250                   | 92 - 97 | 663 HS  |         |
| SRX   | 250                   | 84 - 90 | 570 HF  | 2034    |
| SRX   | 250 T, TC             | 87      | 570 HF  | 2037    |
| TDR   | 250                   | 88 - 92 | 590 HF  | 570 HF  |
| TT    | 250                   | 87 - 92 | 580 HF  | 2034    |
| TT    | 250                   | 93 - 03 | 611 SI  | 632 SI  |
| TY    | 250                   | 77 - 78 | 2032    | 2034    |
| TY    | 250                   | 81      | 2033    | 2037    |
| TY    | 250                   | 84 - 90 | 2049    | 2032    |
| TY    | 250 R                 | 91 - 92 | 559 HF  | 2032    |
| TY    | 250 Z                 | 93 - 96 | 559 HF  | 559 HF  |
| TY    | 250 Z (Scottish)      | 96      | 575 RSI | 632 RSI |
| TZ    | 250                   | 02 - 05 | 624 DC* | 659 RQ  |
| TZ    | 250                   | 82 - 85 | 504 HF  |         |
| TZ    | 250                   | 90 - 01 | 624 DC* | 659 RQ  |
| TZR   | 250                   | 87 - 88 | 590 HF* | 570 HF  |
| TZR   | 250                   | 89 - 92 | 634 HF* | 570 HF  |
| TZR   | 250 R                 | 94      | 566 HF* | 659 HF  |
| VP    | 250 X-City            | 07 - 09 | 181 MS  | 155 MS  |
| WR    | 250                   | 90 - 97 | 611 SI  | 632 SI  |
| WR    | 250                   | 98 - 02 | 694 SI  | 604 SI  |
| WR    | 250 F                 | 01 - 02 | 694 SI  | 604 SI  |
| WR    | 250 F                 | 03 - 13 | 694 SI  | 790 SI  |
| WR    | 250 F Efi             | 15 - 17 | 694 SI  | 790 SI  |
| WR    | 250 F Efi             | 18 -    | 840 SI  | 790 SI  |
| WR    | 250 F Enduro GP       | 18 -    | 840 SI  | 790 SI  |
| WR    | 250 R                 | 08 - 15 | 694 HS  | 790 LS  |
| WR    | 250 X                 | 08 - 16 | 627 HS  | 790 LS  |
| XG    | 250 Tricker           | 05 - 11 | 728 HF  | 632 HF  |
| XS    | 250 C                 | 77 - 78 | 507 HF  | 507 HF  |
| XS    | 250 C                 | 81      | 2113    | 2066    |
| XS    | 250 D, E              | 79 - 80 | 507 HF  | 2066    |
| XS    | 250 SE, SF            | 80 - 81 | 528 HF  | 2066    |
| XT    | 250                   | 80 - 81 | 2034    | 2034    |
| XT    | 250                   | 08      | 728 HF  | 632 HF  |
| XV    | 250 Route 66          | 88 - 90 | 550 HF  | 2034    |
| XV    | 250 S Virago          | 95 - 07 | 691 HS  | 2034    |
| XV    | 250 Virago            | 88      | 550 HF  | 2034    |
| XV    | 250 Virago            | 89 - 94 | 616 HF  | 2034    |
| XVS   | 250 Drag Star         | 01 - 04 | 691 HF  | 2199    |
| YBR   | 250                   | 07 - 11 | 638 HF  |         |
| YD    | 250                   | 86      | 2037    | 2035    |
| YD    | 250 S                 | 90      | 555 HF  | 2035    |

\* = 2 sets required / 2 jeux pour l'Avant.

Full compound selection, see under "Brake pad 1:1 Drawings" / Sélection complète de composés, voir "1:1 Schémas Plaquettes de frein".

**RECOMMENDED**

1xx = Scooter Pads  
5xx = Street, Off Road & Racing Pads  
2xxx = Brake Shoes



| YAMAHA |                            |         |         |         |  |
|--------|----------------------------|---------|---------|---------|--|
| YFM    | 250                        | 89 - 91 | 2035    | 576 SI  |  |
| YFM    | 250 AN Bruin 2x4           | 05 - 07 | 536 SI* |         |  |
| YFM    | 250 Bear Tracker           | 01 - 04 | 536 SI* |         |  |
| YFM    | 250 Raptor Left/Rear       | 09 - 14 | 850 SI  | 592 SI  |  |
| YFM    | 250 Raptor Right           | 09 - 14 | 849 SI  |         |  |
| YFM    | 250 Timberwolf (YFB 250 G) | 95      | 2035    | 2035    |  |
| YFU1W  | 250 Pro Hauler             | 89 - 90 | 2035    | 2177    |  |
| YP     | 250 D Majesty DX           | 98 - 00 | 128 MS  | 155 MS  |  |
| YP     | 250 Majesty                | 96 - 04 | 128 MS  | 2066    |  |
| YP     | 250 Majesty DX/ABS         | 99 - 14 | 128 MS  | 155 MS  |  |
| YP     | 250 X-Max                  | 05 - 09 | 194 MS  | 155 MS  |  |
| YP     | 250 X-Max                  | 10 - 13 | 181 MS  | 155 MS  |  |
| YP     | 250 X-Max                  | 14 - 16 | 181 MS  | 221 MS  |  |
| YTZ    | 250 Tri Moto               | 85 - 86 | 575 SI  | 575 SI  |  |
| YZ     | 250                        | 74 - 79 | 2033    | 2035    |  |
| YZ     | 250                        | 80      | 2033    | 2034    |  |
| YZ     | 250                        | 81      | 2033    | 2037    |  |
| YZ     | 250                        | 82 - 84 | 2036    | 2034    |  |
| YZ     | 250                        | 85 - 87 | 580 SI  | 2034    |  |
| YZ     | 250                        | 88      | 580 RSI | 575 RSI |  |
| YZ     | 250                        | 89      | 611 RSI | 584 RSI |  |
| YZ     | 250                        | 98 - 02 | 694 RSI | 604 RSI |  |
| YZ     | 250                        | 03 - 07 | 694 RSI | 790 RSI |  |
| YZ     | 250                        | 08 - 18 | 840 RSI | 790 RSI |  |
| YZ     | 250 A                      | 90      | 611 RSI | 632 RSI |  |
| YZ     | 250 B1-J1                  | 91 - 97 | 611 RSI | 648 RSI |  |
| YZ     | 250 F                      | 01 - 02 | 694 RSI | 604 RSI |  |
| YZ     | 250 F                      | 03 - 06 | 694 RSI | 790 RSI |  |
| YZ     | 250 F                      | 07 - 13 | 840 RSI | 790 RSI |  |
| YZ     | 250 F Efi                  | 14 - 18 | 840 RSI | 790 RSI |  |
| YZ     | 250 FX Efi                 | 15      | 840 SI  | 790 SI  |  |
| YZ     | 250 WRA,WRB                | 90 - 91 | 611 RSI | 632 RSI |  |
| YZF    | 250 R25                    | 15 - 18 | 931 HS  | 932 HF  |  |
| VP     | 300 Varsity                | 03 - 04 | 151 MS  | 151 MS  |  |
| VP     | 300 Varsity                | 05 - 06 | 181 MS  | 151 MS  |  |
| YFM    | 300 Warrior                | 89      | 536 SI  | 584 SI  |  |
| YP     | 300 X-Max                  | 17 - 18 | 229 CT  | 230 CT  |  |
| MT-03  | 321                        | 16 - 18 | 931 HS  | 932 HF  |  |
| YZF    | 321 R3                     | 15 - 18 | 931 HS  | 932 HF  |  |
| BW     | 350                        | 87 - 88 | 2049    | 2032    |  |
| RD     | 350                        | 73 - 79 | 504 HF  | 2064    |  |
| RD     | 350 LC                     | 80      | 535 HF* | 2064    |  |
| RD     | 350 LC                     | 81 - 82 | 547 HF* | 2064    |  |
| RD     | 350 LC                     | 85      | 570 HF* | 570 HF  |  |
| RD     | 350 LC YPVS                | 83 - 84 | 550 HF* | 555 HF  |  |
| RD     | 350 LC, F                  | 85 - 90 | 570 HS* | 570 LS  |  |
| RD     | 350 R                      | 91 - 95 | 570 HS* | 570 LS  |  |
| RZ     | 350                        | 84 - 85 | 550 HF* | 555 HF  |  |
| RZ     | 350                        | 86 - 88 | 570 HS* | 570 LS  |  |
| TT     | 350                        | 86 - 87 | 580 SI  | 2034    |  |
| TT     | 350                        | 95 - 00 | 611 SI  | 632 SI  |  |
| TY     | 350                        | 86      | 2049    | 2032    |  |
| XT     | 350                        | 85 - 96 | 575 HF  | 2034    |  |
| YFM    | 350 Bruin 2x4, 4x4         | 04 - 07 | 536 SI* |         |  |
| YFM    | 350 ERT, ERU               | 87 - 88 | 2028    | 576 HF  |  |
| YFM    | 350 ERW, ERA-G             | 89 - 95 | 2035    | 576 HF  |  |
| YFM    | 350 FWB L, LC Big Bear     | 99      | 536 SI* | 2066    |  |
| YFM    | 350 FWT, FWU Big Bear      | 87 - 88 | 2114    | 576 HF  |  |
| YFM    | 350 FWW, FWA-G Big Bear    | 89 - 95 | 2178    | 576 HF  |  |
| YFM    | 350 FXG-FXM Wolverine      | 95 - 11 | 536 SI* | 592 SI  |  |
| YFM    | 350 R Raptor               | 04 - 14 | 592 SI* | 592 SI  |  |
| YFM    | 350 UH, UJ, UK             | 96 - 98 | 2178    | 2066    |  |
| YFM    | 350 XG,XH Warrior          | 95 - 96 | 536 SI* | 592 SI  |  |
| YFM    | 350 XT, XU Warrior         | 87 - 88 | 575 SI* | 592 SI  |  |
| YFM    | 350 XW, XA-M Warrior       | 89 - 07 | 536 SI* | 536 SI  |  |
| YFP    | 350 U Terrapro             | 88      | 2035    | 2177    |  |
| YFZ    | 350 Banshee                | 87 - 89 | 575 SI* | 592 SI  |  |
| YFZ    | 350 Banshee                | 90 - 06 | 536 SI* | 592 SI  |  |
| XS     | 360 B                      | 76      | 504 HF  | 2064    |  |
| XS     | 360 C, D                   | 77      | 507 HF  | 507 HF  |  |
| YZ     | 360                        | 89      | 611 SI  | 584 SI  |  |
| 400    | Artesia                    | 91 - 92 | 650 HS  | 575 LS  |  |

**RECOMMENDED**

1xx = Scooter Pads  
5xx = Street, Off Road & Racing Pads  
2xxx = Brake Shoes



| YAMAHA |                                  |         |         |         |  |
|--------|----------------------------------|---------|---------|---------|--|
| DT     | 400 all models                   | 75 - 77 | 2035    | 2037    |  |
| FZ     | 400 N                            | 87      | 555 HF* | 570 HF  |  |
| FZ     | 400 R                            | 85      | 570 HF* | 570 HF  |  |
| FZR    | 400                              | 87      | 555 HF* | 570 HF  |  |
| FZR    | 400                              | 88 - 90 | 590 HS* | 570 LS  |  |
| FZR    | 400 A                            | 90      | 613 HS  | 570 LS  |  |
| FZR    | 400 R                            | 91 - 94 | 634 HS* | 570 LS  |  |
| RD     | 400                              | 73 - 76 | 504 HF  |         |  |
| RD     | 400                              | 77      | 504 HF  | 504 HF  |  |
| RD     | 400                              | 78 - 79 | 528 HF  | 528 HF  |  |
| RD     | 400                              | 79      | 507 HF* | 528 HF  |  |
| SR     | 400                              | 76      |         | 2037    |  |
| SR     | 400                              | 77      | 507 HF  | 507 HF  |  |
| SR     | 400                              | 14 - 16 | 663 HS  |         |  |
| SRX    | 400                              | 85 - 86 | 613 HF  | 570 HF  |  |
| SRX    | 400                              | 87      | 590 HF  | 570 HF  |  |
| WR     | 400 F                            | 98      | 694 SI  | 648 SI  |  |
| WR     | 400 F                            | 99 - 00 | 694 SI  | 604 SI  |  |
| XJ     | 400                              | 80 - 81 | 535 HF  |         |  |
| XJ     | 400                              | 82      | 550 HF* | 550 HF  |  |
| XJ     | 400 Diversion                    | 91 - 93 | 663 HS  | 570 LS  |  |
| XJ     | 400 Maxim, Seca                  | 81      | 547 HF* | 2063    |  |
| XJR    | 400 R                            | 95 - 96 | 706 HS  | 555 LS  |  |
| XS     | 400                              | 77      | 507 HF  | 507 HF  |  |
| XS     | 400                              | 78 - 81 | 2113    | 2066    |  |
| XS     | 400                              | 82 - 83 | 550 HF  | 2066    |  |
| XS     | 400                              | 85      | 550 HF  | 2066    |  |
| XS     | 400 DOHC                         | 82      | 550 HF  | 2066    |  |
| XS     | 400 SE Left/Rear                 | 80 - 81 | 528 HF  | 2066    |  |
| XS     | 400 SE Right                     | 80 - 81 | 545 HF  |         |  |
| XS     | 400 SG, SH, SF                   | 80 - 81 | 528 HF  | 2066    |  |
| XS     | 400 Z                            | 83      | 555 HF  | 555 HF  |  |
| XT     | 400                              | 86      | 575 HF  | 2063    |  |
| XV     | 400 Virago, SPL                  | 88      | 616 HF  | 2065    |  |
| YFM    | 400 FAM Kodiak                   | 00 - 02 | 536 SI* | 754 SI  |  |
| YFM    | 400 FAR Kodiak Automatic         | 03      | 536 SI* | 2066    |  |
| YFM    | 400 FWN Big Bear 4WD             | 00 - 11 | 536 SI* | 754 SI  |  |
| YFM    | 400 FWNH Big Bear-Buckmaster 4WD | 00 - 11 | 536 SI* | 754 SI  |  |
| YFM    | 400 N Big Bear 2WD               | 00 - 11 | 536 SI* | 754 SI  |  |
| YP     | 400 Majesty                      | 04      | 170 MS  | 185 MS  |  |
| YP     | 400 Majesty                      | 05 - 13 | 128 MS* | 185 MS  |  |
| YP     | 400 R X-Max                      | 13 - 16 | 181 MS  | 195 MS  |  |
| YP     | 400 RA X-Max                     | 14 - 16 | 181 MS  | 195 MS  |  |
| YZ     | 400                              | 77 - 79 | 2033    | 2035    |  |
| YZ     | 400                              | 98      | 694 RSI | 648 RSI |  |
| YZ     | 400 F                            | 99      | 694 RSI | 604 RSI |  |
| IT     | 425                              | 80      | 2033    | 2035    |  |
| WR     | 426 F                            | 01 - 02 | 694 SI  | 604 SI  |  |
| YZ     | 426 F                            | 00 - 02 | 694 RSI | 604 RSI |  |
| WR     | 450 F                            | 03 - 15 | 694 SI  | 790 SI  |  |
| WR     | 450 F Efi                        | 16 - 18 | 840 SI  | 790 SI  |  |
| WR     | 450 F Enduro GP                  | 18 -    | 840 SI  | 790 SI  |  |
| YFM    | 450 FA_ Kodiak                   | 03 - 07 | 536 SI* | 754 SI  |  |
| YFM    | 450 Wolverine                    | 06 - 10 | 536 SI* | 754 SI  |  |
| YFZ    | 450 S Left/Rear                  | 04 - 05 | 638 SI  | 592 SI  |  |
| YFZ    | 450 S Right                      | 04 - 05 | 611 SI  |         |  |
| YFZ    | 450 S Left/Rear                  | 06 - 09 | 638 SI  | 709 SI  |  |
| YFZ    | 450 S Right                      | 06 - 09 | 611 SI  |         |  |
| YXR    | 450 Rhino Left/Rear              | 06 - 09 | 611 SI  | 816 SI  |  |
| YXR    | 450 Rhino Right                  | 06 - 09 | 638 SI  |         |  |
| YZ     | 450 F                            | 03 - 07 | 694 RSI | 790 RSI |  |
| YZ     | 450 F                            | 08 - 09 | 840 RSI | 790 RSI |  |
| YZ     | 450 F Efi                        | 10 - 17 | 840 RSI | 790 RSI |  |
| YZ     | 450 F Efi                        | 18 -    | 840 RSI | 790 RSI |  |
| YZ     | 450 FX Efi                       | 16      | 840 SI  | 790 SI  |  |
| IT     | 465                              | 81 - 82 | 2036    | 2037    |  |
| YZ     | 465                              | 80      | 2036    | 2035    |  |
| YZ     | 465                              | 81      | 2036    | 2037    |  |
| IT     | 490                              | 84      | 2036    | 2037    |  |
| YZ     | 490                              | 81 - 82 | 2036    | 2037    |  |
| YZ     | 490                              | 83      | 2036    | 2034    |  |

\* = 2 sets required / 2 jeux pour l'Avant.



**RECOMMENDED**

1xx = Scooter Pads  
 5xx = Street, Off Road & Racing Pads  
 2xxx = Brake Shoes



| YAMAHA |                        |         |         |        |  |
|--------|------------------------|---------|---------|--------|--|
| YZ     | 490                    | 84      | 2036    | 2037   |  |
| YZ     | 490                    | 85 - 90 | 580 SI  | 2037   |  |
| FZR    | 500 (Austria)          | 89      | 555 HF* | 555 HF |  |
| FZR    | 500 R (Austria)        | 90 - 91 | 645 HS* | 555 LS |  |
| IT     | 500 G, H.              | 80 - 81 | 2033    | 2035   |  |
| RD     | 500                    | 83      | 555 HF* | 555 HF |  |
| RD     | 500 LC                 | 84 - 86 | 555 HF* | 570 HF |  |
| RZ     | 500                    | 84 - 86 | 555 HF* | 570 HF |  |
| SR     | 500                    | 78 - 91 | 507 HF  | 2037   |  |
| SR     | 500                    | 92 - 98 | 2190    | 2037   |  |
| TX     | 500 A, B               | 74 - 77 | 504 HF  | 2063   |  |
| WR     | 500 B                  | 91      | 611 SI  | 575 SI |  |
| WR     | 500 ZD,ZE              | 92 - 93 | 611 SI  | 632 SI |  |
| XJ     | 500 (Austria)          | 81 - 83 | 547 HF  | 2066   |  |
| XP     | 500 TMAX               | 01 - 03 | 170 MS  | 169 MS |  |
| XP     | 500 TMAX               | 04 - 07 | 128 MS* | 185 MS |  |
| XP     | 500 TMAX               | 08 - 11 | 198 MS* | 185 MS |  |
| XP     | 500 TMAX Tech Max      | 11      | 198 MS* | 185 MS |  |
| XS     | 500                    | 75 - 77 | 504 HF* | 2063   |  |
| XS     | 500                    | 77 - 81 | 507 HF  | 507 HF |  |
| XS     | 500 DOHC               | 82      | 550 HF  |        |  |
| XT     | 500 (Austria)          | 83      | 550 HF  | 2037   |  |
| XT     | 500                    | 76 - 80 | 2035    | 2037   |  |
| XT     | 500                    | 86 - 89 | 575 HF  | 2037   |  |
| XT     | 500 E (Austria)        | 90 - 96 | 650 HS  | 575 LS |  |
| XV     | 500 K, Virago          | 83      | 550 HF  | 2063   |  |
| XV     | 500 SE                 | 83      | 550 HF  | 2063   |  |
| XP     | 530 TMAX               | 12 - 18 | 198 MS* | 169 MS |  |
| XP     | 530 TMAX DX            | 17 - 18 | 198 MS* | 169 MS |  |
| XP     | 530 TMAX Iron Max      | 15 - 18 | 198 MS* | 169 MS |  |
| XP     | 530 TMAX SX            | 17 - 18 | 198 MS* | 169 MS |  |
| XV     | 535 DX Virago          | 98 - 03 | 663 HS  | 2065   |  |
| XV     | 535 S Virago           | 96 - 03 | 663 HS  | 2065   |  |
| XV     | 535 Virago             | 88 - 95 | 616 HF  | 2065   |  |
| XJ     | 550 Maxim              | 81 - 83 | 547 HF  | 2063   |  |
| XJ     | 550 Seca               | 81 - 83 | 547 HF  | 2066   |  |
| XT     | 550                    | 82 - 83 | 2037    | 2037   |  |
| XZ     | 550                    | 82      | 547 HF* | 2063   |  |
| XZ     | 550                    | 83 - 84 | 550 HF* | 2063   |  |
| XZ     | 550 RJ, RK             | 82 - 83 | 550 HF  | 2063   |  |
| XZ     | 550 S                  | 83 - 84 | 550 HF* | 2063   |  |
| YFM    | 550 FGPW Grizzly Left  | 09 - 16 | 850 SI  | 852 SI |  |
| YFM    | 550 FGPW Grizzly Right | 09 - 16 | 849 SI  | 851 SI |  |
| DT     | 600 N                  | 85      | 575 HF  | 2034   |  |
| FJ     | 600                    | 84 - 85 | 555 HF* | 555 HF |  |
| FZ     | 600                    | 86 - 87 | 555 HF* | 555 HF |  |
| FZ     | 600 S, SC              | 86 - 89 | 555 HF* | 570 HF |  |
| FZ6    | 600                    | 04 - 08 | 691 HS* | 657 LS |  |
| FZ6    | 600 Fazer              | 04 - 08 | 691 HS* | 657 LS |  |
| FZ6    | 600 Fazer S2           | 07 - 09 | 634 HS* | 657 LS |  |
| FZ6    | 600 Fazer S2 ABS       | 07 - 09 | 634 HS* | 657 LS |  |
| FZ6    | 600 S2                 | 07 - 09 | 634 HS* | 657 LS |  |
| FZ6    | 600 S2 ABS             | 07 - 09 | 634 HS* | 657 LS |  |
| FZ6R   | 600                    | 09 - 14 | 691 HS* | 614 LS |  |
| FZR    | 600                    | 89      | 555 HF* | 555 HF |  |
| FZR    | 600 R                  | 90 - 91 | 645 HS* | 555 LS |  |
| FZR    | 600 R                  | 92 - 95 | 665 HS* | 555 LS |  |
| FZS    | 600 Fazer              | 98 - 03 | 634 HS* | 570 LS |  |
| FZS    | 600 S Fazer            | 01 - 03 | 634 HS* | 570 LS |  |
| SRX    | 600                    | 86 - 87 | 570 HF* | 570 HF |  |
| SRX    | 600                    | 88 - 89 | 590 HF  | 570 HF |  |
| SRX    | 600                    | 90 - 99 | 613 HS  | 570 LS |  |
| TT     | 600                    | 85 - 88 | 575 HF  | 2034   |  |
| TT     | 600                    | 89      | 596 HF  | 2034   |  |
| TT     | 600                    | 90 - 92 | 580 HF  | 2034   |  |
| TT     | 600 E,S                | 96 - 01 | 671 HF  | 675 HF |  |
| TT     | 600 K,L                | 83 - 84 | 2036    | 2034   |  |
| TT     | 600 R                  | 93 - 95 | 671 HF  | 632 HF |  |
| TT     | 600 R                  | 98 - 07 | 671 HF  | 675 HF |  |
| XJ     | 600                    | 83 - 91 | 555 HF* | 555 HF |  |
| XJ     | 600 N                  | 91 - 97 | 663 HS  | 570 LS |  |
| XJ     | 600 N                  | 98 - 03 | 691 HS* | 570 LS |  |



**RECOMMENDED**

1xx = Scooter Pads  
 5xx = Street, Off Road & Racing Pads  
 2xxx = Brake Shoes



| YAMAHA |                         |         |         |        |  |
|--------|-------------------------|---------|---------|--------|--|
| XJ     | 600 S Diversion         | 91 - 97 | 663 HS  | 570 LS |  |
| XJ     | 600 S Diversion         | 98 - 03 | 691 HS* | 570 LS |  |
| XJ6    | 600 Diversion           | 09 - 15 | 691 HS* | 614 LS |  |
| XJ6-F  | 600                     | 09 - 12 | 691 HS* | 614 LS |  |
| XJ6-F  | 600                     | 13 - 15 | 691 HS* | 657 LS |  |
| XJ6-N  | 600                     | 09 - 12 | 691 HS* | 614 LS |  |
| XJ6-N  | 600                     | 13 - 15 | 691 HS* | 657 LS |  |
| XJ6-S  | 600                     | 09 - 12 | 691 HS* | 614 LS |  |
| XJ6-S  | 600                     | 13 - 15 | 691 HS* | 657 LS |  |
| XT     | 600                     | 83 - 86 | 550 HF  | 2037   |  |
| XT     | 600 E                   | 90 - 03 | 650 HS  | 575 LS |  |
| XT     | 600 K                   | 91 - 94 | 650 HS  | 575 LS |  |
| XT     | 600 Tenere              | 83 - 84 | 550 HF  | 2037   |  |
| XT     | 600 Z                   | 86 - 88 | 596 HF  | 2037   |  |
| XT     | 600 Z, Tenere           | 87 - 90 | 596 HF  | 575 HF |  |
| YFM    | 600 4x4 Grizzly         | 98 - 01 | 592 SI* | 2066   |  |
| YX     | 600 Radian              | 87 - 90 | 555 HF* | 2063   |  |
| YZF    | 600 R Thunder Cat       | 96 - 03 | 634 HS* | 555 LS |  |
| YZF    | 600 R6                  | 99 - 02 | 634 HS* | 728 LS |  |
| YZF    | 600 R6                  | 03 - 04 | 634 HS* | 657 LS |  |
| YZF    | 600 R6                  | 05 - 16 | 634 HS* | 657 LS |  |
| YZF    | 600 R6                  | 17 - 18 | 634 HS* | 834 LS |  |
| TX     | 650                     | 72 - 73 | 504 HF  |        |  |
| XJ     | 650                     | 80 - 82 | 507 HF* | 2065   |  |
| XJ     | 650                     | 83      | 550 HF  | 2065   |  |
| XJ     | 650 G, H, SH Left/Rear  | 80 - 83 | 545 HF  | 2065   |  |
| XJ     | 650 G, H, SH Right      | 80 - 83 | 528 HF  |        |  |
| XJ     | 650 Seca                | 81 - 83 | 547 HF* | 2065   |  |
| XJ     | 650 Turbo               | 81 - 82 | 550 HF* | 2065   |  |
| XS     | 650                     | 75 - 77 | 504 HF* | 2064   |  |
| XS     | 650                     | 75 - 85 | 507 HF* | 507 HF |  |
| XS     | 650                     | 77 - 79 | 507 HF* | 2064   |  |
| XS     | 650                     | 80 - 82 | 545 HF  | 507 HF |  |
| XS     | 650 SE                  | 80 - 82 | 507 HF  | 507 HF |  |
| XS     | 650 SJ, SK              | 82      | 507 HF* | 2064   |  |
| XS     | 650 SK, Heritage        | 83      | 507 HF* | 507 HF |  |
| XVS    | 650 A Drag Star Classic | 98 - 06 | 663 HS  | 2065   |  |
| XVS    | 650 Drag Star           | 97 - 06 | 663 HS  | 2065   |  |
|        | 660 Rhino Left/Rear     | 05 - 08 | 611 SI  | 816 SI |  |
|        | 660 Rhino Right         | 05 - 08 | 638 SI  |        |  |
| MT-03  | 660                     | 06 - 13 | 691 HS* | 675 LS |  |
| SZR    | 660                     | 96 - 01 | 566 HF  | 519 HF |  |
| XT     | 660 R                   | 04 - 11 | 674 HS  | 675 LS |  |
| XT     | 660 X                   | 04 - 13 | 706 HS  | 675 LS |  |
| XT     | 660 Z Tenere            | 08 - 14 | 671 HS* | 675 LS |  |
| XT     | 660 Z Tenere ABS        | 11 - 14 | 671 HS* | 675 LS |  |
| XTZ    | 660 Tenere              | 91 - 98 | 650 HS  | 575 LS |  |
| YFM    | 660 FWAP 4x4 Grizzly    | 02 - 08 | 592 SI* | 799 SI |  |
| YFM    | 660 RN Raptor           | 01 - 09 | 592 SI* | 592 SI |  |
| FZ     | 700                     | 87 - 88 | 555 HF* | 555 HF |  |
| FZX    | 700 Fazer               | 87 - 88 | 555 HF  | 555 HF |  |
| MT-07  | 700                     | 14 - 18 | 634 HS* | 657 LS |  |
| MT-07  | 700 Moto Cage           | 15 - 17 | 634 HS* | 657 LS |  |
| MT-07  | 700 SP                  | 18 -    | 634 HS* | 657 LS |  |
| MT-07  | 700 Tracer              | 16 - 18 | 634 HS* | 657 LS |  |
| XJ     | 700                     | 86 - 89 | 555 HF  | 2065   |  |
| XJ     | 700 Maxim               | 85 - 89 | 555 HF  | 555 HF |  |
| XSR    | 700                     | 16 - 18 | 634 HS* | 657 LS |  |
| XV     | 700 L, LC               | 84 - 87 | 555 HF* | 2065   |  |
| XV     | 700 Virago              | 87      | 555 HF  | 2065   |  |
| YFM    | 700 FGPW Grizzly Left   | 07 - 17 | 850 SI  | 852 SI |  |
| YFM    | 700 FGPW Grizzly Right  | 07 - 17 | 849 SI  | 851 SI |  |
| YFM    | 700 R Raptor Left/Rear  | 06 - 08 | 611 SI  | 816 SI |  |
| YFM    | 700 R Raptor Right      | 06 - 08 | 638 SI  |        |  |
| YFM    | 700 Raptor              | 09 - 12 | 611 SI  | 816 SI |  |
| YFM    | 700 Raptor              | 09 - 12 | 638 SI  |        |  |
| YFM    | 700 Raptor              | 13 - 14 | 611 SI  | 709 SI |  |
| YFM    | 700 Raptor              | 13 - 14 | 638 SI  |        |  |
| YXR    | 700 Rhino Left          | 08 - 14 | 638 SI  | 638 SI |  |
| YXR    | 700 Rhino Right         | 08 - 14 | 611 SI  | 611 SI |  |
|        | 750 Maxim               | 81      | 547 HF  | 555 HF |  |
| FZ     | 750                     | 85 - 86 | 555 HF* | 555 HF |  |

\* = 2 sets required / 2 jeux pour l'Avant.

Full compound selection, see under "Brake pad 1:1 Drawings" / Sélection complète de composés, voir "1:1 Schémas Plaquettes de frein".

**RECOMMENDED**

1xx = Scooter Pads  
5xx = Street, Off Road & Racing Pads  
2xxx = Brake Shoes



| YAMAHA |                            |         |         |        |  |
|--------|----------------------------|---------|---------|--------|--|
| FZ     | 750 Genesis                | 86      | 555 HF* | 570 HF |  |
| FZ     | 750 Genesis                | 87 - 88 | 555 HF* | 555 HF |  |
| FZ     | 750 Genesis                | 89 - 92 | 590 HS* | 555 LS |  |
| FZR    | 750 R                      | 89 - 92 | 624 HS* | 555 LS |  |
| FZR    | 750 R Genesis              | 87 - 88 | 613 HF* | 555 HF |  |
| FZX    | 750 Fazer                  | 86 - 90 | 555 HF* | 555 HF |  |
| TX     | 750                        | 73 - 74 | 504 HF* | 2065   |  |
| TX     | 750 A                      | 73 - 76 | 504 HF* | 555 HF |  |
| VF     | 750 Virago                 | 88      | 555 HF  | 2065   |  |
| XJ     | 750                        | 83 - 87 | 555 HF* | 555 HF |  |
| XJ     | 750 E                      | 81 - 83 | 507 HF  | 2065   |  |
| XJ     | 750 Maxim                  | 82      | 550 HF* | 2065   |  |
| XJ     | 750 Seca                   | 81 - 83 | 547 HF* | 2065   |  |
| XS     | 750                        | 77 - 80 | 507 HF* | 507 HF |  |
| XS     | 750 H, J, K                | 81 - 82 | 545 HF  | 507 HF |  |
| XS     | 750 SE Left/Rear           | 79 - 80 | 545 HF  | 507 HF |  |
| XS     | 750 SE Right               | 79 - 80 | 528 HF  |        |  |
| XTZ    | 750 Super Tenere Left/Rear | 89 - 95 | 611 HF  | 633 HF |  |
| XTZ    | 750 Super Tenere Right     | 89 - 95 | 638 HF  |        |  |
| XV     | 750                        | 89 - 92 | 555 HS  | 2065   |  |
| XV     | 750 MK                     | 83      | 528 HF  | 2063   |  |
| XV     | 750 SE                     | 81 - 83 | 545 HF  | 2063   |  |
| XV     | 750 Virago                 | 94 - 97 | 663 HS* | 2065   |  |
| YZF    | 750 R, SP                  | 93 - 97 | 683 HS* | 555 LS |  |
| YZF    | 750 R7 OW02                | 99 - 02 | 634 HS* | 733 LS |  |
| YZF    | 750 R7 OW02 Race kit       | 99 - 01 | 729 HS* |        |  |
|        | 800 Fazer 8                | 10 - 15 | 634 HS* | 657 LS |  |
| FZ8    | 800                        | 10 - 14 | 634 HS* | 657 LS |  |
| TDM    | 850                        | 91 - 95 | 590 HS* | 555 LS |  |
| TDM    | 850                        | 96 - 01 | 645 HS* | 555 LS |  |
| TRX    | 850 (Italy)                | 95 - 99 | 706 HS* | 555 LS |  |
| TRX    | 850                        | 95 - 00 | 613 HS* | 555 LS |  |
| XS     | 850                        | 80 - 81 | 507 HF* | 507 HF |  |
| XS     | 850 Left/Rear              | 81      | 545 HF  | 507 HF |  |
| XS     | 850 Right                  | 81      | 528 HF  |        |  |
|        | 900 Niken                  | 18 -    | 634 HS* |        |  |
| MT-09  | 900                        | 14 - 18 | 634 HS* | 657 LS |  |
| MT-09  | 900 SP                     | 18 -    | 634 HS* | 657 LS |  |
| MT-09  | 900 Sport Tracker          | 15 - 16 | 634 HS* | 657 LS |  |
| MT-09  | 900 Street Rally           | 14 - 16 | 634 HS* | 657 LS |  |
| MT-09  | 900 Tracer                 | 15 - 18 | 634 HS* | 657 LS |  |
| MT-09  | 900 Tracer GT              | 18 -    | 634 HS* | 657 LS |  |
| TDM    | 900                        | 02 - 14 | 634 HS* | 769 LS |  |
| XJ     | 900                        | 83 - 93 | 555 HF* | 555 HF |  |
| XJ     | 900 F                      | 85 - 93 | 555 HF* | 555 HF |  |
| XJ     | 900 S, Diversion           | 94 - 03 | 663 HS* | 555 LS |  |
| XSR    | 900                        | 16 - 18 | 634 HS* | 657 LS |  |
| XSR    | 900 Abarth                 | 17 - 18 | 634 HS* | 657 LS |  |
| XV     | 920                        | 81 - 82 | 507 HF  |        |  |
| XV     | 920 J                      | 82      | 547 HF  | 2065   |  |
| XV     | 920 K, MK, Virago          | 83      | 545 HF  | 550 HF |  |
| XV     | 920 Virago                 | 81      | 547 HF* | 555 HF |  |
| SCR    | 950 Scrambler              | 17 - 18 | 663 HS  | 769 LS |  |
| XV     | 950 Bolt                   | 14 - 18 | 663 HS  | 769 LS |  |
| XV     | 950 Bolt C-Spec            | 15 - 18 | 663 HS  | 769 LS |  |
| XV     | 950 Bolt Racer             | 17 - 18 | 663 HS  | 769 LS |  |
| XV     | 950 Bolt R-Spec            | 14 - 18 | 663 HS  | 769 LS |  |
| XVS    | 950 A Midnight Star        | 09 - 13 | 663 HS  | 769 LS |  |
| FZ1    | 1000 Fazer                 | 06 - 16 | 634 HS* | 657 LS |  |
| FZR    | 1000                       | 94 - 95 | 683 HS* | 555 LS |  |
| FZR    | 1000 EX UP                 | 90 - 91 | 645 HS* | 555 LS |  |
| FZR    | 1000 EX UP                 | 92 - 93 | 665 HS* | 555 LS |  |
| FZR    | 1000 Genesis               | 87 - 89 | 613 HF* | 555 HF |  |
| FZS    | 1000 Fazer                 | 01 - 05 | 634 HS* | 770 LS |  |
| GTS    | 1000                       | 93 - 99 | 682 HF  | 555 HF |  |
| MT-10  | 1000                       | 16 - 18 | 634 HS* | 657 LS |  |
| MT-10  | 1000 SP                    | 17 - 18 | 634 HS* | 657 LS |  |
| MT-10  | 1000 Tourer Ed.            | 17 - 18 | 634 HS* | 657 LS |  |
| XV     | 1000 L, C                  | 84 - 85 | 555 HF* | 555 HF |  |
| XV     | 1000 SE                    | 83 - 85 | 547 HF* | 2065   |  |
| XV     | 1000 TR1                   | 81 - 83 | 507 HF* | 2065   |  |
| XV     | 1000 Virago                | 86 - 88 | 555 HF* | 2065   |  |

**RECOMMENDED**

1xx = Scooter Pads  
5xx = Street, Off Road & Racing Pads  
2xxx = Brake Shoes



| YAMAHA |                            |         |         |        |  |
|--------|----------------------------|---------|---------|--------|--|
| YZF    | 1000 R Thunder Ace         | 96 - 99 | 634 HS* | 555 LS |  |
| YZF    | 1000 R1                    | 98 - 01 | 634 SP* | 733 LS |  |
| YZF    | 1000 R1                    | 02 - 03 | 634 SP* | 728 LS |  |
| YZF    | 1000 R1                    | 04 - 06 | 634 SP* | 657 LS |  |
| YZF    | 1000 R1                    | 15 - 18 | 634 SP* | 834 LS |  |
| YZF    | 1000 R1(4-pad)             | 07 - 14 | 839 SP* | 657 LS |  |
| YZF    | 1000 R1(4-pad) ABS         | 12 - 14 | 839 SP* | 657 LS |  |
| YZF    | 1000 R1 SP                 | 06      | 634 SP* | 657 LS |  |
| YZF    | 1000 R1M                   | 15 - 18 | 634 SP* | 834 LS |  |
| YZF    | 1000 R1S                   | 16      | 634 SP* | 834 LS |  |
|        | 1100 SE, Maxim             | 81      | 547 HF  |        |  |
| BT     | 1100 Bulldog               | 02 - 06 | 634 HS* | 555 LS |  |
| FJ     | 1100                       | 83 - 85 | 555 HF* | 555 HF |  |
| XJ     | 1100                       | 81      | 547 HF* | 528 HF |  |
| XS     | 1100 E,F,G,H               | 78 - 81 | 507 HF* | 507 HF |  |
| XS     | 1100 LH Midnight           | 81      | 547 HF* | 528 HF |  |
| XS     | 1100 SF, SG, SH, LG        |         |         |        |  |
|        | Left/Rear                  | 79 - 81 | 545 HF  | 507 HF |  |
| XS     | 1100 SF, SG, SH, LG Right  | 79 - 81 | 528 HF  |        |  |
| XV     | 1100 Virago                | 86 - 93 | 555 HF* | 2065   |  |
| XV     | 1100 Virago                | 94 - 98 | 663 HS* | 2065   |  |
| XV     | 1100 Virago                | 99      | 691 HS* | 555 LS |  |
| XVS    | 1100 Drag Star             | 99 - 06 | 691 HS* | 555 LS |  |
| XVS    | 1100 Drag Star Classic     | 00 - 06 | 691 HS* | 555 LS |  |
| FJ     | 1200                       | 86 - 87 | 555 HF* | 555 HF |  |
| FJ     | 1200                       | 88 - 90 | 613 HF* | 555 HF |  |
| FJ     | 1200 ABS                   | 91 - 93 | 613 HS* | 555 LS |  |
| V-MAX  | 1200                       | 85 - 89 | 555 HF* | 555 HF |  |
| V-MAX  | 1200                       | 90 - 92 | 555 HS* | 555 LS |  |
| V-MAX  | 1200                       | 93 - 03 | 645 HS* | 555 LS |  |
| XJR    | 1200 (Italy)               | 95 - 98 | 706 HS* | 555 LS |  |
| XJR    | 1200                       | 94 - 98 | 613 HS* | 555 LS |  |
| XJR    | 1200 SP                    | 97 - 98 | 613 HS* | 555 LS |  |
| XT     | 1200 Z Super Tenere        | 14 - 18 | 634 SP* | 769 LS |  |
| XT     | 1200 ZE Super Tenere       | 14 - 18 | 634 SP* | 769 LS |  |
| XT     | 1200 ZE Super Tenere       |         |         |        |  |
|        | Raid Ed.                   | 18 -    | 634 SP* | 769 LS |  |
| XTZ    | 1200 Super Tenere          | 10 - 13 | 634 SP* | 769 LS |  |
| XV     | 1200                       | 84 - 87 | 555 HF* | 555 HF |  |
| XV     | 1200 Venture Royale        | 85      | 555 HF* | 555 HF |  |
| XV     | 1200 Z12T                  | 84 - 87 | 555 HF* | 555 HF |  |
| XVT    | 1200 T, Vent. Royale       | 84 - 85 | 555 HF* | 555 HF |  |
| FJR    | 1300                       | 01 - 03 | 634 HS* | 769 LS |  |
| FJR    | 1300 A                     | 13 - 18 | 740 HS* | 769 LS |  |
| FJR    | 1300 ABS                   | 03 - 05 | 634 HS* | 769 LS |  |
| FJR    | 1300 ABS                   | 06 - 12 | 740 HS* | 769 LS |  |
| FJR    | 1300 AE                    | 16 - 18 | 740 HS* | 769 LS |  |
| FJR    | 1300 AS                    | 13 - 18 | 740 HS* | 769 LS |  |
| XJR    | 1300                       | 99 - 01 | 634 HS* | 555 LS |  |
| XJR    | 1300                       | 02 - 18 | 634 HS* | 770 LS |  |
| XJR    | 1300 Racer                 | 15 - 18 | 634 HS* | 770 LS |  |
| XJR    | 1300 SP                    | 01      | 634 HS* | 555 LS |  |
| XVS    | 1300 A Midnight Star       | 07 - 11 | 691 HS* | 769 LS |  |
| XVS    | 1300 Custom                | 14 - 16 | 691 HS  | 769 LS |  |
| XVS    | 1300 Stryker               | 11 - 14 | 663 HS  | 769 LS |  |
| XVZ    | 1300 A Royal Star          | 96 - 07 | 613 HS* | 590 LS |  |
| XVZ    | 1300 AT Royal Star         |         |         |        |  |
|        | Tour Classic               | 97 - 07 | 613 HS* | 590 LS |  |
| XVZ    | 1300 Royal Star Boulevard  | 99 - 01 | 613 HS* | 590 LS |  |
| XVZ    | 1300 TF Royal Star Venture | 99 - 01 | 663 HS* | 590 LS |  |
| XVZ    | 1300 Venture Royale        | 86 - 89 | 613 HF* | 590 HF |  |
| XVZ    | 1300 Venture Royale        | 90 - 95 | 613 HS* | 590 LS |  |
| XV     | 1600 A Wild Star           | 99 - 07 | 663 HS* | 590 LS |  |
| MT-01  | 1700                       | 05 - 06 | 634 HS* | 654 LS |  |
| MT-01  | 1700                       | 07 - 16 | 839 HS* | 654 LS |  |
| VMX    | 1700 V-Max                 | 09 - 16 | 839 HS* | 769 LS |  |
| XV     | 1700 PC Road Star Warrior  | 03 - 07 | 634 HS* | 769 LS |  |
| XV     | 1700 Road Star Warrior     | 02      | 634 HS* | 590 LS |  |
| XV     | 1900 A                     | 11      | 740 HS* | 769 LS |  |
| XV     | 1900 A Midnight Star       | 06 - 10 | 634 HS* | 769 LS |  |

\* = 2 sets required / 2 jeux pour l'Avant.



**RECOMMENDED**

1xx = Scooter Pads  
 5xx = Street, Off Road & Racing Pads  
 2xxx = Brake Shoes



**RECOMMENDED**

1xx = Scooter Pads  
 5xx = Street, Off Road & Racing Pads  
 2xxx = Brake Shoes



**ZANELLA**

|     |                     |    |        |  |
|-----|---------------------|----|--------|--|
|     | 50 Racing Moped     | 92 | 519 HF |  |
| RZA | 125                 | 92 | 519 HF |  |
| TZ4 | 125 Patagonia (ARG) | 92 | 608 HF |  |

**ZERO**

|     |        |         |         |         |
|-----|--------|---------|---------|---------|
| DS  | ZF11.4 | 13      | 694 HS  | 790 LS  |
| DS  | ZF11.4 | 14      | 694 HS  | 675 LS  |
| DS  | ZF12.5 | 15      | 674 HS  | 675 LS  |
| DS  | ZF13.0 | 16 - 17 | 674 HS  | 675 LS  |
| DS  | ZF6.0  | 10 - 12 | 708 HF  | 544 HF  |
| DS  | ZF8.5  | 13      | 694 HS  | 790 LS  |
| DS  | ZF8.5  | 14      | 694 HS  | 675 LS  |
| DS  | ZF9.0  | 10 - 12 | 708 HF  | 544 HF  |
| DS  | ZF9.4  | 15      | 674 HS  | 675 LS  |
| DS  | ZF9.8  | 16 - 17 | 674 HS  | 675 LS  |
| DSR | ZF13.0 | 16 - 17 | 674 HS  | 675 LS  |
| FX  | ZF2.8  | 13      | 694 HS  | 790 LS  |
| FX  | ZF2.8  | 14      | 694 HS  | 675 LS  |
| FX  | ZF2.8  | 15      | 671 HS  | 675 LS  |
| FX  | ZF3.3  | 16 - 17 | 674 HS  | 675 LS  |
| FX  | ZF5.7  | 13      | 694 HS  | 790 LS  |
| FX  | ZF5.7  | 14      | 694 HS  | 675 LS  |
| FX  | ZF5.7  | 15      | 671 HS  | 675 LS  |
| FX  | ZF6.5  | 16 - 17 | 674 HS  | 675 LS  |
| FXS | ZF3.3  | 16 - 17 | 674 HS  | 675 LS  |
| FXS | ZF6.5  | 16 - 17 | 674 HS  | 675 LS  |
| MX  |        | 10 - 12 | 708 HF  | 544 HF  |
| MX  | ZF2.8  | 13      | 694 RSI | 790 RSI |
| MX  | ZF5.7  | 13      | 694 RSI | 790 RSI |
| S   | ZF11.4 | 13      | 694 HS  | 790 LS  |
| S   | ZF11.4 | 14      | 694 HS  | 675 LS  |
| S   | ZF12.5 | 15      | 674 HS  | 675 LS  |
| S   | ZF13.0 | 16 - 17 | 674 HS  | 675 LS  |
| S   | ZF6.0  | 10 - 12 | 708 HF  | 544 HF  |
| S   | ZF8.5  | 13      | 694 HS  | 790 LS  |
| S   | ZF8.5  | 14      | 694 HS  | 675 LS  |
| S   | ZF9.4  | 15      | 674 HS  | 675 LS  |
| S   | ZF9.8  | 16 - 17 | 674 HS  | 675 LS  |
| SR  | ZF11.4 | 14      | 694 HS  | 675 LS  |
| SR  | ZF12.5 | 15      | 674 HS  | 675 LS  |
| SR  | ZF13.0 | 16 - 17 | 674 HS  | 675 LS  |
| X   |        | 10 - 12 | 708 HF  | 544 HF  |
| XU  |        | 11 - 12 | 708 HF  | 544 HF  |
| XU  | ZF2.8  | 13      | 694 HS  | 790 LS  |
| XU  | ZF5.7  | 13      | 694 HS  | 790 LS  |

**ZUNDAPP**

|    |                   |         |        |  |
|----|-------------------|---------|--------|--|
| KS | 50 Supersport     | 76 - 79 | 532 HF |  |
| KS | 50 TT Watercooled | 80 - 81 | 532 HF |  |
| KS | 80                | 80      | 532 HF |  |
| KS | 80 Super          | 80 - 84 | 574 HF |  |
| KS | 80 Super          | 83 - 84 | 560 HF |  |
| KS | 80 Touring        | 81      | 532 HF |  |
| KS | 125               | 79      | 560 HF |  |
| KS | 175               | 78 - 82 | 506 HF |  |

**ZWEIRAD ROTH**

|  |                 |    |        |  |
|--|-----------------|----|--------|--|
|  | 50 Rebell Sport | 75 | 532 HF |  |
|  | 80 Rebell Sport | 75 | 532 HF |  |

\* = 2 sets required / 2 jeux pour l'Avant.





# MOTOCROSS



Photo: Sarah Gutierrez



|                  |                |         | COMPOUND CHOICE |    |    |     | COMPOUND CHOICE |    |   |   |
|------------------|----------------|---------|-----------------|----|----|-----|-----------------|----|---|---|
|                  |                |         | RSI             | SI | CS | RSI | SI              | CS |   |   |
| <b>APRILIA</b>   |                |         |                 |    |    |     |                 |    |   |   |
| MXV              | 450            | 09 - 13 | 694             | △  | △  | △   | 790             | △  | △ | △ |
| <b>BENELLI</b>   |                |         |                 |    |    |     |                 |    |   |   |
| BX               | 449 Cross      | 07 - 09 | 671             | △  | △  | △   | 675             | △  | △ | △ |
| <b>CCM</b>       |                |         |                 |    |    |     |                 |    |   |   |
|                  | 450 MX         | 08 - 10 | 671             | △  | △  | △   | 790             | △  | △ | △ |
| <b>GAS GAS</b>   |                |         |                 |    |    |     |                 |    |   |   |
| MC               | 125            | 03 - 13 | 694             | △  | △  | △   | 604             | △  | △ | △ |
| MC               | 250            | 97 - 99 | 671             | △  | △  | △   | 675             | △  | △ | △ |
| <b>HONDA</b>     |                |         |                 |    |    |     |                 |    |   |   |
| CR               | 80 R, RB       | 92 - 02 | 584             | △  | △  |     | 604             | △  | △ | △ |
| CR               | 85 R, R Expert | 03 - 12 | 592             | △  | △  | △   | 604             | △  | △ | △ |
| CR               | 125 R          | 95 - 01 | 694             | △  | △  | △   | 604             | △  | △ | △ |
| CR               | 125 R          | 02 - 07 | 694             | △  | △  | △   | 777             | △  | △ | △ |
| CR               | 125 RH, RJ, RK | 87 - 94 | 603             | △  | △  |     | 604             | △  | △ | △ |
| CRF              | 150 R          | 07 - 18 | 592             | △  | △  | △   | 777             | △  | △ | △ |
| CRF              | 250 R          | 04 - 09 | 694             | △  | △  | △   | 777             | △  | △ | △ |
| CRF              | 250 R Efi      | 10 - 17 | 694             | △  | △  | △   | 777             | △  | △ | △ |
| CRF              | 250 R Efi      | 18 -    | 694             | △  | △  | △   | 777             | △  | △ | △ |
| CR               | 250 R          | 87 - 94 | 603             | △  | △  |     | 604             | △  | △ | △ |
| CR               | 250 R          | 95 - 01 | 694             | △  | △  | △   | 604             | △  | △ | △ |
| CR               | 250 R          | 02 - 07 | 694             | △  | △  | △   | 777             | △  | △ | △ |
| CRF              | 450 R          | 02 - 08 | 694             | △  | △  | △   | 777             | △  | △ | △ |
| CRF              | 450 Efi        | 09 - 12 | 694             | △  | △  | △   | 777             | △  | △ | △ |
| CRF              | 450 R Efi      | 13 - 18 | 694             | △  | △  | △   | 777             | △  | △ | △ |
| CRF              | 450 RX Efi     | 17 - 18 | 694             | △  | △  | △   | 777             | △  | △ | △ |
| CR               | 500 R          | 87 - 94 | 603             | △  | △  |     | 604             | △  | △ | △ |
| CR               | 500 R          | 95 - 01 | 694             | △  | △  | △   | 604             | △  | △ | △ |
| <b>HUSABERG</b>  |                |         |                 |    |    |     |                 |    |   |   |
| FC               | 400            | 99 - 02 | 671             | △  | △  | △   | 675             | △  | △ | △ |
| FC               | 450            | 03 - 08 | 671             | △  | △  | △   | 675             | △  | △ | △ |
| FC               | 470 , e        | 01 - 02 | 671             | △  | △  | △   | 675             | △  | △ | △ |
| FC               | 501            | 99 - 01 | 671             | △  | △  | △   | 675             | △  | △ | △ |
| FC               | 550            | 01 - 05 | 671             | △  | △  | △   | 675             | △  | △ | △ |
| FC               | 600            | 99 - 01 | 671             | △  | △  | △   | 675             | △  | △ | △ |
| <b>HUSQVARNA</b> |                |         |                 |    |    |     |                 |    |   |   |
| CR               | 65             | 12 - 13 | 783             | △  | △  | △   | 872             | △  | △ | △ |
| TC               | 65             | 17 - 18 | 783             | △  | △  | △   | 783             | △  | △ | △ |
| TC               | 85             | 14 - 18 | 885             | △  | △  | △   | 872             | △  | △ | △ |
| TC               | 125            | 14 - 18 | 671             | △  | △  | △   | 791             | △  | △ | △ |
| CR               | 125            | 05 - 13 | 671             | △  | △  | △   | 791             | △  | △ | △ |
| CR               | 250            | 96 - 04 | 671             | △  | △  | △   | 675             | △  | △ | △ |
| CR               | 250            | 05      | 671             | △  | △  | △   | 791             | △  | △ | △ |
| FC               | 250            | 14 - 18 | 671             | △  | △  | △   | 791             | △  | △ | △ |
| TC               | 250            | 02 - 03 | 671             | △  | △  | △   | 675             | △  | △ | △ |
| TC               | 250            | 04 - 13 | 671             | △  | △  | △   | 791             | △  | △ | △ |
| TC               | 250            | 14 - 18 | 671             | △  | △  | △   | 791             | △  | △ | △ |
| TC               | 300            | 14 - 15 | 671             | △  | △  | △   | 791             | △  | △ | △ |
| FC               | 350            | 14 - 18 | 671             | △  | △  | △   | 791             | △  | △ | △ |
| TC               | 449            | 11 - 13 | 671             | △  | △  | △   | 791             | △  | △ | △ |
| TC               | 450            | 02 - 03 | 671             | △  | △  | △   | 675             | △  | △ | △ |
| TC               | 450            | 04 - 10 | 671             | △  | △  | △   | 791             | △  | △ | △ |
| FC               | 450            | 14 - 18 | 671             | △  | △  | △   | 791             | △  | △ | △ |
| TC               | 510            | 02 - 03 | 671             | △  | △  | △   | 675             | △  | △ | △ |
| TC               | 510            | 04 - 10 | 671             | △  | △  | △   | 791             | △  | △ | △ |
| TC               | 570            | 01 - 13 | 671             | △  | △  | △   | 675             | △  | △ | △ |
| TC               | 610            | 96 - 13 | 671             | △  | △  | △   | 675             | △  | △ | △ |
| <b>KAWASAKI</b>  |                |         |                 |    |    |     |                 |    |   |   |
| KX               | 65             | 00 - 15 | 752             | △  | △  | △   | 536             | △  | △ |   |
| KX               | 80             | 88 - 96 | 544             | △  | △  | △   | 592             | △  | △ | △ |
| KX               | 80             | 97 - 00 | 726             | △  | △  | △   | 592             | △  | △ | △ |
| KX               | 85             | 01 - 18 | 726             | △  | △  | △   | 592             | △  | △ | △ |
| KX               | 85 II          | 01 - 13 | 726             | △  | △  | △   | 592             | △  | △ | △ |
| KX               | 100            | 88 - 96 | 544             | △  | △  | △   | 592             | △  | △ | △ |
| KX               | 100            | 97 - 18 | 726             | △  | △  | △   | 592             | △  | △ | △ |
| KX               | 125            | 86      | 546             | △  | △  |     | 586             | △  | △ |   |

△ = Available quality / Qualité disponible.



## COMPOUND CHOICE



## COMPOUND CHOICE



| KAWASAKI      |                     |  |         | RSI | SI | CS |   | RSI | SI | CS |  |
|---------------|---------------------|--|---------|-----|----|----|---|-----|----|----|--|
| KX            | 125                 |  | 89 - 93 | 611 | △  | △  |   | 632 | △  | △  |  |
| KX            | 125                 |  | 94      | 694 | △  | △  | △ | 632 | △  | △  |  |
| KX            | 125                 |  | 95 - 08 | 694 | △  | △  | △ | 604 | △  | △  |  |
| KX            | 250                 |  | 86      | 546 | △  | △  |   | 586 | △  | △  |  |
| KX            | 250                 |  | 89 - 93 | 611 | △  | △  |   | 632 | △  | △  |  |
| KX            | 250                 |  | 94      | 694 | △  | △  | △ | 632 | △  | △  |  |
| KX            | 250                 |  | 95 - 08 | 694 | △  | △  | △ | 604 | △  | △  |  |
| KX-F          | 250                 |  | 04 - 10 | 694 | △  | △  | △ | 790 | △  | △  |  |
| KX-F          | 250 DFI             |  | 11 - 18 | 694 | △  | △  | △ | 790 | △  | △  |  |
| KX-F          | 450                 |  | 06 - 08 | 694 | △  | △  | △ | 790 | △  | △  |  |
| KX-F          | 450 DFI             |  | 09 - 18 | 694 | △  | △  | △ | 790 | △  | △  |  |
| KX            | 500                 |  | 86      | 546 | △  | △  |   | 586 | △  | △  |  |
| KX            | 500                 |  | 89 - 93 | 611 | △  | △  |   | 632 | △  | △  |  |
| KX            | 500                 |  | 94 - 95 | 694 | △  | △  | △ | 632 | △  | △  |  |
| KX            | 500                 |  | 96 - 04 | 694 | △  | △  | △ | 604 | △  | △  |  |
| <b>KTM</b>    |                     |  |         |     |    |    |   |     |    |    |  |
| SX            | 60                  |  | 99      | 559 | △  | △  | △ |     |    |    |  |
| SX            | 65                  |  | 00 - 01 | 559 | △  | △  | △ | 574 | △  | △  |  |
| SX            | 65                  |  | 02 - 03 | 783 | △  | △  | △ | 574 | △  | △  |  |
| SX            | 65                  |  | 04 - 08 | 783 | △  | △  | △ | 794 | △  | △  |  |
| SX            | 65                  |  | 09 - 18 | 783 | △  | △  | △ | 783 | △  | △  |  |
| SX            | 85 (19"/16" wheels) |  | 13 - 18 | 885 | △  | △  | △ | 872 | △  | △  |  |
| SX            | 85                  |  | 04 - 10 | 783 | △  | △  | △ | 783 | △  | △  |  |
| SX            | 85                  |  | 11      | 783 | △  | △  | △ | 872 | △  | △  |  |
| SX            | 85                  |  | 12 - 18 | 885 | △  | △  | △ | 872 | △  | △  |  |
| SX            | 125                 |  | 96 - 03 | 671 | △  | △  | △ | 675 | △  | △  |  |
| SX            | 125                 |  | 04 - 18 | 671 | △  | △  | △ | 791 | △  | △  |  |
| SX            | 144                 |  | 07 - 08 | 671 | △  | △  | △ | 791 | △  | △  |  |
| SX            | 150                 |  | 09 - 18 | 671 | △  | △  | △ | 791 | △  | △  |  |
| SX            | 200                 |  | 03 - 04 | 671 | △  | △  | △ | 791 | △  | △  |  |
| SX            | 250                 |  | 96 - 02 | 671 | △  | △  | △ | 675 | △  | △  |  |
| SX            | 250                 |  | 03 - 18 | 671 | △  | △  | △ | 791 | △  | △  |  |
| SX-F          | 250                 |  | 06 - 18 | 671 | △  | △  | △ | 791 | △  | △  |  |
| SX-F          | 350                 |  | 11 - 18 | 671 | △  | △  | △ | 791 | △  | △  |  |
| SX            | 360                 |  | 96 - 97 | 671 | △  | △  | △ | 675 | △  | △  |  |
| SX            | 380                 |  | 98 - 02 | 671 | △  | △  | △ | 675 | △  | △  |  |
| SX            | 400 Racing          |  | 00 - 02 | 671 | △  | △  | △ | 675 | △  | △  |  |
| XC-F          | 450                 |  | 06 - 17 | 671 | △  | △  | △ | 791 | △  | △  |  |
| SX-F          | 450                 |  | 03 - 18 | 671 | △  | △  | △ | 791 | △  | △  |  |
| XC-F          | 505                 |  | 08 - 09 | 671 | △  | △  | △ | 791 | △  | △  |  |
| SX            | 505 Racing          |  | 07 - 09 | 671 | △  | △  | △ | 791 | △  | △  |  |
| SX-F          | 520 Racing          |  | 00 - 02 | 671 | △  | △  | △ | 675 | △  | △  |  |
| SX-F          | 525 Racing          |  | 03      | 671 | △  | △  | △ | 675 | △  | △  |  |
| SX-F          | 525 Racing          |  | 04 - 06 | 671 | △  | △  | △ | 791 | △  | △  |  |
| SX            | 620                 |  | 95 - 99 | 671 | △  | △  | △ | 675 | △  | △  |  |
| <b>LEM</b>    |                     |  |         |     |    |    |   |     |    |    |  |
| RX            | 65                  |  | 05 - 10 | 794 | △  | △  |   | 794 | △  | △  |  |
| <b>POLINI</b> |                     |  |         |     |    |    |   |     |    |    |  |
| X5            | 65 RP               |  | 05 - 06 | 794 | △  | △  |   | 794 | △  | △  |  |
| <b>SHERCO</b> |                     |  |         |     |    |    |   |     |    |    |  |
| SX            | 250 2.5i-F          |  | 09 - 11 | 671 | △  | △  | △ | 790 | △  | △  |  |
| <b>SUZUKI</b> |                     |  |         |     |    |    |   |     |    |    |  |
| RM            | 65                  |  | 03 - 06 | 752 | △  | △  | △ | 536 | △  | △  |  |
| RM            | 80                  |  | 96 - 01 | 702 | △  | △  | △ | 544 | △  | △  |  |
| RM            | 85 , L              |  | 02 - 04 | 702 | △  | △  | △ | 544 | △  | △  |  |
| RM            | 85 , L              |  | 05 - 18 | 726 | △  | △  | △ | 820 | △  | △  |  |
| RM            | 100                 |  | 03      | 726 | △  | △  | △ | 592 | △  | △  |  |
| RM            | 125                 |  | 88      | 611 | △  | △  |   | 584 | △  | △  |  |
| RM            | 125                 |  | 89 - 90 | 611 | △  | △  |   | 632 | △  | △  |  |
| RM            | 125                 |  | 91 - 95 | 611 | △  | △  |   | 648 | △  | △  |  |
| RM            | 125                 |  | 96 - 09 | 694 | △  | △  | △ | 604 | △  | △  |  |
| RM            | 250                 |  | 87 - 88 | 611 | △  | △  |   | 584 | △  | △  |  |
| RM            | 250                 |  | 89 - 90 | 611 | △  | △  |   | 632 | △  | △  |  |
| RM            | 250                 |  | 91 - 95 | 611 | △  | △  |   | 648 | △  | △  |  |
| RM            | 250                 |  | 96 - 09 | 694 | △  | △  | △ | 604 | △  | △  |  |
| RMX           | 250                 |  | 89 - 95 | 611 | △  | △  |   | 648 | △  | △  |  |
| RMX           | 250                 |  | 96 - 98 | 694 | △  | △  | △ | 648 | △  | △  |  |

△ = Available quality / Qualité disponible.

To select compound for off-road front/rear - see page 13-14 / Pour sélectionner vos plaquettes off-road avant/arrière - voir page 13-14.



|               |             |         | COMPOUND CHOICE |    |    |     | COMPOUND CHOICE |    |   |   |
|---------------|-------------|---------|-----------------|----|----|-----|-----------------|----|---|---|
|               |             |         | RSI             | SI | CS | RSI | SI              | CS |   |   |
| <b>SUZUKI</b> |             |         |                 |    |    |     |                 |    |   |   |
| RM-Z          | 250         | 04 - 09 | 694             | △  | △  | △   | 790             | △  | △ | △ |
| RM-Z          | 250 Efi     | 10 - 18 | 694             | △  | △  | △   | 790             | △  | △ | △ |
| RM-Z          | 450         | 05 - 07 | 694             | △  | △  | △   | 790             | △  | △ | △ |
| RM-Z          | 450 Efi     | 08 - 17 | 694             | △  | △  | △   | 790             | △  | △ | △ |
| RM-Z          | 450 Efi     | 18 -    | 694             | △  | △  | △   | 790             | △  | △ | △ |
| RM            | 500         | 87 - 89 | 611             | △  | △  |     | 592             | △  | △ | △ |
| <b>TM</b>     |             |         |                 |    |    |     |                 |    |   |   |
|               | 80 Cross    | 96 - 00 | 671             | △  | △  | △   | 675             | △  | △ | △ |
|               | 80 Junior   | 96 - 00 | 544             | △  | △  | △   | 592             | △  | △ | △ |
| MX            | 85          | 01 - 12 | 671             | △  | △  | △   | 604             | △  | △ | △ |
| MX            | 85          | 13 - 18 | 777             | △  | △  | △   | 777             | △  | △ | △ |
|               | 125         | 96 - 00 | 671             | △  | △  | △   | 675             | △  | △ | △ |
|               | 125         | 01 - 04 | 671             | △  | △  | △   | 604             | △  | △ | △ |
|               | 125         | 05 - 17 | 671             | △  | △  | △   | 790             | △  | △ | △ |
|               | 250         | 01 - 04 | 671             | △  | △  | △   | 604             | △  | △ | △ |
|               | 250         | 05      | 671             | △  | △  | △   | 790             | △  | △ | △ |
|               | 250 E       | 95 - 00 | 671             | △  | △  | △   | 675             | △  | △ | △ |
|               | 250 F       | 01 - 04 | 671             | △  | △  | △   | 604             | △  | △ | △ |
|               | 250 F       | 05 - 17 | 671             | △  | △  | △   | 790             | △  | △ | △ |
|               | 300         | 98 - 00 | 671             | △  | △  | △   | 675             | △  | △ | △ |
|               | 300         | 01 - 04 | 671             | △  | △  | △   | 604             | △  | △ | △ |
|               | 300         | 05      | 671             | △  | △  | △   | 790             | △  | △ | △ |
|               | 320         | 96 - 97 | 671             | △  | △  | △   | 675             | △  | △ | △ |
|               | 400 F       | 00      | 671             | △  | △  | △   | 675             | △  | △ | △ |
|               | 400 F       | 01      | 671             | △  | △  | △   | 604             | △  | △ | △ |
|               | 450 F       | 02 - 04 | 671             | △  | △  | △   | 604             | △  | △ | △ |
|               | 450 F       | 05 - 17 | 671             | △  | △  | △   | 790             | △  | △ | △ |
|               | 530 F       | 01 - 04 | 671             | △  | △  | △   | 604             | △  | △ | △ |
|               | 530 F       | 05      | 671             | △  | △  | △   | 790             | △  | △ | △ |
| <b>YAMAHA</b> |             |         |                 |    |    |     |                 |    |   |   |
| YZ            | 80          | 93 - 01 | 589             | △  | △  | △   | 592             | △  | △ | △ |
| YZ            | 85 , LW     | 02 - 18 | 589             | △  | △  | △   | 592             | △  | △ | △ |
| YZ            | 125         | 88      | 580             | △  | △  |     | 575             | △  | △ |   |
| YZ            | 125         | 89      | 611             | △  | △  |     | 584             | △  | △ |   |
| YZ            | 125         | 90 - 95 | 611             | △  | △  |     | 632             | △  | △ |   |
| YZ            | 125         | 96 - 97 | 611             | △  | △  |     | 648             | △  | △ |   |
| YZ            | 125         | 98 - 02 | 694             | △  | △  | △   | 604             | △  | △ | △ |
| YZ            | 125         | 03 - 07 | 694             | △  | △  | △   | 790             | △  | △ | △ |
| YZ            | 125         | 08 - 18 | 840             | △  | △  | △   | 790             | △  | △ | △ |
| YZ            | 250         | 88      | 580             | △  | △  |     | 575             | △  | △ |   |
| YZ            | 250         | 89      | 611             | △  | △  |     | 584             | △  | △ |   |
| YZ            | 250         | 98 - 02 | 694             | △  | △  | △   | 604             | △  | △ | △ |
| YZ            | 250         | 03 - 07 | 694             | △  | △  | △   | 790             | △  | △ | △ |
| YZ            | 250         | 08 - 18 | 840             | △  | △  | △   | 790             | △  | △ | △ |
| YZ            | 250 A       | 90      | 611             | △  | △  |     | 632             | △  | △ |   |
| YZ            | 250 B1-J1   | 91 - 97 | 611             | △  | △  |     | 648             | △  | △ |   |
| YZ            | 250 F       | 01 - 02 | 694             | △  | △  | △   | 604             | △  | △ | △ |
| YZ            | 250 F       | 03 - 06 | 694             | △  | △  | △   | 790             | △  | △ | △ |
| YZ            | 250 F       | 07 - 13 | 840             | △  | △  | △   | 790             | △  | △ | △ |
| YZ            | 250 F Efi   | 14 - 18 | 840             | △  | △  | △   | 790             | △  | △ | △ |
| YZ            | 250 WRA,WRB | 90 - 91 | 611             | △  | △  |     | 632             | △  | △ |   |
| YZ            | 400         | 98      | 694             | △  | △  | △   | 648             | △  | △ |   |
| YZ            | 400 F       | 99      | 694             | △  | △  | △   | 604             | △  | △ | △ |
| YZ            | 426 F       | 00 - 02 | 694             | △  | △  | △   | 604             | △  | △ | △ |
| YZ            | 450 F       | 03 - 07 | 694             | △  | △  | △   | 790             | △  | △ | △ |
| YZ            | 450 F       | 08 - 09 | 840             | △  | △  | △   | 790             | △  | △ | △ |
| YZ            | 450 F Efi   | 10 - 17 | 840             | △  | △  | △   | 790             | △  | △ | △ |
| YZ            | 450 F Efi   | 18 -    | 840             | △  | △  | △   | 790             | △  | △ | △ |

△ = Available quality / Qualité disponible.

To select compound for off-road front/rear - see page 23-25 / Pour sélectionner vos plaquettes off-road avant/arrière - voir page 23-25.

# ROAD RACING



Photographer: Jon Jessop



COMPOUND CHOICE

COMPOUND CHOICE



| APRILIA        |      |                        |         | DS   | DC | RS |   | RQ  | LS |
|----------------|------|------------------------|---------|------|----|----|---|-----|----|
| RS             | 125  | , Extrema              | 93 - 98 | 601  |    | △  |   | 824 | △  |
| RS             | 125  |                        | 99 - 05 | 601  |    | △  |   | 824 | △  |
| RS             | 125  |                        | 06 - 12 | 844  |    | △  | △ | 747 | △  |
| RS             | 125  | Pista                  | 05 - 07 | 601  |    | △  |   | 824 | △  |
| RS             | 250  |                        | 97 - 02 | 706* | △  | △  | △ | 519 | △  |
| RS             | 250  | Pista                  | 04      | 706* | △  | △  | △ | 519 | △  |
| RSV            | 1000 | Factory Pista          | 04      | 762* | △  | △  | △ | 730 | △  |
| RSV            | 1000 | Mille                  | 97 - 01 | 706* | △  | △  | △ | 730 | △  |
| RSV            | 1000 | Mille                  | 02 - 03 | 762* | △  | △  | △ | 730 | △  |
| RSV            | 1000 | Mille Nera             | 04      | 762* | △  | △  | △ | 730 | △  |
| RSV            | 1000 | Mille R                | 00      | 706* | △  | △  | △ | 730 | △  |
| RSV            | 1000 | Mille R                | 01 - 02 | 762* | △  | △  | △ | 730 | △  |
| RSV            | 1000 | Mille R                | 04      | 762* | △  | △  | △ | 730 | △  |
| RSV            | 1000 | Mille R                | 03      | 762* | △  | △  | △ | 730 | △  |
| RSV            | 1000 | Mille R                | 05 - 07 | 762* | △  | △  | △ | 730 | △  |
| RSV            | 1000 | Mille R Factory        | 04 - 05 | 762* | △  | △  | △ | 730 | △  |
| RSV            | 1000 | Mille SP               | 00      | 706* | △  | △  | △ | 730 | △  |
| RSV4           | 1000 | , ABS                  | 09 - 13 | 841* | △  | △  | △ | 730 | △  |
| RSV4-R         | 1000 | , ABS APRC             | 10      | 841* | △  | △  | △ | 730 | △  |
| RSV4-RF        | 1000 |                        | 15 - 18 | 901* | △  | △  | △ | 730 | △  |
| RSV4-RR        | 1000 |                        | 15 - 18 | 901* | △  | △  | △ | 730 | △  |
| <b>BENELLI</b> |      |                        |         |      |    |    |   |     |    |
|                | 900  | Tornado TRE RS         | 04 - 06 | 762* | △  | △  | △ | 730 | △  |
| <b>BIMOTA</b>  |      |                        |         |      |    |    |   |     |    |
| BB3            | 1000 |                        | 14 - 18 | 901* | △  | △  | △ | 730 | △  |
| DB5            | 1000 | Mille                  | 05 - 11 | 762* | △  | △  | △ | 730 | △  |
| DB5            | 1000 | S                      | 07 - 11 | 762* | △  | △  | △ | 730 | △  |
| SB8            | 1000 | R                      | 98 - 00 | 706* | △  | △  | △ | 519 | △  |
| SB8K           | 1000 |                        | 06      | 706* | △  | △  | △ | 519 | △  |
| SB8K           | 1000 | Santamonica            | 07 - 09 | 762* | △  | △  | △ | 519 | △  |
| YB11           | 1000 |                        | 97 - 00 | 566* | △  | △  | △ | 519 | △  |
| DB7            | 1098 |                        | 08      | 762* | △  | △  | △ | 730 | △  |
| DB7            | 1099 |                        | 09      | 901* | △  | △  | △ | 519 | △  |
| 3D             | 1100 | Tesi                   | 07 - 11 | 762* | △  | △  | △ | 730 | △  |
| SB6            | 1100 |                        | 97 - 00 | 566* |    | △  | △ | 519 | △  |
| DB8            | 1198 |                        | 10 - 14 | 901* | △  | △  | △ | 730 | △  |
| <b>BMW</b>     |      |                        |         |      |    |    |   |     |    |
| S              | 1000 | RR                     | 09 - 18 | 870* | △  | △  | △ | 675 | △  |
| S              | 1000 | RR HP4                 | 12 - 14 | 901* | △  | △  | △ | 675 | △  |
| R              | 1100 | S With Integral ABS    | 01 - 05 | 778* |    |    | △ | 742 | △  |
| R              | 1100 | S Without Integral ABS | 01 - 05 | 796* |    |    | △ | 742 | △  |
|                | 1200 | HP2 Sport              | 08 - 10 | 901* | △  | △  | △ | 671 | △  |
| K              | 1200 | R                      | 05 - 08 | 778* |    |    | △ | 742 | △  |
| K              | 1300 | R                      | 09 - 15 | 778* |    |    | △ | 742 | △  |
| K              | 1300 | R Dynamic              | 11 - 15 | 778* |    |    | △ | 742 | △  |
| <b>DUCATI</b>  |      |                        |         |      |    |    |   |     |    |
|                | 748  | R                      | 00      | 706* | △  | △  | △ | 519 | △  |
|                | 748  | R                      | 01 - 02 | 762* | △  | △  | △ | 519 | △  |
|                | 748  | SP                     | 95 - 97 | 566* |    | △  | △ | 519 | △  |
|                | 748  | SPS                    | 98 - 99 | 706* | △  | △  | △ | 519 | △  |
|                | 749  | , S                    | 03 - 07 | 762* | △  | △  | △ | 730 | △  |
|                | 749  | R                      | 04 - 07 | 762* | △  | △  | △ | 730 | △  |
|                | 848  |                        | 08 - 10 | 706* | △  | △  | △ | 730 | △  |
|                | 848  | EVO                    | 11 - 12 | 841* | △  | △  | △ | 730 | △  |
|                | 899  | Panigale               | 14 - 15 | 900* | △  | △  | △ | 730 | △  |
|                | 900  | SS Supersport          | 95 - 97 | 566  |    | △  | △ | 519 | △  |
|                | 916  | Biposto                | 94      | 566* |    | △  | △ | 519 | △  |
|                | 916  | SPS                    | 97 - 98 | 706* | △  | △  | △ | 519 | △  |
|                | 959  | Panigale               | 16 - 18 | 900* | △  | △  | △ | 730 | △  |
|                | 959  | Panigale Corse         | 18 -    | 900* | △  | △  | △ | 730 | △  |
| D16RR          | 990  | Desmosedici RR         | 07 - 08 | 841* | △  | △  | △ | 730 | △  |
|                | 996  | , SPS                  | 99 - 01 | 706* | △  | △  | △ | 519 | △  |
|                | 996  | R                      | 01      | 762* | △  | △  | △ | 519 | △  |
|                | 998  | , S                    | 02      | 706* | △  | △  | △ | 519 | △  |
|                | 998  | R                      | 02      | 762* | △  | △  | △ | 519 | △  |
|                | 999  | , S                    | 03 - 07 | 762* | △  | △  | △ | 730 | △  |
|                | 999  | R                      | 03 - 07 | 762* | △  | △  | △ | 730 | △  |
|                | 1098 |                        | 07 - 08 | 841* | △  | △  | △ | 730 | △  |

\* = 2 sets required / 2 jeux pour l'Avant.

△ = Available quality / Qualité disponible.

To select compound for racing front/rear - see page 19-22 / Pour sélectionner vos plaquettes racing avant/arrière - voir page 19-22.



COMPOUND CHOICE

COMPOUND CHOICE



| DUCATI                        |  |         |      | DS | DC | RS |     | RQ | LS |
|-------------------------------|--|---------|------|----|----|----|-----|----|----|
| 1098 R                        |  | 08 - 10 | 841* | △  | △  | △  | 730 | △  | △  |
| 1098 R Bayliss LE             |  | 09 - 10 | 841* | △  | △  | △  | 730 | △  | △  |
| 1098 S                        |  | 07 - 08 | 841* | △  | △  | △  | 730 | △  | △  |
| 1100 Panigale V4              |  | 18 -    | 841* | △  | △  | △  | 730 | △  | △  |
| 1100 Panigale V4 S            |  | 18 -    | 841* | △  | △  | △  | 730 | △  | △  |
| 1100 Panigale V4 Speciale     |  | 18 -    | 841* | △  | △  | △  | 730 | △  | △  |
| 1198                          |  | 09 - 13 | 841* | △  | △  | △  | 730 | △  | △  |
| 1198 S                        |  | 09 - 12 | 841* | △  | △  | △  | 730 | △  | △  |
| 1198 SP                       |  | 11 - 12 | 841* | △  | △  | △  | 730 | △  | △  |
| 1199 Panigale                 |  | 12 - 14 | 841* | △  | △  | △  | 730 | △  | △  |
| 1199 Panigale R               |  | 13 - 15 | 841* | △  | △  | △  | 730 | △  | △  |
| 1199 Panigale S               |  | 12 - 14 | 841* | △  | △  | △  | 730 | △  | △  |
| 1199 Superleggera             |  | 14      | 841* | △  | △  | △  | 730 | △  | △  |
| 1299 Panigale                 |  | 15 - 17 | 841* | △  | △  | △  | 730 | △  | △  |
| 1299 Panigale R               |  | 15 - 17 | 841* | △  | △  | △  | 730 | △  | △  |
| 1299 Panigale R Final Edition |  | 17 - 18 | 841* | △  | △  | △  | 730 | △  | △  |
| 1299 Panigale S               |  | 15 - 17 | 841* | △  | △  | △  | 730 | △  | △  |
| 1299 Panigale S Anniversario  |  | 17      | 841* | △  | △  | △  | 730 | △  | △  |
| 1299 Superleggera             |  | 17      | 841* | △  | △  | △  | 730 | △  | △  |
| <b>EBR</b>                    |  |         |      |    |    |    |     |    |    |
| 1190 RS                       |  | 12 - 15 | 856  | △  |    | △  | 857 |    | △  |
| <b>HARLEY DAVIDSON</b>        |  |         |      |    |    |    |     |    |    |
| XR 1200                       |  | 08 - 10 | 860* | △  |    | △  | 808 |    | △  |
| <b>HONDA</b>                  |  |         |      |    |    |    |     |    |    |
| NSF 100                       |  | 06      | 688  |    |    | △  | 604 | △  |    |
| RS 125                        |  | 95 - 03 | 566  |    | △  | △  | 618 | △  |    |
| CBR 250 R (Nissin cal)        |  | 11 - 13 | 627  |    | △  | △  | 881 |    | △  |
| RS 250 R                      |  | 91 - 92 | 622* |    | △  | △  | 614 | △  | △  |
| RS 250 R                      |  | 93      | 566* |    | △  | △  | 618 | △  | △  |
| CBR 400 RR                    |  | 87 - 89 | 627* |    | △  | △  | 614 | △  | △  |
| RVF 400 RR (NC35)             |  | 90 - 96 | 622* |    | △  | △  | 623 | △  | △  |
| CBR 500 R                     |  | 13 - 18 | 700  | △  | △  | △  | 881 | △  | △  |
| CB 600 Hornet                 |  | 98 - 06 | 627* |    | △  | △  | 657 | △  | △  |
| CB 600 Hornet                 |  | 07 - 12 | 627* |    | △  | △  | 834 | △  | △  |
| CB 600 Hornet, S              |  | 00 - 03 | 627* |    | △  | △  | 657 | △  | △  |
| CBR 600 F3                    |  | 95 - 98 | 627* |    | △  | △  | 657 | △  | △  |
| CBR 600 F4, F4 Sport          |  | 99 - 06 | 734* |    | △  | △  | 657 | △  | △  |
| CBR 600 RR                    |  | 03 - 04 | 734* |    | △  | △  | 657 | △  | △  |
| CBR 600 RR                    |  | 05 - 06 | 809* | △  | △  | △  | 657 | △  | △  |
| CBR 600 RR                    |  | 07 - 08 | 809* | △  | △  | △  | 834 | △  | △  |
| CBR 600 RR ABS                |  | 09 - 18 | 809* | △  | △  | △  | 834 | △  | △  |
| CBR 650 F                     |  | 14 - 18 | 700* | △  | △  | △  | 881 | △  | △  |
| CBR 650 F ABS                 |  | 14 - 18 | 700* | △  | △  | △  | 881 | △  | △  |
| RVF 750 RR (RC-45)            |  | 94 - 98 | 622* |    | △  | △  | 623 | △  | △  |
| CBR 900 RR Fireblade          |  | 92 - 97 | 622* |    | △  | △  | 657 | △  | △  |
| CBR 900 RR Fireblade          |  | 98 - 03 | 734* |    | △  | △  | 657 | △  | △  |
| CBR 1000 RR Fireblade         |  | 04 - 05 | 809* | △  | △  | △  | 657 | △  | △  |
| CBR 1000 RR Fireblade         |  | 06 - 08 | 809* | △  | △  | △  | 834 | △  | △  |
| CBR 1000 RR Fireblade ABS     |  | 09 - 16 | 809* | △  | △  | △  | 834 | △  | △  |
| CBR 1000 RR Fireblade         |  | 17 - 18 | 947* |    | △  | △  | 834 | △  | △  |
| CBR 1000 RR SP                |  | 14 - 18 | 901* | △  | △  | △  | 834 | △  | △  |
| CBR 1000 RR SP2               |  | 17 - 18 | 901* | △  | △  | △  | 834 | △  | △  |
| RC213V-S 1000                 |  | 16 - 18 | 901* | △  | △  | △  | 730 | △  | △  |
| VTR 1000 F Firestorm          |  | 97 - 07 | 622* |    | △  | △  | 657 | △  | △  |
| VTR 1000 SP-1, SP-2           |  | 00 - 06 | 734* |    | △  | △  | 657 | △  | △  |
| <b>KAWASAKI</b>               |  |         |      |    |    |    |     |    |    |
| EX 250 R Ninja                |  | 08 - 12 | 638  | △  | △  | △  | 638 | △  | △  |
| EX 300 R Ninja, ABS           |  | 13 - 17 | 638  | △  | △  | △  | 638 | △  | △  |
| Z 400 Ninja                   |  | 18 -    | 638  | △  | △  | △  | 638 | △  | △  |
| ZXR 400                       |  | 91 - 02 | 666* |    | △  | △  | 556 | △  | △  |
| ZX-6R 600 (Ninja ZX6)         |  | 93 - 97 | 631* |    | △  | △  | 687 | △  | △  |
| ZX-6R 600 (Ninja ZX6R)        |  | 95 - 97 | 631* |    | △  | △  | 687 | △  | △  |
| ZX-6R 600 Ninja               |  | 98 - 01 | 686* |    | △  | △  | 687 | △  | △  |
| ZX-6R 600 Ninja               |  | 07 - 17 | 838* | △  | △  | △  | 687 | △  | △  |
| ZX-6RR 600 Ninja              |  | 03 - 06 | 788* | △  | △  | △  | 687 | △  | △  |
| ZX-6R 636 Ninja               |  | 02      | 686* |    | △  | △  | 687 | △  | △  |
| ZX-6R 636 Ninja               |  | 03 - 06 | 788* | △  | △  | △  | 687 | △  | △  |
| ZX-6R 636 Ninja               |  | 13 - 16 | 894* |    | △  | △  | 834 | △  | △  |

Applications  
Racing

\* = 2 sets required / 2 jeux pour l'Avant.

△ = Available quality / Qualité disponible.

To select compound for racing front/rear - see page 19-22 / Pour sélectionner vos plaquettes racing avant/arrière - voir page 19-22.



COMPOUND CHOICE

COMPOUND CHOICE



| KAWASAKI          |      |                 |         |      | DS | DC | RS |     | RQ | LS |
|-------------------|------|-----------------|---------|------|----|----|----|-----|----|----|
| ZX-6R             | 636  | Ninja ABS       | 13 - 16 | 894* |    | △  | △  | 834 | △  | △  |
| ZX-7R             | 750  | Ninja           | 96 - 03 | 686* |    | △  | △  | 556 | △  | △  |
| ZX-7RR            | 750  | Ninja           | 96 - 02 | 676* |    | △  | △  | 715 | △  | △  |
| ZX-9R             | 900  | Ninja           | 96 - 01 | 686* |    | △  | △  | 687 | △  | △  |
| ZX-9R             | 900  | Ninja           | 02 - 03 | 782* |    | △  | △  | 687 | △  | △  |
| Z                 | 1000 |                 | 03 - 06 | 782* |    | △  | △  | 687 | △  | △  |
| Z                 | 1000 |                 | 07 - 09 | 838* |    | △  | △  | 657 | △  | △  |
| ZX                | 1000 | H2 Carbon Ninja | 17 - 18 | 841* | △  | △  | △  | 730 | △  | △  |
| ZX                | 1000 | H2 Ninja        | 15 - 18 | 841* | △  | △  | △  | 730 | △  | △  |
| ZX                | 1000 | H2R Ninja       | 15 - 18 | 841* | △  | △  | △  | 730 | △  | △  |
| ZX-10R            | 1000 | Ninja           | 04 - 07 | 788* | △  | △  | △  | 687 | △  | △  |
| ZX-10R            | 1000 | Ninja           | 08 - 10 | 806* | △  | △  | △  | 687 | △  | △  |
| ZX-10R            | 1000 | Ninja           | 11 - 15 | 806* | △  | △  | △  | 834 | △  | △  |
| ZX-10R            | 1000 | Ninja           | 16 - 18 | 841* | △  | △  | △  | 834 | △  | △  |
| ZX-10R            | 1000 | Ninja ABS       | 12 - 15 | 806* | △  | △  | △  | 834 | △  | △  |
| ZX-10R            | 1000 | Ninja SE        | 18 -    | 841* | △  | △  | △  | 834 | △  | △  |
| ZX-10RR           | 1000 | Ninja           | 17 - 18 | 841* | △  | △  | △  | 834 | △  | △  |
| ZX-12R            | 1200 | Ninja           | 00 - 03 | 686* |    | △  | △  | 556 | △  | △  |
| ZX-12R            | 1200 | Ninja           | 04 - 06 | 788* |    | △  | △  | 556 | △  | △  |
| <b>KTM</b>        |      |                 |         |      |    |    |    |     |    |    |
| RC                | 250  |                 | 14 - 15 | 877  |    | △  | △  | 675 | △  | △  |
| RC                | 390  |                 | 14 - 18 | 877  |    | △  | △  | 675 | △  | △  |
|                   | 690  | Duke R          | 14 - 17 | 841* | △  | △  | △  | 675 | △  | △  |
| RC8               | 1190 |                 | 08 - 11 | 841* | △  | △  | △  | 730 | △  | △  |
| RC8               | 1190 | R               | 09 - 15 | 841* | △  | △  | △  | 730 | △  | △  |
| RC8               | 1190 | R Track         | 11 - 15 | 841* | △  | △  | △  | 730 | △  | △  |
| <b>MORIWAKI</b>   |      |                 |         |      |    |    |    |     |    |    |
| MD                | 250  |                 | 09      | 782  |    | △  | △  | 618 | △  |    |
| <b>MOTO-GUZZI</b> |      |                 |         |      |    |    |    |     |    |    |
|                   | 1200 | MGS-01 Corsa    | 05 - 13 | 762* | △  | △  | △  | 730 | △  | △  |
| <b>MV AGUSTA</b>  |      |                 |         |      |    |    |    |     |    |    |
|                   | 675  | F3              | 11 - 12 | 706* | △  | △  | △  | 763 | △  | △  |
|                   | 675  | F3              | 13 - 14 | 706* | △  | △  | △  | 730 | △  | △  |
|                   | 675  | F3              | 15 - 17 | 901* | △  | △  | △  | 730 | △  | △  |
|                   | 675  | F3 RC           | 16 - 17 | 901* | △  | △  | △  | 730 | △  | △  |
|                   | 750  | F4 SPR          | 01 - 03 | 676* |    | △  | △  | 763 | △  | △  |
|                   | 750  | F4/F4S          | 99 - 02 | 676* |    | △  | △  | 763 | △  | △  |
|                   | 800  | F3              | 14 - 17 | 901* | △  | △  | △  | 763 | △  | △  |
|                   | 800  | F3 RC           | 16 - 17 | 901* | △  | △  | △  | 730 | △  | △  |
|                   | 1000 | F4 LH44         | 18 -    | 841* | △  | △  | △  | 763 | △  | △  |
|                   | 1000 | F4 R            | 06 - 07 | 762* | △  | △  | △  | 763 | △  | △  |
|                   | 1000 | F4 R            | 12 - 15 | 841* | △  | △  | △  | 763 | △  | △  |
|                   | 1000 | F4 RC           | 15 - 18 | 841* | △  | △  | △  | 763 | △  | △  |
|                   | 1000 | F4 RR           | 12 - 17 | 841* | △  | △  | △  | 763 | △  | △  |
|                   | 1000 | F4S             | 04 - 06 | 676* |    | △  | △  | 763 | △  | △  |
|                   | 1078 | F4 CC           | 08 - 11 | 841* | △  | △  | △  | 763 | △  | △  |
|                   | 1078 | F4 RR           | 08 - 11 | 841* | △  | △  | △  | 763 | △  | △  |
| <b>SUZUKI</b>     |      |                 |         |      |    |    |    |     |    |    |
| GSX-R             | 250  |                 | 17 - 18 | 627  |    | △  | △  | 657 | △  | △  |
| GSX-R             | 600  |                 | 04 - 05 | 806* | △  | △  | △  | 765 | △  | △  |
| GSX-R             | 600  |                 | 06 - 10 | 806* | △  | △  | △  | 833 | △  | △  |
| GSX-R             | 600  |                 | 11 - 18 | 841* | △  | △  | △  | 834 | △  | △  |
| GSX-R             | 600  |                 | 97 - 03 | 631* |    | △  | △  | 556 | △  | △  |
| SV                | 650  | ,S Left/Rear    | 99 - 02 | 705  |    |    | △  | 556 | △  | △  |
| SV                | 650  | ,S Right        | 99 - 02 | 704  |    |    | △  |     |    |    |
| SV                | 650  | ,S Left/Rear    | 03 - 12 | 705  |    |    | △  | 657 | △  | △  |
| SV                | 650  | ,S Right        | 03 - 12 | 704  |    |    | △  |     |    |    |
| SV                | 650  | ,S ABS          | 07 - 10 | 705  |    |    | △  | 657 | △  | △  |
| SV                | 650  | ,S ABS          | 15 - 18 | 705  |    |    | △  | 657 | △  | △  |
| GSX-R             | 750  |                 | 04 - 05 | 806* | △  | △  | △  | 765 | △  | △  |
| GSX-R             | 750  |                 | 06 - 10 | 806* | △  | △  | △  | 833 | △  | △  |
| GSX-R             | 750  |                 | 11 - 18 | 841* | △  | △  | △  | 834 | △  | △  |
| GSX-R             | 750  |                 | 94 - 99 | 686* |    | △  | △  | 556 | △  | △  |
| GSX-R             | 750  | Y               | 00 - 03 | 631* |    | △  | △  | 556 | △  | △  |
| GSX-R             | 1000 |                 | 03      | 788* |    | △  | △  | 765 | △  | △  |
| GSX-R             | 1000 |                 | 04 - 06 | 806* | △  | △  | △  | 765 | △  | △  |
| GSX-R             | 1000 |                 | 07 - 08 | 806* | △  | △  | △  | 833 | △  | △  |

\* = 2 sets required / 2 jeux pour l'Avant.

△ = Available quality / Qualité disponible.

To select compound for racing front/rear - see page 19-22 / Pour sélectionner vos plaquettes racing avant/arrière - voir page 19-22.





COMPOUND CHOICE

COMPOUND CHOICE



| SUZUKI  |                      |         |      | DS | DC | RS |     | RQ | LS |
|---------|----------------------|---------|------|----|----|----|-----|----|----|
| GSX-R   | 1000                 | 09 - 11 | 806* | △  | △  | △  | 834 | △  | △  |
| GSX-R   | 1000                 | 12 - 18 | 841* | △  | △  | △  | 834 | △  | △  |
| GSX-R   | 1000                 | 01 - 02 | 686* |    | △  | △  | 765 | △  | △  |
| GSX-R   | 1000 R               | 17 - 18 | 841* | △  | △  | △  | 834 | △  | △  |
| SV      | 1000 , S             | 03 - 07 | 631* |    | △  | △  | 657 | △  | △  |
| TL      | 1000 RW              | 98 - 02 | 686* |    | △  | △  | 556 | △  | △  |
| TL      | 1000 S V-Twin        | 97 - 01 | 631* |    | △  | △  | 556 | △  | △  |
| GSX-R   | 1100                 | 93 - 97 | 686* |    | △  | △  | 556 | △  | △  |
| TRIUMPH |                      |         |      |    |    |    |     |    |    |
|         | 600 Daytona          | 03 - 04 | 624* |    | △  | △  | 614 | △  | △  |
| TT      | 600                  | 00 - 03 | 624* |    | △  | △  | 614 | △  | △  |
|         | 675 Daytona          | 06 - 08 | 782* |    | △  | △  | 614 | △  | △  |
|         | 675 Daytona R Triple | 11 - 12 | 901* | △  | △  | △  | 614 | △  | △  |
|         | 675 Daytona R Triple | 13 - 18 | 901* | △  | △  | △  | 675 | △  | △  |
|         | 675 Daytona Triple   | 09 - 12 | 864* |    | △  | △  | 614 | △  | △  |
|         | 675 Daytona Triple   | 13 - 18 | 864* |    | △  | △  | 675 | △  | △  |
| YAMAHA  |                      |         |      |    |    |    |     |    |    |
| TZ      | 125                  | 97 - 00 | 624  |    | △  | △  | 659 | △  |    |
| TZ      | 250                  | 02 - 05 | 624* |    | △  | △  | 659 | △  |    |
| TZ      | 250                  | 90 - 01 | 624* |    | △  | △  | 659 | △  |    |
| YZF     | 250 R25              | 15 - 18 | 931  | △  | △  | △  | 932 | △  |    |
| YZF     | 321 R3               | 15 - 18 | 931  | △  | △  | △  | 932 | △  |    |
| YZF     | 600 R6               | 99 - 02 | 634* | △  | △  | △  | 728 | △  | △  |
| YZF     | 600 R6               | 03 - 04 | 634* | △  | △  | △  | 657 | △  | △  |
| YZF     | 600 R6               | 05 - 16 | 634* | △  | △  | △  | 657 | △  | △  |
| YZF     | 600 R6               | 17 - 18 | 634* | △  | △  | △  | 834 | △  | △  |
| YZF     | 750 R, SP            | 93 - 97 | 683* |    |    | △  | 555 | △  | △  |
| YZF     | 750 R7 OW02          | 99 - 02 | 634* |    | △  | △  | 733 | △  | △  |
| YZF     | 750 R7 OW02 Race kit | 99 - 01 | 729* |    | △  | △  |     |    |    |
| YZF     | 1000 R1              | 98 - 01 | 634* | △  | △  | △  | 733 | △  | △  |
| YZF     | 1000 R1              | 02 - 03 | 634* | △  | △  | △  | 728 | △  | △  |
| YZF     | 1000 R1              | 04 - 06 | 634* | △  | △  | △  | 657 | △  | △  |
| YZF     | 1000 R1              | 15 - 18 | 634* | △  | △  | △  | 834 | △  | △  |
| YZF     | 1000 R1(4-pad)       | 07 - 14 | 839* | △  | △  | △  | 657 | △  | △  |
| YZF     | 1000 R1(4-pad) ABS   | 12 - 14 | 839* | △  | △  | △  | 657 | △  | △  |
| YZF     | 1000 R1 SP           | 06      | 634* | △  | △  | △  | 657 | △  | △  |
| YZF     | 1000 R1M             | 15 - 18 | 634* | △  | △  | △  | 834 | △  | △  |
| YZF     | 1000 R1S             | 16      | 634* | △  | △  | △  | 834 | △  | △  |

Applications  
Racing

\* = 2 sets required / 2 jeux pour l'Avant.

△ = Available quality / Qualité disponible.

To select compound for racing front/rear - see page 19-22 / Pour sélectionner vos plaquettes racing avant/arrière - voir page 19-22.



# CALIPERS

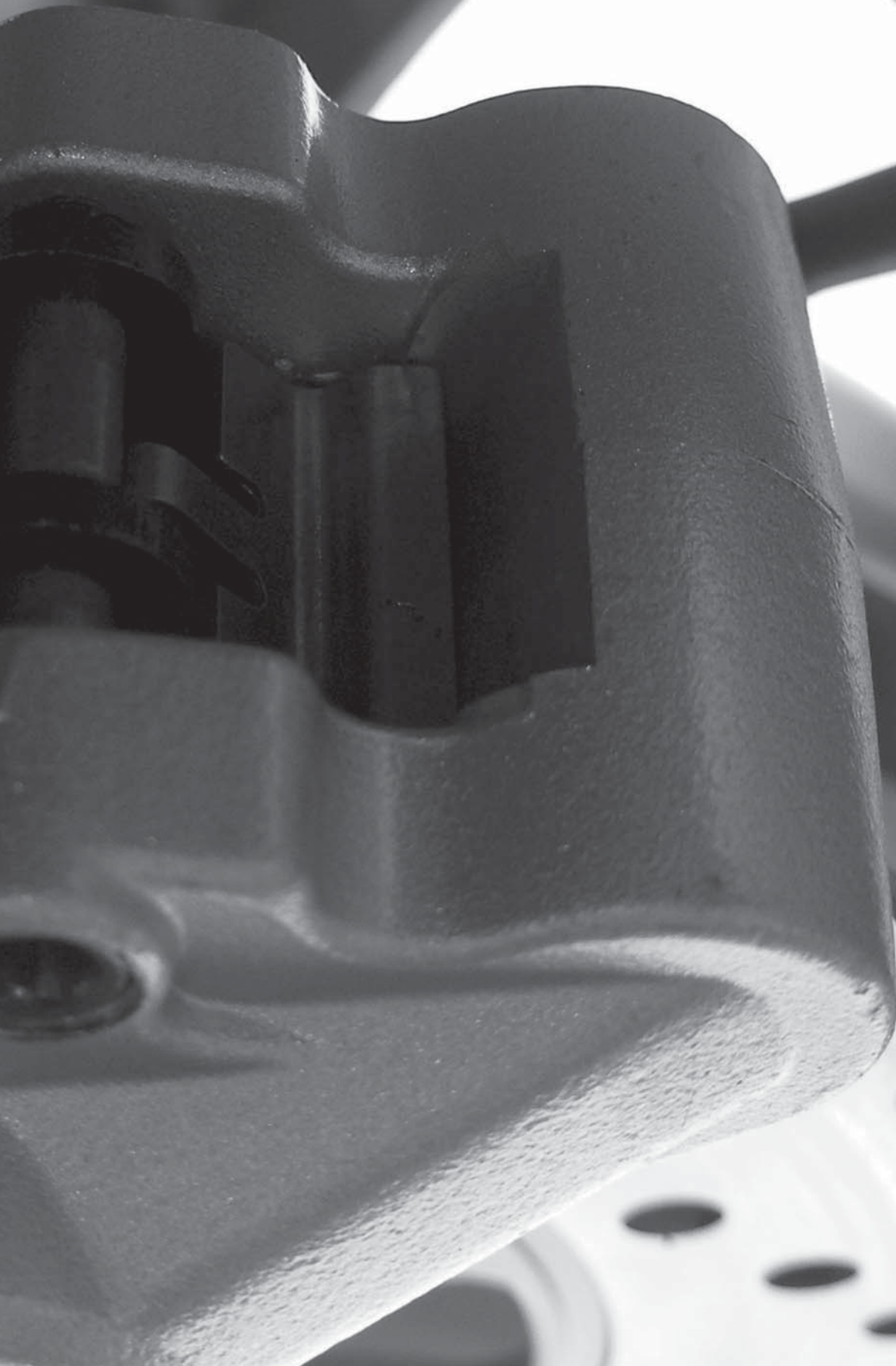



### ACCOSSATO

|   |     |
|---|-----|
| AGPZ01, 108 mm CNC Monoblock, 4 Piston/4 Pad    | 805 |
| AGPZ02, 108 mm Forged Monoblock, 4 Piston/4 Pad | 805 |
| AGPZ03, 108 mm Forged Monoblock, 4 Piston/4 Pad | 805 |
| AGPZ04, 108 mm Forged Monoblock, 4 Piston/4 Pad | 805 |
| AGPZ05, 100 mm CNC Monoblock, 4 Piston/2 Pad    | 845 |
| AGPZ06, 60 mm CNC Moto 3, 2 Piston/2 Pad        | 805 |
| AGPZ07, 100 mm Forged Monoblock, 4 Piston/2 Pad | 845 |

### A.P. RACING CALIPERS

|  |     |
|--|-----|
| 6 Piston 3366/3367 Series                  | 660 |
| 6 Piston 4466/4477 Series                  | 707 |
| CP-2382/2383                               | 569 |
| CP-2696-36E0/38E0                          | 523 |
| CP-2868-8E0/9E0                            | 698 |
| CP-3369-2E0/3E0                            | 599 |
| CP-3385-2E0/3E0                            | 599 |
| CP-3386-2E0/3E0                            | 599 |
| CP-3485-8S0/9S0                            | 661 |
| CP-3548                                    | 718 |
| CP-3569-2S0/3S0                            | 599 |
| CP-3569-4S0/5S0                            | 661 |
| CP-3586-4S0/5S0                            | 661 |
| CP-3696-2E0                                | 523 |
| CP-3697-2E0                                | 523 |
| CP-3769-2S0/3S0                            | 599 |
| CP-4226-2S0/3S0                            | 719 |
| CP-4484-2S0/3S0                            | 720 |
| CP-4485                                    | 751 |
| CP-4488 Two Pad Radial 4 Piston Monoblock  | 785 |
| CP-4638-2E0                                | 523 |
| CP-4679-2S0/3S0                            | 751 |
| CP-6688 Four Pad Radial 4 Piston Monoblock | 805 |

### BERINGER

|                                 |     |
|---------------------------------|-----|
| 2 Piston Classic Billet Caliper | 506 |
| 4 Piston Caliper                | 631 |
| 6 Piston Caliper                | 771 |
| 6 Piston Endurance Caliper      | 779 |

### BRAKING

|                       |     |
|-----------------------|-----|
| Front cross           | 694 |
| Front Harley Davidson | 676 |
| Rear cross (1 piston) | 777 |
| Rear cross (2 piston) | 604 |
| Street, Supermotard   | 706 |

### BREMBO RACING CALIPERS

|  |     |
|--|-----|
| 100 mm Motard Radial XA78910, P4 30/34       | 706 |
| 100 mm Radial 220A16810, P4 30/34            | 706 |
| 100 mm Radial 220A80310, P4 30/34            | 706 |
| 100 mm Radial Caliper .484, 220B47310, P4 32 | 841 |
| 100 mm Radial Monoblock 220988530, P4 34     | 841 |
| 100 mm Radial Monoblock XA7G210/11, P4 32/36 | 711 |
| 100 mm Radial Monoblock XA7G240/41, P4 32/36 | 711 |
| 108 mm Motard Radial XA69510, P4 30/34       | 706 |
| 108 mm Radial 220A01610, P4 30/34            | 706 |
| 108 mm Radial 220A80210, P4 30/34            | 706 |
| 108 mm Radial Caliper .484, 220B47310, P4 32 | 841 |
| 108 mm Radial Monoblock 220A39710, P4 34     | 841 |
| 108N, P2 38                                  | 506 |
| Billet 20.4756.52/62, racing                 | 566 |
| Billet P2.24 X20.60.01, racing               | 732 |
| F08  | 506 |
| Floating Motocross Caliper 22.5930.62        | 671 |
| Goldline 20.5161.42/51, road                 | 519 |
| Goldline 20.6951.50, road                    | 730 |
| Goldline 4 pad 20.7850.11/21, road           | 762 |
| Goldline single pin 20.5165.55/65, road      | 566 |
| Goldline two pin 20.6800, road               | 706 |
| GP X10.48.13/14, racing                      | 695 |
| Monoblock X101740/41, P4 32/36               | 711 |
| Motard Axial XA32950, P4 34                  | 762 |

### BREMBO RACING CALIPERS

|   |     |
|---|-----|
| Moto3/SBK XA88810/11, P2 34                                 | 887 |
| Moto3/SBK XA88820/21, P2 34                                 | 887 |
| Motocross Caliper 22.2180.20                                | 675 |
| Off Road 122A99021, P2 24                                   | 671 |
| Off Road XQ21361, P2 28                                     | 671 |
| Off Road XQ21390, PF 26                                     | 791 |
| Racing rear X206001, P2 24                                  | 759 |
| Racing rear X206101, P4 24 (24 mm disc height)              | 942 |
| Racing rear X206101, P4 24 (30 mm disc height)              | 941 |
| Racing rear X206121, P4 24 (24 mm disc height)              | 942 |
| Racing rear X206121, P4 24 (30 mm disc height)              | 941 |
| Racing rear X988870, P2 34 (24 mm disc height)              | 942 |
| Racing rear X988870, P2 34 (30 mm disc height)              | 941 |
| Racing rear XA1J040, P2 30 (24 mm disc height)              | 942 |
| Racing rear XA1J040, P2 30 (30 mm disc height)              | 941 |
| Radial 220A16820, P4 30/34                                  | 706 |
| Radial GP4 RX 220B01010                                     | 841 |
| Radial Monoblock X973760/61, P4 32/36                       | 711 |
| Radial Monoblock X99C460/61, P4 34                          | 805 |
| Radial Monoblock XA8Y310/11                                 | 845 |
| Radial Monoblock XA93310/11                                 | 711 |
| Radial XA3B830/31, P4 32/36                                 | 711 |
| Radial XA3B860/61, P4 32/36                                 | 711 |
| SBK Racing DX XB0.B1.31, P4 30/34                           | 889 |
| SBK Racing DX XB0.B1.31, P4 30/34 (for Radiators X93.12.50) | 909 |
| SBK Racing SX XB0.B1.30, P4 30/34                           | 889 |
| SBK Racing SX XB0.B1.30, P4 30/34 (for Radiators X93.12.50) | 909 |
| Supersport 120A44110, P2 34                                 | 730 |

### GMA

|                                 |     |
|---------------------------------|-----|
| 2 Piston Caliper, large Model A | 512 |
| 2 Piston Caliper, small Model B | 560 |
| 4 Piston front Model F          | 559 |

### HARRISON/BILLET CALIPERS

|                 |     |
|-----------------|-----|
| 4 Piston Billet | 737 |
| Big-6           | 737 |
| Mini-6          | 656 |

### HHI

|                  |     |
|------------------|-----|
| 4 Piston Caliper | 678 |
| 6 Piston Caliper | 676 |

### ISR CALIPERS

|                                |     |
|--------------------------------|-----|
| 2 Piston (22-023/026)          | 504 |
| 2 Piston (22-027/028/029)      | 519 |
| 2 Piston (22-030/033)          | 523 |
| 2 Piston (22-036)              | 655 |
| 4 Piston (22-025)              | 519 |
| 4 Piston (22-043)              | 655 |
| 6 Piston Racing Caliper, large | 656 |
| 6 Piston Racing Caliper, small | 655 |

### JAYBRAKE

|                              |     |
|------------------------------|-----|
| 2 Piston Caliper ADC/ADCS    | 560 |
| 2 Piston Dual Series Caliper | 559 |
| 4 Piston Caliper A4 P/L      | 686 |
| 4 Piston J-Four Caliper      | 686 |
| 4 Piston Quad Series Caliper | 559 |

### MOTO-MASTER

|                          |     |
|--------------------------|-----|
| Supermoto Racing Caliper | 631 |
|--------------------------|-----|

### MOTOR FACTORY

|                             |     |
|-----------------------------|-----|
| 4 Piston Caliper front/rear | 678 |
|-----------------------------|-----|

### NISSIN

|                              |     |
|------------------------------|-----|
| 3 Piston Racing Rear Caliper | 766 |
| 4 Piston Caliper             | 624 |
| 4 Piston Racing Caliper      | 711 |
| 4 Piston Racing Caliper      | 825 |
| 6 Piston Racing Caliper      | 729 |

\* = 2 sets required / 2 jeux pour l'Avant.

Compound selection, see under "Brake pad drawings" / Sélection de composants, voir sous les schémas des plaquettes de frein.

**NISSIN**

6 Piston Racing Radial Monobloc Caliper (Z0901) 865

**PERFORMANCE MACHINE**

112 X 6B 729

112 X 6QC 729

112 X 6RSB 683

112 X 6SSB 683

124 X 4HR 662

125 X 2 559

125 X 4R 678

125 X 4RSPH 678

125 X 4S 559

125 X 4SL 559

125 X 6 658

125 X 6QC 683

137 X 4 662

137 X 4B 678

137 X 6 658

162 X 2 509

4 Piston Vintage Caliper 678

**PFM**

6 Piston Racing Caliper 707

**PVM**

4 Pad Caliper 805

6 Piston Caliper 677

**REVTECH**

Wilwood Caliper front/rear 566

**SJP**

2 Piston Caliper (30-375) 559

4 Piston Caliper (30-370) 559

\* = 2 sets required / 2 jeux pour l'Avant.

Compound selection, see under "Brake pad drawings" / Sélection de composants, voir sous les schémas des plaquettes de frein.



# BRAKE PADS

1:1 DRAWINGS, COMPOUNDS, FITMENTS

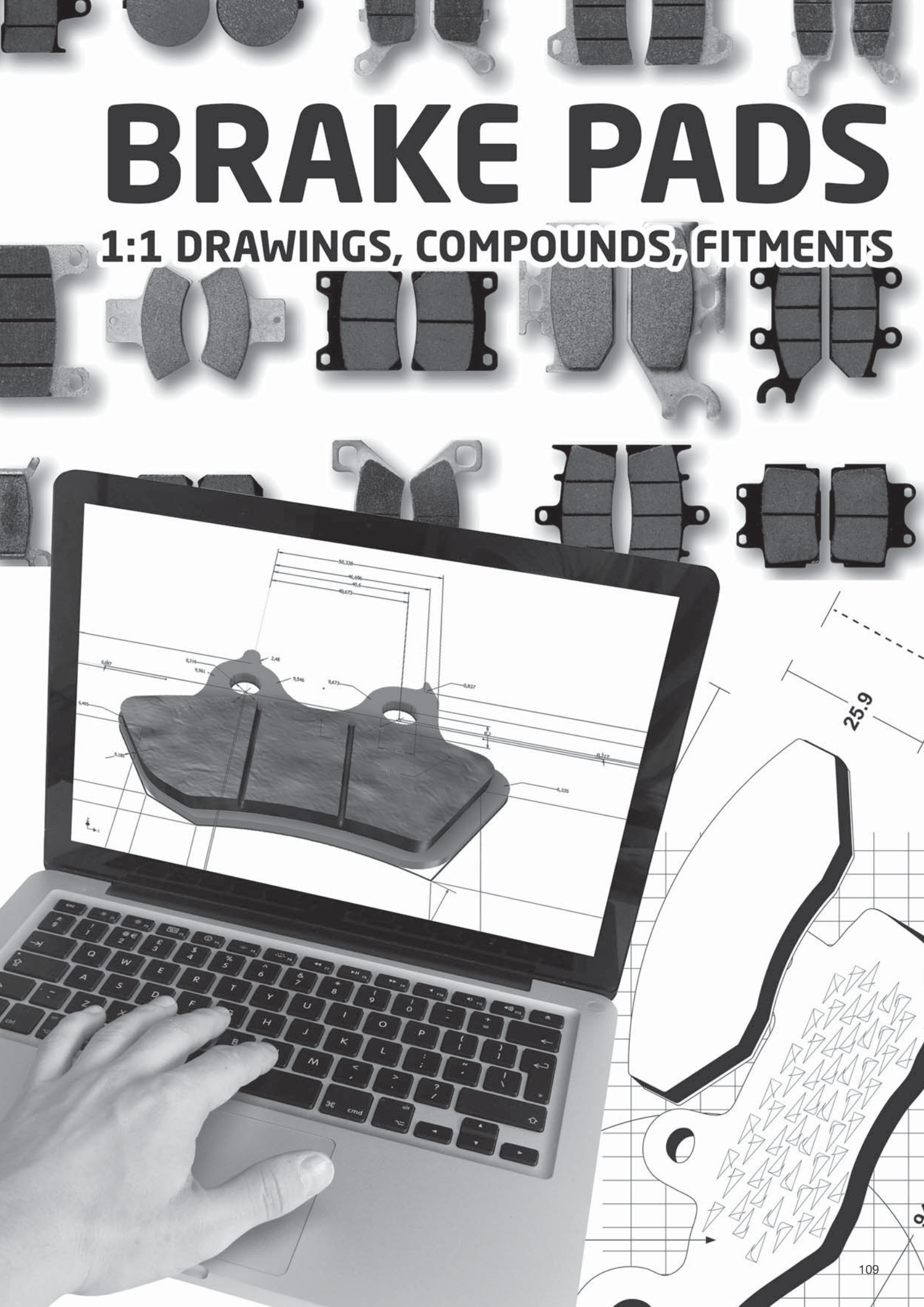

## Applications

### SBS 100 Recommended compound



| <b>DAELIM</b>       |       |           |           |
|---------------------|-------|-----------|-----------|
| 50 Delfino          | 99    | <b>HF</b> |           |
| 50 E-Five           | 03-08 | <b>HF</b> |           |
| 50 History, S-Five  | 01    | <b>HF</b> | <b>HF</b> |
| 50 Message II       | 02    | <b>HF</b> |           |
| 50 Tapo             | 99-04 | <b>HF</b> |           |
| 50 Vivo             | 99    | <b>HF</b> |           |
| SE 50 Cordi         | 06-12 | <b>HF</b> |           |
| 100 Delfino         | 99-04 | <b>HF</b> |           |
| 125 Altino          | 02-04 | <b>CT</b> |           |
| 125 DLX, Otello DLX | 01-02 | <b>CT</b> | <b>CT</b> |
| 125 History         | 01-06 | <b>CT</b> | <b>CT</b> |
| 125 Message II      | 00    | <b>CT</b> |           |
| 125 Otello          | 99-00 | <b>CT</b> |           |
| 125 Otello          | 08    |           | <b>CT</b> |
| 125 S2              | 06-08 |           | <b>CT</b> |
| 125 S2 FI           | 07-15 |           | <b>CT</b> |
| NS 125 II           | 00    | <b>CT</b> |           |
| SL 125 U3 FI        | 07-09 |           | <b>CT</b> |



| <b>DAELIM</b>    |       |           |           |
|------------------|-------|-----------|-----------|
| 250 S2           | 06-10 |           | <b>CT</b> |
| <b>HONDA</b>     |       |           |           |
| CB 50 all models | 80-81 | <b>HF</b> |           |
| CRM 50           | 88-92 | <b>HF</b> |           |
| MB 50 S          | 80-82 | <b>HF</b> |           |
| MBX 50           | 80-82 | <b>HF</b> |           |
| MRX 50           | 88-92 | <b>HF</b> |           |
| SP 50            | 91    | <b>HF</b> |           |
| CB 80            | 80-81 | <b>HF</b> |           |
| <b>PEUGEOT</b>   |       |           |           |
| 50 Vivacity      | 08-14 | <b>HF</b> |           |
| <b>SACHS</b>     |       |           |           |
| 50 MadAss 4T     | 05-09 |           | <b>HF</b> |
| 125 MadAss       | 09    |           | <b>HF</b> |

### SBS 101 Recommended compound



| <b>AEON</b>        |       |           |           |
|--------------------|-------|-----------|-----------|
| 50 Aero            | 06    | <b>HF</b> |           |
| 50 Regal           | 06    | <b>HF</b> |           |
| 50 Torch           | 06-09 | <b>HF</b> |           |
| 90 Regal           | 06    | <b>HF</b> |           |
| 100 Pulsar         | 06    | <b>HF</b> |           |
| 110 Aero           | 06    | <b>HF</b> |           |
| 110 Pulsar         | 06    | <b>HF</b> |           |
| 125 Co-In          | 14    | <b>CT</b> |           |
| 125 Elite          | 13-14 |           | <b>CT</b> |
| 125 Urban          | 11-13 |           | <b>CT</b> |
| 150 Pulsar         | 06    | <b>CT</b> |           |
| 250 Elite          | 11-14 |           | <b>CT</b> |
| 350 Urban          | 11-13 |           | <b>CT</b> |
| 400 Elite          | 13-18 |           | <b>CT</b> |
| <b>APRILIA</b>     |       |           |           |
| RS-4 50            | 12-18 |           | <b>HF</b> |
| RS-4 50 Replica    | 16-17 |           | <b>HF</b> |
| SX 50 Ltd.         | 07-15 |           | <b>CT</b> |
| <b>BENELLI</b>     |       |           |           |
| 350 Zenzero        | 12-15 |           | <b>CT</b> |
| <b>CPI</b>         |       |           |           |
| 50 Baby            | 02    | <b>HF</b> |           |
| 50 Hussar          | 01-02 | <b>HF</b> |           |
| 50 Mars            | 01-02 | <b>HF</b> |           |
| 50 Popcorn         | 01-02 | <b>HF</b> |           |
| <b>FANTIC</b>      |       |           |           |
| 50 Regolarna Casa  | 08-09 |           | <b>HF</b> |
| 50 Supersei Motard | 08-09 |           | <b>HF</b> |
| <b>GARELLI</b>     |       |           |           |
| 125 Raider         | 02    |           | <b>CT</b> |
| <b>HYOSUNG</b>     |       |           |           |
| 50 Avanti          | 99-02 | <b>HF</b> |           |
| 50 Rush            | 97-01 | <b>HF</b> |           |
| 50 Sense           | 98-07 | <b>HF</b> |           |
| 50 Super Cab       | 95-98 | <b>HF</b> |           |
| 50 Super Cab Plus  | 98    | <b>HF</b> |           |
| SB 50              | 00-03 | <b>HF</b> |           |
| SB 50 P            | 00-03 | <b>HF</b> |           |



| <b>HYOSUNG</b>     |       |           |           |
|--------------------|-------|-----------|-----------|
| SD 50              | 00-06 | <b>HF</b> |           |
| SF 50              | 99-06 | <b>HF</b> |           |
| 100 Cab            | 98-01 | <b>HF</b> |           |
| EZ 100             | 00-05 | <b>HF</b> |           |
| 110 Midas Plus     | 98-04 | <b>HF</b> |           |
| FX 110 110         | 02-04 | <b>HF</b> |           |
| KR 110 Master      | 04-05 | <b>HF</b> |           |
| <b>ITALJET</b>     |       |           |           |
| 100 Millennium 2T  | 01    | <b>HF</b> |           |
| 125 Millennium     | 00-03 | <b>CT</b> |           |
| 150 Millennium     | 00-03 | <b>CT</b> |           |
| <b>KEEWAY</b>      |       |           |           |
| 50 Flash           | 07-12 | <b>HF</b> |           |
| 50 Hurricane       | 06-16 | <b>HF</b> |           |
| 90 Hurricane       | 06-09 | <b>HF</b> |           |
| <b>MAICO</b>       |       |           |           |
| 50 Cruiser         | 99    | <b>HF</b> |           |
| 50 Thunderbike I   | 99    | <b>HF</b> |           |
| 50 Thunderbike II  | 99    | <b>HF</b> |           |
| C-1 50 Hard Enduro | 99    | <b>HF</b> |           |
| R-1 50 Superbike   | 99    | <b>HF</b> |           |
| X-1 50 SuperCross  | 99    | <b>HF</b> |           |
| <b>MZ</b>          |       |           |           |
| 50 (MUZ)           |       |           |           |
| Moskito SX         | 00-02 | <b>HF</b> |           |
| <b>PETERSON</b>    |       |           |           |
| 50 Hurricane       | 95    |           | <b>HF</b> |
| SR 50 Racing       | 95    |           | <b>HF</b> |
| 80 Hurricane       | 95    |           | <b>HF</b> |
| SR 80 Racing       | 95    |           | <b>HF</b> |
| <b>PGO</b>         |       |           |           |
| 50 Big Max         | 03-17 | <b>HF</b> |           |
| 50 Comet           | 91-92 | <b>HF</b> |           |
| 50 Galaxy          | 91-97 | <b>HF</b> |           |
| 50 Road 66         | 95    | <b>HF</b> |           |
| PS 50              | 93    | <b>HF</b> |           |
| 90 Galaxy          | 92-94 | <b>HF</b> |           |



| <b>PIAGGIO VESPA</b>   |       |           |           |
|------------------------|-------|-----------|-----------|
| 50 New Liberty S       | 16-18 | <b>HF</b> |           |
| 50 Typhoon             | 06-14 | <b>HF</b> |           |
| NRG 50 Power DD        | 06-16 | <b>HF</b> |           |
| NRG 50 Purejet         | 06-07 | <b>HF</b> |           |
| <b>QUADRO</b>          |       |           |           |
| 350 3                  | 16    |           | <b>MS</b> |
| 350 4                  | 16    |           | <b>MS</b> |
| D 350                  | 11-15 |           | <b>CT</b> |
| <b>RIEJU</b>           |       |           |           |
| RS2 50 NKD             | 06-10 |           | <b>HF</b> |
| RS3 50                 | 12-17 |           | <b>HF</b> |
| <b>SULA</b>            |       |           |           |
| 50 Thunder Bird        | 99    | <b>HF</b> |           |
| 100 Thunder Bird       | 99    | <b>HF</b> |           |
| 125 Thunder Bird       | 99    | <b>CT</b> |           |
| <b>SUZUKI</b>          |       |           |           |
| AE 50 R/L              | 88-93 | <b>HF</b> |           |
| AH 50 Adress           | 92-95 | <b>HF</b> |           |
| CP 50                  | 85-90 | <b>HF</b> |           |
| CR 50 DC               | 87    | <b>HF</b> |           |
| ZZ 50 Scooter          | 92    | <b>HF</b> |           |
| AH 80 Adress, V, Tune  | 88-91 | <b>HF</b> |           |
| AH 100 V Adress        | 91-94 | <b>HF</b> |           |
| UK 110 Adress          | 15-18 | <b>HF</b> |           |
| AN 125                 | 06-08 | <b>CT</b> |           |
| LIDO 125 Vario Scooter | 90-93 | <b>CT</b> |           |
| UE 125                 | 01-03 | <b>CT</b> |           |
| UE 150 CT              | 02-03 | <b>CT</b> |           |
| <b>TGB</b>             |       |           |           |
| 50 101R                | 05-09 | <b>HF</b> |           |
| 50 101S                | 99-02 | <b>HF</b> |           |
| 50 202T                | 99-02 | <b>HF</b> |           |
| 50 303R                | 99-14 | <b>HF</b> |           |
| 50 309 Racing          | 05    | <b>HF</b> |           |
| 50 507                 | 05    | <b>HF</b> |           |
| 50 Akros               | 99-04 | <b>HF</b> |           |
| 50 Bull&t RS/RR        | 11-17 |           | <b>HF</b> |
| 50 Bullet              | 09    | <b>HF</b> | <b>HF</b> |
| 50 Bunny               | 97-00 | <b>HF</b> |           |



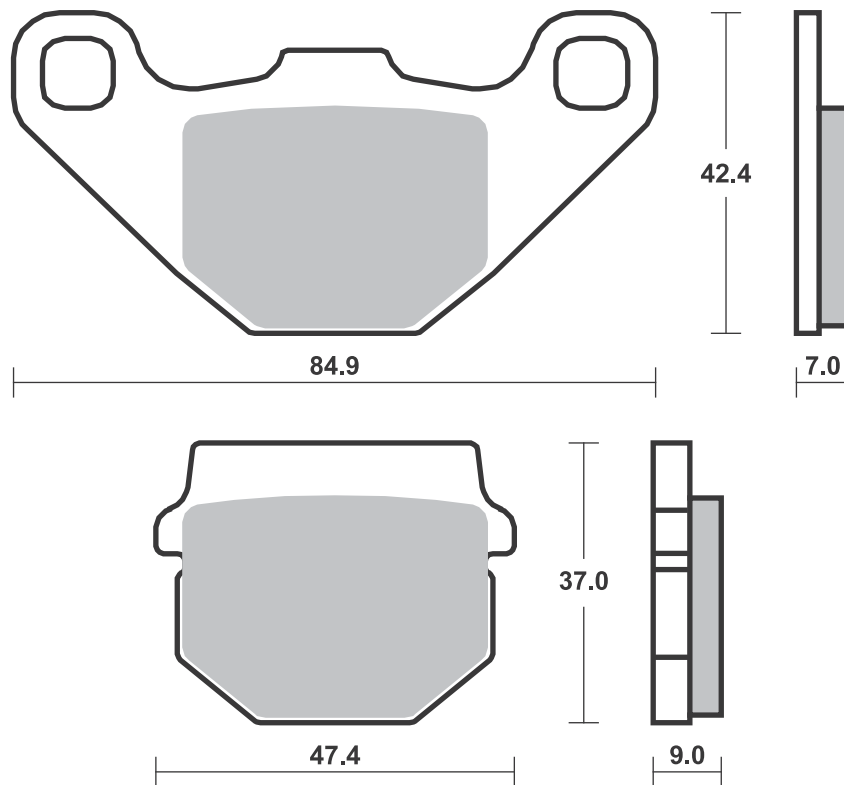
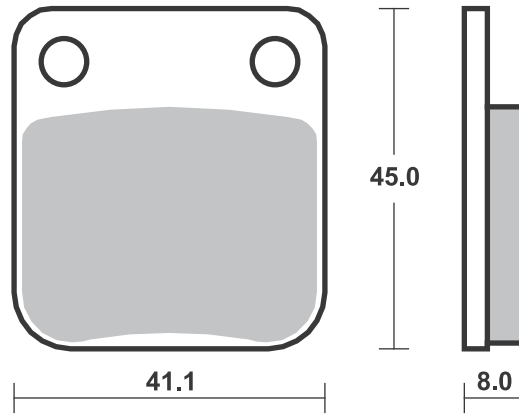

**SBS 101** Recommended compound

| <b>TGB</b>       |       |           |           |
|------------------|-------|-----------|-----------|
| 50 Double X      | 05    | <b>HF</b> |           |
| 50 Ergon         | 96-00 | <b>HF</b> |           |
| 50 Hawk          | 09-14 | <b>HF</b> |           |
| 50 Hiw's         | 99    | <b>HF</b> |           |
| 50 Hook          | 10-12 | <b>HF</b> |           |
| 50 J409          | 00-03 | <b>HF</b> |           |
| 50 Tapo RS       | 11-12 | <b>HF</b> |           |
| 50 Trigger       | 99-03 | <b>HF</b> |           |
| <b>R</b>         |       |           | <b>HF</b> |
| 50 X             | 06-14 |           |           |
| 90 101S          | 99-02 | <b>HF</b> |           |
| 90 202T          | 99-02 | <b>HF</b> |           |
| 90 Akros         | 99    | <b>HF</b> |           |
| 90 Ergon         | 99-02 | <b>HF</b> |           |
| 90 Hiw's         | 99    | <b>HF</b> |           |
| 90 Trigger       | 99-02 | <b>HF</b> |           |
| 125 101S         | 99-03 | <b>CT</b> |           |
| 125 202T         | 99    | <b>CT</b> |           |
| 125 303R         | 99-08 | <b>CT</b> |           |
| 125 309 RS       | 00    | <b>HF</b> |           |
| 125 Bull&t RS/RR | 11-14 |           | <b>HF</b> |
| 125 Hook         | 10    | <b>HF</b> |           |
| <b>UVM</b>       |       |           |           |
| 50 BeThere       | 99    | <b>HF</b> |           |
| 50 Bingo         | 99    | <b>HF</b> |           |
| 125 BeThere      | 99    | <b>CT</b> |           |
| 125 Bingo        | 99    | <b>CT</b> |           |
| 125 Paragon      | 99    | <b>CT</b> |           |

**SBS 102** Recommended compound

| <b>ADLY</b>       |       |           |           |
|-------------------|-------|-----------|-----------|
| 50 Panther        | 01-09 | <b>HF</b> |           |
| 50 Silver Fox     | 06-09 | <b>HF</b> |           |
| 50 Super Sonic    | 00-05 | <b>HF</b> |           |
| 50 Thunderbike    | 97-09 | <b>HF</b> |           |
| <b>RS</b>         |       |           | <b>HF</b> |
| 50 Super Sonic    | 06-08 | <b>HF</b> |           |
| 100 Panther       | 01-06 | <b>HF</b> |           |
| 100 Silver Fox    | 06    | <b>HF</b> |           |
| 100 Super Sonic   | 01-05 | <b>HF</b> |           |
| 100 Thunderbike   | 01-04 | <b>HF</b> | <b>HF</b> |
| 125 Super Sonic   | 01-05 | <b>CT</b> |           |
| 125 Thunderbike   | 01-04 | <b>CT</b> | <b>CT</b> |
| <b>EASY RIDER</b> |       |           |           |
| 50 Easy Rider     | 99    | <b>HF</b> |           |
| <b>GILERA</b>     |       |           |           |
| 50 Eaglet         | 97-99 |           | <b>HF</b> |
| <b>KREIDLER</b>   |       |           |           |
| 50 Florett        | 99-06 | <b>HF</b> |           |
| 50 Florett XL     | 99-06 | <b>HF</b> |           |
| <b>MALAGUTI</b>   |       |           |           |
| 125 Blog          | 10    |           | <b>CT</b> |
| 160 Blog          | 10-11 |           | <b>CT</b> |
| <b>PEUGEOT</b>    |       |           |           |
| 50 Buxy           |       |           |           |
| (Hengtong cal.)   | 94-97 | <b>HF</b> |           |
| 50 Kisbee         | 10-14 | <b>HF</b> |           |
| 50 Kisbee RS      | 11-17 | <b>HF</b> |           |



| <b>PEUGEOT</b>     |       |           |  |
|--------------------|-------|-----------|--|
| 50 Speedake        |       |           |  |
| (Hengtong cal.)    | 94-01 | <b>HF</b> |  |
| 50 Speedfight LC,  |       |           |  |
| (Hengtong cal.)    | 96-15 | <b>HF</b> |  |
| 50 Squab           |       |           |  |
| (Hengtong cal.)    | 94-04 | <b>HF</b> |  |
| 50 Trekker Offroad | 99-01 | <b>HF</b> |  |
| 50 Vivacity        |       |           |  |
| (Hengtong cal.)    | 05-07 | <b>HF</b> |  |
| 100 Vivacity       |       |           |  |
| (Hengtong cal.)    | 05-07 | <b>HF</b> |  |
| <b>SIAM</b>        |       |           |  |
| 50 Mat             | 97    | <b>HF</b> |  |
| 100 Mat            | 97    | <b>HF</b> |  |
| <b>SMC</b>         |       |           |  |
| 50 Easy Rider      | 97    | <b>HF</b> |  |
| <b>SUZUKI</b>      |       |           |  |
| AJ 50 Sepia        | 92-96 | <b>HF</b> |  |
| AH 80 Scooter      | 92-94 | <b>HF</b> |  |

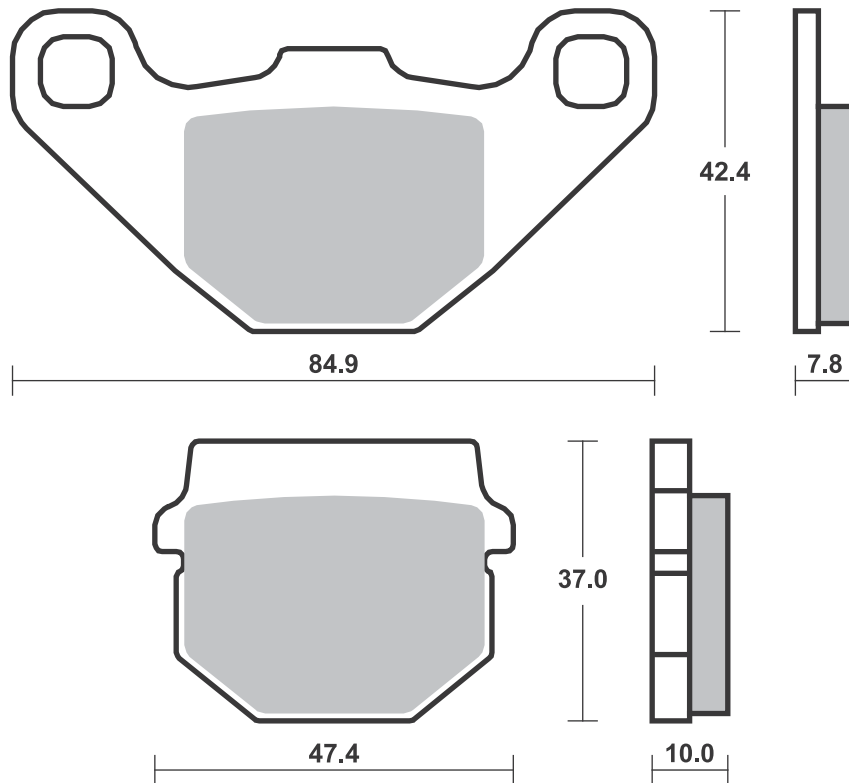
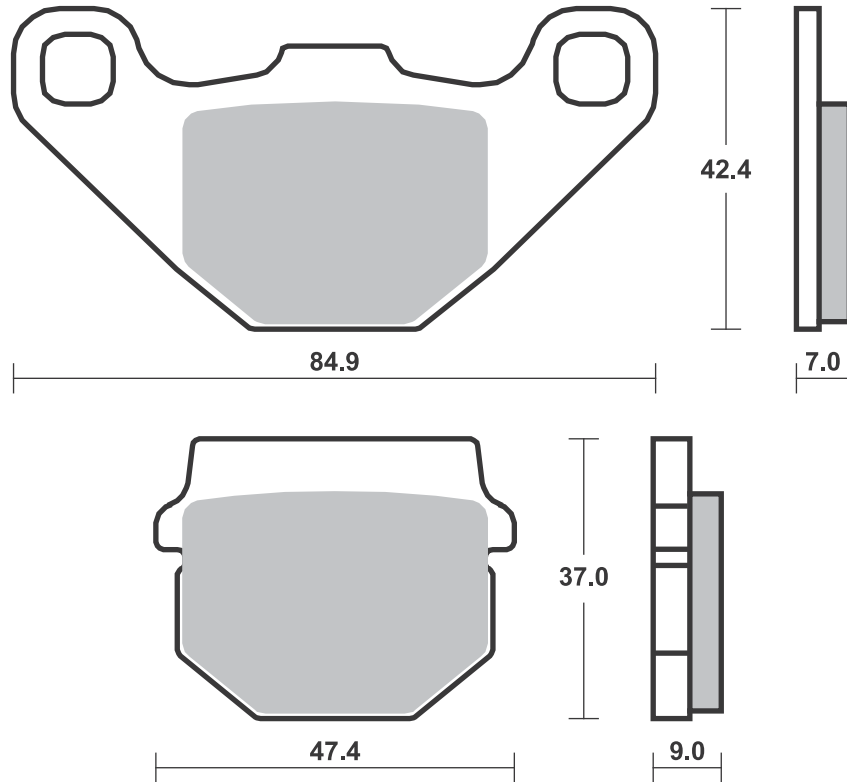

## Applications

### SBS 103 Recommended compound



| <b>CAGIVA</b>  |       |           |  |
|----------------|-------|-----------|--|
| 50 Mito        | 99-06 | <b>HF</b> |  |
| 125 Stella     | 97-08 | <b>CT</b> |  |
| <b>DAELIM</b>  |       |           |  |
| 110 City Ace   | 03-07 | <b>HF</b> |  |
| <b>GARELLI</b> |       |           |  |
| 125 Joker 2    | 02    | <b>CT</b> |  |
| 150 Joker 2    | 02    | <b>CT</b> |  |
| <b>HONDA</b>   |       |           |  |
| MBX 50 S       | 83-85 | <b>HF</b> |  |
| NS 50 F, Aero  | 88-91 | <b>HF</b> |  |
| NS-1 50        | 91-94 | <b>HF</b> |  |
| NSR 50         | 89-90 | <b>HF</b> |  |
| NSR 75 FII     | 88-00 | <b>HF</b> |  |
| NSR 80 R       | 87-92 | <b>HF</b> |  |



| <b>HYOSUNG</b>  |       |           |  |
|-----------------|-------|-----------|--|
| 125 Boomer      | 03    | <b>CT</b> |  |
| 125 Exceed      | 02-06 | <b>CT</b> |  |
| 150 Exceed      | 02-04 | <b>CT</b> |  |
| <b>KYMCO</b>    |       |           |  |
| 100 Spike       | 02-06 | <b>HF</b> |  |
| 110 Spike       | 03-06 | <b>HF</b> |  |
| 125 Jetix       | 08-15 | <b>CT</b> |  |
| 125 Spike       | 02-06 | <b>CT</b> |  |
| <b>MZ</b>       |       |           |  |
| 125 Mantizz S   | 07    | <b>CT</b> |  |
| <b>SYM</b>      |       |           |  |
| 125 Wolf Legend | 02-05 | <b>CT</b> |  |

### SBS 104 Recommended compound



| <b>HONDA</b>                    |       |           |  |
|---------------------------------|-------|-----------|--|
| 100 Lead                        | 00-08 | <b>HF</b> |  |
| NHX 110                         | 10-12 | <b>CT</b> |  |
| NES 125 @                       | 01-06 | <b>CT</b> |  |
| NES 150 @                       | 01-06 | <b>CT</b> |  |
| CH 250 Spacy,<br>Freeway Fusion | 88-93 | <b>MS</b> |  |
| <b>PGO</b>                      |       |           |  |
| 50 T-Rex 3 (TR3-50)             | 02-16 | <b>HF</b> |  |

### SBS 105 Recommended compound



| <b>APRILIA</b>    |       |           |           |
|-------------------|-------|-----------|-----------|
| RS 50             | 06-11 | <b>HF</b> |           |
| RX 50             | 06-14 | <b>HF</b> |           |
| <b>BARIGO</b>     |       |           |           |
| Scooter electric  | 97    | <b>HF</b> |           |
| <b>BETA</b>       |       |           |           |
| 50 Eikon          | 99-03 | <b>HF</b> | <b>HF</b> |
| 50 Techno         | 96    | <b>HF</b> | <b>HF</b> |
| 50 Tempo          | 92-96 | <b>HF</b> |           |
| RR 50 Enduro      | 99-09 | <b>HF</b> |           |
| RR 50 Pro Race    | 98    | <b>HF</b> |           |
| RR 50 Standard    | 99-08 | <b>HF</b> |           |
| RR 50 Supermotard | 99-03 | <b>HF</b> |           |
| RR 50 Supermotard | 04-07 | <b>HF</b> | <b>HF</b> |
| 125 Eikon         | 99-03 | <b>CT</b> | <b>CT</b> |
| 150 Eikon         | 99-03 | <b>CT</b> | <b>CT</b> |
| 250 Eikon         | 99-10 | <b>CT</b> | <b>CT</b> |



| <b>BULTACO</b>              |       |           |           |
|-----------------------------|-------|-----------|-----------|
| 50 Astro                    | 01-06 | <b>HF</b> |           |
| 50 Lobito                   | 99-06 | <b>HF</b> |           |
| <b>CAGIVA</b>               |       |           |           |
| 50 Corsa                    | 98    | <b>HF</b> |           |
| 50 Mantis                   | 99    | <b>HF</b> |           |
| 50 Mito                     | 99-06 | <b>HF</b> | <b>HF</b> |
| 50 Progress                 | 98-99 | <b>HF</b> |           |
| <b>CPI</b>                  |       |           |           |
| 50 Supermoto,<br>Supercross | 03-09 | <b>HF</b> | <b>HF</b> |
| <b>DERBI</b>                |       |           |           |
| 50 Atlantis                 | 99-08 | <b>HF</b> |           |
| 50 Atlantis 4T              | 04-10 | <b>HF</b> |           |
| 50 Atlantis Bullet          | 04-05 | <b>HF</b> |           |
| 50 Atlantis H2O             | 01    | <b>HF</b> |           |



| <b>DERBI</b>             |       |           |           |
|--------------------------|-------|-----------|-----------|
| 50 Atlantis              |       |           |           |
| H2O Wave                 | 01    | <b>HF</b> |           |
| 50 Atlantis Wave         | 01-02 | <b>HF</b> |           |
| 50 Aventura              | 96    | <b>HF</b> |           |
| 50 Black Devil           | 04    | <b>HF</b> | <b>HF</b> |
| 50 DRD Pro corse         | 06-08 | <b>HF</b> | <b>HF</b> |
| 50 DRD Racing R          | 05-10 | <b>HF</b> | <b>HF</b> |
| 50 DRD Racing R<br>Ltd.  | 05    | <b>HF</b> | <b>HF</b> |
| 50 DRD Racing SM         | 05    | <b>HF</b> | <b>HF</b> |
| 50 DRD Racing SM<br>Ltd. | 05    | <b>HF</b> | <b>HF</b> |
| 50 Fenix                 | 94-07 | <b>HF</b> | <b>HF</b> |
| 50 Furax                 | 96-98 | <b>HF</b> | <b>HF</b> |
| 50 Hunter                | 97-99 | <b>HF</b> |           |
| 50 Manhattan             | 99    | <b>HF</b> |           |
| 50 Predator LC           | 99-02 | <b>HF</b> | <b>HF</b> |
| 50 Predator O2           | 00-02 | <b>HF</b> | <b>HF</b> |

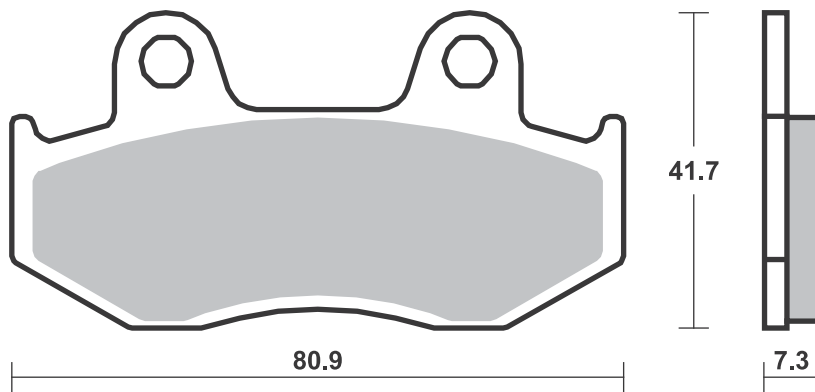
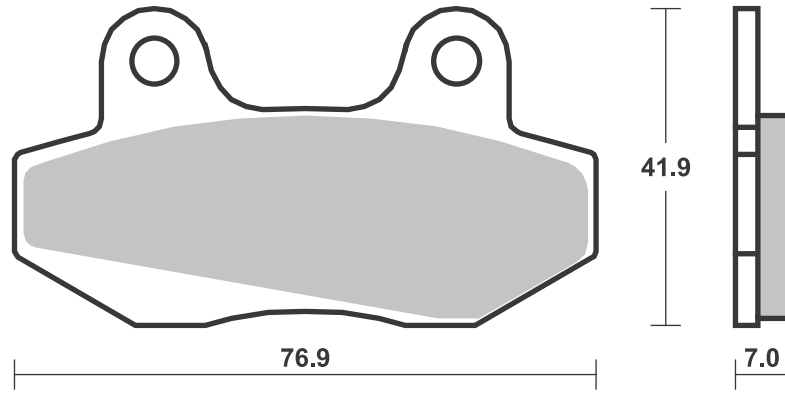

*If required with springs -  
see SBS 188*

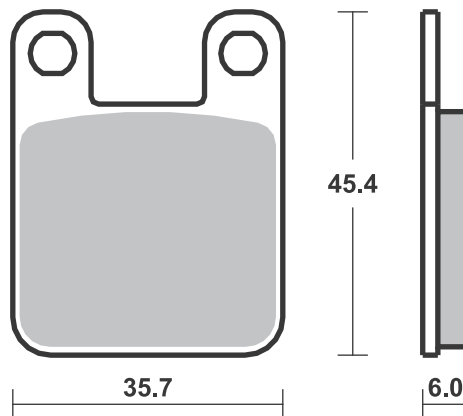

## SBS 105 Recommended compound



| DERBI               |       |    |    |
|---------------------|-------|----|----|
| 50 Rambla           | 06    | HF | HF |
| 50 Savannah         | 91-97 | HF |    |
| 50 Senda L          | 99-01 | HF | HF |
| 50 Senda R DRD      | 03-04 |    | HF |
| 50 Senda R,         |       |    |    |
| X-Treme             | 94-04 | HF | HF |
| 50 Senda SM DRD     | 03-04 | HF | HF |
| 50 Senda SM DRD     |       |    |    |
| Black Edition       | 03-04 |    | HF |
| 50 Senda SM,        |       |    |    |
| X-Treme             | 99-06 | HF | HF |
| 50 Stinger          | 96    | HF |    |
| 50 Vamos FL         | 95-99 | HF |    |
| 50 Vamos L          | 95    | HF |    |
| 50 Vamos R          |       |    |    |
| (A.J.P. cal.)       | 95    | HF |    |
| 50 Variant Sport-R  | 01-13 | HF |    |
| 50 X-Race R         | 05-09 | HF | HF |
| 50 X-Treme R        | 05    | HF | HF |
| GP 50               | 01    | HF |    |
| GP1 50              | 01-03 | HF | HF |
| GPR 50 R            | 98-03 |    | HF |
| GPX1 50             | 06    |    | HF |
| ST 50 Paddock       | 96-99 | HF |    |
| 100 Atlantis 4T     | 04-06 | HF |    |
| 100 Atlantis O2/H2O | 01    | HF |    |
| 125 Predator        | 99    | CT |    |

## FACTORY

|              |    |  |    |
|--------------|----|--|----|
| RP 50 Desert | 04 |  | HF |
| SM 50 Chrono | 04 |  | HF |
| SP 50 Chrono | 04 |  | HF |
| YR 50 Desert | 04 |  | HF |

## FANTIC

|                   |       |    |    |
|-------------------|-------|----|----|
| 50 Trial .5 .7 .9 | 89-91 | HF | HF |
|-------------------|-------|----|----|

## GARELLI

|        |    |  |    |
|--------|----|--|----|
| 50 Xo  | 12 |  | HF |
| GSP 50 | 12 |  | HF |

## GILERA

|                    |       |    |    |
|--------------------|-------|----|----|
| 50 H@k             | 99-02 | HF | HF |
| 50 Zulu            | 01-03 | HF | HF |
| GSM 50 Supermotard | 01-13 | HF | HF |
| RCR 50             | 04-13 | HF | HF |
| SMT 50             | 04-13 | HF | HF |
| 125 GSM            | 00    | CT | CT |
| SC 125             | 06-07 |    | CT |

## HERO ENVOY

|    |    |    |  |
|----|----|----|--|
| 50 | 99 | HF |  |
|----|----|----|--|

## HRD

|                  |       |  |    |
|------------------|-------|--|----|
| 50 Sonic 2       |       |  |    |
| Supermotard      | 00-02 |  | HF |
| 50 Sonic 2 Trail | 00-02 |  | HF |

## HUSQVARNA

|           |    |    |    |
|-----------|----|----|----|
| 50 Racing | 98 | HF |    |
| SM 50     | 02 |    | HF |
| WR 50     | 02 |    | HF |
| WRS 50    | 98 | HF |    |

## ITALJET

|                 |       |    |    |
|-----------------|-------|----|----|
| 50 Dragster     | 99-06 | HF | HF |
| 50 Formula Air  | 99-00 | HF |    |
| 50 Formula L.C. | 98-00 | HF | HF |
| 50 Torpedo      | 98-99 | HF |    |
| 50 Torpedo 4T   | 01-03 | HF |    |



| ITALJET          |       |    |    |
|------------------|-------|----|----|
| 125 Dragster     | 99-03 | CT | CT |
| 125 Formula L.C. | 99-03 | CT | CT |
| 125 Jupiter      | 02-03 |    | CT |
| 125 Torpedo      | 99-06 | CT |    |
| 125 Twin         | 98-01 | CT | CT |
| 150 Jupiter      | 02-03 |    | CT |
| 150 Torpedo 4T   | 01    | CT |    |
| 180 Dragster     | 99-03 | CT | CT |

## MACAL

|                     |    |    |  |
|---------------------|----|----|--|
| AM5/6 50 Trophy     | 99 | HF |  |
| AM5/6 50 Trophy H2O | 99 | HF |  |

## MALAGUTI

|          |       |    |    |
|----------|-------|----|----|
| 50 Fifty | 04    |    | HF |
| NKD 50   | 04-09 |    | HF |
| XSM 50   | 03-14 |    | HF |
| XTM 50   | 03-11 | HF | HF |

## MBK

|            |       |    |    |
|------------|-------|----|----|
| 50 X-Limit | 04-16 | HF | HF |
| 50 X-Power | 04-13 |    | HF |

## MINARELLI

|       |    |    |  |
|-------|----|----|--|
| MR 80 | 96 | HF |  |
|-------|----|----|--|

## MOTORHISPANIA

|                    |       |    |    |
|--------------------|-------|----|----|
| MH 50 Furia 6v     | 99    | HF | HF |
| MH 50 Furia Max    | 06-10 | HF | HF |
| MH 50 Urban Bike   | 06-10 |    | HF |
| RX 50 Racing       | 00-05 | HF | HF |
| RYZ 50 Enduro      | 05-13 | HF | HF |
| RYZ 50 Supermotard | 05-10 | HF | HF |

## PEUGEOT

|                       |       |    |    |
|-----------------------|-------|----|----|
| 50 Blaster            | 09-12 | HF |    |
| 50 Blaster Furios     | 11-12 | HF | HF |
| 50 Blaster RS12       | 09-12 | HF |    |
| 50 Buxy (A.J.P. cal.) | 94-97 | HF |    |
| 50 Elyseo             | 02-05 | HF | HF |
| 50 Elyseo             |       |    |    |
| (A.J.P. cal.)         | 99-01 | HF |    |
| 50 Elystar            | 03-05 | HF |    |
| 50 Jet C-Tech         | 09    | HF | HF |
| 50 Jet-Force          | 03-10 | HF | HF |
| 50 Looxor             | 02-05 | HF |    |
| 50 Looxor             | 06    | HF | HF |
| 50 Ludix              | 04-08 | HF |    |
| 50 Speedake           |       |    |    |
| (A.J.P. cal.)         | 94-01 | HF |    |
| 50 Speedfight 2       |       |    |    |
| A/C                   | 01-08 | HF |    |
| 50 Speedfight 2       |       |    |    |
| L/C                   | 01-08 | HF | HF |
| 50 Speedfight 2       |       |    |    |
| X-Race, Furious,      |       |    |    |
| 206 WRC               | 01-02 | HF | HF |
| 50 Speedfight         |       |    |    |
| LBD/LBDP              | 00    | HF | HF |
| 50 Speedfight LC,     |       |    |    |
| (A.J.P. cal.)         | 96-15 | HF |    |
| 50 Speedfight         |       |    |    |
| Lemans                | 11    | HF | HF |
| 50 Squab              |       |    |    |
| (A.J.P. cal.)         | 94-04 | HF |    |
| 50 TKR Furious        | 05-10 | HF |    |
| 50 TKR WRC            | 05-10 | HF |    |
| 50 Trekker Metal-X    | 01-08 | HF |    |
| 50 Trekker Road       | 99-00 | HF |    |



| PEUGEOT               |       |    |    |
|-----------------------|-------|----|----|
| 50 Trekker            |       |    |    |
| Streetboard           | 00-02 | HF |    |
| 50 Trekker Urban      |       |    |    |
| Black                 | 00    | HF |    |
| 50 Vivacity           |       |    |    |
| (A.J.P. cal.)         | 99-07 | HF |    |
| XP 6 50 Enduro        | 06-12 | HF | HF |
| XP 6 50 Supermotard   | 06-12 | HF | HF |
| XP 6 50 Trail         | 04-05 | HF | HF |
| XP S-6 50 Enduro      | 02-05 | HF | HF |
| XP S-6 50 Supermotard | 04-05 |    | HF |
| XR 6 50 Race Spec     | 02-07 |    | HF |
| XR 7 50               | 08-10 |    | HF |
| 100 Elyseo            | 02-05 | HF | HF |
| 100 Elyseo            |       |    |    |
| (A.J.P. cal.)         | 99-01 | HF |    |
| 100 Looxor            | 02-07 | HF | HF |
| 100 Speedfight        | 00-07 | HF | HF |
| 100 Speedfight 2,     |       |    |    |
| X-Race                | 01-07 | HF | HF |
| 100 Trekker Road      | 99-04 | HF |    |
| 100 Vivacity          |       |    |    |
| (A.J.P. cal.)         | 99-07 | HF |    |
| 125 Elyseo            |       |    |    |
| (A.J.P. cal.)         | 99    | CT |    |
| 125 Ludix             | 04-05 | CT |    |
| 125 Satelis           | 04-05 | CT |    |

## PIAGGIO VESPA

|            |       |    |  |
|------------|-------|----|--|
| 50 Diesis  | 02-05 | HF |  |
| 100 Diesis | 02-03 | HF |  |

## RIEJU

|                  |       |    |    |
|------------------|-------|----|----|
| 50 First, H2O    | 97-99 | HF |    |
| 50 Racing        |       |    |    |
| Spec. Edition    | 01    |    | HF |
| 50 Spike Racing  | 02-06 |    | HF |
| 50 Spike Racing  | 02-06 | HF | HF |
| 50 Tango         | 08-12 |    | HF |
| 50 Windy         | 97    | HF |    |
| MRX 50 , Racing  | 02-09 | HF | HF |
| MRX 50 Pro       | 05-09 |    | HF |
| NKD 50           | 04-07 |    | HF |
| RRX 50           | 08    | HF | HF |
| RRX 50 Spike     | 08    | HF | HF |
| RS1 50 , Castrol | 01-03 |    | HF |
| RS1 50 Evolution | 96-00 | HF | HF |
| RS3 50 Pro       | 12-17 |    | HF |
| SMX 50           | 02-09 |    | HF |
| SMX 50           | 02-09 | HF | HF |
| SMX 50 Pro       | 08-09 |    | HF |

## ROXON

|            |    |    |    |
|------------|----|----|----|
| 50 Duel SM | 06 | HF | HF |
| 50 Duel TT | 06 | HF | HF |

## SHERCO

|                 |       |  |    |
|-----------------|-------|--|----|
| 50 Supermotard, |       |  |    |
| Enduro          | 02-06 |  | HF |

## SIMSON

|          |    |    |  |
|----------|----|----|--|
| 125 Star | 99 | CT |  |
|----------|----|----|--|

## SUZUKI

|                     |       |    |    |
|---------------------|-------|----|----|
| AY 50 , Katana      | 96-08 | HF |    |
| AY 50 W             | 00-04 |    | HF |
| AY 50 WR            | 00-05 |    | HF |
| RMX 50              | 00-02 | HF | HF |
| SMX 50 Super Motard | 00-02 | HF | HF |
| UF 50 Estilete      | 00-02 | HF |    |

*If required with springs -  
see SBS 188*

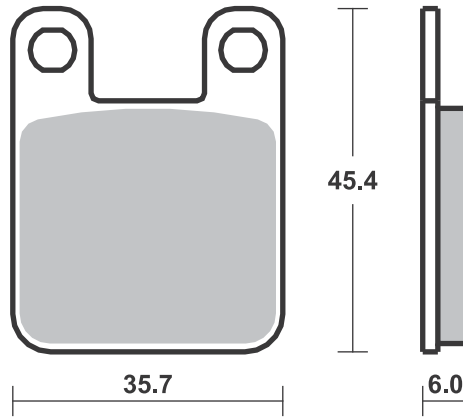

**SBS 105** Recommended compound

| <b>SUZUKI</b> |                |       |           |
|---------------|----------------|-------|-----------|
| UX            | 50 W Zillion   | 99-02 | <b>HF</b> |
| <b>TOMOS</b>  |                |       |           |
|               | 50 Hip Hop     | 06-08 | <b>HF</b> |
|               | 50 Racing      | 06-08 | <b>HF</b> |
|               | 50 Street Soul | 06-08 | <b>HF</b> |
|               | 50 Youngst'r   | 06-08 | <b>HF</b> |
| SE            | 50             | 05-06 | <b>HF</b> |
| <b>YAMAHA</b> |                |       |           |
| DT            | 50 R           | 04-08 | <b>HF</b> |
| TZR           | 50             | 03-04 | <b>HF</b> |
|               |                |       |           |
|               |                |       |           |
|               |                |       |           |
|               |                |       |           |

**SBS 106** Recommended compound

| <b>APRILIA</b> |                   |       |           |
|----------------|-------------------|-------|-----------|
| AF1            | 50 AE             | 86-96 | <b>HF</b> |
| AF1            | 50 Europa, Futura | 90-92 | <b>HF</b> |
| MX             | 50                | 03-10 | <b>HF</b> |
| RS             | 50 , Replica      | 00-05 | <b>HF</b> |
| RS             | 50                | 96-99 | <b>HF</b> |
| RX             | 50                | 90-14 | <b>HF</b> |
| RX             | 50 Racing         | 04-06 | <b>HF</b> |
|                | 125 Leonardo      | 96    | <b>CT</b> |
| <b>CAGIVA</b>  |                   |       |           |
|                | 50 Blues          | 89    | <b>HF</b> |
|                | 50 Cocis          | 88    | <b>HF</b> |
| <b>KYMCO</b>   |                   |       |           |
| B              | 125 Freeway       | 93-95 | <b>CT</b> |
|                |                   |       |           |
|                |                   |       |           |

**SBS 107** Recommended compound

| <b>GARELLI</b>  |               |       |           |
|-----------------|---------------|-------|-----------|
|                 | Xo Electric   | 12    | <b>HF</b> |
|                 | 125 Xo        | 12    | <b>CT</b> |
|                 | 150 Xo        | 12    | <b>CT</b> |
|                 | 200 Xo        | 12    | <b>CT</b> |
| <b>MALAGUTI</b> |               |       |           |
|                 | 125 Centro ie | 08-11 | <b>CT</b> |
|                 | 160 Centro ie | 08-11 | <b>CT</b> |
| <b>MBK</b>      |               |       |           |
|                 | 125 Flame R/F | 95-03 | <b>CT</b> |
|                 | 150 Vertex    | 97    | <b>CT</b> |
| <b>YAMAHA</b>   |               |       |           |
|                 | 50 Cygnus     | 96-01 | <b>HF</b> |
| DT              | 50 R          | 96-97 | <b>HF</b> |
| TDR             | 50            | 90-92 | <b>HF</b> |
| TZM             | 50 R          | 94-97 | <b>HF</b> |



| <b>YAMAHA</b> |                  |       |           |
|---------------|------------------|-------|-----------|
| TZR           | 50               | 90-92 | <b>HF</b> |
|               | 105 Crypton      | 98-04 | <b>HF</b> |
| DT            | 125 R            | 96-07 | <b>CT</b> |
| XC            | 125 Cygnus F     | 00-08 | <b>CT</b> |
| XC            | 125 F            | 00-08 | <b>CT</b> |
| XC            | 125 TR Cygnus, R | 96-98 | <b>CT</b> |
| XC            | 150 Fly One R    | 98-02 | <b>CT</b> |
|               |                  |       |           |
|               |                  |       |           |
|               |                  |       |           |
|               |                  |       |           |
|               |                  |       |           |



Available compounds **HF • CT**

**SBS 105**

*If required with springs -  
see SBS 188*

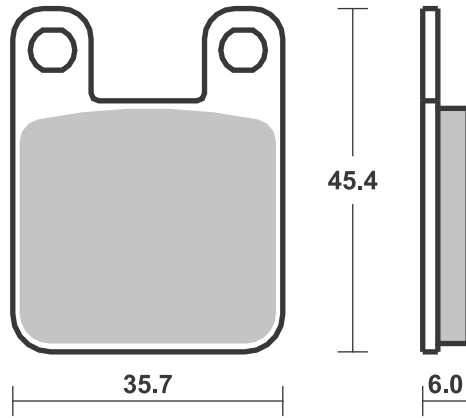

Available compounds **HF • CT**

**SBS 106**

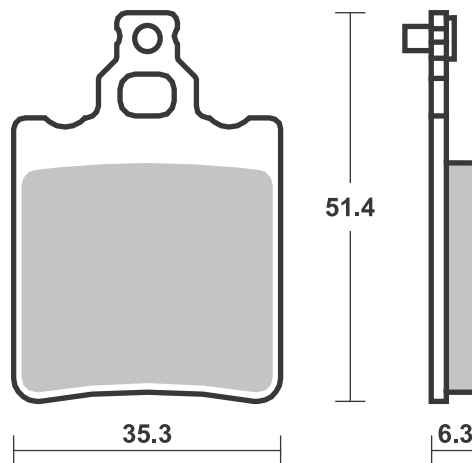

Available compounds **HF • CT**

**SBS 107**

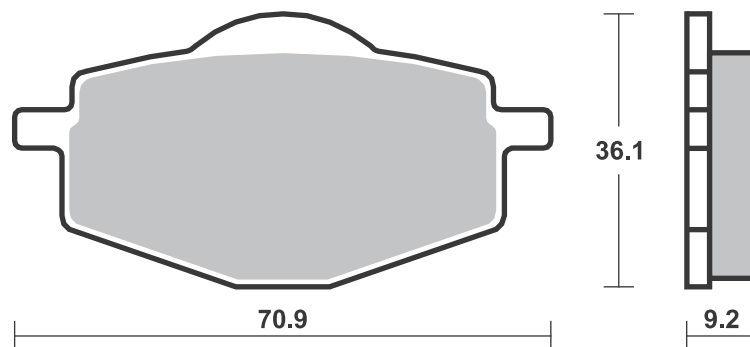

## Applications

### SBS 108 Recommended compound



| <b>APRILIA</b>   |       |           |  |
|------------------|-------|-----------|--|
| 125 Leonardo     |       |           |  |
| (Grimeca cal.)   | 99-06 | <b>CT</b> |  |
| 125 Scarabeo,    |       |           |  |
| Scarabeo GT      | 99-03 | <b>CT</b> |  |
| 125 Sportcity    | 04-12 | <b>CT</b> |  |
| 150 Leonardo     |       |           |  |
| (Grimeca cal.)   | 99-05 | <b>CT</b> |  |
| 150 Scarabeo     | 99-04 | <b>CT</b> |  |
| 200 Scarabeo,    |       |           |  |
| Scarabeo GT      | 02-03 | <b>CT</b> |  |
| 200 Sportcity    | 04-08 | <b>CT</b> |  |
| 250 Leonardo     |       |           |  |
| (Grimeca cal.)   | 99-05 | <b>MS</b> |  |
| 250 Sportcity ie | 06-08 | <b>MS</b> |  |
| 300 Leonardo     |       |           |  |
| (Grimeca cal.)   | 05-06 | <b>MS</b> |  |
| 400 Scarabeo ie  | 07-08 | <b>MS</b> |  |



| <b>APRILIA</b>     |       |           |  |
|--------------------|-------|-----------|--|
| 500 Atlantic       |       |           |  |
| Left/Rear          | 02-05 | <b>MS</b> |  |
| 500 Scarabeo       | 03-06 | <b>MS</b> |  |
| 500 Scarabeo Class | 10-11 | <b>MS</b> |  |
| 500 Scarabeo ie    | 07-11 | <b>MS</b> |  |
| <b>CAGIVA</b>      |       |           |  |
| 50 Blues           | 89    | <b>HF</b> |  |
| <b>DERBI</b>       |       |           |  |
| 125 Rambla         | 08-14 | <b>CT</b> |  |
| 300 Rambla         | 08-12 | <b>MS</b> |  |
| <b>GILERA</b>      |       |           |  |
| 125 Cougar         | 99-02 | <b>CT</b> |  |
| <b>MALAGUTI</b>    |       |           |  |
| 125 Runner         | 87    | <b>CT</b> |  |



| <b>MALAGUTI</b>     |       |           |  |
|---------------------|-------|-----------|--|
| 125 Sport City Cube | 08    | <b>CT</b> |  |
| 200 Sport City Cube | 08    | <b>CT</b> |  |
| 250 Sport City Cube | 08    | <b>MS</b> |  |
| 300 Sport City Cube | 08    | <b>MS</b> |  |
| GT 500 Spidermax    | 04-10 | <b>MS</b> |  |
| RS 500 Spidermax    | 09-11 | <b>MS</b> |  |
| <b>SIMSON</b>       |       |           |  |
| 125 Schikra         | 99    | <b>CT</b> |  |

### SBS 109 Recommended compound



| <b>APRILIA</b>        |       |           |  |
|-----------------------|-------|-----------|--|
| 50 Red Rose           | 90-94 | <b>HF</b> |  |
| AF1 50 AE             | 86-96 | <b>HF</b> |  |
| AF1 50 Europa, Futura | 90-92 | <b>HF</b> |  |
| <b>BENELLI</b>        |       |           |  |
| 50 Chrono             | 92-93 | <b>HF</b> |  |
| <b>KTM</b>            |       |           |  |
| GO 50                 | 94-97 | <b>HF</b> |  |
| <b>MALAGUTI</b>       |       |           |  |
| 50 Centro             | 93-96 | <b>HF</b> |  |
| F-12 50 Phantom L.C.  | 94-98 | <b>HF</b> |  |
| F-15 50 Fire Fox L.C. | 96-08 | <b>HF</b> |  |
| <b>YAMAHA</b>         |       |           |  |
| DT 50 R               | 98-03 | <b>HF</b> |  |

### SBS 110 Recommended compound



| <b>HONDA</b>                   |       |           |  |
|--------------------------------|-------|-----------|--|
| NH 50 Lead                     | 86-93 | <b>HF</b> |  |
| NH 80 Lead Scooter             | 86-95 | <b>HF</b> |  |
| <b>KYMCO</b>                   |       |           |  |
| 50 Manboy                      | 95-00 | <b>HF</b> |  |
| 50 Zap (Disc<br>Brake version) | 95-00 | <b>HF</b> |  |
| SP 90 Yup                      | 95-99 | <b>HF</b> |  |
| <b>SYM</b>                     |       |           |  |
| 50 Bullet                      | 93    | <b>HF</b> |  |
| 50 Cinderella                  | 01-00 | <b>HF</b> |  |
| 50 Mio                         | 05-16 | <b>HF</b> |  |
| DD 50                          | 02-12 | <b>HF</b> |  |
| 100 Cinderella                 | 01    | <b>HF</b> |  |
| 100 Mio                        | 05-16 | <b>HF</b> |  |

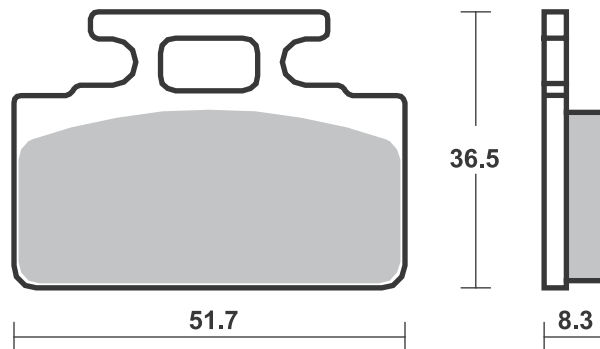
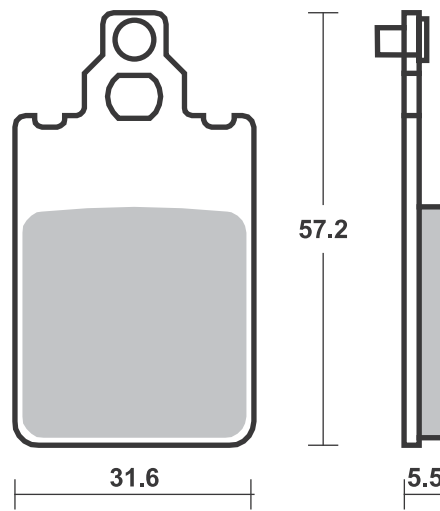
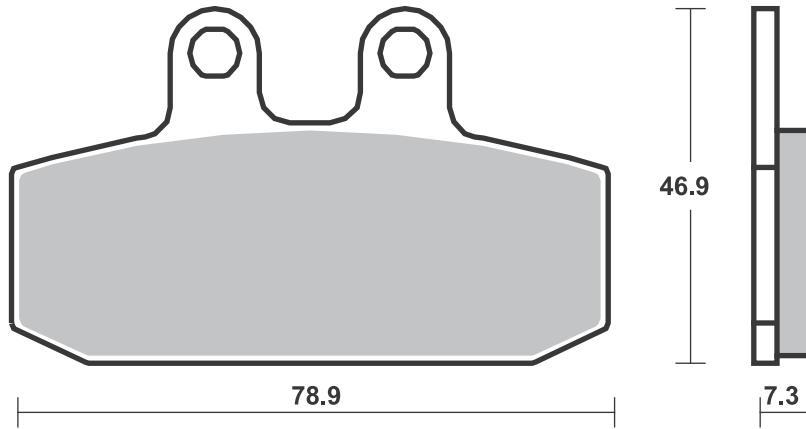

## Applications



### SBS 111 Recommended compound

|                 |                               |       |  |  |
|-----------------|-------------------------------|-------|---|---|
| <b>ADLY</b>     |                               |       |   |   |
|                 | 25 Silver Fox                 | 00-05 | <b>HF</b>   |   |
|                 | 50 Cat                        | 01-08 | <b>HF</b>   |   |
|                 | 50 Cosy                       | 01-08 | <b>HF</b>   |   |
|                 | 50 Fox                        | 00-09 | <b>HF</b>   |   |
|                 | 50 Fox Plus                   | 01-09 | <b>HF</b>   |   |
|                 | 50 Jet                        | 96-99 | <b>HF</b>   |   |
|                 | 50 Pista,<br>Pista Twin Light | 96-99 | <b>HF</b>   |   |
|                 | 50 Silver Fox                 | 00-05 | <b>HF</b>   |   |
| RT              | 50 Road Tracer                | 02-06 | <b>HF</b>   |   |
|                 | 70 Fox Plus                   | 01-05 | <b>HF</b>   |   |
|                 | 70 Pista,<br>Pista Twin Light | 01-05 | <b>HF</b>   |   |
|                 | 80 Cosy                       | 01-06 | <b>HF</b>   |   |
| RT              | 90 Road Tracer                | 02-06 | <b>HF</b>   |   |
|                 | 100 Cat                       | 01-08 | <b>HF</b>   |   |
|                 | 100 Jet                       | 96-99 | <b>HF</b>   |   |
|                 | 100 Silver Fox                | 01-05 | <b>HF</b>   |   |
| RT              | 100 Road Tracer               | 02-06 | <b>HF</b>   |   |
|                 | 125 Cat                       | 01-04 | <b>CT</b>   |   |
| <b>BS VILLA</b> |                               |       |   |   |
| AX              | 50                            | 93    | <b>HF</b>   |   |
| GZ              | 50                            | 93    | <b>HF</b>   |   |
| <b>CAGIVA</b>   |                               |       |   |   |
|                 | 50 City                       | 08    | <b>HF</b>   |   |
| <b>FANTIC</b>   |                               |       |   |   |
|                 | 50 Big Wheel                  | 93    | <b>HF</b>   |   |
|                 | 50 Grinta                     | 95-96 | <b>HF</b>   |   |
|                 | 50 Leader                     | 95    | <b>HF</b>   |   |
|                 | 50 Pony SR                    | 93-95 | <b>HF</b>   |   |
|                 | 50 Queenie                    | 95-96 | <b>HF</b>   |   |
| <b>GARELLI</b>  |                               |       |   |   |
|                 | 50 Starter                    | 02    | <b>HF</b>   |   |
| CPR             | 50                            | 02    | <b>HF</b>   |   |
| FX              | 50                            | 02-06 | <b>HF</b>   |   |

|                 |                   |       |  |  |
|-----------------|-------------------|-------|---|---|
| <b>GARELLI</b>  |                   |       |   |   |
| PMX             | 50 Rally          | 00    | <b>HF</b>   |   |
| SR              | 50 Pony           | 95-02 | <b>HF</b>   |   |
| <b>ITALJET</b>  |                   |       |   |   |
|                 | 50 Bazooka        | 93-02 | <b>HF</b>   |   |
|                 | 50 Cruise         | 95-97 | <b>HF</b>   |   |
|                 | 50 Pista 2        | 92-97 | <b>HF</b>   |   |
|                 | 50 Scoop          | 93-97 | <b>HF</b>   |   |
|                 | 50 Yankee 8       | 94-02 | <b>HF</b>   | <b>HF</b>   |
| <b>LEM</b>      |                   |       |   |   |
|                 | 50 Flash          | 94-98 | <b>HF</b>   |   |
| <b>MBK</b>      |                   |       |   |   |
|                 | 50 Target         | 92-95 | <b>HF</b>   |   |
|                 | 100 Booster       | 99-02 | <b>HF</b>   |   |
| <b>MZ</b>       |                   |       |   |   |
|                 | 50 (MUZ) Moskito  | 99-02 | <b>HF</b>   |   |
|                 | 125 (MUZ) Moskito | 99-02 | <b>CT</b>   |   |
| <b>PETERSON</b> |                   |       |   |   |
|                 | 50 Hurricane      | 95    | <b>HF</b>   |   |
| SR              | 50 Racing         | 95    | <b>HF</b>   |   |
|                 | 80 Hurricane      | 95    | <b>HF</b>   |   |
| SR              | 80 Racing         | 95    | <b>HF</b>   |   |
| <b>PEUGEOT</b>  |                   |       |   |   |
|                 | 50 V-Clic         | 08-13 | <b>HF</b>   |   |
| <b>PGO</b>      |                   |       |   |   |
|                 | 50 Big Max        | 94-02 | <b>HF</b>   |   |
|                 | 50 Big Max Sport  | 96-04 | <b>HF</b>   |   |
|                 | 50 Comet          | 93-97 | <b>HF</b>   |   |
|                 | 50 EPS            | 96-97 | <b>HF</b>   |   |
|                 | 50 Hot            | 97-09 | <b>HF</b>   |   |
|                 | 50 Mega           | 96-99 | <b>HF</b>   |   |
|                 | 50 Tornado        | 96-02 | <b>HF</b>   |   |
| PMX             | 50                | 97-03 | <b>HF</b>   |   |

|                 |                  |       |  |  |
|-----------------|------------------|-------|---|---|
| <b>PGO</b>      |                  |       |   |   |
|                 | 80 Big Max       | 94-98 | <b>HF</b>   |   |
|                 | 90 Big Max       | 97-06 | <b>HF</b>   |   |
|                 | 90 Tornado       | 00    | <b>HF</b>   |   |
|                 | 100 Big Max      | 96-99 | <b>HF</b>   |   |
| PMX             | 110              | 00-01 | <b>HF</b>   |   |
|                 | 125 Kung Fu      | 00    |   | <b>CT</b>   |
|                 | 125 Tornado      | 96-97 | <b>CT</b>   |   |
| <b>SHE-LUNG</b> |                  |       |   |   |
|                 | 50 Falcon        | 97    | <b>HF</b>   |   |
|                 | 125 Mars         | 97    | <b>CT</b>   |   |
| <b>SIAMOTO</b>  |                  |       |   |   |
|                 | 50 Birdie        | 02-04 | <b>HF</b>   |   |
| <b>SULA</b>     |                  |       |   |   |
|                 | 50 City Bird     | 99    | <b>HF</b>   |   |
| <b>TGB</b>      |                  |       |   |   |
|                 | 250 Dynasty      | 06    |   | <b>CT</b>   |
| <b>YAMAHA</b>   |                  |       |   |   |
|                 | 50 Axis Pro Foot | 92-99 | <b>HF</b>   |   |
| CR              | 50 Target        | 91-95 | <b>HF</b>   |   |
| CR              | 50 Z             | 91-95 | <b>HF</b>   |   |
| JOG             | 50 (Spain)       | 88    | <b>HF</b>   |   |
| JOG             | 50 R             | 02-07 | <b>HF</b>   |   |
| RS              | 50 Champ         | 88-93 | <b>HF</b>   |   |
| YE              | 50 Zest (Japan)  | 92-95 | <b>HF</b>   |   |
| YE              | 80 Zest (Japan)  | 93-95 | <b>HF</b>   |   |
|                 | 90 Axis Pro Foot | 94    | <b>HF</b>   |   |
| CR              | 90 Target        | 91-94 | <b>HF</b>   |   |
| JOG             | 90               | 90-91 | <b>HF</b>   |   |
| YA              | 90 Axis          | 90-93 | <b>HF</b>   |   |
| YW              | 100 Booster      | 99-02 | <b>HF</b>   |   |

### SBS 112 Recommended compound

|              |                       |       |  |  |
|--------------|-----------------------|-------|---|---|
| <b>HONDA</b> |                       |       |   |   |
| NH           | 50 Lead SS,MR,<br>MSE | 84-85 | <b>HF</b>   |   |
| NH           | 80 Lead Scooter       | 85    | <b>HF</b>   |   |
| NH           | 125 Lead Scooter      | 86-87 | <b>CT</b>   |   |
|              |                       |       |   |   |
|              |                       |       |   |   |
|              |                       |       |   |   |
|              |                       |       |   |   |
|              |                       |       |   |   |
|              |                       |       |   |   |
|              |                       |       |   |   |
|              |                       |       |   |   |
|              |                       |       |   |   |
|              |                       |       |   |   |
|              |                       |       |   |   |
|              |                       |       |   |   |
|              |                       |       |   |   |
|              |                       |       |   |   |
|              |                       |       |   |   |

Brake Pad 1:1 Drawings, Compounds, Fitments

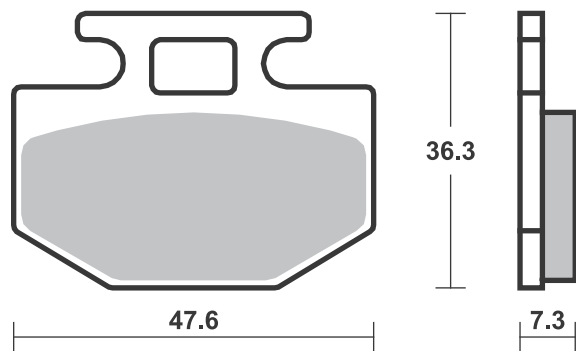
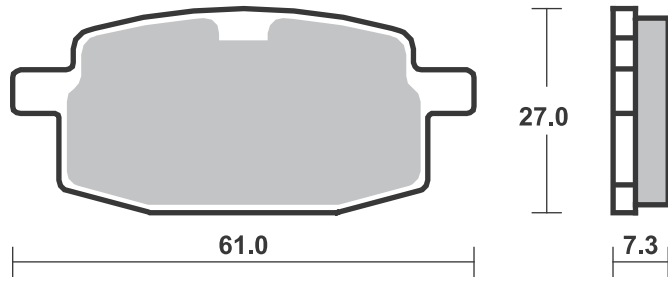

**SBS 113 Recommended compound**



| <b>APRILIA</b>  |                  |       |           |    |
|-----------------|------------------|-------|-----------|----|
| RX              | 125              | 92    |           | CT |
| <b>KYMCO</b>    |                  |       |           |    |
|                 | 125 Agility City | 11-17 |           | CT |
| <b>MALAGUTI</b> |                  |       |           |    |
| F-10            | 50               | 92-93 | <b>HF</b> |    |
| <b>PEUGEOT</b>  |                  |       |           |    |
| SV              | 50 Roland Garros | 93    | <b>HF</b> |    |
| SV              | 50 Sport         | 93    | <b>HF</b> |    |
|                 |                  |       |           |    |
|                 |                  |       |           |    |
|                 |                  |       |           |    |
|                 |                  |       |           |    |
|                 |                  |       |           |    |
|                 |                  |       |           |    |
|                 |                  |       |           |    |
|                 |                  |       |           |    |
|                 |                  |       |           |    |
|                 |                  |       |           |    |
|                 |                  |       |           |    |
|                 |                  |       |           |    |
|                 |                  |       |           |    |
|                 |                  |       |           |    |
|                 |                  |       |           |    |
|                 |                  |       |           |    |
|                 |                  |       |           |    |
|                 |                  |       |           |    |
|                 |                  |       |           |    |
|                 |                  |       |           |    |
|                 |                  |       |           |    |
|                 |                  |       |           |    |
|                 |                  |       |           |    |
|                 |                  |       |           |    |

**SBS 114 Recommended compound**



| <b>APRILIA</b>       |                   |       |           |  |
|----------------------|-------------------|-------|-----------|--|
| LX                   | 50 Amico, Sport   | 92-97 | <b>HF</b> |  |
| SR                   | 50 Europa         | 93-94 | <b>HF</b> |  |
| SR                   | 50 Urban Kid      | 93-07 | <b>HF</b> |  |
| SR                   | 50 Viper          | 93-94 | <b>HF</b> |  |
| <b>ATALA</b>         |                   |       |           |  |
| AT10                 | 25                | 97    | <b>HF</b> |  |
|                      | 50 Skeggia        | 98-00 | <b>HF</b> |  |
| AT10                 | 50                | 97    | <b>HF</b> |  |
| <b>MBK</b>           |                   |       |           |  |
|                      | 50 Booster        |       |           |  |
|                      | Next Gen.         | 97-06 | <b>HF</b> |  |
|                      | 50 Booster Rocket | 95-02 | <b>HF</b> |  |
|                      | 50 Booster Track  | 97-02 | <b>HF</b> |  |
|                      | 50 Equalis        | 96-98 | <b>HF</b> |  |
|                      | 50 Evolis         | 92-98 | <b>HF</b> |  |
|                      | 50 Fizz           | 93-00 | <b>HF</b> |  |
|                      | 50 Forte          | 94-98 | <b>HF</b> |  |
|                      | 50 Nitro          | 97-10 | <b>HF</b> |  |
|                      | 50 Ovetto         | 97-10 | <b>HF</b> |  |
|                      | 80 Evolis         | 94-98 | <b>HF</b> |  |
| <b>PGO</b>           |                   |       |           |  |
|                      | 50 Rodoshow       | 01-09 | <b>HF</b> |  |
|                      | 90 Rodoshow       | 02-06 | <b>HF</b> |  |
| <b>PIAGGIO VESPA</b> |                   |       |           |  |
|                      | 50 Zip & Zip      | 94-97 | <b>HF</b> |  |
|                      |                   |       |           |  |
|                      |                   |       |           |  |
|                      |                   |       |           |  |
|                      |                   |       |           |  |
|                      |                   |       |           |  |
|                      |                   |       |           |  |
|                      |                   |       |           |  |
|                      |                   |       |           |  |
|                      |                   |       |           |  |
|                      |                   |       |           |  |
|                      |                   |       |           |  |
|                      |                   |       |           |  |
|                      |                   |       |           |  |
|                      |                   |       |           |  |
|                      |                   |       |           |  |
|                      |                   |       |           |  |
|                      |                   |       |           |  |
|                      |                   |       |           |  |
|                      |                   |       |           |  |
|                      |                   |       |           |  |
|                      |                   |       |           |  |
|                      |                   |       |           |  |
|                      |                   |       |           |  |
|                      |                   |       |           |  |
|                      |                   |       |           |  |
|                      |                   |       |           |  |
|                      |                   |       |           |  |
|                      |                   |       |           |  |
|                      |                   |       |           |  |
|                      |                   |       |           |  |



| <b>SHE-LUNG</b> |                 |       |           |  |
|-----------------|-----------------|-------|-----------|--|
|                 | 50 Racer        | 96    | <b>HF</b> |  |
| <b>SUZUKI</b>   |                 |       |           |  |
| AP              | 50              | 95-02 | <b>HF</b> |  |
| AY              | 50, Katana      | 96-04 | <b>HF</b> |  |
| <b>YAMAHA</b>   |                 |       |           |  |
| JOG-Z           | 50              | 90-91 | <b>HF</b> |  |
| NS              | 50 Aerox        | 13-18 | <b>HF</b> |  |
| YE              | 50 Zest (Italy) | 92-95 | <b>HF</b> |  |
| YH              | 50              | 98-07 | <b>HF</b> |  |
| YM              | 50 Breeze, Fizz | 95    | <b>HF</b> |  |
| YQ              | 50 Aerox        | 97-12 | <b>HF</b> |  |
| YE              | 80 Zest (Italy) | 93-94 | <b>HF</b> |  |
|                 |                 |       |           |  |
|                 |                 |       |           |  |
|                 |                 |       |           |  |
|                 |                 |       |           |  |
|                 |                 |       |           |  |
|                 |                 |       |           |  |
|                 |                 |       |           |  |
|                 |                 |       |           |  |
|                 |                 |       |           |  |
|                 |                 |       |           |  |
|                 |                 |       |           |  |
|                 |                 |       |           |  |
|                 |                 |       |           |  |
|                 |                 |       |           |  |
|                 |                 |       |           |  |
|                 |                 |       |           |  |
|                 |                 |       |           |  |
|                 |                 |       |           |  |
|                 |                 |       |           |  |
|                 |                 |       |           |  |
|                 |                 |       |           |  |
|                 |                 |       |           |  |
|                 |                 |       |           |  |
|                 |                 |       |           |  |
|                 |                 |       |           |  |
|                 |                 |       |           |  |
|                 |                 |       |           |  |
|                 |                 |       |           |  |
|                 |                 |       |           |  |
|                 |                 |       |           |  |
|                 |                 |       |           |  |
|                 |                 |       |           |  |
|                 |                 |       |           |  |
|                 |                 |       |           |  |
|                 |                 |       |           |  |
|                 |                 |       |           |  |
|                 |                 |       |           |  |

Brake Pad 1:1 Drawings, Compounds, Fitments

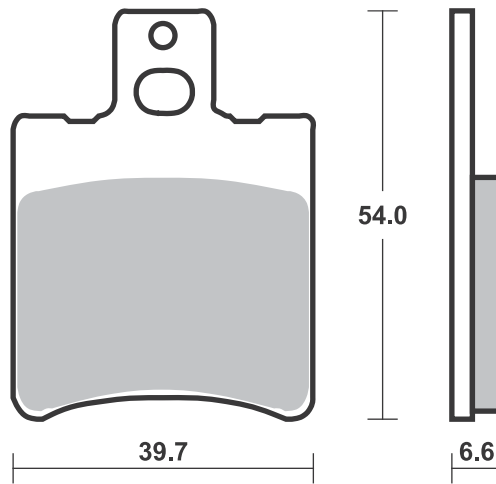
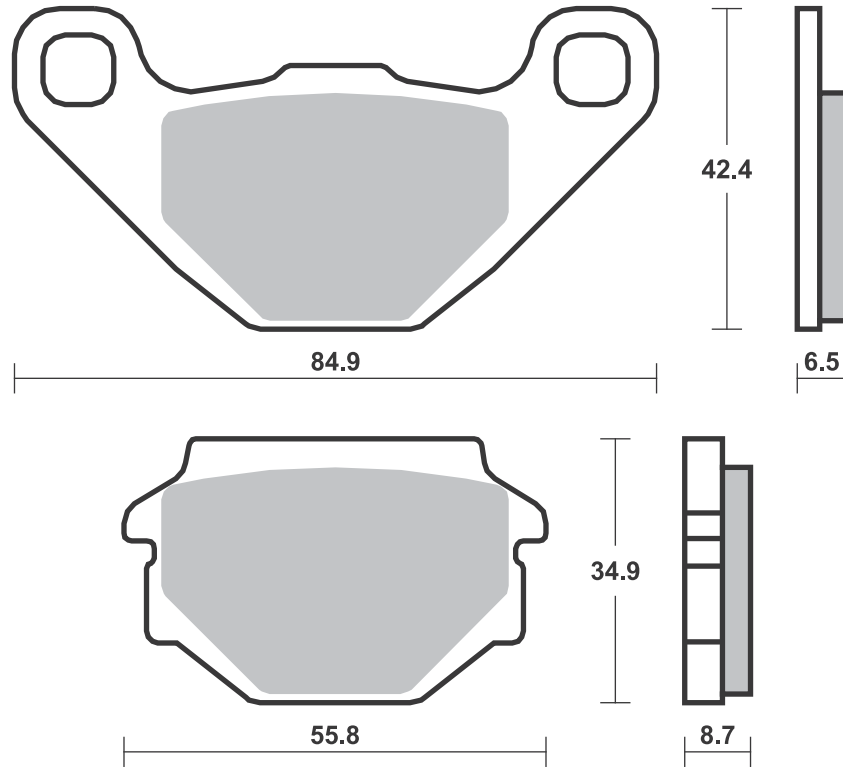





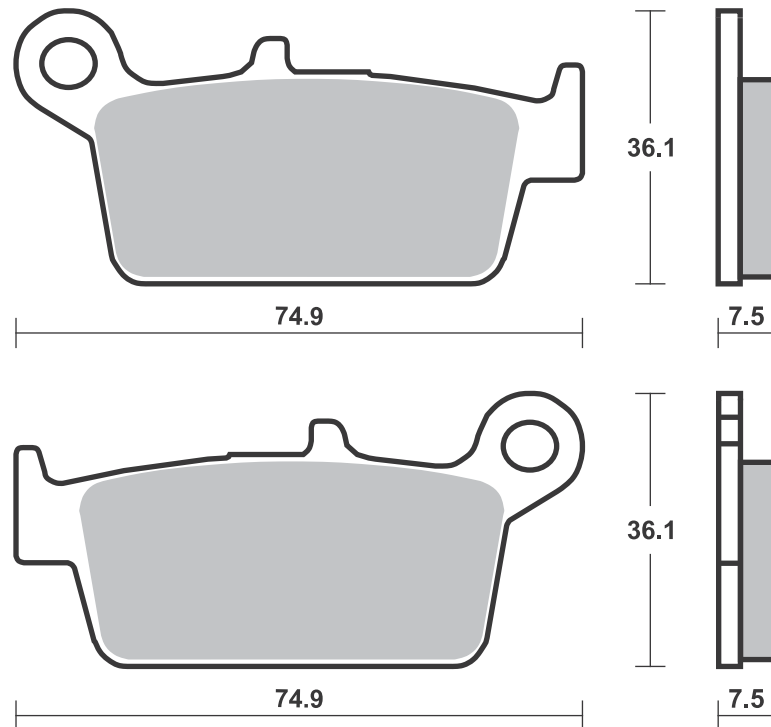
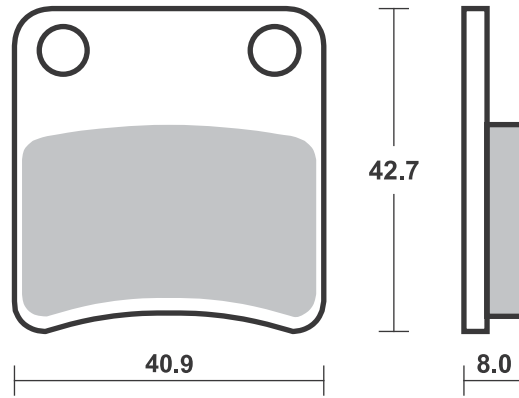

Brake Pad 1:1 Drawings,  
Compounds, Fitments



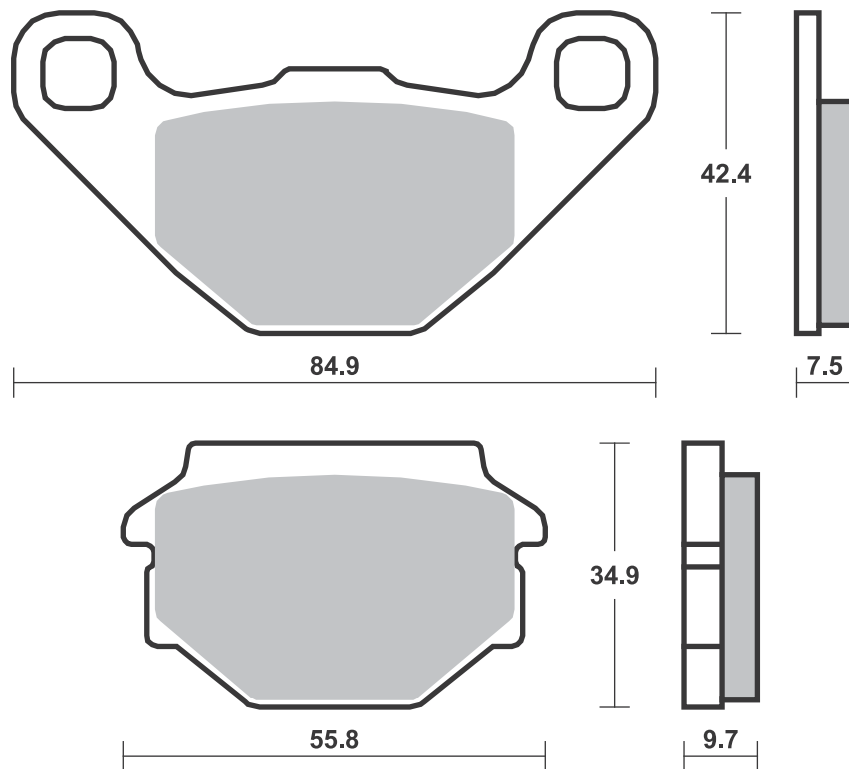
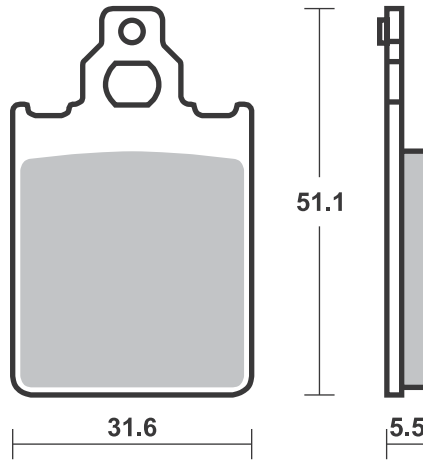

## Applications

### SBS 119 Recommended compound



|                |                      |       |           |
|----------------|----------------------|-------|-----------|
| <b>AEON</b>    |                      |       |           |
|                | 125 Oz               | 14    | <b>CT</b> |
|                | 125 Urban            | 14    | <b>CT</b> |
| <b>DAELIM</b>  |                      |       |           |
| QL             | 125 Steezer          | 17-18 | <b>CT</b> |
| S              | 125 to VIN           |       |           |
|                | SDC007440            | 17-18 | <b>CT</b> |
| SV             | 125 S3               | 11-15 | <b>CT</b> |
| <b>HONDA</b>   |                      |       |           |
| NS-1           | 75                   | 92-00 | <b>HF</b> |
| NSR            | 80 R                 | 93-95 | <b>HF</b> |
| <b>ITALJET</b> |                      |       |           |
|                | 50 Rollercraft       | 08-12 | <b>HF</b> |
|                | 125 Torpedo          | 08-11 | <b>CT</b> |
|                | 150 Torpedo          | 08-12 | <b>CT</b> |
| <b>KEEWAY</b>  |                      |       |           |
|                | 100 Partner          | 06-10 | <b>HF</b> |
|                | 110 Partner          | 06-07 | <b>HF</b> |
|                | 125 Speed            | 06-12 | <b>CT</b> |
|                | 150 Speed            | 06-09 | <b>CT</b> |
| <b>KYMCO</b>   |                      |       |           |
|                | 50 B&W               | 04-06 | <b>HF</b> |
|                | 50 Dink, Dink Sport, |       |           |
|                | B&W                  | 99-02 | <b>HF</b> |
|                | 50 K-Pipe            | 12-13 | <b>HF</b> |
|                | 50 New Dink          | 08-13 | <b>HF</b> |
|                | 50 Spacer            | 99-06 | <b>HF</b> |



|              |                     |       |              |
|--------------|---------------------|-------|--------------|
| <b>KYMCO</b> |                     |       |              |
|              | 50 Super-9 A/C      | 02-07 | <b>HF</b>    |
|              | 50 Super-9 L/C      | 02-07 | <b>HF</b>    |
|              | 50 Yager            | 01-07 | <b>HF</b>    |
|              | 100 Cobra Racer     | 99-03 | <b>HF</b>    |
|              | 125 Agility 16+     | 14-16 | <b>CT</b>    |
|              | 125 B&W, Dink Sport | 99-06 | <b>CT CT</b> |
|              | 125 Cruiser         | 99    | <b>CT</b>    |
|              | 125 Dink            | 96-09 | <b>CT CT</b> |
|              | 125 Grand Dink      | 02-07 | <b>CT CT</b> |
|              | 125 Movie           | 99-08 | <b>CT</b>    |
|              | 125 Movie XL        | 01-09 | <b>CT</b>    |
|              | 125 New Dink        | 08-10 | <b>CT CT</b> |
|              | 125 Quannon         | 08-12 | <b>CT CT</b> |
|              | 125 Spacer          | 99-03 | <b>CT CT</b> |
|              | 125 Techno GT       | 06-10 | <b>CT</b>    |
|              | 125 Yager           | 01-07 | <b>CT CT</b> |
|              | 125 Yager GT        | 09    | <b>CT</b>    |
|              | 150 B&W             | 01-05 | <b>CT CT</b> |
|              | 150 Dink            | 99-04 | <b>CT CT</b> |
|              | 150 Grand Dink      | 02-11 | <b>CT CT</b> |
|              | 150 Movie XL        | 01-09 | <b>CT</b>    |
|              | 150 Quannon         | 10-14 | <b>CT CT</b> |
|              | 150 Spacer          | 99-04 | <b>CT CT</b> |
|              | 150 Yager           | 01-05 | <b>CT CT</b> |
|              | 150 Zing            | 99-13 | <b>CT</b>    |
|              | 200 Agility 16+     | 14-17 | <b>CT</b>    |
|              | 200 Agility R16     | 11-15 | <b>CT</b>    |
|              | 200 Dink            | 04-12 | <b>CT CT</b> |
|              | 200 i New Dink      | 08-12 | <b>CT CT</b> |
|              | 200 Like i          | 10-16 | <b>CT CT</b> |
|              | 200 Yager           | 04-13 | <b>CT CT</b> |



|              |                     |       |              |
|--------------|---------------------|-------|--------------|
| <b>KYMCO</b> |                     |       |              |
|              | 250 B&W, Dink Sport | 01-06 | <b>MS MS</b> |
|              | 250 People          | 03-12 | <b>MS</b>    |
|              | 250 Yup             | 03-05 | <b>MS MS</b> |
|              | 300 People Si Right | 08-10 | <b>CT</b>    |
| <b>SYM</b>   |                     |       |              |
| RS           | 125                 | 05-06 | <b>CT</b>    |
| RS           | 150                 | 05-06 | <b>CT</b>    |

### SBS 120 Recommended compound



|                |                 |       |           |
|----------------|-----------------|-------|-----------|
| <b>APRILIA</b> |                 |       |           |
| MX             | 50              | 03-10 | <b>HF</b> |
| RS             | 50 , Replica    | 00-05 | <b>HF</b> |
| RX             | 50              | 90-14 | <b>HF</b> |
| RX             | 50 Racing       | 04-06 | <b>HF</b> |
| ETX            | 125             | 99-92 | <b>CT</b> |
| RX             | 125             | 92    | <b>CT</b> |
| <b>BENELLI</b> |                 |       |           |
|                | 400 Velvet Dusk | 03-04 | <b>CT</b> |
| <b>BETA</b>    |                 |       |           |
| RR             | 50 Enduro Alu   | 04-07 | <b>HF</b> |
| RR             | 50 Supermotard  |       |           |
|                | Alu             | 04-05 | <b>HF</b> |
| <b>CPI</b>     |                 |       |           |
|                | 50 GTR          | 02    | <b>HF</b> |
|                | 50 GTS          | 02-03 | <b>HF</b> |
|                | 125 GTR, GTS    | 02-03 | <b>CT</b> |
|                | 200 GTR, GTS    | 02-03 | <b>CT</b> |
| RP             | 50 Desert       | 04    | <b>HF</b> |
| SM             | 50 Chrono       | 04    | <b>HF</b> |
| SP             | 50 Chrono       | 04    | <b>HF</b> |
| YR             | 50 Desert       | 04    | <b>HF</b> |
| <b>GILERA</b>  |                 |       |           |
|                | 50 DNA          | 01-07 | <b>HF</b> |
|                | 125 DNA         | 01-03 | <b>CT</b> |
| FX             | 125 Runner      |       |           |
|                | (Grimeca cal.)  | 00-05 | <b>CT</b> |



|                      |                   |       |           |
|----------------------|-------------------|-------|-----------|
| <b>GILERA</b>        |                   |       |           |
| FX                   | 125 Runner SP     |       |           |
|                      | (Grimeca cal.)    | 00-03 | <b>CT</b> |
| VX                   | 125 Runner 4T     |       |           |
|                      | (Grimeca cal.)    | 01-12 | <b>CT</b> |
|                      | 175 Mad Mud       | 02    | <b>CT</b> |
|                      | 180 DNA           | 01-03 | <b>CT</b> |
| FXR                  | 180 Runner        | 98-99 | <b>CT</b> |
| FXR                  | 180 Runner        |       |           |
|                      | (Grimeca cal.)    | 00-03 | <b>CT</b> |
| FXR                  | 180 Runner SP     |       |           |
|                      | (Grimeca cal.)    | 00    | <b>CT</b> |
| VXR                  | 180 Runner 4T     |       |           |
|                      | (Grimeca cal.)    | 01-08 | <b>CT</b> |
| FX                   | 200 Runner SP     | 98-01 | <b>CT</b> |
| VXR                  | 200 Runner 4T     |       |           |
|                      | (Grimeca cal.)    | 01-09 | <b>CT</b> |
| <b>MALAGUTI</b>      |                   |       |           |
| XSM                  | 50                | 03-14 | <b>HF</b> |
| R                    | 125 Madison       | 99-09 | <b>CT</b> |
|                      | 150 Madison       | 99-03 | <b>CT</b> |
|                      | 180 Madison       | 02    | <b>CT</b> |
| S                    | 200 Madison       | 03-06 | <b>CT</b> |
| <b>PIAGGIO VESPA</b> |                   |       |           |
| GTX                  | 125 SuperHexagon  |       |           |
|                      | (Grimeca cal.)    |       |           |
|                      | (11" wheels)      | 00    | <b>CT</b> |
| LXT                  | 180 Hexagon       | 99-00 | <b>CT</b> |
| GT                   | 250 Hexagon       | 99-03 | <b>MS</b> |
| GTX                  | 250 Super Hexagon | 01-02 | <b>MS</b> |
| <b>RIEJU</b>         |                   |       |           |
| RS1                  | 50 , Castrol      | 01-03 | <b>HF</b> |



|                      |                   |       |           |
|----------------------|-------------------|-------|-----------|
| <b>PIAGGIO VESPA</b> |                   |       |           |
| GTX                  | 180 SuperHexagon  |       |           |
|                      | (Grimeca cal.)    |       |           |
|                      | (11" wheels)      | 00    | <b>CT</b> |
| LXT                  | 180 Hexagon       | 99-00 | <b>CT</b> |
| GT                   | 250 Hexagon       | 99-03 | <b>MS</b> |
| GTX                  | 250 Super Hexagon | 01-02 | <b>MS</b> |
| <b>RIEJU</b>         |                   |       |           |
| RS1                  | 50 , Castrol      | 01-03 | <b>HF</b> |

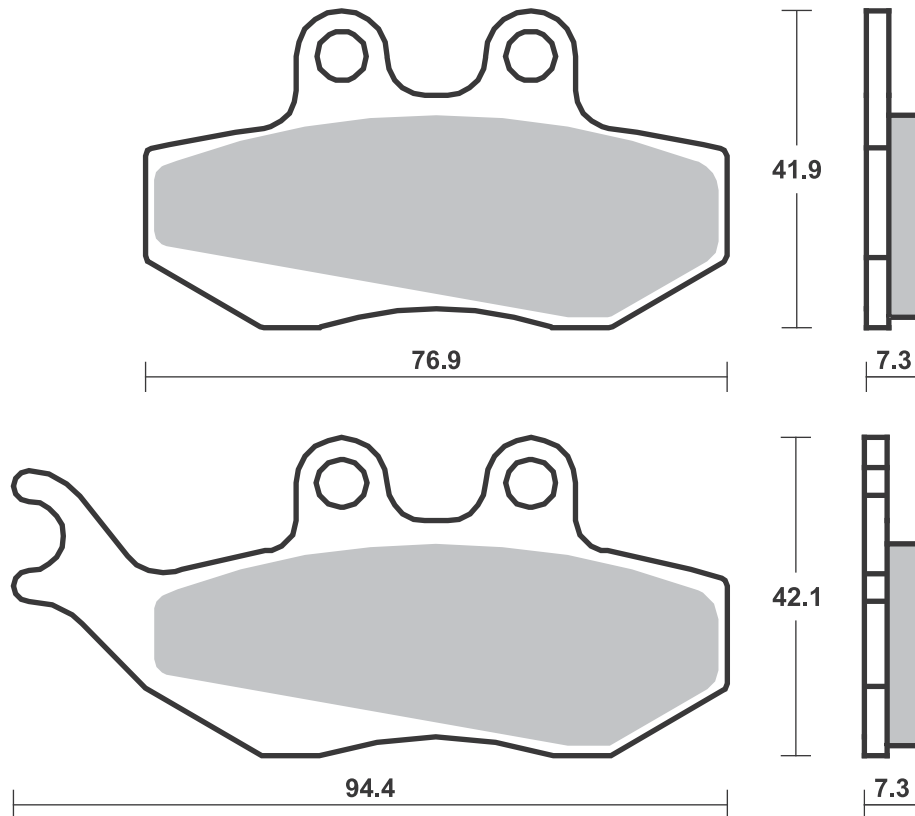
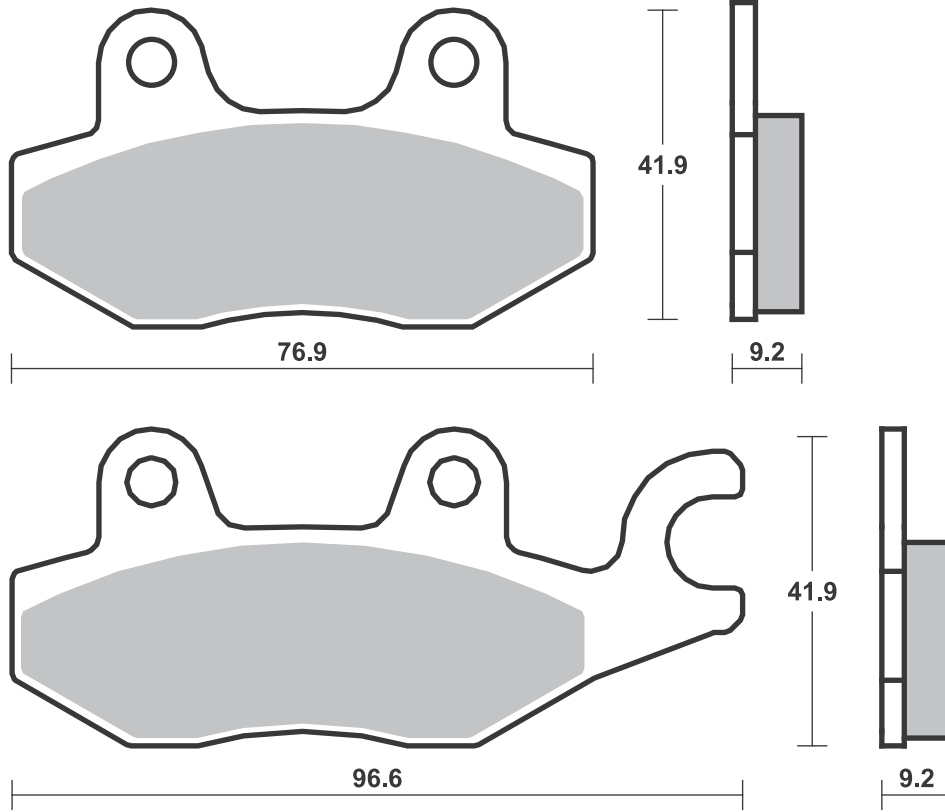

**SBS 121 Recommended compound**



| <b>DAELIM</b>      |       |  |           |
|--------------------|-------|--|-----------|
| 50 Besbi           | 07    |  | <b>HF</b> |
| <b>ENDRESS</b>     |       |  |           |
| EMR 50             | 95    |  | <b>HF</b> |
| <b>HONDA</b>       |       |  |           |
| CRM 50             | 88-96 |  | <b>HF</b> |
| NH 50 Lead         | 94    |  | <b>HF</b> |
| 75 Yupy            | 90-95 |  | <b>HF</b> |
| NS-1 75            | 92-00 |  | <b>HF</b> |
| NSR 80 R           | 87-95 |  | <b>HF</b> |
| NH 90 Yupy         | 90-94 |  | <b>HF</b> |
| NS 150             | 92-95 |  | <b>HF</b> |
| <b>ITALJET</b>     |       |  |           |
| 125 Amarcord       | 08-16 |  | <b>HF</b> |
| <b>KYMCO</b>       |       |  |           |
| 50 Cobra Cross     | 01-06 |  | <b>HF</b> |
| 50 Cobra Exclusive | 01-04 |  | <b>HF</b> |
| 50 Cobra Racer     | 01-04 |  | <b>HF</b> |
| 50 Easy            | 01    |  | <b>HF</b> |
| 50 Filly LX        | 01    |  | <b>HF</b> |
| 50 Heroism         | 95-96 |  | <b>HF</b> |
| 50 Scout           | 95-00 |  | <b>HF</b> |
| 50 Topboy          |       |  |           |
| on/off road        | 96-05 |  | <b>HF</b> |
| 50 Topboy          |       |  |           |
| Racer/Cross        | 01-05 |  | <b>HF</b> |
| 50 Yup             | 01    |  | <b>HF</b> |
| CX 50 Curio Super  | 94-97 |  | <b>HF</b> |



| <b>KYMCO</b>       |       |  |           |
|--------------------|-------|--|-----------|
| DD 50 Sniper       | 94-96 |  | <b>HF</b> |
| K12 50             | 95-00 |  | <b>HF</b> |
| KB 50              | 95-00 |  | <b>HF</b> |
| ZX 50 Fever        | 96-01 |  | <b>HF</b> |
| 100 Topboy         |       |  |           |
| on/off road        | 99-00 |  | <b>HF</b> |
| KB 100             | 99-00 |  | <b>HF</b> |
| 150 Freeway        | 95-00 |  | <b>HF</b> |
| <b>PEUGEOT</b>     |       |  |           |
| SV 50 Geo          | 93-99 |  | <b>HF</b> |
| SV 50 L            | 93    |  | <b>HF</b> |
| SV 80 Geo          | 93-98 |  | <b>HF</b> |
| SV 125 C Executive | 96-98 |  | <b>HF</b> |
| SV 125 Executive   | 94-95 |  | <b>HF</b> |
| SV 125 Geo         | 93-98 |  | <b>HF</b> |

**SBS 122 Recommended compound**



| <b>SUZUKI</b>      |       |  |           |
|--------------------|-------|--|-----------|
| AN 50              | 95    |  | <b>HF</b> |
| TR 50 Street Magic | 97-00 |  | <b>HF</b> |
| AH 100 V Adress    | 95-96 |  | <b>HF</b> |
| UG 110 Hokuto      | 00-02 |  | <b>HF</b> |
| 125 Vecstar        | 94-97 |  | <b>CT</b> |
| AH 125 V Adress    | 95    |  | <b>HF</b> |
| AN 125 R           | 94-05 |  | <b>CT</b> |
| UC 125 Epicuro     | 99-02 |  | <b>CT</b> |
| AN 150             | 98-01 |  | <b>CT</b> |
| UC 150 Epicuro     | 99-02 |  | <b>CT</b> |
| 250 Vecstar        | 94    |  | <b>CT</b> |

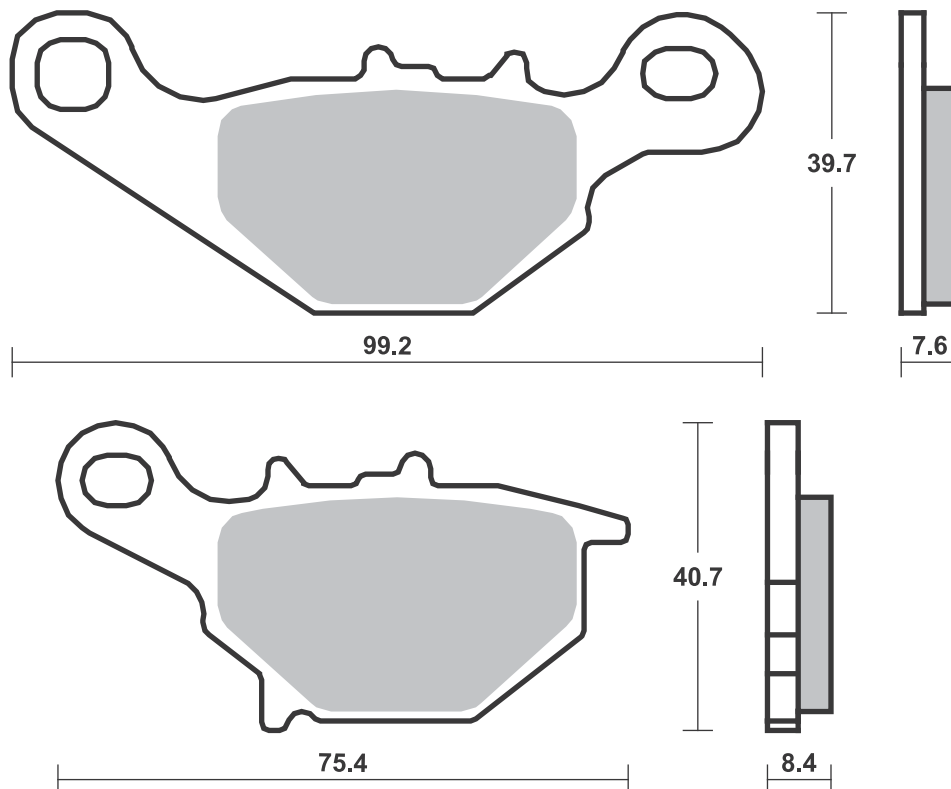
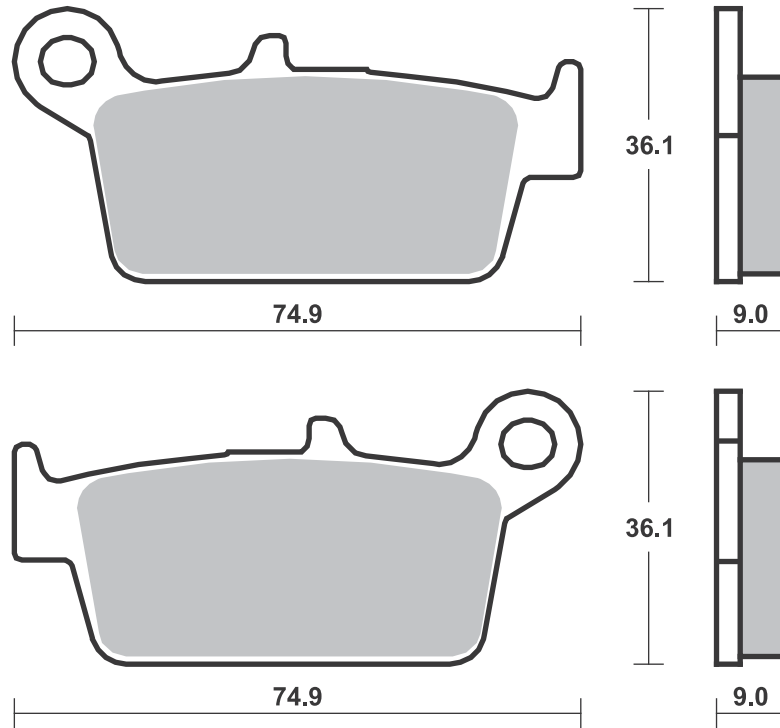

## Applications

### SBS 123 Recommended compound



|                                  |       |           |           |
|----------------------------------|-------|-----------|-----------|
| <b>APRILIA</b>                   |       |           |           |
| 50 Amico, Scooter                | 92    | <b>HF</b> |           |
| 50 Amico, GL, GLE                | 93-98 | <b>HF</b> |           |
| 50 Business                      | 97-98 | <b>HF</b> |           |
| 50 Classic                       | 96-99 | <b>HF</b> |           |
| 50 Club                          | 97-99 | <b>HF</b> |           |
| 50 Gulliver                      | 96-00 | <b>HF</b> |           |
| 50 McGulliver                    | 00    | <b>HF</b> |           |
| 50 Rally                         | 95-01 | <b>HF</b> |           |
| 50 Scarabeo Ditech               | 02-06 | <b>HF</b> |           |
| 50 Scarabeo Street               | 00-06 | <b>HF</b> |           |
| 50 Scarabeo,<br>2nd series       | 94-99 | <b>HF</b> |           |
| 50 Sonic, GP                     | 99-09 | <b>HF</b> |           |
| 50 Younger                       | 97    | <b>HF</b> |           |
| AC 50 Rally                      | 95-02 | <b>HF</b> |           |
| LC 50 Rally                      | 96-01 | <b>HF</b> | <b>HF</b> |
| SR 50 Ditech                     | 01-06 | <b>HF</b> |           |
| SR 50 Racing                     | 00-04 | <b>HF</b> |           |
| SR 50 Replica<br>(Liquid Cooled) | 96    | <b>HF</b> |           |
| SR 50 Stealth, Racing            | 97-00 | <b>HF</b> | <b>HF</b> |
| SR 50 Street                     | 05-12 | <b>HF</b> |           |
| 125 Leonardo                     | 96    | <b>CT</b> |           |
| <b>ATALA</b>                     |       |           |           |
| 25 Carosello                     | 97    | <b>HF</b> |           |
| 50 Carosello                     | 97-01 | <b>HF</b> |           |
| 50 Hacker                        | 95-00 | <b>HF</b> |           |
| 125 Hacker                       | 98    | <b>CT</b> |           |
| <b>BENELLI</b>                   |       |           |           |
| 50 Chrono                        | 94    | <b>HF</b> |           |
| 50 Nemo, Quadra                  | 94    | <b>HF</b> |           |
| 50 Pepe                          | 99-11 | <b>HF</b> |           |
| 491 50 GT, Sport                 | 98-99 | <b>HF</b> |           |
| 491 50 Naked                     | 99-02 | <b>HF</b> |           |
| 491 50 Racing                    | 99-04 | <b>HF</b> | <b>HF</b> |
| 491 50 RR, -GP                   | 00-02 | <b>HF</b> | <b>HF</b> |
| 491 50 ST                        | 01-02 | <b>HF</b> |           |
| 491 50 Superbike                 | 99-04 | <b>HF</b> | <b>HF</b> |
| K2 50 Air                        | 98-01 | <b>HF</b> | <b>HF</b> |
| K2 50 LC                         | 99-01 | <b>HF</b> | <b>HF</b> |
| K2 50 Namur                      | 99    | <b>HF</b> | <b>HF</b> |
| 100 Naked                        | 02-03 | <b>HF</b> |           |
| K2 100 Biposto                   | 99-01 | <b>HF</b> |           |
| LX 100 Pepe                      | 02-06 | <b>HF</b> |           |
| 125 Adiva                        | 00-05 | <b>CT</b> |           |
| 125 Velvet,<br>Velvet Touring    | 99    | <b>CT</b> |           |
| 150 Adiva                        | 00-05 | <b>CT</b> |           |
| 150 Velvet,<br>Velvet Touring    | 00-12 | <b>CT</b> |           |
| 250 Velvet,<br>Velvet Touring    | 99-08 | <b>CT</b> |           |
| 400 Velvet Dusk                  | 03-04 |           | <b>CT</b> |
| <b>BETA</b>                      |       |           |           |
| 50 Ark AirCooled                 | 99-12 | <b>HF</b> |           |
| 50 Ark K Series                  | 97-05 | <b>HF</b> | <b>HF</b> |
| 50 Ark LC                        | 99-12 | <b>HF</b> | <b>HF</b> |
| 50 Chrono 13                     | 94-99 | <b>HF</b> |           |
| 50 Eikon                         | 04-07 | <b>HF</b> |           |
| 50 Quadra                        | 95-96 | <b>HF</b> |           |
| 50 Tempo                         | 99    | <b>HF</b> |           |
| 50 Tempo<br>(13" wheels)         | 00-02 | <b>HF</b> |           |
| 50 Tempo<br>(16" wheels)         | 00-02 | <b>HF</b> |           |
| 125 Eikon                        | 04-06 | <b>CT</b> |           |
| 150 Eikon                        | 04    | <b>CT</b> |           |



|                               |       |           |           |
|-------------------------------|-------|-----------|-----------|
| <b>CPI</b>                    |       |           |           |
| 50 GTR                        | 03-09 |           | <b>HF</b> |
| <b>DERBI</b>                  |       |           |           |
| 50 Vamos R<br>(Brembo cal.)   | 95    |           | <b>HF</b> |
| <b>GARELLI</b>                |       |           |           |
| 50 Flo'                       | 00-02 | <b>HF</b> |           |
| 125 Panther                   | 02    |           | <b>CT</b> |
| 150 Panther                   | 02    |           | <b>CT</b> |
| 250 Panther                   | 02    |           | <b>CT</b> |
| <b>GENERIC</b>                |       |           |           |
| 50 Toxic                      | 07-16 |           | <b>HF</b> |
| 50 Trigger SM                 | 06-14 |           | <b>HF</b> |
| 50 Trigger SM<br>Competition  | 08-14 |           | <b>HF</b> |
| 50 Trigger X                  | 06-14 |           | <b>HF</b> |
| 50 Trigger X<br>Competition   | 08-12 |           | <b>HF</b> |
| <b>GILERA</b>                 |       |           |           |
| 50 Eaglet                     | 97-99 |           | <b>HF</b> |
| 50 Ice                        | 02-05 |           | <b>HF</b> |
| 50 Stalker                    | 97-01 |           | <b>HF</b> |
| DT 50 Stalker                 | 01-05 |           | <b>HF</b> |
| NRG 50                        | 94-95 |           | <b>HF</b> |
| 70 Runner Malossi             | 98    |           | <b>HF</b> |
| 200 Stalker                   | 97-01 |           | <b>CT</b> |
| <b>HERCULES</b>               |       |           |           |
| 50 Gipsy, Splinter,<br>Reggae | 95    |           | <b>HF</b> |
| <b>HONDA</b>                  |       |           |           |
| 50 Formula                    | 94-98 |           | <b>HF</b> |
| 50 Sky Classic                | 00-03 |           | <b>HF</b> |
| 50 Sky Vetro                  | 00-02 |           | <b>HF</b> |
| SFX 50 Sport                  | 96-04 |           | <b>HF</b> |
| SGX 50 Sky DX                 | 97-03 |           | <b>HF</b> |
| SH 50 Fifty, Scoopy           | 00-03 |           | <b>HF</b> |
| SH 50 T                       | 97    |           | <b>HF</b> |
| SXR 50                        | 98-00 |           | <b>HF</b> |
| SZX 50 X8R-S                  | 98-04 |           | <b>HF</b> |
| SZX 50 X8R-X                  | 98-01 |           | <b>HF</b> |
| <b>HYOSUNG</b>                |       |           |           |
| 125 Boomer                    | 03    |           | <b>CT</b> |
| 125 Exceed                    | 02-06 |           | <b>CT</b> |
| 125 Grand Prix                | 98-04 |           | <b>CT</b> |
| 125 Hyper                     | 99-09 |           | <b>CT</b> |
| GPS 125 D                     | 00-03 |           | <b>CT</b> |
| 150 Exceed                    | 02-04 |           | <b>CT</b> |
| 150 Grand Prix                | 98-01 |           | <b>CT</b> |
| <b>ITALJET</b>                |       |           |           |
| 50 Formula                    | 94-00 |           | <b>HF</b> |
| 80 Formula                    | 94-97 |           | <b>HF</b> |
| 125 Formula                   | 94-03 |           | <b>CT</b> |
| <b>KEEWAY</b>                 |       |           |           |
| 125 Arn                       | 06-08 |           | <b>CT</b> |
| 150 Arn                       | 06-08 |           | <b>CT</b> |
| <b>MACAL</b>                  |       |           |           |
| 50 Flash                      | 99    |           | <b>HF</b> |
| <b>MALAGUTI</b>               |       |           |           |
| 50 Ciak                       | 00-09 |           | <b>HF</b> |
| 50 Ciak Twin Disk             | 02-09 |           | <b>HF</b> |



|                                    |       |  |           |
|------------------------------------|-------|--|-----------|
| <b>MALAGUTI</b>                    |       |  |           |
| 50 Yesterday                       | 97-02 |  | <b>HF</b> |
| EL 50 Crosser                      | 97-00 |  | <b>HF</b> |
| F-10 50 Jet-Line                   | 94-98 |  | <b>HF</b> |
| F-10 50 Timemachine                | 03-09 |  | <b>HF</b> |
| F-10 50 WAP                        | 02-09 |  | <b>HF</b> |
| F-12 50 Phantom A.C.               | 99-03 |  | <b>HF</b> |
| F-12 50 Phantom Digit              | 02-10 |  | <b>HF</b> |
| F-12 50 Phantom<br>L.C. dd         | 99-09 |  | <b>HF</b> |
| F-12 50 Racing Life                | 03-09 |  | <b>HF</b> |
| F-12 50 Tyre Track                 | 03-09 |  | <b>HF</b> |
| F-15 50 Mechatronic                | 03-08 |  | <b>HF</b> |
| SL 50 Centro                       | 96-00 |  | <b>HF</b> |
| 100 Ciak                           | 00-01 |  | <b>HF</b> |
| F-12 100 Phantom A.C.              | 00-03 |  | <b>HF</b> |
| F-12 100 Phantom<br>Twin Disk      | 02-03 |  | <b>HF</b> |
| 125 Ciak,<br>Ciak Master           | 02-06 |  | <b>CT</b> |
| F-18 125 , Warrior                 | 00-02 |  | <b>CT</b> |
| 150 Ciak,<br>Ciak Master           | 02-08 |  | <b>CT</b> |
| F-18 150                           | 00-03 |  | <b>CT</b> |
| <b>MBK</b>                         |       |  |           |
| 50 Booster 12"                     | 03-10 |  | <b>HF</b> |
| 50 Booster Naked                   | 04-16 |  | <b>HF</b> |
| 50 Booster Spirit                  | 00-16 |  | <b>HF</b> |
| 50 Flipper                         | 99-04 |  | <b>HF</b> |
| 50 Mach G                          | 02-03 |  | <b>HF</b> |
| 100 Nitro                          | 00-03 |  | <b>HF</b> |
| YN 100 Ovetto                      | 00-02 |  | <b>HF</b> |
| 125 Doodo                          | 01-05 |  | <b>CT</b> |
| 150 Doodo                          | 01    |  | <b>CT</b> |
| <b>MOTRON</b>                      |       |  |           |
| 50 Spike                           | 97-98 |  | <b>HF</b> |
| 50 Sting                           | 95-98 |  | <b>HF</b> |
| 50 Syncro                          | 97-98 |  | <b>HF</b> |
| 50 Thunder                         | 95-98 |  | <b>HF</b> |
| <b>PEUGEOT</b>                     |       |  |           |
| 50 Buxy<br>(Brembo cal.)           | 94-97 |  | <b>HF</b> |
| 50 Speedake<br>(Brembo cal.)       | 94-01 |  | <b>HF</b> |
| 50 Speedfight LC,<br>(Brembo cal.) | 96-15 |  | <b>HF</b> |
| 50 Zenith Luxe                     | 94-00 |  | <b>HF</b> |
| <b>PROTOS</b>                      |       |  |           |
| 50 Ellisse<br>Scootercar           | 98    |  | <b>HF</b> |
| <b>QUADRO</b>                      |       |  |           |
| D 350                              | 11-15 |  | <b>CT</b> |
| <b>SIAM</b>                        |       |  |           |
| 50 Falcon                          | 97    |  | <b>HF</b> |
| 50 Scross                          | 97    |  | <b>HF</b> |
| <b>SUZUKI</b>                      |       |  |           |
| AY 50 W                            | 00-04 |  | <b>HF</b> |
| AY 50 WR                           | 00-05 |  | <b>HF</b> |
| <b>TOMOS</b>                       |       |  |           |
| 50 Revival                         | 02-04 |  | <b>HF</b> |
| 50 Streetmate                      | 03-05 |  | <b>HF</b> |



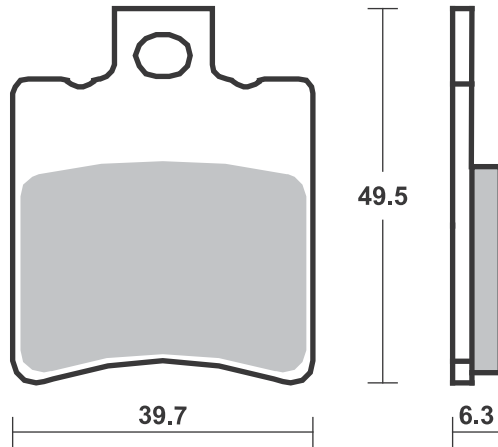

**SBS 123** Recommended compound

| <b>YAMAHA</b> |                    |       |           |
|---------------|--------------------|-------|-----------|
|               | 50 Jog R/RR        | 02-18 | <b>HF</b> |
|               | 50 Neo's 4         | 09-18 | <b>HF</b> |
|               | 50 Why             | 99-07 | <b>HF</b> |
| BW            | 50 Bump            | 97-02 | <b>HF</b> |
| BW            | 50 Next Generation | 96-07 | <b>HF</b> |
| BW            | 50 Sports Spec R   | 02-06 | <b>HF</b> |
| BW            | 50 Spy             | 95-03 | <b>HF</b> |
| YA            | 50 Axis Mofa       | 97-02 | <b>HF</b> |
| YN            | 50 Neo's, LC       | 97-16 | <b>HF</b> |
|               | 100 Aerox          | 00-06 | <b>HF</b> |
|               | 100 Neo's          | 00-02 | <b>HF</b> |
| XN            | 125 Teos           | 01-04 | <b>CT</b> |
|               | 150 Teos           | 02-05 | <b>CT</b> |
|               |                    |       |           |
|               |                    |       |           |
|               |                    |       |           |
|               |                    |       |           |
|               |                    |       |           |
|               |                    |       |           |
|               |                    |       |           |

**SBS 124** Recommended compound

| <b>HONDA</b> |          |       |           |
|--------------|----------|-------|-----------|
| SJ           | 50 Bali  | 93-98 | <b>HF</b> |
| EX           | 100 Bali | 96-03 | <b>HF</b> |
| SJ           | 100 Bali | 97-03 | <b>HF</b> |
|              |          |       |           |
|              |          |       |           |
|              |          |       |           |
|              |          |       |           |
|              |          |       |           |
|              |          |       |           |
|              |          |       |           |
|              |          |       |           |
|              |          |       |           |
|              |          |       |           |
|              |          |       |           |
|              |          |       |           |

**SBS 125** Recommended compound

| <b>HONDA</b> |           |       |           |
|--------------|-----------|-------|-----------|
| NHX          | 110       | 08-09 | <b>HF</b> |
| SCV          | 110 Lead  | 08-09 | <b>HF</b> |
| CH           | 125 Spacy | 94-01 | <b>CT</b> |
| PS           | 125 i     | 07-13 | <b>CT</b> |
| SES          | 125 Dylan | 02-07 | <b>CT</b> |
| SH           | 125       | 02-08 | <b>CT</b> |
| PS           | 150 i     | 07-11 | <b>CT</b> |
| SES          | 150 Dylan | 02-06 | <b>CT</b> |
| SH           | 150       | 02-08 | <b>CT</b> |
|              |           |       |           |
|              |           |       |           |
|              |           |       |           |
|              |           |       |           |
|              |           |       |           |
|              |           |       |           |
|              |           |       |           |
|              |           |       |           |
|              |           |       |           |
|              |           |       |           |

| <b>SUZUKI</b> |                      |       |           |
|---------------|----------------------|-------|-----------|
|               | 250 Sky Wave Type II | 98-01 | <b>MS</b> |
| AN            | 250 Burgman          | 98-03 | <b>MS</b> |
| AN            | 400 Burgman          | 99-00 | <b>MS</b> |
|               |                      |       |           |
|               |                      |       |           |
|               |                      |       |           |
|               |                      |       |           |
|               |                      |       |           |
|               |                      |       |           |

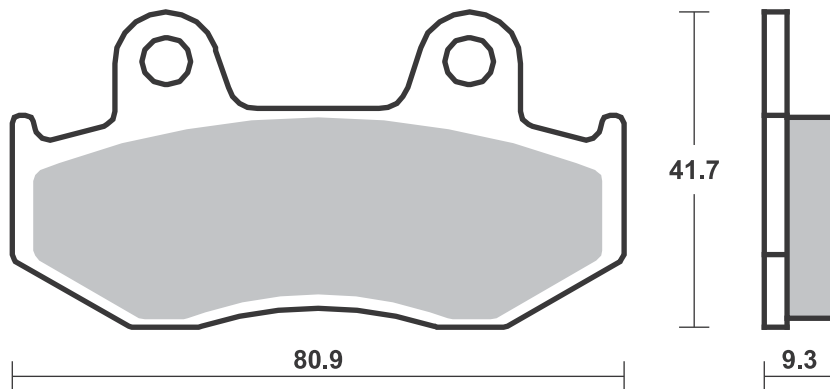
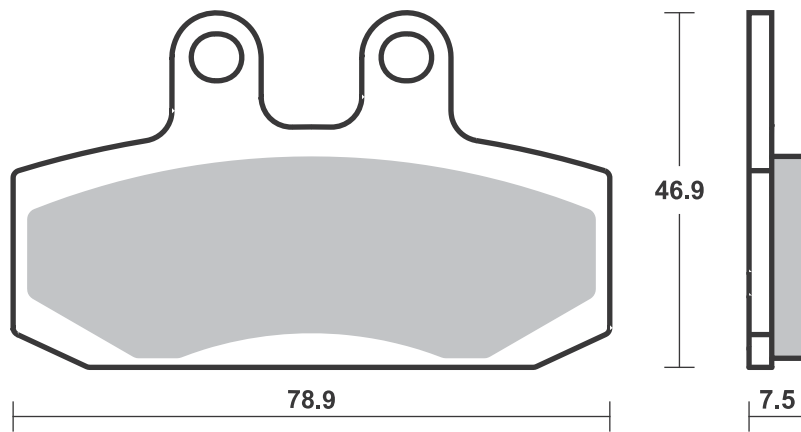
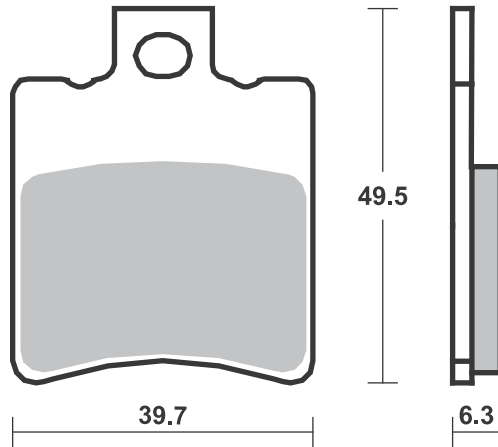

**SBS 126** Recommended compound



|               |       |           |  |
|---------------|-------|-----------|--|
| <b>CAGIVA</b> |       |           |  |
| 80 City       | 93-95 | <b>HF</b> |  |
|               |       |           |  |
|               |       |           |  |
|               |       |           |  |
|               |       |           |  |
|               |       |           |  |
|               |       |           |  |
|               |       |           |  |
|               |       |           |  |
|               |       |           |  |
|               |       |           |  |
|               |       |           |  |
|               |       |           |  |
|               |       |           |  |
|               |       |           |  |

**SBS 127** Recommended compound



|                       |       |           |  |
|-----------------------|-------|-----------|--|
| <b>HONDA</b>          |       |           |  |
| CN 250                | 93-04 | <b>CT</b> |  |
| CN 250 Helix (Fusion) | 92    | <b>CT</b> |  |
| CN 250 Scooter        | 88-92 | <b>CT</b> |  |
|                       |       |           |  |
|                       |       |           |  |
|                       |       |           |  |
|                       |       |           |  |
|                       |       |           |  |
|                       |       |           |  |
|                       |       |           |  |
|                       |       |           |  |
|                       |       |           |  |
|                       |       |           |  |
|                       |       |           |  |
|                       |       |           |  |
|                       |       |           |  |

**SBS 128** Recommended compound



|                       |       |           |  |
|-----------------------|-------|-----------|--|
| <b>ITALJET</b>        |       |           |  |
| 125 Jupiter           | 02-03 | <b>CT</b> |  |
| 150 Jupiter           | 02-03 | <b>CT</b> |  |
| 250 Jupiter           | 01-03 | <b>CT</b> |  |
| <b>MBK</b>            |       |           |  |
| 250 Skyliner          | 00-02 | <b>MS</b> |  |
| 400 Skyliner          | 04    | <b>MS</b> |  |
| <b>YAMAHA</b>         |       |           |  |
| YP 250 D Majesty DX   | 98-00 | <b>MS</b> |  |
| YP 250 Majesty        | 96-04 | <b>MS</b> |  |
| YP 250 Majesty DX/ABS | 99-14 | <b>MS</b> |  |
| YP 400 Majesty        | 05-13 | <b>MS</b> |  |
| XP 500 TMAX           | 04-07 | <b>MS</b> |  |
|                       |       |           |  |
|                       |       |           |  |
|                       |       |           |  |
|                       |       |           |  |
|                       |       |           |  |

Brake Pad 1:1 Drawings,  
Compounds, Fitments

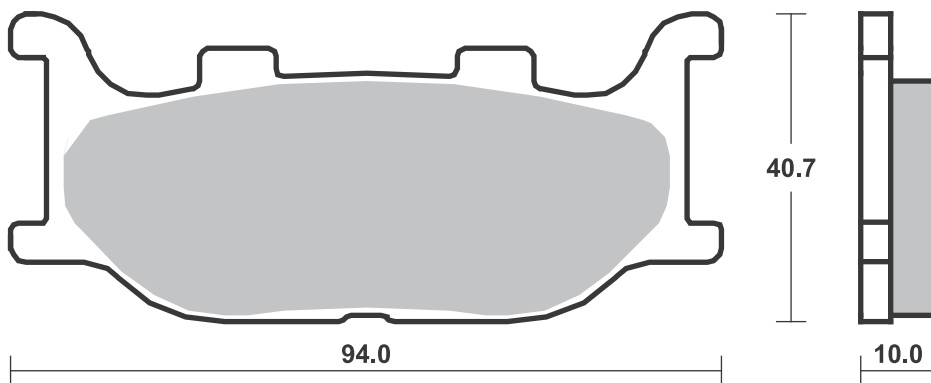
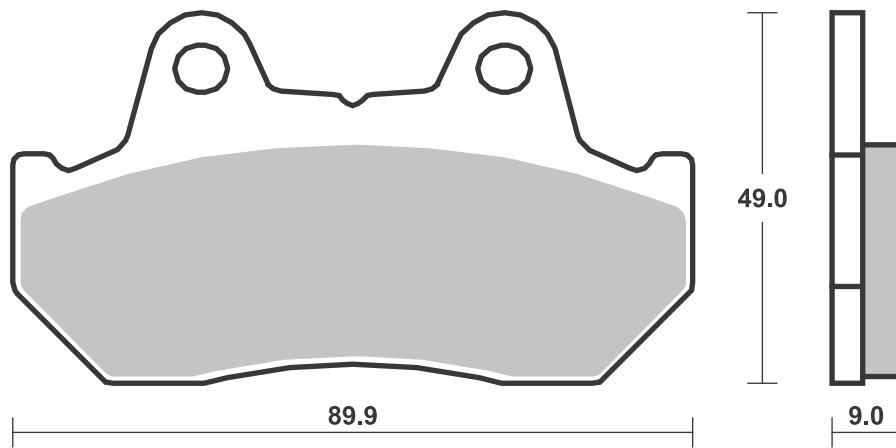
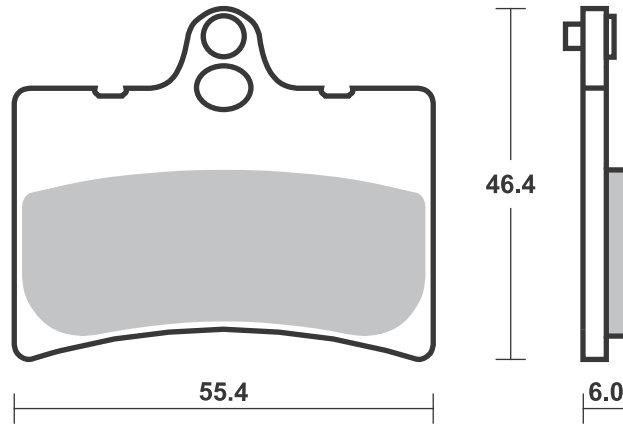

**SBS 129 Recommended compound**



| <b>HONDA</b> |                   |       |           |
|--------------|-------------------|-------|-----------|
| SZX          | 50 X8R-S          | 98-04 | <b>HF</b> |
| SZX          | 50 X8R-X          | 98-01 | <b>HF</b> |
| <b>KYMCO</b> |                   |       |           |
| DD           | 50 Sniper         | 94-96 | <b>HF</b> |
|              | 150 Heroism       | 95-97 | <b>CT</b> |
| <b>SYM</b>   |                   |       |           |
|              | 50 Jet Sport X SR | 06-14 | <b>HF</b> |
|              |                   |       |           |
|              |                   |       |           |
|              |                   |       |           |
|              |                   |       |           |
|              |                   |       |           |
|              |                   |       |           |
|              |                   |       |           |
|              |                   |       |           |
|              |                   |       |           |
|              |                   |       |           |

**SBS 130 Recommended compound**



| <b>GILERA</b>        |                              |       |           |
|----------------------|------------------------------|-------|-----------|
|                      | 50 Easy Moving               | 96-11 | <b>HF</b> |
|                      | 50 Typhoon                   | 96-01 | <b>HF</b> |
|                      | 125 Typhoon                  | 96-00 | <b>CT</b> |
| <b>PIAGGIO VESPA</b> |                              |       |           |
|                      | 25 Zip II Cat DT             | 01    | <b>HF</b> |
|                      | 50 Free (Disc Brake version) | 93-96 | <b>HF</b> |
|                      | 50 Storm                     | 96-97 | <b>HF</b> |
|                      | 50 Typhoon                   | 96-09 | <b>HF</b> |
|                      | 50 Zip II                    | 01-15 | <b>HF</b> |
|                      | 50 Zip II Cat DT             | 01-12 | <b>HF</b> |
| NRG                  | 50                           | 96-00 | <b>HF</b> |
| NTT                  | 50                           | 96    | <b>HF</b> |
| RST                  | 50 Sfera                     | 95-99 | <b>HF</b> |
| TPH                  | 50                           | 96-97 | <b>HF</b> |
|                      | 80 Skipper                   | 96-94 | <b>HF</b> |
|                      | 80 Typhoon                   | 96-99 | <b>HF</b> |



| <b>PIAGGIO VESPA</b> |                       |       |           |
|----------------------|-----------------------|-------|-----------|
|                      | 125 Skipper           | 96-98 | <b>CT</b> |
|                      | 125 Typhoon           | 96-03 | <b>CT</b> |
| TPH                  | 125                   | 96-03 | <b>CT</b> |
| <b>PUCH</b>          |                       |       |           |
|                      | 50 Typhoon (Austria)  | 96    | <b>HF</b> |
|                      | 125 Typhoon (Austria) | 82    | <b>CT</b> |
|                      |                       |       |           |
|                      |                       |       |           |
|                      |                       |       |           |
|                      |                       |       |           |
|                      |                       |       |           |
|                      |                       |       |           |
|                      |                       |       |           |
|                      |                       |       |           |
|                      |                       |       |           |
|                      |                       |       |           |
|                      |                       |       |           |

**SBS 131 Recommended compound**



| <b>GILERA</b> |           |       |           |
|---------------|-----------|-------|-----------|
|               | 50 Eaglet | 96    | <b>HF</b> |
|               | 50 Rally  | 87    | <b>HF</b> |
| RI            | 50        | 91    | <b>HF</b> |
| <b>KTM</b>    |           |       |           |
| GXE           | 50        | 89-92 | <b>HF</b> |
| GXR           | 50        | 89-91 | <b>HF</b> |
| MX            | 50        | 91    | <b>HF</b> |
|               |           |       |           |
|               |           |       |           |
|               |           |       |           |
|               |           |       |           |
|               |           |       |           |
|               |           |       |           |
|               |           |       |           |
|               |           |       |           |
|               |           |       |           |
|               |           |       |           |

Brake Pad 1:1 Drawings, Compounds, Fitments

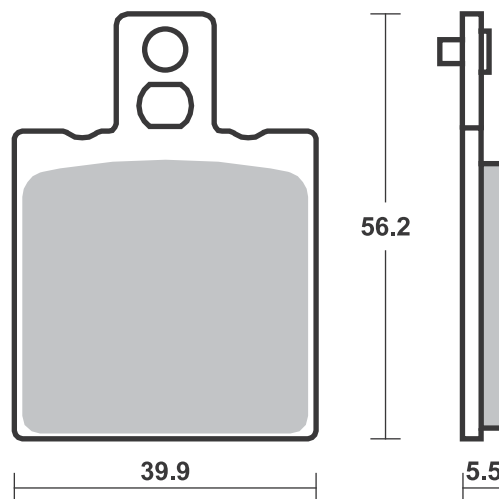
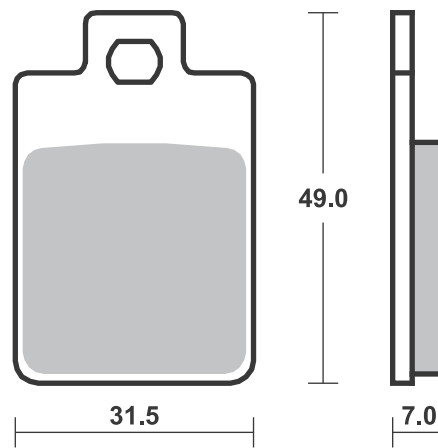
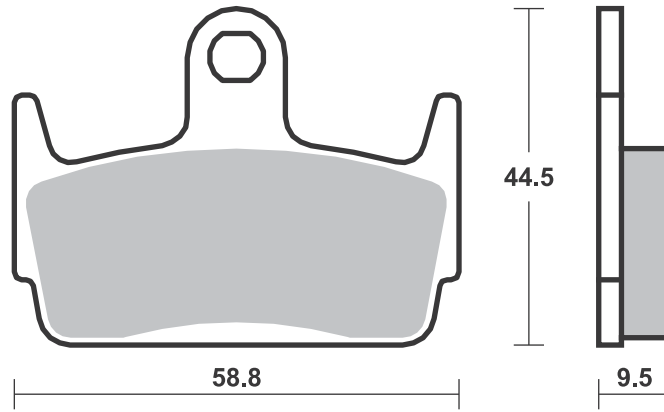

**SBS 132** Recommended compound



| APRILIA  |                |       |       |
|----------|----------------|-------|-------|
|          | 50 Red Rose    | 88-89 | HF    |
| GILERA   |                |       |       |
|          | 50 503         | 91-94 | HF HF |
| R        | 50             | 96    | HF    |
| KEEWAY   |                |       |       |
|          | 125 Speed      | 06-12 | CT    |
|          | 150 Speed      | 06-09 | CT    |
| MALAGUTI |                |       |       |
|          | 50 Enduro Dune | 87-88 | HF HF |
| CR-1     | 50 Crosser     | 95-96 | HF    |
| F-12     | 50 Phantom     | 94-98 | HF    |
| F-15     | 50 Fire Fox    | 96-08 | HF    |
| RST      | 50 Sport       | 87    | HF HF |
| TGB      |                |       |       |
|          | 50 Corona      | 03-05 | HF    |
| R        | 50 X           | 06-14 | HF    |

**SBS 133** Recommended compound



| PUCH |    |    |    |
|------|----|----|----|
| MAXI | 80 | 88 | HF |



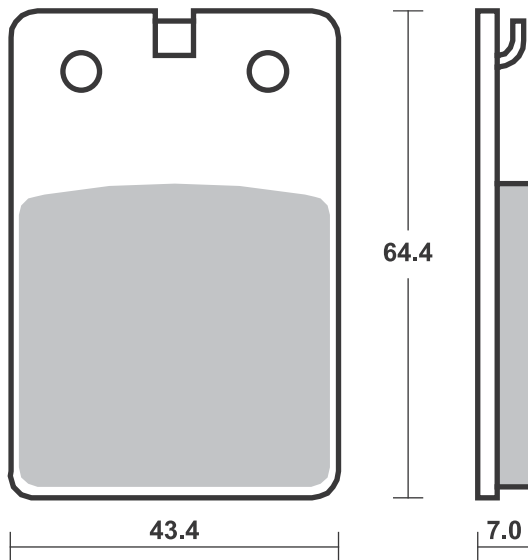
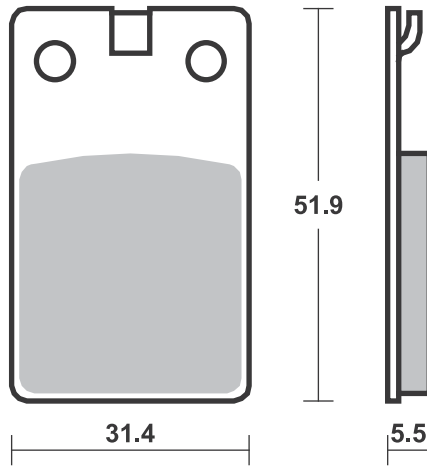

**SBS 134** Recommended compound**BENELLI**

|  |                     |       |           |
|--|---------------------|-------|-----------|
|  | 125 Caffenero Right | 08-11 | <b>CT</b> |
|  | 250 Caffenero Right | 08-14 | <b>MS</b> |

**KYMCO**

|   |                  |       |           |
|---|------------------|-------|-----------|
| S | 250 People Right | 06-08 | <b>MS</b> |
|---|------------------|-------|-----------|

**SUZUKI**

|    |                   |       |           |
|----|-------------------|-------|-----------|
| UH | 200 Burgman       | 14-18 | <b>CT</b> |
| AN | 400 Burgman Right | 07-18 | <b>MS</b> |

**YAMAHA**

|     |      |       |           |
|-----|------|-------|-----------|
| TZM | 50 R | 94-97 | <b>HF</b> |
| TZR | 50   | 90-02 | <b>HF</b> |

**SBS 135** Recommended compound**PEUGEOT**

|  |                    |       |           |
|--|--------------------|-------|-----------|
|  | 125 Django Allure  | 14-16 | <b>CT</b> |
|  | 125 Django Evasion | 14-16 | <b>CT</b> |
|  | 125 Django Sport   | 14-16 | <b>CT</b> |
|  | 150 Django Allure  | 14-15 | <b>CT</b> |
|  | 150 Django Evasion | 14-15 | <b>CT</b> |
|  | 150 Django Sport   | 14-15 | <b>CT</b> |

**SUZUKI**

|      |          |       |           |
|------|----------|-------|-----------|
| GSXR | 50       | 87    | <b>HF</b> |
| OR   | 50 E     | 80    | <b>HF</b> |
| RG   | 50 GAG   | 87-92 | <b>HF</b> |
| RG   | 50 Gamma | 90-96 | <b>HF</b> |
| TV   | 50 Wolf  | 89-91 | <b>HF</b> |
| ZR   | 50       | 81-87 | <b>HF</b> |

**SYM**

|  |           |       |           |
|--|-----------|-------|-----------|
|  | 125 Husky | 96-98 | <b>CT</b> |
|--|-----------|-------|-----------|

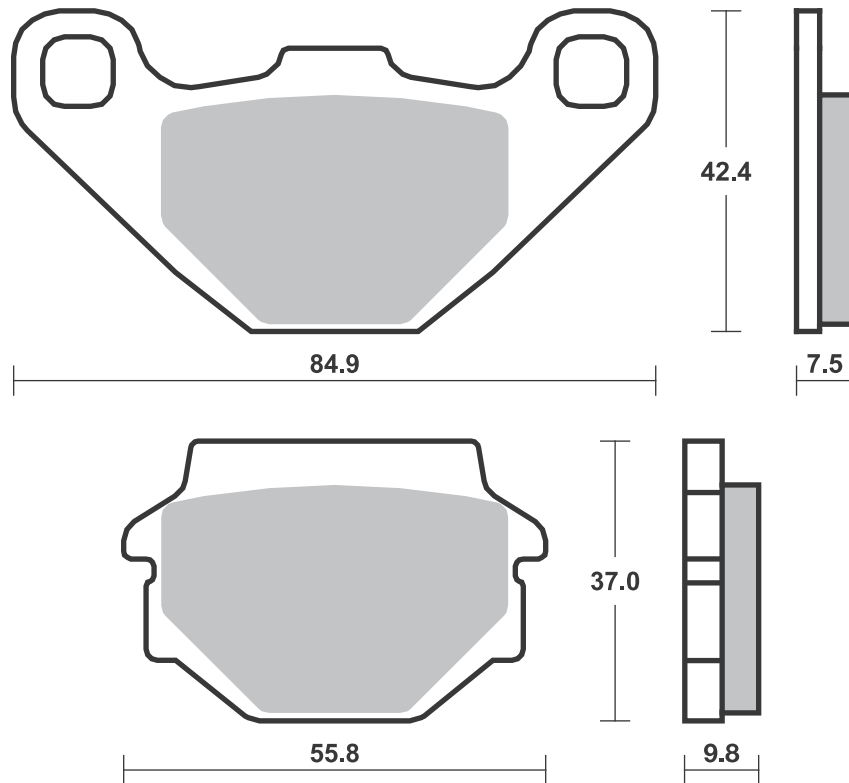
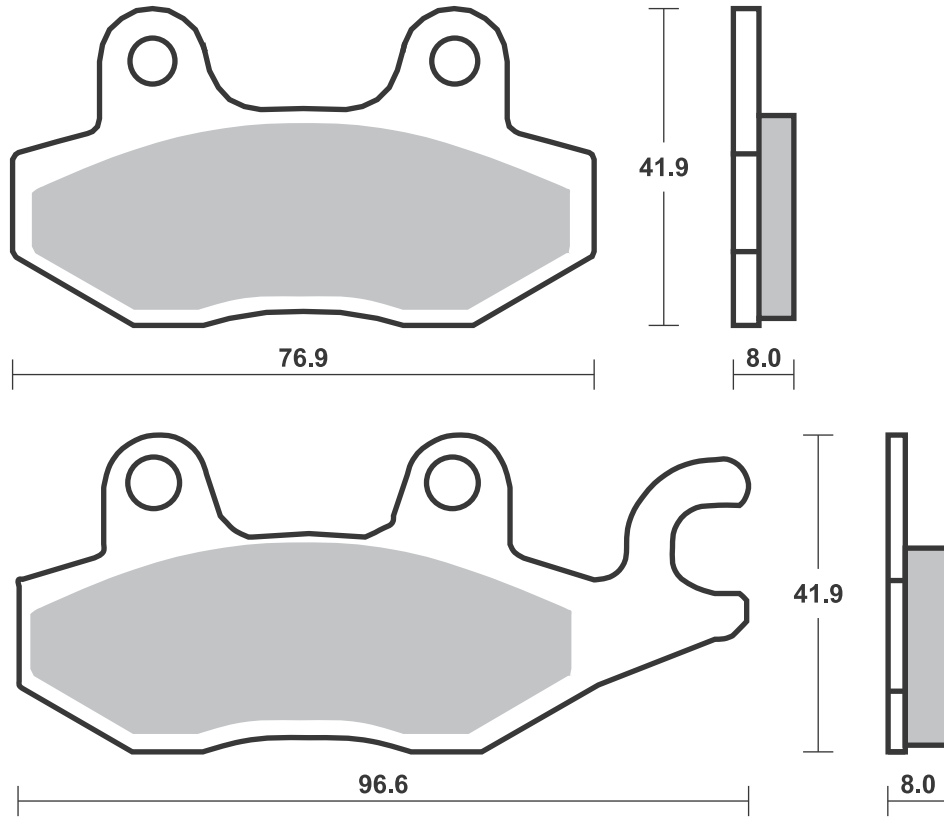



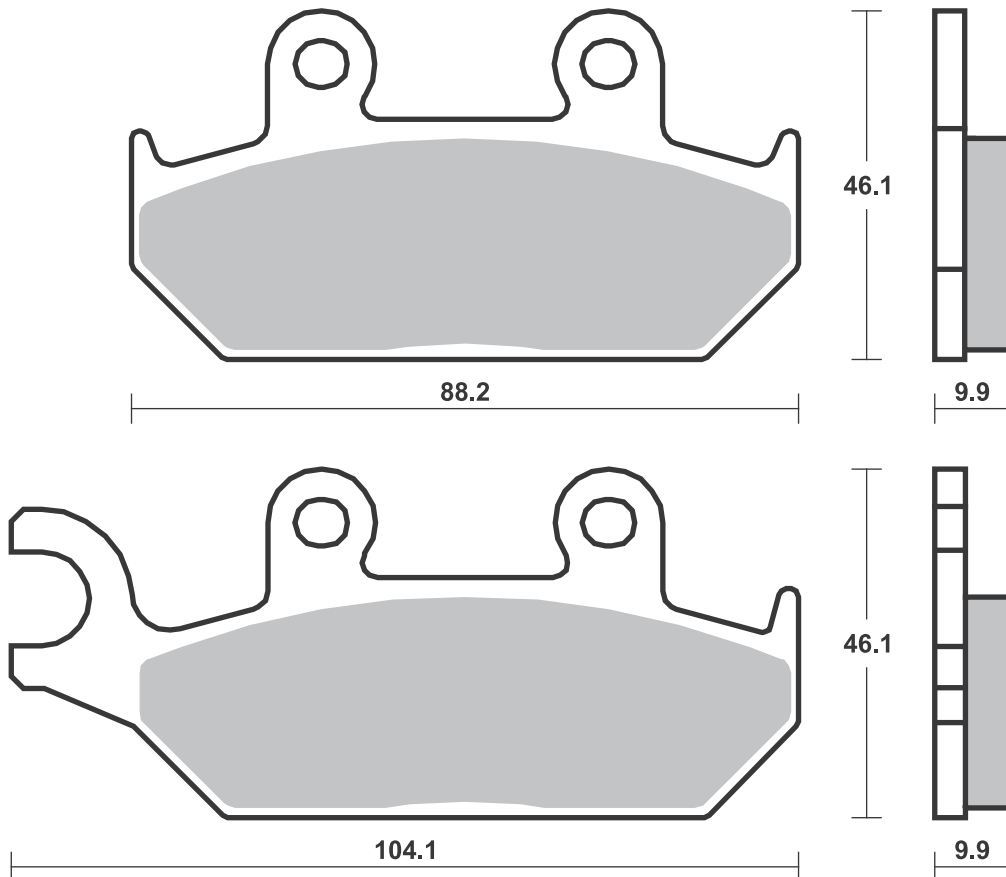
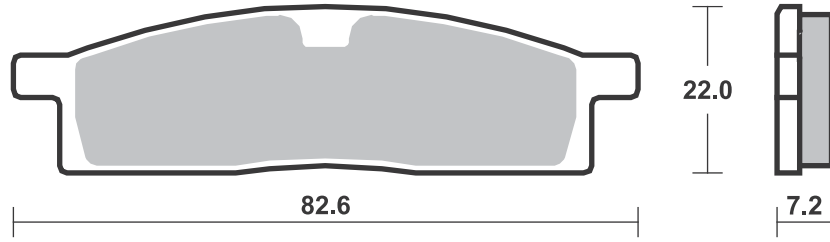

## Applications

### SBS 138 Recommended compound



| APRILIA                           |       |           |
|-----------------------------------|-------|-----------|
| 50 Tuono                          | 04-07 | <b>HF</b> |
| ET 50                             | 85-90 | <b>HF</b> |
| RS 50                             | 93-95 | <b>HF</b> |
| RS 50                             | 96-99 | <b>HF</b> |
| BETA                              |       |           |
| 50 Crono 502                      | 97-02 | <b>HF</b> |
| 50 Quadra                         | 97-00 | <b>HF</b> |
| 50 Tempo                          | 97-98 | <b>HF</b> |
| CAGIVA                            |       |           |
| 50 Cocis                          | 88    | <b>HF</b> |
| 50 Cucciolo                       | 97-99 | <b>HF</b> |
| 50 Nuvola                         | 00    | <b>HF</b> |
| 125 Cucciolo                      | 00-01 | <b>CT</b> |
| 125 Nuvola                        | 00    | <b>CT</b> |
| DERBI                             |       |           |
| 50 Easy                           | 96-98 | <b>HF</b> |
| KTM                               |       |           |
| 50 Comet PL, TS,<br>RLW, RS, RS4L | 86-91 | <b>HF</b> |
| GP 50 DXL, RS1                    | 76-79 | <b>HF</b> |
| PGO                               |       |           |
| 50 G-Max Doppler                  | 06    | <b>HF</b> |
| PUCH                              |       |           |
| MAXI 80                           | 88    | <b>HF</b> |



| SIMSON      |    |           |
|-------------|----|-----------|
| 50 Spatz    | 99 | <b>HF</b> |
| 50 Sperber  | 99 | <b>HF</b> |
| 50 Star     | 99 | <b>HF</b> |
| 125 Schikra | 99 | <b>CT</b> |

### SBS 139 Recommended compound



| HONDA                  |       |           |
|------------------------|-------|-----------|
| CRM 50 (Made in Spain) | 93-96 | <b>HF</b> |
|                        |       |           |
|                        |       |           |
|                        |       |           |
|                        |       |           |
|                        |       |           |
|                        |       |           |
|                        |       |           |
|                        |       |           |
|                        |       |           |
|                        |       |           |
|                        |       |           |
|                        |       |           |
|                        |       |           |
|                        |       |           |
|                        |       |           |
|                        |       |           |
|                        |       |           |
|                        |       |           |
|                        |       |           |
|                        |       |           |
|                        |       |           |
|                        |       |           |
|                        |       |           |
|                        |       |           |
|                        |       |           |
|                        |       |           |
|                        |       |           |
|                        |       |           |
|                        |       |           |
|                        |       |           |

Brake Pad 1:1 Drawings, Compounds, Fitments

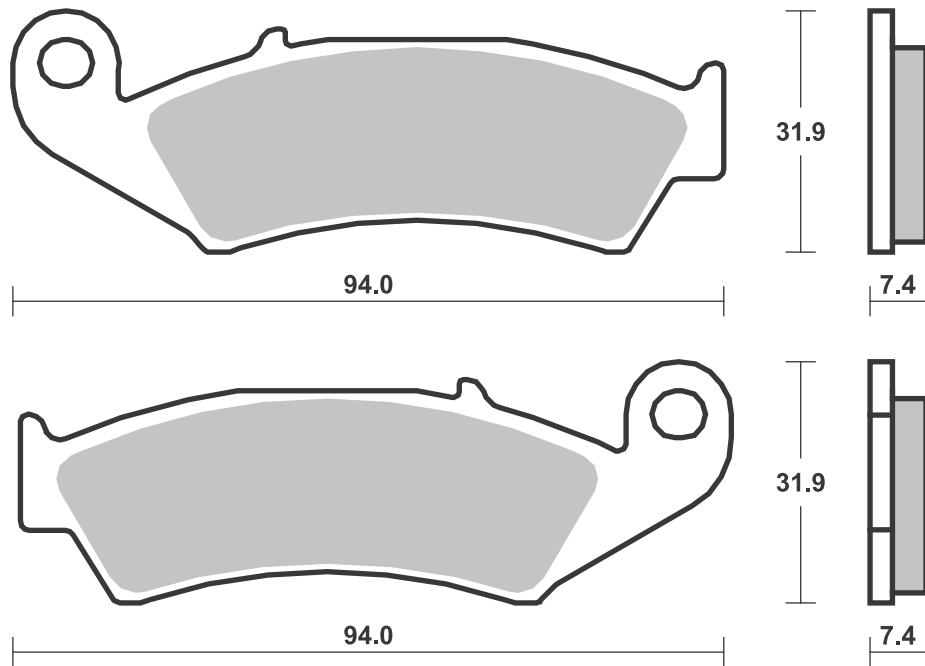
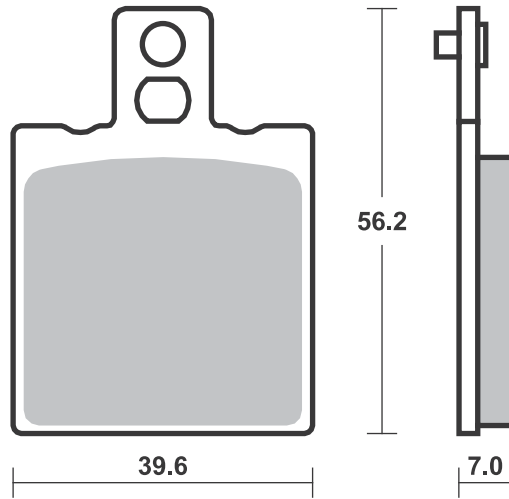

## Applications

### SBS 140 Recommended compound



| <b>CAGIVA</b>    |       |           |  |
|------------------|-------|-----------|--|
| 50 City          | 95-97 | <b>HF</b> |  |
| <b>GARELLI</b>   |       |           |  |
| KRS 50           | 02    | <b>HF</b> |  |
| PMX 50 Sport     | 00    | <b>HF</b> |  |
| 125 Freeland     | 02    | <b>CT</b> |  |
| 125 T-Rex        | 00    | <b>CT</b> |  |
| 150 Freeland     | 02    | <b>CT</b> |  |
| <b>PEUGEOT</b>   |       |           |  |
| 50 Tweet         | 10-13 | <b>HF</b> |  |
| 50 Tweet Evo     | 14-15 | <b>HF</b> |  |
| 50 Tweet Evo RS  | 14-17 | <b>HF</b> |  |
| 50 Tweet RS      | 10-13 | <b>HF</b> |  |
| 125 Tweet        | 10-13 | <b>CT</b> |  |
| 125 Tweet Evo    | 14-17 | <b>HF</b> |  |
| 125 Tweet Evo RS | 14-16 | <b>HF</b> |  |
| 125 Tweet RS     | 10-13 | <b>CT</b> |  |
| LXR 125          | 10-13 | <b>CT</b> |  |
| 150 Tweet        | 10-13 | <b>CT</b> |  |
| 150 Tweet RS     | 10-13 | <b>CT</b> |  |
| LXR 200          | 10-11 | <b>CT</b> |  |
| <b>PGO</b>       |       |           |  |
| i-Dep            | 09    | <b>HF</b> |  |
| 50 Dr. Big       | 01-06 | <b>HF</b> |  |
| 50 G-Max         | 06-17 | <b>HF</b> |  |
| 50 Libra         | 10    | <b>HF</b> |  |
| 50 Ligero        | 06-11 | <b>HF</b> |  |
| 50 T-Rex         | 99-06 | <b>HF</b> |  |
| PMS 50           | 99-03 | <b>HF</b> |  |
| PMX 50 Naked     | 06-08 | <b>HF</b> |  |
| PMX 50 Sport     | 01-08 | <b>HF</b> |  |
| 100 My Bubu      | 02-05 | <b>HF</b> |  |
| 110 T-Rex        | 99-07 | <b>HF</b> |  |
| 125 Charge A, B  | 02    | <b>CT</b> |  |



| <b>PGO</b>                 |       |           |  |
|----------------------------|-------|-----------|--|
| 125 Ligero                 | 06-11 | <b>CT</b> |  |
| 125 My Bubu,<br>Young Bubu | 02-05 | <b>CT</b> |  |
| 125 T-Rex (2 stroke)       | 99-16 | <b>CT</b> |  |
| 125 T-Rex (4 stroke)       | 99-02 | <b>CT</b> |  |
| 150 TR3                    | 02-04 | <b>CT</b> |  |
| 150 T-Rex                  | 01-06 | <b>CT</b> |  |
| <b>SYM</b>                 |       |           |  |
| 50 Allo                    | 11-15 | <b>HF</b> |  |
| 50 Crox                    | 14-15 | <b>CT</b> |  |
| 50 Fiddle                  | 09-14 | <b>HF</b> |  |
| 50 Fiddle III              | 16-18 | <b>CT</b> |  |
| 50 Jet 4 Naked             | 11-13 | <b>HF</b> |  |
| 50 Jet 4 R                 | 11-13 | <b>HF</b> |  |
| 50 Jet BasiX               | 07-09 | <b>HF</b> |  |
| 50 Jet Euro X              | 05-12 | <b>HF</b> |  |
| 50 Jet Sport X             | 06-14 | <b>HF</b> |  |
| 50 Jet Sport X SR          | 06-14 | <b>HF</b> |  |
| 50 Jet, Alpha              | 95-97 | <b>HF</b> |  |
| 50 Jungle                  | 96-02 | <b>HF</b> |  |
| 50 Mask                    | 00-05 | <b>HF</b> |  |
| 50 Mask LC                 | 00-05 | <b>HF</b> |  |
| 50 Orbit II                | 12-13 | <b>HF</b> |  |
| 50 Red Devil               | 97-09 | <b>HF</b> |  |
| 50 Super Fancy             | 95-97 | <b>HF</b> |  |
| 50 Symphony                | 09-15 | <b>HF</b> |  |
| 50 Symphony SR             | 11-15 | <b>HF</b> |  |
| 50 Symphony ST             | 15    | <b>CT</b> |  |
| 50 Symply                  | 08-14 | <b>HF</b> |  |
| 50 X'Pro                   | 13-17 | <b>HF</b> |  |
| 100 Jet                    | 00    | <b>HF</b> |  |
| 100 Jet Euro X             | 05    | <b>HF</b> |  |
| 100 Jet Sport X            | 05    | <b>HF</b> |  |
| 100 Party                  | 97-00 | <b>HF</b> |  |
| 100 Super Fancy            | 95-00 | <b>HF</b> |  |



| <b>SYM</b>      |       |           |           |
|-----------------|-------|-----------|-----------|
| 110 Star        | 03    | <b>HF</b> |           |
| 125 Allo        | 11-15 | <b>CT</b> |           |
| 125 Citycom     | 09-14 | <b>CT</b> |           |
| 125 Crox        | 14-15 | <b>CT</b> |           |
| 125 Fiddle      | 09-16 | <b>CT</b> |           |
| 125 Fiddle III  | 16-18 | <b>CT</b> |           |
| 125 Jet 14      | 17-18 | <b>CT</b> |           |
| 125 Jet 4       | 11-13 | <b>HF</b> |           |
| 125 Megalo      | 02-05 | <b>CT</b> |           |
| 125 New Duke    | 02-07 | <b>CT</b> |           |
| 125 Super Duke  | 95-01 | <b>CT</b> |           |
| 125 Symphony    | 09-15 | <b>CT</b> |           |
| 125 Symphony EX | 17    | <b>CT</b> |           |
| 125 Symphony S  | 11-17 | <b>CT</b> |           |
| 125 Symphony SR | 11-17 | <b>CT</b> |           |
| 125 Symphony ST | 15-18 | <b>CT</b> |           |
| 125 Symply      | 08-14 | <b>CT</b> |           |
| 125 X'Pro       | 14-16 | <b>CT</b> |           |
| HD 125 Evo DT   | 10    | <b>CT</b> |           |
| HD2 125 Evo     | 14    | <b>CT</b> |           |
| 150 Attila      | 00-03 | <b>CT</b> |           |
| 150 Crox        | 14-16 | <b>CT</b> |           |
| 150 Jet 4       | 11-14 | <b>HF</b> |           |
| 150 Super Duke  | 96-01 | <b>CT</b> |           |
| 150 Symphony S  | 11-15 | <b>CT</b> |           |
| 150 Symphony SR | 11-15 | <b>CT</b> |           |
| 200 Fiddle II   | 11-13 | <b>CT</b> |           |
| 200 Fiddle III  | 16-18 | <b>CT</b> |           |
| 200 Joyride Evo | 09-15 | <b>CT</b> |           |
| HD 200 Evo      | 07-13 | <b>CT</b> |           |
| HD2 200 Evo     | 14    | <b>CT</b> |           |
| 300 Citycom     | 09-15 | <b>CT</b> | <b>CT</b> |
| 300 Citycom S   | 15-17 | <b>CT</b> | <b>CT</b> |

### SBS 141 Recommended compound



| <b>BENELLI</b>           |       |           |  |
|--------------------------|-------|-----------|--|
| 50 49X<br>(Quattro Nove) | 08-13 | <b>HF</b> |  |
| <b>CAGIVA</b>            |       |           |  |
| 50 Nag                   | 08    | <b>HF</b> |  |
| <b>CPI</b>               |       |           |  |
| 50 Aragon Club           | 07-09 | <b>HF</b> |  |
| 50 Aragon GP             | 06-09 | <b>HF</b> |  |
| 50 Aragon SP             | 07-09 | <b>HF</b> |  |
| 50 Freaky                | 07    | <b>HF</b> |  |
| 50 Hussar                | 03-06 | <b>HF</b> |  |
| 50 Oliver                | 03-12 | <b>HF</b> |  |
| 50 Oliver City           | 03-12 | <b>HF</b> |  |
| 50 Oliver Sport          | 03-12 | <b>HF</b> |  |
| 50 Popcorn               | 03-06 | <b>HF</b> |  |
| 125 Aragon GP            | 07-12 | <b>CT</b> |  |
| <b>GARELLI</b>           |       |           |  |
| 50 Flexi                 | 12    | <b>HF</b> |  |
| 50 Xo                    | 12    | <b>HF</b> |  |
| GSP 50                   | 12    | <b>HF</b> |  |
| <b>GENERIC</b>           |       |           |  |
| 50 Ideo                  | 06-13 | <b>HF</b> |  |
| 50 ROC                   | 08-11 | <b>HF</b> |  |



| <b>GENERIC</b>             |       |           |  |
|----------------------------|-------|-----------|--|
| 50 Stroke                  | 08-12 | <b>HF</b> |  |
| 50 XOR                     | 06-13 | <b>HF</b> |  |
| 125 Soho                   | 07-16 | <b>CT</b> |  |
| 125 Stroke                 | 08-15 | <b>CT</b> |  |
| 125 XOR                    | 07-11 | <b>CT</b> |  |
| <b>ITALJET</b>             |       |           |  |
| SX1 50                     | 08-10 | <b>HF</b> |  |
| <b>KEEWAY</b>              |       |           |  |
| 50 Flash Electric          | 10-12 | <b>HF</b> |  |
| 50 Focus                   | 06-15 | <b>HF</b> |  |
| 50 Matrix                  | 06-15 | <b>HF</b> |  |
| 50 Matrix Electric         | 10-15 | <b>HF</b> |  |
| 50 Matrix Racing<br>Sport  | 10-16 | <b>HF</b> |  |
| F-NKD 50                   | 10-11 | <b>HF</b> |  |
| RY8 50                     | 07-16 | <b>HF</b> |  |
| 125 Focus                  | 06-08 | <b>CT</b> |  |
| 125 Matrix                 | 06-08 | <b>CT</b> |  |
| 125 Matrix Racing<br>Sport | 10-16 | <b>CT</b> |  |
| 150 Focus                  | 06-09 | <b>CT</b> |  |
| 150 Matrix                 | 06-08 | <b>CT</b> |  |
| 150 Matrix Racing<br>Sport | 10-12 | <b>CT</b> |  |



| <b>KYMCO</b>          |       |           |  |
|-----------------------|-------|-----------|--|
| 50 Calypso            | 97-99 | <b>HF</b> |  |
| 50 Heroism            | 97-99 | <b>HF</b> |  |
| 125 Calypso           | 99    | <b>CT</b> |  |
| 125 Heroism           | 95-97 | <b>CT</b> |  |
| 150 Heroism           | 95-97 | <b>CT</b> |  |
| <b>PEUGEOT</b>        |       |           |  |
| e-Vivacity            | 11-15 | <b>HF</b> |  |
| 50 Vivacity Sportline | 11    | <b>HF</b> |  |
| SV 80                 | 96-98 | <b>HF</b> |  |
| <b>TGB</b>            |       |           |  |
| GT 50 Veloce          | 09-12 | <b>HF</b> |  |



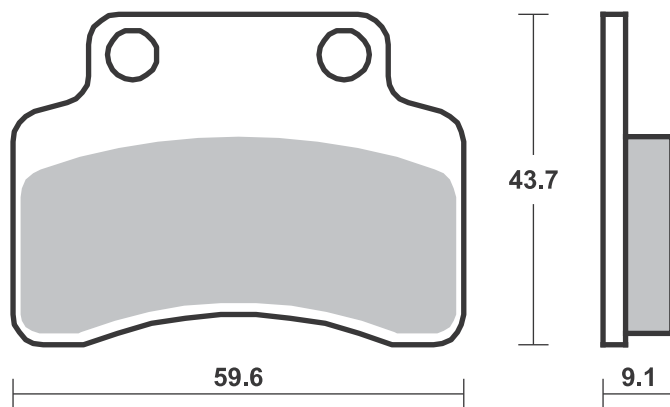
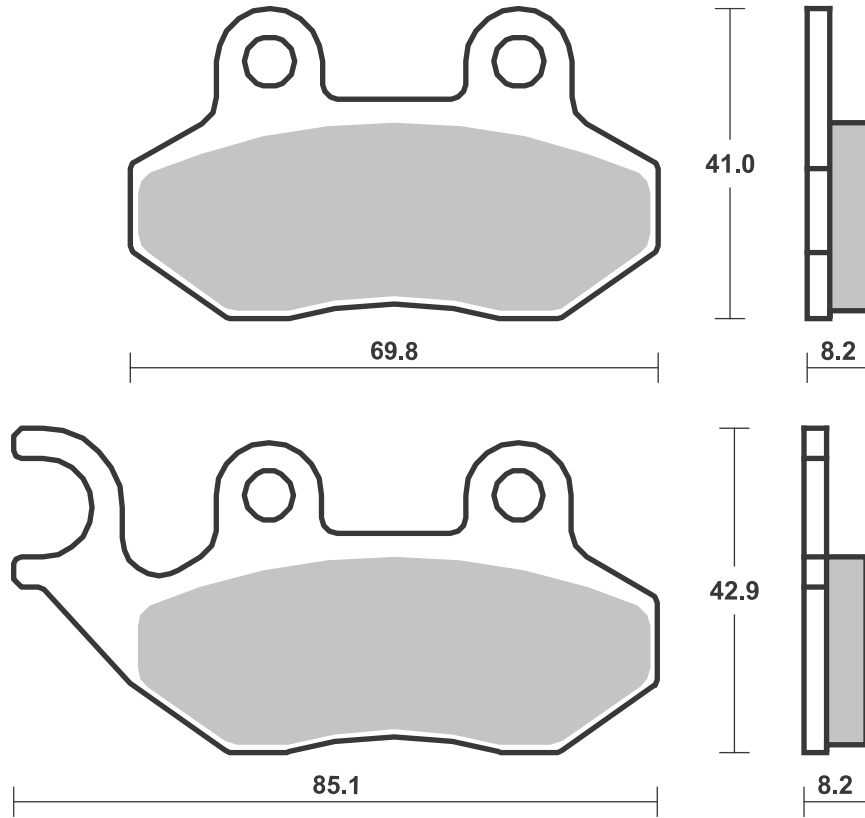



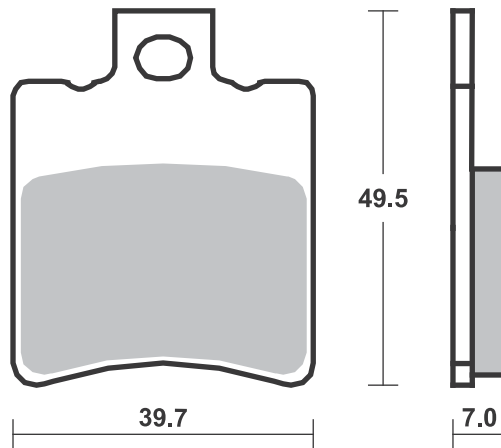
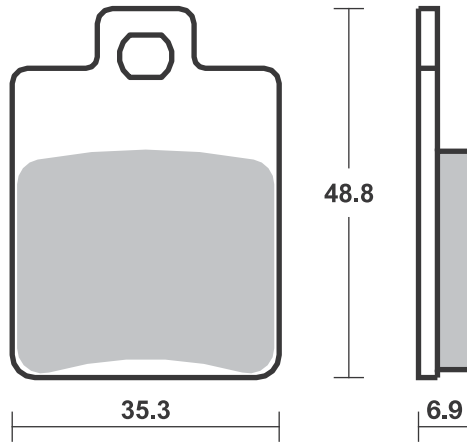

**SBS 144** Recommended compound

| <b>DAELIM</b> |                |       |           |
|---------------|----------------|-------|-----------|
| SC            | 125 Besbi      | 08-13 | <b>CT</b> |
| <b>HONDA</b>  |                |       |           |
| CB            | 50 Replica     | 99-00 | <b>HF</b> |
| SRX           | 50 Shadow      | 98-99 | <b>HF</b> |
| SRX           | 90 Shadow      | 99    | <b>HF</b> |
| <b>KYMCO</b>  |                |       |           |
|               | 50 Cobra Cross | 99-00 | <b>HF</b> |
|               | 50 Cobra Racer | 99-00 | <b>HF</b> |
|               | 50 Super-9     | 00-01 | <b>HF</b> |
|               | 50 ZX 12       | 06    | <b>HF</b> |
| ZX            | 50 Super Fever | 02-06 | <b>HF</b> |
|               | 90 Manboy      | 96-01 | <b>HF</b> |
|               | 125 Super-9    | 00-01 | <b>CT</b> |
|               | 250 Super-9    | 00-05 | <b>CT</b> |
|               |                |       |           |
|               |                |       |           |
|               |                |       |           |
|               |                |       |           |
|               |                |       |           |
|               |                |       |           |
|               |                |       |           |
|               |                |       |           |
|               |                |       |           |
|               |                |       |           |

**SBS 145** Recommended compound

| <b>CPI</b>    |           |       |           |
|---------------|-----------|-------|-----------|
|               | 50 GTS    | 02-03 | <b>HF</b> |
| <b>MBK</b>    |           |       |           |
|               | 50 Nitro  | 97-10 | <b>HF</b> |
|               | 50 Stunt  | 00-10 | <b>HF</b> |
| <b>QUADRO</b> |           |       |           |
|               | 350 3     | 16    | <b>MS</b> |
|               | 350 4     | 16    | <b>MS</b> |
| <b>YAMAHA</b> |           |       |           |
|               | 50 Slider | 00-05 | <b>HF</b> |
| NS            | 50 Aerox  | 13-18 | <b>HF</b> |
| YQ            | 50 Aerox  | 97-12 | <b>HF</b> |

**SBS 146** Recommended compound

| <b>DAELIM</b>   |                      |       |           |
|-----------------|----------------------|-------|-----------|
|                 | 125 Otello           | 08    | <b>CT</b> |
|                 | 125 S2 FI            | 07-15 | <b>CT</b> |
| QL              | 125 Steezer          | 17-18 | <b>CT</b> |
| S               | 125 from             |       |           |
|                 | VIN SDC007441        | 17-18 | <b>CT</b> |
| S               | 125 to               |       |           |
|                 | VIN SDC007440        | 17-18 | <b>CT</b> |
| SL              | 125 U3 FI            | 07-09 | <b>CT</b> |
| SV              | 125 S3               | 11-15 | <b>CT</b> |
| S               | 300                  | 17-18 | <b>MS</b> |
| <b>KAWASAKI</b> |                      |       |           |
| SC              | 250 Epsilon          | 02-06 | <b>MS</b> |
| <b>SUZUKI</b>   |                      |       |           |
|                 | 250 Sky Wave Type II | 98-01 | <b>MS</b> |



| <b>SUZUKI</b> |                   |       |           |
|---------------|-------------------|-------|-----------|
| AN            | 250 Burgman       | 98-06 | <b>MS</b> |
| AN            | 400 Burgman       | 99-06 | <b>MS</b> |
| <b>SYM</b>    |                   |       |           |
|               | 125 GTS           | 07-11 | <b>CT</b> |
|               | 125 Joymax Sport  | 16    | <b>CT</b> |
|               | 250 GTS           | 07-11 | <b>MS</b> |
|               | 250 Joymax Sport  | 16-17 | <b>MS</b> |
|               | 300 Joymax Evo    | 10-12 | <b>MS</b> |
|               | 300 Joymax Sport  | 16-17 | <b>MS</b> |
|               | 300 Joyride Evo i | 10    | <b>MS</b> |
| GTS           | 300 Evo i         | 11-15 | <b>MS</b> |
|               | 500 GT            | 07-04 | <b>MS</b> |
|               |                   |       |           |
|               |                   |       |           |
|               |                   |       |           |
|               |                   |       |           |
|               |                   |       |           |
|               |                   |       |           |
|               |                   |       |           |
|               |                   |       |           |
|               |                   |       |           |
|               |                   |       |           |

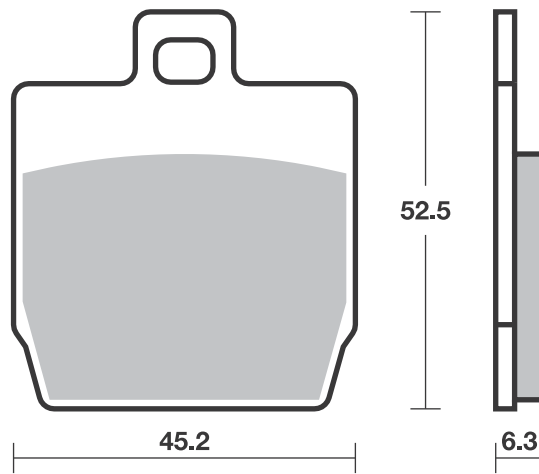
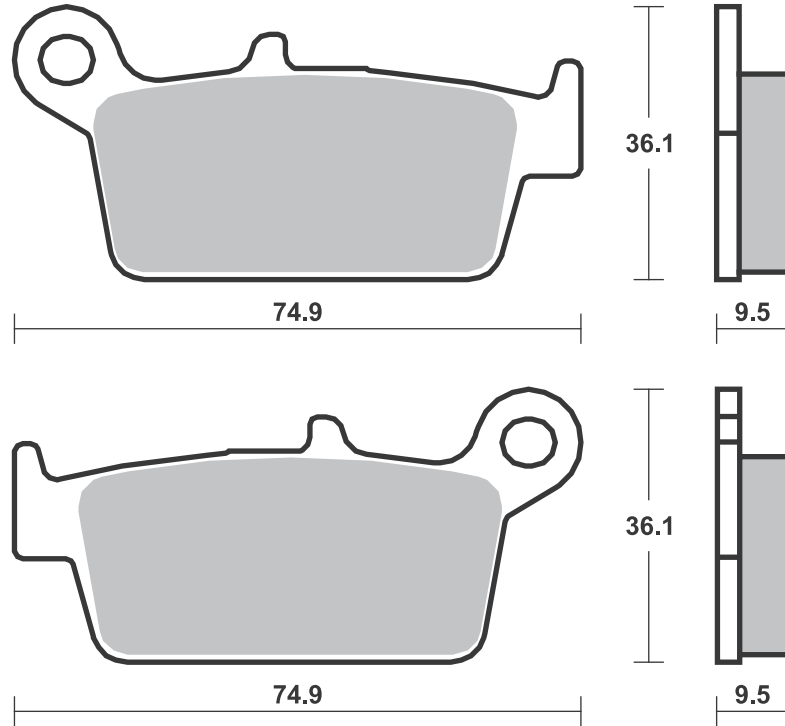

1 set = 4 pcs.

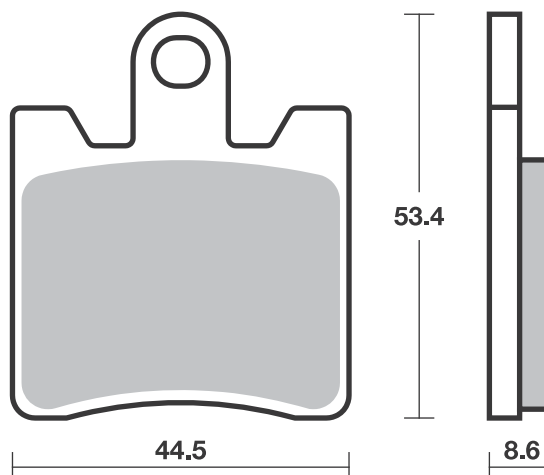



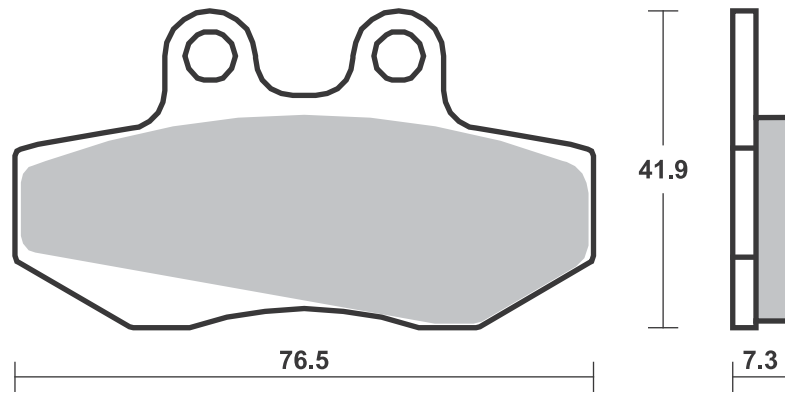
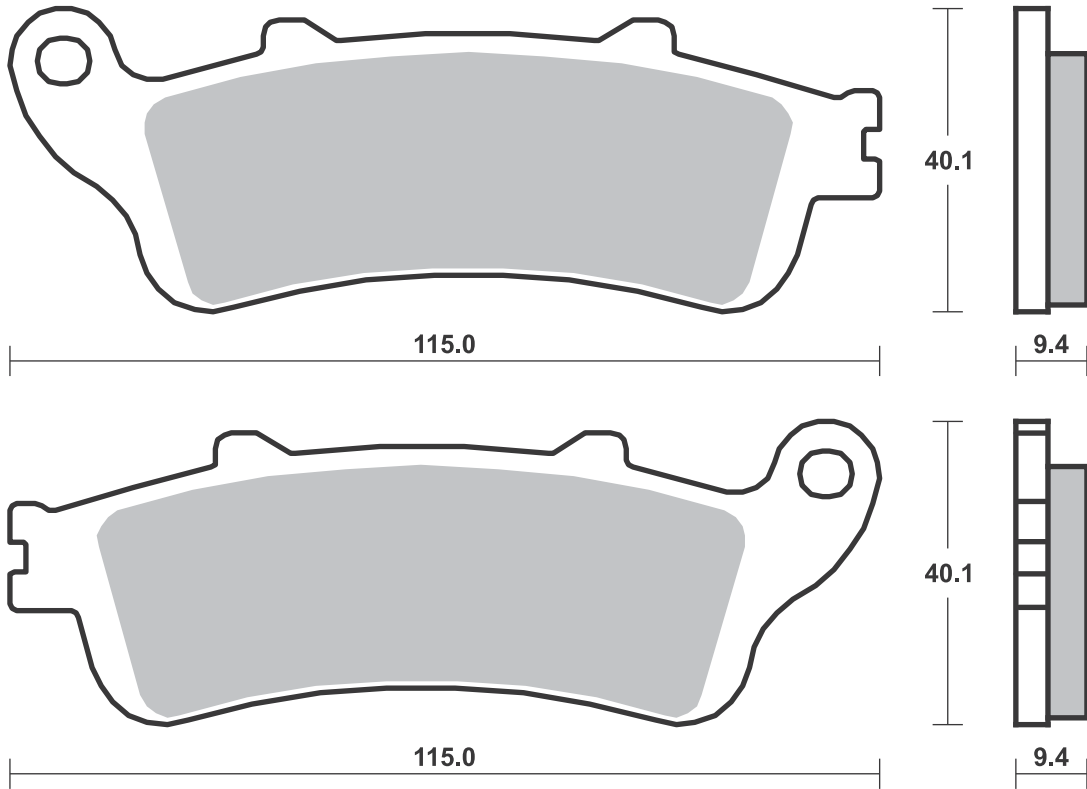





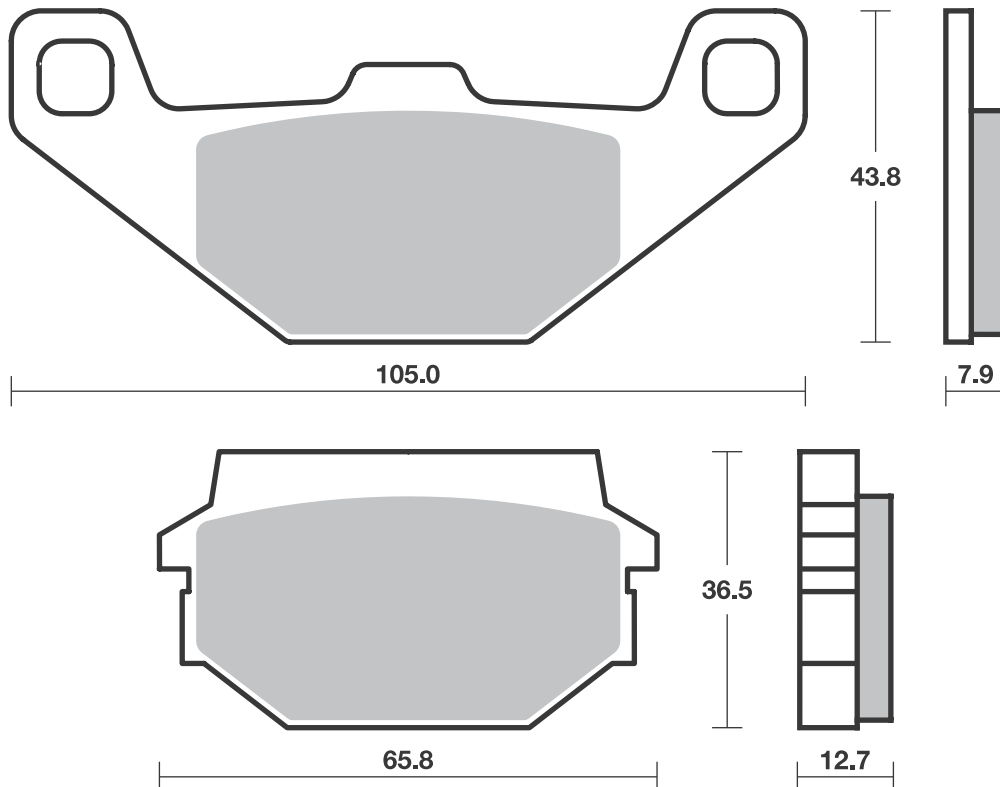
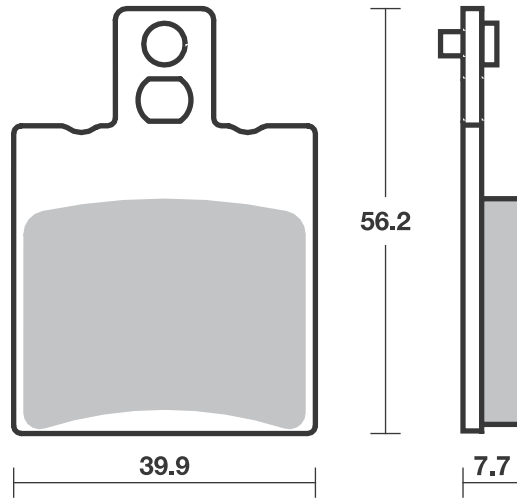



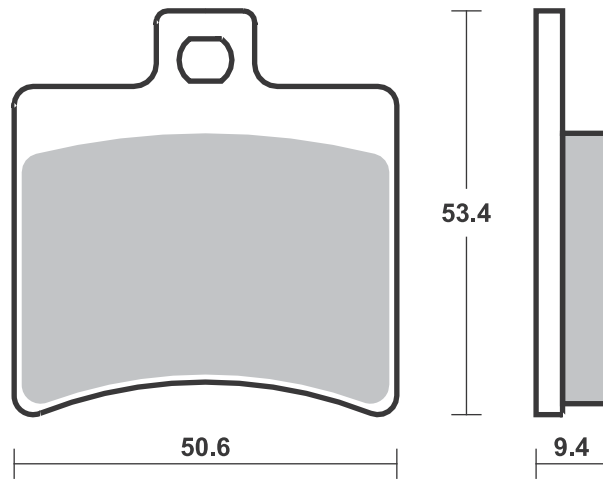
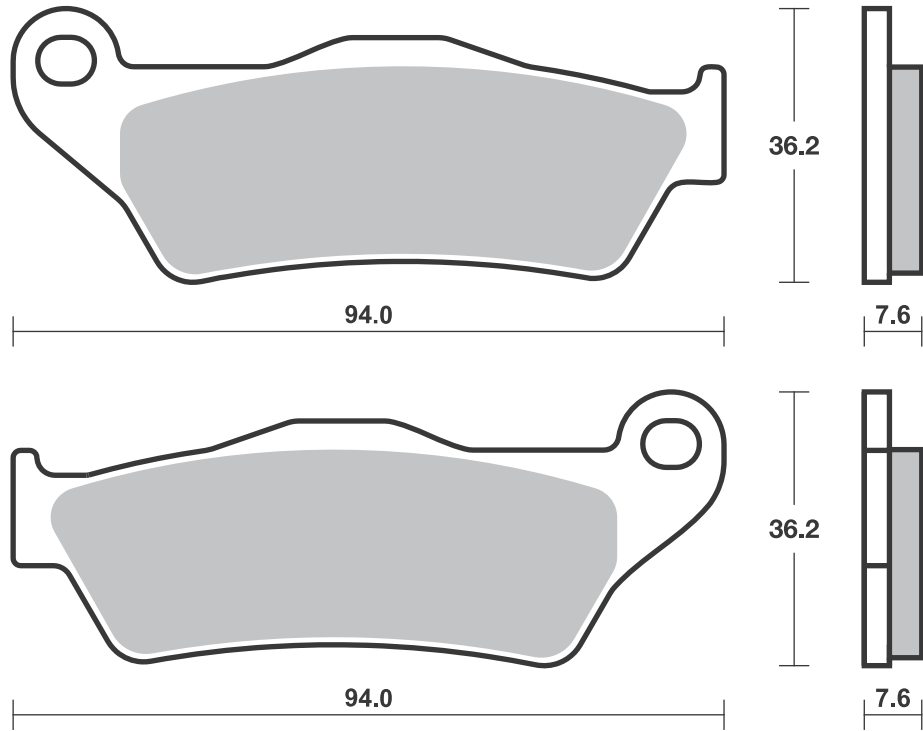



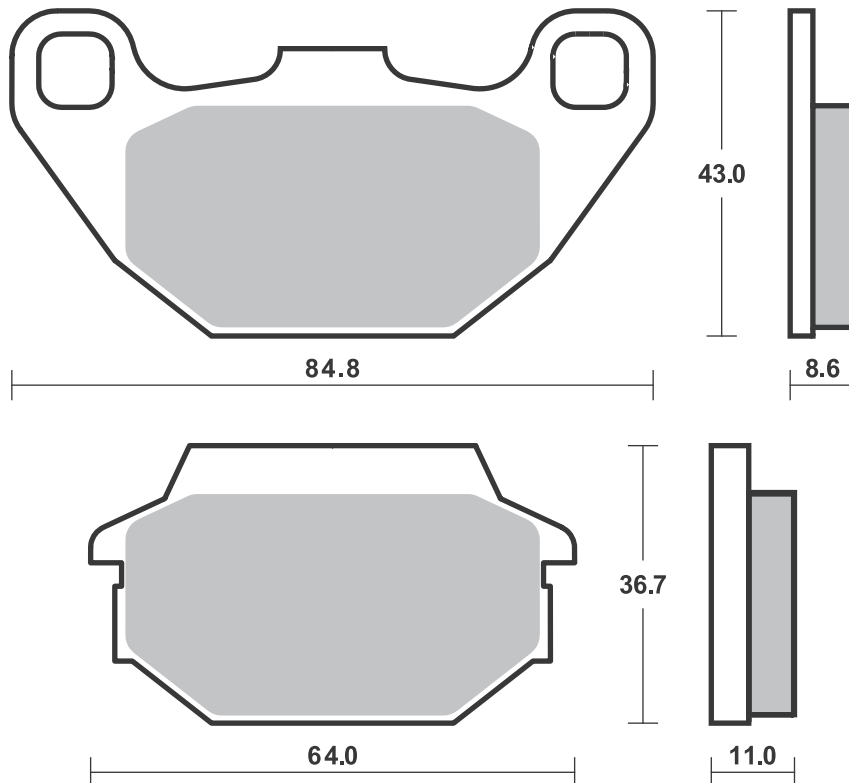
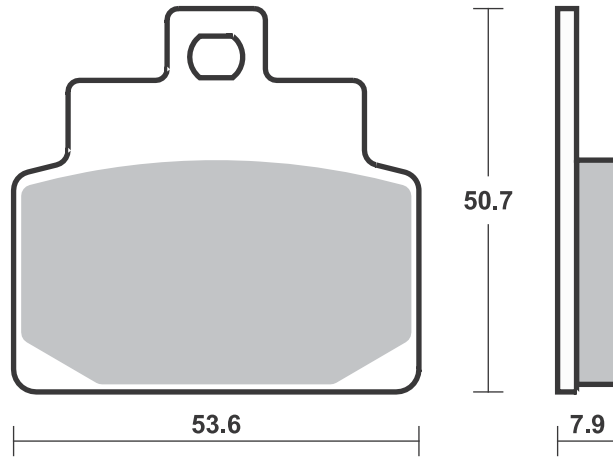



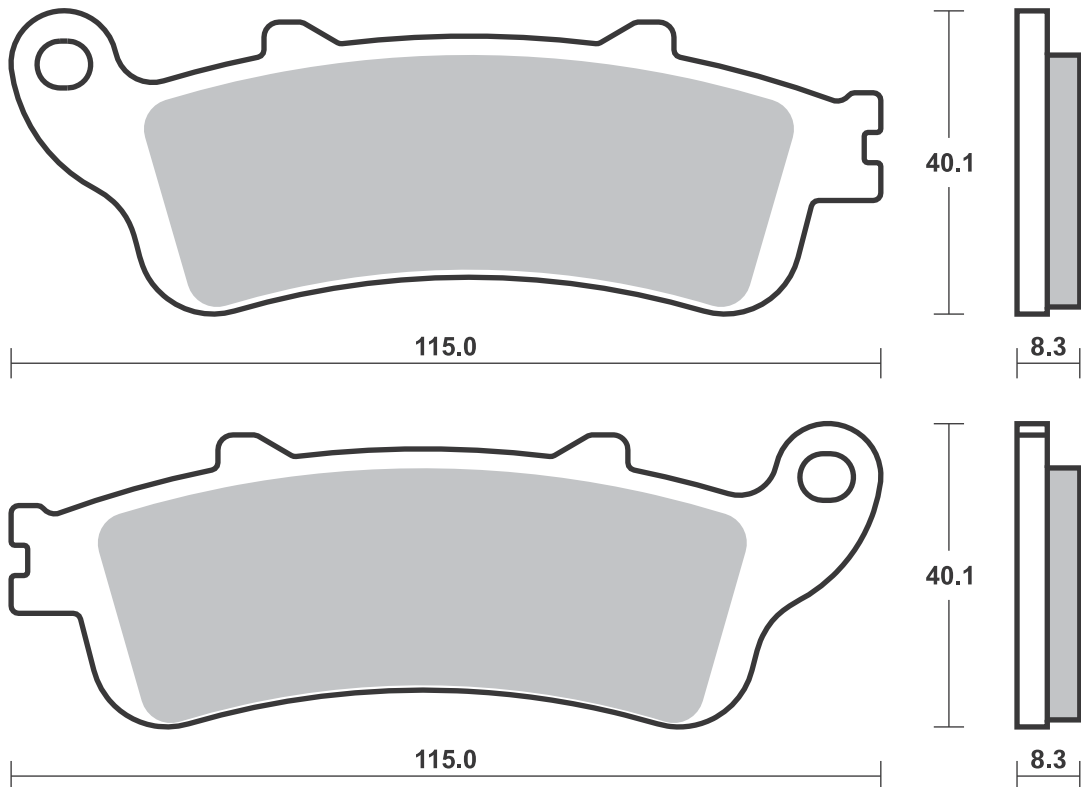
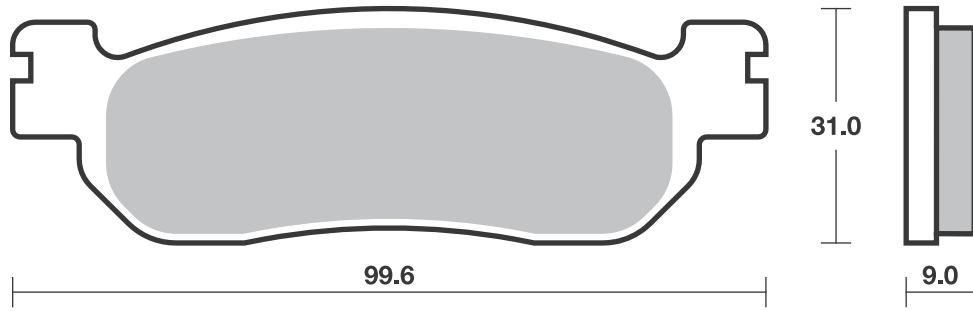





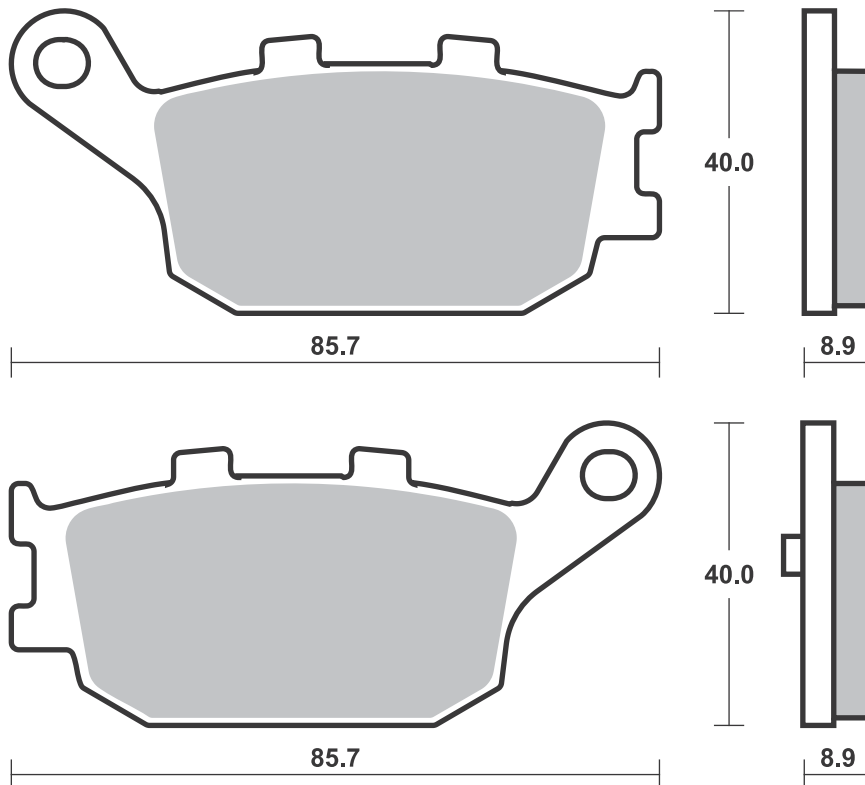
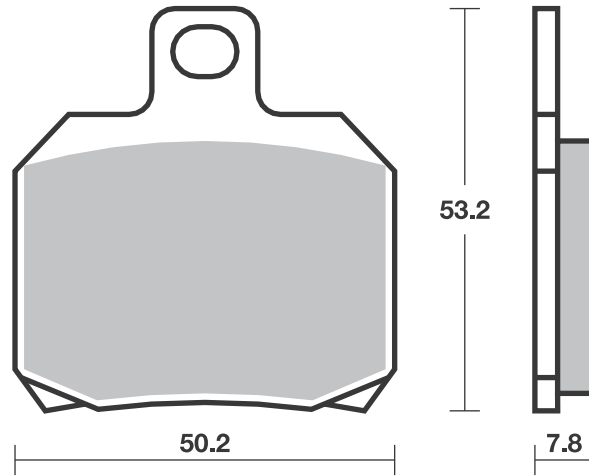



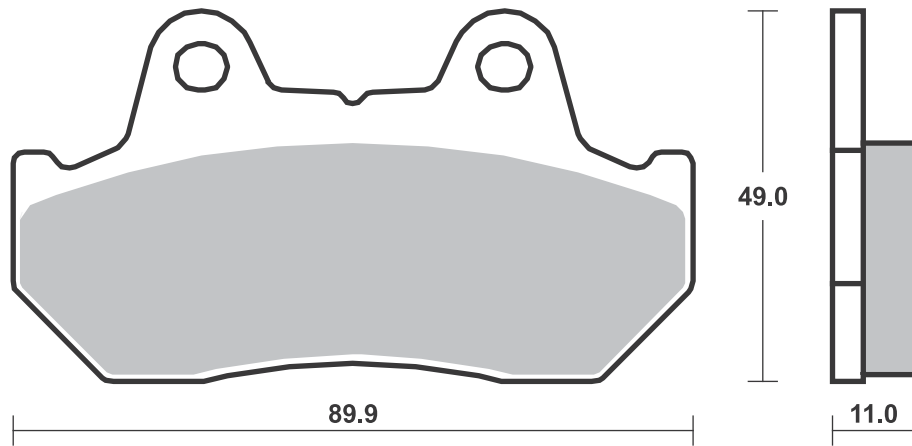
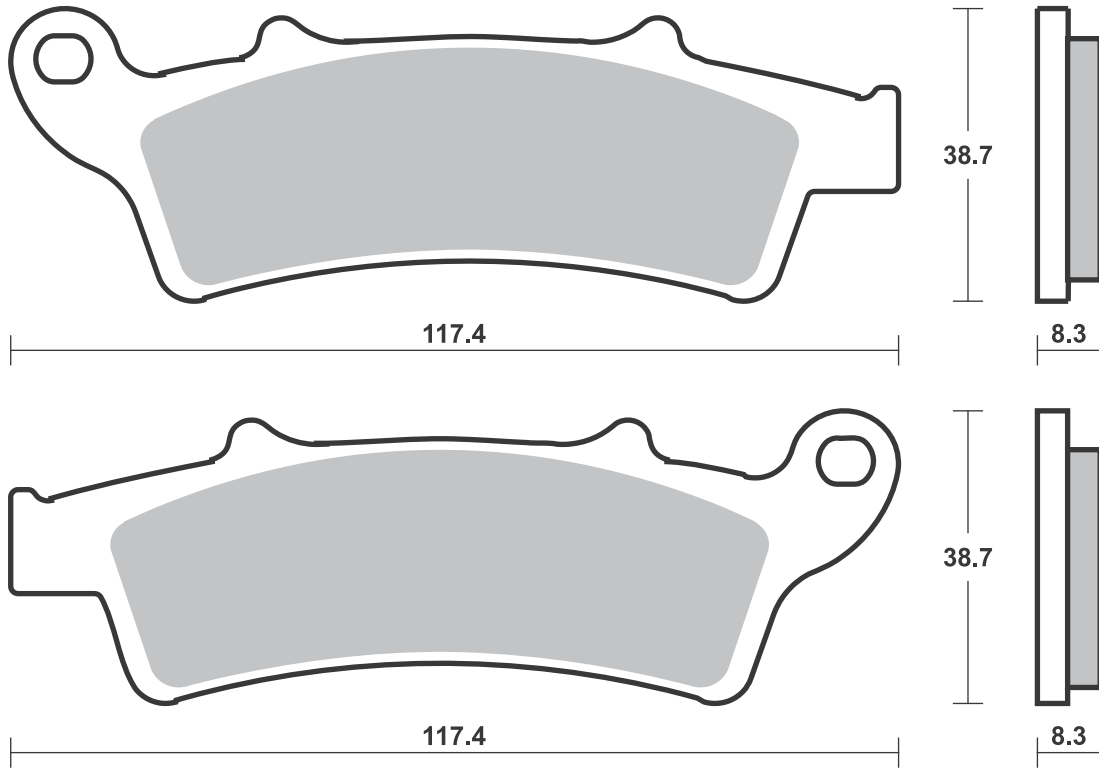



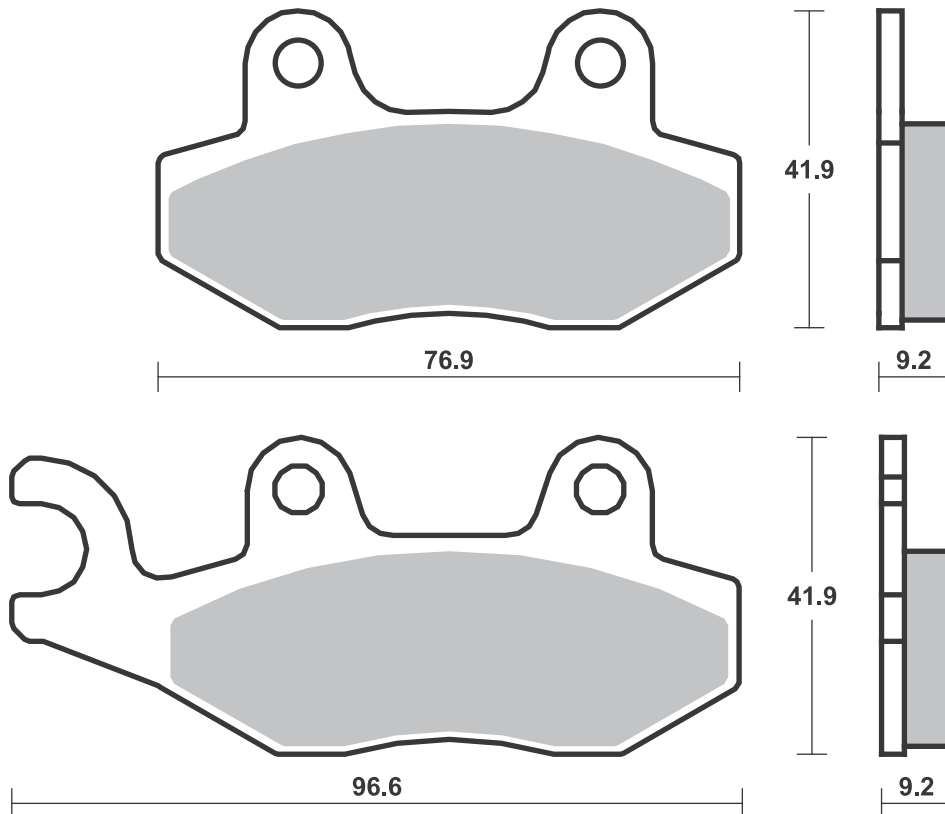
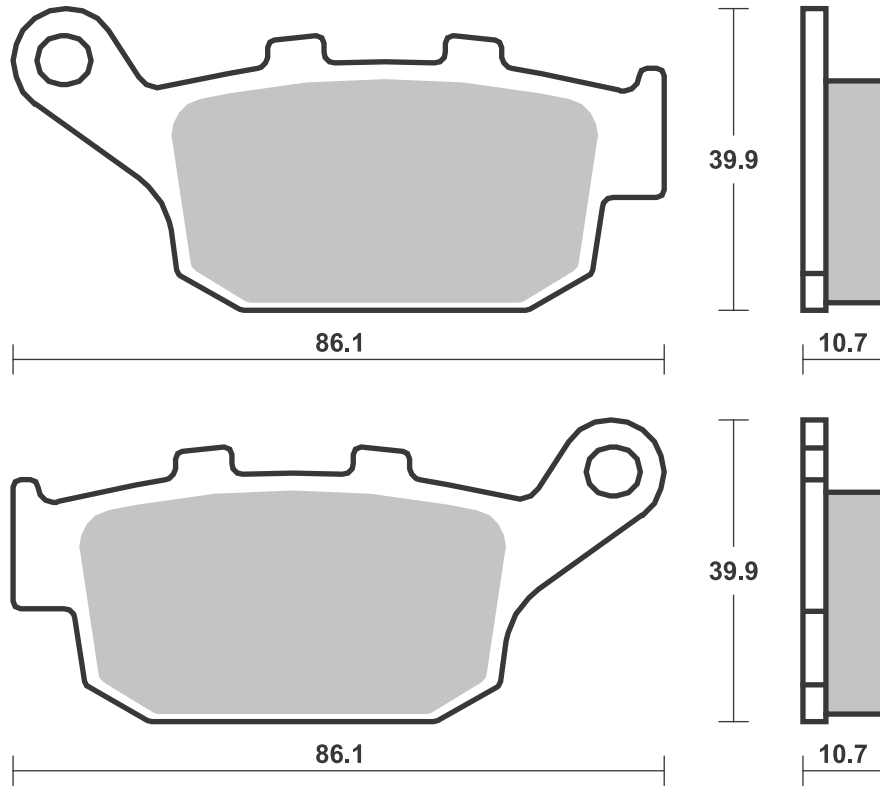



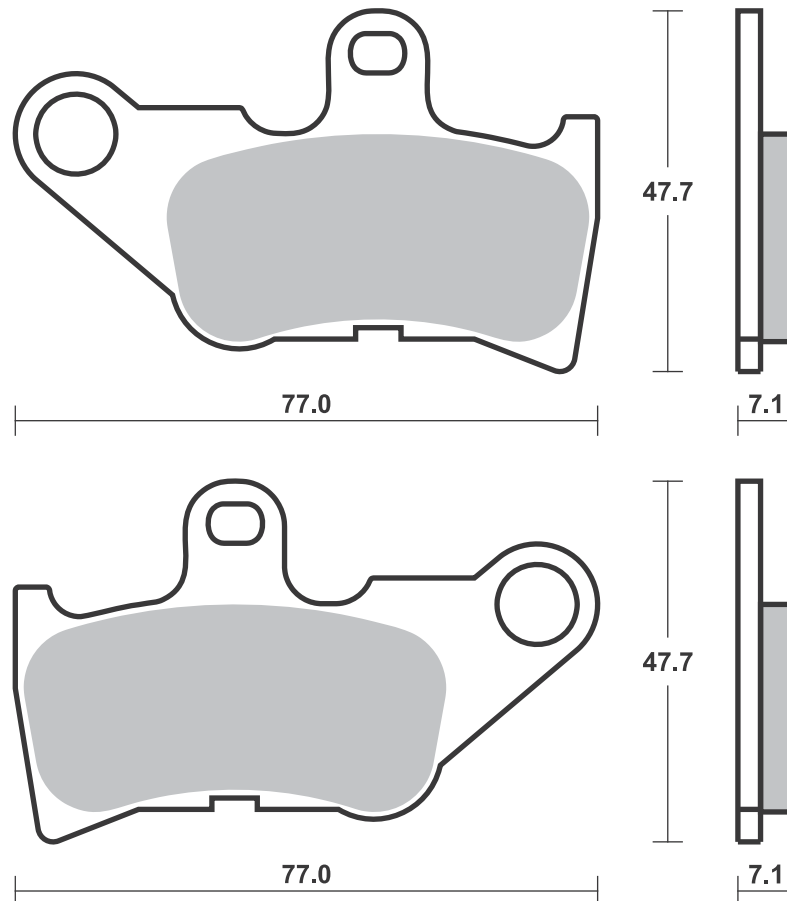
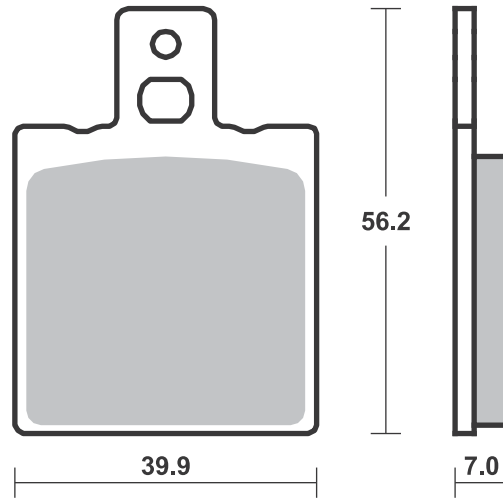

## Applications

### SBS 166 Recommended compound



| <b>BENELLI</b>       |  |       |           |
|----------------------|--|-------|-----------|
|                      | 125 Adiva  | 00-05 | <b>CT</b> |
|                      | 150 Adiva  | 00-05 | <b>CT</b> |
| <b>GILERA</b>        |  |       |           |
| ST                   | 125 Runner   | 08-11 | <b>CT</b> |
| VX                   | 125 Runner 4T<br>(Grimeca cal.)                    | 01-12 | <b>CT</b> |
| VX                   | 125 Runner 4T<br>(Hengtong cal.)                   | 01-12 | <b>CT</b> |
| VXR                  | 180 Runner 4T<br>(Grimeca cal.)                    | 01-08 | <b>CT</b> |
| VXR                  | 180 Runner 4T<br>(Hengtong cal.)                   | 01-08 | <b>CT</b> |
| ST                   | 200 Runner   | 08-11 | <b>CT</b> |
| VXR                  | 200 Runner 4T<br>(Grimeca cal.)                    | 01-09 | <b>CT</b> |
| VXR                  | 200 Runner 4T<br>(Hengtong cal.)                   | 01-09 | <b>CT</b> |
| <b>PIAGGIO VESPA</b> |  |       |           |
|                      | 125 946  | 14-16 | <b>CT</b> |
| GT                   | 125 L  | 04-09 | <b>CT</b> |
| GTS                  | 125  | 07-10 | <b>CT</b> |
| GTS                  | 125 Super  | 10-13 | <b>CT</b> |
| GTS                  | 125 Super i.e.                                     | 15-16 | <b>CT</b> |
| GTS                  | 125 Supersport                                     | 13    | <b>CT</b> |
| GTS                  | 125 Touring  | 18-   | <b>CT</b> |
| GTV                  | 125  | 08-09 | <b>CT</b> |
| GTX                  | 125 SuperHexagon<br>(Grimeca cal.)<br>(11" wheels) | 00    | <b>CT</b> |



| <b>PIAGGIO VESPA</b> |   |       |           |
|----------------------|---|-------|-----------|
| GTX                  | 125 SuperHexagon<br>(Hengtong cal.)<br>(11" wheels) | 00    | <b>CT</b> |
| GTX                  | 125 SuperHexagon<br>(Hengtong cal.)<br>(12" wheels) | 01-03 | <b>CT</b> |
| GTX                  | 180 SuperHexagon<br>(Grimeca cal.)<br>(11" wheels)  | 00    | <b>CT</b> |
| GTX                  | 180 SuperHexagon<br>(Hengtong cal.)<br>(11" wheels) | 00    | <b>CT</b> |
| GTX                  | 180 SuperHexagon<br>(Hengtong cal.)<br>(12" wheels) | 01-03 | <b>CT</b> |
| GT                   | 200 L   | 04-09 | <b>CT</b> |
|                      | 250 GT 60   | 06-07 | <b>MS</b> |
| GTS                  | 250 ABS   | 06-07 | <b>MS</b> |
| GTV                  | 250   | 08-10 | <b>MS</b> |
| GTX                  | 250 Super Hexagon                                   | 01-02 | <b>MS</b> |
|                      | 300 Sei Giorni                                      | 18-   | <b>MS</b> |
| GTS                  | 300 i.e.  | 12-15 | <b>MS</b> |
| GTS                  | 300 Super   | 09-12 | <b>MS</b> |
| GTS                  | 300 Super Sport i.e.                                | 11-15 | <b>MS</b> |
| GTS                  | 300 Touring ABS                                     | 17    | <b>MS</b> |
| GTS                  | 300 Touring i.e.                                    | 11-12 | <b>MS</b> |
| GTS                  | 300 Yacht Club                                      | 18-   | <b>MS</b> |
| GTV                  | 300 i.e.  | 11-15 | <b>MS</b> |

### SBS 167 Recommended compound



| <b>DERBI</b>   |                             |       |           |
|----------------|-----------------------------|-------|-----------|
|                | 50 Senda DRD Pro<br>SM      | 05-11 | <b>HF</b> |
|                | 125 Boulevard               | 03-07 | <b>CT</b> |
|                | 125 Senda Baja              | 06-12 | <b>CT</b> |
|                | 150 Boulevard               | 03-09 | <b>CT</b> |
| <b>ITALJET</b> |                             |       |           |
|                | 50 Jet-Set                  | 02-03 | <b>HF</b> |
|                | 100 Millennium 2T           | 01    | <b>HF</b> |
|                | 125 Jet-Set                 | 02-03 | <b>CT</b> |
|                | 125 Millennium              | 00-03 | <b>CT</b> |
|                | 150 Jet-Set                 | 02-03 | <b>CT</b> |
|                | 150 Millennium              | 00-03 | <b>CT</b> |
| <b>PEUGEOT</b> |                             |       |           |
|                | 50 Elystar                  | 03-05 | <b>HF</b> |
|                | 125 Elyseo                  | 00-07 | <b>CT</b> |
|                | 125 Elystar                 | 03-07 | <b>CT</b> |
|                | 125 Geopolis                | 06-09 | <b>CT</b> |
|                | 125 Jet-Force<br>Compressor | 03-04 | <b>CT</b> |
|                | 125 Looxor                  | 03-07 | <b>CT</b> |
|                | 125 Satelis                 | 04-16 | <b>CT</b> |
|                | 125 Satelis ABS             | 04-08 | <b>CT</b> |
| RS             | 125 Geopolis                | 10-13 | <b>CT</b> |
|                | 150 Elyseo                  | 00-04 | <b>CT</b> |
|                | 150 Elystar                 | 03-04 | <b>CT</b> |
|                | 400 Geopolis<br>(AJP cal.)  | 07-12 | <b>CT</b> |
|                | 600 Satelis ABS             | 04-12 | <b>CT</b> |



| <b>RIEJU</b>  |                  |       |           |
|---------------|------------------|-------|-----------|
| RS2           | 50 Matrix        | 03-09 | <b>HF</b> |
| <b>SHERCO</b> |                  |       |           |
| SE            | 50 Enduro        | 07    | <b>HF</b> |
| SM            | 50 Supermotard   | 07-13 | <b>HF</b> |
| <b>YAMAHA</b> |                  |       |           |
| DT            | 50 R             | 04-08 | <b>HF</b> |
| DT            | 50 X Supermotard | 04-08 | <b>HF</b> |



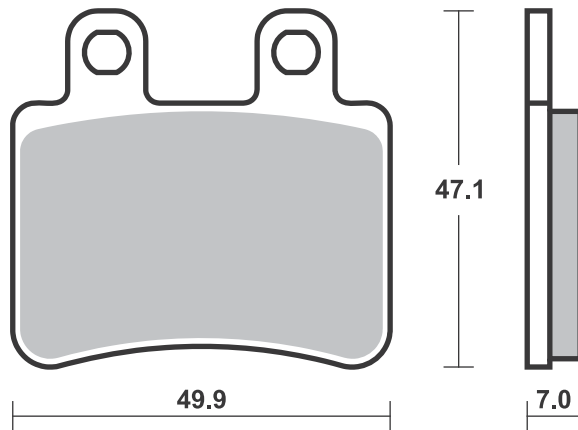
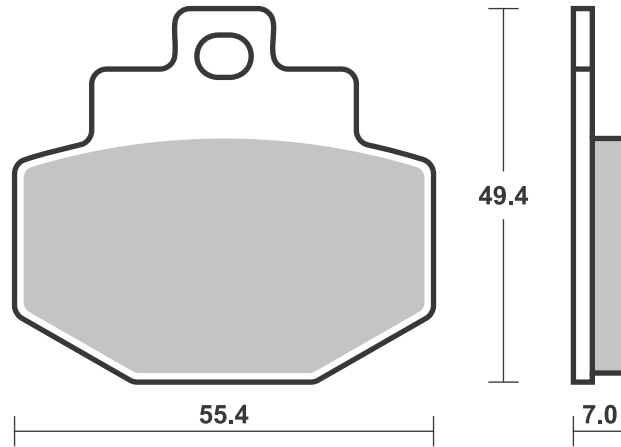

## Applications

### SBS 168 Recommended compound



|                |                              |       |    |
|----------------|------------------------------|-------|----|
| <b>APRILIA</b> |                              |       |    |
| 50             | Tuono                        | 04-07 | HF |
| <b>BETA</b>    |                              |       |    |
| RR             | 50 Enduro                    | 10-18 | HF |
| RR             | 50 Supermotard               | 08-13 | HF |
| <b>DERBI</b>   |                              |       |    |
|                | 50 Black Devil               | 04    | HF |
|                | 50 DRD Racing R              | 05-10 | HF |
|                | 50 DRD Racing R<br>Ltd.      | 05    | HF |
|                | 50 DRD Racing SM             | 05    | HF |
|                | 50 DRD Racing SM<br>Ltd.     | 05    | HF |
|                | 50 Senda SM DRD              |       |    |
|                | Black Edition                | 03-04 | HF |
|                | 125 Senda Baja               | 06-12 | HF |
| <b>FANTIC</b>  |                              |       |    |
|                | 50 Regolarna Casa            | 08-09 | HF |
|                | 50 Supersei Motard           | 08-09 | HF |
| <b>GAS GAS</b> |                              |       |    |
| EC             | 50 Rookie                    | 05    | HF |
| <b>GENERIC</b> |                              |       |    |
|                | 50 Toxic                     | 07-16 | HF |
|                | 50 Trigger SM                | 06-14 | HF |
|                | 50 Trigger SM<br>Competition | 08-14 | HF |
|                | 50 Trigger X                 | 06-14 | HF |



|                      |                             |       |    |
|----------------------|-----------------------------|-------|----|
| <b>GENERIC</b>       |                             |       |    |
|                      | 50 Trigger X<br>Competition | 08-12 | HF |
| <b>MALAGUTI</b>      |                             |       |    |
|                      | 50 Fifty                    | 04    | HF |
| NKD                  | 50                          | 04-09 | HF |
|                      | 125 Phantom Max             | 04-08 | CT |
|                      | 200 Phantom Max             | 04-05 | CT |
|                      | 250 Password                | 06-08 | CT |
|                      | 250 Phantom Max             | 05-08 | CT |
| RS                   | 250 Madison                 | 05-11 | CT |
| <b>MBK</b>           |                             |       |    |
|                      | 50 X-Power                  | 04-13 | HF |
| <b>MOTORHISPANIA</b> |                             |       |    |
| MH                   | 50 Urban Bike               | 06-10 | HF |
| <b>PEUGEOT</b>       |                             |       |    |
| XP S-6               | 50 Supermotard              | 04-05 | HF |
|                      | 125 Elyseo                  | 00-07 | CT |
|                      | 125 Elystar                 | 03-07 | CT |
|                      | 125 Jet-Force<br>Compressor | 03-04 | CT |
|                      | 125 Satelis                 | 06-16 | CT |
|                      | 150 Elyseo                  | 00-04 | CT |
|                      | 150 Elystar                 | 03-04 | CT |
|                      | 400 Geopolis<br>(AJP cal.)  | 07-12 | CT |



|                      |                  |       |    |
|----------------------|------------------|-------|----|
| <b>PIAGGIO VESPA</b> |                  |       |    |
| BV                   | 200              | 05    | CT |
| <b>SHERCO</b>        |                  |       |    |
| SE                   | 50 Enduro        | 07    | HF |
| SM                   | 50 Supermotard   | 07-13 | HF |
| <b>YAMAHA</b>        |                  |       |    |
| DT                   | 50 X Supermotard | 04-08 | HF |
| TZR                  | 50               | 03-04 | HF |

### SBS 169 Recommended compound



|               |                   |       |    |
|---------------|-------------------|-------|----|
| <b>YAMAHA</b> |                   |       |    |
| XP            | 500 TMAX          | 01-03 | MS |
| XP            | 530 TMAX          | 12-18 | MS |
| XP            | 530 TMAX DX       | 17-18 | MS |
| XP            | 530 TMAX Iron Max | 15-18 | MS |
| XP            | 530 TMAX SX       | 17-18 | MS |

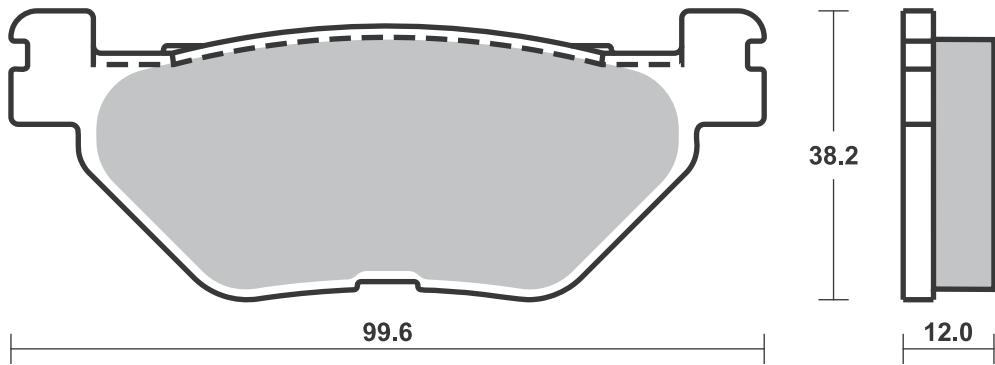
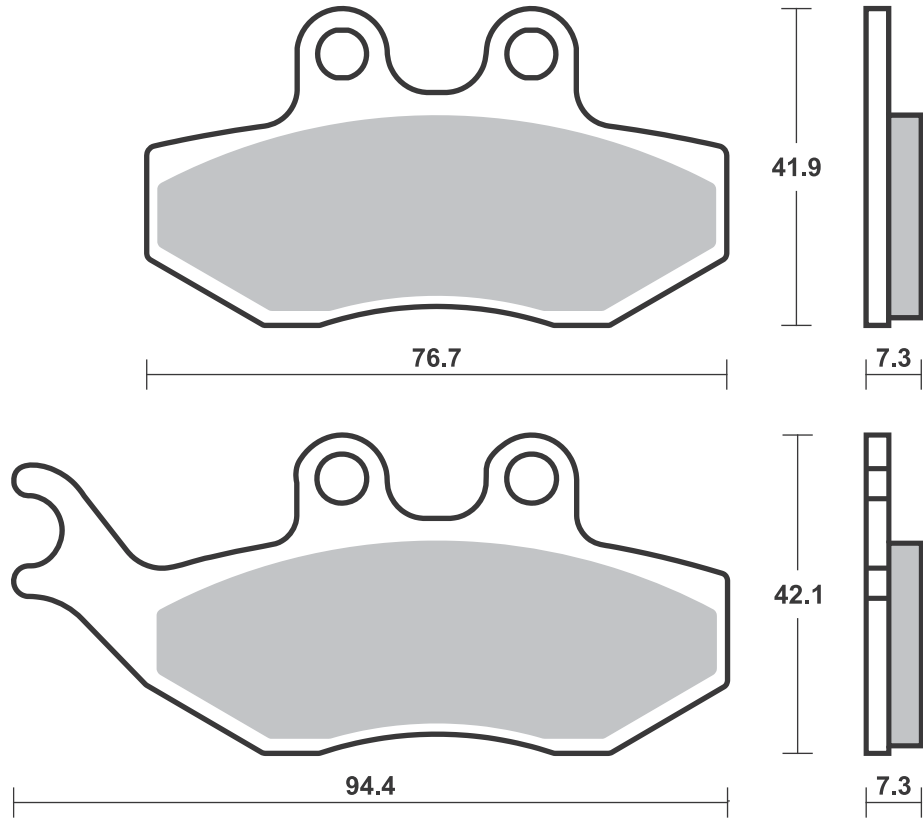

**SBS 170** Recommended compound



| <b>YAMAHA</b> |             |       |           |
|---------------|-------------|-------|-----------|
| YP            | 400 Majesty | 04    | <b>MS</b> |
| XP            | 500 TMAX    | 01-03 | <b>MS</b> |
|               |             |       |           |
|               |             |       |           |
|               |             |       |           |
|               |             |       |           |
|               |             |       |           |
|               |             |       |           |
|               |             |       |           |
|               |             |       |           |
|               |             |       |           |
|               |             |       |           |
|               |             |       |           |
|               |             |       |           |
|               |             |       |           |
|               |             |       |           |
|               |             |       |           |
|               |             |       |           |
|               |             |       |           |
|               |             |       |           |
|               |             |       |           |

**SBS 171** Recommended compound



| <b>KYMCO</b> |                |       |           |
|--------------|----------------|-------|-----------|
|              | 250 Grand Dink | 01-10 | <b>MS</b> |
| <b>SYM</b>   |                |       |           |
|              | 125 Voyager    | 05    | <b>CT</b> |
| RV           | 250 Efi        | 10    | <b>MS</b> |
|              | 250 Joymax     | 07-10 | <b>MS</b> |
|              | 250 Voyager    | 05    | <b>MS</b> |
| GTS          | 300            | 09-13 | <b>MS</b> |
|              |                |       |           |
|              |                |       |           |
|              |                |       |           |
|              |                |       |           |
|              |                |       |           |
|              |                |       |           |
|              |                |       |           |
|              |                |       |           |
|              |                |       |           |
|              |                |       |           |
|              |                |       |           |
|              |                |       |           |
|              |                |       |           |
|              |                |       |           |
|              |                |       |           |
|              |                |       |           |
|              |                |       |           |
|              |                |       |           |

**SBS 172** Recommended compound



| <b>KYMCO</b> |                |       |           |
|--------------|----------------|-------|-----------|
|              | 250 Grand Dink | 01-10 | <b>MS</b> |
|              |                |       |           |
|              |                |       |           |
|              |                |       |           |
|              |                |       |           |
|              |                |       |           |
|              |                |       |           |
|              |                |       |           |
|              |                |       |           |
|              |                |       |           |
|              |                |       |           |
|              |                |       |           |
|              |                |       |           |
|              |                |       |           |
|              |                |       |           |
|              |                |       |           |
|              |                |       |           |
|              |                |       |           |
|              |                |       |           |
|              |                |       |           |
|              |                |       |           |
|              |                |       |           |

Brake Pad 1:1 Drawings, Compounds, Fitments

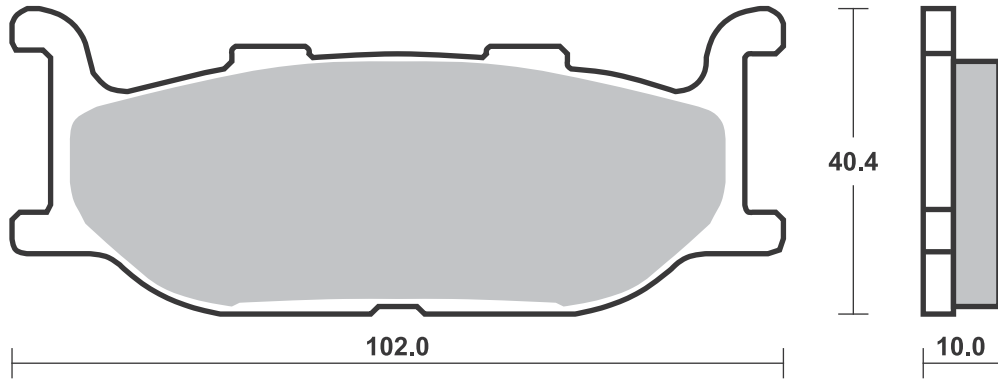

1 set = 4 pcs.

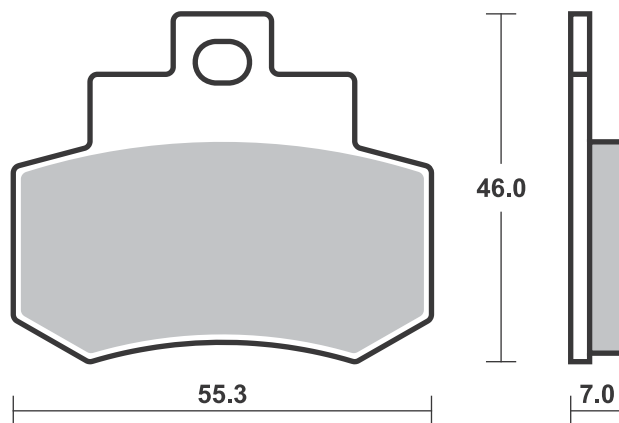
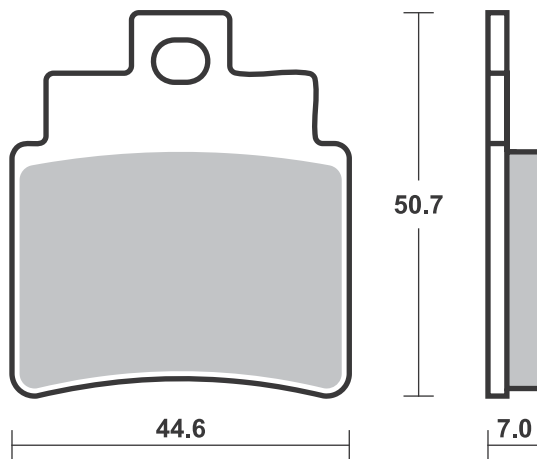

**SBS 173** Recommended compound



| <b>ITALJET</b> |             |       |           |
|----------------|-------------|-------|-----------|
|                | 250 Jupiter | 01-03 | <b>CT</b> |
| <b>KEEWAY</b>  |             |       |           |
| <b>TX</b>      | 50 SM       | 10-12 | <b>HF</b> |
| <b>RIEJU</b>   |             |       |           |
| <b>NKD</b>     | 50          | 04-07 | <b>HF</b> |
| <b>RS2</b>     | 50 Matrix   | 03-09 | <b>HF</b> |
| <b>RS3</b>     | 50          | 12-17 | <b>HF</b> |
|                |             |       |           |
|                |             |       |           |
|                |             |       |           |
|                |             |       |           |
|                |             |       |           |
|                |             |       |           |
|                |             |       |           |
|                |             |       |           |
|                |             |       |           |
|                |             |       |           |
|                |             |       |           |
|                |             |       |           |
|                |             |       |           |
|                |             |       |           |
|                |             |       |           |
|                |             |       |           |
|                |             |       |           |
|                |             |       |           |
|                |             |       |           |
|                |             |       |           |
|                |             |       |           |

**SBS 174** Recommended compound



| <b>KAWASAKI</b> |             |       |           |
|-----------------|-------------|-------|-----------|
| <b>SC</b>       | 250 Epsilon | 02-06 | <b>MS</b> |
| <b>SUZUKI</b>   |             |       |           |
| <b>AN</b>       | 250 Burgman | 04-06 | <b>MS</b> |
| <b>AN</b>       | 400 Burgman | 01-06 | <b>MS</b> |
|                 |             |       |           |
|                 |             |       |           |
|                 |             |       |           |
|                 |             |       |           |
|                 |             |       |           |
|                 |             |       |           |
|                 |             |       |           |
|                 |             |       |           |
|                 |             |       |           |
|                 |             |       |           |
|                 |             |       |           |
|                 |             |       |           |
|                 |             |       |           |
|                 |             |       |           |
|                 |             |       |           |
|                 |             |       |           |
|                 |             |       |           |
|                 |             |       |           |
|                 |             |       |           |
|                 |             |       |           |
|                 |             |       |           |

Brake Pad 1:1 Drawings, Compounds, Fitments

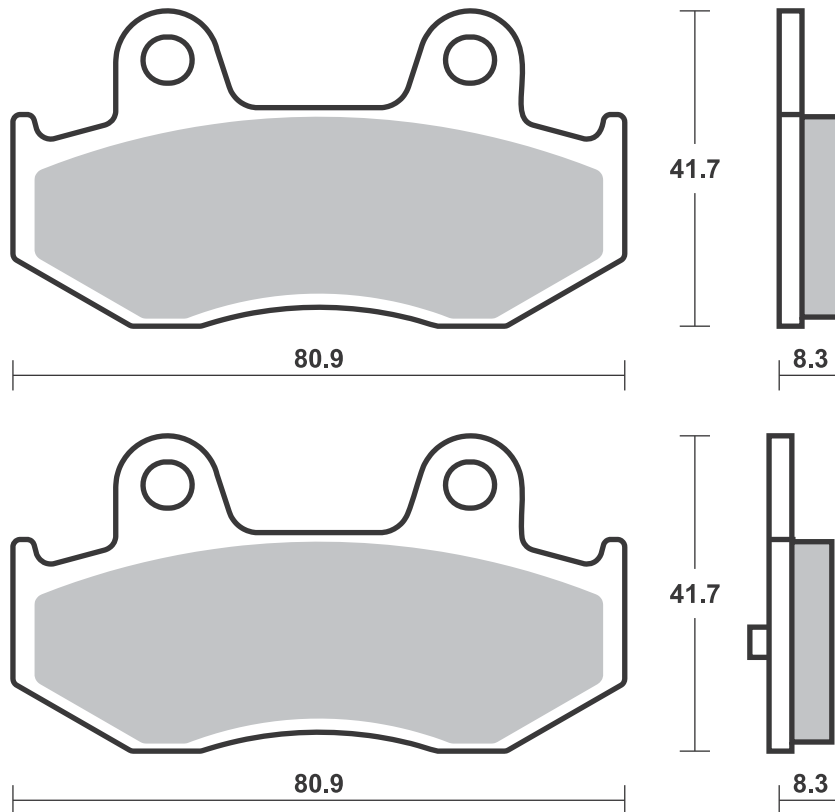
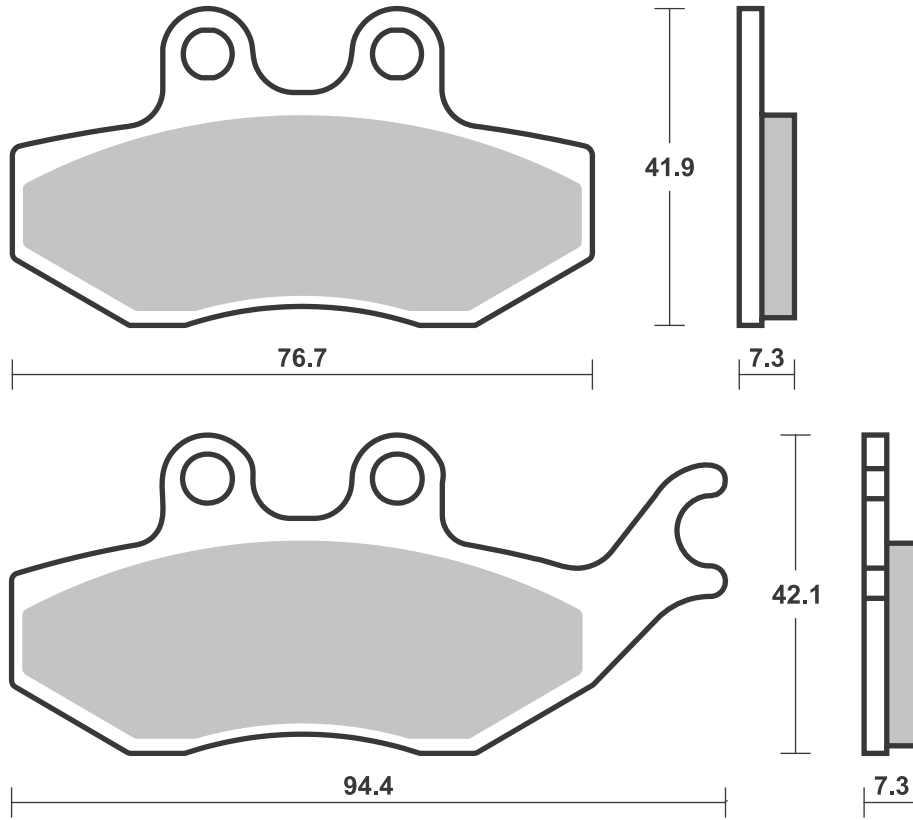

**SBS 175 Recommended compound**



| BMW     |       |           |
|---------|-------|-----------|
| 125 C1  | 00-03 | <b>CT</b> |
| 200 C1  | 02-04 | <b>CT</b> |
| C 400 X | 18-   | <b>MS</b> |
|         |       |           |
|         |       |           |
|         |       |           |
|         |       |           |
|         |       |           |
|         |       |           |
|         |       |           |
|         |       |           |
|         |       |           |
|         |       |           |
|         |       |           |
|         |       |           |
|         |       |           |
|         |       |           |
|         |       |           |
|         |       |           |
|         |       |           |
|         |       |           |
|         |       |           |
|         |       |           |
|         |       |           |
|         |       |           |
|         |       |           |
|         |       |           |
|         |       |           |
|         |       |           |
|         |       |           |
|         |       |           |
|         |       |           |
|         |       |           |
|         |       |           |

**SBS 176 Recommended compound**



| BMW              |       |           |
|------------------|-------|-----------|
| 125 C1           | 00-03 | <b>CT</b> |
| 200 C1           | 02-04 | <b>CT</b> |
| MALAGUTI         |       |           |
| 125 Madison 3    | 08-09 | <b>CT</b> |
| 250 Madison 3 ie | 08-11 | <b>CT</b> |
|                  |       |           |
|                  |       |           |
|                  |       |           |
|                  |       |           |
|                  |       |           |
|                  |       |           |
|                  |       |           |
|                  |       |           |
|                  |       |           |
|                  |       |           |
|                  |       |           |
|                  |       |           |
|                  |       |           |
|                  |       |           |
|                  |       |           |
|                  |       |           |
|                  |       |           |
|                  |       |           |
|                  |       |           |
|                  |       |           |
|                  |       |           |
|                  |       |           |
|                  |       |           |
|                  |       |           |
|                  |       |           |
|                  |       |           |
|                  |       |           |
|                  |       |           |
|                  |       |           |
|                  |       |           |
|                  |       |           |
|                  |       |           |
|                  |       |           |
|                  |       |           |
|                  |       |           |
|                  |       |           |
|                  |       |           |
|                  |       |           |
|                  |       |           |
|                  |       |           |
|                  |       |           |
|                  |       |           |
|                  |       |           |
|                  |       |           |

Brake Pad 1:1 Drawings, Compounds, Fitments



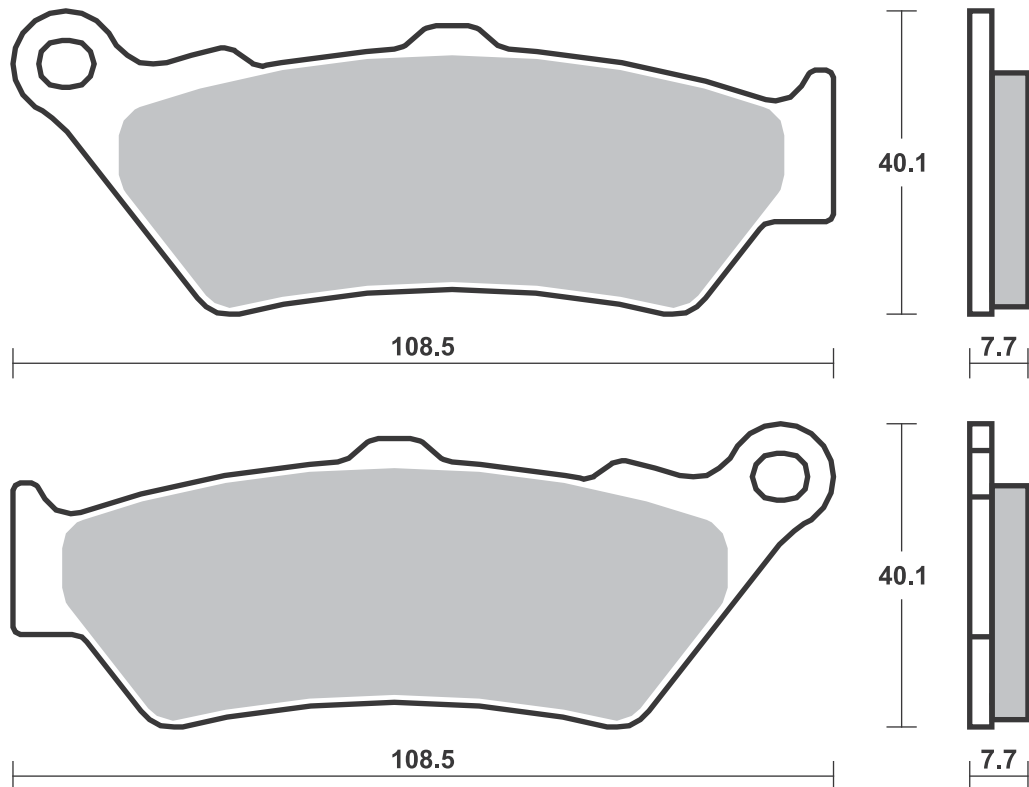
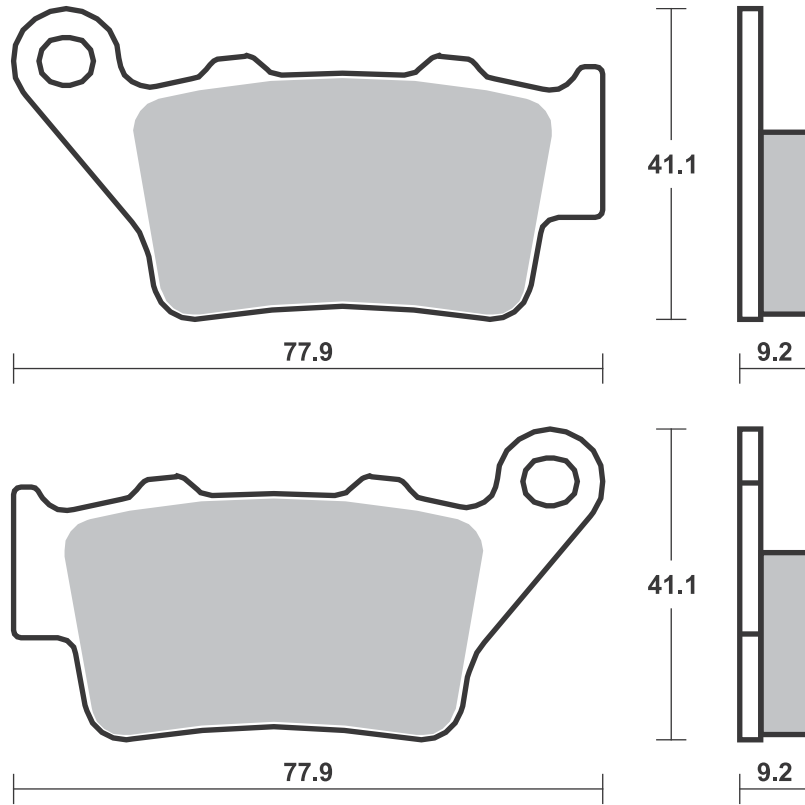

## Applications

### SBS 177 Recommended compound



| <b>APRILIA</b>       |                                  |       |              |
|----------------------|----------------------------------|-------|--------------|
|                      | 50 Sport City One                | 08-12 | <b>HF</b>    |
| SR                   | 125 Max                          | 12-17 | <b>CT CT</b> |
| SR                   | 125 Sport City One               | 12    | <b>CT</b>    |
| SR                   | 300 Max                          | 12-18 | <b>MS MS</b> |
| SRV                  | 850                              | 12-18 | <b>MS</b>    |
| <b>DERBI</b>         |                                  |       |              |
|                      | 50 Boulevard                     | 09-13 | <b>HF</b>    |
| <b>GILERA</b>        |                                  |       |              |
|                      | 50 Runner PJ                     | 06-11 | <b>HF</b>    |
|                      | 50 Runner SP                     | 06-12 | <b>HF</b>    |
|                      | 125 Nexus                        | 07-12 | <b>CT CT</b> |
| FX                   | 125 Runner<br>(Hengtong cal.)    | 00-05 | <b>CT</b>    |
| FX                   | 125 Runner SP<br>(Hengtong cal.) | 00-03 | <b>CT</b>    |
| ST                   | 125 Runner                       | 08-13 | <b>CT</b>    |
| VX                   | 125 Runner 4T<br>(Hengtong cal.) | 01-12 | <b>CT</b>    |
| FXR                  | 180 Runner<br>(Hengtong cal.)    | 00-03 | <b>CT</b>    |
| FXR                  | 180 Runner SP<br>(Hengtong cal.) | 00    | <b>CT</b>    |
| VXR                  | 180 Runner                       | 01-08 | <b>CT</b>    |
| VXR                  | 180 Runner 4T<br>(Hengtong cal.) | 01-08 | <b>CT</b>    |
| ST                   | 200 Runner                       | 08-11 | <b>CT</b>    |
| VXR                  | 200 Runner 4T<br>(Hengtong cal.) | 01-09 | <b>CT</b>    |
|                      | 250 Nexus                        | 07-08 | <b>MS MS</b> |
| GP                   | 800                              | 08-15 | <b>MS</b>    |
| <b>PEUGEOT</b>       |                                  |       |              |
|                      | 50 CityStar                      | 14-16 | <b>HF</b>    |
|                      | 125 Active                       | 13    | <b>CT</b>    |
|                      | 125 CityStar                     | 11-15 | <b>CT</b>    |
|                      | 125 Geopolis                     | 06-09 | <b>CT</b>    |
| RS                   | 125 Geopolis                     | 10-13 | <b>CT</b>    |
|                      | 200 CityStar                     | 13-16 | <b>CT</b>    |
|                      | 250 Geopolis                     | 06-11 | <b>MS MS</b> |
|                      | 250 Satelis                      | 06-11 | <b>MS MS</b> |
| <b>PIAGGIO VESPA</b> |                                  |       |              |
|                      | 50 Fly                           | 05-17 | <b>HF</b>    |
|                      | 50 Primavera                     | 14-17 | <b>HF</b>    |
|                      | 50 Sprint                        | 15-17 | <b>HF</b>    |
| TPH                  | 50 2T                            | 11-17 | <b>HF</b>    |
|                      | 100 Fly                          | 07-15 | <b>HF</b>    |



| <b>PIAGGIO VESPA</b> |   |       |              |
|----------------------|---|-------|--------------|
|                      | 100 Zip   | 07-10 | <b>HF</b>    |
|                      | 125 946   | 14-16 | <b>CT</b>    |
|                      | 125 Beverly   | 02-09 | <b>CT CT</b> |
|                      | 125 Carnaby   | 08-11 | <b>CT CT</b> |
|                      | 125 Fly   | 05-13 | <b>CT</b>    |
|                      | 125 Primavera                                       | 14-16 | <b>CT</b>    |
|                      | 125 Primavera 70                                    | 16    | <b>CT</b>    |
|                      | 125 Sprint  | 16-17 | <b>CT</b>    |
|                      | 125 Sprint S  | 17    | <b>CT</b>    |
|                      | 125 Sprint Sport                                    | 17    | <b>CT</b>    |
|                      | 125 X10 Executive<br>Left/Rear                      | 13-15 | <b>MS</b>    |
|                      | 125 X7  | 08-12 | <b>CT</b>    |
|                      | 125 X8  | 04-10 | <b>CT</b>    |
|                      | 125 X9 Evolution<br>Left/Rear                       | 06-11 | <b>CT</b>    |
|                      | 125 X9 Left/Rear                                    | 04-11 | <b>CT</b>    |
|                      | 125 Xevo  | 08-13 | <b>CT</b>    |
| GT                   | 125 L   | 04-09 | <b>CT</b>    |
| GTS                  | 125   | 07-10 | <b>CT</b>    |
| GTS                  | 125 Super   | 10-13 | <b>CT</b>    |
| GTS                  | 125 Super i.e.                                      | 15-16 | <b>CT</b>    |
| GTS                  | 125 Supersport                                      | 13    | <b>CT</b>    |
| GTS                  | 125 Touring   | 18-   | <b>CT</b>    |
| GTV                  | 125   | 08-09 | <b>CT</b>    |
| GTX                  | 125 SuperHexagon<br>(Hengtong cal.)<br>(11" wheels) | 00    | <b>CT</b>    |
| GTX                  | 125 SuperHexagon<br>(Hengtong cal.)<br>(12" wheels) | 01-03 | <b>CT</b>    |
|                      | 150 Fly   | 06-07 | <b>CT</b>    |
|                      | 150 Primavera                                       | 14-17 | <b>CT</b>    |
|                      | 150 X8 Street                                       | 06-08 | <b>CT</b>    |
| GTX                  | 180 SuperHexagon<br>(Hengtong cal.)<br>(11" wheels) | 00    | <b>CT</b>    |
| GTX                  | 180 SuperHexagon<br>(Hengtong cal.)<br>(12" wheels) | 01-03 | <b>CT</b>    |
|                      | 200 Beverly   | 02-03 | <b>CT CT</b> |
|                      | 200 Carnaby   | 08-12 | <b>CT CT</b> |
|                      | 200 X8  | 04-05 | <b>CT</b>    |
| BV                   | 200   | 02-04 | <b>CT CT</b> |
| BV                   | 200   | 05    | <b>CT</b>    |
| GT                   | 200 L   | 04-09 | <b>CT</b>    |
|                      | 250 Beverly   | 07-08 | <b>MS MS</b> |
|                      | 250 GT 60   | 06-07 | <b>MS</b>    |
|                      | 250 X7  | 08-09 | <b>MS</b>    |



| <b>PIAGGIO VESPA</b> |                                     |       |              |
|----------------------|-------------------------------------|-------|--------------|
|                      | 250 X8                              | 06-09 | <b>MS</b>    |
|                      | 250 X9 Left/Rear                    | 05-10 | <b>MS</b>    |
|                      | 250 Xevo                            | 08-11 | <b>MS</b>    |
| BV                   | 250                                 | 06    | <b>MS MS</b> |
| GTS                  | 250 ABS                             | 06-07 | <b>MS</b>    |
| GTV                  | 250                                 | 08-10 | <b>MS</b>    |
|                      | 300 Beverly i.e.                    | 11-18 | <b>MS</b>    |
|                      | 300 Beverly Tourer                  | 07-08 | <b>MS MS</b> |
|                      | 300 Carnaby Cruiser                 | 10-13 | <b>MS MS</b> |
|                      | 300 Sei Giorni                      | 18-   | <b>MS</b>    |
|                      | 300 X7 Evo i.e.                     | 11-13 | <b>MS</b>    |
| GTS                  | 300 i.e.                            | 12-15 | <b>MS</b>    |
| GTS                  | 300 Super                           | 09-12 | <b>MS</b>    |
| GTS                  | 300 Super Sport i.e.                | 11-15 | <b>MS</b>    |
| GTS                  | 300 Touring ABS                     | 17    | <b>MS</b>    |
| GTS                  | 300 Touring i.e.                    | 11-12 | <b>MS</b>    |
| GTS                  | 300 Yacht Club                      | 18-   | <b>MS</b>    |
| GTV                  | 300 i.e.                            | 11-15 | <b>MS</b>    |
|                      | 350 Beverly S                       | 14-18 | <b>MS</b>    |
|                      | 350 Beverly Sport<br>Touring ie ABS | 12-18 | <b>MS</b>    |
|                      | 350 X10 Executive<br>Left/Rear      | 13-16 | <b>MS</b>    |
| BV                   | 350                                 | 12-17 | <b>MS</b>    |
|                      | 400 MP3 iE                          | 07-10 | <b>MS</b>    |
|                      | 400 MP3 LT iE                       | 09-10 | <b>MS</b>    |
|                      | 400 MP3 LT Touring                  | 11-12 | <b>MS</b>    |
|                      | 400 MP3 Touring                     | 11-12 | <b>MS</b>    |
|                      | 400 X8 Left/Rear                    | 07-08 | <b>MS MS</b> |
|                      | 400 Xevo Left/Rear                  | 08-11 | <b>MS MS</b> |
|                      | 500 MP3                             | 10    | <b>MS</b>    |
|                      | 500 MP3 LT Touring<br>Business      | 11-13 | <b>MS</b>    |
|                      | 500 MP3 LT Touring<br>Business ABS  | 14-15 | <b>MS</b>    |
|                      | 500 MP3 LT Touring<br>Sport         | 11-13 | <b>MS</b>    |
|                      | 500 MP3 LT Touring<br>Sport ABS     | 14-15 | <b>MS</b>    |
|                      | 500 MP3 Touring<br>Business         | 11-12 | <b>MS</b>    |
|                      | 500 MP3 Touring<br>Sport            | 11-12 | <b>MS</b>    |
|                      | 500 X10 Executive<br>Left/Rear      | 13-15 | <b>MS</b>    |

### SBS 178 Recommended compound



| <b>LAVERDA</b> |                 |       |           |
|----------------|-----------------|-------|-----------|
|                | 125 Phoenix     | 01-04 | <b>CT</b> |
|                | 150 Phoenix     | 01-04 | <b>CT</b> |
|                | 200 Phoenix     | 01-04 | <b>CT</b> |
| <b>SYM</b>     |                 |       |           |
| RS             | 50              | 05-09 | <b>HF</b> |
| RS21           | 50              | 02-09 | <b>HF</b> |
|                | 125 Euro MX     | 03-04 | <b>CT</b> |
|                | 125 Joyride     | 01-09 | <b>CT</b> |
|                | 125 Joyride Evo | 10-12 | <b>CT</b> |
|                | 125 Joyride S   | 16-17 | <b>CT</b> |
| RS             | 125             | 05-06 | <b>CT</b> |
| RS21           | 125 , R         | 02    | <b>CT</b> |



| <b>SYM</b> |               |       |           |
|------------|---------------|-------|-----------|
| VS         | 125           | 09-13 | <b>CT</b> |
|            | 150 Euro MX   | 03-06 | <b>CT</b> |
|            | 150 Joyride   | 01-06 | <b>CT</b> |
| RS         | 150           | 05-06 | <b>CT</b> |
|            | 200 Joyride   | 01-08 | <b>CT</b> |
|            | 200 Joyride S | 16-17 | <b>CT</b> |

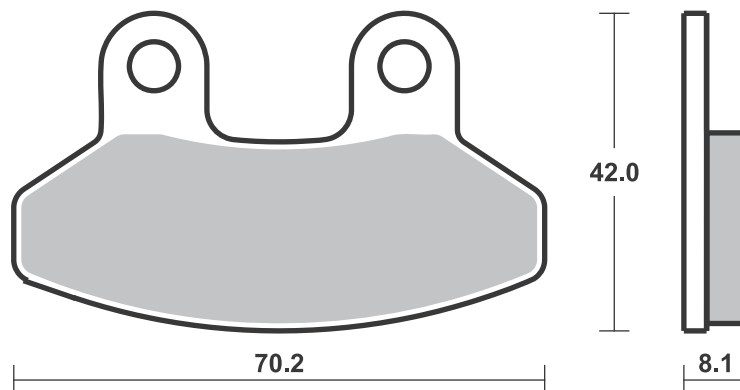
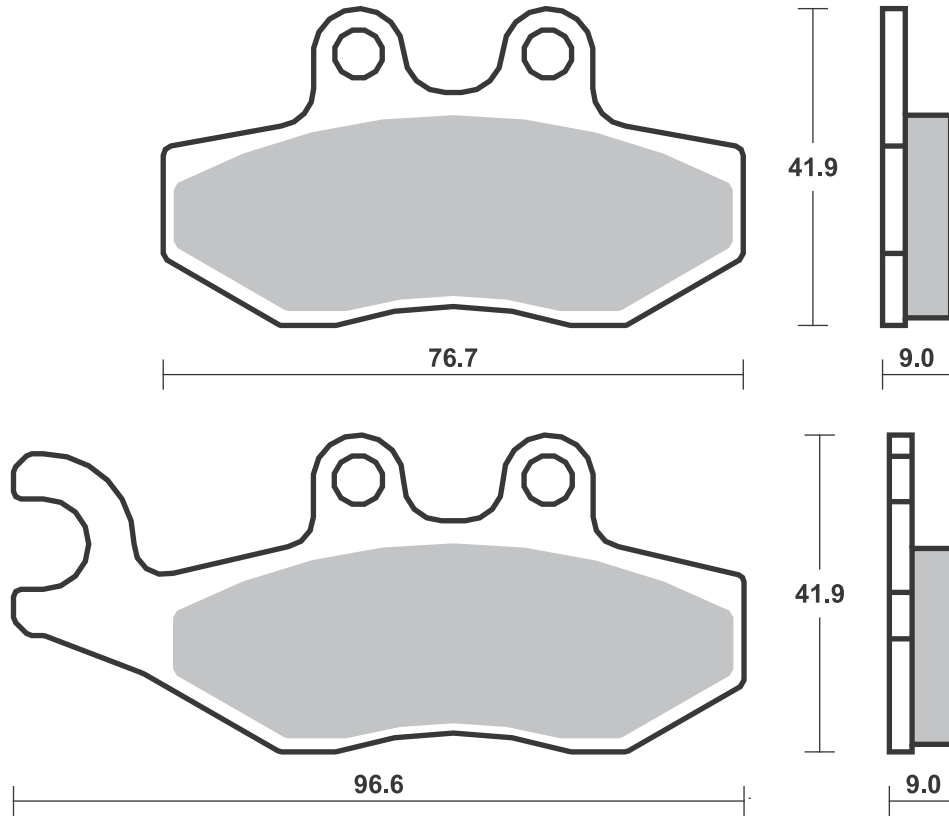



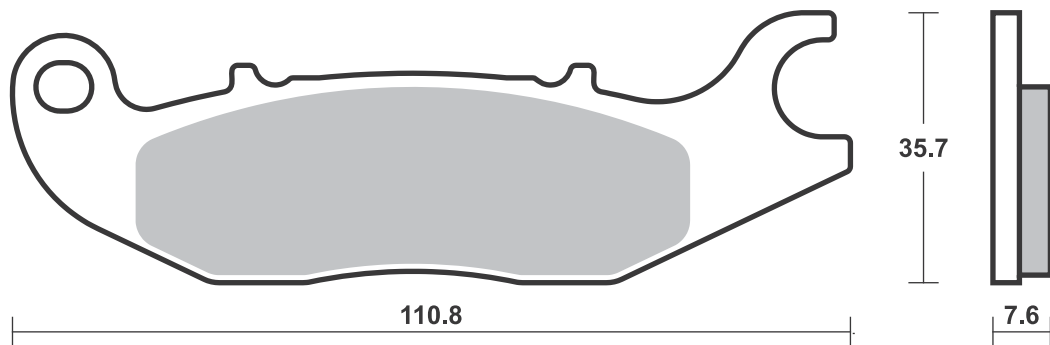
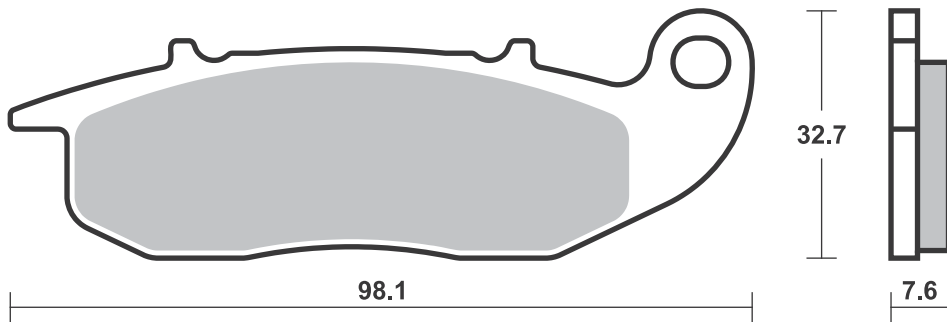
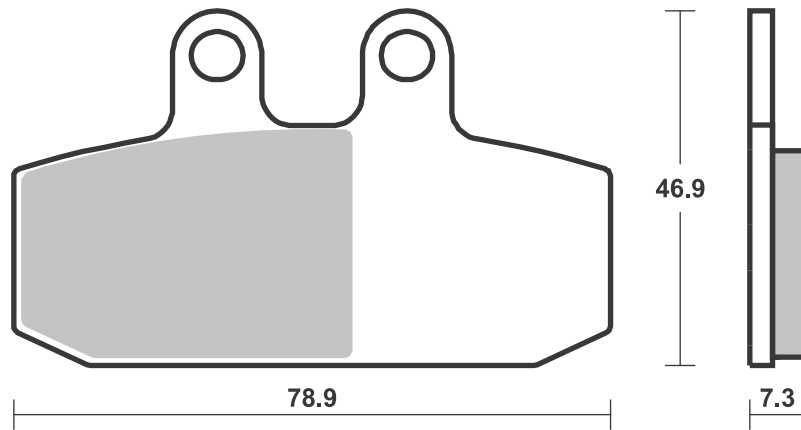
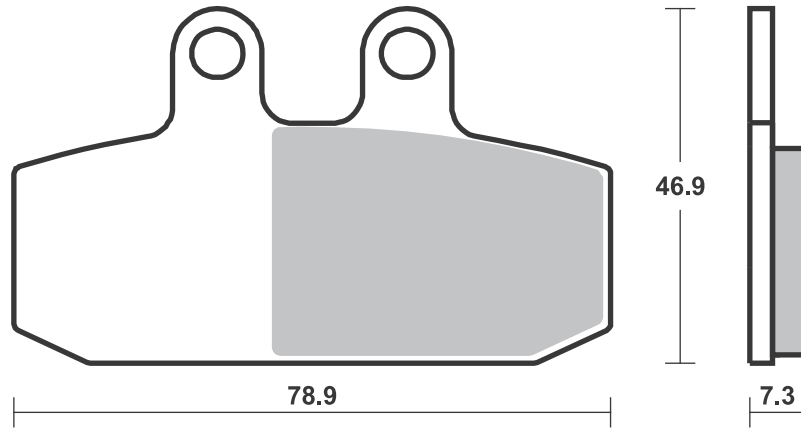



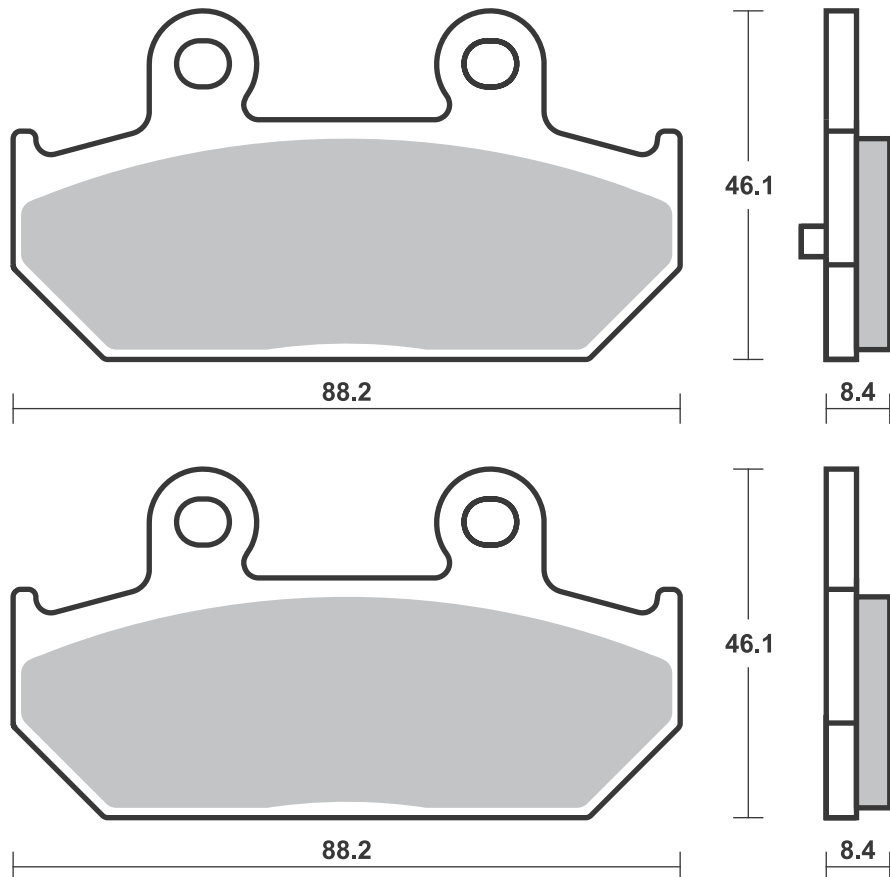
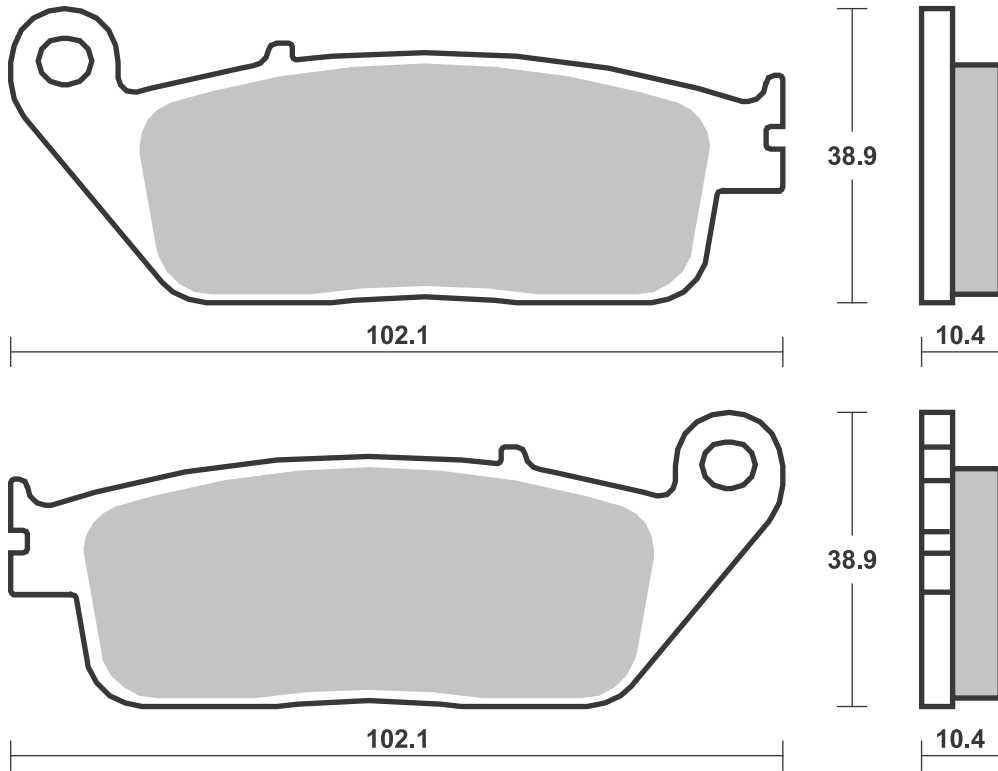

**SBS 183** Recommended compound



| <b>BMW</b> |               |       |              |
|------------|---------------|-------|--------------|
| C          | 600 Evolution | 12-18 | <b>MS MS</b> |
| C          | 600 Sport     | 12-15 | <b>MS MS</b> |
| C          | 650 GT        | 12-18 | <b>MS MS</b> |
| C          | 650 Sport     | 16-18 | <b>MS MS</b> |

| <b>DAELIM</b> |        |       |           |
|---------------|--------|-------|-----------|
|               | 125 S2 | 06-08 | <b>CT</b> |
|               | 250 S2 | 06-10 | <b>CT</b> |

| <b>HONDA</b> |                    |       |           |
|--------------|--------------------|-------|-----------|
| NSS          | 125 Forza          | 15-18 | <b>CT</b> |
| SH           | 125                | 13-18 | <b>CT</b> |
| SH           | 150                | 13-18 | <b>CT</b> |
| CN           | 250 Helix (Fusion) | 93-03 | <b>MS</b> |
| SH           | 300 i SH30         | 15-18 | <b>MS</b> |

| <b>KAWASAKI</b> |     |       |           |
|-----------------|-----|-------|-----------|
| J               | 125 | 15-18 | <b>CT</b> |
| J               | 300 | 14-18 | <b>MS</b> |

| <b>KYMCO</b> |                |       |              |
|--------------|----------------|-------|--------------|
|              | 125 Downtown i | 10-14 | <b>CT</b>    |
|              | 125 New G-Dink | 12-14 | <b>CT</b>    |
|              | 125 Super Dink | 10-15 | <b>CT</b>    |
|              | 200 Downtown i | 10-15 | <b>CT</b>    |
|              | 250 Xciting    | 04-05 | <b>MS MS</b> |
|              | 250 Xciting    | 06-09 | <b>MS</b>    |
|              | 300 Downtown i | 10-15 | <b>MS</b>    |
|              | 300 New G-Dink | 12-16 | <b>MS</b>    |
|              | 300 People Gti | 10-13 | <b>MS</b>    |
|              | 300 Xciting Ri | 08-14 | <b>MS</b>    |



| <b>KYMCO</b> |                   |       |           |
|--------------|-------------------|-------|-----------|
|              | 500 Xciting       | 04-15 | <b>MS</b> |
|              | 500 Xciting i Evo |       |           |
|              | ABS               | 11-13 | <b>MS</b> |
|              | 500 Xciting R ABS | 09-13 | <b>MS</b> |
|              | 700 MyRoad, ABS   | 09-15 | <b>MS</b> |

| <b>PEUGEOT</b> |                 |       |           |
|----------------|-----------------|-------|-----------|
|                | 125 Satelis ABS | 04-08 | <b>CT</b> |
|                | 300 Geopolis GT | 14-16 | <b>MS</b> |
|                | 400 Geopolis GT | 14-15 | <b>MS</b> |
|                | 400 Geopolis RS | 08-16 | <b>MS</b> |
|                | 400 Satelis i   | 14-16 | <b>MS</b> |
|                | 500 Satelis     | 07-11 | <b>MS</b> |
|                | 600 Satelis ABS | 04-12 | <b>CT</b> |

| <b>SUZUKI</b> |               |       |           |
|---------------|---------------|-------|-----------|
| AN            | 650 A Burgman |       |           |
|               | Executive     | 04-12 | <b>MS</b> |
| AN            | 650 Burgman   | 02-15 | <b>MS</b> |
| AN            | 650 Z Burgman |       |           |
|               | Executive     | 13-18 | <b>MS</b> |

**SBS 184** Recommended compound



| <b>HONDA</b> |                |       |           |
|--------------|----------------|-------|-----------|
| FJS          | 400 Silverwing | 06-08 | <b>MS</b> |
| SW-T         | 400            | 09-13 | <b>MS</b> |
| SW-T         | 400 ABS        | 09-14 | <b>MS</b> |
| FJS          | 600 Silverwing | 01-18 | <b>MS</b> |
| SW-T         | 600            | 11-13 | <b>MS</b> |



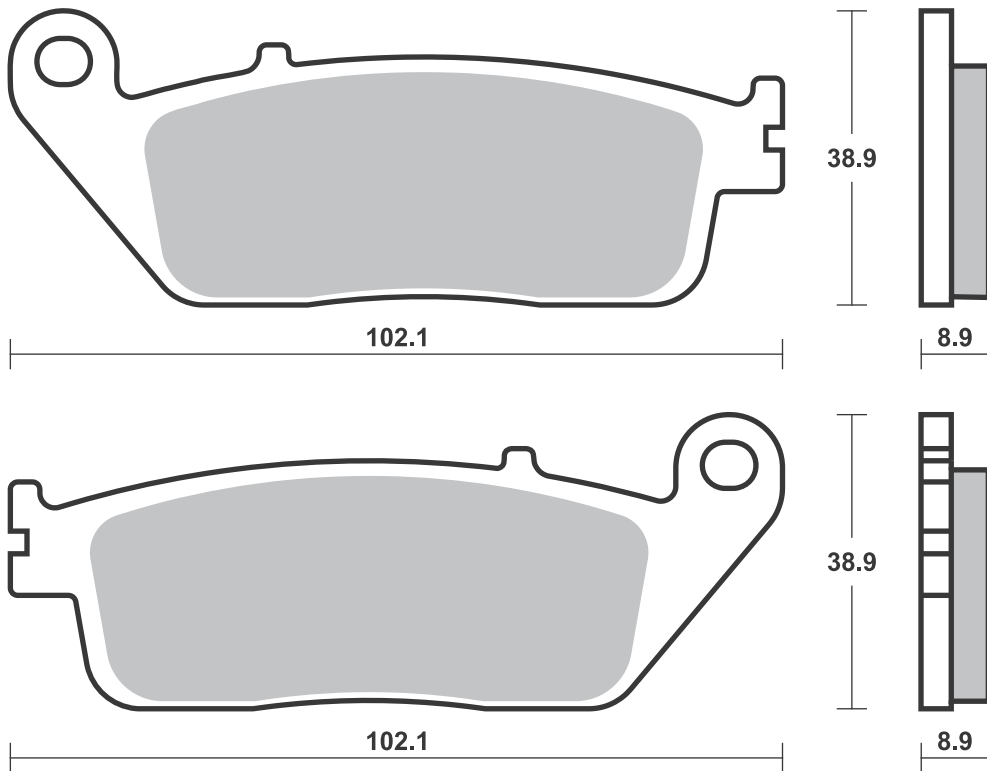
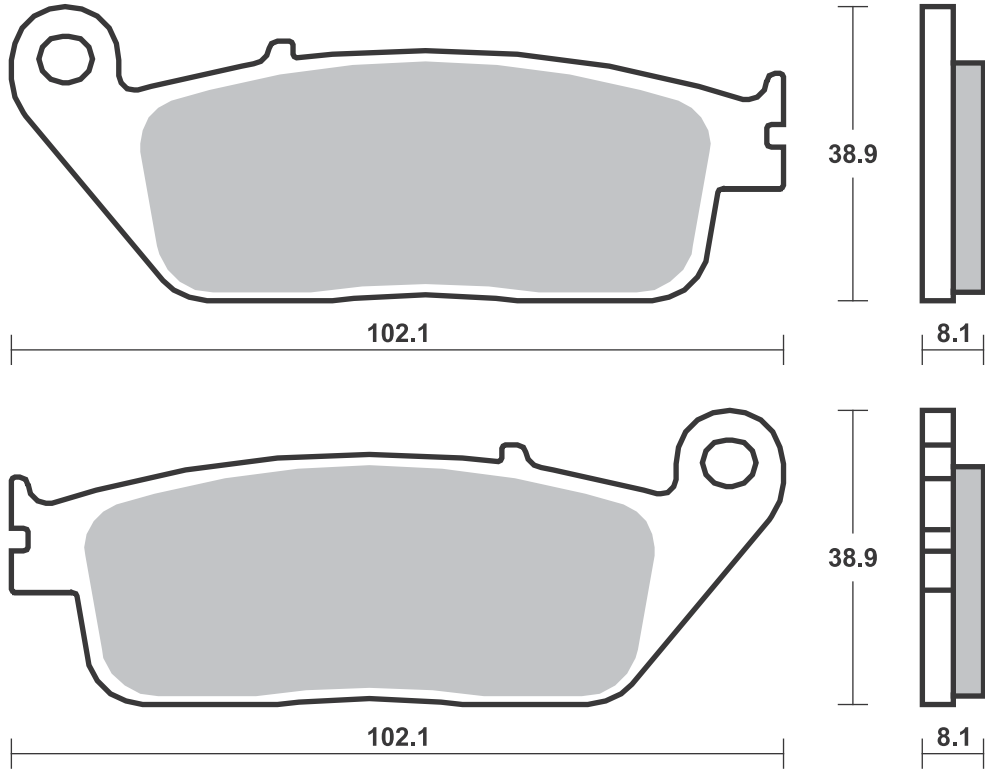



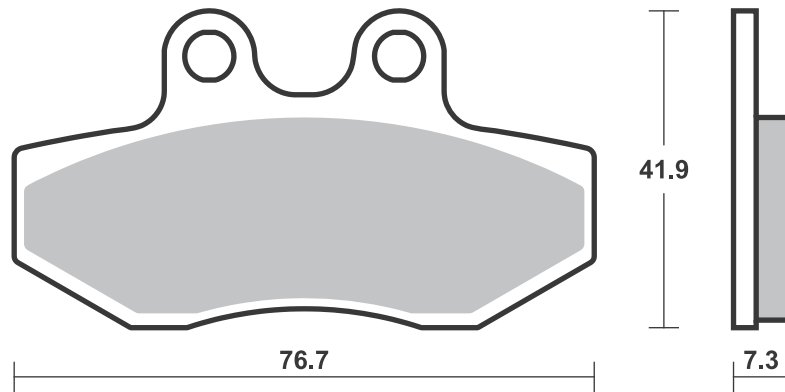
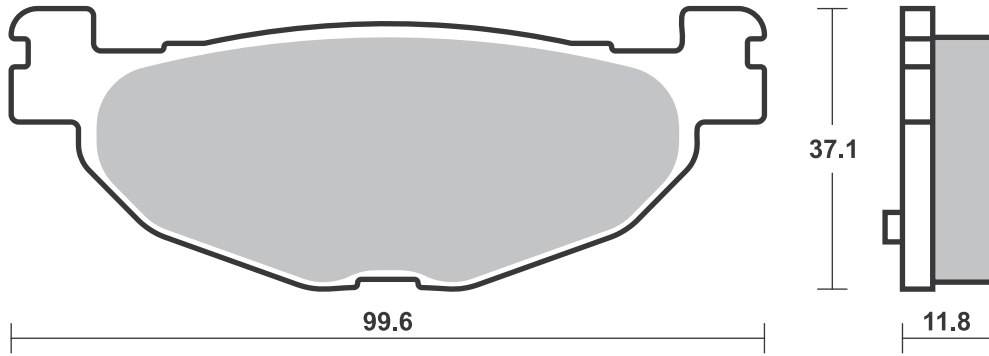

## Applications

### SBS 187 Recommended compound



| PIAGGIO VESPA      |       |    |
|--------------------|-------|----|
| 125 Medley         | 16-18 | CT |
| 125 Medley S       | 17-18 | CT |
| 125 MP3 Efi        | 08-11 | CT |
| 125 MP3 Hybrid     | 09-12 | CT |
| 125 MP3 Yourban    | 11-12 | CT |
| 125 X10 Executive  |       |    |
| Left/Rear          | 13-15 | MS |
| 125 X10 Executive  |       |    |
| Right              | 13-15 | MS |
| 125 X7             | 08-12 | CT |
| 125 X9 Evolution   |       |    |
| Right              | 06-11 | CT |
| 125 X9 Right       | 04-11 | CT |
| 125 Xevo           | 08-13 | CT |
| 150 Medley         | 16-18 | CT |
| 250 MP3 Efi        | 08-09 | MS |
| 250 MP3 LT iE      | 09    | MS |
| 250 X7             | 08-09 | MS |
| 250 X9 Right       | 05-10 | MS |
| 250 Xevo           | 08-11 | MS |
| 300 Beverly i.e.   | 11-18 | MS |
| 300 MP3 Hybrid     | 11-12 | MS |
| 300 MP3 Hybrid iE  | 11-18 | MS |
| 300 MP3 iE         | 10-18 | MS |
| 300 MP3 LT         | 13-18 | MS |
| 300 MP3 LT         |       |    |
| Business           | 13-18 | MS |
| 300 MP3 LT iE ABS  | 14-18 | MS |
| 300 MP3 LT Sport   |       |    |
| ABS                | 14-18 | MS |
| 300 MP3 LT Touring | 11-12 | MS |



| PIAGGIO VESPA      |       |    |
|--------------------|-------|----|
| 300 MP3 Touring    | 11-12 | MS |
| 300 MP3 Yourban iE | 11-18 | MS |
| 300 X7 Evo i.e.    | 11-13 | MS |
| 350 Beverly S      | 14-18 | MS |
| 350 Beverly Sport  |       |    |
| Touring ie         | 12-18 | MS |
| 350 Beverly Sport  |       |    |
| Touring ie ABS     | 12-18 | MS |
| 350 X10 Executive  |       |    |
| Left/Rear          | 13-16 | MS |
| 350 X10 Executive  |       |    |
| Right              | 13-16 | MS |
| BV 350             | 12-17 | MS |
| 400 X8 Right       | 07-08 | MS |
| 400 Xevo Right     | 08-11 | MS |
| 500 X10 Executive  |       |    |
| Left/Rear          | 13-15 | MS |
| 500 X10 Executive  |       |    |
| Right              | 13-15 | MS |

### SBS 188 Recommended compound



| BETA             |       |    |
|------------------|-------|----|
| 50 AJP Caliper   |       |    |
| incl. pin/spring | 90-18 | HF |
| CAGIVA           |       |    |
| 50 AJP Caliper   |       |    |
| incl. pin/spring | 90-18 | HF |
| DERBI            |       |    |
| 50 AJP Caliper   |       |    |
| incl. pin/spring | 90-18 | HF |
| GILERA           |       |    |
| 50 AJP Caliper   |       |    |
| incl. pin/spring | 90-18 | HF |
| ITALJET          |       |    |
| 50 AJP Caliper   |       |    |
| incl. pin/spring | 90-18 | HF |
| MALAGUTI         |       |    |
| 50 AJP Caliper   |       |    |
| incl. pin/spring | 91-18 | HF |
| MBK              |       |    |
| 50 AJP Caliper   |       |    |
| incl. pin/spring | 89-18 | HF |
| MOTORHISPANIA    |       |    |
| 50 AJP Caliper   |       |    |
| incl. pin/spring | 89-18 | HF |



| PEUGEOT          |       |    |
|------------------|-------|----|
| 50 AJP Caliper   |       |    |
| incl. pin/spring | 89-18 | HF |
| PIAGGIO VESPA    |       |    |
| 50 AJP Caliper   |       |    |
| incl. pin/spring | 91-18 | HF |
| RIEJU            |       |    |
| 50 AJP Caliper   |       |    |
| incl. pin/spring | 91-18 | HF |
| SHERCO           |       |    |
| 50 AJP Caliper   |       |    |
| incl. pin/spring | 91-18 | HF |
| SUZUKI           |       |    |
| 50 AJP Caliper   |       |    |
| incl. pin/spring | 91-18 | HF |
| YAMAHA           |       |    |
| 50 AJP Caliper   |       |    |
| incl. pin/spring | 91-18 | HF |

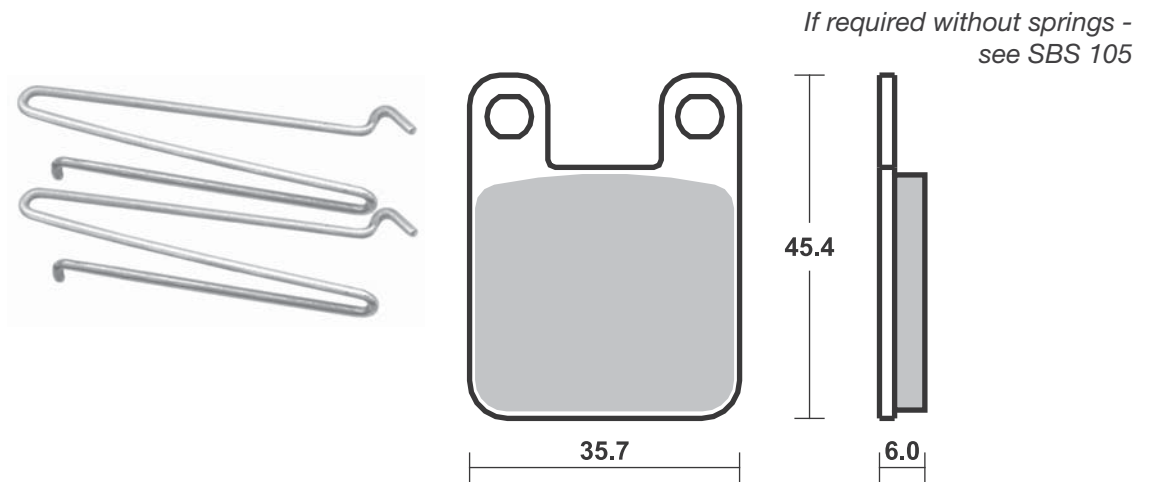
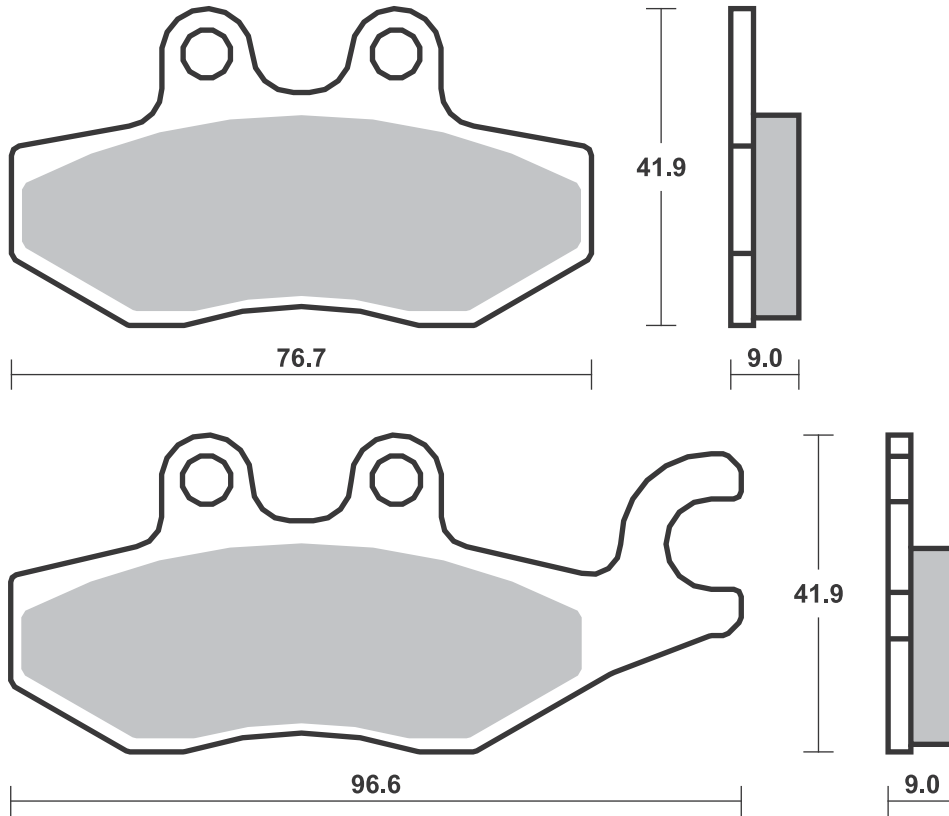

**SBS 189 Recommended compound**



| <b>APRILIA</b>       |                  |       |           |
|----------------------|------------------|-------|-----------|
| RS-4                 | 50               | 12-18 | <b>MS</b> |
| RS-4                 | 50 Replica       | 16-17 | <b>MS</b> |
| <b>DERBI</b>         |                  |       |           |
|                      | 50 DRD Pro corse | 06-08 | <b>MS</b> |
| GPX1                 | 50               | 06    | <b>MS</b> |
| <b>GILERA</b>        |                  |       |           |
| SC                   | 125              | 06-07 | <b>MS</b> |
| <b>MOTORHISPANIA</b> |                  |       |           |
| RX                   | 50 R             | 08-14 | <b>MS</b> |
| <b>PEUGEOT</b>       |                  |       |           |
| XR 7                 | 50               | 08-10 | <b>MS</b> |
| <b>RIEJU</b>         |                  |       |           |
| RS3                  | 50 Pro           | 12-17 | <b>MS</b> |

**SBS 190 Recommended compound**



| <b>MBK</b>    |              |       |           |
|---------------|--------------|-------|-----------|
| YP            | 125 Flame X  | 05-12 | <b>CT</b> |
| <b>YAMAHA</b> |              |       |           |
| NXC           | 125 Cygnus X | 05-09 | <b>CT</b> |
|               |              |       |           |
|               |              |       |           |
|               |              |       |           |
|               |              |       |           |
|               |              |       |           |
|               |              |       |           |
|               |              |       |           |
|               |              |       |           |
|               |              |       |           |
|               |              |       |           |
|               |              |       |           |
|               |              |       |           |
|               |              |       |           |
|               |              |       |           |
|               |              |       |           |
|               |              |       |           |
|               |              |       |           |
|               |              |       |           |
|               |              |       |           |

**SBS 191 Recommended compound**



| <b>GILERA</b>        |                  |       |           |
|----------------------|------------------|-------|-----------|
| RC                   | 500 Fuoco ie     | 08-17 | <b>MS</b> |
| <b>PIAGGIO VESPA</b> |                  |       |           |
|                      | 125 MP3          | 06-07 | <b>CT</b> |
|                      | 125 X8           | 05-10 | <b>CT</b> |
|                      | 200 X8           | 05    | <b>CT</b> |
|                      | 250 MP3          | 06-07 | <b>MS</b> |
|                      | 250 X8           | 06-09 | <b>MS</b> |
|                      | 250 X9 Left/Rear | 05-10 | <b>MS</b> |
|                      |                  |       |           |
|                      |                  |       |           |
|                      |                  |       |           |
|                      |                  |       |           |
|                      |                  |       |           |
|                      |                  |       |           |
|                      |                  |       |           |
|                      |                  |       |           |
|                      |                  |       |           |
|                      |                  |       |           |
|                      |                  |       |           |
|                      |                  |       |           |
|                      |                  |       |           |
|                      |                  |       |           |
|                      |                  |       |           |
|                      |                  |       |           |
|                      |                  |       |           |
|                      |                  |       |           |
|                      |                  |       |           |
|                      |                  |       |           |

Brake Pad 1:1 Drawings, Compounds, Fitments

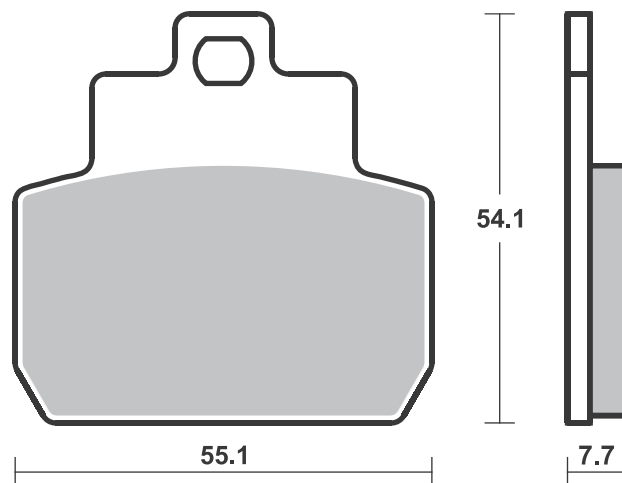
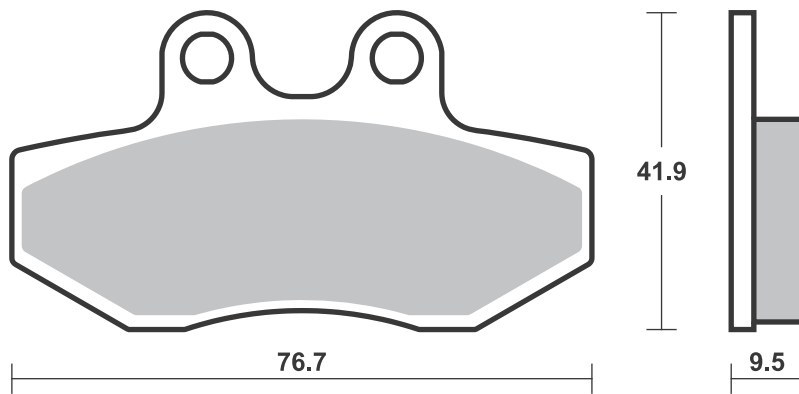
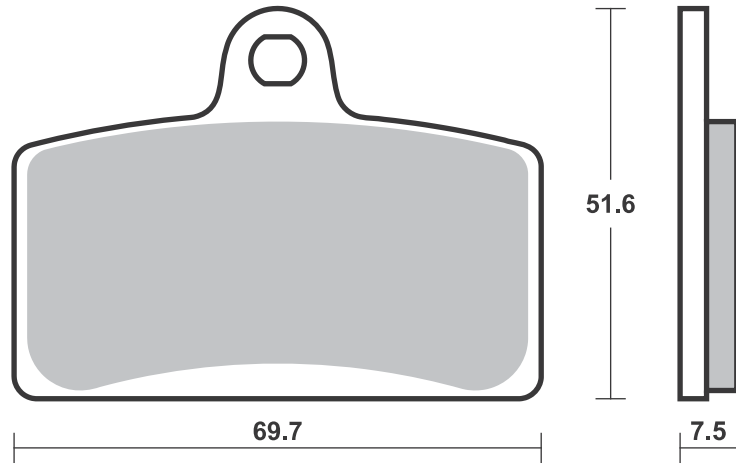

**SBS 192** Recommended compound



| <b>HONDA</b> |                |       |           |
|--------------|----------------|-------|-----------|
| FES          | 125 S-Wing     | 07-11 | <b>CT</b> |
| SH           | 125 i          | 09-12 | <b>HF</b> |
| FES          | 150 S-Wing     | 07-11 | <b>CT</b> |
| SH           | 150 i          | 09-12 | <b>HF</b> |
| NSS          | 250            | 05-13 | <b>MS</b> |
| NSS          | 250 Forza      | 05-13 | <b>MS</b> |
| PS           | 250            | 05-06 | <b>MS</b> |
| NSS          | 300 Forza      | 14-18 | <b>MS</b> |
| SH           | 300 i          | 07-18 | <b>MS</b> |
| SW-T         | 400            | 09-13 | <b>MS</b> |
| SW-T         | 400 ABS        | 09-14 | <b>MS</b> |
| FJS          | 600 Silverwing | 09-18 | <b>MS</b> |
| SW-T         | 600            | 11-13 | <b>MS</b> |

| <b>SUZUKI</b> |             |       |           |
|---------------|-------------|-------|-----------|
| UH            | 125 Burgman | 07-18 | <b>CT</b> |
| UX            | 125 SIXteen | 08-12 | <b>CT</b> |
| UX            | 150 SIXteen | 08-16 | <b>CT</b> |
| UH            | 200         | 07    | <b>CT</b> |
| UH            | 200 Burgman | 07-13 | <b>CT</b> |

**SBS 193** Recommended compound



| <b>HONDA</b> |            |       |           |
|--------------|------------|-------|-----------|
| FES          | 125 S-Wing | 07-11 | <b>CT</b> |
| NSS          | 125 Forza  | 15-18 | <b>CT</b> |
| SH           | 125        | 13-18 | <b>HF</b> |
| SH           | 125 i      | 09-12 | <b>HF</b> |
| FES          | 150 S-Wing | 07-11 | <b>CT</b> |
| SH           | 150        | 13-18 | <b>HF</b> |
| SH           | 150 i      | 09-12 | <b>HF</b> |
| NSS          | 250        | 05-13 | <b>MS</b> |
| NSS          | 250 Forza  | 05-13 | <b>MS</b> |
| NSS          | 300 Forza  | 14-18 | <b>MS</b> |
| SH           | 300 i      | 07-18 | <b>HF</b> |
| SH           | 300 i SH30 | 15-18 | <b>MS</b> |



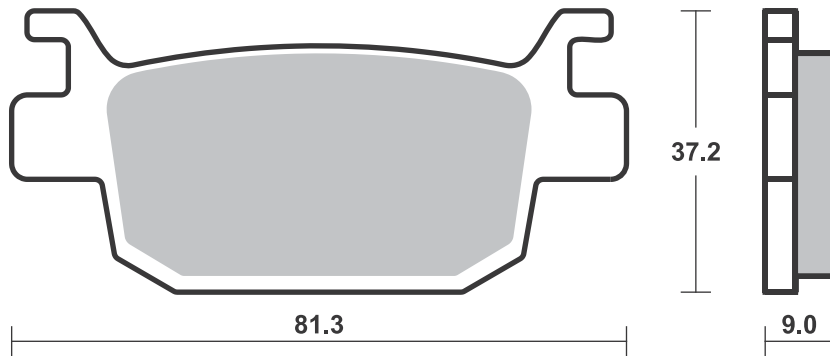
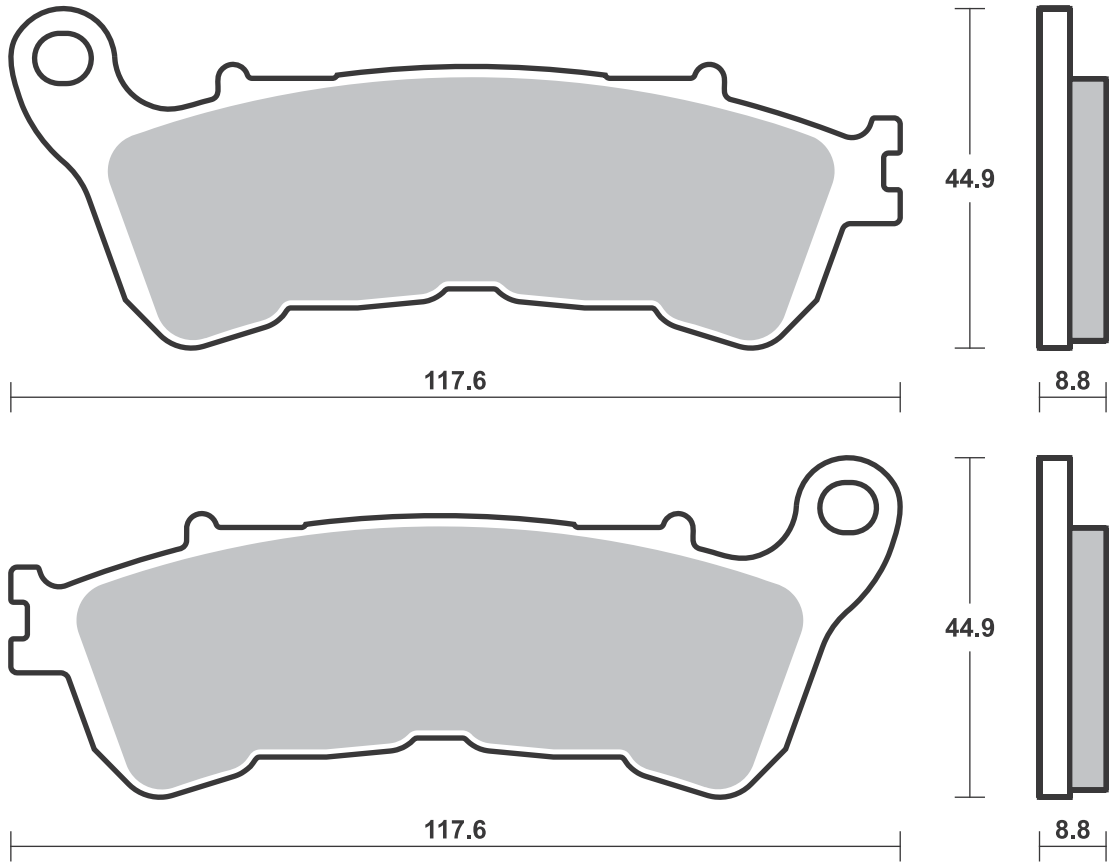

**SBS 194**

**Recommended compound**



|            |                |       |           |
|------------|----------------|-------|-----------|
| <b>MBK</b> |                |       |           |
|            | 125 Skycruiser | 06-14 | <b>CT</b> |

|               |           |       |           |
|---------------|-----------|-------|-----------|
| <b>YAMAHA</b> |           |       |           |
| YP            | 125 X-Max | 06-09 | <b>CT</b> |
| YP            | 250 X-Max | 05-09 | <b>MS</b> |

**SBS 195**

**Recommended compound**



|              |                |       |           |
|--------------|----------------|-------|-----------|
| <b>KYMCO</b> |                |       |           |
|              | 125 K-XCTi     | 14    | <b>MS</b> |
|              | 125 New G-Dink | 12-14 | <b>CT</b> |
| S            | 125 People     | 05-08 | <b>CT</b> |
| S            | 200 People     | 05-07 | <b>CT</b> |
|              | 250 Xciting    | 06-09 | <b>MS</b> |
| S            | 250 People     |       |           |
|              | Left/Rear      | 06-08 | <b>MS</b> |
|              | 300 K-XCTi     | 12-15 | <b>MS</b> |
|              | 300 New G-Dink | 12-16 | <b>MS</b> |
|              | 300 People Si  |       |           |
|              | Left/Rear      | 08-10 | <b>CT</b> |
|              | 300 Xciting Ri | 08-14 | <b>MS</b> |

|               |              |       |           |
|---------------|--------------|-------|-----------|
| <b>YAMAHA</b> |              |       |           |
| YP            | 400 R X-Max  | 13-16 | <b>MS</b> |
| YP            | 400 RA X-Max | 14-16 | <b>MS</b> |

Brake Pad 1:1 Drawings, Compounds, Fitments

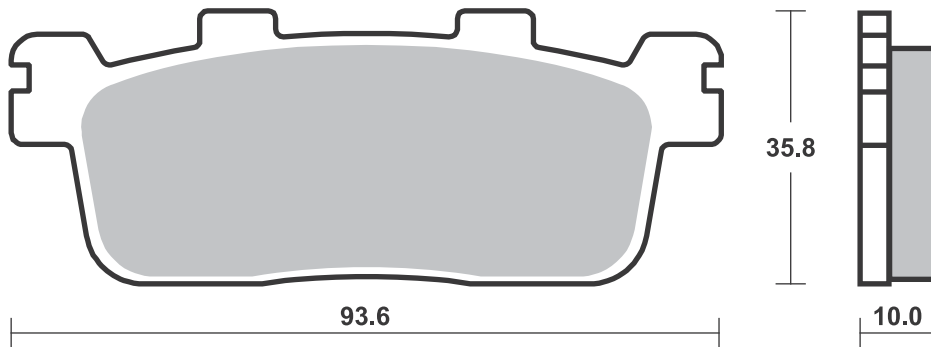
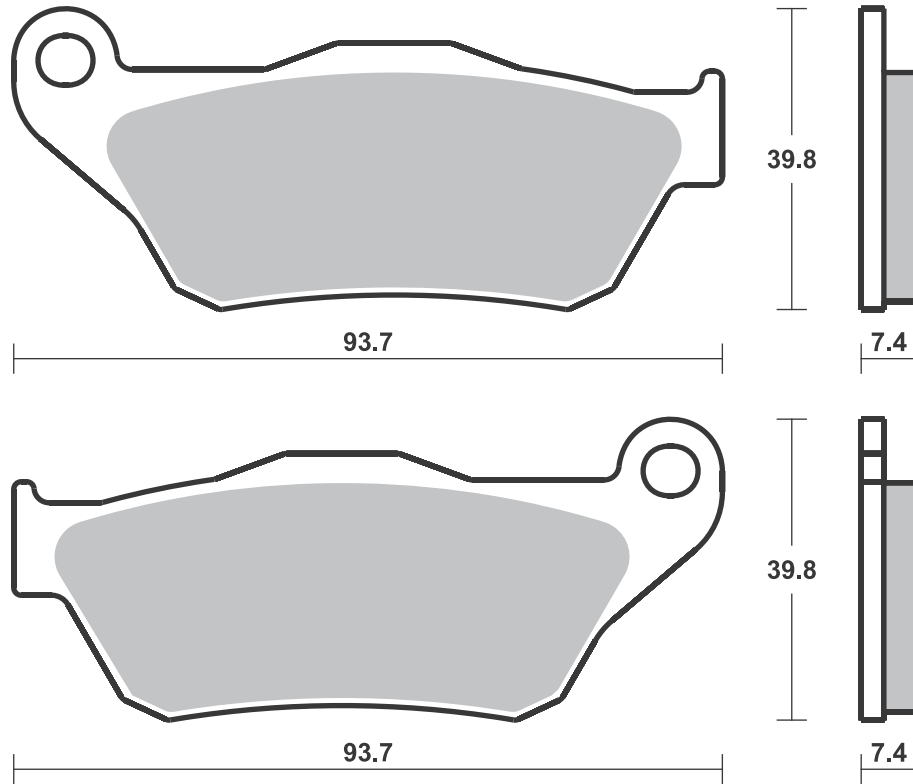

**SBS 196** Recommended compound**BENELLI**

|               |           |       |           |
|---------------|-----------|-------|-----------|
| 250 Caffenero |           |       |           |
|               | Left/Rear | 08-14 | <b>MS</b> |

**SUZUKI**

|    |             |       |           |
|----|-------------|-------|-----------|
| UH | 125 Burgman | 07-18 | <b>CT</b> |
| UX | 125 SIXteen | 08-12 | <b>CT</b> |
| UX | 150 SIXteen | 08-16 | <b>CT</b> |
| UH | 200 Burgman | 07-18 | <b>CT</b> |

**SBS 197** Recommended compound**APRILIA**

|    |         |       |           |
|----|---------|-------|-----------|
| SX | 50 Ltd. | 07-15 | <b>CT</b> |
|----|---------|-------|-----------|

**BENELLI**

|               |           |       |              |
|---------------|-----------|-------|--------------|
| 125 Caffenero |           |       |              |
|               | Left/Rear | 08-11 | <b>CT CT</b> |
|               | 125 MJ    | 10    | <b>CT CT</b> |
|               | 150 MJ    | 10    | <b>CT CT</b> |
| 250 Caffenero |           |       |              |
|               | Left/Rear | 08-14 | <b>MS</b>    |

**GARELLI**

|  |        |    |           |
|--|--------|----|-----------|
|  | 200 Xo | 12 | <b>CT</b> |
|--|--------|----|-----------|

**KYMCO**

|   |            |       |           |
|---|------------|-------|-----------|
| S | 250 People |       |           |
|   | Left/Rear  | 06-08 | <b>MS</b> |

**PEUGEOT**

|    |                      |       |              |
|----|----------------------|-------|--------------|
|    | 50 Django Heritage   | 14-16 | <b>HF</b>    |
|    | 125 Django Heritage  | 14-16 | <b>CT</b>    |
|    | 125 Geopolis         |       |              |
|    | (Nissin cal.)        | 07-09 | <b>CT CT</b> |
|    | 125 Vivacity         | 10-16 | <b>CT</b>    |
| GT | 125 Satelis Sport    | 11-12 | <b>CT CT</b> |
|    | 150 Django Heritage  | 14-15 | <b>CT</b>    |
|    | 300 Geopolis GT      | 14-16 | <b>MS</b>    |
|    | 300 Geopolis Premium |       |              |
|    | (Nissin cal.)        | 10-13 | <b>MS MS</b> |
|    | 300 Geopolis RS      |       |              |
|    | (Nissin cal.)        | 10-14 | <b>MS MS</b> |

**PEUGEOT**

|              |                 |       |              |
|--------------|-----------------|-------|--------------|
| 300 Geostyle |                 |       |              |
|              | (Nissin cal.)   | 10-12 | <b>MS MS</b> |
|              | 300 Satelis     | 13-16 | <b>MS MS</b> |
| 400 Geopolis |                 |       |              |
|              | (Nissin cal.)   | 07-12 | <b>MS MS</b> |
|              | 400 Geopolis GT | 14-15 | <b>MS</b>    |
|              | 400 Geopolis RS | 08-16 | <b>MS</b>    |
|              | 400 Satelis i   | 14-16 | <b>MS</b>    |
|              | 500 Satelis     | 07-11 | <b>MS</b>    |

**PGO**

|  |           |       |           |
|--|-----------|-------|-----------|
|  | 125 Libra | 10-12 | <b>CT</b> |
|  | 125 X-Hot | 10-11 | <b>CT</b> |

**SUZUKI**

|    |             |       |           |
|----|-------------|-------|-----------|
| AN | 400 Burgman |       |           |
|    | Left/Rear   | 07-18 | <b>MS</b> |

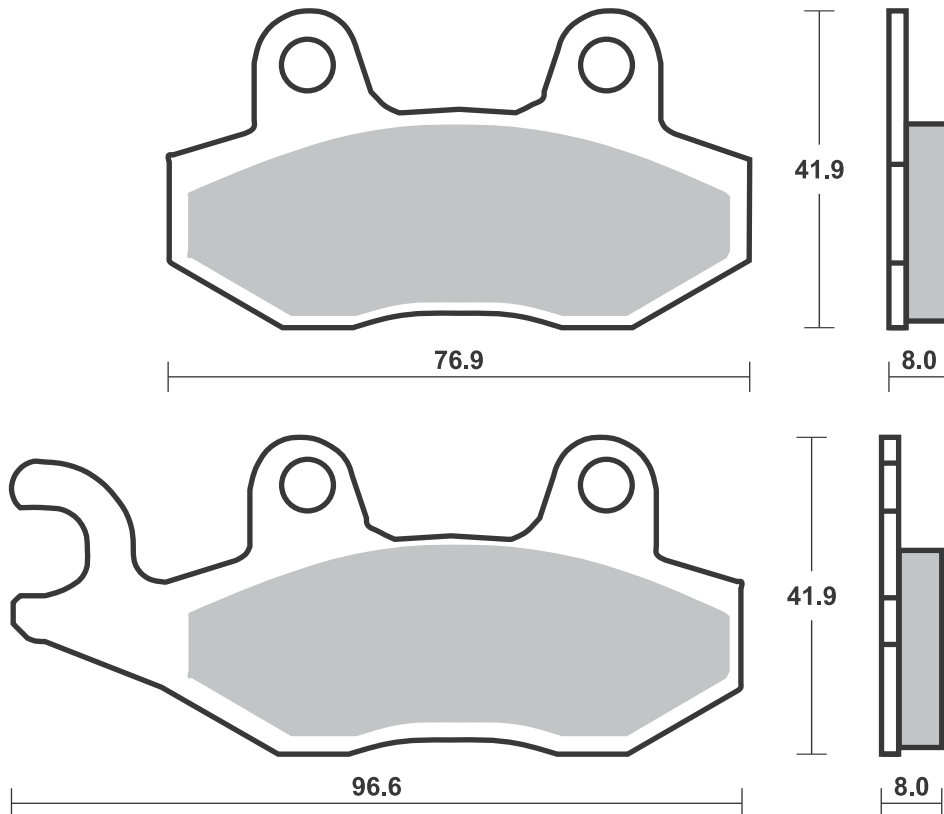
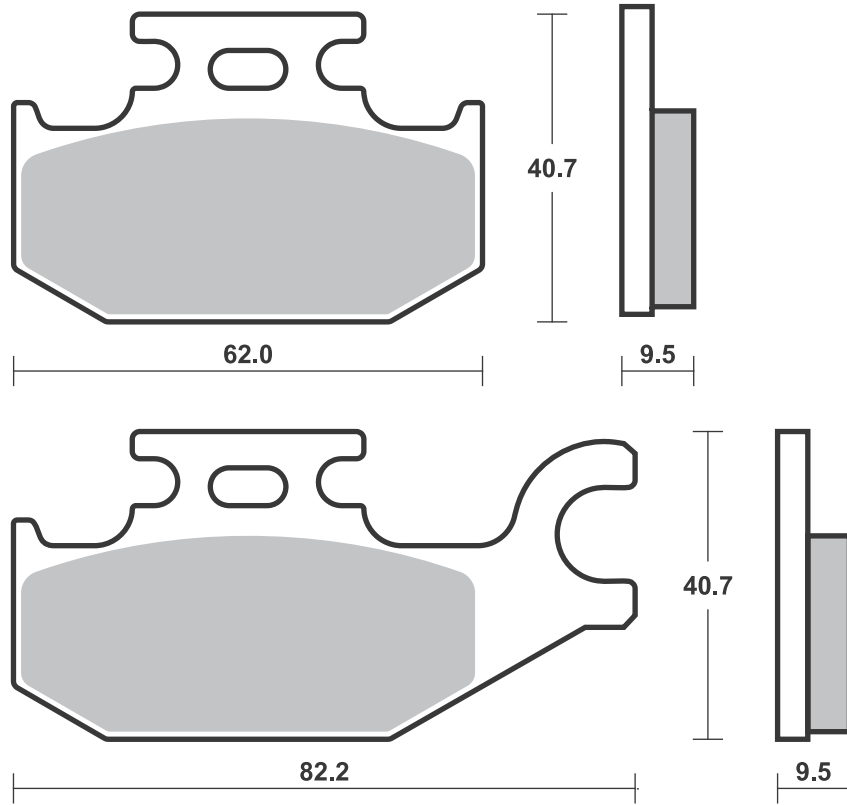

**SBS 198** Recommended compound



**YAMAHA**

|    |                   |       |           |
|----|-------------------|-------|-----------|
| XP | 500 TMAX          | 08-11 | <b>MS</b> |
| XP | 500 TMAX Tech Max | 11    | <b>MS</b> |
| XP | 530 TMAX          | 12-18 | <b>MS</b> |
| XP | 530 TMAX DX       | 17-18 | <b>MS</b> |
| XP | 530 TMAX Iron Max | 15-18 | <b>MS</b> |
| XP | 530 TMAX SX       | 17-18 | <b>MS</b> |
|    |                   |       |           |
|    |                   |       |           |
|    |                   |       |           |
|    |                   |       |           |
|    |                   |       |           |
|    |                   |       |           |
|    |                   |       |           |
|    |                   |       |           |

**SBS 199** Recommended compound



**BETA**

|    |                |       |           |
|----|----------------|-------|-----------|
| RR | 50 Enduro      | 10-18 | <b>HF</b> |
| RR | 50 Supermotard | 08-13 | <b>HF</b> |
|    |                |       |           |
|    |                |       |           |
|    |                |       |           |
|    |                |       |           |
|    |                |       |           |
|    |                |       |           |
|    |                |       |           |
|    |                |       |           |
|    |                |       |           |
|    |                |       |           |
|    |                |       |           |
|    |                |       |           |
|    |                |       |           |
|    |                |       |           |
|    |                |       |           |
|    |                |       |           |
|    |                |       |           |

**SBS 200** Recommended compound



**GARELLI**

|  |             |    |           |
|--|-------------|----|-----------|
|  | Xo Electric | 12 | <b>HF</b> |
|  | 125 Flexi   | 12 | <b>HF</b> |
|  | 125 Xo      | 12 | <b>CT</b> |
|  | 150 Xo      | 12 | <b>CT</b> |

**ITALJET**

|  |                |       |           |
|--|----------------|-------|-----------|
|  | 50 Rollercraft | 08-12 | <b>HF</b> |
|  | 125 Torpedo    | 08-11 | <b>CT</b> |
|  | 150 Torpedo    | 08-12 | <b>CT</b> |

**KEEWAY**

|     |    |       |           |
|-----|----|-------|-----------|
| RY8 | 50 | 10-16 | <b>HF</b> |
|-----|----|-------|-----------|

**KYMCO**

|  |            |       |           |           |
|--|------------|-------|-----------|-----------|
|  | 50 Nexxon  | 08-12 | <b>HF</b> | <b>HF</b> |
|  | 125 Nexxon | 08-12 | <b>CT</b> | <b>CT</b> |



**KYMCO**

|  |              |       |           |           |
|--|--------------|-------|-----------|-----------|
|  | 150 Straight | 08-11 | <b>CT</b> | <b>CT</b> |
|--|--------------|-------|-----------|-----------|

**PEUGEOT**

|  |                         |       |           |
|--|-------------------------|-------|-----------|
|  | 50 Speedfight 3 (AC)    | 10-16 | <b>HF</b> |
|  | 50 Speedfight 3 (LC)    | 10-16 | <b>HF</b> |
|  | 50 Speedfight 3 RS (LC) | 10-16 | <b>HF</b> |
|  | 50 Speedfight 4 (AC)    | 15-16 | <b>HF</b> |
|  | 50 Speedfight 4 (LC)    | 15-16 | <b>HF</b> |

**SACHS**

|  |              |       |           |
|--|--------------|-------|-----------|
|  | 50 MadAss    | 04-05 | <b>HF</b> |
|  | 50 MadAss 4T | 05-09 | <b>HF</b> |
|  | 125 MadAss   | 09    | <b>HF</b> |

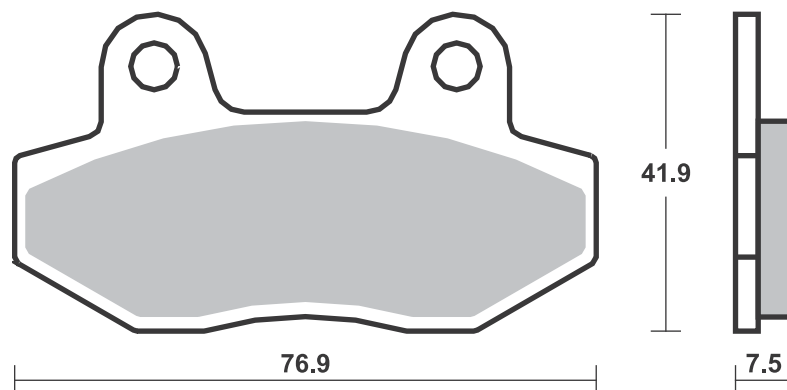
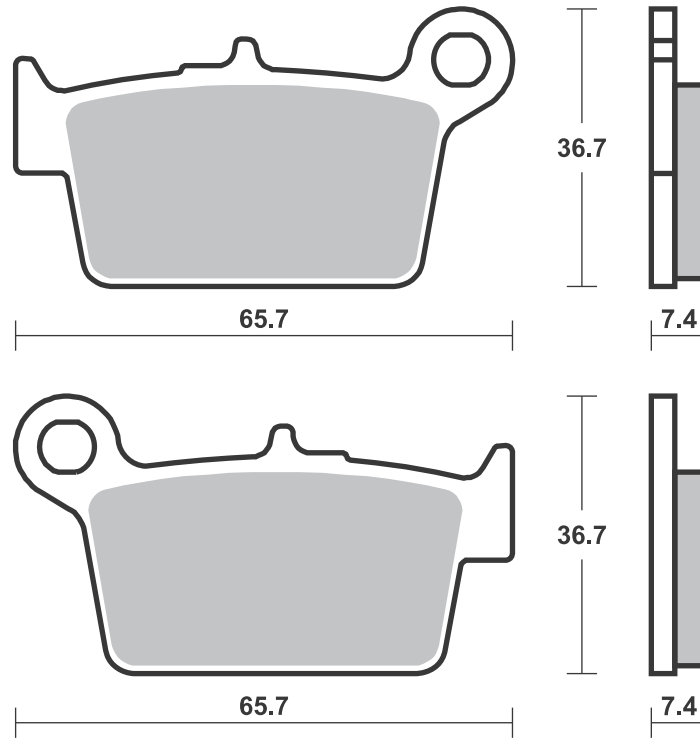
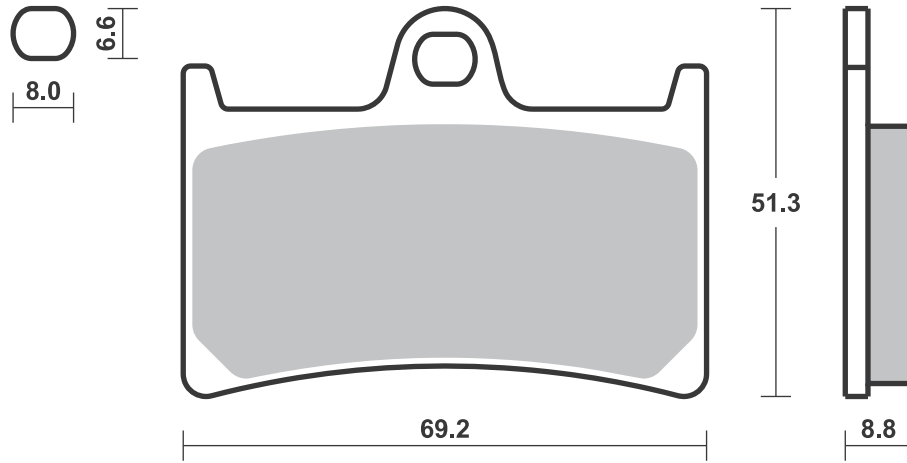

## Applications

### SBS 201 Recommended compound



| <b>DAELIM</b>  |                  |       |           |
|----------------|------------------|-------|-----------|
| S              | 125 from         |       |           |
|                | VIN SDC007441    | 17-18 | <b>CT</b> |
| S              | 300              | 17-18 | <b>MS</b> |
| <b>PEUGEOT</b> |                  |       |           |
| LXR            | 125              | 10-13 | <b>CT</b> |
| LXR            | 200              | 10-11 | <b>CT</b> |
| <b>SYM</b>     |                  |       |           |
|                | 125 Joymax Sport | 16    | <b>CT</b> |
|                | 125 Joyride      | 07-09 | <b>CT</b> |
|                | 125 Joyride Evo  | 10-12 | <b>CT</b> |
|                | 125 Joyride S    | 16-17 | <b>CT</b> |
| HD             | 125 Evo DT       | 10    | <b>CT</b> |
| HD2            | 125 Evo          | 14    | <b>CT</b> |
|                | 200 Joyride S    | 16-17 | <b>CT</b> |
| HD             | 200 Evo          | 07-13 | <b>CT</b> |
| HD2            | 200 Evo          | 14    | <b>CT</b> |
|                | 250 GTS          | 07-11 | <b>MS</b> |
|                | 250 Joymax       | 07-10 | <b>MS</b> |
|                | 250 Joymax Sport | 16-17 | <b>MS</b> |
| RV             | 250 Efi          | 10    | <b>MS</b> |
|                | 300 Cruisym      | 17    | <b>MS</b> |
|                | 300 Joymax Evo   | 10-12 | <b>MS</b> |
|                | 300 Joymax Sport | 16-17 | <b>MS</b> |



| <b>SYM</b> |                   |       |           |
|------------|-------------------|-------|-----------|
|            | 300 Joyride Evo i | 10    | <b>MS</b> |
| GTS        | 300               | 09-13 | <b>MS</b> |
| GTS        | 300 Evo i         | 11-15 | <b>MS</b> |
| <b>TGB</b> |                   |       |           |
|            | 125 X-Large       | 11    | <b>CT</b> |
|            | 125 X-Motion      | 08-12 | <b>CT</b> |
|            | 250 X-Motion      | 08-09 | <b>CT</b> |
|            | 300 X-Motion      | 10-12 | <b>CT</b> |

### SBS 202 Recommended compound



| <b>GILERA</b>        |                  |       |           |
|----------------------|------------------|-------|-----------|
|                      | 50 Runner PJ     | 06-11 | <b>HF</b> |
|                      | 50 Runner SP     | 06-12 | <b>HF</b> |
|                      | 50 Runner SP,    |       |           |
|                      | Purejet          | 98-05 | <b>HF</b> |
|                      | 50 Stalker       | 97-01 | <b>HF</b> |
| DT                   | 50 Stalker       | 01-05 | <b>HF</b> |
| FX                   | 125 Runner       |       |           |
|                      | (Grimeca cal.)   | 00-05 | <b>CT</b> |
| FX                   | 125 Runner       |       |           |
|                      | (Hengtong cal.)  | 00-05 | <b>CT</b> |
| FX                   | 125 Runner SP    |       |           |
|                      | (Grimeca cal.)   | 00-03 | <b>CT</b> |
| FX                   | 125 Runner SP    |       |           |
|                      | (Hengtong cal.)  | 00-03 | <b>CT</b> |
| ST                   | 125 Runner       | 12-13 | <b>CT</b> |
| FXR                  | 180 Runner       |       |           |
|                      | (Grimeca cal.)   | 00-03 | <b>CT</b> |
| FXR                  | 180 Runner       |       |           |
|                      | (Hengtong cal.)  | 00-03 | <b>CT</b> |
| FXR                  | 180 Runner SP    |       |           |
|                      | (Grimeca cal.)   | 00    | <b>CT</b> |
| FXR                  | 180 Runner SP    |       |           |
|                      | (Hengtong cal.)  | 00    | <b>CT</b> |
|                      | 200 Stalker      | 97-01 | <b>CT</b> |
| FX                   | 200 Runner SP    | 98-01 | <b>CT</b> |
| RC                   | 500 Fuoco ie     | 08-17 | <b>MS</b> |
| <b>PEUGEOT</b>       |                  |       |           |
|                      | 50 Tweet Evo RS  | 14-17 | <b>HF</b> |
|                      | 50 Tweet RS      | 10-13 | <b>HF</b> |
|                      | 125 Tweet Evo    | 14-17 | <b>HF</b> |
|                      | 125 Tweet Evo RS | 14-16 | <b>HF</b> |
|                      | 125 Tweet RS     | 10-13 | <b>CT</b> |
|                      | 150 Tweet RS     | 10-13 | <b>CT</b> |
| <b>PIAGGIO VESPA</b> |                  |       |           |
|                      | 50 Liberty       | 97-14 | <b>HF</b> |



| <b>PIAGGIO VESPA</b> |                     |       |           |
|----------------------|---------------------|-------|-----------|
|                      | 50 Liberty 4T       | 00-12 | <b>HF</b> |
|                      | 50 Zip Disco        | 96-99 | <b>HF</b> |
|                      | 50 Zip Fast Rider   | 96-97 | <b>HF</b> |
|                      | 50 Zip RST          | 98-99 | <b>HF</b> |
|                      | 50 Zip Sport        |       |           |
|                      | Production          | 96-99 | <b>HF</b> |
| ET2                  | 50                  | 97-06 | <b>HF</b> |
| ET4                  | 50                  | 00-05 | <b>HF</b> |
| LX                   | 50 2T/4T            | 05-12 | <b>HF</b> |
| S                    | 50 2T               | 07-14 | <b>HF</b> |
| S                    | 50 4T               | 09-14 | <b>HF</b> |
|                      | 125 MP3             | 06-07 | <b>CT</b> |
|                      | 125 MP3 Efi         | 08-11 | <b>CT</b> |
|                      | 125 MP3 Hybrid      | 09-12 | <b>CT</b> |
|                      | 125 MP3 Yourban     | 11-12 | <b>CT</b> |
|                      | 125 Sfera           | 95-01 | <b>CT</b> |
|                      | 125 Zip II 4T       | 00-08 | <b>CT</b> |
| ET4                  | 125                 | 96-10 | <b>CT</b> |
| LE                   | 125 Liberty         | 99-03 | <b>CT</b> |
| LX                   | 125 4T              | 05-13 | <b>CT</b> |
| PX                   | 125                 | 02-11 | <b>CT</b> |
| PX                   | 125 70              | 16    | <b>CT</b> |
| S                    | 125 4T              | 07-10 | <b>CT</b> |
|                      | 150 Liberty         | 99-03 | <b>CT</b> |
| ET4                  | 150                 | 02-06 | <b>CT</b> |
| PX                   | 150                 | 02-06 | <b>CT</b> |
|                      | 200 Liberty         | 06-13 | <b>CT</b> |
| PX                   | 200                 | 02-07 | <b>CT</b> |
|                      | 250 LX 60           | 06-10 | <b>MS</b> |
|                      | 250 MP3             | 06-07 | <b>MS</b> |
|                      | 250 MP3 Efi         | 08-09 | <b>MS</b> |
|                      | 250 MP3 LT iE       | 09    | <b>MS</b> |
|                      | 300 MP3 Hybrid      | 11-12 | <b>MS</b> |
|                      | 300 MP3 Hybrid iE   | 11-18 | <b>MS</b> |
|                      | 300 MP3 iE          | 10-18 | <b>MS</b> |
|                      | 300 MP3 LT          | 13-18 | <b>MS</b> |
|                      | 300 MP3 LT Business | 13-18 | <b>MS</b> |



| <b>PIAGGIO VESPA</b> |                    |       |           |
|----------------------|--------------------|-------|-----------|
|                      | 300 MP3 LT Touring | 11-12 | <b>MS</b> |
|                      | 300 MP3 Touring    | 11-12 | <b>MS</b> |
|                      | 300 MP3 Yourban iE | 11-18 | <b>MS</b> |
|                      | 400 MP3 iE         | 07-10 | <b>MS</b> |
|                      | 400 MP3 LT iE      | 09-10 | <b>MS</b> |
|                      | 400 MP3 LT Touring | 11-12 | <b>MS</b> |
|                      | 400 MP3 Touring    | 11-12 | <b>MS</b> |
|                      | 500 MP3            | 10    | <b>MS</b> |
|                      | 500 MP3 LT Touring |       |           |
|                      | Business           | 11-13 | <b>MS</b> |
|                      | 500 MP3 LT Touring |       |           |
|                      | Sport              | 11-13 | <b>MS</b> |
|                      | 500 MP3 Touring    |       |           |
|                      | Business           | 11-12 | <b>MS</b> |
|                      | 500 MP3 Touring    |       |           |
|                      | Sport              | 11-12 | <b>MS</b> |
| <b>SYM</b>           |                    |       |           |
|                      | 50 Fiddle III      | 16-18 | <b>CT</b> |
|                      | 125 Fiddle III     | 16-18 | <b>CT</b> |
|                      | 125 Jet 14         | 17-18 | <b>CT</b> |
|                      | 125 Symphony S     | 11-17 | <b>CT</b> |
|                      | 125 Symphony SR    | 11-17 | <b>CT</b> |
|                      | 125 Symphony ST    | 15-18 | <b>CT</b> |
|                      | 150 Symphony S     | 11-15 | <b>CT</b> |
|                      | 150 Symphony SR    | 11-15 | <b>CT</b> |
|                      | 200 Fiddle III     | 16-18 | <b>CT</b> |



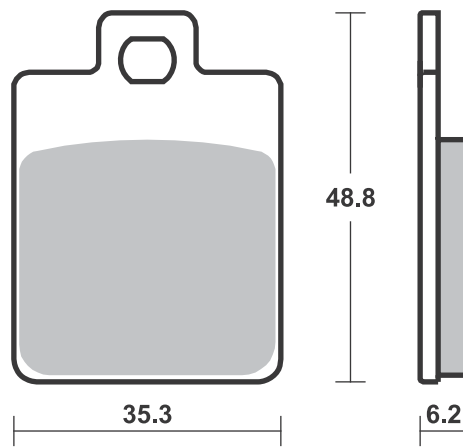
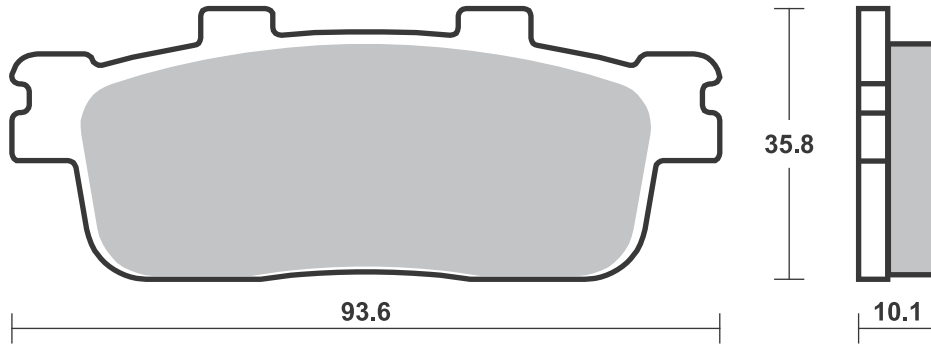

**SBS 203** Recommended compound



| <b>DERBI</b>         |       |           |           |
|----------------------|-------|-----------|-----------|
| 125 Senda DRD SM     | 10-14 | <b>HF</b> |           |
| <b>MOTORHISPANIA</b> |       |           |           |
| RX 50 R              | 08-14 | <b>HF</b> |           |
| <b>RIEJU</b>         |       |           |           |
| MRT 50               | 09-15 | <b>HF</b> | <b>HF</b> |
| MRT 50 Supermotard   | 09-17 | <b>HF</b> | <b>HF</b> |
| RRX 50               | 08    | <b>HF</b> | <b>HF</b> |
| <b>TGB</b>           |       |           |           |
| 50 Bull&t RS/RR      | 11-17 | <b>HF</b> |           |
| 50 Bullet            | 10-12 | <b>HF</b> |           |
| 125 Bull&t RS/RR     | 11-14 | <b>HF</b> |           |
|                      |       |           |           |
|                      |       |           |           |
|                      |       |           |           |
|                      |       |           |           |
|                      |       |           |           |
|                      |       |           |           |
|                      |       |           |           |
|                      |       |           |           |
|                      |       |           |           |
|                      |       |           |           |
|                      |       |           |           |
|                      |       |           |           |
|                      |       |           |           |
|                      |       |           |           |
|                      |       |           |           |
|                      |       |           |           |
|                      |       |           |           |

**SBS 204** Recommended compound



| <b>KAWASAKI</b>  |       |           |  |
|------------------|-------|-----------|--|
| J 125            | 15-18 | <b>CT</b> |  |
| J 300            | 14-18 | <b>MS</b> |  |
| <b>KYMCO</b>     |       |           |  |
| 125 Downtown i   | 10-14 | <b>CT</b> |  |
| 125 New Downtown | 16-17 | <b>CT</b> |  |
| 125 People GTi   | 12-15 | <b>CT</b> |  |
| 125 Super Dink   | 10-15 | <b>CT</b> |  |
| 125 X-Town       | 16-17 | <b>MS</b> |  |
| 200 Downtown i   | 10-15 | <b>CT</b> |  |
| 200 People GTi   | 12-15 | <b>CT</b> |  |
| 300 Downtown i   | 10-15 | <b>MS</b> |  |
| 300 People GTi   | 12-15 | <b>MS</b> |  |
| 300 X-Town       | 16-17 | <b>MS</b> |  |
| 350 New Downtown | 16-17 | <b>MS</b> |  |
|                  |       |           |  |
|                  |       |           |  |
|                  |       |           |  |
|                  |       |           |  |
|                  |       |           |  |
|                  |       |           |  |
|                  |       |           |  |
|                  |       |           |  |
|                  |       |           |  |
|                  |       |           |  |
|                  |       |           |  |
|                  |       |           |  |
|                  |       |           |  |
|                  |       |           |  |
|                  |       |           |  |
|                  |       |           |  |
|                  |       |           |  |
|                  |       |           |  |
|                  |       |           |  |

Brake Pad 1:1 Drawings,  
Compounds, Fitments

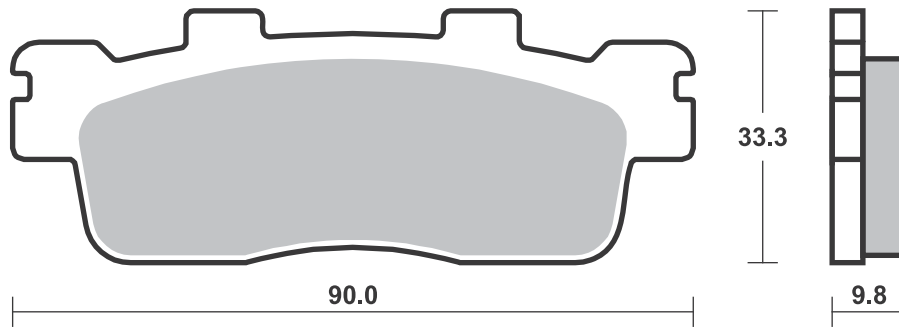
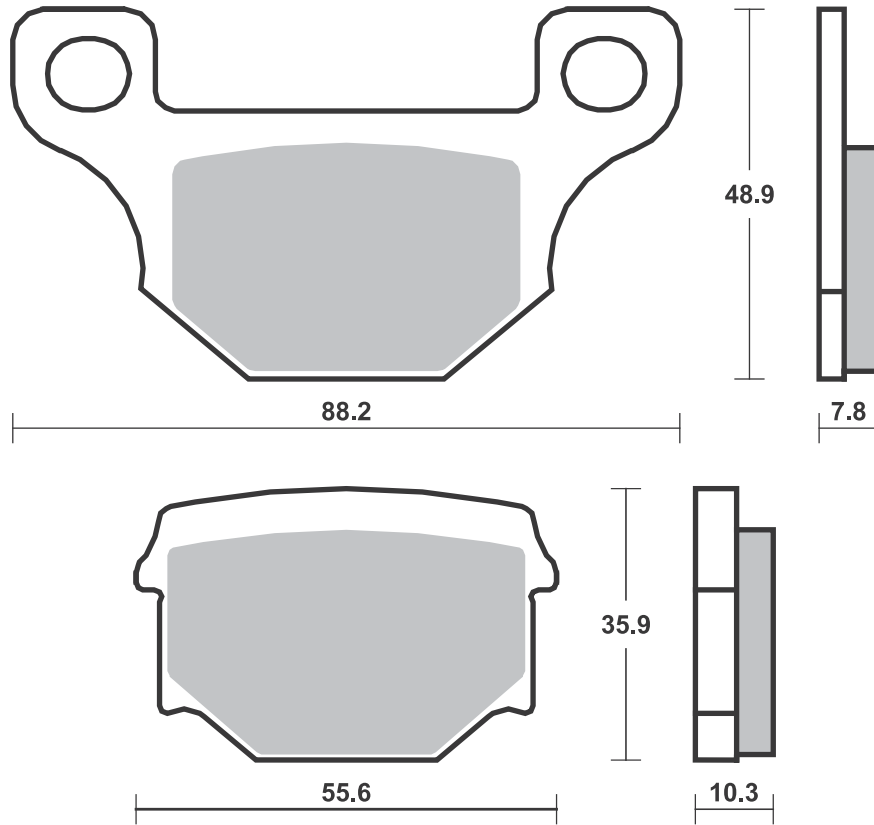



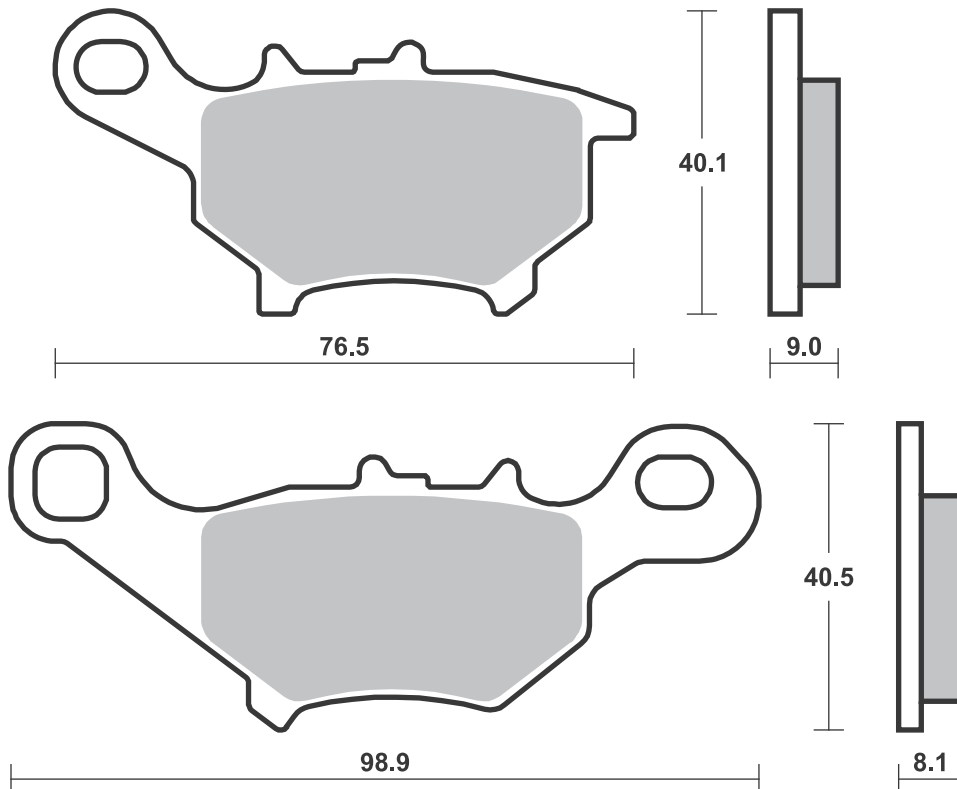
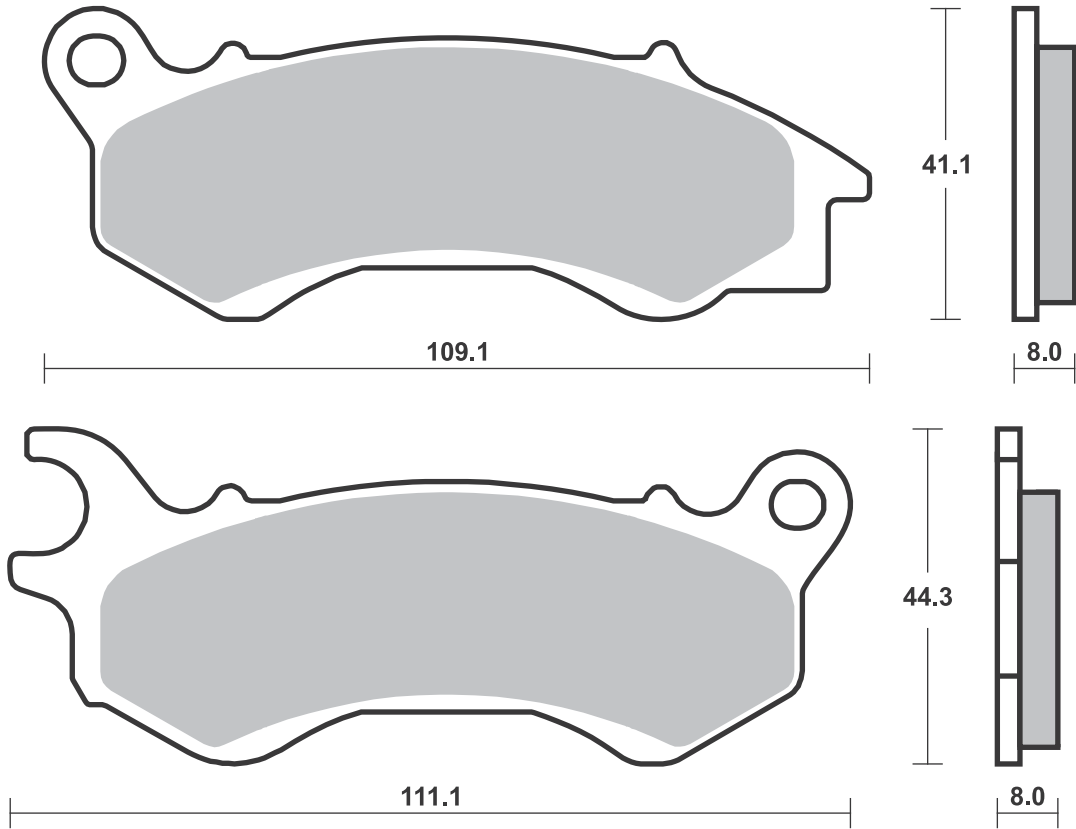



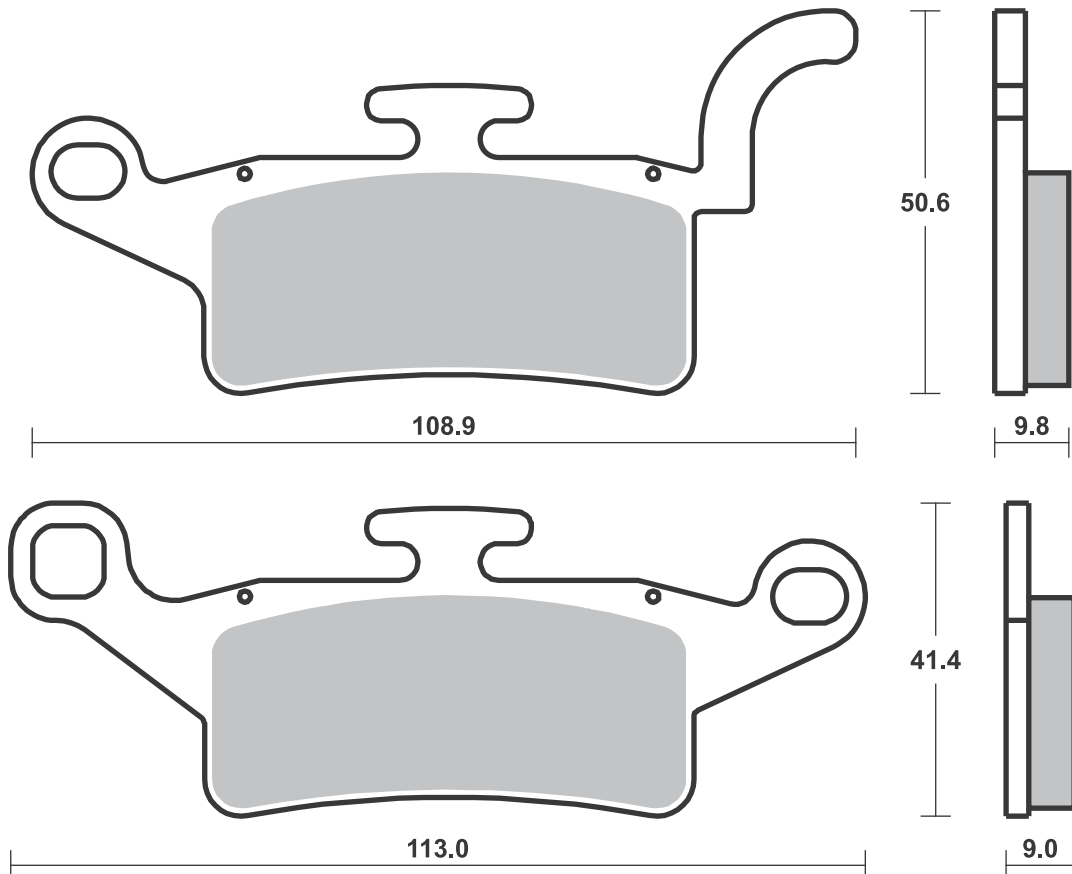
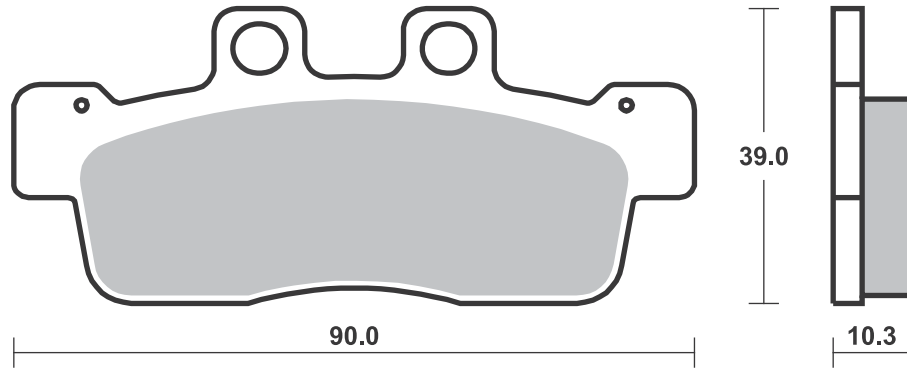



## Applications

### SBS 209 Recommended compound



| APRILIA       |                                    |       |           |
|---------------|------------------------------------|-------|-----------|
| SRV           | 850 (Parking Brake)                | 12-18 | <b>HF</b> |
| BMW           |                                    |       |           |
| C             | 600 Evolution<br>(Parking Brake)   | 12-18 | <b>HF</b> |
| C             | 600 Sport<br>(Parking Brake)       | 12-15 | <b>HF</b> |
| C             | 650 GT<br>(Parking Brake)          | 12-15 | <b>HF</b> |
| GILERA        |                                    |       |           |
| RC            | 500 Fuoco ie<br>(Parking Brake)    | 08-17 | <b>HF</b> |
| GP            | 800 (Parking Brake)                | 08-15 | <b>HF</b> |
| HONDA         |                                    |       |           |
| FJS           | 400 Silverwing<br>(Parking Brake)  | 06-08 | <b>HF</b> |
| FJS           | 600 Silverwing<br>(Parking Brake)  | 01-18 | <b>HF</b> |
| DN-01         | 680 (Parking Brake)                | 08-11 | <b>HF</b> |
| PIAGGIO VESPA |                                    |       |           |
|               | 125 MP3<br>(Parking Brake)         | 06-07 | <b>HF</b> |
|               | 125 MP3 Efi<br>(Parking Brake)     | 08-11 | <b>HF</b> |
|               | 125 MP3 Hybrid<br>(Parking Brake)  | 09-12 | <b>HF</b> |
|               | 125 MP3 Yourban<br>(Parking Brake) | 11-12 | <b>HF</b> |



| PIAGGIO VESPA |  |       |           |
|---------------|--|-------|-----------|
|               | 250 MP3<br>(Parking Brake)                 | 06-07 | <b>HF</b> |
|               | 250 MP3 Efi<br>(Parking Brake)             | 08-09 | <b>HF</b> |
|               | 250 MP3 LT iE<br>(Parking Brake)           | 09    | <b>HF</b> |
|               | 300 MP3 Hybrid<br>(Parking Brake)          | 11-12 | <b>HF</b> |
|               | 300 MP3 Hybrid iE<br>(Parking Brake)       | 11-18 | <b>HF</b> |
|               | 300 MP3 iE<br>(Parking Brake)              | 10-18 | <b>HF</b> |
|               | 300 MP3 LT<br>(Parking Brake)              | 13-18 | <b>HF</b> |
|               | 300 MP3 LT Business<br>(Parking Brake)     | 13-18 | <b>HF</b> |
|               | 300 MP3 LT iE ABS<br>(Parking Brake)       | 14-18 | <b>HF</b> |
|               | 300 MP3 LT Sport<br>ABS<br>(Parking Brake) | 14-18 | <b>HF</b> |
|               | 300 MP3 LT Touring<br>(Parking Brake)      | 11-12 | <b>HF</b> |
|               | 300 MP3 Touring<br>(Parking Brake)         | 11-12 | <b>HF</b> |
|               | 300 MP3 Yourban iE<br>(Parking Brake)      | 11-18 | <b>HF</b> |
|               | 350 X10 Executive<br>(Parking Brake)       | 13-16 | <b>HF</b> |
|               | 400 MP3 iE<br>(Parking Brake)              | 07-10 | <b>HF</b> |



| PIAGGIO VESPA |   |       |           |
|---------------|---|-------|-----------|
|               | 400 MP3 LT iE<br>(Parking Brake)                      | 09-10 | <b>HF</b> |
|               | 400 MP3 LT Touring<br>(Parking Brake)                 | 11-12 | <b>HF</b> |
|               | 400 MP3 Touring<br>(Parking Brake)                    | 11-12 | <b>HF</b> |
|               | 500 MP3<br>(Parking Brake)                            | 10    | <b>HF</b> |
|               | 500 MP3 LT Touring<br>Business<br>(Parking Brake)     | 11-13 | <b>HF</b> |
|               | 500 MP3 LT Touring<br>Business ABS<br>(Parking Brake) | 14-15 | <b>HF</b> |
|               | 500 MP3 LT Touring<br>Sport<br>(Parking Brake)        | 11-13 | <b>HF</b> |
|               | 500 MP3 LT Touring<br>Sport ABS<br>(Parking Brake)    | 14-15 | <b>HF</b> |
|               | 500 MP3 Touring<br>Business<br>(Parking Brake)        | 11-12 | <b>HF</b> |
|               | 500 MP3 Touring<br>Sport<br>(Parking Brake)           | 11-12 | <b>HF</b> |
|               | 500 X10 Executive<br>(Parking Brake)                  | 13-15 | <b>HF</b> |

### SBS 210 Recommended compound



| TGB |              |       |           |
|-----|--------------|-------|-----------|
|     | 125 X-Large  | 11    | <b>CT</b> |
|     | 125 X-Motion | 08-12 | <b>CT</b> |
|     | 250 X-Motion | 08-09 | <b>MS</b> |
|     | 300 X-Motion | 10-12 | <b>MS</b> |
|     |              |       |           |
|     |              |       |           |
|     |              |       |           |
|     |              |       |           |
|     |              |       |           |
|     |              |       |           |
|     |              |       |           |
|     |              |       |           |
|     |              |       |           |
|     |              |       |           |
|     |              |       |           |
|     |              |       |           |
|     |              |       |           |
|     |              |       |           |
|     |              |       |           |
|     |              |       |           |
|     |              |       |           |
|     |              |       |           |
|     |              |       |           |
|     |              |       |           |
|     |              |       |           |
|     |              |       |           |
|     |              |       |           |
|     |              |       |           |
|     |              |       |           |
|     |              |       |           |
|     |              |       |           |
|     |              |       |           |
|     |              |       |           |
|     |              |       |           |
|     |              |       |           |
|     |              |       |           |
|     |              |       |           |
|     |              |       |           |
|     |              |       |           |
|     |              |       |           |
|     |              |       |           |
|     |              |       |           |

Brake Pad 1:1 Drawings, Compounds, Fitments



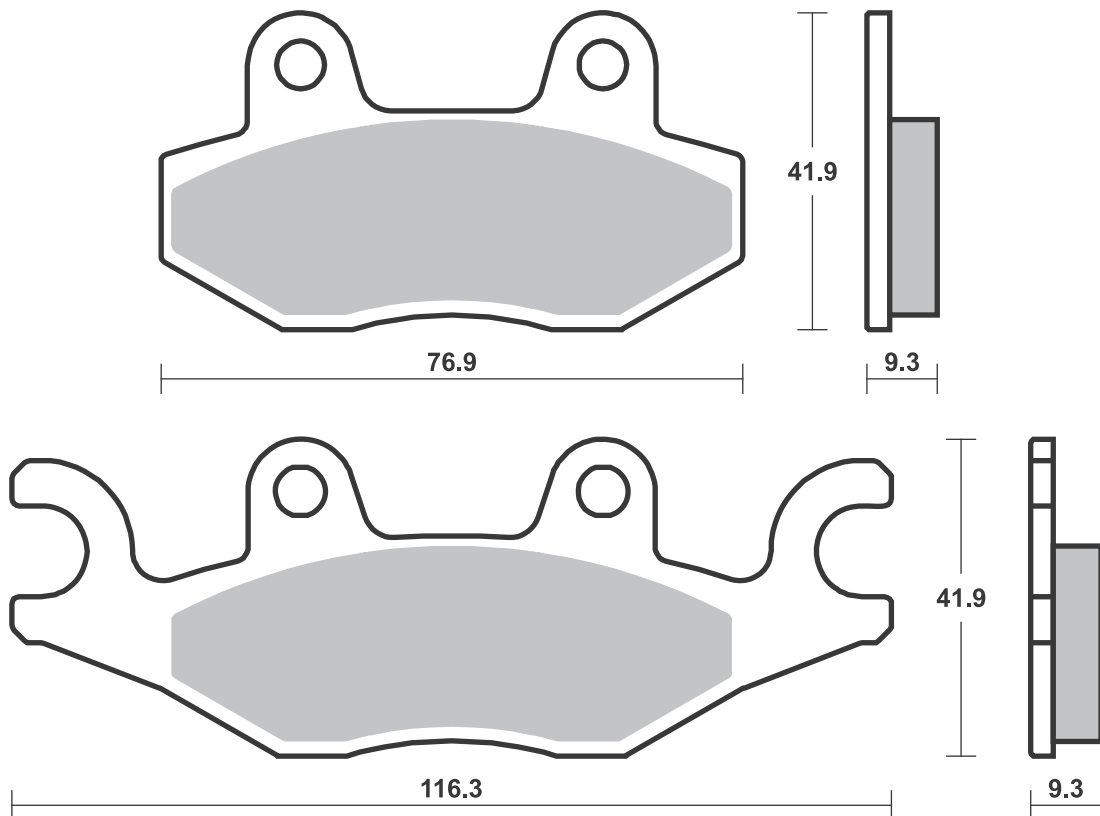
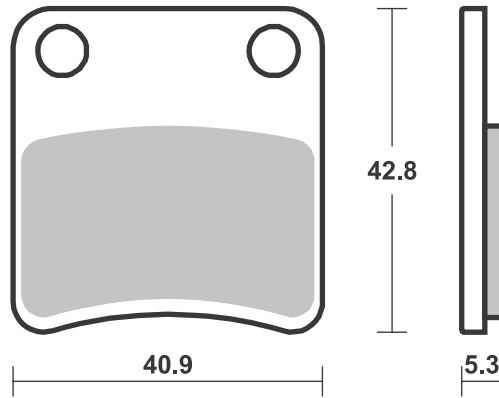

**SBS 211 Recommended compound**



| <b>ELSTARS</b>   |                 |       |              |
|------------------|-----------------|-------|--------------|
|                  | 125 Blade S     | 10-11 | <b>HF HF</b> |
| <b>GENERIC</b>   |                 |       |              |
| SM               | 50 Mini Trigger | 08-09 | <b>HF HF</b> |
| X                | 50 Mini Trigger | 08-09 | <b>HF HF</b> |
| <b>ITALJET</b>   |                 |       |              |
|                  | 50 Pit Jet      | 07-09 | <b>HF HF</b> |
|                  | 125 Pit Jet     | 07-09 | <b>HF HF</b> |
| <b>LAMBRETTA</b> |                 |       |              |
|                  | 50 Pato         | 08-09 | <b>HF</b>    |
| <b>LIFAN</b>     |                 |       |              |
| LF               | 125 Off Road    | 07    | <b>HF</b>    |
| <b>MOTOM</b>     |                 |       |              |
|                  | 50 Spasso       | 08-09 | <b>HF</b>    |
| <b>QUADZILLA</b> |                 |       |              |
| WK               | 140             | 06-08 | <b>HF</b>    |
| <b>STOMP</b>     |                 |       |              |
|                  | 125 Elite       | 07-09 | <b>HF</b>    |
|                  |                 |       |              |
|                  |                 |       |              |
|                  |                 |       |              |
|                  |                 |       |              |
|                  |                 |       |              |
|                  |                 |       |              |
|                  |                 |       |              |
|                  |                 |       |              |
|                  |                 |       |              |

**SBS 212 Recommended compound**



| <b>KYMCO</b> |                   |       |           |
|--------------|-------------------|-------|-----------|
|              | 400 Xciting i     | 12-14 | <b>MS</b> |
|              | 500 Xciting       | 04-15 | <b>MS</b> |
|              | 500 Xciting i Evo |       |           |
|              | ABS               | 11-13 | <b>MS</b> |
|              | 500 Xciting R ABS | 09-13 | <b>MS</b> |
|              | 700 MyRoad, ABS   | 09-15 | <b>MS</b> |
|              |                   |       |           |
|              |                   |       |           |
|              |                   |       |           |
|              |                   |       |           |
|              |                   |       |           |
|              |                   |       |           |
|              |                   |       |           |
|              |                   |       |           |
|              |                   |       |           |
|              |                   |       |           |
|              |                   |       |           |
|              |                   |       |           |
|              |                   |       |           |
|              |                   |       |           |
|              |                   |       |           |
|              |                   |       |           |
|              |                   |       |           |
|              |                   |       |           |
|              |                   |       |           |
|              |                   |       |           |
|              |                   |       |           |

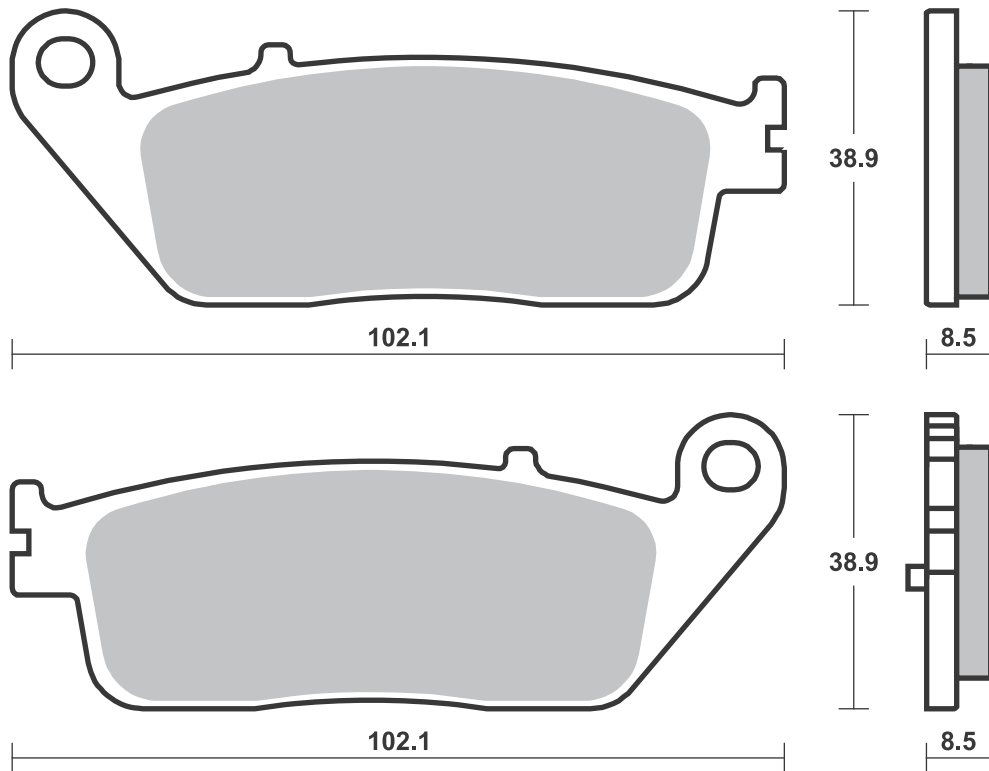
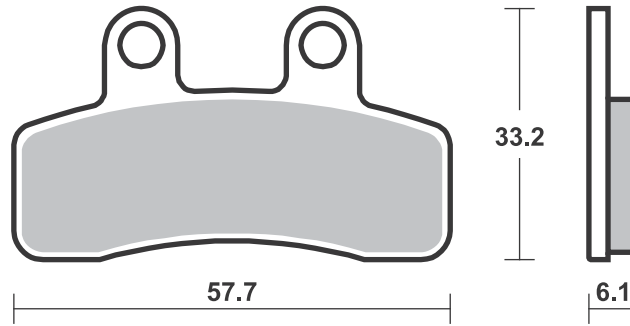

**SBS 213** Recommended compound



| <b>LIFAN</b>     |              |       |           |
|------------------|--------------|-------|-----------|
| LF               | 125 Off Road | 07    | <b>HF</b> |
| <b>QUADZILLA</b> |              |       |           |
| WK               | 140          | 06-08 | <b>HF</b> |
| <b>STOMP</b>     |              |       |           |
|                  | 125 Elite    | 07-09 | <b>HF</b> |
|                  |              |       |           |
|                  |              |       |           |
|                  |              |       |           |
|                  |              |       |           |
|                  |              |       |           |
|                  |              |       |           |
|                  |              |       |           |
|                  |              |       |           |
|                  |              |       |           |
|                  |              |       |           |
|                  |              |       |           |
|                  |              |       |           |

**SBS 214** Recommended compound



| <b>KYMCO</b> |               |       |           |
|--------------|---------------|-------|-----------|
|              | 400 Xciting i | 12-14 | <b>MS</b> |
| <b>SYM</b>   |               |       |           |
|              | 400 i Maxsym  | 11    | <b>MS</b> |
|              |               |       |           |
|              |               |       |           |
|              |               |       |           |
|              |               |       |           |
|              |               |       |           |
|              |               |       |           |
|              |               |       |           |
|              |               |       |           |
|              |               |       |           |
|              |               |       |           |
|              |               |       |           |
|              |               |       |           |
|              |               |       |           |
|              |               |       |           |

**SBS 215** Recommended compound



| <b>SYM</b> |                    |       |           |
|------------|--------------------|-------|-----------|
|            | 300 Cruisym        | 17    | <b>MS</b> |
|            | 400 i Maxsym       | 12-17 | <b>MS</b> |
|            | 600 i Maxsym       | 14-18 | <b>MS</b> |
|            | 600 i Maxsym Sport | 18-   | <b>MS</b> |
|            |                    |       |           |
|            |                    |       |           |
|            |                    |       |           |
|            |                    |       |           |
|            |                    |       |           |
|            |                    |       |           |
|            |                    |       |           |
|            |                    |       |           |
|            |                    |       |           |
|            |                    |       |           |
|            |                    |       |           |
|            |                    |       |           |
|            |                    |       |           |
|            |                    |       |           |

Brake Pad 1:1 Drawings,  
Compounds, Fitments

Available compounds **HF • CT**

**SBS 213**

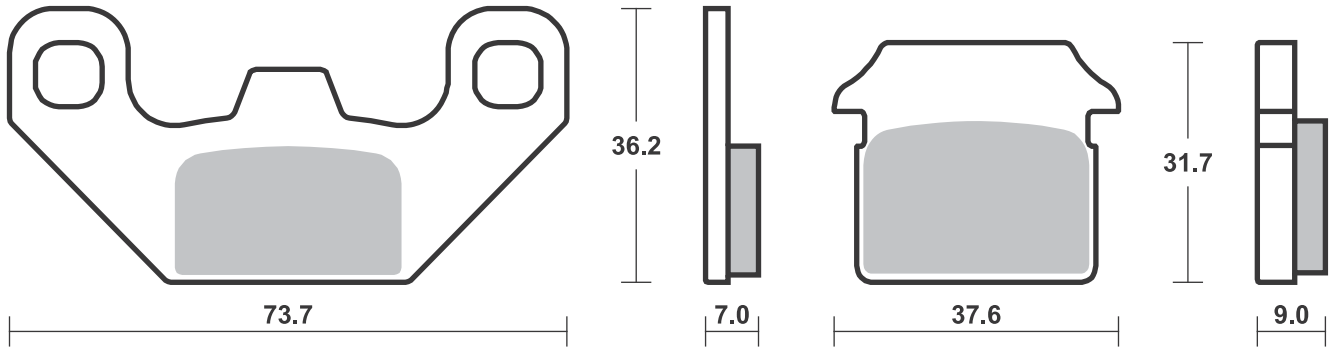

Available compounds **HF • CT • MS**

**SBS 214**

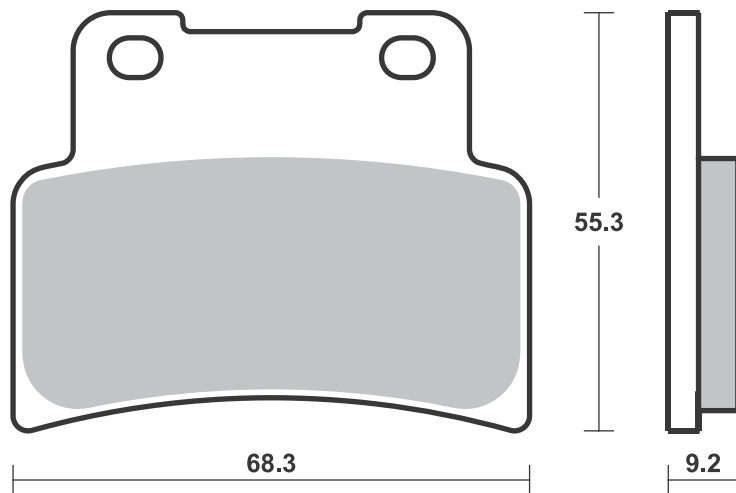

Available compounds **HF • CT • MS**

**SBS 215**

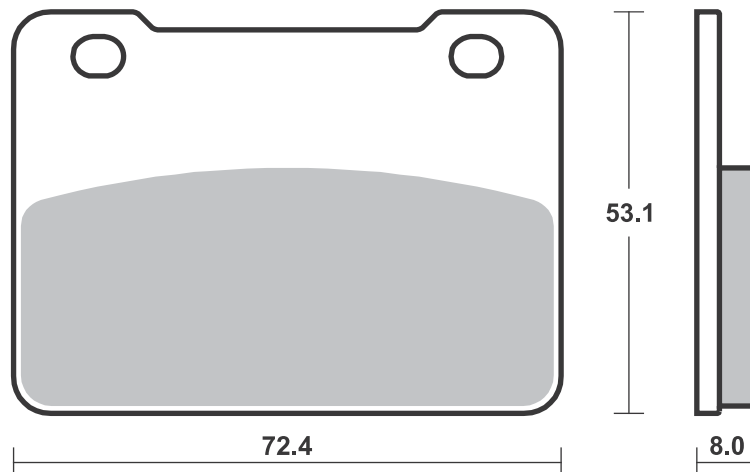



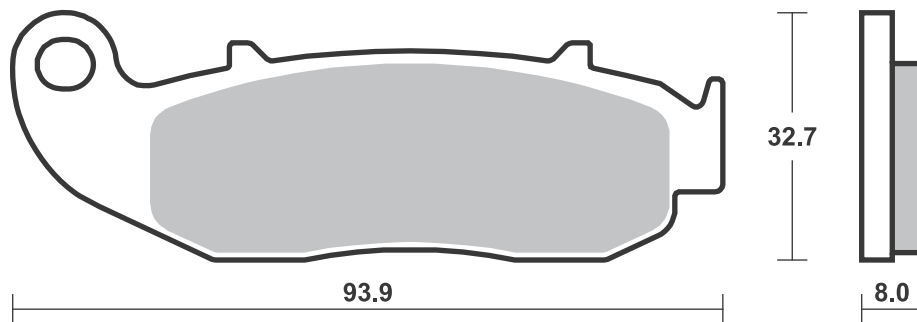
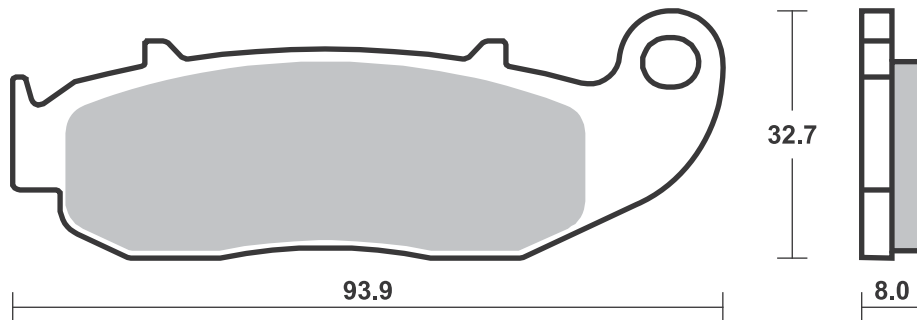
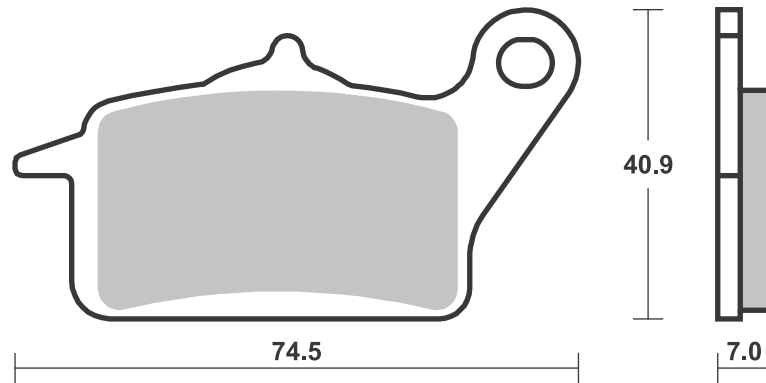
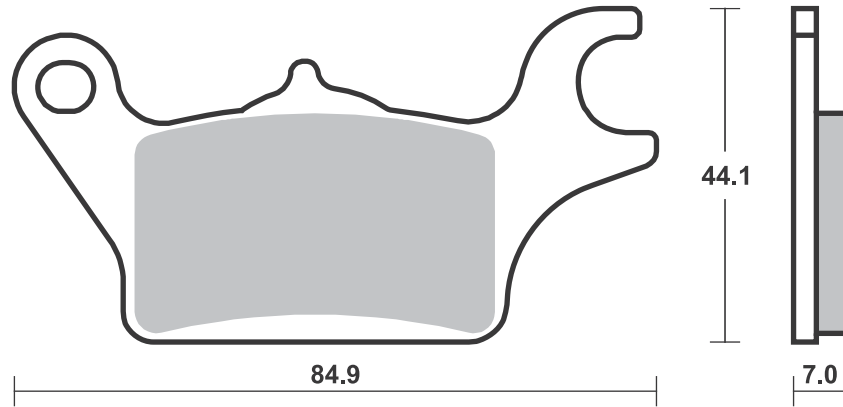

**SBS 218 Recommended compound**



| <b>SYM</b>         |       |           |
|--------------------|-------|-----------|
| 400 i Maxsym       | 11-17 | <b>MS</b> |
| 600 i Maxsym       | 14-18 | <b>MS</b> |
| 600 i Maxsym Sport | 18-   | <b>MS</b> |
|                    |       |           |
|                    |       |           |
|                    |       |           |
|                    |       |           |
|                    |       |           |
|                    |       |           |
|                    |       |           |
|                    |       |           |
|                    |       |           |
|                    |       |           |
|                    |       |           |
|                    |       |           |
|                    |       |           |
|                    |       |           |
|                    |       |           |
|                    |       |           |
|                    |       |           |
|                    |       |           |
|                    |       |           |
|                    |       |           |
|                    |       |           |

**SBS 219 Recommended compound**



| <b>PEUGEOT</b> |       |           |           |
|----------------|-------|-----------|-----------|
| 400 Metropolis | 15-16 | <b>MS</b> | <b>MS</b> |
|                |       |           |           |
|                |       |           |           |
|                |       |           |           |
|                |       |           |           |
|                |       |           |           |
|                |       |           |           |
|                |       |           |           |
|                |       |           |           |
|                |       |           |           |
|                |       |           |           |
|                |       |           |           |
|                |       |           |           |
|                |       |           |           |
|                |       |           |           |
|                |       |           |           |
|                |       |           |           |
|                |       |           |           |
|                |       |           |           |
|                |       |           |           |
|                |       |           |           |
|                |       |           |           |
|                |       |           |           |
|                |       |           |           |
|                |       |           |           |
|                |       |           |           |
|                |       |           |           |

Brake Pad 1:1 Drawings, Compounds, Fitments



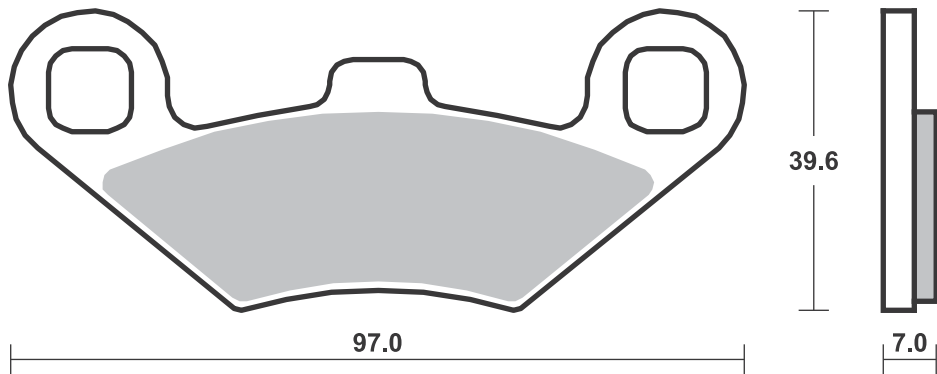
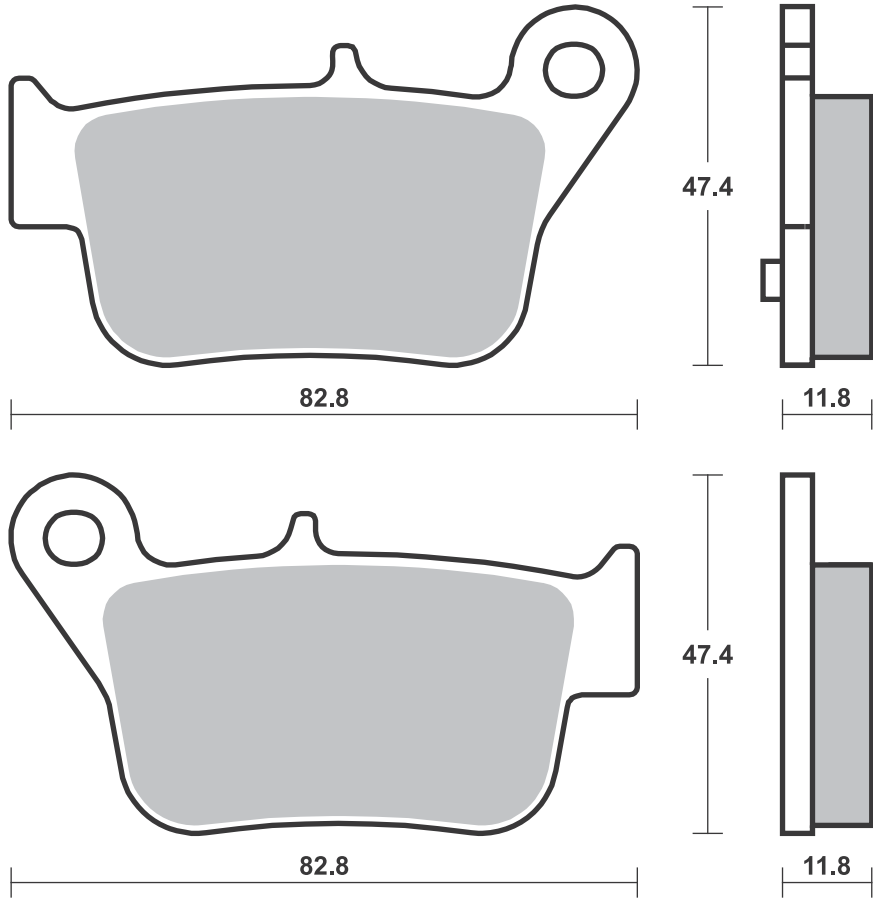



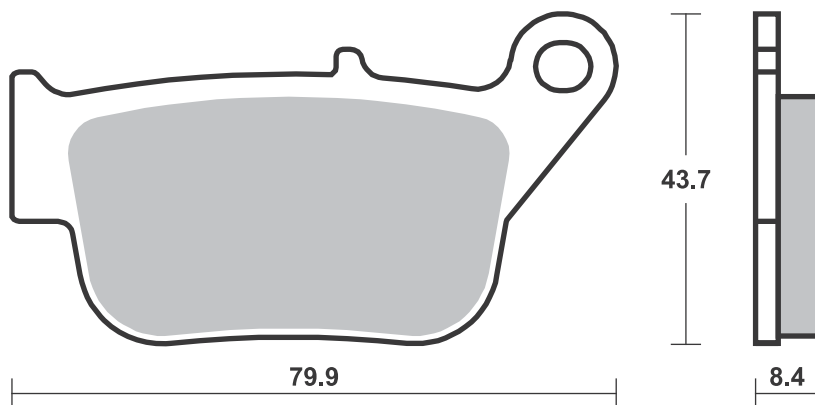
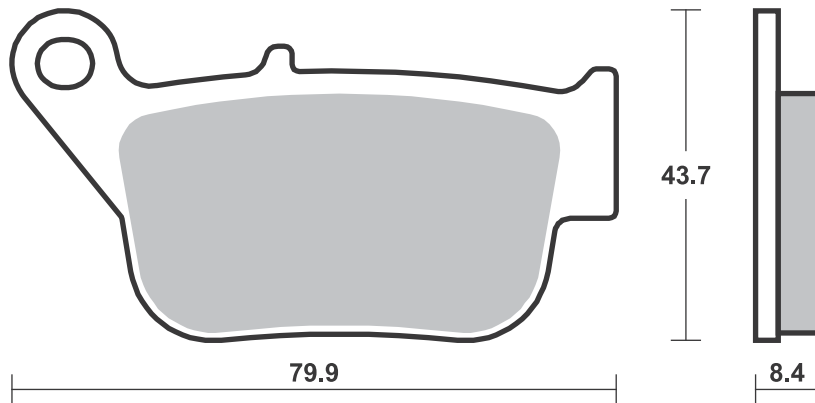
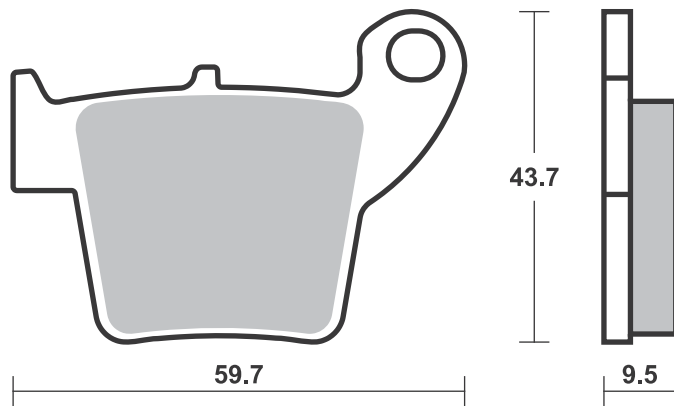
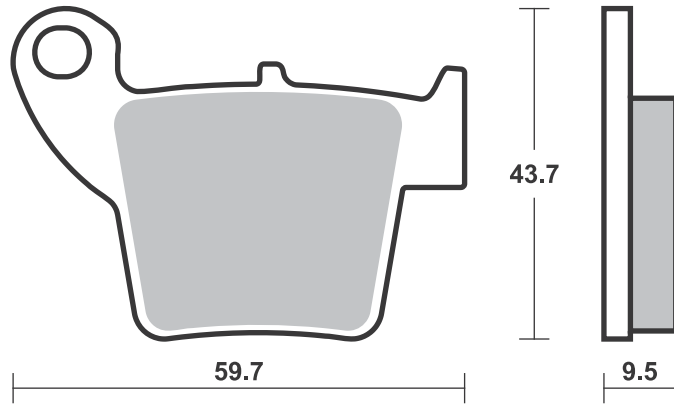



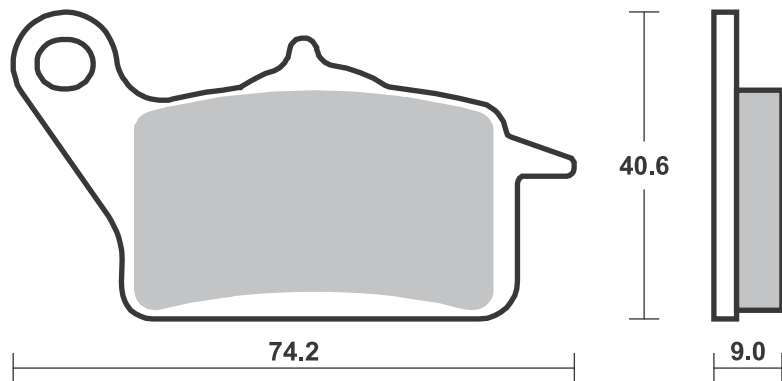
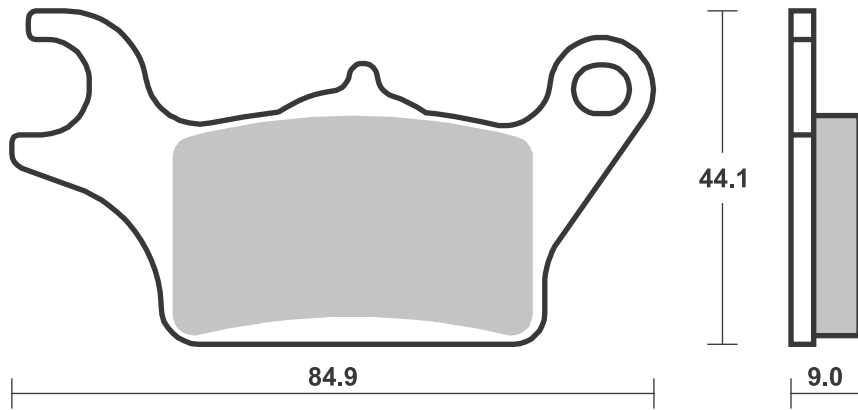
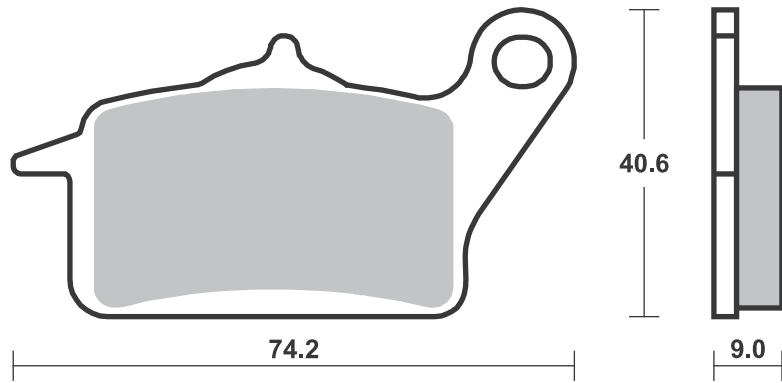
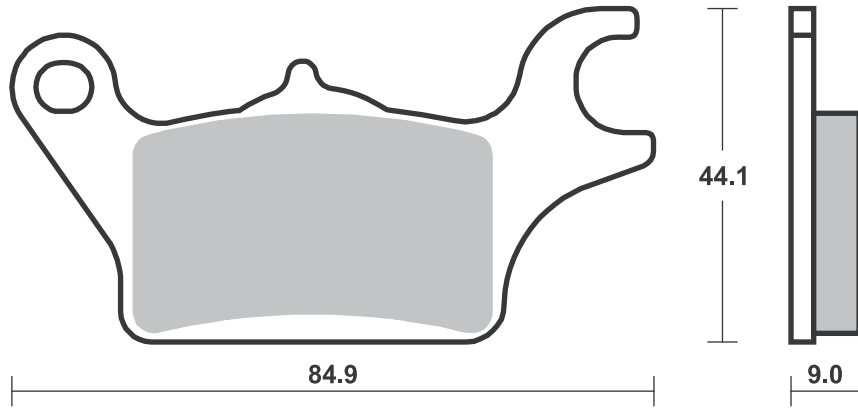



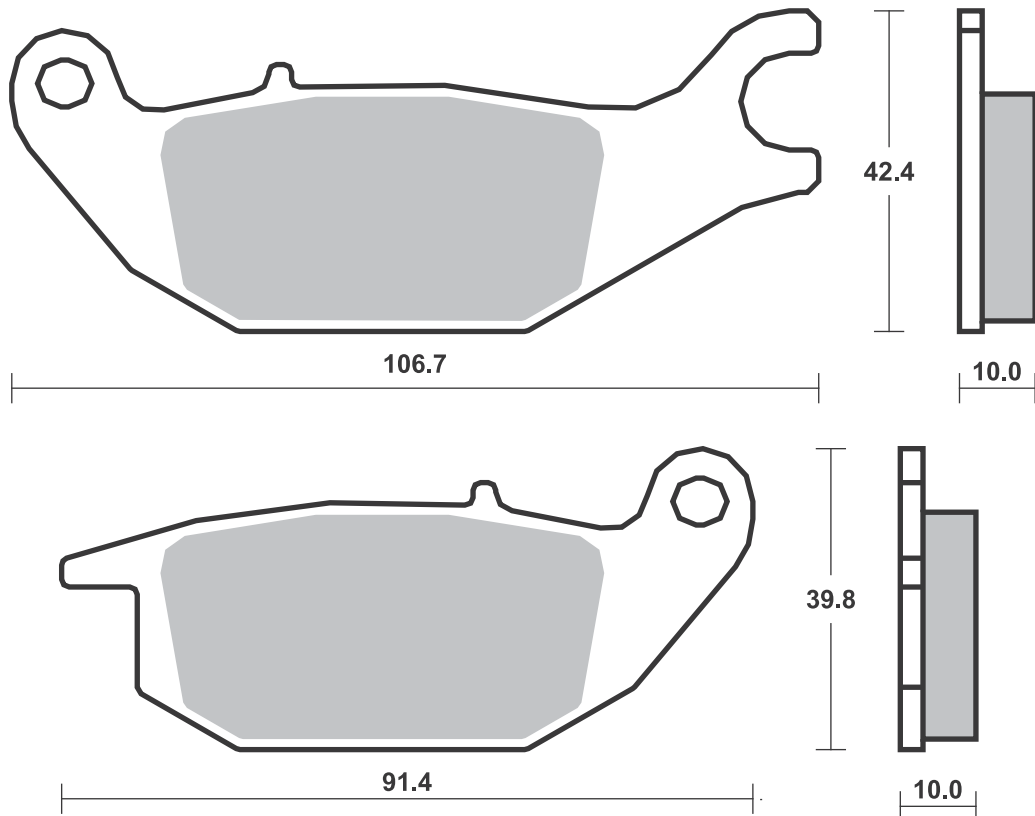
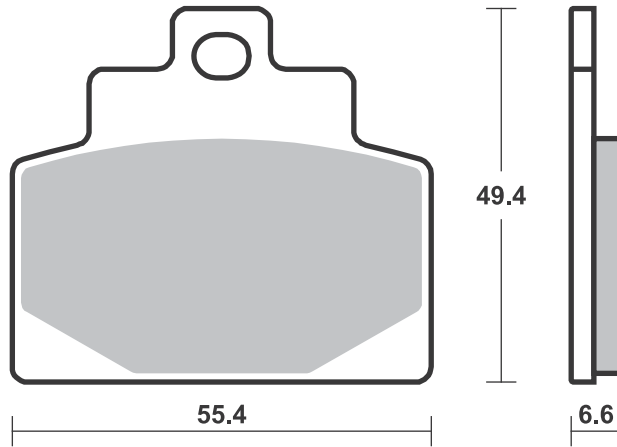

**SBS 226** Recommended compound



**YAMAHA**

|     |           |       |    |
|-----|-----------|-------|----|
| GPD | 125 N-Max | 15-18 | CT |
| GPD | 155 N-Max | 15-18 | CT |

**SBS 227** Recommended compound



**YAMAHA**

|     |           |       |    |
|-----|-----------|-------|----|
| GPD | 125 N-Max | 15-18 | CT |
| GPD | 155 N-Max | 15-18 | CT |

Brake Pad 1:1 Drawings,  
Compounds, Fitments



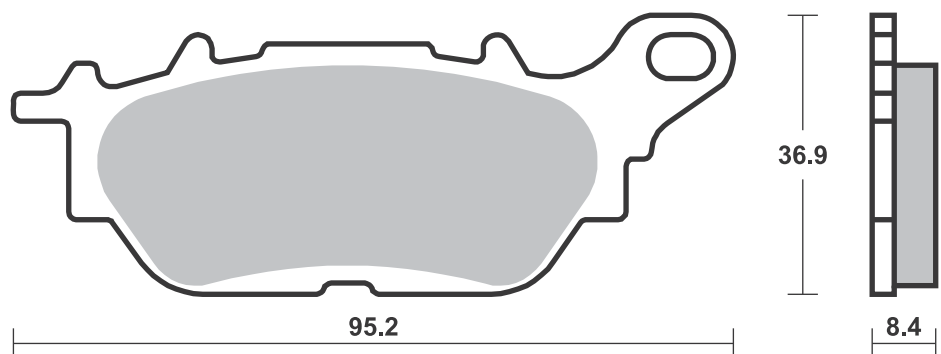
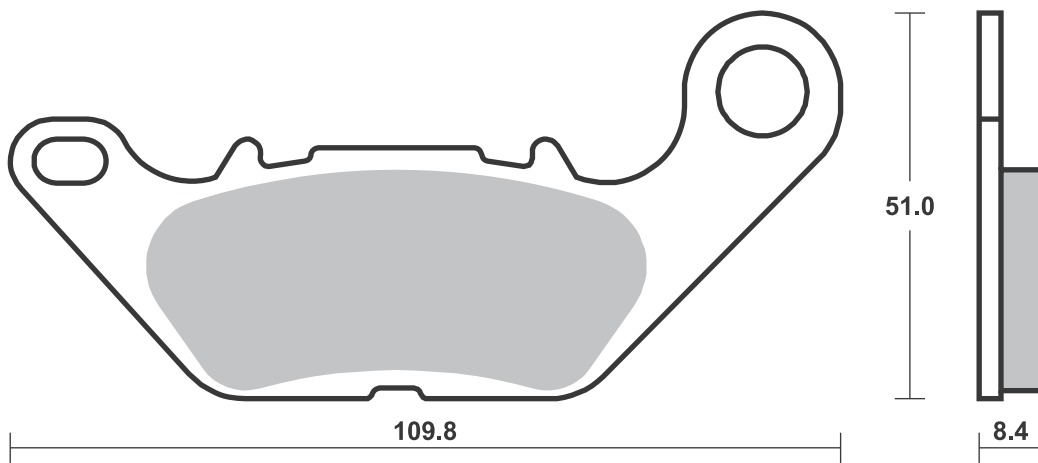
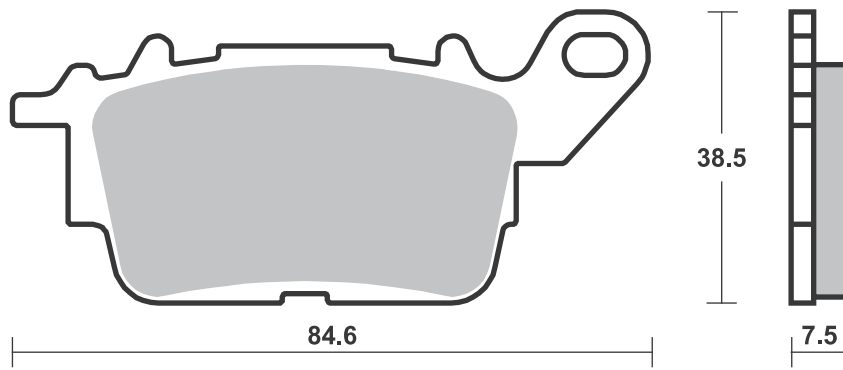
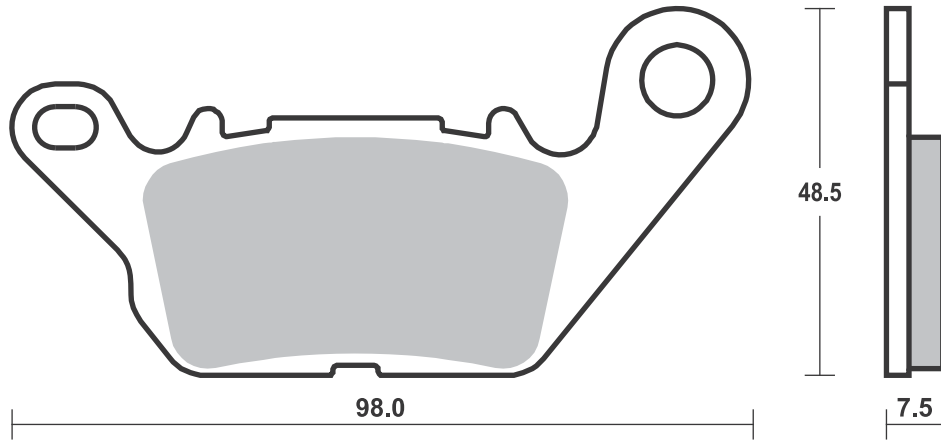



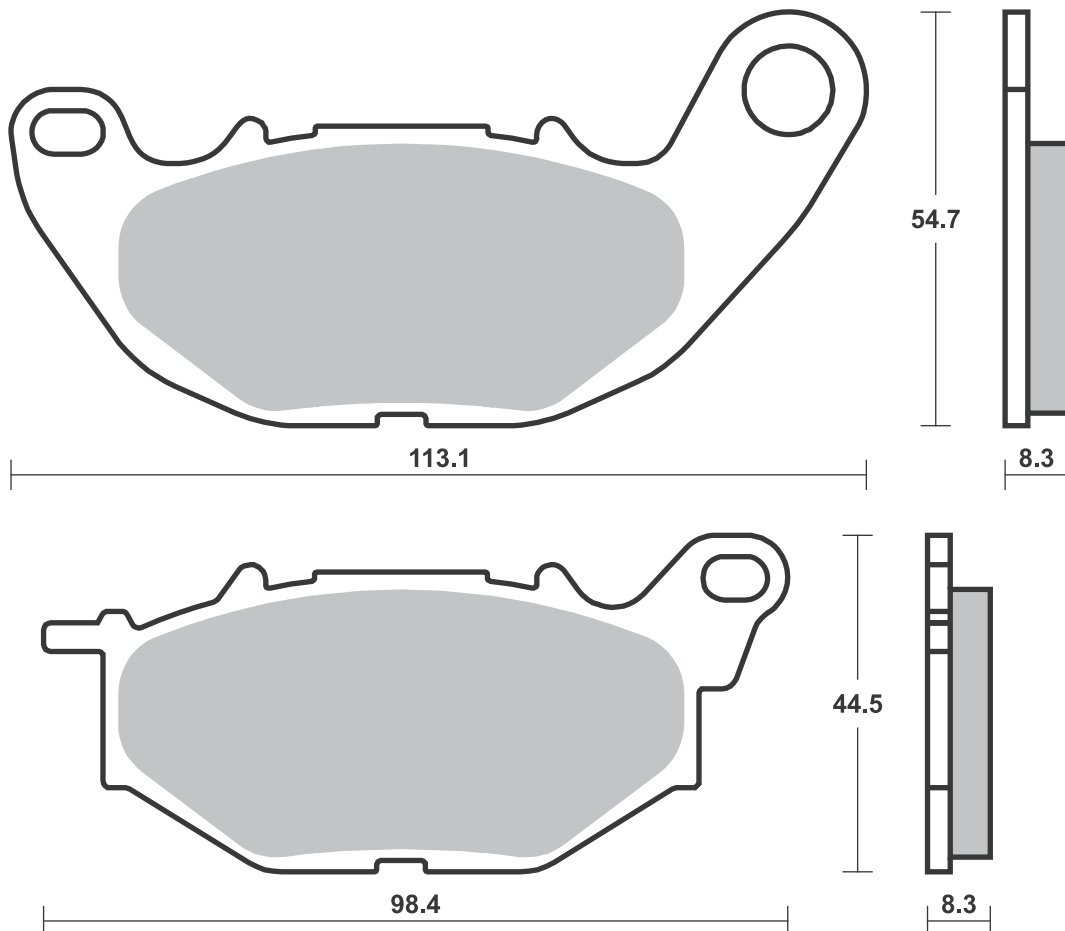
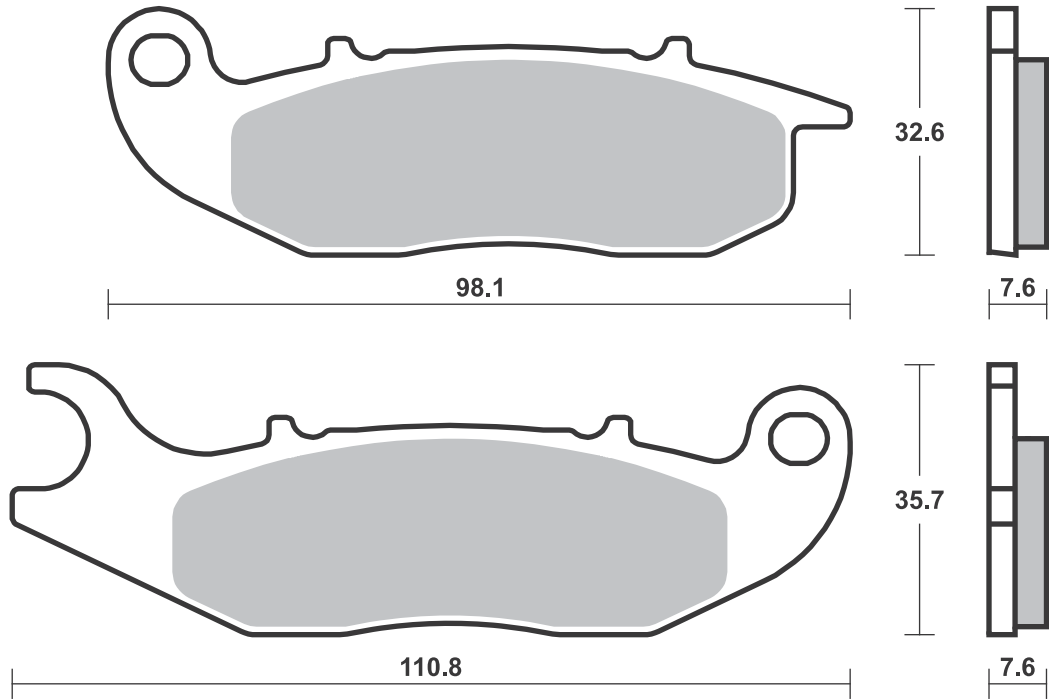



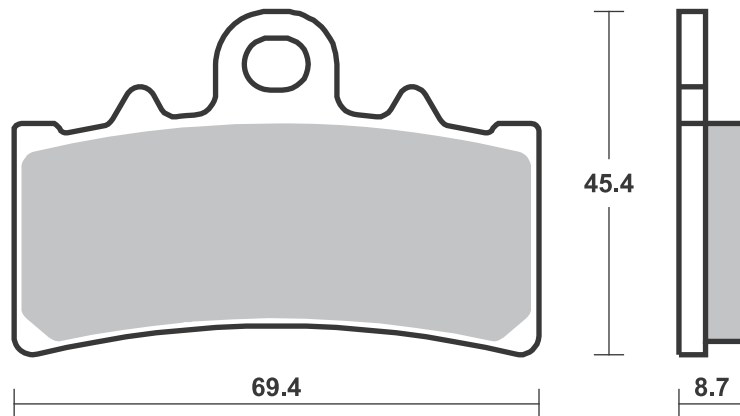
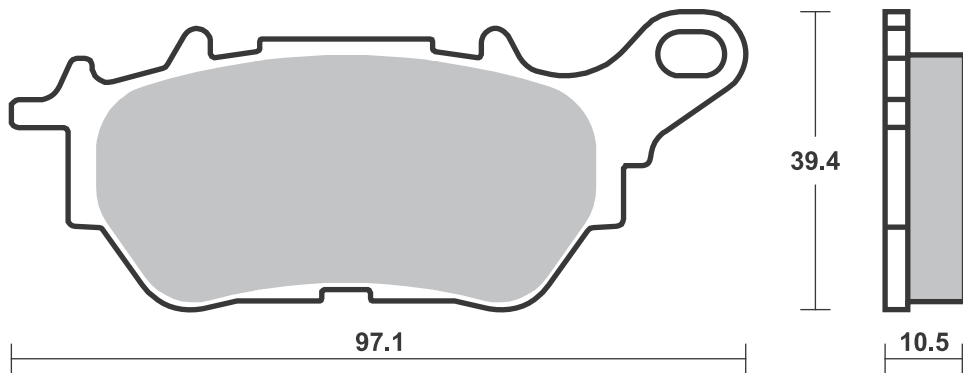
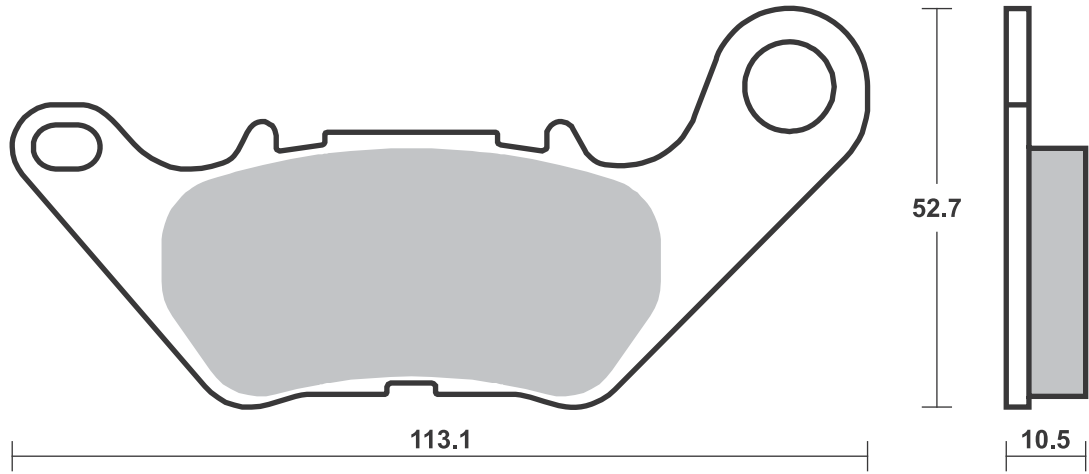

**SBS 500** Recommended compound**YAMAHA**

|     |        |       |           |
|-----|--------|-------|-----------|
| FS  | 50 DX  | 75-79 | <b>HF</b> |
| FS1 | 50 DX  | 77-78 | <b>HF</b> |
| RD  | 50     | 76-78 | <b>HF</b> |
| RD  | 90     | 76-79 | <b>HF</b> |
| RD  | 100 D  | 76-79 | <b>HF</b> |
| RS  | 100 DX | 77-79 | <b>HF</b> |
| RX  | 100    | 76-79 | <b>HF</b> |
| RD  | 125 DX | 75-77 | <b>HF</b> |
| RS  | 125 DX | 76-79 | <b>HF</b> |
| RD  | 200 DX | 76-78 | <b>HF</b> |
|     |        |       |           |
|     |        |       |           |
|     |        |       |           |
|     |        |       |           |
|     |        |       |           |
|     |        |       |           |
|     |        |       |           |
|     |        |       |           |
|     |        |       |           |

**SBS 501** Recommended compound**HONDA**

|    |                |       |           |
|----|----------------|-------|-----------|
| CB | 250 G, T       | 74-76 | <b>HF</b> |
| CJ | 250 T          | 76-78 | <b>HF</b> |
| CB | 350 F, F1      | 73-76 | <b>HF</b> |
| CB | 360 G, T       | 73-76 | <b>HF</b> |
| CJ | 360 T          | 76-78 | <b>HF</b> |
| CL | 360            | 74-77 | <b>HF</b> |
| CB | 400 F, F1, F2  | 75-79 | <b>HF</b> |
| CB | 450 K5, K6, K7 | 72-77 | <b>HF</b> |
| CB | 500 F          | 72-75 | <b>HF</b> |
| CB | 500 T          | 75-78 | <b>HF</b> |
| CB | 550 F          | 75-79 | <b>HF</b> |
| CB | 550 K          | 74-78 | <b>HF</b> |
| CB | 750 A          | 76-78 | <b>HF</b> |
| CB | 750 F1         | 75-76 | <b>HF</b> |
| CB | 750 K Four     | 77-78 | <b>HF</b> |
|    |                |       |           |
|    |                |       |           |
|    |                |       |           |

**SBS 502** Recommended compound**HONDA**

|    |                |       |           |
|----|----------------|-------|-----------|
| CB | 750 K0-K6 Four | 70-76 | <b>HF</b> |
|    |                |       |           |
|    |                |       |           |
|    |                |       |           |
|    |                |       |           |
|    |                |       |           |
|    |                |       |           |
|    |                |       |           |
|    |                |       |           |
|    |                |       |           |
|    |                |       |           |
|    |                |       |           |
|    |                |       |           |
|    |                |       |           |
|    |                |       |           |
|    |                |       |           |
|    |                |       |           |

Available compounds **HF**

**SBS 500**

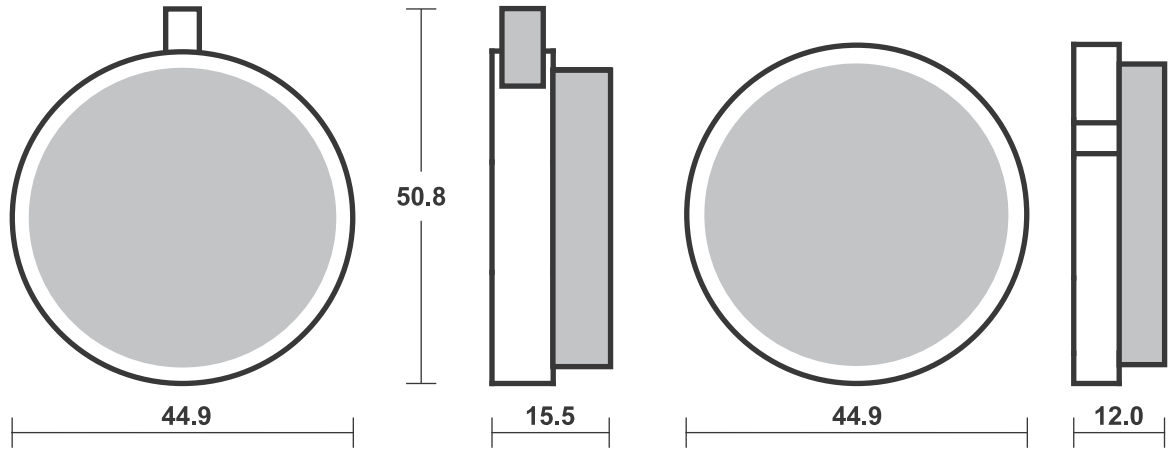

Available compounds **HF • DCC**

**SBS 501**

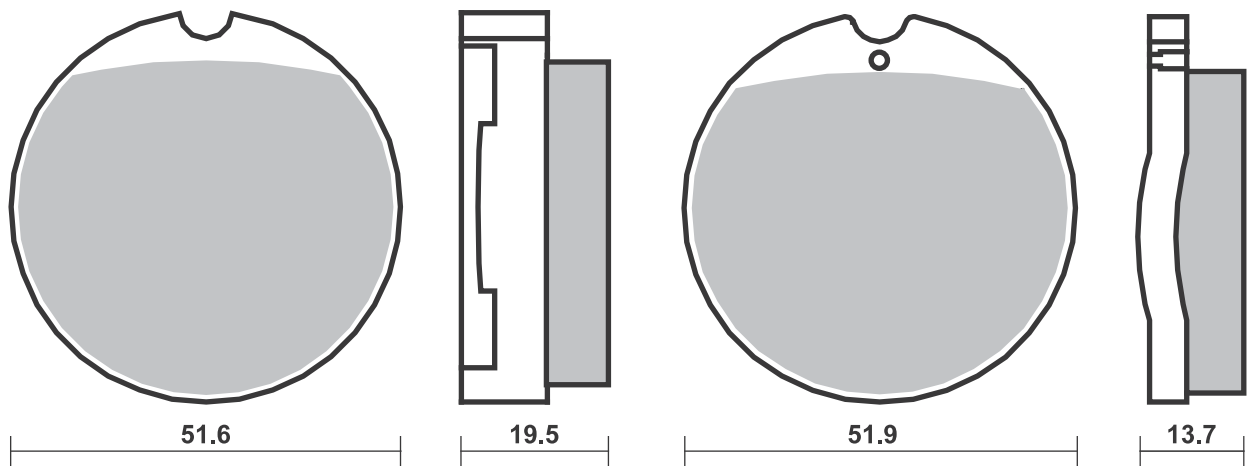

Available compounds **HF**

**SBS 502**

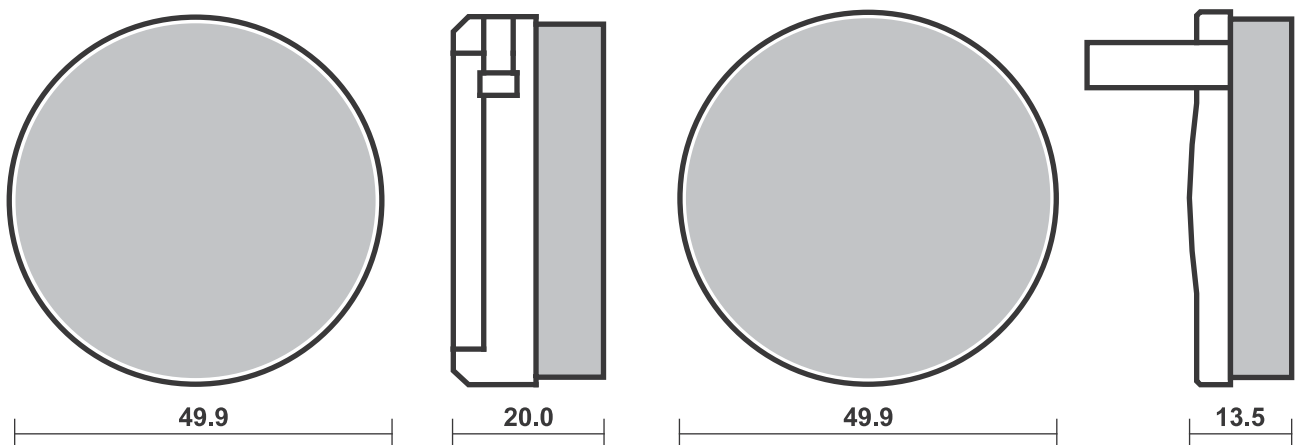

**SBS 503 Recommended compound**



| <b>KAWASAKI</b> |                |       |    |
|-----------------|----------------|-------|----|
| S2A             | 350            | 73    | HF |
| S3              | 400            | 74-75 | HF |
| S3A             | 400            | 74-75 | HF |
| KH              | 500 H1         | 74-75 | HF |
| Z               | 750 H          | 72-75 | HF |
| Z1              | 900 Z1 A, Z1 B | 73-75 | HF |
| <b>SUZUKI</b>   |                |       |    |
| RE              | 5M, A          | 75-77 | HF |
| RM              | 50             | 75-76 | HF |
| GT              | 100            | 78    | HF |
| GT              | 125            | 75-78 | HF |
| GT              | 185            | 75-77 | HF |
| RG              | 185            | 75-77 | HF |
| GT              | 250            | 73-78 | HF |
| GT              | 380            | 73-77 | HF |
| GT              | 500            | 75-77 | HF |
| GT              | 550            | 73-77 | HF |



| <b>SUZUKI</b> |     |       |    |
|---------------|-----|-------|----|
| GT            | 750 | 73-77 | HF |
|               |     |       |    |
|               |     |       |    |
|               |     |       |    |
|               |     |       |    |
|               |     |       |    |
|               |     |       |    |
|               |     |       |    |
|               |     |       |    |
|               |     |       |    |
|               |     |       |    |

**SBS 504 Recommended compound**



| <b>ISR CALIPERS</b>   |          |       |       |
|-----------------------|----------|-------|-------|
| 2 Piston (22-023/026) |          |       |       |
| <b>YAMAHA</b>         |          |       |       |
| RD                    | 250      | 73-77 | HF    |
| RD                    | 250      | 77    | HF HF |
| TZ                    | 250      | 82-85 | HF    |
| RD                    | 350      | 73-79 | HF    |
| XS                    | 360 B    | 76    | HF    |
| RD                    | 400      | 73-76 | HF    |
| RD                    | 400      | 77    | HF HF |
| TX                    | 500 A, B | 74-77 | HF    |
| XS                    | 500      | 75-77 | HF    |
| TX                    | 650      | 72-73 | HF    |
| XS                    | 650      | 75-77 | HF    |
| TX                    | 750      | 73-74 | HF    |
| TX                    | 750 A    | 73-76 | HF    |
|                       |          |       |       |
|                       |          |       |       |

**SBS 505 Recommended compound**



| <b>NORTON</b> |              |       |       |
|---------------|--------------|-------|-------|
| MK2           | 850 Commando | 73-75 | HF    |
| MK3           | 850 Commando | 75-77 | HF HF |
|               |              |       |       |
|               |              |       |       |
|               |              |       |       |
|               |              |       |       |
|               |              |       |       |
|               |              |       |       |
|               |              |       |       |
|               |              |       |       |
|               |              |       |       |
|               |              |       |       |

Brake Pad 1:1 Drawings, Compounds, Fitments



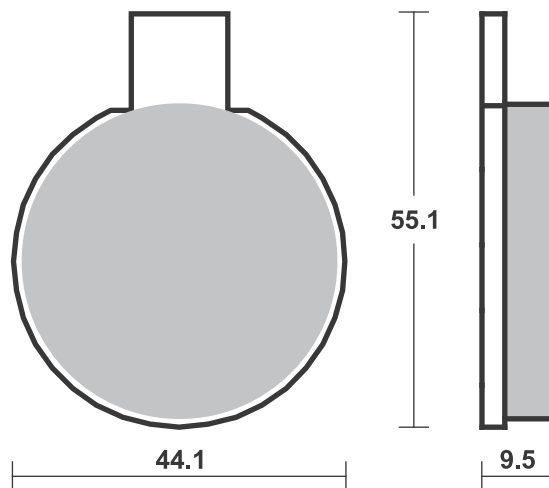
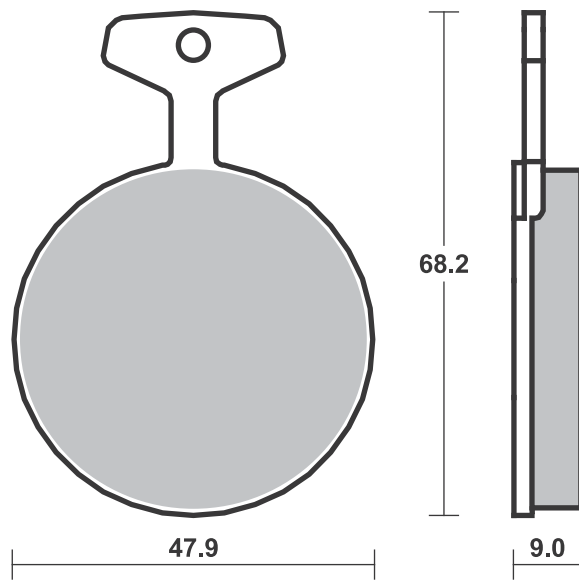
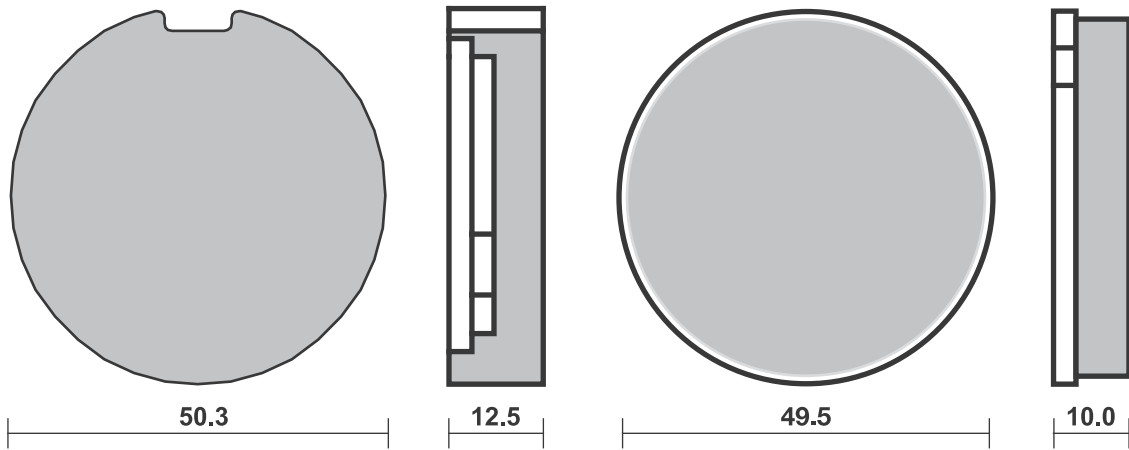

## SBS 506

## Recommended compound



|                |             |    |    |
|----------------|-------------|----|----|
| <b>APRILIA</b> |             |    |    |
| AF1            | 250 Replica | 90 | HF |

|                |                |       |    |
|----------------|----------------|-------|----|
| <b>BENELLI</b> |                |       |    |
|                | 350 4T Turismo | 80    | HF |
|                | 354            | 78-82 | HF |
|                | 500 4T         | 76    | HF |
|                | 750 Sei        | 75-78 | HF |
|                | 900 Sei        | 84    | HF |

|                                 |  |  |  |
|---------------------------------|--|--|--|
| <b>BERINGER</b>                 |  |  |  |
| 2 Piston Classic Billet Caliper |  |  |  |

|               |            |       |    |
|---------------|------------|-------|----|
| <b>BIMOTA</b> |            |       |    |
|               | all models | 82-88 | HF |
| SB3           | 1000 D     | 83    | HF |

|            |                |       |    |
|------------|----------------|-------|----|
| <b>BMW</b> |                |       |    |
| R65        | 650 GS         | 87-92 | HF |
| R65        | 650 GS         | 91-92 | HS |
| R65        | 650 LS         | 82-85 | HF |
| R65/1      | 650            | 86    | HF |
| K75        | 750            | 90    | LS |
| K75        | 750 C          | 85-88 | HF |
| K75        | 750 RT         | 91-96 | LS |
| K75        | 750 S, C       | 85-95 | HF |
| R80        | 800            | 77-85 | HF |
| R80        | 800 G/S P.-D.  | 86    | HF |
| R80        | 800 GS         | 81-87 | HF |
| R80        | 800 GS         | 91-92 | HS |
| R80        | 800 R          | 91-95 | LS |
| R80        | 800 RT         | 83    | HF |
| R80/7      | 800            | 79-81 | HF |
| K1         | 1000           | 89    | LS |
| K100       | 1000 LT        | 87    | HF |
| K100       | 1000 LT        | 92-94 | LS |
| K100       | 1000 LT ABS    | 89    | LS |
| K100       | 1000 RS        | 90-92 | LS |
| K100       | 1000 RS ABS    | 88-89 | LS |
| K100       | 1000 RS, RT    | 83-89 | HF |
| R100       | 1000           | 81-84 | HF |
| R100       | 1000 CS,RS, RT | 81-84 | HF |
| R100       | 1000 R         | 91-95 | LS |
| R100       | 1000 RS        | 76-80 | HF |
| R100       | 1000 RS        | 93-95 | LS |
| R100       | 1000 S         | 78-80 | HF |
| R100       | 1000 T         | 79-84 | HF |
| K1100      | 1100 LT/SE     | 92-00 | LS |
| K1100      | 1100 RS        | 93-96 | LS |
| R1100      | 1100 RS        | 93-94 | LS |
| K          | 1200 GT (K41)  |       |    |
|            | With Integral  |       |    |
|            | ABS            | 02-05 | LS |
| K          | 1200 RS        | 97-05 | LS |

|                               |  |  |  |
|-------------------------------|--|--|--|
| <b>BREMBO RACING CALIPERS</b> |  |  |  |
| 108N, P2 38                   |  |  |  |
| F08                           |  |  |  |

|           |     |    |    |
|-----------|-----|----|----|
| <b>CZ</b> |     |    |    |
| CZ        | 180 | 93 | HF |

|               |                |       |    |
|---------------|----------------|-------|----|
| <b>DUCATI</b> |                |       |    |
|               | 250 Desmo      | 70-77 | HF |
|               | 350 Desmo      | 70-77 | HF |
|               | 350 F3         | 86-89 | HF |
|               | 500 Sport      | 77-82 | HF |
|               | 600 Pantah TL, |       |    |
|               | SL             | 78-89 | HF |
|               | 600 SL,        |       |    |
|               | TL Pantah      | 76-89 | HF |



|               |                    |       |    |
|---------------|--------------------|-------|----|
| <b>DUCATI</b> |                    |       |    |
|               | 650 Pantah         | 84-89 | HF |
|               | 750 F1             | 86-98 | HF |
|               | 750 GT             | 74-76 | HF |
|               | 750 Paso           | 87    | HF |
|               | 750 Sport          | 90    | HS |
|               | 750 SS             | 74-76 | HF |
|               | 750 SS             | 91-98 | HF |
|               | 851 Strada         | 91-92 | HF |
|               | 860 GT             | 75-77 | HF |
|               | 860 GT             | 85    | HF |
|               | 888 Roche          |       |    |
|               | Replica            | 91    | HF |
|               | 900 GTS            | 77-79 | HF |
|               | 900 Mike           |       |    |
|               | Hailwood           |       |    |
|               | Replica            | 85-86 | HF |
|               | 900 S2 Desmo       | 85    | HF |
|               | 900 Sport          | 77-78 | HF |
|               | 900 SS             | 78-89 | HF |
| 906           | 900 Paso           | 89    | HF |
|               | 1000 /6 Mike       |       |    |
|               | Hailwood           |       |    |
|               | Replica            | 85    | HF |
|               | 1000 Mille Replica | 84-85 | HF |
|               | 1000 S2 Desmo      | 85    | HF |

|                 |                 |    |    |
|-----------------|-----------------|----|----|
| <b>HERCULES</b> |                 |    |    |
|                 | 125 Silver Star |    |    |
|                 | Classic         | 93 | HF |

|              |               |       |    |
|--------------|---------------|-------|----|
| <b>HOREX</b> |               |       |    |
|              | 80 Rebell T   | 86    | HF |
|              | 80 Sport L    | 86    | HF |
|              | 125 Imperator | 96    | HF |
|              | 125 Regent    | 96    | HF |
|              | 560 E         | 86-88 | HF |
|              | 600 Columbus  | 87-88 | HF |

|               |                    |       |      |
|---------------|--------------------|-------|------|
| <b>INDIAN</b> |                    |       |      |
|               | 1700 Chief         |       |      |
|               | Blackhawk          | 11-13 | H.LS |
|               | 1700 Chief Bomber  | 10-13 | H.LS |
|               | 1700 Chief Classic | 10-13 | H.LS |
|               | 1700 Chief Dark    |       |      |
|               | Horse              | 10-13 | H.LS |
|               | 1700 Chief Deluxe  | 09-13 | H.LS |
|               | 1700 Chief         |       |      |
|               | Roadmaster         | 09-13 | H.LS |
|               | 1700 Chief         |       |      |
|               | Standard           | 09-13 | H.LS |
|               | 1700 Chief Vintage | 09-13 | H.LS |

|             |           |       |    |
|-------------|-----------|-------|----|
| <b>JAWA</b> |           |       |    |
| CZ          | 125 2T    | 95-00 | HF |
| CZ          | 125 MX    | 95-00 | HF |
| CZ          | 180       | 92    | HF |
|             | 300 Trail | 93    | HF |

|                |                |       |    |
|----------------|----------------|-------|----|
| <b>LAVERDA</b> |                |       |    |
| SFC            | 500            | 81-83 | HF |
| SFC            | 600            | 86-89 | HF |
|                | 650 V-Six      | 93    | HS |
| SF2            | 750            | 74-78 | HF |
| SF3            | 750            | 74-78 | HF |
| SF3            | 750 RGS Corsa, |       |    |
|                | Executive      | 77-79 | HF |
|                | 1000 Jota      | 76-79 | HF |
| 3C             | 1000 3CE, 3CL  | 74-75 | HF |
| RGS            | 1000           | 83    | HF |
| RGS            | 1000 Jota      | 86    | HF |



|                |                |       |    |
|----------------|----------------|-------|----|
| <b>LAVERDA</b> |                |       |    |
| SFC            | 1000           | 85-86 | HF |
| TGA            | 1000 Executive | 84    | HF |
|                | 1200 Mirage    | 78-80 | HF |

|                   |                      |       |    |
|-------------------|----------------------|-------|----|
| <b>MOTO-GUZZI</b> |                      |       |    |
| NTX               | 350                  | 90    | HF |
| V35               | 350 C                | 82-86 | HF |
| V35               | 350 Florida          | 85-86 | HF |
| V35               | 350 GT               | 90    | HF |
| V35               | 350 III              | 87    | HF |
| V35               | 350 TT               | 86    | HF |
| NTX               | 650                  | 90-02 | HF |
| V65               | 650 Florida          | 86-94 | HF |
| V65               | 650 GT               | 90-94 | HF |
| NTX               | 750                  | 90-93 | LS |
| S3                | 750 Left             | 75-76 | HF |
| S3                | 750 Right            | 75-76 | HF |
| SP                | 750                  | 91-92 | HS |
| V75               | 750                  | 86-88 | HF |
| V75               | 750 Duna             | 86-90 | HF |
| V75               | 750 TT               |       |    |
|                   | Paris-Dakar          | 86    | HF |
|                   | 850 Le Mans          | 76-79 | HF |
| T                 | 850                  | 74-76 | HF |
| T3                | 850                  | 75-80 | HF |
| T4                | 850                  | 75-82 | HF |
| T5                | 850                  | 75-88 | HF |
| T5                | 850 N.T.             | 86-88 | HF |
|                   | 1000 California II   | 85-88 | HF |
|                   | 1000 California III  |       |    |
|                   | C                    | 91-95 | HS |
|                   | 1000 California III, |       |    |
|                   | Fuel Injection       | 89    | HF |
|                   | 1000 Daytona         | 91-02 | HF |
|                   | 1000 Le Mans IV      | 85-89 | HF |
|                   | 1000 Le Mans, V      | 90-98 | HS |
| GT                | 1000 V               | 91    | HS |
| S                 | 1000                 | 90    | HS |
| SP                | 1000 III             | 91-94 | HS |
| SP                | 1000 Le Mans         |       |    |
|                   | Left/Rear            | 79-83 | HF |
| SP                | 1000 Le Mans         |       |    |
|                   | Right                | 79-83 | HF |
| V                 | 1000 Strada          | 93-94 | HF |
|                   | 1100 California      | 96-99 | HS |

|                  |  |  |  |
|------------------|--|--|--|
| <b>MV AGUSTA</b> |  |  |  |
| all models       |  |  |  |

|           |                |       |    |
|-----------|----------------|-------|----|
| <b>MZ</b> |                |       |    |
|           | 125 Roadstar   | 92-94 | HF |
|           | 125 Sportstar  | 93-98 | HF |
| ETZ       | 125            | 82-92 | HF |
| ETZ       | 150            | 82-95 | HF |
| ETZ       | 250            | 82-84 | HF |
|           | 251 (MUZ)      |       |    |
|           | Sportstar      | 96-98 | HF |
|           | 251 Saxon Tour | 93-98 | HF |
| ETZ       | 251            | 89    | HF |
| ETZ       | 300 LUX        | 90    | HF |
| ETZ       | 300 X          | 88    | HF |
|           | 301 (MUZ)      |       |    |
|           | Sportstar      | 96-98 | HF |
|           | 301 Saxon Tour | 93-98 | HF |
| ETZ       | 301            | 90-92 | HF |
|           | 500 Saxon      |       |    |
|           | Country        | 92-98 | HF |
|           | 500 Saxon Fun  | 92-98 | HF |
|           | 500 Saxon      |       |    |
|           | Voyager        | 93-98 | HF |

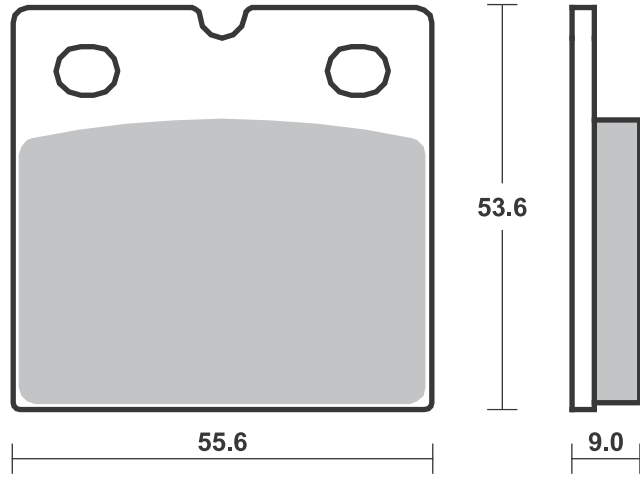

**SBS 506 Recommended compound**



| <b>MZ</b>                  |       |           |           |
|----------------------------|-------|-----------|-----------|
| 500 Silver Star<br>Classic | 93-98 | <b>HF</b> |           |
| <b>NORTON</b>              |       |           |           |
| 600 Commander              | 90    | <b>HF</b> | <b>HF</b> |
| 600 Interpol               | 83-88 | <b>HF</b> | <b>HF</b> |
| 600 Wankel<br>Classic      | 88-89 | <b>HF</b> | <b>HF</b> |
| F-1 600                    | 90    |           | <b>HF</b> |
| <b>OSSA</b>                |       |           |           |
| 500 Yanqee                 | 78    | <b>HF</b> |           |
| <b>SWM</b>                 |       |           |           |
| XP 350 Sahara              | 83    | <b>HF</b> |           |



| <b>TRIUMPH</b>         |       |           |           |
|------------------------|-------|-----------|-----------|
| 750 Bonneville<br>U.K. | 87    | <b>HF</b> | <b>HF</b> |
| <b>ZUNDAPP</b>         |       |           |           |
| KS 175                 | 78-82 | <b>HF</b> |           |

**SBS 507 Recommended compound**



| <b>YAMAHA</b>       |       |           |           |
|---------------------|-------|-----------|-----------|
| XS 250 C            | 77-78 | <b>HF</b> | <b>HF</b> |
| XS 250 D, E         | 79-80 | <b>HF</b> |           |
| XS 360 C, D         | 77    | <b>HF</b> | <b>HF</b> |
| RD 400              | 79    | <b>HF</b> |           |
| SR 400              | 77    | <b>HF</b> | <b>HF</b> |
| XS 400              | 77    | <b>HF</b> | <b>HF</b> |
| SR 500              | 78-91 | <b>HF</b> |           |
| XS 500              | 77-81 | <b>HF</b> | <b>HF</b> |
| XJ 650              | 80-82 | <b>HF</b> |           |
| XS 650              | 75-85 | <b>HF</b> | <b>HF</b> |
| XS 650              | 77-79 | <b>HF</b> |           |
| XS 650              | 80-82 |           | <b>HF</b> |
| XS 650 SE           | 80-82 | <b>HF</b> | <b>HF</b> |
| XS 650 SJ, SK       | 82    | <b>HF</b> |           |
| XS 650 SK, Heritage | 83    | <b>HF</b> | <b>HF</b> |
| XJ 750 E            | 81-83 | <b>HF</b> |           |
| XS 750              | 77-80 | <b>HF</b> | <b>HF</b> |
| XS 750 H, J, K      | 81-82 |           | <b>HF</b> |



| <b>YAMAHA</b>                       |       |           |           |
|-------------------------------------|-------|-----------|-----------|
| XS 750 SE Left/Rear                 | 79-80 |           | <b>HF</b> |
| XS 850                              | 80-81 | <b>HF</b> | <b>HF</b> |
| XS 850 Left/Rear                    | 81    |           | <b>HF</b> |
| XV 920                              | 81-82 | <b>HF</b> |           |
| XV 1000 TR1                         | 81-83 | <b>HF</b> |           |
| XS 1100 E,F,G,H                     | 78-81 | <b>HF</b> | <b>HF</b> |
| XS 1100 SF, SG, SH,<br>LG Left/Rear | 79-81 |           | <b>HF</b> |

**SBS 508 Recommended compound**



| <b>HONDA</b>                |       |           |  |
|-----------------------------|-------|-----------|--|
| CB 750 SS                   | 77-79 | <b>HF</b> |  |
| GL 1000 K1,<br>K2 Gold Wing | 75-77 | <b>HF</b> |  |

Brake Pad 1:1 Drawings, Compounds, Fitments

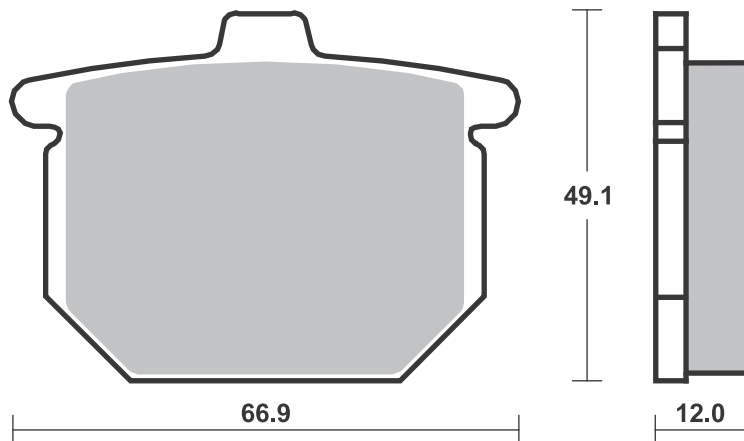
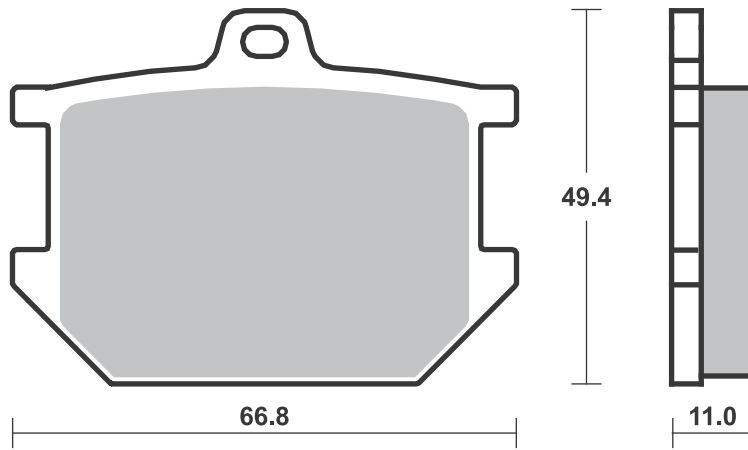
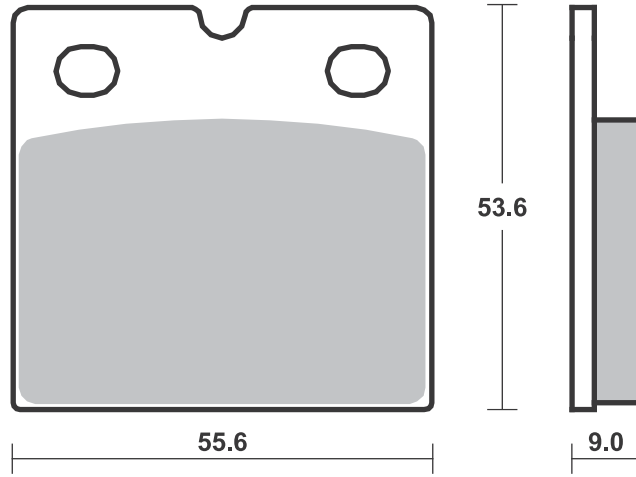

Applications

**SBS 509** Recommended compound



| <b>HONDA</b>               |                         |       |           |
|----------------------------|-------------------------|-------|-----------|
| CB                         | 750 F1                  | 75-76 | <b>HF</b> |
| GL                         | 1000 K1,                |       |           |
|                            | K2 Gold Wing 75-77      |       | <b>HF</b> |
| GL                         | 1000 K3 Gold Wing 78-79 |       | <b>HF</b> |
| <b>PERFORMANCE MACHINE</b> |                         |       |           |
| 162 X 2                    |                         |       |           |
|                            |                         |       |           |
|                            |                         |       |           |
|                            |                         |       |           |
|                            |                         |       |           |
|                            |                         |       |           |
|                            |                         |       |           |
|                            |                         |       |           |
|                            |                         |       |           |
|                            |                         |       |           |
|                            |                         |       |           |
|                            |                         |       |           |

**SBS 510** Recommended compound



| <b>KAWASAKI</b> |          |       |           |
|-----------------|----------|-------|-----------|
| KH              | 250      | 76-80 | <b>HF</b> |
| Z               | 250      | 78-80 | <b>HF</b> |
| KH              | 400      | 76-78 | <b>HF</b> |
| Z               | 400      | 79    | <b>HF</b> |
| Z               | 400 C1   | 80-85 | <b>HF</b> |
| Z               | 440 C    | 80-81 | <b>HF</b> |
| Z               | 440 LTD  | 80-82 | <b>HF</b> |
| KH              | 500      | 76-79 | <b>HF</b> |
| Z               | 500      | 79-80 | <b>HF</b> |
| Z               | 550      | 80-85 | <b>HF</b> |
| Z               | 650      | 77-82 | <b>HF</b> |
| Z               | 750 B    | 76-79 | <b>HF</b> |
| Z               | 750 LTD  | 80    | <b>HF</b> |
| Z               | 900 A    | 76-77 | <b>HF</b> |
| Z               | 1000     | 76-81 | <b>HF</b> |
| Z               | 1000 GL  | 80-82 | <b>HF</b> |
| Z               | 1000 H1  | 80-83 | <b>HF</b> |
| Z               | 1000 LTD | 77-79 | <b>HF</b> |



| <b>KAWASAKI</b> |        |       |           |
|-----------------|--------|-------|-----------|
| Z               | 1000 R | 78-79 | <b>HF</b> |
|                 |        |       |           |
|                 |        |       |           |
|                 |        |       |           |
|                 |        |       |           |
|                 |        |       |           |
|                 |        |       |           |
|                 |        |       |           |
|                 |        |       |           |
|                 |        |       |           |
|                 |        |       |           |
|                 |        |       |           |
|                 |        |       |           |
|                 |        |       |           |
|                 |        |       |           |
|                 |        |       |           |
|                 |        |       |           |
|                 |        |       |           |
|                 |        |       |           |
|                 |        |       |           |

**SBS 511** Recommended compound



| <b>SUZUKI</b> |       |       |           |
|---------------|-------|-------|-----------|
| GS            | 400   | 77-78 | <b>HF</b> |
| GS            | 425   | 79    | <b>HF</b> |
| GS            | 750   | 76-77 | <b>HF</b> |
| GS            | 750 D | 77-79 | <b>HF</b> |
| GS            | 750 E | 77-79 | <b>HF</b> |
| GS            | 850   | 79-81 | <b>HF</b> |
|               |       |       |           |
|               |       |       |           |
|               |       |       |           |
|               |       |       |           |
|               |       |       |           |
|               |       |       |           |
|               |       |       |           |
|               |       |       |           |
|               |       |       |           |
|               |       |       |           |
|               |       |       |           |
|               |       |       |           |
|               |       |       |           |
|               |       |       |           |
|               |       |       |           |
|               |       |       |           |

Brake Pad 1:1 Drawings, Compounds, Fitments

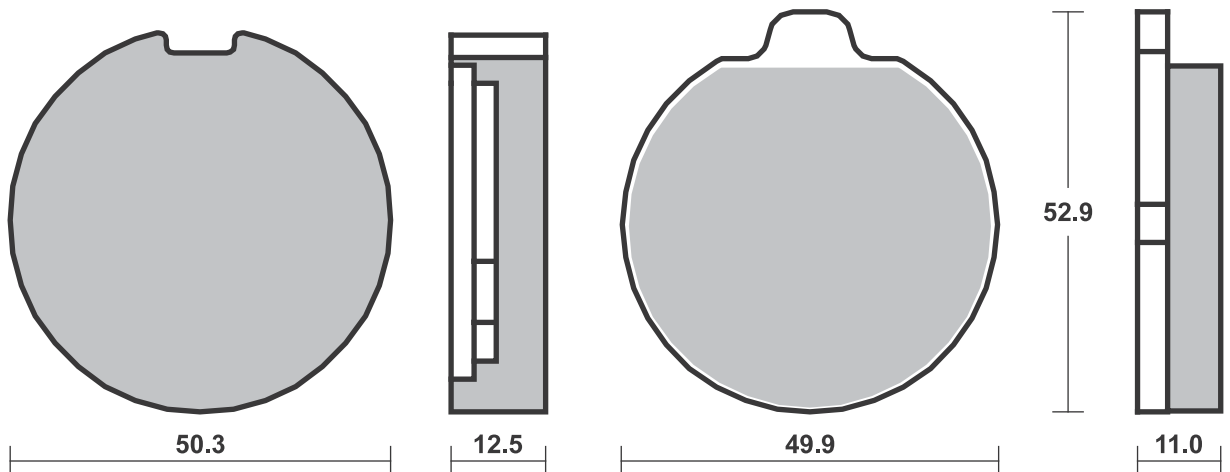
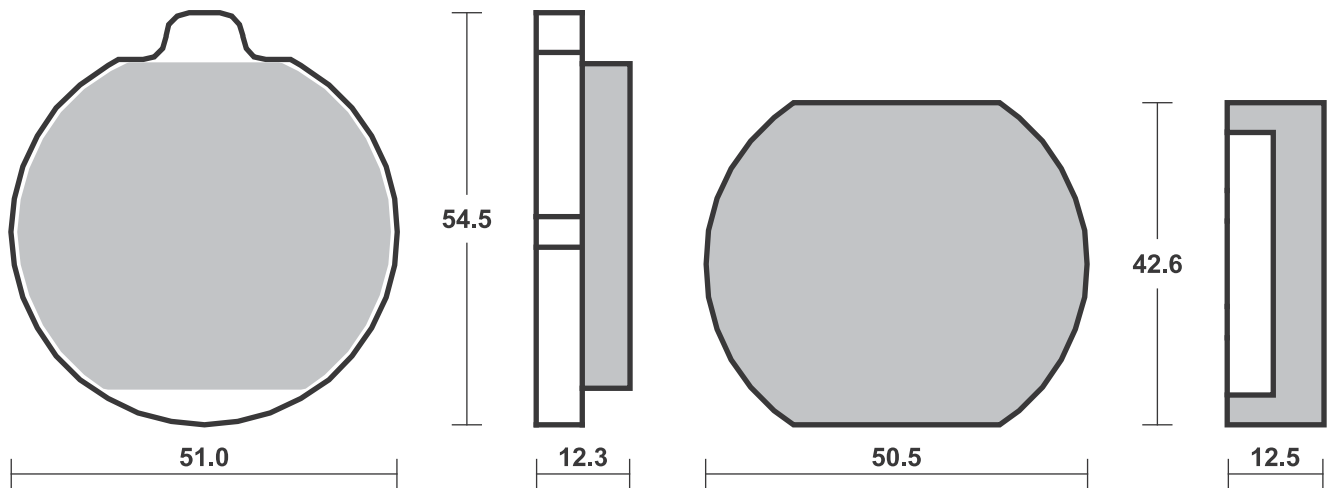
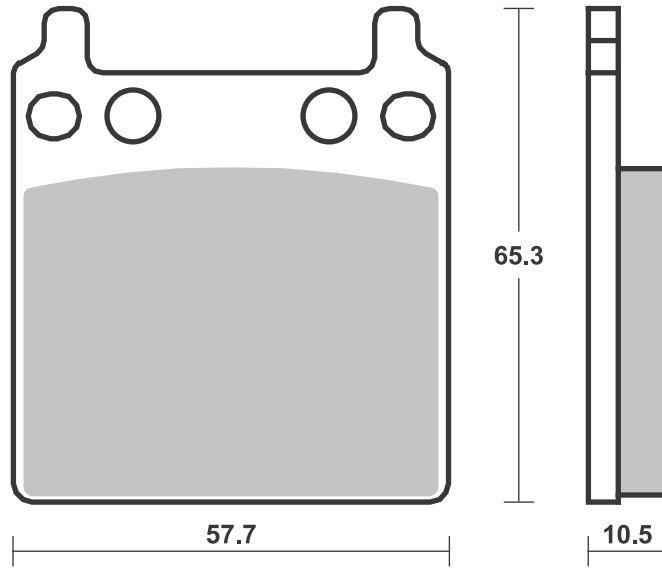

## Applications

### SBS 512 Recommended compound



|                                    |  |  |  |
|------------------------------------|--|--|--|
| <b>GMA</b>                         |  |  |  |
| 2 Piston Caliper,<br>large Model A |  |  |  |

|                 |           |       |           |
|-----------------|-----------|-------|-----------|
| <b>KAWASAKI</b> |           |       |           |
| Z               | 500       | 79-80 | <b>HF</b> |
| Z               | 650       | 78-82 | <b>HF</b> |
| Z               | 1000      | 76-81 | <b>HF</b> |
| Z               | 1000 F1   | 80-82 | <b>HF</b> |
| Z               | 1000 GL   | 80-82 | <b>HF</b> |
| Z               | 1000 H1   | 80-83 | <b>HF</b> |
| Z               | 1000 MKII | 79-80 | <b>HF</b> |
| Z               | 1000 R    | 78-79 | <b>HF</b> |
| Z               | 1000 ST   | 79-81 | <b>HF</b> |
| Z               | 1100 ST   | 81-83 | <b>HF</b> |
| Z               | 1300      | 79-81 | <b>HF</b> |
| Z               | 1300 DF1  | 84    | <b>HF</b> |

|               |                 |       |           |
|---------------|-----------------|-------|-----------|
| <b>SUZUKI</b> |                 |       |           |
| GSX           | 250             | 81-82 | <b>HF</b> |
| GSX           | 250             | 86-87 | <b>HF</b> |
| GSX           | 400 F           | 81-84 | <b>HF</b> |
| GSX           | 400 FD          | 83    | <b>HF</b> |
| GSX           | 400 FWS         | 86-87 | <b>HF</b> |
| GSX           | 400 FX, FZ      | 81-82 | <b>HF</b> |
| GS            | 450             | 86    | <b>HF</b> |
| GS            | 500             | 80-85 | <b>HF</b> |
| GS            | 500 E (Austria) | 78-79 | <b>HF</b> |
| GS            | 500 E (Austria) | 81-82 | <b>HF</b> |
| GS            | 550             | 77-84 | <b>HF</b> |
| GR            | 650             | 83-84 | <b>HF</b> |
| GS            | 650             | 81-83 | <b>HF</b> |



|               |                      |       |           |
|---------------|----------------------|-------|-----------|
| <b>SUZUKI</b> |                      |       |           |
| GS            | 650 G                | 83-87 | <b>HF</b> |
| GS            | 650 Turbo, XN        | 83-85 | <b>HF</b> |
| GS            | 700                  | 85    | <b>HF</b> |
| GS            | 750                  | 76-79 | <b>HF</b> |
| GS            | 750 D                | 77-79 | <b>HF</b> |
| GS            | 750 E                | 77-79 | <b>HF</b> |
| GS            | 750 SD               | 83    | <b>HF</b> |
| GSX           | 750 E                | 82-83 | <b>HF</b> |
| GSX           | 750 EF               | 80-86 | <b>HF</b> |
| GSX           | 750 ES               | 83-85 | <b>HF</b> |
| GSX           | 750 ES, EF, STS      | 86-88 | <b>HF</b> |
| GSX           | 750 L                | 80-82 | <b>HF</b> |
| GSX           | 750 S                | 82    | <b>HF</b> |
| GSX           | 750 S, Katana        | 85-86 | <b>HF</b> |
| GS            | 850                  | 79-82 | <b>HF</b> |
| GS            | 850 G                | 83-86 | <b>HF</b> |
| GSX           | 850 G                | 83-85 | <b>HF</b> |
| XN            | 850                  | 83-85 | <b>HF</b> |
| G             | 1000 SZ              | 82    | <b>HF</b> |
| GS            | 1000                 | 78-81 | <b>HF</b> |
| GS            | 1000 ET              | 81    | <b>HF</b> |
| GS            | 1000 EX              | 81    | <b>HF</b> |
| GSX           | 1000 S, Katana       | 82-84 | <b>HF</b> |
| GS            | 1100                 | 81-83 | <b>HF</b> |
| GS            | 1100 ED, ESD, GD     | 83    | <b>HF</b> |
| GS            | 1100 G               | 86-88 | <b>HF</b> |
| GS            | 1100 GKD, SD,<br>GLD | 83    | <b>HF</b> |
| GS            | 1100 L               | 79    | <b>HF</b> |
| GSX           | 1100                 | 86    | <b>HF</b> |
| GSX           | 1100 E               | 82-84 | <b>HF</b> |



|               |                 |       |           |
|---------------|-----------------|-------|-----------|
| <b>SUZUKI</b> |                 |       |           |
| GSX           | 1100 E, L       | 79-81 | <b>HF</b> |
| GSX           | 1100 S          | 82-83 | <b>HF</b> |
| GT            | 1100            | 80    | <b>HF</b> |
| GV            | 1200 GLG Madura | 86    | <b>HF</b> |
| GV            | 1400 Cavalcade  | 85-86 | <b>HF</b> |

### SBS 513 Recommended compound



|                        |                             |       |                  |
|------------------------|-----------------------------|-------|------------------|
| <b>HARLEY DAVIDSON</b> |                             |       |                  |
| XLCH                   | 1000                        | 73    | <b>H.HF</b>      |
| FL                     | 1200 FLH Police             | 75-79 | <b>H.HF H.HF</b> |
| FLH                    | 1200                        | 74-76 | <b>H.HF H.HF</b> |
| FLH                    | 1200                        | 80    | <b>H.HF</b>      |
| FLH                    | 1200 Anniversary            | 78    | <b>H.HF H.HF</b> |
| FLH                    | 1200 Touring                | 77-78 | <b>H.HF H.HF</b> |
| FLHS                   | 1200                        | 77-80 | <b>H.HF H.HF</b> |
| FX                     | 1200                        | 74-80 | <b>H.HF</b>      |
| FXE                    | 1200                        | 74-80 | <b>H.HF</b>      |
| FXS                    | 1200                        | 78-79 | <b>H.HF</b>      |
| FLH                    | 1340 80                     | 78-80 | <b>H.HF H.HF</b> |
| FLH                    | 1340 80                     | 81    | <b>H.HF</b>      |
| FLH                    | 1340 Electra Glide          | 82-83 | <b>H.HF</b>      |
| FLH                    | 1340 Electra Glide<br>Spec. | 84    | <b>H.HF</b>      |
| FXB                    | 1340 80                     | 80-81 | <b>H.HF</b>      |
| FXB                    | 1340 Sturgis                | 82    | <b>H.HF</b>      |
| FXE                    | 1340 80                     | 78-81 | <b>H.HF</b>      |
| FXE                    | 1340 Super Glide            | 83-84 | <b>H.HF</b>      |
| FXEF                   | 1340 80 Fat Bob             | 79-81 | <b>H.HF</b>      |
| FXR                    | 1340                        | 78-81 | <b>H.HF</b>      |
| FXS                    | 1340 80                     | 79-81 | <b>H.HF</b>      |
| FXS                    | 1340 Low Rider              | 82    | <b>H.HF</b>      |
| FXWG                   | 1340 80                     | 80-81 | <b>H.HF</b>      |
| FXWG                   | 1340 Wide Glide             | 82    | <b>H.HF</b>      |
| FXE                    | 1450 Series                 | 74-77 | <b>H.HF</b>      |



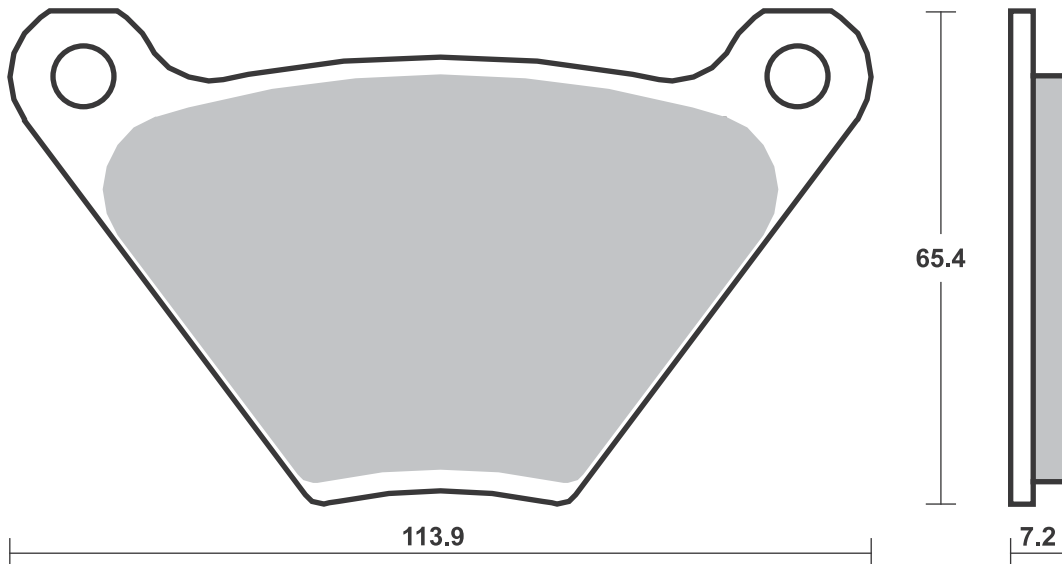
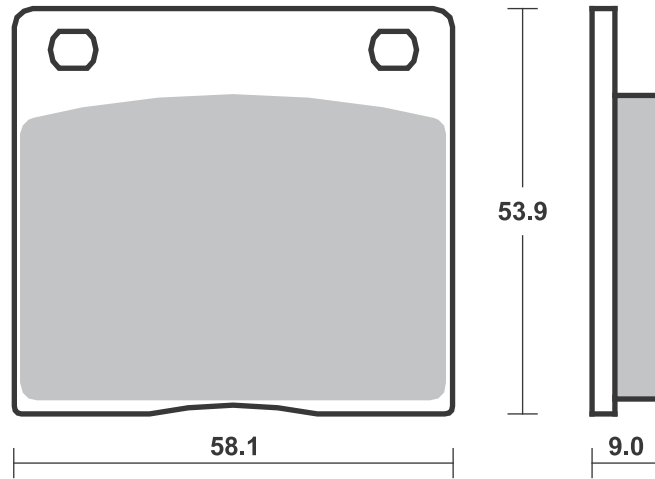

**SBS 514** Recommended compound



| <b>KAWASAKI</b> |          |       |           |
|-----------------|----------|-------|-----------|
| Z               | 650      | 78-79 | <b>HF</b> |
| Z               | 750 B    | 76-79 | <b>HF</b> |
| Z               | 1000 LTD | 77-79 | <b>HF</b> |
|                 |          |       |           |
|                 |          |       |           |
|                 |          |       |           |
|                 |          |       |           |
|                 |          |       |           |
|                 |          |       |           |
|                 |          |       |           |
|                 |          |       |           |
|                 |          |       |           |
|                 |          |       |           |
|                 |          |       |           |
|                 |          |       |           |
|                 |          |       |           |
|                 |          |       |           |
|                 |          |       |           |
|                 |          |       |           |
|                 |          |       |           |

**SBS 515** Recommended compound



| <b>SUZUKI</b> |                 |       |           |
|---------------|-----------------|-------|-----------|
| GT            | 125             | 78-82 | <b>HF</b> |
| RG            | 125             | 79-80 | <b>HF</b> |
| GT            | 200 X5 (Nien)   | 79-82 | <b>HF</b> |
| XS            | 200             | 79    | <b>HF</b> |
| GT            | 250             | 78-81 | <b>HF</b> |
| RG            | 250             | 78-82 | <b>HF</b> |
| GT            | 380 Asco        | 77    | <b>HF</b> |
| GS            | 400             | 78-82 | <b>HF</b> |
| GS            | 425             | 80    | <b>HF</b> |
| GS            | 500             | 80-81 | <b>HF</b> |
| GS            | 500 E (Austria) | 78-79 | <b>HF</b> |
| GT            | 500             | 73-75 | <b>HF</b> |
| GS            | 550             | 77-79 | <b>HF</b> |
| GT            | 550             | 78    | <b>HF</b> |
| GS            | 750             | 78-79 | <b>HF</b> |
| GS            | 1000            | 78-80 | <b>HF</b> |
|               |                 |       |           |
|               |                 |       |           |
|               |                 |       |           |
|               |                 |       |           |
|               |                 |       |           |
|               |                 |       |           |
|               |                 |       |           |
|               |                 |       |           |
|               |                 |       |           |

**SBS 516** Recommended compound



| <b>KAWASAKI</b> |               |       |           |
|-----------------|---------------|-------|-----------|
| KH              | 125           | 77-80 | <b>HF</b> |
| Z               | 200           | 77-81 | <b>HF</b> |
| <b>SUZUKI</b>   |               |       |           |
| AC              | 50 DX         | 81-86 | <b>HF</b> |
| AC              | 50 RG, ZR, Z1 | 79-84 | <b>HF</b> |
| GT              | 50            | 77-80 | <b>HF</b> |
| X-1             | 50            | 79    | <b>HF</b> |
|                 |               |       |           |
|                 |               |       |           |
|                 |               |       |           |
|                 |               |       |           |
|                 |               |       |           |
|                 |               |       |           |
|                 |               |       |           |
|                 |               |       |           |
|                 |               |       |           |
|                 |               |       |           |
|                 |               |       |           |
|                 |               |       |           |
|                 |               |       |           |
|                 |               |       |           |
|                 |               |       |           |
|                 |               |       |           |
|                 |               |       |           |
|                 |               |       |           |
|                 |               |       |           |

Brake Pad 1:1 Drawings, Compounds, Fitments

Available compounds **HF**

**SBS 514**

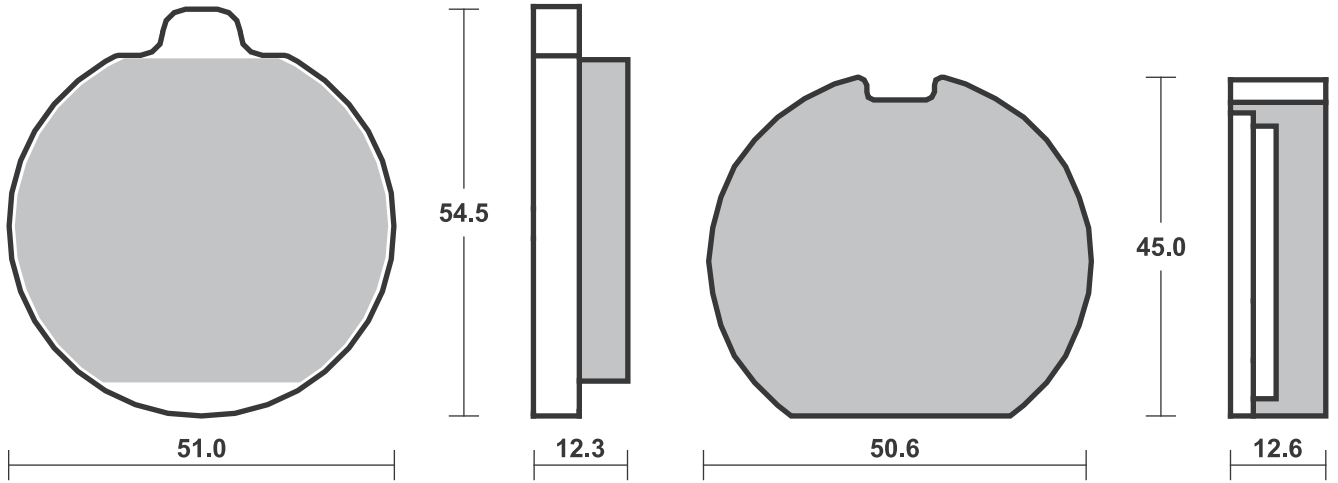

Available compounds **HF**

**SBS 515**

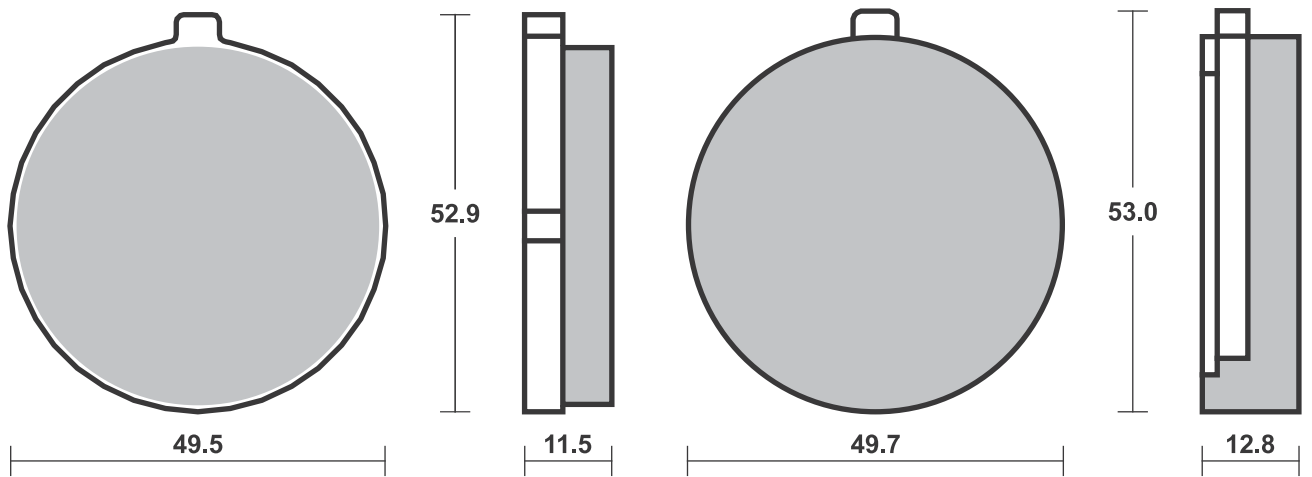

Available compounds **HF**

**SBS 516**

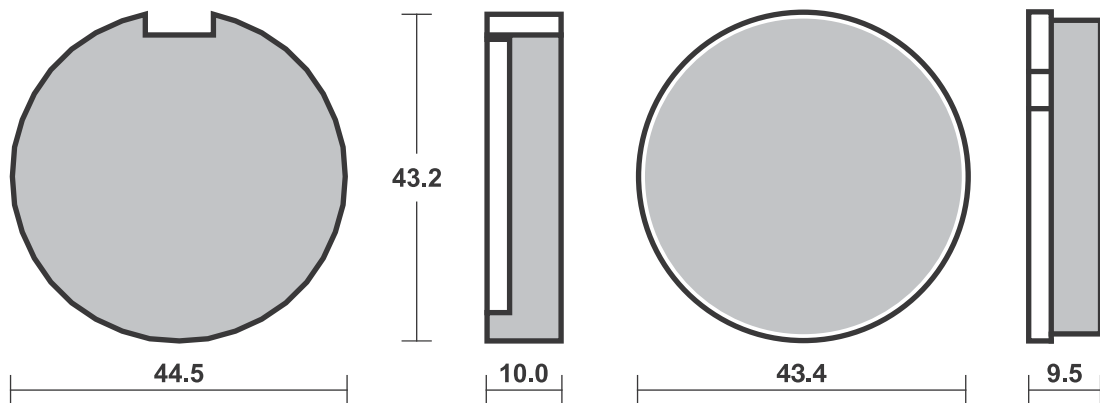

## Applications

### SBS 517 Recommended compound



| <b>HONDA</b> |                   |       |           |           |
|--------------|-------------------|-------|-----------|-----------|
| MT           | 125 R             | 78    | <b>HF</b> |           |
| CB           | 400 N             | 78-82 | <b>HF</b> |           |
| CB           | 400 NZ            | 79    | <b>HF</b> |           |
| CX           | 400               | 81    | <b>HF</b> |           |
| GL           | 400               | 77-80 | <b>HF</b> |           |
| CX           | 500               | 78-80 | <b>HF</b> |           |
| CB           | 750 F             | 77-80 | <b>HF</b> | <b>HF</b> |
| CB           | 750 SS            | 77-79 |           | <b>HF</b> |
| CB           | 900 F             | 78-80 | <b>HF</b> | <b>HF</b> |
| CBX          | 1000              | 78-80 | <b>HF</b> | <b>HF</b> |
| GL           | 1000 Gold Wing    | 81    | <b>HF</b> | <b>HF</b> |
| GL           | 1000 Gr. Tour.    |       |           |           |
|              | Gold Wing         | 81-82 | <b>HF</b> | <b>HF</b> |
| GL           | 1000 K3 Gold Wing | 78-79 | <b>HF</b> |           |
| GL           | 1100 A Gold Wing  | 79-83 | <b>HF</b> | <b>HF</b> |
|              |                   |       |           |           |
|              |                   |       |           |           |

### SBS 518 Recommended compound



| <b>KAWASAKI</b> |          |       |           |  |
|-----------------|----------|-------|-----------|--|
| Z               | 400 D, S | 76-77 | <b>HF</b> |  |
|                 |          |       |           |  |
|                 |          |       |           |  |
|                 |          |       |           |  |
|                 |          |       |           |  |
|                 |          |       |           |  |
|                 |          |       |           |  |
|                 |          |       |           |  |
|                 |          |       |           |  |
|                 |          |       |           |  |
|                 |          |       |           |  |
|                 |          |       |           |  |
|                 |          |       |           |  |
|                 |          |       |           |  |
|                 |          |       |           |  |

### SBS 519 Recommended compound



| <b>ALFER</b>   |                |       |           |           |
|----------------|----------------|-------|-----------|-----------|
| MC             | 80             | 87    | <b>HF</b> |           |
| MC             | 125            | 87    | <b>HF</b> |           |
| MC             | 125            | 88    |           | <b>HF</b> |
| GR             | 250 Enduro     | 85    | <b>HF</b> |           |
| GR             | 250 Enduro     | 88    |           | <b>HF</b> |
| MC             | 250            | 85    | <b>HF</b> |           |
| MC             | 250            | 87    | <b>HF</b> | <b>HF</b> |
| MC             | 250            | 88    |           | <b>HF</b> |
| GR             | 300            | 85    | <b>HF</b> |           |
| GR             | 300 Enduro     | 88    |           | <b>HF</b> |
|                |                |       |           |           |
| <b>APRILIA</b> |                |       |           |           |
|                | 50 Tuareg      | 85    | <b>HF</b> |           |
|                | 125 Classic    | 96-03 |           | <b>HF</b> |
|                | 125 Red Rose   | 89-97 |           | <b>HF</b> |
|                | 125 Sport Pro. | 92    |           | <b>HF</b> |
|                | 125 Tuareg     | 87-92 |           | <b>HF</b> |
|                | 125 Tuareg AS  | 86    |           | <b>HF</b> |



| <b>APRILIA</b> |                  |       |            |            |
|----------------|------------------|-------|------------|------------|
|                | 125 Tuareg Rally | 89-94 |            | <b>HF</b>  |
|                | 125 Tuono        | 04-07 |            | <b>HF</b>  |
| AF1            | 125              | 87-88 |            | <b>HF</b>  |
| AF1            | 125 Europa,      |       |            |            |
|                | Futura           | 90-92 |            | <b>HF</b>  |
| AF1            | 125 Replica,     |       |            |            |
|                | Sintesi          | 89-91 |            | <b>HF</b>  |
| ETX            | 125 Tuareg       | 86-87 |            | <b>HF</b>  |
|                | 200 Climber      | 93-95 | <b>RSI</b> | <b>RSI</b> |
|                | 250 Tuareg Rally | 86    |            | <b>HF</b>  |
| MX             | 250 Cross        | 85    | <b>SI</b>  |            |
| RS             | 250              | 95-02 |            | <b>HF</b>  |
| RS             | 250 Pista        | 04    |            | <b>HF</b>  |
| RX             | 250              | 86    | <b>HF</b>  |            |
|                | 350 Tuareg       | 86    |            | <b>HF</b>  |
|                | 350 Tuareg       | 88-89 |            | <b>HF</b>  |
|                | 350 Tuareg Wind  | 87-87 |            | <b>HF</b>  |
| ETX            | 350              | 85-86 |            | <b>HF</b>  |



| <b>APRILIA</b>   |                 |       |           |           |
|------------------|-----------------|-------|-----------|-----------|
| ETX              | 350             | 86-92 |           | <b>SI</b> |
|                  | 600 Tuareg      | 86-87 |           | <b>HF</b> |
|                  | 600 Tuareg Wind | 88    |           | <b>HF</b> |
| ETX              | 600             | 86-92 |           | <b>HF</b> |
|                  |                 |       |           |           |
| <b>ARMSTRONG</b> |                 |       |           |           |
| MX               | 500             | 86    | <b>SI</b> |           |
| MX               | 600             | 86    | <b>SI</b> |           |
|                  |                 |       |           |           |
| <b>ASPES</b>     |                 |       |           |           |
|                  | 125 Sintesi     | 88    |           | <b>HF</b> |
|                  |                 |       |           |           |
| <b>ATK</b>       |                 |       |           |           |
| ATK              | 250 CC,MX       | 91-92 |           | <b>SI</b> |
| ATK              | 350 ES CC,MX,   |       |           |           |
|                  | STD             | 91-92 |           | <b>SI</b> |
| ATK              | 350 GS          | 93    | <b>SI</b> | <b>SI</b> |
| ATK              | 406 CC,MX       | 91-92 |           | <b>SI</b> |

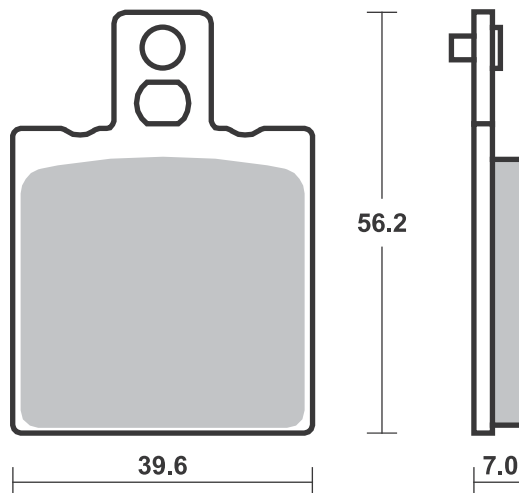
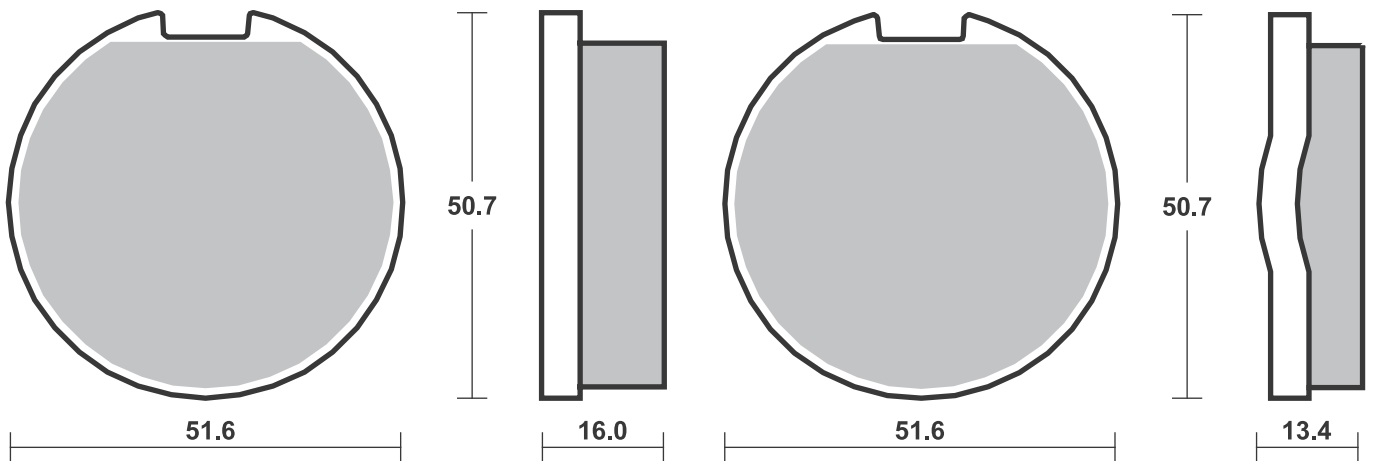
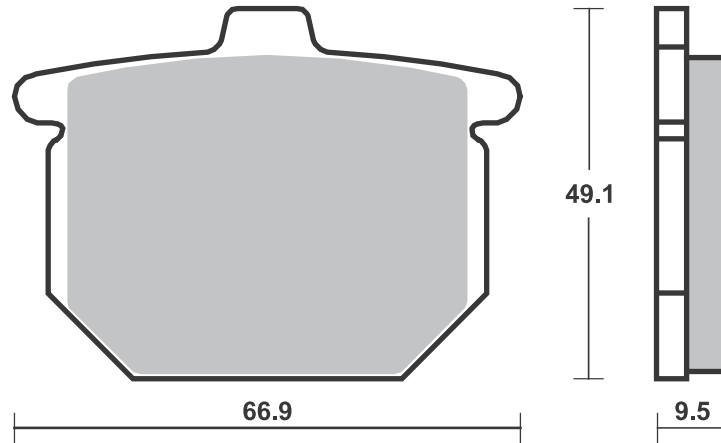

## Applications

## SBS 519 Recommended compound



|                               |                  |       |           |            |
|-------------------------------|------------------|-------|-----------|------------|
| <b>ATK</b>                    |                  |       |           |            |
| ATK                           | 560              | 84-88 | <b>SI</b> |            |
| ATK                           | 604 ES CC,MX,    |       |           |            |
|                               | STD              | 91-92 |           | <b>SI</b>  |
| ATK                           | 640              | 93    | <b>SI</b> | <b>SI</b>  |
| <b>BENELLI</b>                |                  |       |           |            |
|                               | 124 T            | 83-85 | <b>HF</b> |            |
|                               | 125 2CE          | 76-78 | <b>HF</b> |            |
|                               | 125 Custom       | 85    | <b>HF</b> |            |
|                               | 125 Jarno        | 89    |           | <b>HF</b>  |
|                               | 125 Sport        | 82-89 | <b>HF</b> |            |
|                               | 125 T            | 76    | <b>HF</b> |            |
|                               | 125 TT           | 86    | <b>HF</b> |            |
| BX                            | 125              | 89    |           | <b>SI</b>  |
| BXK                           | 125              | 88    | <b>HF</b> |            |
| E                             | 125 L.C.         | 85    | <b>HF</b> |            |
|                               | 250 2CE          | 76    | <b>HF</b> |            |
|                               | 250 Disc         | 76    | <b>HF</b> |            |
|                               | 304              | 83    | <b>HF</b> |            |
|                               | 350 4T Turismo   | 80    | <b>HF</b> |            |
|                               | 354              | 78-82 | <b>HF</b> |            |
|                               | 354 Sport        | 83-85 | <b>HF</b> | <b>HF</b>  |
|                               | 500 -4           | 76    | <b>HF</b> |            |
|                               | 500 4T           | 76    | <b>HF</b> |            |
|                               | 654 Sport        | 83    | <b>HF</b> | <b>HF</b>  |
|                               | 900 Tornado 3    | 00-06 |           | <b>LS</b>  |
| TnT                           | 1100             | 04    |           | <b>LS</b>  |
| <b>BETA</b>                   |                  |       |           |            |
| KR                            | 50               | 86-87 | <b>HF</b> |            |
| KR                            | 50 Twin          | 88    | <b>HF</b> | <b>HF</b>  |
| ALP                           | 240              | 96    |           | <b>RSI</b> |
| CR                            | 250              | 83    | <b>SI</b> |            |
| ALP                           | 260              | 96    |           | <b>RSI</b> |
|                               | 500 GS, RV       | 84    | <b>HF</b> |            |
| <b>BIMOTA</b>                 |                  |       |           |            |
| YB7                           | 400              | 89    |           | <b>HF</b>  |
|                               | 500 Vdue         | 97-00 |           | <b>HF</b>  |
|                               | 600 Bellaria     | 91    |           | <b>HF</b>  |
| YB9                           | 600 SRI          | 97    |           | <b>HF</b>  |
| BB1                           | 650 Supermono    | 97-00 |           | <b>HF</b>  |
| SB7                           | 750              | 96-88 |           | <b>HF</b>  |
| YB4                           | 750              | 89    |           | <b>HF</b>  |
| 1D                            | 851 Tesi         | 91    |           | <b>HF</b>  |
| 1D                            | 900 Tesi         | 93    |           | <b>HF</b>  |
| DB2                           | 900              | 92-00 |           | <b>HF</b>  |
| DB3                           | 900 Mantra       | 97-00 |           | <b>HF</b>  |
| DB4                           | 900              | 99-00 |           | <b>LS</b>  |
| 1D                            | 906 Tesi         | 91    |           | <b>HF</b>  |
|                               | 1000 Furano      | 92-93 |           | <b>HF</b>  |
| 2D                            | 1000 Tesi        | 04-06 |           | <b>LS</b>  |
| SB8                           | 1000 R           | 98-00 |           | <b>LS</b>  |
| SB8K                          | 1000             | 06    |           | <b>LS</b>  |
| SB8K                          | 1000 Santamonica | 07-09 |           | <b>LS</b>  |
| YB11                          | 1000             | 97-00 |           | <b>HF</b>  |
| YB6                           | 1000             | 89    |           | <b>HF</b>  |
| YB8                           | 1000             | 90    |           | <b>HF</b>  |
|                               | 1002 Dieci       | 91    |           | <b>HF</b>  |
| DB7                           | 1099             | 09    |           | <b>LS</b>  |
| SB6                           | 1100             | 97-00 |           | <b>HF</b>  |
| <b>BREMBO RACING CALIPERS</b> |                  |       |           |            |
| Goldline 20.5161.42/51,       |                  |       |           |            |
| road                          |                  |       |           |            |
| <b>CAGIVA</b>                 |                  |       |           |            |
|                               | 50 Cocis         | 89    | <b>HF</b> | <b>HF</b>  |
|                               | 50 Lucky         |       |           |            |
|                               | Explorer         | 88-02 | <b>HF</b> |            |



|               |                    |       |           |           |
|---------------|--------------------|-------|-----------|-----------|
| <b>CAGIVA</b> |                    |       |           |           |
|               | 50 Prima           | 92    | <b>HF</b> | <b>HF</b> |
|               | 50 Super City      | 93-95 |           | <b>HF</b> |
|               | 50 Supercity       | 92    | <b>HF</b> | <b>HF</b> |
|               | 50 W 4             | 92    | <b>HF</b> | <b>HF</b> |
|               | 80 Cocis           | 91    | <b>HF</b> |           |
|               | 80 Super City      | 94-84 |           | <b>HF</b> |
|               | 80 Supercity       | 92-93 | <b>HF</b> | <b>HF</b> |
|               | 80 W 4             | 92    | <b>HF</b> | <b>HF</b> |
| LR            | 80                 | 83    | <b>HF</b> |           |
| SST           | 80                 | 83    | <b>HF</b> |           |
| SXT           | 80                 | 83    | <b>HF</b> |           |
|               | 125 Aletta Electra | 87    | <b>HF</b> |           |
|               | 125 Aletta Oro     | 86-89 |           | <b>HF</b> |
|               | 125 Blues          | 87-85 |           | <b>HF</b> |
|               | 125 Blues          | 93    | <b>HF</b> | <b>HF</b> |
|               | 125 Cruiser        | 88-89 |           | <b>HF</b> |
|               | 125 Dakar          | 86    | <b>HF</b> |           |
|               | 125 Elefantre      | 87-88 | <b>HF</b> |           |
|               | 125 Enduro         | 86    | <b>HF</b> |           |
|               | 125 Freccia        | 89    |           | <b>HF</b> |
|               | 125 Freccia        |       |           |           |
|               | C 12 R             | 91    |           | <b>HF</b> |
|               | 125 Mito           | 91-07 |           | <b>HF</b> |
|               | 125 Planet         | 97-07 |           | <b>HF</b> |
|               | 125 Raptor         | 03-10 |           | <b>HF</b> |
|               | 125 Supercity      | 92-00 |           | <b>HF</b> |
|               | 125 Tamanaco       | 89    |           | <b>HF</b> |
|               | 125 W 8            | 92-95 | <b>HF</b> | <b>HF</b> |
| K7            | 125                | 91-94 |           | <b>HF</b> |
| N1            | 125                | 96-99 |           | <b>HF</b> |
| WMX           | 125 GP-Replica     | 86-89 | <b>SI</b> |           |
| WRX           | 125                | 85    | <b>HF</b> |           |
|               | 200 Elefant        | 86    | <b>HF</b> |           |
| MXR           | 250                | 82    | <b>HF</b> |           |
| SST           | 250 Ala Verde      | 81-82 | <b>HF</b> |           |
| WMX           | 250 GP             | 82    | <b>SI</b> |           |
|               | 350 Alazzurra      | 85-87 | <b>HF</b> | <b>HF</b> |
|               | 350 Elefant        | 86-89 |           | <b>HF</b> |
|               | 350 W 12           | 92-95 |           | <b>HF</b> |
| SST           | 350                | 83    | <b>HF</b> |           |
| SST           | 350 Ala Verde      | 81-82 | <b>HF</b> |           |
| SXT           | 350 Ala Rosa       | 82    | <b>HF</b> |           |
| T4            | 350 E              | 87-91 | <b>HF</b> |           |
| T4            | 350 R              | 87-99 | <b>HF</b> |           |
| MXR           | 400                | 82    | <b>HF</b> |           |
|               | 500 Mito           | 07    |           | <b>LS</b> |
|               | 500 River          | 00-01 |           | <b>HF</b> |
| MXR           | 500                | 82    | <b>HF</b> |           |
| T4            | 500 E              | 87-90 | <b>HF</b> |           |
| WMX           | 500                | 85-86 | <b>SI</b> |           |
| WMX           | 500 Cross          | 87    | <b>SI</b> | <b>SI</b> |
| SP            | 525 Mito           | 08-10 |           | <b>LS</b> |
|               | 600 River          | 94-99 |           | <b>HF</b> |
|               | 650 Alazzurra      | 84    | <b>HF</b> | <b>HF</b> |
|               | 650 Elefant        | 86-87 |           | <b>HF</b> |
|               | 750 Elefant        | 88    | <b>HF</b> | <b>HF</b> |
|               | 750 Lucky          |       |           |           |
|               | Explorer           | 88    |           | <b>HF</b> |
| <b>CAN-AM</b> |                    |       |           |           |
|               | 200 ASE            | 86    | <b>SI</b> |           |
|               | 250 ASE            | 86    | <b>SI</b> |           |
|               | 250 MX LC          | 86    | <b>SI</b> |           |
|               | 350 ASE            | 86    | <b>SI</b> |           |
|               | 406 ASE            | 87    | <b>SI</b> |           |
|               | 500 ASE            | 86    | <b>SI</b> |           |
|               | 500 MX             | 86    | <b>SI</b> |           |
|               | 560 Sonic          | 86-14 | <b>SI</b> |           |



|                  |                   |       |           |           |
|------------------|-------------------|-------|-----------|-----------|
| <b>DB MOTORS</b> |                   |       |           |           |
| ZZ               | 50 Pirat          | 00-05 | <b>HF</b> | <b>HF</b> |
| ZZ               | 50 Sport          | 00-05 | <b>HF</b> |           |
| <b>DERBI</b>     |                   |       |           |           |
|                  | 125 Mulhacen      | 07    |           | <b>HF</b> |
|                  | 125 Terra         | 07    |           | <b>HF</b> |
|                  | 250 RC            | 85    | <b>HF</b> |           |
| <b>DUCATI</b>    |                   |       |           |           |
|                  | 350               | 75-78 | <b>HF</b> |           |
|                  | 350 F3            | 86-90 | <b>HF</b> | <b>HF</b> |
|                  | 350 GTV           | 77    | <b>HF</b> | <b>HF</b> |
|                  | 350 Indiana       | 86-91 |           | <b>HF</b> |
|                  | 350 Paso          | 86    | <b>HF</b> | <b>HF</b> |
|                  | 350 Sport         | 77-80 | <b>HF</b> | <b>HF</b> |
|                  | 400 Monster       |       |           |           |
|                  | (Japan)           | 01-06 |           | <b>LS</b> |
|                  | 400 SS, Junior    | 92-97 |           | <b>HF</b> |
|                  | 400 SS, Nuda      | 92-96 |           | <b>HF</b> |
|                  | 500 GTV           | 77-82 | <b>HF</b> | <b>HF</b> |
|                  | 500 Pantah        | 85-89 | <b>HF</b> | <b>HF</b> |
|                  | 500 Sport Desmo   | 77-82 | <b>HF</b> |           |
|                  | 500 Twin GTL      | 75-80 | <b>HF</b> |           |
|                  | 502 Single        | 93    |           | <b>HF</b> |
|                  | 502 Supermono     | 93    |           | <b>HF</b> |
|                  | 600 Monster       | 00-01 |           | <b>LS</b> |
|                  | 600 SL,           |       |           |           |
|                  | TL Pantah         | 76-89 |           | <b>HF</b> |
|                  | 600 SS            |       |           |           |
|                  | Supersport        | 95-00 |           | <b>HF</b> |
| M                | 600 Monster       | 94-99 |           | <b>HF</b> |
|                  | 620 Monster       |       |           |           |
|                  | Dark i.e.         | 02-06 |           | <b>LS</b> |
|                  | 620 Monster i.e., |       |           |           |
|                  | s i.e.            | 02-06 |           | <b>LS</b> |
|                  | 650 Indiana       | 86-89 |           | <b>HF</b> |
|                  | 695 Monster       | 07-12 |           | <b>LS</b> |
|                  | 748 , S           | 99-02 |           | <b>LS</b> |
|                  | 748 Biposto       | 95-98 |           | <b>HF</b> |
|                  | 748 R             | 00-02 |           | <b>LS</b> |
|                  | 748 SP            | 95-97 |           | <b>HF</b> |
|                  | 748 SPS           | 98-99 |           | <b>LS</b> |
|                  | 750 Indiana       | 85-86 |           | <b>HF</b> |
|                  | 750 Monster       | 96-99 |           | <b>HF</b> |
|                  | 750 Monster       | 00-01 |           | <b>LS</b> |
|                  | 750 Monster i.e.  | 02    |           | <b>LS</b> |
|                  | 750 Paso          | 86    | <b>HF</b> | <b>HF</b> |
|                  | 750 Paso          | 87    |           | <b>HF</b> |
|                  | 750 Paso          | 88    | <b>HF</b> | <b>HF</b> |
|                  | 750 SS            |       |           |           |
|                  | Supersport        | 95-99 |           | <b>HF</b> |
|                  | 750 SS, Carenara  | 92-98 |           | <b>HF</b> |
|                  | 750 SS, Nuda      | 92    |           | <b>HF</b> |
|                  | 750 Super Sport   | 92-94 |           | <b>HF</b> |
|                  | 800 Monster       |       |           |           |
|                  | Dark i.e.,        |       |           |           |
|                  | s i.e.            | 03-07 |           | <b>LS</b> |
|                  | 800 Monster i.e., |       |           |           |
|                  | s i.e.            | 03-07 |           | <b>LS</b> |
|                  | 800 Monster S2R   | 05-07 |           | <b>LS</b> |
|                  | 800 Monster S2R   |       |           |           |
|                  | ABS               | 05-07 |           | <b>LS</b> |
|                  | 851 Strada        | 89    |           | <b>HF</b> |
|                  | 851 Superbike     | 90    |           | <b>HF</b> |
|                  | 888 SP V          | 93    |           | <b>HF</b> |
|                  | 888 SP4           | 92-95 |           | <b>HF</b> |
|                  | 888 SPO           | 93    |           | <b>HF</b> |
|                  | 888 SPS           | 92-95 |           | <b>HF</b> |
|                  | 888 Strada        | 93    |           | <b>HF</b> |
|                  | 888 Superbike     | 93    |           | <b>HF</b> |

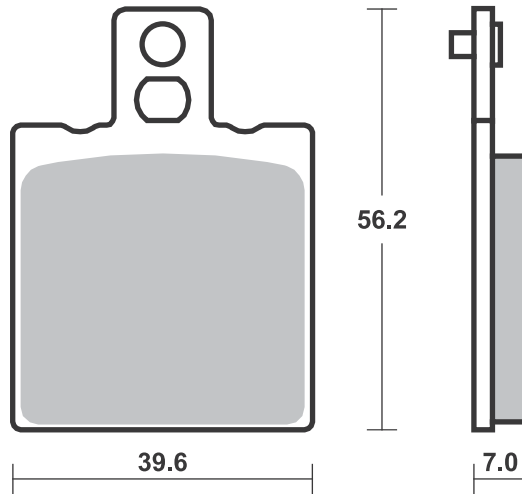

**SBS 519** Recommended compound



| <b>DUCATI</b>  |                    |       |              |
|----------------|--------------------|-------|--------------|
|                | 900 FE             | 97-98 | <b>HF</b>    |
|                | 900 M,             |       |              |
|                | IL Monster         | 93-99 | <b>HF</b>    |
|                | 900 Monster        | 00-01 | <b>LS</b>    |
|                | 900 Monster i.e.   | 02    | <b>LS</b>    |
|                | 900 SL             | 92-97 | <b>HF</b>    |
|                | 900 SS             | 90-94 | <b>HF</b>    |
|                | 900 SS             |       |              |
|                | Supersport         | 95-97 | <b>HF</b>    |
|                | 900 SSR            | 92    | <b>HF</b>    |
| 906            | 900 Paso           | 89    | <b>HF</b>    |
| 907            | 900 I. E.          | 90-93 | <b>HF</b>    |
| M              | 900 Street         |       |              |
|                | Monster            | 94-99 | <b>HF</b>    |
| MH             | 900                | 00-01 | <b>LS</b>    |
|                | 916 Biposto        | 94    | <b>HF</b>    |
|                | 916 Monster S4     | 01-03 | <b>LS</b>    |
|                | 916 SPS            | 97-98 | <b>LS</b>    |
|                | 996 , SPS          | 99-01 | <b>LS</b>    |
|                | 996 Monster        |       |              |
|                | S4R                | 04-06 | <b>LS</b>    |
|                | 996 R              | 01    | <b>LS</b>    |
|                | 998 , S            | 02    | <b>LS</b>    |
|                | 998 R              | 02    | <b>LS</b>    |
|                | 1000 Monster       |       |              |
|                | Dark i.e.,         |       |              |
|                | s i.e.             | 03-06 | <b>LS</b>    |
|                | 1000 Monster i.e., |       |              |
|                | s i.e.             | 03-06 | <b>LS</b>    |
| <b>FANTIC</b>  |                    |       |              |
|                | 50 Koala           | 88-89 | <b>HF HF</b> |
| RC             | 50 Caballero       | 91    | <b>HF HF</b> |
| RS             | 50 Caballero       | 91    | <b>HF HF</b> |
|                | 250 Coach          | 91-98 | <b>HF</b>    |
| <b>GARELLI</b> |                    |       |              |
|                | 50 Tiger XLE       | 86    | <b>HF HF</b> |
|                | 50 Urka            | 91    | <b>HF</b>    |
| GTA            | 125                | 80-82 | <b>HF HF</b> |
| GTA            | 125                | 83-85 | <b>HF</b>    |
| XR             | 125 Tiger XRD      | 85    | <b>HF</b>    |
| <b>GILERA</b>  |                    |       |              |
| SP             | 01                 | 90    | <b>HF</b>    |
|                | 50 Rally, R1       | 92-96 | <b>HF</b>    |
|                | 50 Sioux           | 92    | <b>HF HF</b> |
| RC             | 50 Top Rally       | 90    | <b>HF HF</b> |
|                | 125 Arizona        |       |              |
|                | Hawk               | 86-89 | <b>HF</b>    |
|                | 125 Crono          | 92-95 | <b>HF</b>    |
|                | 125 Freestyle      | 92-95 | <b>HF</b>    |
|                | 125 HX, HE         | 83    | <b>HF</b>    |
|                | 125 KK, KR, KZ     | 86-91 | <b>HF</b>    |
|                | 125 MX1, MRX,      |       |              |
|                | SP01               | 89-93 | <b>HF</b>    |
|                | 125 R1, R1S        | 90-92 | <b>HF</b>    |
|                | 125 SP02           | 90-94 | <b>HF</b>    |
| CX             | 125                | 91-95 | <b>HF</b>    |
| MXR            | 125                | 90    | <b>HF</b>    |
| RX             | 125                | 83    | <b>HF</b>    |
| XR2            | 125                | 90    | <b>HF</b>    |
|                | 200 Fast Bike      | 87    | <b>HF</b>    |
|                | 200 RX             | 83    | <b>HF</b>    |
| RV             | 200                | 85-86 | <b>HF</b>    |
|                | 250 Arizona        |       |              |
|                | Hawk               | 86-91 | <b>HF</b>    |
|                | 250 Arizona Rally  | 86-91 | <b>HF</b>    |
|                | 250 Arizona Rally  | 08    | <b>HF</b>    |
| NGR            | 250                | 85    | <b>HF</b>    |

| <b>GILERA</b>       |                           |       |              |
|---------------------|---------------------------|-------|--------------|
|                     | 350 Saturno               |       |              |
|                     | Bialbero                  | 90    | <b>HF</b>    |
| XRT                 | 350                       | 90    | <b>HF</b>    |
|                     | 500 Saturno               |       |              |
|                     | Bialbero                  | 90    | <b>HF</b>    |
|                     | 500 Saturno               |       |              |
|                     | Piuma                     | 90-94 | <b>HF</b>    |
|                     | 600 Northwest             | 91-94 | <b>HF</b>    |
| RC                  | 600                       | 88    | <b>HF</b>    |
| XRT                 | 600                       | 89    | <b>HF</b>    |
| <b>HERCULES</b>     |                           |       |              |
| ZX                  | 125                       | 86    | <b>HF</b>    |
| <b>HUSQVARNA</b>    |                           |       |              |
| CR                  | 125                       | 85-90 | <b>SI</b>    |
| CX                  | 125                       | 84-85 | <b>SI</b>    |
|                     | 200 Prof                  | 86    | <b>SI</b>    |
| CR                  | 240                       | 84-85 | <b>SI</b>    |
| CR                  | 250                       | 85-87 | <b>SI</b>    |
| CX                  | 250                       | 84-85 | <b>SI</b>    |
|                     | 400 Enduro                | 85-88 | <b>SI</b>    |
|                     | 430 Enduro                | 85-88 | <b>SI</b>    |
| CR                  | 500                       | 86-87 | <b>SI</b>    |
| CX/CR               | 500                       | 84-85 | <b>SI</b>    |
| TC                  | 500                       | 86    | <b>SI</b>    |
|                     | 504                       | 83    | <b>SI</b>    |
| TE                  | 510                       | 86-87 | <b>SI</b>    |
| <b>ISR CALIPERS</b> |                           |       |              |
|                     | 2 Piston (22-027/028/029) |       |              |
|                     | 4 Piston (22-025)         |       |              |
| <b>ITALJET</b>      |                           |       |              |
|                     | 350                       | 83    | <b>HF</b>    |
| <b>KEEWAY</b>       |                           |       |              |
|                     | 125 Enduro                | 07-08 | <b>HF</b>    |
|                     | 125 X-Ray                 | 07-08 | <b>HF</b>    |
| <b>KREIDLER</b>     |                           |       |              |
|                     | 125 Mustang               | 83-87 | <b>HF</b>    |
| <b>KTM</b>          |                           |       |              |
| GXE                 | 50                        | 87-88 | <b>HF</b>    |
| MX                  | 50                        | 87-90 | <b>SI</b>    |
| RSV                 | 50                        | 86-89 | <b>SI</b>    |
|                     | 80 RSL, L, RS,            |       |              |
|                     | RL, Bora,                 |       |              |
|                     | Chopper                   | 80-85 | <b>HF HF</b> |
| PL                  | 80 Watercooled            | 85-88 | <b>HF HF</b> |
| RLW                 | 80                        | 80-81 | <b>SI SI</b> |
| MX                  | 85                        | 90    | <b>SI</b>    |
| LC                  | 125                       | 85    | <b>SI</b>    |
| LC                  | 125                       | 86    | <b>SI SI</b> |
| MX                  | 125                       | 85    | <b>SI</b>    |
| MX                  | 125                       | 86    | <b>SI SI</b> |
| XC                  | 125                       | 85    | <b>SI</b>    |
| XC                  | 125                       | 86-89 | <b>SI SI</b> |
|                     | 250 Baja                  | 86-89 | <b>SI</b>    |
|                     | 250 Country,Baja          | 85    | <b>SI</b>    |
| LC                  | 250                       | 85    | <b>SI</b>    |
| LC                  | 250                       | 86    | <b>SI SI</b> |
| MC                  | 250                       | 83-84 | <b>SI SI</b> |
| MX                  | 250                       | 83-84 | <b>SI SI</b> |
| MX                  | 250                       | 85    | <b>SI</b>    |
| MX                  | 250                       | 86    | <b>SI SI</b> |
| XC                  | 250                       | 85    | <b>SI</b>    |
| XC                  | 250                       | 86-89 | <b>SI SI</b> |
| XC                  | 300                       | 85    | <b>SI</b>    |

| <b>KTM</b>      |                  |       |              |
|-----------------|------------------|-------|--------------|
| XC              | 300              | 86-90 | <b>SI SI</b> |
|                 | 350 Country      |       |              |
|                 | Cross            | 85    | <b>SI</b>    |
|                 | 350 GS           | 83-85 | <b>SI</b>    |
| GS4             | 350 500 K4       | 82-83 | <b>SI</b>    |
| K4              | 350 500 K4       | 82-83 | <b>SI</b>    |
| XC              | 350 , MC         | 81-83 | <b>SI</b>    |
|                 | 390 GS           | 83    | <b>SI</b>    |
| XC              | 390 , MC         | 81-83 | <b>SI</b>    |
| XC              | 420 , MC         | 81-83 | <b>SI</b>    |
| MC              | 495 Leleu        | 82-83 | <b>SI</b>    |
| MX              | 495 Leleu        | 82-83 | <b>SI</b>    |
| GS              | 500 500 K4       |       |              |
|                 | Enduro           | 83    | <b>SI</b>    |
| LC              | 500              | 85    | <b>SI</b>    |
| LC              | 500              | 86-89 | <b>SI SI</b> |
| MX              | 500              | 85    | <b>SI</b>    |
| MX              | 500              | 86    | <b>SI SI</b> |
| XC              | 500 , MC         | 81-83 | <b>SI</b>    |
| 4T              | 600 Enduro       | 84-86 | <b>SI</b>    |
| GS              | 600              | 85    | <b>SI</b>    |
| XC              | 600 Cross        | 85    | <b>SI</b>    |
| XCE             | 600 Cross        | 85    | <b>SI</b>    |
|                 | 620 Duke         | 96-98 | <b>HF</b>    |
|                 | 640 Duke         | 99-02 | <b>HF</b>    |
| <b>LAVERDA</b>  |                  |       |              |
|                 | 50 Gaucho        | 92    | <b>HF HF</b> |
| OR              | 50 Atlas         | 86    | <b>HF HF</b> |
| OR              | 50 Atlas         | 90-92 | <b>HF HF</b> |
|                 | 125 Custom       | 86-99 | <b>HF</b>    |
| CU              | 125 Ride         | 86-99 | <b>HF</b>    |
| LB              | 125 Uno          | 85-89 | <b>HF</b>    |
| GS              | 350 Lesmo        | 86-89 | <b>HF HF</b> |
| PF              | 350 Alpino       | 77-83 | <b>HF HF</b> |
| RS              | 350 Alpino       | 77-83 | <b>HF HF</b> |
|                 | 500 Alpino, S    | 77-83 | <b>HF HF</b> |
| OR              | 600 Atlas        | 86-90 | <b>HF</b>    |
|                 | 650              | 92    | <b>HF</b>    |
|                 | 668 668          | 96-97 | <b>HF</b>    |
|                 | 668 Ghost,       |       |              |
|                 | Diamante         | 97    | <b>HF</b>    |
|                 | 750 Cup          | 98-01 | <b>HF</b>    |
|                 | 750 Diamante     | 97-01 | <b>HF</b>    |
|                 | 750 Ghost Strike | 97-01 | <b>HF</b>    |
|                 | 750 S Formula    | 97-01 | <b>HF</b>    |
|                 | 750 S,           |       |              |
|                 | S Carenata       | 97-01 | <b>HF</b>    |
|                 | 750 Sport        | 99-01 | <b>HF</b>    |
|                 | 750 Strike/      |       |              |
|                 | Black Strike     | 99-01 | <b>HF</b>    |
|                 | 750 T8           | 98-01 | <b>HF</b>    |
| JOTA            | 1000             | 95    | <b>HF</b>    |
| <b>MAICO</b>    |                  |       |              |
| GM              | 250 LC           | 85    | <b>SI</b>    |
| MD              | 250              | 83-85 | <b>SI SI</b> |
| GM              | 500 LC           | 85-86 | <b>SI</b>    |
| <b>MALAGUTI</b> |                  |       |              |
|                 | 50 Enduro        | 85-87 | <b>HF</b>    |
| MRX             | 50               | 89    | <b>HF</b>    |
| RST             | 50               | 90    | <b>HF HF</b> |
| <b>MALANCA</b>  |                  |       |              |
|                 | 125 Mark         | 85    | <b>HF</b>    |
| <b>MONTESA</b>  |                  |       |              |
|                 | 260 Evasion      | 92    | <b>RSI</b>   |
|                 | 309 Cota         | 89-90 | <b>RSI</b>   |



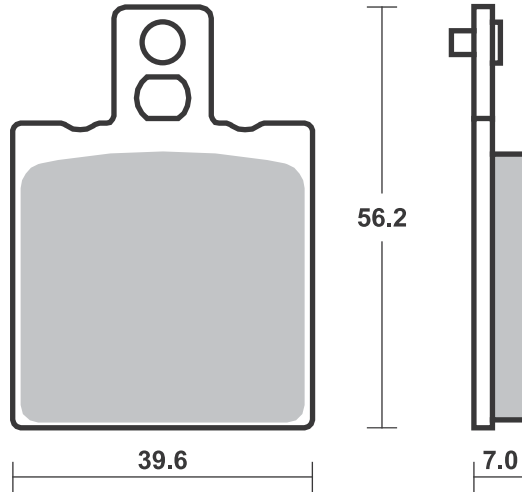

## Applications

**SBS 519**
**Recommended compound**

| <b>MONTESA</b> |                |       |            |
|----------------|----------------|-------|------------|
|                | 310 Cota       | 89-92 | <b>RSI</b> |
|                | 311 Cota Trial | 92    | <b>RSI</b> |

**MOTO-GUZZI**

|     |                    |       |           |           |
|-----|--------------------|-------|-----------|-----------|
|     | 125 Custom         | 85    | <b>HF</b> |           |
|     | 125 Enduro TT      | 85    | <b>HF</b> |           |
| BX  | 125                | 92    | <b>HF</b> | <b>HF</b> |
|     | 240 /4             | 77    | <b>HF</b> |           |
|     | 250 TS             | 75-76 | <b>HF</b> |           |
|     | 350                | 77-81 | <b>HF</b> | <b>HF</b> |
|     | 350 Falco          | 88    | <b>HF</b> | <b>HF</b> |
|     | 350 Imola          | 78-84 | <b>HF</b> | <b>HF</b> |
|     | 350 Nevada         | 92-97 | <b>HF</b> |           |
| NTX | 350                | 88    | <b>HF</b> | <b>HF</b> |
| NTX | 350                | 90    | <b>HF</b> |           |
| V35 | 350 C              | 82-86 |           | <b>HF</b> |
| V35 | 350 Florida        | 85-86 |           | <b>HF</b> |
| V35 | 350 GT             | 77    | <b>HF</b> |           |
| V35 | 350 GT             | 90    |           | <b>HF</b> |
| V35 | 350 II, Imola,     |       |           |           |
|     | Imola II           | 77    | <b>HF</b> | <b>HF</b> |
|     | 400                | 77-84 | <b>HF</b> | <b>HF</b> |
|     | 500                | 77-80 | <b>HF</b> | <b>HF</b> |
|     | 500 Monza          | 78-85 | <b>HF</b> | <b>HF</b> |
| V50 | 500 1,2,3, Monza   |       |           |           |
|     | Chopper            | 77    | <b>HF</b> | <b>HF</b> |
|     | 650                | 80-84 | <b>HF</b> | <b>HF</b> |
|     | 650 Florida        | 85-84 | <b>HF</b> | <b>HF</b> |
| GT  | 650 Sessantacinque |       |           |           |
|     |                    | 89    | <b>HF</b> | <b>HF</b> |
| NTX | 650                | 90-02 | <b>HF</b> |           |
| V65 | 650 Lario          | 86-94 | <b>HF</b> | <b>HF</b> |
| V65 | 650 NTX            | 87-02 | <b>HF</b> | <b>HF</b> |
| V65 | 650 SP, Chopper    | 80-84 | <b>HF</b> | <b>HF</b> |
| V65 | 650 TT             | 86-94 | <b>HF</b> | <b>HF</b> |
|     | 750 Ippogrifo      | 97    | <b>HF</b> | <b>HF</b> |
|     | 750 Nevada         | 92-96 | <b>HF</b> |           |
|     | 750 Nevada,        |       |           |           |
|     | Club/Base          | 97-02 | <b>HF</b> | <b>HF</b> |
|     | 750 Targa          | 89    | <b>HF</b> | <b>HF</b> |
| NTX | 750                | 89    | <b>HF</b> | <b>HF</b> |
| RS  | 1000 Daytona       | 97-00 |           | <b>HF</b> |
| V   | 1000 Strada        | 93-94 |           | <b>HF</b> |
| V10 | 1000 Centauro      | 96-00 |           | <b>HF</b> |
|     | 1100 Sport         | 96-04 |           | <b>HF</b> |
| EV  | 1100 California    | 97-00 |           | <b>HF</b> |
| EV  | 1100 California,   |       |           |           |
|     | 80, Touring        | 01    |           | <b>LS</b> |
| V11 | 1100 , Scura,      |       |           |           |
|     | Sport Scura        | 02-05 |           | <b>LS</b> |
| V11 | 1100 Lemans,       |       |           |           |
|     | Lemans             |       |           |           |
|     | Tenni,             |       |           |           |
|     | Lemans             |       |           |           |
|     | Rosso              |       |           |           |
|     | Corsa              | 01-06 |           | <b>LS</b> |
| V11 | 1100 Sport         | 97-00 |           | <b>HF</b> |
| V11 | 1100 Sport Rosso   |       |           |           |
|     | Mandell            | 01-06 |           | <b>LS</b> |
| V11 | 1100 Sport,        |       |           |           |
|     | Sport Naked        | 01-05 |           | <b>LS</b> |

| <b>MOTO-MORINI</b> |              |       |           |
|--------------------|--------------|-------|-----------|
| XE                 | 250 Country  | 88    | <b>HF</b> |
|                    | 350 Coguaro  | 90-95 | <b>HF</b> |
|                    | 350 Coguaro, |       |           |
|                    | New York     | 90-94 | <b>HF</b> |
|                    | 350 Dart     | 88    | <b>HF</b> |
|                    | 350 Dart     | 90-92 | <b>HF</b> |
|                    | 350 Indiana  | 88    | <b>HF</b> |

| <b>MOTO-MORINI</b> |                   |       |           |
|--------------------|-------------------|-------|-----------|
|                    | 350 Kanguro       | 88    | <b>HF</b> |
| RLX                | 350 Excalibur     | 90-92 | <b>HF</b> |
|                    | 400 Dart          | 89-92 | <b>HF</b> |
|                    | 400 S             | 82    | <b>HF</b> |
|                    | 400 S             | 82    | <b>HF</b> |
|                    | 500 Sei V Classic | 89    | <b>HF</b> |
|                    | 501 Camel         | 88    | <b>HF</b> |
|                    | 501 Coguaro       | 89    | <b>HF</b> |
|                    | 501 Excalibur     | 89    | <b>HF</b> |
|                    | 501 New York      | 89    | <b>HF</b> |
| RLX                | 501 Excalibur     | 90    | <b>HF</b> |
|                    | 650 Indiana       | 88    | <b>HF</b> |
|                    | 750 Indiana       | 88    | <b>HF</b> |

| <b>MOTO-MORINI</b> |           |       |           |
|--------------------|-----------|-------|-----------|
|                    | 660 (MUZ) |       |           |
|                    | Skorpion  |       |           |
|                    | Cup       | 99    | <b>HF</b> |
|                    | 660 (MUZ) |       |           |
|                    | Skorpion  |       |           |
|                    | Replica   | 97-99 | <b>HF</b> |
|                    | 660 (MUZ) |       |           |
|                    | Skorpion  |       |           |
|                    | Sport     | 95-99 | <b>HF</b> |
|                    | 660 (MUZ) |       |           |
|                    | Skorpion  |       |           |
|                    | Tour      | 95-00 | <b>HF</b> |
|                    | 660 (MUZ) |       |           |
|                    | Skorpion  |       |           |
|                    | Traveller | 99-00 | <b>HF</b> |

| <b>MOTO-MORINI</b> |            |    |           |
|--------------------|------------|----|-----------|
|                    | 500 Yanqee | 78 | <b>HF</b> |

| <b>REWACO</b> |     |       |           |
|---------------|-----|-------|-----------|
|               | FX4 | 07    | <b>HF</b> |
|               | FX5 | 07    | <b>HF</b> |
|               | FX6 | 07    | <b>HF</b> |
|               | HS4 | 01    | <b>HF</b> |
|               | HS5 | 01    | <b>HF</b> |
|               | HS6 | 01    | <b>HF</b> |
|               | RF1 | 07-14 | <b>HF</b> |

| <b>SACHS</b> |          |    |           |
|--------------|----------|----|-----------|
| SW           | 80 Lotus | 82 | <b>HF</b> |

| <b>SANGLAS</b> |        |       |           |
|----------------|--------|-------|-----------|
|                | 400 Y  | 79-80 | <b>HF</b> |
|                | 500 S2 | 79-80 | <b>HF</b> |

| <b>SIMSON</b> |              |       |           |
|---------------|--------------|-------|-----------|
|               | 50 Habict CX | 01-99 | <b>HF</b> |
|               | 80 IFA       | 89    | <b>HF</b> |
| SR            | 80 -2 CE     | 87    | <b>HF</b> |
| S             | 83 CX        | 93    | <b>HF</b> |
| S             | 83 OR        | 83    | <b>HF</b> |

| <b>SWM</b> |              |    |            |
|------------|--------------|----|------------|
|            | 125 GP       | 86 | <b>HF</b>  |
|            | 125 S1-S2    | 83 | <b>HF</b>  |
|            | 250 Explorer | 86 | <b>SI</b>  |
|            | 250 Pioner   | 86 | <b>SI</b>  |
|            | 250 S1-S2    | 83 | <b>HF</b>  |
| TRL        | 329 MJ       | 86 | <b>RSI</b> |

| <b>TORNAX</b> |    |    |           |
|---------------|----|----|-----------|
| RX            | 80 | 83 | <b>HF</b> |

| <b>YAMAHA</b> |     |       |           |
|---------------|-----|-------|-----------|
| SZR           | 660 | 96-01 | <b>HF</b> |

| <b>ZANELLA</b> |           |    |           |
|----------------|-----------|----|-----------|
|                | 50 Racing |    |           |
|                | Moped     | 92 | <b>HF</b> |
| RZA            | 125       | 92 | <b>HF</b> |

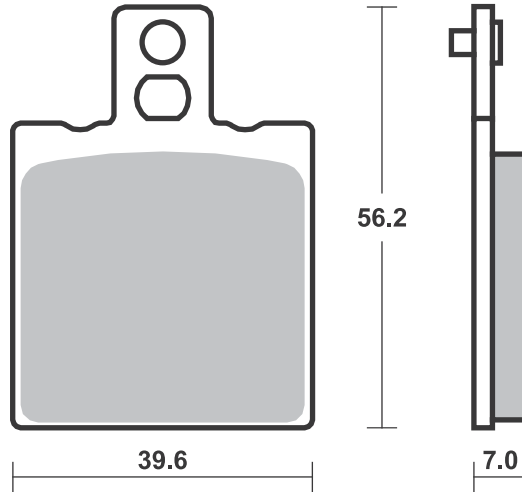

## SBS 520 Recommended compound



| <b>BMW</b> |         |       |           |
|------------|---------|-------|-----------|
| R60/7      | 600     | 76-77 | <b>HF</b> |
| R75/6      | 750     | 74-76 | <b>HF</b> |
| R75/7      | 750     | 76-77 | <b>HF</b> |
| R80/7      | 800     | 77-81 | <b>HF</b> |
| R90        | 900 S   | 73-76 | <b>HF</b> |
| R90/6      | 900     | 73-76 | <b>HF</b> |
| R100       | 1000 RS | 76-80 | <b>HF</b> |
| R100       | 1000 S  | 76-80 | <b>HF</b> |
| R100       | 1000 T  | 79-84 | <b>HF</b> |
| R100/7     | 1000    | 78-80 | <b>HF</b> |
|            |         |       |           |
|            |         |       |           |
|            |         |       |           |
|            |         |       |           |
|            |         |       |           |
|            |         |       |           |
|            |         |       |           |
|            |         |       |           |
|            |         |       |           |
|            |         |       |           |
|            |         |       |           |
|            |         |       |           |
|            |         |       |           |
|            |         |       |           |
|            |         |       |           |
|            |         |       |           |
|            |         |       |           |
|            |         |       |           |
|            |         |       |           |
|            |         |       |           |
|            |         |       |           |
|            |         |       |           |

## SBS 522 Recommended compound



| <b>KAWASAKI</b> |           |       |           |
|-----------------|-----------|-------|-----------|
| KH              | 90        | 78-83 | <b>HF</b> |
| KH              | 100 EX, G | 81-82 | <b>HF</b> |
| Z               | 400       | 78-79 | <b>HF</b> |
|                 |           |       |           |
|                 |           |       |           |
|                 |           |       |           |
|                 |           |       |           |
|                 |           |       |           |
|                 |           |       |           |
|                 |           |       |           |
|                 |           |       |           |
|                 |           |       |           |
|                 |           |       |           |
|                 |           |       |           |
|                 |           |       |           |
|                 |           |       |           |
|                 |           |       |           |
|                 |           |       |           |
|                 |           |       |           |
|                 |           |       |           |
|                 |           |       |           |
|                 |           |       |           |
|                 |           |       |           |
|                 |           |       |           |
|                 |           |       |           |
|                 |           |       |           |
|                 |           |       |           |
|                 |           |       |           |
|                 |           |       |           |

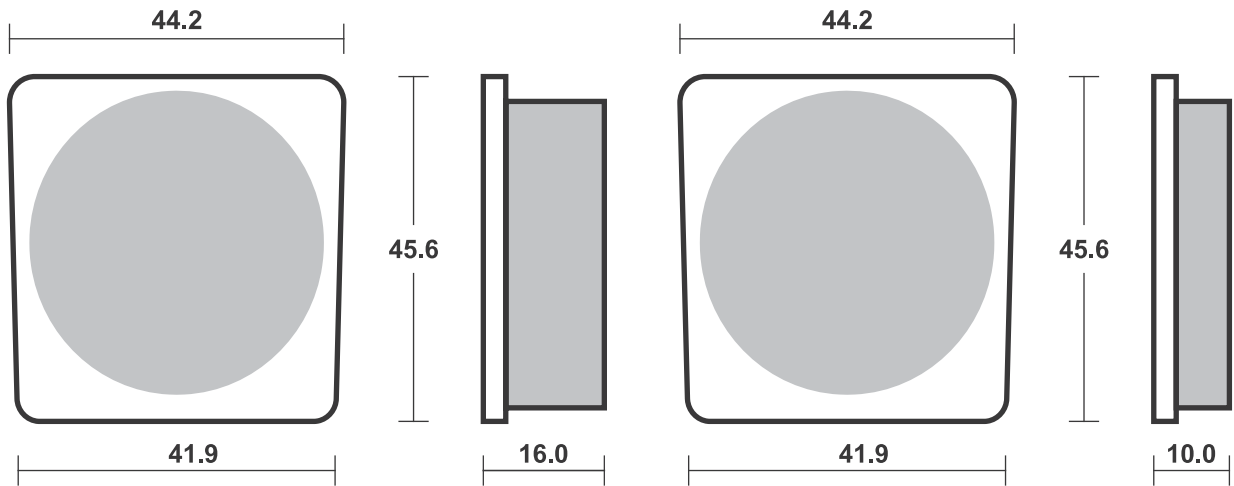
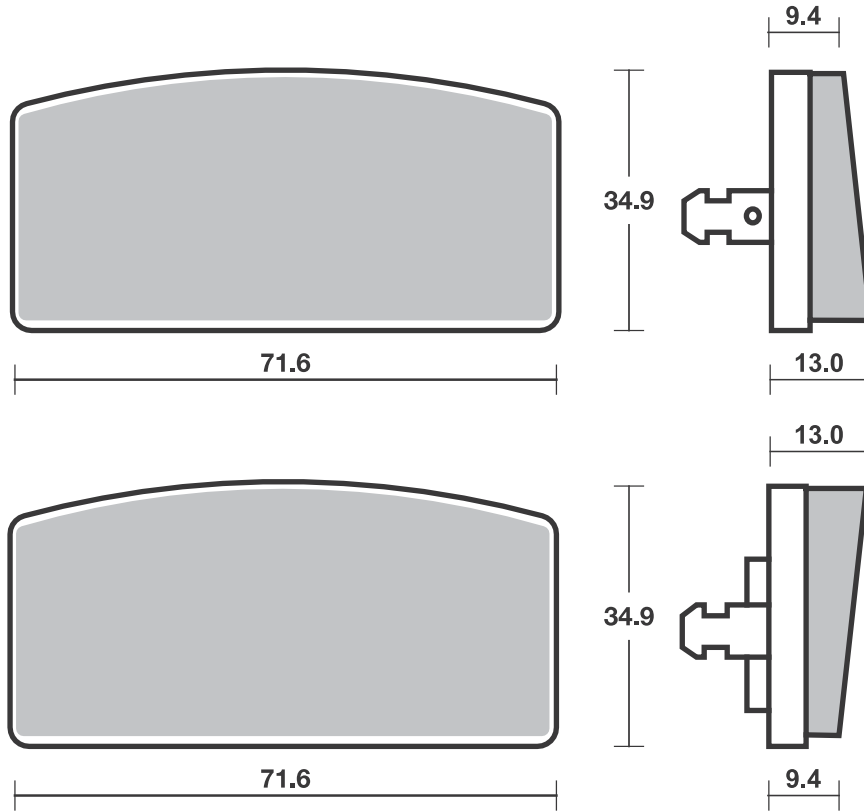

**SBS 523** Recommended compound**A.P. RACING CALIPERS**

|                   |  |  |
|-------------------|--|--|
| CP-2696-36E0/38E0 |  |  |
| CP-3696-2E0       |  |  |
| CP-3697-2E0       |  |  |
| CP-4638-2E0       |  |  |

**DUCATI**

|           |       |    |
|-----------|-------|----|
| 750 Sport | 74-76 | HF |
|-----------|-------|----|

**ISR CALIPERS**

|                       |  |  |
|-----------------------|--|--|
| 2 Piston (22-030/033) |  |  |
|-----------------------|--|--|

**TRIUMPH**

|                   |                   |       |       |
|-------------------|-------------------|-------|-------|
| 750 Trident T160V | 75-77             | HF    | HF    |
| T140              | 750 D,E,FV        |       |       |
|                   | Bonneville        | 76-81 | HF HF |
| T140              | 750 ES Bonneville | 81-83 | HF HF |
| TR65              | 750 Thunderbird   | 81-83 | HF    |
| TR7T              | 750 Tiger Trail   | 81-83 | HF    |

**TRIUMPH**

|      |                   |       |    |    |
|------|-------------------|-------|----|----|
| TR7V | 750 Tiger         | 73-81 | HF | HF |
| TSS  | 750               | 83    | HF | HF |
| TSS  | 750 Electro Eight |       |    |    |
|      | Valve             | 84    | HF |    |
| TSX  | 750               | 83    | HF | HF |

**SBS 524** Recommended compound**HYOSUNG**

|               |             |          |
|---------------|-------------|----------|
| 125 Cruise II | 99-06       | HF       |
| 125 Cruise II |             |          |
|               | Classic     | 99-06 HF |
|               | 125 Cruiser | 92-06 HF |
| GA            | 125         | 98-06 HF |
| GA            | 125 F       | 00-06 HF |
| GF            | 125         | 98-04 HF |
| GS            | 125         | 99 HF    |
| TN            | 125         | 92-95 HF |

**KREIDLER**

|            |       |    |
|------------|-------|----|
| 50 Florett | 81-82 | HF |
|------------|-------|----|

**SUZUKI**

|    |                |       |    |
|----|----------------|-------|----|
| GP | 125 all models | 77-84 | HF |
|----|----------------|-------|----|

**SBS 525** Recommended compound**HONDA**

|    |             |       |    |
|----|-------------|-------|----|
| CB | 50 J, K1    | 75-79 | HF |
| SS | 50 ZB2      | 75-80 | HF |
| CB | 90          | 79-84 | HF |
| CG | 110         | 77-79 | HF |
| CB | 125 J       | 79    | HF |
| CB | 125 S       | 76-78 | HF |
| MT | 125 R       | 77    | HF |
| FL | 250 Odyssey | 77-84 | HF |

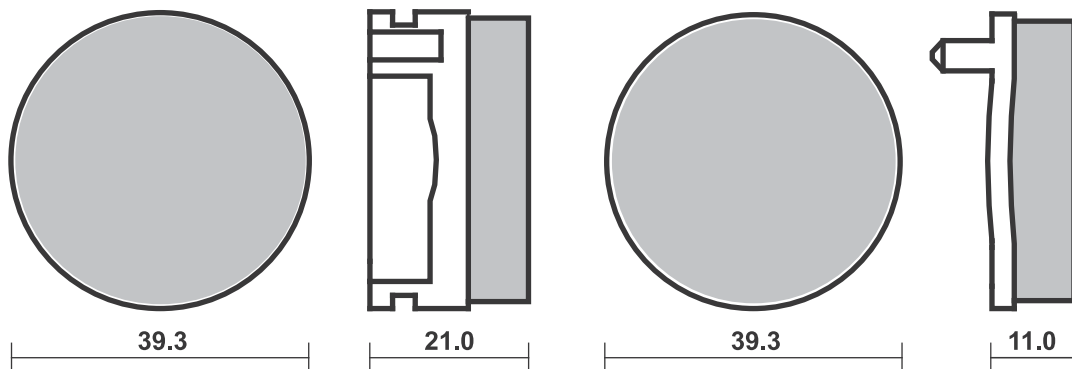
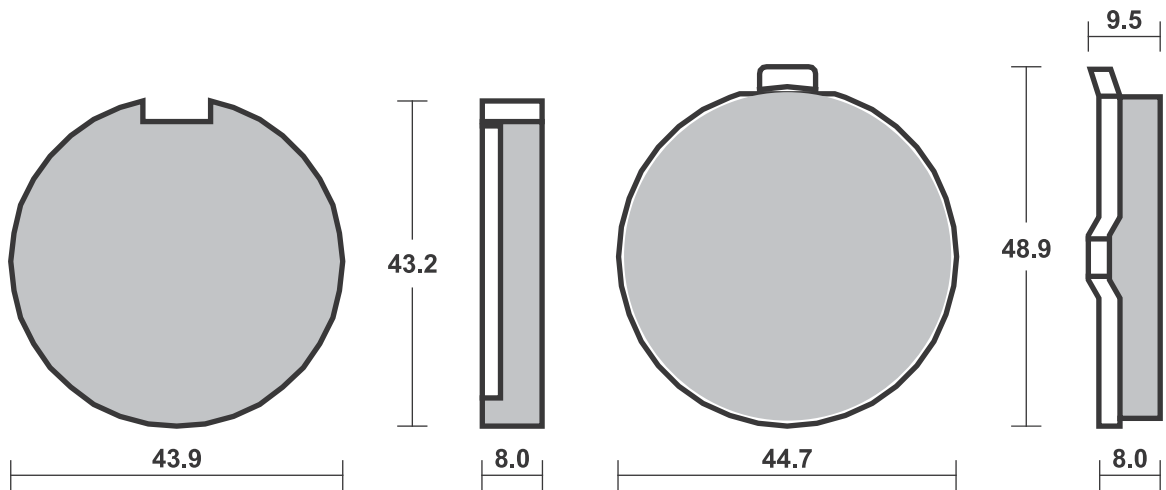
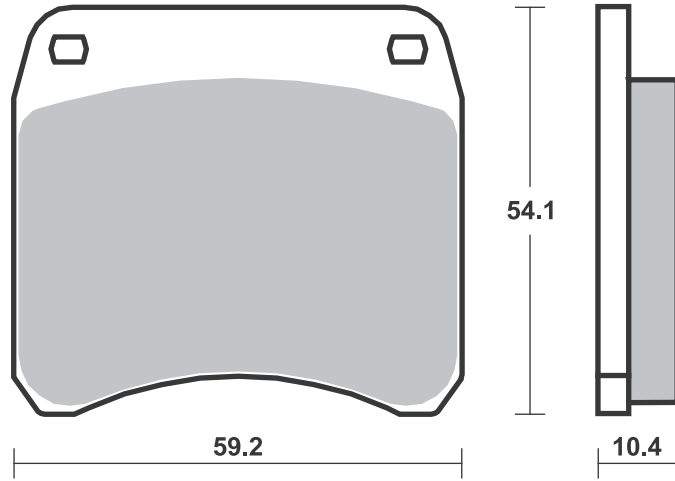





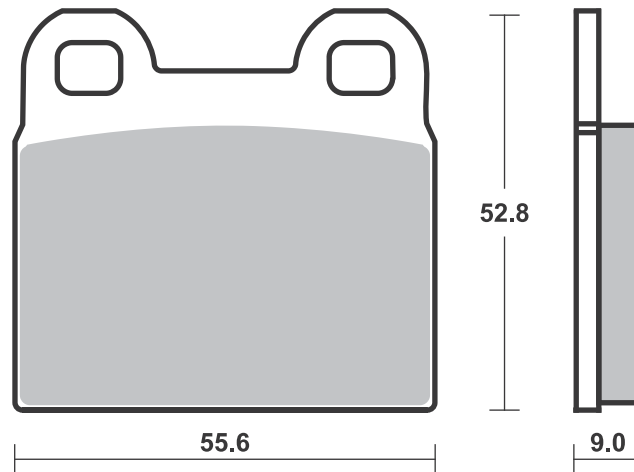
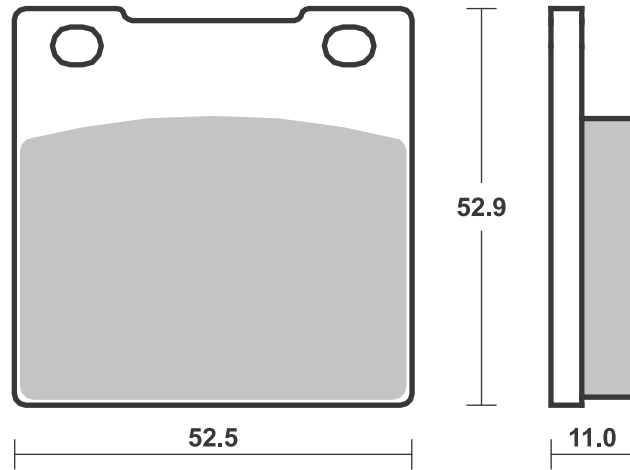

**SBS 528 Recommended compound**



**YAMAHA**

|    |                  |       |           |           |
|----|------------------|-------|-----------|-----------|
| GX | 250 Right        | 80-85 | <b>HF</b> |           |
| RD | 250              | 78-79 | <b>HF</b> | <b>HF</b> |
| RD | 250 DX Right     | 80    | <b>HF</b> |           |
| XS | 250 SE, SF       | 80-81 | <b>HF</b> |           |
| RD | 400              | 78-79 | <b>HF</b> | <b>HF</b> |
| RD | 400              | 79    |           | <b>HF</b> |
| XS | 400 SE Left/Rear | 80-81 | <b>HF</b> |           |
| XS | 400 SG, SH, SF   | 80-81 | <b>HF</b> |           |
| XJ | 650 G, H,        |       |           |           |
|    | SH Right         | 80-83 | <b>HF</b> |           |
| XS | 750 SE Right     | 79-80 | <b>HF</b> |           |
| XV | 750 MK           | 83    | <b>HF</b> |           |
| XS | 850 Right        | 81    | <b>HF</b> |           |
| XJ | 1100             | 81    |           | <b>HF</b> |
| XS | 1100 LH Midnight | 81    |           | <b>HF</b> |
| XS | 1100 SF, SG, SH, |       |           |           |
|    | LG Right         | 79-81 | <b>HF</b> |           |
|    |                  |       |           |           |
|    |                  |       |           |           |
|    |                  |       |           |           |
|    |                  |       |           |           |
|    |                  |       |           |           |
|    |                  |       |           |           |
|    |                  |       |           |           |
|    |                  |       |           |           |
|    |                  |       |           |           |
|    |                  |       |           |           |
|    |                  |       |           |           |
|    |                  |       |           |           |
|    |                  |       |           |           |
|    |                  |       |           |           |
|    |                  |       |           |           |
|    |                  |       |           |           |
|    |                  |       |           |           |
|    |                  |       |           |           |
|    |                  |       |           |           |
|    |                  |       |           |           |
|    |                  |       |           |           |
|    |                  |       |           |           |
|    |                  |       |           |           |
|    |                  |       |           |           |
|    |                  |       |           |           |

**SBS 529 Recommended compound**



**HONDA**

|    |                   |       |           |  |
|----|-------------------|-------|-----------|--|
| CB | 100 N             | 79-80 | <b>HF</b> |  |
| CB | 125 T             | 85    | <b>HF</b> |  |
| CB | 125 T, T1, T2, TZ | 77-81 | <b>HF</b> |  |
|    |                   |       |           |  |
|    |                   |       |           |  |
|    |                   |       |           |  |
|    |                   |       |           |  |
|    |                   |       |           |  |
|    |                   |       |           |  |
|    |                   |       |           |  |
|    |                   |       |           |  |
|    |                   |       |           |  |
|    |                   |       |           |  |
|    |                   |       |           |  |
|    |                   |       |           |  |
|    |                   |       |           |  |
|    |                   |       |           |  |
|    |                   |       |           |  |
|    |                   |       |           |  |
|    |                   |       |           |  |
|    |                   |       |           |  |
|    |                   |       |           |  |
|    |                   |       |           |  |

Brake Pad 1:1 Drawings, Compounds, Fitments

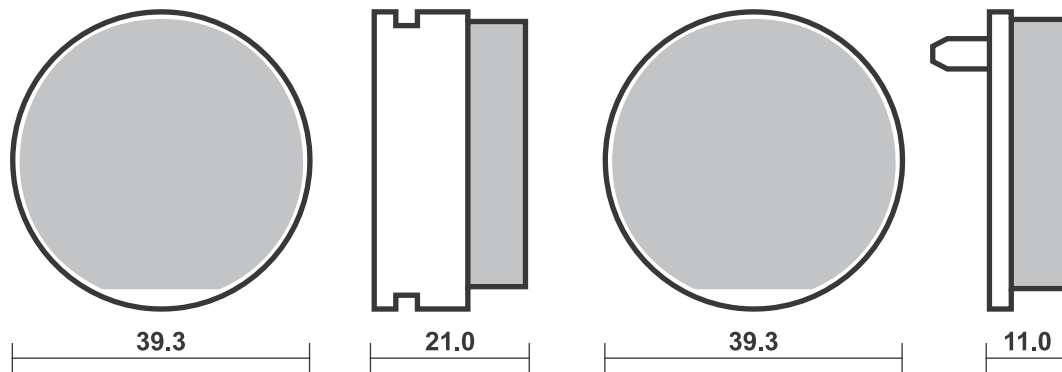
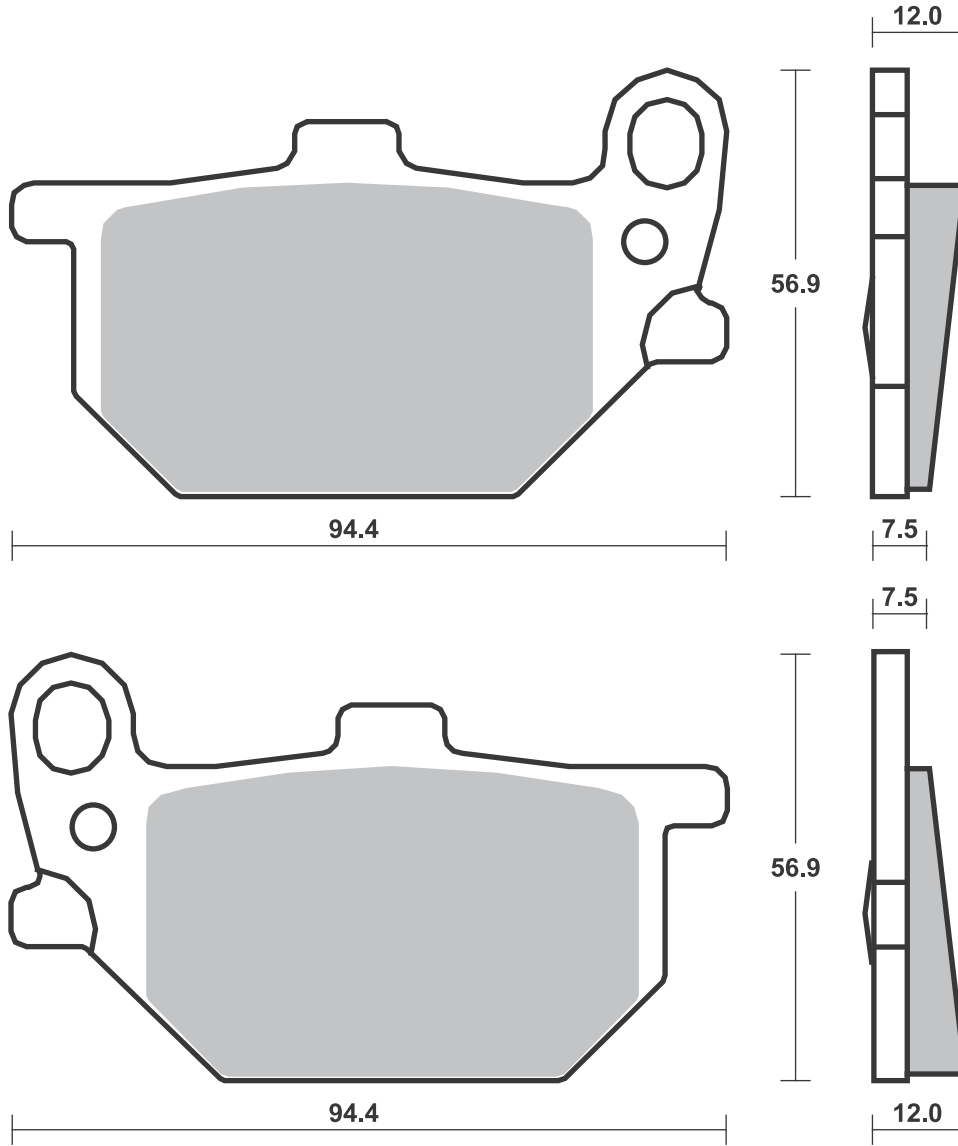

**SBS 530** Recommended compound



**KAWASAKI**

|   |          |       |           |
|---|----------|-------|-----------|
| Z | 1300     | 79-81 | <b>HF</b> |
| Z | 1300 DF1 | 84    | <b>HF</b> |
|   |          |       |           |
|   |          |       |           |
|   |          |       |           |
|   |          |       |           |
|   |          |       |           |
|   |          |       |           |
|   |          |       |           |
|   |          |       |           |
|   |          |       |           |
|   |          |       |           |
|   |          |       |           |
|   |          |       |           |
|   |          |       |           |
|   |          |       |           |
|   |          |       |           |
|   |          |       |           |
|   |          |       |           |

**SBS 531** Recommended compound



**YAMAHA**

|     |        |       |           |
|-----|--------|-------|-----------|
| FS1 | 50 DX  | 79-81 | <b>HF</b> |
| RD  | 50 M   | 79-80 | <b>HF</b> |
| RD  | 100    | 80-82 | <b>HF</b> |
| RS  | 100 DX | 80-82 | <b>HF</b> |
| RD  | 125 DX | 78-81 | <b>HF</b> |
| RS  | 125 DX | 80-86 | <b>HF</b> |
| RD  | 200 DX | 78-81 | <b>HF</b> |
|     |        |       |           |
|     |        |       |           |
|     |        |       |           |
|     |        |       |           |
|     |        |       |           |
|     |        |       |           |
|     |        |       |           |
|     |        |       |           |
|     |        |       |           |
|     |        |       |           |
|     |        |       |           |
|     |        |       |           |
|     |        |       |           |
|     |        |       |           |
|     |        |       |           |
|     |        |       |           |

**SBS 532** Recommended compound



|                |              |    |           |
|----------------|--------------|----|-----------|
| <b>ATK</b>     |              |    |           |
| ATK            | 560          | 86 | <b>HF</b> |
| <b>BENELLI</b> |              |    |           |
|                | 254          | 83 | <b>HF</b> |
| <b>BETA</b>    |              |    |           |
|                | 50 Squirrel  | 83 | <b>HF</b> |
| MG             | 125          | 83 | <b>HF</b> |
| <b>CASAL</b>   |              |    |           |
| RZ             | 50           | 82 | <b>HF</b> |
| <b>CIMATTI</b> |              |    |           |
|                | 50 Gringo    | 85 | <b>HF</b> |
| <b>FANTIC</b>  |              |    |           |
|                | 50 Super SIX | 83 | <b>HF</b> |



|                 |                  |       |           |
|-----------------|------------------|-------|-----------|
| <b>GARELLI</b>  |                  |       |           |
|                 | 50 S, Sport 40   | 80    | <b>HF</b> |
|                 | 80 Sport         | 83    | <b>HF</b> |
| <b>HERCULES</b> |                  |       |           |
|                 | 50 Ultra         | 79-83 | <b>HF</b> |
| RS              | 50               | 79-83 | <b>HF</b> |
|                 | 80 Ultra AC      | 81    | <b>HF</b> |
|                 | 80 Ultra AC Ch.  | 81-83 | <b>HF</b> |
|                 | 80 Ultra Chopper | 81-83 | <b>HF</b> |
| RX-9            | 80               | 82-83 | <b>HF</b> |
| RX-9            | 80 Aircooled     | 82-83 | <b>HF</b> |
| KX-5            | 125              | 87    | <b>HF</b> |
| <b>HOREX</b>    |                  |       |           |
|                 | 80 Rebell N      | 83    | <b>HF</b> |



|                 |                   |       |           |
|-----------------|-------------------|-------|-----------|
| <b>MALAGUTI</b> |                   |       |           |
|                 | 50 Chopper 25,    |       |           |
|                 | 40, 80, Fifty     | 83    | <b>HF</b> |
|                 | 50 Chopper HF,    |       |           |
|                 | Watercooled       | 83    | <b>HF</b> |
| RCW             | 50 Ronco          | 83    | <b>HF</b> |
| V4              | 50 Olympique      | 83    | <b>HF</b> |
| XL              | 50 Sport          | 83-85 | <b>HF</b> |
|                 | 125 Runner        | 86    | <b>HF</b> |
| <b>MALANCA</b>  |                   |       |           |
|                 | 125 Enduro Mark   |       |           |
|                 | ST 54, GT55       | 79-83 | <b>HF</b> |
| <b>MOTRON</b>   |                   |       |           |
| GL4             | 50 ID Flash       | 92    | <b>HF</b> |
| GTD             | 50 Italian Max, 2 | 92    | <b>HF</b> |
| RZ1             | 50 Compact        | 92    | <b>HF</b> |

Brake Pad 1:1 Drawings, Compounds, Fitments

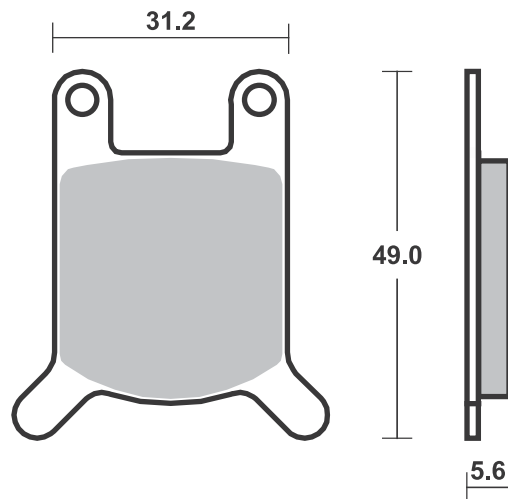
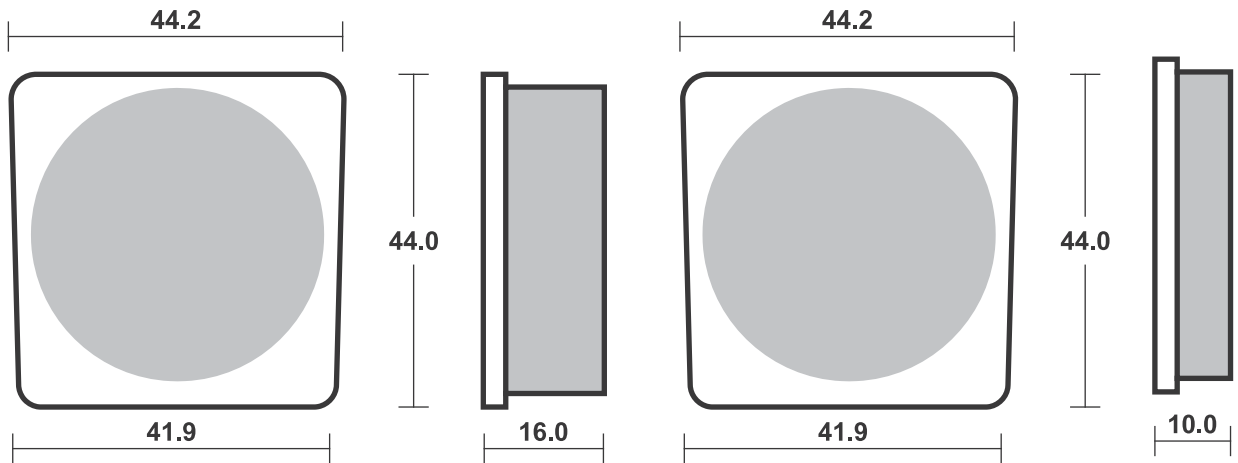
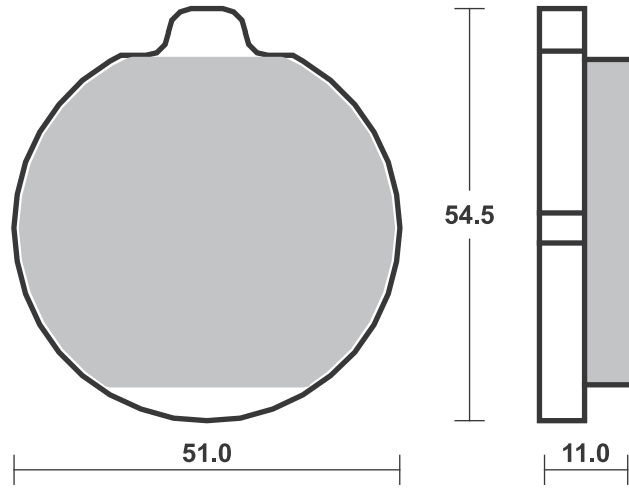

## Applications

### SBS 532 Recommended compound



| <b>OSSA</b>           |       |           |  |
|-----------------------|-------|-----------|--|
| 350 TU-YO             | 82    | <b>HF</b> |  |
| <b>PUCH</b>           |       |           |  |
| 50 all models         | 86    | <b>HF</b> |  |
| 50 Cobra 6 GT,<br>GTL | 80-84 | <b>HF</b> |  |
| 50 Monza 4 SL,<br>GSL | 80-83 | <b>HF</b> |  |
| <b>REAL</b>           |       |           |  |
| 80 Nevada Sport 00    |       | <b>HF</b> |  |
| <b>RIXE</b>           |       |           |  |
| RS 80 W               | 82    | <b>HF</b> |  |
| <b>SACHS</b>          |       |           |  |
| SA 80 Lotus           | 80-81 | <b>HF</b> |  |



| <b>ZUNDAPP</b>      |       |           |  |
|---------------------|-------|-----------|--|
| KS 50 Supersport    | 76-79 | <b>HF</b> |  |
| KS 50 TT            |       |           |  |
| Watercooled         | 80-81 | <b>HF</b> |  |
| KS 80               | 80    | <b>HF</b> |  |
| KS 80 Touring       | 81    | <b>HF</b> |  |
| <b>ZWEIRAD ROTH</b> |       |           |  |
| 50 Rebell Sport     | 75    | <b>HF</b> |  |
| 80 Rebell Sport     | 75    | <b>HF</b> |  |

### SBS 533 Recommended compound



| <b>SUZUKI</b>     |       |           |  |
|-------------------|-------|-----------|--|
| GN 250            | 86-97 | <b>HF</b> |  |
| GNX 250           | 82-84 | <b>HF</b> |  |
| GS 250            | 80-82 | <b>HF</b> |  |
| GSX 250           | 80-82 | <b>HF</b> |  |
| GN 400            | 80    | <b>HF</b> |  |
| GSX 400           | 80-83 | <b>HF</b> |  |
| GSX 400 F         | 81-84 | <b>HF</b> |  |
| GS 450            | 80-83 | <b>HF</b> |  |
| GS 700            | 85    | <b>HF</b> |  |
| GV 700 GLG Madura | 86    | <b>HF</b> |  |
| GSX 750 E         | 82-83 | <b>HF</b> |  |
| GSX 750 EF        | 80-86 | <b>HF</b> |  |
| GSX 750 ES        | 83-85 | <b>HF</b> |  |
| GSX 750 L         | 80-82 | <b>HF</b> |  |
| GSX 750 S         | 82    | <b>HF</b> |  |
| GS 850            | 80-82 | <b>HF</b> |  |
| GS 850 G          | 83-86 | <b>HF</b> |  |
| GSX 850 G         | 83-85 | <b>HF</b> |  |



| <b>SUZUKI</b>      |       |           |  |
|--------------------|-------|-----------|--|
| GS 1000            | 80-81 | <b>HF</b> |  |
| GS 1100            | 82-83 | <b>HF</b> |  |
| GV 1200 GLG Madura | 86    | <b>HF</b> |  |

### SBS 534 Recommended compound



| <b>SUZUKI</b>       |       |           |  |
|---------------------|-------|-----------|--|
| GSX 250             | 85-87 | <b>HF</b> |  |
| GSX 400 E, S        | 85-86 | <b>HF</b> |  |
| GSX 400 FWS         | 86-87 | <b>HF</b> |  |
| GS 450              | 85    | <b>HF</b> |  |
| GS 500              | 81-85 | <b>HF</b> |  |
| GS 500 E (Austria)  | 81-82 | <b>HF</b> |  |
| GS 550              | 80-84 | <b>HF</b> |  |
| GR 650              | 83-84 | <b>HF</b> |  |
| GR 650 X            | 83-84 | <b>HF</b> |  |
| GS 650              | 81-83 | <b>HF</b> |  |
| GS 650 G            | 83-87 | <b>HF</b> |  |
| GS 650 Turbo, XN    | 83-85 | <b>HF</b> |  |
| GSX 650 GT          | 86    | <b>HF</b> |  |
| GS 750 SD           | 83    | <b>HF</b> |  |
| GSX 750 ES, EF, STS | 86-88 | <b>HF</b> |  |
| GSX 750 S, Katana   | 85-86 | <b>HF</b> |  |
| XN 850              | 83-85 | <b>HF</b> |  |
| G 1000 SZ           | 82    | <b>HF</b> |  |



| <b>SUZUKI</b>           |       |           |  |
|-------------------------|-------|-----------|--|
| GS 1000 ET              | 81    | <b>HF</b> |  |
| GS 1000 EX              | 81    | <b>HF</b> |  |
| GSX 1000 S, Katana      | 82-84 | <b>HF</b> |  |
| GS 1100                 | 81    | <b>HF</b> |  |
| GS 1100 ED, ESD, GD     | 83    | <b>HF</b> |  |
| GS 1100 G               | 86-88 | <b>HF</b> |  |
| GS 1100 GKD, SD,<br>GLD | 83    | <b>HF</b> |  |
| GS 1100 L               | 79    | <b>HF</b> |  |
| GSX 1100                | 86    | <b>HF</b> |  |
| GSX 1100 E              | 82-84 | <b>HF</b> |  |
| GSX 1100 E, L           | 79-81 | <b>HF</b> |  |
| GSX 1100 S              | 82-83 | <b>HF</b> |  |
| GT 1100                 | 80    | <b>HF</b> |  |
| GV 1400 Cavalcade       | 85-86 | <b>HF</b> |  |

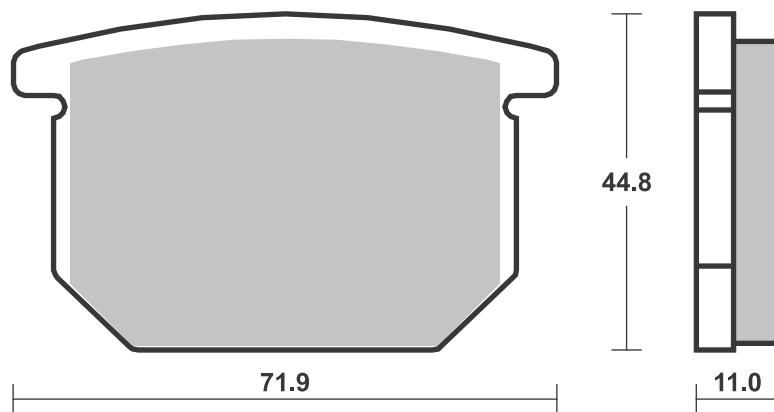
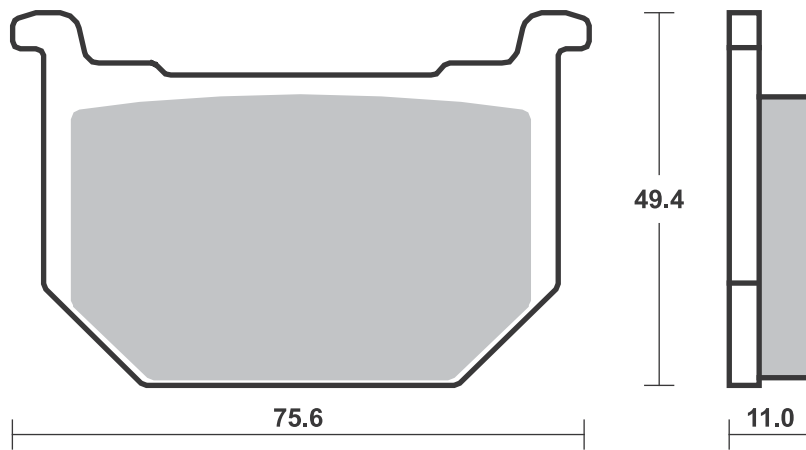
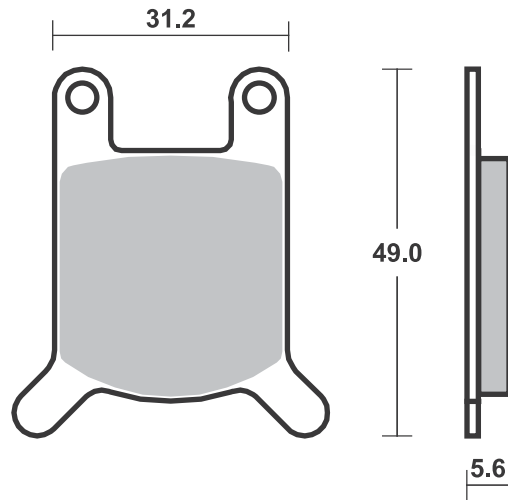

**SBS 535** Recommended compound**YAMAHA**

|    |        |       |           |
|----|--------|-------|-----------|
| RD | 250 LC | 80    | <b>HF</b> |
| RD | 350 LC | 80    | <b>HF</b> |
| XJ | 400    | 80-81 | <b>HF</b> |
|    |        |       |           |
|    |        |       |           |
|    |        |       |           |
|    |        |       |           |
|    |        |       |           |
|    |        |       |           |
|    |        |       |           |
|    |        |       |           |
|    |        |       |           |
|    |        |       |           |
|    |        |       |           |
|    |        |       |           |
|    |        |       |           |
|    |        |       |           |
|    |        |       |           |
|    |        |       |           |
|    |        |       |           |
|    |        |       |           |
|    |        |       |           |
|    |        |       |           |
|    |        |       |           |
|    |        |       |           |
|    |        |       |           |

**SBS 536** Recommended compound

|               |                 |       |           |
|---------------|-----------------|-------|-----------|
| <b>DAELIM</b> |                 |       |           |
|               | 100 Altino      | 99-03 | <b>HF</b> |
| NF            | 125             | 03    | <b>HF</b> |
| VS            | 125 , Evolution | 95-08 | <b>HF</b> |
|               |                 |       |           |

|              |        |       |           |
|--------------|--------|-------|-----------|
| <b>HONDA</b> |        |       |           |
| MBX          | 80 FWD | 83-86 | <b>HF</b> |
| CB           | 125 RS | 83    | <b>HF</b> |
| CG           | 125    | 04-08 | <b>HF</b> |
| CG           | 150    | 04-05 | <b>HF</b> |
| ATC          | 250 R  | 81    | <b>SI</b> |

|                  |            |       |           |
|------------------|------------|-------|-----------|
| <b>HUSQVARNA</b> |            |       |           |
|                  | all models |       |           |
|                  | CR,TC,TE,  |       |           |
|                  | WR         | 92-94 | <b>SI</b> |

|                |     |       |           |
|----------------|-----|-------|-----------|
| <b>HYOSUNG</b> |     |       |           |
| TE             | 400 | 05-06 | <b>SI</b> |
| TE             | 450 | 07-11 | <b>SI</b> |

|                 |                  |       |            |
|-----------------|------------------|-------|------------|
| <b>KAWASAKI</b> |                  |       |            |
| KX              | 65               | 00-15 | <b>RSI</b> |
| BN              | 125 Eliminator   | 98-99 | <b>HF</b>  |
| KLX             | 125              | 10-14 | <b>HF</b>  |
| KLX             | 125 D-Tracker    | 10-14 | <b>HF</b>  |
| Z               | 125 Pro          | 17-18 | <b>HF</b>  |
| KLX             | 150 D-Tracker    | 16-18 | <b>HF</b>  |
| KLX             | 150 L            | 14-15 | <b>HF</b>  |
| KVF             | 300 Brute Force  | 13-17 | <b>SI</b>  |
| KVF             | 360 Prairie 2x4, |       |            |
|                 | 4x4              | 03-08 | <b>SI</b>  |
| KVF             | 400 Prairie      | 97-98 | <b>SI</b>  |
| KVF             | 400 Prairie 2x4  | 99-01 | <b>SI</b>  |
| KVF             | 400 Prairie 4x4  | 99-02 | <b>SI</b>  |



|             |                  |       |           |
|-------------|------------------|-------|-----------|
| <b>MASH</b> |                  |       |           |
|             | 125 Cafe Racer   | 14-16 | <b>HF</b> |
|             | 125 Seventy Five | 14-17 | <b>HF</b> |
|             | 250 Cafe Racer   | 14-16 | <b>HF</b> |
|             | 250 Two Fifty    | 14-17 | <b>HF</b> |

|            |             |       |           |
|------------|-------------|-------|-----------|
| <b>PGO</b> |             |       |           |
|            | 50 Bugrider | 06    | <b>HF</b> |
| BR         | 150 Bugxter | 05-07 | <b>HF</b> |

|               |                |        |            |
|---------------|----------------|--------|------------|
| <b>SUZUKI</b> |                |        |            |
| RM            | 65             | 03-06  | <b>RSI</b> |
| DR            | 125            | 86-022 | <b>HF</b>  |
| GX            | 125 R          | 88-03  | <b>HF</b>  |
| RH            | 125 X          | 87     | <b>HF</b>  |
| SP            | 125            | 86-88  | <b>HF</b>  |
| SX            | 125            | 85-86  | <b>HF</b>  |
| TS            | 125            | 85-89  | <b>HF</b>  |
| DR            | 200            | 86-88  | <b>SI</b>  |
| DR            | 200 S          | 15-17  | <b>SI</b>  |
| DR            | 200 SE         | 96-13  | <b>SI</b>  |
| DR            | 200 T          | 96     | <b>SI</b>  |
| SP            | 200            | 86-88  | <b>HF</b>  |
| SX            | 200 R          | 85-89  | <b>HF</b>  |
| RH            | 240 X          | 87     | <b>HF</b>  |
| TS            | 240 X          | 85-90  | <b>HF</b>  |
| DR            | 250            | 85-89  | <b>HF</b>  |
| LT-F          | 250 Ozark      | 03-13  | <b>SI</b>  |
| LT-Z          | 250 Quad Sport | 04-11  | <b>SI</b>  |
| RH            | 250            | 85-87  | <b>HF</b>  |
| SP            | 250            | 85     | <b>HF</b>  |
| TS            | 250 X          | 85-89  | <b>HF</b>  |
| LT-A          | 400 Eiger      |        |            |
|               | 2WD/4WD        | 02-07  | <b>SI</b>  |
| LT-F          | 400 Eiger      |        |            |
|               | 2WD/4WD        | 02-07  | <b>SI</b>  |



|               |              |    |           |
|---------------|--------------|----|-----------|
| <b>SUZUKI</b> |              |    |           |
| LT-A          | 500 F Vinson | 02 | <b>SI</b> |

|               |                  |       |              |
|---------------|------------------|-------|--------------|
| <b>YAMAHA</b> |                  |       |              |
| SX            | 125 R            | 88    | <b>HF</b>    |
| SX            | 200 R            | 88-98 | <b>HF</b>    |
| YFS           | 200 R Blaster    | 03-06 | <b>SI</b>    |
| YFM           | 250 AN Bruin 2x4 | 05-07 | <b>SI</b>    |
| YFM           | 250 Bear Tracker | 01-04 | <b>SI</b>    |
| YFM           | 300 Warrior      | 89    | <b>SI</b>    |
| YFM           | 350 Bruin 2x4,   |       |              |
|               | 4x4              | 04-07 | <b>SI</b>    |
| YFM           | 350 FWB L,       |       |              |
|               | LC Big Bear      | 99    | <b>SI</b>    |
| YFM           | 350 FXG-FXM      |       |              |
|               | Wolverine        | 95-11 | <b>SI</b>    |
| YFM           | 350 XG,          |       |              |
|               | XH Warrior       | 95-96 | <b>SI</b>    |
| YFM           | 350 XW, XA-M     |       |              |
|               | Warrior          | 89-07 | <b>SI SI</b> |
| YFZ           | 350 Banshee      | 90-06 | <b>SI</b>    |
| YFM           | 400 FAM Kodiak   | 00-02 | <b>SI</b>    |
| YFM           | 400 FAR Kodiak   |       |              |
|               | Automatic        | 03    | <b>SI</b>    |
| YFM           | 400 FWN Big      |       |              |
|               | Bear 4WD         | 00-11 | <b>SI</b>    |
| YFM           | 400 FWNH Big     |       |              |
|               | Bear-            |       |              |
|               | Buckmaster       |       |              |
|               | 4WD              | 00-11 | <b>SI</b>    |
| YFM           | 400 N Big Bear   |       |              |
|               | 2WD              | 00-11 | <b>SI</b>    |
| YFM           | 450 FA_ Kodiak   | 03-07 | <b>SI</b>    |
| YFM           | 450 Wolverine    | 06-10 | <b>SI</b>    |



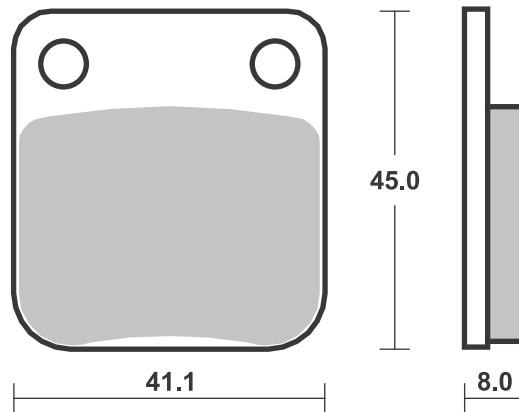
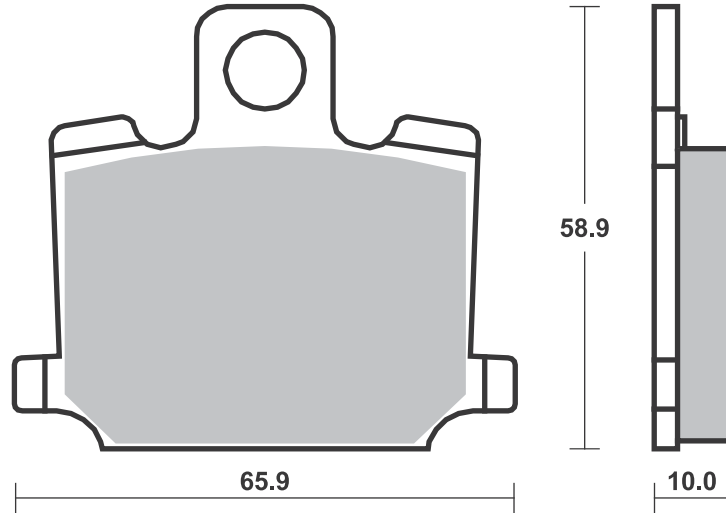

## Applications

### SBS 537 Recommended compound



| <b>HARLEY DAVIDSON</b> |                  |       |             |
|------------------------|------------------|-------|-------------|
| XLH                    | 883              | 70-83 | <b>H.HF</b> |
| XL                     | 1000             | 78    | <b>H.HF</b> |
| XLCH                   | 1000             | 78-80 | <b>H.HF</b> |
| XLH                    | 1000 Sportster   | 79-85 | <b>H.HF</b> |
| XLS                    | 1000 Anniversary | 82    | <b>H.HF</b> |
| XLS                    | 1000 Roadster    | 79-82 | <b>H.HF</b> |
| XLS                    | 1000 Sportster   | 83    | <b>H.HF</b> |
| XLX                    | 1000 61          | 83-84 | <b>H.HF</b> |
| XR                     | 1000             | 85    | <b>H.HF</b> |
| FX                     | 1200             | 74-80 | <b>H.HF</b> |
| FXE                    | 1200             | 74-80 | <b>H.HF</b> |
| FXS                    | 1200             | 78-79 | <b>H.HF</b> |
| FLHT                   | 1340 Tour Glide  | 84    | <b>H.HF</b> |
| FXB                    | 1340 80          | 80-81 | <b>H.HF</b> |
| FXB                    | 1340 Sturgis     | 82    | <b>H.HF</b> |
| FXE                    | 1340             | 82    | <b>H.HF</b> |
| FXE                    | 1340 80          | 78-81 | <b>H.HF</b> |
| FXE                    | 1340 Super Glide | 83-84 | <b>H.HF</b> |
| FXEF                   | 1340 80 Fat Bob  | 79-81 | <b>H.HF</b> |
| FXR                    | 1340             | 78-81 | <b>H.HF</b> |



| <b>HARLEY DAVIDSON</b> |                     |       |             |
|------------------------|---------------------|-------|-------------|
| FXR                    | 1340 Super Glide    | 82-83 | <b>H.HF</b> |
| FXRS                   | 1340 Low Glide      | 82-84 | <b>H.HF</b> |
| FXRS                   | 1340 Super Glide II | 82-83 | <b>H.HF</b> |
| FXRT                   | 1340 Super Glide II | 83    | <b>H.HF</b> |
| FXS                    | 1340 80             | 79-81 | <b>H.HF</b> |
| FXS                    | 1340 Low Rider      | 82    | <b>H.HF</b> |
| FXSB                   | 1340 Low Rider      | 83    | <b>H.HF</b> |
| FXWG                   | 1340 80             | 80-81 | <b>H.HF</b> |
| FXWG                   | 1340 Wide Glide     | 82-84 | <b>H.HF</b> |

### SBS 538 Recommended compound



| <b>SUZUKI</b> |                |       |           |
|---------------|----------------|-------|-----------|
| GP            | 100            | 78-81 | <b>HF</b> |
| GP            | 125 C (Norway) | 78    | <b>HF</b> |
|               |                |       |           |
|               |                |       |           |
|               |                |       |           |
|               |                |       |           |
|               |                |       |           |
|               |                |       |           |
|               |                |       |           |
|               |                |       |           |
|               |                |       |           |
|               |                |       |           |
|               |                |       |           |
|               |                |       |           |
|               |                |       |           |
|               |                |       |           |
|               |                |       |           |
|               |                |       |           |
|               |                |       |           |
|               |                |       |           |
|               |                |       |           |

### SBS 539 Recommended compound



| <b>KAWASAKI</b> |                    |       |           |
|-----------------|--------------------|-------|-----------|
| GPZ             | 400                | 83-84 | <b>HF</b> |
| Z               | 400 J              | 80-85 | <b>HF</b> |
| Z               | 400 T (Belt Drive) | 83-85 | <b>HF</b> |
| Z               | 440 H              | 82-83 | <b>HF</b> |
| Z               | 500                | 81-83 | <b>HF</b> |
| Z               | 550                | 80-85 | <b>HF</b> |
| Z               | 550 E, LTD         | 81-84 | <b>HF</b> |
| Z               | 550 GP             | 81-83 | <b>HF</b> |
| Z               | 550 LTD            | 81-85 | <b>HF</b> |
| Z               | 650                | 81-84 | <b>HF</b> |
| Z               | 650 F              | 81-84 | <b>HF</b> |
| Z               | 700                | 83-88 | <b>HF</b> |
| GPZ             | 750                | 82    | <b>HF</b> |
| Z               | 750                | 84-86 | <b>HF</b> |
| Z               | 750 E              | 80-81 | <b>HF</b> |
| Z               | 750 GT             | 82-85 | <b>HF</b> |
| Z               | 750 L              | 80-83 | <b>HF</b> |
| Z               | 750 LTD            | 80-81 | <b>HF</b> |



| <b>KAWASAKI</b> |                |       |           |
|-----------------|----------------|-------|-----------|
| Z               | 750 LTD        |       |           |
|                 | Belt Drive     | 83-85 | <b>HF</b> |
| Z               | 750 LTD Twin   | 82    | <b>HF</b> |
| Z               | 750 N, LTD     | 82-85 | <b>HF</b> |
| Z               | 750 Sp.        | 83-84 | <b>HF</b> |
| KZ              | 1000           | 87-01 | <b>HF</b> |
| Z               | 1000 F1        | 80-82 | <b>HF</b> |
| Z               | 1000 J         | 79-83 | <b>HF</b> |
| Z               | 1000 K, M, CSR | 81-84 | <b>HF</b> |
| Z               | 1000 LTD       | 81-84 | <b>HF</b> |
| Z               | 1000 MKII      | 79-80 | <b>HF</b> |
| Z               | 1000 Police    | 82-84 | <b>HF</b> |
| Z               | 1000 ST        | 79-81 | <b>HF</b> |
| GPZ             | 1100           | 81-82 | <b>HF</b> |
| Z               | 1100 GP        | 81    | <b>HF</b> |
| Z               | 1100 L1, LTD   | 83    | <b>HF</b> |
| Z               | 1100 Spectre   | 82-83 | <b>HF</b> |
| Z               | 1100 ST        | 81-83 | <b>HF</b> |



| <b>KAWASAKI</b> |               |       |           |
|-----------------|---------------|-------|-----------|
| Z               | 1300 , Sports | 79-83 | <b>HF</b> |
|                 |               |       |           |
|                 |               |       |           |
|                 |               |       |           |
|                 |               |       |           |
|                 |               |       |           |
|                 |               |       |           |
|                 |               |       |           |
|                 |               |       |           |
|                 |               |       |           |
|                 |               |       |           |
|                 |               |       |           |
|                 |               |       |           |
|                 |               |       |           |
|                 |               |       |           |
|                 |               |       |           |
|                 |               |       |           |
|                 |               |       |           |
|                 |               |       |           |
|                 |               |       |           |
|                 |               |       |           |
|                 |               |       |           |

Brake Pad 1:1 Drawings, Fitments, Compounds

Available compounds **H.HF • H.CT**

**SBS 537**

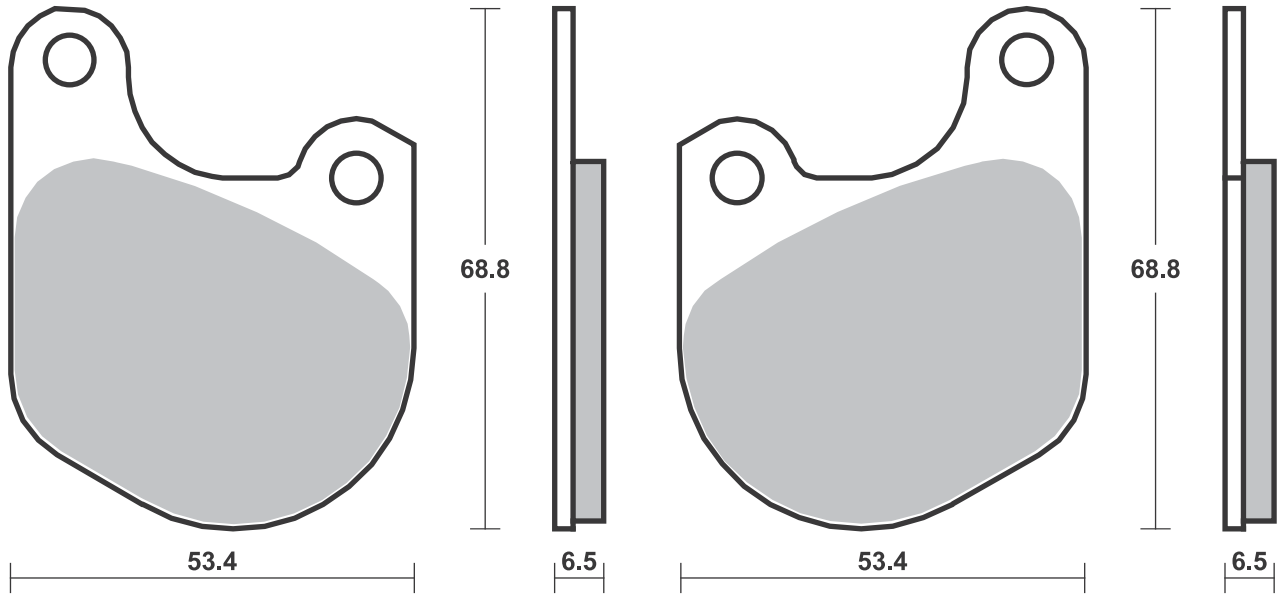

Available compounds **HF**

**SBS 538**

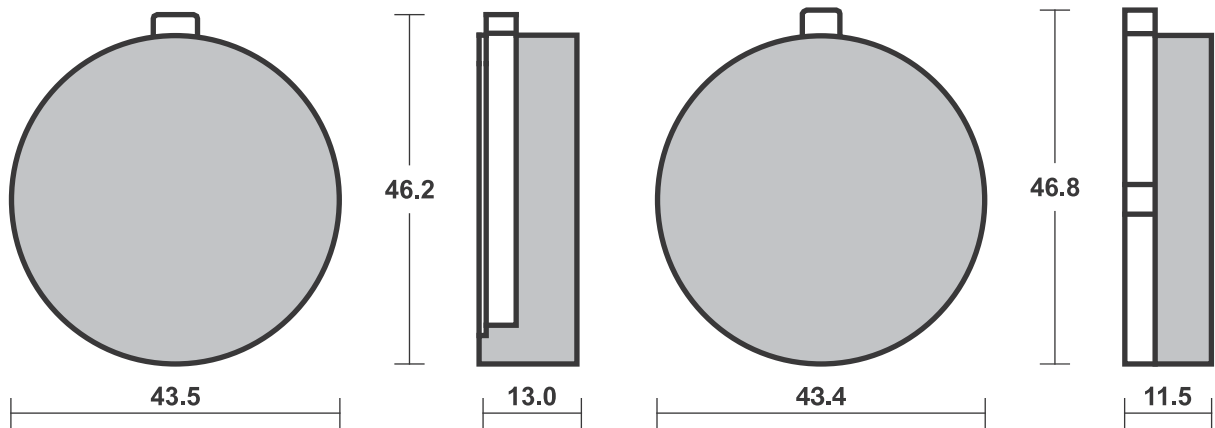

Available compounds **HF • DCC**

**SBS 539**

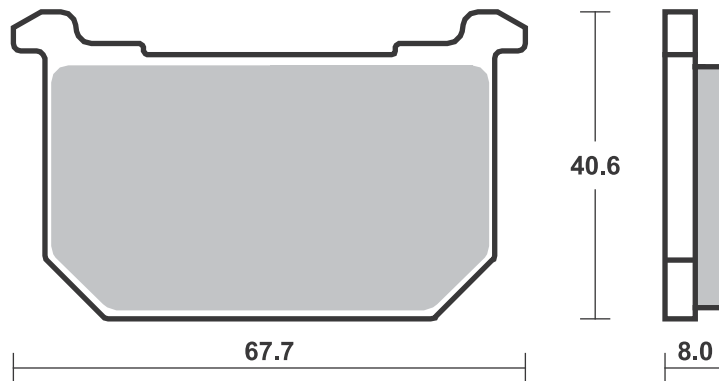



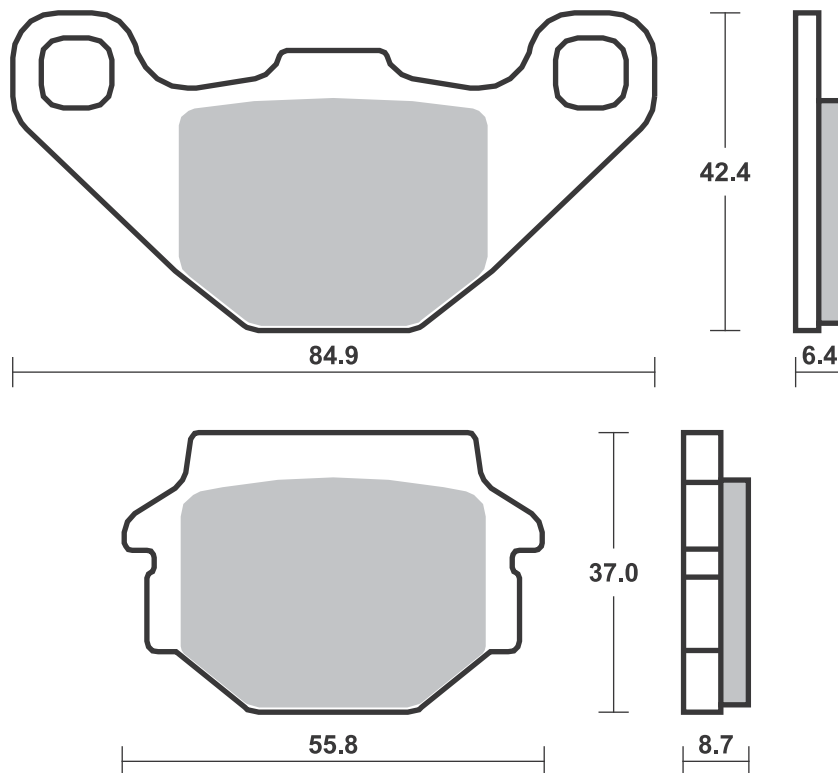
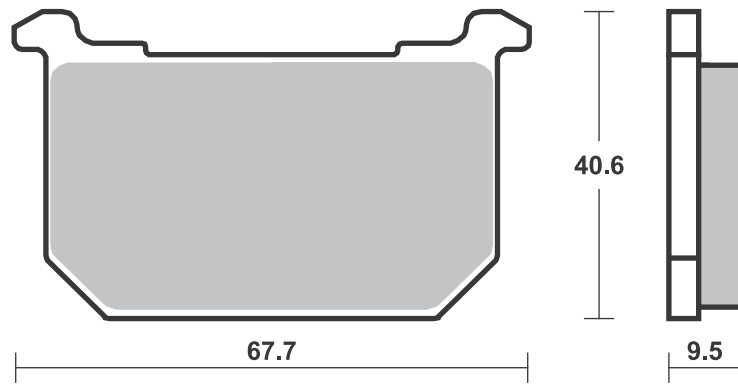

**SBS 542** Recommended compound

| <b>HONDA</b> |                         |       |       |
|--------------|-------------------------|-------|-------|
| CB           | 125 TDC                 | 83-89 | HF    |
| CBX          | 250 RSE                 | 84-85 | HF    |
| GB           | 250 Clubman             | 88-97 | HF    |
| NS           | 250 R                   | 85    | HF    |
| NSR          | 250 R                   | 87    | HF    |
|              | 400 Xelvis              | 93    | HF HF |
| CB           | 400                     | 81-82 | HF HF |
| CB           | 400 Four                | 81-85 | HF    |
| CB           | 400 Hawk                | 81-85 | HF HF |
| CB           | 400 N                   | 82-85 | HF    |
| CB           | 400 Twin                | 82-86 | HF    |
| CBR          | 400 F, FII              | 85    | HF HF |
| CBR          | 400 R                   | 87    | HF    |
| CM           | 400 T                   | 82-84 | HF    |
| GB           | 400 T.T.                | 88-92 | HF    |
| NS           | 400 R                   | 85-87 | LS    |
| NV           | 400 Custom              | 88    | HF    |
| CB           | 450 T                   | 82-86 | HF    |
| CM           | 450 A, C                | 82-86 | HF    |
| CMX          | 450 Rebel               | 86-88 | HF    |
| CBR          | 500 F (Austria)         | 87-90 | LS    |
| CX           | 500 C                   | 81-82 | HF    |
| CX           | 500 Silver W.,<br>Turbo | 83-85 | HF HF |
| CX           | 500 Turbo               | 82-83 | HF    |
| FT           | 500                     | 82-84 | HF HF |
| GB           | 500 T.T.                | 88-92 | HF    |
| GL           | 500                     | 82    | HF    |
| GL           | 500 D                   | 81-82 | HF    |
| NS           | 500 R                   | 85    | HS LS |
| VF           | 500 F, FII              | 84-86 | HF HF |
| VT           | 500 C Shadow            | 83-86 | HF    |
| XBR          | 500 S                   | 85-89 | HF    |
| CB           | 550 SC                  | 83-84 | HF    |
| CBR          | 600 F Hurricane         | 87-90 | LS    |
| CBX          | 600 E                   | 85    | HF    |
| XL           | 600 LM, RM              | 85-87 | HF    |
| XL           | 600 V, Transalp         | 87-90 | HS    |
| CB           | 650                     | 85    | HF    |
| CB           | 650 SC                  |       |       |
|              | Nighthawk               | 83-85 | HF    |
| CBX          | 650 ED, SC, SCD         | 83    | HF    |
| CX           | 650 C                   | 83-86 | HF    |
| CX           | 650 E                   | 83-86 | HF    |
| CX           | 650 Turbo               | 83-86 | HF HF |
| GL           | 650 D                   | 83-84 | HF    |
| CB           | 700 SC                  | 84-86 | HF    |
| VF           | 700 C Magna             | 84    | HF    |
| VF           | 700 C Magna             | 87    | HF    |
| VF           | 700 F Interceptor       | 84-85 | HF    |
| VF           | 700 S                   | 84-85 | HF    |
| VFR          | 700 F, F2               | 86-87 | LS    |
| VT           | 700 C, Shadow           | 87    | HF    |
| CB           | 750 C                   | 82-84 | HF    |
| CB           | 750 C, F, FII, K        | 85-86 | HF    |
| CB           | 750 F                   | 81-82 | HF HF |
| CB           | 750 K                   | 81-82 | HF HF |
| CB           | 750 KZ                  | 82    | HF    |
| CBR          | 750 Hurricane           | 87-00 | LS    |
| CBX          | 750                     | 84-88 | HF HF |
| CBX          | 750 F                   | 84-88 | HF HF |
| NV           | 750 CG Shadow           | 86-89 | HF    |
| VF           | 750 C                   | 82-84 | HF    |
| VF           | 750 C, Magna            | 88-93 | HF    |
| VF           | 750 F                   | 83-84 | HF HF |
| VF           | 750 S                   | 85    | HF    |
| VF           | 750 Sport               | 82-83 | HF    |
| VFR          | 750 F                   | 86-87 | LS    |
| VP           | 750 CH, Custom          | 87    | HF    |
| VT           | 750 C, Shadow           | 86-96 | HF    |



| <b>HONDA</b> |                   |       |       |
|--------------|-------------------|-------|-------|
| XLV          | 750 R             | 83-85 | HF    |
| VT           | 800 C             | 88-94 | HF    |
| CB           | 900 C             | 82    | HF HF |
| CB           | 900 F, F2         | 81-84 | HF    |
| CB           | 1000 C            | 83-84 | HF HF |
| CBR          | 1000 F            | 87-88 | LS    |
| CBX          | 1000              | 81-82 | HF    |
| VF           | 1000 F, FII       | 84-86 | HF HF |
| VF           | 1000 FII Bol d'Or | 85    | HF HF |
| VF           | 1000 R            | 84-87 | HF    |
| VF           | 1000 R            | 86    | HF HF |
| VT           | 1000 C            | 88    | HF    |
| CB           | 1100 F            | 83-85 | HF HF |
| CB           | 1100 R, RD        | 81-83 | HF HF |
| GL           | 1100 -1, DLX      |       |       |
|              | Gold Wing         | 81-87 | HF HF |
| GL           | 1100 Gold Wing    | 82-83 | HF    |
| VF           | 1100 C            | 83-86 | HF    |
| VF           | 1100 S            | 84-85 | HF    |
| VT           | 1100 C Shadow     | 87-93 | HF    |
| GL           | 1200 A,           |       |       |
|              | I Gold Wing       | 84-86 | HF    |
| GL           | 1200 DX           |       |       |
|              | Gold Wing         | 86-87 | HF    |
| GL           | 1200 Gold Wing    | 84-86 | HF    |
| GL           | 1500 A, SE,       |       |       |
|              | I Gold Wing       | 94-99 | LS    |
| GL           | 1500 Gold Wing,   |       |       |
|              | Gold Wing SE      | 88-99 | LS    |
| GLX          | 1500              | 88-99 | HF    |

| <b>SYM</b> |               |    |    |
|------------|---------------|----|----|
|            | 110 Bullet    | 93 | HF |
|            | 125 Aero Wolf | 02 | HF |

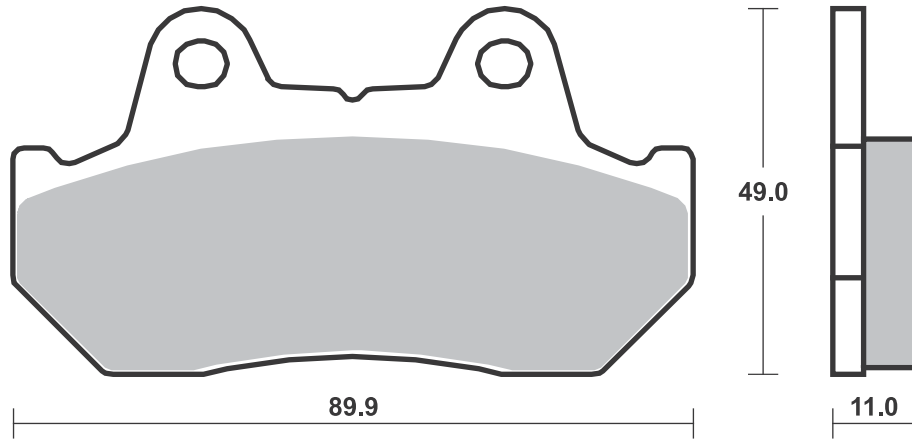

**SBS 543** Recommended compound



**HARLEY DAVIDSON**

|      |                    |       |             |
|------|--------------------|-------|-------------|
| XL   | 1000               | 78    | <b>H.HF</b> |
| XLCH | 1000               | 78-80 | <b>H.HF</b> |
| XLH  | 1000 Sportster     | 79-82 | <b>H.HF</b> |
| XLS  | 1000 Roadster      | 79-82 | <b>H.HF</b> |
| FLH  | 1340 Classic       | 82-83 | <b>H.HF</b> |
| FLH  | 1340 Electra Glide | 82-83 | <b>H.HF</b> |
| FLH  | 1340 Heritage      | 81    | <b>H.HF</b> |
| FLT  | 1340 80            | 80-81 | <b>H.HF</b> |
| FLT  | 1340 80 Classic    | 81    | <b>H.HF</b> |
| FLT  | 1340 Classic       | 82-83 | <b>H.HF</b> |
| FLT  | 1340 Tour Glide    | 82    | <b>H.HF</b> |

Brake Pad 1:1 Drawings,  
Compounds, Fitments



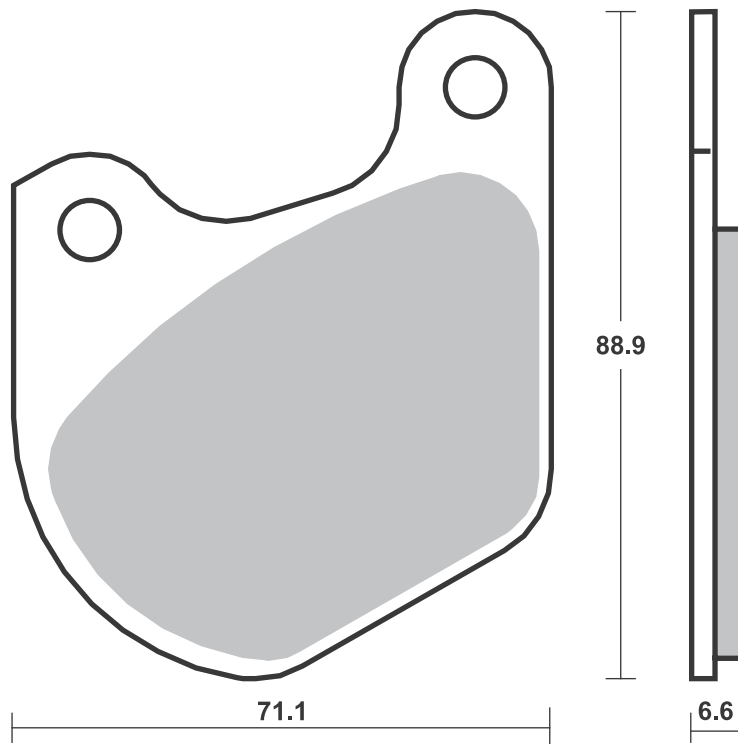
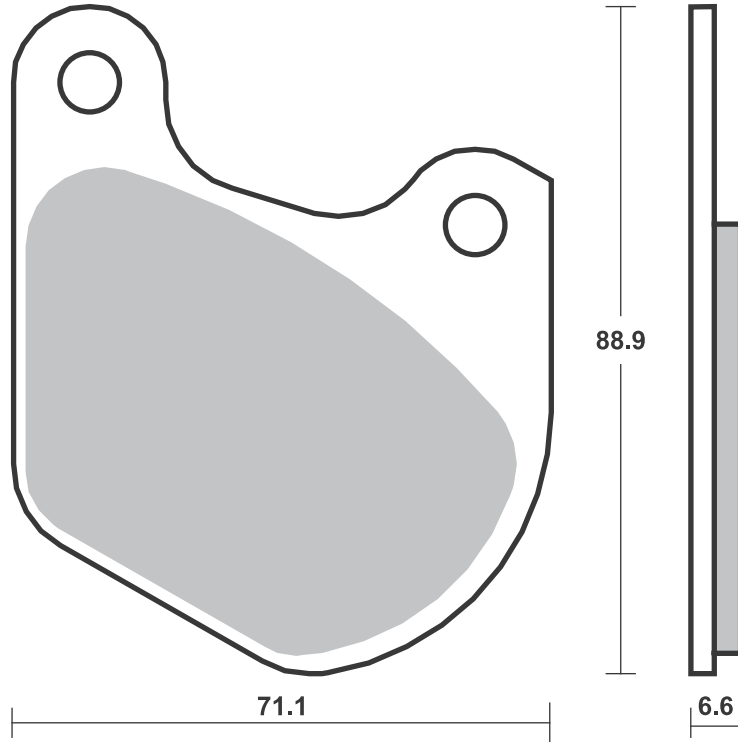

**SBS 544** Recommended compound

| <b>ADLY</b>     |       |           |           |
|-----------------|-------|-----------|-----------|
| 150 ATV         | 05-07 | <b>SI</b> | <b>SI</b> |
| 150 Interceptor | 05-07 | <b>SI</b> | <b>SI</b> |
| 300 ATV         | 05-11 | <b>SI</b> | <b>SI</b> |

| <b>AEON</b> |       |           |           |
|-------------|-------|-----------|-----------|
| 100 Revo 2  | 04-06 |           | <b>SI</b> |
| 125 Pulsar  | 06    | <b>HF</b> |           |

| <b>APRILIA</b>         |       |  |           |
|------------------------|-------|--|-----------|
| 125 Tuono ABS          | 17-18 |  | <b>HF</b> |
| RS-4 125 (J.Juan cal.) | 11-18 |  | <b>HF</b> |
| RS-4 125 Replica, ABS  | 16-18 |  | <b>HF</b> |
| RX 125 Enduro          | 08-12 |  | <b>HF</b> |
| RX 125 Supermotard     | 08-12 |  | <b>HF</b> |

| <b>BOMBARDIER</b> |       |           |  |
|-------------------|-------|-----------|--|
| 200 Rally 2x4     | 03-06 | <b>SI</b> |  |

| <b>CAN-AM</b> |       |           |           |
|---------------|-------|-----------|-----------|
| DS 90 X       | 08-17 | <b>SI</b> | <b>SI</b> |

| <b>CECTEK</b>      |       |  |           |
|--------------------|-------|--|-----------|
| 500 EFI Gladiator  | 09-13 |  | <b>HF</b> |
| 500 EFI King Cobra | 09-13 |  | <b>HF</b> |
| 500 EFI Quadrift   | 09-11 |  | <b>HF</b> |
| 500 i Estoc        | 10    |  | <b>HF</b> |

| <b>CPI</b>  |       |           |  |
|-------------|-------|-----------|--|
| XS 250 Quad | 06-08 | <b>SI</b> |  |

| <b>DAELIM</b>      |       |           |  |
|--------------------|-------|-----------|--|
| ST 250 Sector Quad | 05-06 | <b>SI</b> |  |

| <b>DERBI</b> |       |           |  |
|--------------|-------|-----------|--|
| DXR 200 Quad |       |           |  |
| (Front disc) | 04-07 | <b>SI</b> |  |
| DXR 250 Quad |       |           |  |
| (Front disc) | 04-07 | <b>SI</b> |  |

| <b>E-TON</b>    |       |           |  |
|-----------------|-------|-----------|--|
| VXL 250 Vector, |       |           |  |
| ST Vector       | 06-07 | <b>SI</b> |  |
| VTX 300 Vortex, |       |           |  |
| ST Vortex       | 07    | <b>SI</b> |  |
| VXL 300 Vector, |       |           |  |
| ST Vector       | 07-13 | <b>SI</b> |  |

| <b>FACTORY</b> |       |  |           |
|----------------|-------|--|-----------|
| 50 Helix       | 04-06 |  | <b>SI</b> |
| 50 Rex         | 04-06 |  | <b>SI</b> |
| 100 Helix      | 04-06 |  | <b>SI</b> |
| 100 Rex        | 04-06 |  | <b>SI</b> |

| <b>FANTIC</b>  |    |  |           |
|----------------|----|--|-----------|
| 125 Regolarina |    |  |           |
| Casa           | 08 |  | <b>HF</b> |
| 125 Supersei   |    |  |           |
| Motard         | 08 |  | <b>HF</b> |

| <b>HYOSUNG</b> |       |  |           |
|----------------|-------|--|-----------|
| GD 125 EXIV    | 12-16 |  | <b>HF</b> |

| <b>KAWASAKI</b> |       |  |                     |
|-----------------|-------|--|---------------------|
| AR 50           | 81-82 |  | <b>HF</b>           |
| KMX 50          | 88-93 |  | <b>HF</b>           |
| KSR 50 I (50)   | 90-91 |  | <b>HF</b> <b>HF</b> |
| AR 80           | 81-82 |  | <b>HF</b>           |
| KD 80           | 88-90 |  | <b>HF</b>           |
| KSR 80 II (80)  | 90-91 |  | <b>HF</b> <b>HF</b> |

| <b>KAWASAKI</b>   |       |  |            |
|-------------------|-------|--|------------|
| KX 80             | 84-87 |  | <b>SI</b>  |
| KX 80             | 88-96 |  | <b>RSI</b> |
| KX 100            | 88-92 |  | <b>RSI</b> |
| KX 100            | 95-96 |  | <b>RSI</b> |
| KDX 125           | 90-94 |  | <b>SI</b>  |
| KMX 125           | 86    |  | <b>HF</b>  |
| KX 125            | 82    |  | <b>SI</b>  |
| ZL 125 Eliminator | 97-99 |  | <b>HF</b>  |
| KMX 200           | 88-90 |  | <b>HF</b>  |
| KX 250            | 82    |  | <b>SI</b>  |
| KXT 250 Tecate    | 84    |  | <b>HF</b>  |

| <b>PGO</b>  |       |  |           |
|-------------|-------|--|-----------|
| 50 X-Rider  | 03-10 |  | <b>SI</b> |
| 125 X-Rider | 03-10 |  | <b>SI</b> |
| 150 X-Rider | 03-10 |  | <b>SI</b> |

| <b>POLARIS</b> |       |            |            |
|----------------|-------|------------|------------|
| 200 Phoenix    | 05-09 | <b>ATS</b> |            |
| 200 Sawtooth   | 06-07 | <b>ATS</b> | <b>ATS</b> |

| <b>RIEJU</b> |       |  |           |
|--------------|-------|--|-----------|
| RS2 125 NKD  | 06-07 |  | <b>HF</b> |
| RS2 125 Pro  | 08-12 |  | <b>HF</b> |

| <b>ROXON</b>   |    |  |           |
|----------------|----|--|-----------|
| 150 Quad Sport |    |  |           |
| Spirit         | 06 |  | <b>SI</b> |

| <b>SUZUKI</b> |       |  |            |
|---------------|-------|--|------------|
| CC 50 Tune    | 92-97 |  | <b>HF</b>  |
| LIDO 75 Style | 84-94 |  | <b>HF</b>  |
| RM 80         | 90-95 |  | <b>SI</b>  |
| RM 80         | 96-01 |  | <b>RSI</b> |
| ZZ 80 Sepia   | 90-92 |  | <b>HF</b>  |
| RM 85 , L     | 02-04 |  | <b>RSI</b> |

| <b>TM</b> |       |  |            |
|-----------|-------|--|------------|
| 80 Junior | 96-00 |  | <b>RSI</b> |

| <b>ZERO</b> |       |  |           |
|-------------|-------|--|-----------|
| DS ZF6.0    | 10-12 |  | <b>HF</b> |
| DS ZF9.0    | 10-12 |  | <b>HF</b> |
| MX          | 10-12 |  | <b>HF</b> |
| S ZF6.0     | 10-12 |  | <b>HF</b> |
| X           | 10-12 |  | <b>HF</b> |
| XU          | 11-12 |  | <b>HF</b> |

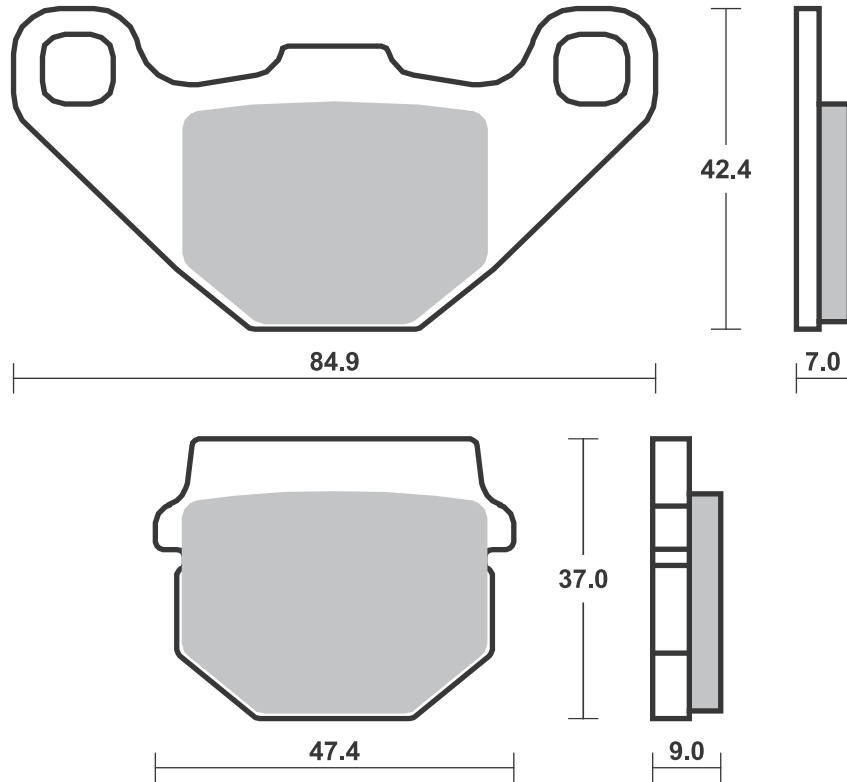

**SBS 545** Recommended compound



**YAMAHA**

|    |                  |       |           |
|----|------------------|-------|-----------|
| GX | 250 Left         | 80-85 | <b>HF</b> |
| RD | 250 DX Left/Rear | 80    | <b>HF</b> |
| XS | 400 SE Right     | 80-81 | <b>HF</b> |
| XJ | 650 G, H, SH     |       |           |
|    | Left/Rear        | 80-83 | <b>HF</b> |
| XS | 650              | 80-82 | <b>HF</b> |
| XS | 750 H, J, K      | 81-82 | <b>HF</b> |
| XS | 750 SE Left/Rear | 79-80 | <b>HF</b> |
| XV | 750 SE           | 81-83 | <b>HF</b> |
| XS | 850 Left/Rear    | 81    | <b>HF</b> |
| XV | 920 K, MK,       |       |           |
|    | Virago           | 83    | <b>HF</b> |
| XS | 1100 SF, SG, SH, |       |           |
|    | LG Left/Rear     | 79-81 | <b>HF</b> |

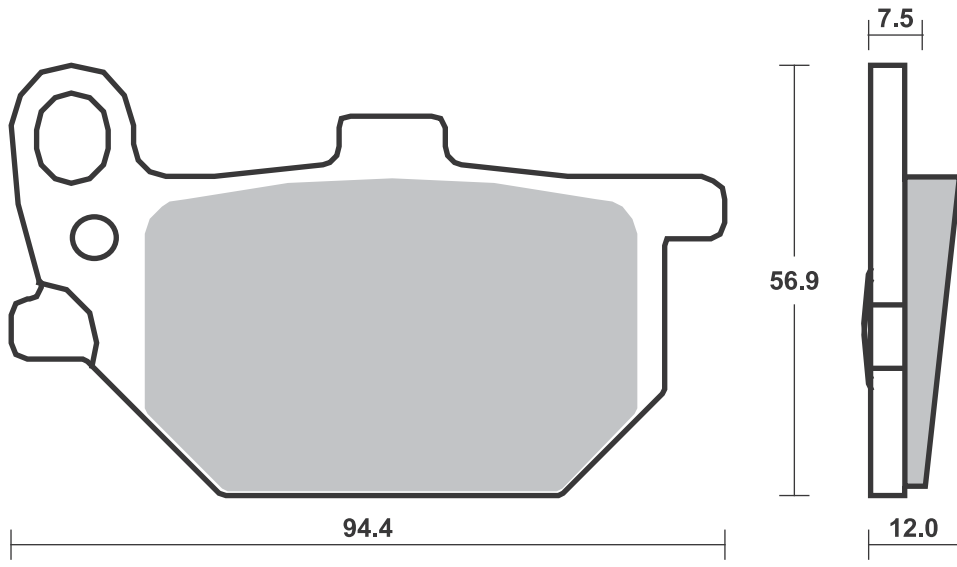
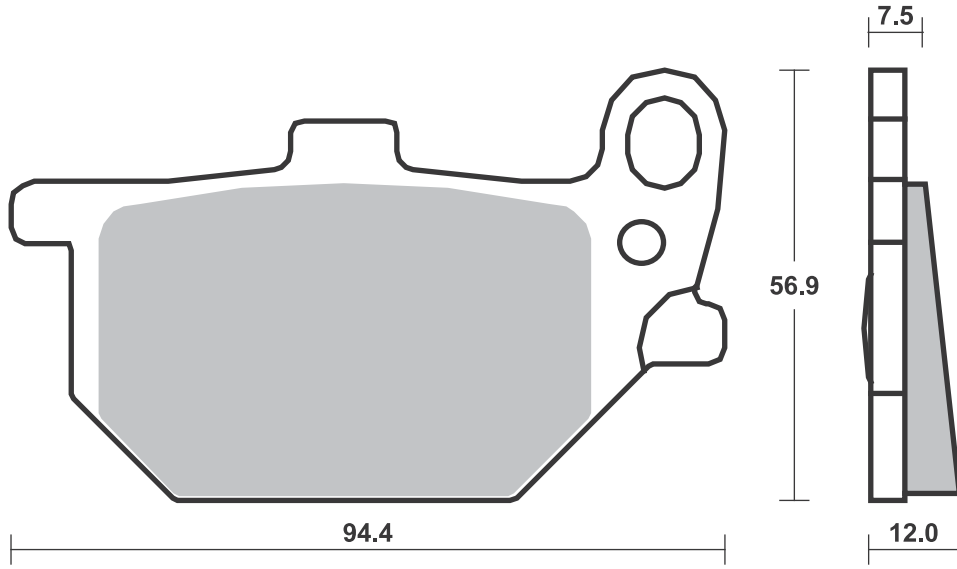

## Applications

### SBS 546 Recommended compound



| <b>BATAVUS</b>           |       |  |            |
|--------------------------|-------|--|------------|
| 50 Grand Prix            | 80    |  | <b>HF</b>  |
| <b>BOMBARDIER</b>        |       |  |            |
| 200 Rally 2x4            | 05-06 |  | <b>SI</b>  |
| <b>KAWASAKI</b>          |       |  |            |
| KH 100 EX                | 88-93 |  | <b>HF</b>  |
| KH 100 GH                | 83-87 |  | <b>HF</b>  |
| AR 125                   | 82-94 |  | <b>HF</b>  |
| KE 125                   | 86-91 |  | <b>HF</b>  |
| KH 125                   | 82-98 |  | <b>HF</b>  |
| KX 125                   | 83-85 |  | <b>SI</b>  |
| KX 125                   | 86    |  | <b>RSI</b> |
| KDX 200 C                | 86-88 |  | <b>SI</b>  |
| KDX 200 SR               | 89-92 |  | <b>SI</b>  |
| Z 200                    | 83-85 |  | <b>HF</b>  |
| 250 Estrella             | 92-99 |  | <b>HF</b>  |
| GPZ 250 Belt Drive       | 83-84 |  | <b>HF</b>  |
| KL 250 (KLR 250)         | 85-97 |  | <b>HF</b>  |
| KR 250                   | 85    |  | <b>HF</b>  |
| KX 250                   | 83-85 |  | <b>SI</b>  |
| KX 250                   | 86    |  | <b>RSI</b> |
| KXT 250 Tecate           | 85-86 |  | <b>SI</b>  |
| Z 250 T, Scorpion        | 89    |  | <b>HF</b>  |
| KLF 300 Bayou            | 88-04 |  | <b>SI</b>  |
| GPZ 305                  | 81-96 |  | <b>HF</b>  |
| KLR 350                  | 85    |  | <b>HF</b>  |
| FX 400 R                 | 86-88 |  | <b>HF</b>  |
| GPZ 400                  | 85-87 |  | <b>HF</b>  |
| LX 400 Eliminator,<br>SE | 90    |  | <b>HF</b>  |



| <b>KAWASAKI</b>      |       |  |            |
|----------------------|-------|--|------------|
| Z 400 F              | 84-86 |  | <b>HF</b>  |
| ZR 400 F             | 83-84 |  | <b>HF</b>  |
| ZX 400               | 85    |  | <b>HF</b>  |
| GPZ 500              | 95-96 |  | <b>HF</b>  |
| GPZ 500 S            | 88    |  | <b>HF</b>  |
| GPZ 500 S            | 89-92 |  | <b>HS</b>  |
| KX 500               | 83-85 |  | <b>SI</b>  |
| KX 500               | 86    |  | <b>RSI</b> |
| ZR 500 (Z 500 F)     | 83-87 |  | <b>HF</b>  |
| KX 550 A             | 83    |  | <b>SI</b>  |
| Z 550 F              | 83-84 |  | <b>HF</b>  |
| Z 550 GT             | 83-01 |  | <b>HF</b>  |
| ZR 550 A1, GP        | 83-84 |  | <b>HF</b>  |
| KL 600               | 84-86 |  | <b>HF</b>  |
| KLR 600              | 84-86 |  | <b>HF</b>  |
| KLR 600 E            | 85-94 |  | <b>HF</b>  |
| <b>KTM</b>           |       |  |            |
| MX 125 -<br>600 ccm. | 91    |  | <b>SI</b>  |
| GS 125               | 89-90 |  | <b>SI</b>  |
| MX 125               | 89-90 |  | <b>SI</b>  |
| GS 250               | 89-90 |  | <b>SI</b>  |
| MX 250               | 89-90 |  | <b>SI</b>  |
| MX 300               | 90    |  | <b>SI</b>  |
| LC4 350              | 92-95 |  | <b>SI</b>  |
| MX 500               | 89-91 |  | <b>SI</b>  |
| <b>LAVERDA</b>       |       |  |            |
| 700 El Cid           | 90    |  | <b>HF</b>  |



| <b>POLARIS</b>    |       |  |           |
|-------------------|-------|--|-----------|
| 200 Phoenix       | 05-14 |  | <b>SI</b> |
| <b>SUZUKI</b>     |       |  |           |
| 50 Wolf           | 89-94 |  | <b>HF</b> |
| RB 50             | 87    |  | <b>HF</b> |
| GT 80 L/C         | 81    |  | <b>HF</b> |
| RG 80 Gamma       | 85-87 |  | <b>HF</b> |
| TRS 118           | 82-83 |  | <b>HF</b> |
| GN 125            | 91-04 |  | <b>HF</b> |
| GS 125 ESZ        | 82    |  | <b>HF</b> |
| GT 125            | 80-82 |  | <b>HF</b> |
| TR 125            | 83-86 |  | <b>HF</b> |
| TU 125 XT         | 99    |  | <b>HF</b> |
| X4 125 , X3E      | 78-80 |  | <b>HF</b> |
| ET 240            | 86    |  | <b>HF</b> |
| NZ 250            | 86-91 |  | <b>HF</b> |
| GSX 400 EFX       | 82    |  | <b>HF</b> |
| GSX 400 FD        | 83    |  | <b>HF</b> |
| GSX 400 FX, FZ    | 81-82 |  | <b>HF</b> |
| GSX 400 S, Katana | 83-86 |  | <b>HF</b> |
| GS 450            | 86    |  | <b>HF</b> |

### SBS 547 Recommended compound



| <b>YAMAHA</b>       |       |  |           |
|---------------------|-------|--|-----------|
| RD 50 MX            | 81-87 |  | <b>HF</b> |
| RX 50 K             | 83-85 |  | <b>HF</b> |
| RD 80 MX            | 81-86 |  | <b>HF</b> |
| RX 80 SE            | 82-84 |  | <b>HF</b> |
| RD 250 LC           | 81-82 |  | <b>HF</b> |
| RD 350 LC           | 81-82 |  | <b>HF</b> |
| XJ 400 Maxim, Seca  | 81    |  | <b>HF</b> |
| XJ 500 (Austria)    | 81-83 |  | <b>HF</b> |
| XJ 550 Maxim        | 81-83 |  | <b>HF</b> |
| XJ 550 Seca         | 81-83 |  | <b>HF</b> |
| XZ 550              | 82    |  | <b>HF</b> |
| XJ 650 Seca         | 81-83 |  | <b>HF</b> |
| 750 Maxim           | 81    |  | <b>HF</b> |
| XJ 750 Seca         | 81-83 |  | <b>HF</b> |
| XV 920 J            | 82    |  | <b>HF</b> |
| XV 920 Virago       | 81    |  | <b>HF</b> |
| XV 1000 SE          | 83-85 |  | <b>HF</b> |
| 1100 SE, Maxim      | 81    |  | <b>HF</b> |
| XJ 1100             | 81    |  | <b>HF</b> |
| XS 1100 LH Midnight | 81    |  | <b>HF</b> |

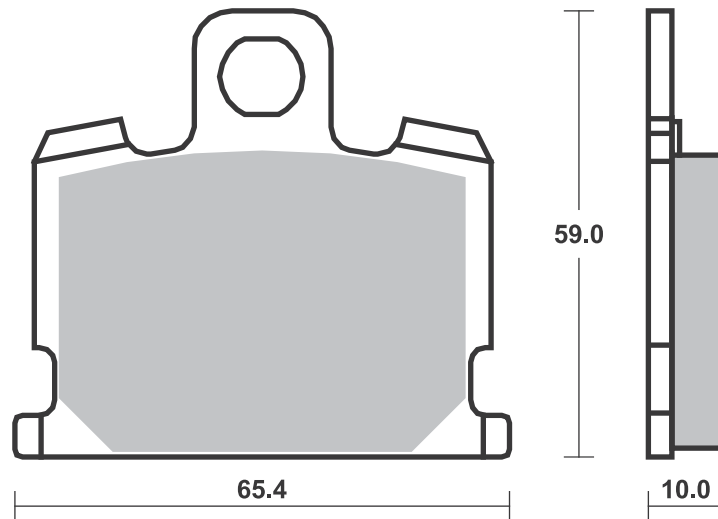
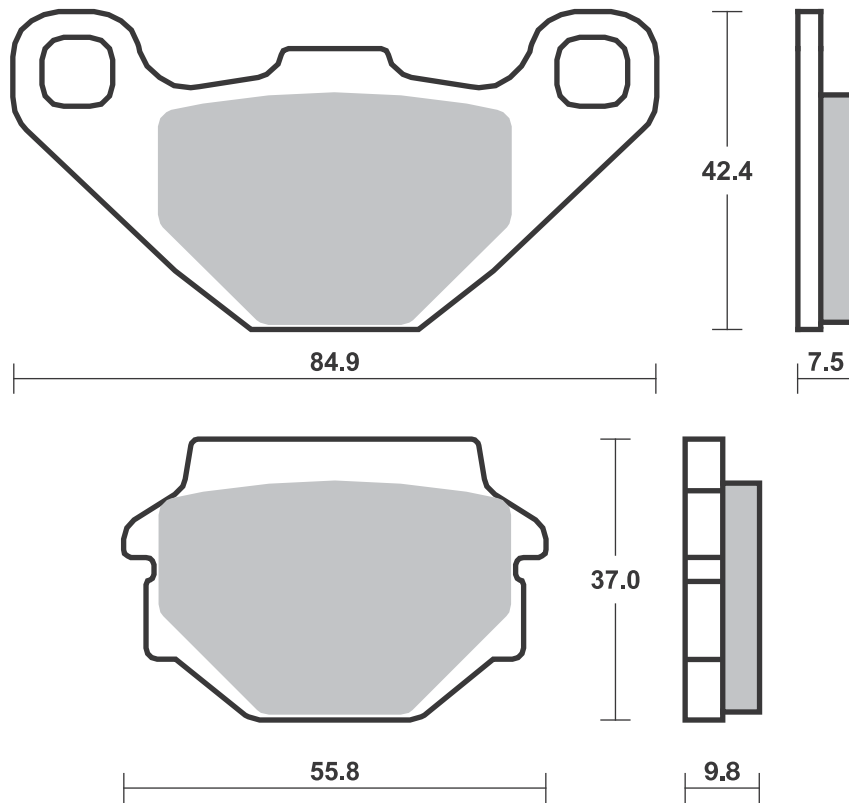





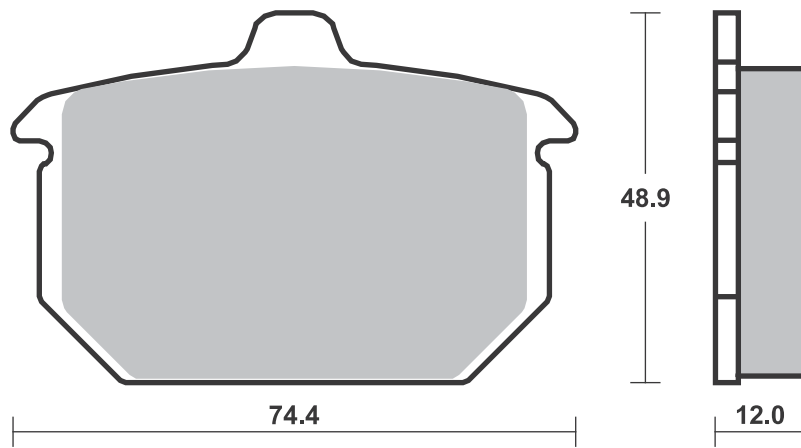
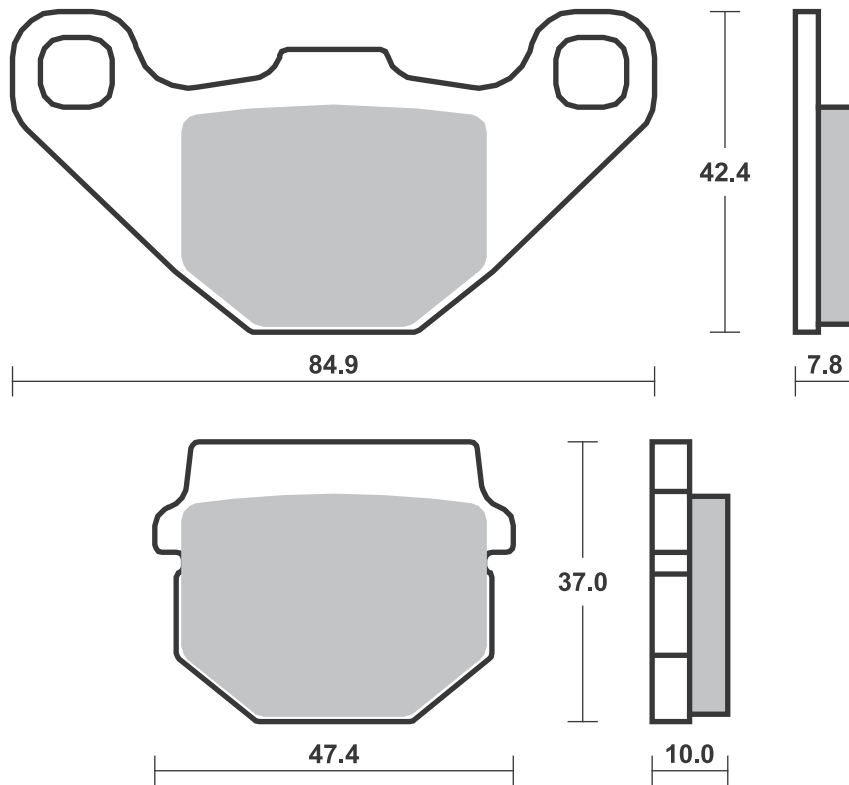

## Applications

### SBS 550 Recommended compound



| YAMAHA |               |       |       |
|--------|---------------|-------|-------|
| DT     | 80 LC         | 81-84 | HF    |
| RD     | 80 LC         | 81-82 | HF    |
| RX     | 100           | 84-87 | HF    |
| RX     | 115 S         | 82-85 | HF    |
| RD     | 125 LC        | 82-84 | HF    |
| SR     | 125           | 92-96 | HF    |
| XV     | 240 Virago    | 92-98 | HF    |
| RD     | 250 LC        | 83-84 | HF    |
| XV     | 250 Route 66  | 88-90 | HF    |
| XV     | 250 Virago    | 88    | HF    |
| RD     | 350 LC YPVS   | 83-84 | HF    |
| RZ     | 350           | 84-85 | HF    |
| XJ     | 400           | 82    | HF HF |
| XS     | 400           | 82-83 | HF    |
| XS     | 400           | 85    | HF    |
| XS     | 400 DOHC      | 82    | HF    |
| XS     | 500 DOHC      | 82    | HF    |
| XT     | 500 (Austria) | 83    | HF    |



| YAMAHA |                      |       |    |
|--------|----------------------|-------|----|
| XV     | 500 K, Virago        | 83    | HF |
| XV     | 500 SE               | 83    | HF |
| XZ     | 550                  | 83-84 | HF |
| XZ     | 550 RJ, RK           | 82-83 | HF |
| XZ     | 550 S                | 83-84 | HF |
| XT     | 600                  | 83-86 | HF |
| XT     | 600 Tenere           | 83-84 | HF |
| XJ     | 650                  | 83    | HF |
| XJ     | 650 Turbo            | 81-82 | HF |
| XJ     | 750 Maxim            | 82    | HF |
| XV     | 920 K, MK,<br>Virago | 83    | HF |

### SBS 551 Recommended compound



| FACTORY |                |       |    |
|---------|----------------|-------|----|
| YR      | 125            | 06    | HF |
| HONDA   |                |       |    |
| MBX     | 80             | 83-86 | HF |
| MBX     | 80 DX          | 82-86 | HF |
| MBX     | 80 SW, SWD     | 83    | HF |
| CBX     | 125 Custom     | 88    | HF |
| FS      | 125 Sonic      | 03-04 | HF |
| MBX     | 125 RWB        | 84-86 | HF |
| CB      | 250 Rebel      | 86-96 | HF |
| CMX     | 250 Rebel      | 85-12 | HF |
| HYOSUNG |                |       |    |
|         | 125 Grand Prix |       |    |
|         | Plus           | 02-05 | HF |
| GT      | 125 Comet      | 02-03 | HF |
| GV      | 125 Aquila     | 02-04 | HF |
| RT      | 125 Karion     | 02-06 | HF |



| HYOSUNG |                  |       |    |
|---------|------------------|-------|----|
| RX      | 125              | 00-07 | HF |
| XRX     | 125 Offroad      | 99-06 | HF |
| GV      | 250              | 02-09 | HF |
| XRX     | 400              | 05-08 | HF |
|         | 600 Comet        | 03    | HF |
| GV      | 650 Aquila       | 04-05 | HF |
| KYMCO   |                  |       |    |
| CK      | 125              | 04-13 | HF |
| DX      | 150 Custom       | 93-96 | HF |
| NSR     | 150              | 93    | HF |
| SYM     |                  |       |    |
|         | 125 Wolf Classic | 05    | HF |
| MF      | 180              | 03    | HF |

### SBS 552 Recommended compound



| HONDA |                |       |    |
|-------|----------------|-------|----|
| VT    | 250 F          | 83-87 | HF |
| VTR   | 250            | 88-89 | HF |
| CBX   | 400 F, F2, F2C | 82-84 | HF |
| VF    | 400 F          | 85-86 | HF |
| VF    | 400 FD         | 83-85 | HF |
| VT    | 400 E          | 83-86 | HF |
| VT    | 500 E          | 83-85 | HF |
| VT    | 500 ED         | 82    | HF |
| CBX   | 550 F, F2      | 82-86 | HF |
| CBX   | 650 E          | 83-90 | HF |

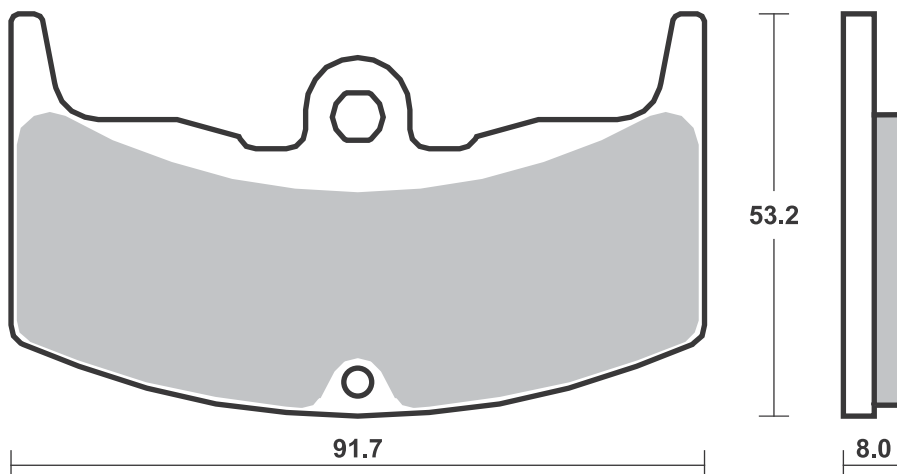
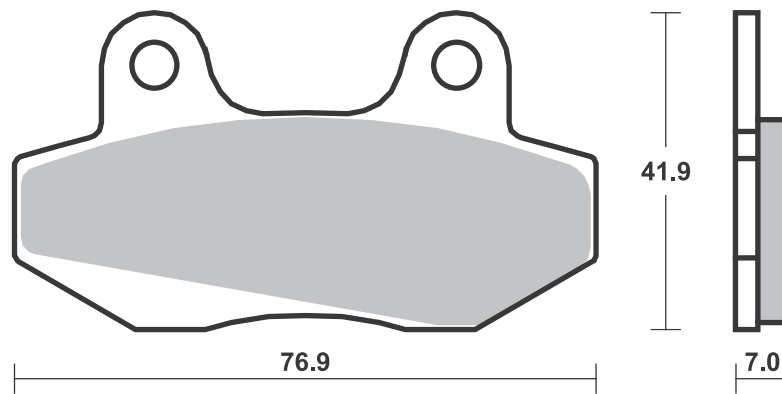
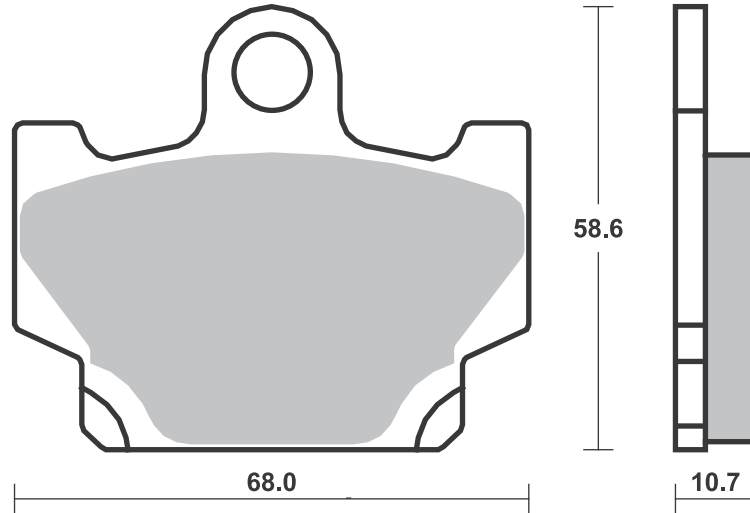

**SBS 553** Recommended compound



**HARLEY DAVIDSON**

|      |                    |       |             |
|------|--------------------|-------|-------------|
| FLH  | 1200               | 80    | <b>H.HF</b> |
| FLH  | 1340 80            | 81    | <b>H.HF</b> |
| FLH  | 1340 Classic       | 82-83 | <b>H.HF</b> |
| FLH  | 1340 Electra Glide |       |             |
|      | Spec.              | 84    | <b>H.HF</b> |
| FLH  | 1340 Heritage      | 81    | <b>H.HF</b> |
| FLHT | 1340 Tour Glide    | 84    | <b>H.HF</b> |
| FLT  | 1340               | 84-85 | <b>H.HF</b> |
| FLT  | 1340 80            | 80-81 | <b>H.HF</b> |
| FLT  | 1340 80 Classic    | 81    | <b>H.HF</b> |
| FLT  | 1340 Classic       | 82-83 | <b>H.HF</b> |
| FLT  | 1340 Tour Glide    | 82    | <b>H.HF</b> |

Brake Pad 1:1 Drawings,  
Compounds, Fitments

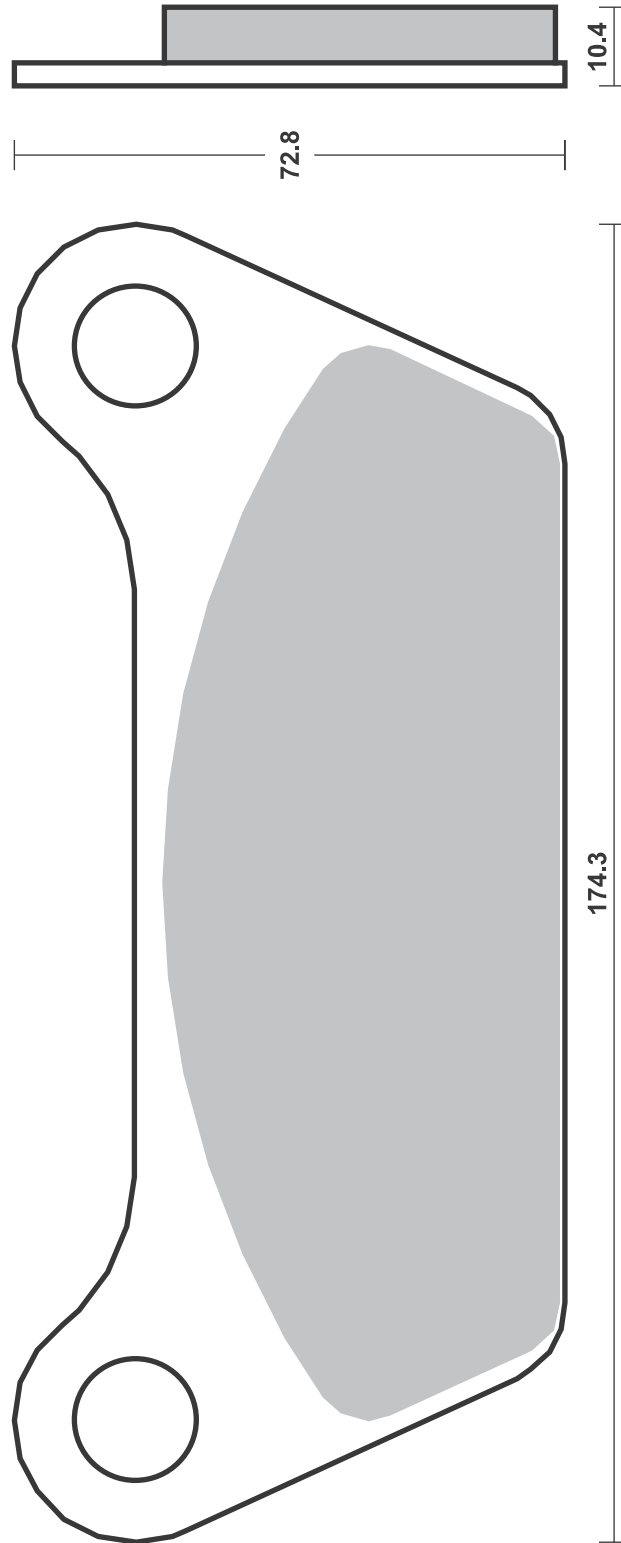

## Applications

### SBS 554 Recommended compound



| <b>BENELLI</b>      |       |    |    |
|---------------------|-------|----|----|
| 900 Sei             | 81-83 | HF |    |
| <b>BMW</b>          |       |    |    |
| R65/1 650           | 86    | HF |    |
| R80 800             | 86-88 | HF |    |
| R80 800 GS Mystic   | 91-95 | HS |    |
| R80 800 GS Paris    |       |    |    |
| Dakar               | 88-94 | HS |    |
| R80 800 RT          | 85    | HF |    |
| R100 1000 GS        | 87-94 | HF |    |
| R100 1000 GS Mystic | 91-94 | HS |    |
| R100 1000 RT        | 91-95 | HS |    |
| <b>MOTO-GUZZI</b>   |       |    |    |
| 1000                | 81-83 | HF | HF |
| SP 1000 Le Mans     |       |    |    |
| Left/Rear           | 79-83 |    | HF |
| <b>TRIUMPH</b>      |       |    |    |
| 750 Bonneville      | 84    | HF |    |

### SBS 555 Recommended compound



| <b>YAMAHA</b>       |       |    |    |
|---------------------|-------|----|----|
| FJ 100 L, LC        | 84    | HF | HF |
| TZR 125             | 89-92 | HF |    |
| TZR 125             | 93-94 |    | HF |
| FZ 250 Phazer N, S  | 85-86 | HF |    |
| RD 250 LC           | 83-84 |    | HF |
| YD 250 S            | 90    | HF |    |
| RD 350 LC YPVS      | 83-84 |    | HF |
| RZ 350              | 84-85 |    | HF |
| FZ 400 N            | 87    | HF |    |
| FZR 400             | 87    | HF |    |
| XJR 400 R           | 95-96 |    | LS |
| XS 400 Z            | 83    | HF | HF |
| FZR 500 (Austria)   | 89    | HF | HF |
| FZR 500 R (Austria) | 90-91 |    | LS |
| RD 500              | 83    | HF | HF |
| RD 500 LC           | 84-86 | HF |    |
| RZ 500              | 84-86 | HF |    |
| FJ 600              | 84-85 | HF | HF |
| FZ 600              | 86-87 | HF | HF |
| FZ 600 S, SC        | 86-89 | HF |    |
| FZR 600             | 89    | HF | HF |
| FZR 600 R           | 90-95 |    | LS |
| XJ 600              | 83-91 | HF | HF |
| YX 600 Radian       | 87-90 | HF |    |
| YZF 600 R Thunder   |       |    |    |
| Cat                 | 96-03 |    | LS |
| FZ 700              | 87-88 | HF | HF |
| FZX 700 Fazer       | 87-88 | HF | HF |
| XJ 700              | 86-89 | HF |    |
| XJ 700 Maxim        | 85-89 | HF | HF |
| XV 700 L, LC        | 84-87 | HF |    |



| <b>YAMAHA</b>       |       |    |    |
|---------------------|-------|----|----|
| XV 700 Virago       | 87    | HF |    |
| 750 Maxim           | 81    |    | HF |
| FZ 750              | 85-86 | HF | HF |
| FZ 750 Genesis      | 86    | HF |    |
| FZ 750 Genesis      | 87-88 | HF | HF |
| FZ 750 Genesis      | 89-92 |    | LS |
| FZR 750 R           | 89-92 |    | LS |
| FZR 750 R Genesis   | 87-88 |    | HF |
| FZX 750 Fazer       | 86-90 | HF | HF |
| TX 750 A            | 73-76 |    | HF |
| VF 750 Virago       | 88    | HF |    |
| XJ 750              | 83-87 | HF | HF |
| XV 750              | 89-92 | HS |    |
| YZF 750 R, SP       | 93-97 |    | LS |
| TDM 850             | 91-01 |    | LS |
| TRX 850 (Italy)     | 95-99 |    | LS |
| TRX 850             | 95-00 |    | LS |
| XJ 900              | 83-93 | HF | HF |
| XJ 900 F            | 85-93 | HF | HF |
| XJ 900 S, Diversion | 94-03 |    | LS |
| XV 920 Virago       | 81    |    | HF |
| FZR 1000            | 94-95 |    | LS |
| FZR 1000 EX UP      | 90-93 |    | LS |
| FZR 1000 Genesis    | 87-89 |    | HF |
| GTS 1000            | 93-99 |    | HF |
| XV 1000 L, C        | 84-85 | HF | HF |
| XV 1000 Virago      | 86-88 | HF |    |
| YZF 1000 R Thunder  |       |    |    |
| Ace                 | 96-99 |    | LS |
| BT 1100 Bulldog     | 02-06 |    | LS |
| FJ 1100             | 83-85 | HF | HF |



| <b>YAMAHA</b>      |       |    |    |
|--------------------|-------|----|----|
| XV 1100 Virago     | 86-93 | HF |    |
| XV 1100 Virago     | 99    |    | LS |
| XVS 1100 Drag Star | 99-06 |    | LS |
| XVS 1100 Drag Star |       |    |    |
| Classic            | 00-06 |    | LS |
| FJ 1200            | 86-87 | HF | HF |
| FJ 1200            | 88-90 |    | HF |
| FJ 1200 ABS        | 91-93 |    | LS |
| V-MAX 1200         | 85-89 | HF | HF |
| V-MAX 1200         | 90-92 | HS | LS |
| V-MAX 1200         | 93-03 |    | LS |
| XJR 1200 (Italy)   | 95-98 |    | LS |
| XJR 1200           | 94-98 |    | LS |
| XJR 1200 SP        | 97-98 |    | LS |
| XV 1200            | 84-87 | HF | HF |
| XV 1200 Venture    |       |    |    |
| Royale             | 85    | HF | HF |
| XV 1200 Z12T       | 84-87 | HF | HF |
| XVT 1200 T, Vent.  |       |    |    |
| Royale             | 84-85 | HF | HF |
| XJR 1300           | 99-01 |    | LS |
| XJR 1300 SP        | 01    |    | LS |

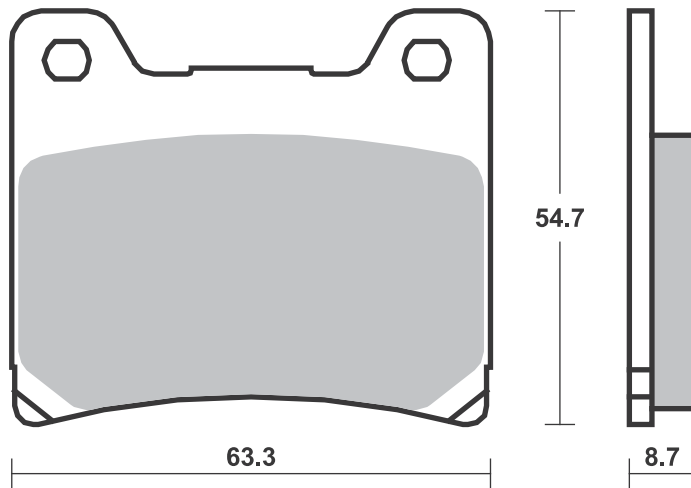
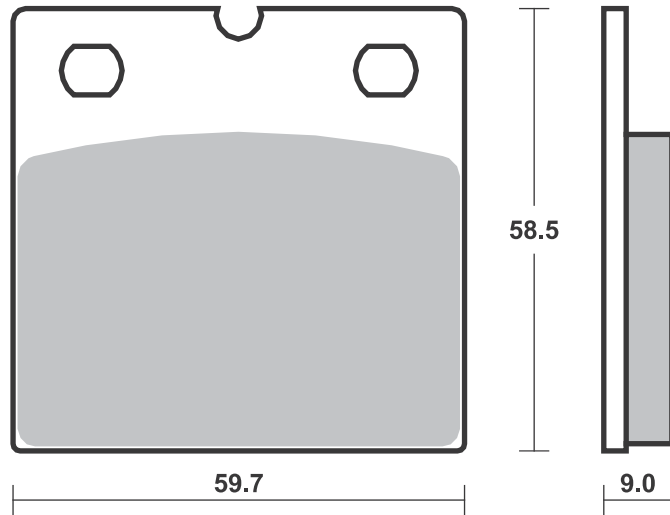

## SBS 556

## Recommended compound



| <b>HYOSUNG</b> |           |    |    |
|----------------|-----------|----|----|
| GT             | 250 Comet | 02 | LS |
|                | 600 Comet | 02 | LS |

| <b>KAWASAKI</b> |              |       |    |
|-----------------|--------------|-------|----|
| Z               | 250          | 78-80 | HF |
| Z               | 250 J        | 81-85 | HF |
| ZX-4            | 400          | 90    | LS |
| ZXR             | 400          | 89-90 | HF |
| ZXR             | 400          | 91-02 | LS |
|                 | 600 R, Ninja | 89-96 | HF |
| ZX-7R           | 750 Ninja    | 89-03 | LS |
| ZXR             | 750 R        | 89-95 | LS |
| ZRX             | 1100         | 96-00 | LS |
| ZX              | 1100         | 93-97 | LS |
| ZZR             | 1100         | 94-01 | LS |
| ZRX             | 1200         | 01-04 | LS |
| ZRX             | 1200 R       | 01-08 | LS |
| ZRX             | 1200 S       | 01-07 | LS |
| ZX-12R          | 1200 Ninja   | 00-03 | LS |
| ZX-12R          | 1200 Ninja   | 04-06 | LS |
| ZZR             | 1200         | 02-04 | LS |

| <b>SUZUKI</b> |                  |       |       |
|---------------|------------------|-------|-------|
| RG            | 125 Wolf         | 92-94 | HF    |
|               | 250 Across       | 90-99 | HF    |
|               | 250 Bandit       | 90-96 | LS    |
|               | 250 Cobra        | 90-92 | LS    |
|               | 250 Wolf         | 90-92 | LS    |
| GF            | 250              | 88    | HF    |
| GSX           | 250 S, Katana    | 91    | LS    |
| GSX-R         | 250              | 88-89 | HF    |
| GSX-R         | 250 R            | 89-91 | LS    |
| RG            | 250              | 83-84 | HF HF |
| RG            | 250 Gamma        | 84-88 | HF    |
| RGV           | 250              | 88    | LS    |
| RGV           | 250              | 89-90 | HF    |
| TV            | 250              | 88    | HF    |
|               | 350 Goose        | 92-99 | HF    |
| GSF           | 400 Bandit       | 91-97 | LS    |
| GSX           | 400 F            | 89-92 | HF    |
| GSX           | 400 FWS          | 83    | HF HF |
| GSX           | 400 Impulse      | 94-96 | LS    |
| GSX           | 400 S, Katana    | 92    | LS    |
| GSX           | 400 X            | 86-89 | HF    |
| GSX-R         | 400              | 87-89 | HF    |
| GSX-R         | 400 F            | 85-86 | HF    |
| GSX-R         | 400 R            | 90-95 | LS    |
| RF            | 400 RVC          | 93-97 | LS    |
| GS            | 500              | 89-03 | LS    |
| GS            | 500              | 04-08 | HF    |
| GS            | 500 F            | 04-08 | HF    |
| GSX           | 500              | 83-85 | HF HF |
| RG            | 500              | 85-87 | HF    |
| RG            | 500 Gamma        | 85-86 | HF    |
| GS            | 550              | 83-86 | HF HF |
| GSX           | 550              | 83-87 | HF HF |
| GSF           | 600 Bandit       | 95-99 | LS    |
| GSF           | 600 Bandit /     |       |       |
|               | S Bandit         |       |       |
|               | Left/Rear        | 00-04 | LS    |
| GSX           | 600 FW Left      | 98-04 | LS    |
| GSX           | 600 Katana       | 88-89 | HF    |
| GSX           | 600 Katana       | 90-97 | LS    |
| GSX-R         | 600              | 92-93 | LS    |
| GSX-R         | 600              | 97-03 | LS    |
| RF            | 600 R            | 93-96 | LS    |
| SV            | 650 ,S Left/Rear | 99-02 | LS    |
| GS            | 750 Katana       | 85-86 | HF HF |
| GS            | 750 RF           | 85    | HF    |
| GSX           | 750 ES           | 84-85 | HF HF |



| <b>SUZUKI</b> |                  |       |       |
|---------------|------------------|-------|-------|
| GSX           | 750 FW           |       |       |
|               | Left/Rear        | 98-02 | LS    |
| GSX           | 750 Katana       | 89-96 | LS    |
| GSX           | 750 Left/Rear    | 98-08 | LS    |
| GSX-R         | 750              | 85-87 | HF    |
| GSX-R         | 750              | 88-99 | LS    |
| GSX-R         | 750 Y            | 00-03 | LS    |
| TL            | 1000 RW          | 98-02 | LS    |
| TL            | 1000 S V-Twin    | 97-01 | LS    |
| GSX           | 1100             | 86-87 | HF HF |
| GSX           | 1100 F           | 93-96 | LS    |
| GSX           | 1100 G Left/Rear | 96-98 | LS    |
| GSX           | 1100 Katana      | 93    | LS    |
| GSX-R         | 1100             | 86-88 | HF    |
| GSX-R         | 1100             | 89-97 | LS    |
| GSF           | 1200 Bandit      | 95-05 | LS    |
| GSF           | 1200 S Bandit    | 01-05 | LS    |
| GSX           | 1200             | 99-01 | LS    |
| GSX-R         | 1300 Hayabusa    | 99-07 | LS    |



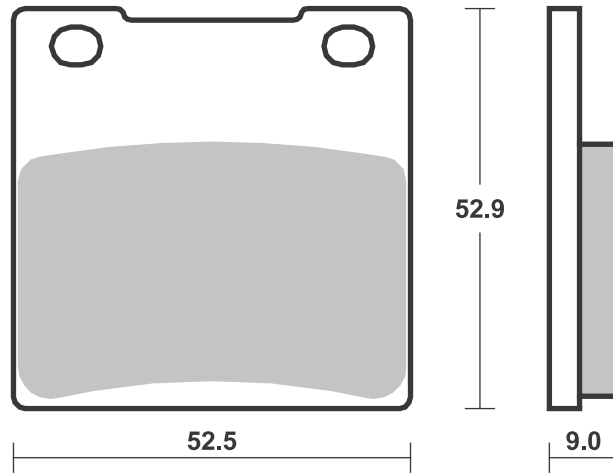

## Applications

### SBS 557 Recommended compound



| <b>HYOSUNG</b>  |                       |       |              |
|-----------------|-----------------------|-------|--------------|
|                 | 125 GA-4              | 99    | <b>HF</b>    |
| GA              | 300                   | 98-01 | <b>HF</b>    |
| <b>KAWASAKI</b> |                       |       |              |
| BR              | 250                   | 86-90 | <b>HF</b>    |
| CS              | 250                   | 86-90 | <b>HF</b>    |
| EL              | 250                   | 91-94 | <b>HF</b>    |
| EL              | 250                   | 93-94 | <b>HS</b>    |
| EL              | 250 Eliminator        | 88-89 | <b>HF</b>    |
| EX              | 250 R Ninja           | 86-87 | <b>HF HF</b> |
| GPZ             | 250                   | 83-85 | <b>HF</b>    |
| GPZ             | 250 R                 | 86-87 | <b>HF HF</b> |
| KR              | 250                   | 85    | <b>HF</b>    |
| LX              | 250 Eliminator,<br>SE | 90-95 | <b>HS</b>    |
| Z               | 250 Eliminator        | 88    | <b>HF</b>    |
| EL              | 252                   | 97-00 | <b>HS</b>    |
| EX              | 305                   | 83    | <b>HF</b>    |
| GPZ             | 305                   | 83-96 | <b>HF</b>    |
|                 | 400 Eliminator        | 94-95 | <b>LS</b>    |
| EN              | 400 Twin              | 85-89 | <b>HF</b>    |
| FX              | 400 R                 | 86-88 | <b>HF</b>    |
| GPZ             | 400                   | 85-87 | <b>HF</b>    |
| KLE             | 400 Vulcan            | 90    | <b>HS</b>    |
| Z               | 400 Eliminator        | 88    | <b>HF HF</b> |
| ZX              | 400                   | 85    | <b>HF</b>    |
| ZX              | 400                   | 86-87 | <b>HF HF</b> |
| EN              | 450                   | 85-90 | <b>HF</b>    |
| Z               | 450 LTD               | 84-89 | <b>HF</b>    |
| EN              | 500                   | 90-96 | <b>HS</b>    |
| EN              | 500                   | 98-04 | <b>HS</b>    |
| EN              | 500 Vulcan            | 96-97 | <b>HS</b>    |
| GPZ             | 500 R (Austria)       | 85-87 | <b>HF HF</b> |
| GPZ             | 500 S                 | 87    | <b>HF</b>    |
| GPZ             | 500 S                 | 89-92 | <b>LS</b>    |
| ZL              | 500 (Austria)         | 85-90 | <b>HF</b>    |
| GPZ             | 550                   | 84-87 | <b>HF HF</b> |
| GT              | 550                   | 85-01 | <b>HF</b>    |
| Z               | 550 F                 | 85-88 | <b>HF</b>    |
| ZX              | 550                   | 84-89 | <b>HF HF</b> |
| GPZ             | 600 R                 | 85-89 | <b>HF HF</b> |
| Z               | 600 GP                | 83-89 | <b>HF HF</b> |
| ZL              | 600                   | 85-91 | <b>HF</b>    |
| ZX              | 600 Ninja             | 85-87 | <b>HF HF</b> |



| <b>KAWASAKI</b> |                        |       |              |
|-----------------|------------------------|-------|--------------|
| VN              | 700 Vulcan             | 85    | <b>HF</b>    |
| ZN              | 700                    | 84-89 | <b>HF HF</b> |
|                 | 750 Vulcan             | 93-94 | <b>HF</b>    |
| GPZ             | 750                    | 83-87 | <b>HF HF</b> |
| GPZ             | 750 R                  | 85-86 | <b>HF HF</b> |
| GPZ             | 750 T                  | 83-85 | <b>HF HF</b> |
| GT              | 750                    | 86-91 | <b>HF HF</b> |
| VN              | 750 Vulcan             | 86-94 | <b>HF</b>    |
| VZ              | 750 Twin               | 88    | <b>HF</b>    |
| Z               | 750                    | 83    | <b>HF</b>    |
| Z               | 750 Eliminator         | 88    | <b>HF HF</b> |
| Z               | 750 LTD Twin           | 83-85 | <b>HF HF</b> |
| Z               | 750 Turbo              | 84-86 | <b>HF HF</b> |
| ZX              | 750 E, GP              | 83-85 | <b>HF HF</b> |
| VN              | 800 Vulcan,<br>Classic | 95-97 | <b>HS</b>    |
| GPZ             | 900 R                  | 84-89 | <b>HF HF</b> |
| ZL              | 900 Eliminator         | 85-86 | <b>HF HF</b> |
| ZX              | 900                    | 83-84 | <b>HF HF</b> |
| GPZ             | 1000 RX                | 86-88 | <b>HS LS</b> |
| GTR             | 1000                   | 86-93 | <b>HS LS</b> |
| GTR             | 1000                   | 94-06 | <b>LS</b>    |
| Z               | 1000 R Ninja           | 86-88 | <b>HF HF</b> |
| ZL              | 1000                   | 86-87 | <b>HF HF</b> |
| GPZ             | 1100                   | 83-86 | <b>HF HF</b> |
| Z               | 1100 GP                | 83-86 | <b>HF HF</b> |
| Z               | 1100 LTD               | 85-87 | <b>HF HF</b> |
| Z               | 1100 R, LTD            | 84    | <b>HF HF</b> |
| ZN              | 1100 LTD               | 84    | <b>HF HF</b> |
| ZX              | 1100 GP                | 83    | <b>HF HF</b> |
| ZG              | 1200 Voyager XII       | 86-93 | <b>HS LS</b> |
| Z               | 1300                   | 85    | <b>HF HF</b> |
| ZN              | 1300                   | 83-84 | <b>HF HF</b> |
| ZN              | 1300 Voy.              | 85-86 | <b>HF HF</b> |
| VN              | 1500 Classic           | 97-04 | <b>LS</b>    |
| VN              | 1500 Classic<br>Tourer |       |              |
|                 | Left/Rear              | 98-01 | <b>LS</b>    |
| VN              | 1500 Sumo              | 88-92 | <b>HF HF</b> |
| VN              | 1500 Vulcan            | 87-92 | <b>HS LS</b> |
| VN              | 1500 Vulcan, SE        | 87-92 | <b>HS LS</b> |

### SBS 558 Recommended compound



| <b>BENELLI</b> |            |       |              |
|----------------|------------|-------|--------------|
| TNT            | 125        | 17    | <b>HF</b>    |
| <b>HONDA</b>   |            |       |              |
| MBX            | 80         | 86-87 | <b>HF</b>    |
| MTX            | 80 R       | 87    | <b>HF</b>    |
| CR             | 125 RE, RF | 84-85 | <b>SI</b>    |
| CR             | 125 RG     | 86    | <b>SI</b>    |
| MTX            | 125 R      | 84-95 | <b>HF</b>    |
| NSR            | 125 F      | 88-89 | <b>HF</b>    |
| XL             | 125 R      | 86    | <b>HF</b>    |
| MTX            | 200 R      | 85-86 | <b>HF</b>    |
| ATC            | 250 R      | 85-86 | <b>SI SI</b> |
| ATC            | 250 X      | 85    | <b>SI</b>    |
| CB             | 250 RS     | 85    | <b>HF</b>    |
| CH             | 250 Spacy  | 85-86 | <b>HF</b>    |
| CN             | 250 Spazio | 88-89 | <b>HF</b>    |
| CR             | 250 RE, RF | 84-85 | <b>SI</b>    |
| CR             | 250 RG     | 86    | <b>SI</b>    |



| <b>HONDA</b> |                 |       |              |
|--------------|-----------------|-------|--------------|
| FTR          | 250             | 86    | <b>HF HF</b> |
| TRX          | 250 R           | 86-89 | <b>SI</b>    |
| TRX          | 250 X Fourtrax  | 87    | <b>SI</b>    |
| XL           | 250 R           | 84-87 | <b>HF</b>    |
| XLR          | 250 R           | 88-89 | <b>SI</b>    |
| XR           | 250 R           | 84-87 | <b>SI</b>    |
| ATC          | 350 X           | 85    | <b>SI</b>    |
| XL           | 350 R           | 84-87 | <b>HF</b>    |
| XR           | 350 R           | 84-85 | <b>SI</b>    |
| CR           | 500 RE, RF      | 84-85 | <b>SI</b>    |
| CR           | 500 RG          | 86    | <b>SI</b>    |
| XL           | 500 R           | 83-87 | <b>HF</b>    |
| XR           | 500 R           | 86    | <b>SI</b>    |
| XR           | 500 R, Pro Link | 83-84 | <b>HF</b>    |
| XL           | 600 R           | 83-86 | <b>HF</b>    |
| XLM          | 600 LM          | 87-91 | <b>HF</b>    |
| XR           | 600 R           | 83-87 | <b>SI</b>    |

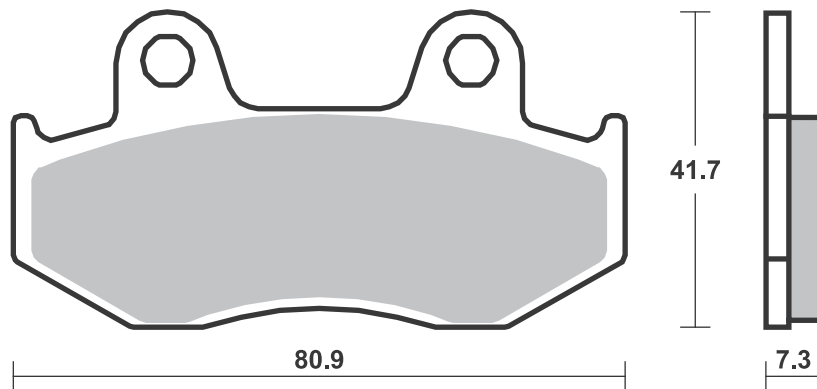
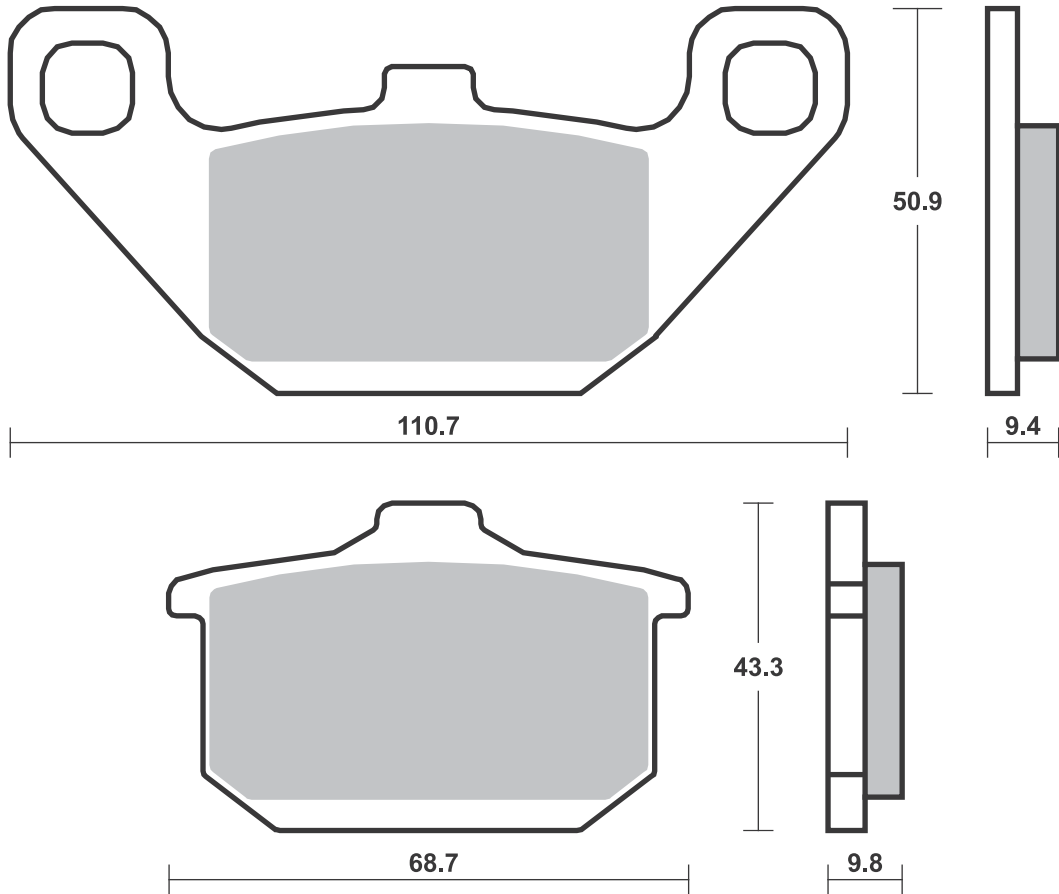

**SBS 559** Recommended compound

|                |                 |       |                |
|----------------|-----------------|-------|----------------|
| <b>AJP</b>     |                 |       |                |
| MX             | 200             | 09-11 | <b>HF</b>      |
| <b>ALFER</b>   |                 |       |                |
| MC             | 80              | 87    | <b>HF</b>      |
| <b>APRILIA</b> |                 |       |                |
| TX             | 240             | 86-88 | <b>RSI</b>     |
|                | 280 R, Climber  | 92    | <b>RSI RSI</b> |
| TX             | 311             | 86    | <b>RSI</b>     |
| TX             | 312 M           | 88    | <b>RSI RSI</b> |
| TXR            | 312 M           | 88    | <b>RSI RSI</b> |
| <b>ATK</b>     |                 |       |                |
| ATK            | 560             | 87-88 | <b>HF</b>      |
| <b>BENELLI</b> |                 |       |                |
| BXK            | 125             | 88    | <b>HF</b>      |
| <b>BETA</b>    |                 |       |                |
|                | 50 Rev          | 00-09 | <b>HF HF</b>   |
|                | 50 Super Trial  | 92    | <b>HF</b>      |
| ST             | 50              | 97    | <b>HF HF</b>   |
|                | 80 EVO Junior   | 10-11 | <b>HF HF</b>   |
|                | 80 Rev          | 00-07 | <b>HF HF</b>   |
| ALP            | 125             | 99-09 | <b>RSI RSI</b> |
| ALP            | 125 4-stroke    | 00-05 | <b>RSI RSI</b> |
| SR             | 125 34          | 89    | <b>HF</b>      |
| TR             | 125 34,35       | 89-90 | <b>RSI RSI</b> |
| TRIAL          | 125             | 97    | <b>RSI</b>     |
| ALP            | 200 4-stroke    | 00-05 | <b>RSI RSI</b> |
|                | 240 Super Trial | 92    | <b>RSI</b>     |
| ALP            | 240             | 92    | <b>RSI</b>     |
| ALP            | 240             | 96    | <b>RSI</b>     |
|                | 250 Techno      | 96    | <b>RSI RSI</b> |
|                | 250 Zero        | 91    | <b>RSI</b>     |
| ALP            | 250             | 92    | <b>RSI</b>     |
| ALP            | 250             | 97-03 | <b>RSI RSI</b> |
|                | 260 Zero        | 91    | <b>RSI</b>     |
| ALP            | 260             | 96    | <b>RSI</b>     |
| TR             | 260 34,35,ZERO  | 89-92 | <b>RSI</b>     |
| <b>BLATA</b>   |                 |       |                |
|                | 125 Enduro      | 07-08 | <b>HF</b>      |
|                | 125 Motard      | 07-08 | <b>HF</b>      |
| <b>CPI</b>     |                 |       |                |
|                | 125 Supermoto   | 07-12 | <b>HF</b>      |
| <b>DERBI</b>   |                 |       |                |
| DS             | 50              | 88    | <b>HF</b>      |
| FD             | 50 Yumbo        | 84    | <b>HF</b>      |
| FD             | 50 Yumbo Extra  | 87    | <b>HF</b>      |
| FDS            | 50              | 87    | <b>HF</b>      |
| FDT            | 50              | 87-85 | <b>HF</b>      |
| FDT            | 50 Coppa        | 85    | <b>HF</b>      |
| FDX            | 50              | 89    | <b>HF</b>      |
| GP1            | 50              | 05    | <b>HF</b>      |
| GPR            | 50 Nude         | 04-10 | <b>HF</b>      |
| GPR            | 50 Racing       | 04-13 | <b>HF</b>      |
|                | 75 GPR          | 89    | <b>HF</b>      |
|                | 75 Sport, Coppa | 84    | <b>HF</b>      |
| GPR            | 75 Sport        | 92    | <b>HF</b>      |
| GPR            | 80 Cup          | 04-05 | <b>HF</b>      |
|                | 125 Senda R 4T  | 04-12 | <b>HF</b>      |
|                | 125 Senda       |       |                |
|                | X-Treme         |       |                |
|                | SM 4T           | 04-05 | <b>HF</b>      |
|                | 125 Terra       | 07    | <b>HF</b>      |
| GP1            | 125             | 05-06 | <b>HF</b>      |
| GPR            | 125             | 05-06 | <b>HF</b>      |



|                    |                        |       |                |
|--------------------|------------------------|-------|----------------|
| <b>DERBI</b>       |                        |       |                |
| GPR                | 125 Nude               | 05-08 | <b>HF</b>      |
| GPR                | 125 Racing             | 09    | <b>HF</b>      |
| <b>FACTORY</b>     |                        |       |                |
| R12                | 50 Phantom             |       |                |
|                    | Agua                   | 06    | <b>RSI</b>     |
| R14                | 50 Phantom             |       |                |
|                    | Agua                   | 04    | <b>RSI</b>     |
| R14                | 50 Phantom Aire        | 03    | <b>RSI</b>     |
| R2                 | 65 Phantom             | 04    | <b>RSI</b>     |
| YR                 | 125                    | 06    | <b>HF</b>      |
| <b>FANTIC</b>      |                        |       |                |
|                    | 250 K-Roo              | 93-95 | <b>RSI RSI</b> |
|                    | 305                    | 89-90 | <b>RSI RSI</b> |
|                    | 307 Trial              | 91-94 | <b>RSI RSI</b> |
| <b>GAC</b>         |                        |       |                |
|                    | 50 New T.T.            | 87    | <b>HF</b>      |
| <b>GARELLI</b>     |                        |       |                |
|                    | 50 Ciclone LC,         |       |                |
|                    | SM                     | 86    | <b>HF</b>      |
|                    | 50 Sahel               | 91    | <b>HF</b>      |
| <b>GAS GAS</b>     |                        |       |                |
| TXT                | 50 Boy                 | 04    | <b>RSI RSI</b> |
|                    | 125 Delta              | 91    | <b>HF</b>      |
|                    | 125 Pampera            | 96-03 | <b>RSI RSI</b> |
|                    | 125 Trial              | 91    | <b>RSI</b>     |
|                    | 200 Pampera            | 99-08 | <b>RSI RSI</b> |
| TX                 | 200                    | 97-98 | <b>RSI RSI</b> |
|                    | 250 Pampera            | 96-99 | <b>RSI RSI</b> |
|                    | 250 Trial              | 89-96 | <b>RSI RSI</b> |
| GT                 | 250 Contact            | 92-93 | <b>RSI RSI</b> |
| TX                 | 270                    | 97-98 | <b>RSI RSI</b> |
| TX                 | 320                    | 97-99 | <b>RSI RSI</b> |
|                    | 325 Halley PXC         | 86    | <b>RSI RSI</b> |
|                    | 327 Trial              | 89-90 | <b>RSI RSI</b> |
| GT                 | 327 Contact            | 89-90 | <b>RSI RSI</b> |
|                    | 370 Pampera            | 96-00 | <b>RSI RSI</b> |
| <b>GILERA</b>      |                        |       |                |
|                    | 125 Surfer             | 00    | <b>HF HF</b>   |
| <b>GMA</b>         |                        |       |                |
|                    | 4 Piston front Model F |       |                |
| <b>HRD</b>         |                        |       |                |
|                    | 125 Supermotard        | 00-02 | <b>HF</b>      |
|                    | 125 Trail              | 00-02 | <b>HF</b>      |
| <b>HUSQVARNA</b>   |                        |       |                |
|                    | 50 Husky Boy J,        |       |                |
|                    | R, S                   | 01-10 | <b>RSI</b>     |
| <b>J. J. COBAS</b> |                        |       |                |
| TR1                | 250                    | 85    | <b>HF</b>      |
| Trial              | 250                    | 85    | <b>RSI</b>     |
| <b>JAYBRAKE</b>    |                        |       |                |
|                    | 2 Piston Dual Series   |       |                |
|                    | Caliper                |       |                |
|                    | 4 Piston Quad Series   |       |                |
|                    | Caliper                |       |                |
| <b>JCM</b>         |                        |       |                |
|                    | 125 Europa             | 89    | <b>RSI RSI</b> |
|                    | 125 SR                 | 89    | <b>RSI RSI</b> |
|                    | 240 Europa             | 89    | <b>RSI RSI</b> |



|                            |                    |       |                |
|----------------------------|--------------------|-------|----------------|
| <b>JCM</b>                 |                    |       |                |
|                            | 240 SR             | 89    | <b>RSI RSI</b> |
|                            | 325 Europa         | 89    | <b>RSI</b>     |
|                            | 325 SR             | 89    | <b>RSI RSI</b> |
| <b>KTM</b>                 |                    |       |                |
| SX                         | 60                 | 99    | <b>RSI</b>     |
| SX                         | 65                 | 00-01 | <b>RSI</b>     |
| <b>MACBOR</b>              |                    |       |                |
| XC                         | 50 510 Racing      | 04    | <b>RSI</b>     |
| XC                         | 50 512 Racing      | 04    | <b>RSI</b>     |
| XC                         | 50 515 R 6V        | 04    | <b>RSI</b>     |
| <b>MALAGUTI</b>            |                    |       |                |
|                            | 50 Fifty Evolution | 91    | <b>HF</b>      |
| NKD                        | 50 Dragon          | 06-09 | <b>HF</b>      |
| <b>MONTESA</b>             |                    |       |                |
|                            | 125 Cota           | 88    | <b>RSI RSI</b> |
|                            | 260 Evasion        | 92    | <b>RSI</b>     |
|                            | 304 Cota           | 88    | <b>RSI RSI</b> |
|                            | 307 Cota           | 89    | <b>RSI RSI</b> |
|                            | 307 Cota Trial     | 88-89 | <b>RSI RSI</b> |
|                            | 309 Cota           | 89-90 | <b>RSI</b>     |
|                            | 310 Cota           | 89-92 | <b>RSI</b>     |
|                            | 311 Cota Trial     | 92    | <b>RSI</b>     |
|                            | 315 Cota R         | 97-04 | <b>RSI RSI</b> |
|                            | 335 Cota           | 87-91 | <b>RSI RSI</b> |
| M7                         | 360 Enduro         | 85    | <b>HF</b>      |
| <b>MORBIDELLI</b>          |                    |       |                |
|                            | 125 cc             | 76    | <b>HF HF</b>   |
| <b>MOTORHISPANIA</b>       |                    |       |                |
| RYZ                        | 125 Arena Enduro   | 05-07 | <b>HF HF</b>   |
| <b>PERFORMANCE MACHINE</b> |                    |       |                |
|                            | 125 X 2            |       |                |
|                            | 125 X 4S           |       |                |
|                            | 125 X 4SL          |       |                |
| <b>PEUGEOT</b>             |                    |       |                |
| XPS                        | 125 CT             | 06-07 | <b>HF HF</b>   |
| <b>PUCH</b>                |                    |       |                |
|                            | 50 Condor          | 90    | <b>HF</b>      |
| TZX                        | 50                 | 92    | <b>HF</b>      |
|                            | 75 Cobra           | 85    | <b>HF</b>      |
| <b>RIEJU</b>               |                    |       |                |
|                            | 50 Drac            | 97    | <b>HF HF</b>   |
|                            | 50 FD4 Super       |       |                |
|                            | Marathon           | 85    | <b>HF</b>      |
|                            | 50 Tangoo          | 10-12 | <b>HF</b>      |
| RR                         | 50 , Supermotard   | 96-05 | <b>HF HF</b>   |
| RS1                        | 50                 | 92-05 | <b>HF</b>      |
| RV                         | 50                 | 80    | <b>HF</b>      |
|                            | 75 K6,             |       |                |
|                            | LC Strada          | 87    | <b>HF</b>      |
|                            | 75 P6,             |       |                |
|                            | LC Strada          | 87    | <b>HF</b>      |
| MR                         | 80 C, E            | 88-90 | <b>HF</b>      |
| MR                         | 80 Cross           | 87    | <b>HF</b>      |
| MR                         | 80 Enduro          | 87    | <b>HF</b>      |
| RST                        | 80                 | 91-93 | <b>HF HF</b>   |
|                            | 125 Tango          | 06-12 | <b>HF</b>      |
|                            | 125 Tango Pro      | 08    | <b>HF</b>      |
| MRX                        | 125                | 03-08 | <b>HF</b>      |
| MRX                        | 125                | 03-08 | <b>HF HF</b>   |
| RR                         | 125                | 97-99 | <b>HF HF</b>   |

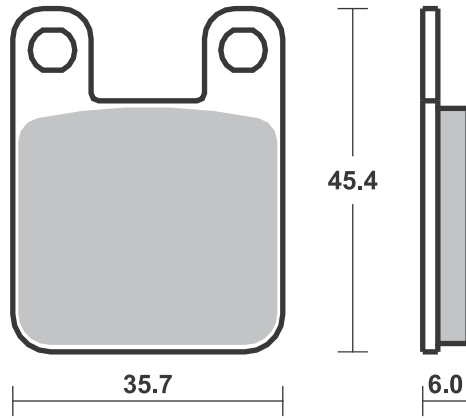

## Applications

### SBS 559 Recommended compound



| <b>RIEJU</b>  |               |       |              |
|---------------|---------------|-------|--------------|
| RS3           | 125           | 10-13 | <b>HF</b>    |
| SMX           | 125           | 03-07 | <b>HF</b>    |
| SMX           | 125           | 03-07 | <b>HF HF</b> |
|               | 250 Tango     | 08-15 | <b>HF</b>    |
| <b>SCORPA</b> |               |       |              |
| TY-S          | 115 F Trial   | 06    | <b>HF</b>    |
| TY-S          | 125 F Trial   | 06-08 | <b>HF</b>    |
| <b>SHERCO</b> |               |       |              |
|               | 80 0.8        | 01-03 | <b>HF HF</b> |
|               | 125           | 02    | <b>HF</b>    |
|               | 125 City Corp |       |              |
|               | 4T Enduro     | 03-07 | <b>HF</b>    |
|               | 125 City Corp |       |              |
|               | 4T SM         | 03-07 | <b>HF</b>    |
| ST            | 125 1.25      | 01-05 | <b>HF HF</b> |
| ST            | 200 2.0       | 01    | <b>HF HF</b> |



| <b>SHERCO</b> |                           |       |                |
|---------------|---------------------------|-------|----------------|
| ST            | 250                       | 99-00 | <b>RSI RSI</b> |
| <b>SIMSON</b> |                           |       |                |
|               | 125 SM                    | 01    | <b>HF</b>      |
| <b>SJP</b>    |                           |       |                |
|               | 2 Piston Caliper (30-375) |       |                |
|               | 4 Piston Caliper (30-370) |       |                |
| <b>SUZUKI</b> |                           |       |                |
| DR            | 50 Big                    | 89-02 | <b>HF</b>      |
| <b>TOMOS</b>  |                           |       |                |
| MC            | 125 T                     | 06-08 | <b>HF</b>      |
| SE            | 125                       | 05-08 | <b>HF</b>      |
| SM            | 125 F                     | 06-08 | <b>HF</b>      |



| <b>YAMAHA</b> |             |       |              |
|---------------|-------------|-------|--------------|
| XT            | 125 R       | 05-13 | <b>HF</b>    |
| XT            | 125 X       |       |              |
|               | Supermotard | 05-13 | <b>HF</b>    |
| TY            | 250 R       | 91-92 | <b>HF</b>    |
| TY            | 250 Z       | 93-96 | <b>HF HF</b> |

### SBS 560 Recommended compound



| <b>ASPES</b>   |                |       |              |
|----------------|----------------|-------|--------------|
|                | 125 Yuma       | 76-79 | <b>HF</b>    |
| <b>BETA</b>    |                |       |              |
|                | 125 TS, Custom | 83    | <b>HF</b>    |
| <b>CAGIVA</b>  |                |       |              |
|                | 650 Alazzurra  | 85-88 | <b>HF HF</b> |
| <b>FANTIC</b>  |                |       |              |
|                | 125 Strada     | 83-85 | <b>HF</b>    |
| HP1            | 125 Sport      | 86    | <b>HF</b>    |
| <b>GARELLI</b> |                |       |              |
| GTA            | 125            | 86    | <b>HF</b>    |
| TSR            | 125            | 83    | <b>HF</b>    |
| <b>GILERA</b>  |                |       |              |
|                | 80 TG 1, 2, 3  | 77-82 | <b>HF</b>    |



| <b>GILERA</b>   |                                 |       |           |
|-----------------|---------------------------------|-------|-----------|
|                 | 125 TG 1, 2, 3                  |       |           |
|                 | (alu wheels)                    | 77-85 | <b>HF</b> |
|                 | 125 TG1, GR1,                   |       |           |
|                 | RTX                             | 77-85 | <b>HF</b> |
| RV              | 125                             | 86-88 | <b>HF</b> |
|                 | 200 T4, T4C, T4S                | 79-82 | <b>HF</b> |
| RV              | 200                             | 85-86 | <b>HF</b> |
| <b>GMA</b>      |                                 |       |           |
|                 | 2 Piston Caliper, small Model B |       |           |
| <b>JAYBRAKE</b> |                                 |       |           |
|                 | 2 Piston Caliper ADC/ADCS       |       |           |
| <b>KREIDLER</b> |                                 |       |           |
|                 | 125 Mustang                     | 83-87 | <b>HF</b> |



| <b>MOTO-MORINI</b> |            |       |           |
|--------------------|------------|-------|-----------|
|                    | 125 Strada | 80    | <b>HF</b> |
|                    | 250 Strada | 80    | <b>HF</b> |
|                    | 350 K2     | 84-87 | <b>HF</b> |
|                    | 350 Strada | 76-81 | <b>HF</b> |
|                    | 500 Strada | 80-82 | <b>HF</b> |
| <b>ZUNDAPP</b>     |            |       |           |
| KS                 | 80 Super   | 83-84 | <b>HF</b> |
| KS                 | 125        | 79    | <b>HF</b> |

### SBS 561 Recommended compound



| <b>HONDA</b> |              |       |           |
|--------------|--------------|-------|-----------|
| CB           | 450 N        | 84-85 | <b>HF</b> |
| CB           | 450 SC       |       |           |
|              | Nighthawk    | 82    | <b>HF</b> |
| CB           | 650 SCC      |       |           |
|              | Nighthawk    | 82    | <b>HF</b> |
| VT           | 700 C Shadow | 84-86 | <b>HF</b> |
| VT           | 750 C        | 83-85 | <b>HF</b> |
|              |              |       |           |
|              |              |       |           |
|              |              |       |           |
|              |              |       |           |
|              |              |       |           |
|              |              |       |           |
|              |              |       |           |
|              |              |       |           |
|              |              |       |           |
|              |              |       |           |
|              |              |       |           |

Brake Pad 1:1 Drawings, Compounds, Fitments

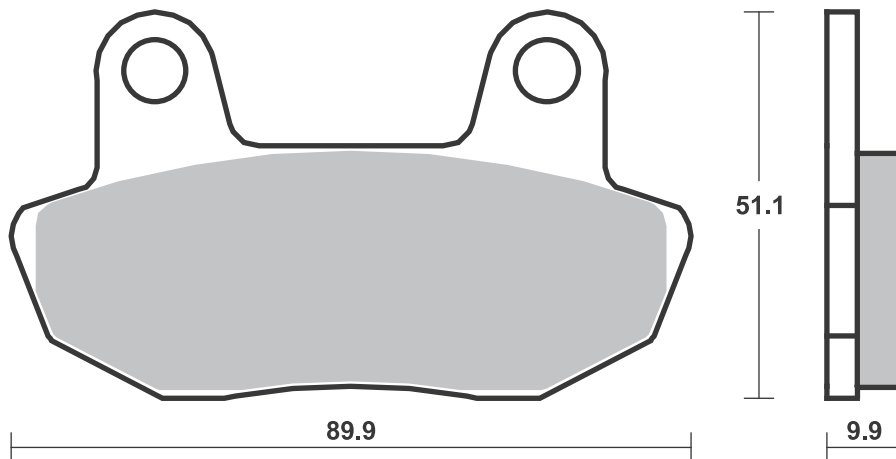
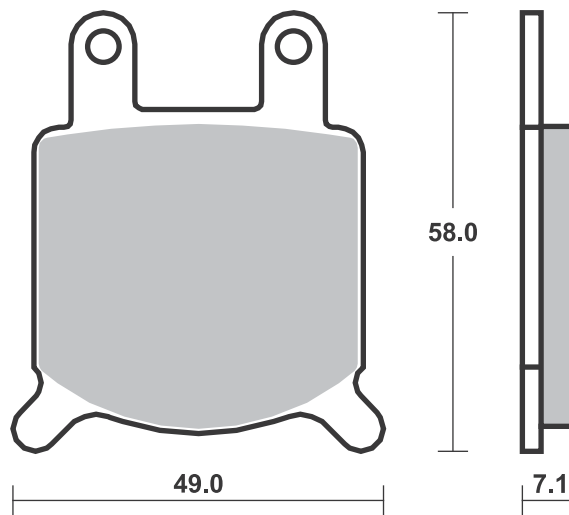
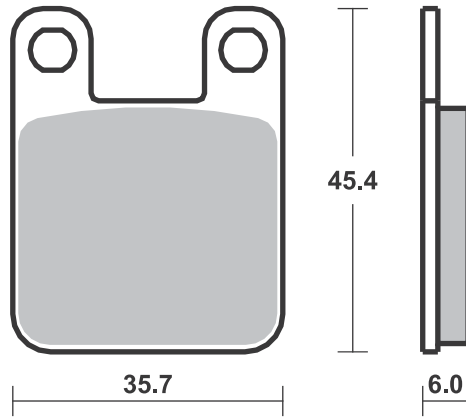

**SBS 562 Recommended compound**

| <b>HONDA</b> |       |       |           |
|--------------|-------|-------|-----------|
| ATC          | 200 X | 83-85 | <b>SI</b> |
| ATC          | 250 R | 82-84 | <b>SI</b> |
| ATC          | 250 X | 85    | <b>SI</b> |
| ATC          | 350 X | 85-89 | <b>SI</b> |
|              |       |       |           |
|              |       |       |           |
|              |       |       |           |
|              |       |       |           |
|              |       |       |           |
|              |       |       |           |
|              |       |       |           |
|              |       |       |           |
|              |       |       |           |
|              |       |       |           |
|              |       |       |           |
|              |       |       |           |

**SBS 566 Recommended compound**

| <b>APRILIA</b>                          |                   |       |            |
|---|-------------------|-------|------------|
| RS-4                                    | 125 (J.Juan cal.) | 11-18 | <b>HS</b>  |
| RS                                      | 250               | 95-96 | <b>HF</b>  |
| <b>BETA</b>                             |                   |       |            |
|   | 125 Jonathan      | 99-05 | <b>HF</b>  |
|   | 350 4.0 Motard    | 04-06 | <b>RSI</b> |
|   | 350 Euro          | 99-03 | <b>HF</b>  |
|   | 350 Jonathan      | 02-03 | <b>HF</b>  |
|   | 350 M4            |       |            |
|   | (Brembo cal.)     | 06-07 | <b>HF</b>  |
| <b>BIMOTA</b>                           |                   |       |            |
| YB7                                     | 400               | 89    | <b>HF</b>  |
|   | 500 Vdue          | 97-00 | <b>HF</b>  |
|   | 600 Bellaria      | 91    | <b>HF</b>  |
| YB9                                     | 600 SRI           | 97    | <b>HF</b>  |
| BB1                                     | 650 Supermono     | 97-00 | <b>HF</b>  |
| SB7                                     | 750               | 96-88 | <b>HF</b>  |
| YB4                                     | 750               | 89    | <b>HF</b>  |
| 1D                                      | 851 Tesi          | 91    | <b>HF</b>  |
| 1D                                      | 900 Tesi          | 93    | <b>HF</b>  |
| DB2                                     | 900               | 92-00 | <b>HF</b>  |
| DB3                                     | 900 Mantra        | 97-00 | <b>HF</b>  |
| 1D                                      | 906 Tesi          | 91    | <b>HF</b>  |
|   | 1000 Furano       | 92-93 | <b>HF</b>  |
| 2D                                      | 1000 Tesi         | 04-06 | <b>HS</b>  |
| YB11                                    | 1000              | 97-00 | <b>HF</b>  |
| YB6                                     | 1000              | 89    | <b>HF</b>  |
| YB8                                     | 1000              | 90    | <b>HF</b>  |
|   | 1002 Dieci        | 91    | <b>HF</b>  |
| SB6                                     | 1100              | 97-00 | <b>HF</b>  |
| <b>BORILE</b>                           |                   |       |            |
| B                                       | 500 CR, MT        | 02-04 | <b>HF</b>  |
| <b>BREMBO RACING CALIPERS</b>           |                   |       |            |
| Billet 20.4756.52/62, racing            |                   |       |            |
| Goldline single pin 20.5165.55/65, road |                   |       |            |
| <b>CAGIVA</b>                           |                   |       |            |
|   | 125 Mito          | 93-07 | <b>HF</b>  |
|   | 125 Planet        | 97-07 | <b>HF</b>  |



| <b>CAGIVA</b>     |                  |       |           |
|-------------------|------------------|-------|-----------|
|                   | 125 Raptor       | 03-10 | <b>HF</b> |
|                   | 500 Mito         | 07    | <b>HS</b> |
|                   | 500 River        | 00-01 | <b>HF</b> |
| SP                | 525 Mito         | 08-10 | <b>HS</b> |
|                   | 600 River        | 94-99 | <b>HF</b> |
| <b>CANNONDALE</b> |                  |       |           |
| S                 | 440              | 03    | <b>HF</b> |
| <b>DUCATI</b>     |                  |       |           |
|                   | 400 SS, Junior   | 92-97 | <b>HF</b> |
|                   | 400 SS, Nuda     | 92-96 | <b>HF</b> |
|                   | 502 Single       | 93    | <b>HF</b> |
|                   | 502 Supermono    | 93    | <b>HF</b> |
|                   | 600 SS           |       |           |
|                   | Supersport       | 95-00 | <b>HF</b> |
| M                 | 600 Monster      | 94-99 | <b>HF</b> |
|                   | 748 Biposto      | 95-98 | <b>HF</b> |
|                   | 748 SP           | 95-97 | <b>HF</b> |
|                   | 750 Monster      | 96-99 | <b>HF</b> |
|                   | 750 SS           | 91-98 | <b>HF</b> |
|                   | 750 SS           |       |           |
|                   | Supersport       | 95-99 | <b>HF</b> |
|                   | 750 SS, Carenara | 92-98 | <b>HF</b> |
|                   | 750 SS, Nuda     | 92    | <b>HF</b> |
|                   | 750 Super Sport  | 92-94 | <b>HF</b> |
|                   | 851 Strada       | 89    | <b>HF</b> |
|                   | 851 Strada       | 91-92 | <b>HF</b> |
|                   | 851 Superbike    | 90    | <b>HF</b> |
|                   | 888 Roche        |       |           |
|                   | Replica          | 91    | <b>HF</b> |
|                   | 888 SP V         | 93    | <b>HF</b> |
|                   | 888 SP4          | 92-95 | <b>HF</b> |
|                   | 888 SPO          | 93    | <b>HF</b> |
|                   | 888 SPS          | 92-95 | <b>HF</b> |
|                   | 888 Strada       | 93    | <b>HF</b> |
|                   | 888 Superbike    | 93    | <b>HF</b> |
|                   | 900 FE           | 97-98 | <b>HF</b> |
|                   | 900 M,           |       |           |
|                   | IL Monster       | 93-99 | <b>HF</b> |
|                   | 900 SL           | 92-97 | <b>HF</b> |
|                   | 900 SS           | 90-94 | <b>HF</b> |
|                   | 900 SS           |       |           |
|                   | Supersport       | 95-97 | <b>HF</b> |



| <b>DUCATI</b>    |                    |       |             |
|------------------|--------------------|-------|-------------|
|                  | 900 SSR            | 92    | <b>HF</b>   |
| 907              | 900 I. E.          | 90-93 | <b>HF</b>   |
| M                | 900 Street         |       |             |
|                  | Monster            | 94-99 | <b>HF</b>   |
|                  | 916 Biposto        | 94    | <b>HF</b>   |
| <b>FANTIC</b>    |                    |       |             |
| TZ               | 125 SM             | 12    | <b>HF</b>   |
| <b>GAS GAS</b>   |                    |       |             |
| SM               | 125                | 02-13 | <b>HF</b>   |
| SM               | 250                | 02-13 | <b>HF</b>   |
| SM               | 400 fse            | 02    | <b>HF</b>   |
| SM               | 450 fse            | 03-06 | <b>HF</b>   |
| SM               | 450 FSR            | 07-13 | <b>HF</b>   |
| <b>GILERA</b>    |                    |       |             |
|                  | 350 Saturno        |       |             |
|                  | Bialbero           | 90    | <b>HF</b>   |
|                  | 500 Saturno        |       |             |
|                  | Bialbero           | 90    | <b>HF</b>   |
|                  | 500 Saturno        |       |             |
|                  | Piuma              | 90-94 | <b>HF</b>   |
| <b>HONDA</b>     |                    |       |             |
| RS               | 125                | 95-03 | #DC         |
| RS               | 250 R              | 93    | #DC         |
| <b>HUSQVARNA</b> |                    |       |             |
| SM               | 400 R              | 02    | <b>HF</b>   |
| SM               | 450 R              | 03-04 | <b>HF</b>   |
| SM               | 570 R              | 01-08 | <b>HF</b>   |
| <b>INDIAN</b>    |                    |       |             |
|                  | 1700 Chief         |       |             |
|                  | Blackhawk          | 11-13 | <b>H.HS</b> |
|                  | 1700 Chief         |       |             |
|                  | Bomber             | 10-13 | <b>H.HS</b> |
|                  | 1700 Chief Classic | 10-13 | <b>H.HS</b> |
|                  | 1700 Chief Dark    |       |             |
|                  | Horse              | 10-13 | <b>H.HS</b> |
|                  | 1700 Chief Deluxe  | 09-13 | <b>H.HS</b> |
|                  | 1700 Chief         |       |             |
|                  | Roadmaster         | 09-13 | <b>H.HS</b> |



Drawings 1:1

Available compounds **HF • SI • RSI**

**SBS 562**

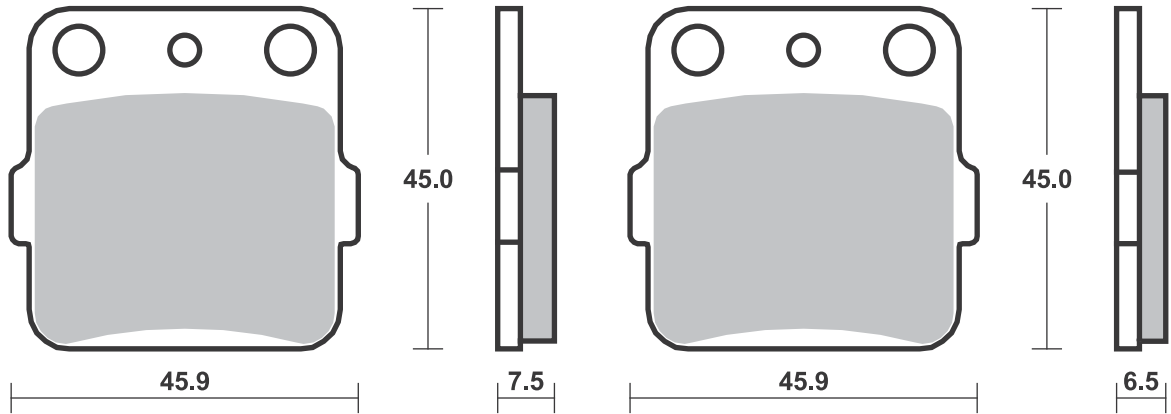

Available compounds **HF • HS • RSI • DC • RS • DCC • H.HF • H.HS • H.CT**

**SBS 566**

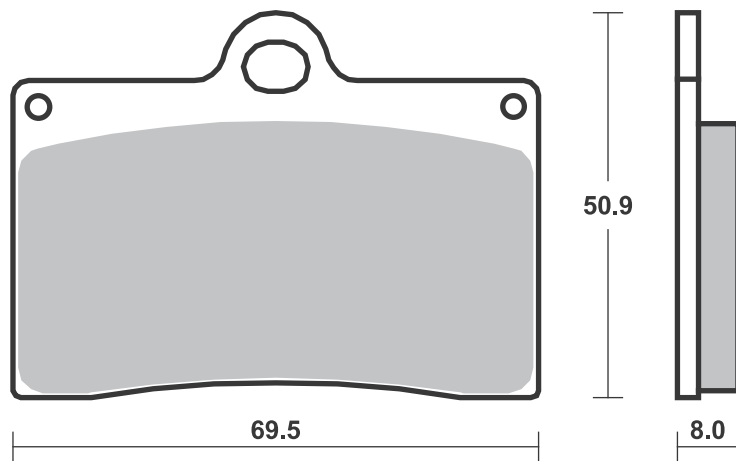

**SBS 566**      Recommended compound



|                    |       |             |  |  |
|--------------------|-------|-------------|--|--|
| <b>INDIAN</b>      |       |             |  |  |
| 1700 Chief         |       |             |  |  |
| Standard           | 09-13 | <b>H.HS</b> |  |  |
| 1700 Chief Vintage | 09-13 | <b>H.HS</b> |  |  |
| <b>ITALJET</b>     |       |             |  |  |
| 900 Grifon         | 00    | <b>HF</b>   |  |  |
| <b>J. J. COBAS</b> |       |             |  |  |
| TR1 250            | 85    | <b>HF</b>   |  |  |
| <b>KTM</b>         |       |             |  |  |
| 125 Sting          | 99    | <b>HF</b>   |  |  |
| SX 450 SM Factory  |       |             |  |  |
| Replica            | 04-07 | <b>RSI</b>  |  |  |
| 600 Duke           | 93-94 | <b>HF</b>   |  |  |
| 620 Duke           | 96-98 | <b>HF</b>   |  |  |
| 640 Duke           | 99-02 | <b>HF</b>   |  |  |
| LC4 640 Supermoto  | 03    | <b>HF</b>   |  |  |
| LC4 660 SM Factory |       |             |  |  |
| Replica            | 02    | <b>RSI</b>  |  |  |
| SMC 660 Supermoto  | 03    | <b>HF</b>   |  |  |
| <b>LAVERDA</b>     |       |             |  |  |
| 650                | 92    | <b>HF</b>   |  |  |
| 668 668            | 96-97 | <b>HF</b>   |  |  |
| 668 Ghost,         |       |             |  |  |
| Diamante           | 97    | <b>HF</b>   |  |  |
| 750 Cup            | 98-01 | <b>HF</b>   |  |  |
| 750 Diamante       | 97-01 | <b>HF</b>   |  |  |
| 750 Ghost Strike   | 97-01 | <b>HF</b>   |  |  |
| 750 S Formula      | 97-01 | <b>HF</b>   |  |  |
| 750 S,             |       |             |  |  |
| S Carenata         | 97-01 | <b>HF</b>   |  |  |
| 750 Sport          | 99-01 | <b>HF</b>   |  |  |
| 750 Strike/        |       |             |  |  |
| Black Strike       | 99-01 | <b>HF</b>   |  |  |
| 750 T8             | 98-01 | <b>HF</b>   |  |  |
| TTS 800            | 99    | <b>HF</b>   |  |  |
| JOTA 1000          | 95    | <b>HF</b>   |  |  |



|                    |       |           |  |  |
|--------------------|-------|-----------|--|--|
| <b>MOTO-GUZZI</b>  |       |           |  |  |
| 750 Ippogrifo      | 97    | <b>HF</b> |  |  |
| 1000 Daytona       | 91-02 | <b>HF</b> |  |  |
| 1000 Quota         | 92    | <b>HF</b> |  |  |
| RS 1000 Daytona    | 97-00 | <b>HF</b> |  |  |
| V10 1000 Centauro  | 96-00 | <b>HF</b> |  |  |
| 1100 California    |       |           |  |  |
| Jackal             | 00    | <b>HF</b> |  |  |
| 1100 California    |       |           |  |  |
| Jackal Basic       | 00    | <b>HF</b> |  |  |
| 1100 California    |       |           |  |  |
| Special            | 99-00 | <b>HF</b> |  |  |
| 1100 Sport         | 96-04 | <b>HF</b> |  |  |
| EV 1100 California | 97-00 | <b>HF</b> |  |  |
| V11 1100 Sport     | 97-00 | <b>HF</b> |  |  |
| <b>MZ</b>          |       |           |  |  |
| 660 (MUZ)          |       |           |  |  |
| Skorpion           |       |           |  |  |
| Cup                | 99    | <b>HF</b> |  |  |
| 660 (MUZ)          |       |           |  |  |
| Skorpion           |       |           |  |  |
| Replica            | 97-99 | <b>HF</b> |  |  |
| 660 (MUZ)          |       |           |  |  |
| Skorpion           |       |           |  |  |
| Sport              | 95-99 | <b>HF</b> |  |  |
| 660 (MUZ)          |       |           |  |  |
| Skorpion           |       |           |  |  |
| Tour               | 95-00 | <b>HF</b> |  |  |
| 660 (MUZ)          |       |           |  |  |
| Skorpion           |       |           |  |  |
| Traveller          | 99-00 | <b>HF</b> |  |  |
| <b>NORTON</b>      |       |           |  |  |
| F-1 600            | 90    | <b>HF</b> |  |  |
| TT 600             | 92    | <b>HF</b> |  |  |
| <b>PGO</b>         |       |           |  |  |
| 250 G-Max          | 06-07 | <b>HF</b> |  |  |



|                            |       |            |  |  |
|----------------------------|-------|------------|--|--|
| <b>REVTECH</b>             |       |            |  |  |
| Wilwood Caliper front/rear |       |            |  |  |
| <b>SACHS</b>               |       |            |  |  |
| 125 X-Road                 | 05-07 | <b>HF</b>  |  |  |
| XTC 125                    | 99-07 | <b>HF</b>  |  |  |
| XTC-N 125                  | 99-07 | <b>HF</b>  |  |  |
| 500 MadAss                 | 05-08 | <b>HF</b>  |  |  |
| 650 Roadster               |       |            |  |  |
| V1.6                       | 01-05 | <b>HF</b>  |  |  |
| 800 B-805                  | 02-04 | <b>HS</b>  |  |  |
| 800 Roadster V2            | 00-05 | <b>HF</b>  |  |  |
| 800 S-805                  | 03-04 | <b>HS</b>  |  |  |
| <b>TM</b>                  |       |            |  |  |
| SMR 125                    | 05    | <b>RSI</b> |  |  |
| SMF 400 F                  | 02    | <b>RSI</b> |  |  |
| SMR 400 F                  | 03    | <b>RSI</b> |  |  |
| SMR 450 F                  | 04    | <b>RSI</b> |  |  |
| SMX 450 F                  | 03    | <b>RSI</b> |  |  |
| SMR 530 F                  | 03    | <b>RSI</b> |  |  |
| SMX 600 F                  | 03    | <b>RSI</b> |  |  |
| <b>VOR</b>                 |       |            |  |  |
| SM 400                     | 02    | <b>RSI</b> |  |  |
| SM 450                     | 02-04 | <b>RSI</b> |  |  |
| 500 492 Super              |       |            |  |  |
| Motard                     | 00-01 | <b>HF</b>  |  |  |
| SM 530                     | 02-04 | <b>RSI</b> |  |  |
| <b>VOXAN</b>               |       |            |  |  |
| 1000 Cafe Racer            | 01-06 | <b>HS</b>  |  |  |
| 1000 Roadster              | 01-06 | <b>HS</b>  |  |  |
| <b>YAMAHA</b>              |       |            |  |  |
| TZR 250 R                  | 94    | <b>HF</b>  |  |  |
| SZR 660                    | 96-01 | <b>HF</b>  |  |  |

**SBS 569**      Recommended compound



|                             |  |  |  |  |
|-----------------------------|--|--|--|--|
| <b>A.P. RACING CALIPERS</b> |  |  |  |  |
| CP-2382/2383                |  |  |  |  |
|                             |  |  |  |  |
|                             |  |  |  |  |
|                             |  |  |  |  |
|                             |  |  |  |  |
|                             |  |  |  |  |
|                             |  |  |  |  |
|                             |  |  |  |  |
|                             |  |  |  |  |
|                             |  |  |  |  |
|                             |  |  |  |  |
|                             |  |  |  |  |
|                             |  |  |  |  |
|                             |  |  |  |  |
|                             |  |  |  |  |
|                             |  |  |  |  |
|                             |  |  |  |  |
|                             |  |  |  |  |
|                             |  |  |  |  |
|                             |  |  |  |  |
|                             |  |  |  |  |
|                             |  |  |  |  |
|                             |  |  |  |  |
|                             |  |  |  |  |
|                             |  |  |  |  |
|                             |  |  |  |  |
|                             |  |  |  |  |
|                             |  |  |  |  |
|                             |  |  |  |  |
|                             |  |  |  |  |
|                             |  |  |  |  |
|                             |  |  |  |  |
|                             |  |  |  |  |
|                             |  |  |  |  |
|                             |  |  |  |  |
|                             |  |  |  |  |
|                             |  |  |  |  |
|                             |  |  |  |  |
|                             |  |  |  |  |
|                             |  |  |  |  |
|                             |  |  |  |  |
|                             |  |  |  |  |
|                             |  |  |  |  |

Brake Pad 1:1 Drawings, Compounds, Fitments

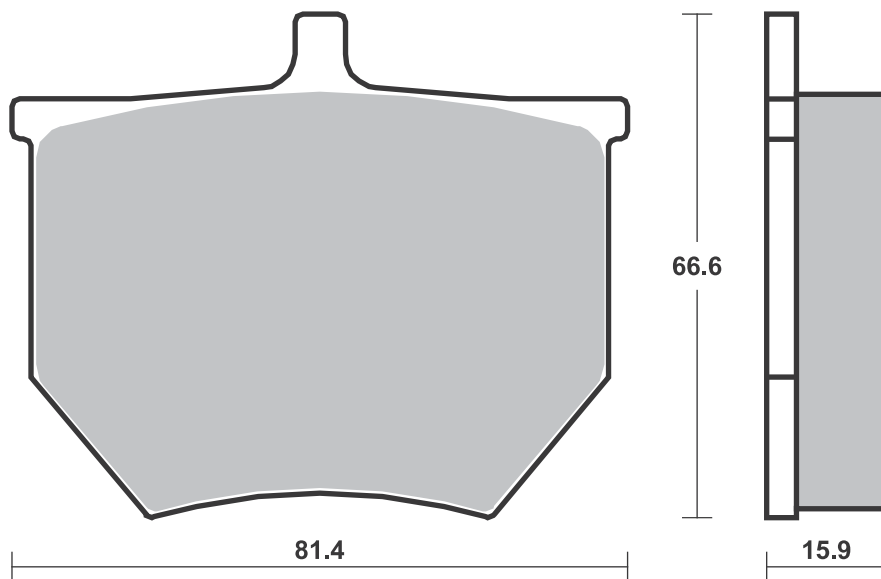
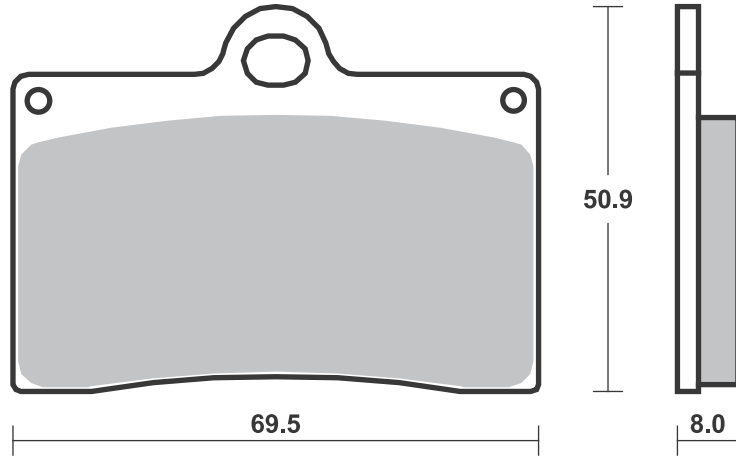

Applications

**SBS 570** Recommended compound



| YAMAHA |           |       |       |
|--------|-----------|-------|-------|
| FZR    | 50        | 90-91 | HF    |
| TZR    | 80        | 89-91 | HF    |
| RD     | 125 LC    | 85-87 | HF    |
| TZR    | 125       | 87-88 | HF    |
| TZR    | 125       | 89-92 | HF    |
| TZR    | 125 R     | 94-04 | HF    |
| SDR    | 200       | 88-89 | HF    |
| FZ     | 250 R     | 85    | HF    |
| FZR    | 250       | 87-88 | HF    |
| FZR    | 250 R     | 89-99 | HF    |
| FZX    | 250 Zeal  | 91-92 | LS    |
| R1-Z   | 250       | 90-92 | HF    |
| RZ     | 250 RR    | 88    | HS LS |
| RZR    | 250       | 90    | HS LS |
| SRX    | 250       | 84-90 | HF    |
| SRX    | 250 T, TC | 87    | HF    |
| TDR    | 250       | 88-92 | HF    |
| TZR    | 250       | 87-92 | HF    |



| YAMAHA |               |       |       |
|--------|---------------|-------|-------|
| RD     | 350 LC        | 85    | HF HF |
| RD     | 350 LC, F     | 85-90 | HS LS |
| RD     | 350 R         | 91-95 | HS LS |
| RZ     | 350           | 86-88 | HS LS |
| FZ     | 400 N         | 87    | HF    |
| FZ     | 400 R         | 85    | HF HF |
| FZR    | 400           | 87    | HF HF |
| FZR    | 400           | 88-90 | LS    |
| FZR    | 400 A         | 90    | LS    |
| FZR    | 400 R         | 91-94 | LS    |
| SRX    | 400           | 85-87 | HF    |
| XJ     | 400 Diversion | 91-93 | LS    |
| RD     | 500 LC        | 84-86 | HF    |
| RZ     | 500           | 84-86 | HF    |
| FZ     | 600 S, SC     | 86-89 | HF    |
| FZS    | 600 Fazer     | 98-03 | LS    |
| FZS    | 600 S Fazer   | 01-03 | LS    |
| SRX    | 600           | 86-87 | HF HF |



| YAMAHA |                 |       |    |
|--------|-----------------|-------|----|
| SRX    | 600             | 88-89 | HF |
| SRX    | 600             | 90-99 | LS |
| XJ     | 600 N           | 91-03 | LS |
| XJ     | 600 S Diversion | 91-03 | LS |
| FZ     | 750 Genesis     | 86    | HF |
|        |                 |       |    |
|        |                 |       |    |
|        |                 |       |    |
|        |                 |       |    |
|        |                 |       |    |
|        |                 |       |    |
|        |                 |       |    |
|        |                 |       |    |
|        |                 |       |    |
|        |                 |       |    |
|        |                 |       |    |
|        |                 |       |    |

**SBS 571** Recommended compound



| HONDA |                |       |       |
|-------|----------------|-------|-------|
| CBX   | 400 Custom     | 88    | HF HF |
| CBX   | 400 F          | 85-86 | HF HF |
| CBX   | 400 F, F2, F2C | 82-84 | HF    |
| NV    | 400 Custom     | 88    | HF    |
| VF    | 400 F          | 85-86 | HF    |
| VF    | 400 FD         | 83-85 | HF    |
| VT    | 400 E          | 83-86 | HF    |
| CBX   | 550 F, F2      | 82-86 | HF    |
|       |                |       |       |
|       |                |       |       |
|       |                |       |       |
|       |                |       |       |
|       |                |       |       |
|       |                |       |       |
|       |                |       |       |
|       |                |       |       |
|       |                |       |       |

**SBS 572** Recommended compound



| HONDA |                   |       |       |
|-------|-------------------|-------|-------|
| CB    | 125 T, Superdream | 82-83 | HF    |
| CBX   | 125 F             | 84-88 | HF    |
| CBX   | 250 S             | 88    | HF    |
| CN    | 250 Spazio        | 88-92 | HF    |
| NS    | 250 R             | 85    | HF    |
| CM    | 400 C             | 81    | HF    |
| NS    | 400 R             | 85-87 | HS    |
| VF    | 400 Integra       | 86-88 | HF HF |
| CB    | 450 SC            |       |       |
|       | Nighthawk         | 83-86 | HF    |
| CX    | 500               | 81    | HF    |
| CX    | 500 Euro          | 82-84 | HF HF |
| CX    | 500 Turbo         | 82-83 | HF    |
| GL    | 500               | 82    | HF    |
| GL    | 500 I             | 81-82 | HF    |
| CX    | 650 E             | 83-86 | HF    |
| VF    | 700 C Magna       | 85-86 | HF    |



| HONDA  |                        |       |    |
|--------|------------------------|-------|----|
| VF     | 700 F Interceptor      | 84-85 | HF |
| CB     | 750 SC                 | 82-83 | HF |
| XLV    | 750 R                  | 86-88 | HF |
| CB     | 900 F, F2              | 81-84 | HF |
| CBX    | 1000                   | 81-82 | HF |
| GL     | 1100 Gold Wing         | 82-83 | HF |
| VF     | 1100 C                 | 83-86 | HF |
| VF     | 1100 S                 | 84-85 | HF |
| GL     | 1200 A,<br>I Gold Wing | 84-86 | HF |
| GL     | 1200 DX                |       |    |
|        | Gold Wing              | 86-87 | HF |
| GL     | 1200 Gold Wing         | 84-86 | HF |
|        |                        |       |    |
| XINGFU |                        |       |    |
| XF     | 150 A                  | 97    | HF |

Brake Pad 1:1 Drawings,  
Compounds, Fitments

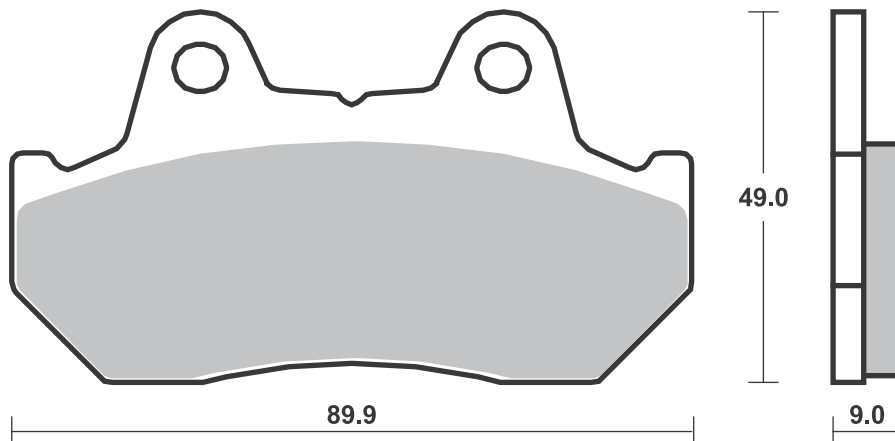
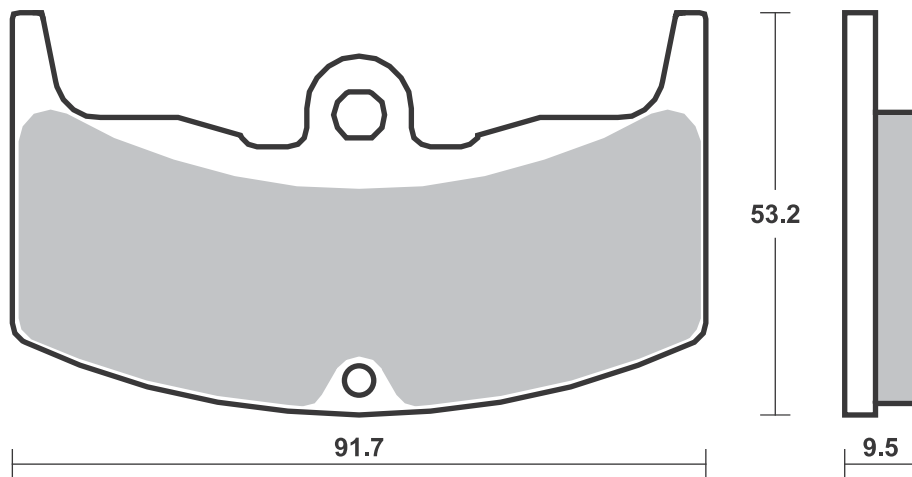
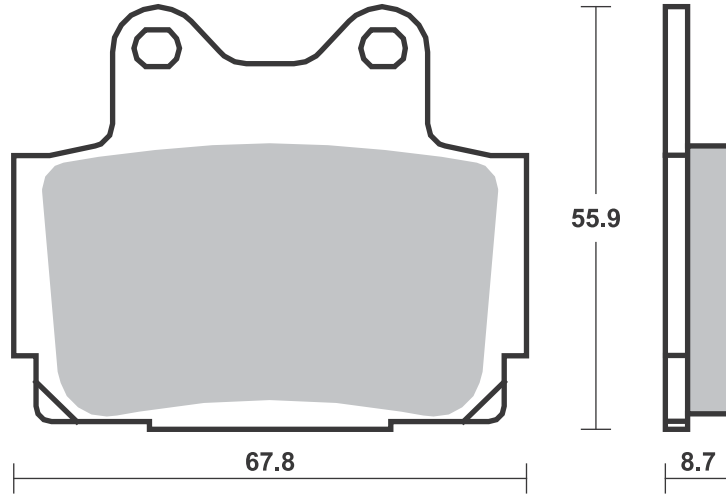

## Applications

### SBS 574 Recommended compound



| <b>APRILIA</b>  |       |           |  |
|-----------------|-------|-----------|--|
| 50 Tuareg       | 86-96 | <b>HF</b> |  |
| 50 Tuareg Rally | 90-96 | <b>HF</b> |  |
| 125 Strada      | 85    | <b>HF</b> |  |
| 125 Tuareg Wind | 88    | <b>HF</b> |  |
| AF-1 125        | 88    | <b>HF</b> |  |
| 240 Climber     | 89-90 | <b>HF</b> |  |
| 275 Climber     | 89-90 | <b>HF</b> |  |

| <b>BETA</b>    |       |            |  |
|----------------|-------|------------|--|
| 350 4.0 Motard | 04-06 | <b>RSI</b> |  |
| ALP 350 4.0    | 04-05 | <b>RSI</b> |  |

| <b>CAGIVA</b>         |       |           |           |
|-----------------------|-------|-----------|-----------|
| 50 Lucky              |       |           |           |
| Explorer              | 88-02 | <b>HF</b> |           |
| 80 Cocis              | 91    | <b>HF</b> |           |
| 125 Aletta Electra    | 83-86 | <b>HF</b> |           |
| 125 Aletta Oro        | 85-89 | <b>HF</b> | <b>HF</b> |
| 125 Cruiser           | 89    | <b>HF</b> | <b>HF</b> |
| 125 E2                | 86    | <b>HF</b> |           |
| 125 Elefant           | 81-88 | <b>HF</b> |           |
| 125 SST               | 81    | <b>HF</b> |           |
| 125 Tamanaco          | 87-92 | <b>HF</b> |           |
| 125 WSTX Aletta Rossa | 83-84 | <b>HF</b> |           |
| N90 125               | 91-98 | <b>HF</b> |           |
| 200 Aletta Electra    | 83    | <b>HF</b> |           |
| 200 Cross             | 83-86 | <b>HF</b> |           |

| <b>FANTIC</b> |    |           |           |
|---------------|----|-----------|-----------|
| 50 .1 Oasis   | 87 | <b>HF</b> | <b>HF</b> |



| <b>FANTIC</b> |       |           |           |
|---------------|-------|-----------|-----------|
| 50 .1 Raider  |       |           |           |
| Rally         | 87    | <b>HF</b> |           |
| 50 Koala      | 90    | <b>HF</b> | <b>HF</b> |
| 50 Oasis      | 90    | <b>HF</b> | <b>HF</b> |
| 75 Oasis      | 89    | <b>HF</b> | <b>HF</b> |
| 125 Raider    | 83-85 | <b>HF</b> |           |
| HP1 125 Sport | 87    | <b>HF</b> |           |

| <b>GARELLI</b> |    |           |  |
|----------------|----|-----------|--|
| 125 Tiger XLE  | 86 | <b>HF</b> |  |

| <b>GILERA</b> |    |           |  |
|---------------|----|-----------|--|
| X1 125        | 89 | <b>HF</b> |  |
| NGR 250       | 85 | <b>HF</b> |  |

| <b>JCM</b> |    |            |  |
|------------|----|------------|--|
| 233 Vega   | 88 | <b>HF</b>  |  |
| 325 Europa | 89 | <b>RSI</b> |  |
| 333 Vega   | 88 | <b>HF</b>  |  |

| <b>KTM</b> |       |            |  |
|------------|-------|------------|--|
| SX 65      | 00-03 | <b>RSI</b> |  |

| <b>LAVERDA</b>       |       |           |           |
|----------------------|-------|-----------|-----------|
| 125 Formula          | 86-89 | <b>HF</b> |           |
| GS 125 Lesmo         | 86-94 | <b>HF</b> | <b>HF</b> |
| LB 125 Strada, Sport | 85    | <b>HF</b> |           |

| <b>MALAGUTI</b> |    |           |           |
|-----------------|----|-----------|-----------|
| 50 Evolution    | 91 | <b>HF</b> |           |
| ES 50 Dune      | 89 | <b>HF</b> | <b>HF</b> |



| <b>MALAGUTI</b> |       |           |           |
|-----------------|-------|-----------|-----------|
| MDX 50          | 86-87 | <b>HF</b> |           |
| RST 50 Sport    | 87    | <b>HF</b> | <b>HF</b> |

| <b>MALANCA</b>   |       |           |           |
|------------------|-------|-----------|-----------|
| E2 80 C80        | 80    | <b>HF</b> | <b>HF</b> |
| GTI 80           | 80    | <b>HF</b> | <b>HF</b> |
| E2 125 125       | 80-84 | <b>HF</b> | <b>HF</b> |
| E2 125 CS ob one |       |           |           |
| 5N, 6N, Racing   | 80    | <b>HF</b> | <b>HF</b> |
| E2 125 Sport     | 80    | <b>HF</b> | <b>HF</b> |
| GTI 125          | 80    | <b>HF</b> | <b>HF</b> |

| <b>ZUNDAPP</b> |       |           |  |
|----------------|-------|-----------|--|
| KS 80 Super    | 80-84 | <b>HF</b> |  |

### SBS 575 Recommended compound



| <b>GILERA</b>    |       |           |  |
|------------------|-------|-----------|--|
| 125 Apache       | 91-94 | <b>HF</b> |  |
| RC 125 Top Rally | 90-93 | <b>HF</b> |  |
| 250 Oregon       |       |           |  |
| Quad             | 07-11 | <b>SI</b> |  |
| RC 600 Top Rally | 90-94 | <b>HF</b> |  |

| <b>YAMAHA</b>      |       |            |           |
|--------------------|-------|------------|-----------|
| DT 50 R            | 89-95 | <b>HF</b>  |           |
| YSR 50             | 87-92 | <b>HF</b>  |           |
| DT 80 LC-2         | 85-92 | <b>HF</b>  |           |
| RD 80 LC           | 83-85 | <b>HF</b>  |           |
| TDR 80             | 89    | <b>HF</b>  | <b>HF</b> |
| TZR 80             | 92-95 | <b>HF</b>  | <b>HF</b> |
| YSR 80             | 86-92 | <b>HF</b>  |           |
| DT 125 LC          | 85-87 | <b>HF</b>  |           |
| DT 125 R, Electric | 88-03 | <b>HF</b>  | <b>HF</b> |
| SR 125 Flame       | 96    | <b>HF</b>  |           |
| TDR 125 R          | 93-03 | <b>LS</b>  |           |
| YBR 125            | 06-07 | <b>HF</b>  |           |
| YZ 125             | 88    | <b>RSI</b> |           |
| XC 150 Fly One     | 92-99 | <b>HF</b>  |           |
| RT 180             | 95-96 | <b>SI</b>  |           |
| DT 200             | 85-87 | <b>HF</b>  |           |
| DT 200             | 89    | <b>HF</b>  | <b>HF</b> |
| IT 200             | 85-86 | <b>SI</b>  |           |
| TT 200             | 86-89 | <b>HF</b>  |           |
| 225 Serow          | 85-87 | <b>HF</b>  |           |
| TT 225 S,T         | 86-00 | <b>HF</b>  |           |
| TTR 225            | 01-04 | <b>SI</b>  |           |
| XT 225             | 92-00 | <b>HF</b>  |           |
| XT 225 Serow       | 86    | <b>HF</b>  |           |



| <b>YAMAHA</b>       |       |            |           |
|---------------------|-------|------------|-----------|
| IT 250              | 85-86 | <b>SI</b>  |           |
| TY 250 Z (Scottish) | 96    | <b>RSI</b> |           |
| YTZ 250 Tri Moto    | 85-86 | <b>SI</b>  | <b>SI</b> |
| YZ 250              | 88    | <b>RSI</b> |           |
| XT 350              | 85-96 | <b>HF</b>  |           |
| YFM 350 XT,         |       |            |           |
| XU Warrior          | 87-88 | <b>SI</b>  |           |
| YFZ 350 Banshee     | 87-89 | <b>SI</b>  |           |
| 400 Artesia         | 91-92 | <b>LS</b>  |           |
| XT 400              | 86    | <b>HF</b>  |           |
| WR 500 B            | 91    | <b>SI</b>  |           |
| XT 500              | 86-89 | <b>HF</b>  |           |
| XT 500 E (Austria)  | 90-96 | <b>LS</b>  |           |
| DT 600 N            | 85    | <b>HF</b>  |           |
| TT 600              | 85-88 | <b>HF</b>  |           |
| XT 600 E            | 90-03 | <b>LS</b>  |           |
| XT 600 K            | 91-94 | <b>LS</b>  |           |
| XT 600 Z, Tenere    | 87-90 | <b>HF</b>  |           |
| XTZ 660 Tenere      | 91-98 | <b>LS</b>  |           |

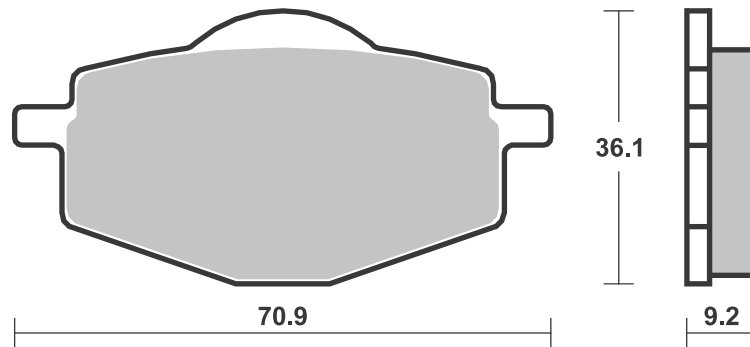
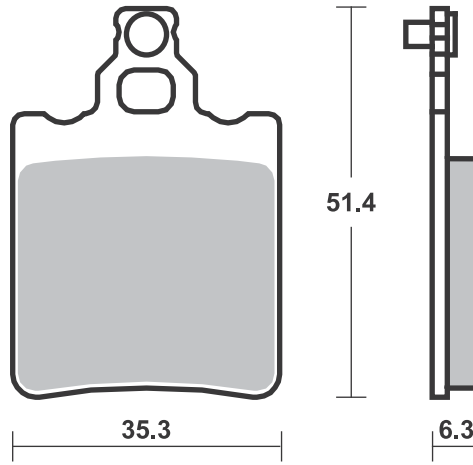

**SBS 576** Recommended compound



| <b>YAMAHA</b> |                  |       |  |           |
|---------------|------------------|-------|--|-----------|
| YT            | 175 Tri Moto     | 82-83 |  | <b>HF</b> |
| YFM           | 200 DXS-DXW      |       |  |           |
|               | Moto 4           | 86-87 |  | <b>HF</b> |
| YFM           | 200 N Moto 4     | 85-89 |  | <b>HF</b> |
| YTM           | 200 K-N Tri Moto | 83-85 |  | <b>HF</b> |
| YFM           | 225 Moto 4       | 86-88 |  | <b>HF</b> |
| YTM           | 225 DRN,         |       |  |           |
|               | DRS Tri Moto     | 85-86 |  | <b>HF</b> |
| YTM           | 225 DXK,         |       |  |           |
|               | DXN Tri Moto     | 83-85 |  | <b>HF</b> |
| YFM           | 250              | 89-91 |  | <b>SI</b> |
| YFM           | 350 ERT, ERU     | 87-88 |  | <b>HF</b> |
| YFM           | 350 ERW, ERA-G   | 89-95 |  | <b>HF</b> |
| YFM           | 350 FWT, FWU     |       |  |           |
|               | Big Bear         | 87-88 |  | <b>HF</b> |
| YFM           | 350 FWW,         |       |  |           |
|               | FWA-G            |       |  |           |
|               | Big Bear         | 89-95 |  | <b>HF</b> |

**SBS 577** Recommended compound



| <b>SUZUKI</b> |                 |       |           |           |
|---------------|-----------------|-------|-----------|-----------|
| GSX-R         | 250             | 88-89 | <b>HF</b> |           |
| GSX           | 400 X           | 86-89 | <b>HF</b> |           |
| GSX-R         | 400             | 87    | <b>HF</b> |           |
| RG            | 500             | 85-87 | <b>HF</b> |           |
| RG            | 500 Gamma       | 85-86 | <b>HF</b> |           |
| VS            | 600 GL Intruder | 97    | <b>HS</b> |           |
| GSX           | 650 GT          | 86    |           | <b>HF</b> |
| VS            | 700 GLFG        | 86-87 | <b>HF</b> |           |
| GS            | 750 RF          | 85    | <b>HF</b> |           |
| GSX-R         | 750             | 85-87 | <b>HF</b> |           |
| VS            | 750 Intruder    | 86-91 | <b>HF</b> |           |
| VS            | 800 Intruder    | 91-99 | <b>HS</b> |           |
| GSX           | 1100            | 85    | <b>HF</b> | <b>HF</b> |
| GSX           | 1100            | 88-89 |           | <b>HF</b> |
| GSX           | 1100            | 90-93 |           | <b>LS</b> |
| GSX-R         | 1100            | 86-88 | <b>HF</b> |           |
| GS            | 1150 EG         | 86-87 | <b>HF</b> | <b>HF</b> |
| GS            | 1150 ES         | 84-85 | <b>HF</b> | <b>HF</b> |



| <b>SUZUKI</b> |                  |       |           |           |
|---------------|------------------|-------|-----------|-----------|
| GL            | 1400 Cavalcade   | 87-88 |           | <b>HF</b> |
| GV            | 1400 Cavalcade   |       |           |           |
|               | LXE              | 87-90 | <b>HS</b> | <b>LS</b> |
| VS            | 1400 GL Intruder | 87-04 | <b>HS</b> | <b>LS</b> |
| VL            | 1500 Intruder LC | 98-01 | <b>HS</b> | <b>LS</b> |
|               |                  |       |           |           |
|               |                  |       |           |           |
|               |                  |       |           |           |
|               |                  |       |           |           |
|               |                  |       |           |           |
|               |                  |       |           |           |
|               |                  |       |           |           |
|               |                  |       |           |           |
|               |                  |       |           |           |
|               |                  |       |           |           |
|               |                  |       |           |           |
|               |                  |       |           |           |

**SBS 578** Recommended compound



| <b>SUZUKI</b> |           |       |           |  |
|---------------|-----------|-------|-----------|--|
| GF            | 250       | 88    | <b>HF</b> |  |
| RG            | 250 Gamma | 84-88 | <b>HF</b> |  |
| GSX-R         | 400 F     | 85-86 | <b>HF</b> |  |
|               |           |       |           |  |
|               |           |       |           |  |
|               |           |       |           |  |
|               |           |       |           |  |
|               |           |       |           |  |
|               |           |       |           |  |
|               |           |       |           |  |
|               |           |       |           |  |
|               |           |       |           |  |
|               |           |       |           |  |
|               |           |       |           |  |
|               |           |       |           |  |
|               |           |       |           |  |
|               |           |       |           |  |
|               |           |       |           |  |
|               |           |       |           |  |
|               |           |       |           |  |
|               |           |       |           |  |
|               |           |       |           |  |
|               |           |       |           |  |
|               |           |       |           |  |
|               |           |       |           |  |
|               |           |       |           |  |

Brake Pad 1:1 Drawings, Compounds, Fitments



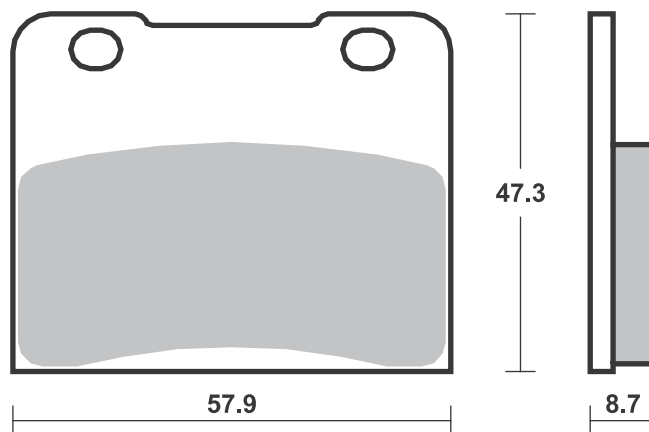
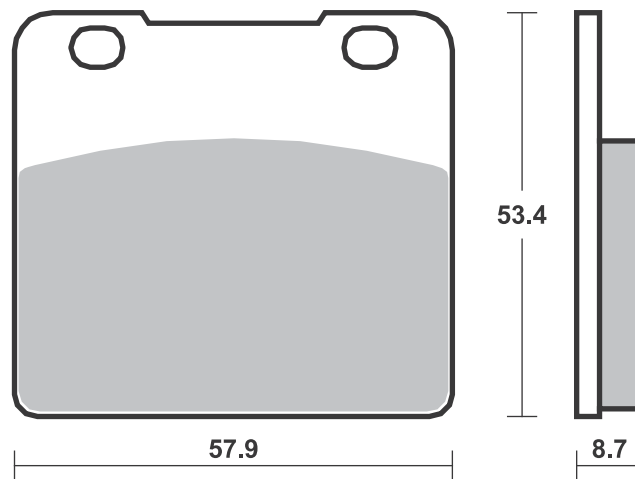
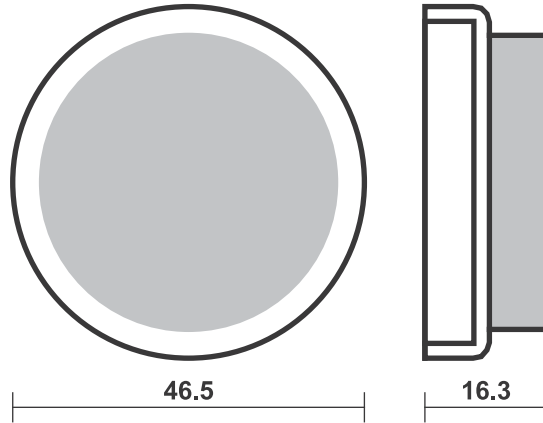

## Applications

### SBS 579 Recommended compound



| HARLEY DAVIDSON |                 |       |             |
|-----------------|-----------------|-------|-------------|
| XLH             | 883 Series      | 88-99 | <b>H.HS</b> |
| XLH             | 883 Sportster   | 85-99 | <b>H.HF</b> |
| XLH             | 1100            | 87-88 | <b>H.HS</b> |
| XLH             | 1100 Sportster  | 85-86 | <b>H.HF</b> |
| XLX             | 1100            | 86    | <b>H.HF</b> |
| XLH             | 1200 Sportster  | 90-99 | <b>H.HS</b> |
| FLHS            | 1340 Electra    |       |             |
|                 | Glide           |       |             |
|                 | Sport           | 90    | <b>H.HS</b> |
| FLHT            | 1340 Electra    |       |             |
|                 | Glide           | 85-86 | <b>H.HF</b> |
| FLHT            | 1340 Electra    |       |             |
|                 | Glide           |       |             |
|                 | Classic         | 87-99 | <b>H.HS</b> |
| FLHTC           | 1340 Electra    |       |             |
|                 | Glide           |       |             |
|                 | Classic         | 85-86 | <b>H.HF</b> |
| FLHTC           | 1340 Electra    |       |             |
|                 | Glide           |       |             |
|                 | Classic         | 90-99 | <b>H.HS</b> |
| FLHTC           | 1340 Ultra      |       |             |
|                 | Classic         | 90-99 | <b>H.HS</b> |
| FLST            | 1340 Heritage   |       |             |
|                 | Softail         | 86-87 | <b>H.HF</b> |
| FLST            | 1340 Heritage   |       |             |
|                 | Softail         | 88-99 | <b>H.HS</b> |
| FLSTC           | 1340 Heritage   |       |             |
|                 | Softail Cl.     | 90-99 | <b>H.HS</b> |
| FLSTF           | 1340 Fat Boy    | 90-99 | <b>H.HS</b> |
| FLSTN           | 1340 Heritage   |       |             |
|                 | Softail         |       |             |
|                 | Nost.           | 93-99 | <b>H.HS</b> |
| FLT             | 1340            | 84-85 | <b>H.HF</b> |
| FLT/H           | 1340 Series     | 86-87 | <b>H.HS</b> |
| FLTC            | 1340 Tour Glide |       |             |
|                 | Classic         | 85-86 | <b>H.HF</b> |
| FLTC            | 1340 Tour Glide |       |             |
|                 | Classic         | 90    | <b>H.HS</b> |
| FXDB            | 1340 Dyna       |       |             |
|                 | Glide           |       |             |
|                 | Daytona         | 91-99 | <b>H.HS</b> |
| FXDB            | 1340 Dyna Glide |       |             |
|                 | Sturgis         | 91-99 | <b>H.HF</b> |
| FXDB            | 1340 Sturgis    | 91-99 | <b>H.HS</b> |



| HARLEY DAVIDSON |                 |       |             |
|-----------------|-----------------|-------|-------------|
| FXDL            | 1340 Dyna       |       |             |
|                 | Low             |       |             |
|                 | Rider           | 93-99 | <b>H.HS</b> |
| FXDWG           | 1340 Dyna       |       |             |
|                 | Wide            |       |             |
|                 | Glide           | 93-99 | <b>H.HS</b> |
| FXE             | 1340            | 85-86 | <b>H.HF</b> |
| FXLR            | 1340 Low        |       |             |
|                 | Rider           |       |             |
|                 | Custom          | 87-88 | <b>H.HS</b> |
| FXLR            | 1340 Low        |       |             |
|                 | Rider           |       |             |
|                 | Custom          | 93-99 | <b>H.HS</b> |
| FXR             | 1340            | 87-88 | <b>H.HS</b> |
| FXR             | 1340 Super      |       |             |
|                 | Glide           | 85-86 | <b>H.HF</b> |
| FXR             | 1340 Super      |       |             |
|                 | Glide           | 90-99 | <b>H.HS</b> |
| FXRD            | 1340 Sport      |       |             |
|                 | Glide           |       |             |
|                 | GTE             | 85-86 | <b>H.HF</b> |
| FXRS            | 1340 Low Rider  | 85-86 | <b>H.HF</b> |
| FXRS            | 1340 Low Rider  |       |             |
|                 | Sport           | 87-99 | <b>H.HS</b> |
| FXRS            | 1340 Low Rider  |       |             |
|                 | Sport Ed.       | 90-99 | <b>H.HS</b> |
| FXRS            | 1340 Low Rider, |       |             |
|                 | Convert.        | 90-99 | <b>H.HS</b> |
| FXRT            | 1340 Sport      |       |             |
|                 | Glide           | 85-86 | <b>H.HF</b> |
| FXRT            | 1340 Sport      |       |             |
|                 | Glide           | 90-99 | <b>H.HS</b> |
| FXST            | 1340 Softail    | 84-86 | <b>H.HF</b> |
| FXSTC           | 1340 Softail    |       |             |
|                 | Custom          | 85-86 | <b>H.HF</b> |
| FXSTC           | 1340 Softail    |       |             |
|                 | Custom          | 88-99 | <b>H.HS</b> |
| FXSTS           | 1340 Springer   |       |             |
|                 | Softail         | 90-99 | <b>H.HS</b> |
| FXWG            | 1340            | 87-88 | <b>H.HS</b> |
| FXWG            | 1340 Wide       |       |             |
|                 | Glide           | 85-86 | <b>H.HF</b> |
| FLSTS/I         | 1450 Heritage   |       |             |
|                 | Springer        | 00-03 | <b>H.HS</b> |



| HARLEY DAVIDSON |               |       |             |
|-----------------|---------------|-------|-------------|
| FLSTSC/I        | 1450 Springer |       |             |
|                 | Softail       |       |             |
|                 | Classic       | 06    | <b>H.HS</b> |
| FLT             | 1450 Series   | 88-99 | <b>H.HS</b> |
| FXSTS/I         | 1450 Softail  | 05-06 | <b>H.HS</b> |
| FXSTS/I         | 1450 Springer |       |             |
|                 | Softail       | 00-04 | <b>H.HS</b> |
| FLSTSC/I        | 1584 Softail  | 07    | <b>H.HS</b> |

### SBS 580 Recommended compound



| YAMAHA |     |       |            |
|--------|-----|-------|------------|
| YZ     | 125 | 85-87 | <b>SI</b>  |
| YZ     | 125 | 88    | <b>RSI</b> |
| IT     | 200 | 86    | <b>HF</b>  |
| NX     | 250 | 88    | <b>HF</b>  |
| TT     | 250 | 87-92 | <b>HF</b>  |
| YZ     | 250 | 85-87 | <b>SI</b>  |
| YZ     | 250 | 88    | <b>RSI</b> |
| TT     | 350 | 86-87 | <b>SI</b>  |
| YZ     | 490 | 85-89 | <b>SI</b>  |
| TT     | 600 | 90-92 | <b>HF</b>  |

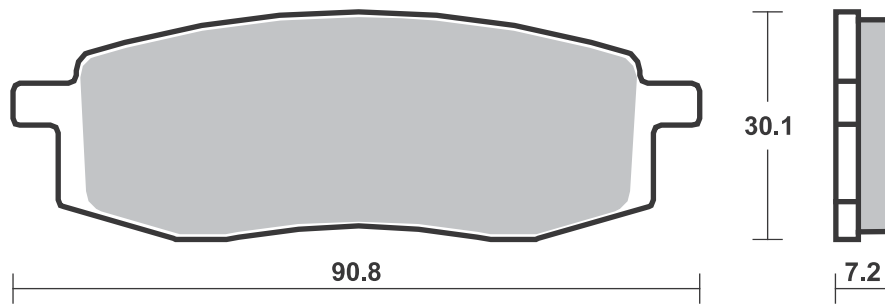
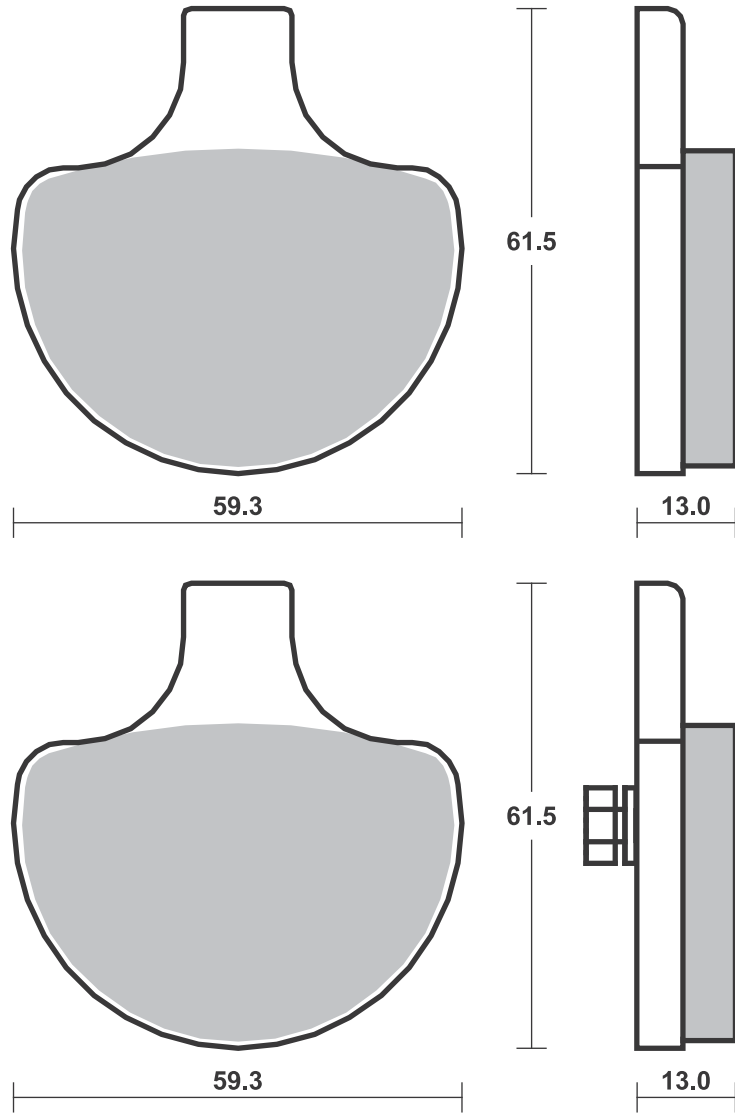

**SBS 581** Recommended compound



| <b>MAICO</b> |               |       |    |    |
|--------------|---------------|-------|----|----|
| GM           | 250 Star      | 86    | HF | HF |
| GP           | 250 E         | 87    | HF | HF |
| GP           | 250 Motocross | 87    | HF | HF |
| GP           | 400 E         | 87-88 | HF | HF |
| GP           | 400 Motocross | 87-88 | HF | HF |
| GM           | 500 Star      | 86    | HF | HF |
| GP           | 500 E         | 87    | HF | HF |
| GP           | 500 Motocross | 87    | HF | HF |
| GP           | 550           | 87    | HF | HF |

| <b>SUZUKI</b> |                     |       |    |  |
|---------------|---------------------|-------|----|--|
| GZ            | 125 Marauder        | 00-11 | HF |  |
| RM            | 125                 | 85-86 | HF |  |
| VL            | 125 Intruder LC     | 00-08 | HF |  |
| GZ            | 250 Marauder        | 00-08 | HF |  |
| RM            | 250                 | 85    | HF |  |
| TU            | 250 X Super Classic | 97-00 | HF |  |



| <b>SUZUKI</b> |              |       |    |  |
|---------------|--------------|-------|----|--|
| VL            | 250 Intruder | 00-07 | HF |  |
| LS            | 400 Savage   | 87-91 | HF |  |
| RM            | 500          | 85-87 | HF |  |
| LS            | 650          | 05    | HF |  |
| LS            | 650 P        | 86-88 | HF |  |
| LS            | 650 P Savage | 95-04 | HF |  |

**SBS 582** Recommended compound



| <b>SUZUKI</b> |             |       |    |  |
|---------------|-------------|-------|----|--|
| RM            | 250         | 86    | HF |  |
| DR            | 500         | 89    | HF |  |
| DR            | 600 Djebel  | 86-88 | HF |  |
| DR            | 600 S Dakar | 85-87 | HF |  |
| SP            | 600 F       | 85-87 | HF |  |

**SBS 583** Recommended compound



| <b>KTM</b> |    |       |    |  |
|------------|----|-------|----|--|
| MX         | 80 | 86-92 | HF |  |

Brake Pad 1:1 Drawings, Compounds, Fitments

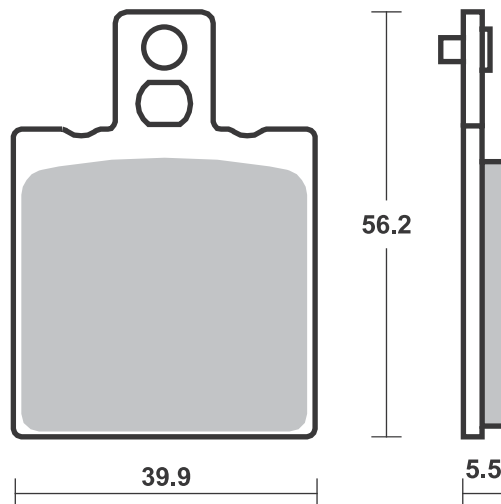
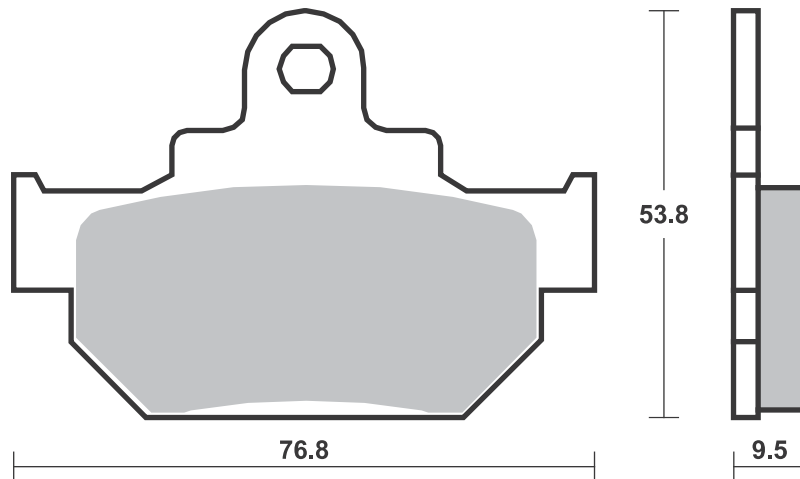
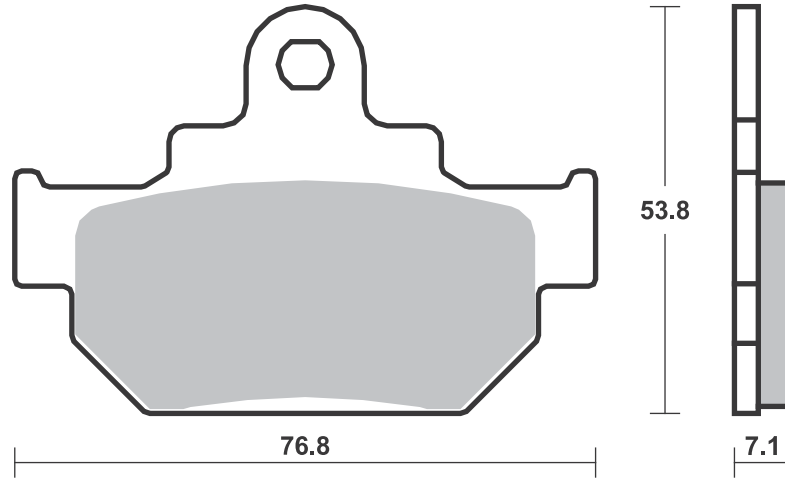



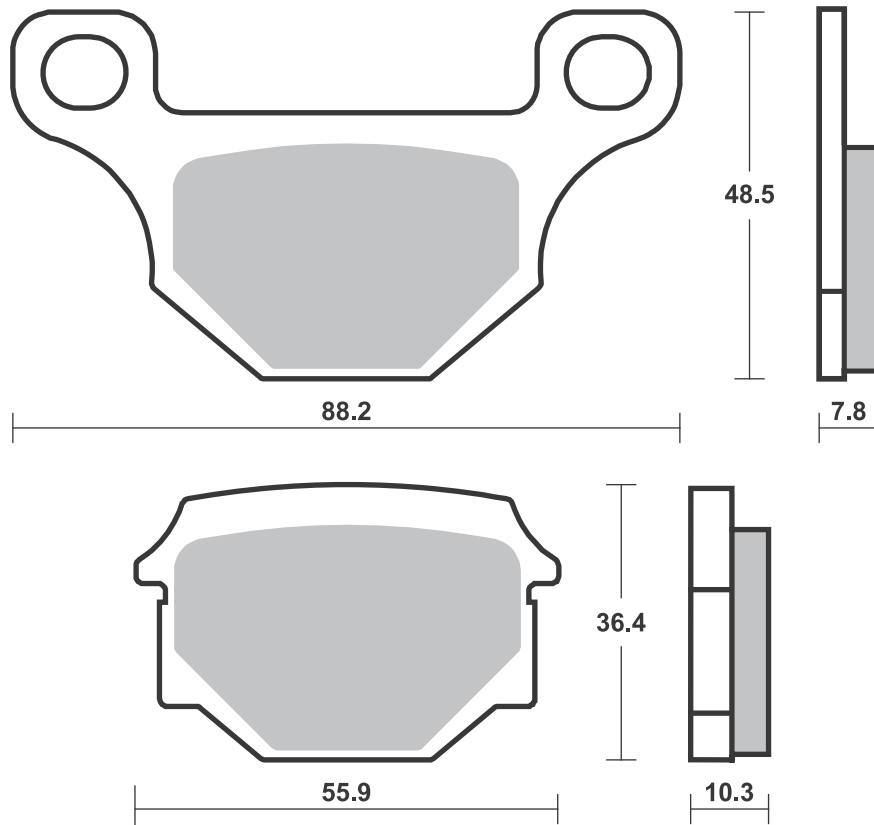
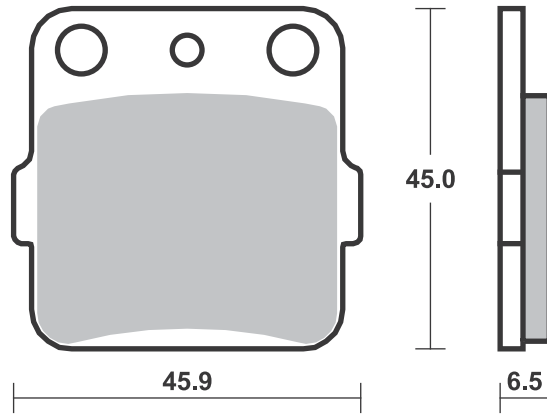

Brake Pad 1:1 Drawings,  
Compounds, Fitments





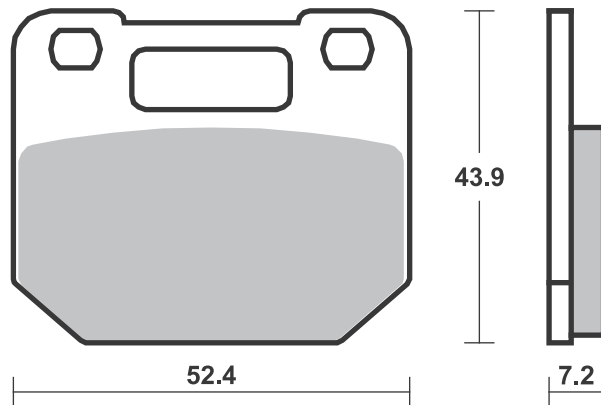
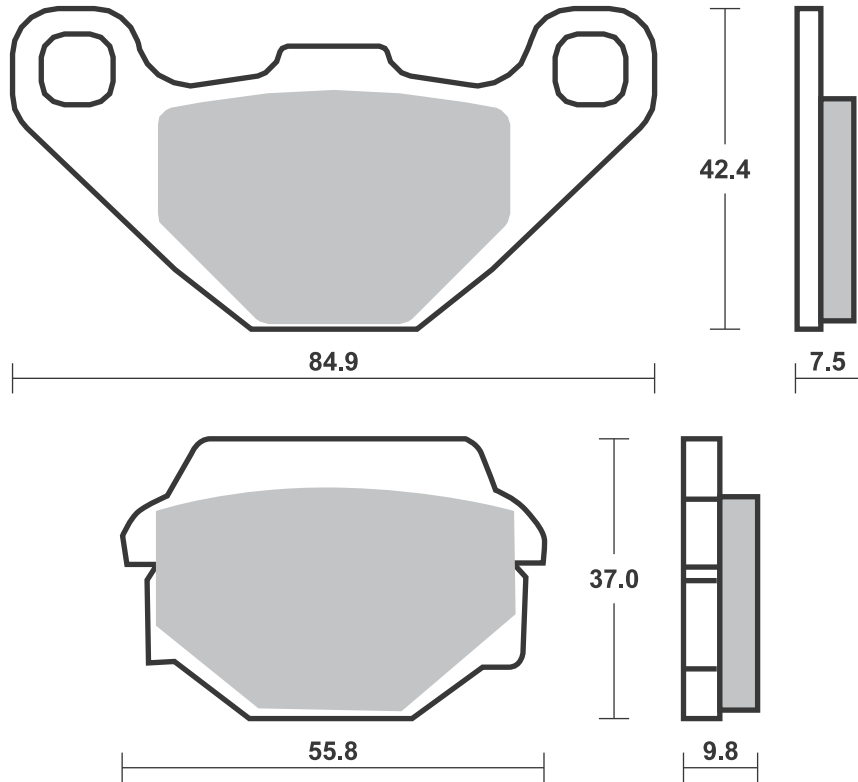

## Applications

### SBS 588 Recommended compound



| <b>APRILIA</b> |                     |       |           |
|----------------|---------------------|-------|-----------|
|                | 125 Red Rose        | 89    | <b>HF</b> |
|                | 125 Tuareg          | 86    | <b>HF</b> |
|                | 125 Tuareg Rally    | 86-93 | <b>HF</b> |
| ETX            | 125                 | 84-86 | <b>HF</b> |
| ETX            | 125 Tuareg          | 86-87 | <b>HF</b> |
| MX             | 125 Cross           | 85    | <b>HF</b> |
|                | 250 Tuareg Rally    | 86    | <b>HF</b> |
|                | 350 Tuareg          | 86    | <b>HF</b> |
|                | 350 Tuareg Wind     | 87    | <b>HF</b> |
| ETX            | 350                 | 85-86 | <b>HF</b> |
|                | 600 Tuareg          | 86-87 | <b>HF</b> |
| ETX            | 600                 | 86-92 | <b>HF</b> |
| NA             | 850 Mana GT,<br>ABS | 09-13 | <b>HF</b> |
| NA             | 850 Mana, ABS       | 08-11 | <b>HF</b> |

| <b>CAGIVA</b> |              |       |           |
|---------------|--------------|-------|-----------|
|               | 125 Blues    | 87-85 | <b>HF</b> |
|               | 125 Roadster | 94-97 | <b>HF</b> |
|               | 200 Roadster | 96-01 | <b>HF</b> |

| <b>FANTIC</b> |            |    |           |
|---------------|------------|----|-----------|
|               | 250 Raider | 85 | <b>HF</b> |

| <b>GARELLI</b> |               |    |           |
|----------------|---------------|----|-----------|
|                | 125 Tiger XLE | 86 | <b>HF</b> |

| <b>GILERA</b> |                |       |           |
|---------------|----------------|-------|-----------|
|               | 125 Fast Bike  | 88-89 | <b>HF</b> |
|               | 125 KK, KR, KZ | 86-91 | <b>HF</b> |
|               | 125 R1, R1S    | 90-92 | <b>HF</b> |
| ER            | 125 Rally      | 87    | <b>HF</b> |
| MXR           | 125            | 90    | <b>HF</b> |
| RRT           | 125 Nebraska   | 87    | <b>HF</b> |
| RTX           | 125            | 86    | <b>HF</b> |



| <b>GILERA</b> |                   |    |           |
|---------------|-------------------|----|-----------|
| RX            | 125 Arizona       |    |           |
|               | Hawk              | 85 | <b>HF</b> |
| X1            | 125               | 89 | <b>HF</b> |
| XR2           | 125               | 90 | <b>HF</b> |
|               | 200 Arizona       |    |           |
|               | Hawk              | 85 | <b>HF</b> |
|               | 200 ER            | 87 | <b>HF</b> |
|               | 200 Fast Bike     | 87 | <b>HF</b> |
|               | 250 Arizona Rally | 08 | <b>HF</b> |
|               | 350 Dakota        | 85 | <b>HF</b> |
| XRT           | 350               | 90 | <b>HF</b> |
|               | 500 Dakota        | 86 | <b>HF</b> |
| RC            | 600               | 88 | <b>HF</b> |
| XRT           | 600               | 89 | <b>HF</b> |

| <b>HONDA</b> |                     |       |           |
|--------------|---------------------|-------|-----------|
| CA           | 125 Rebel           | 97-00 | <b>HF</b> |
| CLR          | 125 Cityfly         | 99-03 | <b>HF</b> |
| CRM          | 125 , R             | 90-98 | <b>HF</b> |
| MTX          | 125 Camel, Italy    | 88-98 | <b>HF</b> |
| MTX          | 125 R, Italy        | 86    | <b>HF</b> |
| NS           | 125 Italy           | 85-88 | <b>HF</b> |
| NSR          | 125 F, R            | 90-92 | <b>HF</b> |
| NSR          | 125 R, Italy        | 89-01 | <b>HF</b> |
| NX           | 125 , Transcity     | 90-98 | <b>HF</b> |
| RTV          | 125 NRS, Italy      | 87    | <b>HF</b> |
| XL           | 125 R, P.D., Italy  | 85    | <b>HF</b> |
| XL           | 125 R, P.D., Italy, |       |           |
|              | EX                  | 87    | <b>HF</b> |
| XL           | 200 R, P.D., Italy  | 85    | <b>HF</b> |

| <b>MOTO-GUZZI</b> |           |       |           |
|-------------------|-----------|-------|-----------|
| V7                | 750 Racer | 12-14 | <b>HF</b> |
| V7                | 750 Stone | 12-14 | <b>HF</b> |
| V7 II             | 750 Racer | 15-16 | <b>HF</b> |



| <b>MOTO-GUZZI</b> |                  |       |           |
|-------------------|------------------|-------|-----------|
| V7 II             | 750 Scrambler    | 16    | <b>HF</b> |
| V7 II             | 750 Special      | 15-16 | <b>HF</b> |
| V7 II             | 750 Stone        | 15-16 | <b>HF</b> |
| V7 II             | 750 Stornello    | 16    | <b>HF</b> |
| V7 II             | 750 Stornello    |       |           |
|                   | Ltd. Edition     | 17-18 | <b>HF</b> |
| V7 III            | 750 Anniversario | 17-18 | <b>HF</b> |
| V7 III            | 750 Carbon       | 18-   | <b>HF</b> |
| V7 III            | 750 Euro 4       | 17-18 | <b>HF</b> |
| V7 III            | 750 Milano       | 18-   | <b>HF</b> |
| V7 III            | 750 Racer        | 17-18 | <b>HF</b> |
| V7 III            | 750 Rough        | 18-   | <b>HF</b> |
| V7 III            | 750 Special      | 17-18 | <b>HF</b> |
| V7 III            | 750 Stone        | 17-18 | <b>HF</b> |
| V9                | 850 Bobber       | 16-17 | <b>HF</b> |
| V9                | 850 Roamer       | 16-17 | <b>HF</b> |
| V9                | 850 X-Track      | 17    | <b>HF</b> |

| <b>MOTO-MORINI</b> |               |       |           |
|--------------------|---------------|-------|-----------|
|                    | 350 Excalibur | 87-89 | <b>HF</b> |
|                    | 350 Kanguro   | 88    | <b>HF</b> |
|                    | 501 Camel     | 88    | <b>HF</b> |
|                    | 501 Excalibur | 87    | <b>HF</b> |

| <b>SACHS</b> |                 |       |           |
|--------------|-----------------|-------|-----------|
|              | 125 Roadster V2 | 01    | <b>HF</b> |
| ZX           | 125             | 99-02 | <b>HF</b> |
| ZZ           | 125             | 99-02 | <b>HF</b> |

| <b>SIMSON</b> |        |    |           |
|---------------|--------|----|-----------|
|               | 125    | 01 | <b>HF</b> |
|               | 125 RS | 01 | <b>HF</b> |

### SBS 589 Recommended compound



| <b>YAMAHA</b> |         |       |            |
|---------------|---------|-------|------------|
| YZ            | 80      | 86-92 | <b>SI</b>  |
| YZ            | 80      | 93-01 | <b>RSI</b> |
| YZ            | 85 , LW | 02-18 | <b>RSI</b> |
| TT-R          | 125 LW  | 00-18 | <b>SI</b>  |

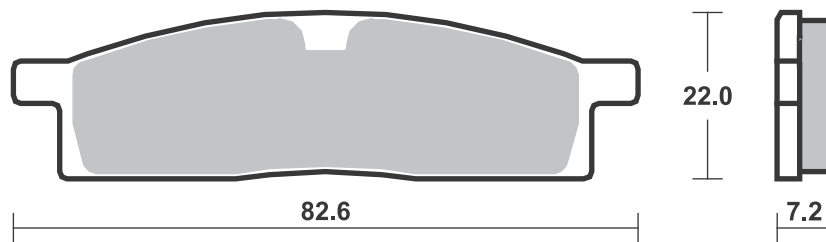
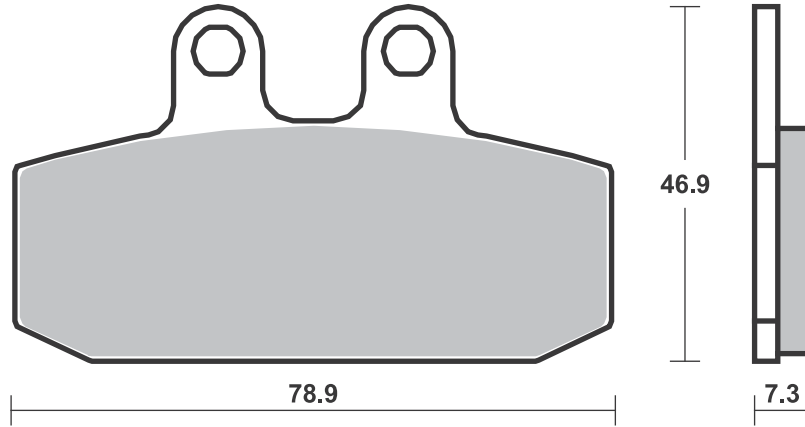



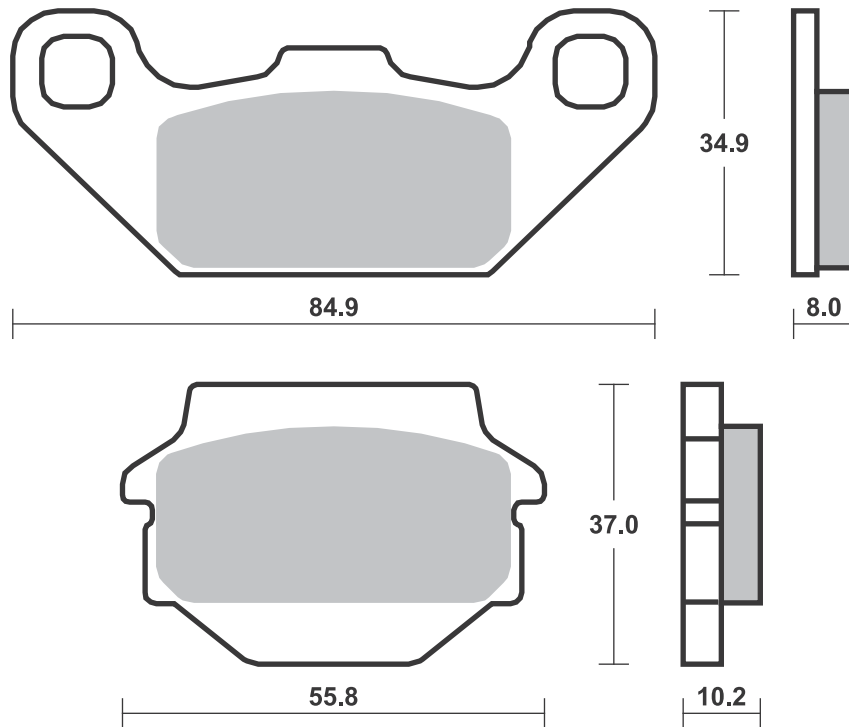
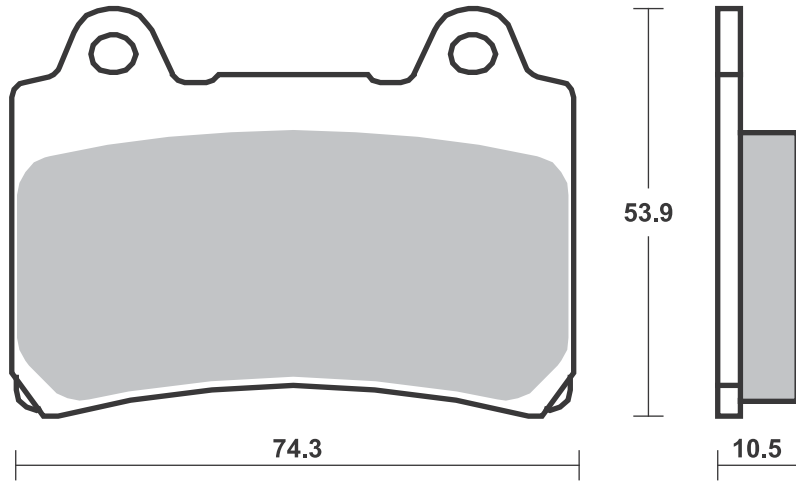

**SBS 592** Recommended compound

| <b>ARCTIC CAT</b>        |       |            |            |
|--------------------------|-------|------------|------------|
| 400 DVX                  | 04-08 | <b>SI</b>  |            |
| <b>HONDA</b>             |       |            |            |
| CR 85 R, R Expert        | 03-12 | <b>RSI</b> |            |
| CRF 150 R                | 07-18 | <b>RSI</b> |            |
| ATC 200 X                | 83-85 | <b>SI</b>  |            |
| TRX 250 EX Sportrax      | 01-08 | <b>SI</b>  |            |
| TRX 250 X                | 08-13 | <b>SI</b>  |            |
| TRX 300 EX Sportrax      | 01-08 | <b>SI</b>  | <b>SI</b>  |
| TRX 300 X                | 09    | <b>SI</b>  | <b>SI</b>  |
| TRX 400 EX Sportrax      | 01-08 | <b>SI</b>  | <b>SI</b>  |
| TRX 400 Fourtrax EX      | 99-00 | <b>SI</b>  | <b>SI</b>  |
| TRX 400 X                | 09-12 | <b>SI</b>  | <b>SI</b>  |
| TRX 420 FA / FPA         | 09-13 | <b>SI</b>  |            |
| TRX 420 FPE / FPM<br>4x4 | 09-14 | <b>SI</b>  |            |
| TRX 450 EX Sportrax      | 01-05 | <b>SI</b>  | <b>SI</b>  |
| <b>KAWASAKI</b>          |       |            |            |
| KX 80                    | 88-00 |            | <b>RSI</b> |
| KX 85                    | 01-18 |            | <b>RSI</b> |
| KX 85 II                 | 01-13 |            | <b>RSI</b> |
| KX 100                   | 88-18 |            | <b>RSI</b> |
| KLX 140 , L              | 08-18 | <b>SI</b>  |            |
| KSF 250 Mojave           | 87-02 | <b>SI</b>  |            |
| KXF 250 Tecate           | 87-88 | <b>SI</b>  |            |
| KXT 250 Tecate           | 87-88 | <b>SI</b>  |            |
| KEF 300 Lakota           | 95-04 | <b>SI</b>  |            |
| KFX 400                  | 02-05 | <b>SI</b>  |            |
| KFX 450 Left/Rear        | 07-15 |            | <b>SI</b>  |



| <b>SUZUKI</b>                |       |           |            |
|------------------------------|-------|-----------|------------|
| RM 100                       | 03    |           | <b>RSI</b> |
| LT 230                       | 86-93 |           | <b>SI</b>  |
| LT 250                       | 89-90 |           | <b>SI</b>  |
| LT-Z 400 Quad Sport          | 02-15 | <b>SI</b> |            |
| RM 500                       | 87-89 |           | <b>RSI</b> |
| DR-Z 800                     | 88-90 |           | <b>LS</b>  |
| <b>TM</b>                    |       |           |            |
| 80 Junior                    | 96-00 |           | <b>RSI</b> |
| <b>YAMAHA</b>                |       |           |            |
| YZ 80                        | 93-01 |           | <b>RSI</b> |
| YZ 85 , LW                   | 02-18 |           | <b>RSI</b> |
| YFS 200 R Blaster            | 03-06 |           | <b>SI</b>  |
| YFM 250 Raptor<br>Left/Rear  | 09-14 |           | <b>SI</b>  |
| YFM 350 FXG-FXM<br>Wolverine | 95-11 |           | <b>SI</b>  |
| YFM 350 R Raptor             | 04-14 | <b>SI</b> | <b>SI</b>  |
| YFM 350 XG,XH<br>Warrior     | 95-96 |           | <b>SI</b>  |
| YFM 350 XT, XU<br>Warrior    | 87-88 |           | <b>SI</b>  |
| YFZ 350 Banshee              | 87-06 |           | <b>SI</b>  |
| YFZ 450 S Left/Rear          | 04-05 |           | <b>SI</b>  |
| YFM 600 4x4 Grizzly          | 98-01 | <b>SI</b> |            |
| YFM 660 FWAP 4x4<br>Grizzly  | 02-08 | <b>SI</b> |            |
| YFM 660 RN Raptor            | 01-09 | <b>SI</b> | <b>SI</b>  |

**SBS 593** Recommended compound

| <b>HONDA</b>               |       |           |           |
|----------------------------|-------|-----------|-----------|
| CBR 250 F                  | 86    |           | <b>HF</b> |
| CBR 250 Hurricane          | 87    |           | <b>HF</b> |
| NSR 250 R                  | 87    |           | <b>HF</b> |
| VT 250 F                   | 88-90 |           | <b>HF</b> |
| VTR 250                    | 90    |           | <b>HS</b> |
| VTZ 250                    | 88-99 |           | <b>HF</b> |
| CB 350 S.G.<br>(U.K. only) | 87-90 |           | <b>HF</b> |
| NX 350                     | 88-99 |           | <b>HF</b> |
| CB 400 N                   | 86    |           | <b>HF</b> |
| CBR 400 F                  | 92-96 |           | <b>HS</b> |
| CBR 400 R                  | 87    |           | <b>HF</b> |
| VFR 400 R                  | 86-87 | <b>HF</b> | <b>HF</b> |
| VFR 400 R                  | 87-88 |           | <b>HS</b> |
| CB 450 S                   | 86-88 |           | <b>HF</b> |
| CBR 500 F (Austria)        | 87-90 |           | <b>HS</b> |
| CBR 600 F Hurricane        | 87-90 |           | <b>HS</b> |
| CBR 600 F, Super<br>Sport  | 91-94 |           | <b>HS</b> |
| NTV 600 Revere             | 88-92 |           | <b>HF</b> |
| XRV 750 Africa Twin        | 90-92 |           | <b>HS</b> |

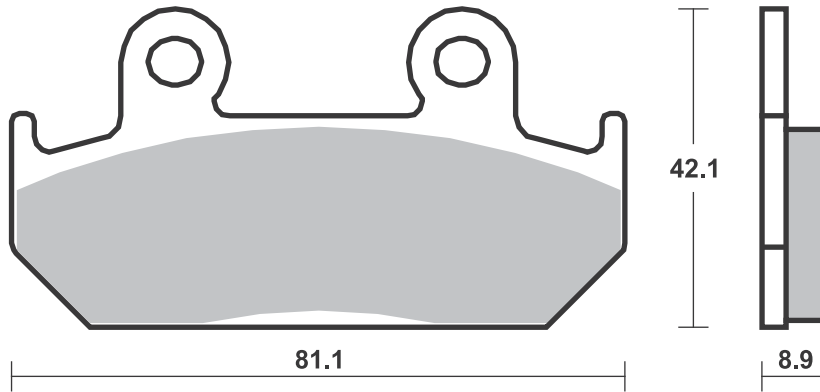
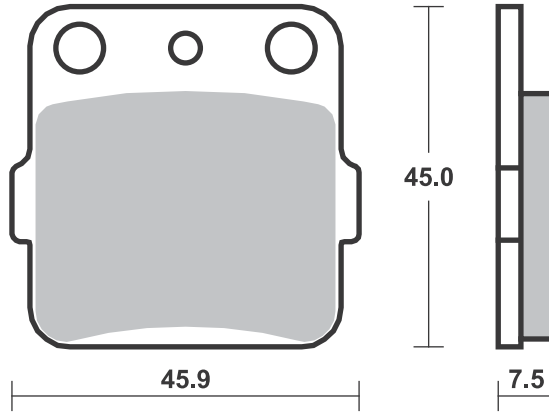

**SBS 594** Recommended compound

| <b>APRILIA</b>     |       |           |           |
|--------------------|-------|-----------|-----------|
| 350 Tuareg Wind    | 88    | <b>HF</b> |           |
| 600 Tuareg Wind    | 88    | <b>HF</b> |           |
| <b>CAGIVA</b>      |       |           |           |
| 125 Cruiser        | 88-89 | <b>HF</b> |           |
| 350 Elefant        | 86-89 | <b>HF</b> |           |
| 650 Elefant        | 86-87 | <b>HF</b> |           |
| 750 Elefant Bifaro | 90    | <b>HF</b> |           |
| 750 Lucky Explorer | 88    | <b>HF</b> |           |
| <b>DUCATI</b>      |       |           |           |
| 350 Indiana        | 86-91 | <b>HF</b> |           |
| 650 Indiana        | 86-89 | <b>HF</b> |           |
| 750 Indiana        | 85-86 | <b>HF</b> |           |
| <b>GILERA</b>      |       |           |           |
| 350 Dakota         | 86-89 | <b>HF</b> |           |
| <b>LAVERDA</b>     |       |           |           |
| OR 600 Atlas       | 86-90 | <b>HF</b> |           |
| <b>MOTO-MORINI</b> |       |           |           |
| 350 Excalibur      | 86    | <b>HF</b> | <b>HF</b> |
| 350 Indiana        | 88    | <b>HF</b> |           |
| 501 Excalibur      | 86-91 | <b>HF</b> | <b>HF</b> |
| 501 Excalibur      | 89    | <b>HF</b> |           |
| 501 New York       | 89    | <b>HF</b> |           |
| 650 Indiana        | 88    | <b>HF</b> |           |
| 750 Indiana        | 88    | <b>HF</b> |           |

**SBS 595** Recommended compound

| <b>BENELLI</b>         |       |           |           |
|------------------------|-------|-----------|-----------|
| 50 Devil               | 92    | <b>HF</b> |           |
| 50 Spring              | 92    | <b>HF</b> |           |
| <b>BETA</b>            |       |           |           |
| AE 50 Four Twin        | 88    | <b>HF</b> |           |
| ALP 50                 | 91-00 | <b>HF</b> |           |
| RV 50                  | 88    | <b>HF</b> |           |
| VRS 50                 | 86    | <b>HF</b> |           |
| ALP 125                | 90    | <b>HF</b> |           |
| TR 125 32,33           | 86-87 | <b>HF</b> |           |
| TR 125 34              | 88    | <b>HF</b> |           |
| TR 240 33              | 86-88 | <b>HF</b> |           |
| 260 Synt               | 92    | <b>HF</b> |           |
| TR 260 34              | 86-88 | <b>HF</b> |           |
| <b>FANTIC</b>          |       |           |           |
| 50 Trial               | 83    | <b>HF</b> |           |
| 125 Trial              | 78-84 | <b>HF</b> |           |
| 125 Trial Professional | 87    | <b>HF</b> | <b>HF</b> |
| 125 Trial Progress 1   | 87    | <b>HF</b> |           |
| HP1 125 Strada         | 85    | <b>HF</b> |           |
| 201 Trial              | 85-91 | <b>HF</b> |           |
| 201 Trial Progress 2   | 87    | <b>HF</b> |           |
| 241 Trial Progress 2   | 87    | <b>HF</b> | <b>HF</b> |
| 243 Trial              | 87-90 | <b>HF</b> | <b>HF</b> |
| 301 Trial              | 85-91 | <b>HF</b> |           |



| <b>FANTIC</b>          |       |           |           |
|------------------------|-------|-----------|-----------|
| 301 Trial Progress 2   | 87    | <b>HF</b> |           |
| 303 Trial Professional | 87    | <b>HF</b> | <b>HF</b> |
| 343 Trial Progress 2   | 87    | <b>HF</b> | <b>HF</b> |
| <b>GARELLI</b>         |       |           |           |
| 323 Trial              | 86    | <b>HF</b> |           |
| <b>GILERA</b>          |       |           |           |
| 50 Bullit              | 90-97 | <b>HF</b> |           |
| <b>JCM</b>             |       |           |           |
| 125 Oxygene            | 89    | <b>HF</b> |           |
| 125 Week-End           | 89    | <b>HF</b> |           |
| 233 Vega               | 88    | <b>HF</b> |           |
| 240 Enduro             | 91    | <b>HF</b> |           |
| 240 Oxygene            | 89    | <b>HF</b> |           |
| 240 Week-End           | 89    | <b>HF</b> |           |
| 250 Trial              | 87    | <b>HF</b> |           |
| 250 Week-End           | 91    | <b>HF</b> |           |
| 325 Oxygene            | 89    | <b>HF</b> |           |
| 325 Week-End           | 89    | <b>HF</b> |           |
| 333 Vega               | 87-88 | <b>HF</b> |           |
| <b>MALAGUTI</b>        |       |           |           |
| 50 Fifty Full, CX, Top | 85    | <b>HF</b> |           |
| 50 Fifty Mistral       | 90-95 | <b>HF</b> |           |
| CH 50                  | 86    | <b>HF</b> |           |



| <b>MALAGUTI</b> |       |           |  |
|-----------------|-------|-----------|--|
| MGX 450 Ronco   | 87-11 | <b>HF</b> |  |
| <b>MONTESA</b>  |       |           |  |
| H7 360 Enduro   | 86    | <b>HF</b> |  |
| <b>RIEJU</b>    |       |           |  |
| 50 Drag         | 92    | <b>HF</b> |  |
| RS1 50          | 92-05 | <b>HF</b> |  |
| <b>TOMOS</b>    |       |           |  |
| BT 50 S         | 89    | <b>HF</b> |  |
| N 50 AT, BT     | 91-95 | <b>HF</b> |  |
| CTX 80          | 89    | <b>HF</b> |  |



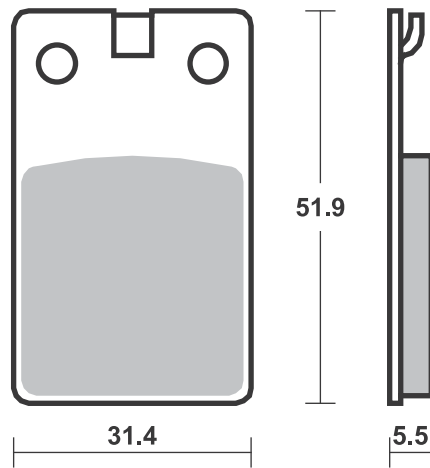
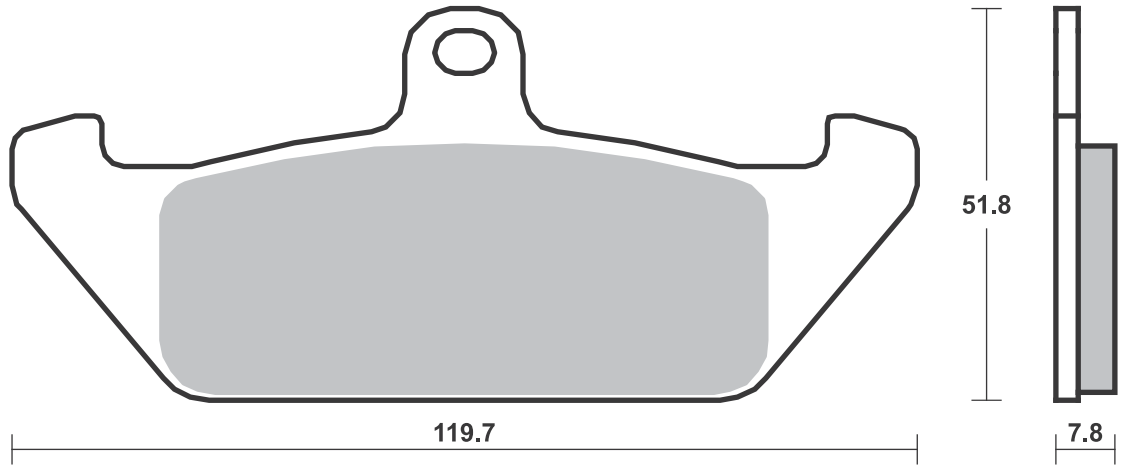

**SBS 596** Recommended compound**MALAGUTI**

|     |                |    |           |
|-----|----------------|----|-----------|
| MDX | 50 Gold Enduro | 87 | <b>HF</b> |
| MLX | 50 Enduro      | 87 | <b>HF</b> |

**MOTO-GUZZI**

|     |     |       |           |
|-----|-----|-------|-----------|
| NTX | 750 | 90-93 | <b>HS</b> |
|-----|-----|-------|-----------|

**YAMAHA**

|    |               |       |           |
|----|---------------|-------|-----------|
| RT | 180           | 90-93 | <b>HF</b> |
| TT | 600           | 89    | <b>HF</b> |
| XT | 600 Z         | 86-88 | <b>HF</b> |
| XT | 600 Z, Tenere | 87-90 | <b>HF</b> |

**SBS 597** Recommended compound**HYOSUNG**

|    |           |    |           |
|----|-----------|----|-----------|
| GT | 250 Comet | 02 | <b>HS</b> |
|    | 600 Comet | 02 | <b>HS</b> |

**KAWASAKI**

|      |                   |       |           |
|------|-------------------|-------|-----------|
| EX   | 250 R Ninja       | 88-07 | <b>HF</b> |
| GPX  | 250 R             | 88-91 | <b>HF</b> |
| ZR   | 250 Balius        | 91-95 | <b>HF</b> |
| ZZR  | 250               | 90-01 | <b>HS</b> |
|      | 400 Eliminator    | 94-95 | <b>HS</b> |
| EX-4 | 400               | 95    | <b>HF</b> |
| GPX  | 400               | 87    | <b>HF</b> |
| GPZ  | 400 R             | 89    | <b>LS</b> |
| GPZ  | 400 S             | 88-90 | <b>HF</b> |
| KLE  | 400               | 91-94 | <b>HS</b> |
| ZZR  | 400               | 90-94 | <b>LS</b> |
| ER-5 | 500               | 97-00 | <b>HS</b> |
| EX   | 500               | 87-89 | <b>HF</b> |
| EX   | 500               | 90-93 | <b>HS</b> |
| EX   | 500 Ninja         | 94-97 | <b>HS</b> |
| GPX  | 500 R (Austria)   | 88-93 | <b>HF</b> |
| GPZ  | 500 S (Austria)   | 87-93 | <b>HF</b> |
| KL   | 500 Tengai        |       |           |
|      | (Austria)         | 89-91 | <b>HS</b> |
| KLE  | 500               | 91-07 | <b>HS</b> |
| ZZR  | 500 (Austria)     | 90-92 | <b>LS</b> |
| ZR   | 550 Zephyr        | 90-99 | <b>HS</b> |
| GPX  | 600 R             | 88-93 | <b>HF</b> |
| GPX  | 600 R             | 94-96 | <b>HS</b> |
| GPZ  | 600 R             | 94    | <b>HS</b> |
| ZL   | 600 B2 Eliminator | 95-98 | <b>HS</b> |
| ZX   | 600 Ninja R       | 88-97 | <b>HS</b> |

**KAWASAKI**

|       |             |       |           |
|-------|-------------|-------|-----------|
| ZX-6R | 600 (ZX6)   | 90-93 | <b>LS</b> |
| ZZR   | 600         | 90-92 | <b>LS</b> |
| KLR   | 650 Tengai  | 89-92 | <b>HS</b> |
| GPX   | 750 R       | 87-89 | <b>HF</b> |
| ZR    | 750 Zephyr  | 91-95 | <b>HS</b> |
| ZR    | 750 Zephyr  |       |           |
|       | Left/Rear   | 96-97 | <b>LS</b> |
| GPZ   | 900 R       | 90-96 | <b>LS</b> |
| GTR   | 1000        | 94-06 | <b>HS</b> |
| ZX-10 | 1000        | 88-90 | <b>HS</b> |
|       | 1100 Zephyr |       |           |
|       | Left/Rear   | 97-02 | <b>LS</b> |
| ZR    | 1100 Zephyr | 92-95 | <b>LS</b> |
| ZZR   | 1100        | 90-93 | <b>LS</b> |

**SUZUKI**

|     |               |       |           |
|-----|---------------|-------|-----------|
| RG  | 125 Wolf      | 92-94 | <b>HF</b> |
|     | 200 Wolf      | 92-96 | <b>HF</b> |
|     | 250 Across    | 90-99 | <b>HF</b> |
|     | 250 Bandit    | 90-96 | <b>HS</b> |
|     | 250 Djebel    | 93-95 | <b>HF</b> |
| GSX | 250 S, Katana | 91    | <b>HS</b> |
| SW1 | 250           | 92-95 | <b>HS</b> |
| GSF | 400 Bandit    | 91-92 | <b>HS</b> |
| GS  | 450           | 90    | <b>HS</b> |
| GS  | 500           | 89-95 | <b>HS</b> |
| DR  | 800 S, Big    | 91-95 | <b>HS</b> |
| VX  | 800 L-P       | 90-93 | <b>HS</b> |
| GSX | 1100          | 91-93 | <b>HS</b> |
| GSX | 1100 G        | 94-95 | <b>HS</b> |

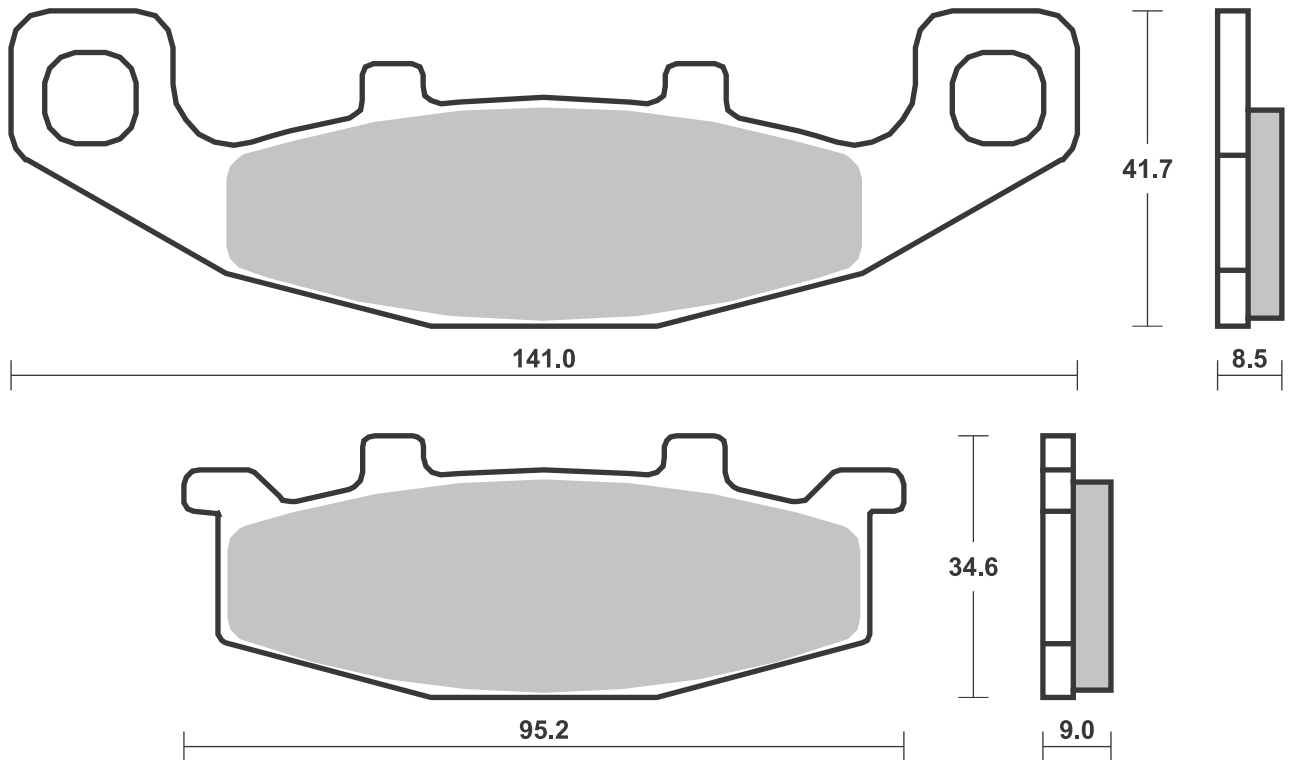
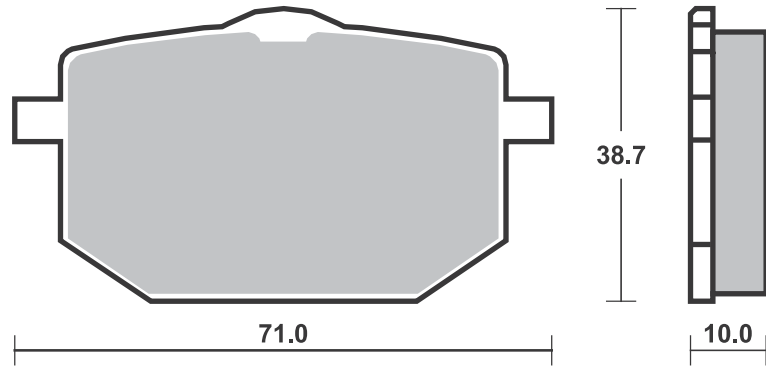

**SBS 598 Recommended compound**



| <b>HONDA</b>      |        |       |           |
|-------------------|--------|-------|-----------|
| CB                | 450 DX | 89-92 | <b>HF</b> |
| CB                | 450 N  | 86-89 | <b>HF</b> |
| <b>MOTO-GUZZI</b> |        |       |           |
| V65               | 650 GT | 90-94 | <b>HF</b> |
|                   |        |       |           |
|                   |        |       |           |
|                   |        |       |           |
|                   |        |       |           |
|                   |        |       |           |
|                   |        |       |           |
|                   |        |       |           |
|                   |        |       |           |
|                   |        |       |           |
|                   |        |       |           |
|                   |        |       |           |
|                   |        |       |           |
|                   |        |       |           |
|                   |        |       |           |
|                   |        |       |           |
|                   |        |       |           |
|                   |        |       |           |
|                   |        |       |           |
|                   |        |       |           |

**SBS 599 Recommended compound**



| <b>A.P. RACING CALIPERS</b> |  |  |  |
|-----------------------------|--|--|--|
| CP-3369-2E0/3E0             |  |  |  |
| CP-3385-2E0/3E0             |  |  |  |
| CP-3386-2E0/3E0             |  |  |  |
| CP-3569-2S0/3S0             |  |  |  |
| CP-3769-2S0/3S0             |  |  |  |
|                             |  |  |  |
|                             |  |  |  |
|                             |  |  |  |
|                             |  |  |  |
|                             |  |  |  |
|                             |  |  |  |
|                             |  |  |  |
|                             |  |  |  |
|                             |  |  |  |
|                             |  |  |  |
|                             |  |  |  |
|                             |  |  |  |
|                             |  |  |  |
|                             |  |  |  |
|                             |  |  |  |
|                             |  |  |  |
|                             |  |  |  |
|                             |  |  |  |
|                             |  |  |  |

**SBS 600 Recommended compound**



| <b>HONDA</b> |               |       |           |
|--------------|---------------|-------|-----------|
| CB           | 250           | 88-98 | <b>HF</b> |
| CD           | 250 UJ        | 88-92 | <b>HF</b> |
| NV           | 400 Steed     | 88    | <b>HF</b> |
| NX           | 500 Dominator |       |           |
|              | (Austria)     | 93-96 | <b>HS</b> |
|              | 600 Steed     | 88-91 | <b>HS</b> |
| NV           | 600 C         | 88-96 | <b>HF</b> |
| NX           | 650 Dominator | 93-96 | <b>HS</b> |
| VFR          | 700 F, F2     | 86-87 | <b>HS</b> |
| CBR          | 750 Hurricane | 87-00 | <b>HS</b> |
| VFR          | 750 F         | 86-87 | <b>HS</b> |
| CBR          | 1000 F        | 87-88 | <b>HS</b> |
|              |               |       |           |
|              |               |       |           |
|              |               |       |           |
|              |               |       |           |
|              |               |       |           |
|              |               |       |           |
|              |               |       |           |
|              |               |       |           |
|              |               |       |           |
|              |               |       |           |
|              |               |       |           |
|              |               |       |           |
|              |               |       |           |
|              |               |       |           |
|              |               |       |           |
|              |               |       |           |
|              |               |       |           |
|              |               |       |           |
|              |               |       |           |
|              |               |       |           |

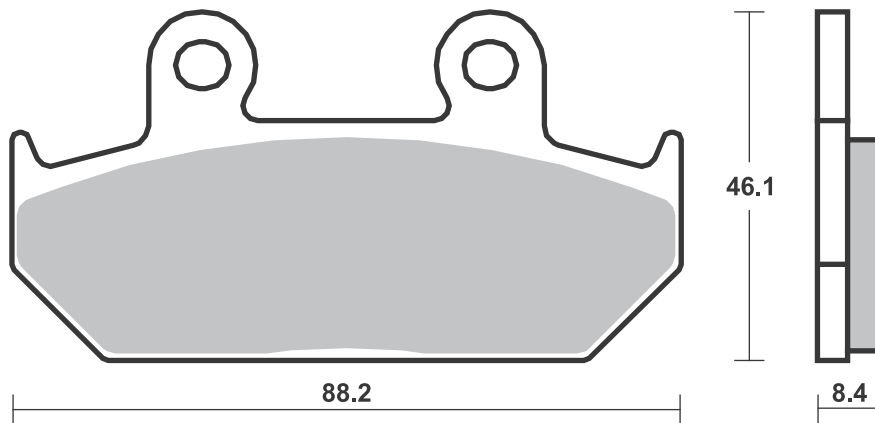
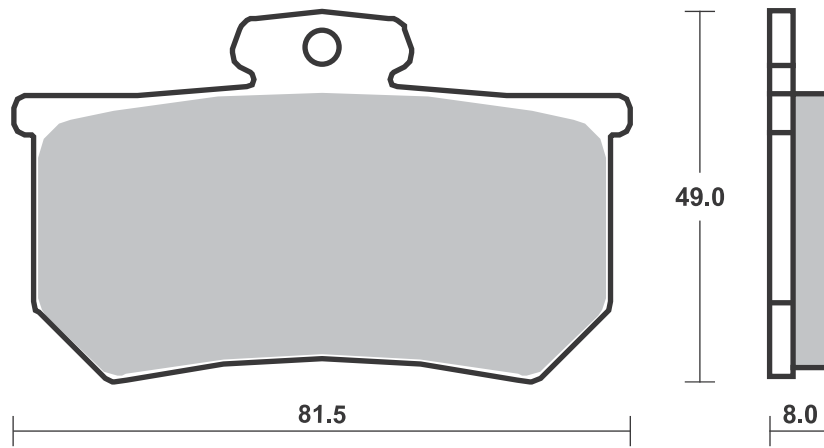
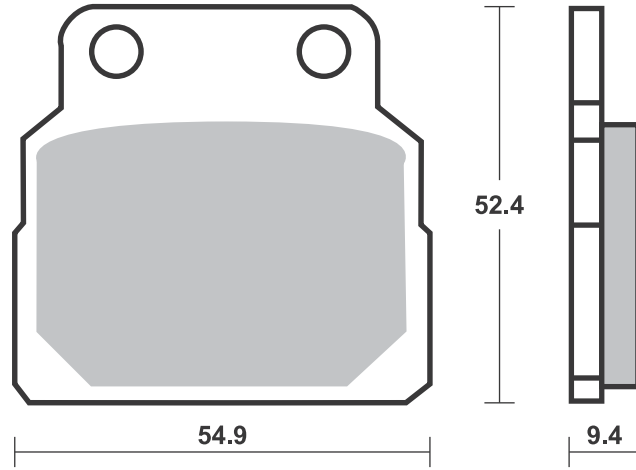



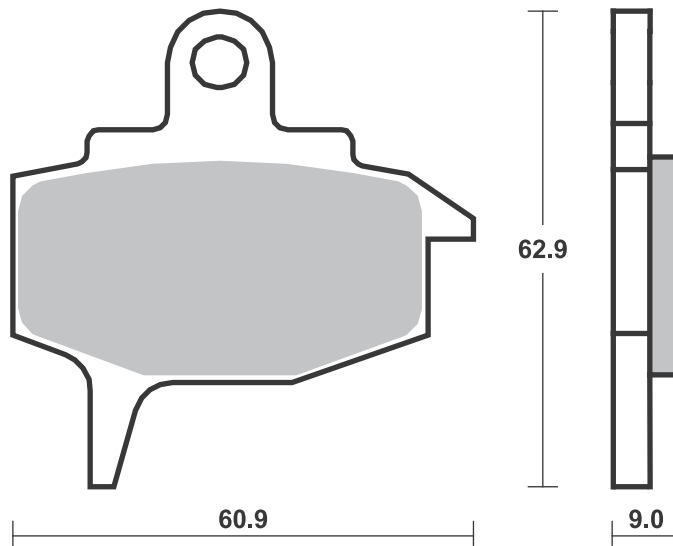
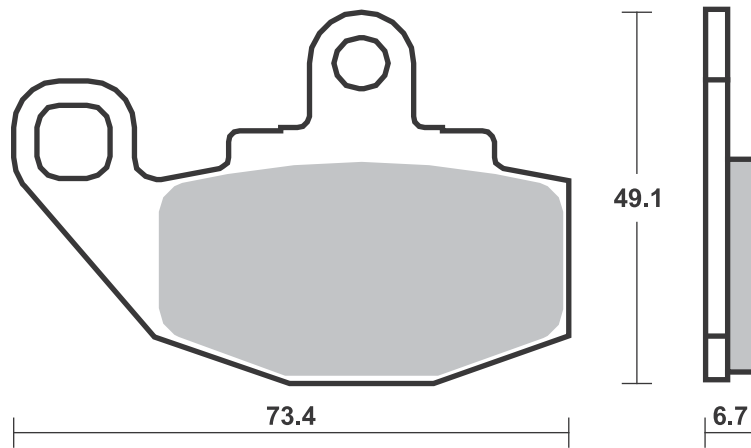
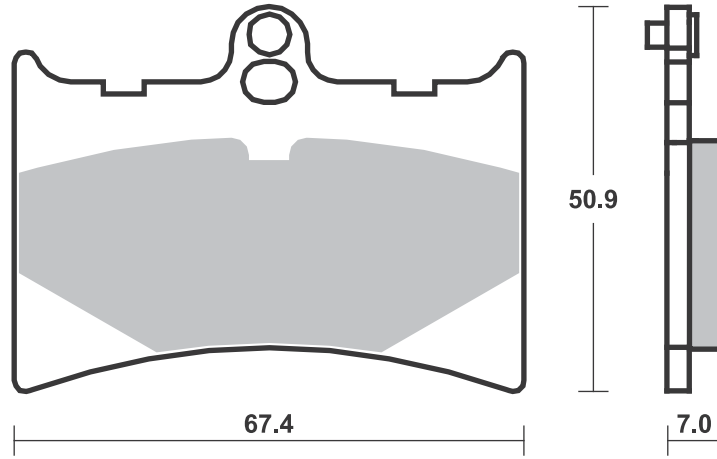

**SBS 603** Recommended compound

| <b>HONDA</b> |                |       |            |
|--------------|----------------|-------|------------|
| CRM          | 75 R           | 90-94 | <b>HF</b>  |
| CR           | 125 RH, RJ, RK | 87-94 | <b>RSI</b> |
| AX-1         | 250            | 90    | <b>HF</b>  |
| CR           | 250 R          | 87-94 | <b>RSI</b> |
| CRM          | 250 R          | 90    | <b>HF</b>  |
| NX           | 250            | 88-90 | <b>HF</b>  |
| TRX          | 250 R          | 86-89 | <b>SI</b>  |
| TRX          | 250 X Fourtrax | 87    | <b>SI</b>  |
| XL           | 250 Degree     | 91    | <b>HF</b>  |
| XLR          | 250 R Baja     | 88-90 | <b>SI</b>  |
| XR           | 250 L          | 91-92 | <b>HF</b>  |
| XR           | 250 R          | 88-95 | <b>SI</b>  |
| ATC          | 350 X          | 86-89 | <b>SI</b>  |
| CR           | 500 R          | 87-94 | <b>RSI</b> |
| XR           | 600 R          | 88-92 | <b>SI</b>  |
|              |                |       |            |
|              |                |       |            |
|              |                |       |            |
|              |                |       |            |
|              |                |       |            |
|              |                |       |            |
|              |                |       |            |
|              |                |       |            |

**SBS 604** Recommended compound

| <b>AJP</b>            |                    |       |            |
|-----------------------|--------------------|-------|------------|
| PR5                   | 250 Enduro         | 09    | <b>SI</b>  |
| PR5                   | 250 Supermotard    | 09    | <b>SI</b>  |
| PR7                   | 650 Adventure      | 17    | <b>HF</b>  |
| <b>BIMOTA</b>         |                    |       |            |
| BBX                   | 508 Enduro         | 12    | <b>SI</b>  |
| <b>BRAKING</b>        |                    |       |            |
| Rear cross (2 piston) |                    |       |            |
| <b>CPI</b>            |                    |       |            |
|                       | 125 Sahel          | 02    | <b>HF</b>  |
| <b>FANTIC</b>         |                    |       |            |
|                       | 50 Regolarna       |       |            |
|                       | Competizione 08-09 |       | <b>HF</b>  |
| MX                    | 50 Regolarna       |       |            |
|                       | Competizione 08    |       | <b>RSI</b> |
| MX                    | 65 Regolarna       |       |            |
|                       | Competizione 08    |       | <b>RSI</b> |
|                       | 80 Regolarna       |       |            |
|                       | Competizione 08    |       | <b>HF</b>  |
| MX                    | 85 Regolarna       |       |            |
|                       | Competizione 08    |       | <b>RSI</b> |
|                       | 125 Regolarna      |       |            |
|                       | Competizione 08    |       | <b>HF</b>  |
| <b>GAS GAS</b>        |                    |       |            |
| EC                    | 125                | 00-06 | <b>SI</b>  |
| MC                    | 125                | 03-13 | <b>RSI</b> |
| SM                    | 125                | 02-13 | <b>HF</b>  |
| EC                    | 200                | 00-09 | <b>SI</b>  |
| EC                    | 200 Hobby          | 07-16 | <b>SI</b>  |
| EC                    | 250                | 00-11 | <b>SI</b>  |
| EC                    | 250 fse            | 02-11 | <b>SI</b>  |
| MC                    | 250                | 00-13 | <b>SI</b>  |
| SM                    | 250                | 02-13 | <b>HF</b>  |
| EC                    | 300                | 00-11 | <b>SI</b>  |
|                       | 400 Pampera        | 06-09 | <b>SI</b>  |



| <b>GAS GAS</b> |                 |       |            |
|----------------|-----------------|-------|------------|
| EC             | 400 fse         | 02    | <b>SI</b>  |
| SM             | 400 fse         | 02    | <b>HF</b>  |
| EC             | 450 fse         | 03-15 | <b>SI</b>  |
| EC             | 450 FSR         | 07-16 | <b>SI</b>  |
| SM             | 450 fse         | 03-06 | <b>HF</b>  |
| SM             | 450 FSR         | 07-13 | <b>HF</b>  |
| EC             | 515 fsr         | 08-16 | <b>SI</b>  |
| <b>HM</b>      |                 |       |            |
| CRE            | 50              | 06-13 | <b>HF</b>  |
|                | 125 Supermotard | 00-02 | <b>HF</b>  |
| CRE            | 125 Enduro      | 95-01 | <b>SI</b>  |
| CRE            | 125 Supermotard | 03    | <b>HF</b>  |
|                | 250 Supermotard | 00-02 | <b>HF</b>  |
| CRE            | 250 Enduro      | 95-01 | <b>SI</b>  |
| CRE            | 250 Supermotard | 03    | <b>HF</b>  |
| <b>HONDA</b>   |                 |       |            |
| CRM            | 75 R            | 90-94 | <b>HF</b>  |
| CR             | 80 R, RB        | 92-02 | <b>RSI</b> |
| CRM            | 80              | 89-92 | <b>HF</b>  |
| CR             | 85 R, R Expert  | 03-12 | <b>RSI</b> |
| NSF            | 100             | 06    | <b>HF</b>  |
| CR             | 125 R           | 95-01 | <b>RSI</b> |
| CR             | 125 RH, RJ, RK  | 87-94 | <b>RSI</b> |
| CRF            | 230 L           | 08-10 | <b>SI</b>  |
| CRF            | 230 M           | 09-12 | <b>SI</b>  |
| SL             | 230             | 97-01 | <b>HF</b>  |
| CR             | 250 R           | 87-01 | <b>RSI</b> |
| XLR            | 250 R SPL       | 94    | <b>SI</b>  |
| XR             | 250 L           | 91-97 | <b>HF</b>  |
| XR             | 250 R           | 90-95 | <b>SI</b>  |
| XR             | 250 S, R        | 96-00 | <b>HF</b>  |
| XR             | 300             | 10-12 | <b>HF</b>  |
| XR             | 400 R           | 96-04 | <b>SI</b>  |
| XR             | 400 Supermotard | 00-03 | <b>RSI</b> |
| XR             | 440 R           | 00-03 | <b>SI</b>  |
| CR             | 500 R           | 87-01 | <b>RSI</b> |
| XR             | 600 R           | 91-00 | <b>SI</b>  |



| <b>HONDA</b>    |                 |       |            |
|-----------------|-----------------|-------|------------|
| XR              | 650 L           | 93-12 | <b>HF</b>  |
| XR              | 650 R           | 00-11 | <b>SI</b>  |
| <b>HYOSUNG</b>  |                 |       |            |
| XRX             | 400             | 05-08 | <b>HF</b>  |
| <b>KAWASAKI</b> |                 |       |            |
| KX              | 125             | 95-08 | <b>RSI</b> |
| KLX             | 250             | 98-07 | <b>SI</b>  |
| KLX             | 250             | 14-16 | <b>HF</b>  |
| KLX             | 250 S           | 09-14 | <b>HF</b>  |
| KLX             | 250 SF          | 09-10 | <b>HF</b>  |
| KX              | 250             | 95-08 | <b>RSI</b> |
| KLX             | 300 R           | 97-07 | <b>SI</b>  |
| KLX             | 400 R           | 03-04 | <b>SI</b>  |
| KLX             | 400 SR          | 03-04 | <b>HF</b>  |
| KX              | 500             | 96-04 | <b>RSI</b> |
| KLX             | 650 R D1        | 96    | <b>SI</b>  |
| <b>SHERCO</b>   |                 |       |            |
| SE              | 450 4.5i Enduro | 04    | <b>SI</b>  |
| <b>SUZUKI</b>   |                 |       |            |
| DR              | 125 SM          | 08-12 | <b>HF</b>  |
| RM              | 125             | 96-09 | <b>RSI</b> |
| RM              | 250             | 96-09 | <b>RSI</b> |
| RMX             | 250 X-K1        | 99    | <b>SI</b>  |
| DR-Z            | 400 S/E         | 00-12 | <b>HF</b>  |
| DR-Z            | 400 SM          | 05-10 | <b>RSI</b> |
| <b>TM</b>       |                 |       |            |
| MX              | 85              | 01-12 | <b>RSI</b> |
|                 | 125             | 01-04 | <b>RSI</b> |
|                 | 125 Enduro      | 01-04 | <b>SI</b>  |
| SMR             | 125             | 05    | <b>RSI</b> |
|                 | 250             | 01-04 | <b>RSI</b> |
|                 | 250 Enduro      | 01-04 | <b>SI</b>  |
|                 | 250 F           | 01-04 | <b>RSI</b> |
|                 | 250 F Enduro    | 01-04 | <b>SI</b>  |



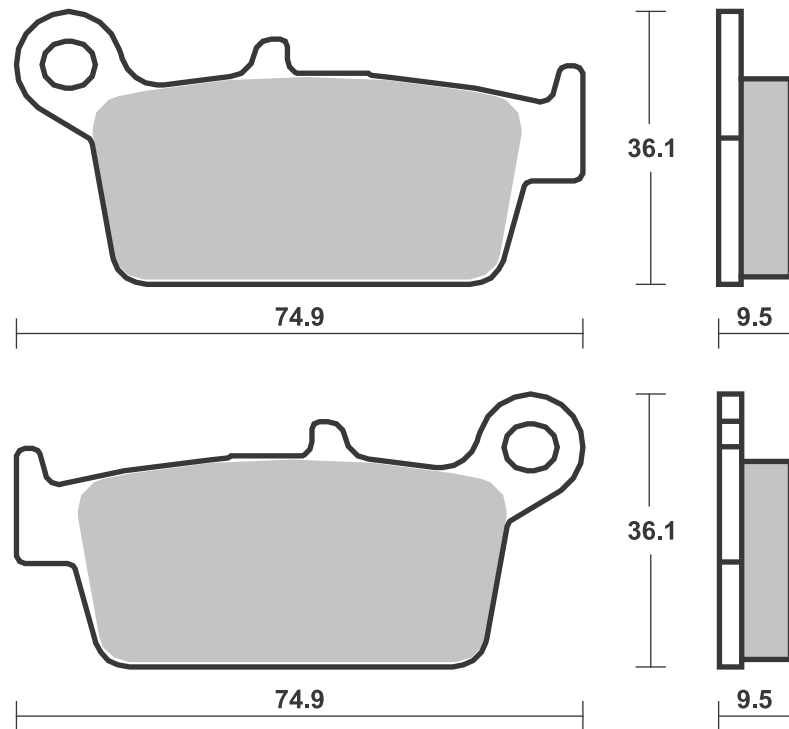
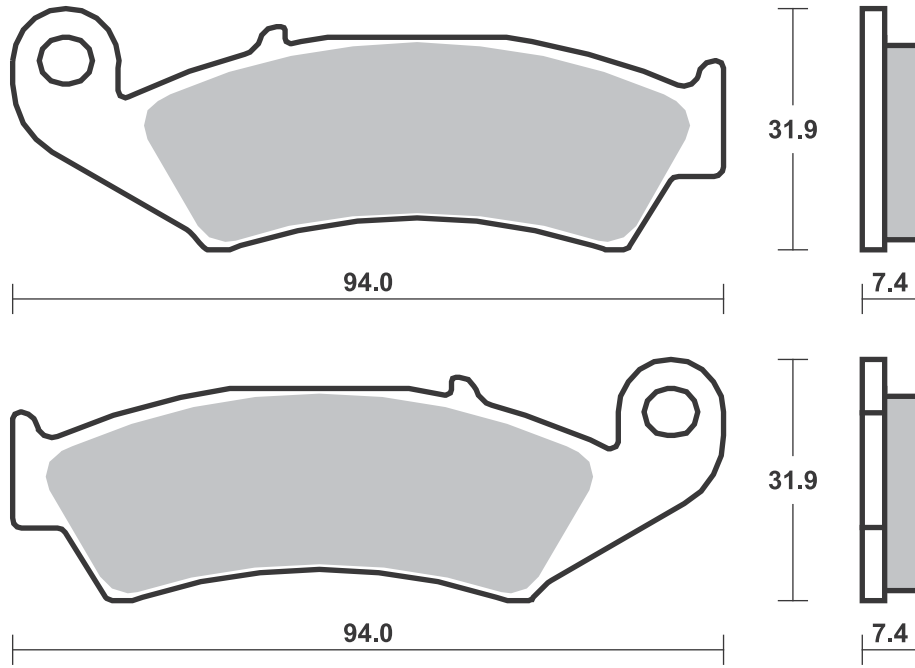

## SBS 604

## Recommended compound



| <b>TM</b> |              |       |            |
|-----------|--------------|-------|------------|
|           | 300          | 01-04 | <b>RSI</b> |
|           | 300 Enduro   | 01-04 | <b>SI</b>  |
|           | 400 F        | 01    | <b>RSI</b> |
|           | 400 F Enduro | 01    | <b>SI</b>  |
| SMF       | 400 F        | 02    | <b>RSI</b> |
| SMR       | 400 F        | 03    | <b>RSI</b> |
|           | 450 F        | 02-04 | <b>RSI</b> |
|           | 450 F Enduro | 02-04 | <b>SI</b>  |
| SMR       | 450 F        | 04    | <b>RSI</b> |
| SMX       | 450 F        | 03-04 | <b>RSI</b> |
|           | 530 F        | 01-04 | <b>RSI</b> |
|           | 530 F Enduro | 01-04 | <b>SI</b>  |
| SMR       | 530 F        | 03    | <b>RSI</b> |
| SMX       | 600 F        | 03    | <b>RSI</b> |
| SMX       | 660 F        | 04    | <b>RSI</b> |

**YAMAHA**

|    |       |       |            |
|----|-------|-------|------------|
| WR | 125   | 98-02 | <b>SI</b>  |
| YZ | 125   | 98-02 | <b>RSI</b> |
| WR | 250   | 98-02 | <b>SI</b>  |
| WR | 250 F | 01-02 | <b>SI</b>  |
| YZ | 250   | 98-02 | <b>RSI</b> |
| YZ | 250 F | 01-02 | <b>RSI</b> |
| WR | 400 F | 99-00 | <b>SI</b>  |
| YZ | 400 F | 99    | <b>RSI</b> |
| WR | 426 F | 01-02 | <b>SI</b>  |
| YZ | 426 F | 00-02 | <b>RSI</b> |

## SBS 605

## Recommended compound



| <b>APRILIA</b> |               |       |           |
|----------------|---------------|-------|-----------|
|                | 125 Tuareg    | 87-92 | <b>HF</b> |
|                | 125 Tuareg AS | 86    | <b>HF</b> |
| STX            | 125           | 84    | <b>HF</b> |
| ETX            | 350           | 86-92 | <b>HF</b> |

**BETA**

|    |     |    |           |
|----|-----|----|-----------|
| RX | 50  | 84 | <b>HF</b> |
| RX | 125 | 84 | <b>HF</b> |

**GILERA**

|    |     |       |           |
|----|-----|-------|-----------|
| RV | 200 | 85-86 | <b>HF</b> |
|----|-----|-------|-----------|

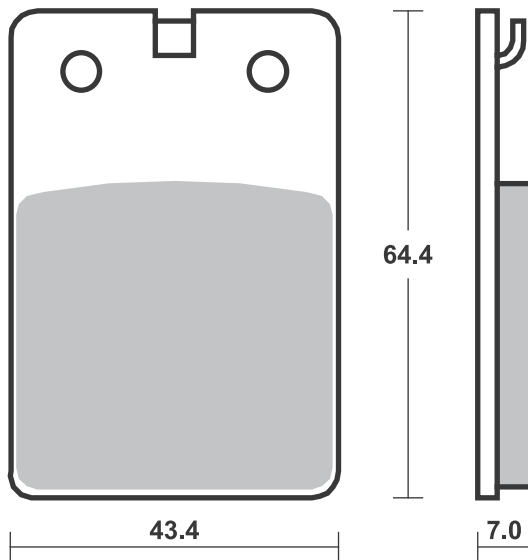
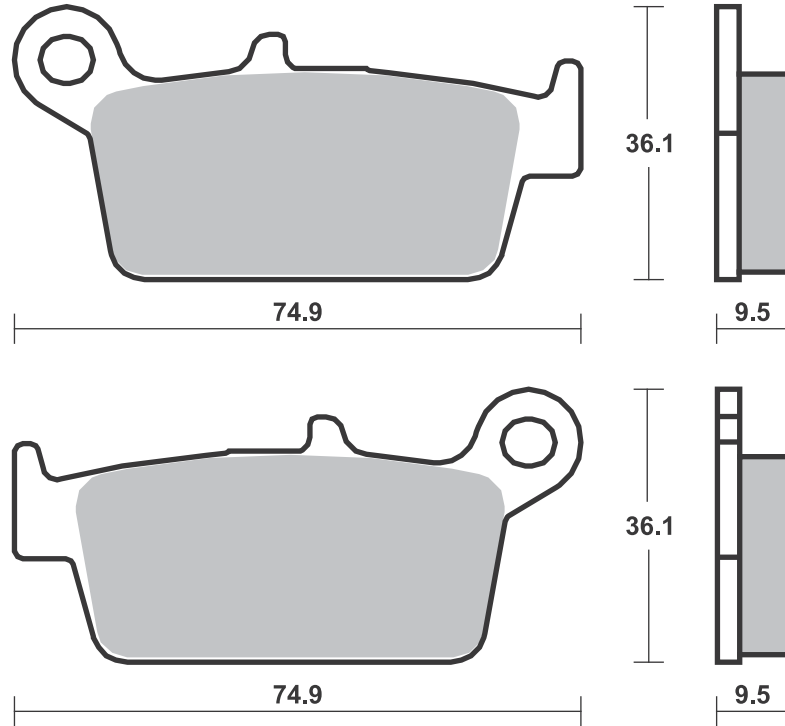

**SBS 606** Recommended compound

| <b>APRILIA</b>     |               |       |           |
|--------------------|---------------|-------|-----------|
| ETX                | 125 PV        | 86-02 | <b>HF</b> |
| RX                 | 125           | 86-89 | <b>HF</b> |
| TX                 | 125           | 86    | <b>HF</b> |
| <b>MOTO-MORINI</b> |               |       |           |
|                    | 125 KJ        | 84-88 | <b>HF</b> |
|                    | 350 Excalibur | 87-89 | <b>HF</b> |
|                    | 350 K2        | 84-87 | <b>HF</b> |
|                    | 501 Excalibur | 87    | <b>HF</b> |
|                    |               |       |           |
|                    |               |       |           |
|                    |               |       |           |
|                    |               |       |           |
|                    |               |       |           |
|                    |               |       |           |
|                    |               |       |           |
|                    |               |       |           |
|                    |               |       |           |
|                    |               |       |           |
|                    |               |       |           |
|                    |               |       |           |
|                    |               |       |           |
|                    |               |       |           |

**SBS 607** Recommended compound

| <b>APRILIA</b> |                 |       |           |
|----------------|-----------------|-------|-----------|
|                | 50 Red Rose     |       |           |
|                | Classic         | 92-94 | <b>HF</b> |
|                | 50 Tuareg       | 86-96 | <b>HF</b> |
|                | 50 Tuareg Rally | 90-96 | <b>HF</b> |
|                | 125 Tuareg Wind | 88    | <b>HF</b> |
|                | 240 Climber     | 89-90 | <b>HF</b> |
|                | 275 Climber     | 89-90 | <b>HF</b> |
| <b>ATK</b>     |                 |       |           |
| ATK            | 560             | 89-91 | <b>HF</b> |
| ATK            | 604             | 91    | <b>HF</b> |
| ATK            | 604 Quadracer   | 90    | <b>HF</b> |
| <b>BETA</b>    |                 |       |           |
| ALP            | 50              | 91-00 | <b>HF</b> |
| MX             | 50 Enduro       | 92    | <b>HF</b> |
| ALP            | 125             | 90    | <b>HF</b> |
| TR             | 125 34          | 88    | <b>HF</b> |

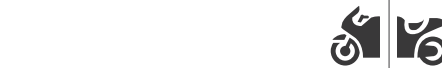

| <b>BETA</b>     |                |       |           |
|-----------------|----------------|-------|-----------|
| TR              | 260 34         | 86-88 | <b>HF</b> |
| <b>DERBI</b>    |                |       |           |
|                 | 75 GPR         | 89    | <b>HF</b> |
| GPR             | 75 Sport       | 92    | <b>HF</b> |
| <b>FANTIC</b>   |                |       |           |
|                 | 50 Fast        | 88    | <b>HF</b> |
|                 | 50 Oasis       | 90    | <b>HF</b> |
|                 | 75 Oasis       | 89    | <b>HF</b> |
| <b>GARELLI</b>  |                |       |           |
|                 | 50 Sahel       | 91    | <b>HF</b> |
| <b>MALAGUTI</b> |                |       |           |
| MDX             | 50 Gold Enduro | 87    | <b>HF</b> |
| MLX             | 50 Enduro      | 87    | <b>HF</b> |



| <b>PEUGEOT</b> |       |    |           |
|----------------|-------|----|-----------|
| XPLD           | 50 AV | 90 | <b>HF</b> |
|                |       |    |           |
|                |       |    |           |
|                |       |    |           |
|                |       |    |           |
|                |       |    |           |
|                |       |    |           |
|                |       |    |           |
|                |       |    |           |
|                |       |    |           |
|                |       |    |           |
|                |       |    |           |
|                |       |    |           |
|                |       |    |           |
|                |       |    |           |
|                |       |    |           |
|                |       |    |           |
|                |       |    |           |
|                |       |    |           |
|                |       |    |           |

**SBS 608** Recommended compound

| <b>APRILIA</b> |               |       |           |
|----------------|---------------|-------|-----------|
| AF1            | 125           | 87-88 | <b>HF</b> |
| AF-1           | 125           | 88    | <b>HF</b> |
| <b>CAGIVA</b>  |               |       |           |
| WMX            | 50            | 89    | <b>HF</b> |
|                | 125 Cross     | 86    | <b>SI</b> |
|                | 125 Cruiser   | 89    | <b>HF</b> |
|                | 125 Freccia   | 89    | <b>HF</b> |
|                | 125 Supercity | 92-00 | <b>HF</b> |
|                | 125 Tamanaco  | 87-92 | <b>HF</b> |
| WMX            | 125           | 88-90 | <b>SI</b> |
|                | 250 Cross     | 86    | <b>SI</b> |
| WMX            | 250           | 88-90 | <b>SI</b> |
| <b>GILERA</b>  |               |       |           |
|                | 125 Apache    | 91-94 | <b>HF</b> |
| RC             | 125 Top Rally | 90-93 | <b>HF</b> |
| RC             | 600 Top Rally | 90-94 | <b>HF</b> |



| <b>HM</b>        |            |       |           |
|------------------|------------|-------|-----------|
| CRE              | 50         | 98-01 | <b>HF</b> |
| <b>HUSABERG</b>  |            |       |           |
|                  | all models | 89-92 | <b>SI</b> |
|                  | 350        | 91-92 | <b>SI</b> |
|                  | 500        | 91-98 | <b>SI</b> |
|                  | 501 Enduro | 91-94 | <b>SI</b> |
|                  | 600 Enduro | 91-94 | <b>SI</b> |
| <b>HUSQVARNA</b> |            |       |           |
|                  | all models |       |           |
|                  | TE,TC,WR,  |       |           |
|                  | CR,AE      | 89    | <b>SI</b> |
| CR/WR            | 125        | 91    | <b>SI</b> |
| WR               | 125        | 85-90 | <b>SI</b> |
| WRK              | 125        | 90    | <b>SI</b> |
| WR               | 240        | 87-91 | <b>SI</b> |
| WRK              | 240        | 90    | <b>SI</b> |



| <b>HUSQVARNA</b> |            |       |           |
|------------------|------------|-------|-----------|
| CR               | 250        | 91    | <b>SI</b> |
| WR/XC            | 250        | 87-90 | <b>SI</b> |
| WR               | 260        | 90-93 | <b>SI</b> |
| TE               | 350 Enduro | 90    | <b>SI</b> |
| WR               | 400        | 87-88 | <b>SI</b> |
|                  | 430 Auto   | 87    | <b>SI</b> |
| CR               | 430        | 87-89 | <b>SI</b> |
| WR               | 430        | 87-89 | <b>SI</b> |
| XC               | 430        | 87-88 | <b>SI</b> |
| XC               | 500        | 87-88 | <b>SI</b> |
|                  | 510        | 87-90 | <b>SI</b> |
| TC               | 610 Cross  | 91    | <b>SI</b> |
| TE               | 610        | 91-95 | <b>SI</b> |
| <b>KRAM-IT</b>   |            |       |           |
| ER               | 125        | 89-93 | <b>SI</b> |
| MC               | 250        | 89    | <b>SI</b> |
| ER               | 300        | 89    | <b>SI</b> |

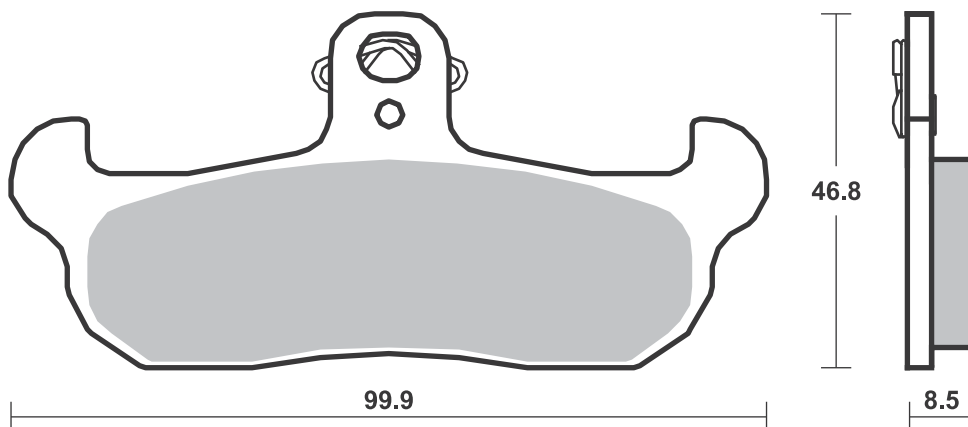
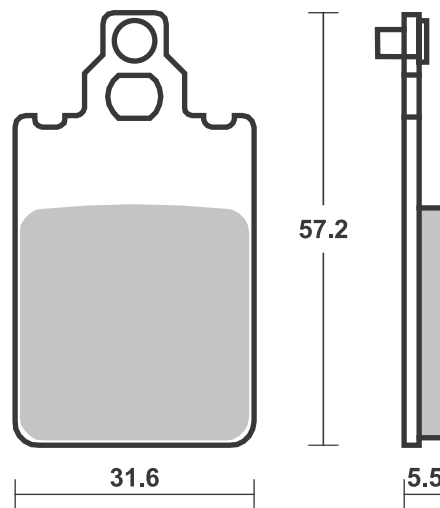
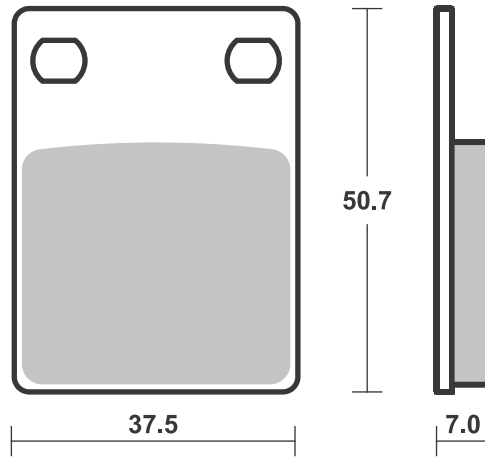



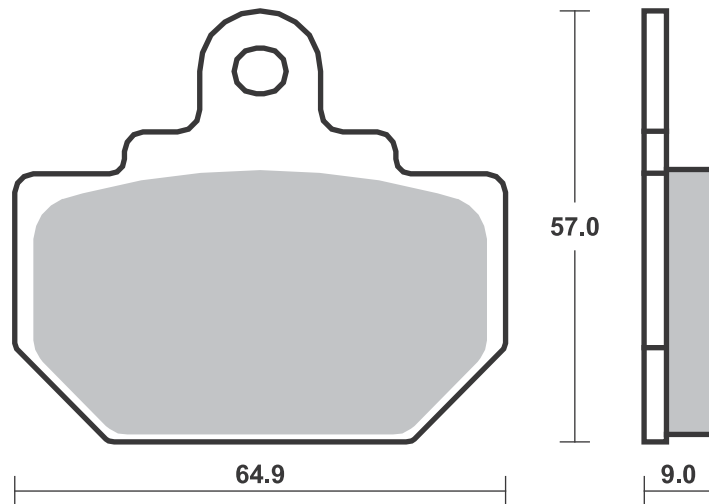
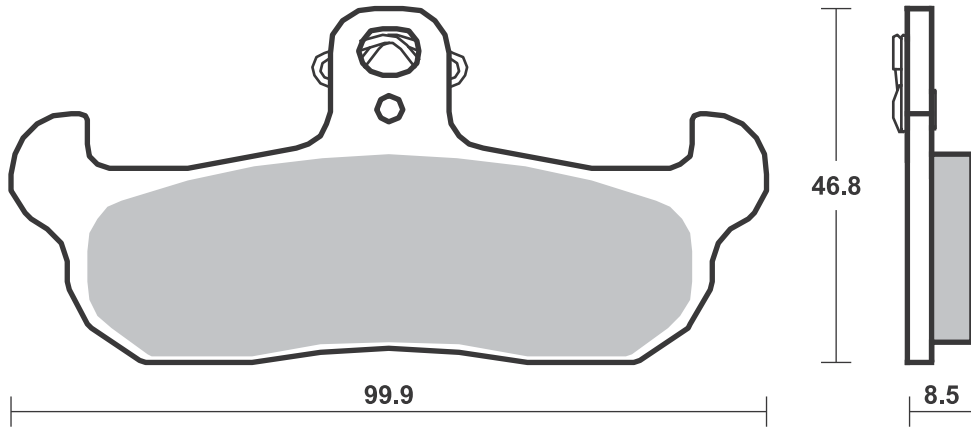

## Applications

### SBS 611 Recommended compound



|            |    |           |           |  |
|------------|----|-----------|-----------|--|
| <b>ATK</b> |    |           |           |  |
| all models | 94 | <b>SI</b> | <b>SI</b> |  |

|               |       |           |  |  |
|---------------|-------|-----------|--|--|
| <b>CAGIVA</b> |       |           |  |  |
| 110 Passing   | 94    | <b>HF</b> |  |  |
| 600 Canyon    | 95-99 | <b>HS</b> |  |  |

|                |       |           |           |  |
|----------------|-------|-----------|-----------|--|
| <b>CAN-AM</b>  |       |           |           |  |
| 800 Commander  |       |           |           |  |
| Left/Rear      | 11-14 |           | <b>SI</b> |  |
| 800 Commander  |       |           |           |  |
| Right          | 11-14 | <b>SI</b> |           |  |
| 1000 Commander |       |           |           |  |
| Left/Rear      | 11-14 |           | <b>SI</b> |  |
| 1000 Commander |       |           |           |  |
| MAX Right      | 14-16 | <b>SI</b> |           |  |
| 1000 Commander |       |           |           |  |
| Right          | 11-14 | <b>SI</b> |           |  |
| 1000 Maverick  |       |           |           |  |
| Right          | 13-17 | <b>SI</b> |           |  |

|                   |       |           |  |  |
|-------------------|-------|-----------|--|--|
| <b>CF MOTO</b>    |       |           |  |  |
| 550 U-Force Right | 15-16 | <b>SI</b> |  |  |
| 550 Z-Force Right | 15-16 | <b>SI</b> |  |  |
| 800 Z-Force EX    |       |           |  |  |
| Right             | 15    | <b>SI</b> |  |  |

|              |       |  |           |  |
|--------------|-------|--|-----------|--|
| <b>DERBI</b> |       |  |           |  |
| DXR 200 Quad |       |  |           |  |
| (Front drum) | 04-05 |  | <b>SI</b> |  |
| DXR 250 Quad |       |  |           |  |
| (Front drum) | 04-05 |  | <b>SI</b> |  |

|              |    |  |           |  |
|--------------|----|--|-----------|--|
| <b>HONDA</b> |    |  |           |  |
| NSR 150      | 02 |  | <b>HF</b> |  |

|              |       |  |           |  |
|--------------|-------|--|-----------|--|
| <b>HOREX</b> |       |  |           |  |
| VR6 1200     | 11-16 |  | <b>LS</b> |  |

|                  |       |           |  |  |
|------------------|-------|-----------|--|--|
| <b>HUSQVARNA</b> |       |           |  |  |
| all models       |       |           |  |  |
| CR,TC,TE,        |       |           |  |  |
| WR               | 92-94 | <b>SI</b> |  |  |

|                |       |           |  |  |
|----------------|-------|-----------|--|--|
| <b>HYOSUNG</b> |       |           |  |  |
| 125 Aquila     | 00-04 | <b>HF</b> |  |  |

|                        |       |            |  |  |
|------------------------|-------|------------|--|--|
| <b>KAWASAKI</b>        |       |            |  |  |
| KLX 125                | 10-14 | <b>HF</b>  |  |  |
| KLX 125 D-Tracker      | 10-14 | <b>HF</b>  |  |  |
| KX 125                 | 89-93 | <b>RSI</b> |  |  |
| KLX 140 , L            | 08-18 | <b>SI</b>  |  |  |
| KLX 150 D-Tracker      | 16-18 | <b>HF</b>  |  |  |
| KLX 150 L              | 14-15 | <b>HF</b>  |  |  |
| KDX 200                | 93    | <b>SI</b>  |  |  |
| KDX 250 SR             | 91-94 | <b>SI</b>  |  |  |
| KLX 250                | 14-16 | <b>HF</b>  |  |  |
| KLX 250 S              | 09-14 | <b>HF</b>  |  |  |
| KLX 250 SF             | 09-10 | <b>HF</b>  |  |  |
| KX 250                 | 89-93 | <b>RSI</b> |  |  |
| EL 252                 | 01-03 | <b>HS</b>  |  |  |
| KLF 300 Bayou          |       |            |  |  |
| Left/Rear              | 89-05 | <b>SI</b>  |  |  |
| KLF 400 Bayou Left     | 93-99 | <b>SI</b>  |  |  |
| KX 500                 | 89-93 | <b>RSI</b> |  |  |
| KLR 650                | 08-10 | <b>HS</b>  |  |  |
| KVF 650 Brute Force    |       |            |  |  |
| 4x4i Left              | 05-11 | <b>SI</b>  |  |  |
| KRF 750 Teryx 4x4 Left | 08-13 | <b>SI</b>  |  |  |
| KVF 750 Brute Force    |       |            |  |  |
| 4x4i Left              | 05-15 | <b>SI</b>  |  |  |



|                      |       |           |  |  |
|----------------------|-------|-----------|--|--|
| <b>KAWASAKI</b>      |       |           |  |  |
| 800 Mule Pro FX      |       |           |  |  |
| Left                 | 15-17 | <b>SI</b> |  |  |
| KRF 800 Teryx BEF/   |       |           |  |  |
| CEF/DEF Left         | 14-17 | <b>SI</b> |  |  |
| KRT 800 Teryx 4 BEF/ |       |           |  |  |
| CEF/DEF Left         | 14-17 | <b>SI</b> |  |  |

|                    |       |            |  |  |
|--------------------|-------|------------|--|--|
| <b>SUZUKI</b>      |       |            |  |  |
| EN 125             | 05-09 | <b>HF</b>  |  |  |
| RM 125             | 87    | <b>SI</b>  |  |  |
| RM 125             | 88-95 | <b>RSI</b> |  |  |
| TS 125             | 89-96 | <b>HF</b>  |  |  |
| TS 200 R           | 90-94 | <b>HF</b>  |  |  |
| DR 250             | 90-95 | <b>HF</b>  |  |  |
| RM 250             | 87-95 | <b>RSI</b> |  |  |
| RMX 250            | 89-95 | <b>RSI</b> |  |  |
| LT-F 300 King Quad |       |            |  |  |
| Left/Rear          | 02    | <b>SI</b>  |  |  |
| DR 350             | 90-99 | <b>HF</b>  |  |  |
| LT-R 450 Left/Rear | 06-12 | <b>SI</b>  |  |  |
| LT-A 500 FY        |       |            |  |  |
| Quadmaster         |       |            |  |  |
| Left               | 00-08 | <b>SI</b>  |  |  |
| LT-F 500 F Right   | 98-07 | <b>SI</b>  |  |  |
| RM 500             | 87-89 | <b>RSI</b> |  |  |

|                     |       |           |           |  |
|---------------------|-------|-----------|-----------|--|
| <b>TRIUMPH</b>      |       |           |           |  |
| 750 Trident         |       |           |           |  |
| Left/Rear           | 91-98 | <b>HS</b> | <b>LS</b> |  |
| 800 America         | 03-06 |           | <b>LS</b> |  |
| 800 Bonneville      | 01-04 |           | <b>LS</b> |  |
| 800 Bonneville      |       |           |           |  |
| America             | 02-06 |           | <b>LS</b> |  |
| 800 Bonneville T100 |       |           |           |  |
| Centennial          |       |           |           |  |
| Edition             | 02-04 |           | <b>LS</b> |  |
| 800 Bonneville      |       |           |           |  |
| T100 Paul           |       |           |           |  |
| Smith               | 06-08 |           | <b>LS</b> |  |
| 800 Speedmaster     | 03-04 |           | <b>LS</b> |  |
| 900 America         | 07-16 |           | <b>LS</b> |  |
| 900 Bonneville      | 09-11 |           | <b>LS</b> |  |
| 900 Bonneville      |       |           |           |  |
| Newchurch           | 15    |           | <b>LS</b> |  |
| 900 Bonneville SE   | 09-13 |           | <b>LS</b> |  |
| 900 Bonneville      |       |           |           |  |
| Spirit              | 15    |           | <b>LS</b> |  |
| 900 Bonneville      |       |           |           |  |
| Street Cup          | 17-18 |           | <b>LS</b> |  |
| 900 Bonneville      |       |           |           |  |
| T100                | 05-18 |           | <b>LS</b> |  |
| 900 Bonneville      |       |           |           |  |
| T100 Black          | 16-18 |           | <b>LS</b> |  |
| 900 Bonneville      |       |           |           |  |
| T214                | 15    |           | <b>LS</b> |  |
| 900 Daytona, Sprint |       |           |           |  |
| Left/Rear           | 93    | <b>HS</b> | <b>LS</b> |  |
| 900 Scrambler       | 06-16 |           | <b>LS</b> |  |
| 900 Speedmaster     | 05-15 |           | <b>LS</b> |  |
| 900 Street          |       |           |           |  |
| Scrambler           | 17-18 |           | <b>LS</b> |  |
| 900 Street Twin     | 16-18 |           | <b>LS</b> |  |
| 900 Thruxton        | 04-05 |           | <b>LS</b> |  |
| 900 Thruxton Ace    | 15    |           | <b>LS</b> |  |
| 900 Tiger           |       |           |           |  |
| Left/Rear           | 93-98 | <b>HS</b> | <b>LS</b> |  |
| 900 Trident         |       |           |           |  |
| Left/Rear           | 91-98 | <b>HS</b> | <b>LS</b> |  |
| 900 Trophy          |       |           |           |  |
| Left/Rear           | 91-95 | <b>HS</b> | <b>LS</b> |  |



|                       |       |           |           |  |
|-----------------------|-------|-----------|-----------|--|
| <b>TRIUMPH</b>        |       |           |           |  |
| T509 900 Speed Triple | 97-01 |           | <b>LS</b> |  |
| T595 950 Daytona      | 96-98 |           | <b>LS</b> |  |
| 955 Daytona           |       |           |           |  |
| Centennial            | 02-04 |           | <b>LS</b> |  |
| 955 Daytona to        |       |           |           |  |
| VIN 132512            | 99-06 |           | <b>LS</b> |  |
| 955 Speed Triple      | 99-06 |           | <b>LS</b> |  |
| 955 Sprint RS         | 00-05 |           | <b>LS</b> |  |
| 955 Sprint ST         | 99-04 |           | <b>LS</b> |  |
| 1000 Trophy           |       |           |           |  |
| Left/Rear             | 91-95 | <b>HS</b> | <b>LS</b> |  |
| 1050 Speed 94         | 15-16 |           | <b>LS</b> |  |
| 1050 Speed 94R        | 15-16 |           | <b>LS</b> |  |
| 1050 Speed Triple     | 16-17 |           | <b>LS</b> |  |
| 1050 Speed Triple     | 05-15 |           | <b>LS</b> |  |
| 1050 Speed Triple R   | 12-18 |           | <b>LS</b> |  |
| 1050 Speed Triple S   | 16-18 |           | <b>LS</b> |  |
| 1050 Sprint GT ABS    | 10-15 |           | <b>LS</b> |  |
| 1050 Sprint GT SE     |       |           |           |  |
| ABS                   | 10-15 |           | <b>LS</b> |  |
| 1050 Sprint ST        | 05-11 |           | <b>LS</b> |  |
| 1050 Tiger Sport      | 15-18 |           | <b>LS</b> |  |
| 1200 Bonneville       |       |           |           |  |
| T120                  | 16-18 |           | <b>LS</b> |  |
| 1200 Bonneville       |       |           |           |  |
| T120 Black            | 16-18 |           | <b>LS</b> |  |
| 1200 Thruxton         | 16-18 |           | <b>LS</b> |  |
| 1200 Thruxton R       | 16-18 |           | <b>LS</b> |  |
| 1200 Tiger Explorer   | 12-17 |           | <b>LS</b> |  |
| 1200 Tiger XCA        | 18-   |           | <b>LS</b> |  |
| 1200 Tiger XCX        | 18-   |           | <b>LS</b> |  |
| 1200 Tiger XR         | 18-   |           | <b>LS</b> |  |
| 1200 Tiger XRT        | 18-   |           | <b>LS</b> |  |
| 1200 Tiger XRX        | 18-   |           | <b>LS</b> |  |
| 1200 Tiger XRX Low    | 18-   |           | <b>LS</b> |  |
| 1200 Trophy           |       |           |           |  |
| Left/Rear             | 91-95 | <b>HS</b> | <b>LS</b> |  |
| 1200 Trophy SE        | 13-18 |           | <b>LS</b> |  |

|                      |       |            |           |  |
|----------------------|-------|------------|-----------|--|
| <b>YAMAHA</b>        |       |            |           |  |
| FZR 50               | 92    | <b>HF</b>  |           |  |
| YD 80                | 89    | <b>HF</b>  |           |  |
| WR 125               | 91-97 | <b>SI</b>  |           |  |
| XTZ 125              | 05-08 | <b>HF</b>  |           |  |
| YZ 125               | 89-97 | <b>RSI</b> |           |  |
| DT 200 WR            | 91-93 | <b>HF</b>  |           |  |
| WR 200               | 91-92 | <b>SI</b>  |           |  |
| TT-R 230             | 05    | <b>SI</b>  |           |  |
| TT 250               | 93-03 | <b>SI</b>  |           |  |
| WR 250               | 90-97 | <b>SI</b>  |           |  |
| YZ 250               | 89    | <b>RSI</b> |           |  |
| YZ 250 A             | 90    | <b>RSI</b> |           |  |
| YZ 250 B1-J1         | 91-97 | <b>RSI</b> |           |  |
| YZ 250 WRA,WRB       | 90-91 | <b>RSI</b> |           |  |
| TT 350               | 95-00 | <b>SI</b>  |           |  |
| YZ 360               | 89    | <b>SI</b>  |           |  |
| YFZ 450 S Right      | 04-09 | <b>SI</b>  |           |  |
| YXR 450 Rhino        |       |            |           |  |
| Left/Rear            | 06-09 | <b>SI</b>  |           |  |
| WR 500 B             | 91    | <b>SI</b>  |           |  |
| WR 500 ZD,ZE         | 92-93 | <b>SI</b>  |           |  |
| 660 Rhino            |       |            |           |  |
| Left/Rear            | 05-08 | <b>SI</b>  |           |  |
| YFM 700 R Raptor     |       |            |           |  |
| Left/Rear            | 06-08 | <b>SI</b>  |           |  |
| YFM 700 Raptor       | 09-14 | <b>SI</b>  |           |  |
| YXR 700 Rhino Right  | 08-14 | <b>SI</b>  | <b>SI</b> |  |
| XTZ 750 Super Tenere |       |            |           |  |
| Left/Rear            | 89-95 | <b>HF</b>  |           |  |



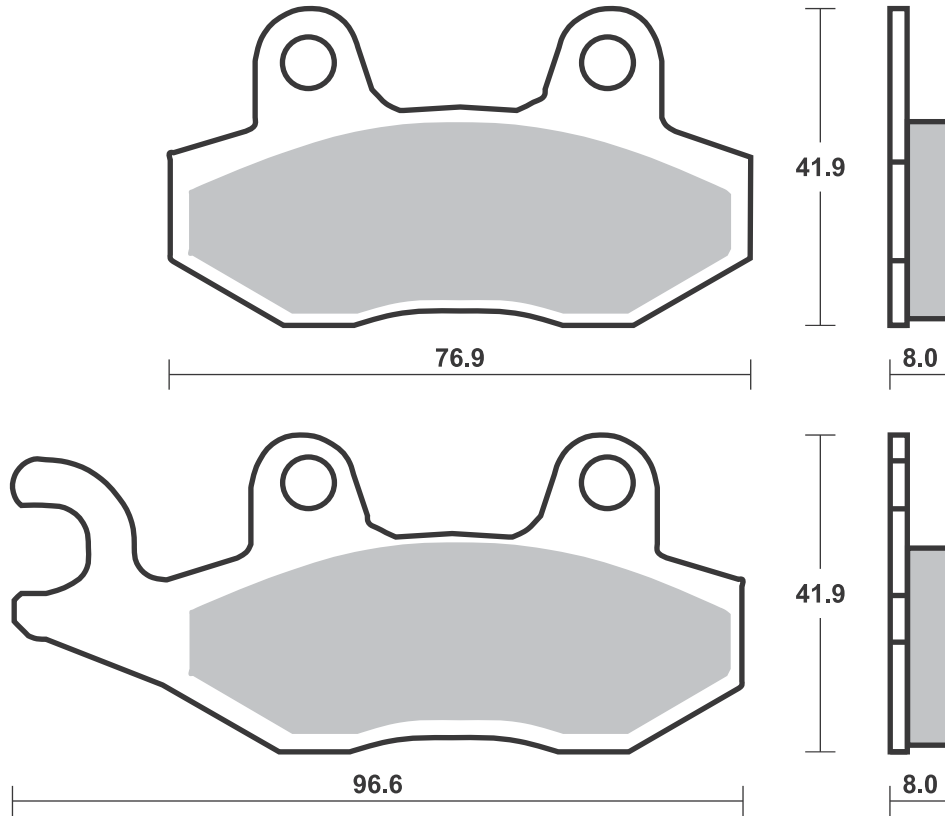

## Applications

### SBS 613 Recommended compound



| YAMAHA |               |       |    |
|--------|---------------|-------|----|
| FZR    | 400 A         | 90    | HS |
| SRX    | 400           | 85-86 | HF |
| SRX    | 600           | 90-99 | HS |
| FZR    | 750 R Genesis | 87-88 | HF |
| TRX    | 850           | 95-00 | HS |
| FZR    | 1000 Genesis  | 87-89 | HF |
| FJ     | 1200          | 88-90 | HF |
| FJ     | 1200 ABS      | 91-93 | HS |
| XJR    | 1200          | 94-98 | HS |
| XJR    | 1200 SP       | 97-98 | HS |
| XVZ    | 1300 A Royal  |       |    |
|        | Star          | 96-07 | HS |
| XVZ    | 1300 AT Royal |       |    |
|        | Star Tour     |       |    |
|        | Classic       | 97-07 | HS |
| XVZ    | 1300 Royal    |       |    |
|        | Star          |       |    |
|        | Boulevard     | 99-01 | HS |



| YAMAHA |              |       |    |
|--------|--------------|-------|----|
| XVZ    | 1300 Venture |       |    |
|        | Royale       | 86-89 | HF |
| XVZ    | 1300 Venture |       |    |
|        | Royale       | 90-95 | HS |

### SBS 614 Recommended compound



| BUELL   |                    |       |    |
|---------|--------------------|-------|----|
|         | 500 Blast          | 01-09 | HF |
| XB9R    | 984 Firebolt       | 02-10 | LS |
| XB9S    | 984 Lightning      | 03-10 | LS |
| XB9SX   | 984 CityX          | 05-10 | LS |
| M2      | 1200 Cyclone       | 98-02 | LS |
| S1      | 1200 Lightning     | 98-02 | LS |
| S1      | 1200 Whitelighting |       |    |
|         |                    | 98-02 | LS |
| S3      | 1200 Thunderbolt   |       |    |
|         |                    | 98-02 | LS |
| X1      | 1200 Lightning     | 01-02 | LS |
| XB12R   | 1200 Firebolt      | 04-10 | LS |
| XB12S   | 1200 Lightning     | 04-08 | LS |
| XB12Scg | 1200 Lightning     | 06-10 | LS |
| XB12Ss  | 1200 Lightning     |       |    |
|         | Long               | 06-10 | LS |
| XB12STT | 1200 Super TT      | 07-10 | LS |
| XB12X   | 1200 Ulysses       | 06-10 | LS |

| HONDA |                 |       |    |
|-------|-----------------|-------|----|
| CBR   | 250 Hurricane   | 87    | HF |
| CBR   | 250 R, RR       | 90    | HF |
| CBR   | 250 RJ          | 88    | HF |
| NSR   | 250 R, SP       | 90    | LS |
| NSR   | 250 RJ          | 88-89 | HF |
| RS    | 250 R           | 91-92 | HF |
| VT    | 250 Spada       | 89    | HF |
| VTR   | 250             | 98-02 | HF |
| CB    | 400 Super       |       |    |
|       | Four            | 92-95 | LS |
| CB-1  | 400 (CB 400 F)  | 89-90 | LS |
| CBR   | 400 RR          | 87-89 | LS |
| NTV   | 400 Bros II     | 88    | HF |
| VFR   | 400 R           | 87-88 | LS |
| VRX   | 400 T Roadstar  | 95-99 | LS |
| NX    | 500 Dominator   |       |    |
|       | (Austria)       | 88-96 | LS |
| NTV   | 600 Bros I      | 88-93 | HF |
| NTV   | 600 Revere      | 88-92 | HF |
| XL    | 600 V,          |       |    |
|       | Transalpino     | 91-99 | LS |
| NT    | 650 Hawk GT     | 88-91 | LS |
| NT    | 650 V Deauville | 98-00 | LS |
| NTV   | 650             | 94-97 | LS |



| HONDA |                 |       |    |
|-------|-----------------|-------|----|
| NTV   | 650 Bros        | 88-97 | LS |
| NTV   | 650 Revere      | 88-93 | LS |
| NX    | 650 Dominator   | 93-96 | LS |
| NX    | 650 Dominator   |       |    |
|       | J-K             | 88-92 | LS |
| XL    | 650 V Transalp  | 00-07 | LS |
| XR    | 650 Africa Twin | 88-89 | LS |
| NC    | 700 S           | 12-13 | LS |
| NC    | 700 X           | 12-13 | LS |
| VFR   | 700 F           |       |    |
|       | Interceptor     | 88-89 | LS |
| XL    | 700 Transalp    | 08-11 | LS |
| XR    | 750 Africa Twin | 90-03 | LS |

| MOTO-GUZZI |            |    |    |
|------------|------------|----|----|
|            | 1000 Quota | 92 | HF |

| SUZUKI |              |       |    |
|--------|--------------|-------|----|
| XF     | 650 Freewind | 97-02 | LS |

| TRIUMPH |                |       |    |
|---------|----------------|-------|----|
|         | 600 Daytona    | 03-04 | LS |
|         | 600 Speed Four | 03-06 | LS |
| TT      | 600            | 00-03 | LS |
|         | 650 Daytona    | 05-06 | LS |
|         | 675 Daytona    | 06-08 | LS |
|         | 675 Daytona    |       |    |
|         | R Triple       | 11-12 | LS |
|         | 675 Daytona    |       |    |
|         | Triple         | 09-12 | LS |
|         | 675 Street     |       |    |
|         | Triple         | 08-12 | LS |
|         | 675 Street     |       |    |
|         | Triple R       | 09-12 | LS |
|         | 800 Tiger      | 11-14 | LS |
|         | 800 Tiger XC   | 11-17 | LS |
|         | 800 Tiger XC   |       |    |
|         | ABS            | 12-14 | LS |
|         | 800 Tiger XCA  | 15-17 | LS |
|         | 800 Tiger XCA  | 18-   | LS |
|         | 800 Tiger XCR  | 15-17 | LS |
|         | 800 Tiger XCX  | 18-   | LS |
|         | 800 Tiger XR   | 15-17 | LS |
|         | 800 Tiger XR   | 18-   | LS |



| TRIUMPH |                  |       |    |
|---------|------------------|-------|----|
|         | 800 Tiger XRT    | 15-17 | LS |
|         | 800 Tiger XRT    | 18-   | LS |
|         | 800 Tiger XRX    | 15-17 | LS |
|         | 800 Tiger XRX    | 18-   | LS |
|         | 800 Tiger XRX    |       |    |
|         | Low              | 18-   | LS |
|         | 955 Daytona      |       |    |
|         | from VIN         |       |    |
|         | 132513           | 99-01 | LS |
|         | 1200 Bonneville  |       |    |
|         | Bobber           | 17    | LS |
|         | 1200 Bonneville  |       |    |
|         | Bobber           |       |    |
|         | Black            | 18-   | LS |
|         | 1200 Speedmaster |       |    |
|         |                  | 18-   | LS |

| YAMAHA |               |       |    |
|--------|---------------|-------|----|
| FZ6R   | 600           | 09-14 | LS |
| XJ6    | 600 Diversion | 09-15 | LS |
| XJ6-F  | 600           | 09-12 | LS |
| XJ6-N  | 600           | 09-12 | LS |
| XJ6-S  | 600           | 09-12 | LS |

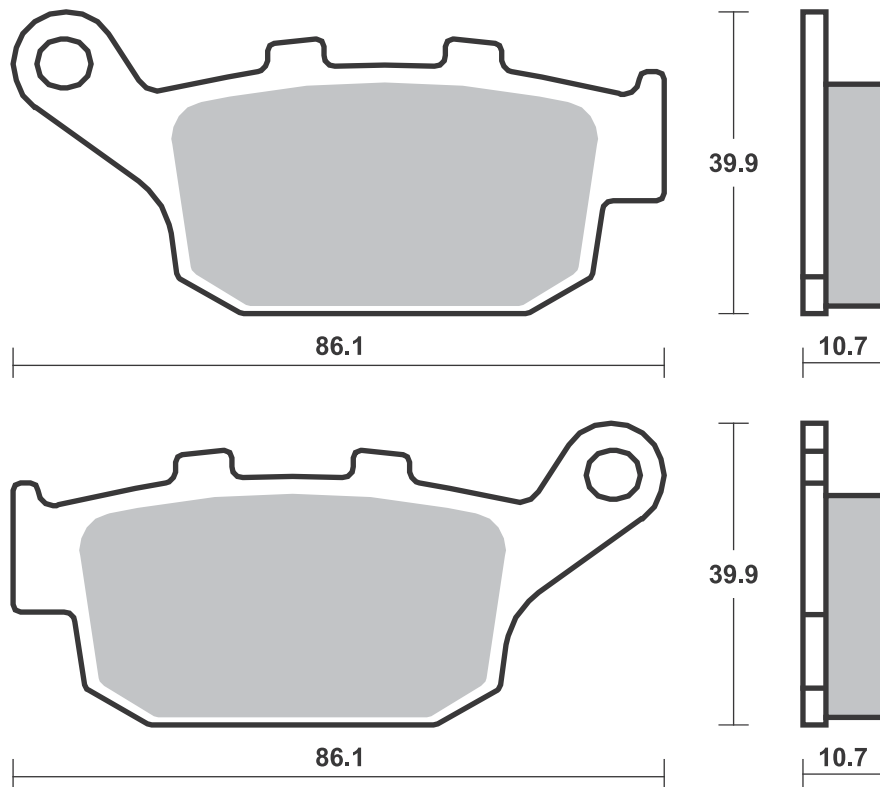
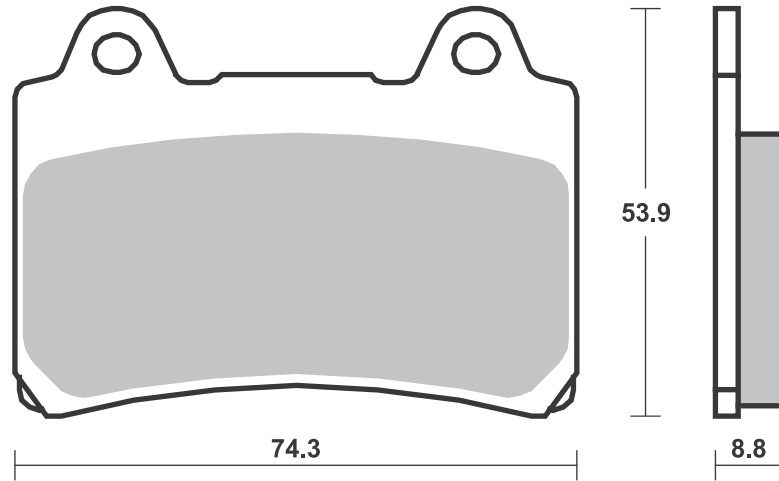

**SBS 615** Recommended compound



**KAWASAKI**

|      |                 |       |                     |
|------|-----------------|-------|---------------------|
| EX   | 250 R Ninja     | 88-07 | <b>HF</b>           |
| GPX  | 250 R           | 88-91 | <b>HF</b>           |
| KR-1 | 250 S           | 89    | <b>HF</b> <b>HF</b> |
| KR-1 | 250 S           | 90    | <b>HF</b>           |
| ZXR  | 250             | 90    | <b>HS</b> <b>LS</b> |
| ZXR  | 250 R           | 89    | <b>HS</b> <b>LS</b> |
| GPX  | 400             | 87    | <b>HF</b>           |
| GPZ  | 400 R           | 89    | <b>HS</b>           |
| ZR   | 400 Xanthus     |       |                     |
|      | (ZR 400D1)      | 92-95 | <b>HS</b>           |
| ZX-4 | 400             | 88-89 | <b>HF</b> <b>HF</b> |
| EX   | 500             | 94-96 | <b>HS</b>           |
| GPZ  | 500             | 97-04 | <b>HS</b>           |
| GPZ  | 500 S (Austria) | 94-01 | <b>HS</b>           |
| ZR   | 550 Zephyr      | 90-92 | <b>LS</b>           |
| ZR   | 550 Zephyr (D)  |       |                     |
|      | from VIN        |       |                     |
|      | B024010-        | 93-01 | <b>HS</b>           |

**SUZUKI**

|     |           |       |           |
|-----|-----------|-------|-----------|
| RGV | 250       | 93-95 | <b>HF</b> |
| RGV | 250 Gamma | 91-92 | <b>HF</b> |
| GSX | 1100 G    | 94-95 | <b>LS</b> |

**SBS 616** Recommended compound



**YAMAHA**

|    |                 |       |           |
|----|-----------------|-------|-----------|
| XV | 250 Virago      | 89-94 | <b>HF</b> |
| XV | 400 Virago, SPL | 88    | <b>HF</b> |
| XV | 535 Virago      | 88-95 | <b>HF</b> |

Brake Pad 1:1 Drawings, Compounds, Fitments

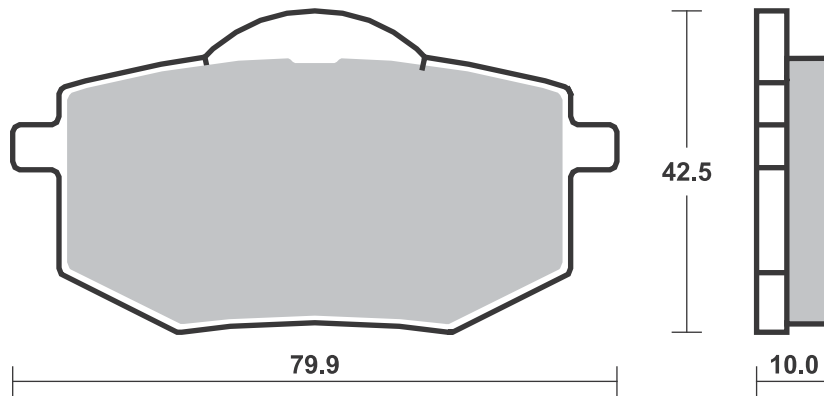
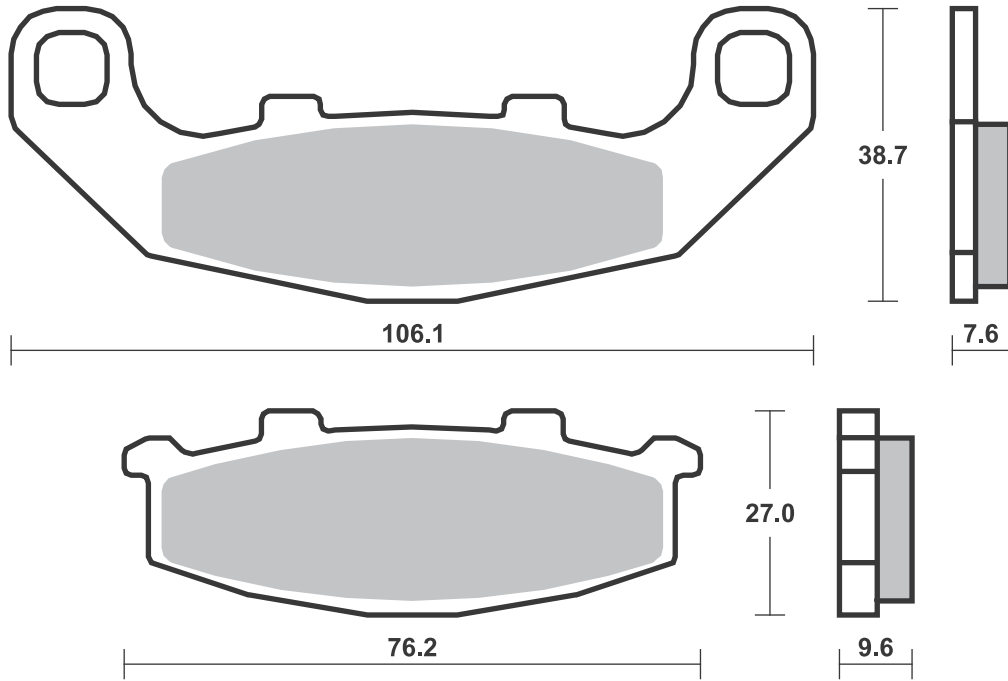

**SBS 617 Recommended compound**



**YAMAHA**

|    |              |       |           |
|----|--------------|-------|-----------|
| YT | 125 Tri Moto | 80-81 | <b>HF</b> |
|    |              |       |           |
|    |              |       |           |
|    |              |       |           |
|    |              |       |           |
|    |              |       |           |
|    |              |       |           |
|    |              |       |           |
|    |              |       |           |
|    |              |       |           |
|    |              |       |           |
|    |              |       |           |

**SBS 618 Recommended compound**



**HONDA**

|    |           |       |           |
|----|-----------|-------|-----------|
| R  | 50 Monkey | 88    | <b>HF</b> |
| R  | 80 Lead   | 88-95 | <b>HF</b> |
| NS | 125       | 89    | <b>HF</b> |
| R  | 125 Lead  | 88    | <b>HF</b> |
| RS | 125       | 95-03 | <b>RQ</b> |
| RS | 125 R     | 91-94 | <b>HF</b> |
| NS | 250       | 89    | <b>HF</b> |
| RS | 250 R     | 93    | <b>RQ</b> |

**MORIWAKI**

|    |     |    |           |
|----|-----|----|-----------|
| MD | 250 | 09 | <b>RQ</b> |
|----|-----|----|-----------|

**SYM**

|  |             |    |           |
|--|-------------|----|-----------|
|  | 50 Feel-big | 98 | <b>HF</b> |
|  | 50 Pure     | 98 | <b>HF</b> |
|  |             |    |           |
|  |             |    |           |
|  |             |    |           |

**SBS 619 Recommended compound**



**BENELLI**

|      |         |    |           |
|------|---------|----|-----------|
| KB-X | 50 Race | 14 | <b>HF</b> |
|------|---------|----|-----------|

**YAMAHA**

|       |    |       |           |
|-------|----|-------|-----------|
| JOG-Z | 50 | 88-89 | <b>HF</b> |
| TZR   | 80 | 92-95 | <b>HF</b> |

Brake Pad 1:1 Drawings, Compounds, Fitments

|  |  |  |  |
|--|--|--|--|
|  |  |  |  |
|  |  |  |  |
|  |  |  |  |
|  |  |  |  |
|  |  |  |  |
|  |  |  |  |
|  |  |  |  |
|  |  |  |  |
|  |  |  |  |
|  |  |  |  |

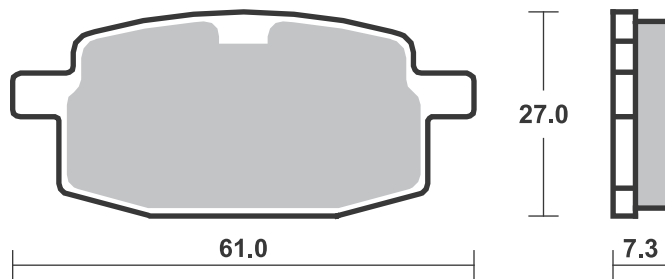
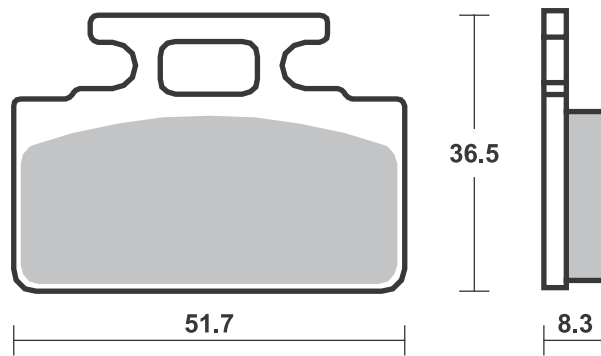
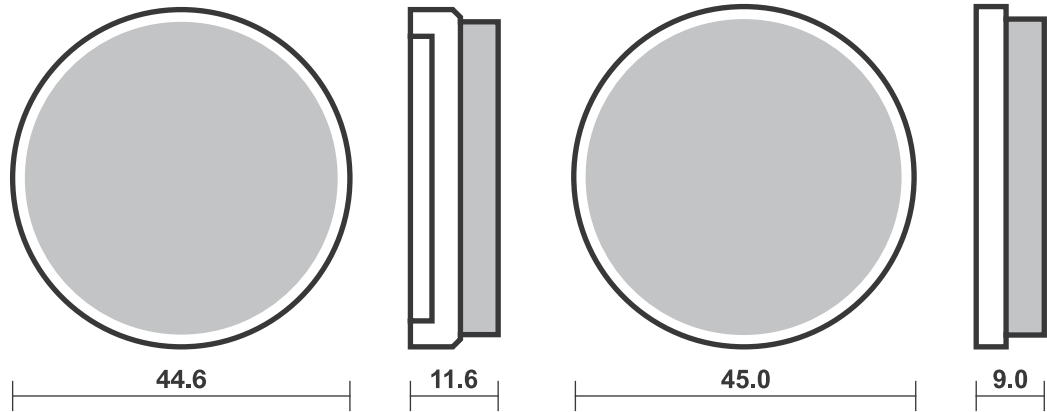

**SBS 620** Recommended compound

| <b>SUZUKI</b> |                |       |           |
|---------------|----------------|-------|-----------|
| GSX           | 400 F          | 89-92 | <b>HF</b> |
| GSX           | 600 Katana     | 88-89 | <b>HF</b> |
| GSX           | 600 Katana     | 90-97 | <b>HS</b> |
| GSX           | 750 Katana     | 89-96 | <b>HS</b> |
| VX            | 800 L-P        | 90-93 | <b>LS</b> |
| GSX           | 1100           | 88-89 | <b>HF</b> |
| GSX           | 1100           | 90-93 | <b>HS</b> |
| GSX           | 1100           | 91-93 | <b>LS</b> |
| GSX           | 1100 F         | 93-96 | <b>HS</b> |
| GL            | 1400 Cavalcade | 87-88 | <b>HF</b> |
|               |                |       |           |
|               |                |       |           |
|               |                |       |           |
|               |                |       |           |
|               |                |       |           |
|               |                |       |           |
|               |                |       |           |
|               |                |       |           |

**SBS 621** Recommended compound

| <b>KTM</b> |                                  |       |           |
|------------|----------------------------------|-------|-----------|
| EXC        | 125                              | 90    | <b>HF</b> |
| GS         | 125                              | 88    | <b>HF</b> |
| MX         | 125                              | 88    | <b>HF</b> |
|            | 250 GS, EXC,<br>Enduro<br>Models | 91    | <b>HF</b> |
| EXC        | 250                              | 90    | <b>HF</b> |
| GS         | 250                              | 88    | <b>HF</b> |
| MX         | 250                              | 88    | <b>HF</b> |
| EXC        | 300                              | 90    | <b>HF</b> |
| EXC        | 350                              | 88-90 | <b>HF</b> |
| GS         | 350                              | 88-92 | <b>HF</b> |
| MX         | 350                              | 88    | <b>HF</b> |
| MX         | 500                              | 88    | <b>HF</b> |
| EXC        | 600                              | 88    | <b>HF</b> |
| MX         | 600                              | 88-89 | <b>HF</b> |
|            |                                  |       |           |
|            |                                  |       |           |
|            |                                  |       |           |
|            |                                  |       |           |



| <b>MAICO</b> |                |       |           |
|--------------|----------------|-------|-----------|
|              | all models     | 89    | <b>HF</b> |
|              | all models     | 91    | <b>HF</b> |
| GP           | 250 all models | 89    | <b>HF</b> |
|              | 350            | 93-95 | <b>HF</b> |
| GP           | 400 all models | 89    | <b>HF</b> |
|              | 500            | 93-94 | <b>HF</b> |
| GP           | 500 all models | 89    | <b>HF</b> |
|              |                |       |           |
|              |                |       |           |
|              |                |       |           |
|              |                |       |           |
|              |                |       |           |
|              |                |       |           |
|              |                |       |           |
|              |                |       |           |

**SBS 622** Recommended compound

| <b>HONDA</b> |                  |       |           |
|--------------|------------------|-------|-----------|
| NS           | 125              | 89    | <b>HF</b> |
| NS           | 250              | 89    | <b>HF</b> |
| NSR          | 250 R, SP        | 90    | <b>HS</b> |
| NSR          | 250 RJ           | 88-89 | <b>HF</b> |
| RS           | 250 R            | 91-92 | <b>DC</b> |
| NTV          | 400 Bros II      | 88    | <b>HF</b> |
| RVF          | 400 RR (NC35)    | 90-96 | <b>HF</b> |
| VFR          | 400 R            | 89-92 | <b>HS</b> |
| VTR          | 400 R (NC 30)    | 90    | <b>HS</b> |
| NTV          | 600 Bros I       | 88-93 | <b>HF</b> |
| NTV          | 650 Bros         | 88-97 | <b>HS</b> |
| NR           | 750              | 92    | <b>HS</b> |
| RVF          | 750 RR (RC-45)   | 94-98 | <b>HS</b> |
| VFR          | 750 R            | 88-93 | <b>HS</b> |
| CB           | 900 Hornet       | 02-07 | <b>HS</b> |
| CBR          | 900 RR Fireblade | 92-97 | <b>HS</b> |
| CB           | 1000 F (Big One) | 93-97 | <b>HS</b> |
| VTR          | 1000 F Firestorm | 97-07 | <b>HS</b> |
|              |                  |       |           |
|              |                  |       |           |
|              |                  |       |           |
|              |                  |       |           |
|              |                  |       |           |
|              |                  |       |           |
|              |                  |       |           |
|              |                  |       |           |



| <b>HONDA</b> |          |       |           |
|--------------|----------|-------|-----------|
| CB           | 1300 X-4 | 97-03 | <b>HS</b> |
|              |          |       |           |
|              |          |       |           |
|              |          |       |           |
|              |          |       |           |
|              |          |       |           |
|              |          |       |           |
|              |          |       |           |
|              |          |       |           |
|              |          |       |           |
|              |          |       |           |
|              |          |       |           |
|              |          |       |           |
|              |          |       |           |
|              |          |       |           |



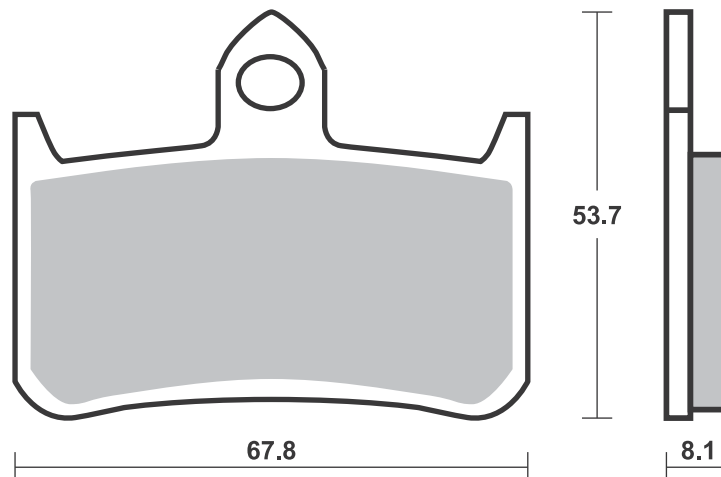
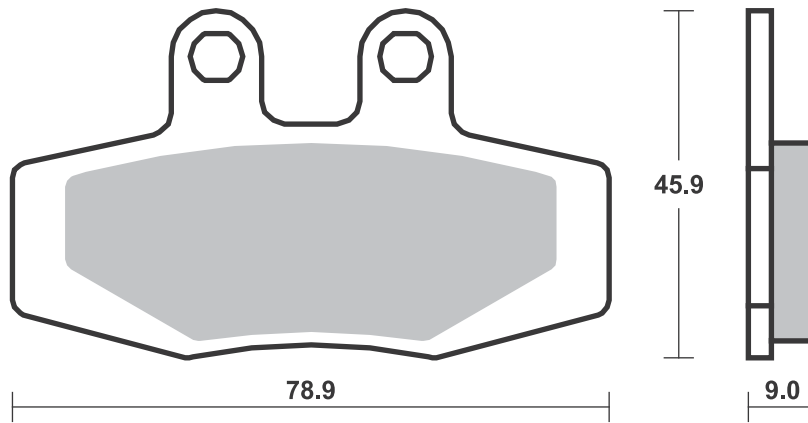
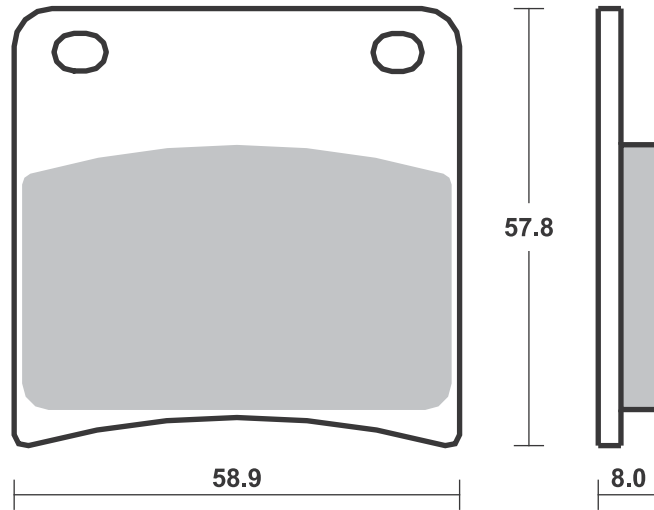

**SBS 623** Recommended compound



| <b>HONDA</b> |                |       |           |
|--------------|----------------|-------|-----------|
| RVF          | 400 RR (NC35)  | 90-96 | <b>HF</b> |
| VFR          | 400 R          | 89-92 | <b>LS</b> |
| VTR          | 400 R (NC 30)  | 90    | <b>LS</b> |
| RVF          | 750 RR (RC-45) | 94-98 | <b>LS</b> |
| VFR          | 750 R          | 88-93 | <b>LS</b> |
|              |                |       |           |
|              |                |       |           |
|              |                |       |           |
|              |                |       |           |
|              |                |       |           |
|              |                |       |           |
|              |                |       |           |
|              |                |       |           |
|              |                |       |           |
|              |                |       |           |
|              |                |       |           |
|              |                |       |           |
|              |                |       |           |
|              |                |       |           |
|              |                |       |           |
|              |                |       |           |
|              |                |       |           |
|              |                |       |           |
|              |                |       |           |

**SBS 624** Recommended compound



| <b>MZ</b>      |       |           |  |
|----------------|-------|-----------|--|
| 1000 (MUZ) S   | 03-10 | <b>HS</b> |  |
| 1000 (MUZ) SF  | 05-10 | <b>HS</b> |  |
| 1000 (MUZ) SFX | 07    | <b>HS</b> |  |
| 1000 (MUZ) SN  | 05    | <b>HS</b> |  |
| 1000 (MUZ) ST  | 07-10 | <b>HS</b> |  |
|                |       |           |  |
|                |       |           |  |
|                |       |           |  |
|                |       |           |  |
|                |       |           |  |
|                |       |           |  |
|                |       |           |  |
|                |       |           |  |
|                |       |           |  |
|                |       |           |  |
|                |       |           |  |
|                |       |           |  |
|                |       |           |  |
|                |       |           |  |
|                |       |           |  |
|                |       |           |  |
|                |       |           |  |

| <b>NISSIN</b>    |  |  |  |
|------------------|--|--|--|
| 4 Piston Caliper |  |  |  |

| <b>SUZUKI</b> |             |       |           |
|---------------|-------------|-------|-----------|
| RGV           | 250         | 88    | <b>HS</b> |
| GSX-R         | 400 R       | 90-95 | <b>HS</b> |
| GSX-R         | 600         | 92-93 | <b>HS</b> |
| GSX-R         | 750         | 88-93 | <b>HS</b> |
| GSX           | 1100 Katana | 93    | <b>HS</b> |
| GSX-R         | 1100        | 89-92 | <b>HS</b> |
| GSF           | 1200 Bandit | 95-96 | <b>HS</b> |
|               |             |       |           |
|               |             |       |           |
|               |             |       |           |
|               |             |       |           |
|               |             |       |           |
|               |             |       |           |
|               |             |       |           |
|               |             |       |           |
|               |             |       |           |
|               |             |       |           |
|               |             |       |           |
|               |             |       |           |
|               |             |       |           |
|               |             |       |           |
|               |             |       |           |

| <b>TRIUMPH</b>   |                  |           |           |
|------------------|------------------|-----------|-----------|
| 600 Daytona      | 03-04            | <b>HS</b> |           |
| 600 Speed Four   | 03-06            | <b>HS</b> |           |
| TT 600           | 00-03            | <b>HS</b> |           |
| 650 Daytona      | 05-06            | <b>HS</b> |           |
| 750 Daytona      | 91-92            | <b>HS</b> |           |
| 900 Daytona      | 91-98            | <b>HS</b> |           |
| 900 Speed Triple | 94-96            | <b>HS</b> |           |
| 900 Sprint       | 94-98            | <b>HS</b> |           |
| 900 Trophy       | 96-03            | <b>HS</b> |           |
| T509             | 900 Speed Triple | 97-01     | <b>HS</b> |
| T595             | 950 Daytona      | 96-98     | <b>HS</b> |



| <b>TRIUMPH</b>    |       |           |  |
|-------------------|-------|-----------|--|
| 955 Daytona       |       |           |  |
| Centennial        | 02-04 | <b>HS</b> |  |
| 955 Daytona from  |       |           |  |
| VIN 132513        | 99-01 | <b>HS</b> |  |
| 955 Daytona to    |       |           |  |
| VIN 132512        | 99-06 | <b>HS</b> |  |
| 955 Speed Triple  | 99-06 | <b>HS</b> |  |
| 955 Sprint RS     | 00-05 | <b>HS</b> |  |
| 955 Sprint ST     | 99-04 | <b>HS</b> |  |
| 1000 Daytona      | 92    | <b>HS</b> |  |
| 1050 Sprint GT    |       |           |  |
| ABS               | 10-15 | <b>HS</b> |  |
| 1050 Sprint GT SE |       |           |  |
| ABS               | 10-15 | <b>HS</b> |  |
| 1050 Sprint ST    | 05-11 | <b>HS</b> |  |
| 1200 Daytona      | 91-97 | <b>HS</b> |  |
| 1200 Tiger        |       |           |  |
| Explorer          | 12-15 | <b>SP</b> |  |
| 1200 Trophy       | 96-03 | <b>HS</b> |  |
| 1600 Thunderbird  | 09-18 | <b>HS</b> |  |
| 1700 Thunderbird  |       |           |  |
| Commander         | 14-18 | <b>HS</b> |  |
| 1700 Thunderbird  |       |           |  |
| LT                | 14-18 | <b>HS</b> |  |
| 1700 Thunderbird  |       |           |  |
| Nightstorm        | 14-18 | <b>HS</b> |  |
| 1700 Thunderbird  |       |           |  |
| Storm             | 11-18 | <b>HS</b> |  |
| 2300 Rocket III   | 04-13 | <b>HS</b> |  |
| 2300 Rocket III   |       |           |  |
| Classic           | 07-13 | <b>HS</b> |  |



| <b>TRIUMPH</b>  |       |           |  |
|-----------------|-------|-----------|--|
| 2300 Rocket III |       |           |  |
| Roadster        | 10-18 | <b>HS</b> |  |
| 2300 Rocket III |       |           |  |
| Touring         | 13-14 | <b>HS</b> |  |
| 2300 Rocket X   | 15    | <b>HS</b> |  |
|                 |       |           |  |
|                 |       |           |  |
|                 |       |           |  |
|                 |       |           |  |
|                 |       |           |  |
|                 |       |           |  |
|                 |       |           |  |
|                 |       |           |  |
|                 |       |           |  |
|                 |       |           |  |
|                 |       |           |  |
|                 |       |           |  |
|                 |       |           |  |
|                 |       |           |  |
|                 |       |           |  |
|                 |       |           |  |
|                 |       |           |  |
|                 |       |           |  |
|                 |       |           |  |
|                 |       |           |  |
|                 |       |           |  |
|                 |       |           |  |
|                 |       |           |  |
|                 |       |           |  |
|                 |       |           |  |
|                 |       |           |  |
|                 |       |           |  |
|                 |       |           |  |
|                 |       |           |  |
|                 |       |           |  |
|                 |       |           |  |

| <b>YAMAHA</b> |       |       |           |
|---------------|-------|-------|-----------|
| TZ            | 125   | 97-00 | <b>DC</b> |
| TZ            | 250   | 02-05 | <b>DC</b> |
| TZ            | 250   | 90-01 | <b>DC</b> |
| FZR           | 750 R | 89-92 | <b>HS</b> |

Brake Pad 1:1 Drawings, Compounds, Fitments

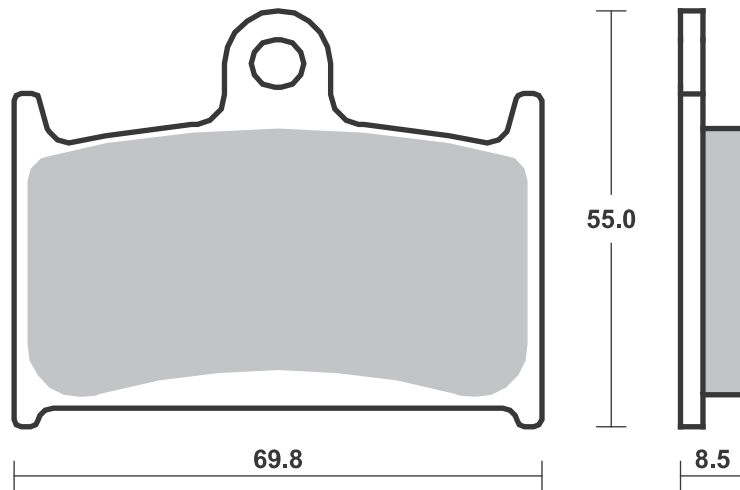
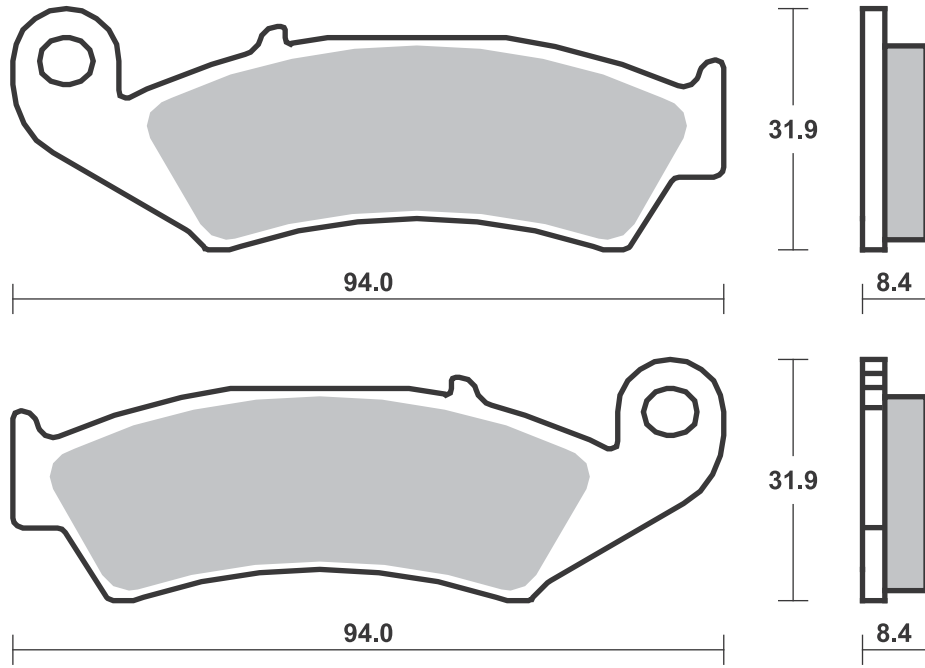



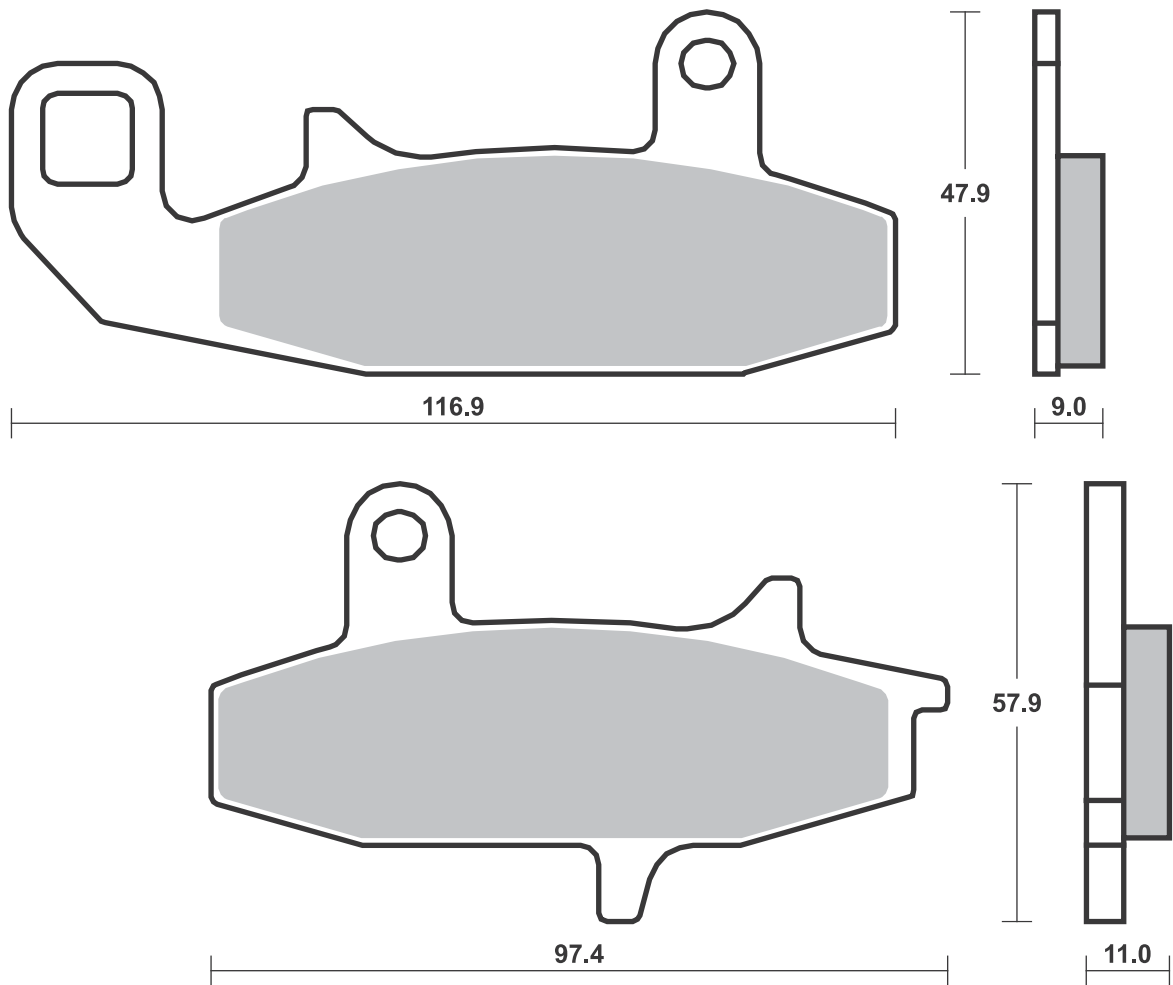
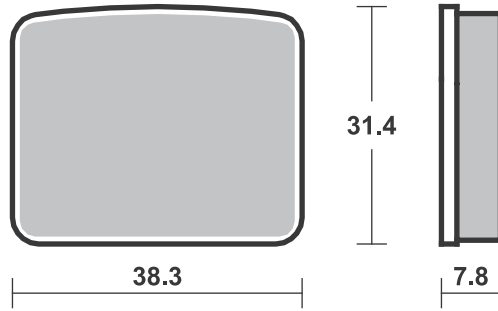

## Applications

### SBS 627 Recommended compound



|                        |       |           |           |
|------------------------|-------|-----------|-----------|
| <b>BUELL</b>           |       |           |           |
| 500 Blast              | 01-09 | <b>HF</b> |           |
| <b>CAGIVA</b>          |       |           |           |
| 900 Gran Canyon        | 99-04 | <b>HS</b> |           |
| 1000 Navigator, T      | 00-05 | <b>HS</b> |           |
| <b>HONDA</b>           |       |           |           |
| RS 125 R               | 91-94 | <b>HF</b> |           |
| 250 Steed              | 93-96 | <b>HF</b> |           |
| CB 250                 | 92-05 | <b>HF</b> |           |
| CBR 250 Nighthawk      | 92-95 | <b>HF</b> |           |
| CBR 250 R (Nissin cal) | 11-13 | <b>HS</b> |           |
| CBR 250 R, RR          | 90    | <b>HF</b> |           |
| CBR 250 RJ             | 88    | <b>HF</b> |           |
| VT 250 Spada           | 89    | <b>HF</b> |           |
| CB-1 400 (CB 400 F)    | 89-90 | <b>HS</b> |           |
| CBR 400 RR             | 87-89 | <b>HS</b> |           |
| NV 400 Steed           | 92-93 | <b>HS</b> |           |
| CB 500                 | 94-96 | <b>HS</b> |           |
| 600 Steed              | 92-02 | <b>HS</b> |           |
| CB 600 Hornet          | 98-12 | <b>HS</b> |           |
| CB 600 Hornet, S       | 00-03 | <b>HS</b> |           |
| CBF 600 N              | 04-11 | <b>HS</b> |           |
| CBF 600 S              | 04-11 | <b>HS</b> |           |
| CBR 600 F              | 11-13 | <b>HS</b> |           |
| CBR 600 F3             | 95-98 | <b>HS</b> |           |
| VT 600 C, Shadow       | 94-00 | <b>HS</b> |           |
| VT 600 CD Shadow       |       |           |           |
| VLX                    | 94-00 | <b>HS</b> |           |
| FMX 650                | 05-08 | <b>HS</b> |           |
| NT 650 Hawk GT         | 88-91 | <b>HS</b> |           |
| NTV 650 Revere         | 88-93 | <b>HS</b> |           |
| NC 700 S               | 12-13 | <b>HS</b> |           |
| NC 700 X               | 12-13 | <b>HS</b> |           |
| VFR 700 F Interceptor  | 88-89 | <b>HS</b> |           |
| CB 750 N, F,           |       |           |           |
| Seven Fifty            | 92-95 | <b>HS</b> |           |
| VFR 750 F              | 88-98 | <b>HS</b> |           |
| PC 800 Pacific Coast   | 89-97 | <b>HS</b> |           |
| VFR 950 F, Carat       | 92    | <b>HS</b> |           |
| CBR 1000 F             | 89-92 | <b>HS</b> |           |
| VFR 1000               | 89    | <b>HS</b> |           |
| ST 1100                | 90-02 | <b>HS</b> |           |
| ST 1100 ABS-TCS        | 92-95 | <b>HS</b> |           |
| VT 1100 C Shadow       | 94-96 | <b>HS</b> |           |
| VT 1100 C2 Shadow      |       |           |           |
| A.C.E.                 | 95-04 | <b>HS</b> |           |
| VT 1100 C2 Y           | 00-05 | <b>HS</b> |           |
| VT 1100 C3 Shadow      |       |           |           |
| Aero                   | 98-04 | <b>HS</b> |           |
| VT 1100 T Shadow       | 98-04 | <b>HS</b> |           |
| VT 1300 CX A Fury      | 10-18 | <b>HS</b> |           |
| VTX 1300 C             | 04-09 | <b>HS</b> |           |
| VTX 1300 S             | 03-07 | <b>HS</b> |           |
| GL 1500 F6 C Valkyrie  | 96-02 | <b>HS</b> |           |
| <b>HYOSUNG</b>         |       |           |           |
| 125 V2                 | 99-11 | <b>HF</b> |           |
| 250 Aquila             | 00-09 | <b>HF</b> |           |
| <b>KAWASAKI</b>        |       |           |           |
| KLE 300 Versys-X       | 17-18 | <b>HS</b> |           |
| KLE 650 Versys         | 15-18 | <b>HS</b> |           |
| KLE 650 Versys LT      | 15-16 | <b>HS</b> |           |
| Z 650 ABS              | 17-18 | <b>HS</b> |           |
| Z 750 , ABS            | 07-12 | <b>HS</b> |           |
| Z 800 e                | 13-16 | <b>HS</b> |           |
| <b>KYMCO</b>           |       |           |           |
| 250 Venox              | 01-14 | <b>HF</b> | <b>HF</b> |



|                     |       |           |  |
|---------------------|-------|-----------|--|
| <b>MASH</b>         |       |           |  |
| 400 Scrambler       | 13-17 | <b>HS</b> |  |
| 500 Five Hundred    | 13-16 | <b>HS</b> |  |
| <b>SUZUKI</b>       |       |           |  |
| 250 Impulse         | 95    | <b>HS</b> |  |
| DL 250 V-Strom      | 17-18 | <b>HF</b> |  |
| GSX-R 250           | 17-18 | <b>HF</b> |  |
| GW 250 Inazuma      | 12-18 | <b>HS</b> |  |
| GW 250 Inazuma F    | 15-18 | <b>HS</b> |  |
| GSX 400 Impulse     | 94-96 | <b>HS</b> |  |
| RF 400 RVC          | 93-97 | <b>HS</b> |  |
| GSF 600 Bandit      | 95-99 | <b>HS</b> |  |
| RF 600 R, RR        | 93-96 | <b>HS</b> |  |
| C 1500 T Intruder   | 13-18 | <b>HS</b> |  |
| <b>SWM</b>          |       |           |  |
| 440 Gran Milano     | 15-17 | <b>HS</b> |  |
| 440 Gran Turismo    | 15-18 | <b>HS</b> |  |
| 440 Silver Vase     | 15-18 | <b>HS</b> |  |
| 440 Six Days        | 18-   | <b>HS</b> |  |
| <b>TRIUMPH</b>      |       |           |  |
| 660 Street Triple   |       |           |  |
| S A2                | 17-18 | <b>HS</b> |  |
| 675 Street Triple   | 08-17 | <b>HS</b> |  |
| 765 Street Triple S | 17-18 | <b>HS</b> |  |
| 800 America         | 03-06 | <b>HS</b> |  |
| 800 Bonneville      | 01-04 | <b>HS</b> |  |
| 800 Bonneville      |       |           |  |
| America             | 02-06 | <b>HS</b> |  |
| 800 Bonneville      |       |           |  |
| T100                |       |           |  |
| Centennial          |       |           |  |
| Edition             | 02-04 | <b>HS</b> |  |
| 800 Bonneville      |       |           |  |
| T100                |       |           |  |
| Paul Smith          | 06-08 | <b>HS</b> |  |
| 800 Speedmaster     | 03-04 | <b>HS</b> |  |
| 800 Tiger           | 11-14 | <b>HS</b> |  |
| 800 Tiger XC        | 11-17 | <b>HS</b> |  |
| 800 Tiger XC ABS    | 12-14 | <b>HS</b> |  |
| 800 Tiger XCA       | 15-17 | <b>HS</b> |  |
| 800 Tiger XCR       | 15-17 | <b>HS</b> |  |
| 800 Tiger XR        | 15-17 | <b>HS</b> |  |
| 800 Tiger XR        | 18-   | <b>HS</b> |  |
| 800 Tiger XRT       | 15-17 | <b>HS</b> |  |
| 800 Tiger XRX       | 15-17 | <b>HS</b> |  |
| 900 Adventurer      | 96-02 | <b>HS</b> |  |
| 900 America         | 07-16 | <b>HS</b> |  |
| 900 Bonneville      | 05-11 | <b>HS</b> |  |
| 900 Bonneville      |       |           |  |
| Newchurch           | 15    | <b>HS</b> |  |
| 900 Bonneville SE   | 09-13 | <b>HS</b> |  |
| 900 Bonneville      |       |           |  |
| Spirit              | 15    | <b>HS</b> |  |
| 900 Bonneville      |       |           |  |
| Street Cup          | 17-18 | <b>HS</b> |  |
| 900 Bonneville      |       |           |  |
| T100                | 05-18 | <b>HS</b> |  |
| 900 Bonneville      |       |           |  |
| T100 Black          | 16-18 | <b>HS</b> |  |
| 900 Bonneville      |       |           |  |
| T214                | 15    | <b>HS</b> |  |
| 900 Legend TT       | 99-01 | <b>HS</b> |  |
| 900 Scrambler       | 06-16 | <b>HS</b> |  |
| 900 Speedmaster     | 05-15 | <b>HS</b> |  |
| 900 Street          |       |           |  |
| Scrambler           | 17-18 | <b>HS</b> |  |
| 900 Street Twin     | 16-18 | <b>HS</b> |  |
| 900 Thruxton        | 04-05 | <b>HS</b> |  |



|                  |       |           |           |
|------------------|-------|-----------|-----------|
| <b>TRIUMPH</b>   |       |           |           |
| 900 Thruxton Ace | 15    | <b>HS</b> |           |
| 900 Thunderbird  | 96-05 | <b>HS</b> |           |
| 900 Thunderbird  |       |           |           |
| Sport            | 03-04 | <b>HS</b> |           |
| 900 Tiger        | 99-00 | <b>HS</b> |           |
| 955 Tiger        | 01-04 | <b>HS</b> | <b>HF</b> |
| 955 Tiger        | 04-06 | <b>HS</b> |           |
| 1200 Bonneville  |       |           |           |
| Bobber           | 17    | <b>HS</b> |           |
| 1200 Bonneville  |       |           |           |
| T120             | 16-18 | <b>HS</b> |           |
| 1200 Bonneville  |       |           |           |
| T120 Black       | 16-18 | <b>HS</b> |           |
| 1200 Thruxton    | 16-18 | <b>HS</b> |           |
| <b>VOXAN</b>     |       |           |           |
| 1000 Scrambler   | 01-03 | <b>HF</b> |           |
| <b>YAMAHA</b>    |       |           |           |
| WR 125 R, XY     | 09-16 | <b>HF</b> |           |
| WR 250 X         | 08-16 | <b>HS</b> |           |

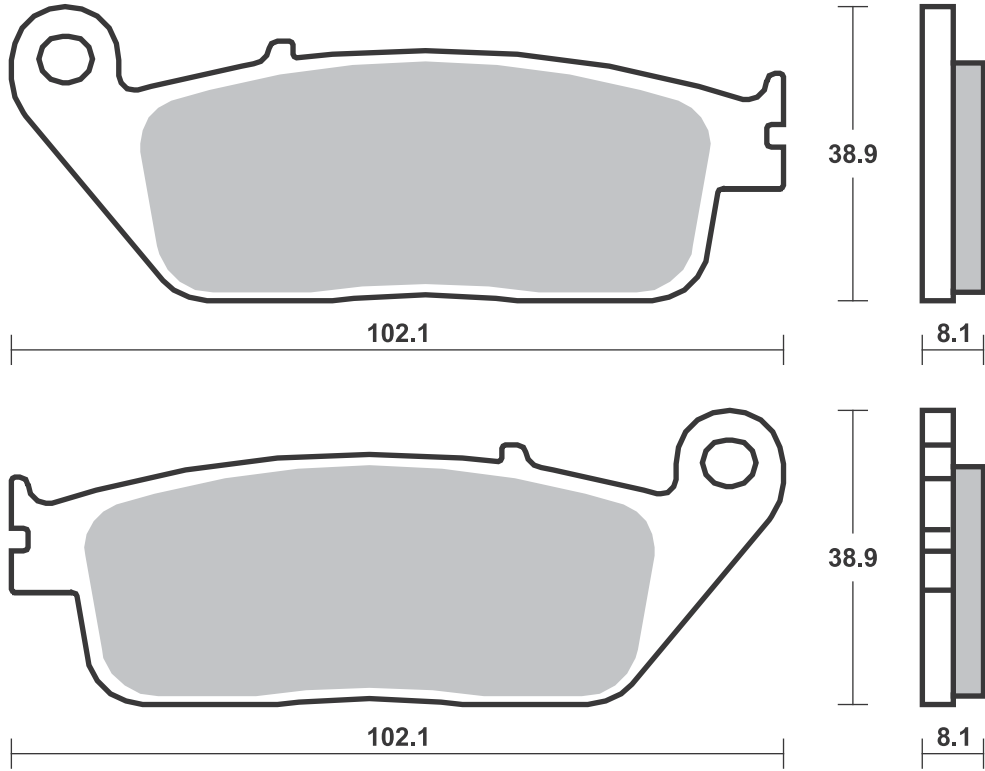

**SBS 628**

Recommended compound



| <b>HONDA</b> |       |    |           |
|--------------|-------|----|-----------|
| Lead         | 80 SS | 85 | <b>HF</b> |
|              |       |    |           |
|              |       |    |           |
|              |       |    |           |
|              |       |    |           |
|              |       |    |           |
|              |       |    |           |
|              |       |    |           |
|              |       |    |           |
|              |       |    |           |
|              |       |    |           |
|              |       |    |           |
|              |       |    |           |
|              |       |    |           |
|              |       |    |           |
|              |       |    |           |
|              |       |    |           |
|              |       |    |           |
|              |       |    |           |
|              |       |    |           |
|              |       |    |           |
|              |       |    |           |
|              |       |    |           |
|              |       |    |           |
|              |       |    |           |

**SBS 629**

Recommended compound



| <b>HONDA</b> |            |       |           |
|--------------|------------|-------|-----------|
| TLM          | 220        | 89-91 | <b>HF</b> |
| AX-1         | 250        | 90    | <b>HF</b> |
| CRM          | 250 R      | 90    | <b>HF</b> |
| XLR          | 250 R Baja | 88-90 | <b>SI</b> |
| TLM          | 260 R      | 90    | <b>HF</b> |
|              |            |       |           |
|              |            |       |           |
|              |            |       |           |
|              |            |       |           |
|              |            |       |           |
|              |            |       |           |
|              |            |       |           |
|              |            |       |           |
|              |            |       |           |
|              |            |       |           |
|              |            |       |           |
|              |            |       |           |
|              |            |       |           |
|              |            |       |           |
|              |            |       |           |
|              |            |       |           |
|              |            |       |           |
|              |            |       |           |
|              |            |       |           |
|              |            |       |           |
|              |            |       |           |
|              |            |       |           |

Brake Pad 1:1 Drawings,  
Compounds, Fitments



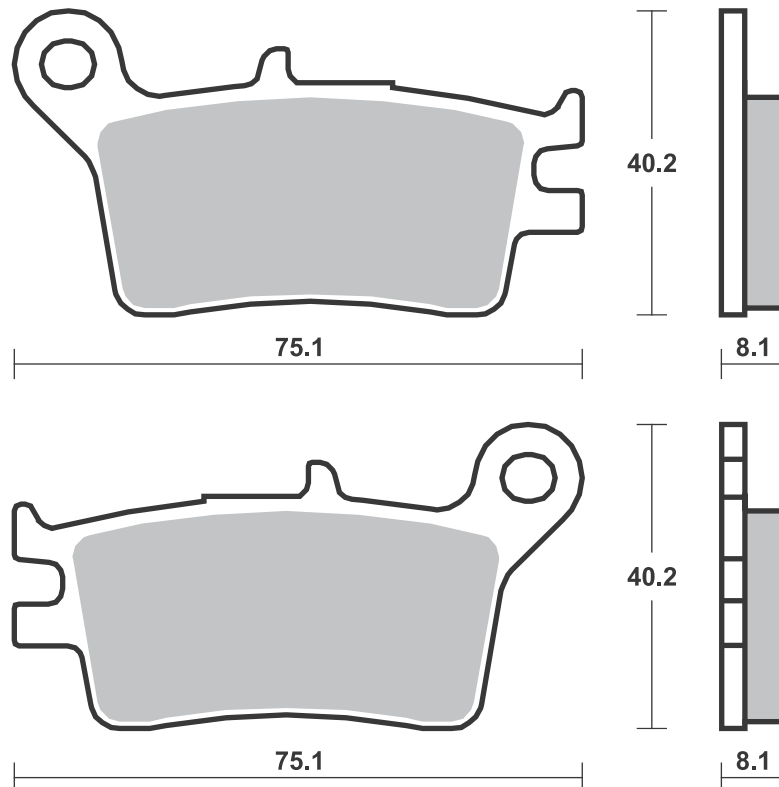
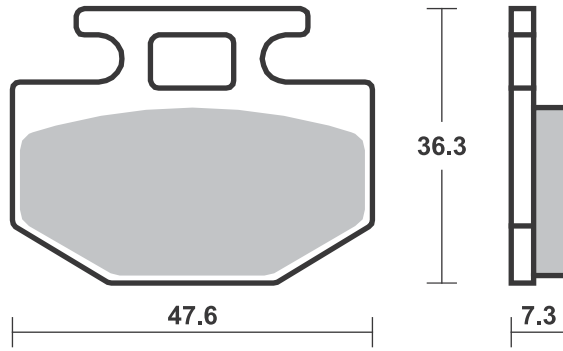

## Applications

### SBS 630 Recommended compound



| DAELIM |               |       |    |
|--------|---------------|-------|----|
|        | 125 Roadwin   | 04-12 | HF |
|        | 125 Rocket    | 99-01 | HF |
| VL     | 125 Daystar   | 00-12 | HF |
| VT     | 125 Evolution | 00-03 | HF |
| VT     | 125 Magna     | 97-99 | HF |
|        | 250 Roadwin   | 08-12 | HF |

| HONDA |                       |       |    |
|-------|-----------------------|-------|----|
| VRX   | 400 T Roadstar        | 95-99 | HS |
| DN-01 | 680                   | 08-11 | LS |
| VF    | 750 C,<br>CD Magna    | 94-98 | HS |
| VFR   | 750 F                 | 88-98 | LS |
| VFR   | 950 F, Carat          | 92    | LS |
| CBR   | 1000 F                | 89-92 | LS |
| VFR   | 1000                  | 89    | LS |
| CTX   | 1300                  | 14-18 | LS |
| GL    | 1500 F6 C<br>Valkyrie | 96-02 | LS |

| INDIAN |                              |       |      |
|--------|------------------------------|-------|------|
|        | 1800 Chief                   | 15-18 | H.LS |
|        | 1800 Chief Classic           | 14-18 | H.LS |
|        | 1800 Chief Dark<br>Horse     | 15-18 | H.LS |
|        | 1800 Chief Vintage           | 14-18 | H.LS |
|        | 1800 Chieftain               | 14-18 | H.LS |
|        | 1800 Chieftain<br>Classic    | 15-18 | H.LS |
|        | 1800 Chieftain<br>Dark Horse | 15-18 | H.LS |



| INDIAN |                                |       |      |
|--------|--------------------------------|-------|------|
|        | 1800 Chieftain<br>Limited      | 15-18 | H.LS |
|        | 1800 Dark Horse                | 16-18 | H.LS |
|        | 1800 Roadmaster                | 15-18 | H.LS |
|        | 1800 Roadmaster<br>Classic     | 15-18 | H.LS |
|        | 1800 Roadmaster<br>Elite       | 15-18 | H.LS |
|        | 1800 Springfield               | 16-18 | H.LS |
|        | 1800 Springfield<br>Dark Horse | 15-18 | H.LS |

| TRIUMPH |                          |       |    |
|---------|--------------------------|-------|----|
|         | 900 Adventurer           | 96-02 | LS |
|         | 900 Legend TT            | 99-01 | LS |
|         | 900 Thunderbird          | 96-05 | LS |
|         | 900 Thunderbird<br>Sport | 03-04 | LS |
|         | 900 Tiger                | 99-00 | LS |

| VICTORY |                            |       |      |
|---------|----------------------------|-------|------|
|         | 1634 Hammer                | 08    | H.LS |
|         | 1634 Kingpin<br>all models | 08-12 | H.LS |
|         | 1634 Vegas                 | 08-17 | H.LS |
|         | 1634 Vegas 8-Ball          | 08-17 | H.LS |
|         | 1634 Vegas<br>Jackpot      | 08    | H.LS |
|         | 1731 Boardwalk             | 13-15 | H.LS |
|         | 1731 Cross<br>Country      | 10-17 | H.LS |



| VICTORY |                             |       |      |
|---------|-----------------------------|-------|------|
|         | 1731 Cross<br>Country       |       |      |
|         | 8-Ball                      | 14-16 | H.LS |
|         | 1731 Cross<br>Country Tour  | 12-17 | H.LS |
|         | 1731 Cross Roads            | 10-12 | H.LS |
|         | 1731 Cross<br>Roads 8-Ball  | 14    | H.LS |
|         | 1731 Cross Roads<br>Classic | 14    | H.LS |
|         | 1731 Gunner                 | 15-17 | H.LS |
|         | 1731 Hammer                 | 09-11 | H.LS |
|         | 1731 Hammer<br>8-Ball       | 10-16 | H.LS |
|         | 1731 Hammer S               | 09-17 | H.LS |
|         | 1731 Hard-Ball              | 12-13 | H.LS |
|         | 1731 High-Ball              | 12-17 | H.LS |
|         | 1731 Jackpot                | 10-16 | H.LS |
|         | 1731 Judge                  | 13-17 | H.LS |
|         | 1731 Kingpin                | 10-12 | H.LS |
|         | 1731 Kingpin<br>8-Ball      | 10-11 | H.LS |
|         | 1731 Magnum                 | 15-17 | H.LS |
|         | 1731 Magnum X-1             | 15-17 | H.LS |
|         | 1731 Vegas                  | 10-17 | H.LS |
|         | 1731 Vegas 8-Ball           | 10-17 | H.LS |
|         | 1731 Vegas<br>Jackpot       | 09    | H.LS |
|         | 1731 Vision<br>all models   | 08-17 | H.LS |

### SBS 631 Recommended compound



| BERINGER |                  |  |  |
|----------|------------------|--|--|
|          | 4 Piston Caliper |  |  |

| HUSABERG |          |       |     |
|----------|----------|-------|-----|
| FS       | 400 e, c | 01-03 | RSI |
| FS       | 450 e, c | 03-05 | RSI |
| FS       | 650 e, c | 01-05 | RSI |

| KAWASAKI |                  |       |    |
|----------|------------------|-------|----|
| KR-1     | 250 S            | 90    | HF |
| ZX-4     | 400              | 90    | HS |
| ZXR      | 400              | 89-90 | HF |
| ZZR      | 400              | 90-94 | HS |
| GPZ      | 500              | 93-95 | HS |
| ZZR      | 500 (Austria)    | 90-98 | HS |
|          | 600 R, Ninja     | 89-96 | HF |
| ZX-6R    | 600 (Ninja ZX6)  | 93-97 | HS |
| ZX-6R    | 600 (Ninja ZX6R) | 95-97 | HS |
| ZX-6R    | 600 (ZX6)        | 90-93 | HS |
| ZZR      | 600              | 90-05 | HS |
| ZX-7R    | 750 Ninja        | 89-95 | HS |
| ZXR      | 750 R            | 89-95 | HS |
| GPZ      | 900 R            | 90-96 | HS |
| ZX-9R    | 900 Ninja        | 94-95 | HS |
| KLE      | 1000 Versys      | 12-18 | SP |
| KLE      | 1000 Versys ABS  | 15-16 | SP |
| KLE      | 1000 Versys LT   | 15-16 | SP |
| ZR       | 1100 Zephyr      | 92-95 | HS |
| ZX       | 1100             | 93-97 | HS |
| ZZR      | 1100             | 90-01 | HS |
| ZZR      | 1200             | 02-04 | HS |
| VN       | 1700 Voyager     | 09-16 | HS |



| KAWASAKI |      |       |    |
|----------|------|-------|----|
| VN       | 2000 | 04-10 | HS |

| MOTO-MASTER |                          |  |  |
|-------------|--------------------------|--|--|
|             | Supermoto Racing Caliper |  |  |

| SUZUKI |                  |       |    |
|--------|------------------|-------|----|
| RG     | 125 F, Gamma     | 92-96 | HF |
| RG     | 200 Gamma        | 91-94 | HS |
|        | 250 Cobra        | 90-92 | HS |
|        | 250 Wolf         | 90-92 | HS |
| GSX-R  | 250 R            | 89-91 | HS |
| RGV    | 250              | 89-90 | HF |
| RGV    | 250              | 93-95 | HF |
| RGV    | 250 Gamma        | 91-92 | HF |
| TV     | 250              | 88    | HF |
|        | 350 Goose        | 92-99 | HF |
| GSF    | 400 Bandit       | 93-97 | HS |
| GSX    | 400 S, Katana    | 92    | HS |
| GSX-R  | 400              | 88-89 | HF |
| GSR    | 600              | 06-10 | HS |
| GSX-R  | 600              | 97-03 | HS |
| GSF    | 650 Bandit       | 07-11 | HS |
| GSF    | 650 Bandit ABS   | 07-12 | HS |
| GSF    | 650 S Bandit     | 07-11 | HS |
| GSF    | 650 S Bandit ABS | 07-13 | HS |
| GSX    | 650 F            | 08-18 | HS |
| GSX-R  | 750 Y            | 00-03 | HS |
| SV     | 1000, S          | 03-07 | HS |
| TL     | 1000 S V-Twin    | 97-01 | HS |
| GSF    | 1200 Bandit      | 06    | HS |
| GSF    | 1200 S Bandit    | 06    | HS |



| SUZUKI |                   |       |    |
|--------|-------------------|-------|----|
| GSF    | 1250 A Bandit     | 07-18 | HS |
| GSF    | 1250 Bandit       | 06-18 | HS |
| GSF    | 1250 F Bandit     | 12-18 | HS |
| GSF    | 1250 S Bandit     | 06-18 | HS |
| GSF    | 1250 SA Bandit    | 07-18 | HS |
| GSX    | 1250 FA Bandit    | 16-18 | HS |
| GSX    | 1250 FA Traveller | 15-16 | HS |

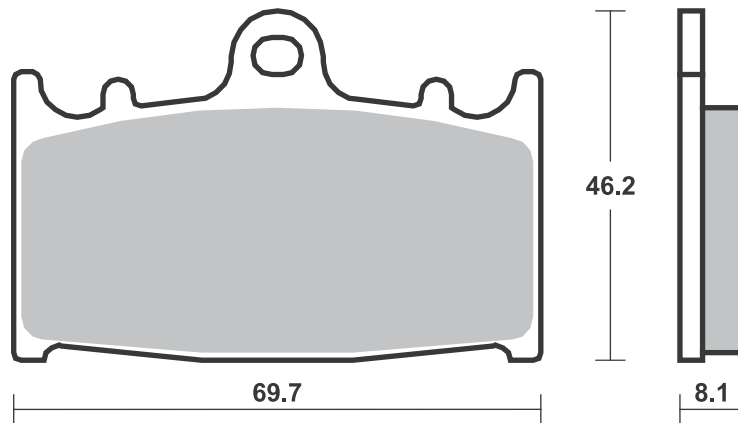
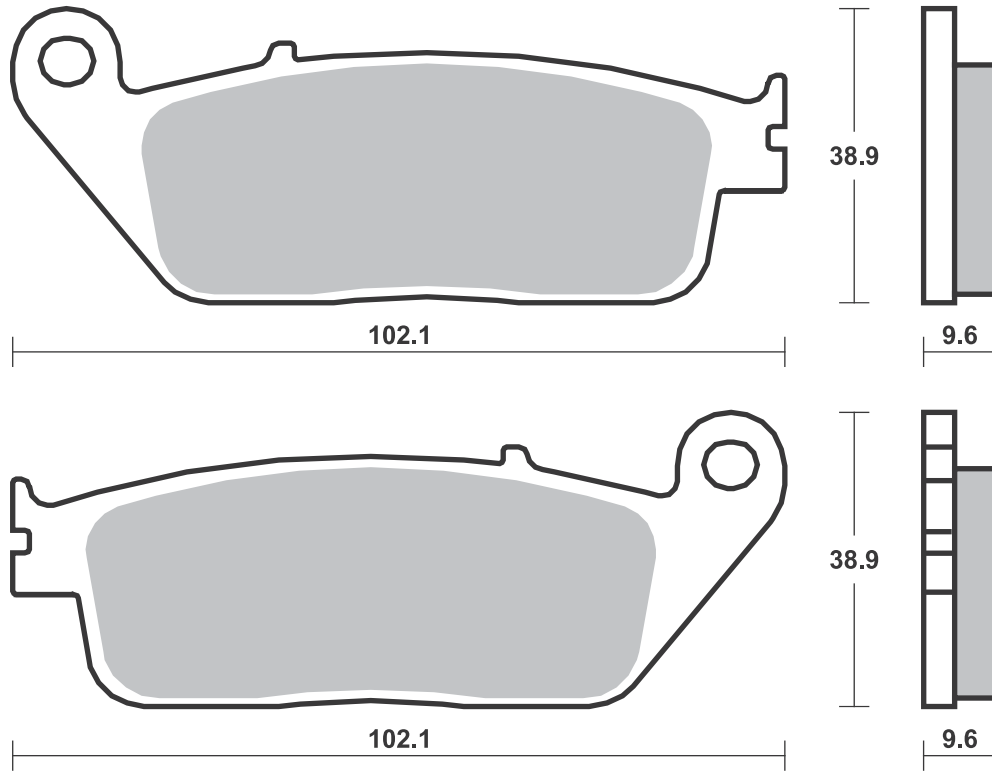

**SBS 632** Recommended compound

| <b>CANNONDALE</b> |            |       |            |
|-------------------|------------|-------|------------|
| MX                | 400        | 00-03 | <b>RSI</b> |
| C                 | 440 R      | 03    | <b>RSI</b> |
| E                 | 440 , A, R | 03    | <b>RSI</b> |
| S                 | 440        | 03    | <b>HF</b>  |
| X                 | 440        | 03    | <b>RSI</b> |

| <b>KAWASAKI</b> |        |       |            |
|-----------------|--------|-------|------------|
| KDX             | 125    | 90-94 | <b>SI</b>  |
| KX              | 125    | 89-94 | <b>RSI</b> |
| KDX             | 200    | 93-99 | <b>SI</b>  |
| KDX             | 200 SR | 89-92 | <b>SI</b>  |
| KDX             | 220 R  | 97-05 | <b>SI</b>  |
| KDX             | 250 SR | 91-94 | <b>SI</b>  |
| KLX             | 250    | 93-96 | <b>SI</b>  |
| KX              | 250    | 89-94 | <b>RSI</b> |
| KX              | 500    | 89-95 | <b>RSI</b> |
| KLX             | 650    | 93-96 | <b>SI</b>  |
| KLX             | 650 R  | 93-95 | <b>SI</b>  |

| <b>SUZUKI</b> |            |       |            |
|---------------|------------|-------|------------|
| RM            | 125        | 89-90 | <b>RSI</b> |
| TS            | 125        | 89-96 | <b>HF</b>  |
| TS            | 200 R      | 90-94 | <b>HF</b>  |
|               | 250 Djebel | 93-95 | <b>HF</b>  |
| DR            | 250        | 90-95 | <b>HF</b>  |
| RM            | 250        | 89-90 | <b>RSI</b> |

| <b>YAMAHA</b> |    |    |           |
|---------------|----|----|-----------|
| FZR           | 50 | 92 | <b>HF</b> |
| YD            | 80 | 89 | <b>HF</b> |



| <b>YAMAHA</b> |                  |       |            |
|---------------|------------------|-------|------------|
| DT            | 125 X            |       |            |
|               | Supermotard      | 05-08 | <b>HF</b>  |
| WR            | 125              | 91-97 | <b>SI</b>  |
| YZ            | 125              | 90-95 | <b>RSI</b> |
| DT            | 200 WR           | 91-93 | <b>HF</b>  |
| WR            | 200              | 91-92 | <b>SI</b>  |
| TT            | 250              | 93-03 | <b>SI</b>  |
| TY            | 250 Z (Scottish) | 96    | <b>RSI</b> |
| WR            | 250              | 90-97 | <b>SI</b>  |
| XG            | 250 Tricker      | 05-11 | <b>HF</b>  |
| XT            | 250              | 08    | <b>HF</b>  |
| YZ            | 250 A            | 90    | <b>RSI</b> |
| YZ            | 250 WRA,WRB      | 90-91 | <b>RSI</b> |
| TT            | 350              | 95-00 | <b>SI</b>  |
| WR            | 500 ZD,ZE        | 92-93 | <b>SI</b>  |
| TT            | 600 R            | 93-95 | <b>HF</b>  |

**SBS 633** Recommended compound

| <b>MZ</b> |            |       |           |
|-----------|------------|-------|-----------|
|           | 125 SM, SX | 99-08 | <b>HF</b> |
| RT        | 125        | 06-08 | <b>HF</b> |

| <b>TRIUMPH</b> |              |       |           |
|----------------|--------------|-------|-----------|
|                | 750 Daytona  | 91-92 | <b>LS</b> |
|                | 900 Daytona  | 91-94 | <b>LS</b> |
|                | 900 Daytona  |       |           |
|                | Super III    | 94-98 | <b>LS</b> |
|                | 900 Trophy   | 96-03 | <b>LS</b> |
|                | 1000 Daytona | 92    | <b>LS</b> |
|                | 1200 Daytona | 91-97 | <b>LS</b> |
|                | 1200 Trophy  | 96-03 | <b>LS</b> |

| <b>VOXAN</b> |                |       |           |
|--------------|----------------|-------|-----------|
|              | 1000 Scrambler | 01-03 | <b>HF</b> |

| <b>YAMAHA</b> |                  |       |           |
|---------------|------------------|-------|-----------|
| XTZ           | 750 Super Tenere |       |           |
|               | Left/Rear        | 89-95 | <b>HF</b> |

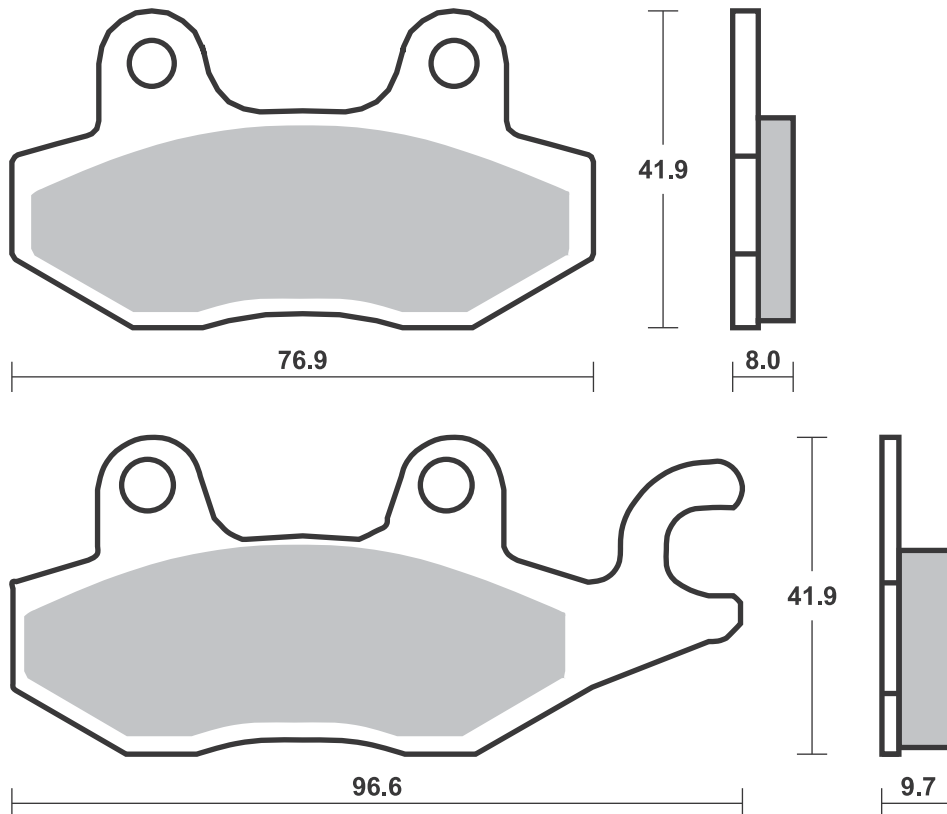
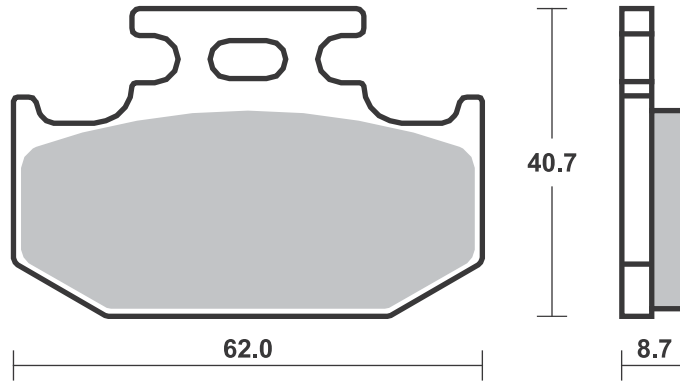



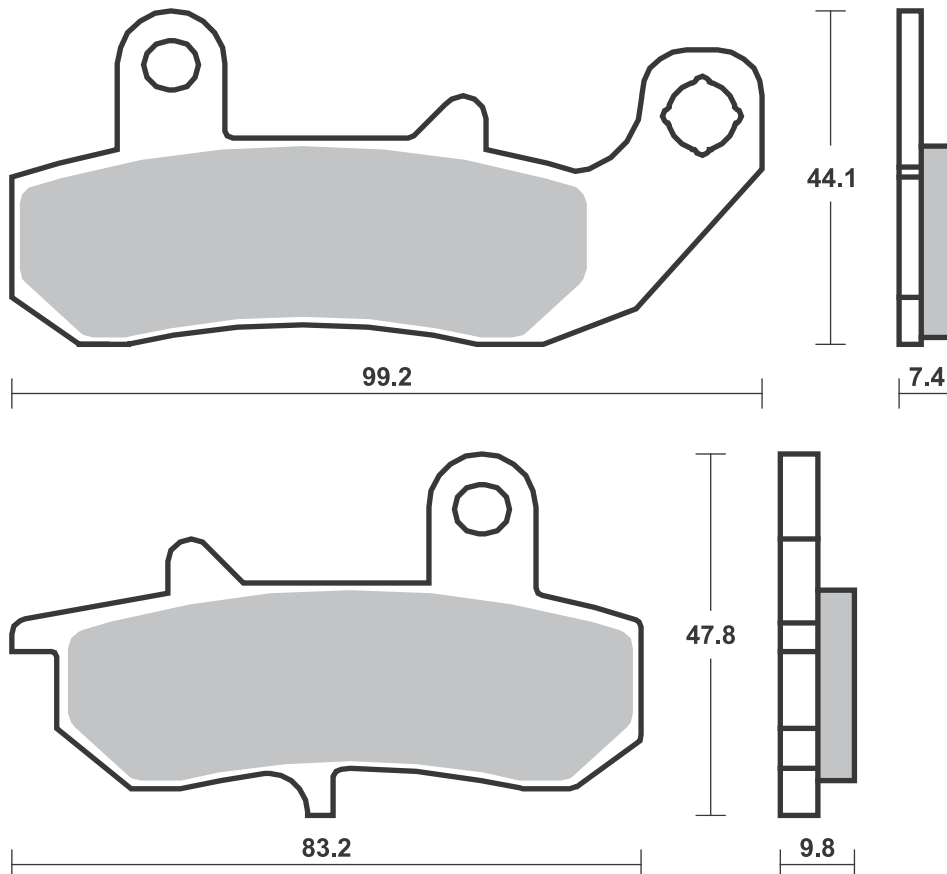
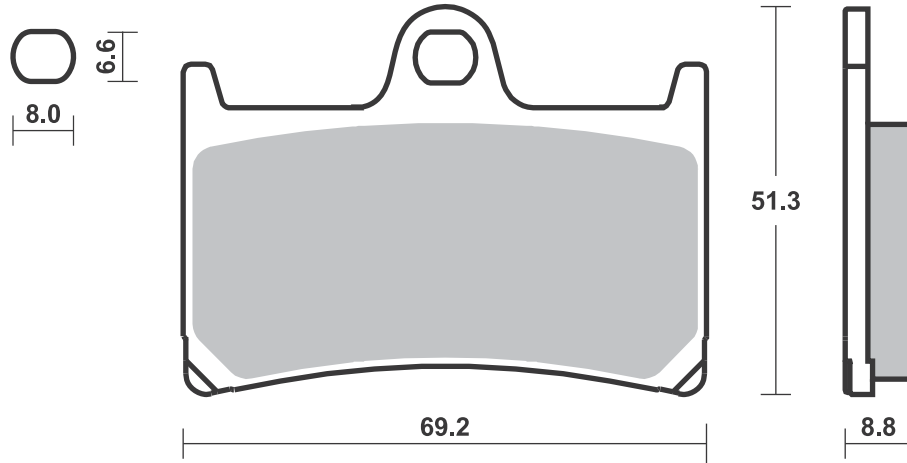





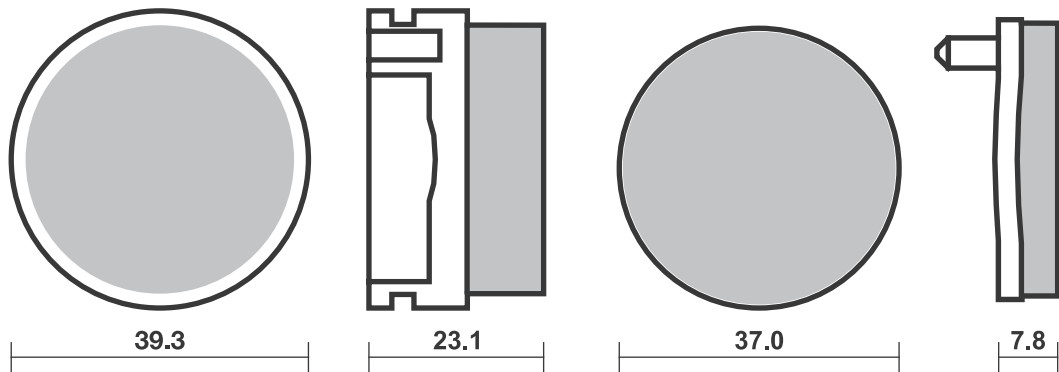
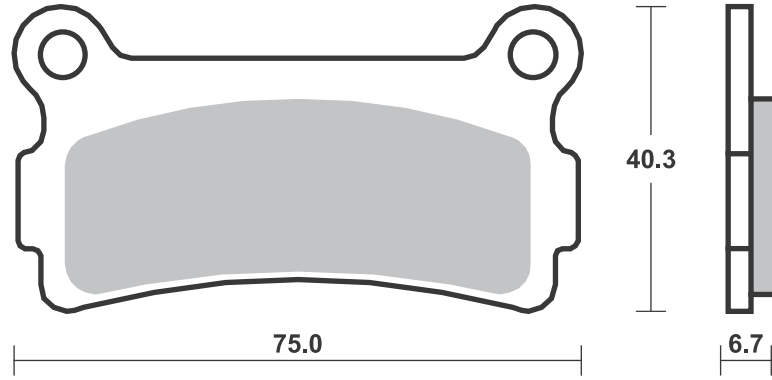

## Applications

### SBS 638 Recommended compound



| AEON         |       |  |           |
|--------------|-------|--|-----------|
| 125 Overland | 02-11 |  | <b>SI</b> |
| 180 Overland | 02-11 |  | <b>SI</b> |
| 180 Roadster | 02-09 |  | <b>SI</b> |

| ARCTIC CAT |       |  |           |
|------------|-------|--|-----------|
| 50 DVX     | 06-08 |  | <b>SI</b> |
| 90 DVX     | 06-14 |  | <b>SI</b> |

| CAGIVA            |       |  |           |
|-------------------|-------|--|-----------|
| 500 Canyon        | 99-01 |  | <b>LS</b> |
| 600 Canyon        | 95-99 |  | <b>LS</b> |
| 900 Canyon I.E.   | 97    |  | <b>LS</b> |
| 900 Elefant I.E.  | 91-92 |  | <b>LS</b> |
| 900 Gran Canyon   | 99-04 |  | <b>LS</b> |
| 1000 Navigator, T | 00-05 |  | <b>LS</b> |

| CAN-AM             |       |  |           |
|--------------------|-------|--|-----------|
| 800 Commander      |       |  |           |
| Left/Rear          | 11-14 |  | <b>SI</b> |
| 1000 Commander     |       |  |           |
| Left/Rear          | 11-14 |  | <b>SI</b> |
| 1000 Commander     |       |  |           |
| MAX Left           | 14-16 |  | <b>SI</b> |
| 1000 Maverick Left | 13-17 |  | <b>SI</b> |

| CF MOTO          |       |  |           |
|------------------|-------|--|-----------|
| 550 U-Force Left | 15-16 |  | <b>SI</b> |
| 550 Z-Force Left | 15-16 |  | <b>SI</b> |
| 800 Z-Force EX   |       |  |           |
| Left             | 15    |  | <b>SI</b> |

| HONDA        |       |  |           |
|--------------|-------|--|-----------|
| CB 125 F     | 15-18 |  | <b>HF</b> |
| CA 250 Rebel | 90-95 |  | <b>HF</b> |

| HYOSUNG |       |  |           |
|---------|-------|--|-----------|
| GV 250  | 17-18 |  | <b>HF</b> |
| GV 300  | 16-17 |  | <b>HF</b> |

| JINCHENG     |    |  |           |
|--------------|----|--|-----------|
| JC 125 2A/3A | 97 |  | <b>HF</b> |

| KAWASAKI             |       |  |           |
|----------------------|-------|--|-----------|
| BN 125 Eliminator A3 | 00-07 |  | <b>HF</b> |



| KAWASAKI            |       |  |           |           |  |
|---------------------|-------|--|-----------|-----------|--|
| EX 250 R Ninja      | 08-12 |  | <b>HF</b> | <b>HF</b> |  |
| EX 250 SL Ninja     | 15-17 |  | <b>HS</b> | <b>LS</b> |  |
| Z 250 SL            | 15-17 |  | <b>HF</b> | <b>HF</b> |  |
| EX 300 R Ninja, ABS | 13-17 |  | <b>HS</b> | <b>LS</b> |  |
| KLE 300 Versys-X    | 17-18 |  |           | <b>LS</b> |  |
| KLF 300 Bayou Right | 89-05 |  | <b>SI</b> |           |  |
| Z 300               | 15-16 |  | <b>HS</b> | <b>LS</b> |  |
| KLF 400 Bayou Right | 93-99 |  | <b>SI</b> |           |  |
| Z 400 Ninja         | 18-   |  | <b>HS</b> | <b>LS</b> |  |
| KLR 650             | 08-10 |  |           | <b>LS</b> |  |

|                     |       |  |           |  |  |
|---------------------|-------|--|-----------|--|--|
| KVF 650 Brute Force |       |  |           |  |  |
| 4x4i Right          | 05-11 |  | <b>SI</b> |  |  |
| KRF 750 Teryx 4x4   |       |  |           |  |  |
| Right               | 08-13 |  | <b>SI</b> |  |  |
| KVF 750 Brute Force |       |  |           |  |  |
| 4x4i Right          | 05-15 |  | <b>SI</b> |  |  |

|                 |       |  |           |  |  |
|-----------------|-------|--|-----------|--|--|
| 800 Mule Pro FX |       |  |           |  |  |
| Right           | 15-17 |  | <b>SI</b> |  |  |

|               |       |  |           |  |  |
|---------------|-------|--|-----------|--|--|
| KRF 800 Teryx |       |  |           |  |  |
| BEF/CEF/DEF   |       |  |           |  |  |
| Right         | 14-17 |  | <b>SI</b> |  |  |

|                 |       |  |           |  |  |
|-----------------|-------|--|-----------|--|--|
| KRT 800 Teryx 4 |       |  |           |  |  |
| BEF/CEF/DEF     |       |  |           |  |  |
| Right           | 14-17 |  | <b>SI</b> |  |  |

| KREIDLER      |       |  |           |  |  |
|---------------|-------|--|-----------|--|--|
| 125 Florett D | 07-08 |  | <b>HF</b> |  |  |
| 125 Florett   |       |  |           |  |  |
| RMC-F         | 07-08 |  | <b>HF</b> |  |  |

| MOTOR UNION  |       |  |           |  |  |
|--------------|-------|--|-----------|--|--|
| HK 250 Hooke | 97-99 |  | <b>HF</b> |  |  |

| SUZUKI             |       |  |           |           |  |
|--------------------|-------|--|-----------|-----------|--|
| LT-F 300 King Quad |       |  |           |           |  |
| Right              | 02    |  | <b>SI</b> |           |  |
| LT-R 450 Right     | 06-12 |  | <b>SI</b> |           |  |
| LT-A 500 FY        |       |  |           |           |  |
| Quadmaster         |       |  |           |           |  |
| Right              | 00-08 |  | <b>SI</b> |           |  |
| LT-F 500 F Left    | 98-07 |  | <b>SI</b> |           |  |
| DR 800 S, Big      | 91-95 |  |           | <b>LS</b> |  |
| DR 800 ST Big      | 96-98 |  |           | <b>LS</b> |  |



| TRIUMPH           |       |  |           |           |  |
|-------------------|-------|--|-----------|-----------|--|
| 750 Trident Right | 91-98 |  | <b>HS</b> |           |  |
| 900 Bonneville    | 05-08 |  |           | <b>LS</b> |  |
| 900 Daytona       | 94-98 |  |           | <b>LS</b> |  |
| 900 Daytona,      |       |  |           |           |  |
| Sprint Right      | 93    |  | <b>HS</b> |           |  |
| 900 Speed Triple  | 94-96 |  |           | <b>LS</b> |  |
| 900 Sprint        | 94-98 |  |           | <b>LS</b> |  |
| 900 Tiger Right   | 93-98 |  | <b>HS</b> |           |  |
| 900 Trident Right | 91-98 |  | <b>HS</b> |           |  |
| 900 Trophy Right  | 91-95 |  | <b>HS</b> |           |  |
| 955 Tiger         | 04-06 |  |           | <b>LS</b> |  |
| 1000 Trophy Right | 91-95 |  | <b>HS</b> |           |  |
| 1050 Tiger        | 07-13 |  |           | <b>LS</b> |  |
| 1050 Tiger SE     | 09-13 |  |           | <b>LS</b> |  |
| 1200 Trophy Right | 91-95 |  | <b>HS</b> |           |  |

| YAMAHA               |       |  |           |           |  |
|----------------------|-------|--|-----------|-----------|--|
| FZR 50               | 90-91 |  | <b>HF</b> |           |  |
| YBR 250              | 07-11 |  | <b>HF</b> |           |  |
| YFZ 450 S Left/Rear  | 04-09 |  | <b>SI</b> |           |  |
| YXR 450 Rhino Right  | 06-09 |  | <b>SI</b> |           |  |
| 660 Rhino Right      | 05-08 |  | <b>SI</b> |           |  |
| YFM 700 R Raptor     |       |  |           |           |  |
| Right                | 06-08 |  | <b>SI</b> |           |  |
| YFM 700 Raptor       | 09-14 |  | <b>SI</b> |           |  |
| YXR 700 Rhino Left   | 08-14 |  | <b>SI</b> | <b>SI</b> |  |
| XTZ 750 Super Tenere |       |  |           |           |  |
| Right                | 89-95 |  | <b>HF</b> |           |  |

### SBS 639 Recommended compound



| YAMAHA    |       |  |           |
|-----------|-------|--|-----------|
| FZR 250 R | 89-99 |  | <b>HF</b> |
| R1-Z 250  | 90-92 |  | <b>HF</b> |

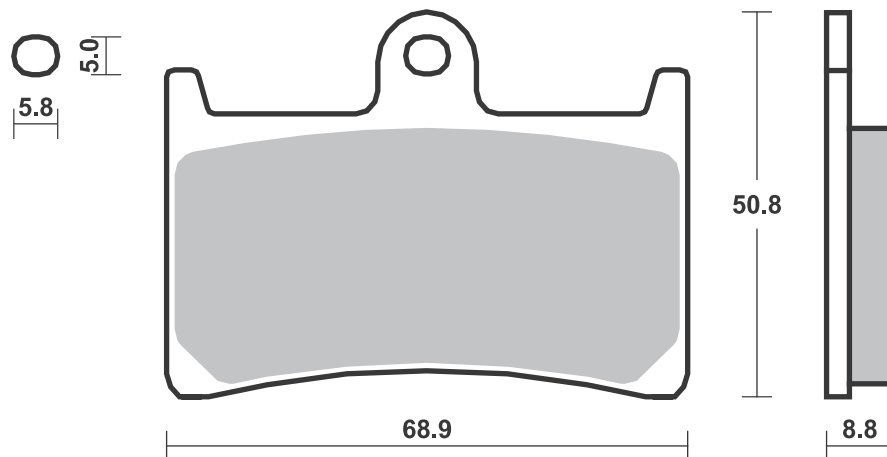
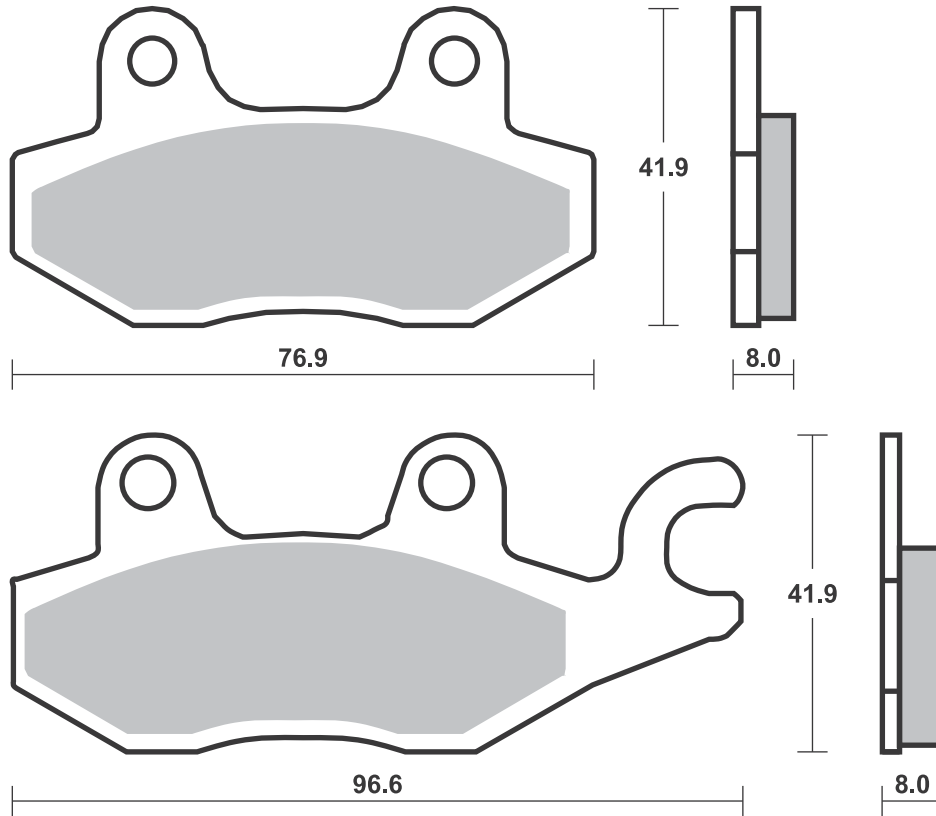



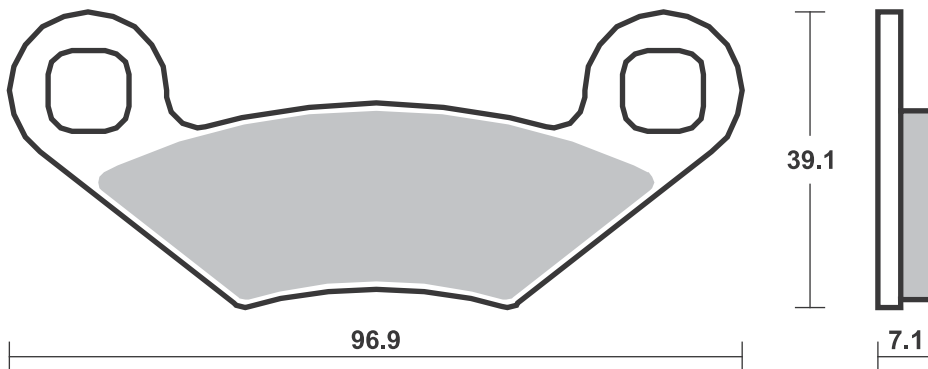
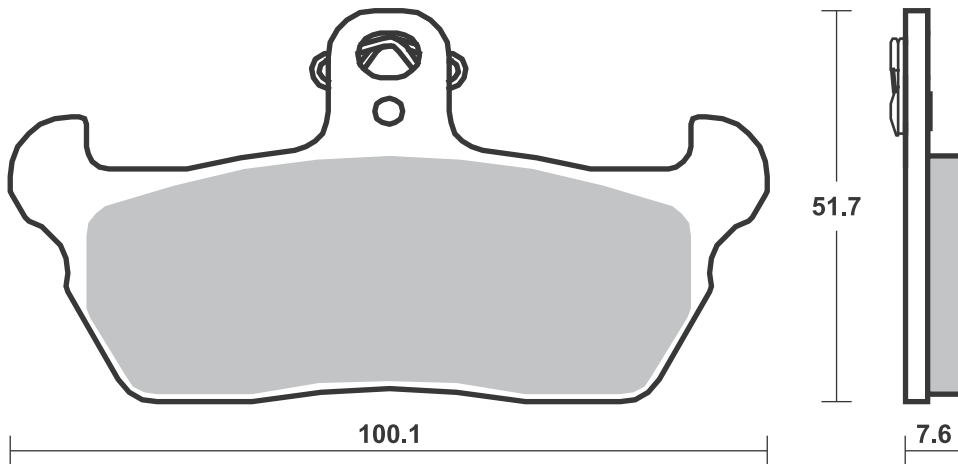
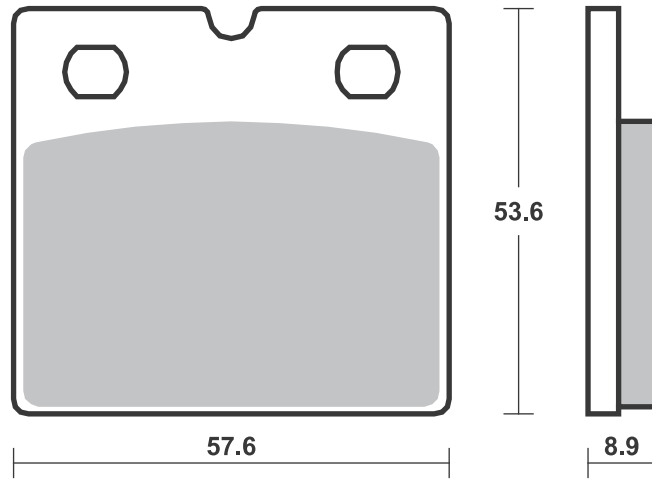



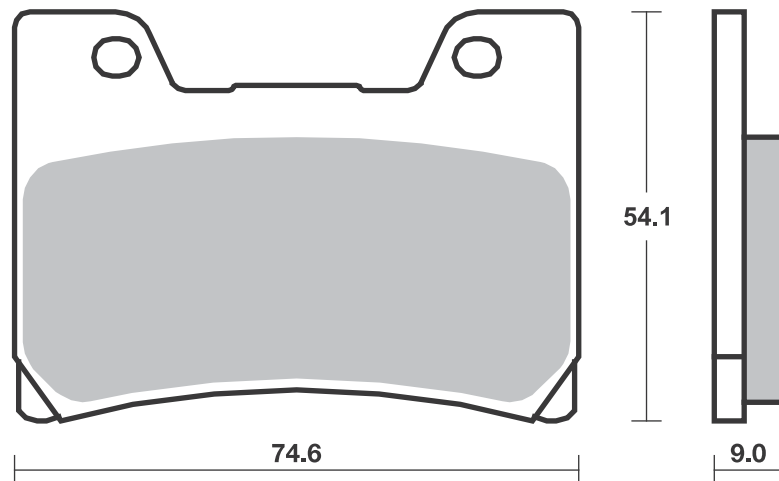
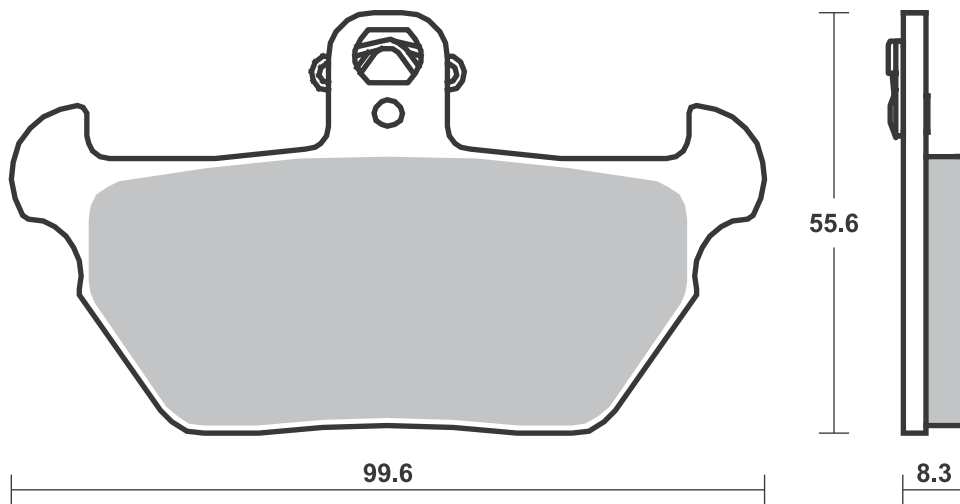
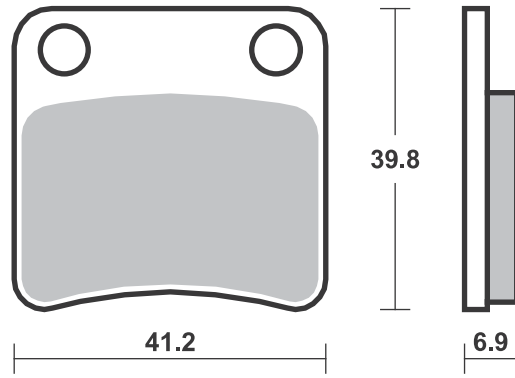

**SBS 646** Recommended compound



| <b>HONDA</b> |              |       |           |
|--------------|--------------|-------|-----------|
| CRM          | 125 , R      | 90-98 | <b>HF</b> |
| NSR          | 125 F, R     | 90-92 | <b>HF</b> |
| NSR          | 125 R, Italy | 89-01 | <b>HF</b> |
|              |              |       |           |
|              |              |       |           |
|              |              |       |           |
|              |              |       |           |
|              |              |       |           |
|              |              |       |           |
|              |              |       |           |
|              |              |       |           |
|              |              |       |           |
|              |              |       |           |
|              |              |       |           |
|              |              |       |           |
|              |              |       |           |

**SBS 647** Recommended compound



| <b>CAGIVA</b> |                  |       |           |
|---------------|------------------|-------|-----------|
|               | 500 Canyon       | 99-01 | <b>HS</b> |
|               | 750 Elefant      | 93-95 | <b>HS</b> |
|               | 900 Canyon I.E.  | 97    | <b>HS</b> |
|               | 900 Elefant I.E. | 91-92 | <b>HS</b> |
|               |                  |       |           |
|               |                  |       |           |
|               |                  |       |           |
|               |                  |       |           |
|               |                  |       |           |
|               |                  |       |           |
|               |                  |       |           |
|               |                  |       |           |
|               |                  |       |           |
|               |                  |       |           |
|               |                  |       |           |
|               |                  |       |           |

| <b>HONDA</b> |                    |       |           |
|--------------|--------------------|-------|-----------|
| CB           | 125 TT             | 90    | <b>HF</b> |
| NX           | 500 Dominator      |       |           |
|              | (Austria)          | 88-92 | <b>HS</b> |
| VT           | 600 C, Shadow      | 88-93 | <b>HS</b> |
| XL           | 600 V, Transalpino | 91-93 | <b>HS</b> |
| NX           | 650 Dominator      |       |           |
|              | J-K                | 88-92 | <b>HS</b> |
| XRV          | 650 Africa Twin    | 88-89 | <b>HS</b> |
| GL           | 1500 A, SE,        |       |           |
|              | I Gold Wing        | 94-99 | <b>HS</b> |
| GL           | 1500 Gold Wing,    |       |           |
|              | Gold Wing SE       | 88-99 | <b>HS</b> |



| <b>HONDA</b> |      |       |           |
|--------------|------|-------|-----------|
| GLX          | 1500 | 88-99 | <b>HF</b> |
|              |      |       |           |
|              |      |       |           |
|              |      |       |           |
|              |      |       |           |
|              |      |       |           |
|              |      |       |           |
|              |      |       |           |
|              |      |       |           |
|              |      |       |           |
|              |      |       |           |
|              |      |       |           |
|              |      |       |           |
|              |      |       |           |
|              |      |       |           |

**SBS 648** Recommended compound



| <b>SUZUKI</b> |             |       |            |
|---------------|-------------|-------|------------|
| RM            | 125         | 91-95 | <b>RSI</b> |
| DR-Z          | 250         | 01-07 | <b>SI</b>  |
| RM            | 250         | 91-95 | <b>RSI</b> |
| RMX           | 250         | 89-98 | <b>RSI</b> |
| DR            | 350         | 90-99 | <b>HF</b>  |
| DR            | 350 V, W, X | 97-99 | <b>SI</b>  |
| DR            | 650 SE T-W  | 96-99 | <b>HF</b>  |
|               |             |       |            |
|               |             |       |            |
|               |             |       |            |
|               |             |       |            |
|               |             |       |            |
|               |             |       |            |
|               |             |       |            |
|               |             |       |            |
|               |             |       |            |
|               |             |       |            |
|               |             |       |            |
|               |             |       |            |
|               |             |       |            |

| <b>YAMAHA</b> |           |       |            |
|---------------|-----------|-------|------------|
| YZ            | 125       | 96-97 | <b>RSI</b> |
| YZ            | 250 B1-J1 | 91-97 | <b>RSI</b> |
| WR            | 400 F     | 98    | <b>SI</b>  |
| YZ            | 400       | 98    | <b>RSI</b> |
|               |           |       |            |
|               |           |       |            |
|               |           |       |            |
|               |           |       |            |
|               |           |       |            |
|               |           |       |            |
|               |           |       |            |
|               |           |       |            |
|               |           |       |            |
|               |           |       |            |
|               |           |       |            |
|               |           |       |            |
|               |           |       |            |
|               |           |       |            |

Brake Pad 1:1 Drawings, Compounds, Fitments



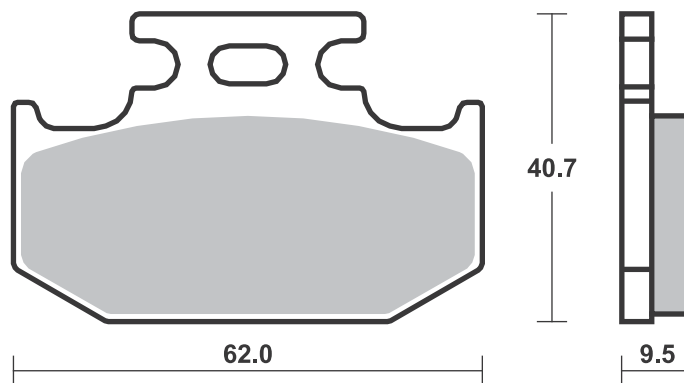
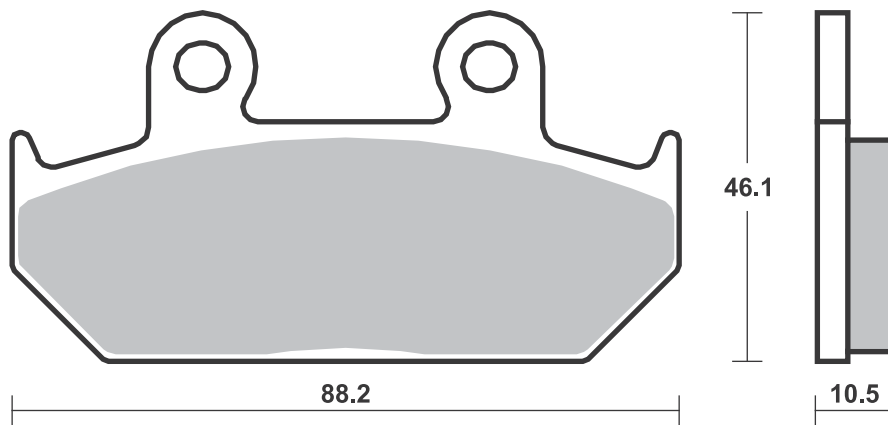
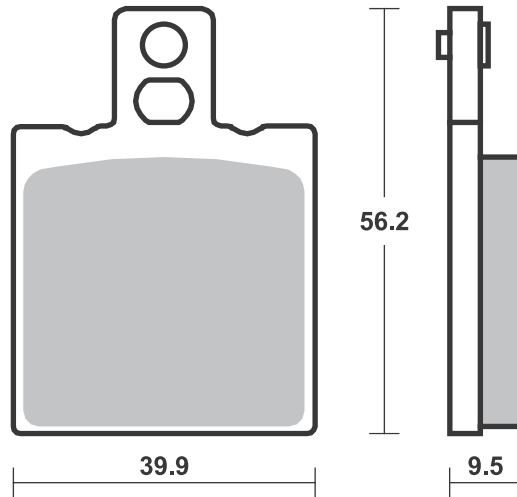

**SBS 649** Recommended compound



**ARCTIC CAT**

|         |       |           |
|---------|-------|-----------|
| 400 DVX | 04-08 | <b>SI</b> |
|---------|-------|-----------|

**HYOSUNG**

|        |       |           |
|--------|-------|-----------|
| TE 400 | 05-06 | <b>SI</b> |
| TE 450 | 07-11 | <b>SI</b> |

**KAWASAKI**

|         |       |           |
|---------|-------|-----------|
| KFX 400 | 02-05 | <b>SI</b> |
|---------|-------|-----------|

**SUZUKI**

|                     |       |           |
|---------------------|-------|-----------|
| LT 250              | 88-94 | <b>SI</b> |
| LT-Z 400 Quad Sport | 02-15 | <b>SI</b> |
| LT-R 450 Left/Rear  | 06-12 | <b>SI</b> |
| LT 500              | 87-95 | <b>SI</b> |

**SBS 650** Recommended compound



**YAMAHA**

|                    |       |           |
|--------------------|-------|-----------|
| 400 Artesia        | 91-92 | <b>HS</b> |
| XT 500 E (Austria) | 90-96 | <b>HS</b> |
| XT 600 E           | 90-03 | <b>HS</b> |
| XT 600 K           | 91-94 | <b>HS</b> |
| XTZ 660 Tenere     | 91-98 | <b>HS</b> |

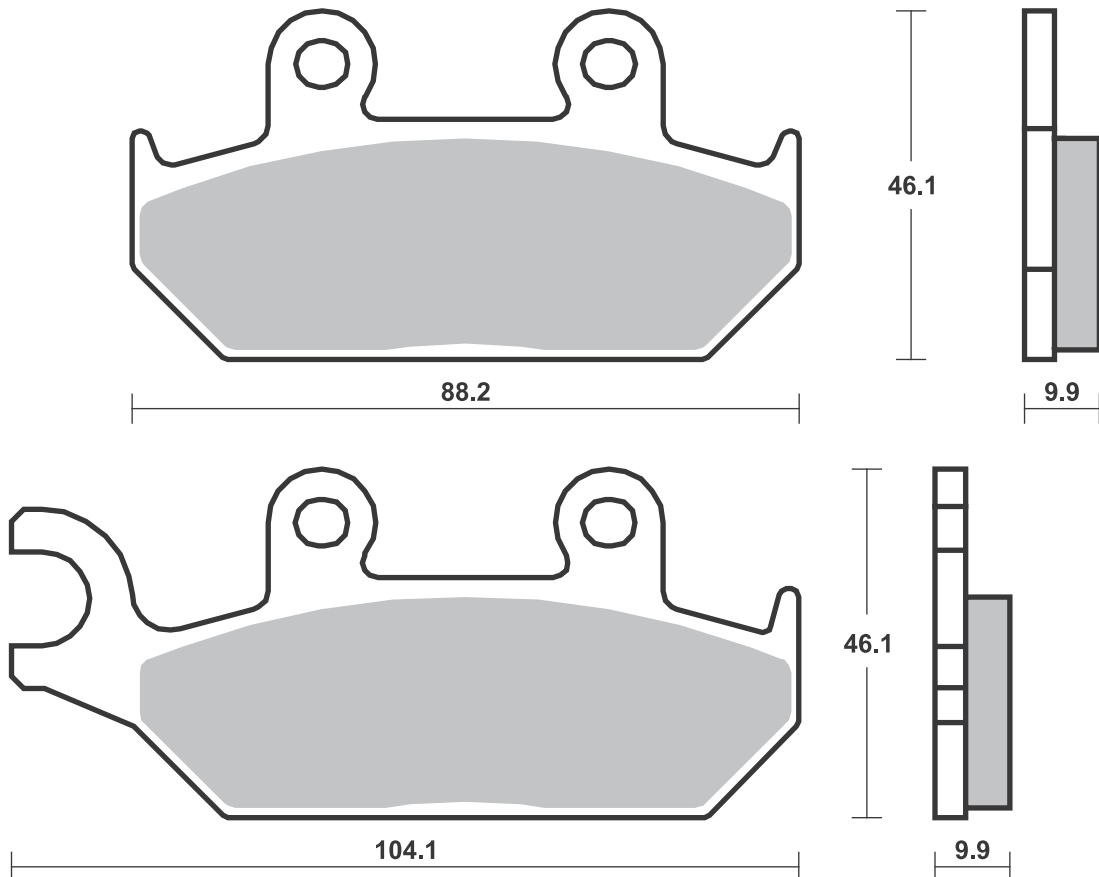
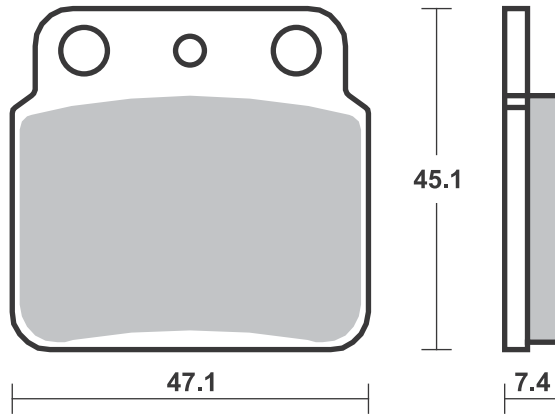

**SBS 651 Recommended compound**



| <b>APRILIA</b> |                  |       |           |
|----------------|------------------|-------|-----------|
|                | 125 Pegaso       | 92-99 | <b>HF</b> |
|                | 125 Tuareg Rally | 92    | <b>HF</b> |
| MX             | 125              | 04-07 | <b>HF</b> |
| MX             | 125 Supermoto    | 07    | <b>HF</b> |
| SX             | 125              | 08-13 | <b>HF</b> |
|                | 600 Pegaso       | 90-92 | <b>HF</b> |
|                | 650 Pegaso       | 92-94 | <b>HF</b> |
| <b>CAGIVA</b>  |                  |       |           |
| WMX            | 50               | 89    | <b>HF</b> |
|                |                  |       |           |
|                |                  |       |           |
|                |                  |       |           |
|                |                  |       |           |
|                |                  |       |           |
|                |                  |       |           |
|                |                  |       |           |
|                |                  |       |           |
|                |                  |       |           |
|                |                  |       |           |
|                |                  |       |           |
|                |                  |       |           |
|                |                  |       |           |
|                |                  |       |           |
|                |                  |       |           |
|                |                  |       |           |

**SBS 652 Recommended compound**



| <b>APRILIA</b> |                  |       |           |
|----------------|------------------|-------|-----------|
|                | 125 Classic      | 96-03 | <b>HF</b> |
|                | 125 Pegaso       | 90-91 | <b>HF</b> |
|                | 125 Red Rose     | 90-97 | <b>HF</b> |
|                | 125 Tuareg Rally | 92    | <b>HF</b> |
|                | 125 Tuareg Wind  | 90-94 | <b>HF</b> |
| <b>HRD</b>     |                  |       |           |
|                | 50 GS Enduro     | 00-02 | <b>HF</b> |
|                | 125 Supermotard  | 00-02 | <b>HF</b> |
|                | 125 Trail        | 00-02 | <b>HF</b> |
| <b>ITALJET</b> |                  |       |           |
| SM             | 125              | 02-05 | <b>HF</b> |
| <b>RIEJU</b>   |                  |       |           |
| MRX            | 125              | 03-08 | <b>HF</b> |
| SMX            | 125              | 03-07 | <b>HF</b> |
| <b>SIMSON</b>  |                  |       |           |
|                | 125 SM           | 01    | <b>HF</b> |
|                |                  |       |           |
|                |                  |       |           |
|                |                  |       |           |
|                |                  |       |           |
|                |                  |       |           |
|                |                  |       |           |
|                |                  |       |           |
|                |                  |       |           |
|                |                  |       |           |
|                |                  |       |           |
|                |                  |       |           |
|                |                  |       |           |

Brake Pad 1:1 Drawings,  
Compounds, Fitments

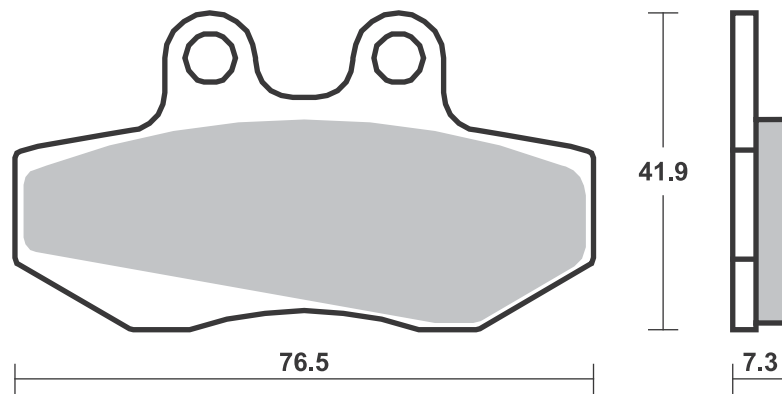
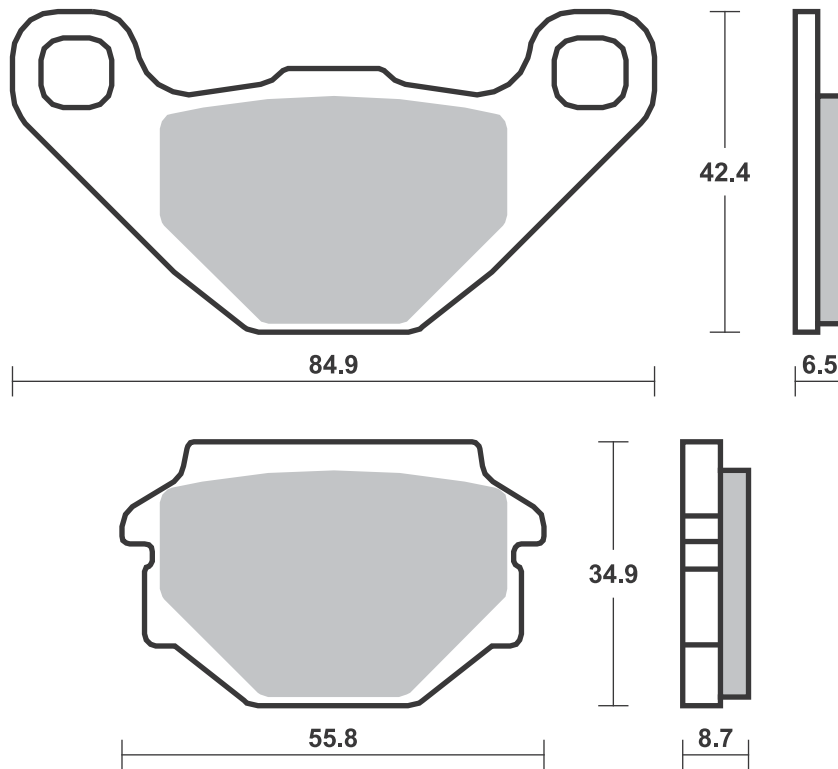

**SBS 653 Recommended compound**



**YAMAHA**

|     |                  |       |    |
|-----|------------------|-------|----|
| DT  | 125 Tenere Scout | 90-94 | HF |
| DTZ | 125 Tenere       | 90-94 | HF |
|     |                  |       |    |
|     |                  |       |    |
|     |                  |       |    |
|     |                  |       |    |
|     |                  |       |    |
|     |                  |       |    |
|     |                  |       |    |
|     |                  |       |    |
|     |                  |       |    |
|     |                  |       |    |
|     |                  |       |    |
|     |                  |       |    |
|     |                  |       |    |
|     |                  |       |    |
|     |                  |       |    |
|     |                  |       |    |
|     |                  |       |    |
|     |                  |       |    |
|     |                  |       |    |
|     |                  |       |    |
|     |                  |       |    |
|     |                  |       |    |
|     |                  |       |    |
|     |                  |       |    |
|     |                  |       |    |
|     |                  |       |    |
|     |                  |       |    |
|     |                  |       |    |
|     |                  |       |    |
|     |                  |       |    |

**SBS 654 Recommended compound**



**HONDA**

|     |                |       |    |
|-----|----------------|-------|----|
| VTR | 250            | 98-02 | HF |
| CB  | 400 Super Four | 92-95 | HS |
| NTV | 650            | 94-97 | HS |
| ST  | 1100           | 90-02 | LS |
| ST  | 1100 ABS-TCS   | 92-95 | LS |

**YAMAHA**

|       |      |       |    |
|-------|------|-------|----|
| MT-01 | 1700 | 05-16 | LS |
|       |      |       |    |
|       |      |       |    |
|       |      |       |    |
|       |      |       |    |
|       |      |       |    |
|       |      |       |    |
|       |      |       |    |
|       |      |       |    |
|       |      |       |    |
|       |      |       |    |
|       |      |       |    |
|       |      |       |    |
|       |      |       |    |
|       |      |       |    |
|       |      |       |    |
|       |      |       |    |
|       |      |       |    |
|       |      |       |    |
|       |      |       |    |
|       |      |       |    |
|       |      |       |    |
|       |      |       |    |
|       |      |       |    |
|       |      |       |    |
|       |      |       |    |
|       |      |       |    |
|       |      |       |    |
|       |      |       |    |
|       |      |       |    |
|       |      |       |    |
|       |      |       |    |
|       |      |       |    |
|       |      |       |    |
|       |      |       |    |
|       |      |       |    |
|       |      |       |    |
|       |      |       |    |
|       |      |       |    |

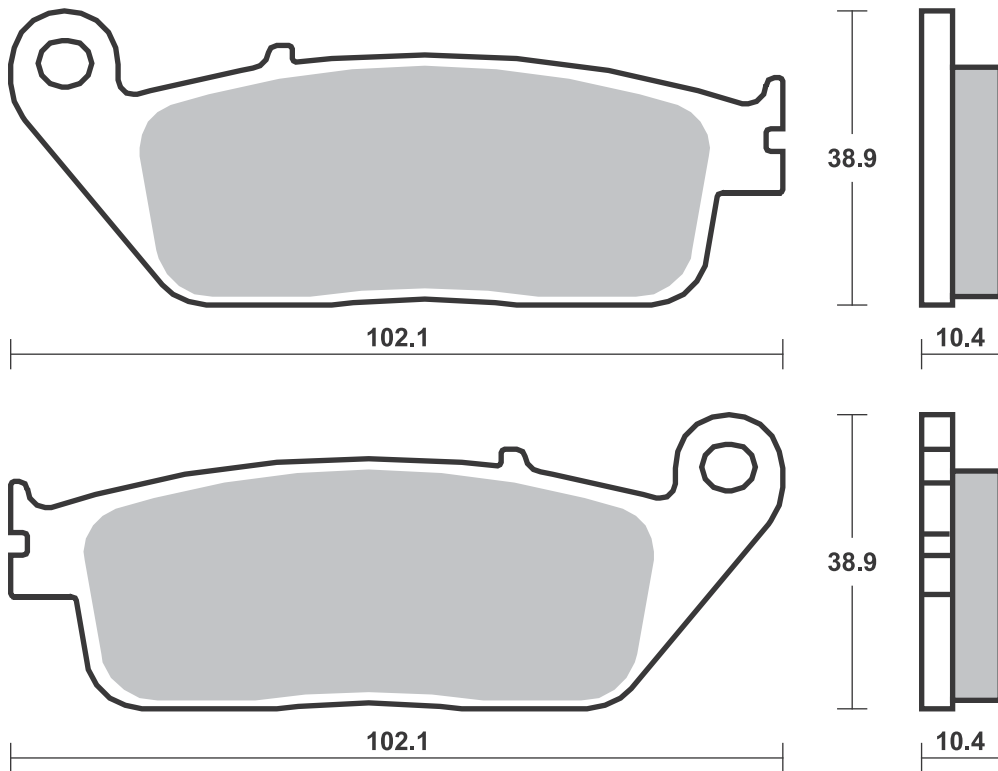
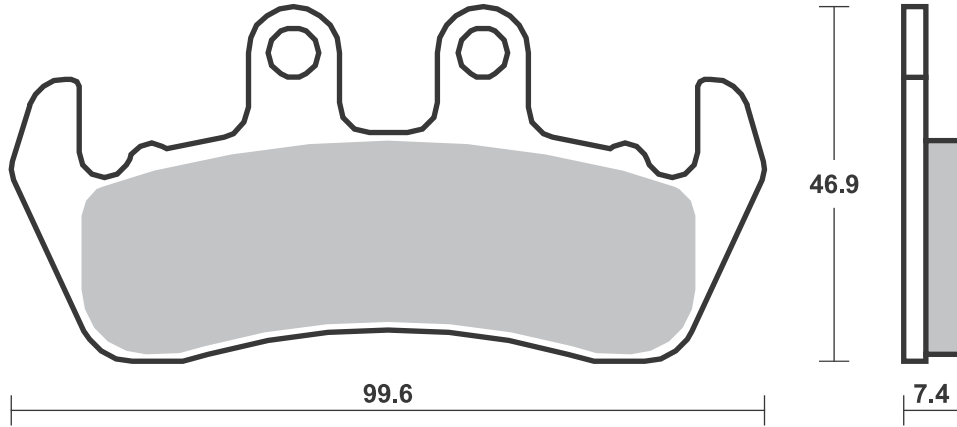





1 set = 6 pcs.

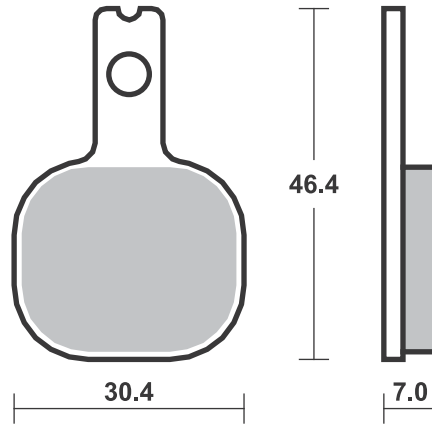

1 set = 6 pcs.

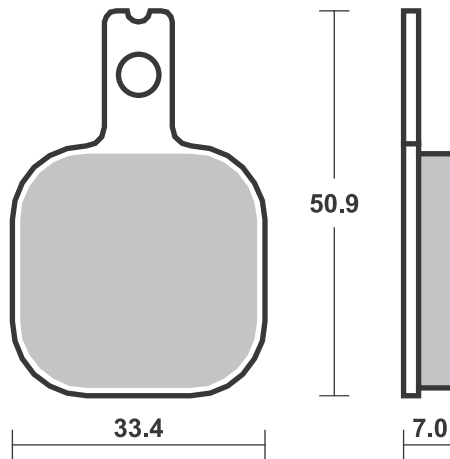

## Applications

### SBS 657 Recommended compound



| <b>HONDA</b>    |                    |       |    |
|-----------------|--------------------|-------|----|
| CBR             | 400 F              | 92-96 | LS |
| CBF             | 500                | 04-08 | LS |
| CBF             | 500 ABS            | 04-08 | LS |
| CB              | 600 Hornet         | 98-06 | LS |
| CB              | 600 Hornet         |       |    |
|                 | (Japan)            | 98-99 | LS |
| CB              | 600 Hornet ABS     | 07-12 | LS |
| CB              | 600 Hornet, S      | 00-03 | LS |
| CBF             | 600 N              | 04-11 | LS |
| CBF             | 600 N ABS          | 08-11 | LS |
| CBF             | 600 S              | 04-11 | LS |
| CBF             | 600 S ABS          | 08-11 | LS |
| CBR             | 600 F ABS          | 11-13 | LS |
| CBR             | 600 F,             |       |    |
|                 | Super Sport        | 91-94 | LS |
| CBR             | 600 F3             | 95-98 | LS |
| CBR             | 600 F4, F4 Sport   | 99-06 | LS |
| CBR             | 600 RR             | 03-04 | LS |
| CBR             | 600 RR             | 05-06 | LS |
| FMX             | 650                | 05-08 | LS |
| NT              | 650 V Deauville    | 01    | LS |
| NC              | 700 D Integra      | 12-13 | LS |
| NC              | 700 SA ABS         | 12-13 | LS |
| NC              | 700 SD ABS         | 12-13 | LS |
| NC              | 700 XA ABS         | 12-13 | LS |
| NC              | 700 XD ABS         | 12-13 | LS |
| XL              | 700 Transalp       |       |    |
|                 | ABS                | 08-12 | LS |
| CB              | 750 N, F,          |       |    |
|                 | Seven Fifty        | 92-95 | LS |
| NR              | 750                | 92    | LS |
| CB              | 900 Hornet         | 02-07 | LS |
| CBR             | 900 RR Fireblade   | 92-03 | LS |
| CB              | 1000 F (Big One)   | 93-97 | LS |
| CBF             | 1000               | 06-11 | LS |
| CBF             | 1000 F ABS         | 15-18 | LS |
| CBF             | 1000 Limited       |       |    |
|                 | Edition            | 09-14 | LS |
| CBR             | 1000 RR Fireblade  | 04-05 | LS |
| CRF             | 1000 L Africa Twin | 16-18 | LS |
| CRF             | 1000 L Africa Twin |       |    |
|                 | Adventure          |       |    |
|                 | Sports             | 18-   | LS |
| VTR             | 1000 F Firestorm   | 97-07 | LS |
| VTR             | 1000 SP-1, SP-2    | 00-06 | LS |
| CB              | 1100 , EX          | 14-18 | LS |
| CB              | 1100               | 13    | LS |
| CB              | 1100 EX ABS        | 17-18 | LS |
| CB              | 1100 RS ABS        | 17-18 | LS |
| VT              | 1100 C2 Shadow     |       |    |
|                 | A.C.E.             | 95-04 | LS |
| VT              | 1100 C2 Y          | 00-05 | LS |
| VT              | 1100 C3 Shadow     |       |    |
|                 | Aero               | 98-04 | LS |
| VT              | 1100 T Shadow      | 98-04 | LS |
| CB              | 1300               | 05-13 | LS |
| CB              | 1300 S             | 11-15 | LS |
| VT              | 1300 CX A Fury     | 10-18 | LS |
| VTX             | 1300 C             | 04-09 | LS |
| VTX             | 1300 S             | 03-07 | LS |
| <b>KAWASAKI</b> |                    |       |    |
| EN              | 650 Vulcan S       | 15-18 | LS |
| EN              | 650 Vulcan S       |       |    |
|                 | Cafe               | 17-18 | LS |
| EN              | 650 Vulcan S SE    | 17-18 | LS |
| EX              | 650 Ninja ABS      | 17-18 | LS |
| Z               | 650 ABS            | 17-18 | LS |
| Z               | 750 , ABS          | 07-12 | LS |
| Z               | 900 RS             | 18-   | LS |

| <b>KAWASAKI</b> |                   |       |    |
|-----------------|-------------------|-------|----|
| Z               | 900 RS Cafe       | 18-   | LS |
| KLE             | 1000 Versys       | 12-18 | LS |
| KLE             | 1000 Versys ABS   | 15-16 | LS |
| KLE             | 1000 Versys LT    | 15-16 | LS |
| KLV             | 1000 Left/Rear    | 04-07 | LS |
| Z               | 1000              | 07-09 | LS |
| <b>SUZUKI</b>   |                   |       |    |
| DL              | 250 V-Strom       | 17-18 | HF |
| GSX-R           | 250               | 17-18 | HF |
| GW              | 250 Inazuma       | 12-18 | LS |
| GW              | 250 Inazuma F     | 15-18 | LS |
| DL              | 650 V-Strom       |       |    |
|                 | Left/Rear         | 04-18 | LS |
| DL              | 650 V-Strom XT    |       |    |
|                 | Left/Rear         | 15-18 | LS |
| GSF             | 650 Bandit        | 07-11 | LS |
| GSF             | 650 Bandit /      |       |    |
|                 | S Bandit          |       |    |
|                 | Left/Rear         |       |    |
|                 | ABS               | 06    | LS |
| GSF             | 650 Bandit ABS    | 07-12 | LS |
| GSF             | 650 S Bandit      | 07-11 | LS |
| GSF             | 650 S Bandit      |       |    |
|                 | ABS               | 07-13 | LS |
| GSX             | 650 F             | 08-18 | HF |
| SV              | 650 ,S ABS        | 07-18 | LS |
| SV              | 650 ,S Left/Rear  | 03-12 | LS |
| GSR             | 750 Left/Rear     | 11-16 | LS |
| GSX-S           | 750               | 17-18 | LS |
| GSX-S           | 750 Left/Rear     | 15-16 | LS |
| GSX-S           | 750 Z Left/Rear   | 15-16 | LS |
| DL              | 1000 V-Strom      |       |    |
|                 | Left/Rear         | 02-13 | LS |
| GSX-S           | 1000              | 15-18 | LS |
| GSX-S           | 1000 F            | 15-18 | LS |
| SV              | 1000 , S          | 03-07 | LS |
| GSF             | 1200 Bandit       | 06    | LS |
| GSF             | 1200 S Bandit     | 06    | LS |
| GSF             | 1250 A Bandit     | 07-18 | LS |
| GSF             | 1250 Bandit       | 06-18 | LS |
| GSF             | 1250 F Bandit     | 12-18 | LS |
| GSF             | 1250 S Bandit     | 06-18 | LS |
| GSF             | 1250 SA Bandit    | 07-18 | LS |
| GSX             | 1250 FA Bandit    | 16-18 | LS |
| GSX             | 1250 FA Traveller | 15-16 | LS |
|                 | 1300 B-King       | 07    | LS |
| <b>YAMAHA</b>   |                   |       |    |
| FZ6             | 600               | 04-08 | LS |
| FZ6             | 600 Fazer         | 04-08 | LS |
| FZ6             | 600 Fazer S2      | 07-09 | LS |
| FZ6             | 600 Fazer S2      |       |    |
|                 | ABS               | 07-09 | LS |
| FZ6             | 600 S2            | 07-09 | LS |
| FZ6             | 600 S2 ABS        | 07-09 | LS |
| XJ6-F           | 600               | 13-15 | LS |
| XJ6-N           | 600               | 13-15 | LS |
| XJ6-S           | 600               | 13-15 | LS |
| YZF             | 600 R6            | 03-04 | LS |
| YZF             | 600 R6            | 05-16 | LS |
| MT-07           | 700               | 14-18 | LS |
| MT-07           | 700 Moto Cage     | 15-17 | LS |
| MT-07           | 700 SP            | 18-   | LS |
| MT-07           | 700 Tracer        | 16-18 | LS |
| XSR             | 700               | 16-18 | LS |
|                 | 800 Fazer 8       | 10-15 | LS |
| FZ8             | 800               | 10-14 | LS |
| MT-09           | 900               | 14-18 | LS |
| MT-09           | 900 SP            | 18-   | LS |
| <b>YAMAHA</b>   |                   |       |    |
| MT-09           | 900 Sport         |       |    |
|                 | Tracker           | 15-16 | LS |
| MT-09           | 900 Street Rally  | 14-16 | LS |
| MT-09           | 900 Tracer        | 15-18 | LS |
| MT-09           | 900 Tracer GT     | 18-   | LS |
| XSR             | 900               | 16-18 | LS |
| XSR             | 900 Abarth        | 17-18 | LS |
| FZ1             | 1000 Fazer        | 06-16 | LS |
| MT-10           | 1000              | 16-18 | LS |
| MT-10           | 1000 SP           | 17-18 | LS |
| MT-10           | 1000 Tourer Ed.   | 17-18 | LS |
| YZF             | 1000 R1           | 04-06 | LS |
| YZF             | 1000 R1(4-pad)    | 07-14 | LS |
| YZF             | 1000 R1(4-pad)    |       |    |
|                 | ABS               | 12-14 | LS |
| YZF             | 1000 R1 SP        | 06    | LS |

| <b>YAMAHA</b> |                  |       |    |
|---------------|------------------|-------|----|
| MT-09         | 900 Sport        |       |    |
|               | Tracker          | 15-16 | LS |
| MT-09         | 900 Street Rally | 14-16 | LS |
| MT-09         | 900 Tracer       | 15-18 | LS |
| MT-09         | 900 Tracer GT    | 18-   | LS |
| XSR           | 900              | 16-18 | LS |
| XSR           | 900 Abarth       | 17-18 | LS |
| FZ1           | 1000 Fazer       | 06-16 | LS |
| MT-10         | 1000             | 16-18 | LS |
| MT-10         | 1000 SP          | 17-18 | LS |
| MT-10         | 1000 Tourer Ed.  | 17-18 | LS |
| YZF           | 1000 R1          | 04-06 | LS |
| YZF           | 1000 R1(4-pad)   | 07-14 | LS |
| YZF           | 1000 R1(4-pad)   |       |    |
|               | ABS              | 12-14 | LS |
| YZF           | 1000 R1 SP       | 06    | LS |

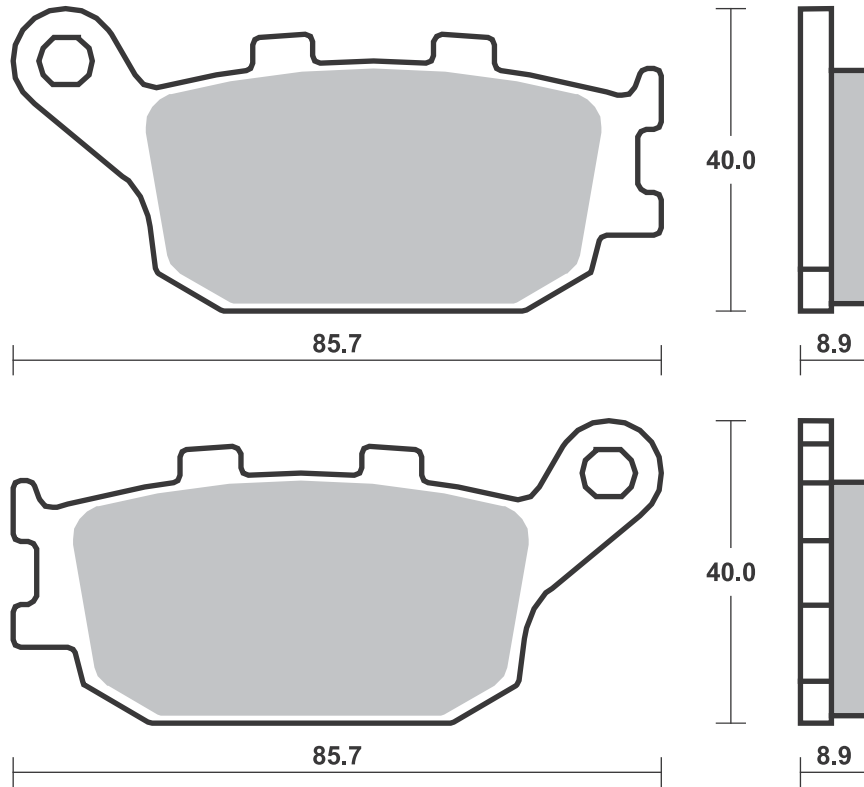

**SBS 658** Recommended compound



| <b>BUELL</b> |            |       |           |
|--------------|------------|-------|-----------|
|              | all models | 94-97 | <b>HF</b> |
| RS           | 1200       | 12    | <b>HF</b> |

| <b>PERFORMANCE MACHINE</b> |  |  |  |
|----------------------------|--|--|--|
| 125 X 6                    |  |  |  |
| 137 X 6                    |  |  |  |
|                            |  |  |  |
|                            |  |  |  |
|                            |  |  |  |
|                            |  |  |  |
|                            |  |  |  |
|                            |  |  |  |
|                            |  |  |  |
|                            |  |  |  |
|                            |  |  |  |
|                            |  |  |  |
|                            |  |  |  |
|                            |  |  |  |
|                            |  |  |  |
|                            |  |  |  |
|                            |  |  |  |
|                            |  |  |  |

**SBS 659** Recommended compound



| <b>YAMAHA</b> |       |       |           |
|---------------|-------|-------|-----------|
| TZ            | 125   | 97-00 | <b>RQ</b> |
| TZ            | 250   | 02-05 | <b>RQ</b> |
| TZ            | 250   | 90-01 | <b>RQ</b> |
| TZR           | 250 R | 94    | <b>HF</b> |

|  |  |  |  |
|--|--|--|--|
|  |  |  |  |
|  |  |  |  |
|  |  |  |  |
|  |  |  |  |
|  |  |  |  |
|  |  |  |  |
|  |  |  |  |
|  |  |  |  |
|  |  |  |  |
|  |  |  |  |
|  |  |  |  |
|  |  |  |  |
|  |  |  |  |
|  |  |  |  |
|  |  |  |  |
|  |  |  |  |
|  |  |  |  |
|  |  |  |  |
|  |  |  |  |

**SBS 660** Recommended compound



| <b>A.P. RACING CALIPERS</b> |  |  |  |
|-----------------------------|--|--|--|
| 6 Piston 3366/3367 Series   |  |  |  |

|  |  |  |  |
|--|--|--|--|
|  |  |  |  |
|  |  |  |  |
|  |  |  |  |
|  |  |  |  |
|  |  |  |  |
|  |  |  |  |
|  |  |  |  |
|  |  |  |  |
|  |  |  |  |
|  |  |  |  |
|  |  |  |  |
|  |  |  |  |
|  |  |  |  |
|  |  |  |  |
|  |  |  |  |
|  |  |  |  |
|  |  |  |  |
|  |  |  |  |
|  |  |  |  |
|  |  |  |  |
|  |  |  |  |
|  |  |  |  |
|  |  |  |  |
|  |  |  |  |

Brake Pad 1:1 Drawings,  
Compounds, Fitments

Available compounds **HF • RQ • H.HF • H.CT**

**SBS 658**

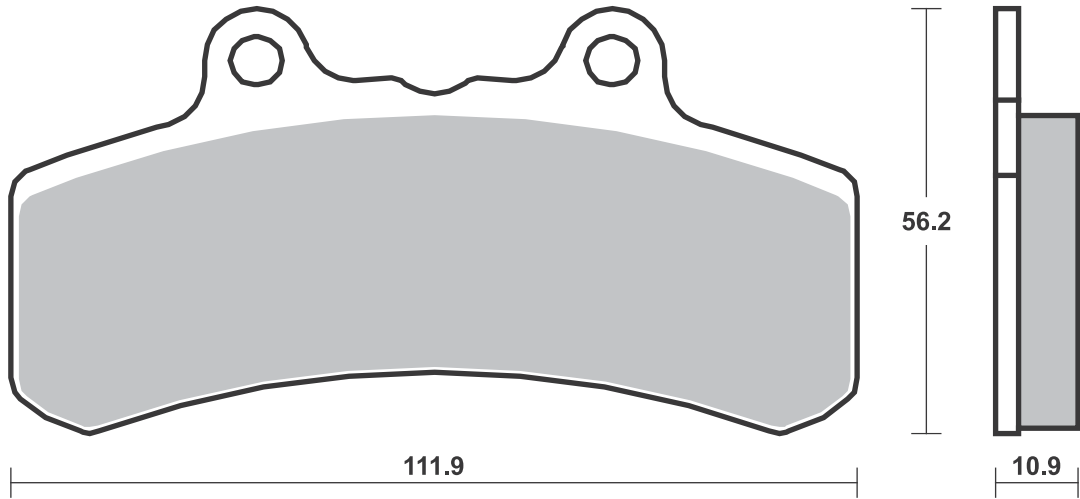

Available compounds **HF • RQ**

**SBS 659**

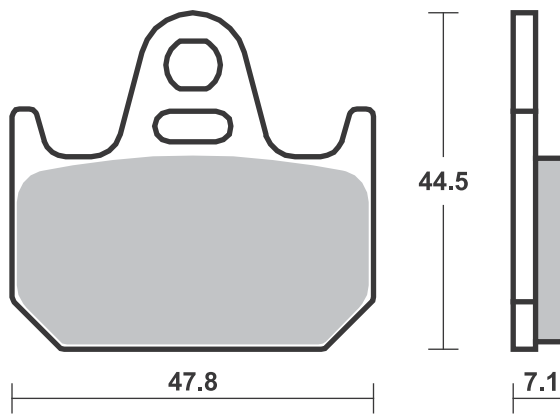

Available compounds **RS • RQ**

**SBS 660**

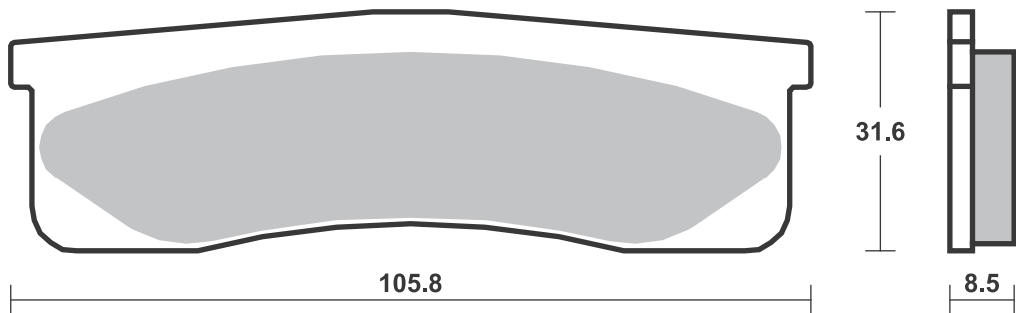

**SBS 661** Recommended compound



| <b>A.P. RACING CALIPERS</b> |  |
|-----------------------------|--|
| CP-3485-8S0/9S0             |  |
| CP-3569-4S0/5S0             |  |
| CP-3586-4S0/5S0             |  |
|                             |  |
|                             |  |
|                             |  |
|                             |  |
|                             |  |
|                             |  |
|                             |  |
|                             |  |
|                             |  |
|                             |  |
|                             |  |
|                             |  |
|                             |  |
|                             |  |

**SBS 662** Recommended compound



| <b>PERFORMANCE MACHINE</b> |  |
|----------------------------|--|
| 124 X 4HR                  |  |
| 137 X 4                    |  |
|                            |  |
|                            |  |
|                            |  |
|                            |  |
|                            |  |
|                            |  |
|                            |  |
|                            |  |
|                            |  |
|                            |  |
|                            |  |
|                            |  |
|                            |  |
|                            |  |
|                            |  |

**SBS 663** Recommended compound



| <b>YAMAHA</b> |                  |       |           |
|---------------|------------------|-------|-----------|
| FZX           | 250 Zeal         | 91-92 | <b>HS</b> |
| SRV           | 250              | 92-97 | <b>HS</b> |
| SR            | 400              | 14-16 | <b>HS</b> |
| XJ            | 400 Diversion    | 91-93 | <b>HS</b> |
| XV            | 535 DX Virago    | 98-03 | <b>HS</b> |
| XV            | 535 S Virago     | 96-03 | <b>HS</b> |
| XJ            | 600 N            | 91-97 | <b>HS</b> |
| XJ            | 600 S Diversion  | 91-97 | <b>HS</b> |
| XVS           | 650 A Drag Star  |       |           |
|               | Classic          | 98-06 | <b>HS</b> |
| XVS           | 650 Drag Star    | 97-06 | <b>HS</b> |
| XV            | 750 Virago       | 94-97 | <b>HS</b> |
| XJ            | 900 S, Diversion | 94-03 | <b>HS</b> |
| SCR           | 950 Scrambler    | 17-18 | <b>HS</b> |
| XV            | 950 Bolt         | 14-18 | <b>HS</b> |
| XV            | 950 Bolt C-Spec  | 15-18 | <b>HS</b> |
| XV            | 950 Bolt Racer   | 17-18 | <b>HS</b> |
| XV            | 950 Bolt R-Spec  | 14-18 | <b>HS</b> |

| <b>YAMAHA</b> |                    |       |           |
|---------------|--------------------|-------|-----------|
| XVS           | 950 A Midnight     |       |           |
|               | Star               | 09-13 | <b>HS</b> |
| XV            | 1100 Virago        | 94-98 | <b>HS</b> |
| XVS           | 1300 Stryker       | 11-14 | <b>HS</b> |
| XVZ           | 1300 TF Royal Star |       |           |
|               | Venture            | 99-01 | <b>HS</b> |
| XV            | 1600 A Wild Star   | 99-07 | <b>HS</b> |
|               |                    |       |           |
|               |                    |       |           |
|               |                    |       |           |
|               |                    |       |           |
|               |                    |       |           |
|               |                    |       |           |
|               |                    |       |           |
|               |                    |       |           |
|               |                    |       |           |

Brake Pad 1:1 Drawings, Compounds, Fitments

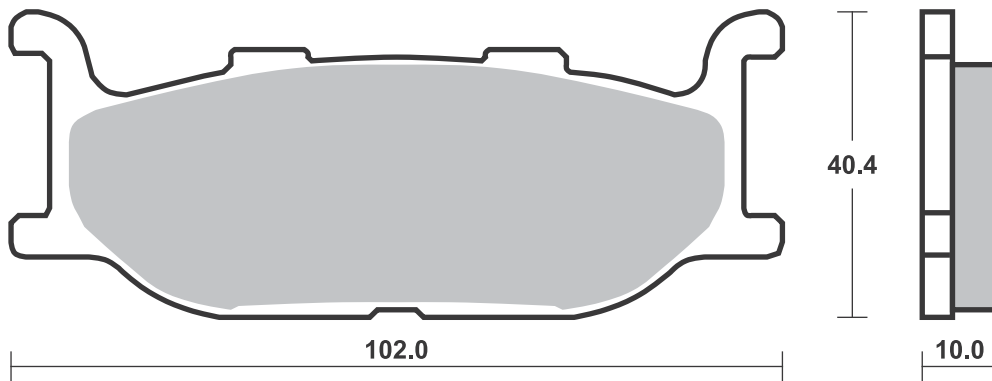
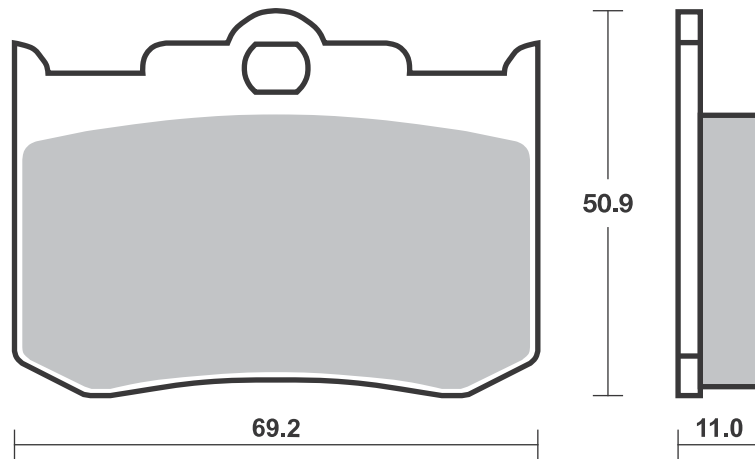
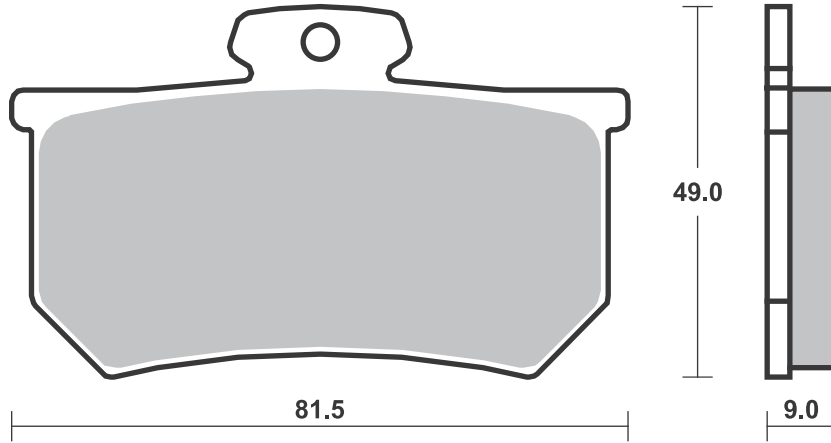

## SBS 664 Recommended compound



| HONDA |       |       |           |
|-------|-------|-------|-----------|
| TLM   | 220   | 89-91 | <b>HF</b> |
| TLM   | 260 R | 90    | <b>HF</b> |
|       |       |       |           |
|       |       |       |           |
|       |       |       |           |
|       |       |       |           |
|       |       |       |           |
|       |       |       |           |
|       |       |       |           |
|       |       |       |           |
|       |       |       |           |
|       |       |       |           |
|       |       |       |           |
|       |       |       |           |
|       |       |       |           |
|       |       |       |           |

## SBS 665 Recommended compound



| YAMAHA |            |       |           |
|--------|------------|-------|-----------|
| FZR    | 600 R      | 92-95 | <b>HS</b> |
| FZR    | 1000 EX UP | 92-93 | <b>HS</b> |
|        |            |       |           |
|        |            |       |           |
|        |            |       |           |
|        |            |       |           |
|        |            |       |           |
|        |            |       |           |
|        |            |       |           |
|        |            |       |           |
|        |            |       |           |
|        |            |       |           |
|        |            |       |           |
|        |            |       |           |
|        |            |       |           |
|        |            |       |           |

## SBS 666 Recommended compound



| KAWASAKI |     |       |           |
|----------|-----|-------|-----------|
| ZXR      | 400 | 91-02 | <b>HS</b> |
|          |     |       |           |
|          |     |       |           |
|          |     |       |           |
|          |     |       |           |
|          |     |       |           |
|          |     |       |           |
|          |     |       |           |
|          |     |       |           |
|          |     |       |           |
|          |     |       |           |
|          |     |       |           |
|          |     |       |           |
|          |     |       |           |
|          |     |       |           |
|          |     |       |           |



Available compounds **HF**

**SBS 664**

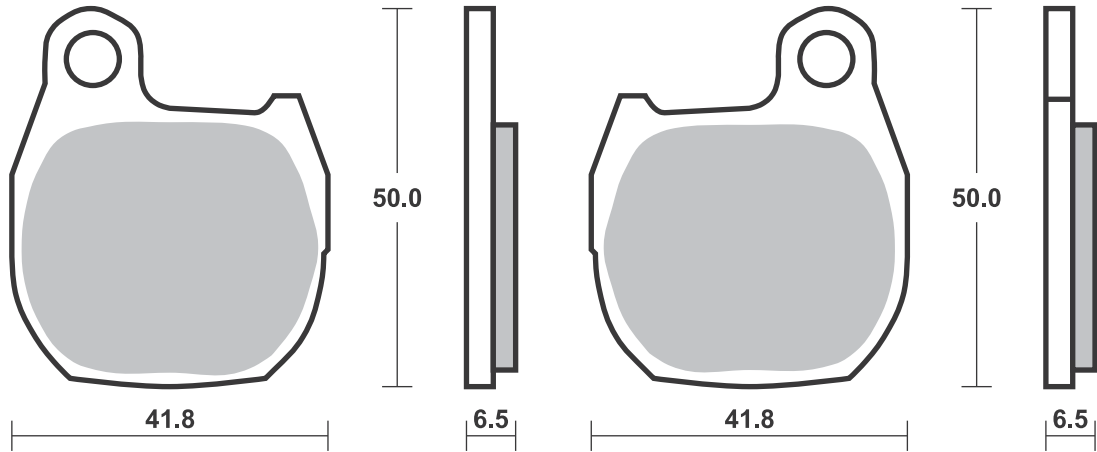

Available compounds **HF • HS**

**SBS 665**

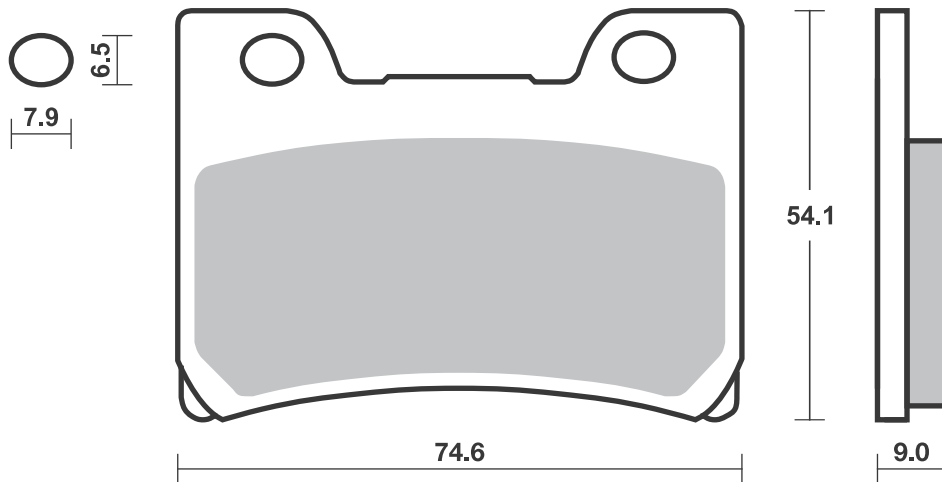

Available compounds **HF • HS • RS**

**SBS 666**

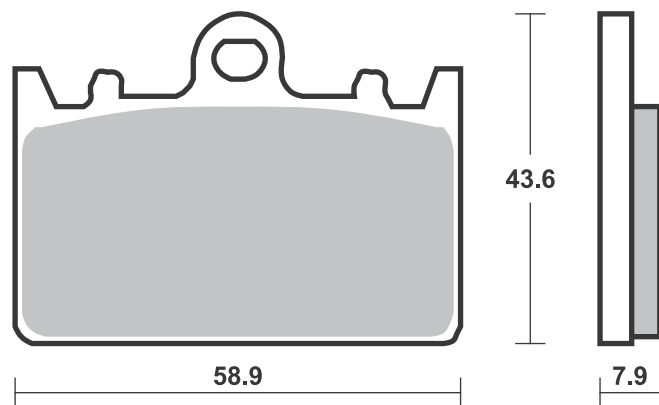



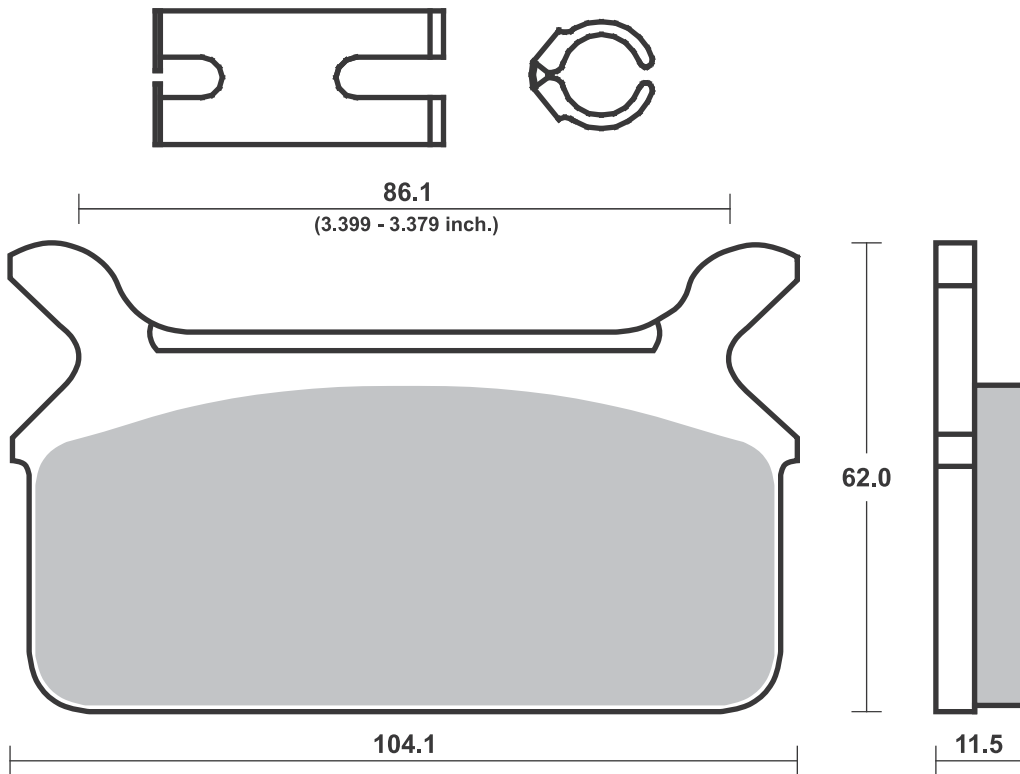
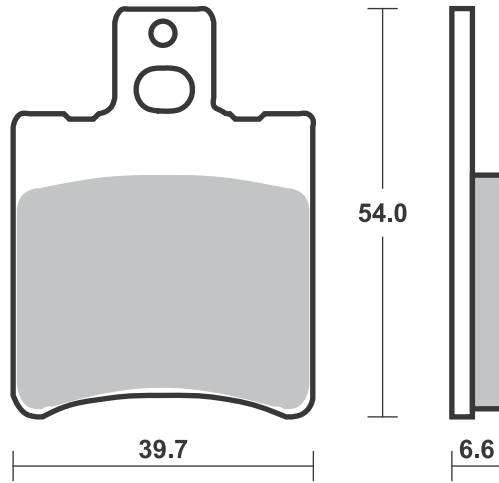

Brake Pad 1:1 Drawings,  
Compounds, Fitments

**SBS 669** Recommended compound



| <b>HARLEY DAVIDSON</b> |                    |       |             |
|------------------------|--------------------|-------|-------------|
| XLH                    | 883 Series         | 88-99 | <b>H.LS</b> |
| XLH                    | 883 Sportster      | 87-99 | <b>H.HF</b> |
| XLH                    | 1100               | 87-88 | <b>H.LS</b> |
| XLH                    | 1200 Sportster     | 90-99 | <b>H.LS</b> |
| FLHT                   | 1340 Electra Glide |       |             |
|                        | Classic            | 87-99 | <b>H.LS</b> |
| FLHTC                  | 1340 Electra Glide |       |             |
|                        | Classic            | 93    | <b>H.LS</b> |
| FLSTC                  | 1340 Heritage      |       |             |
|                        | Softail Cl.        | 90-99 | <b>H.LS</b> |
| FLSTF                  | 1340 Fat Boy       | 90-99 | <b>H.LS</b> |
| FLSTN                  | 1340 Heritage      |       |             |
|                        | Softail Nost.      | 93-99 | <b>H.LS</b> |
| FXDB                   | 1340 Dyna Glide    |       |             |
|                        | Daytona            | 91-99 | <b>H.LS</b> |
| FXDB                   | 1340 Dyna Glide    |       |             |
|                        | Sturgis            | 91-99 | <b>H.HF</b> |
| FXDB                   | 1340 Sturgis       | 91-99 | <b>H.LS</b> |
| FXDL                   | 1340 Dyna Low      |       |             |
|                        | Rider              | 93-99 | <b>H.LS</b> |
| FXDWG                  | 1340 Dyna Wide     |       |             |
|                        | Glide              | 93-99 | <b>H.LS</b> |
| FXE                    | 1340               | 82    | <b>H.HF</b> |
| FXLR                   | 1340 Low Rider     |       |             |
|                        | Custom             | 87-88 | <b>H.LS</b> |
| FXLR                   | 1340 Low Rider     |       |             |
|                        | Custom             | 93-99 | <b>H.LS</b> |
| FXR                    | 1340               | 87-88 | <b>H.LS</b> |
| FXR                    | 1340 Super Glide   | 90-99 | <b>H.LS</b> |
| FXRS                   | 1340 Low Rider     |       |             |
|                        | Sport              | 87-99 | <b>H.LS</b> |



| <b>HARLEY DAVIDSON</b> |                  |       |             |
|------------------------|------------------|-------|-------------|
| FXRS                   | 1340 Low Rider   |       |             |
|                        | Sport Ed.        | 90-99 | <b>H.LS</b> |
| FXRS                   | 1340 Low Rider,  |       |             |
|                        | Convert.         | 90-99 | <b>H.LS</b> |
| FXRT                   | 1340 Sport Glide | 90-99 | <b>H.LS</b> |
| FXSTC                  | 1340 Softail     |       |             |
|                        | Custom           | 88-99 | <b>H.LS</b> |
| FXSTS                  | 1340 Springer    |       |             |
|                        | Softail          | 90-99 | <b>H.LS</b> |
| FXWG                   | 1340             | 87-88 | <b>H.LS</b> |

**SBS 670** Recommended compound



| <b>HONDA</b> |           |       |           |
|--------------|-----------|-------|-----------|
|              | 50 Giorno | 92-94 | <b>HF</b> |
|              | 50 Jazz   | 92    | <b>HF</b> |
| GP           | 50 Dio    | 89-90 | <b>HF</b> |
| SC           | 50 1-ZX   | 92-95 | <b>HF</b> |
| SP           | 50        | 92    | <b>HF</b> |
|              |           |       |           |
|              |           |       |           |
|              |           |       |           |
|              |           |       |           |
|              |           |       |           |
|              |           |       |           |
|              |           |       |           |
|              |           |       |           |
|              |           |       |           |
|              |           |       |           |
|              |           |       |           |
|              |           |       |           |
|              |           |       |           |
|              |           |       |           |
|              |           |       |           |
|              |           |       |           |

Brake Pad 1:1 Drawings, Compounds, Fitments

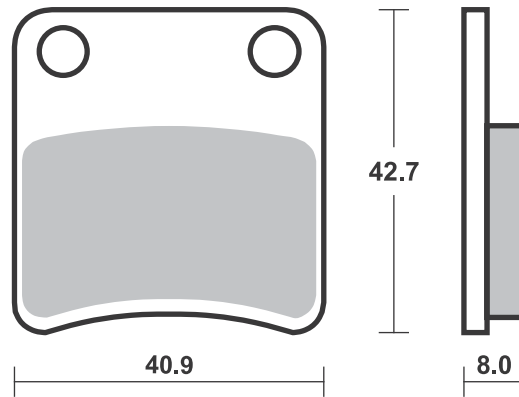
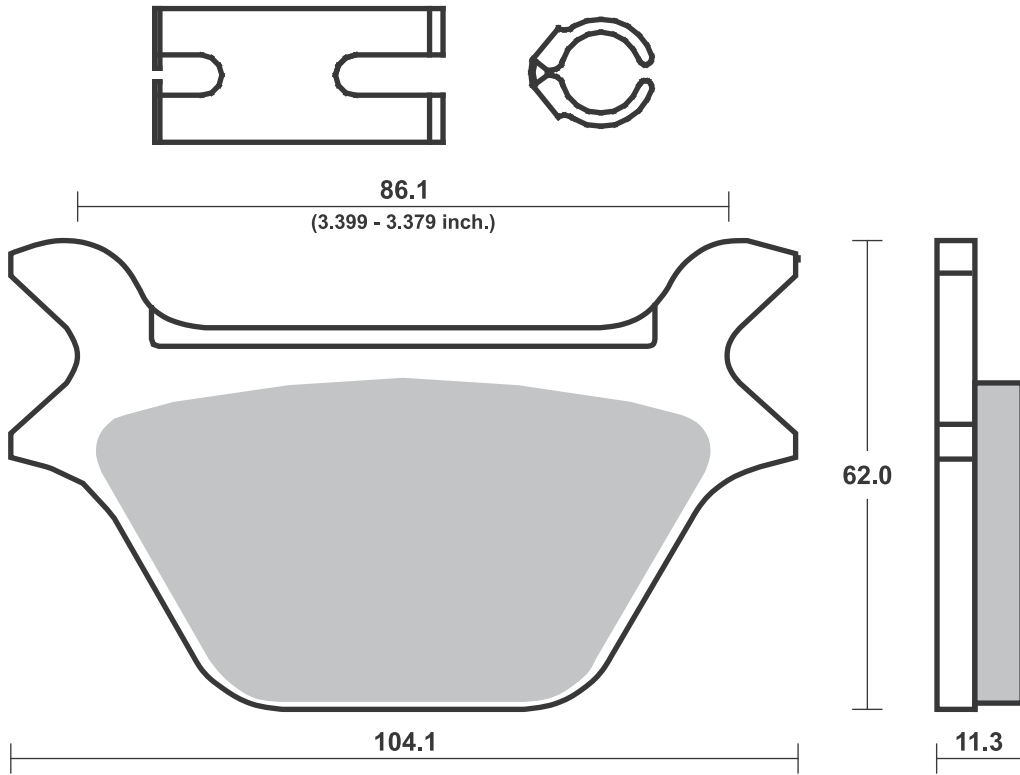

## Applications

### SBS 671 Recommended compound



| <b>ALFER</b> |                 |    |            |
|--------------|-----------------|----|------------|
| VRE          | 125 4-stroke    | 00 | <b>SI</b>  |
| VR           | 250 Cross       | 99 | <b>RSI</b> |
| VR           | 250 Enduro      | 99 | <b>SI</b>  |
| VR           | 250 No Limit    | 99 | <b>RSI</b> |
| VR           | 250 Supermotard | 99 | <b>RSI</b> |

| <b>APRILIA</b> |                 |       |           |
|----------------|-----------------|-------|-----------|
| MX             | 125             | 04-07 | <b>HF</b> |
| MX             | 125 Supermoto   | 07    | <b>HF</b> |
| RX             | 125             | 97-99 | <b>HF</b> |
| RX             | 125 Enduro      | 08-12 | <b>HF</b> |
| RX             | 125 Supermotard | 08-12 | <b>HF</b> |
| SX             | 125             | 08-13 | <b>HF</b> |
| RST            | 1000 Futura     | 01-03 | <b>LS</b> |

| <b>BENELLI</b> |            |       |            |
|----------------|------------|-------|------------|
| BX             | 449 Cross  | 07-09 | <b>RSI</b> |
| BX             | 505 Enduro | 08    | <b>SI</b>  |

| <b>BIMOTA</b> |      |       |           |
|---------------|------|-------|-----------|
| DBX           | 1100 | 13-18 | <b>LS</b> |

| <b>BMW</b> |                   |       |           |
|------------|-------------------|-------|-----------|
| G          | 450 X             | 08-10 | <b>SI</b> |
|            | 1200 HP2 Enduro   | 04-06 | <b>LS</b> |
|            | 1200 HP2 Sport    | 08-10 | <b>LS</b> |
| K          | 1200 GT (K44)     |       |           |
|            | With Integral     |       |           |
|            | ABS               | 04-08 | <b>LS</b> |
| R          | 1200 Nine-T       | 14-18 | <b>LS</b> |
| R          | 1200 Nine-T Pure  | 17-18 | <b>LS</b> |
| R          | 1200 Nine-T Racer | 17-18 | <b>LS</b> |
| R          | 1200 Nine-T       |       |           |
|            | Scrambler         | 16-18 | <b>LS</b> |
| R          | 1200 Nine-T       |       |           |
|            | Urban GS          | 17-18 | <b>LS</b> |
| K          | 1300 GT           | 09-10 | <b>LS</b> |

| <b>BREMBO RACING CALIPERS</b> |  |  |  |
|-------------------------------|--|--|--|
| Floating Motocross            |  |  |  |
| Caliper 22.5930.62            |  |  |  |
| Off Road 122A99021,           |  |  |  |
| P2 24                         |  |  |  |
| Off Road XQ21361,             |  |  |  |
| P2 28                         |  |  |  |

| <b>CAGIVA</b> |             |       |           |
|---------------|-------------|-------|-----------|
|               | 750 Elefant | 93-95 | <b>LS</b> |
|               | 900 Elefant | 93-97 | <b>HF</b> |

| <b>CCM</b> |               |       |            |
|------------|---------------|-------|------------|
|            | 450 MX        | 08-10 | <b>RSI</b> |
| GP         | 450           | 16    | <b>SI</b>  |
| 604        | 600 RS        | 01    | <b>HF</b>  |
| 604E       | 600 Sport     | 99-01 | <b>SI</b>  |
| 604E       | 600 Supermoto | 99-01 | <b>SI</b>  |
| C25        | 600           | 96-98 | <b>SI</b>  |
|            | 644 DS        | 03-06 | <b>HF</b>  |
|            | 644 R30       | 02-06 | <b>HF</b>  |

| <b>DUCATI</b> |                  |       |           |
|---------------|------------------|-------|-----------|
|               | 620 Multistrada  | 05-06 | <b>HS</b> |
|               | 695 Monster      | 07-12 | <b>HS</b> |
|               | 800 Monster S2R  | 05-07 | <b>HS</b> |
|               | 800 Monster S2R  |       |           |
|               | ABS              | 05-07 | <b>HS</b> |
|               | 950 Multistrada  | 17-18 | <b>LS</b> |
|               | 1200 Multistrada | 15-16 | <b>LS</b> |
|               | 1200 Multistrada |       |           |
|               | Enduro           | 16-18 | <b>LS</b> |



| <b>DUCATI</b> |                    |       |           |
|---------------|--------------------|-------|-----------|
|               | 1200 Multistrada   |       |           |
|               | Enduro Pro         | 18-   | <b>LS</b> |
|               | 1200 Multistrada S | 15-17 | <b>LS</b> |
|               | 1200 Multistrada S |       |           |
|               | D-air              | 15-17 | <b>LS</b> |
|               | 1200 Multistrada S |       |           |
|               | Pikes Peak         | 16-17 | <b>LS</b> |
|               | 1260 Multistrada   | 18-   | <b>LS</b> |
|               | 1260 Multistrada S | 18-   | <b>LS</b> |
|               | 1260 Multistrada S |       |           |
|               | D-air              | 18-   | <b>LS</b> |
|               | 1260 Multistrada S |       |           |
|               | Pikes Peak         | 18-   | <b>LS</b> |

| <b>FACTORY</b> |     |       |           |
|----------------|-----|-------|-----------|
| YR             | 250 | 99-03 | <b>SI</b> |

| <b>GAS GAS</b> |             |       |            |
|----------------|-------------|-------|------------|
|                | 50 Wild HP  | 04-07 | <b>SI</b>  |
| EC             | 125         | 97-99 | <b>SI</b>  |
|                | 200 Wild HP | 08-09 | <b>SI</b>  |
| EC             | 200         | 99    | <b>SI</b>  |
|                | 240 Wild HP | 04-06 | <b>SI</b>  |
|                | 250 Wild HP | 08    | <b>SI</b>  |
| EC             | 250         | 97-99 | <b>SI</b>  |
| MC             | 250         | 97-99 | <b>RSI</b> |
|                | 300 Wild HP | 03-05 | <b>SI</b>  |
| EC             | 300         | 99    | <b>SI</b>  |
|                | 450 Wild HP | 03-09 | <b>SI</b>  |
|                | 515 Wild HP | 09    | <b>SI</b>  |

| <b>HARLEY DAVIDSON</b> |                |       |             |
|------------------------|----------------|-------|-------------|
| XG                     | 500 Street     | 16-18 | <b>H.HF</b> |
| XG                     | 750 Street     | 16-17 | <b>H.HF</b> |
| XG                     | 750 Street Rod | 18-   | <b>H.HF</b> |

| <b>HIGHLAND</b> |                |       |            |
|-----------------|----------------|-------|------------|
|                 | 450 MX         | 06-09 | <b>RSI</b> |
|                 | 950 V2 Motard  | 00-08 | <b>HF</b>  |
|                 | 950 V2 Outback | 99-08 | <b>HF</b>  |

| <b>HONDA</b> |               |       |           |
|--------------|---------------|-------|-----------|
| NX           | 500 Dominator |       |           |
|              | (Austria)     | 97-99 | <b>HS</b> |

| <b>HUSABERG</b> |            |       |            |
|-----------------|------------|-------|------------|
|                 | all models | 93-98 | <b>SI</b>  |
| TE              | 125        | 13    | <b>SI</b>  |
| FE              | 250        | 13    | <b>SI</b>  |
| TE              | 250        | 11-13 | <b>SI</b>  |
| TE              | 300        | 11-13 | <b>SI</b>  |
| FE              | 350        | 13    | <b>SI</b>  |
| FE              | 390        | 10-13 | <b>SI</b>  |
| FC              | 400        | 99-02 | <b>RSI</b> |
| FE              | 400 ,S,E   | 99-03 | <b>SI</b>  |
| FC              | 450        | 03-08 | <b>RSI</b> |
| FE              | 450        | 09-13 | <b>SI</b>  |
| FE              | 450 e      | 04-08 | <b>SI</b>  |
| FX              | 450 e      | 03-08 | <b>RSI</b> |
| FC              | 470 , e    | 01-02 | <b>RSI</b> |
| FX              | 470 e      | 01-02 | <b>RSI</b> |
| FC              | 501        | 99-01 | <b>RSI</b> |
| FE              | 501 ,S,E   | 99-04 | <b>SI</b>  |
| FE              | 501        | 13    | <b>SI</b>  |
| FC              | 550        | 01-05 | <b>RSI</b> |
| FE              | 550 e      | 04-08 | <b>SI</b>  |
| FE              | 570        | 09-13 | <b>SI</b>  |
| FC              | 600        | 99-01 | <b>RSI</b> |
| FE              | 600 ,S,E   | 99-02 | <b>SI</b>  |
| FE              | 650 e      | 01-08 | <b>SI</b>  |



| <b>HUSABERG</b> |       |       |            |
|-----------------|-------|-------|------------|
| FX              | 650 e | 01-05 | <b>RSI</b> |

| <b>HUSQVARNA</b> |                  |       |            |
|------------------|------------------|-------|------------|
| CR               | 125              | 96-13 | <b>RSI</b> |
| SM               | 125 S            | 09-13 | <b>HF</b>  |
| SM               | 125 S 4T         | 11-13 | <b>HF</b>  |
| SM               | 125 Supermotard, |       |            |
|                  | S                | 99-13 | <b>HF</b>  |

|     |                |       |            |
|-----|----------------|-------|------------|
| TC  | 125            | 14-18 | <b>RSI</b> |
| TE  | 125            | 14-16 | <b>SI</b>  |
| TE  | 125 4T         | 11-13 | <b>HF</b>  |
| TX  | 125            | 17-18 | <b>SI</b>  |
| WR  | 125            | 96-13 | <b>SI</b>  |
| WRE | 125            | 96-13 | <b>SI</b>  |
| CR  | 250            | 96-05 | <b>RSI</b> |
| FC  | 250            | 14-18 | <b>RSI</b> |
| FE  | 250            | 14-18 | <b>SI</b>  |
| TC  | 250            | 02-18 | <b>RSI</b> |
| TE  | 250            | 02-18 | <b>SI</b>  |
| TE  | 250 4T         | 10-13 | <b>SI</b>  |
| WR  | 250            | 96-13 | <b>SI</b>  |
| TC  | 300            | 14-15 | <b>RSI</b> |
| TE  | 300            | 14-18 | <b>SI</b>  |
| WR  | 300            | 09-13 | <b>SI</b>  |
| TE  | 310 4T         | 10-13 | <b>SI</b>  |
| FC  | 350            | 14-18 | <b>RSI</b> |
| FE  | 350            | 14-18 | <b>SI</b>  |
| TE  | 350            | 96-13 | <b>SI</b>  |
| WR  | 360            | 98-13 | <b>SI</b>  |
| TE  | 400            | 01-13 | <b>SI</b>  |
| TE  | 410            | 96-13 | <b>SI</b>  |
| TC  | 449            | 11-13 | <b>RSI</b> |
| TE  | 449            | 11-13 | <b>SI</b>  |
| FC  | 450            | 14-18 | <b>RSI</b> |
| FE  | 450            | 14-18 | <b>SI</b>  |
| TC  | 450            | 02-10 | <b>RSI</b> |
| TE  | 450            | 02-14 | <b>SI</b>  |
| FE  | 501            | 14-18 | <b>SI</b>  |
| TC  | 510            | 02-10 | <b>RSI</b> |
| TE  | 510            | 02-10 | <b>SI</b>  |
| TE  | 510 Centennial | 04-05 | <b>SI</b>  |
| TE  | 511            | 11-14 | <b>SI</b>  |
| TC  | 570            | 01-13 | <b>RSI</b> |
| TE  | 570            | 01-13 | <b>SI</b>  |
| TC  | 610            | 96-13 | <b>RSI</b> |
| TE  | 610 Rallye     | 96-13 | <b>RSI</b> |
| TE  | 630            | 10-13 | <b>HS</b>  |
| TE  | 630            | 14    | <b>SI</b>  |

| <b>KRAM-IT</b> |     |       |           |
|----------------|-----|-------|-----------|
| GS             | 250 | 97-00 | <b>SI</b> |
| MX             | 250 | 97-00 | <b>SI</b> |
| SM             | 250 | 97-00 | <b>SI</b> |

| <b>KTM</b> |               |       |            |
|------------|---------------|-------|------------|
|            | most models   | 94    | <b>SI</b>  |
|            | 125 SuperMoto | 00-03 | <b>HF</b>  |
| EXC        | 125 Enduro    | 99-15 | <b>SI</b>  |
| EXE        | 125           | 00    | <b>HF</b>  |
| GS         | 125           | 92-97 | <b>SI</b>  |
| LC2        | 125           | 99    | <b>HF</b>  |
| MX         | 125           | 92-93 | <b>SI</b>  |
| SX         | 125           | 96-18 | <b>RSI</b> |
| SX         | 144           | 07-08 | <b>RSI</b> |
| SX         | 150           | 09-18 | <b>RSI</b> |
| EXC        | 200 Enduro    | 99-16 | <b>SI</b>  |
| SX         | 200           | 03-04 | <b>RSI</b> |
| EXC        | 250 Enduro    | 99-08 | <b>SI</b>  |
| EXC        | 250 Enduro 4T | 99-06 | <b>SI</b>  |
| EXC        | 250 TPI       | 18-   | <b>SI</b>  |

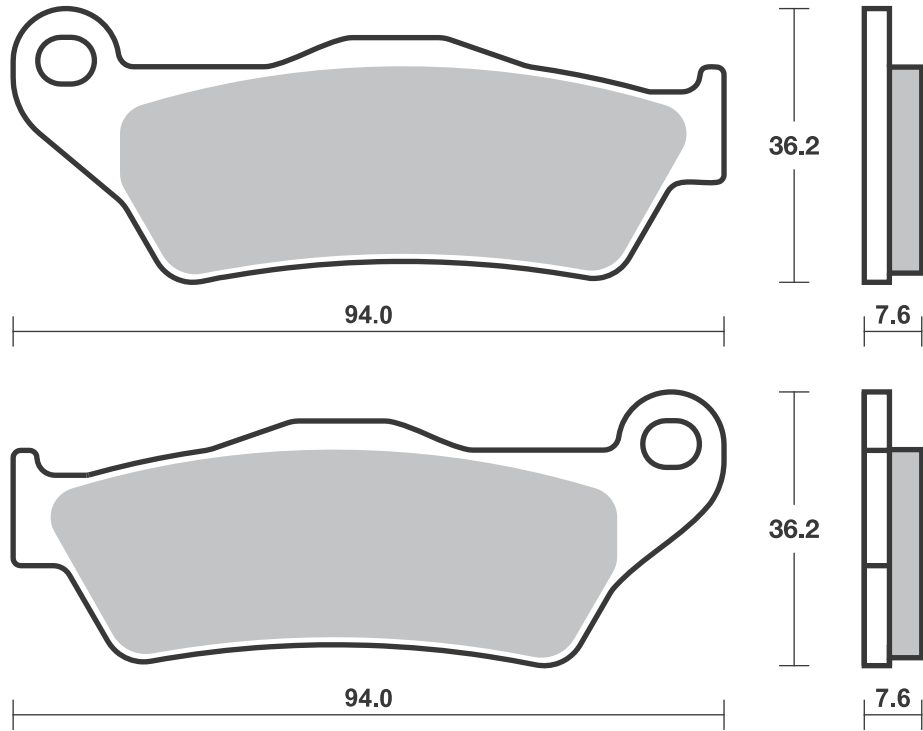



| <b>KTM</b> |                      |       |            |
|------------|----------------------|-------|------------|
| EXC-F      | 250 Enduro           | 07-18 | <b>SI</b>  |
| MX         | 250                  | 92-93 | <b>SI</b>  |
| SX         | 250                  | 96-18 | <b>RSI</b> |
| SX-F       | 250                  | 06-18 | <b>RSI</b> |
| EXC        | 300                  | 93-96 | <b>SI</b>  |
| EXC        | 300 Enduro           | 99-08 | <b>SI</b>  |
| EXC        | 300 TPI              | 18-   | <b>SI</b>  |
| MX         | 300                  | 92    | <b>SI</b>  |
| EXC-F      | 350                  | 11-18 | <b>SI</b>  |
| SX-F       | 350                  | 11-18 | <b>RSI</b> |
| MX         | 360                  | 96-97 | <b>SI</b>  |
| SX         | 360                  | 96-97 | <b>RSI</b> |
| XC         | 360                  | 96-97 | <b>SI</b>  |
| EXC        | 380 Enduro           | 99    | <b>SI</b>  |
| MX         | 380                  | 98    | <b>SI</b>  |
| SX         | 380                  | 98-02 | <b>RSI</b> |
| XC         | 380                  | 98-03 | <b>SI</b>  |
| EXC        | 400 Racing           | 00-07 | <b>SI</b>  |
| LC4        | 400                  | 93-02 | <b>SI</b>  |
| LC4-E      | 400 Enduro           | 99-02 | <b>SI</b>  |
| SC         | 400                  | 99-00 | <b>SI</b>  |
| SX         | 400 Racing           | 00-02 | <b>RSI</b> |
| SXC        | 400 Tiainen          |       |            |
|            | Replica              | 99-00 | <b>SI</b>  |
| EXC-F      | 450 Racing           | 04-18 | <b>SI</b>  |
| SX-F       | 450                  | 03-18 | <b>RSI</b> |
| XC-F       | 450                  | 06-17 | <b>RSI</b> |
| EXC-F      | 500                  | 12-18 | <b>SI</b>  |
| MX         | 500                  | 92-93 | <b>SI</b>  |
| SX         | 505 Racing           | 07-09 | <b>RSI</b> |
| XC-F       | 505                  | 08-09 | <b>RSI</b> |
| EXC        | 520 Racing           | 00-02 | <b>SI</b>  |
| SX-F       | 520 Racing           | 00-02 | <b>RSI</b> |
| EXC        | 525 Racing           | 03-06 | <b>SI</b>  |
| SX-F       | 525 Racing           | 03-06 | <b>RSI</b> |
| EXC        | 530 Racing           | 08-11 | <b>SI</b>  |
| SXC        | 540 Tiainen          |       |            |
|            | Replica              | 99-00 | <b>SI</b>  |
| LC4        | 600 Six Days         | 92    | <b>SI</b>  |
| LC4        | 620 Competition      | 99-02 | <b>SI</b>  |
| LC4        | 620 Competition      |       |            |
|            | SuperMoto            | 00-01 | <b>HF</b>  |
| LC4        | 620 RXC              | 95    | <b>SI</b>  |
| LC4        | 620 Supercompetition |       |            |
|            |                      | 01    | <b>HF</b>  |
| SC         | 620                  | 99-00 | <b>SI</b>  |
| SX         | 620                  | 95-99 | <b>RSI</b> |
| LC4        | 625 SC               |       |            |
|            | Supermoto            | 02-04 | <b>HF</b>  |
| SXC        | 625                  | 03-04 | <b>HF</b>  |
| LC4        | 640 Adventure        | 99-04 | <b>HF</b>  |
| LC4-E      | 640 Enduro           | 99-04 | <b>HF</b>  |
| LC4-E      | 640 Supermoto        | 99-02 | <b>HF</b>  |
| LC4        | 660 Rallye           | 01-03 | <b>HF</b>  |
|            | 790 Duke             | 18-   | <b>HS</b>  |
|            | 950 R                |       |            |
|            | Superenduro          | 06-08 | <b>LS</b>  |
|            | 950 SM               | 05-07 | <b>LS</b>  |
|            | 950 SM R             | 07-09 | <b>LS</b>  |
|            | 990 Adventure R      | 10-12 | <b>LS</b>  |
|            | 990 Adventure,       |       |            |
|            | Adventure S,         |       |            |
|            | ABS                  | 06-11 | <b>LS</b>  |
|            | 990 Supermoto        | 07-11 | <b>LS</b>  |
|            | 990 Supermoto R      | 10    | <b>LS</b>  |
|            | 990 Supermoto T      | 09-13 | <b>LS</b>  |
|            | 1050 Adventure       | 15-16 | <b>LS</b>  |
|            | 1090 Super           |       |            |
|            | Adventure            | 17-18 | <b>LS</b>  |



| <b>KTM</b>         |                    |       |            |
|--------------------|--------------------|-------|------------|
|                    | 1090 Super         |       |            |
|                    | Adventure R        | 17-18 | <b>LS</b>  |
|                    | 1190 Adventure     | 13-16 | <b>LS</b>  |
|                    | 1290 Super         |       |            |
|                    | Adventure          | 15-18 | <b>LS</b>  |
|                    | 1290 Super         |       |            |
|                    | Adventure R        | 17-18 | <b>LS</b>  |
|                    | 1290 Super         |       |            |
|                    | Adventure S        | 17-18 | <b>LS</b>  |
|                    | 1290 Super         |       |            |
|                    | Adventure T        | 17-18 | <b>LS</b>  |
| <b>MAICO</b>       |                    |       |            |
|                    | 250 Motocross/     |       |            |
|                    | Enduro             | 99-01 | <b>SI</b>  |
|                    | 500 Motocross/     |       |            |
|                    | Enduro             | 99    | <b>SI</b>  |
|                    | 500 Supermotard    | 99    | <b>HF</b>  |
| <b>MOTO-GUZZI</b>  |                    |       |            |
| ES                 | 1100 Quota         | 99-03 | <b>HF</b>  |
| V                  | 1100 Brevia, ABS   | 05-07 | <b>LS</b>  |
|                    | 1200 Griso 8V      | 07-13 | <b>LS</b>  |
|                    | 1200 Norge         | 06-14 | <b>LS</b>  |
|                    | 1200 Norge GT 8V   | 10-13 | <b>LS</b>  |
|                    | 1200 Sport         | 07-08 | <b>LS</b>  |
|                    | 1200 Sport 8V      | 12-13 | <b>LS</b>  |
|                    | 1200 Sport 8V SE   | 12-15 | <b>LS</b>  |
|                    | 1200 Stelvio       | 08-11 | <b>LS</b>  |
|                    | 1200 Stelvio 8V SE | 12-16 | <b>LS</b>  |
|                    | 1200 Stelvio NTX   | 09-11 | <b>LS</b>  |
| V                  | 1200 Brevia        | 08-13 | <b>LS</b>  |
| <b>MOTO-MORINI</b> |                    |       |            |
|                    | 1200 Granferro     | 10    | <b>LS</b>  |
|                    | 1200 Granpasso     | 08-13 | <b>LS</b>  |
|                    | 1200 GT            | 10    | <b>LS</b>  |
|                    | 1200 Scrambler     | 09-10 | <b>LS</b>  |
| <b>PRAGA</b>       |                    |       |            |
| ED                 | 250                | 99-03 | <b>SI</b>  |
| CD                 | 610                | 99-03 | <b>SI</b>  |
| <b>RIEJU</b>       |                    |       |            |
| MRX                | 250 Marathon       | 10-12 | <b>SI</b>  |
| MRX                | 450 Marathon       | 08-12 | <b>SI</b>  |
| <b>SHERCO</b>      |                    |       |            |
| SE-R               | 125                | 17    | <b>SI</b>  |
| SE                 | 250 , R            | 14    | <b>SI</b>  |
| SE                 | 250 2.5i Enduro    | 06-11 | <b>SI</b>  |
| SE                 | 250 F, F-R         | 14-18 | <b>SI</b>  |
| SE                 | 250 i/R            | 12-13 | <b>SI</b>  |
| SE                 | 250 i-F            | 13    | <b>SI</b>  |
| SX                 | 250 2.5i-F         | 09-11 | <b>RSI</b> |
| SCF-R              | 300                | 16-18 | <b>SI</b>  |
| SE                 | 300 , R            | 14-18 | <b>SI</b>  |
| SE                 | 300 3.0i-F         | 10-11 | <b>SI</b>  |
| SE                 | 300 F, F-R         | 14-18 | <b>SI</b>  |
| SE                 | 300 i/R            | 12-13 | <b>SI</b>  |
| SE                 | 300 i-F            | 13    | <b>SI</b>  |
| SE                 | 450 4.5i Enduro    | 04-11 | <b>SI</b>  |
| SE                 | 450 F, F-R         | 14-18 | <b>SI</b>  |
| SE                 | 450 iR             | 12-13 | <b>SI</b>  |
| SE                 | 510 5.1i Enduro    | 06-11 | <b>SI</b>  |
| SE                 | 510 iR             | 12-13 | <b>SI</b>  |
| <b>SWM</b>         |                    |       |            |
| RS                 | 300 R              | 15-18 | <b>SI</b>  |
| RS                 | 500 R              | 15-18 | <b>SI</b>  |



| <b>TM</b>        |                  |       |            |
|------------------|------------------|-------|------------|
|                  | 80 Cross         | 96-00 | <b>RSI</b> |
| MX               | 85               | 01-12 | <b>RSI</b> |
|                  | 125              | 96-17 | <b>RSI</b> |
|                  | 125 Enduro       | 01-17 | <b>SI</b>  |
|                  | 250              | 01-05 | <b>RSI</b> |
|                  | 250 E            | 95-00 | <b>RSI</b> |
|                  | 250 Enduro       | 01-15 | <b>SI</b>  |
|                  | 250 F            | 01-17 | <b>RSI</b> |
|                  | 250 F Enduro     | 00-17 | <b>SI</b>  |
|                  | 300              | 98-05 | <b>RSI</b> |
|                  | 300 Enduro       | 01-05 | <b>SI</b>  |
|                  | 320              | 96-97 | <b>RSI</b> |
|                  | 400 F            | 00-01 | <b>RSI</b> |
|                  | 400 F Enduro     | 01    | <b>SI</b>  |
|                  | 450 F            | 02-17 | <b>RSI</b> |
|                  | 450 F Enduro     | 02-17 | <b>SI</b>  |
| FT               | 450 Fi           | 17    | <b>RSI</b> |
|                  | 530 F            | 01-05 | <b>RSI</b> |
|                  | 530 F Enduro     | 01-05 | <b>SI</b>  |
| <b>TRIUMPH</b>   |                  |       |            |
|                  | 800 Tiger XCA    | 18-   | <b>HS</b>  |
|                  | 800 Tiger XCX    | 18-   | <b>HS</b>  |
|                  | 800 Tiger XRT    | 18-   | <b>HS</b>  |
|                  | 800 Tiger XRX    | 18-   | <b>HS</b>  |
|                  | 800 Tiger XRX    |       |            |
|                  | Low              | 18-   | <b>HS</b>  |
|                  | 1200 Bonneville  |       |            |
|                  | Bobber Black     | 18-   | <b>HS</b>  |
|                  | 1200 Speedmaster | 18-   | <b>HS</b>  |
| <b>VERTEMATI</b> |                  |       |            |
| C                | 500 Cross        | 02-04 | <b>RSI</b> |
| E                | 501 Enduro       | 02-04 | <b>SI</b>  |
| S                | 501 Supermotard  | 02-04 | <b>HF</b>  |
| <b>VOR</b>       |                  |       |            |
|                  | 400 Cross        | 00-01 | <b>RSI</b> |
|                  | 400 Enduro       | 00-01 | <b>SI</b>  |
| EN               | 400              | 02-03 | <b>SI</b>  |
| MX               | 400              | 02    | <b>RSI</b> |
| EN               | 450              | 02-04 | <b>SI</b>  |
| MX               | 450              | 02-04 | <b>RSI</b> |
|                  | 500 492 Enduro   | 99    | <b>SI</b>  |
|                  | 500 495 Cross    | 99    | <b>RSI</b> |
| EN               | 530              | 02-04 | <b>SI</b>  |
| MX               | 530              | 02-04 | <b>RSI</b> |
| <b>WRM</b>       |                  |       |            |
|                  | 450 MX           | 06-08 | <b>RSI</b> |
| <b>YAMAHA</b>    |                  |       |            |
| YZF              | 125 R            | 08-13 | <b>HF</b>  |
| FZH              | 150 Fazer        | 11-14 | <b>HF</b>  |
| TT               | 600 E,S          | 96-01 | <b>HF</b>  |
| TT               | 600 R            | 93-95 | <b>HF</b>  |
| TT               | 600 R            | 98-07 | <b>HF</b>  |
| XT               | 660 Z Tenere     | 08-14 | <b>HS</b>  |
| XT               | 660 Z Tenere ABS | 11-14 | <b>HS</b>  |
| <b>ZERO</b>      |                  |       |            |
| FX               | ZF2.8            | 15    | <b>HS</b>  |
| FX               | ZF5.7            | 15    | <b>HS</b>  |



Drawings 1:1

Available compounds **HF • HS • LS • CS • SI • RSI • RQ • H.HF • H.CT • H.LS** **SBS 671**

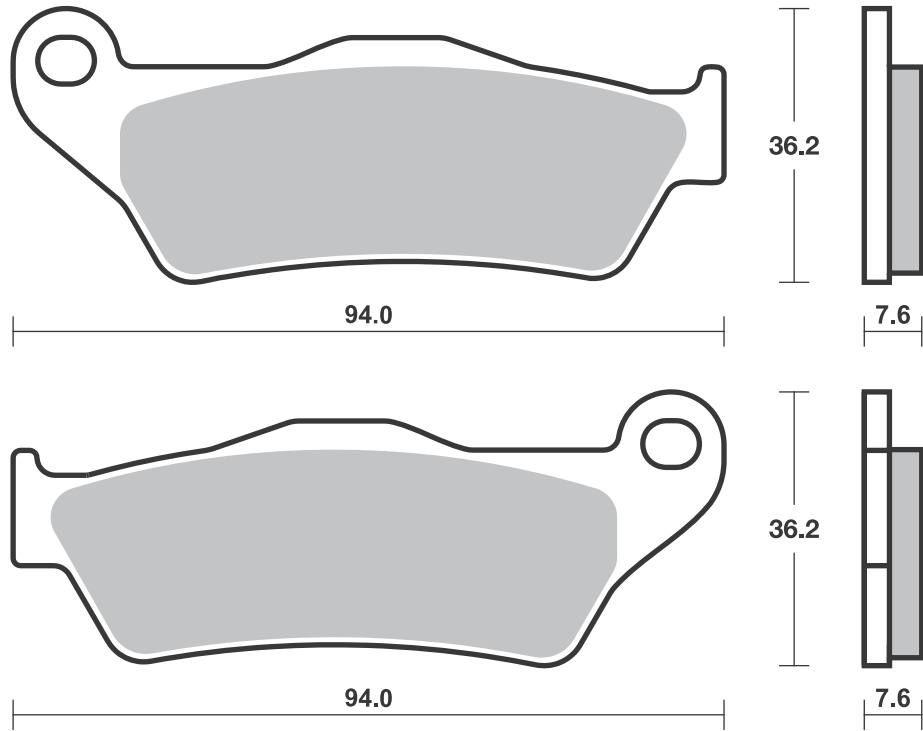

**SBS 672 Recommended compound**

| <b>BETA</b>   |          |       |           |
|---------------|----------|-------|-----------|
| TR            | 125 34   | 92    | <b>HF</b> |
| TR            | 125 36   | 92    | <b>HF</b> |
| <b>CAGIVA</b> |          |       |           |
|               | 50 Prima | 93-94 | <b>HF</b> |
|               | 80 Prima | 92    | <b>HF</b> |
|               |          |       |           |
|               |          |       |           |
|               |          |       |           |
|               |          |       |           |
|               |          |       |           |
|               |          |       |           |
|               |          |       |           |
|               |          |       |           |
|               |          |       |           |
|               |          |       |           |

**SBS 674 Recommended compound**

| <b>APRILIA</b> |                    |       |           |
|----------------|--------------------|-------|-----------|
|                | 650 Moto           | 95-03 | <b>HF</b> |
|                | 650 Pegaso         | 95-00 | <b>HS</b> |
|                | 650 Pegaso i.e.    | 01-04 | <b>HS</b> |
|                | 650 Pegaso i.e.    |       |           |
|                | Tuscany            |       |           |
|                | Tibet Raid         | 04    | <b>HS</b> |
|                | 650 Pegaso Trail   | 06-08 | <b>HS</b> |
|                | 650 Starck         | 96-01 | <b>HF</b> |
| ETV            | 1000 Caponord      | 01-08 | <b>HS</b> |
| ETV            | 1000 Caponord      |       |           |
|                | Rally Raid         | 04-08 | <b>HS</b> |
| <b>BENELLI</b> |                    |       |           |
|                | 500 Leoncino Trail | 18-   | <b>HS</b> |
| <b>BIMOTA</b>  |                    |       |           |
| DBX            | 1100               | 13-18 | <b>HS</b> |
| <b>BMW</b>     |                    |       |           |
| F              | 650 ,ST            | 94-00 | <b>HF</b> |
| F              | 650 CS Scarver     | 02-06 | <b>HS</b> |
| F              | 650 GS             | 08-12 | <b>HS</b> |
| F              | 650 GS ABS         | 01-07 | <b>HF</b> |
| F              | 650 GS ABS         | 08-12 | <b>HS</b> |
| F              | 650 GS Dakar       | 01-07 | <b>HF</b> |
| F              | 650 GS, Rallye     | 01-07 | <b>HF</b> |
| F              | 650 ST Strada      | 97-01 | <b>HF</b> |
| G              | 650 GS             | 09-15 | <b>HS</b> |
| G              | 650 GS Sertao      | 12-14 | <b>HS</b> |
| G              | 650 Xchallenge     | 06-07 | <b>HS</b> |
| G              | 650 Xcountry       | 06-09 | <b>HS</b> |
| F              | 700 GS             | 13-16 | <b>HS</b> |
| F              | 750 GS             | 18-   | <b>HS</b> |
| F              | 800 GS             | 08-18 | <b>HS</b> |
| F              | 850 GS             | 18-   | <b>HS</b> |
|                | 1200 HP2 Enduro    | 04-06 | <b>HS</b> |
| R              | 1200 GS            | 13-18 | <b>LS</b> |
| R              | 1200 GS Adventure  | 14-16 | <b>LS</b> |
| R              | 1200 R             | 15-18 | <b>LS</b> |
| R              | 1200 RS            | 14-18 | <b>LS</b> |
| R              | 1200 RT            | 14-18 | <b>LS</b> |
| K              | 1600 B             | 17-18 | <b>LS</b> |
| K              | 1600 Grand         |       |           |
|                | America            | 18-   | <b>LS</b> |
| K              | 1600 GT            | 11-18 | <b>LS</b> |
| K              | 1600 GTL           | 11-18 | <b>LS</b> |



| <b>CF MOTO</b>         |                     |       |             |
|------------------------|---------------------|-------|-------------|
|                        | 400 NK Efi          | 17    | <b>HS</b>   |
|                        | 650 NK              | 14-16 | <b>HS</b>   |
|                        | 650 NK Efi          | 17    | <b>HS</b>   |
|                        | 650 TK              | 14-15 | <b>HS</b>   |
| <b>DUCATI</b>          |                     |       |             |
|                        | 400 Scrambler       |       |             |
|                        | Sixty Two           | 16-18 | <b>HS</b>   |
|                        | 1000 Biposto        | 07-08 | <b>HS</b>   |
|                        | 1000 GT             | 05-10 | <b>HS</b>   |
|                        | 1000 GT Touring     | 09-10 | <b>HS</b>   |
|                        | 1000 Paul Smart     | 05-08 | <b>HS</b>   |
|                        | 1000 Sport, Sport S | 05-09 | <b>HS</b>   |
|                        | 1200 Diavel         | 11-18 | <b>LS</b>   |
|                        | 1200 Diavel Strada  | 11-14 | <b>LS</b>   |
|                        | 1200 Xdiavel        | 16-18 | <b>LS</b>   |
|                        | 1200 Xdiavel S      | 16-18 | <b>LS</b>   |
| <b>HARLEY DAVIDSON</b> |                     |       |             |
| XG                     | 500 Street          | 16-18 | <b>H.HF</b> |
| XG                     | 750 Street          | 16-17 | <b>H.HF</b> |
| XG                     | 750 Street Rod      | 18-   | <b>H.HF</b> |
| <b>HONDA</b>           |                     |       |             |
| CBR                    | 250 R (Bybre cal)   | 11    | <b>HS</b>   |
| CB                     | 500                 | 97-05 | <b>HS</b>   |
| CB                     | 500 S               | 98-03 | <b>HS</b>   |
| FX                     | 650 Vigor           | 99-02 | <b>HS</b>   |
| NT                     | 650 V Deauville     | 98-01 | <b>HS</b>   |
| NX                     | 650 Dominator       | 97-99 | <b>HS</b>   |
| SLR                    | 650                 | 97-99 | <b>HS</b>   |
| <b>HUSQVARNA</b>       |                     |       |             |
| TR                     | 650 Strada          | 13    | <b>HS</b>   |
| TR                     | 650 Terra           | 13    | <b>HS</b>   |
| FE                     | 701 Enduro          | 17    | <b>HS</b>   |
| <b>INDIAN</b>          |                     |       |             |
|                        | 1000 Scout Sixty    | 17-18 | <b>H.HS</b> |
|                        | 1200 Scout          | 17-18 | <b>H.HS</b> |
|                        | 1200 Scout Bobber   | 17-18 | <b>H.HS</b> |
| <b>KTM</b>             |                     |       |             |
| LC4                    | 450 Rally           | 11-16 | <b>SI</b>   |
| LC4                    | 640 Adventure       | 05-07 | <b>HF</b>   |
|                        | 690 Enduro          | 08-14 | <b>HS</b>   |



| <b>KTM</b>        |                    |       |           |
|-------------------|--------------------|-------|-----------|
|                   | 690 Enduro R       | 09-17 | <b>HS</b> |
|                   | 950 R              |       |           |
|                   | Superenduro        | 06-08 | <b>HS</b> |
| LC8               | 950 Adventure      | 02-07 | <b>HS</b> |
|                   | 990 Adventure R    | 10-12 | <b>HS</b> |
|                   | 990 Adventure,     |       |           |
|                   | Adventure S,       |       |           |
|                   | ABS                | 06-11 | <b>HS</b> |
| <b>MOTO-GUZZI</b> |                    |       |           |
|                   | 940 Custom         | 07    | <b>LS</b> |
|                   | 1100 California EV | 06    | <b>LS</b> |
|                   | 1100 California EV |       |           |
|                   | Touring            | 06    | <b>LS</b> |
|                   | 1100 California    |       |           |
|                   | Jackal             | 00    | <b>HF</b> |
|                   | 1100 California    |       |           |
|                   | Jackal             | 01-06 | <b>LS</b> |
|                   | 1100 California    |       |           |
|                   | Jackal Basic       | 00    | <b>HF</b> |
|                   | 1100 California    |       |           |
|                   | Jackal Basic       | 01-06 | <b>LS</b> |
|                   | 1100 California    |       |           |
|                   | Special            | 99-00 | <b>HF</b> |
|                   | 1100 California    |       |           |
|                   | Special            | 01    | <b>LS</b> |
|                   | 1100 California    |       |           |
|                   | Special            |       |           |
|                   | Sport Alloy        | 02-06 | <b>LS</b> |
|                   | 1100 California    |       |           |
|                   | Stone Metal        | 02-03 | <b>LS</b> |
|                   | 1100 California    |       |           |
|                   | Stone,             |       |           |
|                   | Stone              |       |           |
|                   | Touring            | 02-05 | <b>LS</b> |
|                   | 1100 California    |       |           |
|                   | Titanium           | 03-05 | <b>LS</b> |
|                   | 1100 California    |       |           |
|                   | Vintage            | 06-13 | <b>LS</b> |
|                   | 1100 Grico         | 05-10 | <b>LS</b> |
| ES                | 1100 Quota         | 99-03 | <b>HF</b> |
|                   | 1400 Audace        | 15-17 | <b>LS</b> |
|                   | 1400 California    |       |           |
|                   | Custom             | 13-15 | <b>LS</b> |
|                   | 1400 California    |       |           |
|                   | Touring            | 13-15 | <b>LS</b> |

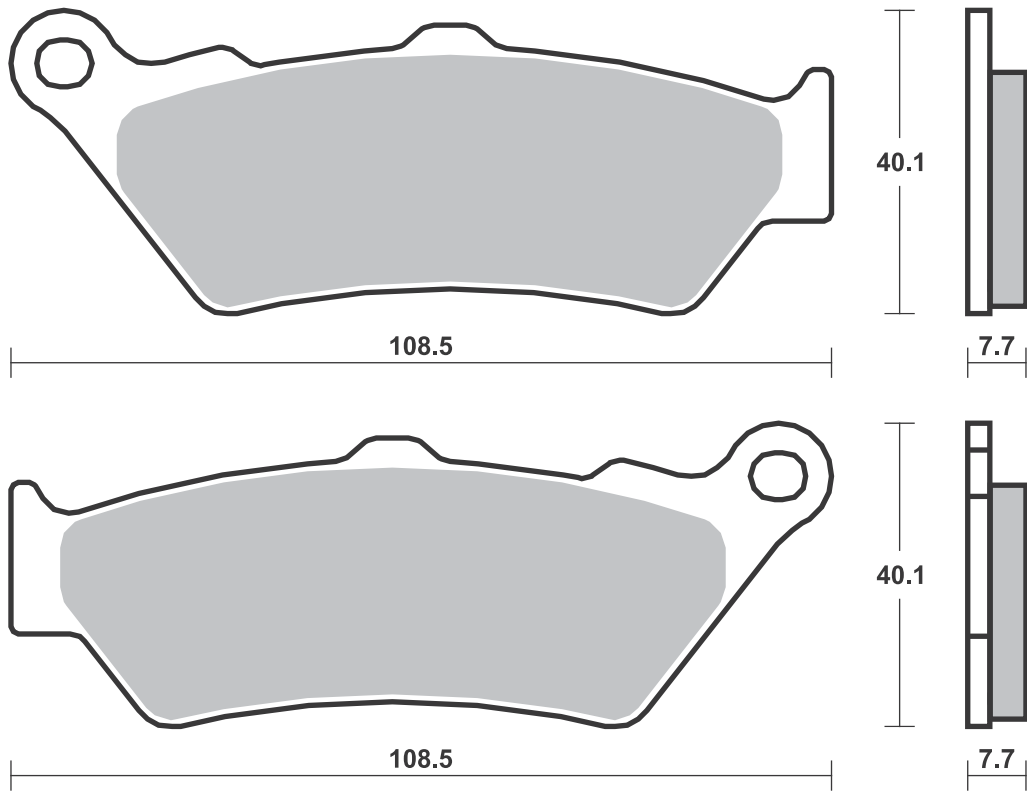
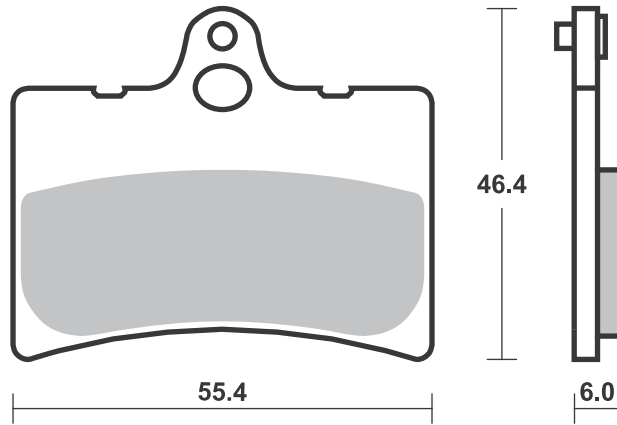

## Applications

### SBS 674 Recommended compound



| <b>MOTO-GUZZI</b>         |       |           |  |
|---------------------------|-------|-----------|--|
| 1400 California           |       |           |  |
| Touring SE                | 16-17 | <b>LS</b> |  |
| 1400 Eldorado             | 15-17 | <b>LS</b> |  |
| <b>MGX-21 1400 Flying</b> |       |           |  |
| Fortress                  | 15-17 | <b>LS</b> |  |
| <b>MOTO-MORINI</b>        |       |           |  |
| 1200 Granpasso            | 08-13 | <b>HS</b> |  |
| 1200 GT                   | 10    | <b>HS</b> |  |
| 1200 Scrambler            | 09-10 | <b>HS</b> |  |
| <b>ROYAL ENFIELD</b>      |       |           |  |
| 535 Continental           |       |           |  |
| GT                        | 14-17 | <b>HS</b> |  |
| <b>SWM</b>                |       |           |  |
| 600 Superdual             |       |           |  |
| GT Pack                   | 18-   | <b>HS</b> |  |
| 600 Superdual T           | 18-   | <b>HS</b> |  |
| 600 Superdual X           | 18-   | <b>HS</b> |  |
| <b>TRIUMPH</b>            |       |           |  |
| 1600 Thunderbird          | 09-18 | <b>LS</b> |  |
| 1700 Thunderbird          |       |           |  |
| Commander                 | 14-18 | <b>LS</b> |  |
| 1700 Thunderbird          |       |           |  |
| LT                        | 14-18 | <b>LS</b> |  |
| 1700 Thunderbird          |       |           |  |
| Nightstorm                | 14-18 | <b>LS</b> |  |
| 1700 Thunderbird          |       |           |  |
| Storm                     | 11-18 | <b>LS</b> |  |



| <b>TRIUMPH</b>    |       |             |  |
|-------------------|-------|-------------|--|
| 2300 Rocket III   | 04-13 | <b>LS</b>   |  |
| 2300 Rocket III   |       |             |  |
| Classic           | 07-13 | <b>LS</b>   |  |
| 2300 Rocket III   |       |             |  |
| Roadster          | 10-18 | <b>LS</b>   |  |
| 2300 Rocket III   |       |             |  |
| Touring           | 13-14 | <b>LS</b>   |  |
| 2300 Rocket X     | 15    | <b>LS</b>   |  |
| <b>VICTORY</b>    |       |             |  |
| 1200 Octane       | 17    | <b>H.HS</b> |  |
| 1500 Kingpin      | 04-05 | <b>H.LS</b> |  |
| 1500 Touring      |       |             |  |
| Cruiser           | 03-06 | <b>H.LS</b> |  |
| 1500 V92C         |       |             |  |
| Cruiser           | 98-02 | <b>H.LS</b> |  |
| 1500 V92C         |       |             |  |
| Deluxe            | 01-02 | <b>H.LS</b> |  |
| 1500 V92SC        |       |             |  |
| Sport             |       |             |  |
| Cruiser           | 00-02 | <b>H.LS</b> |  |
| 1500 Vegas        | 03-05 | <b>H.LS</b> |  |
| 1500 Vegas        |       |             |  |
| 8-Ball            | 05    | <b>H.LS</b> |  |
| 1634 Hammer       | 05-07 | <b>H.LS</b> |  |
| 1634 Hammer S     | 06-08 | <b>H.LS</b> |  |
| 1634 Kingpin      | 06-07 | <b>H.LS</b> |  |
| 1634 Kingpin Tour | 06-07 | <b>H.LS</b> |  |
| 1634 Vegas        | 06-07 | <b>H.LS</b> |  |
| 1634 Vegas        |       |             |  |
| 8-Ball            | 06-07 | <b>H.LS</b> |  |



| <b>VICTORY</b> |             |             |           |
|----------------|-------------|-------------|-----------|
| 1634 Vegas     |             |             |           |
| Jackpot        | 06-07       | <b>H.LS</b> |           |
| <b>YAMAHA</b>  |             |             |           |
| DT             | 125 X       |             |           |
|                | Supermotard |             |           |
|                |             | 05-08       | <b>HF</b> |
| XT             | 660 R       | 04-11       | <b>HS</b> |
| <b>ZERO</b>    |             |             |           |
| DS             | ZF12.5      | 15          | <b>HS</b> |
| DS             | ZF13.0      | 16-17       | <b>HS</b> |
| DS             | ZF9.4       | 15          | <b>HS</b> |
| DS             | ZF9.8       | 16-17       | <b>HS</b> |
| DSR            | ZF13.0      | 16-17       | <b>HS</b> |
| FX             | ZF3.3       | 16-17       | <b>HS</b> |
| FX             | ZF6.5       | 16-17       | <b>HS</b> |
| FXS            | ZF3.3       | 16-17       | <b>HS</b> |
| FXS            | ZF6.5       | 16-17       | <b>HS</b> |
| S              | ZF12.5      | 15          | <b>HS</b> |
| S              | ZF13.0      | 16-17       | <b>HS</b> |
| S              | ZF9.4       | 15          | <b>HS</b> |
| S              | ZF9.8       | 16-17       | <b>HS</b> |
| SR             | ZF12.5      | 15          | <b>HS</b> |
| SR             | ZF13.0      | 16-17       | <b>HS</b> |

### SBS 675 Recommended compound



| <b>ALFER</b>     |                 |           |            |
|------------------|-----------------|-----------|------------|
| VRE              | 125 4-stroke    | 00        | <b>SI</b>  |
| VR               | 250 Cross       | 99        | <b>RSI</b> |
| VR               | 250 Enduro      | 99        | <b>SI</b>  |
| VR               | 250 No Limit    | 99        | <b>RSI</b> |
| VR               | 250 Supermotard |           |            |
|                  |                 | 99        | <b>RSI</b> |
| <b>APRILIA</b>   |                 |           |            |
| 650 Pegaso       |                 |           |            |
| Factory          | 07-09           | <b>LS</b> |            |
| 650 Pegaso i.e.  | 01-04           | <b>LS</b> |            |
| 650 Pegaso i.e.  |                 |           |            |
| Tuscany          |                 |           |            |
| Tibet Raid       | 04              | <b>LS</b> |            |
| 650 Pegaso       |                 |           |            |
| Strada           | 05-09           | <b>LS</b> |            |
| 650 Pegaso Trail | 06-08           | <b>LS</b> |            |
| 750 Dorsoduro    |                 |           |            |
| Factory          | 12-13           | <b>LS</b> |            |
| SL               | 750 Shiver GT,  |           |            |
|                  | ABS             | 09-12     | <b>LS</b>  |
| SL               | 750 Shiver, ABS | 07-18     | <b>LS</b>  |
| SMV              | 750 Dorsoduro   | 08-18     | <b>LS</b>  |
| NA               | 850 Mana        | 07        | <b>LS</b>  |
|                  | 900 Dorsoduro   | 18-       | <b>LS</b>  |
|                  | 900 Shiver      | 18-       | <b>LS</b>  |
|                  | 1200 Caponord   | 13-18     | <b>LS</b>  |
|                  | 1200 Caponord   |           |            |
|                  | Rally           | 15-18     | <b>LS</b>  |
|                  | 1200 Caponord   |           |            |
|                  | Travel Pack     | 16-18     | <b>LS</b>  |



| <b>APRILIA</b>  |                 |           |            |
|-----------------|-----------------|-----------|------------|
| 1200 Dorsoduro, |                 |           |            |
| ABS             | 11-14           | <b>LS</b> |            |
| <b>BENELLI</b>  |                 |           |            |
| BX              | 449 Cross       | 07-09     | <b>RSI</b> |
| BX              | 449 Supermotard |           |            |
|                 |                 | 08-10     | <b>RSI</b> |
| BX              | 505 Enduro      | 08        | <b>SI</b>  |
| <b>BETA</b>     |                 |           |            |
| 125 Jonathan    | 99-05           | <b>HF</b> |            |
| 350 Euro        | 99-03           | <b>HF</b> |            |
| 350 Jonathan    | 02-03           | <b>HF</b> |            |
| <b>BMW</b>      |                 |           |            |
| G               | 310 GS          | 17-18     | <b>LS</b>  |
| G               | 310 R           | 16-18     | <b>LS</b>  |
| F               | 650 , ST        | 94-00     | <b>HF</b>  |
| F               | 650 CS Scarver  | 02-06     | <b>LS</b>  |
| F               | 650 GS          | 08-12     | <b>LS</b>  |
| F               | 650 GS ABS      | 01-07     | <b>HF</b>  |
| F               | 650 GS ABS      | 08-12     | <b>LS</b>  |
| F               | 650 GS Dakar    | 01-07     | <b>HF</b>  |
| F               | 650 GS, Rallye  | 01-07     | <b>HF</b>  |
| F               | 650 ST Strada   | 97-01     | <b>HF</b>  |
| G               | 650 GS          | 09-15     | <b>LS</b>  |
| G               | 650 GS Sertao   | 12-14     | <b>LS</b>  |
| G               | 650 Xchallenge  | 06-07     | <b>LS</b>  |
| G               | 650 Xcountry    | 06-09     | <b>LS</b>  |
| G               | 650 Xmoto       | 06-07     | <b>LS</b>  |
| F               | 700 GS          | 13-16     | <b>LS</b>  |



| <b>BMW</b>                    |                |       |           |
|-------------------------------|----------------|-------|-----------|
| F                             | 750 GS         | 18-   | <b>LS</b> |
| F                             | 800 GS         | 08-18 | <b>LS</b> |
| F                             | 800 GT         | 13-18 | <b>LS</b> |
| F                             | 800 R          | 09-18 | <b>LS</b> |
| F                             | 800 S          | 06-10 | <b>LS</b> |
| F                             | 800 ST         | 06-12 | <b>LS</b> |
| F                             | 800 ST Touring | 11-12 | <b>LS</b> |
| F                             | 850 GS         | 18-   | <b>LS</b> |
| R                             | 850 RT         | 96-01 | <b>LS</b> |
| S                             | 1000 R         | 13-18 | <b>LS</b> |
| S                             | 1000 RR        | 09-18 | <b>LS</b> |
| S                             | 1000 RR HP4    | 12-14 | <b>LS</b> |
| <b>BORILE</b>                 |                |       |           |
| B                             | 500 CR, MT     | 02-04 | <b>HF</b> |
| <b>BREMBO RACING CALIPERS</b> |                |       |           |
| Motocross Caliper             |                |       |           |
| 22.2180.20                    |                |       |           |
| <b>CCM</b>                    |                |       |           |
| GP                            | 450            | 16    | <b>SI</b> |
| 604                           | 600 RS         | 01    | <b>HF</b> |
| 604E                          | 600 Sport      | 99-01 | <b>SI</b> |
| 604E                          | 600 Supermoto  | 99-01 | <b>SI</b> |
| C25                           | 600            | 96-98 | <b>SI</b> |
|                               | 644 DS         | 03-06 | <b>HF</b> |
|                               | 644 R30        | 02-06 | <b>HF</b> |
| <b>CF MOTO</b>                |                |       |           |
|                               | 400 NK Efi     | 17    | <b>LS</b> |

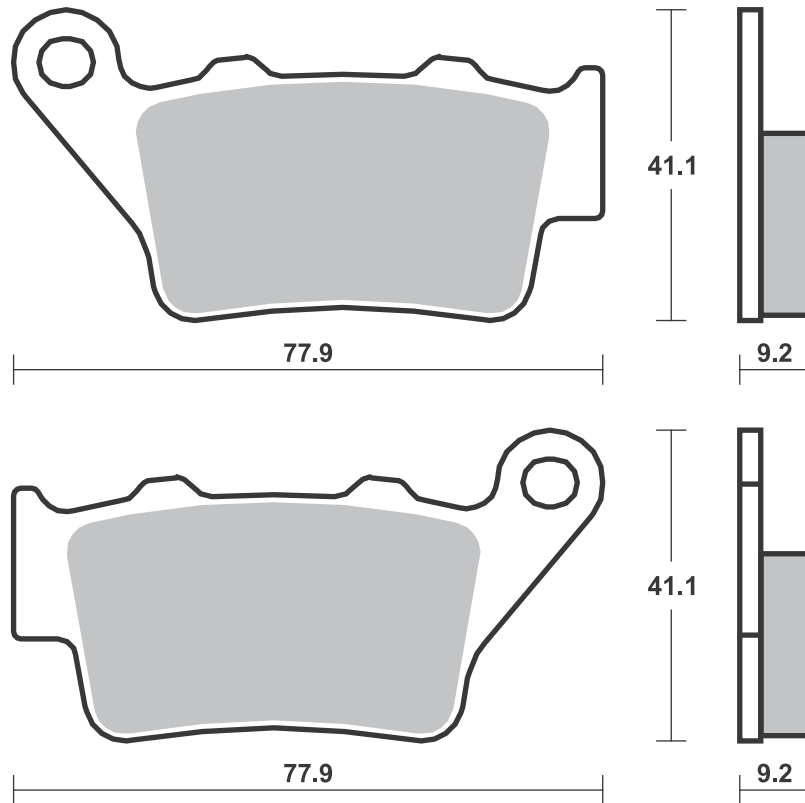
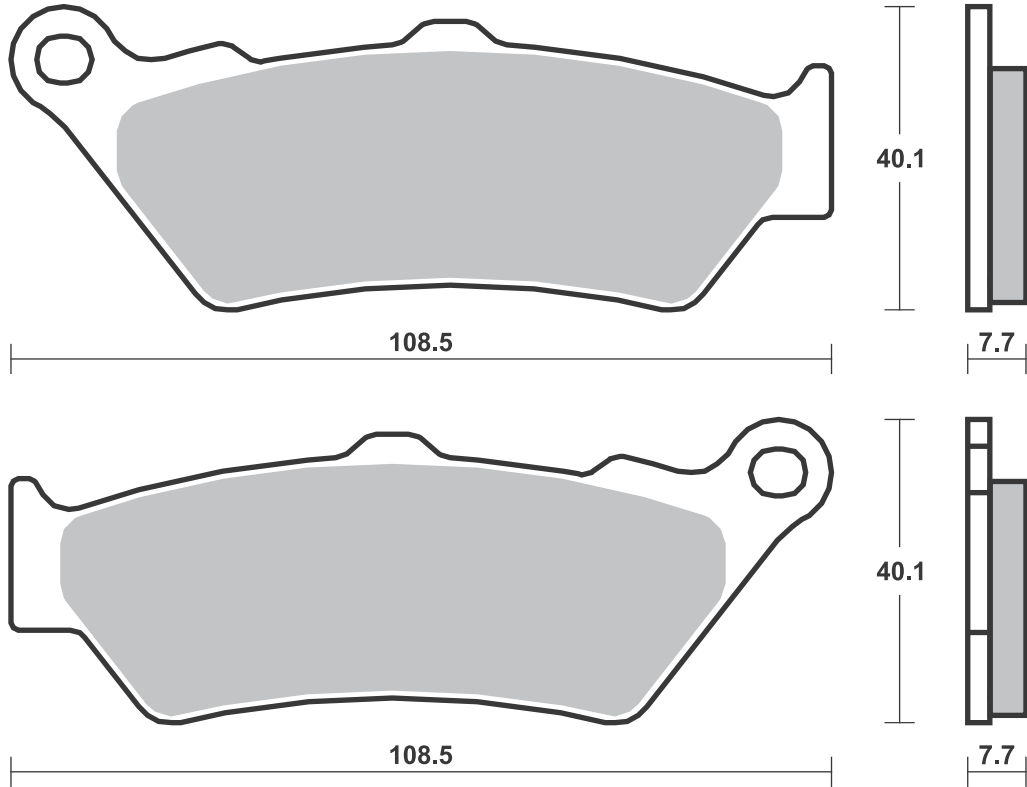

## Applications

**SBS 675** Recommended compound

| <b>CF MOTO</b> |       |           |  |
|----------------|-------|-----------|--|
| 650 NK         | 14-16 | <b>LS</b> |  |
| 650 NK Efi     | 17    | <b>LS</b> |  |
| 650 TK         | 14-15 | <b>LS</b> |  |

| <b>DUCATI</b>    |       |           |  |
|------------------|-------|-----------|--|
| 400 Scrambler    |       |           |  |
| Sixty Two        | 16-18 | <b>LS</b> |  |
| 797 Monster      | 17-18 | <b>LS</b> |  |
| 797 Monster+     | 17-18 | <b>LS</b> |  |
| 800 Scrambler    | 17-18 | <b>LS</b> |  |
| 800 Scrambler    |       |           |  |
| Classic          | 15-18 | <b>LS</b> |  |
| 800 Scrambler CR | 17-18 | <b>LS</b> |  |
| 800 Scrambler CR |       |           |  |
| Cafe Racer       | 17-18 | <b>LS</b> |  |
| 800 Scrambler    |       |           |  |
| Enduro           | 15-16 | <b>LS</b> |  |
| 800 Scrambler    |       |           |  |
| Flat Track Pro   | 16    | <b>LS</b> |  |
| 800 Scrambler    |       |           |  |
| Full Throttle    | 15-18 | <b>LS</b> |  |
| 800 Scrambler    |       |           |  |
| Icon             | 15-18 | <b>LS</b> |  |
| 800 Scrambler    |       |           |  |
| Mach 2.0         | 18-   | <b>LS</b> |  |
| 800 Scrambler    |       |           |  |
| Street Classic   | 17-18 | <b>LS</b> |  |
| 800 Scrambler    |       |           |  |
| Urban Enduro     | 16    | <b>LS</b> |  |
| 800 Scrambler-X  |       |           |  |
| DS Desert        |       |           |  |
| Sled             | 17-18 | <b>LS</b> |  |
| 1000 Biposto     | 07-08 | <b>LS</b> |  |
| 1000 GT          | 05-10 | <b>LS</b> |  |
| 1000 GT Touring  | 09-10 | <b>LS</b> |  |
| 1000 Paul Smart  | 05-08 | <b>LS</b> |  |
| 1000 Sport,      |       |           |  |
| Sport S          | 05-09 | <b>LS</b> |  |
| 1100 Scrambler   | 18-   | <b>LS</b> |  |
| 1100 Scrambler   |       |           |  |
| Special          | 18-   | <b>LS</b> |  |
| 1100 Scrambler   |       |           |  |
| Sport            | 18-   | <b>LS</b> |  |

| <b>FACTORY</b> |     |       |           |
|----------------|-----|-------|-----------|
| YR             | 250 | 99-03 | <b>SI</b> |

| <b>FANTIC</b> |    |           |  |
|---------------|----|-----------|--|
| 125 Caballero |    |           |  |
| Flat Track    | 17 | <b>LS</b> |  |
| 500 Caballero | 17 | <b>LS</b> |  |

| <b>GAS GAS</b> |     |       |            |
|----------------|-----|-------|------------|
| EC             | 125 | 97-99 | <b>SI</b>  |
| EC             | 200 | 99    | <b>SI</b>  |
| EC             | 250 | 97-99 | <b>SI</b>  |
| MC             | 250 | 97-99 | <b>RSI</b> |
| EC             | 300 | 99    | <b>SI</b>  |

| <b>HIGHLAND</b> |       |            |  |
|-----------------|-------|------------|--|
| 450 MX          | 06-09 | <b>RSI</b> |  |
| 950 V2 Motard   | 00-08 | <b>HF</b>  |  |
| 950 V2 Outback  | 99-08 | <b>HF</b>  |  |

| <b>HONDA</b> |                   |       |           |
|--------------|-------------------|-------|-----------|
| CBR          | 250 R (Bybre cal) | 11    | <b>LS</b> |
| CB           | 500               | 97-05 | <b>LS</b> |
| CB           | 500 S             | 98-03 | <b>LS</b> |
| NX           | 500 Dominator     |       |           |
|              | (Austria)         | 97-99 | <b>LS</b> |



| <b>HONDA</b> |               |       |           |
|--------------|---------------|-------|-----------|
| FX           | 650 Vigor     | 99-02 | <b>LS</b> |
| NX           | 650 Dominator | 97-99 | <b>LS</b> |
| SLR          | 650           | 97-99 | <b>LS</b> |

| <b>HRD</b> |              |       |           |
|------------|--------------|-------|-----------|
|            | 50 GS Enduro | 00-02 | <b>HF</b> |

| <b>HUSABERG</b> |          |       |            |
|-----------------|----------|-------|------------|
| FC              | 400      | 99-02 | <b>RSI</b> |
| FE              | 400 ,S,E | 99-03 | <b>SI</b>  |
| FS              | 400 e, c | 01-03 | <b>RSI</b> |
| FC              | 450      | 03-08 | <b>RSI</b> |
| FE              | 450 e    | 04-08 | <b>SI</b>  |
| FS              | 450 c    | 06-08 | <b>RSI</b> |
| FS              | 450 e, c | 03-05 | <b>RSI</b> |
| FX              | 450 e    | 03-08 | <b>RSI</b> |
| FC              | 470 , e  | 01-02 | <b>RSI</b> |
| FX              | 470 e    | 01-02 | <b>RSI</b> |
| FC              | 501      | 99-01 | <b>RSI</b> |
| FE              | 501 ,S,E | 99-04 | <b>SI</b>  |
| FC              | 550      | 01-05 | <b>RSI</b> |
| FE              | 550 e    | 04-08 | <b>SI</b>  |
| FC              | 600      | 99-01 | <b>RSI</b> |
| FE              | 600 ,S,E | 99-02 | <b>SI</b>  |
| FE              | 650 e    | 01-08 | <b>SI</b>  |
| FS              | 650 e, c | 01-08 | <b>RSI</b> |
| FX              | 650 e    | 01-05 | <b>RSI</b> |

| <b>HUSQVARNA</b> |                  |       |            |
|------------------|------------------|-------|------------|
| CR               | 125              | 96-04 | <b>RSI</b> |
| SM               | 125 S            | 09-13 | <b>HF</b>  |
| SM               | 125 S 4T         | 11-13 | <b>HF</b>  |
| SM               | 125 Supermotard, |       |            |
|                  | S                | 99-13 | <b>HF</b>  |
| TE               | 125 4T           | 11-13 | <b>HF</b>  |
| WR               | 125              | 96-13 | <b>SI</b>  |
| WRE              | 125 Sport,       | 96-13 | <b>SI</b>  |
| CR               | 250              | 96-04 | <b>RSI</b> |
| TC               | 250              | 02-03 | <b>RSI</b> |
| TE               | 250              | 02-13 | <b>SI</b>  |
| WR               | 250              | 96-13 | <b>SI</b>  |
| TE               | 350              | 96-13 | <b>SI</b>  |
| WR               | 360              | 98-13 | <b>SI</b>  |
| SM               | 400 R            | 02    | <b>HF</b>  |
| TE               | 400              | 01-13 | <b>SI</b>  |
|                  | 401 Svartpilen   | 17-18 | <b>LS</b>  |
|                  | 401 Vitpilen     | 17-18 | <b>LS</b>  |
| TE               | 410              | 96-13 | <b>SI</b>  |
| SM               | 450 R            | 03-04 | <b>HF</b>  |
| SM               | 450 R            | 05    | <b>RSI</b> |
| TC               | 450              | 02-03 | <b>RSI</b> |
| TE               | 450              | 02-10 | <b>SI</b>  |
| SM               | 510 R            | 05    | <b>RSI</b> |
| TC               | 510              | 02-03 | <b>RSI</b> |
| TE               | 510              | 02-10 | <b>SI</b>  |
| TE               | 510 Centennial   | 04-05 | <b>SI</b>  |
|                  | 570 Nox          | 01-03 | <b>HF</b>  |
| SM               | 570 R            | 01-08 | <b>HF</b>  |
| TC               | 570              | 01-13 | <b>RSI</b> |
| TE               | 570              | 01-13 | <b>SI</b>  |
| LT               | 610              | 00-02 | <b>HF</b>  |
| SM               | 610 Super        |       |            |
|                  | Motard, S        | 98-00 | <b>HF</b>  |
| TC               | 610              | 96-13 | <b>RSI</b> |
| TE               | 610 Rallye       | 96-13 | <b>RSI</b> |
| SMR              | 630              | 04-08 | <b>RSI</b> |
| TR               | 650 Strada       | 13    | <b>LS</b>  |
| TR               | 650 Terra        | 13    | <b>LS</b>  |
|                  | 701 Svartpilen   | 18-   | <b>LS</b>  |
|                  | 701 Vitpilen     | 18-   | <b>LS</b>  |



| <b>HUSQVARNA</b> |                 |       |           |
|------------------|-----------------|-------|-----------|
| FE               | 701 Enduro      | 17    | <b>LS</b> |
| SM               | 701 Supermoto   | 15-18 | <b>LS</b> |
|                  | 900 Nuda        | 12-13 | <b>LS</b> |
|                  | 900 Nuda R, ABS | 12-13 | <b>LS</b> |

| <b>HYOSUNG</b> |        |       |           |
|----------------|--------|-------|-----------|
| RX             | 450 SM | 08-11 | <b>LS</b> |

| <b>INDIAN</b> |                   |       |             |
|---------------|-------------------|-------|-------------|
|               | 1000 Scout Sixty  | 17-18 | <b>H.LS</b> |
|               | 1200 Scout        | 17-18 | <b>H.LS</b> |
|               | 1200 Scout Bobber | 17-18 | <b>H.LS</b> |

| <b>KRAM-IT</b> |         |       |            |
|----------------|---------|-------|------------|
|                | 250 SMR | 00    | <b>RSI</b> |
| GS             | 250     | 97-00 | <b>SI</b>  |
| MX             | 250     | 97-00 | <b>SI</b>  |
| SM             | 250     | 97-00 | <b>SI</b>  |

| <b>KTM</b> |                      |       |            |
|------------|----------------------|-------|------------|
|            | most models          | 94    | <b>SI</b>  |
|            | 125 Duke             | 11-18 | <b>LS</b>  |
|            | 125 Sting            | 99    | <b>HF</b>  |
|            | 125 SuperMoto        | 00-03 | <b>HF</b>  |
| EXC        | 125 Enduro           | 99-03 | <b>SI</b>  |
| EXE        | 125                  | 00    | <b>HF</b>  |
| LC2        | 125                  | 99    | <b>HF</b>  |
| RC         | 125                  | 14-18 | <b>LS</b>  |
| SX         | 125                  | 96-03 | <b>RSI</b> |
|            | 200 Duke             | 12-17 | <b>LS</b>  |
| EXC        | 200 Enduro           | 99-03 | <b>SI</b>  |
| RC         | 200                  | 14-18 | <b>LS</b>  |
|            | 250 Duke             | 14-15 | <b>LS</b>  |
| EXC        | 250 Enduro           | 99-03 | <b>SI</b>  |
| EXC        | 250 Enduro 4T        | 99-03 | <b>SI</b>  |
| RC         | 250                  | 14-15 | <b>LS</b>  |
| SX         | 250                  | 96-02 | <b>RSI</b> |
| EXC        | 300 Enduro           | 99-03 | <b>SI</b>  |
| MX         | 360                  | 96-97 | <b>SI</b>  |
| SX         | 360                  | 96-97 | <b>RSI</b> |
| XC         | 360                  | 96-97 | <b>SI</b>  |
| EXC        | 380 Enduro           | 99    | <b>SI</b>  |
| MX         | 380                  | 98    | <b>SI</b>  |
| SX         | 380                  | 98-02 | <b>RSI</b> |
| XC         | 380                  | 98-03 | <b>SI</b>  |
|            | 390 Duke             | 13-15 | <b>LS</b>  |
| RC         | 390                  | 14-18 | <b>LS</b>  |
| EXC        | 400 Racing           | 00-03 | <b>SI</b>  |
| LC4-E      | 400 Enduro           | 99-02 | <b>SI</b>  |
| SC         | 400                  | 99-00 | <b>SI</b>  |
| SX         | 400 Racing           | 00-02 | <b>RSI</b> |
| SXC        | 400 Tiainen          |       |            |
|            | Replica              | 99-00 | <b>SI</b>  |
|            | 450 Rally            | 11-16 | <b>SI</b>  |
| EXC        | 520 Racing           | 00-02 | <b>SI</b>  |
| SX-F       | 520 Racing           | 00-02 | <b>RSI</b> |
| EXC        | 525 Racing           | 03    | <b>SI</b>  |
| SX-F       | 525 Racing           | 03    | <b>RSI</b> |
| SXC        | 540 Tiainen          |       |            |
|            | Replica              | 99-00 | <b>SI</b>  |
| LC4        | 620 Competition      | 99-02 | <b>SI</b>  |
| LC4        | 620 Competition      |       |            |
|            | SuperMoto            | 00-01 | <b>HF</b>  |
| LC4        | 620 RXC              | 95    | <b>SI</b>  |
| LC4        | 620 Supercompetition |       |            |
|            | 01                   |       | <b>HF</b>  |
| SC         | 620                  | 99-00 | <b>SI</b>  |
| SX         | 620                  | 95-99 | <b>RSI</b> |
| LC4        | 625 SC               |       |            |
|            | Supermoto            | 02-04 | <b>HF</b>  |

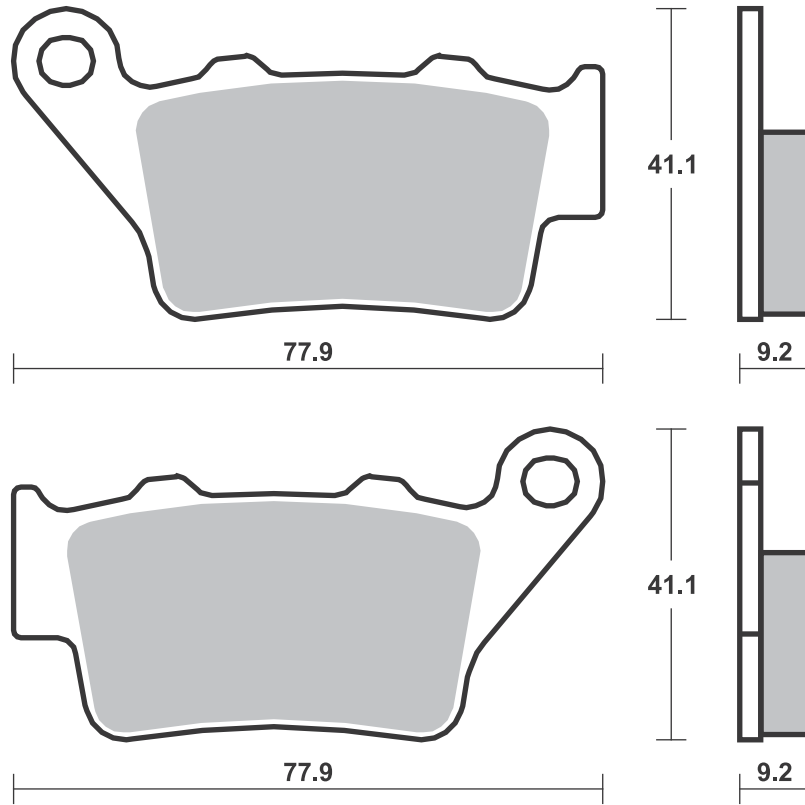

## Applications

### SBS 675 Recommended compound



| <b>KTM</b> |                  |       |            |
|------------|------------------|-------|------------|
| SMC        | 625              | 05-06 | <b>HF</b>  |
| SXC        | 625              | 03-04 | <b>HF</b>  |
|            | 640 Duke         | 03-06 | <b>HF</b>  |
| LC4        | 640 Adventure    | 99-07 | <b>HF</b>  |
| LC4        | 640 Supermoto    | 03-04 | <b>HF</b>  |
| LC4-E      | 640 Enduro       | 99-04 | <b>HF</b>  |
| LC4-E      | 640 Supermoto    | 99-02 | <b>HF</b>  |
| LC4        | 660 Rallye       | 01-03 | <b>HF</b>  |
| LC4        | 660 SM Factory   |       |            |
|            | Replica          | 02    | <b>RSI</b> |
| SMC        | 660 Supermoto    | 03-04 | <b>HF</b>  |
|            | 690 Duke         | 08-11 | <b>LS</b>  |
|            | 690 Duke ABS     | 12-18 | <b>LS</b>  |
|            | 690 Duke R       | 10-11 | <b>LS</b>  |
|            | 690 Duke R       | 14-17 | <b>LS</b>  |
|            | 690 Enduro       | 08-14 | <b>LS</b>  |
|            | 690 Enduro R     | 09-17 | <b>LS</b>  |
|            | 690 SM           | 07-11 | <b>LS</b>  |
|            | 690 SMC          | 08-10 | <b>LS</b>  |
|            | 690 Supermoto R  | 08-09 | <b>LS</b>  |
|            | 790 Duke         | 18-   | <b>LS</b>  |
| LC8        | 950 Adventure    | 02-07 | <b>LS</b>  |
|            | 990 Super Duke   | 04-13 | <b>LS</b>  |
|            | 990 Super Duke R | 09-13 | <b>LS</b>  |

| <b>MAICO</b> |                          |       |           |
|--------------|--------------------------|-------|-----------|
|              | 250 Motocross/<br>Enduro | 99-01 | <b>SI</b> |
|              | 500 Motocross/<br>Enduro | 99    | <b>SI</b> |
|              | 500 Supermotard          | 99    | <b>HF</b> |

| <b>PRAGA</b> |     |       |           |
|--------------|-----|-------|-----------|
| ED           | 250 | 99-03 | <b>SI</b> |
| CD           | 610 | 99-03 | <b>SI</b> |

| <b>ROYAL ENFIELD</b> |                 |       |           |
|----------------------|-----------------|-------|-----------|
|                      | 535 Continental |       |           |
|                      | GT              | 14-17 | <b>LS</b> |

| <b>SWM</b> |                 |       |           |
|------------|-----------------|-------|-----------|
|            | 600 Superdual   |       |           |
|            | GT Pack         | 18-   | <b>LS</b> |
|            | 600 Superdual T | 18-   | <b>LS</b> |
|            | 600 Superdual X | 18-   | <b>LS</b> |
|            | 650 Superdual   | 15-18 | <b>LS</b> |



| <b>TM</b> |              |       |            |
|-----------|--------------|-------|------------|
|           | 80 Cross     | 96-00 | <b>RSI</b> |
|           | 125          | 96-00 | <b>RSI</b> |
|           | 250 E        | 95-00 | <b>RSI</b> |
|           | 250 F Enduro | 00    | <b>SI</b>  |
|           | 300          | 98-00 | <b>RSI</b> |
|           | 320          | 96-97 | <b>RSI</b> |
|           | 400 F        | 00    | <b>RSI</b> |

| <b>TRIUMPH</b> |                     |       |           |
|----------------|---------------------|-------|-----------|
|                | 660 Street          |       |           |
|                | Triple S A2         | 17-18 | <b>LS</b> |
|                | 675 Daytona R       |       |           |
|                | Triple              | 13-18 | <b>LS</b> |
|                | 675 Daytona         |       |           |
|                | Triple              | 13-18 | <b>LS</b> |
|                | 675 Street Triple   | 13-17 | <b>LS</b> |
|                | 675 Street Triple R | 13-17 | <b>LS</b> |
|                | 675 Street Triple   |       |           |
|                | RX                  | 15-16 | <b>LS</b> |
|                | 765 Street Triple   |       |           |
|                | R                   | 17-18 | <b>LS</b> |
|                | 765 Street Triple   |       |           |
|                | R Low               | 17-18 | <b>LS</b> |
|                | 765 Street Triple   |       |           |
|                | RS                  | 17-18 | <b>LS</b> |
|                | 765 Street Triple S | 17-18 | <b>LS</b> |

| <b>VERTEMATI</b> |                 |       |            |
|------------------|-----------------|-------|------------|
| C                | 500 Cross       | 02-04 | <b>RSI</b> |
| E                | 501 Enduro      | 02-04 | <b>SI</b>  |
| S                | 501 Supermotard | 02-04 | <b>HF</b>  |

| <b>VICTORY</b> |             |    |             |
|----------------|-------------|----|-------------|
|                | 1200 Octane | 17 | <b>H.LS</b> |

| <b>VOR</b> |                |       |            |
|------------|----------------|-------|------------|
|            | 400 Cross      | 00-01 | <b>RSI</b> |
|            | 400 Enduro     | 00-01 | <b>SI</b>  |
| EN         | 400            | 02-03 | <b>SI</b>  |
| MX         | 400            | 02    | <b>RSI</b> |
| SM         | 400            | 02    | <b>RSI</b> |
| EN         | 450            | 02-04 | <b>SI</b>  |
| MX         | 450            | 02-04 | <b>RSI</b> |
| SM         | 450            | 02-04 | <b>RSI</b> |
|            | 500 492 Enduro | 99    | <b>SI</b>  |



| <b>VOR</b> |               |       |            |
|------------|---------------|-------|------------|
|            | 500 492 Super |       |            |
|            | Motard        | 00-01 | <b>HF</b>  |
|            | 500 495 Cross | 99    | <b>RSI</b> |
| EN         | 530           | 02-04 | <b>SI</b>  |
| MX         | 530           | 02-04 | <b>RSI</b> |
| SM         | 530           | 02-04 | <b>RSI</b> |

| <b>YAMAHA</b> |                  |       |           |
|---------------|------------------|-------|-----------|
| WR            | 125 R, XY        | 09-16 | <b>HF</b> |
| TT            | 600 E,S          | 96-01 | <b>HF</b> |
| TT            | 600 R            | 98-07 | <b>HF</b> |
| MT-03         | 660              | 06-13 | <b>LS</b> |
| XT            | 660 R            | 04-11 | <b>LS</b> |
| XT            | 660 X            | 04-13 | <b>LS</b> |
| XT            | 660 Z Tenere     | 08-14 | <b>LS</b> |
| XT            | 660 Z Tenere ABS | 11-14 | <b>LS</b> |

| <b>ZERO</b> |        |       |           |
|-------------|--------|-------|-----------|
| DS          | ZF11.4 | 14    | <b>LS</b> |
| DS          | ZF12.5 | 15    | <b>LS</b> |
| DS          | ZF13.0 | 16-17 | <b>LS</b> |
| DS          | ZF8.5  | 14    | <b>LS</b> |
| DS          | ZF9.4  | 15    | <b>LS</b> |
| DS          | ZF9.8  | 16-17 | <b>LS</b> |
| DSR         | ZF13.0 | 16-17 | <b>LS</b> |
| FX          | ZF2.8  | 14-15 | <b>LS</b> |
| FX          | ZF3.3  | 16-17 | <b>LS</b> |
| FX          | ZF5.7  | 14-15 | <b>LS</b> |
| FX          | ZF6.5  | 16-17 | <b>LS</b> |
| FXS         | ZF3.3  | 16-17 | <b>LS</b> |
| FXS         | ZF6.5  | 16-17 | <b>LS</b> |
| S           | ZF11.4 | 14    | <b>LS</b> |
| S           | ZF12.5 | 15    | <b>LS</b> |
| S           | ZF13.0 | 16-17 | <b>LS</b> |
| S           | ZF8.5  | 14    | <b>LS</b> |
| S           | ZF9.4  | 15    | <b>LS</b> |
| S           | ZF9.8  | 16-17 | <b>LS</b> |
| SR          | ZF11.4 | 14    | <b>LS</b> |
| SR          | ZF12.5 | 15    | <b>LS</b> |
| SR          | ZF13.0 | 16-17 | <b>LS</b> |

### SBS 676 Recommended compound



| <b>BRAKING</b>        |                    |       |           |
|-----------------------|--------------------|-------|-----------|
| Front Harley Davidson |                    |       |           |
| <b>BUELL</b>          |                    |       |           |
| M2                    | 1200 Cyclone       | 98-02 | <b>HS</b> |
| S1                    | 1200 Lightning     | 98-02 | <b>HS</b> |
| S1                    | 1200 Whitelighting | 98-02 | <b>HS</b> |
| S3                    | 1200 Thunderbolt   | 98-02 | <b>HS</b> |
| X1                    | 1200 Lightning     | 01-02 | <b>HS</b> |
| <b>HHI</b>            |                    |       |           |
| 6 Piston Caliper      |                    |       |           |
| <b>HONDA</b>          |                    |       |           |
| CB                    | 1300 SF            | 98-00 | <b>HS</b> |
| <b>KAWASAKI</b>       |                    |       |           |
| ZX-7RR                | 750 Ninja          | 96-02 | <b>HS</b> |



| <b>MV AGUSTA</b> |                   |       |           |
|------------------|-------------------|-------|-----------|
|                  | 750 Brutale,      |       |           |
|                  | Brutale S         | 01-05 | <b>HS</b> |
|                  | 750 F4 SPR        | 01-03 | <b>HS</b> |
|                  | 750 F4/F4S        | 99-02 | <b>HS</b> |
|                  | 910 Brutale       | 06-08 | <b>HS</b> |
|                  | 910 Brutale R     | 06-08 | <b>HS</b> |
|                  | 910 Brutale S     | 06-08 | <b>HS</b> |
|                  | 1000 F4 Mamba     | 04-06 | <b>HS</b> |
|                  | 1000 F4 Tamburini | 04-06 | <b>HS</b> |
|                  | 1000 F4S          | 04-06 | <b>HS</b> |



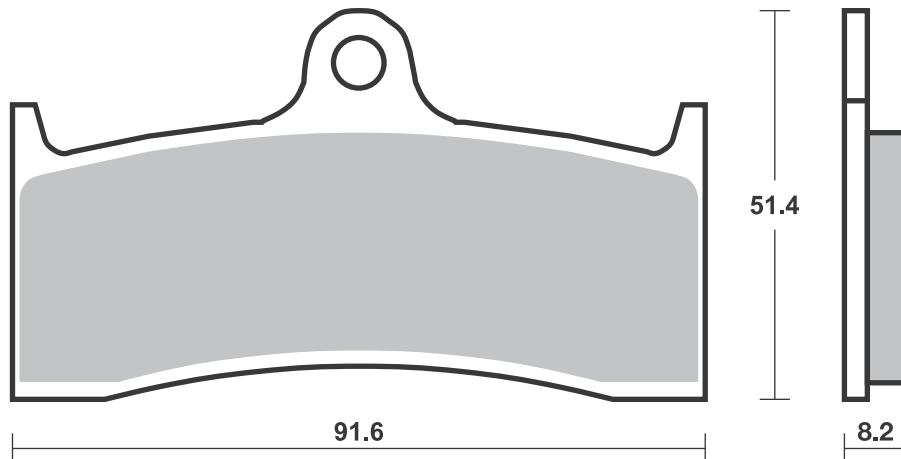
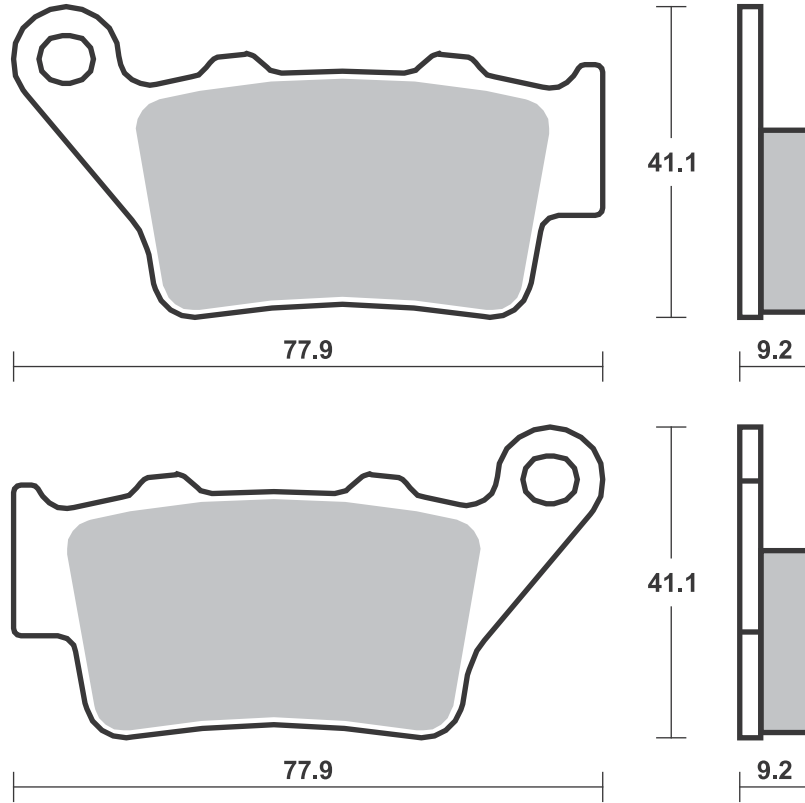



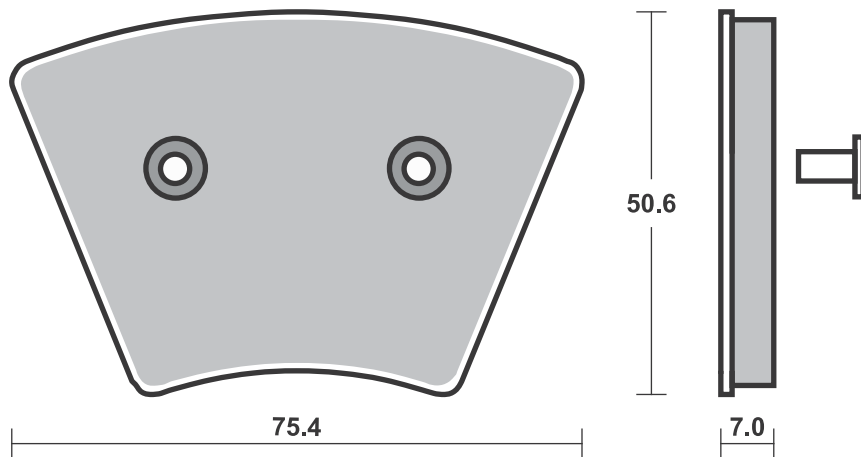
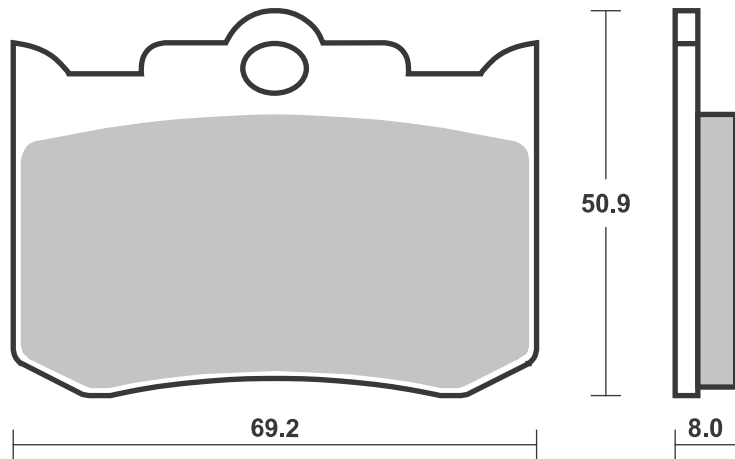
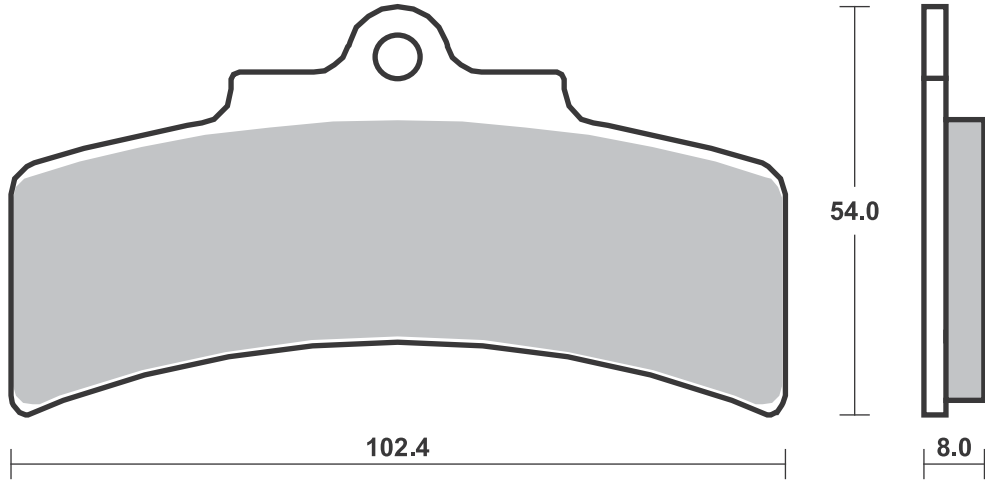



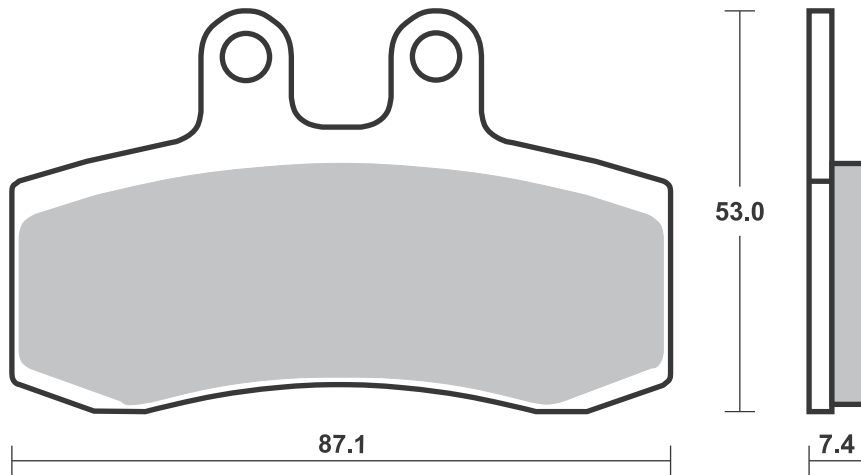
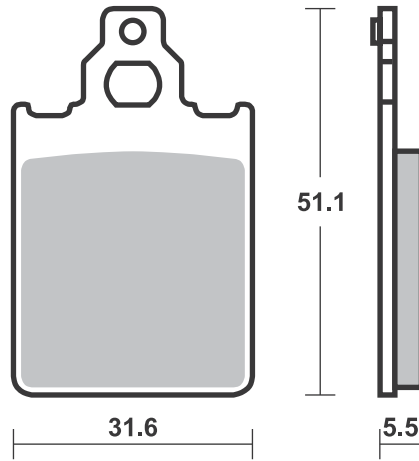

**SBS 682** Recommended compound



**YAMAHA**

|     |      |       |           |
|-----|------|-------|-----------|
| GTS | 1000 | 93-99 | <b>HF</b> |
|     |      |       |           |
|     |      |       |           |
|     |      |       |           |
|     |      |       |           |
|     |      |       |           |
|     |      |       |           |
|     |      |       |           |
|     |      |       |           |
|     |      |       |           |
|     |      |       |           |
|     |      |       |           |
|     |      |       |           |
|     |      |       |           |
|     |      |       |           |
|     |      |       |           |
|     |      |       |           |
|     |      |       |           |
|     |      |       |           |
|     |      |       |           |
|     |      |       |           |
|     |      |       |           |
|     |      |       |           |
|     |      |       |           |
|     |      |       |           |
|     |      |       |           |
|     |      |       |           |
|     |      |       |           |
|     |      |       |           |
|     |      |       |           |

**SBS 683** Recommended compound



|                            |           |       |           |
|----------------------------|-----------|-------|-----------|
| <b>PERFORMANCE MACHINE</b> |           |       |           |
| 112 X 6RSB                 |           |       |           |
| 112 X 6SSB                 |           |       |           |
| 125 X 6QC                  |           |       |           |
|                            |           |       |           |
| <b>TRIUMPH</b>             |           |       |           |
| 900 Daytona                |           |       |           |
| Super III                  |           |       |           |
|                            |           | 94-98 | <b>HS</b> |
|                            |           |       |           |
| <b>YAMAHA</b>              |           |       |           |
| YZF                        | 750 R, SP | 93-97 | <b>HS</b> |
| FZR                        | 1000      | 94-95 | <b>HS</b> |
|                            |           |       |           |
|                            |           |       |           |
|                            |           |       |           |
|                            |           |       |           |
|                            |           |       |           |
|                            |           |       |           |
|                            |           |       |           |
|                            |           |       |           |
|                            |           |       |           |
|                            |           |       |           |
|                            |           |       |           |
|                            |           |       |           |
|                            |           |       |           |
|                            |           |       |           |
|                            |           |       |           |
|                            |           |       |           |
|                            |           |       |           |
|                            |           |       |           |
|                            |           |       |           |
|                            |           |       |           |
|                            |           |       |           |
|                            |           |       |           |
|                            |           |       |           |
|                            |           |       |           |
|                            |           |       |           |
|                            |           |       |           |
|                            |           |       |           |
|                            |           |       |           |
|                            |           |       |           |
|                            |           |       |           |

Brake Pad 1:1 Drawings,  
Compounds, Fitments

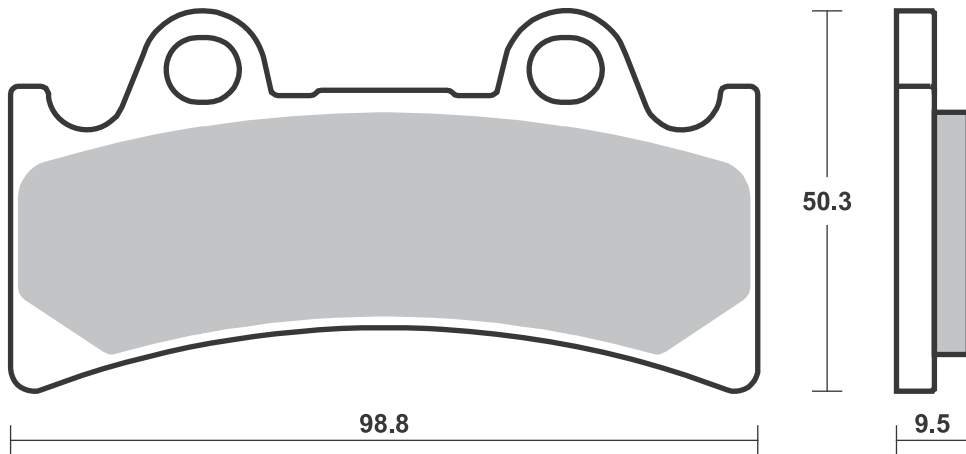
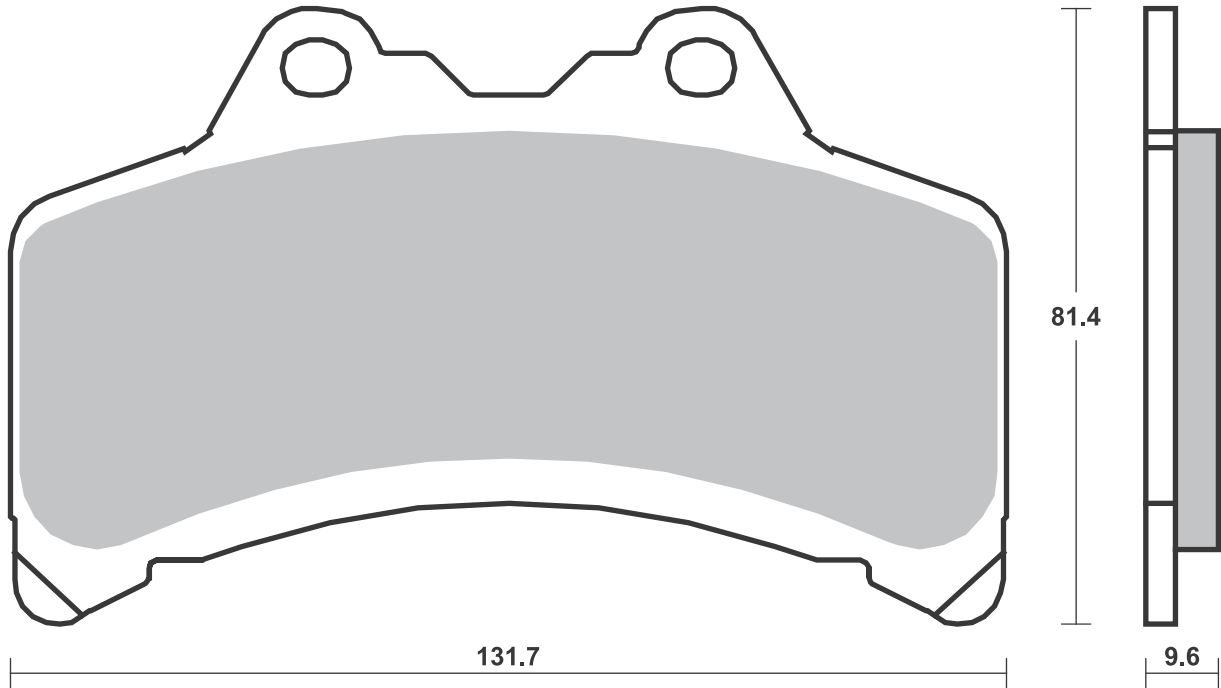

**SBS 684**

Recommended compound



**APRILIA**

|    |     |       |           |
|----|-----|-------|-----------|
| RX | 125 | 91-92 | <b>HF</b> |
|----|-----|-------|-----------|

**MZ**

|                  |       |           |  |
|------------------|-------|-----------|--|
| 660 (MUZ)        |       |           |  |
| Baghira          | 96-00 | <b>HF</b> |  |
| 660 (MUZ) Black  |       |           |  |
| Panther          | 00-06 | <b>HF</b> |  |
| 660 (MUZ)        |       |           |  |
| Mastiff          | 96-06 | <b>HF</b> |  |
| 660 (MUZ) Street |       |           |  |
| Moto             | 00-06 | <b>HF</b> |  |
| 660 (MUZ) Super  |       |           |  |
| Moto             | 07    | <b>HF</b> |  |

**SACHS**

|                 |       |           |
|-----------------|-------|-----------|
| 125 X-Road      | 05-07 | <b>HF</b> |
| XTC 125         | 99-07 | <b>HF</b> |
| XTC-N 125       | 99-07 | <b>HF</b> |
| ZX 125          | 99-02 | <b>HF</b> |
| ZZ 125          | 99-02 | <b>HF</b> |
| 500 MadAss      | 05-08 | <b>HF</b> |
| 650 Roadster    |       |           |
| V1.6            | 01-05 | <b>HF</b> |
| 800 Roadster V2 | 00-05 | <b>HF</b> |

**SIMSON**

|        |    |           |
|--------|----|-----------|
| 125    | 01 | <b>HF</b> |
| 125 RS | 01 | <b>HF</b> |

**SBS 685**

Recommended compound



**HONDA**

|     |            |       |           |           |
|-----|------------|-------|-----------|-----------|
| CBR | 1000 F, FP | 93-99 | <b>HS</b> | <b>LS</b> |
|-----|------------|-------|-----------|-----------|

|  |  |  |  |  |
|--|--|--|--|--|
|  |  |  |  |  |
|  |  |  |  |  |
|  |  |  |  |  |
|  |  |  |  |  |
|  |  |  |  |  |
|  |  |  |  |  |
|  |  |  |  |  |
|  |  |  |  |  |
|  |  |  |  |  |
|  |  |  |  |  |
|  |  |  |  |  |
|  |  |  |  |  |
|  |  |  |  |  |
|  |  |  |  |  |
|  |  |  |  |  |
|  |  |  |  |  |
|  |  |  |  |  |
|  |  |  |  |  |
|  |  |  |  |  |
|  |  |  |  |  |
|  |  |  |  |  |

Brake Pad 1:1 Drawings,  
Compounds, Fitments



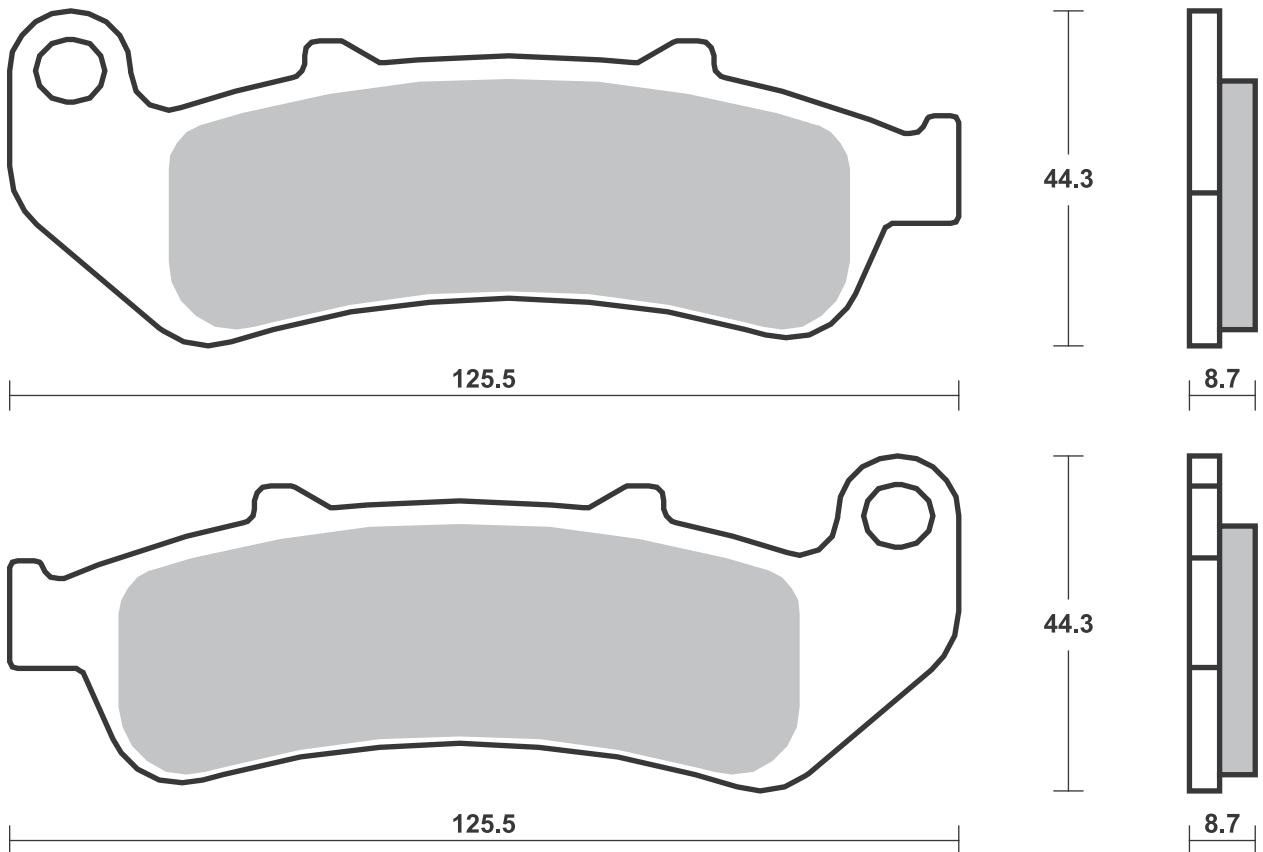
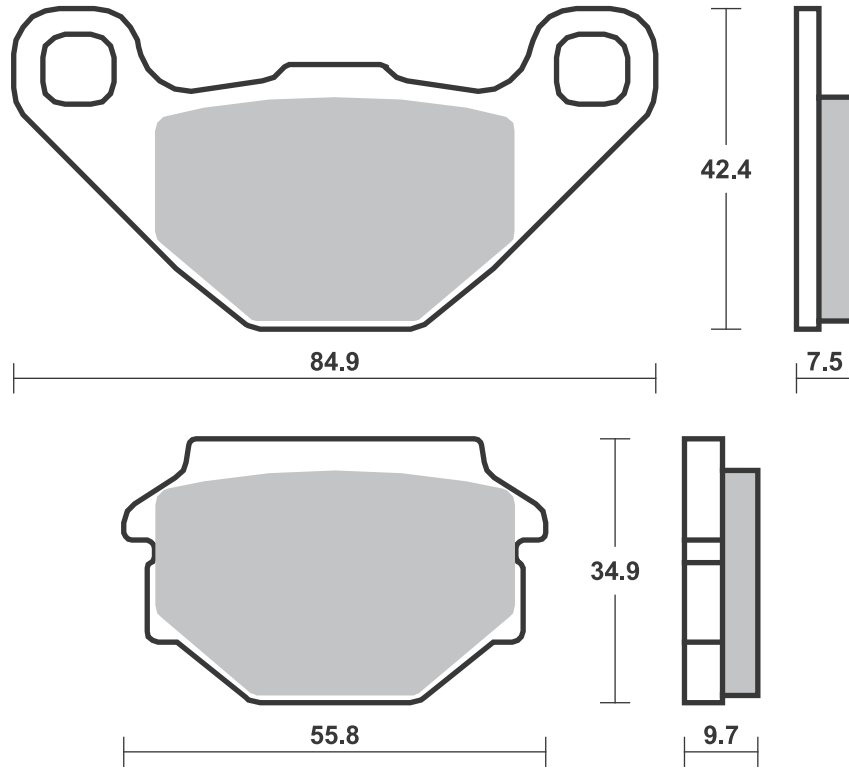

**SBS 686** Recommended compound

| <b>JAYBRAKE</b>         |  |  |  |
|-------------------------|--|--|--|
| 4 Piston Caliper A4 P/L |  |  |  |
| 4 Piston J-Four Caliper |  |  |  |

| <b>KAWASAKI</b> |            |       |           |
|-----------------|------------|-------|-----------|
| ZX-6R           | 600 Ninja  | 98-01 | <b>HS</b> |
| ZX-6R           | 636 Ninja  | 02    | <b>HS</b> |
| ZX-7R           | 750 Ninja  | 96-03 | <b>HS</b> |
| ZX-9R           | 900 Ninja  | 96-01 | <b>HS</b> |
| ZRX             | 1100       | 96-00 | <b>HS</b> |
| ZRX             | 1200       | 01-04 | <b>HS</b> |
| ZRX             | 1200 R     | 01-08 | <b>HS</b> |
| ZRX             | 1200 S     | 01-07 | <b>HS</b> |
| ZX-12R          | 1200 Ninja | 00-03 | <b>HS</b> |
| VN              | 1500 Mean  |       |           |
|                 | Streak     | 02-03 | <b>HS</b> |
| VN              | 1600 Mean  |       |           |
|                 | Streak     | 04    | <b>HS</b> |

| <b>SUZUKI</b> |               |       |           |
|---------------|---------------|-------|-----------|
| GSX-R         | 750           | 94-99 | <b>HS</b> |
| GSX-R         | 1000          | 01-02 | <b>HS</b> |
| TL            | 1000 RW       | 98-02 | <b>HS</b> |
| GSX-R         | 1100          | 93-97 | <b>HS</b> |
| GSF           | 1200 Bandit   | 01-05 | <b>HS</b> |
| GSF           | 1200 S Bandit | 01-05 | <b>HS</b> |
| GSX-R         | 1300 Hayabusa | 99-07 | <b>HS</b> |



| <b>SUZUKI</b> |               |       |           |
|---------------|---------------|-------|-----------|
| GSX           | 1400          | 02-07 | <b>HS</b> |
| VZ            | 1600 Marauder | 04    | <b>HS</b> |

**SBS 687** Recommended compound

| <b>KAWASAKI</b> |                 |       |           |
|-----------------|-----------------|-------|-----------|
|                 | 400 Ninja R     |       |           |
|                 | Left/Rear       | 11    | <b>LS</b> |
| ZZR             | 500 (Austria)   | 93-98 | <b>LS</b> |
| ZR              | 550 Zephyr      | 93-99 | <b>LS</b> |
| ZR              | 550 Zephyr (D)  |       |           |
|                 | from VIN        |       |           |
|                 | B024010-        | 93-01 | <b>LS</b> |
| ZX-6R           | 600 (Ninja ZX6) | 93-97 | <b>LS</b> |
| ZX-6R           | 600 (Ninja      |       |           |
|                 | ZX6R)           | 95-97 | <b>LS</b> |
| ZX-6R           | 600 Ninja       | 98-01 | <b>LS</b> |
| ZX-6R           | 600 Ninja       | 07-17 | <b>LS</b> |
| ZX-6RR          | 600 Ninja       | 03-06 | <b>LS</b> |
| ZZR             | 600             | 93-05 | <b>LS</b> |
| ZX-6R           | 636 Ninja       | 02    | <b>LS</b> |
| ZX-6R           | 636 Ninja       | 03-06 | <b>LS</b> |
| ER-6f           | 650 Left/Rear   | 06-16 | <b>LS</b> |
| ER-6n           | 650 Left/Rear   | 06-16 | <b>LS</b> |
| KLE             | 650 Versys      |       |           |
|                 | Left/Rear       | 07-14 | <b>LS</b> |
| Z               | 750 Left/Rear   | 04-06 | <b>LS</b> |
| Z               | 750 S Left/Rear | 05-06 | <b>LS</b> |
| ZX-9R           | 900 Ninja       | 94-03 | <b>LS</b> |
| Z               | 1000            | 10-16 | <b>LS</b> |
| Z               | 1000 ABS        | 15-18 | <b>LS</b> |
| Z               | 1000            | 03-06 | <b>LS</b> |
| Z               | 1000 R          | 17-18 | <b>LS</b> |
| Z               | 1000 SE         | 14-16 | <b>LS</b> |
| Z               | 1000 SX         | 11-18 | <b>LS</b> |
| ZX-10R          | 1000 Ninja      | 04-10 | <b>LS</b> |
| GPZ             | 1100 (ZX 1100)  |       |           |
|                 | Left/Rear       | 95-99 | <b>LS</b> |
| GPZ             | 1100 ABS,       |       |           |
|                 | Horizont        |       |           |
|                 | Left/Rear       | 97-99 | <b>LS</b> |

Available compounds **HF • HS • DC • RS • H.HF • H.HS • H.CT**

**SBS 686**

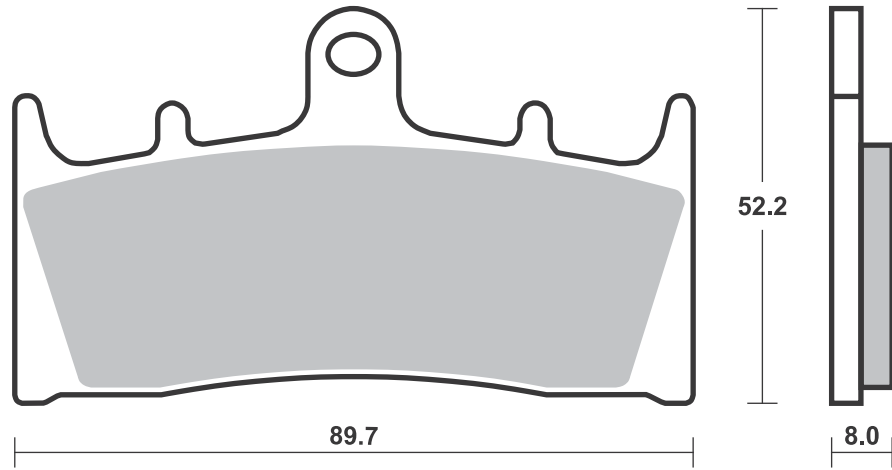

HF / HS - Th. 8.0  
RS / DC - Th. 9.5

Available compounds **HF • LS • RQ**

**SBS 687**

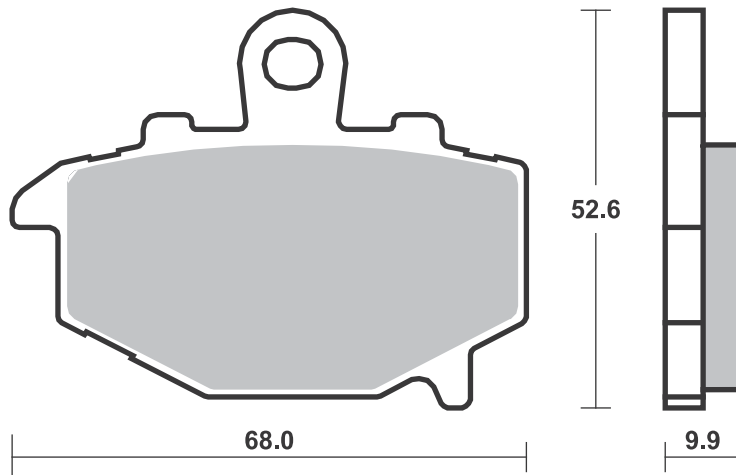
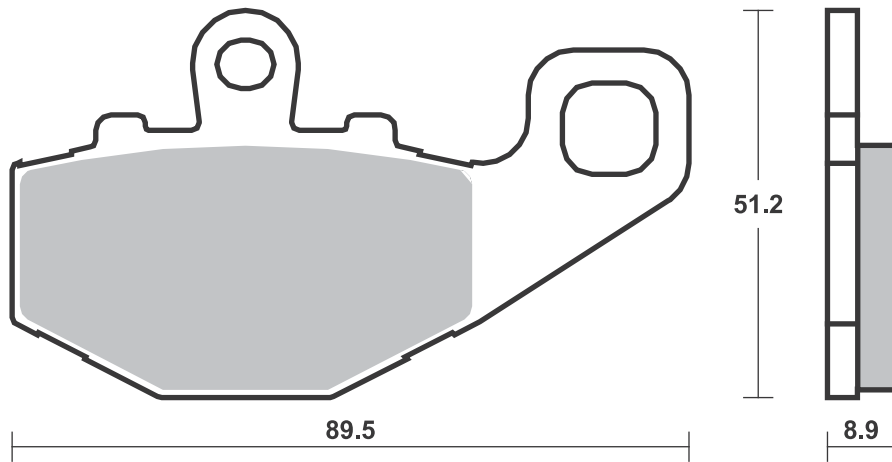

Brake Pad 1:1 Drawings,  
Compounds, Fitments

**SBS 688** Recommended compound



**CF MOTO**

|           |    |           |
|-----------|----|-----------|
| 125 Papio | 17 | <b>HF</b> |
|-----------|----|-----------|

**DAELIM**

|             |       |           |
|-------------|-------|-----------|
| 125 Roadwin | 04-12 | <b>HF</b> |
| 250 Roadwin | 08-12 | <b>HF</b> |

**HONDA**

|                  |       |           |
|------------------|-------|-----------|
| NSF 100          | 06    | <b>RS</b> |
| VT 125 C1 Shadow | 99-08 | <b>HF</b> |
| VT 125 C2 Shadow | 99-08 | <b>HF</b> |
| XLV 125 Varadero | 01-11 | <b>HF</b> |
| NSR 150          | 02    | <b>HF</b> |
| CBF 250          | 04-08 | <b>HF</b> |
| CB 300           | 10    | <b>HF</b> |

**KYMCO**

|             |       |           |
|-------------|-------|-----------|
| 125 Hipster | 01-06 | <b>HF</b> |
| 125 K-Pipe  | 13-15 | <b>HF</b> |
| 125 Pulsar  | 01-13 | <b>HF</b> |
| 125 Zing    | 96-14 | <b>HF</b> |
| CK-1 125    | 14-16 | <b>HF</b> |
| 150 Hipster | 01-06 | <b>HF</b> |

**LONCIN**

|          |    |           |
|----------|----|-----------|
| LX 110 4 | 02 | <b>HF</b> |
| LX 125   | 02 | <b>HF</b> |

**TGB**

|            |    |           |
|------------|----|-----------|
| 50 Buffalo | 03 | <b>HF</b> |
|------------|----|-----------|

**SBS 689** Recommended compound



**APRILIA**

|            |       |           |
|------------|-------|-----------|
| 125 Pegaso | 92-99 | <b>HF</b> |
|------------|-------|-----------|

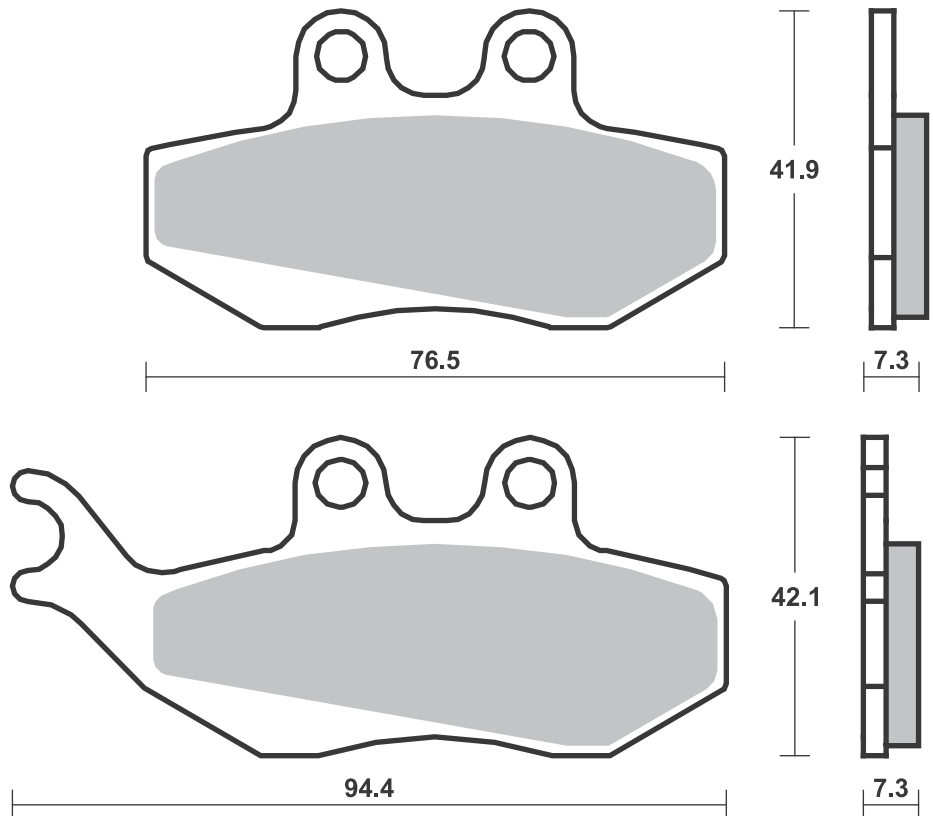
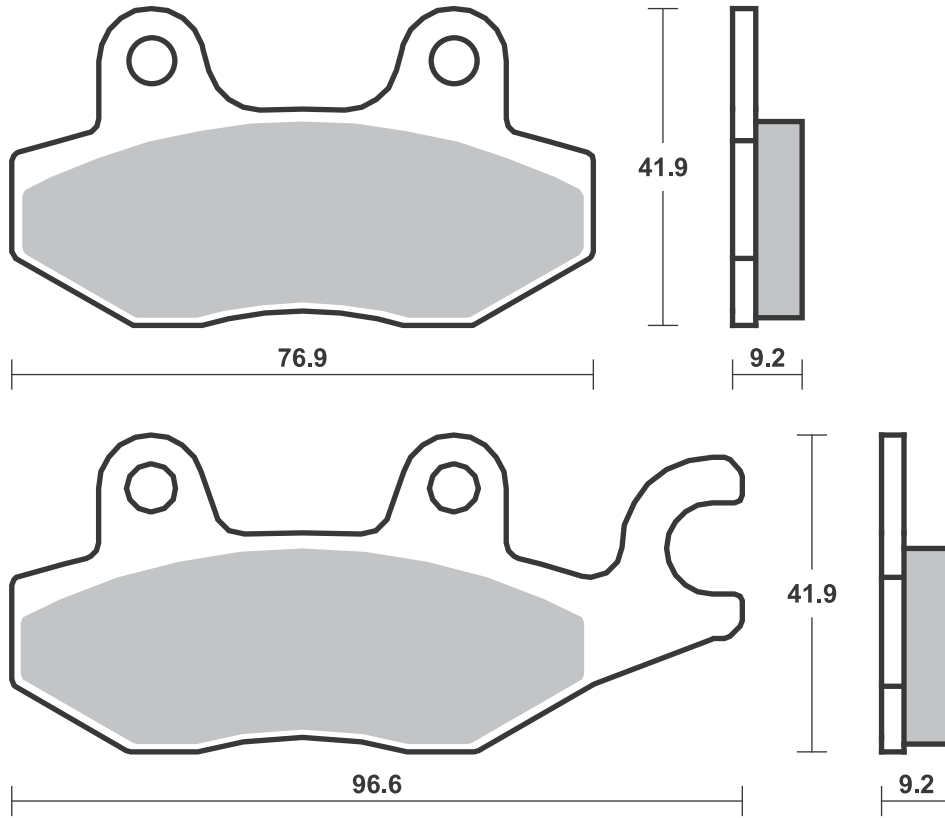

**SBS 690 Recommended compound****JINCHENG**

|    |        |    |    |
|----|--------|----|----|
| JC | 125 2B | 97 | HF |
|----|--------|----|----|

**MOTOR UNION**

|    |             |       |    |
|----|-------------|-------|----|
| JC | 125 2B Deer | 98-99 | HF |
|----|-------------|-------|----|

**SBS 691 Recommended compound****BAOXIN**

|    |       |    |    |
|----|-------|----|----|
| BX | 125 L | 97 | HF |
|----|-------|----|----|

**JIANSHE**

|    |       |    |    |
|----|-------|----|----|
| JS | 125 3 | 02 | HF |
|----|-------|----|----|

**JINCHENG**

|    |         |       |    |
|----|---------|-------|----|
| JC | 150 T-D | 06-09 | HF |
|----|---------|-------|----|

**KEEWAY**

|  |                 |       |    |
|--|-----------------|-------|----|
|  | 250 Supershadow | 06-09 | HF |
|--|-----------------|-------|----|

**LONCIN**

|    |       |    |    |
|----|-------|----|----|
| LX | 150 6 | 02 | HF |
|----|-------|----|----|

**MZ**

|  |              |       |    |
|--|--------------|-------|----|
|  | 1000 (MUZ) S | 01-02 | HF |
|--|--------------|-------|----|

**QUINGOI**

|    |        |       |    |
|----|--------|-------|----|
| QM | 125 2V | 02-05 | HF |
|----|--------|-------|----|

**YAMAHA**

|    |     |       |    |
|----|-----|-------|----|
| SR | 125 | 97-02 | HF |
|----|-----|-------|----|

|     |       |       |    |
|-----|-------|-------|----|
| TDR | 125 R | 93-03 | HS |
|-----|-------|-------|----|

|     |     |    |    |
|-----|-----|----|----|
| TZR | 125 | 93 | HF |
|-----|-----|----|----|

|    |            |       |    |
|----|------------|-------|----|
| XV | 125 Virago | 97-00 | HF |
|----|------------|-------|----|

|     |               |       |    |
|-----|---------------|-------|----|
| XVS | 125 Drag Star | 00-06 | HF |
|-----|---------------|-------|----|

|    |              |       |    |
|----|--------------|-------|----|
| XV | 250 S Virago | 95-07 | HS |
|----|--------------|-------|----|

|     |               |       |    |
|-----|---------------|-------|----|
| XVS | 250 Drag Star | 01-04 | HF |
|-----|---------------|-------|----|

|     |     |       |    |
|-----|-----|-------|----|
| FZ6 | 600 | 04-08 | HS |
|-----|-----|-------|----|

|     |           |       |    |
|-----|-----------|-------|----|
| FZ6 | 600 Fazer | 04-08 | HS |
|-----|-----------|-------|----|

**YAMAHA**

|      |     |       |    |
|------|-----|-------|----|
| FZ6R | 600 | 09-14 | HS |
|------|-----|-------|----|

|    |       |       |    |
|----|-------|-------|----|
| XJ | 600 N | 98-03 | HS |
|----|-------|-------|----|

|    |                 |       |    |
|----|-----------------|-------|----|
| XJ | 600 S Diversion | 98-03 | HS |
|----|-----------------|-------|----|

|     |               |       |    |
|-----|---------------|-------|----|
| XJ6 | 600 Diversion | 09-15 | HS |
|-----|---------------|-------|----|

|       |     |       |    |
|-------|-----|-------|----|
| XJ6-F | 600 | 09-15 | HS |
|-------|-----|-------|----|

|       |     |       |    |
|-------|-----|-------|----|
| XJ6-N | 600 | 09-15 | HS |
|-------|-----|-------|----|

|       |     |       |    |
|-------|-----|-------|----|
| XJ6-S | 600 | 09-15 | HS |
|-------|-----|-------|----|

|       |     |       |    |
|-------|-----|-------|----|
| MT-03 | 660 | 06-13 | HS |
|-------|-----|-------|----|

|    |             |    |    |
|----|-------------|----|----|
| XV | 1100 Virago | 99 | HS |
|----|-------------|----|----|

|     |                |       |    |
|-----|----------------|-------|----|
| XVS | 1100 Drag Star | 99-06 | HS |
|-----|----------------|-------|----|

|     |                |  |  |
|-----|----------------|--|--|
| XVS | 1100 Drag Star |  |  |
|-----|----------------|--|--|

|  |         |       |    |
|--|---------|-------|----|
|  | Classic | 00-06 | HS |
|--|---------|-------|----|

|     |                 |  |  |
|-----|-----------------|--|--|
| XVS | 1300 A Midnight |  |  |
|-----|-----------------|--|--|

|  |      |       |    |
|--|------|-------|----|
|  | Star | 07-11 | HS |
|--|------|-------|----|

|     |             |       |    |
|-----|-------------|-------|----|
| XVS | 1300 Custom | 14-16 | HS |
|-----|-------------|-------|----|

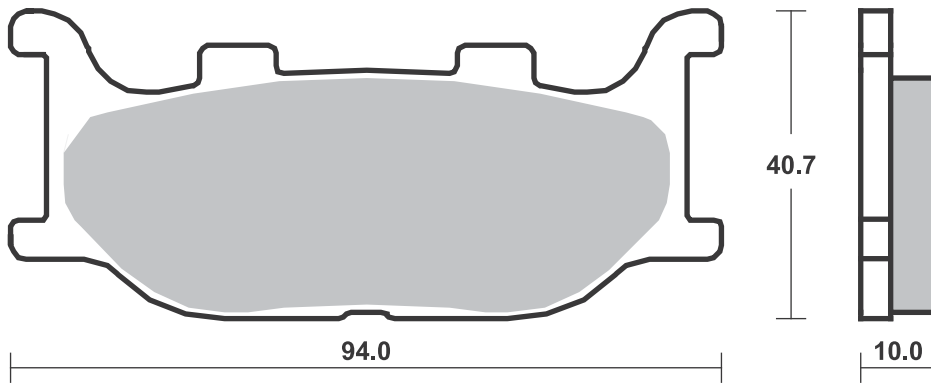
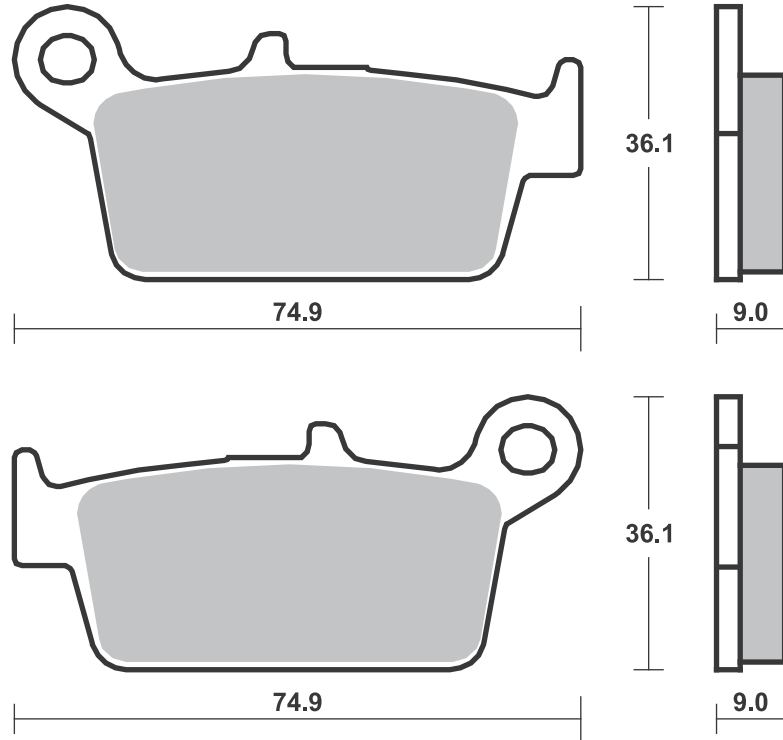

## Applications

### SBS 692 Recommended compound



| <b>APRILIA</b> |                 |       |           |
|----------------|-----------------|-------|-----------|
|                | 125 Pegaso      | 90-91 | <b>HF</b> |
|                | 125 Tuareg Wind | 90-94 | <b>HF</b> |
| RX             | 125             | 91    | <b>HF</b> |
| RX             | 125             | 97-99 | <b>HF</b> |
|                | 600 Tuareg      | 88-89 | <b>HF</b> |
|                | 600 Tuareg Wind | 90-94 | <b>HF</b> |
|                | 650 Moto        | 95-03 | <b>HF</b> |
|                | 650 Pegaso      | 95-00 | <b>HF</b> |
|                | 650 Starck      | 96-01 | <b>HF</b> |

| <b>BUELL</b> |            |       |           |
|--------------|------------|-------|-----------|
|              | all models | 94-97 | <b>HF</b> |
| RS           | 1200       | 12    | <b>HF</b> |

| <b>CAGIVA</b> |           |       |           |
|---------------|-----------|-------|-----------|
|               | 125 Cross | 86    | <b>SI</b> |
|               | 125 W 8   | 96-01 | <b>HF</b> |
| WMX           | 125       | 89-90 | <b>SI</b> |
| WMX           | 250       | 89-90 | <b>SI</b> |
|               | 600 W 16  | 95-97 | <b>HF</b> |

| <b>FANTIC</b> |              |    |           |
|---------------|--------------|----|-----------|
|               | 50 .1 Raider | 87 | <b>HF</b> |
|               | 50 Strada    | 83 | <b>HF</b> |

| <b>HUSQVARNA</b> |           |       |           |
|------------------|-----------|-------|-----------|
| CR/WR            | 125       | 91    | <b>SI</b> |
| WR               | 240       | 91    | <b>SI</b> |
| CR               | 250       | 91    | <b>SI</b> |
| WR               | 260       | 90-93 | <b>SI</b> |
| TC               | 610 Cross | 91    | <b>SI</b> |
| TE               | 610       | 91-95 | <b>SI</b> |



| <b>KRAM-IT</b> |              |       |           |
|----------------|--------------|-------|-----------|
|                | 50 Scrambler | 90    | <b>HF</b> |
| ER             | 125          | 89-93 | <b>SI</b> |
| MC             | 250          | 89    | <b>SI</b> |
| ER             | 300          | 89    | <b>SI</b> |

| <b>KTM</b> |     |       |           |
|------------|-----|-------|-----------|
| MX         | 125 | 89-93 | <b>SI</b> |
| MX         | 250 | 89-93 | <b>SI</b> |
| MX         | 500 | 89-93 | <b>SI</b> |

| <b>YAMAHA</b> |             |       |           |
|---------------|-------------|-------|-----------|
| TDR           | 125 (Italy) | 90-93 | <b>SI</b> |

### SBS 694 Recommended compound



| <b>AJP</b> |                 |    |           |
|------------|-----------------|----|-----------|
| PR5        | 250 Enduro      | 09 | <b>SI</b> |
| PR5        | 250 Supermotard | 09 | <b>SI</b> |

| <b>APRILIA</b> |     |       |            |
|----------------|-----|-------|------------|
| MXV            | 450 | 09-13 | <b>RSI</b> |
| RXV            | 450 | 06-13 | <b>SI</b>  |
| RXV            | 550 | 06-13 | <b>SI</b>  |

| <b>BETA</b> |                  |       |           |
|-------------|------------------|-------|-----------|
| RR          | 125              | 18-   | <b>SI</b> |
| RR          | 250              | 05-09 | <b>SI</b> |
|             | 300 Crosstrainer | 15    | <b>SI</b> |
| RR          | 300              | 13-18 | <b>SI</b> |
| RR          | 350 Efi          | 15    | <b>SI</b> |
| RR          | 350 Efi Racing   | 15    | <b>SI</b> |
| RR          | 350 Enduro       | 12-14 | <b>SI</b> |
| RR          | 390              | 15-18 | <b>SI</b> |
| RR          | 400 Enduro       | 05    | <b>SI</b> |
| RR          | 430              | 15-18 | <b>SI</b> |
| RR          | 430 Racing       | 15-18 | <b>SI</b> |
| RR          | 450 Cross        |       |           |
|             | Country          | 12    | <b>SI</b> |
| RR          | 450 Enduro       | 05-07 | <b>SI</b> |
| RR          | 480              | 15-18 | <b>SI</b> |
| RR          | 480 Racing       | 15-18 | <b>SI</b> |
| RR          | 498 Enduro       | 12-14 | <b>SI</b> |
| RR          | 525 Enduro       | 05-13 | <b>SI</b> |

| <b>BIMOTA</b> |            |    |           |
|---------------|------------|----|-----------|
| BBX           | 300 Enduro | 12 | <b>SI</b> |
| BBX           | 508 Enduro | 12 | <b>SI</b> |

| <b>BRAKING</b> |             |  |  |
|----------------|-------------|--|--|
|                | Front cross |  |  |

| <b>CANNONDALE</b> |            |       |            |
|-------------------|------------|-------|------------|
| MX                | 400        | 00-03 | <b>RSI</b> |
| C                 | 440 R      | 03    | <b>RSI</b> |
| E                 | 440 , A, R | 03    | <b>RSI</b> |
| X                 | 440        | 03    | <b>RSI</b> |

| <b>CPI</b> |           |    |           |
|------------|-----------|----|-----------|
|            | 125 Sahel | 02 | <b>HF</b> |

| <b>FANTIC</b> |                    |       |            |
|---------------|--------------------|-------|------------|
|               | 50 Regolarna       |       |            |
|               | Competizione 08-09 |       | <b>HF</b>  |
| MX            | 50 Regolarna       |       |            |
|               | Competizione 08    |       | <b>RSI</b> |
| MX            | 65 Regolarna       |       |            |
|               | Competizione 08    |       | <b>RSI</b> |
|               | 80 Regolarna       |       |            |
|               | Competizione 08    |       | <b>HF</b>  |
| MX            | 85 Regolarna       |       |            |
|               | Competizione 08    |       | <b>RSI</b> |
|               | 125 Caballero      |       |            |
|               | Enduro 2T          | 12-10 | <b>HF</b>  |



| <b>FANTIC</b> |                 |    |           |
|---------------|-----------------|----|-----------|
|               | 125 Caballero   |    |           |
|               | Motard 2T       | 10 | <b>HF</b> |
|               | 125 Regolarna   |    |           |
|               | Competizione 08 |    | <b>HF</b> |

| <b>GAS GAS</b> |               |       |            |
|----------------|---------------|-------|------------|
|                | 125 Enducross | 93    | <b>SI</b>  |
| EC             | 125           | 00-06 | <b>SI</b>  |
| MC             | 125           | 03-13 | <b>RSI</b> |
| EC             | 200           | 00-17 | <b>SI</b>  |
| EC             | 200 Hobby     | 07-16 | <b>SI</b>  |
| XC             | 200           | 18-   | <b>SI</b>  |
| EC             | 250           | 00-18 | <b>SI</b>  |
| EC             | 250 Enduro    |       |            |
|                | GP 18         | 18-   | <b>SI</b>  |
| EC             | 250 fse       | 02-11 | <b>SI</b>  |
| MC             | 250           | 00-13 | <b>SI</b>  |
| XC             | 250           | 17    | <b>SI</b>  |
| EC             | 300           | 00-18 | <b>SI</b>  |
| EC             | 300 Enduro    |       |            |
|                | GP 18         | 18-   | <b>SI</b>  |
| XC             | 300           | 18-   | <b>SI</b>  |
|                | 400 Pampera   | 06-09 | <b>SI</b>  |
| EC             | 400 fse       | 02    | <b>SI</b>  |
| EC             | 450 fse       | 03-15 | <b>SI</b>  |
| EC             | 450 FSR       | 07-16 | <b>SI</b>  |
| EC             | 515 fsr       | 08-16 | <b>SI</b>  |



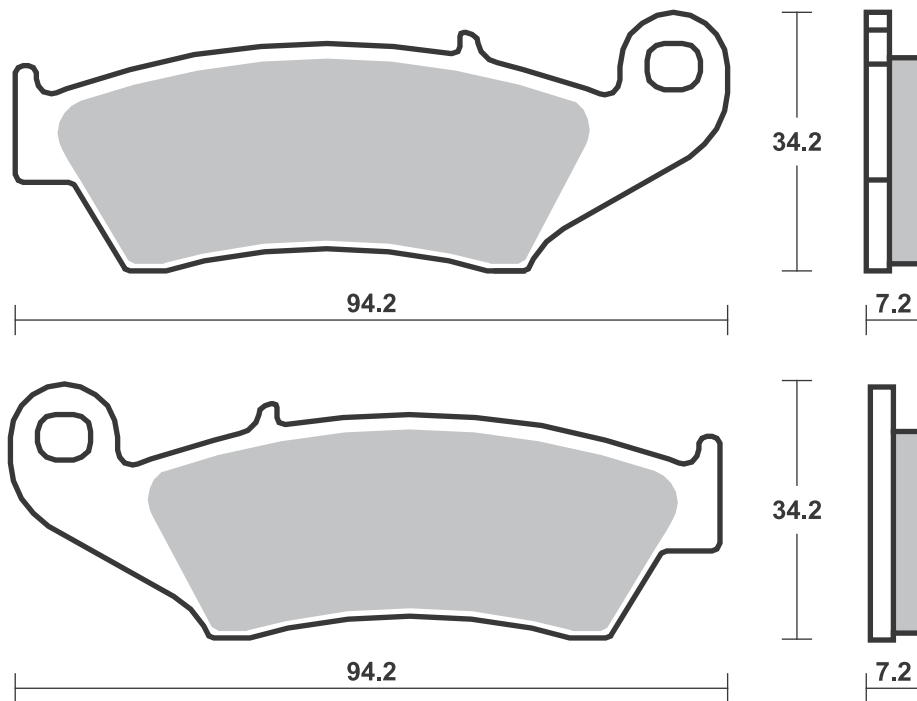
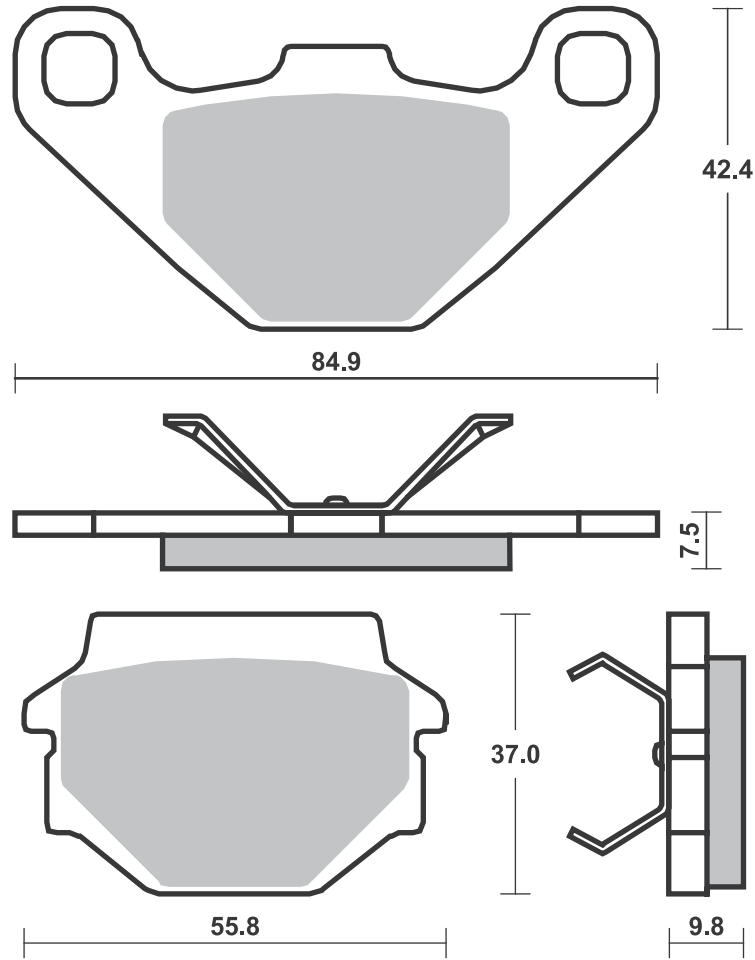

## SBS 694 Recommended compound



| <b>HM</b> |                 |       |            |
|-----------|-----------------|-------|------------|
|           | 125 Supermotard | 00-02 | <b>HF</b>  |
| CR        | 125 Supermotard | 04-06 | <b>RSI</b> |
| CRE       | 125 Enduro      | 95-06 | <b>SI</b>  |
| CRE       | 125 Supermotard | 03    | <b>HF</b>  |
|           | 250 Supermotard | 00-02 | <b>HF</b>  |
| CRE       | 250 Enduro      | 95-03 | <b>SI</b>  |
| CRE       | 250 F Enduro    | 04-13 | <b>SI</b>  |
| CRE       | 250 Supermotard | 03    | <b>HF</b>  |
| CRE       | 250 Supermotard | 04-07 | <b>RSI</b> |
| CRE       | 250 X Enduro    | 04-13 | <b>SI</b>  |
| CRF       | 250 Supermotard | 04-06 | <b>RSI</b> |
| CRE       | 450 F Enduro    | 02-13 | <b>SI</b>  |
| CRE       | 450 X Enduro    | 04-13 | <b>SI</b>  |
| CRF       | 450 Supermotard | 02-06 | <b>RSI</b> |

**HONDA**

|     |                       |       |            |
|-----|-----------------------|-------|------------|
| CR  | 125 R                 | 95-07 | <b>RSI</b> |
| CRE | 125                   | 02-07 | <b>SI</b>  |
| CRF | 125 F                 | 14-18 | <b>SI</b>  |
| XLR | 125 R                 | 98-01 | <b>HF</b>  |
| XR  | 125 L                 | 03-07 | <b>HF</b>  |
| CRF | 150 F                 | 03-06 | <b>SI</b>  |
| CTX | 200                   | 04-06 | <b>SI</b>  |
| CRF | 230                   | 04-09 | <b>SI</b>  |
| CRF | 230 L                 | 08-10 | <b>SI</b>  |
| CRF | 230 M                 | 09-12 | <b>SI</b>  |
| SL  | 230                   | 97-01 | <b>HF</b>  |
| CR  | 250 R                 | 95-07 | <b>RSI</b> |
| CRE | 250                   | 02-07 | <b>SI</b>  |
| CRE | 250 F                 | 04    | <b>SI</b>  |
| CRF | 250 R                 | 04-09 | <b>RSI</b> |
| CRF | 250 R Efi             | 10-18 | <b>RSI</b> |
| CRF | 250 X                 | 04-14 | <b>SI</b>  |
| XLR | 250 R SPL             | 94    | <b>SI</b>  |
| XR  | 250 L                 | 93-97 | <b>HF</b>  |
| XR  | 250 S, R              | 96-00 | <b>HF</b>  |
| XR  | 300                   | 10-12 | <b>HF</b>  |
| XR  | 400 R                 | 96-04 | <b>SI</b>  |
| XR  | 400 Supermotard       | 00-03 | <b>RSI</b> |
| XR  | 440 R                 | 00-03 | <b>SI</b>  |
| CRE | 450 F                 | 02-06 | <b>SI</b>  |
| CRF | 450 Efi               | 09-12 | <b>RSI</b> |
| CRF | 450 R                 | 02-08 | <b>RSI</b> |
| CRF | 450 R Efi             | 13-18 | <b>RSI</b> |
| CRF | 450 RX Efi            | 17-18 | <b>SI</b>  |
| CRF | 450 X                 | 05-18 | <b>SI</b>  |
| TRX | 450 R                 | 04-09 | <b>SI</b>  |
| CR  | 500 R                 | 95-01 | <b>RSI</b> |
| XL  | 600 V,<br>Transalpino | 97-99 | <b>HS</b>  |
| XR  | 600 R                 | 93-00 | <b>SI</b>  |
| XL  | 650 V Transalp        | 00-07 | <b>HS</b>  |
| XR  | 650 L                 | 93-12 | <b>HF</b>  |
| XR  | 650 R                 | 00-11 | <b>SI</b>  |
| TRX | 700 XX                | 08-12 | <b>SI</b>  |
| XL  | 700 Transalp          | 08-11 | <b>HS</b>  |
| XRV | 750 Africa Twin       | 93-03 | <b>HS</b>  |

**KAWASAKI**

|      |         |       |            |
|------|---------|-------|------------|
| KX   | 125     | 94-08 | <b>RSI</b> |
| KDX  | 200     | 94-99 | <b>SI</b>  |
| KDX  | 220 R   | 97-05 | <b>SI</b>  |
| KLX  | 250     | 93-96 | <b>SI</b>  |
| KLX  | 250     | 98-07 | <b>SI</b>  |
| KX   | 250     | 94-08 | <b>RSI</b> |
| KX-F | 250     | 04-10 | <b>RSI</b> |
| KX-F | 250 DFI | 11-18 | <b>RSI</b> |
| KLX  | 300 R   | 97-07 | <b>SI</b>  |
| KLX  | 400 R   | 03-04 | <b>SI</b>  |
| KLX  | 400 SR  | 03-04 | <b>HF</b>  |



| <b>KAWASAKI</b> |          |       |            |
|-----------------|----------|-------|------------|
| KLX             | 450 R    | 07-12 | <b>SI</b>  |
| KX-F            | 450      | 06-08 | <b>RSI</b> |
| KX-F            | 450 DFI  | 09-18 | <b>RSI</b> |
| KX              | 500      | 94-04 | <b>RSI</b> |
| KLX             | 650      | 93-96 | <b>SI</b>  |
| KLX             | 650 R    | 93-95 | <b>SI</b>  |
| KLX             | 650 R D1 | 96    | <b>SI</b>  |

**SUZUKI**

|      |             |       |            |
|------|-------------|-------|------------|
| DR   | 125 SM      | 08-12 | <b>HF</b>  |
| RM   | 125         | 96-09 | <b>RSI</b> |
| DR-Z | 250         | 01-07 | <b>SI</b>  |
| RM   | 250         | 96-09 | <b>RSI</b> |
| RMX  | 250         | 96-98 | <b>RSI</b> |
| RMX  | 250 X-K1    | 99    | <b>SI</b>  |
| RM-Z | 250         | 04-09 | <b>RSI</b> |
| RM-Z | 250 Efi     | 10-18 | <b>RSI</b> |
| DR   | 350 V, W, X | 97-99 | <b>SI</b>  |
| DR-Z | 400 S/E     | 00-12 | <b>HF</b>  |
| DR-Z | 400 SM      | 05-10 | <b>RSI</b> |
| RMX  | 450 Z Efi   | 10    | <b>SI</b>  |
| RMX  | 450 Z Efi   | 17-18 | <b>SI</b>  |
| RM-Z | 450         | 05-07 | <b>RSI</b> |
| RM-Z | 450 Efi     | 08-17 | <b>RSI</b> |
| RM-Z | 450 Efi     | 18-   | <b>RSI</b> |
| DR   | 650 SE T-W  | 96-99 | <b>HF</b>  |

**YAMAHA**

|    |           |       |            |
|----|-----------|-------|------------|
| WR | 125       | 98-02 | <b>SI</b>  |
| YZ | 125       | 98-07 | <b>RSI</b> |
| WR | 250       | 98-02 | <b>SI</b>  |
| WR | 250 F     | 01-13 | <b>SI</b>  |
| WR | 250 F Efi | 15-17 | <b>SI</b>  |
| WR | 250 R     | 08-15 | <b>HS</b>  |
| YZ | 250       | 98-07 | <b>RSI</b> |
| YZ | 250 F     | 01-06 | <b>RSI</b> |
| WR | 400 F     | 98-00 | <b>SI</b>  |
| YZ | 400       | 98    | <b>RSI</b> |
| YZ | 400 F     | 99    | <b>RSI</b> |
| WR | 426 F     | 01-02 | <b>SI</b>  |
| YZ | 426 F     | 00-02 | <b>RSI</b> |
| WR | 450 F     | 03-15 | <b>SI</b>  |
| YZ | 450 F     | 03-07 | <b>RSI</b> |

**ZERO**

|    |        |       |            |
|----|--------|-------|------------|
| DS | ZF11.4 | 13-14 | <b>HS</b>  |
| DS | ZF8.5  | 13-14 | <b>HS</b>  |
| FX | ZF2.8  | 13-14 | <b>HS</b>  |
| FX | ZF5.7  | 13-14 | <b>HS</b>  |
| MX | ZF2.8  | 13    | <b>RSI</b> |
| MX | ZF5.7  | 13    | <b>RSI</b> |
| S  | ZF11.4 | 13-14 | <b>HS</b>  |
| S  | ZF8.5  | 13-14 | <b>HS</b>  |
| SR | ZF11.4 | 14    | <b>HS</b>  |
| XU | ZF2.8  | 13    | <b>HS</b>  |
| XU | ZF5.7  | 13    | <b>HS</b>  |

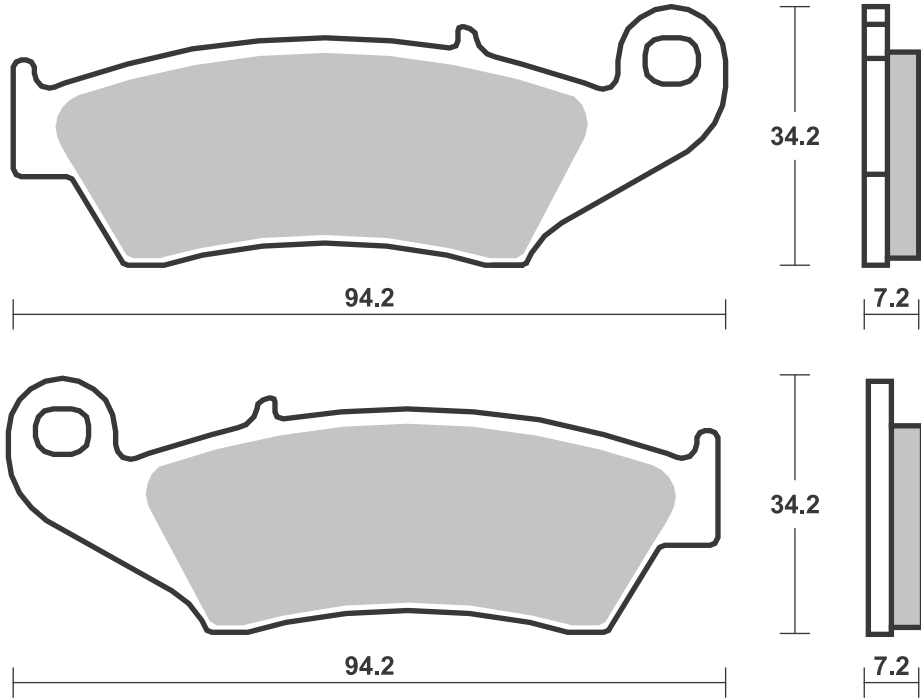

**SBS 695** Recommended compound



**APRILIA**

|     |             |       |    |
|-----|-------------|-------|----|
| SXV | 450 Van den |       |    |
|     | Bosch Rep.  | 08-10 | RS |
| SXV | 550 Van den |       |    |
|     | Bosch Rep.  | 08-10 | RS |

**BREMBO RACING CALIPERS**

|                         |  |  |  |
|-------------------------|--|--|--|
| GP X10.48.13/14, racing |  |  |  |
|                         |  |  |  |
|                         |  |  |  |
|                         |  |  |  |
|                         |  |  |  |
|                         |  |  |  |
|                         |  |  |  |
|                         |  |  |  |
|                         |  |  |  |
|                         |  |  |  |
|                         |  |  |  |

**SBS 697** Recommended compound



**BENELLI**

|     |                  |    |    |
|-----|------------------|----|----|
| 666 | 125 Born in Hell | 98 | HF |
|     |                  |    |    |
|     |                  |    |    |
|     |                  |    |    |
|     |                  |    |    |
|     |                  |    |    |
|     |                  |    |    |
|     |                  |    |    |
|     |                  |    |    |
|     |                  |    |    |
|     |                  |    |    |

**SBS 698** Recommended compound



**A.P. RACING CALIPERS**

|                 |  |  |  |
|-----------------|--|--|--|
| CP-2868-8E0/9E0 |  |  |  |
|                 |  |  |  |
|                 |  |  |  |
|                 |  |  |  |
|                 |  |  |  |
|                 |  |  |  |
|                 |  |  |  |
|                 |  |  |  |
|                 |  |  |  |
|                 |  |  |  |
|                 |  |  |  |

Brake Pad 1:1 Drawings,  
Compounds, Fitments

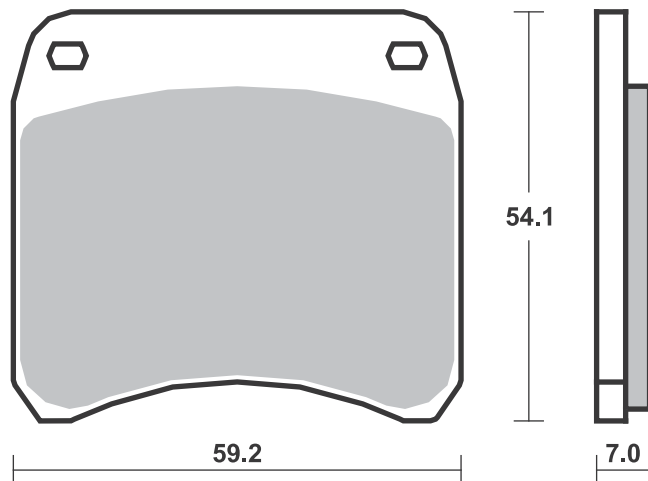
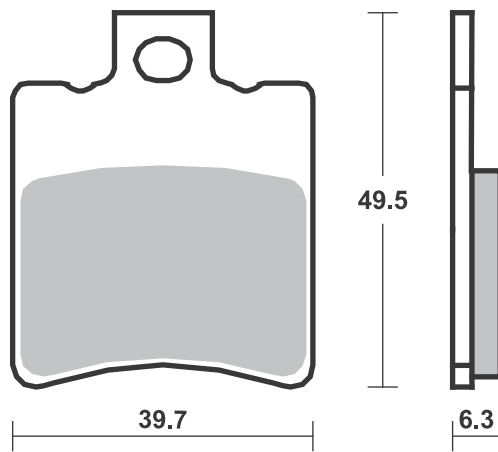
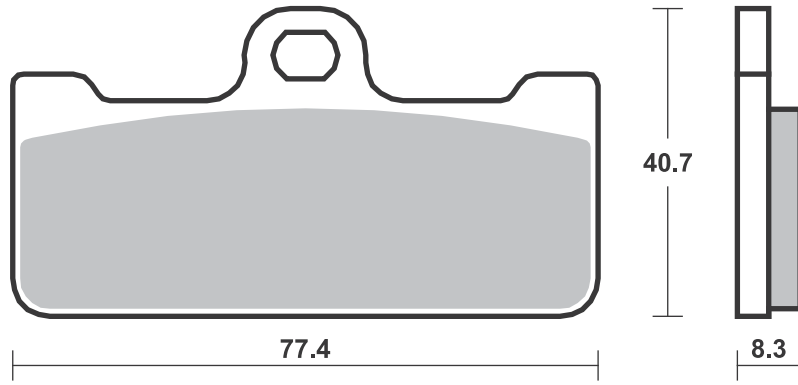

**SBS 699** Recommended compound



| JAWA |       |    |
|------|-------|----|
| 350  | 93-95 | HF |
|      |       |    |
|      |       |    |
|      |       |    |
|      |       |    |
|      |       |    |
|      |       |    |
|      |       |    |
|      |       |    |
|      |       |    |
|      |       |    |
|      |       |    |
|      |       |    |
|      |       |    |
|      |       |    |
|      |       |    |
|      |       |    |
|      |       |    |
|      |       |    |
|      |       |    |
|      |       |    |
|      |       |    |
|      |       |    |
|      |       |    |
|      |       |    |
|      |       |    |
|      |       |    |
|      |       |    |
|      |       |    |
|      |       |    |

**SBS 700** Recommended compound



| HONDA              |       |    |
|--------------------|-------|----|
| CBR 250 RR         | 17-18 | HS |
| CBR 300 F          | 14-16 | HS |
| CBR 300 F ABS      | 14-17 | HS |
| CBR 300 R          | 14-18 | HS |
| CMX 300 Rebel      | 17    | HS |
| CB 500 F           | 13-18 | HS |
| CB 500 X           | 13-18 | HS |
| CBF 500            | 04-08 | HS |
| CBR 500 R          | 13-18 | HS |
| CMX 500 Rebel      | 17-18 | HS |
| XL 600 V,          |       |    |
| Transalpino        | 94-96 | HS |
| CB 650 F           | 14-18 | HS |
| CBR 650 F          | 14-18 | HS |
| CBR 650 F ABS      | 14-18 | HS |
| CTX 700            | 14-18 | HS |
| CTX 700 D ABS      |       |    |
| w/DCT              | 13-15 | HS |
| CTX 700 N          | 14-18 | HS |
| CTX 700 ND ABS     |       |    |
| w/DCT              | 14-15 | HS |
| NC 750 D Integra   | 14-18 | HS |
| NC 750 S w/DCT     | 14-18 | HS |
| NC 750 X w/DCT     | 14-18 | HS |
| NM4 750 Vultus ABS |       |    |
| w/DCT              | 15-18 | HS |
| VT 750 Black Widow | 01-03 | HS |
| VT 750 C2 Shadow   |       |    |
| A.C.E.             | 97-03 | HS |
| VT 750 C2 Shadow   |       |    |
| Spirit             | 07-11 | HS |



| HONDA            |       |    |
|------------------|-------|----|
| VT 750 C2B       | 11-18 | HS |
| VT 750 C4 Shadow | 04-05 | HS |
| VT 750 RS        | 11-13 | HS |
| VT 750 S         | 11-12 | HS |
| CBF 1000         | 06-11 | HS |
| CBF 1000 Limited |       |    |
| Edition          | 09-14 | HS |
|                  |       |    |
|                  |       |    |
|                  |       |    |
|                  |       |    |
|                  |       |    |
|                  |       |    |
|                  |       |    |
|                  |       |    |
|                  |       |    |
|                  |       |    |
|                  |       |    |
|                  |       |    |
|                  |       |    |
|                  |       |    |
|                  |       |    |
|                  |       |    |
|                  |       |    |
|                  |       |    |
|                  |       |    |
|                  |       |    |
|                  |       |    |
|                  |       |    |
|                  |       |    |
|                  |       |    |
|                  |       |    |
|                  |       |    |

Brake Pad 1:1 Drawings, Compounds, Fitments

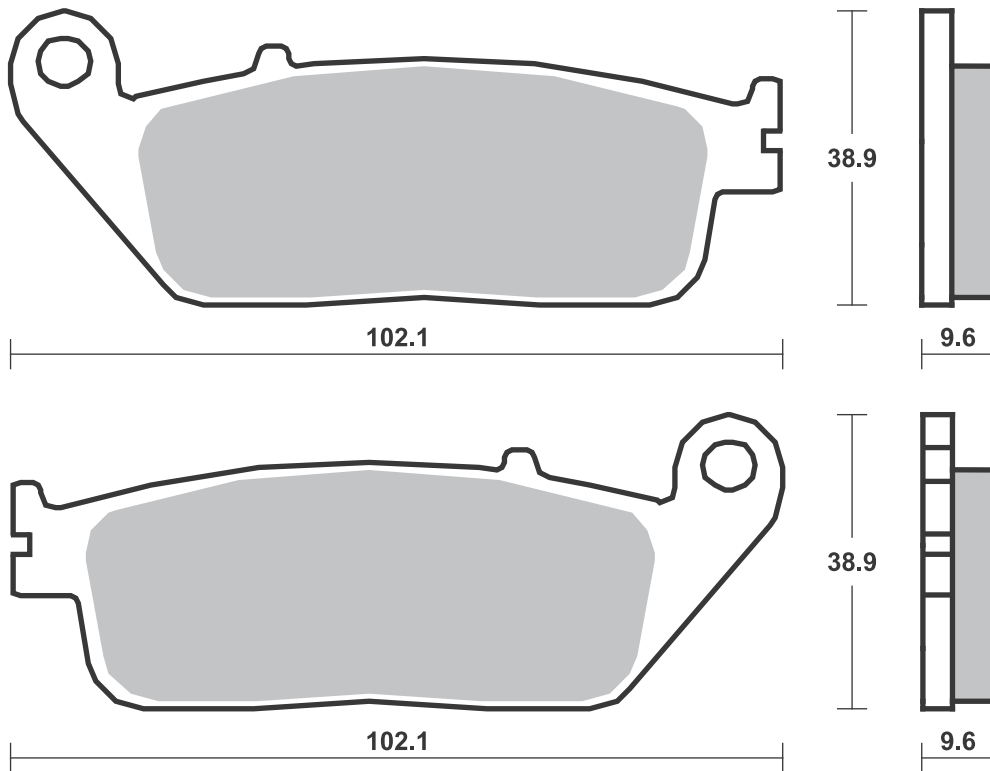
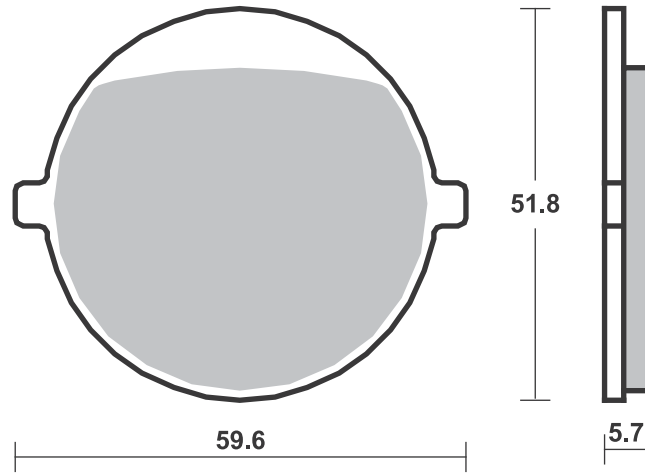

**SBS 701** Recommended compound



| <b>SUZUKI</b> |                       |       |           |
|---------------|-----------------------|-------|-----------|
| RF            | 900 RR,RS,RS2,<br>T,V | 94-97 | <b>LS</b> |
|               |                       |       |           |
|               |                       |       |           |
|               |                       |       |           |
|               |                       |       |           |
|               |                       |       |           |
|               |                       |       |           |
|               |                       |       |           |
|               |                       |       |           |
|               |                       |       |           |
|               |                       |       |           |
|               |                       |       |           |
|               |                       |       |           |
|               |                       |       |           |
|               |                       |       |           |
|               |                       |       |           |
|               |                       |       |           |
|               |                       |       |           |
|               |                       |       |           |
|               |                       |       |           |
|               |                       |       |           |
|               |                       |       |           |
|               |                       |       |           |

**SBS 702** Recommended compound



| <b>SUZUKI</b> |        |       |            |
|---------------|--------|-------|------------|
| RM            | 80     | 96-01 | <b>RSI</b> |
| RM            | 85 , L | 02-04 | <b>RSI</b> |
| DR-Z          | 125 L  | 03-18 | <b>SI</b>  |
|               |        |       |            |
|               |        |       |            |
|               |        |       |            |
|               |        |       |            |
|               |        |       |            |
|               |        |       |            |
|               |        |       |            |
|               |        |       |            |
|               |        |       |            |
|               |        |       |            |
|               |        |       |            |
|               |        |       |            |
|               |        |       |            |
|               |        |       |            |
|               |        |       |            |
|               |        |       |            |
|               |        |       |            |
|               |        |       |            |
|               |        |       |            |
|               |        |       |            |
|               |        |       |            |
|               |        |       |            |

Brake Pad 1:1 Drawings, Compounds, Fitments



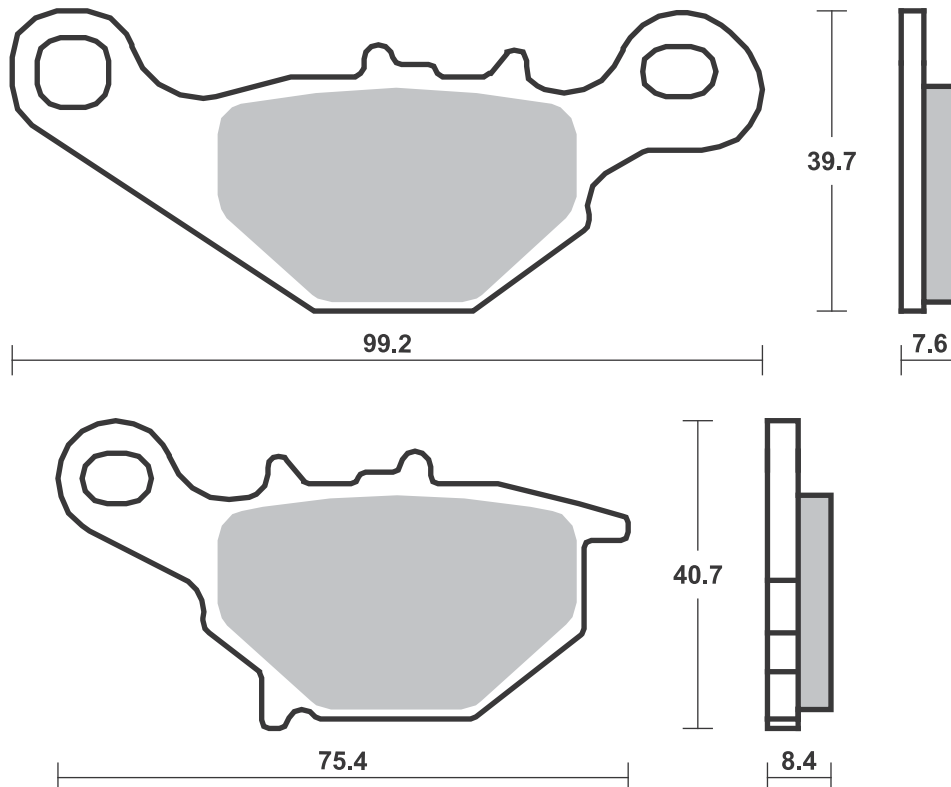
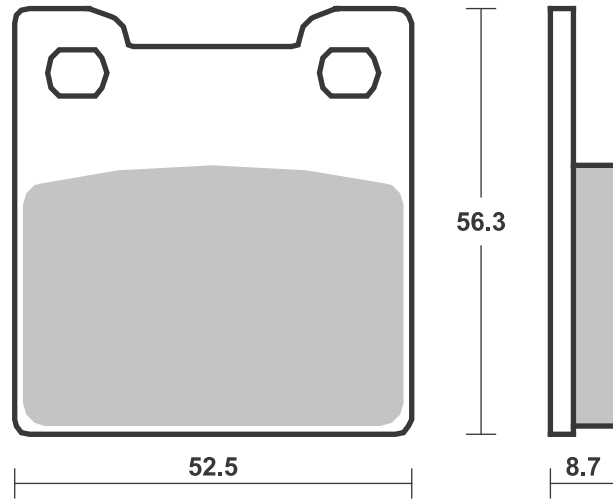

**SBS 703** Recommended compound



| BMW   |                         |       |    |
|-------|-------------------------|-------|----|
| R     | 850 C                   | 99-01 | HS |
| R     | 850 GS                  | 99-07 | HS |
| R     | 850 R                   | 96-02 | HS |
| R     | 850 RT                  | 96-01 | HS |
| R     | 1100 GS                 | 99    | HS |
| R     | 1100 R Cast<br>wheels   | 99-01 | HS |
| R     | 1100 R Spoke<br>wheels  | 99-06 | HS |
| R     | 1100 RT Cast<br>wheels  | 95-01 | HS |
| R     | 1100 RT Spoke<br>wheels | 95-01 | HS |
| R     | 1100 S                  | 99-00 | HS |
| R1100 | 1100 GS                 | 94-01 | HS |
| R1100 | 1100 RS                 | 94-01 | HS |
| R     | 1150 GS                 | 00-01 | HS |
| K     | 1200 LT                 | 99-00 | HS |
| K     | 1200 RS                 | 97-00 | HS |
| R     | 1200 C                  | 98-02 | HS |
|       |                         |       |    |
|       |                         |       |    |
|       |                         |       |    |
|       |                         |       |    |
|       |                         |       |    |
|       |                         |       |    |
|       |                         |       |    |
|       |                         |       |    |
|       |                         |       |    |
|       |                         |       |    |
|       |                         |       |    |
|       |                         |       |    |
|       |                         |       |    |
|       |                         |       |    |
|       |                         |       |    |

**SBS 704** Recommended compound



| KAWASAKI |                                    |       |    |
|----------|------------------------------------|-------|----|
|          | 400 Ninja R Right                  | 11    | HS |
| ER-6f    | 650 Right                          | 06-16 | HS |
| ER-6n    | 650 Right                          | 06-16 | HS |
| KLE      | 650 Versys Right                   | 07-14 | HS |
| W        | 650                                | 99-05 | HF |
| Z        | 750 Right                          | 04-06 | HS |
| Z        | 750 S Right                        | 05-06 | HS |
| ZR       | 750 Zephyr Right                   | 96-98 | HS |
| ZR-7     | 750 Left/Rear                      | 99-04 | LS |
| ZR-7     | 750 Right                          | 99-04 | HS |
| ZR-7S    | 750 Left/Rear                      | 01-04 | LS |
| ZR-7S    | 750 Right                          | 01-04 | HS |
| VN       | 800 Drifter                        | 99-02 | LS |
| W        | 800                                | 11-16 | HS |
| KLV      | 1000 Right                         | 04-07 | HS |
|          | 1100 Zephyr Right                  | 97-02 | HS |
| GPZ      | 1100 (ZX 1100)<br>Right            | 95-99 | HS |
| GPZ      | 1100 ABS,<br>Horizont<br>Right     | 97-99 | HS |
| VN       | 1500 Classic<br>Tourer<br>Fi Right | 00-04 | HS |
| VN       | 1500 Classic<br>Tourer Right       | 98-01 | HS |
| VN       | 1500 Drifter                       | 99-02 | LS |
| VN       | 1600 Classic Right                 | 03-08 | HS |
| VN       | 1700 Classic Right                 | 09-14 | HS |
| VN       | 1700 Classic<br>Tourer Right       | 09-14 | HS |



| SUZUKI |                                       |       |    |
|--------|---------------------------------------|-------|----|
| RV     | 125 VanVan                            | 03-18 | HF |
| RV     | 200 VanVan                            | 16-18 | HF |
| GS     | 500                                   | 96-08 | HS |
| GS     | 500 F                                 | 04-08 | HS |
| GSF    | 600 Bandit /<br>S Bandit<br>Right     | 00-04 | HS |
| GSX    | 600 FW Right                          | 98-04 | HS |
| DL     | 650 V-Strom<br>Right                  | 04-18 | HS |
| DL     | 650 V-Strom XT<br>Right               | 15-18 | HS |
| GSF    | 650 Bandit /<br>S Bandit<br>Right     | 05    | HS |
| GSF    | 650 Bandit /<br>S Bandit<br>Right ABS | 06    | HS |
| SFV    | 650 Gladius<br>Right                  | 09-16 | HS |
| SV     | 650 ,S Right                          | 99-12 | HS |
| SV     | 650 Right                             | 16-18 | HS |
| SV     | 650 X Right                           | 18-   | HS |
| XF     | 650 Freewind                          | 97-02 | HS |
| GSR    | 750 Right                             | 11-14 | HS |
| GSX    | 750 FW Right                          | 98-02 | HS |
| GSX    | 750 Right                             | 98-08 | HS |
| GSX-S  | 750 Right                             | 15-16 | HS |
| GSX-S  | 750 Z Right                           | 15-16 | HS |
| C      | 800 Intruder                          | 05-18 | HS |
| M      | 800 Intruder                          | 05-18 | HS |



| SUZUKI |                            |       |    |
|--------|----------------------------|-------|----|
| VL     | 800 Intruder LC<br>Volusia | 01-04 | HS |
| VZ     | 800 Marauder               | 97-04 | HS |
| DL     | 1000 V-Strom<br>Right      | 02-13 | HS |
| GSX    | 1100 G Right               | 96-98 | HS |
| C      | 1500 Intruder<br>Right     | 05-10 | HS |
| M      | 1500 Intruder<br>Right     | 09-18 | HS |
| VL     | 1500 Intruder LC<br>Right  | 02    | HS |
|        |                            |       |    |
|        |                            |       |    |
|        |                            |       |    |
|        |                            |       |    |
|        |                            |       |    |
|        |                            |       |    |
|        |                            |       |    |
|        |                            |       |    |
|        |                            |       |    |
|        |                            |       |    |
|        |                            |       |    |
|        |                            |       |    |
|        |                            |       |    |
|        |                            |       |    |
|        |                            |       |    |
|        |                            |       |    |
|        |                            |       |    |
|        |                            |       |    |
|        |                            |       |    |

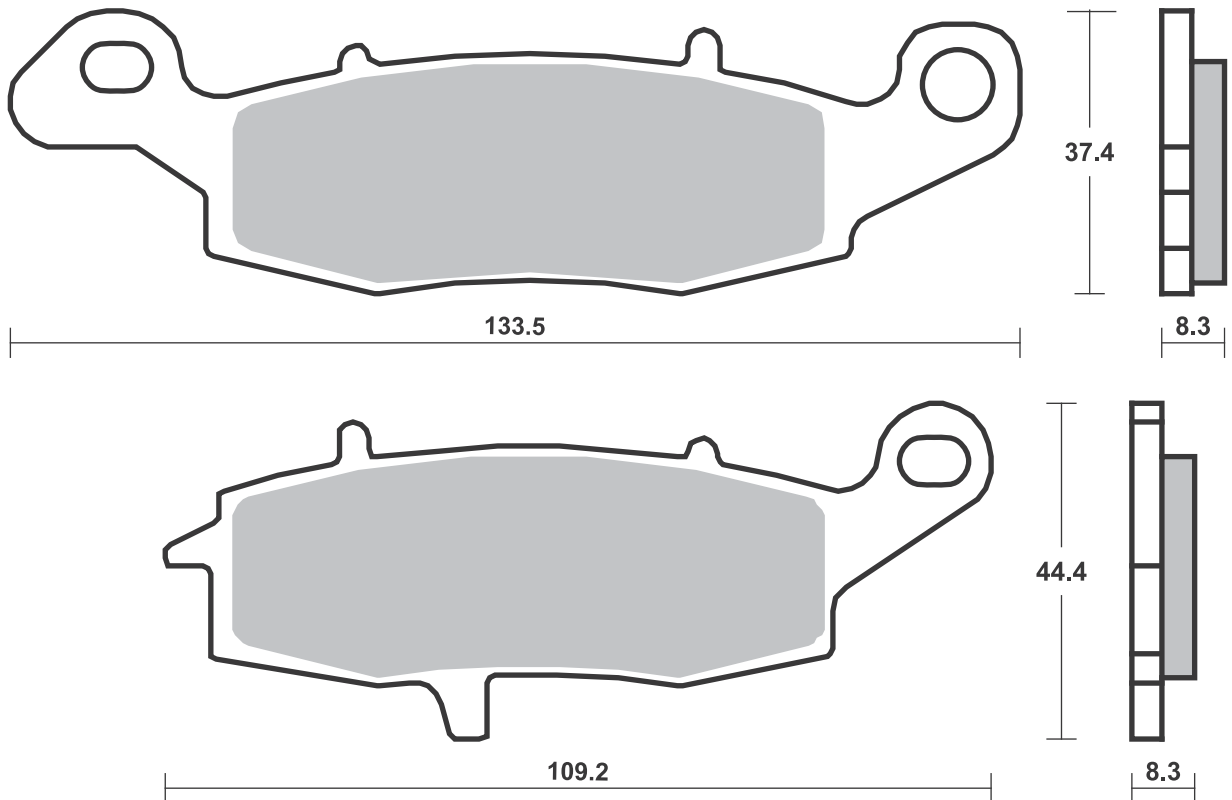
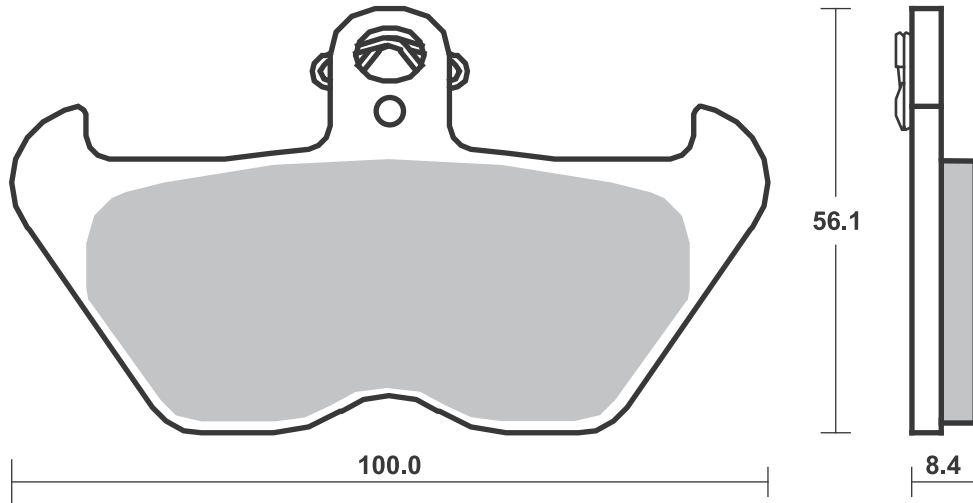

Brake Pad 1:1 Drawings,  
Compounds, Fitments

## Applications

### SBS 705 Recommended compound



| KAWASAKI           |       |           |           |
|--------------------|-------|-----------|-----------|
| 400 Ninja R        |       |           |           |
| Left/Rear          | 11    |           | <b>HS</b> |
| ER-5 500           | 01-07 |           | <b>HS</b> |
| ER-6f 650          | 06-16 | Left/Rear | <b>HS</b> |
| ER-6n 650          | 06-16 | Left/Rear | <b>HS</b> |
| KLE 650 Versys     |       |           |           |
| Left/Rear          | 07-14 |           | <b>HS</b> |
| KLR 650            | 95-04 |           | <b>HS</b> |
| Z 750              | 04-06 | Left/Rear | <b>HS</b> |
| Z 750 S            | 05-06 | Left/Rear | <b>HS</b> |
| ZR 750 Zephyr      |       |           |           |
| Left/Rear          | 96-97 |           | <b>HS</b> |
| ZR-7 750           | 99-04 | Left/Rear | <b>HS</b> |
| ZR-7S 750          | 01-04 | Left/Rear | <b>HS</b> |
| VN 800 Classic     | 98-99 |           | <b>HS</b> |
| VN 800 Drifter     | 99-02 |           | <b>HS</b> |
| VN 900 Classic     | 06-16 |           | <b>HS</b> |
| VN 900 Classic SE  | 11-16 |           | <b>HS</b> |
| VN 900 Custom      | 07-16 |           | <b>HS</b> |
| KLV 1000           | 04-07 | Left/Rear | <b>HS</b> |
| 1100 Zephyr        |       |           |           |
| Left/Rear          | 97-02 |           | <b>HS</b> |
| GPZ 1100 (ZX 1100) |       |           |           |
| Left/Rear          | 95-99 |           | <b>HS</b> |
| GPZ 1100 ABS,      |       |           |           |
| Horizont           |       |           |           |
| Left/Rear          | 97-99 |           | <b>HS</b> |
| VN 1500 Classic    | 97-04 |           | <b>HS</b> |
| VN 1500 Classic Fi | 00-04 |           | <b>HS</b> |



| KAWASAKI        |       |  |           |
|-----------------|-------|--|-----------|
| VN 1500 Classic |       |  |           |
| Tourer Fi       |       |  |           |
| Left/Rear       | 00-04 |  | <b>HS</b> |
| VN 1500 Classic |       |  |           |
| Tourer          |       |  |           |
| Left/Rear       | 98-01 |  | <b>HS</b> |
| VN 1500 Drifter | 99-02 |  | <b>HS</b> |
| VN 1600 Classic |       |  |           |
| Left/Rear       | 03-08 |  | <b>HS</b> |
| VN 1700 Classic |       |  |           |
| Left/Rear       | 09-14 |  | <b>HS</b> |
| VN 1700 Classic |       |  |           |
| Tourer          |       |  |           |
| Left/Rear       | 09-14 |  | <b>HS</b> |

#### SUZUKI

|                      |       |      |           |
|----------------------|-------|------|-----------|
| GSF 250 VS, S Bandit | 95-00 |      | <b>HS</b> |
| TU 250 X             | 09-18 |      | <b>HF</b> |
| GSF 600 Bandit /     |       |      |           |
| S Bandit             |       |      |           |
| Left/Rear            | 00-04 |      | <b>HS</b> |
| GSX 600 FW           | 98-04 | Left | <b>HS</b> |
| DL 650 V-Strom       |       |      |           |
| Left/Rear            | 04-17 |      | <b>HS</b> |
| DL 650 V-Strom XT    |       |      |           |
| Left/Rear            | 15-17 |      | <b>HS</b> |
| GSF 650 Bandit /     |       |      |           |
| S Bandit             |       |      |           |
| Left/Rear            | 05    |      | <b>HS</b> |



| SUZUKI                |       |  |           |
|-----------------------|-------|--|-----------|
| GSF 650 Bandit /      |       |  |           |
| S Bandit              |       |  |           |
| Left/Rear             |       |  |           |
| ABS                   | 06    |  | <b>HS</b> |
| SFV 650 Gladius       |       |  |           |
| Left/Rear             | 09-16 |  | <b>HS</b> |
| SV 650 ,S ABS         | 07-18 |  | <b>HS</b> |
| SV 650 ,S Left/Rear   | 99-12 |  | <b>HS</b> |
| SV 650 Left/Rear      | 16-18 |  | <b>HS</b> |
| SV 650 X Left/Rear    | 18-   |  | <b>HS</b> |
| GSR 750 Left/Rear     | 11-16 |  | <b>HS</b> |
| GSX 750 FW            |       |  |           |
| Left/Rear             | 98-02 |  | <b>HS</b> |
| GSX 750 Left/Rear     | 98-08 |  | <b>HS</b> |
| GSX-S 750 Left/Rear   | 15-16 |  | <b>HS</b> |
| GSX-S 750 Z Left/Rear | 15-16 |  | <b>HS</b> |
| DR 800 ST Big         | 96-98 |  | <b>HS</b> |
| DL 1000 V-Strom       |       |  |           |
| Left/Rear             | 02-13 |  | <b>HS</b> |
| GSX 1100 G Left/Rear  | 96-98 |  | <b>HS</b> |
| C 1500 Intruder       |       |  |           |
| Left/Rear             | 05-10 |  | <b>HS</b> |
| M 1500 Intruder       |       |  |           |
| Left/Rear             | 09-18 |  | <b>HS</b> |
| VL 1500 Intruder LC   |       |  |           |
| Left/Rear             | 02    |  | <b>HS</b> |

### SBS 706 Recommended compound



| APRILIA              |       |  |           |
|----------------------|-------|--|-----------|
| RS 250               | 97-02 |  | <b>HF</b> |
| RS 250 Pista         | 04    |  | <b>HF</b> |
| 650 Pegaso           |       |  |           |
| Strada               | 05-09 |  | <b>HS</b> |
| 750 Dorsoduro        |       |  |           |
| Factory              | 12-13 |  | <b>HS</b> |
| SMV 750 Dorsoduro    | 08    |  | <b>HS</b> |
| 1000 Blue Marlin     | 02    |  | <b>HS</b> |
| RST 1000 Futura      | 01-03 |  | <b>HS</b> |
| RSV 1000 Falco SL, R | 00-04 |  | <b>HS</b> |
| RSV 1000 Mille       | 97-01 |  | <b>HS</b> |
| RSV 1000 Mille R     | 00    |  | <b>HS</b> |
| RSV 1000 Mille SP    | 00    |  | <b>HS</b> |
| RSV 1000 Tuono       |       |  |           |
| Fighter              | 03-05 |  | <b>HS</b> |
| RSV 1000 Tuono R,    |       |  |           |
| ABS                  | 04-12 |  | <b>HS</b> |
| RSV 1000 Tuono V4 R  | 11-13 |  | <b>HS</b> |
| 1200 Dorsoduro,      |       |  |           |
| ABS                  | 11-14 |  | <b>HS</b> |

| BENELLI       |       |  |           |
|---------------|-------|--|-----------|
| TnT 1100      | 04    |  | <b>HS</b> |
| TnT 1130      | 05-14 |  | <b>HS</b> |
| TnT 1130 Trek | 06-12 |  | <b>SP</b> |
| TnT 1130 Trek |       |  |           |
| Amazonas      | 07-15 |  | <b>SP</b> |

#### BIMOTA

|            |       |  |           |
|------------|-------|--|-----------|
| DB4 900    | 99-00 |  | <b>HS</b> |
| SB8 1000 R | 98-00 |  | <b>HS</b> |
| SB8K 1000  | 06    |  | <b>HS</b> |

#### BMW

|                     |       |  |           |
|---------------------|-------|--|-----------|
| G 650 Xmoto         | 06-07 |  | <b>HS</b> |
| F 800 GT            | 13-18 |  | <b>HS</b> |
| F 800 R             | 09-14 |  | <b>HS</b> |
| F 800 S             | 06-10 |  | <b>HS</b> |
| F 800 ST            | 06-12 |  | <b>HS</b> |
| F 800 ST Touring    | 11-12 |  | <b>HS</b> |
| R 1200 Nine-T Pure  | 17-18 |  | <b>HS</b> |
| R 1200 Nine-T Racer | 17-18 |  | <b>HS</b> |
| R 1200 Nine-T       |       |  |           |
| Scrambler           | 16-18 |  | <b>HS</b> |
| R 1200 Nine-T       |       |  |           |
| Urban GS            | 17-18 |  | <b>SP</b> |

#### BRAKING

|                     |  |  |  |
|---------------------|--|--|--|
| Street, Supermotard |  |  |  |
|---------------------|--|--|--|

#### BRAMMO

|         |       |  |           |
|---------|-------|--|-----------|
| Empulse | 14-16 |  | <b>HS</b> |
|---------|-------|--|-----------|



| BREMBO RACING CALIPERS    |  |  |  |
|---------------------------|--|--|--|
| 100 mm Motard Radial      |  |  |  |
| XA78910, P4 30/34         |  |  |  |
| 100 mm Radial 220A16810,  |  |  |  |
| P4 30/34                  |  |  |  |
| 100 mm Radial 220A80310,  |  |  |  |
| P4 30/34                  |  |  |  |
| 108 mm Motard Radial      |  |  |  |
| XA69510, P4 30/34         |  |  |  |
| 108 mm Radial 220A01610,  |  |  |  |
| P4 30/34                  |  |  |  |
| 108 mm Radial 220A80210,  |  |  |  |
| P4 30/34                  |  |  |  |
| Goldline two pin 20.6800, |  |  |  |
| road                      |  |  |  |
| Radial 220A16820,         |  |  |  |
| P4 30/34                  |  |  |  |

#### CAGIVA

|                  |       |  |           |
|------------------|-------|--|-----------|
| 650 Raptor       | 01-08 |  | <b>HS</b> |
| 650 V-Raptor     | 01-08 |  | <b>HS</b> |
| 1000 Raptor      | 00-08 |  | <b>HS</b> |
| 1000 V-Raptor    | 00-08 |  | <b>HS</b> |
| 1000 Xtra Raptor | 02-06 |  | <b>HS</b> |

#### DUCATI

|                   |       |  |           |
|-------------------|-------|--|-----------|
| 400 Monster       |       |  |           |
| (Japan)           | 01-06 |  | <b>HS</b> |
| 600 Monster       | 00-01 |  | <b>HS</b> |
| 620 Monster       |       |  |           |
| Dark i.e.         | 02-06 |  | <b>HS</b> |
| 620 Monster i.e., |       |  |           |
| s i.e.            | 02-06 |  | <b>HS</b> |

Drawings 1:1

Available compounds **HF • HS • RS • SP**

**SBS 705**

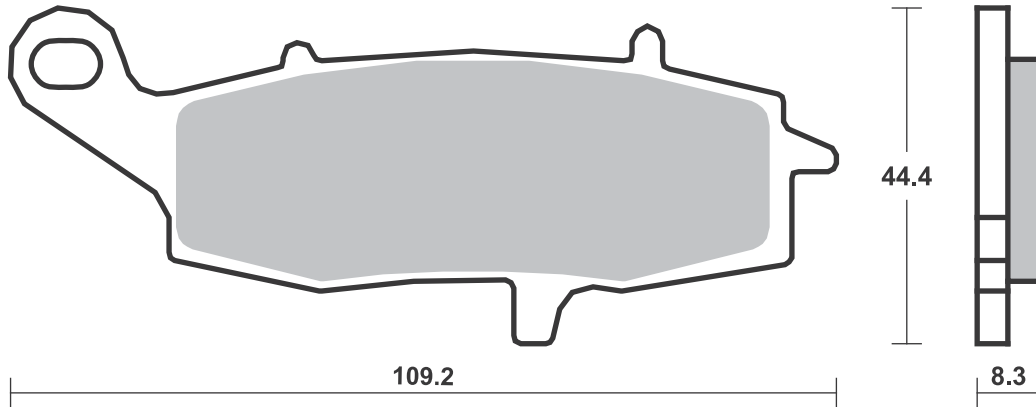
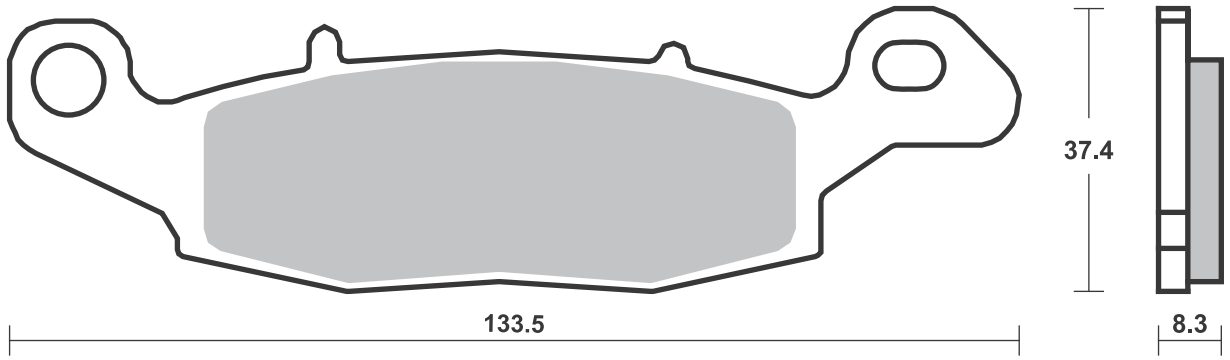

Available compounds **HF • HS • SP • DC • RS • DS • H.HF • H.HS • H.CT**

**SBS 706**

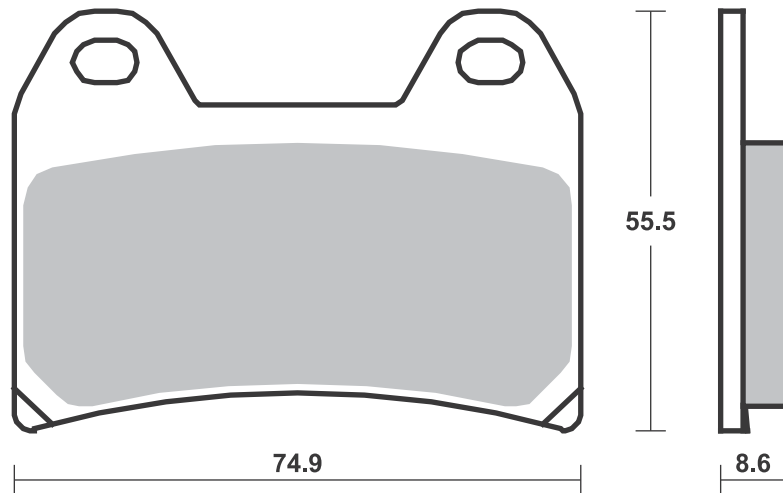



| DUCATI             |       |           |  |
|--------------------|-------|-----------|--|
| 620 Multistrada    |       |           |  |
| Dark               | 05-06 | <b>HS</b> |  |
| 620 Sport          | 03-06 | <b>HS</b> |  |
| 696 Monster        | 08-12 | <b>HS</b> |  |
| 748 , S            | 99-02 | <b>HS</b> |  |
| 748 R              | 00    | <b>HS</b> |  |
| 748 SPS            | 98-99 | <b>HS</b> |  |
| 750 Monster        | 00-01 | <b>HS</b> |  |
| 750 Monster i.e.   | 02    | <b>HS</b> |  |
| 750 Sport          | 00-02 | <b>HS</b> |  |
| 750 Super Sport    | 00-02 | <b>HS</b> |  |
| 795 Monster        | 12    | <b>HS</b> |  |
| 796 Hypermotard    |       |           |  |
| ABS                | 10-12 | <b>HS</b> |  |
| 796 Monster        | 11-14 | <b>HS</b> |  |
| 796 Monster ABS    | 11-14 | <b>HS</b> |  |
| 800 Monster        |       |           |  |
| Dark i.e.,         |       |           |  |
| s i.e.             | 03-07 | <b>HS</b> |  |
| 800 Monster i.e.,  |       |           |  |
| s i.e.             | 03-07 | <b>HS</b> |  |
| 800 Sport          | 03-06 | <b>HS</b> |  |
| 800 Supersport     | 03-06 | <b>HS</b> |  |
| 848                | 08-10 | <b>HS</b> |  |
| 848 Streetfighter  | 12-15 | <b>HS</b> |  |
| 900 Monster        | 00-01 | <b>HS</b> |  |
| 900 Monster i.e.   | 02    | <b>HS</b> |  |
| 900 Super Sport    | 98-02 | <b>HS</b> |  |
| MH 900             | 00-01 | <b>HS</b> |  |
| 916 Monster S4     | 01-03 | <b>HS</b> |  |
| 916 Sport          |       |           |  |
| Touring 4          | 99-01 | <b>HS</b> |  |
| 916 SPS            | 97-98 | <b>HS</b> |  |
| 944 Sport Touring  | 98-03 | <b>HS</b> |  |
| 944 ST2            | 97-03 | <b>HS</b> |  |
| 992 ST3            | 04-07 | <b>HS</b> |  |
| 992 ST3s ABS       | 06-07 | <b>HS</b> |  |
| 996 , SPS          | 99-01 | <b>HS</b> |  |
| 996 Monster S4R    | 04-06 | <b>HS</b> |  |
| 996 ST4s           | 02-06 | <b>HS</b> |  |
| 996 ST4s ABS       | 03-06 | <b>HS</b> |  |
| 998 , S            | 02    | <b>HS</b> |  |
| 1000 Monster       |       |           |  |
| Dark i.e.,         |       |           |  |
| s i.e.             | 03-06 | <b>HS</b> |  |
| 1000 Monster i.e., |       |           |  |
| s i.e.             | 03-06 | <b>HS</b> |  |
| 1000 Monster S2R   | 06-07 | <b>HS</b> |  |
| 1000 Multistrada   | 07    | <b>HS</b> |  |
| 1000 Multistrada   |       |           |  |
| DS                 | 03-06 | <b>HS</b> |  |
| 1000 Multistrada   |       |           |  |
| S DS               | 05-06 | <b>HS</b> |  |
| 1000 Supersport    |       |           |  |
| DS                 | 03-06 | <b>HS</b> |  |
| 1100 Hypermotard   |       |           |  |
| EVO                | 10-13 | <b>HS</b> |  |
| 1100 Monster       | 09-13 | <b>HS</b> |  |
| 1100 Monster ABS   | 09-10 | <b>HS</b> |  |
| 1100 Monster EVO   | 11-13 | <b>HS</b> |  |
| 1100 Monster EVO   |       |           |  |
| ABS                | 11-13 | <b>HS</b> |  |
| 1100 Monster S     | 09-13 | <b>HS</b> |  |
| 1100 Monster S     |       |           |  |
| ABS                | 09-10 | <b>HS</b> |  |
| 1100 Multistrada   | 07-09 | <b>HS</b> |  |
| 1100 Multistrada S | 07-09 | <b>HS</b> |  |
| 1200 Multistrada   | 10-14 | <b>SP</b> |  |
| 1200 Multistrada S |       |           |  |
| GT                 | 12-14 | <b>SP</b> |  |



| DUCATI                  |       |           |  |
|-------------------------|-------|-----------|--|
| 1200 Multistrada S      |       |           |  |
| Pikes Peak              | 11-14 | <b>SP</b> |  |
| 1200 Multistrada S      |       |           |  |
| Sport                   | 10-14 | <b>SP</b> |  |
| 1200 Multistrada S      |       |           |  |
| Touring                 | 10-14 | <b>SP</b> |  |
| <b>HOREX</b>            |       |           |  |
| VR6 1200                | 11-16 | <b>HS</b> |  |
| <b>HUSQVARNA</b>        |       |           |  |
| 570 Nox                 | 01-03 | <b>HF</b> |  |
| LT 610                  | 00-02 | <b>HF</b> |  |
| SM 610 Super            |       |           |  |
| Motard, S               | 98-00 | <b>HF</b> |  |
| SMR 630                 | 04-08 | <b>RS</b> |  |
| 701 Svartpilen          | 18-   | <b>HS</b> |  |
| 701 Vitpilen            | 18-   | <b>HS</b> |  |
| 900 Nuda                | 12-13 | <b>HS</b> |  |
| <b>KTM</b>              |       |           |  |
| SMC 625                 | 05-06 | <b>HF</b> |  |
| 640 Duke                | 03-06 | <b>HF</b> |  |
| LC4 640 Supermoto       | 04    | <b>HF</b> |  |
| SMC 660 Supermoto       | 04-07 | <b>HF</b> |  |
| 690 Duke ABS            | 12-18 | <b>HS</b> |  |
| 1050 Adventure          | 15-16 | <b>SP</b> |  |
| 1090 Super              |       |           |  |
| Adventure               | 17-18 | <b>SP</b> |  |
| 1090 Super              |       |           |  |
| Adventure R             | 17-18 | <b>SP</b> |  |
| 1190 Adventure          | 13-16 | <b>SP</b> |  |
| 1290 Super              |       |           |  |
| Adventure               | 15-18 | <b>SP</b> |  |
| 1290 Super              |       |           |  |
| Adventure R             | 17-18 | <b>SP</b> |  |
| 1290 Super              |       |           |  |
| Adventure S             | 17-18 | <b>SP</b> |  |
| 1290 Super              |       |           |  |
| Adventure T             | 17-18 | <b>SP</b> |  |
| <b>MOTO-GUZZI</b>       |       |           |  |
| 750 Brevia              | 03-09 | <b>HS</b> |  |
| 750 Nevada              |       |           |  |
| Classic ie              | 06-11 | <b>HF</b> |  |
| 750 Nevada,             |       |           |  |
| Nevada Club             | 03-16 | <b>HF</b> |  |
| V7 750 Cafe Classic     | 10-13 | <b>HS</b> |  |
| V7 750 Classic          | 09-12 | <b>HS</b> |  |
| V7 750 Clubman          |       |           |  |
| Racer                   | 10    | <b>HS</b> |  |
| V7 750 Racer            | 11-14 | <b>HS</b> |  |
| V7 750 Stone            | 12-14 | <b>HS</b> |  |
| V7 II 750 Racer         | 15-16 | <b>HS</b> |  |
| V7 II 750 Scrambler     | 16    | <b>HS</b> |  |
| V7 II 750 Special       | 15-16 | <b>HS</b> |  |
| V7 II 750 Stone         | 15-16 | <b>HS</b> |  |
| V7 II 750 Stornello     | 16    | <b>HS</b> |  |
| V7 II 750 Stornello     |       |           |  |
| Ltd. Edition            | 17-18 | <b>HS</b> |  |
| V7 III 750 Anniversario | 17-18 | <b>HS</b> |  |
| V7 III 750 Carbon       | 18-   | <b>HS</b> |  |
| V7 III 750 Euro 4       | 17-18 | <b>HS</b> |  |
| V7 III 750 Milano       | 18-   | <b>HS</b> |  |
| V7 III 750 Racer        | 17-18 | <b>HS</b> |  |
| V7 III 750 Rough        | 18-   | <b>HS</b> |  |
| V7 III 750 Special      | 17-18 | <b>HS</b> |  |
| V7 III 750 Stone        | 17-18 | <b>HS</b> |  |
| V9 850 Bobber           | 16-17 | <b>HS</b> |  |
| V9 850 Roamer           | 16-17 | <b>HS</b> |  |



| MOTO-GUZZI          |       |           |  |
|---------------------|-------|-----------|--|
| V9 850 X-Track      | 17    | <b>HS</b> |  |
| 940 Custom          | 07    | <b>HS</b> |  |
| 1100 California     |       |           |  |
| EV                  | 06    | <b>HS</b> |  |
| 1100 California     |       |           |  |
| EV                  |       |           |  |
| Touring             | 06    | <b>HS</b> |  |
| 1100 California     |       |           |  |
| Jackal              | 01-06 | <b>HS</b> |  |
| 1100 California     |       |           |  |
| Jackal              |       |           |  |
| Basic               | 01-06 | <b>HS</b> |  |
| 1100 California     |       |           |  |
| Special             | 01    | <b>HS</b> |  |
| 1100 California     |       |           |  |
| Special             |       |           |  |
| Sport Alloy         | 02-06 | <b>HS</b> |  |
| 1100 California     |       |           |  |
| Stone Metal         | 02-03 | <b>HS</b> |  |
| 1100 California     |       |           |  |
| Stone,              |       |           |  |
| Stone               |       |           |  |
| Touring             | 02-05 | <b>HS</b> |  |
| 1100 California     |       |           |  |
| Titanium            | 03-05 | <b>HS</b> |  |
| 1100 California     |       |           |  |
| Vintage             | 06-13 | <b>HS</b> |  |
| 1100 Griso          | 05-10 | <b>HS</b> |  |
| EV 1100 California, |       |           |  |
| 80, Touring         | 01    | <b>HS</b> |  |
| V 1100 Brevia       | 04    | <b>HS</b> |  |
| V 1100 Brevia, ABS  | 05-07 | <b>HS</b> |  |
| V11 1100 , Scura,   |       |           |  |
| Sport               |       |           |  |
| Scura               | 02-05 | <b>HS</b> |  |
| V11 1100 Lemans,    |       |           |  |
| Lemans              |       |           |  |
| Tenni,              |       |           |  |
| Lemans              |       |           |  |
| Rosso               |       |           |  |
| Corsa               | 01-06 | <b>HS</b> |  |
| V11 1100 Sport      |       |           |  |
| Rosso               |       |           |  |
| Mandell             | 01-06 | <b>HS</b> |  |
| V11 1100 Sport,     |       |           |  |
| Sport               |       |           |  |
| Naked               | 01-05 | <b>HS</b> |  |
| 1200 Griso 8V       | 07-13 | <b>HS</b> |  |
| 1200 Norge          | 06-14 | <b>HS</b> |  |
| 1200 Norge GT       |       |           |  |
| 8V                  | 10-13 | <b>HS</b> |  |
| 1200 Sport          | 07-08 | <b>HS</b> |  |
| 1200 Sport 4V       | 09-11 | <b>HS</b> |  |
| 1200 Sport 8V       | 12-13 | <b>HS</b> |  |
| 1200 Sport 8V SE    | 12-15 | <b>HS</b> |  |
| 1200 Stelvio        | 08-11 | <b>SP</b> |  |
| 1200 Stelvio 8V     |       |           |  |
| SE                  | 12-16 | <b>SP</b> |  |
| 1200 Stelvio NTX    | 09-11 | <b>SP</b> |  |
| V 1200 Brevia       | 08-13 | <b>HS</b> |  |
| 1400 Audace         | 15-17 | <b>HS</b> |  |
| 1400 California     |       |           |  |
| Custom              | 13-15 | <b>HS</b> |  |
| 1400 California     |       |           |  |
| Touring             | 13-15 | <b>HS</b> |  |
| 1400 California     |       |           |  |
| Touring SE          | 16-17 | <b>HS</b> |  |
| 1400 Eldorado       | 15-17 | <b>HS</b> |  |
| MGX-21 1400 Flying  |       |           |  |
| Fortress            | 15-17 | <b>HS</b> |  |

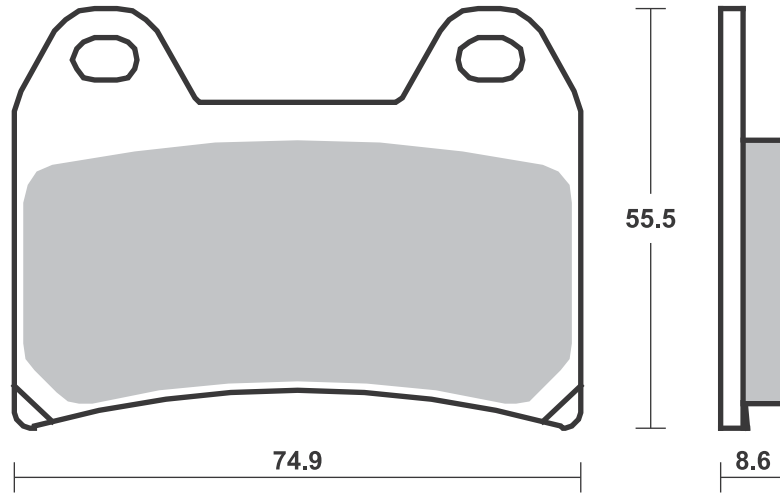





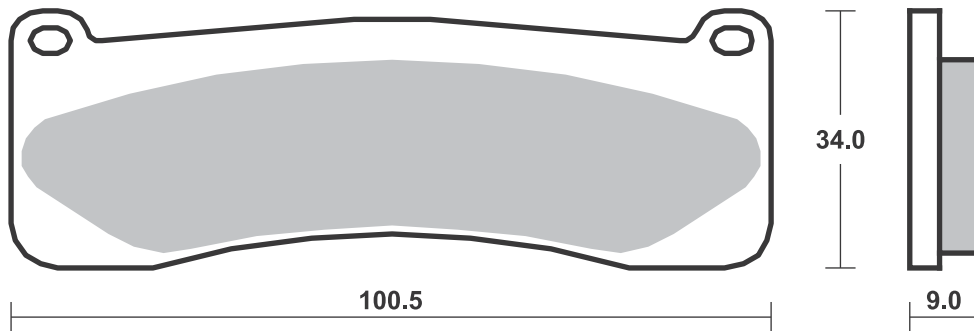
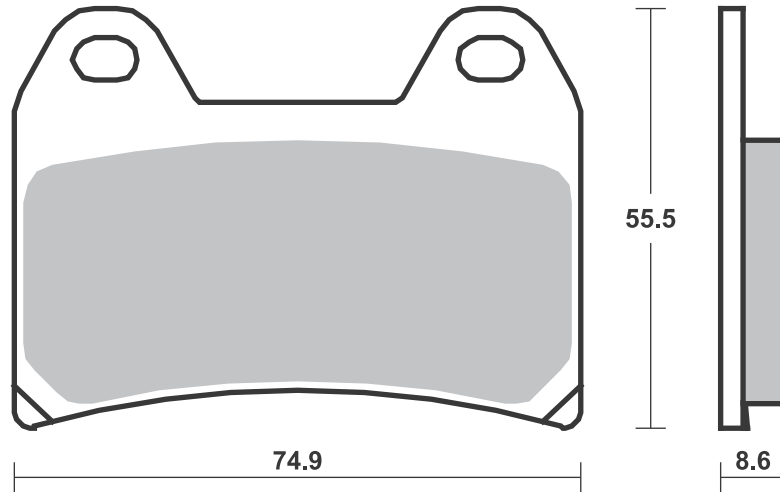



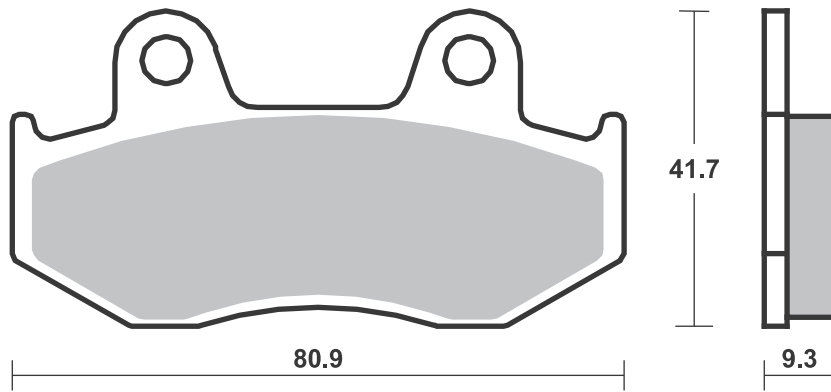
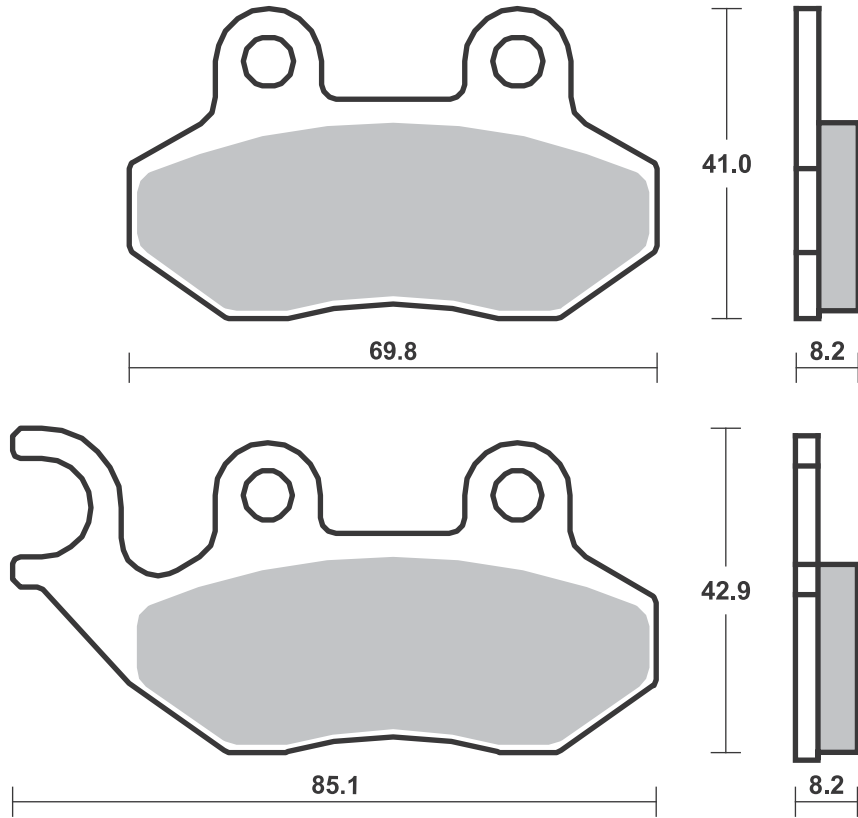

**SBS 711** Recommended compound**BREMBO RACING CALIPERS**

|                         |  |
|-------------------------|--|
| 100 mm Radial Monoblock |  |
| XA7G210/11, P4 32/36    |  |
| 100 mm Radial Monoblock |  |
| XA7G240/41, P4 32/36    |  |
| Monoblock X101740/41,   |  |
| P4 32/36                |  |
| Radial Monoblock        |  |
| X973760/61, P4 32/36    |  |
| Radial Monoblock        |  |
| XA93310/11              |  |
| Radial XA3B830/31,      |  |
| P4 32/36                |  |
| Radial XA3B860/61,      |  |
| P4 32/36                |  |

**NISSIN**

|                         |  |
|-------------------------|--|
| 4 Piston Racing Caliper |  |
|                         |  |
|                         |  |
|                         |  |
|                         |  |
|                         |  |
|                         |  |
|                         |  |
|                         |  |
|                         |  |
|                         |  |
|                         |  |
|                         |  |
|                         |  |
|                         |  |
|                         |  |
|                         |  |

**SBS 713** Recommended compound

|              |             |       |           |
|--------------|-------------|-------|-----------|
| <b>HONDA</b> |             |       |           |
| CA           | 125 Rebel   | 95-96 | <b>HF</b> |
| CMX          | 250 C Rebel | 96-00 | <b>HF</b> |

|                 |     |       |           |
|-----------------|-----|-------|-----------|
| <b>JINCHENG</b> |     |       |           |
| JC              | 250 | 06-09 | <b>HF</b> |

|               |                  |       |           |
|---------------|------------------|-------|-----------|
| <b>KEEWAY</b> |                  |       |           |
|               | 125 Superlight   | 06-16 | <b>HF</b> |
|               | 150 Superlight   | 06-16 | <b>HF</b> |
|               | 250 Land Cruiser | 06-14 | <b>HF</b> |

|                 |               |       |           |
|-----------------|---------------|-------|-----------|
| <b>KREIDLER</b> |               |       |           |
|                 | 125 Enduro    | 07-08 | <b>HF</b> |
|                 | 125 Supermoto | 07-08 | <b>HF</b> |
|                 | 200 Enduro    | 07-08 | <b>HF</b> |

|           |            |       |           |
|-----------|------------|-------|-----------|
| <b>MZ</b> |            |       |           |
|           | 125 SM, SX | 02-08 | <b>HF</b> |

|                |        |       |           |
|----------------|--------|-------|-----------|
| <b>QUINGOI</b> |        |       |           |
| QM             | 125 GY | 02-05 | <b>HF</b> |

|  |  |  |  |
|--|--|--|--|
|  |  |  |  |
|  |  |  |  |
|  |  |  |  |
|  |  |  |  |
|  |  |  |  |
|  |  |  |  |
|  |  |  |  |
|  |  |  |  |
|  |  |  |  |
|  |  |  |  |
|  |  |  |  |

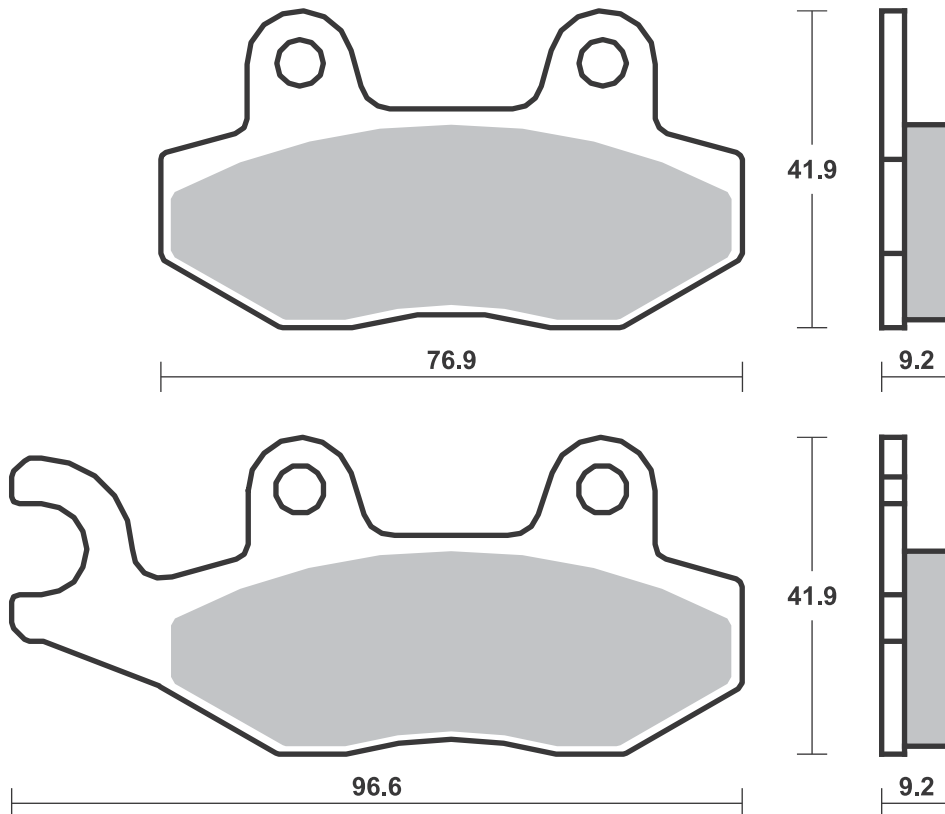
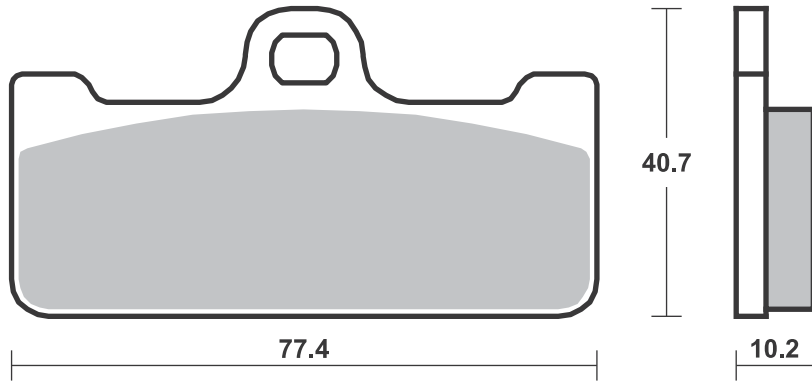

**SBS 714** Recommended compound

| <b>SUZUKI</b> |                |       |           |
|---------------|----------------|-------|-----------|
| RF            | 900 RR,RS,RS2, |       |           |
|               | T,V            | 94-97 | <b>HS</b> |
| GSF           | 1200 Bandit    | 97-00 | <b>HS</b> |
|               |                |       |           |
|               |                |       |           |
|               |                |       |           |
|               |                |       |           |
|               |                |       |           |
|               |                |       |           |
|               |                |       |           |
|               |                |       |           |
|               |                |       |           |
|               |                |       |           |

**SBS 715** Recommended compound

| <b>HARLEY DAVIDSON</b> |                    |       |             |
|------------------------|--------------------|-------|-------------|
| XL                     | 883 L Super        |       |             |
|                        | Low                | 14-18 | <b>H.LS</b> |
| XL                     | 883 N Iron         | 14-18 | <b>H.LS</b> |
| XL                     | 883 R Roadster     | 14-15 | <b>H.LS</b> |
| XL                     | 1200 C, CA, CB,    |       |             |
|                        | CP Custom          | 14-18 | <b>H.LS</b> |
| XL                     | 1200 CX            | 17    | <b>H.LS</b> |
| XL                     | 1200 Roadster      | 18-   | <b>H.LS</b> |
| XL                     | 1200 T Super Low   | 15-17 | <b>H.LS</b> |
| XL                     | 1200 V             |       |             |
|                        | Seventy-Two        | 14-16 | <b>H.LS</b> |
| XL                     | 1200 X Forty-Eight | 14-18 | <b>H.LS</b> |

| <b>HONDA</b> |             |       |           |
|--------------|-------------|-------|-----------|
| VT           | 750 C2S ABS | 13-14 | <b>LS</b> |
| VT           | 750 CS ABS  | 13-14 | <b>LS</b> |
| CB           | 1300 R      | 02-04 | <b>LS</b> |
| CB           | 1300 SF     | 98-00 | <b>LS</b> |



| <b>HONDA</b> |          |       |           |
|--------------|----------|-------|-----------|
| CB           | 1300 X-4 | 97-03 | <b>LS</b> |

| <b>KAWASAKI</b> |                  |       |           |
|-----------------|------------------|-------|-----------|
| ZX-7RR          | 750 Ninja        | 96-02 | <b>LS</b> |
| GTR             | 1400             | 07-16 | <b>LS</b> |
| GTR             | 1400 ABS         | 07-16 | <b>LS</b> |
| ZZR             | 1400             | 06-14 | <b>LS</b> |
| ZZR             | 1400 ABS         | 06-14 | <b>LS</b> |
| ZZR             | 1400 Performance |       |           |
|                 | Sport            | 17-18 | <b>LS</b> |
| ZZR             | 1400 SE          | 16-18 | <b>LS</b> |

| <b>MZ</b> |                |       |           |
|-----------|----------------|-------|-----------|
|           | 1000 (MUZ) S   | 03-10 | <b>LS</b> |
|           | 1000 (MUZ) SF  | 05-10 | <b>LS</b> |
|           | 1000 (MUZ) SFX | 07    | <b>LS</b> |
|           | 1000 (MUZ) SN  | 05    | <b>LS</b> |
|           | 1000 (MUZ) ST  | 07-10 | <b>LS</b> |

**SBS 716** Recommended compound

| <b>POLARIS</b> |                  |       |            |
|----------------|------------------|-------|------------|
|                | 250 2x4, 4x4     | 90-93 | <b>ATS</b> |
|                | 250 Big Boss     |       |            |
|                | 4x6, 6x6         | 89-93 | <b>ATS</b> |
|                | 250 Trail Blazer | 90-07 | <b>ATS</b> |
|                | 250 Trail Boss   | 91-99 | <b>ATS</b> |
|                | 250 Trail Boss   |       |            |
|                | 2x4, 4x4         | 91-92 | <b>ATS</b> |
|                | 250 Xplorer 4x4  | 00-02 | <b>ATS</b> |
|                | 300 2x4, 4x4     | 94-95 | <b>ATS</b> |
|                | 300 Big Boss     |       |            |
|                | 6x6              | 94    | <b>ATS</b> |
|                | 300 Hawkeye      |       |            |
|                | 2x4, 4x4         | 07-11 | <b>ATS</b> |
|                | 300 Xplorer 4x4  | 96-99 | <b>ATS</b> |
|                | 300 Xpress 2x4   | 98-99 | <b>ATS</b> |
|                | 300 Xpress L     | 96-97 | <b>ATS</b> |
|                | 325 Magnum       |       |            |
|                | 2x4, 4x4         | 00-02 | <b>ATS</b> |



| <b>POLARIS</b> |                  |       |            |
|----------------|------------------|-------|------------|
|                | 325 Trail Boss   | 00-02 | <b>ATS</b> |
|                | 330 ATP          | 04-05 | <b>ATS</b> |
|                | 330 ATP          | 06-05 | <b>ATS</b> |
|                | 330 Magnum       |       |            |
|                | 2x4, 4x4         | 03-13 | <b>ATS</b> |
|                | 330 Trail Boss   | 03-14 | <b>ATS</b> |
|                | 335 Sportsman    |       |            |
|                | 4x4              | 99-02 | <b>ATS</b> |
|                | 350 Big Boss     | 93    | <b>ATS</b> |
|                | 350 L 2x4, 4x4   | 90    | <b>ATS</b> |
|                | 350 L 4x4        | 93    | <b>ATS</b> |
|                | 350 Sportsman    |       |            |
|                | 4x4              | 93    | <b>ATS</b> |
|                | 350 Trail Boss   |       |            |
|                | 2x4, 4x4         | 88-89 | <b>ATS</b> |
|                | 350 Trail Boss L |       |            |
|                | 2x4              | 91-93 | <b>ATS</b> |



| <b>POLARIS</b> |                  |       |            |
|----------------|------------------|-------|------------|
|                | 350 Trail Boss L |       |            |
|                | 4x4              | 91    | <b>ATS</b> |
|                | 400 Big Boss L   |       |            |
|                | 6x6              | 96    | <b>ATS</b> |
|                | 400 L 2x4        | 94-95 | <b>ATS</b> |
|                | 400 L 4x4        | 94    | <b>ATS</b> |
|                | 400 Scrambler    |       |            |
|                | 2x4, 4x4         | 00-03 | <b>ATS</b> |
|                | 400 Scrambler    |       |            |
|                | 4x4              | 98-03 | <b>ATS</b> |
|                | 400 Scrambler L  |       |            |
|                | 4x4              | 95-97 | <b>ATS</b> |
|                | 400 Sport        | 99-00 | <b>ATS</b> |
|                | 400 Sport L      | 94-98 | <b>ATS</b> |
|                | 400 Sportsman    | 01-13 | <b>ATS</b> |
|                | 400 Sportsman L  |       |            |
|                | 4x4              | 94-97 | <b>ATS</b> |
|                | 400 Trail Blazer | 03-04 | <b>ATS</b> |

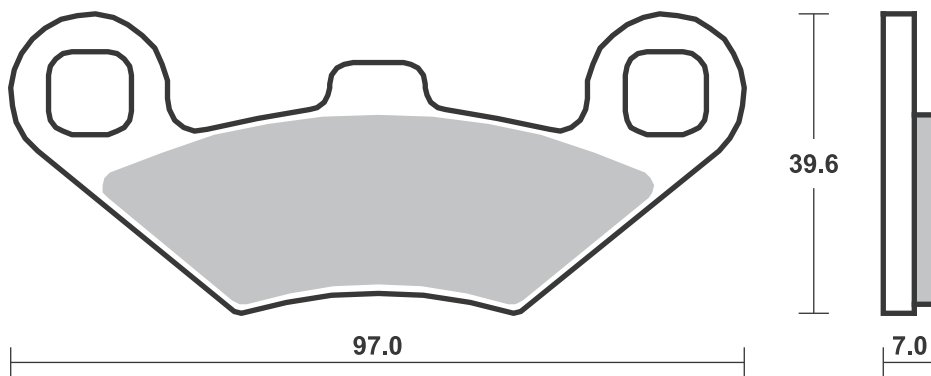
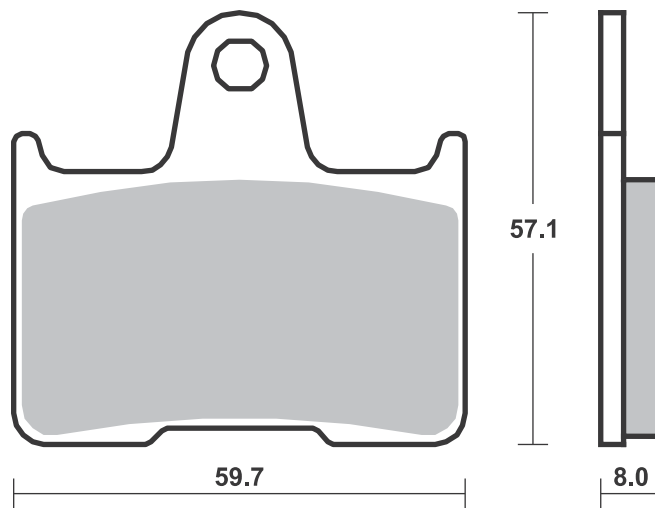
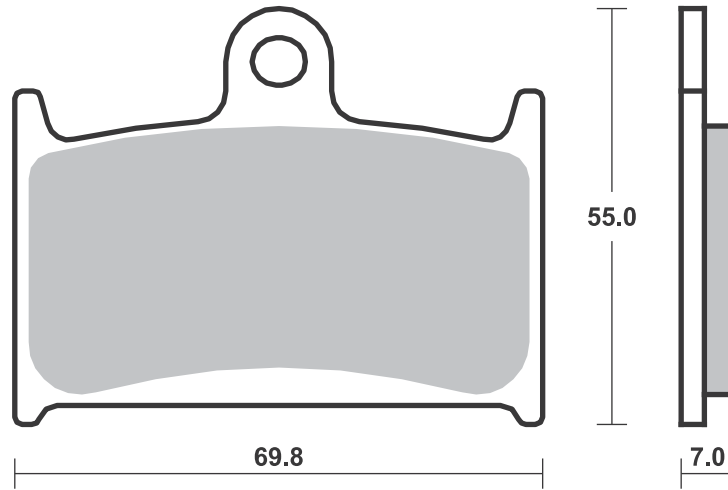

**SBS 716** Recommended compound



| POLARIS           |       |     |     |
|-------------------|-------|-----|-----|
| 400 Xplorer L 4x4 | 95-02 | ATS |     |
| 400 Xpress L      | 96-97 | ATS |     |
| 425 2x4, 4x4      |       |     |     |
| Magnum            | 95-98 | ATS |     |
| 425 Magnum 6x6    | 96    | ATS |     |
| 425 Xpedition 4x4 | 00-03 | ATS |     |
| 450 Sportsman     | 06-09 | ATS |     |
| 455 Diesel EBS    |       |     |     |
| 4x4               | 99-01 | ATS |     |
| 500 ATP HO        | 04-05 | ATS | ATS |
| 500 Big Boss 6x6  | 98-99 | ATS |     |
| 500 Magnum        |       |     |     |
| 2x4, 4x4          | 02-07 | ATS |     |
| 500 Magnum 4x4    | 00-01 | ATS |     |
| 500 Outlaw        | 06-09 | ATS | ATS |
| 500 Predator      | 03-13 | ATS | ATS |

| POLARIS         |       |     |  |
|-----------------|-------|-----|--|
| 500 Predator e  | 06-13 | ATS |  |
| 500 Ranger 6x6  | 00-02 | ATS |  |
| 500 Scrambler   |       |     |  |
| 2x4             | 01-02 | ATS |  |
| 500 Scrambler   |       |     |  |
| 4x4             | 97-13 | ATS |  |
| 500 Sportsman   |       |     |  |
| 4x4             | 96-14 | ATS |  |
| 500 Sportsman   |       |     |  |
| 6x6             | 00-11 | ATS |  |
| 500 Sportsman   |       |     |  |
| EBS 4x4         | 98-02 | ATS |  |
| 500 Xplorer 4x4 | 97    | ATS |  |

**SBS 717** Recommended compound



| POLARIS          |       |     |  |
|------------------|-------|-----|--|
| 250 2x4, 4x4     | 90-93 | ATS |  |
| 250 Big Boss     |       |     |  |
| 4x6, 6x6         | 89-93 | ATS |  |
| 250 Big Boss     |       |     |  |
| 4x6, 6x6         |       |     |  |
| Middle Axle      |       |     |  |
| Brake            | 89-93 | ATS |  |
| 250 Trail Blazer | 90-98 | ATS |  |
| 250 Trail Boss   | 91-99 | ATS |  |
| 250 Trail Boss   |       |     |  |
| 2x4, 4x4         | 91-92 | ATS |  |
| 300 2x4, 4x4     | 94-95 | ATS |  |
| 300 Big Boss 6x6 | 94    | ATS |  |
| 300 Big Boss 6x6 |       |     |  |
| Middle Axle      |       |     |  |
| Brake            | 94    | ATS |  |
| 300 Xplorer 4x4  | 96-99 | ATS |  |
| 300 Xpress 2x4   | 98-99 | ATS |  |
| 300 Xpress L     | 96-97 | ATS |  |
| 350 Big Boss     | 93    | ATS |  |

| POLARIS          |       |     |  |
|------------------|-------|-----|--|
| 350 Big Boss     |       |     |  |
| Middle Axle      |       |     |  |
| Brake            | 93    | ATS |  |
| 350 L 2x4, 4x4   | 90    | ATS |  |
| 350 L 4x4        | 93    | ATS |  |
| 350 Sportsman    |       |     |  |
| 4x4              | 93    | ATS |  |
| 350 Trail Boss   |       |     |  |
| 2x4, 4x4         | 88-89 | ATS |  |
| 350 Trail Boss L |       |     |  |
| 2x4              | 91-93 | ATS |  |
| 350 Trail Boss L |       |     |  |
| 4x4              | 91    | ATS |  |
| 400 Big Boss L   |       |     |  |
| 6x6              | 96    | ATS |  |
| 400 L 2x4        | 94-95 | ATS |  |
| 400 L 4x4        | 94    | ATS |  |
| 400 Scrambler    |       |     |  |
| 4x4              | 98    | ATS |  |

| POLARIS           |       |     |  |
|-------------------|-------|-----|--|
| 400 Scrambler L   |       |     |  |
| 4x4               | 95-97 | ATS |  |
| 400 Sport L       | 94-98 | ATS |  |
| 400 Sportsman L   |       |     |  |
| 4x4               | 94-97 | ATS |  |
| 400 Xplorer L 4x4 | 95-99 | ATS |  |
| 400 Xpress L      | 96-97 | ATS |  |
| 425 2x4, 4x4      |       |     |  |
| Magnum            | 95-98 | ATS |  |
| 425 Magnum 6x6    | 96    | ATS |  |
| 500 Big Boss 6x6  | 98-99 | ATS |  |
| 500 Big Boss 6x6  |       |     |  |
| Middle Axle       |       |     |  |
| Brake             | 98-99 | ATS |  |
| 500 Scrambler     |       |     |  |
| 4x4               | 97    | ATS |  |
| 500 Sportsman     |       |     |  |
| 4x4               | 96-14 | ATS |  |
| 500 Xplorer 4x4   | 97    | ATS |  |

**SBS 718** Recommended compound



| A.P. RACING CALIPERS |  |  |  |
|----------------------|--|--|--|
| CP-3548              |  |  |  |
|                      |  |  |  |
|                      |  |  |  |
|                      |  |  |  |
|                      |  |  |  |
|                      |  |  |  |
|                      |  |  |  |
|                      |  |  |  |
|                      |  |  |  |
|                      |  |  |  |
|                      |  |  |  |
|                      |  |  |  |
|                      |  |  |  |
|                      |  |  |  |
|                      |  |  |  |
|                      |  |  |  |
|                      |  |  |  |
|                      |  |  |  |

Brake Pad 1:1 Drawings, Compounds, Fitments



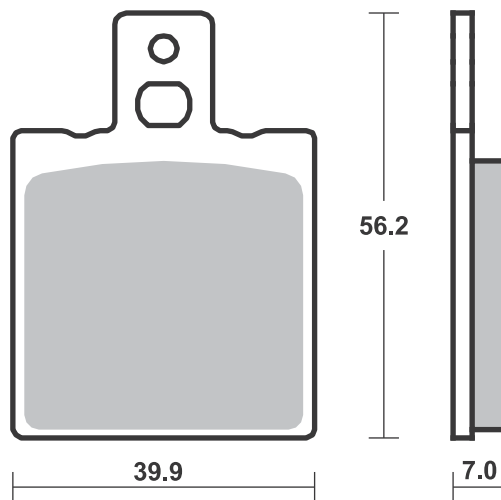
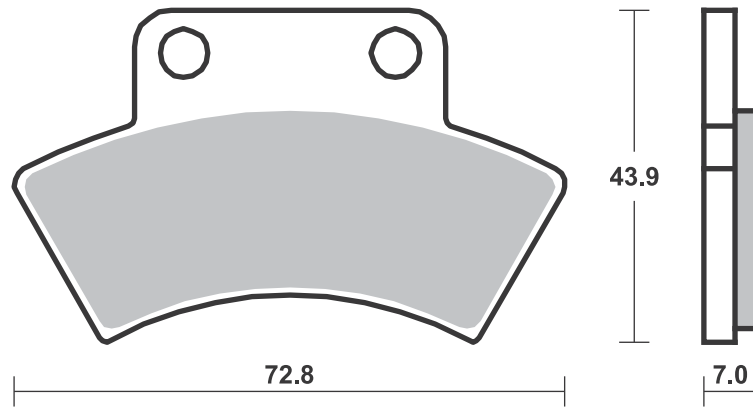
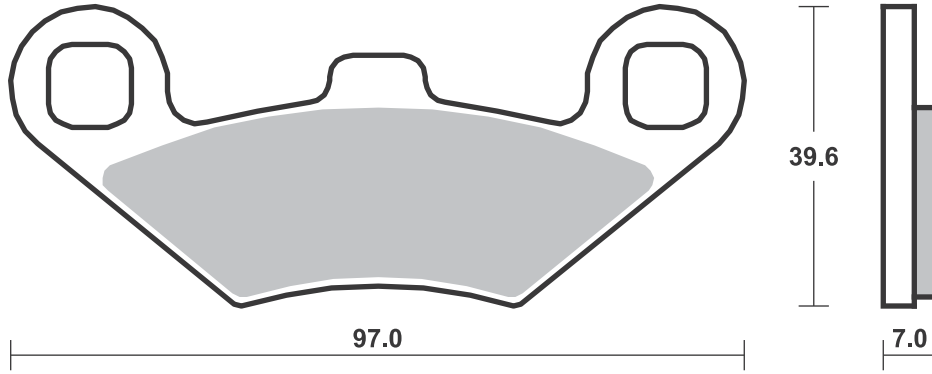



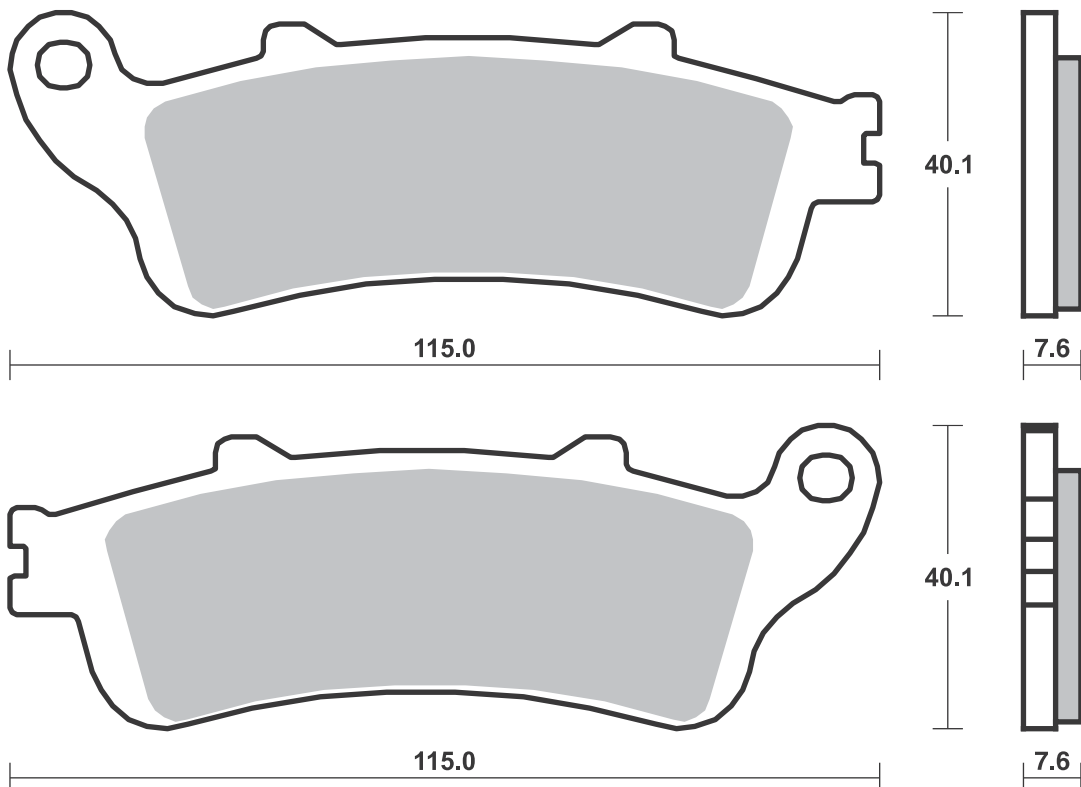
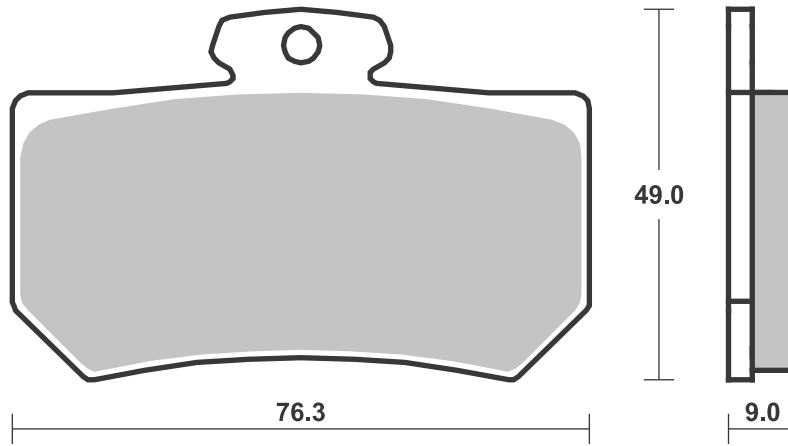
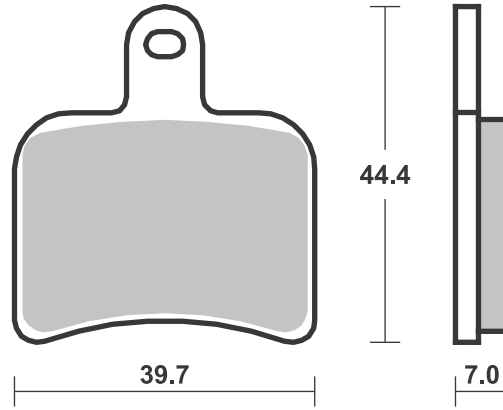



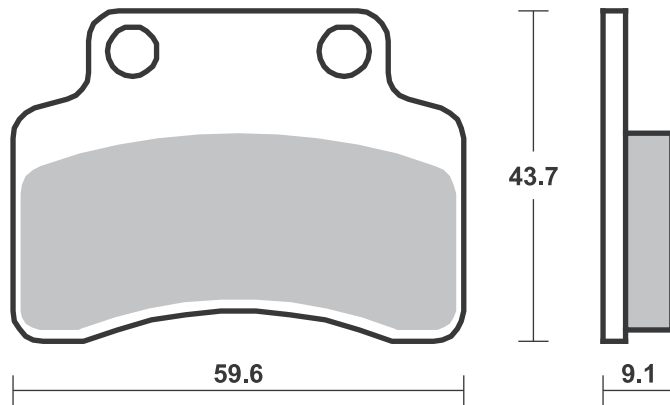
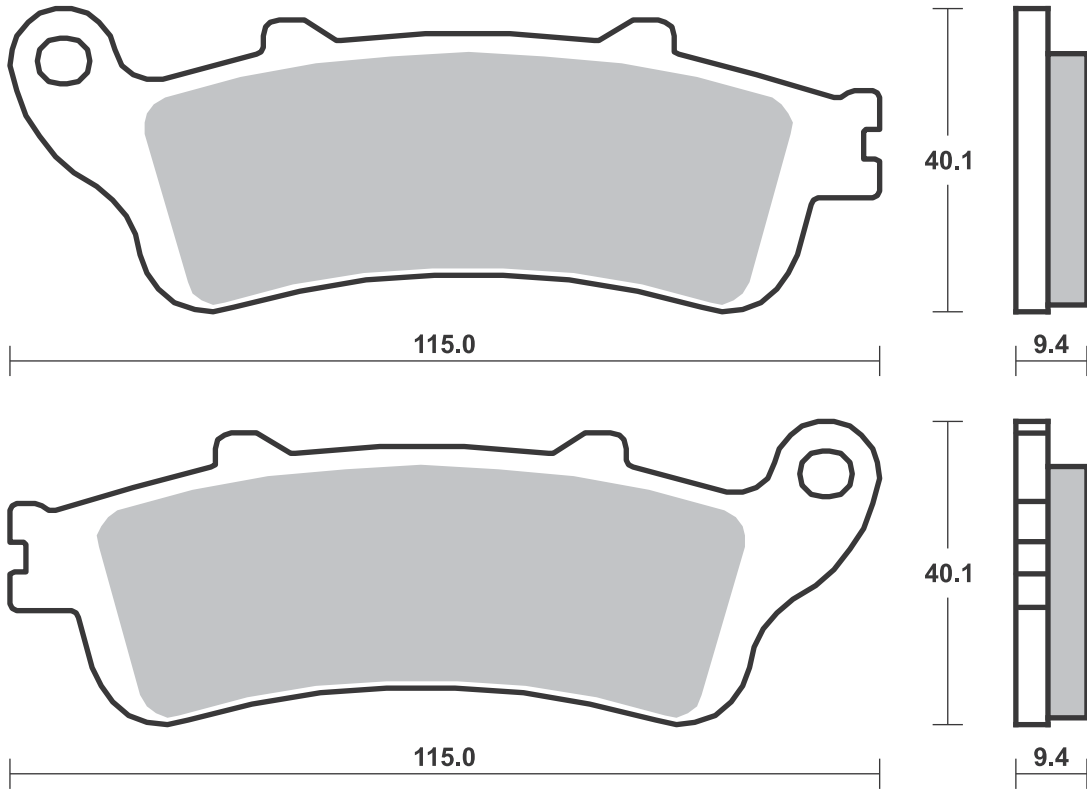

**SBS 726** Recommended compound



| <b>KAWASAKI</b> |                     |       |            |
|-----------------|---------------------|-------|------------|
| KX              | 80                  | 97-00 | <b>RSI</b> |
| KX              | 85                  | 01-18 | <b>RSI</b> |
| KX              | 85 II               | 01-13 | <b>RSI</b> |
| KX              | 100                 | 97-18 | <b>RSI</b> |
| KL              | 250 Super<br>Sherpa | 00-02 | <b>SI</b>  |
| <b>SUZUKI</b>   |                     |       |            |
| RM              | 85 , L              | 05-18 | <b>RSI</b> |
| RM              | 100                 | 03    | <b>RSI</b> |
|                 |                     |       |            |
|                 |                     |       |            |
|                 |                     |       |            |
|                 |                     |       |            |
|                 |                     |       |            |
|                 |                     |       |            |
|                 |                     |       |            |
|                 |                     |       |            |
|                 |                     |       |            |
|                 |                     |       |            |
|                 |                     |       |            |
|                 |                     |       |            |
|                 |                     |       |            |
|                 |                     |       |            |
|                 |                     |       |            |
|                 |                     |       |            |
|                 |                     |       |            |
|                 |                     |       |            |
|                 |                     |       |            |
|                 |                     |       |            |
|                 |                     |       |            |
|                 |                     |       |            |
|                 |                     |       |            |

**SBS 727** Recommended compound



| <b>HONDA</b> |                  |       |           |
|--------------|------------------|-------|-----------|
| CB           | 400 Super Four S | 97-02 | <b>HS</b> |
|              |                  |       |           |
|              |                  |       |           |
|              |                  |       |           |
|              |                  |       |           |
|              |                  |       |           |
|              |                  |       |           |
|              |                  |       |           |
|              |                  |       |           |
|              |                  |       |           |
|              |                  |       |           |
|              |                  |       |           |
|              |                  |       |           |
|              |                  |       |           |
|              |                  |       |           |
|              |                  |       |           |
|              |                  |       |           |
|              |                  |       |           |
|              |                  |       |           |
|              |                  |       |           |
|              |                  |       |           |
|              |                  |       |           |
|              |                  |       |           |
|              |                  |       |           |
|              |                  |       |           |
|              |                  |       |           |

**SBS 728** Recommended compound



| <b>YAMAHA</b> |                       |       |           |
|---------------|-----------------------|-------|-----------|
| TW            | 125                   | 99-07 | <b>HF</b> |
| DT            | 175                   | 00    | <b>HF</b> |
| TW            | 200                   | 01-15 | <b>HF</b> |
|               | 225 Bronco,<br>Cellow | 97-02 | <b>HF</b> |
| XT            | 225                   | 01    | <b>HF</b> |
| XG            | 250 Tricker           | 05-11 | <b>HF</b> |
| XT            | 250                   | 08    | <b>HF</b> |
| YZF           | 600 R6                | 99-02 | <b>LS</b> |
| YZF           | 1000 R1               | 02-03 | <b>LS</b> |
|               |                       |       |           |
|               |                       |       |           |
|               |                       |       |           |
|               |                       |       |           |
|               |                       |       |           |
|               |                       |       |           |
|               |                       |       |           |
|               |                       |       |           |
|               |                       |       |           |
|               |                       |       |           |
|               |                       |       |           |
|               |                       |       |           |
|               |                       |       |           |
|               |                       |       |           |
|               |                       |       |           |
|               |                       |       |           |
|               |                       |       |           |
|               |                       |       |           |
|               |                       |       |           |
|               |                       |       |           |
|               |                       |       |           |
|               |                       |       |           |
|               |                       |       |           |
|               |                       |       |           |

Brake Pad 1:1 Drawings,  
Compounds, Fitments

Available compounds **SI • RSI • CS**

**SBS 726**

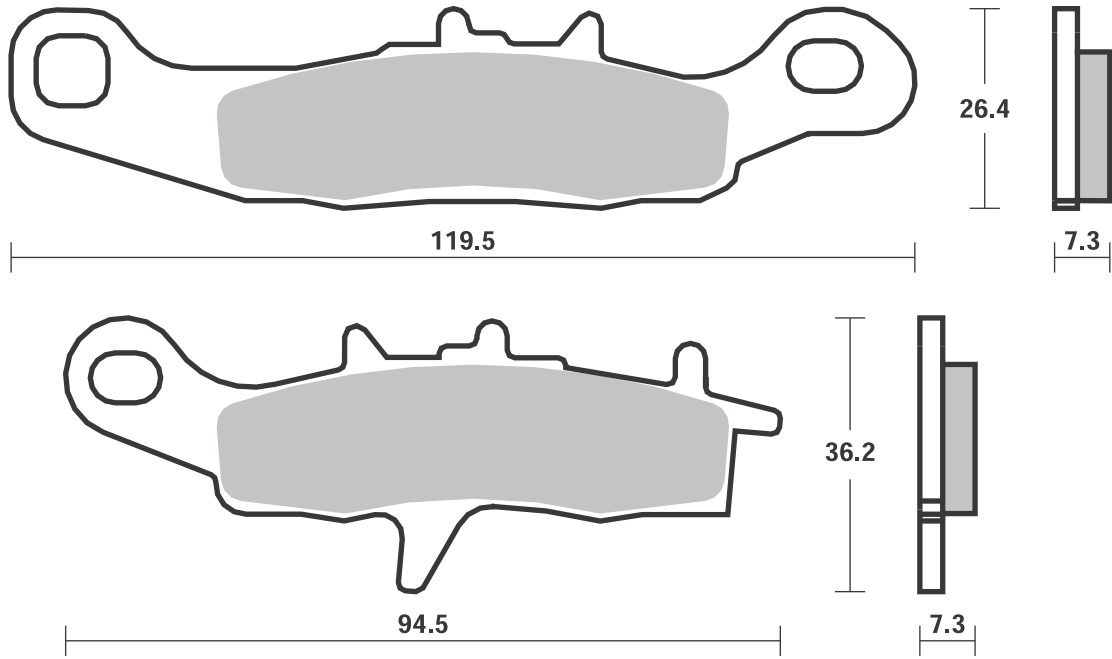

Available compounds **HF • HS**

**SBS 727**

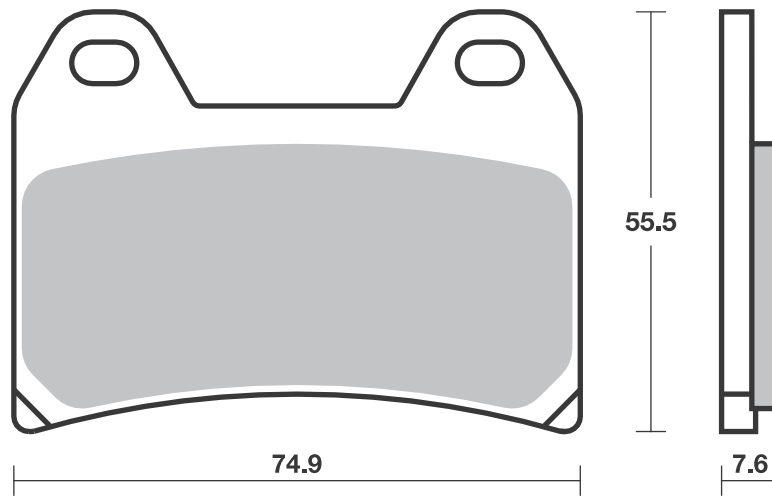

Available compounds **HF • LS • RQ**

**SBS 728**

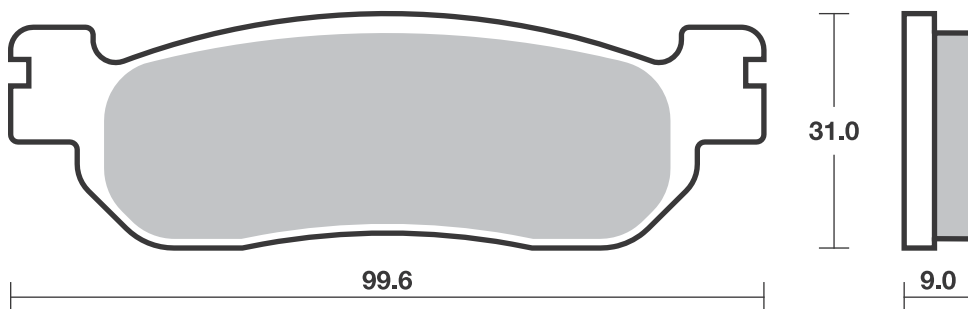

**SBS 729 Recommended compound**



|                            |             |       |           |
|----------------------------|-------------|-------|-----------|
| <b>NISSIN</b>              |             |       |           |
| 6 Piston Racing Caliper    |             |       |           |
| <b>PERFORMANCE MACHINE</b> |             |       |           |
| 112 X 6B                   |             |       |           |
| 112 X 6QC                  |             |       |           |
| <b>YAMAHA</b>              |             |       |           |
| YZF                        | 750 R7 OW02 |       |           |
|                            | Race kit    | 99-01 | <b>HS</b> |
|                            |             |       |           |
|                            |             |       |           |
|                            |             |       |           |
|                            |             |       |           |
|                            |             |       |           |
|                            |             |       |           |
|                            |             |       |           |
|                            |             |       |           |
|                            |             |       |           |
|                            |             |       |           |
|                            |             |       |           |
|                            |             |       |           |
|                            |             |       |           |
|                            |             |       |           |
|                            |             |       |           |

**SBS 730 Recommended compound**



|                |                  |       |           |
|----------------|------------------|-------|-----------|
| <b>APRILIA</b> |                  |       |           |
|                | 1000 Blue Marlin | 02    | <b>LS</b> |
| ETV            | 1000 Caponord    | 01-08 | <b>LS</b> |
| ETV            | 1000 Caponord    |       |           |
|                | Rally Raid       | 04-08 | <b>LS</b> |
| RSV            | 1000 Factory     |       |           |
|                | Pista            | 04    | <b>LS</b> |
| RSV            | 1000 Falco SL,   |       |           |
|                | R                | 00-04 | <b>LS</b> |
| RSV            | 1000 Mille       | 97-03 | <b>LS</b> |
| RSV            | 1000 Mille Nera  | 04    | <b>LS</b> |
| RSV            | 1000 Mille R     | 00-02 | <b>LS</b> |
| RSV            | 1000 Mille R     | 04    | <b>LS</b> |
| RSV            | 1000 Mille R     | 03    | <b>LS</b> |
| RSV            | 1000 Mille R     | 05-07 | <b>LS</b> |
| RSV            | 1000 Mille R     |       |           |
|                | Factory          | 04-05 | <b>LS</b> |
| RSV            | 1000 Mille SP    | 00    | <b>LS</b> |
| RSV            | 1000 Tuono       |       |           |
|                | Fighter          | 03-05 | <b>LS</b> |
| RSV            | 1000 Tuono R     | 03    | <b>LS</b> |
| RSV            | 1000 Tuono R,    |       |           |
|                | ABS              | 04-12 | <b>LS</b> |
| RSV            | 1000 Tuono R     |       |           |
|                | Factory,         |       |           |
|                | ABS              | 06-12 | <b>LS</b> |
| RSV            | 1000 Tuono       |       |           |
|                | V4 R             | 11-14 | <b>LS</b> |
| RSV4           | 1000 , ABS       | 09-13 | <b>LS</b> |
| RSV4-R         | 1000 , ABS       |       |           |
|                | APRC             | 10    | <b>LS</b> |
| RSV4-RF        | 1000             | 15-18 | <b>LS</b> |
| RSV4-RR        | 1000             | 15-18 | <b>LS</b> |
| RSV            | 1100 Tuono V4    | 15    | <b>LS</b> |
| RSV            | 1100 Tuono V4    |       |           |
|                | Factory          | 16-18 | <b>LS</b> |
| RSV            | 1100 Tuono       |       |           |
|                | V4 RR            | 15-18 | <b>LS</b> |
| <b>BENELLI</b> |                  |       |           |
| BN             | 302              | 14    | <b>LS</b> |
|                | 500 Leoncino     | 16-17 | <b>LS</b> |
| TRK            | 502              | 16-17 | <b>LS</b> |
| BN             | 600              | 12-17 | <b>LS</b> |
| BN             | 600 GT           | 14-15 | <b>LS</b> |



|                   |                 |       |              |
|-------------------|-----------------|-------|--------------|
| <b>BENELLI</b>    |                 |       |              |
|                   | 756 Cue         | 07-12 | <b>LS</b>    |
|                   | 899 Trek        | 07-12 | <b>LS</b>    |
| TnT               | 899             | 07-15 | <b>LS</b>    |
| TnT               | 899 Century     |       |              |
|                   | Racer           | 11    | <b>LS</b>    |
|                   | 900 Tornado TRE | 03-06 | <b>LS</b>    |
|                   | 900 Tornado TRE |       |              |
|                   | RS              | 04-06 | <b>LS</b>    |
| TnT               | 1130            | 05-14 | <b>LS</b>    |
| TnT               | 1130 Cafe Racer | 05-13 | <b>LS</b>    |
| TnT               | 1130 Century    |       |              |
|                   | Racer           | 11-12 | <b>LS</b>    |
| TnT               | 1130 Officine   | 07    | <b>LS</b>    |
| TnT               | 1130 R          | 17    | <b>LS</b>    |
| TnT               | 1130 Sport      | 05-08 | <b>LS</b>    |
| TnT               | 1130 Titanium   | 05-08 | <b>LS</b>    |
| TnT               | 1130 Trek       | 06-12 | <b>LS</b>    |
| TnT               | 1130 Trek       |       |              |
|                   | Amazonas        | 07-15 | <b>LS</b>    |
| <b>BIMOTA</b>     |                 |       |              |
| 3D                | 800 Tesi        | 16    | <b>LS</b>    |
| BB3               | 1000            | 14-18 | <b>LS</b>    |
| DB5               | 1000 Mille      | 05-11 | <b>LS</b>    |
| DB5               | 1000 S          | 07-11 | <b>LS</b>    |
| DB6               | 1000 Delirio    | 07-09 | <b>LS</b>    |
| DB10              | 1078 Bimotard   | 12    | <b>LS</b>    |
| DB5               | 1078 RE         | 12    | <b>LS</b>    |
| DB7               | 1098            | 08    | <b>LS</b>    |
| 3D                | 1100 Tesi       | 07-11 | <b>LS</b>    |
| DB6R              | 1100 Delirio    | 08-09 | <b>LS</b>    |
| DB8               | 1198            | 10-14 | <b>LS</b>    |
|                   | 1200 Impeto     | 16-17 | <b>LS</b>    |
| DB11              | 1200 VLX        | 13    | <b>LS</b>    |
| DB12              | 1200            | 12    | <b>LS</b>    |
| DB9               | 1200 Brivido    | 12-18 | <b>LS</b>    |
| <b>BOMBARDIER</b> |                 |       |              |
|                   | 500 Traxter 4x4 | 99-00 | <b>HF HF</b> |
| <b>BRAMMO</b>     |                 |       |              |
|                   | Empulse         | 14-16 | <b>LS</b>    |



|                               |                  |       |           |
|-------------------------------|------------------|-------|-----------|
| <b>BREMBO RACING CALIPERS</b> |                  |       |           |
| Goldline 20.6951.50, road     |                  |       |           |
| Supersport 120A44110,         |                  |       |           |
| P2 34                         |                  |       |           |
| <b>CAGIVA</b>                 |                  |       |           |
|                               | 650 Raptor       | 01-08 | <b>LS</b> |
|                               | 650 V-Raptor     | 01-08 | <b>LS</b> |
|                               | 1000 Raptor      | 00-08 | <b>LS</b> |
|                               | 1000 V-Raptor    | 00-08 | <b>LS</b> |
|                               | 1000 X3 Raptor   | 04    | <b>LS</b> |
|                               | 1000 X-Raptor    | 03-04 | <b>LS</b> |
|                               | 1000 Xtra Raptor | 02-06 | <b>LS</b> |
| <b>DERBI</b>                  |                  |       |           |
| GP1                           | 50               | 05    | <b>HF</b> |
| GPR                           | 50 Nude          | 04-10 | <b>HF</b> |
| GPR                           | 50 Racing        | 04-13 | <b>HF</b> |
| GP1                           | 125              | 05-06 | <b>HF</b> |
| GP1                           | 250              | 05-09 | <b>HF</b> |
|                               | 659 Mulhacen     | 05-07 | <b>LS</b> |
|                               | 659 Mulhacen     |       |           |
|                               | Cafe             | 08    | <b>LS</b> |
| <b>DUCATI</b>                 |                  |       |           |
|                               | 620 Multistrada  | 05-06 | <b>LS</b> |
|                               | 620 Multistrada  |       |           |
|                               | Dark             | 05-06 | <b>LS</b> |
|                               | 620 Sport        | 03-06 | <b>LS</b> |
|                               | 696 Monster      | 08-12 | <b>LS</b> |
|                               | 749 , S          | 03-07 | <b>LS</b> |
|                               | 749 R            | 04-07 | <b>LS</b> |
|                               | 750 Sport        | 00-02 | <b>LS</b> |
|                               | 750 Super Sport  | 00-02 | <b>LS</b> |
|                               | 795 Monster      | 12    | <b>LS</b> |
|                               | 796 Hypermotard  |       |           |
|                               | ABS              | 10-12 | <b>LS</b> |
|                               | 796 Monster      | 11-14 | <b>LS</b> |
|                               | 796 Monster      |       |           |
|                               | ABS              | 11-14 | <b>LS</b> |
|                               | 800 Hypermotard  | 13-15 | <b>LS</b> |
|                               | 800 Hypermotard  |       |           |
|                               | ABS              | 13-15 | <b>LS</b> |
|                               | 800 Hypermotard  |       |           |
|                               | SP               | 13-15 | <b>LS</b> |

Brake Pad 1:1 Drawings, Compounds, Fitments



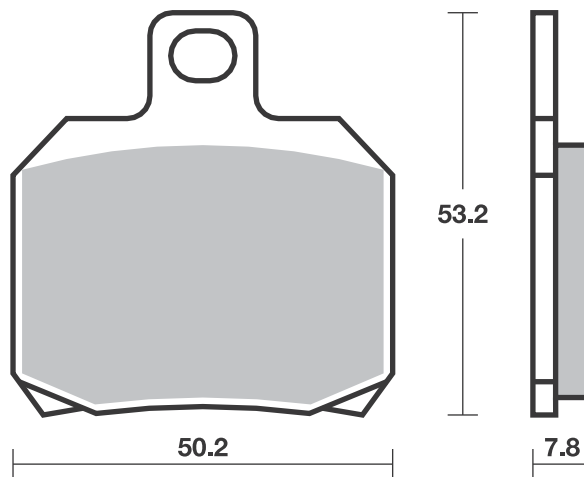
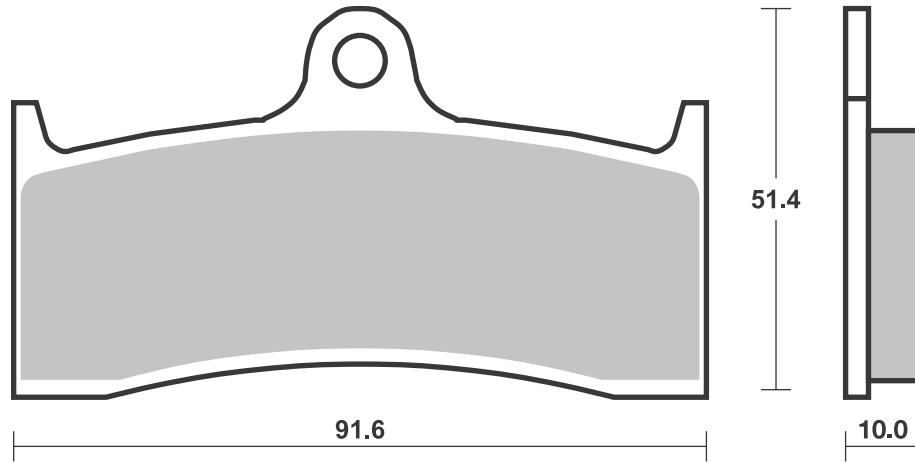

## Applications

### SBS 730 Recommended compound



| <b>DUCATI</b>         |       |           |  |
|-----------------------|-------|-----------|--|
| 800 Hypermotard       |       |           |  |
| SP ABS                | 13-15 | <b>LS</b> |  |
| 800 Hyperstrada       | 13-15 | <b>LS</b> |  |
| 800 Hyperstrada       |       |           |  |
| ABS                   | 13-15 | <b>LS</b> |  |
| 800 Sport             | 03-06 | <b>LS</b> |  |
| 800 Supersport        | 03-06 | <b>LS</b> |  |
| 821 Monster           | 14-18 | <b>LS</b> |  |
| 821 Monster           |       |           |  |
| Dark                  | 15-16 | <b>LS</b> |  |
| 848                   | 08-10 | <b>LS</b> |  |
| 848 EVO               | 11-12 | <b>LS</b> |  |
| 848 Streetfighter     | 12-15 | <b>LS</b> |  |
| 848 Streetfighter     |       |           |  |
| S                     | 12-15 | <b>LS</b> |  |
| 899 Panigale          | 14-15 | <b>LS</b> |  |
| 900 Super Sport       | 98-02 | <b>LS</b> |  |
| 916 Sport Touring     |       |           |  |
| 4                     | 99-01 | <b>LS</b> |  |
| 939 Hypermotard       | 16-18 | <b>LS</b> |  |
| 939 Hypermotard       |       |           |  |
| SP                    | 16-18 | <b>LS</b> |  |
| 939 Hyperstrada       | 16    | <b>LS</b> |  |
| 939 SuperSport        | 17-18 | <b>LS</b> |  |
| 939 SuperSport S      | 17-18 | <b>LS</b> |  |
| 944 Sport Touring     | 98-03 | <b>LS</b> |  |
| 944 ST2               | 97-03 | <b>LS</b> |  |
| 959 Panigale          | 16-18 | <b>LS</b> |  |
| 959 Panigale          |       |           |  |
| Corse                 | 18-   | <b>LS</b> |  |
| D16RR 990 Desmosedici |       |           |  |
| RR                    | 07-08 | <b>LS</b> |  |
| 992 ST3               | 04-07 | <b>LS</b> |  |
| 992 ST3s ABS          | 06-07 | <b>LS</b> |  |
| 996 ST4s              | 02-06 | <b>LS</b> |  |
| 996 ST4s ABS          | 03-06 | <b>LS</b> |  |
| 998 Monster           |       |           |  |
| S4Rs                  | 06    | <b>LS</b> |  |
| 999 , S               | 03-07 | <b>LS</b> |  |
| 999 Monster S4R       | 07-08 | <b>LS</b> |  |
| 999 Monster           |       |           |  |
| S4RS                  | 07-08 | <b>LS</b> |  |
| 999 R                 | 03-07 | <b>LS</b> |  |
| 1000 Hypermotard      | 06    | <b>LS</b> |  |
| 1000 Monster S2R      | 06-07 | <b>LS</b> |  |
| 1000 Multistrada      | 07    | <b>LS</b> |  |
| 1000 Multistrada      |       |           |  |
| DS                    | 03-06 | <b>LS</b> |  |
| 1000 Multistrada      |       |           |  |
| S DS                  | 05-06 | <b>LS</b> |  |
| 1000 Supersport       |       |           |  |
| DS                    | 03-06 | <b>LS</b> |  |
| 1098                  | 07-08 | <b>LS</b> |  |
| 1098 R                | 08-10 | <b>LS</b> |  |
| 1098 R Bayliss LE     | 09-10 | <b>LS</b> |  |
| 1098 S                | 07-08 | <b>LS</b> |  |
| 1098 Streetfighter    | 09-14 | <b>LS</b> |  |
| 1098 Streetfighter    |       |           |  |
| S                     | 09-13 | <b>LS</b> |  |
| 1100 Hypermotard      | 07-13 | <b>LS</b> |  |
| 1100 Hypermotard      |       |           |  |
| EVO                   | 10-13 | <b>LS</b> |  |
| 1100 Hypermotard      |       |           |  |
| EVO SP                | 10-12 | <b>LS</b> |  |
| 1100 Monster          | 09-13 | <b>LS</b> |  |
| 1100 Monster ABS      | 09-10 | <b>LS</b> |  |
| 1100 Monster EVO      | 11-13 | <b>LS</b> |  |
| 1100 Monster EVO      |       |           |  |
| ABS                   | 11-13 | <b>LS</b> |  |
| 1100 Monster S        | 09-13 | <b>LS</b> |  |



| <b>DUCATI</b>     |       |           |  |
|-------------------|-------|-----------|--|
| 1100 Monster S    |       |           |  |
| ABS               | 09-10 | <b>LS</b> |  |
| 1100 Multistrada  | 07-09 | <b>LS</b> |  |
| 1100 Multistrada  |       |           |  |
| S                 | 07-09 | <b>LS</b> |  |
| 1100 Panigale     |       |           |  |
| V4                | 18-   | <b>LS</b> |  |
| 1100 Panigale     |       |           |  |
| V4 S              | 18-   | <b>LS</b> |  |
| 1100 Panigale     |       |           |  |
| V4                |       |           |  |
| Speciale          | 18-   | <b>LS</b> |  |
| 1198              | 09-13 | <b>LS</b> |  |
| 1198 S            | 09-12 | <b>LS</b> |  |
| 1198 SP           | 11-12 | <b>LS</b> |  |
| 1199 Panigale     | 12-14 | <b>LS</b> |  |
| 1199 Panigale R   | 13-15 | <b>LS</b> |  |
| 1199 Panigale S   | 12-14 | <b>LS</b> |  |
| 1199 Superleggera |       |           |  |
| 14                |       | <b>LS</b> |  |
| 1200 Monster      | 14-18 | <b>LS</b> |  |
| 1200 Monster R    | 16-18 | <b>LS</b> |  |
| 1200 Monster S    | 14-18 | <b>LS</b> |  |
| 1200 Multistrada  | 10-14 | <b>LS</b> |  |
| 1200 Multistrada  |       |           |  |
| S GT              | 12-14 | <b>LS</b> |  |
| 1200 Multistrada  |       |           |  |
| S Pikes           |       |           |  |
| Peak              | 11-14 | <b>LS</b> |  |
| 1200 Multistrada  |       |           |  |
| S Sport           | 10-14 | <b>LS</b> |  |
| 1200 Multistrada  |       |           |  |
| S Touring         | 10-14 | <b>LS</b> |  |
| 1299 Panigale     | 15-17 | <b>LS</b> |  |
| 1299 Panigale R   | 15-17 | <b>LS</b> |  |
| 1299 Panigale R   |       |           |  |
| Final             |       |           |  |
| Edition           | 17-18 | <b>LS</b> |  |
| 1299 Panigale S   | 15-17 | <b>LS</b> |  |
| 1299 Panigale S   |       |           |  |
| Anniversario      |       |           |  |
| 17                |       | <b>LS</b> |  |
| 1299 Superleggera |       |           |  |
| 17                |       | <b>LS</b> |  |

#### GILERA

|                |    |           |  |
|----------------|----|-----------|--|
| 600 Supersport | 02 | <b>LS</b> |  |
|----------------|----|-----------|--|

#### HONDA

|              |       |           |  |
|--------------|-------|-----------|--|
| RC213V-S1000 | 16-18 | <b>LS</b> |  |
|--------------|-------|-----------|--|

#### HOREX

|                  |    |           |  |
|------------------|----|-----------|--|
| VR6 1200 Cafe    |    |           |  |
| Racer            | 17 | <b>LS</b> |  |
| VR6 1200 Classic | 17 | <b>LS</b> |  |

#### KAWASAKI

|                   |       |           |  |
|-------------------|-------|-----------|--|
| ZX 1000 H2 Carbon |       |           |  |
| Ninja             | 17-18 | <b>LS</b> |  |
| ZX 1000 H2 Ninja  | 15-18 | <b>LS</b> |  |
| ZX 1000 H2R Ninja | 15-18 | <b>LS</b> |  |

#### KTM

|                  |       |           |  |
|------------------|-------|-----------|--|
| RC8 1190         | 08-11 | <b>LS</b> |  |
| RC8 1190 R       | 09-15 | <b>LS</b> |  |
| RC8 1190 R Track | 11-15 | <b>LS</b> |  |
| 1290 Super       |       |           |  |
| Duke GT          | 16-18 | <b>LS</b> |  |
| 1290 Super       |       |           |  |
| Duke R           | 14-18 | <b>LS</b> |  |



| <b>LAVERDA</b> |    |           |  |
|----------------|----|-----------|--|
| TTS 800        | 99 | <b>HF</b> |  |
| SFC 1000       | 04 | <b>LS</b> |  |

#### MONDIAL

|                  |       |           |  |
|------------------|-------|-----------|--|
| 1000 EVO         | 04    | <b>LS</b> |  |
| 1000 Piega       | 03-04 | <b>LS</b> |  |
| 1000 RZ Nuda     | 04    | <b>LS</b> |  |
| 1000 Starfighter | 04    | <b>LS</b> |  |

#### MOTO-GUZZI

|                     |       |           |  |
|---------------------|-------|-----------|--|
| 750 Brevia          | 03-09 | <b>LS</b> |  |
| 750 Nevada          |       |           |  |
| Classic ie          | 06-11 | <b>HF</b> |  |
| 750 Nevada,         |       |           |  |
| Nevada Club         | 03-16 | <b>HF</b> |  |
| V7 750 Cafe Classic | 10-13 | <b>LS</b> |  |
| V7 750 Classic      | 09-12 | <b>LS</b> |  |
| V7 750 Clubman      |       |           |  |
| Racer               | 10    | <b>LS</b> |  |
| V7 750 Racer        | 11    | <b>LS</b> |  |
| V 1100 Brevia       | 04    | <b>LS</b> |  |
| 1200 MGS-01         |       |           |  |
| Corsa               | 05-13 | <b>LS</b> |  |
| 1200 Sport 4V       | 09-11 | <b>LS</b> |  |

#### MOTO-MORINI

|                 |       |           |  |
|-----------------|-------|-----------|--|
| 1200 11 1/2     | 18-   | <b>LS</b> |  |
| 1200 9 1/2      | 06-09 | <b>LS</b> |  |
| 1200 Corsaro    | 06-13 | <b>LS</b> |  |
| 1200 Corsaro ZZ | 18-   | <b>LS</b> |  |
| 1200 Milano     | 18-   | <b>LS</b> |  |
| 1200 Scrambler  | 18-   | <b>LS</b> |  |
| 1200 Sport      | 08-13 | <b>LS</b> |  |

#### MV AGUSTA

|                |       |           |  |
|----------------|-------|-----------|--|
| 675 Brutale    | 12-15 | <b>LS</b> |  |
| 675 F3         | 13-17 | <b>LS</b> |  |
| 675 F3 RC      | 16-17 | <b>LS</b> |  |
| 800 Brutale    | 13-17 | <b>LS</b> |  |
| 800 Brutale    |       |           |  |
| Dragster       | 15-18 | <b>LS</b> |  |
| 800 Brutale    |       |           |  |
| Dragster RC    | 17-18 | <b>LS</b> |  |
| 800 Brutale    |       |           |  |
| Dragster RR    | 15-18 | <b>LS</b> |  |
| 800 Brutale    |       |           |  |
| Dragster RR    |       |           |  |
| LH44           | 18-   | <b>LS</b> |  |
| 800 Brutale    |       |           |  |
| Dragster RR    |       |           |  |
| Pirelli        | 18-   | <b>LS</b> |  |
| 800 Brutale RC | 18-   | <b>LS</b> |  |
| 800 Brutale RR | 16-17 | <b>LS</b> |  |
| 800 F3 RC      | 16-17 | <b>LS</b> |  |
| 800 Rivale     | 13-17 | <b>LS</b> |  |
| 800 RVS#1      | 18-   | <b>LS</b> |  |
| 800 Stradale   | 15-16 | <b>LS</b> |  |
| 800 Turismo    |       |           |  |
| Veloce         | 14-16 | <b>LS</b> |  |
| 800 Turismo    |       |           |  |
| Veloce Lusso   | 14-16 | <b>LS</b> |  |
| 800 Turismo    |       |           |  |
| Veloce RC      | 17-18 | <b>LS</b> |  |

#### NORTON

|              |       |           |  |
|--------------|-------|-----------|--|
| 961 Commando |       |           |  |
| Cafe Racer   | 11-14 | <b>LS</b> |  |
| 961 Commando |       |           |  |
| Cafe Racer   |       |           |  |
| MKII         | 18-   | <b>LS</b> |  |

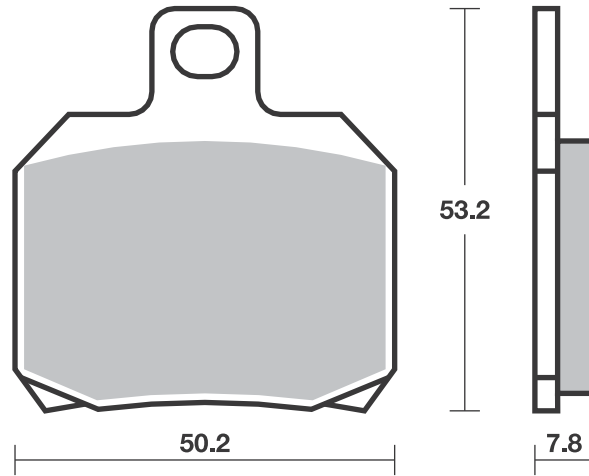

SBS 730 Recommended compound



**NORTON**

|               |        |    |
|---------------|--------|----|
| 961 Commando  |        |    |
| SE            | 10- 14 | LS |
| 961 Commando  |        |    |
| SF            | 13- 15 | LS |
| 961 Commando  |        |    |
| SF Sport      | 11- 15 | LS |
| 961 Commando  |        |    |
| Sport         | 18-    | LS |
| 961 Dominator |        |    |
| Naked         | 17- 18 | LS |
| 1200 V4 RR    | 18-    | LS |

**RIEJU**

|               |        |    |
|---------------|--------|----|
| 50 Tangoo     | 10- 12 | HF |
| 125 Marathon  |        |    |
| Pro           | 09- 14 | HF |
| 125 Marathon  |        |    |
| Pro           |        |    |
| Supermotard   | 09- 15 | HF |
| 125 Tango     | 08- 12 | HF |
| 125 Tango Pro | 08     | HF |
| 250 Tango     | 08- 15 | HF |

**VICTORY**

|            |        |      |
|------------|--------|------|
| Empulse TT | 16- 17 | H.LS |
|------------|--------|------|

**VOXAN**

|                 |         |    |
|-----------------|---------|----|
| 1000 Cafe Racer | 01 - 06 | LS |
| 1000 Roadster   | 01 - 06 | LS |
| VB1 1000 EVO    | 04- 06  | LS |

SBS 732 Recommended compound



**BREMBO RACING CALIPERS**

Billet P2.24 X20.60.01,  
racing

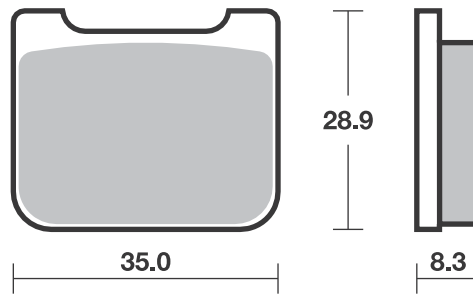
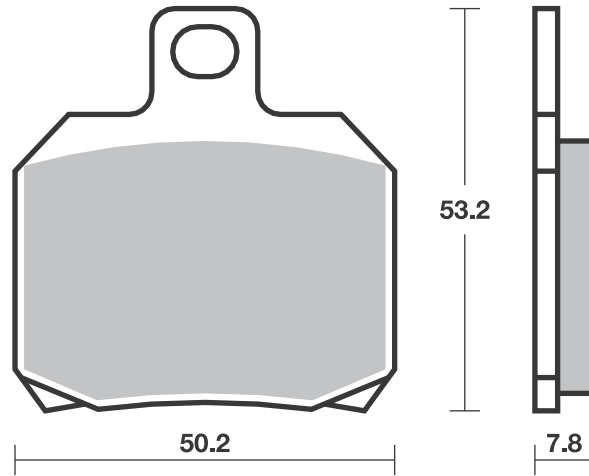

**SBS 733** Recommended compound**YAMAHA**

|     |             |       |    |
|-----|-------------|-------|----|
| YZF | 750 R7 OW02 | 99-02 | LS |
| YZF | 1000 R1     | 98-01 | LS |
|     |             |       |    |
|     |             |       |    |
|     |             |       |    |
|     |             |       |    |
|     |             |       |    |
|     |             |       |    |
|     |             |       |    |
|     |             |       |    |
|     |             |       |    |
|     |             |       |    |
|     |             |       |    |
|     |             |       |    |
|     |             |       |    |
|     |             |       |    |
|     |             |       |    |
|     |             |       |    |
|     |             |       |    |
|     |             |       |    |
|     |             |       |    |
|     |             |       |    |
|     |             |       |    |
|     |             |       |    |
|     |             |       |    |
|     |             |       |    |
|     |             |       |    |
|     |             |       |    |
|     |             |       |    |
|     |             |       |    |
|     |             |       |    |
|     |             |       |    |
|     |             |       |    |
|     |             |       |    |

**SBS 734** Recommended compound**HONDA**

|     |                       |       |    |
|-----|-----------------------|-------|----|
| CB  | 600 Hornet<br>(Japan) | 98-99 | HS |
| CBR | 600 F4, F4 Sport      | 99-06 | HS |
| CBR | 600 RR                | 03-04 | HS |
| CBR | 900 RR Fireblade      | 98-03 | HS |
| VTR | 1000 SP-1, SP-2       | 00-06 | HS |
| CB  | 1100 , EX             | 14-18 | HS |
| CB  | 1100 EX ABS           | 17-18 | HS |
| CB  | 1300                  | 05-13 | HS |
| CB  | 1300 R                | 02-04 | HS |

**HYOSUNG**

|    |              |       |    |
|----|--------------|-------|----|
| GD | 125 EXIV     | 12-16 | HF |
| GD | 250 EXIV-R   | 15-17 | HS |
| GT | 250 iR       | 15    | HS |
| GV | 250          | 17-18 | HS |
| GT | 300 R        | 16-17 | HS |
| GV | 300          | 16-17 | HS |
| GT | 650 i        | 13    | HS |
| GT | 650 i Naked  | 15    | HS |
| GT | 650 iR       | 13-15 | HS |
| ST | 700          | 11-13 | HS |
| ST | 700 i Deluxe | 13    | HS |
|    |              |       |    |
|    |              |       |    |
|    |              |       |    |
|    |              |       |    |
|    |              |       |    |
|    |              |       |    |
|    |              |       |    |
|    |              |       |    |
|    |              |       |    |
|    |              |       |    |
|    |              |       |    |
|    |              |       |    |
|    |              |       |    |
|    |              |       |    |
|    |              |       |    |
|    |              |       |    |
|    |              |       |    |
|    |              |       |    |
|    |              |       |    |
|    |              |       |    |
|    |              |       |    |
|    |              |       |    |

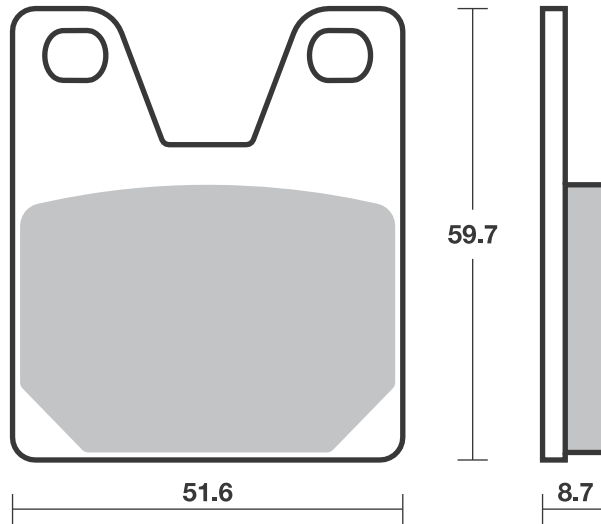

HF / HS / SP - Th. 7.2  
RS / DC - Th. 8.0

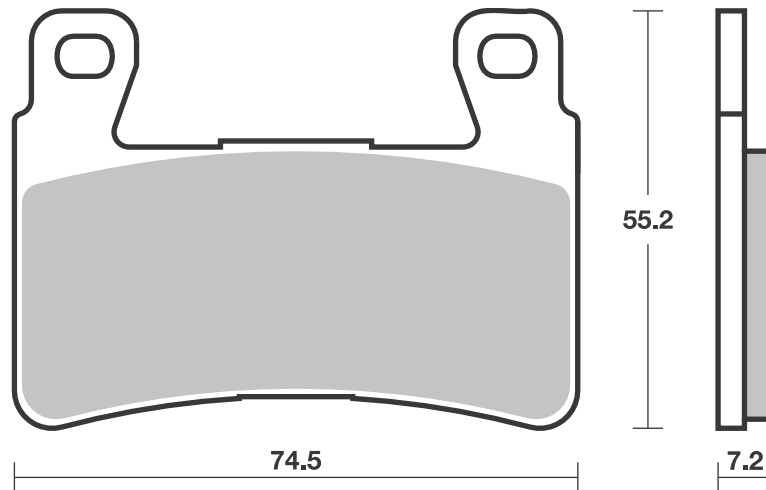

**SBS 735 Recommended compound**

| <b>HONDA</b>    |  |       |             |  |
|-----------------|--|-------|-------------|--|
| NT              | 650 V Deauville                              | 02-05 | <b>HS</b>   |  |
| VFR             | 800 FI                                       | 98-01 | <b>HS</b>   |  |
| VFR             | 800 V-TEC, ABS                               | 02-05 | <b>HS</b>   |  |
| XL              | 1000 Varadero                                | 99    | <b>HS</b>   |  |
| XL              | 1000 Varadero<br>(Linked<br>brake<br>system) | 00-06 | <b>HS</b>   |  |
| CB              | 1100 Hornet                                  | 99    | <b>HS</b>   |  |
| CB              | 1100 X-11                                    | 00-03 | <b>HS</b>   |  |
| CBR             | 1100 XX Super<br>Blackbird                   | 96-07 | <b>HS</b>   |  |
| ST              | 1300 Pan<br>European,<br>ABS                 | 02-07 | <b>HS</b>   |  |
| GL              | 1800 Gold Wing                               | 01-16 | <b>HS</b>   |  |
| GL              | 1800 Gold Wing<br>F6B                        | 13-16 | <b>HS</b>   |  |
| VTX             | 1800   | 01-12 | <b>HS</b>   |  |
| <b>KAWASAKI</b> |  |       |             |  |
| EN              | 650 Vulcan S                                 | 15-18 | <b>HS</b>   |  |
| EN              | 650 Vulcan S<br>Cafe                         | 17-18 | <b>HS</b>   |  |
| EN              | 650 Vulcan S SE                              | 17-18 | <b>HS</b>   |  |
| EX              | 650 Ninja ABS                                | 17-18 | <b>HS</b>   |  |
| <b>VICTORY</b>  |  |       |             |  |
|                 | 1731 Vision<br>all models                    | 08-17 | <b>H.HS</b> |  |

**SBS 736 Recommended compound**

| <b>HONDA</b> |  |       |           |  |
|--------------|--|-------|-----------|--|
| NT           | 650 V Deauville                              | 02-05 | <b>LS</b> |  |
| NT           | 700 Deauville<br>ABS                         | 06-12 | <b>LS</b> |  |
| NT           | 700 V Varadero,<br>ABS                       | 10-13 | <b>LS</b> |  |
| VFR          | 800  | 06-13 | <b>LS</b> |  |
| VFR          | 800 ABS                                      | 06-13 | <b>LS</b> |  |
| VFR          | 800 FI                                       | 98-01 | <b>LS</b> |  |
| VFR          | 800 V-TEC, ABS                               | 02-05 | <b>LS</b> |  |
| XL           | 1000 Varadero                                | 99    | <b>LS</b> |  |
| XL           | 1000 Varadero                                | 07-13 | <b>LS</b> |  |
| XL           | 1000 Varadero<br>(Linked<br>brake<br>system) | 00-06 | <b>LS</b> |  |
| XL           | 1000 Varadero<br>ABS                         | 04-13 | <b>LS</b> |  |
| CB           | 1100 Hornet                                  | 99    | <b>LS</b> |  |
| CB           | 1100 X-11                                    | 00-03 | <b>LS</b> |  |
| CBR          | 1100 XX Super<br>Blackbird                   | 96-07 | <b>LS</b> |  |
| VT           | 1300 CXA A Fury<br>ABS                       | 10-18 | <b>LS</b> |  |
| VTX          | 1800   | 01-12 | <b>LS</b> |  |
|              |  |       |           |  |
|              |  |       |           |  |
|              |  |       |           |  |
|              |  |       |           |  |
|              |  |       |           |  |
|              |  |       |           |  |
|              |  |       |           |  |
|              |  |       |           |  |
|              |  |       |           |  |
|              |  |       |           |  |
|              |  |       |           |  |



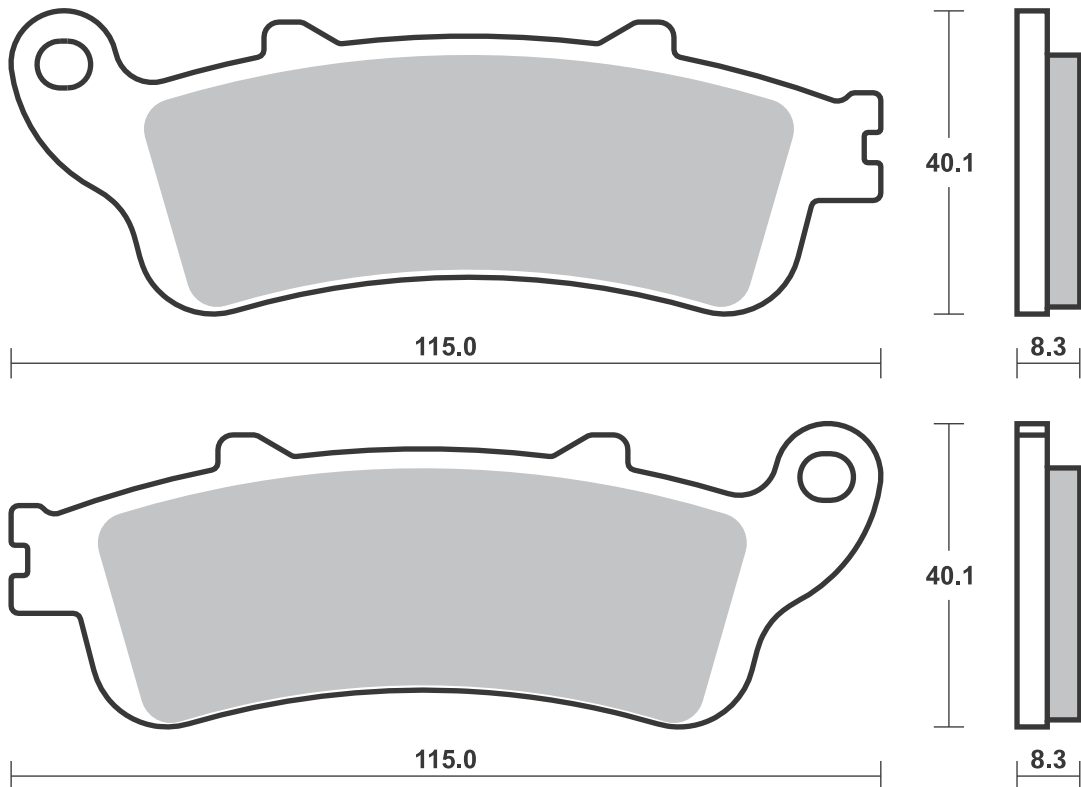
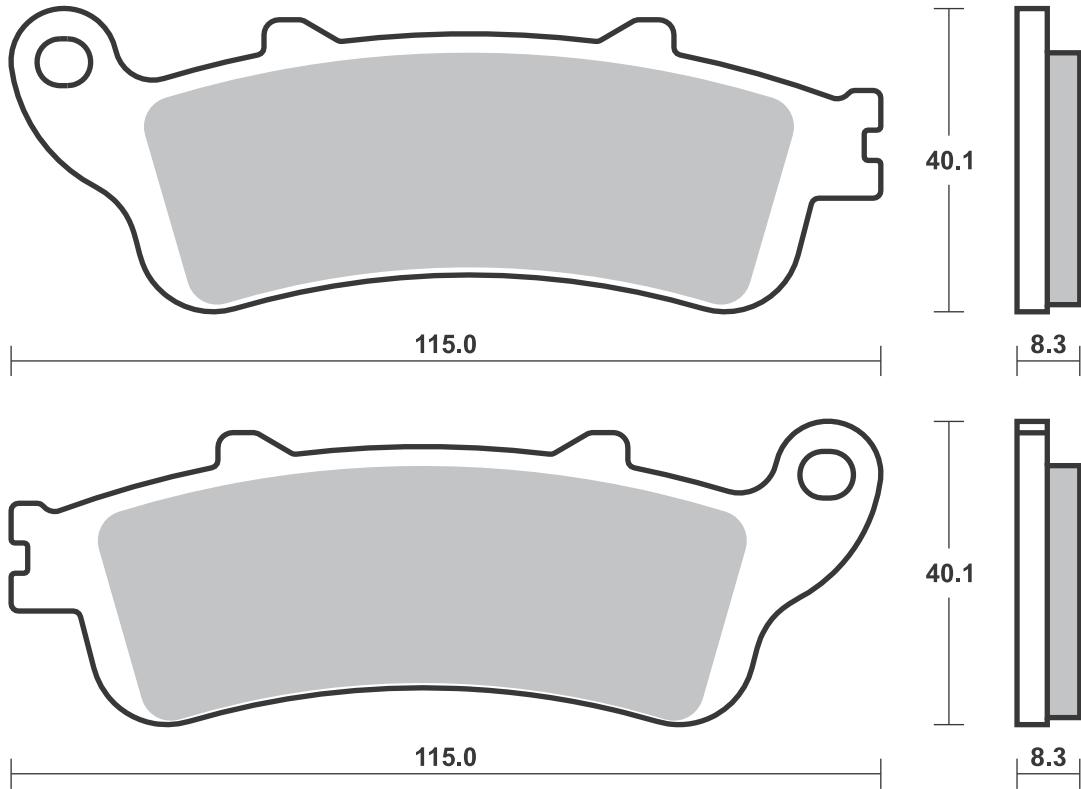



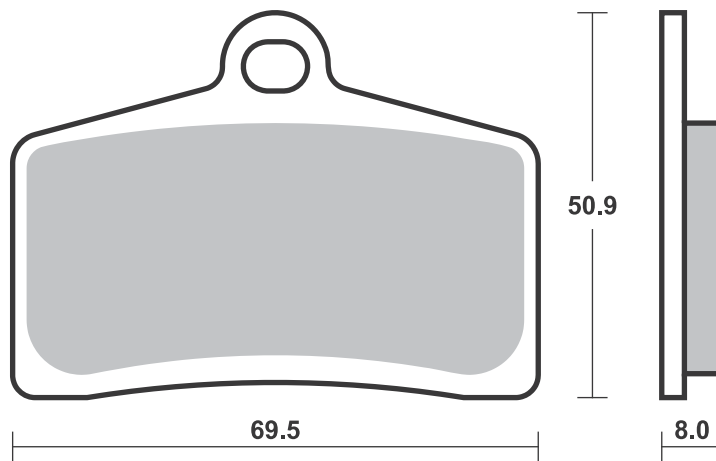
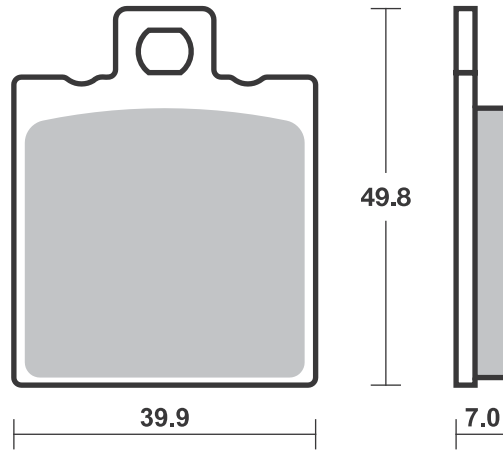

1 set = 4 pcs.

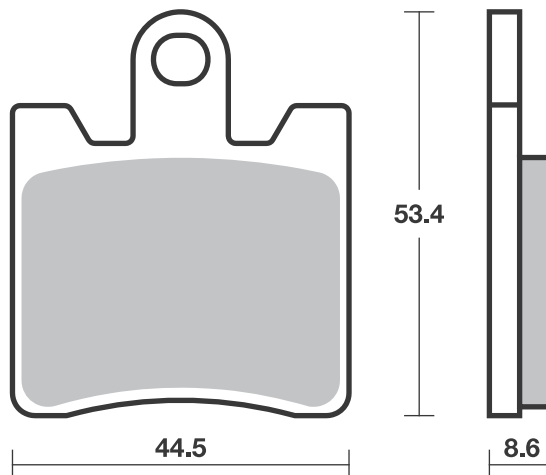



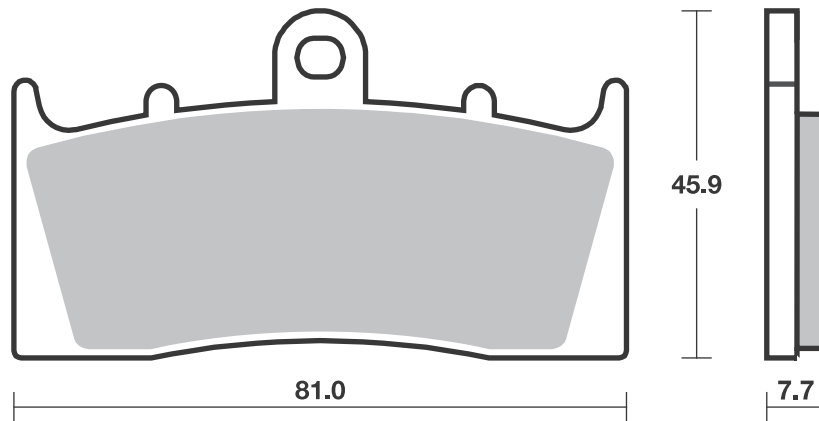
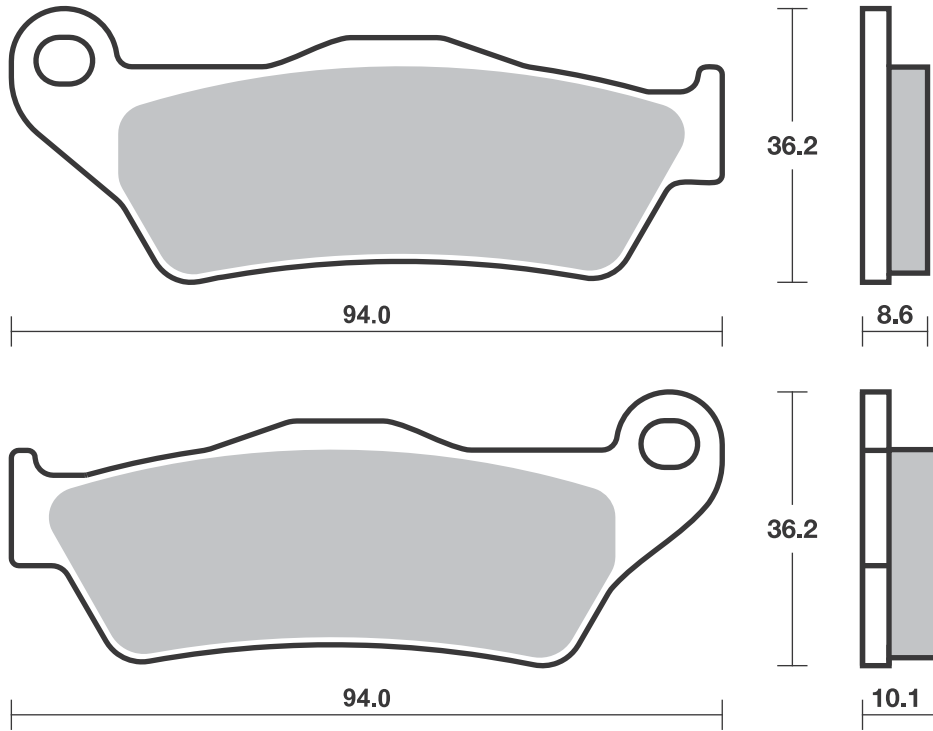



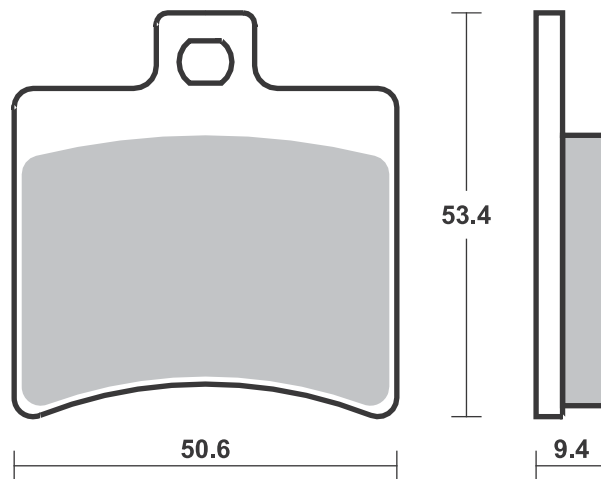
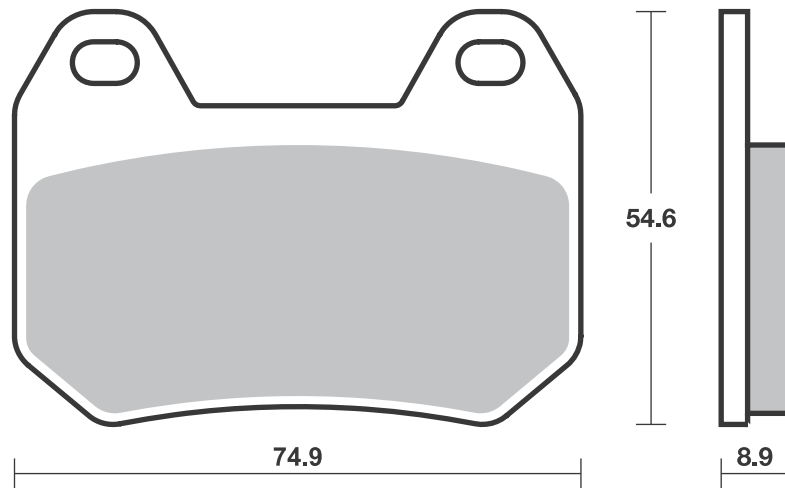





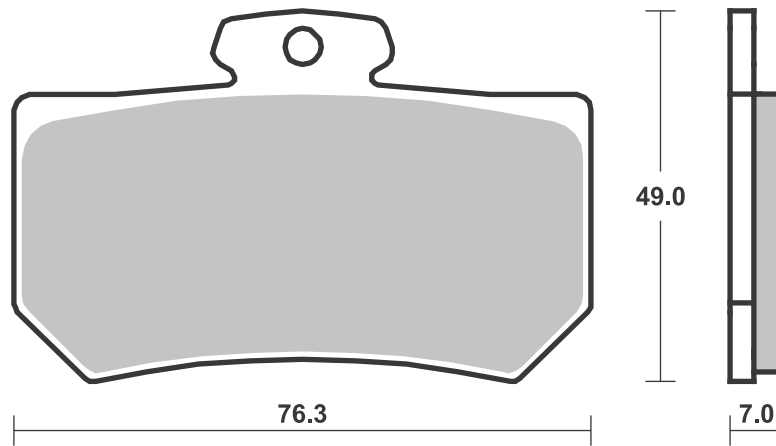
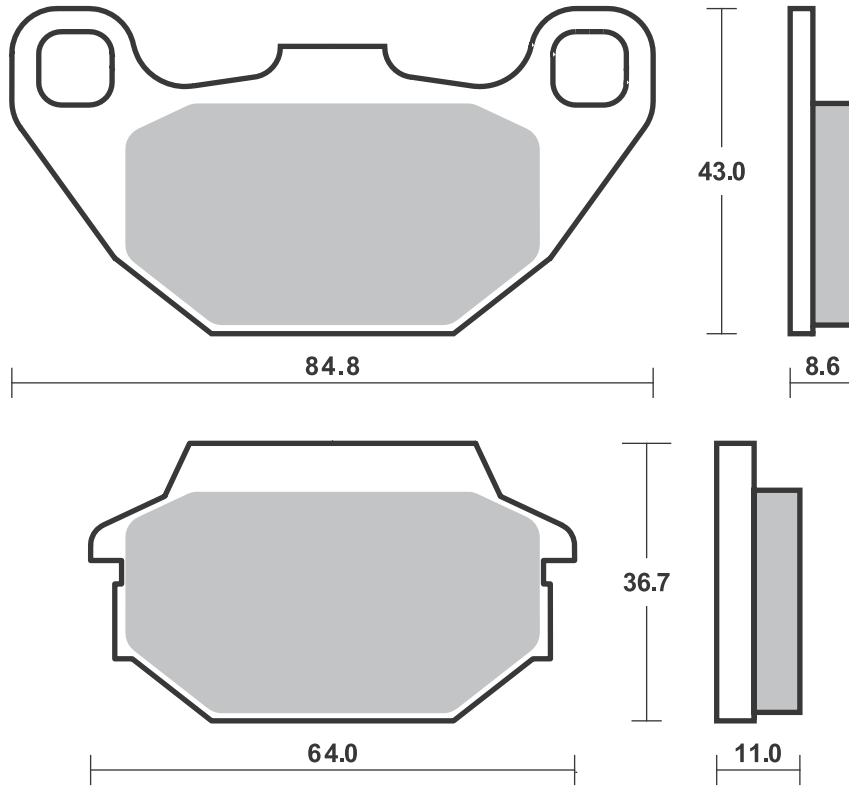

**SBS 752 Recommended compound**



| <b>KAWASAKI</b> |    |       |            |  |
|-----------------|----|-------|------------|--|
| KX              | 65 | 00-15 | <b>RSI</b> |  |
| <b>SUZUKI</b>   |    |       |            |  |
| RM              | 65 | 03-06 | <b>RSI</b> |  |
|                 |    |       |            |  |
|                 |    |       |            |  |
|                 |    |       |            |  |
|                 |    |       |            |  |
|                 |    |       |            |  |
|                 |    |       |            |  |
|                 |    |       |            |  |
|                 |    |       |            |  |
|                 |    |       |            |  |
|                 |    |       |            |  |
|                 |    |       |            |  |
|                 |    |       |            |  |
|                 |    |       |            |  |
|                 |    |       |            |  |
|                 |    |       |            |  |
|                 |    |       |            |  |
|                 |    |       |            |  |
|                 |    |       |            |  |
|                 |    |       |            |  |
|                 |    |       |            |  |
|                 |    |       |            |  |
|                 |    |       |            |  |
|                 |    |       |            |  |

**SBS 754 Recommended compound**



| <b>BOMBARDIER</b> |                   |       |           |           |
|-------------------|-------------------|-------|-----------|-----------|
| DS                | 250 Left/Rear     | 06    | <b>SI</b> | <b>SI</b> |
|                   | 330 Outlander     |       |           |           |
|                   | Left/Rear         | 03-06 | <b>SI</b> | <b>SI</b> |
|                   | 400 Outlander     |       |           |           |
|                   | Left/Rear         | 03-06 | <b>SI</b> | <b>SI</b> |
|                   | 400 Outlander     |       |           |           |
|                   | Max Left/Rear     | 03-06 | <b>SI</b> | <b>SI</b> |
|                   | 500 Quest         |       |           |           |
|                   | Left/Rear         | 02-06 | <b>SI</b> | <b>SI</b> |
|                   | 500 Traxter 4x4   |       |           |           |
|                   | Left/Rear         | 01-06 | <b>SI</b> |           |
|                   | 500 Traxter Max   |       |           |           |
|                   | Left/Rear         | 03-05 | <b>SI</b> |           |
|                   | 650 Quest         |       |           |           |
|                   | Left/Rear         | 02-06 | <b>SI</b> | <b>SI</b> |
|                   | 650 Quest Max     |       |           |           |
|                   | Left/Rear         | 03-06 | <b>SI</b> |           |
|                   | 650 Traxter Max   |       |           |           |
|                   | Left/Rear         | 03-05 | <b>SI</b> |           |
| DS                | 650 Left/Rear     | 01-06 | <b>SI</b> | <b>SI</b> |
|                   | 800 Outlander     |       |           |           |
|                   | Left/Rear         | 06    | <b>SI</b> | <b>SI</b> |
|                   | 800 Outlander XT  |       |           |           |
|                   | Left/Rear         | 06    | <b>SI</b> | <b>SI</b> |
| <b>CAN-AM</b>     |                   |       |           |           |
|                   | 400 Outlander EFi |       |           |           |
|                   | Left/Rear         | 09-14 | <b>SI</b> | <b>SI</b> |
|                   | 400 Outlander MAX |       |           |           |
|                   | STD Left/Rear     | 07-13 | <b>SI</b> | <b>SI</b> |
|                   | 400 Outlander MAX |       |           |           |
|                   | XT Left/Rear      | 07-13 | <b>SI</b> | <b>SI</b> |
|                   | 400 Outlander STD |       |           |           |
|                   | Left/Rear         | 07-14 | <b>SI</b> | <b>SI</b> |
|                   | 400 Outlander XT  |       |           |           |
|                   | Left/Rear         | 07-14 | <b>SI</b> | <b>SI</b> |



| <b>CAN-AM</b> |                   |       |           |           |
|---------------|-------------------|-------|-----------|-----------|
|               | 500 Outlander MAX |       |           |           |
|               | STD Left/Rear     | 07-12 | <b>SI</b> | <b>SI</b> |
|               | 500 Outlander MAX |       |           |           |
|               | XT Left/Rear      | 07-12 | <b>SI</b> | <b>SI</b> |
|               | 500 Outlander STD |       |           |           |
|               | Left/Rear         | 07-12 | <b>SI</b> | <b>SI</b> |
|               | 500 Outlander XT  |       |           |           |
|               | Left/Rear         | 07-12 | <b>SI</b> | <b>SI</b> |
|               | 500 Renegade      |       |           |           |
|               | Left/Rear         | 08-11 | <b>SI</b> | <b>SI</b> |
|               | 650 Outlander MAX |       |           |           |
|               | STD Left/Rear     | 07-12 | <b>SI</b> | <b>SI</b> |
|               | 650 Outlander MAX |       |           |           |
|               | XT Left/Rear      | 07-12 | <b>SI</b> | <b>SI</b> |
|               | 650 Outlander STD |       |           |           |
|               | Left/Rear         | 07-12 | <b>SI</b> | <b>SI</b> |
|               | 650 Outlander XT  |       |           |           |
|               | Left/Rear         | 07-12 | <b>SI</b> | <b>SI</b> |
|               | 800 Outlander MAX |       |           |           |
|               | LTD Left/Rear     | 07-11 | <b>SI</b> | <b>SI</b> |
|               | 800 Outlander MAX |       |           |           |
|               | STD Left/Rear     | 07-11 | <b>SI</b> | <b>SI</b> |
|               | 800 Outlander MAX |       |           |           |
|               | XT Left/Rear      | 07-11 | <b>SI</b> | <b>SI</b> |
|               | 800 Outlander STD |       |           |           |
|               | Left/Rear         | 07-11 | <b>SI</b> | <b>SI</b> |
|               | 800 Renegade EFi  |       |           |           |
|               | Left/Rear         | 07-11 | <b>SI</b> | <b>SI</b> |
|               | 800 Renegade      |       |           |           |
|               | Left/Rear         | 08-11 | <b>SI</b> | <b>SI</b> |
|               | 800 Renegade X    |       |           |           |
|               | Left/Rear         | 08-11 | <b>SI</b> | <b>SI</b> |
|               | 1000 Commander    |       |           |           |
|               | MAX Left          | 14-16 | <b>SI</b> |           |



| <b>CAN-AM</b>     |                              |       |           |           |
|-------------------|------------------------------|-------|-----------|-----------|
|                   | 1000 Maverick Left           | 13-17 |           | <b>SI</b> |
| <b>CANNONDALE</b> |                              |       |           |           |
|                   | 440 Blaze Left/Rear          | 03    | <b>SI</b> | <b>SI</b> |
|                   | 440 Cannibal                 |       |           |           |
|                   | Left/Rear                    | 03    | <b>SI</b> | <b>SI</b> |
|                   | 440 Glamis                   |       |           |           |
|                   | Left/Rear                    | 03    | <b>SI</b> | <b>SI</b> |
|                   | 440 Moto Left/Rear           | 03    | <b>SI</b> | <b>SI</b> |
|                   | 440 Speed                    |       |           |           |
|                   | Left/Rear                    | 03    | <b>SI</b> | <b>SI</b> |
| <b>JOHN DEERE</b> |                              |       |           |           |
|                   | 500 Buck EX,                 |       |           |           |
|                   | EXT Left/Rear                | 05    | <b>SI</b> |           |
|                   | 500 Buck Left/Rear           | 05    | <b>SI</b> |           |
|                   | 500 Trail Buck               |       |           |           |
|                   | Left/Rear                    | 05    | <b>SI</b> |           |
|                   | 650 Trail Buck EX,           |       |           |           |
|                   | EXT Left/Rear                | 05    | <b>SI</b> |           |
|                   | 650 Trail Buck               |       |           |           |
|                   | Left/Rear                    | 05    | <b>SI</b> |           |
| <b>YAMAHA</b>     |                              |       |           |           |
| YFM               | 400 FAM Kodiak               | 00-02 |           | <b>SI</b> |
| YFM               | 400 FWN Big Bear             |       |           |           |
|                   | 4WD                          | 00-11 |           | <b>SI</b> |
| YFM               | 400 FWNH Big Bear-Buckmaster |       |           |           |
|                   | 4WD                          | 00-11 |           | <b>SI</b> |
| YFM               | 400 N Big Bear               |       |           |           |
|                   | 2WD                          | 00-11 |           | <b>SI</b> |
| YFM               | 450 FA_ Kodiak               | 03-07 |           | <b>SI</b> |
| YFM               | 450 Wolverine                | 06-10 |           | <b>SI</b> |

Brake Pad 1:1 Drawings, Compounds, Fitments

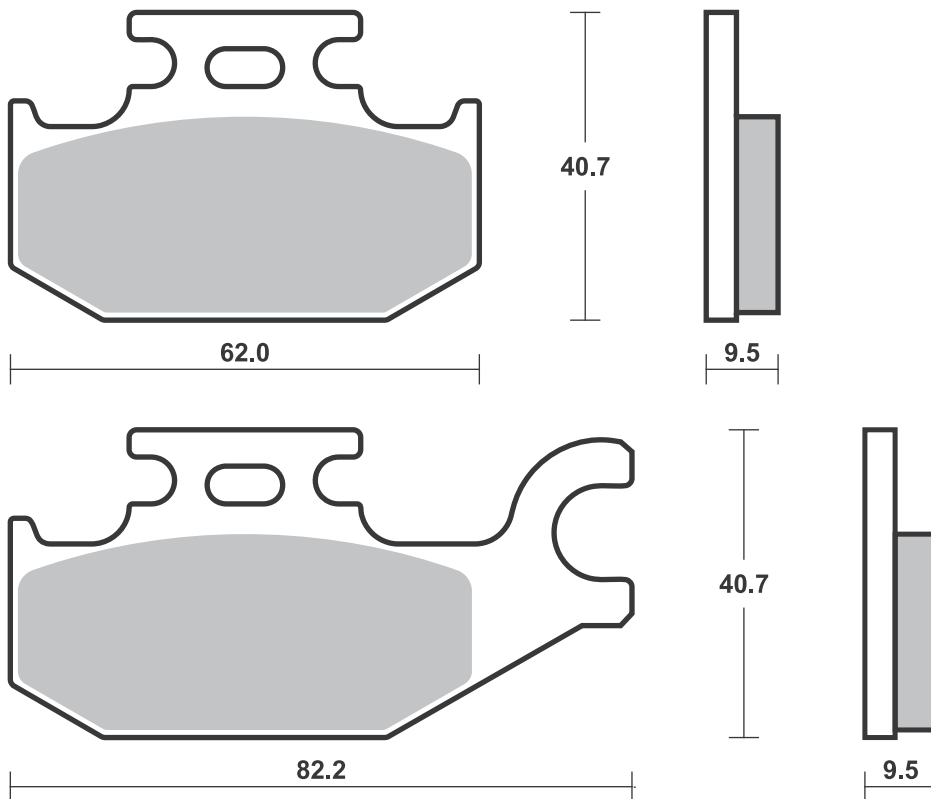
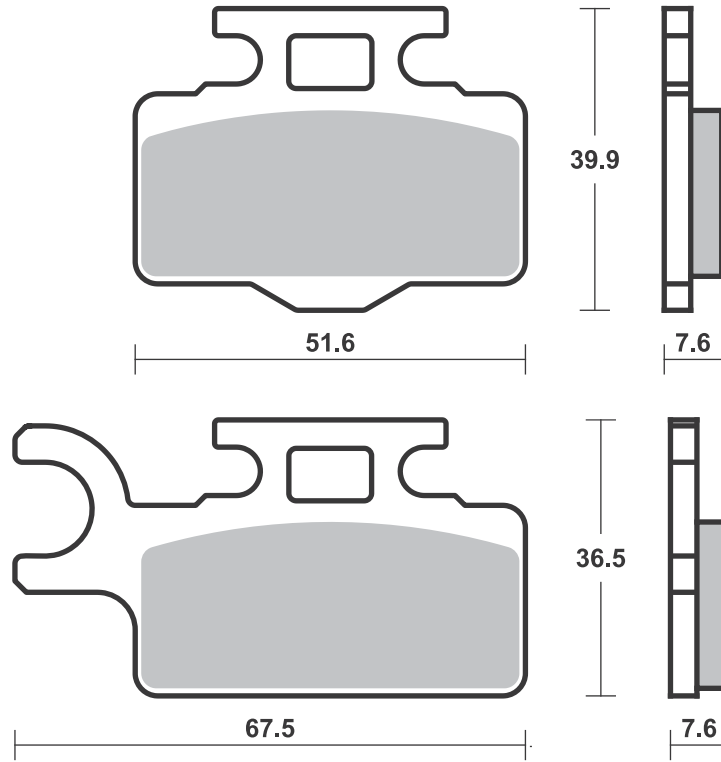

## Applications

### SBS 755 Recommended compound



| POLARIS           |       |  |     |
|-------------------|-------|--|-----|
| 250 Trail Blazer  | 99-07 |  | ATS |
| 250 Xplorer 4x4   | 00-02 |  | ATS |
| 325 Magnum        |       |  |     |
| 2x4, 4x4          | 00-02 |  | ATS |
| 325 Trail Boss    | 00-02 |  | ATS |
| 325 Xpedition     | 00-01 |  | ATS |
| 330 Trail Boss    | 03-14 |  | ATS |
| 335 Sportsman     |       |  |     |
| 4x4               | 99-02 |  | ATS |
| 400 Scrambler     |       |  |     |
| 2x4, 4x4          | 00-03 |  | ATS |
| 400 Scrambler     |       |  |     |
| 4x4               | 99-03 |  | ATS |
| 400 Sport         | 99-00 |  | ATS |
| 400 Sportsman     | 01-13 |  | ATS |
| 400 Trail Blazer  | 03-04 |  | ATS |
| 400 Xplorer L 4x4 | 00-02 |  | ATS |
| 425 Xpedition 4x4 | 00-03 |  | ATS |



| POLARIS        |       |  |     |
|----------------|-------|--|-----|
| 455 Diesel EBS |       |  |     |
| 4x4            | 99-01 |  | ATS |
| 500 Magnum 4x4 | 00-01 |  | ATS |
| 500 Scrambler  |       |  |     |
| 2x4            | 01-02 |  | ATS |
| 500 Scrambler  |       |  |     |
| 4x4            | 98-13 |  | ATS |
| 500 Sportsman  |       |  |     |
| EBS 4x4        | 98-02 |  | ATS |

### SBS 756 Recommended compound



| POLARIS        |    |  |     |
|----------------|----|--|-----|
| 400 Big Boss L |    |  |     |
| 6x6 Middle     |    |  |     |
| Axle Brake     | 96 |  | ATS |
| 425 Magnum     |    |  |     |
| 6x6 Middle     |    |  |     |
| Axle Brake     | 96 |  | ATS |
|                |    |  |     |
|                |    |  |     |
|                |    |  |     |
|                |    |  |     |
|                |    |  |     |
|                |    |  |     |
|                |    |  |     |
|                |    |  |     |
|                |    |  |     |
|                |    |  |     |
|                |    |  |     |
|                |    |  |     |
|                |    |  |     |
|                |    |  |     |
|                |    |  |     |
|                |    |  |     |

### SBS 757 Recommended compound



| POLARIS       |       |  |     |
|---------------|-------|--|-----|
| 500 Sportsman |       |  |     |
| 6x6           | 00-11 |  | ATS |
|               |       |  |     |
|               |       |  |     |
|               |       |  |     |
|               |       |  |     |
|               |       |  |     |
|               |       |  |     |
|               |       |  |     |
|               |       |  |     |
|               |       |  |     |
|               |       |  |     |
|               |       |  |     |
|               |       |  |     |
|               |       |  |     |
|               |       |  |     |
|               |       |  |     |
|               |       |  |     |
|               |       |  |     |
|               |       |  |     |
|               |       |  |     |
|               |       |  |     |
|               |       |  |     |

Brake Pad 1:1 Drawings, Compounds, Fitments

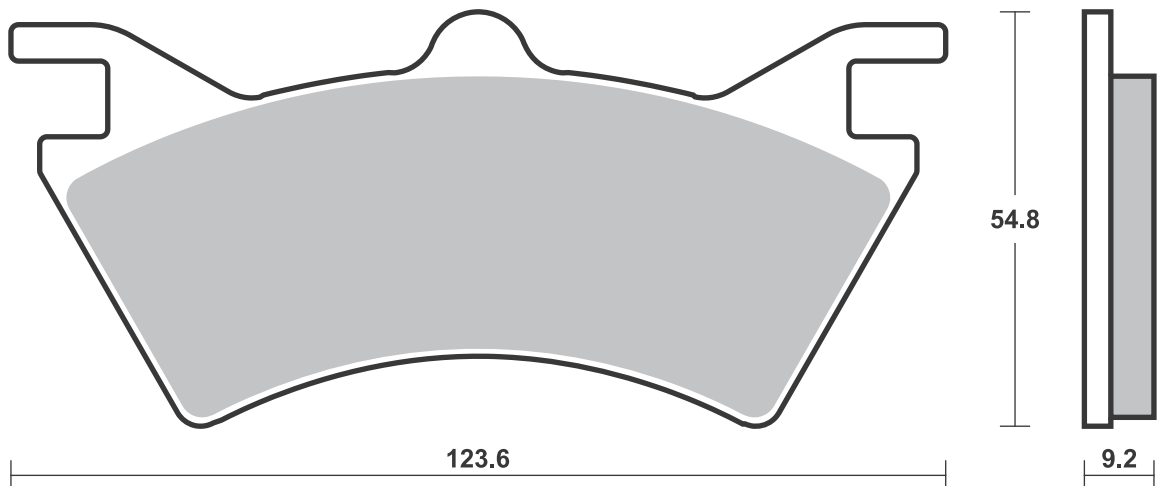
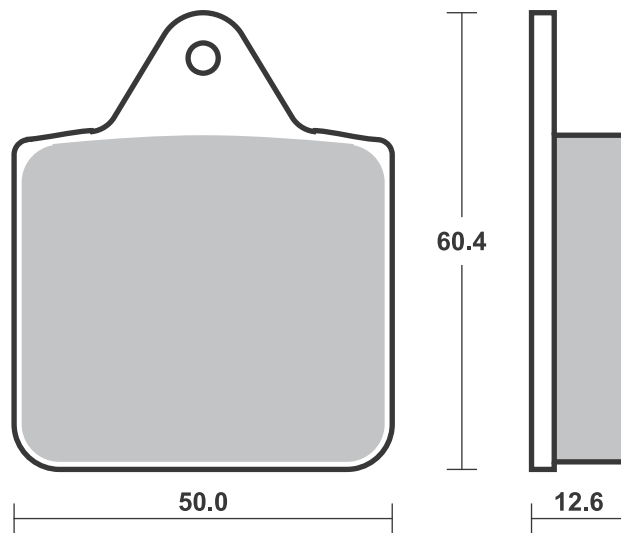
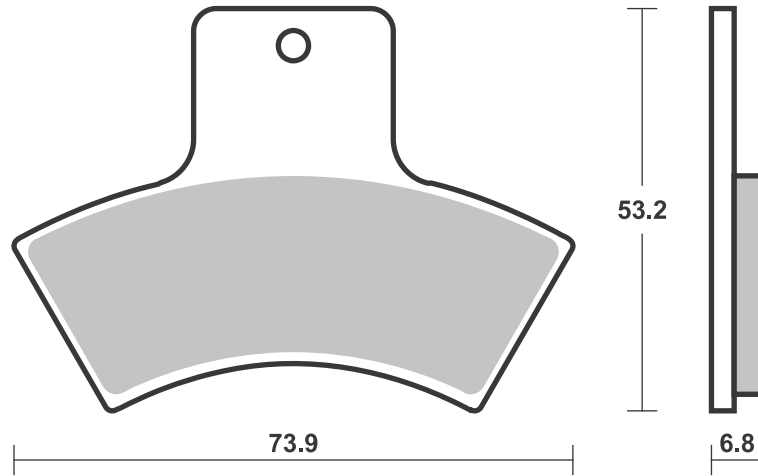



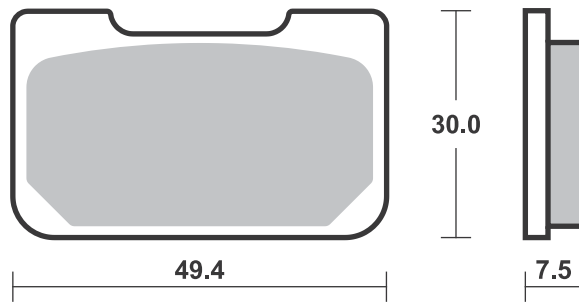
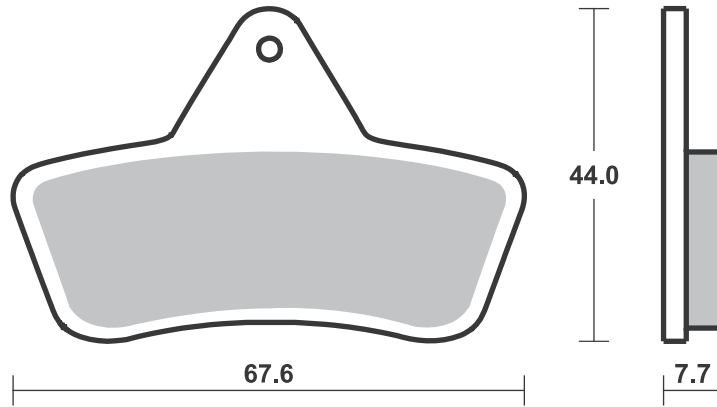

1 set = 4 pcs.

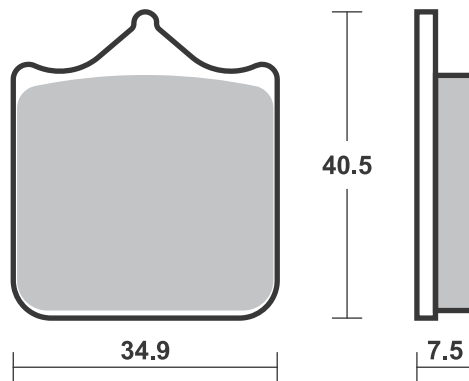

## Applications

### SBS 762 Recommended compound



| <b>BREMBO RACING CALIPERS</b>  |  |  |  |
|--------------------------------|--|--|--|
| Motard Axial XA32950,<br>P4 34 |  |  |  |

| <b>CAGIVA</b>  |       |  |           |
|----------------|-------|--|-----------|
| 1000 X3 Raptor | 04    |  | <b>HS</b> |
| 1000 X-Raptor  | 03-04 |  | <b>HS</b> |

| <b>DERBI</b>         |       |  |           |
|----------------------|-------|--|-----------|
| 659 Mulhacen         | 06-07 |  | <b>HS</b> |
| 659 Mulhacen<br>Cafe | 08    |  | <b>HS</b> |

| <b>DUCATI</b>       |       |  |           |
|---------------------|-------|--|-----------|
| 748 R               | 01-02 |  | <b>HS</b> |
| 749 , S             | 03-07 |  | <b>HS</b> |
| 749 R               | 04-07 |  | <b>HS</b> |
| 996 R               | 01    |  | <b>HS</b> |
| 998 Monster<br>S4Rs | 06    |  | <b>HS</b> |
| 998 R               | 02    |  | <b>HS</b> |
| 999 , S             | 03-07 |  | <b>HS</b> |
| 999 Monster S4R     | 07-08 |  | <b>HS</b> |
| 999 Monster<br>S4RS | 07-08 |  | <b>HS</b> |
| 999 R               | 03-07 |  | <b>HS</b> |
| 1000 Hypermotard    | 06    |  | <b>HS</b> |

| <b>GILERA</b>  |    |  |           |
|----------------|----|--|-----------|
| 600 Supersport | 02 |  | <b>HS</b> |

| <b>HUSQVARNA</b>  |       |  |           |
|-------------------|-------|--|-----------|
| SMR 449           | 11-13 |  | <b>RS</b> |
| SM 450 R          | 05-13 |  | <b>RS</b> |
| SM 450 RR         | 06-10 |  | <b>RS</b> |
| SM 510 Centennial | 06    |  | <b>RS</b> |
| SM 510 R          | 05-10 |  | <b>RS</b> |
| SMR 511           | 11-13 |  | <b>RS</b> |
| SM 610 ie         | 07-10 |  | <b>RS</b> |
| SM 630            | 10    |  | <b>HS</b> |
| STR 650 CRC       | 07    |  | <b>HF</b> |
| SM 701 Supermoto  | 15-18 |  | <b>HS</b> |

| <b>HYOSUNG</b> |       |  |           |
|----------------|-------|--|-----------|
| RX 450 SM      | 08-11 |  | <b>HS</b> |



| <b>KTM</b>          |       |  |           |
|---------------------|-------|--|-----------|
| 690 Duke            | 08-11 |  | <b>HS</b> |
| 690 Duke R          | 10-11 |  | <b>HS</b> |
| 690 SM              | 07-11 |  | <b>HS</b> |
| 690 SMC             | 08-10 |  | <b>HS</b> |
| 690 Supermoto<br>R  | 08-09 |  | <b>HS</b> |
| 950 SM              | 05-07 |  | <b>HS</b> |
| 950 SM R            | 07-09 |  | <b>HS</b> |
| 990 Super Duke      | 04-13 |  | <b>HS</b> |
| 990 Super Duke<br>R | 09-13 |  | <b>HS</b> |
| 990 Supermoto       | 07-11 |  | <b>HS</b> |
| 990 Supermoto T     | 09-13 |  | <b>HS</b> |

| <b>LAVERDA</b> |    |  |           |
|----------------|----|--|-----------|
| SFC 1000       | 04 |  | <b>HS</b> |

| <b>MONDIAL</b>   |       |  |           |
|------------------|-------|--|-----------|
| 1000 EVO         | 04    |  | <b>HS</b> |
| 1000 Piega       | 03-04 |  | <b>HS</b> |
| 1000 RZ Nuda     | 04    |  | <b>HS</b> |
| 1000 Starfighter | 04    |  | <b>HS</b> |

| <b>MOTO-GUZZI</b>    |       |  |           |
|----------------------|-------|--|-----------|
| 1200 MGS-01<br>Corsa | 05-13 |  | <b>SP</b> |

| <b>MOTO-MORINI</b> |    |  |           |
|--------------------|----|--|-----------|
| 1200 Granferro     | 10 |  | <b>HS</b> |

| <b>MV AGUSTA</b> |       |  |           |
|------------------|-------|--|-----------|
| 1000 F4 R        | 06-07 |  | <b>HS</b> |

| <b>NORTON</b>              |       |  |           |
|----------------------------|-------|--|-----------|
| 961 Commando<br>Cafe Racer | 11-14 |  | <b>HS</b> |
| 961 Commando<br>SE         | 12-14 |  | <b>HS</b> |
| 961 Commando<br>SF         | 13-15 |  | <b>HS</b> |

| <b>SHERCO</b>              |    |  |           |
|----------------------------|----|--|-----------|
| SM 450 4.5i<br>Supermotard | 06 |  | <b>RS</b> |



| <b>SWM</b>      |       |  |           |
|-----------------|-------|--|-----------|
| 440 Gran Milano | 18-   |  | <b>HS</b> |
| SM 450 R        | 15-17 |  | <b>HS</b> |
| SM 500 R        | 18-   |  | <b>HS</b> |
| 650 Superdual   | 15-18 |  | <b>HS</b> |

| <b>TM</b> |    |  |           |
|-----------|----|--|-----------|
| SMX 450 F | 04 |  | <b>RS</b> |
| SMX 660 F | 04 |  | <b>RS</b> |

| <b>TRIUMPH</b>    |       |  |           |
|-------------------|-------|--|-----------|
| 1050 Speed 94     | 15-16 |  | <b>HS</b> |
| 1050 Speed Triple | 08-15 |  | <b>HS</b> |

### SBS 763 Recommended compound



| <b>MV AGUSTA</b>          |       |  |           |
|---------------------------|-------|--|-----------|
| 675 F3                    | 11-12 |  | <b>LS</b> |
| 750 Brutale,<br>Brutale S | 01-05 |  | <b>LS</b> |
| 750 F4 SPR                | 01-03 |  | <b>LS</b> |
| 750 F4/F4S                | 99-02 |  | <b>LS</b> |
| 800 F3                    | 14-17 |  | <b>LS</b> |
| 910 Brutale               | 06-08 |  | <b>LS</b> |
| 910 Brutale R             | 06-08 |  | <b>LS</b> |
| 910 Brutale S             | 06-08 |  | <b>LS</b> |
| 920 Brutale               | 12-14 |  | <b>LS</b> |
| 989 Brutale R             | 09    |  | <b>LS</b> |
| 990 Brutale R             | 10-11 |  | <b>LS</b> |
| 1000 F4 LH44              | 18-   |  | <b>LS</b> |
| 1000 F4 Mamba             | 04-06 |  | <b>LS</b> |
| 1000 F4 R                 | 06-07 |  | <b>LS</b> |
| 1000 F4 R                 | 12-15 |  | <b>LS</b> |
| 1000 F4 RC                | 15-18 |  | <b>LS</b> |
| 1000 F4 RR                | 12-17 |  | <b>LS</b> |



| <b>MV AGUSTA</b>   |       |  |           |
|--------------------|-------|--|-----------|
| 1000 F4 Tamburini  | 04-06 |  | <b>LS</b> |
| 1000 F4S           | 04-06 |  | <b>LS</b> |
| 1078 Brutale RR    | 09    |  | <b>LS</b> |
| 1078 F4 CC         | 08-11 |  | <b>LS</b> |
| 1078 F4 RR         | 08-11 |  | <b>LS</b> |
| 1090 Brutale Corse | 14-16 |  | <b>LS</b> |
| 1090 Brutale R     | 12-15 |  | <b>LS</b> |
| 1090 Brutale RR    | 10-17 |  | <b>LS</b> |



1 set = 4 pcs.

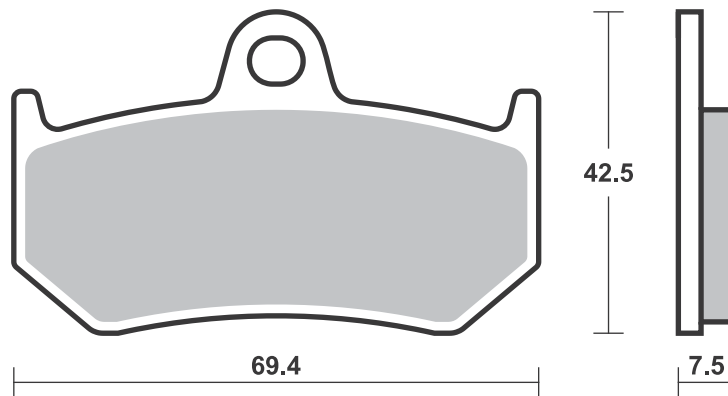
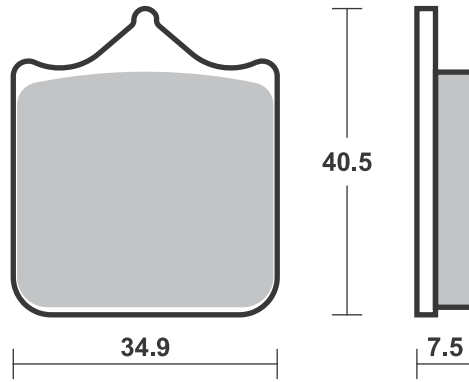



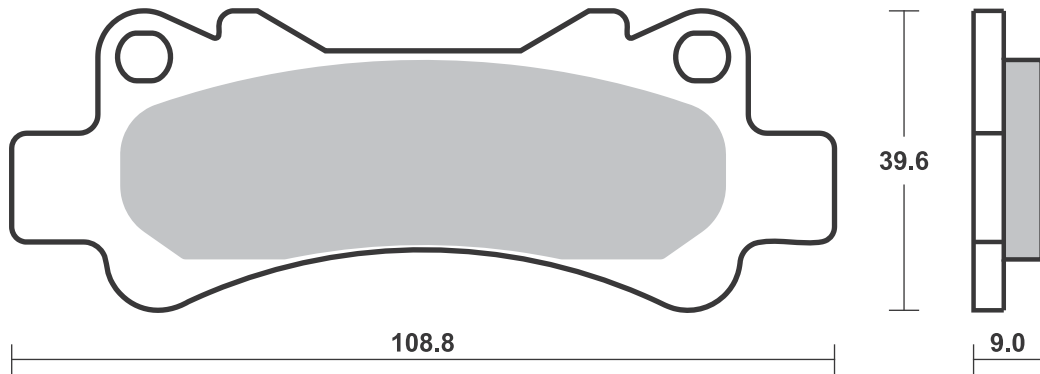
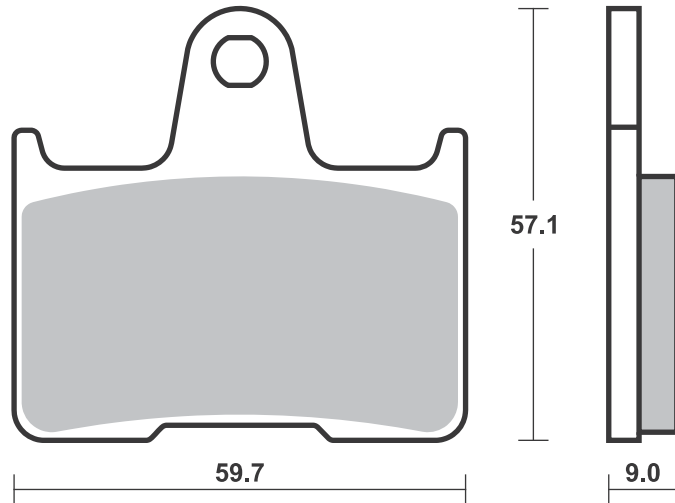

## SBS 767

## Recommended compound

**BOMBARDIER**

|    |                 |       |    |
|----|-----------------|-------|----|
| DS | 250 Right       | 06    | SI |
|    | 330 Outlander   |       |    |
|    | Right           | 03-06 | SI |
|    | 400 Outlander   |       |    |
|    | Max Right       | 03-06 | SI |
|    | 400 Outlander   |       |    |
|    | Right           | 03-06 | SI |
|    | 500 Quest Right | 02-06 | SI |
|    | 500 Traxter 4x4 |       |    |
|    | Left/Rear       | 01-06 | SI |
|    | 500 Traxter 4x4 |       |    |
|    | Right           | 01-06 | SI |
|    | 500 Traxter Max |       |    |
|    | Left/Rear       | 03-05 | SI |
|    | 500 Traxter Max |       |    |
|    | Right           | 03-05 | SI |
|    | 650 Quest Max   |       |    |
|    | Left/Rear       | 03-06 | SI |
|    | 650 Quest Max   |       |    |
|    | Right           | 03-06 | SI |
|    | 650 Quest Right | 02-06 | SI |
|    | 650 Traxter Max |       |    |
|    | Left/Rear       | 03-05 | SI |
|    | 650 Traxter Max |       |    |
|    | Right           | 03-05 | SI |
| DS | 650 Right       | 01-06 | SI |
|    | 800 Outlander   |       |    |
|    | Right           | 06    | SI |
|    | 800 Outlander   |       |    |
|    | XT Right        | 06    | SI |

**CAN-AM**

|  |               |       |    |
|--|---------------|-------|----|
|  | 400 Outlander |       |    |
|  | Efi Right     | 09-14 | SI |
|  | 400 Outlander |       |    |
|  | MAX STD       |       |    |
|  | Right         | 07-13 | SI |
|  | 400 Outlander |       |    |
|  | MAX XT        |       |    |
|  | Right         | 07-13 | SI |
|  | 400 Outlander |       |    |
|  | STD Right     | 07-14 | SI |
|  | 400 Outlander |       |    |
|  | XT Right      | 07-14 | SI |
|  | 500 Outlander |       |    |
|  | MAX STD       |       |    |
|  | Right         | 07-12 | SI |
|  | 500 Outlander |       |    |
|  | MAX XT        |       |    |
|  | Right         | 07-12 | SI |
|  | 500 Outlander |       |    |
|  | STD Right     | 07-12 | SI |
|  | 500 Outlander |       |    |
|  | XT Right      | 07-12 | SI |
|  | 500 Renegade  |       |    |
|  | Right         | 08-11 | SI |
|  | 650 Outlander |       |    |
|  | MAX STD       |       |    |
|  | Right         | 07-12 | SI |
|  | 650 Outlander |       |    |
|  | MAX XT        |       |    |
|  | Right         | 07-12 | SI |
|  | 650 Outlander |       |    |
|  | STD Right     | 07-12 | SI |
|  | 650 Outlander |       |    |
|  | XT Right      | 07-12 | SI |
|  | 800 Outlander |       |    |
|  | MAX LTD       |       |    |
|  | Right         | 07-11 | SI |

**CAN-AM**

|  |                |       |    |
|--|----------------|-------|----|
|  | 800 Outlander  |       |    |
|  | MAX STD        |       |    |
|  | Right          | 07-11 | SI |
|  | 800 Outlander  |       |    |
|  | MAX XT         |       |    |
|  | Right          | 07-11 | SI |
|  | 800 Outlander  |       |    |
|  | STD Right      | 07-11 | SI |
|  | 800 Outlander  |       |    |
|  | XT Right       | 07-11 | SI |
|  | 800 Renegade   |       |    |
|  | Efi Right      | 07-11 | SI |
|  | 800 Renegade   |       |    |
|  | Right          | 08-11 | SI |
|  | 800 Renegade   |       |    |
|  | X Right        | 08-11 | SI |
|  | 1000 Commander |       |    |
|  | MAX Right      | 14-16 | SI |
|  | 1000 Maverick  |       |    |
|  | Right          | 13-17 | SI |

**CANNONDALE**

|  |                  |    |    |
|--|------------------|----|----|
|  | 440 Blaze Right  | 03 | SI |
|  | 440 Cannibal     |    |    |
|  | Right            | 03 | SI |
|  | 440 Glamis Right | 03 | SI |
|  | 440 Moto Right   | 03 | SI |
|  | 440 Speed Right  | 03 | SI |

**JOHN DEERE**

|  |                |    |    |
|--|----------------|----|----|
|  | 500 Buck EX,   |    |    |
|  | EXT            |    |    |
|  | Left/Rear      | 05 | SI |
|  | 500 Buck EX,   |    |    |
|  | EXT Right      | 05 | SI |
|  | 500 Buck       |    |    |
|  | Left/Rear      | 05 | SI |
|  | 500 Buck Right | 05 | SI |
|  | 500 Trail Buck |    |    |
|  | Left/Rear      | 05 | SI |
|  | 500 Trail Buck |    |    |
|  | Right          | 05 | SI |
|  | 650 Trail Buck |    |    |
|  | EX, EXT        |    |    |
|  | Left/Rear      | 05 | SI |
|  | 650 Trail Buck |    |    |
|  | EX, EXT        |    |    |
|  | Right          | 05 | SI |
|  | 650 Trail Buck |    |    |
|  | Left/Rear      | 05 | SI |
|  | 650 Trail Buck |    |    |
|  | Right          | 05 | SI |

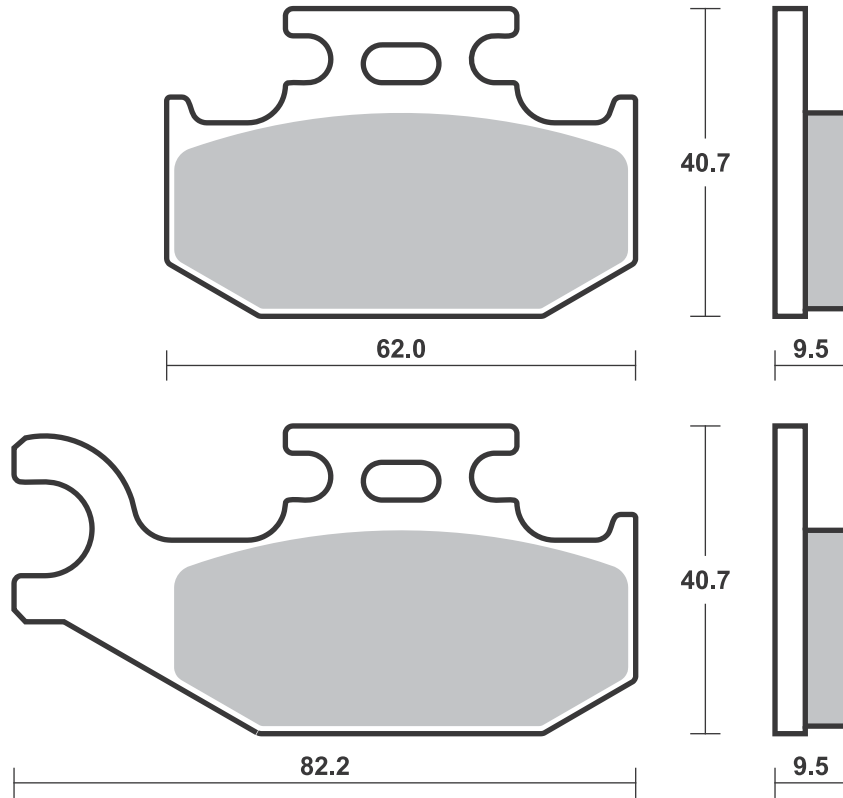

**SBS 769** Recommended compound



| <b>HYOSUNG</b> |                                     |       |           |
|----------------|-------------------------------------|-------|-----------|
| GV             | 650 Aguilã                          | 04-05 | <b>HF</b> |
| <b>YAMAHA</b>  |                                     |       |           |
| TDM            | 900                                 | 02-14 | <b>LS</b> |
| SCR            | 950 Scrambler                       | 17-18 | <b>LS</b> |
| XV             | 950 Bolt                            | 14-18 | <b>LS</b> |
| XV             | 950 Bolt C-Spec                     | 15-18 | <b>LS</b> |
| XV             | 950 Bolt Racer                      | 17-18 | <b>LS</b> |
| XV             | 950 Bolt R-Spec                     | 14-18 | <b>LS</b> |
| XVS            | 950 A Midnight<br>Star              | 09-13 | <b>LS</b> |
| XT             | 1200 Z Super<br>Tenere              | 14-18 | <b>LS</b> |
| XT             | 1200 ZE Super<br>Tenere             | 14-18 | <b>LS</b> |
| XT             | 1200 ZE Super<br>Tenere<br>Raid Ed. | 18-   | <b>LS</b> |

| <b>YAMAHA</b> |                              |       |           |
|---------------|------------------------------|-------|-----------|
| XTZ           | 1200 Super Tenere            | 10-13 | <b>LS</b> |
| FJR           | 1300                         | 01-03 | <b>LS</b> |
| FJR           | 1300 A                       | 13-18 | <b>LS</b> |
| FJR           | 1300 ABS                     | 03-12 | <b>LS</b> |
| FJR           | 1300 AE                      | 16-18 | <b>LS</b> |
| FJR           | 1300 AS                      | 13-18 | <b>LS</b> |
| XVS           | 1300 A Midnight<br>Star      | 07-11 | <b>LS</b> |
| XVS           | 1300 Custom                  | 14-16 | <b>LS</b> |
| XVS           | 1300 Stryker                 | 11-14 | <b>LS</b> |
| VMX           | 1700 V-Max                   | 09-16 | <b>LS</b> |
| XV            | 1700 PC Road<br>Star Warrior | 03-07 | <b>LS</b> |
| XV            | 1900 A                       | 11    | <b>LS</b> |
| XV            | 1900 A Midnight<br>Star      | 06-10 | <b>LS</b> |

**SBS 770** Recommended compound



| <b>YAMAHA</b> |            |       |           |
|---------------|------------|-------|-----------|
| FZS           | 1000 Fazer | 01-05 | <b>LS</b> |
| XJR           | 1300       | 02-18 | <b>LS</b> |
| XJR           | 1300 Racer | 15-18 | <b>LS</b> |
|               |            |       |           |
|               |            |       |           |
|               |            |       |           |
|               |            |       |           |
|               |            |       |           |
|               |            |       |           |
|               |            |       |           |
|               |            |       |           |
|               |            |       |           |
|               |            |       |           |
|               |            |       |           |

**SBS 771** Recommended compound



| <b>BERINGER</b>  |  |  |  |
|------------------|--|--|--|
| 6 Piston Caliper |  |  |  |
|                  |  |  |  |
|                  |  |  |  |
|                  |  |  |  |
|                  |  |  |  |
|                  |  |  |  |
|                  |  |  |  |
|                  |  |  |  |
|                  |  |  |  |
|                  |  |  |  |
|                  |  |  |  |
|                  |  |  |  |

Brake Pad 1:1 Drawings, Compounds, Fitments

Available compounds **HF • LS**

**SBS 769**

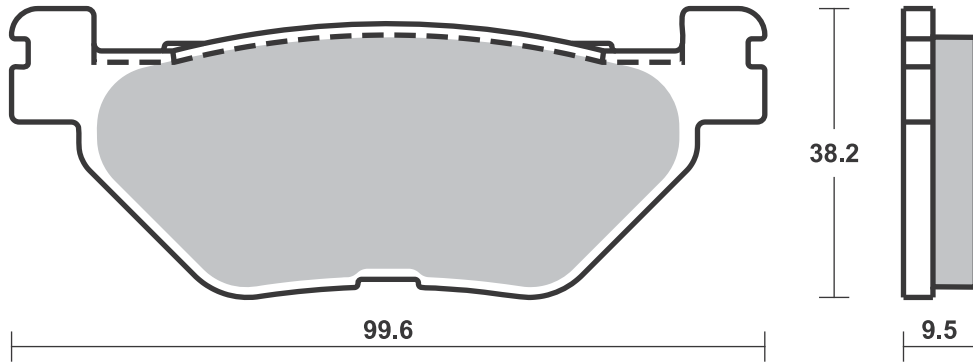

Available compounds **HF • LS**

**SBS 770**

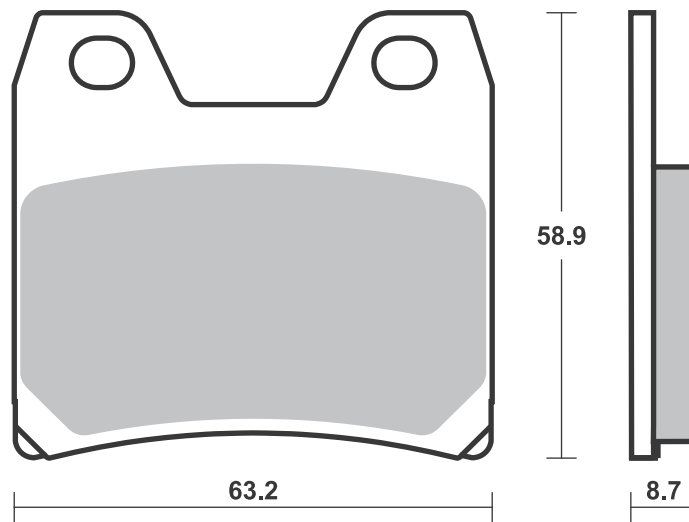

Available compounds **HF • HS • RS • RQ**

**SBS 771**

1 set = 6 pcs.

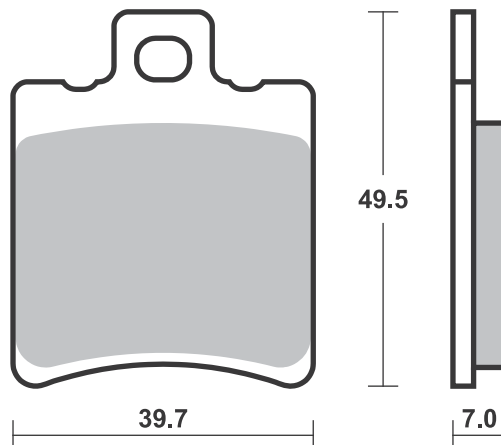





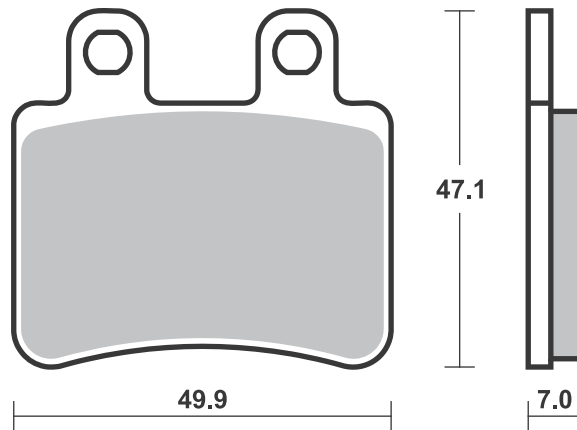
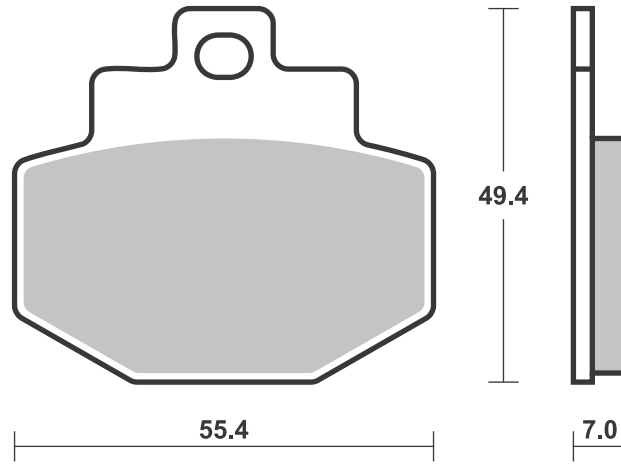

**SBS 774** Recommended compound

| <b>AJP</b> |                 |       |           |
|------------|-----------------|-------|-----------|
| PR3        | 125 Enduro      | 08-12 | <b>HF</b> |
| PR3        | 125 Supermotard | 08-12 | <b>HF</b> |
| MX         | 200             | 09-11 | <b>HF</b> |
| PR3        | 200 Enduro      | 08-12 | <b>HF</b> |
| PR3        | 200 Supermotard | 08-12 | <b>HF</b> |

| <b>BETA</b> |                 |       |           |
|-------------|-----------------|-------|-----------|
|             | 125 M4          | 06    | <b>HF</b> |
|             | 125 Urban       | 10-15 | <b>HF</b> |
| ALP         | 125 4-stroke    | 06-09 | <b>HF</b> |
| RR          | 125 Enduro 4T   | 10-15 | <b>HF</b> |
| RR          | 125 Supermotard | 08-09 | <b>HF</b> |
|             | 200 Urban       | 10    | <b>HF</b> |
| ALP         | 200 4-stroke    | 06    | <b>HF</b> |
| ALP         | 350 4.0         | 04-06 | <b>HF</b> |

| <b>DERBI</b> |                |       |           |
|--------------|----------------|-------|-----------|
|              | 125 Mulhacen   | 07    | <b>HF</b> |
|              | 125 Senda R 4T | 04-12 | <b>HF</b> |
|              | 125 Senda      |       |           |
|              | X-Treme        |       |           |
|              | SM 4T          | 04-05 | <b>HF</b> |

| <b>FANTIC</b> |               |    |           |
|---------------|---------------|----|-----------|
|               | 125 Regolarna |    |           |
|               | Casa          | 08 | <b>HF</b> |
|               | 125 Supersei  |    |           |
|               | Motard        | 08 | <b>HF</b> |

| <b>GAS GAS</b> |             |       |           |
|----------------|-------------|-------|-----------|
|                | 125 Pampera | 04-13 | <b>HF</b> |



| <b>GAS GAS</b> |             |       |           |
|----------------|-------------|-------|-----------|
|                | 250 Pampera | 02-13 | <b>HF</b> |
|                | 280 Pampera | 04-08 | <b>HF</b> |

| <b>HM</b> |    |       |           |
|-----------|----|-------|-----------|
| CRE       | 50 | 06-13 | <b>HF</b> |

| <b>KEEWAY</b> |            |       |           |
|---------------|------------|-------|-----------|
|               | 125 Enduro | 07-08 | <b>HF</b> |
|               | 125 X-Ray  | 07-08 | <b>HF</b> |

| <b>SHERCO</b> |           |       |           |
|---------------|-----------|-------|-----------|
| SE            | 125 1.25F | 10-12 | <b>HF</b> |

| <b>YAMAHA</b> |             |       |           |
|---------------|-------------|-------|-----------|
| XT            | 125 X       |       |           |
|               | Supermotard | 05-13 | <b>HF</b> |

**SBS 775** Recommended compound

| <b>ARCTIC CAT</b> |         |       |           |
|-------------------|---------|-------|-----------|
|                   | 250 DVX | 06-09 | <b>SI</b> |
|                   | 300 DVX | 09-16 | <b>SI</b> |

| <b>GILERA</b> |            |       |           |
|---------------|------------|-------|-----------|
|               | 250 Oregon |       |           |
|               | Quad       | 07-11 | <b>SI</b> |

| <b>KYMCO</b> |                |       |           |
|--------------|----------------|-------|-----------|
|              | 250 MXU        | 06-14 | <b>SI</b> |
|              | 250 Urban Quad | 06    | <b>SI</b> |
| KXR          | 250            | 04-14 | <b>SI</b> |
|              | 300 Maxxer     | 06-13 | <b>SI</b> |
|              | 300 Maxxer     |       |           |
|              | Supermoto      | 15    | <b>SI</b> |

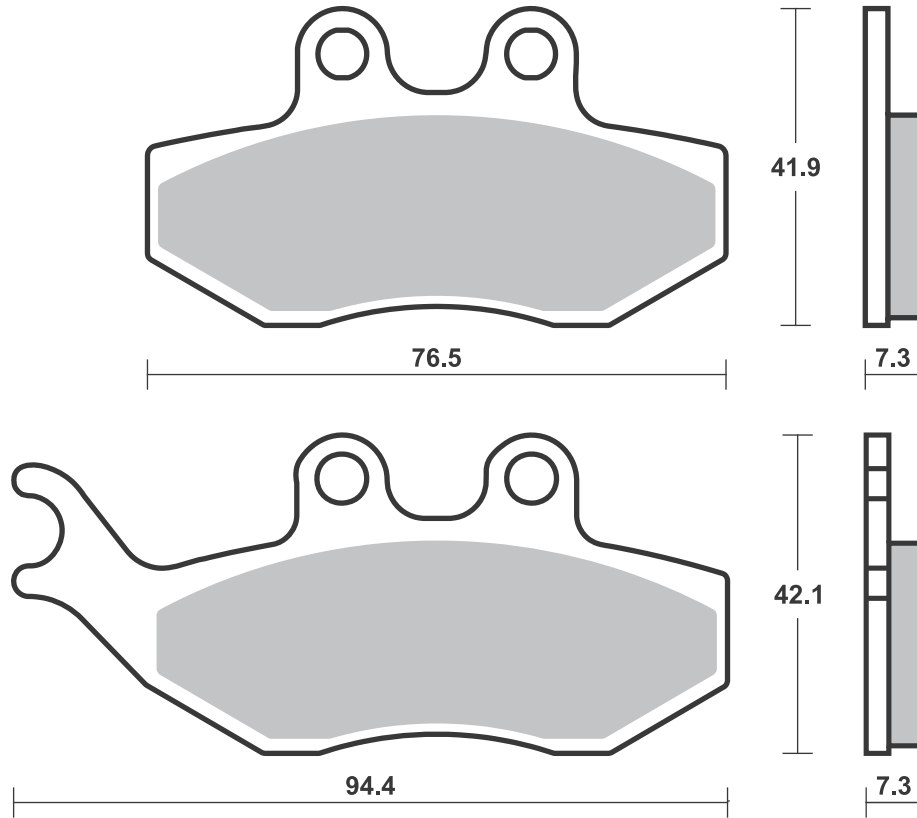

1 set = 4 pcs.

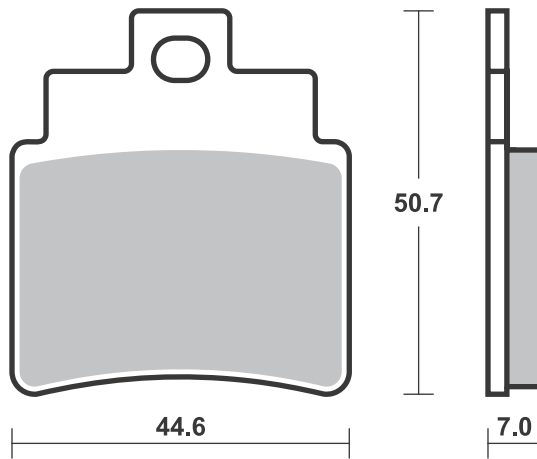

## Applications

### SBS 777 Recommended compound



| <b>BRAKING</b>        |                 |       |            |
|-----------------------|-----------------|-------|------------|
| Rear cross (1 piston) |                 |       |            |
| <b>FANTIC</b>         |                 |       |            |
| 125 Caballero         |                 |       |            |
| Enduro 2T             | 12-10           |       | <b>HF</b>  |
| 125 Caballero         |                 |       |            |
| Motard 2T             | 10              |       | <b>HF</b>  |
| 125 Caballero         |                 |       |            |
| Motard 4T             | 10              |       | <b>HF</b>  |
| 125 Caballero         |                 |       |            |
| Regularita 4T         | 10              |       | <b>HF</b>  |
| 200 Caballero         |                 |       |            |
| Motard 4T             | 10              |       | <b>HF</b>  |
| 200 Caballero         |                 |       |            |
| Regularita 4T         | 10              |       | <b>HF</b>  |
| 250 Enduro 4T         | 16-17           |       | <b>HF</b>  |
| <b>HM</b>             |                 |       |            |
| CR                    | 125 Supermotard | 04-06 | <b>RSI</b> |
| CRE                   | 125 Enduro      | 02-06 | <b>SI</b>  |
| CRM                   | 125 X           |       |            |
|                       | Supermotard     | 07    | <b>RSI</b> |
| CRE                   | 250 Enduro      | 02-03 | <b>SI</b>  |
| CRE                   | 250 F Enduro    | 04-13 | <b>SI</b>  |
| CRE                   | 250 Supermotard | 04-07 | <b>RSI</b> |
| CRE                   | 250 X Enduro    | 04-13 | <b>SI</b>  |
| CRF                   | 250 Supermotard | 04-06 | <b>RSI</b> |
| CRM                   | 250 X           |       |            |
|                       | Supermotard     | 07-13 | <b>RSI</b> |
| CRE                   | 450 F Enduro    | 02-13 | <b>SI</b>  |
| CRE                   | 450 X Enduro    | 04-13 | <b>SI</b>  |



| <b>HM</b>      |                 |       |            |
|----------------|-----------------|-------|------------|
| CRF            | 450 Supermotard | 02-06 | <b>RSI</b> |
| CRM            | 450 X           |       |            |
|                | Supermotard     | 07-13 | <b>RSI</b> |
| CRM            | 500 X           |       |            |
|                | Supermotard     | 07-13 | <b>RSI</b> |
| <b>HONDA</b>   |                 |       |            |
| CR             | 125 R           | 02-07 | <b>RSI</b> |
| CRE            | 125             | 02-07 | <b>SI</b>  |
| CRE            | 125 RR          | 11    | <b>SI</b>  |
| CRF            | 150 R           | 07-18 | <b>RSI</b> |
| CR             | 250 R           | 02-07 | <b>RSI</b> |
| CRE            | 250             | 02-07 | <b>SI</b>  |
| CRE            | 250 F           | 04    | <b>SI</b>  |
| CRF            | 250 R           | 04-09 | <b>RSI</b> |
| CRF            | 250 R Efi       | 10-17 | <b>RSI</b> |
| CRF            | 250 R Efi       | 18-   | <b>RSI</b> |
| CRF            | 250 X           | 04-14 | <b>SI</b>  |
| CRE            | 450 F           | 02-06 | <b>SI</b>  |
| CRF            | 450 Efi         | 09-12 | <b>RSI</b> |
| CRF            | 450 R           | 02-08 | <b>RSI</b> |
| CRF            | 450 R Efi       | 13-18 | <b>RSI</b> |
| CRF            | 450 RX Efi      | 17-18 | <b>SI</b>  |
| CRF            | 450 X           | 05-18 | <b>SI</b>  |
| <b>MEGELLI</b> |                 |       |            |
|                | 125 M, R, S     | 08-10 | <b>HF</b>  |
| <b>SUZUKI</b>  |                 |       |            |
| RME            | 50              | 10    | <b>HF</b>  |



| <b>TM</b> |    |       |            |
|-----------|----|-------|------------|
| MX        | 85 | 13-18 | <b>RSI</b> |
| SM        | 85 | 18-   | <b>RSI</b> |

### SBS 778 Recommended compound



| <b>BMW</b> |                 |       |           |
|------------|-----------------|-------|-----------|
| R          | 850 R           | 03-07 | <b>HS</b> |
| R          | 1100 S With     |       |           |
|            | Integral ABS    | 01-05 | <b>HS</b> |
| R          | 1150 GS         |       |           |
|            | (Brembo cal.)   | 02-05 | <b>HS</b> |
| R          | 1150 R          | 01-06 | <b>HS</b> |
| R          | 1150 R Rockster | 03-05 | <b>HS</b> |
| R          | 1150 RS         | 01-04 | <b>HS</b> |
| K          | 1200 LT With    |       |           |
|            | Integral ABS    | 01-08 | <b>HS</b> |
| K          | 1200 R          | 05-08 | <b>HS</b> |
| K          | 1200 R Sport    | 05-07 | <b>HS</b> |
| R          | 1200 C Classic  | 03-04 | <b>HS</b> |
| R          | 1200 C          |       |           |
|            | Independent     | 03-04 | <b>HS</b> |
| R          | 1200 C Montauk  | 02-04 | <b>HS</b> |
| R          | 1200 CL         | 03-04 | <b>HS</b> |
| R          | 1200 R          | 07-14 | <b>HS</b> |
| K          | 1300 R          | 09-15 | <b>SP</b> |
| K          | 1300 R Dynamic  | 11-15 | <b>SP</b> |
| K          | 1600 B          | 17-18 | <b>HS</b> |
| K          | 1600 Grand      |       |           |
|            | America         | 18-   | <b>HS</b> |
| K          | 1600 GT         | 11-18 | <b>HS</b> |
| K          | 1600 GTL        | 11-18 | <b>HS</b> |

Brake Pad 1:1 Drawings, Compounds, Fitments

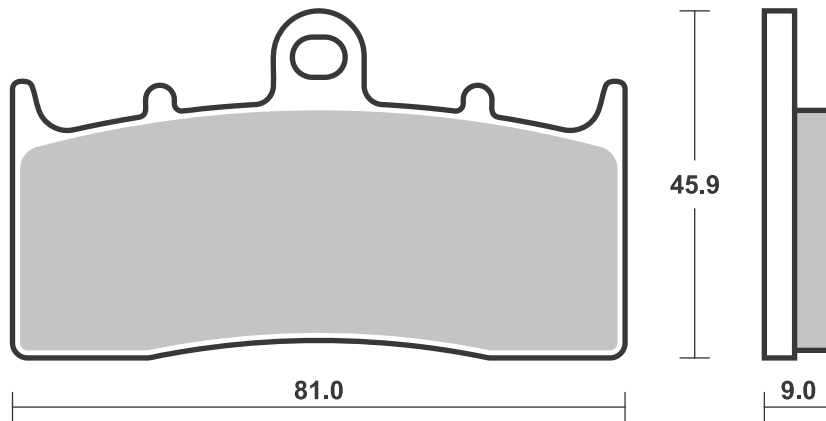
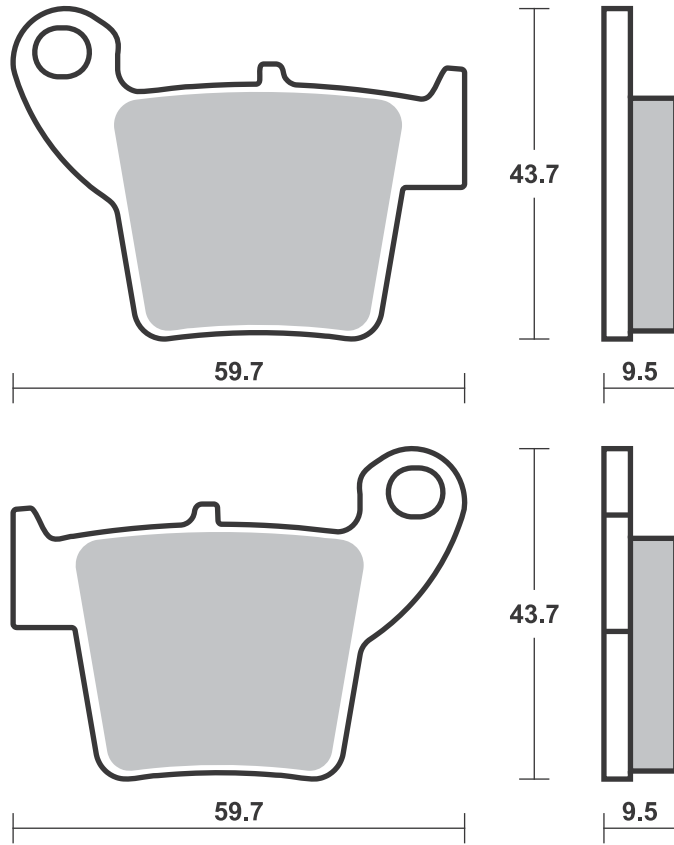

**SBS 779**

**Recommended compound**



|                    |  |
|--------------------|--|
| <b>BERINGER</b>    |  |
| 6 Piston Endurance |  |
| Caliper            |  |
|                    |  |
|                    |  |
|                    |  |
|                    |  |
|                    |  |
|                    |  |
|                    |  |
|                    |  |
|                    |  |
|                    |  |
|                    |  |
|                    |  |
|                    |  |
|                    |  |
|                    |  |
|                    |  |
|                    |  |
|                    |  |
|                    |  |
|                    |  |
|                    |  |
|                    |  |
|                    |  |
|                    |  |
|                    |  |
|                    |  |
|                    |  |
|                    |  |
|                    |  |
|                    |  |
|                    |  |
|                    |  |
|                    |  |
|                    |  |
|                    |  |
|                    |  |
|                    |  |
|                    |  |
|                    |  |

**SBS 780**

**Recommended compound**



|               |        |       |    |  |
|---------------|--------|-------|----|--|
| <b>KEEWAY</b> |        |       |    |  |
| TX            | 125 SM | 10-16 | HF |  |
|               |        |       |    |  |
|               |        |       |    |  |
|               |        |       |    |  |
|               |        |       |    |  |
|               |        |       |    |  |
|               |        |       |    |  |
|               |        |       |    |  |
|               |        |       |    |  |
|               |        |       |    |  |
|               |        |       |    |  |
|               |        |       |    |  |
|               |        |       |    |  |
|               |        |       |    |  |
|               |        |       |    |  |
|               |        |       |    |  |
|               |        |       |    |  |
|               |        |       |    |  |
|               |        |       |    |  |
|               |        |       |    |  |
|               |        |       |    |  |
|               |        |       |    |  |
|               |        |       |    |  |
|               |        |       |    |  |
|               |        |       |    |  |
|               |        |       |    |  |
|               |        |       |    |  |
|               |        |       |    |  |
|               |        |       |    |  |
|               |        |       |    |  |
|               |        |       |    |  |
|               |        |       |    |  |
|               |        |       |    |  |
|               |        |       |    |  |
|               |        |       |    |  |
|               |        |       |    |  |
|               |        |       |    |  |
|               |        |       |    |  |
|               |        |       |    |  |
|               |        |       |    |  |

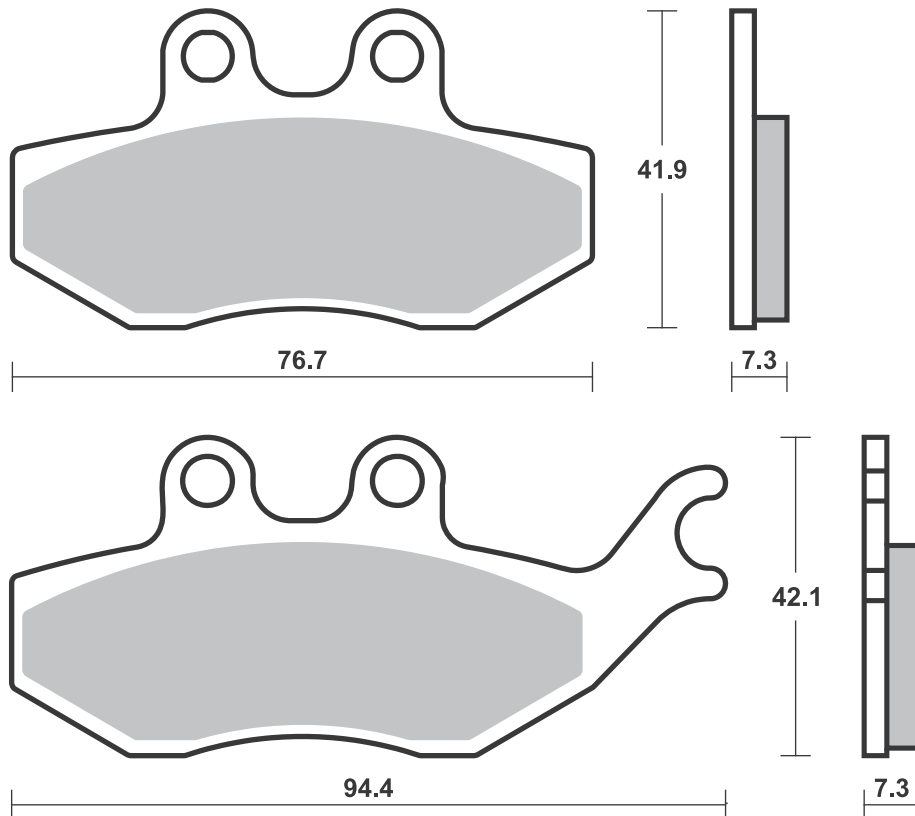
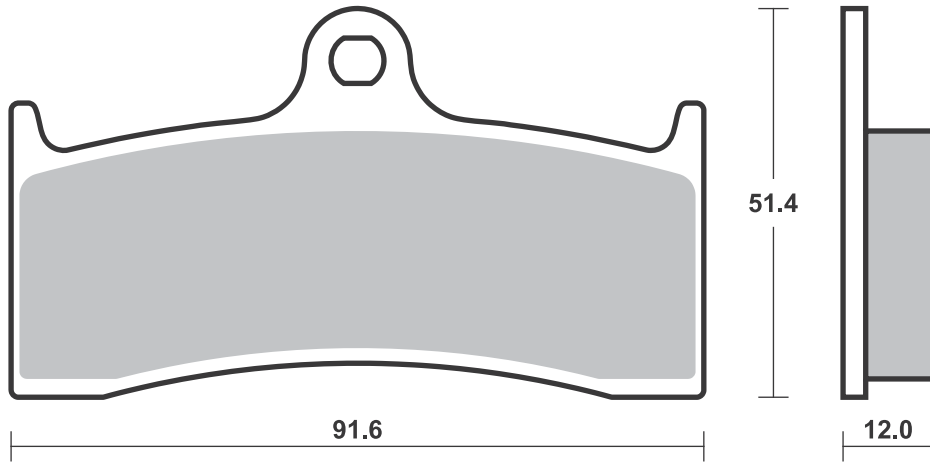

Applications

**SBS 782** Recommended compound



| <b>INDIAN</b>               |       |             |  |
|-----------------------------|-------|-------------|--|
| 1800 Chief                  | 15-18 | <b>H.HS</b> |  |
| 1800 Chief Classic          | 14-18 | <b>H.HS</b> |  |
| 1800 Chief Dark Horse       | 15-18 | <b>H.HS</b> |  |
| 1800 Chief Vintage          | 14-18 | <b>H.HS</b> |  |
| 1800 Chieftain              | 14-18 | <b>H.HS</b> |  |
| 1800 Chieftain Classic      | 15-18 | <b>H.HS</b> |  |
| 1800 Chieftain Dark Horse   | 15-18 | <b>H.HS</b> |  |
| 1800 Chieftain Limited      | 15-18 | <b>H.HS</b> |  |
| 1800 Dark Horse             | 16-18 | <b>H.HS</b> |  |
| 1800 Roadmaster             | 15-18 | <b>H.HS</b> |  |
| 1800 Roadmaster Classic     | 15-18 | <b>H.HS</b> |  |
| 1800 Roadmaster Elite       | 15-18 | <b>H.HS</b> |  |
| 1800 Springfield            | 16-18 | <b>H.HS</b> |  |
| 1800 Springfield Dark Horse | 15-18 | <b>H.HS</b> |  |
| <b>KAWASAKI</b>             |       |             |  |
| Z 800                       | 13-16 | <b>HS</b>   |  |
| Z 800 ABS                   | 13-16 | <b>HS</b>   |  |
| Z 800 e ABS                 | 13-16 | <b>HS</b>   |  |
| Z 900                       | 17-18 | <b>HS</b>   |  |
| ZX-9R 900 Ninja             | 02-03 | <b>HS</b>   |  |
| Z 1000                      | 03-06 | <b>HS</b>   |  |



| <b>MORIWAKI</b>           |       |             |  |
|---------------------------|-------|-------------|--|
| MD 250                    | 09    | #DC         |  |
| <b>SUZUKI</b>             |       |             |  |
| GSX-S 750                 | 17-18 | <b>HS</b>   |  |
| 1340 B-King               | 08-14 | <b>HS</b>   |  |
| <b>TRIUMPH</b>            |       |             |  |
| 675 Daytona               | 06-08 | <b>HS</b>   |  |
| 675 Street Triple R       | 09-17 | <b>HS</b>   |  |
| 675 Street Triple RX      | 15-16 | <b>HS</b>   |  |
| 1050 Speed Triple         | 05-07 | <b>HS</b>   |  |
| 1050 Tiger                | 07-13 | <b>HS</b>   |  |
| 1050 Tiger SE             | 09-13 | <b>HS</b>   |  |
| 1050 Tiger Sport          | 15-18 | <b>HS</b>   |  |
| <b>VICTORY</b>            |       |             |  |
| 1634 Hammer               | 08    | <b>H.HS</b> |  |
| 1634 Kingpin all models   | 08-12 | <b>H.HS</b> |  |
| 1634 Vegas                | 08-17 | <b>H.HS</b> |  |
| 1634 Vegas 8-Ball         | 08-17 | <b>H.HS</b> |  |
| 1634 Vegas Jackpot        | 08    | <b>H.HS</b> |  |
| 1731 Boardwalk            | 13-15 | <b>H.HS</b> |  |
| 1731 Cross Country        | 10-17 | <b>H.HS</b> |  |
| 1731 Cross Country 8-Ball | 14-16 | <b>H.HS</b> |  |



| <b>VICTORY</b>           |       |             |  |
|--------------------------|-------|-------------|--|
| 1731 Cross Country Tour  | 12-17 | <b>H.HS</b> |  |
| 1731 Cross Roads         | 10-12 | <b>H.HS</b> |  |
| 1731 Cross Roads 8-Ball  | 14    | <b>H.HS</b> |  |
| 1731 Cross Roads Classic | 14    | <b>H.HS</b> |  |
| 1731 Gunner              | 15-17 | <b>H.HS</b> |  |
| 1731 Hammer              | 09-11 | <b>H.HS</b> |  |
| 1731 Hammer 8-Ball       | 10-16 | <b>H.HS</b> |  |
| 1731 Hammer S            | 09-17 | <b>H.HS</b> |  |
| 1731 Hard-Ball           | 12-13 | <b>H.HS</b> |  |
| 1731 High-Ball           | 12-17 | <b>H.HS</b> |  |
| 1731 Jackpot             | 10-16 | <b>H.HS</b> |  |
| 1731 Judge               | 13-17 | <b>H.HS</b> |  |
| 1731 Kingpin             | 10-12 | <b>H.HS</b> |  |
| 1731 Kingpin 8-Ball      | 10-11 | <b>H.HS</b> |  |
| 1731 Magnum              | 15-17 | <b>H.HS</b> |  |
| 1731 Magnum X-1          | 15-17 | <b>H.HS</b> |  |
| 1731 Vegas               | 10-17 | <b>H.HS</b> |  |
| 1731 Vegas 8-Ball        | 10-17 | <b>H.HS</b> |  |
| 1731 Vegas Jackpot       | 09    | <b>H.HS</b> |  |

**SBS 783** Recommended compound



| <b>HUSQVARNA</b> |       |            |            |
|------------------|-------|------------|------------|
| CR 65            | 12-13 | <b>RSI</b> |            |
| TC 65            | 17-18 | <b>RSI</b> | <b>RSI</b> |
| <b>KTM</b>       |       |            |            |
| SX 65            | 02-08 | <b>RSI</b> |            |
| SX 65            | 09-18 | <b>RSI</b> | <b>RSI</b> |
| SX 85            | 04-10 | <b>RSI</b> | <b>RSI</b> |
| SX 85            | 11    | <b>RSI</b> |            |

Brake Pad 1:1 Drawings, Compounds, Fitments



HF / HS / SP - Th. 7.0  
RS / DC - Th. 8.3

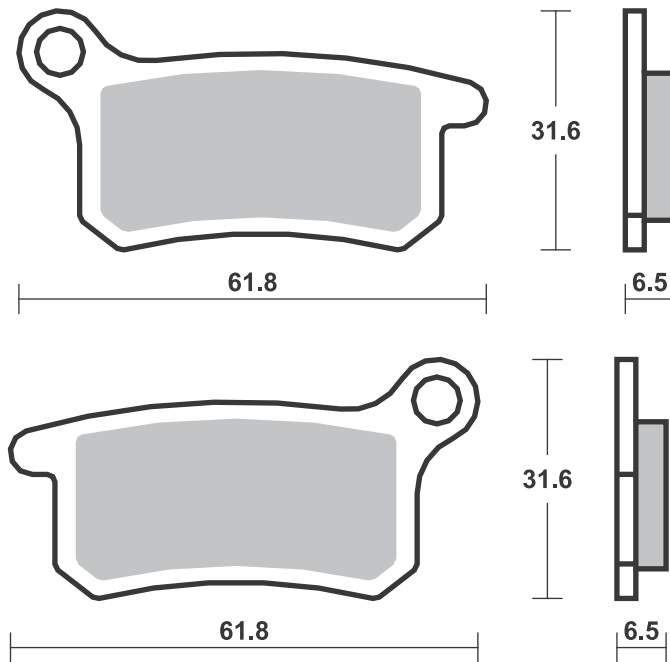
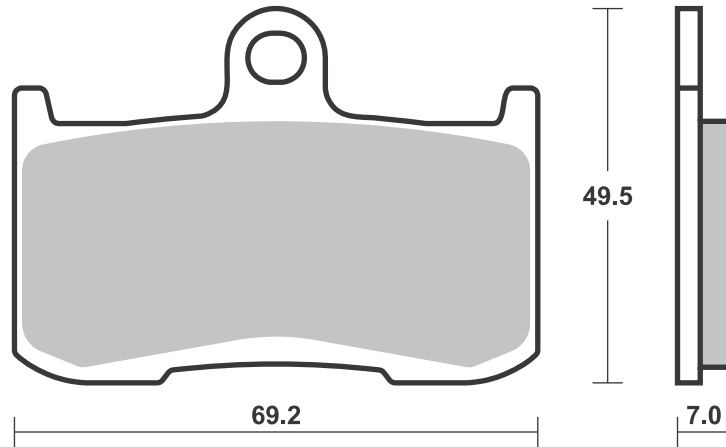

**SBS 784** Recommended compound



**CF MOTO**

|           |    |           |
|-----------|----|-----------|
| 125 Papio | 17 | <b>HF</b> |
|-----------|----|-----------|

**HONDA**

|           |       |           |
|-----------|-------|-----------|
| CBR 125 R | 03-10 | <b>HF</b> |
|-----------|-------|-----------|

|                  |       |           |
|------------------|-------|-----------|
| XLV 125 Varadero | 01-11 | <b>HF</b> |
|------------------|-------|-----------|

|           |       |           |
|-----------|-------|-----------|
| CBR 150 R | 00-10 | <b>HF</b> |
|-----------|-------|-----------|

**YAMAHA**

|             |    |           |
|-------------|----|-----------|
| YZF 150 R15 | 14 | <b>HF</b> |
|-------------|----|-----------|

**SBS 785** Recommended compound



**A.P. RACING CALIPERS**

|                        |  |  |
|------------------------|--|--|
| CP-4488 Two Pad Radial |  |  |
|------------------------|--|--|

|                    |  |  |
|--------------------|--|--|
| 4 Piston Monoblock |  |  |
|--------------------|--|--|

Brake Pad 1:1 Drawings,  
Compounds, Fitments

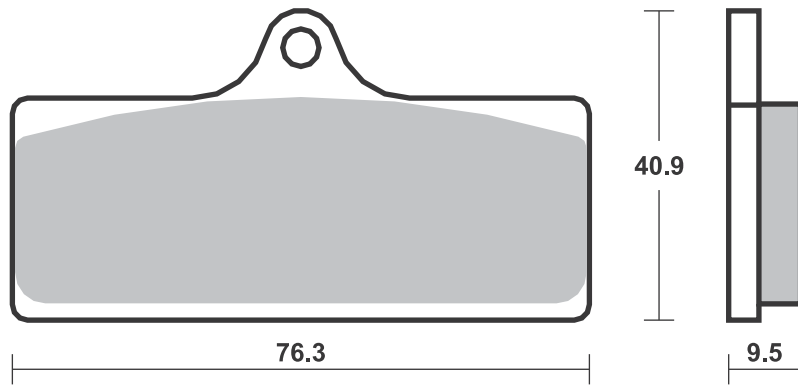
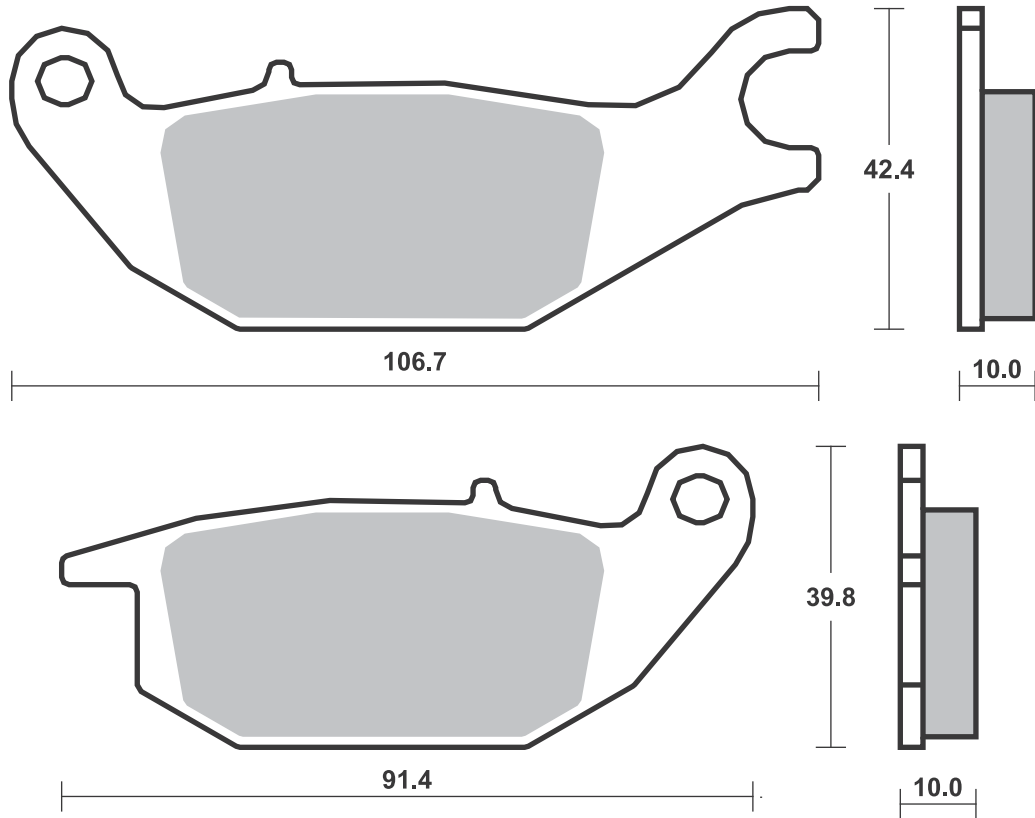

**SBS 787** Recommended compound



| <b>POLARIS</b> |       |  |            |
|----------------|-------|--|------------|
| 325 Xpedition  | 02    |  | <b>ATS</b> |
| 330 ATP        | 06-05 |  | <b>ATS</b> |
| 330 E Trail    |       |  |            |
| Blazer         | 08-12 |  | <b>ATS</b> |
| 330 Magnum     |       |  |            |
| 2x4, 4x4       | 03-13 |  | <b>ATS</b> |
| 450 Sportsman  | 06-09 |  | <b>ATS</b> |
| 500 E          |       |  |            |
| Scrambler      |       |  |            |
| 2x4, 4x4       | 08-11 |  | <b>ATS</b> |
| 500 Magnum     |       |  |            |
| 2x4, 4x4       | 02-07 |  | <b>ATS</b> |
| 500 Predator e | 06-13 |  | <b>ATS</b> |
| 500 Sportsman  |       |  |            |
| HO (to         |       |  |            |
| 15.12.2008)    | 03-08 |  | <b>ATS</b> |
| 600 Sportsman  | 03-06 |  | <b>ATS</b> |
| 700 Sportsman  | 02-09 |  | <b>ATS</b> |



| <b>POLARIS</b> |       |  |            |
|----------------|-------|--|------------|
| 700 Sportsman  |       |  |            |
| MV 700         | 05-06 |  | <b>ATS</b> |
| 800 Sportsman  |       |  |            |
| (to            |       |  |            |
| 15.12.2008)    | 05-08 |  | <b>ATS</b> |

**SBS 788** Recommended compound



| <b>DERBI</b> |    |  |           |
|--------------|----|--|-----------|
| 659 Mulhacen | 05 |  | <b>HS</b> |

| <b>KAWASAKI</b> |            |       |           |
|-----------------|------------|-------|-----------|
| ZX-6RR          | 600 Ninja  | 03-06 | <b>HS</b> |
| ZX-6R           | 636 Ninja  | 03-06 | <b>HS</b> |
| ZX-10R          | 1000 Ninja | 04-07 | <b>HS</b> |
| ZX-12R          | 1200 Ninja | 04-06 | <b>HS</b> |
| VN              | 1600 Mean  |       |           |
|                 | Streak     | 05    | <b>HS</b> |

| <b>SUZUKI</b> |               |       |           |
|---------------|---------------|-------|-----------|
| GSX-R         | 1000          | 03    | <b>HS</b> |
| M             | 1600 Intruder | 05-07 | <b>HS</b> |

**SBS 789** Recommended compound



| <b>SUZUKI</b> |                  |       |           |
|---------------|------------------|-------|-----------|
| C             | 1500 Intruder    |       |           |
|               | Left/Rear        | 05-10 | <b>LS</b> |
| VL            | 1500 Intruder LC |       |           |
|               | Left/Rear        | 02    | <b>LS</b> |

Available compounds **SI • RSI • ATS**

**SBS 787**

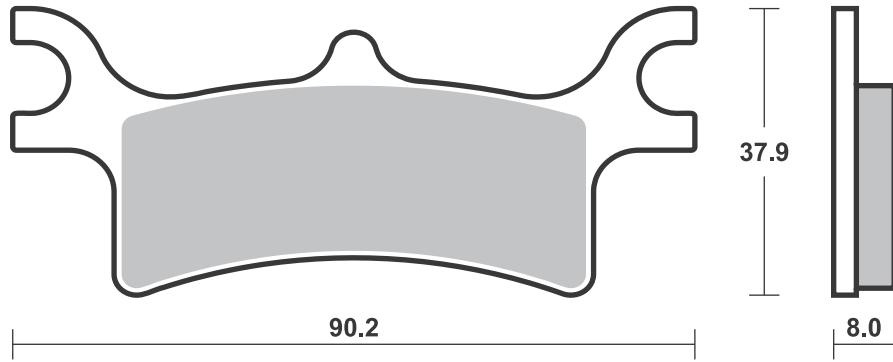

Available compounds **HS • DC • RS • DS • SP**

**SBS 788**

1 set = 4 pcs.

HS / SP - Th. 7.9  
RS / DC / DS - Th. 9.5

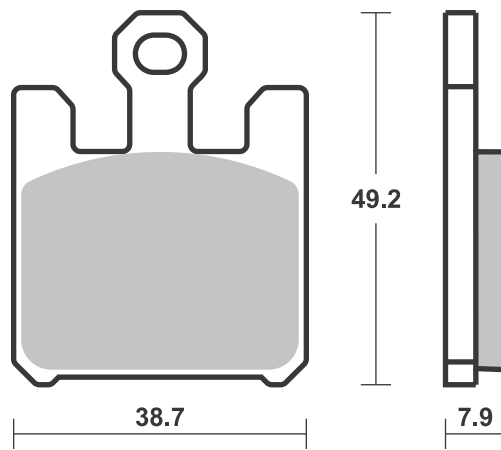

Available compounds **HF • LS**

**SBS 789**

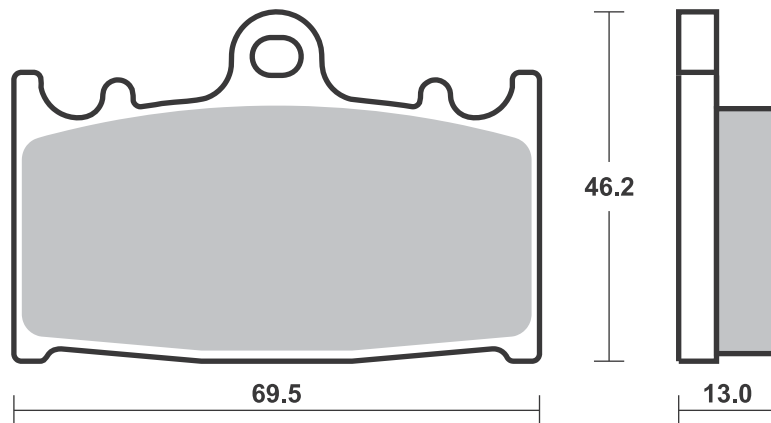

**SBS 790** Recommended compound

| <b>APRILIA</b> |                        |       |            |
|----------------|------------------------|-------|------------|
| MXV            | 450                    | 09-13 | <b>RSI</b> |
| RXV            | 450                    | 06-13 | <b>SI</b>  |
| SXV            | 450                    | 06-13 | <b>RSI</b> |
| SXV            | 450 Van den Bosch Rep. | 08-10 | <b>RSI</b> |
| RXV            | 550                    | 06-13 | <b>SI</b>  |
| SXV            | 550                    | 06-13 | <b>RSI</b> |
| SXV            | 550 Van den Bosch Rep. | 08-10 | <b>RSI</b> |

| <b>BETA</b> |                   |       |           |
|-------------|-------------------|-------|-----------|
| RR          | 125               | 18-   | <b>SI</b> |
| RR          | 250               | 05-09 | <b>SI</b> |
|             | 300 Crosstrainer  | 15    | <b>SI</b> |
| RR          | 300               | 13-18 | <b>SI</b> |
| RR          | 350 Efi           | 15    | <b>SI</b> |
| RR          | 350 Efi Racing    | 15    | <b>SI</b> |
| RR          | 350 Enduro        | 12-14 | <b>SI</b> |
| RR          | 390               | 15-18 | <b>SI</b> |
| RR          | 400 Enduro        | 05    | <b>SI</b> |
| RR          | 430               | 15-18 | <b>SI</b> |
| RR          | 430 Racing        | 15-18 | <b>SI</b> |
| RR          | 450 Cross Country | 12    | <b>SI</b> |
| RR          | 450 Enduro        | 05-07 | <b>SI</b> |
| RR          | 480               | 15-18 | <b>SI</b> |
| RR          | 480 Racing        | 15-18 | <b>SI</b> |
| RR          | 498 Enduro        | 12-14 | <b>SI</b> |
| RR          | 525 Enduro        | 05-13 | <b>SI</b> |

| <b>BIMOTA</b> |            |    |           |
|---------------|------------|----|-----------|
| BBX           | 300 Enduro | 12 | <b>SI</b> |

| <b>CCM</b> |        |       |            |
|------------|--------|-------|------------|
|            | 450 MX | 08-10 | <b>RSI</b> |

| <b>GAS GAS</b> |                  |       |           |
|----------------|------------------|-------|-----------|
| EC             | 200              | 17    | <b>SI</b> |
| XC             | 200              | 18-   | <b>SI</b> |
| EC             | 250              | 12-18 | <b>SI</b> |
| EC             | 250 Enduro GP 18 | 18-   | <b>SI</b> |
| XC             | 250              | 17    | <b>SI</b> |
| EC             | 300              | 12-18 | <b>SI</b> |
| EC             | 300 Enduro GP 18 | 18-   | <b>SI</b> |
| XC             | 300              | 18-   | <b>SI</b> |

|     |                       |       |           |
|-----|-----------------------|-------|-----------|
| HM  |                       |       |           |
| CRE | 50 Six Comp.          | 07-12 | <b>HF</b> |
| CRM | 50 Derapage Comp.     | 07-12 | <b>HF</b> |
| CRE | 125 Six Comp.         | 10-11 | <b>HF</b> |
| CRM | 125 Derapage Comp. 2T | 11-12 | <b>HF</b> |
| CRM | 125 Derapage Comp. 4T | 11-12 | <b>HF</b> |

| <b>KAWASAKI</b> |         |       |            |
|-----------------|---------|-------|------------|
| KX-F            | 250     | 04-10 | <b>RSI</b> |
| KX-F            | 250 DFI | 11-18 | <b>RSI</b> |
| KLX             | 450 R   | 07-12 | <b>SI</b>  |
| KX-F            | 450     | 06-08 | <b>RSI</b> |
| KX-F            | 450 DFI | 09-18 | <b>RSI</b> |

| <b>SHERCO</b> |                 |       |            |
|---------------|-----------------|-------|------------|
| SE            | 250 2.5i Enduro | 06-11 | <b>SI</b>  |
| SX            | 250 2.5i-F      | 09-11 | <b>RSI</b> |
| SE            | 300 3.0i-F      | 10-11 | <b>SI</b>  |
| SE            | 450 4.5i Enduro | 05-11 | <b>SI</b>  |



| <b>SHERCO</b> |                      |       |            |
|---------------|----------------------|-------|------------|
| SM            | 450 4.5i Supermotard | 06    | <b>RSI</b> |
| SE            | 510 5.1i Enduro      | 06-11 | <b>SI</b>  |

| <b>SUZUKI</b> |           |       |            |
|---------------|-----------|-------|------------|
| RM-Z          | 250       | 04-09 | <b>RSI</b> |
| RM-Z          | 250 Efi   | 10-18 | <b>RSI</b> |
| RMX           | 450 Z Efi | 10    | <b>SI</b>  |
| RMX           | 450 Z Efi | 17-18 | <b>SI</b>  |
| RM-Z          | 450       | 05-07 | <b>RSI</b> |
| RM-Z          | 450 Efi   | 08-17 | <b>RSI</b> |
| RM-Z          | 450 Efi   | 18-   | <b>RSI</b> |

| <b>TM</b> |              |       |            |
|-----------|--------------|-------|------------|
|           | 125          | 05-17 | <b>RSI</b> |
|           | 125 Enduro   | 05-17 | <b>SI</b>  |
|           | 250          | 05    | <b>RSI</b> |
|           | 250 Enduro   | 05-15 | <b>SI</b>  |
|           | 250 F        | 05-17 | <b>RSI</b> |
|           | 250 F Enduro | 05-17 | <b>SI</b>  |
|           | 300          | 05    | <b>RSI</b> |
|           | 300 Enduro   | 05    | <b>SI</b>  |
|           | 450 F        | 05-17 | <b>RSI</b> |
|           | 450 F Enduro | 05-17 | <b>SI</b>  |
| FT        | 450 Fi       | 17    | <b>RSI</b> |
|           | 530 F        | 05    | <b>RSI</b> |
|           | 530 F Enduro | 05    | <b>SI</b>  |

| <b>YAMAHA</b> |                 |       |            |
|---------------|-----------------|-------|------------|
| YZ            | 125             | 03-18 | <b>RSI</b> |
| WR            | 250 F           | 03-13 | <b>SI</b>  |
| WR            | 250 F Efi       | 15-18 | <b>SI</b>  |
| WR            | 250 F Enduro GP | 18-   | <b>SI</b>  |
| WR            | 250 R           | 08-15 | <b>LS</b>  |
| WR            | 250 X           | 08-16 | <b>LS</b>  |
| YZ            | 250             | 03-18 | <b>RSI</b> |
| YZ            | 250 F           | 03-13 | <b>RSI</b> |
| YZ            | 250 F Efi       | 14-18 | <b>RSI</b> |
| YZ            | 250 FX Efi      | 15    | <b>SI</b>  |
| WR            | 450 F           | 03-15 | <b>SI</b>  |
| WR            | 450 F Efi       | 16-18 | <b>SI</b>  |
| WR            | 450 F Enduro GP | 18-   | <b>SI</b>  |
| YZ            | 450 F           | 03-09 | <b>RSI</b> |
| YZ            | 450 F Efi       | 10-18 | <b>RSI</b> |
| YZ            | 450 FX Efi      | 16    | <b>SI</b>  |

| <b>ZERO</b> |        |    |            |
|-------------|--------|----|------------|
| DS          | ZF11.4 | 13 | <b>LS</b>  |
| DS          | ZF8.5  | 13 | <b>LS</b>  |
| FX          | ZF2.8  | 13 | <b>LS</b>  |
| FX          | ZF5.7  | 13 | <b>LS</b>  |
| MX          | ZF2.8  | 13 | <b>RSI</b> |
| MX          | ZF5.7  | 13 | <b>RSI</b> |
| S           | ZF11.4 | 13 | <b>LS</b>  |
| S           | ZF8.5  | 13 | <b>LS</b>  |
| XU          | ZF2.8  | 13 | <b>LS</b>  |
| XU          | ZF5.7  | 13 | <b>LS</b>  |

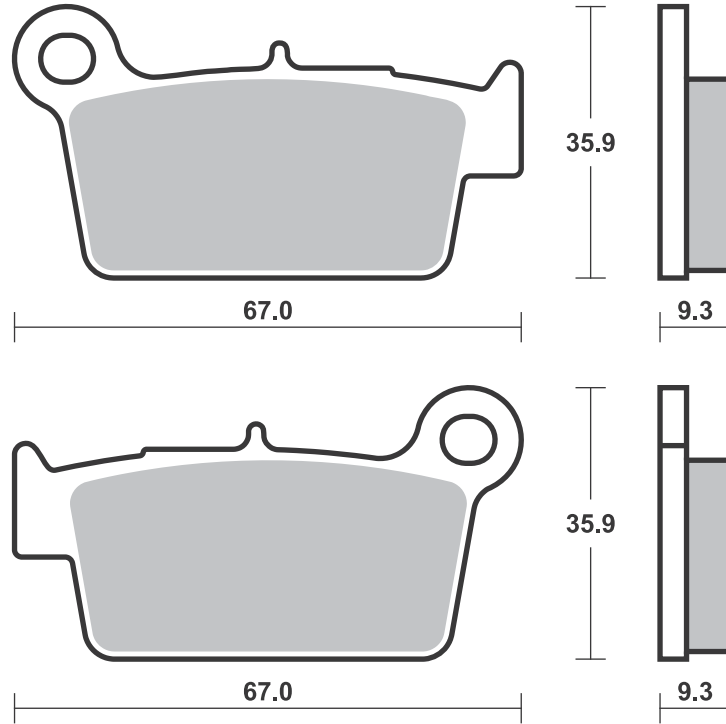

## Applications

### SBS 791 Recommended compound



| <b>BMW</b> |         |       |            |
|------------|---------|-------|------------|
| G          | 450 SMR | 09-10 | <b>RSI</b> |
| G          | 450 X   | 08-10 | <b>SI</b>  |

#### BREMBO RACING CALIPERS

Off Road XQ21390, PF 26

#### HUSABERG

|    |     |       |           |
|----|-----|-------|-----------|
| TE | 125 | 13    | <b>SI</b> |
| FE | 250 | 13    | <b>SI</b> |
| TE | 250 | 11-13 | <b>SI</b> |
| TE | 300 | 11-13 | <b>SI</b> |
| FE | 350 | 13    | <b>SI</b> |
| FE | 390 | 10-13 | <b>SI</b> |
| FE | 450 | 09-13 | <b>SI</b> |
| FE | 501 | 13    | <b>SI</b> |
| FE | 570 | 09-13 | <b>SI</b> |

#### HUSQVARNA

|     |        |       |            |
|-----|--------|-------|------------|
| CR  | 125    | 05-13 | <b>RSI</b> |
| TC  | 125    | 14-18 | <b>RSI</b> |
| TE  | 125    | 14-16 | <b>SI</b>  |
| TX  | 125    | 17-18 | <b>SI</b>  |
| CR  | 250    | 05    | <b>RSI</b> |
| FC  | 250    | 14-18 | <b>RSI</b> |
| FE  | 250    | 14-18 | <b>SI</b>  |
| TC  | 250    | 04-18 | <b>RSI</b> |
| TE  | 250    | 14-18 | <b>SI</b>  |
| TE  | 250 4T | 10-13 | <b>SI</b>  |
| TC  | 300    | 14-15 | <b>RSI</b> |
| TE  | 300    | 14-18 | <b>SI</b>  |
| WR  | 300    | 09-13 | <b>SI</b>  |
| TE  | 310 4T | 10-13 | <b>SI</b>  |
| FC  | 350    | 14-18 | <b>RSI</b> |
| FE  | 350    | 14-18 | <b>SI</b>  |
| SMR | 449    | 11-13 | <b>RSI</b> |
| TC  | 449    | 11-13 | <b>RSI</b> |
| TE  | 449    | 11-13 | <b>SI</b>  |
| FC  | 450    | 14-18 | <b>RSI</b> |
| FE  | 450    | 14-18 | <b>SI</b>  |
| FS  | 450    | 15-18 | <b>RSI</b> |
| SM  | 450 R  | 06-13 | <b>RSI</b> |
| SM  | 450 RR | 06-10 | <b>RSI</b> |
| TC  | 450    | 04-10 | <b>RSI</b> |
| TE  | 450    | 14    | <b>SI</b>  |

#### HUSQVARNA

|     |                |       |            |
|-----|----------------|-------|------------|
| FE  | 501            | 14-18 | <b>SI</b>  |
| SM  | 510 Centennial | 06    | <b>RSI</b> |
| SM  | 510 R          | 06-10 | <b>RSI</b> |
| TC  | 510            | 04-10 | <b>RSI</b> |
| SMR | 511            | 11-13 | <b>RSI</b> |
| TE  | 511            | 11-14 | <b>SI</b>  |
| SM  | 610 ie         | 07-10 | <b>RSI</b> |
| SM  | 630            | 10    | <b>HF</b>  |
| TE  | 630            | 10-13 | <b>HF</b>  |
| TE  | 630            | 14    | <b>SI</b>  |
| STR | 650 CRC        | 07    | <b>HF</b>  |

#### KTM

|       |                           |       |            |
|-------|---------------------------|-------|------------|
| EXC   | 125 Enduro                | 04-15 | <b>SI</b>  |
| SX    | 125                       | 04-18 | <b>RSI</b> |
| SX    | 144                       | 07-08 | <b>RSI</b> |
| SX    | 150                       | 09-18 | <b>RSI</b> |
| EXC   | 200 Enduro                | 04-16 | <b>SI</b>  |
| SX    | 200                       | 03-04 | <b>RSI</b> |
| EXC   | 250 Enduro                | 04-08 | <b>SI</b>  |
| EXC   | 250 Enduro 4T             | 04-06 | <b>SI</b>  |
| EXC   | 250 TPI                   | 18-   | <b>SI</b>  |
| EXC-F | 250 Enduro                | 07-18 | <b>SI</b>  |
| SX    | 250                       | 03-18 | <b>RSI</b> |
| SX-F  | 250                       | 06-18 | <b>RSI</b> |
| EXC   | 300 Enduro                | 04-08 | <b>SI</b>  |
| EXC   | 300 TPI                   | 18-   | <b>SI</b>  |
| EXC-F | 350                       | 11-18 | <b>SI</b>  |
| SX-F  | 350                       | 11-18 | <b>RSI</b> |
| EXC   | 400 Racing                | 04-07 | <b>SI</b>  |
| EXC-F | 450 Racing                | 04-18 | <b>SI</b>  |
| SX    | 450 SM Factory<br>Replica | 04-07 | <b>RSI</b> |
| SX    | 450 SMR                   | 04-15 | <b>RSI</b> |
| SX-F  | 450                       | 03-18 | <b>RSI</b> |
| XC-F  | 450                       | 06-17 | <b>RSI</b> |
| EXC-F | 500                       | 12-18 | <b>SI</b>  |
| SX    | 505 Racing                | 07-09 | <b>RSI</b> |
| XC-F  | 505                       | 08-09 | <b>RSI</b> |
| EXC   | 525 Racing                | 04-06 | <b>SI</b>  |
| SX    | 525 SMR                   | 04-07 | <b>RSI</b> |
| SX-F  | 525 Racing                | 04-06 | <b>RSI</b> |
| EXC   | 530 Racing                | 08-11 | <b>SI</b>  |
| SX    | 560 SMR                   | 06-07 | <b>RSI</b> |

#### RIEJU

|     |              |       |           |
|-----|--------------|-------|-----------|
| MRX | 250 Marathon | 10-12 | <b>SI</b> |
| MRX | 450 Marathon | 08-12 | <b>SI</b> |

#### SHERCO

|       |            |       |           |
|-------|------------|-------|-----------|
| SE-R  | 125        | 17    | <b>SI</b> |
| SE    | 250 , R    | 14    | <b>SI</b> |
| SE    | 250 F, F-R | 14-18 | <b>SI</b> |
| SE    | 250 i/R    | 12-13 | <b>SI</b> |
| SE    | 250 i-F    | 13    | <b>SI</b> |
| SCF-R | 300        | 16-18 | <b>SI</b> |
| SE    | 300 , R    | 14-18 | <b>SI</b> |
| SE    | 300 F, F-R | 14-18 | <b>SI</b> |
| SE    | 300 i/R    | 12-13 | <b>SI</b> |
| SE    | 300 i-F    | 13    | <b>SI</b> |
| SE    | 450 F, F-R | 14-18 | <b>SI</b> |
| SE    | 450 iR     | 12-13 | <b>SI</b> |
| SE    | 510 iR     | 12-13 | <b>SI</b> |

#### SWM

|    |       |       |           |
|----|-------|-------|-----------|
| RS | 300 R | 15-18 | <b>SI</b> |
| SM | 450 R | 15-17 | <b>HF</b> |
| RS | 500 R | 15-18 | <b>SI</b> |
| SM | 500 R | 18-   | <b>HF</b> |

#### WRM

|  |        |       |            |
|--|--------|-------|------------|
|  | 450 MX | 06-08 | <b>RSI</b> |
|--|--------|-------|------------|

### SBS 792 Recommended compound



| <b>RIEJU</b> |         |       |           |
|--------------|---------|-------|-----------|
| RS2          | 125 Pro | 08-12 | <b>HF</b> |

#### SYM

|    |     |       |           |
|----|-----|-------|-----------|
| VS | 125 | 07-13 | <b>HF</b> |
| VS | 150 | 07-15 | <b>HF</b> |



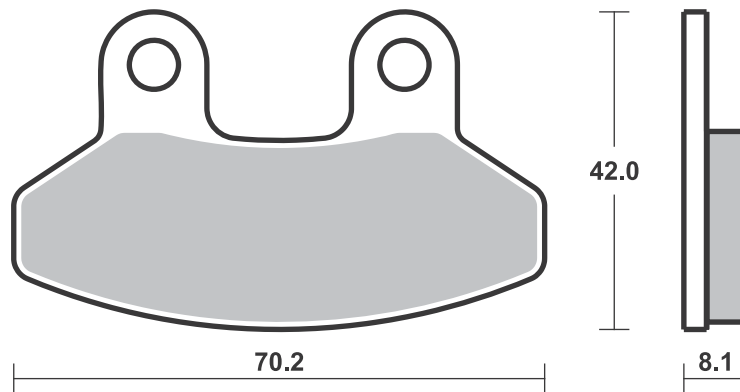
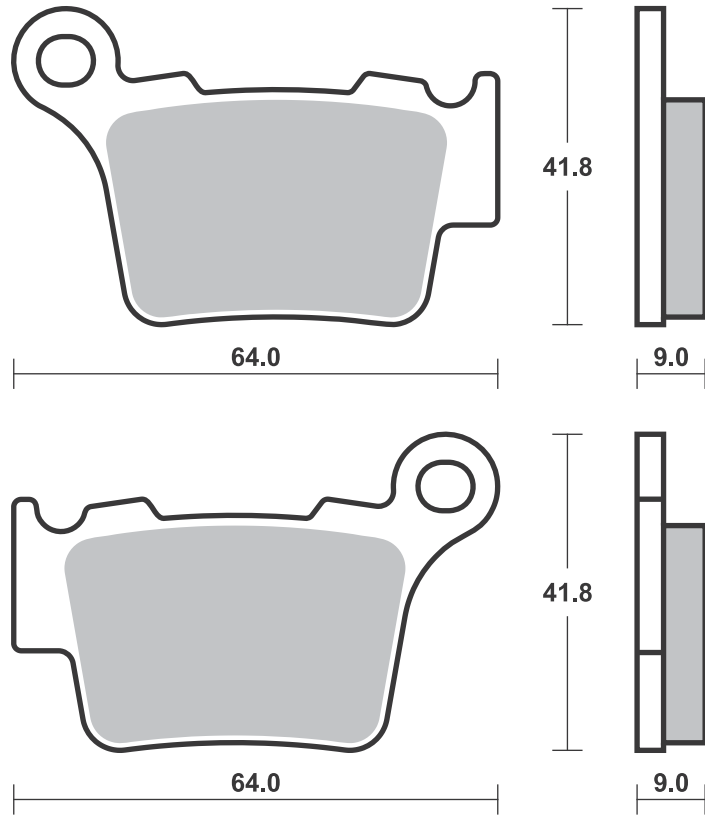



## Applications

### SBS 794 Recommended compound

|                  |               |       |            |  |  |               |           |            |            |  |  |               |       |            |            |  |  |
|------------------|---------------|-------|------------|---|---|---------------|-----------|------------|------------|---|---|---------------|-------|------------|------------|---|---|
| <b>COBRA</b>     |               |       |            |   |   | <b>KTM</b>    |           |            |            |   |   | <b>POLINI</b> |       |            |            |   |   |
| CX               | 50 Big Wheel  | 10-14 | <b>RSI</b> | <b>RSI</b>  | SX  | 50 Pro Senior |           |            |            |   | X3  | 50 R          | 04-06 | <b>RSI</b> | <b>RSI</b> |   |   |
| CX               | 50 Junior     | 07-10 | <b>RSI</b> |   |   | LC            | 02-03     | <b>RSI</b> |            |   | X5  | 65 RP         | 05-06 | <b>RSI</b> | <b>RSI</b> |   |   |
| CX               | 50 Junior     | 11-13 | <b>RSI</b> | <b>RSI</b>  | SX  | 50 Pro Senior |           |            |            |   |   |               |       |            |            |   |   |
| CX               | 50 Senior     | 07-13 | <b>RSI</b> | <b>RSI</b>  |   | LC            | 04-09     | <b>RSI</b> | <b>RSI</b> |   |   |               |       |            |            |   |   |
| <b>HUSQVARNA</b> |               |       |            |   |   | SX            | 50 Senior |            |            |   |   |               |       |            |            |   |   |
| CR               | 50 Pro Senior | 06    |            | <b>RSI</b>  |   | Adventure     | 04-07     | <b>RSI</b> |            |   |   |               |       |            |            |   |   |
| CR               | 50 Senior     | 06    |            | <b>RSI</b>  | SX  | 65            | 04-08     |            | <b>RSI</b> |   |   |               |       |            |            |   |   |
| SM               | 50            | 10-12 |            | <b>RSI</b>  | <b>LEM</b>  |               |           |            |            |   |   |               |       |            |            |   |   |
| TC               | 50            | 17-18 | <b>RSI</b> | <b>RSI</b>  |   | 50 CX2, CX3,  |           |            |            |   |   |               |       |            |            |   |   |
| <b>KTM</b>       |               |       |            |   |   |               | RX2, RX3  | 03-06      | <b>RSI</b> | <b>RSI</b>  |   |               |       |            |            |   |   |
| SM               | 50 Supermoto  | 06    | <b>RSI</b> | <b>RSI</b>  |   | 50 R2, R3,    |           |            |            |   |   |               |       |            |            |   |   |
| SX               | 50            | 09-18 | <b>RSI</b> | <b>RSI</b>  |   | R3 XC         | 03-06     | <b>RSI</b> | <b>RSI</b> |   |   |               |       |            |            |   |   |
| SX               | 50 Mini       | 09-18 | <b>RSI</b> | <b>RSI</b>  | FX  | 65            | 05-10     | <b>RSI</b> | <b>RSI</b> |   |   |               |       |            |            |   |   |
| SX               | 50 Pro Junior |       |            |   | RX  | 150           | 11        |            | <b>RSI</b> |   |   |               |       |            |            |   |   |
|                  | LC            | 02-05 | <b>RSI</b> |   | <b>POLINI</b>   |               |           |            |            |   |   |               |       |            |            |   |   |
|                  |               |       |            |   | X1  | 50 R          | 04-06     | <b>RSI</b> | <b>RSI</b> |   |   |               |       |            |            |   |   |

### SBS 795 Recommended compound

|              |                |       |           |  |  |
|--------------|----------------|-------|-----------|---|---|
| <b>BUELL</b> |                |       |           |   |   |
| XB9R         | 984 Firebolt   | 02-10 | <b>HS</b> |   |   |
| XB9S         | 984 Lightning  | 03-10 | <b>HS</b> |   |   |
| XB9SX        | 984 CityX      | 05-10 | <b>HS</b> |   |   |
| XB12R        | 1200 Firebolt  | 04-08 | <b>HS</b> |   |   |
| XB12S        | 1200 Lightning | 04-08 | <b>HS</b> |   |   |
| XB12Scg      | 1200 Lightning | 06-08 | <b>HS</b> |   |   |
| XB12Ss       | 1200 Lightning |       |           |   |   |
|              | Long           | 06-08 | <b>HS</b> |   |   |
| XB12STT      | 1200 Super TT  | 07-10 | <b>HS</b> |   |   |
| XB12X        | 1200 Ulysses   | 06-10 | <b>HS</b> |   |   |
|              |                |       |           |   |   |
|              |                |       |           |   |   |
|              |                |       |           |   |   |
|              |                |       |           |   |   |
|              |                |       |           |   |   |
|              |                |       |           |   |   |
|              |                |       |           |   |   |
|              |                |       |           |   |   |
|              |                |       |           |   |   |

### SBS 796 Recommended compound

|            |                |       |           |  |  |            |           |  |  |  |  |  |
|------------|----------------|-------|-----------|---|---|------------|-----------|--|--|---|---|--|
| <b>BMW</b> |                |       |           |   |   | <b>BMW</b> |           |  |  |   |   |  |
| R          | 850 RT With    |       |           | K   | 1200 GT (K44)   |            |           |  |  |   |   |  |
|            | Integral       |       |           |   | With  |            |           |  |  |   |   |  |
|            | ABS            | 01-06 | <b>HS</b> |   | Integral  |            |           |  |  |   |   |  |
| R          | 1100 S Without |       |           |   | ABS   | 04-08      | <b>HS</b> |  |  |   |   |  |
|            | Integral       |       |           | K   | 1200 RS   | 01-05      | <b>HS</b> |  |  |   |   |  |
|            | ABS            | 01-05 | <b>HS</b> | K   | 1200 S  | 05-08      | <b>HS</b> |  |  |   |   |  |
| R          | 1150 GS        |       |           | R   | 1200 GS   | 04-12      | <b>SP</b> |  |  |   |   |  |
|            | Adventurer     |       |           | R   | 1200 GS   |            |           |  |  |   |   |  |
|            | (Tokico cal.)  | 02-05 | <b>HS</b> |   | Tripple   |            |           |  |  |   |   |  |
| R          | 1150 RT With   |       |           |   | Black   | 11-16      | <b>SP</b> |  |  |   |   |  |
|            | Integral       |       |           | R   | 1200 RT   | 06-13      | <b>HS</b> |  |  |   |   |  |
|            | ABS            | 01-06 | <b>HS</b> | R   | 1200 S  | 06-07      | <b>HS</b> |  |  |   |   |  |
|            | 1200 HP2       |       |           | R   | 1200 ST   | 06-07      | <b>HS</b> |  |  |   |   |  |
|            | Megamoto       | 06-08 | <b>HS</b> | K   | 1300 GT   | 09-10      | <b>HS</b> |  |  |   |   |  |
| K          | 1200 GT (K41)  |       |           | K   | 1300 S  | 09-15      | <b>HS</b> |  |  |   |   |  |
|            | With           |       |           |   |   |            |           |  |  |   |   |  |
|            | Integral       |       |           |   |   |            |           |  |  |   |   |  |
|            | ABS            | 02-05 | <b>HS</b> |   |   |            |           |  |  |   |   |  |

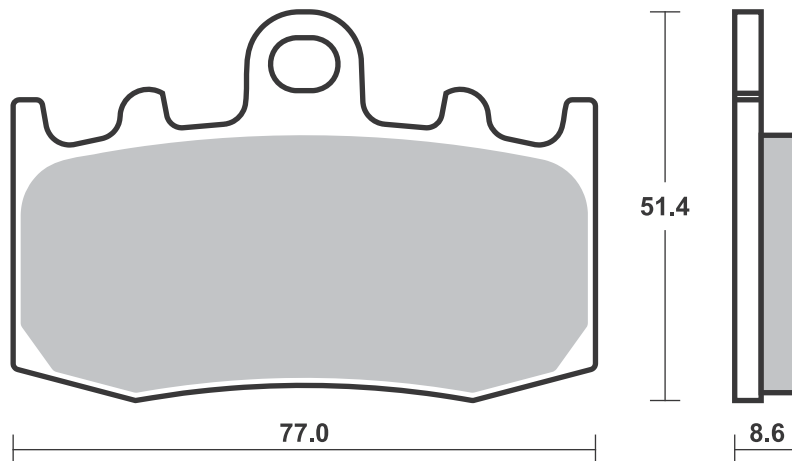
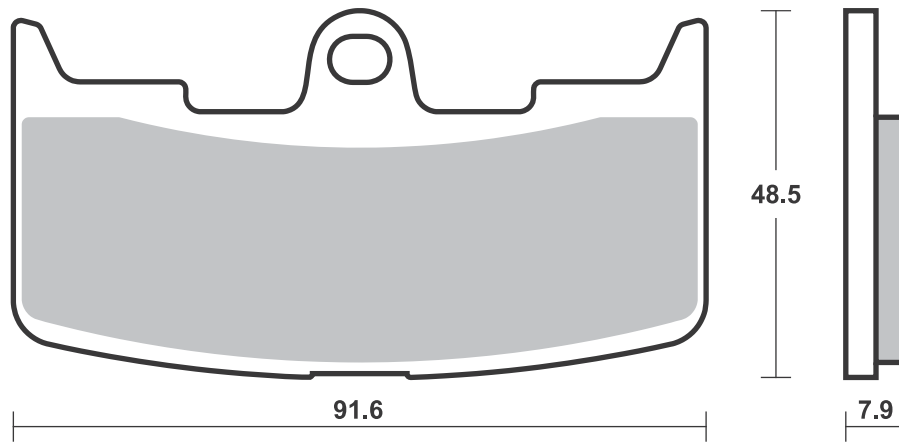
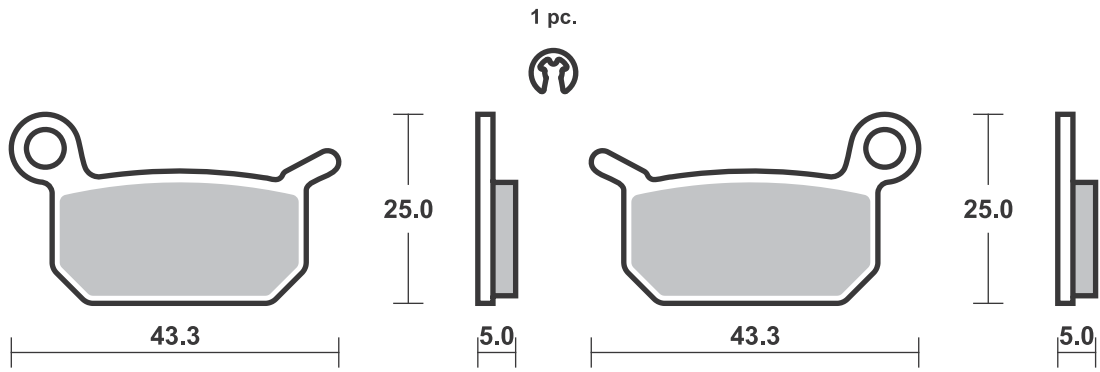

**SBS 797** Recommended compound



| <b>HONDA</b> |         |       |           |
|--------------|---------|-------|-----------|
| CBF          | 125     | 09-18 | <b>HF</b> |
| CBR          | 125 R   | 03-18 | <b>HF</b> |
| MSX          | 125     | 14-18 | <b>HF</b> |
| CBR          | 150 R   | 00-10 | <b>HF</b> |
| <b>RIEJU</b> |         |       |           |
| RS2          | 125 NKD | 06-07 | <b>HF</b> |
|              |         |       |           |
|              |         |       |           |
|              |         |       |           |
|              |         |       |           |
|              |         |       |           |
|              |         |       |           |
|              |         |       |           |
|              |         |       |           |
|              |         |       |           |
|              |         |       |           |
|              |         |       |           |
|              |         |       |           |
|              |         |       |           |
|              |         |       |           |
|              |         |       |           |
|              |         |       |           |
|              |         |       |           |
|              |         |       |           |
|              |         |       |           |
|              |         |       |           |
|              |         |       |           |
|              |         |       |           |

**SBS 798** Recommended compound



| <b>KAWASAKI</b> |                   |       |           |
|-----------------|-------------------|-------|-----------|
| KFX             | 450 Right         | 07-15 | <b>SI</b> |
| KVF             | 650 Brute Force   |       |           |
|                 | 4x4 Right         | 05-11 | <b>SI</b> |
| KVF             | 650 Prairie Right | 01-03 | <b>SI</b> |
| KFX             | 700 V-Force       |       |           |
|                 | Right             | 04-13 | <b>SI</b> |
| KSV             | 700 V-Force       |       |           |
|                 | Right             | 04-11 | <b>SI</b> |
| KVF             | 700 Prairie Right | 04-13 | <b>SI</b> |
| <b>SUZUKI</b>   |                   |       |           |
| LT-V            | 700 Quadrunner    |       |           |
|                 | Twin Peaks        |       |           |
|                 | Right             | 04-06 | <b>SI</b> |
|                 |                   |       |           |
|                 |                   |       |           |
|                 |                   |       |           |
|                 |                   |       |           |
|                 |                   |       |           |
|                 |                   |       |           |
|                 |                   |       |           |
|                 |                   |       |           |
|                 |                   |       |           |
|                 |                   |       |           |
|                 |                   |       |           |
|                 |                   |       |           |
|                 |                   |       |           |
|                 |                   |       |           |
|                 |                   |       |           |
|                 |                   |       |           |
|                 |                   |       |           |
|                 |                   |       |           |
|                 |                   |       |           |
|                 |                   |       |           |
|                 |                   |       |           |
|                 |                   |       |           |
|                 |                   |       |           |

Brake Pad 1:1 Drawings,  
Compounds, Fitments

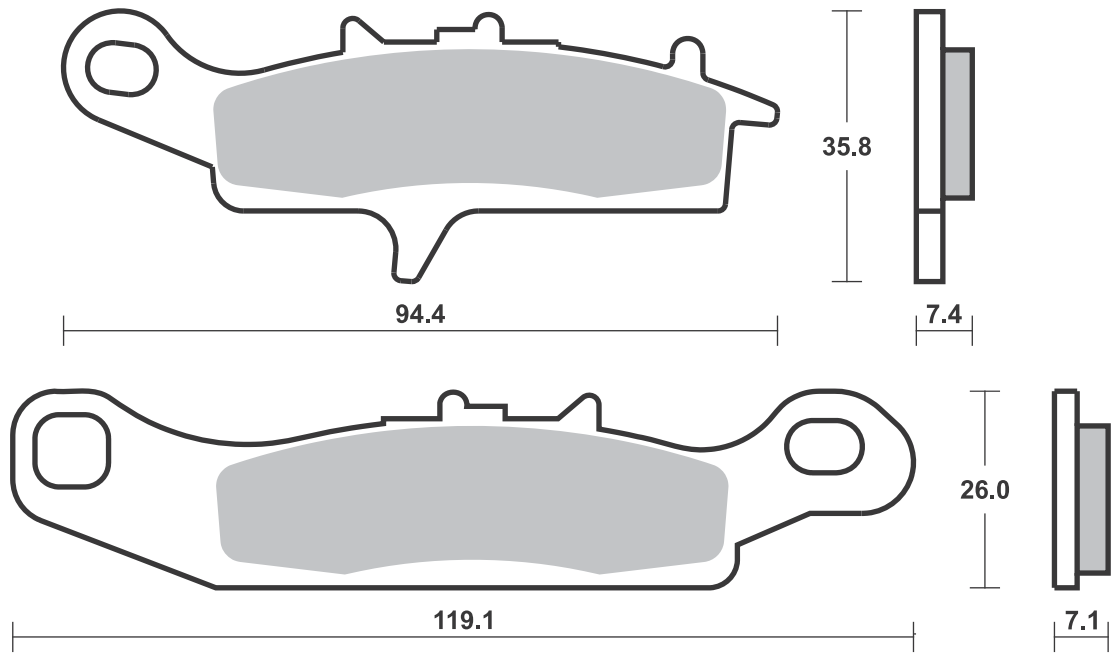
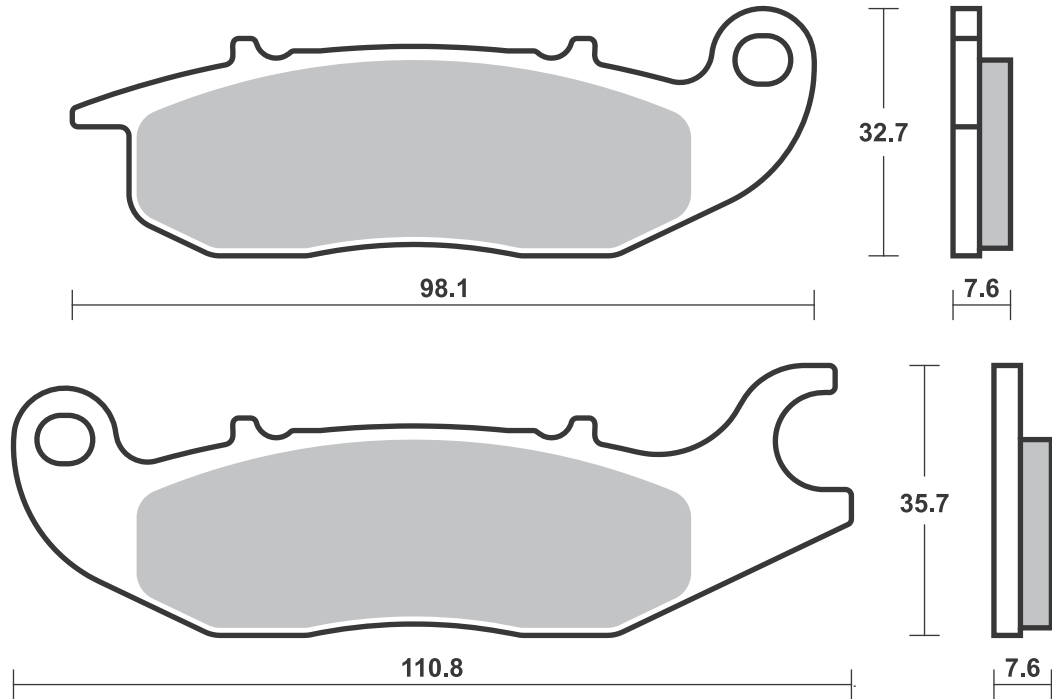

**SBS 799** Recommended compound



| CF MOTO            |       |  |    |
|--------------------|-------|--|----|
| 450 C-Force L      | 16-17 |  | SI |
| 450 G-Force L      | 16-17 |  | SI |
| CF 500 Terralander | 13-15 |  | SI |
| 550 C-Force        | 16-17 |  | SI |
| CF 625 Terralander | 11-15 |  | SI |
| CF 800 Terralander | 12-14 |  | SI |
| GOES               |       |  |    |
| 520 Max            | 07-12 |  | SI |
| G 520              | 07-12 |  | SI |
| G 525              | 12-14 |  | SI |
| G 620              | 11-14 |  | SI |
| G 625 A            | 12-14 |  | SI |

| YAMAHA           |       |  |    |
|------------------|-------|--|----|
| YFM 660 FWAP 4x4 |       |  |    |
| Grizzly          | 02-08 |  | SI |
|                  |       |  |    |
|                  |       |  |    |
|                  |       |  |    |
|                  |       |  |    |
|                  |       |  |    |
|                  |       |  |    |
|                  |       |  |    |
|                  |       |  |    |
|                  |       |  |    |

**SBS 800** Recommended compound



| POLARIS                     |       |     |     |
|-----------------------------|-------|-----|-----|
| EV-LSV                      | 10-11 |     | ATS |
| LSV 4x4                     | 11-12 |     | ATS |
| Ranger 48v                  |       |     |     |
| EV                          | 13-16 |     | ATS |
| 500 Ranger 2x4              | 08-07 |     | ATS |
| 500 Ranger 2x4              |       |     |     |
| EFI                         | 08-13 |     | ATS |
| 500 Ranger 2x4,<br>4x4, 6x6 | 02-13 | ATS | ATS |
| 500 Ranger 4x4              | 12-13 |     | ATS |
| 500 Ranger XP               | 06-09 | ATS | ATS |
| 700 Ranger 4x4              |       |     |     |
| EFI                         | 08    |     | ATS |
| 700 Ranger 6x6              |       |     |     |
| EFI                         | 12-13 |     | ATS |
| 800 Ranger                  |       |     |     |
| RZR4 EFI                    | 12-14 |     | ATS |
| 800 Ranger XP               | 12-13 |     | ATS |

| POLARIS   |       |  |     |
|-----------|-------|--|-----|
| 800 RZR-4 | 10-14 |  | ATS |
|           |       |  |     |
|           |       |  |     |
|           |       |  |     |
|           |       |  |     |
|           |       |  |     |
|           |       |  |     |
|           |       |  |     |
|           |       |  |     |
|           |       |  |     |
|           |       |  |     |
|           |       |  |     |

**SBS 801** Recommended compound



| KAWASAKI             |       |    |  |
|----------------------|-------|----|--|
| KFX 450 Left/Rear    | 07-15 | SI |  |
| KVF 650 Brute Force  |       |    |  |
| 4x4 Left             | 05-11 | SI |  |
| KVF 650 Prairie Left | 01-03 | SI |  |
| KFX 700 V-Force Left | 04-13 | SI |  |
| KSV 700 V-Force Left | 04-11 | SI |  |
| KVF 700 Prairie Left | 04-13 | SI |  |
| SUZUKI               |       |    |  |
| LT-V 700 Quadrunner  |       |    |  |
| Twin Peaks           |       |    |  |
| Left                 | 04-06 | SI |  |
|                      |       |    |  |
|                      |       |    |  |
|                      |       |    |  |
|                      |       |    |  |
|                      |       |    |  |
|                      |       |    |  |
|                      |       |    |  |
|                      |       |    |  |
|                      |       |    |  |
|                      |       |    |  |

Brake Pad 1:1 Drawings, Compounds, Fitments

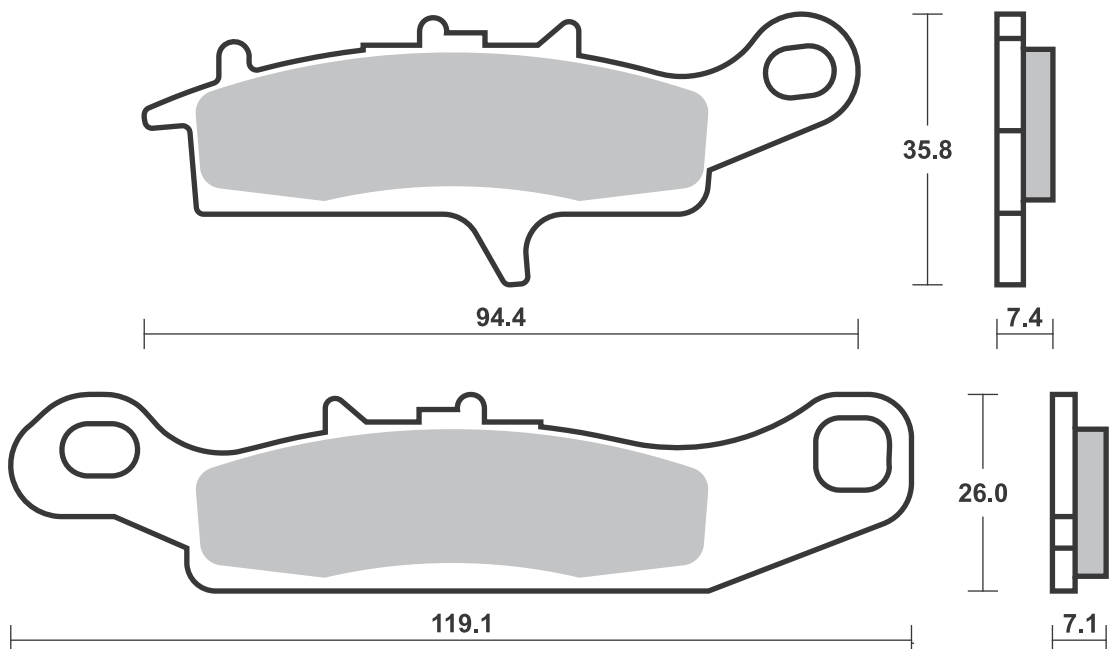
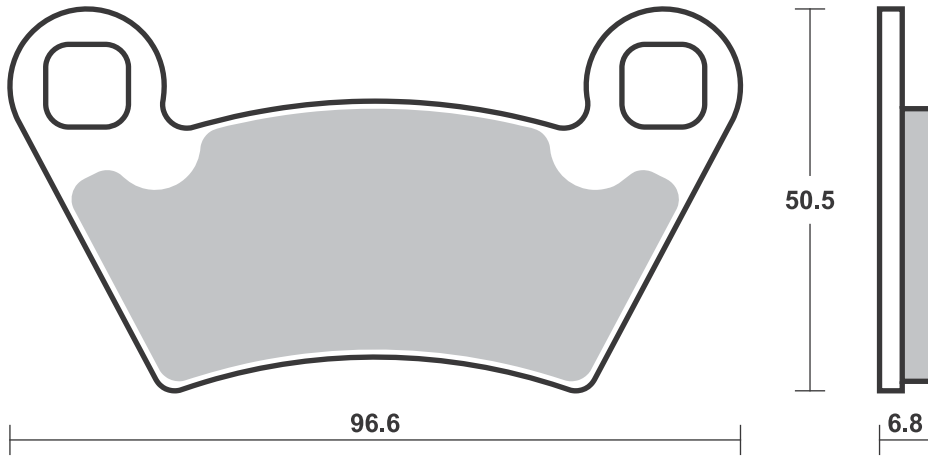
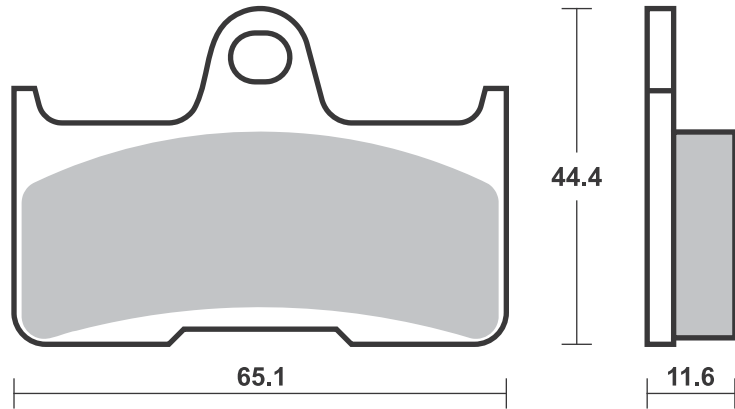

## Applications

### SBS 802 Recommended compound



| <b>AJP</b>          |                 |       |                       |
|---------------------|-----------------|-------|-----------------------|
| PR3                 | 125 Enduro      | 08-12 | <b>HF</b>             |
| PR3                 | 125 Supermotard | 08-12 | <b>HF</b>             |
| PR4                 | 125 Enduro      | 04-12 | <b>HF</b>             |
| PR4                 | 125 Supermotard | 04-09 | <b>HF</b>             |
| PR3                 | 200 Enduro      | 08-12 | <b>HF</b>             |
| PR3                 | 200 Supermotard | 08-12 | <b>HF</b>             |
| PR4                 | 200 Enduro      | 04    | <b>HF</b>             |
| PR4                 | 200 Supermotard | 04    | <b>HF</b>             |
| <b>BETA</b>         |                 |       |                       |
| 80 EVO              |                 | 09-10 | <b>RSI</b>            |
| 80 Rev              |                 | 08-10 | <b>RSI</b>            |
| 125 EVO             |                 | 09-14 | <b>RSI</b>            |
| 125 Rev 3           |                 | 00-05 | <b>RSI</b> <b>RSI</b> |
| 125 Rev 3           |                 | 06-08 | <b>RSI</b>            |
| 200 EVO             |                 | 09-14 | <b>RSI</b>            |
| 200 Rev 3           |                 | 06-08 | <b>RSI</b>            |
| 250 4-T Rev 3       |                 | 07-11 | <b>RSI</b>            |
| 250 EVO (2-T / 4-T) |                 | 09-14 | <b>RSI</b>            |
| 250 Rev 3           |                 | 00-04 | <b>RSI</b> <b>RSI</b> |
| 250 Rev 3           |                 | 05-09 | <b>RSI</b>            |
| 270 Rev 3           |                 | 00-04 | <b>RSI</b> <b>RSI</b> |
| 270 Rev 3           |                 | 05-08 | <b>RSI</b>            |
| 290 EVO             |                 | 09-13 | <b>RSI</b>            |



| <b>BETA</b>    |             |       |            |
|----------------|-------------|-------|------------|
| 300 EVO        |             | 09-15 | <b>RSI</b> |
| <b>GAS GAS</b> |             |       |            |
| TX             | 125 Randone | 12-13 | <b>RSI</b> |
| TXT            | 125         | 04-13 | <b>RSI</b> |
| TXT            | 200         | 04-10 | <b>RSI</b> |
| TXT            | 250         | 04-07 | <b>RSI</b> |
| TXT            | 280         | 04    | <b>RSI</b> |
| TXT            | 300         | 04-06 | <b>RSI</b> |
| TXT            | 300 Pro     | 07-11 | <b>RSI</b> |
| <b>HONDA</b>   |             |       |            |
| 250 Cota 4RT   |             | 04-16 | <b>RSI</b> |
| Cota 260 4RT   |             | 04-16 | <b>RSI</b> |
| <b>MONTESA</b> |             |       |            |
| 250 Cota 4RT   |             | 04-16 | <b>RSI</b> |
| Cota 260 4RT   |             | 04-16 | <b>RSI</b> |
| 360 315R       |             | 01-04 | <b>RSI</b> |
| <b>OSSA</b>    |             |       |            |
| TR             | 125 i       | 15    | <b>RSI</b> |
| TR             | 250 i       | 15    | <b>RSI</b> |
| TR             | 280 i       | 10-15 | <b>RSI</b> |



| <b>OSSA</b>   |                  |       |            |
|---------------|------------------|-------|------------|
| TR            | 280 i Explorer   | 12-15 | <b>RSI</b> |
| TR            | 300 i            | 15    | <b>RSI</b> |
| <b>SCORPA</b> |                  |       |            |
| SY            | 115 F Trial      | 06    | <b>RSI</b> |
|               | 125 Twenty Trial | 16-18 | <b>RSI</b> |
| SY            | 125 F Trial      | 06-11 | <b>RSI</b> |
|               | 250 Twenty Trial | 16-18 | <b>RSI</b> |
| SY            | 250 F Trial      | 06-11 | <b>RSI</b> |
| SY            | 250 Trial        | 00-01 | <b>RSI</b> |
|               | 300 Twenty Trial | 16-18 | <b>RSI</b> |
| <b>SHERCO</b> |                  |       |            |
| ST            | 125 1.25         | 06-11 | <b>RSI</b> |
| ST            | 250 2.5          | 01    | <b>RSI</b> |
| ST            | 290 2.9          | 01    | <b>RSI</b> |
| ST            | 300              | 16-18 | <b>RSI</b> |
| ST            | 320 3.2F         | 05    | <b>RSI</b> |
| <b>TRS</b>    |                  |       |            |
|               | 250 ONE          | 16-18 | <b>RSI</b> |
|               | 280 ONE          | 16-18 | <b>RSI</b> |
|               | 300 ONE          | 16-18 | <b>RSI</b> |

### SBS 803 Recommended compound



| <b>APRILIA</b>    |                    |       |                       |
|-------------------|--------------------|-------|-----------------------|
| 50 Mini RX        |                    | 04    | <b>RSI</b>            |
| <b>BETA</b>       |                    |       |                       |
| 50 ProRace 12/10  |                    | 04    | <b>RSI</b> <b>RSI</b> |
| <b>FACTORY</b>    |                    |       |                       |
| R12               | 50 Phantom Agua    | 06    | <b>RSI</b>            |
| R14               | 50 Phantom Agua    | 04    | <b>RSI</b>            |
| R2                | 65 Phantom         | 04    | <b>RSI</b>            |
| <b>GAS GAS</b>    |                    |       |                       |
| TX                | 125 Randone        | 12-13 | <b>RSI</b>            |
| TXT               | 125 (Formula cal.) | 12-13 | <b>RSI</b>            |
| TXT               | 125                | 04-13 | <b>RSI</b>            |
| TXT               | 125 Pro Racing     | 14    | <b>RSI</b>            |
| TXT               | 125 Pro Replica    | 13    | <b>RSI</b>            |
| TXT               | 200                | 04-10 | <b>RSI</b>            |
| TXT               | 250 (Formula cal.) | 12-13 | <b>RSI</b>            |
| TXT               | 250                | 04-07 | <b>RSI</b>            |
| TXT               | 250 Pro Racing     | 14-18 | <b>RSI</b>            |
| TXT               | 250 Pro Replica    | 13-14 | <b>RSI</b>            |
| TXT               | 280 (Formula cal.) | 12    | <b>RSI</b>            |
| TXT               | 280                | 04    | <b>RSI</b>            |
| TXT               | 280 Pro Racing     | 14-18 | <b>RSI</b>            |
| TXT               | 280 Pro Replica    | 13    | <b>RSI</b>            |
| TXT               | 300 (Formula cal.) | 12    | <b>RSI</b>            |
| TXT               | 300                | 04-06 | <b>RSI</b>            |
| TXT               | 300 Pro            | 07-11 | <b>RSI</b>            |
| TXT               | 300 Pro Racing     | 14-18 | <b>RSI</b>            |
| TXT               | 300 Pro Replica    | 13    | <b>RSI</b>            |
| <b>HONDA</b>      |                    |       |                       |
| 250 Cota 4RT      |                    | 04-16 | <b>RSI</b>            |
| Cota 260 4Ride    |                    | 16-18 | <b>RSI</b>            |
| Cota 260 4RT      |                    | 04-16 | <b>RSI</b>            |
| Cota 260 4RT Race |                    |       |                       |
| Replica           |                    | 15-18 | <b>RSI</b>            |
| Cota 300 RR       |                    | 16-18 | <b>RSI</b>            |
| 360 315R          |                    | 01-04 | <b>RSI</b>            |
| <b>OSSA</b>       |                    |       |                       |
| TR                | 125 i              | 15    | <b>RSI</b>            |
| TR                | 250 i              | 15    | <b>RSI</b>            |
| TR                | 280 i              | 10-15 | <b>RSI</b>            |
| TR                | 280 i Explorer     | 12-15 | <b>RSI</b>            |
| TR                | 300 Factory R      | 15    | <b>RSI</b>            |
| TR                | 300 i              | 15    | <b>RSI</b>            |
| <b>SCORPA</b>     |                    |       |                       |
| SY                | 115 F Trial        | 06    | <b>RSI</b>            |
| TY-S              | 115 F Trial        | 06    | <b>RSI</b>            |



| <b>HUSQVARNA</b>  |                |       |            |
|-------------------|----------------|-------|------------|
| CR                | 50 Junior      | 06    | <b>RSI</b> |
| CR                | 50 Pro Senior  | 06    | <b>RSI</b> |
| CR                | 50 Senior      | 06    | <b>RSI</b> |
| SM                | 50             | 10-12 | <b>HF</b>  |
| <b>JOTAGAS</b>    |                |       |            |
| JT                | 125            | 14-18 | <b>RSI</b> |
| JT                | 250            | 14-18 | <b>RSI</b> |
| JT                | 280            | 14-18 | <b>RSI</b> |
| JT                | 300            | 14-18 | <b>RSI</b> |
| <b>MACBOR</b>     |                |       |            |
| XC                | 50 510 Racing  | 04    | <b>RSI</b> |
| XC                | 50 512 Pro     | 04    | <b>RSI</b> |
| XC                | 50 512 Racing  | 04    | <b>RSI</b> |
| XC                | 50 512 T       | 04    | <b>RSI</b> |
| XC                | 50 515 R 6V    | 04    | <b>RSI</b> |
| <b>MONTESA</b>    |                |       |            |
| 250 Cota 4RT      |                | 04-16 | <b>RSI</b> |
| Cota 260 4Ride    |                | 16-18 | <b>RSI</b> |
| Cota 260 4RT      |                | 04-16 | <b>RSI</b> |
| Cota 260 4RT Race |                |       |            |
| Replica           |                | 15-18 | <b>RSI</b> |
| Cota 300 RR       |                | 16-18 | <b>RSI</b> |
| 360 315R          |                | 01-04 | <b>RSI</b> |
| <b>OSSA</b>       |                |       |            |
| TR                | 125 i          | 15    | <b>RSI</b> |
| TR                | 250 i          | 15    | <b>RSI</b> |
| TR                | 280 i          | 10-15 | <b>RSI</b> |
| TR                | 280 i Explorer | 12-15 | <b>RSI</b> |
| TR                | 300 Factory R  | 15    | <b>RSI</b> |
| TR                | 300 i          | 15    | <b>RSI</b> |
| <b>SCORPA</b>     |                |       |            |
| SY                | 115 F Trial    | 06    | <b>RSI</b> |
| TY-S              | 115 F Trial    | 06    | <b>RSI</b> |



| <b>SCORPA</b>    |                    |       |            |
|------------------|--------------------|-------|------------|
| 125 Twenty Trial |                    | 16-18 | <b>RSI</b> |
| SY               | 125 F Trial        | 06-11 | <b>RSI</b> |
| TY-S             | 125 F Trial        | 06-08 | <b>RSI</b> |
|                  | 250 Twenty Trial   | 16-18 | <b>RSI</b> |
| SY               | 250 F Trial        | 06-11 | <b>RSI</b> |
| SY               | 250 Trial          | 00-01 | <b>RSI</b> |
|                  | 300 Twenty Trial   | 16-18 | <b>RSI</b> |
| <b>SHERCO</b>    |                    |       |            |
| ST               | 80 (Formula cal.)  | 13-14 | <b>RSI</b> |
| ST               | 125 (Formula cal.) | 13-14 | <b>RSI</b> |
| ST               | 125 1.25           | 06-11 | <b>RSI</b> |
| ST               | 250 (Formula cal.) | 13-14 | <b>RSI</b> |
| ST               | 250 2.5            | 01    | <b>RSI</b> |
| ST               | 290 (Formula cal.) | 13-14 | <b>RSI</b> |
| ST               | 290 2.9            | 01    | <b>RSI</b> |
| ST               | 300                | 16-18 | <b>RSI</b> |
| ST               | 305 (Formula cal.) | 13-14 | <b>RSI</b> |
| ST               | 320 3.2F           | 05    | <b>RSI</b> |
| <b>TRS</b>       |                    |       |            |
|                  | 250 ONE            | 16-18 | <b>RSI</b> |
|                  | 280 ONE            | 16-18 | <b>RSI</b> |
|                  | 300 ONE            | 16-18 | <b>RSI</b> |
| <b>VERTIGO</b>   |                    |       |            |
| 300 Combat Camo  |                    |       |            |
| Works            |                    | 15-18 | <b>RSI</b> |
| 300 Combat Ice   |                    |       |            |
| Hell             |                    | 15-18 | <b>RSI</b> |
| 300 Combat RR    |                    | 15-18 | <b>RSI</b> |



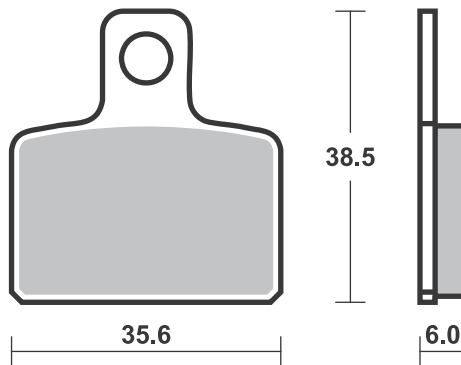
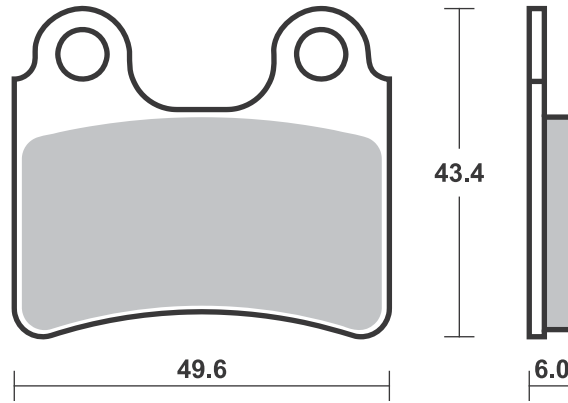

**SBS 805** Recommended compound



**A.P. RACING CALIPERS**

CP-6688 Four Pad Radial  
4 Piston Monoblock

**ACCOSSATO**

AGPZ01, 108 mm CNC  
Monoblock, 4 Piston/4 Pad  
AGPZ02, 108 mm Forged  
Monoblock, 4 Piston/4 Pad  
AGPZ03, 108 mm Forged  
Monoblock, 4 Piston/4 Pad  
AGPZ04, 108 mm Forged  
Monoblock, 4 Piston/4 Pad  
AGPZ06, 60 mm CNC Moto 3,  
2 Piston/2 Pad

**BREMBO RACING CALIPERS**

Radial Monoblock  
X99C460/61, P4 34

**PVM**

4 Pad Caliper

**SBS 806** Recommended compound



**KAWASAKI**

|        |                |        |           |
|--------|----------------|--------|-----------|
| Z      | 900 RS         | 18-    | <b>HS</b> |
| Z      | 900 RS Cafe    | 18-    | <b>HS</b> |
| Z      | 1000           | 10- 16 | <b>HS</b> |
| Z      | 1000 ABS       | 15- 18 | <b>HS</b> |
| Z      | 1000 SE        | 14- 16 | <b>HS</b> |
| Z      | 1000 SX        | 11- 18 | <b>HS</b> |
| ZX     | 1000 H2 SX     | 18-    | <b>HS</b> |
| ZX-10R | 1000 Ninja     | 08- 15 | <b>HS</b> |
| ZX-10R | 1000 Ninja ABS | 12- 15 | <b>SP</b> |

**SUZUKI**

|       |                   |        |           |
|-------|-------------------|--------|-----------|
| GSX-R | 600               | 04- 10 | <b>HS</b> |
| GSX-R | 750               | 04- 10 | <b>HS</b> |
| DL    | 1000 V-Strom      | 14- 18 | <b>SP</b> |
| DL    | 1000 V-Strom XT   | 17- 18 | <b>SP</b> |
| GSX-R | 1000              | 04- 11 | <b>HS</b> |
| GSX-R | 1300 Hayabusa     | 08- 12 | <b>HS</b> |
| M     | 1800 R Intruder   | 06- 16 | <b>HS</b> |
| M     | 1800 R2 Intruder  | 08- 10 | <b>HS</b> |
| M     | 1800 RBZ Intruder | 16- 17 | <b>HS</b> |

Brake Pad 1:1 Drawings,  
Compounds, Fitments

1 set = 4 pcs.

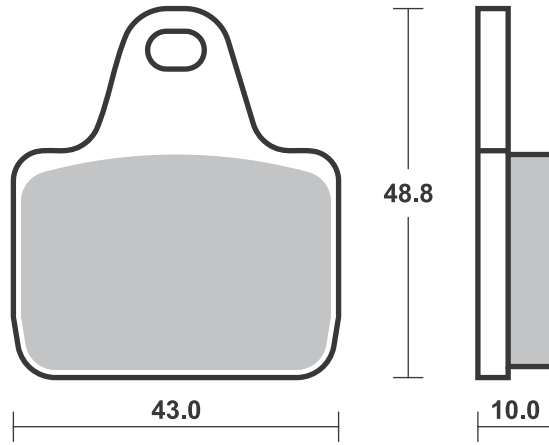

HS / SP - Th. 8.0  
RS / DC / DS - Th. 9.0

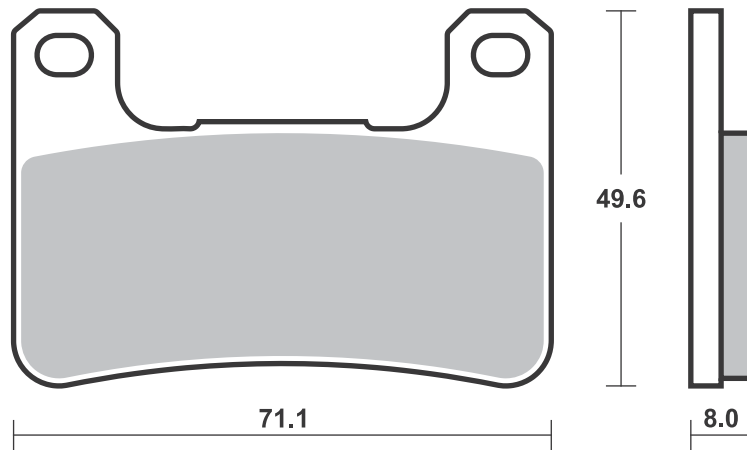

**SBS 807 Recommended compound**



| <b>HARLEY DAVIDSON</b> |                    |       |             |
|------------------------|--------------------|-------|-------------|
| XL                     | 883 C Sportster    |       |             |
|                        | Custom             | 04-13 | <b>H.HS</b> |
| XL                     | 883 L Sportster    |       |             |
|                        | Low                | 06-13 | <b>H.HS</b> |
| XL                     | 883 L Super Low    | 11-13 | <b>H.HS</b> |
| XL                     | 883 N Iron         | 13    | <b>H.HS</b> |
| XL                     | 883 R Roadster     | 10-13 | <b>H.HS</b> |
| XL                     | 883 Sportster      | 04-13 | <b>H.HS</b> |
| XL                     | 883 Sportster R    | 05-13 | <b>H.HS</b> |
| XL                     | 1200 C Sportster   |       |             |
|                        | Custom             | 04-13 | <b>H.HS</b> |
| XL                     | 1200 L Sportster   |       |             |
|                        | Low                | 07-10 | <b>H.HS</b> |
| XL                     | 1200 N Nightster   | 07-12 | <b>H.HS</b> |
| XL                     | 1200 R Sportster   |       |             |
|                        | Roadster           | 04-09 | <b>H.HS</b> |
| XL                     | 1200 V Seventy-Two | 11-13 | <b>H.HS</b> |
| XL                     | 1200 X Forty-Eight | 11-13 | <b>H.HS</b> |
|                        |                    |       |             |
|                        |                    |       |             |
|                        |                    |       |             |
|                        |                    |       |             |
|                        |                    |       |             |
|                        |                    |       |             |
|                        |                    |       |             |
|                        |                    |       |             |
|                        |                    |       |             |
|                        |                    |       |             |
|                        |                    |       |             |
|                        |                    |       |             |
|                        |                    |       |             |
|                        |                    |       |             |
|                        |                    |       |             |
|                        |                    |       |             |
|                        |                    |       |             |
|                        |                    |       |             |

**SBS 808 Recommended compound**



| <b>HARLEY DAVIDSON</b> |                    |       |             |
|------------------------|--------------------|-------|-------------|
| XL                     | 883 C Sportster    |       |             |
|                        | Custom             | 04-13 | <b>H.LS</b> |
| XL                     | 883 L Sportster    |       |             |
|                        | Low                | 06-13 | <b>H.LS</b> |
| XL                     | 883 L Super Low    | 11-13 | <b>H.LS</b> |
| XL                     | 883 N Iron         | 13    | <b>H.LS</b> |
| XL                     | 883 R Roadster     | 10-13 | <b>H.LS</b> |
| XL                     | 883 Sportster      | 04-13 | <b>H.LS</b> |
| XL                     | 883 Sportster R    | 05-13 | <b>H.LS</b> |
| XL                     | 1200 C Sportster   |       |             |
|                        | Custom             | 04-13 | <b>H.LS</b> |
| XL                     | 1200 L Sportster   |       |             |
|                        | Low                | 07-10 | <b>H.LS</b> |
| XL                     | 1200 N Nightster   | 07-12 | <b>H.LS</b> |
| XL                     | 1200 R Sportster   |       |             |
|                        | Roadster           | 04-09 | <b>H.LS</b> |
| XL                     | 1200 V Seventy-Two | 11-13 | <b>H.LS</b> |
| XL                     | 1200 X Forty-Eight | 11-13 | <b>H.LS</b> |
| XR                     | 1200               | 08-10 | <b>H.LS</b> |
| XR                     | 1200 X             | 10-13 | <b>H.LS</b> |
|                        |                    |       |             |
|                        |                    |       |             |
|                        |                    |       |             |
|                        |                    |       |             |
|                        |                    |       |             |
|                        |                    |       |             |
|                        |                    |       |             |
|                        |                    |       |             |
|                        |                    |       |             |
|                        |                    |       |             |
|                        |                    |       |             |
|                        |                    |       |             |
|                        |                    |       |             |
|                        |                    |       |             |
|                        |                    |       |             |
|                        |                    |       |             |
|                        |                    |       |             |
|                        |                    |       |             |
|                        |                    |       |             |
|                        |                    |       |             |
|                        |                    |       |             |
|                        |                    |       |             |
|                        |                    |       |             |

Brake Pad 1:1 Drawings, Compounds, Fitments

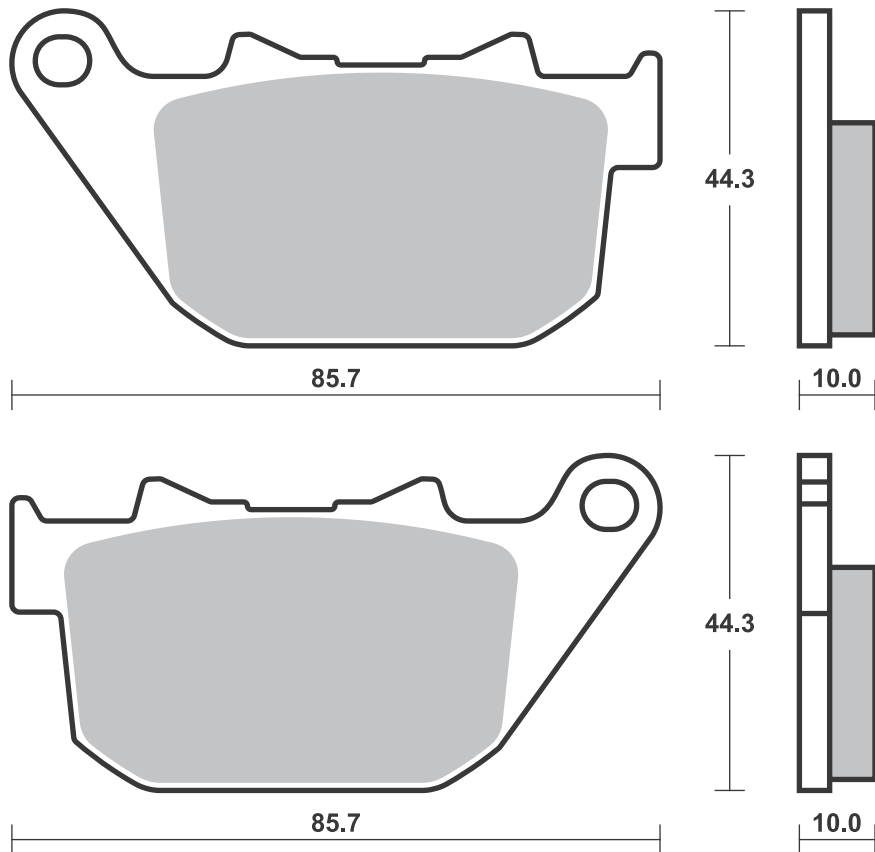
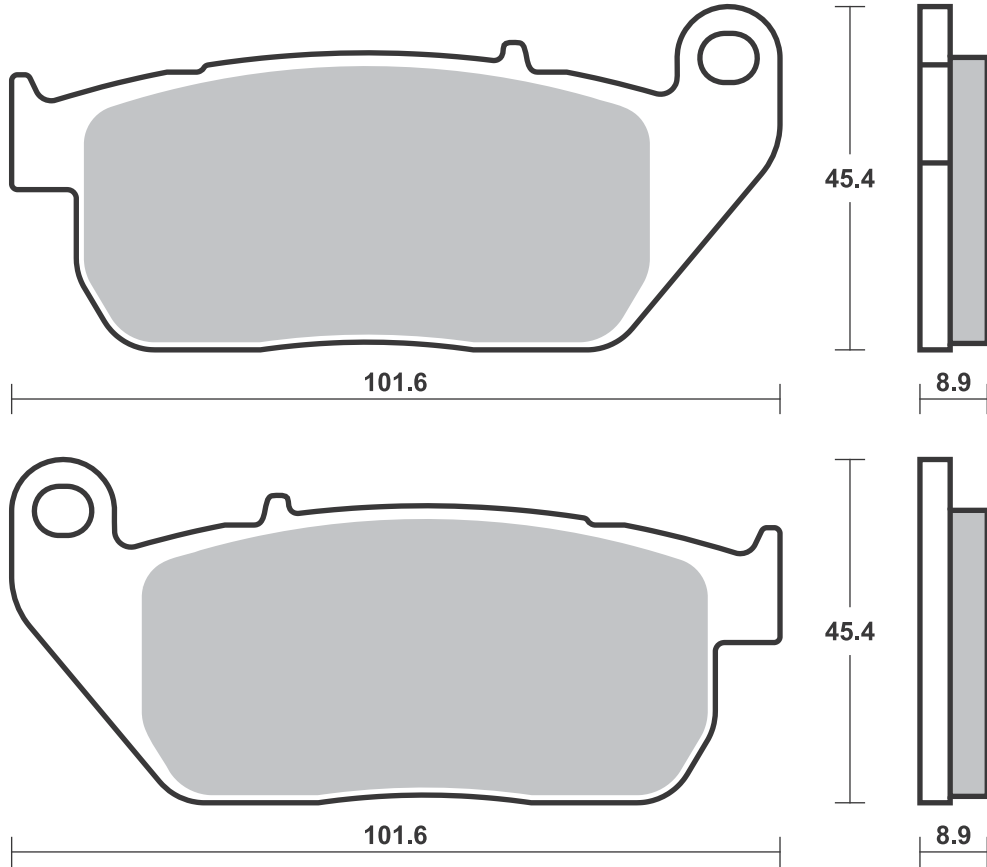



HS / SP - Th. 8.0  
RS / DC / DS - Th. 9.0

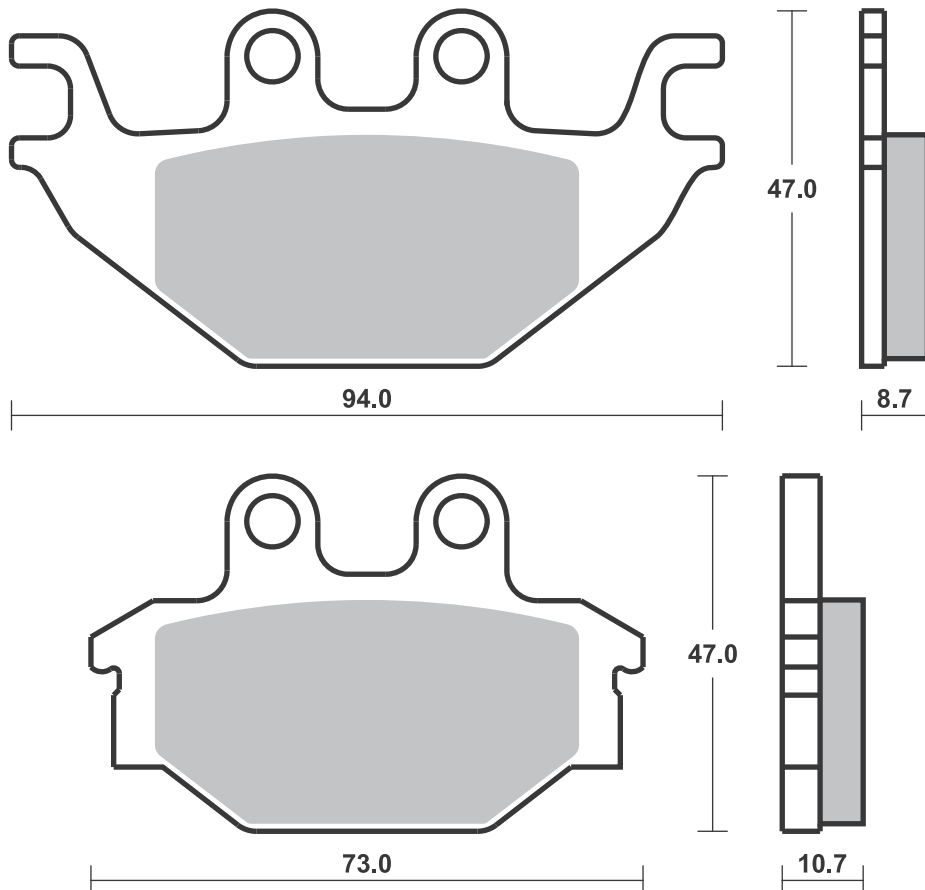
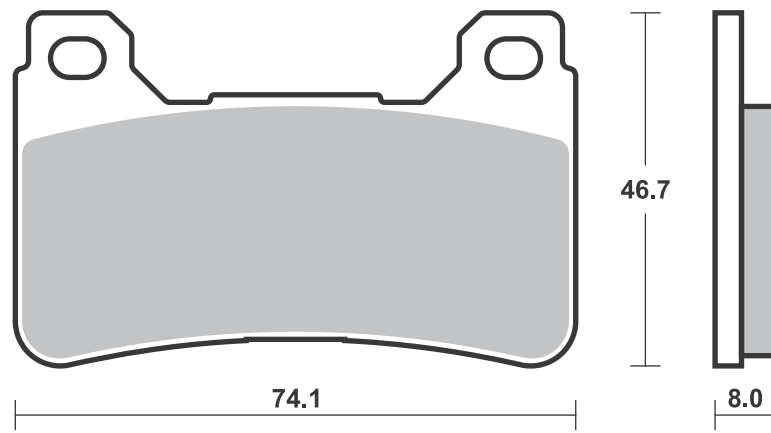





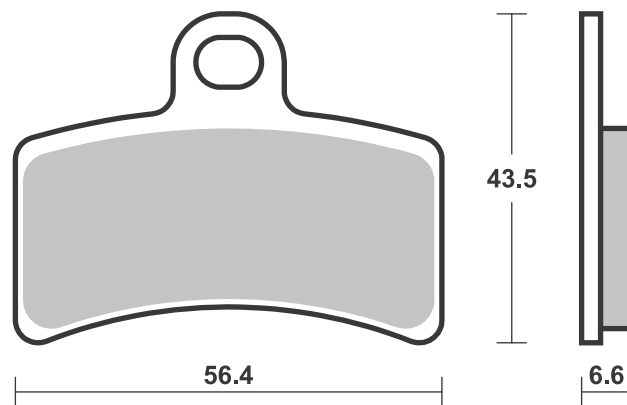
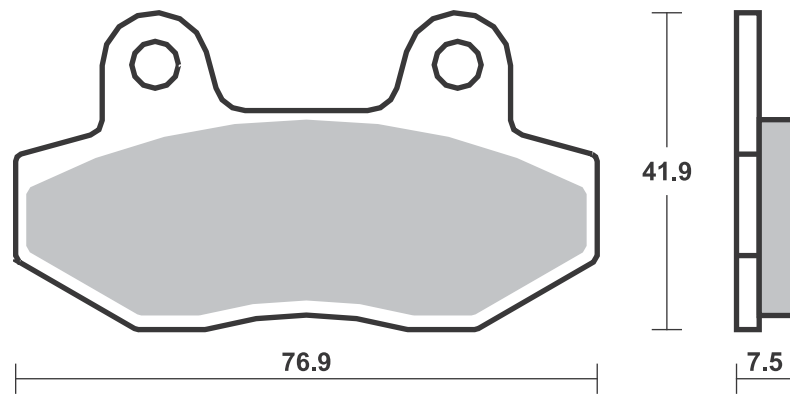
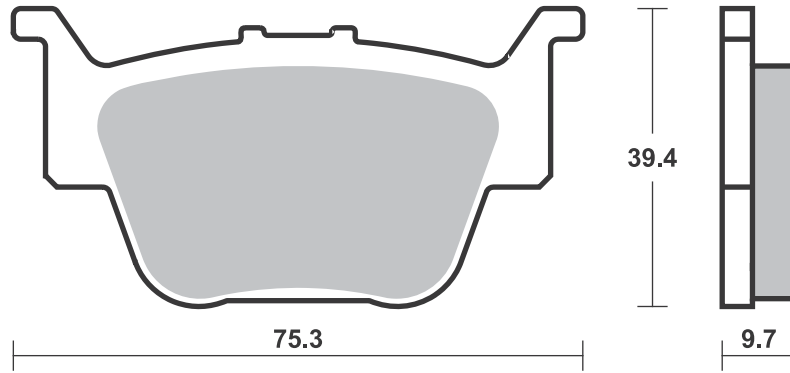



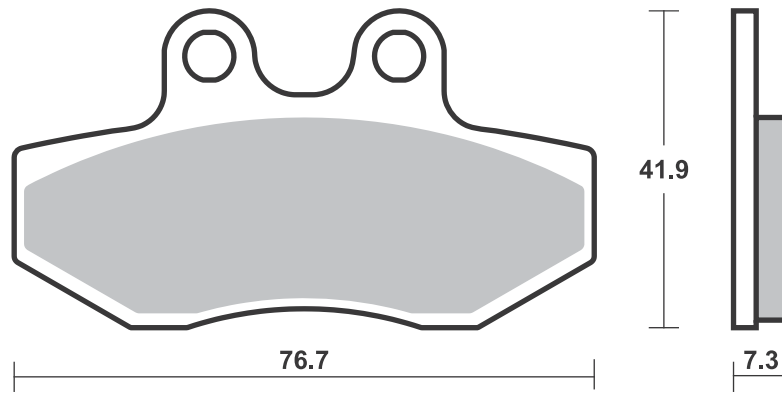
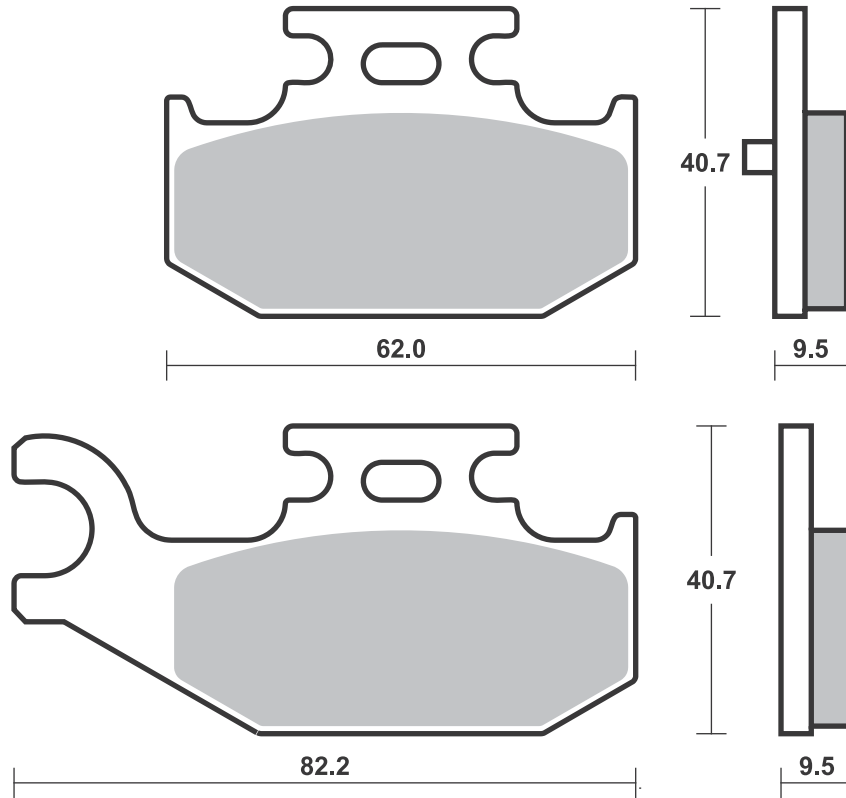

**SBS 820 Recommended compound**



**SUZUKI**

|    |        |       |     |
|----|--------|-------|-----|
| RM | 85 , L | 05-18 | RSI |
|    |        |       |     |
|    |        |       |     |
|    |        |       |     |
|    |        |       |     |
|    |        |       |     |
|    |        |       |     |
|    |        |       |     |
|    |        |       |     |
|    |        |       |     |
|    |        |       |     |
|    |        |       |     |
|    |        |       |     |
|    |        |       |     |
|    |        |       |     |
|    |        |       |     |
|    |        |       |     |
|    |        |       |     |
|    |        |       |     |
|    |        |       |     |
|    |        |       |     |
|    |        |       |     |
|    |        |       |     |

**SBS 821 Recommended compound**



**APRILIA**

|      |                  |       |    |
|------|------------------|-------|----|
|      | 125 Tuono ABS    | 17-18 | HS |
| RS-4 | 125 (AJP cal.)   | 11-18 | HS |
| RS-4 | 125 Replica, ABS | 16-18 | HS |

**BLATA**

|  |            |       |    |
|--|------------|-------|----|
|  | 125 Enduro | 07-08 | HS |
|  | 125 Motard | 07-08 | HS |

**DERBI**

|     |            |       |    |
|-----|------------|-------|----|
| GPR | 80 Cup     | 04-05 | HS |
| GPR | 125        | 05-06 | HS |
| GPR | 125 Nude   | 05-08 | HS |
| GPR | 125 Racing | 09    | HS |

**MALAGUTI**

|     |           |       |    |
|-----|-----------|-------|----|
| NKD | 50 Dragon | 06-09 | HS |
|-----|-----------|-------|----|

**MOTORHISPANIA**

|     |           |       |    |
|-----|-----------|-------|----|
| MH7 | 125 Naked | 08-14 | HS |
| RX  | 125 R     | 08-14 | HS |

**RIEJU**

|     |           |       |    |
|-----|-----------|-------|----|
|     | 125 Tango | 06-07 | HS |
| RS3 | 125       | 10-13 | HS |

**TOMOS**

|    |       |       |    |
|----|-------|-------|----|
| SM | 125 F | 06-08 | HS |
|    |       |       |    |
|    |       |       |    |
|    |       |       |    |

Brake Pad 1:1 Drawings, Compounds, Fitments

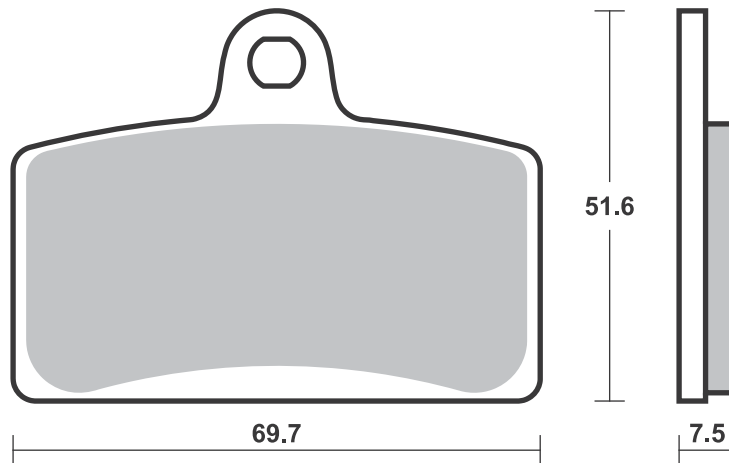
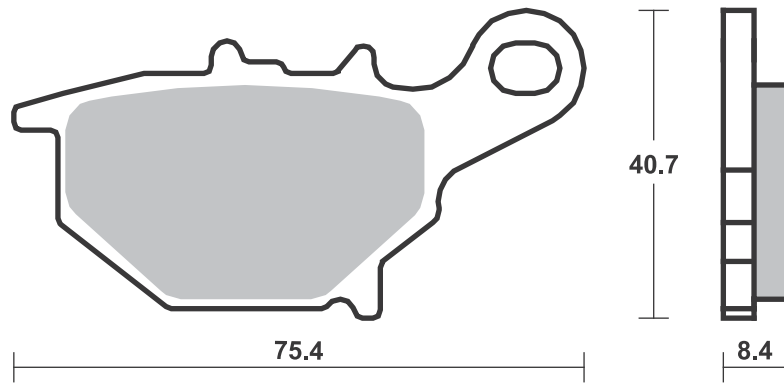
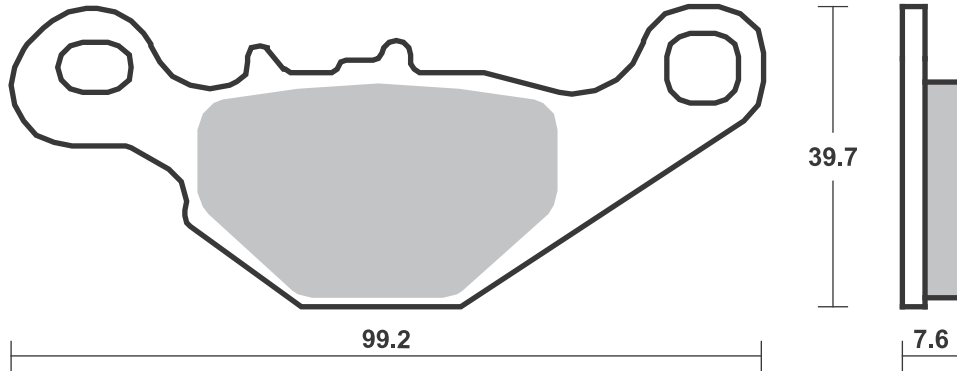

## Applications

### SBS 822 Recommended compound

| <b>ARCTIC CAT</b>  |       |     |     | <b>ARCTIC CAT</b>   |       |     |     |
|--------------------|-------|-----|-----|---------------------|-------|-----|-----|
| 250 2x4            | 05-06 | ATS | ATS | 700 Diesel          | 06-14 | ATS | ATS |
| 300 2x4            | 10-13 | ATS | ATS | 700 H1              | 09-10 | ATS | ATS |
| 300 4x4            | 05    | ATS | ATS | 700 Prowler         | 08    | ATS | ATS |
| 400 2x4/4x4 (FIS)  | 05-07 | ATS | ATS | 700 Wildcat Sport   | 15-16 | ATS |     |
| TRV 400            | 09-13 | ATS | ATS | 700 Wildcat Sport   |       |     |     |
| 450 H1             | 10    | ATS | ATS | LTD.                | 16    | ATS |     |
| XC 450             | 11-14 | ATS | ATS | 700 Wildcat Sport   |       |     |     |
| 500 2x4/4x4 (FIS)  | 05-09 | ATS | ATS | LTD. EPS            | 17    | ATS |     |
| 500 TBX 4x4        | 05-06 | ATS | ATS | 700 Wildcat Sport   |       |     |     |
| 500 TRV 4x4        | 05-06 | ATS | ATS | XT                  | 15    | ATS |     |
| 550 H1             | 09-13 | ATS | ATS | 700 Wildcat Sport   |       |     |     |
| 550 LTD            | 09-12 | ATS | ATS | XT EPS              | 16-17 | ATS |     |
| 550 Prowler        | 09-14 | ATS | ATS | TBX 700             | 12-14 | ATS | ATS |
| TRV 550            | 09-14 | ATS | ATS | TRV 700             | 09-12 | ATS | ATS |
| 650 H1 4x4 Aut.    | 05-11 | ATS | ATS | 1000 Prowler        | 09    | ATS | ATS |
| 650 Prowler        | 06-08 | ATS | ATS | 1000 Thundercat     | 09-14 | ATS | ATS |
| 650 V2 4x4 Aut.    | 05-06 | ATS | ATS | 1000 Wildcat 4X     | 16    | ATS |     |
| 650 V2 4x4 Aut. LE | 05-06 | ATS | ATS | 1000 Wildcat X      | 16    | ATS |     |
|                    |       |     |     | <b>ARCTIC CAT</b>   |       |     |     |
|                    |       |     |     | 1000 Wildcat X Ltd. | 17    | ATS |     |
|                    |       |     |     | 1000 Wildcat X SE   | 17    | ATS |     |
|                    |       |     |     | TRV 1000            | 09-14 | ATS | ATS |
|                    |       |     |     | <b>KYMCO</b>        |       |     |     |
|                    |       |     |     | 400 Maxxer          | 08-10 | ATS | ATS |
|                    |       |     |     | 400 MXU             | 08-11 | ATS | ATS |
|                    |       |     |     | 450 i Maxxer        | 10-14 | ATS | ATS |
|                    |       |     |     | 450 i MXU           | 11-14 | ATS | ATS |
|                    |       |     |     | <b>POLARIS</b>      |       |     |     |
|                    |       |     |     | 300 Hawkeye         |       |     |     |
|                    |       |     |     | 2x4, 4x4            | 06    | ATS | ATS |

### SBS 824 Recommended compound

| <b>APRILIA</b>   |                 |
|------------------|-----------------|
| RS 125 , Extrema | 93-98 <b>HF</b> |
| RS 125           | 99-05 <b>HF</b> |
| RS 125 Pista     | 05-07 <b>HF</b> |
|                  |                 |
|                  |                 |
|                  |                 |
|                  |                 |
|                  |                 |
|                  |                 |
|                  |                 |
|                  |                 |
|                  |                 |
|                  |                 |
|                  |                 |
|                  |                 |
|                  |                 |
|                  |                 |
|                  |                 |
|                  |                 |

### SBS 825 Recommended compound

| <b>NISSIN</b>           |  |
|-------------------------|--|
| 4 Piston Racing Caliper |  |
|                         |  |
|                         |  |
|                         |  |
|                         |  |
|                         |  |
|                         |  |
|                         |  |
|                         |  |
|                         |  |
|                         |  |
|                         |  |
|                         |  |
|                         |  |
|                         |  |
|                         |  |
|                         |  |

Brake Pad 1:1 Drawings,  
Compounds, Fitments

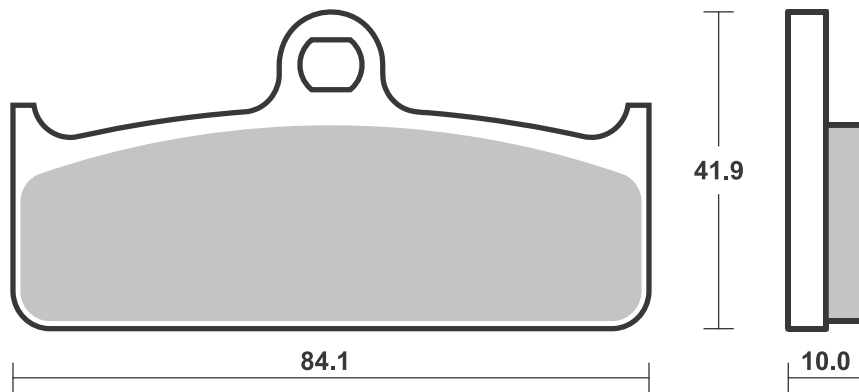
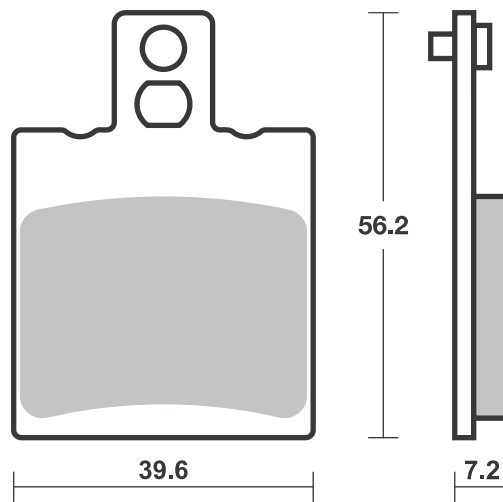
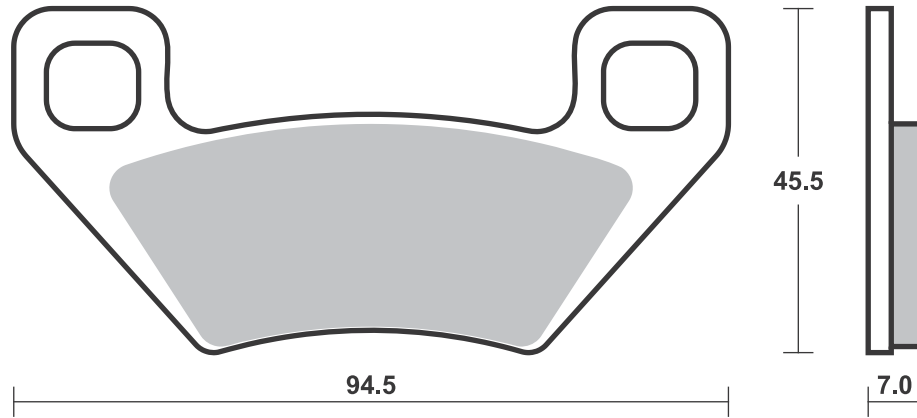

**HARLEY DAVIDSON**

|          |                |       |                  |
|----------|----------------|-------|------------------|
| XL       | 883 R          |       |                  |
|          | Sportster      | 00-03 | <b>H.HS H.LS</b> |
| XL       | 883 Sportster  |       |                  |
|          | Custom         | 00-03 | <b>H.HS H.LS</b> |
| XLH      | 883 Sportster  | 00-03 | <b>H.HS H.LS</b> |
| XLH      | 883 Sportster  |       |                  |
|          | Hugger         | 00-03 | <b>H.HS H.LS</b> |
| VRSCA    | 1130 V-Rod     | 02-05 | <b>H.HS H.LS</b> |
| VRSCB    | 1130 V-Rod     | 04    | <b>H.HS H.LS</b> |
| XL       | 1200 Sportster |       |                  |
|          | Custom         | 00-03 | <b>H.HS H.LS</b> |
| XL       | 1200 Sportster |       |                  |
|          | Sport          | 00-03 | <b>H.HS H.LS</b> |
| XLH      | 1200 Sportster | 00-03 | <b>H.HS H.LS</b> |
| FLHR/I   | 1450 Road King | 00-06 | <b>H.HS H.LS</b> |
| FLHRCI   | 1450 Road King |       |                  |
|          | Classic        | 00-06 | <b>H.HS H.LS</b> |
| FLHRS/I  | 1450 Road King |       |                  |
|          | King           |       |                  |
|          | Custom         | 04-06 | <b>H.HS H.LS</b> |
| FLHT/I   | 1450 Electra   |       |                  |
|          | Glide          |       |                  |
|          | Standard       | 00-06 | <b>H.HS H.LS</b> |
| FLHTC/I  | 1450 Electra   |       |                  |
|          | Glide          |       |                  |
|          | Classic        | 00-06 | <b>H.HS H.LS</b> |
| FLHTCUI  | 1450 Ultra     |       |                  |
|          | Classic        |       |                  |
|          | Electra        |       |                  |
|          | Glide          | 00-06 | <b>H.HS H.LS</b> |
| FLHXI    | 1450 Street    |       |                  |
|          | Glide          | 06    | <b>H.HS H.LS</b> |
| FLSTC    | 1450 Softail   | 06-07 | <b>H.HS H.LS</b> |
| FLSTC/I  | 1450 Heritage  |       |                  |
|          | Softail        |       |                  |
|          | Classic        | 00-04 | <b>H.HS H.LS</b> |
| FLSTCI   | 1450 Softail   | 06    | <b>H.HS H.LS</b> |
| FLSTF    | 1450 Fat Boy   | 06-07 | <b>H.HS H.LS</b> |
| FLSTF/I  | 1450 Fat Boy   | 00-04 | <b>H.HS H.LS</b> |
| FLSTFI   | 1450 Fat Boy   | 06    | <b>H.HS H.LS</b> |
| FLSTI    | 1450 Heritage  |       |                  |
|          | Softail        | 06    | <b>H.HS</b>      |
| FLSTN/I  | 1450 Softail   |       |                  |
|          | Deluxe         | 06    | <b>H.HS H.LS</b> |
| FLSTS/I  | 1450 Heritage  |       |                  |
|          | Springer       | 00-03 | <b>H.LS</b>      |
| FLSTSC/I | 1450 Springer  |       |                  |
|          | Softail        |       |                  |
|          | Classic        | 06    | <b>H.LS</b>      |
| FLTR/I   | 1450 Road      |       |                  |
|          | Glide          |       |                  |
|          | Classic        | 00-06 | <b>H.HS H.LS</b> |
| FXD      | 1450 Dyna      |       |                  |
|          | Super          |       |                  |
|          | Glide          | 00-03 | <b>H.HS H.LS</b> |
| FXDBI    | 1450 Dyna      |       |                  |
|          | Street Bob     | 06    | <b>H.HS H.LS</b> |
| FXDC/I   | 1450 Dyna      |       |                  |
|          | Super          |       |                  |
|          | Glide          |       |                  |
|          | Custom         | 05-06 | <b>H.HS H.LS</b> |
| FXDI     | 1450 35th      |       |                  |
|          | Anniversary    |       |                  |
|          | Super          |       |                  |
|          | Glide          | 06    | <b>H.HS</b>      |
| FXDI     | 1450 Dyna      |       |                  |
|          | Super          |       |                  |
|          | Glide          | 04-07 | <b>H.HS H.LS</b> |
| FXDL     | 1450 Dyna Low  |       |                  |
|          | Rider          | 00-03 | <b>H.HS H.LS</b> |



**HARLEY DAVIDSON**

|         |                  |       |                  |
|---------|------------------|-------|------------------|
| FXDLI   | 1450 Dyna Low    |       |                  |
|         | Rider            | 04-06 | <b>H.HS H.LS</b> |
| FXDS    | 1450 Dyna        |       |                  |
|         | Convertible      | 00-02 | <b>H.HS H.LS</b> |
| FXDWG   | 1450 Dyna Wide   |       |                  |
|         | Glide            | 00-03 | <b>H.HS H.LS</b> |
| FXDWGI  | 1450 Dyna Wide   |       |                  |
|         | Glide            | 04-06 | <b>H.HS H.LS</b> |
| FXDX    | 1450 Dyna        |       |                  |
|         | Super            |       |                  |
|         | Glide            |       |                  |
|         | Sport            | 00-03 | <b>H.HS H.LS</b> |
| FXDXI   | 1450 Dyna        |       |                  |
|         | Super            |       |                  |
|         | Glide            |       |                  |
|         | Sport            | 04-06 | <b>H.HS H.LS</b> |
| FXDXT   | 1450 Dyna        |       |                  |
|         | Super            |       |                  |
|         | Glide            |       |                  |
|         | T-Sport          | 00-03 | <b>H.HS H.LS</b> |
| FXST/I  | 1450 Softail     |       |                  |
|         | Standard         | 00-05 | <b>H.HS H.LS</b> |
| FXST/I  | 1450 Softail     |       |                  |
|         | Standard         | 06    | <b>H.HS</b>      |
| FXSTB/I | 1450 Night Train | 00-05 | <b>H.HS H.LS</b> |
| FXSTB/I | 1450 Night Train | 06    | <b>H.HS</b>      |
| FXSTD/I | 1450 Softail     |       |                  |
|         | Deuce            | 00-05 | <b>H.HS H.LS</b> |
| FXSTD/I | 1450 Softail     |       |                  |
|         | Deuce            | 06    | <b>H.HS</b>      |
| FXSTS/I | 1450 Softail     | 05    | <b>H.LS</b>      |
| FXSTS/I | 1450 Springer    |       |                  |
|         | Softail          | 00-04 | <b>H.LS</b>      |
| FLHR    | 1584 Road King   | 07    | <b>H.HS H.LS</b> |
| FLHRC   | 1584 Road King   |       |                  |
|         | Classic          | 07    | <b>H.HS H.LS</b> |
| FLHRS   | 1584 Road King   |       |                  |
|         | Custom           | 07    | <b>H.HS H.LS</b> |
| FLHT    | 1584 Electra     |       |                  |
|         | Glide            |       |                  |
|         | Standard         | 07    | <b>H.HS H.LS</b> |
| FLHTC   | 1584 Electra     |       |                  |
|         | Glide            |       |                  |
|         | Classic          | 07    | <b>H.HS H.LS</b> |
| FLHTCU  | 1584 Ultra       |       |                  |
|         | Classic          |       |                  |
|         | Electra          |       |                  |
|         | Glide            | 07-08 | <b>H.HS H.LS</b> |
| FLHX    | 1584 Street      |       |                  |
|         | Glide            | 07    | <b>H.HS H.LS</b> |
| FLSTC   | 1584 Heritage    |       |                  |
|         | Softail          |       |                  |
|         | Classic          | 07    | <b>H.HS</b>      |
| FLSTF   | 1584 Fat Boy     | 07    | <b>H.HS</b>      |
| FLSTN   | 1584 Softail     |       |                  |
|         | Deluxe           | 07    | <b>H.HS</b>      |
| FXD     | 1584 Dyna        |       |                  |
|         | Super            |       |                  |
|         | Glide            | 07    | <b>H.HS H.LS</b> |
| FXDB    | 1584 Dyna        |       |                  |
|         | Street Bob       | 07    | <b>H.HS H.LS</b> |
| FXDC    | 1584 Dyna        |       |                  |
|         | Super            |       |                  |
|         | Glide            |       |                  |
|         | Custom           | 07    | <b>H.HS H.LS</b> |
| FXDL    | 1584 Dyna        |       |                  |
|         | Low Rider        | 07    | <b>H.HS H.LS</b> |
| FXDWG   | 1584 Dyna        |       |                  |
|         | Wide             |       |                  |
|         | Glide            | 07    | <b>H.HS H.LS</b> |

**HARLEY DAVIDSON**

|       |                  |    |             |
|-------|------------------|----|-------------|
| FXST  | 1584 Softail     |    |             |
|       | Standard         | 07 | <b>H.HS</b> |
| FXSTB | 1584 Night Train | 07 | <b>H.HS</b> |
| FXSTC | 1584 Softail     |    |             |
|       | Custom           | 07 | <b>H.HS</b> |
| FXSTD | 1584 Softail     |    |             |
|       | Deuce            | 07 | <b>H.HS</b> |

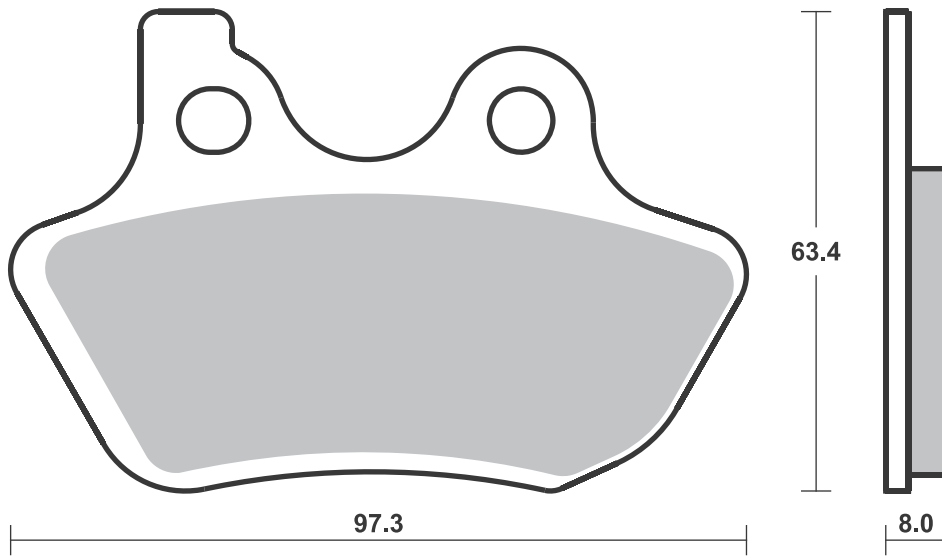
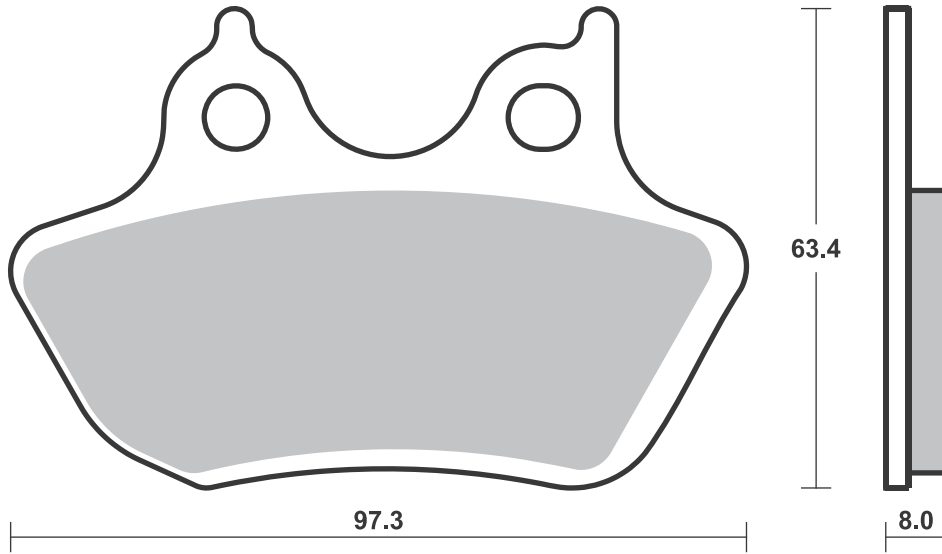



## Applications

### SBS 827 Recommended compound



| ARCTIC CAT                              |       |  |            |
|---|-------|--|------------|
| 250 2x4 (Man. Hand Brake)               | 99-04 |  | <b>ATS</b> |
| 250 4x4 (Man. Hand Brake)               | 00-04 |  | <b>ATS</b> |
| 300 2x4 (Man. Hand Brake)               | 98-04 |  | <b>ATS</b> |
| 300 4x4 (Man. Hand Brake)               | 98-05 |  | <b>ATS</b> |
| 375 2x4/4x4 (Man. Hand Brake)           | 02    |  | <b>ATS</b> |
| 400 2x4 (Man. Hand Brake)               | 98-02 |  | <b>ATS</b> |
| 400 2x4/4x4 (FIS) Aut.(Man. Hand Brake) | 03-04 |  | <b>ATS</b> |
| 400 2x4/4x4 (FIS) (Man. Hand Brake)     | 02-04 |  | <b>ATS</b> |
| 400 4x4 (Man. Hand Brake)               | 98-04 |  | <b>ATS</b> |
| 400 TBX 4x4 (Man. Hand Brake)           | 04    |  | <b>ATS</b> |
| 454 Bear Cat 2x4/4x4 (Man. Hand Brake)  | 98    |  | <b>ATS</b> |
| 500 2x4 (FIS)(Man. Hand Brake)          | 02    |  | <b>ATS</b> |
| 500 2x4 (Man. Hand Brake)               | 02    |  | <b>ATS</b> |



| ARCTIC CAT                           |       |  |            |
|--------------------------------------|-------|--|------------|
| 500 4x4 (FIS) Aut. (Man. Hand Brake) | 02-03 |  | <b>ATS</b> |
| 500 4x4 (FIS)(Man. Hand Brake)       | 02-03 |  | <b>ATS</b> |
| 500 4x4 (Man. Hand Brake)            | 98-02 |  | <b>ATS</b> |
| 500 TBX 4x4 (Man. Hand Brake)        | 03-04 |  | <b>ATS</b> |
| 500 TBX 4x4 Aut. (Man. Hand Brake)   | 02    |  | <b>ATS</b> |
| 500 TRV 4x4 (Man. Hand Brake)        | 03-04 |  | <b>ATS</b> |

### SBS 828 Recommended compound



| HONDA                        |       |  |              |
|------------------------------|-------|--|--------------|
| CBR 250 R ABS (Nissin cal)   | 11-13 |  | <b>HS</b>    |
| CBF 500 ABS                  | 04-08 |  | <b>HS</b>    |
| CB 600 Hornet ABS            | 07-12 |  | <b>HS</b>    |
| CBF 600 N ABS                | 08-11 |  | <b>HS</b>    |
| CBF 600 S ABS                | 08-11 |  | <b>HS</b>    |
| CBR 600 F ABS                | 11-13 |  | <b>HS</b>    |
| DN-01 680                    | 08-11 |  | <b>HS</b>    |
| NC 700 D Integra             | 12-13 |  | <b>HS</b>    |
| NC 700 SA ABS                | 12-13 |  | <b>HS</b>    |
| NC 700 SD ABS                | 12-13 |  | <b>HS</b>    |
| NC 700 XA ABS                | 12-13 |  | <b>HS</b>    |
| NC 700 XD ABS                | 12-13 |  | <b>HS</b>    |
| NT 700 Deauville ABS         | 06-12 |  | <b>HS</b>    |
| NT 700 V Varadero, ABS       | 10-13 |  | <b>HS</b>    |
| XL 700 Transalp ABS          | 08-12 |  | <b>HS</b>    |
| VT 750 C2S ABS               | 13-14 |  | <b>HS</b>    |
| VT 750 CS ABS                | 13-14 |  | <b>HS</b>    |
| VFR 800                      | 06-13 |  | <b>HS</b>    |
| VFR 800 ABS                  | 06-13 |  | <b>HS</b>    |
| VFR 800 Crossrunner          | 11-13 |  | <b>HS</b>    |
| CB 1000 R ABS                | 08-16 |  | <b>HS</b>    |
| CBF 1000 ABS                 | 06-11 |  | <b>HS LS</b> |
| CBF 1000 F ABS               | 15-18 |  | <b>HS</b>    |
| CBF 1000 Limited Edition ABS | 09-14 |  | <b>HS LS</b> |
| XL 1000 Varadero             | 07-13 |  | <b>SP</b>    |
| XL 1000 Varadero ABS         | 04-13 |  | <b>HS</b>    |
| CB 1100                      | 13    |  | <b>HS</b>    |
| VFR 1200 XC Crosstourer      | 12-18 |  | <b>SP</b>    |



| HONDA                          |       |  |           |
|--------------------------------|-------|--|-----------|
| VFR 1200 XDC Crosstourer w/DCT | 12-18 |  | <b>SP</b> |
| CB 1300 S                      | 11-15 |  | <b>HS</b> |
| CTX 1300                       | 14-18 |  | <b>HS</b> |
| ST 1300 Pan European, ABS      | 08-18 |  | <b>HS</b> |
| VT 1300 CXA A Fury ABS         | 10-18 |  | <b>HS</b> |

| SUZUKI            |       |  |           |
|-------------------|-------|--|-----------|
| C 1800 R Intruder | 08-11 |  | <b>HS</b> |

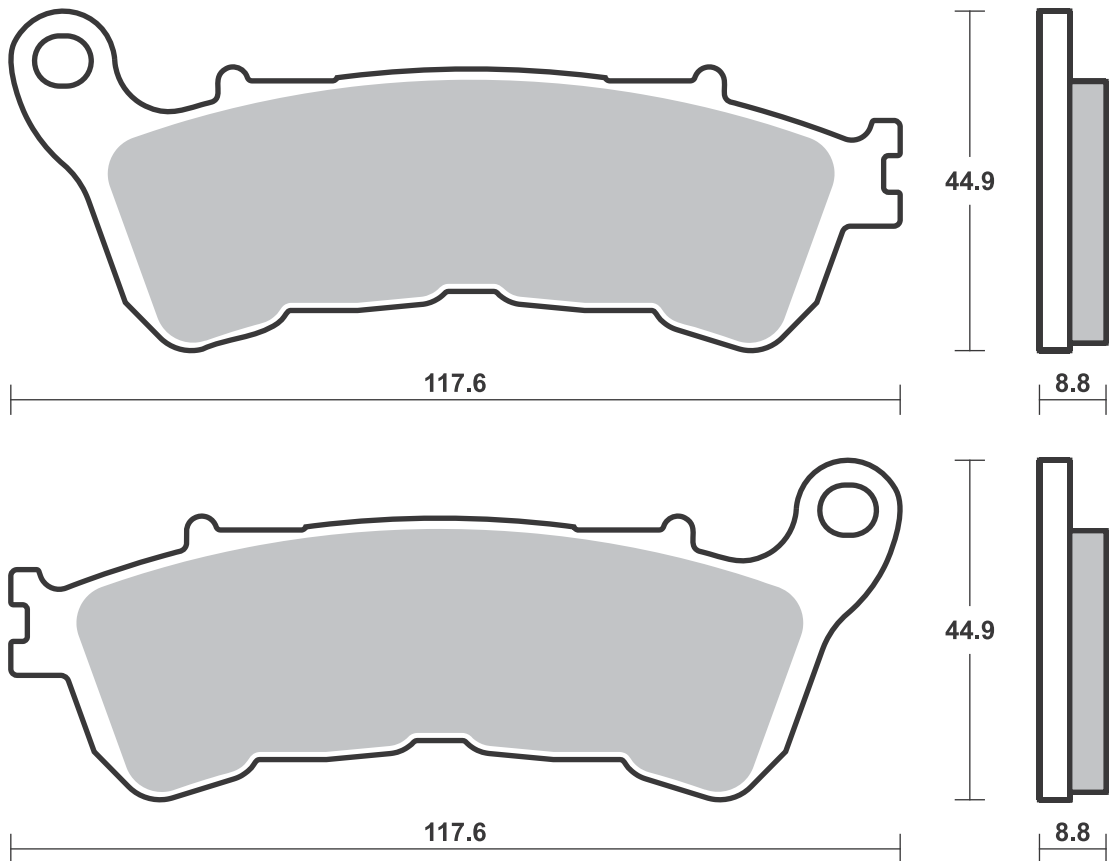
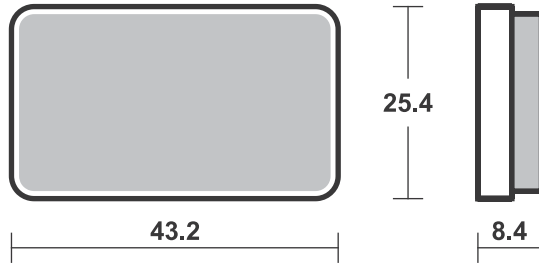

**SBS 829 Recommended compound**



| <b>HONDA</b> |                |       |           |
|--------------|----------------|-------|-----------|
| TRX          | 500 all models | 05-14 | <b>SI</b> |
| TRX          | 680 FA6        |       |           |
|              | Rincon         | 06-15 | <b>SI</b> |
| TRX          | 680 FGA6       |       |           |
|              | Rincon         | 06-15 | <b>SI</b> |
| TRX          | 700 XX         | 08-12 | <b>SI</b> |
|              |                |       |           |
|              |                |       |           |
|              |                |       |           |
|              |                |       |           |
|              |                |       |           |
|              |                |       |           |
|              |                |       |           |
|              |                |       |           |
|              |                |       |           |
|              |                |       |           |
|              |                |       |           |
|              |                |       |           |
|              |                |       |           |
|              |                |       |           |

**SBS 830 Recommended compound**



| <b>HARLEY DAVIDSON</b> |                |       |                  |
|------------------------|----------------|-------|------------------|
| VRSCA                  | 1130 V-Rod     | 06-10 | <b>H.HS H.LS</b> |
| VRSCD                  | 1130 Night     |       |                  |
|                        | Rod            | 06-08 | <b>H.HS H.LS</b> |
| VRSCR                  | 1130 Street    |       |                  |
|                        | Rod            | 06-07 | <b>H.HS H.LS</b> |
| VRSCAW                 | 1250 V-Rod     | 08-10 | <b>H.HS H.LS</b> |
| VRSCDX                 | 1250 Night     |       |                  |
|                        | Rod            |       |                  |
|                        | Special        | 08-17 | <b>H.HS H.LS</b> |
| VRSCF                  | 1250 Muscle    | 09-17 | <b>H.HS H.LS</b> |
| VRSCX                  | 1250 V-Rod     | 08-10 | <b>H.HS H.LS</b> |
| FLHR                   | 1584 Road      |       |                  |
|                        | King           | 08-10 | <b>H.HS H.LS</b> |
| FLHRC                  | 1584 Road      |       |                  |
|                        | King           |       |                  |
|                        | Classic        | 08-10 | <b>H.HS H.LS</b> |
| FLHT                   | 1584 Electra   |       |                  |
|                        | Glide          |       |                  |
|                        | Standard       | 08-10 | <b>H.HS H.LS</b> |
| FLHTC                  | 1584 Electra   |       |                  |
|                        | Glide          |       |                  |
|                        | Classic        | 08-10 | <b>H.HS H.LS</b> |
| FLHTCi                 | 1584 Ultra     |       |                  |
|                        | Electra        |       |                  |
|                        | Glide          |       |                  |
|                        | Classic        | 08-10 | <b>H.HS H.LS</b> |
| FLHTCU                 | 1584 Ultra     |       |                  |
|                        | Classic        |       |                  |
|                        | Electra        |       |                  |
|                        | Glide          | 09-10 | <b>H.HS H.LS</b> |
| FLHTK                  | 1584 Electra   |       |                  |
|                        | Glide Ultra    |       |                  |
|                        | LTD            | 10    | <b>H.HS H.LS</b> |
| FLHX                   | 1584 Street    |       |                  |
|                        | Glide          | 08-10 | <b>H.HS H.LS</b> |
| FLTR                   | 1584 Road      |       |                  |
|                        | Glide          | 08-10 | <b>H.HS H.LS</b> |
| FLTRU                  | 1584 Road      |       |                  |
|                        | Glide Ultra    | 11-16 | <b>H.HS H.LS</b> |
| FLTRX                  | 1584 Road      |       |                  |
|                        | Glide          |       |                  |
|                        | Custom         | 10    | <b>H.HS H.LS</b> |
| FLHR                   | 1690 Road King | 11-16 | <b>H.HS H.LS</b> |



| <b>HARLEY DAVIDSON</b> |                |       |                  |
|------------------------|----------------|-------|------------------|
| FLHTCU                 | 1690 Ultra     |       |                  |
|                        | Classic        |       |                  |
|                        | Electra        |       |                  |
|                        | Glide          | 11-16 | <b>H.HS H.LS</b> |
| FLHTCUL                | 1690 Electra   |       |                  |
|                        | Glide          |       |                  |
|                        | Ultra          |       |                  |
|                        | Classic        |       |                  |
|                        | Low            | 15-16 | <b>H.HS H.LS</b> |
| FLHTCUTG               | 1690 Tri Glide |       |                  |
|                        | Ultra          |       |                  |
|                        | Classic        |       |                  |
|                        | Trike          | 09-13 | <b>H.HS</b>      |
| FLHTK                  | 1690 Ultra     |       |                  |
|                        | Classic        |       |                  |
|                        | Electra        |       |                  |
|                        | Glide          | 10-16 | <b>H.HS H.LS</b> |
| FLHTKL                 | 1690 Ultra     |       |                  |
|                        | Limited        |       |                  |
|                        | Low            | 15-16 | <b>H.HS H.LS</b> |
| FLHX                   | 1690 Street    |       |                  |
|                        | Glide          | 11-16 | <b>H.HS H.LS</b> |
| FLHXS                  | 1690 Street    |       |                  |
|                        | Glide          |       |                  |
|                        | Special        | 14-16 | <b>H.HS H.LS</b> |
| FLHXXX                 | 1690 Street    |       |                  |
|                        | Glide          |       |                  |
|                        | Trike          | 10-11 | <b>H.HS</b>      |
| FLTRX                  | 1690 Road      |       |                  |
|                        | Glide          | 15-16 | <b>H.HS H.LS</b> |
| FLTRXS                 | 1690 Road      |       |                  |
|                        | Glide          |       |                  |
|                        | Special        | 15-16 | <b>H.HS H.LS</b> |
| FLHR                   | 1750 Road      |       |                  |
|                        | King           | 17-18 | <b>H.HS H.LS</b> |
| FLHRC                  | 1750 Road      |       |                  |
|                        | King           |       |                  |
|                        | Classic        | 17    | <b>H.HS H.LS</b> |
| FLHRXS                 | 1750 Road      |       |                  |
|                        | King           |       |                  |
|                        | Special        | 18-   | <b>H.HS</b>      |



| <b>HARLEY DAVIDSON</b> |                   |       |                  |
|------------------------|-------------------|-------|------------------|
| FLHTCU                 | 1750 Ultra        |       |                  |
|                        | Classic           |       |                  |
|                        | Electra           |       |                  |
|                        | Glide             | 17-18 | <b>H.HS H.LS</b> |
| FLHTK                  | 1750 Ultra        |       |                  |
|                        | Limited           | 17-18 | <b>H.HS H.LS</b> |
| FLHTKL                 | 1750 Ultra        |       |                  |
|                        | Limited           |       |                  |
|                        | Low               | 17-18 | <b>H.HS H.LS</b> |
| FLHX                   | 1750 Street       |       |                  |
|                        | Glide             | 17-18 | <b>H.HS H.LS</b> |
| FLHX                   | 1750 Street Glide |       |                  |
|                        | Special           | 17-18 | <b>H.HS H.LS</b> |
| FLHXS                  | 1750 Street Glide |       |                  |
|                        | Special           | 17-18 | <b>H.HS H.LS</b> |
| FLTRU                  | 1750 Road Glide   |       |                  |
|                        | Ultra             | 17-18 | <b>H.HS H.LS</b> |
| FLTRX                  | 1750 Road Glide   | 17-18 | <b>H.HS H.LS</b> |
| FLTRXS                 | 1750 Road Glide   |       |                  |
|                        | Special           | 17-18 | <b>H.HS H.LS</b> |
| FLHRSE5                | 1802 CVO Road     |       |                  |
|                        | King              | 14-15 | <b>H.HS H.LS</b> |
| FLHTKSE                | 1802 CVO          |       |                  |
|                        | Limited           | 14-16 | <b>H.HS H.LS</b> |
| FLHXSE                 | 1802 CVO Street   |       |                  |
|                        | Glide             | 10-16 | <b>H.HS H.LS</b> |
| FLTRUSE                | 1802 CVO Road     |       |                  |
|                        | Glide Ultra       | 11-16 | <b>H.HS H.LS</b> |
| FLHTKSE                | 1870 CVO          |       |                  |
|                        | Limited           | 17    | <b>H.HS H.LS</b> |
| FLHXSE                 | 1870 CVO Street   |       |                  |
|                        | Glide             | 17    | <b>H.HS H.LS</b> |
| FLHTKSE                | 1917 CVO          |       |                  |
|                        | Limited           | 18-   | <b>H.HS H.LS</b> |
| FLHXSE                 | 1917 CVO Street   |       |                  |
|                        | Glide             | 18-   | <b>H.HS H.LS</b> |
| FLTRXSE                | 1917 CVO Road     |       |                  |
|                        | Glide             | 18-   | <b>H.HS H.LS</b> |

Brake Pad 1:1 Drawings, Compounds, Fitments

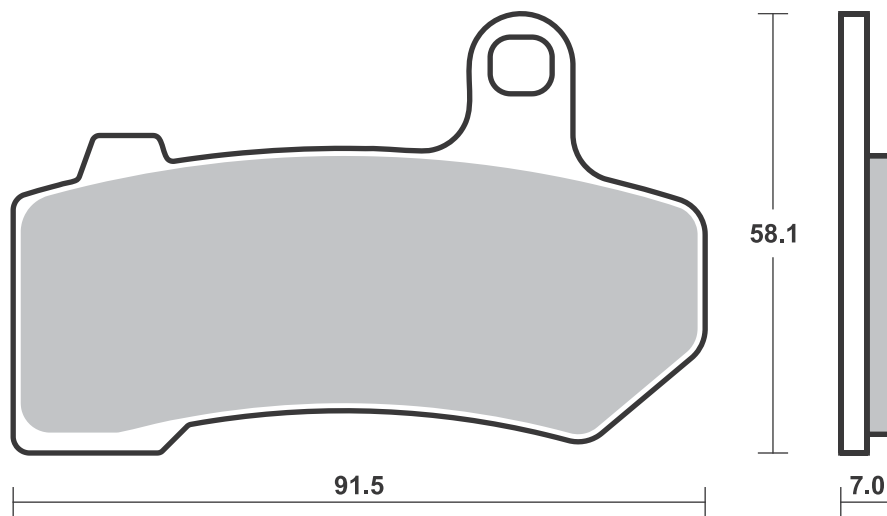
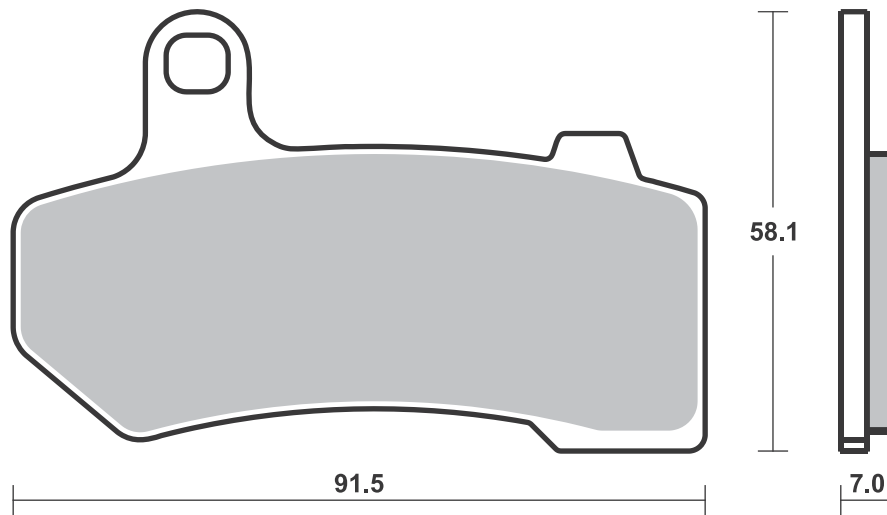
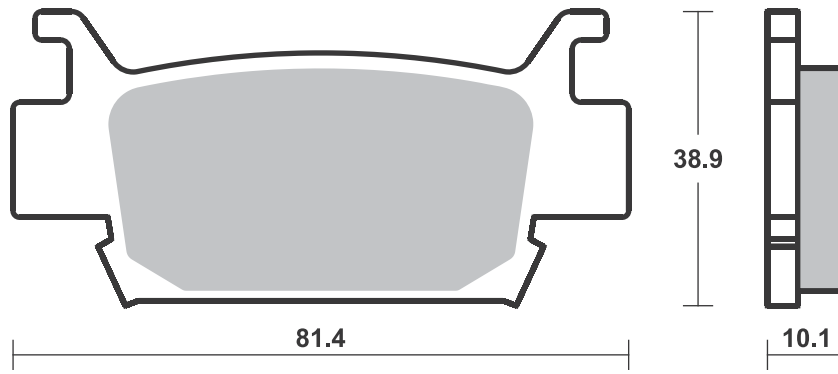

**SBS 832**

**Recommended compound**



**BENELLI**

|     |                    |     |           |
|-----|--------------------|-----|-----------|
|     | 250 Leoncino       | 18- | <b>LS</b> |
| BN  | 302                | 15  | <b>LS</b> |
| BN  | 302 Tornado        | 16  | <b>LS</b> |
|     | 402 S              | 18- | <b>LS</b> |
|     | 500 Leoncino       |     |           |
|     | Cinquecento        | 18- | <b>LS</b> |
|     | 500 Leoncino Trail | 18- | <b>LS</b> |
| TRK | 502                | 18- | <b>LS</b> |
|     | 752 S              | 18- | <b>LS</b> |
|     |                    |     |           |
|     |                    |     |           |
|     |                    |     |           |
|     |                    |     |           |
|     |                    |     |           |
|     |                    |     |           |
|     |                    |     |           |
|     |                    |     |           |
|     |                    |     |           |
|     |                    |     |           |
|     |                    |     |           |
|     |                    |     |           |
|     |                    |     |           |
|     |                    |     |           |
|     |                    |     |           |
|     |                    |     |           |
|     |                    |     |           |
|     |                    |     |           |
|     |                    |     |           |
|     |                    |     |           |
|     |                    |     |           |

**SBS 833**

**Recommended compound**



**SUZUKI**

|       |                 |       |           |
|-------|-----------------|-------|-----------|
| GSR   | 600             | 06-10 | <b>LS</b> |
| GSX-R | 600             | 06-10 | <b>LS</b> |
| GSX-R | 750             | 06-10 | <b>LS</b> |
| DL    | 1000 V-Strom    | 14-18 | <b>LS</b> |
| DL    | 1000 V-Strom XT | 17-18 | <b>LS</b> |
| GSX-R | 1000            | 07-08 | <b>LS</b> |
| GSX-R | 1300 Hayabusa   | 08-12 | <b>LS</b> |
| GSX-R | 1300 Hayabusa   | 13-18 | <b>LS</b> |
|       | 1340 B-King     | 08-14 | <b>LS</b> |
|       |                 |       |           |
|       |                 |       |           |
|       |                 |       |           |
|       |                 |       |           |
|       |                 |       |           |
|       |                 |       |           |
|       |                 |       |           |
|       |                 |       |           |
|       |                 |       |           |
|       |                 |       |           |
|       |                 |       |           |
|       |                 |       |           |
|       |                 |       |           |
|       |                 |       |           |
|       |                 |       |           |
|       |                 |       |           |
|       |                 |       |           |
|       |                 |       |           |
|       |                 |       |           |
|       |                 |       |           |
|       |                 |       |           |
|       |                 |       |           |
|       |                 |       |           |
|       |                 |       |           |
|       |                 |       |           |
|       |                 |       |           |
|       |                 |       |           |
|       |                 |       |           |
|       |                 |       |           |

Brake Pad 1:1 Drawings,  
Compounds, Fitments

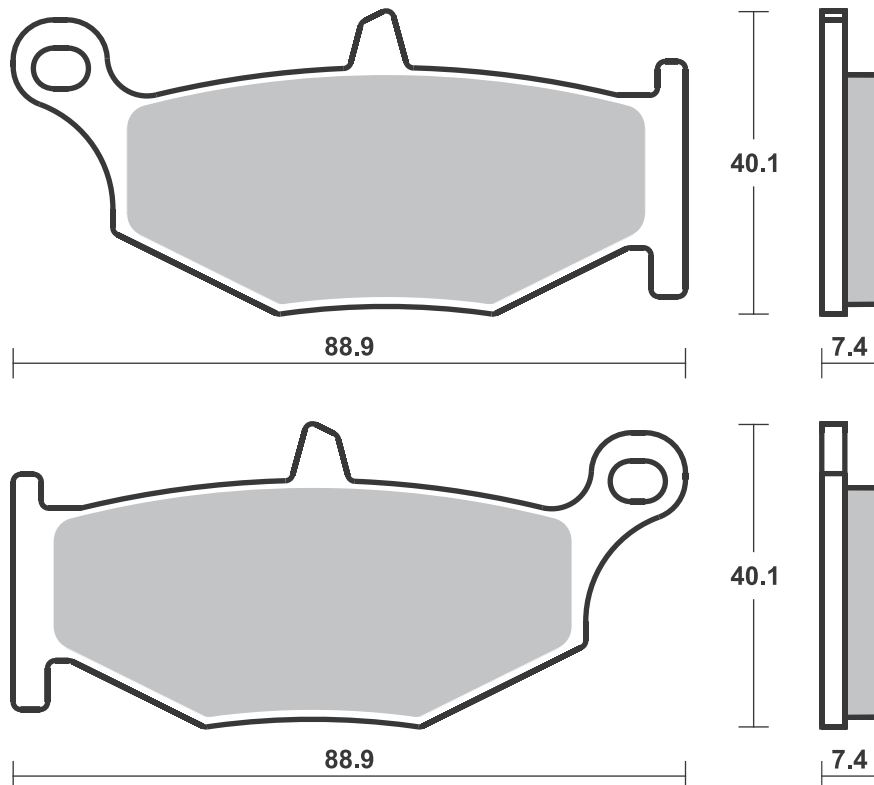
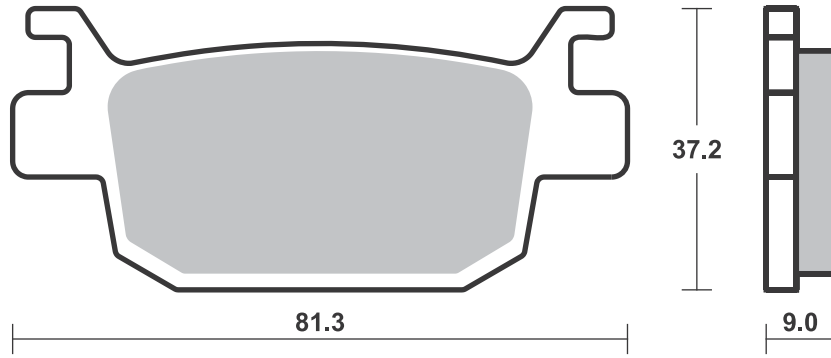





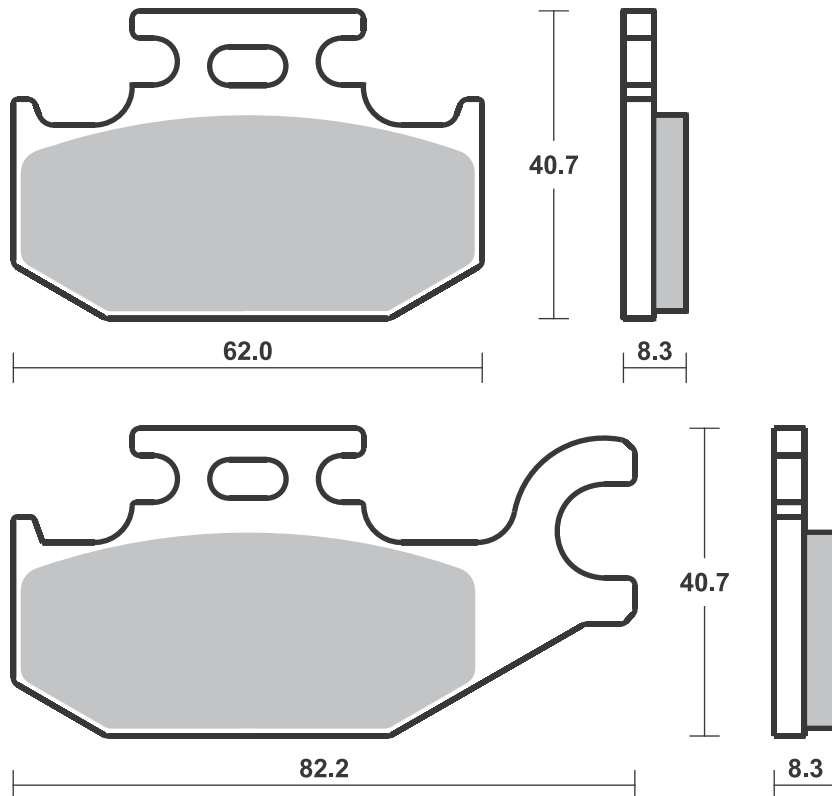
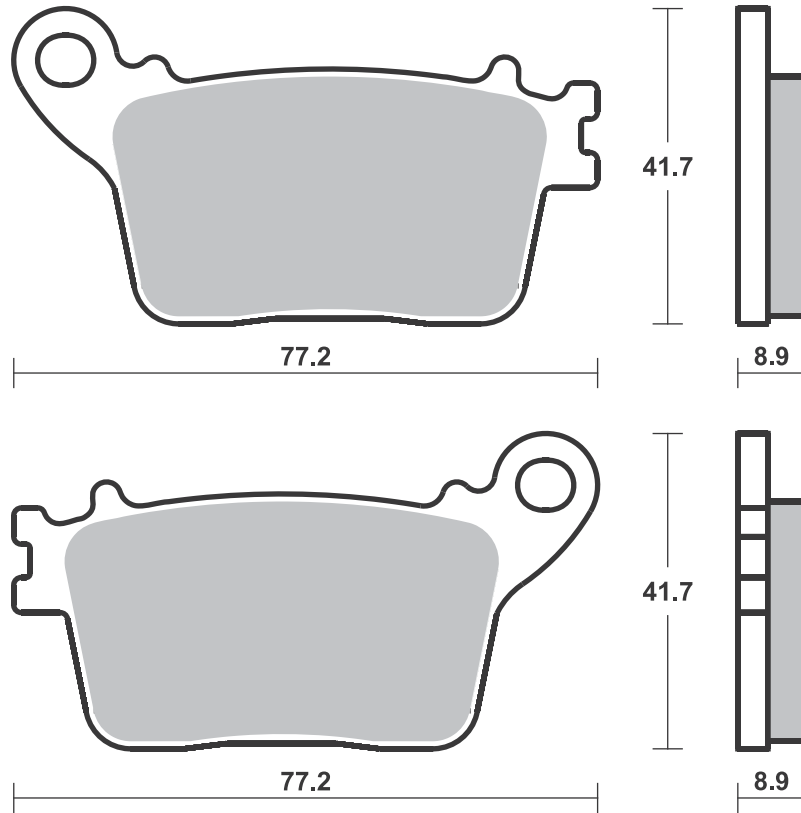

**SBS 836**

Recommended compound



| <b>SUZUKI</b> |               |       |           |
|---------------|---------------|-------|-----------|
| KLT-A         | 400 King Quad |       |           |
|               | Right         | 08-14 | <b>SI</b> |
| KLT-F         | 400 King Quad |       |           |
|               | Right         | 08-14 | <b>SI</b> |
| LT-A          | 400 King Quad |       |           |
|               | Right         | 08-14 | <b>SI</b> |
| LT-F          | 400 King Quad |       |           |
|               | Right         | 08-14 | <b>SI</b> |
| LT-A          | 450 King Quad |       |           |
|               | Right         | 08-14 | <b>SI</b> |
| LT-A          | 500 King Quad |       |           |
|               | Right         | 11-14 | <b>SI</b> |
| LT-A          | 700 King Quad |       |           |
|               | Right         | 05-11 | <b>SI</b> |
| LT-A          | 750 King Quad |       |           |
|               | Right         | 08-14 | <b>SI</b> |
|               |               |       |           |
|               |               |       |           |
|               |               |       |           |
|               |               |       |           |
|               |               |       |           |
|               |               |       |           |
|               |               |       |           |
|               |               |       |           |
|               |               |       |           |
|               |               |       |           |
|               |               |       |           |
|               |               |       |           |
|               |               |       |           |
|               |               |       |           |
|               |               |       |           |
|               |               |       |           |
|               |               |       |           |
|               |               |       |           |

**SBS 838**

Recommended compound



| <b>KAWASAKI</b> |             |       |           |
|-----------------|-------------|-------|-----------|
| ZX-6R           | 600 Ninja   | 07-17 | <b>HS</b> |
| Z               | 750 R       | 11-12 | <b>HS</b> |
| Z               | 1000        | 07-09 | <b>HS</b> |
| GTR             | 1400        | 07-16 | <b>HS</b> |
| GTR             | 1400 ABS    | 07-16 | <b>HS</b> |
| ZZR             | 1400        | 06-14 | <b>HS</b> |
| ZZR             | 1400 ABS    | 06-14 | <b>HS</b> |
| <b>SUZUKI</b>   |             |       |           |
|                 | 1300 B-King | 07    | <b>HS</b> |
|                 |             |       |           |
|                 |             |       |           |
|                 |             |       |           |
|                 |             |       |           |
|                 |             |       |           |
|                 |             |       |           |
|                 |             |       |           |
|                 |             |       |           |
|                 |             |       |           |
|                 |             |       |           |
|                 |             |       |           |
|                 |             |       |           |
|                 |             |       |           |
|                 |             |       |           |
|                 |             |       |           |
|                 |             |       |           |
|                 |             |       |           |
|                 |             |       |           |
|                 |             |       |           |
|                 |             |       |           |
|                 |             |       |           |
|                 |             |       |           |
|                 |             |       |           |

Brake Pad 1:1 Drawings, Compounds, Fitments

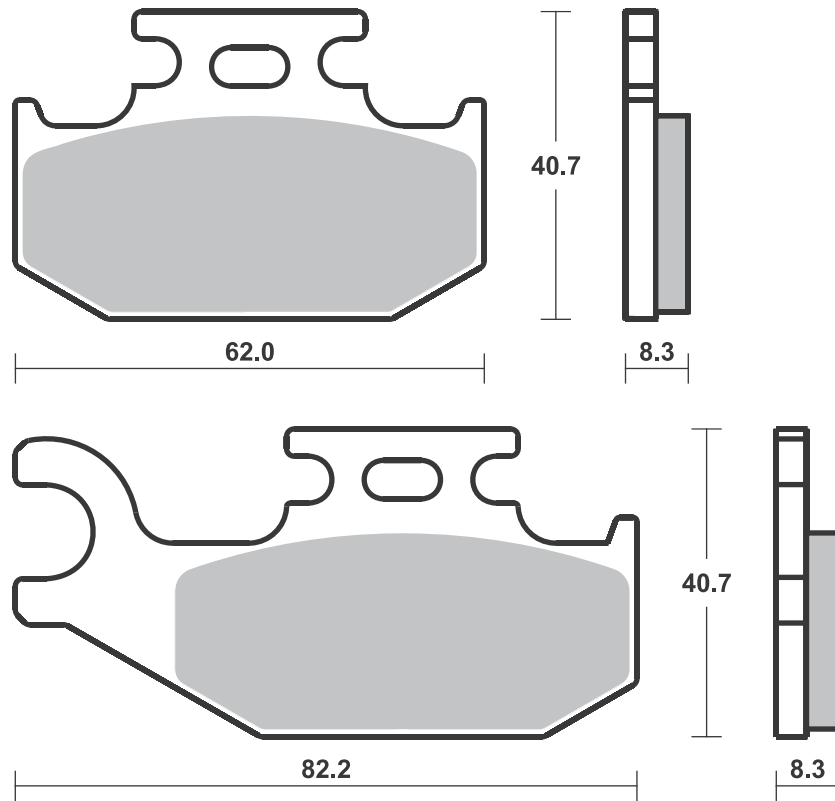

1 set = 4 pcs.

HS / SP - Th. 7.8  
RS / DC / DS - Th. 9.0

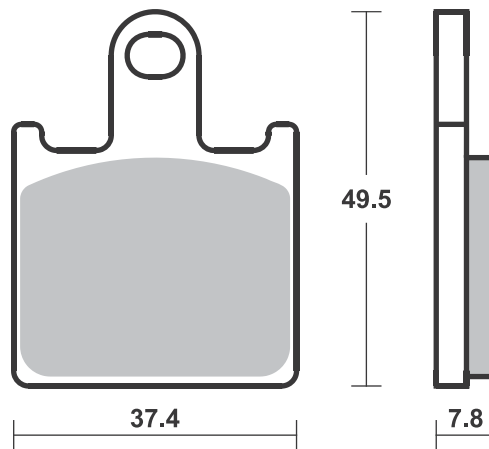



1 set = 2 pcs. small / large

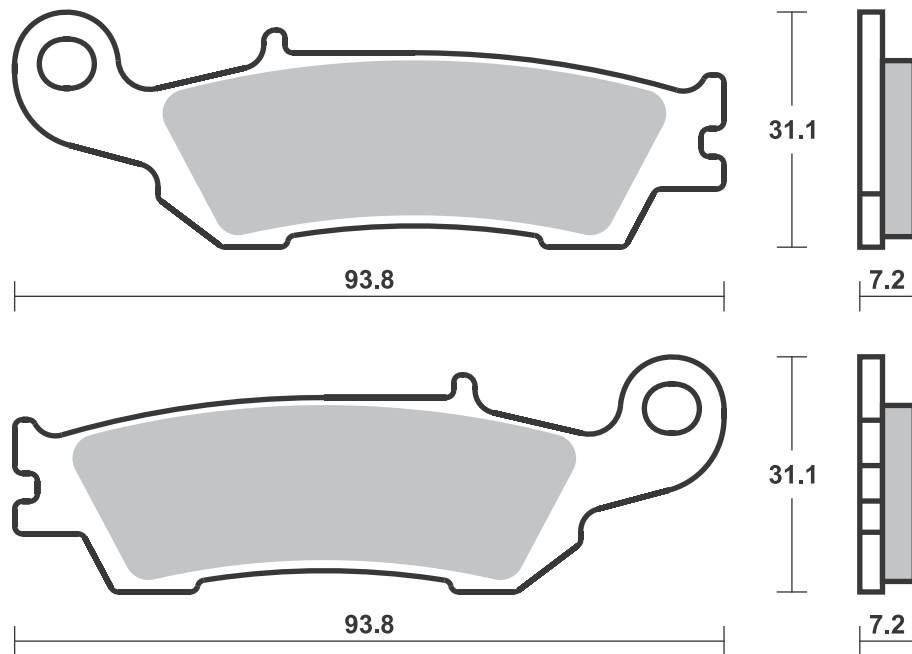
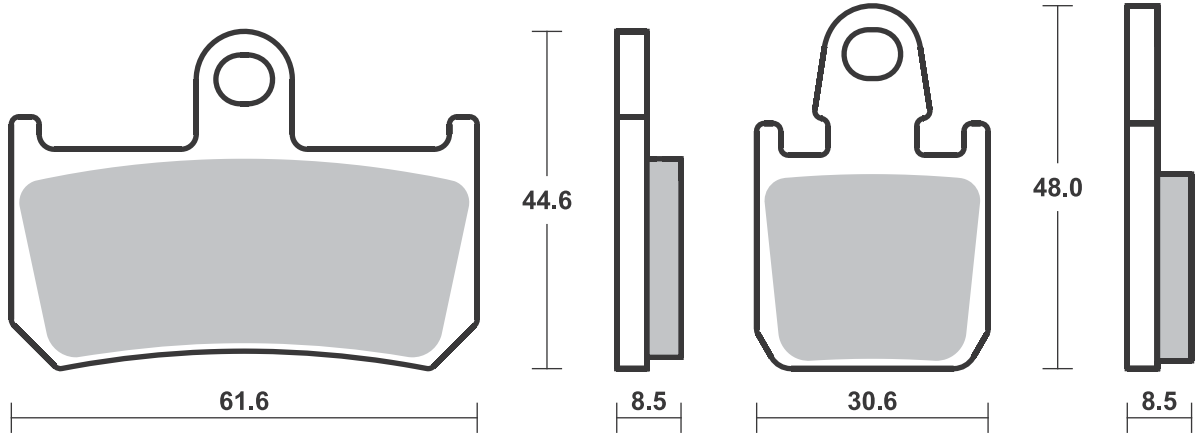

**SBS 841** Recommended compound**APRILIA**

|        |                 |       |           |
|--------|-----------------|-------|-----------|
| RSV4   | 1000 , ABS      | 09-13 | <b>SP</b> |
| RSV4-R | 1000 , ABS APRC | 10    | <b>SP</b> |

**BENELLI**

|     |        |    |           |
|-----|--------|----|-----------|
| TnT | 1130 R | 17 | <b>HS</b> |
|-----|--------|----|-----------|

**BIMOTA**

|    |             |       |           |
|----|-------------|-------|-----------|
| 3D | 800 Tesi    | 16    | <b>HS</b> |
|    | 1200 Impeto | 16-17 | <b>HS</b> |

**BREMBO RACING CALIPERS**

|                         |  |  |  |
|-------------------------|--|--|--|
| 100 mm Radial Caliper   |  |  |  |
| .484, 220B47310, P4 32  |  |  |  |
| 100 mm Radial Monoblock |  |  |  |
| 220988530, P4 34        |  |  |  |
| 108 mm Radial Caliper   |  |  |  |
| .484, 220B47310, P4 32  |  |  |  |
| 108 mm Radial Monoblock |  |  |  |
| 220A39710, P4 34        |  |  |  |
| Radial GP4 RX 220B01010 |  |  |  |

**DUCATI**

|       |                    |       |           |
|-------|--------------------|-------|-----------|
|       | 848 EVO            | 11-12 | <b>HS</b> |
|       | 848 Streetfighter  |       |           |
|       | S                  | 12-15 | <b>HS</b> |
| D16RR | 990 Desmosedici    |       |           |
|       | RR                 | 07-08 | <b>HS</b> |
|       | 1098               | 07-08 | <b>HS</b> |
|       | 1098 R             | 08-10 | <b>SP</b> |
|       | 1098 R Bayliss LE  | 09-10 | <b>SP</b> |
|       | 1098 S             | 07-08 | <b>HS</b> |
|       | 1098 Streetfighter | 09-14 | <b>HS</b> |
|       | 1098 Streetfighter |       |           |
|       | S                  | 09-13 | <b>HS</b> |
|       | 1100 Hypermotard   | 07-13 | <b>HS</b> |
|       | 1100 Hypermotard   |       |           |
|       | EVO SP             | 10-12 | <b>HS</b> |
|       | 1100 Panigale V4   | 18-   | <b>SP</b> |
|       | 1100 Panigale V4   |       |           |
|       | S                  | 18-   | <b>SP</b> |
|       | 1100 Panigale V4   |       |           |
|       | Speciale           | 18-   | <b>SP</b> |
|       | 1198               | 09-13 | <b>SP</b> |
|       | 1198 S             | 09-12 | <b>SP</b> |
|       | 1198 SP            | 11-12 | <b>SP</b> |
|       | 1199 Panigale      | 12-14 | <b>SP</b> |
|       | 1199 Panigale R    | 13-15 | <b>SP</b> |
|       | 1199 Panigale S    | 12-14 | <b>SP</b> |
|       | 1199 Superleggera  | 14    | <b>SP</b> |
|       | 1200 Monster R     | 16-18 | <b>HS</b> |
|       | 1200 Monster S     | 14-18 | <b>HS</b> |
|       | 1200 Multistrada S | 15-17 | <b>SP</b> |
|       | 1200 Multistrada S |       |           |
|       | D-air              | 15-17 | <b>SP</b> |
|       | 1200 Multistrada S |       |           |
|       | Pikes Peak         | 16-17 | <b>SP</b> |
|       | 1260 Multistrada   | 18-   | <b>SP</b> |
|       | 1260 Multistrada S | 18-   | <b>SP</b> |
|       | 1260 Multistrada S |       |           |
|       | D-air              | 18-   | <b>SP</b> |
|       | 1260 Multistrada S |       |           |
|       | Pikes Peak         | 18-   | <b>SP</b> |
|       | 1299 Panigale      | 15-17 | <b>SP</b> |
|       | 1299 Panigale R    | 15-17 | <b>SP</b> |
|       | 1299 Panigale R    |       |           |
|       | Final Edition      | 17-18 | <b>SP</b> |
|       | 1299 Panigale S    | 15-17 | <b>SP</b> |
|       | 1299 Panigale S    |       |           |
|       | Anniversario       | 17    | <b>SP</b> |
|       | 1299 Superleggera  | 17    | <b>SP</b> |

**HOREX**

|     |                 |    |           |
|-----|-----------------|----|-----------|
| VR6 | 1200 Cafe Racer | 17 | <b>HS</b> |
| VR6 | 1200 Classic    | 17 | <b>HS</b> |

**HUSQVARNA**

|    |             |       |           |
|----|-------------|-------|-----------|
| FS | 450         | 15-18 | <b>RS</b> |
|    | 900 Nuda R, |       |           |
|    | ABS         | 12-13 | <b>HS</b> |

**KAWASAKI**

|         |                |       |           |
|---------|----------------|-------|-----------|
| Z       | 1000 R         | 17-18 | <b>HS</b> |
| ZX      | 1000 H2 Carbon |       |           |
|         | Ninja          | 17-18 | <b>SP</b> |
| ZX      | 1000 H2 Ninja  | 15-18 | <b>SP</b> |
| ZX      | 1000 H2R Ninja | 15-18 | <b>SP</b> |
| ZX-10R  | 1000 Ninja     | 16-18 | <b>SP</b> |
| ZX-10R  | 1000 Ninja SE  | 18-   | <b>SP</b> |
| ZX-10RR | 1000 Ninja     | 17-18 | <b>SP</b> |

**KTM**

|     |               |       |           |
|-----|---------------|-------|-----------|
| SX  | 450 SMR       | 13-15 | <b>RS</b> |
|     | 690 Duke R    | 14-17 | <b>HS</b> |
|     | 990 Supermoto |       |           |
|     | R             | 10    | <b>HS</b> |
| RC8 | 1190          | 08-11 | <b>SP</b> |
| RC8 | 1190 R        | 09-15 | <b>SP</b> |
| RC8 | 1190 R Track  | 11-15 | <b>SP</b> |
|     | 1290 Super    |       |           |
|     | Duke R        | 14-18 | <b>HS</b> |

**MV AGUSTA**

|  |                 |       |           |
|--|-----------------|-------|-----------|
|  | 1000 F4 LH44    | 18-   | <b>SP</b> |
|  | 1000 F4 R       | 12-15 | <b>SP</b> |
|  | 1000 F4 RC      | 15-18 | <b>SP</b> |
|  | 1000 F4 RR      | 12-17 | <b>SP</b> |
|  | 1078 Brutale RR | 09    | <b>HS</b> |
|  | 1078 F4 CC      | 08-11 | <b>SP</b> |
|  | 1078 F4 RR      | 08-11 | <b>SP</b> |
|  | 1090 Brutale    |       |           |
|  | Corse           | 14-16 | <b>HS</b> |
|  | 1090 Brutale RR | 10-17 | <b>HS</b> |

**NORTON**

|  |            |     |           |
|--|------------|-----|-----------|
|  | 1200 V4 RR | 18- | <b>HS</b> |
|--|------------|-----|-----------|

**SUZUKI**

|       |               |       |           |
|-------|---------------|-------|-----------|
| GSX-R | 600           | 11-18 | <b>HS</b> |
| GSX-R | 750           | 11-18 | <b>HS</b> |
| GSX-R | 1000          | 12-18 | <b>SP</b> |
| GSX-R | 1000 R        | 17-18 | <b>SP</b> |
| GSX-S | 1000          | 15-18 | <b>HS</b> |
| GSX-S | 1000 F        | 15-18 | <b>HS</b> |
| GSX-R | 1300 Hayabusa | 13-18 | <b>HS</b> |

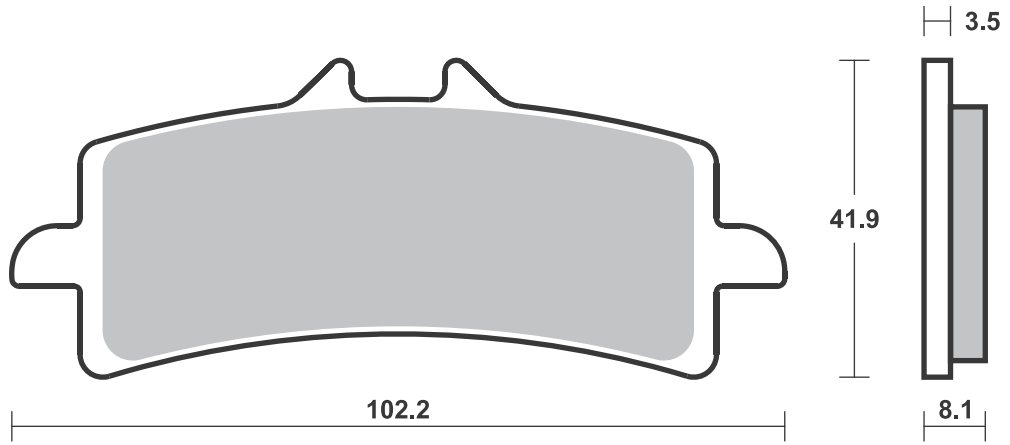

**SBS 842** Recommended compound



**APRILIA**

|     |            |       |            |
|-----|------------|-------|------------|
| SXV | 450        | 06-13 | <b>RSI</b> |
| SXV | 550        | 06-13 | <b>RSI</b> |
|     | 650 Pegaso |       |            |
|     | Factory    | 07-09 | <b>HS</b>  |

**HUSABERG**

|    |          |       |            |
|----|----------|-------|------------|
| FS | 450 c    | 06-08 | <b>RSI</b> |
| FS | 650 e, c | 06-08 | <b>RSI</b> |

**KTM**

|    |         |       |            |
|----|---------|-------|------------|
| SX | 450 SMR | 04-06 | <b>RSI</b> |
| SX | 525 SMR | 04-07 | <b>RSI</b> |

**SBS 843** Recommended compound



**HM**

|     |                   |       |            |
|-----|-------------------|-------|------------|
| CRM | 125 X Supermotard | 07    | <b>RSI</b> |
| CRM | 250 X Supermotard | 07-13 | <b>RSI</b> |
| CRM | 450 X Supermotard | 07-13 | <b>RSI</b> |
| CRM | 500 X Supermotard | 07-13 | <b>RSI</b> |

**KTM**

|    |         |       |            |
|----|---------|-------|------------|
| SX | 450 SMR | 07-12 | <b>RSI</b> |
| SX | 560 SMR | 06-07 | <b>RSI</b> |

Brake Pad 1:1 Drawings,  
Compounds, Fitments



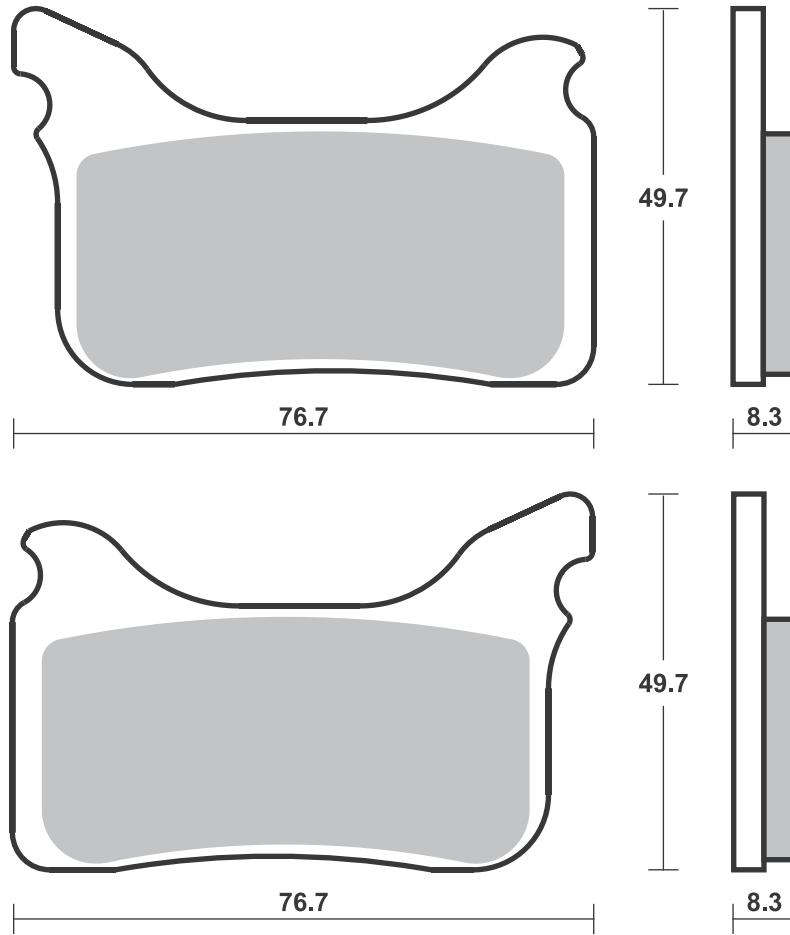

1 set = 4 pcs.

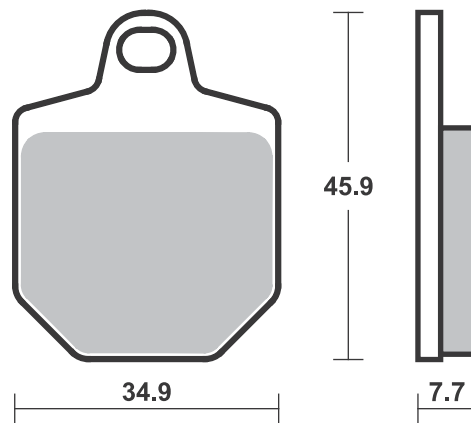

SBS 844 Recommended compound



APRILIA

|     |                    |       |    |
|-----|--------------------|-------|----|
| RS  | 125                | 06-12 | HF |
| SL  | 750 Shiver GT, ABS | 09-12 | HS |
| SL  | 750 Shiver, ABS    | 07-18 | HS |
| SMV | 750 Dorsoduro      | 09-18 | HS |
| NA  | 850 Mana           | 07    | HS |
| NA  | 850 Mana GT, ABS   | 09-13 | HS |
| NA  | 850 Mana, ABS      | 08-11 | HS |
|     | 900 Dorsoduro      | 18-   | HS |
|     | 900 Shiver         | 18-   | HS |

YAMAHA

|     |       |       |    |
|-----|-------|-------|----|
| MT  | 125   | 14-18 | HF |
| YZF | 125 R | 14-18 | HF |

SBS 845 Recommended compound



ACCOSSATO

|  |
|--|
| AGPZ05, 100 mm CNC<br>Monoblock, 4 Piston/2 Pad    |
| AGPZ07, 100 mm Forged<br>Monoblock, 4 Piston/2 Pad |

BREMBO RACING CALIPERS

|                                |
|--------------------------------|
| Radial Monoblock<br>XA8Y310/11 |
|--------------------------------|

Brake Pad 1:1 Drawings, Compounds, Fitments

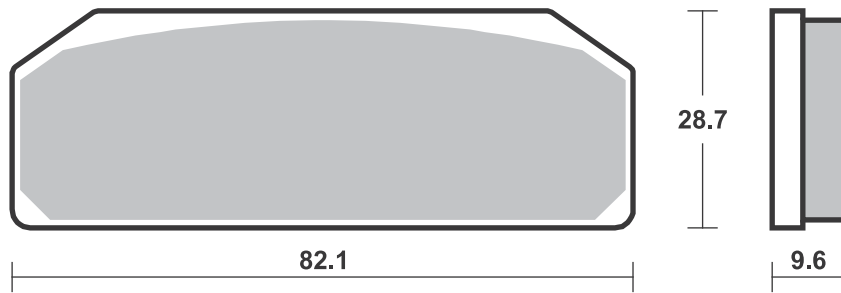
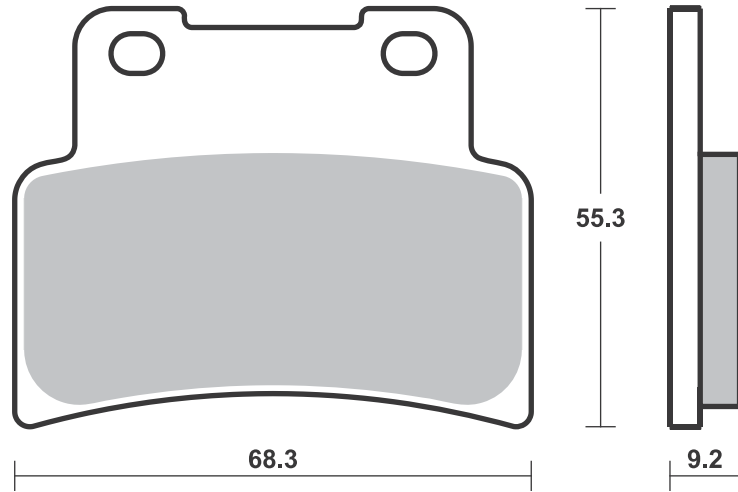

**SBS 846** Recommended compound

| <b>HARLEY DAVIDSON</b> |                       |    |             |
|------------------------|-----------------------|----|-------------|
| FLSTI                  | 1450 Heritage         |    |             |
|                        | Softail               | 06 | <b>H.LS</b> |
| FXDI                   | 1450 35th Anniversary |    |             |
|                        | Super Glide           | 06 | <b>H.LS</b> |
| FXST/I                 | 1450 Softail          |    |             |
|                        | Standard              | 06 | <b>H.LS</b> |
| FXSTB/I                | 1450 Night Train      | 06 | <b>H.LS</b> |
| FXSTD/I                | 1450 Softail          |    |             |
|                        | Deuce                 | 06 | <b>H.LS</b> |
| FXSTS/I                | 1450 Softail          | 06 | <b>H.LS</b> |
| FLSTC                  | 1584 Heritage         |    |             |
|                        | Softail               |    |             |
|                        | Classic               | 07 | <b>H.LS</b> |
| FLSTF                  | 1584 Fat Boy          | 07 | <b>H.LS</b> |
| FLSTN                  | 1584 Softail          |    |             |
|                        | Deluxe                | 07 | <b>H.LS</b> |
| FLSTSC/I               | 1584 Softail          | 07 | <b>H.LS</b> |
| FXST                   | 1584 Softail          |    |             |
|                        | Standard              | 07 | <b>H.LS</b> |
| FXSTB                  | 1584 Night Train      | 07 | <b>H.LS</b> |
| FXSTC                  | 1584 Softail          |    |             |
|                        | Custom                | 07 | <b>H.LS</b> |
| FXSTD                  | 1584 Softail          |    |             |
|                        | Deuce                 | 07 | <b>H.LS</b> |

**SBS 847** Recommended compound

| <b>DAELIM</b> |                 |       |           |
|---------------|-----------------|-------|-----------|
| ST            | 250 Sector      |       |           |
|               | Quad            | 05-06 | <b>SI</b> |
| <b>E-TON</b>  |                 |       |           |
| RXL           | 150 Viper       | 07    | <b>SI</b> |
| VXL           | 250 Vector,     |       |           |
|               | ST Vector       | 06-07 | <b>SI</b> |
| VTX           | 300 Vortex,     |       |           |
|               | ST Vortex       | 07    | <b>SI</b> |
| VXL           | 300 Vector,     |       |           |
|               | ST Vector       | 07-13 | <b>SI</b> |
| <b>SYM</b>    |                 |       |           |
| SB            | 125 Wolf Ni     | 11-13 | <b>HF</b> |
|               | 200 Quadlander  | 12-13 | <b>SI</b> |
|               | 200 Trackrunner | 05-08 | <b>SI</b> |
|               | 250 Quadlander  | 06-07 | <b>SI</b> |
|               | 300 City Max    | 06-07 | <b>SI</b> |

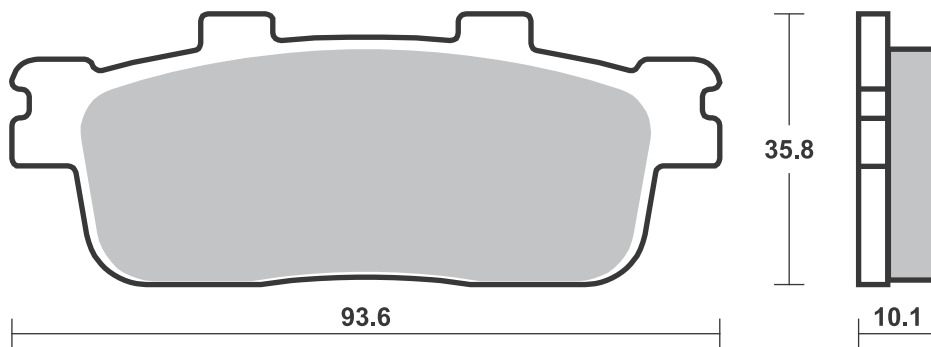
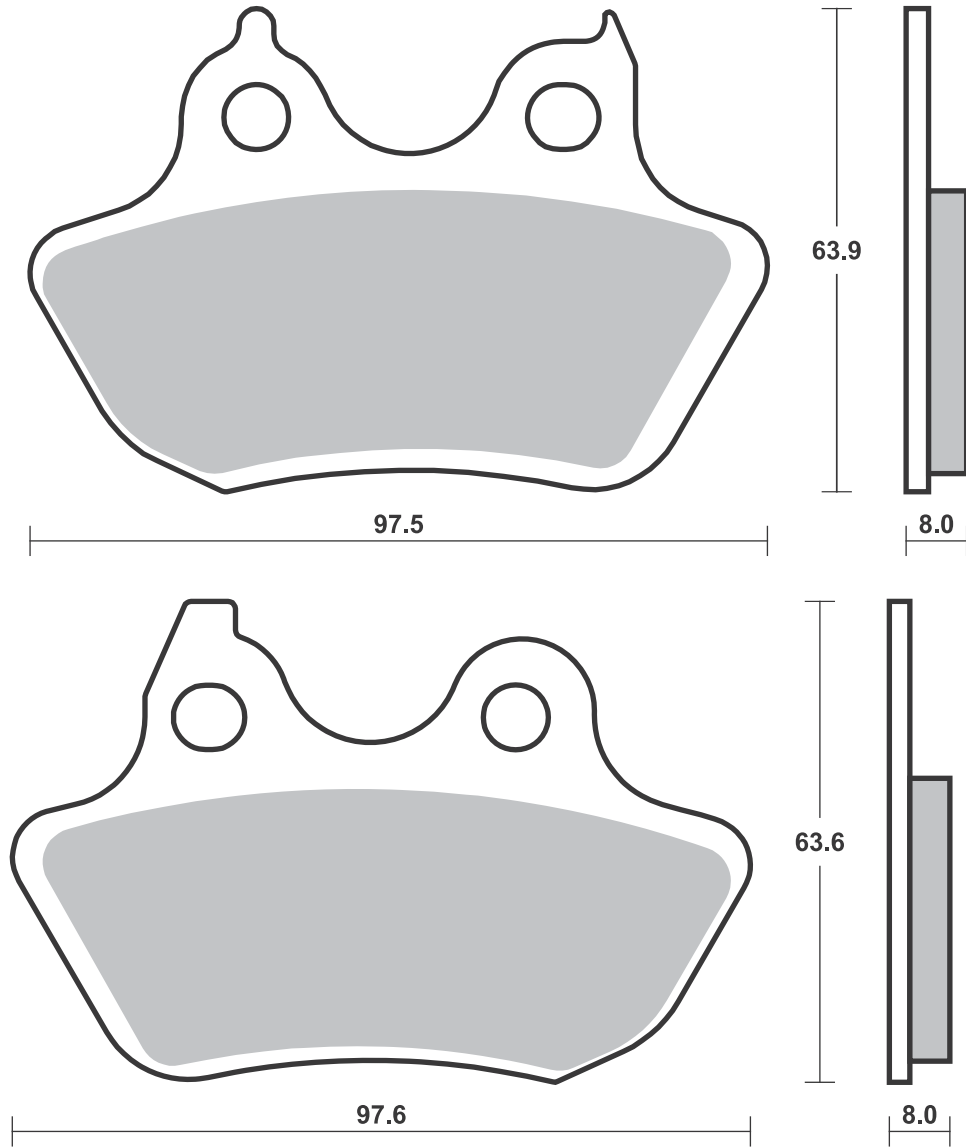

**SBS 848**

Recommended compound



**ADLY**

|     |           |       |           |
|-----|-----------|-------|-----------|
| ATV | 300 Sport | 07-13 | <b>SI</b> |
|-----|-----------|-------|-----------|

**CPI**

|    |          |       |           |
|----|----------|-------|-----------|
| XS | 250 Quad | 06-08 | <b>SI</b> |
|----|----------|-------|-----------|

**PGO**

|    |             |       |           |
|----|-------------|-------|-----------|
| BR | 200 Bgrider | 07    | <b>HF</b> |
| BR | 250 Bgrider | 05-12 | <b>HF</b> |

**QUADZILLA**

|     |         |       |           |
|-----|---------|-------|-----------|
| XRV | 250 , E | 06-07 | <b>HF</b> |
|-----|---------|-------|-----------|

**SBS 849**

Recommended compound



**YAMAHA**

|     |                  |       |           |
|-----|------------------|-------|-----------|
| YFM | 250 Raptor Right | 09-14 | <b>SI</b> |
| YFM | 550 FGPW Grizzly |       |           |
|     | Right            | 09-16 | <b>SI</b> |
| YFM | 700 FGPW Grizzly |       |           |
|     | Right            | 07-17 | <b>SI</b> |

Brake Pad 1:1 Drawings,  
Compounds, Fitments

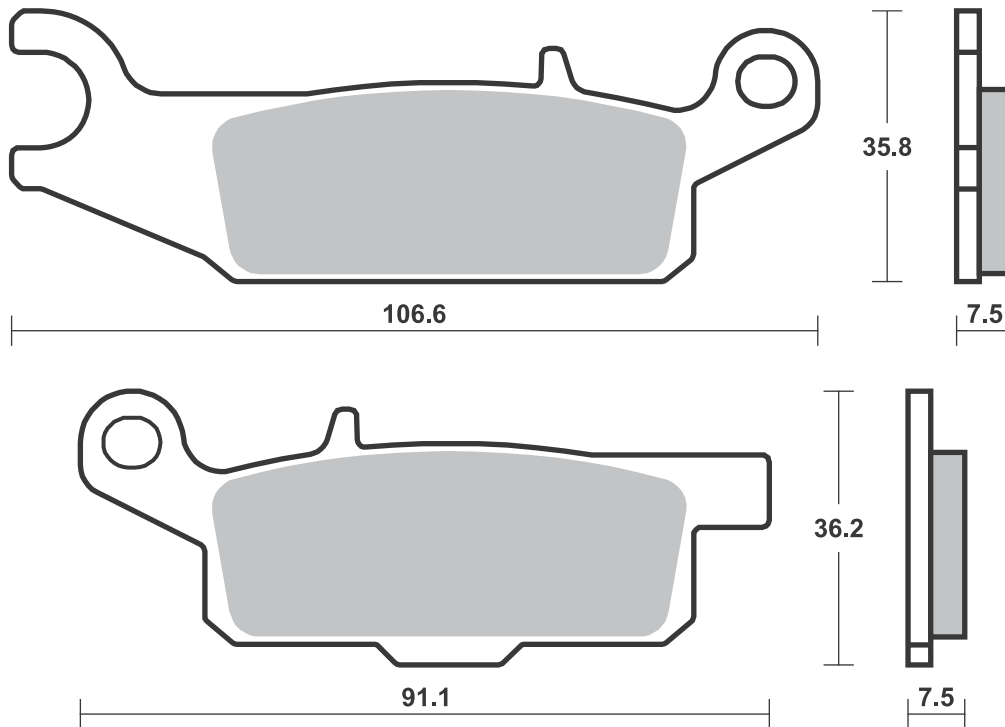
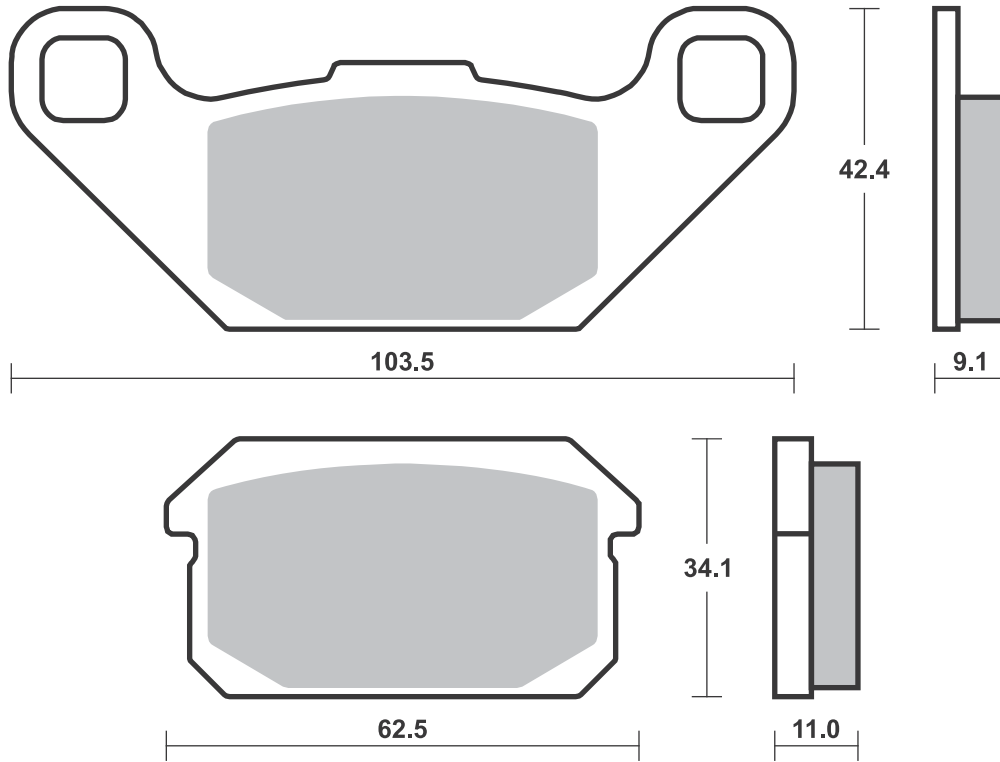

**SBS 850 Recommended compound**

**YAMAHA**

|     |                  |       |           |
|-----|------------------|-------|-----------|
| YFM | 250 Raptor       |       |           |
|     | Left/Rear        | 09-14 | <b>SI</b> |
| YFM | 550 FGPW Grizzly |       |           |
|     | Left             | 09-16 | <b>SI</b> |
| YFM | 700 FGPW Grizzly |       |           |
|     | Left             | 07-17 | <b>SI</b> |
|     |                  |       |           |
|     |                  |       |           |
|     |                  |       |           |
|     |                  |       |           |
|     |                  |       |           |
|     |                  |       |           |
|     |                  |       |           |
|     |                  |       |           |
|     |                  |       |           |
|     |                  |       |           |
|     |                  |       |           |
|     |                  |       |           |
|     |                  |       |           |
|     |                  |       |           |
|     |                  |       |           |
|     |                  |       |           |
|     |                  |       |           |
|     |                  |       |           |
|     |                  |       |           |
|     |                  |       |           |
|     |                  |       |           |
|     |                  |       |           |

**SBS 851 Recommended compound**

**YAMAHA**

|     |                  |       |           |
|-----|------------------|-------|-----------|
| YFM | 550 FGPW Grizzly |       |           |
|     | Right            | 09-16 | <b>SI</b> |
| YFM | 700 FGPW Grizzly |       |           |
|     | Right            | 07-17 | <b>SI</b> |
|     |                  |       |           |
|     |                  |       |           |
|     |                  |       |           |
|     |                  |       |           |
|     |                  |       |           |
|     |                  |       |           |
|     |                  |       |           |
|     |                  |       |           |
|     |                  |       |           |
|     |                  |       |           |
|     |                  |       |           |
|     |                  |       |           |
|     |                  |       |           |
|     |                  |       |           |
|     |                  |       |           |
|     |                  |       |           |
|     |                  |       |           |
|     |                  |       |           |
|     |                  |       |           |
|     |                  |       |           |
|     |                  |       |           |
|     |                  |       |           |
|     |                  |       |           |



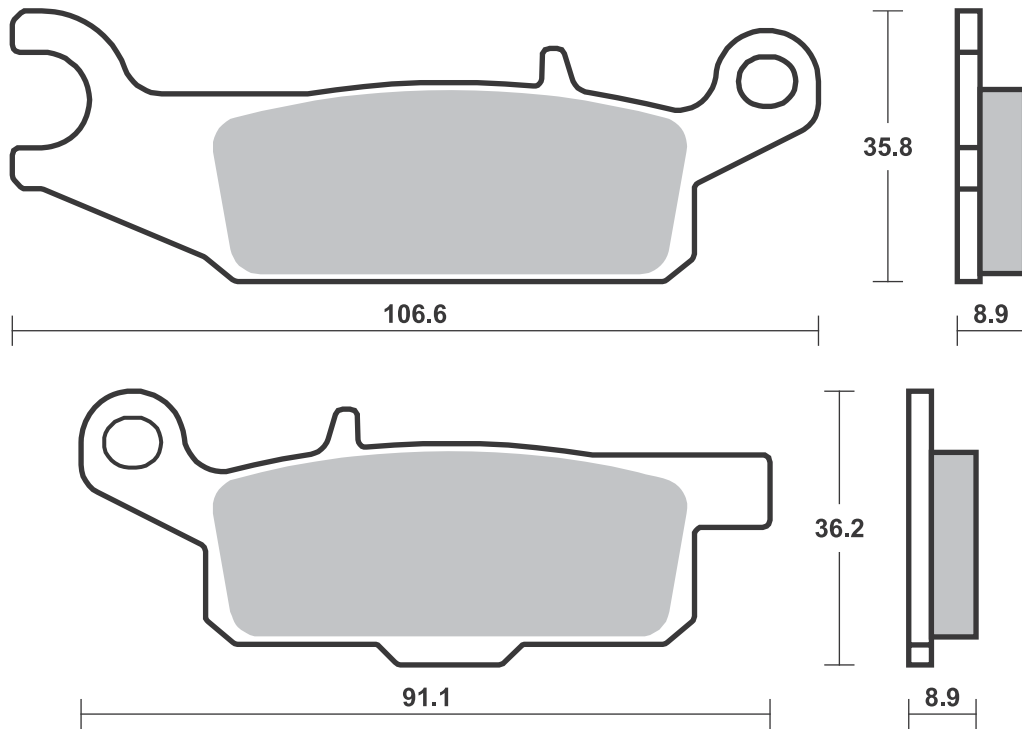
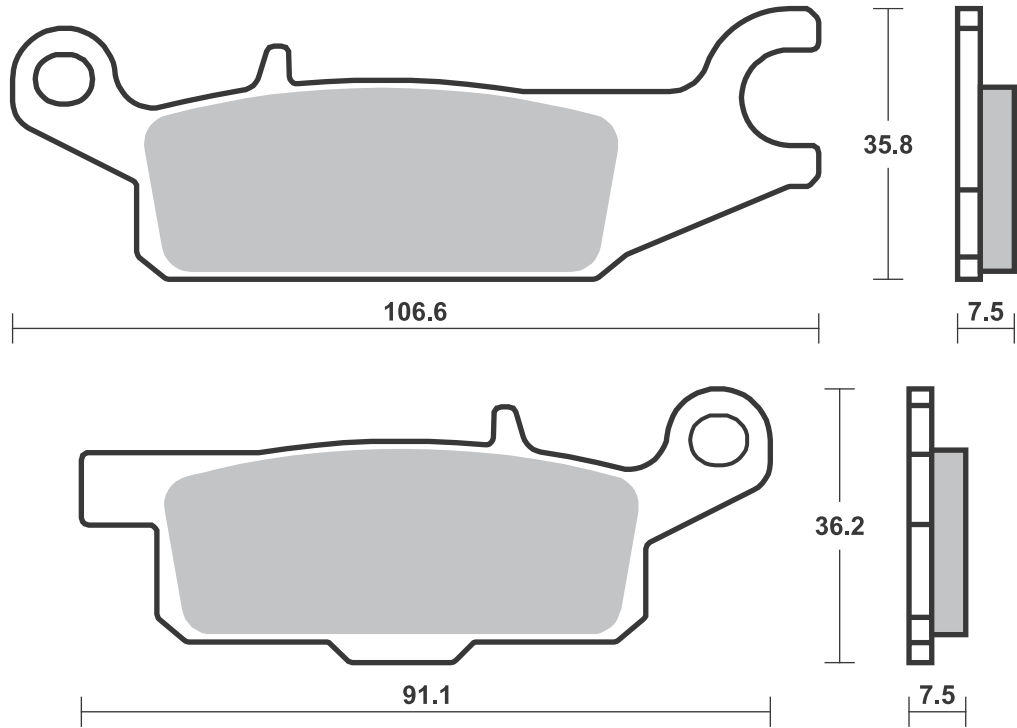

**SBS 852** Recommended compound



**YAMAHA**

|     |                  |       |           |
|-----|------------------|-------|-----------|
| YFM | 550 FGPW Grizzly |       |           |
|     | Left             | 09-16 | <b>SI</b> |
| YFM | 700 FGPW Grizzly |       |           |
|     | Left             | 07-17 | <b>SI</b> |

Brake Pad 1:1 Drawings,  
Compounds, Fitments

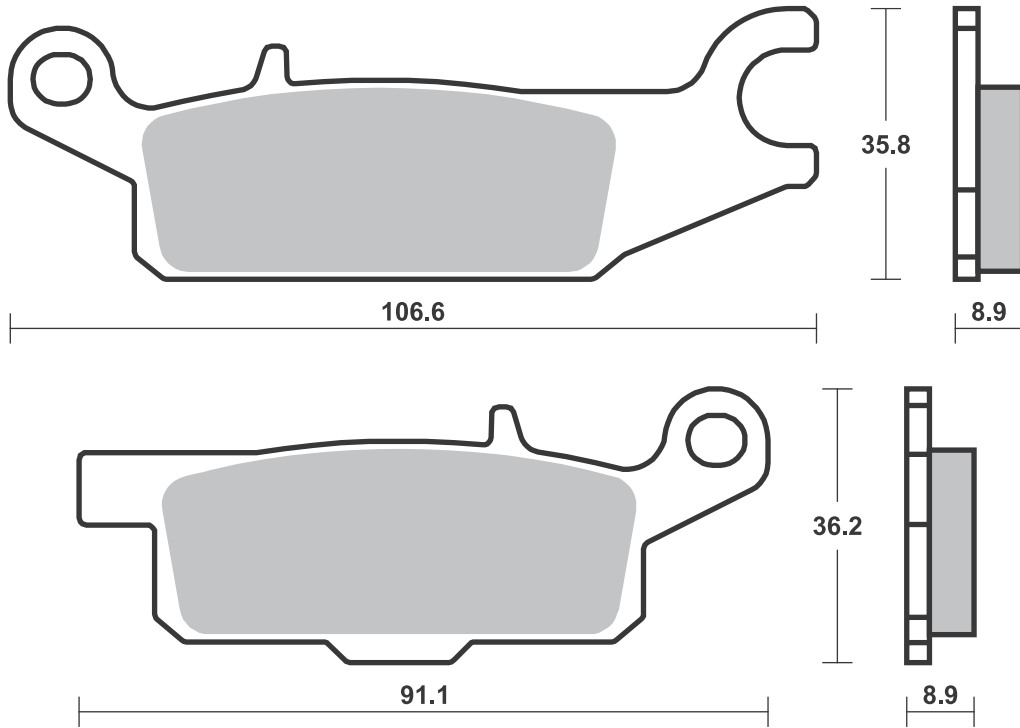

## SBS 853 Recommended compound



| HARLEY DAVIDSON |                   |       |      |
|-----------------|-------------------|-------|------|
| FLSTC           | 1584 Heritage     |       |      |
|                 | Softail           |       |      |
|                 | Classic           | 08-11 | H.HS |
| FLSTF           | 1584 Fat Boy      | 08-11 | H.HS |
| FLSTFB          | 1584 Fat Boy      |       |      |
|                 | Special           | 10-11 | H.HS |
| FLSTN           | 1584 Softail      |       |      |
|                 | Deluxe            | 08-11 | H.HS |
| FXCW            | 1584 Rocker       | 08-09 | H.HS |
| FXCWC           | 1584 Rocker C     | 08-13 | H.HS |
| FXD             | 1584 Dyna         |       |      |
|                 | Super             |       |      |
|                 | Glide             | 08-10 | H.HS |
| FXDB            | 1584 Dyna         |       |      |
|                 | Street Bob        | 08-13 | H.HS |
| FXDC            | 1584 Dyna         |       |      |
|                 | Super             |       |      |
|                 | Glide             |       |      |
|                 | Custom            | 08-13 | H.HS |
| FXDF            | 1584 Fat Bob      | 08-11 | H.HS |
| FXDL            | 1584 Dyna Low     |       |      |
|                 | Rider             | 08-13 | H.HS |
| FXDWG           | 1584 Dyna Wide    |       |      |
|                 | Glide             | 08-10 | H.HS |
| FXST            | 1584 Softail      |       |      |
|                 | Standard          | 08-14 | H.HS |
| FXSTB           | 1584 Night Train  | 08-09 | H.HS |
| FXSTC           | 1584 Softail      |       |      |
|                 | Custom            | 08-10 | H.HS |
| FLD             | 1690 Switchback   | 12-16 | H.HS |
| FLHRC           | 1690 Road King    |       |      |
|                 | Classic           | 11-16 | H.HS |
| FLHTC           | 1690 Electra      |       |      |
|                 | Glide             |       |      |
|                 | Classic           | 11-16 | H.HS |
| FLHTK           | 1690 Ultra        |       |      |
|                 | Electra           |       |      |
|                 | Glide             | 11-16 | H.HS |
| FLS             | 1690 Softail Slim | 12-14 | H.HS |
| FLSTC           | 1690 Heritage     |       |      |
|                 | Softail           |       |      |
|                 | Classic           | 12-14 | H.HS |
| FLSTF           | 1690 Fat Boy      | 12-14 | H.HS |
| FLSTF           | 1690 Fat Boy      |       |      |
|                 | Special           | 12-14 | H.HS |
| FLSTFB          | 1690 Fat Boy      | 12-14 | H.HS |
| FLSTN           | 1690 Softail      |       |      |
|                 | Deluxe            | 12-14 | H.HS |
| FXDB            | 1690 Dyna         |       |      |
|                 | Street Bob        | 14-17 | H.HS |
| FXDBA           | 1690 Dyna         |       |      |
|                 | Street Bob        | 13-17 | H.HS |
| FXDBB           | 1690 Dyna         |       |      |
|                 | Street Bob        | 14-17 | H.HS |
| FXDBP           | 1690 Dyna         |       |      |
|                 | Street Bob        | 13-17 | H.HS |
| FXDC            | 1690 Dyna         |       |      |
|                 | Super             |       |      |
|                 | Glide             |       |      |
|                 | Custom            | 14    | H.HS |
| FXDF            | 1690 Dyna         |       |      |
|                 | Wide Glide        | 12-17 | H.HS |
| FXDF            | 1690 Fat Bob      | 12-17 | H.HS |
| FXDL            | 1690 Dyna         |       |      |
|                 | Low Rider         | 14-17 | H.HS |
| FXDLS           | 1690 Dyna         |       |      |
|                 | Low Rider         |       |      |
|                 | S                 | 17    | H.HS |
| FXS             | 1690 Blackline    | 13-17 | H.HS |
| FXSB            | 1690 Breakout     | 14    | H.HS |



| HARLEY DAVIDSON |                  |       |      |
|-----------------|------------------|-------|------|
| FLSTNSE         | 1802 CVO Softail |       |      |
|                 | Deluxe           | 14    | H.HS |
| FXSBSE          | 1802 CVO         |       |      |
|                 | Breakout         | 13-14 | H.HS |

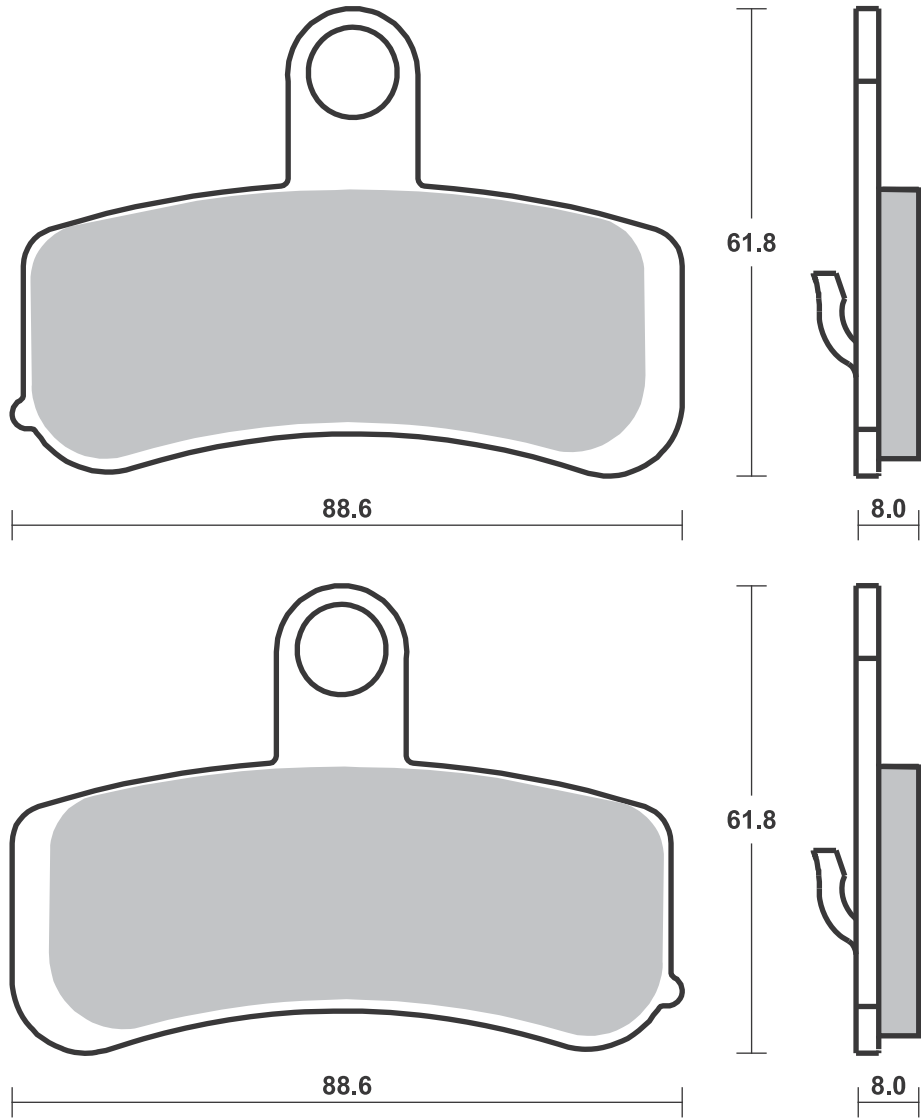

## Applications

### SBS 854 Recommended compound



| HARLEY DAVIDSON |      |                               |              |
|-----------------|------|-------------------------------|--------------|
| FLSTC           | 1584 | Heritage Softail              |              |
|                 |      | Classic 08-11                 | <b>H.L.S</b> |
| FLSTF           | 1584 | Fat Boy 08-11                 | <b>H.L.S</b> |
| FLSTFB          | 1584 | Fat Boy Special 10-11         | <b>H.L.S</b> |
| FLSTN           | 1584 | Softail Deluxe 08-11          | <b>H.L.S</b> |
| FXCW            | 1584 | Rocker 08-09                  | <b>H.L.S</b> |
| FXCWC           | 1584 | Rocker C 08-13                | <b>H.L.S</b> |
| FXD             | 1584 | Dyna Super Glide 08-10        | <b>H.L.S</b> |
| FXDB            | 1584 | Dyna Street Bob 08-13         | <b>H.L.S</b> |
| FXDC            | 1584 | Dyna Super Glide Custom 08-13 | <b>H.L.S</b> |
| FXDF            | 1584 | Fat Bob 08-11                 | <b>H.L.S</b> |
| FXDL            | 1584 | Dyna Low Rider 08-13          | <b>H.L.S</b> |
| FXDWG           | 1584 | Dyna Wide Glide 08-10         | <b>H.L.S</b> |
| FXST            | 1584 | Softail Standard 08-17        | <b>H.L.S</b> |
| FXSTB           | 1584 | Night Train 08-09             | <b>H.L.S</b> |
| FXSTC           | 1584 | Softail Custom 08-10          | <b>H.L.S</b> |
| FLD             | 1690 | Switchback 12-16              | <b>H.L.S</b> |
| FLHRC           | 1690 | Road King Classic 11-16       | <b>H.L.S</b> |
| FLHTC           | 1690 | Electra Glide Classic 11-16   | <b>H.L.S</b> |



| HARLEY DAVIDSON |      |                                |              |
|-----------------|------|--------------------------------|--------------|
| FLHTK           | 1690 | Ultra Electra                  |              |
|                 |      | Glide 11-16                    | <b>H.L.S</b> |
| FLS             | 1690 | Softail Slim 12-17             | <b>H.L.S</b> |
| FLSTC           | 1690 | Heritage Softail Classic 12-17 | <b>H.L.S</b> |
| FLSTF           | 1690 | Fat Boy 12-17                  | <b>H.L.S</b> |
| FLSTFB          | 1690 | Fat Boy Special 12-14          | <b>H.L.S</b> |
| FLSTN           | 1690 | Softail Deluxe 12-17           | <b>H.L.S</b> |
| FXDB            | 1690 | Dyna Street Bob 14-17          | <b>H.L.S</b> |
| FXDBA           | 1690 | Dyna Street Bob 13-17          | <b>H.L.S</b> |
| FXDBB           | 1690 | Dyna Street Bob 14-17          | <b>H.L.S</b> |
| FXDBP           | 1690 | Dyna Street Bob 13-17          | <b>H.L.S</b> |
| FXDC            | 1690 | Dyna Super Glide Custom 14     | <b>H.L.S</b> |
| FXDF            | 1690 | Dyna Wide Glide 12-17          | <b>H.L.S</b> |
| FXDF            | 1690 | Fat Bob 12-17                  | <b>H.L.S</b> |
| FXDL            | 1690 | Dyna Low Rider 14-17           | <b>H.L.S</b> |
| FXDLS           | 1690 | Dyna Low Rider S 17            | <b>H.L.S</b> |
| FXS             | 1690 | Blackline 13-17                | <b>H.L.S</b> |
| FXSB            | 1690 | Breakout 14-17                 | <b>H.L.S</b> |



| HARLEY DAVIDSON |      |                          |              |
|-----------------|------|--------------------------|--------------|
| FLSS            | 1802 | Softail Slim S 16-17     | <b>H.L.S</b> |
| FLSTFBS         | 1802 | Fat Boy S 16-17          | <b>H.L.S</b> |
| FLSTNSE         | 1802 | CVO Softail Deluxe 14-17 | <b>H.L.S</b> |
| FXSBSE          | 1802 | CVO Breakout 13-14       | <b>H.L.S</b> |

### SBS 855 Recommended compound



| PGO |     |                |           |
|-----|-----|----------------|-----------|
|     | 50  | Bugrider 06    | <b>HF</b> |
| BR  | 150 | Bugxter 05-07  | <b>HF</b> |
| BR  | 200 | Bugrider 07    | <b>HF</b> |
| BR  | 250 | Bugrider 05-12 | <b>HF</b> |

| QUADZILLA |     |           |           |
|-----------|-----|-----------|-----------|
| XRV       | 250 | , E 06-07 | <b>HF</b> |

Brake Pad 1:1 Drawings, Compounds, Fitments

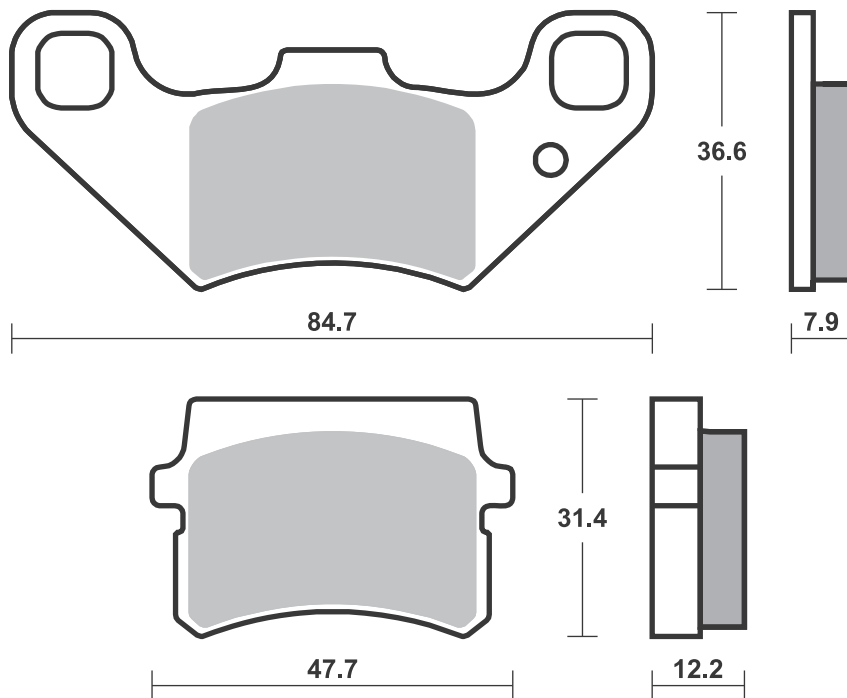
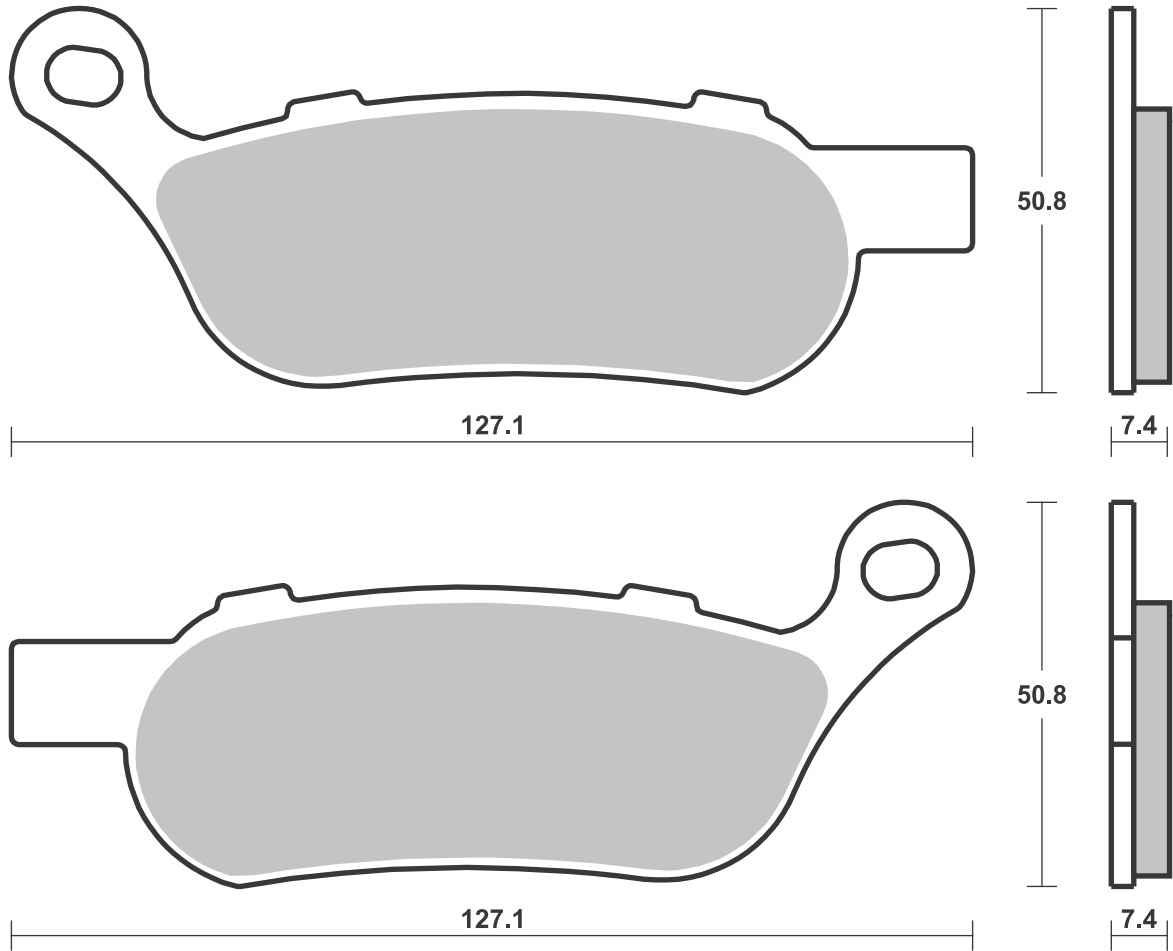

**SBS 856** Recommended compound



| <b>BUELL</b> |                |       |           |
|--------------|----------------|-------|-----------|
|              | 1125 CR        | 09-10 | <b>HS</b> |
|              | 1125 R         | 08-10 | <b>HS</b> |
| XB12R        | 1200 Firebolt  | 09-10 | <b>HS</b> |
| XB12Scg      | 1200 Lightning | 09-10 | <b>HS</b> |
| XB12Ss       | 1200 Lightning |       |           |
|              | Long           | 09-10 | <b>HS</b> |
| <b>EBR</b>   |                |       |           |
|              | 1190 RS        | 12-15 | <b>HS</b> |
|              | 1190 RX        | 14-15 | <b>HS</b> |
|              | 1190 SX        | 14-15 | <b>HS</b> |

**SBS 857** Recommended compound



| <b>BUELL</b> |         |       |           |
|--------------|---------|-------|-----------|
|              | 1125 CR | 09-10 | <b>LS</b> |
|              | 1125 R  | 08-10 | <b>LS</b> |
| <b>EBR</b>   |         |       |           |
|              | 1190 RS | 12-15 | <b>LS</b> |
|              | 1190 RX | 14-15 | <b>LS</b> |
|              | 1190 SX | 14-15 | <b>LS</b> |

**SBS 858** Recommended compound



| <b>MBK</b>    |               |       |           |
|---------------|---------------|-------|-----------|
| XC            | 125 Waap      | 08-12 | <b>HF</b> |
| <b>YAMAHA</b> |               |       |           |
|               | 115 D'elight  | 14-18 | <b>HF</b> |
| XC            | 125 Vity      | 08-13 | <b>HF</b> |
| YBR           | 125           | 08-16 | <b>HF</b> |
| YS            | 125           | 17-18 | <b>HF</b> |
|               | 135 Crypton X | 08-14 | <b>HF</b> |
| YZF           | 150 R15       | 14    | <b>HF</b> |

Brake Pad 1:1 Drawings,  
Compounds, Fitments



Drawings 1:1

Available compounds **HS • RS • DS**

**SBS 856**

1 set = 4 pcs.

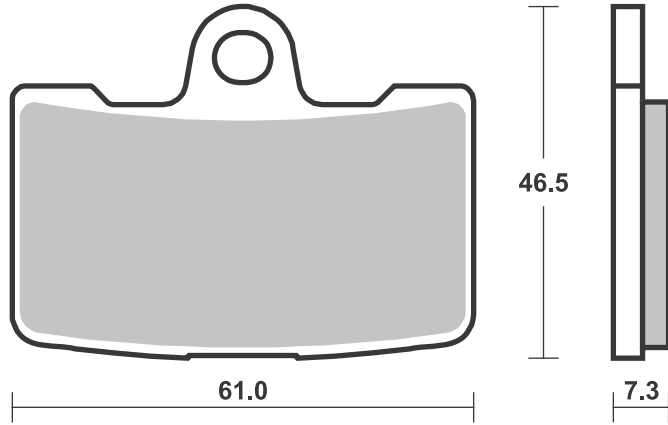

Available compounds **LS**

**SBS 857**

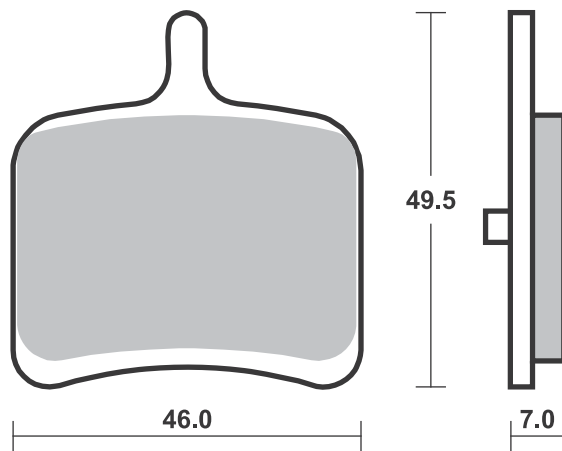

Available compounds **HF**

**SBS 858**

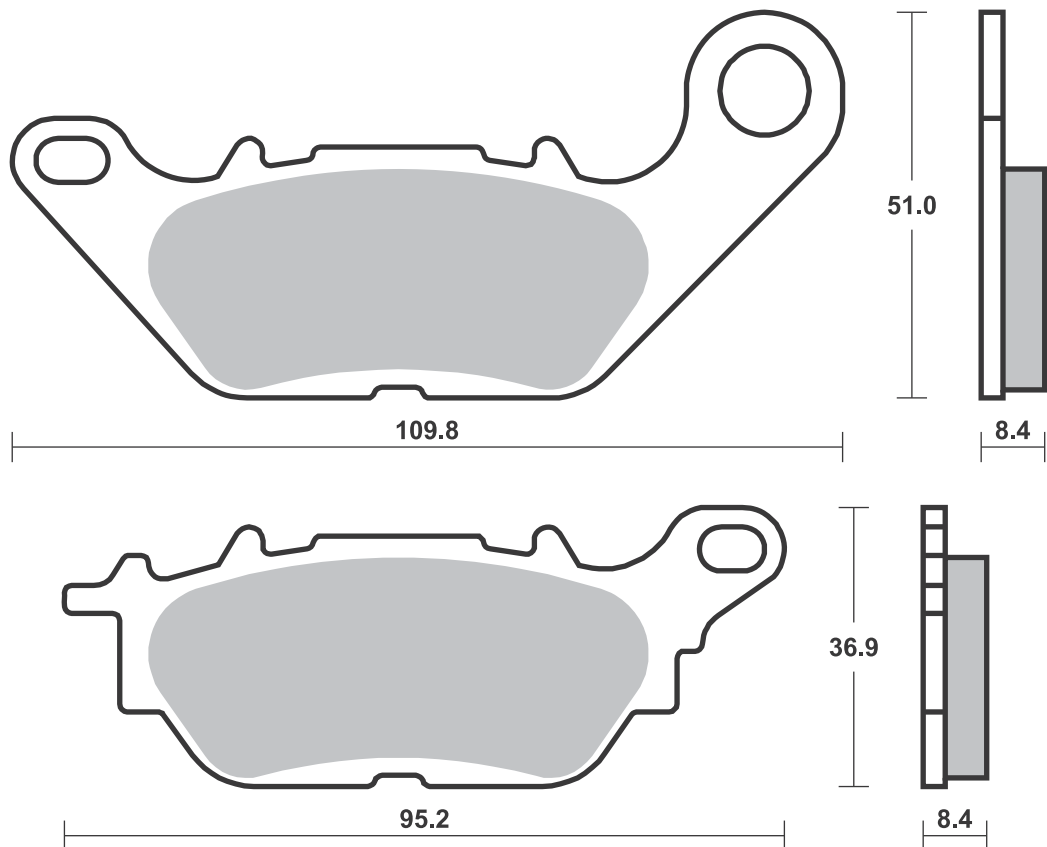

Dimensions in mm / Dimensions en mm  
1" = 25.4 mm , 1 mm = 0.04"

**SBS 859** Recommended compound



| <b>AJP</b>    |                |       |           |  |
|---------------|----------------|-------|-----------|--|
| PR3           | 125 Enduro     | 13-15 | <b>HF</b> |  |
| PR3           | 125 Enduro Pro | 13-15 | <b>HF</b> |  |
| PR3           | 125 Extreme    | 13-15 | <b>HF</b> |  |
| PR3           | 125 Supermoto  | 13-15 | <b>HF</b> |  |
| PR4           | 125 Enduro     | 13-15 | <b>HF</b> |  |
| PR4           | 125 Enduro Pro | 13-15 | <b>HF</b> |  |
| PR4           | 125 Supermoto  | 13-15 | <b>HF</b> |  |
| PR4           | 125 Trail      | 13-15 | <b>HF</b> |  |
| PR3           | 240 MX         | 13-15 | <b>SI</b> |  |
| PR5           | 250 Enduro     | 10-15 | <b>HF</b> |  |
| PR5           | 250 Extreme    | 12-15 | <b>HF</b> |  |
| PR5           | 250 Supermoto  | 10-15 | <b>HF</b> |  |
| PR7           | 650 Adventure  | 17    | <b>HF</b> |  |
| <b>DERBI</b>  |                |       |           |  |
|               | 125 Mulhacen   | 08-11 | <b>HF</b> |  |
|               | 125 Terra      | 08-13 | <b>HF</b> |  |
|               | 125 Terra      |       |           |  |
|               | Adventure      | 08-14 | <b>HF</b> |  |
| <b>HONDA</b>  |                |       |           |  |
| CRE           | 125 RR         | 11    | <b>SI</b> |  |
| CRF           | 250 L          | 13-15 | <b>SI</b> |  |
| CRF           | 250 L ABS      | 17-18 | <b>SI</b> |  |
| CRF           | 250 M          | 14-18 | <b>SI</b> |  |
| CRF           | 250 Rally      | 17-18 | <b>SI</b> |  |
| <b>SCORPA</b> |                |       |           |  |
|               | 250 T-Ride     | 08-11 | <b>HF</b> |  |

**SBS 860** Recommended compound



| <b>HARLEY DAVIDSON</b> |                   |       |             |  |
|------------------------|-------------------|-------|-------------|--|
| XR                     | 1200              | 08-10 | <b>H.HS</b> |  |
| XR                     | 1200 X            | 10-13 | <b>H.HS</b> |  |
| FXST                   | 1584 Softail      |       |             |  |
|                        | Standard          | 15-17 | <b>H.HS</b> |  |
| FLS                    | 1690 Softail      |       |             |  |
|                        | Slim              | 15-17 | <b>H.HS</b> |  |
| FLSTC                  | 1690 Heritage     |       |             |  |
|                        | Softail           |       |             |  |
|                        | Classic           | 15-17 | <b>H.HS</b> |  |
| FLSTF                  | 1690 Fat Boy      | 15-17 | <b>H.HS</b> |  |
| FLSTFB                 | 1690 Fat Boy      | 15-17 | <b>H.HS</b> |  |
| FLSTN                  | 1690 Softail      |       |             |  |
|                        | Deluxe            | 15-17 | <b>H.HS</b> |  |
| FXSB                   | 1690 Breakout     | 15-17 | <b>H.HS</b> |  |
| FLDE                   | 1750 Softail      |       |             |  |
|                        | Deluxe            | 18-   | <b>H.HS</b> |  |
| FLFB                   | 1750 Fat Boy      | 18-   | <b>H.HS</b> |  |
| FLHC                   | 1750 Heritage     |       |             |  |
|                        | Classic           | 18-   | <b>H.HS</b> |  |
| FLSL                   | 1750 Softail Slim | 18-   | <b>H.HS</b> |  |
| FXBB                   | 1750 Street Bob   | 18-   | <b>H.HS</b> |  |
| FXBR                   | 1750 Breakout     | 18-   | <b>H.HS</b> |  |
| FXFB                   | 1750 Fat Bob      | 18-   | <b>H.HS</b> |  |
| FXLR                   | 1750 Low Rider    | 18-   | <b>H.HS</b> |  |
| FLSS                   | 1802 Softail      |       |             |  |
|                        | Slim S            | 16-17 | <b>H.HS</b> |  |
| FLSTFBS                | 1802 Fat Boy S    | 16-17 | <b>H.HS</b> |  |
| FLSTNSE                | 1802 CVO          |       |             |  |
|                        | Softail           |       |             |  |
|                        | Deluxe            | 15-17 | <b>H.HS</b> |  |
| FLFBS                  | 1870 Fat Boy      | 18-   | <b>H.HS</b> |  |



| <b>HARLEY DAVIDSON</b> |               |     |             |  |
|------------------------|---------------|-----|-------------|--|
| FLHCS                  | 1870 Heritage |     |             |  |
|                        | Classic       | 18- | <b>H.HS</b> |  |
| FXBRS                  | 1870 Breakout | 18- | <b>H.HS</b> |  |



|  |  |  |  |  |
|--|--|--|--|--|
|  |  |  |  |  |
|  |  |  |  |  |
|  |  |  |  |  |
|  |  |  |  |  |
|  |  |  |  |  |
|  |  |  |  |  |
|  |  |  |  |  |
|  |  |  |  |  |
|  |  |  |  |  |
|  |  |  |  |  |
|  |  |  |  |  |
|  |  |  |  |  |
|  |  |  |  |  |
|  |  |  |  |  |
|  |  |  |  |  |
|  |  |  |  |  |
|  |  |  |  |  |
|  |  |  |  |  |
|  |  |  |  |  |
|  |  |  |  |  |
|  |  |  |  |  |
|  |  |  |  |  |
|  |  |  |  |  |
|  |  |  |  |  |

Brake Pad 1:1 Drawings, Compounds, Fitments

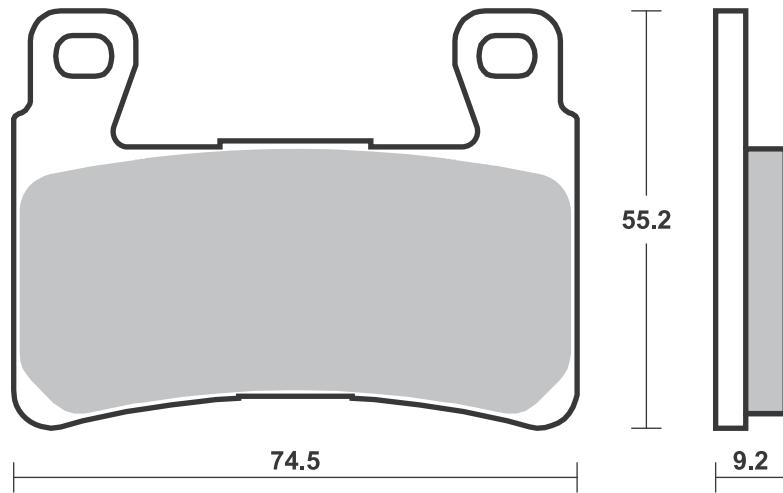
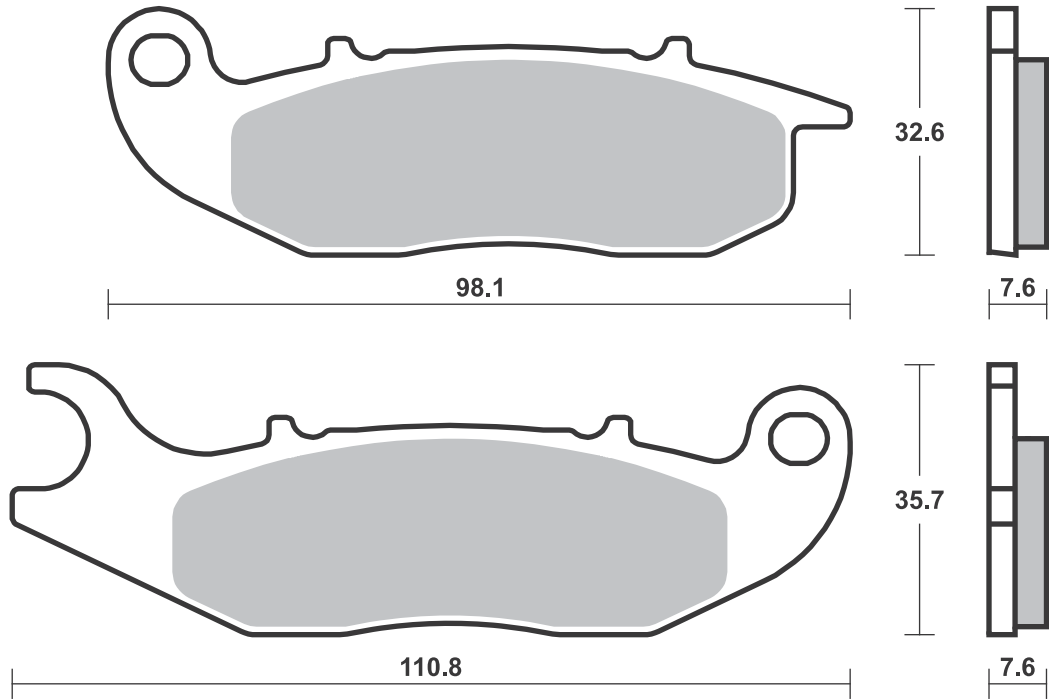

**SBS 861** Recommended compound



|             |                 |        |           |
|-------------|-----------------|--------|-----------|
| <b>BETA</b> |                 |        |           |
|             | 125 M4          | 06     | <b>HF</b> |
|             | 125 Urban       | 10- 15 | <b>HF</b> |
| ALP         | 125 4-stroke    | 06-09  | <b>HF</b> |
| RR          | 125 Enduro 4T   | 10- 15 | <b>HF</b> |
| RR          | 125 Supermotard | 08-09  | <b>HF</b> |
|             | 200 Urban       | 10     | <b>HF</b> |
| ALP         | 200 4-stroke    | 06     | <b>HF</b> |
|             | 350 M4          |        |           |
|             | (Brempo cal.)   | 06-07  | <b>HF</b> |
| ALP         | 350 4.0         | 06     | <b>HF</b> |
|             |                 |        |           |
|             |                 |        |           |
|             |                 |        |           |
|             |                 |        |           |
|             |                 |        |           |
|             |                 |        |           |
|             |                 |        |           |
|             |                 |        |           |
|             |                 |        |           |
|             |                 |        |           |
|             |                 |        |           |
|             |                 |        |           |
|             |                 |        |           |
|             |                 |        |           |
|             |                 |        |           |
|             |                 |        |           |
|             |                 |        |           |
|             |                 |        |           |
|             |                 |        |           |
|             |                 |        |           |
|             |                 |        |           |
|             |                 |        |           |
|             |                 |        |           |
|             |                 |        |           |
|             |                 |        |           |
|             |                 |        |           |
|             |                 |        |           |
|             |                 |        |           |

**SBS 862** Recommended compound



|              |                   |        |           |
|--------------|-------------------|--------|-----------|
| <b>HONDA</b> |                   |        |           |
| VFR          | 800 Crossrunner   | 11- 13 | <b>LS</b> |
| VFR          | 800 F             | 14- 18 | <b>LS</b> |
| VFR          | 800 X Crossrunner | 15- 18 | <b>LS</b> |
| CB           | 1000 R            | 18-    | <b>LS</b> |
| CB           | 1000 R            | 08-16  | <b>LS</b> |
| CB           | 1000 R ABS        | 08- 16 | <b>LS</b> |
| CB           | 1000 R+           | 18-    | <b>LS</b> |
| VFR          | 1200 F            | 10-18  | <b>LS</b> |
|              |                   |        |           |
|              |                   |        |           |
|              |                   |        |           |
|              |                   |        |           |
|              |                   |        |           |
|              |                   |        |           |
|              |                   |        |           |
|              |                   |        |           |
|              |                   |        |           |
|              |                   |        |           |
|              |                   |        |           |
|              |                   |        |           |
|              |                   |        |           |
|              |                   |        |           |
|              |                   |        |           |
|              |                   |        |           |
|              |                   |        |           |
|              |                   |        |           |
|              |                   |        |           |
|              |                   |        |           |
|              |                   |        |           |
|              |                   |        |           |
|              |                   |        |           |
|              |                   |        |           |
|              |                   |        |           |
|              |                   |        |           |
|              |                   |        |           |
|              |                   |        |           |
|              |                   |        |           |
|              |                   |        |           |
|              |                   |        |           |
|              |                   |        |           |
|              |                   |        |           |
|              |                   |        |           |
|              |                   |        |           |
|              |                   |        |           |
|              |                   |        |           |
|              |                   |        |           |
|              |                   |        |           |

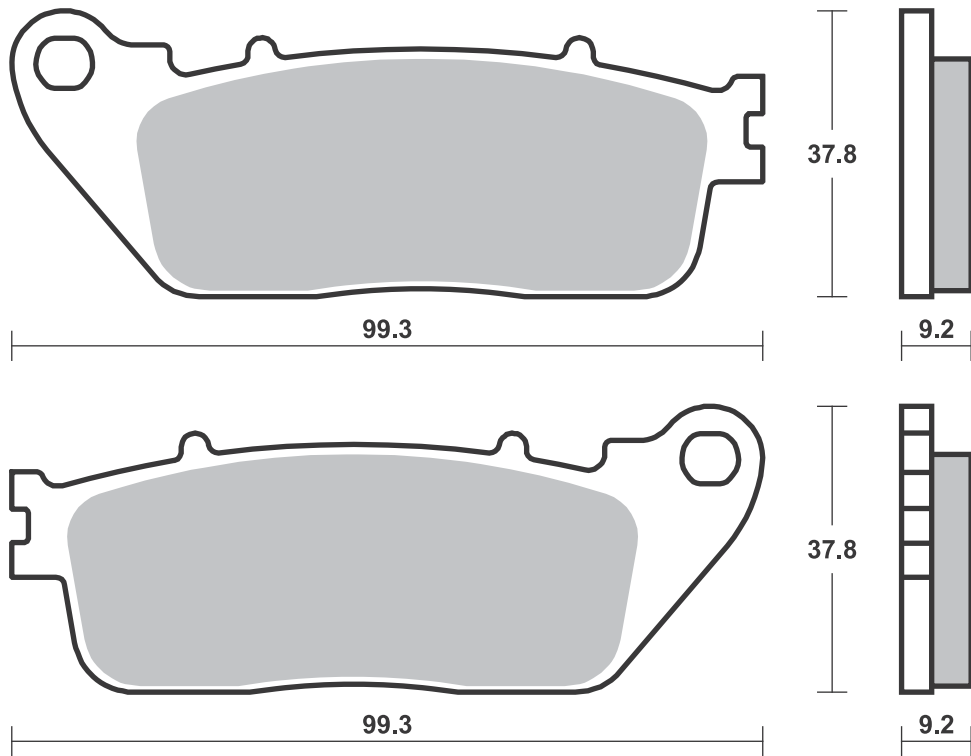
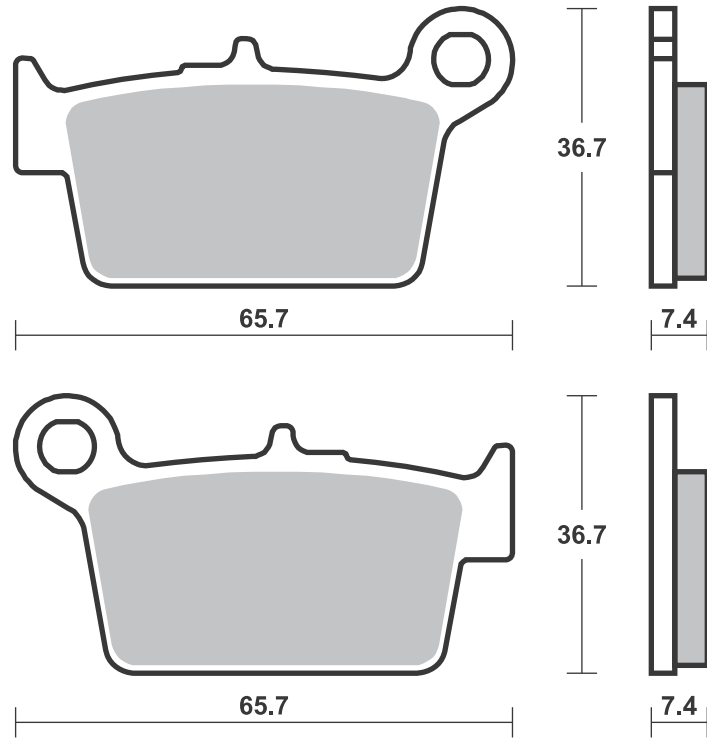

**SBS 864 Recommended compound**



**TRIUMPH**

|                    |       |           |
|--------------------|-------|-----------|
| 675 Daytona Triple | 09-18 | <b>HS</b> |
|                    |       |           |
|                    |       |           |
|                    |       |           |
|                    |       |           |
|                    |       |           |
|                    |       |           |
|                    |       |           |
|                    |       |           |
|                    |       |           |
|                    |       |           |
|                    |       |           |
|                    |       |           |
|                    |       |           |
|                    |       |           |
|                    |       |           |
|                    |       |           |

**SBS 865 Recommended compound**



**NISSIN**

|                          |  |  |
|--------------------------|--|--|
| 6 Piston Racing Radial   |  |  |
| Monobloc Caliper (Z0901) |  |  |
|                          |  |  |
|                          |  |  |
|                          |  |  |
|                          |  |  |
|                          |  |  |
|                          |  |  |
|                          |  |  |
|                          |  |  |
|                          |  |  |
|                          |  |  |
|                          |  |  |
|                          |  |  |
|                          |  |  |
|                          |  |  |
|                          |  |  |
|                          |  |  |

**SBS 866 Recommended compound**



**KTM**

|    |         |       |            |
|----|---------|-------|------------|
| SX | 450 ATV | 08-10 | <b>RSI</b> |
| XC | 450 ATV | 08-10 | <b>SI</b>  |
| SX | 505 ATV | 08-12 | <b>RSI</b> |
| XC | 505 ATV | 08-12 | <b>SI</b>  |
|    |         |       |            |
|    |         |       |            |
|    |         |       |            |
|    |         |       |            |
|    |         |       |            |
|    |         |       |            |
|    |         |       |            |
|    |         |       |            |
|    |         |       |            |
|    |         |       |            |
|    |         |       |            |
|    |         |       |            |
|    |         |       |            |
|    |         |       |            |
|    |         |       |            |
|    |         |       |            |
|    |         |       |            |
|    |         |       |            |

Brake Pad 1:1 Drawings,  
Compounds, Fitments

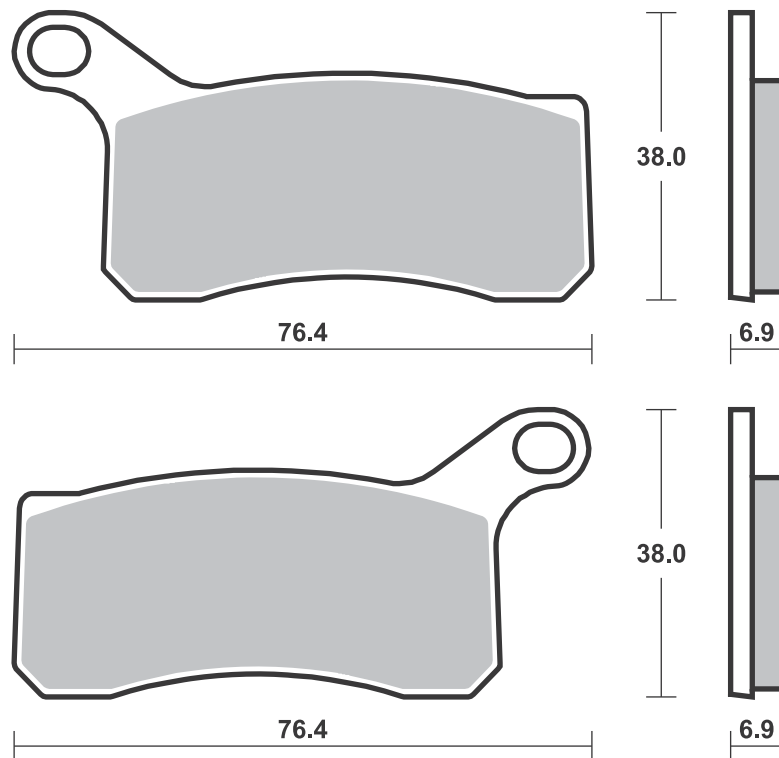
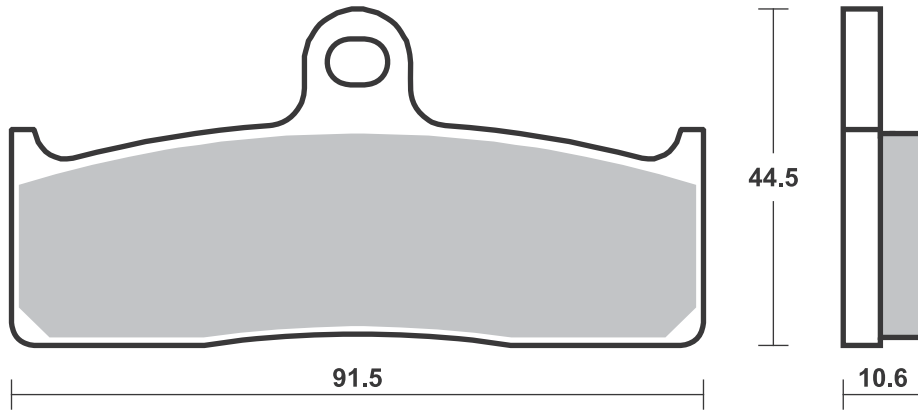
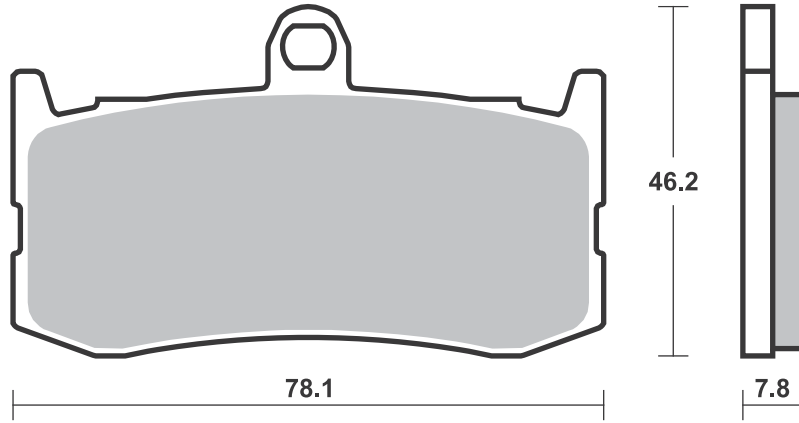

**SBS 867** Recommended compound



| <b>KTM</b> |         |       |     |
|------------|---------|-------|-----|
| SX         | 450 ATV | 08-10 | RSI |
| XC         | 450 ATV | 08-10 | SI  |
| SX         | 505 ATV | 08-12 | RSI |
| XC         | 505 ATV | 08-12 | SI  |

**SBS 869** Recommended compound



| <b>HONDA</b> |              |       |    |
|--------------|--------------|-------|----|
| VFR          | 1200 F       | 10-18 | HS |
| VFR          | 1200 F w/DCT | 10-18 | HS |

Brake Pad 1:1 Drawings,  
Compounds, Fitments



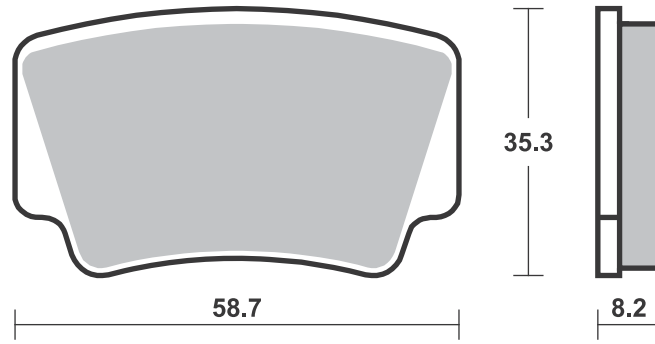

1 set = 4 pcs.

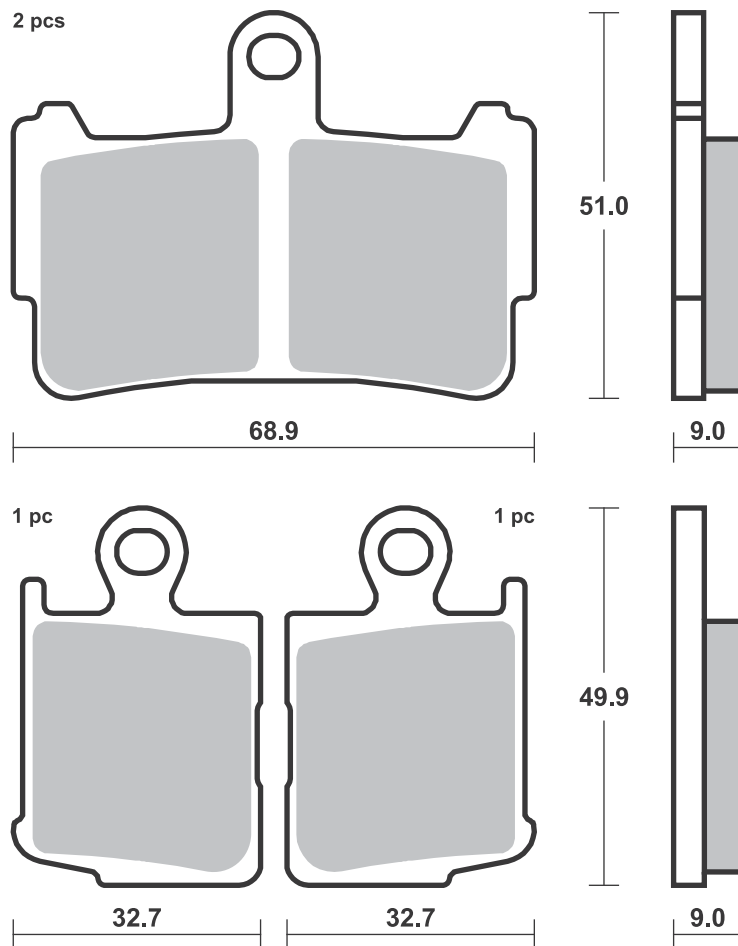

**SBS 870 Recommended compound**



| <b>BMW</b> |         |        |           |
|------------|---------|--------|-----------|
| S          | 1000 R  | 13- 18 | <b>HS</b> |
| S          | 1000 RR | 09- 18 | <b>SP</b> |
|            |         |        |           |
|            |         |        |           |
|            |         |        |           |
|            |         |        |           |
|            |         |        |           |
|            |         |        |           |
|            |         |        |           |
|            |         |        |           |
|            |         |        |           |
|            |         |        |           |
|            |         |        |           |
|            |         |        |           |
|            |         |        |           |
|            |         |        |           |
|            |         |        |           |

**SBS 872 Recommended compound**



| <b>HUSQVARNA</b> |    |        |            |
|------------------|----|--------|------------|
| CR               | 65 | 12- 13 | <b>RSI</b> |
| TC               | 85 | 14- 18 | <b>RSI</b> |
|                  |    |        |            |
|                  |    |        |            |
|                  |    |        |            |
|                  |    |        |            |
|                  |    |        |            |
|                  |    |        |            |
|                  |    |        |            |
|                  |    |        |            |
|                  |    |        |            |
|                  |    |        |            |
|                  |    |        |            |
|                  |    |        |            |
|                  |    |        |            |
|                  |    |        |            |
|                  |    |        |            |
|                  |    |        |            |

| <b>KTM</b> |                |        |            |
|------------|----------------|--------|------------|
|            | Freeride       |        |            |
|            | Electric       | 12- 14 | <b>RSI</b> |
| E-SM       | Freeride       | 15- 16 | <b>RSI</b> |
| E-SX       | Freeride       | 15- 16 | <b>RSI</b> |
| E-XC       | Freeride       | 15- 18 | <b>RSI</b> |
| SX         | 85 (19"/       |        |            |
|            | 16" wheels)    | 13- 18 | <b>RSI</b> |
| SX         | 85             | 11- 18 | <b>RSI</b> |
|            | 250 Freeride R | 14- 18 | <b>RSI</b> |
|            | 350 Freeride   | 12- 17 | <b>RSI</b> |
|            |                |        |            |
|            |                |        |            |
|            |                |        |            |
|            |                |        |            |
|            |                |        |            |
|            |                |        |            |
|            |                |        |            |
|            |                |        |            |

**SBS 877 Recommended compound**



| <b>BMW</b> |        |        |           |
|------------|--------|--------|-----------|
| G          | 310 GS | 17- 18 | <b>HS</b> |
| G          | 310 R  | 16- 18 | <b>HS</b> |
|            |        |        |           |
|            |        |        |           |
|            |        |        |           |
|            |        |        |           |
|            |        |        |           |
|            |        |        |           |
|            |        |        |           |
|            |        |        |           |
|            |        |        |           |
|            |        |        |           |
|            |        |        |           |
|            |        |        |           |
|            |        |        |           |
|            |        |        |           |
|            |        |        |           |
|            |        |        |           |
|            |        |        |           |

| <b>FANTIC</b> |               |    |           |
|---------------|---------------|----|-----------|
|               | 125 Caballero |    |           |
|               | Flat Track    | 17 | <b>HS</b> |
|               |               |    |           |
|               |               |    |           |
|               |               |    |           |
|               |               |    |           |
|               |               |    |           |
|               |               |    |           |
|               |               |    |           |
|               |               |    |           |
|               |               |    |           |
|               |               |    |           |
|               |               |    |           |
|               |               |    |           |
|               |               |    |           |
|               |               |    |           |
|               |               |    |           |
|               |               |    |           |
|               |               |    |           |

| <b>HUSQVARNA</b> |                |        |           |
|------------------|----------------|--------|-----------|
|                  | 401 Svartpilen | 17- 18 | <b>HS</b> |
|                  | 401 Vitpilen   | 17- 18 | <b>HS</b> |
|                  |                |        |           |
|                  |                |        |           |
|                  |                |        |           |
|                  |                |        |           |
|                  |                |        |           |
|                  |                |        |           |
|                  |                |        |           |
|                  |                |        |           |
|                  |                |        |           |
|                  |                |        |           |
|                  |                |        |           |
|                  |                |        |           |
|                  |                |        |           |
|                  |                |        |           |
|                  |                |        |           |
|                  |                |        |           |
|                  |                |        |           |

| <b>KTM</b> |          |        |           |
|------------|----------|--------|-----------|
|            | 125 Duke | 11- 18 | <b>HS</b> |
| RC         | 125      | 14- 18 | <b>HS</b> |
|            | 200 Duke | 12- 17 | <b>HS</b> |
| RC         | 200      | 14- 18 | <b>HS</b> |
|            | 250 Duke | 14- 15 | <b>HS</b> |
| RC         | 250      | 14- 15 | <b>HS</b> |
|            |          |        |           |
|            |          |        |           |
|            |          |        |           |
|            |          |        |           |
|            |          |        |           |
|            |          |        |           |
|            |          |        |           |
|            |          |        |           |
|            |          |        |           |
|            |          |        |           |
|            |          |        |           |
|            |          |        |           |
|            |          |        |           |
|            |          |        |           |
|            |          |        |           |
|            |          |        |           |
|            |          |        |           |



| <b>KTM</b> |          |        |           |
|------------|----------|--------|-----------|
|            | 390 Duke | 13- 15 | <b>HS</b> |
| RC         | 390      | 14- 18 | <b>HS</b> |
|            |          |        |           |
|            |          |        |           |
|            |          |        |           |
|            |          |        |           |
|            |          |        |           |
|            |          |        |           |
|            |          |        |           |
|            |          |        |           |
|            |          |        |           |
|            |          |        |           |
|            |          |        |           |
|            |          |        |           |
|            |          |        |           |
|            |          |        |           |
|            |          |        |           |
|            |          |        |           |
|            |          |        |           |
|            |          |        |           |
|            |          |        |           |

Brake Pad 1:1 Drawings, Compounds, Fitments

Drawings 1:1

Available compounds **HS • DC • RS • DS • SP**

**SBS 870**

1 set = 4 pcs.

HS / SP - Th. 8.0  
RS / DC / DS - Th. 8.7

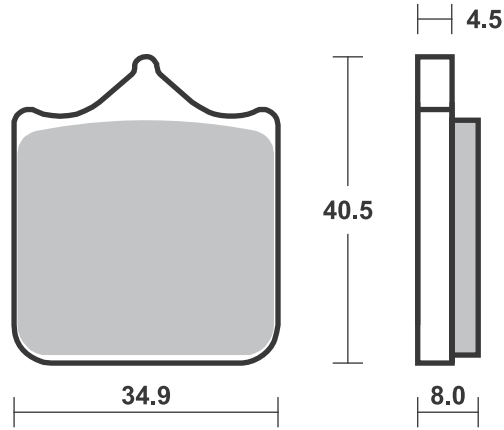

Available compounds **SI • RSI • CS**

**SBS 872**

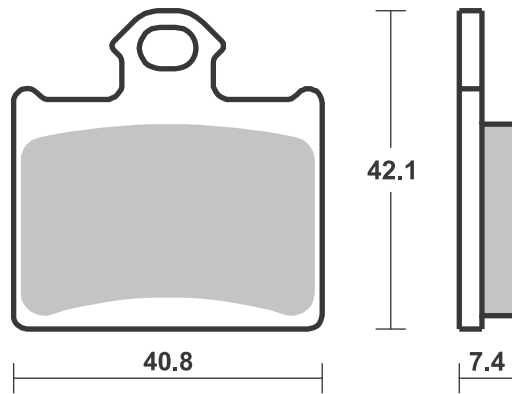

Available compounds **HF • HS • DC • RS**

**SBS 877**

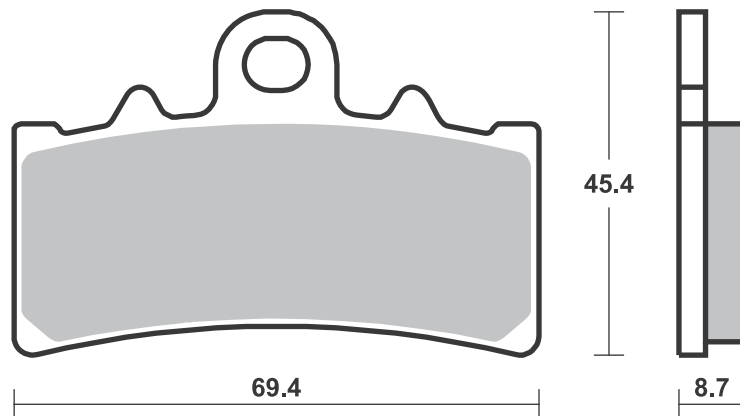

**SBS 878 Recommended compound**



**CECTEK**

|                    |       |           |
|--------------------|-------|-----------|
| 500 EFI King Cobra | 09-13 | <b>HF</b> |
| 500 EFI Quadrift   | 09-11 | <b>HF</b> |
| 500 i Estoc        | 10    | <b>HF</b> |

**PGO**

|                |       |           |
|----------------|-------|-----------|
| 500 Bug        | 08-14 | <b>HF</b> |
| BR 500 i Racer | 07-08 | <b>HF</b> |

**SBS 879 Recommended compound**



**APRILIA**

|   |       |           |
|---|-------|-----------|
| NA 850 Mana GT,<br>ABS<br>(Parking Brake) | 09-13 | <b>HF</b> |
|---|-------|-----------|

**HONDA**

|  |       |           |
|--|-------|-----------|
| CTX 700 D ABS w/DCT<br>(Parking Brake)         | 13-15 | <b>HF</b> |
| CTX 700 ND ABS<br>w/DCT<br>(Parking Brake)     | 14-15 | <b>HF</b> |
| NC 700 D Integra<br>w/DCT<br>(Parking Brake)   | 12-13 | <b>HF</b> |
| NC 700 SD ABS w/DCT<br>(Parking Brake)         | 12-13 | <b>HF</b> |
| NC 700 XD ABS w/DCT<br>(Parking Brake)         | 12-13 | <b>HF</b> |
| 750 X-ADV<br>(Parking Brake)                   | 17-18 | <b>HF</b> |
| NC 750 D Integra<br>w/DCT<br>(Parking Brake)   | 14-18 | <b>HF</b> |
| NC 750 S w/DCT<br>(Parking Brake)              | 14-18 | <b>HF</b> |
| NC 750 X w/DCT<br>(Parking Brake)              | 14-18 | <b>HF</b> |
| NM4 750 Vultus ABS<br>w/DCT<br>(Parking Brake) | 15-18 | <b>HF</b> |
| CRF 1000 L Africa Twin<br>(Parking Brake)      | 16-18 | <b>HF</b> |



**HONDA**

|  |       |           |
|--|-------|-----------|
| CRF 1000 L Africa Twin<br>Adventure<br>Sports<br>(Parking Brake) | 18-   | <b>HF</b> |
| VFR 1200 F w/DCT<br>(Parking Brake)                              | 10-18 | <b>HF</b> |
| VFR 1200 XDC<br>Crosstourer<br>w/DCT<br>(Parking Brake)          | 12-18 | <b>HF</b> |

Brake Pad 1:1 Drawings, Compounds, Fitments

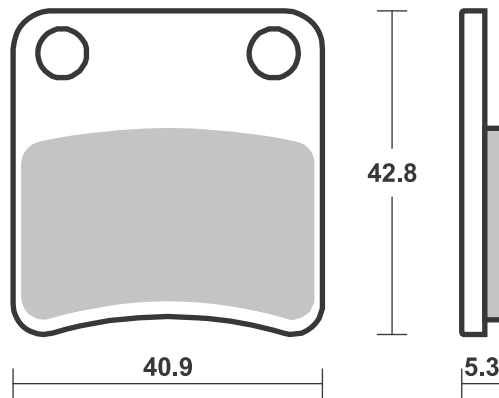
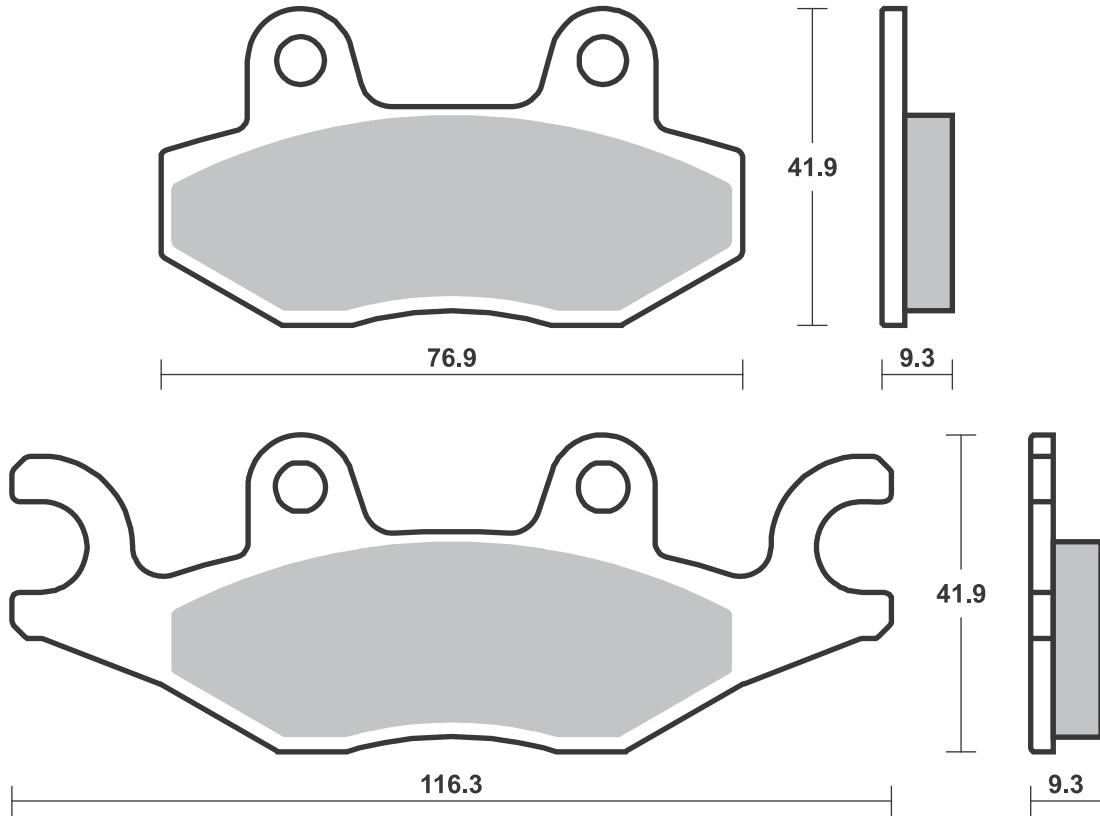

**SBS 880 Recommended compound**



| <b>HONDA</b> |                    |       |           |
|--------------|--------------------|-------|-----------|
| GL           | 1800 Gold Wing     | 01-16 | <b>LS</b> |
| GL           | 1800 Gold Wing F6B | 13-16 | <b>LS</b> |
|              |                    |       |           |
|              |                    |       |           |
|              |                    |       |           |
|              |                    |       |           |
|              |                    |       |           |
|              |                    |       |           |
|              |                    |       |           |
|              |                    |       |           |
|              |                    |       |           |
|              |                    |       |           |
|              |                    |       |           |
|              |                    |       |           |
|              |                    |       |           |
|              |                    |       |           |
|              |                    |       |           |
|              |                    |       |           |
|              |                    |       |           |
|              |                    |       |           |
|              |                    |       |           |
|              |                    |       |           |
|              |                    |       |           |
|              |                    |       |           |
|              |                    |       |           |
|              |                    |       |           |
|              |                    |       |           |
|              |                    |       |           |
|              |                    |       |           |
|              |                    |       |           |
|              |                    |       |           |
|              |                    |       |           |
|              |                    |       |           |
|              |                    |       |           |
|              |                    |       |           |
|              |                    |       |           |
|              |                    |       |           |
|              |                    |       |           |
|              |                    |       |           |
|              |                    |       |           |
|              |                    |       |           |

**SBS 881 Recommended compound**



| <b>HONDA</b> |                    |       |           |
|--------------|--------------------|-------|-----------|
| CBR          | 250 R (Nissin cal) | 11-13 | <b>LS</b> |
| CBR          | 250 R ABS          |       |           |
|              | (Nissin cal)       | 11-13 | <b>LS</b> |
| CBR          | 250 RR             | 17-18 | <b>LS</b> |
| CBR          | 300 F              | 14-16 | <b>LS</b> |
| CBR          | 300 F ABS          | 14-17 | <b>LS</b> |
| CBR          | 300 R              | 14-18 | <b>LS</b> |
| CMX          | 300 Rebel          | 17    | <b>LS</b> |
| CB           | 500 F              | 13-18 | <b>LS</b> |
| CB           | 500 X              | 13-18 | <b>LS</b> |
| CBR          | 500 R              | 13-18 | <b>LS</b> |
| CMX          | 500 Rebel          | 17-18 | <b>LS</b> |
| CB           | 650 F              | 14-18 | <b>LS</b> |
| CBR          | 650 F              | 14-18 | <b>LS</b> |
| CBR          | 650 F ABS          | 14-18 | <b>LS</b> |
| CTX          | 700                | 14-18 | <b>LS</b> |
| CTX          | 700 D ABS w/DCT    | 13-15 | <b>LS</b> |
| CTX          | 700 N              | 14-18 | <b>LS</b> |
| CTX          | 700 ND ABS         |       |           |
|              | w/DCT              | 14-15 | <b>LS</b> |
|              | 750 X-ADV          | 17-18 | <b>LS</b> |
| NC           | 750 D Integra      | 14-18 | <b>LS</b> |
| NC           | 750 S w/DCT        | 14-18 | <b>LS</b> |
| NC           | 750 X w/DCT        | 14-18 | <b>LS</b> |
| NM4          | 750 Vultus ABS     |       |           |
|              | w/DCT              | 15-18 | <b>LS</b> |



| <b>KAWASAKI</b> |           |       |           |
|-----------------|-----------|-------|-----------|
| Z               | 800       | 13-16 | <b>LS</b> |
| Z               | 800 ABS   | 13-16 | <b>LS</b> |
| Z               | 800 e     | 13-16 | <b>LS</b> |
| Z               | 800 e ABS | 13-16 | <b>LS</b> |
| Z               | 900       | 17-18 | <b>LS</b> |

| <b>SUZUKI</b> |                 |       |           |
|---------------|-----------------|-------|-----------|
| SFV           | 650 Gladius     |       |           |
|               | Left/Rear       | 09-16 | <b>LS</b> |
| SV            | 650 Left/Rear   | 16-18 | <b>LS</b> |
| SV            | 650 X Left/Rear | 18-   | <b>LS</b> |

| <b>KAWASAKI</b> |               |       |           |
|-----------------|---------------|-------|-----------|
| KLE             | 650 Versys    | 15-18 | <b>LS</b> |
| KLE             | 650 Versys LT | 15-16 | <b>LS</b> |
| Z               | 750 R         | 11-12 | <b>LS</b> |

Brake Pad 1:1 Drawings, Compounds, Fitments

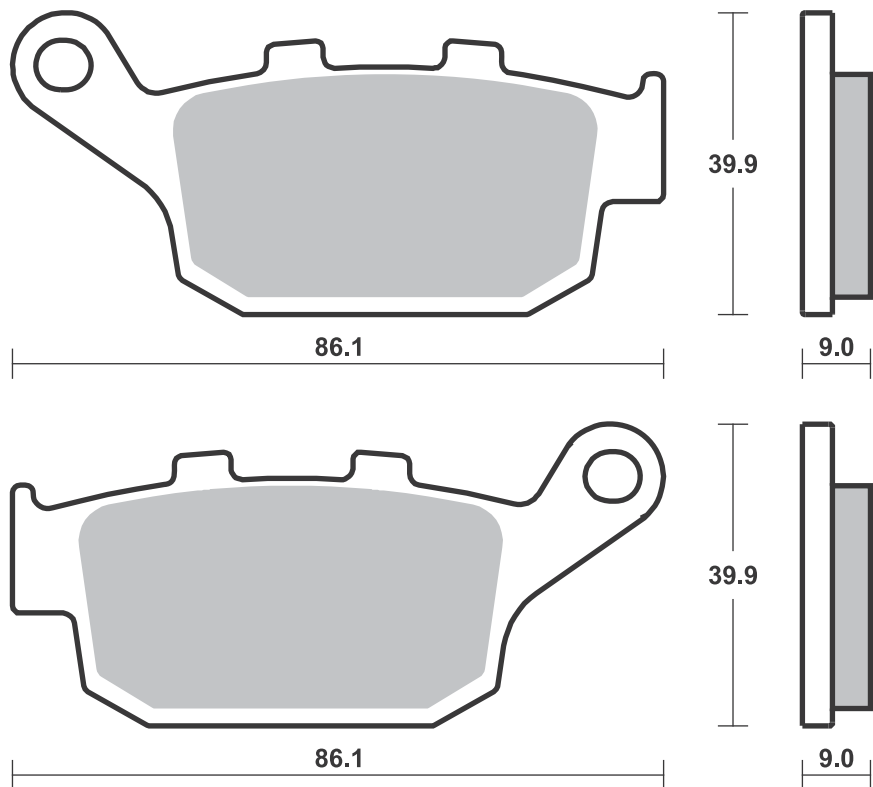
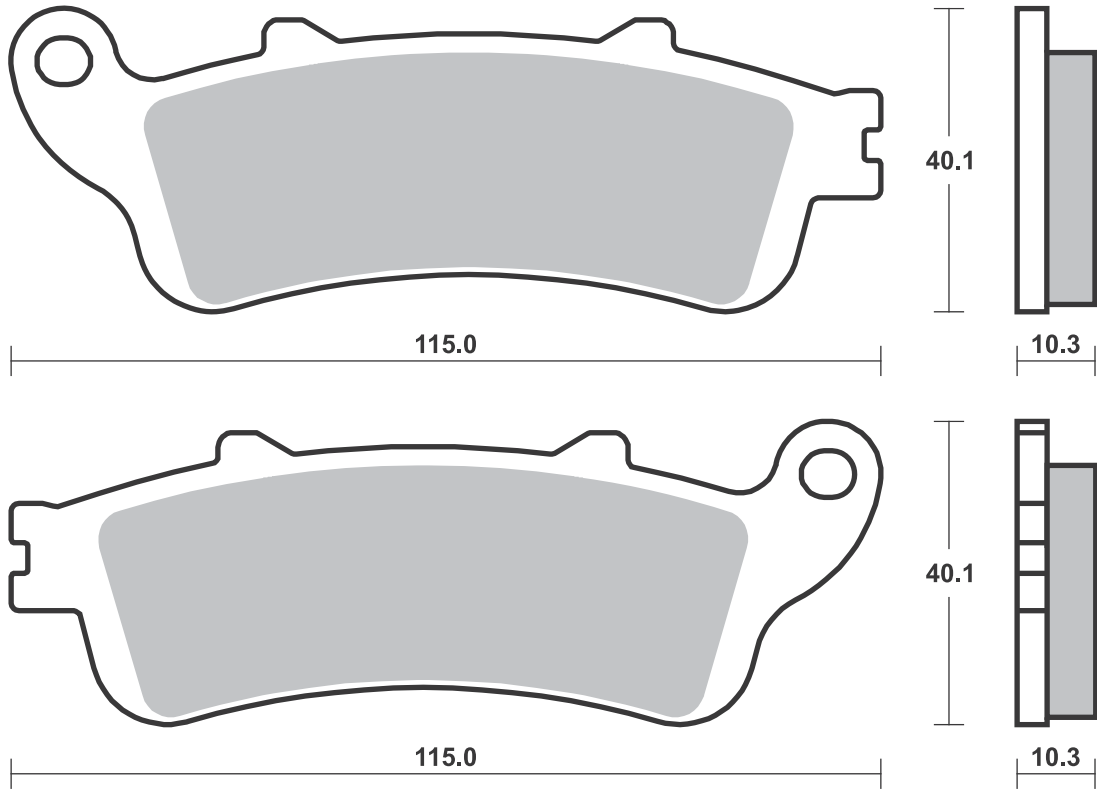

**SBS 885** Recommended compound**GAS GAS**

|     |                    |       |            |
|-----|--------------------|-------|------------|
| TXT | 125 (Formula cal.) | 12-13 | <b>RSI</b> |
| TXT | 250 (Formula cal.) | 12-13 | <b>RSI</b> |
| TXT | 280 (Formula cal.) | 12    | <b>RSI</b> |
| TXT | 300 (Formula cal.) | 12    | <b>RSI</b> |

**HUSQVARNA**

|    |    |       |            |
|----|----|-------|------------|
| TC | 85 | 14-18 | <b>RSI</b> |
|----|----|-------|------------|

**KTM**

|      |                |       |            |
|------|----------------|-------|------------|
|      | Freeride       |       |            |
|      | Electric       | 12-14 | <b>RSI</b> |
| E-SM | Freeride       | 15-16 | <b>RSI</b> |
| E-SX | Freeride       | 15-16 | <b>RSI</b> |
| E-XC | Freeride       | 15-18 | <b>RSI</b> |
| SX   | 85 (19"/       |       |            |
|      | 16" wheels)    | 13-18 | <b>RSI</b> |
| SX   | 85             | 12-18 | <b>RSI</b> |
|      | 250 Freeride R | 14-18 | <b>RSI</b> |
|      | 350 Freeride   | 12-17 | <b>RSI</b> |

**SHERCO**

|    |                    |       |            |
|----|--------------------|-------|------------|
| ST | 80 (Formula cal.)  | 13-14 | <b>RSI</b> |
| ST | 125 (Formula cal.) | 13-14 | <b>RSI</b> |
| ST | 250 (Formula cal.) | 13-14 | <b>RSI</b> |
| ST | 290 (Formula cal.) | 13-14 | <b>RSI</b> |
| ST | 305 (Formula cal.) | 13-14 | <b>RSI</b> |

**SBS 886** Recommended compound**KAWASAKI**

|    |                     |       |           |
|----|---------------------|-------|-----------|
| VN | 900 Classic         | 06-16 | <b>LS</b> |
| VN | 900 Classic SE      | 11-16 | <b>LS</b> |
| VN | 900 Custom          | 07-16 | <b>LS</b> |
| VN | 1500 Classic Fi     | 00-04 | <b>LS</b> |
| VN | 1500 Classic        |       |           |
|    | Tourer Fi           |       |           |
|    | Left/Rear           | 00-04 | <b>LS</b> |
| VN | 1500 Mean Streak    | 02-03 | <b>LS</b> |
| VN | 1600 Classic        |       |           |
|    | Left/Rear           | 03-08 | <b>LS</b> |
| VN | 1600 Mean Streak    | 04-05 | <b>LS</b> |
| VN | 1700 Classic        |       |           |
|    | Left/Rear           | 09-14 | <b>LS</b> |
| VN | 1700 Classic Tourer |       |           |
|    | Left/Rear           | 09-14 | <b>LS</b> |
| VN | 1700 Voyager        | 09-16 | <b>LS</b> |
| VN | 2000                | 04-10 | <b>LS</b> |

**SUZUKI**

|    |                 |       |           |
|----|-----------------|-------|-----------|
| C  | 1500 T Intruder | 13-18 | <b>LS</b> |
| M  | 1500 Intruder   |       |           |
|    | Left/Rear       | 09-18 | <b>LS</b> |
| M  | 1600 Intruder   | 05-07 | <b>LS</b> |
| VZ | 1600 Marauder   | 04    | <b>LS</b> |



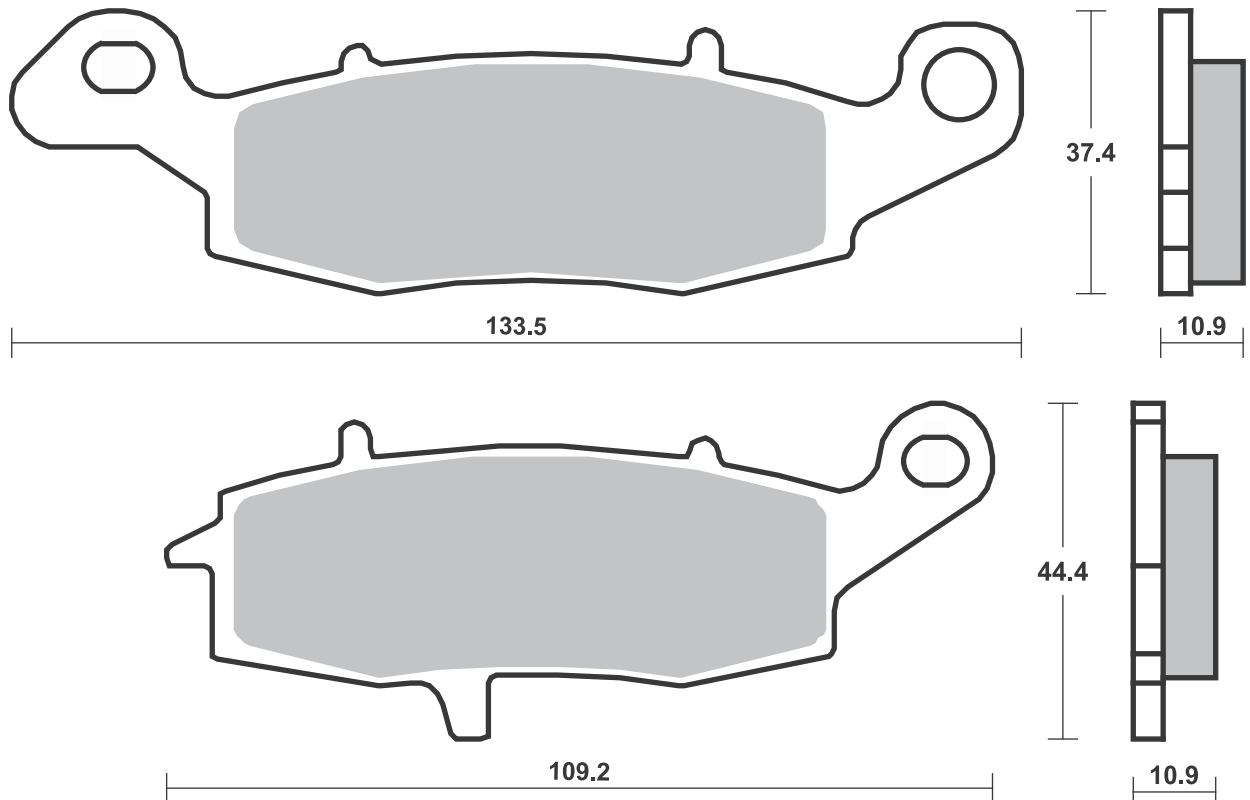
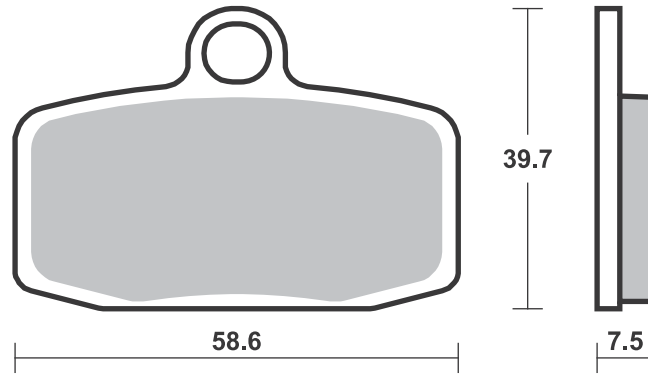

**SBS 887** Recommended compound



| <b>BREMBO RACING CALIPERS</b> |  |  |
|-------------------------------|--|--|
| Moto3/SBK XA88810/11,         |  |  |
| P2 34                         |  |  |
| Moto3/SBK XA88820/21,         |  |  |
| P2 34                         |  |  |
|                               |  |  |
|                               |  |  |
|                               |  |  |
|                               |  |  |
|                               |  |  |
|                               |  |  |
|                               |  |  |
|                               |  |  |
|                               |  |  |
|                               |  |  |
|                               |  |  |
|                               |  |  |

**SBS 889** Recommended compound



| <b>BREMBO RACING CALIPERS</b> |  |  |
|-------------------------------|--|--|
| SBK Racing DX XB0.B1.31,      |  |  |
| P4 30/34                      |  |  |
| SBK Racing SX XB0.B1.30,      |  |  |
| P4 30/34                      |  |  |
|                               |  |  |
|                               |  |  |
|                               |  |  |
|                               |  |  |
|                               |  |  |
|                               |  |  |
|                               |  |  |
|                               |  |  |
|                               |  |  |
|                               |  |  |
|                               |  |  |
|                               |  |  |
|                               |  |  |

**SBS 892** Recommended compound



| <b>HONDA</b>                |       |  |           |
|-----------------------------|-------|--|-----------|
| VFR 1200 F w/DCT            | 10-18 |  | <b>LS</b> |
| VFR 1200 XC Crosstourer     | 12-18 |  | <b>LS</b> |
| VFR 1200 XDC<br>Crosstourer |       |  |           |
| w/DCT                       | 12-18 |  | <b>LS</b> |
|                             |       |  |           |
|                             |       |  |           |
|                             |       |  |           |
|                             |       |  |           |
|                             |       |  |           |
|                             |       |  |           |
|                             |       |  |           |
|                             |       |  |           |
|                             |       |  |           |
|                             |       |  |           |
|                             |       |  |           |
|                             |       |  |           |
|                             |       |  |           |
|                             |       |  |           |
|                             |       |  |           |
|                             |       |  |           |
|                             |       |  |           |
|                             |       |  |           |

Brake Pad 1:1 Drawings, Compounds, Fitments

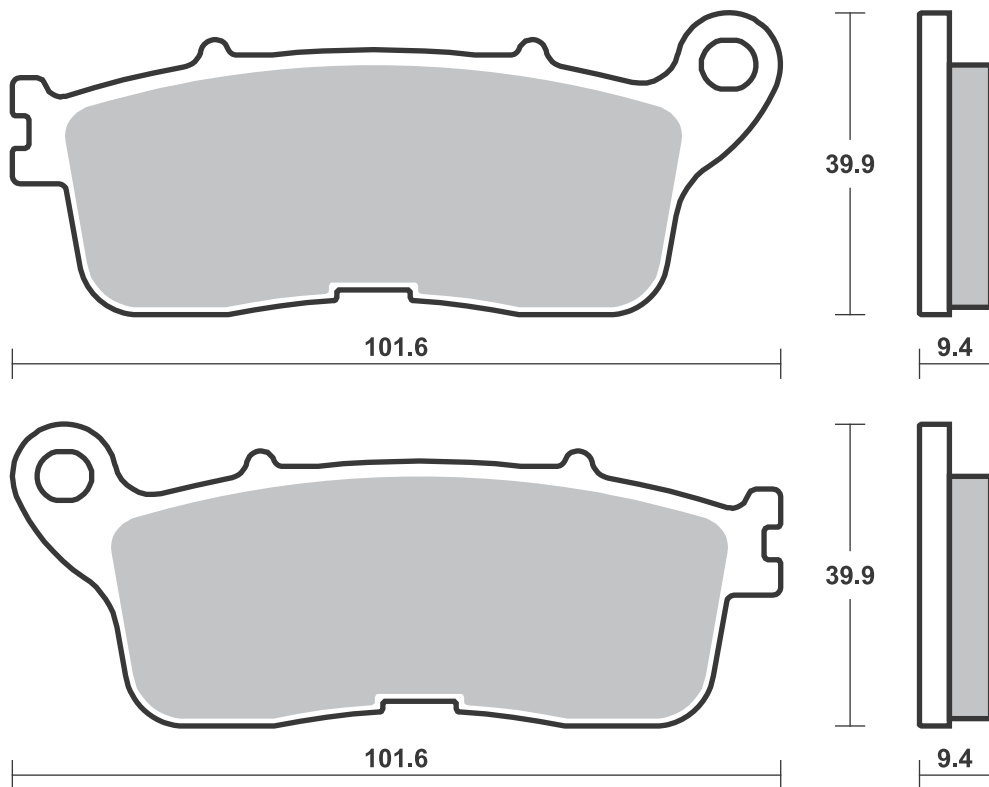
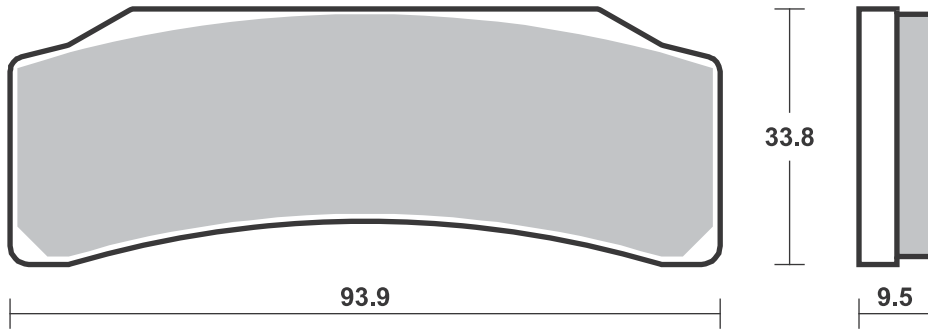
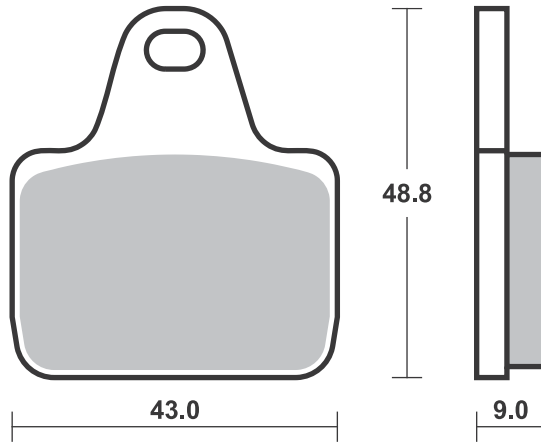

**SBS 893 Recommended compound**



| <b>SYM</b> |                  |       |           |
|------------|------------------|-------|-----------|
| SN         | 250 Ni Wolf      | 14-15 | <b>HF</b> |
| SN         | 250 T2 Wolf      | 12-15 | <b>HF</b> |
|            | 300 Wolf Cafe    |       |           |
|            | Racer            | 15    | <b>HF</b> |
|            | 300 Wolf Classic | 15    | <b>HF</b> |
| SB         | 300 Cafe Racer   | 16-17 | <b>HF</b> |
|            |                  |       |           |
|            |                  |       |           |
|            |                  |       |           |
|            |                  |       |           |
|            |                  |       |           |
|            |                  |       |           |
|            |                  |       |           |
|            |                  |       |           |
|            |                  |       |           |
|            |                  |       |           |
|            |                  |       |           |

**SBS 894 Recommended compound**



| <b>KAWASAKI</b> |               |       |           |
|-----------------|---------------|-------|-----------|
| ZX-6R           | 636 Ninja     | 13-16 | <b>HS</b> |
| ZX-6R           | 636 Ninja ABS | 13-16 | <b>HS</b> |
|                 |               |       |           |
|                 |               |       |           |
|                 |               |       |           |
|                 |               |       |           |
|                 |               |       |           |
|                 |               |       |           |
|                 |               |       |           |
|                 |               |       |           |
|                 |               |       |           |
|                 |               |       |           |
|                 |               |       |           |
|                 |               |       |           |
|                 |               |       |           |
|                 |               |       |           |
|                 |               |       |           |

**SBS 895 Recommended compound**



| <b>BETA</b> |                     |       |            |
|-------------|---------------------|-------|------------|
|             | 125 EVO             | 09-14 | <b>RSI</b> |
|             | 200 EVO             | 09-14 | <b>RSI</b> |
|             | 250 EVO (2-T / 4-T) | 09-14 | <b>RSI</b> |
|             | 290 EVO             | 09-13 | <b>RSI</b> |
|             | 300 EVO             | 09-15 | <b>RSI</b> |
|             |                     |       |            |
|             |                     |       |            |
|             |                     |       |            |
|             |                     |       |            |
|             |                     |       |            |
|             |                     |       |            |
|             |                     |       |            |
|             |                     |       |            |
|             |                     |       |            |
|             |                     |       |            |
|             |                     |       |            |
|             |                     |       |            |

Brake Pad 1:1 Drawings,  
Compounds, Fitments

Drawings 1:1

Available compounds **HF • HS**

**SBS 893**

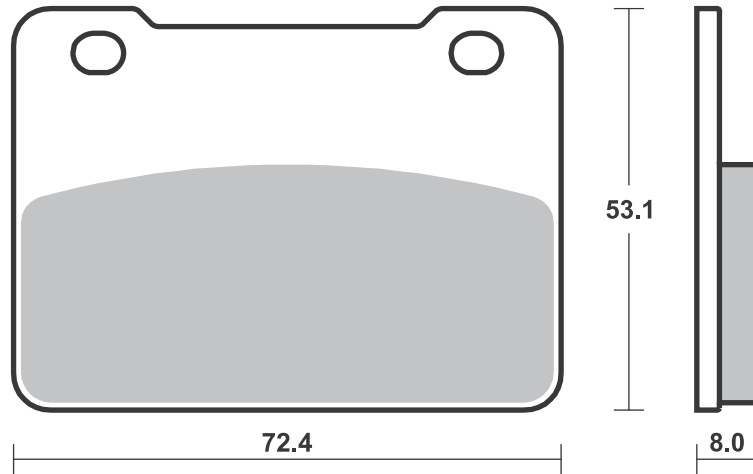

Available compounds **HS • DC • RS • SP**

**SBS 894**

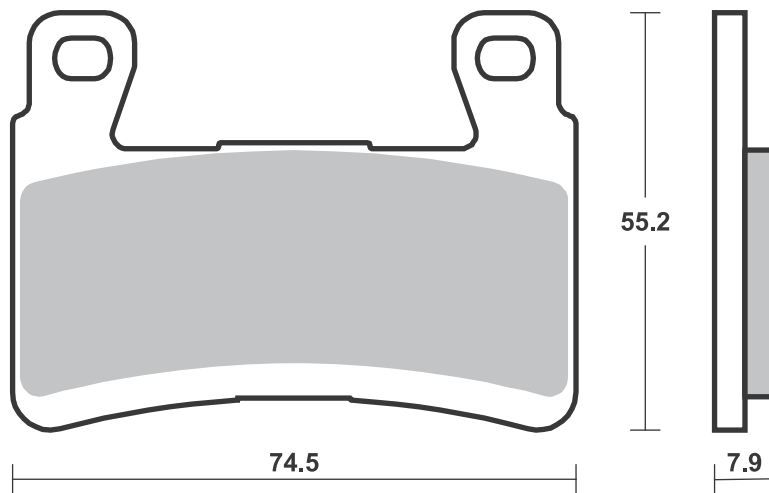

Available compounds **HF • RSI**

**SBS 895**

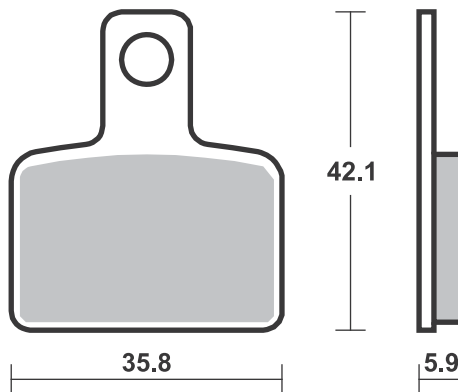

**SBS 896 Recommended compound**



| BETA          |       |     |
|---------------|-------|-----|
| 80 Rev        | 08-10 | RSI |
| 125 Rev 3     | 06-08 | RSI |
| 200 Rev 3     | 06-08 | RSI |
| 250 4-T Rev 3 | 07-11 | RSI |
| 250 Rev 3     | 05-09 | RSI |
| 270 Rev 3     | 05-08 | RSI |
|               |       |     |
|               |       |     |
|               |       |     |
|               |       |     |
|               |       |     |
|               |       |     |
|               |       |     |
|               |       |     |
|               |       |     |
|               |       |     |
|               |       |     |
|               |       |     |
|               |       |     |
|               |       |     |
|               |       |     |

**SBS 897 Recommended compound**



| POLARIS            |       |         |
|--------------------|-------|---------|
| EV-LSV             | 10-11 | ATS     |
| LSV 4x4            | 11-12 | ATS     |
| Ranger 48v EV      | 13-16 | ATS     |
| 500 Ranger 2x4     | 08-07 | ATS     |
| 500 Ranger 2x4 EFi | 08-13 | ATS     |
| 500 Ranger 4x4     | 12-13 | ATS     |
| 700 MVRS 4x4       | 08    | ATS ATS |
| 700 Ranger 4x4 EFi | 08    | ATS     |
| 700 Ranger 6x6 EFi | 12-13 | ATS     |
| 800 MVRS 4x4       | 08    | ATS ATS |
| 800 Ranger 4x4 EFi | 10    | ATS ATS |
| 800 Ranger 6x6 EFi | 12-15 | ATS ATS |
| 800 Ranger Crew    | 12-15 | ATS ATS |
| 800 Ranger RZR4    |       |         |
| EFi                | 12-14 | ATS     |
| 800 Ranger XP      | 12-13 | ATS     |
| 800 RZR-4          | 10-14 | ATS     |
| 900 Ranger 4x4     |       |         |



| POLARIS               |       |     |     |
|-----------------------|-------|-----|-----|
| Diesel                | 10-14 | ATS | ATS |
| 900 Ranger RZR4       |       |     |     |
| XP EFi                | 12-15 | ATS | ATS |
| 900 Ranger RZR4       |       |     |     |
| XP4 EFi               | 12-14 | ATS | ATS |
| 1000 General EPS      | 16-17 | ATS |     |
| 1000 Ranger RZR XP 14 |       | ATS | ATS |
| 1050 MV Diesel Crew   | 13-17 | ATS | ATS |
|                       |       |     |     |
|                       |       |     |     |
|                       |       |     |     |
|                       |       |     |     |
|                       |       |     |     |
|                       |       |     |     |
|                       |       |     |     |
|                       |       |     |     |
|                       |       |     |     |
|                       |       |     |     |
|                       |       |     |     |
|                       |       |     |     |
|                       |       |     |     |

**SBS 898 Recommended compound**



| POLARIS          |       |     |
|------------------|-------|-----|
| 450 Outlaw MXR   | 09-11 | ATS |
| 450 Outlaw S     | 08    | ATS |
| 525 Outlaw       | 07-13 | ATS |
| 525 Outlaw IRS   | 08-13 | ATS |
| 525 Outlaw S     | 08-11 | ATS |
| 570 Ranger RZR   |       |     |
| EFi              | 12-13 | ATS |
| 800 Ranger RZR   |       |     |
| EFi              | 08-14 | ATS |
| 800 Ranger RZR S |       |     |
| EFi              | 09-15 | ATS |
| 800 RZR          | 08-15 | ATS |
| 1000 General EPS | 16-17 | ATS |
|                  |       |     |
|                  |       |     |
|                  |       |     |
|                  |       |     |
|                  |       |     |
|                  |       |     |
|                  |       |     |
|                  |       |     |
|                  |       |     |

Brake Pad 1:1 Drawings, Compounds, Fitments

Available compounds **HF • RSI**

**SBS 896**

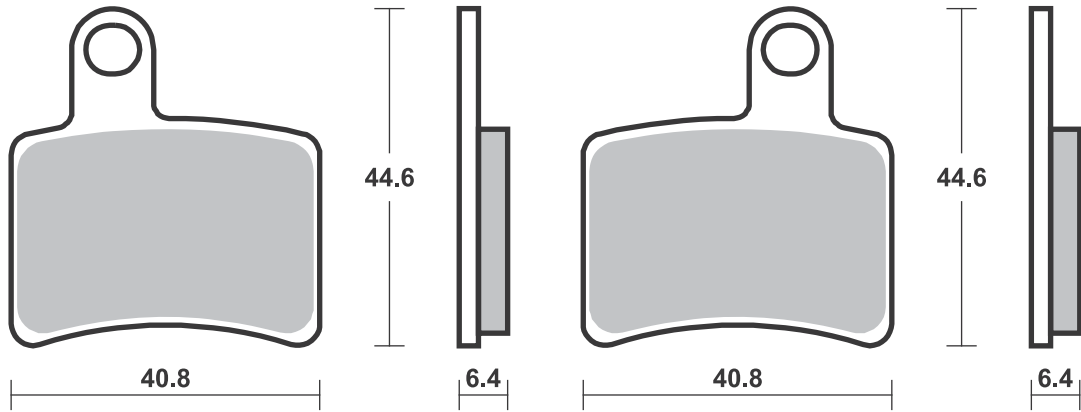

Available compounds **SI • RSI • ATS**

**SBS 897**

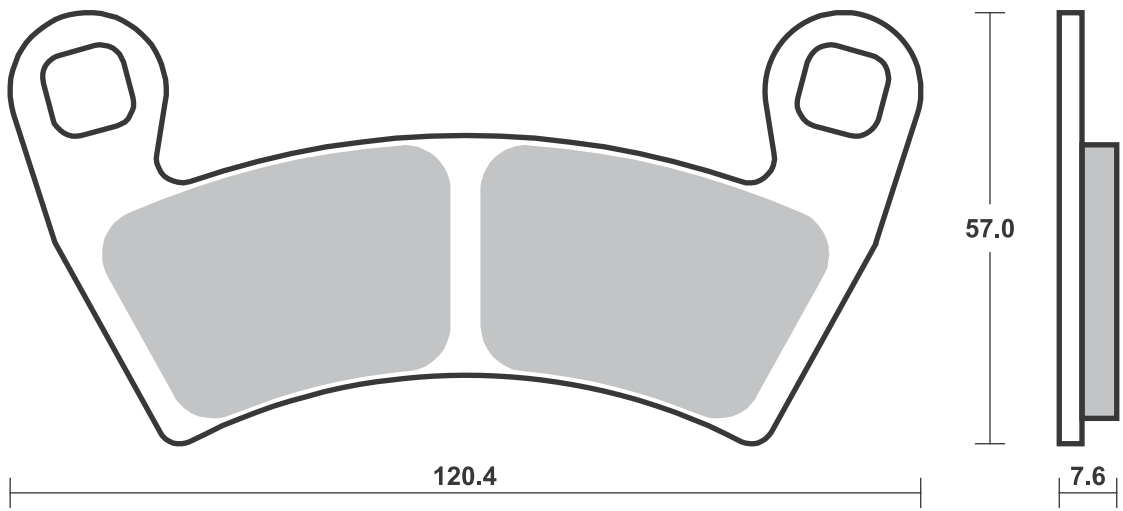

Available compounds **SI • RSI • ATS**

**SBS 898**

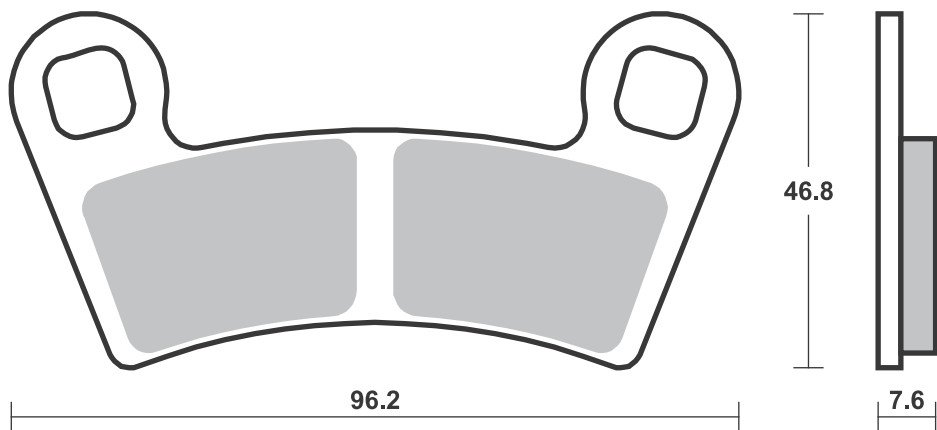

## Applications

### SBS 899 Recommended compound



| <b>POLARIS</b>   |       |            |            |
|------------------|-------|------------|------------|
| 500 Sportsman HO |       |            |            |
| (from            |       |            |            |
| 16.12.2008)      | 09-14 |            | <b>ATS</b> |
| 550 Sportsman    | 11-14 | <b>ATS</b> | <b>ATS</b> |
| 550 Sportsman    |       |            |            |
| EPS              | 10-14 | <b>ATS</b> | <b>ATS</b> |
| 550 Sportsman    |       |            |            |
| EPS X2           | 14    | <b>ATS</b> | <b>ATS</b> |
| 550 Sportsman    |       |            |            |
| Touring EPS      | 10-12 | <b>ATS</b> | <b>ATS</b> |
| 550 Sportsman X2 | 10-14 | <b>ATS</b> | <b>ATS</b> |
| 550 Sportsman XP | 09-12 | <b>ATS</b> | <b>ATS</b> |
| 550 Sportsman XP |       |            |            |
| EPS              | 09-14 | <b>ATS</b> | <b>ATS</b> |
| 550 Sportsman XP |       |            |            |
| Touring EPS      | 12-14 | <b>ATS</b> | <b>ATS</b> |
| 800 Sportsman    |       |            |            |
| (from            |       |            |            |
| 16.12.2008)      | 09-14 |            | <b>ATS</b> |
| 850 Forest       | 15    | <b>ATS</b> | <b>ATS</b> |
| 850 Scrambler    | 15    | <b>ATS</b> | <b>ATS</b> |
| 850 Scrambler HO |       |            |            |
| EPS              | 13-15 | <b>ATS</b> | <b>ATS</b> |
| 850 Scrambler MD | 15    | <b>ATS</b> | <b>ATS</b> |
| 850 Scrambler XP |       |            |            |
| HO EPS           | 14-15 | <b>ATS</b> | <b>ATS</b> |
| 850 Sportsman    | 11-13 | <b>ATS</b> | <b>ATS</b> |
| 850 Sportsman    |       |            |            |
| MV               | 12    | <b>ATS</b> | <b>ATS</b> |
| 850 Sportsman    |       |            |            |
| Touring          | 14-15 | <b>ATS</b> | <b>ATS</b> |



| <b>POLARIS</b>    |       |            |            |
|-------------------|-------|------------|------------|
| 850 Sportsman     |       |            |            |
| Touring EPS       | 10-13 | <b>ATS</b> | <b>ATS</b> |
| 850 Sportsman     |       |            |            |
| Touring HO        |       |            |            |
| EPS               | 13-14 | <b>ATS</b> | <b>ATS</b> |
| 850 Sportsman     |       |            |            |
| Touring MD        | 15    | <b>ATS</b> | <b>ATS</b> |
| 850 Sportsman X2  | 11    | <b>ATS</b> | <b>ATS</b> |
| 850 Sportsman XP  | 09-14 | <b>ATS</b> | <b>ATS</b> |
| 850 Sportsman XP  |       |            |            |
| EPS               | 09-14 | <b>ATS</b> | <b>ATS</b> |
| 850 Sportsman XP  |       |            |            |
| HO EPS            | 13-14 | <b>ATS</b> | <b>ATS</b> |
| 850 Sportsman XP  |       |            |            |
| HO EPS MD         | 15    | <b>ATS</b> | <b>ATS</b> |
| 850 Sportsman XP  |       |            |            |
| Touring EPS       | 15    | <b>ATS</b> | <b>ATS</b> |
| 1000 Forest       | 15    | <b>ATS</b> | <b>ATS</b> |
| 1000 Scrambler MD | 15-16 | <b>ATS</b> | <b>ATS</b> |
| 1000 Scrambler XP | 15-17 | <b>ATS</b> | <b>ATS</b> |
| 1000 Scrambler XP |       |            |            |
| HO EPS            | 14    | <b>ATS</b> | <b>ATS</b> |
| 1000 Sportsman MD | 15-16 | <b>ATS</b> | <b>ATS</b> |
| 1000 Sportsman    |       |            |            |
| Touring           | 15-17 | <b>ATS</b> | <b>ATS</b> |
| 1000 Sportsman XP | 15-17 | <b>ATS</b> | <b>ATS</b> |

### SBS 900 Recommended compound



| <b>APRILIA</b>       |       |  |           |
|----------------------|-------|--|-----------|
| RSV 1000 Tuono V4 R  | 14    |  | <b>HS</b> |
| RSV 1100 Tuono V4    | 15    |  | <b>HS</b> |
| RSV 1100 Tuono V4    |       |  |           |
| Factory              | 16-18 |  | <b>HS</b> |
| RSV 1100 Tuono V4 RR | 15-18 |  | <b>HS</b> |
| 1200 Caponord        | 13-18 |  | <b>SP</b> |
| 1200 Caponord Rally  | 15-18 |  | <b>SP</b> |
| 1200 Caponord        |       |  |           |
| Travel Pack          | 16-18 |  | <b>SP</b> |

| <b>BMW</b>          |       |  |           |
|---------------------|-------|--|-----------|
| F 800 R             | 15-18 |  | <b>HS</b> |
| S 1000 XR           | 15-18 |  | <b>SP</b> |
| R 1200 GS           | 13-18 |  | <b>SP</b> |
| R 1200 GS Adventure | 14-16 |  | <b>SP</b> |
| R 1200 Nine-T       | 14-18 |  | <b>HS</b> |
| R 1200 R            | 15-18 |  | <b>HS</b> |
| R 1200 RS           | 14-18 |  | <b>HS</b> |
| R 1200 RT           | 14-18 |  | <b>HS</b> |

| <b>CAN-AM</b>         |       |  |           |
|-----------------------|-------|--|-----------|
| 1330 Spyder F3        | 15-18 |  | <b>HS</b> |
| 1330 Spyder F3        |       |  |           |
| Limited               | 16-18 |  | <b>HS</b> |
| 1330 Spyder F3-S      | 15-18 |  | <b>HS</b> |
| 1330 Spyder F3-T      | 16-18 |  | <b>HS</b> |
| 1330 Spyder RS        | 14-16 |  | <b>HS</b> |
| 1330 Spyder RS RSS 13 |       |  | <b>HS</b> |
| 1330 Spyder RSS       | 14-15 |  | <b>HS</b> |
| 1330 Spyder RSS       |       |  |           |
| Special Series        | 15    |  | <b>HS</b> |



| <b>CAN-AM</b>      |       |  |           |
|--------------------|-------|--|-----------|
| 1330 Spyder RT     | 14-18 |  | <b>HS</b> |
| 1330 Spyder RT     |       |  |           |
| Limited            | 13-18 |  | <b>HS</b> |
| 1330 Spyder RT RTS | 13    |  | <b>HS</b> |
| 1330 Spyder RTS    | 14-15 |  | <b>HS</b> |
| 1330 Spyder RTS    |       |  |           |
| Special Series     | 15    |  | <b>HS</b> |
| 1330 Spyder ST     | 14-16 |  | <b>HS</b> |
| 1330 Spyder ST     |       |  |           |
| Limited            | 13-15 |  | <b>HS</b> |
| 1330 Spyder ST STS | 13    |  | <b>HS</b> |
| 1330 Spyder STS    | 14-15 |  | <b>HS</b> |
| 1330 Spyder STS    |       |  |           |
| Special Series     | 15    |  | <b>HS</b> |

  

| <b>DUCATI</b>   |       |  |           |
|-----------------|-------|--|-----------|
| 797 Monster     | 17-18 |  | <b>HS</b> |
| 797 Monster+    | 17-18 |  | <b>HS</b> |
| 800 Hypermotard | 13-15 |  | <b>HS</b> |
| 800 Hypermotard |       |  |           |
| ABS             | 13-15 |  | <b>HS</b> |
| 800 Hypermotard |       |  |           |
| SP              | 13-15 |  | <b>HS</b> |
| 800 Hypermotard |       |  |           |
| SP ABS          | 13-15 |  | <b>HS</b> |
| 800 Hyperstrada | 13-15 |  | <b>HS</b> |
| 800 Hyperstrada |       |  |           |
| ABS             | 13-15 |  | <b>HS</b> |
| 800 Scrambler   | 17-18 |  | <b>HS</b> |
| 800 Scrambler   |       |  |           |
| Classic         | 15-18 |  | <b>HS</b> |



| <b>DUCATI</b>      |       |  |           |
|--------------------|-------|--|-----------|
| 800 Scrambler CR   | 17-18 |  | <b>HS</b> |
| 800 Scrambler CR   |       |  |           |
| Cafe Racer         | 17-18 |  | <b>HS</b> |
| 800 Scrambler      |       |  |           |
| Enduro             | 15-16 |  | <b>HS</b> |
| 800 Scrambler Flat |       |  |           |
| Track Pro          | 16    |  | <b>HS</b> |
| 800 Scrambler Full |       |  |           |
| Throttle           | 15-18 |  | <b>HS</b> |
| 800 Scrambler Icon | 15-18 |  | <b>HS</b> |
| 800 Scrambler      |       |  |           |
| Mach 2.0           | 18-   |  | <b>HS</b> |
| 800 Scrambler      |       |  |           |
| Street Classic     | 17-18 |  | <b>HS</b> |
| 800 Scrambler      |       |  |           |
| Urban Enduro       | 16    |  | <b>HS</b> |
| 800 Scrambler-X    |       |  |           |
| DS Desert Sled     | 17-18 |  | <b>HS</b> |
| 821 Monster        | 14-18 |  | <b>HS</b> |
| 821 Monster Dark   | 15-16 |  | <b>HS</b> |
| 899 Panigale       | 14-15 |  | <b>HS</b> |
| 939 Hypermotard    | 16-18 |  | <b>HS</b> |
| 939 Hypermotard    |       |  |           |
| SP                 | 16-18 |  | <b>HS</b> |
| 939 Hyperstrada    | 16    |  | <b>HS</b> |
| 939 SuperSport     | 17-18 |  | <b>HS</b> |
| 939 SuperSport S   | 17-18 |  | <b>HS</b> |
| 950 Multistrada    | 17-18 |  | <b>HS</b> |
| 959 Panigale       | 16-18 |  | <b>HS</b> |
| 959 Panigale Corse | 18-   |  | <b>HS</b> |
| 1100 Scrambler     | 18-   |  | <b>HS</b> |



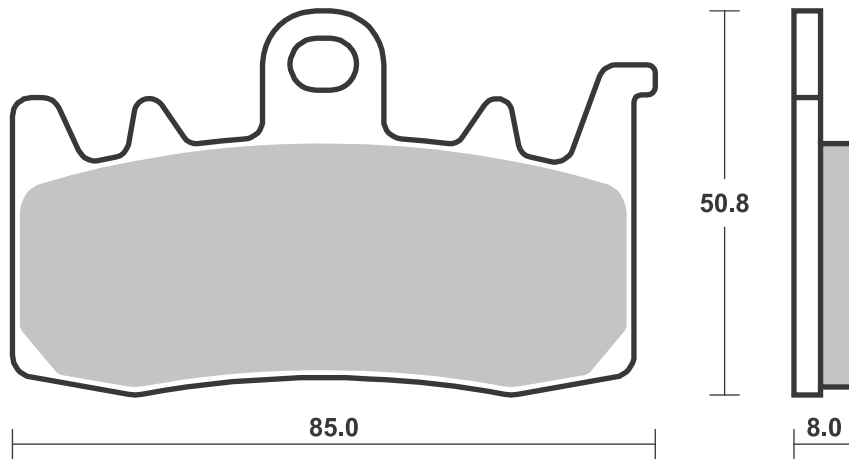
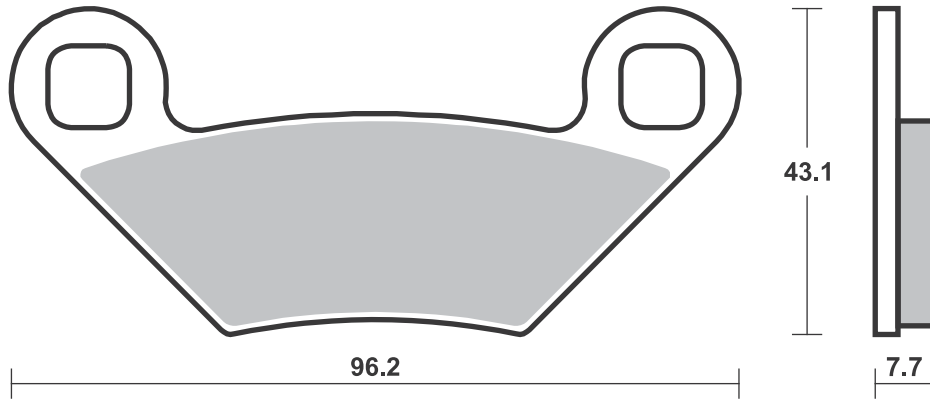

## Applications

### SBS 900 Recommended compound



| <b>DUCATI</b>    |        |           |  |
|------------------|--------|-----------|--|
| 1100 Scrambler   |        |           |  |
| Special          | 18-    | <b>HS</b> |  |
| 1100 Scrambler   |        |           |  |
| Sport            | 18-    | <b>HS</b> |  |
| 1200 Monster     | 14- 18 | <b>HS</b> |  |
| 1200 Multistrada | 15- 16 | <b>SP</b> |  |
| 1200 Multistrada |        |           |  |
| Enduro           | 16- 18 | <b>SP</b> |  |
| 1200 Multistrada |        |           |  |
| Enduro Pro       | 18-    | <b>SP</b> |  |

| <b>FANTIC</b> |    |           |  |
|---------------|----|-----------|--|
| 500 Caballero | 17 | <b>HS</b> |  |

| <b>KYMCO</b> |     |    |           |
|--------------|-----|----|-----------|
| AK           | 550 | 17 | <b>HS</b> |

| <b>MV AGUSTA</b> |        |           |  |
|------------------|--------|-----------|--|
| 800 Rivale       | 13- 17 | <b>HS</b> |  |
| 800 Stradale     | 15- 16 | <b>HS</b> |  |
| 800 Turismo      |        |           |  |
| Veloce           | 14- 16 | <b>HS</b> |  |
| 800 Turismo      |        |           |  |
| Veloce           |        |           |  |
| Lusso            | 14- 16 | <b>HS</b> |  |
| 800 Turismo      |        |           |  |
| Veloce RC        | 17- 18 | <b>HS</b> |  |



| <b>NORTON</b> |        |           |  |
|---------------|--------|-----------|--|
| 961 Commando  |        |           |  |
| Cafe Racer    |        |           |  |
| MKII          | 18-    | <b>HS</b> |  |
| 961 Commando  |        |           |  |
| Sport         | 18-    | <b>HS</b> |  |
| 961 Dominator |        |           |  |
| Naked         | 17- 18 | <b>HS</b> |  |

| <b>TRIUMPH</b> |        |           |  |
|----------------|--------|-----------|--|
| 765 Street     |        |           |  |
| Triple R       | 17- 18 | <b>HS</b> |  |
| 765 Street     |        |           |  |
| Triple R       |        |           |  |
| Low            | 17- 18 | <b>HS</b> |  |
| 1200 Tiger     |        |           |  |
| Explorer       | 16- 17 | <b>SP</b> |  |
| 1200 Tiger XCA | 18-    | <b>SP</b> |  |
| 1200 Tiger XCX | 18-    | <b>SP</b> |  |
| 1200 Tiger XR  | 18-    | <b>SP</b> |  |
| 1200 Tiger XRT | 18-    | <b>SP</b> |  |
| 1200 Tiger XRX | 18-    | <b>SP</b> |  |
| 1200 Tiger XRX |        |           |  |
| Low            | 18-    | <b>SP</b> |  |

### SBS 901 Recommended compound



| <b>APRILIA</b> |      |        |           |
|----------------|------|--------|-----------|
| RSV4-RF        | 1000 | 15- 18 | <b>SP</b> |
| RSV4-RR        | 1000 | 15- 18 | <b>SP</b> |

| <b>BIMOTA</b> |          |        |           |
|---------------|----------|--------|-----------|
| BB3           | 1000     | 14- 18 | <b>SP</b> |
| DB7           | 1099     | 09     | <b>HS</b> |
| DB8           | 1198     | 10- 14 | <b>SP</b> |
| DB11          | 1200 VLX | 13     | <b>HS</b> |

| <b>BMW</b> |                |        |           |
|------------|----------------|--------|-----------|
| S          | 1000 RR HP4    | 12- 14 | <b>SP</b> |
|            | 1200 HP2 Sport | 08- 10 | <b>SP</b> |

| <b>DUCATI</b>  |  |        |           |
|----------------|--|--------|-----------|
| 1200 Diavel    |  | 11- 18 | <b>HS</b> |
| 1200 Diavel    |  |        |           |
| Strada         |  | 11- 14 | <b>HS</b> |
| 1200 Xdiavel   |  | 16- 18 | <b>HS</b> |
| 1200 Xdiavel S |  | 16- 18 | <b>HS</b> |

| <b>HONDA</b> |             |        |           |
|--------------|-------------|--------|-----------|
| CBR          | 1000 RR SP  | 14- 18 | <b>SP</b> |
| CBR          | 1000 RR SP2 | 17- 18 | <b>SP</b> |
| RC213V-S     | 1000        | 16- 18 | <b>SP</b> |

| <b>KAWASAKI</b> |                  |        |           |
|-----------------|------------------|--------|-----------|
| ZZR             | 1400 Performance |        |           |
|                 | Sport            | 17- 18 | <b>HS</b> |
| ZZR             | 1400 SE          | 16- 18 | <b>HS</b> |



| <b>KTM</b> |        |           |  |
|------------|--------|-----------|--|
| 1290 Super |        |           |  |
| Duke GT    | 16- 18 | <b>HS</b> |  |

| <b>MOTO-MORINI</b> |     |           |  |
|--------------------|-----|-----------|--|
| 1200 Corsaro       |     |           |  |
| ZZ                 | 18- | <b>HS</b> |  |
| 1200 Milano        | 18- | <b>HS</b> |  |
| 1200 Scrambler     | 18- | <b>HS</b> |  |

| <b>MV AGUSTA</b> |        |           |  |
|------------------|--------|-----------|--|
| 675 F3           | 15- 17 | <b>HS</b> |  |
| 675 F3 RC        | 16- 17 | <b>HS</b> |  |
| 800 F3           | 14- 17 | <b>HS</b> |  |
| 800 F3 RC        | 16- 17 | <b>HS</b> |  |

| <b>TRIUMPH</b> |        |           |  |
|----------------|--------|-----------|--|
| 675 Daytona    |        |           |  |
| R Triple       | 11- 18 | <b>HS</b> |  |
| 765 Street     |        |           |  |
| Triple RS      | 17- 18 | <b>HS</b> |  |
| 1050 Speed     |        |           |  |
| 94R            | 15- 16 | <b>HS</b> |  |
| 1050 Speed     |        |           |  |
| Triple         | 16- 17 | <b>HS</b> |  |
| 1050 Speed     |        |           |  |
| Triple R       | 12- 15 | <b>HS</b> |  |
| 1050 Speed     |        |           |  |
| Triple S       | 16- 18 | <b>HS</b> |  |
| 1200 Thruxton  |        |           |  |
| R              | 16- 18 | <b>HS</b> |  |

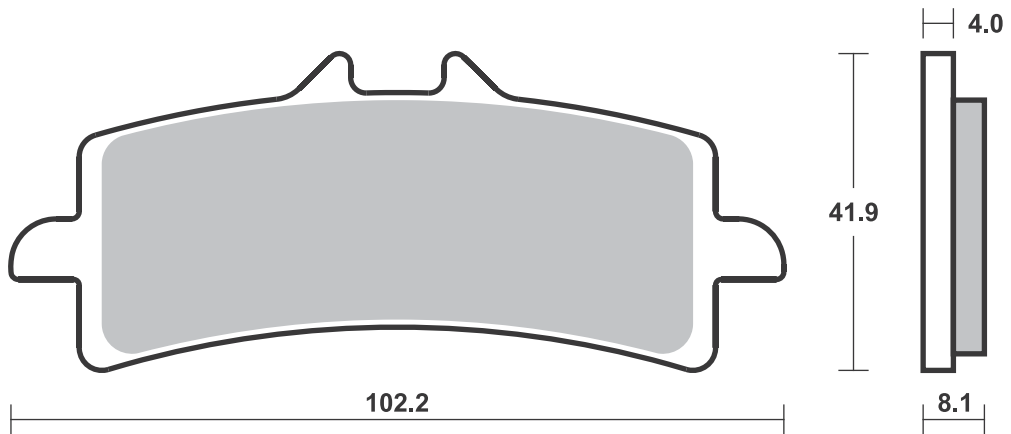
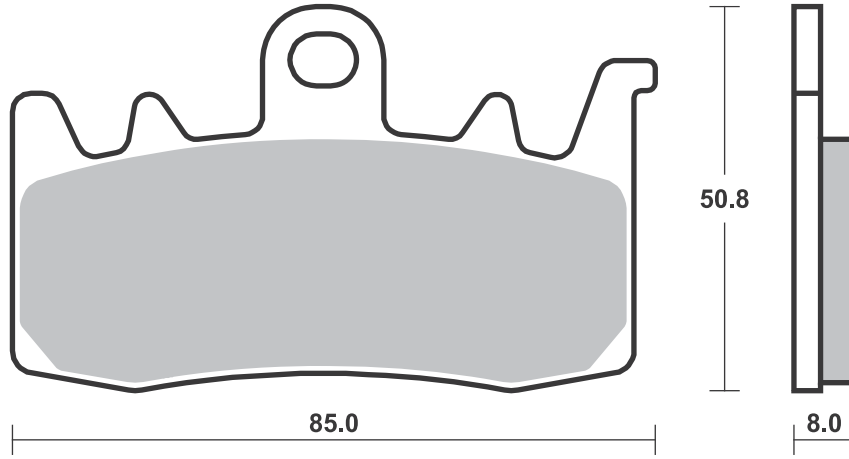

**SBS 904** Recommended compound



| <b>HARLEY DAVIDSON</b> |      |           |             |
|------------------------|------|-----------|-------------|
| FLHTCUTG               | 1690 | Tri Glide |             |
|                        |      | Ultra     |             |
|                        |      | Classic   |             |
|                        |      | Trike     | 09- 13      |
|                        |      |           | <b>H.LS</b> |
| FLHXXX                 | 1690 | Street    |             |
|                        |      | Glide     |             |
|                        |      | Trike     | 10- 11      |
|                        |      |           | <b>H.LS</b> |
|                        |      |           |             |
|                        |      |           |             |
|                        |      |           |             |
|                        |      |           |             |
|                        |      |           |             |
|                        |      |           |             |
|                        |      |           |             |
|                        |      |           |             |
|                        |      |           |             |
|                        |      |           |             |
|                        |      |           |             |
|                        |      |           |             |
|                        |      |           |             |
|                        |      |           |             |
|                        |      |           |             |
|                        |      |           |             |
|                        |      |           |             |
|                        |      |           |             |
|                        |      |           |             |
|                        |      |           |             |
|                        |      |           |             |
|                        |      |           |             |
|                        |      |           |             |
|                        |      |           |             |
|                        |      |           |             |
|                        |      |           |             |
|                        |      |           |             |
|                        |      |           |             |
|                        |      |           |             |
|                        |      |           |             |
|                        |      |           |             |

**SBS 905** Recommended compound



| <b>POLARIS</b> |     |         |           |
|----------------|-----|---------|-----------|
|                | 170 | Ranger  |           |
|                |     | RZR     | 09- 16    |
|                |     |         | <b>SI</b> |
|                | 200 | Phoenix | 10- 14    |
|                |     |         | <b>SI</b> |
|                |     |         |           |
|                |     |         |           |
|                |     |         |           |
|                |     |         |           |
|                |     |         |           |
|                |     |         |           |
|                |     |         |           |
|                |     |         |           |
|                |     |         |           |
|                |     |         |           |
|                |     |         |           |
|                |     |         |           |
|                |     |         |           |
|                |     |         |           |
|                |     |         |           |
|                |     |         |           |
|                |     |         |           |
|                |     |         |           |
|                |     |         |           |
|                |     |         |           |
|                |     |         |           |
|                |     |         |           |
|                |     |         |           |
|                |     |         |           |
|                |     |         |           |
|                |     |         |           |
|                |     |         |           |
|                |     |         |           |
|                |     |         |           |
|                |     |         |           |
|                |     |         |           |
|                |     |         |           |
|                |     |         |           |
|                |     |         |           |
|                |     |         |           |

Brake Pad 1:1 Drawings, Compounds, Fitments

1 set = 4 pcs.

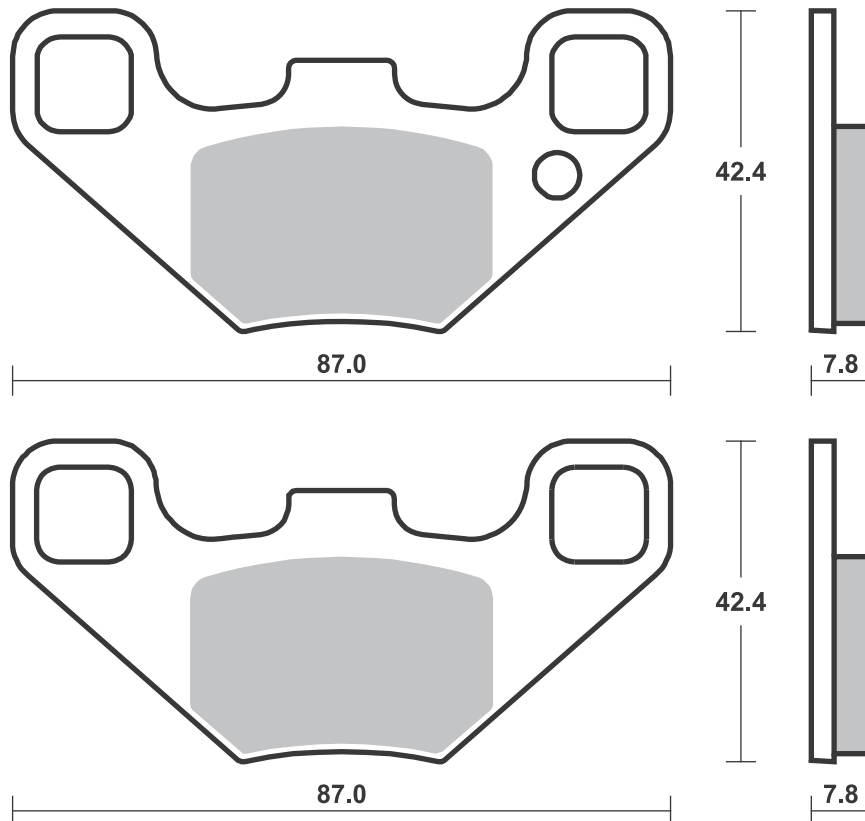
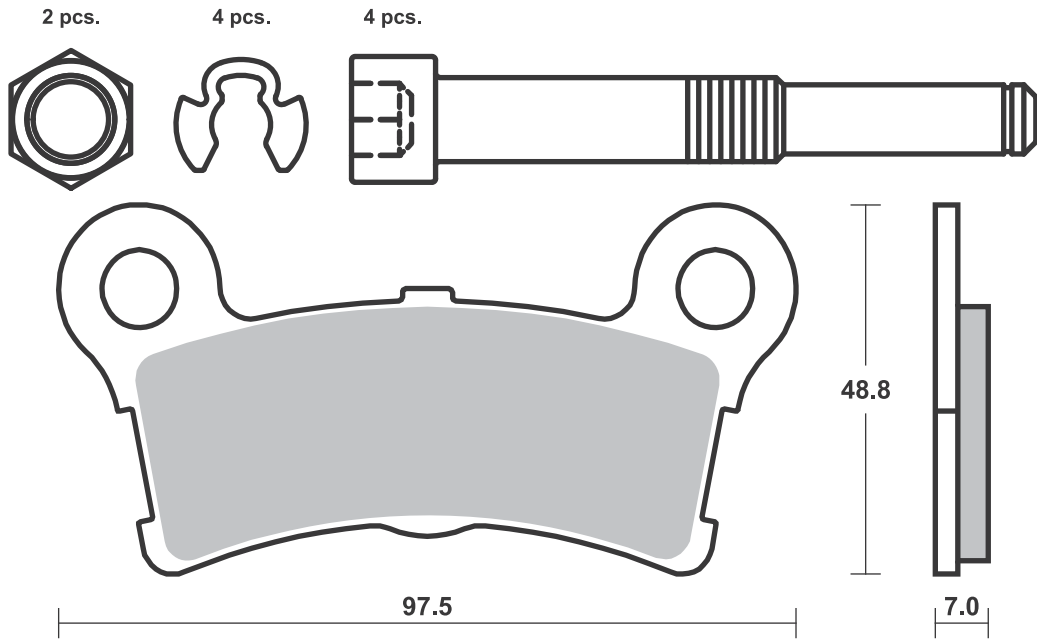

**SBS 906** Recommended compound



**POLARIS**

|                |       |    |
|----------------|-------|----|
| 170 Ranger RZR | 09-16 | SI |
|                |       |    |
|                |       |    |
|                |       |    |
|                |       |    |
|                |       |    |
|                |       |    |
|                |       |    |
|                |       |    |
|                |       |    |
|                |       |    |
|                |       |    |
|                |       |    |
|                |       |    |
|                |       |    |
|                |       |    |
|                |       |    |
|                |       |    |

**SBS 907** Recommended compound



**CAN-AM**

|        |       |    |
|--------|-------|----|
| DS 450 | 08-12 | SI |
|        |       |    |
|        |       |    |
|        |       |    |
|        |       |    |
|        |       |    |
|        |       |    |
|        |       |    |
|        |       |    |
|        |       |    |
|        |       |    |
|        |       |    |
|        |       |    |
|        |       |    |
|        |       |    |
|        |       |    |
|        |       |    |
|        |       |    |

**SBS 908** Recommended compound



**CAN-AM**

|        |       |    |
|--------|-------|----|
| DS 450 | 08-12 | SI |
|--------|-------|----|

**JOHN DEERE**

|               |       |    |    |
|---------------|-------|----|----|
| HPX 350 Gator | 10-14 | SI | SI |
|---------------|-------|----|----|

|  |  |  |  |
|--|--|--|--|
|  |  |  |  |
|  |  |  |  |
|  |  |  |  |
|  |  |  |  |
|  |  |  |  |
|  |  |  |  |
|  |  |  |  |
|  |  |  |  |
|  |  |  |  |
|  |  |  |  |
|  |  |  |  |
|  |  |  |  |
|  |  |  |  |
|  |  |  |  |
|  |  |  |  |
|  |  |  |  |
|  |  |  |  |
|  |  |  |  |

Brake Pad 1:1 Drawings,  
Compounds, Fitments

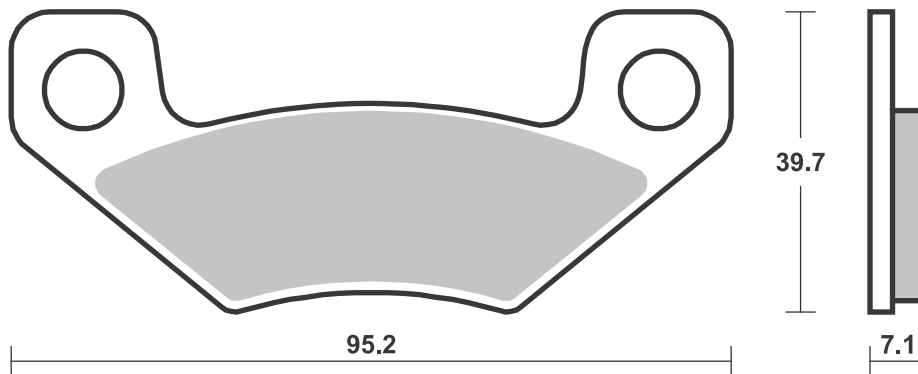
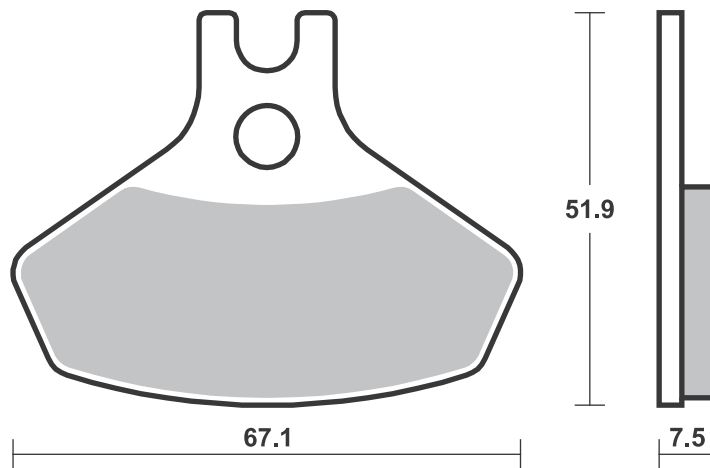
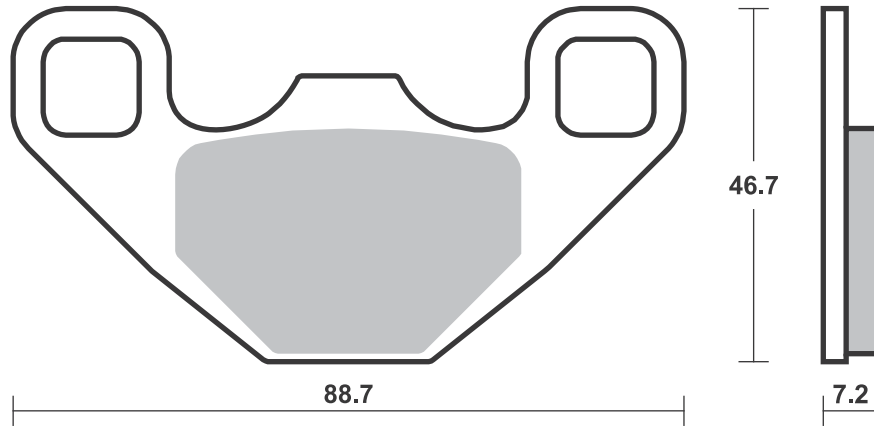

**SBS 909** Recommended compound



| <b>BREMBO RACING CALIPERS</b> |  |  |  |
|-------------------------------|--|--|--|
| SBK Racing DX XB0.B1.31,      |  |  |  |
| P4 30/34                      |  |  |  |
| (for Radiators X93.12.50)     |  |  |  |
| SBK Racing SX XB0.B1.30,      |  |  |  |
| P4 30/34                      |  |  |  |
| (for Radiators X93.12.50)     |  |  |  |
|                               |  |  |  |
|                               |  |  |  |
|                               |  |  |  |
|                               |  |  |  |
|                               |  |  |  |
|                               |  |  |  |
|                               |  |  |  |
|                               |  |  |  |
|                               |  |  |  |
|                               |  |  |  |
|                               |  |  |  |
|                               |  |  |  |
|                               |  |  |  |
|                               |  |  |  |
|                               |  |  |  |
|                               |  |  |  |
|                               |  |  |  |
|                               |  |  |  |
|                               |  |  |  |
|                               |  |  |  |
|                               |  |  |  |
|                               |  |  |  |
|                               |  |  |  |
|                               |  |  |  |
|                               |  |  |  |
|                               |  |  |  |
|                               |  |  |  |
|                               |  |  |  |
|                               |  |  |  |
|                               |  |  |  |
|                               |  |  |  |
|                               |  |  |  |
|                               |  |  |  |
|                               |  |  |  |

**SBS 910** Recommended compound



| <b>CAN-AM</b>      |       |    |    |
|--------------------|-------|----|----|
| 450 Outlander MAX  |       |    |    |
| Right/Rear         | 15-17 | SI | SI |
| 450 Outlander      |       |    |    |
| Right/Rear         | 15-17 | SI | SI |
| 500 Outlander MAX  |       |    |    |
| Right/Rear         | 13-14 | SI | SI |
| 500 Outlander      |       |    |    |
| Right/Rear         | 13-14 | SI | SI |
| 500 Renegade       |       |    |    |
| Right/Rear         | 12-14 | SI | SI |
| 650 Outlander MAX  |       |    |    |
| Right/Rear         | 13-15 | SI | SI |
| 650 Outlander      |       |    |    |
| Right/Rear         | 13-15 | SI | SI |
| 800 Outlander MAX  |       |    |    |
| Right/Rear         | 13-14 | SI | SI |
| 800 Outlander      |       |    |    |
| Right/Rear         | 12-15 | SI | SI |
| 800 Renegade       |       |    |    |
| Right/Rear         | 12-15 | SI | SI |
| 1000 Outlander MAX |       |    |    |
| Right/Rear         | 12-16 | SI | SI |
| 1000 Outlander     |       |    |    |
| Right/Rear         | 12-15 | SI | SI |
| 1000 Renegade      |       |    |    |
| Right/Rear         | 12-16 | SI | SI |
|                    |       |    |    |
|                    |       |    |    |
|                    |       |    |    |
|                    |       |    |    |
|                    |       |    |    |
|                    |       |    |    |
|                    |       |    |    |
|                    |       |    |    |
|                    |       |    |    |
|                    |       |    |    |
|                    |       |    |    |
|                    |       |    |    |
|                    |       |    |    |
|                    |       |    |    |
|                    |       |    |    |
|                    |       |    |    |
|                    |       |    |    |
|                    |       |    |    |
|                    |       |    |    |
|                    |       |    |    |
|                    |       |    |    |
|                    |       |    |    |
|                    |       |    |    |
|                    |       |    |    |
|                    |       |    |    |
|                    |       |    |    |
|                    |       |    |    |
|                    |       |    |    |
|                    |       |    |    |
|                    |       |    |    |

Brake Pad 1:1 Drawings, Compounds, Fitments



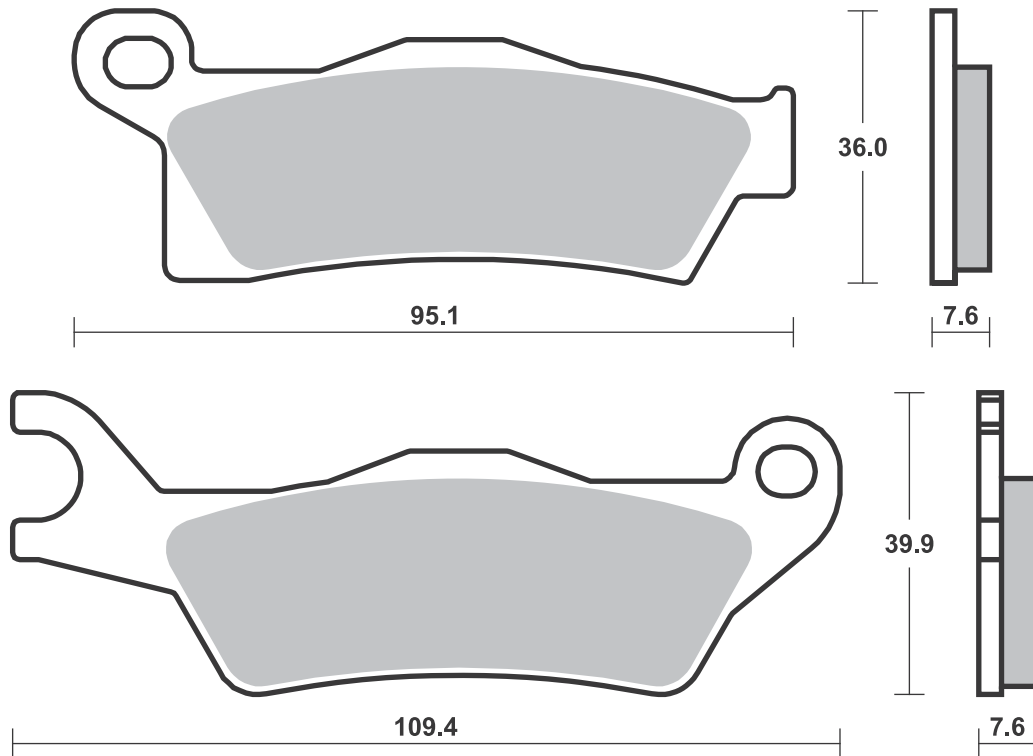
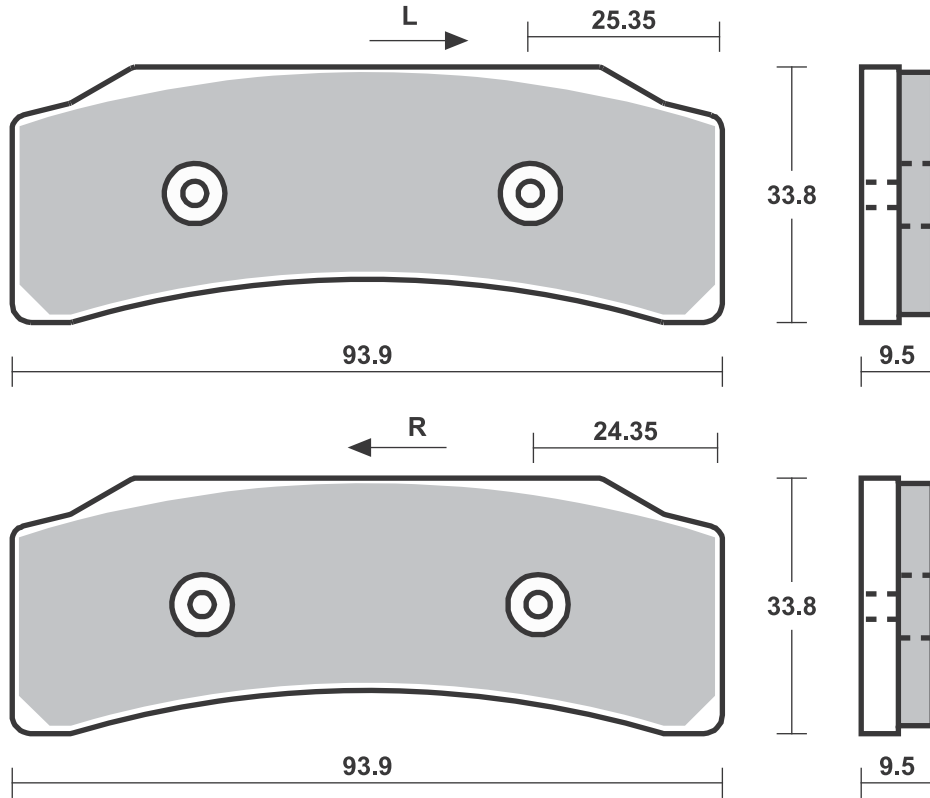



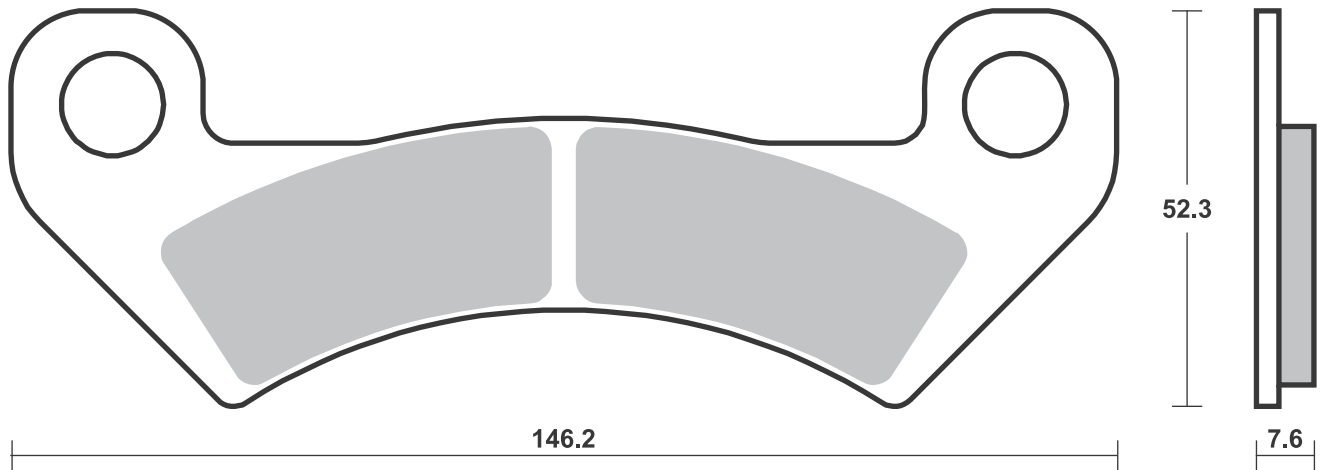
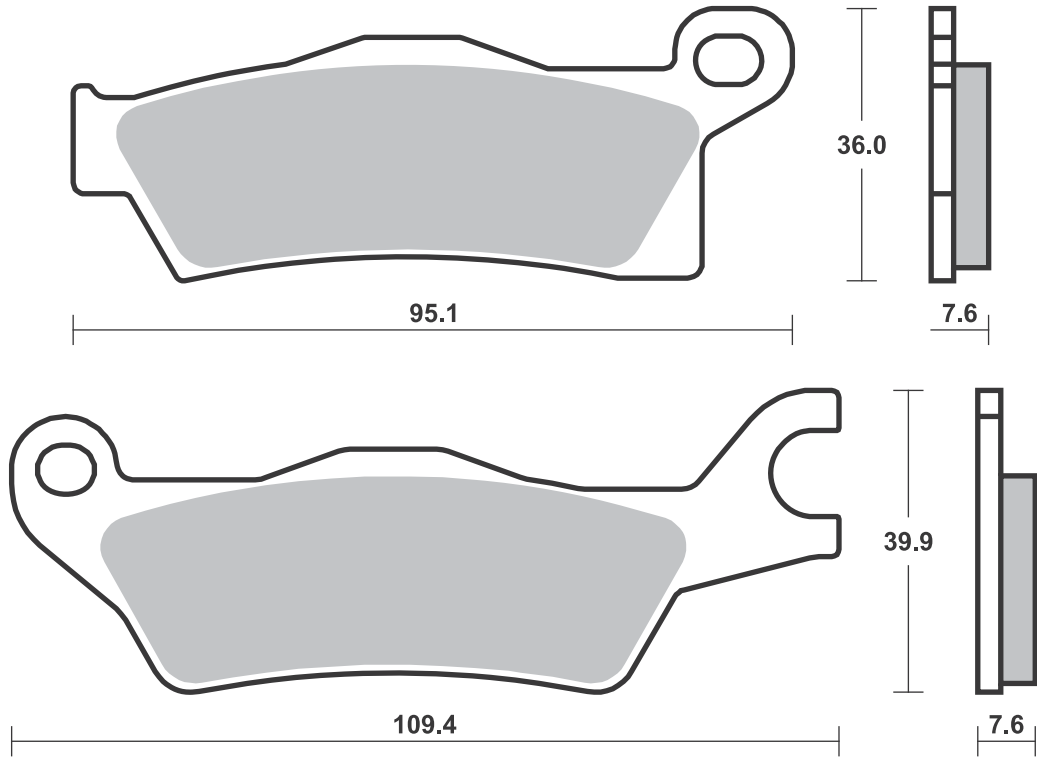

**SBS 914** Recommended compound



**CF MOTO**

|    |                 |       |           |
|----|-----------------|-------|-----------|
|    | 450 C-Force L   | 16-17 | <b>SI</b> |
|    | 450 G-Force L   | 16-17 | <b>SI</b> |
| CF | 500 Terralander | 13-15 | <b>SI</b> |
|    | 550 C-Force     | 16-17 | <b>SI</b> |
| CF | 625 Terralander | 11-15 | <b>SI</b> |
| CF | 800 Terralander | 12-14 | <b>SI</b> |

**GOES**

|   |         |       |           |
|---|---------|-------|-----------|
|   | 360 Max | 08-14 | <b>SI</b> |
|   | 520 Max | 07-12 | <b>SI</b> |
| G | 520     | 07-12 | <b>SI</b> |
| G | 525     | 12-14 | <b>SI</b> |
| G | 620     | 11-14 | <b>SI</b> |
| G | 625 A   | 12-14 | <b>SI</b> |

**SBS 915** Recommended compound



**HONDA**

|     |           |       |           |
|-----|-----------|-------|-----------|
| CB  | 125 R     | 18-   | <b>HF</b> |
| CBR | 125 R     | 11-18 | <b>HF</b> |
| MSX | 125       | 14-18 | <b>HF</b> |
| CRF | 250 L     | 13-15 | <b>SI</b> |
| CRF | 250 L ABS | 17-18 | <b>SI</b> |
| CRF | 250 M     | 14-18 | <b>SI</b> |
| CRF | 250 Rally | 17-18 | <b>SI</b> |
| CB  | 300 R     | 18-   | <b>HF</b> |

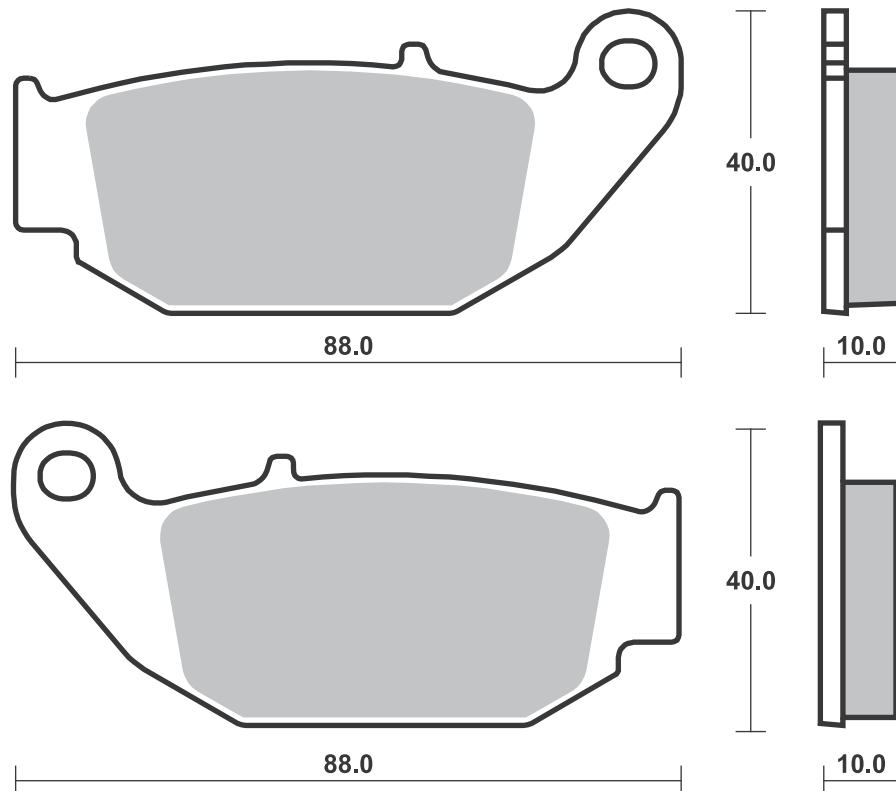
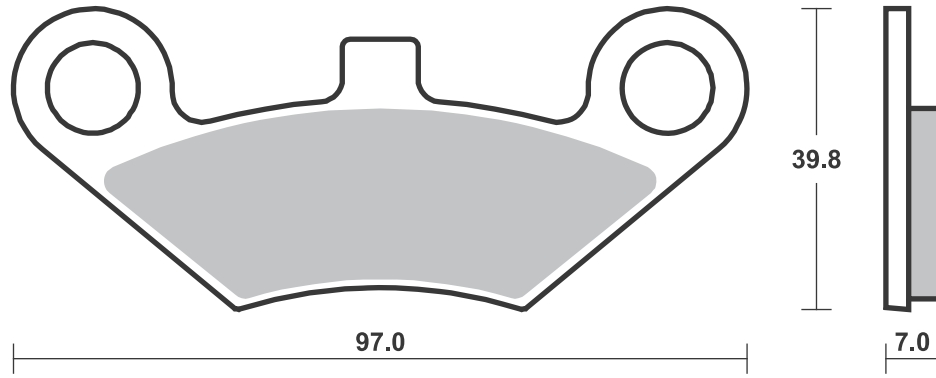

**SBS 920 Recommended compound**



**SUZUKI**

|   |                   |       |    |
|---|-------------------|-------|----|
| C | 1800 R Intruder   | 08-11 | LS |
| M | 1800 R Intruder   | 06-16 | LS |
| M | 1800 R2 Intruder  | 08-10 | LS |
| M | 1800 RBZ Intruder | 16-17 | LS |
|   |                   |       |    |
|   |                   |       |    |
|   |                   |       |    |
|   |                   |       |    |
|   |                   |       |    |
|   |                   |       |    |
|   |                   |       |    |
|   |                   |       |    |
|   |                   |       |    |
|   |                   |       |    |
|   |                   |       |    |
|   |                   |       |    |
|   |                   |       |    |
|   |                   |       |    |
|   |                   |       |    |
|   |                   |       |    |
|   |                   |       |    |
|   |                   |       |    |
|   |                   |       |    |

**SBS 921 Recommended compound**



**KYMCO**

|  |                 |       |    |
|--|-----------------|-------|----|
|  | 400 Maxxer      |       |    |
|  | (Parking Brake) | 08-10 | HF |
|  | 400 MXU         |       |    |
|  | (Parking Brake) | 08-11 | HF |
|  | 450 i Maxxer    |       |    |
|  | (Parking Brake) | 10-14 | HF |
|  | 450 i MXU       |       |    |
|  | (Parking Brake) | 11-14 | HF |
|  |                 |       |    |
|  |                 |       |    |
|  |                 |       |    |
|  |                 |       |    |
|  |                 |       |    |
|  |                 |       |    |
|  |                 |       |    |
|  |                 |       |    |
|  |                 |       |    |
|  |                 |       |    |
|  |                 |       |    |
|  |                 |       |    |
|  |                 |       |    |
|  |                 |       |    |
|  |                 |       |    |
|  |                 |       |    |
|  |                 |       |    |
|  |                 |       |    |
|  |                 |       |    |
|  |                 |       |    |

Brake Pad 1:1 Drawings,  
 Compounds, Fitments

Drawings 1:1

Available compounds **HF • LS**

**SBS 920**

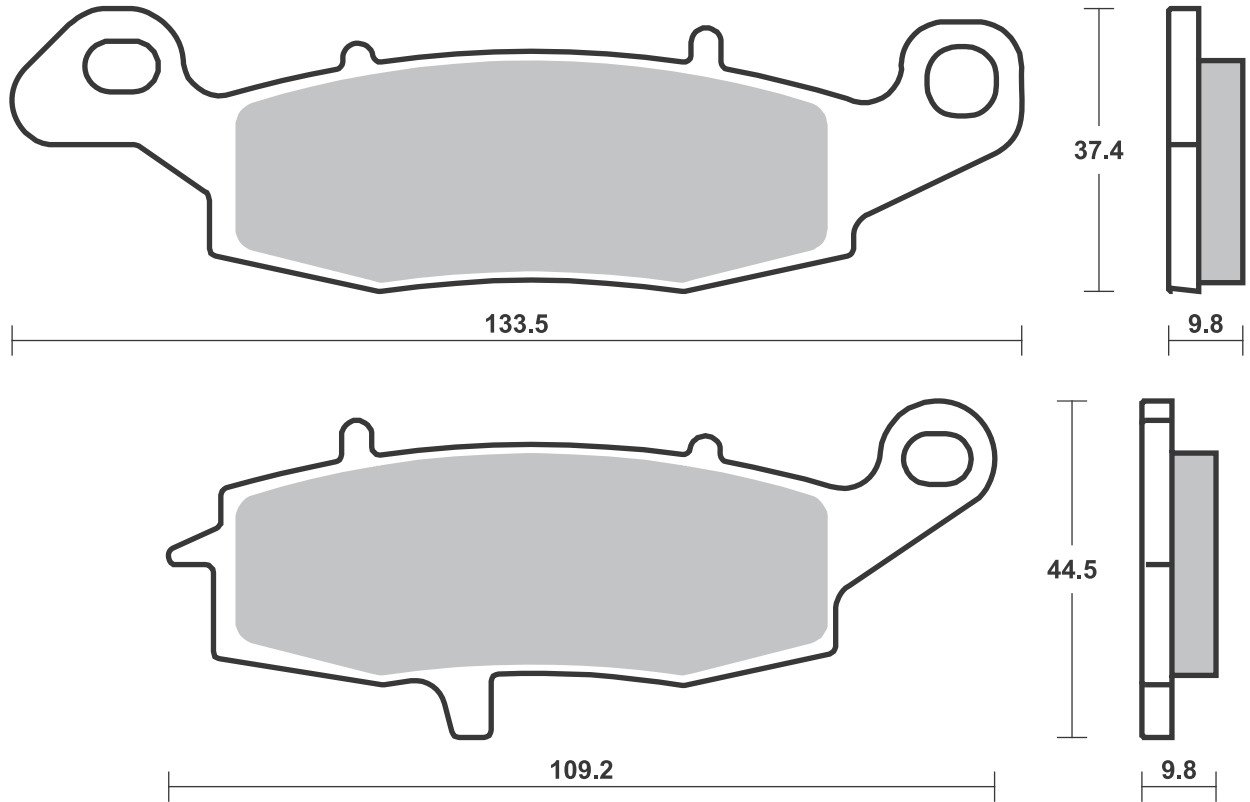

Available compounds **HF**

**SBS 921**

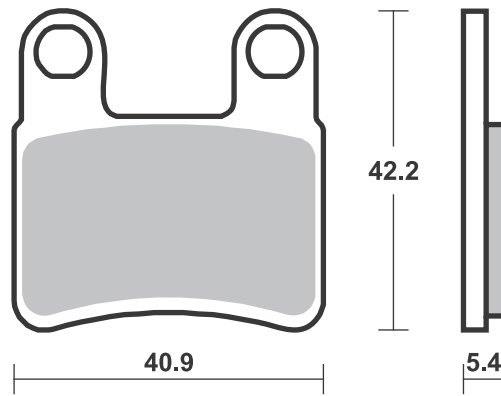

**SBS 922** Recommended compound



**HARLEY DAVIDSON**

|                         |       |             |
|-------------------------|-------|-------------|
| FLHTCUTG 1690 Tri Glide |       |             |
| Ultra                   | 14-16 | <b>H.HS</b> |
| FLRT 1690 Freewheeler   |       |             |
|                         | 15-16 | <b>H.HS</b> |
| FLHTCUTG 1750 Tri Glide |       |             |
| Ultra                   | 17-18 | <b>H.HS</b> |
| FLRT 1750 Freewheeler   |       |             |
|                         | 17-18 | <b>H.HS</b> |

Brake Pad 1:1 Drawings,  
Compounds, Fitments



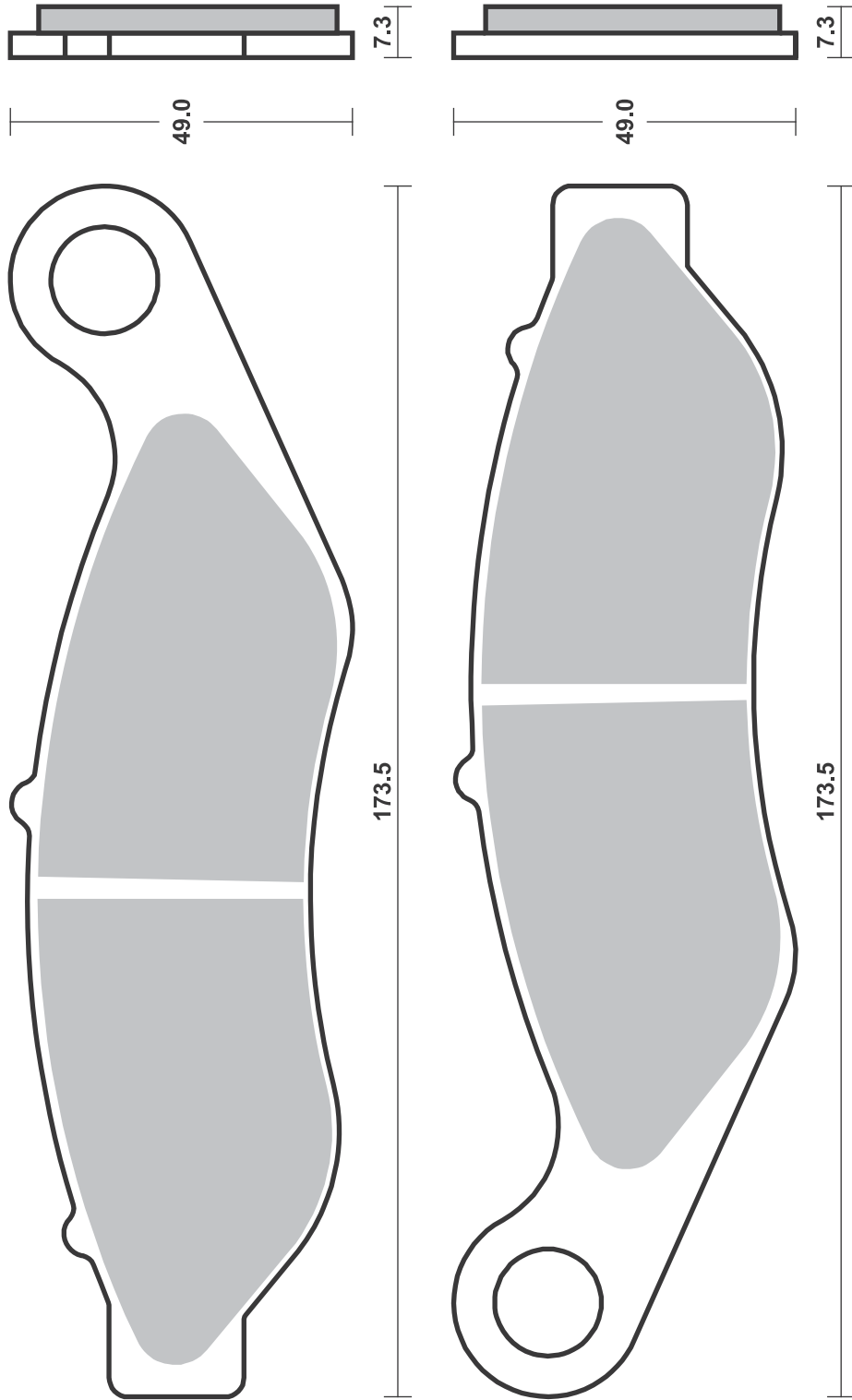

SBS 923 Recommended compound



HARLEY DAVIDSON

|                         |        |             |
|-------------------------|--------|-------------|
| FLHTCUTG 1690 Tri Glide |        |             |
| Ultra                   | 14- 16 | <b>H.LS</b> |
| FLRT 1690 Freewheeler   |        |             |
|                         | 15- 16 | <b>H.LS</b> |
| FLHTCUTG 1750 Tri Glide |        |             |
| Ultra                   | 17- 18 | <b>H.LS</b> |
| FLRT 1750 Freewheeler   |        |             |
|                         | 17- 18 | <b>H.LS</b> |

SBS 924 Recommended compound



HARLEY DAVIDSON

|    |            |        |             |             |
|----|------------|--------|-------------|-------------|
| XG | 500 Street | 14- 15 | <b>H.HF</b> | <b>H.HF</b> |
| XG | 750 Street | 14- 15 | <b>H.HF</b> | <b>H.HF</b> |

Brake Pad 1:1 Drawings, Compounds, Fitments

1 set = 4 pcs.

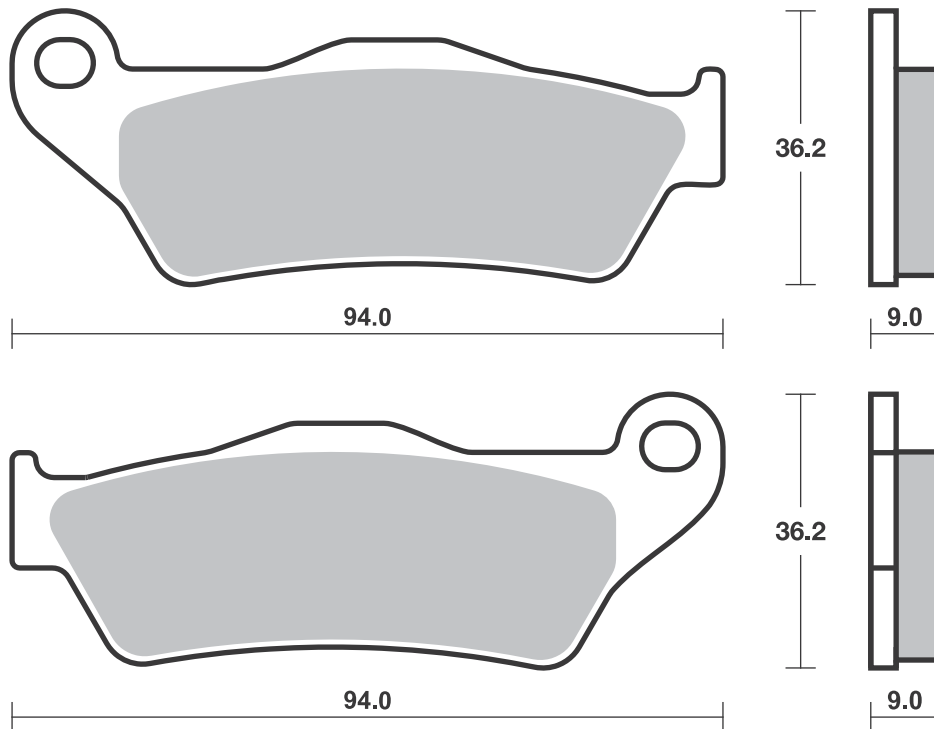
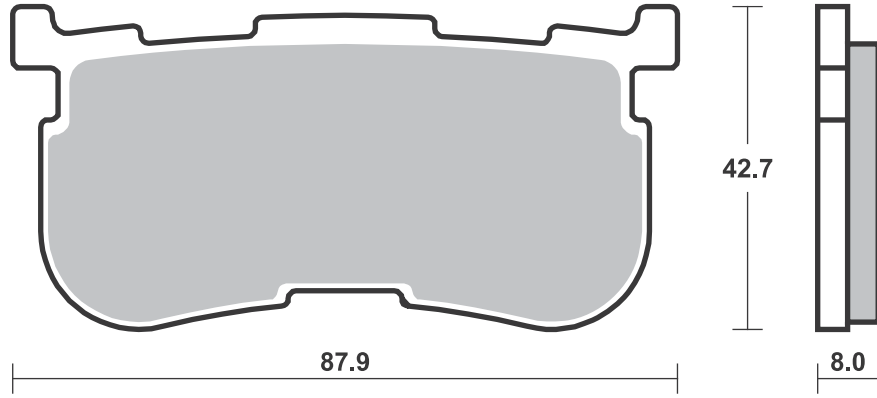



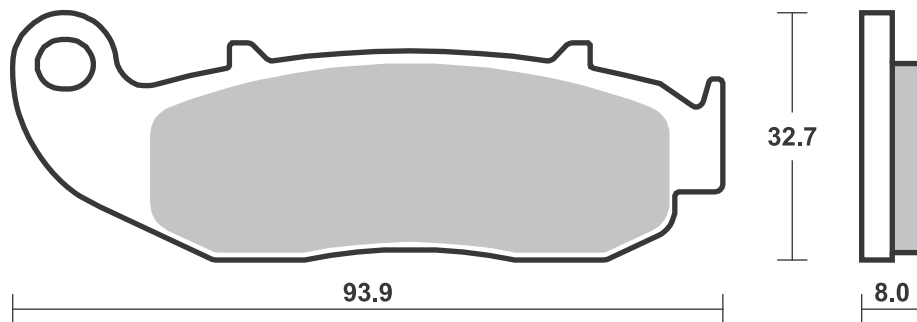
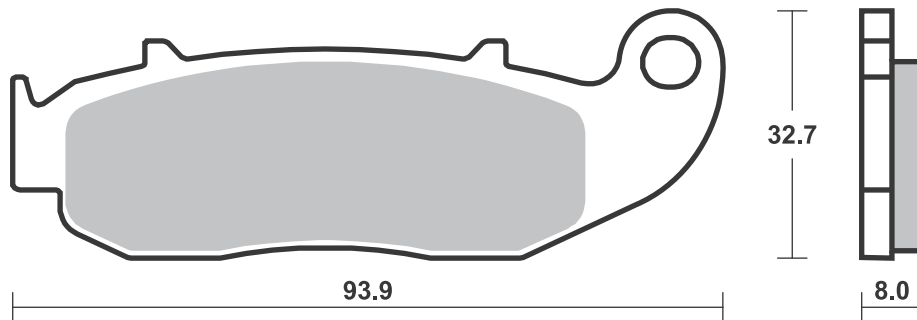
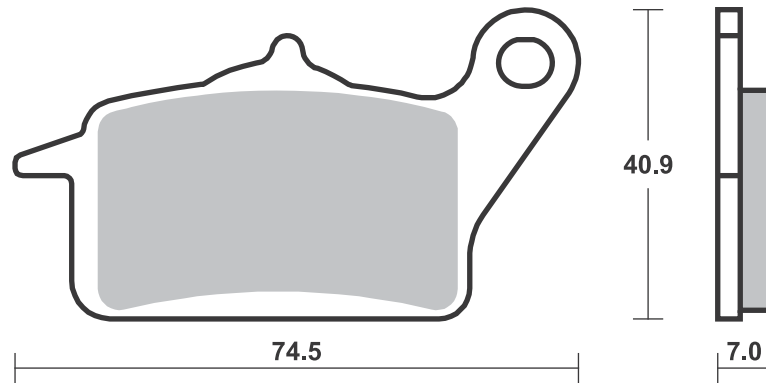
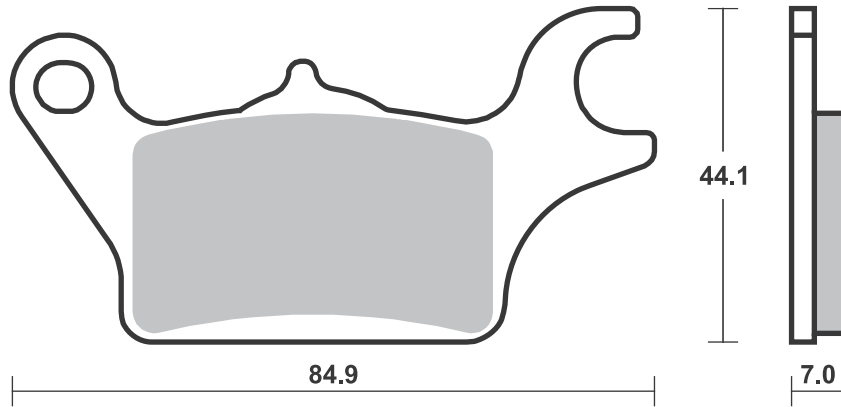



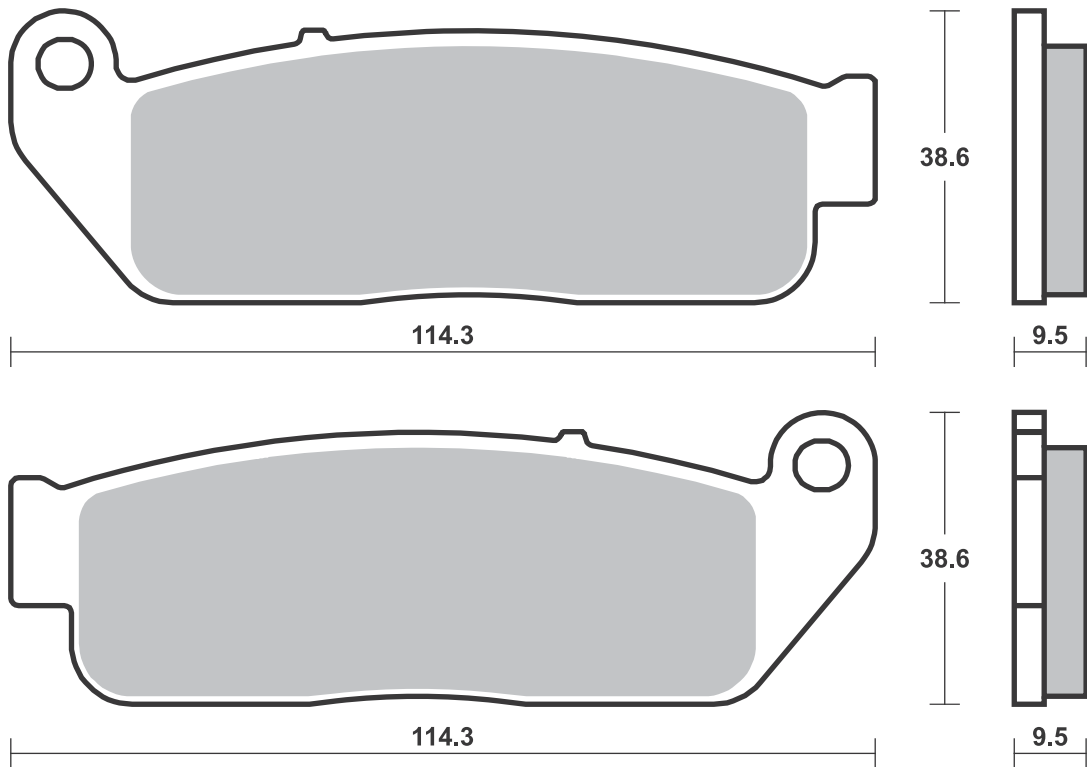
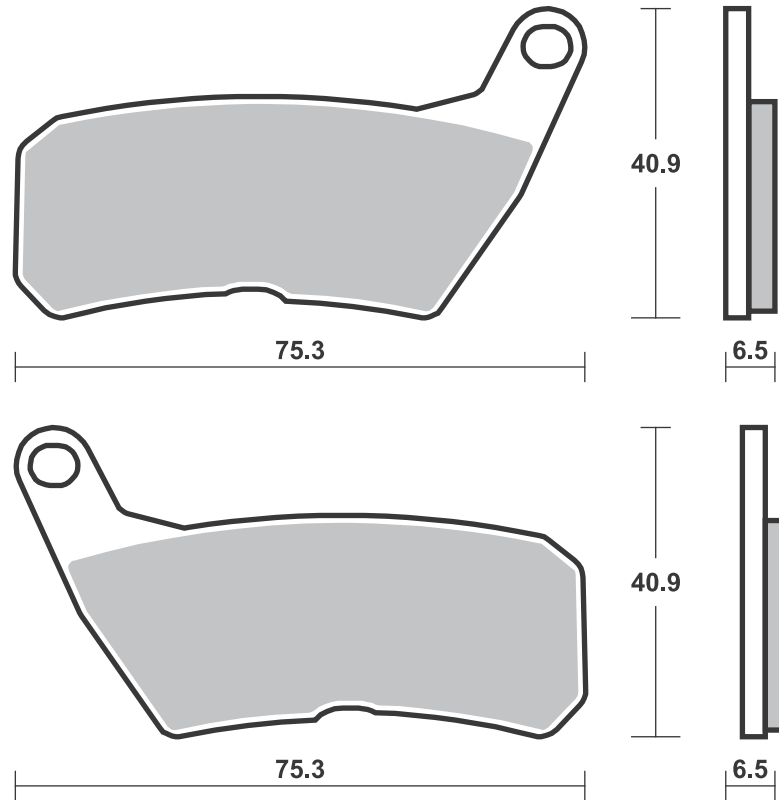

Brake Pad 1:1 Drawings,  
Compounds, Fitments

**SBS 930**

**Recommended compound**



**INDIAN**

|                  |       |             |
|------------------|-------|-------------|
| 1000 Scout Sixty | 16    | <b>H.LS</b> |
| 1130 Scout       | 15-16 | <b>H.LS</b> |
|                  |       |             |
|                  |       |             |
|                  |       |             |
|                  |       |             |
|                  |       |             |
|                  |       |             |
|                  |       |             |
|                  |       |             |
|                  |       |             |
|                  |       |             |
|                  |       |             |
|                  |       |             |
|                  |       |             |
|                  |       |             |
|                  |       |             |
|                  |       |             |
|                  |       |             |
|                  |       |             |
|                  |       |             |
|                  |       |             |
|                  |       |             |
|                  |       |             |
|                  |       |             |
|                  |       |             |
|                  |       |             |
|                  |       |             |
|                  |       |             |
|                  |       |             |
|                  |       |             |
|                  |       |             |
|                  |       |             |
|                  |       |             |
|                  |       |             |
|                  |       |             |

**SBS 931**

**Recommended compound**



**YAMAHA**

|             |       |           |
|-------------|-------|-----------|
| MT-25 250   | 16-17 | <b>HS</b> |
| YZF 250 R25 | 15-18 | <b>HS</b> |
| MT-03 321   | 16-18 | <b>HS</b> |
| YZF 321 R3  | 15-18 | <b>HS</b> |
|             |       |           |
|             |       |           |
|             |       |           |
|             |       |           |
|             |       |           |
|             |       |           |
|             |       |           |
|             |       |           |
|             |       |           |
|             |       |           |
|             |       |           |
|             |       |           |
|             |       |           |
|             |       |           |
|             |       |           |
|             |       |           |
|             |       |           |
|             |       |           |
|             |       |           |
|             |       |           |
|             |       |           |
|             |       |           |
|             |       |           |
|             |       |           |
|             |       |           |
|             |       |           |
|             |       |           |
|             |       |           |
|             |       |           |
|             |       |           |
|             |       |           |
|             |       |           |
|             |       |           |
|             |       |           |
|             |       |           |
|             |       |           |
|             |       |           |
|             |       |           |
|             |       |           |
|             |       |           |
|             |       |           |
|             |       |           |
|             |       |           |



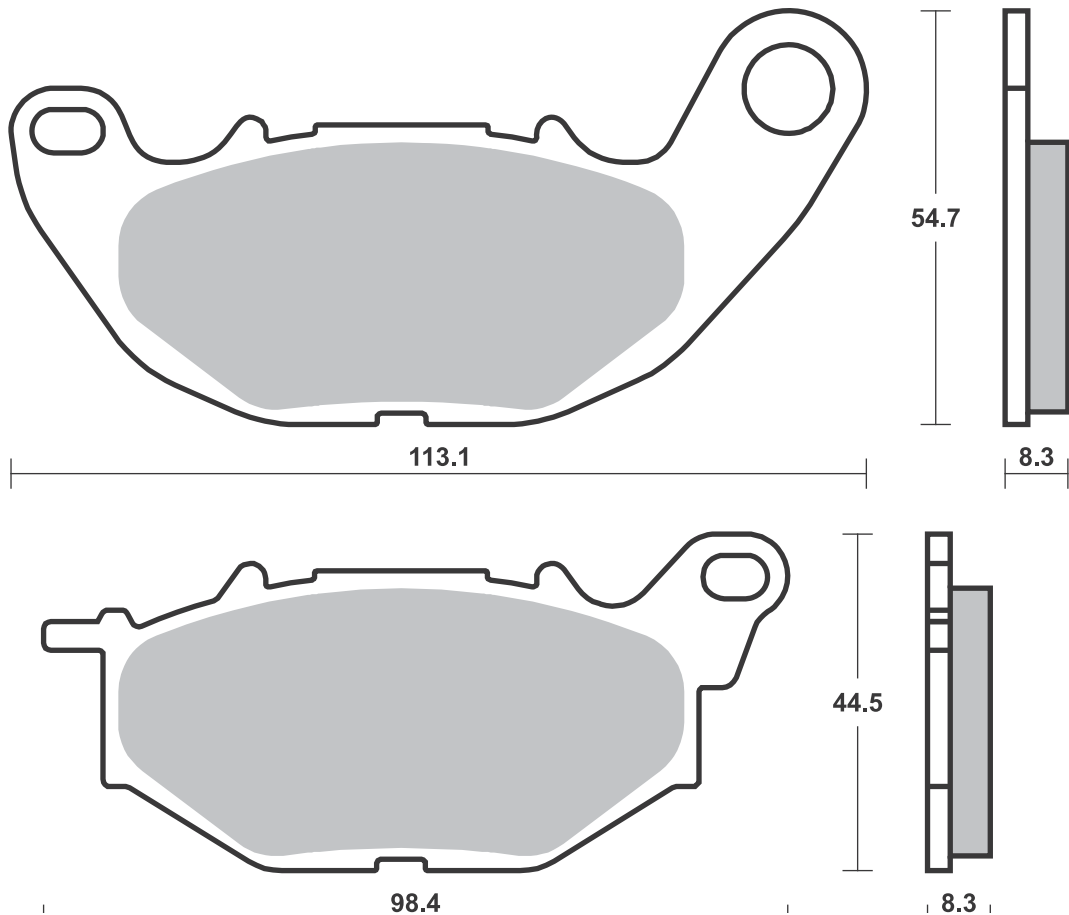
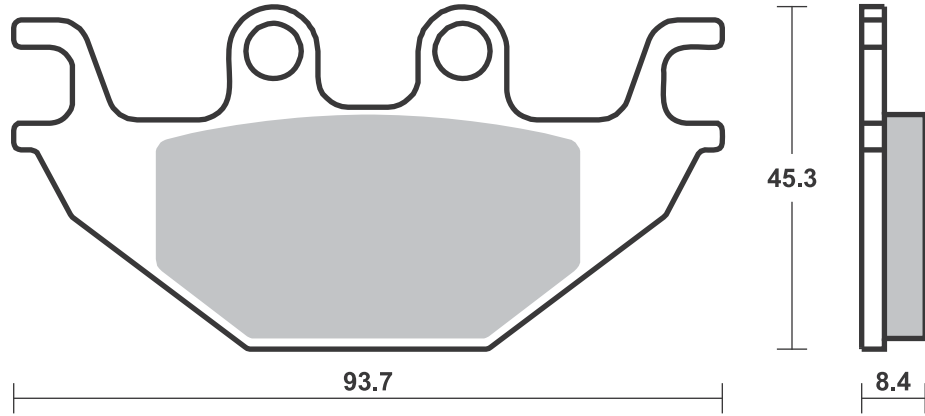



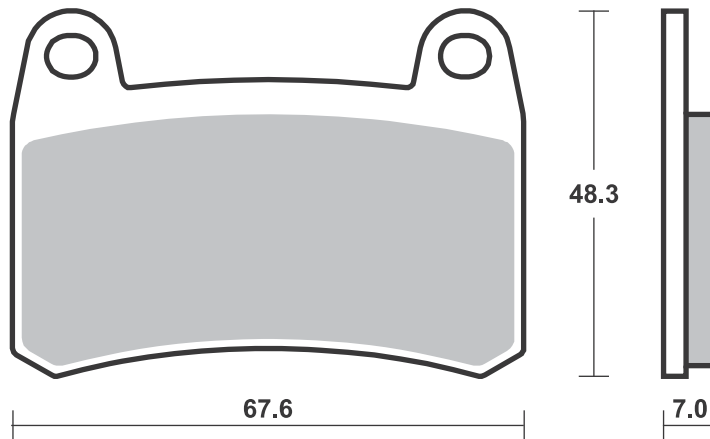
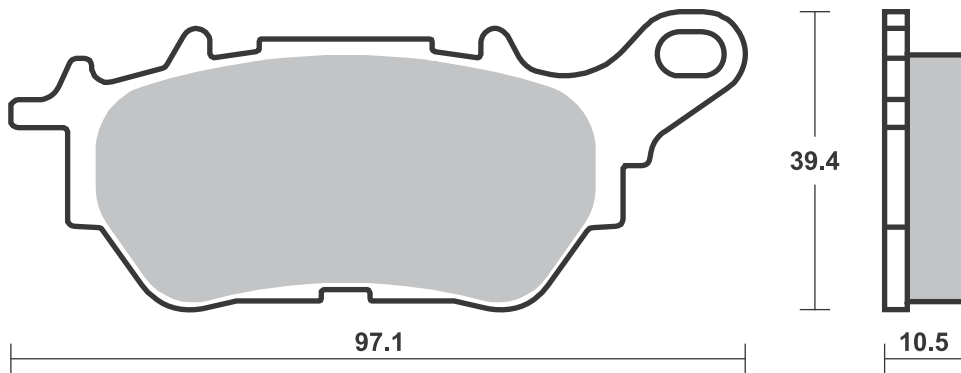
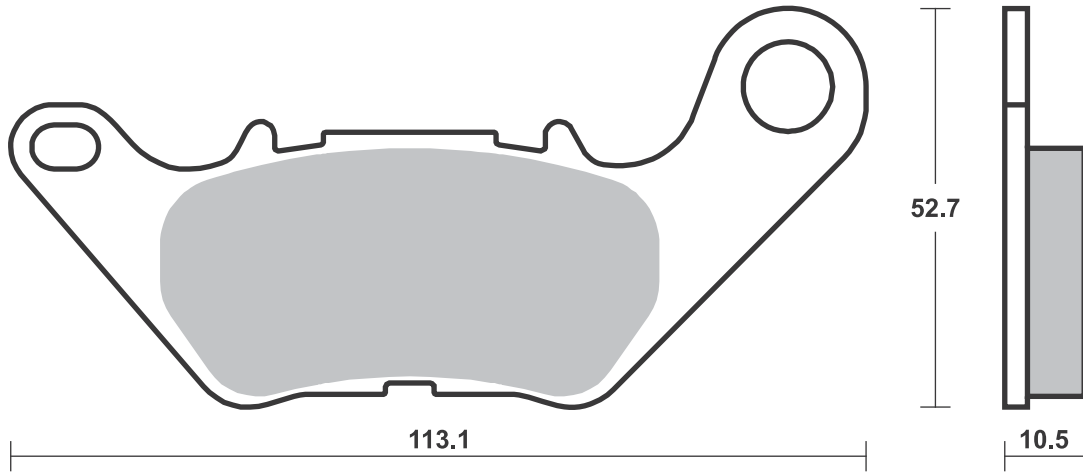

**SBS 934** Recommended compound



| <b>HARLEY DAVIDSON</b> |                              |        |             |
|------------------------|------------------------------|--------|-------------|
| XL                     | 883 L Super Low              | 14- 18 | <b>H.HS</b> |
| XL                     | 883 N Iron                   | 14- 18 | <b>H.HS</b> |
| XL                     | 883 R Roadster               | 14- 15 | <b>H.HS</b> |
| XL                     | 1200 C, CA, CB,<br>CP Custom | 14- 18 | <b>H.HS</b> |
| XL                     | 1200 CX                      | 17     | <b>H.HS</b> |
| XL                     | 1200 Roadster                | 18-    | <b>H.HS</b> |
| XL                     | 1200 T Super Low             | 15- 17 | <b>H.HS</b> |
| XL                     | 1200 V Seventy-Two           | 14- 16 | <b>H.HS</b> |
| XL                     | 1200 X Forty-Eight           | 14- 18 | <b>H.HS</b> |
|                        |                              |        |             |
|                        |                              |        |             |
|                        |                              |        |             |
|                        |                              |        |             |
|                        |                              |        |             |
|                        |                              |        |             |
|                        |                              |        |             |
|                        |                              |        |             |
|                        |                              |        |             |
|                        |                              |        |             |
|                        |                              |        |             |
|                        |                              |        |             |
|                        |                              |        |             |
|                        |                              |        |             |
|                        |                              |        |             |
|                        |                              |        |             |
|                        |                              |        |             |
|                        |                              |        |             |

**SBS 939** Recommended compound



| <b>GAS GAS</b> |                         |        |            |
|----------------|-------------------------|--------|------------|
| TXT            | 125 Pro Racing          | 14     | <b>RSI</b> |
| TXT            | 125 Pro Replica         | 13     | <b>RSI</b> |
| TXT            | 250 Pro Racing          | 14- 18 | <b>RSI</b> |
| TXT            | 250 Pro Replica         | 13- 14 | <b>RSI</b> |
| TXT            | 280 Pro Racing          | 14- 18 | <b>RSI</b> |
| TXT            | 280 Pro Replica         | 13     | <b>RSI</b> |
| TXT            | 300 Pro Racing          | 14- 18 | <b>RSI</b> |
| TXT            | 300 Pro Replica         | 13     | <b>RSI</b> |
|                |                         |        |            |
| <b>HONDA</b>   |                         |        |            |
| Cota           | 260 4Ride               | 16- 18 | <b>RSI</b> |
| Cota           | 260 4RT Race<br>Replica | 15- 18 | <b>RSI</b> |
| Cota           | 300 RR                  | 16- 18 | <b>RSI</b> |
|                |                         |        |            |
| <b>JOTAGAS</b> |                         |        |            |
| JT             | 125                     | 14- 18 | <b>RSI</b> |
| JT             | 250                     | 14- 18 | <b>RSI</b> |
| JT             | 280                     | 14- 18 | <b>RSI</b> |
| JT             | 300                     | 14- 18 | <b>RSI</b> |
|                |                         |        |            |
| <b>MONTESA</b> |                         |        |            |
| Cota           | 260 4Ride               | 16- 18 | <b>RSI</b> |
| Cota           | 260 4RT Race<br>Replica | 15- 18 | <b>RSI</b> |
| Cota           | 300 RR                  | 16- 18 | <b>RSI</b> |



| <b>OSSA</b>    |               |        |            |
|----------------|---------------|--------|------------|
| TR             | 300 Factory R | 15     | <b>RSI</b> |
|                |               |        |            |
| <b>VERTIGO</b> |               |        |            |
|                | 300 Combat    |        |            |
|                | Camo Works    | 15- 18 | <b>RSI</b> |
|                | 300 Combat    |        |            |
|                | Ice Hell      | 15- 18 | <b>RSI</b> |
|                | 300 Combat RR | 15- 18 | <b>RSI</b> |
|                |               |        |            |
|                |               |        |            |
|                |               |        |            |
|                |               |        |            |
|                |               |        |            |
|                |               |        |            |
|                |               |        |            |
|                |               |        |            |

Brake Pad 1:1 Drawings, Compounds, Fitments

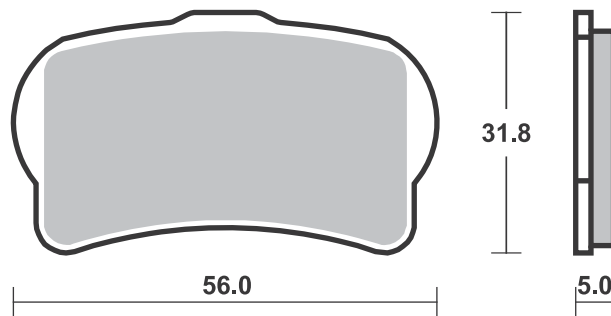
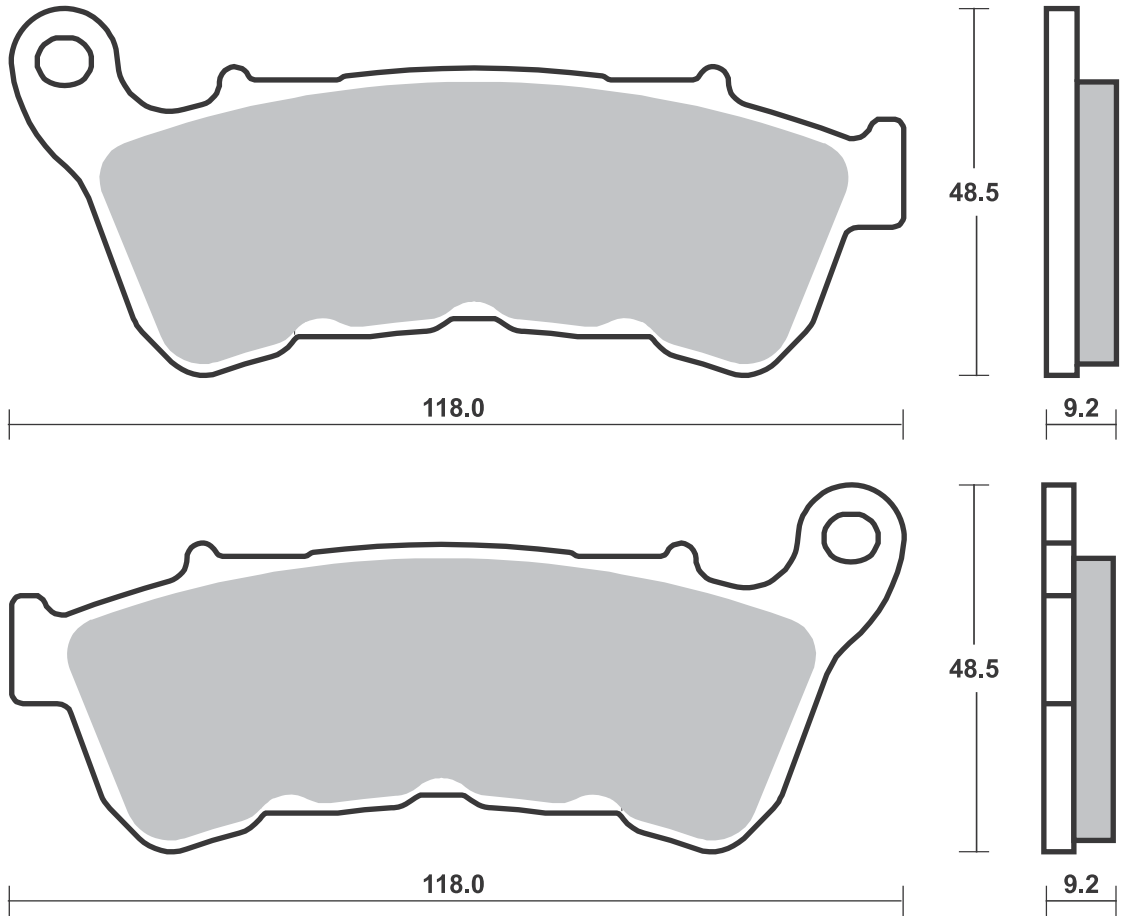

**SBS 940** Recommended compound



| <b>HONDA</b> |                    |       |    |
|--------------|--------------------|-------|----|
| CB           | 125 R              | 18-   | HS |
| CB           | 300 R              | 18-   | HS |
|              | 750 X-ADV          | 17-18 | HS |
| CRF          | 1000 L Africa Twin | 16-18 | HS |
| CRF          | 1000 L Africa Twin |       |    |
|              | Adventure          |       |    |
|              | Sports             | 18-   | HS |
|              |                    |       |    |
|              |                    |       |    |
|              |                    |       |    |
|              |                    |       |    |
|              |                    |       |    |
|              |                    |       |    |
|              |                    |       |    |
|              |                    |       |    |
|              |                    |       |    |
|              |                    |       |    |
|              |                    |       |    |
|              |                    |       |    |
|              |                    |       |    |

**SBS 941** Recommended compound



| <b>BREMBO RACING CALIPERS</b> |                            |  |  |
|-------------------------------|----------------------------|--|--|
|                               | Racing rear X206101, P4 24 |  |  |
|                               | (30 mm disc height)        |  |  |
|                               | Racing rear X206121, P4 24 |  |  |
|                               | (30 mm disc height)        |  |  |
|                               | Racing rear X988870, P2 34 |  |  |
|                               | (30 mm disc height)        |  |  |
|                               | Racing rear XA1J040, P2 30 |  |  |
|                               | (30 mm disc height)        |  |  |
|                               |                            |  |  |
|                               |                            |  |  |
|                               |                            |  |  |
|                               |                            |  |  |
|                               |                            |  |  |
|                               |                            |  |  |
|                               |                            |  |  |
|                               |                            |  |  |
|                               |                            |  |  |
|                               |                            |  |  |
|                               |                            |  |  |
|                               |                            |  |  |

**SBS 942** Recommended compound



| <b>BREMBO RACING CALIPERS</b> |                            |  |  |
|-------------------------------|----------------------------|--|--|
|                               | Racing rear X206101, P4 24 |  |  |
|                               | (24 mm disc height)        |  |  |
|                               | Racing rear X206121, P4 24 |  |  |
|                               | (24 mm disc height)        |  |  |
|                               | Racing rear X988870, P2 34 |  |  |
|                               | (24 mm disc height)        |  |  |
|                               | Racing rear XA1J040, P2 30 |  |  |
|                               | (24 mm disc height)        |  |  |
|                               |                            |  |  |
|                               |                            |  |  |
|                               |                            |  |  |
|                               |                            |  |  |
|                               |                            |  |  |
|                               |                            |  |  |
|                               |                            |  |  |
|                               |                            |  |  |
|                               |                            |  |  |
|                               |                            |  |  |
|                               |                            |  |  |
|                               |                            |  |  |

Brake Pad 1:1 Drawings,  
Compounds, Fitments

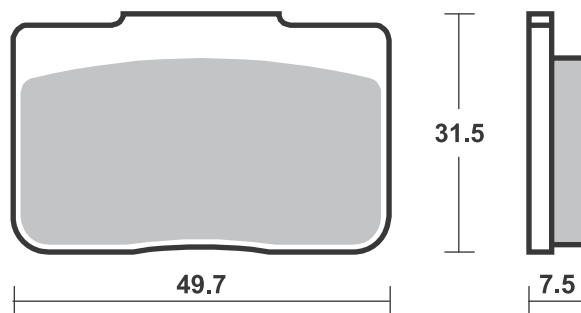
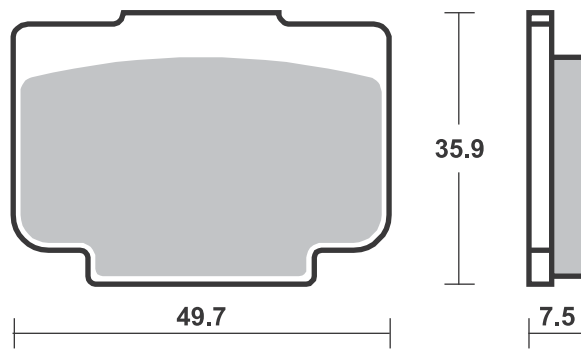
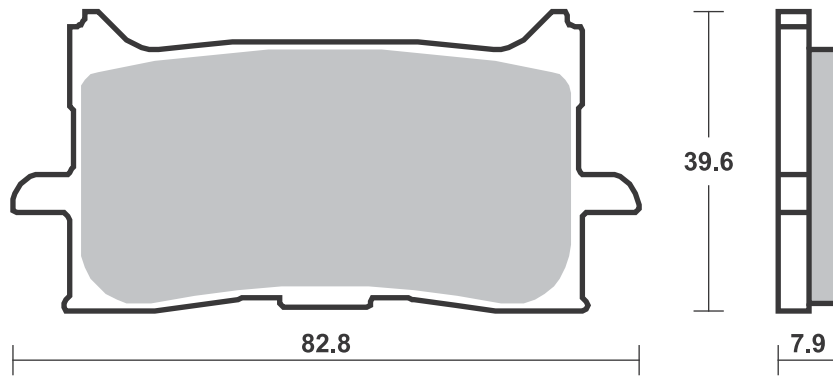

**SBS 944** Recommended compound



| RBS CARS      |       |    |
|---------------|-------|----|
| 900 Adventure | 15-16 | HS |
|               |       |    |
|               |       |    |
|               |       |    |
|               |       |    |
|               |       |    |
|               |       |    |
|               |       |    |
|               |       |    |
|               |       |    |
|               |       |    |
|               |       |    |
|               |       |    |
|               |       |    |
|               |       |    |
|               |       |    |

**SBS 945** Recommended compound



| KYMCO      |       |    |
|------------|-------|----|
| 500 MXU    | 09-14 | SI |
| 500 MXU DX | 11-13 | SI |
| 550 MXU    | 12-15 | SI |
| 700 MXU    | 13-15 | SI |
| UXV 700    | 14-16 | SI |
|            |       |    |
|            |       |    |
|            |       |    |
|            |       |    |
|            |       |    |
|            |       |    |
|            |       |    |
|            |       |    |
|            |       |    |
|            |       |    |
|            |       |    |
|            |       |    |
|            |       |    |
|            |       |    |

**SBS 946** Recommended compound



| ARCTIC CAT                 |       |     |
|----------------------------|-------|-----|
| 700 Wildcat Sport          | 15-16 | ATS |
| 700 Wildcat Sport LTD.     | 16    | ATS |
| 700 Wildcat Sport LTD. EPS | 17    | ATS |
| 700 Wildcat Sport XT       | 15    | ATS |
| 700 Wildcat Sport XT EPS   | 16-17 | ATS |
|                            |       |     |
|                            |       |     |
|                            |       |     |
|                            |       |     |
|                            |       |     |
|                            |       |     |
|                            |       |     |
|                            |       |     |
|                            |       |     |
|                            |       |     |
|                            |       |     |
|                            |       |     |
|                            |       |     |
|                            |       |     |
|                            |       |     |

|  |  |
|--|--|
|  |  |
|  |  |
|  |  |
|  |  |
|  |  |
|  |  |
|  |  |
|  |  |
|  |  |
|  |  |
|  |  |
|  |  |
|  |  |
|  |  |
|  |  |
|  |  |
|  |  |
|  |  |
|  |  |
|  |  |
|  |  |
|  |  |
|  |  |

|  |  |
|--|--|
|  |  |
|  |  |
|  |  |
|  |  |
|  |  |
|  |  |
|  |  |
|  |  |
|  |  |
|  |  |
|  |  |
|  |  |
|  |  |
|  |  |
|  |  |
|  |  |
|  |  |
|  |  |
|  |  |
|  |  |
|  |  |
|  |  |
|  |  |

Brake Pad 1:1 Drawings, Compounds, Fitments



Available compounds **HS**

**SBS 944**

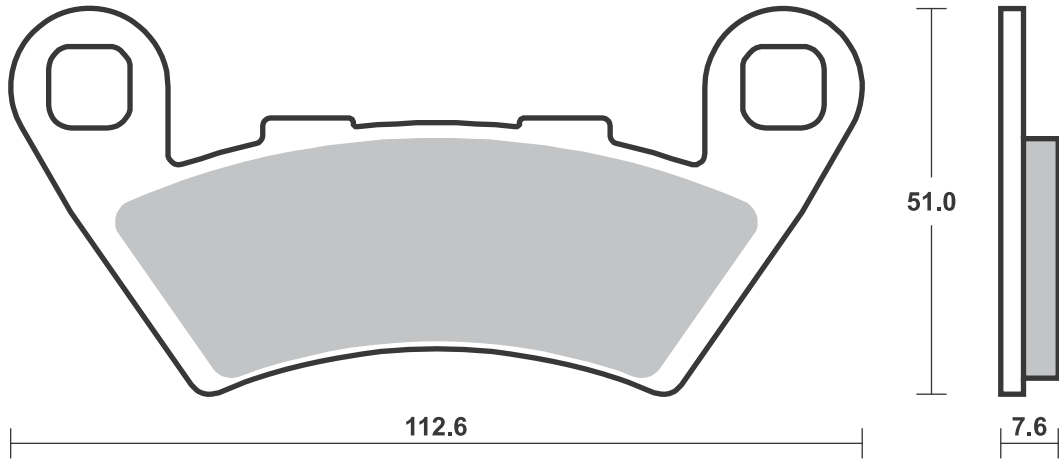

Available compounds **SI • RSI**

**SBS 945**

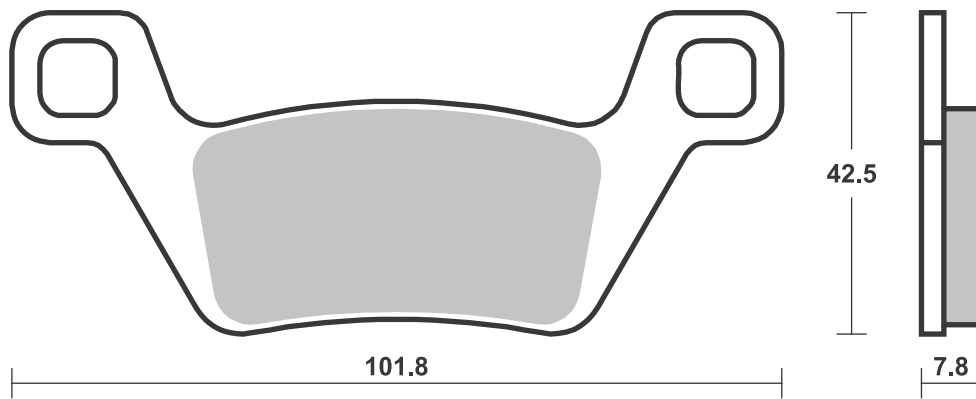

Available compounds **SI • RSI • ATS**

**SBS 946**

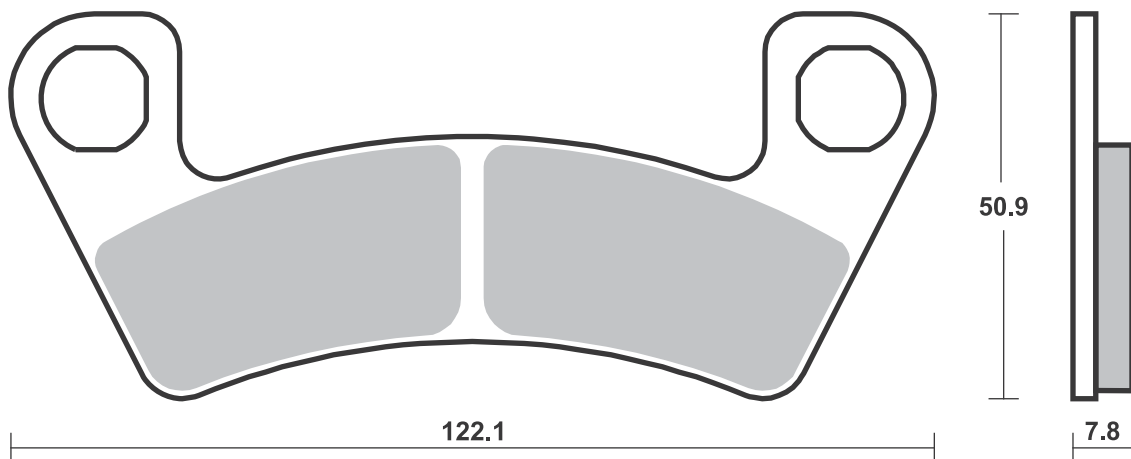

**SBS 947** Recommended compound

| <b>HONDA</b> |             |       |           |
|--------------|-------------|-------|-----------|
| CB           | 1000 R      | 18-   | <b>HS</b> |
| CB           | 1000 R+     | 18-   | <b>HS</b> |
| CBR          | 1000 RR     |       |           |
|              | Fireblade   | 17-18 | <b>SP</b> |
| CB           | 1100 RS ABS | 17-18 | <b>HS</b> |
|              |             |       |           |
|              |             |       |           |
|              |             |       |           |
|              |             |       |           |
|              |             |       |           |
|              |             |       |           |
|              |             |       |           |
|              |             |       |           |
|              |             |       |           |
|              |             |       |           |
|              |             |       |           |
|              |             |       |           |
|              |             |       |           |
|              |             |       |           |
|              |             |       |           |
|              |             |       |           |
|              |             |       |           |
|              |             |       |           |
|              |             |       |           |

**SBS 948** Recommended compound

| <b>CAN-AM</b> |                                |       |           |
|---------------|--------------------------------|-------|-----------|
|               | 1330 Spyder F3                 | 15-18 | <b>HS</b> |
|               | 1330 Spyder F3 Limited         | 16-18 | <b>HS</b> |
|               | 1330 Spyder F3-S               | 15-18 | <b>HS</b> |
|               | 1330 Spyder F3-T               | 16-18 | <b>HS</b> |
|               | 1330 Spyder RS                 | 14-16 | <b>HS</b> |
|               | 1330 Spyder RS RSS             | 13    | <b>HS</b> |
|               | 1330 Spyder RSS Special Series | 15    | <b>HS</b> |
|               | 1330 Spyder RT Limited         | 13-18 | <b>HS</b> |
|               | 1330 Spyder RT RTS             | 13    | <b>HS</b> |
|               | 1330 Spyder RTS Special Series | 15    | <b>HS</b> |
|               | 1330 Spyder ST Limited         | 13-15 | <b>HS</b> |
|               | 1330 Spyder ST STS             | 13    | <b>HS</b> |
|               | 1330 Spyder STS Special Series | 15    | <b>HS</b> |



| <b>CAN-AM</b> |                                |    |           |
|---------------|--------------------------------|----|-----------|
|               | 1330 Spyder STS Special Series | 15 | <b>HS</b> |
|               |                                |    |           |
|               |                                |    |           |
|               |                                |    |           |
|               |                                |    |           |
|               |                                |    |           |
|               |                                |    |           |
|               |                                |    |           |
|               |                                |    |           |
|               |                                |    |           |
|               |                                |    |           |
|               |                                |    |           |
|               |                                |    |           |
|               |                                |    |           |
|               |                                |    |           |
|               |                                |    |           |
|               |                                |    |           |
|               |                                |    |           |
|               |                                |    |           |
|               |                                |    |           |
|               |                                |    |           |
|               |                                |    |           |

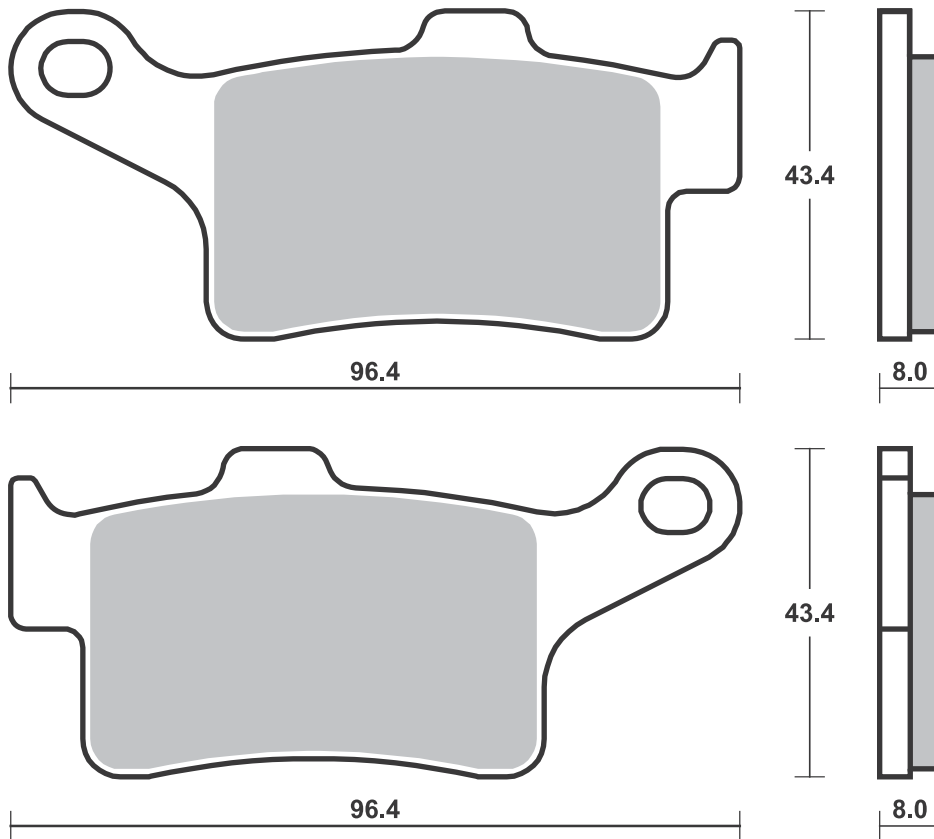
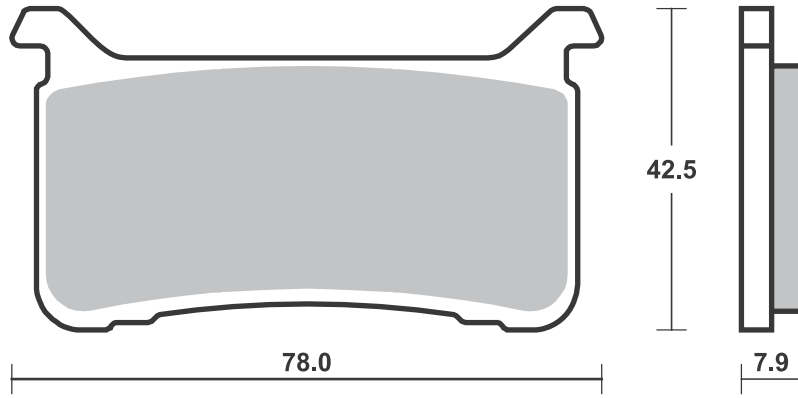

**SBS 949** Recommended compound



**HARLEY DAVIDSON**

|        |                   |     |             |
|--------|-------------------|-----|-------------|
| FLDE   | 1750 Softail      |     |             |
|        | Deluxe            | 18- | <b>H.LS</b> |
| FLFB   | 1750 Fat Boy      | 18- | <b>H.LS</b> |
| FLHC   | 1750 Heritage     |     |             |
|        | Classic           | 18- | <b>H.LS</b> |
| FLHRXS | 1750 Road King    |     |             |
|        | Special           | 18- | <b>H.LS</b> |
| FLSL   | 1750 Softail Slim | 18- | <b>H.LS</b> |
| FXBB   | 1750 Street Bob   | 18- | <b>H.LS</b> |
| FXBR   | 1750 Breakout     | 18- | <b>H.LS</b> |
| FXFB   | 1750 Fat Bob      | 18- | <b>H.LS</b> |
| FXLR   | 1750 Low Rider    | 18- | <b>H.LS</b> |
| FLFBS  | 1870 Fat Boy      | 18- | <b>H.LS</b> |
| FLHCS  | 1870 Heritage     |     |             |
|        | Classic           | 18- | <b>H.LS</b> |
| FXBRS  | 1870 Breakout     | 18- | <b>H.LS</b> |

Brake Pad 1:1 Drawings,  
Compounds, Fitments

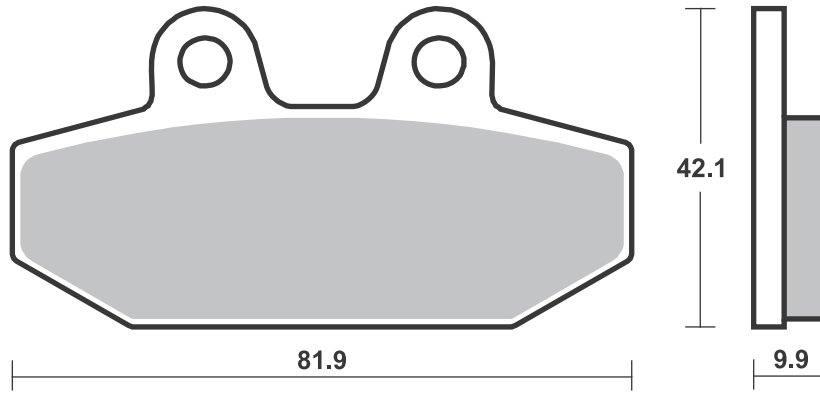



# CROSSLIST

**BRAKE PADS**

**SAME SHAPE / DIFFERENT THICKNESS**

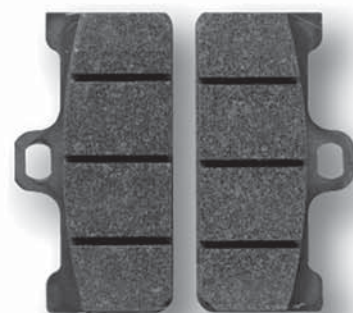
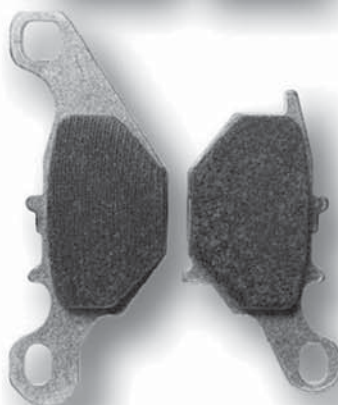
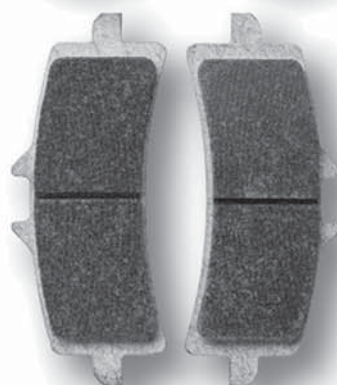
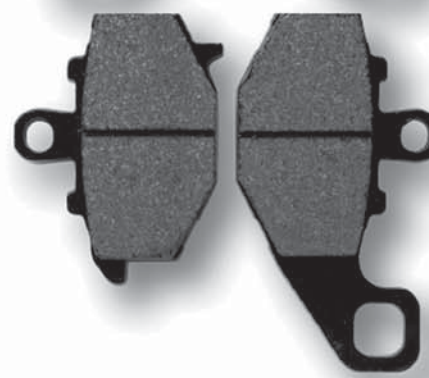
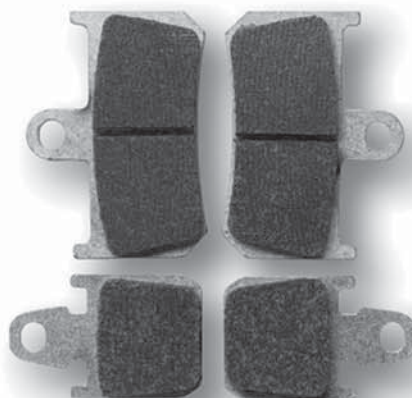
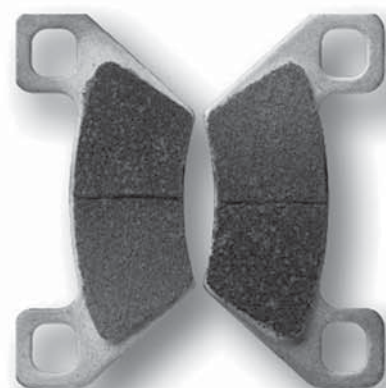
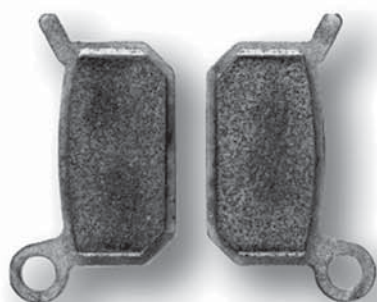
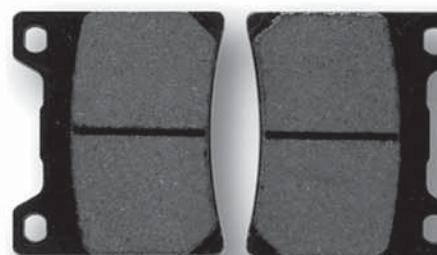
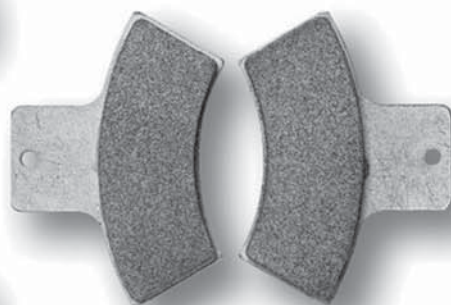

| SBS Ref. | Total th. | SBS Ref. | Total th. | SBS Ref. | Total th. | SBS Ref. | Total th. | SBS Ref. | Total th. |
|----------|-----------|----------|-----------|----------|-----------|----------|-----------|----------|-----------|
| 103      | 7.0       | 200      | 7.5       |          |           |          |           |          |           |
| 104      | 7.3       | 125      | 9.3       |          |           |          |           |          |           |
| 115      | 8.0       | 209      | 5.3       |          |           |          |           |          |           |
| 116      | 7.5       | 121      | 9.0       | 144      | 9.5       |          |           |          |           |
| 119      | 9.2       | 134      | 8.0       |          |           |          |           |          |           |
| 121      | 9.0       | 144      | 9.5       | 116      | 7.5       |          |           |          |           |
| 123      | 6.3       | 143      | 7.0       |          |           |          |           |          |           |
| 125      | 9.3       | 104      | 7.3       |          |           |          |           |          |           |
| 127      | 9.0       | 160      | 11.0      |          |           |          |           |          |           |
| 131      | 5.5       | 138      | 7.0       |          |           |          |           |          |           |
| 134      | 8.0       | 119      | 9.2       |          |           |          |           |          |           |
| 138      | 7.0       | 131      | 5.5       |          |           |          |           |          |           |
| 142      | 6.9       | 202      | 6.2       |          |           |          |           |          |           |
| 143      | 7.0       | 123      | 6.3       |          |           |          |           |          |           |
| 144      | 9.5       | 116      | 7.5       | 121      | 9.0       |          |           |          |           |
| 147      | 9.4       | 156      | 8.3       |          |           |          |           |          |           |
| 156      | 8.3       | 147      | 9.4       |          |           |          |           |          |           |
| 160      | 11.0      | 127      | 9.0       |          |           |          |           |          |           |
| 163      | 9.2       | 197      | 8.0       |          |           |          |           |          |           |
| 181      | 10.4      | 183      | 8.1       | 184      | 8.9       |          |           |          |           |
| 183      | 8.1       | 184      | 8.9       | 181      | 10.4      |          |           |          |           |
| 184      | 8.9       | 181      | 10.4      | 183      | 8.1       |          |           |          |           |
| 197      | 8.0       | 163      | 9.2       |          |           |          |           |          |           |
| 200      | 7.5       | 103      | 7.0       |          |           |          |           |          |           |
| 202      | 6.2       | 142      | 6.9       |          |           |          |           |          |           |
| 209      | 5.3       | 115      | 8.0       |          |           |          |           |          |           |
| 216      | 7.0       | 222      | 9.0       |          |           |          |           |          |           |
| 222      | 9.0       | 216      | 7.0       |          |           |          |           |          |           |
| 508      | 12.0      | 517      | 9.5       |          |           |          |           |          |           |
| 517      | 9.5       | 508      | 12.0      |          |           |          |           |          |           |
| 519      | 7.0       | 583      | 5.5       |          |           |          |           |          |           |
| 523      | 10.4      | 698      | 7.0       |          |           |          |           |          |           |
| 526      | 11.0      | 556      | 9.0       |          |           |          |           |          |           |
| 539      | 8.0       | 540      | 9.5       |          |           |          |           |          |           |
| 540      | 9.5       | 539      | 8.0       |          |           |          |           |          |           |
| 542      | 11.0      | 572      | 9.0       |          |           |          |           |          |           |
| 551      | 7.0       | 814      | 7.5       |          |           |          |           |          |           |
| 552      | 8.0       | 571      | 9.5       |          |           |          |           |          |           |
| 556      | 9.0       | 526      | 11.0      |          |           |          |           |          |           |
| 558      | 7.3       | 709      | 9.3       |          |           |          |           |          |           |
| 571      | 9.5       | 552      | 8.0       |          |           |          |           |          |           |
| 572      | 9.0       | 542      | 11.0      |          |           |          |           |          |           |
| 581      | 7.1       | 582      | 9.5       |          |           |          |           |          |           |
| 582      | 9.5       | 581      | 7.1       |          |           |          |           |          |           |
| 583      | 5.5       | 519      | 7.0       |          |           |          |           |          |           |
| 584      | 6.5       | 592      | 7.5       |          |           |          |           |          |           |
| 590      | 10.5      | 613      | 8.8       |          |           |          |           |          |           |
| 592      | 7.5       | 584      | 6.5       |          |           |          |           |          |           |
| 599      | 8.0       | 661      | 9.0       |          |           |          |           |          |           |
| 600      | 8.4       | 647      | 10.5      | 650      | 9.9       |          |           |          |           |
| 604      | 9.5       | 690      | 9.0       |          |           |          |           |          |           |
| 611      | 8.0       | 713      | 9.2       |          |           |          |           |          |           |
| 613      | 8.8       | 590      | 10.5      |          |           |          |           |          |           |
| 614      | 10.7      | 881      | 9.0       |          |           |          |           |          |           |
| 624      | 8.5       | 714      | 7.0       |          |           |          |           |          |           |
| 627      | 8.1       | 700      | 9.6       | 654      | 10.4      | 630      | 9.6       |          |           |
| 630      | 9.6       | 627      | 8.1       | 700      | 9.6       | 654      | 10.4      |          |           |
| 632      | 8.7       | 648      | 9.5       |          |           |          |           |          |           |
| 638      | 8.0       | 688      | 9.2       |          |           |          |           |          |           |
| 647      | 10.5      | 600      | 8.4       | 650      | 9.9       |          |           |          |           |
| 648      | 9.5       | 632      | 8.7       |          |           |          |           |          |           |
| 650      | 9.9       | 600      | 8.4       | 647      | 10.5      |          |           |          |           |
| 654      | 10.4      | 630      | 9.6       | 627      | 8.1       | 700      | 9.6       |          |           |
| 661      | 9.0       | 599      | 8.0       |          |           |          |           |          |           |
| 662      | 11.0      | 678      | 8.0       |          |           |          |           |          |           |
| 670      | 8.0       | 879      | 5.3       |          |           |          |           |          |           |
| 671      | 7.6       | 742      | 8.6/10.1  | 924      | 9.0       |          |           |          |           |
| 676      | 8.2       | 729      | 10.0      | 779      | 12.0      |          |           |          |           |
| 678      | 8.0       | 662      | 11.0      |          |           |          |           |          |           |
| 688      | 9.2       | 638      | 8.0       |          |           |          |           |          |           |
| 690      | 9.0       | 604      | 9.5       |          |           |          |           |          |           |
| 695      | 8.3       | 711      | 10.2      |          |           |          |           |          |           |







# BRAKE SHOES

## DRAWINGS, FITMENTS

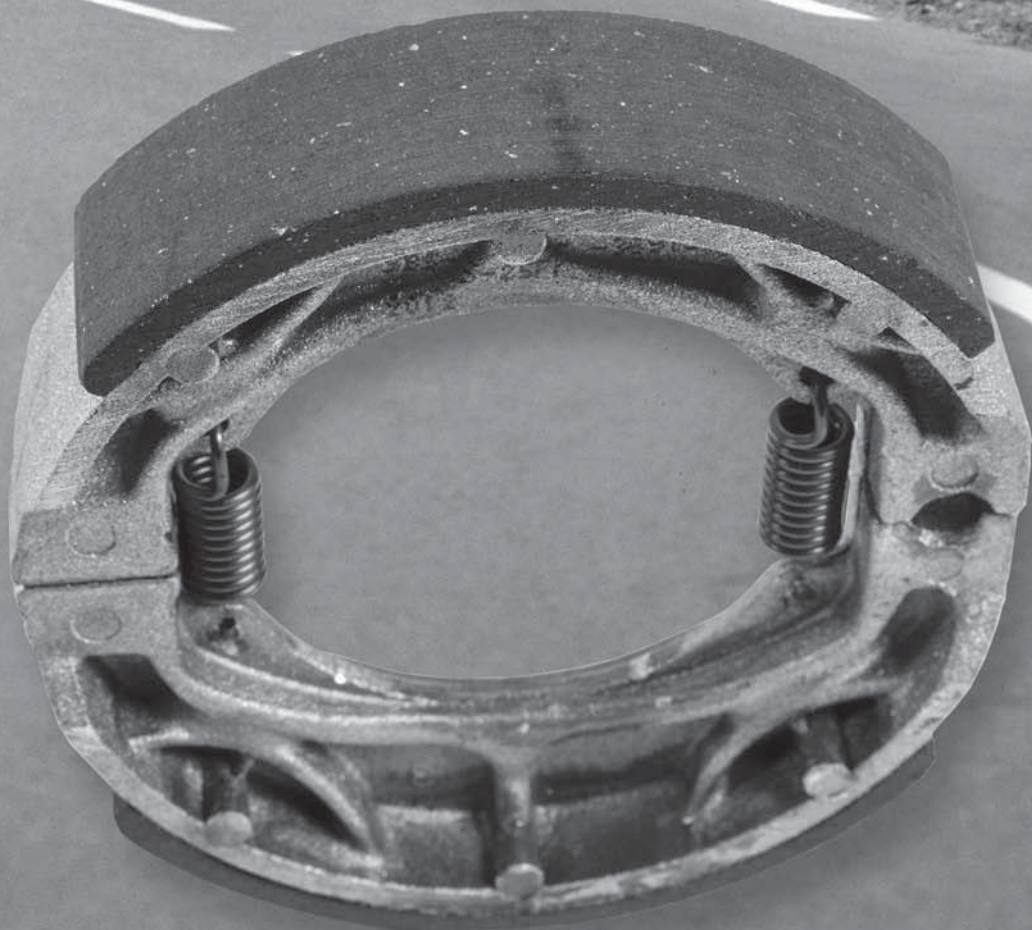



| HONDA |                   |       |     |
|-------|-------------------|-------|-----|
| CRF   | 50 F              | 04-18 | • • |
| NA    | 50 Express        | 79-81 | •   |
| NB    | 50 ME, Aero       | 83-87 | •   |
| NC    | 50 Express        | 77-80 | • • |
| NC    | 50 Express        | 81-83 | •   |
| ND    | 50 C, ML Melody   | 82-85 | •   |
| NE    | 50 MF, MG,        |       |     |
|       | TH Vision         | 85-87 | •   |
| NN    | 50 MD Gyro        | 84    | • • |
| NP    | 50 Melody D Mini  | 83-87 | •   |
| NQ    | 50 D, Spree       | 84-87 | • • |
| NT    | 50 F, G,          |       |     |
|       | H Melody Mini     | 85-87 | • • |
| NX    | 50 A, B, MC Caren | 82    | •   |
| OR    | 50                | 93    | •   |
| PA    | 50                | 78-81 | •   |
| PA    | 50                | 82-83 | • • |
| PC    | 50 K1             | 79    | • • |



| HONDA |                 |       |     |
|-------|-----------------|-------|-----|
| QR    | 50              | 93-03 | •   |
| QR    | 50 ED, EF       | 82-92 | •   |
| SA    | 50 Elite LX, SR | 88-93 | •   |
| SB    | 50              | 88-89 | • • |
| TG    | 50 M Gyro S     | 85-86 | • • |
| XR    | 50 R            | 00-03 | • • |
| Z     | 50 R, RD        | 80-99 | • • |
| CT    | 70              | 91-94 | • • |

| PEUGEOT |    |       |   |
|---------|----|-------|---|
| ST      | 50 | 98-99 | • |
| STL 2   | 50 | 90-94 | • |

| SUZUKI |    |       |     |
|--------|----|-------|-----|
| DR-Z   | 70 | 08-18 | • • |

| YAMAHA |    |       |     |
|--------|----|-------|-----|
| TT-R   | 50 | 06-18 | • • |

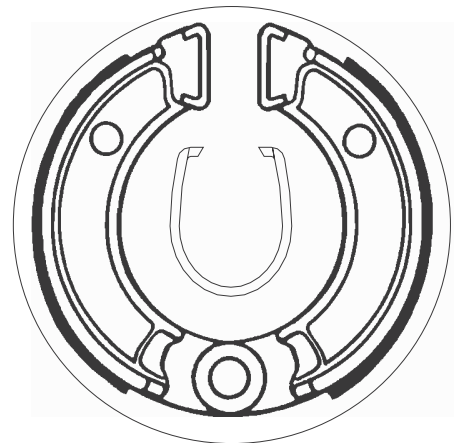

| HERCULES |          |    |   |
|----------|----------|----|---|
|          | 50 Limbo | 95 | • |

| HONDA |                   |       |     |
|-------|-------------------|-------|-----|
| GP    | 50 Dio            | 89-90 | •   |
| NA    | 50 Express        | 79-81 | •   |
| NB    | 50 ME, Aero       | 83-87 | •   |
| NC    | 50 Express        | 81-83 | •   |
| ND    | 50 C, ML Melody   | 82-85 | •   |
| NE    | 50 MF, MG,        |       |     |
|       | TH Vision         | 85-87 | •   |
| NH    | 50 Lead           | 83    | •   |
| NH    | 50 Lead           | 86-94 | •   |
| NH    | 50 Lead           |       |     |
|       | (Drum vers.)      | 94    | •   |
| NH    | 50 Lead SS,MR,    |       |     |
|       | MSE               | 84-85 | •   |
| NP    | 50 Melody D Mini  | 83-87 | •   |
| NS    | 50 F, Aero        | 88-91 | •   |
| NS-1  | 50                | 91-94 | •   |
| NU    | 50 MC Runaway,    |       |     |
|       | Express           | 82-83 | •   |
| NV    | 50 MSD Stream     | 84-86 | • • |
| NX    | 50 A, B, MC Caren | 82    | •   |
| OR    | 50                | 93    | •   |
| PX    | 50                | 82-83 | •   |
| QR    | 50 ED, EF         | 82-92 | •   |
| SA    | 50 Elite LX, SR   | 88-93 | •   |
| Lead  | 80 SS             | 85    | •   |
| NH    | 80 Lead Scooter   | 85-95 | •   |
| NH    | 80 MD Lead, Aero  | 83-84 | •   |
| R     | 80 Lead           | 88-95 | •   |

| PGO |         |       |   |
|-----|---------|-------|---|
|     | 50 Star | 91-93 | • |
|     | 80 Star | 91-95 | • |

| PEUGEOT |               |       |   |
|---------|---------------|-------|---|
|         | 50 Metropolis | 85-90 | • |
|         | 50 Rapido     | 85-93 | • |
|         | 50 Zenith     | 94-01 | • |
| SC      | 50            | 85-90 | • |
| ST      | 50            | 98-99 | • |
| STL 2   | 50            | 90-94 | • |
| SC      | 75            | 74-77 | • |
| SX      | 75            | 74-77 | • |
|         | 80 Metropolis | 80    | • |
| SX      | 80            | 85-94 | • |
| SX      | 80 Pro        | 85-94 | • |

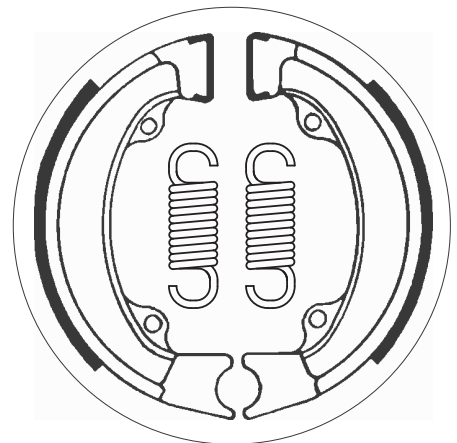



| <b>APRILIA</b>                   |       |   |   |
|----------------------------------|-------|---|---|
| 50 Amico                         | 90-91 | • | • |
| 50 Amico, GL, GLE                | 93-98 | • |   |
| 50 Gulliver                      | 96-00 | • |   |
| 50 Rally                         | 95-01 | • |   |
| 50 Scarabeo Street               | 00-06 | • |   |
| 50 Scarabeo,<br>2nd series       | 94-99 | • |   |
| 50 Sonic, GP                     | 99-09 | • |   |
| AC 50 Rally                      | 95-02 | • |   |
| LX 50 Amico, Sport               | 92-97 | • |   |
| SR 50 Europa                     | 93-94 | • |   |
| SR 50 Replica                    | 94-96 | • |   |
| SR 50 Replica<br>(Liquid Cooled) | 96    | • |   |
| SR 50 Urban Kid                  | 93-07 | • |   |
| SR 50 Viper                      | 93-94 | • |   |
| SR 50 WWW,<br>Netscaper          | 97-99 | • |   |
| <b>BENELLI</b>                   |       |   |   |
| 50 Chrono                        | 92-94 | • |   |
| 50 Nemo, Quadra                  | 94    | • |   |
| 50 Pepe                          | 99-11 | • |   |
| 491 50 GT, Sport                 | 98-99 | • |   |
| 491 50 Naked                     | 99-02 | • |   |
| 491 50 ST                        | 01-02 | • |   |
| <b>BETA</b>                      |       |   |   |
| 50 Chrono 13                     | 94-99 | • |   |
| 50 Quadra                        | 95-96 | • |   |
| 50 Tempo                         | 92-96 | • |   |
| <b>BS VILLA</b>                  |       |   |   |
| AX 50                            | 93    | • |   |
| GZ 50                            | 93    | • |   |
| <b>CAGIVA</b>                    |       |   |   |
| 50 City                          | 92-97 | • |   |
| <b>E-TON</b>                     |       |   |   |
| RXL 150 Viper                    | 07    | • |   |
| <b>HERCULES</b>                  |       |   |   |
| 50 Gipsy, Splinter,<br>Reggae    | 95    | • |   |
| 50 Limbo                         | 95    | • |   |
| SR 50 Samba                      | 93    | • | • |
| SR 80 Samba                      | 93    | • | • |
| <b>HONDA</b>                     |       |   |   |
| 50 Sky Classic                   | 00-03 | • |   |
| 50 Sky Vetro                     | 00-02 | • |   |
| C 50 all models                  | 75-93 | • | • |
| CF 50 Chaly                      | 79    | • | • |
| NH 50 Lead                       | 83    | • |   |
| NH 50 Lead (Drum vers.)          | 94    | • |   |
| PK 50 Walaroo DX-STD             | 90-01 | • |   |
| R 50 Monkey                      | 88    | • |   |
| SFX 50 Sport                     | 96-04 | • |   |
| SGX 50 Sky DX                    | 97-03 | • |   |
| SH 50 City Express               | 84-96 | • |   |
| SH 50 Scoopy                     | 88-04 | • |   |
| SH 50 T                          | 97    | • |   |
| SJ 50 Bali                       | 93-98 | • |   |
| SS 50 K2                         | 75-77 | • | • |
| SS 50 ZB2                        | 75-80 | • |   |
| ST 50 Dax                        | 78-93 | • | • |
| ATC 70 K1                        | 76-77 | • |   |
| C 70 all models                  | 75-83 | • | • |
| CF 70 K2, C                      | 78    | • | • |

| <b>HONDA</b>                 |       |   |   |
|------------------------------|-------|---|---|
| ST 70 Dax                    | 78-93 | • | • |
| 75 Yupy                      | 90-95 | • |   |
| NF 75                        | 79    | • | • |
| SA 75 Vision                 | 89-92 | • |   |
| SH 75 Scoopy                 | 88-95 | • |   |
| XR 75 K5                     | 79    | • |   |
| CH 80 Elite                  | 85-88 | • |   |
| NH 80 Aero                   | 85    | • |   |
| NH 80 MD Lead, Aero          | 83-84 | • |   |
| SH 80 Scoopy                 | 88-93 | • |   |
| C 90 all models              | 75-92 | • | • |
| EZ 90 Cub                    | 90-95 | • | • |
| TRX 90                       | 93-01 | • |   |
| H 100 A, SD, SG, SJ          | 82-92 | • | • |
| SJ 100 Bali                  | 97-03 | • |   |
| ANF 125 i Innova             | 07-11 | • |   |
| ANF 125 Innova               | 03-06 | • |   |
| ATC 125 ME, MF, MG,<br>MH    | 84-87 | • |   |
| CB 125                       | 72-74 | • | • |
| CB 125 S                     | 84-85 | • |   |
| CG 125 A, B, C               | 77-84 | • | • |
| CG 125 E, F, J               | 85-91 | • |   |
| CH 125 D, E, Spacy,<br>Elite | 83-84 | • | • |
| MTX 125 Camel, Italy         | 88-98 | • |   |
| NH 125 Lead Scooter          | 86-87 | • |   |
| NH 125 Lead, Aero            | 83-84 | • | • |
| NS 125 Italy                 | 85-88 | • |   |
| NSR 125 F                    | 88-89 | • |   |
| RTV 125 NRS, Italy           | 87    | • |   |
| SL 125 K1A                   | 76    | • | • |
| TRX 125                      | 85-88 | • |   |
| XL 125 K3                    | 79    | • |   |
| CH 150 D Elite               | 85-87 | • | • |
| ATC 185 A, S, SB             | 80-83 | • |   |
| ATC 200                      | 81-83 | • |   |
| ATC 200 E Big Red            | 82-83 | • |   |
| ATC 200 ES Big Red           | 84    | • |   |
| ATC 200 M                    | 84-85 | • |   |
| ATC 200 S                    | 84-86 | • |   |
| XL 200 R, P.D., Italy        | 85    | • |   |
| <b>KTM</b>                   |       |   |   |
| GO 50                        | 94-97 | • |   |
| <b>KYMCO</b>                 |       |   |   |
| 50 Agility                   | 05-08 | • |   |
| 50 Agility (4T) R10          | 06-14 | • |   |
| 50 Agility (4T) R12          | 06-15 | • |   |
| 50 Agility Basic             | 07    | • | • |
| 50 Calypso                   | 97-99 | • |   |
| 50 Cobra Cross               | 99-06 | • |   |
| 50 Cobra Exclusive           | 01-04 | • |   |
| 50 Cobra Racer               | 99-04 | • |   |
| 50 Dink, Dink Sport,<br>B&W  | 99-02 | • |   |
| 50 Easy                      | 01    | • |   |
| 50 Filly                     | 99-03 | • | • |
| 50 Filly LX                  | 01    | • |   |
| 50 Heroism                   | 95-99 | • |   |
| 50 Manboy                    | 95-00 | • |   |
| 50 MXer                      | 03-07 | • |   |
| 50 MXU                       | 05-10 | • |   |
| 50 Refined                   | 94-98 | • | • |
| 50 Scout                     | 95-00 | • |   |
| 50 Sento                     | 08-10 | • |   |
| 50 Spacer                    | 99-06 | • |   |
| 50 Topboy                    |       |   |   |
| on/off road                  | 96-05 | • |   |



| <b>KYMCO</b>    |       |   |   |
|-----------------|-------|---|---|
| 50 Topboy       |       |   |   |
| Racer/Cross     | 01-05 | • |   |
| 50 Yager        | 01-07 | • |   |
| 50 Yup          | 01    | • |   |
| CX 50           | 94-97 | • |   |
| DJ 50           | 99-02 | • |   |
| DJ 50 Refined   | 99-02 | • |   |
| DJW 50          | 94-97 | • |   |
| DJX 50          | 91-92 | • |   |
| DJY 50          | 93-06 | • |   |
| K12 50          | 95-00 | • |   |
| KB 50           | 95-00 | • |   |
| 80 Filly        | 99-02 | • | • |
| 90 Manboy       | 96-01 | • | • |
| 100 Cobra Racer | 99-03 | • | • |
| 100 Topboy      |       |   |   |
| on/off road     | 99-00 | • | • |
| KB 100          | 99-00 | • | • |
| 125 Agility     | 06-11 | • | • |
| 125 Calypso     | 99    | • | • |
| 125 Heroism     | 95-97 | • | • |
| 125 MXer        | 03-07 | • | • |
| B 125 Freeway   | 93-95 | • | • |
| D2 125 Freeway  | 95-92 | • | • |
| 150 Freeway     | 95-00 | • | • |
| 150 MXer        | 03-13 | • | • |
| 150 MXU         | 05-17 | • | • |

| <b>MALAGUTI</b>       |       |   |  |
|-----------------------|-------|---|--|
| 50 Centro             | 93-96 | • |  |
| 50 Ciak               | 00-09 | • |  |
| 50 Yesterday          | 97-02 | • |  |
| F-10 50               | 92-93 | • |  |
| F-10 50 Jet-Line      | 94-98 | • |  |
| F-12 50 Phantom       | 94-98 | • |  |
| F-12 50 Phantom A.C.  | 99-03 | • |  |
| F-12 50 Phantom L.C.  | 94-98 | • |  |
| F-15 50 Fire Fox      | 96-08 | • |  |
| F-15 50 Fire Fox L.C. | 96-08 | • |  |
| SL 50 Centro          | 96-00 | • |  |

| <b>PEUGEOT</b>    |       |   |   |
|-------------------|-------|---|---|
| e-Vivacity        | 11-15 | • |   |
| 50 Buxy           |       |   |   |
| (A.J.P. cal.)     | 94-97 | • |   |
| 50 Buxy           |       |   |   |
| (Brembo cal.)     | 94-97 | • |   |
| 50 Buxy           |       |   |   |
| (Hengtong cal.)   | 94-97 | • |   |
| 50 Elyseo         |       |   |   |
| (A.J.P. cal.)     | 99-01 | • |   |
| 50 Looxor         | 02-05 | • |   |
| 50 Ludix          | 04-08 | • |   |
| 50 Ludix          |       |   |   |
| (Drum front)      | 04-05 | • | • |
| 50 Metropolis     | 85-90 | • |   |
| 50 Speedake       |       |   |   |
| (A.J.P. cal)      | 94-01 | • |   |
| 50 Speedake       |       |   |   |
| (Brembo cal.)     | 94-01 | • |   |
| 50 Speedake       |       |   |   |
| (Hengtong cal.)   | 94-01 | • |   |
| 50 Speedfight 3   |       |   |   |
| (AC)              | 10-16 | • |   |
| 50 Speedfight LC, |       |   |   |
| (A.J.P. cal.)     | 96-15 | • |   |
| 50 Speedfight LC, |       |   |   |
| (Brembo cal.)     | 96-15 | • |   |
| 50 Speedfight LC, |       |   |   |
| (Hengtong cal.)   | 96-15 | • |   |



| <b>PEUGEOT</b>      |       |   |   |
|---------------------|-------|---|---|
| 50 Squab            |       |   |   |
| (A.J.P. cal.)       | 94-04 | • |   |
| 50 Squab            |       |   |   |
| (Hengtong cal.)     | 94-04 | • |   |
| 50 Trekker Road     | 99-00 | • |   |
| 50 Tweet            | 10-13 | • |   |
| 50 V-Clic           | 08-13 | • |   |
| 50 Zenith           | 94-01 | • |   |
| 50 Zenith Luxe      | 94-00 | • |   |
| SC 50               | 85-90 | • |   |
| SV 50 APS           | 91    | • | • |
| SV 50 Geo           | 91    | • | • |
| SV 50 Geo           | 92-99 | • |   |
| SV 50 J,Junior      | 93-97 | • | • |
| SV 50 L             | 93    | • |   |
| SV 50 Roland Garros | 93    | • |   |
| SV 50 Sport         | 93    | • |   |
| SX 50               | 75-80 | • |   |
| SC 75               | 74-77 | • |   |
| SX 75               | 74-77 | • |   |
| 80 Metropolis       | 80    | • |   |
| SC 80               | 76-79 | • | • |
| SV 80 Geo           | 91-98 | • |   |
| SX 80               | 85-94 | • |   |
| SX 80 Pro           | 85-94 | • |   |
| 100 Elyseo          |       |   |   |
| (A.J.P. cal.)       | 99-01 | • |   |
| 125 Ludix           | 04-05 | • |   |
| SV 125 C Executive  | 96-98 | • |   |
| SV 125 Executive    | 94-95 | • |   |
| SV 125 Geo          | 91-98 | • |   |

| <b>PGO</b> |       |   |  |
|------------|-------|---|--|
| 50 Star    | 91-93 | • |  |
| 80 Star    | 91-95 | • |  |

| <b>SYM</b>      |       |   |  |
|-----------------|-------|---|--|
| 50 Fiddle       | 09-14 | • |  |
| 50 Jet, Alpha   | 95-97 | • |  |
| 50 Jungle       | 96-02 | • |  |
| 50 Mask         | 00-05 | • |  |
| 50 Mask LC      | 00-05 | • |  |
| 50 Red Devil    | 97-09 | • |  |
| 50 Super Fancy  | 95-97 | • |  |
| RS 50           | 05-09 | • |  |
| 100 Super Fancy | 95-00 | • |  |
| 125 Attila      | 95-02 | • |  |
| 150 Super Duke  | 96-01 | • |  |

| <b>YAMAHA</b>    |       |   |  |
|------------------|-------|---|--|
| 50 Axis Pro Foot | 92-99 | • |  |
| XC 150 Fly One   | 92-99 | • |  |



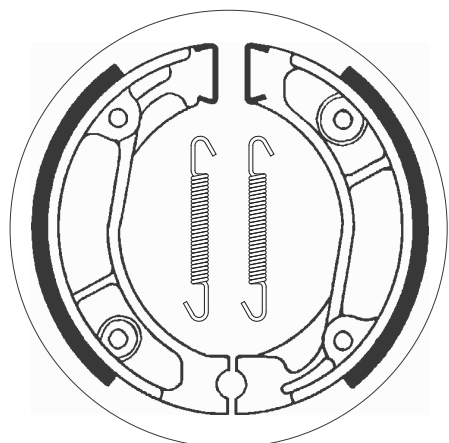

| HONDA |                          |       |   |
|-------|--------------------------|-------|---|
| CB    | 50 all models            | 80-81 | • |
| CB    | 50 all models            | 81    | • |
| CB    | 50 J, K1                 | 75-79 | • |
| MB    | 50 S                     | 80-82 | • |
| MBX   | 50                       | 80-82 | • |
| MBX   | 50 S                     | 83-85 | • |
| MRX   | 50                       | 88-92 | • |
| MT    | 50 S                     | 80-93 | • |
| MTX   | 50 SC-SD                 | 83-84 | • |
| NSR   | 50                       | 89-90 | • |
| XL    | 50                       | 77-82 | • |
| NSR   | 75 FII                   | 88-00 | • |
| XR    | 75 K4                    | 75-79 | • |
| XR    | 75 K5                    | 79    | • |
| CR    | 80 R2                    | 85    | • |
| CR    | 80 RA, RB                | 80-81 | • |
| CR    | 80 RC                    | 82    | • |
| MBX   | 80                       | 83-87 | • |
| MBX   | 80 DX                    | 82-86 | • |
| MBX   | 80 FWD                   | 83-86 | • |
| MBX   | 80 SW, SWD               | 83    | • |
| MCX   | 80                       | 82-85 | • |
| MTX   | 80 R                     | 87    | • |
| MTX   | 80 RF                    | 83-84 | • |
| XR    | 80                       | 79-84 | • |
| C     | 90                       | 93-02 | • |
| NH    | 90 Yupy                  | 90-94 | • |
| CB    | 100 N                    | 79-80 | • |
| XL    | 100 all models           | 78-85 | • |
| XR    | 100                      | 81-84 | • |
| CB    | 125 J                    | 79    | • |
| CB    | 125 S                    | 76-78 | • |
| CB    | 125 S                    | 79-82 | • |
| CBX   | 125 Custom               | 88    | • |
| CR    | 125 M2, M3, M4           | 76-78 | • |
| CT    | 125 C                    | 85    | • |
| MT    | 125 R                    | 77-78 | • |
| MTX   | 125 R                    | 84-95 | • |
| MTX   | 125 R, Italy             | 86    | • |
| MTX   | 125 RWD                  | 83-84 | • |
| NX    | 125 , Transcity          | 90-98 | • |
| R     | 125 Lead                 | 88    | • |
| SL    | 125 K1D, E, F, G,<br>K2A | 76-80 | • |

| HONDA |                        |       |   |
|-------|------------------------|-------|---|
| TL    | 125                    | 76    | • |
| XL    | 125 K2                 | 78    | • |
| XL    | 125 K3                 | 79    | • |
| XL    | 125 R                  | 86    | • |
| XL    | 125 R, P.D., Italy     | 85    | • |
| XL    | 125 R, P.D., Italy, EX | 87    | • |
| XL    | 125 S                  | 79-84 | • |
| XLR   | 125 R                  | 98-01 | • |
| XR    | 125 L                  | 03-07 | • |
| CRF   | 150 F                  | 03-06 | • |
| CBX   | 185 Custom             | 88    | • |
| XL    | 185 S                  | 79-83 | • |
| CTX   | 200                    | 04-06 | • |
| MTX   | 200 R                  | 85-86 | • |
| MTX   | 200 RWD                | 83-84 | • |
| TL    | 200 J, Y               | 76-78 | • |
| TLR   | 200 Fatcat             | 86-87 | • |
| TLR   | 200 G, H               | 86-87 | • |
| TR    | 200                    | 86-87 | • |
| XL    | 200 R                  | 83-84 | • |
| XR    | 200                    | 80-84 | • |
| XR    | 200 R                  | 84-02 | • |
| XR    | 200 R, Pro Link        | 81-83 | • |
| CRF   | 230                    | 04-09 | • |
| RTL   | 250 SG                 | 86    | • |
| TL    | 250                    | 75-76 | • |
| TL    | 250 K1                 | 79    | • |
| TLM   | 250 RJ                 | 89    | • |
| TLR   | 250 R                  | 85-87 | • |
| XL    | 250 R                  | 84-87 | • |
| XLR   | 250 R                  | 88-89 | • |
| XR    | 250 R                  | 84-89 | • |
| NX    | 350                    | 88-99 | • |
| XR    | 350 R                  | 83-85 | • |
| XR    | 500 R, Pro Link        | 83-84 | • |
| XR    | 600 R                  | 83-90 | • |

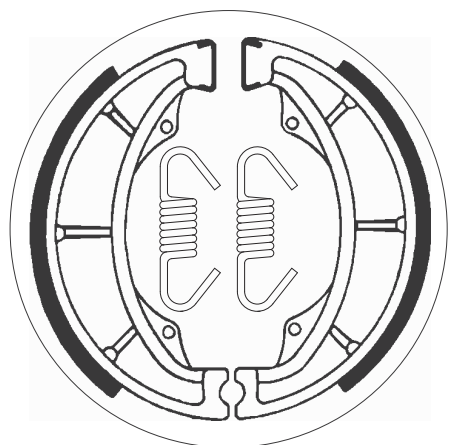

| HONDA    |        |       |   |
|----------|--------|-------|---|
| ATC      | 250 R  | 81    | • |
| HYOSUNG  |        |       |   |
| GV       | 250    | 02-09 | • |
| KAWASAKI |        |       |   |
| KH       | 100    | 78-81 | • |
| KH       | 100 EX | 88-93 | • |
| KE       | 125    | 86-91 | • |
| KH       | 125    | 82-98 | • |
| KZ       | 200    | 78-79 | • |
| Z        | 200    | 77-81 | • |
| Z        | 200    | 83-85 | • |
| KZ       | 250    | 80-83 | • |
| SUZUKI   |        |       |   |
| PV       | 50     | 82-97 | • |
| RG       | 80     | 85-87 | • |

| SUZUKI |                |       |   |
|--------|----------------|-------|---|
| RG     | 80 Gamma       | 88-93 | • |
| RM     | 80             | 83-85 | • |
| TS     | 90             | 71-73 | • |
| A      | 100 all models | 74-80 | • |
| ACC    | 100            | 70-72 | • |
| ASS    | 100            | 69-71 | • |
| GP     | 100            | 79-92 | • |
| RM     | 100            | 76-78 | • |
| TS     | 100            | 73-75 | • |
| TS     | 100            | 75-81 | • |
| TS     | 100 E          | 82-87 | • |
| B      | 120            | 71-77 | • |
| DR     | 125            | 82-84 | • |
| DR     | 125            | 86-02 | • |
| EN     | 125            | 05-09 | • |
| GN     | 125            | 82-10 | • |
| GP     | 125 all models | 77-84 | • |
| GP     | 125 C (Norway) | 78    | • |



| SUZUKI           |       |   |   |
|------------------|-------|---|---|
| GS 125           | 82-84 | • | • |
| GS 125 E, Katana | 90-94 |   | • |
| GS 125 ESD       | 83-94 | • | • |
| GS 125 ESZ       | 82    |   | • |
| GT 125           | 75-82 |   | • |
| GX 125 R         | 88-03 |   | • |
| GZ 125 Marauder  | 00-11 |   | • |
| RG 125           | 79-80 |   | • |
| RG 125 Gamma     | 85-90 |   | • |
| RM 125           | 75-78 | • | • |
| RM 125           | 79-83 | • | • |
| SP 125           | 82-83 | • | • |
| SP 125           | 86-88 |   | • |
| TS 125           | 72    |   | • |
| TS 125           | 73-81 | • | • |
| TS 125           | 82    | • |   |
| TS 125           | 84    | • |   |
| TS 125           | 84    | • | • |
| X4 125 , X3E     | 78-80 |   | • |
| GT 185           | 75-77 |   | • |
| TS 185           | 74-81 | • | • |
| DR 200           | 86-88 |   | • |
| DR 200 S         | 15-17 |   | • |
| DR 200 SE        | 96-13 |   | • |
| DR 200 T         | 96    |   | • |
| GT 200 X5 (Nien) | 79-82 |   | • |
| SB 200           | 79-81 |   | • |
| SP 200           | 86-88 |   | • |
| SX 200 R         | 85-89 |   | • |
| XS 200           | 79    |   | • |
| DR 250           | 82-83 | • | • |



| SUZUKI                 |       |   |   |
|------------------------|-------|---|---|
| DR 250                 | 85-89 |   | • |
| GN 250                 | 86-97 |   | • |
| GZ 250 Marauder        | 00-08 |   | • |
| RM 250                 | 76-78 | • |   |
| SP 250                 | 85    |   | • |
| TU 250 X Super Classic | 97-00 |   | • |
| VL 250 Intruder        | 00-07 |   | • |
| RL 325                 | 80-82 |   | • |
| RM 400                 | 78    | • |   |
| RM 465                 | 81-82 |   | • |
| DR 500                 | 89    |   | • |
| RM 500                 | 83-87 |   | • |
| DR 600 Djebel          | 86-88 |   | • |
| DR 600 S Dakar         | 85-87 |   | • |
| SP 600 F               | 85-87 |   | • |
| YAMAHA                 |       |   |   |
| 225 Serow              | 85-87 |   | • |

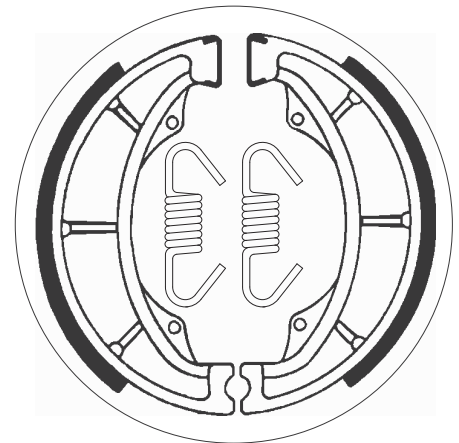

| HYOSUNG         |       |   |   |
|-----------------|-------|---|---|
| 110 Midas Plus  | 98-04 | • | • |
| FX 110 110      | 02-04 |   | • |
| KR 110 Master   | 04-05 |   | • |
| KAWASAKI        |       |   |   |
| AE 50           | 81-82 | • | • |
| AR 50           | 81-82 |   | • |
| KMX 50          | 88-93 |   | • |
| AE 80           | 81-86 | • | • |
| AR 80           | 81-82 |   | • |
| KD 80           | 80-87 | • | • |
| KD 80           | 88-90 |   | • |
| KMX 80          | 87-92 |   | • |
| KC 100          | 80-83 | • | • |
| KE 100          | 79-97 | • | • |
| KH 100          | 76-77 | • | • |
| KH 100          | 78-81 |   | • |
| KH 100 EX, G    | 81-82 |   | • |
| KH 100 GH       | 83-87 |   | • |
| KM 100          | 78-81 | • | • |
| KLF 110 Mojave  | 87-88 | • |   |
| KLT 110         | 84-86 | • |   |
| KLX 110         | 02-18 |   | • |
| KLT 160         | 85    | • |   |
| KLT 185         | 86-87 | • |   |
| KLT 200         | 81-84 | • |   |
| KLT 250         | 82-83 | • |   |
| KLT 250 Police  | 84    | • |   |
| KLT 250 Prairie | 83-85 | • |   |



| PUCH             |       |   |   |
|------------------|-------|---|---|
| AP 50            | 71-80 | • | • |
| SUZUKI           |       |   |   |
| A 50             | 71-76 | • | • |
| AC 50 DX         | 81-86 |   | • |
| AC 50 RG, ZR, Z1 | 79-84 |   | • |
| AP 50            | 75-78 | • | • |
| AP 50            | 95-02 |   | • |
| F 50             | 71-73 | • | • |
| FR 50            | 74-81 | • | • |
| GT 50            | 77-80 |   | • |
| OR 50            | 79    | • | • |
| RB 50            | 87    |   | • |
| RM 50            | 75-76 |   | • |
| RM 50            | 78-80 | • | • |
| RV 50            | 72-82 | • | • |
| TS 50            | 80-83 | • |   |
| TS 50 ERA        | 80    | • | • |
| TS 50 KN         | 79    | • | • |
| X-1 50           | 79    |   | • |
| FR 70            | 74-76 | • | • |
| FR 80            | 76-83 | • | • |
| GT 80 L/C        | 81    |   | • |
| RM 80            | 77-79 | • | • |
| RT 80            | 81-82 | • | • |
| RV 90            | 73-81 | • | • |
| TS 90            | 71-73 | • |   |
| A 100 all models | 74-80 |   | • |
| ASS 100          | 69-71 |   | • |
| GP 100           | 78-92 |   | • |
| RM 100           | 76-81 | • |   |

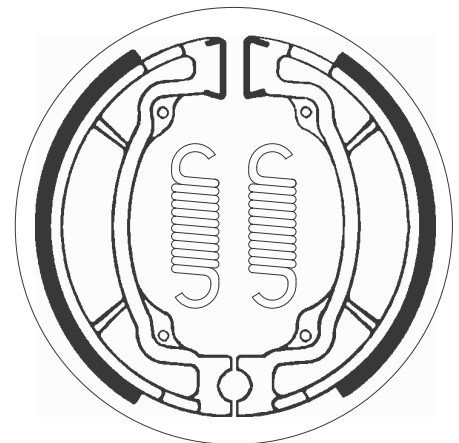



ø110x30

SBS 2015

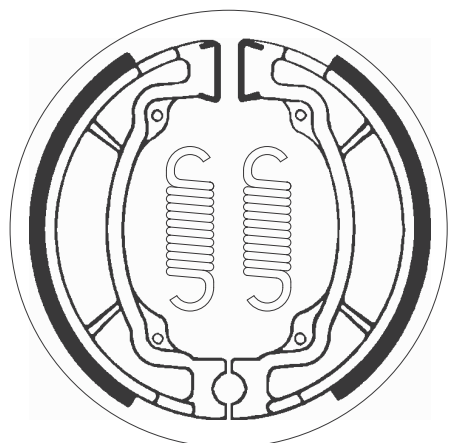

**SUZUKI**

|      |            |       |   |   |
|------|------------|-------|---|---|
| TS   | 100        | 73-75 | • |   |
|      | 110 Smash  | 03-06 | • | • |
| DR-Z | 110        | 02-06 | • | • |
| FX   | 110 Shogun | 98-02 | • | • |
| CS   | 125 D      | 83-85 | • | • |
| TS   | 125        | 72    | • |   |
| RL   | 325        | 80-82 | • |   |
|      |            |       |   |   |
|      |            |       |   |   |
|      |            |       |   |   |
|      |            |       |   |   |
|      |            |       |   |   |
|      |            |       |   |   |
|      |            |       |   |   |

ø150x28

SBS 2016

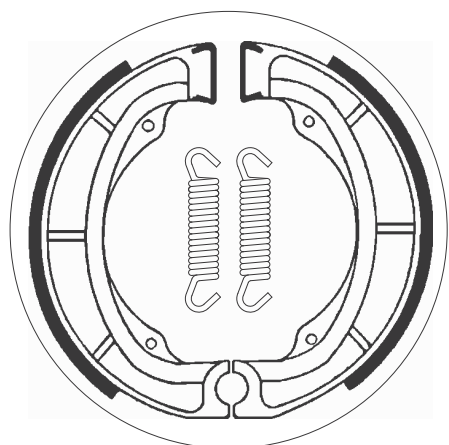

**KAWASAKI**

|     |     |       |   |  |
|-----|-----|-------|---|--|
| KDX | 250 | 80-82 | • |  |
| KL  | 250 | 78-80 | • |  |
| KX  | 250 | 75-81 | • |  |
| KZ  | 250 | 80-83 | • |  |
| KX  | 420 | 80-81 | • |  |

**SUZUKI**

|      |         |       |   |  |
|------|---------|-------|---|--|
| ALT  | 125     | 84-86 | • |  |
| LT   | 125 E-H | 84-87 | • |  |
| LT   | 160     | 89-92 | • |  |
| LT-F | 160     | 91-04 | • |  |
| ALT  | 185     | 85-87 | • |  |
| LT   | 185     | 84-87 | • |  |
| SB   | 200     | 79-81 | • |  |
| LT   | 230     | 85-86 | • |  |
| LT-F | 230     | 86-87 | • |  |
| RM   | 250     | 76-78 | • |  |
| RM   | 250     | 79    | • |  |

**SUZUKI**

|    |       |       |   |   |
|----|-------|-------|---|---|
| TS | 250   | 74-82 | • | • |
| TS | 250 X | 85-89 | • | • |
| SP | 370   | 77-79 | • | • |
| DR | 400   | 79-81 | • | • |
| PE | 400   | 79-81 | • | • |
| RM | 400   | 78    | • | • |
| RM | 400   | 79    | • | • |
| SP | 400   | 80-82 | • | • |
| DR | 500   | 83-88 | • | • |
|    |       |       |   |   |
|    |       |       |   |   |
|    |       |       |   |   |
|    |       |       |   |   |
|    |       |       |   |   |
|    |       |       |   |   |
|    |       |       |   |   |

ø110x25

SBS 2017

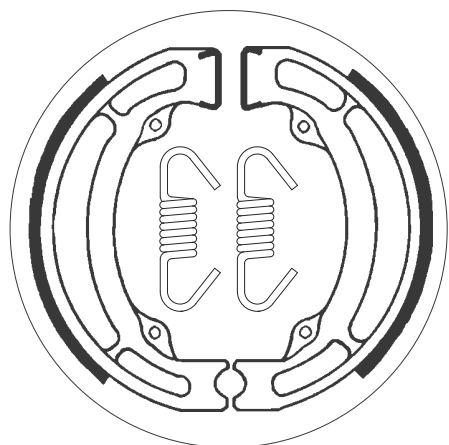

**SUZUKI**

|      |               |       |   |   |
|------|---------------|-------|---|---|
| GSXR | 50            | 87    | • |   |
| LT-A | 50 Quadmaster | 01-05 | • |   |
| LT-Z | 50 Quadsport  | 06-17 | • |   |
| OR   | 50            | 80    | • | • |
| OR   | 50 E          | 80    | • | • |
| RM   | 50            | 81-82 | • | • |
| TS   | 50            | 80-83 | • | • |
| TS   | 50 ERZ1       | 80-83 | • | • |
| ZR   | 50            | 81-87 | • | • |
| DS   | 80            | 80-96 | • | • |
| JR   | 80            | 01-07 | • | • |
| RM   | 80            | 80-81 | • | • |
| RM   | 80            | 83-85 | • | • |
| TS   | 80            | 81-82 | • | • |
| LT-Z | 90 Quadsport  | 07-14 | • | • |
| DR   | 100           | 83-90 | • | • |
| TS   | 100 E         | 82-87 | • | • |
| DR-Z | 125 K         | 03-12 | • | • |

**SUZUKI**

|      |       |       |   |  |
|------|-------|-------|---|--|
| DR-Z | 125 L | 03-18 | • |  |
| TS   | 125   | 82    | • |  |
|      |       |       |   |  |
|      |       |       |   |  |
|      |       |       |   |  |
|      |       |       |   |  |
|      |       |       |   |  |
|      |       |       |   |  |
|      |       |       |   |  |
|      |       |       |   |  |
|      |       |       |   |  |
|      |       |       |   |  |
|      |       |       |   |  |
|      |       |       |   |  |



| SUZUKI                 |       |   |  |
|------------------------|-------|---|--|
| GNX 250                | 82-84 | • |  |
| GS 250                 | 80-82 | • |  |
| GSX 250                | 80-81 | • |  |
| GSX 250                | 85    | • |  |
| GT 250                 | 78-81 | • |  |
| SW1 250                | 92-95 | • |  |
| GS 300                 | 82-85 | • |  |
| GN 400                 | 80    | • |  |
| GSX 400                | 80-83 | • |  |
| GSX 400 E, S           | 85-86 | • |  |
| GSX 400 EFX            | 82    | • |  |
| LS 400 Savage          | 87-91 | • |  |
| LT-A 400 Eiger 2WD/4WD | 02-07 | • |  |
| LT-F 400 Eiger 2WD/4WD | 02-07 | • |  |
| GS 425                 | 79-80 | • |  |
| GS 450                 | 80-83 | • |  |
| GS 450                 | 85    | • |  |
| GR 650 X               | 83-84 | • |  |



| SUZUKI            |       |   |  |
|-------------------|-------|---|--|
| LS 650            | 05    | • |  |
| LS 650 P          | 86-88 | • |  |
| LS 650 P Savage   | 95-04 | • |  |
| S40 650 Boulevard | 05-18 | • |  |

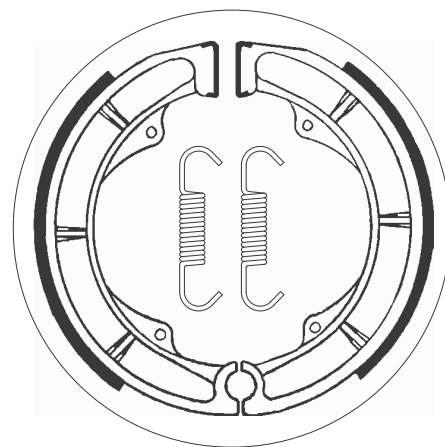

| HONDA                  |       |   |  |
|------------------------|-------|---|--|
| ATC 80                 | 76-78 | • |  |
| ATC 90 K1, K2, K3      | 73-78 | • |  |
| TRX 90                 | 93-01 | • |  |
| ATC 110 all models     | 79-85 | • |  |
| ATC 125 ME, MF, MG, MH | 84-87 | • |  |
| TRX 125                | 85-88 | • |  |
| CD 175 all models      | 71-78 | • |  |
| ATC 185 A, S, SB       | 80-83 | • |  |
| ATC 200                | 81-83 | • |  |
| ATC 200 E Big Red      | 82-83 | • |  |
| ATC 200 ES Big Red     | 84    | • |  |
| ATC 200 M              | 84-85 | • |  |
| ATC 200 S              | 84-86 | • |  |
| TRX 200                | 84    | • |  |
| TRX 200                | 90-91 | • |  |
| TRX 200 D Type II      | 91-97 | • |  |
| TRX 200 SX             | 86-88 | • |  |
| ATC 250 ES, SX         | 85-87 | • |  |



| HONDA          |       |   |  |
|----------------|-------|---|--|
| FL 250 Odyssey | 77-84 | • |  |

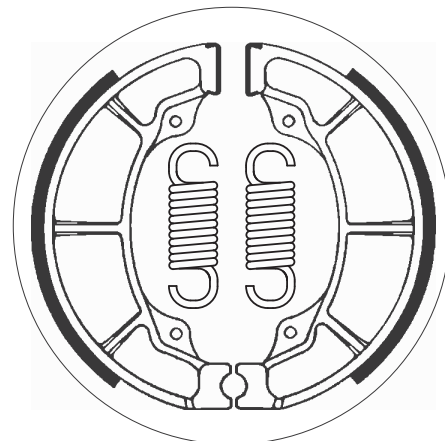

| HONDA     |       |   |  |
|-----------|-------|---|--|
| CBX 125 F | 84-88 | • |  |

  

| SUZUKI              |       |   |  |
|---------------------|-------|---|--|
| ALT 50              | 83-84 | • |  |
| CL 50 D, Suzi, Love | 83    | • |  |
| CS 50 Roadie        | 83    | • |  |
| JR 50               | 89-07 | • |  |
| LT 50               | 84-02 | • |  |

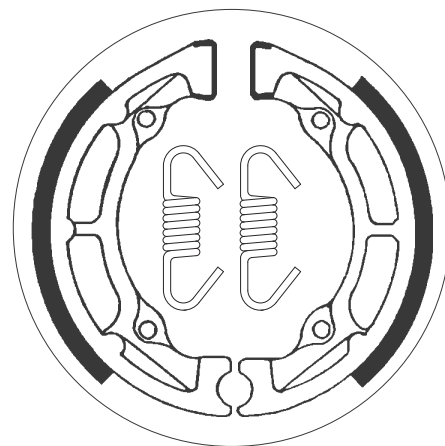

ø95x20

SBS 2021

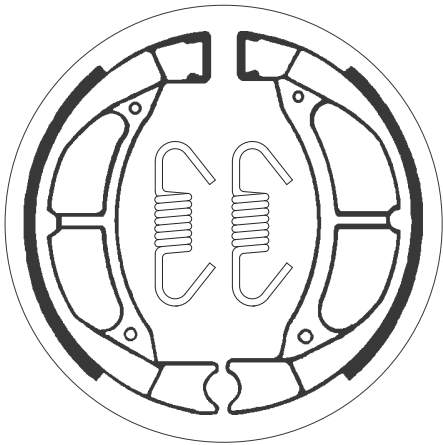

| <b>MBK</b>    |                          |         |     |
|---------------|--------------------------|---------|-----|
|               | 50 Active                | 89      | • • |
|               | 50 Hot Champ             | 91 - 97 | •   |
|               | 75 Active                | 90      | • • |
|               | 80 Active                | 89      | • • |
| <b>YAMAHA</b> |                          |         |     |
|               | 50 Beluga                | 88 - 89 | • • |
| CA            | 50 Riva Salient          | 83 - 86 | •   |
| CG            | 50 A, B Riva Jog         | 90 - 91 | •   |
| CY            | 50 F Jog                 | 94      | •   |
| JOG           | 50 (Spain)               | 88      | •   |
| JOG           | 50 CY                    | 90 - 92 | •   |
| JOG           | 50 E                     | 88 - 90 | •   |
| JOG-Z         | 50                       | 90 - 91 | •   |
| LC            | 50 M, Bop, G,<br>H Champ | 80 - 81 | • • |
| MS            | 50                       | 85 - 86 | •   |
| RS            | 50 Champ                 | 88 - 93 | •   |



| <b>YAMAHA</b> |  |         |     |
|---------------|--|---------|-----|
| SA            | 50 M, ME Passola                       | 80 - 84 | •   |
| SG            | 50 Sting                               | 84 - 91 | • • |
| SH            | 50 E, F Razz                           | 93 - 95 | •   |
| SH            | 50 Mint                                | 93 - 96 | •   |
| SH            | 50 T,EMT,U,MU,W,<br>MW,A,MA,B,D,<br>MD | 87 - 93 | •   |
| YE            | 50 Zest (Japan)                        | 92 - 95 | •   |
| CH            | 80 Beluga (CH 80)                      | 90      | •   |
| YE            | 80 Zest (Japan)                        | 93 - 95 | •   |
| JOG           | 90                                     | 90 - 91 | •   |

ø100x20

SBS 2022

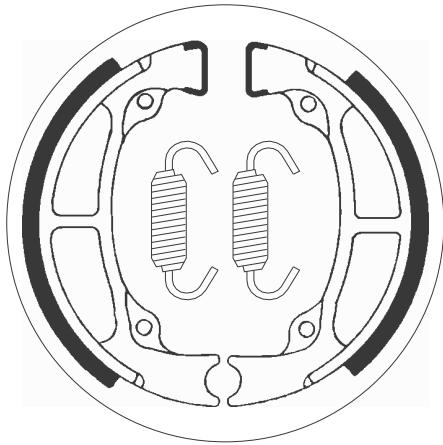

| <b>SUZUKI</b> |    |         |   |
|---------------|----|---------|---|
| RM            | 80 | 82 - 85 | • |
|               |    |         |   |
|               |    |         |   |
|               |    |         |   |
|               |    |         |   |
|               |    |         |   |
|               |    |         |   |
|               |    |         |   |
|               |    |         |   |
|               |    |         |   |
|               |    |         |   |
|               |    |         |   |
|               |    |         |   |
|               |    |         |   |
|               |    |         |   |
|               |    |         |   |
|               |    |         |   |
|               |    |         |   |
|               |    |         |   |
|               |    |         |   |
|               |    |         |   |
|               |    |         |   |

ø140x25

SBS 2023

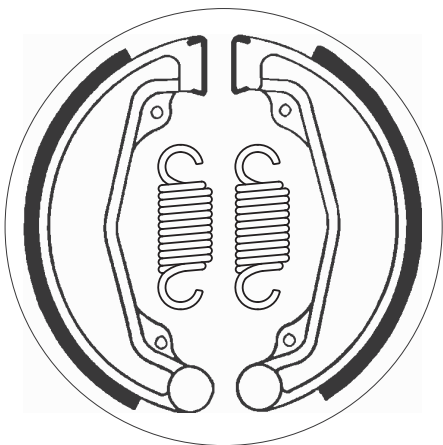

| <b>HONDA</b> |               |         |     |
|--------------|---------------|---------|-----|
| CD           | 125           | 82      | •   |
| CM           | 125           | 82 - 85 | •   |
| CD           | 185 T         | 78 - 82 | •   |
| CM           | 185 T         | 78 - 79 | •   |
| CD           | 200 T         | 79      | •   |
| CM           | 200 TA, TB    | 80 - 82 | •   |
| CB           | 250 Nighthawk | 91 - 02 | •   |
| CL           | 250 SC        | 81      | •   |
| CM           | 250 C         | 82 - 83 | •   |
| MT           | 250 K1        | 74 - 76 | • • |
| XL           | 250           | 78 - 79 | •   |
| XL           | 250 S         | 78 - 81 | •   |
| XR           | 250           | 79 - 80 | •   |
| XL           | 350           | 76 - 78 | •   |
| XL           | 500 SZ        | 80      | •   |
|              |               |         |     |
|              |               |         |     |
|              |               |         |     |
|              |               |         |     |
|              |               |         |     |
|              |               |         |     |
|              |               |         |     |
|              |               |         |     |
|              |               |         |     |
|              |               |         |     |

### SBS 2024

ø160x30



#### HONDA

|     |               |       |   |
|-----|---------------|-------|---|
| ATC | 250 ES, SX    | 85-87 | • |
| CB  | 250 G, T      | 74-76 | • |
| CB  | 250 K3-K5     | 73-75 | • |
| CJ  | 250 T         | 76-78 | • |
| TRX | 250           | 85-87 | • |
| TRX | 300           | 88-00 | • |
| TRX | 300 4WD       | 88-00 | • |
| CB  | 350 F, F1     | 73-76 | • |
| CB  | 350 K4        | 74    | • |
| CB  | 360 G, T      | 73-76 | • |
| CJ  | 360 T         | 76-78 | • |
| CL  | 360           | 74-77 | • |
| CB  | 400 F, F1, F2 | 75-79 | • |
| CB  | 400 NZ        | 79    | • |
|     |               |       |   |
|     |               |       |   |
|     |               |       |   |
|     |               |       |   |
|     |               |       |   |
|     |               |       |   |
|     |               |       |   |
|     |               |       |   |
|     |               |       |   |
|     |               |       |   |

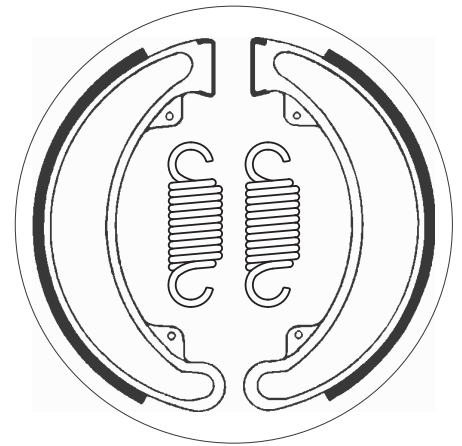

### SBS 2025

ø110x30



#### KAWASAKI

|     |       |       |   |
|-----|-------|-------|---|
| KH  | 125   | 77-80 | • |
| KX  | 125   | 83-85 | • |
| KDX | 200   | 83-85 | • |
| KDX | 200 C | 86-88 | • |
|     |       |       |   |
|     |       |       |   |
|     |       |       |   |
|     |       |       |   |
|     |       |       |   |
|     |       |       |   |
|     |       |       |   |
|     |       |       |   |
|     |       |       |   |
|     |       |       |   |
|     |       |       |   |
|     |       |       |   |
|     |       |       |   |
|     |       |       |   |
|     |       |       |   |
|     |       |       |   |
|     |       |       |   |
|     |       |       |   |
|     |       |       |   |
|     |       |       |   |
|     |       |       |   |

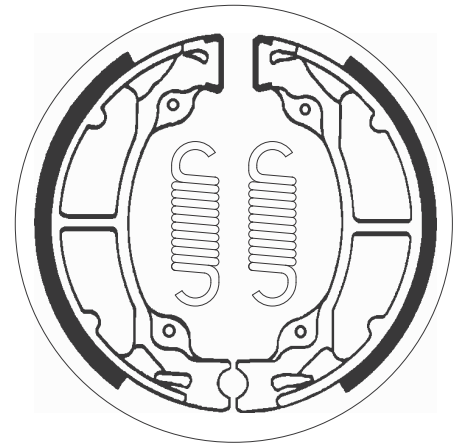

### SBS 2026

ø130x30



#### CAGIVA

|    |       |       |   |
|----|-------|-------|---|
| T4 | 350 R | 87-99 | • |
| T4 | 500 E | 87-90 | • |

#### HONDA

|     |                |       |   |
|-----|----------------|-------|---|
| CA  | 125 Rebel      | 95-00 | • |
| VT  | 125 C1 Shadow  | 99-08 | • |
| VT  | 125 C2 Shadow  | 99-08 | • |
| CBX | 185 F          | 84    | • |
| CBX | 250 RSE        | 84-85 | • |
| XL  | 250 S          | 81    | • |
| XLR | 400            | 83    | • |
| XL  | 500 R          | 83-87 | • |
| XL  | 500 RC         | 82    | • |
| XL  | 500 SZ         | 80    | • |
| XR  | 500 R          | 86    | • |
| XR  | 500 R Pro Link | 81-82 | • |
| XR  | 500 SZ, SA     | 79-80 | • |
| XL  | 600 LM, RM     | 85-87 | • |



#### HONDA

|     |                 |       |   |
|-----|-----------------|-------|---|
| XL  | 600 R           | 83-86 | • |
| XL  | 600 V, Transalp | 87-90 | • |
| XLM | 600 LM          | 87-91 | • |
|     |                 |       |   |
|     |                 |       |   |
|     |                 |       |   |
|     |                 |       |   |
|     |                 |       |   |
|     |                 |       |   |
|     |                 |       |   |
|     |                 |       |   |
|     |                 |       |   |
|     |                 |       |   |
|     |                 |       |   |
|     |                 |       |   |
|     |                 |       |   |
|     |                 |       |   |
|     |                 |       |   |
|     |                 |       |   |
|     |                 |       |   |
|     |                 |       |   |
|     |                 |       |   |
|     |                 |       |   |
|     |                 |       |   |

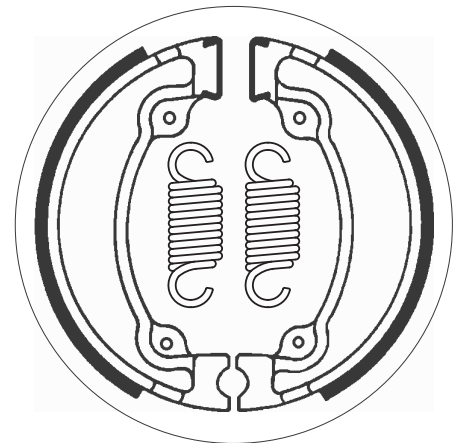

Dimensions in mm / Dimensions en mm  
1" = 25.4 mm , 1 mm = 0.04"

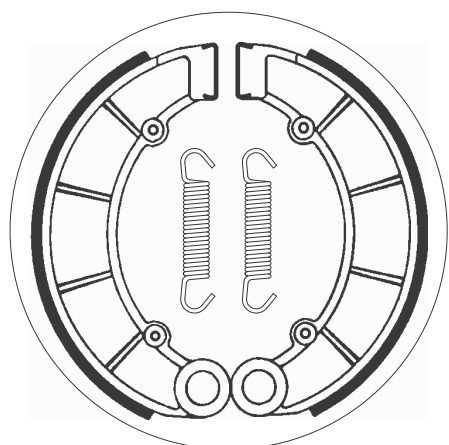

| <b>HONDA</b> |                   |        |   |
|--------------|-------------------|--------|---|
| CB           | 650               | 79- 81 | • |
| CB           | 650 C             | 80- 85 | • |
| CB           | 650 SCC Nighthawk | 82     | • |
| CB           | 650 Z             | 78- 81 | • |
| CB           | 750 A             | 76- 78 | • |
| CB           | 750 C             | 80- 84 | • |
| CB           | 750 C, F, FII, K  | 85- 86 | • |
| CB           | 750 K Four        | 77- 78 | • |
| CB           | 750 K, L          | 79- 80 | • |
| CB           | 750 K0-K6 Four    | 70- 76 | • |
| CB           | 750 KZ            | 82     | • |
| CB           | 750 PZ            | 81- 84 | • |
| CB           | 750 SC            | 82- 83 | • |
|              |                   |        |   |
|              |                   |        |   |
|              |                   |        |   |
|              |                   |        |   |

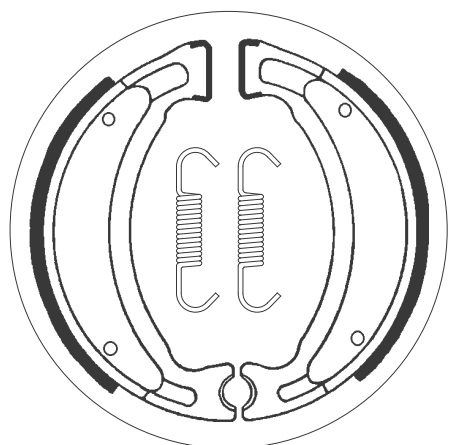

| <b>ADLY</b>       |                  |        |     | <b>KEEWAY</b>   |                    |        |     |
|-------------------|------------------|--------|-----|-----------------|--------------------|--------|-----|
|                   | 25 Silver Fox    | 00- 05 | •   |                 | 50 Flash           | 07- 12 | •   |
|                   | 50 Fox           | 00- 09 | •   |                 | 50 Flash Electric  | 10- 12 | •   |
|                   | 50 Jet           | 96- 99 | •   |                 | 50 Hurricane       | 06- 16 | •   |
|                   | 50 Pista,        |        |     |                 | 50 Matrix          | 06- 15 | •   |
|                   | Pista Twin Light | 96- 99 | •   | F-NKD           | 50                 | 10- 11 | •   |
|                   | 50 Silver Fox    | 00- 09 | •   | RY8             | 50                 | 07- 09 | •   |
|                   | 100 Jet          | 96- 99 | •   |                 |                    |        |     |
|                   | 100 Silver Fox   | 06     | •   |                 |                    |        |     |
| <b>BARIGO</b>     |                  |        |     | <b>KOTIR</b>    |                    |        |     |
|                   | Scooter electric | 97     | •   | RS              | 50                 | 90     | • • |
| <b>BENELLI</b>    |                  |        |     | <b>KREIDLER</b> |                    |        |     |
|                   | 50 Naked         | 02     | •   |                 | 50 Florett         | 99- 06 | •   |
| LX                | 100 Pepe         | 02- 06 | •   |                 |                    |        |     |
| <b>CPI</b>        |                  |        |     | <b>KTM</b>      |                    |        |     |
|                   | 50 Baby          | 02     | •   | X-1             | 50                 | 98- 91 | •   |
|                   | 50 Hussar        | 01- 06 | •   |                 |                    |        |     |
|                   | 50 Mars          | 01- 02 | •   | <b>LEM</b>      |                    |        |     |
|                   | 50 Oliver        | 03- 12 | •   |                 | 50 Flash           | 94- 98 | •   |
|                   | 50 Oliver City   | 03- 12 | •   |                 | 50 Ghibli          | 90- 95 | • • |
|                   | 50 Oliver Sport  | 03- 12 | •   |                 |                    |        |     |
|                   | 50 Popcorn       | 01- 02 | •   | <b>MAICO</b>    |                    |        |     |
| <b>DERBI</b>      |                  |        |     |                 | 50 Classic         | 99     | • • |
| DXR               | 200 Quad         |        |     |                 | 50 Cruiser         | 99     | •   |
|                   | (Front drum)     | 04- 05 | •   |                 | 50 Thunderbike I   | 99     | •   |
| DXR               | 250 Quad         |        |     |                 | 50 Thunderbike II  | 99     | •   |
|                   | (Front drum)     | 04- 05 | •   |                 | 50 Trafficjammer   | 99     | • • |
|                   |                  |        |     | C-1             | 50 Hard Enduro     | 99     | •   |
|                   |                  |        |     | R-1             | 50 Superbike       | 99     | •   |
|                   |                  |        |     | X-1             | 50 SuperCross      | 99     | •   |
| <b>EASY RIDER</b> |                  |        |     | <b>MBK</b>      |                    |        |     |
|                   | 50 Easy Rider    | 99     | •   |                 | 50 Equalis         | 96- 98 | •   |
|                   |                  |        |     |                 | 50 Fizz            | 93- 00 | •   |
|                   |                  |        |     |                 | 50 Forte           | 94- 98 | •   |
| <b>FANTIC</b>     |                  |        |     |                 | 50 Sorriso         | 92- 95 | • • |
|                   | 50 Pony          | 93- 96 | • • |                 | 50 Target          | 92- 95 | •   |
|                   | 50 Pony SR       | 93- 95 | •   |                 | 80 Evolis          | 94- 98 | •   |
|                   | 50 Queenie       | 95- 96 | •   |                 | 125 Flame R/F      | 95- 03 | •   |
| <b>GENERIC</b>    |                  |        |     | <b>POLARIS</b>  |                    |        |     |
|                   | 50 Ideo          | 06- 13 | •   |                 | 250 Cyclone        | 87     | •   |
|                   | 50 XOR           | 06- 13 | •   |                 | 350 Trail Boss 2x4 | 85- 87 | •   |
|                   |                  |        |     |                 |                    |        |     |
|                   |                  |        |     |                 |                    |        |     |



|                       |       |     |
|-----------------------|-------|-----|
| <b>SMC</b>            |       |     |
| 50 Easy Rider         | 97    | •   |
| <b>SULA</b>           |       |     |
| 50 City Bird          | 99    | •   |
| 50 Thunder Bird       | 99    | •   |
| 100 Thunder Bird      | 99    | •   |
| 125 Thunder Bird      | 99    | •   |
| <b>YAMAHA</b>         |       |     |
| CR 50 Target          | 91-95 | •   |
| CX 50                 | 88-93 | • • |
| CY 50 F Jog           | 94    | •   |
| DT 50 LCD             | 98-01 | •   |
| DT 50 R               | 98-03 | •   |
| YE 50 Zest (Italy)    | 92-95 | •   |
| YFM 50 Raptor         | 04-11 | •   |
| YSR 50                | 87-91 | •   |
| 80 Beluga             | 81-89 | • • |
| CV 80 Riva            | 83-87 | • • |
| CW 80 Beluga          | 81-83 | • • |
| PW 80                 | 91-08 | •   |
| TY 80                 | 83-84 | •   |
| YFM 80                | 92-94 | •   |
| YFM 80 Badger         | 95-07 | •   |
| YFM 80 Grizzly        | 05-08 | •   |
| YFM 80 Raptor         | 02-08 | •   |
| YSR 80                | 86-92 | •   |
| CR 90 Target          | 91-94 | •   |
| TT-R 90               | 00-10 | •   |
| YFM 90 RY Raptor      | 09-15 | •   |
| RS 100 DX             | 77-82 | •   |
| RT 100 A-H            | 90-96 | • • |
| YB 100                | 82-86 | •   |
| YB 100                | 87-92 | • • |
| YFM 100 Champ         | 89-91 | •   |
| YZ 100                | 82-83 | •   |
| TT-R 110              | 08-18 | •   |
| SR 125 SE             | 82    | •   |
| TT-R 125              | 00-13 | • • |
| TT-R 125 LW           | 00-18 | •   |
| TW 125                | 99-07 | •   |
| XT 125                | 82-86 | •   |
| YFA 125 1 D, E Breeze | 92-93 | •   |
| YFA 125 1 F Breeze    | 94    | •   |



|                          |       |     |
|--------------------------|-------|-----|
| <b>YAMAHA</b>            |       |     |
| YFA 125 1 G-M Breeze     | 95-07 | •   |
| YFA 125 1 W, A, B Breeze | 89-91 | •   |
| YFM 125 Grizzly          | 04-13 | •   |
| XC 150 Fly One R         | 98-02 | •   |
| YT 175 Tri Moto          | 82-83 | •   |
| SR 185 Exiter, H, J      | 81-82 | •   |
| BW 200                   | 85-88 | • • |
| TT 200                   | 86-89 | •   |
| TW 200                   | 87-15 | •   |
| XT 200                   | 85-95 | •   |
| YFM 200 DXS-DXW          |       |     |
| Moto 4                   | 86-87 | •   |
| YFM 200 N Moto 4         | 85-89 | •   |
| YFS 200 U-P Blaster      | 88-02 | •   |
| YTM 200 EK, EL Tri Moto  | 83-84 | •   |
| YTM 200 ERN Tri Moto     | 85    | •   |
| YTM 200 K-N Tri Moto     | 83-85 | •   |
| TT 225 S,T               | 86-00 | •   |
| TTR 225                  | 01-04 | •   |
| XT 225                   | 92-01 | •   |
| XT 225 Serow             | 86    | •   |
| YFM 225 Moto 4           | 86-88 | •   |
| YTM 225 DRN,             |       |     |
| DRS Tri Moto             | 85-86 | •   |
| YTM 225 DXK,             |       |     |
| DXN Tri Moto             | 83-85 | •   |
| YFB 250 Timberwolf       | 92-94 | •   |
| YFM 350 ERT, ERU         | 87-88 | •   |

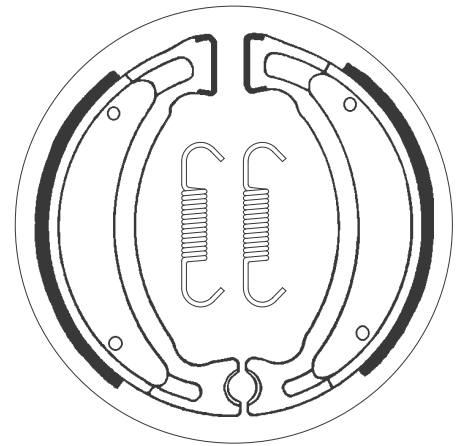

|               |       |   |
|---------------|-------|---|
| <b>HONDA</b>  |       |   |
| NX 250        | 88-90 | • |
| XL 250 Degree | 91    | • |
| XL 250 R      | 82-83 | • |
| XL 250 S      | 78-80 | • |
| XR 250        | 79-80 | • |
| XR 250 R      | 81-83 | • |
| XL 350 R      | 84-87 | • |
|               |       |   |
|               |       |   |
|               |       |   |
|               |       |   |
|               |       |   |
|               |       |   |
|               |       |   |
|               |       |   |
|               |       |   |
|               |       |   |
|               |       |   |
|               |       |   |

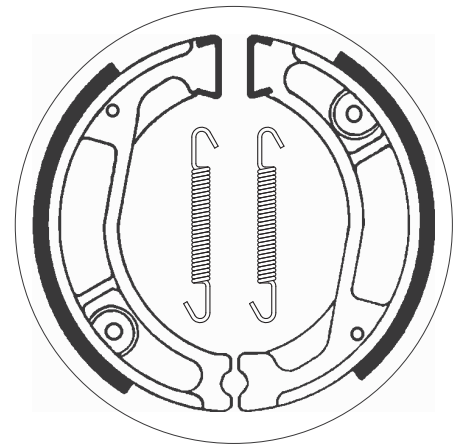

ø130x25

SBS 2030

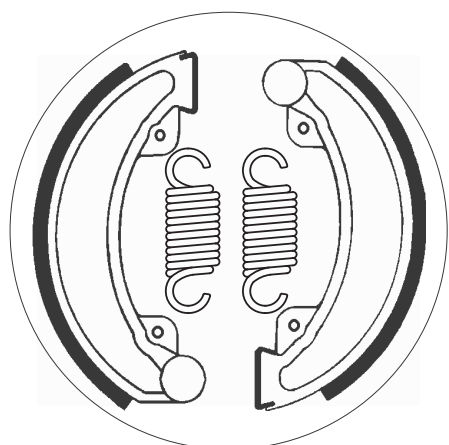

**HONDA**

|    |                |       |   |  |
|----|----------------|-------|---|--|
| CR | 250 R          | 81-82 | • |  |
| XR | 250 R          | 81-83 | • |  |
| CR | 450 R          | 81    | • |  |
| CR | 480 R          | 82    | • |  |
| XR | 500 R Pro Link | 81-82 | • |  |
|    |                |       |   |  |
|    |                |       |   |  |
|    |                |       |   |  |
|    |                |       |   |  |
|    |                |       |   |  |
|    |                |       |   |  |
|    |                |       |   |  |
|    |                |       |   |  |
|    |                |       |   |  |
|    |                |       |   |  |
|    |                |       |   |  |

ø140x25

SBS 2031

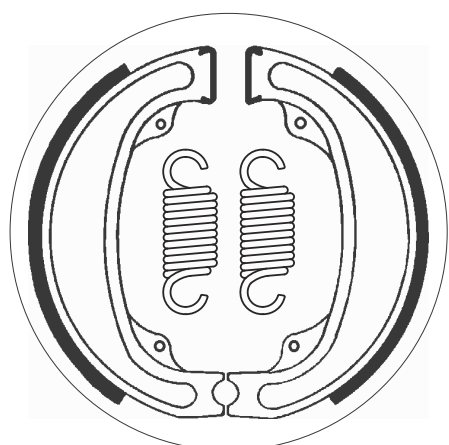

**HONDA**

|    |            |       |   |  |
|----|------------|-------|---|--|
| CR | 125 R      | 79-81 | • |  |
| CR | 250 RZ, RA | 79-80 | • |  |
| XR | 500 SZ, SA | 79-80 | • |  |
|    |            |       |   |  |
|    |            |       |   |  |
|    |            |       |   |  |
|    |            |       |   |  |
|    |            |       |   |  |
|    |            |       |   |  |
|    |            |       |   |  |
|    |            |       |   |  |
|    |            |       |   |  |
|    |            |       |   |  |
|    |            |       |   |  |
|    |            |       |   |  |
|    |            |       |   |  |

ø110x25

SBS 2032

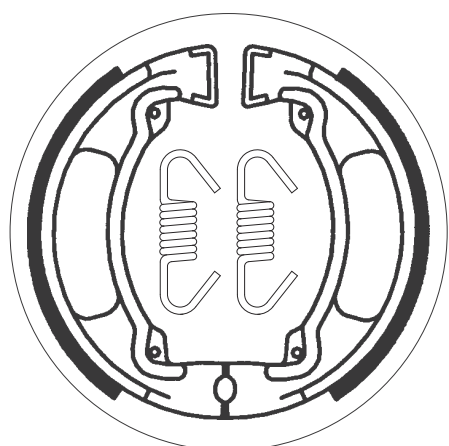

|                |            |       |   |   |
|----------------|------------|-------|---|---|
| <b>CPI</b>     |            |       |   |   |
|                | 50 Popcorn | 03-06 | • |   |
| <b>GARELLI</b> |            |       |   |   |
| SR             | 50 Pony    | 95-02 | • |   |
| <b>YAMAHA</b>  |            |       |   |   |
| DT             | 50 M, MX   | 78-86 | • | • |
| FS             | 50 DX      | 75-79 | • |   |
| FS1            | 50 DX      | 77-81 | • |   |
| FS1            | 50 E       | 74-76 | • | • |
| FS1            | 50 SE      | 81-82 | • | • |
| LB             | 50 Chappy  | 80-83 | • | • |
| RD             | 50         | 76-78 | • |   |
| RD             | 50 M       | 79-80 | • |   |
| RD             | 50 MX      | 81-87 | • |   |
| RX             | 50 K       | 83-85 | • |   |
| TY             | 50, M      | 77-80 | • | • |
| V              | 50 M, P    | 74-82 | • | • |

|               |              |       |   |   |
|---------------|--------------|-------|---|---|
| <b>YAMAHA</b> |              |       |   |   |
| YSR           | 50           | 92    | • |   |
| RD            | 60           | 73-75 | • | • |
| V             | 70 A         | 76    | • | • |
| V             | 75 A         | 77    | • | • |
| DT            | 80 MX        | 81-83 | • | • |
| LB2           | 80 Bop 2     | 80    | • | • |
| RD            | 80 LC        | 81-85 | • |   |
| RD            | 80 MX        | 81-86 | • |   |
| RX            | 80 SE        | 82-84 | • |   |
| TY            | 80           | 77-82 | • |   |
| V             | 80           | 79-82 | • | • |
| YZ            | 80           | 74-79 | • |   |
| V             | 90           | 78    | • | • |
| YA            | 90 Axis      | 90-93 | • |   |
| AG            | 100 Farmbike | 80-91 | • |   |
| DT            | 100          | 76-80 | • |   |
| RS            | 100          | 75-80 | • | • |
| RX            | 100          | 76-79 | • |   |

Dimensions in mm / Dimensions en mm  
1" = 25.4 mm , 1 mm = 0.04"

Applications for this part number continues on following page.



**YAMAHA**

|                |       |     |
|----------------|-------|-----|
| RX 100         | 84-87 | •   |
| YB 100         | 78-81 | • • |
| YB 100         | 82-86 | •   |
| YZ 100         | 78-81 | •   |
| RX 115 S       | 82-85 | •   |
| IT 125 G, H, J | 80-82 | •   |
| TY 125         | 80-82 | •   |
| YZ 125         | 74-75 | •   |
| TY 175         | 77-80 | •   |
| TY 250         | 77-78 | •   |
| TY 250         | 84-90 | •   |
| TY 250 R       | 91-92 | •   |
| BW 350         | 87-88 | •   |
| TY 350         | 86    | •   |
|                |       |     |
|                |       |     |
|                |       |     |

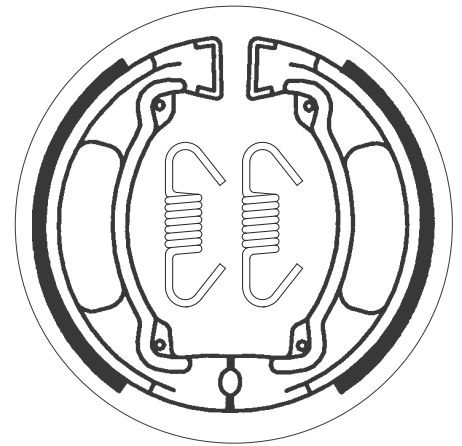

**YAMAHA**

|              |       |   |
|--------------|-------|---|
| YZ 125       | 76-83 | • |
| IT 175       | 80-82 | • |
| IT 250       | 80-82 | • |
| TY 250       | 81    | • |
| YZ 250       | 74-81 | • |
| YZ 400       | 77-79 | • |
| IT 425       | 80    | • |
| IT 500 G, H. | 80-81 | • |
|              |       |   |
|              |       |   |
|              |       |   |
|              |       |   |
|              |       |   |
|              |       |   |
|              |       |   |
|              |       |   |

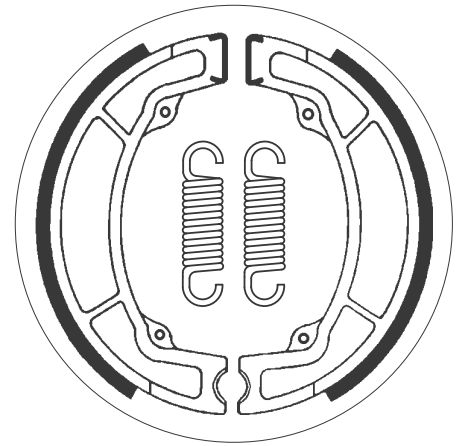

**PEUGEOT**

|           |       |   |
|-----------|-------|---|
| 125 Tweet | 10-13 | • |
| 150 Tweet | 10-13 | • |

**YAMAHA**

|                    |       |     |
|--------------------|-------|-----|
| YFM 50 Raptor      | 04-11 | •   |
| DT 80 LC           | 81-84 | •   |
| DT 80 LC-2         | 85-92 | •   |
| TZR 80             | 89-91 | •   |
| VN 80 NW           | 88    | • • |
| YFM 80             | 87-88 | •   |
| YFM 80             | 92-94 | •   |
| YFM 80 Badger      | 95-07 | •   |
| YFM 80 Grizzly     | 05-08 | •   |
| YFM 80 N, S Moto 4 | 85-86 | •   |
| YFM 80 Raptor      | 02-08 | •   |
| 100 Aerox          | 00-06 | •   |
| 100 Neo's          | 00-02 | •   |
| AG 100 Farmbike    | 80-93 | •   |



**YAMAHA**

|                     |       |     |
|---------------------|-------|-----|
| DT 100              | 76-80 | •   |
| YFM 100 Champ       | 87-91 | •   |
| YZ 100              | 78-83 | •   |
| BL 125 Beluga       | 85-87 | • • |
| BL 125 Beluga       | 88-93 | •   |
| DT 125 E, MX, LC    | 74-85 | • • |
| DT 125 LC           | 85-87 | •   |
| DT 125 MX           | 90-93 | • • |
| DT 125 Tenere       | 89-90 | •   |
| IT 125 G, H, J      | 80-82 | •   |
| RD 125 DX           | 75-77 | •   |
| RD 125 LC           | 82-87 | •   |
| RS 125 DX           | 76-86 | •   |
| SR 125 SE           | 82    | •   |
| TY 125              | 80-82 | •   |
| TZR 125             | 87-88 | •   |
| XC 125 Beluga       | 85    | • • |
| XC 125 Beluga, Riva | 87-92 | •   |



Brake Shoe Drawings, Fitments



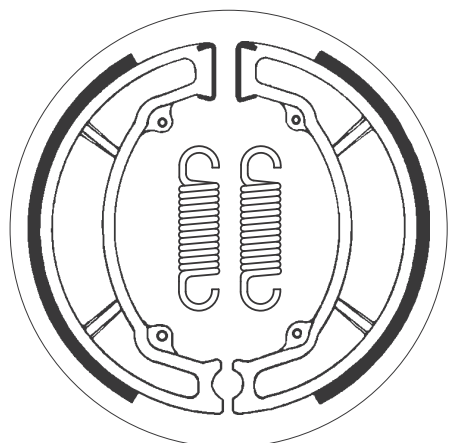

| <b>YAMAHA</b> |                   |       |   |  |
|---------------|-------------------|-------|---|--|
| XC            | 125 Cygnus F      | 00-08 | • |  |
| XC            | 125 E, F Riva     | 93-95 | • |  |
| XC            | 125 F             | 00-08 | • |  |
| XC            | 125 TR Cygnus, R  | 96-98 | • |  |
| XT            | 125               | 82-86 | • |  |
| XV            | 125 Virago        | 97-00 | • |  |
| YBR           | 125               | 06-07 | • |  |
| YFA           | 125 1 D, E Breeze | 92-93 | • |  |
| YFA           | 125 1 F Breeze    | 94    | • |  |
| YFA           | 125 1 G-M Breeze  | 95-07 | • |  |
| YFA           | 125 1 W, A,       |       |   |  |
|               | B Breeze          | 89-91 | • |  |
| YFM           | 125 Grizzly       | 04-13 | • |  |
| YP            | 125               | 89    | • |  |
| YZ            | 125               | 74-82 | • |  |
|               | 135 Crypton X     | 08-14 | • |  |
| DT            | 175               | 95-99 | • |  |
| DT            | 175               | 00    | • |  |
| DT            | 175 all models    | 74-83 | • |  |
| IT            | 175               | 80-82 | • |  |
| TY            | 175               | 77-80 | • |  |
| RT            | 180               | 90-93 | • |  |
| RT            | 180               | 95-96 | • |  |
| SR            | 185 Exiter, H, J  | 81-82 | • |  |
| DT            | 200               | 85-87 | • |  |
| TW            | 200               | 87-00 | • |  |
| XC            | 200 Riva          | 87-91 | • |  |
| XT            | 200               | 85-95 | • |  |
| TT-R          | 230               | 05    | • |  |
| FZ            | 250 Phazer N, S   | 85-86 | • |  |
| SR            | 250               | 90-93 | • |  |
| SR            | 250 SE            | 80-82 | • |  |
| SRX           | 250               | 84-90 | • |  |
| TT            | 250               | 87-92 | • |  |
| TY            | 250               | 77-78 | • |  |
| XT            | 250               | 80-81 | • |  |
| XV            | 250 Route 66      | 88-90 | • |  |
| XV            | 250 Route 66      | 95-97 | • |  |
| XV            | 250 S Virago      | 95-07 | • |  |
| XV            | 250 Virago        | 88-94 | • |  |
| XVS           | 250 V-Star        | 08-12 | • |  |
| YZ            | 250               | 80    | • |  |
| YZ            | 250               | 82-87 | • |  |
| TT            | 350               | 86-87 | • |  |

| <b>YAMAHA</b> |         |       |   |  |
|---------------|---------|-------|---|--|
| XT            | 350     | 85-96 | • |  |
| YZ            | 490     | 83    | • |  |
| DT            | 600 N   | 85    | • |  |
| TT            | 600     | 85-92 | • |  |
| TT            | 600 K,L | 83-84 | • |  |
|               |         |       |   |  |
|               |         |       |   |  |
|               |         |       |   |  |
|               |         |       |   |  |
|               |         |       |   |  |
|               |         |       |   |  |
|               |         |       |   |  |
|               |         |       |   |  |
|               |         |       |   |  |
|               |         |       |   |  |
|               |         |       |   |  |
|               |         |       |   |  |
|               |         |       |   |  |
|               |         |       |   |  |
|               |         |       |   |  |
|               |         |       |   |  |
|               |         |       |   |  |
|               |         |       |   |  |
|               |         |       |   |  |
|               |         |       |   |  |

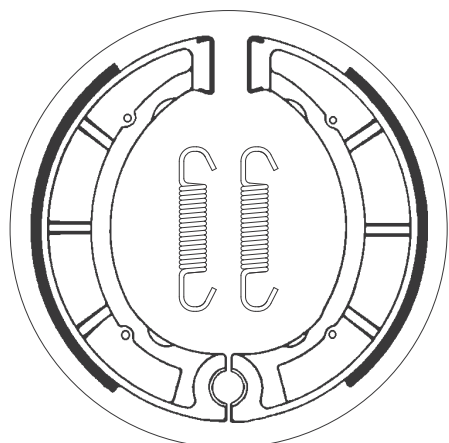

| <b>YAMAHA</b> |                |       |   |  |
|---------------|----------------|-------|---|--|
| DT            | 250 all models | 75-80 | • |  |
| SR            | 250 SE         | 80-82 | • |  |
| YD            | 250            | 86    | • |  |
| YD            | 250 S          | 90    | • |  |
| YFB           | 250 Timberwolf | 92-94 | • |  |
| YFB           | 250 Timberwolf | 95-96 | • |  |
| YFB           | 250 Timberwolf |       |   |  |
|               | 4WD            | 94-03 | • |  |
| YFM           | 250            | 89-91 | • |  |
| YFM           | 250 Timberwolf |       |   |  |
|               | (YFB 250 G)    | 95    | • |  |
| YFU1TW        | 250 Pro Hauler | 89    | • |  |
| YFU1W         | 250 Pro Hauler | 89-90 | • |  |
| YZ            | 250            | 74-79 | • |  |
| YFM           | 350 ERW, ERA-G | 89-95 | • |  |
| YFP           | 350 U Terrapro | 88    | • |  |
| DT            | 400 all models | 75-77 | • |  |
| YZ            | 400            | 77-79 | • |  |

| <b>YAMAHA</b> |           |       |   |  |
|---------------|-----------|-------|---|--|
| IT            | 425       | 80    | • |  |
| YZ            | 465       | 80    | • |  |
| IT            | 500 G, H, | 80-81 | • |  |
| XT            | 500       | 76-80 | • |  |
|               |           |       |   |  |
|               |           |       |   |  |
|               |           |       |   |  |
|               |           |       |   |  |
|               |           |       |   |  |
|               |           |       |   |  |
|               |           |       |   |  |
|               |           |       |   |  |
|               |           |       |   |  |
|               |           |       |   |  |
|               |           |       |   |  |
|               |           |       |   |  |
|               |           |       |   |  |
|               |           |       |   |  |
|               |           |       |   |  |
|               |           |       |   |  |
|               |           |       |   |  |
|               |           |       |   |  |
|               |           |       |   |  |
|               |           |       |   |  |

**SBS 2036****ø130x22****YAMAHA**

|    |         |       |   |
|----|---------|-------|---|
| YZ | 125     | 84    | • |
| IT | 250     | 84    | • |
| YZ | 250     | 82-84 | • |
| IT | 465     | 81-82 | • |
| YZ | 465     | 80-81 | • |
| IT | 490     | 84    | • |
| YZ | 490     | 81-84 | • |
| TT | 600 K,L | 83-84 | • |
|    |         |       |   |
|    |         |       |   |
|    |         |       |   |
|    |         |       |   |
|    |         |       |   |
|    |         |       |   |
|    |         |       |   |
|    |         |       |   |
|    |         |       |   |
|    |         |       |   |

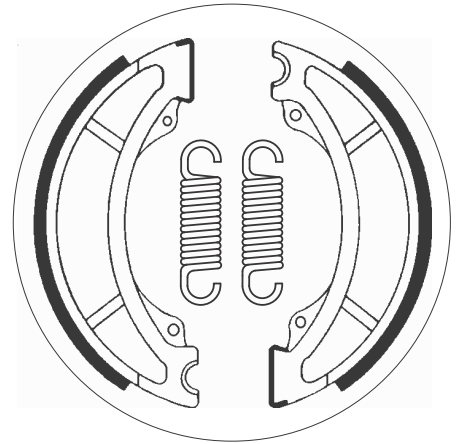
**SBS 2037****ø150x25****YAMAHA**

|     |                  |       |   |
|-----|------------------|-------|---|
| RD  | 125 DX           | 78-81 | • |
| YP  | 125              | 89    | • |
| XC  | 180 Cygnus, Riva | 83-85 | • |
| RD  | 200 A, B         | 74-75 | • |
| RD  | 200 DX           | 76-81 | • |
| RS  | 200              | 79    | • |
| DT  | 250 all models   | 75-80 | • |
| IT  | 250              | 80-82 | • |
| IT  | 250              | 84-86 | • |
| SRX | 250 T, TC        | 87    | • |
| TY  | 250              | 81    | • |
| YD  | 250              | 86    | • |
| YZ  | 250              | 81    | • |
| DT  | 400 all models   | 75-77 | • |
| SR  | 400              | 76    | • |
| IT  | 465              | 81-82 | • |
| YZ  | 465              | 81    | • |
| IT  | 490              | 84    | • |

**YAMAHA**

|    |               |       |   |
|----|---------------|-------|---|
| YZ | 490           | 81-82 | • |
| YZ | 490           | 84-90 | • |
| SR | 500           | 78-98 | • |
| XT | 500 (Austria) | 83    | • |
| XT | 500           | 76-80 | • |
| XT | 500           | 86-89 | • |
| XT | 550           | 82-83 | • |
| XT | 600           | 83-86 | • |
| XT | 600 Tenere    | 83-84 | • |
| XT | 600 Z         | 86-88 | • |
|    |               |       |   |
|    |               |       |   |
|    |               |       |   |
|    |               |       |   |
|    |               |       |   |
|    |               |       |   |
|    |               |       |   |
|    |               |       |   |
|    |               |       |   |
|    |               |       |   |

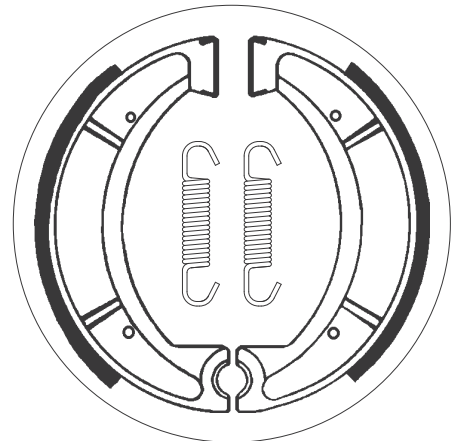
**SBS 2038****ø160x30****KAWASAKI**

|     |                  |       |   |
|-----|------------------|-------|---|
| KLF | 185 Bayou        | 85-88 | • |
| KLF | 220 Bayou        | 88-02 | • |
| BR  | 250              | 86-90 | • |
| EL  | 250              | 91-94 | • |
| EL  | 250 Eliminator   | 88-89 | • |
| GPZ | 250              | 83-85 | • |
| GPZ | 250 Belt Drive   | 83-84 | • |
| Z   | 250              | 80-83 | • |
| Z   | 250 T, Scorpion  | 89    | • |
| EL  | 252              | 97-03 | • |
| KLF | 300 A1, A2 Bayou | 86-87 | • |
| KLF | 300 Bayou        | 88-04 | • |
| EX  | 305              | 83    | • |
| GPZ | 305              | 81-96 | • |
| KZ  | 305              | 81-82 | • |
| KZ  | 305              | 87-88 | • |
| Z   | 305              | 81-82 | • |
| GPZ | 400 S            | 88-90 | • |

**KAWASAKI**

|      |              |       |   |
|------|--------------|-------|---|
| KZ   | 400          | 78-79 | • |
| KZ   | 400 H1 (LTD) | 79    | • |
| Z    | 400          | 78-79 | • |
| Z    | 400 D, S     | 76-77 | • |
| Z    | 400 F        | 84-86 | • |
| ZR   | 400 F        | 83-84 | • |
| KZ   | 440, LTD     | 83-85 | • |
| KZ   | 440          | 80-83 | • |
| KZ   | 440 C        | 80-81 | • |
| KZ   | 440 C, Twin  | 81-83 | • |
| KZ   | 440 LTD      | 80-82 | • |
| Z    | 440 C        | 80-81 | • |
| Z    | 440 C, Twin  | 81-83 | • |
| Z    | 440 LTD      | 80-84 | • |
| ER-5 | 500          | 97-07 | • |
| EX   | 500          | 87-93 | • |
|      | 500          | 93-95 | • |
| GPZ  | 500 S        | 87-88 | • |

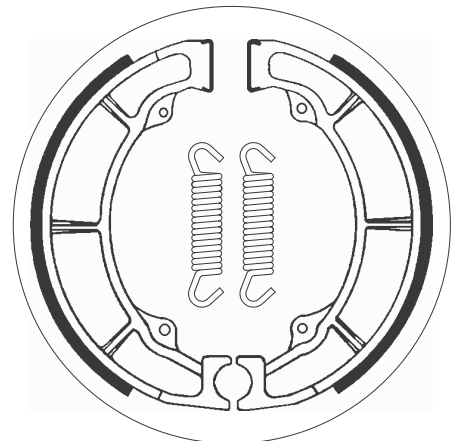

ø160x30

SBS 2038

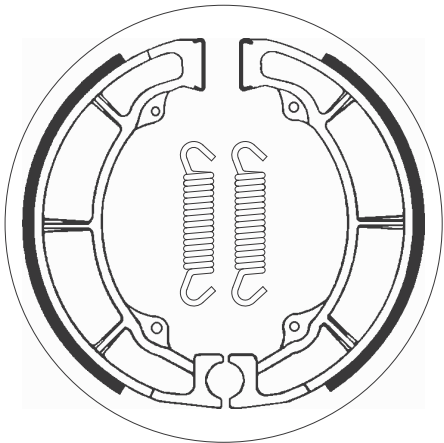

| KAWASAKI |                 |       |   |
|----------|-----------------|-------|---|
| PZ       | 500 S (Austria) | 87-93 | • |
| ZR       | 500 (Z 500 F)   | 83-87 | • |
| Z        | 550 F           | 83-88 | • |
| ZR       | 550 A1, GP      | 83-84 | • |
| W        | 650             | 99-05 | • |
|          |                 |       |   |
|          |                 |       |   |
|          |                 |       |   |
|          |                 |       |   |
|          |                 |       |   |
|          |                 |       |   |
|          |                 |       |   |
|          |                 |       |   |
|          |                 |       |   |
|          |                 |       |   |
|          |                 |       |   |
|          |                 |       |   |

ø120x28

SBS 2039

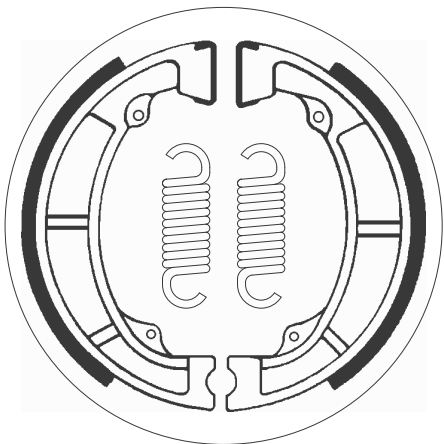

| KAWASAKI |                |       |   |
|----------|----------------|-------|---|
| KE       | 125            | 76-85 | • |
| KX       | 125            | 74-81 | • |
| KDX      | 175            | 80-82 | • |
| KE       | 175            | 76-83 | • |
| KL       | 250            | 80-84 | • |
| KLX      | 250            | 79-80 | • |
| KT       | 250 all models | 75-80 | • |
|          |                |       |   |
|          |                |       |   |
|          |                |       |   |
|          |                |       |   |
|          |                |       |   |
|          |                |       |   |
|          |                |       |   |
|          |                |       |   |
|          |                |       |   |
|          |                |       |   |
|          |                |       |   |
|          |                |       |   |
|          |                |       |   |

ø140x28

SBS 2040

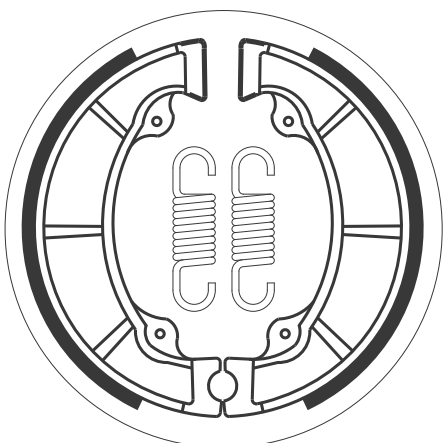

| KAWASAKI |             |       |   |
|----------|-------------|-------|---|
| KLF      | 185 Bayou   | 86-88 | • |
| KLT      | 200         | 81-84 | • |
| KLF      | 220 Bayou   | 88-02 | • |
| KDX      | 250         | 80-84 | • |
| KL       | 250         | 78-80 | • |
| KLT      | 250         | 82-83 | • |
| KLT      | 250 Police  | 84    | • |
| KLT      | 250 Prairie | 83-85 | • |
| KX       | 250         | 75-81 | • |
| KXT      | 250 Tecate  | 84    | • |
| KX       | 420         | 80-81 | • |
|          |             |       |   |
|          |             |       |   |
|          |             |       |   |
|          |             |       |   |
|          |             |       |   |
|          |             |       |   |
|          |             |       |   |
|          |             |       |   |
|          |             |       |   |
|          |             |       |   |
|          |             |       |   |
|          |             |       |   |
|          |             |       |   |

**SBS 2041**

ø130x25



| BOMBARDIER     |       |   |
|----------------|-------|---|
| 50 Quest       | 03-04 | • |
| DS 50          | 02-06 | • |
| 90 Quest       | 03-04 | • |
| DS 90          | 02-06 | • |
| CAN-AM         |       |   |
| DS 50          | 07-11 | • |
| DS 70          | 08-14 | • |
| DS 90          | 07-17 | • |
| HONDA          |       |   |
| TRX 70         | 86-87 | • |
| CB 125 S       | 84-85 | • |
| CG 125 E, F, J | 85-91 | • |
| CH 125 Spacy   | 94-01 | • |
| CR 125 R       | 79-81 | • |
| CR 125 RC      | 82    | • |
| CH 250 Elite   | 85-86 | • |



| HONDA          |       |   |
|----------------|-------|---|
| CH 250 Elite   | 87-90 | • |
| CH 250 Spacy,  |       |   |
| Freeway Fusion | 88-93 | • |
| CN 250         | 93-04 | • |
| CN 250 Spazio  | 88-89 | • |
| CR 250 R       | 81-82 | • |
| XL 250 R       | 82-83 | • |
| CR 480 R       | 82    | • |

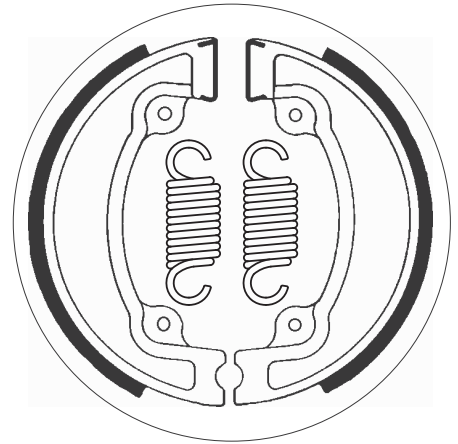

**SBS 2042**

ø130x22



| HONDA         |       |   |
|---------------|-------|---|
| CR 125 RD     | 83    | • |
| CR 125 RE, RF | 84-85 | • |
| MBX 125 RWB   | 84-86 | • |
| CR 250 R      | 83    | • |
| CR 250 RE, RF | 84-85 | • |
| XR 350 R      | 83    | • |
| CR 480 R      | 83    | • |
| CR 500 RE, RF | 84-85 | • |

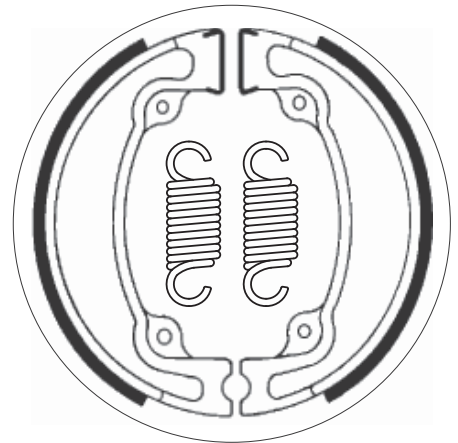

**SBS 2043**

ø86x20



| AEON        |       |   |
|-------------|-------|---|
| 100 Revo 2  | 04-06 | • |
| HONDA       |       |   |
| CR 80 R     | 86-91 | • |
| CR 80 RF    | 85    | • |
| MB 80       | 80-83 | • |
| POLARIS     |       |   |
| 90 Predator | 03-14 | • |

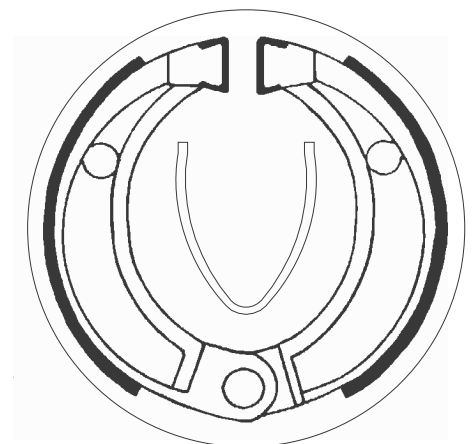

Dimensions in mm / Dimensions en mm  
1" = 25.4 mm , 1 mm = 0.04"

ø160x30

SBS 2044

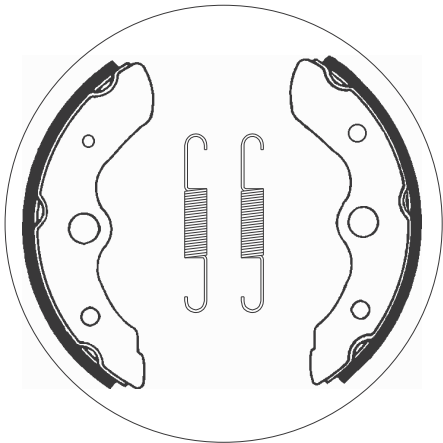

| HONDA |               |       |   |
|-------|---------------|-------|---|
| TRX   | 200           | 84    | • |
| TRX   | 250           | 85-87 | • |
| FL    | 350 R Odyssey | 85-87 | • |
| FL    | 400 R Pilot   | 89-90 | • |
|       |               |       |   |
|       |               |       |   |
|       |               |       |   |
|       |               |       |   |
|       |               |       |   |
|       |               |       |   |
|       |               |       |   |
|       |               |       |   |
|       |               |       |   |
|       |               |       |   |

ø160x30

SBS 2045

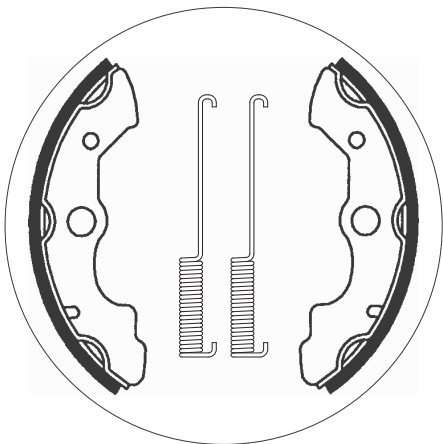

| HONDA |                |       |   |
|-------|----------------|-------|---|
| TRX   | 350 all models | 86-89 | • |
|       |                |       |   |
|       |                |       |   |
|       |                |       |   |
|       |                |       |   |
|       |                |       |   |
|       |                |       |   |
|       |                |       |   |
|       |                |       |   |
|       |                |       |   |
|       |                |       |   |
|       |                |       |   |
|       |                |       |   |
|       |                |       |   |

ø180x35

SBS 2046

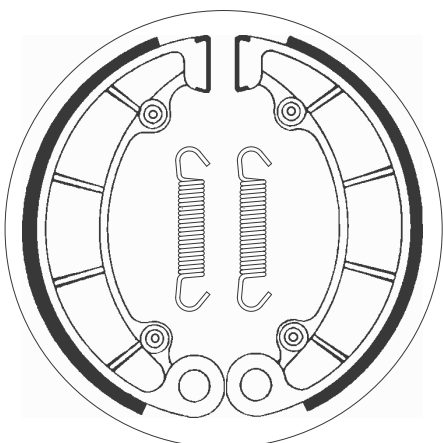

| HONDA |                   |       |   |
|-------|-------------------|-------|---|
| TRX   | 350 all models    | 86-89 | • |
| TRX   | 500 all models    | 05-14 | • |
| CB    | 700 SC            | 84-86 | • |
| VF    | 700 C Magna       | 85-87 | • |
| VT    | 700 C Shadow      | 86    | • |
| VT    | 700 C, Shadow     | 87    | • |
| VF    | 750 C, CD Magna   | 94-98 | • |
| VF    | 750 C, Magna      | 88-93 | • |
| VP    | 750 CH, Custom    | 87    | • |
| VT    | 750 Black Widow   | 01-03 | • |
| VT    | 750 C, Shadow     | 86-96 | • |
| VT    | 750 C2 Shadow     |       |   |
|       | A.C.E.            | 97-03 | • |
| VT    | 750 C2 Shadow     |       |   |
|       | Spirit            | 07-11 | • |
| VT    | 750 C4 Shadow     | 04-05 | • |
| PC    | 800 Pacific Coast | 89-97 | • |
| VT    | 800 C             | 88-94 | • |

| HONDA |               |       |   |
|-------|---------------|-------|---|
| VT    | 1000 C        | 88    | • |
| VT    | 1100 C Shadow | 87-96 | • |
|       |               |       |   |
|       |               |       |   |
|       |               |       |   |
|       |               |       |   |
|       |               |       |   |
|       |               |       |   |
|       |               |       |   |
|       |               |       |   |
|       |               |       |   |
|       |               |       |   |
|       |               |       |   |
|       |               |       |   |
|       |               |       |   |
|       |               |       |   |

Dimensions in mm / Dimensions en mm  
 1" = 25.4 mm , 1 mm = 0.04"





**SBS 2052**

ø180x36



**SUZUKI**

|      |                 |       |   |
|------|-----------------|-------|---|
| LT-F | 280 4WD         | 91-98 | • |
| LT-F | 300             | 88-90 | • |
| LT-F | 300 King Quad   | 91-01 | • |
| LT-F | 300 King Quad   |       |   |
|      | Left/Rear       | 02    | • |
| VS   | 600 GL Intruder | 97    | • |
| GV   | 700 GLG Madura  | 86    | • |
| VS   | 700 GLFG        | 86-87 | • |
| VS   | 750 Intruder    | 86-91 | • |
| C    | 800 Intruder    | 05-18 | • |
| C50  | 800 Boulevard   | 05-18 | • |
| M    | 800 Intruder    | 05-18 | • |
| M50  | 800 Boulevard   | 05-18 | • |
| S50  | 800 Boulevard   | 05-18 | • |
| VL   | 800 Intruder    |       |   |
|      | LC Volusia      | 01-04 | • |
| VS   | 800 Intruder    | 91-99 | • |
| VZ   | 800 Marauder    | 97-04 | • |

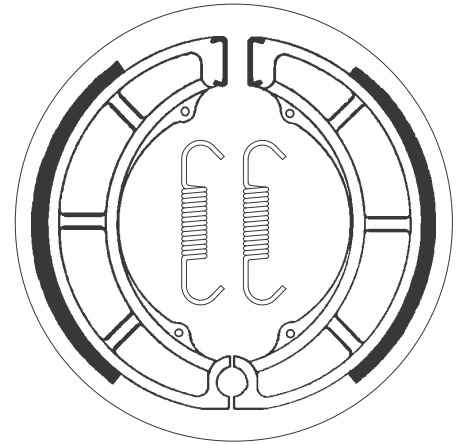

**SBS 2053**

ø165x32



**KAWASAKI**

|     |              |       |   |
|-----|--------------|-------|---|
| KAF | 300 Mule 500 | 92-95 | • |
| KAF | 300 Mule 550 | 03-05 | • |

**SUZUKI**

|      |                            |       |   |
|------|----------------------------|-------|---|
| LT   | 250 4WD                    | 87-98 | • |
| LT-F | 250                        | 88-01 | • |
| LT-F | 250 4WD V,<br>W Quadrunner | 97-98 | • |
|      |                            |       |   |
|      |                            |       |   |
|      |                            |       |   |
|      |                            |       |   |
|      |                            |       |   |
|      |                            |       |   |
|      |                            |       |   |
|      |                            |       |   |
|      |                            |       |   |
|      |                            |       |   |
|      |                            |       |   |
|      |                            |       |   |
|      |                            |       |   |
|      |                            |       |   |
|      |                            |       |   |
|      |                            |       |   |
|      |                            |       |   |

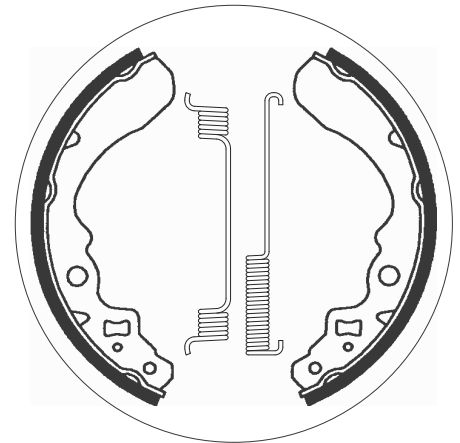

**SBS 2054**

ø160x30



**KAWASAKI**

|     |                  |       |   |
|-----|------------------|-------|---|
| KLF | 300 A1, A2 Bayou | 86-87 | • |
|-----|------------------|-------|---|

|  |  |  |  |
|--|--|--|--|
|  |  |  |  |
|  |  |  |  |
|  |  |  |  |
|  |  |  |  |
|  |  |  |  |
|  |  |  |  |
|  |  |  |  |
|  |  |  |  |
|  |  |  |  |
|  |  |  |  |
|  |  |  |  |
|  |  |  |  |
|  |  |  |  |
|  |  |  |  |
|  |  |  |  |
|  |  |  |  |
|  |  |  |  |
|  |  |  |  |
|  |  |  |  |
|  |  |  |  |
|  |  |  |  |

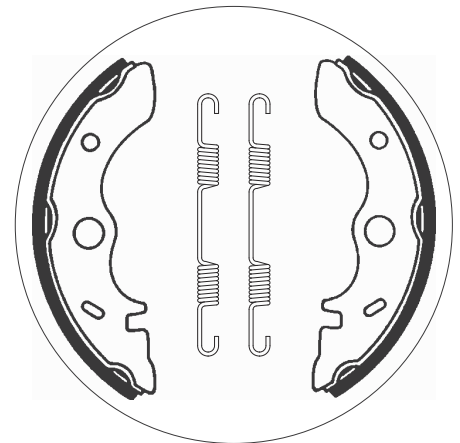

Dimensions in mm / Dimensions en mm  
1" = 25.4 mm , 1 mm = 0.04"



ø140x30

SBS 2055

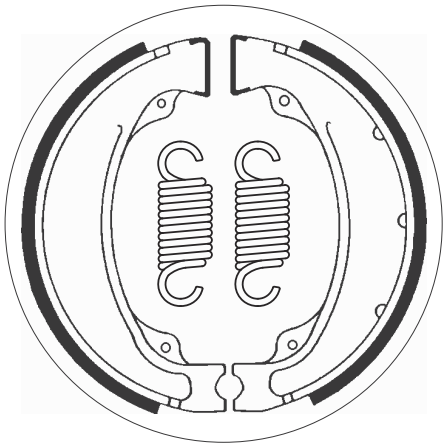

| HONDA |                 |       |   |
|-------|-----------------|-------|---|
| TRX   | 250 EX Sportrax | 01-08 | • |
| TRX   | 250 Recon       | 97-14 | • |
| TRX   | 250 X           | 08-13 | • |
| XBR   | 500 S           | 85-89 | • |
| XLV   | 750 R           | 83-88 | • |
|       |                 |       |   |
|       |                 |       |   |
|       |                 |       |   |
|       |                 |       |   |
|       |                 |       |   |
|       |                 |       |   |
|       |                 |       |   |
|       |                 |       |   |
|       |                 |       |   |

ø120x35

SBS 2056

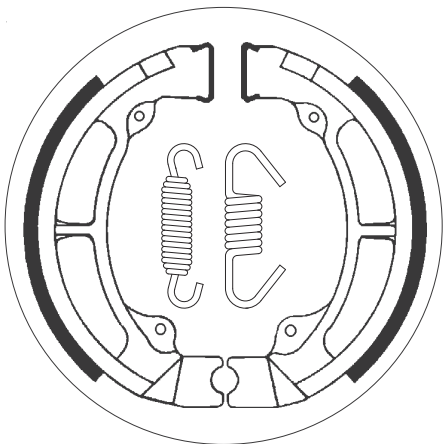

| KAWASAKI |               |       |   |
|----------|---------------|-------|---|
| KE       | 175           | 79-83 | • |
| KDX      | 200           | 83-85 | • |
| KL       | 250 (KLR 250) | 85-97 | • |
| KL       | 250           | 80-84 | • |
|          |               |       |   |
|          |               |       |   |
|          |               |       |   |
|          |               |       |   |
|          |               |       |   |
|          |               |       |   |
|          |               |       |   |
|          |               |       |   |
|          |               |       |   |
|          |               |       |   |

ø95x20

SBS 2057

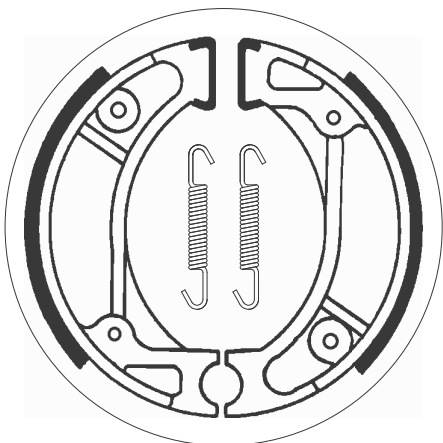

| BS VILLA |    |    |   |
|----------|----|----|---|
| ZX       | 50 | 93 | • |

| HONDA |                      |       |     |
|-------|----------------------|-------|-----|
|       | 50 Dio, Life         | 94-96 | • • |
|       | 50 Super Dio         |       |     |
|       | (Japan)              | 94-96 | • • |
| CH    | 50 P Metropolitan II | 02-06 | • • |
| CHF   | 50 Metropolitan      | 02-05 | • • |
| CR    | 50 RE, RF            | 84-85 | • • |
| GP    | 50 Dio               | 91    | • • |
| HSC   | 50 ZR, 01 Scooter    | 92-95 | • • |
| NPS   | 50 Zoomer            | 01-12 | • • |
| NU    | 50 MC Runaway,       |       |     |
|       | Express              | 82-83 | • • |
| PK    | 50 Walaroo DX-STD    | 90-01 | • • |
| QR    | 50                   | 93-03 | • • |
| SA    | 50 J Vision          | 88-94 | • • |
| SR    | 50 Dio               | 93    | • • |

| HONDA |              |       |     |
|-------|--------------|-------|-----|
| SR    | 50 Super Dio | 91-92 | • • |
| SZ    | 50 Tact S    | 93-96 | • • |
| TLM   | 50 F         | 85    | • • |
| ZX    | 50 Super Dio | 92-01 | • • |
| CR    | 60 RF, RG    | 85-86 | • • |
| CRF   | 70 F         | 04-14 | • • |
| XR    | 70           | 97-12 | • • |
| SA    | 75 Vision    | 89-92 | • • |
| CH    | 80 Elite     | 85-88 | • • |
| CR    | 80 RC        | 82    | • • |
| CR    | 80 RD, RE    | 83-84 | • • |
| CR    | 80 RF        | 85    | • • |
| CRF   | 80 F         | 04-14 | • • |
| NH    | 80 Aero      | 85    | • • |
| XR    | 80 R         | 85-88 | • • |
| CRF   | 100 F        | 04-14 | • • |
| XR    | 100 R        | 85-03 | • • |
| CRF   | 110 F        | 13-18 | • • |

**SBS 2057**

ø95x20



| <b>HONDA</b> |                |       |   |
|--------------|----------------|-------|---|
| CRF          | 125 F          | 14-18 | • |
| TLR          | 200 D, E, F    | 83-85 | • |
| TLR          | 200 G, H       | 86-87 | • |
| <b>KYMCO</b> |                |       |   |
| CX           | 50             | 94-97 | • |
| CX           | 50 Curio Super | 94-97 | • |
| DJ           | 50             | 99-02 | • |
| DJ           | 50 Refined     | 99-02 | • |
| DJW          | 50             | 94-97 | • |
| DJX          | 50             | 91-92 | • |
| DJY          | 50             | 93-06 | • |
| ZX           | 50 Fever       | 96-01 | • |
| <b>SYM</b>   |                |       |   |
|              | 50 Mio         | 05-16 | • |
| DD           | 50             | 02-12 | • |

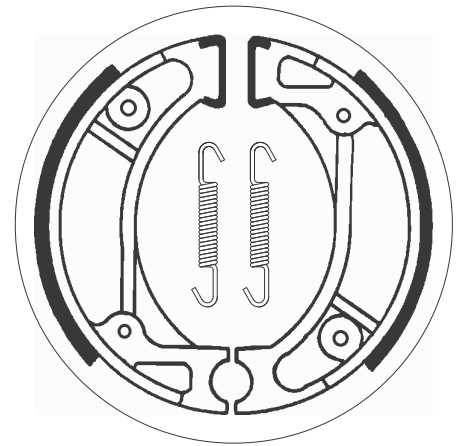

**SBS 2058**

ø140x40



| <b>HONDA</b> |                      |       |   |
|--------------|----------------------|-------|---|
| CA           | 250 Rebel            | 90-95 | • |
| CB           | 250                  | 88-05 | • |
| CB           | 250 N                | 78-81 | • |
| CB           | 250 NA, NB, T, TZ    | 77-81 | • |
| CM           | 250 TB               | 81    | • |
| CB           | 350 S.G. (U.K. only) | 87-90 | • |
| CB           | 400 A                | 77-81 | • |
| CB           | 400 Four             | 81-85 | • |
| CB           | 400 N                | 78-86 | • |
| CB           | 400 N, T, Hawk       | 78-82 | • |
| CB           | 400 T1, T2           | 77-78 | • |
| CB           | 400 Twin             | 82-86 | • |
| CM           | 400 A, T, TZ         | 79    | • |
| CM           | 400 C                | 81    | • |
| CM           | 400 E                | 80-81 | • |
| CM           | 400 T                | 79-84 | • |
| GB           | 400 T.T.             | 88-92 | • |
| CB           | 450 N                | 84-89 | • |



| <b>HONDA</b> |                  |       |   |
|--------------|------------------|-------|---|
| CB           | 450 S            | 86-88 | • |
| CB           | 450 SC Nighthawk | 82-86 | • |
| CB           | 450 T            | 82-86 | • |
| CM           | 450 A, C         | 82-86 | • |
| CMX          | 450 Rebel        | 86-88 | • |
| VT           | 500 C Shadow     | 83-86 | • |
| VT           | 500 E            | 83-85 | • |
| VT           | 500 ED           | 82    | • |
| CB           | 550 SC           | 83-84 | • |

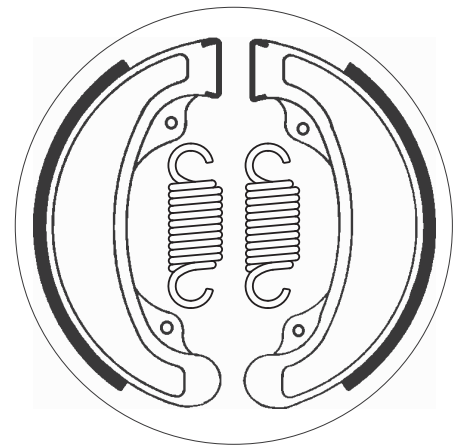

**SBS 2059**

ø160x40



| <b>HONDA</b> |                   |       |   |
|--------------|-------------------|-------|---|
| CB           | 500               | 94-96 | • |
| CX           | 500               | 78-80 | • |
| CX           | 500 C             | 81-82 | • |
| CX           | 500 Z, A, B       | 79-81 | • |
| GB           | 500 T.T.          | 88-92 | • |
| GL           | 500 D             | 81-82 | • |
| GL           | 500 I             | 81-82 | • |
| NV           | 600 C             | 88-96 | • |
| VT           | 600 C, Shadow     | 88-00 | • |
| VT           | 600 CD Shadow VLX | 94-00 | • |
| CB           | 650 SC Nighthawk  | 83-85 | • |
| CBX          | 650 E             | 83-90 | • |
| CBX          | 650 ED, SC, SCD   | 83    | • |
| CX           | 650 C             | 83-86 | • |
| GL           | 650 D             | 83-84 | • |
| VF           | 700 C Magna       | 84    | • |
| VF           | 700 S             | 84-85 | • |
| VT           | 700 C Shadow      | 84-85 | • |



| <b>HONDA</b> |               |       |   |
|--------------|---------------|-------|---|
| CB           | 750 Nighthawk | 91-02 | • |
| VF           | 750 C         | 82-84 | • |
| VF           | 750 S         | 85    | • |
| VF           | 750 Sport     | 82-83 | • |
| VT           | 750 C         | 83-85 | • |

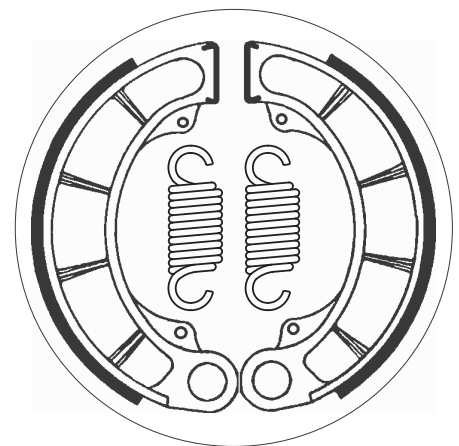

Dimensions in mm / Dimensions en mm  
1" = 25.4 mm , 1 mm = 0.04"

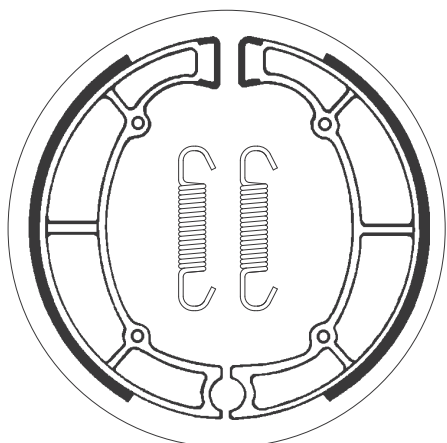

**KAWASAKI**

|    |                     |       |   |
|----|---------------------|-------|---|
| EN | 400 Twin            | 85-89 | • |
| Z  | 400 J               | 80-85 | • |
| Z  | 400 T (Belt Drive)  | 83-85 | • |
| EN | 450                 | 85-90 | • |
| Z  | 450 LTD             | 84-89 | • |
| EN | 500                 | 90-96 | • |
| EN | 500                 | 98-04 | • |
| EN | 500 Vulcan          | 96-97 | • |
| ZL | 500 (Austria)       | 85-90 | • |
| GT | 550                 | 85-01 | • |
| KZ | 550                 | 80-84 | • |
| KZ | 550 A1              | 80    | • |
| Z  | 550                 | 80-85 | • |
| Z  | 550 C3, LTD         | 82-84 | • |
| Z  | 550 GT              | 83-01 | • |
| Z  | 550 GT, LTD         | 82-85 | • |
| Z  | 550 LTD             | 81-85 | • |
| Z  | 550 M1, LTD         | 83-86 | • |
| ZL | 600                 | 85-91 | • |
| ZL | 600 B2 Eliminator   | 95-98 | • |
| KZ | 650                 | 77-84 | • |
| KZ | 650 F               | 81-84 | • |
| Z  | 650                 | 77-84 | • |
| Z  | 650 F               | 81-84 | • |
| VN | 700 Vulcan          | 85    | • |
|    | 750 Vulcan          | 93-94 | • |
| KZ | 750                 | 83-84 | • |
| KZ | 750 LTD             | 80-81 | • |
| KZ | 750 M1              | 82-85 | • |
| VN | 750 Vulcan          | 86-94 | • |
| VZ | 750 Twin            | 88    | • |
| Z  | 750                 | 83    | • |
| Z  | 750 LTD             | 80    | • |
| Z  | 750 M1              | 82-85 | • |
| VN | 800 Classic         | 98-99 | • |
| VN | 800 Vulcan Classic  | 96-06 | • |
| VN | 800 Vulcan, Classic | 95-97 | • |
|    |                     |       |   |
|    |                     |       |   |
|    |                     |       |   |
|    |                     |       |   |
|    |                     |       |   |
|    |                     |       |   |
|    |                     |       |   |
|    |                     |       |   |
|    |                     |       |   |
|    |                     |       |   |
|    |                     |       |   |

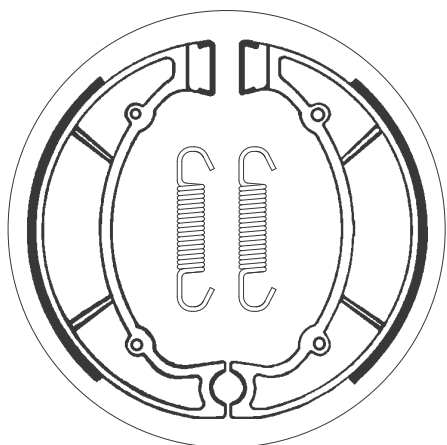

**YAMAHA**

|    |                 |       |   |
|----|-----------------|-------|---|
| XJ | 400 Maxim, Seca | 81    | • |
| XT | 400             | 86    | • |
| TX | 500 A, B        | 74-77 | • |
| XS | 500             | 75-77 | • |
| XV | 500 K, Virago   | 83    | • |
| XV | 500 SE          | 83    | • |
| XJ | 550 Maxim       | 81-83 | • |
| XZ | 550             | 82-84 | • |
| XZ | 550 RJ, RK      | 82-83 | • |
| XZ | 550 S           | 83-84 | • |
| YX | 600 Radian      | 87-90 | • |
| XV | 750 MK          | 83    | • |
| XV | 750 SE          | 81-83 | • |
|    |                 |       |   |
|    |                 |       |   |
|    |                 |       |   |
|    |                 |       |   |
|    |                 |       |   |
|    |                 |       |   |
|    |                 |       |   |
|    |                 |       |   |
|    |                 |       |   |
|    |                 |       |   |
|    |                 |       |   |

**SBS 2064**

ø180x30

**YAMAHA**

|       |                  |       |   |
|-------|------------------|-------|---|
| YDS-7 | 200              | 73-75 | • |
| RD    | 250              | 73-77 | • |
| RD    | 250 DX Left/Rear | 80    | • |
| RD    | 250 LC           | 80-82 | • |
| RD    | 350              | 73-79 | • |
| RD    | 350 LC           | 80-82 | • |
| XS    | 360 B            | 76    | • |
| XS    | 650              | 75-79 | • |
| XS    | 650 SJ, SK       | 82    | • |
|       |                  |       |   |
|       |                  |       |   |
|       |                  |       |   |
|       |                  |       |   |
|       |                  |       |   |
|       |                  |       |   |
|       |                  |       |   |

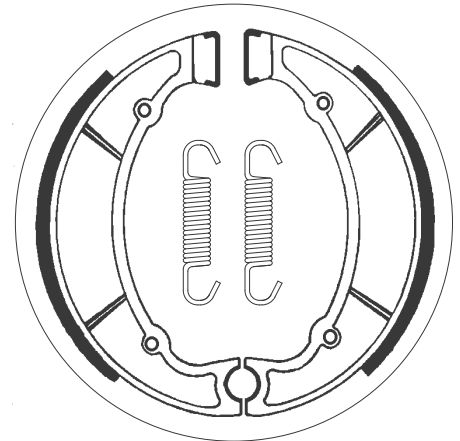
**SBS 2065**

ø200x40

**YAMAHA**

|     |                    |       |   |
|-----|--------------------|-------|---|
| XV  | 400 Virago, SPL    | 88    | • |
| XV  | 535 DX Virago      | 98-03 | • |
| XV  | 535 S Virago       | 96-03 | • |
| XV  | 535 Virago         | 87-97 | • |
| XJ  | 650                | 80-83 | • |
| XJ  | 650 G, H, SH       |       |   |
|     | Left/Rear          | 80-83 | • |
| XJ  | 650 Seca           | 81-83 | • |
| XJ  | 650 Turbo          | 81-82 | • |
| XVS | 650 A Drag Star    |       |   |
|     | Classic            | 98-06 | • |
| XVS | 650 Drag Star      | 97-06 | • |
| XVS | 650 V-Star Classic | 98-06 | • |
| XVS | 650 V-Star Custom  | 98-06 | • |
| XJ  | 700                | 86-89 | • |
| XV  | 700 L, LC          | 84-87 | • |
| XV  | 700 Virago         | 87    | • |
| TX  | 750                | 73-74 | • |

**YAMAHA**

|    |             |       |   |
|----|-------------|-------|---|
| VF | 750 Virago  | 88    | • |
| XJ | 750 E       | 81-83 | • |
| XJ | 750 Maxim   | 82    | • |
| XJ | 750 Seca    | 81-83 | • |
| XV | 750         | 89-92 | • |
| XV | 750 Virago  | 93-97 | • |
| XV | 920 J       | 82    | • |
| XV | 1000 SE     | 83-85 | • |
| XV | 1000 TR1    | 81-83 | • |
| XV | 1000 Virago | 86-88 | • |
| XV | 1100        | 94-97 | • |
| XV | 1100 Virago | 86-98 | • |
|    |             |       |   |
|    |             |       |   |
|    |             |       |   |
|    |             |       |   |

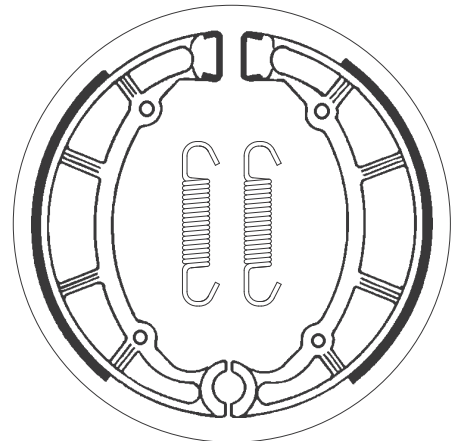
**SBS 2066**

ø160x30



**YAMAHA**

|     |                  |       |   |
|-----|------------------|-------|---|
| XS  | 250 C            | 81    | • |
| XS  | 250 D, E         | 79-80 | • |
| XS  | 250 SE, SF       | 80-81 | • |
| YP  | 250 Majesty      | 96-04 | • |
| YFM | 350 Big Bear     |       |   |
|     | Special Edition  | 99    | • |
| YFM | 350 FWB L,       |       |   |
|     | LC Big Bear      | 99    | • |
| YFM | 350 FWH, FWJ,    |       |   |
|     | FWK Big Bear     | 96-98 | • |
| YFM | 350 UH, UJ, UK   | 96-98 | • |
| XS  | 400              | 78-83 | • |
| XS  | 400              | 85    | • |
| XS  | 400 DOHC         | 82    | • |
| XS  | 400 SE Left/Rear | 80-81 | • |
| XS  | 400 SG, SH, SF   | 80-81 | • |
| YFM | 400 FAR Kodiak   |       |   |
|     | Automatic        | 03    | • |

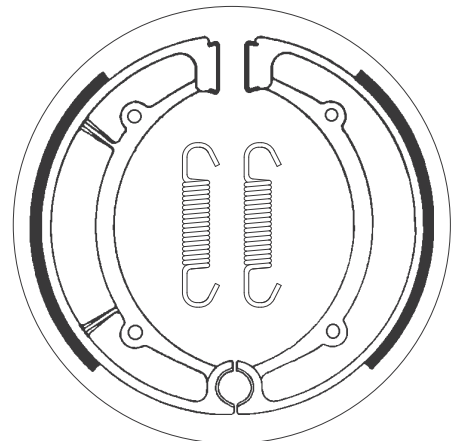

**YAMAHA**

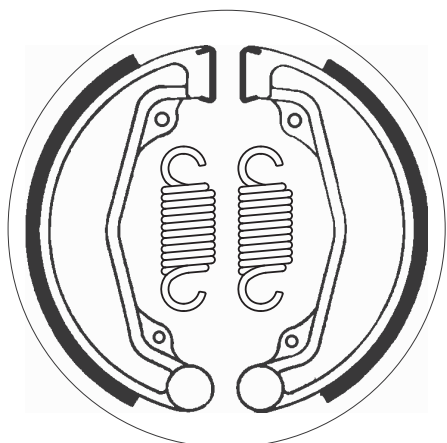
|     |                 |       |   |
|-----|-----------------|-------|---|
| YFM | 400 Kodiak      | 93-99 | • |
| XJ  | 500 (Austria)   | 81-83 | • |
| XJ  | 550 Seca        | 81-83 | • |
| YFM | 600 4x4 Grizzly | 98-01 | • |
|     |                 |       |   |
|     |                 |       |   |
|     |                 |       |   |
|     |                 |       |   |
|     |                 |       |   |
|     |                 |       |   |
|     |                 |       |   |



 Dimensions in mm / Dimensions en mm  
 1" = 25.4 mm , 1 mm = 0.04"

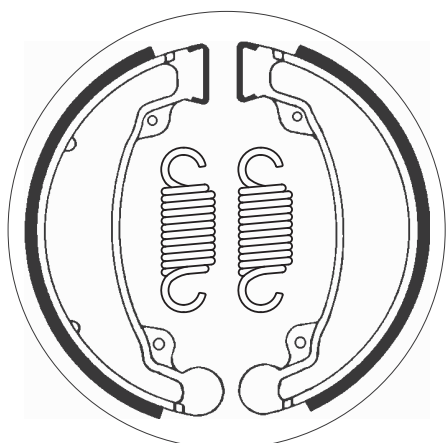

| HONDA |           |        |   |
|-------|-----------|--------|---|
| CB    | 175 K3-K7 | 74- 76 | • |
| CB    | 200 B, T  | 74- 79 | • |
| CB    | 250 RS    | 80- 85 | • |
| CL    | 250 SC    | 81     | • |
| VT    | 250 F     | 83- 90 | • |
| VTR   | 250       | 88- 90 | • |
| VTZ   | 250       | 88- 99 | • |
| XL    | 500 SB    | 81     | • |
|       |           |        |   |
|       |           |        |   |
|       |           |        |   |
|       |           |        |   |
|       |           |        |   |
|       |           |        |   |
|       |           |        |   |
|       |           |        |   |
|       |           |        |   |
|       |           |        |   |

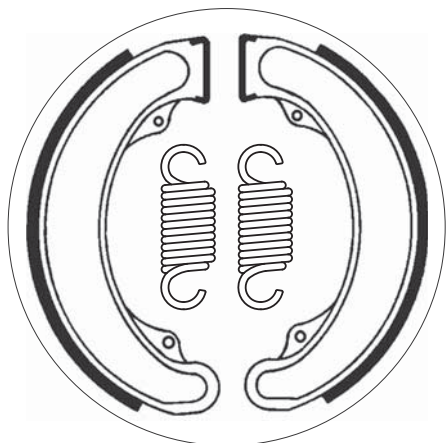

| DAELIM |                   |        |   | HONDA |               |        |   |
|--------|-------------------|--------|---|-------|---------------|--------|---|
|        | 50 Delfino        | 99     | • | CD    | 185 T         | 78- 82 | • |
|        | 50 Tapo           | 99- 04 | • | CM    | 185 T         | 78- 79 | • |
|        | 50 Vivo           | 99     | • | CD    | 200 T         | 79     | • |
|        | 100 Delfino       | 99- 04 | • | CM    | 200 TA, TB    | 80- 82 | • |
|        | 125 Rocket        | 99- 01 | • | CB    | 250 Nighthawk | 91- 02 | • |
| NS     | 125 II            | 00     | • | CD    | 250 UJ        | 88- 92 | • |
| VT     | 125 Evolution     | 00- 03 | • | CM    | 250 C         | 82- 83 | • |
|        |                   |        |   | CMX   | 250 C Rebel   | 96- 00 | • |
| HONDA  |                   |        |   | CMX   | 250 Rebel     | 85- 12 | • |
| ATC    | 70 all models     | 78- 85 | • |       |               |        |   |
| CB     | 125 RS            | 83     | • |       |               |        |   |
| CB     | 125 T             | 85     | • |       |               |        |   |
| CB     | 125 T, Superdream | 82- 83 | • |       |               |        |   |
| CB     | 125 T, T1, T2, TZ | 77- 81 | • |       |               |        |   |
| CB     | 125 TDC           | 83- 89 | • |       |               |        |   |
| CB     | 125 TT            | 90     | • |       |               |        |   |
| CD     | 125               | 82     | • |       |               |        |   |
| CM     | 125               | 82- 85 | • |       |               |        |   |



| HONDA |     |        |   |
|-------|-----|--------|---|
| XL    | 250 | 78- 79 | • |
| XL    | 350 | 76- 78 | • |
|       |     |        |   |
|       |     |        |   |
|       |     |        |   |
|       |     |        |   |
|       |     |        |   |
|       |     |        |   |
|       |     |        |   |
|       |     |        |   |
|       |     |        |   |
|       |     |        |   |
|       |     |        |   |
|       |     |        |   |
|       |     |        |   |
|       |     |        |   |
|       |     |        |   |

SBS 2071

ø180x30



| HONDA |           |       |   |
|-------|-----------|-------|---|
| CB    | 250 K3-K5 | 73-75 | • |
| CB    | 350 K4    | 74    | • |
| CM    | 400 E     | 80-81 | • |
|       |           |       |   |
|       |           |       |   |
|       |           |       |   |
|       |           |       |   |
|       |           |       |   |
|       |           |       |   |
|       |           |       |   |
|       |           |       |   |
|       |           |       |   |
|       |           |       |   |
|       |           |       |   |
|       |           |       |   |
|       |           |       |   |

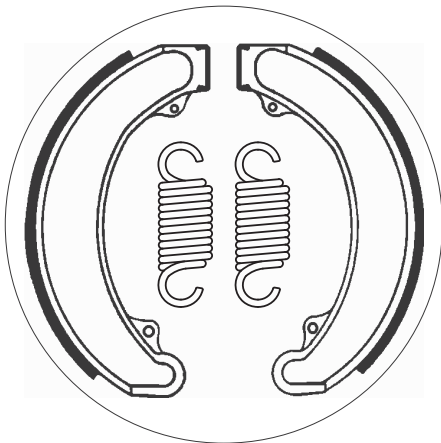

SBS 2072

ø180x30



| HONDA |                         |       |   |
|-------|-------------------------|-------|---|
| CB    | 450 K5, K6, K7          | 72-77 | • |
| CB    | 500 F                   | 72-75 | • |
| CB    | 500 T                   | 75-78 | • |
| TRX   | 500 Foreman,<br>Rubicon | 00-09 | • |
| CB    | 550 F                   | 75-79 | • |
| CB    | 550 K                   | 74-78 | • |
|       |                         |       |   |
|       |                         |       |   |
|       |                         |       |   |
|       |                         |       |   |
|       |                         |       |   |
|       |                         |       |   |
|       |                         |       |   |
|       |                         |       |   |
|       |                         |       |   |
|       |                         |       |   |
|       |                         |       |   |
|       |                         |       |   |

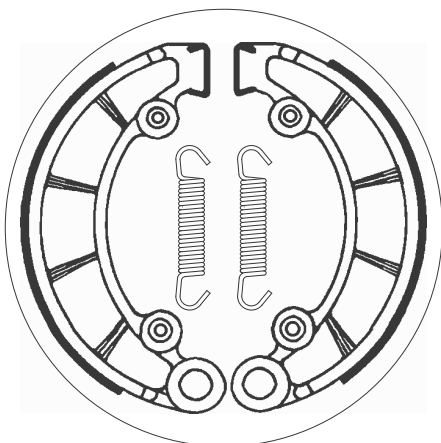

SBS 2074

ø80x18



| HONDA |            |       |     |
|-------|------------|-------|-----|
| PA    | 50         | 78-81 | •   |
| PA    | 50 Camino  | 80-86 | • • |
| PF    | 50 M Nocio | 75-80 | • • |
| PX    | 50         | 82-84 | • • |
| QA    | 50 K1-K3   | 87-89 | • • |
|       |            |       |     |
|       |            |       |     |
|       |            |       |     |
|       |            |       |     |
|       |            |       |     |
|       |            |       |     |
|       |            |       |     |
|       |            |       |     |
|       |            |       |     |
|       |            |       |     |
|       |            |       |     |
|       |            |       |     |
|       |            |       |     |
|       |            |       |     |

| KTM |                        |       |     |
|-----|------------------------|-------|-----|
| SX  | 50 Adventure           | 98-03 | • • |
| SX  | 50 Pro Junior LC       | 02-05 | • • |
| SX  | 50 Pro Senior LC       | 02-03 | • • |
| SX  | 50 Senior<br>Adventure | 04-07 | • • |
|     |                        |       |     |
|     |                        |       |     |
|     |                        |       |     |
|     |                        |       |     |
|     |                        |       |     |
|     |                        |       |     |
|     |                        |       |     |
|     |                        |       |     |
|     |                        |       |     |
|     |                        |       |     |
|     |                        |       |     |
|     |                        |       |     |
|     |                        |       |     |
|     |                        |       |     |

| MOTOBECANE |               |       |   |
|------------|---------------|-------|---|
|            | 50 all models | 88-89 | • |
|            |               |       |   |
|            |               |       |   |
|            |               |       |   |
|            |               |       |   |
|            |               |       |   |
|            |               |       |   |
|            |               |       |   |
|            |               |       |   |
|            |               |       |   |
|            |               |       |   |
|            |               |       |   |
|            |               |       |   |
|            |               |       |   |
|            |               |       |   |
|            |               |       |   |

| PEUGEOT |        |       |     |
|---------|--------|-------|-----|
|         | 50 103 | 71-75 | • • |
|         |        |       |     |
|         |        |       |     |
|         |        |       |     |
|         |        |       |     |
|         |        |       |     |
|         |        |       |     |
|         |        |       |     |
|         |        |       |     |
|         |        |       |     |
|         |        |       |     |
|         |        |       |     |
|         |        |       |     |
|         |        |       |     |
|         |        |       |     |
|         |        |       |     |



| PEUGEOT |        |    |     |
|---------|--------|----|-----|
|         | 50 104 | 76 | • • |
|         | 50 105 | 82 | • • |
|         |        |    |     |
|         |        |    |     |
|         |        |    |     |
|         |        |    |     |
|         |        |    |     |
|         |        |    |     |
|         |        |    |     |
|         |        |    |     |
|         |        |    |     |
|         |        |    |     |
|         |        |    |     |
|         |        |    |     |
|         |        |    |     |
|         |        |    |     |

  

| PUCH |                    |       |     |
|------|--------------------|-------|-----|
|      | 50 Cobra 6 GT, GTL | 80-84 | •   |
|      | 50 Maxi 30         |       |     |
|      | all models         |       |     |
|      | (excl. Spain)      | 69-80 | • • |
|      | 50 Maxi 40         |       |     |
|      | all models         | 69-80 | • • |
|      | 50 Monza 4 GP,     |       |     |
|      | all models         | 79-83 | • • |
|      | 50 Monza 4 SL      | 79    | • • |
|      | 50 Monza 4 SL, GSL | 80-83 | •   |
|      |                    |       |     |
|      |                    |       |     |
|      |                    |       |     |
|      |                    |       |     |
|      |                    |       |     |
|      |                    |       |     |
|      |                    |       |     |
|      |                    |       |     |
|      |                    |       |     |
|      |                    |       |     |
|      |                    |       |     |
|      |                    |       |     |
|      |                    |       |     |
|      |                    |       |     |

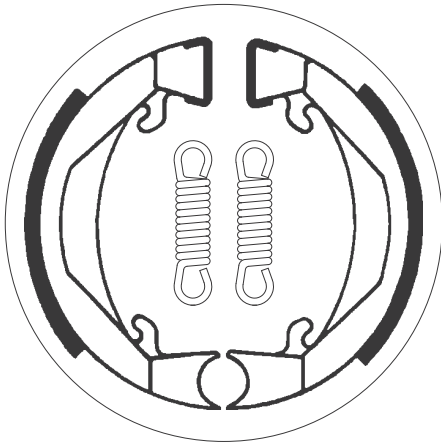

ø160x25

SBS 2075

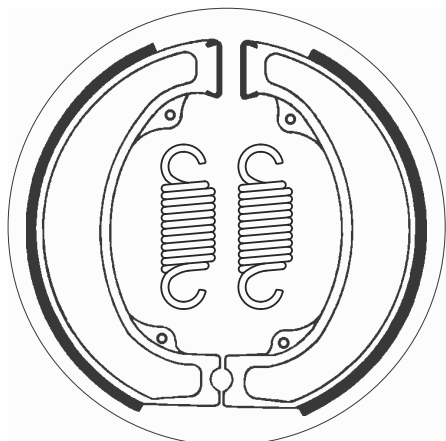

| HONDA |            |       |   |
|-------|------------|-------|---|
| CR    | 250 RZ, RA | 79-80 | • |
| XL    | 500 SB     | 81    | • |
|       |            |       |   |
|       |            |       |   |
|       |            |       |   |
|       |            |       |   |
|       |            |       |   |
|       |            |       |   |
|       |            |       |   |
|       |            |       |   |
|       |            |       |   |
|       |            |       |   |
|       |            |       |   |
|       |            |       |   |
|       |            |       |   |
|       |            |       |   |
|       |            |       |   |
|       |            |       |   |
|       |            |       |   |
|       |            |       |   |
|       |            |       |   |
|       |            |       |   |
|       |            |       |   |

ø130x25

SBS 2077

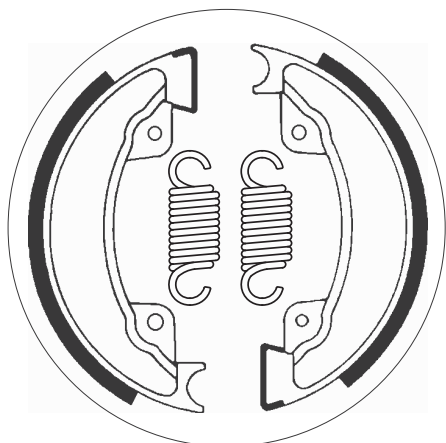

| HONDA |        |    |   |
|-------|--------|----|---|
| XLR   | 400    | 83 | • |
| XL    | 500 RC | 82 | • |
|       |        |    |   |
|       |        |    |   |
|       |        |    |   |
|       |        |    |   |
|       |        |    |   |
|       |        |    |   |
|       |        |    |   |
|       |        |    |   |
|       |        |    |   |
|       |        |    |   |
|       |        |    |   |
|       |        |    |   |
|       |        |    |   |
|       |        |    |   |
|       |        |    |   |
|       |        |    |   |
|       |        |    |   |
|       |        |    |   |
|       |        |    |   |
|       |        |    |   |

ø110x25

SBS 2080

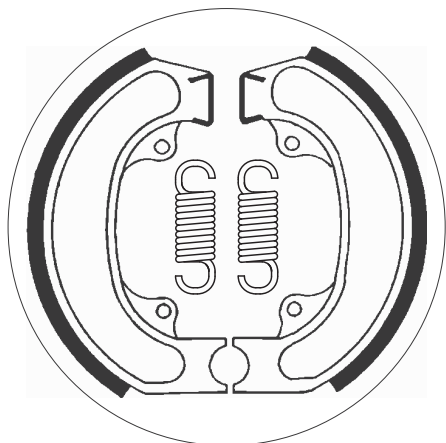

| HONDA |                 |       |   |
|-------|-----------------|-------|---|
| SH    | 50 City Express | 84-96 | • |
| SH    | 50 Scoopy       | 88-04 | • |
| SH    | 75 Scoopy       | 88-95 | • |
| SH    | 80 Scoopy       | 88-93 | • |
|       |                 |       |   |
|       |                 |       |   |
|       |                 |       |   |
|       |                 |       |   |
|       |                 |       |   |
|       |                 |       |   |
|       |                 |       |   |
|       |                 |       |   |
|       |                 |       |   |
|       |                 |       |   |
|       |                 |       |   |
|       |                 |       |   |
|       |                 |       |   |
|       |                 |       |   |
|       |                 |       |   |
|       |                 |       |   |
|       |                 |       |   |
|       |                 |       |   |
|       |                 |       |   |
|       |                 |       |   |
|       |                 |       |   |

**SBS 2082** **ø130x25**



| <b>HONDA</b> |                    |       |   |
|--------------|--------------------|-------|---|
| CH           | 250 Elite          | 85-86 | • |
| CH           | 250 Spacy          | 85-86 | • |
| CN           | 250 Helix (Fusion) | 92-03 | • |
|              |                    |       |   |
|              |                    |       |   |
|              |                    |       |   |
|              |                    |       |   |
|              |                    |       |   |
|              |                    |       |   |
|              |                    |       |   |

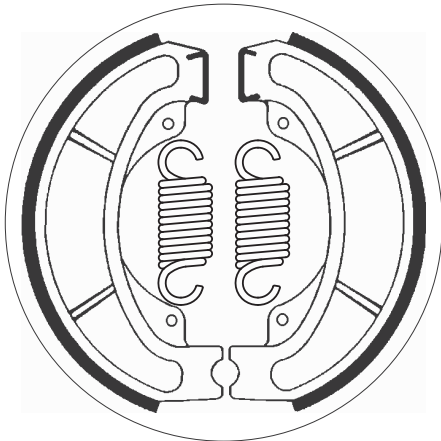

**SBS 2083** **ø130x26**



| <b>HONDA</b> |               |       |   |
|--------------|---------------|-------|---|
| TRX          | 200           | 90-91 | • |
| TRX          | 200 D Type II | 91-97 | • |
| TRX          | 200 SX        | 86-88 | • |
| TRX          | 250 Recon     | 97-14 | • |
|              |               |       |   |
|              |               |       |   |
|              |               |       |   |
|              |               |       |   |
|              |               |       |   |
|              |               |       |   |
|              |               |       |   |

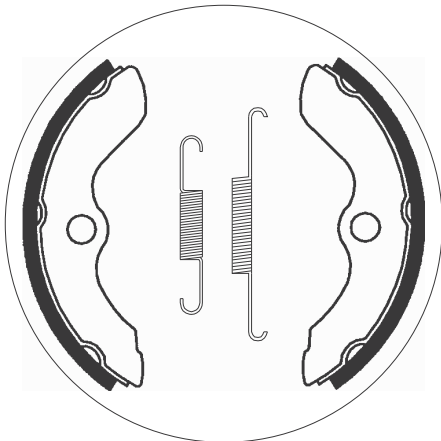

**SBS 2085** **ø160x21**



| <b>HONDA</b> |                           |       |   |
|--------------|---------------------------|-------|---|
| TRX          | 300 4WD                   | 88-00 | • |
| TRX          | 350 Rancher / ES 2x4, 4x4 | 00-09 | • |
| TRX          | 400 AT                    | 04-11 | • |
| TRX          | 400 FW Fourtrax Foreman   | 95-02 | • |
| TRX          | 450 Foreman ES, Foreman S | 98-04 | • |
| TRX          | 500 Foreman, Rubicon      | 00-09 | • |
| TRX          | 650 FA Rincon             | 03-05 | • |
| TRX          | 650 FGA Rincon            | 04-05 | • |
|              |                           |       |   |
|              |                           |       |   |
|              |                           |       |   |
|              |                           |       |   |

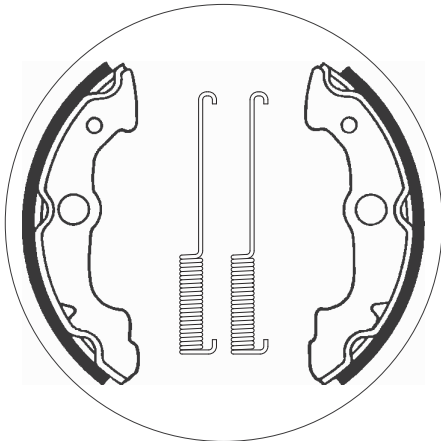



ø100x28

SBS 2087

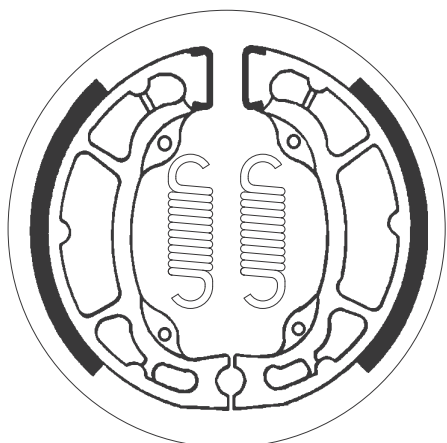

| KAWASAKI |    |        |     |
|----------|----|--------|-----|
| KX       | 80 | 79- 82 | • • |
|          |    |        |     |
|          |    |        |     |
|          |    |        |     |
|          |    |        |     |
|          |    |        |     |
|          |    |        |     |
|          |    |        |     |
|          |    |        |     |
|          |    |        |     |
|          |    |        |     |
|          |    |        |     |
|          |    |        |     |
|          |    |        |     |
|          |    |        |     |
|          |    |        |     |
|          |    |        |     |

ø180x30

SBS 2088

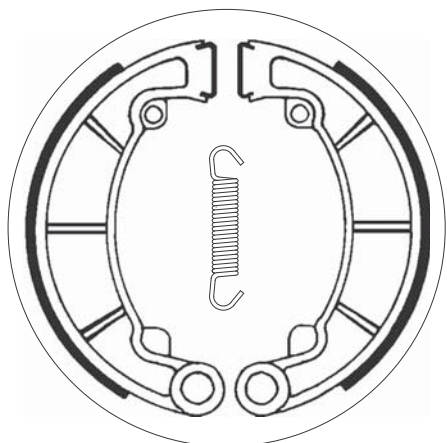

| KAWASAKI |     |        |   |
|----------|-----|--------|---|
| KH       | 250 | 76- 80 | • |
| S2A      | 350 | 73     | • |
| KH       | 400 | 76- 78 | • |
| KZ       | 400 | 74- 77 | • |
|          |     |        |   |
|          |     |        |   |
|          |     |        |   |
|          |     |        |   |
|          |     |        |   |
|          |     |        |   |
|          |     |        |   |
|          |     |        |   |
|          |     |        |   |
|          |     |        |   |
|          |     |        |   |
|          |     |        |   |
|          |     |        |   |
|          |     |        |   |
|          |     |        |   |

ø200x35

SBS 2091

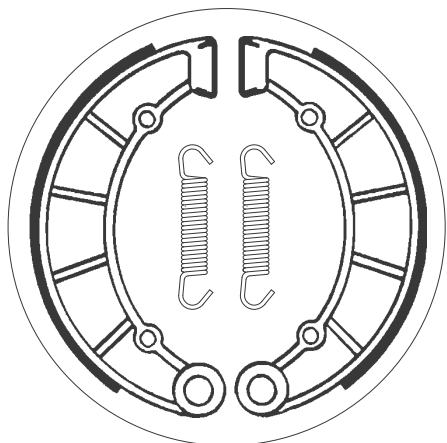

| KAWASAKI |                |        |   |
|----------|----------------|--------|---|
| KZ       | 750 H          | 72- 75 | • |
| Z        | 750 H          | 72- 75 | • |
| KZ       | 900            | 76- 77 | • |
| KZ       | 900 A          | 76- 77 | • |
| Z        | 900 A          | 76- 77 | • |
| Z1       | 900 Z1 A, Z1 B | 73- 75 | • |
|          |                |        |   |
|          |                |        |   |
|          |                |        |   |
|          |                |        |   |
|          |                |        |   |
|          |                |        |   |
|          |                |        |   |
|          |                |        |   |
|          |                |        |   |
|          |                |        |   |
|          |                |        |   |
|          |                |        |   |
|          |                |        |   |
|          |                |        |   |
|          |                |        |   |
|          |                |        |   |

**SBS 2092**

ø95x20



**KAWASAKI**

|    |    |    |   |  |
|----|----|----|---|--|
| KX | 80 | 83 | • |  |
|    |    |    |   |  |
|    |    |    |   |  |
|    |    |    |   |  |
|    |    |    |   |  |
|    |    |    |   |  |
|    |    |    |   |  |
|    |    |    |   |  |
|    |    |    |   |  |
|    |    |    |   |  |
|    |    |    |   |  |
|    |    |    |   |  |
|    |    |    |   |  |
|    |    |    |   |  |
|    |    |    |   |  |
|    |    |    |   |  |
|    |    |    |   |  |
|    |    |    |   |  |
|    |    |    |   |  |
|    |    |    |   |  |
|    |    |    |   |  |
|    |    |    |   |  |

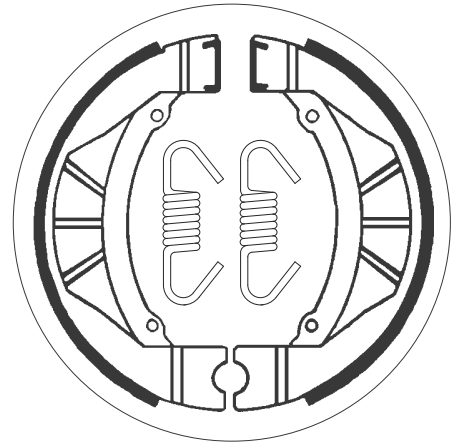

**SBS 2093**

ø90x20



**KAWASAKI**

|     |     |       |   |   |
|-----|-----|-------|---|---|
| KX  | 60  | 83-03 | • | • |
| KX  | 80  | 83-87 | • | • |
| KLX | 110 | 02-18 | • |   |

**SUZUKI**

|      |     |       |   |   |
|------|-----|-------|---|---|
| RM   | 60  | 03    | • | • |
| DR-Z | 110 | 02-06 | • |   |

|  |  |  |  |  |
|--|--|--|--|--|
|  |  |  |  |  |
|  |  |  |  |  |
|  |  |  |  |  |
|  |  |  |  |  |
|  |  |  |  |  |
|  |  |  |  |  |
|  |  |  |  |  |
|  |  |  |  |  |
|  |  |  |  |  |
|  |  |  |  |  |
|  |  |  |  |  |
|  |  |  |  |  |
|  |  |  |  |  |
|  |  |  |  |  |
|  |  |  |  |  |
|  |  |  |  |  |
|  |  |  |  |  |
|  |  |  |  |  |
|  |  |  |  |  |
|  |  |  |  |  |
|  |  |  |  |  |
|  |  |  |  |  |

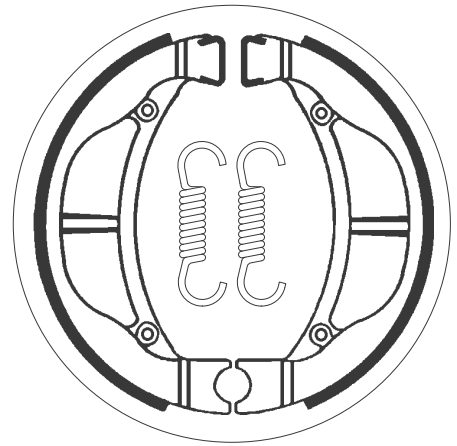

**SBS 2094**

ø100x25



**SUZUKI**

|     |       |       |   |   |
|-----|-------|-------|---|---|
| FZ  | 50    | 79-83 | • | • |
| S   | 50 K  | 93    | • | • |
| TS  | 50    | 84-02 | • | • |
| TSW | 50    | 91    | • | • |
| CS  | 80 CD | 83-85 | • | • |
| TS  | 80 X  | 84-87 | • | • |

|  |  |  |  |  |
|--|--|--|--|--|
|  |  |  |  |  |
|  |  |  |  |  |
|  |  |  |  |  |
|  |  |  |  |  |
|  |  |  |  |  |
|  |  |  |  |  |
|  |  |  |  |  |
|  |  |  |  |  |
|  |  |  |  |  |
|  |  |  |  |  |
|  |  |  |  |  |
|  |  |  |  |  |
|  |  |  |  |  |
|  |  |  |  |  |
|  |  |  |  |  |
|  |  |  |  |  |
|  |  |  |  |  |
|  |  |  |  |  |
|  |  |  |  |  |
|  |  |  |  |  |
|  |  |  |  |  |
|  |  |  |  |  |

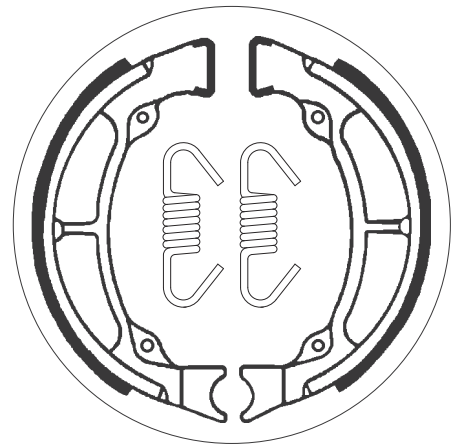

Dimensions in mm / Dimensions en mm  
1" = 25.4 mm , 1 mm = 0.04"

ø180x28

SBS 2097

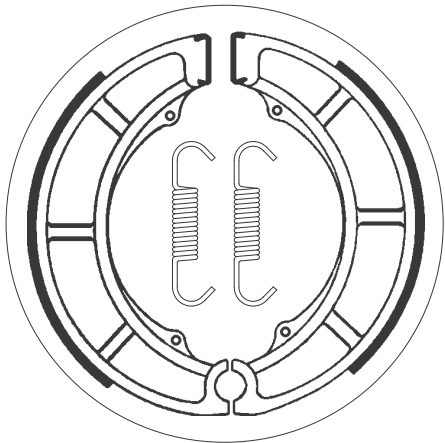

**SUZUKI**

|     |               |       |   |
|-----|---------------|-------|---|
| GT  | 250           | 73-78 | • |
| GT  | 380           | 73-77 | • |
| GT  | 380 Asco      | 77    | • |
| GS  | 400           | 77-82 | • |
| GSX | 400           | 81-83 | • |
| GSX | 400 S, Katana | 83-86 | • |
|     |               |       |   |
|     |               |       |   |
|     |               |       |   |
|     |               |       |   |
|     |               |       |   |
|     |               |       |   |
|     |               |       |   |
|     |               |       |   |
|     |               |       |   |
|     |               |       |   |

ø180x40

SBS 2098

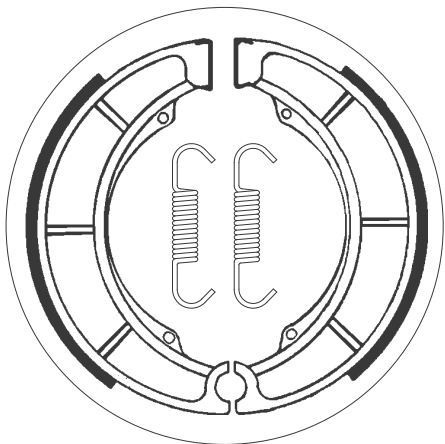

**SUZUKI**

|      |                            |       |   |
|------|----------------------------|-------|---|
| RE   | 5M, A                      | 75-77 | • |
| LT   | 250                        | 85-86 | • |
| LT-F | 250 4WD V,<br>W Quadrunner | 97-98 | • |
| LT   | 300                        | 87-89 | • |
| GT   | 500                        | 73-77 | • |
| GT   | 550                        | 73-77 | • |
| GT   | 750                        | 73-77 | • |
|      |                            |       |   |
|      |                            |       |   |
|      |                            |       |   |
|      |                            |       |   |
|      |                            |       |   |
|      |                            |       |   |
|      |                            |       |   |
|      |                            |       |   |
|      |                            |       |   |
|      |                            |       |   |

ø180x32

SBS 2099

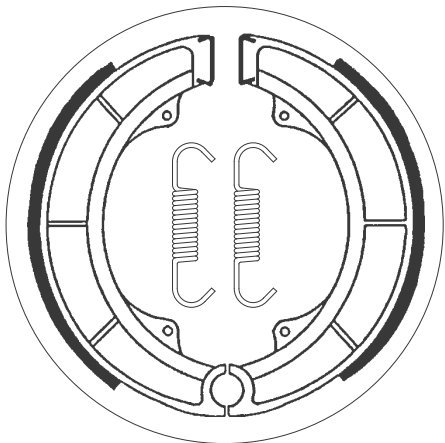

**SUZUKI**

|    |     |    |   |
|----|-----|----|---|
| GS | 550 | 77 | • |
| GT | 550 | 78 | • |
|    |     |    |   |
|    |     |    |   |
|    |     |    |   |
|    |     |    |   |
|    |     |    |   |
|    |     |    |   |
|    |     |    |   |
|    |     |    |   |
|    |     |    |   |
|    |     |    |   |
|    |     |    |   |
|    |     |    |   |
|    |     |    |   |
|    |     |    |   |

**SBS 2101**

ø80x20



**SUZUKI**

|      |                  |       |     |
|------|------------------|-------|-----|
| CL   | 50 D, Suzi, Love | 83    | •   |
| FA   | 50               | 80-91 | • • |
| FS   | 50 Snip          | 80-81 | • • |
| LT-A | 50 Quadmaster    | 01-05 | •   |
| LT-Z | 50 Quadsport     | 06-17 | •   |
| LT   | 80               | 87-06 | •   |
|      |                  |       |     |
|      |                  |       |     |
|      |                  |       |     |
|      |                  |       |     |
|      |                  |       |     |
|      |                  |       |     |
|      |                  |       |     |
|      |                  |       |     |
|      |                  |       |     |
|      |                  |       |     |
|      |                  |       |     |
|      |                  |       |     |
|      |                  |       |     |
|      |                  |       |     |
|      |                  |       |     |

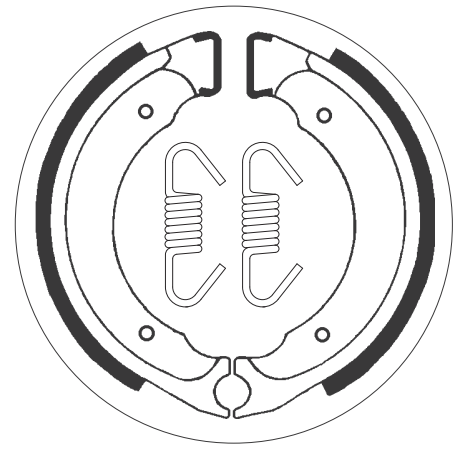

**SBS 2102**

ø120x22



**SUZUKI**

|    |     |       |   |
|----|-----|-------|---|
| RM | 125 | 81-87 | • |
| RM | 250 | 81-83 | • |
|    |     |       |   |
|    |     |       |   |
|    |     |       |   |
|    |     |       |   |
|    |     |       |   |
|    |     |       |   |
|    |     |       |   |
|    |     |       |   |
|    |     |       |   |
|    |     |       |   |
|    |     |       |   |
|    |     |       |   |
|    |     |       |   |
|    |     |       |   |
|    |     |       |   |
|    |     |       |   |
|    |     |       |   |

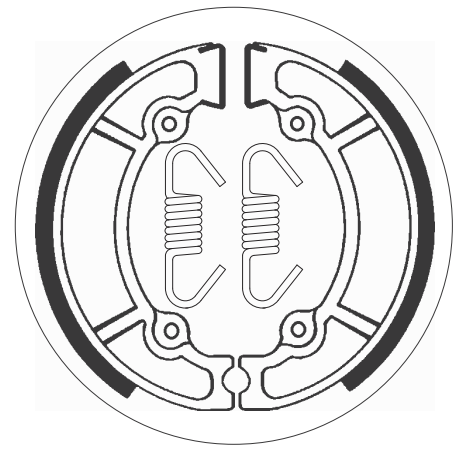

**SBS 2103**

ø120x28



**SUZUKI**

|     |          |       |   |
|-----|----------|-------|---|
|     | 50 Wolf  | 89-94 | • |
| RG  | 50 GAG   | 87-92 | • |
| RG  | 50 Gamma | 90-96 | • |
| S   | 50 K     | 93    | • |
| TS  | 50       | 84-02 | • |
| TSW | 50       | 91    | • |
| TV  | 50 Wolf  | 89-91 | • |
| TS  | 80 X     | 84-87 | • |
| RM  | 100      | 79-81 | • |
| RM  | 125      | 79-80 | • |
| TS  | 125      | 85-89 | • |
| TS  | 240 X    | 85-90 | • |
|     |          |       |   |
|     |          |       |   |
|     |          |       |   |
|     |          |       |   |
|     |          |       |   |
|     |          |       |   |
|     |          |       |   |
|     |          |       |   |
|     |          |       |   |
|     |          |       |   |
|     |          |       |   |
|     |          |       |   |
|     |          |       |   |
|     |          |       |   |
|     |          |       |   |
|     |          |       |   |

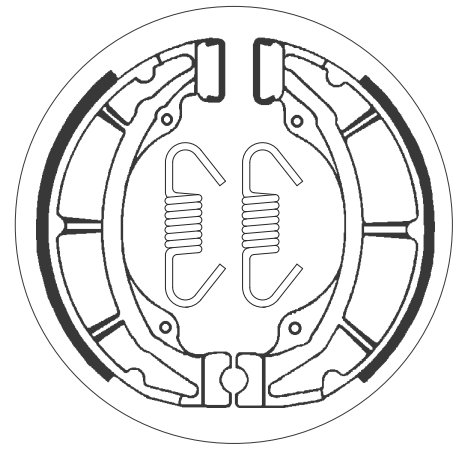

Dimensions in mm / Dimensions en mm  
1" = 25.4 mm , 1 mm = 0.04"

ø130x22

SBS 2104

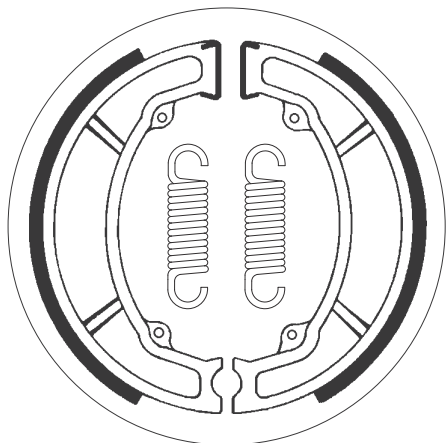

**SUZUKI**

|      |              |       |   |
|------|--------------|-------|---|
| LT   | 80           | 87-06 | • |
| LT-Z | 90 QuadSport | 07-14 | • |
| PE   | 175          | 82    | • |
| RM   | 250          | 80    | • |
| RM   | 250          | 84-86 | • |
| RM   | 400          | 80    | • |
|      |              |       |   |
|      |              |       |   |
|      |              |       |   |
|      |              |       |   |
|      |              |       |   |
|      |              |       |   |
|      |              |       |   |

ø150x22

SBS 2107

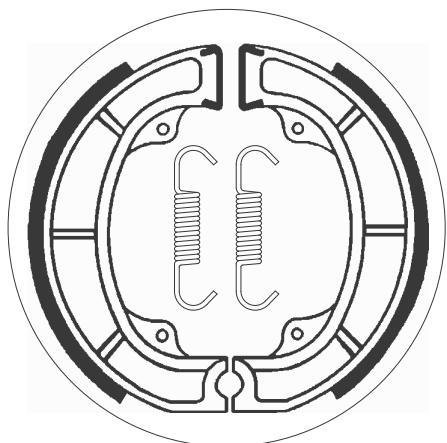

**SUZUKI**

|     |       |       |   |
|-----|-------|-------|---|
| ALT | 125 D | 83    | • |
| LT  | 125 D | 83    | • |
| RM  | 250   | 81-82 | • |
| RM  | 465   | 81-82 | • |
|     |       |       |   |
|     |       |       |   |
|     |       |       |   |
|     |       |       |   |
|     |       |       |   |
|     |       |       |   |
|     |       |       |   |
|     |       |       |   |

ø130x22

SBS 2108

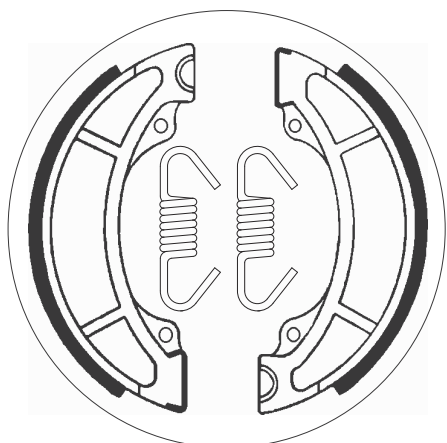

**SUZUKI**

|    |     |       |   |
|----|-----|-------|---|
| RM | 125 | 84    | • |
| RM | 250 | 83-84 | • |
| RM | 500 | 83-84 | • |
|    |     |       |   |
|    |     |       |   |
|    |     |       |   |
|    |     |       |   |
|    |     |       |   |
|    |     |       |   |
|    |     |       |   |
|    |     |       |   |
|    |     |       |   |

**SBS 2110**

ø165x28



| SUZUKI |         |       |   |
|--------|---------|-------|---|
| LT     | 250 4WD | 87-98 | • |
| LT-F   | 250     | 88-01 | • |
|        |         |       |   |
|        |         |       |   |
|        |         |       |   |
|        |         |       |   |
|        |         |       |   |
|        |         |       |   |
|        |         |       |   |
|        |         |       |   |
|        |         |       |   |
|        |         |       |   |
|        |         |       |   |
|        |         |       |   |
|        |         |       |   |
|        |         |       |   |
|        |         |       |   |
|        |         |       |   |
|        |         |       |   |
|        |         |       |   |

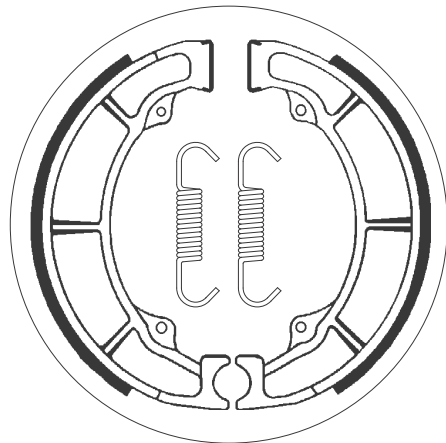

**SBS 2111**

ø160x30



| SUZUKI |            |    |   |
|--------|------------|----|---|
| DR     | 750 S, Big | 88 | • |
|        |            |    |   |
|        |            |    |   |
|        |            |    |   |
|        |            |    |   |
|        |            |    |   |
|        |            |    |   |
|        |            |    |   |
|        |            |    |   |
|        |            |    |   |
|        |            |    |   |
|        |            |    |   |
|        |            |    |   |
|        |            |    |   |
|        |            |    |   |
|        |            |    |   |
|        |            |    |   |
|        |            |    |   |
|        |            |    |   |
|        |            |    |   |

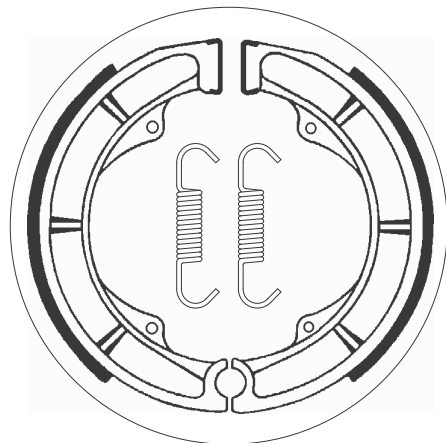

**SBS 2112**

ø80x17



| MBK    |                  |       |     |
|--------|------------------|-------|-----|
| 50     | Champ            | 91    | • • |
| YAMAHA |                  |       |     |
| CA     | 50 Riva Salient  | 83-86 | •   |
| CG     | 50 A, B Riva Jog | 90-91 | •   |
| JOG    | 50 E             | 88-90 | •   |
| MA     | 50 M, QT 50      | 80-86 | • • |
| MJ     | 50 J,M Towny     | 82    | • • |
| MJ     | 50 M Towny       | 81-93 | • • |
| MS     | 50               | 85-86 | •   |
| PW     | 50               | 80-87 | • • |
| PW     | 50               | 90-95 | • • |
| PW     | 50 H1            | 96-18 | • • |
| QA     | 50 Pocke         | 83-85 | • • |
| QB     | 50 Vogel         | 83-85 | • • |
| QT     | 50 Yamahopper    | 79-87 | • • |
| SA     | 50 M, ME Passola | 80-84 | •   |
| SH     | 50 E, F Razz     | 93-95 | •   |



| YAMAHA |                                  |       |   |
|--------|----------------------------------|-------|---|
| SH     | 50 Mint                          | 93-96 | • |
| SH     | 50 T,EMT,U,MU,W,<br>MW,A,MA,B,D, |       |   |
|        | MD                               | 87-93 | • |
|        |                                  |       |   |
|        |                                  |       |   |
|        |                                  |       |   |
|        |                                  |       |   |
|        |                                  |       |   |
|        |                                  |       |   |
|        |                                  |       |   |
|        |                                  |       |   |
|        |                                  |       |   |
|        |                                  |       |   |
|        |                                  |       |   |
|        |                                  |       |   |
|        |                                  |       |   |
|        |                                  |       |   |
|        |                                  |       |   |
|        |                                  |       |   |
|        |                                  |       |   |
|        |                                  |       |   |

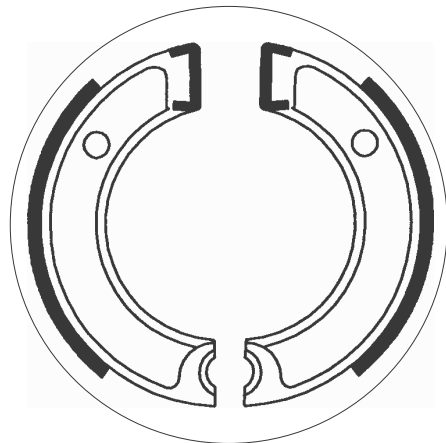

Dimensions in mm / Dimensions en mm  
1" = 25.4 mm , 1 mm = 0.04"

ø180x30

SBS 2113

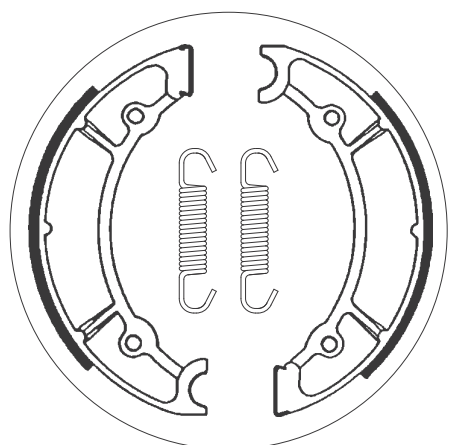

**YAMAHA**

|       |          |       |   |
|-------|----------|-------|---|
| RD    | 200 A, B | 74-75 | • |
| YDS-7 | 200      | 73-75 | • |
| XS    | 250 C    | 81    | • |
| XS    | 400      | 78-81 | • |

ø160x30

SBS 2114

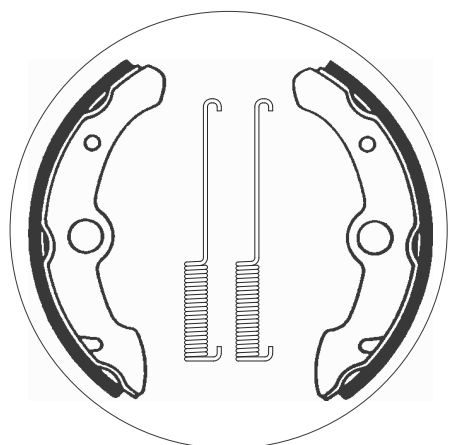

**YAMAHA**

|     |              |       |   |
|-----|--------------|-------|---|
| YFM | 350 FWT,     |       |   |
|     | FWU Big Bear | 87-88 | • |

ø130x28

SBS 2115

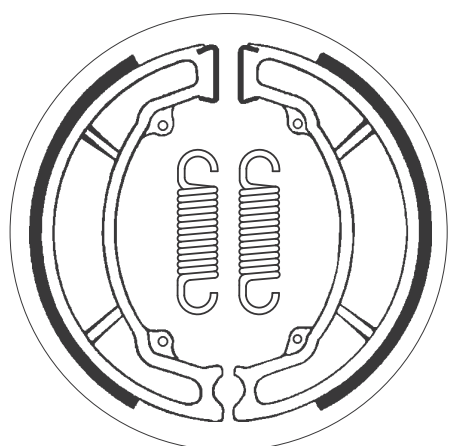

**YAMAHA**

|    |                  |       |   |
|----|------------------|-------|---|
| BL | 125 Beluga       | 88-93 | • |
| XC | 125 Beluga, Riva | 87-92 | • |
| XC | 125 E, F Riva    | 93-95 | • |
| XC | 180 Cygnus, Riva | 83-85 | • |
| XC | 200 Riva         | 87-91 | • |

**SBS 2116**

ø162x25



| HUSQVARNA |            |           |     |
|-----------|------------|-----------|-----|
|           | all models | 72-79     | • • |
|           | all models | 87-88     | •   |
|           | all models | TE,TC,WR, |     |
|           | CR,AE      | 89        | •   |
| CR        | 125        | 83-84     | •   |
| CR/RL     | 125        | 81-82     | •   |
| WR        | 125        | 80        | •   |
| XC        | 125        | 85        | •   |
| CR        | 250        | 81-84     | •   |
| WR/OR     | 250        | 80        | •   |
| WR/OR     | 390        | 80        | •   |
| WRX       | 400        | 85        | •   |
|           | 430 Enduro | 85-88     | •   |
| CR        | 430        | 82        | •   |
| WR        | 430        | 87-89     | •   |
| CR        | 500        | 83-84     | •   |
| CX/CR     | 500        | 84-85     | •   |

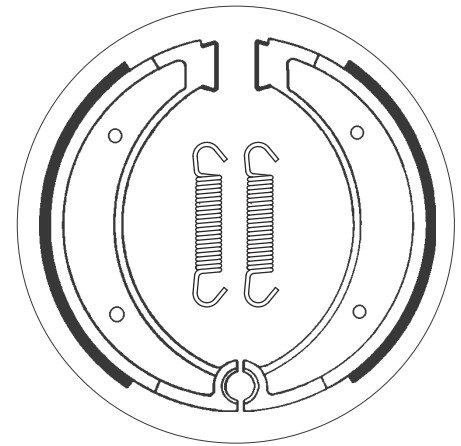

**SBS 2117**

ø160x30



| HUSQVARNA |            |       |     |
|-----------|------------|-------|-----|
|           | all rear   |       |     |
|           | drum       |       |     |
|           | models     | 86    | •   |
| CR        | 125        | 85-90 | •   |
| CR/RL     | 125        | 81-82 | •   |
| WR        | 125        | 80    | •   |
| WR        | 125        | 85-90 | •   |
| WR/XC     | 125        | 82    | • • |
| WR/XC     | 125        | 83-84 | •   |
| CR        | 250        | 81-82 | •   |
| CR        | 250        | 85-87 | •   |
| WR/OR     | 250        | 80    | •   |
| WR/XC     | 250        | 81-82 | • • |
| WR/XC     | 250        | 83-84 | •   |
| WR/OR     | 390        | 80    | •   |
| WR/XC     | 390        | 82    | • • |
|           | 400 Enduro | 85-88 | •   |
| WR        | 400        | 87-88 | •   |



| HUSQVARNA |          |       |     |
|-----------|----------|-------|-----|
|           | 430 Auto | 87    | •   |
| CR        | 430      | 82    | •   |
| CR        | 430      | 87-89 | •   |
| CR/WR/CS  | 430      | 81    | • • |
| XC        | 430      | 87-88 | •   |
| CR        | 500      | 86-87 | •   |
| TC        | 500      | 86    | •   |
| WR/XC/AE  | 500      | 83-84 | •   |
| XC        | 500      | 87-88 | •   |
|           | 504      | 83    | •   |
|           | 510      | 87-89 | •   |
| TE        | 510      | 86-87 | •   |

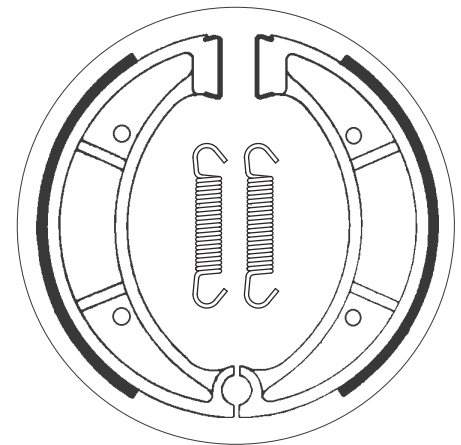

**SBS 2118**

ø160x25



| HUSQVARNA |     |       |   |
|-----------|-----|-------|---|
| CR        | 125 | 83-84 | • |
| WR/XC     | 125 | 83-84 | • |
| CR        | 250 | 83-84 | • |
| WR/XC     | 250 | 83-84 | • |
| WRX       | 400 | 85    | • |
| CR        | 500 | 83-84 | • |
| WR/XC/AE  | 500 | 83-84 | • |

| KTM |           |    |   |
|-----|-----------|----|---|
|     | 250 Cross | 83 | • |
|     | 500 Cross | 82 | • |

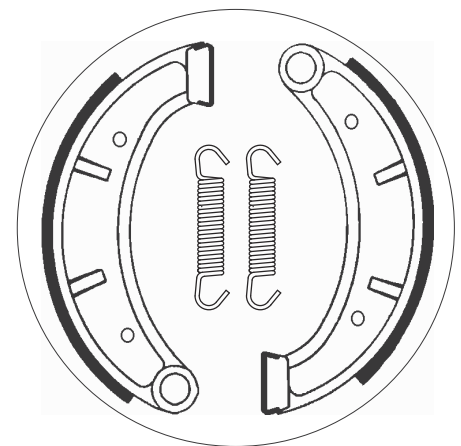

Dimensions in mm / Dimensions en mm  
1" = 25.4 mm , 1 mm = 0.04"



ø130x30

SBS 2120

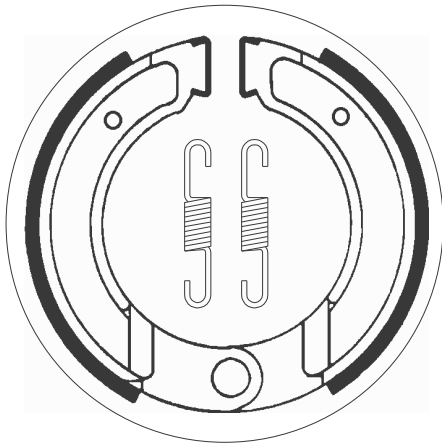

| KTM |           |       |     |
|-----|-----------|-------|-----|
|     | 40 Comet  | 91-95 | • • |
|     | 125       | 83    | • • |
| GS  | 125       | 83    | •   |
| LL  | 125       | 83    | •   |
|     | 175       | 72-78 | • • |
|     | 175       | 79-82 | •   |
|     | 250 Cross | 80-81 | • • |
|     |           |       |     |
|     |           |       |     |
|     |           |       |     |
|     |           |       |     |
|     |           |       |     |
|     |           |       |     |
|     |           |       |     |
|     |           |       |     |
|     |           |       |     |
|     |           |       |     |
|     |           |       |     |
|     |           |       |     |
|     |           |       |     |

ø181x25

SBS 2121

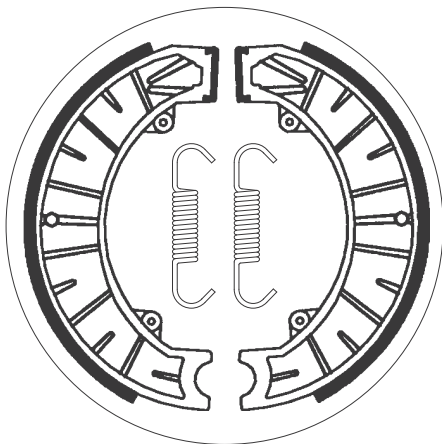

| KTM |                   |       |     |
|-----|-------------------|-------|-----|
|     | 175               | 79-82 | •   |
|     | 250 Cross         | 82    | • • |
|     | 250 Cross         | 83    | •   |
|     | 350 GS            | 83-85 | •   |
|     | 390 GS            | 83    | •   |
| MC  | 495 Leleu         | 82-83 | •   |
| MX  | 495 Leleu         | 82-83 | •   |
|     | 500 Cross         | 82    | •   |
| GS  | 500 500 K4 Enduro | 83    | •   |
|     |                   |       |     |
|     |                   |       |     |
|     |                   |       |     |
|     |                   |       |     |
|     |                   |       |     |
|     |                   |       |     |
|     |                   |       |     |
|     |                   |       |     |
|     |                   |       |     |
|     |                   |       |     |
|     |                   |       |     |
|     |                   |       |     |
|     |                   |       |     |
|     |                   |       |     |
|     |                   |       |     |

ø130x22

SBS 2122

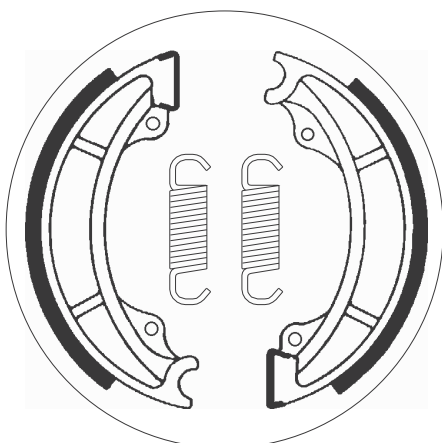

| ATK |                  |       |     |
|-----|------------------|-------|-----|
| ATK | 560              | 84-85 | •   |
| KTM |                  |       |     |
| MX  | 80               | 86-90 | •   |
| GS  | 125              | 83    | •   |
| GS  | 125              | 84-85 | • • |
| LL  | 125              | 83    | •   |
| MX  | 125              | 84    | • • |
| MX  | 125              | 85    | •   |
| XC  | 125              | 85    | •   |
|     | 250 Baja         | 86-89 | •   |
|     | 250 Country,Baja | 85    | •   |
| GS  | 250              | 83-85 | • • |
| MX  | 250              | 84    | • • |
| MX  | 250              | 85    | •   |
| GS  | 300              | 85    | • • |
| MX  | 300              | 85-89 | •   |
| XC  | 300 (Drum vers.) | 85    | • • |

| KTM |                     |       |     |
|-----|---------------------|-------|-----|
| XC  | 300                 | 85    | •   |
|     | 350 Country Cross   | 85    | •   |
|     | 350 GS (Drum vers.) | 83-85 | • • |
|     | 390 GS (Drum vers.) | 83    | • • |
| GS  | 420                 | 84-87 | • • |
| MX  | 495                 | 84    | • • |
| LC  | 500                 | 85    | •   |
| MX  | 500                 | 83-84 | • • |
| MX  | 500                 | 85    | •   |
| GS  | 600                 | 84    | • • |
| GS  | 600                 | 85    | •   |
|     |                     |       |     |
|     |                     |       |     |
|     |                     |       |     |
|     |                     |       |     |
|     |                     |       |     |
|     |                     |       |     |
|     |                     |       |     |
|     |                     |       |     |
|     |                     |       |     |
|     |                     |       |     |
|     |                     |       |     |
|     |                     |       |     |
|     |                     |       |     |
|     |                     |       |     |
|     |                     |       |     |

Dimensions in mm / Dimensions en mm  
1" = 25.4 mm , 1 mm = 0.04"

**SBS 2139**

ø200x30



| <b>BMW</b> |            |       |   |
|------------|------------|-------|---|
| R45        | 450        | 78-80 | • |
| R60        | 600 Series | 74-80 | • |
| R60/7      | 600        | 76-77 | • |
| R65        | 650        | 78-80 | • |
| R70        | 700 Series | 74-80 | • |
| R75/6      | 750        | 74-76 | • |
| R75/7      | 750        | 76-77 | • |
| R80        | 800        | 81    | • |
| R80/7      | 800        | 77-78 | • |
| R90        | 900 S      | 73-76 | • |
| R90        | 900 Series | 74-80 | • |
| R90/6      | 900        | 73-76 | • |
| R100       | 1000       | 79-81 | • |
| R100       | 1000 S     | 76-77 | • |
| R100/7     | 1000       | 78-80 | • |
|            |            |       |   |
|            |            |       |   |

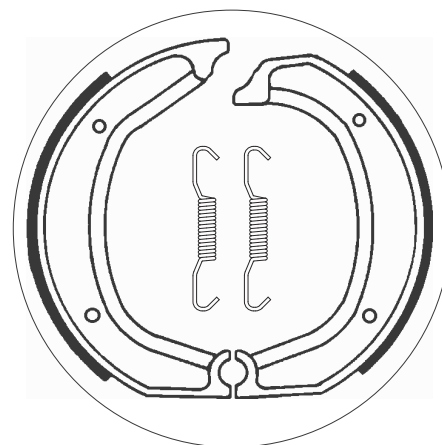

**SBS 2140**

ø200x25



| <b>BMW</b> |                 |       |   |
|------------|-----------------|-------|---|
| R45        | 450             | 80-85 | • |
| R65        | 650             | 80    | • |
| R65        | 650 GS          | 87-92 | • |
| K75        | 750 C           | 85-88 | • |
| R75        | 750             | 86    | • |
|            | 800 Touring     | 87    | • |
| R80        | 800             | 77-88 | • |
| R80        | 800 G/S P.-D.   | 86    | • |
| R80        | 800 GS          | 81-87 | • |
| R80        | 800 GS          | 91-92 | • |
| R80        | 800 GS Mystic   | 91-95 | • |
| R80        | 800 RT          | 83    | • |
| R80        | 800 RT          | 85    | • |
| R100       | 1000 all models | 81-84 | • |
| R100       | 1000 GS         | 87-94 | • |
| R100       | 1000 GS Mystic  | 91-94 | • |
|            |                 |       |   |
|            |                 |       |   |

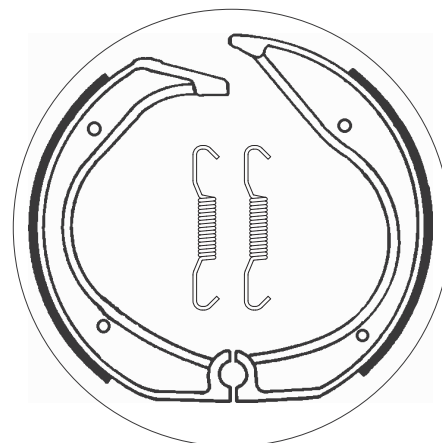

**SBS 2141**

ø220x25



| <b>BMW</b> |        |       |   |
|------------|--------|-------|---|
| R65        | 650 LS | 82-85 | • |
|            |        |       |   |
|            |        |       |   |
|            |        |       |   |
|            |        |       |   |
|            |        |       |   |
|            |        |       |   |
|            |        |       |   |
|            |        |       |   |
|            |        |       |   |
|            |        |       |   |
|            |        |       |   |
|            |        |       |   |
|            |        |       |   |

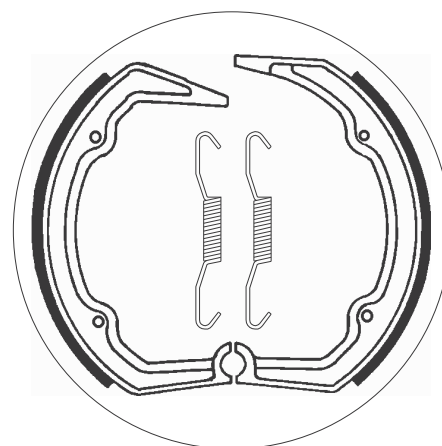

Dimensions in mm / Dimensions en mm  
1" = 25.4 mm , 1 mm = 0.04"

ø200x27

SBS 2143

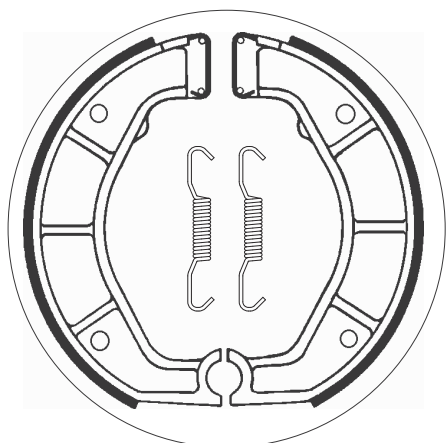

**BMW**

|      |         |       |   |
|------|---------|-------|---|
| R80  | 800 R   | 93-94 | • |
| R100 | 1000 R  | 92-95 | • |
| R100 | 1000 RT | 91-95 | • |
|      |         |       |   |
|      |         |       |   |
|      |         |       |   |
|      |         |       |   |
|      |         |       |   |
|      |         |       |   |
|      |         |       |   |
|      |         |       |   |
|      |         |       |   |
|      |         |       |   |
|      |         |       |   |

ø150x24

SBS 2146

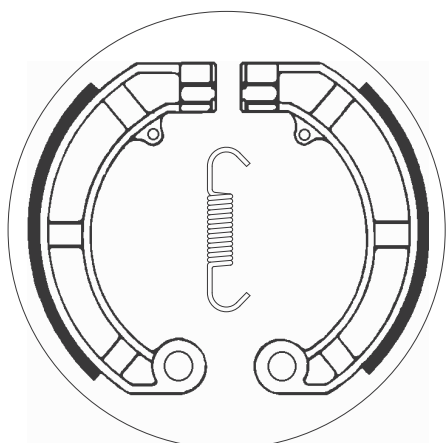

**PIAGGIO VESPA**

|    |                   |       |   |   |
|----|-------------------|-------|---|---|
|    | 50 HP             | 92-97 | • | • |
|    | 50 V FL2          | 90    | • | • |
| PK | 50                | 83-98 | • | • |
| PK | 50 Special        | 83-98 | • | • |
| PK | 50 XL             | 86-98 | • | • |
| PK | 50 XL 2           | 86-98 | • | • |
| PK | 125               | 83-89 | • | • |
| PK | 125 Automatica    | 84-89 | • | • |
| PK | 125 Special       | 83-89 | • | • |
| PK | 125 XL            | 86-89 | • | • |
| PX | 125               | 78-89 | • | • |
| PX | 125 Arcobalenco   | 83-89 | • | • |
|    | 150 Sprint Veloce | 75-80 | • | • |
| PX | 150               | 78-82 | • | • |
| PX | 150 Arcobalenco   | 83-88 | • | • |
| GS | 160               | 75-80 | • | • |
| SS | 180               | 75-80 | • | • |
|    | 200 Rally         | 75-80 | • | • |

**PIAGGIO VESPA**

|    |                 |       |   |   |
|----|-----------------|-------|---|---|
| PE | 200             | 83-88 | • | • |
| PX | 200 Arcobalenco | 83-85 | • | • |
| PX | 200 E           | 78-85 | • | • |
|    |                 |       |   |   |
|    |                 |       |   |   |
|    |                 |       |   |   |
|    |                 |       |   |   |
|    |                 |       |   |   |
|    |                 |       |   |   |
|    |                 |       |   |   |
|    |                 |       |   |   |
|    |                 |       |   |   |
|    |                 |       |   |   |
|    |                 |       |   |   |
|    |                 |       |   |   |

ø160x30

SBS 2171

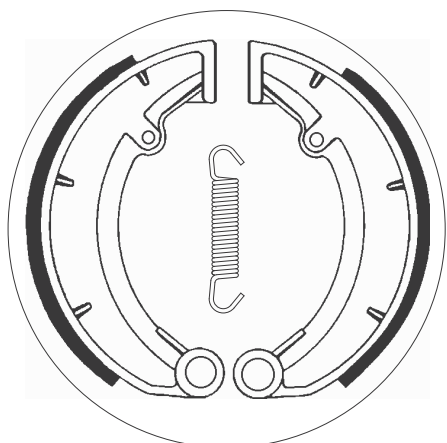

**MZ**

|     |     |       |   |   |
|-----|-----|-------|---|---|
| TS  | 125 | 73-85 | • | • |
| TS  | 150 | 73-85 | • | • |
| ETZ | 250 | 82-84 | • | • |
| ETZ | 250 | 85-92 | • | • |
| TS  | 250 | 73-81 | • | • |
|     |     |       |   |   |
|     |     |       |   |   |
|     |     |       |   |   |
|     |     |       |   |   |
|     |     |       |   |   |
|     |     |       |   |   |
|     |     |       |   |   |
|     |     |       |   |   |
|     |     |       |   |   |
|     |     |       |   |   |
|     |     |       |   |   |

**SBS 2172**

ø150x30



| <b>MZ</b> |     |       |   |
|-----------|-----|-------|---|
| ETZ       | 125 | 82-84 | • |
| ETZ       | 125 | 85-92 | • |
| TS        | 125 | 73-85 | • |
| ETZ       | 150 | 82-84 | • |
| ETZ       | 150 | 85-92 | • |
| TS        | 150 | 73-85 | • |
|           |     |       |   |
|           |     |       |   |
|           |     |       |   |
|           |     |       |   |
|           |     |       |   |
|           |     |       |   |
|           |     |       |   |
|           |     |       |   |

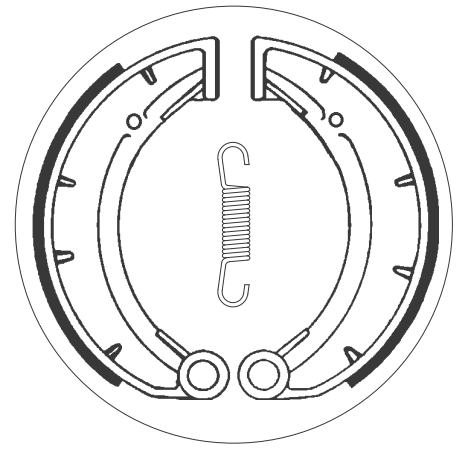

**SBS 2177**

ø170x27



| <b>YAMAHA</b> |                |       |   |
|---------------|----------------|-------|---|
| YFU1TW        | 250 Pro Hauler | 89    | • |
| YFU1W         | 250 Pro Hauler | 89-90 | • |
| YFP           | 350 U Terrapro | 88    | • |
|               |                |       |   |
|               |                |       |   |
|               |                |       |   |
|               |                |       |   |
|               |                |       |   |
|               |                |       |   |
|               |                |       |   |
|               |                |       |   |
|               |                |       |   |

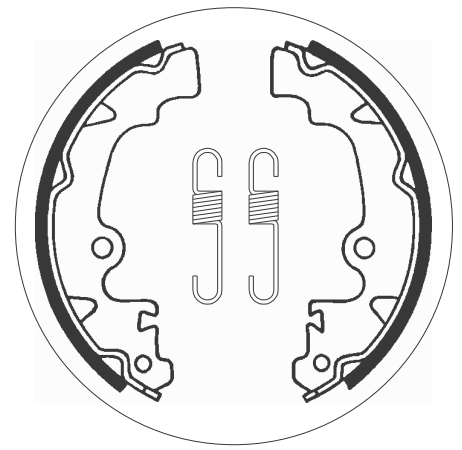

**SBS 2178**

ø160x25



| <b>YAMAHA</b> |                                    |       |   |
|---------------|------------------------------------|-------|---|
| YFM           | 350 Big Bear<br>Special<br>Edition | 99    | • |
| YFM           | 350 FWH, FWJ,<br>FWK Big Bear      | 96-98 | • |
| YFM           | 350 FWW,<br>FWA-G<br>Big Bear      | 89-95 | • |
| YFM           | 350 UH, UJ, UK                     | 96-98 | • |
| YFM           | 400 Kodiak                         | 93-99 | • |
|               |                                    |       |   |
|               |                                    |       |   |
|               |                                    |       |   |
|               |                                    |       |   |
|               |                                    |       |   |
|               |                                    |       |   |

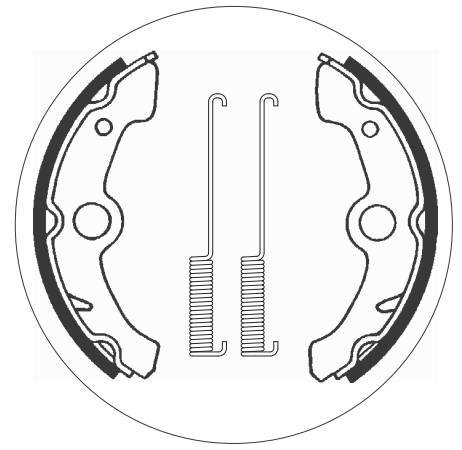

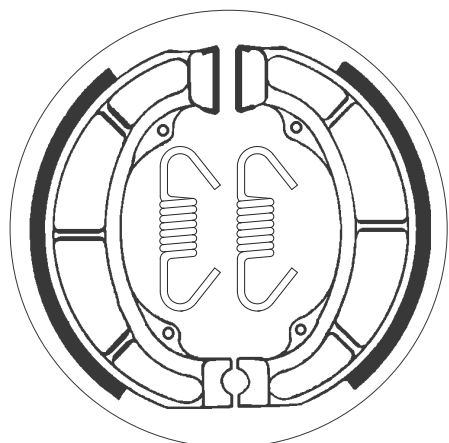

| <b>ATALA</b> |       |   |  |
|--------------|-------|---|--|
| 50 Hacker    | 95-00 | • |  |

| <b>CAGIVA</b> |    |   |  |
|---------------|----|---|--|
| 50 Mantis     | 99 | • |  |

| <b>DERBI</b>  |       |   |  |
|---------------|-------|---|--|
| 50 Atlantis   | 99-08 | • |  |
| 50 Easy       | 96-98 | • |  |
| 50 Hunter     | 97-99 | • |  |
| 50 Manhattan  | 99    | • |  |
| 50 Vamos FL   | 95-99 | • |  |
| 50 Vamos L    | 95    | • |  |
| ST 50 Paddock | 96-99 | • |  |

| <b>HUSQVARNA</b> |    |   |  |
|------------------|----|---|--|
| WRS 50           | 98 | • |  |

| <b>PGO</b> |       |   |  |
|------------|-------|---|--|
| 150 T-Rex  | 01-06 | • |  |

| <b>SUZUKI</b>   |       |   |   |
|-----------------|-------|---|---|
| 50 Lido Scooter | 89-94 | • | • |
| AH 50 Adress    | 92-95 | • |   |

**SUZUKI**

|                        |       |   |   |
|------------------------|-------|---|---|
| AJ 50 Sepia            | 92-96 | • |   |
| AY 50 , Katana         | 96-08 | • |   |
| CP 50 CHF              | 85    | • | • |
| UF 50 Estilete         | 00-02 | • |   |
| UX 50 W Zillion        | 99-02 | • |   |
| ZZ 50 Scooter          | 92    | • |   |
| LIDO 75 Style          | 84-94 | • |   |
| AH 80 Adress, V, Tune  | 88-91 | • |   |
| AH 80 Scooter          | 92-94 | • |   |
| CP 80                  | 85-93 | • | • |
| AH 100 V Adress        | 91-94 | • |   |
| 125 Vecstar            | 94-97 | • |   |
| AN 125                 | 06-08 | • |   |
| AN 125 R               | 94-05 | • |   |
| LIDO 125 Vario Scooter | 90-93 | • |   |
| AN 150                 | 98-01 | • |   |
| LT 160                 | 89-92 | • |   |
| LT-F 160               | 91-04 | • |   |
| 250 Vecstar            | 94    | • |   |

**VELOCIFERO**

|               |    |   |  |
|---------------|----|---|--|
| 50 Velocifero | 94 | • |  |
|---------------|----|---|--|

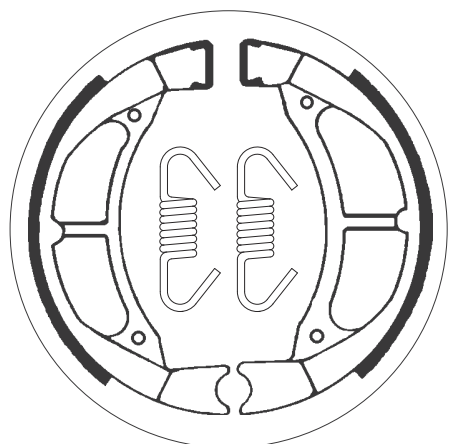

| <b>SUZUKI</b> |       |   |  |
|---------------|-------|---|--|
| RM 80         | 82-89 | • |  |

| <b>YAMAHA</b> |       |   |   |
|---------------|-------|---|---|
| JOG-Z 50      | 88-89 | • |   |
| YZ 50         | 80-83 | • | • |
| YZ 60         | 85    | • | • |
| BW 80         | 86-90 | • | • |
| CJ 80         | 86-88 | • | • |
| PW 80         | 83-85 | • |   |
| PW 80         | 91-08 | • |   |
| TY 80         | 77-84 | • |   |
| YZ 80         | 74-79 | • |   |
| YZ 80         | 80-85 | • | • |
| YZ 80         | 86-92 | • |   |
| TT-R 90       | 00-10 | • |   |

| <b>YAMAHA</b> |       |   |  |
|---------------|-------|---|--|
| TT-R 110      | 08-18 | • |  |

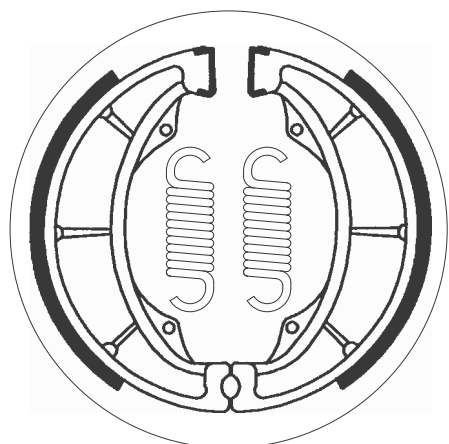

| <b>KAWASAKI</b>      |       |   |  |
|----------------------|-------|---|--|
| KLF 110 Mojave       | 87-88 | • |  |
| KLT 110              | 84-86 | • |  |
| AR 125               | 82-94 | • |  |
| BN 125 Eliminator    | 98-99 | • |  |
| BN 125 Eliminator A3 | 00-07 | • |  |
| KE 125               | 76-85 | • |  |
| KX 125               | 74-82 | • |  |
| KLT 160              | 85    | • |  |
| KDX 175              | 80-82 | • |  |
| KE 175               | 76-78 | • |  |
| KLT 185              | 86-87 | • |  |
| KDX 250              | 83-84 | • |  |
| KLX 250              | 79-80 | • |  |
| KT 250 all models    | 75-80 | • |  |
| KX 250               | 82-85 | • |  |
| Z 250                | 81-83 | • |  |

| <b>KAWASAKI</b>  |       |   |  |
|------------------|-------|---|--|
| Z 250 Eliminator | 88    | • |  |
| KX 500           | 83-85 | • |  |
| KL 600           | 84-86 | • |  |
| KLR 600          | 84-86 | • |  |
| KLR 600 E        | 85-94 | • |  |

| <b>SUZUKI</b> |       |   |  |
|---------------|-------|---|--|
| TU 125 XT     | 99    | • |  |
| NZ 250        | 86-91 | • |  |

**SBS 2184**

ø170x26

**PIAGGIO VESPA**

|            |       |   |
|------------|-------|---|
| 125 Cosa   | 89-91 | • |
| 125 Cosa 2 | 92-97 | • |
| 150 Cosa   | 89-91 | • |
| 200 Cosa   | 89-91 | • |
| 200 Cosa 2 | 92-97 | • |
|            |       |   |
|            |       |   |
|            |       |   |
|            |       |   |
|            |       |   |
|            |       |   |
|            |       |   |
|            |       |   |
|            |       |   |
|            |       |   |
|            |       |   |
|            |       |   |
|            |       |   |

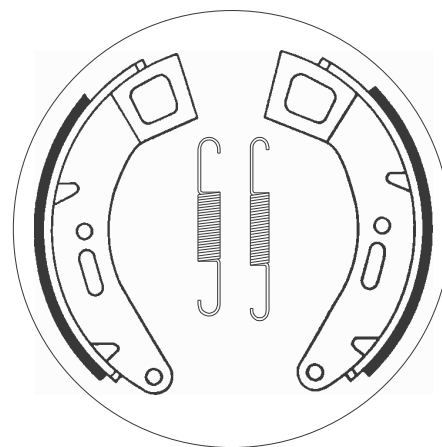
**SBS 2185**

ø170x26

**PIAGGIO VESPA**

|            |       |   |
|------------|-------|---|
| 125 Cosa   | 89-91 | • |
| 125 Cosa 2 | 92-97 | • |
| 150 Cosa   | 89-91 | • |
| 200 Cosa   | 89-91 | • |
| 200 Cosa 2 | 92-97 | • |
|            |       |   |
|            |       |   |
|            |       |   |
|            |       |   |
|            |       |   |
|            |       |   |
|            |       |   |
|            |       |   |
|            |       |   |
|            |       |   |
|            |       |   |
|            |       |   |
|            |       |   |

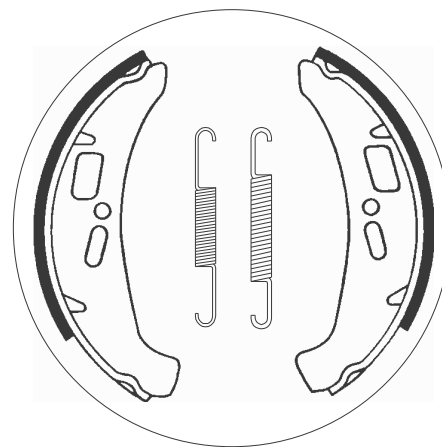
**SBS 2186**

ø110x25

**PIAGGIO VESPA**

|          |       |   |
|----------|-------|---|
| 50 Sfera | 91-99 | • |
| 80 Sfera | 94-99 | • |
|          |       |   |
|          |       |   |
|          |       |   |
|          |       |   |
|          |       |   |
|          |       |   |
|          |       |   |
|          |       |   |
|          |       |   |
|          |       |   |
|          |       |   |
|          |       |   |
|          |       |   |
|          |       |   |
|          |       |   |

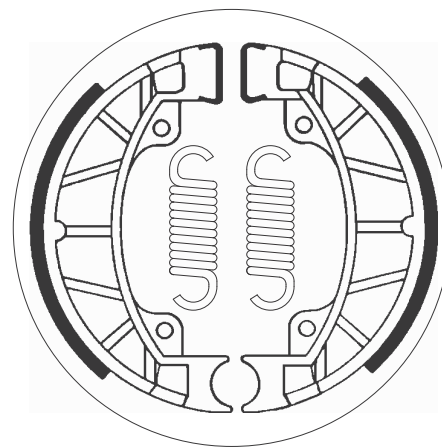

ø100x20

SBS 2187

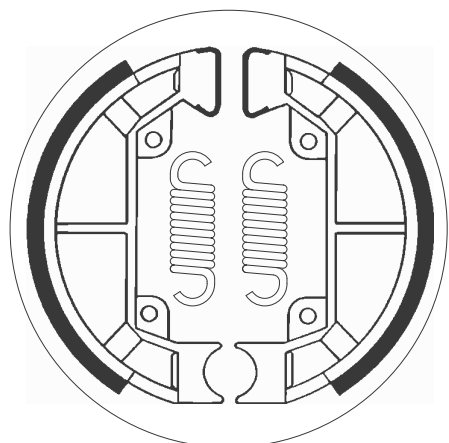

| GILERA         |        |   |
|----------------|--------|---|
| 50 Easy Moving | 96- 11 | • |
| 50 Storm       | 94- 98 | • |
| 50 Typhoon     | 93- 95 | • |
| NRG 50         | 94- 95 | • |
| 80 Typhoon     | 95- 99 | • |
| PIAGGIO VESPA  |        |   |
| 50 Quartz      | 92- 96 | • |
| 50 Sfera       | 91- 99 | • |
| 50 Storm       | 94- 97 | • |
| 50 Typhoon     | 94- 95 | • |
| 50 Zip         | 92- 93 | • |
| 50 Zip & Zip   | 94- 97 | • |
| NRG.1 50       | 94- 95 | • |
| TPH 50         | 93- 95 | • |
| 80 Sfera       | 94- 99 | • |

| PUCH                 |        |   |
|----------------------|--------|---|
| 50 Storm (Austria)   | 78- 83 | • |
| 50 Typhoon (Austria) | 95     | • |

ø110x23

SBS 2188

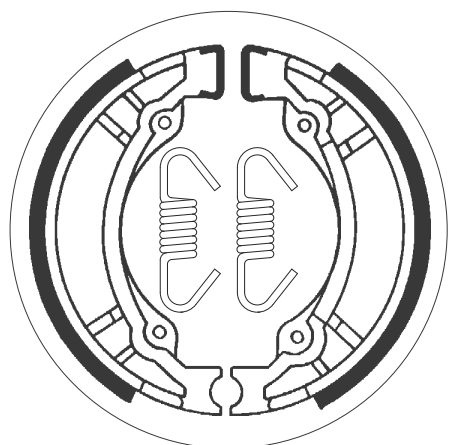

| PGO                |        |   |
|--------------------|--------|---|
| 50 Big Max         | 94- 02 | • |
| 50 Big Max Sport   | 96- 04 | • |
| 50 Comet           | 91- 97 | • |
| 50 Galaxy          | 91- 97 | • |
| PS 50              | 93     | • |
| 90 Galaxy          | 92- 94 | • |
| 100 Big Max        | 96- 99 | • |
| SUZUKI             |        |   |
| TR 50 Street Magic | 97- 00 | • |
| UG 110 Hokuto      | 00- 02 | • |
| SYM                |        |   |
| 125 Husky          | 96- 98 | • |
| 125 Super Duke     | 95- 01 | • |
| 150 Husky          | 99- 02 | • |

| TGB     |        |   |
|---------|--------|---|
| 50 202T | 99- 02 | • |

ø130x25

SBS 2189

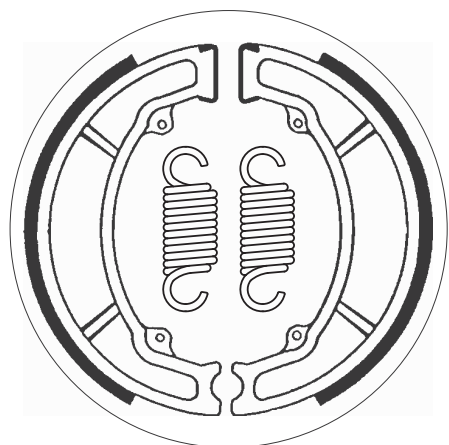

| HONDA          |        |   |
|----------------|--------|---|
| CN 250 Helix   | 86- 87 | • |
| CN 250 Scooter | 88- 92 | • |
| CN 250 Spazio  | 88- 92 | • |
| VELOCIFERO     |        |   |
| 50 Velocifero  | 94     | • |

SBS 2190

ø200x25



YAMAHA

SR 500 92-98 •

|  |  |  |
|--|--|--|
|  |  |  |
|  |  |  |
|  |  |  |
|  |  |  |
|  |  |  |
|  |  |  |
|  |  |  |
|  |  |  |
|  |  |  |
|  |  |  |
|  |  |  |
|  |  |  |
|  |  |  |
|  |  |  |
|  |  |  |
|  |  |  |
|  |  |  |
|  |  |  |
|  |  |  |

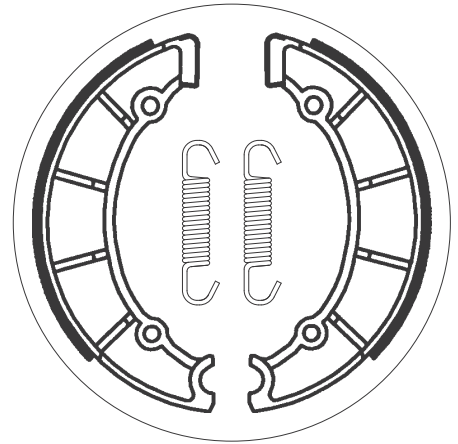

SBS 2192

ø150x25



YAMAHA

SR 250 90-93 •

|  |  |  |
|--|--|--|
|  |  |  |
|  |  |  |
|  |  |  |
|  |  |  |
|  |  |  |
|  |  |  |
|  |  |  |
|  |  |  |
|  |  |  |
|  |  |  |
|  |  |  |
|  |  |  |
|  |  |  |
|  |  |  |
|  |  |  |
|  |  |  |
|  |  |  |
|  |  |  |
|  |  |  |
|  |  |  |



SBS 2193

ø90x20



HONDA

PXR 50 all models 85-02 •

|  |  |  |
|--|--|--|
|  |  |  |
|  |  |  |
|  |  |  |
|  |  |  |
|  |  |  |
|  |  |  |
|  |  |  |
|  |  |  |
|  |  |  |
|  |  |  |
|  |  |  |
|  |  |  |
|  |  |  |
|  |  |  |
|  |  |  |
|  |  |  |
|  |  |  |
|  |  |  |
|  |  |  |
|  |  |  |
|  |  |  |

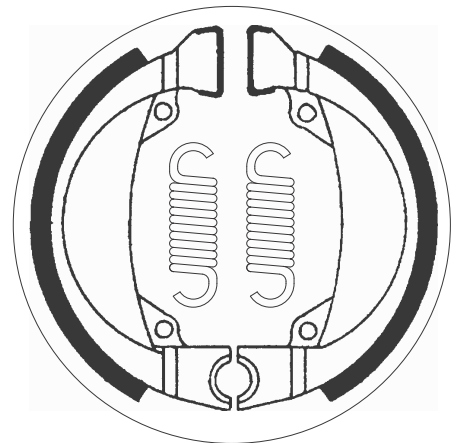

Dimensions in mm / Dimensions en mm  
1" = 25.4 mm , 1 mm = 0.04"



ø95x20

SBS 2194

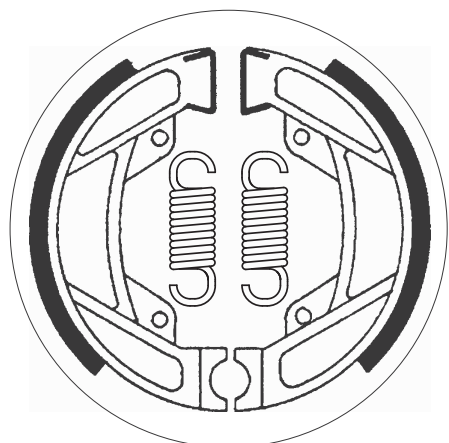

| <b>HONDA</b> |                 |       |     |
|--------------|-----------------|-------|-----|
| PXR          | 50 all models   | 85-02 | •   |
| <b>MBK</b>   |                 |       |     |
|              | 50 Evasion      |       |     |
|              | straight wheels | 01    | • • |
|              | 50 Hardrock     |       |     |
|              | straight wheels | 01    | • • |
|              | 50 Magnum       |       |     |
|              | straight wheels | 01    | • • |
|              | 50 Passion      |       |     |
|              | straight wheels | 01    | • • |
|              |                 |       |     |
|              |                 |       |     |
|              |                 |       |     |
|              |                 |       |     |

ø110x25

SBS 2195

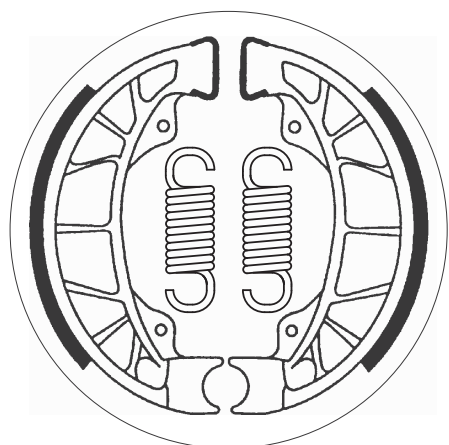

| <b>GILERA</b>        |                   |       |   |
|----------------------|-------------------|-------|---|
|                      | 50 Eaglet         | 96    | • |
|                      | 50 Runner         | 97-05 | • |
|                      | 125 Typhoon       | 96-00 | • |
| <b>PIAGGIO VESPA</b> |                   |       |   |
|                      | 25 Zip II Cat DT  | 01    | • |
|                      | 50 Zip Disco      | 96-99 | • |
|                      | 50 Zip Fast Rider | 96-97 | • |
|                      | 50 Zip II         | 01-15 | • |
|                      | 50 Zip II Cat DT  | 01-12 | • |
| ET2                  | 50                | 97-06 | • |
| ET4                  | 50                | 00-05 | • |
| LX                   | 50 2T/4T          | 05-12 | • |
|                      | 125 Hexagon       | 94-95 | • |
|                      | 125 Sfera         | 95-01 | • |
|                      | 125 Skipper       | 93-95 | • |
|                      | 125 Zip II 4T     | 00-08 | • |
| ET4                  | 125               | 96-10 | • |
| <b>PIAGGIO VESPA</b> |                   |       |   |
| LX4                  | 125 Hexagon       | 99-07 | • |
| TPH                  | 125               | 96-03 | • |
|                      | 150 Hexagon       | 94-97 | • |
|                      |                   |       |   |
|                      |                   |       |   |
|                      |                   |       |   |
|                      |                   |       |   |
|                      |                   |       |   |
|                      |                   |       |   |
|                      |                   |       |   |
|                      |                   |       |   |

ø105x20

SBS 2196



| <b>PIAGGIO VESPA</b> |                |       |   |
|----------------------|----------------|-------|---|
|                      | 50 Free (Disc  |       |   |
|                      | Brake version) | 97-99 | • |
|                      | 50 Zip         | 92-93 | • |
|                      |                |       |   |
|                      |                |       |   |
|                      |                |       |   |
|                      |                |       |   |
|                      |                |       |   |
|                      |                |       |   |
|                      |                |       |   |
|                      |                |       |   |
|                      |                |       |   |
|                      |                |       |   |
|                      |                |       |   |

**SBS 2197**

ø180x35



**KAWASAKI**

|     |                     |       |   |
|-----|---------------------|-------|---|
| KLF | 300 Bayou Left/Rear | 89-05 | • |
| KLF | 400 Bayou Left      | 93-99 | • |
| KVF | 400 Prairie         | 97-98 | • |
|     |                     |       |   |
|     |                     |       |   |
|     |                     |       |   |
|     |                     |       |   |
|     |                     |       |   |
|     |                     |       |   |
|     |                     |       |   |
|     |                     |       |   |
|     |                     |       |   |
|     |                     |       |   |
|     |                     |       |   |
|     |                     |       |   |
|     |                     |       |   |
|     |                     |       |   |
|     |                     |       |   |
|     |                     |       |   |

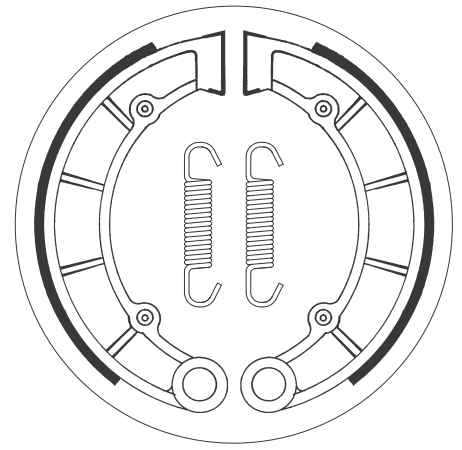

**SBS 2198**

ø160x30



**HONDA**

|     |               |       |   |
|-----|---------------|-------|---|
| FES | 125 Pantheon  | 98-02 | • |
| FES | 150 Pantheon  | 99-02 | • |
| FES | 250 Foresight | 98-99 | • |
|     |               |       |   |
|     |               |       |   |
|     |               |       |   |
|     |               |       |   |
|     |               |       |   |
|     |               |       |   |
|     |               |       |   |
|     |               |       |   |
|     |               |       |   |
|     |               |       |   |
|     |               |       |   |
|     |               |       |   |
|     |               |       |   |
|     |               |       |   |
|     |               |       |   |
|     |               |       |   |
|     |               |       |   |

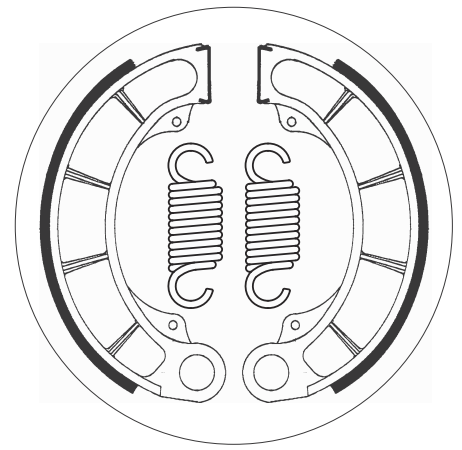

**SBS 2199**

ø130x28



**MBK**

|    |              |       |   |
|----|--------------|-------|---|
| YP | 125 Skyliner | 99-00 | • |
|----|--------------|-------|---|

**YAMAHA**

|     |               |       |   |
|-----|---------------|-------|---|
| XN  | 125 Teos      | 01-04 | • |
| XVS | 125 Drag Star | 00-06 | • |
| YBR | 125           | 08-16 | • |
| YP  | 125 R Majesty | 99-00 | • |
|     | 150 Teos      | 02-05 | • |
| YP  | 180 R Majesty | 03    | • |
| XVS | 250 Drag Star | 01-04 | • |
|     |               |       |   |
|     |               |       |   |
|     |               |       |   |
|     |               |       |   |
|     |               |       |   |
|     |               |       |   |
|     |               |       |   |
|     |               |       |   |
|     |               |       |   |
|     |               |       |   |
|     |               |       |   |
|     |               |       |   |
|     |               |       |   |
|     |               |       |   |
|     |               |       |   |
|     |               |       |   |

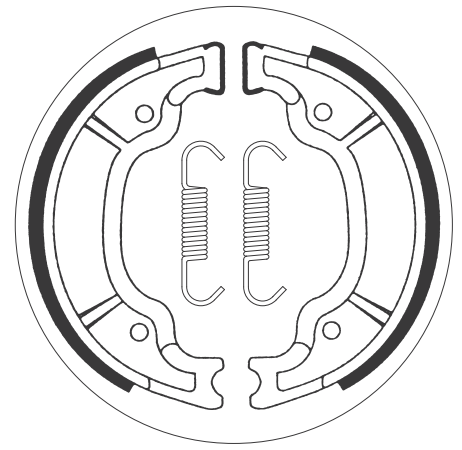

Brake Shoe Drawings, Fitments

ø100x20

SBS 2200

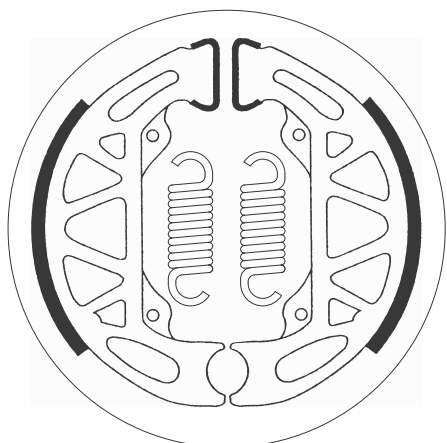

| <b>GILERA</b>        |                      |       |   |
|----------------------|----------------------|-------|---|
|                      | 50 Typhoon           | 96-01 | • |
| <b>PIAGGIO VESPA</b> |                      |       |   |
|                      | 50 Zip Fast Rider    | 93-95 | • |
| NRG                  | 50                   | 96-00 | • |
| NRG                  | 50 mc2               | 97-99 | • |
| NTT                  | 50                   | 96    | • |
| RST                  | 50 Sfera             | 95-99 | • |
| TPH                  | 50                   | 96-97 | • |
| <b>PUCH</b>          |                      |       |   |
|                      | 50 Typhoon (Austria) | 96    | • |
|                      |                      |       |   |
|                      |                      |       |   |
|                      |                      |       |   |
|                      |                      |       |   |
|                      |                      |       |   |

ø120x25

SBS 2201

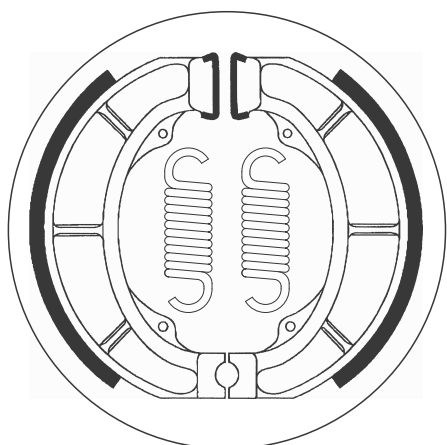

| <b>APRILIA</b> |                             |       |   |
|----------------|-----------------------------|-------|---|
|                | 50 Compay                   | 09-13 | • |
|                | 50 Habana/Custom            | 99-02 | • |
|                | 50 Mojito Retro             | 99-03 | • |
|                | 50 Mojito,<br>Mojito Custom | 99-03 | • |
|                |                             |       |   |
|                |                             |       |   |
|                |                             |       |   |
|                |                             |       |   |
|                |                             |       |   |
|                |                             |       |   |
|                |                             |       |   |
|                |                             |       |   |
|                |                             |       |   |
|                |                             |       |   |

ø130x28

SBS 2202

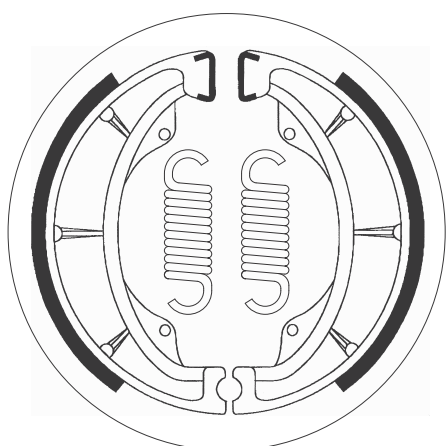

| <b>SUZUKI</b> |             |       |   |
|---------------|-------------|-------|---|
| UC            | 125 Epicuro | 99-02 | • |
| UC            | 150 Epicuro | 99-02 | • |
|               |             |       |   |
|               |             |       |   |
|               |             |       |   |
|               |             |       |   |
|               |             |       |   |
|               |             |       |   |
|               |             |       |   |
|               |             |       |   |
|               |             |       |   |
|               |             |       |   |
|               |             |       |   |
|               |             |       |   |

**SBS 2203****ø130x25****KYMCO**

|                     |       |   |
|---------------------|-------|---|
| 50 Agility (4T) R16 | 06-15 | • |
| 50 People           | 99-06 | • |
| 50 Super-8          | 08-16 | • |
| 125 Movie           | 99-08 | • |
| 125 People          | 01-09 | • |
| 150 People          | 01-06 | • |
|                     |       |   |
|                     |       |   |
|                     |       |   |
|                     |       |   |
|                     |       |   |
|                     |       |   |
|                     |       |   |
|                     |       |   |
|                     |       |   |

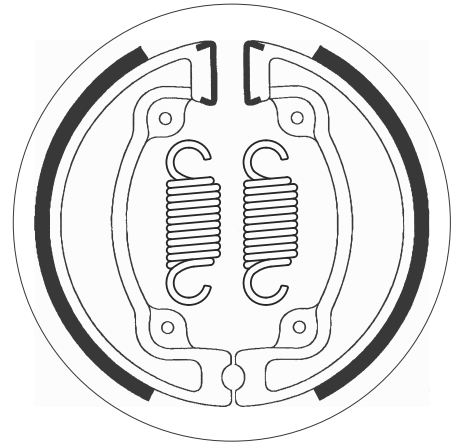
**SBS 2205****ø140x25****APRILIA**

|                              |       |   |
|------------------------------|-------|---|
| 125 Habana/Custom            | 00-02 | • |
| 125 Mojito,<br>Mojito Custom | 02-12 | • |
| SR 125                       | 99-03 | • |
| SR 150                       | 00-03 | • |

**DERBI**

|               |       |   |
|---------------|-------|---|
| 125 Boulevard | 03-07 | • |
| 150 Boulevard | 03-09 | • |

**GILERA**

|               |       |   |
|---------------|-------|---|
| FX 125 Runner | 97-99 | • |
| FX 150 Runner | 97-01 | • |
| FX 200 Runner | 97-98 | • |

**PIAGGIO VESPA**

|            |       |   |
|------------|-------|---|
| 50 Fly     | 05-17 | • |
| 50 Liberty | 97-14 | • |

**PIAGGIO VESPA**

|                    |       |   |
|--------------------|-------|---|
| 50 Liberty 4T      | 00-12 | • |
| 100 Fly            | 07-15 | • |
| 100 Zip            | 07-10 | • |
| 125 Fly            | 05-13 | • |
| LE 125 Liberty     | 99-03 | • |
| LX 125 Hexagon     | 99-00 | • |
| LX 125 Skipper, ST | 99-04 | • |
| 150 Fly            | 06-07 | • |
| 150 Liberty        | 99-03 | • |
| LXT 180 Hexagon    | 99-00 | • |

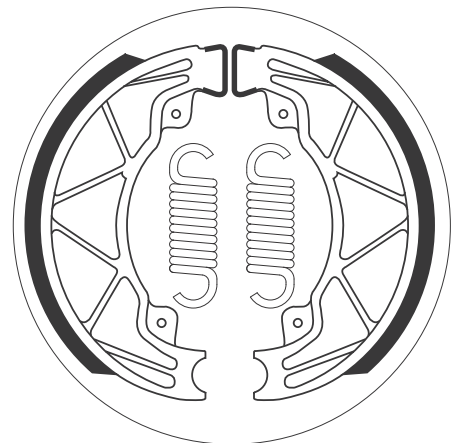
**SBS 2206****ø105x25****DERBI**

|                             |       |   |
|-----------------------------|-------|---|
| 50 Aventura                 | 96    | • |
| 50 Vamos R<br>(A.J.P. cal.) | 95    | • |
| 50 Vamos R<br>(Brembo cal.) | 95    | • |
| 50 Variant Sport-R          | 01-13 | • |

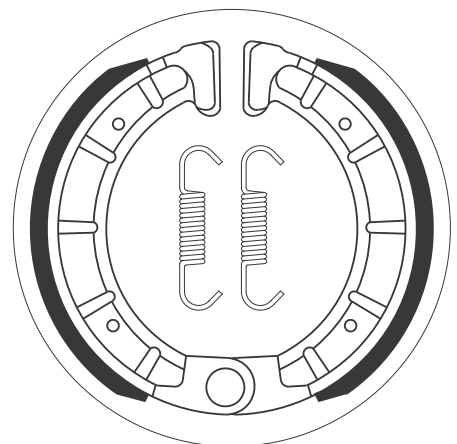

ø160x30

SBS 2207

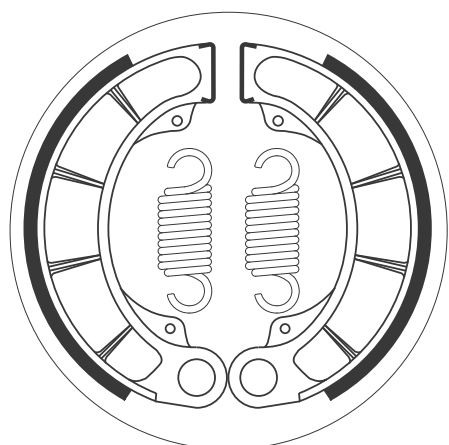

| HONDA |                 |       |   |
|-------|-----------------|-------|---|
| TRX   | 350 Rancher /ES |       |   |
|       | 2x4, 4x4        | 00-09 | • |
| TRX   | 400 AT          | 04-11 | • |
| TRX   | 400 FW Fourtrax |       |   |
|       | Foreman         | 95-02 | • |
| TRX   | 450 Foreman ES, |       |   |
|       | Foreman S       | 98-04 | • |
|       |                 |       |   |
|       |                 |       |   |
|       |                 |       |   |
|       |                 |       |   |
|       |                 |       |   |
|       |                 |       |   |
|       |                 |       |   |
|       |                 |       |   |
|       |                 |       |   |
|       |                 |       |   |

ø130x25

SBS 2208

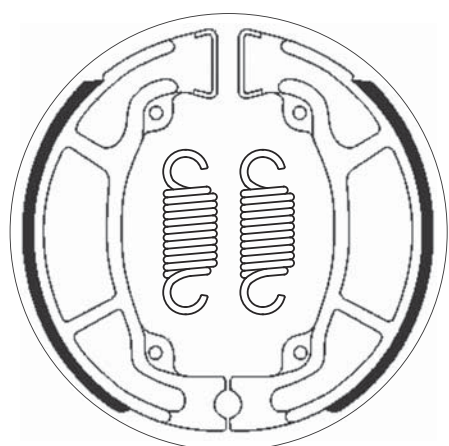

| HONDA |           |       |   |
|-------|-----------|-------|---|
| NES   | 125 @     | 01-06 | • |
| PCX   | 125       | 09-18 | • |
| PS    | 125 i     | 07-13 | • |
| SES   | 125 Dylan | 02-07 | • |
| SH    | 125       | 02-08 | • |
| NES   | 150 @     | 01-06 | • |
| PCX   | 150       | 12-18 | • |
| PS    | 150 i     | 07-11 | • |
| SES   | 150 Dylan | 02-06 | • |
| SH    | 150       | 02-08 | • |
|       |           |       |   |
|       |           |       |   |
|       |           |       |   |
|       |           |       |   |
|       |           |       |   |
|       |           |       |   |
|       |           |       |   |
|       |           |       |   |
|       |           |       |   |

ø150x28

SBS 2209

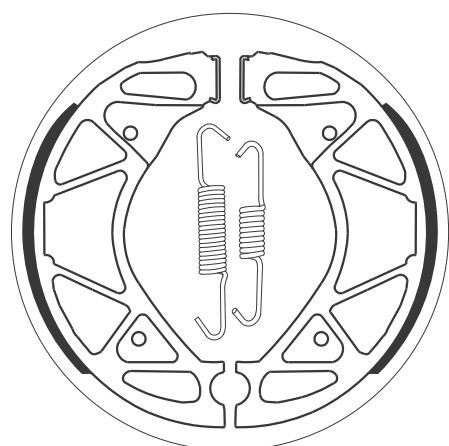

| YAMAHA |              |       |   |
|--------|--------------|-------|---|
|        | 125 Xenter   | 12-18 | • |
| BWs    | 125          | 10-11 | • |
| NXC    | 125 Cygnus   | 10-11 | • |
| NXC    | 125 Cygnus X | 05-09 | • |
| YW     | 125 Z        | 10-11 | • |
|        | 150 Xenter   | 12-18 | • |
|        |              |       |   |
|        |              |       |   |
|        |              |       |   |
|        |              |       |   |
|        |              |       |   |
|        |              |       |   |
|        |              |       |   |
|        |              |       |   |
|        |              |       |   |
|        |              |       |   |
|        |              |       |   |
|        |              |       |   |
|        |              |       |   |
|        |              |       |   |
|        |              |       |   |
|        |              |       |   |
|        |              |       |   |



# CROSSLIST

SBS -

EBC / DP / VESRAH / FERODO / CL BRAKES / HARLEY DAVIDSON OE

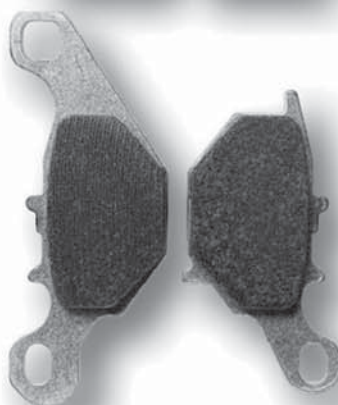
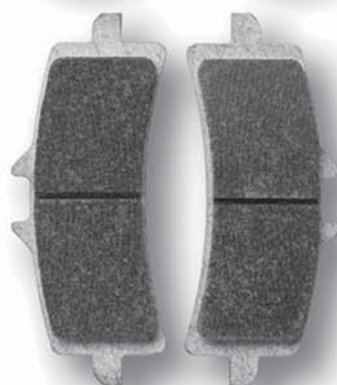
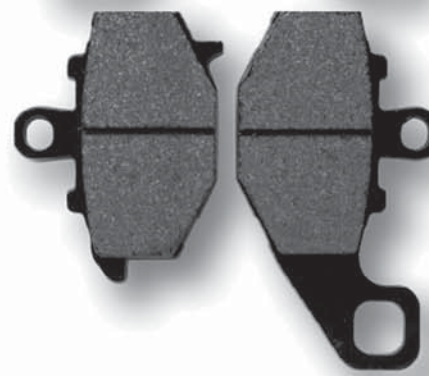
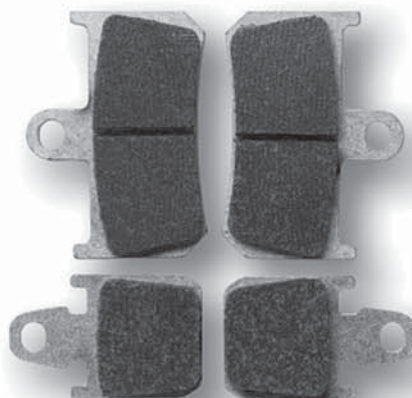
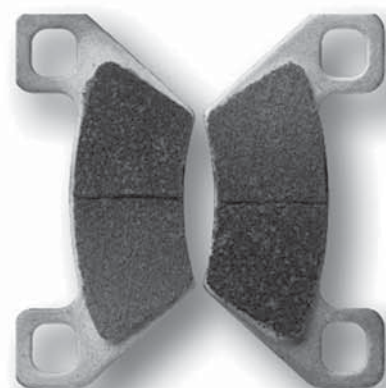
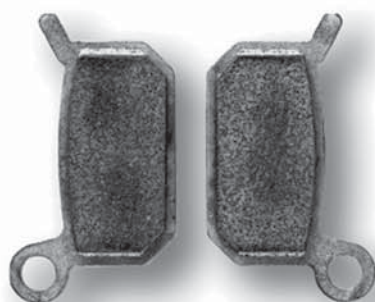
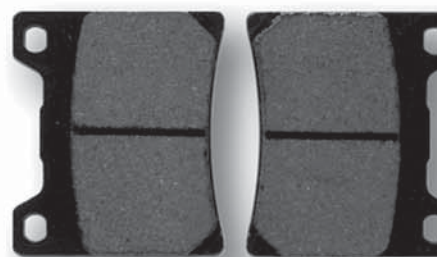
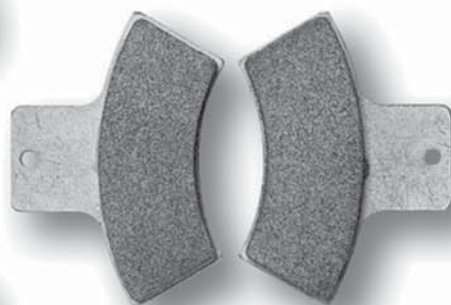
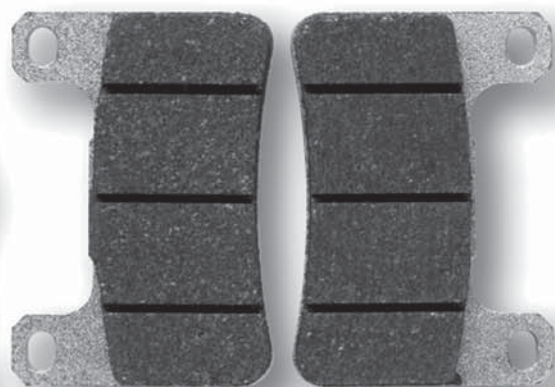

| <b>EBC No.</b> | <b>SBS No.</b> | <b>EBC No.</b> | <b>SBS No.</b> | <b>EBC No.</b> | <b>SBS No.</b> | <b>EBC No.</b> | <b>SBS No.</b> |
|----------------|----------------|----------------|----------------|----------------|----------------|----------------|----------------|
| FA11           | 504            | FA83/2         | 548            | FA151          | 110            | FA208          | 175            |
| FA12           | 502            | FA84           | 592            | FA151          | 618            | FA208          | 675            |
| FA13           | 501            | FA84/2         | 562            | FA152          | 632            | FA209          | 176            |
| FA16           | 523            | FA84/3         | 584            | FA152/2        | 648            | FA209          | 674            |
| FA18           | 506            | FA85           | 557            | FA153          | 629            | FA209/2        | 176            |
| FA20           | 617            | FA86           | 103            | FA155          | 637            | FA209/2        | 674            |
| FA21           | 576            | FA86           | 200            | FA156          | 126            | FA210          | 658            |
| FA22           | 520            | FA86           | 551            | FA156          | 672            | FA214          | 197            |
| FA24/2         | 513            | FA86           | 814            | FA157          | 635            | FA214          | 611            |
| FA26           | 679            | FA88           | 555            | FA158          | 631            | FA215          | 134            |
| FA27           | 505            | FA90           | 561            | FA159          | 642            | FA215          | 638            |
| FA28           | 500            | FA92           | 104            | FA160          | 645            | FA216          | 678            |
| FA29           | 508            | FA92           | 558            | FA161          | 556            | FA216/2        | 662            |
| FA31           | 517            | FA93           | 203            | FA162          | 659            | FA217          | 660            |
| FA32           | 509            | FA93           | 585            | FA163          | 641            | FA218          | 695            |
| FA33           | 510            | FA94           | 579            | FA164          | 636            | FA218/2        | 711            |
| FA34           | 507            | FA95           | 566            | FA165          | 134            | FA220          | 639            |
| FA35           | 511            | FA98           | 133            | FA165          | 638            | FA222          | 701            |
| FA36           | 512            | FA98           | 605            | FA165/2        | 633            | FA226          | 183            |
| FA37           | 514            | FA99           | 132            | FA166          | 653            | FA226          | 184            |
| FA38           | 515            | FA99           | 595            | FA167          | 148            | FA226          | 627            |
| FA39           | 516            | FA101          | 107            | FA167          | 186            | FA228          | 163            |
| FA40           | 525            | FA101          | 575            | FA167          | 652            | FA228          | 713            |
| FA41           | 528            | FA102          | 578            | FA167          | 817            | FA229          | 705            |
| FA42           | 531            | FA103          | 577            | FA169          | 111            | FA230          | 122            |
| FA43           | 521            | FA104          | 570            | FA169          | 619            | FA230          | 702            |
| FA45           | 526            | FA105          | 580            | FA170          | 644            | FA231          | 704            |
| FA46           | 538            | FA106          | 581            | FA171          | 640            | FA231/2        | 886            |
| FA47           | 138            | FA106/2        | 582            | FA172          | 137            | FA232          | 717            |
| FA47           | 519            | FA107A         | 599            | FA172          | 650            | FA234          | 129            |
| FA47/2         | 131            | FA109          | 573            | FA173          | 118            | FA235          | 141            |
| FA47/2         | 583            | FA110          | 587            | FA173          | 684            | FA235          | 723            |
| FA47/3         | 646            | FA111          | 610            | FA174          | 162            | FA236          | 624            |
| FA48           | 522            | FA115          | 105            | FA174          | 657            | FA244          | 706            |
| FA50           | 532            | FA115          | 559            | FA175          | 656            | FA249          | 729            |
| FA51           | 533            | FA116          | 109            | FA176          | 112            | FA249          | 676            |
| FA52           | 529            | FA116          | 607            | FA176          | 628            | FA249/2        | 779            |
| FA54           | 100            | FA118          | 596            | FA177          | 681            | FA251          | 692            |
| FA54           | 536            | FA119          | 136            | FA179          | 170            | FA252          | 198            |
| FA55           | 503            | FA119          | 589            | FA179          | 663            | FA252          | 634            |
| FA56           | 524            | FA120          | 594            | FA180          | 666            | FA254          | 715            |
| FA57           | 527            | FA121          | 593            | FA181          | 151            | FA255          | 130            |
| FA60           | 106            | FA122          | 598            | FA181          | 671            | FA256          | 108            |
| FA60           | 574            | FA123          | 590            | FA182          | 665            | FA256          | 124            |
| FA61           | 545            | FA124          | 600            | FA183          | 677            | FA256          | 588            |
| FA62           | 530            | FA124/2        | 647            | FA184          | 655            | FA257          | 115            |
| FA63           | 556            | FA125          | 139            | FA185          | 694            | FA257          | 670            |
| FA64           | 535            | FA125          | 603            | FA186          | 117            | FA257/2        | 209            |
| FA65           | 534            | FA126          | 601            | FA186          | 680            | FA257/2        | 879            |
| FA67           | 135            | FA128          | 591            | FA187          | 622            | FA258          | 726            |
| FA67           | 546            | FA129          | 597            | FA188          | 686            | FA260          | 142            |
| FA67           | 586            | FA130          | 602            | FA189          | 685            | FA261          | 736            |
| FA67/2         | 541            | FA131          | 144            | FA190          | 683            | FA261/2        | 880            |
| FA68           | 539            | FA131          | 604            | FA191          | 682            | FA263          | 707            |
| FA68           | 540            | FA131/2        | 116            | FA192          | 687            | FA264          | 140            |
| FA69/2         | 127            | FA131/3        | 121            | FA193          | 123            | FA264          | 708            |
| FA69/2         | 572            | FA131/3        | 690            | FA193          | 143            | FA266          | 157            |
| FA69/3         | 160            | FA132          | 621            | FA193          | 697            | FA266          | 730            |
| FA69/3         | 542            | FA134          | 608            | FA194          | 168            | FA267          | 733            |
| FA70           | 547            | FA135          | 197            | FA194          | 774            | FA268          | 145            |
| FA71           | 537            | FA135          | 611            | FA196          | 181            | FA270          | 755            |
| FA72           | 543            | FA136          | 616            | FA196          | 654            | FA271          | 758            |
| FA74           | 606            | FA137          | 649            | FA196          | 700            | FA272          | 719            |
| FA76           | 560            | FA140          | 161            | FA197          | 119            | FA273          | 756            |
| FA77           | 554            | FA140          | 614            | FA197          | 688            | FA275          | 155            |
| FA78           | 549            | FA141          | 615            | FA198          | 699            | FA275          | 728            |
| FA79           | 553            | FA142          | 183            | FA199          | 128            | FA281          | 147            |
| FA80           | 552            | FA142          | 184            | FA199          | 691            | FA281          | 722            |
| FA80/2         | 571            | FA142          | 627            | FA200          | 669            | FA283          | 146            |
| FA81           | 550            | FA143          | 623            | FA201          | 668            | FA283          | 740            |
| FA83           | 101            | FA145          | 624            | FA204          | 625            | FA291          | 815            |
| FA83           | 544            | FA146          | 620            | FA206          | 114            | FA294          | 743            |
| FA83/2         | 102            | FA147          | 626            | FA206          | 667            | FA296          | 734            |



| EBC No. | SBS No. | EBC No. | SBS No. | EBC No. | SBS No. | EBC No. | SBS No. |
|---------|---------|---------|---------|---------|---------|---------|---------|
| FA297   | 150     | FA388   | 828     | FA491   | 864     |         |         |
| FA298   | 152     | FA389   | 694     | FA491   | 870     |         |         |
| FA298   | 747     | FA390   | 809     | FA492   | 208     |         |         |
| FA299   | 750     | FA393   | 190     | FA495   | 895     |         |         |
| FA301   | 153     | FA393   | 823     | FA496   | 881     |         |         |
| FA302   | 752     | FA395   | 822     | FA498   | 204     |         |         |
| FA303   | 802     | FA396   | 122     | FA499/4 | 869     |         |         |
| FA304   | 746     | FA396   | 702     | FA600   | 945     |         |         |
| FA305   | 154     | FA398   | 908     | FA602   | 872     |         |         |
| FA305   | 749     | FA399   | 189     | FA603   | 205     |         |         |
| FA306   | 178     | FA399   | 821     | FA605   | 904     |         |         |
| FA306   | 792     | FA400   | 826     | FA606   | 877     |         |         |
| FA307   | 196     | FA401   | 820     | FA607   | 195     |         |         |
| FA307   | 754     | FA403   | 896     | FA607   | 863     |         |         |
| FA313   | 757     | FA405   | 842     | FA608   | 212     |         |         |
| FA314   | 787     | FA407   | 703     | FA610   | 912     |         |         |
| FA315   | 785     | FA408   | 185     | FA611   | 845     |         |         |
| FA317   | 767     | FA409   | 830     | FA612   | 885     |         |         |
| FA319   | 169     | FA410   | 829     | FA613   | 778     |         |         |
| FA319/2 | 769     | FA411   | 174     | FA617   | 911     |         |         |
| FA320   | 763     | FA412   | 182     | FA618   | 910     |         |         |
| FA321   | 166     | FA413   | 835     | FA627   | 215     |         |         |
| FA321   | 772     | FA414   | 836     | FA627   | 893     |         |         |
| FA322   | 762     | FA415   | 193     | FA629   | 915     |         |         |
| FA323   | 125     | FA415   | 832     | FA630   | 900     |         |         |
| FA323   | 709     | FA416   | 855     | FA636   | 892     |         |         |
| FA323/2 | 104     | FA417   | 838     | FA638   | 922     |         |         |
| FA323/2 | 558     | FA418   | 187     | FA640   | 934     |         |         |
| FA324   | 159     | FA419   | 833     | FA641/4 | 923     |         |         |
| FA325   | 794     | FA424   | 676     | FA643   | 924     |         |         |
| FA335   | 796     | FA425   | 191     | FA644   | 939     |         |         |
| FA336   | 165     | FA425   | 831     | FA650   | 219     |         |         |
| FA337   | 106     | FA427   | 201     | FA650   | 716     |         |         |
| FA337   | 574     | FA427   | 847     | FA652   | 223     |         |         |
| FA342   | 801     | FA428   | 816     | FA654   | 928     |         |         |
| FA343   | 225     | FA430   | 194     | FA655   | 222     |         |         |
| FA343   | 784     | FA430   | 837     | FA658   | 933     |         |         |
| FA344   | 799     | FA431   | 848     | FA662   | 230     |         |         |
| FA345   | 795     | FA432   | 214     | FA662   | 932     |         |         |
| FA346   | 777     | FA432   | 844     | FA663   | 229     |         |         |
| FA347   | 782     | FA433/4 | 843     | FA663   | 931     |         |         |
| FA348   | 770     | FA434   | 846     | FA672   | 929     |         |         |
| FA349   | 798     | FA435/4 | 805     | FA673   | 889     |         |         |
| FA350   | 167     | FA435/4 | 887     | FA678   | 221     |         |         |
| FA350   | 773     | FA436   | 834     | FA679   | 940     |         |         |
| FA351   | 803     | FA442/4 | 839     | FA681   | 224     |         |         |
| FA353   | 177     | FA443   | 850     | FA691   | 925     |         |         |
| FA354   | 800     | FA444   | 849     | FA693   | 228     |         |         |
| FA355   | 171     | FA445   | 852     | FA693   | 859     |         |         |
| FA355   | 775     | FA446   | 851     | FA694   | 226     |         |         |
| FA356   | 172     | FA447   | 841     |         |         |         |         |
| FA357   | 783     | FA448   | 211     |         |         |         |         |
| FA358   | 158     | FA450   | 840     |         |         |         |         |
| FA363   | 742     | FA452   | 897     |         |         |         |         |
| FA366   | 789     | FA453   | 914     |         |         |         |         |
| FA367   | 790     | FA454/4 | 856     |         |         |         |         |
| FA368   | 791     | FA456   | 898     |         |         |         |         |
| FA369   | 788     | FA457   | 853     |         |         |         |         |
| FA373   | 813     | FA458   | 854     |         |         |         |         |
| FA374   | 173     | FA460   | 857     |         |         |         |         |
| FA374   | 780     | FA462   | 866     |         |         |         |         |
| FA375   | 180     | FA463   | 867     |         |         |         |         |
| FA375   | 797     | FA464   | 227     |         |         |         |         |
| FA377   | 810     | FA464   | 858     |         |         |         |         |
| FA379   | 806     | FA465   | 228     |         |         |         |         |
| FA380   | 198     | FA465   | 859     |         |         |         |         |
| FA380   | 634     | FA468   | 907     |         |         |         |         |
| FA381   | 807     | FA475   | 899     |         |         |         |         |
| FA382   | 113     | FA484   | 210     |         |         |         |         |
| FA382   | 651     | FA484   | 878     |         |         |         |         |
| FA384   | 206     | FA488   | 862     |         |         |         |         |
| FA387   | 808     | FA489   | 906     |         |         |         |         |
| FA388   | 192     | FA490   | 905     |         |         |         |         |

| DP No. | SBS No. | DP No.  | SBS No. | DP No. | SBS No. | DP No. | SBS No. |
|--------|---------|---------|---------|--------|---------|--------|---------|
| DP001  | 111     | DP208   | 581     | DP408  | 136     | DP623  | 176     |
| DP001  | 619     | DP209   | 582     | DP409  | 590     | DP623  | 674     |
| DP002  | 117     | DP210   | 577     | DP409  | 613     | DP625  | 703     |
| DP002  | 680     | DP211   | 163     | DP410  | 645     | DP626  | 695     |
| DP008  | 120     | DP211   | 197     | DP411  | 197     | DP626  | 711     |
| DP008  | 689     | DP211   | 611     | DP411  | 611     | DP628  | 742     |
| DP009  | 140     | DP211   | 713     | DP412  | 134     | DP629  | 707     |
| DP009  | 708     | DP212   | 620     | DP412  | 633     | DP630  | 706     |
| DP012  | 595     | DP213   | 624     | DP412  | 638     | DP631  | 157     |
| DP013  | 145     | DP213   | 714     | DP413  | 137     | DP631  | 730     |
| DP014  | 180     | DP214   | 626     | DP413  | 650     | DP633  | 123     |
| DP014  | 797     | DP215   | 635     | DP414  | 170     | DP633  | 697     |
| DP015  | 152     | DP216   | 686     | DP414  | 663     | DP634  | 114     |
| DP015  | 747     | DP217   | 701     | DP415  | 665     | DP634  | 667     |
| DP101  | 517     | DP218   | 122     | DP416  | 683     | DP635  | 142     |
| DP102  | 508     | DP218   | 702     | DP417  | 616     | DP638  | 762     |
| DP103  | 526     | DP219   | 146     | DP418  | 198     | DP639  | 778     |
| DP104  | 127     | DP219   | 740     | DP418  | 634     | DP640  | 815     |
| DP104  | 572     | DP220   | 765     | DP419  | 733     | DP641  | 796     |
| DP105  | 160     | DP300   | 510     | DP420  | 155     | DP701  | 506     |
| DP105  | 542     | DP302   | 510     | DP420  | 728     | DP811  | 562     |
| DP106  | 552     | DP303   | 530     | DP421  | 128     | DP811  | 592     |
| DP106  | 571     | DP304   | 512     | DP421  | 691     | DP812  | 104     |
| DP107  | 100     | DP305   | 510     | DP423  | 769     | DP812  | 558     |
| DP107  | 536     | DP307   | 556     | DP424  | 169     | DP813  | 610     |
| DP108  | 108     | DP308   | 539     | DP500  | 523     | DP814  | 603     |
| DP108  | 588     | DP308   | 540     | DP502  | 899     | DP814  | 139     |
| DP108  | 124     | DP308/9 | 539     | DP504  | 869     | DP815  | 604     |
| DP109  | 600     | DP308/9 | 540     | DP508  | 872     | DP815  | 144     |
| DP110  | 593     | DP309   | 539     | DP509  | 870     | DP816  | 584     |
| DP111  | 103     | DP309   | 540     | DP510  | 904     | DP817  | 649     |
| DP111  | 551     | DP310   | 113     | DP514  | 885     | DP821  | 591     |
| DP111  | 561     | DP310   | 135     | DP519  | 877     | DP841  | 576     |
| DP112  | 622     | DP310   | 546     | DP524  | 915     | DP843  | 637     |
| DP113  | 623     | DP310   | 586     | DP528  | 900     | DP844  | 756     |
| DP114  | 104     | DP310   | 651     | DP535  | 700     | DP900  | 579     |
| DP114  | 558     | DP310   | 684     | DP537  | 715     | DP901  | 549     |
| DP115  | 614     | DP310   | 692     | DP538  | 924     | DP902  | 642     |
| DP115  | 881     | DP310   | 118     | DP552  | 931     | DP902  | 716     |
| DP115  | 161     | DP311   | 557     | DP557  | 932     | DP902  | 219     |
| DP116  | 647     | DP312   | 102     | DP600  | 506     | DP903  | 643     |
| DP117  | 181     | DP312   | 101     | DP601  | 143     | DP904  | 668     |
| DP117  | 183     | DP312   | 544     | DP601  | 138     | DP905  | 669     |
| DP117  | 627     | DP312   | 548     | DP601  | 519     | DP906  | 513     |
| DP117  | 630     | DP313   | 602     | DP601  | 737     | DP907  | 537     |
| DP117  | 654     | DP314   | 597     | DP602  | 132     | DP908  | 543     |
| DP118  | 184     | DP315   | 632     | DP602  | 595     | DP909  | 717     |
| DP118  | 700     | DP315   | 648     | DP604  | 601     | DP911  | 662     |
| DP119  | 110     | DP316   | 615     | DP605  | 608     | DP911  | 678     |
| DP119  | 112     | DP317   | 631     | DP606  | 621     | DP912  | 658     |
| DP119  | 618     | DP318   | 556     | DP607  | 105     | DP913  | 662     |
| DP119  | 628     | DP319   | 666     | DP607  | 188     | DP914  | 758     |
| DP120  | 629     | DP320   | 677     | DP607  | 559     | DP915  | 755     |
| DP121  | 657     | DP320   | 687     | DP608  | 640     | DP916  | 509     |
| DP121  | 162     | DP321   | 694     | DP609  | 636     | DP917  | 560     |
| DP122  | 685     | DP322   | 705     | DP610  | 109     | DP918  | 750     |
| DP124  | 721     | DP323   | 704     | DP610  | 607     | DP919  | 767     |
| DP125  | 880     | DP324   | 676     | DP611  | 574     | DP919  | 816     |
| DP126  | 722     | DP324   | 729     | DP611  | 106     | DP920  | 196     |
| DP126  | 736     | DP326   | 726     | DP612  | 653     | DP920  | 754     |
| DP126  | 147     | DP328   | 752     | DP613  | 148     | DP921  | 777     |
| DP127  | 734     | DP400   | 504     | DP613  | 652     | DP922  | 782     |
| DP127  | 860     | DP401   | 507     | DP614  | 566     | DP923  | 783     |
| DP128  | 156     | DP402   | 547     | DP615  | 644     | DP926  | 795     |
| DP128  | 735     | DP402   | 535     | DP617  | 151     | DP927  | 125     |
| DP129  | 784     | DP403   | 550     | DP617  | 671     | DP927  | 174     |
| DP200  | 503     | DP404   | 555     | DP618  | 641     | DP927  | 709     |
| DP202  | 515     | DP405   | 580     | DP620  | 554     | DP931  | 770     |
| DP203  | 512     | DP406   | 107     | DP621  | 116     | DP932  | 787     |
| DP204  | 511     | DP406   | 575     | DP621  | 121     | DP935  | 791     |
| DP205  | 533     | DP406   | 596     | DP621  | 690     | DP937  | 746     |
| DP206  | 534     | DP407   | 570     | DP622  | 175     | DP940  | 790     |
| DP207  | 556     | DP408   | 589     | DP622  | 675     | DP942  | 788     |

| <b>DP No.</b> | <b>SBS No.</b> | <b>DP No.</b> | <b>SBS No.</b> | <b>DP No.</b> | <b>SBS No.</b> | <b>DP No.</b> | <b>SBS No.</b> |
|---------------|----------------|---------------|----------------|---------------|----------------|---------------|----------------|
| DP944         | 191            | SDP952        | 774            |               |                |               |                |
| DP944         | 813            | SDP964        | 838            |               |                |               |                |
| DP944         | 831            | SDP976        | 839            |               |                |               |                |
| DP946         | 789            | SDP978        | 841            |               |                |               |                |
| DP947         | 806            | SDP978        | 901            |               |                |               |                |
| DP948         | 807            | SDP993        | 856            |               |                |               |                |
| DP949         | 808            | SDP999        | 864            |               |                |               |                |
| DP950         | 809            |               |                |               |                |               |                |
| DP952         | 774            |               |                |               |                |               |                |
| DP953         | 820            |               |                |               |                |               |                |
| DP956         | 822            |               |                |               |                |               |                |
| DP957         | 826            |               |                |               |                |               |                |
| DP962         | 830            |               |                |               |                |               |                |
| DP963         | 833            |               |                |               |                |               |                |
| DP964         | 838            |               |                |               |                |               |                |
| DP967         | 810            |               |                |               |                |               |                |
| DP967         | 930            |               |                |               |                |               |                |
| DP971         | 846            |               |                |               |                |               |                |
| DP973         | 834            |               |                |               |                |               |                |
| DP973         | 862            |               |                |               |                |               |                |
| DP976         | 839            |               |                |               |                |               |                |
| DP978         | 841            |               |                |               |                |               |                |
| DP978         | 901            |               |                |               |                |               |                |
| DP979         | 850            |               |                |               |                |               |                |
| DP980         | 849            |               |                |               |                |               |                |
| DP981         | 852            |               |                |               |                |               |                |
| DP982         | 851            |               |                |               |                |               |                |
| DP983         | 840            |               |                |               |                |               |                |
| DP984         | 898            |               |                |               |                |               |                |
| DP986         | 853            |               |                |               |                |               |                |
| DP987         | 854            |               |                |               |                |               |                |
| DP989         | 866            |               |                |               |                |               |                |
| DP990         | 867            |               |                |               |                |               |                |
| DP993         | 856            |               |                |               |                |               |                |
| DP996         | 897            |               |                |               |                |               |                |
| DP997         | 898            |               |                |               |                |               |                |
| DP997         | 800            |               |                |               |                |               |                |
| DP999         | 864            |               |                |               |                |               |                |
| ODO009        | 708            |               |                |               |                |               |                |
| ODP001        | 619            |               |                |               |                |               |                |
| ODP004        | 559            |               |                |               |                |               |                |
| ODP005        | 607            |               |                |               |                |               |                |
| ODP011        | 544            |               |                |               |                |               |                |
| ODP012        | 595            |               |                |               |                |               |                |
| ODP014        | 797            |               |                |               |                |               |                |
| ODP015        | 747            |               |                |               |                |               |                |
| RDP324        | 676            |               |                |               |                |               |                |
| RDP324        | 729            |               |                |               |                |               |                |
| RDP626        | 695            |               |                |               |                |               |                |
| RDP626        | 711            |               |                |               |                |               |                |
| RDP629        | 707            |               |                |               |                |               |                |
| RDP638        | 762            |               |                |               |                |               |                |
| RDP922        | 782            |               |                |               |                |               |                |
| RDP976        | 839            |               |                |               |                |               |                |
| RDP977        | 845            |               |                |               |                |               |                |
| RDP977        | 805            |               |                |               |                |               |                |
| RDP978        | 841            |               |                |               |                |               |                |
| SDP127        | 734            |               |                |               |                |               |                |
| SDP127        | 860            |               |                |               |                |               |                |
| SDP310        | 546            |               |                |               |                |               |                |
| SDP504        | 869            |               |                |               |                |               |                |
| SDP509        | 870            |               |                |               |                |               |                |
| SDP638        | 762            |               |                |               |                |               |                |
| SDP640        | 815            |               |                |               |                |               |                |
| SDP844        | 756            |               |                |               |                |               |                |
| SDP911        | 662            |               |                |               |                |               |                |
| SDP911        | 678            |               |                |               |                |               |                |
| SDP922        | 782            |               |                |               |                |               |                |
| SDP926        | 795            |               |                |               |                |               |                |
| SDP942        | 788            |               |                |               |                |               |                |
| SDP947        | 806            |               |                |               |                |               |                |
| SDP950        | 809            |               |                |               |                |               |                |
| SDP952        | 168            |               |                |               |                |               |                |

| <b>Vesrah No.</b> | <b>SBS No.</b> | <b>Vesrah No.</b> | <b>SBS No.</b> | <b>Vesrah No.</b> | <b>SBS No.</b> | <b>Vesrah No.</b> | <b>SBS No.</b> |
|-------------------|----------------|-------------------|----------------|-------------------|----------------|-------------------|----------------|
| VD-101            | 502            | VD-162/2          | 209            | VD-251            | 645            | VD-342            | 101            |
| VD-102            | 501            | VD-163            | 657            | VD-252            | 137            | VD-342            | 544            |
| VD-108            | 509            | VD-163            | 162            | VD-252            | 650            | VD-342/2          | 102            |
| VD-109            | 525            | VD-164            | 685            | VD-252/2          | 137            | VD-342/2          | 548            |
| VD-110            | 521            | VD-165            | 722            | VD-253            | 659            | VD-343            | 624            |
| VD-112            | 517            | VD-165            | 147            | VD-255            | 170            | VD-343/2          | 714            |
| VD-112/2          | 508            | VD-165/2          | 721            | VD-255            | 663            | VD-344            | 631            |
| VD-117            | 526            | VD-165/2          | 736            | VD-256            | 114            | VD-344/4          | 789            |
| VD-119            | 529            | VD-165/3          | 156            | VD-256            | 667            | VD-345/2          | 620            |
| VD-120            | 100            | VD-165/3          | 735            | VD-257            | 665            | VD-346            | 203            |
| VD-120            | 536            | VD-165/4          | 880            | VD-258            | 683            | VD-346            | 585            |
| VD-123            | 160            | VD-166            | 894            | VD-259            | 682            | VD-347            | 626            |
| VD-123            | 542            | VD-166/2          | 734            | VD-260            | 128            | VD-348            | 635            |
| VD-123/2          | 127            | VD-167            | 784            | VD-260            | 170            | VD-349            | 686            |
| VD-123/2          | 572            | VD-168            | 777            | VD-260            | 185            | VD-350            | 701            |
| VD-123/3          | 542            | VD-169            | 753            | VD-260            | 691            | VD-351            | 122            |
| VD-127            | 584            | VD-169            | 158            | VD-261            | 637            | VD-351            | 702            |
| VD-127            | 592            | VD-170            | 809            | VD-262            | 706            | VD-352            | 705            |
| VD-127/2          | 592            | VD-171            | 813            | VD-262/2          | 727            | VD-353            | 146            |
| VD-127/3          | 562            | VD-172            | 192            | VD-264            | 733            | VD-353            | 740            |
| VD-129            | 571            | VD-172            | 828            | VD-265            | 155            | VD-354            | 788            |
| VD-129/2          | 552            | VD-173            | 193            | VD-265            | 728            | VD-355            | 806            |
| VD-130            | 561            | VD-174            | 834            | VD-266            | 196            | VD-356            | 174            |
| VD-131            | 103            | VD-175            | 829            | VD-266            | 754            | VD-357            | 182            |
| VD-131            | 148            | VD-177            | 180            | VD-266/2          | 835            | VD-358            | 820            |
| VD-131            | 551            | VD-177            | 797            | VD-267            | 165            | VD-359            | 833            |
| VD-131            | 814            | VD-178            | 862            | VD-268            | 770            | VD-403            | 518            |
| VD-134            | 104            | VD-178            | 892            | VD-269            | 169            | VD-412            | 514            |
| VD-134            | 558            | VD-179            | 869            | VD-269/2          | 769            | VD-413            | 522            |
| VD-134/2          | 125            | VD-180            | 205            | VD-270            | 799            | VD-414            | 510            |
| VD-134/2          | 709            | VD-181            | 859            | VD-271            | 790            | VD-420            | 539            |
| VD-134/3          | 174            | VD-181            | 228            | VD-272            | 206            | VD-420/2          | 540            |
| VD-137            | 112            | VD-182            | 784            | VD-273            | 190            | VD-423            | 530            |
| VD-137            | 628            | VD-182            | 915            | VD-273            | 823            | VD-425            | 113            |
| VD-138            | 610            | VD-185            | 892            | VD-275            | 185            | VD-425            | 135            |
| VD-139            | 603            | VD-186            | 216            | VD-275            | 815            | VD-425            | 546            |
| VD-139            | 139            | VD-187            | 940            | VD-276            | 816            | VD-425            | 586            |
| VD-139/2          | 623            | VD-202            | 500            | VD-277            | 839            | VD-425            | 651            |
| VD-140            | 573            | VD-204            | 504            | VD-278            | 851            | VD-425            | 684            |
| VD-142            | 593            | VD-205            | 507            | VD-278/2          | 849            | VD-425            | 692            |
| VD-143            | 600            | VD-213            | 531            | VD-279            | 852            | VD-425            | 118            |
| VD-143/2          | 647            | VD-215            | 528            | VD-279/2          | 850            | VD-426            | 557            |
| VD-144            | 604            | VD-216            | 545            | VD-280            | 840            | VD-427            | 597            |
| VD-144            | 144            | VD-221            | 535            | VD-281            | 207            | VD-428            | 602            |
| VD-144/2          | 121            | VD-222            | 617            | VD-282            | 858            | VD-430            | 615            |
| VD-144/2          | 144            | VD-228            | 547            | VD-282            | 227            | VD-432            | 632            |
| VD-144/2          | 690            | VD-234            | 576            | VD-283            | 208            | VD-432/2          | 648            |
| VD-144/3          | 116            | VD-235            | 550            | VD-289            | 931            | VD-433            | 666            |
| VD-146            | 598            | VD-236            | 555            | VD-290            | 932            | VD-434            | 687            |
| VD-147            | 614            | VD-239            | 107            | VD-301            | 503            | VD-435            | 704            |
| VD-147            | 161            | VD-239            | 575            | VD-306            | 512            | VD-435/2          | 886            |
| VD-147/2          | 158            | VD-240            | 570            | VD-309            | 516            | VD-435/2          | 920            |
| VD-147/2          | 881            | VD-241            | 580            | VD-312            | 524            | VD-436            | 715            |
| VD-150            | 110            | VD-242            | 590            | VD-314            | 538            | VD-436/2          | 765            |
| VD-150            | 618            | VD-242/2          | 613            | VD-318            | 511            | VD-437            | 676            |
| VD-152            | 108            | VD-242/3          | 590            | VD-320            | 515            | VD-437            | 729            |
| VD-152            | 588            | VD-244            | 589            | VD-322            | 533            | VD-437/2          | 779            |
| VD-153            | 629            | VD-244            | 136            | VD-324            | 534            | VD-438            | 726            |
| VD-154            | 622            | VD-245            | 596            | VD-327            | 556            | VD-439            | 778            |
| VD-156            | 183            | VD-246            | 616            | VD-327/2          | 556            | VD-439            | 743            |
| VD-156            | 212            | VD-247            | 111            | VD-328            | 578            | VD-440            | 752            |
| VD-156            | 627            | VD-247            | 619            | VD-329            | 581            | VD-441            | 801            |
| VD-156            | 630            | VD-248            | 198            | VD-329/2          | 582            | VD-442            | 798            |
| VD-156/2          | 184            | VD-248            | 634            | VD-331            | 577            | VD-443            | 782            |
| VD-156/2          | 630            | VD-248/2          | 198            | VD-332            | 591            | VD-444            | 838            |
| VD-156/2          | 700            | VD-249            | 639            | VD-335            | 587            | VD-9000           | 796            |
| VD-156/3          | 181            | VD-250            | 119            | VD-340            | 197            | VD-9001           | 802            |
| VD-156/3          | 654            | VD-250            | 134            | VD-340            | 120            | VD-9003           | 803            |
| VD-160            | 860            | VD-250            | 638            | VD-340            | 611            | VD-9004           | 189            |
| VD-160            | 664            | VD-250            | 688            | VD-340/2          | 163            | VD-9004           | 821            |
| VD-161            | 694            | VD-250/2          | 633            | VD-340/2          | 713            | VD-9006           | 783            |
| VD-162            | 115            | VD-250/2          | 688            | VD-340/4          | 611            | VD-9007           | 148            |
| VD-162            | 670            | VD-250/3          | 638            | VD-341            | 649            | VD-9007           | 652            |

| Vesrah No. | SBS No. | Vesrah No. | SBS No. | Vesrah No. | SBS No. | Vesrah No. | SBS No. |
|------------|---------|------------|---------|------------|---------|------------|---------|
| VD-9009    | 807     | VD-917     | 553     | VD-974     | 152     |            |         |
| VD-901     | 679     | VD-918     | 549     | VD-974     | 747     |            |         |
| VD-9010    | 808     | VD-919     | 579     | VD-975     | 658     |            |         |
| VD-9011    | 805     | VD-920     | 574     | VD-976     | 153     |            |         |
| VD-9012    | 140     | VD-920     | 106     | VD-977     | 824     |            |         |
| VD-9012    | 708     | VD-924     | 594     | VD-979     | 767     |            |         |
| VD-9013    | 173     | VD-926     | 625     | VD-979/2   | 836     |            |         |
| VD-9013    | 780     | VD-927     | 641     | VD-981     | 772     |            |         |
| VD-9015    | 192     | VD-928     | 560     | VD-981     | 166     |            |         |
| VD-9015    | 197     | VD-930     | 133     | VD-982     | 681     |            |         |
| VD-9015    | 774     | VD-930     | 605     | VD-983     | 177     |            |         |
| VD-9017    | 159     | VD-931     | 606     | VD-986     | 762     |            |         |
| VD-9018    | 179     | VD-932     | 132     | VD-987     | 171     |            |         |
| VD-9019    | 150     | VD-932     | 595     | VD-987     | 775     |            |         |
| VD-9022    | 826     | VD-933     | 554     | VD-988     | 172     |            |         |
| VD-9023    | 822     | VD-934     | 640     | VD-991     | 794     |            |         |
| VD-9024    | 800     | VD-935     | 527     | VD-992     | 787     |            |         |
| VD-9025    | 830     | VD-936     | 621     | VD-993     | 795     |            |         |
| VD-9026    | 210     | VD-936     | 124     | VD-994     | 178     |            |         |
| VD-9026    | 810     | VD-937     | 109     | VD-994     | 792     |            |         |
| VD-9027    | 677     | VD-937     | 607     | VD-995     | 154     |            |         |
| VD-9030    | 842     | VD-938     | 636     | VD-995     | 746     |            |         |
| VD-9031    | 841     | VD-939     | 643     | VD-995     | 749     |            |         |
| VD-9031    | 901     | VD-940     | 642     | VD-996     | 141     |            |         |
| VD-9033    | 826     | VD-941     | 644     | VD-996     | 723     |            |         |
| VD-9033    | 846     | VD-942     | 608     | VD-997     | 791     |            |         |
| VD-9034    | 853     | VD-943     | 601     | VD-998     | 763     |            |         |
| VD-9035    | 854     | VD-944     | 678     | VD-999     | 167     |            |         |
| VD-9036    | 897     | VD-944/2   | 662     | VD-999     | 773     |            |         |
| VD-9037    | 898     | VD-945     | 566     |            |         |            |         |
| VD-9038    | 856     | VD-946     | 105     |            |         |            |         |
| VD-9039    | 661     | VD-946     | 188     |            |         |            |         |
| VD-904     | 505     | VD-946     | 559     |            |         |            |         |
| VD-9044    | 195     | VD-947     | 151     |            |         |            |         |
| VD-9045    | 201     | VD-947     | 194     |            |         |            |         |
| VD-9045    | 204     | VD-947     | 671     |            |         |            |         |
| VD-9045    | 847     | VD-947/2   | 742     |            |         |            |         |
| VD-9046    | 866     | VD-948     | 123     |            |         |            |         |
| VD-9047    | 867     | VD-948     | 697     |            |         |            |         |
| VD-9048    | 864     | VD-948/2   | 143     |            |         |            |         |
| VD-9049    | 899     | VD-949     | 117     |            |         |            |         |
| VD-9050    | 905     | VD-949     | 680     |            |         |            |         |
| VD-9050    | 906     | VD-950     | 717     |            |         |            |         |
| VD-9052    | 844     | VD-952     | 716     |            |         |            |         |
| VD-9053    | 870     | VD-952     | 219     |            |         |            |         |
| VD-9056    | 191     | VD-953     | 175     |            |         |            |         |
| VD-9057    | 904     | VD-953     | 675     |            |         |            |         |
| VD-9058    | 885     | VD-955     | 130     |            |         |            |         |
| VD-906     | 523     | VD-956     | 668     |            |         |            |         |
| VD-906/2   | 698     | VD-957     | 669     |            |         |            |         |
| VD-9060    | 908     | VD-958     | 176     |            |         |            |         |
| VD-9061    | 911     | VD-958     | 674     |            |         |            |         |
| VD-9062    | 910     | VD-959     | 703     |            |         |            |         |
| VD-9063    | 872     | VD-960     | 145     |            |         |            |         |
| VD-9068    | 877     | VD-960     | 129     |            |         |            |         |
| VD-907     | 506     | VD-961     | 707     |            |         |            |         |
| VD-9070    | 900     | VD-962     | 129     |            |         |            |         |
| VD-9071    | 187     | VD-963     | 755     |            |         |            |         |
| VD-9073    | 200     | VD-964     | 157     |            |         |            |         |
| VD-9075    | 922     | VD-964     | 730     |            |         |            |         |
| VD-9076    | 923     | VD-965     | 758     |            |         |            |         |
| VD-908     | 537     | VD-967/2   | 120     |            |         |            |         |
| VD-9082    | 934     | VD-967/2   | 168     |            |         |            |         |
| VD-909     | 543     | VD-967/2   | 774     |            |         |            |         |
| VD-910     | 520     | VD-967/2   | 689     |            |         |            |         |
| VD-911     | 138     | VD-968     | 142     |            |         |            |         |
| VD-911     | 519     | VD-968     | 202     |            |         |            |         |
| VD-911/2   | 131     | VD-969     | 695     |            |         |            |         |
| VD-911/2   | 583     | VD-969/2   | 711     |            |         |            |         |
| VD-911/2   | 646     | VD-970     | 720     |            |         |            |         |
| VD-911/4   | 149     | VD-971     | 750     |            |         |            |         |
| VD-912     | 532     | VD-972     | 746     |            |         |            |         |
| VD-915     | 513     | VD-973     | 757     |            |         |            |         |

| Ferodo No. | SBS No. | Ferodo No. | SBS No. | Ferodo No. | SBS No. | Ferodo No. | SBS No. |
|------------|---------|------------|---------|------------|---------|------------|---------|
| FDB88      | 505     | FDB383     | 575     | FDB680     | 123     | FDB2073    | 156     |
| FDB108     | 506     | FDB384     | 203     | FDB680     | 143     | FDB2073    | 721     |
| FDB118     | 502     | FDB384     | 585     | FDB680     | 677     | FDB2073    | 735     |
| FDB119     | 501     | FDB386     | 570     | FDB680     | 771     | FDB2073    | 736     |
| FDB120     | 503     | FDB389     | 577     | FDB680     | 697     | FDB2074    | 157     |
| FDB132     | 510     | FDB390     | 578     | FDB695     | 606     | FDB2074    | 730     |
| FDB134     | 509     | FDB404     | 581     | FDB696     | 133     | FDB2075    | 722     |
| FDB136     | 525     | FDB411     | 580     | FDB696     | 605     | FDB2075    | 147     |
| FDB137     | 521     | FDB436     | 132     | FDB697     | 109     | FDB2079    | 860     |
| FDB150     | 511     | FDB436     | 595     | FDB697     | 607     | FDB2080    | 726     |
| FDB151     | 512     | FDB437     | 587     | FDB699     | 653     | FDB2080    | 798     |
| FDB155     | 520     | FDB438     | 108     | FDB706     | 148     | FDB2081    | 149     |
| FDB157     | 504     | FDB438     | 588     | FDB706     | 652     | FDB2081    | 646     |
| FDB177     | 507     | FDB449     | 590     | FDB731     | 113     | FDB2083    | 155     |
| FDB178     | 515     | FDB452     | 600     | FDB731     | 541     | FDB2083    | 728     |
| FDB181     | 514     | FDB481     | 597     | FDB731     | 651     | FDB2084    | 733     |
| FDB182     | 508     | FDB485     | 668     | FDB736     | 640     | FDB2085    | 146     |
| FDB182     | 517     | FDB494     | 602     | FDB737     | 137     | FDB2085    | 740     |
| FDB183     | 526     | FDB495     | 603     | FDB737     | 650     | FDB2085    | 743     |
| FDB184     | 528     | FDB495     | 139     | FDB741     | 666     | FDB2086    | 174     |
| FDB185     | 513     | FDB496     | 623     | FDB754     | 657     | FDB2087    | 119     |
| FDB202     | 527     | FDB497     | 163     | FDB754     | 162     | FDB2087    | 134     |
| FDB204     | 554     | FDB497     | 197     | FDB781     | 170     | FDB2087    | 638     |
| FDB205     | 560     | FDB497     | 611     | FDB781     | 663     | FDB2087    | 688     |
| FDB207     | 138     | FDB497     | 713     | FDB782     | 681     | FDB2090    | 152     |
| FDB207     | 519     | FDB498     | 601     | FDB783     | 116     | FDB2090    | 747     |
| FDB207     | 131     | FDB499     | 608     | FDB828     | 684     | FDB2095    | 153     |
| FDB207     | 583     | FDB508     | 615     | FDB828     | 118     | FDB2096    | 154     |
| FDB213     | 532     | FDB515     | 636     | FDB847     | 658     | FDB2096    | 749     |
| FDB217     | 534     | FDB529     | 641     | FDB864     | 683     | FDB2097    | 750     |
| FDB218     | 533     | FDB531     | 614     | FDB865     | 682     | FDB2099    | 727     |
| FDB220     | 530     | FDB531     | 161     | FDB866     | 672     | FDB2100    | 117     |
| FDB244     | 160     | FDB533     | 622     | FDB866     | 126     | FDB2100    | 680     |
| FDB244     | 542     | FDB538     | 127     | FDB889     | 114     | FDB2101    | 129     |
| FDB247     | 545     | FDB538     | 572     | FDB889     | 667     | FDB2102    | 746     |
| FDB248     | 522     | FDB539     | 604     | FDB892     | 694     | FDB2103    | 815     |
| FDB248     | 531     | FDB539     | 144     | FDB2001    | 669     | FDB2105    | 159     |
| FDB249     | 535     | FDB557     | 624     | FDB2002    | 685     | FDB2106    | 168     |
| FDB250     | 100     | FDB557     | 714     | FDB2003    | 128     | FDB2106    | 774     |
| FDB250     | 536     | FDB561     | 621     | FDB2003    | 691     | FDB2107    | 105     |
| FDB250     | 643     | FDB569     | 620     | FDB2005    | 175     | FDB2107    | 559     |
| FDB277     | 547     | FDB570     | 181     | FDB2005    | 675     | FDB2108    | 178     |
| FDB298     | 540     | FDB570     | 654     | FDB2006    | 176     | FDB2108    | 792     |
| FDB299     | 539     | FDB570     | 700     | FDB2006    | 674     | FDB2109    | 802     |
| FDB310     | 552     | FDB574     | 631     | FDB2007    | 695     | FDB2110    | 752     |
| FDB310     | 571     | FDB583     | 596     | FDB2012    | 687     | FDB2111    | 715     |
| FDB311     | 550     | FDB591     | 616     | FDB2013    | 591     | FDB2111    | 765     |
| FDB312     | 103     | FDB592     | 594     | FDB2014    | 576     | FDB2113    | 593     |
| FDB312     | 200     | FDB605     | 198     | FDB2015    | 589     | FDB2114    | 734     |
| FDB312     | 551     | FDB605     | 634     | FDB2015    | 136     | FDB2115    | 772     |
| FDB312     | 814     | FDB605     | 639     | FDB2016    | 649     | FDB2115    | 166     |
| FDB313     | 102     | FDB606     | 626     | FDB2017    | 637     | FDB2119    | 125     |
| FDB313     | 101     | FDB607     | 635     | FDB2018    | 151     | FDB2119    | 709     |
| FDB313     | 544     | FDB624     | 574     | FDB2018    | 671     | FDB2120    | 762     |
| FDB313     | 548     | FDB624     | 106     | FDB2036    | 676     | FDB2121    | 755     |
| FDB314     | 135     | FDB625     | 115     | FDB2036    | 729     | FDB2123    | 711     |
| FDB314     | 546     | FDB625     | 670     | FDB2037    | 130     | FDB2124    | 778     |
| FDB314     | 586     | FDB631     | 633     | FDB2039    | 742     | FDB2125    | 796     |
| FDB314     | 692     | FDB636     | 111     | FDB2040    | 678     | FDB2126    | 169     |
| FDB333     | 537     | FDB636     | 619     | FDB2041    | 662     | FDB2127    | 803     |
| FDB334     | 543     | FDB637     | 665     | FDB2042    | 706     | FDB2128    | 167     |
| FDB335     | 549     | FDB659     | 632     | FDB2048    | 705     | FDB2128    | 773     |
| FDB336     | 553     | FDB659     | 648     | FDB2049    | 704     | FDB2129    | 150     |
| FDB337     | 555     | FDB661     | 584     | FDB2050    | 644     | FDB2130    | 158     |
| FDB338     | 556     | FDB662     | 613     | FDB2050    | 703     | FDB2133    | 122     |
| FDB339     | 557     | FDB663     | 647     | FDB2054    | 717     | FDB2133    | 702     |
| FDB342     | 523     | FDB664     | 630     | FDB2055    | 642     | FDB2139    | 777     |
| FDB352     | 579     | FDB666     | 645     | FDB2055    | 716     | FDB2140    | 172     |
| FDB381     | 562     | FDB672     | 121     | FDB2055    | 219     | FDB2141    | 171     |
| FDB381     | 592     | FDB672     | 690     | FDB2056    | 142     | FDB2141    | 775     |
| FDB382     | 104     | FDB673     | 582     | FDB2058    | 701     | FDB2142    | 177     |
| FDB382     | 558     | FDB677     | 120     | FDB2060    | 124     | FDB2143    | 784     |
| FDB383     | 107     | FDB677     | 689     | FDB2062    | 145     | FDB2143    | 225     |

| Ferodo No. | SBS No. | Ferodo No. | SBS No. | Ferodo No. | SBS No. | Ferodo No. | SBS No. |
|------------|---------|------------|---------|------------|---------|------------|---------|
| FDB2144    | 686     | FDB2233    | 852     |            |         |            |         |
| FDB2145    | 795     | FDB2236    | 800     |            |         |            |         |
| FDB2146    | 179     | FDB2238    | 858     |            |         |            |         |
| FDB2147    | 173     | FDB2238    | 862     |            |         |            |         |
| FDB2147    | 780     | FDB2238    | 227     |            |         |            |         |
| FDB2148    | 196     | FDB2240    | 856     |            |         |            |         |
| FDB2148    | 754     | FDB2241    | 857     |            |         |            |         |
| FDB2149    | 767     | FDB2242    | 859     |            |         |            |         |
| FDB2150    | 770     | FDB2242    | 228     |            |         |            |         |
| FDB2156    | 769     | FDB2244    | 843     |            |         |            |         |
| FDB2157    | 783     | FDB2245    | 842     |            |         |            |         |
| FDB2158    | 782     | FDB2248    | 204     |            |         |            |         |
| FDB2162    | 790     | FDB2250    | 853     |            |         |            |         |
| FDB2163    | 789     | FDB2251    | 854     |            |         |            |         |
| FDB2164    | 788     | FDB2252    | 864     |            |         |            |         |
| FDB2165    | 791     | FDB2253    | 862     |            |         |            |         |
| FDB2166    | 805     | FDB2254    | 195     |            |         |            |         |
| FDB2167    | 707     | FDB2254    | 863     |            |         |            |         |
| FDB2169    | 180     | FDB2255    | 870     |            |         |            |         |
| FDB2169    | 797     | FDB2256    | 205     |            |         |            |         |
| FDB2171    | 732     | FDB2257    | 872     |            |         |            |         |
| FDB2173    | 182     | FDB2258    | 881     |            |         |            |         |
| FDB2175    | 758     | FDB2259    | 869     |            |         |            |         |
| FDB2176    | 787     | FDB2260    | 841     |            |         |            |         |
| FDB2177    | 757     | FDB2262    | 885     |            |         |            |         |
| FDB2178    | 806     | FDB2263    | 897     |            |         |            |         |
| FDB2179    | 807     | FDB2264    | 208     |            |         |            |         |
| FDB2180    | 808     | FDB2265    | 900     |            |         |            |         |
| FDB2181    | 809     | FDB2266    | 877     |            |         |            |         |
| FDB2182    | 813     | FDB2267    | 895     |            |         |            |         |
| FDB2183    | 794     | FDB2271    | 907     |            |         |            |         |
| FDB2184    | 810     | FDB2272    | 908     |            |         |            |         |
| FDB2186    | 187     | FDB2273    | 911     |            |         |            |         |
| FDB2187    | 183     | FDB2274    | 910     |            |         |            |         |
| FDB2187    | 627     | FDB2275    | 915     |            |         |            |         |
| FDB2188    | 801     | FDB2276    | 899     |            |         |            |         |
| FDB2190    | 140     | FDB2277    | 224     |            |         |            |         |
| FDB2190    | 708     | FDB2278    | 889     |            |         |            |         |
| FDB2191    | 141     | FDB2279    | 221     |            |         |            |         |
| FDB2191    | 723     | FDB2280    | 932     |            |         |            |         |
| FDB2192    | 110     | FDB2281    | 892     |            |         |            |         |
| FDB2192    | 618     | FDB2282    | 216     |            |         |            |         |
| FDB2193    | 799     | FDB2283    | 933     |            |         |            |         |
| FDB2194    | 659     | FDB2284    | 207     |            |         |            |         |
| FDB2196    | 192     | FRP202     | 569     |            |         |            |         |
| FDB2196    | 828     | FRP408     | 566     |            |         |            |         |
| FDB2197    | 820     | FRP410     | 599     |            |         |            |         |
| FDB2198    | 763     | FRP410     | 661     |            |         |            |         |
| FDB2200    | 185     | FRP415     | 656     |            |         |            |         |
| FDB2201    | 189     | FRP418     | 660     |            |         |            |         |
| FDB2201    | 821     |            |         |            |         |            |         |
| FDB2202    | 846     |            |         |            |         |            |         |
| FDB2206    | 861     |            |         |            |         |            |         |
| FDB2206    | 199     |            |         |            |         |            |         |
| FDB2208    | 194     |            |         |            |         |            |         |
| FDB2208    | 837     |            |         |            |         |            |         |
| FDB2210    | 830     |            |         |            |         |            |         |
| FDB2213    | 833     |            |         |            |         |            |         |
| FDB2216    | 844     |            |         |            |         |            |         |
| FDB2216    | 214     |            |         |            |         |            |         |
| FDB2217    | 839     |            |         |            |         |            |         |
| FDB2218    | 841     |            |         |            |         |            |         |
| FDB2219    | 840     |            |         |            |         |            |         |
| FDB2220    | 838     |            |         |            |         |            |         |
| FDB2221    | 834     |            |         |            |         |            |         |
| FDB2224    | 190     |            |         |            |         |            |         |
| FDB2224    | 823     |            |         |            |         |            |         |
| FDB2226    | 201     |            |         |            |         |            |         |
| FDB2226    | 847     |            |         |            |         |            |         |
| FDB2228    | 845     |            |         |            |         |            |         |
| FDB2230    | 849     |            |         |            |         |            |         |
| FDB2231    | 850     |            |         |            |         |            |         |
| FDB2232    | 851     |            |         |            |         |            |         |

| CL Brakes No. | SBS No. | CL Brakes No. | SBS No. | CL Brakes No. | SBS No. | CL Brakes No. | SBS No. |
|---------------|---------|---------------|---------|---------------|---------|---------------|---------|
| 1033          | 762     | 1219          | 872     | 2307          | 123     | 2430          | 703     |
| 1034          | 752     | 1223          | 773     | 2307          | 667     | 2451          | 558     |
| 1066          | 770     | 1223          | 167     | 2308          | 626     | 2451          | 104     |
| 1067          | 784     | 1224          | 858     | 2309          | 665     | 2451          | 125     |
| 1067          | 225     | 1224          | 227     | 2309          | 645     | 2451          | 709     |
| 1075          | 805     | 1228          | 885     | 2310          | 600     | 2457          | 108     |
| 1076          | 777     | 1229          | 897     | 2311          | 645     | 2457          | 588     |
| 1078          | 783     | 1231          | 880     | 2313          | 630     | 2466          | 541     |
| 1083          | 782     | 1232          | 900     | 2313          | 654     | 2466          | 692     |
| 1084          | 769     | 1233          | 877     | 2313          | 700     | 2469          | 544     |
| 1089          | 574     | 1235          | 836     | 2313          | 181     | 2469          | 548     |
| 1101          | 796     | 1236          | 835     | 2314          | 604     | 2469          | 101     |
| 1102          | 767     | 2245          | 622     | 2314          | 144     | 2469          | 102     |
| 1102          | 816     | 2246          | 624     | 2326          | 633     | 2472          | 651     |
| 1102          | 836     | 2247          | 566     | 2326          | 638     | 2472          | 684     |
| 1103          | 790     | 2248          | 647     | 2326          | 688     | 2472          | 118     |
| 1108          | 791     | 2249          | 131     | 2326          | 173     | 2539          | 706     |
| 1110          | 788     | 2249          | 519     | 2326          | 780     | 2546          | 691     |
| 1123          | 749     | 2249          | 646     | 2328          | 562     | 2546          | 170     |
| 1123          | 154     | 2249          | 737     | 2328          | 584     | 2546          | 663     |
| 1128          | 794     | 2249          | 138     | 2328          | 592     | 2584          | 677     |
| 1129          | 843     | 2249          | 583     | 2329          | 695     | 2599          | 513     |
| 1133          | 806     | 2251          | 631     | 2329          | 711     | 2601          | 672     |
| 1134          | 809     | 2252          | 593     | 2332          | 506     | 2601          | 126     |
| 1139          | 895     | 2252          | 174     | 2342          | 668     | 2602          | 722     |
| 1140          | 813     | 2253          | 613     | 2352          | 671     | 2602          | 735     |
| 1141          | 798     | 2254          | 683     | 2352          | 924     | 2602          | 736     |
| 1142          | 801     | 2255          | 686     | 2352          | 742     | 2602          | 147     |
| 1144          | 652     | 2256          | 627     | 2353          | 675     | 2602          | 156     |
| 1145          | 789     | 2257          | 685     | 2353          | 175     | 2602          | 159     |
| 1146          | 774     | 2258          | 640     | 2360          | 137     | 2602          | 721     |
| 1146          | 168     | 2260          | 680     | 2360          | 650     | 2621          | 551     |
| 1147          | 810     | 2260          | 109     | 2361          | 634     | 2621          | 814     |
| 1148          | 797     | 2260          | 117     | 2361          | 639     | 2621          | 103     |
| 1148          | 180     | 2260          | 607     | 2361          | 198     | 2621          | 200     |
| 1149          | 807     | 2263          | 116     | 2362          | 682     | 2694          | 533     |
| 1150          | 808     | 2269          | 659     | 2363          | 666     | 2696          | 619     |
| 1151          | 775     | 2280          | 577     | 2369          | 658     | 2696          | 111     |
| 1151          | 171     | 2280          | 512     | 2370          | 669     | 2699          | 579     |
| 1152          | 820     | 2281          | 620     | 2377          | 559     | 2700          | 537     |
| 1159          | 828     | 2282          | 556     | 2381          | 687     | 2701          | 549     |
| 1159          | 192     | 2283          | 555     | 2382          | 572     | 2702          | 553     |
| 1163          | 833     | 2284          | 575     | 2382          | 127     | 2711          | 734     |
| 1164          | 709     | 2284          | 107     | 2383          | 705     | 2711          | 860     |
| 1165          | 787     | 2285          | 557     | 2384          | 704     | 2713          | 733     |
| 1167          | 824     | 2287          | 618     | 2384          | 886     | 2718          | 543     |
| 1171          | 822     | 2287          | 110     | 2385          | 623     | 2720          | 707     |
| 1172          | 830     | 2288          | 611     | 2386          | 582     | 2750          | 726     |
| 1174          | 834     | 2288          | 713     | 2387          | 581     | 2792          | 580     |
| 1175          | 740     | 2288          | 197     | 2388          | 635     | 2794          | 588     |
| 1175          | 146     | 2289          | 542     | 2389          | 615     | 2794          | 124     |
| 1177          | 838     | 2289          | 160     | 2390          | 701     | 2799          | 591     |
| 1180          | 839     | 2296          | 657     | 2390          | 556     | 2801          | 594     |
| 1183          | 840     | 2296          | 162     | 2391          | 663     | 2802          | 550     |
| 1184          | 847     | 2298          | 614     | 2391          | 170     | 2807          | 547     |
| 1184          | 201     | 2298          | 881     | 2392          | 616     | 2813          | 715     |
| 1185          | 841     | 2298          | 161     | 2393          | 596     | 2813          | 765     |
| 1187          | 844     | 2299          | 632     | 2396          | 674     | 2814          | 508     |
| 1187          | 214     | 2299          | 648     | 2396          | 176     | 2814          | 517     |
| 1192          | 849     | 2300          | 694     | 2398          | 601     | 2827          | 730     |
| 1193          | 850     | 2301          | 570     | 2399          | 621     | 2827          | 157     |
| 1194          | 851     | 2302          | 603     | 2399          | 124     | 2828          | 728     |
| 1195          | 852     | 2302          | 139     | 2400          | 608     | 2828          | 155     |
| 1203          | 763     | 2303          | 644     | 2400          | 641     | 2840          | 554     |
| 1204          | 866     | 2304          | 597     | 2404          | 729     | 2847          | 507     |
| 1205          | 867     | 2305          | 590     | 2404          | 779     | 2899          | 676     |
| 1207          | 870     | 2306          | 546     | 2404          | 676     | 2900          | 742     |
| 1209          | 864     | 2306          | 586     | 2408          | 536     | 2914          | 702     |
| 1211          | 846     | 2306          | 692     | 2408          | 670     | 2914          | 122     |
| 1212          | 853     | 2306          | 113     | 2408          | 100     | 2922          | 719     |
| 1213          | 854     | 2306          | 651     | 2424          | 589     | 2923          | 735     |
| 1216          | 869     | 2307          | 697     | 2424          | 136     | 2923          | 754     |
| 1217          | 862     | 2307          | 114     | 2430          | 644     | 2923          | 196     |



| CL Brakes No. | SBS No. | CL Brakes No. | SBS No. | CL Brakes No. | SBS No. | CL Brakes No. | SBS No. |
|---------------|---------|---------------|---------|---------------|---------|---------------|---------|
| 2923          | 156     | 3036          | 638     | 3092          | 201     |               |         |
| 2924          | 717     | 3037          | 106     | 3094          | 204     |               |         |
| 2925          | 755     | 3037          | 574     | 3095          | 155     |               |         |
| 2926          | 758     | 3038          | 115     | 3096          | 200     |               |         |
| 2927          | 642     | 3038          | 670     | 3097          | 181     |               |         |
| 2927          | 716     | 3039          | 140     | 3098          | 208     |               |         |
| 2927          | 219     | 3039          | 708     | 3099          | 858     |               |         |
| 2950          | 698     | 3041          | 129     | 3099          | 227     |               |         |
| 2958          | 750     | 3043          | 142     | 3100          | 219     |               |         |
| 2960          | 778     | 3043          | 202     | 3102          | 205     |               |         |
| 2961          | 714     | 3045          | 130     |               |         |               |         |
| 2987          | 746     | 3047          | 141     |               |         |               |         |
| 3001          | 138     | 3047          | 723     |               |         |               |         |
| 3003          | 183     | 3049          | 146     |               |         |               |         |
| 3004          | 109     | 3049          | 740     |               |         |               |         |
| 3006          | 116     | 3051          | 122     |               |         |               |         |
| 3006          | 121     | 3051          | 702     |               |         |               |         |
| 3006          | 690     | 3053          | 117     |               |         |               |         |
| 3008          | 107     | 3054          | 166     |               |         |               |         |
| 3008          | 575     | 3054          | 772     |               |         |               |         |
| 3009          | 110     | 3055          | 152     |               |         |               |         |
| 3009          | 618     | 3055          | 747     |               |         |               |         |
| 3011          | 160     | 3056          | 159     |               |         |               |         |
| 3011          | 542     | 3057          | 157     |               |         |               |         |
| 3012          | 118     | 3057          | 730     |               |         |               |         |
| 3012          | 135     | 3058          | 170     |               |         |               |         |
| 3013          | 114     | 3059          | 184     |               |         |               |         |
| 3013          | 123     | 3060          | 177     |               |         |               |         |
| 3013          | 143     | 3061          | 169     |               |         |               |         |
| 3013          | 149     | 3062          | 119     |               |         |               |         |
| 3013          | 164     | 3062          | 688     |               |         |               |         |
| 3013          | 718     | 3063          | 167     |               |         |               |         |
| 3013          | 697     | 3063          | 773     |               |         |               |         |
| 3014          | 121     | 3064          | 153     |               |         |               |         |
| 3014          | 144     | 3065          | 183     |               |         |               |         |
| 3014          | 604     | 3065          | 627     |               |         |               |         |
| 3015          | 105     | 3066          | 182     |               |         |               |         |
| 3015          | 559     | 3067          | 178     |               |         |               |         |
| 3017          | 127     | 3067          | 792     |               |         |               |         |
| 3017          | 572     | 3068          | 154     |               |         |               |         |
| 3018          | 100     | 3069          | 148     |               |         |               |         |
| 3018          | 536     | 3069          | 186     |               |         |               |         |
| 3019          | 104     | 3069          | 190     |               |         |               |         |
| 3019          | 558     | 3069          | 652     |               |         |               |         |
| 3020          | 124     | 3069          | 817     |               |         |               |         |
| 3020          | 108     | 3069          | 823     |               |         |               |         |
| 3020          | 588     | 3070          | 171     |               |         |               |         |
| 3021          | 108     | 3071          | 172     |               |         |               |         |
| 3022          | 101     | 3072          | 179     |               |         |               |         |
| 3022          | 102     | 3073          | 125     |               |         |               |         |
| 3022          | 544     | 3074          | 174     |               |         |               |         |
| 3024          | 113     | 3075          | 185     |               |         |               |         |
| 3024          | 118     | 3076          | 161     |               |         |               |         |
| 3024          | 135     | 3077          | 187     |               |         |               |         |
| 3024          | 546     | 3078          | 163     |               |         |               |         |
| 3025          | 128     | 3079          | 158     |               |         |               |         |
| 3025          | 691     | 3080          | 180     |               |         |               |         |
| 3026          | 147     | 3081          | 173     |               |         |               |         |
| 3026          | 156     | 3082          | 192     |               |         |               |         |
| 3027          | 145     | 3083          | 193     |               |         |               |         |
| 3027          | 129     | 3083          | 832     |               |         |               |         |
| 3028          | 151     | 3084          | 191     |               |         |               |         |
| 3028          | 671     | 3084          | 831     |               |         |               |         |
| 3029          | 111     | 3085          | 194     |               |         |               |         |
| 3029          | 619     | 3085          | 837     |               |         |               |         |
| 3031          | 120     | 3086          | 134     |               |         |               |         |
| 3031          | 168     | 3087          | 197     |               |         |               |         |
| 3031          | 689     | 3087          | 713     |               |         |               |         |
| 3033          | 155     | 3087          | 163     |               |         |               |         |
| 3033          | 728     | 3089          | 195     |               |         |               |         |
| 3034          | 132     | 3089          | 863     |               |         |               |         |
| 3034          | 595     | 3090          | 196     |               |         |               |         |
| 3036          | 134     | 3091          | 198     |               |         |               |         |



# **BRAKE PINS**

## **FITMENTS, DRAWINGS**



|                  |               |         | Complete set |  |  |
|------------------|---------------|---------|--------------|---|---|
| <b>HONDA</b>     |               |         |              |   |   |
| CR               | 125 R         | 98 - 01 | 4000         | 4506  | 4505  |
| CR               | 125 R         | 02 - 07 | 4001         | 4506  | 4508  |
| CR               | 250 R         | 95 - 01 | 4000         | 4506  | 4505  |
| CR               | 250 R         | 02 - 07 | 4001         | 4506  | 4508  |
| CRF              | 250 R         | 04 - 09 | 4001         | 4506  | 4508  |
| CRF              | 250 R Efi     | 10 - 17 | 4001         | 4506  | 4508  |
| CRF              | 250 R Efi     | 18 -    | 4001         | 4506  | 4508  |
| CRF              | 250 X         | 04 - 14 | 4001         | 4506  | 4508  |
| CRF              | 450 R         | 02 - 08 | 4001         | 4506  | 4508  |
| CRF              | 450 Efi       | 09 - 12 | 4001         | 4506  | 4508  |
| CRF              | 450 R Efi     | 13 - 18 | 4001         | 4506  | 4508  |
| CRF              | 450 RX Efi    | 17 - 18 | 4001         | 4506  | 4508  |
| CRF              | 450 X         | 05 - 18 | 4001         | 4506  | 4508  |
| <b>HUSQVARNA</b> |               |         |              |   |   |
| CR               | 125           | 05 - 13 | 4003         | 4507  | 4510  |
| TC               | 125           | 14 - 18 | 4003         | 4507  | 4510  |
| TE               | 125           | 14 - 16 | 4003         | 4507  | 4510  |
| TX               | 125           | 17 - 18 | 4003         | 4507  | 4510  |
| CR               | 250           | 05      | 4003         | 4507  | 4510  |
| FC               | 250           | 14 - 18 | 4003         | 4507  | 4510  |
| FE               | 250           | 14 - 18 | 4003         | 4507  | 4510  |
| TC               | 250           | 04 - 18 | 4003         | 4507  | 4510  |
| TE               | 250           | 02 - 18 | 4003         | 4507  | 4510  |
| TE               | 300           | 14 - 18 | 4003         | 4507  | 4510  |
| FC               | 350           | 14 - 18 | 4003         | 4507  | 4510  |
| FE               | 350           | 14 - 18 | 4003         | 4507  | 4510  |
| TC               | 449           | 11 - 13 | 4003         | 4507  | 4510  |
| FC               | 450           | 14 - 18 | 4003         | 4507  | 4510  |
| FE               | 450           | 14 - 18 | 4003         | 4507  | 4510  |
| TE               | 450           | 14      | 4003         | 4507  | 4510  |
| FE               | 501           | 14 - 18 | 4003         | 4507  | 4510  |
| TE               | 511           | 11 - 13 | 4003         | 4507  | 4510  |
| <b>KAWASAKI</b>  |               |         |              |   |   |
| KX               | 125           | 95 - 96 | 4000         | 4506  | 4505  |
| KX               | 125           | 97 - 08 | 4002         | 4509  | 4505  |
| KX               | 250           | 95 - 96 | 4000         | 4506  | 4505  |
| KX               | 250           | 97 - 08 | 4002         | 4509  | 4505  |
| KX-F             | 250           | 04 - 10 | 4002         | 4509  | 4505  |
| KX-F             | 250 DFI       | 11 - 18 | 4002         | 4509  | 4505  |
| KX-F             | 450           | 06 - 08 | 4002         | 4509  | 4505  |
| KX-F             | 450 DFI       | 09 - 18 | 4002         | 4509  | 4505  |
| <b>KTM</b>       |               |         |              |   |   |
| EXC              | 125 Enduro    | 04 - 15 | 4003         | 4507  | 4510  |
| SX               | 125           | 00 - 18 | 4003         | 4507  | 4510  |
| SX               | 144           | 07 - 08 | 4003         | 4507  | 4510  |
| SX               | 150           | 09 - 18 | 4003         | 4507  | 4510  |
| EXC              | 200 Enduro    | 04 - 16 | 4003         | 4507  | 4510  |
| SX               | 200           | 03 - 04 | 4003         | 4507  | 4510  |
| EXC              | 250 Enduro    | 04 - 08 | 4003         | 4507  | 4510  |
| EXC              | 250 Enduro 4T | 04 - 06 | 4003         | 4507  | 4510  |
| EXC              | 250 TPI       | 18 -    | 4003         | 4507  | 4510  |
| EXC-F            | 250 Enduro    | 07 - 18 | 4003         | 4507  | 4510  |
| SX               | 250           | 03 - 18 | 4003         | 4507  | 4510  |
| SX-F             | 250           | 06 - 18 | 4003         | 4507  | 4510  |
| XC               | 250           | 06 - 14 | 4003         | 4507  | 4510  |
| EXC              | 300 Enduro    | 04 - 08 | 4003         | 4507  | 4510  |
| EXC              | 300 TPI       | 18 -    | 4003         | 4507  | 4510  |
| XC               | 300           | 06 - 14 | 4003         | 4507  | 4510  |
| EXC-F            | 350           | 11 - 18 | 4003         | 4507  | 4510  |
| SX-F             | 350           | 11 - 18 | 4003         | 4507  | 4510  |
| XC-F             | 350           | 12 - 17 | 4003         | 4507  | 4510  |
| EXC              | 400 Racing    | 00 - 07 | 4003         | 4507  | 4510  |
| SX               | 400 Racing    | 00 - 02 | 4003         | 4507  | 4510  |
| EXC-F            | 450 Racing    | 04 - 18 | 4003         | 4507  | 4510  |
| SX-F             | 450           | 03 - 18 | 4003         | 4507  | 4510  |
| XC-F             | 450           | 06 - 17 | 4003         | 4507  | 4510  |
| EXC-F            | 500           | 12 - 18 | 4003         | 4507  | 4510  |
| XC-F             | 505           | 08 - 09 | 4003         | 4507  | 4510  |
| EXC              | 520 Racing    | 00 - 02 | 4003         | 4507  | 4510  |



## SBS 4000



| <b>HONDA</b>    |            |         |   |  |  |
|-----------------|------------|---------|---|--|--|
| CR              | 125 R      | 98 - 01 | • |  |  |
| CR              | 250 R      | 95 - 01 | • |  |  |
| <b>KAWASAKI</b> |            |         |   |  |  |
| KX              | 125        | 95 - 96 | • |  |  |
| KX              | 250        | 95 - 96 | • |  |  |
| <b>SUZUKI</b>   |            |         |   |  |  |
| RM              | 125        | 99 - 04 | • |  |  |
| RM              | 250        | 99 - 04 | • |  |  |
| RM-Z            | 250        | 07      | • |  |  |
| RM-Z            | 450        | 05 - 07 | • |  |  |
| <b>YAMAHA</b>   |            |         |   |  |  |
| YZ              | 125        | 98 - 18 | • |  |  |
| WR              | 250 F      | 03 - 13 | • |  |  |
| YZ              | 250        | 98 - 18 | • |  |  |
| YZ              | 250 F      | 01 - 13 | • |  |  |
| YZ              | 250 F Efi  | 14 - 18 | • |  |  |
| YZ              | 250 FX Efi | 15      | • |  |  |
| YZ              | 400        | 98      | • |  |  |
| YZ              | 426 F      | 00 - 02 | • |  |  |
| WR              | 450 F      | 03 - 15 | • |  |  |
| WR              | 450 F Efi  | 16 - 18 | • |  |  |
| YZ              | 450 F      | 03 - 09 | • |  |  |
| YZ              | 450 F Efi  | 10 - 17 | • |  |  |
|                 |            |         |   |  |  |
|                 |            |         |   |  |  |
|                 |            |         |   |  |  |
|                 |            |         |   |  |  |
|                 |            |         |   |  |  |
|                 |            |         |   |  |  |
|                 |            |         |   |  |  |
|                 |            |         |   |  |  |
|                 |            |         |   |  |  |
|                 |            |         |   |  |  |

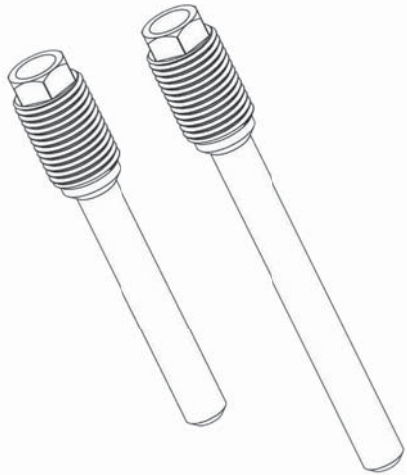

## SBS 4001



| <b>HONDA</b>  |            |         |   |  |  |
|---------------|------------|---------|---|--|--|
| CR            | 125 R      | 02 - 07 | • |  |  |
| CR            | 250 R      | 02 - 07 | • |  |  |
| CRF           | 250 R      | 04 - 09 | • |  |  |
| CRF           | 250 R Efi  | 10 - 17 | • |  |  |
| CRF           | 250 R Efi  | 18 -    | • |  |  |
| CRF           | 250 X      | 04 - 14 | • |  |  |
| CRF           | 450 Efi    | 09 - 12 | • |  |  |
| CRF           | 450 R      | 02 - 08 | • |  |  |
| CRF           | 450 R Efi  | 13 - 18 | • |  |  |
| CRF           | 450 RX Efi | 17 - 18 | • |  |  |
| CRF           | 450 X      | 05 - 18 | • |  |  |
| <b>SUZUKI</b> |            |         |   |  |  |
| RM            | 125        | 05 - 09 | • |  |  |
| RM            | 250        | 05 - 09 | • |  |  |
| RM-Z          | 250        | 08 - 09 | • |  |  |
| RM-Z          | 250 Efi    | 10 - 18 | • |  |  |
| RM-Z          | 450 Efi    | 08 - 17 | • |  |  |
| RM-Z          | 450 Efi    | 18 -    | • |  |  |
|               |            |         |   |  |  |
|               |            |         |   |  |  |
|               |            |         |   |  |  |
|               |            |         |   |  |  |
|               |            |         |   |  |  |
|               |            |         |   |  |  |
|               |            |         |   |  |  |
|               |            |         |   |  |  |
|               |            |         |   |  |  |
|               |            |         |   |  |  |
|               |            |         |   |  |  |

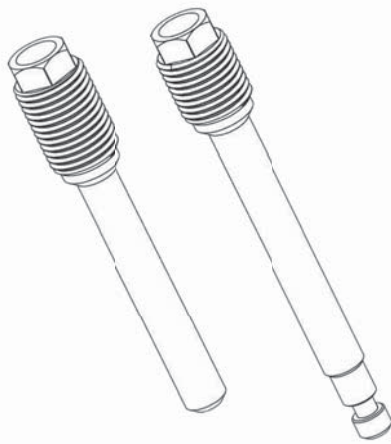



SBS 4509



SBS 4505



**KAWASAKI**

|      |         |         |   |  |  |
|------|---------|---------|---|--|--|
| KX   | 125     | 97 - 08 | • |  |  |
| KX   | 250     | 97 - 08 | • |  |  |
| KX-F | 250     | 04 - 10 | • |  |  |
| KX-F | 250 DFI | 11 - 18 | • |  |  |
| KX-F | 450     | 06 - 08 | • |  |  |
| KX-F | 450 DFI | 09 - 18 | • |  |  |

**SUZUKI**

|      |     |         |   |  |  |
|------|-----|---------|---|--|--|
| RM-Z | 250 | 04 - 06 | • |  |  |
|      |     |         |   |  |  |
|      |     |         |   |  |  |
|      |     |         |   |  |  |
|      |     |         |   |  |  |
|      |     |         |   |  |  |
|      |     |         |   |  |  |
|      |     |         |   |  |  |
|      |     |         |   |  |  |
|      |     |         |   |  |  |
|      |     |         |   |  |  |



SBS 4507



SBS 4510



**HUSQVARNA**

|    |     |         |   |  |  |
|----|-----|---------|---|--|--|
| CR | 125 | 05 - 13 | • |  |  |
| TC | 125 | 14 - 18 | • |  |  |
| TE | 125 | 14 - 16 | • |  |  |
| TX | 125 | 17 - 18 | • |  |  |
| CR | 250 | 05      | • |  |  |
| FC | 250 | 14 - 18 | • |  |  |
| FE | 250 | 14 - 18 | • |  |  |
| TC | 250 | 04 - 18 | • |  |  |
| TE | 250 | 02 - 18 | • |  |  |
| TE | 300 | 14 - 18 | • |  |  |
| FC | 350 | 14 - 18 | • |  |  |
| FE | 350 | 14 - 18 | • |  |  |
| TC | 449 | 11 - 13 | • |  |  |
| FC | 450 | 14 - 18 | • |  |  |
| FE | 450 | 14 - 18 | • |  |  |
| TE | 450 | 14      | • |  |  |
| FE | 501 | 14 - 18 | • |  |  |
| TE | 511 | 11 - 13 | • |  |  |

**KTM**

|       |               |         |   |  |  |
|-------|---------------|---------|---|--|--|
| EXC   | 125 Enduro    | 04 - 15 | • |  |  |
| SX    | 125           | 00 - 18 | • |  |  |
| SX    | 144           | 07 - 08 | • |  |  |
| SX    | 150           | 09 - 18 | • |  |  |
| EXC   | 200 Enduro    | 04 - 16 | • |  |  |
| SX    | 200           | 03 - 04 | • |  |  |
| EXC   | 250 Enduro    | 04 - 08 | • |  |  |
| EXC   | 250 Enduro 4T | 04 - 06 | • |  |  |
| EXC   | 250 TPI       | 18 -    | • |  |  |
| EXC-F | 250 Enduro    | 07 - 18 | • |  |  |
| SX    | 250           | 03 - 18 | • |  |  |
| SX-F  | 250           | 06 - 18 | • |  |  |
| XC    | 250           | 06 - 14 | • |  |  |
| EXC   | 300 Enduro    | 04 - 08 | • |  |  |
| EXC   | 300 TPI       | 18 -    | • |  |  |
| XC    | 300           | 06 - 14 | • |  |  |
| EXC-F | 350           | 11 - 18 | • |  |  |
| SX-F  | 350           | 11 - 18 | • |  |  |
| XC-F  | 350           | 12 - 17 | • |  |  |
| EXC   | 400 Racing    | 00 - 07 | • |  |  |
| SX    | 400 Racing    | 00 - 02 | • |  |  |
| EXC-F | 450 Racing    | 04 - 18 | • |  |  |
| SX-F  | 450           | 03 - 18 | • |  |  |
| XC-F  | 450           | 06 - 17 | • |  |  |

## SBS 4003



| KTM   |            |         |   |  |
|-------|------------|---------|---|--|
| EXC-F | 500        | 12 - 18 | • |  |
| XC-F  | 505        | 08 - 09 | • |  |
| EXC   | 520 Racing | 00 - 02 | • |  |
| SX-F  | 520 Racing | 00 - 02 | • |  |
| EXC   | 525 Racing | 03 - 06 | • |  |
| SX-F  | 525 Racing | 03 - 06 | • |  |
| XC-F  | 525        | 07      | • |  |
| EXC   | 530 Racing | 08 - 11 | • |  |
|       |            |         |   |  |
|       |            |         |   |  |
|       |            |         |   |  |
|       |            |         |   |  |
|       |            |         |   |  |
|       |            |         |   |  |
|       |            |         |   |  |
|       |            |         |   |  |
|       |            |         |   |  |
|       |            |         |   |  |
|       |            |         |   |  |
|       |            |         |   |  |
|       |            |         |   |  |
|       |            |         |   |  |
|       |            |         |   |  |
|       |            |         |   |  |



## SBS 4004



| YAMAHA |                 |         |   |  |
|--------|-----------------|---------|---|--|
| WR     | 250 F Efi       | 17 - 18 | • |  |
| WR     | 250 F Enduro GP | 18 -    | • |  |
| WR     | 250 X           | 08 - 16 | • |  |
| WR     | 450 F Enduro GP | 18 -    | • |  |
|        |                 |         |   |  |
|        |                 |         |   |  |
|        |                 |         |   |  |
|        |                 |         |   |  |
|        |                 |         |   |  |
|        |                 |         |   |  |
|        |                 |         |   |  |
|        |                 |         |   |  |
|        |                 |         |   |  |
|        |                 |         |   |  |
|        |                 |         |   |  |
|        |                 |         |   |  |
|        |                 |         |   |  |
|        |                 |         |   |  |
|        |                 |         |   |  |
|        |                 |         |   |  |
|        |                 |         |   |  |
|        |                 |         |   |  |

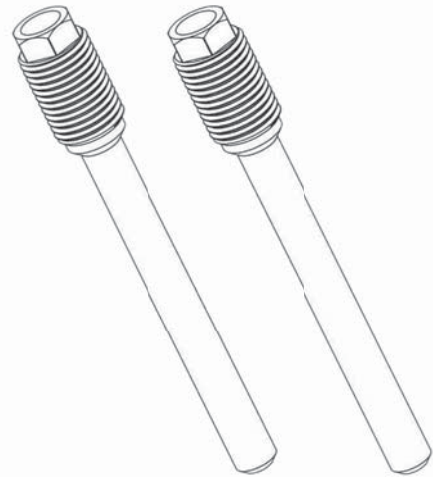

## SBS 4505



| HONDA    |         |         |  |   |
|----------|---------|---------|--|---|
| CR       | 125 R   | 98 - 01 |  | • |
| CR       | 250 R   | 95 - 01 |  | • |
| KAWASAKI |         |         |  |   |
| KX       | 125     | 95 - 08 |  | • |
| KX       | 250     | 95 - 08 |  | • |
| KX-F     | 250     | 04 - 10 |  | • |
| KX-F     | 250 DFI | 11 - 18 |  | • |
| KX-F     | 450     | 06 - 08 |  | • |
| KX-F     | 450 DFI | 09 - 18 |  | • |
| SUZUKI   |         |         |  |   |
| RM       | 125     | 99 - 04 |  | • |
| RM       | 250     | 99 - 04 |  | • |
| RM-Z     | 250     | 04 - 07 |  | • |
| RM-Z     | 450     | 05 - 07 |  | • |
|          |         |         |  |   |
|          |         |         |  |   |
|          |         |         |  |   |
|          |         |         |  |   |
|          |         |         |  |   |
|          |         |         |  |   |
|          |         |         |  |   |
|          |         |         |  |   |
|          |         |         |  |   |
|          |         |         |  |   |
|          |         |         |  |   |
|          |         |         |  |   |
|          |         |         |  |   |
|          |         |         |  |   |
|          |         |         |  |   |
|          |         |         |  |   |
|          |         |         |  |   |
|          |         |         |  |   |

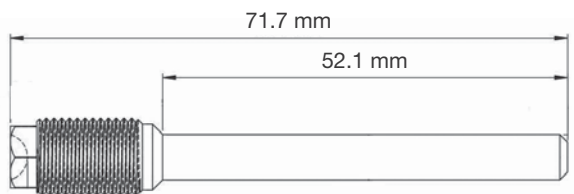

























# CHOICE OF CHAMPIONS SINCE 2001

**CHOICE OF TT CHAMPIONS**

Michael Dunlop  
WINNER  
SEVEN  
TT  
2011

1st of 10 in TT  
1st of 10 in 1000cc  
1st of 10 in 600cc

**sbs**  
THE POWER TO STOP YOU®

**CHOICE OF TT CHAMPIONS**

Michael Dunlop  
WINNER  
SEVEN  
TT  
2010

1st of 10 in TT  
1st of 10 in 1000cc  
1st of 10 in 600cc

**sbs**  
THE POWER TO STOP YOU®

**CHOICE OF TT CHAMPIONS**

Eoin Mackintosh  
1st of 10 in TT  
1st of 10 in 1000cc  
1st of 10 in 600cc

**sbs**  
THE POWER TO STOP YOU®

**World Supersport Champion 2014**

SBS congratulates Pata Honda's  
Major Michael van der Mark  
with the 2014 World Supersport 600 title.

**sbs**  
THE POWER TO STOP YOU®

**TT Isle of Man**

Michael Dunlop  
1st of 10 in TT  
1st of 10 in 1000cc  
1st of 10 in 600cc

**sbs**  
THE POWER TO STOP YOU®

**TT Isle of Man**  
**sbs THE WINNING EDGE**

1st of 10 in TT  
1st of 10 in 1000cc  
1st of 10 in 600cc

Michael Dunlop  
KING OF THE ROADS

**sbs**  
THE POWER TO STOP YOU®

**2012**  
**WORLD SUPERSPORT CHAMPION**  
Kenan Sofuoglu

Team Kawasaki Lenceria Racing

**sbs**  
THE POWER TO STOP YOU®

**sbs 2011**  
**WORLD SUPERBIKE CHAMPION**  
Carlos Checa

Aprilia Racing

**sbs**  
THE POWER TO STOP YOU®

**2011 WORLD CHAMPIONS**

MX2 - Ken Roczen  
MX1 - Antonio Cairoli

**sbs**  
THE POWER TO STOP YOU®

**sbs 2010**  
**WORLD SUPERSPORT CHAMPION**  
Kenan Sofuoglu

Team Kato Honda

**sbs**  
THE POWER TO STOP YOU®

**sbs Living Off Road**  
**2010 WORLD CHAMPIONS**

MX2 - Tony Cairoli  
MX4 - Marvin Musquin

**sbs**  
THE POWER TO STOP YOU®

**WORLD CHAMPION**  
**2008**  
Andrew Pitt  
SUPERSPORT 600

**sbs**  
THE POWER TO STOP YOU®

**SBS #1 AGAIN!**  
**2007 SUPERSPORT WORLD CHAMPION**  
Kenan Sofuoglu

USE SBS DUAL-SIDED BRAKE PADS

**sbs**  
THE POWER TO STOP YOU®

**DUAL CHAMPIONS**  
**THE CHOICE OF 2007**  
WORLD CHAMPIONS

Dual Carbon

**sbs**  
THE POWER TO STOP YOU®

**HIGH 5 FOR SBS!**

ALL TOP 5 RIDERS  
2006 WORLD SUPERSPORT  
USED SBS BRAKE PADS:

Dual Carbon  
Dual Sinter

**sbs**  
THE POWER TO STOP YOU®

**CHOICE OF WORLD CHAMPIONS**

2005

**sbs**  
THE POWER TO STOP YOU®

**CHOICE OF WORLD CHAMPIONS**

2004  
2003  
2001

**sbs**  
THE POWER TO STOP YOU®

**WORLD CHAMPION!**

SBS congratulates  
Chris Vermeulen &  
Team Ecckl Kawasaki Racing Team  
winning the  
2003 World Supersport title.

SBS is proud to be  
a technical partner of  
Team Ecckl Kawasaki Racing Team.

**sbs**  
THE POWER TO STOP YOU®

**World Champion!**

SBS congratulates  
Andrew Pitt (AUS) and  
Team Ecckl Kawasaki Racing  
with the 2001  
World Supersport 600 title.

SBS is proud to be a  
technical sponsor of  
Team Ecckl Kawasaki Racing

SBS Dual Carbon  
designed for Road Racing

**sbs**  
THE POWER TO STOP YOU®

**sbs**

THE POWER TO STOP YOU®

**BRAKE PADS FOR ALL YOUR POWERSPORT NEEDS - MADE IN DENMARK**



## HI-TECH BRAKE SOLUTIONS MADE IN EUROPE

At SBS, we develop and manufacture hi-tech brake solutions.

Our ranges of brake pads, brake discs, brake shoes and other important parts cover all relevant motorcycles, scooters and ATV/UTVs on the market, regardless of make and model. SBS is your single source for brake parts and components.

We are a global market leader within brakes for powered two-wheelers. Our R&D department continuously innovates with new materials and technologies to achieve ultimate performance, longer lifetime, higher comfort and more eco-friendly products.

Our products are tested by reality. Dynamometer testing is supplemented with numerous street and race track tests. We work together with some of the world's best road racing and motocross riders, when they race towards podium positions.

We create the power to stop you. Made in Europe. You decide where and how to use it. Go Ahead!

