



THE NEW MINI COUNTRYMAN.



ADD STORIES.

The people you never hear from are always the ones with the stories to tell. Chances are that they're in a MINI Countryman, living each day like an adventure. It's a versatile, five-seater Sports Activity Vehicle that's more comfortable than ever. With powerful engines and some serious off-road capabilities, it tackles even the trickiest terrain with ease. So what are you waiting for? The world won't explore itself.

For more information on the options available for each model, contact your MINI retailer or visit buildmymini.ca



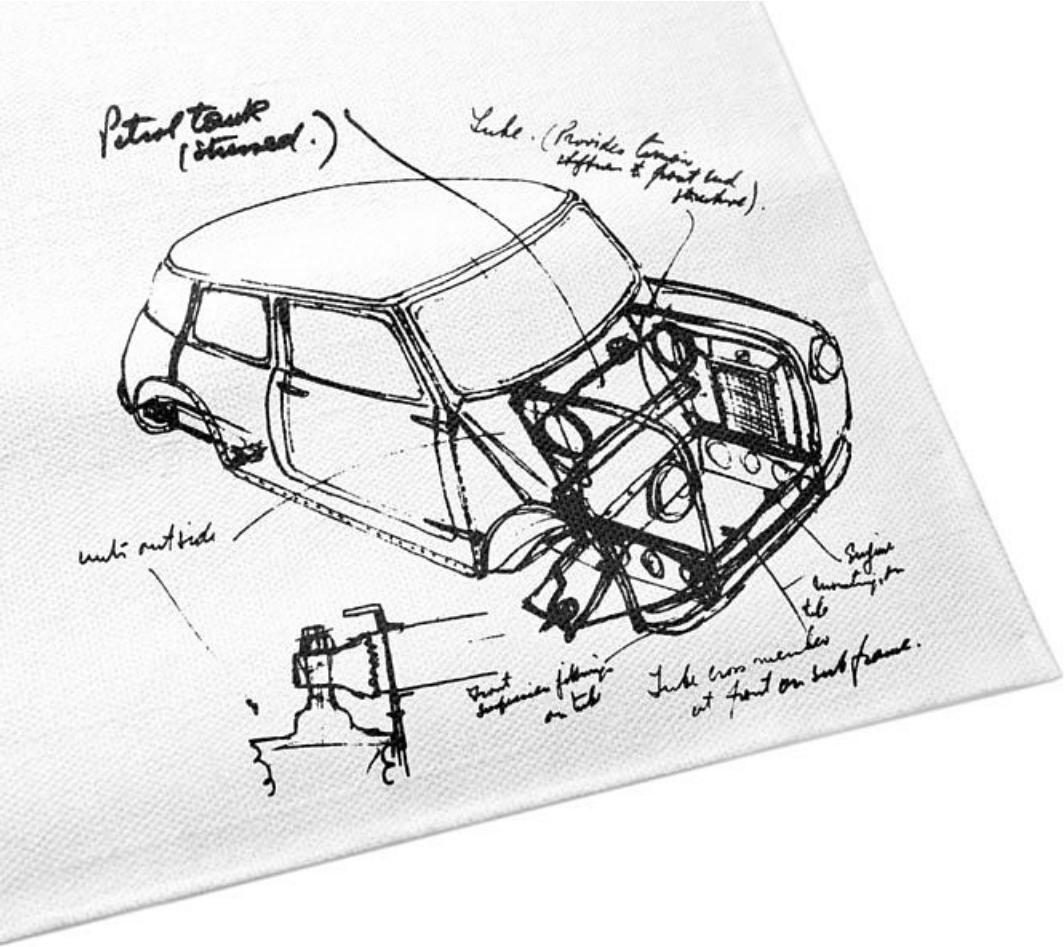

MAKING THE MINI: BREAKING THE MOULD.

When Sir Alec Issigonis sketched his initial idea for the Mini on a tablecloth in 1956, his innovative compact design was the perfect response to some of the biggest automotive questions of his era. Almost everything about it was unconventional: he increased the track width as far as he could, mounted the engine lengthwise, and positioned the instrument cluster centrally for both left and right-hand drive. This ensured maximum space inside the car. The concept was unprecedented – and his revolutionary Mini soon became an icon.

The first ever Countryman available to buy was the Austin Mini Countryman in 1960. A roomy estate with a long wheelbase and robust wooden appliques, it was designed for trips through the country. With more space than usual and all the charm of a classic Mini, it won fans the world over.

Motorsport legend John Cooper saw star racing potential in the original Mini – so he created a model for the track. Braking, inducing oversteer and then drifting around corners became effortless for rally drivers, thanks to its lightweight and short overhangs. Racing around tight bends at high speed, now synonymous with the classic MINI go-kart feeling, laid the foundation for a succession of spectacular wins at the Monte Carlo rally. Here, the Mini proved that agile handling beats sheer power, every time. To honour Cooper’s vision, the thoroughbreds of the MINI range bear the name John Cooper Works.

The compact design of Alec Issigonis and racing pedigree of John Cooper have defined the Mini from the very beginning and remain hallmarks of every iteration to this day. Their legacy of innovation lives on in the latest MINI – and the cutting-edge technology within.







DISCOVERY IS DESTINY.

You'll feel it in the first few metres: as big as it feels on the inside, the new Countryman is still a MINI through and through. Gliding through the city, coasting through the mountains – it's all effortless. It's just under 4.3 metres long, which means it has some serious luggage capacity in addition to ample legroom. There's also a range of built-in features designed to make epic tours even easier and breezier, like the picnic bench and MINI Connected.

THE ONLY THING THAT SHOULD STOP YOU IS THE VIEW.

Main roads will only take you so far. Where the tarmac ends, the adventure really begins. And in the MINI Countryman, the only thing that's going to stop you is the view. Luckily there's an optional cushioned picnic bench for moments just like these. Just pull it out from beneath the loading shelf and soak in the sunset.

The loading shelf, fastening straps and lashing eyes in the optional storage package keep luggage in place and ensure optimal weight distribution. The luggage compartment also comes with extra LED lights and a 12-volt socket – perfect for powering a coolbox.



LUGGAGE, MEMENTOS, MEMORIES ...

Destined for higher things: If the luggage space available somehow isn't enough, you can find even more storage options in the high-quality MINI Original Accessories range, like the roof rail system for the luggage rack and roofbox.

ORIGINAL MINI ACCESSORIES
mini.ca/accessories



... TAKE IT ALL WITH YOU.



Great views guaranteed: The optional panoramic sunroof provides a clear view of the sky above and makes the interior feel roomier. The front section opens and slides back electronically. If it gets too bright, there's also a blind for the tinted glass.



You can use the luggage space in the MINI Countryman in any number of ways: the flat load compartment floor folds away and the rear backrests fold down in a 40:20:40 split. The rear seat bench slides forward to provide even more room, and splits in a 40:60 arrangement.

Luggage area, width x height x depth:
859 x 718 x 813 mm
Through-loading depth with rear seats
folded down: 1595 mm

The backlighting of the three MINI Yours Interior Styles comes into its own in darkness, bringing an atmospheric glow to the inside of your MINI at night.

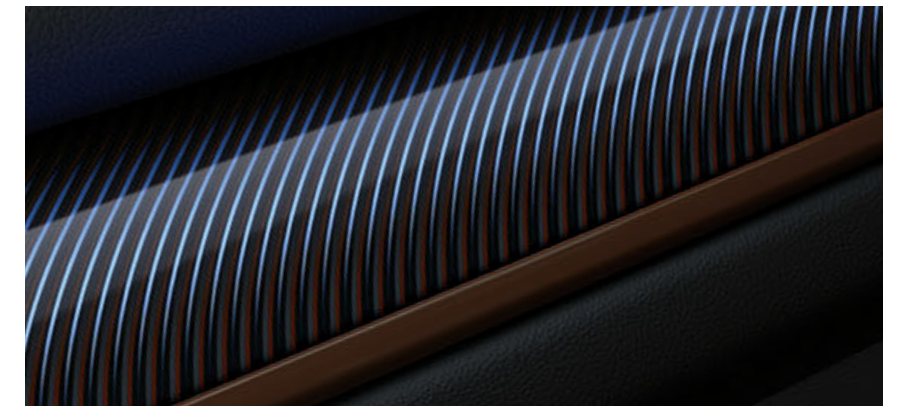

FIND YOUR COUNTRYMAN.

On the following pages, you'll get your first look at all the ways in which you can personalize your MINI Countryman. Let's start with the essentials: the engine. You can choose from 2 turbocharged petrol engines, or go for a cutting-edge plug-in hybrid with 6-speed Steptronic transmission and electronic ALL4 all-wheel drive. All engines use the powerful and efficient MINI Twin Power Turbo technology.

All of the engine variants are fitted with a track-style sequential 6-speed manual gearbox as standard. 6-speed Steptronic transmission is available upon request for the Cooper variant, while an 8-speed Steptronic gearbox is an option for the Cooper ALL4 or Cooper S ALL4 variants. What's more, intelligent ALL4 all-wheel drive in Cooper and Cooper S models ensures optimum traction on all road surfaces. See page 34 for details. For a quick and easy model overview, see the fold-out page on the right.



COOPER.

A 1.5-l 3-cylinder petrol engine (134 hp) offers a handy blend of oomph and economy. A classic MINI contrast colour is available at no extra cost for the roof and exterior mirror caps. The exhaust pipe comes with a chrome trim. Bonnet stripes available on request.



COOPER S.

Better, faster, stronger: With a 2.0-l 4-cylinder petrol engine (189 hp) the Cooper S packs the biggest punch. Highlights include the red S at the rear, side scuttles and the mesh radiator grille with inner chrome trim. Twin chrome-plated exhaust pipes (right and left). MINI ALL4 Exterior Optic package available on request and includes bumper attachments in high-gloss black and an underride guard feature at both the front and rear in silver.

Standard MINI Driving Modes adapt the performance of your MINI to match your mood and the road conditions. In the MID and GREEN modes, optional Dynamic Damping Control softens the suspension to keep the drive enjoyably smooth. If you want to feel like you're tearing up tarmac in a go-kart, select SPORT mode.

On the fold-out page: the Cooper in the exclusive Chestnut paint finish (for MINI Countryman only), with standard roof rails and side-skirt attachments in satin white aluminium, plus optional 19" MINI Yours Masterpiece light-alloy wheels in exclusive Dark Spectre Grey with burnished rims.



COOPER S E ALL4.

Slick combo: A 3-cylinder petrol engine (134 hp) at the front with an 87-hp e-motor at the rear axle. Instantly recognizable with the gold MINI Plug-in Hybrid logo on the side scuttles and at the rear. Charging port at left side scuttle. Yellow Cooper "S" on the front grille and tailgate. Single chrome-plated tailpipe at rear apron on the left-hand side.





FAST-FORWARD TO THE FUTURE.

The new MINI Countryman Plug-in Hybrid combines an electric motor and battery with a conventional petrol engine to offer drivers the best of both worlds. The result is emission-free fun out on the road, at practically no cost to space or practicality. Thanks to its high-voltage, lithium ion battery, the Plug-in Hybrid can drive electric-only and virtually emission-free for up to 40km*. The e-motor backs up the petrol engine via the boost function and enables electric all-wheel drive.

The central display (1) shows the power distribution between the two engines. A combined display (2) replaces the rev counter, and shows the available power. The battery can be charged both during the journey and externally at any 230-volt power supply via the supplied cable (3). A full charge (from 0%) takes approx. 3 h 15 min.

* Information is preliminary and subject to change closer to market launch.

MINI ELECTRIC





INTO THE WILD. MINI COUNTRYMAN.

Meet the biggest, most rugged, most adventurous MINI ever made. The new MINI Countryman is designed and equipped to inspire and accommodate your next great story – with more space for every escape, ALL4 all-wheel drive for every road, and a long list of premium cabin features to enhance every journey. And with the all-new plug-in hybrid version, you can enjoy MINI's agile performance, while keeping your promise to the environment at every point along the way.

So go forth. Leave the city behind, and find yourself off the beaten path.

Add friends. Add memories. Add meaning. And when you return, go tell your story.

DIFFERENT SHADES OF ADVENTURE.



Moonwalk Grey

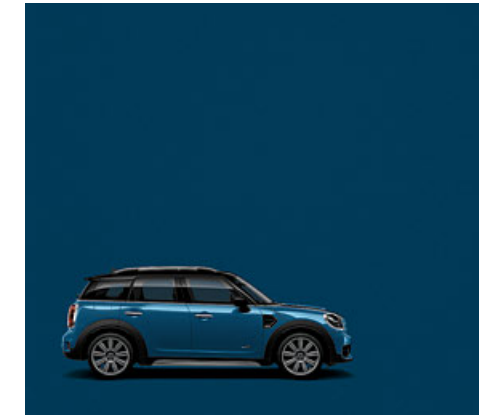

Island Blue

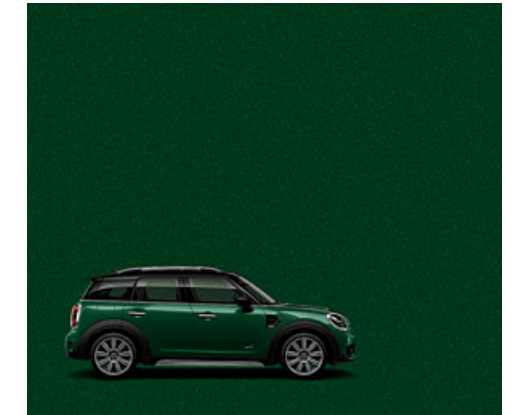

British Racing Green

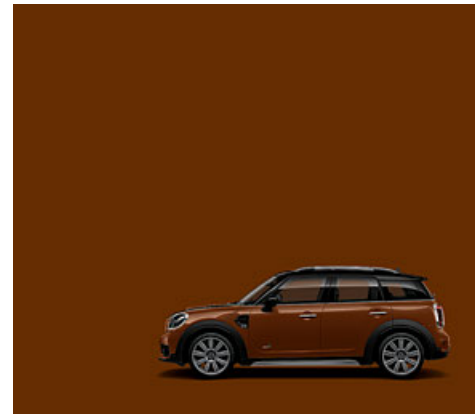

Chestnut

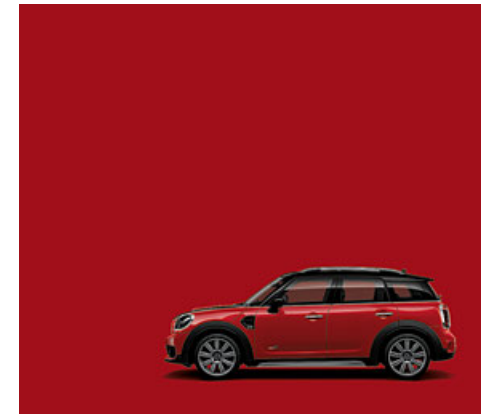

Chili Red

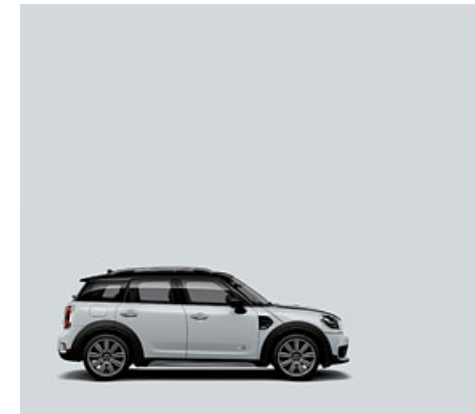

Light White

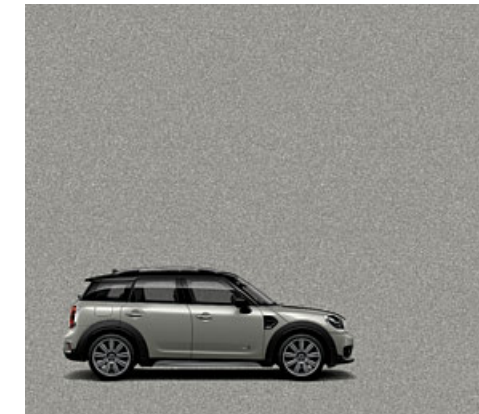

Melting Silver

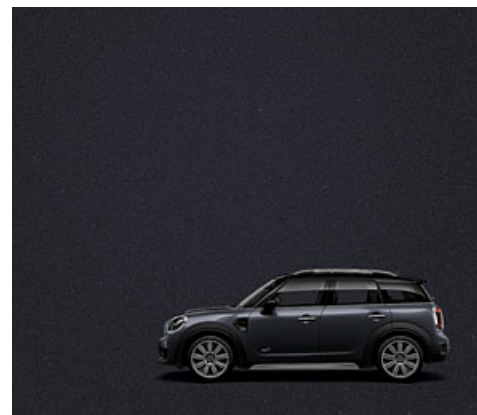

Thunder Grey

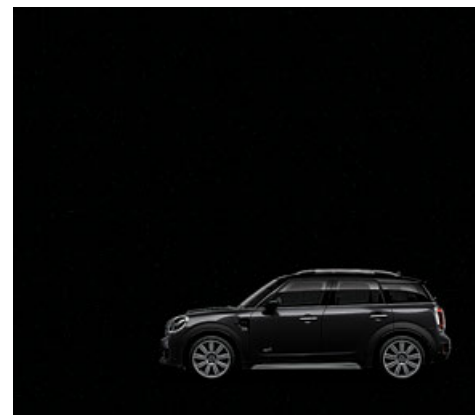

Midnight Black

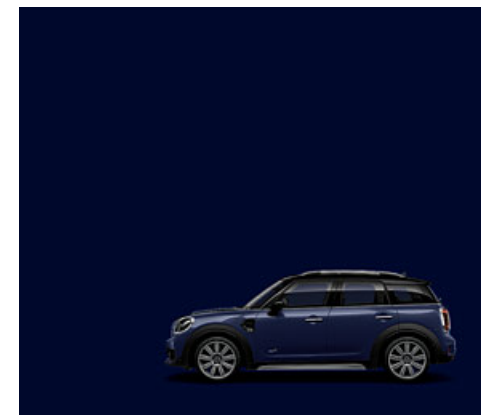

Exclusive finish:
MINI Yours Lapisluxury Blue

Roof and exterior mirror caps.

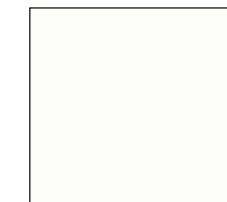

Aspen White

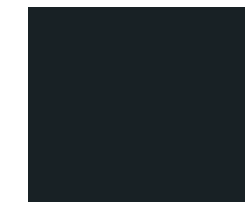

Jet Black

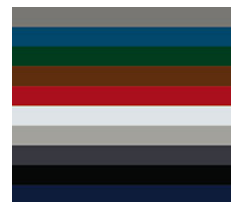

Body colour



11 ALLOY RIMS – ONE DECISION.

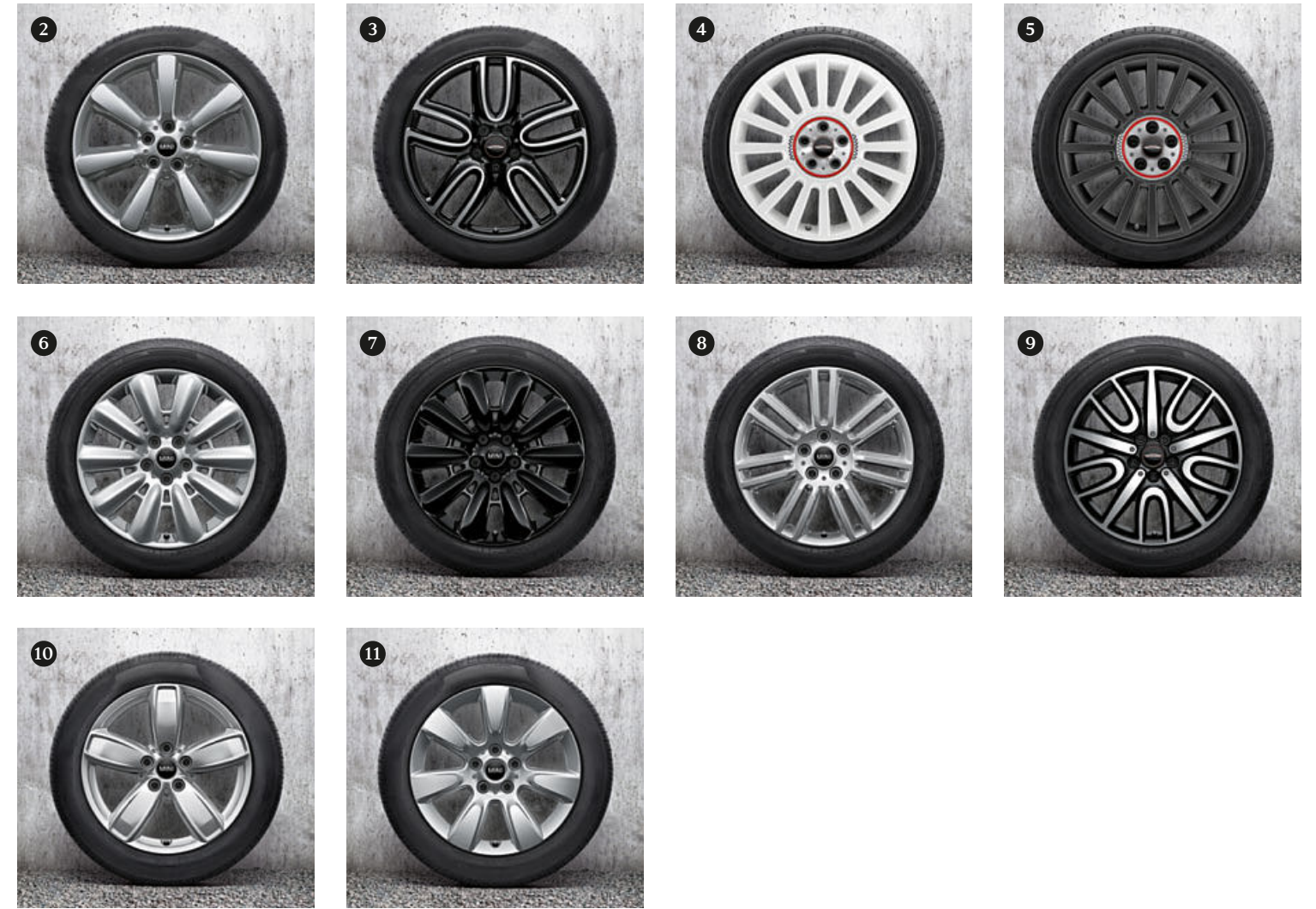

1 19" MINI Yours Masterpiece, burnished

2 19" Edge Spoke

3 19" John Cooper Works Course Spoke, burnished

4 19" John Cooper Works Rallye Spoke, White*

5 19" John Cooper Works Rallye Spoke, Grey*

6 18" Pin Spoke

7 18" Pin Spoke, Black

8 18" Pair Spoke

9 18" John Cooper Works Thrill Spoke, burnished Anthracite

10 17" Channel Spoke

11 17" Imprint Spoke

* Available at mini.ca/accessories



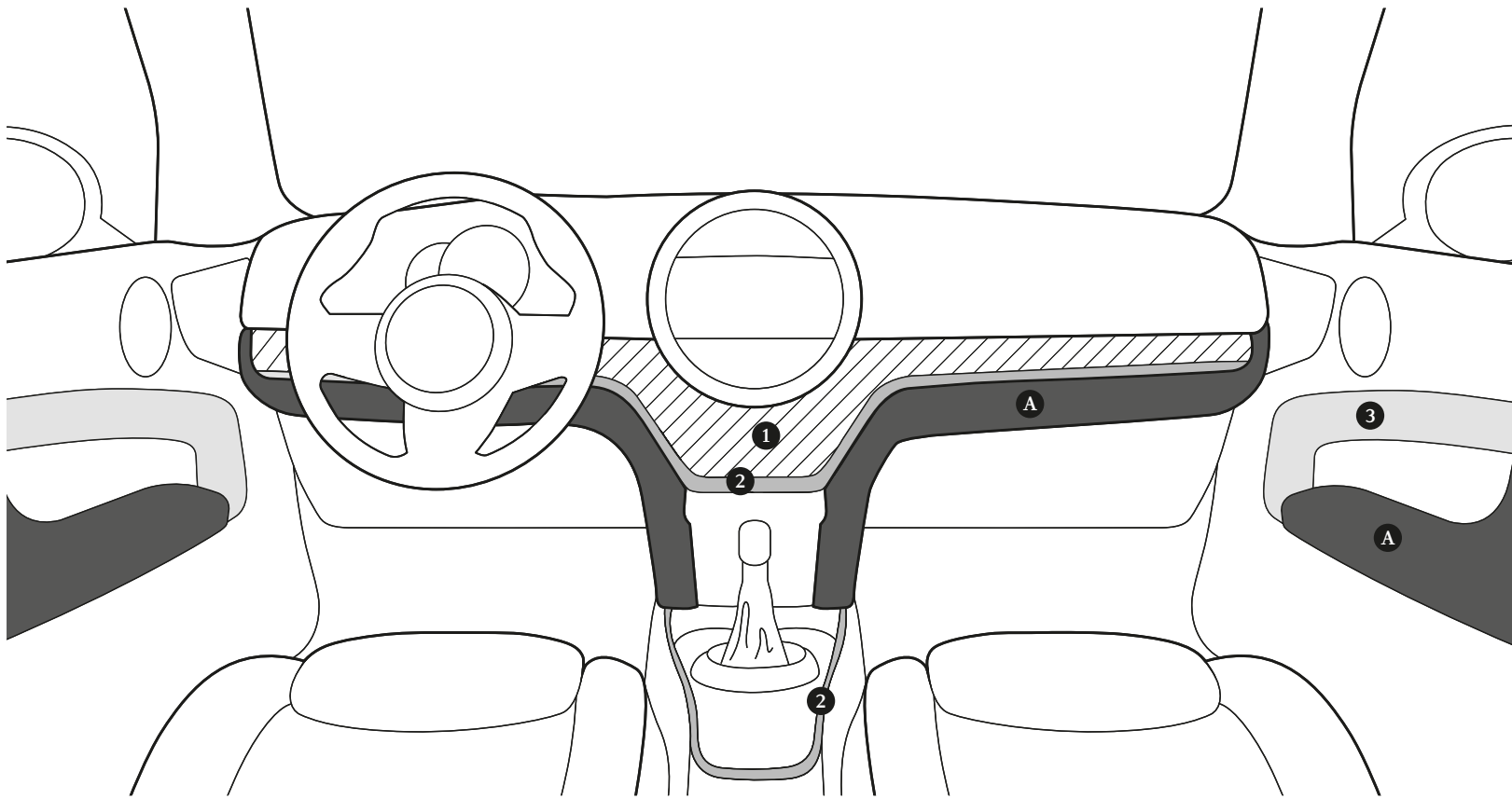

INTERIOR ELEMENTS IN DETAIL.

Four high-quality Interior Styles are available for personalizing the inside of your MINI – 3 of them with MINI Yours Illumination. Choose a style for the central design elements: decorative cockpit trim (1), a matching contrast trim (2) and the decorative door trims (3). Then select a suitable colour from the Colour Line (A) range for the kneepads and armrests in the doors. The fold-out page on the left has all the details of the Piano Black Interior Style in combination with the British Oak Colour Line; the fold-out on the right shows the MINI Yours Chestnut illuminated Interior Style with the Carbon Black Colour Line.

The 4 Interior Styles.

Piano Black Interior Style.



Piano Black



Dark British Oak



Piano Black

MINI Yours Piano Black illuminated Interior Style.

(Illumination colours defined by ambient lighting.)

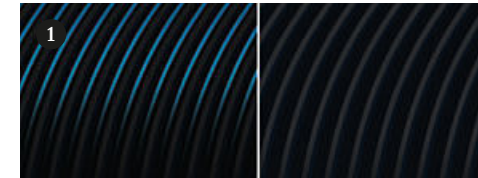

Piano Black illuminated, Piano Black



Hazy Grey

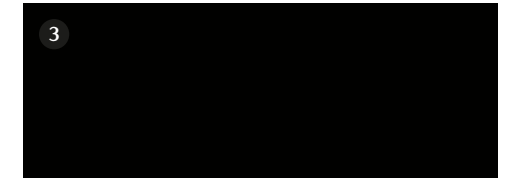

Piano Black

MINI Yours British Oak illuminated Interior Style.

(Red and blue graphics for illumination colours. Painted and backlit plastic surfaces. No real wood.)

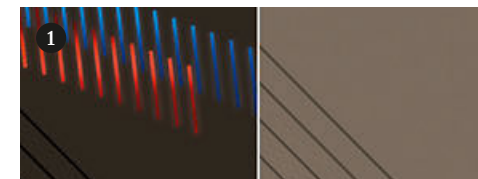

British Oak illuminated, British Oak



Hazy Grey



British Oak

MINI Yours Chestnut illuminated Interior Style.

(Illumination colours defined by ambient lighting in pin-stripe pattern.)

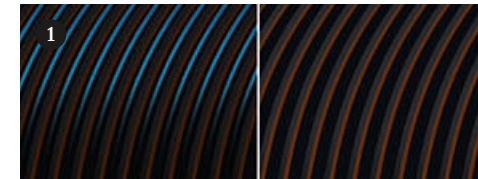

Chestnut illuminated, Chestnut



Chestnut

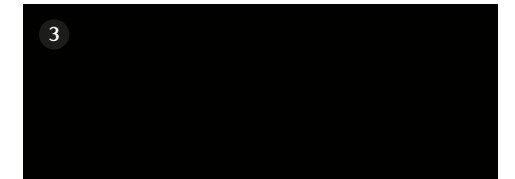

Piano Black

4 Colour Lines.



Malt Brown



Satellite Grey



British Oak

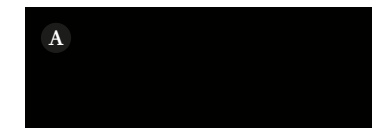

Carbon Black

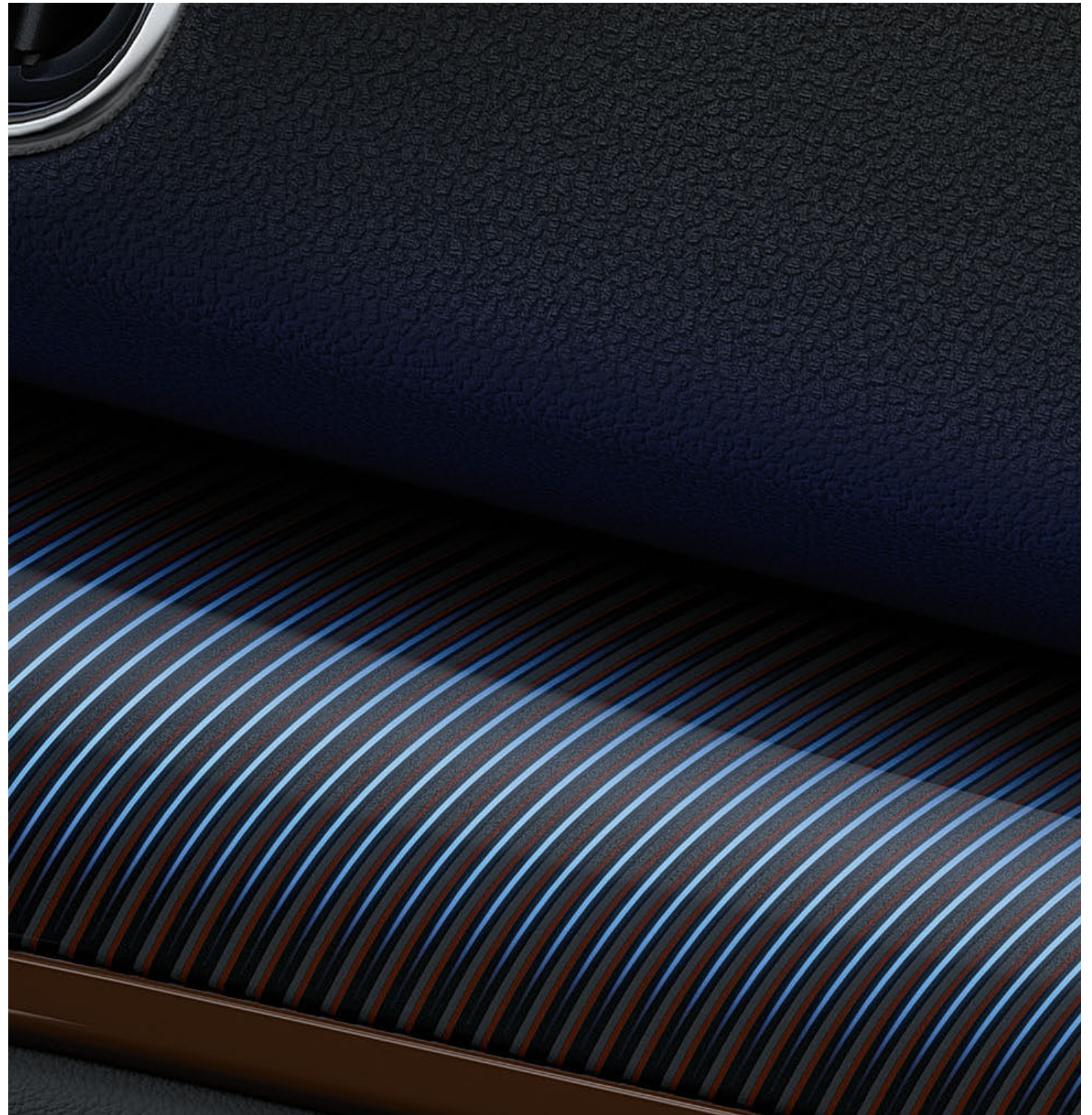

THE EDGE OF YOUR SEAT HAS NEVER BEEN SO COSY.



Chester leather
sport seat,
British Oak



John Cooper Works
Dinamica/leather
sport seat,
Carbon Black, available on
John Cooper Works variant only.

AT HOME IN SECONDS.



Cross Punch leather*
sport seat,
Carbon Black



Cord cloth/leather
sport seat,
Carbon Black



Black Pearl cloth/leatherette
sport seat,
Carbon Black



Lounge leather*
sport seat,
Satellite Grey



MINI Yours Lounge leather*
Carbon Black,
incl. Dinamica armrests in
Carbon Black

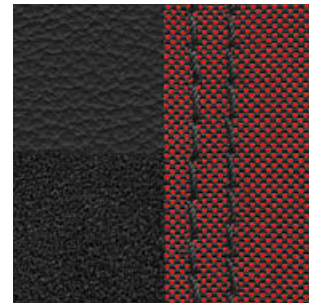

John Cooper Works
Dinamica/leather, Carbon Black,
incl. Dinamica armrests in
Carbon Black, available on
John Cooper Works variant only



Lounge leather*
Satellite Grey,
incl. leatherette armrests in
Carbon Black



Chester leather*
British Oak,
incl. leatherette armrests in
Carbon Black

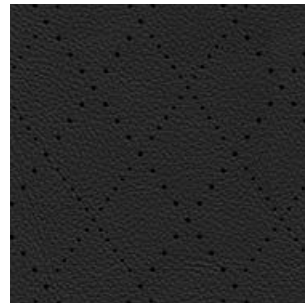

Cross Punch leather*
Carbon Black,
incl. leatherette armrests in
Carbon Black

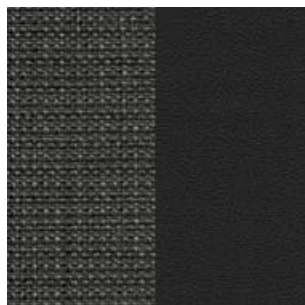

Black Pearl cloth/leatherette
Carbon Black,
incl. cloth armrests in
Black Pearl



Cord cloth/leather
Carbon Black,
incl. Cord armrests in
Carbon Black

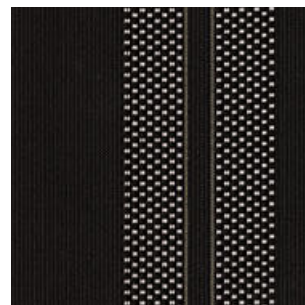

Double Stripe cloth
Carbon Black,
incl. Carbon Black armrests



Leatherette
Carbon Black,
incl. leatherette armrests in
Carbon Black



The optional electric front seat adjustment features two memory buttons that remembers the preferred seating position, including armrest, recline and lumbar support settings for two different drivers.



MINI YOURS.

The Carbon Black MINI Yours seat in luxurious Lounge leather isn't just made – it's crafted. The smooth feel of the leather against your hand, the detailed stitching of the Union Jack in the headrest, the braided edging ... the beauty is in the detail.

buildmymini.ca

* Leather upholstery includes seats (base and backrest), and front and rear headrests.

PUTTING THE COUNTRY INTO COUNTRYMAN.

The MINI ALL4 Exterior Optic package brings out the tireless off-road workhorse in the MINI Countryman. Bumper attachments in high-gloss black and an underride guard feature at both the front and rear, while the standard roof rails and side skirts in satin white aluminium underscore the SAV's ready-for-anything profile.

buildmymini.ca





JOHN COOPER WORKS. SPORTS PACKAGES FOR THE MINI COUNTRYMAN.



For an authentic race-car feeling outside and in, look no further than the John Cooper Works Exterior package. Dashing looks are guaranteed thanks to exclusive 18" John Cooper Works Thrill Spoke burnished wheels, the aerodynamic kit and the John Cooper Works rear spoiler. A stiffer sports suspension system is available.

The John Cooper Works Interior package comes with an Anthracite headliner, John Cooper Works sports leather steering wheel with multifunction controls, stainless steel pedals, the John Cooper Works gear lever knob plus optional John Cooper Works cloth upholstery with racing stripe. Both packages include custom door sill finishers and offer the optional and iconic Chili Red paint.



BIG ON SMALL DETAILS: MINI YOURS.

The MINI Yours customization programme provides a wealth of options for those who prize individuality and refined style. The range represents the best of British craftsmanship, and each item has its own story to tell.

Here are a few examples: the MINI Yours sports leather steering wheel including soft nappa leather and contrast stitching, burnished 19" MINI Yours Masterpiece wheel rims, illuminated MINI Yours Interior Styles and the spectacular exterior colour MINI Yours Lapisluxury Blue – a deep shade of ultramarine.

The MINI Yours logo with Union Jack and sewing needle features on all MINI Yours leather upholstery. The MINI Yours seat in Carbon Black is made from the finest leather. It comes with braided edging, a Union Jack on the back of the headrest, plus dinamica armrests in the same colour.

GO YOUR OWN WAY.

The best views are at the top, and ALL4 gets you there. The intelligent all-wheel drive system provides supreme traction when you need it, down dirt tracks, cobbled streets or even across the snowy plains. Now you can really run wild.



WITH ALL4 ANYTHING'S POSSIBLE.

The ALL4 all-wheel drive in the MINI Countryman is an intelligent torque vectoring system that maximizes traction on virtually any surface. Its electro-hydraulic multi-disc clutch* is linked to Dynamic Stability Control and smoothly varies the amount of drive torque distributed from the MINI Twin Power Turbo engine to the front and rear axles according to the driving situation. That all means supreme traction, maximum stability and even more fun cruising around corners.

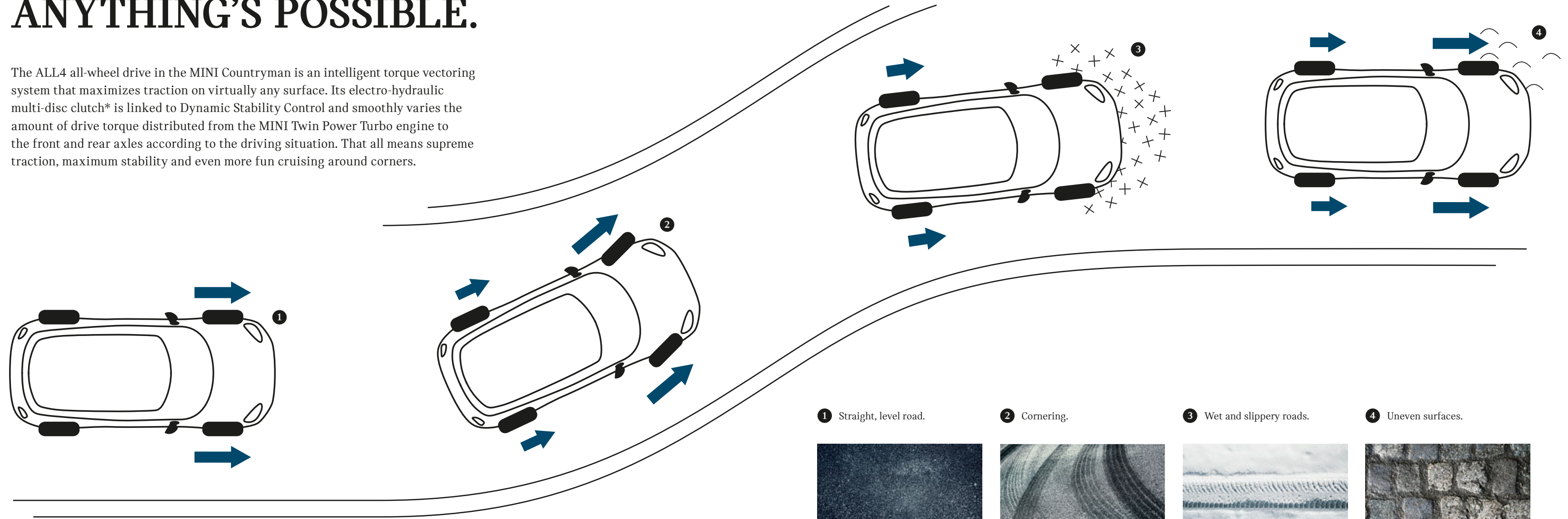

 Drive torque

1 Straight, level road.



To maintain efficiency in normal driving situations, e.g. on straight, level roads, the system diverts 100% of the torque to the front axle.

2 Cornering.

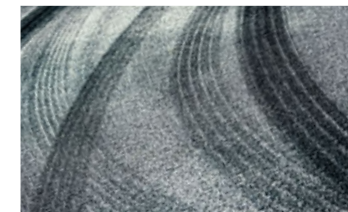

ALL4 allocates enough torque to the rear axle to counter the onset of over/understeer and increase stability.

3 Wet and slippery roads.



More torque is directed to the rear axle – in some cases up to 100% – when a loss of grip occurs at the front. This counteracts understeer and ensures optimal traction.

4 Uneven surfaces.



ALL4 rapidly allocates the optimum amount of power to each axle to ensure maximum traction on uneven roads.

* Different ALL4 technology is used in the MINI Countryman Plug-in Hybrid (page 15).

THE BEST JOURNEYS BEGIN WITH PEACE OF MIND.

1 Now you'll never lose sight of the important things. The MINI Head-Up Display projects key driving information into the driver's line of sight without obstructing his view of the road. Depending on the optional equipment fitted, this data can include speed limits, navigation instructions and cruise control settings.

2 The optional Bi-LED light for both high and low beam settings is a clearly visible beacon out on the road. It's like having a lighthouse lamp fitted to your car. The LED cornering light follows and illuminates the curve of the road, while the LED fog lights and MINI Original LED additional headlights ensure optimum visibility when the weather takes a turn for the worse. Whatever the weather, the omega-shaped daytime running

lights in the LED headlights remain a signature of the MINI Countryman design. The High Beam Assist – part of the Driving Assistant – recognizes oncoming vehicles. At speeds of 50 km/h and above, it automatically switches the high beam off to prevent glare affecting oncoming traffic – and back on again once the vehicles have passed. It also recognizes when there is sufficient light, e.g. in built-up urban areas, and dims the lights accordingly.

3 If desired, the tailgate of the MINI Countryman can open and close electronically. All you need is the Comfort Access system: the Easy Opener function means you can open the boot just by waving your foot under the rear of the vehicle.

4 The Park Assist helps you find a suitable parking space and makes parallel parking easy. All you have to do is brake and accelerate as required.

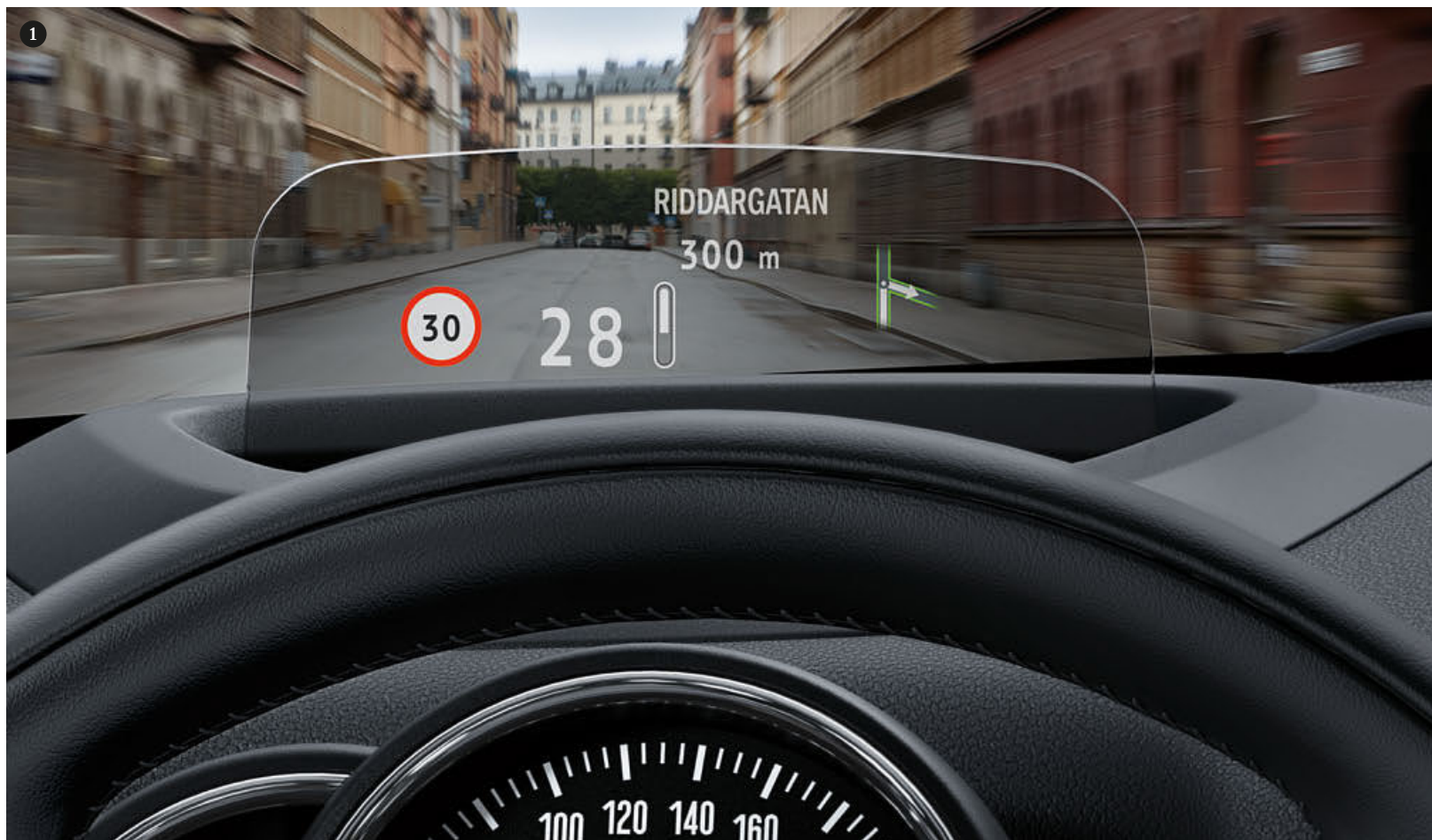



MINI CONNECTED: HELLO WORLD.

Between MINI Connected and its compatible apps, you've got everything you could need to take the hassle out of your journey – or inject a few more thrills into it. Be it loading your online search results into the navigation system or choosing music from one of the countless playlists, you can do it all from behind the wheel. Go online to find out more.

WIRED



With the Wired package you can take full advantage of the MINI Connected world of infotainment. It comes with the Professional navigation system with 8.8-inch touchscreen (or operate with the MINI Touch Controller on the centre console) and in-car wireless charging (plus phone calls via an external antenna). Other features include voice control, 3D satellite map view, MINI Connected XL, 20 GB of entertainment storage and much more.

HELPS YOU IN MORE WAYS THAN ONE.

WELCOME TO MINI CONNECTED.

MINI Connected does more than give you access to the Internet – it's like having a personal assistant out on the road, taking all the hassle out of planning your day. Thanks to the MINI Connected app, you don't even have to be in the car to use it. MINI Connected sends you reminders about meetings, works out how long your trip will take based on traffic updates, provides directions, pinpoints nearby petrol stations and, when you arrive – ideal parking spots. It'll even provide directions on your smartphone once you're out of the car. What more could you want?



CHOOSE YOUR INTERFACE.

1 RADIO MINI VISUAL BOOST.

The standard 6.5" screen includes the ergonomic MINI Controller and MINI Connected interface.

2 MINI PROFESSIONAL NAVIGATION SYSTEM.

Upgrade to the Wired Navigation Package for an 8.8" touchscreen with brand new design and software. This includes an enhanced MINI Controller with handwriting recognition and MINI Connected XL.





DRIVING THE FUTURE OF MOBILITY.

We have never been so connected – and life has never been so fast-paced. So we need vehicles that can keep up with our hectic lifestyles. And this is why a MINI excels in many different ways. A MINI is all about being yourself, enjoying your journey and turning heads along the way.

But it's also about having the right mindset. This means loving what we do. And recognizing the value in certain things, whether it's because they mean something, because they're important or because they look good.

Since 1959, we have strived to retain what sets MINI apart while creating something new. We want to inspire others to help us develop better ways of going places, which we can appreciate today – and in the future.

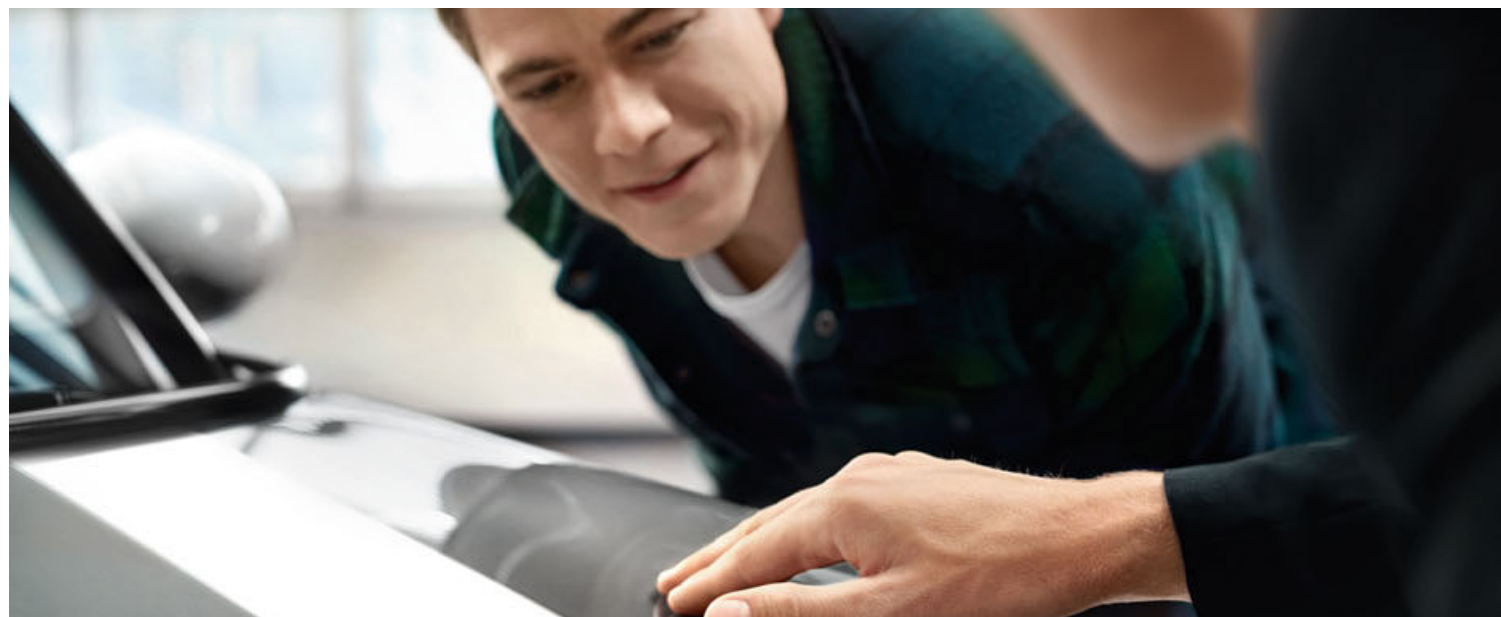

MINI SERVICE.

Everything you need.

Not many people will know your MINI as well as you do. MINI Service specialists however, share your passion entirely. There's nobody better when it comes to electronics, mechanics, bodywork, paintwork or cosmetic repairs – or when you need to pick up a replacement part. Because you'll soon realize that a MINI like yours deserves nothing less than Original MINI Parts.

No-Charge Scheduled Maintenance.

Being a MINI owner has its perks. With every new model year 2017 MINI, you'll also take home a 3-year/ 50,000 km (whichever occurs first) No-Charge Scheduled Maintenance package, which includes engine oil service and air filter replacement, brake fluid change, and more.

Warranty.

Every MINI is supplied with new car limited warranty for a period of 4 years or 80,000 km (whichever occurs first). Rust perforation coverage is also included for a period of 12 years with unlimited mileage. Paint blemishes are covered for a period of 4 years or 80,000 km. To obtain paint and rust perforation service under warranty, MINI Canada requires that the vehicle is inspected every 2 years at an authorized MINI retailer. This warranty does not cover repairing of damages to undercoating or paint due to stone chips, gravel erosion, scratches or other external influences. Repair work can be carried out at any authorized MINI dealer, MINI Service Authorized Workshop, or any other service centre authorized by MINI. Failure to comply with the service schedule provided by the manufacturer may invalidate this warranty.

MINI knows best.

Since you can't always think of everything when on the road, your MINI uses its head too. With the Condition Based Service feature, it automatically reminds you when its next service is due, via the control display.

MINI Roadside Assistance.

Get out, hit the highway, make your mark and throw your worries in the trunk. With MINI Roadside Assistance, you'll get an outstanding 4 years of unlimited travel protection wherever the road takes you. This comprehensive program provides a variety of benefits and services that include towing, lock-out service, on-site assistance, custom-computerized trip routing services and our industry-leading MINI Accident Management services. For more information, simply call us at 1-866-DRV-MINI (378-6464). Our service representatives are here for you 24 hours a day, 365 days a year.



MINI FINANCIAL SERVICES.

The fastest way into a new MINI.

Before you get behind the wheel of your new MINI, get on the right track with MINI Financial Services. Follow these three simple steps to the car of your dreams.

Step 1: Choose one of the available MINI Leasing options, if you're geared towards freedom, or MINI Financing options, if you want to own your car like it owns the road.

Step 2: Choose from the wide variety of Protection Products offered by MINI Financial Services. Every product offered can be tailored to your specific wants and needs.

Recycling.

At every stage, from design to disassembly, recycling is central to the MINI philosophy. For example, all the materials used in each vehicle's manufacture are selected because they can be used in the most sustainable and environmentally friendly way possible. That way, every MINI can be efficiently and ecologically recycled when its driving days are finally done. We have been working on this approach since 1994 at the BMW Group Recycling and Disassembly Centre in Munich, the only facility of its kind.

Step 3: Enjoy the security that comes with total peace of mind. At MINI Financial Services, we've got you covered.

Ready to hit the road? Then head to your nearest MINI Retailer now. Our Sales Advisors know the ins and outs of every product we have to offer, and they can make getting behind the wheel of a MINI as easy as it is to drive a MINI. For more information about MINI Financial Services leasing, financing and insurance products, visit minifinance.ca or your local MINI Retailer.

TECHNICAL DATA FOR THE MINI COUNTRYMAN.

Engine ¹		Cooper	Cooper ALL4	Cooper S ALL4	Cooper S E ALL4
Cylinders/layout/valves per cylinder		3/inline/4	3/inline/4	4/inline/4	3/inline/4
Capacity	cm ³	1499	1499	1998	1499
Stroke/bore	mm	94.6/82	94.6/82	94.6/82	94.6/82
Max. output/max. revs	hp/rpm	134/4400–6000	134/4400–6000	189/5000–6000	134/4400
Max. torque/revs	lb/ft/rpm	162/1250–4300	162/1250–4300	207/1350–4600	162/1250–4300
Compression ratio/recommended fuel	:1	11/91–98 RON	11/91–98 RON	11/91–98 RON	11/91–98 RON
Performance¹					
Max. speed	km/h	200 [200]	200 [200]	221 [221]	193
Electric max. speed	km/h	–	–	–	125*
Acceleration 0–100 km/h	sec.	9.6 [9.6]	9.8 [9.8]	7.3 [7.2]	6.8
Acceleration 80–120 km/h (5th gear)	sec.	10.9 [-] (12.2 [-])	10.9 [-] (12.2 [-])	8.4 [-] (9.2 [-])	–
Fuel consumption^{1,2}					
City	l/100 km	9.6 [9.5]	10.6 [10.3]	11.3 [10.5]	TBC
Highway	l/100 km	7.0 [7.2]	7.4 [7.9]	7.7 [7.4]	TBC
Combined	l/100 km	8.4 [8.4]	9.1 [9.2]	9.7 [9.1]	TBC
Electric range (NEDC) ² /max. total range ²	km	–	–	–	40*
CO ₂ emissions (combined cycle)	g/km	197 [197]	214 [215]	227 [213]	TBC
Tank capacity, approx.	l	61	61	61	36
Weight¹/luggage capacity¹					
Curb Weight ¹	kg	1497 [1524]	1592 [1607]	1646 [1665]	1791
Payload	kg	390 [390]	390 [390]	420 [420]	420
Max. permitted axle load, front/rear	kg	1020/990 [1050/990]	1070/1040 [1090/1040]	1100/1050 [1120/1050]	1115/1200
Luggage capacity	l	450–1390	450–1390	450–1390	405–1275
Wheels					
Tire dimensions, front/rear		225/55 R17 97W	225/55 R17 97W	225/50 R18 95W	225/50 R18 95W
Wheel rim dimensions, front/rear		7.5J x 17 light alloy	7.5J x 17 light alloy	7.5J x 18 light alloy	7.5J x 18 light alloy

* The figures quoted are provisional and are subject to change, to be confirmed closer to market launch.

¹ All figures relate to vehicles with the standard 6-speed manual transmission. Figures in square brackets relate to vehicles with 6-speed/8-speed Steptronic transmission.

² Range and energy consumption may vary due to factors such as driving style, road conditions, external temperature, heating and air conditioning, and preconditioning.

Fuel Consumption based on Natural Resources Canada's (NRCan) newly mandated fuel consumption criteria and 5-Cycle testing methods effective with 2017 model year vehicles.

³ Without driver. Figure quoted is for standard-specification vehicles. Optional equipment will increase this figure.

MINI COUNTRYMAN DIMENSIONS.

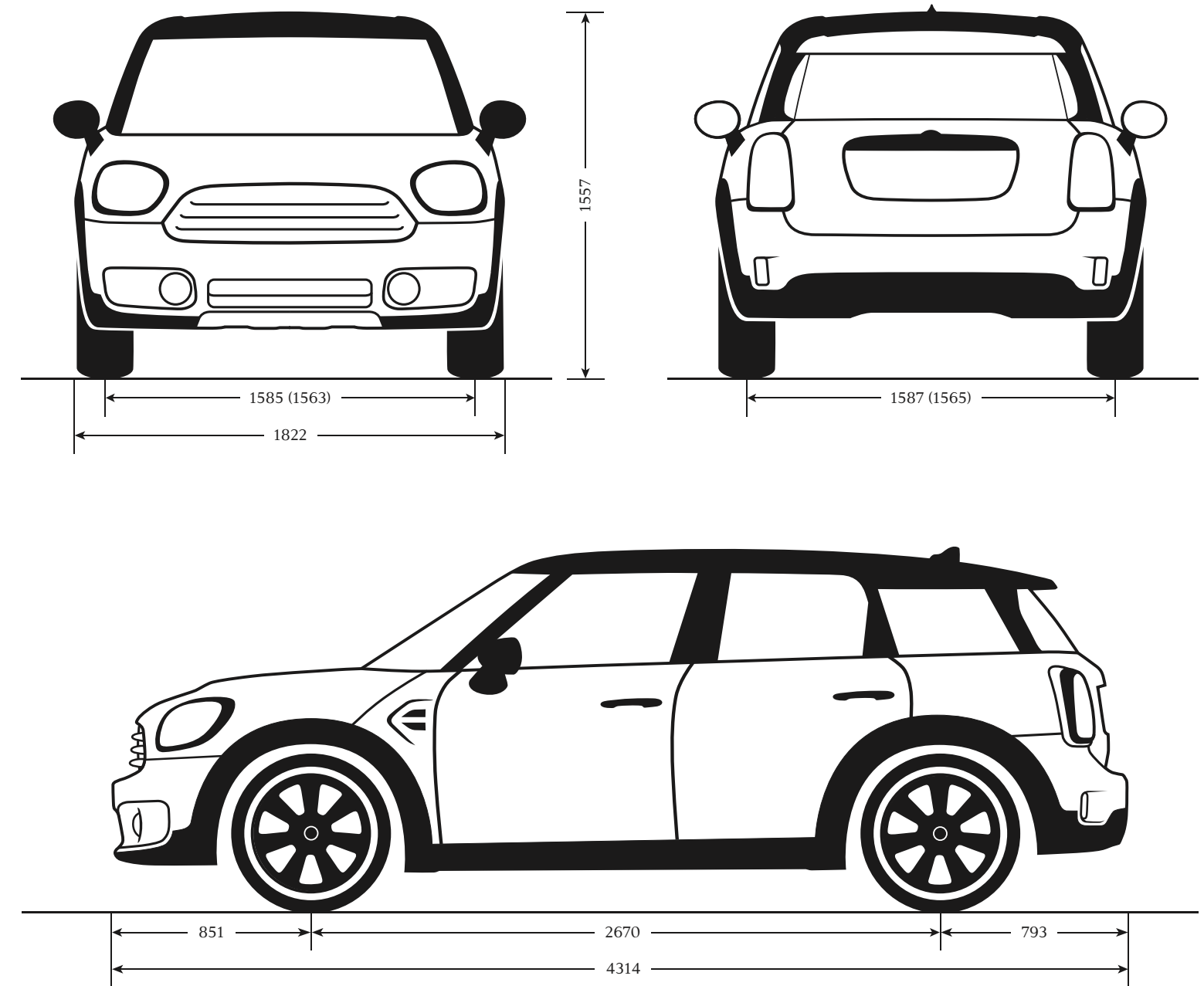

Cooper S figures in brackets.
All figures in mm.



THIS IS WHERE THE FUN REALLY STARTS.

What's the point of revving yourself up without taking it for a spin? Get behind the wheel. Make yourself comfortable in the driver's seat. Listen to the satisfying sound the door makes as it closes behind you. Fasten your seat belt. Adjust the rear-view mirror and start the engine. A whole new experience awaits you: a drive like no other, guaranteed to inspire. So what are you waiting for? Arrange a test drive with your MINI Retailer and find out what it feels like to drive a MINI Countryman.

mini.ca



All specifications, standard features, accessories, equipment, options, fabrics and colours are based on product information available at the time of printing. MINI reserves the right to revise specifications at any time, without notice. Illustrations are representative only. MINI may determine the Model Year designation of its vehicles. Models may be shown with features, accessories, equipment, options, fabrics and/ or colours not available in Canada, or available only at extra cost, or available only on particular models. While MINI takes care to ensure that the information contained in this brochure is accurate, it cannot guarantee complete accuracy. MINI is not responsible for errors or omissions contained in this brochure. Further information about the products shown in this brochure can be obtained from your authorized MINI Retailer and at mini.ca. Not to be reproduced wholly or in part without written permission of MINI Canada, a division of BMW Canada Inc.

© 2017 MINI Canada. "MINI", the MINI logo, all model designations and MINI related marks, images and symbols are the exclusive properties and/or trademarks of BMW AG, used under license.

CDN Part # English: 99 00 2 450 780

Find out more online at mini.ca



facebook.com/minicanada



instagram.com/minicanada



twitter.com/minicanada

ORIGINAL MINI ACCESSORIES
mini.ca/accessories

MINI COLLECTION
minishop.ca

January 2017