



TT TTS

Audi TT Coupé | TT Roadster
Audi TTS Coupé | TTS Roadster

Vorsprung durch Technik 



	Page			
Fascination	4	Audi TT		
	24	Audi TTS		
	38	Audi TT RS/TT RS plus		
Technology	40	Audi ultra	46	S tronic®
	42	TFSI®	48	quattro®
	44	TDI®	50	Audi magnetic ride
Equipment	54	Audi exclusive	82	Headlinings/hood linings
	56	Audi exclusive line	83	Inlays
	64	S line	84	Lights and mirrors
	68	S line competition	85	Exterior equipment
	70	Style guides	87	Interior equipment
	74	Paint finishes	90	Infotainment
	75	Hood colours	91	Assistance systems
	76	Wheels/tyres	91	Technology
	78	Seats/seat upholstery	93	Audi Extended Warranty
Miscellaneous	94	Audi Genuine Accessories	102	Index
	98	Technical data	108	The fascination of Audi
	100	Dimensions		

The equipment for the vehicles illustrated in the Fascination section can be found on page 107.
The fuel consumption and CO₂ emission figures can be found from page 98 onwards.



We've come full circle. A very fast one, admittedly.

Our inspiration for the Audi TT is the circle. Infinite beauty, infinite fascination. It can be seen in many details of the TT and does not just win over those who are inspired by design, but also those with a passion for exciting sports cars.

The current model continues this tradition of fascination. At the same time, its efficiency is right up-to-date – and even ahead of its time: the combination of the economical TDI engine with the quattro all-wheel drive is unique. Enjoy one of the most progressive sports cars you have ever driven.

The fuel consumption and CO₂ emission figures can be found on page 98.

TT

Audi TT Coupé | TT Roadster

A seamless blend of form and function.

Every line of the TT is pure logic. Every detail is pure quality. Every journey is pure emotion.

The fuel consumption and CO₂ emission figures can be found on page 98.



We have taken the characteristic features of the TT and made them even more characteristic.

Short overhangs at the front and rear, a wide track. Plus accentuated wheel arches and clearly visible tailpipes. From its athletic side view to its muscular rear, the Audi TT radiates pure self-confidence.

The fuel consumption and CO₂ emission figures can be found on page 98.





Purism in its most beautiful form. Functional design meets timeless aesthetics. The front is defined by the Audi Singleframe with design elements in high-gloss black and the slim front fog lights. In conjunction with the optional xenon plus headlights, the Audi TT has daytime running lights in LED technology. The sporty, striking diffuser accentuates the vehicle's width at the rear.

The fuel consumption and CO₂ emission figures can be found on page 98.



It has never been easier to be sportier.

Ground-breaking technologies from Audi have one goal: to move you faster whilst at the same time using less fuel. The Audi Space Frame (ASF®) body concept, with its innovative combination of aluminium and steel, is the embodiment of increased driving dynamics, greater driving stability and improved acceleration. The engine in the TT also promises pure driving pleasure: namely more power, more thrust and lower fuel consumption. Turbocharging, TFSI technology and the innovative Audi valvelift system (AVS) enable the 2.0 litre, 4-cylinder engine with a power output of 155 kW in the TT Coupé quattro S tronic to take the car from 0 to 100 km/h in just 5.7 seconds.

The fuel consumption and CO₂ emission figures can be found on page 98.



The acoustic hood of the TT Roadster opens in just 12 seconds. There is hardly a faster way to clear your head.

The Audi TT Roadster is the epitome of open-top driving pleasure. The optional, fully automatic acoustic hood is completely retractable and does not require a tonneau cover. Also available on request: an electrically extending wind deflector.

The fuel consumption and CO₂ emission figures can be found on page 98.



Tight corners, long straights, uneven surfaces – road conditions can alter in a moment. The optional Audi magnetic ride reacts to them in a flash: the adaptive damper system adjusts the suspension of the Audi TT to the prevailing driving situation in just a few milliseconds.

The fuel consumption and CO₂ emission figures can be found on page 98.





The rear spoiler of the Audi TT extends automatically at 120 km/h and improves driving stability. At 80 km/h, it harmoniously dovetails back into the rear line. Alternatively, you can operate the spoiler at the touch of a button.

The fuel consumption and CO₂ emission figures can be found on page 98.





Optional: the Sport button.
 Standard: the desire to drive off immediately.

Even more sport for the sports car. One press of the optional Sport button makes the electromechanical power steering more dynamic and the throttle response even more spontaneous. You will feel the results immediately: in the form of more agility and an even more vibrant engine sound. The onboard computer with larger gear change recommendation display and efficiency program displays tips for reducing fuel consumption. It indicates which of the car's systems are currently consuming energy – for example, the rear window heater – and gives you the option of turning off some of the optional energy consumers.





A flowing transition from outside to inside. The statement of the TT shoulder line, the round air vents, the leather-covered sport steering wheel flattened at the bottom. Clear instruments. If desired, inlays in grey brushed aluminium provide sporty highlights. Ergonomically shaped sport seats with integrated head restraints. Pure sporty elegance. Inside and out.

The fuel consumption and CO₂ emission figures can be found on page 98.



How to make a sport car even sportier.

By giving it even more emotion. More power. More character. By turning it into a TTS. The TTS Roadster and TTS Coupé are the type of sports cars that only Audi can build: made for bursts of speed and relaxed long-distance journeys. And utilising lightweight construction methods to ensure a more efficient – and tremendously pleasurable – drive.

The fuel consumption and CO₂ emission figures can be found on page 99.

TTS

Audi TTS Coupé | TTS Roadster



We have made beauty faster.

200 kW – and the optional Sport button – are at your disposal. They change the characteristics of the TTS. The electromechanical power steering becomes sportier and the throttle response more spontaneous. It is clear right from the start: your TTS drives perceptibly more dynamically and sounds even more powerful.

The fuel consumption and CO₂ emission figures can be found on page 99.



Large air intakes provide the 200 kW engine with sufficient supplies of oxygen and indicate its sportiness. The Audi Singleframe shines with its unique TTS look, whilst the broad sills lend the flanks of the TTS an even more dynamic appearance.

The fuel consumption and CO₂ emission figures can be found on page 99.



The TTS Roadster is equipped with a fully automatic acoustic hood which can be opened completely even while driving at speeds of up to 50 km/h – in just 12 seconds. The intelligent concertina folding action means that no tonneau cover is required; visually, the hood is integrated fully into the car. The standard electrically extending wind deflector ensures better air flow conditions on the interior.

The fuel consumption and CO₂ emission figures can be found on page 99.

Sometimes excellence is denoted by one single detail. In the TTS, it is expressed in many.

The xenon plus headlights with integrated LED daytime running lights give your TTS an unmistakable look at any time of day. The front fog lights are framed by double struts in aluminium look, the horizontal double struts of the Audi Singleframe emphasise the car's dynamic character. The air intake grilles at the side can be recognised by their distinctive diamond-shaped pattern. The ventilated brake system with painted callipers is visible through the standard-fitted 18-inch wheels that feature a 5-parallel-spoke S design; the front callipers bear the TTS logo. In short: the overall appearance exudes power and athleticism.

The fuel consumption and CO₂ emission figures can be found on page 99.







Inside the car a clear design language prevails. The gear lever knob of the optional S tronic sits in your hand well and sets a visually powerful accent. The TTS instrument cluster features grey speedometer and rev counter dials. The clearly arranged driver information system with white, high-resolution display ensures that all the important information is in your field of vision. The onboard computer with larger gear change recommendation display is equipped with an efficiency program that displays tips for reduced fuel consumption. Another brilliant touch is the lap timer which provides you with accurate data on your lap times.

The fuel consumption and CO₂ emission figures can be found on page 99.

The aluminium look and high-gloss black highlights have been deliberately designed to give the interior a powerful, elegant appearance. On request, the standard sport seats with contrasting stitching are available in two-colour silk Nappa leather; the ergonomic shape of the seats provides excellent support, even when a sporty driving style is adopted. The standard flat-bottomed leather-covered multifunction sport steering wheel allows you to control many important radio functions as well as the optional preparation for mobile phone, and conveys a feeling of direct contact with the road.

Challengingly dynamic.

Developed exclusively by quattro GmbH, the RS models represent the very peak of what is technically feasible at Audi. Powerful FSI® engines, RS sport suspensions and high-performance brakes – these are technologies that are derived from motorsport and promise the ultimate in superior, dynamic performance. Likewise their striking, RS specific design.

Equipment and fuel consumption and CO₂ emission figures can be found in the TT RS catalogue.



TT RS

Audi TT RS Coupé | TT RS Roadster
Audi TT RS plus Coupé | TT RS plus Roadster





Audi ultra on the podium: the Audi R18 TDI

Audi ultra:

Every gram less extends the lead.

Audi ultra, the pioneering lightweight technology from Audi, is more than just the sum of its individual components. It combines innovative materials, intelligent design principles and production processes that use resources sparingly into an overall concept. Many Audi ultra lightweight measures have already been implemented in the Audi TT and TTS.

That starts with the body itself. The Audi Space Frame (ASF) in hybrid design combines low weight with high rigidity. An innovative combination of aluminium and steel materials guarantees balanced weight distribution. The body is almost

70% aluminium to minimise vehicle weight and thus fuel consumption. To balance the axle load distribution, steel is used in the rear to achieve the driving feel typical of a sports car. The aluminium components on the front axle and the aluminium alloy wheels not only reduce the overall weight but also the unsprung masses, which in turn leads to a further increase in agility and driving comfort.

Drive technologies such as direct fuel injection and turbocharging have made Audi engines more and more powerful. The modern TDI and TFSI engines in the Audi TT and TTS produce more

power with a smaller engine size, making them lighter than the corresponding engines used in earlier series.

Each lightweight component has an effect on other components, allowing their dimensions to be reduced as well. The result is a continuous development process towards less and less weight and more and more efficiency. In figures: a vehicle that weighs 100 kg less can save up to 0.3 litres of fuel per 100 km.

The fuel consumption and CO₂ emission figures can be found from page 98 onwards.

About weight reduction

The demands placed on modern vehicles are contradictory. On the one hand, they must offer enhanced performance and comfort, on the other they need to be more economical and efficient. Audi ultra resolves this conflict by examining each and every component. We demand the highest functionality combined with the lowest possible weight. The result is an intelligent mix of materials that even allows a reduction in engine size: lighter vehicles no longer need a large engine to be agile. In 2012, for example, the two Audi R18 e-tron quattros and the Audi R18 ultra that drove to podium finishes at Le Mans had V6 engines, whereas their victorious predecessor in 2010, the R15 TDI, had featured a V10 engine.



■ Aluminium sheet
 ■ Cast aluminium
 ■ Aluminium profile
 ■ Cold-formed steel



Audi valvelift system: This variable valvelift system controls the outlet valves so precisely that the combustion chamber is filled perfectly in almost every situation. For the driver, this means a significant improvement in torque and torque build-up. In addition, this technology enables a longer transmission ratio which reduces fuel consumption.

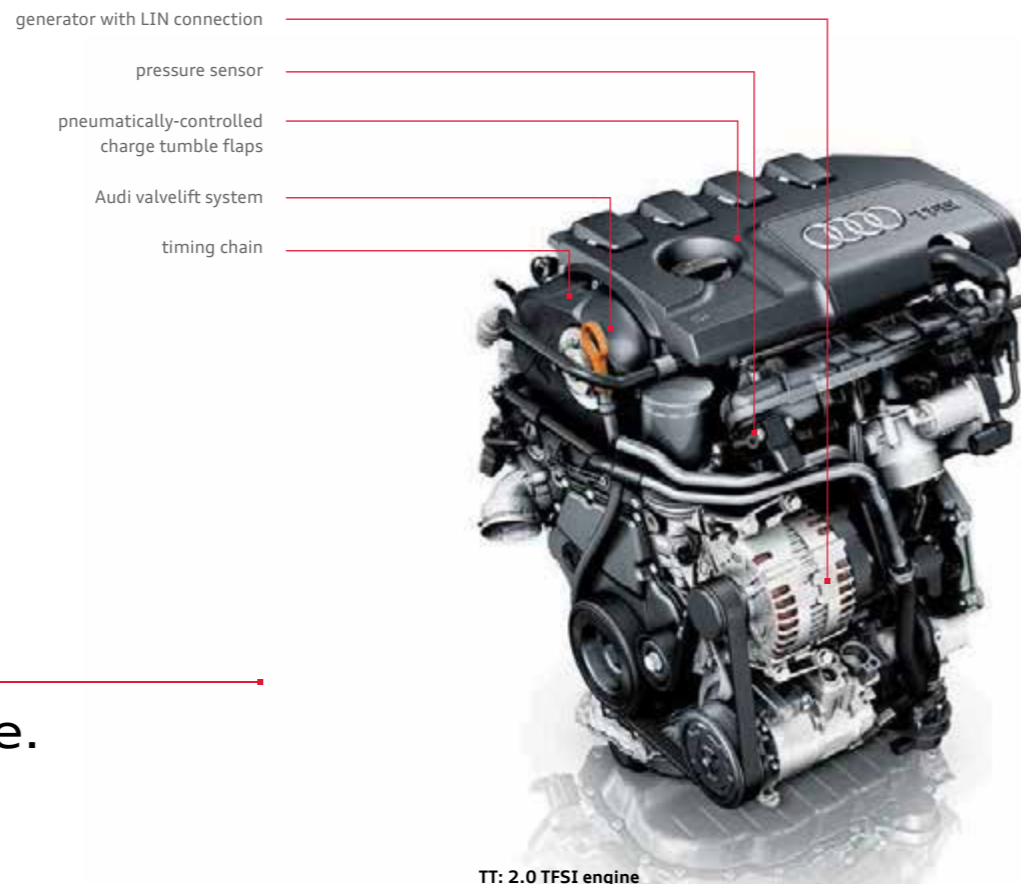

TT: 2.0 TFSI engine

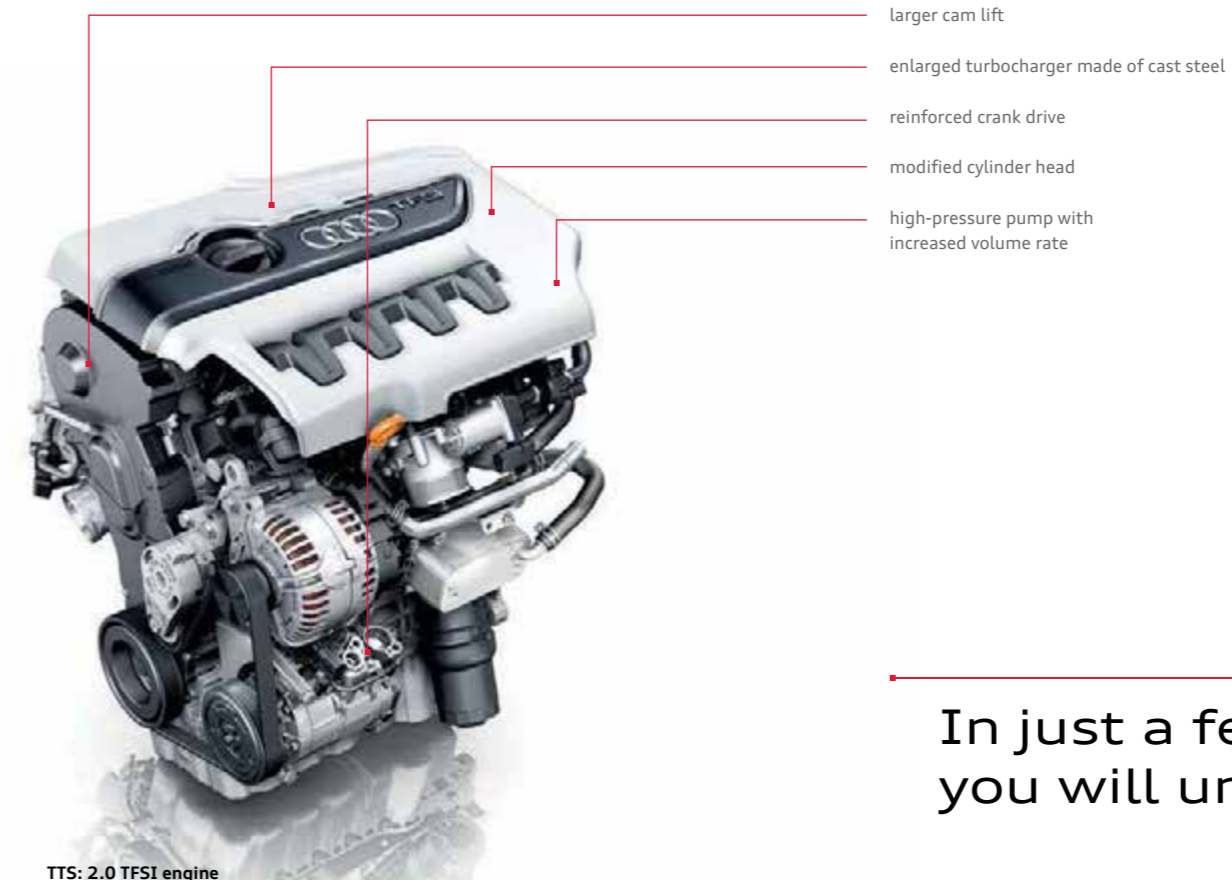

TTS: 2.0 TFSI engine

Many hours of development time. Thousands of miles of testing. And for what reason?

In the TT Coupé and TT Roadster, the 2.0 TFSI's 155 kW will keep you on the move sportily and efficiently. This is ensured in part by the Audi valvelift system (AVS). It alters valve lift and hence reduces fuel consumption. Together with TFSI technology, this means that fuel can actively be saved whilst simultaneously increasing driving pleasure.

The fuel consumption and CO₂ emission figures can be found from page 98 onwards.

With the TFSI engine, the fuel is injected into the combustion chambers in precise doses. There, the fuel evaporates, thereby cooling the intake air. This enables the compression ratio, and consequently engine efficiency, to be increased. This makes the TFSI engine a compact powerhouse and ensures exceptional power delivery.

So much for the theory. In practice, the 2.0 TFSI has impressive torque of 350 Nm over a broad engine speed range from 1,600 to 4,200 rpm. With the optional S tronic in the TT Coupé 2.0 TFSI quattro and TT Roadster 2.0 TFSI quattro, you will accelerate from 0 to 100 km/h in just 5.7 seconds and 5.9 seconds respectively, and continue on to a top speed of 243 km/h.

In just a few seconds you will understand why.

The 200 kW engine has undergone further special development to meet the requirements of the TTS. To generate its power, the crank drive, cylinder head and inlet valves, among other things, have been modified. A better air intake and exhaust system together with a performance-improved turbocharger enable the TTS to fully utilise the potential offered by TFSI technology.

The lively 4-cylinder engine has access to huge power reserves that can be called on dynamically

yet harmoniously across the entire engine speed range. Thanks to turbocharging, the engine develops an impressive 350 Nm of torque over a wide engine speed range of 2,500 to 5,000 rpm, and has spontaneous start-up performance. In this way, the TTS Coupé and the TTS Roadster, both fitted with the optional S tronic, will accelerate you from 0 to 100 km/h in just 5.3 seconds and 5.5 seconds respectively, and continue on to an electronically regulated top speed of 250 km/h.

TDI®

In other words: Where is the tank?

One in every two Audi cars sold today is a diesel. What sounds perfectly normal now was cause for huge excitement 20 years ago, when Audi revolutionised the market with the first 2.5 litre TDI engine. Since then, developments such as common rail technology have made TDI even more efficient. Consequently, since the first TDI, the engines have become more economical, whilst specific output has increased. So it was

only logical that a diesel car should then enter the world of motorsport. And successfully too: in 2006, Audi was the first car maker to win the 24 Hours of Le Mans with a diesel-powered race car, the Audi R10 TDI – and then went on to repeat this victory several times over, most recently in 2012.

Technology with winner's genes awaits you in the Audi TT 2.0 TDI quattro. You will feel its

powerful drive as soon as you accelerate: this is assured by the common rail technology which injects the fuel directly into the combustion chambers at pressures up to 1,800 bar. 125 kW and a maximum torque of 350 Nm take the Coupé and Roadster from 0 to 100 km/h in 7.5 seconds and 7.7 seconds respectively with S tronic.

The fuel consumption and CO₂ emission figures can be found from page 98 onwards.

turbocharger with improved adjustable turbine geometry

engine with reduced friction

compensating shaft module

1,800 bar high-pressure injection system

pressure-regulated oil pump



TT: 2.0 TDI quattro engine



S tronic: 2 multi-plate clutches provide for a sporty dynamism and high efficiency.

What is the benefit of two clutches?

A double saving: time and energy.

The optional 6-speed dual-clutch transmission, available in combination with various engines, facilitates rapid gear changing with hardly any perceptible break in propulsive power and is therefore particularly efficient.

Audi tested this technology in the Sport quattro S1 back in 1985 – and was suitably impressed. Audi drivers will understand the enthusiasm, because the modern S tronic changes gear in under 0.2 seconds. To do this, two multi-plate clutches serve the different gears. One large

clutch transfers the torque via a solid drive shaft to the gearwheels of the odd-numbered gears. A compact second clutch serves the even-numbered gears via a hollow shaft. Both parts of the transmission are permanently active, although there is only ever one actually connected to the engine. For example, if the vehicle is accelerating in third gear, only the first part of the transmission is transferring the power. In the second part of the transmission, however, fourth gear has already been engaged. When changing gear, it is not only the gear

that changes but also the clutch – in just a few hundredths of a second. So quickly and fluently that the driver hardly notices.

Regardless of whether the driver chooses the fully automatic mode with the D (Drive) and S (Sport) programs, or selects to change gear manually with the shift paddles, the gear change feels precise and extremely sporty. Even with all of this dynamic performance, the S tronic still remains very efficient. Because due to its high efficiency, both fuel consumption and emissions are reduced.

The fuel consumption and CO₂ emission figures can be found from page 98 onwards.

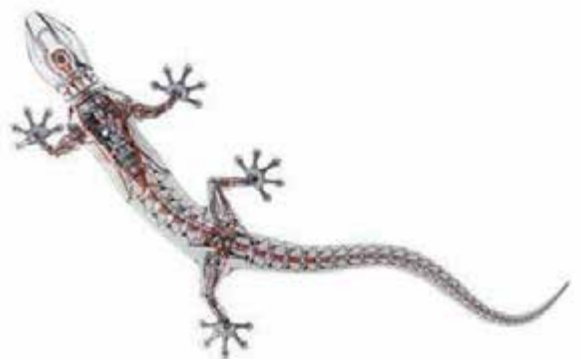

Why only use two wheels when a car has four?

The quattro® permanent all-wheel drive.

Those who know Audi know quattro. And anyone who has driven with quattro never wants to drive any other way. Why? Because this drive system transfers the engine's power to the road in such a convincing way.

quattro is a permanent all-wheel drive system. If the wheels on one axle of the vehicle lose grip on the road and threaten to spin, then the drive force is transferred to the other axle. In the TT, a directly responsive multi-plate clutch with

improved control system permits the torque to be distributed between the front and rear axles as needed. The rapid response and very fast reaction times of this generation of quattro are particularly impressive.

But what makes quattro unique is really the driving feel. "As if you are stuck to the road," our customers say. We put it like this: quattro is just more fun to drive.

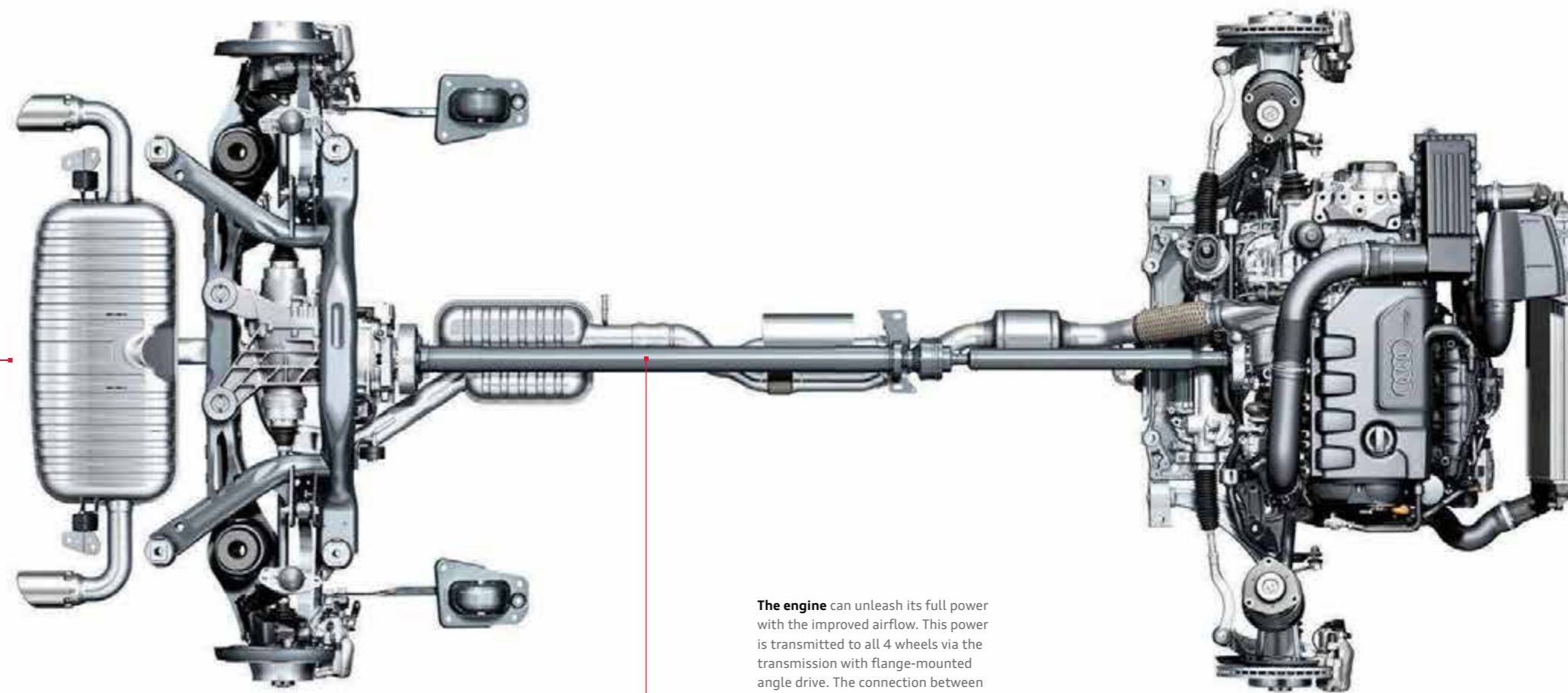

The engine can unleash its full power with the improved airflow. This power is transmitted to all 4 wheels via the transmission with flange-mounted angle drive. The connection between angle drive and rear axle gear is secured by the cardan shaft.



The heart of the shock absorber is a piston with a magnetic coil. The shock absorber oil flows through the piston and is influenced by a variable magnetic field. If the flow resistance increases, the damping forces also increase. This occurs by aligning the iron particles contained within the oil with the lines of the magnetic field.

It is often said that our vehicles have magnetic appeal.

We use it for the suspension.

The optional adaptive damping system Audi magnetic ride is a very special way of moving both sportily and in comfort. The system adjusts the stiffness of the shock absorbers to the road conditions extremely quickly. It is available as an option in the TT, it is fitted as standard in the TTS along with 10 mm lower suspension – for a distinctly sportier driving stance.

Instead of a conventional shock absorber oil, Audi magnetic ride uses a special fluid whose

viscosity can be controlled via an electromagnetic field. Tiny magnetic particles contained in the oil are aligned against the direction of movement of the shock absorber. As a result, the damping force of the shock absorber is increased according to the magnitude of the magnetic field which is applied. Wheel travel sensors and other systems such as steering and ESC supply the Audi magnetic ride control unit with information about the prevailing driving situation, influencing the damping level in fractions of a second.

The driver can choose between two basic settings. In comfort mode, Audi magnetic ride is a comfortable sport suspension for relaxing driving on long journeys. In sport mode, the suspension provides more direct feedback from the road; vehicle response is even more agile.

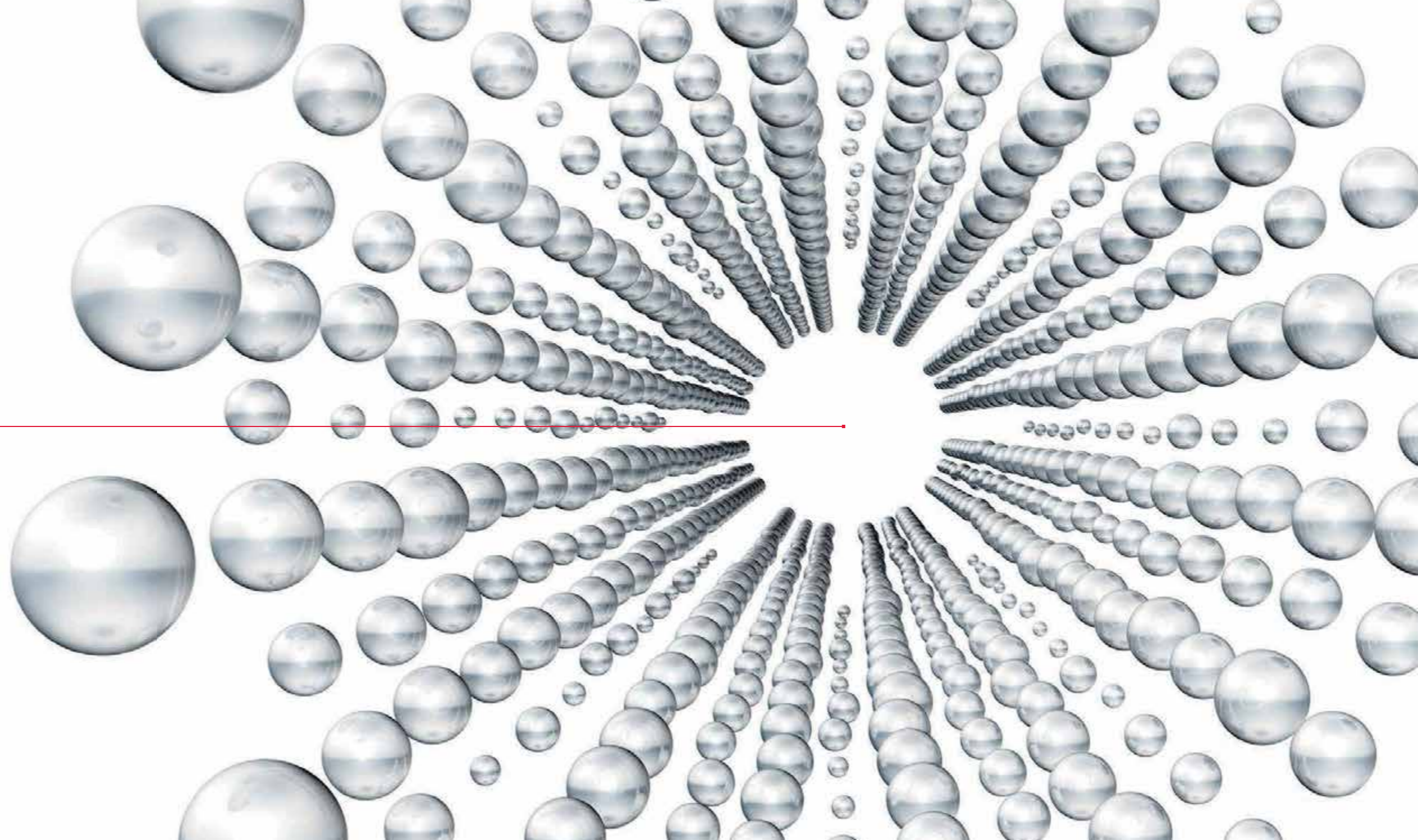



It is the equipment that turns an Audi into your Audi.

Audi exclusive

Exclusivity does not know the meaning of the word compromise. But it is familiar with endless variety.

Each year Audi sells over a million vehicles. Yet they only sell yours once. How is that possible? With Audi exclusive. This makes your Audi unmistakable.

Combine selected décors, coloured leather and a customised paint finish from the large selection of colours available from Audi exclusive to suit your personal wishes. Your unique vehicle will be the result.

Find out more about this topic from your Audi partner and in the Audi exclusive studio in Neckarsulm.

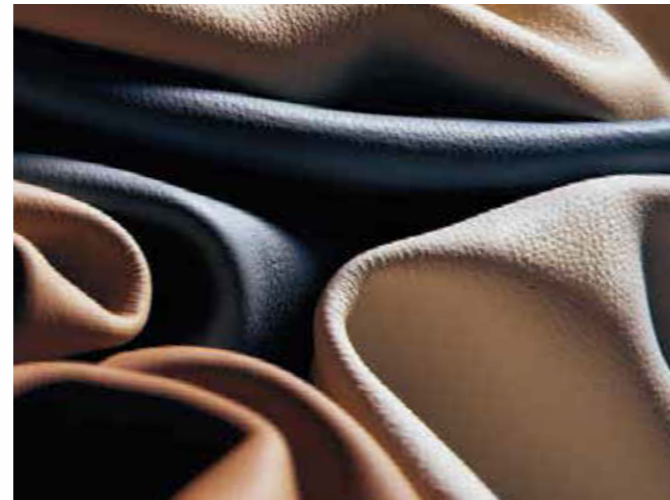

Audi exclusive leather upholstery and trim in fine Nappa leather in crimson red/black with contrasting stitching in crimson red



Sport seats with two-colour seat covers in fine Nappa leather in signal orange/black



Leather-covered multifunction sport steering wheel in 3-spoke design



Gear lever gaiter with coloured stitching

Two-colour seat upholstery



Fine Nappa leather, signal orange/black

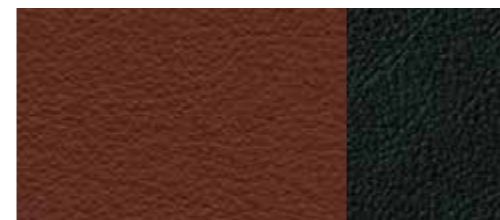

Fine Nappa leather, saddle brown/black



Fine Nappa leather, silver/black

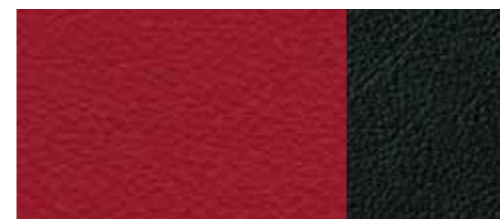

Fine Nappa leather, crimson red/black

Audi exclusive line

Two-colour seat upholstery

seat side bolsters in black/textured structure in a choice of signal orange, saddle brown, silver or crimson red in fine Nappa leather, including heat protection (in direct sunlight)

Seat side bolsters, head restraints, steering wheel rim and gear lever gaiter

with coloured stitching (to match structured look)

Front door trim inserts in leather

(to match structured look)

Leather-covered sport steering wheel in 3-spoke design

with coloured stitching; optional: leather-covered multifunction sport steering wheel in 3-spoke design with or without gear change function, with coloured stitching

Black interior

including black attachments

Floor mats

with coloured piping (to match structured look)

Audi exclusive door sill trims

Headlinings

in black cloth

Audi exclusive line Lifestyle.

Equipment

- ▶ Exterior colour Dakota grey, metallic
- ▶ Hood, beige
- ▶ Fine Nappa leather upholstery and trim, Luxor beige
- ▶ Extended colour leather package
- ▶ Inlays in Dakota grey
- ▶ Door sill trims with "Audi exclusive" logo
- ▶ Floor mats with piping in Luxor beige
- ▶ Audi exclusive cast aluminium wheels, 5-twin-spoke design, size 9 J x 18 with 245/40 R 18 tyres*. From quattro GmbH



Dakota grey, metallic



For an individual touch, **Audi exclusive line Lifestyle** offers a particularly refined package with exterior paint finish in Dakota grey, metallic, a beige hood and high-quality sport seats in Luxor beige. Further extras such as the sporty Audi exclusive 18-inch cast aluminium wheels in 5-twin-spoke design turn your TT Roadster into something really special.

Audi exclusive line Classic.



The TT Roadster concept car was originally presented to the world's public at the Tokyo Motor Show 1995, and was immediately well received, partly on account of its unusual colour design, combining technical metallic grey on the exterior and a red-brown baseball look in the interior. **Audi exclusive line Classic** picks up on this unusual colour design with its exterior paint finish in nimbus grey, pearl effect, and upholstery and trim in impulse leather, Chennai brown, thus recalling the birth of the TT Roadster.

Equipment

- ▶ Exterior colour nimbus grey, pearl effect
- ▶ Hood, black
- ▶ Impulse leather upholstery and trim, Chennai brown, with special seam detail
- ▶ Extended colour leather package
- ▶ Inlays in brushed aluminium, grey
- ▶ Extended aluminium look in the interior
- ▶ Door sill trims with "Audi exclusive" logo
- ▶ Floor mats with piping in Chennai brown
- ▶ Reduced gear lever travel (only for models with manual transmission)
- ▶ Audi exclusive cast aluminium wheels, 7-twin-spoke design, size 9 J x 19 with 255/35 R 19 tyres*. From quattro GmbH



Nimbus grey, pearl effect

*You will find specifications on the technical characteristics of tyres on page 107.

Audi exclusive line Black.

Equipment

- ▶ Exterior colour panther black, crystal effect
 - ▶ Silk Nappa leather upholstery and trim in black with contrasting stitching in silver
 - ▶ Extended leather package
 - ▶ Inlays in panther black
 - ▶ Door sill trims with "Audi exclusive" logo
 - ▶ Floor mats with piping in silver
 - ▶ Reduced gear lever travel (only for models with manual transmission)
 - ▶ Dark-tinted windows (privacy glazing)
- ▶ Leather-covered multifunction sport steering wheel in 3-spoke design with more heavily contoured steering wheel rim
 - ▶ Lights styling package
 - ▶ LED interior lighting package
 - ▶ Audi exclusive cast aluminium wheels in 5-twin-spoke design, size 9 J x 18 with 245/40 R 18 tyres¹. From quattro GmbH
 - ▶ Optional (illustrated below): Audi exclusive cast aluminium wheels, 15-spoke design, matt titanium look, high-gloss turned finish, size 9 J x 19 with 255/35 R 19 tyres¹. From quattro GmbH



Audi exclusive line Black: sporty, dynamic, progressive. Its first-class features in panther black crystal effect paint finish lend the TT Coupé a special brilliance, the Audi exclusive cast aluminium wheels in 15-spoke design in titanium look² give it a wide track and underline its powerful impression. On the interior, sport seats in black leather with contrasting stitching in silver and an extended leather package give the vehicle an individual touch.



Panther black, crystal effect

Audi exclusive line Ice.

Equipment

- ▶ Exterior colour glacier white, metallic
 - ▶ Alcantara/leather combination in spectral silver/black with contrasting stitching in silver
 - ▶ Extended leather package
 - ▶ Inlays in brushed aluminium, grey
 - ▶ Extended aluminium look in the interior
 - ▶ Door sill trims with "Audi exclusive" logo
 - ▶ Floor mats with piping in silver
 - ▶ Reduced gear lever travel (only for models with manual transmission)
 - ▶ Dark-tinted windows (privacy glazing)
- ▶ Leather-covered multifunction sport steering wheel in 3-spoke design with more heavily contoured steering wheel rim
 - ▶ Lights styling package
 - ▶ LED interior lighting package
 - ▶ Audi exclusive cast aluminium wheels, 5-twin-spoke design, size 9 J x 18 with 245/40 R 18 tyres¹. From quattro GmbH
 - ▶ Optional: Audi exclusive cast aluminium wheels, 15-spoke design, matt titanium look, high-gloss turned finish, size 9 J x 19 with 255/35 R 19 tyres¹. From quattro GmbH



Audi exclusive line Ice: stylish, premium quality, innovative. Experience the fascination of Audi in quite a special way. The glacier white metallic paint finish emphasises the classic lines of the TT even more clearly. Inside, an exclusive atmosphere with high-contrast design is waiting for you. The seats caress in Alcantara/leather combination in spectral silver/black with contrasting stitching in silver, and the inlays in brushed aluminium, grey round off the classy appearance.



Glacier white, metallic

¹You will find specifications on the technical characteristics of tyres on page 107. ²Optionally available.

Audi exclusive line Color.

Equipment

- ▶ Exterior colour Dakota grey, metallic, scuba blue, metallic, or volcano red, metallic
- ▶ Fine Nappa leather upholstery and trim in black with coloured contrasting stitching to match the exterior colour
- ▶ Extended leather package
- ▶ Inlays in reflex finish, moor brown/blue/red
- ▶ Door sill trims with "Audi exclusive" logo
- ▶ Floor mats with piping to match the exterior colour
- ▶ Leather-covered multifunction sport steering wheel in 3-spoke design with more heavily contoured steering wheel rim
- ▶ Lights styling package
- ▶ LED interior lighting package
- ▶ Audi exclusive cast aluminium wheels, 5-twin-spoke design, size 9 J x 18 with 245/40 R 18 tyres*. From quattro GmbH
- ▶ Audi exclusive cast aluminium wheels, 15-spoke design, matt titanium look, high-gloss turned finish, size 9 J x 19 with 255/35 R 19 tyres*. From quattro GmbH



Dakota grey, metallic



Scuba blue, metallic



Volcano red, metallic

Audi exclusive line Color: striking, sporty, expressive – the wide variety of this equipment line will win you over. Three fascinating exterior colours – Dakota grey, metallic, scuba blue, metallic or volcano red, metallic – are reflected in the three matching interior equipment versions. The sport seats in black leather have contrasting stitching which picks up on the respective exterior colour. Applications painted in matching colours give your vehicle its individual character.



*You will find specifications on the technical characteristics of tyres on page 107.

S line. Visibly more sportiness.

Driving an Audi TT is a clear commitment to automotive sportiness. The S line packages allow you to enhance the athletic appearance of your Audi TT even more: with equipment that underlines its dynamic body line, gives its interior a perceptibly sporty identity and further improves its driving performance. Choose how to up the sportiness.



S line exterior package

Front bumpers including side radiator grilles, side sills and diffuser insert in distinctive sporty design

Diffuser insert painted in platinum grey

S line logos on the door sill trims and on the front wings

Chromed exhaust tailpipe surrounds

Carbon items for the S line exterior package

Front spoiler edge and separate diffuser insert in carbon



Differentiated with sports bumpers at the front and front spoiler edge in optional carbon



Differentiated with sports bumpers at the rear and optional diffuser insert in carbon



Visibly ergonomic: sport seats, seat upholstery with seat side bolsters in black leather and seat centre panels in black sprint cloth with contrasting stitching and S line embossing on front-seat backrests



S line leather-covered multifunction sport steering wheel in 3-spoke design (optional), in black leather with contrasting stitching and S line emblem



Door sill trims with S line logo



Audi exclusive cast aluminium wheels in 5-twin-spoke design

Seat upholstery



Sprint cloth/leather, black



Perforated Alcantara/leather, black

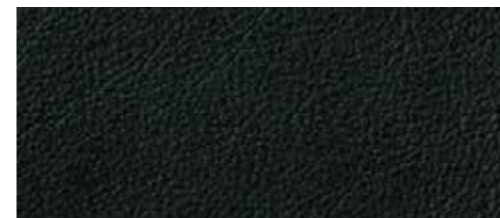

Fine Nappa leather, black

Additional exterior paint finish options



Misano red, pearl effect



Daytona grey, pearl effect

S line sports package

The following equipment ranges are included in the S line package:

Audi exclusive cast aluminium wheels in 5-twin-spoke design
size 9 J x 18 with 245/40 R 18 tyres*.
From quattro GmbH

S line sport suspension

with more dynamic suspension tuning; vehicle 10 mm lower than with sport suspension

S line logos

on the door sill trims and on the front wings

Interior, dashboard and headlining

in black; for cloth/leather or perforated Alcantara/leather seat upholstery with contrasting stitching on seat upholstery, leather-covered sport steering wheel, gear or selector lever gaiter and floor mats

Sport seats, front

S line leather-covered sport steering wheel in 3-spoke design

in black leather (steering wheel grips in perforated leather) with S line emblem; for S tronic with shift paddles

Gear or selector lever knob

in perforated black leather; reduced gear lever travel for manual transmission

Inlays

in centre console and glove compartment in matt brushed aluminium

Extended aluminium look in the interior

for vents, radio and A/C controls, rotary light switch and steering wheel spokes, door pull handles, pedals and footrest.

Optionally available:

Cast aluminium wheels in 10-spoke design
size 9 J x 18 with 245/40 R 18 tyres* and cast aluminium wheels in 7-twin-spoke design, in 7-twin-spoke design in matt titanium look or in 5-segment-spoke design, size 9 J x 19 with 255/35 R 19 tyres*

The following options are available for the seat upholstery:

S line seat upholstery in sprint cloth/leather, perforated Alcantara/leather or fine Nappa leather
each with S line embossing on the front-seat backrests

Leather-covered multifunction sport steering wheel in 3-spoke design

for S tronic optionally with shift paddles – both in black leather (steering wheel grips in perforated leather) with S line emblem

Paint finishes in all standard/optional equipment colours and additionally in the special colours Misano red, pearl effect and Daytona grey, pearl effect

* You will find specifications on the technical characteristics of tyres on page 107.

S line competition.

Equipment

- ▶ Exterior colour glacier white, metallic, Samoa orange, metallic, Daytona grey, pearl effect, or Misano red, pearl effect
- ▶ S line exterior package also with front spoiler edge and diffuser insert in black and with blackened tailpipes
- ▶ Audi exclusive black styling package
- ▶ Fixed rear wing in black
- ▶ Exterior mirror housings in black
- ▶ Audi exclusive cast aluminium wheels in 5-arm rotor design, matt black, high-gloss turned finish, size 9 J x 19 with 255/35 R 19 tyres* (illustrated below)
- ▶ Optional: cast aluminium wheels in 10-spoke design, black, size 9 J x 18 with 245/40 R 18 run-flat tyres*
- ▶ xenon plus including headlight cleaning system
- ▶ S line sport package plus leather-covered multifunction sport steering wheel in 3-spoke design with more heavily contoured steering wheel rim
- ▶ Inlays in matt brushed aluminium; with paint finish Samoa orange, metallic, the inlays are in reflex finish, Samoa orange
- ▶ Leather package
- ▶ Seat upholstery in perforated Alcantara/leather

The TT with S line competition: causes a stir even from afar. Audi exclusive cast aluminium wheels in 5-arm rotor design in matt black as well as black exterior mirrors provide an eye-catching contrast to the 4 attractive paint finishes. The fixed black rear wing stands for powerful dynamics. The front spoiler edge in black, the blackened tailpipes and the black diffuser insert put the finishing touches to the sporty look.



Misano red, pearl effect



*You will find specifications on the technical characteristics of tyres on page 107.



Audi TT Coupé in scuba blue, metallic with cast aluminium wheels in 10-spoke design.
Sport seats in fine Nappa leather, titanium grey, extended colour leather package, extended aluminium-look trim in the interior



Audi TT Coupé in ice silver, metallic, with cast aluminium wheels in 10-spoke design.
Sport seats in a black Alcantara/leather combination, extended leather package, extended aluminium-look trim in the interior





Audi TT Roadster in ice silver, metallic, with cast aluminium wheels in 5-spoke V design.
Sport seats in impulse leather, Chennai brown, extended colour leather package, extended aluminium-look trim in the interior



Audi TT Roadster in ice silver, metallic, and black hood with cast aluminium wheels in 5-spoke V design.
Sport seats in fine Nappa leather, magma red, extended colour leather package, extended aluminium-look trim in the interior



Solid paint finishes



Brilliant black

Metallic paint finishes



Glacier white, metallic

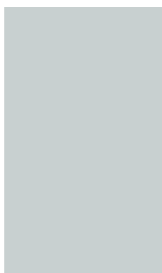

Sahara silver, metallic

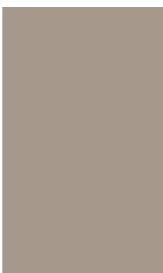

Volcano red, metallic



Pearl effect paint finish



Phantom black, pearl effect

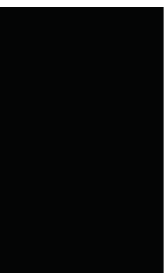

Crystal effect paint finish



Panther black, crystal effect



Customised paint finishes



Audi exclusive customised paint finishes
From quattro GmbH

Hood colours

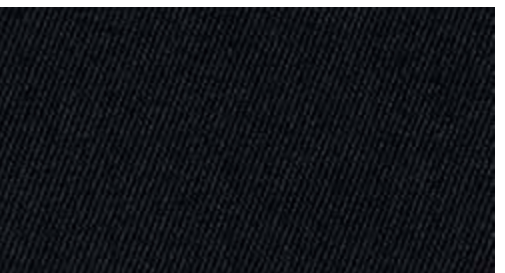

Hood, black



Ibis white

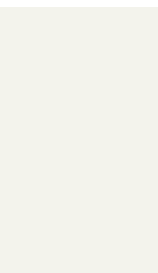

Ice silver, metallic



Oolong grey, metallic



Samoa orange, metallic

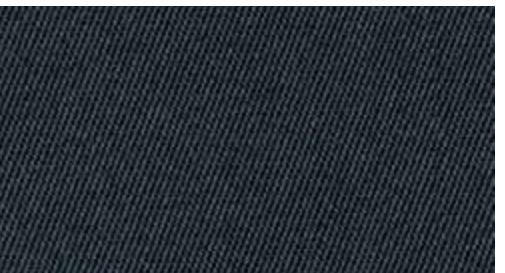

Hood, dark grey



Dakota grey, metallic

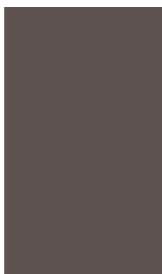

Scuba blue, metallic

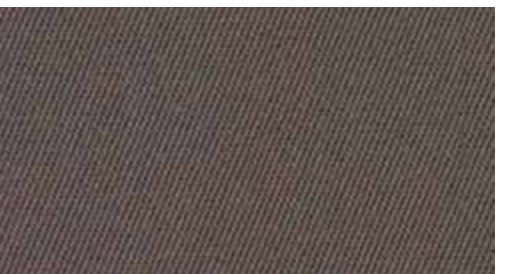

Hood, beige

Wheels/tyres



Cast aluminium wheels in 5-spoke V design
size 8.5 J x 17 with 245/45 R 17 tyres*, optionally available with run-flat tyres



Cast aluminium wheels in 5-parallel-spoke S design
size 9 J x 18 with 245/40 R 18 tyres*, optionally available with run-flat tyres



Audi exclusive cast aluminium wheels in 5-twin-spoke design
size 9 J x 18 with 245/40 R 18 tyres*. From quattro GmbH



Audi exclusive cast aluminium wheels in 5-arm rotor design
size 9 J x 19 with 255/35 R 19 tyres*. From quattro GmbH



Forged aluminium wheels in 7-spoke Y design
size 8.5 J x 17 with 245/45 R 17 tyres*, optionally available with run-flat tyres



Cast aluminium wheels in 7-arm dynamic design
size 9 J x 18 with 245/40 R 18 tyres*, only with run-flat tyres



Audi exclusive cast aluminium wheels in 10-spoke design
size 9 J x 18 with 245/40 R 18 tyres*. From quattro GmbH



Audi exclusive cast aluminium wheels in 5-arm rotor design in matt black, high-gloss turned finish
size 9 J x 19 with 255/35 R 19 tyres*. From quattro GmbH



Cast aluminium wheels in 5-arm dynamic design
size 9 J x 18 with 245/40 R 18 tyres*, optionally available with run-flat tyres



Cast aluminium wheels in 10-spoke design
size 9 J x 18 with 245/40 R 18 tyres*



Audi exclusive cast aluminium wheels in 5-segment-spoke design
size 9 J x 19 with 255/35 R 19 tyres*. From quattro GmbH



Audi exclusive cast aluminium wheels in 5-parallel-spoke star design
size 9 J x 19 with 255/35 R 19 tyres*. From quattro GmbH

Wheels/tyres



Audi exclusive cast aluminium wheels in 7-twin-spoke design
size 9 J x 19 with 255/35 R 19 tyres*. From quattro GmbH



Cast aluminium winter wheels in 10-spoke star design
size 7 J x 16 with 225/55 R 16 tyres*, can be fitted with snow chains, permissible top speed 210 km/h



Cast aluminium winter wheels in 5-parallel-spoke S design
size 9 J x 18 with 245/40 R 18 tyres*, cannot be fitted with snow chains, permissible top speed 240 km/h



Audi exclusive cast aluminium wheels in 7-twin-spoke design in matt titanium look
size 9 J x 19 with 255/35 R 19 tyres*. From quattro GmbH



Forged aluminium winter wheels in 7-spoke Y design
size 7 J x 17 with 225/50 R 17 tyres*, can be fitted with snow chains, permissible top speed 210 km/h, optionally available with run-flat tyres



Cast aluminium winter wheels in 10-spoke design
size 9 J x 18 with 245/40 R 18 tyres*, cannot be fitted with snow chains, permissible top speed 240 km/h

Run-flat tyres

Journey can be continued on a flat tyre at a speed of up to 80 km/h and for a maximum distance of 50 km, without having to change the wheel.

Anti-theft wheel bolts

can only be loosened using adapter provided

Tyre repair kit

12V compressor and tyre sealant, located under the loading floor cover in the luggage compartment; top speed 80 km/h

Tyre pressure loss indicator

monitors the tyres throughout the journey based on the air pressures set and programmed into the system by the driver; if one or more tyres starts to deflate, the tyre pressure loss indicator uses the difference in the rotational speed and the natural frequency of the wheels to calculate the air loss and gives the driver a visual and audible warning; operation via the driver information system. The system is not intended as an alternative to carrying out regular tyre pressure checks.

Vehicle tool kit

under the loading floor in the luggage compartment

Vehicle jack

under the loading floor in the luggage compartment



Sport seats, front
with manual fore/aft, head restraint and backrest angle adjustment; adjustable seat height for both driver and front-passenger seats; with shaped seat side bolsters for better lateral support when cornering (The image shows sport seat, front, in fine Nappa leather, nougat brown.)

Audi exclusive bucket seats, front
with manual fore/aft position, seat height and backrest angle adjustment; no side airbag or ISOFIX child seat mounting. From quattro GmbH

The model-specific standard and optional equipment can be found in the index from page 102 onwards.

Cloth upholstery and trim



Tetriscloth, black

Leather upholstery and trim

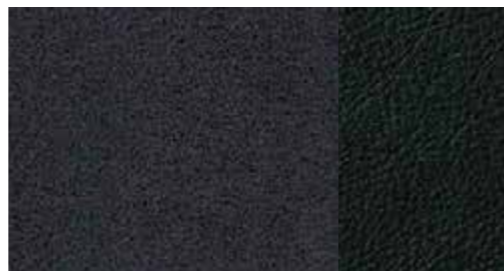

Alcantara/leather, black



Alcantara/leather, titanium grey



Alcantara/leather, spectral silver/black

Leather upholstery and trim

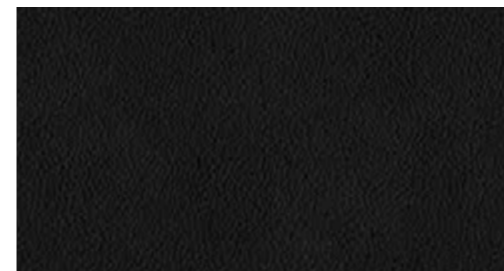

Silk Nappa leather, black

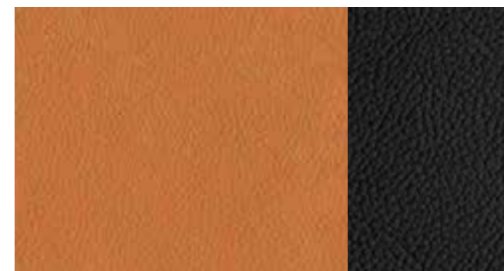

Silk Nappa leather, signal orange/black



Valetta leather, black

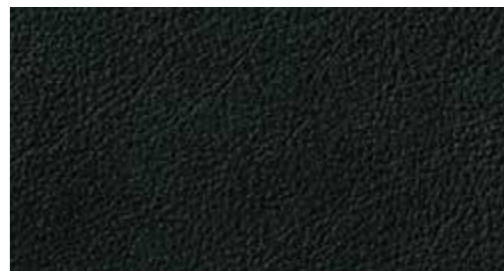

Fine Nappa leather, black



Silk Nappa leather, spectral silver/black



Silk Nappa leather, magma red/black

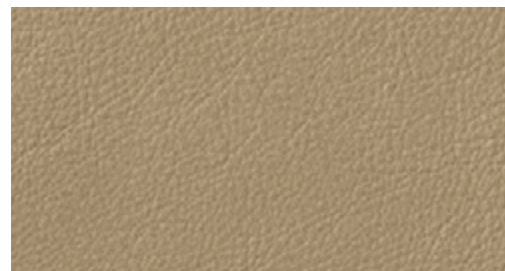
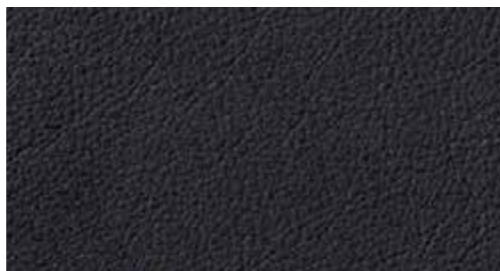

Fine Nappa leather, titanium grey

Leather upholstery and trim**Fine Nappa leather, Luxor beige****Fine Nappa leather, magma red****Impulse leather, black,
with special seam detail****Audi exclusive leather upholstery and trim**
From quattro GmbH**Fine Nappa leather, nougat brown****Fine Nappa leather, garnet red****Impulse leather, Chennai brown,
with special seam detail****Cloth/leather upholstery and trim****Tetris cloth upholstery and trim**

seat centre panels in Tetris cloth in two different pattern versions; seat side bolsters and head restraints in single-colour cloth

Alcantara/leather combination

TT Coupé/Roadster seat centre panels in Alcantara, seat side bolsters and head restraint centre panels in black leather or titanium grey, door and side panel inserts in Alcantara; TTS Coupé/Roadster seat centre panels in Alcantara, seat side bolsters and head restraint centre panels in black leather with contrasting stitching, door and side panel inserts in Alcantara; with S embossing on the front-seat backrests; including heat protection

Valetta leather upholstery and trim

seat centre panels, seat side bolsters, head restraint centre panels and door and side panel inserts in Valetta leather; including heat protection

Fine Nappa leather upholstery and trim

seat centre panels, seat side bolsters, head restraint centre panels as well as door and side panel inserts in fine Nappa leather; including heat protection

Silk Nappa leather upholstery and trim

seat centre panels, seat side bolsters and head restraint centre panels in silk Nappa leather; door and side panel inserts in matching colour in leather; including heat protection; with S embossing on front-seat backrests

**Impulse leather upholstery and trim with special seam detail**

seat centre panels, seat side bolsters, head restraint centre panels as well as door and side panel inserts in fine Nappa leather; decorative leather stitching on seats; steering wheel rim, gear lever knob with gear lever gaiter in black leather with contrasting stitching; including heat protection; also includes the following leather package items finished as described: handbrake grip and centre console armrest in black leather with contrasting stitching; door pull handles in black leather; floor mats with coloured piping

Heat protection

in direct sunlight, for head restraint centre panel, seat side bolsters and seat centre panel for Alcantara/leather combination and silk Nappa leather (each without seat centre panels), as well as for leather upholstery and trim. The special colour pigmentation of the leather prevents an intense build-up of heat. The infrared radiation in sunlight is reflected. The heat protection can reduce surface temperature by up to 20°C.

Leather upholstery and trim**Audi exclusive Alcantara/fine Nappa leather upholstery and trim**

seat centre panels and door trim inserts in Alcantara, seat side bolsters and head restraints in fine Nappa leather including heat protection (in direct sunlight); optional: coloured stitching on seat side bolsters and head restraints; floor mats with leather piping. From quattro GmbH

Leather package

door pull handles, handbrake handle and centre console armrest in leather

additionally for the TTS: handbrake handle and centre console armrest in leather with contrasting stitching

Extended leather package

door pull handles, handbrake grip, centre console armrest, instrument panel cover, centre console trim and door armrests in leather

additionally for the TTS or impulse leather upholstery and trim: instrument panel cover, centre console trim and door armrests in leather with contrasting stitching

Audi exclusive fine Nappa leather upholstery and trim including additional items

seat upholstery, head restraints, door trim inserts, door armrests, door pull handles, centre console trim, centre console armrest, handbrake grip, gear/selector lever knob, gear lever gaiter and instrument panel cover in fine Nappa leather, including heat protection (in direct sunlight), optionally with coloured stitching; floor mats with leather piping. From quattro GmbH

**Extended colour leather package**

door pull handles, handbrake grip, centre console armrest, instrument panel cover, centre console trim and door armrests in leather; instrument panel cover is coloured with interior equipment colours nougat brown and garnet red; door armrests in seat colour with interior equipment colours titanium grey and Luxor beige combined with coloured carpets in seat colour

additionally for the TTS or impulse leather upholstery and trim: instrument panel cover, centre console trim and armrests in the doors with contrasting stitching

Headlinings/hood linings**Headlinings**

in cloth

Audi exclusive headlining in Alcantara

Individual choice of colours for headlining from the range of Audi exclusive colours. From quattro GmbH

Hood lining

in black cloth

Inlays**Inlays**

in the centre console and on the glove compartment in brushed aluminium, grey

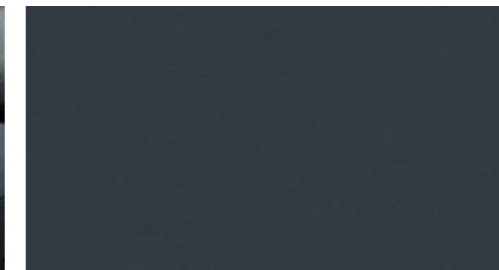

Micrometallic, grey

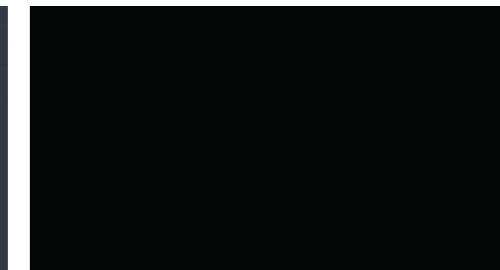

Phantom black
From quattro GmbH

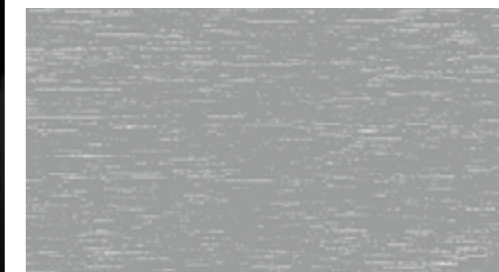

Brushed aluminium, grey

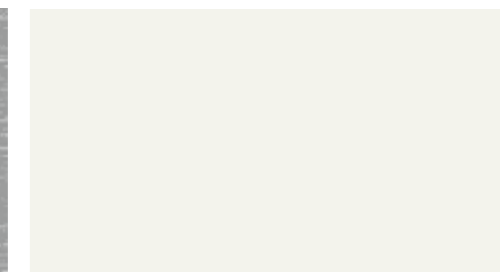

Ibis white
From quattro GmbH



Matt brushed aluminium

Lights

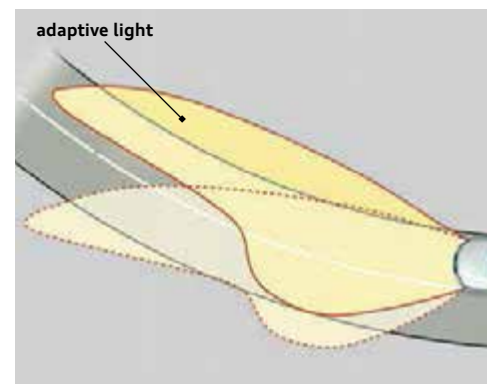

adaptive light

consisting of dynamic cornering light and static turning light; the dynamic cornering light identifies the course of the road from the movement of the steering wheel and variably illuminates bends by pivoting the xenon headlights; operational between speeds of approx. 10 km/h and 110 km/h.

xenon plus

Headlights utilising durable gas discharge technology for dipped and high beam ensure intensive illumination of the road and provide good uniformity and range. The automatic dynamic headlight range control prevents oncoming traffic from being dazzled. The homogeneous daytime running light strip features LED technology with low power consumption; includes headlight cleaning system.

Headlights

ellipsoid main headlights with clear-glass look, in 3-dimensional design, with electric headlight range control and parking light function

Headlight cleaning system

uses water and high pressure, for improved illumination and good visibility with reduced scatter

High-beam assist

working within system limits, it automatically detects the headlights of oncoming traffic, the rear lights of other road users and built-up areas. Depending on the traffic situation, the high beam is automatically switched on or off. The system thereby improves the driver's visibility and safety and ensures a more relaxed drive thanks to the extra comfort and convenience.

Interior lighting

with delayed switch-off and contact switches on all doors; glove compartment and luggage compartment lighting, as well as illuminated vanity mirrors (TT/TTS Coupé only) for driver and front passenger

LED interior lighting package

anti-glare lighting for the passenger compartment with energy-saving and long-lasting LED technology, consisting of: front interior lights including reading lights, illuminated vanity mirrors (TT/TTS Coupé only) for driver and front passenger, glove compartment lighting, door sill and footwell lighting at the front, illuminated door openers as well as active door reflectors (light bulbs)

Door reflectors

passive, when the door is open safeguards against following traffic

Rear lights

in red clear-glass look with white reversing light; 3-dimensional design; LED 3rd brake light and rear number plate lights

Front fog lights

in clear-glass look and halogen technology, integrated in the front apron panel; for better illumination of the road ahead when visibility is poor

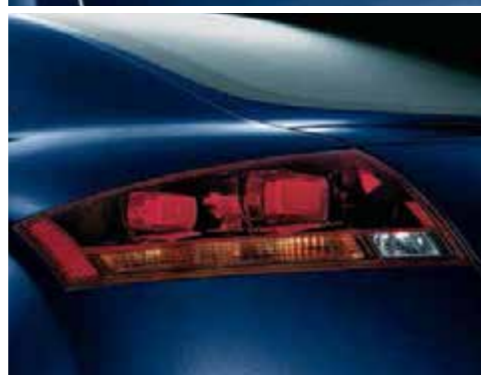

Lights styling package
stylish chrome-look headlight surrounds, black insert for rear lights

Rear fog light

integrated in the centre of the rear bumper

Mirrors



Exterior mirrors with integrated LED indicator light
electrically adjustable, convex, flat or aspherical mirror glass; housing painted in body colour in the TT; housing in aluminium look in the TTS

Also optionally:

heated

including heated windscreen washer jets

heated and electrically folding
including heated windscreen washer jets

heated, electrically folding and
automatically dimming

including heated windscreen washer jets

Exterior mirror housings in Audi exclusive carbon

From quattro GmbH

Mirrors

Interior mirror, dimming

choice of:

automatically dimming, with light/rain sensor
to control the automatic lights-on function and the windscreen wipers, includes coming home/leaving home function: delayed switching-off/automatic switching-on of the main headlights, the rear lights and the number plate lights when parking/opening the vehicle

automatically dimming, with light/rain sensor and digital compass display

as interior mirror, automatically dimming with light/rain sensor and digital compass display; this provides a digitised display of the current direction, the 8 points of the compass (N, NE, E, SE, S, SW, W, NW) are displayed in English

Vanity mirrors

in driver and front-passenger sun visors; illuminated in the TT/TTS Coupé

Roof systems



Acoustic hood

fully automatic, made from insulated 3-layer fabric with improved interior noise and thermal insulation; including integrated, fully automatic cover flaps, hood lining in black, hood opens in 12 seconds



Hood

manual, made from insulated 3-layer fabric, including integrated, manually operated cover flaps



Wind deflector

with electric extend and retract function

Closing systems**Remote control key**

unlocks and locks doors, luggage compartment lid and tank flap; includes convenient closing/opening of the windows

Electronic immobiliser

integrated in the engine management unit, automatically activated by the car key

Garage door opener (HomeLink)

programmable radio-operated remote control, control buttons integrated in the interior light module; can be used to open and/or close garage doors and exterior gates; can be used to control security and lighting systems. For information on compatible hand-held transmitters, please contact your Audi partner or visit www.eurohomelink.com.

Anti-theft alarm

including interior monitoring and tow-away protection via angle of inclination sensor, can be deactivated; horn operates independently of vehicle electrical system; monitors engine and luggage compartments, doors and interior

Preparation for tracking system

Preparation for connecting a tracking system (available from Audi Genuine Accessories) that enables a stolen vehicle to be located

Glazing**Heat-insulating glass**

tinted green; for the rear window, door and side windows; heated rear window; with timer switch

Dark-tinted windows (privacy glazing)

dark-tinted rear window and rear side windows

Windscreen

with grey strip along the top edge

Rear window

with TT/TTS Coupé heated, with timer switch and integrated window aerial; rod aerial on the left rear quarter panel for TT/TTS Roadster

Windscreen cleaning system

2 speeds, 4-speed adjustable intermittent wipe, flick-wipe function, automatic wash/wipe, automatic wiping after the last wash/wipe process

Further exterior equipment**Rear spoiler**

extends electrically depending on vehicle speed; automatically extends at 120 km/h, retracts at 80 km/h; can also be controlled manually using a button in the centre console

Bumpers and sills

in vehicle body colour; for TTS in TTS design, with diffuser insert in platinum grey

Audi Singleframe

radiator grille painted in high-gloss black; for TTS in TTS design, radiator grille in platinum grey with double struts in aluminium look and TTS logo

Exhaust tailpipes

twin tailpipe on the left (1.8 TFSI and 2.0 TDI quattro) dual-branch design, left and right (2.0 TFSI); with TTS, dual-branch exhaust system with oval twin tailpipes

2-tone horn

operated from inner rim of steering wheel

Further exterior equipment**Aluminium tank cap**

with TT embossing

TT logo

on rear and in rev counter

TTS logo

on the rear, in the radiator grille, on the door sill trims, on the front brake callipers, on the leather-covered multifunction sport steering wheel, on the gear lever knob and in the rev counter

**Audi exclusive carbon package**

web incorporated into centre of bottom edge of front bumper in carbon, diffuser insert in carbon. From quattro GmbH

Audi exclusive black styling package

frame of the radiator grille in high-gloss black, radiator grille, number plate holder and fog light mesh inserts in matt black. From quattro GmbH

Seats/seating comfort**Front seats, electrically adjustable**

including electric 4-way lumbar support, electric adjustment of seat height, fore/aft position, seat and seat backrest angle

Seat heating, front

individually adjustable in several stages, heats the seat and backrest centre panels as well as the seat side bolsters

4-way lumbar support

for the front-passenger seat, electric, with horizontal and vertical adjustment

Head restraints

front, height adjustable

Rear seat system

2 rear seats, approved for people up to 1.50 m tall or children up to 12 years of age and 1.25 m tall in a child seat

**Rear seat backrest**

divided, folds down in a 50 : 50 or fully

ISOFIX child seat mounting

for front passenger seat, mounting for child seats in accordance with ISO standard, including deactivation switch for front-passenger airbag

ISOFIX child seat mounting and rear seat with child seat group III approval

ISOFIX child seat mounting for the 2 rear seats, bracket for attaching child seats in accordance with ISO standard; rear seat with child seat group III approval (in accordance with ECE R44)

Steering wheels/gear levers/controls**Leather-covered multifunction sport steering wheel in 3-spoke design**

flattened at the bottom, full-size airbag, adjustable for height and reach; for operating available infotainment features; with TTS emblem for TTS model; for S tronic with shift paddles for manual gear changing

Leather-covered sport steering wheel in 3-spoke design

flattened at the bottom, full-size airbag, adjustable for height and reach; for S tronic with shift paddles for manual gear changing

Audi exclusive leather steering-wheel rim

leather for the steering wheel rim available in all Audi exclusive colours; individual choice of colour for stitching in various Audi exclusive colours with special Audi exclusive seam detail. From quattro GmbH

Gear/selector lever knob

in TT- or TTS-specific design, with gear lever gaiter in leather and trim ring in aluminium look

Gear lever knob in Audi exclusive aluminium

From quattro GmbH

Audi exclusive leather controls

leather for the steering wheel rim, selector or gear lever and selector or gear lever gaiter available in all Audi exclusive colours; individual choice of colour for stitching from a range of Audi exclusive colours. Stitching on the steering wheel rim with special Audi exclusive seam detail. From quattro GmbH

Climate control**Automatic air conditioning**

in special TT look, with sunlight-dependent control; electronically regulates the air temperature, air flow rate and air distribution; flow-through ventilation, ram air control and recirculation mode, footwell vents, activated carbon filter; defroster vents for windscreen and side windows

Ventilation system and heating

continuously variable blower, defroster vents for windscreen and side windows, dust and pollen filter, footwell vents, flow-through ventilation, recirculation mode

Luggage securing and storage systems**Through-loading facility with removable ski/snowboard bag**

removable, secured by a strap, for the practical transportation of long objects, e.g. up to 2 pairs of skis

Storage package

storage net on the front seat backrests; storage compartment under the front seats, storage net in front-passenger footwell, luggage net in the luggage compartment; in TT/TTS Roadster, 2 additional storage compartments in the rear wall behind the seats

Cup holder

2, integrated into the centre console

Lashing points

4 in the luggage compartment, for securing luggage and other objects

Luggage compartment cover

removable

Glove compartment

on the front-passenger side, lockable, with light

Further interior equipment**Footwell trim and floor mats**

front, colour coordinated to the respective interior colour (carpet); with TTS floor mats with coloured piping

Door sill trims with aluminium inlay

on the door sills; TTS with TTS logo

Window controls

electric, with safety system to limit closing force, one-touch opening/closing function; convenience opening/closing via remote control key

Dashboard

padded, with black instrument panel cover

Cigarette lighter and ashtrays

in the front centre console

**Extended aluminium look in the interior**

for vents, radio controls, rotary light switch and steering wheel spokes, inlays in centre console and on glove compartment, door pull handle surrounds, pedals and footrest

Aluminium look in the interior

for vents, radio controls, rotary light switch and steering wheel spokes

MMI® and navigation systems**Navigation system plus with MMI® control logic**

with display frame in high-gloss black, includes 2 navigation DVDs*, 6.5-inch TFT colour display (800 x 480 pixels) with 3D map display, dynamic route guidance (where available), radio with twin tuner, DVD drive for navigation DVD, audio or MP3 CDs (cannot be played when navigation system is being used), 2 integral MMC/SDHC card readers for MP3 (up to 32 GB), AUX-IN connection, arrow display in the driver information system; includes aerial and 9 active loudspeakers, connection of Audi music interface is possible

Navigation system with MMI® control logic

6-inch monochrome display in the centre console for entering destination and route description, dynamic route guidance (where available), radio with twin tuner, CD player for navigation CD, audio or MP3 CDs, aerial diversity, AUX-IN connection, arrow display in the driver information system, includes aerial and 9 active loudspeakers; country navigation CD includes main transport links in Europe (where digitised)

Driver information system

A monochrome display provides you with information from the onboard computer, auto-check system and MMI system displays, plus a digital speed display and gear display (manual and automatic transmission in manual mode). The integrated efficiency program assists you by providing consumption data overviews, a larger gear display (for manual transmission) and tips for more fuel-efficient driving.

Radio and TV systems**chorus radio**

with single CD player, 12-station memory, FM (VHF) and AM (MW) reception, soft-key operating concept and 3-line graphic display, CAN bus networking, speed-dependent volume control, phase diversity, 4 passive loudspeakers, total output 40 watts

**concert radio**

as for chorus radio, but is also MP3 compatible, includes 5-channel amplifier and 9 active loudspeakers, total output 140 watts, AUX-IN connection

**symphony radio**

as for concert radio but also featuring TP memo function, with integrated 6-disc MP3-compatible CD changer (instead of single internal CD player)

TV reception

reception of analogue and digitally broadcast (DVB-T), uncoded television stations (MPEG 2 standard), supports teletext and Electronic Programme Guide (EPG). Facility to connect 2 external AV sources via the optional adapter cable. TV reception depends on local analogue and digital network availability. No AV or TV video output when driving (audio output available when driving)

BOSE surround sound

The system is tuned to the vehicle's acoustics; dynamic driving noise compensation, 8-channel amplifier with a total output of 255 watts, 12 high-performance loudspeakers including centre speaker and subwoofer.

CD changer

in the glove compartment, for 6 CDs, vibration-proof, easily accessible; each CD can be loaded and changed individually

Radio and TV systems**Audi music interface**

for the connection of portable media players such as Apple iPods from generation 4, Apple iPhone (music functionality) as well as USB storage media and MP3 players. The Audi music interface is located in the glove compartment and operated via the navigation system plus with MMI control logic or a leather-covered multifunction steering wheel. Note: Can only be used with a special adapter cable (available from Audi Genuine Accessories). Please contact your Audi partner or visit www.audi.com/mp3 for information on compatible media players. If Audi music interface is ordered the separate AUX-IN connection is omitted.

Adapter cable set for Audi music interface

consisting of 2 connection cables for connecting an iPod/iPhone or data carriers/media players with USB connection (type A); visit www.audi.com/mp3 for information on compatibility; further adapter cables available from Audi Genuine Accessories

Rod aerial

on left rear quarter panel

Audi exclusive iPod preparation

console in the glove compartment; limited operation of iPod via radio or leather-covered multifunction sport steering wheel; the iPod is charged in the console during use; please contact your Audi partner for information on compatible iPod variants. From quattro GmbH

Audi exclusive USB preparation

console in glove compartment for USB sticks or MP3 players with USB extension cable; limited operation via radio or leather-covered multifunction sport steering wheel. From quattro GmbH

Telephone and communication**Preparation for mobile phone (Bluetooth)**

comprises a hands-free facility and a fitting for an optional mobile-specific charger in the front centre console; including connection to the vehicle aerial for reduced SAR radiation inside the vehicle and better reception quality; operated via the radio/navigation systems or a multifunction steering wheel (if available); please contact your Audi partner or visit www.audi.com/bluetooth for adapters and information about which mobile phones are compatible.

Bluetooth interface

Bluetooth-capable mobile phones can be connected to the vehicle via the interface. Hands-free calls can be made in the vehicle via the microphone. Please contact your Audi partner or visit www.audi.com/bluetooth for information on compatible mobile phones.

Voice control system for navigation system plus

The basic functions of the navigation system, radio, CD player, preparation for mobile phone and CD changer can be operated by voice command.

Assistance systems**Hill hold assist**

After the foot brake has been pressed for a long period of time while the vehicle is stationary, the brake pressure that has been built up is maintained for a short while after the brake is released; this automatic braking action makes hill-starts much easier and more comfortable on almost any gradient.

Parking system, rear

makes reverse parking easier within system limits by indicating acoustically how far away the vehicle is from an object detected behind the vehicle; measurement is by ultrasonic sensors integrated discreetly in the bumper

Cruise control

At speeds of 30 km/h and above, the system keeps the set speed constant, provided that engine power and engine braking effect permit it; operated via separate steering column stalk; set speed displayed in the driver information system

Suspensions/brakes**Audi magnetic ride**

adaptive damper system with individual selection of suspension settings (Normal/Sport) via button on the front centre console; improves ride comfort and driving dynamics by regulating the damping forces according to the driving situation; for TTS, vehicle ride height lowered by 10 mm and TTS-specific tuning

Sport button

on the front centre console: pressing the button influences the throttle response and the sound of the engine, the steering characteristics for more direct response from the power steering, and the damping characteristics of Audi magnetic ride for more dynamic suspension tuning

Sport suspension

with dynamically tuned damping

S line sport suspension

with more dynamic suspension tuning; vehicle 10 mm lower than with standard suspension

Suspensions/brakes

Brake callipers
painted dark grey; for TTS painted black with TTS logo

Brake system

diagonally-split dual-circuit brake system (17-inch with TTS), Antilock Brake System (ABS) with Electronic Brake Force Distribution (EBD), hydraulic brake assist, adapted brake booster function, front and rear disc brakes, ventilated at front

Technology/safety**Body Audi Space Frame (ASF®) design**

innovative combination of aluminium and steel, a high degree of rigidity for enhanced handling, greater stability and enhanced safety

Side impact protection

comprising bend-resistant aluminium impact beams in the doors; activation of side airbags by pressure sensors in the doors; protective side padding in the doors

Antilock Brake System (ABS)

with electronic brake-force distribution (EBD) and hydraulic brake assist

Anti-Slip Regulation (ASR)

reduces spinning of the drive wheels by reducing engine output – thereby improving traction and stability on the road surface

Electronic Differential Lock (EDL)

On surfaces with varying levels of grip, this start-off assistant automatically brakes the drive wheels on any surface that is too slippery, thereby ensuring smooth, powerful progress.

Electronic Stabilisation Control (ESC)

with Sport mode, hydraulic brake assist and emergency braking display; improves stability in hazardous situations by targeted braking of individual wheels and intervention in the engine management system

Integrated head restraint system

In the event of a rear-end collision, the design of the front seats restrains the upper torso and offers the head more support than is the case with conventional systems, thereby increasing safety and reducing the danger of whiplash.

**Airbags***

full-size airbags for driver and front passenger; including deactivation switch for front-passenger airbag

Side airbags, front*

integrated into the front seats

Warning and control lights

for, among others: airbag, ABS, ESC/ASR, handbrake on, EDL electronics, alternator, lights, high beam, indicators, brake system, engine oil pressure, closed luggage compartment lid, engine electrics, washer fluid, rear spoiler

First-aid kit

in TT/TTS Roadster in the storage space between the backrests; in TT/TTS Coupé in the right-hand storage space of the rear seat

Safety steering column

increases the safety potential of the seat belt and airbag; for TTS, with mechanical inclination and axial adjustment

Technology/safety**Roll-over bars with aluminium trim**

provide increased safety for driver and front passenger

Audi exclusive leather-covered roll-over bars

leather to match seat upholstery, available in all Audi exclusive and standard colours. From quattro GmbH

Seat belt reminder

for the driver seat; an acoustic and visual warning signal reminds you to fasten your seat belt.

Seat belts

3-point inertia-reel belts for all seats, with seat belt tensioners and belt force limiters at front

Audi exclusive seat belts

available in various Audi exclusive colours to match the Audi exclusive leather range of colours. From quattro GmbH

**Instrument cluster**

TT-specific design with adjustable lighting, dynamic ready-check feature, coolant and outside temperature display, rev counter with digital clock and date display, speedometer with disproportional display, odometer/trip odometer, fuel gauge, warning and control lights, service interval display; for TTS with grey dials and white needles

Electromechanical power steering

speed-sensitive power steering, with active reset assistance, automatic straight-line running correction system, e.g. in side winds or roads with a lateral incline; energy-saving operation, damping of road-induced interference

Reduced gear lever travel

shift travel is shortened; sporty short gear lever. (For manual transmission only)

**S tronic®**

the 6 or 7-speed dual-clutch transmission with electro-hydraulic actuation facilitates faster gear changing with hardly any perceptible break in propulsive power; can be operated via the shift paddles behind the steering wheel or the gear lever; in automatic mode the driver can choose between 2 programs D (normal) and S (sports)

Manual transmission

6-speed, all-synchromesh, with hydraulically operated single-disc dry clutch with asbestos-free linings; with dual-mass flywheel

quattro®

permanent all-wheel drive system with variable torque distribution, electronically controlled multi-plate clutch on the rear axle and Electronic Differential Lock (EDL) via braking intervention on all driven wheels

Recuperation

Increasing the generator voltage converts kinetic energy into usable electrical energy when the vehicle is coasting or braking. This (braking) energy recovery is used to assist the generator during subsequent acceleration, saving up to 3% fuel.

Audi Extended Warranty**Audi Extended Warranty**

can only be ordered directly and on purchase of a new car; is a consistent continuation of the manufacturer's guarantee so that you are protected against risk and can control servicing costs even after the first 2 years. 9 combinations of service life and mileage can be selected:

Additional 1 year Audi Extended Warranty, maximum total mileage 30,000 km

Additional 1 year Audi Extended Warranty, maximum total mileage 60,000 km

Additional 1 year Audi Extended Warranty, maximum total mileage 90,000 km

Additional 2 years Audi Extended Warranty, maximum total mileage 40,000 km

Additional 2 years Audi Extended Warranty, maximum total mileage 80,000 km

Additional 2 years Audi Extended Warranty, maximum total mileage 120,000 km

Additional 3 years Audi Extended Warranty, maximum total mileage 50,000 km

Additional 3 years Audi Extended Warranty, maximum total mileage 100,000 km

Additional 3 years Audi Extended Warranty, maximum total mileage 150,000 km

The Audi TT: clear-cut edges, dynamic lines. Now it's up to you to put the icing on the cake.

The Audi TT is something really special. So are its drivers. With Audi Genuine Accessories, you have the opportunity to turn a sports car into your sports car. High-quality equipment further enhances the dynamism of the Audi TT. And yours too, of course. The following pages contain a small selection from the extensive range of Audi Genuine Accessories on offer.



Further information can be obtained from the Audi TT accessories catalogue, at www.audi.com and from your Audi partner.





1 Cast aluminium wheels in 10-spoke design, royal silver

High quality and striking. In size 9 J x 19 for 255/35 R 19 tyres. Other wheels can be found in the special TT accessories catalogue.

2 Ski and snowboard rack

for convenient transport of up to 6 pairs of skis or 4 snowboards. Lockable. (Can only be used in conjunction with the carrier unit. Carrier unit and other roof rack modules are available from Audi Genuine Accessories.)

3 Mobile phone adapter¹

Low-radiation phone calls through connection with the external aerial. Makes it possible to charge the battery and store the mobile phone safely during driving. Available for many popular mobile phone models. Pre-condition: preparation for mobile phone (Bluetooth).

4 Audi baby seat²

Can be secured using the 3-point belt. The integrated safety harness provides good restraint, whilst the attached hood offers protection from sunlight. With adjustable head restraint. Suitable for infants from birth age weighing up to 13 kg (approx. 12 months). Also available: Audi child seat for children from 9 to 18 kg (approx. 12 months to 4 years) and Audi child seat youngster plus for children from 15 to 36 kg (approx. 4 to 12 years).

5 Luggage compartment liner

Protection for the luggage compartment, tailor-made, washable and sturdy. The edge protects the luggage compartment floor better from leaked liquids.

Film-wrapping

Creates sporty highlights with graphic design elements. The high-quality film is very thin and is resistant to fading and abrasion. It can be removed without leaving behind any residue. (See page 95.)



¹For more detailed information, please contact your Audi partner. ²The separately available ISOFIX-Basis is optional for the Audi baby seat but required for the Audi child seat.

Model	TT 1.8 TFSI (118 kW)	TT 2.0 TFSI (155 kW)	TT 2.0 TFSI quattro (155 kW)	TT 2.0 TDI quattro (125 kW)																																									
Engine type	4-cylinder inline petrol engine with direct fuel injection and turbocharging	4-cylinder inline petrol engine with direct fuel injection, turbocharging and Audi valvelift system	4-cylinder inline petrol engine with direct fuel injection, turbocharging and Audi valvelift system	4-cylinder inline diesel engine with TDI direct injection																																									
Displacement in cc (valves per cylinder)	1798 (4)	1984 (4)	1984 (4)	1968 (4)																																									
Max. output ¹ in kW at rpm	118/4500–6200	155/4300–6000	155/4300–6000	125/4200																																									
Max. torque in Nm at rpm	250/1500–4500	350/1600–4200	350/1600–4200	350/1750–2500																																									
Power transmission/wheels																																													
Drive type	Front-wheel drive	Front-wheel drive	quattro® permanent all-wheel drive	quattro® permanent all-wheel drive																																									
Transmission type	6-speed manual transmission [7-speed S tronic]	6-speed manual transmission [6-speed S tronic]	6-speed S tronic	6-speed manual transmission [6-speed S tronic]																																									
Wheels	Cast aluminium wheels, 7.5 J x 16	Cast aluminium wheels, 7.5 J x 16	Cast aluminium wheels, 7.5 J x 16	Cast aluminium wheels, 7.5 J x 16																																									
Tyres	225/55 R 16²	225/55 R 16²	225/55 R 16²	225/55 R 16²																																									
Weights/capacities	Coupé	Roadster	Coupé	Roadster	Coupé	Roadster	Coupé	Roadster																																					
Unladen weight ³ in kg	1335	[1355]	1380	[1395]	1355	[1375]	1390	[1395]	1455	1500	1465	[1490]	1505	[1535]																															
Gross vehicle weight in kg	1660	[1680]	1625	[1640]	1680	[1700]	1635	[1640]	1780	1745	1790	[1815]	1750	[1780]																															
Permissible roof load in kg	75	[75]	–	[–]	75	[75]	–	[–]	75	–	75	[75]	–	[–]																															
Fuel tank capacity, approx. in l	55	[55]	55	[55]	55	[55]	55	[55]	60	60	60	[60]	60	[60]																															
Performance/consumption ⁴																																													
Top speed in km/h	226	[226]	223	[223]	245	[245]	242	[242]	243	240	226	[224]	223	[222]																															
Acceleration 0–100 km/h in s	7.3	[7.2]	7.5	[7.4]	6.2	[6.1]	6.3	[6.2]	5.7	5.9	7.6	[7.5]	7.8	[7.7]																															
Fuel grade	Sulphur-free super unleaded RON 95 ⁵				Sulphur-free super unleaded RON 95 ⁵				Sulphur-free super unleaded RON 95 ⁵				Sulphur-free diesel ⁶																																
Fuel consumption ⁷ in l/100 km	urban	8.5	[8.4]	8.6	[8.6]	8.9	[9.9]	9.0	[10.0]	9.9	10.2	7.0	[7.0]	7.2	[7.1]	extra-urban	5.2	[5.2]	5.3	[5.3]	5.2	[5.4]	5.4	[5.6]	5.7	5.7	4.3	[4.7]	4.5	[4.8]	combined	6.4	[6.4]	6.5	[6.6]	6.6	[7.1]	6.7	[7.2]	7.2	7.4	5.3	[5.5]	5.5	[5.6]
CO ₂ emissions ⁷ in g/km	urban	198	[194]	199	[200]	208	[229]	208	[231]	232	238	183	[183]	189	[184]	extra-urban	120	[120]	123	[124]	122	[126]	125	[130]	132	133	113	[122]	118	[124]	combined	149	[147]	152	[152]	154	[164]	156	[168]	169	172	139	[144]	144	[146]
Emission standard	EU5				EU5				EU5				EU5																																

Model	TTS 2.0 TFSI quattro (200 kW)																		
Engine type	4-cylinder inline petrol engine with direct fuel injection and turbocharging																		
Displacement in cc (valves per cylinder)	1984 (4)																		
Max. output ¹ in kW at rpm	200/6000																		
Max. torque in Nm at rpm	350/2500–5000																		
Power transmission/wheels																			
Drive type	quattro® permanent all-wheel drive																		
Transmission type	6-speed manual transmission [6-speed S tronic]																		
Wheels	Cast aluminium wheels, 9 J x 18																		
Tyres	245/40 R 18²																		
Weights/capacities	Coupé	Roadster																	
Unladen weight ³ in kg	1485	[1505]	1550	[1570]															
Gross vehicle weight in kg	1810	[1830]	1795	[1815]															
Permissible roof load in kg	75	[75]	–	[–]															
Fuel tank capacity, approx. in l	60	[60]	60	[60]															
Performance/consumption ⁴																			
Top speed in km/h	250 ⁸	[250] ⁸	250 ⁸	[250] ⁸															
Acceleration 0–100 km/h in s	5.5	[5.3]	5.7	[5.5]															
Fuel grade	Sulphur-free super plus 98 RON ⁹																		
Fuel consumption ⁷ in l/100 km	urban	10.8	[10.6]	10.9	[10.8]		extra-urban	6.2	[6.0]	6.4	[6.2]		combined	7.9	[7.7]	8.1	[7.9]		
CO ₂ emissions ⁷ in g/km	urban	252	[245]	255	[251]		extra-urban	145	[140]	150	[145]		combined	184	[179]	189	[184]		
Emission standard	EU5																		

Explanatory notes

¹ The figure given was calculated using the specified measuring procedure (current version of Directive 80/1269/EEC).

² You will find specifications on the technical characteristics of tyres on page 107.

³ Unladen vehicle weight includes driver (68 kg), 7 kg of luggage and fuel tank 90 % full, calculated in accordance with the current version of EC Directive 92/21/EEC. Optional equipment may increase the car’s unladen weight and drag coefficient, whereupon the possible payload limit and the top speed will be reduced accordingly.

⁴ A vehicle’s fuel consumption and CO₂ emissions do not just depend on how efficiently the vehicle uses the fuel, but are also influenced by driving behaviour and other non-technical factors. CO₂ is the greenhouse gas primarily responsible for global warming.

⁵ We recommend using sulphur-free super unleaded RON 95 in accordance with DIN EN 228. If this is not available, use sulphur-free regular unleaded RON 91 in accordance with DIN EN 228; power output will be slightly reduced. Unleaded RON 95 fuel with a maximum ethanol content of 10 % (E10) can generally be used. Fuel consumption details refer to operation with RON 95 fuel in accordance with 692/2008/EC.

⁶ We recommend using sulphur-free diesel in accordance with DIN EN 590. If this is not available, use diesel in accordance with DIN EN 590.

⁷ The figures given were calculated using the specified measuring procedures. The figures do not refer to one individual vehicle and do not form part of any offer, but rather should be used purely for purposes of comparison between the different vehicle models.

⁸ Regulated.

⁹ We recommend using sulphur-free super plus unleaded RON 98 in accordance with DIN EN 228. If not available, use sulphur-free super unleaded fuel (95 RON) complying with DIN EN 228; power output will be slightly reduced. Unleaded RON 95 fuel with a maximum ethanol content of 10 % (E10) can generally be used. Fuel consumption details refer to operation with RON 95 fuel in accordance with 692/2008/EC.

Important note

Inspections are due as shown by the service display.

Audi TT Coupé

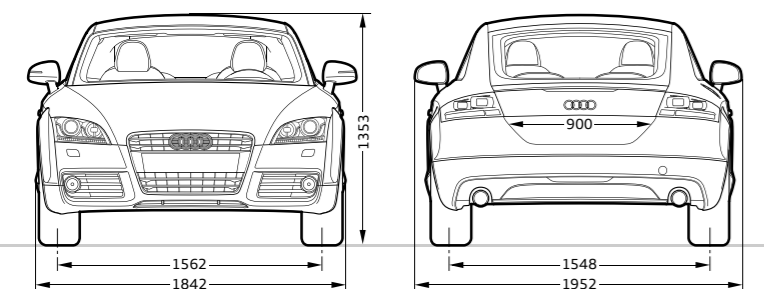
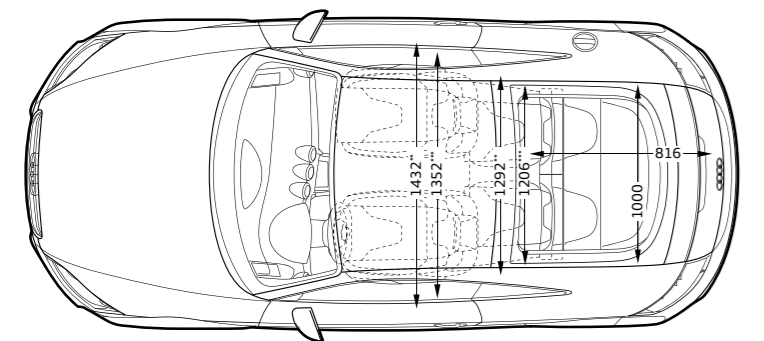
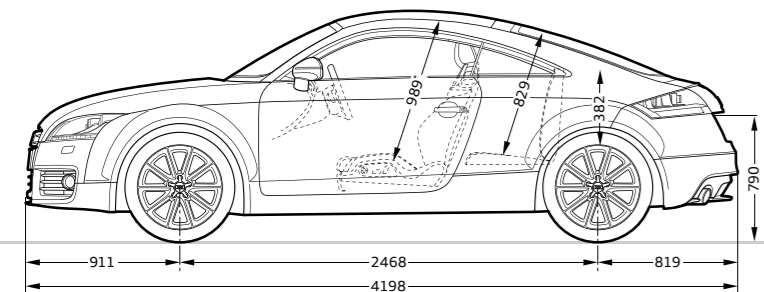

Dimensions in millimetres.

Dimensions were measured with vehicle at unladen weight.
 Luggage compartment volume 292/700 l (measured by the VDA standard test method using 200 x 100 x 50 mm blocks; second value is with the rear seat backrest folded down and the vehicle loaded up to roof height).
 Turning circle approx. 10.9 m.
 *Maximum headroom. **Elbow room width. ***Shoulder room width.

Audi TT Roadster

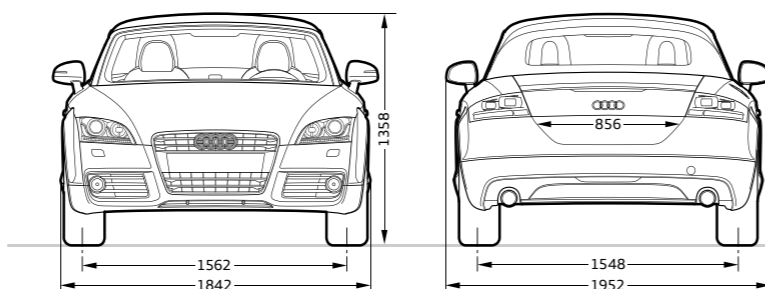
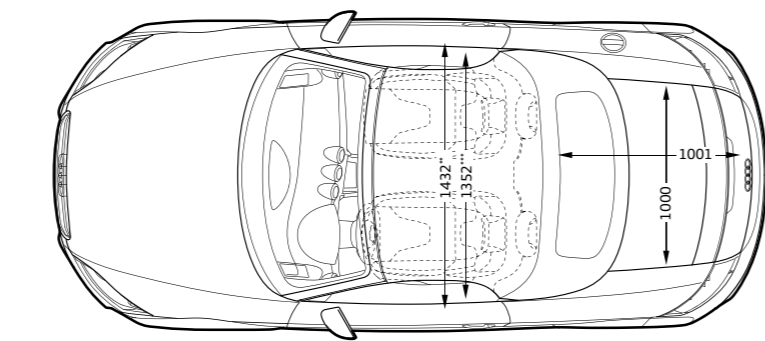
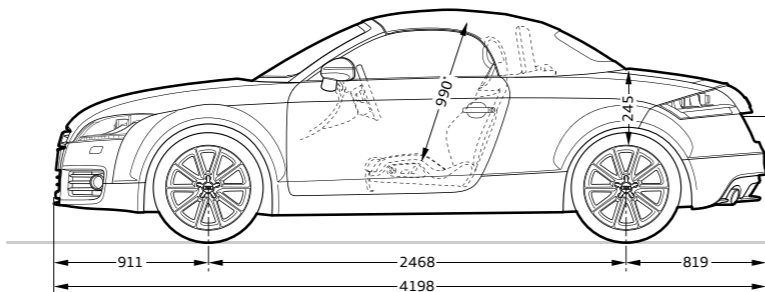

Dimensions in millimetres.

Dimensions were measured with vehicle at unladen weight.
 Luggage compartment volume 250 l (measured by the VDA method using 200 x 100 x 50 mm blocks).
 Turning circle approx. 10.9 m.
 *Maximum headroom. **Elbow room width. ***Shoulder room width.

Audi TTS Coupé

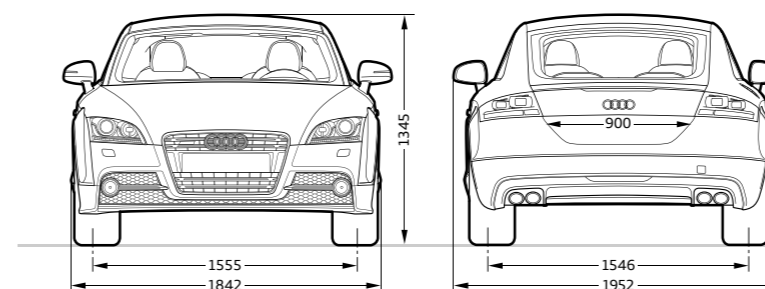
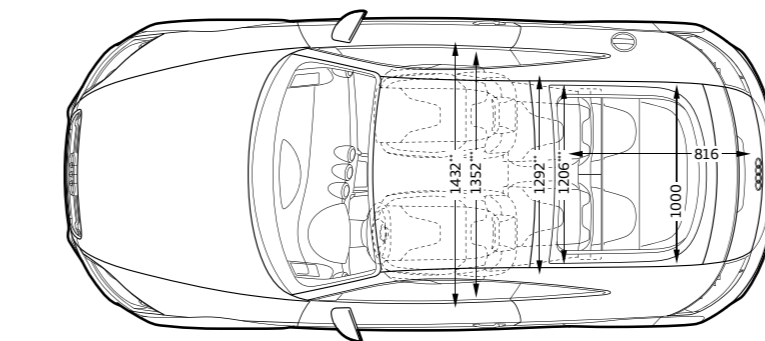
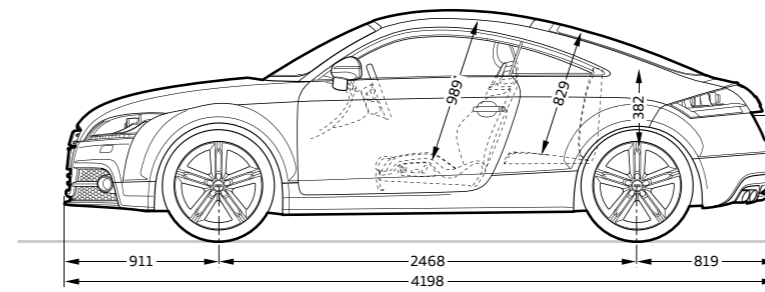

Dimensions in millimetres.





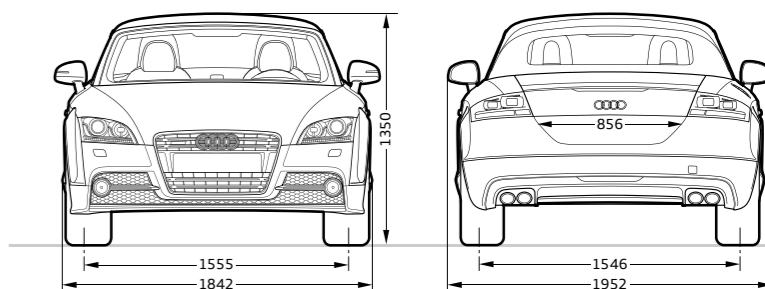
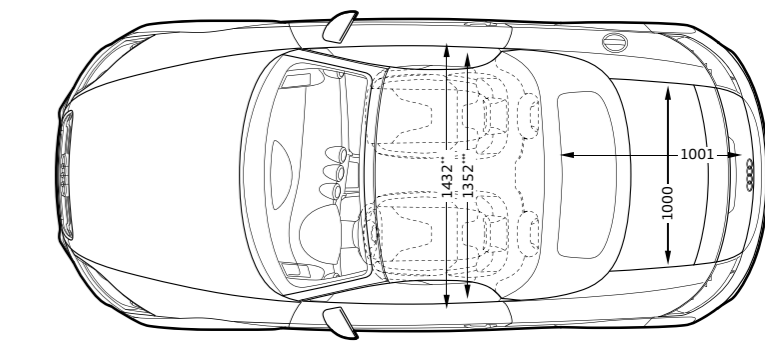
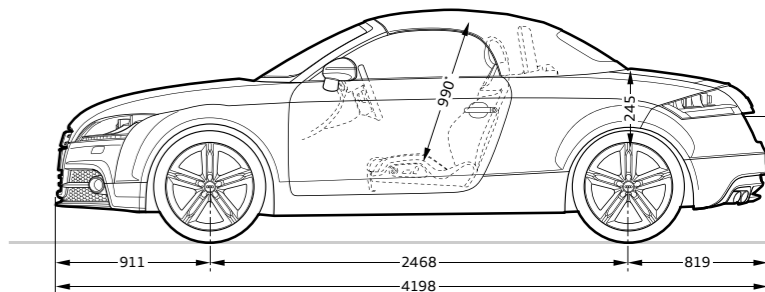











Dimensions were measured with vehicle at unladen weight.
 Luggage compartment volume 292/700 l (measured by the VDA standard test method using 200 x 100 x 50 mm blocks; second value is with the rear seat backrest folded down and the vehicle loaded up to roof height).
 Turning circle approx. 10.9 m.
 *Maximum headroom. **Elbow room width. ***Shoulder room width.









Audi TTS Roadster



















Dimensions in millimetres.

Dimensions were measured with vehicle at unladen weight.
 Luggage compartment volume 250 l (measured by the VDA method using 200 x 100 x 50 mm blocks).
 Turning circle approx. 10.9 m.
 *Maximum headroom. **Elbow room width. ***Shoulder room width.

	Page	TT Coupé	TT Roadster	TTS Coupé	TTS Roadster
Solid paint finishes	74				
 Brilliant black		<input type="checkbox"/>	<input type="checkbox"/>	<input type="checkbox"/>	<input type="checkbox"/>
 Ibis white		<input type="checkbox"/>	<input type="checkbox"/>	<input type="checkbox"/>	<input type="checkbox"/>
Metallic paint finishes	74				
 Glacier white, metallic		<input checked="" type="checkbox"/>	<input checked="" type="checkbox"/>	<input checked="" type="checkbox"/>	<input checked="" type="checkbox"/>
 Ice silver, metallic		<input checked="" type="checkbox"/>	<input checked="" type="checkbox"/>	<input checked="" type="checkbox"/>	<input checked="" type="checkbox"/>
 Dakota grey, metallic		<input checked="" type="checkbox"/>	<input checked="" type="checkbox"/>	<input checked="" type="checkbox"/>	<input checked="" type="checkbox"/>
 Sahara silver, metallic		<input checked="" type="checkbox"/>	<input checked="" type="checkbox"/>	<input checked="" type="checkbox"/>	<input checked="" type="checkbox"/>
 Oolong grey, metallic		<input checked="" type="checkbox"/>	<input checked="" type="checkbox"/>	<input checked="" type="checkbox"/>	<input checked="" type="checkbox"/>
 Scuba blue, metallic		<input checked="" type="checkbox"/>	<input checked="" type="checkbox"/>	<input checked="" type="checkbox"/>	<input checked="" type="checkbox"/>
 Volcano red, metallic		<input checked="" type="checkbox"/>	<input checked="" type="checkbox"/>	<input checked="" type="checkbox"/>	<input checked="" type="checkbox"/>
 Samoa orange, metallic		<input type="checkbox"/>	<input type="checkbox"/>	<input checked="" type="checkbox"/>	<input checked="" type="checkbox"/>
Pearl effect paint finish	75				
 Phantom black, pearl effect		<input checked="" type="checkbox"/>	<input checked="" type="checkbox"/>	<input checked="" type="checkbox"/>	<input checked="" type="checkbox"/>
Crystal effect paint finish	75				
 Panther black, crystal effect		<input type="checkbox"/>	<input type="checkbox"/>	<input checked="" type="checkbox"/>	<input checked="" type="checkbox"/>
Customised paint finishes	75				
 Audi exclusive customised paint finishes		<input checked="" type="checkbox"/>	<input checked="" type="checkbox"/>	<input checked="" type="checkbox"/>	<input checked="" type="checkbox"/>
Hood colours	75				
 Hood, black		<input type="checkbox"/>	<input type="checkbox"/>	<input type="checkbox"/>	<input type="checkbox"/>
 Hood, dark grey		<input type="checkbox"/>	<input type="checkbox"/>	<input type="checkbox"/>	<input type="checkbox"/>
 Hood, beige		<input type="checkbox"/>	<input type="checkbox"/>	<input type="checkbox"/>	<input type="checkbox"/>

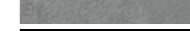
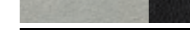
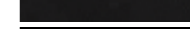
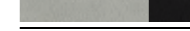

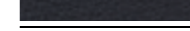

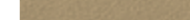

	Page	TT Coupé	TT Roadster	TTS Coupé	TTS Roadster
Wheels/tyres	76				
 17" cast aluminium wheels in 5-spoke V design		<input type="checkbox"/>	<input type="checkbox"/>	<input type="checkbox"/>	<input type="checkbox"/>
 17" forged aluminium wheels in 7-spoke Y design		<input checked="" type="checkbox"/>	<input checked="" type="checkbox"/>	<input type="checkbox"/>	<input type="checkbox"/>
 18" cast aluminium wheels in 5-arm dynamic design		<input checked="" type="checkbox"/>	<input checked="" type="checkbox"/>	<input type="checkbox"/>	<input type="checkbox"/>
 18" cast aluminium wheels in 5-parallel-spoke S design		<input type="checkbox"/>	<input type="checkbox"/>	<input type="checkbox"/>	<input type="checkbox"/>
 18" cast aluminium wheels in 7-arm dynamic design		<input checked="" type="checkbox"/>	<input checked="" type="checkbox"/>	<input type="checkbox"/>	<input type="checkbox"/>
 18" cast aluminium wheels in 10-spoke design		<input checked="" type="checkbox"/>	<input checked="" type="checkbox"/>	<input type="checkbox"/>	<input type="checkbox"/>
 18" Audi exclusive cast aluminium wheels in 5-twin-spoke design		<input checked="" type="checkbox"/>	<input checked="" type="checkbox"/>	<input type="checkbox"/>	<input type="checkbox"/>
 18" Audi exclusive cast aluminium wheels in 10-spoke design		<input checked="" type="checkbox"/>	<input checked="" type="checkbox"/>	<input type="checkbox"/>	<input type="checkbox"/>





	Page	TT Coupé	TT Roadster	TTS Coupé	TTS Roadster
 19" Audi exclusive cast aluminium wheels in 5-segment-spoke design		<input checked="" type="checkbox"/>	<input checked="" type="checkbox"/>	<input checked="" type="checkbox"/>	<input checked="" type="checkbox"/>
 19" Audi exclusive cast aluminium wheels in 5-arm rotor design		<input checked="" type="checkbox"/>	<input checked="" type="checkbox"/>	<input checked="" type="checkbox"/>	<input checked="" type="checkbox"/>
 19" Audi exclusive cast aluminium wheels in 5-arm rotor design in matt black, high-gloss turned finish		<input checked="" type="checkbox"/>	<input checked="" type="checkbox"/>	<input checked="" type="checkbox"/>	<input checked="" type="checkbox"/>
 19" Audi exclusive cast aluminium wheels in 5-parallel-spoke star design		<input type="checkbox"/>	<input type="checkbox"/>	<input checked="" type="checkbox"/>	<input checked="" type="checkbox"/>
 19" Audi exclusive cast aluminium wheels in 7-twin-spoke design		<input checked="" type="checkbox"/>	<input checked="" type="checkbox"/>	<input checked="" type="checkbox"/>	<input checked="" type="checkbox"/>
 19" Audi exclusive cast aluminium wheels in 7-twin-spoke design in matt titanium look		<input checked="" type="checkbox"/>	<input checked="" type="checkbox"/>	<input checked="" type="checkbox"/>	<input checked="" type="checkbox"/>
 19" Audi exclusive cast aluminium wheels in 15-spoke design in matt titanium look, high-gloss turned finish		<input checked="" type="checkbox"/>	<input checked="" type="checkbox"/>	<input checked="" type="checkbox"/>	<input checked="" type="checkbox"/>
 16" cast aluminium winter wheels in 10-spoke star design		<input checked="" type="checkbox"/>	<input checked="" type="checkbox"/>	<input type="checkbox"/>	<input type="checkbox"/>
 17" forged aluminium winter wheels in 7-spoke Y design		<input checked="" type="checkbox"/>	<input checked="" type="checkbox"/>	<input checked="" type="checkbox"/>	<input checked="" type="checkbox"/>

	Page	TT Coupé	TT Roadster	TTS Coupé	TTS Roadster
 18" cast aluminium winter wheels in 5-parallel-spoke S design		<input type="checkbox"/>	<input type="checkbox"/>	<input checked="" type="checkbox"/>	<input checked="" type="checkbox"/>
 18" cast aluminium winter wheels in 10-spoke design		<input checked="" type="checkbox"/>	<input checked="" type="checkbox"/>	<input type="checkbox"/>	<input type="checkbox"/>
Run-flat tyres		<input checked="" type="checkbox"/>	<input checked="" type="checkbox"/>	<input checked="" type="checkbox"/>	<input checked="" type="checkbox"/>
Anti-theft wheel bolts		<input checked="" type="checkbox"/>	<input checked="" type="checkbox"/>	<input checked="" type="checkbox"/>	<input checked="" type="checkbox"/>
Tyre repair kit		<input type="checkbox"/>	<input type="checkbox"/>	<input type="checkbox"/>	<input type="checkbox"/>
Tyre pressure loss indicator		<input checked="" type="checkbox"/>	<input checked="" type="checkbox"/>	<input checked="" type="checkbox"/>	<input checked="" type="checkbox"/>
Vehicle tool kit		<input type="checkbox"/>	<input type="checkbox"/>	<input type="checkbox"/>	<input type="checkbox"/>
Vehicle jack		<input checked="" type="checkbox"/>	<input checked="" type="checkbox"/>	<input checked="" type="checkbox"/>	<input checked="" type="checkbox"/>
Seats	78				
Sport seats, front		<input type="checkbox"/>	<input type="checkbox"/>	<input type="checkbox"/>	<input type="checkbox"/>
Audi exclusive bucket seats, front		<input checked="" type="checkbox"/>	<input checked="" type="checkbox"/>	<input checked="" type="checkbox"/>	<input checked="" type="checkbox"/>
Seat upholstery for sport seats, front	78				
 Tetris cloth, black		<input type="checkbox"/>	<input type="checkbox"/>	<input type="checkbox"/>	<input type="checkbox"/>
 Alcantara/leather, black		<input checked="" type="checkbox"/>	<input checked="" type="checkbox"/>	<input type="checkbox"/>	<input type="checkbox"/>
 Alcantara/leather, titanium grey		<input checked="" type="checkbox"/>	<input checked="" type="checkbox"/>	<input type="checkbox"/>	<input type="checkbox"/>
 Alcantara/leather, spectral silver/black		<input type="checkbox"/>	<input type="checkbox"/>	<input type="checkbox"/>	<input type="checkbox"/>
 Silk Nappa leather, black		<input type="checkbox"/>	<input type="checkbox"/>	<input checked="" type="checkbox"/>	<input checked="" type="checkbox"/>
 Silk Nappa leather, spectral silver/black		<input type="checkbox"/>	<input type="checkbox"/>	<input checked="" type="checkbox"/>	<input checked="" type="checkbox"/>
 Silk Nappa leather, signal orange/black		<input type="checkbox"/>	<input type="checkbox"/>	<input checked="" type="checkbox"/>	<input checked="" type="checkbox"/>
 Silk Nappa leather, magma red/black		<input type="checkbox"/>	<input type="checkbox"/>	<input checked="" type="checkbox"/>	<input checked="" type="checkbox"/>
 Valetta leather, black		<input checked="" type="checkbox"/>	<input checked="" type="checkbox"/>	<input type="checkbox"/>	<input type="checkbox"/>
 Fine Nappa leather, black		<input checked="" type="checkbox"/>	<input checked="" type="checkbox"/>	<input type="checkbox"/>	<input type="checkbox"/>
 Fine Nappa leather, titanium grey		<input checked="" type="checkbox"/>	<input checked="" type="checkbox"/>	<input type="checkbox"/>	<input type="checkbox"/>
 Fine Nappa leather, Luxor beige		<input checked="" type="checkbox"/>	<input checked="" type="checkbox"/>	<input type="checkbox"/>	<input type="checkbox"/>

Standard equipment Optional equipment not available

Country-specific variations possible. Please find out from your local Audi partner which equipment is standard and what optional equipment is available in your country.

	Page	TT Coupé	TT Roadster	TTS Coupé	TTS Roadster
Seat upholstery for sport seats, front (continuation)	78				
 Fine Nappa leather, nougat brown		■	■	–	–
 Fine Nappa leather, magma red		■	■	–	–
 Fine Nappa leather, garnet red		■	■	–	–
 Impulse leather, black, with special seam detail		■	■	■	■
 Impulse leather, Chennai brown, with special seam detail		■	■	■	■
 Audi exclusive leather upholstery and trim		■	■	■	■
Seat upholstery for Audi exclusive bucket seats, front	78				
Fine Nappa leather, black		■	■	■	■
Audi exclusive leather upholstery and trim		■	■	■	■
Leather upholstery and trim	78				
Alcantara/leather combination		■	■	□	□
Valetta leather upholstery and trim		■	■	–	–
Fine Nappa leather upholstery and trim		■	■	–	–
Silk Nappa leather upholstery and trim		–	–	■	■
Impulse leather upholstery and trim with special seam detail		■	■	■	■
Heat protection		□	□	□	□
Audi exclusive fine Nappa leather upholstery and trim		■	■	■	■
Audi exclusive fine Nappa leather upholstery and trim including additional items		■	■	■	■
Audi exclusive Alcantara/fine Nappa leather upholstery and trim		■	■	■	■
Leather package		■	■	□	□
Extended leather package		■	■	■	■
Extended colour leather package		■	■	■	■
Headlinings	82				
Headlining in cloth		□	–	□	–
Audi exclusive headlining in Alcantara		■	–	■	–
Hood lining in cloth		–	□	–	□

	Page	TT Coupé	TT Roadster	TTS Coupé	TTS Roadster
Inlays	83				
 Micrometallic grey		□	□	–	–
 Brushed aluminium, grey		■	■	–	–
 Matt brushed aluminium		–	–	□	□
 Phantom black		■	■	■	■
 Ibis white		■	■	■	■
Lights	84				
adaptive light		■	■	■	■
xenon plus		■	■	□	□
Headlights		□	□	–	–
Headlight cleaning system		■	■	□	□
High-beam assist		■	■	■	■
Interior lighting		□	□	□	□
LED interior lighting package		■	■	■	■
Door reflectors		□	□	□	□
Rear lights		□	□	□	□
Front fog lights		□	□	□	□
Lights styling package		■	■	□	□
Rear fog light		□	□	□	□
Mirrors	84				
Exterior mirrors with integrated LED indicator light		□	□	□	□
Exterior mirrors, heated		■	■	□	□
Exterior mirrors, heated and electrically folding		■	■	■	■
Exterior mirrors, heated, electrically folding and automatically dimming		■	■	■	■
Exterior mirror housings in Audi exclusive carbon		■	■	■	■
Interior mirror, dimming		□	□	□	□

	Page	TT Coupé	TT Roadster	TTS Coupé	TTS Roadster
Interior mirror, automatically dimming with light/rain sensor		■	■	■	■
Interior mirror, automatically dimming with light/rain sensor and digital compass display		■	■	■	■
Vanity mirror		□	□	□	□
Roof systems	85				
Acoustic hood		–	■	–	□
Hood		–	□	–	–
Wind deflector		–	■	–	□
Closing systems	86				
Remote control key		□	□	□	□
Electronic immobiliser		□	□	□	□
Garage door opener (HomeLink)		■	■	■	■
Anti-theft alarm		■	■	■	■
Preparation for tracking system		■	■	■	■
Glazing	86				
Heat-insulating glass		□	□	□	□
Dark-tinted windows (privacy glazing)		■	–	■	–
Windscreen		■	■	■	■
Rear window		□	□	□	□
Windscreen cleaning system		□	□	□	□
Further exterior equipment	86				
Rear spoiler		□	□	□	□
Bumpers and sills		□	□	□	□
Audi Singleframe		□	□	□	□
Exhaust tailpipes		□	□	□	□
2-tone horn		□	□	□	□

	Page	TT Coupé	TT Roadster	TTS Coupé	TTS Roadster
Aluminium tank cap		□	□	□	□
TT logo		□	□	–	–
TTS logo		–	–	□	□
Audi exclusive carbon package		■	■	–	–
Audi exclusive black styling package		■	■	–	–
Seats/seating comfort	87				
Front seats, electrically adjustable		■	■	■	■
Seat heating, front		■	■	□	□
4-way lumbar support		■	■	■	■
Head restraints		□	□	□	□
Rear seat system		□	–	□	–
Rear seat backrest		□	–	□	–
ISOFIX child seat mounting		□	□	□	□
ISOFIX child seat mounting and rear seat with child seat group III approval		■	–	■	–
Steering wheels/gear levers/controls	88				
Leather-covered multifunction sport steering wheel in 3-spoke design*		■	■	□	□
Leather-covered sport steering wheel in 3-spoke design*		□	□	–	–
Audi exclusive leather steering-wheel rim		■	■	■	■
Gear/selector lever knob		□	□	□	□
Gear lever knob in Audi exclusive aluminium		■	■	–	–
Audi exclusive leather controls		■	■	■	■
Climate control	88				
Automatic air conditioning		□	■	□	□
Ventilation system and heating		–	□	–	–

□ Standard equipment ■ Optional equipment – not available

Country-specific variations possible. Please find out from your local Audi partner which equipment is standard and what optional equipment is available in your country.

*With S tronic fitted with shift paddles behind the steering wheel.

	Page	TT Coupé	TT Roadster	TTS Coupé	TTS Roadster
Luggage securing and storage systems	89				
Through-loading facility with removable ski/snowboard bag		–	■	–	■
Storage package		■	■	■	■
Cup holder		□	□	□	□
Lashing points		□	–	□	–
Luggage compartment cover		□	–	□	–
Glove compartment		□	□	□	□
Further interior equipment	89				
Footwell trim and floor mats		□	□	□	□
Door sill trims with aluminium inlay		□	□	□	□
Window controls		□	□	□	□
Dashboard		□	□	□	□
Cigarette lighter and ashtrays		□	□	□	□
Extended aluminium look in the interior		■	■	□	□
Aluminium look in the interior		□	□	–	–
MMI® and navigation systems	90				
Navigation system plus with MMI® control logic		■	■	■	■
Navigation system with MMI® control logic		■	■	■	■
Driver information system		□	□	□	□
Radio and TV systems	90				
chorus radio		■	■	□	□
concert radio		■	■	■	■
symphony radio		■	■	■	■

	Page	TT Coupé	TT Roadster	TTS Coupé	TTS Roadster
TV reception		■	■	■	■
BOSE surround sound		■	■	■	■
CD changer		■	■	■	■
Audi music interface		■	■	■	■
Adapter cable set for Audi music interface		■	■	■	■
Rod aerial		–	□	–	□
Audi exclusive iPod preparation		■	■	■	■
Audi exclusive USB preparation		■	■	■	■
Telephone and communication	91				
Preparation for mobile phone (Bluetooth)		■	■	■	■
Bluetooth interface		■	■	■	■
Voice control system for navigation system plus		■	–	■	–
Assistance systems	91				
Hill hold assist		■	■	■	■
Parking system, rear		■	■	■	■
Cruise control		■	■	■	■
Suspensions/brakes	91				
Audi magnetic ride		■	■	□	□
Sport button		■	■	□	□
Sport suspension		□	□	–	–
S line sport suspension		■	■	–	–
Brake callipers painted dark grey		■	■	–	–
Brake callipers painted black with TTS logo		–	–	□	□
Brake system		□	□	□	□

	Page	TT Coupé	TT Roadster	TTS Coupé	TTS Roadster
Technology/safety	92				
Body Audi Space Frame (ASF®) design		□	□	□	□
Side impact protection		□	□	□	□
Antilock Brake System (ABS)		□	□	□	□
Anti-Slip Regulation (ASR)		□	□	□	□
Electronic Differential Lock (EDL)		□	□	□	□
Electronic Stabilisation Control (ESC)		□	□	□	□
Integrated head restraint system		□	□	□	□
Airbags		□	□	□	□
Side airbags, front		□	□	□	□
Warning and control lights		□	□	□	□
First-aid kit		□	□	□	□
Safety steering column		□	□	□	□
Roll-over bars with aluminium trim		–	□	–	□
Audi exclusive leather-covered roll-over bars		–	■	–	■
Seat belt reminder		□	□	□	□
Seat belts		□	□	□	□
Audi exclusive seat belts		■	■	■	■
Instrument cluster		□	□	□	□
Electromechanical power steering		□	□	□	□
Reduced gear lever travel		■	■	■	■
S tronic®		■	■	■	■
Manual transmission		□	□	□	□
quattro®		■	■	□	□
Recuperation		□	□	□	□
Audi Extended Warranty	93				
Audi Extended Warranty		■	■	■	■

Equipment for the Audi TT Coupé illustrated (p. 4–23):

Paint finish: ice silver, metallic; wheels: cast aluminium wheels in 10-spoke design;
Seats/seat upholstery: sport seats, front, in fine Nappa leather, black;
Inlays: brushed aluminium, grey

Equipment for the Audi TT Roadster illustrated (p. 4–23):

Paint finish: ice silver, metallic; wheels: cast aluminium wheels in 5-spoke V design;
Seats/seat upholstery: sport seats, front, in fine Nappa leather, magma red;
Inlays: brushed aluminium, grey

Equipment for the Audi TTS Coupé illustrated (p. 24–37):

Paint finish: Misano red, pearl effect; wheels: cast aluminium wheels in 5-parallel-spoke S design;
Seats/seat upholstery: sport seats, front, in silk Nappa leather, spectral silver/black;
Inlays: matt brushed aluminium

Equipment for the Audi TTS Roadster illustrated (p. 24–37):

Paint finish: ibis white; wheels: cast aluminium wheels in 5-parallel-spoke S design;
Seats/seat upholstery: sport seats, front, in silk Nappa leather, magma red/black;
Inlays: matt brushed aluminium

Classifications of tyre parameters

The table shows the range of fuel efficiency, wet grip and exterior noise emission classes for the different tyre sizes of the Audi TT Coupé, TT Roadster, Audi TTS Coupé and TTS Roadster.

	Tyre size	Fuel efficiency class	Wet grip class	Exterior noise emission class
Summer tyres	245/45 R 17	G–F	C–B	72–71
	245/40 R 18	F	C–B	73–71
	255/35 R 19	F	B	71
Winter tyres	225/55 R 16	F	E	68
	225/50 R 17	F–E	E–C	72–68
	245/40 R 18	F	E	68

It is not possible to order a specific tyre. Ask your Audi partner about the range of tyres available in your country.

□ Standard equipment ■ Optional equipment – not available

Country-specific variations possible. Please find out from your local Audi partner which equipment is standard and what optional equipment is available in your country.



Responsibility

Living up to our responsibilities is a principle that is firmly anchored in Audi strategy. Alongside commercial success and international competitiveness, our responsibility toward company employees and society as a whole is a key consideration, as is protecting the environment and conserving resources. And what is true in the details – our catalogues are printed on FSC-certified paper – also holds in general: Audi develops cars that are not only sporty and emotive but also ever more efficient. In the long run, Audi wants its products to allow CO₂-neutral

mobility. Seeing to it that production in Audi plants gradually becomes CO₂-neutral is another aspect of our comprehensive approach. Audi is also committed to society – particularly in the fields of education, technology and social projects. At Audi, sustainability is closely linked with how we see the future: the Audi Urban Future Initiative sees Audi working with international experts to get to the root of future urban challenges and trends in mobility.

Discover the world of Audi.



Choosing an Audi means choosing a brand that offers more. More individuality. More exclusivity. More fascination.

The Audi experience

The fascination of Audi can be experienced in many different ways. Audi City in London, for example, gives you digital access to all models at their actual size and in real time. And of course it is always worth visiting one of the major motor shows. This is where Audi always presents its new models and invites you to take a look at how the future is being shaped with “Vorsprung durch Technik”. Anyone interested in seeing how Audi is already putting this into practice will find fascinating insight in the “Vorsprung durch Technik” online special at www.audi.com.

But a look back can also be rewarding: at the Audi mobile museum in Ingolstadt, history and high-tech go hand in hand. A total of 130 historic exhibits and state-of-the-art forms of presentation make for a thrilling symbiosis. Plus, Audi driving experience allows you to live the excitement and countless possibilities of current Audi models. Here, pure driving enjoyment is combined with valuable learning effects. This is ensured by a team of specially trained and highly qualified instructors who provide practical tips to help you optimise your driving skills.



Team spirit

Motorsport is a driving force behind the brand. For years Audi has been among the champions in various racing series, for instance the 24 Hours of Le Mans or the DTM German Touring Car Masters. The values that are crucial in many different areas of sports are also central ones for Audi: precision, passion and technology. No coincidence then that Audi

has been sponsoring sporting events for many years. In the world of winter sports, for example, Audi has been the main sponsor of the German Ski Association (DSV) for almost three decades and has also partnered 14 other national alpine teams. In football, we support national and international teams. And Audi is also a partner for the German Olympic Sports Confederation.

www.audi.com

Information on all the topics mentioned above can be found on our website: www.audi.com.

 www.audi.com

 configurator.audi.com

 www.audi.com/vorsprung-durch-technik

 www.audi.com/driving

 www.audi.com/cr



AUDI AG
85045 Ingolstadt
www.audi.com
Valid from April 2013

Printed in Germany
333/1130.92.18

The models and equipment versions illustrated and described in this brochure and some of the services listed are not available in all countries. Some of the cars illustrated are equipped with optional features for which an extra charge is made. Details concerning the delivery specifications, appearance, performance, dimensions and weights, fuel consumption and running costs of the vehicle were correct to the best of our knowledge at the time of going to press. Deviations from the colours and shapes shown in the illustrations may occur. No liability is accepted for errors and printing errors. The right to introduce modifications is reserved. Not to be reproduced, including in part, without the written approval of AUDI AG.

This brochure is printed on paper made from pulp bleached without the use of chlorine.

