

SEAT MALAGA



SEAT



MALAY

THE CAR FOR EUROPE.

Italian design...German engineering...and all the inspiration of Spain. That's the exciting promise of the Malaga family from SEAT, Spain's leading car manufacturer and one of the largest in Europe.

Styled by Giugiaro...powered by the System Porsche engine...and built in one of Europe's most advanced production plants, the SEAT Malaga is sleek, powerful, practical, economical, formidably European and a full 5-seater, with a version for every requirement.











Wing mirror adjustable from the interior.

The GLX shows you what comfort really means. It's quiet and relaxing, thanks to the lavish use of sound-deadening materials. Power-operated front windows...tinted glass all round...comprehensive instrumentation for total control...rear footwell heating and twin rear courtesy lamps...alloy wheel trims with low-profile tyres...all are standard...all mean you can concentrate on the road without distraction.



Electrically powered windows.



Check-control.





**MALAGA L SALOON.
INSPIRATION WITH PURPOSE.**



System Porsche engine for power and economy...a 5-speed gearbox...Malaga style...and incomparable value for money. That's the promise of the Malaga L.

Packing in this much value is something that makes every SEAT car so special...and it's the result of shrewd investment, planning, and some inspired engineering.

TECHNOLOGY WITHOUT FRONTIERS
in action again.

The Malaga L a has cigar lighter...heated rear window...and rear safety belts fitted as standard.

For practicality, luxury and value that lead the rest in the class, choose the Malaga L.



MALAGA GL SALOON. INSPIRATION AND VALUE.



The Malaga GL gives you all the performance and equipment you would expect in a car costing a lot more.

That's the subtle SEAT combination of Spanish inspiration, Italian design and German engineering working its magic through that soft, comfortable fabric...those adjustable seats with padded head rests...that all-round tinted glass...those tough, body side mouldings...that System Porsche power delivered through a smooth, 5-speed gearbox.

The Malaga GL drives as well as it looks, too, with

instruments and controls which are positive to use and clearly identified...designed to keep the driver in control in all road conditions.



**MALAGA GLX SALOON.
INSPIRED ELEGANCE.**



This is the car which doesn't make a fuss. It doesn't have to.

The Malaga GLX is style and quality, from its Giugiaro elegance to the renowned SEAT attention to detail and prestige touches like central door locking, veloured seating and quiet, powerful heating and ventilation.

Take control in the driver's seat. You'll find the steering wheel adjustable for height...fully-reclining front seats with integral headrests...the 5-speed gear lever in exactly the right position...the seating a pleasure, even at the end of the longest journey.







HATCHBACK MALAGA. INSPIRED ALTERNATIVE.

THE CHOICE IS YOURS.



Whether you prefer a saloon or a hatchback, the Malaga is ready with a model to suit your needs...and trim to meet your requirements, from the ultimate in executive prestige to practical, economical town and country driving.

Choose in confidence that you are buying the best that German engineering, Italian design and Spanish inspiration have to offer.

Choose Malaga, saloon or hatchback, and you choose
TECHNOLOGY WITHOUT FRONTIERS
Technology with style.

INSPIRED ENGINEERING.

From a close collaboration between Seat and Porsche was born a new kind of power system - the astonishing Seat System Porsche engine.

These new engines have been designed for maximum fuel efficiency, minimum maintenance and a longer life than ordinary motors.

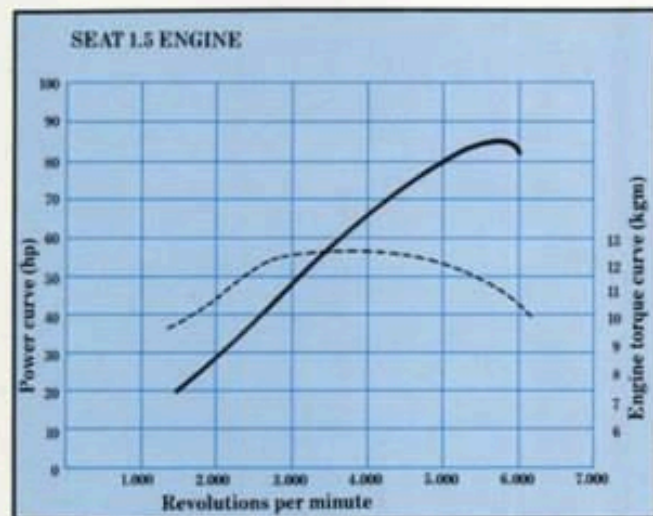

MAXIMUM EFFICIENCY, MINIMUM CONSUMPTION

The Seat System Porsche engines use the "TOP" system. The combustion chambers are formed in the piston head.

The bore/stroke ratio of the pistons in these "super square" engines reduces the amount of inertia. Both the 1.2 and the 1.5 engines, with bores of 75 mm. and 83 mm. respectively, have short strokes of only 67.5 mm. These large-bore cylinders admit wide-diameter valves for improved thermodynamic performance.

The high compression the use low octane fuels (9.5:1 with 90 octane fuel in the 1.2 engine and 10.5:1 with 96 octane fuel in the 1.5 engine). All of this means better energy efficiency and considerably lower fuel consumption.

The carburation system is based on a radically new idea - that the basic combustion element in a modern engine is not petrol, but air.

Consequently, the carburetors in the System Porsche engines (Pierburg for the 1.2 engine and Weber for the 1.5 engine) operate on a mixture of 1 part petrol to 16 parts air. This substantial increase in the normal proportion of air extracts the last drop of energy from the fuel.

SEAT SYSTEM PORSCHE ENGINES FOR THE USE OF UNLEADED AND LEADED FUEL

Traditionally, lead has been added to gasoline to facilitate the operation of combustion engines. It avoids the negative effects (deterioration of mechanical parts) caused by the fuel "explosion".

The consequences of the presence of lead in the environment are very negative, since it is one of the most dangerous poisons. For this reason, Governments are taking measures to reduce the use of lead in gasoline to a minimum. But not all engines are suitable for the use of unleaded gasoline. This fuel, in unprepared engines, causes greater consumption and reduced performance.

The Seat System Porsche engines belong to a new generation of engines, which by virtue of their design and durability give them the outstanding ability to use unleaded gasoline without decreasing their well-known optimum performance.

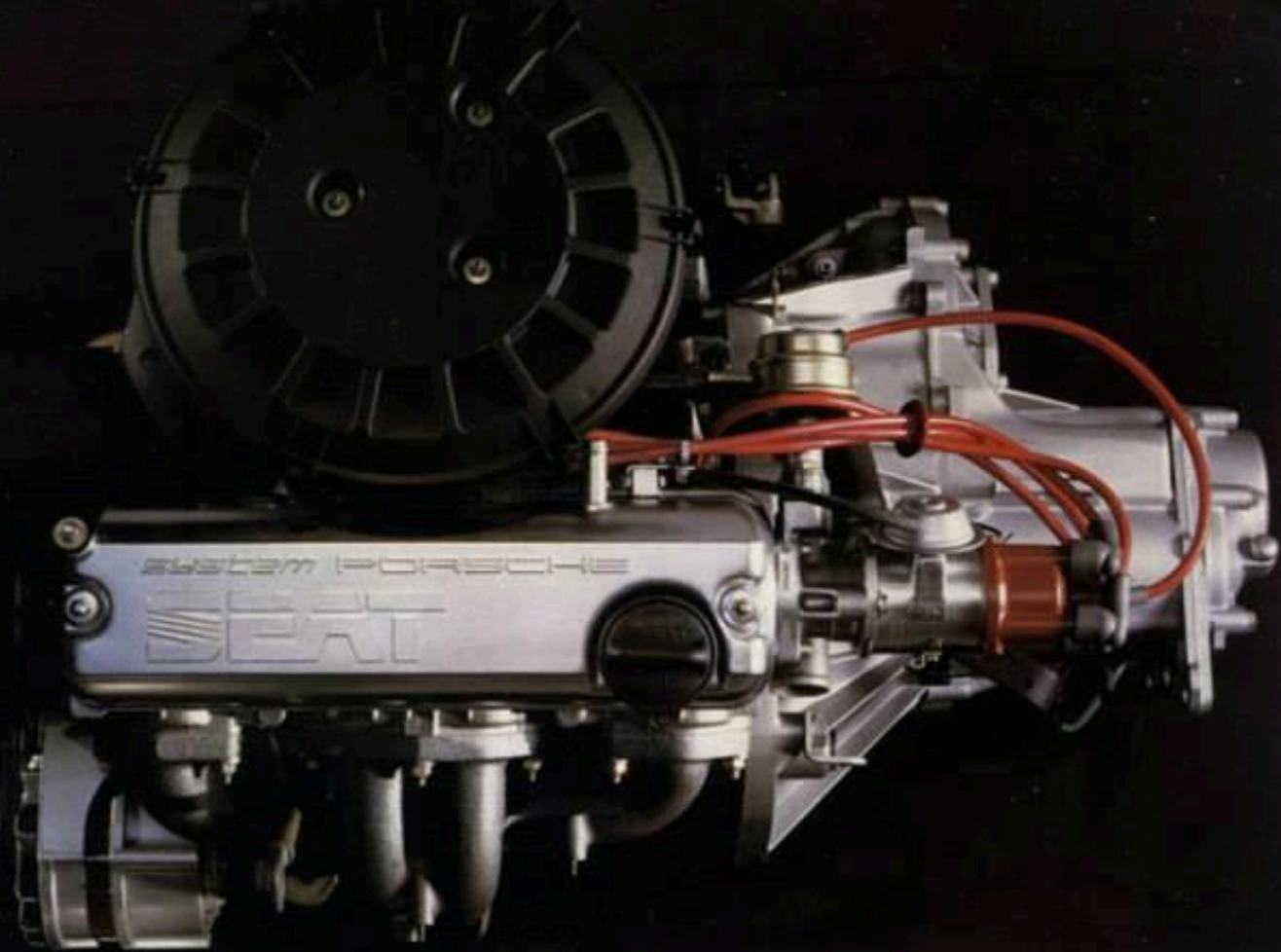

LOW EMISSION OF POISONOUS GASES IN THE SEAT SYSTEM PORSCHE ENGINES

The Seat System Porsche engines are low-polluting and easily meet the strictest European legislation - the A-10 norm applicable in Switzerland and Sweden and the ECE 15-04 regulation in the EEC.

For example, the 1.2 and 1.5 engines issue 51% and 48% less CO₂ than permitted by the A-10 norm, under the most extreme conditions, that of: driving in a congested area following cold start-up.

QUICK STARTS

The ignition system of the Seat System Porsche engine is the most advanced on the market. The points and condenser have been replaced by a Hall-effect booster and an electronic module. As well as eliminating maintenance, this system ensures quick starts every time and reduces the possibilities of damage to the ignition system.

Timing on the Seat System Porsche engines is by means of a single camshaft supported by five bearings, with Elotherm treated eccentric attack cams driven by an HTD-profile synthetic toothed belt and operating maintenance-free hydraulic tappets.

It's a highly reliable system that is also very quiet-running.

REDUCED NOISE

Lubrication is another area of technological innovation. Apart from lubricating, the oil performs two further functions: cooling the piston heads and providing the pressure required by the hydraulic tappets.

The cooling system is in the form of a closed circuit with thermostatic control and forced circulation by means of a pump housed in the block. This system is completed by a radiator communicating directly with an expansion tank and a remote-controlled electric fan.

Along with these new engines, Seat and Porsche have developed a new gearbox that makes for easier gear-changes and low noise.

GREATER RELIABILITY

This new gearbox reduces consumption and provides for an extraordinarily high top gear. It is stronger, more reliable and allows a smoother gear change with greater transmission capacity.

In short, the new generation of Seat engines and gearboxes are the result of innovative thinking that has produced brilliant results.

But, in the final analysis, what it all means is that your new Seat Malaga will be a car with more power, lower fuel consumption and minimum maintenance.

A unique combination that makes the Seat Malaga a very special car.

We call it

TECHNOLOGY WITHOUT FRONTIERS

INSPIRED EQUIPMENT.

Every Malaga is packed with thoughtful touches which combine practicality and style, from the ultra-luxurious GLX to the nippy L.

When you're carrying a heavy load, you'll appreciate the remote-control headlamp beam adjustment, standard on the GLX.

The specially-designed heating and ventilation system (rear outlets standard on the GLX saloon) gives the ideal blend of fresh and recirculated air for all weather conditions.

Five-speed gearboxes are standard in all Malagas, giving superb economy on all journeys. In town, you will appreciate the extremely smooth, light gear-change.

The seating was created by experts in ergonomics and anatomy...and there's room for five adults in comfort. When you carry children, you will appreciate the child-proof safety locks on the rear doors, a standard feature on all models.

On the GLX, the map reading light and height-adjustable steering wheel come as standard.

Look at the stylish and practical body trim - just the thing for those car park bumps. The indicator lights are positioned for maximum visibility and protection against knocks. And all Malagas have halogen headlamps as standard.

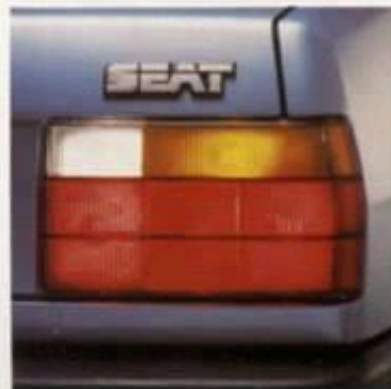

INSPIRED SAFETY.

The Malaga is strong on both active and passive safety.

Because we believe that it is better to minimise the risk of an accident occurring, we gave the Malaga excellent manoeuvrability and twin-circuit brakes with discs at the front and drums at the rear. We also built in a very high degree of all-round visibility which reduces blind spots to a minimum.

We asked structural experts Karmann to design the best possible protection for the passenger compartment. The result was a series of interlocking steel 'rings' which form a central cage, with surrounding body panels designed to crumple progressively, absorbing the energy of impact. Naturally, a laminated windscreen, padded front head restraints and a collapsible steering column are also standard safety equipment.

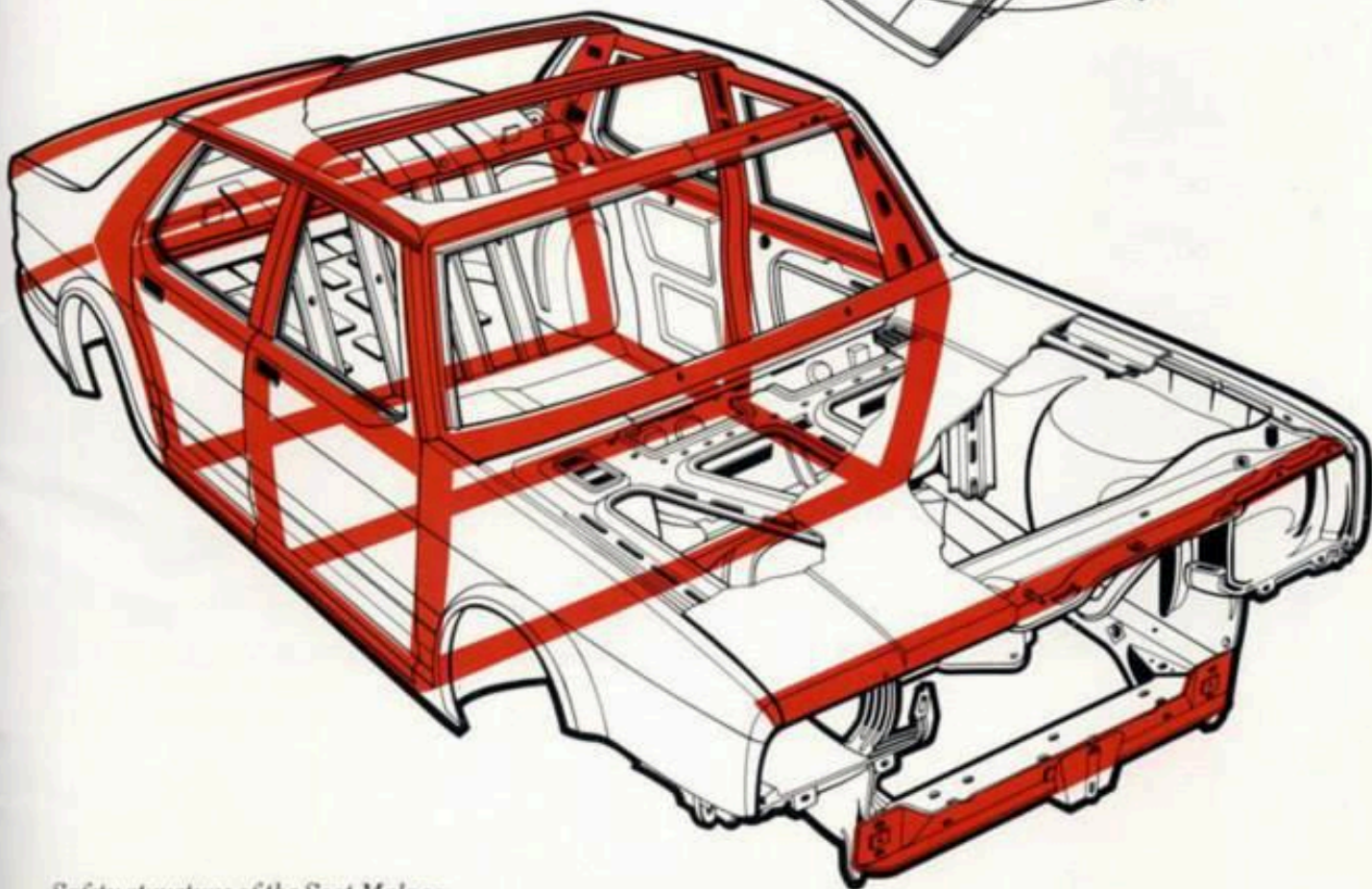
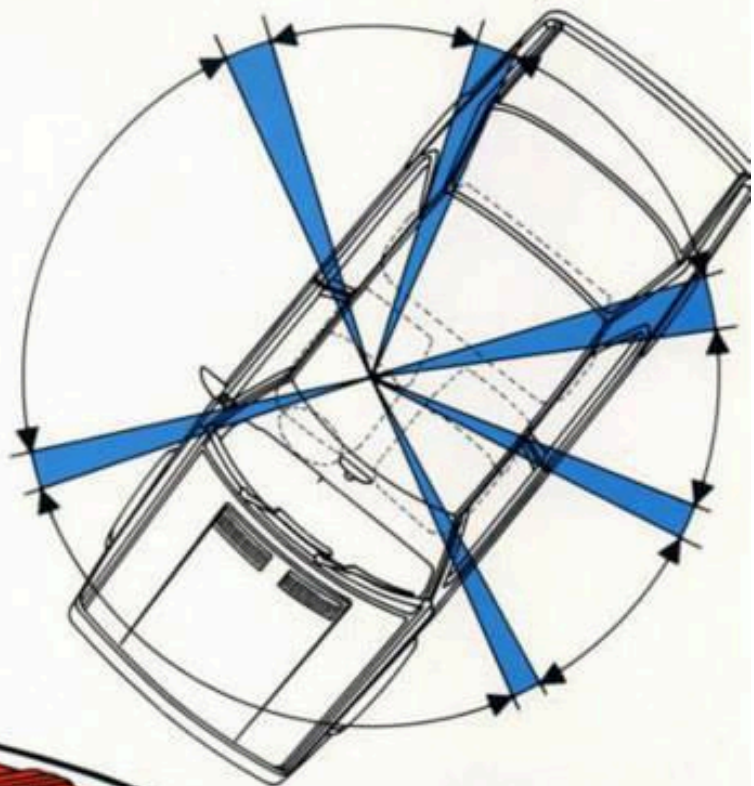

Safety structure of the Seat Malaga.

SEAT. THE STORY OF SUCCESS.

The first SEAT drove off the production line in 1953.

In over 30 years since those early days, SEAT's factories have become one of the western world's most important car producers. They have built over 5 million cars, giving us a wealth of experience and a reputation for engineering quality and reliability that's second to none.



Pamplona factory: Assembly.

THE BEST FROM EUROPE — TECHNOLOGY WITHOUT FRONTIERS

Today, in the spirit of European cooperation, SEAT has close links with Europe's leading automotive research and engineering centres... internationally-respected expert organisations such as Giugiaro and Karmann for styling and structural design and Porsche for engines and gearboxes.

We pay equal attention to efficiency in manufacturing, and we set the highest standards in quality control.

As a result, every SEAT model comes with a 6-year anti-perforation warranty, thanks to our 9-stage rust prevention treatment. In fact, of the time it takes to build a SEAT, we spend over a third painting it.

With our unconditional 12-month parts and labour whole-car guarantee, we believe that SEAT owners can have real peace of mind.



*Zona Franca, Barcelona factory:
Engines, coach-building, assembly.*



Prat de Llobregat factory: Gearboxes.

THE RESEARCH CONTINUES

But manufacturing and quality control are only part of our activities. SEAT also makes a massive investment in research. We operate one of the most advanced R&D operations anywhere in the world's car industry.

We test new materials for suitability. We analyse the physical performance and wear of new engine designs. We analyse production engines at random for pollution control. We pull cars off the production line and test them to destruction. We test new designs on computer simulation equipment...and we use computerised manufacturing to turn our projects into advanced, reliable cars.



Martorell factory. Suspension, brakes and steering, spare parts warehouse, research and study center.

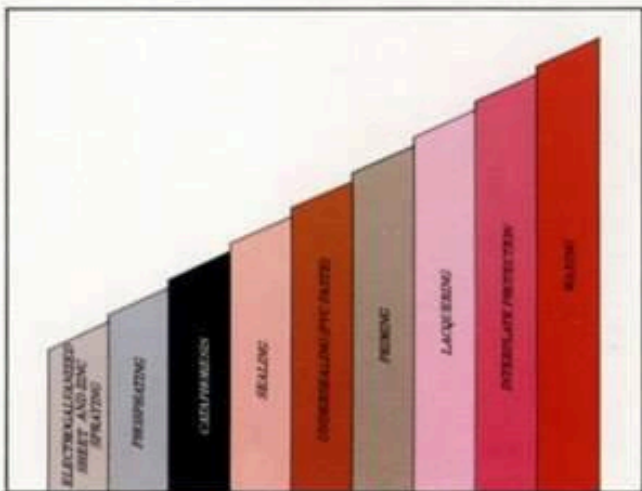

We believe that when you drive a SEAT, you are driving the best in Europe.

A vehicle which signifies

TECHNOLOGY WITHOUT FRONTIERS

...and technology without compromise.

6-YEAR ANTI-CORROSION WARRANTY

Because Malaga is such an outstanding car, it gets an outstanding package of warranties. First, the whole car is guaranteed for 24 months.

And that includes parts and labour.

And second, the bodywork is guaranteed against corrosion for 6 years.

Plus these warranties are valid at any of Seat's 2500 European dealers.





UK

SEAT is committed to a policy of continuous product improvement. Therefore, exact details relating to specification and equipment may differ slightly to those given in this catalogue.

SEAT