

GLA Sport Utility Vehicle



Mercedes-Benz





The GLA. Always restless.

And in the GLA this restlessness is contagious. In this compact premium SUV, even city roads feel like the great wide open. Revel in its sporty, dynamic design, cutting-edge drive systems and a standard of comfort and safety that is unique to Mercedes-Benz. Climb aboard and discover the GLA.

MULTIMEDIA ADVENTURES WITH THE GLA.



Discover the GLA in fascinating HD. With the Mercedes-Benz brochure app for the iPad® and with the Digital Owner's Manual from "Mercedes-Benz Guides" for the iPhone®. Both apps feature a host of films and additional content and are available free of charge at the Apple® iTunes® Store.

Adventure comes in various guises:

**2 | Mercedes-Benz GLA 250 4MATIC
polar silver metallic**

Urban design and equipment line, 5-twin-spoke light-alloy wheels, Exclusive package, leather upholstery in sahara beige/black, satin-finish light brown poplar wood trim

**10 | Mercedes-Benz GLA 220 d 4MATIC
orient brown metallic**

Style design and equipment line, 5-twin-spoke light-alloy wheels, ARTICO man-made leather upholstery in sahara beige, satin-finish light-brown poplar wood trim

**18 | Mercedes-AMG GLA 45 4MATIC
cirrus white**

10-spoke AMG light-alloy wheels, AMG Night package, AMG Exclusive package, RED CUT leather upholstery in black, AMG carbon-fibre trim

All set for adventure:

- 26** | Moving innovation
- 28** | Mercedes me
- 34** | Engines
- 36** | 7G-DCT dual clutch transmission
- 37** | 4MATIC all-wheel drive
- 38** | COLLISION PREVENTION ASSIST PLUS
distance warning
- 40** | COMAND Online multimedia system
- 41** | Harman Kardon® Logic 7® surround sound system
- 42** | Intelligent Light System
- 43** | Reversing camera
- 44** | Panoramic sliding sunroof
- 46** | Mercedes-AMG GLA 45 4MATIC
- 50** | Equipment and packages
- 61** | Genuine Accessories
- 62** | Optional extras
- 64** | Wheels
- 66** | Technical data
- 69** | Upholstery and paintwork

The illustrations may show accessories and optional extras which are not part of the standard specification.



Every ray of sunshine is like a spotlight.

If the road is a stage, the GLA is a true character actor. With its typical SUV proportions and its striking front end, it exudes a self-assured presence. But the GLA is not just an SUV – it is first and foremost a Mercedes, as indicated by the centrally positioned star in the radiator grille and the so-called “dropping line”. This is the design line which extends from the headlamps along the sides to the rear axle, creating an impression of fluid dynamism even when the vehicle is stationary. No wonder the GLA looks so pleased with itself.



THE ART OF LIGHTING

Not so very long ago, headlamps were required simply to provide illumination. Today, many headlamps shine like little works of art. This is attributable above all to LED technology. LEDs are much longer-lasting and more efficient than conventional lights – and they create a fascinating light design. LEDs are optionally available for the GLA,

depending on the selected scope of equipment. LEDs are used in the front and rear indicators, the brake lamps and the rear fog lamp. The daytime running lamps, side lights and tail lamps employ fibre optics, which enable a harmonious transition of light. The resultant lights are absolute gems that provide for a distinctive design, day and night.





High noon. With up to 381 horsepower.

The GLA is driven by true grit, self-confidence, a thirst for adventure – and seven of the most cutting-edge engines in its class, equipped with a high-tech package including turbocharging and direct injection. The engine power is converted virtually directly and extremely efficiently into thrust: via front-wheel drive or particularly dynamic 4MATIC all-wheel drive. Via 6-speed manual transmission, 7G-DCT 7-speed dual clutch transmission or AMG SPEEDSHIFT DCT 7-speed sports transmission.





In the background:
the low-lying sun.

Colour is a vital ingredient of any tale of nature, adventure and freedom. The GLA is available in the special paint finish designo magno mountain grey, for example, or – as shown here – in orient brown metallic. It shines resplendently in the evening sun – and at any other time of the day or night, too.







Tell-tale signs of the GLA's adventurous spirit are to be found wherever you look. The structured bonnet with powerdomes and the radiator grille with two fins lend the front a particularly wide appearance. The bumper features criss-cross grating. And underneath the bumper is the typical SUV-style simulated underguard, which may be in silver, dark chrome or perhaps high-gloss black, according to the selected equipment line or design package. Highlights at the rear are the chrome strip between the lights, the roof spoiler and the optional robust load sill guard.



A night in watching TV? Or how about starring in your very own road movie ...









The interior of the GLA holds a number of surprises in store, with a spacious feeling for a compact car. Particularly in conjunction with the optional panoramic sliding sunroof. And as an SUV offering the comfort and class of a traditional saloon. In all, an ideal setting in which to enjoy your new-found freedom.

The Mercedes-AMG GLA 45 4MATIC. Turning night into day.

Proud SUV or thoroughbred sports car? Discover the thrilling best of both worlds. The world's most powerful series-production 4-cylinder car engine with 381 hp and 475 Nm, a high-performance brake system, a sports transmission, performance-oriented 4MATIC all-wheel drive, speed-sensitive sports steering and a sports suspension, in each case from AMG, propel the Mercedes-AMG GLA 45 4MATIC into a league of its own.









First encounter: a walk around the Mercedes-AMG GLA 45 4MATIC reveals its characteristic features, such as the large AMG light-alloy wheels, the specific rear apron or the sporty tailpipes. The AMG Performance Studio is able to fulfil a whole range of further sporty wishes on request. The AMG DYNAMIC PLUS package with AMG front axle locking differential, for example, improves traction in any driving situation. The AMG RIDE CONTROL sports suspension with Adaptive Damping System and additional RACE transmission mode offers the consummate driving experience – most particularly on race circuits or cordoned-off courses.





The stuff of dreams.
But it won't let you sleep.

AMG PERFORMANCE 4MATIC

280 kW (381 hp) and 475 Nm alone are not enough. This power is transmitted by the performance-oriented 4MATIC all-wheel drive. 4MATIC features a multiple-disc clutch with AMG-specific electro-hydraulic control integrated into the rear axle differential. This allows fully variable torque distribution, from front-wheel drive to a 50 : 50 split. The torque is distributed according to the selected

stage of the Electronic Stability Program ESP® – from sporty with an emphasis on safety to maximum performance on cordoned-off race tracks. Variables influencing power distribution are road speed, lateral and longitudinal acceleration, steering angle, rotational speed difference between individual wheels, choice of gear and accelerator pedal position.



High-performance sport is at home inside the Mercedes-AMG GLA 45 4MATIC. All controls and displays are in performance-oriented design. The AMG instrument cluster or the AMG DRIVE UNIT in the centre console with its AMG DYNAMIC SELECT Controller, for example. This can be used to call up a specific comfortable, sporty, very sporty or quite individual setting, as required. AMG trim also adds to the overall motorsport ambience.



What makes a car a Mercedes?

Deep-rooted traditions: in our case, it is innovative traditions that run deep. We have continually gone down previously uncharted avenues. Milestone by milestone. These ventures spawned the first vehicle with a crumple zone, the first ABS, the first diesel passenger car. The first car. But rather than wallowing in the past, let us look to the future.

Mercedes-Benz Intelligent Drive – on the road to accident-free driving. We develop intelligent assistance systems which actively support the driver and noticeably relieve their workload. They monitor and analyse the vehicle's surroundings and handling characteristics – and warn the driver if they identify any critical situations. When necessary, some of the systems are able to intervene to take corrective action. Potential dangers are identified earlier than ever – and ever more frequently avoided as a result. Discover the fascinating world of Mercedes-Benz Intelligent Drive at www.mercedes-benz-intelligent-drive.com

BlueEFFICIENCY – our vision of emission-free driving. Sustainability is a big word to which we lend real meaning in all that we do, down to the smallest details. From minimising the environmental impact of our production operations to alternative drive configurations.

30! years 4MATIC

4MATIC – driven by new challenges, the vision of optimum traction led the Mercedes-Benz engineers to the International Motor Show in Frankfurt. That is where, in 1985, they unveiled 4MATIC, an innovative traction system working with state-of-the-art microelectronics and hydraulics. Just two years later it entered series production in the E-Class. It has continued its triumphal advance ever since in virtually all model series. And on every terrain. 75 models are now out on the road with 4MATIC and it is tailor-made for each class. Comfortable and efficiently configured for the compact class, right through to extremely sporty for the Mercedes-AMG performance models. For more safety and an intensive driving experience in every single moment.

As you can see, we have major goals in our sights. And what could be better than seeing these aims achieved whilst on a long drive in a Mercedes?

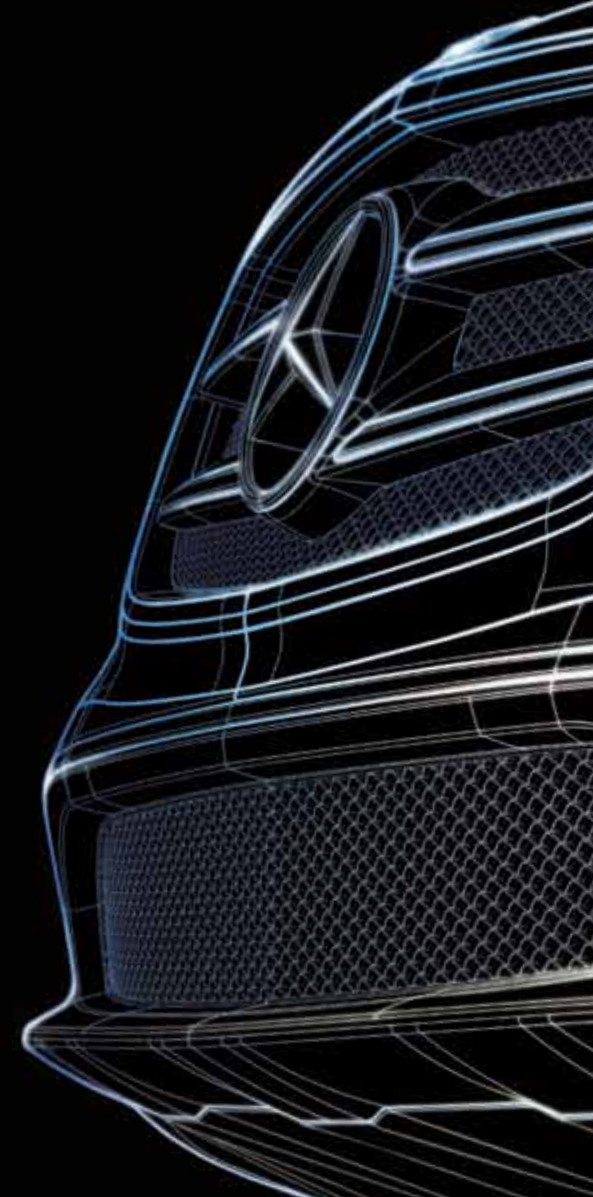



What would motorsport be without Mercedes-Benz?

The first vehicle to ever win an automobile race was powered by a Daimler engine. The first Mercedes was a racing car. The Silver Arrows – a true legend. Mercedes-Benz has a long tradition of involvement with the world of sport. Motorsport shapes the brand and every vehicle bearing the Mercedes star to this day. Discover the brand's unique history first-hand: at the Mercedes-Benz Museum in Stuttgart.

↘ FIND OUT MORE

Discover just what has been moving the world for more than 125 years and take a journey through time as well as through the history of the automobile at the Mercedes-Benz Museum. More than 1500 exhibits await you on 16,500 sqm of floor-space, including unique gems such as the oldest surviving Mercedes from 1902 or the legendary gull-wing models. Welcome to a place of innovation:

www.mercedes-benz-classic.com/museum



What would Mercedes-Benz be without motorsport?

3 June 1934 marked the beginning of the Silver Arrows legend in the International Eifel Race at the Nürburgring. The Silver Arrows works team MERCEDES AMG PETRONAS continued this tradition in the 2014 Formula 1 season. Its successful involvement was crowned by the most impressive double victory of the season, with the team topping both the constructors' and the drivers' rankings. The team's successes are not restricted to the race track, however. Every mile raced also advances the development of hybrid technology for series production.

▾ FIND OUT MORE

Fascinating Formula 1 goes multimedia:

<http://www.facebook.com/MercedesAMGF1>

<http://twitter.com/MERCEDESAMGF1>

<http://www.youtube.com/user/MERCEDESAMGPETRONAS>

<http://plus.google.com/+Mercedesamgf1/posts>

<http://instagram.com/MercedesAMGF1#>

<http://www.MercedesAMGF1.com>



MERCEDES AMG PETRONAS F1 W06 hybrid, 2015 season.

Driving ambition.

The GLA is intended to inspire, to fire your imagination and to rouse your spirits. This is what it did with us when we developed the current engine generation. A cutting-edge technology package in particularly compact and light-weight design produces amazing results: the GLA 250 has an output of 155 kW (211 hp) and, in conjunction with the optional 7G-DCT 7-speed dual clutch transmission, consumes just 5.9–5.7 l/100 km in combined mode. What sounds like a contradiction in terms is actually the logical upshot of turbocharging, direct petrol injection, variable valve timing – and unflagging efforts on the part of our engineers.

The diesel engines: good vibes and virtually no vibrations.

For even more efficient driving, five diesel variants are available. With up to 350 Nm of torque, they offer an effortlessly superior driving experience. Overtaking manoeuvres are performed with an astounding ease born of refined power. The latest generation of common rail direct injection enables efficient combustion and exceptionally smooth and quiet running.

A benchmark in efficiency.

The GLA's low fuel consumption is down to innovative technologies – and our fundamentally holistic approach, dedicated to the efficient husbanding of natural resources. We sum this approach up in one word: **BlueEFFICIENCY**. In concrete terms, this means burning fuel only when it is actually needed, for example. To this end, every GLA is equipped as standard with the **ECO start/stop function**, which temporarily shuts down the engine while the vehicle is stationary, for example in a traffic jam or at a red traffic light. The ECO display is another standard-fit item which helps you to adopt a fuel-saving style of driving – this is still the most effective way of driving with maximum efficiency.

THE ENGINE RANGE

Diesel:

GLA 180 with an output of 80 kW (109 hp) and 260 Nm of torque

GLA 200 d/GLA 200 d 4MATIC with an output of 100 kW (136 hp) and 300 Nm of torque

GLA 220 d/GLA 220 d 4MATIC with an output of 130 kW (177 hp) and 350 Nm of torque

Petrol:

GLA 180 with an output of 90 kW (122 hp) and 200 Nm of torque

GLA 200 with an output of 115 kW (156 hp) and 250 Nm of torque

GLA 250/GLA 250 4MATIC with an output of 155 kW (211 hp) and 350 Nm of torque

↘ FIND OUT MORE

You will find all the technical data for the GLA on page 66/67.

An engine so powerful it deserves its own chapter: the Mercedes-AMG GLA 45 4MATIC is presented in detail, beginning on page 46.

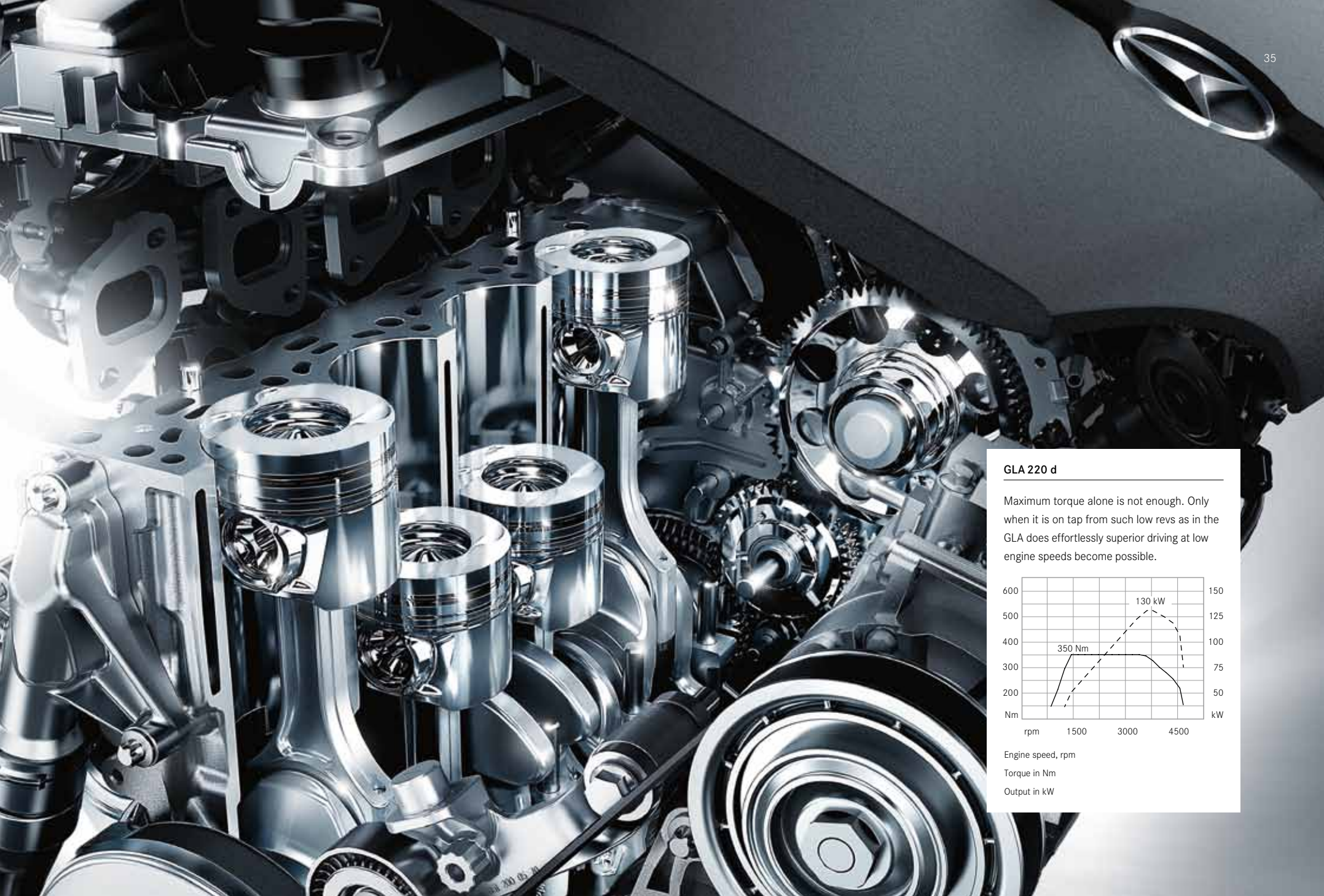

GLA 220 d

Maximum torque alone is not enough. Only when it is on tap from such low revs as in the GLA does effortlessly superior driving at low engine speeds become possible.

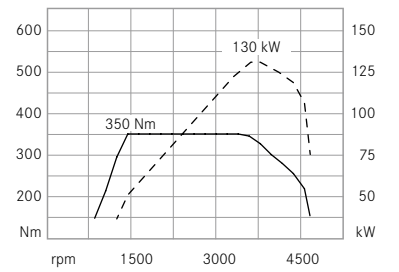

Engine speed, rpm
Torque in Nm
Output in kW



7G-DCT. “Dynamic-performance-without-interruption.”

Some like to change gear themselves, others prefer the automatic option. There are such good grounds for each of these alternatives that we have incorporated them both in a single transmission: the 7-speed dual clutch transmission **7G-DCT**. It comprises two sub-transmissions which each have their own clutch. This offers the advantage that the next gear is already engaged and gear-shifting takes place without any interruption in tractive power. This provides for even more comfortable driving – and above all, automatic gear-shifting is finally as fast as manual mode. We nevertheless appreciate that, however good an automatic transmission may be, many drivers prefer to change gear themselves. Consequently, the package includes steering wheel shift paddles – almost like in motorsport.

The availability of the two transmission variants is dependent on the selected engine model. Further information can be found in the price list, in the online configurator or from your authorised Mercedes-Benz dealer, for example, who will be pleased to advise you.

IN SHORT: THE TRANSMISSION VARIANTS

The **dual clutch transmission 7G-DCT** allows fast, smooth gear-shifting without any interruptions in tractive power. The shift characteristics can be preset from fuel-saving to sporty.

With short, direct shift travel, the **6-speed manual transmission** allows swift, smooth and easy gear shifting.



On the gripping subject of traction.

“I drive so rarely off-road, I don’t need all-wheel drive.” Such thinking is somewhat wide of the mark: the **all-wheel drive system 4MATIC** – optional for the GLA 200 d, GLA 220 d and GLA 250 – is not only a boon in off-road use. It optimises driving safety in snow or wet conditions. It supports dynamic cornering by varying the distribution of driving power between front and rear axle. It increases directional stability at a high speed. And it improves acceleration on loose ground by means of braking intervention to prevent individual wheels from spinning. Experience it for yourself: once you have driven with all-wheel drive, you won’t want to do without it ever again. The scope of 4MATIC features also includes a special off-road driving mode: modified drive characteristics provide for optimised traction, especially on loose ground. And Downhill Speed Regulation (DSR) helps the driver to handle steep downhill driving in a safe and controlled manner.

THE SUSPENSION OPTIONS

An even balance of comfort and dynamism is offered by the **comfort suspension**, fitted as standard.

The **off-road comfort suspension**: higher ground clearance, an improved view and a more distinctive off-road look thanks to a body that has been raised by 30 millimetres.

The **suspension with Adaptive Damping System** allows the driver to adjust the damping characteristics of the vehicle using the DYNAMIC SELECT switch, with a choice of Comfort or Sport mode. The sportily taut tuning of the damping in Sport mode permits a significantly more agile driving style. Since the damping system works steplessly and the tuning for each wheel occurs individually, both driving safety and ride comfort are improved.

The GLA even leads the way when it comes to trailing the vehicle ahead.

However alert you may be at the wheel, a quick distraction may be all it takes to cause a rear-end collision. Such collisions account for around one quarter of all accidents involving injuries in Germany. **Mercedes-Benz Intelligent Drive** aims to reduce this figure substantially in future, too. Intelligent Drive is a fundamental conviction driven by innovation and a due sense of responsibility. But what does it mean in concrete terms?

The GLA is equipped as standard with the system known as **COLLISION PREVENTION ASSIST PLUS**. This system provides the driver with a visual warning when the distance from the vehicle ahead is inadequate. An acoustic warning additionally sounds if the gap continues to close. Even more reassuringly, when the driver brakes, Adaptive Brake Assist is able to build up precisely the brake power which is required to prevent a collision. This is also intended to prevent vehicles behind colliding with the vehicle as a result of excessively heavy braking. **COLLISION PREVENTION ASSIST PLUS** is also able to trigger autonomous partial braking if a rear-end collision appears imminent and the driver fails to react, so preventing an accident or at least minimising the consequences.

▷ FIND OUT MORE

COLLISION PREVENTION ASSIST PLUS is part of an all-embracing concept: **Mercedes-Benz Intelligent Drive**, our generic term for intelligent technologies which actively support the driver and take the strain out of driving. Find out more: on your computer or tablet at www.mercedes-benz-intelligent-drive.com



COLLISION PREVENTION ASSIST PLUS

The distance warning function of **COLLISION PREVENTION ASSIST** is based on a flush-mounted radar sensor in the vehicle's front end which continuously monitors the distance from the vehicle ahead within a speed range from 7 to 250 km/h. Stationary obstacles can be registered when the vehicle is moving at a speed of between 7 and 70 km/h.

We are driven by our vision of accident-free motoring.

We are the first automotive manufacturer worldwide to have developed an **integral safety concept**, aimed at avoiding accidents, ensuring ideal responses to dangers and lessening the consequences of accidents. For the occupants of a Mercedes as well as for other road users.

SAFE DRIVING

The **ATTENTION ASSIST drowsiness detection system** serves to enhance driving safety, particularly on long trips and during night-time driving. It can monitor the steering behaviour of the driver to recognise typical signs of drowsiness and severe loss of attention, and give a visual and audible warning of impending microsleep.

The **ADAPTIVE BRAKE control system** improves braking performance through intelligent intervention: in wet conditions, the brake discs are kept dry. The brake pads are applied automatically when the driver's foot is removed abruptly from the accelerator pedal. And on uphill slopes, the system is able to prevent the vehicle from rolling backwards.

The optional **DISTRONIC PLUS proximity control system** helps to maintain a safe distance from the vehicle ahead, above all in stop-and-go traffic. The system is able to brake the vehicle automatically and subsequently accelerate again as appropriate to the traffic situation.

The optional **Blind Spot Assist** system employs radar sensors to alert drivers to one of the most serious sources of danger in road traffic. When a vehicle is detected in the blind spot, a red triangle lights up in the exterior mirror. An acoustic warning additionally sounds as necessary. The system is active at speeds between 30 and 250 km/h. The optional **Lane Keeping Assist** system is able to recognise when the vehicle is unintentionally drifting out of its lane at speeds between 60 and 200 km/h, duly warning the driver by means of pulsed vibrations on the steering wheel. Blind Spot Assist and Lane Keeping Assist also form part of the optional **Lane Tracking package**.

IN THE EVENT OF DANGER

The optional **PRE-SAFE® occupant protection system** is able to identify critical driving situations in advance and to initiate precautionary measures to protect the vehicle's occupants if it senses an imminent risk of accident. Such measures include reversible belt tensioning or automatic closing of open side windows, for example.

IN AN ACCIDENT

A comprehensive protection system is able to reduce the risk of injury substantially. This system includes the **active bonnet**, which is raised automatically by a couple of centimetres in a collision, so helping to provide better protection for pedestrians or cyclists. In the event of a severe accident, the occupants inside the vehicle are also given extensive protection by up to **nine airbags** (including two optional sidebags in the rear).

AFTER AN ACCIDENT

Every Mercedes-Benz is perfectly trained in first aid. In the event of an accident, the engine can be shut down automatically and the central locking system can be unlocked, in addition to which the hazard warning lights and the interior emergency illumination can be activated. Finally, the **Mercedes-Benz emergency call system**, which is integrated into the optional COMAND Online, is able to transmit GPS position data and important information about the vehicle – though it is to be hoped this will never be necessary. Mercedes-Benz also provides multilingual rescue guidelines which emergency services can download online worldwide at www.mercedes-benz.de/rettungslleitfaden



The internet has changed our lives. Now it is changing the world of driving, too.

Navigation, telephone, audio, video, internet – with the optional **COMAND Online** multimedia system, drivers have a whole host of functions in clear view and at their fingertips. Information is shown in high-resolution and in colour on the large 20.3 cm media display. Operation is simple and intuitive. Fast hard-disc navigation with high-quality topographic map display guides you smoothly to your destination.

In combination with a suitable mobile phone, it is possible to call up internet sites when the vehicle is stationary and to use Mercedes-Benz Apps, such as POI search, weather or internet radio, while on the move. A DVD player, radio, 10 GB of memory for audio files and interfaces for connecting internal devices provide for entertainment tailored to your individual wishes. Other highlights of COMAND Online include the LINGUATRONIC voice control system, a Bluetooth® interface with hands-free function and music transfer via audio streaming.

ADDITIONAL INFOTAINMENT OPTIONS FOR YOUR GLA

Smartphone Integration allows the screen of a personal smartphone to be very simply transposed onto the media display via a USB connection – including a navigation option, telephony, music and messaging functions.

The **Garmin® MAP PILOT** transforms the Audio 20 CD into an intuitively used navigation system featuring voice-operated control and high-resolution 3D map data.

The **Audio 20 CD** multimedia system allows link-up to mobile devices via Bluetooth®. It features a radio, twin tuner, CD drive, telephone keypad and the media display – as an option with 20.3 cm screen diagonal.





- ▾ Information from the Digital Owner's Manual can be called up directly in the vehicle and viewed on the central display. This interactive feature can be accessed from the national Mercedes-Benz website for your country and is also available as an app for smartphones or tablet PCs.

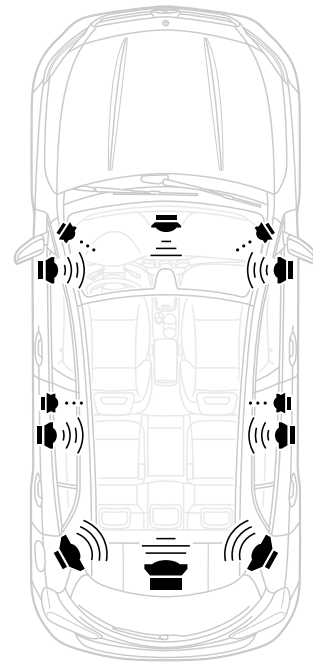

When was the last time you went to a concert?

With twelve loudspeakers, including a woofer, and a 9-channel DSP amplifier, the optional 450 W **Harman Kardon® Logic 7® surround sound system** offers a perfect audio experience – in stereo, and in conjunction with COMAND Online also in DTS and Dolby Digital 5.1 format. This set-up transforms the interior of the GLA into a small concert hall.



-  Centerfill speaker
-  Tweeter
-  Low-/mid-range speaker
-  Mid-range speaker
-  Bass speaker

The Logic 7® multi-channel technology provides for an authentic surround-sound musical experience. Designed to deliver a 360-degree audio experience in every seat.

Bright prospects. Leading lights.

Picture an unlit country road, a clear motorway. A virtually blind bend or thick fog. As you can see: every driving situation looks different. To ensure the best possible visibility at all times, the GLA is optionally available with intelligent lighting. The **Intelligent Light System** with adaptive bi-xenon headlamps adapts automatically to the prevailing driving conditions. See better, look sharper: as well as enhancing safety, this characteristic lighting design gives both the front and the rear of the car an ultra-modern look by day as well as by night. The specially designed fibre-optic tail lamps are complemented by indicators, brake lamps and rear fog lamp in LED technology.

INTELLIGENT LIGHT SYSTEM

The **Intelligent Light System** in detail: **1** | On country roads the offside edge of the carriageway is illuminated substantially more effectively, particularly when the fog lamps are on. **2** | On motorways, visibility is increased by as much as 60 percent. **3** | The active light function improves safety through bends. **4** | The cornering light function improves visibility by providing extra light in the direction of the turn. The enhanced fog light function reduces back-glare resulting from light reflected by the fog. **Adaptive Highbeam Assist** is also optionally available: this function ensures the optimum beam range for the headlamps at all times, without dazzling oncoming traffic.

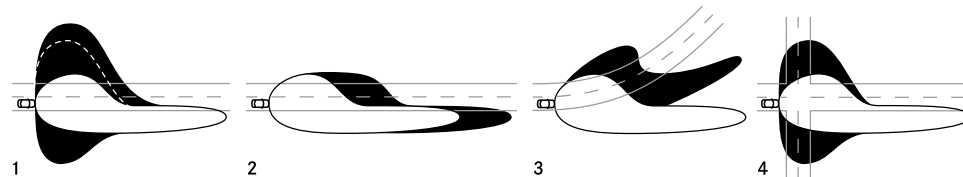

The optional **Light and Sight package** provides the interior with a higher-quality feel and the car with overall optimum visibility. It includes function illumination, which enhances comfort and safety, and ambient lighting, which lends the interior even more atmosphere.



Look forward. To see what's happening behind you.

Reversing and manoeuvring are not the most pleasant situations for a driver. But what used to be rather tricky operations can now be performed with ease. The optional **reversing camera** is switched on automatically when the driver selects reverse gear, and shows the driver the area behind the vehicle on the media display. Dynamic guide-lines provide clear orientation. And when reversing, for example from a house drive or parking space, the driver can switch to a wide-angle view of 180 degrees so as to recognise approaching pedestrians or vehicles sooner. After use, the camera folds in again automatically, ensuring optimum protection from soiling.

MAKE THINGS EASY FOR YOURSELF

The optionally available **Active Parking Assist** with PARKTRONIC facilitates the search for a parking space as well as the manoeuvring into and out of both parallel and end-on parking spaces, whereby it steers the vehicle automatically¹.

The optional **Traffic Sign Assist** system is able to recognise speed limits, no-overtaking restrictions and wrong-way driving, and display an alert in the instrument cluster.

↳ Find out more about **Mercedes-Benz Intelligent Drive**. Our generic term for intelligent technologies which actively support the driver and take the strain out of driving. On your computer or tablet at <http://techcenter.mercedes-benz.com>

¹ Only available in conjunction with 7G-DCT automatic transmission.



The panoramic sliding sunroof.

Light and airy does it: with its large glazed surfaces, the optional panoramic sliding sunroof conjures up a particularly bright and inviting atmosphere. The rear part consists of a fixed panoramic glass roof while the front part is an electric glass sliding sunroof. Two electric sunblinds provide shade from strong sunlight. In the raised position, the glass roof automatically adjusts to three tilt positions to suit the current vehicle speed. The glass roof is lowered at high speeds, reducing the noise level and air circulation in the interior. Conversely, it raises itself again at low speeds.



ADDITIONAL FEATURES FOR A PERFECT CLIMATE

Before a journey, the vehicle interior can be heated or ventilated by the optional **auxiliary heater** – either by timer or by using the remote control. In winter this eliminates the time-consuming task of scraping ice from the windows.

The optional **THERMOTRONIC** automatic climate control with two zones provides an individual feel-good climate on board. Driver and front passenger are able to control the temperature independently of one another. The climate is maintained at the desired level automatically with the aid of sensors.

The Load Compartment package.

Net pockets on the left and right and a folding box are optionally available to keep things tidy in the load compartment. The backrests of the rear bench seat can be positioned at a 15° steeper angle – the so-called cargo position. In this way, the load compartment capacity can be increased by 60 litres, from 421 to 481 litres. The rear bench seat remains usable for passengers when the backrests are in this more upright position. It is also possible to install baby seats facing in the opposite direction to the direction of travel. A 12 V socket in the load compartment rounds off this practical package. In conjunction with comfort seats, manual adjustment of the front passenger seat and the optional Seat Comfort package, the backrest of the front passenger seat can additionally be folded forward to enable long items to be carried.

ADDITIONAL FEATURES FOR SAFE AND CONVENIENT LOADING

For convenient loading and unloading, the optional **EASY-PACK tailgate** opens and closes electromechanically at the simple push of a button.

Keeping everything neat and tidy: the optional **Stowage Space package** comprises a spectacles compartment in the overhead control panel, stowage compartments under the front seats (stowage compartment under the driver's seat is omitted when optional fire extinguisher is ordered), luggage nets on the rear of the front seats and a luggage net in the front passenger footwell.

In order to enlarge the luggage compartment, the **backrests** of the rear seats can be folded forward either together or separately.





Mercedes-AMG GLA 45 4MATIC. High-performance sport.

As you can see: AMG design through and through. Down to the finest detail. Suggesting impressive power, endless traction, incredible deceleration. Rest assured – you can believe your eyes.

HIGHLIGHTS – EXTERIOR

AMG bodystyling and AMG radiator grille with twin fin in matt titanium grey and “AMG” lettering

AMG sports exhaust system with two chromed tailpipe trims in twin tailpipe design

AMG 5-twin-spoke light-alloy wheels, painted titanium grey and with a high-sheen finish, with 235/45 R 19 tyres

HIGHLIGHTS – INTERIOR

Sports seats in ARTICO man-made leather/DINAMICA microfibre with red contrasting topstitching and designo seat belts in red

Air vent surrounds in red

3-spoke multifunction sports steering wheel in leather, with flattened lower section and shift paddles

AMG instrument cluster with AMG main menu and AMG start-up screen

AMG DRIVE UNIT, including AMG DYNAMIC SELECT Controller

Mercedes-AMG GLA 45 4MATIC – technology.

The outstanding performance and efficiency of the Mercedes-AMG GLA 45 4MATIC are the result of extensive development work. The innovative AMG 2.0-litre 4-cylinder turbo engine produces 280 kW (381 hp) from a capacity of only two litres. This high-performance unit, with torque of 475 Nm, accelerates the vehicle from 0 to 100 km/h in 4.4 seconds. In the process, the Mercedes-AMG GLA 45 4MATIC consumes just 7.4 l/100 km of fuel according to the combined cycle, thanks in no small measure to the ECO start/stop function and the new gliding function. The high-performance engine is assembled by hand in accordance with the longstanding AMG philosophy of “One Man – One Engine” – clearly identifiable from the AMG engine plate that bears the signature of the AMG technician who built it.

The **3-stage Electronic Stability Program ESP®** can be used to alter the characteristics of the all-wheel drive system from sporty with an emphasis on safety to maximum performance on cordoned-off race tracks.

The large, internally ventilated and perforated brake discs of the **AMG high-performance braking system** give the vehicle outstanding deceleration characteristics.

The combination of electromechanical **AMG speed-sensitive sports steering**, **AMG sports suspension**, **AMG axles** and performance-oriented **4MATIC all-wheel drive** results in tangibly more precise and agile handling.

The driver can use the **AMG DYNAMIC SELECT Controller** to choose between the 3 pre-defined transmission modes “C” (Comfort), “S” (Sport) and “S+” (Sport Plus) and a further individually configurable mode “I” (Individual).





AMG Performance Studio.

More AMG spirit still for your Mercedes-AMG GLA 45 4MATIC. Further improvements to the driving dynamics are the preserve of, for example, the AMG DYNAMIC PLUS package – which includes an AMG front axle locking differential and AMG Performance steering wheel as well as the AMG RIDE CONTROL sports suspension with Adaptive Damping System and an additional RACE transmission mode. The AMG Aerodynamics package allows you also to give the vehicle a visible sporty flair.

AMG Aerodynamics package

AMG Exterior Carbon-Fibre package

AMG Night package

AMG carbon-fibre exterior mirror housings

AMG Performance exhaust system featuring even more striking engine sound at the mere touch of a button

AMG Performance steering wheel in black nappa leather/DINAMICA microfibre, E-SELECT selector lever with embossed “AMG” emblem and key with “AMG” emblem

AMG Performance seats

AMG 10-spoke light-alloy wheels, painted in titanium grey with a high-sheen finish, with 235/40 R 20 tyres

AMG carbon-fibre trim

Brake callipers in red painted finish

AMG DYNAMIC PLUS package, also including AMG RIDE CONTROL sports suspension with adaptive damping and additional RACE transmission mode

AMG Driver’s package (increase of top speed to 270 km/h and participation in driver training at the AMG Driving Academy)





Reassuringly stylish: the Style equipment line.

Whether you are cruising the boulevards or exploring the countryside, these perfectly matched stylish design and comfort features exude self-assurance and individuality.

HIGHLIGHTS - EXTERIOR

5-twin-spoke light-alloy wheels with 215/60 R 17 tyres

2-fin radiator grille, painted in silver, with chrome insert

Shoulderline trim strip in chrome

Load sill guard in chrome

Aluminium roof rails in high-gloss black

Simulated underguard at front and rear in silver

HIGHLIGHTS - INTERIOR

Comfort seats upholstered in ARTICO man-made leather/Dourados fabric with striking moccasin stitching

Seat Comfort package, including seat cushion depth adjustment

Carbon structure trim (H74)

3-spoke multifunction steering wheel and shift lever in nappa leather

Two-tube instrument cluster, silver-coloured backplate and red needles



Inspiringly progressive: the Urban equipment line.

Take in the sights in your urbane Mercedes. Everywhere you look, there are fresh new design features awaiting discovery, while the interior offers a highly individual style.

HIGHLIGHTS – EXTERIOR

5-twin-spoke light-alloy wheels with 235/50 R 18 tyres

2-fin radiator grille, painted in silver, with chrome insert

Twin-pipe exhaust system with integrated tailpipe trim, chromed

Shoulderline trim strip and load sill guard in chrome

Aluminium roof rails

Simulated underguard at front and rear in dark chrome

HIGHLIGHTS – INTERIOR

Sports seats upholstered in ARTICO man-made leather/Corumba fabric with contrasting topstitching

Seat Comfort package, including seat cushion depth adjustment

Wave-look trim in silver (H50) or anthracite (H51)¹

3-spoke multifunction steering wheel in leather, with perforations in the grip area and contrasting topstitching

Two-tube instrument cluster, silver-coloured backplate and red needles

¹ H50 as part of the Urban equipment line, H51 alternatively available as no-cost option.





Spellbindingly dynamic: the AMG Line.

Give the GLA a sportier character in terms of looks, the feeling behind the wheel and overall exclusiveness. The AMG Line features comprehensive AMG bodystyling, measures to enhance driving dynamics and sporty highlights outside and inside.

HIGHLIGHTS – EXTERIOR

AMG bodystyling with inserts in front splitter and side sill panels and rear apron trim in matt titanium grey

AMG 5-spoke light-alloy wheels, with 235/50 R 18 tyres, painted in titanium grey with a high-shine finish

2-fin radiator grille, painted in silver, with chrome insert

Dynamic Handling package, suspension 15 mm lower, Sports Direct-Steer¹

Perforated front brake discs, brake callipers with "Mercedes-Benz" lettering

Twin-pipe exhaust system with integrated tailpipe trim, chromed

HIGHLIGHTS – INTERIOR

Sports seats upholstered in ARTICO man-made leather/DINAMICA microfibre with red contrasting topstitching

Seat Comfort package, including seat cushion depth adjustment

Light aluminium trim with longitudinal grain (H79)

3-spoke multifunction sports steering wheel in leather, flattened lower section, with perforations in grip area and contrasting topstitching in red

Roof liner in black

Two-tube instrument cluster, silver-coloured backplate and red needles

¹ Comfort suspension available without lowering and Sports Direct-Steer system as a no-cost option.

Genuine Accessories.

The GLA fulfils just about every wish. And for those extra special needs there are Genuine Accessories. These cover almost every conceivable need for more pleasant, practical and individual motoring. The diverse range of items all correspond to a common standard: every accessory has been developed specifically for the GLA in accordance with Mercedes-Benz's high quality standards. Discover the complete range online at www.mercedes-benz-accessories.com

1 The shallow **boot tub** in impact-resistant polyethylene with non-slip effect. Food-safe. With rib structure to fix the separately available stowage box in place.

2 The **New Alustyle "Comfort" combined ski and snowboard rack** for up to six pairs of skis or four snowboards, lockable. A handy pull-out function facilitates loading and unloading.

3 The Mercedes-Benz **Roof Box 400** with a capacity of approx. 400 litres. With handle on each side to facilitate opening and closing. Available in matt silver and black. Maximum load: 75 kg.

4 The convenient, lockable **rear-mounted cycle rack** for the safe transportation of two or three bicycles. Extremely simple to fit to the trailer coupling. Securing your bikes on the carriers is equally straightforward. Maximum load of up to 30 kg per bicycle rail. Therefore suitable for most e-bikes. A smart rolling mechanism ensures that the tailgate can still be opened. The racks can be conveniently folded together for space-saving storage in the luggage compartment, at holiday accommodation or at home.



Optional equipment.

There are countless ways of making the GLA your very own. From small details that add special touches to comfort features which until recently were the preserve of the luxury segment. Take your time to browse around – in this catalogue, by reference to the price list or online. You can configure the GLA according to your very own wishes at the national website for your own country, accessible via www.mercedes-benz.com



1



2



3

1 The **Garmin® MAP PILOT** transforms the Audio 20 CD into an intuitively controlled, voice-operated 3D navigation system with exact representation of streets and buildings along with photo-realistic junction and lane assistants.

2 **Smartphone Integration** allows the screen of a personal smartphone to be very simply transposed onto the media display via a USB connection – including a navigation option, Apple® CarPlay, MirrorLink, telephony and messaging functions via voice-operated control as well as access to the music player.

3 Climb in and start, without picking up the key: the electronic access and drive authorisation system **KEYLESS-GO** makes it possible. Just as convenient: keyless locking from the exterior.

4 The pleasant light emitted by the **ambience lighting** creates a unique sense of wellbeing in the interior. As soon as the doors open, you are welcomed by a mood-enhancing interplay of colour. Particularly at night, this indirect lighting serves to accentuate the lines and quality feel of the interior design. Twelve different colours and five dimming levels are available to create the desired lighting mood.





5 In conjunction with the options bi-xenon headlamps or **Intelligent Light System**, the standard-fit fibre-optic tail lamps are complemented by indicators, brake lamps and a rear fog lamp with LED technology.

6 For convenient loading and unloading, the **EASY-PACK tailgate** opens and closes electromechanically at the simple push of a button. To prevent the door from bumping against any objects, it can be stopped in any position and its opening angle can be restricted.

7 The aluminium **roof rails** or the aluminium roof rails with a high-gloss black finish are in each case harmoniously integrated into the vehicle's design and provide the basis for various roof racks.

8 With the **off-road comfort suspension** the vehicle body is raised by 30 millimetres. This results in improved off-road capability as a consequence of the higher ground clearance, a higher seat position and a more obvious off-road look.



64

R00



08R



01R



R39



R48



R31



R38



77R

Wheels.

Wheels are indispensable on technical grounds, of course. But on an emotional level, too, perfect wheels are an absolutely crucial ingredient of many people's dream car. With this in mind, we have put together a particularly large and diverse selection for you.

STANDARD AND SPECIAL EQUIPMENT

R00 Steel wheel with 10-hole trim, fitted with 215/60 R 17 tyres (standard)

R48 5-twin-spoke light-alloy wheel fitted with 215/60 R 17 tyres (option, included in Style line)

08R Multi-spoke light-alloy wheel fitted with 215/60 R 17 tyres (option)

R31 5-twin-spoke light-alloy wheel fitted with 235/50 R 18 tyres (option, included in Urban line)

01R 5-twin-spoke light-alloy wheel, painted in black and with a high-sheen finish, fitted with 235/50 R 18 tyres (option, forms part of the Night package in conjunction with the Urban line)

R38 5-twin-spoke light-alloy wheel fitted with 235/50 R 18 tyres (option)

R39 AMG 5-spoke light-alloy wheel, painted in tremolite grey and with a high-sheen finish, fitted with 235/45 R 19 tyres (option)



65R



635



664



758



633



655



754



778

GENUINE ACCESSORIES

77R 5-twin-spoke light-alloy wheel¹, painted in vanadium silver, fitted with 235/45 R 19 tyres (also available as an option ex factory)

65R 5-twin-spoke light-alloy wheel¹, painted in black and with a high-sheen finish, fitted with 235/45 R 19 tyres (also as an option ex factory)

AMG

633 AMG 5-spoke light-alloy wheel, painted in titanium grey and with a high-sheen finish, fitted with 235/50 R 18 tyres (included in AMG Line)

635 AMG 5-spoke light-alloy wheel, painted in titanium grey and with a high-sheen finish, fitted with 235/45 R 19 tyres (option)

655 AMG 5-spoke light-alloy wheel, painted in black and with a high-sheen finish, fitted with 235/45 R 19 tyres (option, part of the Night package in conjunction with the AMG Line)

664 AMG 5-spoke light-alloy wheel, painted in black and featuring a rim flange with a high-sheen finish, fitted with 235/45 R 19 tyres (option)

754 AMG 5-twin-spoke light-alloy wheel, painted in titanium grey and with a high-sheen finish, fitted with 235/45 R 19 tyres (standard for Mercedes-AMG GLA 45 4MATIC)

758 AMG 10-spoke light-alloy wheel, painted in titanium grey and with a high-sheen finish, fitted with 235/40 R 20 tyres (option for Mercedes-AMG GLA 45 4MATIC)

778 AMG 10-spoke light-alloy wheel, painted in matt black and featuring a rim flange with a high-sheen finish, fitted with 235/40 R 20 tyres (option for Mercedes-AMG GLA 45 4MATIC)

¹ Genuine Accessory wheels are supplied without tyres.

Technical data.

No. of cylinders/arrangement
Total displacement in cc
Rated output ¹ in kW (hp) at rpm
Rated torque ¹ in Nm at rpm
Transmission [automatic transmission]
Acceleration from 0 to 100 km/h in s [automatic transmission]
Top speed, approx. in km/h [automatic transmission]
Tyre size, front
Tyre size, rear
Fuel
Fuel consumption ² in l/100 km
Urban [automatic transmission]
Extra-urban [automatic transmission]
Combined [automatic transmission]
CO ₂ emissions ² in g/km, combined [automatic transmission]
Emission class ³ /efficiency class ⁴ [automatic transmission]
Tank capacity, of which reserve, approx. in l
Luggage compartment capacity ⁵
Turning circle diameter in m
Kerb weight ⁶ in kg [automatic transmission]
Perm. GVW in kg [automatic transmission]

DIESEL ENGINES

GLA 180 d	GLA 200 d	GLA 200 d 4MATIC	GLA 220 d	GLA 220 d 4MATIC
4/in-line	4/in-line	4/in-line	4/in-line	4/in-line
1461	2143	2143	2143	2143
80 (109)/4000	100 (136)/3200-4000	100 (136)/3400-4400	130 (177)/3600-3800	130 (177)/3600-3800
260/1750-2500	300/1400-3000	300/1400-3000	350/1400-3400	350/1400-3400
6-speed, manual [7G-DCT]	6-speed, manual [7G-DCT]	- [7G-DCT]	- [7G-DCT]	- [7G-DCT]
11.9 [11.9]	9.5 [9.1]	- [9.1]	- [7.7]	- [7.7]
190 [190]	205 [205]	- [200]	- [223]	- [218]
215/60 R 17	215/60 R 17	215/60 R 17	215/60 R 17	215/60 R 17
215/60 R 17	215/60 R 17	215/60 R 17	215/60 R 17	215/60 R 17
Diesel	Diesel	Diesel	Diesel	Diesel
4.8-4.7 [4.7-4.5]	5.4 [5.2-5.0]	- [5.9-5.8]	- [5.2-5.0]	- [5.9-5.8]
4.0-3.6 [3.8-3.6]	3.8-3.5 [3.9-3.7]	- [4.4-4.3]	- [3.9-3.7]	- [4.4-4.3]
4.3-4.0 [4.1-3.9]	4.4-4.2 [4.4-4.2]	- [5.0-4.8]	- [4.4-4.2]	- [5.0-4.8]
113-105 [109-103]	115-110 [115-108]	- [130-127]	- [115-110]	- [130-127]
Euro 6/A [Euro 6/A+]	Euro 6/A [Euro 6/A+]	- [Euro 6/A]	- [Euro 6/A]	- [Euro 6/A]
50/6.0	50/6.0	56/6.0	50/6.0	56/6.0
421/1235	421/1235	421/1235	421/1235	421/1235
11.84	11.84	11.84	11.84	11.84
1440 [1470]	1505 [1535]	- [1595]	- [1535]	- [1595]
1960 [1960]	2020 [2020]	- [2075]	- [2020]	- [2075]

The best for the engine:
Mercedes-Benz genuine engine oils

¹ Details of rated power and rated torque in accordance with Directive 80/1269/EEC in the currently applicable version. ² The figures shown were obtained in accordance with the prescribed measuring process (Regulation [EC] 715/2007 in the currently applicable version). Note according to Directive 1999/94/EC in the currently applicable version: The figures are not based on an individual vehicle and do not constitute part of the product offer; they are provided solely for purposes of comparison between different vehicle models. ³ Data applicable within the European Union only. May vary from country to country. ⁴ Determined on the basis of the measured CO₂ emissions

PETROL ENGINES

	GLA 180	GLA 200	GLA 250	GLA 250 4MATIC	Mercedes-AMG GLA 45 4MATIC
No. of cylinders/arrangement	4/in-line	4/in-line	4/in-line	4/in-line	4/in-line
Total displacement in cc	1595	1595	1991	1991	1991
Rated output ¹ in kW (hp) at rpm	90 (122)/5000	115 (156)/5300	155 (211)/5500	155 (211)/5500	280 (381)/6000
Rated torque ¹ in Nm at rpm	200/1200-4000	250/1200-4000	350/1200-4000	350/1200-4000	475/2250-5000
Transmission [automatic transmission]	6-speed, manual [7G-DCT]	6-speed, manual [7G-DCT]	6-speed, manual [7G-DCT]	- [7G-DCT]	- [AMG SPEEDSHIFT DCT 7-speed sports transmission]
Acceleration from 0 to 100 km/h in s [automatic transmission]	9.0 [8.7]	8.4 [8.1]	6.7 [6.6]	- [6.6]	- [4.4]
Top speed, approx. in km/h [automatic transmission]	200 [200]	215 [215]	235 [235]	- [230]	- [250]
Tyre size, front	215/60 R 17	215/60 R 17	215/60 R 17	215/60 R 17	235/45 ZR 19
Tyre size, rear	215/60 R 17	215/60 R 17	215/60 R 17	215/60 R 17	235/45 ZR 19
Fuel	Premium petrol	Premium petrol	Premium petrol	Premium petrol	Super Plus petrol
Fuel consumption ² in l/100 km Urban [automatic transmission]	7.8-7.6 [7.3]	7.8-7.7 [7.3]	8.2 [7.8-7.6]	- [8.6-8.5]	- [9.6]
Extra-urban [automatic transmission]	4.9-4.6 [4.8-4.5]	4.9-4.7 [4.8-4.5]	5.1-4.9 [4.9-4.5]	- [5.4-5.2]	- [6.1]
Combined [automatic transmission]	6.0-5.7 [5.7-5.5]	6.0-5.8 [5.7-5.5]	6.2-6.1 [5.9-5.7]	- [6.5-6.4]	- [7.4]
CO ₂ emissions ² in g/km, combined [automatic transmission]	138-133 [133-129]	138-134 [133-129]	145-142 [138-132]	- [153-150]	- [172]
Emission class ³ /efficiency class ⁴ [automatic transmission]	Euro 6/C [Euro 6/B]	Euro 6/C [Euro 6/B]	Euro 6/C [Euro 6/B]	- [Euro 6/C]	- [Euro 6/D]
Tank capacity, of which reserve, approx. in l	50/6.0	50/6.0	50/6.0	56/6.0	56/8.0
Luggage compartment capacity ⁵	421/1235	421/1235	421/1235	421/1235	421/1235
Turning circle diameter in m	11.84	11.84	11.84	11.84	11.84
Kerb weight ⁶ in kg [automatic transmission]	1395 [1435]	1395 [1435]	1435 [1460]	- [1505]	- [1585]
Perm. GVW in kg [automatic transmission]	1920 [1920]	1920 [1920]	1945 [1945]	- [1990]	- [2105]

taking into account the mass of the vehicle. ³ Figures in accordance with Directive 70/156/EEC, version 2000/40/EC. ⁴ Figures in accordance with Directive 92/21/EC, version 95/48/EC (kerb weight, fuel tank 90% full, with driver, 68 kg, and luggage, 7 kg) for standard-specification vehicles. Optional equipment and accessories generally increase this figure and reduce the payload accordingly. Further technical data can be found at www.mercedes-benz.com

Dimensions.

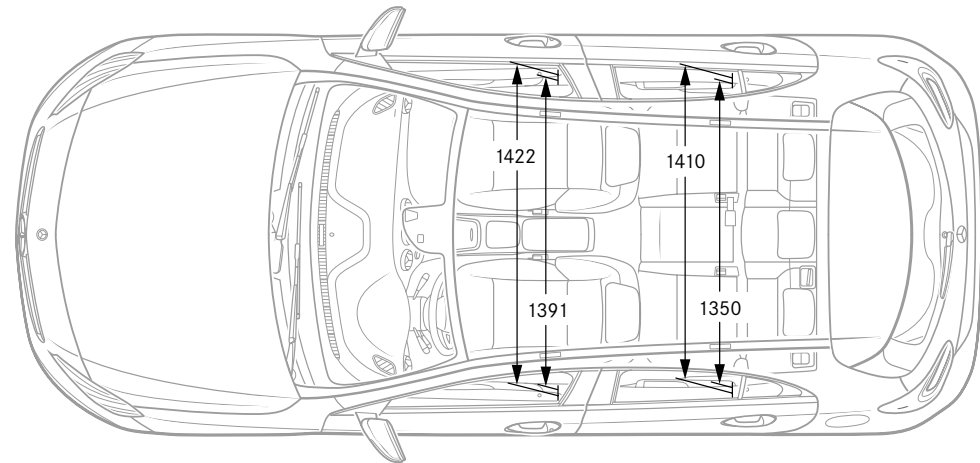
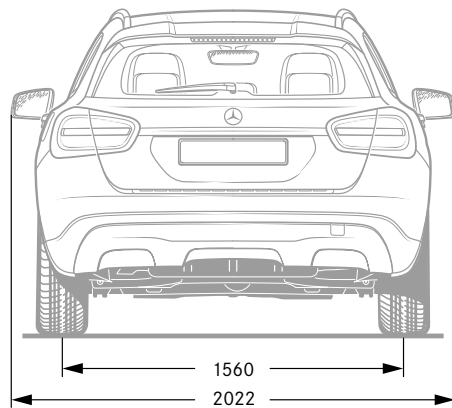
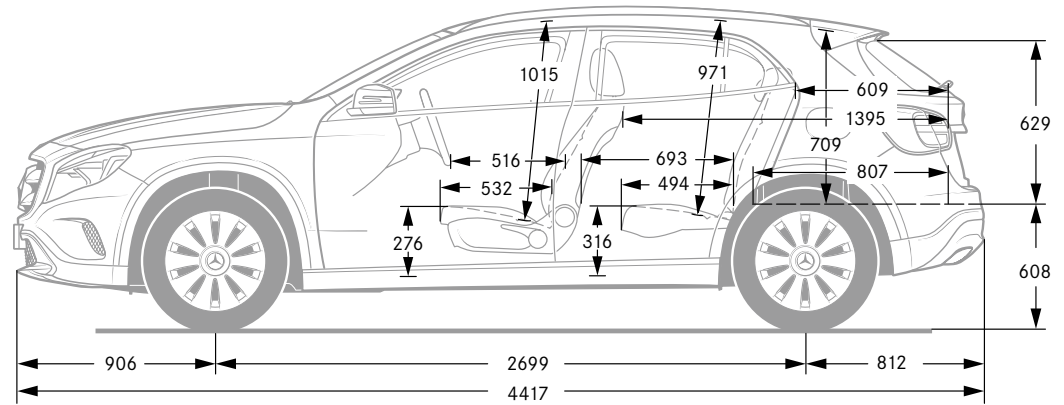
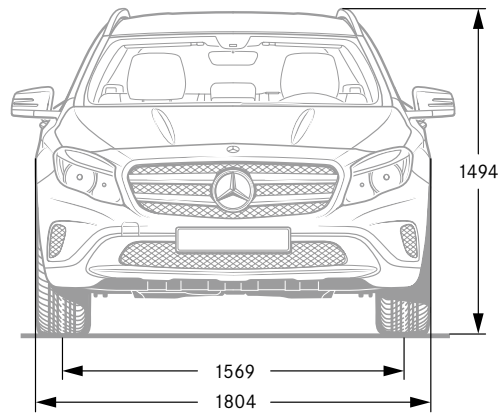

All dimensions in millimetres. The dimensions shown are mean values and apply to standard-specification, unladen vehicles.

Upholstery and trim.

Upholstery

- 021 Coari fabric in black
- 028 Coari fabric in crystal grey
- 105 ARTICO¹ man-made leather in sahara beige
- 111 ARTICO¹ man-made leather in black
- 118 ARTICO¹ man-made leather in crystal grey
- 361 ARTICO man-made leather/Corumba fabric in black
- 368 ARTICO man-made leather/Corumba fabric in crystal grey
- 601 ARTICO man-made leather/Dourados fabric in black
- 604 ARTICO man-made leather/Dourados fabric in tundra brown
- 605 ARTICO man-made leather/Dourados fabric in sahara beige
- 651 ARTICO man-made leather/DINAMICA microfibre in black
- 801 Leather, black
- 804 Leather, nut brown
- 855 Leather, sahara beige/black
- 811 Leather, black RED CUT

Trim

- Carbon fibre look
- H14 High-gloss brown burr walnut¹
- H19 Satin-finish light brown poplar wood¹
- H50 Wave look, silver
- H51 Wave look, anthracite
- H73 AMG carbon fibre¹
- H74 Carbon structure
- H79 Aluminium with light longitudinal grain¹

¹ Optional extra.

Standard equipment



Style¹



Urban¹

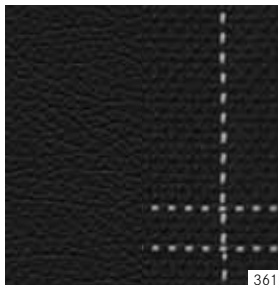

361

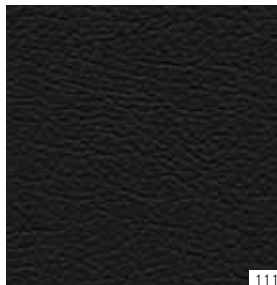

111

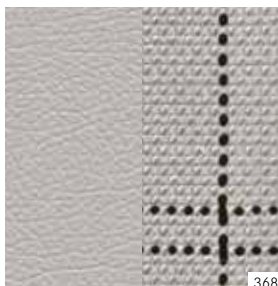

368

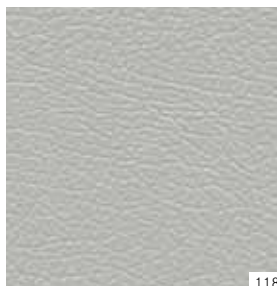

118



105

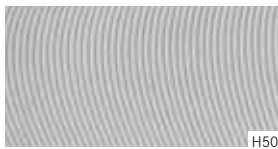

H50



H79



H51



H73

AMG Line¹

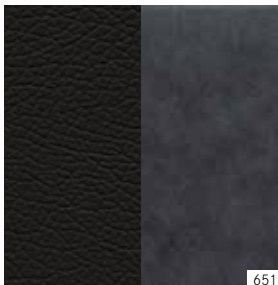

651

Exclusive package¹



801



804

AMG Exclusive package¹

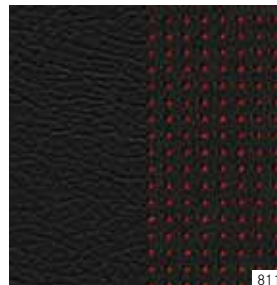

811



855



H79



H19



H79



H79



H73



H14



H73



H73

Paintwork.

Non-metallic paints



589



650

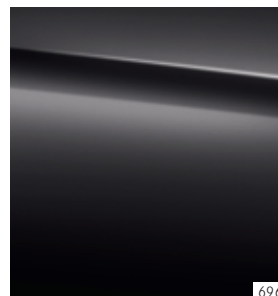

696

Metallic paints¹



162



175

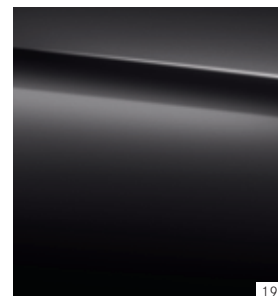

191

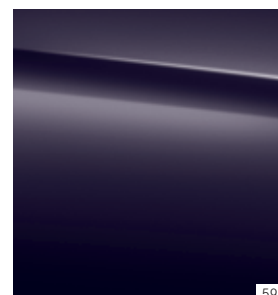

592

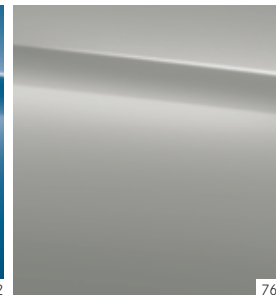

761

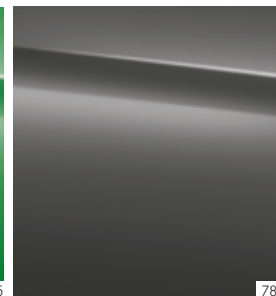

787

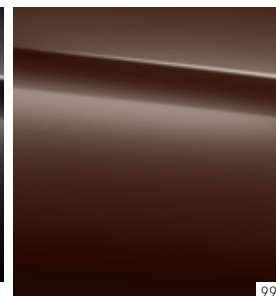

990

designo paint¹

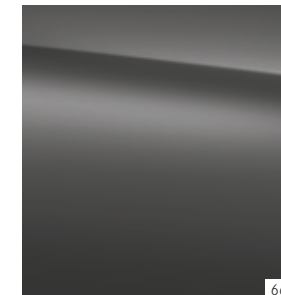

662

Non-metallic paints

589 jupiter red

650 cirrus white

696 night black

Metallic paints¹

162 south seas blue

175 elbaite green

191 cosmos black

592 northern lights violet

761 polar silver

787 mountain grey

990 orient brown

designo paint¹

662 designo mountain grey magno

¹ Optional extra.



Mercedes-Benz is one of the founding partners of the “Laureus Sport for Good Foundation”.

Since the foundation was established in 2000, Mercedes-Benz has been supporting and promoting the aims and values of this worldwide non-profit-making programme: to improve the lives of children and young people who are disadvantaged or suffering from illnesses through social sports projects. Laureus has become a fundamental element of Mercedes-Benz’s social responsibility. Every new Mercedes is an ambassador embodying these values. In buying a Mercedes you are supporting the “Laureus Sport for Good Foundation”.

Please note: changes may have been made to the product since this brochure went to press (19.05.2015). The manufacturer reserves the right during the delivery period to make changes to the design, form, colour or specification, provided these changes, while taking into account the interests of the vendor, can be deemed reasonable with respect to the purchaser. Where the vendor or the manufacturer uses symbols or numbers to describe an order or the subject of an order, no rights may be derived solely from these. The illustrations may include accessories and optional extras which do not form part of the standard specification. Colours may differ slightly from those shown, owing to the limitations of the printing process. This publication is distributed internationally. Information given regarding statutory regulations, legal requirements and taxation and the consequences thereof applies to the Federal Republic of Germany only and is correct at the time of going to press. For current and more specific information in relation to the range of models, features, optional extras and/or colours available in your country, and their pricing, you should contact your nearest authorised Mercedes-Benz passenger car dealer.

www.mercedes-benz.com

Take-back of end-of-life vehicles. At the end of its long life, you can return your GLA to us for environment-friendly disposal in accordance with the European Union (EU) End-Of-Life Vehicle Directive. But that day lies a long way off.

A network of vehicle take-back depots and dismantlers is available to make returning your vehicle as easy as possible for you. You are welcome to return your vehicle to one of these establishments free of charge. In so doing, you will be making a valuable contribution towards closing the recycling loop and preserving resources.

For further information about the recycling and disposal of end-of-life vehicles and take-back conditions, please visit your national Mercedes-Benz website.