



# Q7

Audi Q7/Q7 V12 TDI quattro



Q7	Philosophy	04/05
	quattro®	06/07
	Driving dynamics	08/11
	Design	12/15
	Engine	16/21
	Safety	22/27
	Interior	28/37
Q7 V12 TDI quattro	History	42/43
	Engine	44/45
	Driving enjoyment	46/47
	Design	48/51
	Interior	52/53
	Audi exclusive concept®	54/55
Equipment	Audi exclusive Q7	56/57
	Audi exclusive line Q7	58/59
	S line Q7	60/63
	Style guides Q7	64/65
	Paints	66/67
	Seats/seat covers	68/70
	Equipment and design packages	71/74
	Headlinings, inlays	75/77
	Wheels/tyres	78/81
	Lights and mirrors	82/84
	Exterior equipment	84/87
	Interior equipment	88/94
	Infotainment	95/98
	Assistance systems	98/99
	Technology	100/104
	Audi Service®	106/106
	Audi Genuine Accessories	107/109
	Technical data Q7	110/112
	Dimensions Q7	113/113
	Technical data Q7 V12 TDI quattro	114/114
	Dimensions Q7 V12 TDI quattro	115/115
	Audi efficiency, Audi configurator, Audi tv	116/117

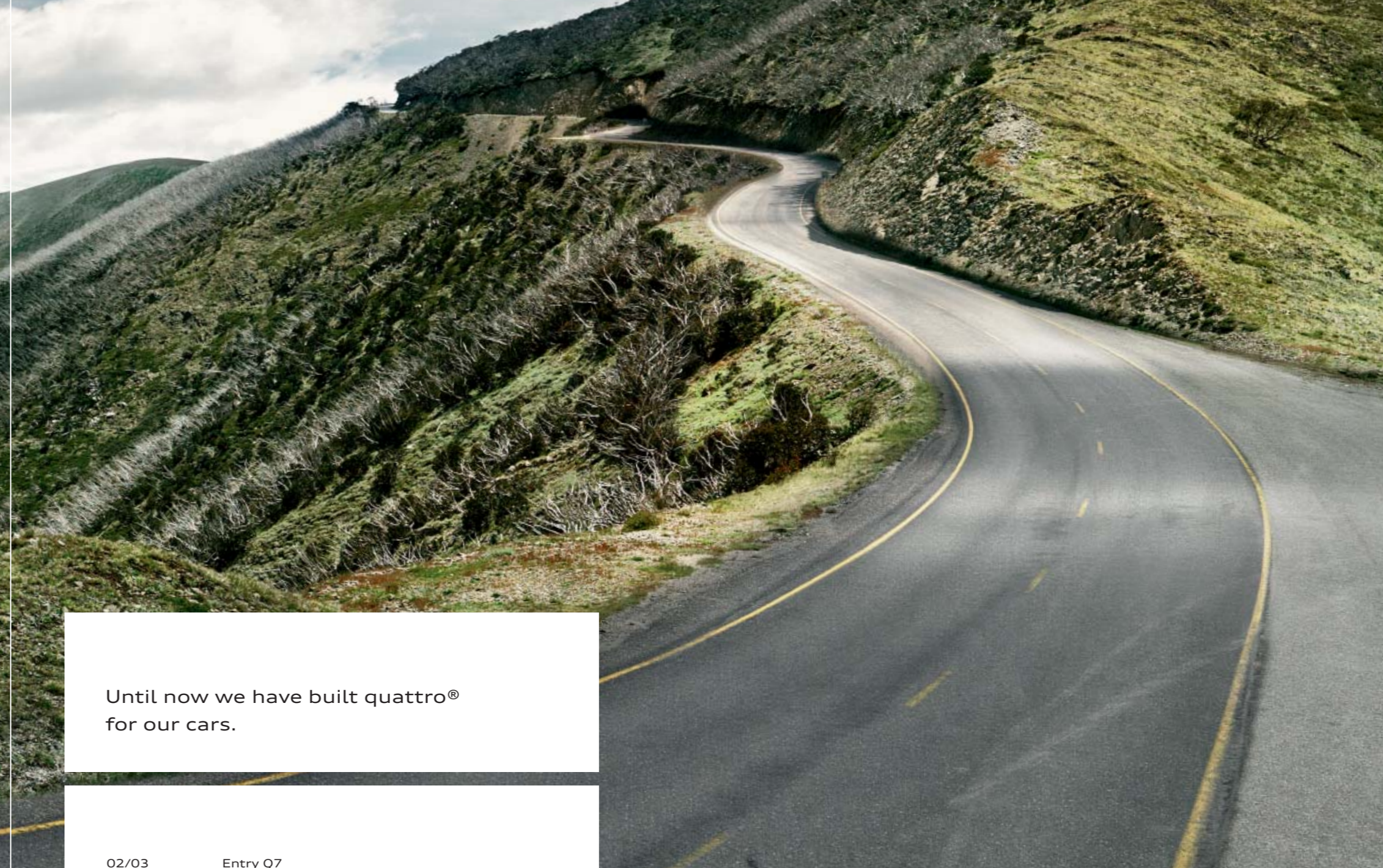

Until now we have built quattro®  
for our cars.



With the Audi Q7 we are building a car for quattro®.

Sometimes, a single question is enough to change the world: why can't you enjoy the outstanding driving features of an all-wheel drive in a passenger car? This thought occurred to the Audi engineers while they were out testing the four by four Iltis. From this simple question came the idea for a permanent all-wheel drive suitable for standard production: quattro was born.

A success story began – and still continues today: with the Audi Q7. A new vehicle concept from the ground up, which, just like the quattro drive itself, has been born from the wealth of ideas, the courage and the passion of the Audi engineers.

The Audi Q7. From the inventor of quattro.

Detailed information about the Audi Q7 V12 TDI quattro can be found from page 40 onwards.





To take you on further, the Audi Q7 skillfully uses all of its power. Its innovative quattro® drive concept takes care of this. The permanent all-wheel drive distributes the drive forces variably to the front and rear axle. Always just as it is required for that particular driving situation. This enables superb traction, good grip and impressive propulsion, both on and off road. Electronic differential locks transfer excess power away from the wheels and provide better adhesion if necessary. The driving power is also used if a wheel spins away or loses contact with the ground. Even faster than any electronic control technology, the centre differential regulates the distribution of power between the front and rear axle.

The Electronic Stabilization Programme ESP supports quattro in the Audi Q7. It was especially extended to include a selectable offroad mode for the Audi Q7. With this, the ESP ensures even more traction and braking power when off-road – and above all, even more fun. Because the off-road mode assists you in driving dynamically away from paved roads or on loose ground. It adjusts the ESP setting depending on the speed, for better deceleration on debris or sandy ground. When driving downhill at low speeds, the automatic hill descent assist system is additionally activated. As soon as a wheel begins to slip, it assists tractability and grip on impracticable terrain.

The fuel consumption and CO<sub>2</sub> emission figures can be found from page 110 onwards.

Detailed information about the Audi Q7 V12 TDI quattro can be found from page 40 onwards.





The optional adaptive air suspension ensures even more independence (standard for Q7 4.2 TDI quattro and Q7 V12). This directly intervenes in damping the individual wheels. By almost eliminating permanent car body movements and automatically reducing rolling or pitching motions when cornering, braking or starting up it ensures a comfortable driving feeling and better grip. At the same time, the adaptive air suspension combines the sporty driving character of a coupé with the excellent suspension comfort of a Saloon, by enabling damping and vehicle height to be variably regulated. The damper adjustment, and with this the handling, can be individually controlled in five stages. With just one move of the hand you can switch between the settings for automatic, comfort, dynamic, off-road and lift, via the MMI®.

The optional comfort and dynamic settings ensure excellent driving comfort or improved handling. In all stages the adaptive air suspension independently lowers the body appropriately for the speed and adjusts the dampers accordingly. Lowering the vehicle height at greater speeds creates a lower centre of gravity, noticeably increasing the driving stability. The off-road mode raises the trims by 25 mm, thus allowing off-road driving at up to 100 km/h. On impracticable terrain or when slowly driving over large obstacles the lift setting assists you by raising the trims by 60 mm. Alongside these diverse characteristics, adaptive air suspension also works as classic height regulation. It keeps the trims in a constant position, independent of load.

The fuel consumption and CO<sub>2</sub> emission figures can be found from page 110 onwards.  
Detailed information about the Audi Q7 V12 TDI quattro can be found from page 40 onwards.



The quattro® permanent all-wheel drive distributes the driving force dynamically and asymmetrically to all wheels as required.

The flat and, due to its aluminium components, especially light double wish-bone axle chassis of the Audi Q7 has reinforced local rigidity and a low centre of gravity. Together with the long wheel base and the large wheel track, this means above all more comfort and running smoothness as well as precise handling and a high degree of track stability.

The high power transmission enabled by the dynamic chassis demands the right amount of control: the standard steering system servotronic. The variable power steering reacts to every touch of the steering wheel and puts you in contact with the road in any driving situation. One special feature: the steering resistance changes depending on speed. So steering when parking or driving slowly is pleasantly smooth and allows precise manoeuvring. At higher speeds, the servotronic noticeably increases the steering resistance, therefore giving more driving stability and control.

The fuel consumption and CO<sub>2</sub> emission figures can be found from page 110 onwards.

Detailed information about the Audi Q7 V12 TDI quattro can be found from page 40 onwards.





The design of the Audi Q7 sets new standards.

In tune with Audi tradition.



With the Audi Q7, Audi has created a high-quality overall appearance by means of a synthesis of robustness and sporty, elegant vehicle lines. The independent, fluent stylistic lines form a new, unique generation of SUVs.

The dynamic roof line and high shoulder section borrow the sporty form of a coupé. The powerful front with distinctive, chrome-framed Audi Single-frame, and vertical chrome struts arouses self-confidence and radiates a sense of presence. With the strong, V-shaped pointed bonnet, the bumpers with standard contrasting paint and the drawn-back headlights with day-time running lights – LED upon request – the Audi Q7 is always striving to push forward, even when at a standstill. The concise sills and high ground clearance emphasise its strong drive side. Upon request the Audi Q7 is available with bumpers and doors sill strips painted in body colour, upgraded door handles and an elegant all-round aluminium look strip.

Its rear is puristic and succinct at the same time and is equipped with the characteristic LED rear lights. The bumper with the integrated underbody protection in conjunction with the encompassing tailgate gives the Audi Q7 an impression of high performance and power. The large wheels, which underline its overall performance, add particular accentuation. The progressive design of the Audi Q7 is always moving: whether day or night, town or country, trip or car park.

The fuel consumption and CO<sub>2</sub> emission figures can be found from page 110 onwards.

Detailed information about the Audi Q7 V12 TDI quattro can be found from page 40 onwards.





On the racing track, our engines regularly astonish the world.

And that is no different on the road.

There is probably no more impressive way to prove the reliability and durability of an engine than being successful at the 24-hour races in Le Mans: After numerous successes in the Audi R8, the first diesel engine left its competitors standing for the first time in 2006: the Audi R10 with TDI technology. With the Audi Q7 we bring this energy onto the road and into your life every day.





The Audi Q7 also sets standards with its engine variants. Thanks to the motor racing-tested TFSI® and TDI technology, the Audi Q7 deploys its tremendous power and dynamism over practically the entire speed range. Sportiness and off-road capability are combined in a very special way. As a measure to increase efficiency and reduce consumption and CO<sub>2</sub> emissions, the Audi Q7 has recuperation available for all six and eight-cylinder engines. Depending on the engine variant, this ensures a significant reduction of the CO<sub>2</sub> emissions.

The fuel consumption and CO<sub>2</sub> emission figures can be found from page 110 onwards.

Detailed information about the Audi Q7 V12 TDI quattro can be found from page 40 onwards.

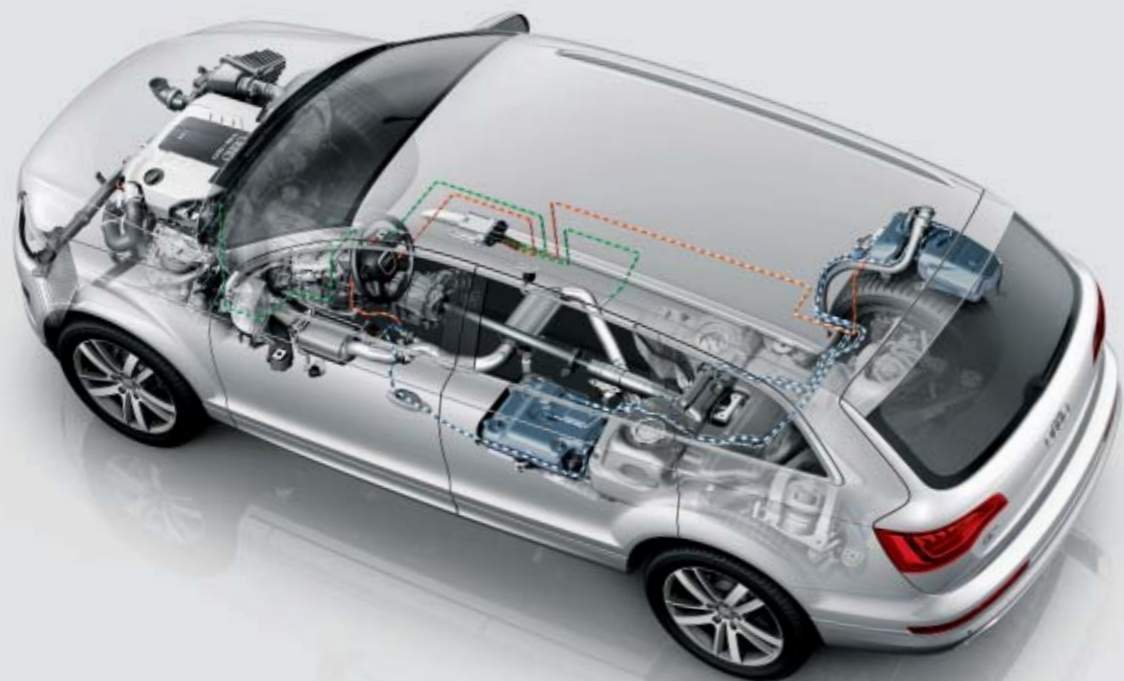

Choose for yourself which power you wish to carry you away: a 3.0 TDI quattro with 150 kW or 176 kW, a 4.2 TDI quattro or one of the powerful TFSI® engines. The 3.0 TDI quattro with 176 kW is also available as a TDI clean diesel quattro.

All the engines comply with the EU5 emissions standard, the TDI clean diesel quattro even complies with the EU6 emissions standard, which does not come into force until 2014. The six and eight cylinder engines are fitted with a recuperation system. When the vehicle is braking or coasting, kinetic energy is converted into electrical energy and then stored in the battery. During acceleration, electrical consumers are supplied with energy from the battery, thus taking the strain off the generator. This increases efficiency and saves up to 3% fuel – particularly in city traffic.

The 3.0 TDI quattro model with 150 kW or 176 kW also has a start-stop system that can help you to save fuel and reduce CO<sub>2</sub> emissions. The functional principle is quite simple: As soon as the car has come to a standstill and the driver's foot is still on the brake, the system stops the engine. When the driver takes his foot off the brake, the engine starts up again. This allows fuel consumption to be reduced even further in city traffic, depending on the driver profile.

In addition to the standard catalytic converter and the diesel particulate filter, the Audi Q7 as a 3.0 TDI clean diesel quattro has a nitrogen oxide catalytic converter with AdBlue®<sup>1</sup> tank. AdBlue® is a biodegradable additive, tiny doses of which are injected upstream of the nitrogen oxide catalytic converter. Combined with other innovations such as the common rail technology with 2,000 bar injection pressure and highly efficient exhaust gas recirculation, a substantial reduction of the nitrogen oxide emissions by up to 90% is achieved.

With the 4.2 TDI quattro with 250 kW, you can also choose a highly efficient and powerful diesel engine. The peak torque of 800 Nm and the running smoothness of the V8 engine impress both over short and long distances.



AdBlue® is a biologically degradable additive. A minimum dose is injected upstream of the nitrogen oxide catalytic converter.

The 3.0 TDI clean diesel quattro has a nitrogen oxide catalytic converter with AdBlue® tank. In combination with the common rail technology and highly efficient exhaust gas recirculation, nitrogen oxide emissions can be reduced by up to 90%.

The Audi Q7 is optionally available with a high-rev V6 TFSI engine with 200 kW or 245 kW. Petrol direct injection is excellently complemented by the compressor charging, because the evaporation of the fuel takes place directly in the combustion chamber and heat is drawn from the fresh air suctioned in. This increases the compression, improves efficiency and power, and results in a significant reduction in CO<sub>2</sub> emissions at the same time. With TFSI technology, displacement is replaced by charging without having to do without dynamics, despite excellent efficiency.

The completely redeveloped eight-gear automatic transmission tiptronic fitted as standard in six and eight-cylinder models supports the Q7 with the optimum transmission of its power to the road. The great strength of the electronically controlled eight-gear tiptronic is its high overall spacing between the shortest and the longest ratio, which also helps to keep the noise level down. In combination with the improved drive train, fuel consumption can also be reduced by up to 5%. Thanks to a highly efficient oil supply pump and heating of the oil after a cold start through coolant (only in the V6 TDI), the new automatic transmission achieves even greater efficiency. As well as increasing efficiency, the eight-gear tiptronic also provides more driving comfort.

No matter which engine variant you decide on, the Audi Q7 convinces again and again – on every journey.

The fuel consumption and CO<sub>2</sub> emission figures can be found from page 110 onwards.

Detailed information about the Audi Q7 V12 TDI quattro can be found from page 40 onwards.

<sup>1</sup> Registered trademark of the Verband der Automobilindustrie e. V. (VDA).

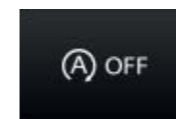

The start-stop system helps save fuel. It can be deactivated through a switch if required, however.



The 3.0 TDI is the latest generation of diesel engines. The outstanding features of the highly efficient engine are its economy, low emissions and high performance.



The combination of supercharging and direct fuel injection gives the new 3.0 TFSI superior potential: more power and dynamics despite reduced consumption.



From our motor racing experience we know about the forces which work on a vehicle.

And how to control them.

Vast jumps over blind mounts, a rapid change of direction, spot-on drifting around tight corners or precise control at high speeds – using the experiences of our rally and motor racing teams we are always continuously developing the safety technology of our vehicles.

The road in front of you was clear just a moment ago, suddenly it is blocked. Even the best driver occasionally experiences critical situations, in which he needs to react as fast as lightning. In doing so he is supported by the Electronic Stabilization Programme ESP. The intelligent system links the active safety systems such as ABS, ASR, EDL, EBD and has two definite goals: track stability for the Audi Q7 and better control for you.

If the wheels threaten to spin away when accelerating, the traction control ASR ensures that power is transferred, as equally as possible. The engine power is metered accordingly. The electronic differential lock EDL increases traction on loose or smooth ground. With the roll-over stabilisation and the trailer stabilisation (in conjunction with an optional trailer towing hitch) two additional safety systems are at your disposal in the Audi Q7. You reduce trailer swinging during spontaneous evasive manoeuvres, grooves in the road or side winds and prevents the tipping limit from being exceeded in certain situations – with a trailer load of up to 3.5 tons.

Seeing and being seen is also a safety issue: standard daytime running lights as well as LED rear lights and LED indicators in the exterior mirrors guarantee the best pre-conditions here. And optional xenon plus also offers the right solution. In addition to its standard equipment, it also has LED daytime running lights and LED indicators in the front bumper. And if you then also decide on adaptive light with dynamic cornering, turning and motorway light, you will have all you could wish for.

The fuel consumption and CO<sub>2</sub> emission figures can be found from page 110 onwards.

Detailed information about the Audi Q7 V12 TDI quattro can be found from page 40 onwards.





The image is an illustration, not a real representation, and shows the technical status of the airbags as a snap-shot.

As well as driving stability, the Electronic Stabilization Programme ESP also takes care of the braking process. With numerous functions, the system assists the large-dimensioned braking system. Its drying function removes water from the brake discs if the road is wet and considerably improves the braking effect. If the driver does not push the brake pedal hard enough in an emergency braking situation, for example, the ESP's hydraulic brake assist recognises the attempt to brake fully and ensures full brake pressure. During the full braking process, the reliable anti-lock braking system ABS then enables better control and increases the tractability. Thanks to the sophisticated aerodynamics of the Audi Q7, channels under the vehicle divert the air flow past the brake discs, ensuring excellent cooling. The 3.0 TFSI (245 kW) quattro and the 4.2 TDI quattro have an optional 20-inch high-performance braking system with carbon-fibre reinforced ceramic brake disks, which is characterised by a high degree of stability, less wear and excellent performance.

Numerous passive systems round off the Audi Q7's safety concept. The rigid and stable passenger cell fulfils all current crash standards. Airbags for driver and front passenger, side airbags at the front and the head airbag system are standard equipment. The latter is effective from the first to the optional third row of seats and covers almost the entire area of the side windows. Extra side airbags for the second row of seats are available if desired.

The lane compliance assistant Audi lane assist detects if you have inadvertently left the traffic lane and lets you know in adequate time via steering wheel vibrations. The lane change assistant Audi side assists informs you with a signal in the exterior mirror as soon as the system detects another vehicle in the adjacent lane. No matter what surprises the road may have in store for the Audi Q7, it is excellently prepared.

Detailed information about the Audi Q7 V12 TDI quattro can be found from page 40 onwards.





Think twice before getting in  
the Audi Q7.

You won't want to get out again.

With its generous amount of space the Audi Q7 gives you a feeling of freedom. The high-quality cockpit has been designed with the driver in mind and is colour coordinated, with the central console raised and easy to operate. Large-area application trims and high-grade decorative elements in chrome finish give the Audi Q7 that certain extra. A look at the sporty displays makes you think of just one thing: go!

Detailed information about the Audi Q7 V12 TDI quattro can be found from page 40 onwards.



Get in and feel at home. The optional climate-controlled comfort seats of the Audi Q7 with perforated leather, active front seat ventilation and seat heating leave nothing to be desired. The luxuriously equipped interior lives up to even the highest demands. Here, clear and functional shapes are combined with dynamic elegance and exclusive materials. Pleasant LED ambient lighting presents the centre console in the proper light. The optional light package of the Audi Q7 also gives you a warm welcome. Among other things, active door reflectors, entrance illumination and background lighting in the doors create a relaxed light atmosphere and help you get in safely in the dark.

Multifunctionality does not have to be complicated, as the latest generation of the Audi Multi Media Interface MMI proves. The central control system of the Performance SUV gives you rapid access to important vehicle information and functions. The optional MMI navigation plus offers you a radio with dual tuner, DVD drive and two SDHC card readers. With a high-quality map display on the high resolution 7-inch colour display, the navigation system guides you safely to your destination. The required navigation data is on the hard disc, which you can also use to store music. The excellent performance of the MMI navigation plus is completed by voice-controlled operation of basic functions for navigation, address book and, if fitted, telephone. Luxury, ultimate comfort and functionality unite in the interior of the Audi Q7. And the best thing about it is, you can experience it for yourself.

Detailed information about the Audi Q7 V12 TDI quattro can be found from page 40 onwards.







With the optional comfort key, the Audi Q7 automatically recognises you and unlocks as soon as a door is operated. Having arrived at your destination, the optional parking system supports you while parking. It warns you acoustically when it recognises obstacles behind the vehicle. If required, the parking system plus offers an even better overview, as it also monitors the area in front of the Audi Q7 and additionally warns you optically via the MMI. The parking system plus with reversing camera is also available as an option. Thanks to the guidelines which are incorporated into the MMI display, parking and hitching trailers is easier than it has ever been.

The generous feeling of space is accentuated with the right sound experience. You can choose between two high-quality sound systems. The BOSE Surround Sound System automatically recognises and compensates for disturbing surrounding noises and adapts the volume to the speed – for a constantly brilliant sound experience. In the Bang & Olufsen Advanced Sound System, two acoustic lenses are automatically extended from the dashboard when the system is started, which ensure an exact and true-to-detail performance on any seat with its precisely aligned horizontal emission. More than 1,000 watts and 14 separate loudspeakers provide an outstanding sound experience. In conjunction with the MMI navigation plus and the integral DVD player, both sound systems enable you to play 5.1 Surround Sound.

Inlays in gloss finish black or optionally in aluminium Trigon or selected woods set visual accents. Together with the fine cloth and leather trims they underline the high quality appearance of the Audi Q7.

The standard-fitted deluxe automatic air conditioner permanently monitors and controls the temperature and air quality in the interior during the journey. The 4-zone deluxe automatic air conditioner ensures an individual pleasant climate in the second and optional third row of seats, if desired.

Detailed information about the Audi Q7 V12 TDI quattro can be found from page 40 onwards.





The Audi Q7 not only opens up space by using its dynamics, power and ground clearance, but also, above all, with its innovative interior concept. The multifunctional seat and loading concept offers you up to 27 various configuration options. So you always have exactly as many seats and as much loading space as you require.

As an equipment variant you can choose between two or three rows of seats. Within these equipment variants, you can then choose again: you can equip the second row with comfort seats, turning the Audi Q7 into a six-seater, which is then equipped with an additional generous central console. Or you decide on a classic five or seven-seater with a bench seat in the second row.

The comfort access function makes getting in easier, even for the rear seats. The optionally available panoramic glass roof provides a clear view of the sky. This electrically operated glass roof reaches to the third row of seats. Thanks to the low air drag coefficient the noise level remains very low, even with the panoramic glass roof open.

Detailed information about the Audi Q7 V12 TDI quattro can be found from page 40 onwards.



Sometimes you just cannot decide what to take with you. The Audi Q7 therefore grants you all the freedom you could require. Unique in its class, it offers a 775 litre luggage compartment volume behind the second row of seats. The loading space comprises all of 330 litres when there are seven people in the vehicle. By tilting the rear seats – all rear seats can be lowered level to the loading area – the loading volume can be increased to up to 2,035 litres as standard. The generous loading width of 1.22 m easily offers room for up to four golf bags lying sideways. There is a large load-through facility located in the second row of seats as standard. When folded down, the loading area offers enough space to stow, for example, snowboards or skis, quickly and with ease.

The optional adaptive air suspension, which lowers the loading sill at the push of a button, and the optionally available electric tailgate with programmable opening angle additionally support loading and unloading.

The Audi Q7 also offers plenty of storage space for the many small things which you like to have around you when out and about. It has several storage compartments, a drawer under the front passenger seat, large pockets in the doors, bottle and drinks holder and an extra compartment for your sunglasses. Anything messy or dirty is best stowed in the optional dirt tray in the luggage compartment.

Detailed information about the Audi Q7 V12 TDI quattro can be found from page 40 onwards.





They say the best is saved till last.  
And this is no exception:

a drive in the Audi Q7 –  
or in the Audi Q7 V12 TDI quattro.

The fuel consumption and CO<sub>2</sub> emission figures can be found from page 110 onwards.

Detailed information about the Audi Q7 V12 TDI quattro can be found from page 40 onwards.



V12 TDI  
quattro



fig. 01

Law of nature n° 1

**All organisms descend from common ancestors.**

2006. The first victory of a racing car with a diesel engine at the legendary Le Mans 24 hours. The car: an Audi R10 TDI, which was able to continue its series of victories in 2007, 2008 and 2010. The Audi Q7 V12 TDI quattro was built using this motor racing experience: it is the continuous evolution of a trail-blazing vehicle. The Audi Q7 V12 TDI quattro is powered by the most powerful diesel engine of its class and has only one goal: to be the victor on any terrain.

The fuel consumption and CO<sub>2</sub> emission figures can be found on page 114.

Law of nature n<sup>o</sup>. 2

Strong species always continue to evolve.

Audi introduced the TDI principle into its series production operations back in 1989 and has continued to optimise it ever since. This technical expertise has culminated in the development of the Audi Q7 V12 TDI quattro.

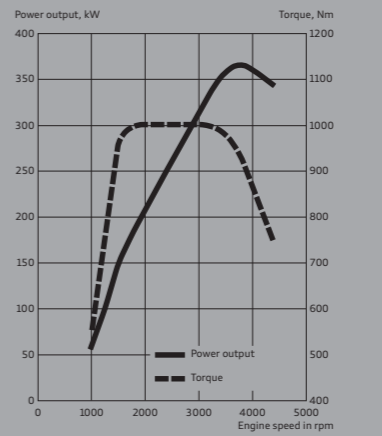
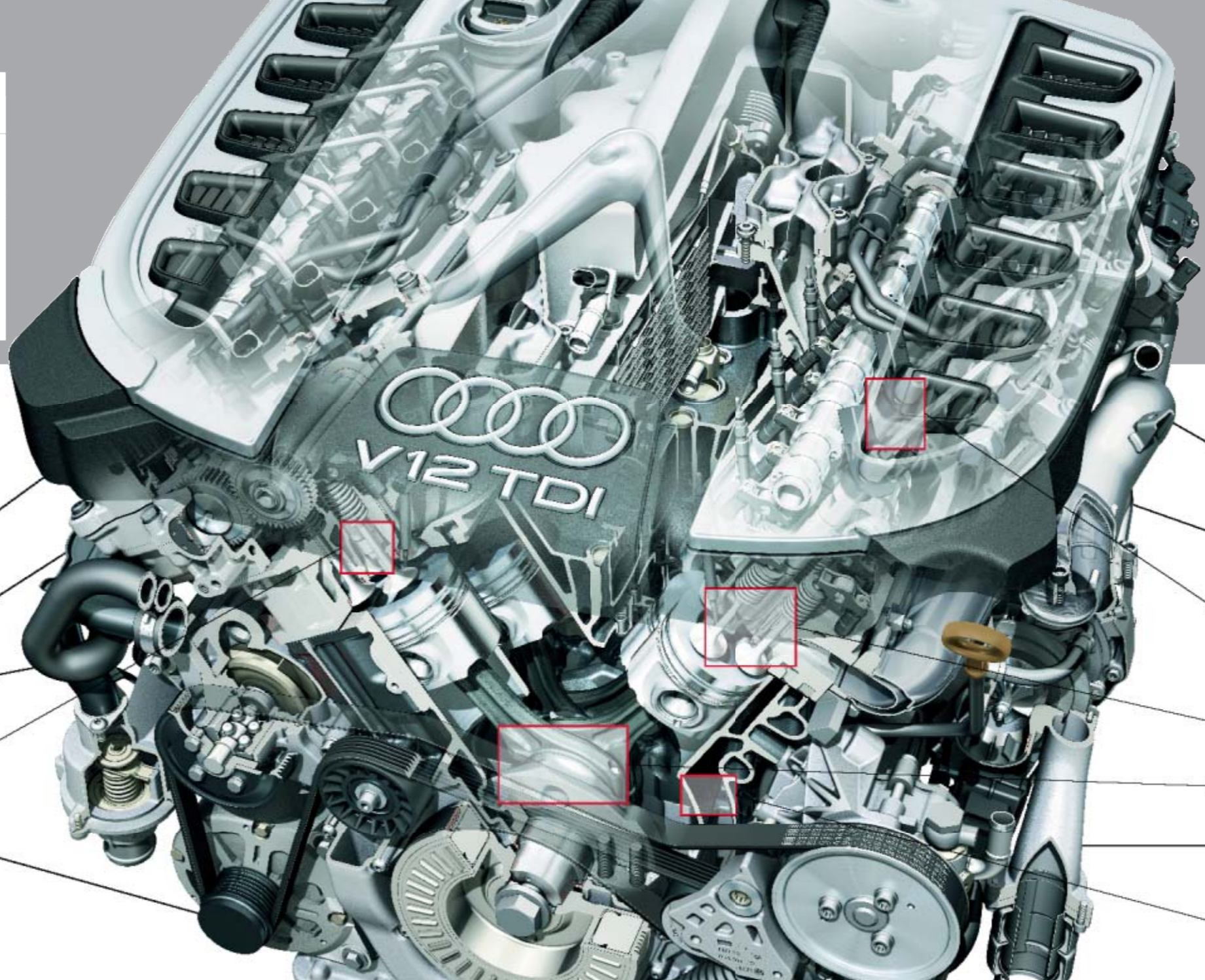

The Audi Q7 V12 TDI quattro reaches its maximum torque of 1,000 Nm at a mere 1,750 rpm and keeps it stable up to 3,250 rpm. Thus excellent performance is at your disposal from an early stage and over a wide range. The engine moves the high-performance SUV with overwhelming supremacy and serenity, without losing its agility.

The first V12 diesel engine in the world in a series production model. Thus begins a new chapter in the history of the diesel engine. With the 6-litre TDI engine, Audi is once again demonstrating its "Vorsprung durch Technik".

Six litre displacement – more than you have ever had before in an Audi Q7. That creates space for power.

368 kW accelerate the Audi Q7 V12 TDI quattro from 0 to 100 km/h in just 5.5 seconds.

Piezo injectors inject the fuel into the combustion chamber at high pressure of up to 2,000 bar. In doing so, the fuel is finely atomised, which results in better combustion.

You can drive the Audi Q7 V12 TDI quattro up to a top speed of 250 km/h – after which the electronic regulation function comes into action.

So much power – with comparatively low fuel consumption. The Audi Q7 V12 TDI quattro consumes 11.3 litres of fuel (combined) per 100 km.

Concentrated energy: with a length of 684 mm, the diesel engine is very compact – an important precondition for integration into a standard production vehicle.

The V12 engine has a cylinder centre to centre distance of 90 mm. Its cylinder angle is just 60° – consequently virtually no vibration-inducing free inertia forces or moments of inertia occur. This results in superb smooth-running performance.

The number of injection processes per work cycle can be exactly adjusted by means of the piezo injectors – up to five processes. Other injection processes are also possible in addition to the main injection. The pilot injection processes temper the acoustic harshness of the combustion process, which is particularly audible at low loads.

The crankshaft is made from a chromium molybdenum steel alloy, the pistons from aluminium.

The maintenance-free chain drive is situated on the rear side of the engine to save space.

The crankcase is made of a high-tech material. It is manufactured using a patented casting process and has remarkable advantages: It is more rigid, more resistant to fatigue and lighter than comparable materials.

Fuel consumption and CO<sub>2</sub> emission figures can be found on page 114.

## Law of nature n° 3

### Assertive individuals tread different paths.

Anyone can drive on normal roads. But it is only when you venture along unknown paths that person strengths are put to use. And in the case of the Audi Q7 V12 TDI quattro, this is the permanent all-wheel drive quattro® which distributes the driving force asymmetrically and dynamically to all wheels as required. This provides you with excellent traction, both on and off the road. Thanks to the standard adaptive air suspension, you can choose between sporty and comfortable suspension settings, just as you wish. Combined with the long wheelbase and the low centre of gravity of the Audi Q7 V12 TDI quattro, this will give you tremendous control and extremely precise handling – even on challenging roads.

The fuel consumption and CO<sub>2</sub> emission figures can be found on page 114.







fig. 04

Law of nature n° 4

**Superiority is evident just from appearance.**

The wheel arch extensions of the Audi Q7 V12 TDI quattro give it a dominant and powerful presence. The xenon plus headlights, in combination with the LED daytime running lights, give the front section an unmistakable appearance. At the rear, special features include oval tailpipes, LED rear lights and a specially designed bumper. Intelligent, attractive details round off the Audi Q7 V12 TDI quattro. Exterior mirrors and roof rails in matt aluminium testify to individuality, whilst the front and rear stainless steel underbody protection sets a clearly visible accent.

The fuel consumption and CO<sub>2</sub> emission figures can be found on page 114.



fig. 04

The chrome-plated singleframe radiator grille gleams invitingly in the sunlight. The powerful standard brake system with 20-inch ventilated discs made of carbon-fibre reinforced ceramics are visible through the optional 21-inch wheels. The discs are light in weight, yet are prone to less wear and deliver excellent performance, even with heavy use. Large, shiny black air inlets in the bumpers ensure the high-performance engine gets the ventilation it needs.

The fuel consumption and CO<sub>2</sub> emission figures can be found on page 114.



fig. 05

Law of nature n° 5

**True character can be seen on the basis of inner values.**

A glance into the cockpit of the Audi Q7 V12 TDI quattro: the screen of the standard MMI navigation plus is positioned high in the centre console and displays a host of important information. The multifunction leather sports steering wheel in 3-spoke design is equipped with chrome-look shift paddles. A sporty atmosphere reigns on the interior – and it invites you to lean back and relax. The standard electrically adjustable sports seats are covered in Verano leather or, on request, in two-tone Fine Nappa leather. They hold you well, even on challenging roads. Carbon inlays lend a special look to the centre console and the dashboard, likewise the aluminium look pedals. Or you can choose the optional full leather package with the dashboard fully covered in leather. You see, the Audi Q7 V12 TDI quattro is a typical Audi – high-quality, sporty and perfectly tailored to your requirements.

The fuel consumption and CO<sub>2</sub> emission figures can be found on page 114.



## Audi Q7 V12 TDI quattro Audi exclusive concept®.

The decision in favour of an Audi is the logical consequence of enthusiasm for clear-cut design, technical superiority and dynamic sportiness. Audi exclusive offers numerous possibilities for all those who would like to give their Audi a personal touch through custom-made fittings. The Q7 Audi exclusive concept in Ipanema Brown metallic with V12 TDI engine is the natural continuation of this idea of an ideal: quite special equipment in an exciting combination for an exclusive car – the out-of-the-ordinary as a limited edition series product.



Exclusive pleasure in a limited edition: the unique features of the Q7 Audi exclusive concept in Fine Nappa leather in alabaster white and chestnut brown with contrasting seams and piping.

Lots of space and an individual look: the rear seat backrest covers and the luggage compartment floor are in American walnut with smoked oak inlays. The luggage compartment side trim is leather in alabaster white.

Elegantly coordinated interior: the gear lever gaiter in chestnut brown with contrasting seams in alabaster white, combined with decorative inlays in American walnut with smoked oak inlays.

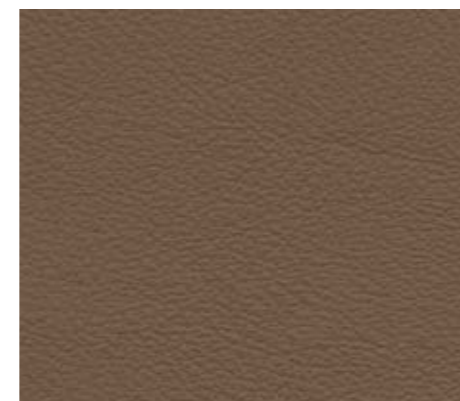
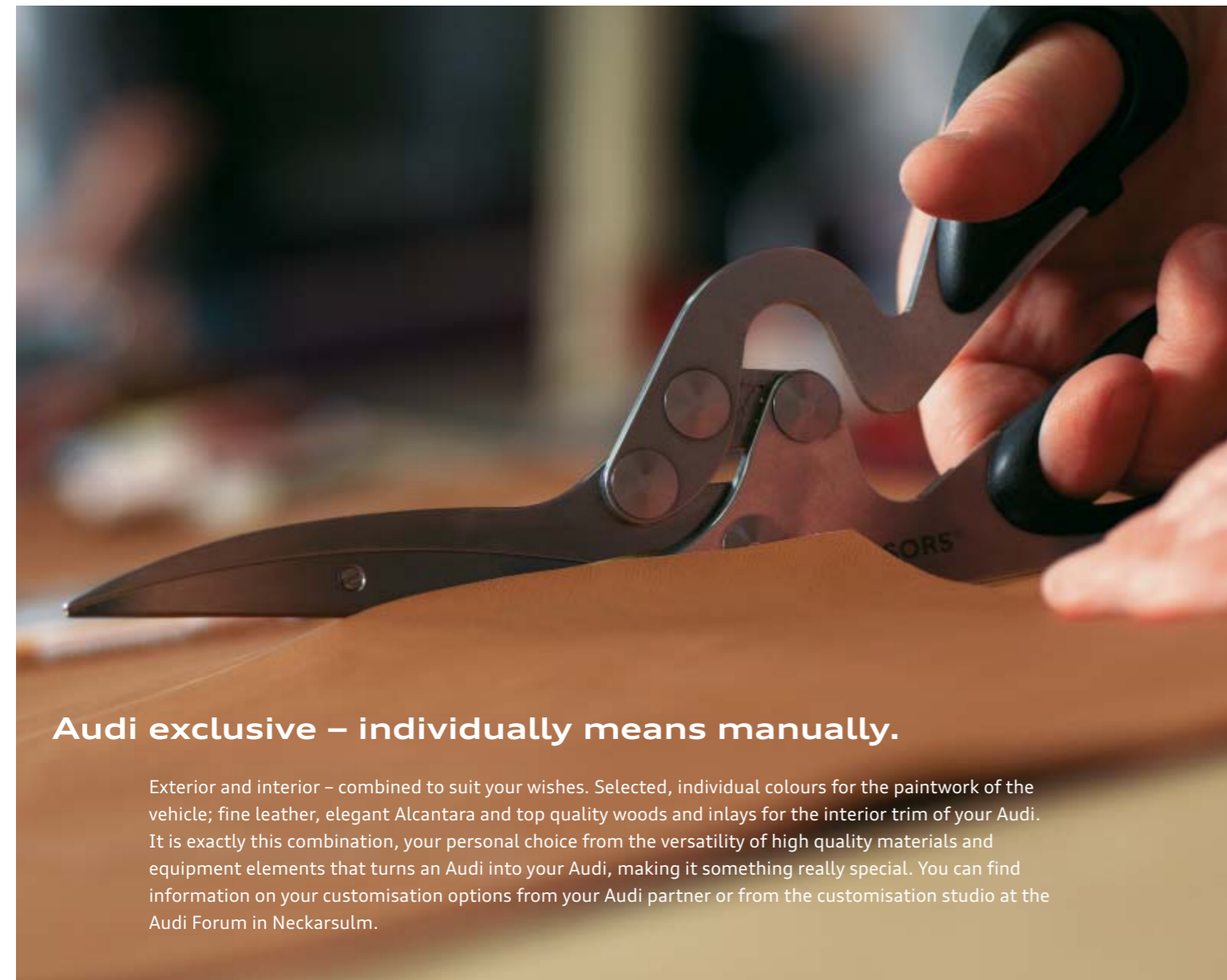

## Audi exclusive – individually means manually.

Exterior and interior – combined to suit your wishes. Selected, individual colours for the paintwork of the vehicle; fine leather, elegant Alcantara and top quality woods and inlays for the interior trim of your Audi. It is exactly this combination, your personal choice from the versatility of high quality materials and equipment elements that turns an Audi into your Audi, making it something really special. You can find information on your customisation options from your Audi partner or from the customisation studio at the Audi Forum in Neckarsulm.



Design package Audi exclusive leather plus with sports seats in black/havanna brown including contrasting seams and the Audi exclusive full leather package.



Seats with seat covers in black/sand beige two-tone look in Fine Nappa leather.

### Seat covers

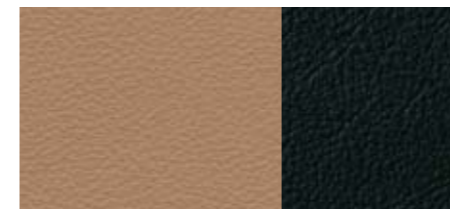

Fine Nappa leather, sand beige/black

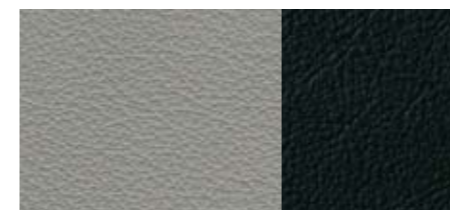

Fine Nappa leather, silver/black



Fine Nappa leather, cognac/black

### Inlays



Matt brushed aluminium

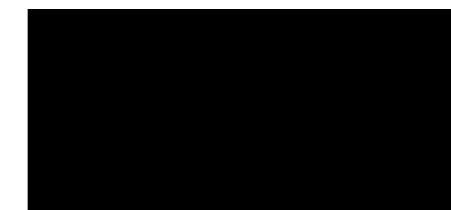

Piano finish black (optional)



Tamo ash dark brown (optional)

## Audi exclusive line

Two-tone seat covers (seat side bolsters black/seat centre panel optionally in sand beige, silver or cognac) in Fine Nappa leather (standard seats);

optional: Sports seats

Side bolsters, head restraints, steering wheel rim and gear lever gaiter with coloured seam (to match seat centre panel)

Door trim inserts (to match seat centre panel)

Multifunction leather steering wheel in 4-spoke design, with coloured seam (to match seat centre panel);

optional: Multifunction sports steering wheel, 3-spoke design with gear-shifting function with coloured seam (to match seat centre panel)

Inlays in Matt brushed aluminium; optional: Tamo ash dark brown or Piano finish, black

Black interior (including black attachments)

Headlining in black cloth

Floor mats with coloured piping (to match seat centre panel)

Comfort centre armrest, leather trimmed

Audi exclusive door sill trims



Gear lever gaiter with coloured seam.



Tamo ash dark brown inlays.



## S line – experience sportiness.

Driving an Audi Q7 is a clear commitment to automotive sportiness. With the S line packages you can enhance the athletic appearance of your Audi Q7 even more: with equipment that underlines its dynamic body lines, gives its interior a perceptibly sporty identity and optimises its driving behaviour even further. Decide on a plus in sportiness – the S line packages from quattro GmbH.

S line only available for six and eight-cylinder models.



Distinctively sporty front bumper including LED indicators.



Diffuser insert in a striking, sporty design, chromed exhaust tailpipe surrounds for 6-cylinder models.

## S line exterior package

Front and rear bumpers, side grilles, door cover strips and diffuser insert in a striking, sporty design

Front and rear bottom bumper section and door cover strips in body colour, centre front spoiler lip and diffuser insert in Platinum Grey

LED front indicators

Headlight cleaning system

Door sill trims with S line logo

S line logos on the front wings (except for 3.0 TFSI quattro [245 kW])

Chrome-plated exhaust tailpipe surrounds (6-cylinder models)

The fuel consumption and CO<sub>2</sub> emission figures can be found from page 110 onwards.



**Visibly ergonomic:** Sports seats with Alcantara/Leather covers with silver seams and S line logos in the front seat backrests, inlays in Matt brushed aluminium.



**Unmistakably S line:** S line multifunction leather sports steering wheel with silver seams.



**Perceptibly sporty:** Selector lever knob in perforated black leather.



**Recognisably dynamic:** Cast aluminium wheels, 5-spoke design.

### Seat covers

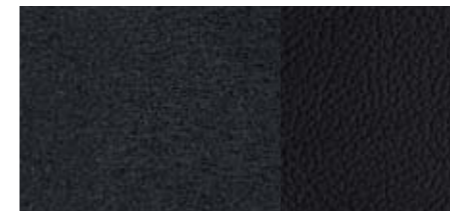

Alcantara/Leather, black

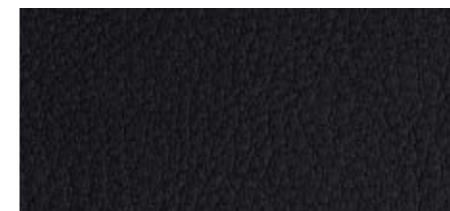

Verano leather, black

### Inlays



Matt brushed aluminium

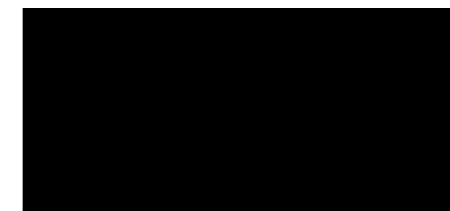

Piano finish black



Fine grain birch wood grey

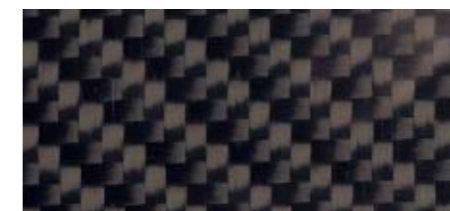

Audi exclusive Carbon

## S line sports package

Cast aluminium wheels, 5-spoke design, size 9 J x 20 with 275/45 R 20 tyres;

optional: Cast aluminium wheels, 10-spoke or 20-spoke design, two-piece, size 10 J x 20 with 295/40 R 20 tyres;

Forged aluminium wheels, 7-double-spoke design or cast aluminium wheels, 5-segment-spoke design, size 10 J x 21 with 295/35 R 21 tyres

S line sports suspension from quattro GmbH with more dynamic suspension tuning and vehicle lowered by 10 mm (with 4.2 TDI quattro: S line adaptive air suspension)

optional: S line adaptive air suspension from quattro GmbH, enables a sporty dynamic to comfortable suspension setting; as opposed to the adaptive air suspension, the S line model offers an additional lowering of a lowered suspension by 20 mm

S line logos on the front wings (except for 3.0 TFSI quattro [245 kW])

Door sill trims with S line logo

Interior, dashboard and headlining in black, with optional silver or black seams on Alcantara/Leather seat covers, sports leather steering wheel, gear lever gaiter and floor mats

S line inlays in Matt brushed aluminium inlays; optional: Piano finish black, Fine grain birch wood grey or Audi exclusive Carbon

Aluminium look vent surrounds

Comfort centre armrest

Sports seats, electrically adjustable, with electrically adjustable lumbar support for both front seats

### Options for seat covers, steering wheels and exterior paints:

Seat covers in Alcantara/Leather or Verano leather, in each case in black and with S line embossed emblem in the front seat backrests

S line multifunction sports leather steering wheel in 3-spoke design with or without gearshift function, both in black leather and with S line emblem. Note: if ordering Audi lane assist, this can only be combined with the respective 4-spoke leather steering wheel without S line emblem

Paints available in all standard colours, and as an additional colour option also in Mugello Blue, pearl effect or Daytona Grey, pearl effect

### Additional exterior colour options



Mugello Blue, pearl effect



Daytona Grey, pearl effect





Audi Q7 in Orca Black metallic with optional aluminium look exterior including full paint finish, with cast aluminium wheels, 5-arm structured design. Equipment: Sport design package with sports seats, Alcantara/Leather, black, inlays Aluminium Trigon and multifunction sports steering wheel in 3-spoke design.



Audi Q7 in Teak Brown metallic with optional aluminium look exterior including full paint finish, with cast aluminium wheels, 5-arm V design. Equipment: Design package leather plus with standard seats, Verano leather savannah beige, inlays Tamo ash dark brown and multifunction sports steering wheel in 3-spoke design.



Paints

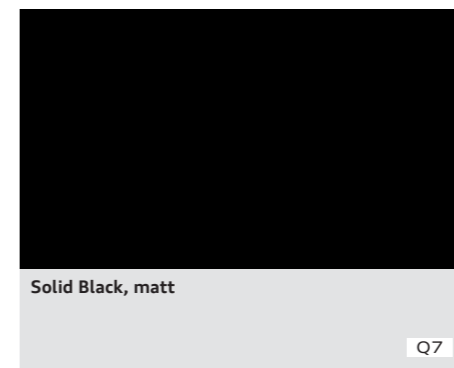
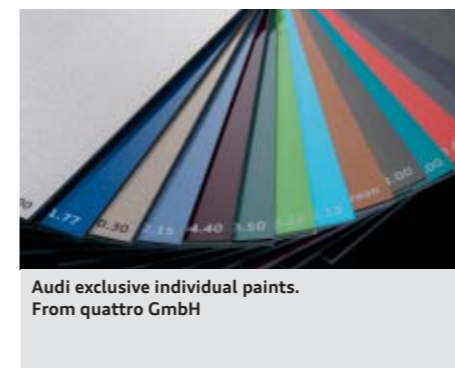
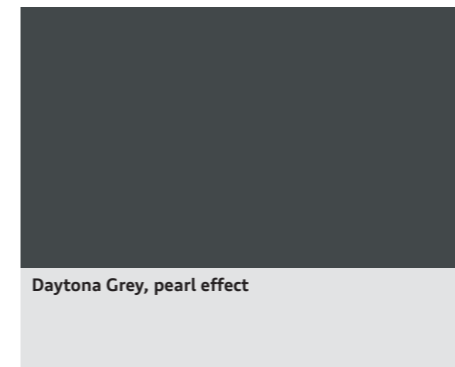
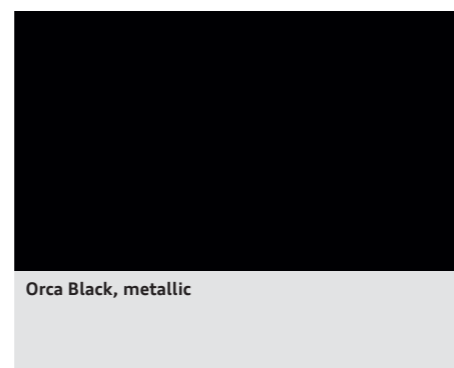
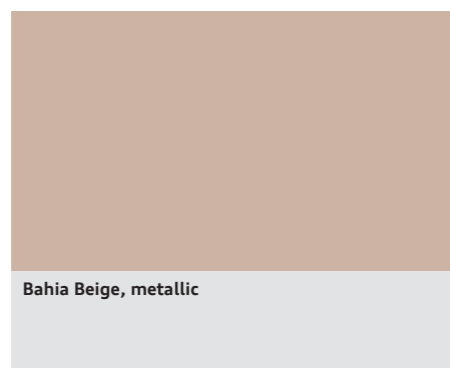
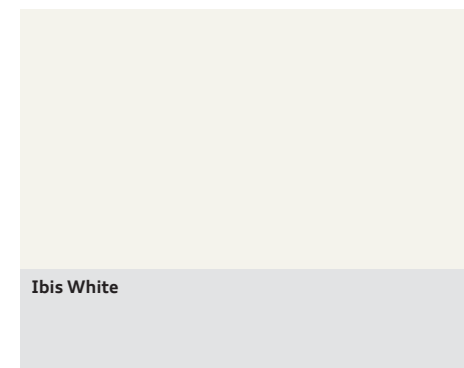
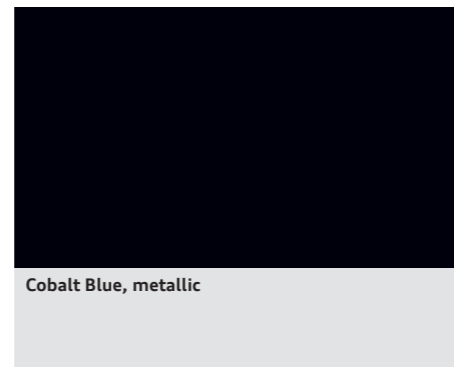
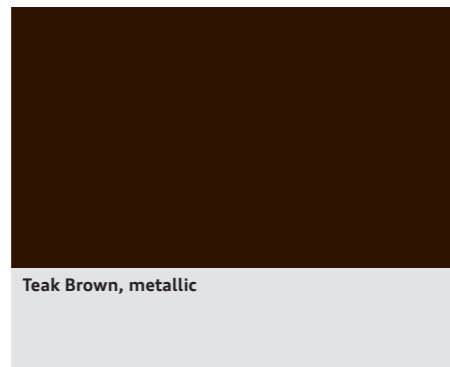
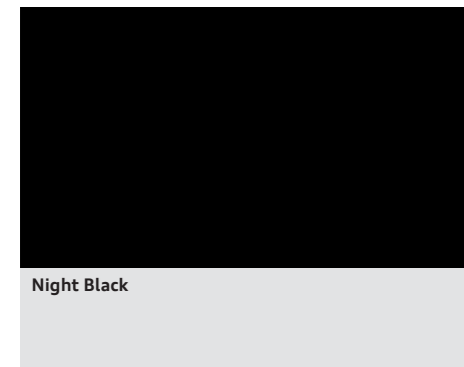

Contrasting paint finish

Cloth and leather equipment for standard seats

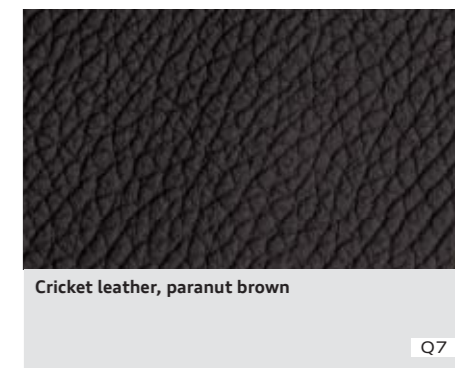
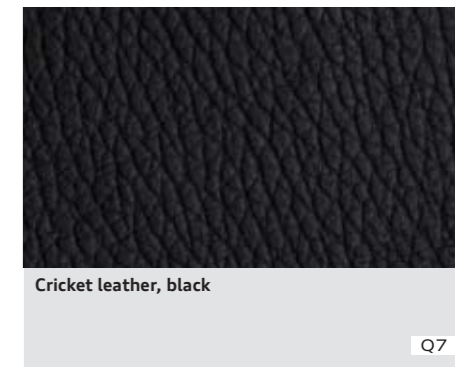
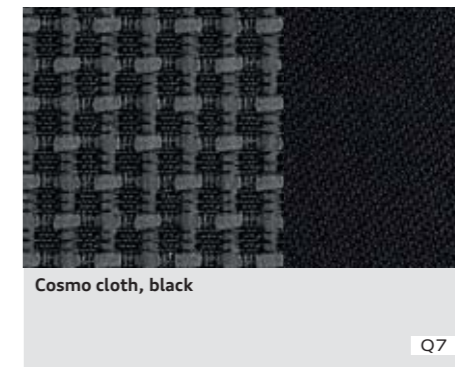

Please find out from your local Audi partner which equipment is standard and what optional equipment is available in your country.

Q7 Only available for Q7 Q7 V12 Only available for Q7 V12 TDI quattro

**Leather upholstery and trim for standard seats**

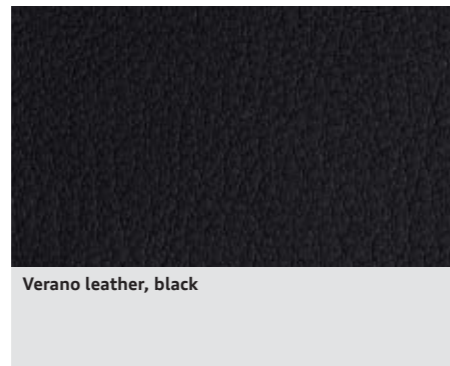

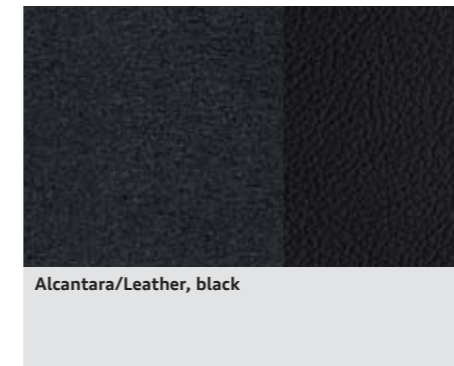

**Leather upholstery and trim for sports seats**

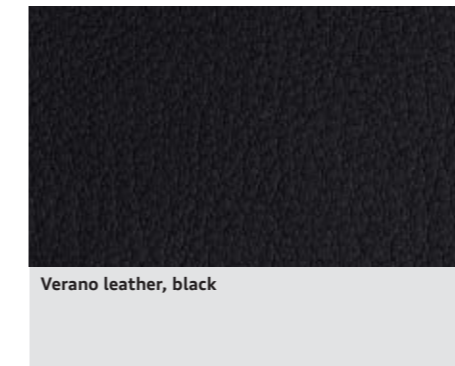

**Leather upholstery and trim for sports seats**



Please find out from your local Audi partner which equipment is standard and what optional equipment is available in your country.

 Only available for Q7  Only available for Q7 V12 TDI quattro

**Standard seats, front**

with manual front/back and seat back angle adjustment, seat height adjustment, belt height and head restraint (Q7 V12: electrical adjustment of the front/back position, backrest and seat height)

**Sports seats, front**

with shaped side bolsters for better lateral support when cornering, electrical adjustment of front/back position, seat height, seat and backrest angle, with manual thigh support setting; includes electrical lumbar support; optionally with memory function. (Q7: Only in conjunction with Alcantara/Leather combination or Verano leather, can be ordered via the sport or leather plus design package)

**Climate-controlled comfort seats, front**

exclusive seat option with shaped side bolsters and soft-feel design for luxurious comfort; actively ventilated and heated; perforated leather on the ventilated seat areas of the front seats and on the non-ventilated seat areas of the 2 outer rear seats. (Q7: Can only be ordered with leather, seat heaters, front seat with electrical adjustment and storage package)

**Alcantara/Leather combination**

for sports seats: head restraints, seat and side bolsters and comfort centre armrest in leather; seat centre sections and door trim in Alcantara. (Can be ordered via the sport design package)

**Cricket leather upholstery and trim**

for standard seats: head restraints, seat and side bolsters and seat centre section in Cricket leather, comfort centre armrest in leather, door trim in Alcantara. (Can be ordered via the leather design package)

Q7

**Verano leather upholstery and trim**

for standard and sports seats: head restraints, seat and side bolsters and seat centre section in Verano leather, comfort centre armrest in leather and door trim in Alcantara. (Q7: Can be ordered via the design package leather plus)

**Fine Nappa leather or Valcona leather upholstery and trim and Alcantara/Leather combination**

**Audi exclusive**

head restraints, seat side bolsters and centre armrest in Fine Nappa or Valcona leather; seat centre section and door panel insert in leather or Alcantara; Alcantara/Leather combination only for sports seats, Valcona leather only for climate-controlled comfort seats. (Can be ordered via the respective Audi exclusive design package)



**Leather package**

Front centre console (also rear centre console for six-seaters) and upholstery for the arm support in the doors as well as for the door handles in Fine Nappa leather with decorative seams in the same colour as the trim. (Q7: Can only be ordered in conjunction with leather or Alcantara/Leather)



**Full leather package**

Dashboard, door rails, instrument panel cover, front central console (also rear central console for six-seaters) and upholstery for the door handle in Fine Nappa leather with decorative seams in a contrasting colour; upholstery for the arm support in the doors in Fine Nappa leather with colour-coordinated decorative seams; includes headlining in Alcantara with contrasting seams and sun visors in Alcantara as well as a manual sunblind at the rear and on the rear side windows. (Q7: Can only be ordered in conjunction with leather or Alcantara/Leather, in combination with S line sports package and Audi exclusive line decorative seams in the same colour as the trim; Q7 V12: In combination with Audi exclusive line decorative seam in the same colour as the trim)

Please find out from your local Audi partner which equipment is standard and what optional equipment is available in your country.

Q7 Only available for Q7 Q7 V12 Only available for Q7 V12 TDI quattro

**Leather package Audi exclusive**

Front centre console (also rear centre console for six-seaters), upholstery for the arm support in the doors as well as for the door handles in Fine Nappa leather with decorative seams. (Q7: Can only be ordered in conjunction with leather or Alcantara/Leather.) From quattro GmbH

**Full leather package Audi exclusive**

Dashboard, door rails, instrument panel cover, front centre console (also rear centre console for six-seaters) and upholstery for the arm support in the doors as well as for the door handles in Audi exclusive leather. Available in chestnut brown, saddle brown, havanna brown, jet grey, crimson red, classic red, night blue, iceland green and smoke blue. Individual choice of colour for seams. From quattro GmbH

**Colour coordinated decorative seams Audi exclusive**

can only be ordered in conjunction with the full leather package. From quattro GmbH



**Design package sport with sports seats, front**

Front seats electrically adjustable, Alcantara/Leather combination seat covers, comfort centre armrest in leather and door trim in Alcantara, inlays (Q7: in gloss finish black; Q7 V12: in Carbon) optionally in Walnut natural, Olive ash beige, Tamo ash dark brown or Aluminium Trigon, vent surrounds in aluminium look, footwell trim and floor mats in velour carpet, optionally in Fresco carpet (colour-matched to the interior)

**Design package basic with standard seats**

Inlays optionally in Walnut natural, Olive ash beige, Tamo ash dark brown or Aluminium Trigon, vent supports in aluminium look, footwell trim and floor mats in velour carpet, optionally in Fresco carpet (colour-matched to the interior)

Q7

**Design package leather with standard seats**

Seat covers in Cricket leather, comfort centre armrest in leather and door trim in Alcantara, inlays in choice of Walnut natural, Olive ash beige, Tamo ash dark brown or Aluminium Trigon, vent surrounds in aluminium look, footwell trim and floor mats in velour carpet, optionally in Fresco carpet (colour-matched to the interior)

Q7



**Design package leather plus with standard seats**

Seat covers in Verano leather, comfort centre armrest in leather and door trim in Alcantara, inlays (Q7: in gloss finish black; Q7 V12: in Carbon) optionally in Walnut natural, Olive ash beige, Tamo ash dark brown or Aluminium Trigon, vent surrounds in aluminium look, footwell trim and floor mats in velour carpet, optionally in Fresco carpet (colour-matched to the interior). (Q7 V12: also front seats, electrically adjustable)

Please find out from your local Audi partner which equipment is standard and what optional equipment is available in your country.

Q7 Only available for Q7 Q7 V12 Only available for Q7 V12 TDI quattro

**Design package leather plus with sports seats, front**

Front seats electrically adjustable, Verano leather seat covers, comfort centre armrest in leather and door trim in Alcantara, inlays (Q7: in gloss finish black; Q7 V12: in Carbon) in choice of Walnut natural, Olive ash beige, Tamo ash dark brown or Aluminium Trigon, vent surrounds in aluminium look, footwell trim and floor mats in velour carpet, optionally in Fresco carpet (colour-matched to the interior)

**Design package Audi exclusive leather with standard seats**

Seat covers in Fine Nappa leather, footwell trim/floor mats in velour carpet, door trim and comfort centre armrest in leather, also aluminium look vent surrounds. From quattro GmbH

**Design package Audi exclusive leather with sports seats**

Seat covers in Fine Nappa leather, footwell trim/foot mats in velour carpet, door trim and comfort centre armrest in leather. Also front sports seats with electric adjustment and electric lumbar support, as well as aluminium look vent surrounds. From quattro GmbH

**Design package Audi exclusive leather with climate-controlled comfort seats**

Seat covers in Valcona leather, footwell trim/foot mats in velour carpet, door trim and comfort centre armrest in leather. Also front climate-controlled comfort seats with electric adjustment, actively ventilated and heated, as well as aluminium-look vent surrounds. From quattro GmbH

**Design package Audi exclusive Alcantara/Leather black with sports seats**

Seat covers in Alcantara/Leather combination (coloured Alcantara, black leather), footwell trim/floor mats in velour carpet, door trim Alcantara, comfort centre armrest in leather. Additional front sports seats with electric adjustment and electric lumbar support, as well as aluminium look vent surrounds. From quattro GmbH

**Design package Audi exclusive leather plus with standard seats**

Seat covers in Fine Nappa leather, including leather-covered seats, door handles and door arm supports, door trim and comfort centre armrest. Footwell trim/floor mats in velour carpet, as well as aluminium look vent surrounds. From quattro GmbH

**Design package Audi exclusive leather plus with sports seats**

Seat covers in Fine Nappa leather, including leather-covered seats, door handles and door arm supports, door trim and comfort centre armrest. Footwell trim/foot mats in velour carpet. Front sports seats with electric adjustment and electric lumbar support, as well as aluminium look vent surrounds. From quattro GmbH

**Design package Audi exclusive leather plus with climate-controlled comfort seats**

Seat covers in Valcona leather, including leather-covered backrests, door handles and door arm supports, door trim and comfort centre armrest, footwell trim/floor mats in velour carpet. Also front climate-controlled comfort seats with electric adjustment, actively ventilated and heated, as well as aluminium look vent surrounds. From quattro GmbH

**Equipment package Audi exclusive line**

black interior (including black attachments), headlining in black cloth, two-tone seat covers (seat side bolsters black/seat centre panel optionally in sand beige, silver or cognac) in Fine Nappa leather, door trim inserts (to match the seat centre panel), inlays in Matt brushed aluminium, optionally in Tamo ash dark brown or Piano finish black (Audi Q7 V12: inlays in Carbon, optionally in Tamo ash dark brown, Piano finish black or Matt brushed aluminium), floor mats with coloured piping (to match the seat centre panel), leather-covered comfort centre armrest, multifunction sport leather steering wheel in 4-spoke design, optional multifunction leather steering wheel in 3-spoke design with coloured seam to match the seat centre panel (Audi Q7 V12: multifunction sport leather steering wheel in 3-spoke design, optionally multifunction sport leather steering wheel in 4-spoke design, with gearshift function and coloured seam (to match the seat centre panel), side bolsters, head restraints, steering wheel rim and gear lever gaiter with coloured seam (to match the seat centre panel), Audi exclusive door sill trims

**Headlining in cloth**

Black cloth

**Headlining in Alcantara**

Alcantara, pale grey

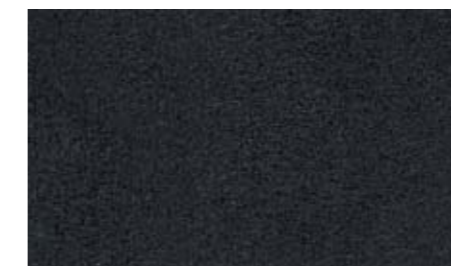

Alcantara, linen beige

Audi exclusive Alcantara, black.  
From quattro GmbH**Headlining**

and attachments coordinated with interior colour

**Headlining**

and attachments in black

**Headlining in Alcantara with contrasting seams**

and attachments in Alcantara including double sun visors coordinated with the interior colour



**Headlining Audi exclusive in Alcantara black with contrasting seams in light grey**

attachments in Alcantara including double sun visors. From quattro GmbH

**Headlining Audi exclusive in Alcantara black, individual choice of colour for contrasting seams**

attachments in Alcantara including double sun visors. From quattro GmbH

Please find out from your local Audi partner which equipment is standard and what optional equipment is available in your country.

 Only available for Q7  Only available for Q7 V12 TDI quattro

## Inlays



Gloss finish black

Q7

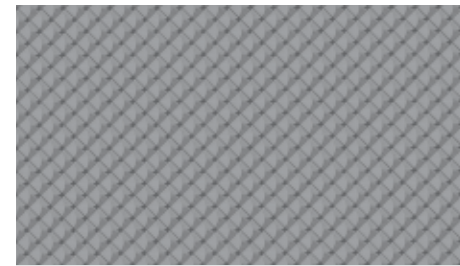

Olive ash beige

Audi exclusive inlays.  
From quattro GmbH

Aluminium Trigon



Tamo ash dark brown



Walnut natural



Carbon

**Inlays**

Gloss finish black in the door trims and in laminar application for the centre console and dashboard

Q7

**Inlays**

in Walnut natural, Olive ash beige, Tamo ash dark brown or Aluminium Trigon in door trims and in laminar application for the centre console and dashboard; including an aluminium inlay in the door trim and on the dashboard with wood inlays. (Can be ordered via design packages)



**Inlays**

in Carbon

**Audi exclusive inlays**

in Poplar wood saffron, Piano finish black, fine-grain Ash wood nougat, Myrtle wood nutmeg or Oak wood sepia. Also available in Carbon design. From quattro GmbH

Please find out from your local Audi partner which equipment is standard and what optional equipment is available in your country.

 Only available for Q7  Only available for Q7 V12 TDI quattro



**Forged aluminium wheels,  
7-arm design**  
size 7.5 J x 18 with 235/60 R 18 tyres

Q7



**Cast aluminium wheels,  
5-arm structured design**  
size 8.5 J x 19 with 265/50 R 19 tyres

Q7



**Audi exclusive cast aluminium wheels,  
5-spoke design<sup>1</sup>**  
size 9 J x 20 with 275/45 R 20 tyres.  
From quattro GmbH

Q7



**Audi exclusive cast aluminium wheels,  
5-segment spoke design<sup>1</sup>,**  
size 10 J x 21 with 295/35 R 21 tyres; including  
wheel arch trims. From quattro GmbH



**Cast aluminium wheels, 6-arm design**  
size 8 J x 18 with 255/55 R 18 tyres

Q7



**Cast aluminium wheels,  
10-spoke V design,**  
anthracite, partially polished, size 9 J x 20  
with 275/45 R 20 tyres

Q7



**Audi exclusive cast aluminium wheels,  
10-spoke design**  
size 10 J x 20 with 295/40 R 20 tyres; including  
wheel arch trims. From quattro GmbH



**Audi exclusive forged aluminium wheels,  
7-double-spoke design**  
polished, two-tone<sup>2</sup>, size 10 J x 21 with  
295/35 R 21 tyres; including wheel arch trims.  
From quattro GmbH



**Cast aluminium wheels, 5-arm V design**  
size 8.5 J x 19 with 265/50 R 19 tyres

Q7



**Audi exclusive cast aluminium wheels,  
20-spoke design**  
two-piece, size 10 J x 20 with 295/40 R 20 tyres;  
including wheel arch trims. From quattro GmbH

Please find out from your local Audi partner which equipment is standard and what optional equipment is available in your country.

Only available for Q7 Only available for Q7 V12 TDI quattro

<sup>1</sup> Optionally also in titanium look.

<sup>2</sup> Optionally also in high-gloss polished finish, single-colour.





**Forged aluminium winter wheels,  
7-arm design**  
size 7.5 J x 18 with 235/60 R 18 tyres,  
can be fitted with snow chains, permissible top  
speed 210 km/h

Q7



**Audi exclusive cast aluminium winter wheels,  
10-spoke design<sup>1</sup>**  
size 10 J x 20 with 275/45 R 20 tyres,  
can be fitted with snow chains, permissible top  
speed 240 km/h. From quattro GmbH



**Cast aluminium winter wheels,  
6-arm design**  
size 8 J x 18 with 255/55 R 18 tyres,  
can be fitted with snow chains, permissible top  
speed 210 km/h

Q7



**Cast aluminium winter wheels,  
10-spoke V design,**  
anthracite, partially polished, size 9 J x 20 with  
275/45 R 20 tyres, cannot be fitted with  
snow chains, permissible top speed 240 km/h

Q7

**All-terrain tyres**  
with forged aluminium wheels, 7-arm design, size 7.5 J x 18 with 235/60 R 18 tyres; the optimum  
tyres for off-road operation; permissible top speed 190 km/h

Q7

**Wheel bolts, anti-theft**  
can only be loosened with the supplied adapter

**Tyre repair kit**  
with 12 volt compressor and tyre sealant, located under the loading floor cover in the luggage com-  
partment; top speed 80 km/h

**Spare wheel**  
size 18 inch with 235/60 R 18 or 255/55 R 18 tyres (for vehicles without a third row of seats)

Q7

**Space-saving spare wheel**  
including jack in the luggage compartment, permissible top speed 80 km/h

Q7

**Tyre pressure control display**  
visual and acoustic warning if the pressure drops in one or more tyres, display in driver information  
system

Q7

**Tyre pressure monitoring system**  
monitors the air pressure set in the tyres and the tyre temperature throughout the journey, also  
works with winter wheels delivered by Audi; air pressures and temperatures of the individual tyres  
can be displayed in the MMI system

Q7 V12

**Vehicle tool kit**  
in the luggage compartment

**Jack**  
in the luggage compartment

Please find out from your local Audi partner which equipment is standard and what optional equipment is available in your country.

Q7 Only available for Q7 Q7 V12 Only available for Q7 V12 TDI quattro

<sup>1</sup> Only available in conjunction with ceramic braking system.

## Lights

**xenon plus**

headlights utilising durable gas discharge technology for dipped and main beam, ensure intensive illumination of the road and provide good uniformity and range, both close-up and in the distance. The automatic dynamic headlight range control prevents oncoming traffic from being dazzled; low-energy LED daytime running lights (includes headlight cleaning system)

Q7

**xenon plus**

headlights utilising durable gas discharge technology for dipped and main beam, ensure intensive illumination of the road and provide good uniformity and range, both close-up and in the distance. The automatic dynamic headlight range control prevents oncoming traffic from being dazzled, low-energy LED daytime running lights with 12 LEDs each on the left and right of the bumper with low energy consumption

Q7 V12

**Headlights**

halogen headlights using free-form technology with clear glass cover, electric headlight range control, daytime running lights, indicator incorporated in the bumper with integrated parking light function

Q7

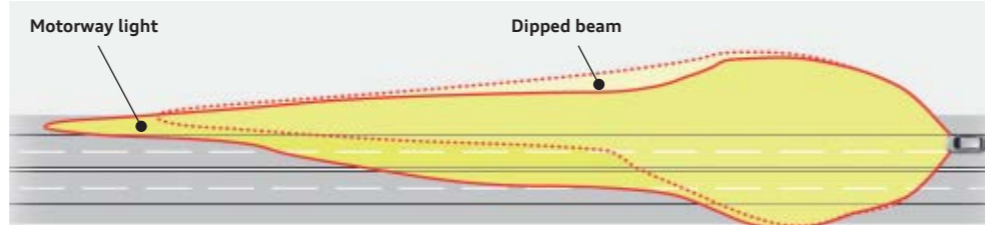
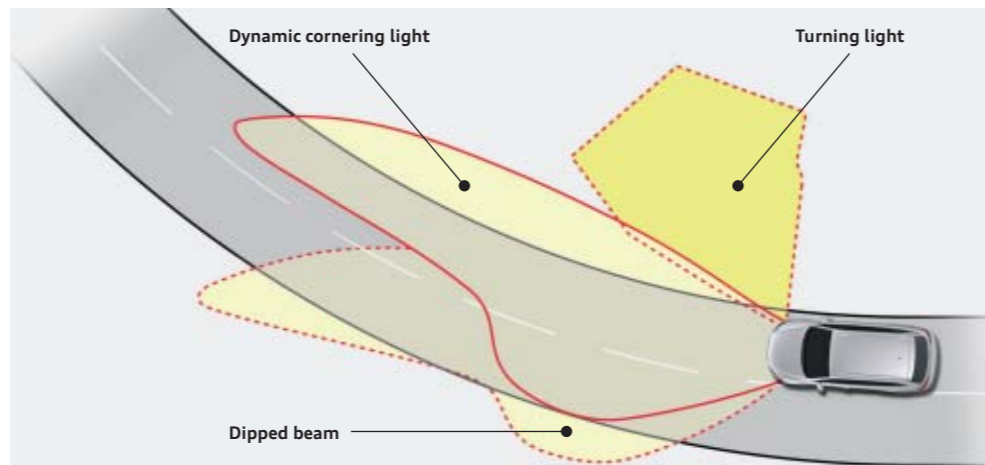
**adaptive light**

dynamic cornering light provided by swivelling headlights; the headlights swivel into the approaching corner or bend to provide better illumination; operational between speeds of approx. 10 km/h and 110 km/h. (Q7: including turning light, illuminates the front side areas of the vehicle with a separate light source at low speeds and the steering wheel on full lock; at speeds of more than 110 km/h, motorway light is activated, for which the light-dark limit is symmetrically raised, thus providing better illumination at larger distances. Can only be ordered in conjunction with xenon plus)

Shown with the Audi Q7

**Main beam assist**

working within system limits, it automatically detects the headlights of oncoming traffic, the rear lights of other road users and built-up areas. Depending on the traffic situation, the main beam is automatically switched on or off. The system thereby improves the driver's visibility and safety and ensures a more relaxed drive thanks to the extra comfort and convenience

**Interior lighting**

with delayed switch-off and contact switches on all doors, includes exiting lights at the front, footwell lights at the front and luggage compartment lighting as well as reading lights, 2 each at the front and rear and one for the optional third row of seats, with optimised illumination

**Audi exclusive cardan reading lights**

(2 lights) located in the rear, providing additional illumination for the rear seats (in the area of the second row of seats), cone of light from reading lamps can be manually adjusted. (Cannot be ordered in conjunction with the panoramic glass roof.)  
From quattro GmbH

**Lighting package**

comprises door front end illumination below the exterior mirrors, ambient lighting of the centre console in LED technology, illuminated vent controls in the instrument panel and centre console at the rear, active door reflectors in the front and rear doors, LED front and rear footwell lighting, rear entrance lighting and illuminated rear ashtray and ambient lighting in the doors

**Door reflectors**

front and rear, passive

Q7

**LED rear lights**

indicator, tail light and brake light in energy-saving LED technology, reversing lights in white; rear fog lights and bumper light strip provides the rear light function when the luggage compartment lid is open; third high-level brake light on the roof spoiler

**Fog lights**

incorporated into the front apron panel; for better illumination of the road ahead when visibility is poor

Q7

**Headlight cleaning system**



uses water and high pressure – for excellent illumination and improved visibility

**Light/rain sensor**

to control the automatic headlights and the windscreen wipers, includes coming home/leaving home function: automatic switching on/delayed switching-off of the rear fog lights, the tail light of rear lights and number plate lighting when parking/opening the vehicle (Q7 V12: without fog lights)

Please find out from your local Audi partner which equipment is standard and what optional equipment is available in your country.

**Q7** Only available for Q7 **Q7 V12** Only available for Q7 V12 TDI quattro

Mirrors	Roof systems
<p><b>Exterior mirrors with integral LED indicators</b> electrically adjustable and heated, convex, flat or aspherical mirror glass; body-coloured housing (Q7 V12: additionally automatically dimming; housing in Matt aluminium)</p>	
<p><b>Exterior mirrors</b> choice of:</p> <p><b>electrically folding</b> <span style="float: right;">Q7</span></p> <p><b>automatically dimming</b> <span style="float: right;">Q7</span></p> <p><b>automatically dimming with memory function</b></p>	
<p><b>Interior mirror</b> can be dimmed, in headlining colour <span style="float: right;">Q7</span></p>	<p><b>Panoramic glass roof</b> three-part, extends to the third row of seats, electrical activation to raise and open the front glass section and to raise the rear glass section, tinted glass, adjustable fine-meshed sun shield over the entire glass area, electric at the front and manual at the rear, convenience closing from outside via the central locking; the bright atmosphere in the interior ensures an open feeling of space and is designed for a pleasant supply of fresh air during the journey. (Optionally available in darker tinted glass)</p> <p>Shown with the Audi Q7</p>

Closing systems
<p><b>Radio-operated remote control</b> for the central locking, incorporated into the vehicle key, opens and locks the doors, windows, luggage compartment and tank filler flap – with variable code; a telltale lamp in the key indicates the locking status of the vehicle</p>
<p><b>Comfort key</b> access and drive-away authorisation system by means of automatic data exchange between the vehicle and the key; the key only needs to be carried with you for opening and starting the vehicle; the engine is started and switched off via the engine start/stop button on the centre console; the vehicle is locked from outside via buttons on all door handles. (Cannot be ordered in combination with the start/stop system)</p>
<p><b>Immobiliser, electronic</b> incorporated in the engine control unit, automatic activation by the vehicle key</p>
<p><b>Luggage compartment lid with electric opening and closing function</b> opening via button on vehicle key, button in the driver's door panel or soft touch button in the luggage compartment lid handle recess, closing via button on inside of luggage compartment lid, with closing assistance and programmable luggage compartment lid opening angle</p>
<p><b>Garage door opener (HomeLink)</b> programmable radio-operated remote control, control button integrated into the front of the roof module; can be used to open several garage doors and exterior gates; control of safety and lighting systems possible. For more information, please contact your Audi partner</p>
<p><b>Anti-theft alarm system</b> including interior monitoring and tow-away protection via angle of inclination sensor; can be deactivated; signal horn independent of vehicle electrical system; monitoring of doors, engine compartment and luggage compartment</p>



Fitting for Tracking Assistant
<p>fitting for the connection of a tracking assistant, by means of which the vehicle can be located if stolen</p>
<p><b>Ignition lock</b> electronic ignition key with integrated chip automatically stores relevant service data of the vehicle</p>
Glazing
<p><b>Heat-insulating glass</b> green tinted</p>
<p><b>Double/acoustic glazing</b> front and side windows with laminated safety glass, 2 panes which are joined together by a plastic film; improves the insulation of outside noise and increases anti-theft protection; optionally available with or without rear tinted windows</p>

<p><b>Dark tinted windows (Privacy glazing)</b> tinted rear window, rear door glazing and rear side windows, optionally with or without double/acoustic glazing</p>

Please find out from your local Audi partner which equipment is standard and what optional equipment is available in your country.

Q7 Only available for Q7 Q7 V12 Only available for Q7 V12 TDI quattro

<p><b>Windscreen</b> made of heat-insulating glass, laminated glass with grey coloured strip along the top edge</p>	<p><b>Trailer towing hitch<sup>1</sup></b> <b>mechanical:</b> removable and lockable spherical head, 13-pole plug with cover; the trailer towing hitch can be stored in the spare wheel well when removed; includes trailer stabilisation system via the Electronic Stabilization Programme ESP</p> <p><b>electrical:</b> electrically swivelling ball head attachment, operated via button in luggage compartment; includes trailer stabilisation system via the Electronic Stabilization Programme ESP; suitable for trailers with bulb or LED lighting. (Cannot be ordered together with the 3.0 TDI clean diesel quattro and third row of seats)</p>
<p><b>Rear window</b> heated, with time switch and integrated antenna</p>	<p><b>High-gloss package</b> Outer window capping trim in aluminium finish (Q7 V12: in Matt aluminium), outer B and C pillar trim in high-gloss black</p>
<p><b>Windscreen cleaning system</b> 2 speeds, automatic switching, touch-wipe function, wash/wipe function, automatic wiping approx. 5 seconds after the last wash/wipe process, including heated windscreen washer jets; rear window wiper with automatic wash/wipe</p>	<p><b>Audi exclusive black styling package</b> radiator grille and number plate bracket in Matt Black, highly polished Black radiator grille frame, front fog light surrounds in Matt Black. From quattro GmbH</p>
<p><b>Sun visors</b> can be folded and swivelled; on the driver and front-passenger side with covered, illuminated make-up mirror</p>	<p><b>Contrasting paint finish</b> Front and rear bumper bottom section and door top strips painted (in Platinum Grey matt or Solid Black matt, depending on exterior colour)</p>
<p><b>Double sun visor</b> for driver and front passenger, simultaneous front and side protection possible, gap between visor and door pillar can be closed by means of pull-out extension</p>	
<p><b>Sunblind</b> manual, for the rear window</p>	
<p><b>Sunblind, manual for the rear window and the rear door windows</b> protects the passengers in the back from direct sunlight</p>	
<p><b>Further exterior equipment</b></p>	
<p><b>Provision for trailer towing hitch</b> including preliminary wiring, bumper cover and cooling equipment for a maximum retrofitted trailer load of 2,500 kg. (Only for 3.0 TDI [176 kW] quattro and 3.0 TFSI [200 kW] quattro)</p>	

Please find out from your local Audi partner which equipment is standard and what optional equipment is available in your country.

 Only available for Q7  Only available for Q7 V12 TDI quattro



#### Aluminium look exterior

trims on front and rear bumpers as well as door covers and inlays in the door handles in aluminium look, including bottom bumper sections and door cover strips in body colour, underbody protection in contrasting colour



#### Bumpers

sporty accentuated bumpers and large side air inlets with high-gloss black paint finish horizontal bars; dynamically shaped wheelhouse widening; eye-catching widening in the lower area of doors and sills



#### Audi Singleframe

high-gloss Black paint, one-piece decorative frame around the radiator grille, chrome-plated, with vertical chrome struts (Q7 V12: double chrome struts); with bright-metal Audi rings in the centre



#### Roof rails

one-piece – no joints, stable and aerodynamic, highlights the coupé-like roof line; in anodised aluminium (Q7 V12: in Matt aluminium), optionally in Black

#### Exhaust tailpipes

dual-branch design (for 3.0 TFSI quattro [245 kW] and 4.2 TDI quattro with trim; Q7 V12: with oval-shaped tailpipes)



#### Tailpipe trims

suitable tailpipe trims are available from Audi Genuine Accessories. For more information, please contact your Audi partner

#### Model name/logo

on rear, quattro logo on rear, in the radiator grille and in the dashboard on the passenger side; on request without the model name; marking "TDI clean diesel" on the rear window (only for 3.0 TDI clean diesel quattro); with 3.0 TFSI (245 kW) quattro "V6T" logo on the front wings



#### Model name/logo

quattro logo on the radiator grille, V12 emblem on the front wings, V12 TDI quattro emblem on the luggage compartment lid; can also be supplied without the model name if required



#### Underbody protection,

front and rear, in stainless steel



<sup>1</sup> When the vehicle with a trailer towing hitch is used for commercial purposes, you will require an EC control unit under certain circumstances.

## Seats/seating comfort

**Third row of seats**

2 seats in the rear with foldable head restraints and 2 additional ISOFIX child seat mountings, can be split and folded down flat to create a level loading floor, for persons up to 1.60 m tall, with comfort entry feature and front/back adjustment for the second row of seats

**Rear seats (second row), 5 or 7 seats (in combination with the third row of seats)**

with backrest angle adjustment and belt height adjustment for the external seats, rear seat backrest can be split and folded 40:60 or fully, provides a level loading floor; including load-through facility

**Comfort seats in the second row, 6 seats (in combination with the third row of seats)**

2 comfortable single seats in the second row, can be split and folded down flat to create a level loading floor, with comfort access function, front/back adjustment and generous centre console with height-adjustable armrest, storage compartment and 2 drinks holders. Only in combination with the third row of seats. The vehicle then offers room for a total of 6 people

**4-way lumbar support**

electrical, for driver and front passenger seat, with vertical and horizontal electric adjustment

**Electrically adjustable front seats**

electrical adjustment of front/back position, seat height and seat and backrest angle; includes electric 4-way lumbar support. (Standard with front sports seats)

**Front/back adjustment for the second row of seats**

manual front/back seat adjustment, 80 mm forwards and 20 mm backwards, to increase the legroom or luggage compartment capacity

**Memory function for the driver seat**

Driver seat with electrical adjustment, memory function for seat adjustment, exterior mirrors and steering wheel (with electrical steering column adjustment)

**Memory function for the front seats**

Driver seat and front passenger seat with electrical adjustment, memory function for seat adjustment, exterior mirrors and steering wheel (with electrical steering column adjustment)

**Seat heating, front**

for driver and front passenger seat, heats seat cushions, backrests and additionally the seat side bolsters on sports or leather front seats; the seat heaters can be individually set for every seat; especially pleasant in the winter

Q7

**Seat heating, front and rear**

for driver and front passenger seat as well as the outer seats in the second row, heats seat cushions, backrests and additionally the seat side bolsters on sports or leather front seats; the seat heaters can be individually set for every seat; particularly pleasant in the winter

**Centre armrest, front**

for the driver and front passenger, fold-open design, with storage compartment (not with CD changer) underneath the centre armrest, includes 2 drinks holders

Q7

**Centre armrest, rear**

in the rear seats, foldable, including 2 drinks holders

**Comfort centre armrest, front**

for driver and front passenger, with fold-open storage compartment on the driver's side, a drinks holder at the front on the passenger side as well as an additional drinks holder in the armrest on the passenger side (fold-open), with storage compartment (not with CD changer) underneath the centre armrest. (Included in scope of design packages)

**Head restraints**

manually height-adjustable at the front, foldable at the rear for the outer seats

Please find out from your local Audi partner which equipment is standard and what optional equipment is available in your country.

Q7 Only available for Q7 Q7 V12 Only available for Q7 V12 TDI quattro

**ISOFIX child seat mounting**

for the outer rear seats of the second row, standard bracket for the safe and practical fastening of ISO standard child seats, including separate childproof safety locks on the rear doors; you can obtain the appropriate child seat from your Audi Partner

**ISOFIX child seat anchor points for the front passenger seat**

with deactivating switch for the front passenger airbag, standard bracket for the practical fastening of ISO standard child seats, compatible child seats can be obtained from your Audi partner (Cannot be ordered in conjunction with climate-controlled front comfort seats)

**Steering wheels/selectors levers/controls**



**Multifunction leather sports steering wheel, 3-spoke design**

with full-size airbag and perforated leather, for the operation of the MMI system, radio, Audi music interface, voice control system and telephone or mobile (if additionally fitted); optionally with shift paddles (Q7 V12: shift paddles in chrome look) behind the steering wheel for changing gear; controls in aluminium look



**Audi exclusive steering wheel rim**

customised with Audi exclusive wood and leather, available as 3 or 4-spoke design and in 5 different finishes. From quattro GmbH



**Leather steering wheel in 4-spoke design**

with full-size airbag, mechanically adjustable for height and reach

Q7



**Multifunction leather steering wheel 4-spoke design**

with full-size airbag, to operate the MMI system, radio, Audi music interface, voice control system and telephone or mobile (if additionally fitted); heated optionally (can be deactivated), controls in aluminium look. Optional: heated, with shift paddles (Q7 V12: shift paddles in chrome look) behind the steering wheel for changing gear

**Steering wheel trim with wooden segments**

available as multifunction steering wheel with/without gearshift function in 4-spoke design, with wooden segments in Walnut natural and Leather black. From quattro GmbH

**Electric steering wheel adjustment**

adjustable in height and reach, with automatic entry and exit function – so that you can comfortably set your desired driving position

**Selector lever knob**

with aluminium look

Q7 V12

**Selector lever knob in leather**

with ring trim

Q7

**Selector lever knob in wood**

in Walnut natural, Olive ash beige or Tamo ash dark brown

Q7

**Selector lever knob Audi exclusive**

can be ordered in 5 different finishes. From quattro GmbH

Q7

**Audi exclusive controls in leather**

leather-covered items: steering wheel rim, gear lever knob and gear lever gaiter.

From quattro GmbH

**Air-conditioning**



**Deluxe automatic air-conditioner**

with sunlight-dependent control, separate temperature and air distribution for driver and front passenger side, indirect ventilation, air conditioning of the rear space via air vents in the B-pillars and the centre console in the rear, automatic air recirculation control using an air quality sensor, button for quick deicing, combined pollution and pollen filter, key recognition



**4-zone deluxe automatic air-conditioner**

in addition to the deluxe automatic air conditioning, temperature adjustment and air distribution at the rear which can be separately adjusted on the left and right hand sides, air outlet nozzles in the C-pillar, air conditioning controls for the rear in the rear centre console, rear functions can also be adjusted using the front control panel; including an additional air conditioning compressor

**Auxiliary heating/ventilation**

with timer and separate radio remote control with function feedback; provides a pleasant climate in the vehicle, even when the vehicle is stationary; the heating warms up the interior and keeps the windows free from ice, the parking ventilation supplies fresh air and lowers the interior temperature

**Luggage securing and storage systems**

**Storage compartments**

in the front and rear door trims, in the centre console at the front and in the roof module and a drawer under the front passenger seat

**Glove compartment**

on the front passenger's side, with illumination and air conditioning, opening via switch on the dashboard

**Storage nets**

in the front area of the centre console on the front passenger side

Please find out from your local Audi partner which equipment is standard and what optional equipment is available in your country.

Q7 Only available for Q7 Q7 V12 Only available for Q7 V12 TDI quattro

**Storage compartment**

with rubber mat in the front central console

**Storage package**

storage net on the front seat backrests, net in the luggage compartment side panel and combined net in the luggage compartment

**Storage package with folding table**

folding table on the front seat backrests, net in the luggage compartment side panel and combined net in the luggage compartment

**Folding tables**

on the front seat backrests

**Drinks holder**

2 in the front centre console, 2 in the rear centre armrest and 2 in the side panels in the area of the optional third row of seats – when not being used serves as holder for luggage compartment cover



**Bottle holder**

for the storage of bottles of up to 1.5 litres in the front and rear door trims, 4 in total

**Clothes hooks**

2 in the rear roof area, also one each on the B pillars on the left and right

**Partition net**

for fastening on the body side or on the folded-down rear seats, useful when the rear seats are up or folded down on one side, as well as when they are completely folded down; removable

**Lashing points**

four in luggage compartment, to secure loads

**Reversible mat**

for luggage compartment, velour on one side, rubber on the other, to cover the luggage compartment, also when rear seats are folded down, with fold-out protective film for the loading sill and bumper



**Double load area floor**

with dirt collecting tray underneath in vehicles without full-size spare wheel; storage compartment behind the second row of seats in vehicles without third row of seats, easy to clean

**Load-through facility with removable ski/snowboard bag**

secured by a strap, for the practical transportation of long items, e.g. up to 4 pairs of skis up to 200 cm in length or 2 snowboards; including rear centre armrest with drinks holders



**Rail system with load-securing kit**

with various lashing points; including telescopic rod and fastening strap, for individual partitioning of the luggage compartment and securing objects

**Luggage compartment**

large-volume with large load-through width, luggage compartment locking with soft-touch function (unlocking with electrical assistance)

**Luggage compartment cover**

can be pulled out with one hand, removable, with separated cover, adaptable to the backrest angle of the second row of seats



**Luggage compartment cover, folding**

extendable, removable, can be folded in the middle, can be stowed away in the double loading floor, including mounting adapter and storage bag, additionally enclosed

**Bicycle mount in luggage compartment**



suitable for transporting up to 2 bicycles with wheel sizes up to 26 inches (e.g. mountain bikes). (Cannot be ordered in conjunction with Bang & Olufsen Advanced Sound System)





Please find out from your local Audi partner which equipment is standard and what optional equipment is available in your country.

 Only available for Q7  Only available for Q7 V12 TDI quattro

Further interior equipment	
<p><b>Footwell trim, in velour carpet</b> optionally in Fresco carpet, coordinated with the interior colour. (Can be ordered via design packages)</p>	<p><b>Dashboard</b> padded, with black or beige trimmed cover</p>
<p><b>Floor mats, front and rear</b> made of Velour or Fresco (two-tone in multicolour loop design), coordinated with the corresponding footwell trim</p>	<p><b>Centre console</b> with air conditioning controls, ashtray, selector levers, MMI terminal, cigarette lighter, 12 volt socket</p>
<p><b>Audi exclusive carpet including floor mats</b> with leather piping, front and rear, colour of mats and piping can be selected individually in various Audi exclusive colours. From quattro GmbH</p>	<p><b>Cigarette lighter and ashtray</b> in the front centre console</p>
<p><b>Sill trims with aluminium inlays</b></p>	<p><b>Grab handles</b> four-fold, foldable, each recessed into roof</p>
<p><b>Aluminium look pedals</b></p>	<p><b>12 volt sockets</b> in the front centre console, on the rear right in the luggage compartment as well as two in the rear centre console</p>
<p><b>Electric windows</b> front and rear with safety system to limit maximum closing force, one-touch opening/closing function; convenience opening/ closing via central locking</p>	<p><b>Audi exclusive cool box</b> with compressor cooling technology, 2 possible temperature settings: -6°C freeze, +6°C cool; volume for four 0.5 litre bottles lying down. From quattro GmbH</p>
<p><b>Door trims</b> in inner panel with cloth cover, integrated armrests, colour coordinated with the interior colour</p>	

Please find out from your local Audi partner which equipment is standard and what optional equipment is available in your country.

 Only available for Q7  Only available for Q7 V12 TDI quattro

MMI® and navigation systems
<p><b>MMI® radio</b> integrated control concept, comprises MMI terminal (control unit) and MMI display (6.5 inch colour display in the dashboard), extra display in the instrument panel, basic personalisation of vehicle functions, integrated radio with phase diversity for optimum reception, single CD player ( supports audio CDs) </p>
<p><b>MMI® radio plus</b> integrated control concept, as MMI radio, additionally 2 SDHC card readers, Audi sound system and TP Memo (automatically saves traffic news); SDHC card reader and single CD drive support MP3 and WMA </p>
<p><b>MMI® navigation</b> including navigation data (DVD), 6.5-inch colour display with high-quality map display and numerous detailed display options, voice control (destination entry via spelling), dynamic route guidance and TMC (where available), MP3 and WMA-compatible DVD player for navigation data (DVD), additional arrow display in the driver information system with colour display, Audi sound system, radio with twin tuner, phase diversity, 2 SDHC card readers for up to 32 GB. (Can only be ordered in conjunction with a driver information system with colour display and multifunction leather steering wheel) </p>
<p><b>Navigation data (DVD)</b> contains navigation data for the following countries (where digitised): Andorra, Austria, Belgium, Croatia, Czech Republic, Denmark, Estonia, Finland, France, Germany, Gibraltar, Great Britain, Greece, Hungary, Ireland, Italy, Latvia, Liechtenstein, Lithuania, Luxembourg, Monaco, the Netherlands, Norway, Poland, Portugal, San Marino, Slovakia, Slovenia, Spain (including the Canary Islands), Sweden, Switzerland, the Vatican City </p>



**MMI® navigation plus**  
including navigation data (hard drive), high-resolution 7-inch colour display with high-quality map display, voice control system (destination entry by means of whole-word input), choice of 3 alternative routes, map displays have topographical map colouring and show sightseeing information and 3D city models, scrolling along the route, joystick map manoeuvring function in the control button, split-screen route information (manoeuvring points, points of interest on motorways, TMC on route), detailed junction map and lane recommendation, dynamic route guidance with TCM (where available), additional arrow display in the driver information system with colour display, Audi sound system, radio with twin tuner, phase diversity, hard drive can also be used to store music (10 GB), MP3, WMA and AAC-compatible DVD player can also be used for music and video DVDs, 2 SDHC card readers (for up to 32 GB). (Can only be ordered in conjunction with a driver information system with colour display and multifunction leather steering wheel)



**Navigation data (hard drive)**

contains navigation data for the following countries (where digitised): Albania, Andorra, Austria, Belarus, Belgium, Bosnia-Herzegovina, Bulgaria, Croatia, Czech Republic, Denmark, Estonia, Finland, France, Germany, Gibraltar, Greece, Hungary, Ireland, Italy, Latvia, Liechtenstein, Lithuania, Luxembourg, Macedonia, Monaco, Montenegro, the Netherlands, Norway, Poland, Portugal, Romania, Russia, San Marino, Serbia, Slovakia, Slovenia, Spain (including the Canary Islands), Sweden, Switzerland, UK, Ukraine, the Vatican

**Driver information system**

a monochrome display provides you with information from the trip computer, auto check system, scope of display of the MMI system and digital speed display. The integrated efficiency program provides assistance in the form of consumption data overviews, a display of additional consumers and fuel-saving tips for adopting an economical driving style

Q7

**Radio and TV systems****Digital Audio Broadcasting reception (DAB)**

reception of digital stations in accordance with the DAB standard in addition to analogue stations; in connection with MMI navigation plus includes reception of DAB+ and DMB audio, the DAB double tuner permanently searches for alternative reception frequencies of the set station, and the station list is updated at the same time. Please note: reception depends on local digital network availability. (Can only be ordered in conjunction with MMI radio plus or a navigation system and double/acoustic glazing)

**TV reception**

reception of analogue and digitally-broadcast (DVB-T) uncoded television stations (MPEG-2 standard), TV image, teletext and EPG (Electronic Programme Guide). Facility to connect 2 external AV sources via the optional adapter cable. Please note: TV reception depends on local analogue and digital network availability. No AV or TV video function when driving (audio function available when driving). (Can only be ordered in conjunction with MMI navigation plus)

**Audi sound system**

6-channel amplifier, 11 speakers with excellent sound, 160 watt total output. (Standard with MMI Radio plus, MMI Navigation and MMI Navigation plus)

Q7

**Bang & Olufsen Advanced Sound System**

surround sound reproduction via 14 loudspeakers each with its own amplifier and exclusive aluminium loudspeaker covers; centre speaker and 2 automatically extending acoustic lenses on the instrument panel for superb true-to-detail sound performance from every seat; 1 midrange speaker and woofer in each front door; 1 tweeter and woofer in the rear doors; 1 subwoofer in the spare wheel well and 2 surround sound loudspeakers in the D-pillar; dynamic driving noise compensation; 14-channel amplifier; highly efficient ICE power amplifiers with a total output of more than 1,000 watts. The reproduction of 5.1 Surround Sound is possible in conjunction with MMI navigation plus and the integrated DVD drive. (Can only be ordered in conjunction with 3.0 TDI clean diesel quattro, 4.2 TDI quattro, 3.0 TFSI and Q7 V12)

**BOSE Surround Sound**

surround sound reproduction, dynamic driving noise compensation; 10-channel amplifier, 14 loudspeakers including a centre speaker in the dashboard and 2 surround loudspeakers in the rear headlining, subwoofer in the spare wheel well – for an extraordinary sound experience; 270 watts total output. The reproduction of 5.1 Surround Sound is possible in conjunction with MMI navigation plus and the integrated DVD drive

**CD changer**

Six-disc CD changer (MP3 and WMA-compatible) underneath the centre armrest, can be controlled via the MMI system; playback of copy-protected music files (DRM) is not possible

**Audi music interface**

for the connection of Apple iPod from generation 4, Apple iPhone (music functionality) as well as USB storage media and MP3 players. The Audi music interface is located in the glove compartment and operated via MMI navigation plus, MMI navigation, MMI radio plus or a multifunction leather steering wheel. Note: can only be used in conjunction with a special adapter cable (Audi Genuine Accessories). Please contact your Audi partner for information on compatible MP3 players

**Adapter cable set for Audi music interface**

consisting of 2 connection cables for the connection of iPod/iPhone or data carrier/media player with USB connection (Type A); further adapter cables available from Audi Genuine Accessories

**CD softbag**

for individual storage of up to 24 CDs

**Driver information system with colour display**

a high-resolution display provides you with information from the trip computer, auto check system, scope of display of the MMI system and digital speed display. The integrated efficiency program provides assistance in form of consumption data overviews, a display of additional consumers and fuel-saving tips for adopting an economical driving style

Please find out from your local Audi partner which equipment is standard and what optional equipment is available in your country.

**Q7** Only available for Q7 **Q7 V12** Only available for Q7 V12 TDI quattro

**Rear Seat Entertainment fitting**

includes pre-installation wiring and mounts for the holders in the driver and front-passenger seat backrests. The appropriate Rear Seat Entertainment package (tablet player with holder) is available as a Plug-and-Play unit from Audi Genuine Accessories

**Rear Seat Entertainment**

with 2 monitors incorporated into the head restraints with 6.5 inch LCD screens; DVD player with six-disc changer, 2 headphones and connections for external sources. From quattro GmbH

**Rear Seat Entertainment plus**

items as Rear Seat Entertainment, but with additional connection to the on-board sound system and TV connection. From quattro GmbH

**Telephones and communications****Bluetooth interface**

Bluetooth-compatible mobile telephones can be connected to the vehicle via the interface. Hands-free calls in the vehicle possible via microphones

Q7

**Mobile phone fittings (Bluetooth)**

including a hands-free device and voice control for the telephone functions and a pre-installation fitting for an optional mobile-specific charger; operated via the MMI navigation plus, MMI navigation, MMI radio plus, the multifunction leather steering wheel or, if available, via the voice control system; please contact your Audi partner for adapters and information on compatible mobile phones

**Bluetooth car phone**

your Bluetooth-compatible mobile phone can easily be connected to the GSM module inside the vehicle (pre-condition: that your mobile has SIM access profile), additional SIM card reader located in the trim of the MMI navigation/MMI navigation plus. Transfer of phone book entries to the vehicle and management of call lists; simple operation using MMI navigation/MMI navigation plus, multifunction steering wheel or voice control system. (Can only be ordered in conjunction with MMI navigation or MMI navigation plus)

**Bluetooth car phone with wireless handset**

in addition to the Bluetooth car phone, the set also includes a handset with colour display and integrated SIM card reader, for discreet phone calls; easy writing of text messages thanks to automatic word recognition. Handset is stored in the comfort centre armrest at the front

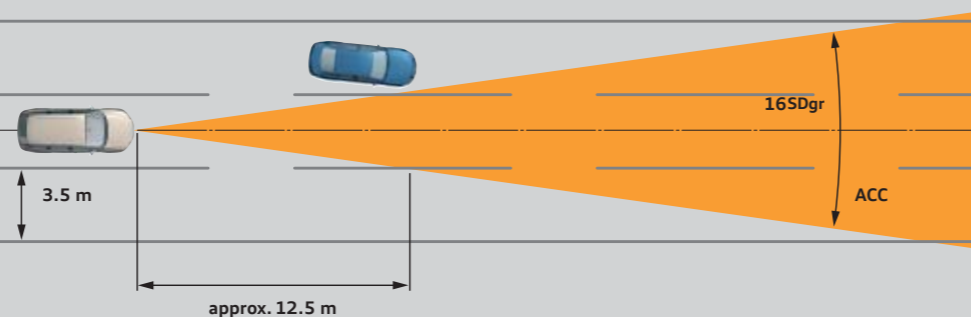
**Assistance systems****adaptive cruise control**

automatic distance control (control range from 0 to 200 km/h); working within system limits, it uses a radar sensor to detect vehicles ahead and maintains this distance by braking and accelerating; 4 programs can be selected individually via the steering column stalk of the cruise control system; including Audi braking guard with warning for driver of an imminent collision with a vehicle travelling in front provided by observation of surroundings

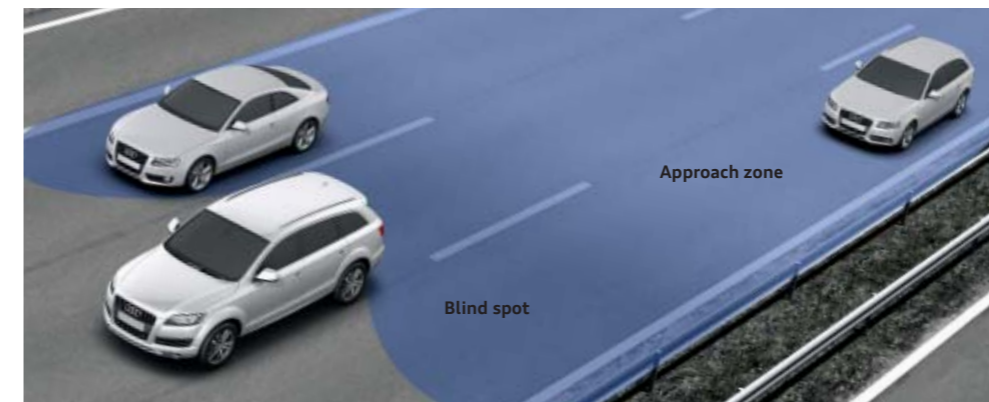
**Audi side assist<sup>1</sup>**

lane changing assistant, from a speed of 30 km/h, monitors within system limits the area at the side behind the vehicle as it is driving along and informs the driver via an LED display in the exterior mirror if the system has detected another vehicle in the adjacent lane; can be activated via the button in the driver's door

**Audi lane assist<sup>1</sup>**

lane compliance assistant, the system creates within system limits a virtual driving lane using a front camera and steering angle sensor; if there is a danger of the vehicle leaving this lane and the indicator has not been actuated, the driver is informed in the form of steering wheel vibrations. (The grey-tinted strip along the windscreen is omitted; can only be ordered in conjunction with the 4-spoke multifunction leather steering wheel)

**Parking system, rear**

makes parking easier by indicating acoustically how far away the vehicle is from an obstacle at the rear; measurement is by ultrasonic sensors concealed in the bumpers

Q7

**Parking system plus**

this extended parking aid offers an acoustic and an additional optical display of the space at the front and rear in the MMI display

**Parking system plus with reversing camera**

acoustic and visual parking aid for the front and rear, image of area behind the vehicle shown on the MMI display, reversing camera concealed in the luggage compartment lid handle. (Can only be ordered in conjunction with MMI navigation plus, MMI navigation or MMI radio plus)

**Cruise control system**

maintains any desired speed above around 30 km/h, provided engine power output and engine braking effect permit; operating via separate steering column stalk, at the same time the speed set is also displayed temporarily in the instrument cluster display. (Depiction in the driver information system, if included in the order)

Please find out from your local Audi partner which equipment is standard and what optional equipment is available in your country.

Q7 Only available for Q7 Q7 V12 Only available for Q7 V12 TDI quattro

<sup>1</sup> The image is an illustration, not a real representation.

## Suspension/brakes

**adaptive air suspension<sup>1</sup>**

electronically controlled air suspension with infinitely variable adaptive damping system on all 4 wheels, automatically controls vehicle level and damping; 5 modes (automatic, comfort, dynamic, offroad, lift), can be selected via the MMI system; including level control and loading level. (Standard for 4.2 TDI quattro and Q7 V12)

**S line adaptive air suspension**

from quattro GmbH, enables a sporty dynamic to comfortable suspension setting, as opposed to the adaptive air suspension, the S line model offers an additional lowering of a lowered suspension by 20 mm

Q7

**Dynamic suspension**

for excellent driving dynamics and ride comfort, comprising  
**front suspension:** independent wheel suspension, double wishbone axle with steering mechanism at the back, aluminium suspension arm, suspension subframe and stabiliser;  
**rear suspension:** independent wheel suspension, double wishbone axle with released upper link level and steering link at the back, aluminium suspension arm, suspension subframe and stabiliser.  
 (Cannot be ordered in conjunction with the 4.2 TDI quattro)

Q7

**S line sports suspension**

from quattro GmbH with more dynamic suspension tuning and suspension lowered by 10 mm

Q7

**Braking system**

dual-circuit, diagonally-split braking system, anti-lock system ABS with electronic brake force distribution EBD, electronic differential lock EDL, traction control ASR, Electronic Stabilisation Programme (ESP), with hydraulic brake assist, ventilated 18-inch front disc brakes and ventilated rear 17-inch disc brakes (ventilated 18-inch disc brakes at front and rear for 3.0 TFSI quattro [245 kW] and 4.2 TDI quattro)

Q7

**Parking brake**

foot-operated parking brake

**Ceramic brake**

20-inch high-performance braking system with carbon-fibre reinforced ceramic brake discs, specially developed cooling channels for the ventilated and perforated brake discs, anthracite brake callipers, with "Audi ceramic" logo at front. (Only for 4.2 TDI quattro and 3.0 TFSI quattro [245 kW] quattro in conjunction with 10 J x 20-inch or 21-inch wheels and tyre pressure monitoring system)

## Technology/safety

**Body, galvanised**

fully-galvanised in areas at risk from corrosion, unitary construction, front and rear areas feature defined crumple zones

**Side impact protection**

in the doors, comprises high-strength aluminium impact bars, highly stress-resistant steel panel alloy in the B-pillars for a controlled energy loss outside

**Childproof safety locks**

mechanical for the rear doors and electric for the rear windows

**Full-size airbags<sup>2</sup>**

for driver and front passenger, two-stage deployment

**Side airbags, front<sup>2</sup>**

integrated into the front seats

Please find out from your local Audi partner which equipment is standard and what optional equipment is available in your country.

**Q7** Only available for Q7 **Q7 V12** Only available for Q7 V12 TDI quattro

<sup>1</sup> The image is an illustration, not a real representation.

<sup>2</sup> The image is an illustration, not a real representation, and shows the technical status of the airbags as a snap-shot.



**Integral head restraint system**  
in the event of a rear-end collision the shape of the seat restrains the upper body and supports the head early; this increases safety and reduces the danger of whiplash

**Instrument cluster**  
with adjustable lighting; round instruments for rev counter, electronic speedometer, coolant temperature display and fuel gauge; time and date display, mileage and trip odometer, warning and control lights, maintenance interval display. (In conjunction with driver information system display for radio station frequency, outside temperature and fuel tank range)

**Safety steering column**  
increases the safety potential of the seat belts and airbags

**Battery energy management**  
consisting of battery diagnosis, quiescent current management and dynamic energy management; ensures a good supply of the vehicle with electrical energy during the journey and when stationary

**Seat belts**  
three-point inertia reel seat belts for all seats (also for the optional third row of seats), with belt height adjustment and belt force limiter for the first row of seats and the outer seats of the second row, front seats additionally with pyrotechnical belt tensioner and seat belt reminder

**Side airbags, rear<sup>1</sup>**  
for the outer seats in the second row; supplement the side impact protection in the doors and the head airbag system

**Head airbag system<sup>1</sup>**  
large-area head airbag system, unfolds as a protective cushion over the entire length of the side windows in the area from the first to the optional third row of seats and protects the occupants in the front and outer rear seats in the event of a side impact

**Belt height adjustment**  
for the front and outer seats of the second row of seats, manually adjustable

**Warning and indicator lamps**  
incorporated for: airbag, ABS, ESP/ASR, activated parking brake, generator, light, main beam, belt warning, indicator lights, brake system, engine oil pressure, engine electronics, immobiliser, pre-heater system (TDI)

**Warning triangle**  
with bracket on the inside of the luggage compartment lid

**First-aid kit**  
in the storage compartment under the front passenger seat

**Traction control (ASR)**  
for excellent traction, prevents the drive wheels from spinning

**Electronic differential lock (EDL)**  
on surfaces with varying levels of grip, this start-off assistant automatically brakes the drive wheels on the surface that is too slippery, thereby ensuring smooth, powerful progress; operates at speeds up to approx. 100 km/h

**Electronic Stabilization Programme (ESP)**  
with hydraulic brake assist; the ESP ensures greater stability in hazardous driving situations by targeted braking of individual wheels and intervention in the engine management system; with extended on and offroad functions, including offroad mode for improved traction on loose ground, with hill start and hill descent assist and roll-over stabilisation

**servotronic**  
rack and pinion power steering with variable steering transmission; due to the speed-dependent control, the driver has a precise steering feel at high speeds and best possible assistance when parking



**tiptronic**  
8-speed automatic transmission with Dynamic Shift Program (DSP), option of manual control via shift paddles on the multifunction leather steering wheel (if ordered)

**tiptronic**  
6-speed tiptronic with Dynamic Shift Program DSP; force transmission takes place by means of a hydraulic torque converter with lock-up clutch

Please find out from your local Audi partner which equipment is standard and what optional equipment is available in your country.

Q7 Only available for Q7 Q7 V12 Only available for Q7 V12 TDI quattro

<sup>1</sup> The image is an illustration, not a real representation, and shows the technical status of the airbags as a snap-shot.

**quattro®<sup>1</sup>**

permanent all-wheel drive with asymmetric/dynamic torque distribution, self-locking centre differential, electronic differential lock (EDL) via braking intervention on all driven wheels

**Recuperation**

with six and eight-cylinder models, increasing the generator voltage converts kinetic energy into usable electrical energy when the vehicle is coasting or braking. This energy is used to assist the generator during a subsequent acceleration, saving up to 3 % fuel

Q7

**Start/stop system**

reduces fuel consumption and CO<sub>2</sub> emissions by switching off the engine when standing, e. g. at traffic lights. When you want to continue your journey, you only have to release the foot brake: the engine starts up again. The system is convenient, quiet and fast. It can be deactivated at any time via a switch. (Only for 3.0 TDI quattro 150 kW and 176 kW each with EU5)

Q7

**Audi TDI clean diesel**

in addition to the standard equipment with catalytic converter and diesel particulate filter, the new exhaust aftertreatment system installed in the model with TDI clean diesel leads to low exhaust emissions. Technically speaking, this is achieved by equipment such as the cylinder pressure regulator, Common Rail injection system with piezo technology with 2,000 bar injection pressure, extremely efficient exhaust gas recirculation system and nitrogen oxide catalyst (DeNOx catalyst) with AdBlue® tank (a biodegradable additive, tiny amounts of which are injected into the catalytic converter). Refill the separate AdBlue® tank as indicated by the information in the display of the instrument cluster. We recommend having the AdBlue® tank refilled by your Audi partner (about every 15,000 km)

Q7

Please find out from your local Audi partner which equipment is standard and what optional equipment is available in your country.

Q7 Only available for Q7 Q7 V12 Only available for Q7 V12 TDI quattro



## Audi Top Service®.

In motorsport, it is a well-rehearsed team comprising know-how and precision which counts. You can expect the same from Audi Service, whether for maintenance, inspection or for professional repair of accident damage. And unlike at a pit-stop, we are not just available for a few seconds, we are available 24 hours a day.

Moreover, your Audi partner offers you an extended warranty if you purchase a new car or Audi CarLife Plus as a subsequent guarantee solution.

### Mobility guarantee<sup>1</sup>

You will receive free assistance as quickly as possible if your Audi should break down or be involved in an accident. Mobility guarantee is initially valid for 2 years and is renewed every time you have an inspection carried out by an Audi partner or whenever you get your vehicle serviced in accordance with the service interval display in the instrument cluster. Further information is available from your Audi partner..

### Pick-up and delivery service

Pick-up and delivery service for workshop appointments. Your vehicle will be picked up and returned to you by your Audi partner. Prices and conditions vary depending on distance from dealership. Further information is available from your Audi partner.

### Round-the-clock assistance

In the event of a breakdown you can reach us.<sup>2</sup> For more information and the telephone number for your country, please contact your Audi partner.

### Audi extended warranty<sup>3</sup>

If you purchase a new vehicle, a 100% Audi manufacturer's guarantee can be easily included in the order so that, even after the two-year guarantee period has expired you are protected against risk and can control costs. The Audi extended warranty offers you an individual combination of service life and mileage for up to 3 years following the end of the manufacturer's guarantee with a maximum mileage of 150,000 km.

### Audi CarLife Plus<sup>3</sup>

If the Audi extended warranty was not ordered when a new car was purchased, Audi CarLife Plus is the subsequent solution for the period following the end of the manufacturer's guarantee. Audi CarLife Plus offers you coverage against damage for many mechanical and electric parts - with benefits for those who sign up early and, if desired, for the entire lifetime of the car.

### Audi Genuine Parts®

Audi Genuine Parts are tailored to the respective Audi model to ensure a perfect fit. Development to production-level standards and extensive testing ensure they not only do the job but also meet exacting requirements in terms of long service life and quality.

<sup>1</sup>Your Audi partner will be happy to inform you whether mobility guarantee is available in your country.

<sup>2</sup>Your Audi partner will be happy to inform you whether the hotline can be contacted free-of-charge in your country.

<sup>3</sup>Your Audi partner will be happy to inform you if the Audi extended warranty and Audi CarLife Plus are available in your country.

Find out from your local Audi partner which service is free-of-charge or available at an additional cost in your country.



## Audi Genuine Accessories

If you are looking for adventure, you need the right equipment.

Provisions, map and sturdy shoes. So you are ready for the next adventure. And your car? You can equip that just as well – with top quality accessories, adapted to each vehicle model right down to the last detail. Audi Genuine Accessories offer top technical quality and a high degree of individual design options. So that you can individually adapt your Audi Q7 to your personal requirements. The following pages will show you a small selection of Audi Genuine Accessories.



# Q7

Audi Q7 Accessories

Detailed information can be obtained from the Audi Q7 Accessories catalogue, at [www.audi.com](http://www.audi.com) and from your Audi partner.





**offroad style package<sup>1</sup>**

You will definitely attract attention with the offroad style package. The striking design of the Audi Q7 is given a sporty and robust flair thanks to its selected details. The entire package comprises wheel housing extensions, door strips, front and rear apron with stainless steel underide protection and running boards, and specific tailpipes. After all, the Audi Q7 typifies the offroad idea like no other Audi. Decide on striking accents or take the entire package – and draw attention to the powerful side of your Audi Q7 in style. All eyes will be on you.

<sup>1</sup> Only available for six and eight-cylinder models.



**Cast aluminium wheels, 5-arm design, two-piece<sup>1</sup>**

The striking feature of the size 9 J x 20 two-piece cast aluminium wheels in 5-arm design are the titanium-screwed cast trims. For tyres of the size 275/45 R 20. For more wheels in dynamic design and winter wheels, please refer to the special accessories catalogue.



**Ski and luggage box (450 l)<sup>2</sup>**

This lockable ski box is particularly suitable for winter holiday use. It offers a large opening angle for easy loading and can be folded up on both sides. Suitable for skis up to 2.10 m long. Also included in the range are a ski and luggage box containing 480 l and a compact luggage box containing 370 l.



**Mobile phone adapter for optional mobile phone fitting (Bluetooth)**

The mobile phone adapter makes use of the optionally installed mobile phone fitting and enables phoning using a hands-free facility. The adapter includes the bracket and the charger and connects the mobile to the aerial. Suitable for many popular mobile phone models.

<sup>2</sup> Can only be used in conjunction with the basic carrier unit. Maximum permissible weight of the carrier unit, attachment components and load of 100 kg must be observed.



**Audi child seat with ISOFIX**

Grows with your child: the Audi child seat with ISOFIX, adjustable seat and seven-fold height adjustment. Suitable from 9 to 18 kg (approx. 1 to 4 years). The Audi baby seat is available for babies up to 13 kg (approx. 15 months), and the Audi child seat youngster for children from 15 to 36 kg (approx. 3½ to 12 years). The variously coloured seat covers are washable.



**Partition grille**

With the practical aids such as the partition grilles (longways and sideways), the luggage compartment can be separated from the rest of the interior and can also be divided lengthways. The partition grille is easy and convenient to attach – without any drilling.



**Care products**

The Audi range of cleaning and care products is specially tailored to the high-quality materials in your Audi. Suited to exterior maintenance or many different applications inside the vehicle, depending on the product.

Model	Audi Q7 3.0 TDI quattro with diesel particulate filter	Audi Q7 3.0 TDI quattro with diesel particulate filter	Audi Q7 3.0 TDI clean diesel quattro with diesel particulate filter and nitrogen oxide catalytic converter <sup>10</sup>	Audi Q7 4.2 TDI quattro with diesel particulate filter
Engine type	V6-cylinder diesel engine with common rail injection system and exhaust gas turbocharger	V6-cylinder diesel engine with common rail injection system and exhaust gas turbocharger	V6-cylinder diesel engine with common rail injection system and exhaust gas turbocharger	V8-cylinder diesel engine with common rail injection system and exhaust gas turbocharger
Displacement in cc (valves per cylinder)	2967 (4)	2967 (4)	2967 (4)	4134 (4)
Max. output <sup>1</sup> in kW at rpm	150/3200–4400	176/3800–4400	176/4000–4400	250/4000
Max. torque in Nm at rpm	450/1250–2750	550/1750–2500	550/2000–2250	800/1750–2750

Power transmission/wheels				
Type of drive	quattro® permanent all-wheel drive	quattro® permanent all-wheel drive	quattro® permanent all-wheel drive	quattro® permanent all-wheel drive
Transmission	8-speed tiptronic	8-speed tiptronic	8-speed tiptronic	8-speed tiptronic
Wheels	Aluminium 7.5 J x 18	Aluminium 7.5 J x 18	Aluminium 7.5 J x 18	Aluminium 8 J x 18
Tyres	235/60 R 18	235/60 R 18	235/60 R 18	255/55 R 18

Weights/capacities									
Unladen weight <sup>2</sup> in kg	2345	[2375]	2345	[2375]	2410	[2440]	2485	[2515]	
Gross vehicle weight <sup>3</sup> in kg	2995	[3125]	2995	[3125]	3060	[3190]	3135	[3265]	
Roof load/trailer nose weight in kg	100/140	[100/130]	100/140	[100/130]	100/140	[100/130]	100/140	[100/130]	
Trailer load limit <sup>4</sup> in kg	<b>unbraked</b>	750	750	750	750	750	750	750	
	<b>12% gradient</b>	3500	[3200]	3500	[3200]	3500	[3200]	3500	[3200]
	<b>8% gradient</b>	3500	[3200]	3500	[3200]	3500	[3200]	3500	[3200]
Fuel tank capacity, approx. in l	100		100		100		100		

Performance/consumption <sup>5</sup>					
Top speed in km/h	202/205 <sup>6</sup>	215/218 <sup>6</sup>	215/218 <sup>6</sup>	242 <sup>6</sup>	
Acceleration 0–100 km/h in s	9.1	7.9	8.1	6.4	
Fuel grade	Diesel sulphur-free <sup>7</sup>	Diesel sulphur-free <sup>7</sup>	Diesel sulphur-free <sup>7</sup>	Diesel sulphur-free <sup>7</sup>	
Fuel consumption <sup>9</sup> in l/100 km	<b>urban</b>	8.2	8.6	10.9	12.0
	<b>extra-urban</b>	6.5	6.7	6.9	7.6
	<b>combined</b>	7.2	7.4	8.4	9.2
CO <sub>2</sub> emissions <sup>9</sup> in g/km	<b>urban</b>	216	225	285	316
	<b>extra-urban</b>	172	178	182	200
	<b>combined</b>	189	195	219	242
Emissions standard	EU 5	EU 5	EU 6	EU 5	

[ ] Data for six and seven-seater.

Model	Audi Q7 3.0 TFSI quattro (200 kW)	Audi Q7 3.0 TFSI quattro (245 kW)
Engine type	V6-cylinder petrol engine with direct fuel injection	V6-cylinder petrol engine with direct fuel injection
Displacement in cc (valves per cylinder)	2995 (4)	2995 (4)
Max. output <sup>1</sup> in kW at rpm	200/4750–6500	245/5500–6500
Max. torque in Nm at rpm	400/2250–4750	440/2900–5300

Power transmission/wheels		
Type of drive	quattro® permanent all-wheel drive	quattro® permanent all-wheel drive
Transmission	8-speed tiptronic	8-speed tiptronic
Wheels	Aluminium 7.5 J x 18	Aluminium 8 J x 18
Tyres	235/60 R 18	255/55 R 18

Weights/capacities					
Unladen weight <sup>2</sup> in kg	2295	[2325]	2315	[2345]	
Gross vehicle weight <sup>3</sup> in kg	2945	[3075]	2965	[3095]	
Roof load/trailer nose weight in kg	100/140	[100/130]	100/140	[100/130]	
Trailer load limit <sup>4</sup> in kg	<b>unbraked</b>	750	750	750	
	<b>12% gradient</b>	3500	[3200]	3500	[3200]
	<b>8% gradient</b>	3500	[3200]	3500	[3200]
Fuel tank capacity, approx. in l	100		100		

Performance/consumption <sup>5</sup>			
Top speed <sup>6</sup> in km/h	222/225 <sup>6</sup>	243/245 <sup>6</sup>	
Acceleration 0–100 km/h in s	7.9	6.9	
Fuel grade	Super sulphur-free RON 95 <sup>8</sup>	Super sulphur-free RON 95 <sup>8</sup>	
Fuel consumption <sup>9</sup> in l/100 km	<b>urban</b>	14.4	14.4
	<b>extra-urban</b>	8.5	8.5
	<b>combined</b>	10.7	10.7
CO <sub>2</sub> emissions <sup>9</sup> in g/km	<b>urban</b>	335	335
	<b>extra-urban</b>	199	199
	<b>combined</b>	249	249
Emissions standard	EU 5	EU 5	

#### Notes

<sup>1</sup> The figure stated was calculated using the specified measuring procedure (current version of Directive 80/1269/EEC).

<sup>2</sup> Weight of car, unladen, with driver (68 kg), luggage (7 kg) and fuel tank 90% full, calculated in accordance with the current version of RL 92/21/EEC. Optional equipment may increase the car's unladen weight and drag coefficient, whereupon the possible payload limit and the top speed will be reduced accordingly.

<sup>3</sup> The payload increases by 100 kg for 6 and 7-seaters.

<sup>4</sup> The engine's power output always decreases with increasing altitude. At 1,000 m above sea level, and for every additional 1,000 m, deduct 10% from the weight of the outfit (trailer load limit + gross weight of the towing vehicle). Figure for trailer load limit applies to factory-fitted trailer towing hitch. If using the vehicle with a trailer towing hitch for commercial purposes, a digital tachograph may be required under certain conditions.

<sup>5</sup> A vehicle's fuel consumption and CO<sub>2</sub> emissions do not just depend on how efficiently the vehicle uses the fuel, but are also influenced by driving behaviour and other non-technical factors. CO<sub>2</sub> is the greenhouse gas primarily responsible for global warming.

<sup>6</sup> Figure applies to air suspension.

<sup>7</sup> We recommend the use of sulphur-free diesel in accordance with DIN EN 590. If not available: Diesel in accordance with EN 590.

<sup>8</sup> We recommend the use of sulphur-free unleaded super RON 95 fuel in accordance with DIN EN 228. If not available: sulphur-free regular unleaded RON 91 fuel in accordance with DIN EN 228, power output will be slightly reduced.

<sup>9</sup> The figures stated were calculated using the specified measuring procedures. The figures do not refer to one individual vehicle and do not form part of any offer, but rather should be used purely for purposes of comparison between the different vehicle models.

<sup>10</sup> We recommend having the separate AdBlue® tank refilled by your Audi partner as indicated by the information in the display of the instrument cluster (about every 15,000 km).

#### Important note

Inspections are due as shown by the service display.



Off-road properties	Six and eight-cylinder models	
Climbing ability as %	60	
Ground clearance in mm	204.8/239.8*	
Overhang angle in °	front	21.0/max. 23.5*
	rear	23.4/max. 25.4*
Ramp angle in °	21.1/23.8*	
Fording depth in mm	500/535*	

Audi Q7 7-seater

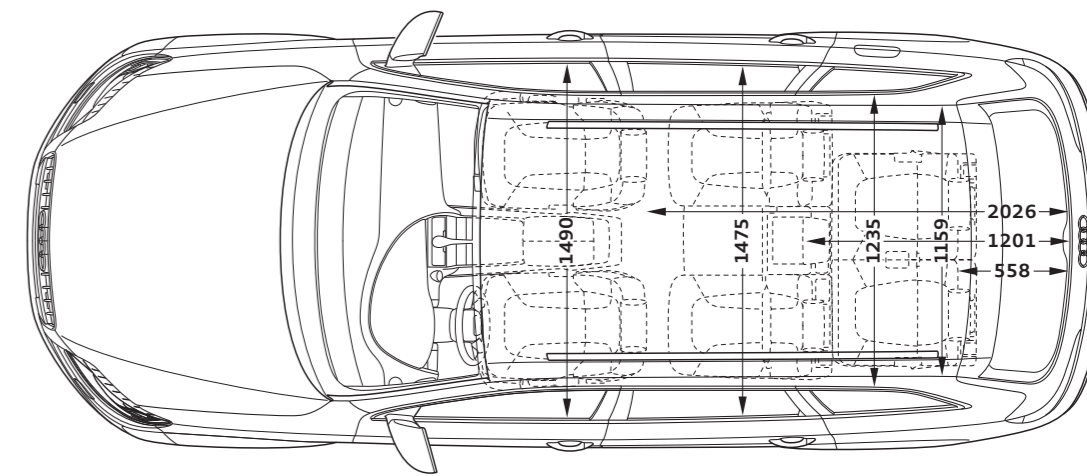
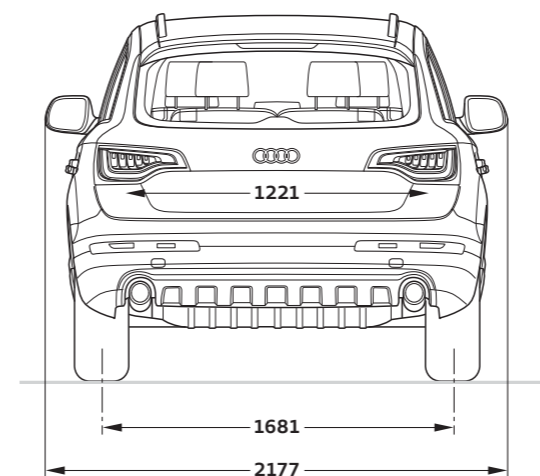
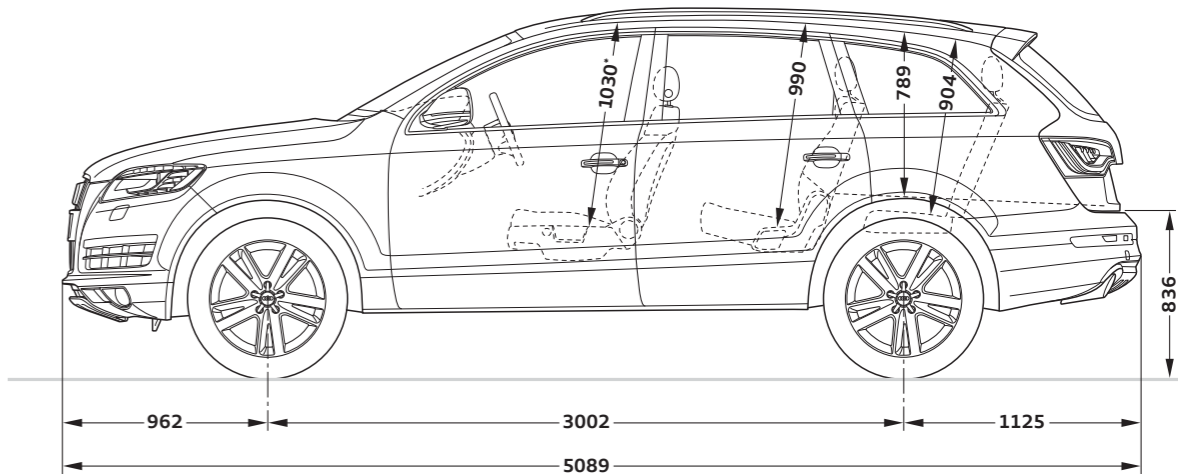
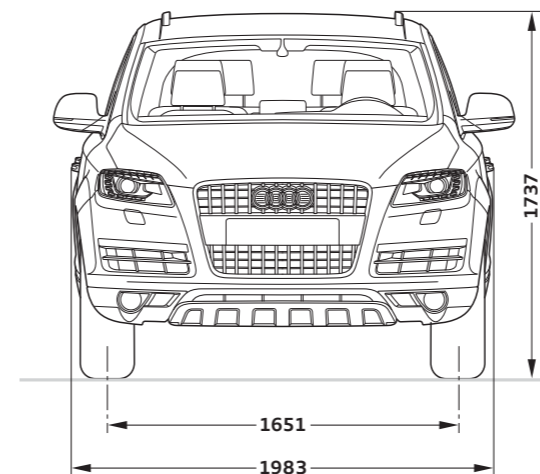

Dimensions in millimetres.

Dimensions were measured with vehicle at unladen weight, ground clearance measured with vehicle carrying its maximum load. Luggage compartment volume in l: 330/2035 (measured by the VDA method using 200 x 100 x 50 mm blocks. Second value is with the rear seat folded down and the vehicle loaded up to roof height). Turning circle approx. 12 m

\* Maximum headroom.

\*\* With optional air suspension, in loading level mode.

\* Figure applies to air suspension.

**Model** Audi Q7 V12 TDI quattro

<b>Engine type</b>	V12-cylinder diesel engine with common rail injection system and exhaust gas turbocharger	
<b>Displacement in cc (valves per cylinder)</b>	5934 (4)	
<b>Max. output<sup>1</sup> in kW at rpm</b>	368/3750	
<b>Max. torque in Nm at rpm</b>	1000/1750-3250	
<b>Power transmission/wheels</b>		
<b>Type of drive</b>	quattro® permanent all-wheel drive	
<b>Transmission</b>	6-speed tiptronic	
<b>Wheels</b>	Cast aluminium wheels 10 J x 20	
<b>Tyres</b>	295/40 R 20	
<b>Weights/capacities</b>		
<b>Unladen weight<sup>2</sup> in kg</b>	2710	
<b>Gross vehicle weight in kg</b>	3405	
<b>Roof load/trailer nose weight in kg</b>	100/120	
<b>Trailer load limit<sup>3</sup> in kg</b>	<b>unbraked</b>	750
	<b>12 % gradient</b>	3300
	<b>8 % gradient</b>	3300
<b>Fuel tank capacity, approx. in l</b>	100	
<b>Performance/consumption<sup>4</sup></b>		
<b>Top speed in km/h</b>	250 <sup>6</sup>	
<b>Acceleration 0-100 km/h in s</b>	5.5	
<b>Fuel grade</b>	Diesel sulphur-free <sup>7</sup>	
<b>Fuel consumption<sup>5</sup> in l/100 km</b>	<b>urban</b>	14.8
	<b>extra-urban</b>	9.3
	<b>combined</b>	11.3
<b>CO<sub>2</sub> emissions<sup>5</sup> in g/km</b>	<b>urban</b>	390
	<b>extra-urban</b>	245
	<b>combined</b>	298
<b>Emissions standard</b>	EU 5	

**Notes**

- <sup>1</sup> The figure stated was calculated using the specified measuring procedure (current version of Directive 80/1269/EEC).
- <sup>2</sup> Weight of car, unladen, with driver (68 kg), luggage (7 kg) and fuel tank 90 % full, calculated in accordance with the current version of RL 92/21/EEC. Optional equipment may increase the car's unladen weight and drag coefficient, whereupon the possible payload limit and the top speed will be reduced accordingly.
- <sup>3</sup> The engine's power output always decreases with increasing altitude. At 1,000 m above sea level, and for every additional 1,000 m, deduct 10 % from the weight of the outfit (trailer load limit + gross weight of the towing vehicle). Figure for trailer load limit applies to factory-fitted trailer towing hitch. If using the vehicle with a trailer towing hitch for commercial purposes, a digital tachograph may be required under certain conditions.
- <sup>4</sup> A vehicle's fuel consumption and CO<sub>2</sub> emissions do not just depend on how efficiently the vehicle uses the fuel, but are also influenced by driving behaviour and other non-technical factors. CO<sub>2</sub> is the greenhouse gas primarily responsible for global warming.
- <sup>5</sup> The values stated were calculated using the specified measuring procedures. The figures do not refer to one individual vehicle and do not form part of any offer, but rather should be used purely for purposes of comparison between the different vehicle models.
- <sup>6</sup> Regulated.
- <sup>7</sup> We recommend the use of sulphur-free diesel in accordance with DIN EN 590. If not available: Diesel in accordance with EN 590.

**Important note**

Inspections are due as shown by the service display.

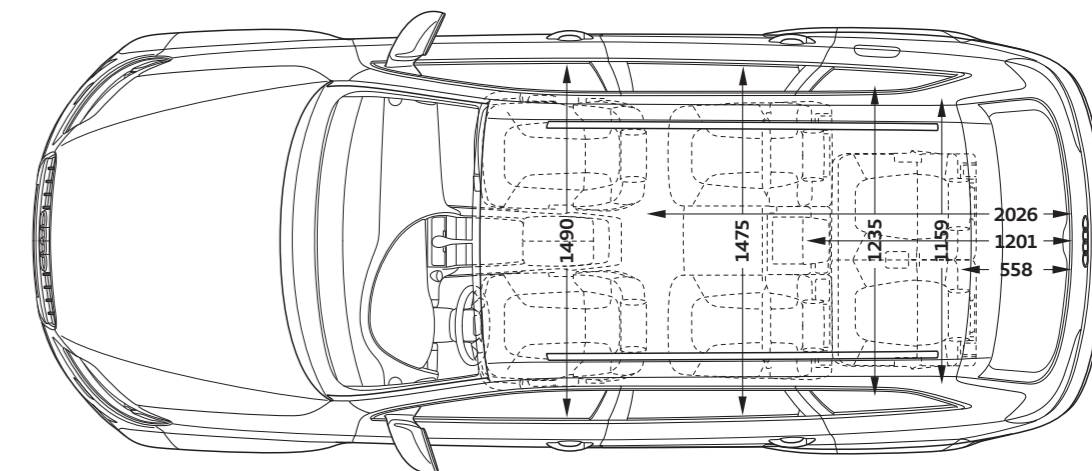
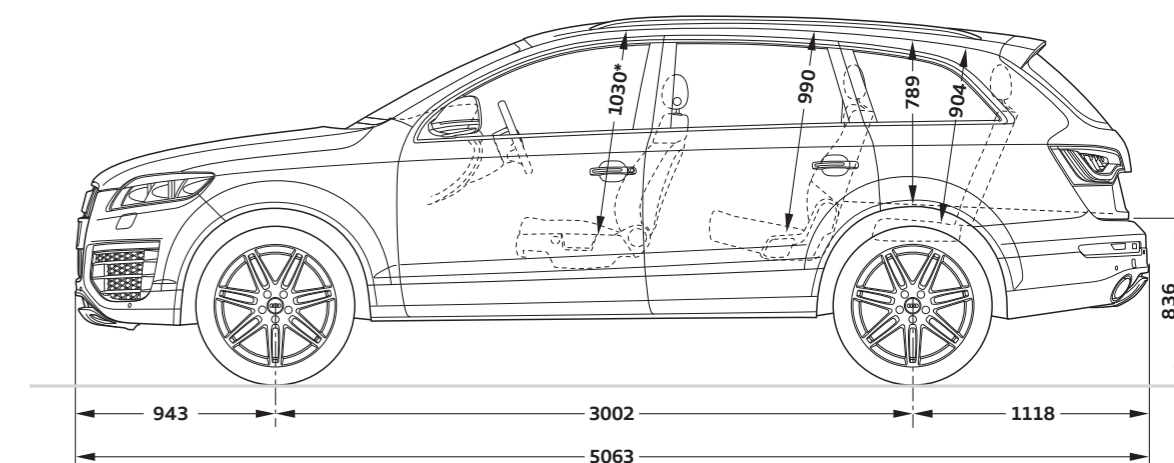
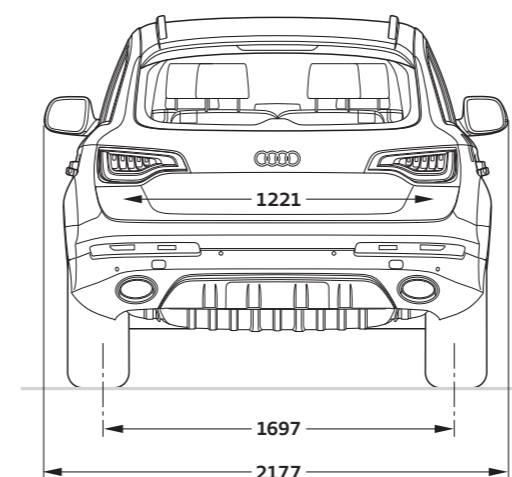
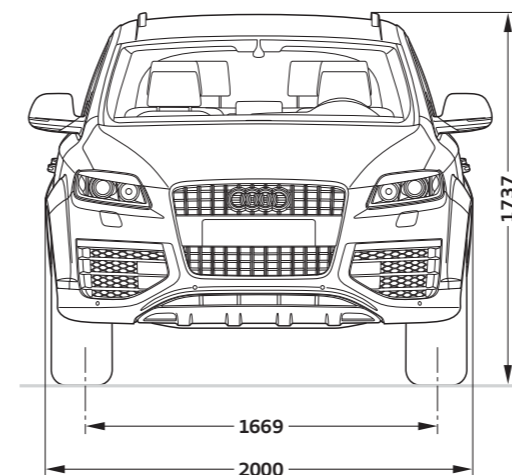
**Audi Q7 V12 TDI quattro 7-seater****Dimensions in millimetres.**

Dimensions were measured with vehicle at unladen weight, ground clearance measured with vehicle carrying its maximum load. Luggage compartment volume in l: 330/2035 (measured by the VDA test method using 200 x 100 x 50 mm blocks. Second value is with the rear seat folded down and the vehicle loaded up to roof height). Turning circle approx. 12 m.

\* Maximum headroom.

\*\* With optional air suspension, in loading level mode.

## Efficiency: standard in every Audi.



Vorsprung durch Technik is the claim to which the Audi brand is committed. It includes giving careful consideration time and again to each droplet of fuel. For many years, Audi has been translating this claim into tangible reality on all its models – and as a developer of numerous innovations is having a lasting influence on efficiency standards in automotive

engineering. Whether with the TDI, FSI® and TFSI® engine concepts, with transmission technologies or with the Audi Space Frame (ASF). To achieve on-going improvements in energy consumption, a number of intelligent efficiency measures – specifically tailored to each vehicle – are combined. Efficiency with a methodical approach – individual and stand-

ard. A commitment which is already leading to convincing results. Audi already has many models in its current range that emit less than 140 g CO<sub>2</sub>/km. An effective way of reducing emissions. And just as impressive as the fact that a large proportion of Audi vehicles already meet the strict EU 5 emissions standard.

All this demonstrates the know-how of Audi – and is what drives us on every day to harmonise sportiness and efficiency in the future.

## At Audi, you get much more than an Audi.

Anybody who chooses an Audi chooses a brand that offers its customers more. More individuality. More exclusivity. And more fascination.

### Audi configurator

Create your own personal Audi using the Audi configurator. All current models, engines, colours and equipment options are available for you to choose from.

> [www.audi.com](http://www.audi.com)

### Audi tv

On Audi tv you can discover whole new sides to our brand with the four rings: exciting commentaries on our models, technical innovations, fascinating events from the fields of motorsport, tradition, culture and lifestyle. Take a look behind the scenes. The latest news every day. Round the clock.

> [www.audi.tv](http://www.audi.tv)



## Equipment Audi Q7 and Audi Q7 V12 TDI quattro.

12 volt sockets	94	Climate-controlled comfort seats, front	70
4-way lumbar support	88	Cloth and leather trim	67
4-zone deluxe automatic air conditioner	91	Cloth headlining	75
Adapter cable set for Audi music interface	97	Clothes hooks	92
adaptive air suspension	100	Comfort centre armrest, front	89
adaptive cruise control	98	Comfort key	85
adaptive light	82	Comfort seats in the second row of seats	88
Alcantara/Leather combination	70	Contrasting paint	67, 86
All-terrain tyres	81	Cricket leather upholstery and trim	70
Aluminium look exterior	87	Cruise control system	99
Anti-theft system	85	Dark tinted windows (Privacy glazing)	85
Audi exclusive black styling package	86	Dashboard	94
Audi exclusive cardan reading lights	83	Deluxe automatic air-conditioning	91
Audi exclusive carpet/floor mats	94	Design packages	72-74
Audi exclusive colour coordinated decorative seams	72	Digital Audio Broadcasting reception (DAB)	96
Audi exclusive controls in leather	91	Door reflector	83
Audi exclusive cool box	94	Door trims	94
Audi exclusive leather upholstery and trim	70	Double loading floor	92
Audi exclusive line inlays	59	Double sun visor	86
Audi exclusive line Q7	58, 59	Double/acoustic glazing	85
Audi exclusive line seat covers	59	Drinks holder	92
Audi exclusive Q7	56, 57	Driver information system with colour display	96
Audi exclusive selector lever knob	91	Driver information system	96
Audi exclusive steering wheel rim	90	Dynamic suspension	100
Audi Genuine Accessories	107-109	Electric steering wheel adjustment	90
Audi lane assist	99	Electric windows	94
Audi music interface	97	Electrically adjustable front seats	88
Audi Service®	106	Electronic differential lock (EDL)	103
Audi side assist	99	Electronic Stabilization Programme (ESP)	103
Audi Singleframe	87	Equipment package Audi exclusive line	74
Audi sound system	96	Exhaust tailpipes	87
Audi TDI clean diesel	104	Exterior mirrors	84
Auxiliary heating/ventilation	91	First-aid kit	103
Bang & Olufsen Advanced Sound System	97	Fitting for Rear Seat Entertainment	98
Battery energy management	102	Fitting for Tracking Assistant	85
Belt height adjustment	103	Floor mats, front and rear	94
Bicycle mount in luggage compartment	93	Folding tables	92
Bluetooth car phone with wireless handset	98	Footwell trim, in velour carpet	94
Bluetooth car phone	98	Front fog lights	83
Bluetooth interface	98	Front/back adjustment for the second row of seats	88
Body galvanised	101	Full leather packages	71, 72
BOSE Surround Sound	97	Full-size airbags	101
Bottle holder	92	Garage door opener (HomeLink)	85
Braking system	101	Glove compartment	91
Bumpers	87	Grab handles	94
CD changer	97	Head restraints	89
CD softbag	97	Head-level airbag system	102
Centre armrest, front and rear	89	Headlight cleaning system	83
Centre console	94	Headlights	82
Ceramic brake	101	Headlining Audi exclusive	75
Childproof safety locks	101	Headlining in Alcantara with contrasting seams	75
Cigarette lighter and ashtray	94	Heat-insulating glass	85

