

# Early Incandescent Lamps

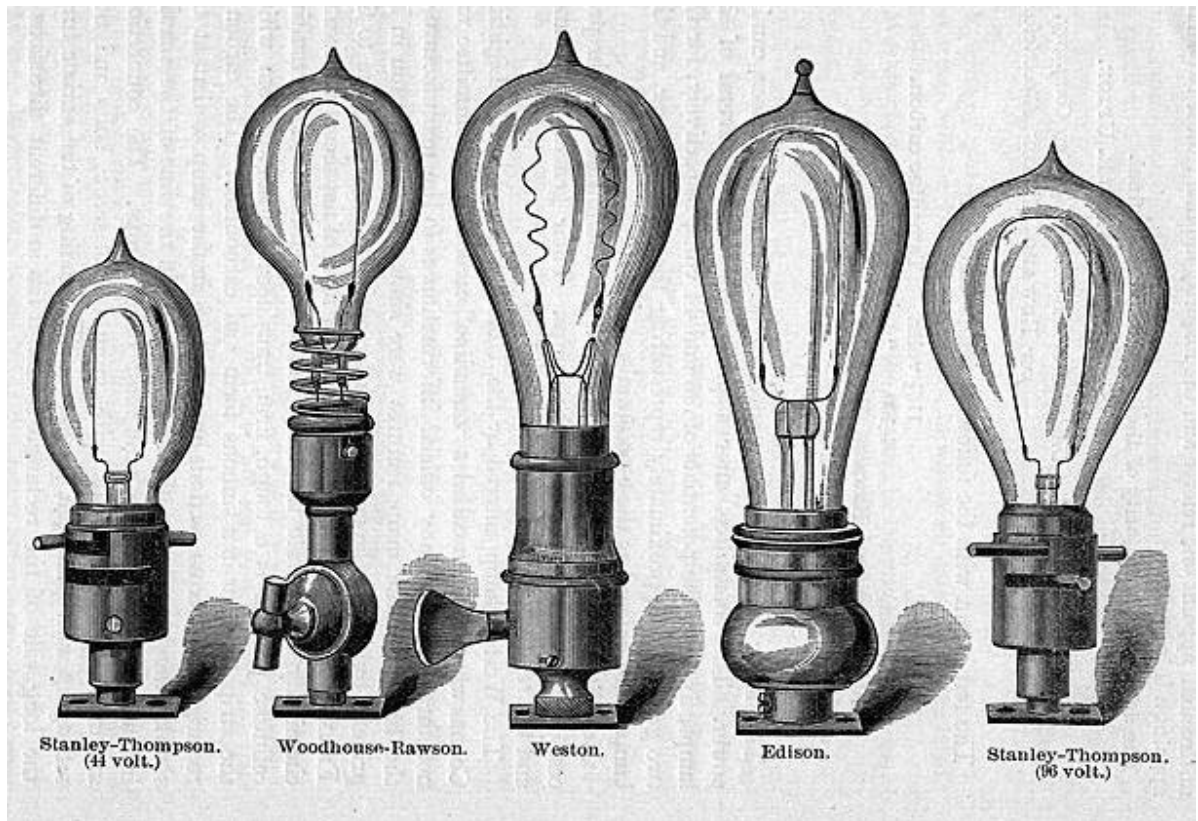

## Introduction

The history of the electric incandescent lamp can be considered to have begun with the invention of the voltaic pile by Alessandro Volta in 1800. Although the steps, sometimes very small steps, toward a practical lamp were many, it would be a rewarding job to treat the very early history in a manner in which the subject deserves. However, although the earlier history needs to be revealed in detail, this site concentrates mainly on lamp development between the years 1880-1925.

The various topics were written in random order, as the material surfaced from the writer's files. This version is simply an attempt to organize, under appropriate general headings, what had been written earlier. A few new topics have been added.

## Contents

<b>1)</b>	<b>Manufacturers</b>	<b>of</b>	<b>Incandescent</b>	<b>Lamps</b>
<a href="#">Incandescent Lamp Manufacturers in Cleveland, 1884-1905</a>	<a href="#">Location of the Swan Lamp Manufacturer</a>	<a href="#">Locations in 1886 and 1894</a>	<a href="#">The Shelby Electric Company</a>	<a href="#">The General Electric Company's Porcelain Factory</a>
<a href="#">GE Incandescent Lamp Manufacture in Fort Wayne, Indiana</a>	<a href="#">Manufacturers of Incandescent Lamps in 1938</a>	<a href="#">The Thomson-Houston Electric Incandescent Lamp, 1884-1893</a>	<a href="#">Hawkeye Electric Manufacturing Company</a>	<a href="#">Fort Wayne Jenney and Indianapolis Jenney</a>
<a href="#">The Sun Electric Company</a>	<a href="#">Lamp Manufacturers in Warren, Ohio</a>	<a href="#">The Excelsior Electric Company</a>		

<b>2)</b>	<b>Carbon</b>	<b>Filament</b>	<b>Lamps</b>
<a href="#">Lamp Descriptions-1885</a>	<a href="#">Franklin Institute Test</a>	<a href="#">The Largest Incandescent Lamp Ever Made</a>	<a href="#">As of 1899</a>
<a href="#">Later Samples of Carbon Filaments</a>	<a href="#">Carbon Filament Configuration and Light Distribution</a>	<a href="#">GEM (General Electric Metallized) Lamp Advertisement</a>	

The Edison Night Lamp  
 Colburn Incandescent Lamps  
 Buckeye Lamp  
 New Incandescent Lamps for Desks  
 The Seel Incandescent Lamp  
 The Heisler Incandescent Lamp  
 Perkins Incandescent Lamps and Sockets  
 The Hill Incandescent Lamp  
 The Freeman Incandescent Lamp  
 Henry Woodward and Mathew Evans Lamp  
 The Nothomb Lamp  
 Miniature Edison Lamps  
 1886 Stanley-Westinghouse Lamp  
 English Double Filament Lamp  
 Bernstein Lowatt Reflector Lamps  
 Westinghouse Series Lamps and Sockets  
 The Lamp of Edward Pollard  
 The Sterling Special Lamp  
 The Incandescent Lamp of Dr. Isaac Adams, Jr.  
The Cruto Lamp

**3) Tantalum Filament Lamps**  
Tantalum Filament Lamps

**4) The Osmium Filament Lamp**  
The Osmium Filament Lamp

**5) Tungsten Filament Lamps**  
 MAZDA Lamps with Sintered Tungsten Filaments  
 "Just" Tungsten Lamp for Burning in Any Position  
 1910 GE MAZDA Lamp With Sintered Tungsten Filament  
 MAZDA Trivia  
 The Gas-Filled Incandescent Lamp  
 The "Grain of Wheat" Lamp  
 The White MAZDA Lamp  
 The Mitchell and White Tipless Construction  
The Kuzel Lamp

6) **Platinum Filament Lamps**  
 Grove's Lamp of 1840  
 A Lamp of Uncertain Origin  
Farmer Lamps of 1859 and 1868

7) **Some Lamp Types**  
 Meridian Lamps  
 Electric Luminous Radiators  
 Hylo-Economical Turn-Down Lamps  
The Nernst Lamp

8) **Some Not-So-Well-Known Lamps**  
 The Elblight Lamp  
 The Livgro Incandescent Lamp  
 Crawford-Voelker Titanium Carbide Lamp  
 The Lamp of C. A. Bäckström  
 Decorative Diffusing Lamp  
 The "New Sunbeam" or "Acorn" Lamp  
 The Van Depoele Incandescent Lamp  
Somoff's Incandescent Lamps

9) **Lamp Parts**  
 Leading-In Conductors  
 Mica Disc Heat Deflectors  
 Incandescent Lamp Carbon Filaments  
 Economizing Platinum Wire in Incandescent Lamps  
Aluminum Leading-in Wires for Incandescent Lamps

10) **Lamp Bases and Sockets**  
 Edison's Early Lamp Base and Socket  
 Ediswan Lamp Terminals in 1893  
 Lamp Bases in Use Before Standardization  
 Incandescent Lamp Sockets in Use Before Standardization  
 The Manufacture of Lamp Bases  
 Hawkeye Base and Socket  
 Lamp Bases Used by Tungstram  
 Candelabra and Miniature Bases  
 Use of Porcelain in Lamp Bases  
Porcelain Lamp Base

A Universal Pull Lamp Socket  
General Electric Locking Socket  
Cutaway Views of Various Lamp Bases and Sockets  
Cartwright Waterproof Socket  
A New Incandescent Lamp Socket  
Convertible Lamp Bases  
Lamp Base Display

**11) Lamp Patents**  
Edison Patent No 444,530 (and Reissue No 12,393)  
Dates on Very Early British Patents  
A Review of the Henry Goebel Defense of 1893  
The Goebel Legend  
Thomson-Houston and Consolidated Patents

**12) Lamp Collections and Exhibits**  
The William J. Hammer Historical Collection of Incandescent Electric Lamps  
Comments on Some Hammer Lamps at the Ford Museum  
Edison Lamps at the Ford Museum  
Exhibits and Collections of Early Incandescent Lamps  
Lamps Collected by Charles Proteus Steinmetz  
Petzinger Filament Collection  
Lamp Display at Philips After 1964  
Collectors and Collections, Past and Present  
General Electric's Edison Exhibit in Chicago in 1893  
Two Small Collections of Early Lamps  
Goebel Original and Reproduced Lamps

**13) Stopper Lamps**  
Various Stopper Lamps  
A Tubular Westinghouse Stopper Lamp  
Low Voltage Westinghouse Stopper Lamps  
Adapters for Westinghouse Stopper Lamps

**14) Lamps Labels and Markings**  
Trademarks  
Trademark Labels of Some Companies in 1914  
Labels of the National Electric Lamp Association  
GEM (General Electric Metallized) Lamp Labels

[MAZDA Bulb Markings](#)  
[Labels Used on Lamps Shipped to Brazil](#)  
[The GE Monogram](#)  
[Three-Voltage Rating of Lamps](#)  
[Labels Used on Manufacturer's Lamps](#)

**15) Miscellaneous Lamp Topics**  
[Dating Edison Lamps, 1880-1905](#)  
[Images of Early Lamps](#)  
[Edison Lamp Replicas](#)  
[The Edison Effect](#)  
[Web Sites of Interest](#)  
[Lighting at the Columbian Exposition of 1893](#)  
[Lamp Exhaust Times at Thomson-Houston](#)  
[National Electric Light Association](#)  
[Excerpt from Letter from Harry Needham](#)  
[Comments from Edison Laboratory National Monument](#)  
[An Inquiry for Lamp Historians](#)  
[The First Windmill-Powered Incandescent Lamps in the World](#)  
[Seeing Inside an Outside-Frosted Lamp](#)  
[Bulb Darkening in Incandescent Lamps](#)  
[Photographs of Eminent Electrical Men](#)  
[Papers of John Robert Crouse, 1905-1932](#)  
[Aylsworth's Niobium Filament Preparation](#)  
[From Alessandro Volta to William Robert Grove](#)  
[World War II Blackout Light](#)  
[Incandescent Lamps for Horses' Harness](#)  
[Preventing Vibration in Incandescent Lamp Filaments](#)  
[Electric Light Plant Nearest the North Pole](#)  
[The Financial State of an Inventor](#)  
[Cut-Out for Series Incandescent Lamps](#)  
[The Incandescent Lamp—Beyond 1925](#)  
[Three 1907 Lamp Advertisements](#)  
[TILCA □ The Incandescent Lamp Collectors Association](#)  
[The Helion Lamp](#)  
[The Rooney Sun-Star Turn-Down Lamp](#)  
[Tri-Light Regulating Key-Socket and Lamp](#)  
[Zenith Incandescent Lamps](#)  
[The Albert Miller Lamp](#)

Economical Regulating Lamp  
The Story of Electricity  
Nela Park - A Brief Early History - Terry Management Style - and  
Incandescent Lamp Advances

<b>16)</b>	<b>Biographical</b>	<b>Sketches</b>			
E.	Q.	Adams			
Mary	R.	Andrews			
E.	J.	Bagnall			
Forée		Bain			
Edgar	G.	Bernard			
<b>Katharine</b>		<b>Blodgett</b>			
Ludwig	K.	Böhm			
Henry	M.	Byllesby			
F.	M.	F.	Cazin		
Sir	William	Crookes			
Ch.	de	Changy			
Additional	Information	on	Ch. De	Changy	
Philip				Diehl	
W.	E.	Forsythe			
St.	George	Lane	Fox-Pitt		
John	H.	Guest			
John	Allen	Heany			
William		Hochhausen			
John	White	Howell			
Wilson	Stout	Howell			
Francis	Jehl	-	An	Obituary	
Achilles	Matveevitch	(de)		Khotinsky	
Rudolf				Langhans	
Lewis	Howard			Latimer	
George	R.			Lean	
James	Bowman			Lindsay	
Matthew				Luckiesh	
Albon				Man	
Hiram	S.			Maxim	
Garrett	Morgan,	Traffic	Light	Inventor	
Aladar	Pacz,	Developer	of	Nonsag	Tungsten
Charles		G.		Perkins	
Marvin				Pipkin	

John	E.	Randall				
William	Edward	Sawyer				
Frederick		Schaefer				
Henry		Schroeder				
M.	M.	M.	Slattery			
William	Stanley,	Jr.				
John	Wellington	Starr				
Royal	F.	Strickland				
Alfred		Swan				
Sir	Joseph	Wilson	Swan			
Franklin	Silas	Terry				
Charles	J.	Van	Depoele			
John		Waring				
Edward	Weston	and	the	Tamidine	Filament	
Willis	Rodney	Whitney	and	the	GEM	Filament
W.	Mattieu	Williams				
O.E.		Woodhouse				
<u>Edmund Louis Gray Zalinski</u>						

**17) Books**  
Corrections to Howell and Schroeder's Book  
Excerpts from John W. Howell's Stories for My Children  
Electric Illumination, Vol II, edited by James Dredge  
Forty Years of Edison Service, 1882-1922  
Farmer on the Electric Light

The author is □

Edward J. Covington  
17279 Hooper Ridge Road  
Millfield, Ohio 45761-9645  
United States of America

ejcov@frogned.net  
740-448-1004

**Incandescent Lamp Manufacturers in Cleveland, 1884-1905**



## **Introduction**

In order to establish the dates of introduction of incandescent lamp manufacture in Cleveland it is necessary to consider briefly the origin of the commercial arc lamp. Charles Francis Brush put Cleveland on the lighting map in 1879 when he demonstrated his arc lamp. The first permanent street lighting in America was installed in that year after a demonstration of its operation was made on Public Square in the downtown area.

Following the success of Thomas Edison's incandescent lamp, also in 1879, manufacturers of arc lamps realized that they too had to get into the incandescent lamp business if they were to survive. In that year Charles Brush sent Thomas J. Montgomery to England in an effort to market his arc lamp there. Eventually this effort led to the formation of the Anglo-American Brush Electric Light Corporation. In due time both arc and incandescent installations were sold in England.

A major step toward introducing incandescent lamp manufacture in Cleveland occurred in 1882 when the Swan lamp interests in England formed the Swan Incandescent Electric Light Company of New York in an effort to market the Swan lamp system in the United States. This company was managed by Thomas Montgomery.

In the summer of 1883 the Brush Electric Company acquired the American rights to the Lane-Fox incandescent lamp patents and at that time added such lamps to its product line. However, the Lane-Fox lamp proved to be unsatisfactory for its applications. On Jun 9, 1884 Brush tested Swan lamps that were obtained from England as well as the Boston plant of the Swan Incandescent Electric Light Company to determine whether or not the Swan lamp would meet his needs. Apparently it did. The Swan lamp was adopted after Brush bought out the Boston business and what followed was the formation of the first lamp producing company in Cleveland, in 1885, - called the Swan Lamp Manufacturing Company.

The facility existed at the site of the Brush Works at East 45th Street and Commerce Avenue.

---

CORRECTION: It was written above that Brush bought out the Swan Incandescent Electric Light Company. That might not have been the case. In a brief report that appeared in the *Electrical World* on Mar 31, 1897 (Vol XXIII, No 465, pg 354), a different scenario was given. It said that the Company was formed in 1882, with a capital stock of \$800,000, to manufacture and sell electric lamps under the patents of Joseph W. Swan. Although lamps might have been made in Boston from 1882 to 1885, from 1885 to 1895 lamps were made only in Cleveland, under license, by the Swan Lamp Manufacturing Company. During that period (1885 - 1895) the only source of revenue for the Swan Incandescent Light Company (of No. 14 White Street, New York City) was the royalty from the licensee. From 1895 to 1897 the New York Company therefore had no income and the Company directors filed for dissolution. When the business dissolved it had only \$6903 in cash.

---

## **Brush-Swan**

Lamps were manufactured by the "Brush-Swan" group from 1885 to 1895 when the Swan Lamp Manufacturing Company was closed. This closing followed the sale of the Brush Electric Company to the Thomson-Houston Electric Company in 1889. The Swan Company had been run successfully by Myron T. Herrick from 1885 to 1894. Herrick had a notable career. When Samuel Mather passed away in 1894 Herrick assumed the presidency of the Society for Savings, a banking institution. Herrick also served two terms on the City Council of Cleveland, a term as Governor of Ohio and two terms as Ambassador to France.

Perhaps the most distinguishing feature of the Brush-Swan lamp was its base. The fourteen or so common bases used in the past (before standardization) could be categorized into three classes. These have been referred to as screw, clip and bayonet. The Edison medium screw base is most familiar in the United States as it is the one used today. The Thomson-Houston base had a drilled central hole in which a thread had been tapped. Clip types included the Westinghouse and United States. The bayonet category included the Schaefer, Perkins (Mather), Ediswan and the Brush-Swan. The Brush-Swan base is shown below.



The Brush-Swan lamp can also be identified by the "goal post" design stem, which can be seen in the image below. The lamp is shown mounted in the socket. A Brush-Swan lamp can be identified by the words "Swan Patents" that are stamped parallel to the axis. The image was scanned from an engraving in a Brush incandescent publication of about 1888.

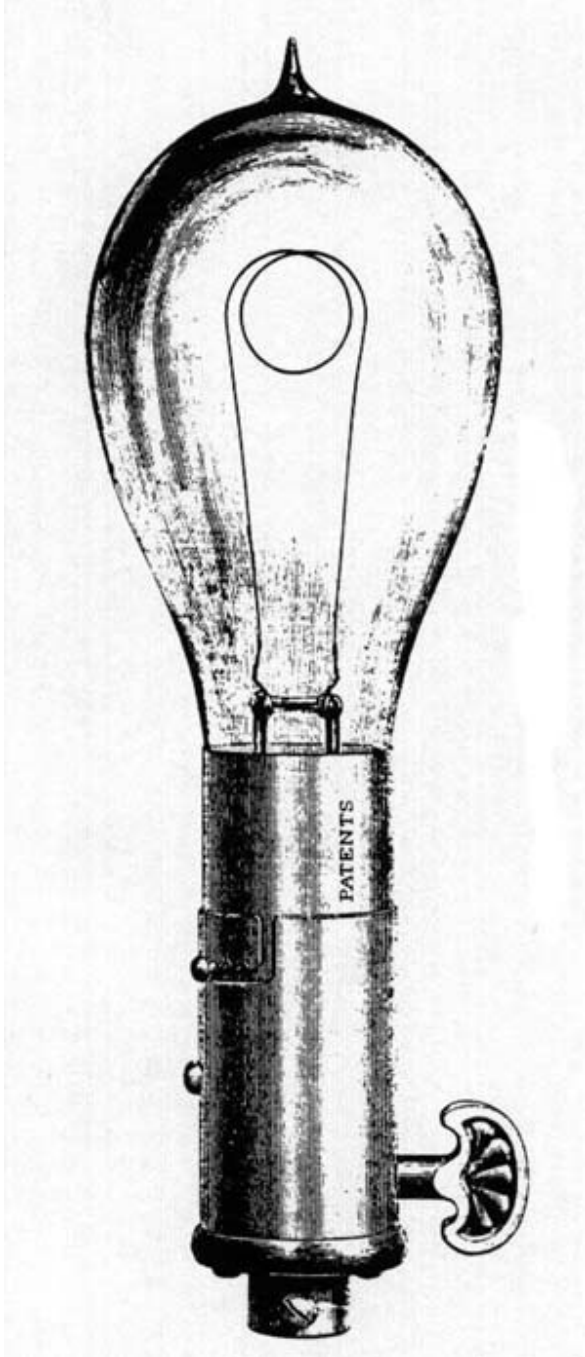

### **The Buckeye Electric Company**

In Feb 1890 Frederick H. Prentiss and William J. Townsend of New York City and Charles H. Rockwell, Dwight W. Rockwell and Alexander G. Wilsey of Cleveland incorporated

The Buckeye Electric Company for the purpose of manufacturing and selling incandescent electric lamps, and other electrical appliances, devices and material.

The Buckeye Electric Company seriously considered taking out a license from the Beacon Vacuum Pump and Electrical Company of Boston for the purpose of manufacturing the "New Beacon" lamp, which had been designed to possibly avoid infringing basic Edison patents. However, after negotiations and lamp testing it was decided the lamp was not satisfactory for marketing. The royalty that would have been paid to Beacon was five cents per lamp.

After the Beacon lamp was eliminated from consideration it was decided to manufacture a lamp that had been patented by Edward Pollard. The patent concerned using silver films in the stem press instead of solid wires. The contract was made with the Boston Incandescent Lamp Company. The decision was made in Oct 1893. A view of the stem area of a Pollard lamp is shown below



Buckeye became part of the National Electric Lamp Company in 1901.

**The Adams-Bagnall Electric Company**

The closing of the Swan Lamp Manufacturing Company in 1895 resulted in the formation of a new company. This company was formed by five men who left the Brush Company after the announced closing of Swan. One of the incorporators of the new company was Thomas E. Adams. Adams was a practical inventor and one of his developments was called the Brush-Adams arc lamp. He was to be in charge of arc lamp production.

Another founder was E. J. Bagnall. Bagnall had worked for Brush for over eight years and had spent seven of them in St. Louis building and operating electric light plants. Bagnall was one of the founders of the St. Louis Engineering Company. He also served as a consulting engineer for the Lindell Railway Company. In his new position he was to be in charge of dynamo and motor construction.

L. H. Rogers was in charge of the business end of the new company. He had been the assistant general manager of the Brush Electric Company as well as the general manager of the Sperry Electric Railway Company. He had worked for Brush for six years.

C. W. Phipps had been with the Brush Electric Company almost from its inception. He had secured patents in London when the Anglo-American Brush Electric Company was formed. He also went to Japan when Brush equipment was introduced there.

Samuel Edward Cox had been secretary and practical manager in the Incandescent Lamp Department of the Brush Electric Company, which was a separate organization known as The Swan Lamp Manufacturing Company. Cox was to have charge of the incandescent lamp department in the new company.

The new company, known as the Adams-Bagnall Electric Company, was to make arc lamps, incandescent lamps and possibly railway motors. They also pursued a tipless lamp following an idea patented by Samuel Cox. Adams-Bagnall stopped producing incandescent lamps in 1897 although they continued to produce arc lamps after that date.

### **The Universal Electric Company**

It appears this company was formed as a result of a job having gone awry. N. S. Possons had worked for the Brush Electric Company for many years but when the company was sold to the Thomson-Houston Electric Company he resigned his position. He then went to work for the Belden Motor Company of Chicago. However, after a building that was to be used to manufacture motors burned, Possons returned to Cleveland. About 1893 he started the Universal Electric Company for the purpose of manufacturing incandescent lamps as well as processed copper. The year 1893 was an active one because of the many litigation cases being tried because of the apparent infringement of Edison patents. Universal entered the field cautiously but went out of business about 1896.

### **Fort Wayne Lamp Company**

When The Adams-Bagnall Electric Company ceased its incandescent lamp business in 1897 it was sold to Ranald McDonald and Samuel Insull. The new organization was known as the Fort Wayne Lamp Company. The name ceased to exist after 1898.

### **The General Incandescent Lamp Company**

This company was the successor of the Fort Wayne Lamp Company. It is surmised that the name was changed after the death of Ranald McDonald in 1898. Joseph Insull served as treasurer and vice-president. The plant was located at the old Brush Works. General became part of the National Electric Lamp Company in 1902.

### **The Royal Incandescent Lamp Company**

The name of the Royal Incandescent Lamp Company first appeared in the Cleveland City Directory in the 1898-99 issue. E. Roberts served as treasurer and manager. It was absorbed into the National Electric Lamp Company in 1902. The Royal label continued to be used and appeared as "New Royal".

### **The Brilliant Electric Company**

The Brilliant Electric Company first appeared in the Cleveland City Directory in the 1903-04 issue. N. S. Possons was president, A. B. Foster, vice-president, I. N. Pennock, treasurer and G. B. Rogers, secretary. Brilliant became part of National in 1905. Their business had not been successful but it continued to operate until the factory closed in 1908.

Some of these early manufacturers of incandescent lamps therefore became part of the National group, which then became part of the General Electric Company in 1912. The Edison group eventually merged with the National people at Nela Park and these two companies therefore became part of today's GE Lighting. A lamp factory still exists at site of the old Brush Works.

The activities that led to, and resulted in, the incandescent lighting business in Cleveland are summarized in the following chronological listing of notable events:

1872 Formation of the Cleveland Telegraph Supply and Manufacturing Co. (CTSMCo).

1875 CTSMCo reorganized as the Telegraph Supply Co.

1877 Manufacture of Brush's dynamo and arc lamp by the Telegraph Supply Co.

1878 First Brush dynamo and arc lamp sold.

1879 Demonstration of Brush arc lamps on Public Square, Cleveland.

1879 Formation of Anglo American Electric Light Co., Ltd.

1880 Formation of Anglo-American Brush Electric Light Corp., Ltd.

1880 Introduction of Lane-Fox system by the Anglo-American Brush Electric Light Corp., Ltd.

1881 The Telegraph Supply Company changed its name to the Brush Electric Co.

1882 Establishment of the Swan Incandescent Electric Light Co., Boston.

1884 Charles F. Brush tested Swan lamps for performance characteristics.

1885 Formation of the Swan Lamp Manufacturing Co.

1886 C.F. Brush granted U.S. Patent No 335,269 for a switch used in the Brush-Swan socket.

1889 The Brush Electric Company sold to the Thomson-Houston Electric Co.

1890 Incorporation of the Buckeye Electric Company.

1892 Formation of the General Electric Co. by merger of Thomson-Houston and the Edison General Electric Co.

1893 Formation of the Universal Electric Co.

1894 Manufacture of a lamp without leading-in wires by the Buckeye Electric Co. The lamp was patented by Edward Pollard (U.S. Patent No 485,478) and it utilized silver films instead of platinum wires.

1895 Dissolution of the Swan Lamp Manufacturing Co.

1895 Beginning of incandescent lamp manufacture by the Adams-Bagnall Electric Co.

1895 Samuel Edward Cox granted U.S. Patent No 548,036 for a tipless lamp, known as the "A-B", which was manufactured by Adams-Bagnall.

1895 Arnold Spiller and John Massey of the Buckeye Electric Co. developed a new sealing-in machine (U.S. Patent No. 537,493).

1895 The Buckeye Electric Co. introduced five new styles of incandescent lamps.

1896 Dissolution of the Universal Electric Co.

1897 End of incandescent lamp manufacture by the Adams-Bagnall Electric Co.

1897 Formation of the Fort Wayne Lamp Co., successor of the incandescent lamp business of Adams-Bagnall.

1898 Formation of the Royal Incandescent Lamp Co.

1899 Dissolution of the Fort Wayne Lamp Co.

1899 Formation of the General Incandescent Lamp Co., the successor of the Fort Wayne Lamp Co.

1901 Formation of the National Electric Lamp Co.

1901 Purchase of the Buckeye Electric Co. by the National Electric Lamp Co.

1901 Purchase of the Royal Incandescent Lamp Co. by the National Electric Lamp Co.

1902 Purchase of the General Incandescent Lamp Co. by the National Electric Lamp Co.

1903 Formation of the Brilliant Electric Co.

1905 Purchase of the Brilliant Electric Co. by the National Electric Lamp Co.

### **Location of the Swan Lamp Manufacturing Company**

The Swan Lamp Manufacturing Company was located in the Brush Electric Company plant in Cleveland, where it rented space. One can view the Brush plant layout by clicking on: [Layout of Brush Electric Company plant.](#)

The writer acknowledges the help of Charles F. Brush and the permission of Jeff Lafavre to cite this reference.

### **Lamp Manufacturer Affiliates**

Although there are many early incandescent lamps that have survived to this day with a variety of different labels, it should be understood that many companies had different divisions or were owned by larger concerns. For example, in 1914 the Westinghouse Company owned H.W. McCandless & Company. In addition, divisions of the Franklin Electric Manufacturing Company were: Aetna, Gilmore, Eastern, Liberty and the Howard Miniature Lamp Company (located at Springdale Avenue and 19th Street, Ampere, NJ).

### **Sawyer-Man Locations in 1886 and 1894**

It is of interest to know the locations of lamp manufacturers in order to obtain a better appreciation of lamp history in general. In 1886 the General Offices of the Sawyer-Man Electric Co. were in the Mutual Life Building, 32 Nassau Street, New York. They had a Philadelphia Office at 205 Walnut Place and their factories were listed as being at 299 Park



Avenue in Brooklyn and at the Thomson- Houston Co. in Lynn, MA. The writer has a Sawyer-Man letterhead dated Feb 2, 1894 and at that time their General Offices were located at 510 West 23rd Street, New York City, and their factories were at 510-534 West 23rd Street and Duquesne Way in Pittsburgh, PA.

### **The Shelby Electric Company**

In the latter part of July, 1896 John Cooper Whiteside mentioned to John Chamberlin Fish, a resident of Shelby, Ohio, the claims Adolphe A. Chaillet made about his idea for an improved incandescent lamp. This aroused the interest of Mr. Fish as it sounded like it would be a good business venture to manufacture such a lamp. John C. Fish was an enthusiastic individual who was always looking for a new outlet for his energy. John Whiteside had been the superintendent at the Cooper Engine Works in Mt. Vernon, Ohio. On August 7, 1896 a newspaper article announced<sup>1</sup> that a contract had been negotiated with Chaillet (of Columbus, Ohio) and Whiteside and some Shelby venture capitalists. These individuals were: W. W. Skiles, G. M. Skiles, M. H. Davis, Jonas Feighner and John Fish. Chaillet and Whiteside were hired as permanent employees of the new company. On August 20, 1896 the stockholders met and elected the board of directors<sup>2</sup>. A description of the Shelby Works appeared in late 1896<sup>4</sup>. It is of interest to quote verbatim from a write-up titled "Shelby Electric Company," which appeared in *Western Electrician* in 1897<sup>13</sup>. The article text was reproduced in *The Shelby News*<sup>14</sup>:

"The village of Shelby, in Ohio, is conspicuous for several things in the manufacturing world, among which is the Shelby Electric company, manufacturer of incandescent lamps. This company was organized in 1896, and began putting its lamps on the market during the early part of 1897. The vigorous advertising methods pursued by the management of the company brought its name into immediate prominence, and the product has, since the start, been taken far in advance of the capacity of the plant.

"The Shelby Electric company is composed of a number of capitalists, who, having been successful in investments in other manufacturing establishments in the village, principally in the steel tube works, which is said to be the largest bicycle tubing establishment in the world, the Shelby Cycle Manufacturing company, which is one of the leading bicycle factories of this country, and the Shelby Mill company, which produces daily nearly 1,000 barrels of flour, thought they saw an opportunity for an investment in the line of incandescent lamp manufacturing, through the chance opportunity of interesting Prof. A. A. Chaillet, formerly of Paris, France. Prof. Chaillet succeeded in demonstrating to these gentlemen and to the electrical engineers whom they consulted that it was possible for him, by using an entirely new method, to produce an incandescent lamp that, he felt confident, would be superior to any on the market.

"In order to demonstrate the practicality of making this lamp, this company was organized, and the \$100,000 of its stock sold within 24 hours after the investigators had been satisfied that Prof. Chaillet could actually produce the

lamp he claimed. The company proceeded very conservatively, building a factory only large enough to manufacture 1,000 lamps a day. That there might be no mistakes, and that the experience of the various factories making incandescent lamps in this country might be taken advantage of, in addition to the knowledge and experience obtained by Prof. Chaillet during the many years he had manufactured incandescent lamps in France and Germany, the company secured the services of Joseph Hardwick, who for a number of years was engaged in the laboratories of the Thomson-Houston Electric company at Lynn, Mass., during which time that company expended a great deal of money in investigating different lamp filaments, and also the services of Charles F. Stilwell, who was intimately connected with Mr. Edison, working with him during the entire period of all of the experimenting at Menlo Park, where the first incandescent lamp was made, and who afterward had entire charge of the Edison factory manufacturing incandescent lamps at Hamilton, Ontario.

"The personnel of any new enterprise is interesting as well as important. For the benefit of those who know the Shelby Electric company only by reputation, the portraits of the men behind it are given, with the following outline sketches:

"W. W. Skiles, the president of the Shelby Electric company, is also president of the Citizens' Bank, president of the Shelby School Board, a director of the Shelby Steel Tube company and also a director of the Shelby Water company, and largely interested in the Shelby Cycle Manufacturing company. Mr. Skiles is senior member of the firm of Skiles & Skiles, well-known railroad attorneys.

"G. M. Skiles, vice-president of the Shelby Electric company and junior member of the law firm of Skiles & Skiles, is also vice-president of the Shelby Water company, a director of the Citizens' bank, a director in the Shelby Cycle Manufacturing company, and is largely interested in the Shelby steel tube works...

"M. H. Davis, treasurer, is president of the American League of Winter Wheat Millers...Mr. Davis is also president of the Shelby Mill company and president of the Shelby Water company, a director of the First National Bank and a director in the Shelby Steel Tube company.

"J. C. Fish, secretary of the Shelby Electric company, and in whose hands the management of its affairs has been placed, is a director of the Shelby Mill company and a director of the Shelby Water company...For the last eight years he has been engaged in the water works department of the John H. McGowan company of Cincinnati, Ohio, as a salesman of water works engines.

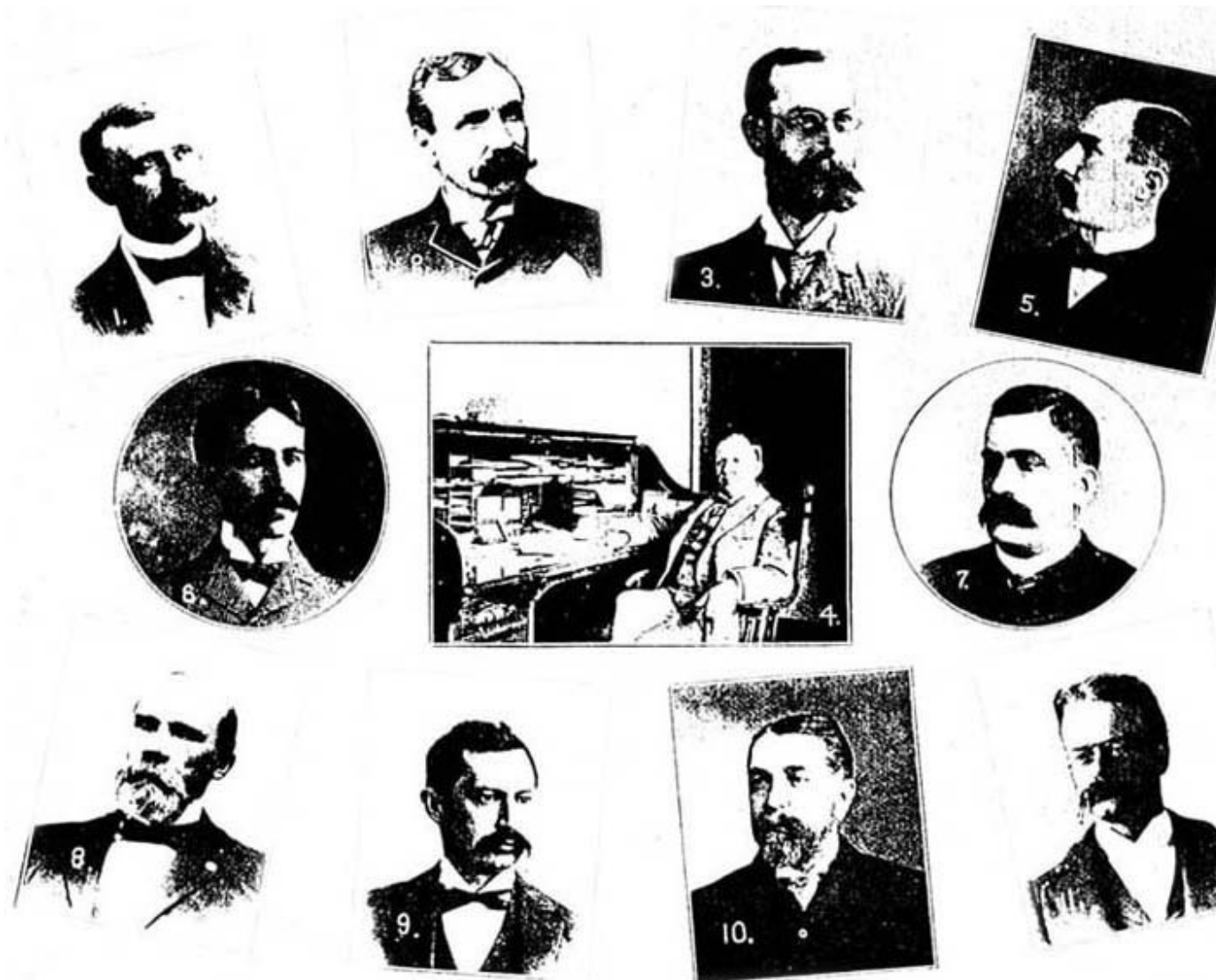

---

---

The above slightly-edited collage was scanned from the *Western Electrician*<sup>13</sup>. The gentlemen are: (1) W. W. Skiles, President; (2) G. M. Skiles, Vice-president; (3) M. H. Davis, Treasurer; (4) John C. Fish, Secretary; (5) A. A. Chaillet, Technical Manager; (6) John C. Whiteside, Superintendent; (7) Jonas Feighner, Director; (8) Henry Wentz, Director; (9) Edwin Mansfield, Director; (10) B. J. Williams, Director; (11) Joseph Hardwick, Lamp Expert.

---

---



Incandescent lamps were manufactured at the Shelby Works from 1897 to 1914. The date of this photograph is not known. The gentleman with the black derby, seated second from the left side and holding the oversized light bulb cutout, is John Chamberlin Fish. Courtesy of The Shelby Museum of History, Shelby, Ohio.

---

"A. A. Chaillet, the technical manager of the company, and upon whom it chiefly depends for its advice regarding all points pertaining to the manufacturing of its product, was engaged in the factory operated by his father near Paris, France, when the incandescent lamp was made by them in Europe. The professor has been engaged as a manufacturer of incandescent lamps since 1878, having had charge of the laboratory of the largest factory in Germany. Mr. Chaillet came to this country in 1892 to manufacture lamps at Marlboro, Mass. He had been engaged in Germany by the Schaefer company to assist it in making filaments and remodeling its plant. This factory was closed by the Edison company shortly after Professor Chaillet had completed his work of remodeling. The professor was then engaged in the designing department of the General Electric company at Lynn, Mass., and has recently completed the design of an electric locomotive for the

Jeffreys Manufacturing company of Columbus, Ohio. Professor Chaillet is not only an electrician of extensive experience and knowledge, but is a thorough chemist and mineralogist.

"John Cooper Whiteside, A. S. M. E., for a number of years superintendent of the Cooper Engine works at Mount Vernon, Ohio, is the superintendent of the Shelby Electric company. Mr. Whiteside has also made a specialty of electrical engineering, and this, with the mechanical knowledge his long experience has brought him, is a great aid to the company, as it puts him in position to give advice on any point pertaining to an electric plant, in the engine, boiler, or any other part of the plant, or to any difficulty in wiring or any of the electrical apparatus.

"Jonas Feighner is one of the directors of the company. Mr. Feighner is one of the most experienced bicycle men in the country, having been connected with the Lozier Manufacturing company of Cleveland, Ohio, for the past 15 years. Mr. Feighner has gained a great reputation as a pusher for trade, and his large experience with the large manufacturing plants in the country has made his advice invaluable to the Shelby Electric company.

"Henry Wentz, director, is a man of extensive experience, being also a director of the Sutter Furniture company and secretary of the Mutual Plate Glass Insurance association. He is largely interested in the Shelby Steel Tube company, and is a director of the Citizens' bank. Mr. Wentz is one of the largest owners of real estate in Shelby, having laid out the boulevard, which is the most beautiful residence portion of the town.

"Edwin Mansfield, another director, is a member of the law firm of Mansfield & Long, and is also largely interested in the Shelby Steel Tube works and a director of the Citizens' bank.

"B. J. Williams, a fourth director, is cashier of the First National bank, a director of the Shelby Steel Tube works and a director in the Shelby Water company.

"Each of the four gentlemen last named is well qualified to act as director of a manufacturing company; they have all been identified with financial transactions of considerable importance.

"Joseph Hardwick, the lamp expert, has had a wide American experience, having served with the Thomson-Houston, Columbia and Universal companies.

"The intention of the company is not to make lamps to see how cheaply they can be made, but to see how well they can be made; and although the Shelby lamps are new to a great many consumers, the price has been generally maintained from the start. The success of the company thus far has been

remarkable, as by the first of March it had received so many orders that it was necessary to begin running nights and to increase the size of the factory...By the middle of April it was decided by the board to again double the size of the factory, and this was done as speedily as possible, the factory now having an output of 4,000 lamps per day, and the force is still obliged to run nights, but another addition to the factory is contemplated.

"The product of the Shelby Electric company is different from that of other manufacturers of lamps, as it makes a specialty of lamps with a tipless bulb of exceedingly high efficiency and long life. The company claims many advantages for its method of production, chief among which is the filament, which is radically different from that used by any other manufacturer, and the method of exhausting, which is said to be much more perfect than that used by any other lamp factory in the country. Each Shelby lamp is tested at its normal voltage for three hours before it is shipped out.

"It is interesting to quote a report of the first factory test from a local paper:

"The object of the first test was to demonstrate the efficiency of the Shelby lamp as compared with others. To do this, lamps of various makes were operated at the same time to show the difference in brilliancy when burning at their normal voltage and candle power. The Shelby lamp was easily distinguished as the most efficient by everyone present. Not satisfied with this test, several lamps of different makes were tested in the same manner, in order to select the most efficient lamp to compare with.

"The most brilliant lamp of other makes having been determined, it was selected for comparison with the Shelby lamp. The result of the conclusion of this test was watched with great interest by all present, and much to the satisfaction of those interested. The difference in favor of the Shelby lamp was so apparent that no doubt was left in the minds of the most skeptical that claims made by Prof. Chaillet for his new filament were not only true but could be considered modest in the extreme. The question of efficiency, although one of the most important in connection with the use of incandescent lamps, is not the only one.

"The purchaser of lamps must consider in connection with the efficiency, the length of life of the lamps he buys, as it is possible to burn lamps at so high an efficiency as to materially shorten the life, thus making the lamp uncommercial. That the remarkable claims of Prof. Chaillet might be verified regarding the life of his lamp at its increased efficiency, the new Shelby lamp and its competitors

were burned at a gradually increased voltage constituting what is known as a forced life test.

'Lamp after lamp of various makes burned out and exploded until the laboratory was lighted alone by the Shelby lamp, not one of the Shelby lamps having been visibly injured by the extreme severity of this conclusive test.

'At present the Shelby Electric company is not a member of the lamp pool.' "

The manufacture of lamps at the Shelby Works was discontinued about 1914. However, lamps with Shelby labels were manufactured after that time at other locations. The sales organization of the Shelby Lamp Division continued until Apr 1, 1925, at which time the name was changed to the Empire Lamp Division, it being headquartered in Buffalo, NY. The name of the factory in Shelby changed through the years. Shortly after it first opened it was referred to locally as the Globe Works<sup>25</sup>. It then became the Richland Carbon Lamp Works and then, after the tungsten filament lamp was manufactured, it was called the Richland Mazda Lamp Works.

**Adolphe A. Chaillet (1867- )**

Of especial interest, as it regards lamps manufactured by The Shelby Electric Company, is A. A. Chaillet. It appears little has been written about him and what has appeared should be put in proper perspective. The reason why Chaillet was brought to Shelby was mentioned above<sup>1</sup>. In the following some additional information is presented.

A. A. Chaillet was living in Shelby in the year 1900 when the U. S. Census was taken. It follows, therefore, that some new information could be obtained by looking at those records. That was done. The census information regarding Chaillet was taken on June 18, 1900<sup>22</sup>. It is stated that Adolphe Chaillet was 32 years of age at that time, having been born in France in November, 1867. In 1900 he lived on Grand Boulevard, Shelby, Sharon Township, Richland County. The place of birth of Adolphe's mother was in Russia and his father's place of birth was in Sweden. It is stated that he had been married for five years.

The wife of Adolphe was listed as Maud L., who, at that time, was 23 years of age, having been born in April, 1877. Her birthplace was in Massachusetts. Maud's mother and father also were born in Massachusetts. The Chaillet's three children were: Alexander B., born in November, 1896; Arnold, born in August, 1898; and, Catherine, five months old and born in January, 1899. The three children were born in Ohio. In actuality a check at the Richland County Vital Records Office in Mansfield, Ohio indicated that Catharine M. was born on December 28, 1899<sup>20, 21</sup>; her mother's maiden name was given as Maud Bickmore.



The original Chaillet lamp, shown at the left, appeared in *Electrical World* on February 6, 1897<sup>7</sup>. The complete details of the lamp design were not revealed in that article. It was a tipless lamp with a carbon filament that was manufactured using a secret process. Quoting directly from the article:

"The lamp possesses a number of peculiar features which it is claimed give to it certain elements of superiority above all others. The filament is square cut by means of automatic machinery from sheets of material produced by a secret chemical process. The cut filament, after being formed, is attached to platinum terminals which are sealed into the sides at the lower end of the lamp bulb. The filament is of such high resistance that in the Shelby lamps it is shorter than that of most other commercial lamps of equal rating. The bulb is not exhausted from the top, which in connection with the exceedingly small filament used makes the completed lamp one of the smallest,

also one of the neatest, lamps on the market."

Chaillet had as assistants, Joseph Hardwick, who had worked in the lamp department of the Thomson-Houston Electric Company and Charles F. Stilwell, the younger brother of Thomas Alva Edison's first wife, Mary. Hardwick also worked for the Universal Electric Company in Cleveland, Ohio, which dissolved in 1896<sup>49</sup>.

In reality it would have been difficult to prove conclusively that a new lamp design would perform in a superior manner to a competitive lamp that had a different filament configuration. The reason for making such a statement here is that while power input into a lamp could be easily measured, the light output had to have been measured in a spherical photometer. In the 1880s and 1890s light output measurements were usually measured with a horizontal photometer. A horizontal measurement determines light output in only one direction rather than a total integrated value. Thus, while the Chaillet design might have been a better one relative to the competitive lamps it is not easy to conclude that now.

Jas. Wormley & Co. had sole agency for the Shelby tipless lamp in Cook County, IL and Minnesota from the first day of manufacture<sup>8</sup>. In 1902 Wormley became a director of Shelby Electric<sup>28</sup>.

This writer finds some mystery in Chaillet's actual role at Shelby Electric. The Company was started based on ideas Chaillet had regarding an improved incandescent lamp. The details of Chaillet's new lamp were never completely revealed however, apparently being considered proprietary in nature. The Chaillet lamp, with a new filament, was tested with others in January, 1897<sup>5, 6</sup>. Manufacturing of the lamp started about February 1, 1897. The lamp was put on the market in March, 1897.



\*\*\*\*\*  
\*\*\*\*\*

**Addendum added April 4, 2002 to this write-up of February 20, 2002**

An article titled "The Shelby Electric Company's Lamp Filaments" appeared in *Electrical Review*, Vol 30, No 10, March 10, 1897, pg 111, in which some confusion regarding the origin of Shelby lamp filaments was discussed. Some manufacturers apparently thought that Shelby filaments were purchased in Europe. The *ER* telegraphed the Shelby Electric Company for the purpose of determining the truth about Shelby filaments. The following are excerpts from Shelby's response:

"The question of taking licenses to manufacture under the Westinghouse patents is one which we have not definitely decided....We have secured copies of the entire number of patents, which they claim to own or control, and we know positively that we do not want to infringe on any of them. We think that we are the only company manufacturing lamps in the United States to-day who can make such a statement. With reference to the filament which we use, we would say that we are using a square filament, not a cellulose filament. Our filament is not imported from Germany. We are manufacturing it here in Shelby, but it is the same filament which our Professor Chaillet discovered in Germany, and one that is most successfully being used by two of the most prominent lamp factories of Europe, by a special arrangement with our Professor Chaillet. The filament is much nearer pure carbon than anything on the market, it being so hard after being carbonized that it will scratch glass very readily....We could ourselves secure patents on over a hundred different devices, which we use in our manufacture, but prefer to keep them secret....We are not selling lamps on prices, but on quality..."

\*\*\*\*\*  
\*\*\*\*\*

Adolphe Chaillet was named technical Manager of the Company and was also on the Board of Directors until their annual meeting on August 29, 1902 when he was not re-elected<sup>28</sup>.

The design that was perhaps most recognized to be a "Shelby" lamp was patented by Chaillet on June 2, 1902<sup>26</sup>. The application for that patent (No. 701,295) was filed on October 22, 1900. The basic idea behind the filament and lamp design was to radiate a large portion of the light in a downward direction when the lamp was burned base-up. The first page of the patent follows.

No. 701,295.

Patented June 3, 1902.

A. A. CHAILLET.  
INCANDESCENT ELECTRIC LAMP.

[Application filed Oct. 22, 1900.]

(No Model.)

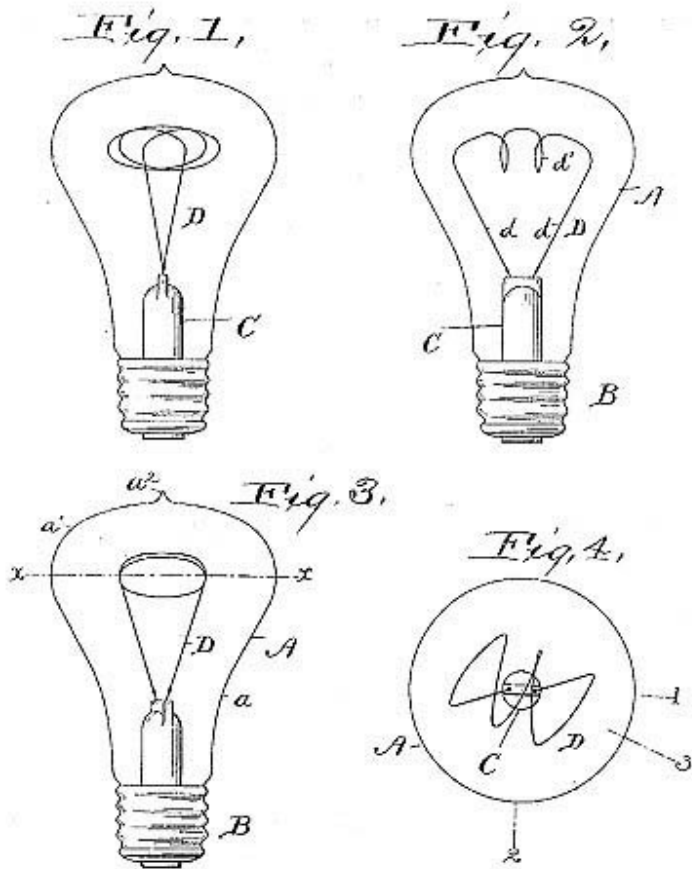

Witnesses:  
E. B. Schust  
H. B. Dummer

Inventor:  
Adolphe A. Chaillet,  
By his Attorney,  
Thurston & Bates.

If one refers to the article in *Western Electrician*<sup>13</sup> it can be seen that Chaillet's early lamp experience in Europe is in some doubt. For example, it's difficult to conclude that Adolphe Chaillet was involved in lamp manufacture in the year 1878 when he was only eleven years of age.

It is of interest to note that Adolphe Chaillet was granted only two U. S. Patents during the time period from 1896 through 1922; both<sup>19, 26</sup> were applied for while he was associated with Shelby Electric.

The activities of A. A. Chaillet after about 1902 are not known to this writer. A look was taken at "The American Family Immigration History Center" website<sup>50</sup> and the name of Chaillet did appear. If one simply inserts the surname "Chaillet" without a first name initial,

nineteen matches appear. One can then determine that Maud Chaillet and her daughter, Catharine, arrived at Ellis Island on July 15, 1904 aboard the ship "Monterey", the port of departure being Veracruz Llave, Veracruz, Mexico. On that same list one finds that A. A. Chaillet arrived at Ellis Island on July 5, 1914 on the ship "Antonio Lopez", the port of departure being Puerto Mexico, Veracruz, Mexico. It was stated that A. A. Chaillet's place of residence was Mexico City. It might be tentatively assumed, therefore, that Chaillet worked in Mexico City from about 1904 to 1914. Corroboration of that conclusion follows from the text card that accompanies one of William J. Hammer's lamps that is now stored in the Henry Ford Museum in Dearborn, Michigan. Lamp No. 1905-798 is a Chaillet lamp that was manufactured in Mexico<sup>53</sup>.

**John Chamberlin Fish (1866-1909)**  
Another contributor to the Shelby Electric incandescent business was John C. Fish. Quoting from a History of Richland County, from 1808 to 1908<sup>33</sup>:

"...He is a native of Sheldon, Vermont, and a son of Cortez F. and Helen (Carlisle) Fish, the former proprietor of a flour mill. The son pursued his education in the public schools of Akron and Shelby, Ohio, and in a private school at Gambier, Ohio...He is now the president of the National Electric Lamp Association, the Shelby Electric Company, the Shelby Printing Company and the Ohio Seamless Tube Company. He is also the vice president of the Shelby Telephone Company, the president of the Auto Call System Company and a director of the Shelby Water Company and the Citizens Bank...

"On the 2d of March, 1892, Mr. Fish was married to Miss Anna M. Roberts, and they have three sons, De Forest R., Cortez Carlisle and John C., aged, respectively, fifteen, twelve and ten years..."

Through use of the 1900 Soundex and Miracode systems<sup>23</sup> and Ohio Cemetery records<sup>44</sup> the life spans of the members of the Fish family were determined: John C. (1866- 1909); Anna May (1867-1939); De Forest R. (1893-1917); Cortez Carlisle (1896-Jan 1965); John C. (1899-1951). Family members are interred in the Oakland Cemetery, Sharon Township.

Although the Shelby Electric Company was organized because of the lamp ideas of A. A. Chaillet, it appears that most of what was made known and published came from John C. Fish. Chaillet's original lamp design was given little coverage in the technical literature of the day; however, a few months after Shelby began production Fish patented a lamp that received much more coverage.<sup>15, 17</sup> The first page of Fish's lamp patent follows:

(No Model.)

J. C. FISH.

INCANDESCENT ELECTRIC LAMP AND PROCESS OF MAKING SAME.  
No. 598,726. Patented Feb. 8, 1898.

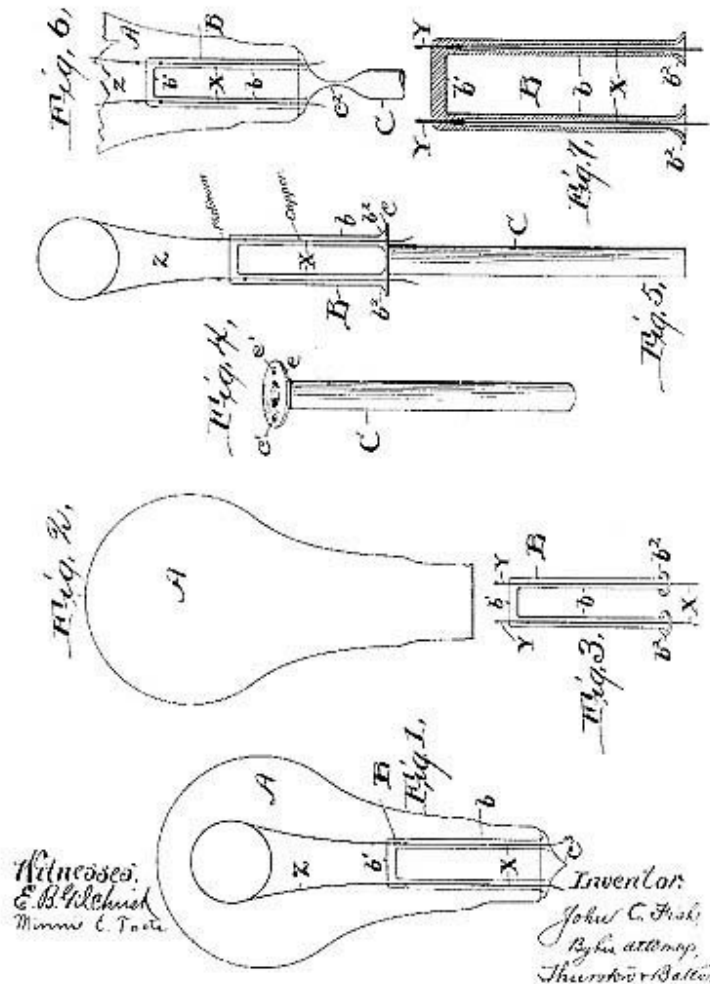

Two lamps, a tipless as well as a tipped one, shown below, were featured in an article in October, 1898<sup>17</sup>. The tipless lamp corresponds to the Fish design shown above. The patent date shown on the lamp is incorrect. The date shown, August 3, 1897, was the application date; the patent was granted on February 8, 1898.

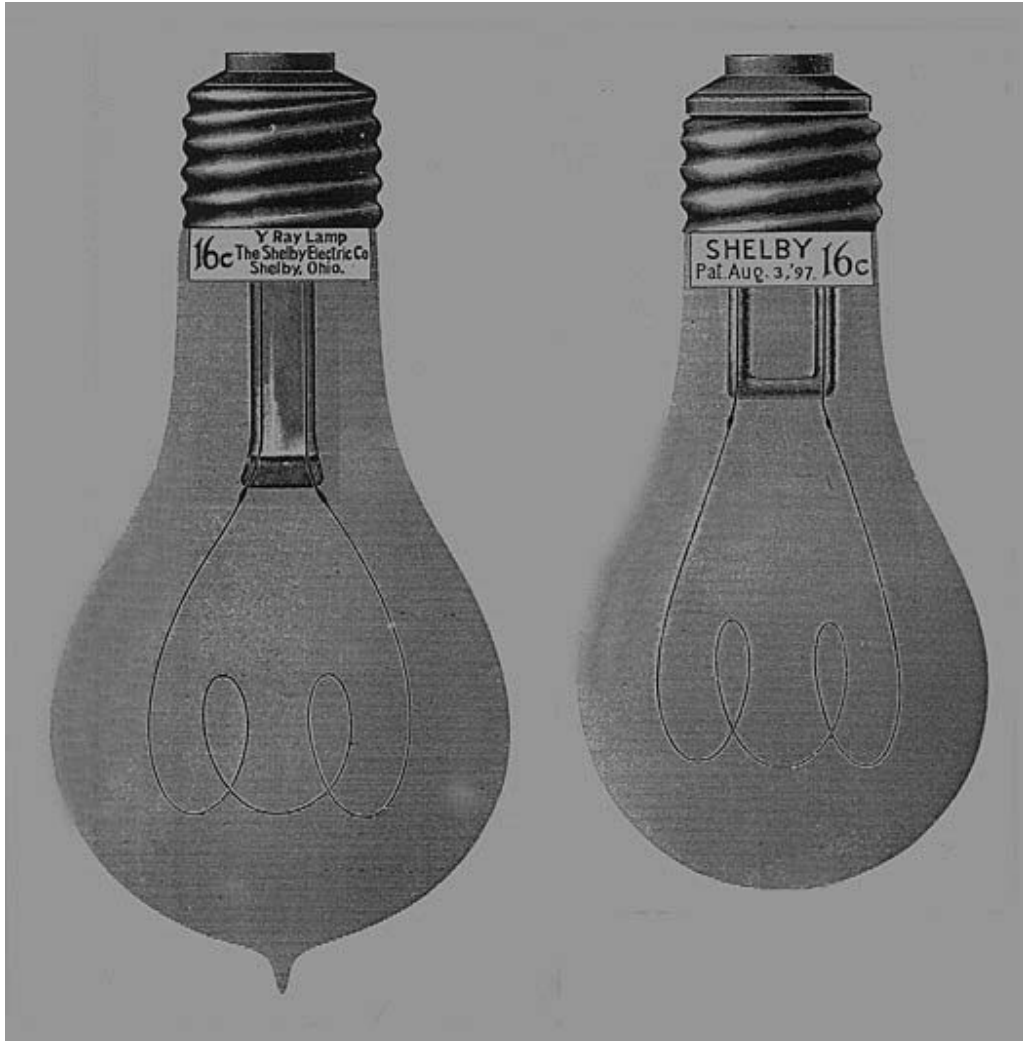

**Lamp Labels and Trade-Marks**  
Some labels that could be found on Shelby lamps are shown below<sup>48</sup>.

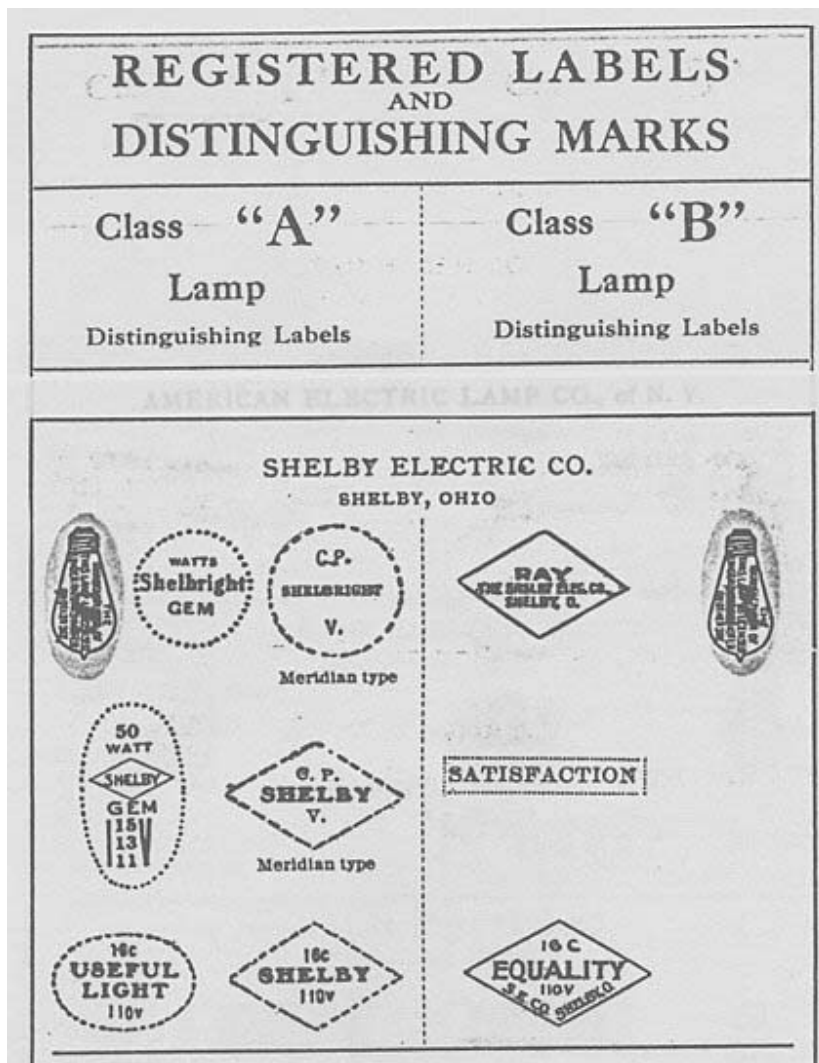

In addition, a list, of unknown origin, found in a desk drawer in 1914, gave the following: A labels; Shelby, Shelby Tipless, Perfection, Shelbright, Useful Light; Anchor. B labels; Ray, Ray Tipless, Equality, Equality Tipless, Satisfaction, Equalight, Ideal, Robertson, Mercury, McDonald & Dumond, Duke, Sunshine, Bluegrass, IECO, E.S. Co., S.E.L.Co.

The Chaillet lamp with the "mushroom-shaped" bulb (U. S. Patent No. 701,295) apparently carried the "Useful Light" label during the later years of manufacture<sup>38</sup>.

As of May 4, 1914 the following labels were used on lamps. From right to left the labels were used on carbon, GEM, miniature MAZDA, and large MAZDA lamps.



The color schemes on the labels were: black letters on cream background and white letters on red background.

In the year 1915 the use of paper labels began to decline and bulb etching became more commonplace. In that year a lamp bulb that had no design etched on the glass bore two labels: a Sales Division label and a rating label placed diametrically opposite one another on the bulb so that the etched design (National Mazda/GE) was halfway between the labels. The labels were attached so that they read horizontally and right side up when the lamp was held tip down. An effort was started in mid 1924 to eliminate sales division labels from the lamps.

In April, 1922 there existed eleven sales offices in the National Lamp Works of the General Electric Company, with one being the Shelby Lamp Division<sup>40</sup>. There were various working factories in twelve different cities in the United States. In Ohio factories were located in Youngstown, Warren, Niles and Cleveland. In Cleveland alone there were twelve factories. Other factories were in St. Louis, Minneapolis, Oakland, Central Falls, Chicago, Buffalo, Bridgeville and Providence.

In July, 1925 eighteen Divisions existed and Shelby labels were authorized for use in four of them: Empire, Pacific, Southern and Southwestern. These labels could be used in different Divisions because of the goodwill they had generated.

A trade-mark used by the Shelby Electric Company follows, along with the date of registration. This occurred after the act of February 20, 1905, which required that a label carry the notation, "Reg. U. S. Pat. Ofc. (date)." The trade mark was: "Shelbright" The word in antique type, the letter S being capital. Registered February 12, 1907. This trade-mark<sup>32</sup> was used continuously in the business since about June, 1904.

## Shelbright

A second trade-mark of the Shelby Electric Company was applied for November 2, 1906 and was registered January 22, 1907. It consisted of the word "Equality." The trade-mark<sup>31</sup> was used continuously in the business since 1901.

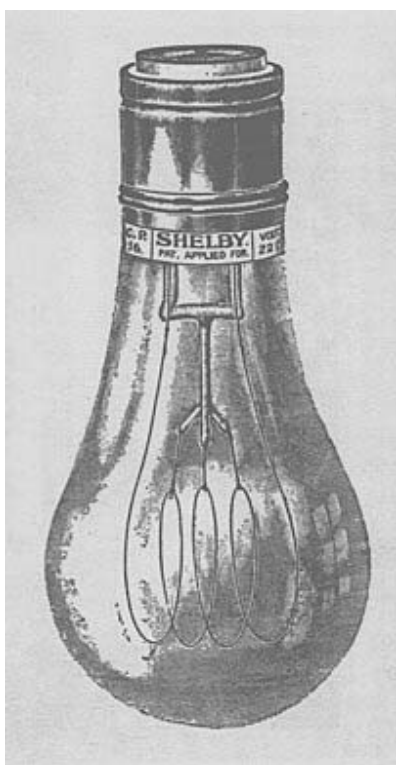

The word 'Equality' is written in a highly decorative, cursive script. The letters are interconnected and feature elaborate flourishes, particularly at the beginning and end of the word. The style is reminiscent of late 19th or early 20th-century decorative typography.

**The 220-Volt Lamp**  
A paper was read before the *London Institution of Electrical Engineers* and then its contents reported in the *Electrical Engineer*, which John C. Fish responded to. His article appeared in a June, 1898 issue of the *Electrical Engineer*<sup>16</sup>. The articles discussed the difficulties of making a 220-volt lamp. Fish pointed out that some of the features of Shelby lamps overcame the technical difficulties, which allowed high voltage lamps to be made. A part of this success was

attributed to the "treating" process. The use of platinum wires as anchors and the "Fish" stem, which was described earlier, eliminated the Edison Effect. The unique stem press can be seen in the engraving shown to the left; the lamp has a Thomson-Houston base. The spacing of the lead wires was in excess of 1/2-inch. The claim was made that "a lamp of 220 volts can be made that will give just as good satisfaction in regard to life, efficiency and maintenance of candle power as it is possible to obtain with any lamp of 110 volts." In addition, Fish pointed out that experimental 500-volt lamps had been made that operated satisfactorily.

It should be pointed out that patent coverage of some of these ideas did not materialize. Patents might have been applied for but were never granted. John C. Fish was granted one lamp-related patent<sup>15</sup> (U. S. 598,726 for a lamp) and A. A. Chaillet was granted two<sup>19, 26</sup> (U. S. 625,321 for a socket and U. S. 701,295 for a lamp). No other patents were found for the years 1896-1922 in which the assignee was the Shelby Electric Company.

### **The National Electric Lamp Company**

In the year 1900 the incandescent lamp industry was in a state of discord. The courts were filled with lawsuits that dealt with patent infringements, and bitter competition had driven lamp prices below actual manufacturing costs. Because of that situation lamp quality became inferior and, therefore, totally unacceptable. The small manufacturers also were not able to compete with the giant in the field, the General Electric Company, as it had the resources to do fundamental research and development work—resources the small manufacturer did not have. The eventual return to quality products was due in large measure to the ideals and success of the National Electric Lamp Company—a consortium of lamp manufacturers.

The formation of National took some time to accomplish. Starting in the year 1884 Franklin Silas Terry managed the Chicago office of the Electrical Supply Company, which had its home base in Ansonia, Connecticut<sup>46</sup>. A former engineer from the Sawyer-Man company, a manufacturer of electric incandescent lamps, suggested to Terry that he should begin to manufacture lamps as he believed it to be a good business opportunity. As a result of that suggestion Terry formed the Sunbeam Incandescent Lamp Company in Chicago in 1889.

In Fostoria, Ohio, a group of men were engaged in several businesses. John Bernard Crouse (1842-1921) and his brother-in-law, Henry Abner Tremaine (1852-1938), had started making incandescent lamps in 1897 under the name "Fostoria." Crouse then brought his son, J. Robert (1874-1946), into the business. Another important person, who had been in the insurance business in Cleveland, was also brought on board. He was Henry Tremaine's cousin, Burton Gad Tremaine (1863-1948). The founding fathers of National Electric Lamp Company were in place; it was only necessary to bring all five individuals together.

At the end of the 1890s Franklin Terry (1862-1926) casually suggested consolidation of the small lamp companies so that all could benefit, by means of common laboratory facilities. That suggestion was made when he met with his competitors during business travels. At a dinner meeting in 1901 he sat next to Burton Tremaine and again made the suggestion. That meeting of the two men, and Terry's suggestion, probably was the catalyst that was needed to get the ball rolling. It turned out that Charles A. Coffin, the head of the General Electric



Company, had suggested that the Fostoria Company combine with GE. Coffin knew H. A. Tremaine and J. B. Crouse because he (Coffin) was a stockholder in the National Carbon Company—a firm founded by Crouse and Tremaine. The suggestions were not acted on until the right circumstances existed. That happened at the jobber's dinner in Chicago in 1901 when B. G. Tremaine sat next to F. S. Terry and Terry again made the suggestion.

The idea had germinated long enough. The five men founded National—with the help of the General Electric Company! GE agreed to put up about 75% of the needed capital and remain as a silent partner. That is, the companies that were eventually purchased were not aware of GE's involvement. GE had the option to obtain the other 25% of the stock. It was an unusual arrangement. At the insistence of Terry and Burton Tremaine, there was to be no person from General Electric involved in the running of National.

The unusual consolidation allowed National to set up laboratories so that all companies that joined the consolidation were free to use the results generated through testing. The individual companies could not afford such facilities. Thus, all companies could receive laboratory results but still remain competitors of the other companies. The idea behind this bold move was simply to compete on the basis of quality. In effect there was not to be any management interference from the National managers, Terry and Tremaine. However, help was extended if the individual companies asked for it. From the standpoint of the small companies, they had the best of all worlds. They continued to operate as though they were independent but they could benefit from the laboratories at the National headquarters in Cleveland. The plan worked—lamp quality eventually reached high levels. In addition, the member companies of National became formidable "competitors" of the General Electric Company. When National was formed, the lamp output from all companies amounted to about 20% of the total lamp production—with General Electric accounting for 80%. However, the ratio was about 50-50 by 1910.

The National organization did not engage in commerce. It had for its objective the advancement of the art of incandescent lamp manufacture and the development of the science and art of illumination.

In the year 1901 eight companies joined the National fold, led by Sunbeam and Fostoria. In 1902 six more became member companies. In 1903 John Fish of the Shelby Electric Company became interested in joining. In Terry's own words<sup>35, 46</sup>:

"In the summer of 1903, Mr. J. C. Fish, manager of the Shelby Electric Company, Shelby, Ohio, came to Cleveland several times for interviews with us, and desired to sell out the Shelby Company. We told him that we did not want to buy, and he spoke about the greater loss to us in a fight than the cost of his company. We replied that we had no thought of fighting him; there was no necessity of a fight; he replied: 'Oh yes, if you don't buy us there will be a fight alright. You have a lot of different companies that you can use against us, and we will be obliged to fight.' He was very anxious for us to come and look his factory over, and the day we did this he had a large table completely covered with printed matter, in envelopes stamped and addressed, and took occasion to show us that he had ready to send out a

pamphlet, which he thought would be injurious to our interests. After a good many negotiations we decided it was better to take over the Shelby Company, which was done on December 1st 1903, payment cash \$201,000 in deferred payments.

"It is well to remember that it was a mighty difficult thing for us to raise the money to take over these different companies. Our business up to this time had not been very profitable, and the business of the different concerns we took over was not in any case profitable. In some cases, like in the purchase of the Warren companies, we were absolutely actually unable to meet our payments when they became due, and the General Electric Company would not furnish the cash, and we were obliged to get extensions of time..."

### **The 1911 Federal Suit Against Incandescent Lamp Companies**

On March 3, 1911 the Attorney-General of the United States, George Woodward Wickersham (1858-1936), brought suit<sup>36</sup> against thirty-five electrical and other manufacturing companies (including The Shelby Electric Company) on the charge of engaging in 'unlawful contracts, combinations and conspiracies to restrain the trade and commerce among and between the several States and Territories of the United States in incandescent lamps and to monopolize the same.' This action was the result of a bill introduced in Congress by Senator John Sherman of Ohio. The bill was passed in 1890 and became known as the Sherman Anti-Trust Act. On October 12, 1911, Judge John M. Killits, sitting in Toledo, Ohio handed down a decree against the manufacturers<sup>37</sup>. As a result of that decree General Electric had to identify a lamp as being GE even though a National label, such as Shelby, existed on it. In addition, it was necessary for the National Electric Lamp group to dissolve. GE was given six months from October 12, 1911 to accomplish this. It is believed that The Shelby Electric Company was dissolved about March 19, 1912.



### **The Incandescent Lamp of Thomas Alva Edison, Jr.**

Thomas Alva Edison, Jr. (1876-1935) was the son of Thomas Edison and his first wife, Mary (Stilwell). He, too, decided to go into the incandescent lamp business. He claimed to have an improved pump and filament. He opened offices in New York City and set out to manufacture his "Edison Junior Improved" incandescent lamp. An engraving of his lamp is shown to the left (*Electrical Engineer*, Vol XXIV, No 502, Dec 16, 1897, pg 590). This plan did not succeed but apparently he negotiated with the Shelby Electric Company and they agreed to manufacture it. This fact can be verified by looking at the text card of one of William J. Hammer's lamps at the Henry Ford Museum. Lamp No. 1899-1025<sup>53</sup> is that of Thomas Edison, Jr and it was manufactured by Shelby.

T. A. Edison, Jr. had a lamp exhibit that was announced in *The Electrical Engineer*, Vol XXV, No. 524, May 19, 1898, pg 557. The exhibit contained about 900 lamps: 4, 8, 10, 16, 32, and 50 c.p. lamps, plain, frosted, red, blue, amber, green, and opal, spherical, tubular and pear shape. It was claimed that his new 500-volt lamp was probably the only one in existence that was made with one continuous filament.

The following year he had another exhibit and it was displayed by "The Edison Jr. Electric Light & Power Co." (*Electrical World and Engineer*, Vol XXXIII, No 20, May 20, 1899, pg 669.) The exhibit had different sizes of primary batteries for general lighting.

### **Comments on Livermore's Centennial Light**

A lamp of the later Chaillet design has received much press during the last 30 years or so because of its longevity<sup>51</sup>. It might be of some interest to comment on that extraordinary performance. Although an explanation of the long life exhibited by the lamp cannot be given with complete certainty, perhaps some understanding will result.

Let us summarize, according to the understanding of the writer, the details of this story. A lamp has been burning in a fire station in Livermore, California since 1901. The lamp was donated to the Fire Department in that year by Dennis Bernal, who owned the Livermore Power and Light Company. It is reported that the lamp consumes about four watts and has been burning continuously as a night light over fire trucks. Although it was turned off temporarily because of a relocation of the station, it has burned since 1901. Still images of the burning lamp can be viewed on the internet<sup>52</sup>. It is stated that the lamp has a carbide filament. The lamp has been declared the oldest known working light bulb by the Guinness Book of World Records.

Certain information, which is lacking in this story, would be beneficial in understanding the long life lamp. For example, the initial operating temperature would allow an approximate calculation of filament evaporation, which is the usual process by which a carbon filament failed. The writer does not believe the filament is composed of a carbide; he is not aware that Shelby Electric, or any other major manufacturer, ever used a carbide filament; it is herein assumed to be a carbon filament of unknown structure. Some carbide filaments (such as silicon carbide and titanium carbide) were tried about 1901 and tungsten had not surfaced as a filament material yet. As it regards carbon filaments, some basic understanding of them is important.

Although other materials could have been used, Edison employed bamboo as the first material in a commercial lamp. Extruded cellulose then came to be the common material used. All such materials had to be carbonized by heating. By the time the Chaillet lamp was introduced in 1897 the industry, in general, was using an extruded, or squirted, cellulose filament that was carbonized and then treated by heating in a hydrocarbon vapor. The final structure of carbon filaments, regardless of initial material, was porous. The filament had little more than a skeleton structure. Treatment in a hydrocarbon gas resulted in a smoothing of the surface and a reduction of inherent hot spots. Perhaps the best filament, from the standpoint of performance, was used in the so-called GEM (General Electric Metallized) lamp, introduced in 1905. That lamp could be operated at a temperature of about 1900 °C (2173 °K)<sup>41</sup>.

Without initial electrical and temperature measurements one cannot expect to be able to determine the present state of the filament because of the apparent blackening of the bulb and the uncertainty of material density and resistivity. If the lamp is actually operating at four watts it follows that the filament temperature is relatively low. One should be cautious to conclude, however, that the present filament temperature is so low that evaporation is not significant and therefore, the filament will burn forever. It probably is not known how such a lamp, with a carbon filament, would eventually fail if significant evaporation is not taking place. To make this point, failure of tungsten filament lamps operated at low filament temperatures might be mentioned. At normal operating temperatures (2600-3000 °K) tungsten filament lamps eventually fail due to evaporation. However, some miniature lamps, which operate at much lower temperatures (1900-2200 °K), can fail by a different mechanism. In that case tungsten atoms migrate on the filament surface with the formation of crystals, which results in the fracture of the wire<sup>43</sup>. Whether or not a similar process would occur in a carbon filament lamp remains to be seen.

Roughly speaking, the evaporation rate of carbon in vacuum is about 100 times higher than the rate of tungsten at the same temperature. Because of that fact tungsten can be operated at higher temperatures than carbon and therefore give off more light at a higher efficacy. As it regards the Centennial Light, if the filament temperature is low enough and all other normal weak points in the lamp are satisfactory (such as leakage of air, attachment of filament to lead wires, baked-out condition of lead wires and glass) then, with the avoidance of mechanical shock (from being hit), the lamp could burn for many more years. The extreme case, of course, is when the lamp is not lighted. One would assume that such a lamp should be operable after a 100-year rest. The question is: How low must the filament temperature be in order for the lamp to operate for 100 years?

### **Acknowledgements**

First and foremost, I thank Mrs. Sally J. Maier and Mr. Kim Heuberger of The Shelby Museum of History, Shelby, Ohio, for their interest and courtesy shown during an off-hours visit to the Museum. Mr. Heuberger also reproduced the photograph, showing the Shelby factory personnel, for use by the writer. Early Shelby newspapers were viewed on film at the Marvin Memorial Library, Shelby, Ohio. A copy of the birth data of Catharine Chaillet was kindly supplied to the writer at the Richland County Vital Records Office in Mansfield, Ohio. Census data and county historical books were viewed at the Western Reserve Historical Society in Cleveland, Ohio. Patent and trade-mark information were obtained at the Cleveland Public Library and the Public Library of Cincinnati and Hamilton County, Cincinnati, Ohio.

### **General**

### **References**

- 1) "A New Factory," *The Shelby News* (Shelby, Ohio), Aug 7, 1896.
- 2) "The Electric Company," *The Shelby News*, Aug 21, 1896.
- 3) Note, *The Shelby News*, Aug 28, 1896.
- 4) "The Shelby Electric Works," *The Shelby News*, Dec 18, 1896.
- 5) "The Shelby Electric Company," *The Shelby News*, Jan 22, 1897.
- 6) "The New Incandescent Lamp of the Shelby Electric Company," *The Shelby News*, Jan 29, 1897.
- 7) "The Shelby Incandescent Lamp," *The Electrical World*, Vol XXIX, No 6, Feb 6, 1897,

- pg 215.
- 8) "A Big Shelby Incandescent Lamp Deal Closed in the West," *The Electrical Engineer*, Vol XXIII, No 461, Mar 3, 1897, pg 254.
  - 9) "Voltage, Amperes, Watts, Ohms, &c.," Joseph Hardwick, *The Shelby News*, Mar 12, 1897.
  - 10) "On the Inconsistency of the Evolution Theory," A. A. Chaillet, *The Shelby News*, Mar 26, 1897.
  - 11) "The Shelby Electric Co., 'Make the Best Incandescent Lamp in the World,' Interview With One of the Oldest Lamp Dealers in the United States Mr. William Wilson of Milwaukee, Wisconsin," *The Shelby News*, Apr 9, 1897.
  - 12) "The Shelby Electric Company," *The Shelby Republican*, Industrial Edition, May 20, 1897.
  - 13) "Shelby Electric Company," *Western Electrician*, Vol XX, No 24, Jun 12, 1897, pg 338.
  - 14) "The Shelby Electric Co., The Personnel of the Company, The Portraits of the Management," *The Shelby News*, Jun 25, 1897.
  - 15) "Incandescent Electric Lamp and Process of Making Same," J. C. Fish, U.S. Patent No. 598,726, Feb 8, 1898, Application filed Aug 3, 1897.
  - 16) "The 220 Volt Lamp in Practice," J. C. Fish, *The Electrical Engineer*, Vol XXV, No 526, Jun 2, 1898, pg 604.
  - 17) "Incandescent Lamps as Manufactured by the Shelby Electric Company, Shelby, O.," *The Electrical Engineer*, Vol XXVI, No 545, Oct 13, 1898, pg 358.
  - 18) "Incandescent Lamps—A Detailed Description of Their Manufacture," *American Electrician*, Vol XI, No 5, May 1899, pg 241.
  - 19) "Socket for Incandescent Lamps," A. A. Chaillet, U.S. Patent No. 625,321, May 23, 1899, Application filed Feb 28, 1898.
  - 20) Birth of Catharine M. Chaillet, Dec 28, 1899, Richland County Vital Records Office, Probate Court, 50 Park Ave., East, Mansfield, Oh, Vol 3, pg 54.
  - 21) Birth Announcement, *The Shelby News*, Jan 5, 1900, pg 5, col 1.
  - 22) 1900 Soundex, Chaillet=C430; 1900 Census, Vol 130, E. D.=136, Sheet 14, Line 96.
  - 23) 1900 Soundex, Fish=F200.
  - 24) "Gain in Effective Illumination from Incandescent Lamps," *American Electrician*, Vol XII, No 7, Jul 1900, pg 362.
  - 25) "Globe Works," *The Shelby News*, Feb 28, 1902.
  - 26) "Incandescent Electric Lamp," A. A. Chaillet, U. S. Patent No 701,295, Jun 3, 1902, Application filed Oct 22, 1900.
  - 27) Improved Incandescent Electric Lamp, *Electrical Review*, Vol 41, No 4, Jul 26, 1902, pg 119.
  - 28) "Shelby Elec. Co., Holds Annual Meeting of Stockholders and Directors," *The Daily Globe*, Aug 29, 1902.
  - 29) "Photometer Attachment," *Electrical World and Engineer*, Vol XLI, No 16, Apr 18, 1903, pg 670.
  - 30) Obituary, "W.W. Skiles," *American Electrician*, Vol XVI, No 2, Feb 1904, pg 110.
  - 31) Trade-Mark No. 59975, "Equality", Registered Jan 22, 1907.
  - 32) Trade-Mark No. 60,569, "Shelbright", Registered Feb 12, 1907.
  - 33) History of Richland County, Ohio, from 1808 to 1908, Vol 2, A. J. Baughman, The S. J. Clarke Publishing Co., Chicago, 1908, pg 1163.

- 34) "Burial of the Late John C. Fish...," *The Daily Globe*, Apr 20, 1909.
- 35) History of the National Electric Lamp Company and Its Subsidiary Companies, F. S. Terry, Nov 28, 1910.
- 36) "Federal Suit Against Incandescent Lamp Companies," *Electrical World*, Vol 57, No 10, Mar 9, 1911, pg 594.
- 37) Final Decree, United States Circuit Court, Northern District of Ohio, Eastern Division, "United States of America vs. General Electric Company et al," Entered October 12, 1911.
- 38) Catalog of Shelby Lamps, Published by The Shelby Electric Co., Shelby, Ohio, U.S.A., ca 1910-1911.
- 39) What's What in Shelby, Ohio—The Biggest Little City in the United States, 1921.
- 40) "How the National Lamp Works of General Electric Company is Organized," *The National-ite*, Apr 1922, pg 8.
- 41) The History of the Incandescent Lamp, John W. Howell and Henry Schroeder, The Maqua Company, Publishers, Schenectady, NY, 1927.
- 42) A History of Nela Park, 1911-1957, Hollis L. Townsend, General Electric Co., 1957.
- 43) "The Life-Voltage Exponent for Tungsten Lamps," E. J. Covington, *Journal of IES*, Vol 2, Jan 1973, pg 83.
- 44) Richland Co., Ohio Cemetery Records, The Richland Co. Chapter of The Ohio Genealogical Society, 1981.
- 45) "Ohio—a Giant in Electric Lamp History," *Country Living*, Feb 1989.
- 46) Franklin Silas Terry, 1862-1926, Industrialist—Paragon of Organization, Harmony and Generosity, Edward J. Covington, 1994.
- 47) Makers of National—The Spirit and People of an Industrial Organization, Edward J. Covington, 1997.
- 48) The Electric Incandescent Lamp, 1880-1925, Edward J. Covington, 1998.
- 49) Incandescent Lamp Manufacturers in Cleveland, 1884-1905, Edward J. Covington, 1999.
- 50) Website. The American Family Immigration History Center. <http://www.ellislandrecords.org/sign/index.asp>. (Surname = Chaillet. No first name initial).
- 51) Website. <http://www.centennialbulb.org/facts.htm>
- 52) Website. <http://www.centennialbulb.org/> then click "video".
- 53) Website. <http://www.frognet.net/~ejcov/hammer.html>

### **The General Electric Company's Porcelain Factory**

From the earliest days of the incandescent lamp electrical insulating materials were required on lamps as well as the sockets. Wood, fiber materials, plaster of Paris and bonsilate were some of the early materials used. It was desirable to utilize a material that would not be affected by acids, alkalies or gases. Porcelain was a good candidate but it was found that high standards could not be maintained by buying from outside vendors. The General Electric Company decided to establish their own plant, which they did about 1892. It was part of the manufacturing complex in Schenectady, New York.

Crude kaolin or china clay was used as starting materials. The treatments received in the firing kilns depended on the intended use. Porcelain was desired for switch bases,

insulators, cut-outs, lamp bases and sockets. Porcelain was desired in high voltage lamps and sockets to avoid electrical breakdown.

### **GE Incandescent Lamp Manufacture in Fort Wayne, Indiana**

A greater knowledge of the places of manufacture of lamps can be gleaned through published literature. In some cases this might help to locate certain lamps to add to established collections. As time marched on, lamp manufacturers were able to develop machinery that resulted in higher production with the attendant need for fewer workers. In the 1923-24 time period this resulted in the closing of some lamp plants. Within the General Electric group, factories in Central Falls, RI, Fort Wayne, IN, St. Louis MO, Cleveland, OH and Minneapolis, MN closed. In this case there still remained factories in St. Louis, and Cleveland. The Westinghouse Lamp Company closed one of its plants in Bloomfield, NJ.

As of Sep 8, 1924 factories that produced large MAZDA lamps were located in the following places: the Edison Lamp Works had plants in East Boston, MA, Harrison, NJ, Newark, NJ, Oakland, CA and Scranton, PA. The National Lamp Works part of GE maintained plants in Cleveland, OH, Warren, OH, St. Louis, MO and Youngstown, OH. The Westinghouse Lamp Company maintained plants in Bloomfield, NJ, Milwaukee, WI and Trenton, NJ.

General Electric opened a plant in Fort Wayne, Indiana in Sep 1906 as a satellite of the Edison plant in Harrison. It was only a manufacturing plant and did no engineering or technical development of its own. By Nov 1908 it was producing 130,000 lamps per week.

Dr. William D. Coolidge had yet to finish his development of ductile tungsten when it was announced that the tungsten filament lamp would be manufactured in Fort Wayne. Manufacturing continued until it was deemed necessary to close the factory on Jan 12, 1924. Therefore, incandescent lamps were manufactured by GE in Fort Wayne from 1906 to 1924.

### **References**

- 1) "Abstract of Report of Lamp Committee, 1923-1924," Association of Edison Illuminating Companies, Presented at the 40th Annual Meeting, Eastern Point New London, CT, Sep 8,9,10 and 11, 1924.
- 2) General Electric at Fort Wayne, Indiana, A 110 Year History, Clovis E. Linkous, Gateway Press, Inc., Baltimore, 1994, pg 237.

### **Manufacturers of Incandescent Lamps in 1938**

Many collectors of incandescent lamps restrict their interest to lamps that were manufactured before a certain year. For example, one might choose the year 1925, when the inside frosted lamp appeared. Identifying and dating lamps can be confusing because of

the several licensees (different labels) and the appearance of carbon filament lamps after the introduction of the tungsten filament lamp. It might help collectors to know who was manufacturing lamps after the period of usual interest. The following list was taken from a paperback book titled Incandescent Electric Lamps, Report No 133, Second Series, published in 1939. It was one in a series issued by the United States Tariff Commission.

In the following, the manufacturer's name and location are given as well as the type(s) of lamps made. The type will be noted by TL (tungsten large), TM (tungsten miniature), CL (carbon large) or CM (carbon miniature).

In 1938 the General Electric Company had six plants in Ohio; three of these were lamp assembly plants, two were glass plants and one was a wire plant. In addition, a lamp-assembly plant existed in Massachusetts, Rhode Island, New Jersey, New York, Missouri and California. The Westinghouse Electric and Manufacturing Company (a licensee of the General Electric Company) had three plants in New Jersey. Of these, two were lamp assembly locations in which wire was made in one, and bases were made in the other.

- 1) General Electric Co. (locations noted above) □ TL, TM
- 2) Westinghouse Electric and Manufacturing Co. (locations noted above) □ TL, TM
- 3) Consolidated Electric Lamp Co. (MA) □ TL
- 4) Hygrade Sylvania Corp. (MA, PA) (Licensee of G.E.) □ TL
- 5) Ken-Rad Tube and Lamp Corp. (KY) (Licensee of G.E.) □ TL
- 6) Chicago Miniature Lamp Co. (IL) (Licensee of G.E.) □ TM
- 7) Tung-Sol Lamp Works (NJ) □ TM
- 8) Birdseye Electric Co. (MA) □ TL
- 9) Everbest Engineering Corp. (NY) □ TL
- 10) Lightmore Appliance Corp. (NY) □ TL
- 11) Slater Electric and Mfg. Co. (NY) □ TL
- 12) Wabash Appliance Corp. (also known as Sun Glo Lamp Works) (NY) □ TL
- 13) American Lamp Works (corp.) (NJ) □ TL
- 14) Atlas Lamp Corp. (NJ) □ TL
- 15) Duro Test Corp. (NJ) □ TL



- 16) Eastern Lamp Co. (also known as Sterling Products Co. and Cosmos Mfg. Co.) (NJ) □ TL, TM
- 17) Elram Lamp Works (NJ) □ TL
- 18) Jewel Incandescent Lamp Co. (corp.) (NJ) □ TL
- 19) Marvel Lamp Co. (corp.) (NJ) □ TL
- 20) Polar Co. (also known as Northern Incandescent Lamp Co.) (NJ) □ TL
- 21) Radiant Lamp Corp. (also known as King Mfg. Co.) (NJ) □ TL
- 22) Wonderlite Co. (corp.) (NJ) □ TL
- 23) Pennsylvania Illuminating Corp. (PA) □ TL
- 24) Warren Lamp Co. (PA) □ TL
- 25) Save Electric Corp. (OH) □ TL
- 26) Carlton Electric Co. (corp.) (NJ) □ TM
- 27) Dura Electric Lamp Co. (NJ) □ TM
- 28) Imperial Miniature Lamp Works (NJ) □ TM
- 29) Vulcan Lamp Works, Inc. (NJ) □ TM
- 30) Herzog Miniature Lamp Works, Inc. (NY) □ TL, TM, CM
- 31) Munder Electrical Co. (MA) □ CL
- 32) North American Electric Lamp Co. (MO) □ CL, CM
- 33) Safety Electric Co. (IL) □ CL, CM

A description of the carbon filament lamps manufactured in 1938 can be found on page 93:

"Carbon filaments are the only nonmetallic filaments now used commercially in lamp construction. Carbon lamps are manufactured chiefly with medium or candelabra screw bases, but they are also equipped with special bases such as the German or French candelabra screw bases or bayonet types. Most carbon-filament lamps are made with clear bulbs, only a small proportion having colored or frosted bulbs. Large lamps are manufactured for use on voltages within the following ranges: 20 to 95, 100 to 130, 200 to 275; in 8-1/2 to 120 watts for general lighting, and 50 to 375 watts for therapeutic

appliances. Straight-side and pear-shaped lamps are now used to withstand shock, excessive vibration, and rough service. Small quantities of round large lamps are used for illumination and decorative purposes. Tubular lamps are used for heating cabinet baths, and globe-shaped lamps for therapeutic treatments and for hair dryers. Other types are produced for dark-room photographic work, and for special appliances.

Miniature carbon lamps are rated from approximately 2 to 8 candlepower and are used on voltages ranging from 10 to 95, 100 to 130, and 200 to 250. They are used principally as pilot lights in automatic telephone switchboard indicators and in sewing machines. They are also used on waffle irons, Fiske indicators (Navy), the interior of refrigerators, and for Christmas trees and other decorative purposes. Special lamps are also made with indented tops for heating medicinal oils and perfumes."



### **The Thomson-Houston Electric Incandescent Lamp, 1884-1893**

In order to understand the origin of the first incandescent lamp introduced by Thomson-Houston in the year 1884 it is necessary to briefly review the history of different companies. The Thomson-Houston Company had been formed in 1883 to produce dynamos and arc lighting; it succeeded the American Electric Company, which had been formed in the year 1880. American Electric was formed based on the patents of Elihu Thomson and Edwin J. Houston. A Lynn syndicate, which consisted of business men, including Charles A. Coffin, bought American Electric in 1883 and renamed it Thomson-Houston.

To continue this story it is necessary to consider some of the lamp companies initiated by William E. Sawyer and Albon Man. These two men started manufacturing low resistance lamps in the year 1878 in the newly-formed Electro-Dynamic Light Company. Because of friction between Sawyer and owners of the company, Sawyer then organized the Eastern Electric Manufacturing Company in 1879. In 1882 Eastern was reorganized as the Consolidated Electric Light Company. The Thomson-Houston Company owned a controlling block of Consolidated stock. Thomson-Houston began to produce an incandescent lamp, based on Sawyer-Man patents, by taking out a license from

Consolidated.

The lamp and socket engraving shown to the left represents the Consolidated lamp as produced in 1886. It was scanned from a publication put out by E. H. Johnson<sup>2</sup>, President of The Edison Electric Light Company, in 1886, that indicated assumed infringements of

Edison patents by competitive manufacturers. The original engraving had arrows pointing to various parts and indicated the Edison patents they supposedly infringed.

It appears that the lamp base and socket design for the Thomson-Houston lamp (based on Sawyer-man patents) resulted after thought was given to the making and breaking of the electrical circuit. The switch in the socket was described in an *Electrical World* article titled "A New Incandescent Lamp Switch". The article<sup>1</sup> read:

"The principal objects to be attained in an incandescent lamp switch are a good contact and rapid make and break, so as to avoid sparking. Among the recent switches designed from this standpoint is that of the Consolidated Electric Light Company, of this city. The switch is shown in perspective in Fig. 1, and its action is apparent. The rectangular contact-maker lies flat against the lower spring when the lamp is turned off, but when it is desired to light up, the turning of the switch beyond a certain point causes it to snap quickly so as to make contact with the upper spring. In the same way the turning off is accomplished with a 'snap,' insuring a rapid break. The lamp bulb with its base is screwed to a solid bearing against the upper contact strip, making a firm contact and preventing a loose joint from being made by a jarring of the parts. Our illustration, Fig. 2, shows the lamp and socket combined."

The lamp switch is shown below, while the lamp-socket combination is essentially similar to the combination shown above and will not be reproduced here.

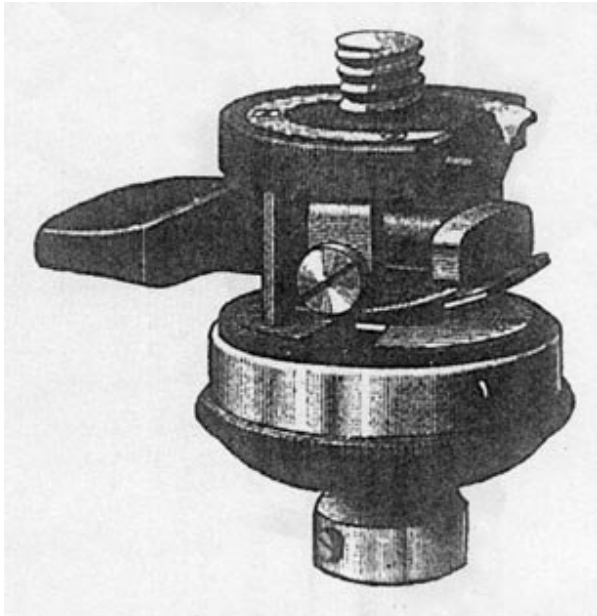

## References

- 1) "A New Incandescent Lamp Switch", The Electrical World, Vol VII, 1886, pg 142.
- 2) "The Edison Electric Light - The Legal and Commercial Status", E. H. Johnson, Oct 7, 1886.

- 3) "Statement of the Methods and Apparatus in Use at the Time the Department Was Closed", H. D. Burnett, Incandescent Lamp Department, Thomson-Houston Electric Company, Lynn, ca Aug 12, 1893.
- 4) "Notes on Development of the Carbon Incandescent Lamp at the Lynn Lamp Works of the Thomson-Houston Electric Company", Letter to F. W. Willcox dated April 12, 1911. This letter was sent in response to a request by Mr. Willcox, for use in connection with the U. S. Government Suit versus the General Electric Company.

## Hawkeye

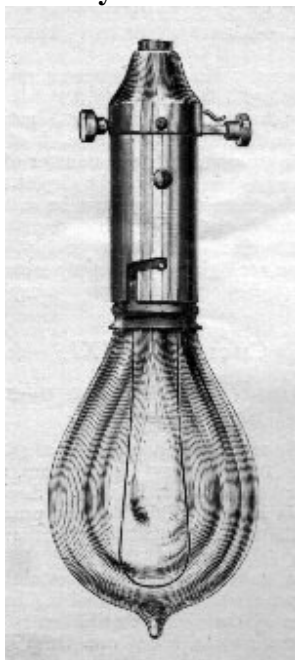

## Electric

## Manufacturing

## Company

The Hawkeye Electric Manufacturing Company had its origin in Oskaloosa, Iowa in either 1886 or 1887. It manufactured incandescent and arc light dynamos, incandescent lamps, and electric motors. The company was established based on the patents of Frank Thone. Growth was quite rapid and new facilities were required by November 1887. The incandescent lamp and socket produced by them is shown to the left. The claim was that the lamp had long life and constant candle power, with no tendency to blacken. Regarding the socket the claim was<sup>2</sup>:

"The merit of the socket, the company claims, consists in the use of a slide to make or break the circuit, instead of a key socket. The advantage in using the slide is that it is positive in its action, and one hand is sufficient to switch the lamp on or off. The socket and lamp are fastened together by a bayonet slot."

In the November 24, 1888 issue of the *Western Electrician* it was announced<sup>3</sup> that the Oskaloosa company sold its entire business to the organization of the same name in Davenport, Iowa. As of January 23, 1889 all business transactions were made out of Davenport. The company in Davenport was incorporated October 26, 1888<sup>8</sup>.

More on Hawkeye base and socket can be found under Section 10 of this website; look for "Hawkeye Base and Socket" and "Incandescent Lamp Sockets in Use Before Standardization." In addition, Thone's patents are listed in a separate writing<sup>10</sup>.

## References

- 1) 1887 Oskaloosa City Directory, pg 40.
- 2) "Hawkeye Electric Company", *Western Electrician*, Vol 2, No 13, Mar 31, 1888, pg 159.
- 3) Business Mention, *Western Electrician*, Vol 3, No 21, Nov 24, 1888, pg 275.
- 4) "The New Thone Electric Motor", *Western Electrician*, Vol 3, No 23, Dec 8, 1888, pg 289.
- 5) Business Mention, *Western Electrician*, Vol 3, No 23, Dec 8, 1888, pg 300.
- 6) Business Mention, *Western Electrician*, Vol 4, Feb 2, 1889, pg 66.
- 7) "Hawkeye Electric Motors", *Western Electrician*, Vol 4, Feb 16, 1889, pg 90.
- 8) "The Hawkeye Electric Company", *Western Electrician*, Vol 4, May 4, 1889, pg 241.
- 9) Business Mention, *Western Electrician*, Vol 7, No 15, Oct 11, 1890, pg 202.

10) Edward J. Covington, The Electric Incandescent Lamp, 1880-1925, Nela Press, E. Cleveland, Ohio, 1998, pg 15.

### **Fort Wayne Jenney and Indianapolis Jenney**

The stories of the Fort Wayne Jenney and Indianapolis Jenney incandescent lamps are not well-known. They are muddled because the two companies that produced these lamps were primarily interested in arc lamps. The manufacturers of arc lamps soon realized that they would also have to develop incandescent lamps because arc lamps were not suitable for use in the home.

The story begins with an arc lamp developed by John William Langley in the State of Michigan. In 1881 he and sixteen other individuals formed The Langely Electric Light Company to utilize five patents filed by him. Manufacture of Langley's lamp was to begin in July of 1881 in Ann Arbor. A firm in Ann Arbor, Ailes & Gratton, was contracted to built prototypes. It was this firm that hired James A. Jenney (1830-1904) and his 17-year-old son, Charles D. Jenney (1864-1926), in June of 1881.

In July of 1881 James Jenney and Walter S. Hicks, a businessman, traveled to Fort Wayne, Indiana to seek out investors for the Langley arc lamp and dynamo. At a dinner table they were seated with one John Kiess, who was employed as a shipping clerk at the Evans-McDonald wholesale dry goods company. Kiess had traveled to Cleveland in 1879 to view the demonstration of the Brush arc lamp on Public Square. In the subsequent conversation Kiess suggested that they talk with his employer, Ranald T. McDonald. McDonald was one who was interested in any enterprise that appeared to have potential. A meeting was set up and subsequently, in November of 1881, the Fort Wayne Electric Light Company (FWELC) was organized for the purpose of manufacturing electric lighting apparatus under the Langley patents. For marketing reasons the firm was called the Fort Wayne Jenney Electric Light Company.

Between August of 1881 and April of 1882 three patents ( Nos 255,999; 261,815; 262,544) were filed by Charles D. Jenney and James A. Jenney, and these were granted between April of 1882 and August of 1882. These were for lamps as well as a dynamo. In 1882 these patents were purchased by FWELC and manufacture of arc lamps began in October of that year. However<sup>18</sup>,

"...Charles Jenney became dissatisfied in Fort Wayne. On February 27, 1885, he petitioned the circuit court to release him from a contract that his father and guardian had made when he was 17 years of age which bound him and his inventions for life to the Fort Wayne 'Jenney' Electric Light Company. He had been given \$10,000 common stock out of a capitalization of \$100,000 issued at the time of the contract probably just for the assignment of his patents...The decision of the court in detail has not been found, but subsequent events show that there was either a negotiated separation, or a court ordered separation.

"It was not only a separation from the company, but also his father. His father, James A. Jenney, still had connections with the Fort Wayne 'Jenney'

Electric Light Company as late as August 24, 1888, but the Fort Wayne Sentinel on May 19, 1888 refers to him as visiting from Boston. He may have left at the time the company dropped the use of 'Jenney' in its name which occurred when the Thomson-Houston Company obtained a controlling share of the stock. This occurred in June of 1888 and James A. Jenney was one stockholder who sold to T-H."

Clovis Linkous<sup>18</sup> discussed the beginning of the Indianapolis business:

"On March 23, 1885, Charles Jenney, Addison Nordyke, Daniel Marmon, Amos Hollowell and Brainard Rorison as a Board of Directors filed Article of Association for a manufacturing company at Indianapolis, IN to be known as The Jenney Electric Light Company. (In less than a month, the name was amended to be Jenney Electric Company.) ...By August, 1885, they were on the street with dynamos, arc lamps and incandescent lamps to demonstrate."

It appears that more information is known about the Fort Wayne incandescent lamp than the Indianapolis lamp. Consider first the Fort Wayne Jenney lamp. Quoting from the *Western Electrician*<sup>5,7</sup>:

"...The lamp, which is the most important feature of any system, is manufactured by this company in a novel way. The material for the filament is suspended in a vacuum in which the carbonization takes place, and is shaped gradually during the process, thus making a filament as flexible as the finest steel wire and insures a long life of the same. The finest filament desired can be manufactured in this manner to withstand a heavy current. After the filament is finished it is connected by a very ingenious apparatus with platinum wires, by means of metals melting at a low temperature, which joins both parts together. This process, in connection with a good vacuum, secures a highly efficient and long-lived lamp. The average candlepower per commercial horse power is 200 candles, and with large lamps somewhat higher. These it is claimed are the best results ever obtained in the world. The company will guarantee ten sixteen-candle lamps per horse power even with a percentage of loss on the circuit. With larger lamps of 20 to 150 candle-power, they will guarantee a proportionately greater economy. The potential adopted for these lamps varies from 10 to 100 volts, according to circumstances and distances, and lamps are made from 10 to 150 candle power. The difficulty of obtaining a reliable and ornamental lamp socket has been overcome. The button is nonsparking, and a half turn separates the two parts of the socket, leaving the terminals entirely clear and ready for connection without the twisting of the wire, □ a feature greatly appreciated by those versed in incandescent circuit construction. Any size of lamp can be attached and disconnected instantly by simply pushing it in or out.

"Fig. 2 shows the ornamental appearance of the socket and the method of connection. Fig. 3 shows the lamp proper with the two terminals, but without the socket, and gives a fair idea of the manner of connection with the socket. Fig. 4 shows the lamp and socket complete."

The lamp shown in Fig. 5 is the style made when used on arc light circuits. Lamps were made for 16, 20, 25, 40, 75, 100 and 150 candle power. An obvious difference between this lamp and those shown in Figs. 3 and 4 is the shape of the bulb and the presence or absence of the filament bridge.



above, Figures 2, 3, 4

From left to right and 5<sup>5,7</sup>

The origin of the Indianapolis Jenney lamp base is not clear to this writer. A picture of an Indianapolis Jenney lamp is shown to the far left. These pictures were kindly provided by Jerry R. Westlick for use with this topic. A patent was granted to John S. Adams in 1888<sup>9</sup> in which a drawing of the lamp and socket shows this type of contact. The lamp might have



been manufactured for only a short time (perhaps from 1885-1889); few examples of this lamp type exist in private collections. In Sep, 1889 the Jenney Electric Co. (of Indianapolis) was purchased by the Fort Wayne Electric Co., it being controlled by the Thomson-Houston Co.

There are six "Jenney" lamps in the William J. Hammer Collection, which is housed at the Ford Museum in Dearborn, Michigan. As noted below, five were made in Indianapolis and one was made in Fort Wayne. Frederick Schaefer worked in the Fort Wayne facility about 1886. He had been granted a patent for the manufacture of filaments (No. 320,297- dated Jun 10, 1885). The descriptions below are due to Hammer.

- 1888-362-----Indianapolis Jenney Lamp Co. (American). Made by J. C. Reed at Indianapolis, IN.
- 1888-363-----Indianapolis Jenney Lamp Co. (American). Made by J. C. Reed in 1888. Ground detector lamp two filaments in series. Three outside connections.
- 1888-364-----Indianapolis Jenney Lamp Co. (American). Lamp No. 3. Made by J. C. Reed. Fused metallic silver clamp enclosed in glass cap to prevent discoloration.
- 1888-365-----Indianapolis Jenney (American). Carbon filament lamp with fused metallic around shank and inside of platinum caps drawn on leads.
- 1888-366-----Indianapolis Jenney Lamp Co. (American). Made by J. C. Reed. Clamp is made of spongy platinum block and cane sugar. The glass balls are to prevent heating.
- 1888-367-----Fort Wayne Jenney Co. (American). Schaefer cellulose carbon filament lamp, carbon paste clamps.

### **Timeline**

Fort Wayne (Jenney) Electric Light Co. organized Nov 1881  
Jenney Electric Light and Power Co. (Fort Wayne) organized Nov 1883  
Thomson-Houston Company formed 1883  
Jenney Electric Light Co. (Jenney Electric Co.) (Indianapolis) formed Mar 1885  
Thomson-Houston started to manufacture incandescent lamps in 1885  
McDonald (FWELC) purchased property and rights of the Sun Mfg. Co. of Woburn, MA 1888  
Thomson-Houston bought controlling interest in the Fort Wayne Jenney Electric Co. Jun, 1888  
Jenney Electric Co. purchased by the Fort Wayne Electric Co. (successor of Fort Wayne Electric Light Co.) Sep 1889  
Thomson-Houston bought the Brush Electric Co. Oct 1889  
Merger of Thomson-Houston Co. and Edison General Electric Co. to form the General Electric Co. Apr 1892

Thus, any manufacture of the "Jenney" lamps after Jun 1888 was done under the control of the Thomson-Houston Company and, after Apr 1892, under the control of the General Electric Company. Incandescent lamps manufactured by the Indianapolis firm of the Jenney Electric Company when not under external control probably were made between 1885 and 1888. Incandescent lamps made by the Fort Wayne concern when not under external control were probably made during the same time period.

The following is an article that appeared in *The Indianapolis News* upon the death of Charles D. Jenney (1864-1926).<sup>14</sup>

#### "A Pioneer in Electricity

"The development in electricity has been so rapid and its application so common, that the present generation probably thinks or cares little of the early inventors in this field of modern life. There, for instance, was Charles D. Jenney, who recently died in this city, and whose name at one time was commonly known to every inventor and manufacturer in the electrical world. The Jenney motor was one of the first that was made, and one of the best. There are many Jenney motors still in use. Mr. Jenney was the first to attach an individual motor to a printing press. Several of his appliances are at the foundation of application of electricity to newspaper machinery. He was one of the early workers in Ft. Wayne and Indianapolis. He was probably the inventor of the third rail □ or at least he made use of the third rail principle before it was commonly introduced in subways and elevated railways. The overhead trolley is only a modification of the third rail, the current being drawn from the wire through the trolley to the mechanism in the car. The Jenney lights in the days when electric illumination came from tall towers in the air, will be remembered by old-timers. He was distinctly an inventor, and had he been financed properly and been held to the development of devices rather than to the business end of electric construction, he would probably been as widely known as some of the greater names in electricity. At any rate, he did his share and made his contribution to his day and generation."

**Note:** Many references spell McDonald's first name as "Ronald". The correct spelling is "Ranald".

#### References

- 1) Frederic Schaefer, "Manufacture of Filaments for Incandescent Lamps", U. S. 320,297, Jun 16, 1885.
- 2) "The Jenney Lighting Interests", *The Electrical World*, Vol 5, 1885, pg 142.
- 3) Arthur S. Hickley, "Carbons for Incandescent Lighting", *The Electrician and Electrical Engineer*, Vol 5, Oct 1886, pp 371-372.
- 4) Arthur S. Hickley, "Incandescent Lamp", U. S. 354,788, Dec 21, 1886.
- 5) "Fort Wayne Jenney Incandescent System", *Western Electrician*, Vol 1, No 2, Jul 9, 1887, pp 13-14.
- 6) "The Fort Wayne Jenney Incandescent System", *The Electrical World*, Vol 10, Jul 16,

- 1887, pg 31.
- 7) "Fort Wayne Jenney Incandescent Lamp", *Western Electrician*, Vol 1, No 5, Jul 30, 1887, pg 52.
- 8) "Ronald T. McDonald", *The Electrical Engineer*, Vol 7, Sep 1888, pg 381.
- 9) [John S. Adams U. S. Patent No. 391,351](#) If a message saying "Search Time Has Expired" comes up, then click on "Full Text" and in the next window click on "Images."
- 10) "The Affairs of the Fort Wayne Electric Company", *The Electrical World*, Vol XIV, No 8, 1889, pg 134.
- 11) "The Factory and Apparatus of the Fort Wayne Electric Corporation", *The Electrical Engineer*, Vol XVII, No 321, Jun 27, 1894, pp 552-566.
- 12) "Death of Ronald T. McDonald", *Electricity*, Vol XV, No 25, Dec 28, 1898, pg 386.
- 13) Obituary Notes, "Mr. Ronald Trevor McDonald", *The Electrical World*, Vol XXXII, No 27, Dec 31, 1898, pg 734.
- 14) The Indianapolis City Directory, 1925.
- 15) "A Pioneer in Electricity", *The Indianapolis News*, May 17, 1926.
- 16) The Indianapolis City Directory, 1927.
- 17) Bob Parker, "The Lights", Old Fort News, Summer 1971, Published by the Allen County-Fort Wayne Historical Society, 15 pages.
- 18) Clovis E. Linkous, General Electric at Fort Wayne, Indiana □ A 110 Year History, Gateway Press, Inc., Baltimore, 1994.
- 19) Nancy Vendrely, "History of GE Sheds Light on Fort Wayne's Past", *Fort Wayne Journal-Gazette*, Sep 27, 1994.

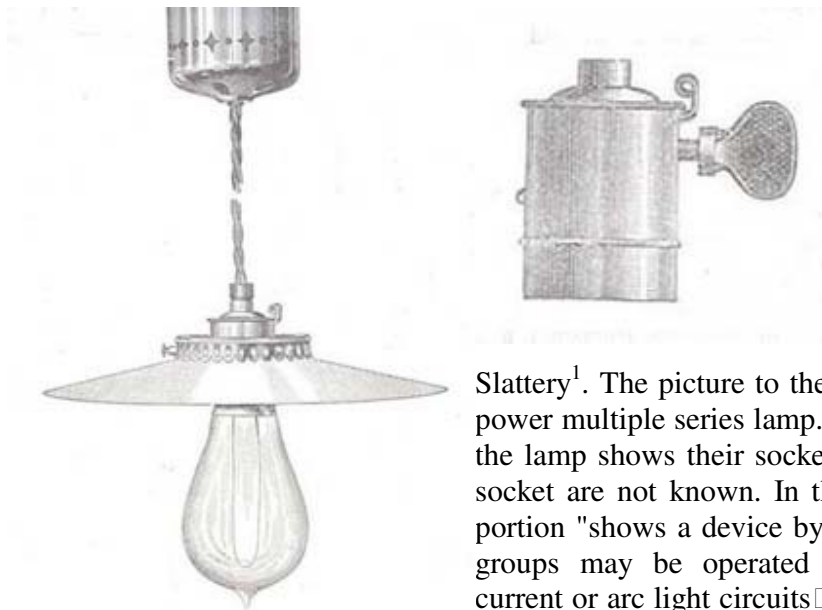

### The Sun Electric Company

The Sun Electric Company, of Woburn, Massachusetts, developed a lighting system in the late 1880s that was the creation of Marmaduke M. M.

Slattery<sup>1</sup>. The picture to the far left is their 16-candle power multiple series lamp. The picture to the right of the lamp shows their socket. Details of the lamp and socket are not known. In the lamp picture the upper portion "shows a device by means of which lamps in groups may be operated with safety on constant current or arc light circuits □ each lamp being supplied with one of these individual cut-outs, in case of

failure of a lamp, the resistance in the brass is automatically switched into circuit, thus taking up the current of the defective lamp."

Slattery moved to Fort Wayne, Indiana in 1887 to work for the Fort Wayne Jenney Electric Light Company. He developed a system there and the incandescent lamp is shown below<sup>2</sup>. It can be seen that the socket represented is that of the "Fort Wayne Jenney." Fort Wayne

acquired the Slattery patents and then purchased the entire assets of the Sun Electric Company as well as the Slattery Incandescent Company, of New York<sup>4</sup>.

The William J. Hammer Collection of Historical Incandescent Electric Lamps contains five Sun manufactured lamps. These are: 1887-340, 1887-376, 1888-361, 1888-372 and 1888-373. The details of these lamps can be found on this web site.

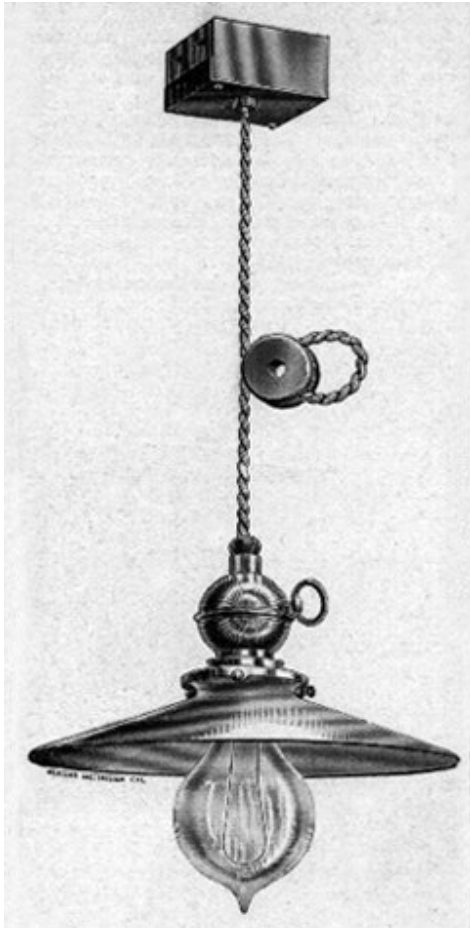

### **Acknowledgement**

I am grateful to Jerry R. Westlick for providing a copy of Reference 1.

### **References**

- 1) "The Sun Electric Company's System and Appliances," *Electrical Review*, Vol 11, No 2, Sep 16, 1887.
- 2) "The Slattery Induction System," *Western Electrician*, Vol 2, No 7, Feb 18, 1888, pg 73.
- 3) M. M. M. Slattery, "Alternating vs. Continuous Currents," *Western Electrician*, Vol 2, No 12, Mar 24, 1888, pp 152-154.
- 4) "The Affairs of the Fort Wayne Electric Company," *The Electrical World*, Vol 14, No 8, 1889, pg 134.

**Lamp Manufacturers in Warren, Ohio**

Warren, Ohio certainly must be unique in that, for its size, it probably had more manufacturers of electric incandescent lamps than any other city. The following companies manufactured electric incandescent lamps in Warren during the specified times. The information that follows was taken from the Warren City Directories:

**1891-92**

The New York & Ohio Co. (used the Packard label)

**1893-94**

The New York & Ohio Co.  
The Warren Electric & Specialty Co.

**1899**

The New York & Ohio Co.  
The Warren Electric & Specialty Co.

**1904**

The Economy Electric Co.  
The Monarch Electric Mfg. Co.  
The New York & Ohio Co.  
The Peerless Electric Co.  
The Standard Electrical Mfg. Co. (Niles)  
The Sterling Electrical Mfg. Co.  
The Warren Electric & Specialty Co.

**1906**

The Economy Electric Co.  
Mahoning Lamp Factory  
The Monarch Electric Mfg. Co.  
The New York & Ohio Co.  
The Peerless Electric Co.  
The Standard Electrical Mfg. Co. (Niles)  
The Sterling Electrical Mfg. Co.  
The Warren Electric & Specialty Co.  
The Holscher Electrical Mfg. Co. (lamp renewer)  
The Niles Electric Co. (Niles) (lamp renewer)

**1908**

The Colonial Electric Co.  
The Economy Electric Co.  
The Holscher Electrical Mfg. Co.  
The Monarch Electric Mfg. Co.  
The New York & Ohio Co.  
The Niles Electric Co. (Niles)  
Ohio Lamp Works  
Mahoning Lamp Works  
The Standard Electrical Mfg. Co. (Niles)  
The Sterling Electrical Mfg. Co.  
The Warren Electric & Specialty Co.

**1910**

The Aladdin Electric Co.  
The Colonial Electric Co.

The Hecklinger	Economy	Electric	Co.
The Mahoning	Holscher	Electric Electrical	Co.
The Ohio	New York	Lamp	Works
Refilled	Carbon	Electric	Ohio
The Standard	Niles	Lamp	Works
The Sterling	Carbon	Lamp	(Niles)
Trumbull	Standard	Electrical	Mfg. Co.
Trumbull	Sterling	Electrical	Mfg. Co.
The Warren Electric & Specialty Co.	Carbon	Lamp	Works
	Mazda	Lamp	Works

The United States Circuit Court, Northern District of Ohio, Eastern Division, on Oct 12, 1911, required that several lamp manufacturing plants, which were owned by the General Electric Company, henceforth inform the public of the relationship that existed between them and GE. It will be seen below that those plants became identified as being Divisions of GE.

**1914**

Colonial		Electric	Division
The Mahoning	Holscher	Electrical	Co.
Ohio	Mazda	Lamp	Division
Packard		Lamp	Division
Peerless		Lamp	Division
Standard		Electric	Division
Sterling	Electric	Lamp	Division
Trumbull Mazda Lamp Division			

**1916**

Colonial		Electric	Division
International		Lamp	Co
Novelty		Lamp	Co
Mahoning	Miniature	Lamp	Division
Ohio			Division
Packard		Lamp	Division
Peerless		Lamp	Division
Standard		Electric	Division
Sterling	Electric	Lamp	Division
Trumbull Mazda Lamp Division			

**1919**

Colonial		Electric	Division
Mahoning	Miniature	lamp	Division
Ohio			Division
Packard		Lamp	Division
Peerless-Brilliant		Lamp	Division

Standard		Electric		Division
Sterling		Electric	Lamp	Division
Sunlight	Electrical	Mfg	Co. (organized in Jun	1917)

Trumbull Mazda Lamp Division

**1921**

Colonial		Electric		Division
Ohio				Division
Packard		Lamp		Division
Peerless-Brilliant		Lamp		Division
Standard		Electric		Division
Sterling		Electric	Lamp	Division
Sunlight	Electrical		Mfg	Co

Trumbull Mazda Lamp Division

**1923**

Ohio				Division
Packard		Lamp		Division
Peerless-Brilliant		Lamp		Division

Sterling Electric Lamp Division

**1925**

Ohio		Mazda	Lamp	Works
Packard		Lamp		Division
Peerless-Brilliant		Lamp		Division

Sterling Electric Lamp Division

**1927**

Ohio Lamp Works of General Electric Co.

**The Excelsior Electric Company**

The Excelsior Electric Company was formed for the purpose of utilizing the patents and know-how of William Hochhausen. The company was located in New York City. The following write-up, regarding incandescent lamps, appeared in Part 3 of a broader description of the company's products<sup>1,2,3</sup>.

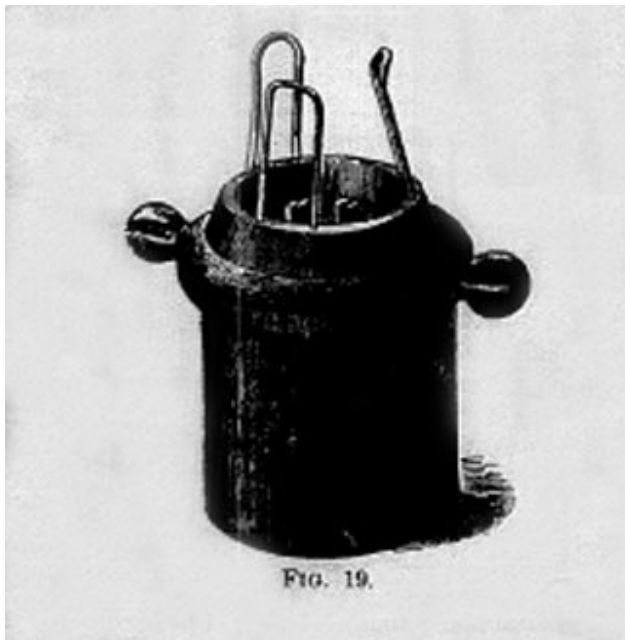

FIG. 18.

"The Excelsior Electric Company seems to have come to the conclusion that the incandescent light has its sphere of usefulness as well as the arc light for it has lately given considerable attention to the subject of incandescent lighting. Besides

making shunt-wound dynamos specially adapted to this purpose, the company proposes to manufacture its own incandescent lamp and accessories. This lamp (Fig. 18) differs from the others in the form given to the carbon loop, which, in this case, assumes the semblance of a letter T. This form of loop is preferable to any other form we have yet seen, for it makes the light-producing focus seem more spherical. The carbon loop is formed of vegetable fibre of a peculiar kind, which is found to last remarkably long. The weak spot in incandescent lamps is generally in the imperfect connection between the wires passing through the glass and the carbon filament. It is claimed that in these lamps the connections are made in an improved manner which leaves nothing to be desired.

"Fig. 19 shows a plain form of holder used with these lamps. The three bent wire springs embrace the lower portion or neck of the lamp, and the small platinum wires protruding through the glass are pinched between the split extremities of the circuit, connecting by means of screws, one on each side. Fig. 20 shows one of these holders mounted on a hand-stand and supporting an Excelsior incandescent lamp. In Fig. 21 we have a more ornamental form of holder, in which the bent wire springs are replaced by sheet brass springs, forming part of a casing.



"The device represented in Fig. 18 is called an 'automatic substituter.' The circuit is divided at first into two branches, one of which includes the electro-magnet shown in the base, together with one of the lamps. The other includes the other lamp, but remains closed only as long as the armature is retracted. When the current is put on, therefore, as soon as the magnet is excited, the second circuit is opened and only the first lamp

remains in circuit. If this lamp breaks, however, the armature instantly falls back and closes the circuit through the second lamp. There are many situations where it would be very desirable to have the incandescent light in connection with the arc light. For instance, there are often places where a few incandescent lights would be more convenient and useful than one arc light. To meet this want attempts have been made to run incandescent lights in the same circuit with arc lights. For instance, it seems quite plausible that if the current in circuit is ten amperes and each incandescent lamp requires a



current of one ampere, by dividing the circuit into ten branches, each of which includes a light, the lamps ought to burn successfully. But the trouble is that if one lamp breaks the nine others will receive the ten amperes among them, or each will receive one-tenth of an ampere more than is 'healthy' for it. This may lead to the rupture of another, and this again causes an increase of one-tenth of an ampere. In short, the breakage of one lamp endangers the rest, and, according to our experience, it generally causes their total destruction, thus breaking the circuit. This is evidently unpractical.



"Mr. Hochhausen, however, has attacked the problem anew, and he has indeed produced a very ingenious solution of it, the principle of which is simple enough. When a lamp breaks or is cut out, he proposes to shunt the surplus current through an equivalent resistance. If two lamps break he diminishes this resistance. Finally, if there is danger that the lamps may burn up altogether, they are all cut out of the circuit. These results are all accomplished by means of an automatic regulator (Fig. 22).

"The switch shown on the right-hand side is normally pulled toward the cover by a spring not shown in the figure. In this condition, the incandescent lamps are cut out of the arc light circuit. The contact piece nearer to the cover of the case is connected to the armature of an electro-magnet within. This electro-

magnet is included in the main circuit, and when the current is passing it attracts its armature, and causes the contact piece outside the case to project out from the surface of the case. If, now, the switch is moved to the right, it is prevented from moving back by the insulated end of this protruding contact. In this condition, the incandescent lamps are included in the circuit—that is to say, the circuit divides at one point into several branches, in which are included the lamps—one in each branch. But there is one of these branches which, instead of a lamp, includes a relay magnet of rather high resistance. Now if a lamp breaks the current increases in all the

remaining branches stated above. The relay feels this increase, and its armature comes against a contact which closes the circuit through another branch, including an equivalent resistance placed in the case, and consisting of wire wound on wooden reels, every turn of the wire being accessible to the air so as to admit of ready cooling. If now another lamp breaks, the armature of the relay is attracted further, and closes a circuit through a lamp placed on top the regulator case to warn the attendant, who immediately proceeds to replace the two broken lamps. But meanwhile another lamp still may break, and as the relay cannot make further compensation there is imminent danger that the other lamps will break.

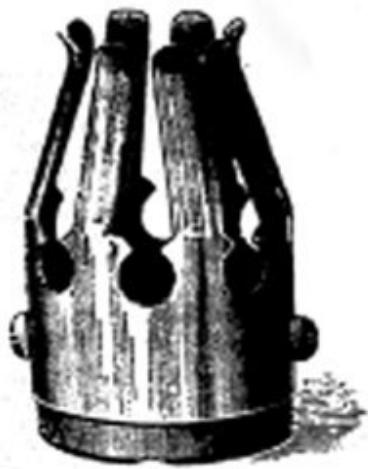

FIG. 21.

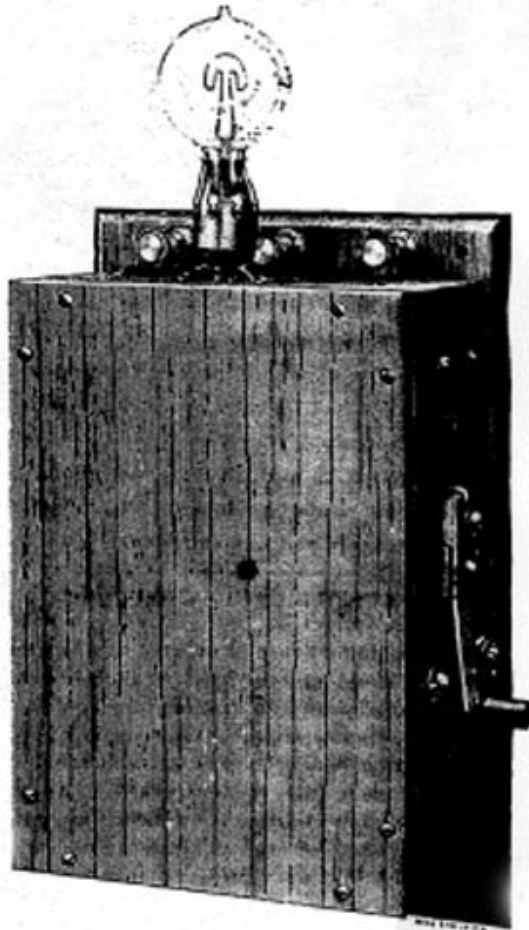

FIG. 22.

This is prevented by a kind of automatic cut-out. The relay is provided with a supplementary armature, which is attracted when the current increases beyond the limit compensated for by the relay itself. The motion of this armature short-circuits the electro-magnet in the main circuit, whose function is to make the contact piece protrude on the outside of the case. Instantly this contact piece moves back close to the surface of the case again, and the switch is quickly pulled back by its spring. As soon as it touches the metallic surface of this contact once again the incandescent lamps are short-circuited and the arc lights are left alone in the circuit. It is evident that the principle of this regulator may be extended not only to one but to several multiple series, and the number of lamps compensated for may be regulated quite easily. The only objection that can be made against this mode of regulation is that there is no economy of energy when only a few of the lights are burning, because the compensating branches absorb the energy previously expended in the lamp in producing light. However, as the number of lights accidentally put out would usually represent only a trifling proportion of the total in use, this objection is not serious. Besides, in cases where this procedure is resorted to, expediency or convenience is generally a more important consideration than economy. It may interest some of our readers to know that the incandescent lamps we used in some of our tests and experiments had an average resistance of 80 ohms cold and approximately 40 ohms when hot. In conclusion we wish to express our thanks to Mr. Hochhausen, electrician of the company, Mr. Oswald, his assistant, and to Mr. Geo. D. Allen, general manager, for courtesies received and facilities placed at our disposal in the preparation of these articles."

GEORGE D. ALLEN,  
General Manager.

THE

W. HOCHHAUSEN,  
Supt. and Electrician.

# Excelsior Electric Co.,

66 & 68 DUANE ST., N. Y.

WE ARE THE SOLE OWNERS OF ALL THE VALUABLE  
PATENTS & IMPROVEMENTS OF V.M. HOCHHAUSEN.

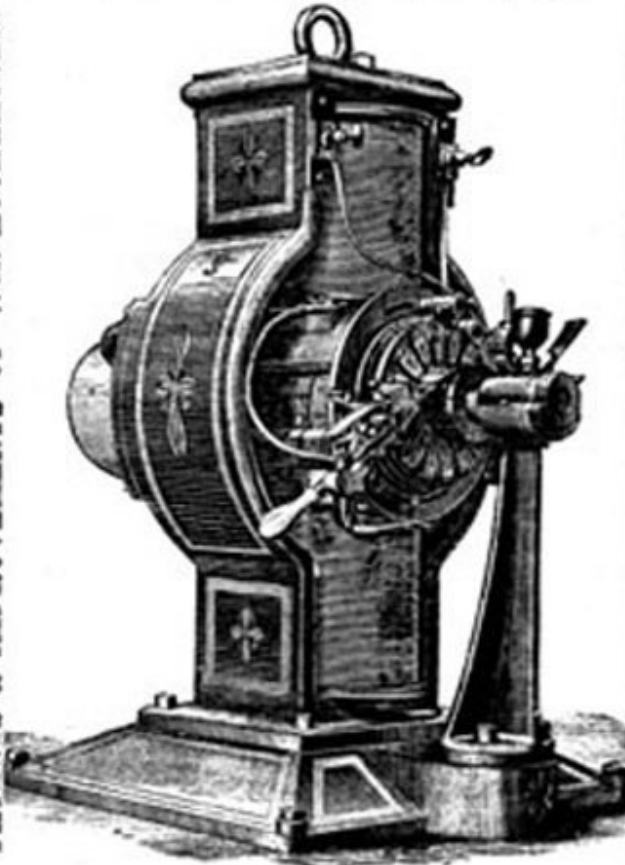

THE MOST PERFECT SYSTEM OF ELECTRIC LIGHTING  
IN THE WORLD.

Our Machine occupies the least space.  
" " requires the least power.  
" " has no equal in steadiness.  
" " requires no attention.  
Our Lamps are perfect in action as well as ornamental.

## Acknowledgment

The writer is grateful to Charles A. Crider for providing a photocopy of the advertisement of the Excelsior Electric Company, which appeared in *The Electrical World*, on January 5, 1884, page viii.

## References

- 1) C. O. Mailloux, "The Electric Lighting System of the Excelsior Electric Company," Part 1, *The Electrical World*, Vol 3, No 1, Jan 5, 1884, pp 1-3.
- 2) C. O. Mailloux, "The Electric Lighting System of the Excelsior Electric Company," Part

- 2, *The Electrical World*, Vol 3, No 2, Jan 12, 1884, pp 9-10.
- 3) C. O. Mailloux, "The Electric Lighting System of the Excelsior Electric Company," Part 3, *The Electrical World*, Vol 3, No 3, Jan 19, 1884, pp 17-19.

## Lamp Descriptions-1885 Franklin Institute Test

In the year 1885 the Franklin Institute of the State of Pennsylvania published a special report on test results of lamps submitted for comparison purposes. This report was published as a supplement to the *Journal of the Franklin Institute*, Sep 1885. The report is rather extensive and deals with topics that usually are not of general interest to lamp collectors. Certain information on the lamps was extracted from the report, however, and is conveyed here.

The lamps that were tested were: Stanley-Thompson (44-volt), Woodhouse-Rawson, Weston (70 & 110-1/2 volts), Edison (94-100 volts), Stanley-Thompson (96-volt), and White (later known as Vitrite and Luminoid Company's "Luminoid"). The Brush-Swan and Bernstein Companies were invited to submit lamps but did not. The lot of Woodhouse-Rawson lamps were obtained from the Van de Poole Company. The Stanley-Thompson lamps had been made by the Union Switch and Signal Company of Pittsburg. The Weston lamps had been made by the United States Electric Lighting Company.

The Weston lamps had "tamidine" filaments. Gun-cotton in the form of flat sheets was treated chemically to separate the nitryl from the cellulose. The resulting cellulose product was a tough, firm, translucent substance from which the strips were cut in a sinuous form and carbonized. The carbon was rectangular in cross section, but was placed in the lamp so that at the shanks, the longer side of the rectangle was in the line of the shanks, instead of at right angles as in most other lamps. The connections were made at the terminals with minute steel screw bolts and nuts setting up with platinum washers. The bending of the carbon turned the long side of the rectangle so that it lay in different directions at different points. The lamp was mounted on a wooden base surrounded by a brass ring. The wires were led down through holes in the wood to the bottom of the base, where one was soldered to a ring and the other was held in place by a small screw, which was concentric with the ring and projecting below its plane. The socket contained two spring clamps against which the terminal ring and screw of the lamp pressed, the lamp being held in place by a lug on the brass ring fitting into a groove in the socket.

The Edison lamps submitted were similar in appearance to those in the marketplace. The carbon was made from bamboo fiber. Lamps employed the usual screw socket.

The carbon in the Woodhouse-Rawson lamps was rectangular in cross section and was cemented by a very neat joint to two platinum wires, which were kept apart by a glass bridge, and then they passed through the base of the lamp. The wires had small loops formed in their ends, the loops being made rigid by imbedding the ends in the glass. Two spring hooks in the socket hook into these loops, making contact. The lamps in the test were used with Swan sockets.

The Stanley-Thompson lamps apparently had filaments made of thread. The lamps were made under the Stanley-Thompson patents. In the small 44-volt lamp the filament was cemented to platinum wires that were kept apart by a glass bridge and then passed through the base of the lamp. The glass bulb of the lamp was set in a hollow in a wooden base and

secured by a cement of plaster of Paris. The wires went through the wood to two small screws.

All lamps except for the Edison gave the appearance of the filaments having been treated in a hydrocarbon vapor. The Weston filaments had only a slight treatment.

The White lamps had an appearance similar to the Woodhouse-Rawson lamps. The filaments were cemented to platinum wires that were separated by a glass bridge, and had loops in their ends for hook connections in spring sockets.

A picture of the lamps, sans the White, is shown below.

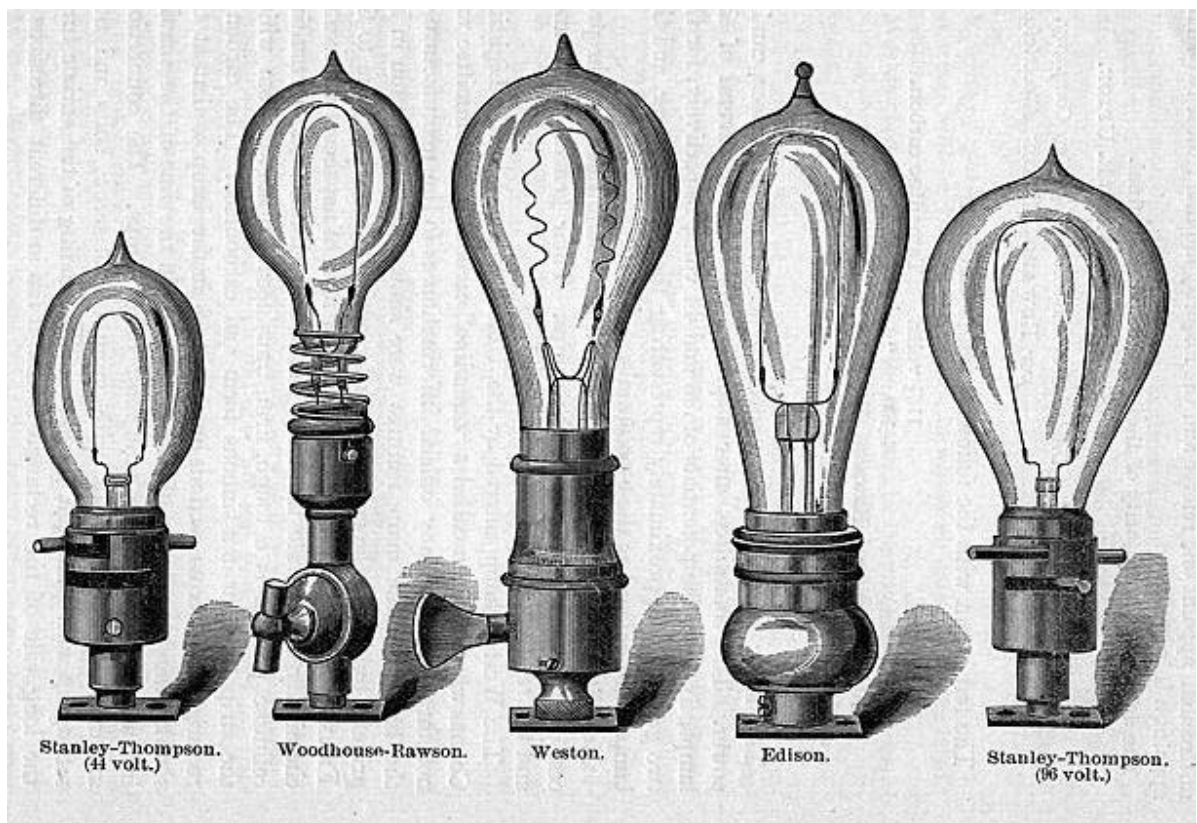

---

### The Largest Incandescent Lamp Ever Made as of 1899

So what was the largest lamp ever made by 1899 and to what purpose was it used? The answer can be found in the *American Electrician*, Vol XI, No 7, Jul 1899, pg 340. In general, very large incandescent lamps were not made because arc lamps would usually better fill the need. However, there was a need for an incandescent lamp, rather than an arc lamp, for application in lighthouses. Such a lamp is shown in the photo below.





The reason an incandescent lamp served the need of a lighthouse better than an arc lamp was "its greater fog penetration, the yellower rays of the glowing filament being dampened out and absorbed to a much less extent than the rays of an arc light."

The Bryan-Marsh Company experimented with large lamps, the largest one rated at 5000 candlepower. The lamp contained the standard double-filament type. The filaments were connected in parallel and operated at 236 volts. The power consumed was about 15 kilowatts at 60 amperes. This lamp burned out after being exhibited for three nights at an Electrical Show. It had been burned in the base up position and the heat softened the glass at the base. The cost of construction and erection of this lamp was over \$1000.

### **Later Samples of Carbon Filaments**

It was mentioned elsewhere (Petzinger Filament Collection) that GE still manufactured carbon filaments as late as 1945. The writer had access to the remains of that production in the early 1960s when the filaments were to be discarded. Although there was no indication of the number of filaments in the remains, the number certainly was in the millions. Before the filaments were discarded the writer removed some representative types to keep for posterity. Some of the larger boxes (2-1/8 x 4-3/8 x 8-1/2 inches) had at least 20,000 filaments in them. A sampling of some of these filaments is shown in the following photo.



In 1959 carbon lamps were manufactured by the North American Electric Lamp Company of St. Louis, MO. They did not manufacture the filaments, however, but purchased them from F.J.& J. Planchon, 78 Rue Lacondamine, Paris, France. A sampling of filaments obtained in 1959 from Planchon is shown below.



## **Carbon Filament Configuration and Light Distribution**

Collectors of early incandescent lamps sometimes come across a lamp that has an unusual carbon filament configuration. At the beginning of the 20th century some manufacturers put lamps on the market that had filament shapes that deviated from the norm. This write-up concerns a few of those different designs that were made when it was desired to have more light directed in a downward direction when the lamps were burned base-up. It is also of interest to know which design might have approached the condition of equal light output in all directions. One such design appears to have achieved that goal.

In 1901 Francis W. Willcox read a paper before the National Electric Light Association that dealt with the distribution of light in vertical and horizontal planes from various standard incandescent filaments. One printed version of that talk appeared in *American Electrician*, Vol XIII, Nov 1901, pg 513. Light distributions from that paper are shown below.

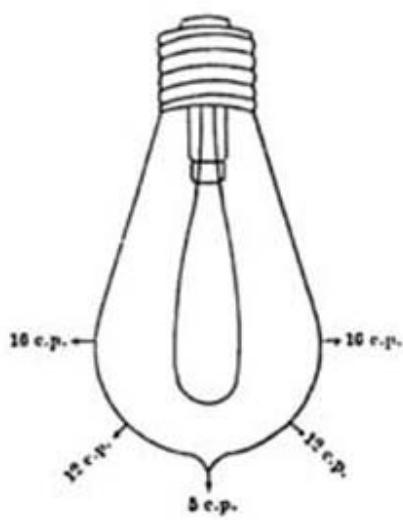

FIG. 1.

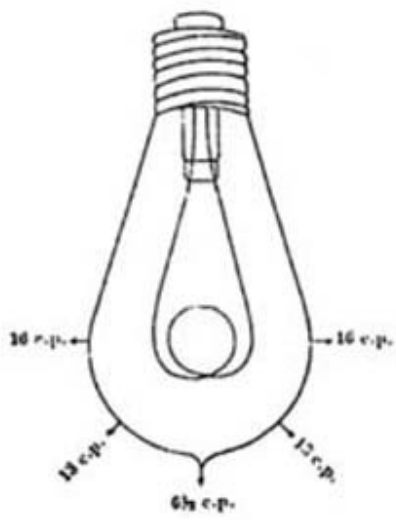

FIG. 2.

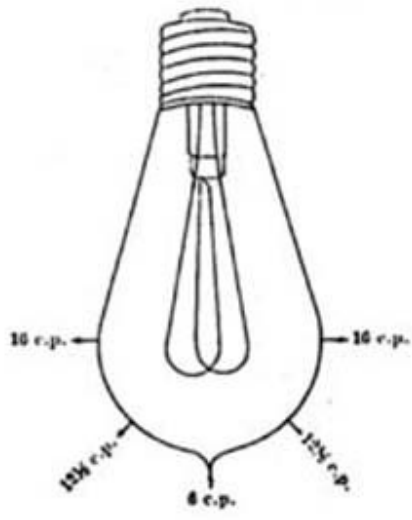
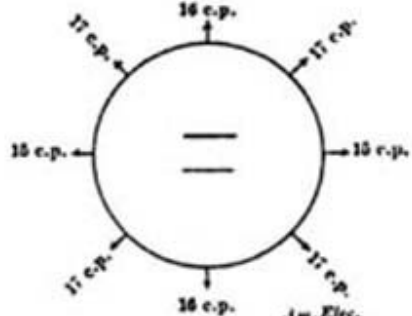
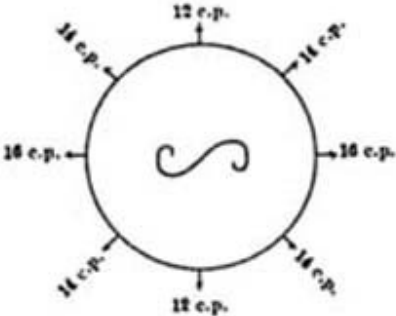
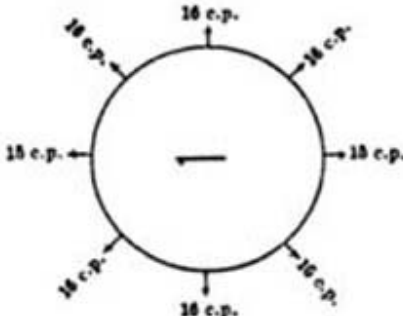

FIG. 3.



Am. Elec.

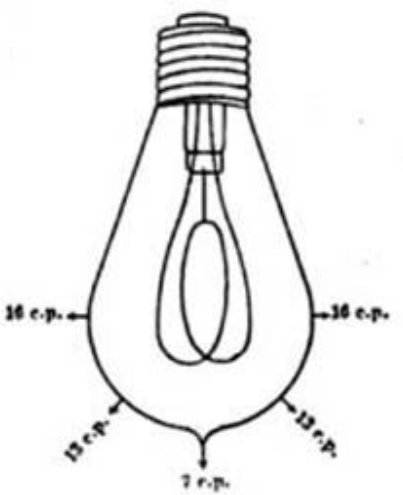

FIG. 4.

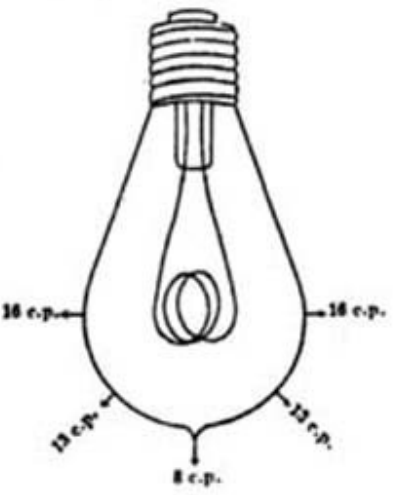

FIG. 5.

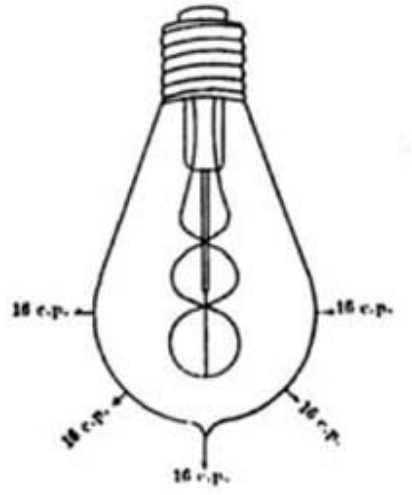
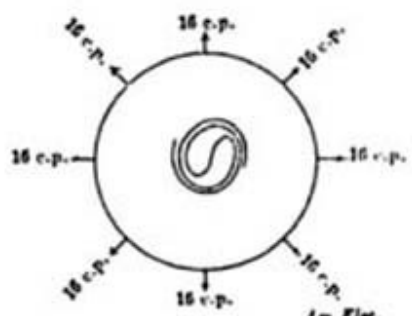
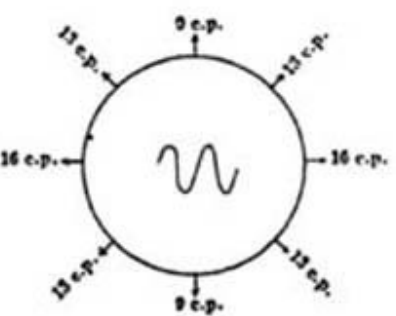
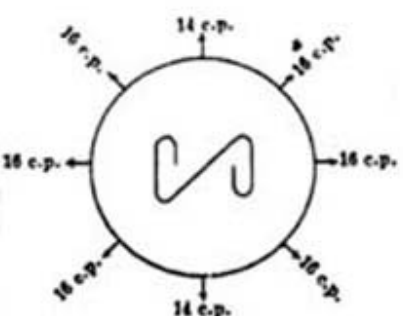
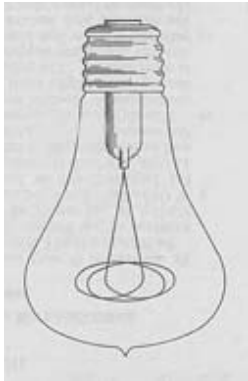

FIG. 6.



Am. Elec.



One filament configuration, not shown above, was designed by A. A. Chaillet while he worked at the Shelby Electric Company, in Shelby, Ohio; the design is shown to the left. The requirement to design the filament so that much of it projected in a downward direction resulted in a bulb shape that was somewhat "mushroom" shaped. This particular design seems to be a popular one among collectors of incandescent lamps. It is also of especial interest because a lamp of that design has become known as the "Livermore Centennial Light." That particular lamp has been in operation for over 100 years. U. S. Patent No. 701,295, applied for in 1900 and granted in 1902, covers its design. The

increased light output in a downward direction was important for some applications. The lamp was manufactured in Shelby, Ohio from 1900 to 1914.

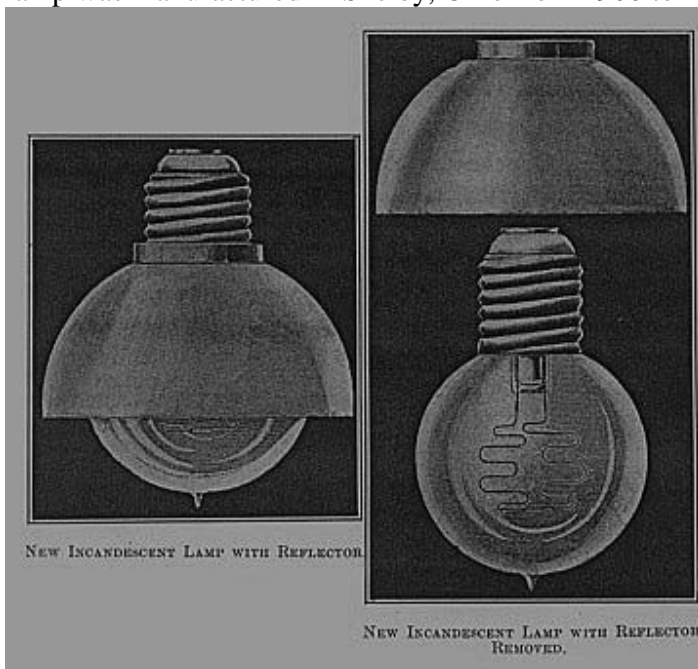

A lamp designed for increased downward light output was put on the market in 1902 by J. H. Bunnell & Co. of New York City. The lamp had a round bulb and a porcelain petticoat reflector. The filament was moulded into several convolutions to direct light downward when burned base-up. It was used for show-windows, display rooms, halls and dining-rooms. It was made for 104, 110, 115 and 118 volts, 16 candle-power and 3.5 watts. The lamp was described in *Electrical Review*, Vol 41, No 26, July 26, 1902, pg 892.

An example of a Bunnell lamp is shown below where the word "SUNSHINE" is etched in a circle around the exhaust tip. The word "SUNSHINE" carries trade-mark No. 40,324. The application was filed on April 17, 1903. The word was used on lamps since July 16, 1902.

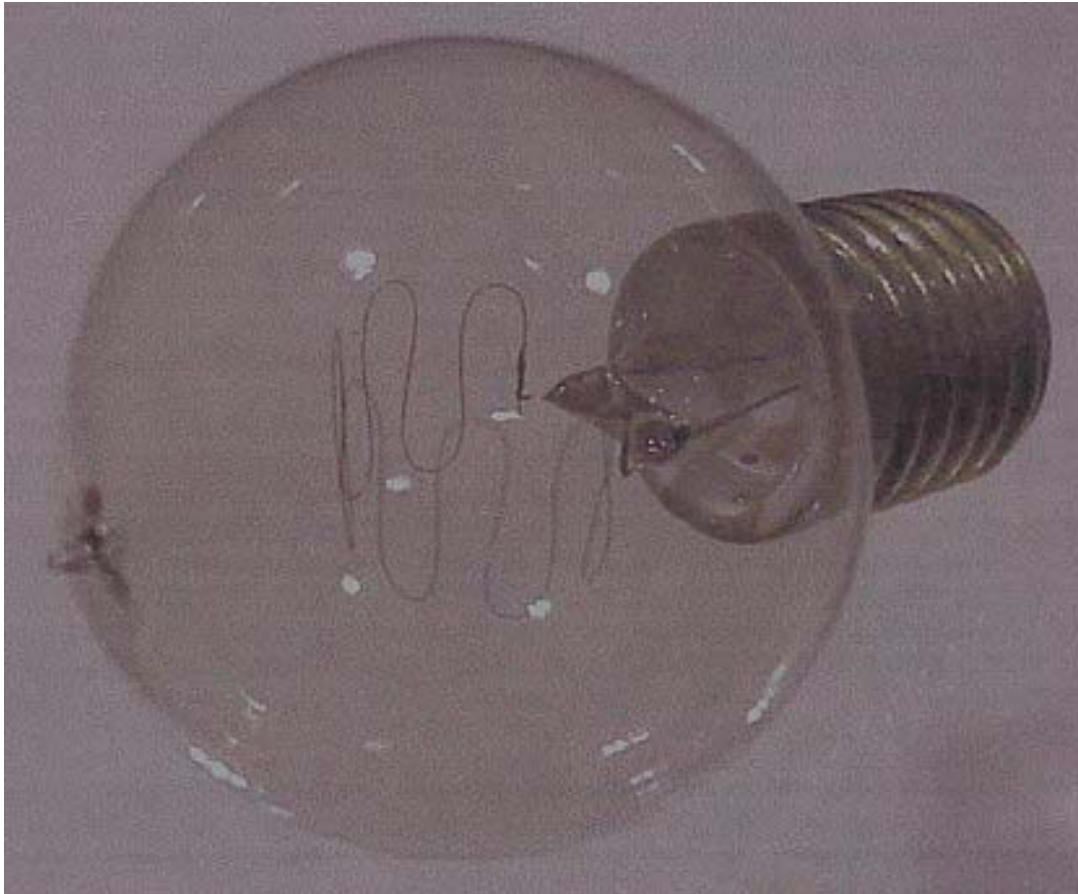

Another lamp that was designed for the same reason, that is, to direct the majority of light downward when the lamp was burned base-up was one manufactured by the Downward Light Electric Company, of New York City. The lamp was made tipless to enhance the downward light output. The word "Downward" was trade-marked (No. 44,037), with the application being filed on Dec 19, 1904; the word was used since Oct, 1903. All but a small percentage of the filament was in a nearly horizontal plane when the lamp burned base-up. The lamp is shown to the left.

It appears that the filament configuration in the first picture above that gives equal light distribution in all directions is that in Fig. 6. Although it was not designed to maximize light output in the downward direction, the design did result in equal light output in all directions; the design, therefore, is in a class by itself. The configuration in Fig. 6 was

patented (U. S. No. 708,432) by Glenn Cannon Webster on Sep 2, 1902. The application was filed on Dec 30, 1901. Webster worked for the Sterling Electrical Manufacturing Company, of Warren, Ohio.

**GEM (General Electric Metallized) Lamp Advertisement**

This advertisement for Meridian lamps (having carbon filaments coated with pyrolytic graphite) shows the patents under which the lamp was manufactured. For example, No. 516,800 was issued to Henry Burnett and Samuel Doane, No. 532,760 was issued to Mark Branin, No. 537,693 was issued to Arturo Malignani, and No. 726,293 was issued to John Howell.

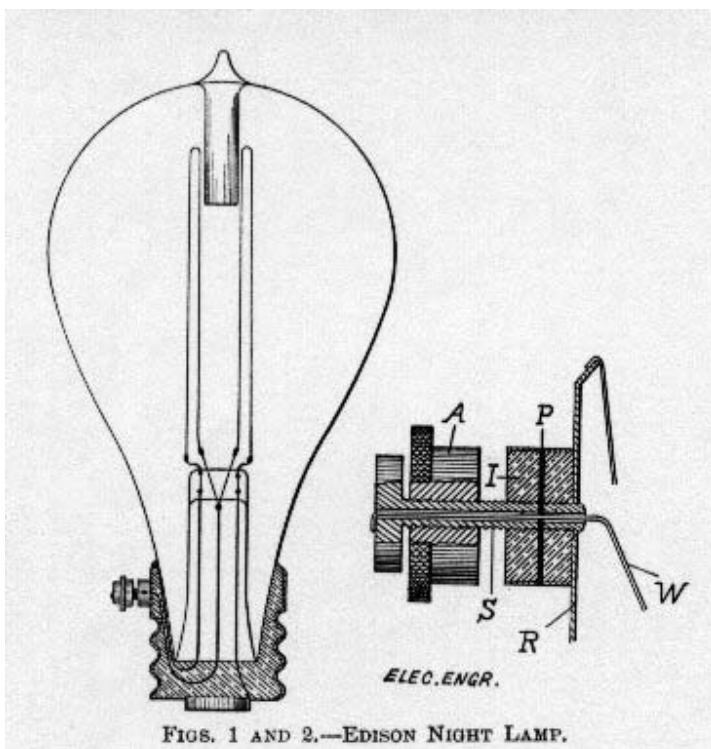

FIGS. 1 AND 2.—EDISON NIGHT LAMP.



**The Edison Night Lamp**

A brief article appeared in *The Electrical Engineer*<sup>1</sup> which described a night light that the Edison General Electric Company introduced in 1892. The following gives that article verbatim:

"It is often desirable in interior illumination to run lamps considerably below their normal candle power, as for instance in the case of hall lights burning all night, or in sick rooms and bedchambers. To accomplish this without loss of energy due to the introduction of external resistances, on direct circuits, the Edison general Electric Co. have brought out what is known as their 'night lamp,' which is illustrated in the accompanying engraving, Fig. 1.

"The lamp, as will be seen, is provided with two filaments connected up in the manner shown, and provided with a special switch at the top of the base, which is shown enlarged in Fig. 2. This small auxiliary switch consists of a short brass tube soldered to the screw ring of the lamp and encircling the screw S, the space between the tube and the screw being filled with insulating material I, and the screw S, being kept from turning by means of the insulating pin P. The screw S is hollow and through it passes the wire W, which is connected to the filaments, which are joined at the centre of the stem.

"Mounted upon screw S, is a brass nut A, which, when screwed up, makes connection between the screw S, and the short brass tube soldered to the screw ring of the base R, to that joined to the ends of the filaments at the centre of the leading-in tube, thus short-circuiting one carbon, and allowing the other to give its full brilliancy. When the nut A is screwed back and in the position shown, both the carbons in the lamp are in series and burn at only a fraction of the normal candle power of the lamp. These night lamps as a rule are frosted and shed a mellow light about the apartment."

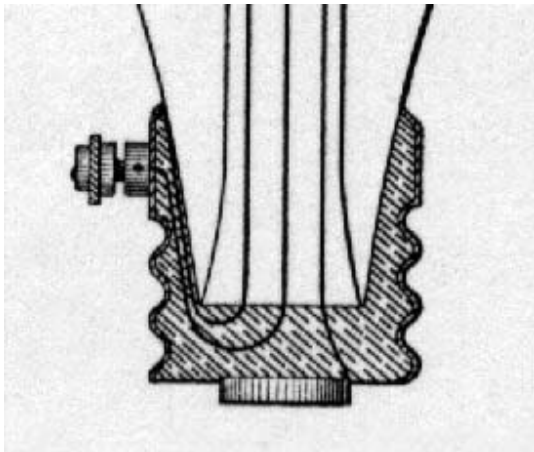

In order to better view the wiring inside the base of the lamp a larger view is shown to the left. If one reads the above description it will be determined that when the brass nut, A, is made to contact the lamp base the filament on the right hand side will light at full intensity.

**Caution** - Because of the unknown nature of wiring of some sockets it is suggested to any collector who might have such a lamp to test it with a resistance meter rather than plugging it into 120 volts.

#### Reference

"The Edison Night Lamp," *The Electrical Engineer*, Vol 14, Jul 20, 1892, pg 67.

#### Colburn

#### Incandescent

#### Lamps

The Colburn system of incandescent lighting was one that was adaptable for ship lighting



as well as lighthouses. A series incandescent dynamo was made in sizes to supply from 25 to 300 sixteen candle power lights. The system was also used for street lighting. Two incandescent lamps are shown below, one with a switch and one without.

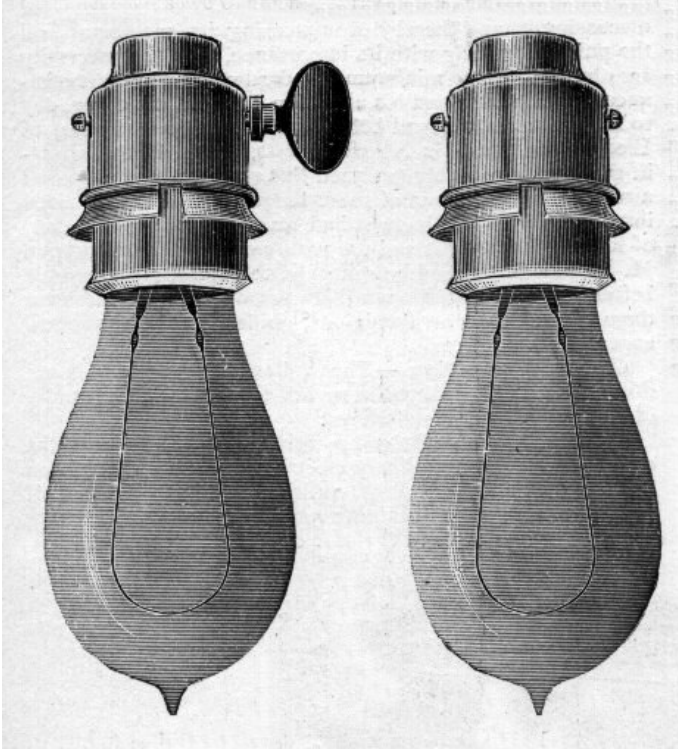

#### Reference

1) "Colburn Electric Light System", *Western Electrician*, Vol 4, Feb 16, 1889, pg 92.

#### Buckeye

#### Lamp

A brief announcement of a Buckeye lamp appeared in 1891<sup>1</sup>. It read:

"The Buckeye Electric company of Cleveland will shortly commence the manufacture on a large scale of a new incandescent lamp, which has recently been perfected. The filament used possesses such a high degree of elasticity that it is possible to take one in ordinary use and draw it out to a perfectly straight line and when released it will resume its normal position. From this carbon the company manufactures a lamp for high voltage circuits in which it guarantees that the filament will not droop against the

bulb. The filament, as shown in the accompanying illustration, is wound in a broad curl, thereby strengthening it, and shortening the lamp from the base.

"At present the company is largely engaged in the manufacture of series lamps for arc circuits."

A brief announcement also appeared in 1894<sup>2</sup> that described Buckeye lamps. That short article is given here verbatim.

"The Buckeye Electric company, Cleveland, O., calls attention in two circulars to its 'special' coiled filament Buckeye incandescent lamp and to the railway incandescent lamps manufactured by the company. The first named lamp is small, compact and of pleasing design and is especially adapted for decorations, steamer lighting or household lighting. It is but 4-1/2 inches long, the standard type being 5-1/2 inches. Its small size makes it particularly valuable for steamer lighting and it has been adopted upon U. S. government war ships, Atlantic liners and many lake and river steamers. The railway lamps have anchored filaments and are made specially for electric railways. They are uniform in current as well as in voltage, burn brilliantly and give long life..."

## References

- 1) "New Buckeye Lamp", *Western Electrician*, Vol 8, No 25, Jun 20, 1891, pg 354.
- 2) *Western Electrician*, Vol 14, No 14, Apr 7, 1894, pg 182. **New Incandescent Lamps for Desks**

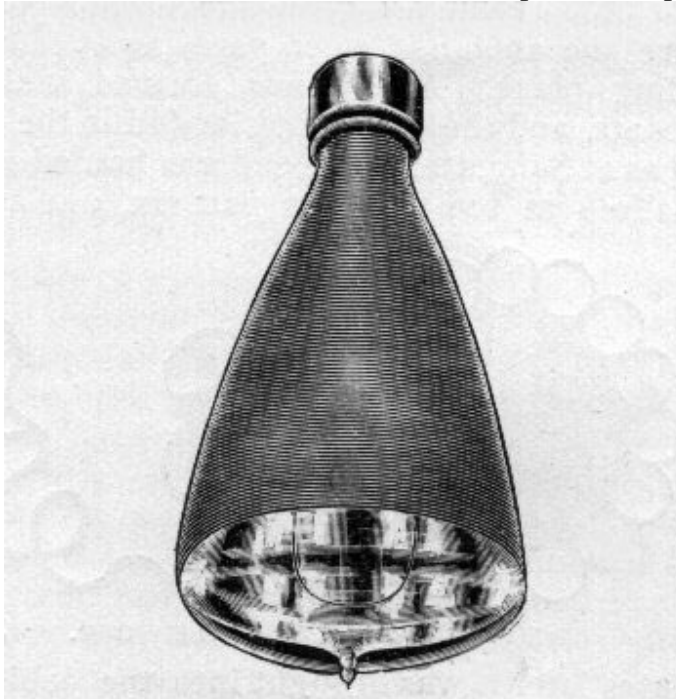

### **New Incandescent Lamps for Desks**

The following is a short article published in 1891 on a new desk lamp:

"In the accompanying illustration is shown a new form of incandescent lamp, specially devised for desks, that is placed on the market by the Central Electric company of Chicago. This lamp differs somewhat in shape from the ordinary incandescent lamp, its sides being almost straight, while the bottom or large end is as nearly flat as possible. The advantage claimed for this form of lamp is that the

straight lines provide better reflecting surfaces and prevent as much as possible, uneven intensities of light upon the object. The inside of the butt and the outside of the globe are silvered, and the incandescent filament is

actually surrounded on three sides by a mirror reflecting all of the light downward. While the lamp may be placed on a level, or a little above the level of the eye, no light strikes the eye directly from the lamp, as the silvering is covered and protected by an opaque substance. The lamp is made to fit any socket."

### **Reference**

1) "New Incandescent Lamps for Desks", *Western Electrician*, Vol 8, No 16, Apr 18, 1891, pg 224. **The Seel Incandescent lamp**

There were several designs of lamps that existed in the magnificent original collection of William J. Hammer but, for one reason or another, are not in the inventory of those housed in the Ford Museum. Some of these lamps are relatively rare because they were manufactured in other countries. At least two such lamps were made by Carl Seel in Germany.

Tim Tromp recently put a message on his website that discussed a Seel lamp which had been acquired for his collection. The writer of this article recommends that anyone interested in the Seel lamp click onto the links in References 2 and 3 below. Clicking onto the Reference 4 link will take you to Seel patent No 382,560.

The following is a verbatim article that appeared in 1888 on a Seel lamp<sup>1</sup>.

### **"The Seel Incandescent Lamp**

"A new incandescent lamp, recently invented by Herr Seel, is being introduced in the Berlin installations. It is made either with a single or double filament, and of a power of from 8, 10, to 30 candles, but recently larger lamps, giving a light of from 200 to 300 standard candles, have been made. The voltage varies from 35 to 100 volts. The inventor claims that in small lamps the energy required per candle is about 3 watts, but in the 200 candle size only 2 watts. The pear-shaped globe, has no point in the centre, so that the light is freely emitted in all directions. The lamp is provided with a metal socket, into which it is cemented by plaster of paris, but the end face of the socket is protected by a disk of serpentine, through which the lamp wires pass. In this way the plaster of paris is prevented from absorbing moisture. The socket is fastened by a bayonet joint into a somewhat larger socket which is free to revolve on a plate, on the face on which are spring terminals of the branch wires, which are brought through the tube of the bracket. Two little studs, which are screwed into the serpentine plate, and are connected with the lamp terminals, form the contact with these springs when the holder is turned into a certain position. When the holder is turned 90° on its vertical axis this contact is interrupted, so that the light is switched on and off by turning the whole lamp with its holder on its axis. In order to avoid touching the lamp itself when switching on or off, the outer socket is provided with a slot, into which engages a pin on an arm, the prolongation of which is shaped into a handle of about the size used with an ordinary gas tap. By turning this handle the rotary movement in one or the

other direction is imparted to the outer socket, and to make sure that even in careless hands the quarter turn should be fully completed, so that the contacts shall be either completely made or completely broken, the spindle of the tap is provided with a disk having flats, against which presses a spring. The filament is prepared from a vegetable or animal fibre, the exact nature of which the inventor keeps secret. In cross section the filament is triangular, and consists of three layers."

It's unfortunate that the writer of the article did not provide a picture of the lamp and "socket". It is assumed that this lamp had no exhaust tip; this is the interpretation of "The pear-shaped globe, has no point in the centre..."

If one looks at this website under the heading "Lamp Collections and Exhibits", then under the topic dealing with the William J. Hammer Collection, some photographs can be viewed. If one clicks on "Lamps Developed by Other Workers by 1904", a Seel lamp can be seen on the top row of lamps, third from the left end. If one examines, under magnification, the card for that lamp on the original photograph it can be seen that his Seel lamp was manufactured in the year 1900.

The writer viewed the Hammer Collection many years ago when the lamps were on display at the Ford Museum. Notes were jotted down regarding several lamps in the display. The writer wrote, about one particular lamp: "A Seel lamp, made in 1890, had a base like Mather but evidently with a pin in the base center<sup>5</sup>."

## References

- 1) "The Seel Incandescent Lamp", *Western Electrician*, Vol 2, No 9, Mar 3, 1888, pg 112.
- 2) [Tim Tromp's Discussion Forum, pictures of his Seel lamp](#)
- 3) [Tim Tromp's pictures of his Seel lamp](#)
- 4) [United States Patent and Trademark Office, Patent No. 382,560, issued to Carl Seel.](#) If a message saying "Search Time Has Expired", then click on "Full Text" and in the next window click on "Images."
- 5) This website, in Section 12, see "Comments on Some Hammer Lamps at the Ford Museum."

## The Heisler Incandescent Lamp

This writer has found very little personal information in the technical literature about Charles Heisler although a few articles regarding the Heisler incandescent system have been uncovered. Some comments made at the end of the year 1887 were<sup>1</sup>:

"The Heisler Electric Light company, which is now mainly devoting its energies to long distance incandescent lighting, is simply overwhelmed with business. An extension of the factory facilities of the concern is contemplated.

"Mr. Chas. Heisler is the pioneer electrical manufacturer of St. Louis, and is the president and proprietor of the following companies: The Heisler Electric Light company; the St. Louis Illuminating company; the American

Carbon company, and the Heisler Electric Bell and Burglar Alarm company."

Another write-up on the Heisler system appeared about a year and a half later<sup>2</sup>. In that article the following information was conveyed:

"...The United Gas Improvement company has for some time past been engaged in thoroughly inspecting and testing different electric light systems with a view to finding one specially adapted to municipal long distance incandescent lighting, which could be economically operated by using the waste products of the gas house and which could produce a light sufficiently brilliant to answer all purposes of street illumination. That it has found what it sought is evident from the fact that a few weeks ago it purchased outright the American patents of Chas Heisler and all the rights, privileges, property and leaseholds of the Heisler Electric Light company of St. Louis, retaining Mr. Heisler in the position of consulting electrician of the company. Mr. Heisler is now in Europe superintending a large exhibit of the Heisler system at the Paris exposition. He also proposes to introduce the Heisler system throughout Europe under the unusually broad patents which were granted to him some six months ago...

"...Under this efficient management and with the financial backing of the United Gas Improvement company, the Heisler Electric Light company will now take its place among the leading companies of the country. Its system will be thoroughly developed in all its details. Increased facilities will be added for manufacturing and nothing will be left undone to secure the introduction of the Heisler system in all parts of the country for municipal lighting. The United Gas Improvement company has in view the enlargement of the present plant sufficient to meet all necessities, and it is rumored that at an early date a large factory will be erected in the east for the manufacture of the Heisler apparatus in that section of the country...

"...The Heisler company is contemplating a fine exhibit at the forthcoming St. Louis exposition and will install there two 300 light machines with the latest improved appliances; 500 lights are rented to the Exposition company, and the remaining 100 will be used in the Heisler exhibits for the purpose of illustrating the different adaptations of the system..."

Later that year (1889) an article appeared on the Heisler Dynamo and Regulator<sup>3</sup> in which the dynamo, regulator and lamps were pictured. Heisler lamps are shown below. From left to right the candle power values are : 30, 50 and 100.

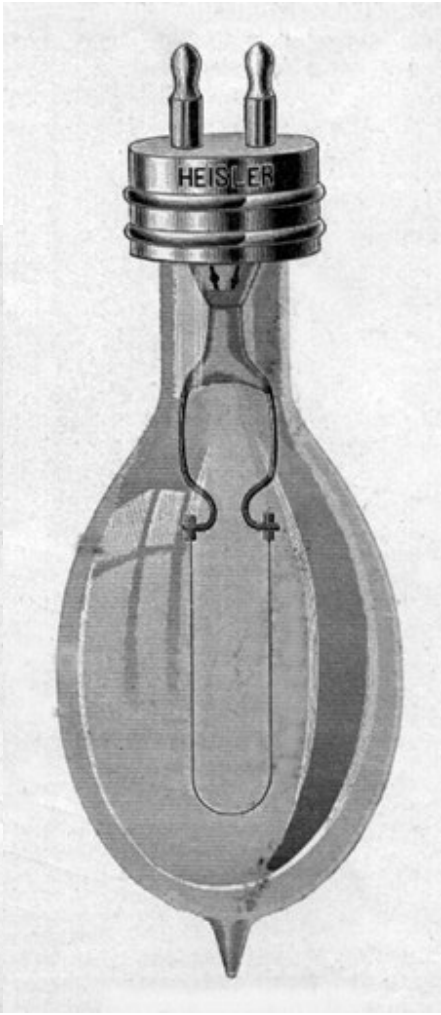
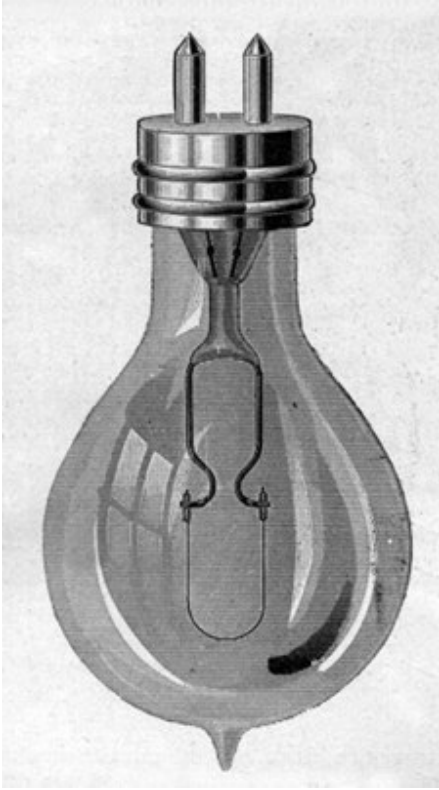

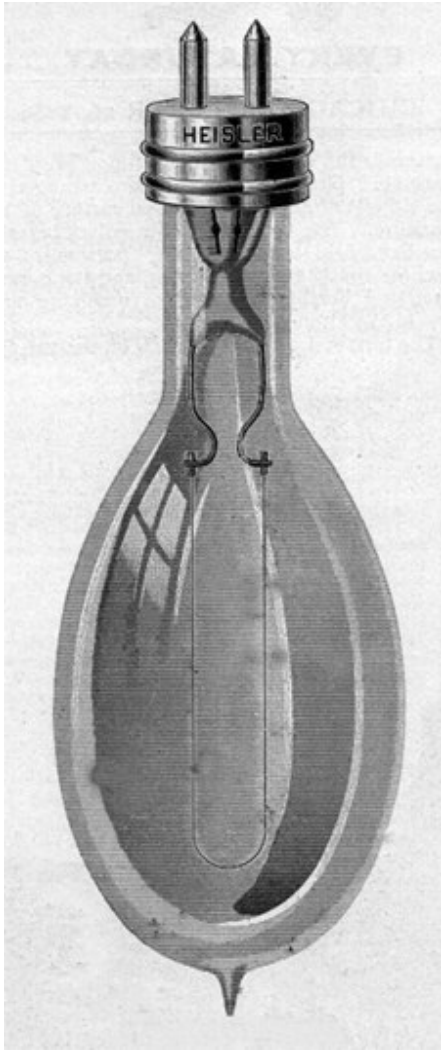

In December of 1890 an article appeared<sup>4</sup> in which it was announced that the manufacturing equipment was being moved from St. Louis to a new site in Gloucester, New Jersey.

**Some U. S. Patents Granted to Charles Heisler**

No.	Date	Description	Assignor	to
327,795	Oct 6, 1885	Incandescent	Electric	Lamp
327,796	Oct 6, 1885	Incandescent	Electric	Lamp
330,586	Nov 17, 1885	Incandescent	Electric	Lamp
379,956	Mar 27, 1888	Regulator for Dynamo	Electric	Machines
380,114	Mar 27, 1888	Incandescent Electric Lamp Holder and Cut-Out		
380,115	Mar 27, 1888	Alternating Current Dynamo	Electric	Machine
380,202	Mar 27, 1888	Incandescent Electric lamp Holder and Cut-Out		
392,513	Nov 6, 1888	System of Incandescent Lighting		
394,180	Dec 11, 1888	Cut-Out for Electric Lamps		
428,604	May 27, 1890	Process of Manufacturing Carbons	United Gas	Improvement

Co.

435,223 □ Aug 26, 1890 □ Electric Cut-Out □ United Gas Improvement Co.

### References

- 1) Correspondence, St. Louis Notes, *Western Electrician*, Vol 2, No 1, Jan 7, 1888, pg 10.
- 2) "Heisler Electric Light Company," *Western Electrician*, Vol 5, Aug 3, 1889, pg 61.
- 3) "Heisler Dynamo and Regulator", *Western Electrician*, Vol 5, No 17, Oct 26, 1889, pg 215.
- 4) "The Heisler Electric Light Co.," *The Electrical Engineer*, Vol 10, Dec 10, 1890, pg 660.

### Perkins Incandescent Lamps and Sockets

Some pictures of lamps and sockets made by the Perkins Electric Lamp Company in 1889<sup>1</sup> are shown below.

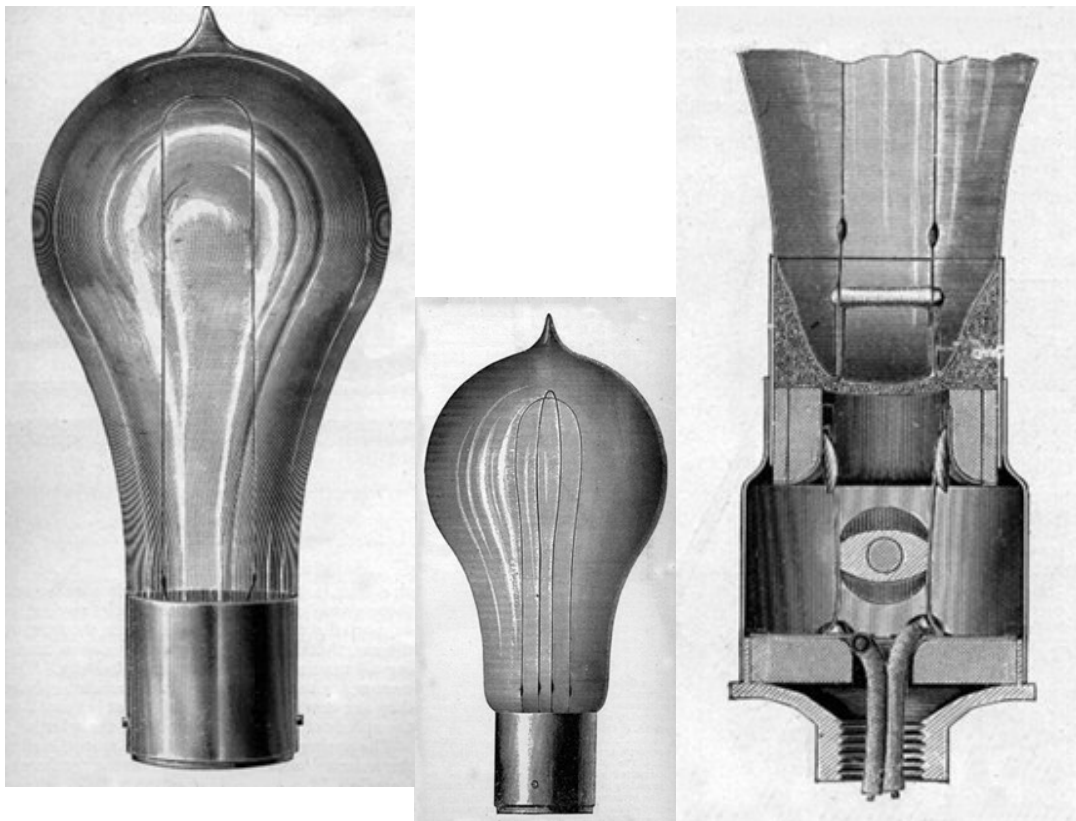

At the far left, above, is a 16-candle power lamp. In the center is a 32-candle power lamp. At the far right the lamp and socket interior are shown. Below, to the left, is a socket design for lamps with either one or two filaments. Below, to the right, is a standard socket design.



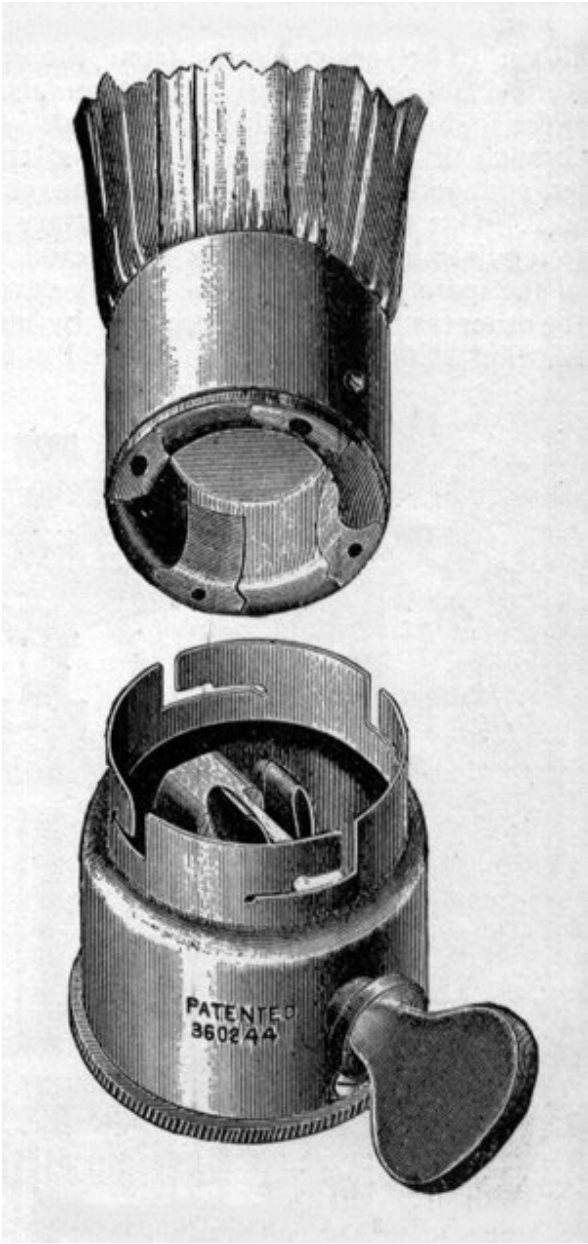



The socket with a patent number of 360244 was granted to Charles G. Perkins on March 29, 1887; the patent was for an electric lamp and socket. The socket with patent number 345008 was granted to Jean Theodore Van Gestel on July 6, 1886; it was for an incandescent lamp and connections.

## Reference

- 1) "Perkins Incandescent Lamp", *Western Electrician*, Vol 4, May 4, 1889, pg 236.

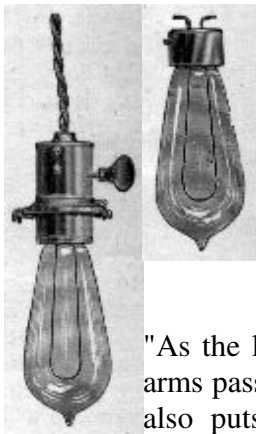

## The Hill Incandescent Lamp

An article in the May 1888 issue of *Western Electrician*<sup>1</sup> described the lighting apparatus of W. S. Hill, of Boston. Two of the figures showed their incandescent lamp. The picture to the far left shows a lamp and key socket. The picture to the near left shows the lamp and the method of attachment to the socket. The lamp terminals are of stout wire that are bent at right angles to form arms. Quoting from the article:

"As the lamp is inserted in the socket and turned partially round, these arms pass under wire springs, which hold the lamp securely in place, and also puts it in electrical connection with the circuit.. A pin in the brasscup of the lamp, and a groove in the socket insure the lamp entering the right place, and limit the turning motion so no injury can come either to the arms or springs."

## Reference

1) "The Hill Electric Lighting Apparatus", *Western Electrician*, Vol 2, No 19, May 12, 1888, pg 231.

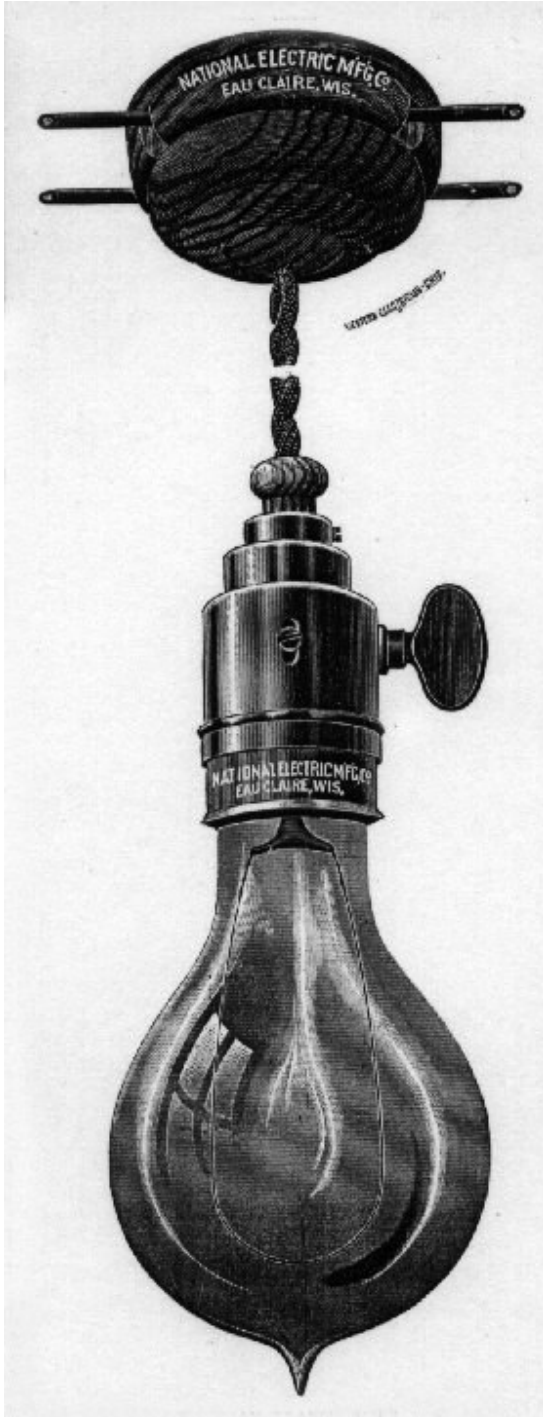

### **The Freeman Incandescent Lamp**

In 1888 Walter K. Freeman, along with others, organized the National Electric Manufacturing Company in Eau Claire, Wisconsin. A transformer system was designed and made for long distance lighting. For many years Freeman had been associated with the United States Electric Lighting Company of New York. Their lamp, shown here<sup>1</sup>, apparently was designed for high efficiency. The 16-candle power lamps had a guaranteed life of 700 hours. The article said:

"The cut shows the lamp suspended from an individual fuse box, constructed with a detachable cover containing the fuse. By a slight turn to the left the cover, with fuse, cord and lamp, may be removed, enabling the operator to replace a burnt fuse while the plant is in operation."

### **Reference**

1) "The Freeman Transformer System", *Western Electrician*, Vol 5, Oct 5, 1889, pg 179. **Henry Woodward and Mathew Evans Lamp**

There are claims in the technical literature, as well as on the internet, that different individuals invented the electric incandescent lamp before the generally-accepted work of Thomas Edison. One might conclude that national pride is involved but the present writer concludes that such assumptions probably have been made because of a lack of understanding of the subject. A few examples of individuals will be given.

If one types the name "James Bowman Lindsay" in a search engine, such as Google, several web pages will be found that describe, in somewhat sketchy terms, a lamp Lindsay developed in his hometown in Scotland in 1835. A writeup on Lindsay can be found on this website. A second name, that of Henry Goebel, also can be mentioned. Much patent litigation resulted because of Goebel's claims for developments that started as early as

1854. A writeup about Goebel can also be found on this website. This writer concludes that neither investigator could rightly claim the practical design developed by Edison. A third case that involves two Canadians will be considered here briefly.

So what precisely did Edison claim in his basic filament and lamp patents? In order to avoid the mistake of assuming that someone invented the practical incandescent lamp before Thomas Edison did, it is necessary to state exactly what the Edison claims were. This can be answered easily by quoting from Howell and Schroeder<sup>5</sup>:

"That is what Edison invented: a lamp with a high resistance filament of carbon in a vacuum contained in a glass container closed at all points by fusion of the glass and having platinum wires imbedded in the glass to carry current through the glass to the filament. And this was the first incandescent lamp which was suitable for the system of general multiple distribution which solved the problem of the 'sub-division of the electric light.'"

Two names of persons who lived in Toronto, Canada can also be found on the internet and the claim is that they, also, preceded Edison in his development. Their story is given below from an article that appeared in *Electrical World and Engineer*<sup>4</sup>.

"The story of the invention of the incandescent lamp by the Canadian, Woodward, has recently again been brought forward. A Canadian correspondent writes that some interesting historical data has recently been supplied by Mr. Wright, of the Toronto Electric Light Company, and Mr. Patriarche, of the Electric Maintenance Company, of Toronto, Ont., relative to the original discovery of the principle of incandescent electric lighting. This discovery is claimed to have been made in the City of Toronto, and patented in Canada and the United States prior to the time when a patent was granted to Edison; and, moreover, that the patent for the Canadian discovery was purchased by Mr. Edison at the time when he was making his original investigations and before he obtained his patent. The details of the story are that Henry Woodward, a medical student, and Matthew Evans, a hotelkeeper, of Toronto, were neighbors and frequently experimented together with a large Smee battery and induction coil, of which Woodward was the possessor. While seated at dusk one evening watching the buzzer of the induction coil, the light of the spark at the contact post attracted their attention. It impressed them with the idea that if they could confine the spark in a globe a marvelous invention would be the result. From this beginning, in the early part of 1873, Woodward and Evans worked to perfect the idea, and on August 3, 1874, they were granted a Canadian patent. The first incandescent lamp was constructed at Morrison's brass foundry in Toronto, and was a very crude affair. It consisted of a water gauge glass with a piece of carbon, filed by hand and drilled at each end, for the electrodes, and hermetically sealed at both ends, having a petcock at one end with a brass tube to exhaust the air. Woodward made the mistake of filling the tube or globe of this lamp with nitrogen after having exhausted the air. Prof. Elihu Thomson is quoted as having said that had he stopped when he had the tube

exhausted he would have had the honor of being the inventor of the incandescent light as used for commercial purposes. After the invention had been tested a company was formed for the supply of electric lights to the public. Some of the original stockholders had invested capital in the enterprise before having seen the light and when asked to put up more money on the same conditions, declined. Woodward became displeased and left for Europe, and is now said to be residing in London, England. Evans died in Toronto last year. The comment on this story is that the principle of the incandescent lamp dates several decades before the Woodward experiments, and that King, Chanzy, Farmer and others in the twenty years preceding 1860 made and used incandescent lamps much superior to the very imperfect one upon which Woodward's claims are based. Moreover, the Edison claims, as sustained in the courts, were not on the discovery of the principles of the incandescent lamp but on a definite combination of parts—all well known—which resulted in the production of a practical form of the incandescent lamp."

H. WOODWARD.  
ELECTRIC LIGHT.

No. 181,613.

Patented Aug. 29, 1876.

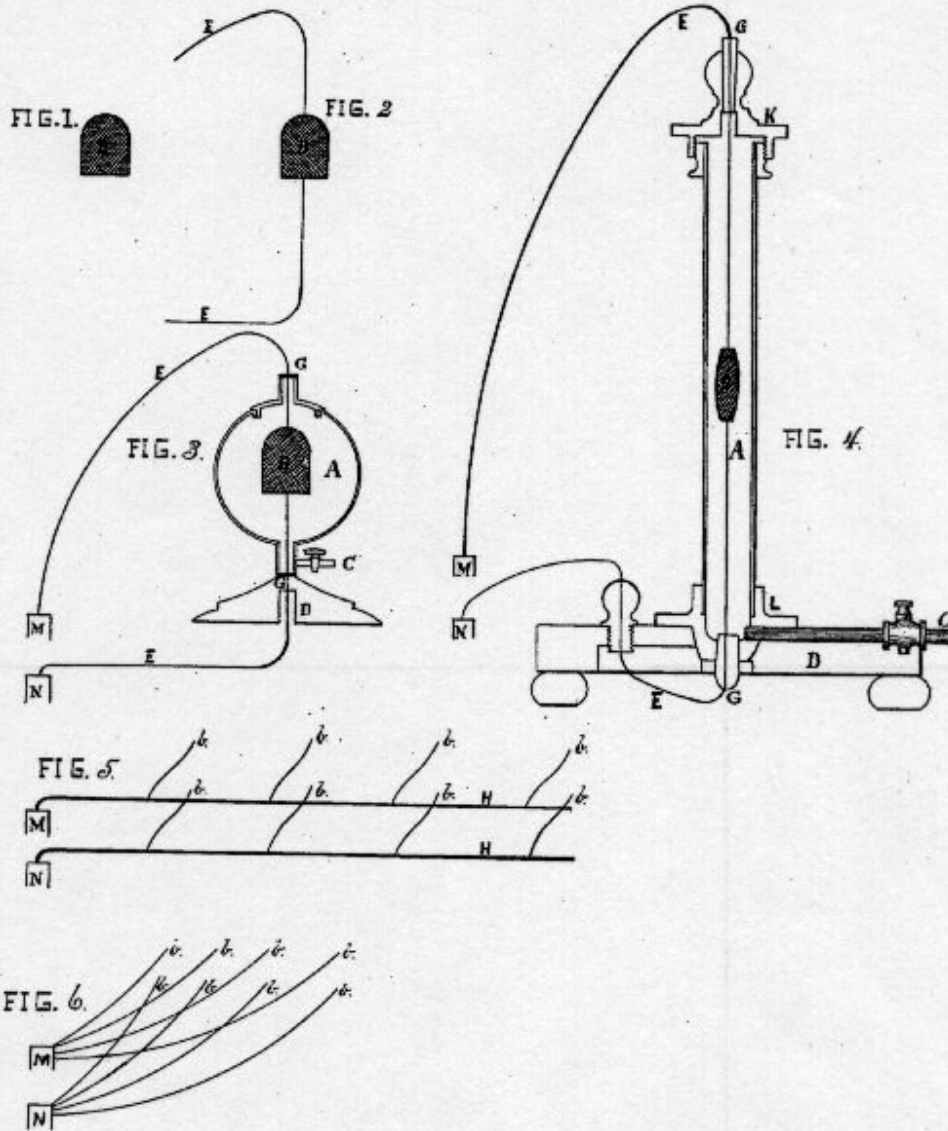

WITNESSES

*Geo. T. Smallwood,*  
*John Roby,*

INVENTOR

*Henry Woodward,*  
By *John J. Halsted*  
Attorney

The drawings from Woodward's 1876 United States patent, which are shown above, are almost exactly the same as those that appeared in Woodward and Evan's 1874 Canadian patent. The carbon burner (labelled "B" □ Fig. 1, for example) can be seen to differ widely from Edison's filament, which is a most important feature of a practical lamp.

As the 1900 article mentioned<sup>4</sup>, earlier workers had advanced to the same or higher degree in their work as did Woodward and Evans. To name a few: J. B. A. M. Jobard in 1838, C. de Changy in 1856, John Wellington Starr in 1845 and Joseph Swan in 1860. All these workers contributed, in one way or another, to the eventual development of the incandescent lamp, but it was Thomas Alva Edison who put the necessary ingredients together to make the lamp and system practical.

### References

- 1) Henry Woodward and Mathew Evans, Electric Light, The Canadian Patent Office Record, Aug 1874, pg 75, No. 3738.
- 2) H. Woodward, Electric Light, U.S. Patent No. 181,613, Aug 29, 1876.
- 3) *Canadian Electrical News*, Feb 1900.
- 4) "Invention of the Incandescent Lamp", *Electrical World and Engineer*, Vol 35, No 15, Apr 14, 1900, pg 540.
- 5) History of the Incandescent Lamp, John W. Howell and Henry Schroeder, The Maqua Company, Publishers, Schenectady, NY, 1927, pg 61.
- 6) [http://www.bouletfermat.com/danny/light\\_bulb\\_patent.html](http://www.bouletfermat.com/danny/light_bulb_patent.html)

### The Nothomb Lamp

The William J. Hammer historical collection of incandescent electric lamps, which is now stored in the Henry Ford Museum in Dearborn, Michigan, contains several lamp designs that were developed in countries other than the United States. One of these was known as the Nothomb lamp. In the chronological listing of Hammer lamps it can be seen<sup>2</sup> that the collection has an 1881 as well as an 1882 lamp<sup>2</sup>. The information that Hammer printed on placards that accompanied the lamps when on display read as follows<sup>2</sup>:

1881-12, Nothomb (French). Low resistance filament, carbon paste clamps, platinum hook supports, blue tip bulb.  
1882-487, Nothomb (French). Small bulb and filament with carbon paste clamps. Made in France.

A short article appeared in 1883<sup>1</sup> that gave some details of this lamp. The information in the article came from the London *Electrical Review*. In part, it said:

"This incandescent lamp is distinguished from its predecessors by the nature of the incandescent filament and the mode of manufacture. The filament consists of cellulose carbonized in a carbureted atmosphere which impregnates it with carbon. It is one millimetre wide and 4/10ths of a millimetre thick; its length depends on the luminous intensity required. The atmosphere of the globe of glass in which it is inclosed consists of azote, hydrogen, or any other inert gas.

"The filament is fixed to conductors by means of a special kind of cement, composed of a mixture of spongy platinum and an organic substance, molasses or sugar, which on carbonizing forms carbon of very close texture and great consistency. The duration of the lamp, according to the experiments made, should be from 800 to 1,000 hours; the luminous power 30, 50 or 100 candles..."

There were four lamp types with currents of one to three amperes and voltages of 45 to 100 volts. One type, of 300 candles, had three filaments and they could be connected in series or parallel. In one case the current drawn was nine amperes at 100 volts. In the other case it drew three amperes at 300 volts. The horseshoe shape of the filament was adopted even though better results were obtained with a spiral filament.

#### References

- 1) "The Nothomb Lamp", *The Electrician*, Vol II, Sep 1883, pg 283. From London *Electrical Review*.
- 2) This website, under "Lamp Collections and Exhibits", then "The William J. Hammer Historical Collection of Incandescent Electric Lamps", then under the years 1881 and 1882.

#### Miniature Edison Lamps

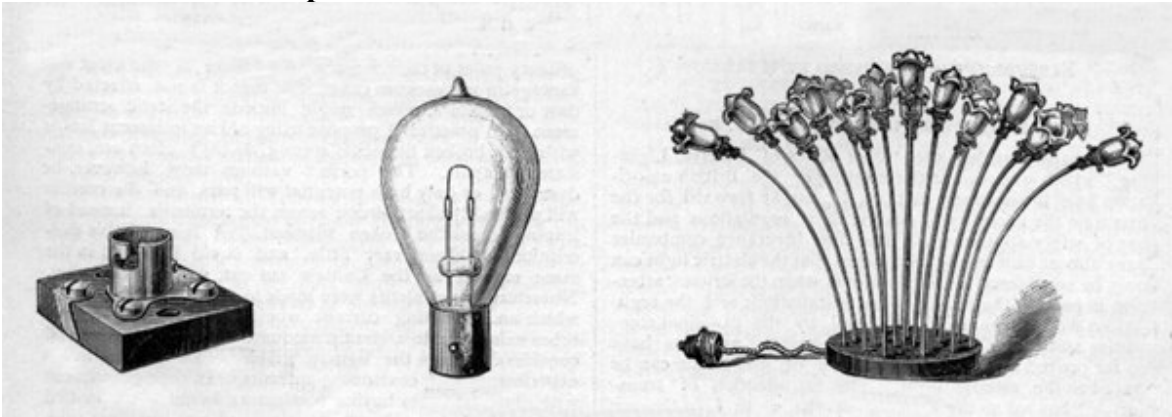

From left to right, Fig. 1, Fig. 2, Fig. 3.

A short article appeared in the technical literature<sup>1</sup> and is reproduced here in its entirety:

"The demand for miniature incandescent lamps is increasing. Not only are they used for purposes of ornamentation and decoration, but for numerous ingenious and useful purposes in the household and other places. At social gatherings these lamps may be placed among loose flowers in bouquet baskets or vases of real or artificial flowers. The accompanying cuts, Figs 1 and 2, represent a small socketed Edison lamp and the receptacle designed to receive it. The base of the receptacle is made of hard fibrous material, the connections being of polished brass. It is shown of actual size in the cut (referring, of course, to the original picture). Fig. 3 shows a 'bunch' or 'spray' fixture. These sprays are fitted up with any number of lamps of any candle power so that they may be used in a basket or vase to contain flowers. As a rule the bunch is set in the basket or vase and the flowers filled in around the lamps. A most pleasing and artistic effect can in this way be produced.



Fancy colored glass shades are also used with these fixtures. These not only heighten the effect of the lights among the flowers, but they keep the plants from resting upon the lamps and thus prevent their withering. The lamps are made by the Edison Lamp Co. in Harrison, N. J."

### Reference

1) "Miniature Edison Lamps", *Western Electrician*, Vol 5, Oct 19, 1889, pg 209.

### 1886 Stanley-Westinghouse Lamp



William Stanley, Jr. (1858-1916)<sup>3</sup> was a prolific inventor who helped to bring alternating current to the world through his work, in part, on the power transformer<sup>2</sup>. In addition, he made a contribution to incandescent lamp development. One lamp he developed is shown above and is a departure from most incandescent lamps. He filed an application for this lamp on October 8, 1885 and it was renewed September 4, 1886. On May 24, 1887 U. S. Patent No. 363,559 was issued to him<sup>1</sup>. Stanley was assignor to George Westinghouse, Jr., having worked for him from 1885 to 1888<sup>2</sup>.

(No Model.)

3 Sheets—Sheet 1.

W. STANLEY, Jr.  
INCANDESCENT ELECTRIC LAMP.

No. 363,559.

Patented May 24, 1887.

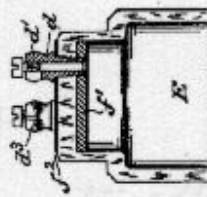
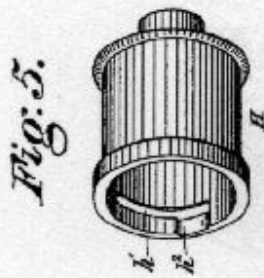
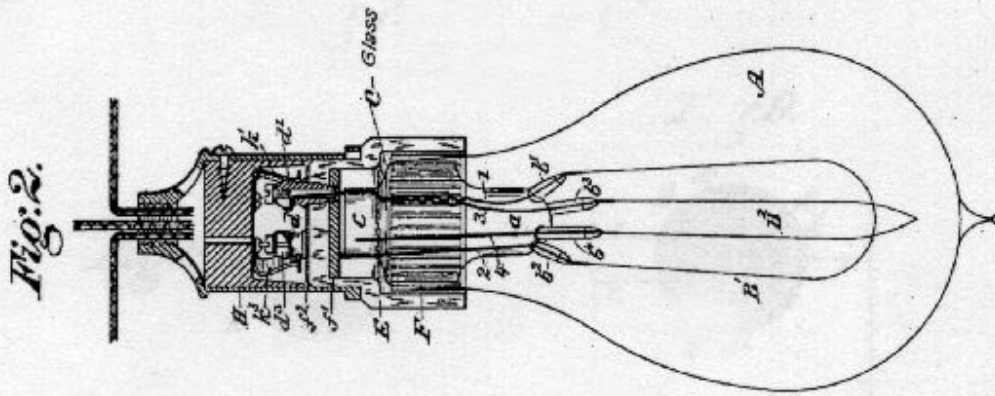
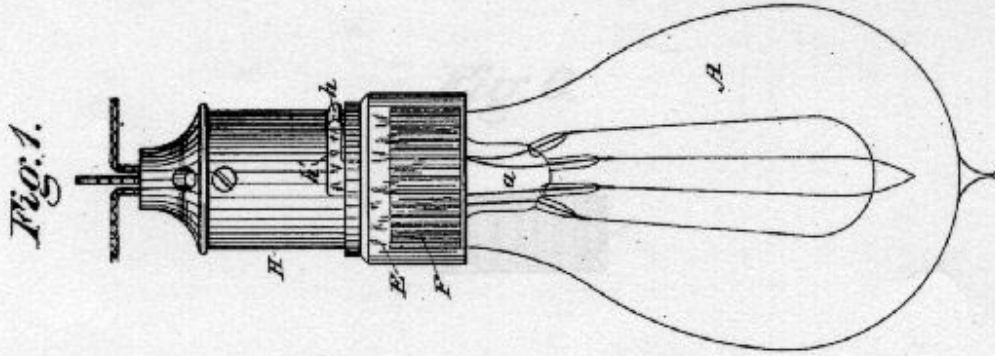

Witnesses.

*J. Snowden Bell.*  
*Roswell C. Gould.*

Inventor.

*William Stanley, Jr.*  
*by Pope & Edgecomb*  
*Attorneys.*

Quoting from the patent:

"The invention relates particularly to the construction of large incandescent electric lamps—such, for instance, as are designed to furnish a light of one hundred candle-power or more."

Regarding the filament(s):

"...In this there are preferably placed two independent filaments supported in planes crossing each other at right angles. The loop of one filament extends beyond that of the other, and for this reason its supporting points are preferably in a lower plane than those carrying the other filament. The upper end of the globe is provided with a short neck, which is designed to fit within a pressed-glass cup provided with means of attachment to the holder."

Regarding the lead-in wires:

"The conducting - wires are led through the neck into the cup, where they are fastened to suitable binding - posts inserted at the lower end of the cup. Preferably, two conductors leading to the respective filaments are secured to one binding - post, and the remaining two conductors lead from the remaining ends of the filaments to independent binding - posts, so that the circuits through the two are independent of each other.

"The cup is preferably secured to its holder by means of a lug upon the cup and a bayonet-joint formed in the holder. The binding-posts which project from the end of the cup are constructed with their outer ends larger than the portions near their points of support. Suitable contact springs are placed in the holder for forming the electrical connections with the respective binding-posts, and these at the same time tend to hold the cup within the holder by reason of their ends passing beyond the large portion of the binding-posts and pressing into the narrowed necks."

In Stanley's patent<sup>1</sup>, he refers to the lamp base as the "cap." What is usually referred to as a socket is called a "holder" by Stanley. It should be mentioned that the patent specifies glass as the material of the cap but in the sample above it appears to be made of wood. The patent also specifies three electrical contacts whereas the above sample appears to have only two.

There is a lamp in The William J. Hammer Historical Collection of Incandescent Electric Lamps<sup>4</sup> that might be similar to the one described here. Hammer's lamp is number 1886-468. The description reads: "Mogul carbon filament lamp. 150cp, 53 volts. Two 75-cp filaments in multiple, solid glass drawn over each platinum lead."

### Acknowledgement

The writer extends a "thank you" to Jerry R. Westlick for use of the photograph of the Stanley-Westinghouse lamp, as well as information regarding it.

### References

- 1) W. Stanley, Jr., U. S. Patent No. 363,559, dated May 24, 1887, "Incandescent Electric Lamp."
- 2) Laurence A. Hawkins, William Stanley (1858-1916) His Life and Work, The Newcomen Society of North America, New York, 1951.
- 3) "William Stanley, Jr", this web site, Section 16 □ "Biographical Sketches".
- 4) This web site, Section 12, "The William J. Hammer Historical Collection of Incandescent Electric Lamps."

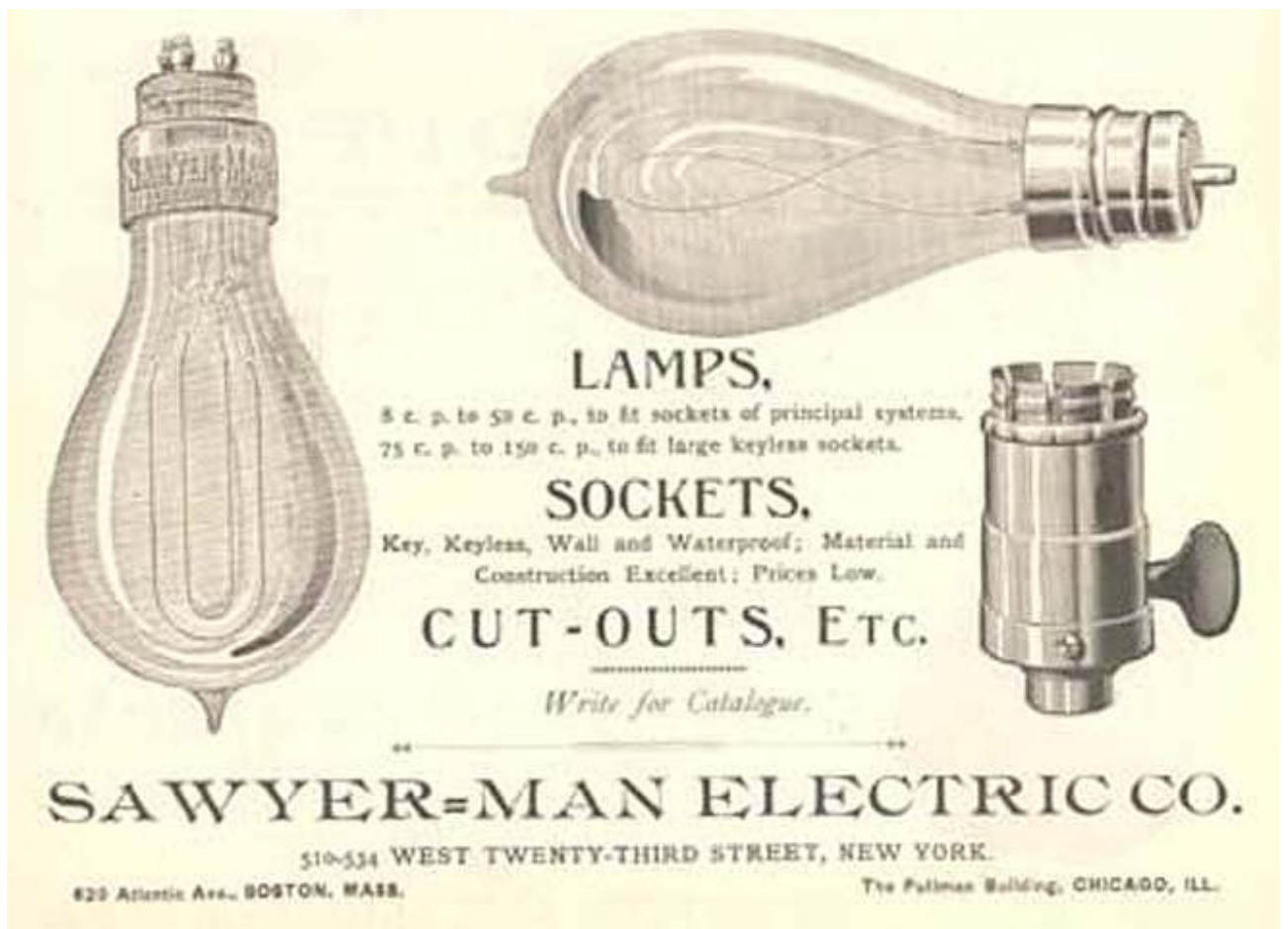

The advertisement features three illustrations of incandescent lamps and one illustration of a socket. On the left is a large, pear-shaped lamp with a visible filament. In the center is a smaller, more rounded lamp. On the right is a cylindrical socket with a side handle. The text is arranged in a central column, with the company name at the bottom.

**LAMPS,**  
3 c. p. to 50 c. p., to fit sockets of principal systems.  
75 c. p. to 150 c. p., to fit large keyless sockets.

**SOCKETS,**  
Key, Keyless, Wall and Waterproof; Material and  
Construction Excellent; Prices Low.

**CUT-OUTS, ETC.**

*Write for Catalogue.*

**SAWYER=MAN ELECTRIC CO.**

510-534 WEST TWENTY-THIRD STREET, NEW YORK.  
629 Atlantic Ave., BOSTON, MASS. The Pullman Building, CHICAGO, ILL.

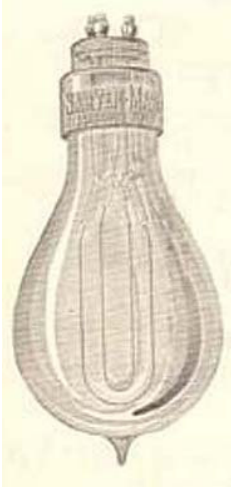

The following seven lamp images appear as a courtesy of Chris Kocsis. The lamp is in his collection.

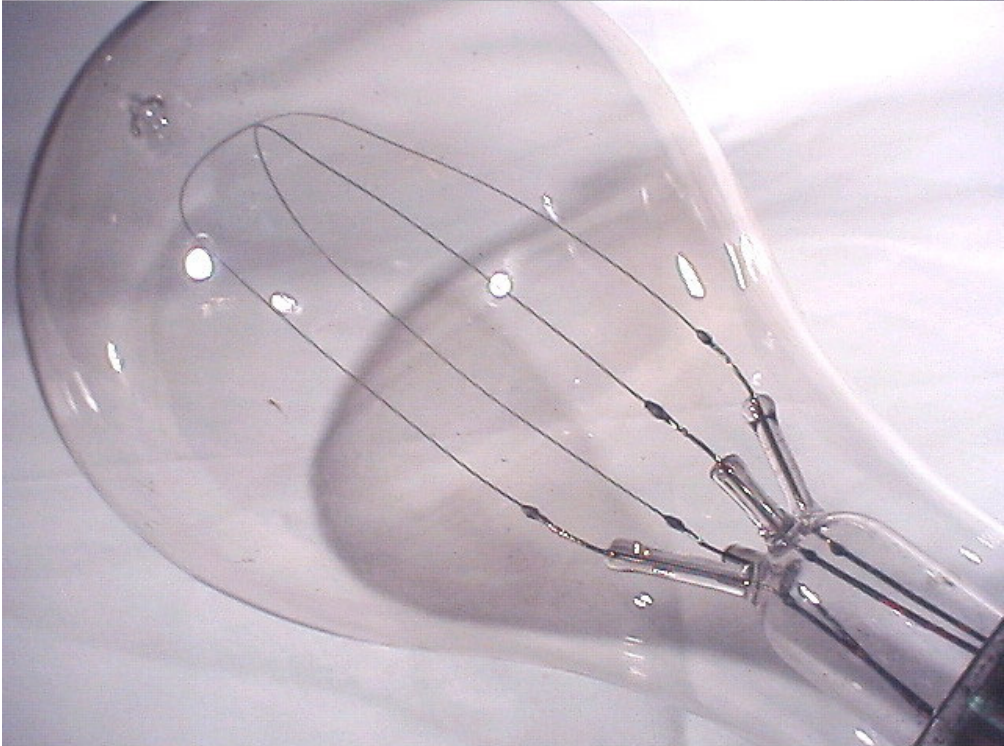
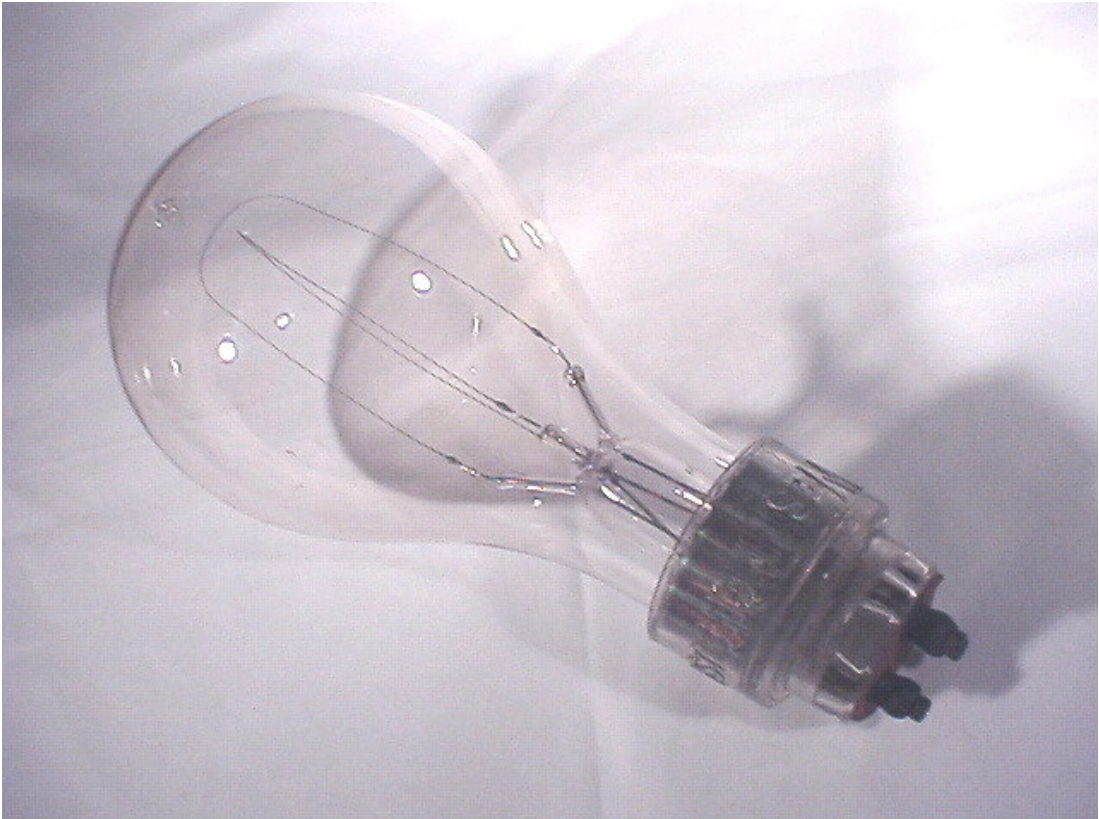



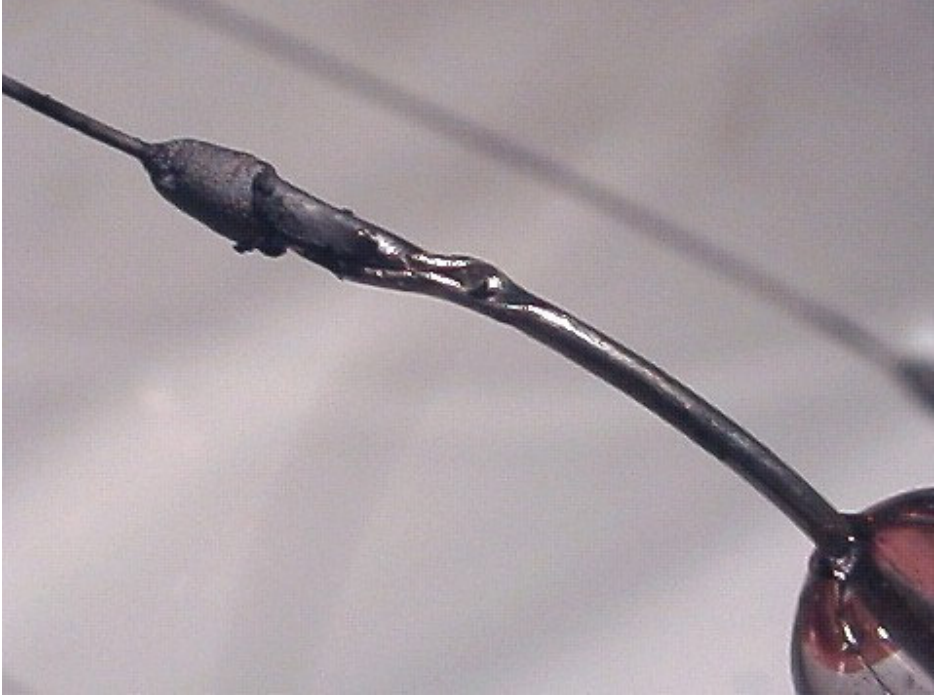
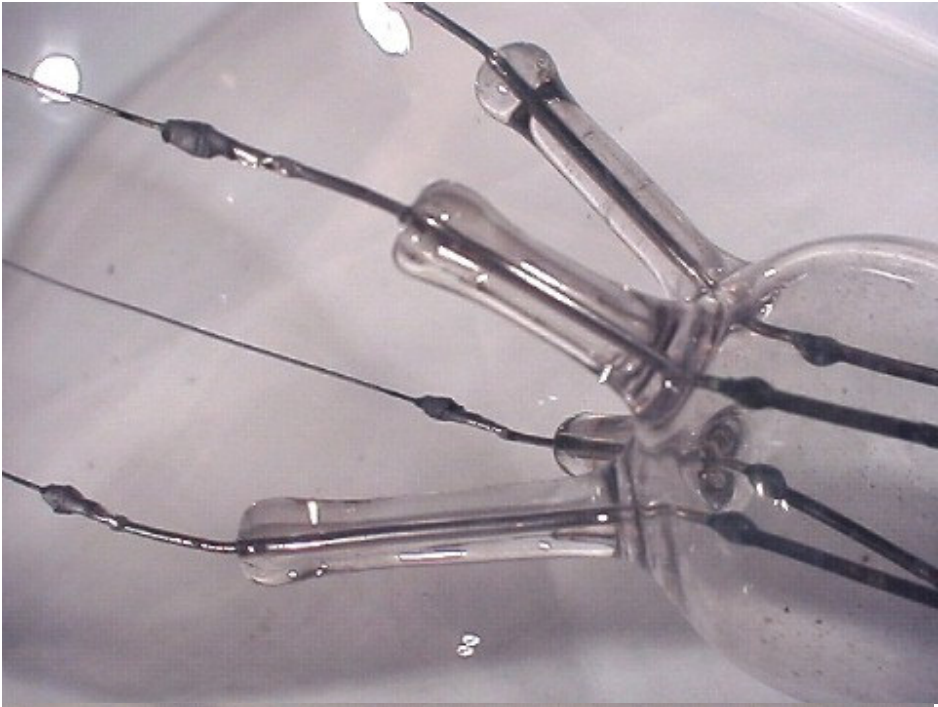



# THE WESTINGHOUSE ELECTRIC COMPANY,

PITTSBURGH, PA.

MANUFACTURERS OF A COMPLETE SYSTEM OF

## INCANDESCENT ELECTRIC LIGHTING

FOR ISOLATED, BLOCK, MUNICIPAL AND CENTRAL STATIONS.

**CONTRACTS FROM**  
DECEMBER 1, 1895 to JULY 1, 1896.

**CENTRAL STATIONS.**

Flathead E. L. Co., Flathead, N. J.	1000 18 c.p.
Altoona Co. E. L. Co., Altoona, Pa.	90 475.
Trenton E. L. & P. Co., Trenton, N. J.	1800 16 c.p.
Keyston E. L. & P. Co., Phila., Pa.	1200 "
" " " " " " " "	1000 "
Clifton E. L. & P. Co., New Castle, Pa.	1000 "
Westinghouse Ill. Co., Schenectady, N. Y.	1000 "
Okolona E. L. Co., Okolona, Ia.	1000 "
East End E. L. Co., Pittsburgh, Pa.	600 "
Beaver Dam E. L. Co., Beaver Dam, Wis.	500 "
Batter E. L. Co., Batter, Pa.	500 "

**ISOLATED PLANTS.**

Calumet Depot, Pittsburgh, Pa.	1800 16 c.p.
Monongahela House, Pittsburgh, Pa.	800 "
Windsor Hotel, New York	400 "
Pennsylvania Lead Co., Pittsburgh, Pa.	400 "
T. C. Jackson, Pittsburgh, Pa.	400 "

**ISOLATED PLANTS.—Con.**

The Pittsburgh Club, Pittsburgh, Pa.	510 16 c.p.
The Westinghouse Air Brake Co., Pittsburgh, Pa.	250 "
The Smith Building, New York	200 "
Shole Yarn Mills, Fall River, Mass.	800 "
Harrison, Bower & Co., Tyrone, Pa.	250 "
The Philadelphia Co., Philadelphia, Pa.	250 "
Jas. Bush, Jr. & Co., Phila., Pa.	200 "
Lombard, Lyren & Co., Hagerstown, N. J.	250 "
Fort William Henry Hotel, Lake George, N. Y.	200 "
Narristown Opera House, Narristown, Pa.	500 "
Whooling Steel Works, Whooling, W. V.	125 "
Atlas Paper Mill Co., Appleton, Wis.	100 "
Kimberly and Clark Co., Appleton, Wis.	75 "
Wiltzer Eliason, Chesterstown, Md.	50 "
Burlington "Free Press," Burlington, Vt.	50 "
Fairbanks, Sore & Co., Chicago, Ill.	50 "
E. Y. Ames, Sparta, Wis.	25 "
Gilman & Gilman, Washington, Pa.	25 "
Str. "Fishkill-on-Hudson," Newburgh, Pa.	25 "
D. Wilson, Altoona, Pa.	25 "
R. L. Marston, New York	25 "
Eric City Iron Works, Erie, Pa.	40 Lights of 100 c.p.

**LAMPS 10, 16, 25, 50 and 150 C. P. GUARANTEED FROM 600 TO 1200 HOURS' LIFE.**

**WESTINGHOUSE, CHURCH, KERR & CO., No. 17 Cortlandt Street, New York.**

### English Double Filament Lamp

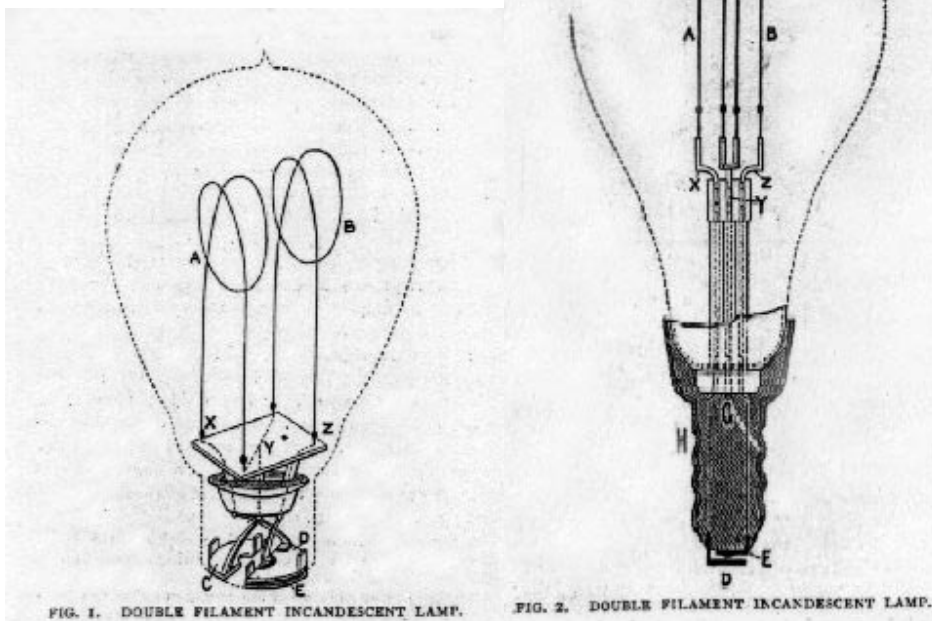

The pictured double filament incandescent lamp was announced in 1893<sup>1</sup>. The following is a verbatim copy of the article:

"In the accompanying cuts are shown the distinctive features of a double filament incandescent lamp that has been recently introduced in the English market. The arrangement is such that when one filament is exhausted, the other may be used. Reference to the cuts will make the details clear. In Fig. 1, the middle wire, Y, is attached to one of the contact plates, C, in the usual manner, and the outer wire, X, is attached to the contact plate, D. The other outer wire, Z, is attached to another contact plate, E, which is placed immediately under the plate, D, but insulated from it by a very thin layer or membrane of non-conducting material. On the lamp being put in the circuit the current entering by the contact plate, E, and issuing by C, or conversely, causes only the one filament, B, to become incandescent, but when B is worn out, the plate, E, can be raised and the insulating material between the two plates, D and E, being withdrawn and scraped away, the plate, D, which had been previously insulated is now brought into the circuit, and thus the other filament, A, is rendered incandescent. In like manner, when more than two filaments are placed in the bulb, their leading in wires are connected to separate contact plates, each insulated from the other, so that each in its turn can be put in circuit by removing or scraping away the insulating material from between it and the contact plate for the filament previously used. As shown in Fig. 2 the middle wire, Y, is connected by a cross wire, G, to the socket, H, the wires, X and Z, being respectively connected to two contact plates, D and E, thin insulating material being placed between them as in the first instance, which is easily removed when one of the filaments is worn out, the other being immediately brought into the circuit. The latter arrangement is especially applicable for lamps used in series as instead of short-circuiting and thus cutting a lamp out, the high potential current penetrates the thin insulating membrane and causes another filament to become incandescent. The cuts are reproduced from the London *Electrical Review*."

#### **Reference**

"Double Filament Incandescent Lamp," *Western Electrician*, Vol 13, No 22, Nov 25, 1893, pg 274. **Bernstein Lowatt Reflector Lamps**

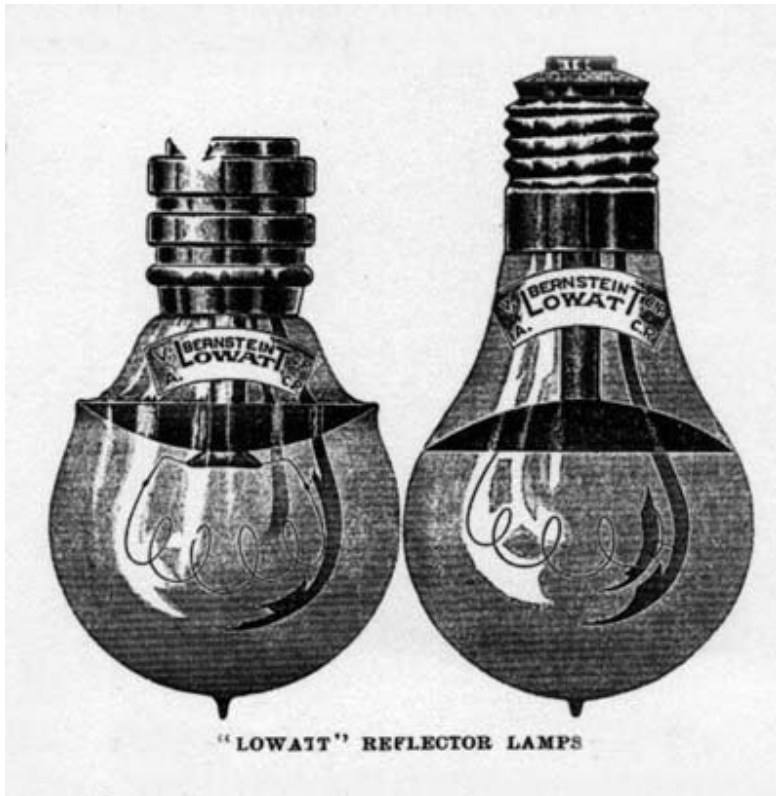

Pictured above are two reflector lamps made by the Bernstein Company of Boston, Massachusetts. The agent for the lamps was the Western Electrical Supply Company of St. Louis, Missouri<sup>1</sup>.

"The lamp has a complete metal reflector entirely within the bulb and situated behind a multi-coiled carbon filament in such a manner as to utilize all of the reflecting surface. The lamps are made with three different types of reflector; a concave form concentrating the light, a convex form dispersing it, and a side reflector for show-window use. Unlike the lamps which are silvered on the outside, the reflector of the 'Lowatt' covers the entire center, making a more efficient reflector. It is also claimed that the 'Lowatt' lamp with a concave reflector shows a candle-power, measured through the tip, of from four to eight times its rated horizontal candle-power."

An aluminum base Lowatt reflector lamp is listed in the Hammer Collection on this website and is labelled 1901-891.

#### Reference

1) "Reflector Incandescent Lamp," *American Electrician*, Vol 13, No 7, Jul 1901, pg 373.

**Westinghouse Series Lamps and Sockets**  
 An article written by Franklin Leonard Pope appeared in *The Electrician and Electrical*

*Engineer*<sup>2</sup> that described the lamp patented by Byllesby and Lange<sup>3</sup> and the socket patented by Pope, Byllesby and Lange<sup>1</sup>. Quoting from that article:

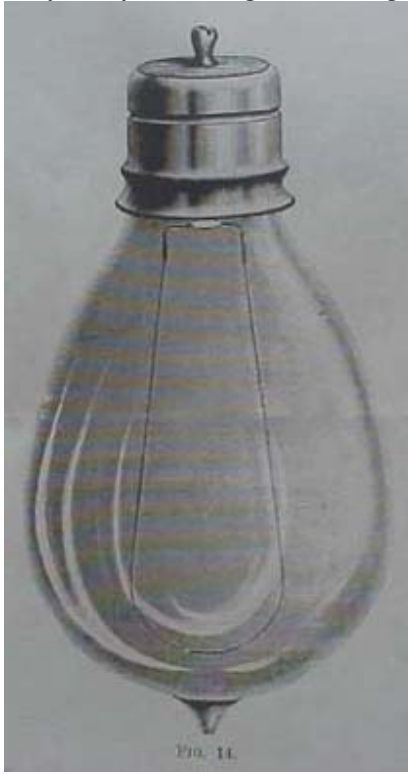

"The incandescent lamps supplied by the Westinghouse company are made in four standard sizes, of 16, 25, 50 and 150 c. p. respectively. The greater number of lamps required are of course of the 16 c. p. grade, of which figure 14 is a correct representation in its natural size. The filament is of carbonized silk, a material which has been found to serve the purpose admirably when properly prepared and treated. The fittings of the 16 c. p. lamp are neat in design, ingenious in construction and arrangement, and extremely convenient and efficient in practical use. One of the terminals of the lamp is connected to the insulated brass tip shown in figure 14, and the other to the thimble or cup of sheet brass into which the neck of the lamp is inserted. The thimble is provided with a semi-circular circumferential groove at the end next the tip of the lamp for a purpose

hereafter to be explained.

"Figure 15 is a full sized perspective view of the lamp socket and key, of which figure 16 is an elevation, the outer casing being shown in section. Figure 17 is a plan of the socket, the cap being removed, and figure 18 is a section in the plane of the line *xx* in figure 17. Figure 19 is a perspective view of the same. A perspective view of the socket showing the key and switch is given in figure 20. The various parts are supported upon a block of insulating material, A, upon one face of which is secured a cylindrical cap, B, having flexible resilient arms, b, adapted to grasp the semi-circular groove upon the lamp fitting, before referred to, when the lamp is

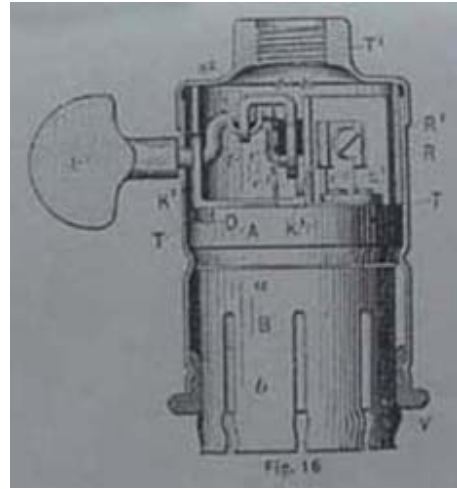
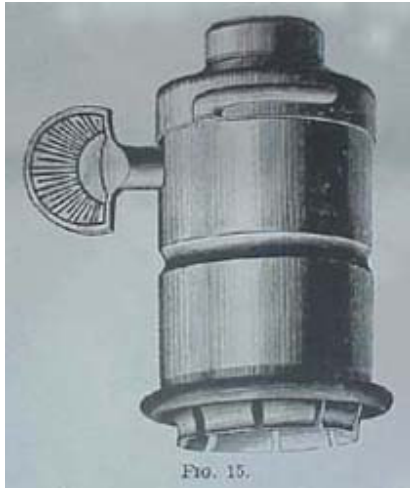

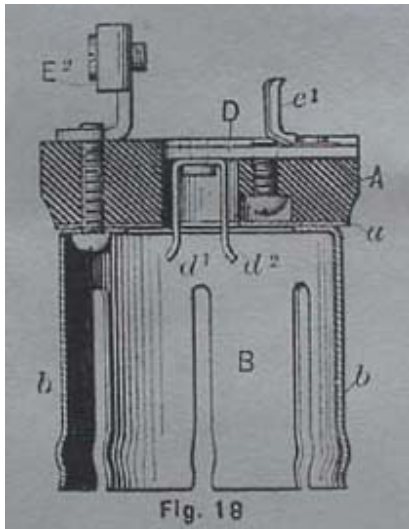

Fig. 18

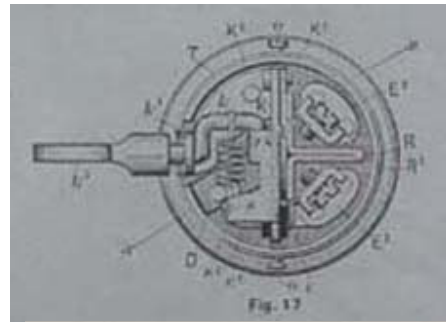

Fig. 17



FIG. 19.

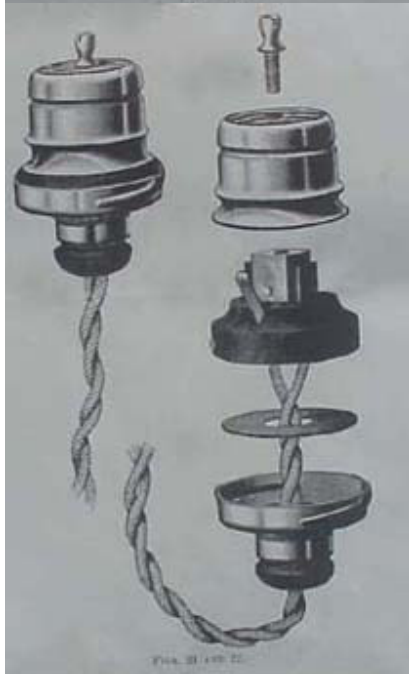

FIG. 21.

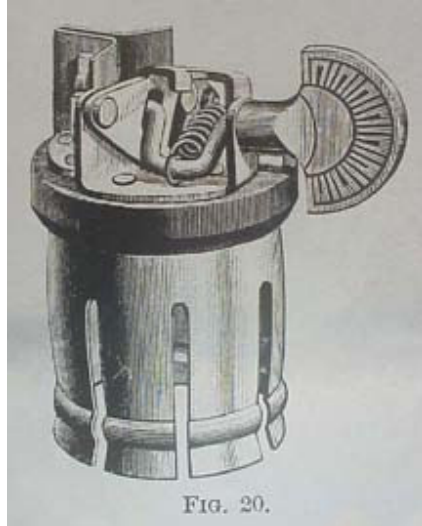

FIG. 20.

shoved into its socket. The opposite face of the block A, carries a metallic conducting bar, D, provided with a spring-jack device  $d^1$ ,  $d^2$ , adapted to receive and grasp the central contact tip of the lamp. The contact-spring  $e$  is brought into electrical connection with another similar spring,  $e^2$ , by means of a moving contact-piece,  $e$ , whenever it is desired to complete the circuit between the terminals B and D, for the purpose of lighting the lamp. The contact-piece  $e$ , is a metallic pin extending through the pivoted plate K, but insulated therefrom. The standard  $K^1$  to which the plate K is pivoted, is

affixed to a crank axis,  $k$ , provided with a thumb piece  $k^3$ . The plate  $k$  receives its motion through the intermediary of a spiral spring,  $s$ , attached at one end to the elbow of the crank axis,  $k$ , and at the other to an arm,  $s^2$ , projecting from the plate  $k$ . When the crank-arm  $k$  is turned by the key, the end of the spring  $s$  is carried to one side or the other of the fulcrum of the plate  $k$ , and thus the tendency is to pull the latter suddenly in the corresponding direction the instant it is over the centre. This snap-movement effectually prevents the formation of an arc between the terminals when the circuit is broken. A tube  $R^1$ , of insulating material surrounds the switch mechanism, and secures it against accidental electrical contact with the metallic case  $T$ . The cap is secured to the case by small set screws,  $o, o$ , which enter slots forming bayonet joints on each side of the cap, as seen in figure 15. It will be observed that the principle of the adjustable contact between the lamp and the socket in the Westinghouse lamp is precisely the same as that of the spring-jack device which has been so long in successful use in the telegraphic service, the simplicity and continued efficiency of which has been well established.

"Figure 21 shows a fitting designed to be attached to a reading or other portable lamp, and connected therewith by a flexible cord conductor. This is adapted to be inserted into any convenient socket from which a lamp has been removed, and will readily be understood without detailed explanation by referring to figure 22, which shows the same device with its component parts separated in order to more clearly exhibit its internal construction."

An 1888 Westinghouse catalog<sup>4</sup> lists additional lamps of different candlepower from what is listed in the Pope article<sup>2</sup>. Lamps of 10, 16, 20 and 25, and 32 c. p. are shown in the picture below. Thus, additional lamps of 10, 20 and 32 c. p. apparently became available between the time the Pope article was written and the 1888 catalog was printed.

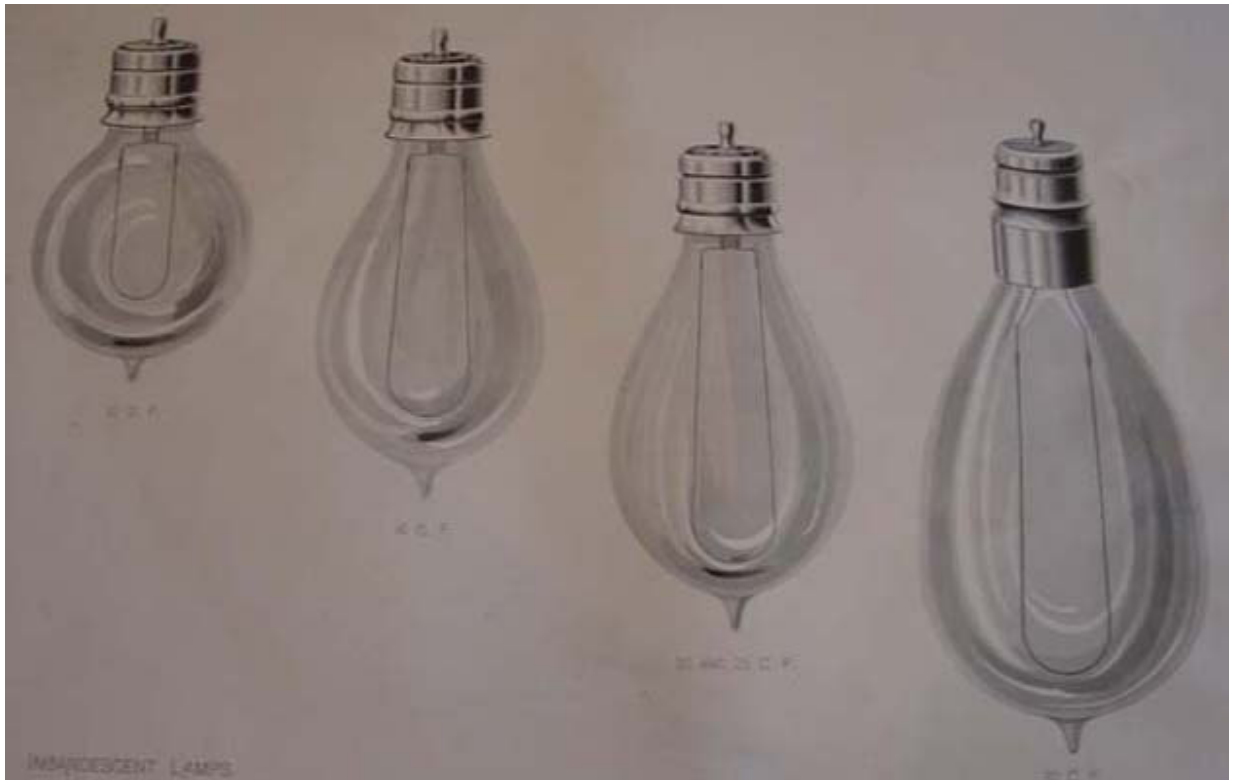

The picture below<sup>4</sup> shows an attachment plug that is exactly as the one shown in the Pope article<sup>2</sup>. However, the socket shown has the general exterior lines of the Lange socket<sup>5</sup> rather than the Pope-Byllesby-Lange socket<sup>1</sup> shown in the Pope article.





Shown below is the lamp of Byllesby and Lange (U. S. 383,616) along with the socket of Pope, Byllesby and Lange (U. S. 366,606) in the center and the socket of Lange (U. S. 434,153) to the right.

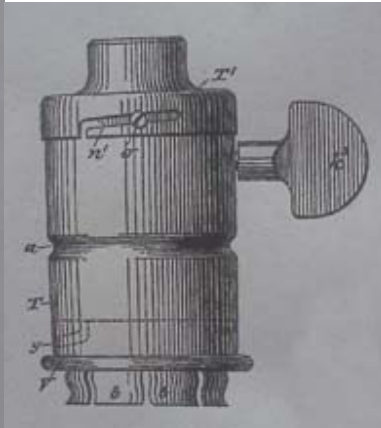
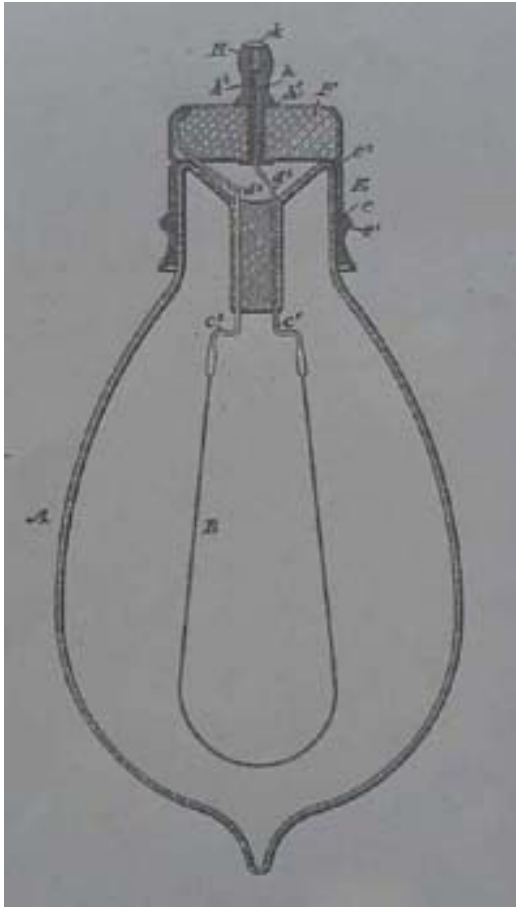

### Acknowledgement

My thanks are given to Jerry R. Westlick for the use of the scanned pictures from the 1888 Westinghouse catalog.

### References

- 1) Frank L. Pope, Henry M. Byllesby and Philip Lange - U. S. Patent No 366,606 - July 12, 1887 - Key-Socket for Incandescent Electric Lights.
- 2) F. L. Pope, "The Westinghouse Alternating System of Electric Lighting," *The*

*Electrician and Electrical Engineer*, Vol 6, Sep 1887, pp 332 - 342.

3) H. M. Byllesby & P. Lange - U. S. Patent No 383,616 - May 29, 1888 - Incandescent Lamp

4) 1888 Westinghouse catalog, in the collection of Jerry R. Westlick.

5) Philip Lange - U. S. Patent No 434,153 - Aug 12, 1890 - Incandescent Lamp Socket

### **The Lamp of Edward Pollard**

The years 1892-1894 were turbulent ones in the electric incandescent lamp manufacturing business. The Edison interests brought suit against many manufacturers who, in their view, infringed on basic Edison patents. Some inventors therefore attempted to design lamps that would not infringe. One such effort was made by Edward Pollard of Cambridge, Massachusetts in 1892<sup>1</sup>.

Pollard's idea was to replace the usual platinum leading-in wires with films of silver. Quoting from *The Electrical Engineer*<sup>4</sup>:

"The leading-in wires in this lamp are replaced by a conductor formed by depositing upon glass a line of silver or other metal in powdered form and then heating the glass sufficiently to cause the metal to adhere to it. The line of minute particles thus embedded in the surface of the glass forms a conductor for the electric current. In embodying this principle in a lamp, as shown in Fig. 1, the interior surface of the tubes 3 3 is coated with sizing, and upon this sizing there is sprinkled fine silver powder, after which the tubes are heated sufficiently to cause the particles of silver to adhere firmly to the glass, the sizing serving to hold the powder in position upon the glass until the glass is raised to the temperature necessary to cause the powder to adhere thereto. While the glass is hot the stem is pinched until its opposite walls come in contact and become welded together, Fig. 1a, thus forming a seal. The ends of the carbon filament are attached within the ends of the glass tubes by carbon paste. The conducting-wires 5 5 are connected by cold-pinching them within the tubes 3 3, having the wire in contact with the silver, as shown in Fig. 1. The silver particles thus united with the glass form a conducting connection between the conducting-wires and the carbon filament.

(No Model.)

E. POLLARD.  
INCANDESCENT ELECTRIC LAMP.

No. 485,478.

Patented Nov. 1, 1892.

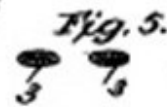
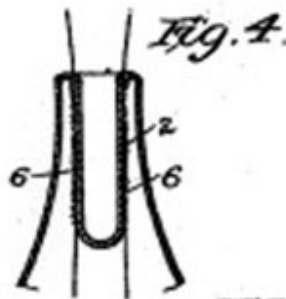
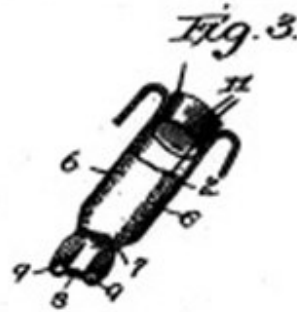
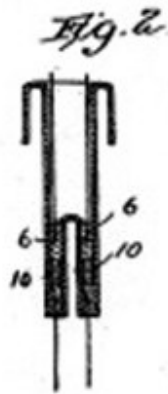
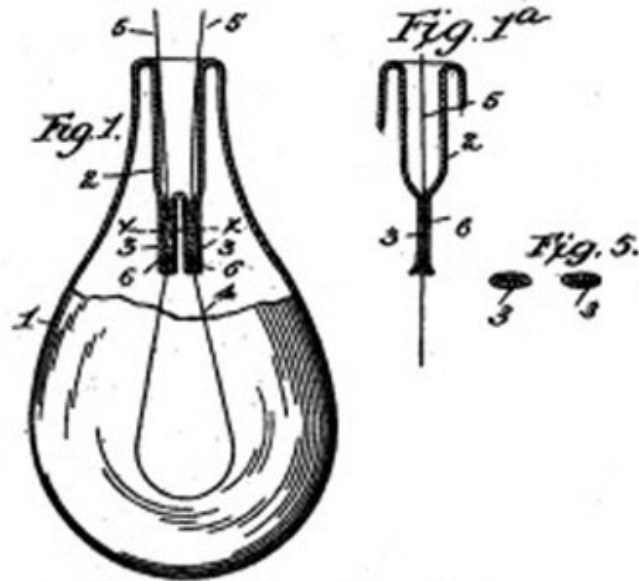

Attest  
Wm. L. Middleton  
F. L. Middleton

Inventor  
Edward Pollard  
by Ellis  
ATTY.

"According to the inventor the best method of obtaining the silver in powdered form is to dissolve the silver in nitric acid and then suspend pieces of copper in the solution to cast down the silver in a very fine powder. The silver is then thoroughly washed and passed through a fine sieve. The sizing used to attach the powder to the glass is made by mixing together copaiba balsam (two parts) and fir balsam (one part.)

"Figs. 2, 3 and 4 show various modifications of the method of applying the conducting powder to the stem. The process has since been further refined and perfected."

It is not known by this writer how many different companies manufactured the Pollard lamp. One such lamp, owned by Jerry R. Westlick has a "Packard" label. If the lamp was made in the United States it is traceable to The New York & Ohio Co., of Warren, Ohio. If it was made in Canada it probably came from the Packard Electric Co., Ltd., located at St. Catharines, Ontario. The three Pollard lamps in the Hammer Collection<sup>12</sup> (1894-455; 1894-457; 1894-461) were made by the Imperial Electric Manufacturing Company. Pollard lamps were also made by the Buckeye Electric Company<sup>3,4</sup> of Cleveland, Ohio and the Boston Incandescent Lamp Company<sup>5,6,7,8</sup>.



The porcelain-insulated Westinghouse-based lamp shown to the left has no label; the red fibre-insulated Thomson-Houston- based lamp in the center has a label stating

"Pollard

Patents";

the Thomson-Houston-based lamp shown to the right has a "Packard" label.

Pollard was a resident of Cambridge, Massachusetts and worked as a glass etcher. This writer is not familiar with that profession and so the word "etcher" was looked up in Webster's New World Dictionary, Third College Edition. The definition found there was:

"**1** to make (a drawing, design, etc.) on metal, glass, etc., by the action of an acid, esp. by coating the surface with wax and letting acid eat into the lines or areas bare with a special needle **2** to prepare (a metal plate, glass, etc.) in this way, for use in printing such drawings or designs **3** to depict or impress sharply and distinctly □ **vi** to make etchings □ **etcher**."

Pollard's wife was Martha W.<sup>11</sup>, and she was the administratrix of his U. S. Patent No. 485,478, issued Nov 1, 1892. The only other patent known to have been granted to Pollard was No. 402,476, for a vapor burner for stoves, granted Apr 30, 1889.

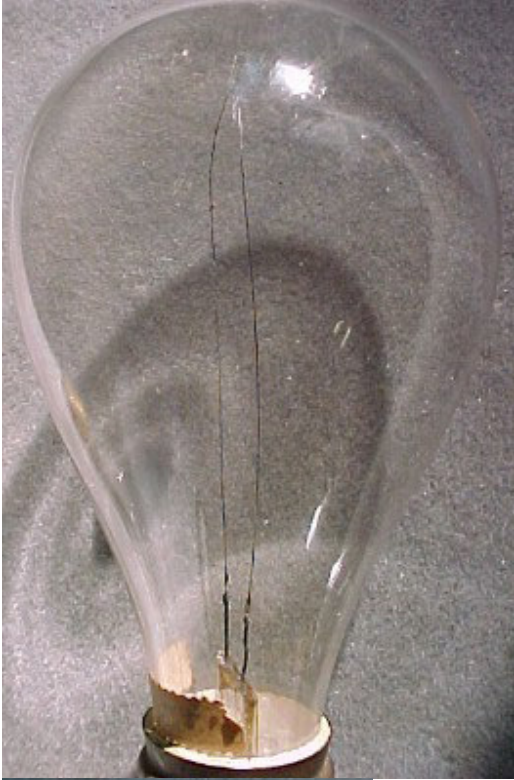

The three pictures shown above are of the same Pollard lamp.

## Acknowledgements

The writer thanks Joyce Syphers, of New Hampshire, for permission to use photographs taken by her of a 63-volt, 16-candlepower Pollard lamp. Jerry R. Westlick, of Ohio, also contributed knowledge and photographs of his 52-volt, 16-candlepower Pollard lamp. The Cambridge Public Library kindly found and supplied information about the Pollards in their City Directories. The Public Documents and Patents Department of the Cincinnati Public Library is always a source of instant response and information. The sharing of information allows these early lamp efforts to be better understood and appreciated.

## References

## and

## Bibliography

- 1) U. S. Patent No. 485,478 granted to Edward Pollard, Nov 1, 1892.
- 2) Minutes Book of the Board of Directors of the Buckeye Electric Company, Oct 26, 1893.
- 3) "The Buckeye Lamp Without Leading-In Wires", *The Electrical Engineer*, Vol 17, No 297, Jan 10, 1894, pg 25.
- 4) "The New Buckeye Lamp Without Leading-In Wires", *The Electrical Engineer*, Vol 17, No 298, Jan 17, 1894, pp 55-56.
- 5) "General Electric vs. Boston Incandescent Lamp Company", *Electricity*, Vol 6, No 14, Apr 18, 1894, pg 180.
- 6) "The Pollard Lamp", *Electrical Review*, Vol 24, No 17, Apr 25, 1894, pg 201.
- 7) "The Pollard Lamp", *The Electrical World*, Vol 23, No 20, May 19, 1894, pg 679.
- 8) "The Decision Against Powdered Silver Leading-In Wires", *The Electrical Engineer*, Vol 17, No 320, Jun 20, 1894, pg 538.
- 9) "The Boston Incandescent Lamp Company Defeated", *Electrical Review*, Vol 24, No 25, Jun 20, 1894, pp 302-303.
- 10) Our Boston Letter, *Electrical Review*, Vol 24, No 25, Jun 20, 1894, pg 303.
- 11) Cambridge City Directories, 1889-1893.
- 12) The William J. Hammer Historical Collection of Incandescent Electric Lamps, which is housed at the Henry Ford Museum, Dearborn, MI.

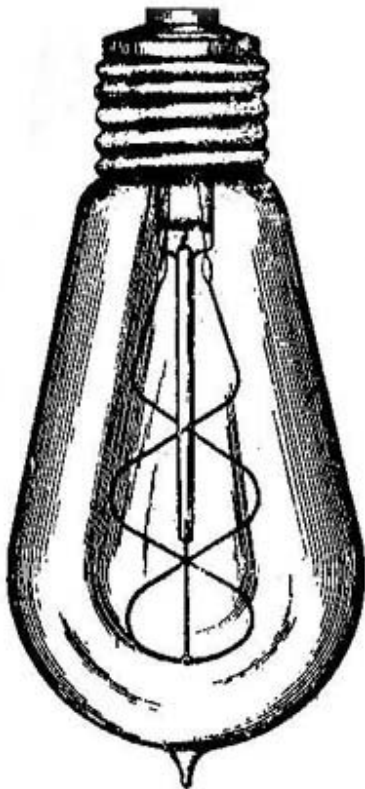

### The Sterling Special Lamp

The following description of a lamp patented by Glenn C. Webster (U. S. 708,432, dated Sep 2, 1902)<sup>2</sup> appeared in *Electrical Review*<sup>3</sup>:

"In the accompanying illustration is shown a new design in the manufacture of incandescent electric lamps, the object of the inventor being to arrange the filament so as to produce a maximum and symmetrical distribution of light-rays, or, in other words, the same measurement of



maximum candle-power at every point in the horizontal and vertical plane.

"Referring to the illustration an ordinary incandescent bulb is used and the pendent glass mount is sealed within the top, conducting wires being connected to the carbon filament in the usual manner. The filament, however, is wound spirally, there being three convolutions. These are in fact two spirals, which are alike in form and arrangement. Thus the lower bend of the double spiral merges into the two central convolutions, and these again merge into the upper convolutions, whose terminals connect with the wire conductors. The spirals are wound in opposite directions and the convolutions are symmetrically arranged one exactly opposite another horizontally. An important characteristic of this filament arrangement is that the relative diameters of the several convolutions differ so that when seen in an end view the convolutions appear in different horizontal planes. The upper convolutions are narrower than the lower ones. The central convolutions are wider than the latter, and hence each set of opposite convolutions is so placed that it is seen from below, and therefore throws light downward, independently of the other two. In this way a maximum aggregation of light can be obtained in a downward direction. The side or lateral distribution of light is also claimed to be uniform, thus perfectly symmetrical effect is obtained.

"To support and steady the filament a glass anchor is employed, which depends from the mount and is formed integrally therewith. This is provided with a wire extension which is rigidly attached to the centre of the lower bend or convolution of the filament. This anchor is also claimed to serve another important function, in that it draws to itself by static induction the carbon dust or fine particles of carbon which are given off from the filament as it grows old and which are ordinarily deposited on the bulb. This obviates the discoloring of the bulb under long-continued service.

"This lamp is the invention of Mr. Glenn C. Webster, of Warren, Ohio, and has been assigned to the Sterling Electrical Manufacturing Company, of Warren, Ohio."

The distribution of light from lamps with different filament configurations<sup>1</sup>, including the present one, can be found on this website in the topic "Carbon Filament Configuration and Light Distribution" in Section 2.

### References

- 1) "Symmetrical Distribution from Incandescent Filaments," *American Electrician*, Vol 13, Oct 1901, pg 513.
- 2) Glenn Cannon Webster, "Incandescent Electric Lamp," U. S. Patent No 708,432, Sep 2, 1902.
- 3) "New Ideas in Incandescent Electric Lamp Manufacture," *Electrical Review*, Vol 41, No 14, Oct 4, 1902, pp 451-452.

## The Incandescent Lamp of Dr. Isaac Adams, Jr.

In the historical development pages of the incandescent lamp there are workers who are seldom mentioned. One of these is Dr. Isaac Adams, Jr. Because minor efforts are worthy of mention in the writings of history, even though they didn't result in the marketing of products, the Adams story is revived here, taken from one of the published articles on the subject. Hammer said<sup>1</sup>:

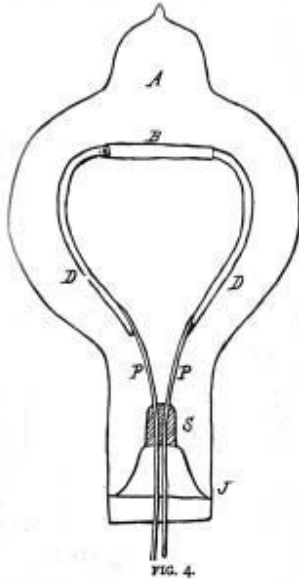

"Dr. Isaac Adams, residing at Gloucester, Mass., testified for the defendants in the suit of the Edison Electric Light Company vs. the United States Electric Lighting Company, on the Edison filament lamp patent, No. 223,898 (hereinafter referred to as the 'Filament Record'), regarding his experiments with incandescent lamps. He was educated as a physician, but while abroad became interested in the manufacture of Geissler tubes, which he took up as a commercial undertaking upon his return to this country, in 1864. Being familiar with the properties of carbon, he, during 1865-6, made a number of lamps just as he had made his Geissler tubes, but with carbon burners about an inch to an inch and a quarter long,

about three-sixteenths of an inch in width and from .005 to .01 of an inch thick; these carbons varied in resistance from .69 to 1.2 ohms, and were made by filing or scraping a block or strip of carbon as thin as he dared to, then dipping it in sugar and then reheating, making it tough and dense. The carbons were cut from gas-retort carbon, blocks of plumbago, carpenters' pencils or from a mixture of lampblack, powdered coke and molasses. Fig. 4 (from *Filament Record*, Vol IV, p. 2691) shows how these lamps were made. A is a glass globe, B a carbon slip; D D copper or brass extension of platinum conductors; P P platinum conductors; S double sleeve of glass fused together and surrounding the platinum conductors; J joint of fused glass shutting out atmosphere.

"The vacuum employed was as perfect as Dr. Adams could make it with his improved mercury pump. Great difficulty was experienced by Dr. Adams in maintaining a vacuum because of the cracking of the glass around his large platinum leading-in wires (No. 16 B. W. G.), made necessary to carry the large current (from 11.5 amperes to 18.8 amperes) required by his carbons. This difficulty was not overcome until he produced a special character of glass from which to make his globes, having the same coefficient of expansion as the platinum. The question of dates was somewhat involved in Dr. Adams' mind when he testified, and it seems probable that no perfect globes were made before 1867. When cross-examined in the above case Dr. Adams said (Vol. IV, p. 2716):

"I had no idea at that time" - 1867-9 - " of having done anything of any special merit, as I thought the introduction of a piece of carbon into a globe to a person who was in the habit of making Geissler tubes was not much of a trick; but I was interested in the fact as to whether or not the big platinum that I put in the glass would hold, because I have always considered - did then, and do now - that I made an invention there which was a useful one. That was my interest in the lamp, and that was about all the interest I had in it. \* \* \* Introducing platinum wires of relatively large cross section was the novelty."

"This shows quite clearly what was the state of Dr. Adams' mind. He did not make a practice of measuring the resistance of his lamps" because" he says, "I was not interested in that direction. I was not proposing to get up a system of lighting, not at all. I was simply making a lamp." He dropped the matter entirely in 1869. He had no records of the life of any of these experimental lamps and could only guess at the life of any of them. It is perhaps unfortunate that Dr. Adams should have regarded his work from the standpoint of the glass-worker rather than that of the electrician, but the fact is that he had not advanced beyond the conceptions of King or Roberts, except so far as the enclosing globe and the leading-in wires were concerned, guaranteeing a better vacuum."

**Note:** Dr. Isaac Adams, Jr. was the son of Isaac Adams<sup>4</sup>, the inventor of the Adams printing press. It appears that Edwin W. Hammer<sup>6</sup> was a half brother of William J. Hammer<sup>5</sup>.

## References

and

## Bibliography

1) Hammer, Edwin W., "Incandescent Lamp Development to the Year 1880," Parts I, II and III, *Electrical World and Engineer*, Vol 36, Dec 1-15, 1900, pp 839-841, 880-882, 918-919.



This write-up is on pages 840-1.

2) Wrege, Charles D., "Rx For a Light: The Story", *Harvard Medical Alumni Bulletin*, Winter, 1963, pp 22-26.

3) Wrege, Charles D., "Bowdoin Man Shines Before Edison," *Bowdoin Orient*, Vol XCII, No 19, Feb 22, 1963.

4) "Adams, Isaac," Who Was Who in America, Historical Volume (1607-1896), pg 83.

5) "Hammer, William Joseph," Who Was Who in America, Vol I (1897-1942), pg 513.

6) "Hammer, Edwin Wesley," Who Was Who in America, Vol III (1951-1960), pg 364.

## The Cruto Lamp

The Cruto lamp was manufactured in Europe and is, therefore, not well known in the United States. The inventor, Alessandro Cruto, likewise is not a familiar figure in lamp history that is written in the United States. A biographical



sketch of Cruto is therefore in order and the write-up by Frank Andrews<sup>8</sup> is used here, with his kind permission.

"Alessandro Cruto was born in Italy on 18th March 1847. He studied chemistry in Turin<sup>\*</sup> and became interested in the idea of making diamonds in the laboratory by the crystallisation of carbon. In September 1873 he produced a layer of dense carbon hard enough to scratch glass. But it was not his expected result and he studied the new material for many years. At a conference on electric lighting in May 1879 he realised that his material was suitable for use as a filament in an incandescent lamp. His first lamp had a filament measuring 12 x 3 x 0.52 mm and gave a bright light. But the efficiency of this lamp was low. By September 1881 he had achieved a successful version of this the first synthetic filament. He formed A. Cruto & Company in February 1882 with very limited backing and had to develop all his own manufacturing methods. After seeing a Swan lamp he realised that he had to reduce the surface area of his filament but due to the impurities present found this to be unsuccessful. He then applied his process to platinum wire changing the process to create a chemical bond between the carbon lamination and the platinum. The platinum wire was then evaporated by passing a high current through it. This bulb was successful and fell outside the scope of the Edison-Swan patents. Unfortunately the limited finance he had obtained prevented him competing against the rich Italian Edison Company. Edison had installed a thermo-electric power station in Milan in 1883 and supplied all the bulbs used on the system. The Cruto bulb was exhibited at the Munich exhibition in 1883. Cruto managed to stay in business but only in a limited way and due to management problems he left the company in 1893. At some stage it appears that the Cruto company may have switched to a standard type of filament. Cruto bulbs were sold in France under the name SYSTEME CRUTO. These were fitted with a bayonet cap and had a single horseshoe shaped filament. He died in 1908."

\* Turin, or Torino, site of the 2006 Winter Olympic Games

According to Heerding<sup>6</sup>, in 1890, Cruto lamps were manufactured in Paris, France by Société de Soudure Electriques des Métaux, in Milan, Italy by Rivolta & Co., and, in Turin, Italy by Società Italiana di Elettricità, Sistema Cruto. Apparently bases other than the Cruto were used as time passed. In addition to the Heisler base, pictured above, in 1896 it is believed the Ediswan base was also used<sup>5</sup>.

An article from *The Electrical World*<sup>3</sup> follows:

"Among the incandescent lamps at the Philadelphia Electrical Exhibition (in 1884), the 'Cruto,' of French manufacture, though not in operation, attracted attention on account of the high claims of efficiency made for it. The construction of this lamp is peculiar. The main object, as in others, is to obtain a filament of the greatest possible homogeneity. The method employed to effect this is quite original and is described in a recent number

of our French contemporary, *L'Electricien*. M. Cruto builds up his filament little by little, and thus obtains a carbon of great density, the pores of which are small as possible.

"The process employed depends upon the fact that certain hydro-carbons are decomposed by heat, and their carbon deposited upon the heating surface. This is the method usually employed for standardizing carbon filaments, as they come from the carbonizing furnace.

"In the present instance the carbon is deposited on a core of platinum raised to incandescence by the passage of a current while in the midst of a hydro-carbon gas.

"The platinum employed is very fine, being only 1/100 millimeter (about .0004 inch) in diameter, and is produced by means of the Wollaston process. This process consists in drawing a silver wire with a platinum core to a very small diameter, and then dissolving the silver in an acid which does not attack the platinum; this leaves a very fine platinum wire. The wire thus made is cut into lengths of 150 millimeters (6 inches) for the 16 c.-p. lamps, and then stretched on a form which gives it a U shape. After this the ends of the wire are placed in two clamps in circuit with a dynamo; the clamps are mounted on a base which forms the stopper to a glass jar. Hydro-carbon gas is admitted through a tube passing through the stopper, and the deposition of carbon takes place in the jar.

"The gas employed here is bicarbonate of hydrogen, produced by the action of sulphuric acid on ethylic alcohol. This gas, after being washed and dried, is stored in a reservoir, whence it is drawn as required.

"In order to produce the deposit of carbon, the jar is filled with gas, and a current is sent through it, of about 150 volts E.M.F.; in order to protect the filament, however, a rheostat is put into the circuit so that the current can be regulated. At the beginning, the resistance of the platinum wire is 350 ohms, but at the end the filament is reduced to 150 ohms. During the process a curious fact is noticed; at the end of five or six minutes the resistance of the filament suddenly increases, and then decreases regularly during the time of formation, which varies from 1 1/2 to 2 hours.

The reactions which take place in the glass jar are very complex, and after three applications the jar must be cleaned. This becomes necessary on account of the deposit of carbon which settles on the walls of the jars and prevents any observation of the interior. As the deposit of carbon proceeds, the interposed resistance is gradually diminished, and the gas renewed from time to time.

"The current has, in addition, a mechanical action on the platinum wire; thus, a repulsion of the two branches of the loop is observed, and a tendency

to take up a certain cardinal position. In order to avoid this tendency, the two sides of the loop are placed in the same plane of the magnetic meridian. If the loops become crossed during the operation, they are brought back to their original position by reversing the direction of the current.

"The filaments so formed are then inserted into the platinum ends forming the terminals of the lamp, and cemented to them by a similar deposition of carbon. This process, it is claimed, gives a most dense and homogeneous filament, and the efficiency of the lamps, according to published accounts, exceeds that of the other lamps which have thus far come into general commercial use. The process is an ingenious one and could be applied in more than one way."



The pictures shown above were kindly supplied for the writer's use by Tim Tromp. The word "CRUTO" is stamped on the brass base. The lamp does not have the "Cruto" base but displays either a Bernstein or a Heisler base; it is believed that the base is that of Heisler.



The picture above shows a Cruto socket and a Cruto lamp base.



Through the courtesy of Jerry Westlick the picture of an 1880s Cruto lamp and wooden socket is shown

There are six Cruto lamps listed in the William J. Hammer Historical Collection of Incandescent Electric Lamps (see this website, Section 12, lamps 1883-24, 1883-38, 1883-505, 1884-521, 1897-1009 and 1902-1029). It appears, therefore, that Cruto lamps were definitely manufactured during the 1883-1902 time period.

### **Acknowledgements**

I am grateful to Frank Andrews for permission to use his biographical sketch of Alessandro Cruto (see Reference 8), and thanks are extended to Tim Tromp for supplying photographs of his lamp for use in this sketchy treatment of the Cruto lamp. Thanks are also given to Jerry Westlick for supplying a photo of a Cruto lamp and socket in his collection. The sketch of Alessandro Cruto was saved from the website

<http://www.piemonte-online.com/personaggi/servizi/cruto.htm>

The writer thanks the originator(s) of that website for use of the sketch.

### **References**

**and**

### **Bibliography**

- 1) "The Cruto Incandescent Lamp," *The Electrician and Electrical Engineer*, Vol 3, Mar 1884, pg 60.
- 2) J. H. Guest, "Experiments with Platinum Filaments," *The Electrician and Electrical Engineer*, Vol 3, May 1884, pg 112.
- 3) "The Cruto Incandescent Lamp," *The Electrical World*, Vol 6, 1885, pg 4.
- 4) Philip Atkinson, "The Elements of Electric Lighting", No XXXI, *Western Electrician*, Vol 2, No 9, Mar 3, 1888, pg 115.
- 5) "The Use of 220-Volt Lamps", *The Electrical World*, Vol 28, No 7, Aug 15, 1896, pp 193-195.
- 6) A. Heerding, *The History of N. V. Philips' Gloeilampenfabrieken*, Vol 1, The Origin of

the Dutch Incandescent Lamp Industry, Cambridge University Press, London, 1985  
(English translation).

7) The History of Tungsram, 1896-1945, Printed in Gutenberg Printing House, Hungary,  
1990, pg 139.

8) <http://www.ysartglass.com/zdbk/Bulbs/LB06inc1800.htm>

### **Tantalum Filament Lamps**

The tantalum filament lamp was developed by Drs. Werner von Bolton and Otto Feuerlein of the Siemens-Halske Company in Berlin. The first lamp that withstood photometric and life testing was completed on Dec 28, 1902. That lamp had a looped shape filament. In Jul 1903 the first tantalum filament lamp was obtained with a wire diameter of about 0.05 mm. It too had a loop filament. The first serviceable lamp for 110 volts was produced in Sep 1903.

The General Electric Company and the National Electric Lamp Company acquired the exclusive rights to manufacture the lamp in the United States on Feb 10, 1906. The first lamp bulletin regarding the tantalum lamp was issued by National on Jan 14, 1907. The first lamp made was a 44-watt design at 22 c.p. and 100-130 volts. By Nov 9, 1907 three new tantalum lamps had been added to that one. The tantalum lamp line then consisted of two sizes in straight sided bulbs and two sizes in round bulbs. Tantalum lamps were described in bulletins up to November 20, 1910. In the following most of these lamps are represented. Descriptions are given following the images.



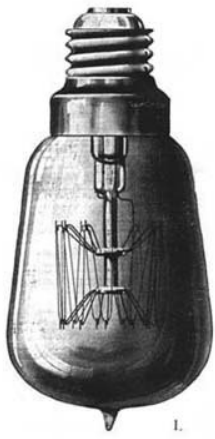

1.



2.



3.



4.



5.

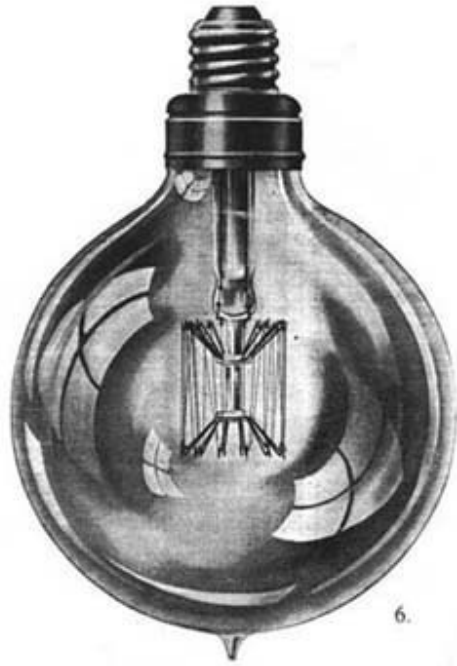

6.



7.



8.

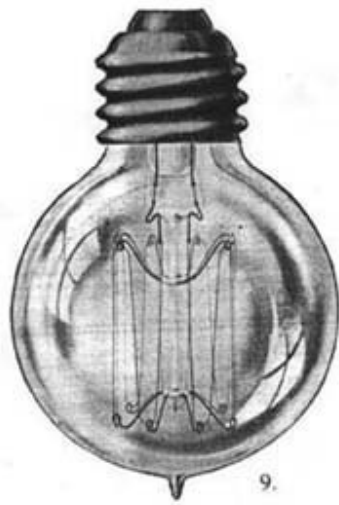

9.

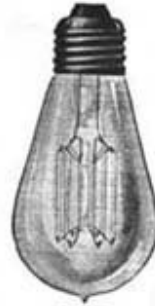

10.



11.



12.



- 1) 20 c.p., 42 watts, 100-125 volts, bulb dia.=  $2\frac{3}{8}$  inches, lamp length= 5 inches.
- 2) 40 c.p., 80 watts, 100-125 volts, bulb dia.=  $3\frac{1}{16}$  inches, lamp length= 7 inches.
- 3) 20 c.p., 40 watts, 100 to 125 volts, bulb dia.=  $2\frac{5}{16}$  inches, lamp length=  $5\frac{1}{4}$  inches.
- 4) 50 watts, 200-250 volts, bulb dia.=  $3\frac{1}{16}$  inches, lamp length=  $5\frac{1}{8}$  inches.
- 5) 25 watts, 100-125 volts, bulb dia.=  $2\frac{3}{8}$  inches, lamp length= 5 inches.
- 6) 80 watts, 100-125 volts, bulb dia.= 5 inches, lamp length=  $7\frac{5}{8}$  inches.

- 7) 40 watts, 100-125 volts, bulb dia.= 3-3/4 inches, lamp length= 6-1/8 inches.
- 8) 80 watts, 200-250 volts, bulb dia.= 5 inches, lamp length= 7-5/8 inches.
- 9) train lighting lamp, 28-34 volts, 8 or 12 c.p., 16 or 25 watts, bulb dia.= 2-5/16 inches, lamp length= 3-1/2 inches; 57-65 volts, 12 c.p., 25 watts, bulb dia.= 2-5/16 inches, lamp length= 3-1/2 inches.
- 10) train lighting lamp, 28-34 volts, 8 or 12 c.p., 16 or 25 watts, bulb dia.= 2-1/8 inches, lamp length= 4-1/4 inches; 57-65 volts, 12 c.p., 25 watts, bulb dia.= 2-1/8 inches, lamp length= 4-1/4 inches.
- 11) train lighting lamp, 57-65 volts, 20 c.p., bulb dia.= 3-3/4 inches, lamp length= 6-1/8 inches; 28-34 volts, 40 c.p., 80 watts, bulb dia.= 5 inches, lamp length= 7-5/8 inches; 57-65 volts, 40 c.p., 80 watts, bulb dia.= 5 inches, lamp length= 7-5/8 inches.
- 12) headlight or side-light for electric vehicles, 28-34 volts, 16 watts, bulb dia.= 2-5/16 inches, lamp length= 3-1/2 inches; 28-34 or 57-65 volts, 25 watts, bulb dia.= 2-5/16 inches, lamp length= 3-1/2 inches.
- 13) 40-watt tantalum lamp in (Type B) Bowl Holophane Reflector.
- 14) 40-watt tantalum lamp in (Type C) Concentrating Holophane Reflector.
- 15) 40-watt tantalum lamp in (Type D) Distributing Holophane Reflector.
- 16) 40-watt Meridian tantalum lamp in Type S-1 Holophane Reflector.

### **The Osmium Filament Lamp**

The osmium filament lamp is one that wasn't utilized to any extent in the United States, in part, because of the advent of the tungsten filament lamp. It was manufactured in Austria and Germany and was marketed in Germany and Great Britain. By 1905 the Vienna firm stopped producing the lamp. The trade name under which the lamp was sold in England was "Osmi", in Germany the name was "Auer-Os" and in Austria it was called "Osmin". It was the invention of Carl Ritter Auer von Welsbach.

The English 50-volt 25-cp lamp, marketed by the General Electric Company, Limited, of London, had a filament length of approximately 15 inches and consisted of three separate hairpin shape filaments connected in series. Lamps were also available at 2.5 cp and 4 volts, 5.5 cp at 8 volts, 10 cp at 25 and 33 volts, 25 cp at 45 to 60 volts and 32 cp at 70 to 75 volts.

Because osmium was a rare and expensive metal the lamps in 1902 were rented and not sold, so that the user would eventually return the lamps to the manufacturer. In 1903, when

a lamp cost \$1.25, the user could recoup \$0.19 if the burned out, but unopened, lamp was returned within 18 months. In that case the filament could be treated and reused.

Of especial interest are the support wires that retained the filament loops. In general the lamps could be burned only in the vertical position with the bend down. This was necessary because the filaments would sag otherwise and possibly touch the bulb wall or each other. The supports were glass rods fused to the bulb. In the lamps first produced, metal loops were attached to the ends of the glass rods and the filaments passed through them. The supports in such a lamp are shown below.



It was found, however, that the filament would burn out at that location. Later in time lamps utilized an improved support system. On May 31, 1901 von Welsbach applied for a patent that was granted as U.S. No 814,632 on Mar 6, 1906. The patent concerned the combination of an osmium filament and a support that was composed of sintered refractory oxides. The support was non-adherent to the filament as well as chemically non-reactive. The material used consisted of a mixture of ten parts by weight of thorium oxide and one part by weight of magnesia. The oxides were mixed as powders and put into a viscous binding solution of sugar. A paste resulted that was shaped into filaments, dried and then heated in air to get rid of the organic material. The filaments were then subjected to a very high temperature until the particles were sintered together. The oxide material was white, as can be seen in the photograph below.



Although the osmium lamp was more efficacious than the incandescent lamps that preceded it, it probably would never have had widespread use. The lamp could best be made for low voltage circuits, even though one was eventually made for 110 volts. In order to use osmium lamps on 110-volt or 220-volt circuits in England, adapters were sold for connecting to a single socket, two three or more lamps in series.

#### **MAZDA Lamps with Sintered Tungsten Filaments**

The precise dating of a lamp can be difficult if it was manufactured during a period of design change. An example is the early MAZDA lamp. The first tungsten lamps employed filaments that were obtained by squirting material through a die, followed by sintering. These were introduced to the public about Jul 1907. Because long lengths of such filaments were difficult to handle, short hairpin shaped segments were made and then welded to support wires. The segments were then connected in series to result in the proper electrical resistance for the line voltage.

The result of the work of Dr. William D. Coolidge was that the tungsten product was ductile; therefore, wire could be drawn into long lengths. Instead of having to make short segments, the required length of wire could be used without the welding operation; the wire was simply wound back and forth over support wires.

Identification of the very first tungsten lamps, utilizing the so-called sintered filaments, can be determined by the weld balls on the support wires close to the lamp base. Starting in early 1911 these weld joints could no longer be seen in lamps that utilized the so-called drawn, or nonsag, tungsten filament.

Clarification of the identification of lamps manufactured at that time should be made. The word MAZDA was first used on a tungsten filament lamp about Dec 21, 1909. At that time only sintered filaments were being used. An example of a lamp showing the weld balls on the lower support wires, as well as a MAZDA label, is shown below.



The nonsag type of wire was first used in lamps starting about Sep 1910. These lamps were sold by the following National members: Banner, Brilliant, Bryan-Marsh, Buckeye, Colonial, Columbia, Fostoria, General Incandescent, Monarch, New York & Ohio, Shelby, Standard, Sterling, Sunbeam and the Warren Electric & Specialty Company.

By Jan 1911 Zokul (in Cleveland) was manufacturing lamps, utilizing nonsag tungsten, for 30-volt and 60-volt circuits in sizes 15 , 25, 30 and 40 watts. By May 1911 they were manufacturing lamps for 110-volt service.



It might be concluded, from what was presented above, that MAZDA lamps were manufactured with sintered tungsten filaments from about Jan 1, 1910 to about May 1911. All lamps used for household purposes in 1910 had sintered tungsten filaments and were also referred to as MAZDA. This writer is making a simplification and stating that a lamp that has the weld balls on the lower supports as well as a MAZDA label was manufactured in 1910.

### "Just" Tungsten Lamp for Burning in Any Position

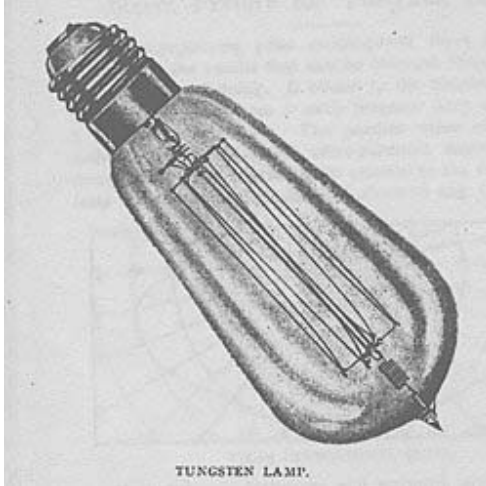

During the days of the sintered tungsten filament lamp, that is, from 1907 to about 1909, the wire had a tendency not to maintain its original length. The filament segments in the new lamp drooped considerably when the lamp was burned in any position. One manufacturer designed a lamp that was meant to reduce the problem of droop. It was introduced first in Europe and then later in the United States. The Just lamp is shown to the left.

Quoting from an article with the above title (*Electrical World*, Vol LII, No 10, Sep 5, 1908, pg 542):

"...In this type the entire filament structure is supported by springs. The central glass rod that carries the two end spiders is attached at both extremities to spiral springs, secured respectively to the leading-in glass protection and to the opposite end of the bulb. The attachment of the filament to the leading-in wires is also flexible. This method of mounting not only permits the lamp to be used at any angle, but renders it less apt to breakage when installed in vertical position. The lamp at present is made only in 25 and 40 cp.

"...The Electrical Accessories Company, 1135 Broadway, New York, represents in this country the Just lamp..."

Perhaps a later design is that shown in the photograph below. In it the two end springs have been eliminated and the hairpin shaped sintered tungsten filaments were mounted to apply tension on the loops at the upper end of the lamp. This lamp used porcelain as the base insulator. Etched in a circle around the exhaust tip is: "Just Tungsten Lamp Pat. Pending". Stamped on the brass base is, apparently, the date: 8-12-08. Also stamped is "220/50" and the word "schr□g". Loosely translated, this word means sloping or slanting.



**1910 GE MAZDA Lamp with Sintered Tungsten Filament**

Under Topic No. 24 above some etchings found on lamps were presented, as transferred onto paper by George Reynolds Brown. These were etchings as found on MAZDA lamps. The example shown here is different from those presented.



The lamp shown above is a 40-watt GE MAZDA of 100-98-96 volts with a sintered tungsten filament. If one looks "below" the paper label, to that location where the straight bulb side changes to a hemispherical one, an etched "GE" monogram can be seen, which is about 5/16-inch in diameter. The GE monogram was used in 1910, but apparently was replaced with one showing the word "MAZDA."

### **MAZDA Trivia**

During the court litigations of 1893 the general counsel for the General Electric Company was Frederick P. Fish. It was he who also suggested the name MAZDA for the newly introduced tungsten filament lamp. It carries the trademark No. 77,779, having been

registered May 3, 1910. The trademark MAZDA was not the name of a lamp but rather the mark of a service. The word MAZDA was first used on lamps on Dec 21, 1909. It's believed that MAZDA lamps made from that date to about May of 1911 utilized sintered tungsten filaments, whereas those made after May 1911 utilized drawn tungsten filaments. Westinghouse used the name MAZDA starting in 1912. The name was not used by the General Electric Company after 1945. In 1921 it was agreed within General Electric that

"Words that are descriptive of the appearance of the lamp will precede the word MAZDA, as in the case of the White MAZDA lamp. Words descriptive of the function of the lamp will follow the word MAZDA, as in the case of the MAZDA Mill Type lamp, the MAZDA Train Lighting lamp, or the MAZDA Motion Picture lamp."

### **The Gas-Filled Incandescent Lamp**

Several early inventors developed incandescent lamps that contained a gas filling. Those early efforts did not result in truly successful products and the aim of this writing is to comment on the features needed in such a lamp for it to be successful. This can be done by comparing early lamp designs with the later successful design of Irving Langmuir.

The necessary attributes of an efficient gas-filled lamp can be determined from the work performed by Nobel Laureate Irving Langmuir. Langmuir's biography and technical articles dealing with incandescent lamps are available in Volumes 12 and 2, respectively, of The Collected Works of Irving Langmuir, C. Guy Suits, General Editor, Pergamon Press, New York, 1960.

In the year 1911 Irving Langmuir began a scientific investigation to understand the effects of the interaction of gases with incandescent filaments. Platinum and tungsten filaments were used with gases such as hydrogen, nitrogen and air. Total power loss from a filament was determined to be mainly via radiation and convection. End losses through the lead wires, being rather small, are excluded from discussion here. Radiation losses could be calculated easily but the convection loss needed to be understood. The convection loss from a filament was found to be dependent on what Langmuir termed the "shape factor" of the filament as well as the thermal conductivity of the fill gas. Very close to the filament in an ordinary household lamp the heat is conducted away from the filament, just as heat is conducted along a poker in a fire. Out away from the filament the heat is then convected away. The region about a filament through which conduction takes place is a few millimeters thick. In the lamp industry this region is referred to as the Langmuir film or sheath. The air

### **Nobel Laureate Dr. Irving Langmuir (1881-1957)**

flow about a vertically or horizontally oriented filament can be visualized by a schlieren technique. It should be mentioned that this boundary layer, through which conduction takes place, is present about any body that is heated relative to the surrounding gas atmosphere. For example, one can sometimes detect the boundary layer and shimmering air flow about a heated furnace when sunlight casts shadows of the furnace on a wall.

Langmuir's study of conduction-convection losses from heated bodies was most extensive and detailed. The conclusion drawn from that work was that the long filament length had to be effectively shortened to reduce the losses. This was accomplished by coiling the tungsten wire. Successful lamps have been made by double coiling and triple coiling. The conduction-convection loss is relatively insensitive to the diameter of the resulting coil. While coiling had the effect of reducing gas losses, another important effect occurred. Bulb blackening was reduced considerably because some of the diffusing tungsten atoms that evaporated during normal lamp usage would diffuse back to the filament and deposit themselves on the filament instead of the inside of the glass bulb. Another effect also occurred because of the gas filling, which initially was nitrogen but eventually was a nitrogen-argon mixture. Lamps were filled roughly at 80% of atmospheric pressure. During normal operation of household lamps the operating pressure then rose to about one atmosphere (750 Torr). After some of the evaporating filament atoms reached the outer boundary of the Langmuir layer the convection currents would carry most of them upwards to deposit on only a portion of the glass surface rather than the entire bulb, as in vacuum lamps. This reduced the overall light output loss.

A view of the boundary layer about a vertically operated coiled-coil filament operating in a lamp with a cold fill pressure of 600 Torr xenon is shown below.



The gas loss from a vertically operated filament is less than that from one operated horizontally. Manufacturing considerations generally dictated when design changes could be implemented. For example, the change from a horizontally oriented coiled-coil filament in the 120-volt, 100-watt household lamp didn't occur until the mid 1950s.

A nice treatment of early so-called gas-filled lamps can be found in the book by Arthur A. Bright Jr., The Electric-Lamp Industry: Technological Change and Economic Development from 1800 to 1947. Start in the index, page 518, under "gas-filled incandescent lamps." Bright gave the following examples of "gas-filled lamps" where the year, inventor, filament material and gas type are given:

1840,	W.	R.	Grove,	platinum,	air
1845,	J.	W.	Starr,	platinum,	air
1856,	C.	de	Changy,	platinum,	air
1859,	M.	G.	Farmer,	platinum,	air
1872,	A.	M.	Lodyguine,	graphite,	nitrogen
1875,	S.	A.	Kosloff,	graphite,	nitrogen
1878,	St. George	Lane-Fox,	platinum-iridium,	air or	nitrogen
1879,		Sawyer-Man,	carbon,		nitrogen
1894,	The Star Electric Lamp Co., carbon, heavy hydrocarbons in "New Sunbeam" lamp				
1894,	Waring Electric Co., carbon, low pressure bromine in "Novak" lamp				
1901,	A. E. G.,	carbon,	low pressure	carbon	monoxide
1908,	Hopfelt, carbon, mercury				

Even if someone had developed a coiled carbon filament lamp employing an inert fill gas it would not have been successful because of the relatively high vapor pressure of carbon at operating temperatures. The situation required a ductile metal filament of low vapor pressure that could be coiled into a small space. Tungsten filled that requirement; however, another problem existed at that time that required its solution before Langmuir's lamp could be manufactured for all wattage ratings. Drawn tungsten wire, with its low vapor pressure, solved many of the design requirements but when it was first developed the wire tended to sag and offset. The work of Aladar Pacz about 1915, which resulted in a non-sagging and non-offsetting wire, assured the success of Langmuir's coiled tungsten filament nitrogen-filled lamp.

### **The "Grain of Wheat" Lamp**

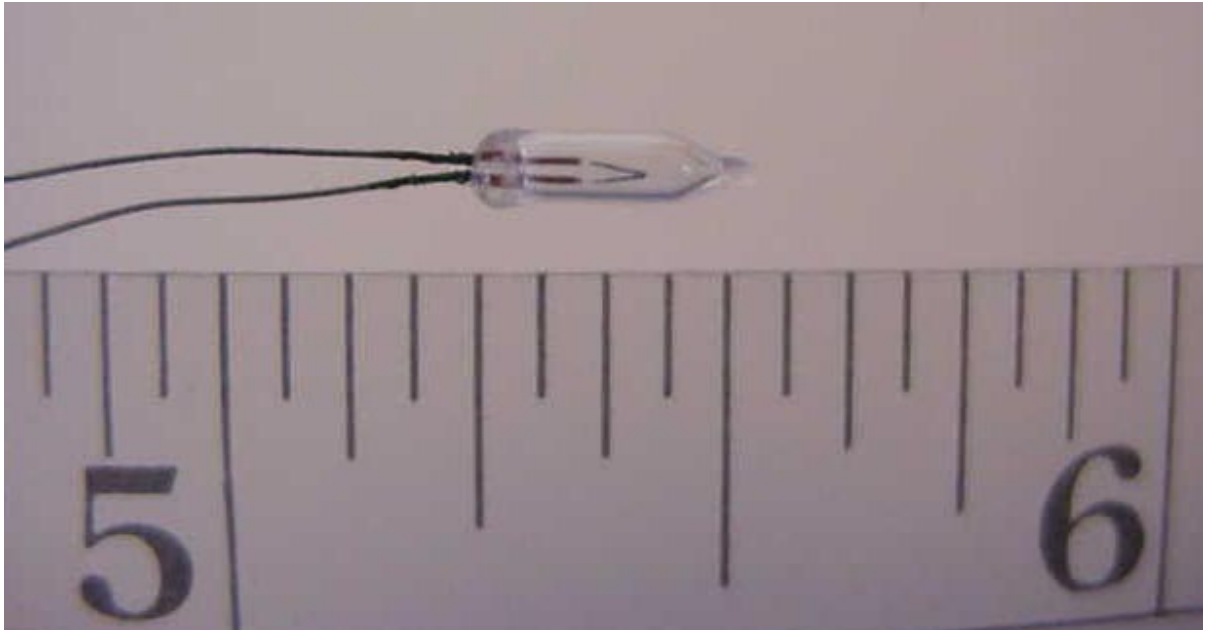

A sample of perhaps the smallest incandescent lamp ever manufactured by the General Electric Company is pictured above; it was referred to as the "grain of wheat" lamp. It was designed to be used in children's surgical instruments. It operates from one dry cell. The lamp consumes 0.17 watt and produces 0.35 lumen. The envelope diameter is 0.058-inch and the tube length, 0.33-inch. It is used with a cylindrical metal lamp holder. The tungsten filament is singly coiled and the lamp interior is evacuated.

Go to: [Early Incandescent Lamps](#)

### **The White MAZDA Lamp**

The bulbs of incandescent lamps made prior to about 1920 were generally manufactured clear, but outside frosting by etching or sandblasting was available on some lamps. By their nature clear bulbs gave glare, which resulted in discomfort for many persons. The outside frosting had at least two drawbacks. It resulted in a weakening of the glass and the outside rough surface was difficult to wipe clean. In terms of light loss by absorption, it decreased it by about 10%<sup>2</sup>.

A bulb was developed about 1920 that diffused the light so that the glare problem was nearly eliminated. This lamp, known as the White MAZDA, had a bulb made of a special white glass<sup>1</sup>. A performance drawback of the special glass was that it absorbed more light than did the frosted bulb. It reduced the light level by 15%<sup>2</sup>. The glass was used for the straight wire vacuum MAZDA lamp with the exhaust tip but then a tipless lamp was introduced which was gas-filled and employed a coiled tungsten filament. The exhaust method was that developed by L. E. Mitchell and A. J. White at Nela Park in 1919. A picture of both lamps follows. The new tipless pear shaped lamp shown is a 50-watt, 115-volt design, with a maximum overall length of 5-1/8 inches. The maximum diameter of the tipless lamp is 2-1/2 inches whereas the lamp with the tip has a maximum diameter of 2-3/8 inches.



The inside frost technique developed by Marvin Pipkin about 1924 did not diffuse the light as well as the white glass lamp but the light loss was only about 1-1/2% instead of the 15% in the White MAZDA<sup>3</sup>.

#### References

- 1) "The White Mazda Lamp", Earl A. Anderson, *General Electric Review*, Vol XXIII, No 8, Aug 1920, pg 712.
- 2) Paul W. Keating, Lamps for a Brighter America - A History of the General Electric Lamp Business, McGraw-Hill Book Co., Inc., 1954, pg 126.
- 3) C. E. Weitz, General Electric Lamps - A Condensed Text on the Design and Operation of Incandescent, Mercury and Fluorescent Light Sources, Large Lamp Department, General Electric Co., Cleveland, OH, Jan 1956, pg 24.

Go to: [Early Incandescent Lamps](#), or, click "Back" on your browser

#### The Mitchell and White Tipless Construction

A feature of the electric incandescent lamp since its inception in 1879 was a glass tip at the bulb end of the lamp. The tip was a remnant of the glass tubing through which the lamp was exhausted of its air (as well as filled with inert gases after the invention of the gas-



filled lamp in 1912.) Visible exhaust tips are commonplace again today on tungsten-halogen lamps. In the early years of production such a protuberance could be the reason for lamp breakage as well as personal injury. The glass tip also affected light distribution. For these reasons it was very desirable to eliminate the tip.

Tipless lamps did appear early in the manufacture of the incandescent lamp but the techniques used were expensive in one way or another. Some of them were practical for certain lamp types but could not be considered for a commodity product that had to be produced at high rates of speed. The seamless butt seal, common on flashlight bulbs, was one such technique. Such lamps had no stem to support the filament; it was held by two lead wires which were embedded in the glass. Higher voltage lamps could not be constructed in that manner.

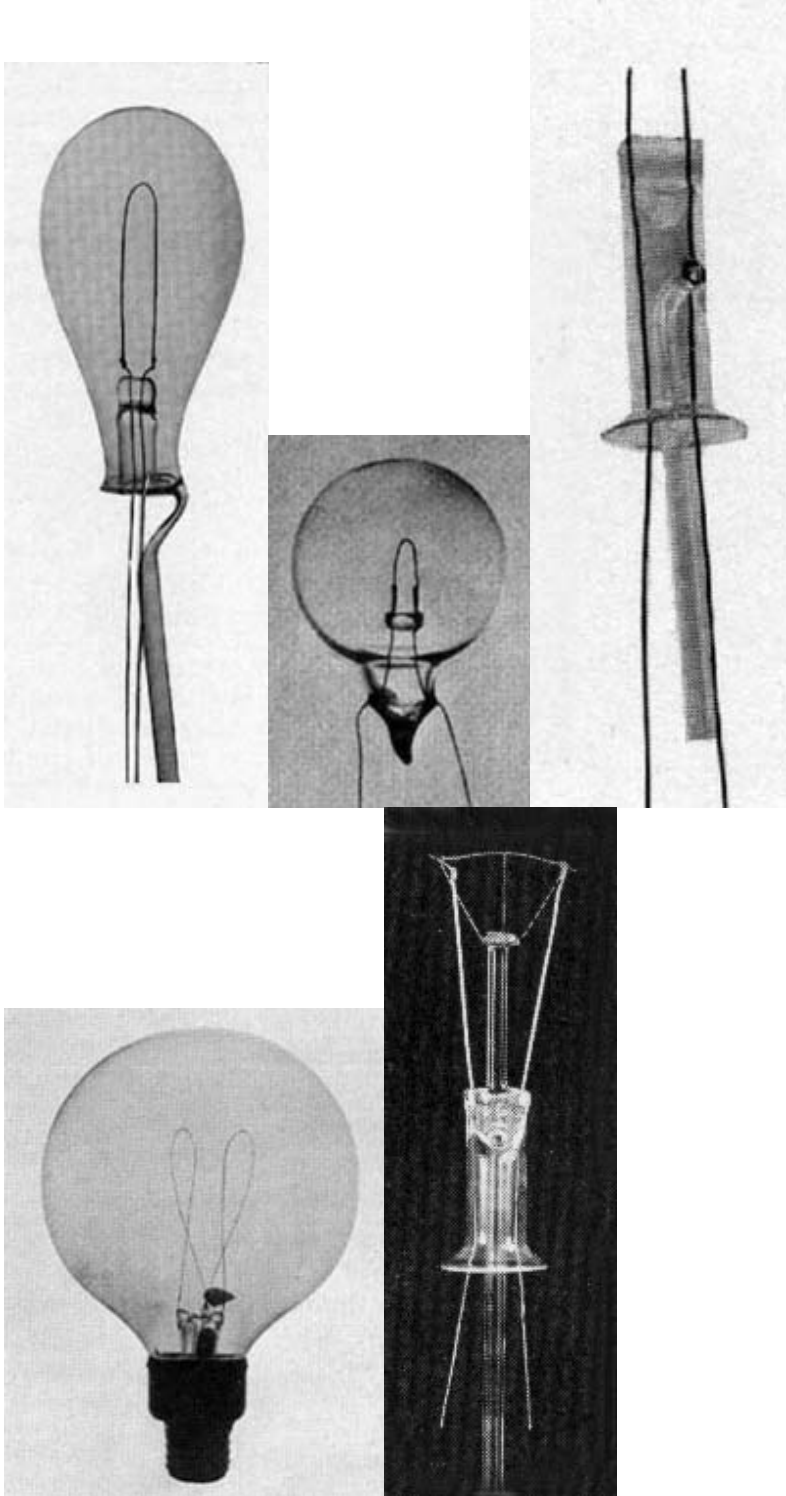

The exhaust methods shown above, from left to right, are: tubulated, butt, Jaeger, Meridian (Burnett-Doane), Mitchell-White.

These pictures were scanned from Howell and Schroeder's book<sup>2</sup>.

One of the methods most used to make a tipless lamp utilized a construction that was patented by Herman J. Jaeger in 1903 (U.S. Patent No. 729,182). It consisted of an "L" shaped exhaust tube that was sealed to the inside of the stem tube after the pinch had been made. A lamp employing this exhaust procedure was marketed for many years by the Tipless Lamp Company.

The General Electric Company marketed a premium lamp from 1906 to 1911 that was tipless. It was a large globular lamp known as the Meridian. The construction was patented by H. D. Burnett and Samuel E. Doane in 1894 (U.S. Patent No. 516,800). Their idea couldn't be used, however, until 1906, after Mark H. Branin of the Edison Lamp Works made a machine improvement that allowed the stem structure to be made. The Meridian was a decorative lamp and was manufactured to compete with the popular Nernst lamp, which employed metal oxides instead of a filament. The Jaeger and Meridian methods of exhaust were too expensive for general use.

An inexpensive method of construction, which eliminated the tip from view and exposure, was invented at Nela Park in 1919. It was Loris E. Mitchell and Arthur J. White who applied for a patent for their construction and procedure and received it in 1922 (U.S. Patent No. 1,423,956, July 25, 1922). It would appear that their invention stopped any further attempts to exhaust lamps differently. Their construction was quickly adopted throughout the world and is still used today.

The Mitchell and White construction permitted the exhaust tube to be inserted when the stem was being made. During the stem-making process, when the glass could still flow, air was blown from the outside at that location where the exhaust tube was sealed into the stem. A hole resulted which could then be used later to exhaust the lamp from the base end. The exhaust tip was then hidden from view by the lamp base. The new tipless lamp was economical, stronger, safer, aesthetically more appealing and also gave a better distribution of light.

Mitchell and White were awarded the Charles A. Coffin Foundation Award in 1924 for their invention of the tipless lamp. From the records of the Foundation the following excerpt gives an account of the achievement:

"Louis Edwin Mitchell and Arthur James White, both foreman in Nela Lamp Division, Nela Park, developed the method and type of equipment which makes possible on a commercial scale the manufacture of tipless Mazda lamps-one of the greatest advances in incandescent lamp manufacture in years. Neither of these men is employed as an engineer, a laboratory man, or a 'researcher.' Mr. White has been with the company twenty-one years and Mr. Mitchell fourteen. They conceived the idea that they could make the tipless lamps of which their manager so often spoke, and they proceeded to do so, after considering, and one by one discarding, all previous efforts as being uncommercial. Their invention, whereby the exhaust tube of the lamp is attached at the seal, has eliminated operations, wrought greater production, made less skill necessary on the part of operators, and reduced shrinkage. Today, nearly 100% of the Mazda lamps manufactured are made

by their method. Among the many desirable things it has accomplished, perhaps the most recent is in connection with automobile headlight lamps. Here it has introduced such accuracy in axial alignment and over-all length as was never dreamed of before-accuracy which is of the utmost importance in focussing."

**Loris**

**Edwin**

**Mitchell**

Loris E. Mitchell (13 October 1890 - 11 March 1960) was a native of Warren, Ohio and was the son of George and Laura (Longmore) Mitchell. He graduated from the Warren Public Schools in the class of 1909.

In 1910 Mitchell worked in the Trumbull Mazda Lamp Works in Warren. Later, he was associated with Arthur James White and after they developed the tipless lamp at Nela Park in 1919 he became known as "Tipless Mitch."

Mitchell joined the Radiotron Division of RCA when it was organized in Cleveland in 1929. He was the manager of tube development in Harrison, New Jersey for nine years before moving, in 1942, to Lancaster, Pennsylvania. In Lancaster Mitchell was credited with considerable cost savings as a result of his plan for reorganizing training and work programs for RCA's electronic tube division. He retired in 1955 after being manager of the Manufacturing Standards Department for fourteen years.

Mitchell was granted nine patents between the years 1922 and 1942. He married Laura Gardner in 1916 and they had two sons, George G. and Robert.

Loris Mitchell passed away in his home in Lancaster as a result of a coronary occlusion. Interment was in Pine Knoll Cemetery in the Warren area.



Back row: Second from left, Loris E. Mitchell; Far right, Arthur J. White  
Front row: Far left, Philip J. Pritchard  
circa 1920<sup>1</sup>

### **Arthur**

### **James**

### **White**

Arthur James White (14 May 1888–31 July 1944) was a native of Youngstown, Ohio and was the son of James and Catherine (Conway) White. He started to work in the lamp business as a glassblower in Youngstown just after the turn of the century.

White was a foreman in the Youngstown Mazda Lamp Plant when he was drafted on 18 December 1917. He was mustered into the 10th Company, Coast Artillery, at Camp Nichols. From there he was transferred to the Enlisted Engineers' Reserve Corps and assigned to Nela Park, in Cleveland, where he helped to develop vacuum tubes that were to be used on wireless telephones. He was released from military service on 14 April 1919.

Both Arthur White and Loris Mitchell were foremen in the Lamp Facilities Laboratory of the Nela Lamp Division. That laboratory was formed in 1915 and was under the direction of Philip J. Pritchard. It had been the desire of Pritchard to eliminate the tip from the lamp. For over a year White and Mitchell worked on the problem. The joint effort led to success and later in time the glass tips on vacuum tubes were also eliminated.

For the last six years of his career in the General Electric lamp business White served as personnel manager at Nela Park. This responsibility followed twenty years as a foreman in a lamp factory at Nela Park.

White was granted eleven patents which were issued between the years 1922 and 1944. He married May E. Code (1890-1974) and lived at 789 Woodview Road in Cleveland Heights, Ohio. Arthur White passed away in St. Luke's Hospital in Cleveland and interment was in Oak Hill Cemetery, Youngstown.

---

Perhaps a few words are in order as it regards Philip J. Pritchard since it was upon his encouragement that Mitchell and White worked and achieved the goal of developing an economical tipless lamp. Philip Pritchard (16 March 1872–05 March 1964) was born in Birmingham, England and started to work in the lamp business in 1901<sup>3</sup>. He served in management positions at the Standard Electric Manufacturing Company, Fostoria Lamp Works, Canadian Sunbeam Incandescent Lamp Works, Nela Lamp Division and the Cleveland Vacuum Tube Works. During World War I he was involved with the manufacture of pliotron tubes at Nela Park and after that was involved with the manufacture of Coolidge x-ray tubes.

Philip Pritchard married Florence Mackey and they had a daughter, Viola. He was interred in Niles, Ohio.

#### References

- 1) The National in the World War (April 6, 1917–November 11, 1918), General Electric Company, 1920, opposite page 242.
- 2) John W. Howell and Henry Schroeder, History of the Incandescent Lamp, The Maqua Company, Publishers, Schenectady, New York, 1927.
- 3) Book of the Incas, 1928.

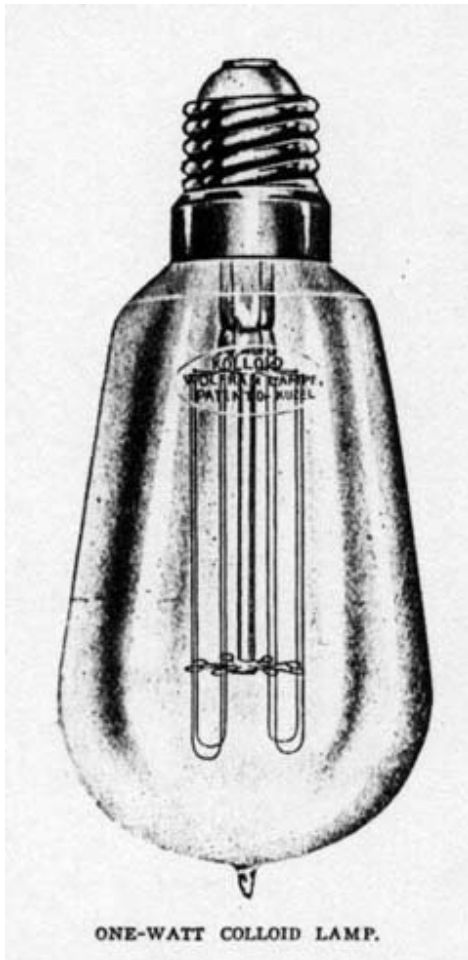

#### The Kuzel Lamp

Collectors of early electric incandescent lamps in the United States tend to mainly look for lamps made at home. However, some types of lamps were made in other countries and imported to the States. Thus, such a lamp would be more collectible in that case. One such lamp was known as the "Kuzel." Two articles that describe this lamp follow<sup>1</sup>:

"The 'Sirius Colloid' lamp, as Dr. Kuzel prefers to call it, is now commercially manufactured at Vienna, Furstenwald-bei-Berlin and at Niukoping, Sweden, and it is stated that active preparations are making for its production in other countries. It has been actively taken up in Europe by Pintsch Brothers, whose names are so widely known in gas lighting, and who are making the lamp in Germany, in rapidly increasing quantities. At present lamps of 25 candle-power, 25 watts

per lamp, are made almost exclusively, although 50 and 100 candle-power lamps have also been supplied to meet a limited demand.

"The Kuzel filament differs from the tungsten and other specific metal or alloy filaments in that its material is obtained by a process of reducing the metals employed to the colloidal state, thereby producing filaments of the requisite dimensions and electrical accuracy, and also of the required chemical purity and at the same time within a reasonable commercial cost.

"Lamps have been made for burning in any position, but up to the present are available commercially in only the simple form adapted to pendant burning alone. The processes of mounting and exhausting are easily performed, but are not the same as those used in the manufacture of carbon lamps. The lamp is shown in the accompanying illustration."

A little over a year later a second article appeared<sup>2</sup> concerning the Kuzel lamp:

"The Kuzel lamp continues to make substantial progress, and although it is not yet manufactured in this country, negotiations are progressing toward that end. In the meantime increasing quantities are being imported, as the European manufacturers are able to spare lamps for this market.

"This lamp has been standard in Europe for some months, and burns in any position. The standard candle-power is twenty American candles, twenty-five watts, for the 110-volt lamp. This type of lamp is made almost to the entire exclusion of the higher candle-powers.

"The lamp is rugged physically, which is due partly to the ingenious anchoring employed, but principally to the superior quality of the filament itself. The colloidal process employed by Dr. Kuzel produces a filament of perfect homogeneity and great elasticity, as well as purity.

"The lamps at present are made in bulbs of practically equivalent sizes to those used for carbon lamps of corresponding candle-powers, and are fitted with the same style of base as is used on all low-candle-power carbon-filament lamps.

"The Kuzel lamps are now manufactured in Austria, Germany, Sweden and Great Britain, and the solidarity of the business is typified by the new factory which has been erected in Vienna. This factory, which is being operated by Kremenezky, has a present capacity of 25,000 lamps per day. Every precaution has been made to increase the plant and equipment to 60,000 per day as rapidly as it may be necessary. Kremenezky has been recognized for years as the leader in high-class carbon-lamp manufacture in Europe, and he has naturally devoted his best energies to the equipping of the new tungsten-lamp factory with the most perfect machinery that has been developed for tungsten-lamp manufacture up to the present time."

It can be seen on this website that W. J. Hammer had Kuzel lamps that were made in 1906, 1907, 1908 and 1911.

### References

- 1) "Kuzel One-Watt Colloid Lamp," *Electrical World*, Vol 49, No 22, Jun 1, 1907, pg 1126.
- 2) Paul M'Junkin, "The Kuzel Lamp," *Electrical Review*, Vol 53, Sep 12, 1908, pg 403.

### Grove's Lamp of 1840



William Robert Grove is shown to the left. The image was scanned from a photocopy of Figure 1 in a thesis written by Michael Leonard Cooper<sup>10</sup> in 1987 titled William Robert Grove (1811-1896) □ Gentleman of Science. The lithograph, by Bosley, is after a Daguerrotype by Antoine Claudet, 21 February, 1849. The availability of the lithograph was by the courtesy of the National Museum of Wales.

Historians who write about the development of the incandescent lamp often start with the lamp design of John Wellington Starr, who was granted a patent, under the name of Edward Augustin King, in England, in the year 1845. It was the first to utilize a carbon illuminant in vacuum. Also mentioned frequently is a lamp design concept that was reported by Grove<sup>3</sup> in the scientific literature, also in 1845; it utilized a coiled platinum filament in a gas atmosphere. A pictorial representation, by an unknown artist, of one idea for the general design configuration, is shown below. This same drawing was used by such authors as Pope<sup>5</sup>, Howell and Schroeder<sup>6</sup>, Jehl<sup>7</sup> and Stoer<sup>9</sup>; it also appeared in an 1885 article regarding Edison patents<sup>4</sup>. This pictorial representation of Grove's idea was not part of his text that was published in 1845<sup>3</sup>. His idea has great merit that cannot be fully appreciated without an explanation accompanying the drawing. Before proceeding with the Grove concept let us gain understanding of a lighting problem that existed in 1840.

Coal mining has always been an activity of extreme importance for mankind. Because of the darkness of mine galleries it was necessary to have a light source for the miners to accomplish their day's work. Perhaps candles were first used, but the presence, sometimes, of a dangerous gas (methane) could result in explosions. If the presence of such a gas was suspected, a person swathed in wet wrappings would slowly proceed into the mine walkways with a candle attached to a long pole. A great advance was made by Humphry Davy, who developed a safety lamp that employed small inlet and exit tubes through which air would flow to the glass-covered candle or oil light source. Later, wire mesh was used in



such lamps. Davy studied the requirements for an explosion and designed his lamp to avoid those conditions.

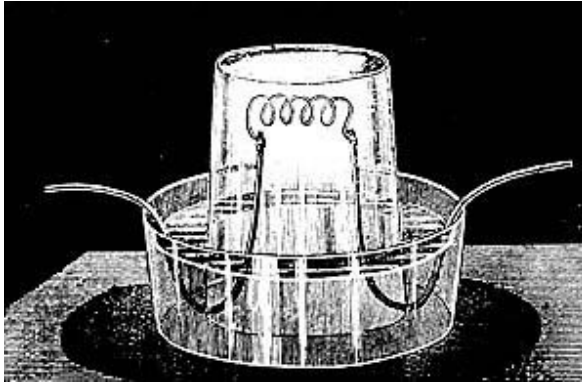

In order to achieve higher light levels, so-called voltaic arcs were used, but mine explosions were still a problem. Boussingault and Auguste De la Rive worked on the problem separately<sup>2</sup> and published articles<sup>8</sup> but they did not arrive at satisfactory solutions. It was then that Grove entered the picture and proposed a design. William Robert Grove, M.A., F.R.S., was Professor of Experimental Philosophy in the London Institution.

It might be of some value to mention briefly the inconsistencies encountered in the literature with regard to early lamp development dates. The Grove lamp is often given a development date of 1840. However, the article mentioned here<sup>3</sup> was published in 1845. In that article Grove gave, perhaps, the reason for the claim, by others, of the earlier date. In Grove's 1845 article he said:

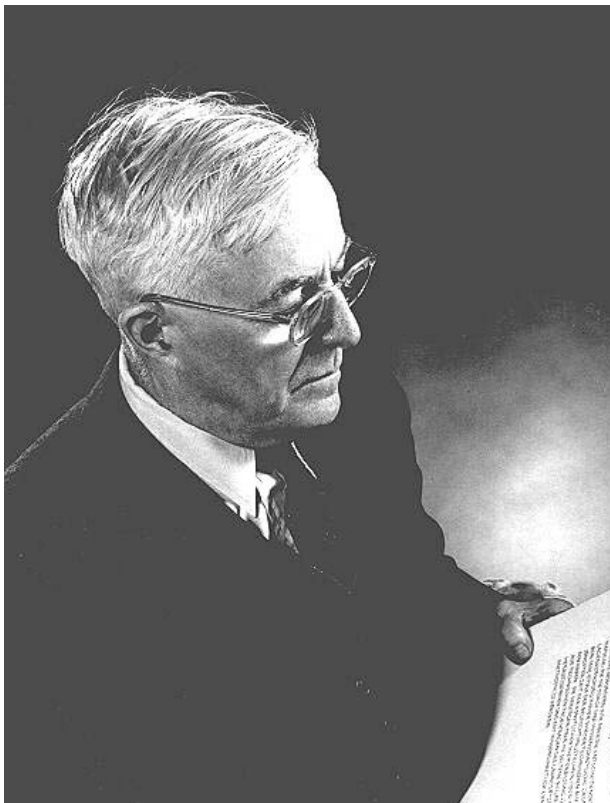

"Four or five years ago, soon after publishing the nitric acid battery, I was naturally struck by the facility and constancy with which the voltaic arc could be obtained by that combination, as compared with any previous one, and made several attempts to reduce it to a practical form for the purposes of illumination, but my success was limited...Not being able satisfactorily to overcome these difficulties, I abandoned it for the time, and made some experiments on another method of voltaic illumination, which appeared to me more applicable to lighting mines; their publication was postponed, and I had nearly forgotten them, until reminded by the papers...mentioned."

Mine illumination was of paramount importance in 1845, otherwise the work area would be in total darkness. Arc lighting was the norm, where the arc existed between two charcoal sticks, operating from a battery source. The problem that existed involved the occasional escape of methane gas from the bedrock, which could result in an explosion. Boussingault

and De la Rive<sup>2</sup> both worked on solutions to that problem. W. R. Grove had worked on the problem earlier but laid the work aside until the papers of Boussingault and De la Rive rekindled his interest in the subject. The following quotes were taken from the article by Grove<sup>3</sup> in *The Philosophical Magazine* of 1845:

"I substituted the voltaic ignition of a platina wire for the disruptive discharge. Any one who has seen the common lecture-table experiment of igniting a platina wire by the voltaic current nearly to the point of fusion, will have no doubt of the brilliancy of the light emitted; although inferior to that of the voltaic arc, yet it is too intense for the naked eye to support, and amply sufficient for the miner to work by. My plan was then to ignite a coil of platinum wire as near to the point of fusion as practicable, in a closed vessel of atmospheric air, or other gas, and the following was one of the apparatus which I used for this purpose, and by the light of which I have experimented and read for hours: □ A coil of platinum wire is attached to two copper wires, the lower parts of which, or those most distant from the platinum, are well-varnished; these are fixed erect in a glass of distilled water, and another cylindrical glass closed at the upper end is inverted over them, so that its open mouth rests on the bottom of the former glass; the projecting ends of the copper wires are connected with a voltaic battery (two or three pairs of the nitric acid combination), and the ignited wire now gives a steady light, which continues without any alteration or inconvenience as long as the battery continues constant, the length of time being of course dependent upon the quantity of the electrolyte in the battery cells. Instead of making the wires pass through water, they may be fixed to metallic caps well-luted to the necks of a glass globe.

"The spirals of the helix should be as nearly approximated as possible, as each aids by its heat that of its neighbour, or rather diminishes the cooling effect of the gaseous atmosphere; the wire should not be too fine, as it would not then become fully ignited; nor too large, as it would not offer sufficient resistance, and would consume too rapidly the battery constituents; for the same reason, *i. e.* increased resistance, it should be as long as the battery is capable of igniting to a full incandescence.

"The helix form offers the advantages, that the cooling effect being lessened, a much longer wire can be ignited by the same battery; by this increased length of wire, the battery fuel is economised, while a greater light is afforded; by the increased heat, the resistance is still further increased, and the consumption still further diminished, so that, contrary to the usual result, the increment of consumption decreases with the exaltation of effect produced. The very necessity of inclosing the coil in a glass recipient also augments the heat, the light, and the resistance; if I remember rightly, Mr. Faraday first proposed inclosing wire in a tube for the purpose of being able to ignite a longer portion of it. Lastly, only two or three cells are required (one indeed might be sometimes sufficient), and the whole apparatus thus becomes portable and economical. The light is perfectly constant, subject to

no fluctuation or interruption, and the heat is not so excessive as to destroy the apparatus.

Grove had an appreciation of the effect of different conductivity gases on the practical application of the lamp. He applied the constant voltage of the battery to his lamp when filled separately with the gases. He filled with hydrogen, carbonic acid (a weak colorless acid,  $H_2CO_3$ ), oxygen, nitrogen and atmospheric air. The observed colorations of the platinum wire were: hydrogen, not visible even in the dark; carbonic acid, cherry-red by daylight; oxygen, incandescent by daylight; nitrogen and atmospheric air gave the same results as oxygen. The reader is reminded that unlike most metals, platinum can be heated in many gases, including air, without severe, or any, oxidation.

It should be mentioned that Grove's work predated the much later work of Irving Langmuir in 1912, when the gas-filled incandescent lamp was developed. That is, the present-day gas-filled lamp has a filament of tightly coiled (tungsten) wire and a filling of low conductivity gas (usually nitrogen and argon, and sometimes, krypton). In a sense, Grove's knowledge and observations could not be universally applied until a better metal filament was found. That occurred with the development of ductile tungsten.

### **Acknowledgements**

The writer is appreciative of the availability of the image of William Robert Grove from Dr. Cooper's Ph. D. thesis; such images of great contributors to science add an important degree of appreciation to a work written so many years later.

The drawing of the Grove concept lamp was scanned from History of the Incandescent Lamp, John W. Howell and Henry Schroeder, The Maqua Company, Schenectady, NY, 1927, page 26.

### **References**

- (1) "On Some Phenomena of the Voltaic Discharge", W.R. Grove, *The Philosophical Magazine*, Vol XVI, 1840, pp 478-482.
- (2) "On the Lighting of Mines by Means of the Electric Lamp", Letter of M. De la Rive to M. Boussingault, *The London, Edinburgh, and Dublin Philosophical Magazine and Journal of Science*, Vol XXVII, 1845, pgs 406-407.
- (3) "On the Application of Voltaic Ignition to Lighting Mines", W. R. Grove, *The London, Edinburgh, and Dublin Philosophical Magazine and Journal of Science*, Vol XXVII, 1845, pgs 442-446.
- (4) "An Analysis of Some of the Edison Patents for Electric Lighting", *The Electrician and Electrical Engineer*, Vol 4, Jul 1885, pp 244-249.
- (5) Evolution of the Electric Incandescent Lamp, Franklin Leonard Pope, Boschen & Wefer, New York, 1889 and 1894, pg 19.
- (6) History of the Incandescent Lamp, John W. Howell and Henry Schroeder, The Maqua Co., Schenectady, NY, 1927, pg 26.
- (7) Menlo Park Reminiscences, Vol 1, Francis Jehl, Edison Institute, Dearborn, Michigan, 1937, pg 231.
- (8) Catalogue of Scientific Papers (1800-1863), Compiled by the Royal Society of London, Scarecrow Reprint Corporation, Metuchen, NJ, 1968.

(9) History of Light and Lighting, G. W. Stoer, Philips Lighting Division, Eindhoven, The Netherlands, 1986, pg 20.

(10) William Robert Grove (1811-96) Gentleman of Science, A thesis submitted by Michael Leonard Cooper, M. Sc., for the degree of Doctor of Philosophy in History of Science, The Open University, United Kingdom, October, 1987.

### A Lamp of Uncertain Origin

Unless references to a lamp development are known, and accessible, it is possible for the facts in the case to become entangled with supposition. It appears that that is the situation with the so-called De la Rue, or De la Rive, lamp that supposedly was developed and reported on within the first two decades of the 1800s. This writer will not add any clarification to the origin of the lamp but it is thought that a discussion of it might lead to the truth by a viewer of this webpage.

Below are seven drawings of the lamp in question that writers have used.



FIG. 138.—De la Rue's Enclosed Incandescing Metallic Wire. Note the fact that this form of incandescing metallic wire gave more light both because of its spiral form and from the fact of its being enclosed.

The picture shown above was scanned from the Houston book of 1905<sup>3</sup>.

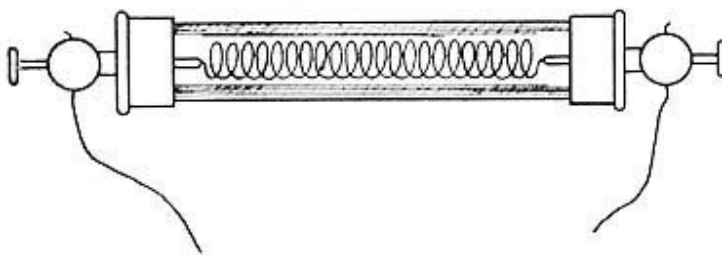

DE LA RUE'S INCANDESCENT LAMP, 1820  
In this lamp, the first one on record, a platinum wire operated in vacuum.

The picture shown above was scanned from the Howell and Schroeder book of 1927<sup>6</sup>.

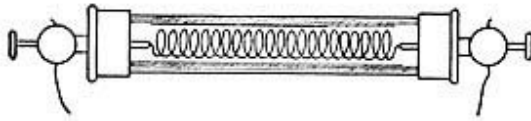

De la Rive's lamp (1820), said to be first incandescent lamp. A platinum wire operated in a vacuum.

The picture shown above was scanned from the Jehl book of 1937<sup>8</sup>.

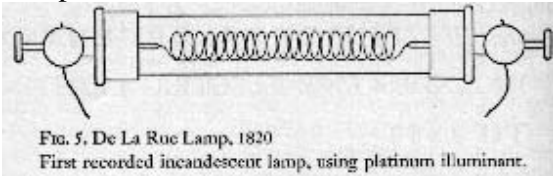

FIG. 5. De La Rue Lamp, 1820  
First recorded incandescent lamp, using platinum illuminant.

The picture shown above was scanned from the Bright book of 1949<sup>11</sup>.

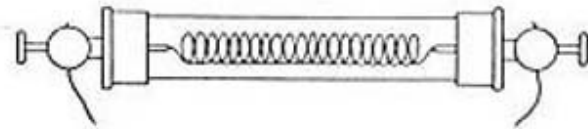
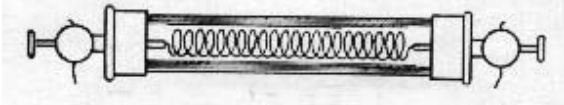

FIGURE 109—*de la Rue platinum filament incandescent lamp, 1820.*

The picture shown above was scanned from A History of Technology, 1958<sup>15</sup>.



The picture shown above was scanned from the 1961 book by Lewis<sup>16</sup>. The picture caption reads: "De La Rue's 1820 lamp containing a coil of platinum wire in a vacuum."

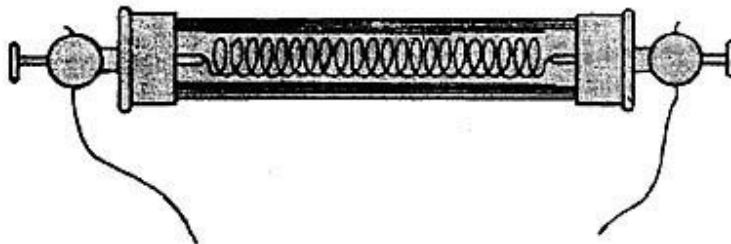

Fig. 4.1. The first attempt to make a practicable incandescent lamp was probably that made by Arthur de la Rive, in 1820. He used a platinum filament in a partial vacuum.

The picture shown above was scanned from the Stoer book of 1986<sup>20</sup>.

The sum total of what the quoted authors said about this lamp in the literature and technical books follows:

"A still nearer approach to the incandescent electric lamp was reached when the wire to be rendered incandescent by the passage of current was placed, as shown in Fig. 138, within a glass enclosing vessel, by means of which it might be protected from the air. Such a vessel was employed by De la Rue, and others, in their experiments on incandescent wires."<sup>3</sup>

"The earliest record of any attempt at making an incandescent lamp was in 1820, when De la Rue made a lamp with a coil of platinum wire for a burner which was enclosed in a piece of glass tubing, the ends of which had brass caps. It was supposed to have had a vacuum, but how this was accomplished is not clear."<sup>6</sup>

"In 1809 De La Rue (England) used a platinum coil in a glass tube with metal caps at the ends. It is possible that some of the air may have been exhausted from the tube, although evidence to this effect is lacking....De la Rue's lamp referred to above may have been of the vacuum type."<sup>7</sup>

"The earliest known attempt to produce an incandescent electric-light was that made in 1820 by De la Rue, using a platinum burner."<sup>9</sup> *The source for this statement was the book by Howell and Schroeder<sup>6</sup>.*

"1820 De La Rue ( □ ) makes a lamp with a coil of platinum for a burner. This was enclosed in a piece of glass tubing, the ends of which had brass caps. It was supposed to have had a vacuum, but how this was accomplished is not clear. This was the earliest record of any attempt to make an incandescent lamp."<sup>10</sup>

"An even earlier incandescent lamp has been credited to the English experimenter De la Rue, who in 1809 is said to have enclosed a coil of platinum wire in glass tubing from which part of the air had been exhausted to prevent too rapid oxidation of the platinum."<sup>11</sup> *The discrepancy in dates between the above statement and the caption in Fig. 5 above is most unusual in this well-researched and documented work.*

"In fact, the first Edison lamp came some 59 years after the Frenchman, De La Rue, had produced an electric 'glow' by heating a coil of platinum in a glass tube...Many investigators followed De La Rue, all of them trying to obtain useful light from the heating of a wire by electric current."<sup>12</sup>

"De la Rue is credited with making a filament incandescent lamp with a coiled platinum wire in 1820. The glass tube was sealed with brass caps and supposedly evacuated."<sup>13</sup>

"Davy's work led also to the first crude incandescent lamps. The man credited with the first such lamp was an Englishman named De la Rue, who used a coil of platinum wire as a 'burner' in a length of glass tubing. This was in 1820."<sup>14</sup>

"Such men as Warren de la Rue (1815-89) and Sir William Grove (1811-96) realized that the success of the filament lamp was intimately linked with the problem of operating the filament in an oxygen-free atmosphere. In the experiments of de la Rue and of Grove (c 1840), directed towards the use of filaments of platinum wire enclosed in glass bulbs as highly evacuated as possible (figure 109), the lamps were found to possess only a short life, mainly owing to the imperfection of the vacuum but partly to the narrow margin between the temperature at which a platinum wire begins to glow and its melting-point." <sup>15</sup>

"De la Rue made the earliest recorded attempt at making an incandescent lamp in 1820, when he mounted a coil of platinum wire in a glass tube. The ends of the tube were fitted with brass caps, to which the ends of the coil were connected. It was said to be a vacuum lamp, but there is no accounting how the vacuum was obtained; it is likely that the platinum coil did not burn in a complete vacuum. As only battery current was available, the cost of operation was prohibitive and the lamp remains of historical rather than practical interest."<sup>16</sup> *It should be mentioned that although no first name is mentioned in the quoted passage, in Lewis' index, on page 126, the lamp is attributed to Warren De la Rue.*

"In 1820, De La Rue had made an incandescent lamp using a filament of platinum wire enclosed in glass tubing."<sup>19</sup>

"The Swiss Auguste Arthur de la Rive in 1820, was probably the first to use a coiled platinum filament in a partly evacuated glass tube."<sup>20</sup>

In addition to the above, Lewis Mumford, in his Technics and Civilization, (1934 and 1963), gave a chronological list of inventions; an incandescent lamp, invented by De la Rue, is among those for the year 1820.

A picture of the so-called De la Rue lamp was shown on the first slide in a technical lecture.<sup>21</sup>

Two names have surfaced as it regards this lamp: De la Rue and De la Rive. The individuals with those names who are considered most likely to have been connected with it was an Englishman, Warren De la Rue (1815-1889), born on the island of Guernsey, off the coast of France, and, Auguste-Arthur De la Rive (1801-1873), a citizen of Geneva, Switzerland. Also considered by this writer are the fathers of these two gentlemen. Warren was a son of Thomas De la Rue (1793-1866) and Auguste-Arthur was a son of Charles Gaspard De la Rive (1770-1834).

Only one independent reference gave a date of 1809 for the lamp development (Reference 7); the others gave 1820; the source of information for the date in Reference 9 was Reference 6. Reference 7 gave, as the source of information for the De la Rue lamp, the two-volume work titled Electric Illumination, which was edited by James Dredge. Both volumes were examined for a reference to De la Rue and only one was found, on pg 9 in

Volume II (published in 1885). That reference was in regard to a liquid voltaic cell; no mention of a coiled platinum filament was found. The date of 1820 will be assumed to be the more likely one in this cursory study. If the lamp was developed in 1820 it would appear that one can rule out Warren De la Rue, based on his age at that time. In addition, Warren De La Rue was granted 23 patents in Great Britain during the period 1849 to 1884. None of the patents dealt with electric lamps. His father, Thomas, could possibly be the inventor. However, through the courtesy of a person at The British Library, it was revealed that Thomas De la Rue was granted nine patents during the period 1832-1862; none of these applied to electric lamps. Based on the Catalogue of Scientific Papers<sup>17</sup>, compiled by the Royal Society of London, no technical or scientific papers were written by Thomas De la Rue. Warren's first published scientific paper occurred in 1836, at age 21. The Catalogue of Scientific Papers contains 55 papers with Warren as sole author and 29 papers with him as a joint author. It would appear, then, that we can tentatively rule out both Warren and Thomas De la Rue as being the inventor of this platinum filament lamp.

If, indeed, the date 1809 is valid then it would seem that Auguste De la Rive can also be ruled out because of his age. De la Rive was a scientist who did a great amount of publishing in the French language. In the Catalogue of Scientific Papers there are listed over 100 articles authored singly by De la Rive, with the first one appearing in the year 1822. He also wrote a three-volume treatise on electricity, titled: A Treatise on Electricity: In Theory and Practice<sup>1</sup>, which was translated into the English language. He also worked on the voltaic disruptive discharge. No mention of a platinum filament lamp could be found in his Treatise. It should be mentioned that De la Rive did spend some time in England which, conceivably, would establish a tie between England and the lamp invention. If such a platinum filament lamp was invented by a De la Rue or De la Rive one might consider examining the works of Charles Gaspard De la Rive.

Although at this late date it might seem of little value to determine the facts in this lamp development, there is justification from a historical standpoint. If a viewer of this website is able to clarify this mystery the present writer would be happy to hear from him/her. It is for the benefit of all that this request is made. Simply send an [e-mail](#) message to me about your De la Rue or De la Rive information.

### **Acknowledgements**

The subject of, and the questions regarding, the De la Rue (or De la Rive) lamp were brought to my attention by R. I. Feigenblatt. He and Noel Lawrence pondered the questions of authorship and date of appearance of this lamp and Dr. Feigenblatt shared some of their collective knowledge with me. I am grateful for their inquisitiveness as we all benefit from searches for the truth. The writer also acknowledges much help regarding patents issued in Great Britain, from Mrs. Maria Lampert, The British Library, London. An informative e-mail response from Mr. Peter D. Hingley, Librarian, Royal Astronomical Society, London, regarding Warren De la Rue, is also greatly appreciated.

### **References**

- (1) A Treatise on Electricity, in Theory and Practice, Aug. De La Rive, Translated by Charles V. Walker, in three volumes, Vol III, 1858, pg 317.
- (2) "Experimental Researches on the Electric Discharge with the Chloride of Silver



- Battery", *Nature*, Vol XXVIII, Aug 16, 1883, pg 381. Abstract of a paper read at the Royal Society on June 14, by Warren De La Rue and Hugo W. Miller.
- (3) Electricity in Every-Day Life, Vol 2, Edwin J. Houston, P. F. Collier & Son, New York, 1905, pg 247.
  - (4) "Thomas De La Rue (1793-1866)", Dictionary of National Biography, Vol V, The Macmillan Co., NY, 1908, pg 763.
  - (5) "Warren De La Rue (1815-1889)", Dictionary of National Biography, Vol XVII, The Macmillan Co., NY, 1909, pg 387.
  - (6) The History of the Incandescent Lamp, John W. Howell and Henry Schroeder, The Maqua Company, Schenectady, NY, 1927, pp 25-26.
  - (7) "The Development of the Incandescent Electric Lamp Up to 1879", Appendix B from the Report of the Lamp Committee, 1928-1929, Association of Edison Illuminating Companies, 1929, pg 4.
  - (8) Menlo Park Reminiscences, Vol 1, Francis Jehl, Edison Institute, Dearborn, MI, 1937, pg 344.
  - (9) Incandescent Electric Lamps, Report No 133, 2nd Series, United States Tariff Commission, Washington, 1939, pg 1.
  - (10) A Chronological History of Economic Development, National Electrical Manufacturers Assoc., New York, 1946, pg 18.
  - (11) The Electric-Lamp Industry: Technological Change and Economic Development from 1800 to 1947, Arthur A. Bright, Jr., The Macmillan Company, New York, 1949, pp 36-37.
  - (12) A Measure for Greatness □ A Short Biography of Edward Weston, David O. Woodbury, McGraw-Hill Book Company, Inc., New York, 1949, pg 112.
  - (13) "Electric Lighting in the First Century of Engineering", R. L. Oetting, *Transactions of the American Institute of Electrical Engineers*, Vol. 71, Part 2, Nov 1952.
  - (14) Lamps for a Brighter America □ A History of the General Electric Lamp Business, Paul W. Keating, McGraw-Hill Book Company, Inc., 1954, pg 7.
  - (15) "The Distribution and Utilization of Electricity", C. Mackechnie Jarvis, A History of Technology, edited by Charles Singer, E.J. Holmyard, A.R. Hall and Trevor I. Williams, Vol V, Oxford at the Clarendon Press, 1958, pp 208-209.
  - (16) The Incandescent Light - A Review of Its Invention and Applications, Floyd A. Lewis, Shorewood Publications, Inc, NY, 1961, pp 14-15.
  - (17) Catalogue of Scientific Papers (1800-1863), Compiled by the Royal Society of London, Scarecrow Reprint Corp., Metuchen, NJ, 1968.
  - (18) "Warren De La Rue", Dictionary of Scientific Biography, Vol IV, Charles Scribner's Sons, New York, 1971, pp 18-19.
  - (19) Early Lighting □ A Pictorial Guide, Compiled and Published by the Rushlight Club, 1979, pg 131.
  - (20) History of Light and Lighting, G. W. Stoer, Philips Lighting Division, Eindhoven, The Netherlands, 1986, pg 20.
  - (21) "The Tungsten Lamp Filament - A Materials Marvel", Slide 1 of 50. <http://neon.memscmu.edu/cramb/27-100/present2000/index.htm> Under "Table of Contents" click on the first PPT Slide.
  - (22) "Auguste-Arthur de La Rive", <http://chem.ch.huji.ac.il/~eugeniik/history/rive.html>

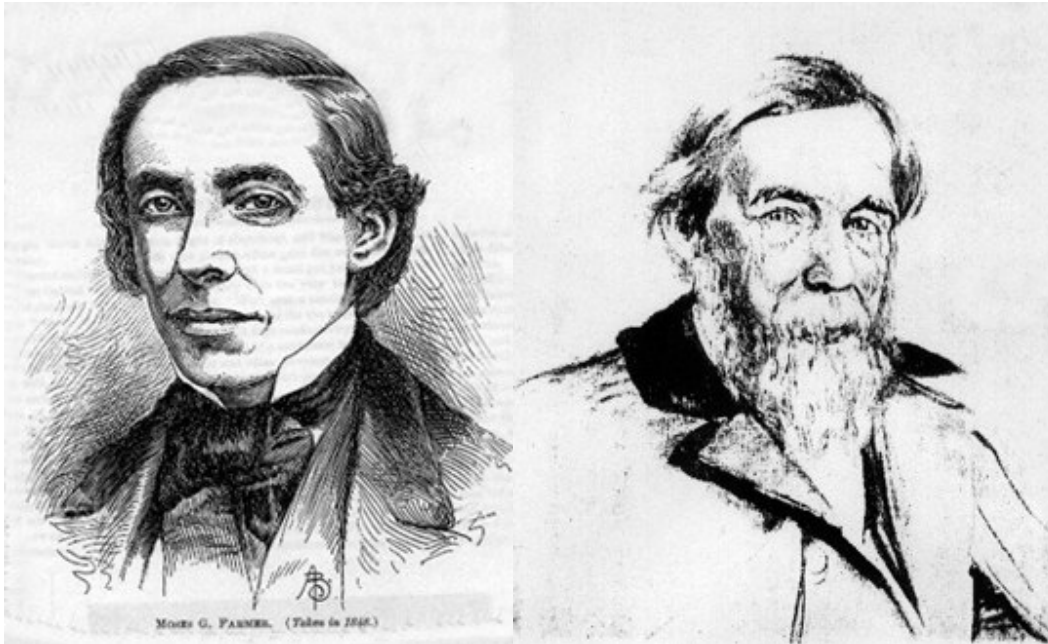

**The  
Farmer  
Lamps  
of  
1859  
and  
1868**  
The  
name  
of an  
inventor  
appears  
in the  
incand  
escent  
lamp

history books who was, perhaps, the first person to have a room in his house lighted by electric incandescent sources. His name was Moses Gerrish Farmer (1820-1893) and he lighted a room in his house in Salem, Massachusetts every night during the month of July, 1859. There is some confusion in the writer's mind about what that particular light source looked like. The material unearthed in this regard is presented here.

Pictured here is Moses Farmer in the year 1848 as well as in 1893, just before his death. The 1848 picture was scanned from reference 11 whereas the 1893 picture was scanned from reference 7.

An article appeared in the *Scientific American* in which Farmer discussed his 1859 lamp<sup>2</sup>:

"There seems to be little doubt but that Professor Moses G. Farmer, at present connected with the torpedo station at Newport, R. I., was the first to make successful experiments with the electric light in this country, and that this discovery dates as far back as 1859. A correspondent of the *New York World* communicates to that paper a recent interview with Professor Farmer, which he commences with the following extract from a letter, written by the professor some time since, to a gentleman in Salem, Mass.:

'Some few of the citizens of Salem...will doubtless recollect a parlor at No. 11 Pearl Street, Salem, Mass., which was lighted every evening during the month of July, 1859, by the electric light, and this electric light was subdivided too! This was nineteen years ago, and it was undoubtedly the first private dwelling house ever lighted by electricity. A galvanic battery, of some three dozen six gallon jars, was placed in the cellar of the house, and it furnished the electric current, which was conveyed by suitable conducting wires to the mantel-

piece of the parlor, where were located two electric lamps, one on each end of the mantel-piece. (I would not wonder if the screw holes were there at this day.) Either lamp could be lighted at pleasure, or both at once, by simply turning a little button to the right for a light, to the left to extinguish it. No matches, no danger, no care to the household, nor to anyone except to the man who attended the battery. The light was noticed as being soft, mild, agreeable to the eye, and more delightful to read or sew by than any light ever seen before. Its use was discontinued at that time, for the simple reason that the acids and zinc consumed in the battery made the light cost about four times as much as an equivalent amount of gas light.'

It was pointed out by Dolbear<sup>11</sup> that in 1859 oil had not been struck yet and the normal burning fuel was a mixture of alcohol and spirits of turpentine.

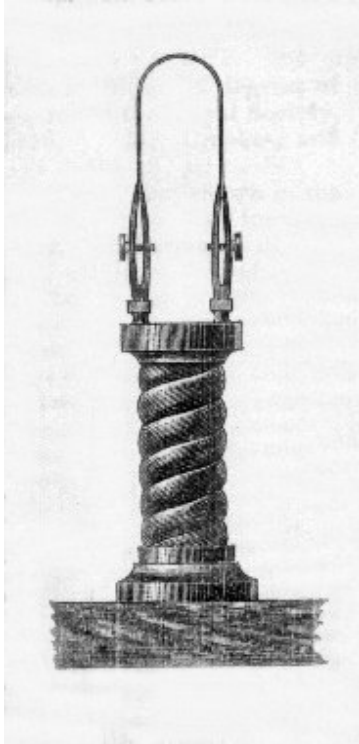

Apparently Farmer became interested in developing a light and operating system after reading about Draper's earlier work<sup>4</sup>. According to this source:

"In 1847 Professor J. W. Draper, of New York, made a very interesting series of investigations on the heat and light evolved by platinum wires when traversed by powerful electric currents, and suggested that the currents might be regulated automatically. The results described by Professor Draper some years afterwards attracted the attention of Professor Moses G. Farmer, then a resident of Salem, Mass., who was thereby led to attempt to make a practical application of Draper's results in an incandescent electric lighting system. Professor Farmer made a great number of experiments, relating not only to the construction of the lamp itself, but to the automatic control and regulation of the current. Among the substances tested for the purpose were aluminum, platinum, iridium, palladium, carbon, etc. Of all the metals, pure iridium was found to give

the best results. The next best in order were alloys of iridium and platinum, and of platinum and palladium. Very satisfactory results were also obtained from carbon when enclosed in an atmosphere free from oxygen, as in the Starr lamp...Two incandescent lamps were placed in the parlor, one on each end of the mantelpiece, and these were connected to the battery in multiple arc. The switches for turning the lamps off and on were placed in a closet in another room. Figure 3 (shown to the left) illustrates one of these lamps. It consists of a thin strip of platinum supported in metallic clamps formed of the blades of ordinary mechanical drawing pens, to which the conducting

wires were led through a hollow section of ornamental metallic gas-tubing, which formed a supporting standard of the lamp..."

The only article found that described the "burner" of the lamp was that by Dolbear<sup>11</sup>. Professor Dolbear said:

"The filament was of platinum wire and the current was maintained by a battery in his cellar. He says that his parlor incandescent lamp had a platinum filament 1-1/2 inches long, .115 of an inch broad and .0008148 of an inch thick, that it gave light equal to five fluid wicks..and a good lamp gave 3 or 4 candle power as we now reckon it. So his five fluid wicks would have given 15 or 20 candle power..."

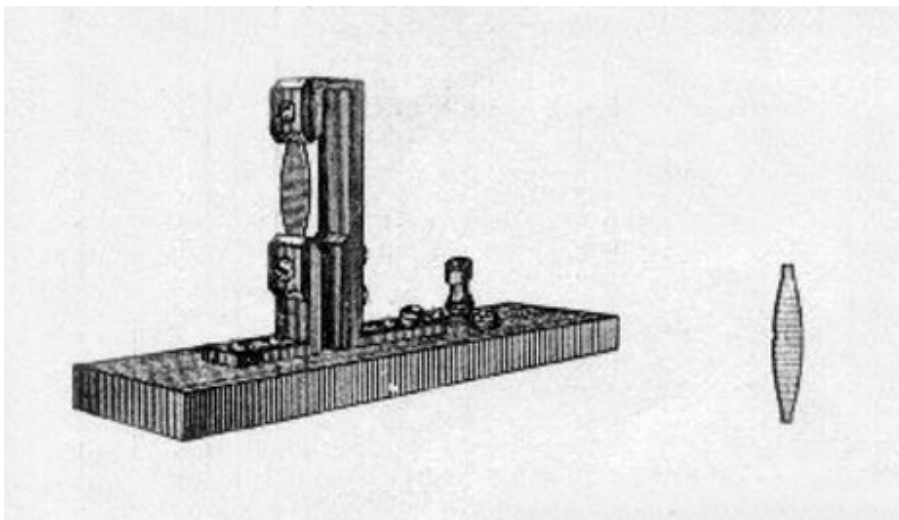

This early work is now left and work that Farmer commenced at a later date is mentioned<sup>4</sup>:

"In 1865, the thermo-electric battery, in which electricity is generated

directly by the heat of coal or other combustible substance, was brought prominently into notice. In the hope that this invention might furnish a cheap source of electric energy, Professor Farmer again turned his attention to the problem of electric illumination. Between 1865 and 1868 he was almost constantly engaged in experimenting in incandescent lamps and electrical generators. During this time he had five such lamps connected in multiple arc. The electric current in the system was controlled by an automatic regulator, so sensitive as to be affected even upon the slight cooling of the lamps by a current of air produced upon the opening or shutting of a door of the room in which the apparatus was placed. This apparatus was on exhibition in Boston until 1868, when it was accidentally destroyed by fire. The form of the lamp employed by Professor Farmer in most of these experiments is shown in figures 4 and 5." (shown above)

The exhibition in 1868, as mentioned above, was held at 109 Court Street<sup>3</sup>.

Moses Farmer patented a stopper lamp, U. S. No 258,903, dated Jun 6, 1882.

## References

- 1) John William Draper, "On the Production of Light by Heat," *The American Journal of Science and Arts*, Vol 4, 2nd Series, Nov 1847, pp 388-402.
- 2) "The First Electric Lamps," *Scientific American*, Jan 11, 1879, pg 17.
- 3) George R. Prescott, The Speaking Telephone, Electric Light, and other Recent Electrical Inventions, D. Appleton & Company, New York, 1879.
- 4) "An Analysis of Some of the Edison Patents for Electric Lighting," *The Electrician and Electrical Engineer*, Vol 4, Jul 1885, pg 246.
- 5) "Professor Moses Gerrish Farmer," *The Electrical Engineer*, Vol 15, No 265, May 31, 1893, pp 519-520. *The Electrical Engineer*, Vol 15, No 266, June 7, 1893, pp 543-544.
- 7) Engraving of Moses Gerrish Farmer, Supplement to *The Electrical Engineer*, Vol 15, No 266, Jun 7, 1893.
- 8) "Prof. Moses G. Farmer," *The Electrical Engineer*, Vol 15, No 266, Jun 7, 1893, pg 545.
- 9) "Prof. Farmer in Chicago," *The Electrical Engineer*, Vol 15, No 266, Jun 7, 1893, pg 550.
- 10) "Burial of Prof. Farmer," *The Electrical Engineer*, Vol 15, No 266, June 7, 1893, pg 564.
- 11) A. E. Dolbear, "Moses G. Farmer as an Electrical Pioneer," *Electricity*, Vol 13, No 4, Aug 4, 1897, pp 56-58.
- 12) Edwin W. Hammer, "Incandescent Lamp Development to the Year 1880□II," *Electrical World and Engineer*, Vol 36, No 23, Dec 8, 1900, pg 880.
- 13) Bernard S. Finn, "Moses Gerrish Farmer," American National Biography, Vol 7, Oxford University Press, New York, 1999, pp 721-722.
- 14) [Finding Aid for the Moses G. Farmer Papers, 1830-1893](#)
- 15) "Death of Professor Moses G. Farmer," *Electrical Review*, Vol 22, No 15, Jun 3, 1893, pg 191.

## Meridian Lamps

On page 172 of their book, Howell and Schroeder described a tipless carbon filament lamp that was called the Meridian; it was a lamp designed to compete with the Nernst Glower. A U.S. patent was issued to Samuel Doane and Henry Burnett as early as 1894 (No 516,800) for the tipless construction but it wasn't used until Mark Branin developed an improved method of manufacturing the stem (U.S. No 532,760). In 1907 tipped and tipless lamps (with GEM filaments) were also called GEM Prismo within the National organization.

Some confusion can exist regarding the term "Meridian" because lamps with carbon, GEM, tantalum and tungsten filaments were marketed that utilized round bulbs that also were called Meridian. In most of those cases, however, the lamps were not of the tipless design. The point to be made here is that the general term Meridian referred to a lamp with a spherically shaped (round) bulb (either 3-3/4 or 5-inch diameter), and limited information suggests that the base used on such a lamp was the skirted medium screw Edison type. Lamps with exhaust tips that utilized the same bulb diameters as the Meridians were also in the product line. Although Howell and Schroeder didn't mention it, it is believed the tipless Meridian lamp usually utilized GEM filaments.

Tantalum Meridian lamps for voltages between 100 and 125 volts were made for 40 watts (bulb diameter=3-3/4 inches) and 80 watts (bulb diameter=5 inches). Tantalum Meridian lamps designed for 200 to 250 volts were made in 50 and 80-watt sizes, the bulb diameters again being 3-3/4 and 5 inches.

Tungsten Meridian lamps for voltages 100 to 125 were made for 40 watts (bulb diameter=3-3/4 inches) and 60 watts (bulb diameter=5 inches). Tungsten Meridian lamps designed for 200 to 250 volts were designed for 45 watts (bulb diameter= 3-3/4 inches) and 60 watts (bulb diameter=5 inches).

Tungsten Meridian lamps were not made tipless nor could they be obtained with colored glass. Usually Meridian lamps were sold with the bulb bowl half frosted. This was so because the lamps were meant to be used with reflectors. However, lamps could be ordered with bulbs clear or fully frosted.

### **Electric Luminous Radiators**

Although electric radiators of the past were not designed as light sources, the heat sources were nothing more than carbon filament lamps. These units were quite popular in 1912. The lamps were made in the 250-watt and 500-watt sizes for voltages between 45 and 130 volts. A 250-watt size was also made for voltages between 200 and 250 volts. Fixtures were made that held from two to six lamps. The larger units were more popular abroad than in the United States.

### **Hylo-Economical Turn-Down Lamps**

One of the desirable features of early liquid fuel and gas lamps was the ability to adjust the light intensity. However, Edison also incorporated the ability to change the light level in a lamp although it was done in an inefficient manner. Occasionally one will find such a lamp and it can be identified by a turn screw at the upper end of the base near the bulb. When one turned the screw a resistance was added in series with the carbon filament. Later this feature of light level adjustment was pursued by Hylo as well as Economical and the following comments describe the types of lamps available in 1910.

It was very difficult to manufacture a carbon filament rated at 1/2 or one candlepower at the normal voltage of 110 volts; therefore two filaments were connected in series. The potential drop over the larger filament was about 20% of the voltage impressed on the lamp. The ratio of the power (watts) consumed on the high brightness step relative to the low brightness one was about six to one. The high brightness level was obtained by means of a switch that either short-circuited or open-circuited the smaller filament.

One lamp type that was available was the Pull String Economical. In that lamp the switch was mounted on the outside of the base and a draw string looped through it. The lamp could be identified by round discs located at the ends of the string. One disc read "BRIGHT" and the other, "DIM". The switch was rotated slightly by the strings. When both filaments were in series only the dim filament was lighted.

Another turn-down lamp type was the Pull String Hylo. In that lamp the switch was concealed in the base. A drawstring entered and exited the base through two small holes. This lamp was designed to give 16, or one candlepower, as well as an off position. Again, when both filaments were in series only the smaller filament gave light.

A third design was the Turn Bulb Hylo. In that design there was a spring contact located on the end base contact. When the bulb was first turned into the socket the low light level came on. Upon further turning of the lamp the higher light level came on. Again, on the low level both filaments were in series whereas on the high light level the small filament was short-circuited.

A fourth design was the Economical Turn Bulb. It had a sliding spring collar on the base. It slid over a contact when the bulb was turned.

Another design was known as the Long Distance Lamp. It was controlled by a small pull chain switch or a lever switch, which was attached to a triple wired cord. The cord was attached to the lamp by three clamps or three thumb screws. This lamp could give a high or low light level or an "off" position.

All the previous designs employed carbon filaments. In those designs the available light level combinations were: 8 and 1/2 c.p.; 16 and 1 c.p.; 32 and 1 c.p. In 1910 there was also a MAZDA Pull String Hylo that employed a sintered tungsten high light level filament and a smaller carbon filament. It was furnished in only one size, 35 watts, 27 c.p. (high level) and 1 c.p. (low level) for voltages 100 to 130 volts.



### **The Nernst Lamp**

An incandescent lamp that did not have the typical look of a "filament in a bulb" met with commercial success for a limited time. It was the Nernst "glower" lamp, which was produced in Europe as well as the United States starting about 1898. Production in Europe stopped about 1909. In the United States it was manufactured by the Nernst Lamp Company in Pittsburg, PA.

The story behind Nernst's lamp creation has been told by Mendelssohn<sup>6</sup>:

"Apart from the electric arc lamp which is not suitable for indoor illumination, the only form of electric lighting known in the 1890s was the newly invented carbon filament lamp of Edison's, the German patent rights of which had been acquired by the A. E. G. (Allgemeine Elektrizitaets Gesellschaft). Its light was not very bright and the lamp requires a vacuum which, at the time, was difficult to provide. It occurred to Nernst that if a solid electrolyte with a very high melting-point could be found, this would make an excellent bright lamp. After various trials, he was satisfied that a mixture containing cerium oxide would do the job. He first tried to interest Siemens in his invention but it seems that they were too hidebound to experiment with novelties and unwilling to spend

money on the development research. After initial tests for which Nernst had come into their Berlin laboratory, Siemens decided not to go ahead with the project. Possibly there was an additional reason for their reluctance. Nernst had immediately taken out a patent on his invention and it is quite possible that the price which he asked for it may have discouraged the firm. He next turned to the A. E. G. who, being a young company, were more adventurous. Moreover, the chairman, Emil Rathenau, was impressed by Nernst's personality and sense of enterprise. This type of professor was a man after his own heart. One of the company's directors, Mammoth, was sent to Goettingen and discussed details with Nernst, including finance. The A. E. G. acquired the patent and took over the development. Nernst got his price, a million marks - a truly staggering sum."

A biographical sketch of Walther Nernst is in order<sup>4</sup>:

"Walther Hermann Nernst (1864-1941), German physicist, was born in Briesen, West Prussia, June 25, 1864. He studied at Zürich, Berlin, Graz, and Würzburg; was an assistant at the University of Berlin, 1905; director of the Physikalische Technische Reichsanstalt at Charlottenburg; and became director of the Physical Institute at the University of Berlin in 1925. His researches included measurement of specific heat at low temperatures and of vapor densities at very high temperatures; electrolytic dissociation, hydration, and diffusion in solutions; and reversible galvanic cells. He invented the now obsolescent Nernst incandescent lamp. Together with Ostwald and Fischer, Nernst was instrumental in interesting Kaiser Wilhelm II and industrial organizations in founding the Kaiser Wilhelm Institutes, which attracted men of international fame. In 1906 Nernst visited the United States and received various honors. He was awarded the Nobel Prize in chemistry in 1920 for his work in thermochemistry, including the third law of thermodynamics. His *Experimental and Theoretical Applications of Thermodynamics to Chemistry* was translated into English in 1916. He died near Mushau, Germany, Nov. 18, 1941.

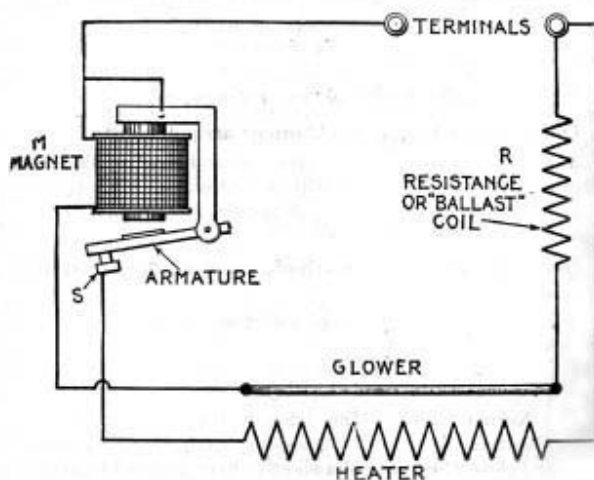

A simple explanation of the lamp circuitry follows<sup>3</sup>:

"Elementary diagram of Nernst lamp. The light producing part of this lamp consists of a *glower* with an insulator of electricity at ordinary temperature and therefore necessitates the employment of some means to raise its temperature up to a point at which it will become a



conductor. This is accomplished by means of a heater coil of fine platinum wire wound on a thin porcelain tube and embedded in cement to protect it from the intense heat of the glower when the latter becomes white hot by the passage of the current. The glower and the heater coil are connected in parallel in operation, and when the lamp is thrown into circuit for lighting, the current flows through the heater coil and raises its temperature to such a degree that the latter, in about 20 seconds, heats the glower to the conducting point. The current now passes through the glower and, raising its temperature to a white heat, makes it luminous. At this moment a sufficient amount of current passes through the glower to make it begin to light. The magnet M, which is in series with the glower is energized strongly enough to attract its armature A, thereby breaking contact with the screw S and throwing the heater coil out of circuit while the glower is left in circuit. Whenever the lamp is turned off by opening the circuit, the armature falls back by gravity into the position shown in readiness for action when it is necessary to relight the lamp. Since the resistance of the material of the glower decreases as its temperature increases, it is necessary to provide some means to prevent the resistance falling to a point at which a considerable current would flow and destroy the glower and its connections. This is accomplished by inserting a resistance coil in series with the glower. This resistance called 'ballast' consists of iron wire which increases in resistance as its temperature increases, and thus compensates for the decrease in the resistance of the glower. It is evident that in consequence of the high temperature coefficient of iron, a point is soon reached, in this matter of compensation, at which any increase of current would increase the resistance of the ballast more than it would decrease the resistance of the glower, and since the lamp is invariably used on a constant pressure circuit no increase of current can occur when this condition is reached."

For pictures of Nernst lamps it is recommended that the viewer click on Reference 8.

Note: the picture of the Nernst lamp shown above was scanned from Reference 2.

## References

## and

## Bibliography

- 1) William J. Hammer, "Important European Electrical and Engineering Developments at the Close of the Nineteenth Century", *Transactions of the American Institute of Electrical Engineers*, Vol 18, Feb 28, 1901, pp 62-74.
- 2) International Library of Technology, International Textbook Company, Scranton, 1905, Section 32, pp 37-45.
- 3) Hawkins Electrical Guide, No 8, Theo Audel & Co., 72 Fifth Ave., New York, 1921, pp 2,501-2,503.
- 4) *Collier's Encyclopedia*, Vol 14, P. F. Collier & Son Corp., New York, 1956, pg 473.
- 5) Fin Stewart, "The Nernst Lamp", TILCA Report, ca 1962, 14 pages.
- 6) K. Mendelssohn, The World of Walther Nernst - The Rise and Fall of German Science, Macmillan Press, London, 1973.
- 7) Brian Bowers, Lengthening the Day - A History of Lighting Technology, Oxford Univ.

Press, Oxford, 1998, pp 121-124.  
8) <http://www.nernst.de/lamp/nernstlamp.htm>

### **The Elblight**

About 1902 a lamp was manufactured by the Edison Lamp Company for the Elblight Company with a base that had a different appearance from other bases of the time. The lamp was made with a porcelain base and two solid rods were utilized for the electrical contacts. The ends of the rods were pointed and very sharp. The reason for this was that the lamp was designed to pierce flexible duplex cable for temporary lighting.

### **The Livgro Incandescent Lamp**

Certainly one of the most interesting periods in the development of the incandescent lamp was during 1893 and 1894. Although the basic Edison patent was about to expire in the latter part of 1894, the General Electric Company was still taking apparent infringers to court, and inventors were still trying to develop lamp designs that did not infringe. One lamp that received some press coverage was made by a company that existed in Harrison, New Jersey, directly opposite the Edison Works. The lamp was designed by a physician from New York, Dr. W. E. Forest. Announcements of the lamp appeared in: *Electricity*, Vol VI, No 25, Jul 4, 1894, pg 315; *Electrical World*, Vol XXIV, No 8, Aug 25, 1894; *The Electrical Engineer*, Vol XVIII, N 322, Jul 4, 1894, pg 4.

The Livgro Incandescent Lamp Co. was organized with capital stock of one million dollars. The lamp could be considered a metal stopper lamp. Quoting directly from *The Electrical Engineer* article:

"The lamp is shown in perspective in the engraving Fig 1, and Fig 2 shows the method of construction adopted. As will be seen, the mount is a plain glass tube, A, 1 inch in length, and 1/4 inch in diameter, open at both ends. A coiled steel wire, B, 8 inches long, is placed within the tube as one of the current conductors. The bottom of the mount is set into a brass thimble, C, filled with a soft molten metal. On cooling, this metal seals the tube and fuses to the wire and thimble. The latter thus becomes the central terminal in the completed lamp.

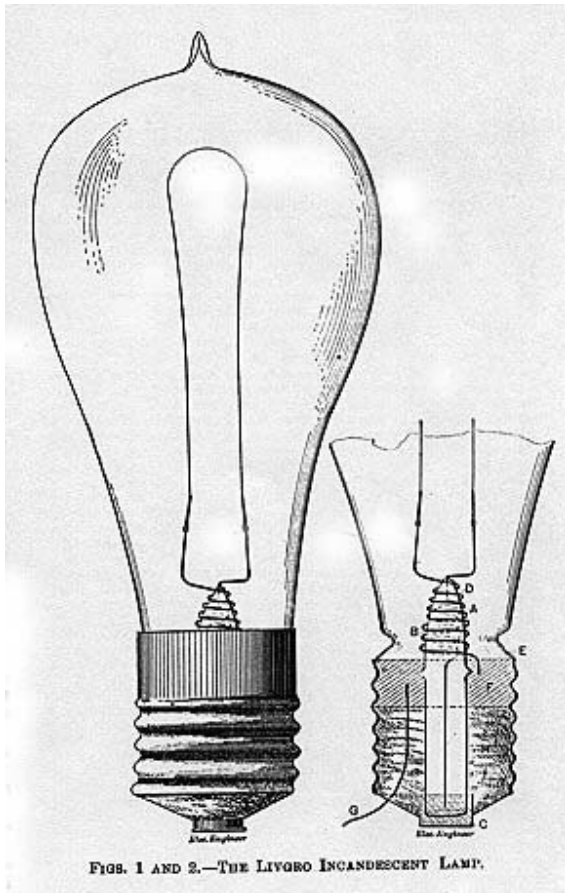

Another coiled wire D is placed outside of the mount and passes through a pin hole in the mica disc E, projecting for a short distance beyond. The mount, with disc wires and filament attached, is then set in the neck of the lamp bulb, the whole is warmed to a proper temperature, the lamp inverted, and a soft molten metal F is poured into the bulb neck upon the disc, hermetically closing the neck.

This metal is cheap, melts at a very low temperature, and has a coefficient of expansion practically the same as that of glass. A copper conducting wire G hangs in the neck of the bulb to which the sealing metal fuses itself. This wire is attached to the screw cap for the other lamp terminal as usual.

The screw-cap, without the porcelain separator and central button, is then slipped over the bulb neck, and a fusible, elastic cement H is poured in, that fills the remaining space in the neck of the bulb, and, at the same time, fastens the screw-cap on, thus rendering plaster unnecessary. The lamp is then ready for the exhausting pump. It will be seen that this lamp has no platinum wires, no glass fusing, no plaster, no leading-in-wires, properly speaking (both conducting wires terminate within the lamp). The incandescent filament is separated from the base by eight inches of steel wire, so that heat cannot be transmitted to the seal; at the same time these wires are held by the mount so that they cannot vibrate and loosen the filament.

The inventor has devised a method of manufacturing these lamps by which hand labor will be but little used, and two or three girls can turn out several thousand per day."

The lamp was to be on the market within 30 days of Jul 4, 1894.

### **Crawford-Voelker Titanium Carbide Lamp**

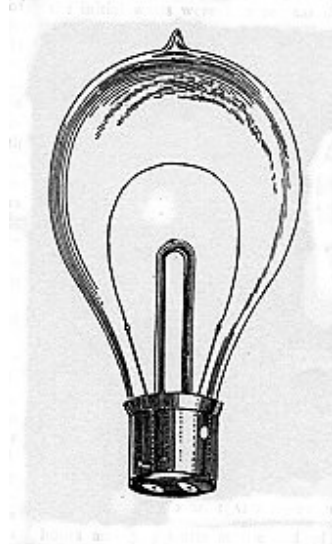

Hammer lamp No 1903-778 shows a 1903 version of a titanium carbide lamp invented by William Lawrence Voelker, an American citizen. An article in the *Electrical World and Engineer*, Vol XXXIX, No 1, Jan 4, 1901, pg 42, gives a few details about this lamp.

This new lamp was introduced to the public in England (note the double contact Edison base). The length of the filament was shorter than a corresponding carbon filament. The claim was that the filament was both tough and elastic. At the time of the article the conclusion had been reached that the development had proceeded to the stage of manufacture. It was claimed that the lamp showed very little darkening during life.

A filament of the carbide had been developed for 500 volts. This was a marked departure from the carbon filament lamp. At such a high voltage arcing would usually proceed between the leads coming out of the stem press. To help reduce or eliminate the possibility of arcing the bulb was made bifurcated as the EW&E drawing, shown here, indicates.

It was also found that lamps made for such a high voltage required the socket to be better insulated.

### **The Lamp of C. A. Bäckström**

A lamp was manufactured by Seely; Taylor Manufacturing Company, 14 Cortland Street, New York. Apparently this same lamp design was manufactured by W. Wiklund of Stockholm, Sweden, as seen by the following advertisement that appeared in a book published in 1892. The filaments had the same twist and the center supports were the same.

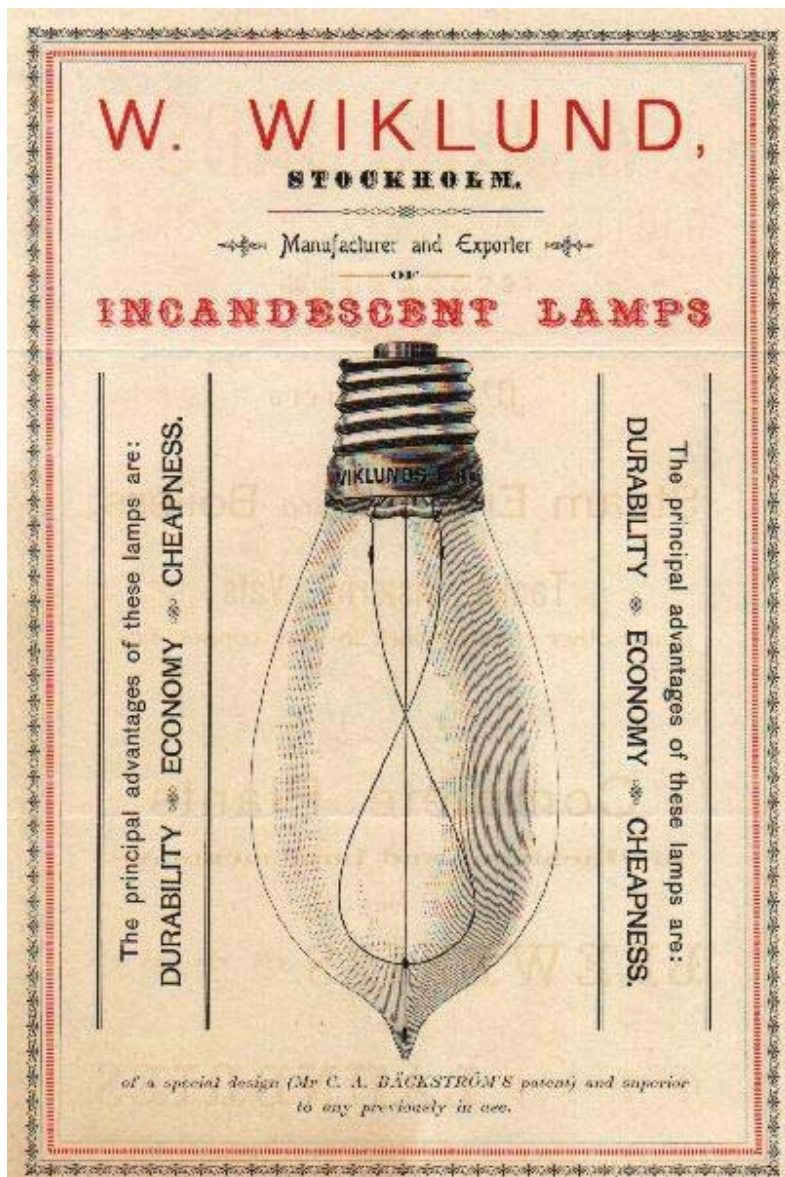

### **Decorative Diffusing Lamp**

An early method of diffusing the bright light from an incandescent lamp was to "flute" the bulb. In addition to the diffusing feature caused by the fluting the lamp could be made attractive and used in the open for aesthetic reasons. One example is shown below. In this case the lamp base is that of Sawyer-Man, or Westinghouse. The base insulation is porcelain.

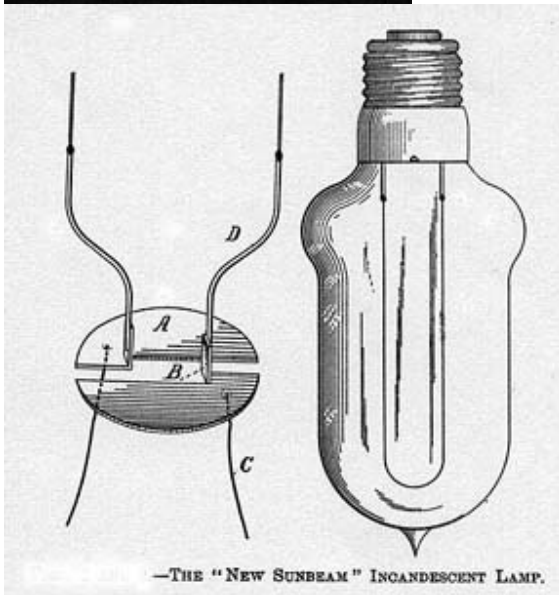

patent. It was called the "New Sunbeam" "Acorn") lamp and it was manufactured by Electric Lamp Company of Chicago, IL., as the Sunbeam Company. The physical design was patented by John Von der Kammer, a citizen who was residing in Chicago in the time period. The lamp design was covered

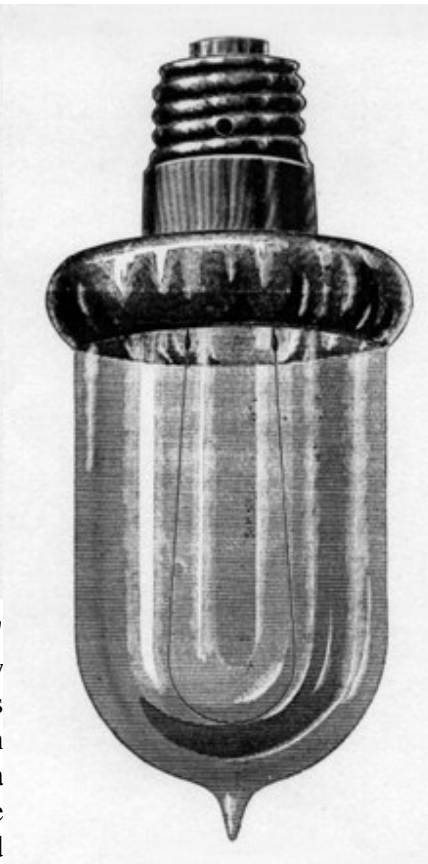

**The "New Sunbeam" or "Acorn" Lamp**

An effort was made in the early 1890s to develop a lamp that had a gas filling and one that did not infringe the basic Edison (also the Star well as by of the lamp German 1891-93 by patent

No. 492,809, dated Mar 7, 1893.

It's of interest to say something about the Star Company as well as the name "New Sunbeam." Apparently the manufacturing facilities of Star were simply the same as for the Sunbeam Incandescent Lamp Company. The officers were the same: David J. Kennedy, President; Albert S. Terry, Treasurer; Franklin S. Terry, Secretary. It appears that the announcement of this lamp was a desperate attempt to manufacture a non-infringing product. The physical design that was patented by Von der Kammer utilized a gas filling □ apparently a hydrocarbon.

"Sunbeam acorn lamps can be furnished in colors as follows: Red, blue, green, amber and frosted. A peculiarity claimed for the material used to color the Sunbeam lamp is that it will not crack or peel off; it will last, too, as long as a lamp ordinarily lasts. The acorn lamp is especially suited for decorative work."<sup>3</sup>

In early 1894 the Star Electric Lamp Company, of Chicago, changed its name to the Sunbeam Lamp Manufacturing Company<sup>17</sup>.

Below is a timetable of some of the activities of that time period:  
□ **1889** □ The Sunbeam Incandescent Lamp Company organized<sup>23</sup>  
□ **Jan 14, 1893** □ A restraining order was secured against the Sunbeam Incandescent Lamp Company of Chicago which prohibited the sale of their incandescent lamps, but not their manufacture<sup>4</sup>.  
□ **Mar 7, 1893** □ Patent No. 492,809 issued to John Von der Kammer<sup>6</sup>  
□ **Mar 18, 1893** □ The Star Electric Lamp Company was organized<sup>9</sup>  
□ **Mar 22, 1893** □ An article describing the Von der Kammer lamp, with a filling of an undisclosed gas, appeared in *The Electrical Engineer*<sup>7</sup>.  
□ **Aug 15, 1894** □ An injunction was brought against the Star Electric Lamp Company<sup>21, 22</sup>

**Note:** The picture on the left, above, was scanned from reference 10. The picture on the right is from reference 3.

## References

- 1) *Western Electrician*, Vol 7, No 21, Nov 22, 1890, pg 286.
- 2) John Von der Kammer, "Illuminator For Electric Lamps," U. S. 457,830, Aug 18, 1891.
- 3) "The Acorn Sunbeam Lamp," *Western Electrician*, Vol 11, No 18, Oct 29, 1892, pg 231.
- 4) Legal Notes, *The Electrical Engineer*, Vol 15, No 246, Jan 18, 1893, pg 70.
- 5) "The Name of the Electrical Supply Company Changed to the Ansonia Electric Company," *Western Electrician*, Vol 12, No 7, Feb 18, 1893, pg 80.
- 6) J. Von der Kammer, "Incandescent Lamp," U. S. 492,809, Patented Mar 7, 1893.
- 7) "The Von der Kammer Incandescent Lamp," *The Electrical Engineer*, Vol 15, No 255, March 22, 1893, pg 281.
- 8) "Incandescent Lamp With Metallic Base," *Western Electrician*, Vol 12, No 12, Mar 25, 1893, pp 156-157.
- 9) New Incorporations, *Western Electrician*," Vol 12, No 12, Mar 25, 1893, pg 163.
- 10) "The 'New Sunbeam' Incandescent Lamp," *The Electrical Engineer*, Vol 15, No 259,

- Apr 19, 1893.
- 11) "Van der Kammer's Incandescent Lamp," *Western Electrician*, Vol 12, No 16, Apr 22, 1893, pg 205.
  - 12) *Western Electrician*, Vol 12, No 16, Apr 22, 1893, pg 206.
  - 13) Business, *Western Electrician*, Vol 12, No 17, Apr 29, 1893, pg 224.
  - 14) Trade News, *Western Electrician*, Vol 12, No 22, Jun 3, 1893, pg 296.
  - 15) Trade News, *Western Electrician*, Vol 13, No 2, Jul 8, 1893, pg 24.
  - 16) Business, *Western Electrician*, Vol 13, No 7, Aug 12, 1893, pg 84.
  - 17) Business, *Western Electrician*," Vol 14, No 5, Feb 3, 1894, pg 59.
  - 18) "Mr. F. S. Terry," *The Electrical Engineer*, Vol 17, No 301, Feb 7, 1894, pg 119.
  - 19) Our Western Letter, *Electrical Review*, Vol 24, Feb 7, 1894, pg 67.
  - 20) "Incandescent Lamp Litigation," *Western Electrician*, Vol 15, No 6, Aug 11, 1894, pg 65.
  - 21) *Western Electrician*, Vol 15, No 6, Aug 11, 1894, pg 66.
  - 22) Legal Notes, Incandescent Lamp Litigation, "Edison Electric Light Co., et al, v Star Electric Lamp Co., et al", *The Electrical Engineer*, Vol 18, No 328, Aug 15, 1894, pg 135.
  - 23) Letterhead, Sunbeam Incandescent Lamp Company, Jan 19, 1912.

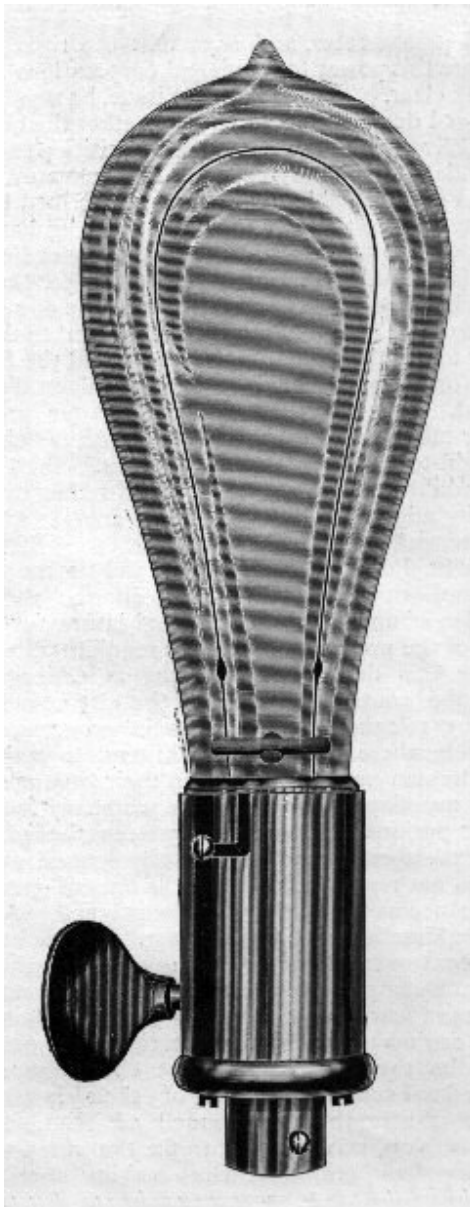

### **The Van Depoele Incandescent Lamp**

It was announced in the *Western Electrician* in March of 1888<sup>1</sup> that the Thomson-Houston Company purchased the motor business of the Van Depoele Electric Manufacturing Company of Chicago. The Van Depoele concern thereafter was to devote its efforts to the production of arc and incandescent lighting. In December of 1888 an article appeared<sup>2</sup> that described their new incandescent system.

Their lamp is shown to the left. They said:

"The lamps are manufactured in sizes from 10 to 150 candle power. The socket is constructed with the utmost simplicity. Two kinds are used, the plain or keyless sockets. The key-sockets may be turned in either direction, and it is impossible to injure them by turning. The lamp when in position is held firmly in place, and cannot possibly jar or work loose."

An average life of 2000 hours was claimed. No mention was made in the article about the design of the lamp base.

In the July 13, 1889 issue of the *Western Electrician* it was announced that the Thomson-Houston Company purchased the lighting business of the Van



Depoele Company<sup>2</sup>. Thus, Thomson-Houston had purchased the entire businesses of the Van Depoele Company.

It's of interest to mention that, to the writers knowledge, the William J. Hammer Historical Collection of Incandescent Lamps never contained a Van Depoele lamp.

### References

- 1) "Purchase of the Van Depoele Motor Business by the Thomson-Houston Co.," *Western Electrician*, Vol 2, No 12, Mar 24, 1888, pg 145.
- 2) "Van Depoele Incandescent System", *Western Electrician*, Vol 3, No 26, Dec 29, 1888, pg 328.
- 3) "Van Depoele Company's Business Purchased", *Western Electrician*, Vol 5, July 13, 1889, pg 16.

### Somoff's Incandescent Lamps

Incandescent lamps were manufactured in the early days for applications other than general lighting. Examples of such lamps were made by J. L. Somoff of New York. The following is a verbatim article<sup>1</sup> that appeared in 1892:

"The decorators who have been resorting to the incandescent lamp to heighten illuminating effects are no longer satisfied with the combinations which can be worked out with the ordinary style of lamps. The call is now for novelties, and it was this demand that led J. L. Somoff of New York to introduce a number of styles of fancy incandescent lamps of low voltage. The sales of such lamps have been steadily growing and, the new year's trade is said to be as brisk as it was at Christmas. There are many wealthy residents in New York and other cities who, not satisfied with the ordinary pear lamps of 16 candle power, have been importing fancy lamps from Germany and France. But with the accompanying cuts it will be seen that all that could be wanted in this line of lamps can now be obtained on this side of the water. The illustrations show some of the novel lamps.

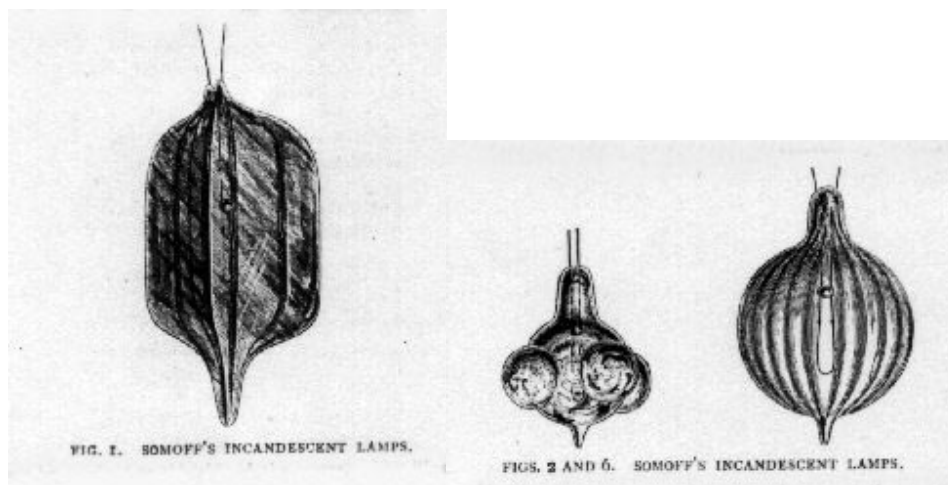

"Fig. 1 is the 'Prism' lamp, which produces a most beautiful display of rainbow colors. The effect is superior to that of the prisms suspended from a gas chandelier. The 'Torch' lamp, Fig. 2, is another one designed by Mr. Somoff for theatrical purposes, etc. It has four lenses fused to it and all the surface around them is frosted. The effect of this combination is to project the light in the form of four condensed beams. Last December 450 of these lamps were shipped to a European theatrical company to be used in the production of the opera 'Robert le Diable.' The lamps were mounted on torches which contained small storage batteries. Little vanes at the bases of the lamps revolved with the least motion of the air and turned the lamps, the beams of light striking in every direction.

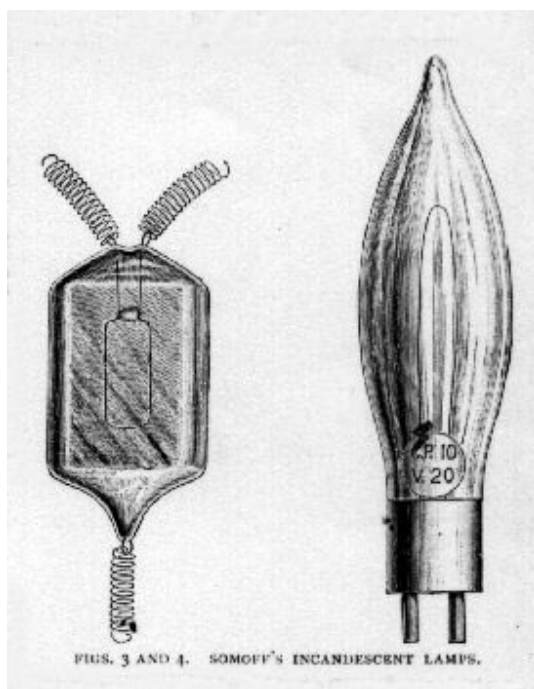

Fig. 3 is the 'Lantern' lamp, English pattern. The storage battery lanterns, as made in England and imported into the United States, have a very shallow reflector and the bull's eye quite close to it. There is no room for any other but a flat lamp. The lamp is suspended from three springs, two of which constitute the terminals. Fig. 4 is a cut of the 'Candle' lamp after the design of A. de Khotinsky, manufacturer in Berlin. A large number of these lamps are yearly imported into the United States on orders from wealthy New Yorkers. Mr. Somoff made this style of lamps as the new protective tariff makes their importation expensive.

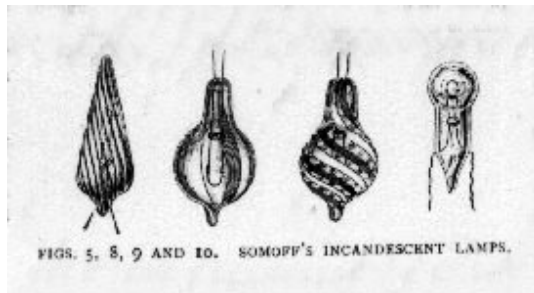

Fig. 5 is the 'Miniature Candle' lamp, whose globe is of corrugated and twisted glass. Fig. 6 represents the 'Corrugated Sphere' lamp. In this the corrugations on the globe produce the pleasing effect of distorting the rays of light. This lamp is also made with the channels of the globe plated with silver, so that it presents a large number of alternate strips of crystal glass and mirrors, and looks as if a great many filaments were enclosed within the globe.

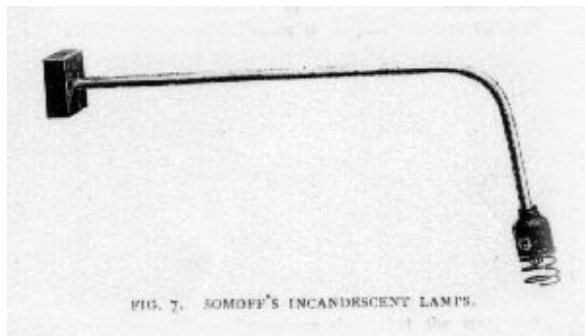
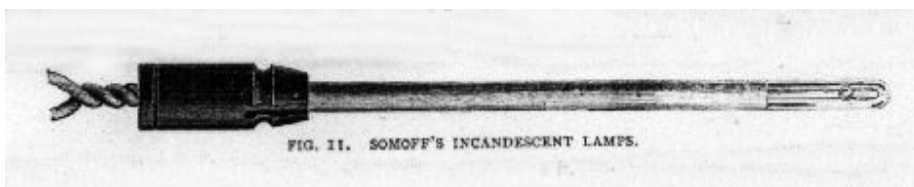

Fig. 7 is a miniature wall bracket. Figs. 8 and 9 are "Striped lamps, the strips being alternately red, blue, milk glass and crystal. These lamps are especially suitable for flower baskets. Placed in the center of a flower the lamps assume the color of the flower. Fig. 10 is a surgical lamp of English design. Fig. 11 is an antiseptic surgical lamp for use by physicians. The part surrounding the filament is of clear glass, and the rest, serving as the handle, is of opaque milk-white glass. Any dirt that might prove infectious can thus be easily seen and washed off."



An example of lights installed by Somoff is the following<sup>2</sup>:

"J. L. Somoff of New York recently installed a plant in Mr. Wilmerding's house on Ninety-third street, New York, consisting of 250 miniature one

candle power lamps of low voltage. The lamps were connected in series of ten on a 110 volt circuit. From ten to fifteen of these lamps were distributed in each room, and were enclosed in colored Japanese lanterns, making a very pleasing effect. The expense for such a plant, it may be mentioned, amounts to no more than in the case of 16 candle power lamps which require 30 ampere. Mr. Somoff also furnished a diamond dealer in Minneapolis, Minn., with some of his "grain" lamps, which are used to show the brilliancy of his diamonds. The lamps are placed in close proximity to the gems, but are hidden from view, and the light is concentrated upon the stone by a miniature reflector."

Somoff added to his line, the following being an example<sup>3</sup>:

"J. L. Somoff of New York has added to his many styles of miniature incandescent lamps a four lens theatrical torchlight from 6 to 10 candle power, each lense being a different color. He now makes also a crystal lense 3/4 inch in diameter. The lens is made in different sizes and can be used in microscopes...."

### **References**

- 1) "Somoff's Incandescent Lamps," *Western Electrician*, Vol 10, No 6, Feb 6, 1892, pg 82.
- 2) Business, *Western Electrician*, Vol 10, No 8, Feb 20, 1892, pg 114.
- 3) Business, *Western Electrician*, Vol 10, No 18, Apr 30, 1892, pg 269. **Leading-In**

### **Conductors**

The incandescent lamp has always required a conductor through which power can be supplied from the outside world into the interior in such a way that an airtight "seal" is obtained. For the first 30 or so years of lamp manufacture platinum served this role very well but substitutes were frequently sought due to the high cost of that metal. This subject is of interest to delve into and a cursory survey of the literature is presented here.

First, the requirements for a good seal should be known. These can be obtained from E.B. Shand's book, Glass Engineering Handbook. They can be found on Shand's pg 119. These are listed below.

- 1) The glass should adhere to the metal as well as "wet" it. The degree of wetting is indicated by the contact angle between the surfaces. For example, a bead of water on a waxed kitchen floor has a high angle and doesn't wet well. On the other hand, the contact angle is less when a bead of water rests on an unwaxed floor□it wets better.

- 2) To avoid cracking, the linear expansion of the metal in the seal should closely match the type of glass being used. There is an exception, however, which will be commented on later, in which it is possible to use very thin metal sections that don't result in glass cracking.

3) The metal used cannot have different structural forms in which it can exist in the temperature range of use.

4) The metal should not have occluded gases in it and the glass should not reach the vaporization stage.

Oxidation of the metal should also be very low. The reason for this being that a thick surface layer of oxide will allow oxygen to diffuse through it from the exterior to the interior of the lamp. This would lead to filament oxidation and burnout.

The common leading-in wire in incandescent lamps today consists of "Dumet" in the sealing region. Dumet was a development of Colin Garfield Fink in 1912. He was issued U.S. Patent No 1,498,908 on Jun 24, 1924. A description of his composite wire will be given later.

Articles appeared in the technical journals of the day that described materials that were used in the hope of replacing platinum. Some of these are mentioned below.

1894 □ Silver Films, Edward Pollard Lamp; *The Electrical Engineer*, Vol XVII, Jan 17, 1894, pg 55.

1894 □ Aluminum, Werner Bolton (*The Electrical Engineer*, Vol XVIII, No 346, Dec 19, 1894, pg 503 and *Electrical Review*, Vol 26, No 7, Feb 13, 1895).

1898 □ Iron-Nickel Alloys (*The Electrical Engineer*, Vol XXV, No 522, May 5, 1898, pg 491).

1899 □ Nickel-Iron Alloy (*Electrical World and Engineer*, Aug 19, 1899, pg 279).

1905-Copper, John H. Guest

1907-Copper, G. Calvert

1907-Copper or Iron, W.R. Whitney, *Electrical World*, Vol XLIX, No 12, pg 583, 1907 and *Electrical World*, Vol LII, No 19, pg 989, 1908).

The use of iron-nickel alloys failed because of the formation of detrimental oxide films. The copper used by Guest was interesting in that the wire was sealed into the glass in circular shape. No explanation was given in this particular article (*American Electrician*, Vol XVII, No 4, Apr 1905, pg 219) for that arrangement. Apparently this seal met with some success. See Hammer lamp, 1907-Guest.

Another seal that probably was successful was the one described by Calvert in 1907 (*Electrical World*, Vol XLIX, No 23, Jun 8, 1907, pg 1166). Calvert used copper from the lamp base to the filament with a portion of the round wire flattened where it was sealed into the glass. It was found that if the thickness of the copper was 0.075 mm no cracking of the

seal occurred. Thus, the procedure of increasing the proportion of surface area to mass reduced the strain in the seal area. This technique is used today in tungsten-halogen lamps where the high quartz bulb temperatures require the use of molybdenum as the conductor.

In his book, The Electric-Lamp Industry: Technological Change and Economic Development from 1800 to 1947, Arthur A. Bright, Jr. also reviewed some of the attempts to replace platinum. The review can be found on pages 205-207.

So what is it that Fink did that resulted in a leading-in wire that is still used today? This is perhaps best told by quoting from Fink's patent. He said:

"In order to make a seal...which will be gas-tight, the leading-in conductor used should preferably have a coefficient of expansion which does not differ greatly from that of the material of the envelope. It is also necessary that there shall be a certain affinity between the material of the envelope, when in a plastic or partially liquid condition, and the surface of the conductor, by reason of which there will be a tendency for the two to stick together. This property is usually spoken of as a "wetting" of the conductor by the material of the envelope. When the envelope consists of ordinary glass, platinum has been found especially suitable for a leading-in conductor because of the fact that it is practically non-oxidizable and has a coefficient of expansion which is nearer to that of the glass than any other metal, and also because platinum is "wet" by glass. Because of the great cost of platinum, however, many efforts have been made to secure a suitable substitute. It has been found that if nickel and iron are alloyed in the proper proportions, a conductor may be obtained which has the same coefficient of expansion as glass. In attempting to use such a conductor in commercial practice, however, difficulty has been experienced because of the large number of seals which are defective. This is probably due to the fact that when subjected to the heat of the flame necessary for the sealing-in operation an oxide coating is formed which is more or less porous and allows air to gradually leak through between the glass and conductor. It has also been found difficult to prevent the formation of bubbles in the seal due to the liberation of gas from the conductor or the formation of gas by chemical reaction during the sealing-in operation.

"I have discovered, however, that there are certain metals whose oxides are readily soluble in glass at lamp seal making temperatures. Among these are copper and cobalt and some of their alloys. Ordinary lead glass, such as commonly used for incandescent lamps and rectifiers, has a coefficient of expansion of about  $8.8 \times 10^{-6}$  while copper and cobalt have coefficients of expansion of about  $17 \times 10^{-6}$  respectively. Hence, solid conductors composed entirely of either of these metals are not commercially suitable for leading-in conductors because of the great difference between their coefficients of expansion and that of glass. By making a composite conductor, however, having a sheath of copper or cobalt and a core of metal having a lower coefficient of expansion than that of glass, and by properly proportioning the relative thicknesses of the core and sheath, it is possible to

provide a conductor, the total radial coefficient of expansion of which is substantially the same as glass with which it is to be used. I have found that if such a conductor is used that there is an even better union in the cold state between the conductor and the glass than in the case of platinum. In actual practice it has been found that by using my invention the number of defective seals has been reduced over 75% from the number commonly found when platinum is employed."

### **Mica Disc Heat Deflector**

The appearance of the gas-filled lamp about 1912 resulted in the addition of a part to some of these lamps. Such lamps were filled with 100% nitrogen to about 0.8 atmosphere. Then, when the lamp operated at full line voltage the heat from the filament resulted in a rise of the gas pressure to about one atmosphere. At this pressure a gas boundary layer of about 1/4-inch thickness exists around the filament. Within this layer the convective flow is laminar and streams upwards due to gravity. Because of the high heat content of this upward flowing gas one was required, in many applications, to operate the lamp only in the base up position. In order to keep the base cement from overheating, a disc was inserted on the glass stem to impede the gas flow. This circular disc was made of mica and was known in the trade as clear muscovite. The thickness of the disc was about 5-10 mils (0.005-0.010 inch).

<b>Incandescent</b>	<b>Lamp</b>	<b>Carbon</b>	<b>"Filaments"</b>
In the early volumes of the <i>Western Electrician</i> Philip Atkinson published a series of articles under the title "The Elements of Electric Lighting." The articles covered a wide range of topics and included among them were discussions of how some of the lamp manufacturers made their carbon "filament" light elements. These comparisons were valid for the year 1888. It is of interest to take advantage of Atkinson's fine work to put these different methods down in a more current information source.			

The method first tried by Thomas Edison was mentioned before his successful use of bamboo was detailed. Regarding bamboo Atkinson said<sup>1</sup>:

### **The Edison Carbons**

"In 1880 he (Edison) patented the process which, with some modifications, he still adheres to. In this process he uses filaments of bamboo, which are taken from the interior, fibrous portion of the plant. The cane, after being cut into sections of the required length, and the hard outer surface removed, is split and shaved down into flat strips, which are then pressed between dies, and fine filaments of the required length and diameter obtained. These are placed in molds made of nickel, in grooves of the required horse shoe form, and closed so as to exclude the air. The molds are then placed in muffles, and the filaments carbonized at a very high temperature. They are then attached to their platinum wire supports, by electro-copper-plating, and introduced into the little lamp globes. The lamp is then attached to a Sprengel air pump, and during the process of exhaustion the filament is

alternately heated and cooled by an electric current; the temperature being gradually raised by increase of current after each cooling, till a high degree of incandescence is attained. This removes all the occluded gases which remain after the carbonizing, and renders the carbon homogeneous, elastic, and refractory at a high degree of temperature. As this is a far more severe test than any to which the carbon will be subjected in use, all imperfect and defective carbons are destroyed in the process, and only the best survive."

Atkinson continued to outline the procedures used by Lane-Fox<sup>2</sup>, Cruto, Swan, Weston and Bernstein<sup>3</sup>.

### **The Lane-Fox Carbons**

"In the manufacture of the Lane-Fox carbons the raw material is obtained from the bass broom, a species of grass fibre. The hard outer surface is removed by immersion in a solution of hot caustic soda or potash and subsequent scraping, after which the alkali is removed with boiling water, and the fibers, in lots of about 100, bound to blocks of plumbago shaped so as to give them the horseshoe form. These blocks, in lots of 50, are imbedded in powdered charcoal in plumbago crucibles, placed in a furnace and subjected for twenty minutes to a white heat. The fibers after being carbonized in this manner are gauged and sorted, and all of the same diameter placed together, after which they are suspended separately from spring clips by attachment at the ends, in large globes filled with a hydro-carbon gas obtained from benzole or coal, and subjected to the process termed flashing, first proposed by Sawyer. This process consists in rendering the filaments incandescent, either by the passage of an electric current or by the heat of a furnace, the latter being the method adopted in the Lane-Fox process. The gas in contact with each filament being decomposed, a layer of hard carbon is deposited which renders the filament denser, smoother, more homogeneous, more durable and more uniform in size; the smaller parts becoming hotter than the larger and thus acquiring a thicker deposit. The increased diameter reduces the resistance and the process is continued till the resistance required for lamps of a given candle power, ranging from 16 to 60, is obtained."

### **The Cruto Carbons**

"These are made by using as a base a fine platinum wire bent into the horse shoe form upon which the carbon is deposited by the flashing process. This is effected by attaching the wires, placed in a long glass vessel, to insulated metallic supports, by which an electric current can be sent through each of them. A current of olefiant gas  $C_2H_4$ , circulates through this vessel, the gas being made from alcohol and sulphuric acid, thus furnishing a gas of pure hydro-carbon. The platinum wires are connected with a shunt circuit so that an electric current passing through them can be graduated to any required strength by a resistance varying from one ohm to 200 ohms. The wire being



heated to incandescence in this manner the gas is decomposed, and carbon deposited. To insure a uniform deposit it is necessary to guard against the influence of the earth's magnetism by placing the wires in a plane at right angles to that indicated by the dip of the magnetic needle; and in the latter part of the process the current is reversed. This operation, which requires about two and a half hours, produces a filament remarkably compact and homogeneous, and uniform in cross section and resistance. Special care is required to maintain uniformity in the successive stages of the process, otherwise the result is a filament of dissimilar superimposed layers of carbon, lacking homogeneity, and practically worthless."

### **The Swan Carbons**

"These carbons are made from cotton twine, prepared by immersion in sulphuric acid diluted with one third part water, by which they attain a consistence similar to that of parchment; they are then thoroughly washed to remove the acid, reduced to a uniform cross-section by being passed through disks, after which they are wound on rods of carbon or earthenware, each in the form of a flat spiral having one convolution, and carbonized by being imbedded in powered charcoal in a crucible raised to a white heat. They are subsequently coated with carbon by the flashing process, and like the Edison carbons, heated and cooled alternately by the electric current to remove the occluded gases, while inclosed in the globe during its exhaustion. Each filament when finished is five inches long and ,005 of an inch in diameter."

### **The Weston Carbons**

"The raw material used for these carbons is cotton or linen cellulose, which by the action of nitric and sulphuric acids is converted into nitro-cellulose—gun-cotton—which is subsequently dissolved in a mixture of alcohol and ether and converted into collodion, and finally has its combustibility reduced by the action of ammonium hydro sulphide or other chemical agent producing a similar effect.

"This artificial product, which Weston calls 'Tamadine,' is an amber-colored, amorphous cellulose of great ductility, tenacity, and homogeneousness. It is rolled into thin sheets between steel roller, and filaments of the sizes required for lamps of different candle power are cut from the edge of the sheet, bent on shapes into the horse-shoe form, carbonized in the usual manner, and flashed in hydro-carbon gas by the electric process. The carbons when finished are highly elastic, and have a smooth brilliant surface like that of a steel watch spring."

### **The Bernstein Carbons**

"These are made from silk ribbon of the finest texture, woven into a hollow cylinder of the required size, from which sections of the proper length are

cut, which are immersed in a thick syrup of cane sugar till saturated, and subsequently in melted paraffine; they are then bent on shapes into the horse-shoe form, placed in graphite molds of the same shape and imbedded in graphite powder, and baked for 24 hours. The subsequent flashing process is the same as that for the Lane-Fox carbons.

"These are the only carbons made from an animal substance, and with a hollow structure; and the advantage claimed for this structure is increase of surface and consequently of radiating capacity with a given degree of resistance."

Atkinson continued with his description of lamp filaments by commenting on their form:

"The shape of the filament varies, the horse-shoe being the most common; the Swan filament, as already mentioned, is a flat spiral, and the same form is adopted for the Brush, while the Maxim resembles a capital M with the angles rounded off. The Sawyer-Man filament resembles a figure 8."

The Weston filament was made in the shape of a horse-shoe as well as in a corrugated fashion. Atkinson then described the method of attachment of the filament to the lead wire.

"The filament is in all cases made largest at the points of attachment, either in the form given previous to carbonizing, or by the subsequent deposition of carbon on the extremities or their insertion into small perforated carbon cylinders. This is necessary for the purpose of better attachment to the platinum wires, but more especially to reduce the resistance and hence the strain on the filament at the points where the current enters and leaves, and to increase the strength where liability to fracture is the greatest. The attachment of the filament to the platinum wires is accomplished by different methods; that of Edison, by copper plating,... The Lane-Fox filaments are cemented into short carbon cylinders, to which also the platinum wires are similarly attached, with a cement made of India ink and plumbago. The attachment of the Cruto filaments is effected by their insertion into tubes formed on the ends of the platinum wires, and the subsequent deposition of carbon by the process on these junctions. The Weston filament terminates in carbon cylinders, nickel plated, each about 3/16 of an inch in length and 1/32 of an inch in diameter, around which are wound in spirals the flattened extremities of the platinum wires. This method is also used with the Bernstein filaments, and is attributed to W. Siemens."

Weston lamps with the two types of filaments are shown below, to the left<sup>3</sup>. Two Swan bulb designs are shown to the right<sup>4</sup>.

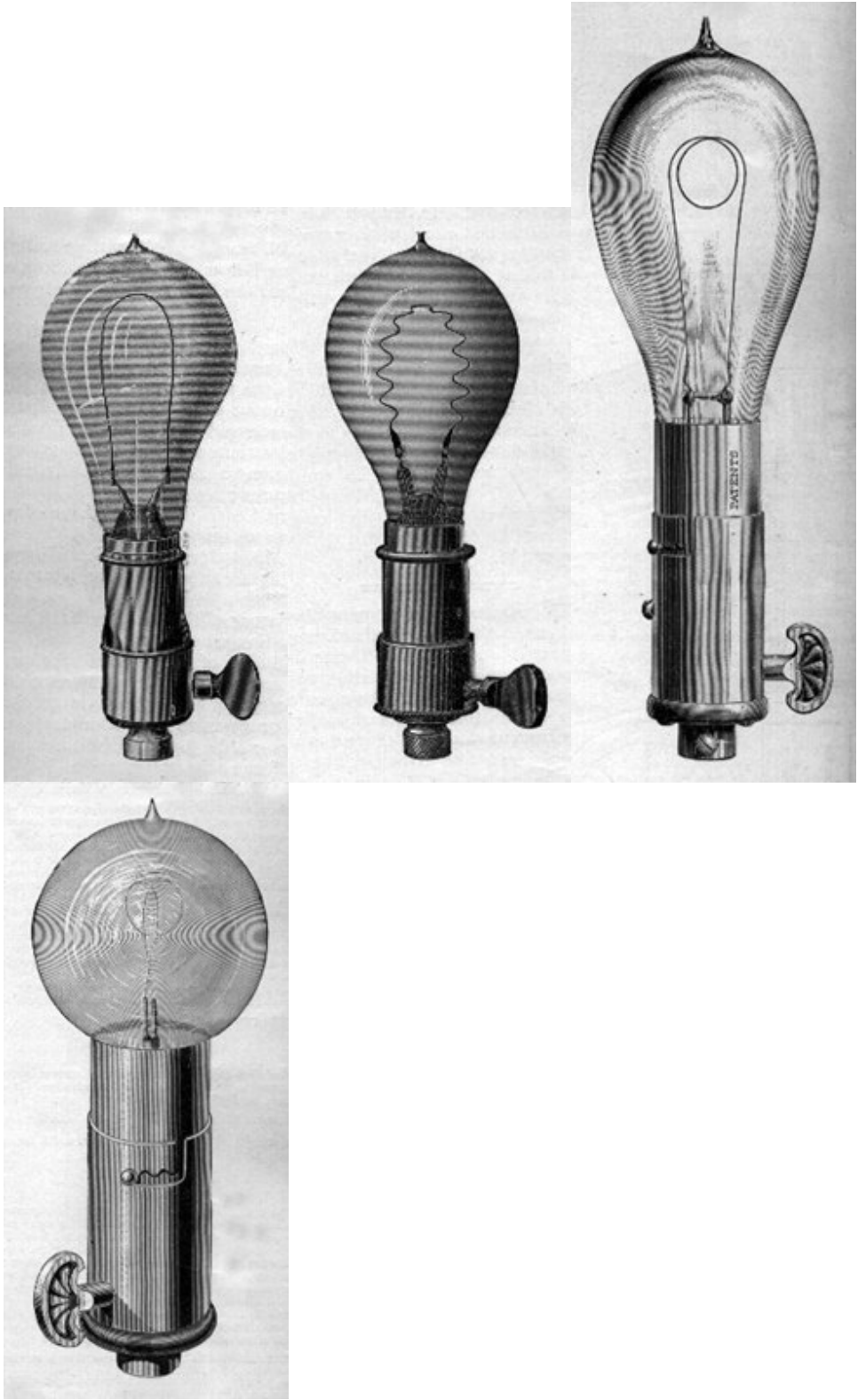

**References**

1) Philip Atkinson, "The Elements of Lighting", No 30, *Western Electrician*, Vol 2, No 7,

- Feb 18, 1888, pg 79.  
 2) Philip Atkinson, "The Elements of Lighting", No 31, *Western Electrician*, Vol 2, No 9, Mar 3, 1888, pg 115.  
 3) Philip Atkinson, "The Elements of Lighting", No 32, *Western Electrician*, Vol 2, No 10, Mar 10, 1888, pg 124.  
 4) Philip Atkinson, "The Elements of Lighting", No 33, *Western Electrician*, Vol 2, No 11, Mar 17, 1888, pg 134.

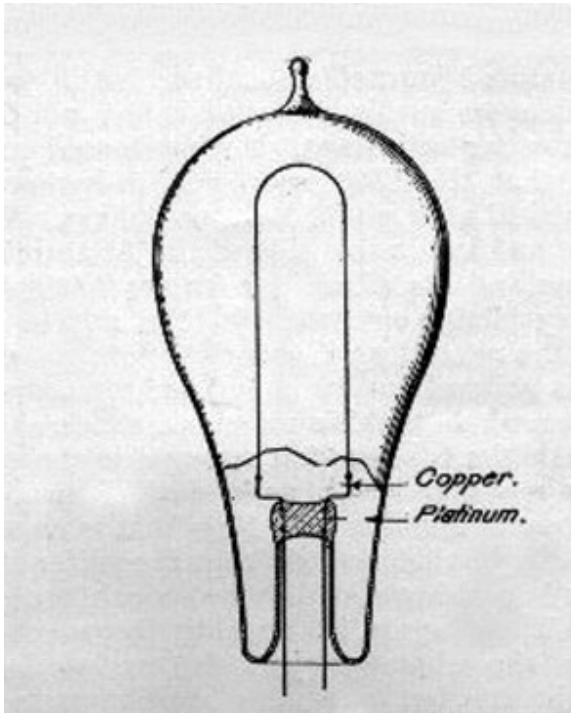

### **Economizing Platinum in Incandescent Lamps**

The following article is taken verbatim from the *Western Electrician*<sup>1</sup>:

"In the manufacture of incandescent lamps the filament is connected to bits of metal called the 'leading-in' conductors. By means of these little pieces of wire the filament within the sealed glass globe is connected with the outside circuit-wires. To maintain a stable vacuum it has been found best to make the leading-in wires of platinum, since its coefficient of expansion is so nearly the same as that of glass that less trouble is caused by its expansion and contraction than is experienced with other metals. It has been the usual

practice to introduce the platinum leading-in wires into a glass tube, and then to fuse and compress the tube around the wires in this manner, tightly sealing them into the glass. These wires have necessarily been of a considerable size, not for electrical reasons but for mechanical reasons, since they are required to support the filament, and to be of such rigidity that they will not be bent by the weight of the filament or by jarring. Of late, however, platinum has advanced very materially in price, and manufacturers are endeavoring to provide a substitute for the metal, or a means by which the amount used in a lamp may be reduced to a minimum. With this object in view Mr. Edison has devised the arrangement of leading-in conductors illustrated in the cut.

"Wires of copper, iron, nickel, silver and other metals, and some alloys having a greater coefficient of expansion than platinum, can be sealed into the glass; but on cooling, although they will still be held mechanically rigid by the glass, they contract sufficiently to permit air to pass into the vacuum. The peculiar feature of Mr. Edison's process is that leading-in wires of two metals are used, one section being of a metal having substantially the same coefficient of expansion as glass, such as platinum, the other being of a

different and cheaper metal. Conductors thus formed of two metals are sealed into the glass, as shown in the illustration. The seal will remain perfect at the platinum sections, and it will, therefore, be immaterial if the copper or other wire contracts away from the glass."

### Reference

- 1) "Economizing Platinum in Incandescent Lamps", *Western Electrician*, Vol 8, No 4, Jan 24, 1891, pg 41. **Aluminum Leading-in Wires for Incandescent Lamps**

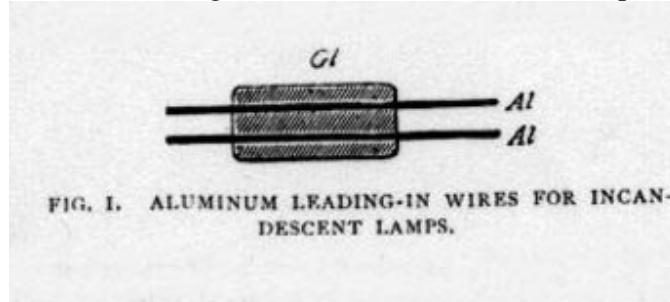

Various metals were tried by inventors to eliminate the need for the expensive platinum that was used in the glass stem press to insure a good vacuum in the lamp. Werner von Bolton suggested that aluminum be

used. An article that appeared in 1894<sup>1</sup> is repeated here verbatim:

"A plan to replace platinum by aluminum, to the use of which metal objections based on rarity are not now ever likely to apply, has been suggested by Werner Bolton, who exhibited lamps made with the substitute at the recent meeting of the German Electro-chemical society in Berlin. The coefficient of expansion of aluminum is much larger than that of glass, and direct sealing in is impracticable. The joint between glass and metal is, however, made in the following ingenious manner:

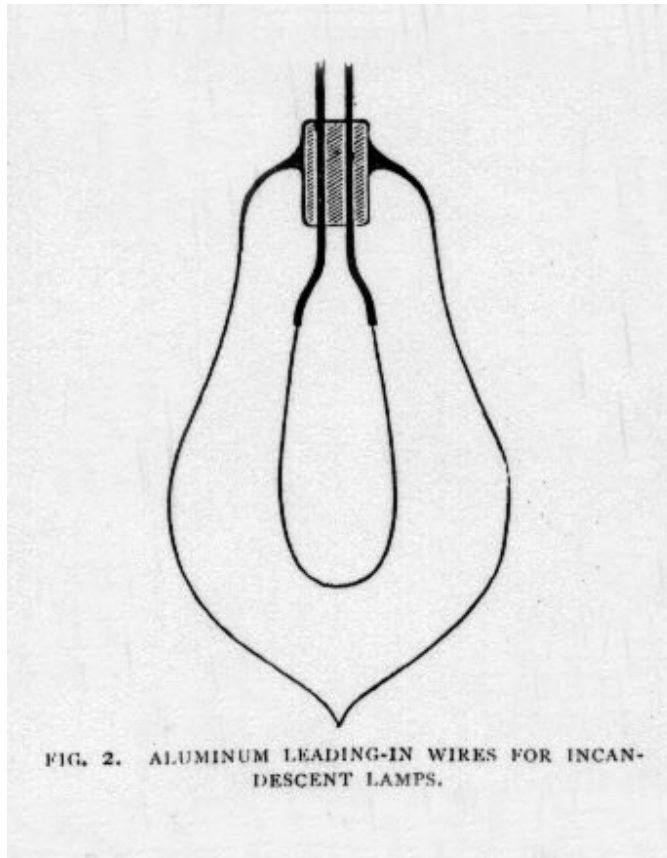

The aluminum is heated in a glass tube until it fuses and the envelope of glass fuses round it. When the composite rod (having a glass envelope and an aluminum core) cools, the glass cracks; but this is of no moment, as the function of the glass is merely to prevent the aluminum melting when it comes to be sealed into the thick glass envelope which ultimately forms the base of the lamp. The

arrangement is shown in Fig. 1, where the aluminum wires, *Al* (about three centimeters in length) are fused into the thick glass envelope *Gl*. The glass envelope carrying the wires is shown sealed into the lamp in Fig. 2, which needs no further explanation.

"The joint between the glass and the aluminum is made tight during the exhaustion of the lamp in the following manner: It is a well known fact that aluminum when amalgamated by contact with a solution containing mercury oxidizes rapidly, becoming covered with the oxide alumina, in the form of a dense powder. This incrustation of oxide, if caused to occur between the aluminum wires and the glass into which they are sealed, is said to make an air-tight joint. These properties are given effect by applying a drop of a strong solution of mercuric chloride to the outer ends of the wires during the exhaustion of the lamp. The liquid is sucked in between the wires and the glass, and causes the amalgamation of the surface of the metal and its consequent oxidation, the oxide being tightly enclosed and forming an air-tight lute. As soon as the joint is tight the ingress of air is, of course, prevented, and oxidation ceases. Should a small leak occur it cures itself by the action of the oxygen on the remaining aluminum amalgam, resulting in the production of a further supply of luting material (alumina) precisely at the point where it is needed. The aspect of the wires with their coating of alumina *o o* is shown in Fig. 3. The cuts are reproduced from the London *Electrician*.

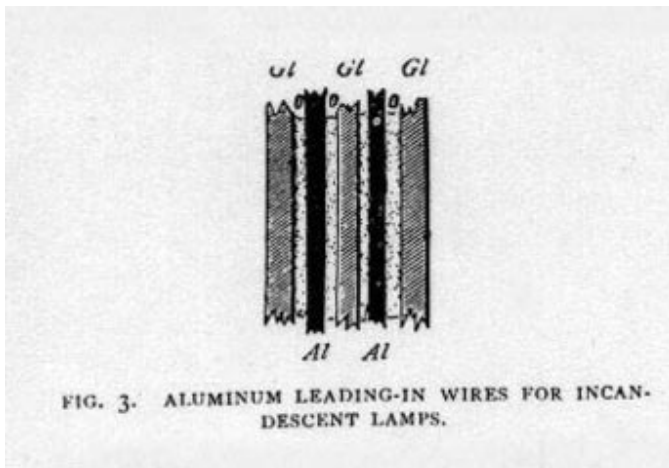

### Reference

1) "Aluminum Leading-in Wires for Incandescent Lamps," *Western Electrician*, Vol 15, No 25, Dec 22, 1894, pg 293.

### Edison's Early Lamp Base and Socket

Changes in lamp base and socket design occurred frequently in the early days of the emerging Edison system. This can best be told and shown, perhaps, by copying verbatim

the contents of a short article that appeared in *The Edison Monthly* of Mar 1925, pgs 57-58. The title of that article is repeated here.

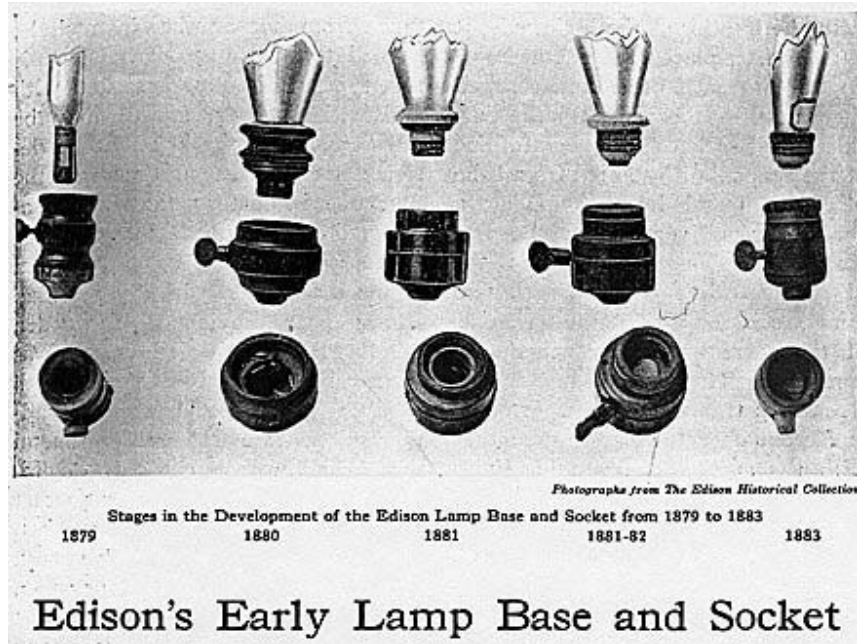

"The carbon glow lamp had not been invented many months before a holder was found to be necessary. It is natural that Edison should have been the first to design and patent such an arrangement, for from the beginning, long before a practical lamp had been discovered, he was arranging for mains, meters, switches and a score of details by which electric light might be introduced into daily life.' Thus *The Electrician* of London, in 1893, paid tribute to Edison's sagacity and wisdom in laying out his plans first and then materializing them.

"After the incandescent lamp had been invented, Edison gave his attention to the problem of devising some means by which the lamp could be easily connected with the electrical circuit. The successful laboratory lamps were all glass, with wires leading out to the electrical supply. He was well aware at the time that the lamp base, and the lamp holder must be essentially simple in all their details, so that no skill would be required in placing or replacing the lamp; or in turning the light on or off.

"Edison's first experimental socket, used at the Menlo Park Exhibition of 1879, was what a present-day radio fan would have designated as being based on the "jack" principle—the lamp was pushed straight into the socket. The base was constructed by simply soldering each of the leading out copper wires to a strip of foil copper, and securing them opposite to each other on the outside of the stem of the lamp. The socket was turned down from wood, hollowed out at the top while its base contained a screw threaded aperture by which it could be fitted to any gas fixture.

"In the interior of the hollowed out part, Edison placed two metal strips opposite to each other and screwed them at their top ends. On the outside of this socket and in front of one of the strips, but insulated from it he placed a metal bushing having a thread through which a thumb screw could play. This bushing and the other strip were connected to two outside screws to which terminals of the current carrying wires were connected. Thus, when the thumb screw was turned in or out, it made or disconnected the electrical contact with the strip. The lamp base was simply inserted into the socket so that its foil strips pressed against those of the socket. But Edison soon began to devise another form that would obviate certain disadvantages, particularly the possibility of the lamp falling out when used in an inverted position.

#### Inspiration From an Oil Can

"One night in the early part of 1880, while Edison was talking upon this subject to some of his assistants, he noticed a kerosene can on a shelf near where he was sitting. Taking it up and unscrewing its cover, he studied the combination for a while and then exclaimed: 'This certainly must make a bang up socket for the lamp.'

"From this idea sprang the Menlo Park experimental socket that was used at the second exhibition of Edison's system towards the end of 1880. It consisted of a turned and hollowed out wooden base, at the inner top of which a metal screw shell was placed to serve as one of the contacts. Below it three inverted U spring shaped strips of metal, at equal distance from one another in a circle, formed the other contact. As in his first types, Edison made sockets with and without keys, and it may be mentioned that the key he designed for the second type was the first one in history that was constructed on a snap principle.

"The second Edison socket permitted lamps to be placed in any position. The lamp was provided with a wooden cup-like base into which its stem was secured by plaster of Paris mixed with gum tragacanth, while one of its leading out wires was soldered to a metal screw shell and the other to a cylindrical flat ring that made contact at the U shaped springs in the socket.

"When Edison moved to New York City in 1881 to introduce his system, he worked out and developed his first commercial socket at the Bergmann and Company's shop in Wooster Stree. This third form or type, having also a wooden base encased in brass sheathing, contained a bevel metal ring at its top and a screw-shell below it for contacts. The plaster of Paris lamp base was similarly constructed to fit the socket. The first Edison plants and the Paris exhibition in 1881 were fitted out with this type, but it was soon found that the lamp base had a radical defect; when it was screwed in tight the tensile strain on the plaster of Paris base often broke the screw and bevel ring apart. This situation created a flurry at the time and after Edison had spent a couple of nights at Bergmann's shops trying various other forms, he



evolved a base with a screw shell at the top and a bottom or soleplate below it and the bevel ring in plaster was discontinued."

---

### Ediswan Lamp Terminals in 1893

The description of Ediswan terminals is made possible here through the courtesy of James D. Hooker, United Kingdom.

-----

In the year 1883 the Edison & Swan United Electric Light Company, Limited was formed. The lamps manufactured by this company were marketed under the trade name "Ediswan." Collectors of incandescent lamps in the United States seldom come across Ediswan lamps of early vintage but such lamps can be located occasionally on the internet. This write-up describes the terminals or electrical contacts that existed on Ediswan lamps in the year 1893 (Incandescent Lamps, Price List, The Edison & Swan United Electric Light Company, Limited, Section 1, Feb. 1, 1893.)

In the common household incandescent lamps of today the electrical contacts are part of what is called the lamp "base." In 1893, in England, lamps could have bases (or "caps"), or not. Descriptions of terminals (electrical contacts) that existed in that year are given and shown below.

<b>Standard</b>						<b>Terminals</b>
Brass	Collars	to	fit	Patent	Bayonet-joint	Holders <input type="checkbox"/> <b>B.C.</b>
Edison	Screws			for	Edison	Sockets <input type="checkbox"/> <b>E.S.</b>
Central	Contact	for	Central	Pin	Bayonet	Holders <input type="checkbox"/> <b>C.C.</b>
Side	Contacts	for	Side		Attachment	Holders <input type="checkbox"/> <b>S.C.</b>
Bottom	Loop	Caps	for	Spring	Holder	(strong) <input type="checkbox"/> <b>B.L.C.</b>
Bottom Loop for Spring Holders <input type="checkbox"/> <b>B.L.</b>						

<b>Miniature</b>						<b>Terminals</b>		
Small	Brass	Collars	to	fit	Patent	Bayonet-joint	Holders <input type="checkbox"/> Small <b>B.C.</b>	
Small	flanged	edison	Screws	to	fit	patent	Edison	Screw Holders <input type="checkbox"/> Small Flanged <b>E.S.</b>
Small	Edison	Screw	to	fit	patent	Edison	Screw Holders <input type="checkbox"/> Small <b>E.S.</b>	
Small	Central	Contact	to	fit	Patent	Central	Contact Holders <input type="checkbox"/> Small <b>C.C.</b>	

At the top of the compound picture shown to the left below is a special brass collar for 50 c.p. and 100 c.p. lamps. Positioned below the brass collar is a 100 c.p. Sunlight lamp designed for 50-100 volts. Although this type of lamp was fitted with lug terminals, often it was recommended that they be used in B.C. holders. In such a case the special brass collar, which allowed adequate ventilation between terminals and holder, was manufactured. The bayonet cap is used on the collar.

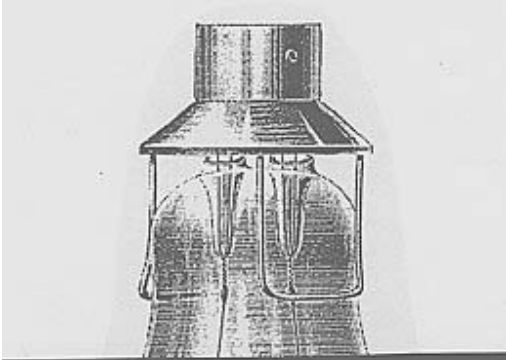

Lamps were available in candlepower values of : 100, 150, 200, 300, 400, 500, 600, 800, 1,000, 1,200, 1,500 and 2,000. The lamps were used for the interior lighting of hotels, restaurants, theatres, workshops, factories, etc. They were used on board ship for cargo lanterns. They also lit railway stations and other applications where a strong steady light was necessary. The lamps are designed with strong copper lugs, which were sealed into glass. They were fit into a lug holder or attached to a flexible cord. The lug holder was made with strong wire prongs, which fit into the curved neck of the lamps.

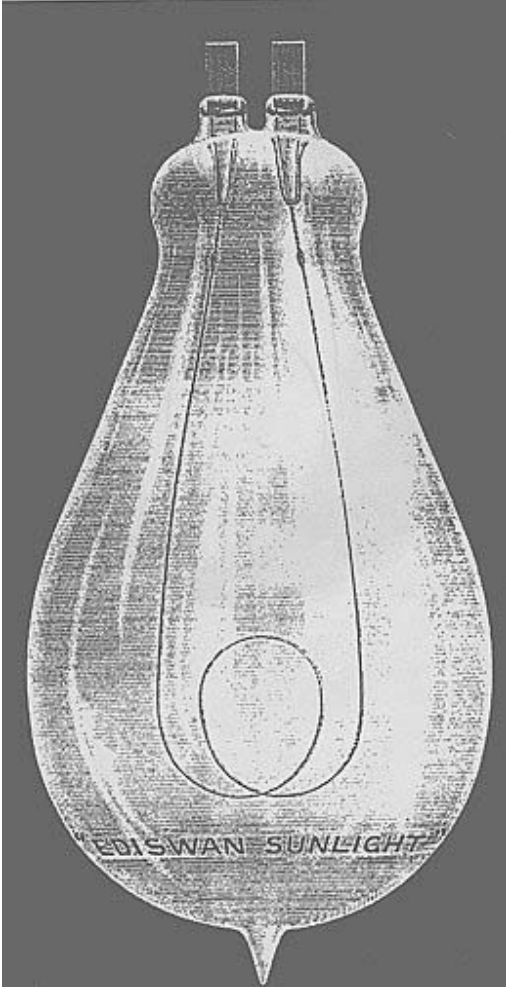

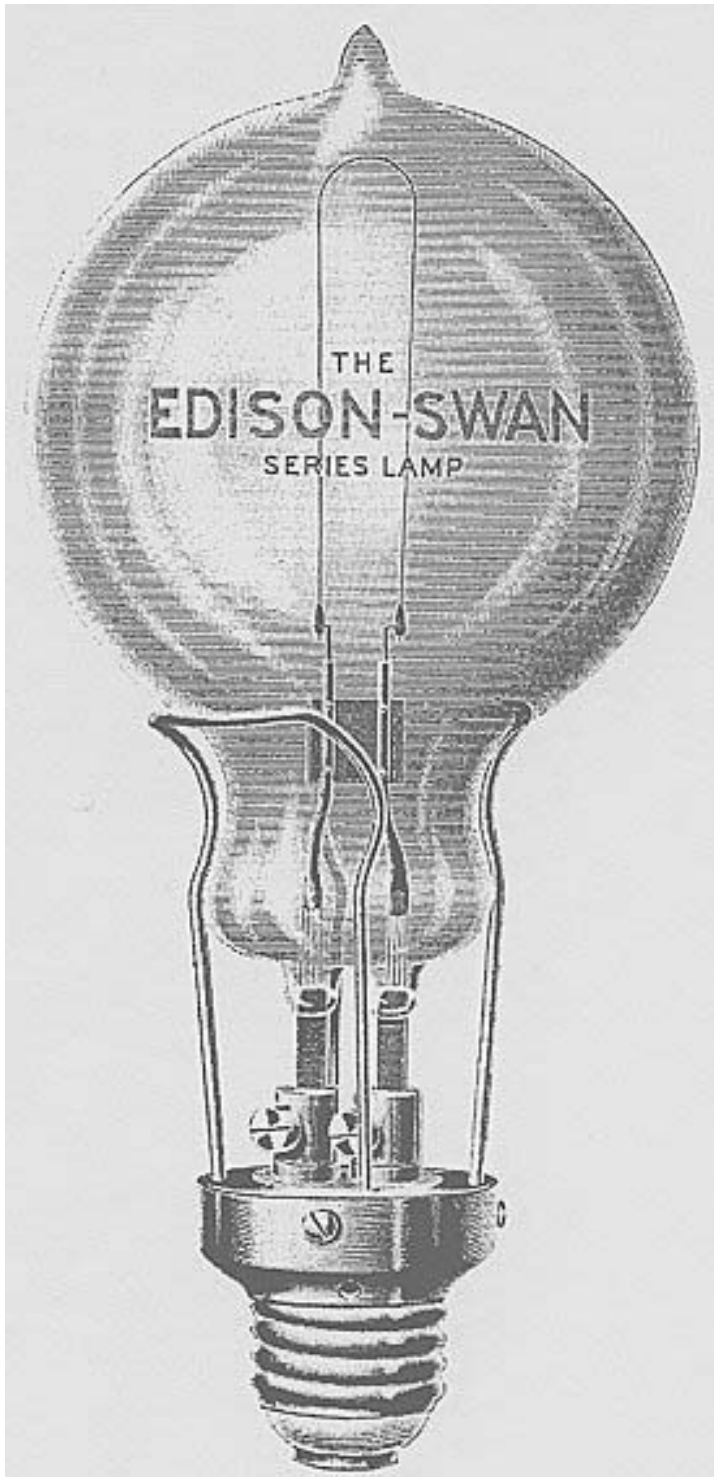

Shown above and to the right is a series lamp that was made with copper lug terminals. The terminals fit into a lug adapter and an Edison base, or cap, is shown.

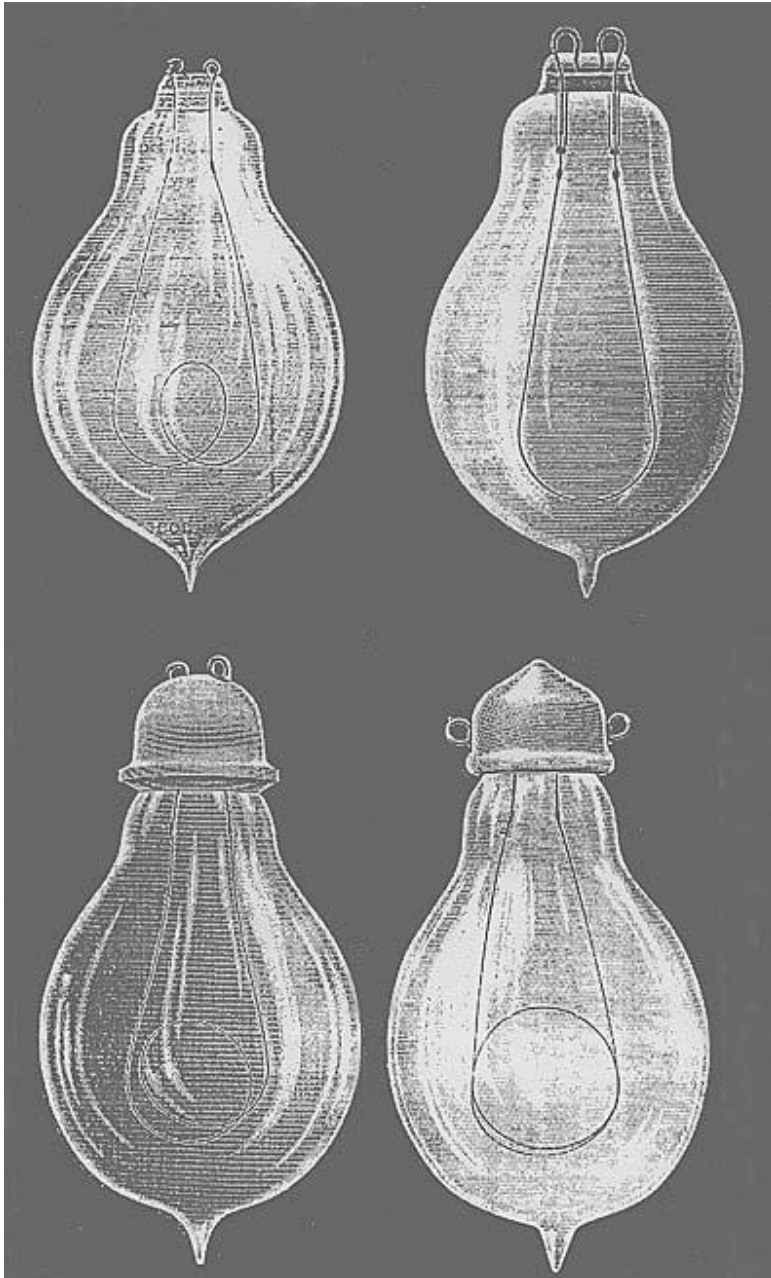

The lamps at the left are:

Top, left:  
Bottom Loops (B.L.) These lamps were made with platinum wires formed into small eyes at the bottom of the lamp. The loops were strong enough to support small-sized lamps. The loops on the 50 c.p. lamp were twisted and therefore fairly strong.

Top, right:  
Copper Loop Lamp. These lamps had strong copper loop terminals and were used for use with strong spring holders, by which the vibration experienced in ships, railway trains, mills, etc., was minimized.

Bottom, left:  
Bottom Loop Cap (B.L.C.) This was an earthenware cap, where the loops projected out at the bottom, in imitation of the ordinary platinum bottom loops. The cap protected the frail platinum loops of the lamp. These were used on board steamers and wherever there was constant or great vibration.

Bottom, right:  
Side Contact Terminal (S.C.) This employed an earthenware cap through the sides of which projected two loops, contact being made by the holder to them. The inconvenience of this design restricted its use to special purpose.

The lamps made with platinum loop terminals are reminiscent of the terminals use on Weston lamps in the United States. Contacts to such loops were usually made with spring loaded hooks.

All lamps are shown approximately full size.

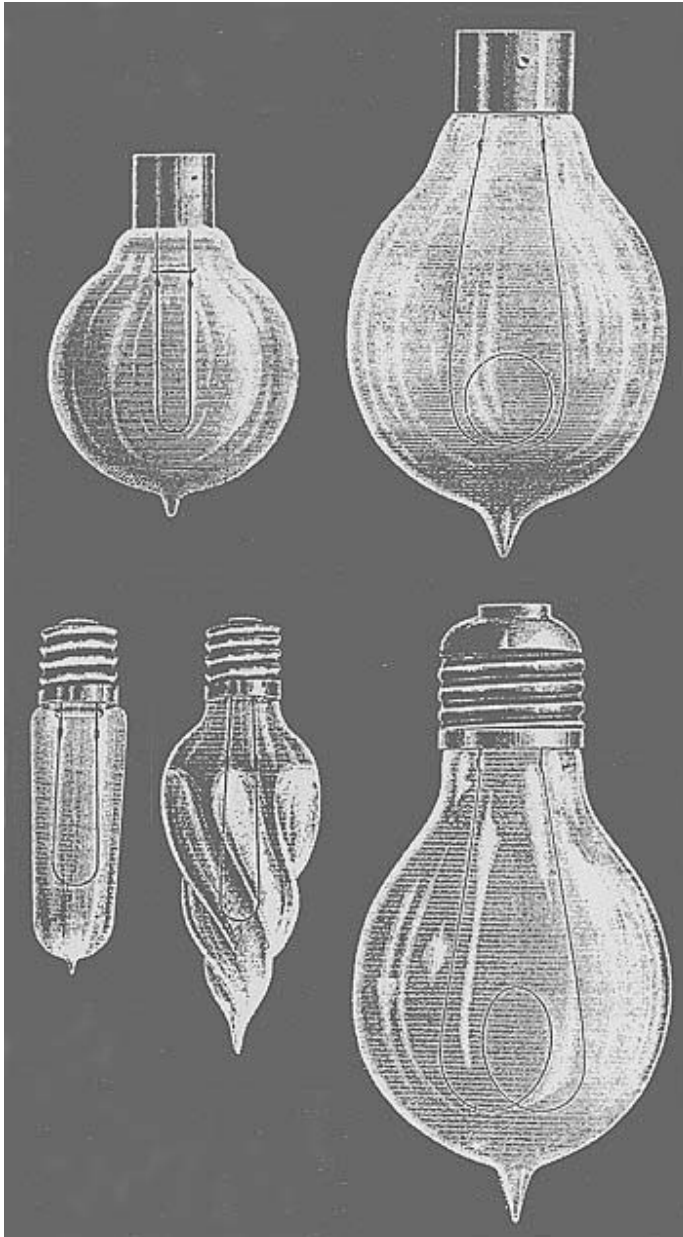

The lamps at the left are:

Top, left: Small Brass Collar (Small B.C.) This was a very useful terminal of the miniature type for most small sized lamps. It was generally used for candle lamps and wherever a secure but small terminal was required.

Top, right: Brass Collar Terminal, B.C. This lamp was capped (based) with a brass collar terminal, suitable for bayonet-joint holders. This was an excellent terminal for all ordinary purposes, more of these being used than any other form. Contact was made by means of two little brass plates (not shown in the picture), which left the collar insulated. The Central Contact Terminal was similar, but with only one brass plate, the collar itself forming the other contact.

Bottom, left and center: Small Edison Screw (Small E.S.) These were candle lamps, without a flange so that the entire terminal was hidden within the holder. Full size.

Bottom, right: Edison Screw Terminal, E.S. This type of terminal (base) was widely used and found to be very satisfactory. However, such a terminal was not recommended in applications where constant vibration of the holder was possible. About full size.

Some terminals are not pictured here. One example is a Small Central Contact (Small C.C.), which is similar to one already described, except for size. Most of the terminals were attached to the lamps by means of plaster so at least four days notice was required when ordering lamps, other than B.L., as collars could become loose if used too soon after manufacture.

It is of interest to mention that the bayonet base used in the United Kingdom, and mentioned herein, was developed by Alfred Swan (1835-1923), youngest brother of Sir

Joseph Swan. The base commonly used in the United States today, the Edison with black glass insulation, was also a development of the fertile mind of Alfred Swan.

### Lamp Bases In Use Before Standardization



Shown above from top to bottom and left to right: Mogul Heisler No. 1601, Schaefer, Fort Wayne "Jenney", Mogul Bernstein No. 1603, Brush-Swan, United States, Thomson-Houston, Loomis, Perkins (or Mather), Westinghouse Stopper, Elblight, Truitt, Ediswan double contact, Italian, Westinghouse, Hawkeye.

### Incandescent Lamp Sockets in Use Before Standardization



Before standardization to the Edison socket, the following sockets were in use in the United States. Shown from top to bottom, and left to right: Siemens-Halske, Hawkeye, Italian, Westinghouse, single contact Ediswan, Brush-Swan, Schaefer, double contact Ediswan, Westinghouse, Perkins (or Mather), Weston, United States, Fort Wayne "Jenney", Edison, Thomson-Houston.

### **The Manufacture of Lamp Bases**

There are interesting peripheral stories connected with incandescent lamp history and some of them concern the parts that make up the lamps. Certainly the origin and characteristics of the glass bulbs would be one of these stories. Another deals with lamp bases. The following is a brief summary of a publication that appeared in 1953 on the occasion of the 100th anniversary of the Providence Base Works, which is located in Providence, RI.

Lamp bases are still made in Providence today by the General Electric Company. The organization had its beginning on Apr 18, 1853. A firm was established by Messrs Mooney and Emerson for the purpose of manufacturing gas burners for domestic and commercial

use. In 1865 Emerson sold his interest in the firm and the organization became known as Mooney and Gleason. Still later the organization became known as Mooney, Arnold and Shaw. After the death of Arnold in 1870 the partnership became known as Mooney and Shaw. In 1875 this partnership ended when the business name was changed to Providence Gas Burner Company.

"The original manufacturers assembled their own bases, using brass caps and cylinders with plaster of paris as the insulating material between the two. The first bases used a screw shell for one terminal and a ring for the other. Because these were bulky, a cone shaped ring and hardwood insulator was substituted and the assembly was held together with plaster of paris. This combination proved impractical as the wood absorbed moisture from the plaster of paris and it had to be abandoned. Fibre later replaced the plaster insulation and in turn was replaced by porcelain insulators in 1898. Glass insulation first came into use in 1903."

In 1882 a General C.H. Barney was treasurer of the Providence business but he resigned his position to take one with the Sawyer- Man Electric Company of New York. Sawyer-Man had been assembling their own bases and General Barney was quick to see that the Providence business was well equipped to supply parts for Sawyer-Man and so in 1887 an order for 5000 parts was given to Providence. By the year 1890 half of the company's business consisted of bases for incandescent lamps.

In 1895 the Providence company was making bases for every type of socket on the market. After the formation of the National Electric Lamp Company in Cleveland in 1901 it was decided that it (National) would buy the Providence business and that occurred in 1902. In 1910 the gas burner business was dropped and the organization became known as the Providence Base Works of General Electric.

Providence became the largest producer of bases in the world. They established plants worldwide and sent base making machinery to China, Japan, Europe and South America. From the original order of 5000 units in 1887 the shipment increased to more than one billion during 1952.

### **Hawkeye Base and Socket**

Lamps and sockets manufactured by The Hawkeye Electric Manufacturing Company of Davenport, Iowa are not found too often and identification of these items can be confusing if there is no manufacturer identification. The bases of the Brush-Swan and Hawkeye lamps were about one inch in diameter, although the Brush-Swan might have been about 1/32-inch larger. Both base types had side pins that locked the lamp into the socket. This feature of the lamp was similar to the base design of the Ediswan lamp (or what is called the bayonet base today). Actually, it is relatively easy to distinguish a Brush-Swan lamp from a Hawkeye lamp (or a Brush-Swan socket from a Hawkeye socket) by the location of the side pins (or receiving slots) relative to the two lamp contacts. The Brush-Swan lamp, when fully engaged in the socket, had its pins located about 45 degrees away from a plane through the contact centers of the two lamps or sockets. The Hawkeye design differed from



the Brush-Swan in that the pins were located perpendicular to the plane through the two contacts. Pictures of these bases can be found in Schroeder's book (page 58), in Howell and Schroeder's book (page 190), as well as in the *The Electrical Engineer*, Volume XVIII, No 341, Nov 14, 1894, pg 407. A sketch by the writer is shown.

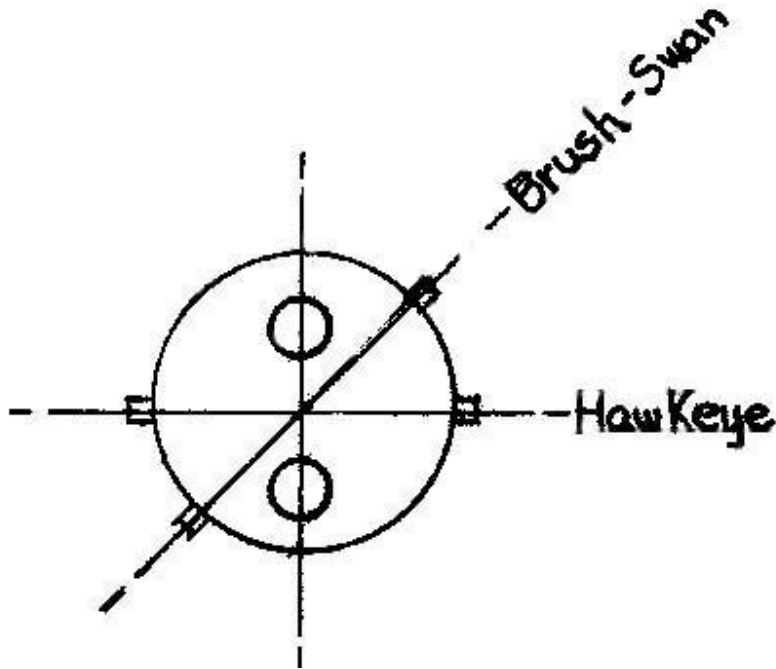

Two patents were granted to Frank Thone of Hawkeye for socket designs. These were U.S. Nos 379,255 and 418,426. An earlier (ca 1887) Hawkeye socket design, for which a patent was applied for, is shown below.



However, the design must not have been too successful. The socket contacts were made of springs and in the process of lamp insertion the spring ends were distorted in the clockwise direction. The springs retained the distorted configuration, in part, probably because they were heated during lamp burning.

#### **Lamp Bases Used by Tungstam**

A book was printed by Tungstam in 1990 that deals with the history of the Tungstam Co. Ltd. in the time period 1896-1945. It was a limited edition and was not for sale, so it's apt not to be widely known. In this section some bases, as shown on page 139 of that book, are given: Edison Normal, Edison Vitrite, Helios, Egger, Marinefassung (fassung=base), Cruto (assumed to be Alessandro Cruto, who, in 1882, hailed from Piosasco, Italy), Russian (can't decipher), Oesen, Siemens, Edison Mignon, Victoria (Brush), Ganz, Thomson-Houston, Oesen Vitrite, Westinghouse, Bernstein, Swan, Swan Mignon, Doppelstift (double pin), Swan Central, Egger Mignon and Swan-Zwerg. A picture of the bases scanned from [The History of Tungstam, 1896-1945](#) is shown below.



Another picture of bases that were used on Tungram lamps is on page 191 of that book. It is reproduced below.

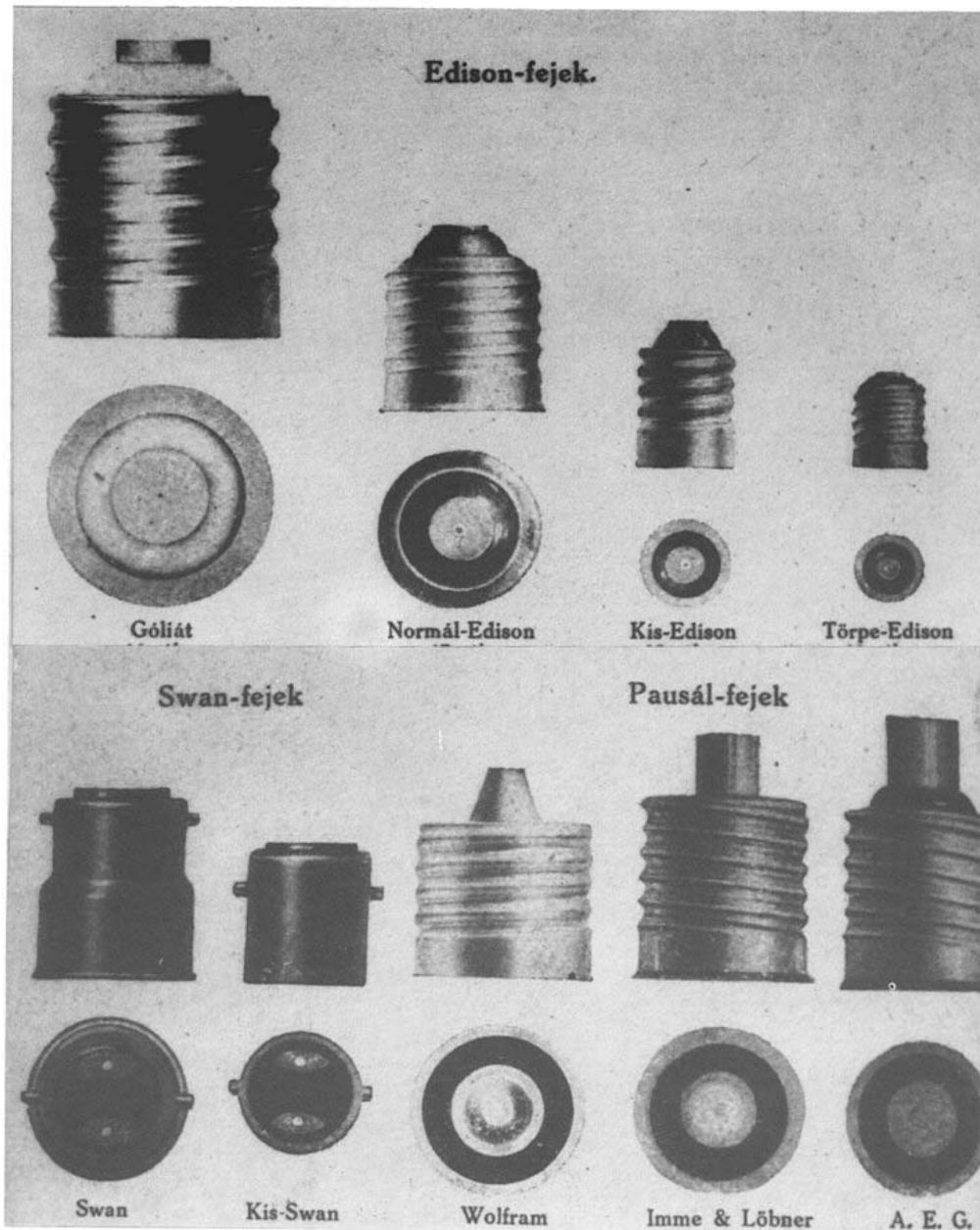

### Candelabra and Miniature Bases

Sometimes it can be difficult to determine whether a lamp with a small base is of European or American manufacture. To make that task of identification somewhat easier, the characteristics of American, French and German designs are given below.



American Edison Candelabra,  
 $7/16'' \times 5/8''$ , 10 threads/inch



German Edison Candelabra,  
 $1/2'' \times 11/16''$ , 10 threads/inch



French Edison Candelabra,  
 $1/2'' \times 11/16''$ , 9 threads/inch



Ediswan Candelabra, Single Contact  
 $19/32'' \times 35/64''$



Ediswan Candelabra, Double Contact



American Edison Miniature,  
 $3/8'' \times 7/16''$ , 14 threads/inch



American Edison Small Miniature (Midget),  
 $7/32'' \times 1/4''$ , 28 threads/inch

## **The Use of Porcelain in Lamp Bases**

The writer is not clear as to the time of the first use of porcelain as an insulator in lamp bases. Perhaps a viewer of this web site will be able to clarify this confusion. The writer has long believed that widespread use of porcelain occurred about 1900. This date was, perhaps, implied in the information on page 188 of the book by Howell and Schroeder. This was also implied by Arthur Bright in his book, on page 116. However, there is considerable evidence that porcelain was used before 1900. It is now believed that this writer simply misinterpreted what Howell and Schroeder said in their book. On page 189 of H & S's book it is said that porcelain was used in the year 1900. This was mentioned simply to say that the following year, 1901, black glass was used. H & S didn't say that porcelain was introduced in 1900. Indeed, in Schroeder's book, on page 58, bases are shown in which porcelain was used in 1892. In addition, there is an article in the *The Electrical Engineer*, Vol XVIII, No 341, Nov 14, 1894, in which images of ten common bases of that day are shown. Of those ten base types the Westinghouse or Sawyer-Man, the Westinghouse Stopper, the United States and the Edison bases appear to have porcelain insulation. Thus, it appears porcelain was used to some extent in the year 1892. Hopefully the year of first introduction will be revealed by a collector.

### **Porcelain Lamp Base**

Occasionally one comes across a carbon filament lamp that has a porcelain Thomson-Houston base. The following is taken verbatim from *Electrical World*, Vol XXIX, No 12, Mar 20, 1897, pg 397; the lamp image has not been included:

"The increasing use of 220-volt distribution systems for incandescent lighting has presented some problems in lamp base insulation which are by no means easy of solution. The ordinary brass base cemented to the lamp with plaster of Paris has proved very undesirable for this purpose in street railway cars, outdoor sign work and in mills and cellars where there is much dampness or corrosive fumes.

"To meet the demand for a lamp base which would obviate as far as possible these difficulties, the Bryant Electric Company, Bridgeport, Conn., has placed upon the market the porcelain base here illustrated. The finest grade of glazed porcelain is used, the contact rings being cemented in such a way that their union with the porcelain is very rigid. The peculiar advantages that this highly insulating substance possesses for this purpose are obvious. The readiness with which it can be cleaned is no small addition to its other valuable qualities. The bases have not been placed upon the market for general sale, but are made only for lamp manufacturers."

### **A Universal Pull Lamp Socket**

In 1893 there were about ten different types of bases used on lamps manufactured in the United States. This resulted in the inability to use lamps of different manufacture in the same socket. An attempt to reduce this problem was made by the Universal Pull Socket and Switch Company, 27 Beaver Street, New York (*Electrical World*, Vol XXII, No 18, Oct 28, 1893, pg 349). They marketed a socket in which lamps with Edison, Westinghouse or

Thomson-Houston bases could be used. This socket, scanned from the *Electrical World* article, follows.

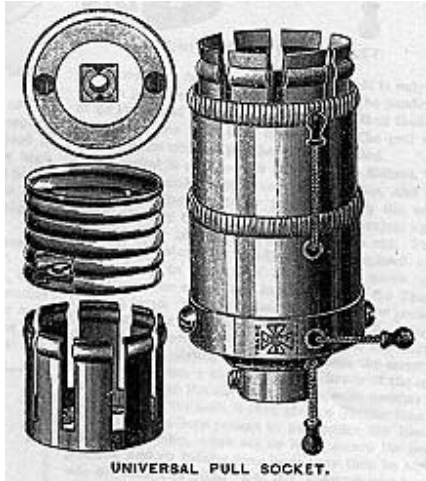

Quoting from the article:

"To turn off a lamp it will be seen that it is only necessary to pull the cord or chain, of which the pendent ball at its lower end may be a luminous one, thus facilitating turning on the light in a dark room. The pull always returns to its original position when released.

The socket is adapted for use with the Edison, Thomson-Houston and Westinghouse lamp bases, and makes and breaks the circuit by merely pulling the cord or chain, whether the lamp be arranged to project upward, downward or laterally, as shown in the cut. For the Thomson-Houston base no adjustment is required; all that is necessary (is) to screw the central split screw of the socket into the screw hole in the front of the Thomson-Houston lamp. For the Edison base the screw neck illustrated must be inserted into the socket to do this. The two opposite screws in the bottom of the top cavity of the socket are slightly loosened, and then the screw neck is inserted in such a manner that the heads of the screws can pass through the diametrically opposite notches in its bottom flange; the neck is then given a quarter turn so as to cause the two hook prongs to pass under the heads of the screws, which, when set up light, secure the neck in position, and an Edison base lamp may then be screwed into the socket as usual. For the Westinghouse base the spring neck is inserted, as shown in the cut, and fastened in the same manner as the screw-neck for the Edison base. The lamp is then inserted and is held by the several prongs of the split spring neck, the pin on the foot of the Westinghouse base passing into the split hollow screw in the 'Universal Socket,' thus making the proper connection."

### **General Electric Locking Socket**

The theft of light bulbs was often a concern. Some effort to reduce this loss resulted in the use of special bases, the use of odd voltages, the etching of the customers name on the bulb, devices that prevented lamp removal without breakage and bulb guards. In the mid 1920s the General Electric Company manufactured a locking socket that was quite effective. In that case one inserted the lamp into the socket and then removed a key that locked the lamp

in the socket. The lamp would then turn freely in either direction and removal was not possible. Breakage would not occur.

### Cutaway Views of Various Lamp Bases and Sockets

In the year 1886 the President of The Edison Electric Light Company, E. H. Johnson, issued a small booklet<sup>1</sup> in which lamps were pictured that were claimed to infringe Edison patents. Two hundred sixty six patents that were issued to the Edison Company during the years 1876 and 1886 were listed and the pictured competitive lamps had the apparent infringing features pointed out. Cutaway pictures of seven competitive lamps and sockets are shown below.

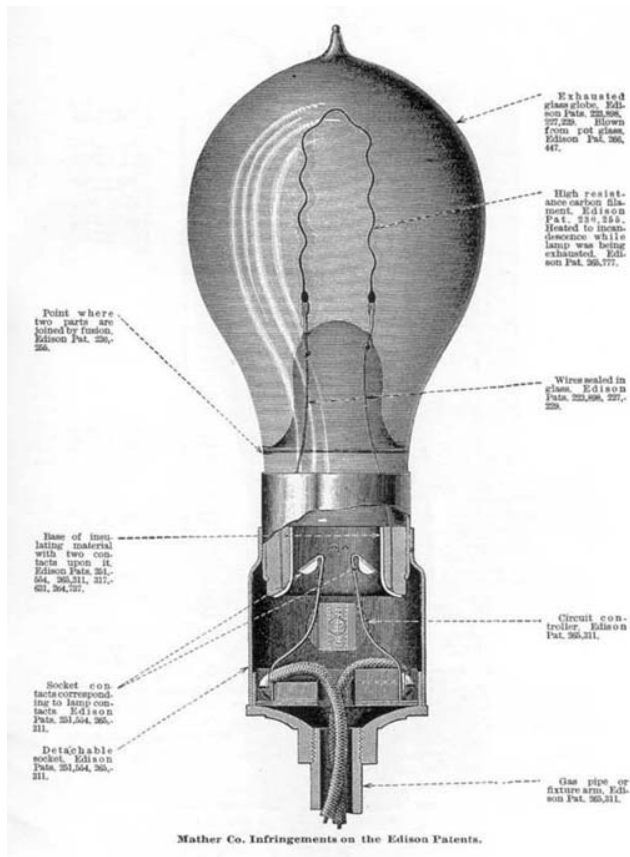

-----

-----



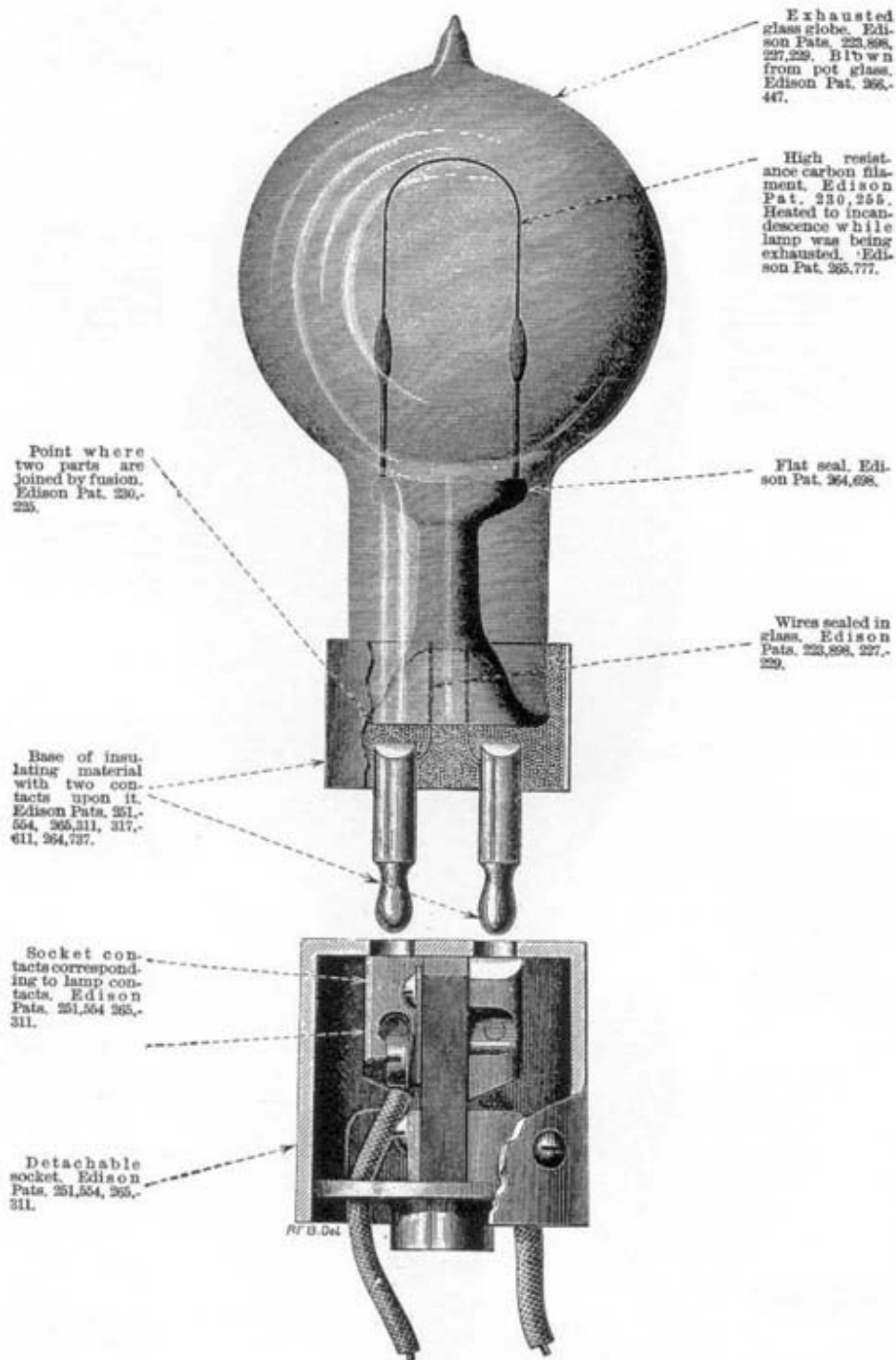

Bernstein Infringements of the Edison Patents.

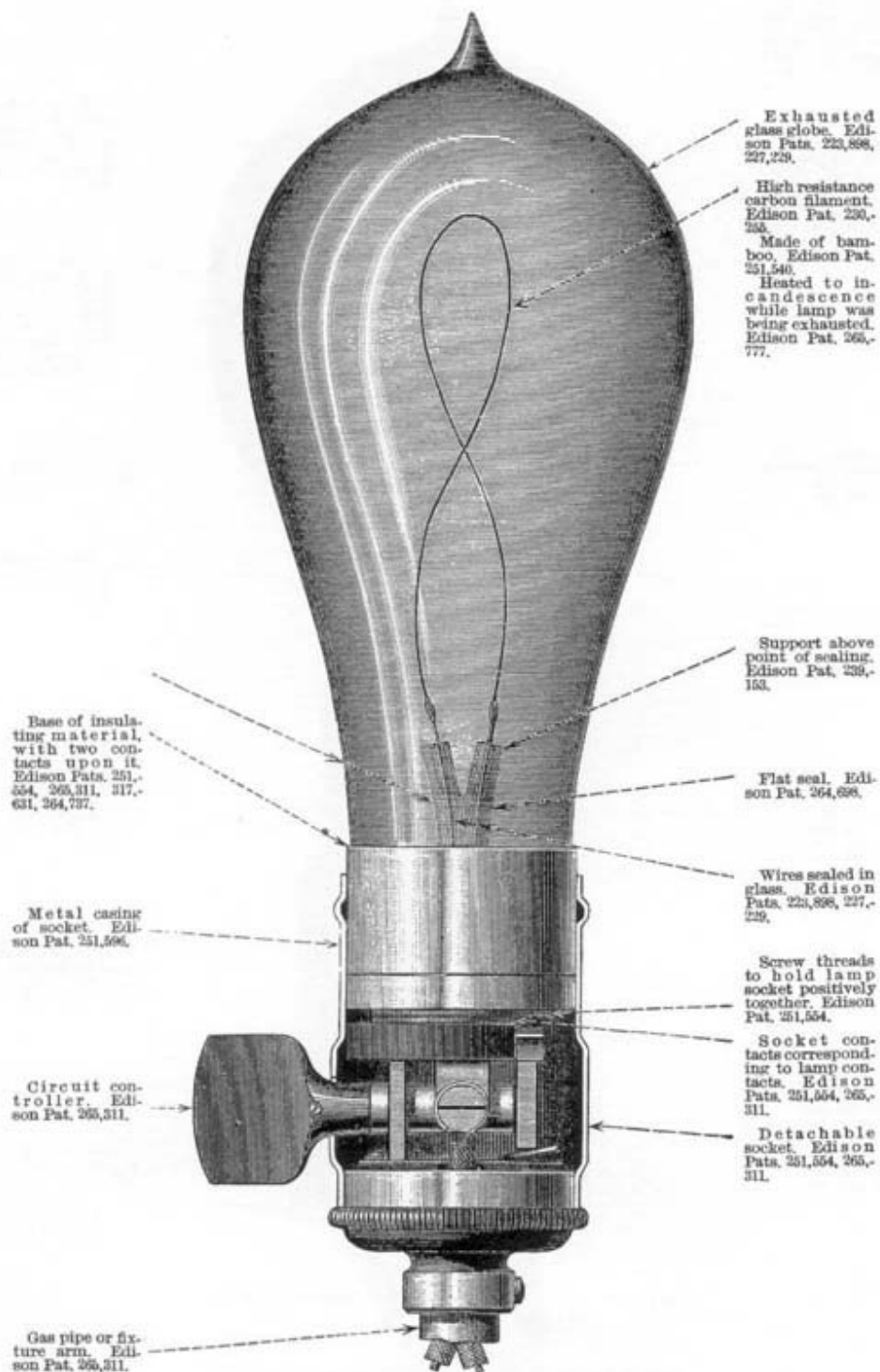

Consolidated Co. (Sawyer-Man) Infringements of the Edison Patents.

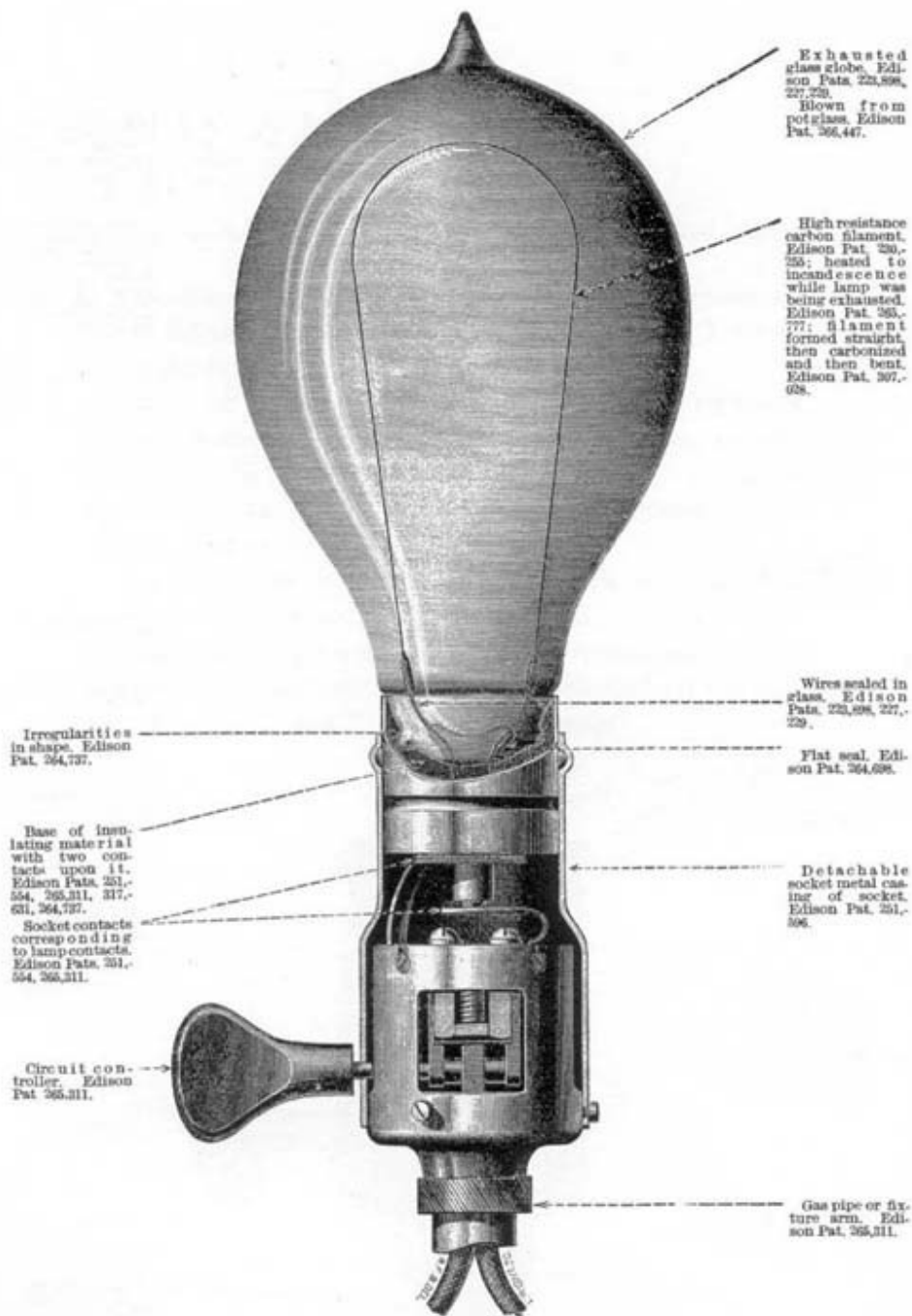

The United States Co. (Weston Lamp) Infringing the Edison Patents.

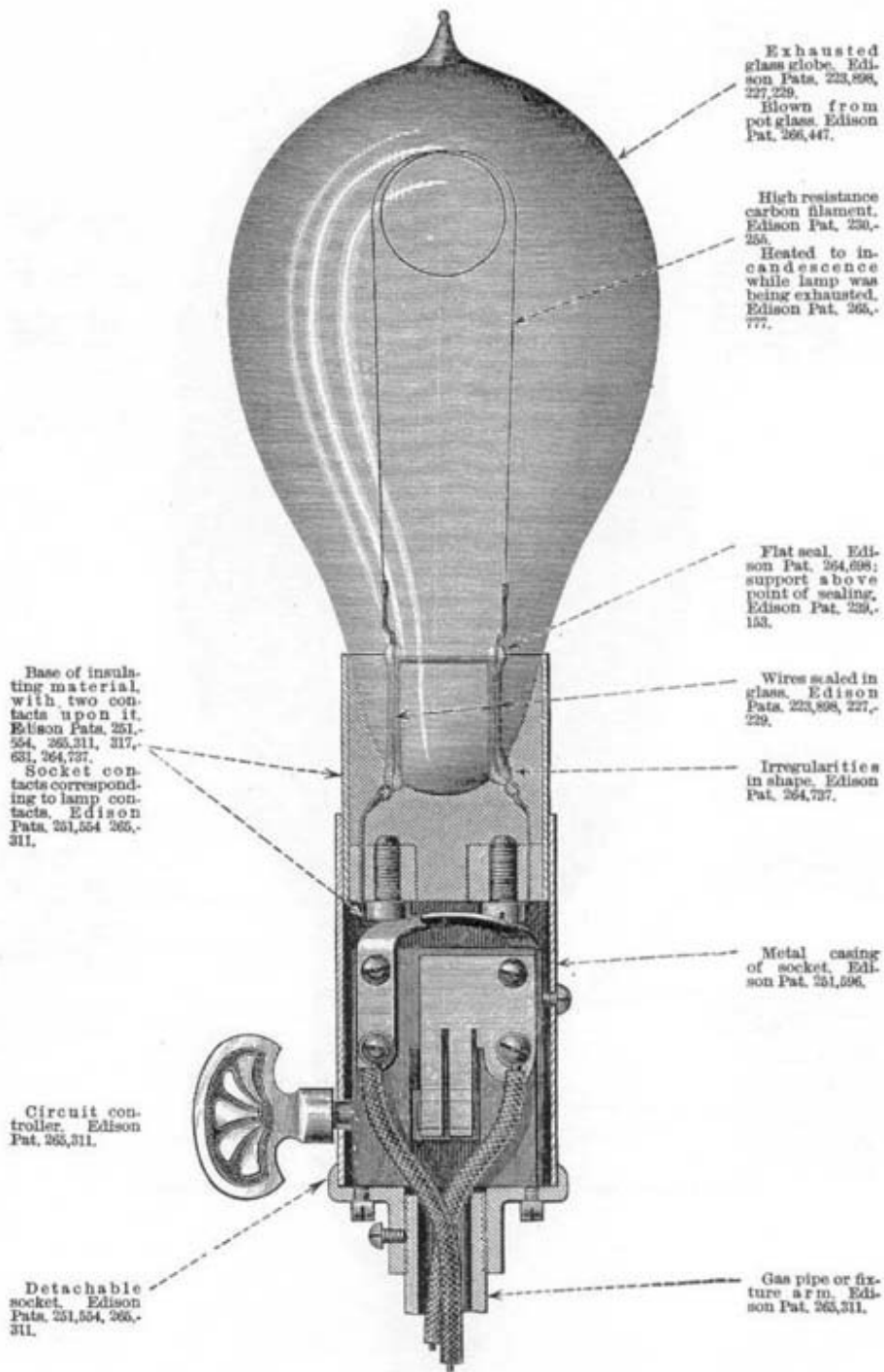

Brush-Swan Infringements of the Edison Patents.

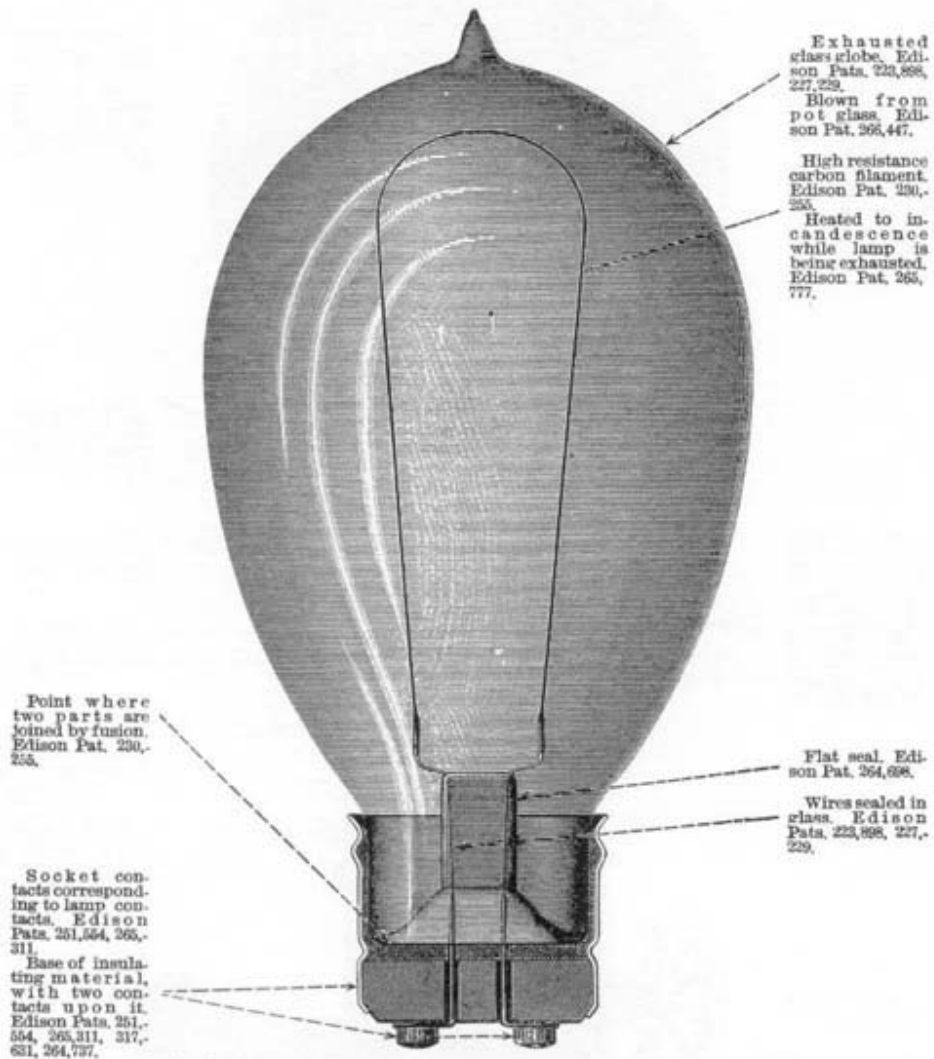

Westinghouse Co. Infringements of the Edison Patents (No. 1).

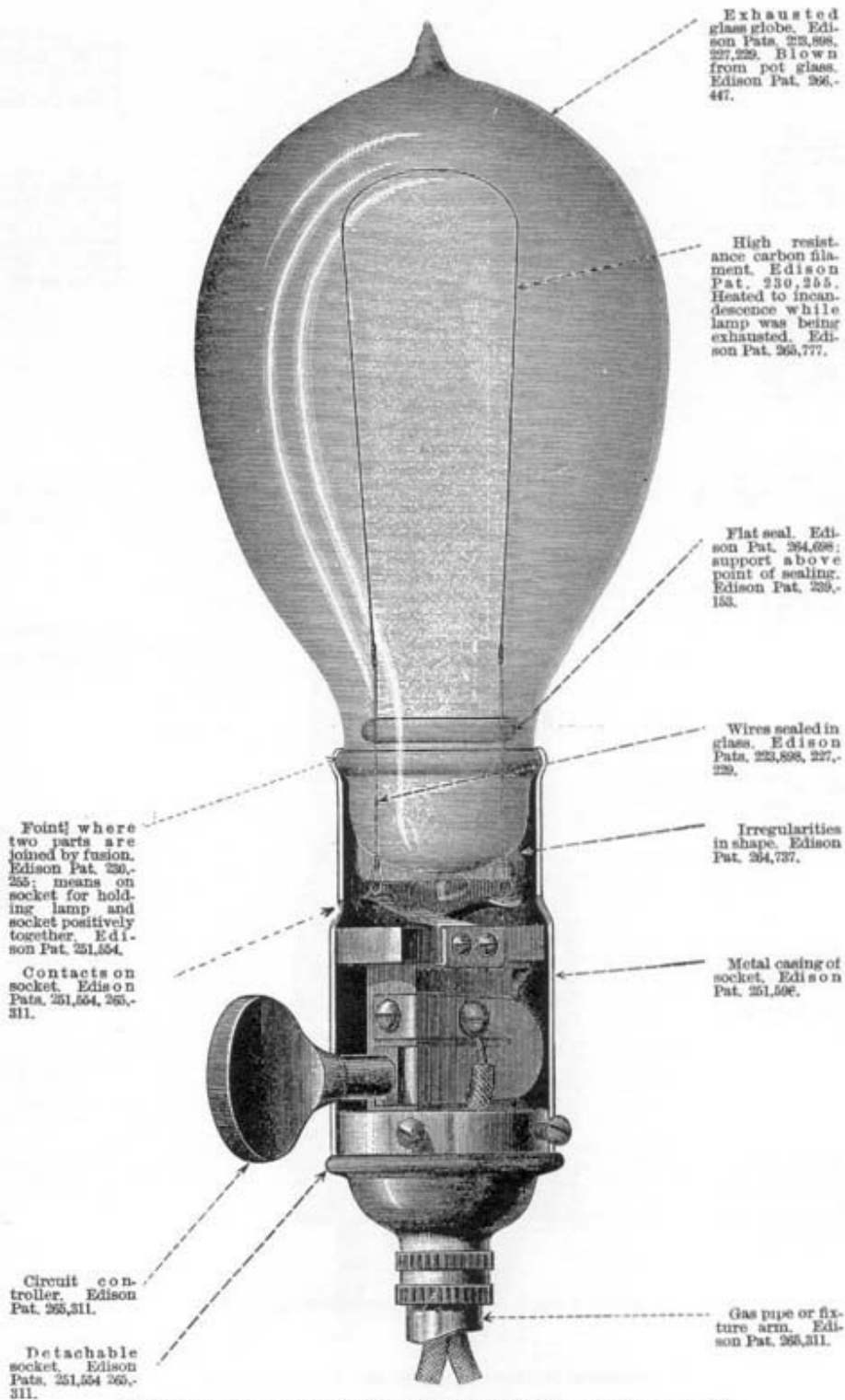

Exhausted glass globe. Edison Pat. 23,898, 227,229. Blown from pot glass. Edison Pat. 266,447.

High resistance carbon filament. Edison Pat. 250,265. Heated to incandescence while lamp was being exhausted. Edison Pat. 268,777.

Flint seal. Edison Pat. 264,698; support above point of sealing. Edison Pat. 239,153.

Wires sealed in glass. Edison Pat. 233,898, 227,229.

Irregularities in shape. Edison Pat. 264,737.

Metal casing of socket. Edison Pat. 261,506.

Point where two parts are joined by fusion. Edison Pat. 230,255; means on socket for holding lamp and socket positively together. Edison Pat. 251,554.

Contacts on socket. Edison Pat. 251,554, 265,311.

Circuit controller. Edison Pat. 265,311.

Detachable socket. Edison Pat. 251,554, 265,311.

Gas pipe or fixture arm. Edison Pat. 265,311.

Westinghouse Co. Infringements on the Edison Patents (No. 2).

## Reference

1) The Edison Electric Light - The Legal and Commercial Status, E. H. Johnson, Oct 7, 1886, 25 pages.

Go to: [Early Incandescent Lamps](#), or click "Back" on your browser

## Cartwright Waterproof Socket

"A new waterproof socket, introduced by the E. S. Greely & Co., is herewith illustrated. It is known as the Cartwright waterproof socket. It is claimed for the device that the porcelain itself, which forms the shell of the socket, is a thoroughly vitrified substance. The metal parts are fastened to the porcelain frame and do not depend for their security upon the sealing compound. The sealing compound itself is of a quality that will stand a zero temperature without deterioration and at the same time will admit of the heat that results from a 3 ampere lamp without softening, although the device is designed simply to meet the requirements of lamps from 1/2 to 1 ampere capacity.

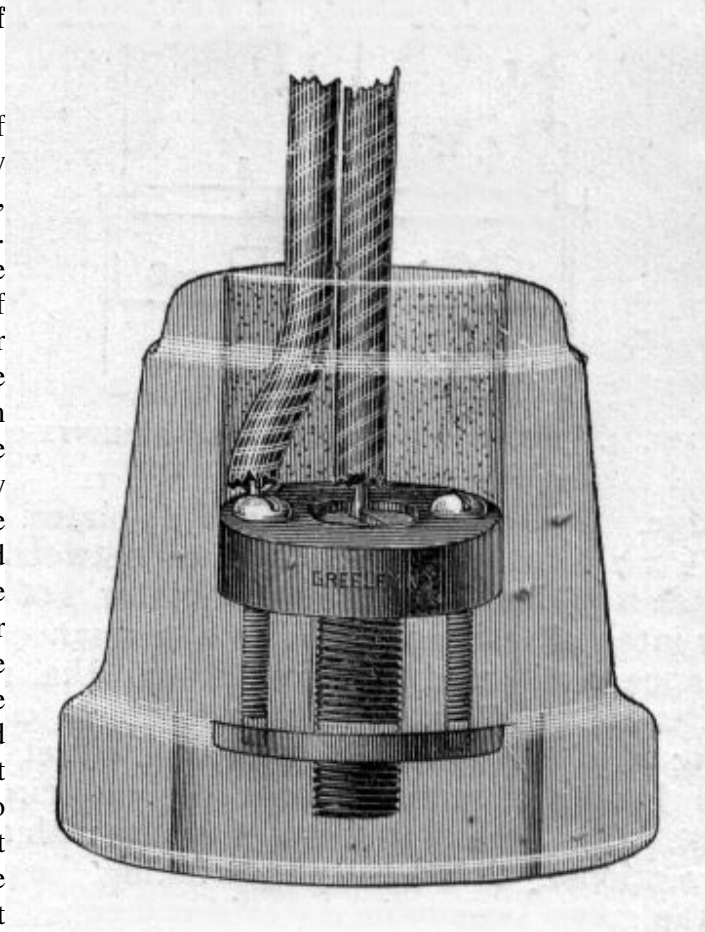

"The Cartwright Waterproof Socket is made in three patterns to accommodate lamps of the Edison, Thomson-Houston and Westinghouse types. They are made, as shown in the illustration, with rubber insulated terminal wires projecting several inches from the shell to admit of rod connections."

**Reference**

1) "Cartwright Waterproof Socket", *Western Electrician*, Vol 8, No 12, Mar 21, 1891, pg 161. **A New Incandescent Lamp Socket**



It is always of interest to unveil lamps or sockets from the past even though they might not be that important in the overall picture. This subject deals with a lamp "socket" that was purported to improve lamp performance. In its entirety the article<sup>1</sup> read:

"Progressive electric light men recognize the fact that perfection in fixtures is as much to be striven after as perfection in the electric light itself. In fact without it perfection in operation can not be approached. A step in the right direction has been taken by the Electric Construction and Supply company of New York, whose new socket for incandescent lamps is illustrated herewith. It is claimed for this socket that by its use a perfect vacuum is obtained in the socket itself, and the consequent loss, where a socket which is not air tight is used, is avoided. It is said that the loss sometimes reaches ten per cent with socket not perfectly air tight.

"To describe the socket, D is a brass shell, fitting into the lamp of course. This fitting is made perfect by stretching over it the rubber cap H. The heat of the lamp vulcanizes the rubber to both the glass and the socket, thus rendering the passage of air impossible; E is a brass screw cap which screws into D. This fitting is also made air tight by a rubber washer which the screwing in of the brass cap presses tightly into the joint. Another rubber washer prevents the passage of air around the stem G. It will be seen that all of the places where the air generally gets through are protected by these thin rubber caps and washers. Although hardly on the market it is said that these sockets have already received the indorsement of some of the large incandescent companies."

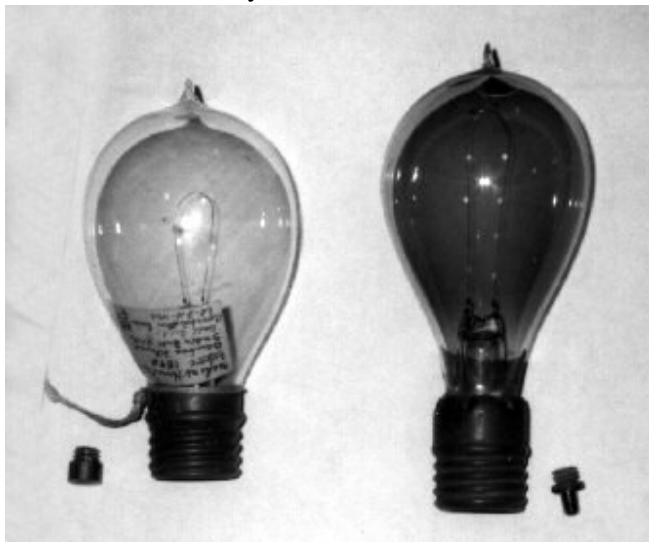

**Reference**

"A New Incandescent Lamp Socket", *Western Electrician*, Vol 2, No 19, May 12, 1888, pg 232. **Convertible Lamp Bases**

The picture shows two lamps that could be used in one of three sockets □ the Edison, Thomson-Houston or



Westinghouse. The lamp on the left could be used in a Thomson-Houston socket, as shown; the base threads that are visible would not have been used. A tapped hole is in the bottom of the base for contact with the T-H socket. If the threaded piece shown is screwed into the center tapped hole the base would be converted into an Edison base and the threads would therefore become functional.

In the picture to the right the same type of lamp base is shown but the small screw contact would convert the base so that it could be used in a Westinghouse socket. Thus, with either lamp, if the small screw contacts were available, the lamp could be used in three different sockets.



**Lamp Base Display**  
 In 1923 M. D. Cooper published an article<sup>1</sup> in the *Electrical World* that was titled "Simplification in the Lamp Industry." It was a time when change was necessary as far as lamp bases (and sockets) and voltages were concerned. That part of Cooper's article that deals with bases is presented here. The selection of standard voltages also had a marked effect on the reduction in the number of lamp types manufactured. Regarding standardization of bases and sockets, Cooper said:

"The average person in buying an electrical article of any kind - a receptacle, a lamp or the like - has little conception of the meaning to him of the simplification work which is embodied in that device. This simplification work may favorably affect any or all of the following attributes of the thing purchased: (1) The quality; (2) the price; (3) the adaptation to the function to be performed; (4) the ready availability of the device in quantities as desired.

"To get a realistic picture of the advantages of simplification, consider for a moment some of the steps toward simplification which have been taken in the incandescent lamp industry, and then visualize what the conditions in the electrical trade would be today if these simplifications had not been accomplished.

### **Fifty-Five Thousand Varieties**

"In the '90s there were in common use in this country fourteen different kinds of bases, with their corresponding sockets, for incandescent lamps. This number does not include the large bases used on series-burning lamps for street lighting. Incandescent lamps for general lighting service were also supplied for each individual voltage between 100 and 130. There was some demand for lamps of 200 volts and above, but for purposes of comparison with present conditions these may be neglected. Without regard to such differences in design of the lamp as shape of bulb, mounting of the filament

or finish of the bulb (such as clear or frosted), there were therefore for each individual size of lamp thirty times fourteen, or 420, possible variations which had to be taken into account in manufacturing that one size of lamp.

"In the year 1900 the only kind of lamp available was the carbon-filament lamp, of which there were five standard sizes - the 2, 4, 6, 8, 16 and 32 cp. Different manufacturers used different forms of filament construction and also different sizes and shapes of bulb. For purposes of illustration, let us say that there were only four of these variations in bulb size and shape. As to bulb finish there were three variations - clear, bowl-frosted and all-frosted. Variations of bulb color can be neglected, since lamps with colored bulbs had a limited application. At the beginning of this century there were, then, four times three, or twelve, possible variations of bulb shape and finish, or twelve times 420, or 5,040, variations in each size of lamp. At least three of the five regular sizes of lamps were each made for three different efficiencies. In respect to size and efficiency there were then eleven variations, and the total number of types of lamps was eleven times 5,040, or about 55,000 - all used in the ordinary course of incandescent lighting.

"The first efforts toward simplification had for their object the standardization of the lamp base. In spite of the general opinion to the contrary, this simplification was not difficult to accomplish. The Edison screw type of base, or the medium screw as it is now called, was chosen as the type for future standardization, and by means of adapters the use of the medium-screw base in the sockets of the other principal types was made possible. The lamp manufacturers contributed very largely to the speed with which the movement was accomplished by offering a lamp with the standard base together with an adapter at the same price which was charged for the lamp carrying the base which it was desired to eliminate. Simultaneously, steps were taken which led to the standardization of the mogul-screw base for series lamps. It was but a few years until the demand for lamps with any except the standardized bases had decreased to an infinitesimal percentage of the total demand, and at the present time, twenty years after, one of the superseded types of bases or sockets is a museum exhibit rather than an article of every-day commerce. This standardization of bases decreased the number of types of lamps in common use for multiple lighting from 55,000 to one-fourteenth of that number, or 3,900."

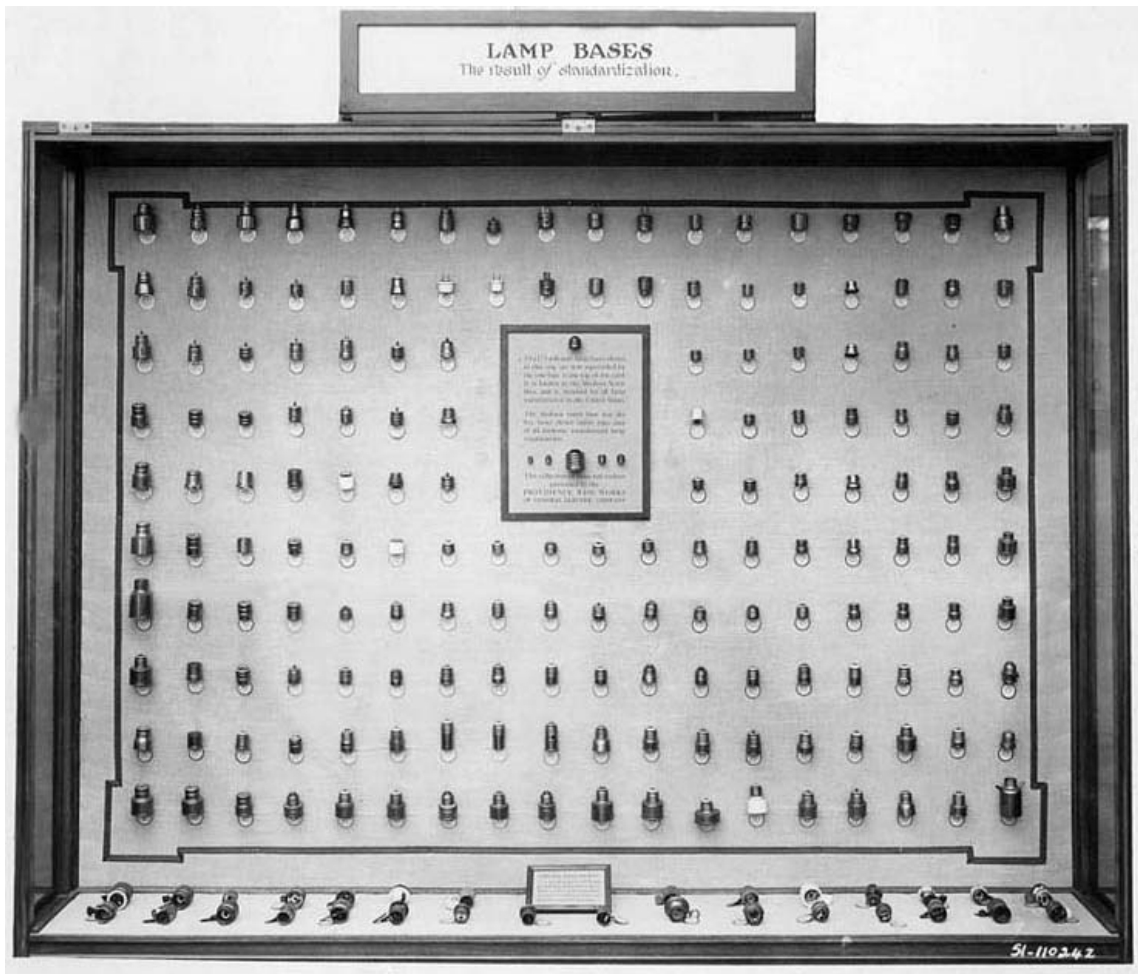

The picture above was taken from original photograph used in Reference No. 1  
 Dimensions of picture in the article are about 2-1/4" by 3"

The base (and socket) display board shown in the Cooper paper was constructed by the Providence Base Works, of the General Electric Company. It has 18 columns and 10 rows of bases - minus 12 bases (where a smaller display board exists.) Therefore there were a total of  $180 - 12 = 168$  different lamp bases on the board. The writer had the opportunity to see the original photograph of that board as well as about two-thirds of the bases. A scanned image of the picture is shown above. With the aid of a hand magnifier and the original photograph, the tag on each base could be read and the base type determined as well. The number of bases on the board that were manufactured by different companies is tabulated below. The Edison medium screw base plus the five new bases shown on the small display board supplanted all of the bases displayed on the board. It is believed that the display bases were made about 1900.

<u>Base Type</u>	<u>No. of Bases</u>	<u>% of Total</u>
Edison	60	35.7
Ediswan	31	18.4
Thomson-Houston	24	14.2
Westinghouse	14	8.3
United States	7	4.1
Brush-Swan	6	3.5
Westinghouse/Edison	4	2.3
Schaefer	3	1.7
Truitt	2	
Hawkeye	2	
Loomis	2	
Westinghouse Stopper	2	
Bernstein	2	
Perkins	2	
Elblight	2	
Cruto	2	
Fort Wayne	1	
Heisler	1	
Thomson-Houston/Edison	1	
	168	88.2% of total

It can be seen that about 88% of the bases displayed on the board were made by eight companies.

Some of the actual bases that were mounted on the display board are shown below.



Edison bases



Edison bases



Ediswan (bayonet) double contact bases



On left: Three single contact Ediswan (bayonet) bases. On right: Truitt base



Brush-Swan bases



Westinghouse bases





United States bases



Thomson-Houston bases



Base types, from left to right: Loomis, Fort Wayne Jenney, Schaefer, Perkins (or Mather)



From left, two Westinghouse Stopper bases, Mogul Heisler round pin base, Mogul Bernstein round pin base



Edison-Westinghouse combination bases

**Note:** The image of M. D. Cooper was taken from Reference 2.

#### **References**

- 1) M. D. Cooper, "Simplification in the Lamp Industry - How the 55,000 Types of Lighting Units in Existence in 1900 Have Been Reduced to 342 - Standardization of Lamp Bases and Voltages," *Electrical World*, Vol 82, No 12, Sep 22, 1923, pp 629-631.
- 2) Book of the Incas, 1928.

#### **Edison U.S. Patent No 444,530 (and Reissue No 12,393)**

Edison's Patent No 444,530 deals with the leading-in wire. The patent figures appear below.

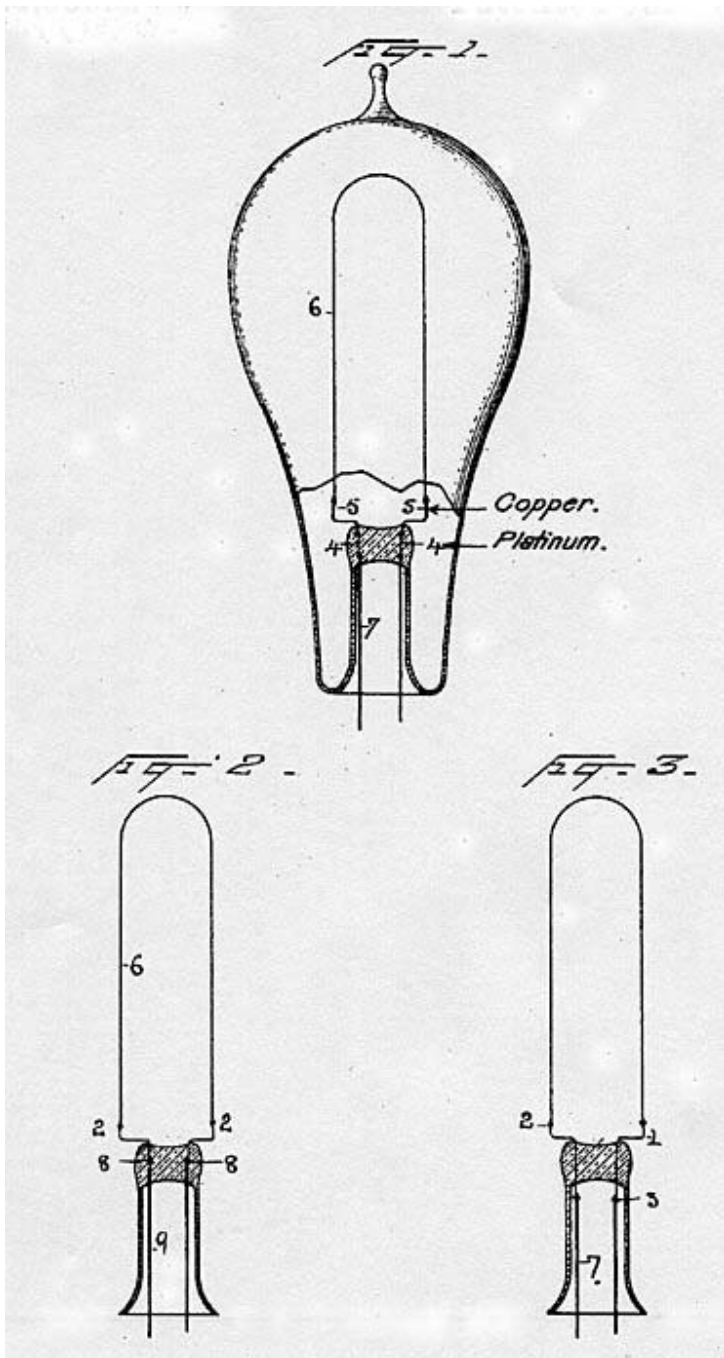

Fig 3 represents the Edison stem press as manufactured in 1889. Fig 1 represented the stated preferable design being patented whereas Fig 2 represented an alternative acceptable design. In Fig 1 the length of the platinum wire was reduced to a length of 1/8th of an inch. Four welds were embedded in the seal region. In time, however, it was found that Fig 1 was not the preferable design for the reason that "the copper wire was not found advantageous to clamp the filament to, and was abandoned as a clamp wire after many inferior lamps had been made" (J. T. Marshall, "The Development of the Manufacture of the Edison Incandescent Electric Lamp - 1881-1905," *Journal of the Franklin Institute*, Vol 160, 1905, pg 28). However, the design in Fig 1 was used from 1890 to 1894. It is surmised that the

advent of the carbon paste joint was a welcome relief from the arduous plating required with the copper inner lead; the new procedure, shown in Figure 2, was also less expensive than the old one. In 1894 the design shown in Fig 2 was adopted for use in manufacturing Edison lamps. The method remained in use as long as carbon filament lamps were manufactured.

The U.S. Patent No 444,530 was applied for Sep 15, 1890 and was issued Jan 13, 1891. It was reissued; the application was filed Jul 12, 1905 and reissued Oct 10, 1905. However, on May 14, 1908 the patent was declared invalid, on the grounds that the wire arrangements simply provided a mechanical improvement (*Electrical World*, Vol LI, No 21, May 23, 1908, pg 1084). It was also claimed that Heisler had used the joint "before the period which the patent was claimed to cover." It was a unimportant point, however, as the patent had already expired (in Jan 1908).

As it concerns this patent, the writer is confused about statements made by Arthur A. Bright, Jr. ([The Electric-Lamp Industry: Technological Change and Economic Development from 1800 to 1947](#), The Macmillan Company, 1949.) On pg 125, and then again on pg 205, he referred to the three-part leading-in wire as the "Siemens" seal. It would be of interest to determine if Siemens had their own seal or whether it was the same as the Edison seal. It would be appreciated if a knowledgeable viewer of this site could clarify this issue for the benefit of the writer and lamp collectors.

### **Dates on Very Early British Patents**

When recently issued U.S. patents are examined, one finds two dates that tell when the application was filed and when the patent was granted or issued. The situation is somewhat different when early British patents are examined. The following briefly explains the meaning of the dates in that case.

Three dates appear on early British patents. As an example, the patent granted to Edward Augustin King (or J.W. Starr) for two lamp designs will be considered. This patent has "A.D. 1845.....No. 10,919." at the top of the pages. Within the document the three dates, in the order in which they appear, are: 4 Nov (1845), 2 May 1846, 4 May 1846. It can be seen then that the patent number is identified with the first date.

The first date is the date of application, the second is when full patent specifications were submitted and the third date was called the date of enrollment; it was the date on which the patent was granted. It follows, therefore, that King's patent was applied for in 1845 but issued in 1846.

Apparently "Patents between 1617 and 1852 were not officially published until a gentleman named Bennett Woodcroft, who was the Superintendent of Specifications and Indexes in 1852, implemented many changes including an extensive programme of publishing. All patents between 1617 and September 1852 were numbered and printed along with those from October 1852 onwards.

"Patents pre 1852 were applied for in theory only with the actual specification being presented within six months of this date and then 'enrolled' a few days later at one of the three Chancery Offices of the applicants choice."

As it regarded the King (or Starr) patent□

"Prior to the Patent Law Reform Act of 1852 the grant of a single patent did not apply to the whole of the United Kingdom. Separate grants were required for each of England, Ireland and Scotland.

"In Scotland application for a patent was made to the Home Secretary. A warrant was issued and 'Sealed', the specification itself was to be lodged with the Chancery Office within four months. Once all this was done the granted patent lasted for (normally) fourteen years. Today (2001) the specifications are held in the care of the Scottish Record Office at Edinburgh.

"Something the British Library does hold...is a volume titled 'Scotland, Alphabetical Index of Patentees 1767 to 1855.' There is an entry under the year 1846 - no exact date is given - for Edward Augustin KING, the title of the invention is listed as 'Light by Electricity.'"

As an aside, the second patent granted to Edward Augustin King (for Magneto-Electric Machines) carries the following three dates: application, 30 Apr (1846); date of full specifications, 30 Oct 1846; enrollment, 30 Oct 1846.

The writer is indebted to Maria Lampert of the British Library for much of this valuable information.

### **A Review of the Henry Goebel Defense of 1893**

---

A picture of Henry Goebel, as well as some additional references that pertain to the 1893 litigation, are added to this existing write-up. The picture was scanned from the *Western Electrician*, Vol 13, No 25, Dec 16, 1893, pg 307.



#### **References re Goebel in *Western Electrician* (WE)**

"Incandescent Lamp Litigation," WE, Vol 12, No 5, Feb 4, 1893, pg 55.

"Incandescent Lamp Litigation," WE, Vol 12, No 16, Apr 22, 1893, pg 207.

"Incandescent Lamp Litigation," WE, Vol 12, No 17, Apr 29, 1893, pg 220-221.

"English View of the Incandescent Lamp Situation," WE, Vol 12, No 23, Jun 10, 1893, pg 306.

"Expiration of the English Incandescent Lamp Patent," WE, Vol 13, No 22, Nov 25, 1893,  
pp 278-279.

"Final Decision in the Hydro-carbon Suit," WE, Vol 13, No 24, Dec 9, 1893, pg 303.

"Henry Goebel," WE, Vol 13, No 25, Dec 16, 1893, pp 307-308.

---

#### **Preface**

This review concerns some of the litigations that occurred in 1893 when the Edison Electric Light Company brought suit against several manufacturers of incandescent lamps for apparently infringing Edison patents. Three such companies fought the court battles by declaring the Edison patents null and void because of the same invention 25 years earlier by Henry Goebel. Two of the companies had injunctions brought against them whereas in the other case the judge declined to grant the injunction. That case, which involved the Columbia Incandescent Lamp Company, of St. Louis, Missouri, was not brought to final hearing before the basic Edison filament patent expired in Nov 1894. The fact that the final hearing was never held in the Columbia case has given some people the notion that it is appropriate to give Goebel credit for the invention. This review was undertaken to see if any new insights resulted after an interval of about 108 years.

Some background information on the development of the electric incandescent lamp might offer the reader perspective for the material that is presented below. The first incandescent lamp was probably invented in England in the year 1841 by Frederick de Moleyns. His lamp contained a platinum filament and it marked the beginning of lamp construction as it would eventually be developed. Then, in 1845, John Wellington Starr, an American who traveled to England, suggested the use of carbon as the illuminant<sup>98</sup>. The story of Goebel's work is said to have started about nine years later, in 1854. It is well known that very significant contributions were made later by men like Sawyer and Man, Swan, Maxim, Perkins and others.

## Introduction

The year 1893 was one that is remembered for several reasons. The United States was in a financial panic, President Grover Cleveland began his second term in the White House, and the Columbian Exposition (Chicago's World Fair) opened in May of that year. In addition, the incandescent lamp industry was in the throes of patent litigations, brought about mainly by the Edison Electric Light Company. The Columbian Exposition served as a pleasurable outlet for the citizens in difficult times. The Exposition also provided an opportunity for George Westinghouse to introduce a non-infringing lamp (known as the Westinghouse Stopper Lamp) at a time when the Edison interests controlled a near-monopoly of the lamp industry. The story of the Stopper lamp is an interesting one but it is outside the



scope of this writing.

The Edison interests believed that many lamp manufacturers were infringing the Edison lamp patents. That view became clear in May 1885 when suit was brought against the United States Electric Lighting Company. Then, in 1886, E. H. Johnson, President of the Edison Electric Light Company, said <sup>2</sup> :

"The fact that Mr. Edison invented the incandescent lamp in the form in which it is now presented by all electric light companies was so widely proclaimed by the publication thereof in every class of literature at the time of the invention, that it would seem very like an insult to the intelligence of the community to recall it. Indeed, a retrospective view of the history of the great invention is rendered unnecessary by the fact that even the infringing companies themselves do not dwell upon their claim to the ownership of original patents, but fortify their position by the assertion that Edison's patents are invalid and open to the public, and offer in corroboration of their statement the apparent apathy of the Edison Company in the matter of defending them."

However, legal action had started in May 1885 against the United States Electric Lighting Co. <sup>3</sup> . That case persisted for many years, ending finally in the Court of Appeals on Oct 4, 1892 - in favor of Edison <sup>4</sup> . It was after the formation of the General Electric Company in 1892, when the Thomson-Houston Electric Company joined forces with the Edison General Electric Company, that courtroom activity increased significantly. For example, legal proceedings had been initiated against the Mather, Perkins, Sunbeam, Germania, Boston Incandescent Lamp and Sawyer-Man companies.

Some litigations involved the alleged earlier invention of the lamp by Henry Goebel. In order to try to justify the lamps being made, it was claimed that as early as 1854, Goebel, a German immigrant, had made lamps that were in all design aspects exactly like the lamp developed by Edison in 1879, and manufactured in late 1880. That is, the lamp contained a



high resistance filament of carbon (the high resistance being necessary, according to Edison, when lamps were to be operated in parallel), platinum lead-in wires in an all-glass envelope, and a high vacuum to prevent disintegration of the carbon; the source of the carbon in late 1880 was bamboo. The complainant found it highly unlikely that an individual with limited financial means, facilities and support personnel could arrive at a design 25 years earlier than that achieved by Edison, which required the synergism of thousands of experiments and numerous technical contributions from highly skilled workers.

The small manufacturer of lamps had a difficult time trying to produce product that did not infringe the Edison patents. It was not until the increased patent litigations of 1893 occurred that attempts were made to develop and sell non-infringing lamps. A notable example of a lamp that was marketed was the so-called Westinghouse Stopper Lamp, which was introduced at the Columbian Exposition. Another stopper lamp was the one manufactured by the Beacon Company. Some lamps were found, upon litigation, to infringe; one such lamp utilized the Edward Pollard silver films in the stem press. Another, called the "Novak", contained a trace of bromine gas. Eventually such lamps disappeared from the marketplace, either because of their inferior performance, higher cost, or patent infringement.

### **Edison Lamp Patents**

Thomas Alva Edison was granted 1093 United States patents during his lifetime. In addition, up until the year 1910 he was granted 1239 foreign patents in 34 countries. Many of the patents dealt with incandescent lamps and associated equipment used in conjunction with the generation of power as well as for the operation of lamps. The basic filament was covered by U.S. Patent No 223,898, which was applied for on Nov 4, 1879 and granted Jan 27, 1880. The patent covering the use of bamboo for the filament, U.S. 251,540, was applied for on Aug 6, 1880 and granted Dec 27, 1881.

As mentioned above, on Oct 7, 1886, E. H. Johnson, published a 25-page booklet that listed Edison patents granted from 1876 to 1886 and showed drawings of the lamps made by the companies that apparently infringed the basic patent <sup>2</sup>. These included the United States Company (Weston lamp), Brush-Swan, two Westinghouse lamps, Bernstein, Mather and Consolidated (Sawyer-Man).

The booklet described the claims of twelve patents that covered the Edison lamp and its component parts. Other patents covered topics such as vacuum pumps, sockets, electric meters, regulators, lamps, chandeliers, batteries, arc lights, electrical conductors, systems of electric lighting and molds for carbonizing. Some of the alleged infringing lamps were illustrated in the booklet and the various infringement locations noted, along with the corresponding Edison patent numbers. The Edison lamp, shown in the Johnson booklet, is reproduced below.

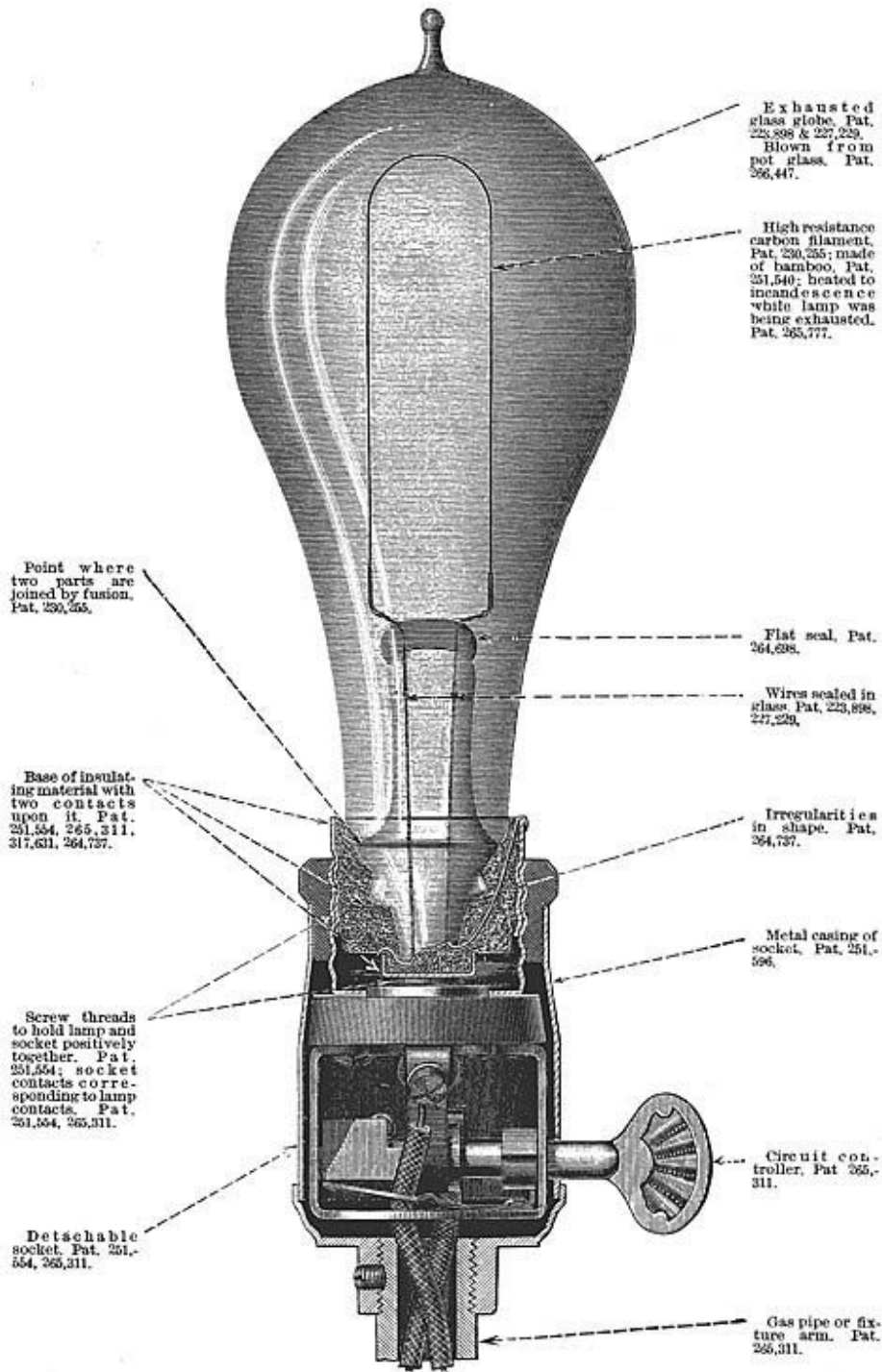

**Franklin Leonard Pope**

This writer believes that the great emphasis that was placed on Henry Goebel's purported early accomplishments before the lamp litigations of the 1890s, was due in large measure to an article Franklin Leonard Pope (1840-1895) published in the *Electrical Engineer* in Jan 1893<sup>8</sup>. Pope also provided affidavits for some court proceedings. He was a highly respected person in electrical circles who wrote historical articles on subjects of the day - one dealt with the telegraph - and he was editor-in-chief of the *Electrical Engineer* in the late 1880s. Pope was also the President of the American Institute of Electrical Engineers in 1886. He wrote a book titled Evolution of the Electric Incandescent Lamp - with two editions appearing<sup>80</sup>. A comment on that book is located in the Discussion section.

## Henry Goebel

Henry Goebel (1818-1893) was born on Apr 20, 1818 in Springe, Germany - a village about 15 miles southwest of Hannover<sup>8,9</sup>. In Germany he was known as Heinrich Göbel, his full name being Johann Heinrich Christoph Conrad Göbel<sup>97</sup>. His father was Johann Heinrich Christian (1781-1845) and his mother, Marie Eleonore (1778-1855)<sup>97</sup>; his father was a landscaper, and later a manufacturer of chocolate.

The following information regarding Goebel was taken from affidavits given for patent litigations (which are included in the References) as well as the above-mentioned article by Pope. The accuracy of the information is uncertain.

In an affidavit, Goebel wrote that he learned the trade of watchmaker and optician in Germany<sup>9</sup>. He became associated with a person there for whom he repaired physical instruments. Supposedly it was from that person that he got the idea of making an electric light by passing an electric current through a carbon conductor placed in a vacuum.

Goebel left Germany with his family in 1848, and after a voyage of about three months, arrived in New York City in the early part of 1849. He resided in the city of New York for the rest of his life. At the time of his death, which was due to pneumonia, seven of his fourteen children survived him<sup>74</sup>.

## Goebel Patents

Henry Goebel was granted three U.S. patents. Although it is believed by this writer that the lamp-related ones were of minor importance from a technical standpoint, the dates of application and issue have some significance. The U.S. patents were: No 47,632, Improvement in Hemmers for Sewing Machines, issued May 9, 1865; No 252,658, Vacuum-Pump, issued Jan 24, 1882; No 266,358, Electric Incandescent Lamp, issued Oct 24, 1882.

The subject of the first patent is of no interest in this writing; only the date is of some importance (to be mentioned later). The second patent deals with a minor modification of the vacuum pump developed by Heinrich Geissler (1814-1879) in 1855. That pump design was apparently used by Goebel at a later date to evacuate vessels (thermometers, barometers, lamps, etc) by the Torricellian method. Goebel's third patent consisted of a method of attaching a filament to lead wires in a lamp. It appears to be a modification of

methods developed by others. Edison's method consisted of a simple crimping of the lead wire over the filament. While the patent was novel it did not advance the development of the incandescent lamp in any measure. Goebel's patents, then, were awarded in 1865 and 1882.

### **The "Goebel Defense"**

Three litigation cases brought by the Edison interests against lamp manufacturers were challenged in the courts by what became known as the "Goebel defense." All other litigants were concerned with details of the basic Edison patents. Because an alleged infringer achieved little success when a basic patent was the issue, a new approach was taken - and that was to claim that someone else invented the lamp before Edison. If it were true that someone other than Edison invented the lamp then anyone would be free to manufacture and sell incandescent lamps. The three companies were:

#### **Beacon Vacuum Pump and Electrical Company, of Boston**

The Beacon Co. was enjoined to engage in lamp manufacture on Feb 18, 1893<sup>24</sup>. Judge L.B.B. Colt, of the United States Circuit Court for the Southern District of New York, granted the temporary injunction. Dissolution of the injunction was not sought because a new lamp had been developed by Cary and Nickerson that was believed not to infringe the Edison patent<sup>65</sup>. One year later, in Feb 1894, large numbers of the "New Beacon" lamp were being shipped.

The reasoning of the court in granting the injunction is important to understand. Quoting from the Feb 18, 1893 opinion of the court<sup>24</sup>:

"There is no denial of infringement in the present case under the construction given to the patent in prior adjudications. The contention of the defendants is, that this motion should be denied on the ground that Henry Goebel, a German watchmaker, living in New York, invented the Edison incandescent lamp as early as 1854, and that, therefore, the Edison patent is void for want of novelty, or, at least, must be limited to the coiled form of filament. This is the same line of attack upon the patent which was unsuccessfully made in the case against the United States Electric Company. It was there urged that the Starr lamp of 1845, the Roberts lamp of 1852, the Lodyguine, Konn, and other lamps which appeared between 1872 and 1876, the Bouliguine lamp of 1877, the Sawyer and Man lamp of 1878, and the Edison platinum lamp of 1879, limited the Edison patent to narrow inventions or rendered it void for want of patentable novelty. But the court, with a most exhaustive review of the prior art before it, refused to take this view and held that the second claim of the patent, read with the specification, covered a broad and fundamental invention, namely, an incandescent lamp composed of a carbon filament hermetically sealed in an all glass chamber exhausted to a practically perfect vacuum, and having leading-in wires of platinum...

"By this invention Edison disclosed to the world for the first time a practical, commercial incandescent lamp, adapted for domestic uses. The problem was by no means easy of solution...

"To subdivide the electric light and embody it in a cheap and durable domestic lamp, capable of successfully competing with gas, had for years baffled the science and skill of the most eminent electricians in this country and in Europe. The difficulty lay in the practical construction of a durable incandescent lamp rather than in a knowledge of the elements which should compose such a structure."

### **Columbia Incandescent Lamp Company, of St. Louis**

After the granting of an injunction against the Beacon Vacuum Pump and Electrical Company no one expected the Columbia Company to also take up the Goebel defense during its court proceedings. However, that is exactly what it did. The person behind the drive to again use the Goebel defense was the President of the Company, J. H. Rhotehamel (1857-1898)<sup>42</sup>. Based on the information presented, Judge Moses Hallett of the United States Circuit Court, for the Eastern District of Missouri, denied the granting of an injunction<sup>38</sup>.

After the injunction was denied, the burden of proof rested with the Columbia Incandescent Lamp Company; it had to produce sufficient testimony to prove their allegation that Henry Goebel was the inventor of the incandescent lamp. That meant a delay of many months, at a minimum, before a trial could begin. Time was to run out, however, for the filament patent was to expire the following year. It should be emphasized, however, that Judge Hallett's only decision was simply not to grant an injunction. The headlines in an article in the *Electrical Review* of Apr 29, 1893 stated that Judge Hallett believed Goebel's lamp preceded Edison's. That is a misstatement of Judge Hallett's decision.

A picture of some Goebel lamps used in that litigation is presented below. Apparently it is the same photograph that was used by Dodd in his book, which was published in 1910<sup>94</sup>. When the picture was discovered in an archive it was noticed that the filaments of some of the lamps had been inked in on the print. It should be pointed out that some of these lamps apparently were made for the purpose of presentation in the court proceedings; this fact was brought out in the affidavits.

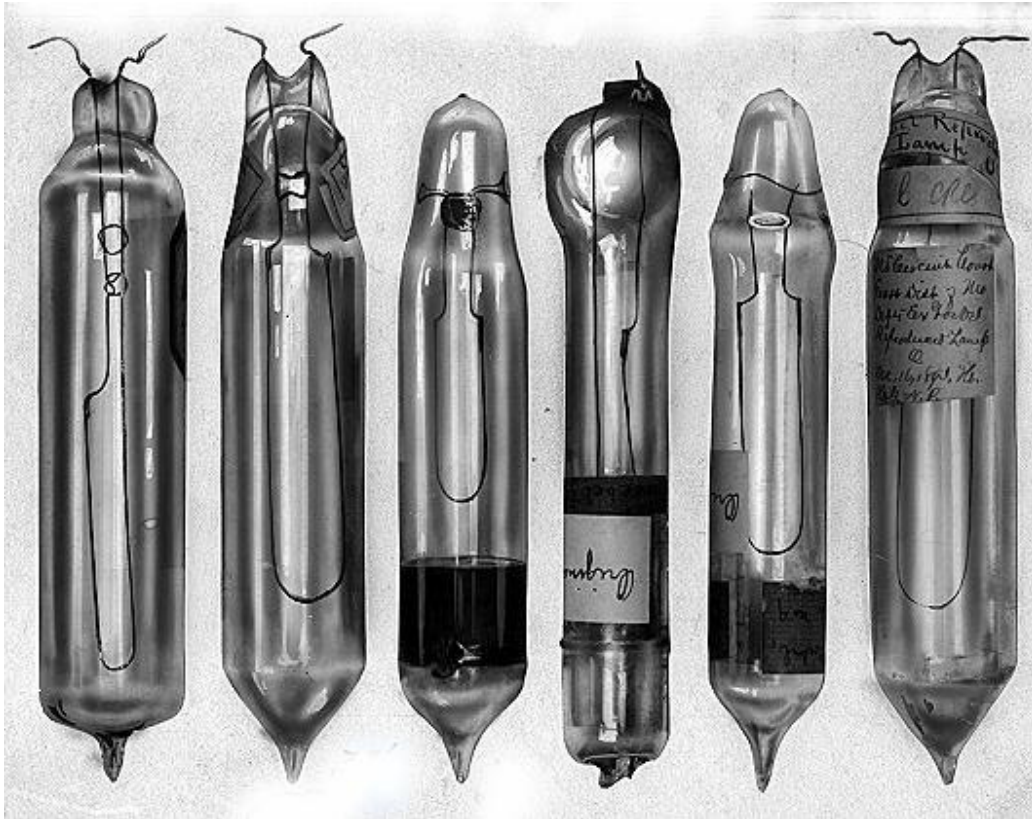

### **The Oconto Case - Electric Manufacturing Company, of Oconto**

The third lamp manufacturer to use the Goebel defense during alleged infringement proceedings was the Electric Manufacturing Company of Oconto, Wisconsin. That litigation became known as the "Oconto Case." A temporary injunction was granted Jul 20, 1893 by Judge William H. Seaman of the United States Circuit Court in Milwaukee<sup>56</sup>. The decision was reaffirmed May 9, 1894<sup>85</sup>; that opinion was written by Judge James G. Jenkins of the United States Circuit Court of Appeals just six months before the expiration date of the Edison patent.

In the opinion of the court<sup>20</sup>:

"It has often been laid down that a meritorious invention is not to be defeated by something which rests in speculation or experiment, or which is rudimentary or incomplete. The law requires not conjecture, but certainty. It is easy after an important invention has gone into public use for persons to come forward with claims that they invented the same thing years before, and to endeavor to establish this by the recollection of witnesses as to events long past. Such evidence is to be received with great caution, and the presumption of novelty arising from the grant of the patent is not to be overcome except upon the most clear and convincing proof."

## Printed Criticisms of the Goebel Case

After the favorable article by Franklin Pope appeared in the *Electrical World*, and after the affidavits given by him in court litigations, Park Benjamin (1849-1922), an author and patent attorney, published a scoffing article in the *Electrical World* that mentioned (and perhaps compared) Goebel with one Daniel Drawbaugh, who lost the legal battle regarding the invention of the telephone to Alexander Graham Bell <sup>16</sup>. In addition, the *London Lighting* published a "witty" article about the litigation involving Goebel, which was reported in the *Electrical Review*, Apr 1, 1893 <sup>30</sup>.

## Expiration of the Edison Filament Patent

The basic filament patent granted to Thomas Edison that was at issue in much litigation, was No 223,898, dated Jan 27, 1880. Ordinarily such a patent would have been in effect for 17 years but a ruling existed which stated that a patent would expire at an earlier time if a foreign patent on the same invention were to expire before the normal period of 17 years passed. As it happened, a similar patent was granted in Canada on Nov 19, 1879; that patent expired Nov 19, 1894. The Edison U.S. patent No 223,898 therefore expired on that same date, Nov 19, 1894.

## Dates of Legal Decisions

The dates of some of the legal decisions, when the Edison group brought suit to obtain restraining orders and injunctions against alleged infringers who used the Goebel defense, are listed below:

On Jan 16, 1893 a restraining order was requested against Beacon <sup>7</sup>  
On Jan 17, 1893 a restraining order was issued against Columbia <sup>6,34</sup>  
On Feb 18, 1893 a preliminary injunction was granted against Beacon <sup>20</sup>  
On Apr 21, 1893 a preliminary injunction was denied against Columbia <sup>38</sup>  
On Jul 20, 1893 a preliminary injunction was granted against Electric Mfg. Co. <sup>56</sup>  
On May 9, 1893 the injunction was sustained against Electric Mfg. Co. <sup>85</sup>

## Discussion

The question of the invention of the practical incandescent lamp was determined in the courts and Thomas Edison is recognized as the true inventor. However, one is obliged to consider the decision made on Apr 21, 1893 as it regards the Columbia Incandescent Lamp Company. It is important, therefore, to comment on that decision as well as Henry Goebel's place in incandescent lamp history.

It would be a large undertaking to obtain and read all the affidavits and arguments that took place during the three litigation cases that involved the Goebel defense in 1893. In addition, this writer is not competent enough to second-guess three jurists. A "final" comment that sums up the conclusion of the court during the appeal of the Oconto case was <sup>85</sup>:

"The conclusions reached by the court are, that without assuming the story of Goebel's invention to be untrue, it is surrounded by such an atmosphere of improbability that until it is thoroughly sifted and sustained upon final hearing, the claim ought not to be allowed to stand in the way of a patent which has already safely passed the ordeal of judicial scrutiny."

Although an injunction in the Columbia case did not take place, perhaps because of the impending expiration of the patent, an appeal in the Oconto case was made and, in effect, that result could speak for the three cases that used the so-called Goebel defense. In that regard it is of interest to quote from the article titled "Judge Seaman's Opinion", which was published in the *Electrical World* on Jul 29, 1893<sup>57</sup>. It read, in part:

"When what has since become known as the Goebel defense was first introduced in the Beacon case at Boston, Judge Colt held that the burden of proof being on the defendants to show 'beyond a reasonable doubt' Goebel's priority of invention. He said in his opinion that the quality and quantity of the defendants' evidence were not sufficiently clear and convincing as to be beyond a reasonable doubt, and according to his interpretation of the law complainants were therefore entitled to an injunction. Judge Hallett, in the Columbia case at St. Louis, also passed upon the Goebel defense, but while agreeing with Judge Colt as to the character of the evidence presented, interpreted the law differently and decided that on the showing made the complainants were not entitled to an injunction. Judge Seaman follows Judge Colt in his decision, and says that 'it is clear that the presumption must be in favor of the patent, and that it cannot be overthrown by a mere doubt,' and adds that new evidence in such a case 'must be sufficient to raise a presumption that it would have defeated the patent had it been produced at the trial. This would demand, at least, the full measure required to overcome the presumptive force of the patent, and that every reasonable doubt be resolved against the defense.' Then, while admitting that the Goebel story 'is interesting, circumstantial and in many respects plausible,' he goes on to show that doubts exist, and decides that the complainant is entitled to an injunction."

Comments will now be made regarding aspects of the story that cast some doubt in the writer's mind, on the possibility of a practical lamp being made by Goebel that antedated the one by Edison. Several aspects of the story are troubling; not all of them will be addressed here. Some of the troubling aspects that are made here were also pointed out in the litigations.

It would be unrealistic not to believe that Henry Goebel was a very talented experimenter at the workbench. He learned by doing and his ability in glass working was notable. Apparently he possessed a curious mind, was intelligent and personable. It should also be believed that he made incandescent lamps and perhaps Geissler tubes. In the days before the year 1879 it seems likely that he might have made incandescent lamps with platinum filaments. Although platinum cannot be raised in temperature to the same extent as carbon (and, therefore will not provide as much light output), such a lamp had practical



advantages. Goebel evacuated lamps by the Torricellian method, which, in general would not be adequate for lamps containing filaments that react severely with air. That is, because mercury, glass, lead wires and filament materials contain occluded gases, those parts would have had to be baked out under vacuum conditions; that would have been difficult for Goebel to do in the 1850s. However, that would not have been a problem with a platinum filament as it can be operated in air for some time. William R. Grove made such a lamp in the year 1840, it being reported in the *Philosophical Magazine* in the year 1845<sup>80</sup>. Platinum wire would have been easily obtained between the years 1854 and 1879.

It was said that Goebel operated his lamps with batteries as the power source; he was not concerned with "subdividing the light" whereby lamps could be operated in parallel. The operation of a lamp with any filament material would be possible without the need to have a high resistance. A high resistance filament can be obtained by having the electrical conductor in wire form that has a small diameter and long length. It was difficult to make a satisfactory carbon filament in wire form before the advent of bamboo, and one would probably not attempt to make such a conductor without good reason.

Goebel did apply for, and was granted, a patent on a sewing machine hemmer in 1865. This writer is troubled by the fact that he did not apply for a lamp patent before 1881 or 1882; certainly that inaction, on his part, raises a question about the nature of the electric lights he was constructing.

Most of what can be documented about Goebel's lamp activities occurred after about 1881. This is an important point because Edison had already developed his lamp by 1879 and found bamboo to be an ideal filament material by 1880. Goebel did have access to the Edison developments regarding the incandescent lamp - perhaps through the German language newspaper *New Yorker Staats-Zeitung*. Also, he was employed for a period of time, about 1881, by a lamp making company, the American Electric Light Company, when he worked on carbon filaments<sup>15</sup>. Many of the affidavits submitted in the Beacon, Columbia as well as the Oconto case were by relatives of Goebel and other persons who were not particularly sophisticated as it regarded technical devices, such as lamps. The information that was presented in the three cases was of questionable accuracy and was circumstantial. Apparently Goebel did not exhibit an electric lamp to the public until May 1882<sup>12</sup>.

Although Franklin Leonard Pope wrote a favorable article about Goebel in Jan 1893, it appears he had met Goebel only a few weeks before that writing<sup>19</sup>. In the first edition of his book, Evolution of the Electric Incandescent Lamp, which was published in 1889, Goebel's name was not mentioned. In the second edition, which was published in Jan 1894, it still was not mentioned<sup>80</sup>. One might surmise that after the litigations of 1893 Pope revised his view of Goebel's alleged contribution to the development of the incandescent lamp. An updated preface, which was dated, appeared in the second edition.

In conclusion, the name of Henry Goebel probably should not be listed with the more significant names associated with the incandescent lamp - such as Starr<sup>98</sup>, Sawyer-Man, Swan and countless others. His is an interesting story but it lacks the documentation needed to put much credence in it; perhaps if certain conditions had been different for him, such as

economic, language and purpose, his name could be included among those who contributed to the development of an important invention. *One judicial decision not to grant an injunction does not mean that Henry Goebel should be given credit for unsubstantiated achievements.* In their book, Edison - His Life and Inventions, Dyer, Martin and Meadowcroft quote, on page 726, Major Sherbourne B. Eaton, an attorney<sup>95</sup>.

"The Goebel case emphasizes two defects in the court procedure in patent cases. One is that they may be spun out almost interminably, even, possibly, to the end of the life of the patent; the other is that the judge who decides the case does not see the witnesses. That adverse decision at St. Louis would never have been made if the court could have seen the men who swore for Goebel. When I met F. P. Fish on his return from St. Louis, after he had argued the Edison side, he felt keenly that disadvantage, to say nothing of the hopeless difficulty of educating the court."

## References

(Reference abbreviations: *EE* = *Electrical Engineer* ; *EW* = *Electrical World* ; *SLPD* = *St. Louis Post-Dispatch* ; *ER* = *Electrical Review* ; *E* = *Electricity* ; *NYW* = *New York World*)

1. "Edison's Electric Light," Francis R. Upton, *Scribner's Monthly*, Feb 1880, pg 531.
2. The Edison Electric Light - The Legal and Commercial Status, E. H. Johnson, Oct 7, 1886, 25 pages.
3. "The Edison Incandescent Lamp Litigation - I," *EE*, Jun 10, 1891, pg 660.
4. "A Broad Decision on Appeal Awarding the Incandescent Lamp to Edison," *EE*, Oct 4, 1892, pg 331.
5. "The Incandescent Lamp Situation," *EW*, Jan 14, 1893, pg 33.
6. "Temporary Injunction Granted Against an Incandescent Light Company," *SLPD*, Jan 17, 1893, pg 3.
7. "Incandescent Lamp Litigation in Boston," *EE*, Vol XV, No 246, Jan 18, 1893, pg 70.
8. "The Carbon Filament Lamp of 1859 - The Story of an Overlooked Invention," Franklin Leonard Pope, *EE*, Vol XV, No 247, Jan 25, 1893, pg 77.
9. "Incandescent Lamp Litigation - Henry Goebel, A New Claimant for Priority," *EE*, Vol XV, No 247, Jan 25, 1893, pg 95.
10. "Incandescent Lamp Litigation, The Goebel Defense - Edison Electric Light Company (General Electric Company) vs Beacon Vacuum Pump and Electrical Company in U.S. Circuit Court, Boston, Jan 24 and 25," *EE*, Vol XV, No 248, Feb 1, 1893, pg 120.
11. "Goebel," *EE*, Vol XV, No 248, Feb 1, 1893, pg 110.
12. "The Latest Electric Light," *EE*, Vol XV, No 248, Feb 1, 1893, pg 121 - reprinted from *NYW*, May 1, 1882.
13. "On a New Claim - The Columbia Incandescent Light Co. Fighting the Edison Patents," *SLPD*, Feb 1, 1893, pg 5.
14. "The Lamp Situation," *EW*, Vol XXI, No 5, Feb 4, 1893, pg 77.
15. "The Edison Lamp Patent," *EW*, Vol XXI, No 25, Feb 4, 1893, pg 78.

16. "Concerning the Latest Claimant," Park Benjamin, *EW*, Vol XXI, No 5, Feb 4, 1893, pg 80.
17. "Goebel's Incandescent Lamp and Filament Planar," *EE*, Vol XV, No 249, Feb 8, 1893, pg 148.
18. "Incandescent Lamp Litigation, The Goebel Defense - Edison Electric Light Company (General Electric Company) vs Beacon Vacuum Pump and Electrical Company in U.S. Circuit Court, Boston, Feb 1 and 2, 1893," *EE*, Vol XV, No 249, Feb 8, 1893, pg 149.
19. "The Edison Lamp Patent - Additional Affidavits," *EW*, Vol XXI, No 6, Feb 11, 1893, pg 102.
20. Legal Notes, Incandescent Lamp Litigation, "An Injunction Granted Against the Beacon Vacuum Pump and Electrical Co. - The Goebel Claims Rejected," *EE*, Vol XV, No 251, Feb 22, 1893, pg 188.
21. The Lamp Decision," *EW*, Vol XXI, No 8, Feb 25, 1893, pg 142.
22. "Judge L.B.B. Colt," *ER*, Vol XXII, Feb 25, 1893, pg 3.
23. "One Year of Electricity," *ER*, Feb 25, 1893, pg 9.
24. "Edison Again - Judge Colt Grants Another Injunction - The Beacon Company, of Boston, Enjoined, and Goebel's Claims and Those of his Witnesses and Experts Discredited," *ER*, Vol XXII, Feb 25, 1893, Supplement.
25. Correspondence, The Beacon Vacuum Pump and Electric Company, "Now That the Decision...," *ER*, Vol XXII, Mar 4, 1893, pg 35.
26. "Incandescent Lamp Litigation - Edison Electric Light Company vs Beacon Vacuum Pump and Electrical Company," *EE*, Vol XV, No 254, Mar 15, 1893, pg 274.
27. "The Incandescent Lamp Situation," *EW*, Vol XXI, No 12, Mar 25, 1893.
28. "Incandescent Lamp News from Boston," *ER*, Vol XXII, Mar 25, 1893, pg 75.
29. "The Incandescent Lamp Situation," *EW*, Vol XXI, No 13, Apr 1, 1893, pg 244.
30. "An English View of the Goebel Case," *ER*, Vol XXII, No 6, Apr 1, 1893, pg 89.
31. "Dr. Ludwig K. Böhm," *ER*, Vol 22, No 8, Apr 15, 1893, pg 105.
32. "The Goebel Case Revived as a Defense in St. Louis," *EE*, Vol XV, No 259, Apr 19, 1893, pg 391.
33. "Goebel's Lamp," *SLPD*, Apr 21, 1893, pg 1.
34. "Columbia Incandescent Lamp Case" and Columbia Incandescent Lamp Case: Defense and Prosecution," *EW*, Vol XXI, No 16, Apr 22, 1893, pg 289.
35. "The Columbia Incandescent Lamp Case," *EW*, Vol XXI, No 16, Apr 22, 1893, pg 291.
36. "Early History of the Manufacture of the Goebel Lamp," *ER*, Vol XXII, No 9, Apr 22, 1893, pg 119.
37. "The Columbia Lamp Case," *ER*, Vol XXII, No 9, Apr 22, 1893, pg 120.
38. "Judge Hallett's Decision Refusing an Injunction Under the Edison Lamp Patent," *EE*, Vol XV, No 260, Apr 26, 1893, pg 416.
39. "Judge Hallett's Decision," *EW*, Vol XXI, No 17, Apr 29, 1893, pg 311.
40. "Decision in the Columbia Incandescent Lamp Suit," *EW*, Vol XXI, No 17, Apr 29, 1893, pg 312.
41. "Effect of Judge Hallett's Decision," *EW*, Vol XXI, No 17, Apr 29, 1893, pg 312.
42. "J. H. Rhotehamel, President of the Columbia Incandescent Lamp Company," *EW*, Vol XXI, No 17, Apr 29, 1893, pg 313.

43. "Praise for the St. Louis Lamp Report," *EW*, Vol XXI, No 17, Apr 29, 1893, pg 313.
44. "Henry Goebel," *EW*, Vol XXI, No 18, Apr 29, 1893, pg 332.
45. "Columbia Wins! - Heinrich Goebel's Lamp Again in Court and the Judge Believes It Preceded Edison's Invention," *ER*, Vol XXII, No 10, Apr 29, 1893, pg 129.
46. "What is Thought of the Case in St. Louis" ; "What Edison's Counsel Say" ; "An Early Account of Goebel's Lamp," *ER*, Vol XXII, No 10, Apr 29, 1893, pg 136.
47. "The St. Louis Lamp Decision," *ER*, Vol XXII, No 10, Apr 29, 1893, pg 134.
48. "The 'Columbian Celebration' in St Louis," *EE*, Vol XV, No 261, May 3, 1893, pg 444.
49. "The Incandescent Lamp Situation," *EE*, Vol XV, No 261, May 3, 1893, pg 426.
50. Correspondence, J. H. Rhotehamel, *ER*, Vol XXII, May 13, 1893, pg 159.
51. "The Oconto Lamp Case," *EE*, Vol XV, No 266, Jun 7, 1893, pg 562.
52. "The Lamp Situation from a Canadian Point of View," *ER*, Vol XXII, Jun 17, 1893, pg 219.
53. "The Oconto Lamp Case at Milwaukee," *EE*, Vol XVI, No 271, Jul 12, 1893, pg 44.
54. "The Oconto Incandescent Lamp Case," *EW*, Vol XXII, No 3, Jul 15, 1893, pg 45.
55. "The Oconto Incandescent lamp Case - II," *EW*, Vol XXII, No 4, Jul 22, 1893, pg 68.
56. "The Oconto Co. Enjoined from Making Lamps," *EE*, Vol XVI, No 273, Jul 26, 1893, pg 92.
57. "Judge Seaman's Opinion," *EW*, Vol XXII, No 5, Jul 29, 1893, pg 78.
58. "Edison Company Wins the Oconto Lamp Case," *ER*, Vol XXII, No 23, Jul 29, 1893, pg 295.
59. "Judge Seaman and the Evidence" ; "A Word to the General Electric," *EW*, Vol XXII, No 5, Jul 29, 1893, pg 77.
60. "Decision in the Oconto Incandescent Lamp Case," *EW*, Vol XXII, No 5, Jul 29, 1893, pg 86.
61. "An Analysis of Judge Seaman's Opinion," *EW*, Vol XXII, No 5, Jul 29, 1893, pg 87.
62. "The New Beacon Lamp," *EW*, Vol XXII, No 6, Aug 5, 1893, pg 165.
63. "The Expiration of the Edison Lamp Patent," *EW*, Vol XXII, No 7, Aug 12, 1893, pg 112.
64. "The Goebel Lamp, No 9," J. H. Rhotehamel, *EE*, Vol XVI, No 276, Aug 16, 1893, pg 162.
65. "The 'New Beacon' Non-Infringing Incandescent Lamp," *EE*, Vol XVI, No 277, Aug 23, 1893, pg 169.
66. Correspondence, re Beacon Vacuum Pump and Electrical Company, *ER*, Vol XXIII, Aug 26, 1893, pg 7.
67. "The Expiration of Edison's English Filament Patent," *ER*, Vol XXIII, Nov 18, 1893, pg 157.
68. "The English Edison Lamp Patent," *EW*, Vol XXII, No 21, Nov 18, 1893, pg 391.
69. "Edison Patent Suit," *EW*, Vol XXII, No 22, Nov 25, 1893, pg 407.
70. "The Oconto Incandescent Lamp Case," *EW*, Vol XXII, No 22, Nov 25, 1893, pg 408.
71. "Henry Goebel Dead," *SLPD*, Dec 5, 1893, pg 1.
72. Correspondence, re The Columbia Incandescent Lamp Company, *ER*, Vol XXIII, Dec 6, 1893, pg 189.

73. "Henry Goebel," *EE*, Vol XVI, No 293, Dec 13, 1893, pg 517.
74. "Obituary," *E*, Vol V, No 22, Dec 13, 1893, pg 261.
75. "Obituary - Henry Goebel," *ER*, Vol 23, No 17, Dec 13, 1893, pg 198.
76. re Henry Goebel, *ER*, Vol 23, No 17, Dec 13, 1893, pg 200.
77. "Death of Henry Goebel," *EW*, Vol XXII, No 26, Dec 16, 1893.
78. "A Western Lamp Factory," *EW*, Vol XXII, No 26, Dec 23, 1893, pg 483.
79. "Columbia Lamps Reduced in Price," *ER*, Vol 24, Jan 10, 1894, pg 15.
80. Evolution of the Electric Incandescent Lamp, Franklin Leonard Pope, Boschen & Wefer Printers and Publishers, New York, 2nd Edition, 1894.
81. "The Buckeye Decision - Full text of Judge Ricks' Decision Dissolving the Temporary Injunction Against the Buckeye Electric Company, of Cleveland, O.," *ER*, Vol 24, No 5, Jan 31, 1894, pg 52.
82. New England Notes (Beacon Vacuum Pump & Electrical Co.), *EE*, Vol XVII, No 300, Jan 31, 1894, pg 104.
83. "Judge Acheson and Judge Hallett," *EW*, Vol XXIII, Feb 10, 1894, pg 171.
84. "The Goebel Lamp Story," *EW*, Vol XXII, No 8, Feb 24, 1894, pg 248.
85. "The Injunction Against the Oconto Co. Sustained - Edison Electric Co. vs Electric Mfg. Co.," *EE*, Vol XVII, No 314, May 9, 1894, pg 420.
86. "Incandescent Lamp Litigation," *EW*, Vol XXIII, No 19, May 12, 1894, pg 634.
87. "The Oconto Lamp Case," *EW*, Vol XXIII, No 19, May 12, 1894, pg 636.
88. "The Columbia High Economy Incandescent Lamp," *ER*, Vol 25, Aug 1, 1894, pg 57.
89. "The Incandescent Lamp Patent," *EW*, Vol XXIV, No 20, Nov 17, 1894, pg 511.
90. "The Edison Lamp Patent on the Incandescent Electric Lamp," *SLPD*, Nov 18, 1894, pg 9.
91. "Where Are We At?," *EE*, Vol XVII, No 342, Nov 21, 1894, pg 419.
92. "Obituary - J. H. Rhotemhamel," *EE*, Vol XXV, No 512, Feb 24, 1898, pg 218.
93. "The Development of the Manufacture of the Edison Incandescent Electric Lamp - 1881-1905," J. T. Marshall, *Journal of the Franklin Institute*, Vol CLX, No 955, Jul 1905, pg 21.
94. Developing an Industry, Philip S. Dodd, The Curtis Press, Detroit, 1910.
95. Edison, His Life and Inventions, Frank Lewis Dyer, Thomas Commerford Martin, William Henry Meadowcroft, Harper & Brothers, New York, 1929.
96. The Electric-Lamp Industry: Technological Change and Economic Development from 1800 to 1947, Arthur A. Bright, Jr., The MacMillan Co., New York, 1949.
97. "Goebel," Neue Deutsche Biographie, Sechter Band, Duncker & Humblot, Berlin, 1964, seite 503.
98. "J.W. Starr: Cincinnati's Forgotten Genius," Charles D. Wrege, *The Cincinnati Historical Society Bulletin*, Vol 34, Summer 1976, No 2, pg 103.



## The Goebel Legend

The book shown to the left ([The Goebel Legend - The Struggle for the Invention of the Incandescent Lamp](#)) is a critique of the alleged achievements in the field of the incandescent lamp, of one Heinrich Göbel (Henry Goebel), whose name almost totally occupied certain technical periodicals during the year 1893. This new writing, which will become available in February 2007 in the German language, was written by Dr. Hans-Christian Rohde, a resident of Springe, Germany. The publisher of the book is zu Klampen. The town of Springe is also the birthplace of Henry Goebel (1818-1893) and it was from there that he emigrated to the United States in 1849.

Dr. Rohde spent several years researching this subject and he accumulated difficult-to-locate materials from the United States as well as Germany. In this monumental work Rohde concludes that Henry Goebel has been given undue credit for the invention. It is widely believed today that the honor of the development of a practical incandescent lamp rightly belongs to Thomas A. Edison.

The following is the abstract for the book:

"In Germany, Heinrich Göbel, born in 1818 in the town of Springe near Hanover, is seen as the first inventor of an electric incandescent light fit for practical use. It is said that Göbel, a German immigrant to New York City, constructed a carbon filament lamp - similar to the one described in Thomas A. Edison's famous patent of 1880 - as early as 1854. But allegedly the work of Heinrich Göbel (or Henry Goebel, as he called himself in America) had been overlooked by commerce and science. According to German encyclopedias, it was just a few months before his death in 1893 that a court of appeals recognized the priority of Göbel's invention. This story is being reviewed and examined here. It can be shown that the wide spread German notion of the origins of the incandescent lamp is wrong. No court ever accepted Goebel's allegation. A thorough review of all affidavits in related suits available for inspection in U. S. archives confirms that Goebel's story is not tenable; it was fraudulent. In 1882, Goebel had already used his pretension for reasons of advertisement for his own business. In 1893, three companies that were producing incandescent lamps without license tried to use Goebel's story to defend preliminary injunctions brought against them by the Edison Electric Light Company. In one case, a judge refused the preliminary injunction asked for, but this fact does not prove the truth of Goebel's story. In Germany, however, reports on those suits in American technical papers were misunderstood, and in the 1920s the legend arose that Heinrich Göbel, a man of true German spirit and blood, was the real inventor of the incandescent lamp. The story was particularly popular during the years of the Nazi regime, but it was retold and believed up to the beginning of the 21st century."

The book consists of 248 pages; the cover measures about 16.2 cm x 24 cm. The text is nearly all in German with a smattering of English. It is meticulously referenced and is a real treasure for the historian who is interested in electric lighting. The book will sell for 29.80 Euro. Details can be learned at:

<http://dan4u.de/zuklampen/bookdetails.php4?wkid=1136738671&id=1165578179&usess=&qx=>

The book image shown above was downloaded from the zu Klampen site given above.

### **About the Author**

Dr. Hans-Christian Rohde, a resident of Springe, Germany, attended school in Springe and then earned a doctorate degree at the Gottfried Wilhelm Leibniz University in Hanover, Germany. In addition to this new work, he published a book on local Jewish communities titled Wir sind Deutsche mit jüdischer Religion: Geschichte der Juden in Eldagsen und Springe, Bennigsen, Gestorf, Völksen (We are Germans with Jewish Religion: History of the Jews in Eldagsen and Springe, Bennigsen, Gestorf, Völksen). In general, Dr. Rohde is interested in German philology, history and political science. **Thomson-Houston and**

### **Consolidated**

### **Patents**

The following lists of patents were copied directly from the original brochure. Patents are listed for the Thomson-Houston Company for the years 1879-1886. Patents for the Consolidated Electric Light Company are for the years 1877-1882.

---

---

## RECORD OF PATENTS

OWNED BY THE

# Thomson-Houston Electric Company

AND ALSO THOSE UNDER WHICH THEY ARE

EXCLUSIVELY LICENSED,

All applicable to Arc and Incandescent, and covering EXCLUSIVELY automatic regulation, and in addition thereto nearly all the practicable methods of an economical and efficient system of Arc and Incandescent lighting.

---

---

### TO THE PATRONS OF THE THOMSON-HOUSTON COMPANY:

The annexed list of patents owned and controlled by the Thomson-Houston Electric Company, numbering eighty-seven, actually owned by it and about forty more under which it is licensed, cover not only the exclusive control of automatic regulation, but in addition thereto nearly every practical and *economical* method of generating and distributing electric current for both arc and incandescent lighting.

The Brush Company has recently issued a circular threatening suits for infringements against users of the Thomson-Houston apparatus in various parts of the country. They furnish a list of the patents controlled by the Brush Electric Company. By referring to such list, it will be observed that after deducting those patents which relate to the manufacture of carbons, metal moulds, electric clocks and secondary batteries there remain left to the Brush Company but twenty-four patents which are applicable to arc and incandescent lighting as against about one hundred and thirty owned and controlled by the Thomson-Houston Company.



THOMSON-HOUSTON ELECTRIC CO., PATENTS.

Date of Issue.	Pat. Office No.	T.H.E.C. No.	DESCRIPTION OF PATENT.
<b>1879.</b>			
Sept. 2,	210,157	1	Improvement in Dynamo-Electric Machines.
Oct. 7,	220,287	2	" " Regulators for Electric Lamps.
Oct. 14,	220,508	3	" " " " " "
<b>1880.</b>			
Jan. 13,	223,557	4	" " Dynamo-Electric Machines.
" 20,	223,646	5	" " Regulators for Electric Lamps.
" 20,	223,658	6	" " Armatures and Commutators.
" 20,	223,659	7	" " Automatic Adjusters for Commutator Brushes.
Oct. 5,	232,910	8	" " Dynamo-Electric Machines.
" 5,	233,047	9	" " " " " "
<b>1881.</b>			
March 1,	238,315	10	" " Current Regulators.
June 7,	242,488	11	" " Commutators.
Nov. 20,	250,175	12	" " Electro Magnetic Devices.
Dec. 6,	250,463	13	" " Electric Lamps.
<b>1882.</b>			
Feb. 21,	253,958	14	" " Electric Lamps.
Apr. 4,	255,824	15	" " Systems of Electrical Distribution.
" 18,	256,605	16	" " Electric Lamps.
" 18,	256,603	17	" " " " " "
May 23,	258,521	18	" " Safety Devices for Electric Lamps.
" 30,	258,648	19	" " Dynamo-Electric Machines.
" 30,	258,649	20	" " " " " "
" 30,	258,684	21	" " Electric Arc Lamps.
June 6,	259,017	22	" " Electric Incandescent Lamps.
July 11,	261,067	23	" " Electric Arc Lamps.
" 25,	261,700	24	" " " " " "
Oct. 10,	265,938	25	" " Means for Preventing Flashing.
" 10,	265,937	26	" " Regulators for Dynamo-Electric Machines.
" 17,	265,993	27	" " Electric Arc Lights.
Dec. 26,	269,605	28	" " Dynamo-Electric Machines.
" 26,	269,606	29	" " Regulators for Dynamo-Electric Machines.

## THOMSON-HOUSTON ELECTRIC CO., PATENTS.

Date of Issue.	Pat. Office No.	T.H.E.C. No.	DESCRIPTION OF PATENT.
<b>1883.</b>			
Feb. 6,	271,947	30	Improvement in Commutators for Dynamo-Electric Machines.
" 6,	271,948	31	" " Electric Current Regulators.
" 13,	272,256	32	" " Dynamo-Electric Machines.
" 13,	272,353	33	" " Electro-Magnetic Retarding Devices.
" 27,	272,920	34	" " Electric Arc Lamps.
M'ch 6,	273,406	35	" " Air Blast Attachments.
" 20,	274,413	36	" " Electric Arc Lamps.
Apr. 3,	275,289	37	" " Safety Self-Closing Shunt Switches.
" 3,	275,290	38	" " " " " "
July 17,	281,416	39	" " Dynamo-Electric Machines.
Aug. 14,	283,167	40	" " Electric Commutators.
" 14,	283,168	41	" " Electric Lamps.
" 14,	283,343	42	" " Dynamo Machines.
" 21,	283,437	43	" " Electric Lamps.
Oct. 16,	286,612	44	" " Dynamo-Electric Machines.
Dec. 4,	289,580	45	" " Safety Devices for Electric Arc Lamps.
<b>1884.</b>			
Feb. 26,	294,004	46	" " Dynamo-Electric Machines.
" 26,	294,005	47	" " Electric Power Distribution Systems.
" 25,	295,839	48	" " Double Carbon Arc Lamps.
Apr. 8,	296,569	49	" " Dynamo-Electric Machines.
" 15,	296,709	50	" " " " " "
" 22,	297,194	51	" " Electric Arc Lamps.
" 22,	297,195	52	" " " " " "
" 22,	297,196	53	" " " " " "
" 22,	297,197	54	" " " " " "
" 22,	297,198	55	" " " " " "
" 22,	297,199	56	" " " " " "
" 22,	297,200	57	" " " " " "
" 22,	297,201	58	" " " " " "
Aug. 5,	302,960	59	" " " " " "
" 5,	302,961	60	" " Focussing Electric Arc Lamps.
" 5,	302,962	61	" " Electric Arc Lamps.

## THOMSON-HOUSTON ELECTRIC CO., PATENTS.

Date of Issue.	Pat. Office No.	T.H.E.C. No.	DESCRIPTION OF PATENT.
Aug. 5,	302,963	62	Improvement in Regulators for Dynamo-Electric Machines.
" 19,	303,762	63	" " Electric Arc Lamps.
" 19,	303,808	64	" " " Lamp Mechanism.
Sept. 2,	304,672	65	" " " Arc Lamps.
" 2,	304,673	66	" " " " "
" 16,	305,413	67	" " " Lamp Mechanism.
Oct. 7,	306,118	68	" " " Arc Lamps.
" 7,	306,119	69	" " " " "
Nov. 11,	307,769	70	" " " " "
" 11,	307,818	71	" " Automatic Cut Outs.
" 11,	307,819	72	" " Cut Outs for Electric Arc Lamps.
Dec. 2,	308,612	73	" " Underground Conduits for Electric Conductors.
<b>1885.</b>			
June 16,	320,017	74	" " Cut Outs for Electric Circuits.
" 16,	320,018	75	" " Electric Lamps.
July 7,	321,463	76	" " " Switches.
" 7,	321,464	77	" " Lightning Arresters,
" 7,	321,461	78	" " Electric Lighting Systems.
" 14,	322,138	79	" " Systems of Electric Distribution.
" 14,	322,139	80	" " " " "
Aug. 11,	323,975	81	" " Dynamo-Electric Machines.
" 11,	323,976	82	" " Automatic Commutator Adjusters.
" 18,	324,501	83	" " Regulators for Dynamo-Electric Machines.
" 18,	324,502	84	" " Electric Arc Lamps.
Sept. 29,	327,030	85	" " Safety Devices for Electrical Circuits.
Oct. 13,	328,253	86	" " Dynamo-Electric Machines.
<b>1886.</b>			
Jan. 5,	333,573	87	" " " " "

PATENTS OWNED BY THE  
 CONSOLIDATED ELECTRIC LIGHT  
 SAWYER-MAN SYSTEM,

UNDER WHICH THE THOMSON-HOUSTON ELECTRIC CO., HAVE EXCLUSIVE

Date.	No. of Pat.	TITLE.
<b>1877.</b>		
Aug. 14,	194,111	Improvement in Electric Engineering System.
" 21,	194,500	" " Electric Candles.
" 28,	194,563	" " Electric Lighting Apparatus.
Nov. 6,	195,834	" " Electric Engineering System.
<b>1878.</b>		
June 18,	205,144	" " Electric Lamp.
" 25,	205,203	" " Electric Lighting System.
" 25,	205,305	" " Regulator.
Nov. 19,	210,151	" " Meter.
" 19,	210,152	" " Switch.
Dec. 10,	210,809	" " Electric Lamp.
<b>1879.</b>		
Jan. 7,	211,202	" " Carbons for Electric Lights.
Sept. 16,	219,771	" " Electric Lamp.
<b>1880.</b>		
Feb. 17,	224,612	" " Carbon Treating Apparatus.
Mar. 23,	225,730	" " Nitrogen.
Apr. 13,	226,483	" " Dynamo.
Apr. 20,	226,632	" " Nitrogen.
May 11,	227,365	" " Switch.
" "	227,386	" " Electric Lamp.
" "	227,387	" " " "
" "	227,388	" " " "
" "	227,389	" " " "
" "	227,390	" " " "
" "	227,454	" " Nitrogen.
" "	227,845	" " Dynamo.
May 25,	228,122	" " Electric Lamp.

## SAWYER-MAN PATENTS.

Date.	No. of Pat.	TITLE.
May 25,	228,123	Improvement in Resistances.
June 29,	229,335	“ “ Carbons for Electric Lights.
“	229,478	“ “ Switch.
July 20,	230,345	“ “ Automatic Regulator.
“	230,346	“ “ Safety-Switch.
Oct. 12,	233,284	“ “ Electric Lamp.
Dec. 14,	235,385	“ “ Dynamo.
“	235,459	“ “ Electric Lamp.
“	235,460	“ “ Switch.
<b>1881.</b>		
Jan. 11,	236,460	“ “ Automatic Regulator.
Feb. 8,	237,608	“ “ Switch.
“	237,632	“ “ Dynamo.
May 10,	241,242	“ “ “
“	241,430	“ “ Electric Lamp.
June 21,	243,196	“ “ Arc Lamp.
	245,976	
Oct. 11,	248,156	“ “ Lamp.
Oct. 18,	248,406	“ “ Electric and Gas Fixture. nD
“	248,407	“ “ Lamp.
“	248,279	“ “ Vacuum Pump.
Nov. 15,	249,716	“ “ Dynamo.
Nov. 29,	250,192	“ “ Lamp.
“	250,193	“ “ Lamp.
<b>1883.</b>		
June 12,	279,399	“ “ Dynamo.
Aug. 7,	282,534	“ “ Electric Lamp.
<b>1881.</b>		
<b>RE-ISSUES.</b>		
July 19,	9,807	“ “ Carbons for Electric Lamps.
Aug. 9,	9,836	“ “ Dynamo.
<b>1882.</b>		
June 6,	10,134	“ “ Electric Lighting System.

### The William J. Hammer Historical Collection of Incandescent Electric Lamps

The Hammer Historical Collection of Incandescent Electric Lamps is probably the most complete collection that described the state of the art during Edison's time. Perhaps it is the most comprehensive collection in the world.

William Hammer was one of the early associates of Thomas Edison and he had a distinguished career. He started to collect lamps as they were developed in the Edison laboratory from the earliest days and continued this activity for several years. Not only were Edison lamps obtained, but lamps from other inventors were also added to his collection.

Hammer exhibited his lamps at various times. His exhibit in 1882 at the International Electrical Exposition at the Crystal Palace, London, England, garnered him a special silver medal. The exhibit of his collection at the St. Louis Exposition of 1904 earned "the Grand Prize." In 1906 Hammer was awarded the "Elliott Cresson" gold medal from the Franklin Institute.

The Hammer Historical Collection of Incandescent Electric Lamps was on exhibit in the Headquarters of the American Institute of Electrical Engineers in the Engineering Societies Building, 29 West 39th Street, New York City for many years; the information given here corresponds to its existence mainly in the year 1913. Prior to being exhibited in the Engineering Societies Building the collection was held in storage by Mr. Samuel Insull of Chicago. In 1913 the collection was displayed in five large glass cases. At that time the collection was owned by the Edison Association of Illuminating Companies. Part of the collection had been purchased by the General Electric Company and donated to the Edison Association.

Case No. 1 contained lamps that represented "the foundation of the art, embracing the initial work of Edison, Swan, Maxim, Lane-Fox, deChangy, deLodyguine, Sawyer, Bernstein, Müller, Akester, Nothomb, Crookes, Swinburne, Kurtzgen, Siemens, Gerard, Boehm, Greinert-Friederich, Latimer and Cruto, from 1878 to 1883."

Case No. 2 contained lamps that represented "the development of the art under Thomas Alva Edison from 1878 to 1913, supplementing the fundamental steps in his work shown in Case No.1."

Case No. 3 contained lamps that represented "the development of the art under the workers contemporaneous with Edison all over the world, from 1883 to 1893, supplementing the fundamental steps shown in Case No.1."

Case No. 4 contained lamps that represented "the development of the art under workers contemporaneous with Edison all over the world, from 1893 to 1903, supplementing the lamps in Cases Nos.1 and 3, and including special regulating, reflecting, advertising, sign and novelty lamps."

Case No. 5 contained lamps that represented "the development of the art under the workers contemporaneous with Edison all over the world, from 1900 to 1913, embracing other than carbon filament lamps, such as Nernst, Tantalum, Helion, Crawford-Voelker, Langhans, Hopfelt, Osmium and Tungsten lamps, and certain gas, vapor, radium, cathode-ray and other phosphorescent lamps which serve to point the way towards 'cold light'."

In addition to individual pictures of lamps in the Hammer Collection, this site also contains photographs of Hammer display cases that existed at two different times, 1904 and 1913. Because of the large size of four of these photographs, with their rather long downloading times, they are not shown with the text but can be viewed by clicking onto the links below; total downloading time can be several minutes.

A picture can be enlarged by clicking on the box that will appear when the mouse arrow is moved from outside the picture boundary to the inside from outside the lower right hand corner boundary; the arrow must be inside the picture boundary to obtain the enlargement box. After viewing a link simply click "Back" on your browser to return to this page.

[Edison Lamps Developed by 1904](#)

[Lamps Developed by Other Workers by 1904](#)

[Combination of Edison and Other Lamps](#)

[Photographs of Hammer Lamp Display Cases, 1913](#)

During the time period May 6-17, 1930 the Hammer collection was removed from Room No. 616 of the Engineering Societies Building. Each item was assigned a transfer number, crated and the entire collection was shipped to the Henry Ford Museum in Dearborn, Michigan; it has remained there until this day (June, 2000). An inventory was taken in 1930 that lists the assigned transfer number, any markings on the lamp, the condition of the lamp and the text on the cards displayed by Hammer. Although the transfer numbers run from one to 1031, the collection contains fewer items, due, in part, probably, to unintentional breakage over time. The lamps contained in Case No. 1 have transfer numbers that range from one to 109. Those lamps in Case No. 2 were numbered 110 to 357. The lamps in Case No. 3 were numbered 358 to 536. The lamps in Case No. 4 were numbered 782 to 1031 and those lamps in Case No. 5 were numbered 537 to 781. The total number of lamps in each case being: Case 1, 109; Case 2, 248; Case 3, 179; Case 4, 250 and Case 5, 245.

Hammer spent countless hours organizing the lamps in the described manner and his setup arranged the lamps in a natural, meaningful way. However, we no longer have the opportunity to see the collection in this arrangement and a different listing for this web site was decided on. The lamps are listed here chronologically according to date of manufacture, and with the transfer numbers arranged in increasing order. Thus, the lamps are listed more or less as they were developed in time.

In the following, some details of lamps from a majority of the collection are given. Only those lamps were considered that could be identified as to the date of manufacture. The first number given is the year of manufacture and the number after the hyphen is the transfer number as assigned in 1930. About 945 lamps are considered.

Hammer mounted nearly every lamp in a wooden pedestal, with the unintentional result that certain features of the lamp, such as the base, are hidden. During a recent (May 2000) visit to the Ford Museum the writer took photographs of three lamps that exist without such pedestals. These lamps were: a 1885 Diehl induction lamp, No. 523; a 1900 Bickström lamp, No. 1023, manufactured by Seely & Taylor; a 1885 Vitrite Luminoid lamp, No. 997. These images are shown below.

From an Archive Room at Nela Park in Cleveland the writer also had access to 20 negatives of individual Hammer lamps. A photograph was taken of each negative, in the sunlight, with the background being the noon day cloudless sky; this was accomplished with a Sony MVC-FD81 Digital Mavica camera. Then a "positive" was obtained through use of a

scanner and Adobe PhotoDeluxe 2.0. These images are also shown below. Although the results leave much to be desired, the writer felt that the viewer might appreciate seeing a "close-up" of individual Hammer lamps, as originally displayed.

#### The William J. Hammer Historical Collection of Incandescent Electric Lamps

- [1878](#) Edison
- [1879](#) Edison
- [1880](#) Edison, Hammer, Maxim, Sawyer, Swan
- [1881](#) Boehm, Edison, Lane-Fox, Maxim, Nothomb, Swan
- [1882](#) Akester, (Belgian), Bernstein, British Electric, Duplex, Edison, Gatehouse, Kurtzgen, Lane-Fox, Latimer, Maxim, Nothomb, Rogers
- [1883](#) Alexander, Bernstein, British Electric, Crookes, Cruto, Edison, Gerard, Greinert-Friederich, Kurtzgen, deLodyguine, Maxim, Maxim-Weston, Møller, Sawyer-Man, Siemens Bros., Siemens-Halske, Swan, Swinburne
- [1884](#) Cruto, Edison, Edison-Swan, Excelsior, Hochhausen, Møller, Richter, Sawyer-Man, Stanley-Thompson, Thompson, Thomson, Weston, White
- [1885](#) Bernstein, Brush-Swan, Diehl, Edison, Schuyler, Swinburne, Vitrite Luminoid, Weston
- [1886](#) Bernstein, Brush-Swan, Edison, Edison-Swan, Franklin, German Edison Company, Greiner, Opperman, Perkins, Sawyer-Man, Schmauser, Stanley-Westinghouse, Thomson-Houston, Westinghouse, Weston
- [1887](#) Edison, Edison-Swan, Greiner, Opperman, Perkins, Remington, Sawyer-Man, Sun, Thomson-Houston, Van Choate
- [1888](#) Bernstein, Edison, Hammer, Fort Wayne Jenney, Indianapolis Jenney, Sun, Thomson-Houston, Van Choate
- [1889](#) Bäckström, Bernstein, Edison, Sawyer-Man, Schuyler, Woodhouse-Rawson
- [1890](#) Bernstein, Edison, Ganz, Pray, Schaefer, Steel, Westinghouse
- [1891](#) Siemens-Halske, Woodhouse-Rawson
- [1892](#) A.B.C., Fitzgerald, Green, Reis, Swan, Woodhouse-Rawson
- [1893](#) Baetz, Buckeye, DeKhotinsky, Edison, Goebel, Green, Jaeger, Novak, Packard, S.A.C., Sawyer-Man, Schultzberge, Sunbeam, Tholes, Westinghouse
- [1894](#) Columbia, Edison, New Beacon, New Pa., Pollard, Sawyer-Man
- [1895](#) American, Gabriel-Argenault, Moore, Vitrite Luminoid
- [1896](#) Adams-Bagnall, Alpha, Edison, Fuller, Moore, Superior
- [1897](#) Cruto, Ediswan, Lynn, Sawyer-Man, Sunshine
- [1898](#) Edison, Edison-Swan, Unknown, Waverly
- [1899](#) Edison, Edison Jr, Unknown
- [1900](#) Bäckström, Edison, I.E. Glow Lamp, Inner Globe, International, Langhans, Miller, Nernst, Radiant
- [1901](#) Bernstein Lowatt, Bryan-Marsh, Edison, Hammer, Imperial, Miller, Nernst, Robertson, Tri-light
- [1902](#) Cruto, Curie, Edison, Ediswan, Elblight, Ganz, Germania, Hammer, Kyle, Moore, Nernst, Talmont, Vitrite Luminoid
- [1903](#) A.E.G., Banner, Barrenberg, Brilliant, Comet, Crawford-Voelker, Edison, Edison-Swan, Erner-Hopkins, G.E., Gilmore, Hammer, Luminous Vacuum Tube,



Nernst, Orient, Packard Zenith, Osmium, Opalescent, Pulu, Shelby, Talmont, Westinghouse, X-Ray

- [1904](#) Anchor, American Miniature and Decorative Lamp Company, Auer Osrampe, Brilliant Reflector, British Thomson-Houston, Bryan-Marsh, Clerici, Compagnie Centrale d'Electricite, Compagnie Generale de Lampes, DeKhotinsky, Downward, Dublgo, Economical, Edison, Edison-Swan, Femco, Goosens-Pope, Imperial, Kremenezky, Larnaude, Manhattan, Miller, Munder, Nernst, Novi, Oolicon Fish Lamp, Packard, Peerless, Phelps Hylo, Philips, Pintsch, Robertson, Schonlauk-Scharfs, Schuckert, Siemens-Halske, Star, Sturme, Sunbeam, Sunlight, Swan, Talmont, Vereinigte A.E.G., Watt Lamp, Westinghouse, Zalinski, Zuger, Zurcher
- [1905](#) Chaillet, Color Cap Lamp, Edison, Heany Zirconium Oxide, Mexican, Morse, Pine Cone Lamp, Siemens-Halske Tantalum
- [1906](#) American, Bastian, Edison, Fabius-Henrion, F.F. Tungsten, G.E. Tungsten, Heany, Hungarian, Just-Hanaman, Kuzel, Linolite, Nernst, O'Brien, Osmin, Osram, Polar, Westinghouse, Zernig
- [1907](#) A.E.G. Tungsten, Bergmann Tungsten, Edison, Elk, G.E. Tungsten, Guest, Hammer, Heany, Helion, Hopfelt, Johnson Anylite, Just Tungsten, Kuzel Sirius Tungsten, N.E.L.Co., Osram, Phosphorescent Color Lamp, Pintsch Sirius Tungsten, Sunbeam Tantalum, Westinghouse Tungsten, Zircon Tungsten
- [1908](#) A.E.G., Brown, G.E. Tungsten, Heany, Hopfelt, Just, Just-Hanaman, Kuzel, Monowatt, Nernst, Osram, Philips, Siemens-Halske, S□nnen, Westinghouse
- [1909](#) Anchor, Bergmann, Durand, Fabren Tungsten, G.E. Tantalum, G.E. Tungsten, N.E.L.A. Tungsten, Nernst, Osmin, Pintsch Sirius, Sirius Colloid, Westinghouse, Z Tungsten
- [1910](#) G.E. Tantalum, G.E. Tungsten, Justram Tungsten, Pope Tungsten, Westinghouse Tungsten, Z Tungsten
- [1911](#) Color Cap, Edison, G.E. Tantalum, G.E. Tungsten, Heany, Kuzel, Nernst, Pope Onion Tungsten, Westinghouse Tungsten
- [1912](#) Anchor, Andrews, Chicago Miniature Sign Lamp, Concave Lamp, Dr. Just Tungsten, Edison, Edison G.E., End-on Pope Tungsten, Envoy, Ever Bright Sign Lamp, G.E. GEM, G.E. Tungsten, Heany Flashing Lamp, Hopfelt, Johnson Lamp Dimmer, LaCarriere Z Tungsten, Neon Gas Tube, Nernst, Osram Tungsten, Pope Tungsten, Special Carbon Lamp, Westinghouse Tungsten, Westinghouse Vertex, Wirt Dimalite
- [1913](#) Candelabra, Cooper-Hewitt, Crystal Covered Lamp, End-on Tungsten Lamp, G.E. Co. Automobile Lamp, G.E. Co. Candelabra, G.E.Co. Commercial Vehicle Lamp, G.E. Co. Flashlight, G.E. Luminescent, G.E. Co. Nitrogen Lamp, G.E. Co. Sign, G.E. Co. Tungsten, Haubner, Linolite Carbon, Linolite Tungsten, Neon Gas Tube, Pope Tungsten, Reco Color Cap, Westinghouse Carbon, Westinghouse Tungsten

## 1878

- 1878-36-----Edison. Oxide of zirconium relic. Early type of lamp made at Menlo Park.
- 1878-61-----One of Edison's earliest lamps. First formed platinum iridium spirals with thermostatic regulator.

- 1878-63-----Edison. Same as No. 61.
- 1878-72-----Thermal Regulator Lamp. This lamp regulates the passage of electricity supplying the platinum iridium spiral through the medium of a diaphragm which is affected by the heated air, gas or fluid inside the lamp.
- 1878-73-----Edison. Relic of one of Edison's early forms of regulating lamps.
- 1878-79-----Edison. Oxide of zirconium lamp, consisting of one or more cores of pipe clay wound with platinum spiral coated with an oxide, etc.
- 1878-84-----Edison. Platinum iridium multiple foil lamp.
- 1878-94-----Edison. Platinum iridium wire spiral coated with titanium oxide.

## 1879

- 1879-86-----Edison. Early paper horse-shoe filament, platinum vice clamps, round seal with white German glass, small bulb, supplemental tip, 16-cp, 110-volt.
- 1879-88-----Edison. Earliest type paper horse-shoe carbon, plain tip, round seal, platinum vice clamps, small round bulbs, 16-cp, 110-volts.
- 1879-194----Edison. One of the street lamp posts used in historic light-up at Menlo Park. Paper horse-shoe carbon filament lamp.

## 1880

- 1880-10-----Edison. Early "B" 8-cp madake bamboo, platinum vice clamps, flat seal, early screw and ring, wooden base.
- 1880-18-----Edison. First tubular "bast" filament lamp, bent platinum vice clamps, round inside seal.
- 1880-23-----Maxim (American). Early paper "Maltese Cross Filament", platina bolt and clamps, blue and black soft glass seal, round tip, sealed bulb.
- 1880-50-----Sawyer (American). Copy of carbon bow lamps made by Jas. Bradley at Edison Lamp Works for court exhibit.
- 1880-53-----Edison. One of the first madake filament lamps made at Menlo Park and used at the 1881 Paris Electrical Exposition and the 1882 Crystal Palace Exposition, England.
- 1880-59-----Sawyer (American). One of Sawyer's earliest carbon bow electric lamps, No. 21. Made in New York.
- 1880-60-----Edison. First long record incandescent lamp. 1589 hours at 16-cp, 110-volts.
- 1880-64-----Edison. First long bulbous lamp with madake bamboo filament, nickel vice clamps, depressed seal, glass drawn around wire platinum leads.
- 1880-65-----Edison. Early egg shaped globe, nickel vice clamps, depressed seal, glass drawn over leads, madake bamboo.
- 1880-66-----Edison. Same as No. 65.
- 1880-68-----Edison. First ground glass lamp ever made. Taken from first lot dipped in hydrofluoric acid by Mr. J.W. Lawson, Chemist.
- 1880-69-----Sawyer (American). Copy of early form of carbon bow incandescent electric lamp, made in New York in 1889 by F.S. Smith. Used in Sawyer-Man Edison patent suits, April 25, 1889.

- 1880-80-----Edison. One of the first nickel vice clamp lamps, pressed seal, bamboo filament, 16-cp, 110-volts, round tip.
- 1880-83-----Edison. Double manila hemp filament lamp, platinum vice clamps, round inside seal, supplemental tip, 110-volts.
- 1880-85-----Edison. Early egg shaped globe, bamboo filament, 16-cp, 110-volts, platinum clamps, round inside seal, supplemental tip.
- 1880-90-----Sawyer (American). Carbon rod with carbon block and carbon roller supports in nitrogen gas, spiral radiating resistance coil, etc.
- 1880-97-----Maxim (American). "M" shaped paper carbon filament, round globe, platinum nut and bolt clamp.
- 1880-99-----Edison. South American bast fibre filament, platinum vice clamp at right angles, round seal, small bulb, supplemental tip.
- 1880-100-----Maxim (American). One of Maxim's earliest lamps, red tip, made in Bridgeport, CT.
- 1880-102-----Sawyer (American). Feeder lamp, contains nitrogen gas; incandescent carbon rod is held between carbon blocks and rollers with automatic feed.
- 1880-103-----Maxim (American). Paper carbon loop, platinum bolt and nut clamps and leads.
- 1880-104-----Swan (English). Early paper base Swan lamp with squirted cellulose carbon spiral, drilled carbon and carbon paste clamp, egg shaped globe.
- 1880-108-----Maxim (American). Maltese Cross paper carbon lamp. Made in Bridgeport, CT.
- 1880-110-----Edison. Tubular lamp, small bamboo filament in short right angle platinum vice clamp, round inside seal.
- 1880-111-----Edison. Special paper hairpin filament treated with hydrocarbon vapors, with novel spring and bolt and nut clamps and with heat radiating attachments.
- 1880-112-----Edison. Early copper plated clamp lamp, bamboo hairpin carbon filament, pressed inside seal, round supplemental globe tip.
- 1880-113-----Edison. Paper horse-shoe carbon filament lamp, platinum vice clamps, round inside seal, round bulb, long supplemental tip.
- 1880-114-----Edison. Paper horse-shoe carbon, 16-cp, platinum vice clamps, large round bulb, supplemental tip, round inside seal, original form wooden base.
- 1880-115-----Edison. Manila hemp fibre, 16-cp, carbonized cocconut shell clamps, large round bulb, round inside seal, supplemental tip.
- 1880-116-----Edison. South American bast fibre, carbon filament, platinum vice clamps, round inside seal, round globe, treated on vacuum pump but tip not sealed off.
- 1880-117-----Edison. Amaranth vegetable fibre carbon filament in platinum vice clamps, solid tip seal, round inside seal.
- 1880-119-----Edison. Monkey bast fibre filament, hydrocarbon treated, small globe, round inside seal, platinum vice clamps.
- 1880-120-----Edison. Tubular lamp with South American bast fibre in silver vice clamps, round inside seal.
- 1880-121-----Edison. Early wooden screw base lamp. B or 8-cp madake bamboo filament, platinum vice clamps, flat inside seal, round tip seal.

- 1880-122-----Edison. Paper horse-shoe carbon filament lamp, large globe, supplemental tip, round inside seal, platina vice clamps. Made for Menlo Park street posts.
- 1880-123-----Edison. South African fibre filament lamp, special small horizontal platina vice clamps, round inside seal, small globe.
- 1880-124-----Edison. Large round globe, supplemental tip, 16-cp, 110 volt, paper horse-shoe carbon, platina vice clamps, round inside seal.
- 1880-125-----Edison. Paper horse-shoe filament in large round globe, supplemental tip, round inside seal, platinum vice clamps.
- 1880-126-----Edison. Early vegetable carbon filament, manila hemp, platina vice clamps, long leads, round inside seal, large bulb, supplemental tip sealed.
- 1880-127-----Edison. Early ground glass globe, paper horse-shoe filament, supplemental tip.
- 1880-128-----Edison. Stopper lamp with paper carbon filament, treated with naphthalene hydrocarbon vapor, rubber stopper luted with compound.
- 1880-129-----Edison. Stopper or separable carbon filament lamp. The inside part carrying filament and neck of globe ground to fit and luted with compound.
- 1880-130-----Edison. Experimental arc lamp in exhausted globe. Rubber stopper luted with compound.
- 1880-132-----Edison. "B" or 8-cp, carbonized bamboo filament in platina vice clamps, pressed (Holzer) inside seal, early wooden screw base.
- 1880-133-----Edison. Bast fibre filament lamp, in platina vice clamps, round inside seal, small bulb, supplemental tip.
- 1880-134-----Edison. South American vegetable fibre carbon filament, special small platinum vice clamps set at right angles, round globe, round inside seal.
- 1880-136-----Edison. 8-cp or B carbonized bamboo filament in platina vice clamps, pressed Holzer inside seal, early wooden screw base.
- 1880-139-----Edison. Carbonized manila hemp filament, platina vice clamp, round inside seal, small globe with supplemental tip.
- 1880-143-----Edison. Copper plated shank on B or 8-cp bamboo carbon filament in platinum vice clamps, Holzer pressed seal, new wood butt (removed). Labeled "Property of Francis R. Upton".
- 1880-145-----Edison. 16-cp paper horse-shoe carbon filament, platinum vice clamps, round inside seal, round bulb, supplemental tip.
- 1880-146-----Edison. Round Japanese paper filament, platinum vice clamps, small round globe, white German glass over round inside seal, supplemental tip.
- 1880-147-----Edison. One of the first Holzer pressed inside seal lamps. Early bamboo filament, early bulbous globe, platinum vice clamps.
- 1880-148-----Edison. A or 16-cp carbonized bamboo filament lamp with early Holzer pressed inside seal, round tip sealed platina clamps with early wooden base.
- 1880-149-----Edison. Early bulbous form of globe with nickel vice clamps for holding 16-cp 110-volt madake bamboo filament, pressed seal, round tip.
- 1880-150-----Edison. 16-cp madake bamboo hairpin carbon filament in pear shaped globe, platinum vice clamps, Holzer pressed inside seal, round supplemental globe tip.
- 1880-151-----Edison. Experimental tube. One of many experiments made by Mr. Edison in studying lamp phenomena such as electrical carrying induction effect.

- 1880-152-----Edison. Madake bamboo carbon filament, 16-cp. Support made of glass covered leads, platinum vice clamps.
- 1880-153-----Edison. Bast fibre filament, 16-cp, nickel vice clamps, egg shaped globe, depressed seal, glass around leads, supplemental tip.
- 1880-154-----Edison. Relic of early paper horse-shoe lamp showing zig-zag platinum wire heat radiators attached to platinum vice clamps.
- 1880-162-----Edison. Relic of early Edison lamp with spring clip and washer clamp with heat radiating metal blocks.
- 1880-164-----Edison. Relic of early inside part of Edison lamp showing depressed stem and glass drawn around platinum leads both above and below seal and showing experimental supplemental clamps.
- 1880-181-----Edison. Early wooden base with brass screw and collar, copper plated clamps, first inside seal, round tip, 8-cp or B bamboo filament.
- 1880-196-----Edison. Historic paper horse-shoe lamp used as the headlight on Edison first electric locomotive at Menlo Park.
- 1880-197-----Describing headlight on first electric locomotive. Lamp suspended by strips of felt in inverted position, etc.
- 1880-910-----Hammer (Copy-1880)(American). This lamp was made for Hammer in 1888 after design of first series multiple lamp that was made in 1880 by Hammer.
- 1880-974-----Edison. First reflector incandescent lamp ever made. Made by Hammer.

## 1881

- 1881-12-----Nothomb (French). Low resistance filament, carbon paste clamps, platinum hook supports, blue tip bulb.
- 1881-15-----Maxim (American). "M" shaped paper carbon filament in early type key socket.
- 1881-16-----Maxim (American). Double "M" paper filament lamp. Egg shaped globe.
- 1881-19-----Edison. Madake bamboo lamp, 16-cp, 110-volt. Used at light-up at first central station for incandescent electric lighting in the world, Holborn Viaduct, 3000-light plant, London, England.
- 1881-20-----Edison. Fine bamboo carbon spiral, copper plated clamps, flat rim collar screw base, pressed seal.
- 1881-22-----Edison. This standard 16-cp, 110-volt lamp was used in the first central station for incandescent electric lighting ever established, which was constructed by Mr. Edw. H. Johnson, etc.
- 1881-25-----Edison. Platinum iridium spiral with flat platinum clamps, flat seal, small bulb. Made in July, 1881.
- 1881-34-----Edison. Standard photometer lamp used by Hammer. Arcing volatilized silver clamp depositing on globe.
- 1881-42-----Edison. 16-cp madake bamboo carbon filament, copper plated by Hammer as an experiment.
- 1881-47-----Boehm (American). Carbon filament paste clamp, made in New York by Dr. Ludwig K. Boehm.

- 1881-51-----Edison. One of the earliest copper plated clamp lamps, bamboo filament, early bulbous globe, pressed seal, round tip, 16-cp, 110-volts. Plated by Hammer.
- 1881-54-----Edison. Early copper plated clamps, 16-cp, 110-volts, madake bamboo.
- 1881-55-----Edison. First silver plated clamp lamp ever made. B or 8-cp, bamboo filament, flat seal.
- 1881-58-----Maxim (American). Standard "M" shaped paper carbon filament lamp with key socket in special box.
- 1881-67-----Edison. Early plumbago filament punched from sheets, pressed at 50,000 pounds to the square inch. Made by E.G. Acheson.



- 1881-75-----Edison. First etched incandescent lamp ever made with name "Edison".
- 1881-77-----Edison. One of first set of opal lamps ever made. Constructed by Wm. Holzer, Superintendent, Edison lamp factory at Menlo Park for Hammer from special glass secured in New York.
- 1881-81-----Lane-Fox (English). Early wooden base, vegetable filament, drilled carbon clamps, mercury sealed leads, tip exhaustion.

- 1881-93-----Lane-Fox (English). 20-cp, side seal tipless lamp, vegetable filament, drilled carbon clamp, mercury sealed. Made by St. George Lane-Fox.
- 1881-95-----Lane-Fox (English). Small tipless side seal, vegetable filament lamp, drilled carbon clamps, mercury sealed around leads.
- 1881-96-----Lane-Fox (English). 20-cp, tipless, side seal bulb, vegetable filament, drilled carbon clamps, mercury sealed leads. Made by St. George Lane-Fox.
- 1881-101-----Swan (English). Early paper tube base lamp, tubular leads, split to receive large shank of filament. From Savoy Theater, London. First theater in world lighted by the incandescent lamp.
- 1881-105-----Swan (English). Early long neck carbon spiral lamp, paper tube removed, center glass support for tubular leads. Used in Savoy Theater plant 1881. First theater lighted by the incandescent lamp.
- 1881-109-----Edison. Bamboo spiral, carbon paste clamps, with heat radiators, glass bridge and round seal. One of set for Paris Electrical Exposition.
- 1881-118-----Edison. B or 8-cp bamboo filament lamp, copper plated clamps, flat Holzer inside seal, flat collar, plaster base.
- 1881-131-----Edison. One of the first bulbous form ground glass globes. 16-cp, bamboo filament, copper plated clamps, flat inside seal.
- 1881-135-----Edison. 16-cp, 110-volt madake bamboo filament, plated copper clamps, glass twisted about leads, with flat collar, plaster butt.
- 1881-137-----Edison. Blinker lamp, bamboo filament, mica blinkers at platinum vice clamps.
- 1881-138-----Edison. 16-cp, 110-volt, bamboo hairpin filament, copper plated clamps, loose filament. Leg vibrated against clamp and arc formed, volatilized copper coating globe.
- 1881-140-----Edison. 16-cp, 110-volt, madake bamboo filament, plated copper clamps, pressed seal, small beveled collar, ring and screw contacts.
- 1881-141-----Edison. 16-cp, 110-volt, bamboo carbon hairpin filament, copper plated clamps, pear shaped globe, round supplemental tip.
- 1881-142-----Edison. Standard 16-cp, madake bamboo filament lamp. Early copper plated clamps, pressed Holzer seal, flat collar, plaster screw base.
- 1881-144-----Edison. Edison storage battery lamp, made for Paris Electrical Exposition, with plaster base, beveled ring and screw contacts.
- 1881-155-----Edison. Bamboo spiral carbon, copper plated clamps, flat inside seal. Made at first Edison Lamp Factory, old Pen Works, Menlo Park.
- 1881-156-----Edison. Bamboo spiral carbon, copper plated clamps, flat inside seal, made at first Edison Lamp Factory, old Electric Pen Works, Menlo Park, NJ.<
- 1881-157-----Edison. Tubular form storage battery lamp, bamboo filament, copper plated clamps, pressed seal.
- 1881-158-----Edison. One of the earliest B or 8-cp copper plated clamp, bamboo filament lamps, pressed inside seal.
- 1881-159-----Edison. Storage battery lamp made for the 1881 Paris Electric Exposition. Copper plated clamps, flat seal.
- 1881-160-----Edison. Plumbago filament punched from sheet, made at great pressure in hydraulic press by Mr. E.G. Acheson.

- 1881-161-----Edison. Plumbago filament lamp, punched from sheet of plumbago put under pressure of 5000 pounds to the square inch by Mr. E.G. Acheson. Copper plated clamps, flat inside seal.
- 1881-163-----Edison. Relic of early Holzer flat seal; inside stem showing spiral clamp for attaching carbonized vegetable filament, platinum leads.
- 1881-165-----Edison. Special lamp with tubular inside part drawn up between the bamboo legs, platina vice clamps.
- 1881-166-----Edison. One of the first B or 8-cp bamboo filament lamps, plated copper clamps, pressed seal, round tip on bulbous globe.
- 1881-167-----Edison. Early bamboo close spiral, copper plated clamps, supplemental copper heat radiating lugs, round seal, small round globe.
- 1881-168-----Edison. Plumbago filament punched from sheet; made at great pressure by Mr. E.G. Acheson.
- 1881-169-----Edison. Vice clamps made of silver. A leg of the filament became loosened forming electric arc which volatilized, silver coating globe. 16-cp, bamboo filament.
- 1881-170-----Edison. Storage battery lamp. Carbonized bamboo filament, plated copper clamps. Made for English Edison Company. A Faure storage battery was used at the Holborn Viaduct Station in 1881 and 1882.
- 1881-171-----Edison. Small storage battery lamp made for the 1881 Paris Electrical Exposition. Bamboo filament, copper plated clamps, pressed inside seal.
- 1881-172-----Edison. Plumbago filament punched from sheet; made at great pressure in hydraulic press by Mr. E.G. Acheson.
- 1881-174-----Edison. One of the first lot of 8-cp bamboo hairpin carbon filaments, plated copper clamps, pressed seal, bulbous globe, round supplemental tip.
- 1881-175-----Edison. Bast fibre tube form battery lamp with special small vice clamps, round inside seal.
- 1881-176-----Edison. Phantom shadow lamp first observed by Hammer. Found in many lamps. When carbon lamps are run and cathodic discharge carries particles in straight lines to glass opposite leg screens the glass, leaving clean line or shadow.
- 1881-177-----Edison. Mine lamp intended to burn under water in globe: 16-cp madake bamboo lamp. Taken to the Crystal Palace Exposition, London.
- 1881-178-----Edison. 16-cp, 102-volt, bamboo hairpin filament, platinum vice clamps, pressed inside seal. This is one of the first beveled plaster butt lamps. Painted with shellac and paint.
- 1881-179-----Edison. Mine lamp submerged in water filled globe, contacts being made under water, however, set up electrolytic action. Used in 1882 exhibit, Crystal Palace Electrical Exposition.
- 1881-180-----Edison. 16-cp madake bamboo filament, copper plated clamps, flat collar, plaster base.
- 1881-182-----Edison. Standard A or 16-cp, 110-volt lamp with madake bamboo hairpin filament, copper plated clamps, pear shaped globe, pressed seal, supplemental round globe tip.
- 1881-183-----Edison. One of earliest copper clamp lamps, flat seal, bulbous globe, bamboo filament, 16-cp.
- 1881-184-----Edison. Madake bamboo filament with tinned copper clamps, pressed inside seal.



- 1881-185-----Edison. Plumbago or graphite lamp. This is No. 4 of the first set made. Filaments punched from sheets pressed at 5000 pounds per square inch.
- 1881-186-----Edison. Carbon spiral bamboo plated copper clamps, flat seal, small round bulb, small tip.
- 1881-187-----Edison. Madake bamboo filament, copper plated clamps, hand blown bulb, pressed seal.
- 1881-188-----Edison. Fine spiral bamboo filament, plated copper clamps, pressed Holzer inside seal, screw base, flat plaster collar cut away.
- 1881-189-----Edison. Early plaster base lamp with flat collar, small tip, 16-cp, bamboo filament, copper plated clamps, flat seal.
- 1881-190-----Edison. One of the first beveled plaster base lamps; 2- 8-cp bamboo filaments in multiple, copper plated clamps, pressed seal.
- 1881-191-----Edison. 16-cp, wooden base with beveled contact ring and screw bottom.
- 1881-192-----Edison. B or 8-cp bamboo filament lamp, copper plated clamps, flat seal, early wooden screw base.
- 1881-203-----Edison. Silvered 16-cp bamboo filament lamp caused by arc between loose fibre filament leg and silver vice clamp.
- 1881-209-----Edison. Bottle form of lamp. Carbonized madake bamboo, 100-cp, multiple leads.
- 1881-489-----Maxim (American). Egg shaped globe, green and blue inside seal, M shaped paper carbon filament, platinum bolt and washer clamps.
- 1881-490-----Maxim (American). M shaped carbonized paper filament lamp, platinum leads and bolt and nut clamps, blue glass inside seal.
- 1881-491-----Maxim (English). English type Maxim paper shaped filament, platinum bolt and nut clamps and leads. Presented to Hammer by the London Light and Power Company.
- 1881-921-----Edison. Lamp and socket as used by Wm.J. Hammer in the first electric lamp sign ever made, etc.
- 1881-927-----Edison. Madake bamboo filament, flat copper plated clamps, moisture-proof plaster collar. Used in London, England in first electric lamp sign ever made. Invented by Hammer. The electric sign industry of the world started with this lamp.

## **1882**

- 1882-13-----Akester (English). Vegetable filament, 57 volts, carbon paste clamps, double glass bridge support, brass base, tip sealed. Made in Scotland.
- 1882-14-----Maxim (American). "M" shaped paper carbonized filament, butt and screw clamp.
- 1882-21-----Edison. Straight strip bamboo carbon filament, made for use with first lot of Faure storage batteries sent to England.
- 1882-27-----Edison. Bottle shaped bulb adopted as standard for short time, reverted to the bulbous type, which has ever since been the standard.
- 1882-35-----Latimer (American). This lamp was invented by Lewis Howard Latimer.

- 1882-37-----Swan (English). Spiral filament of squirted cellulose, carbon paste clamps.
- 1882-39-----British Electric (English). Improved Lane-Fox lamp, vegetable filament, carbon clamps, tipless, bottom seal.
- 1882-41-----Bernstein (American). Series lamp, hollow carbon filament made from carbonized straw with, heavy carbon paste clamps. No record of commercial use.
- 1882-43-----British Electric (English). Improved Lane-Fox lamp. Carbonized vegetable filament, carbon clamps, tipless globe.
- 1882-56----- (Belgian). Thick carbon punched from sheet with large shanks. Set in copper and platinum clamps. Made in Belgium.
- 1882-70-----Rogers (English). 16-cp, tipless lamp bottom seal, carbon filament. Set in drilled carbon clamps, long supporting leads. Made by John B. Rogers.
- 1882-87-----Swan (English). Spiral squirted cellulose carbon filament, carbon paste clamps, early paper and wood base.
- 1882-92-----Bernstein (American). Two hollow carbon filaments in series with heavy carbon paste cross-piece on top and clamps, copper wire and German glass supports, platinum leads.
- 1882-98-----Lane-Fox (English). 20-cp, 61-volt, vegetable filament lamp, drilled carbon clamps, mercury sealed around leads, tip sealed. Made by St. George Lane-Fox on April 22, 1882.
- 1882-106-----Swan (English). 8-cp, straight cellulose filament, carbon paste clamps, small globe, book base attachment.
- 1882-173-----Edison. Small bamboo carbon filament battery lamp. Made by Edison Lamp Company in 1882 and used by Hammer at a New Years Eve dinner.
- 1882-333-----Edison. 8-cp, 55-volt, bottle lamp. Adopted as standard for short time.
- 1882-334-----Edison. 16-cp, 110-volt, carbon filament. Made by twisting together eight strands of South American fibre.
- 1882-335-----Edison. One of the first set of 10-cp, 110-volt lamps, copper plated clamps, bamboo carbon filament, pear shaped globe.
- 1882-483-----Swan (English). Small carbon bow storage battery lamp, carbon paste clamps, platinum leads terminating in loops engaging hooks at bottom of spiral spring socket.
- 1882-484----- (English). Primary battery lamp. Platinum spiral in exhausted globe. For use with primary batteries.
- 1882-485-----Swan (English). Spiral cellulose carbon filament lamp, solid inside stem seal, carbon paste clamps, leads with loop ends to engage hooks in spiral socket.
- 1882-486-----Maxim (American). Tipless round globe, long neck, M shaped paper filament, platinum bolt and washer clamps, long platinum leads in glass with base support and base exhaustion.
- 1882-487-----Nothomb (French). Small bulb and filament with carbon paste clamps. Made in France.
- 1882-488-----Maxim (American). Small bulb, M shaped paper carbon filament, platinum bolt, nut and washer clamps and leads, flat solid glass stem.
- 1882-506-----Kurtzgen (American). Ground glass globe, low resistance carbon filament lamp.

- 1882-873-----Duplex (English). Lamp with two carbon filaments adapted to be operated in parallel or series by means of screws on socket base.
- 1882-875-----Gatehouse (English). Spirals of platinum iridium wire are attached to ends of carbon filament. An increase in resistance by increase in voltage and temperature as carbon reduces in resistance compensating therefor.
- 1882-926-----Edison. First colored incandescent lamp ever made. Made and used many of these at the 1882 Crystal Palace Electrical Exposition, London, England.
- 1882-941-----Gatehouse (English). Carbon filament; ends have spiral of platinum iridium attached thereto, so that as carbon decreases in resistance, the platinum increases and compensates therefor. Made by Mr. Thomas Gatehouse.

### 1883

- 1883-1-----deLodyguine (Russian). Modern type carbon filament lamp. Made in Russia.
- 1883-2-----Siemens-Halske (German). Carbon filament, mounted in drilled carbon clamps.
- 1883-3-----Siemens Bros. (German). 16-cp, cellulose carbon filament, carbon paste and platina clamps.
- 1883-5-----Siemens-Halske (German). 16-cp carbon filament, mounted in drilled carbon clamps, plaster base with brass contact lugs, mounted in socket.
- 1883-9-----Sawyer-Man (American). Tubular lamp, hairpin filament, carbon paste clamps, round inside seal, glass drawn around platinum leads, with snap key socket.
- 1883-11-----Crookes (English). Bottle form, tipless, heavy glass globe, flame shaped carbon filament, carbon paste clamps. Made by Sir William Crookes.
- 1883-17-----Swinburne (English). Carbon filament lamp, carbon paste clamps. Made in London, England by Mr. James Swinburne.
- 1883-24-----Cruto (Italian). 220-volt lamp, two filaments in series, carbon deposit on hairlike platinum core, carbon paste clamps, solid inside knurled collar on brass base.
- 1883-28-----Siemens Bros. (German). 16-cp, 103-volt, cellulose carbon filament, tubular clamps, solid rod glass inside seal, platinum leads. Made by Siemens Bros. at Charlottenburg, Germany.
- 1883-30-----Siemens-Halske (German). Long spiral carbon filament lamp. Carbon paste clamps. Short solid inside seal.
- 1883-31-----Gerard (French). "V" shaped filament rods joined by carbon paste and set in drilled carbon clamps. Made in Paris.
- 1883-32-----Müller (Austria). Double twist spiral filament with hydrocarbon treatment. Large tipless bulb.
- 1883-38-----Cruto (Italian). Single filament lamp, carbon deposited on hairlike platinum wire.
- 1883-40-----Bernstein (American). Low resistance carbon filament, carbon paste clamps, egg shaped globe.
- 1883-45-----British Electric (English). Improved Lane-Fox lamp, tipless, bottom seal, vegetable filament, carbon paste clamps.
- 1883-49-----Kurtzgen (American). Low resistance carbon filament, heavy copper leads wound around shanks for clamps.

- 1883-78-----Möller (Austrian). Single twist carbon filament, copper plated clamps, solid inside seal.
- 1883-332-----Edison. Compound parchment filament, copper plated clamps. Made by John P. Ott, Nov. 12, 1883.
- 1883-474-----Maxim (American). Round globe, M shaped paper carbon filament lamp, platinum bolt and nut clamps and leads.
- 1883-475-----Alexander (English). 48-volt, 1-amp., 10-cp carbon filament, carbon paste clamps, platinum leads supported from base of globe.
- 1883-476-----Maxim (American). M shaped paper carbon filament with platinum bolt, nut and washer and leads, solid round glass ste, brass base. Made by Hiram Maxim for the U.S. Electric Light Co.
- 1883-477-----Greinert-Friederich (German). Small bulb, low resistance carbon filament, heavy carbon shanks, glass drawn over platinum leads, stem filled with plaster. Made in Rhine region of Germany.
- 1883-478-----Maxim (American). M shaped carbonized paper filament, platinum bolt, nut and washer clamps, short solid flat inside seal.
- 1883-479-----Maxim (American). M shaped carbonized paper filament, platinum bolt and washer clamps and leads, long solid inside stem.
- 1883-480-----Greinert-Friederich (German). Small bulb, carbon filament with thickened ends and carbon paste, platinum leads with glass drawn around, inside part filled with plaster. Made on the Rhine.
- 1883-481-----Swan (English). Spiral cellulose filament, carbon paste clamps with hook loops on base for use with spiral spring socket. Made by Swan Company at Newcastle-on-Tyne Works.
- 1883-482-----Maxim (American). M shaped paper carbon filament, platinum bolt and nut clamps and leads, knurled brass base. Made by the U.S. Electric Lighting Company, New York.
- 1883-504-----Sawyer-Man (American). Carbon filament lamp, carbon paste clamps, glass drawn up over platinum leads, large round stem, nickel plated base.
- 1883-505-----Cruto (Italian). 220-volt, two filaments in series, carbon deposited on hair-like platinum core, carbon paste clamps, solid inside seal, knurled collar on brass base.
- 1883-507-----Möller (Austrian). Double twist carbon spiral filament, with hydrocarbon treatment, large tipless globe.
- 1883-508-----Möller (Austrian). Single twist carbon filament, carbon paste clamps, double glass bridge support.
- 1883-509-----Gerard (French). Small V shaped carbon filament, in conical glass globe. Made at Paris, France and sent to 1884 Franklin Institute Electrical Exposition.
- 1883-510----- (English). Swan United Electric Company. Tipless round bulb, spiral cellulose filament, carbon paste clamps, side supported leads with glass bridge. Made at Newcastle-on-Tyne, England.
- 1883-511-----Sawyer-Man (American). Tubular bulb lamp, round inside seal, hairpin filament, carbon paste clamps with glass drawn around platinum leads.
- 1883-512-----Maxim-Weston (American). Maxim M shaped paper carbon filament in Weston lamp mounting. Made by U.S. Electric Lighting Company (M & W Companies), Newark, NJ.

- 1883-513-----*(English)*. Swan United Electric Company. Tipless round bulb, spiral cellulose filament, carbon paste clamps, side supported leads with glass bridge. Made at Newcastle-on-Tyne, England.
- 1883-514-----Sawyer-Man (American). Tubular lamp.
- 1883-536-----Sawyer-Man (American). Tubular lamp.

## 1884

- 1884-205-----Edison. 100-cp straight bamboo carbon filament with folded platinum clamps and glass covered leads.
- 1884-221-----Edison. 500-cp multiple filament carbon lamp.
- 1884-305-----Edison. 100-cp, 100-volt, two-turn spiral bamboo filament, copper plated clamps, glass drawn over leads.
- 1884-316-----Edison. Neutral wire lamp, 16-cp, 110-volt, bamboo filament, copper plated clamps, flat inside seal.
- 1884-317-----Edison. Edison effect lamp with two sheets of platinum foil placed between ends of a 16-cp bamboo filament, copper plated clamps, pressed inside seal.
- 1884-318-----Edison. 16-cp, 110-volt carbon bamboo filament lamp, copper plated clamps, pressed inside seal, with platinum foil neutral between filament terminals for studying Edison effect.
- 1884-319-----Edison. Experimental Edison effect lamp with neutral imbedded in solid glass between terminals of 16-cp bamboo carbon filament, with copper plated clamps, pressed inside seal.
- 1884-320-----Edison. Edison effect lamp, double foil neutrals inserted between terminals of 16-cp bamboo carbon filament, with copper plated clamps, pressed inside seal.
- 1884-321-----Edison. Edison effect lamp, platinum neutral foil placed inside 10-cp carbon filament loop, copper plated clamps, pressed inside seal. Used by Hammer at 1884 Franklin Institute Electrical Exposition, Philadelphia, PA.
- 1884-322-----Edison. Edison effect lamp, platinum foil mounted in center of 10-cp bamboo carbon filament, plated clamps.
- 1884-323-----Edison. Neutral wire ground detector lamp, 16-cp 110-volt bamboo carbon filament, pressed seal, copper plated clamps.
- 1884-324-----Edison. Edison effect lamp. Two 10-cp bamboo carbon filaments with platinum foil neutral in center of crossed filaments, copper plated clamps, pressed inside seal.
- 1884-325-----Edison. 16-cp bamboo filament V shaped, in inverted pear shaped globe, pressed inside seal, copper plated clamps.
- 1884-326-----Edison. Special long platinum spiral lamp, carbon paste clamps, with four platinum wires in solid seal and twisted into single lead.
- 1884-327-----Edison. Madake bamboo filaments, copper clamps plated, flat seal, no collar.
- 1884-328-----Edison. 16-cp bamboo, plated copper clamps, platinum foil neutral for showing Edison effect, early wooden Edison socket base.

- 1884-329-----Edison. Edison effect lamp, two 10-cp bamboo carbon filaments with platinum foil neutral in center of crossed filaments, copper plated clamps, pressed inside seal.
- 1884-330-----Edison. Ground lamp with neutral wire, bamboo filament, plated copper clamps, flat seal. Marking on lamp: 16-c. Edison's patents.
- 1884-331-----Edison. Souvenir storage battery lamp. From lot made by New York Edison Company.
- 1884-442-----Weston. Mammoth lamp. These large lamps were first introduced at the 1884 Franklin Institute Electrical Exposition.
- 1884-447-----Weston. Weston mammoth lamp, 125-cp, platina bolt and nut clamps and leads, tamadine filament. By Edw. Weston, Newark, NJ.
- 1884-493-----Sawyer-Man (American). First lamp ever made in Westinghouse factory, Pittsburgh, by C.F. Reinman, August 24, 1884.
- 1884-494-----Hochhausen (American). Carbon filament lamp.
- 1884-496-----Weston (American). Standard tamadine filament lamp, platinum nut and washer clamps.
- 1884-497-----Edison-Swan (English). Squirted cellulose carbon spiral filament, carbon paste clamps, platinum loop terminals, hook and spiral spring sockets, egg shaped globe. Made at Newcastle-on-Tyne, England after Edison and Swan Companies amalgamated.
- 1884-498-----White (American). 16-cp, 100-volt zig-zag carbon filament, carbon paste clamps, glass drawn around platina leads.
- 1884-499-----Swinburne (English). From Hammond Electric Light Company, London, England.
- 1884-500-----Hochhausen (American). Four leaf clover form carbon filament, carbon paste clamps, flat inside seal. Made by Hochhausen Company.
- 1884-501-----Stanley-Thompson (American). 16-cp, 100-volt twisted carbon filament lamp, carbon paste clamp, wooden base, platinum leads supported from bridge. Made at Pittsburgh.
- 1884-502-----Stanley-Thompson (American). One of the earliest Stanley-Thompson carbon lamps with wooden base.
- 1884-503-----Müller (American). Double twist carbon spiral lamp, carbon paste clamps, egg shape globe.
- 1884-520-----Swinburne (English). Carbon lamp made in London, England by Hammond Electric Light Company.
- 1884-521-----Cruto (Italian). Carbon filament lamp.
- 1884-526-----Weston (American). Early tamadine sinusoidal carbon filament with Maxim platinum leads in white German glass stem. Made at U.S. Electric Light Company's factory, Newark, NJ.

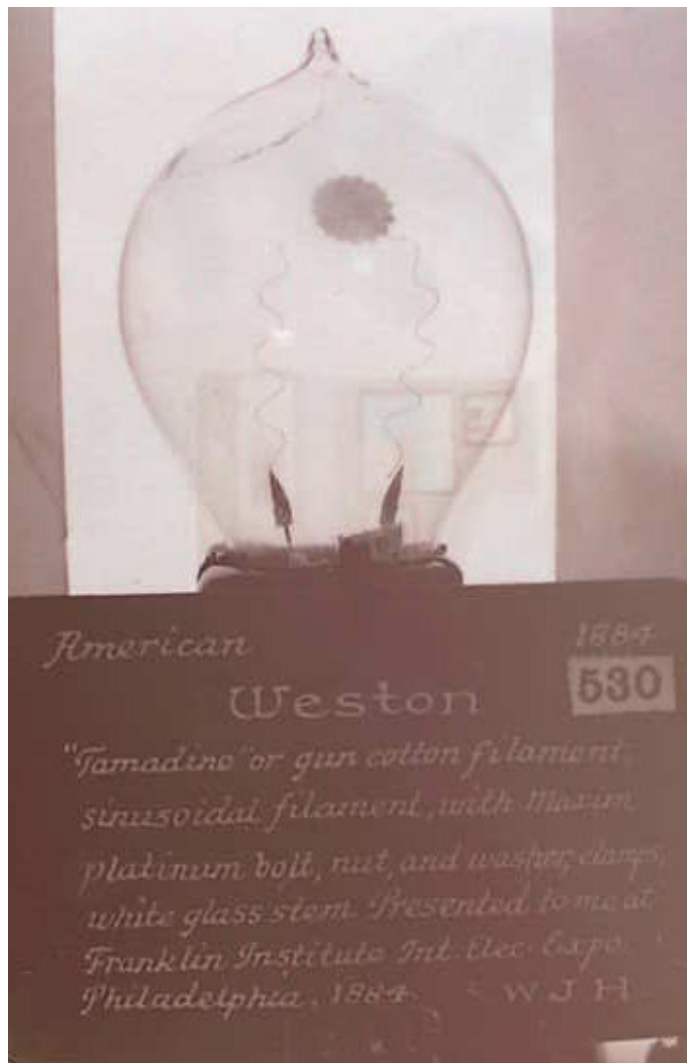

- 1884-530----Weston (American). Tamadine or gun cotton filament, sinusoidal filament with Maxim platinum bolt, nut and washer clamps, white glass stem.
- 1884-531----Richter (American). Flat wavy form carbonized paper filament, long platinum leads supported at sides of inside stem.
- 1884-534----Stanley-Thompson (American). 16-cp, 100-volts, cellulose filament, carbon paste clamps. Made at Westinghouse factory, Pittsburgh, PA. Presented by Edw. P. Thompson.
- 1884-535----Excelsior (American). 16-cp, 100-volt wavy M shaped cellulose carbon filament, copper plated clamps, pressed inside seal, Edison brass base with broad brass collar. Made by Excelsior Company.
- 1884-874----Thompson (American). Incandescent electric lamp. In this lamp there is placed inside the bulb a solenoid, the core of which is attached to the carbon filament.
- 1884-939----Thomson (American). Regulating lamp. Variation in voltage causes the solenoid to push or pull the carbon filament through the springs, regulating its length and candlepower.

- 1884-940-----Thompson (American). Thompson automatic regulating lamp. The carbon is movable by means of the solenoid through the stationary carbon rollers which thus shorten and lengthen the filament.

## 1885

- 1885-224-----Edison. Multiple filament carbon lamp, special.
- 1885-310-----Edison. 100-cp. Three spiral madake bamboo carbon filament, copper plated clamps, glass drawn around leads.
- 1885-311-----Edison. 100-cp, 10-volt, three turn round spiral bamboo filament, copper plated clamps, platinum leads separately sealed in solid glass.
- 1885-312-----Edison. 16-cp, 110-volt, madake bamboo filament, copper plated clamps, plaster butt, pressed inside seal.
- 1885-313-----Edison. Special storage battery carbon lamp, madake bamboo.
- 1885-314-----Edison. 100-cp, 110-volt three-turn round spiral, bamboo filament lamp, copper plated clamps, platinum leads, separately sealed in solid glass.
- 1885-423-----Diehl (American). Induction arc lamp. The secondary of an individual lamp transformer to the two arc electrodes inside the bulb, which is inserted in the primary coil.
- 1885-431-----Diehl (American). Diehl induction arc. No. 10 Diehl lamp, carbon electrodes forming arc in vacuum with secondary of coil inside globe and primary used outside to light by induction.
- 1885-434-----Diehl (American). Diehl induction lamp, one coil is placed inside globe and connected to filament, and other coil wound outside globe, alternating current being employed.
- 1885-436-----Diehl (American). Early type, double carbon filament No. 2E induction lamp, made by Philip Diehl at Elizabeth, NJ.
- 1885-439-----Diehl (American). One of Philip Diehl's earliest induction lamps employing secondary inside lamp, bulb connected with carbon filament and with the primary used on outside.
- 1885-441-----Diehl (American). Early form of Philip Diehl's induction arc lamp. Mr. Diehl's patents for induction arc and incandescent lamps were bought by the Westinghouse Company.
- 1885-462-----Diehl (American). Induction lamp for alternating current circuits, carbon filament with carbon paste clamps connected to secondary winding inside lamp, the primary coil being in the lamp socket.
- 1885-466-----Diehl (American). Induction lamp for use with alternating current.
- 1885-467-----Diehl (American). Induction lamp, carbon filament, with platinum clamps, platinum leads are connected to the secondary winding of an individual lamp transformer, the primary being inside the lamp.
- 1885-517-----Schuyler (American). Treated fibre carbon filament, platinum ribbon leads and clamps, with copper band and mica cut-out around leads. Made at Hartford, CT by Schuyler Company.
- 1885-518-----Brush-Swan (American). Squirted cellulose carbon spiral filament, carbon paste clamps, platinum leads in solid glass stem, round globe. Made at Cleveland, OH.



- 1885-519-----Brush-Swan (American). Spiral cellulose carbon filament, carbon paste clamps, round solid glass stem. Made by Brush-Swan Company at Cleveland, OH.
  - 1885-522-----Swinburne (English). Egg shaped globe, cellulose filament, carbon paste clamps, solid round stem. Made by Mr. James Swinburne at Hammond Electric Light and Power Company, London.
- 



- 1885-523-----Diehl Induction Lamp (American). Early form of Philip Diehl's induction lamp with straight carbon rod to be made incandescent by electromagnetic induction through the glass.

The lamp is from the collections of Henry Ford Museum & Greenfield Village Research Center. The image of the Diehl lamp was taken by the writer at the storage site.

- 
- 1885-524-----Weston (American). Standard tamadine lamp, sinusoidal carbon filament, with Maxim bolt, nut and washer, platinum clamps and leads, white German glass stem, brass base, key socket. Made at U.S. Electric Company's factory, Newark, NJ.
  - 1885-525-----Bernstein (American). Braided silk hollow carbon filament with heavy carbon paste clamps, platinum leads through solid glass, copper wire and soft German glass support, brass collar, and button contacts.
  - 1885-528-----Diehl (American). Induction lamp showing secondary coil inside globe connects to filament.
  - 1885-529-----Brush-Swan (American). Spiral cellulose carbon filament, carbon paste clamps, round solid glass stem. Made by Brush-Swan Company at Cleveland, OH.
  - 1885-894-----Diehl (American). Although this lamp was not designed as a regulating lamp, by reason of the employment on an alternating current in its internal and external coils it could be easily regulated.
- 



- 1885-997-----Vitrite Luminoid (English). 110-cp, 100-volt, spiral cellulose carbon filament, carbon paste clamps, red glass bridge support from platinum leads. From S.S. Burgoyne, which sank at sea in 1898.

The lamp is from the collections of Henry Ford Museum & Greenfield Village Research Center. The lamp image was taken by the writer at the storage site.

---

## 1886

- 1886-227-----Edison. Conical spiral madake bamboo filament, 50-cp, flat seal, carbon paste clamps.
- 1886-293-----Edison. Spiral voltmeter lamp made for use in connection with J.W. Howell's voltmeter.
- 1886-294-----Edison. 16-cp storage battery lamp, bamboo carbon filament, carbon paste clamps.
- 1886-297-----Edison. 100-cp three spiral bamboo carbon filament, copper plated clamps, glass drawn around platinum leads.
- 1886-298-----Edison. 110-cp 110-volt, conical spiral bamboo carbon filament, with heavy shanks, copper clips and copper plated clamps, solid glass drawn around each lead.
- 1886-299-----Edison. 50-cp madake bamboo filament, copper plated clamps, pressed inside seal, nickel plated screw base.
- 1886-300-----Edison. 25-cp municipal series lamp, madake bamboo, copper plated clamp, Holzer pressed inside seal, glass tube over copper leads.
- 1886-301-----Edison. 16-cp carbonized bamboo filament, carbon paste clamps, pressed inside seal.
- 1886-302-----Edison. 16-cp 110-volt, cellulose filament, carbon paste clamps, platinum wire through solid seal, simple tip
- 1886-303-----Edison. 100-cp conical spiral bamboo filament, plated copper clamps.
- 1886-304-----Edison. Edison municipal series lamps as used with paper cut-out, copper plated clamps, pressed inside seal.
- 1886-306-----Edison. Special voltmeter lamp made for use in connection with Mr. J.W. Howell's voltmeter.
- 1886-307-----Edison. 25-cp municipal lamp with series cut-out in base, bamboo filament, copper plated clamps, pressed inside seal.
- 1886-308-----Edison. 50-cp conical spiral bamboo filament with carbon paste clamps.
- 1886-309-----Edison. Series bamboo filament lamp with cut-out for street lighting.
- 1886-339-----Brush-Swan (Austrian). 80 volts, 3-1/2 watts per candle, squirted cellulose carbon filament, carbon paste clamps, red glass inside support. Made in Vienna, Austria.
- 1886-343-----Sawyer-Man (American). 10-cp, 98-volt, 0.36 ampere. Cellulose carbon filament lamp, long platinum leads with glass bridge and supported from globe base.

- 1886-344-----Perkins (American). Single filament carbonized paper clamp from Cumberland Mills, Maine. Platinum ribbon leads and clamps, round inside seal. Made by Mather Electric Company, Manchester, CT.
- 1886-346-----Greiner (American). Straight filament carbon lamp, platinum tube and carbon paste clamps, egg shaped globe. Made at Pittsburgh, PA.
- 1886-347-----Perkins (American). Sinusoidal form of filament. Carbon loops. Flat platinum clamps, and ribbon leads, round inside stem, plaster in base. Made by Mather Co., Manchester, CT.
- 1886-348-----Thomson-Houston (American). T-H series carbon filament lamp, paste clamps, leads in glass tubes tipped by glass ball containing platinum wires. First lamp made by T-H Company at Lynn, MA.
- 1886-349-----Schmauser (American). Battery lamp, vegetable filament, carbon paste clamps, supported from base of globe by platinum leads and glass bridge. Made by Dr. Schmauser.
- 1886-350-----Perkins (American). Two wavy filament paper hairpin carbon lamp, round inside seal, balloon shaped globe, platinum ribbon leads, round inside seal. Made by Mather Company, Manchester, CT.
- 1886-351-----Thomson-Houston (American). First carbon lamp made by Thomson-Houston Company, and so labelled. Made at Lynn, MA in 1886.
- 1886-352-----Weston (American). 16-cp, 107-volt, hairpin carbon filament lamp, spiral platinum and carbon paste clamps. Made by U.S. Electric Light Company, Newark, NJ.
- 1886-353-----German Edison Company (German). 16-cp, 110-volt carbon filament lamp, paste clamps, pressed inside seal. Made in Berlin, Germany by German Edison Company, now Allgemeine Elektrizitätsgesellschaft.
- 1886-354-----Bernstein (American). Hollow carbon made of cotton or silk tightly woven on a mandrel and carbonized, carbon paste clamps.
- 1886-355-----Edison-Swan (English). 20-cp, 110-volt, carbon spiral. Made at Newcastle-onTyne, England.
- 1886-428-----Franklin (American). Incandescent electric lamp. This lamp is one of the few manufactured by the Franklin Company of New York under direction of Dr. Otto A. Moses.
- 1886-437-----Bernstein (American). Double hollow carbonized cotton filament lamp.
- 1886-438-----Franklin (American). Curved hairpin carbon filament, carbon paste clamps, platinum leads. Made by Dr. Otto A. Moses in New York.
- 1886-465-----Westinghouse (American). W mogul. Stanley-Westinghouse. 150-cp, 53-volt mogul lamp. Two 75-cp carbon filaments in parallel, carbon paste clamps, solid glass around each lead.
- 1886-468-----Stanley-Westinghouse (American). Mogul carbon filament lamp, 150-cp, 53 volts. Two 75-cp filaments in multiple, solid glass drawn over each platinum lead.
- 1886-515-----Opperman (English). Squirted filament carbon paste clamps, platinum leads supporting filament from base of globe with glass bridge, egg shaped globe.

**1887**

- 1887-198-----Edison. 24-volt carbon lamp, copper plated clamps, arc at clamp volatilized copper, depositing it on globe.
  - 1887-289-----Edison. Fine bamboo carbon spiral filament lamp, pressed seal, copper plated clamps.
  - 1887-290-----Edison. Municipal series carbon filament lamp, carbon paste clamps, with automatic cut-out, flat seal.
  - 1887-291-----Edison. 32-cp madake bamboo carbon filament, copper plated clamps, pressed inside seal, nickel plated screw base.
  - 1887-292-----Edison. Municipal series carbon filament lamp, carbon paste clamps, with automatic cut-out, flat seal.
  - 1887-336-----Sawyer-Man (American). 16-cp, 100-volt hairpin carbon filament, carbon paste clamps, flat glass inside support, platinum leads.
  - 1887-337-----Greiner (American). Straight carbon filament, egg shaped globe, copper magnesia clamps, tubing around leads and clamps. Made at Pittsburgh, PA.
  - 1887-338-----Sawyer-Man (American). 16-cp, 107-volt, carbon filament, glasstube supports.
  - 1887-340-----Sun (American). Early type of Sun lamp made April, 1887 at Woburn, MA. Cellulose filament, carbon paste clamps, leads supporting filament from base of globe.
  - 1887-341-----Remington (American). Carbon filament lamp, carbon paste clamps, leads supported in white German glass from base, with glass bridge and platinum loop connectors.
  - 1887-342-----Sawyer-Man (American). 16-cp, 50-volt, squirted filament, paste clamps, solid flat white and green stem, close fitting brass collar.
  - 1887-345-----Edison-Swan (English). Carbon spiral, 16-cp, 110-volt. Made at Newcastle-on-Tyne, England.
  - 1887-374-----Sawyer-Man (American). 16-cp, 107-volts. Cellulose carbon hairpin filament in platinum tube, carbon paste clamps held by "Y" shaped tubular stem, Edison screw base.
  - 1887-375-----Sawyer-Man (American). 16-cp, 110-volt, cellulose carbon hairpin filament, platinum tube and carbon paste clamps in tubular "Y" shaped stem. Made by Westinghouse in 1887.
  - 1887-376-----Sun (American). Round hairpin shaped cellulose filament, carbon paste clamps, flat web foot stem, made at Woburn, MA by Sun Company.
  - 1887-377-----Perkins (American). Wave shaped carbon filament, flat platinum leads and clamps.
  - 1887-378-----Sawyer-Man (American). Cellulose carbon filament, platinum tube and carbon paste clamps, tubular supports for leads. Made in New York.
-

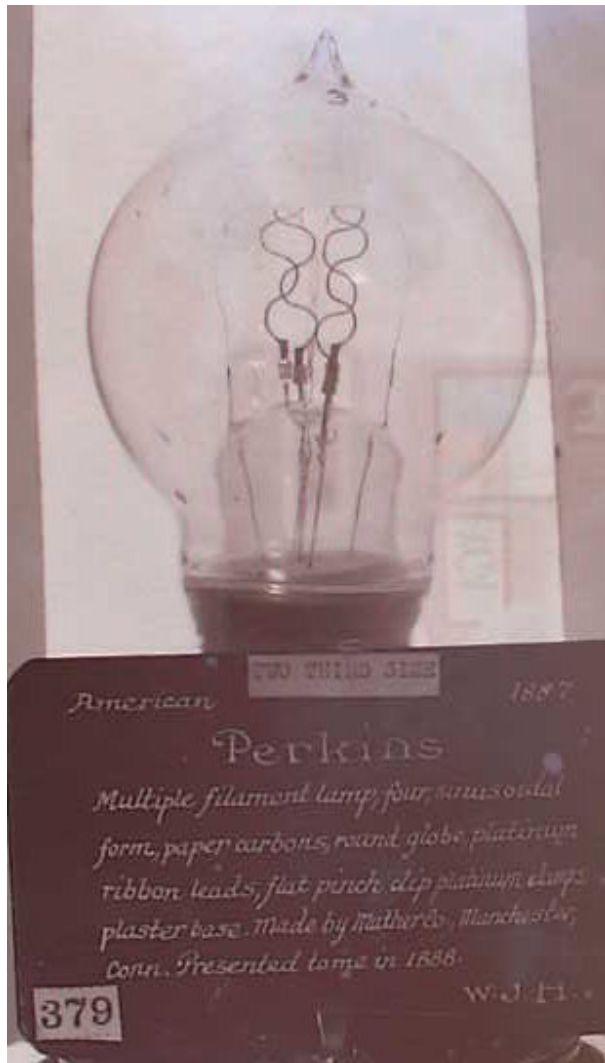

- 1887-379-----Perkins (American). Multiple filament lamp, four sinusoidal form paper carbons, round globe, platinum leads, flat punched clip, platinum clamps, plaster base. Made by Mather Company, Manchester, CT.
- 
- 1887-380-----Sawyer-Man (American). 15-cp, 105-volt, platinum tube and carbon paste clamps, flat solid white glass stem, flanged base collar.
  - 1887-381-----Greiner (American). Egg shaped globe, straight carbon filament with nickel leads at clamps. Made by Greiner at Pittsburgh, PA on Jan. 19, 1887.
  - 1887-382-----Sawyer-Man (American). 16-cp, 117-volt, carbon filament lamp.
  - 1887-383-----Thomson-Houston (American). 16-cp filament, carbon paste clamp, web foot glass lead inside seal.
  - 1887-384-----Van Choate (American). Bottle shaped globe with long carbon hairpin filament supported from base of globe with glass supporting bridge. From Van Choate Company, Boston, MA.

- 1887-385-----Sawyer-Man (American). Fluted bulb. Carbon filament, and carbon paste clamp, solid flat inside seal.
- 1887-386-----Opperman (English). Made in England.
- 1887-425-----Perkins (American). Multiple filament paper carbon lamp, platinum ribbon leads and clamps. Made by the Mather Company, Manchester, CT.
- 1887-430-----Thomson-Houston (American). Carbon filament lamp, carbon paste clamps, platinum leads with glass bridge between supporting filament from base of globe.
- 1887-433-----Van Choate (American). Bottle shaped globe with long carbon hairpin filament supported from base of globe with glass supporting bridge. From Van Choate Company, Boston, MA.
- 1887-445-----Perkins (American). Multiple filament lamp; six sinusoidal form paper carbons, large round globe, round inside seal, platinum ribbon leads with platinum clip. Lamp made by Mather Company, Manchester, CT.
- 1887-676-----Edison. Phosphate of calcium lamp operated by means of an induction coil.

## **1888**

- 1888-220-----Edison. Multiple spiral filament, carbonized bamboo, paste clamps, flat seal.
- 1888-222-----Edison. Multiple filament lamp, four cellulose carbons in parallel, carbon paste clamps. Hammer design.
- 1888-228-----Edison. Multiple filament "resistance" lamp for telegraphic circuits, etc.
- 1888-287-----Edison. Standard series municipal lamp, bamboo, carbon paste clamps.
- 1888-288-----Edison. 16-cp, 110-volt, green colored lamp for sign and decorative effect. From elaborate installation at the Ohio Valley and Middle Atlantic States Centennial Exposition held at Cincinnati, OH in 1888.
- 1888-296-----Edison. Resistance lamp, special tubular form, bamboo carbon paste clamp, from 10,000 ohms cold downward.
- 1888-361-----Sun (American). Squirted carbon filament, carbon paste clamps, web foot inside seal and support, platinum hook connections on base. Made at Woburn, MA.
- 1888-362-----Indianapolis Jenney Lamp Co. (American). Made by J.C. Reed at Indianapolis, IN.
- 1888-363-----Indianapolis Jenney Lamp Co. (American). Made by J.C. Reed in 1888. Ground detector lamp two filaments in series. Three outside connections.
- 1888-364-----Indianapolis Jenney Lamp Co. (American). Lamp No. 3. Made by J.C. Reed. Fused metallic silver clamp enclosed in glass cap to prevent discoloration.
- 1888-365-----Indianapolis Jenney (American). Carbon filament lamp with fused metallic around shank and inside of platinum caps drawn on leads.
- 1888-366-----Indianapolis Jenney Lamp Co. (American). Made by J.C. Reed. Clamp is made of spongy platinum block and cane sugar. The glass balls are to prevent heating.

- 1888-367-----Fort Wayne Jenney Co. (American). Schaefer cellulose carbon filament lamp, carbon paste clamps.
- 1888-368-----Bernstein (American). Heisler Company's series type Bernstein lamp. Hollow braided cotton and fibre filament, carbon paste clamps.
- 1888-369-----Thomson-Houston (American). Cut-out lamp. This blows a fuse. Carbon filament and paste clamp.
- 1888-370-----Bernstein (American). 16-cp, 110-volt, cellulose filament with carbon paste clamps, flat inside seal, platinum leads. From Bernstein & Company, Boston, MA.
- 1888-372-----Sun (American). Made at Woburn, MA. Squirted carbon filament, carbon paste clamps, web foot inside seal and support.
- 1888-373-----Sun (American). Cellulose carbon filament lamp, carbon paste clamps, web foot inside seal, platina leads. Made at Woburn, MA.
- 1888-432-----Hammer (American). Multiple filament lamp, six carbons arranged in a circle with center pedestal and ring supports. Taken to 1889 Paris Exposition. Designed by Hammer and made in Harrison, NJ.
- 1888-435-----Van Choate (American). Bottle shaped globe with long carbon hairpin filament supported from base of globe with glass supporting bridge. From Van Choate Company, Boston, MA.
- 1888-472-----Thomson-Houston (American). Carbon filament lamp, paste clamps, copper leads in glass tubes supported from globe base with platinum leads through base and glass bridge on top.

## 1889

- 1889-204-----Edison. Leyden jar or condenser lamp.
- 1889-286-----Edison. 16-cp, 110-volt, carbon hairpin filament, carbon clamp paste, reduced amount of platinum and copper lead in solid inside seal.
- 1889-357-----Woodhouse-Rawson (English). Battery lamp, cellulose carbon filament, carbon paste clamps, platinum leads in solid round inside seal.
- 1889-358-----Bäckström (Swedish). Carbon filament, paste clamp, wooden base.
- 1889-359-----Woodhouse-Rawson (English). Battery lamp, cellulose carbon filament, carbon paste clamps, platina leads in solid round inside seal.
- 1889-360-----Sawyer-Man (American). 10-cp, 98-volt, 0.36 ampere carbon filament lamp, balloon shaped globe, leads supported from bottom of globe with glass bridge.
- 1889-424-----Thomson-Houston (American). Thomson-Houston series carbon filament lamp. Solid glass drawn around platinum leads, carbon paste clamps, leads bent at right angles, large round globe.
- 1889-450-----Bernstein (American). The carbon filament is made of cotton and silk fibre woven on a mandrel and then carbonized into a hollow filament. Carbon paste clamps and wooden base.
- 1889-469-----Schuyler (American). 125-cp carbon filament lamp made by the Schuyler Company under the Lemp and Wightman patent. With copper band cut-out, round platina leads.

## 1890



- 1890-279-----Edison. Tubular globe, 16-cp, 110-volt, carbon filament lamp, carbon paste clamps, pressed inside seal. Edison. Standard 16-cp, 110-volt lamp in T.H. base, cellulose filament, carbon paste clamps.
- 1890-281-----Edison. Standard 16-cp, 110-volt lamp in T.H. base, cellulose filament, carbon paste clamps.
- 1890-282-----Edison. Standard 16-cp 110-volt carbon filament, carbon paste clamps with minimum platinum and copper leads, pressed inside seal.
- 1890-283-----Edison. 16-cp cellulose carbon hairpin filament, carbon paste clamps, reduced platinum leads, top of screw base beveled.
- 1890-356-----Schaefer (American). Cellulose carbon filament with paste clamps, ground glass stem, plaster in brass base.
- 1890-409-----Bernstein (American). 25-cp, 2.5-amp., carbon filament lamp, round globe, flat inside stem seal, hard rubber base.
- 1890-410-----Westinghouse (American). Inverted V shaped carbon filament, two straight carbon filaments, joined at top by carbon paste and with paste clamps.
- 1890-415-----Pray (American). 16-cp, 52-volt, carbon filament lamp, carbon paste clamp, flat glass inside seal. Made in Boston.
- 1890-416-----Ganz and Co. (Hungarian). From Budapest, Hungary.
- 1890-417-----Schaefer (American). 16-cp carbon lamp. Made by Schaefer Lamp Co.
- 1890-418-----Steel. 8-cp, 20-volt Steel circular carbon filament lamp.
- 1890-419-----Schaefer (American). Small series lamp, cellulose carbon filament, carbon paste clamps, Maltese Cross glass support for leads without stem, plaster and brass base.
- 1890-420-----Steel (English). Experimental lamp with coil of steel wire. Made in London, England.
- 1890-421-----Schaefer (American). 50-cp, 42-volt, carbon lamp. Long copper inside leads, spiral copper clamps and carbon paste.
- 1890-870-----Edison. 16-cp, 110-volt carbon lamp. May be a night light of 1-cp by placing filaments in series by means of thumb screw in base.
- 1890-943-----Edison. Night light with glass tube separator. Burns 16-cp filament or by turning thumb screw in base puts two filaments in series>

## 1891

- 1891-413-----Siemens-Halske (German). From the S.S. Bismarck, Dec. 9, 1891.
- 1891-414-----Woodhouse-Rawson (English). 25-cp, 50-volt, squirted filament, carbon paste clamps, platinum leads terminating in loops, for use with hook contact spiral spring socket.

## 1892

- 1892-400-----Green Stopper (American). Stopper or separable carbon filament lamp. Inside part and neck of bulb are ground to fit and luted with compound.
- 1892-401-----Swan (English). Straight filament Swan lamp. Cellulose filament, glass bridge support, carbon paste clamps. Made by Edison-Swan Company, Newcastle-on-Tyne, England.

- 1892-402-----Woodhouse-Rawson (English). 16-cp, 100-volts, squirted carbon filament, carbon paste clamps, egg shaped globe, platinum leads, supported from base of globe with glass bridge and bent at right angles.
- 1892-403-----Swan (English). Storage battery lamp. Straight cellulose carbon filament, carbon paste clamps.
- 1892-404-----Woodhouse-Rawson (English). 16-cp, 100-volt squirted filament, carbon paste clamps, egg shaped globe, straight platinum leads, supported from base of globe with glass bridge.
- 1892-405-----A.B.C. (American). 16-cp, 110-volt, carbon filament lamp. Made for Alex Bonny and Chapin Co., of New York by Bernstein Electric Company.
- 1892-406-----Fitzgerald (English). Fitzgerald carbon filament lamp, carbon paste clamps, filament supported from base by leads with glass bridge, brass base.
- 1892-412-----A.B.C. (American). 16-cp, 110-volt, carbon paste clamps, flat inside seal. Made for Alex Bonny & Chapin Electric Supply Co., New York, by Bernstein Company.
- 1892-908-----Reis (American). Reis regulating lamp socket for alternating current circuits, employing a choke coil single coil transformer.
- 1892-914-----Ries (American). Ries regulating lamp socket employing ac choke coil single coil transformer. Presented to Hammer by Mr. Elias Ries.

### 1893

- 1893-208-----Edison. Special tubular lamp, 10-cp, cellulose filament and carbon paste clamps, leads supported from base with glass bridge at top and bottom.
- 1893-211-----Edison. Screw thread glass base, annular base ring and center pin contacts. Squirted cellulose filament, paste clamps.
- 1893-276-----Edison. Standard form 16-cp, carbon filament, carbon paste clamps, short platinum leads.
- 1893-387-----Westinghouse (American). Stopper lamp. Moulded globe with spiral flutings, iron leads in solid moulded glass stem, carbon filaments and clamps.
- 1893-388-----Green (American). Stopper lamp. Stopper or separable lamp, pear shaped globe, straight cellulose filament, carbon paste clamps. Made at Hartford, CT Dec. 5, 1893.
- 1893-389-----Westinghouse (American). Stopper lamp. 16-cp, 50-volt separable lamp. Spiral carbon filament, iron leads with Edison base.
- 1893-390-----Novak (American). 25-cp, 110-volt, carbon filament lamp, made by Mather Company at Manchester, CT.
- 1893-391-----Westinghouse (American). Stopper lamp. 16-cp, 50-volt. Inside part and neck of globe are ground to fit and luted with bitumen, etc. Designed to get around Edison patent.
- 1893-392-----Green (American). Stopper lamp. Separable lamp, pear shaped globe, straight cellulose filament, carbon paste clamps. Made at Hartford, CT on Dec. 5, 1893.
- 1893-393-----Westinghouse (American). Ground glass and lead seal stopper lamp. Carbon filament, carbon paste clamp, iron wire leads, 16-cp, 50-volt.

- 1893-394-----DeKhotinsky (American). 16-cp, spiral cellulose carbon filament lamp, carbon paste clamps, platinum lead supports in red glass at base of globe. Made in England.
  - 1893-395-----DeKhotinsky (American). 16-cp, cellulose spiral carbon lamp, carbon paste clamps, in stem, platinum lead supports, English base, tipless bulb, base exhaustion. Made in England.
  - 1893-396-----Green (American). Stopper lamp, carbon filament, paste clamp. Made at Hartford, CT.
  - 1893-397-----Buckeye (American). 16-cp, 110-volt cellulose carbon filament, carbon paste clamps, pressed inside seal. Made by Buckeye Lamp Company, Cleveland, OH.
  - 1893-398-----Westinghouse (American). Stopper lamp. 16-cp, 50-volts, inside part and neck of globe are ground to fit and luted with bitumen, etc. Designed to get around Edison patents.
  - 1893-399-----Packard (American). Stopper lamp. 16-cp, 118-volt stopper or separable lamp. Cellulose filament, carbon paste clamps with heat radiators on leads. Made by Packard Co., Warren, OH.
  - 1893-407-----Westinghouse (American). One of the earliest forms of stopper or separable lamps, with ground glass sealed with bitumen, etc. As used at Chicago Exposition, 1893. This lamp was made to get around the Edison lamp patents and was used in preparing opinion by Betts, Scheffield and Betts for Mr. Westinghouse.
  - 1893-408-----Westinghouse (American). One of the two lamps of the stopper type submitted by Betts, Scheffield and Betts for an opinion in 1893. This lamp was made to get around the Edison patents. The lower part is ground to fit the neck of the globe and is luted with bitumen, etc. Lead was also employed. 50,000 stopper lamps were used to light the World's Fair in Chicago in 1893.
  - 1893-448-----Packard (American). Stopper lamp. 16-cp, 113-volt stopper or separable lamp, cellulose filament, carbon paste clamps with heat radiators on leads. Made by Packard Co., Warren, OH.
  - 1893-449-----Westinghouse (American). Decorated stopper lamp with iron leads, solid moulded stem ground to fit bulb, carbon filament.
  - 1893-452-----Green (American). Egg shaped tipless globe, stopper or separable lamp, cellulose filament, carbon paste clamps, pressed inside seal. Made at Hartford, CT.
  - 1893-458-----Westinghouse (American). Stopper lamp, glass seal, iron leading-in wires. 16-cp.
  - 1893-459-----Westinghouse (American). Stopper lamp. 16-cp, 50-volt stopper or separable carbon filament lamp, iron lead wires. Used to light World's Columbian Exposition, Chicago, 1893.
-



- 1893-938----Schultzberge (American). One of the first of his etched carbon filament lamps, made at Edison's laboratory, Orange, NJ in 1893 by Dr. Schultzberge.
- 
- 1893-947----Jaeger (American). Uranium glass vacuum tube lamp. Glows beautifully when operated with induction coil.
  - 1893-948----DeKhotinsky (American). 50-volt, 16-cp straight carbon filament lamp. Edison brass and porcelain screw base. Made by Captain Achilles DeKhotinsky at Marlboro, MA.
  - 1893-949----Baetz (American). Fiddle-bow lamp. Straight carbon filament, held by copper wire in glass tube with platina leads. Presented to Hammer by Mr. W. Baetz at his shop in New York.

- 1893-950-----DeKhotinsky (American). 50-volt, 16-cp straight carbon filament lamp, Edison brass and porcelain screw base. Made by Captain Achilles DeKhotinsky at Marlboro, MA.
  - 1893-951-----Sunbeam (American). Made in Chicago, IL.
  - 1893-952-----DeKhotinsky (American). 16-cp, 50-volt straight carbon filament. Edison brass and porcelain base. Made by Captain Achilles DeKhotinsky at Marlboro, Ma.
  - 1893-953-----Goebel Lamp (American). Copy for court exhibit. Fiddle-bow carbon lamp, Torricellian vacuum. The Goebel lamp represents one of the greatest frauds ever perpetuated on the electrical profession.
  - 1893-954-----Schultzberge (American). One of the first etched Edison carbon filament lamps. Made at Edison's laboratory, Orange, NJ in 1893 by Dr. Schultzberge.
  - 1893-955-----Sunbeam (American). Von Kamerer. Acorn shaped globe, carbon filament lamp. Made by Sunbeam Lamp Company, Chicago, IL.
  - 1893-956-----DeKhotinsky (American). 16-cp, 50-volt straight carbon filament, Edison brass and porcelain base. Made by Captain Achilles DeKhotinsky at Marlboro, MA.
  - 1893-957-----Novak (American). Made at Manchester, CT by Mather Electric Company.
  - 1893-958-----Westinghouse (American). Moulded design globe. Westinghouse stopper lamp. Iron leading-in wires in solid stem, carbon filament and clamps.
  - 1893-975-----Sawyer-Man (American). 16-cp, 110-volt, spiral carbon filament, carbon paste clamps, porcelain base.
  - 1893-976-----Westinghouse (American). Decorated Westinghouse stopper lamp with iron leads. Solid moulded stem ground to fit bulb. Carbon filament.
  - 1893-977-----Tholes (American). 180-volt, 16-cp Tholes lamp. One of the first high voltage carbon filament lamps made.
-

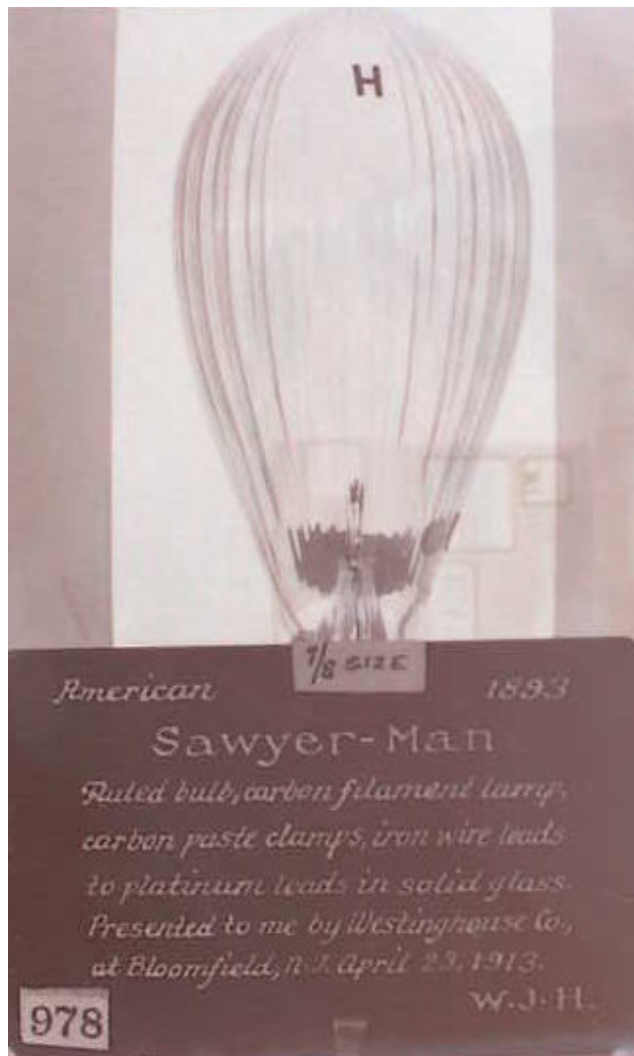

- 1893-978----Sawyer-Man (American). Fluted bulb, carbon filament lamp, carbon paste clamps, iron wire leads to platinum leads in solid glass.
- 
- 1893-1001----DeKhotinsky (American). 16-cp, 100-volt, hairpin shaped filament, cellulose carbon. Made at Marlboro, MA.
  - 1893-1003----Novak (American). 25-cp, 110-volt, squirted filament, carbon paste clamps, solid flat glass stem, long platinum leads, Made at Manchester, CT by Mather Electric Company. Paper label: Patented May 9, 1893, 113-volt, 16-cp.
  - 1893-1004----Goebel (American). Court exhibit copy of a fake lamp, hairpin carbon, Torricellian vacuum. Made at Harrison, NJ.
  - 1893-1005----DeKhotinsky (American). 16-cp, 50-volt carbon lamp, carbon paste clamps.

- 1893-1006---Novak (American). 16-cp, 113-volt hairpin carbon filament, carbon paste clamps, flat punched inside seal, short platinum leads. Made by the Mather Electric Company, Manchester, CT.
- 1893-1015---Goebel (American). Copy of Goebel fake lamp used as court exhibit. Made at Edison Lamp Factory, at Harrison, NJ in 1893.
- 1893-1017---Goebel (American). Copy of Goebel fake lamp made as court exhibit in Edison lamp suits. Made for Hammer at Edison Lamp Works, Harrison, NJ in 1893.
- 1893-1018---Novak (American). 25-cp, 110-volt carbon filament lamp. Made by Mather At Manchester, CT. Label: 113-volt, 16-cp, Patented May 9, 1893.
- 1893-1019---S.A.C. (American). 16-cp, 113-volt, S.A.C. carbon filament lamp. Made October 24, 1893.
- 1893-1020---Sunbeam (American). Von Kamerer - acorn shaped globe, carbon filament lamp. Made by Sunbeam Lamp Company, Chicago.
- 1893-1021---Westinghouse (American). Stopper lamp. 116-cp, 50-volts. Inside part and neck of globe are ground to fit and luted with bitumen, etc. Designed to get around Edison patents. Presented to Hammer at the Chicago Exposition in 1893.

#### **1894**

- 1894-273-----Edison. One of the first anchored oval spiral filament lamps, carbon paste clamps, copper wire anchor.
- 1894-274-----Edison. 51-volt, 16-cp, storage battery lamp. Bamboo filament, carbon paste clamp, wide collar above screw thread.
- 1894-275-----Edison. Early oval type squirted cellulose filament, anchor wire fastened outside on flat seal, high turned-in collar above screw.
- 1894-278-----Edison. 50-cp large loop carbon spiral lamp, T-H base.
- 1894-284-----Edison. 16-cp, 50-volt storage battery lamp, carbon filament, carbon paste clamps, reduced platinum in stem seal, special shank base.
- 1894-285-----Edison. 16-cp, 48-volt storage battery lamp, carbon filament, carbon paste clamps, reduced platinum leads in stem, special shank screw base.
- 1894-444-----New Beacon (American). Stopper lamp made by the Beacon Vacuum Pump and Electric Company, Boston, MA. Carbon filament, paste clamps, separators and radiators on leads.
- 1894-451-----New Pa. (American). 110-volt, 16-cp, stopper lamp, carbon filament, carbon paste clamps, photometer test only.
- 1894-455-----Pollard (American). Pollard lamp, metallic powder fused in grooves in solid glass. Designed to affect Edison's patent on platinum leading-in wires; is a mechanical equivalent.
- 1894-457-----Pollard (American). Metallic powder fused in glass to replace platinum leading-in wires. Made by Imperial Electric Manufacturing Company.
- 1894-461-----Pollard (American). Metallic powder fused in glass to replace platinum leading-in wires. Made by Imperial Electric Manufacturing Company.
- 1894-970-----New Beacon (American). 16-cp, 110-volt, carbon filament stopper lamp. Made by the V.P.& E. Co., May 11, 1894.
- 1894-971-----Sawyer-Man (American). Carbon filament supported by leads and opal glass stem. Lamp sent by Oscar Boehm to Westinghouse.

- 1894-972-----Columbia (American). 16-cp, 113-volt spiral cellulose carbon filament. Made by Columbia Lamp Company, St. Louis, MO.
- 1894-1014----Columbia (American). Triple spiral carbon lamp, 113-volts, 16-cp.

### **1895**

- 1895-527-----Vitrite Luminoid (English). Hairpin shaped cellulose carbon filament, carbon paste clamps, platinum lead supports from globe base with black glass bridge support. English base made in London.
- 1895-671-----Moore (American). Experimental lamp shown at A.I.E.E., April 22, 1896.
- 1895-672-----Moore (American). Experimental vacuum tube lamp shown at A.I.E.E. meeting, April 22, 1896. Presented to Hammer by Mr. D. McFarlan Moore.
- 1895-673-----Moore (American). Experimental vacuum tube lamp shown at A.I.E.E. meeting, April 22, 1896. Presented to Hammer on April 26, 1896 by Mr. D. McFarlan Moore.
- 1895-678-----Moore (American). Experimental tube lamp shown at A.I.E.E. meeting on April 22, 1896 by Mr. D. McFarlan Moore.
- 1895-1012----Gabriel-Argenault (French). Spiral carbon filament lamp.
- 1895-1013----American (American). 16-cp, 113-volt anchored cellulose filament lamp. Made in St. Louis, MO.

### **1896**

- 1896-272-----Edison. 16-cp oval loop, carbon paste clamps, copper wire anchor. (Lamp marked: First 16-1/4, 42-1/2 sample made in 1896).
- 1896-684-----Moore Vacuum Tube (American). Section of Moore vacuum tube used at Marconi A.I.E.E. dinner, January 13, 1902.
- 1896-936-----Alpha (American). Sign letter lamp, enameled top, ground glass globe. 16-cp, 115-volt carbon filament. Made by Aetna Electric Co.
- 1896-963-----Superior (American). 16-cp carbon filament lamp, carbon paste clamps, T-H base.
- 1896-965-----Fuller (English). Carbon filament lamp, made in England, September, 1896.
- 1896-966-----Adams-Bagnall (American). 16-cp, 110-volt spiral carbon filament lamp, tipless globe, bottom seal in inside part, side filament supports. Made in Cleveland, OH by the Adams-Bagnall Company.
- 1896-1010----Adams-Bagnall (American). Tipless globe, 32-cp, 110-volt spiral carbon filament lamp, sealed at base, filaments supported from side of globe. Made in Cleveland, OH.
- 1896-1011----Adams-Bagnall (American). 16-cp, 110-volt spiral carbon filament lamp, tipless globe, bottom seal. No inside part. Side filament supports. Made at Cleveland, OH by Adams-Bagnall Company.

### **1897**



- 1897-961-----Sunshine (Swiss). Zig-zag carbon filament lamp. Made by Stearne Company of Zurich, Switzerland.
- 1897-962-----Sunshine (Swiss). Zig-zag form of carbon filament with reflector. Made by Stearne in Zurich, Switzerland.
- 1897-964-----Lynn (American). 16-cp, 104-volt renewed carbon filament lamp. Renewed by the Lynn Incandescent Lamp Company in 1897, Lynn, MA.
- 1897-1007----Ediswan (English). 110-volt, 16-cp, spiral cellulose carbon filament, carbon paste clamps. Made August 16, 1897.
- 1897-1008----Sawyer-Man (American). 16-cp, 116-volt, oval carbon loop lamp. Made by Sawyer-Man Company, August 3, 1897.
- 1897-1009----Cruto (Italian). Carbon filament lamp made in Italy by Cruto Company which made deposited carbon filaments with hairlike platinum core as early as 1883.

### **1898**

- 1898-277-----Edison. Oval loop carbon filament in green glass globe for decorative effect, 16-cp, 115-volts.
- 1898-959-----Edison-Swan (French). Large cellulose carbon spiral filament lamp made by the French Edison-Swan Lamp Company.
- 1898-960-----Waverly (American). 16-cp oval loop carbon filament railway series lamp. Carbon paste clamps and anchor wire. Made by Sawyer-Man Company.
- 1898-989-----Unknown. One of two lamps taken from Spanish cruiser Maria Theresa, sank off Santiago by U.S. fleet in war with Spain, July 3, 1898 which was raised September 26, 1898 and sank at sea off Cat Island during a storm while being towed north.
- 1898-990-----same as No. 989.

### **1899**

- 1899-271-----Edison. 16-cp, 116-volt oval anchored loop, cellulose filament, carbon paste clamps. (Labeled "Sample of lamp made by us in 1899").
- 1899-877----- Unknown (American). 16-cp, 110-volt silvered reflector lamp. Anchored oval loop cellulose carbon filament. Sent to Edison Lamp Company by Mr. Chas. T. Hughes.
- 1899-1025----Edison, Thomas A. Jr. (American). This lamp made by Shelby Electric Company, Shelby, OH who paid Thomas A. Edison Jr. for use of name.

### **1900**

- 1900-230-----Edison. Mirrored reflector carbon spiral lamp, ground glass.
- 1900-265-----Edison. 110-volt, 35-cp anchored carbon spiral filament, mushroom shaped globe, carbon paste clamps.
- 1900-266-----Edison. Oval anchored cellulose carbon filament, carbon paste clamps, depressed globe tip.
- 1900-267-----Edison. 35-cp, 116-volt spiral cellulose carbon reflector lamp, mushroom globe, upper half ground glass, lower half silvered.

- 1900-268-----Edison. 16-cp, 50-watt, 118-volt, double pear shaped anchored cellulose carbon filament, label in stem, reduced platinum leads, small pressed seal, carbon paste clamps, moulded glass base.
  - 1900-269-----Edison. Oval loop spiral squirted carbon filament, anchored, brass screw base without margin above, flat seal, platinum minimum, 16-cp, 114 volts.
  - 1900-270-----Edison. 28-cp, 110-volt mushroom globe reflector lamp. Ground glass top and silvered lower half, spiral cellulose filament.
  - 1900-635-----Nernst (German). Skeleton of German Nernst lamp showing iron ballast in hydrogen filled bulb and automatic cut-out.
  - 1900-637-----Nernst (English). English type of torch or non-automatic Nernst lamp. Presented to Hammer by the English Nernst Company, London, in 1900.
  - 1900-638-----Nernst (English). English type of automatic Nernst lamp with cut-out, glower, heating coil and ballast. Presented to Hammer by the English Nernst Company in 1900.
  - 1900-640-----Nernst (Hungarian). Single glower torch type with ballast wire in hydrogen and cut-out magnet; has no heating coil; must be warmed with lamp or alcohol torch.
  - 1900-642-----Nernst (Hungarian). Early torch form of lamp; the glower is heated by an alcohol torch to make it conducting; the light can be blown out.
  - 1900-643-----Nernst (Hungarian). Multiple glower torch type Nernst lamp. Made by Eggars and Company, Budapest, Hungary.
  - 1900-652-----Nernst (German). Automatic type, with heating coil, glow wire, ballast and cut-out magnet.
  - 1900-779-----Langhans (German). Dicarbide of silicon lamp made in Berlin, Germany by Dr. Langhans.
  - 1900-780-----Langhans (German). same as 779.
  - 1900-781-----Langhans (German). same as 779.
  - 1900-888-----Radiant (English). Silvered reflector lamp, 16-cp, 105-volts, cellulose carbon filament, carbon paste clamps, platinum lead support. Made by Rose and Bird Ltd., London, England.
  - 1900-909-----Miller (American). Single filament turn lamp. Lifting brass spring off the hook throws resistance element in series with filament.
-

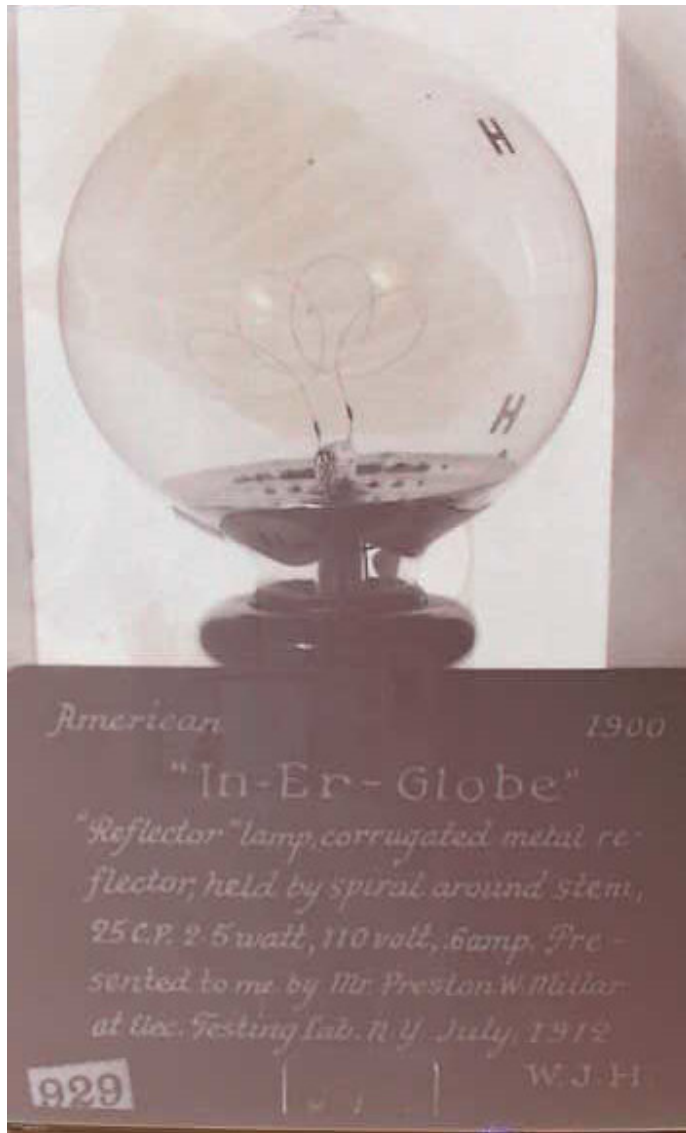

- 1900-929-----"In-Er-Globe" (American). Reflector lamp, corrugated metal reflector held by spiral around stem. 25-cp, 2.5 watts, 110-volts, 0.6 ampere.
- 
- 1900-932-----Edison. Silvered reflector or mushroom bulb type, 36-cp, 116 volts, four spiral anchored cellulose carbon filaments, carbon paste clamps.
  - 1900-968-----I.E. Reflector Glow Lamp (English). Made by I.E. Glow Lamp Company, Ltd. 110-volt, 8-cp cellulose carbon spiral lamp, Ediswan lamp with silvered reflector on lower half. Made in England.
  - 1900-1022----Bäckström (American). Twisted carbon loop anchored to center glass rod, platina tube and carbon paste clamps. From Seely & Taylor Manufacturing Company, New York.



- 1900-1023----Bäckström (American). Twisted carbon loop anchored to center glass rod, platina tube and carbon paste clamps. From Seely & Taylor Manufacturing Company, New York.
  - 1900-1024----International (American). 16-cp, 120-volt oval loop, anchored carbon filament lamp. Made for foreign trade by G.E. Lamp Works.
-

## 1901

- 1901-212-----Edison. 16-cp, 118-volt anchored cellulose carbon filament lamp, pressed seal, silvered reflector, on lower half of round globe.
  - 1901-213-----Edison. Round blackened bulb reflecting lamp, anchored carbon spiral, carbon paste clamps.
  - 1901-216-----Edison. 16-cp, 118-volt reflector type, round anchored cellulose carbon filament, silvered on back half of globe and painted on outside.
  - 1901-262-----Edison. 50-cp, 220-volt cellulose filament lamp. Two anchored 110-volt round loops in series with long glass neck supports, paste clamps, pressed seal.
  - 1901-263-----Edison. 8-cp, 116-volt anchored spiral filament, carbon paste clamps.
  - 1901-264-----Edison. 220-volt, 50-cp, two 110-volt, 25-cp anchored cellulose carbon filaments in series, carbon paste clamps, pressed inside seal.
  - 1901-644-----Nernst (American). American type of automatic Nernst lamp with single glower, heater, ballast and cut-out. Made by American Nernst Company at Pittsburgh, PA.
  - 1901-651-----Nernst (German). Socket base of 100-watt 110-volt dc. type, showing iron wire ballast and cut-out.
  - 1901-658-----Nernst (German). Iron wire ballast in glass, glower containing hydrogen gas.
  - 1901-755-----Nernst (German). German type of automatic Nernst lamp, 100 watts, 105 volts, dc. Made by A.E.G. of Berlin.
-

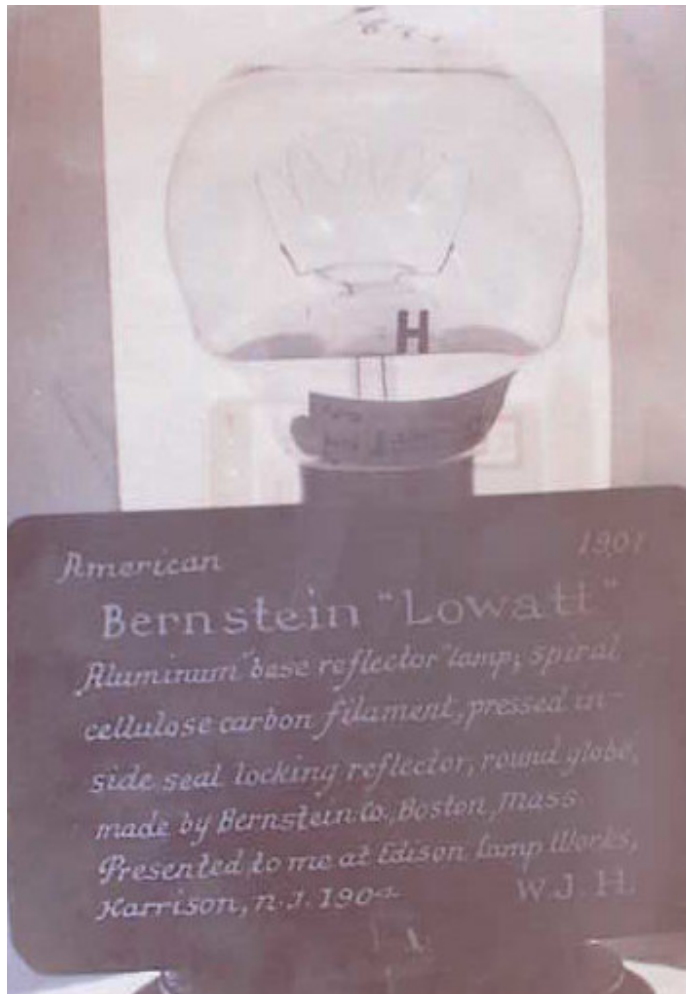

- 1901-891-----Bernstein Lowatt (American). Aluminum base reflector lamp. Spiral cellulose carbon filament, pressed inside seal locking reflector round globe. Made by Bernstein Company, Boston, MA.
- 
- 1901-892-----Edison. Anchored cellulose carbon spiral filament lamp, pressed seal, silver reflector in lower half of round globe.
  - 1901-893-----Bernstein Lowatt (American). Five loop spiral with aluminum reflector. 114 volts.
-



- 1901-900-----Miller (American). First turndown lamp operated by a string or wire, although Mr. W.J. Hammer made one in 1880. Patent: July 9, 1901.
- 
- 1901-912-----Tri-light (American). Turning key throws in 16-cp filament or puts high resistance coil in series or by itself for night light. Made by Gilmore Electric Company, Boston, MA. 16-1-cp.
  - 1901-969-----Bernstein Lowatt (American). Aluminum side reflector lamp, five-turn spiral cellulose carbon filament, carbon paste clamps, 8-cp, 115-volt. Made by Bernstein Lamp Company.
  - 1901-979-----Bryan-Marsh (American). 200-volt carbon lamp. Two single spiral carbon filaments in series. Anchored at top of globe.
  - 1901-980-----Imperial (American). 220-volt double spiral carbon filament lamp. Made by Bryan-Marsh Company, Marlboro, MA. 16-cp.
  - 1901-981-----Imperial (American). 110-volt, 16-cp, cellulose carbon filament lamp. Two filaments in series. Made by Bryan-Marsh Company, Marlboro, MA.

- 1901-982-----Robertson (English). 220-volt, 16-cp. Two carbon filaments in series, carbon paste clamps. Made by Incandescent Lamp Company, Hammersmith, England.
- 1901-983-----Hammer Phosphorescent Lamp Shade (American). Made by Hammer and used by him for 12 years. In 1902 he made self stimulating phosphorescent mixtures with radium, and later painted sockets, switches, telephone transmitters, clock and watch dials, etc.
- 1901-1028----Imperial (American). 220-volt, anchored type, spiral cellulose carbon filament. Made by Bryan-Marsh Company.

## 1902

- 1902-259-----Edison. Oval loop anchored filament, carbon paste clamps, flat seal, 109 volts, 8-cp.
  - 1902-260-----Edison. 106-volt, 8-cp, T-H base, spiral cellulose carbon filament, carbon paste clamps, pressed inside seal.
  - 1902-261-----Edison. 16-cp, 118-volt, standard anchored oval loop squirted carbon filament lamp; carbon paste clamps, flat Holzer seal in stem.
  - 1902-633-----Nernst (American). Westinghouse Nernst. 220-volt, three-glower lamp with flexible platinum expansion leads, two tube heaters. Made Dec. 2, 1902.
  - 1902-634-----Nernst (German). Replacement piece with conical heater and glower for 100-watt, 110-volt dc. type Nernst lamp.
  - 1902-648-----Nernst (French). Nernst lamp, automatic type. Made in France. 0.5 ampere.
  - 1902-661-----Nernst (American). Single glower tube type heater, automatic Nernst lamp. Made at Pittsburg.
  - 1902-663-----Nernst (German). 100-volt, 100-watt dc. type replacement piece; automatic type Nernst lamp with straight glower in center of conical spiral heater. Made in Berlin by A.E.G.
  - 1902-665-----Hammer (American). Phosphorescent flashing and glowing lamp with thermostatic switch. Made by Hammer and used by him from 1902-1912.
  - 1902-666-----Curie (French). Phosphorescent radium lamp. Made by Hammer at the suggestion of Prof. P. Curie and from a sketch made for him by Prof. Curie, etc.
  - 1902-675-----Curie Lamp (French). Gaseous radium emanations condensed by liquid air stimulate phosphorescent zinc sulphide, giving a light permitting fine print to be read some distance away. Made by Hammer at the suggestion of Prof. P. Curie at Paris.
  - 1902-679-----Moore (American). First filamentless Moore lamp with CO<sub>2</sub> gas. 200 hours, 1/4-wpc and soon dropping to 5.6-wpc.
  - 1902-749-----Nernst (German). Standard Nernst lamp 25-cp, 1.5-wpc including wire ballast. The glower steadying resistance or ballast and cut-out magnet are in series and form a shunt around the heating coil.
  - 1902-852-----Talmont (French). 16-cp, 110-volt spiral cellulose carbon filament lamp. No stem. Platinum lead support from globe base. Made in France.
-



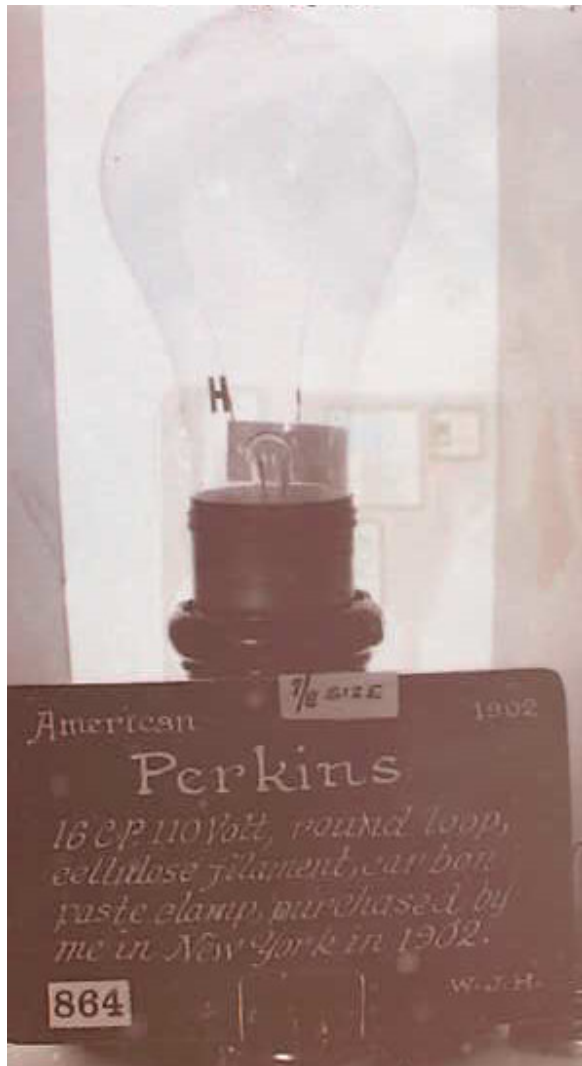

- 1902-864-----Perkins (American). 16-cp, 110-volt round loop cellulose filament, carbon paste clamp. hr size="1" width=100%>
-

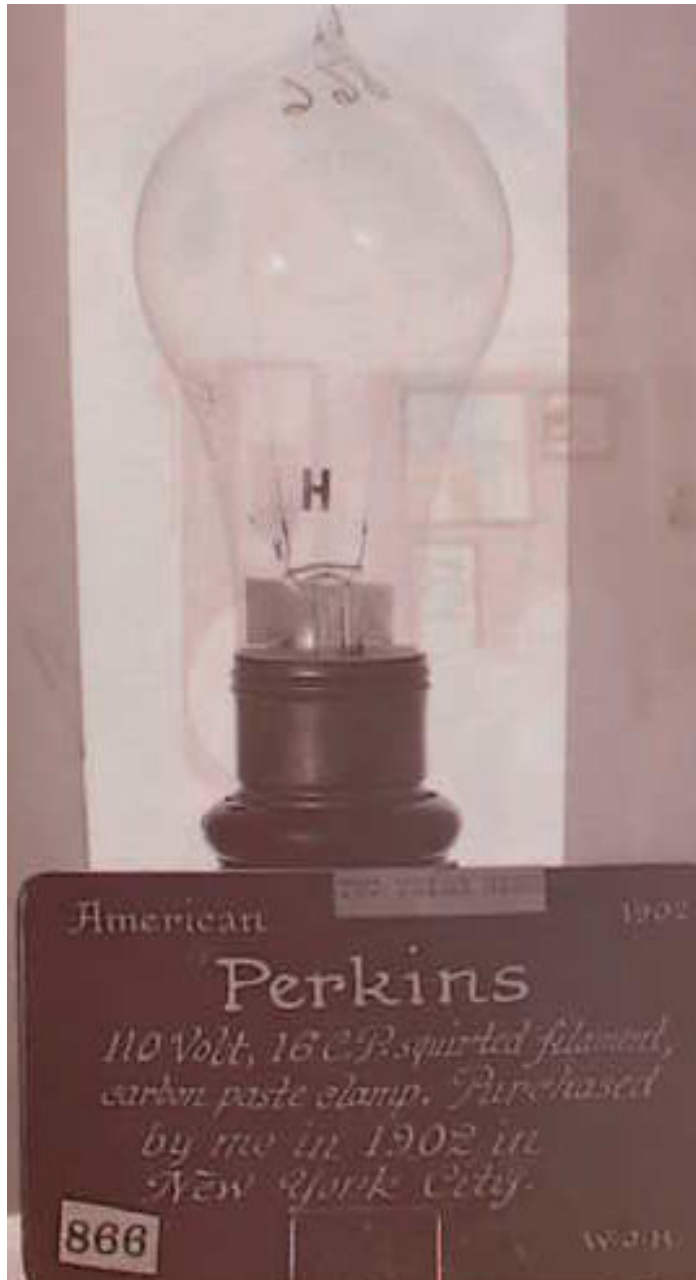

- 1902-866-----Perkins (American). 110-volt 16-cp, squirted filament, carbon paste clamp.
- 
- 1902-867-----Germania (American). 16-cp, 110-volt anchored carbon spiral, carbon paste clamps. Made at Harrison, NJ.
  - 1902-885-----Elblight (American). Lamp with porcelain base carrying two conducting pins for piercing flexible duplex cable for temporary lighting. Made by Edison Lamp Company for Elblight Company.

- 1902-967-----Elblight (American). same as 885.
  - 1902-985-----Sterling Special (American). Anchored double twist spiral cellulose carbon filament. Made by Sterling Electric Manufacturing Company, Warren, OH.
  - 1902-986-----Vitrite Luminoid (English). 100-volt 16-cp anchored cellulose carbon spiral filament, platina leads with glass bridge support.
  - 1902-987-----Kyle (American). 120-volt 50-cp carbon filament lamp with blue and green glass globe for decorative effect. Kyle Patent Feb. 5, 1901.
- 

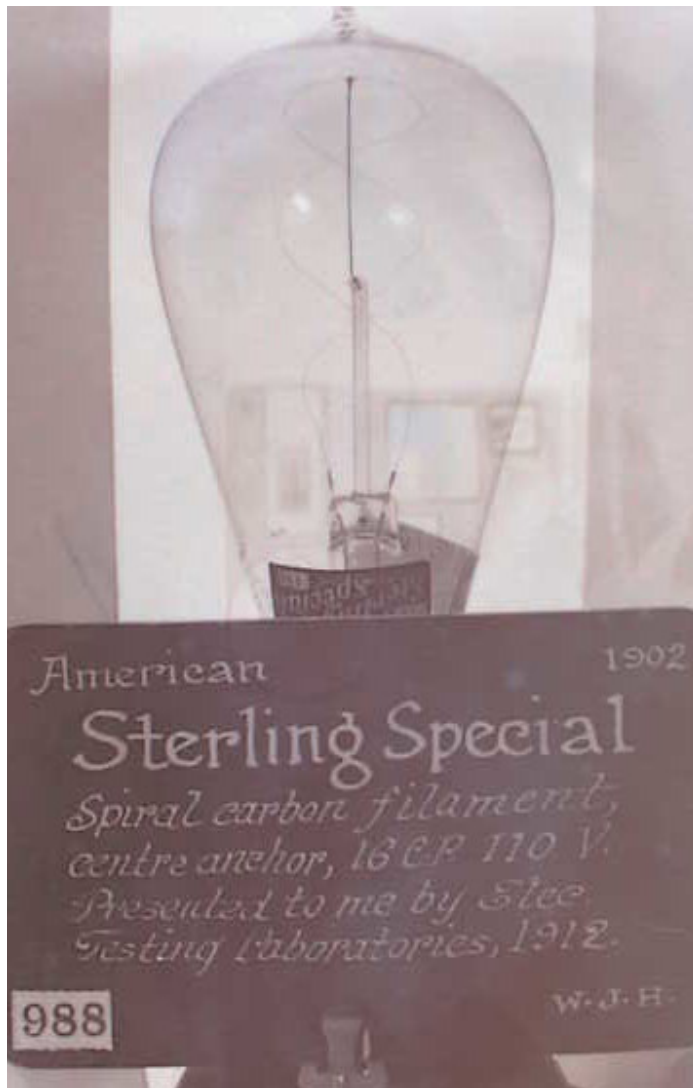

- 1902-988-----Sterling Special (American). Spiral carbon filament lamp, center anchor, 16-cp, 110 volts. Patented Sept. 2, 1902.
-

- 1902-992-----Sterling (American). Sterling Special carbon filament lamp, double twist spiral with center glass and wire support. Made by Sterling Company, Warren, OH, 3-cp, 110-volt.
- 1902-996-----Ganz & Co's. (Hungarian). Three-phase lamp. Contains three carbon filaments. 16-cp, 110-volt.
- 1902-998-----Ediswan (English). Large double spiral cellulose carbon filament. Made by Edison-Swan Company of England.
- 1902-1000----Sterling Spiral (American). 225-volt, 16-cp, double carbon spiral.
- 1902-1026----Perkins (American). 110-volt, 16-cp, carbon spiral lamp.
- 1902-1027----Sterling Special (American). Series lamp with double twist carbon filament supported on anchor wire. Made at Warren, OH by Sterling Company. 16-cp, 110-volt.
- 1902-1029----Cruto (Italian). Three-phase lamp employing three filaments made by depositing carbon on a hairlike platinum core. 16-cp, 110-volt.
- 1902-1030----Ediswan (English). Straight cellulose filament lamp. Made by the Edison-Swan Company at Newcastle-on-Tyne, England.
- 1902-1031----Perkins (American). 16-cp, 118-volt, carbon filament lamp.

### **1903**

- 1903-234-----Edison. Ground glass Meridian carbon lamp, 110 volts. GE.
- 1903-249-----Edison. Series burning lamp, 16-cp, 115-volt, double carbon spiral, central support, paste clamps.
- 1903-250-----Edison. Small ground glass tipless round globe Meridian lamp. 4-turn anchored spiral cellulose carbon, open stem, bottom seal.
- 1903-251-----Edison. Standard 16-cp 118-volt carbonized cellulose, anchored carbon filament. As furnished free by New York Edison Electric Illuminating Company to its consumers and not sold to the general public.
- 1903-252-----Edison. Meridian lamp. Anchored cellulose spiral carbon filament, carbon paste clamps, tipless round glass globe with shade, exhausted through stem at base of lamp.
- 1903-253-----Edison. G.E. Meridan carbon spiral, ground glass, tipless. Made at Harrison, NJ.
- 1903-254-----Edison. 220-volt Meridian lamp, anchored metallized cellulose carbon filament, ground glass round tipless globe, open stem, base seal.
- 1903-255-----Edison. Ground glass Meridan lamp, 4-loop anchored spiral squirted filament, carbon paste clamps, tipless round bulb.
- 1903-256-----Edison. Meridian round globe ground glass with aluminum reflector. Spiral cellulose filament.
- 1903-257-----Edison. Meridian round globe, ground glass with aluminum reflector; spiral cellulose filament.
- 1903-258-----G.E. (American). Metallized. One of first six metallized filament lamps made at Harrison, NJ, soon after November 27, 1903.
- 1903-446-----Packard Zenith (American). 110-volt 50-cp ground glass round bulb, porcelain butt.

- 1903-667-----Hammer (American). Radium lamp. Contains mixture of radium, phosphorescent zinc sulphide. Glows in the dark. Made on May 10, 1903 by Hammer, who was the first to make such mixtures.
  - 1903-668-----Hammer (American). Radium lamp pointing toward cold light; glows in the dark. This lamp was made by Hammer and shown in the Hammer Historical Collection of Lamps at the St. Louis International Exposition of 1904, etc.
  - 1903-674-----Luminous Vacuum Tube (American). Electricity produced by friction of the mercury on double glass tube, when shaken makes residual gas luminous. Hammer made these containing nitrogen, hydrogen, etc. Originally made in Germany.
  - 1903-682-----Puluj (Austria). Phosphorescent lamp made by Prof. Puluj of Prague. Operated in connection with an induction coil. The cathode rays impinge on the phosphorescent plate. Gives a brilliant light. Imported from Germany by Hammer.
  - 1903-744-----Nernst (German). From A.E.G. Berlin, Germany.
  - 1903-774-----Osmium (Austrian). Osmium metal filament lamp made by Auer von Welsbach Company of Vienna, Austria.
  - 1903-775-----Crawford-Voelker (English). Titanium carbide lamp. 200-volt bulbous U shaped bulb. Made in England.
  - 1903-776-----Crawford-Voelker (English). same as 775.
  - 1903-777-----Osmium (Austrian). same as 774.
-

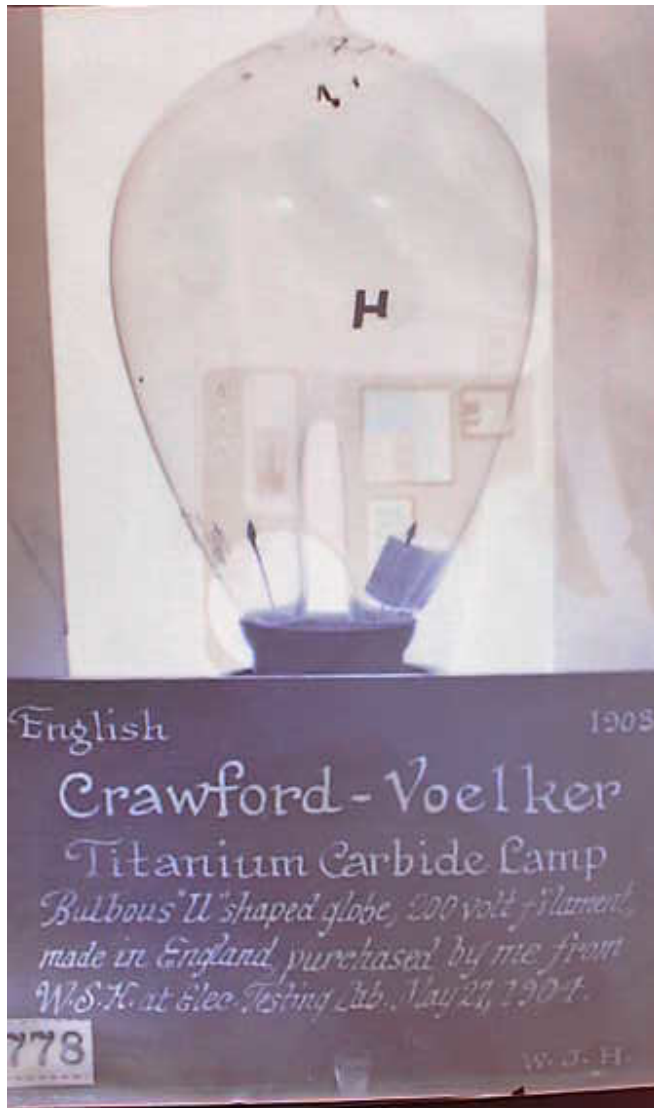

- 1903-778-----Crawford-Voelker (English). Titanium Carbide Lamp. Bulbous U shaped globe, 200-volt filament. Made in England.
- 
- 1903-806-----Hammer (American). Special electric candle lamp for table lamps, brackets, electroliers. Made by Hammer.
  - 1903-849-----Orient (American). 16-cp, 110-volt oval loop anchored cellulose carbon filament, carbon paste clamps, flat inside seal. Made by J.H.B. & Co., Ravenna, OH.
  - 1903-851-----Brilliant (Hungarian). 16-cp, 115-volt spiral carbon reflector lamp, corrugated conical globe. Made at Ujapest, near Budapest, Hungary.
  - 1903-853-----Banner (American). 16-cp, 110-volt anchored oval cellulose filament, carbon paste clamps, flat inside seal. Made at Youngstown, OH.

- 1903-854-----Comet (American). Oval spiral cellulose carbon filament, carbon paste clamps, anchor supported loop, minimum of platinum in solid seal. 16-cp, 110 volts.
- 1903-855-----A.E.G. (German). 220-volt anchored spiral carbon filament, pressed inside seal. Made in Berlin, Germany.
- 1903-856-----Opalescent (American). Special round bulb opalescent lamp, carbon filament, carbon paste clamps.
- 1903-857-----Brilliant, Ground Glass (Hungarian). 16-cp, 110-volt carbon filament lamp in fluted ground glass globe. Made in Budapest, Hungary.
- 1903-859-----Talmont (French). Carbon filament lamp, 25-cp, 110-volt. Made in France.
- 1903-860-----Gilmore (American). 16-cp, 220-volt oval spiral anchored carbon filament, carbon paste clamp, dome shaped globe. Patent applied for.
- 1903-861-----Shelby (American). 16-cp, 225-volt. Anchored spiral carbon, paste clamps. Made at Shelby, OH.
- 1903-862-----Erner-Hopkins (American). Oval loop cellulose carbon spiral filament, double anchors. Made at Columbus, OH at Erner-Hopkins Co.
- 1903-863-----Shelby (American). 16-cp, 110-volt anchored cellulose carbon filament, made of four oval loops in horizontal plane, carbon paste clamps, pressed inside seal. Made by Shelby Company, Shelby, OH.
- 1903-865-----Barrenberg (English). 220-volt, 16-cp anchored spiral, carbon paste clamps, English type porcelain base.
- 1903-918-----Edison. Standard blue glass globe lamp for decorative and sign purposes. 16-cp, 115-volt cellulose carbon filament, brass screw butt fitting closely to neck of globe.
- 1903-920-----Edison. Standard red glass globe lamp for decorative and sign purposes. 16-cp, 115-volt cellulose carbon filament, brass screw butt fitting closely to neck of bulb.
- 1903-993-----X-Ray Lamp (American). X-Ray carbon filament lamp made by Shelby Electric Co., Shelby, OH.
- 1903-994-----Westinghouse (American). 100-cp, 230-volt three-loop oval spiral, double anchored carbon filament lamp with supplemental inside stem.
- 1903-995-----Edison-Swan (English). Storage battery lamp, carbon filament.

## 1904

- 1904-29-----Oolicon Fish Lamp (American). Plaster of paris model of the oolicon fish which the Alaskan Indians set up in a lump of clay as a candle. It is often called the "candle fish" because of its oily nature. This model was shown in the Edison Exhibit at the St. Louis Exposition in 1904.
- 1904-199-----Edison. Special Edison effect lamps made for Edison exhibit at St. Louis Exposition, 1904. Many such lamps were made in 1884 as shown in this collection. These lamps show single and double neutral wire.
- 1904-219-----Edison. Channel buoy lamp, conductors sealed in waterproof base. 100-cp.
- 1904-229-----Edison. Standard Testing Bureau photometer lamp; double carbon hairpin filament in alignment.

- 1904-233-----Edison. Special torpedo lamp made for U.S. Navy Department. Exhibited at St. Louis Exposition in 1904.
- 1904-235-----Edison. Stereopticon lamp with 6-turn conical spiral bamboo filament, carbon paste clamps. Series burning, 50-cp.
- 1904-244-----Edison. Stereopticon lamp, 7-turn round spiral cellulose carbon filament, carbon paste clamps, pressed inside seal, round globe. Series burning, 220-volt, 50-cp.
- 1904-245-----Edison. Municipal series burning lamp with special big screw base, bamboo carbon filament, carbon paste clamps, Holzer flat seal, blue glass drawn over platinum leads. 32-cp, 9.6 amperes.
- 1904-246-----Edison. New form municipal lamp. 30-cp series, carbonized bamboo filament, carbon paste clamps, pressed inside seal and leads covered with dark blue glass.
- 1904-247-----Edison. 100-cp, 110-volt double anchored three-spiral cellulose carbon filament, flat Holzer inside seal.
- 1904-248-----Edison. same as 246.
- 1904-427-----Packard (American). 110-volt, 50-watt GEM Zenith, double loop carbon lamp. Made by Packard Lamp Company.
- 1904-636-----Nernst (American). American type of automatic Nernst lamp. Made by Nernst Lamp Company, Pittsburg, PA. With glower, heater, ballast and cut-out.
- 1904-656-----Nernst (American). Replacement piece for Nernst automatic type of lamp showing glower with flexible support inside heating coil.
- 1904-657-----Nernst (French). Nernst lamp, 100-volt, 0.5 ampere automatic type with glower in center of heating coil. Made in France.
- 1904-662-----Nernst (German). 200-volt, 0.5 ampere Nernst lamp with glower straddling center of oval heating coil. Made by A.E.G. Berlin, Germany.
- 1904-769-----Auer Oslampe (German). 16-cp, 20-volt. Made in Germany. Two filament in series.
- 1904-770-----Auer Oslampe (German). 16-cp, 30-volt. Made in Germany. Two filament in series.
- 1904-771-----Auer Oslampe (German). 25-cp, 45 volts. Made in Germany.
- 1904-772-----Siemens-Halske (German). Tantalum lamp. Made in Berlin, Germany.
- 1904-773-----Auer Oslampe (German). 25-cp, 45-volt. Two filament in series. Made in Germany.
- 1904-799-----Downward (American). 16-cp, 10-volt curved zig-zag squirted filament, carbon paste clamps, tipless globe, base exhaustion. Made by Downward Light Company, 255 4th Avenue, New York.
- 1904-800-----Watt Lamp (Austrian). Made by Scharfs and Company. 110-volt, 16-cp.
- 1904-801-----Min & Dec Lamp Company (American). 16-cp, 110-volt. Four round spiral anchored filaments, squirted carbon and paste clamps, round, tipless globe, flat inside seal.
- 1904-802-----Pintsch (German). Made by Gebruder Pintsch, Berlin, Germany.
- 1904-803-----Robertson Candle Lamp (English). Made in England by Robertson Electric Lamp Company.
- 1904-804-----Compagnie Centrale d'Electricite (French). Made in France. Imported 1904 by F&M 200-volt, 16-cp.



- 1904-805-----Sunlight (English). Ediswan Company Sunlight, spiral carbon filament lamp, carbon paste clamps, double platinum leads through base.
  - 1904-808-----Munder (American). 16-cp, 110-volt squirted oval carbon filament, anchored, flat inside seal, carbon paste clamps. Munder Electric Company of Springfield, MA.
- 

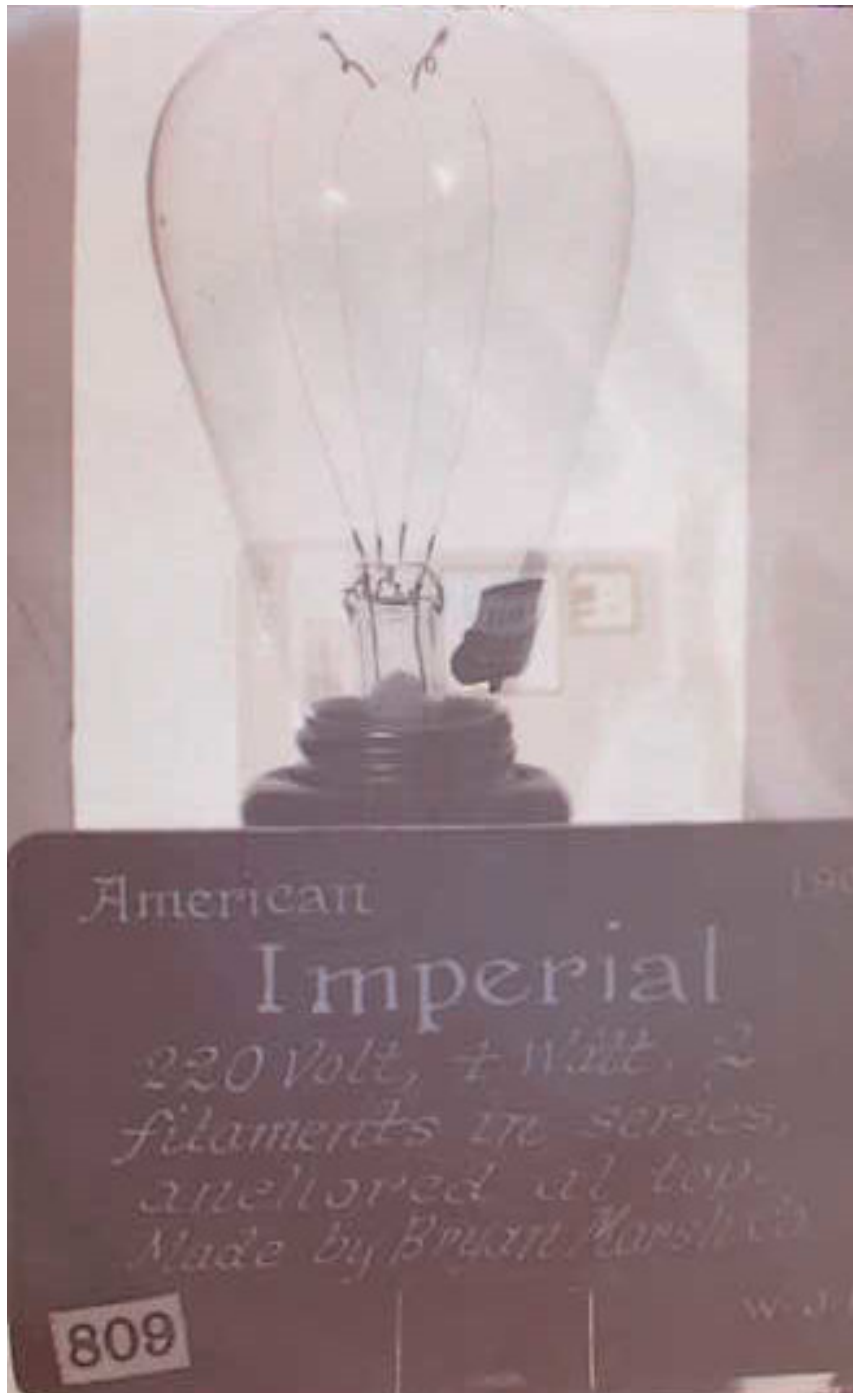

- 1904-809-----Imperial (American). 220-volt, 4-watt. Two filaments in series, anchored at top. Bryan-Marsh Co.
- 

- 1904-810-----Star (American). 16-cp, 110-volt, large anchored carbon loop filament, umbrella shaped globe. Made by Standard Electric Manufacturing Company, Niles, OH.
- 1904-811-----Imperial (American). Oval loop carbon spiral, bottom anchor. Made by Bryan-Marsh Company.
- 1904-812-----Novi (American). 16-cp. anchored spiral carbon filament. Made by Franklin Electric Company, Hartford, CT.
- 1904-813-----Manhattan (American). 16-cp, 110-volt, squirted oval filament, flat inside seal. Manufactured for the Manhattan Electrical Supply Company, New York.
- 1904-814-----Schuckert (Austrian). Carbon lamp made by O.S.W. Oestreicher Schuckertwerke.
- 1904-815-----Sunbeam (English). 225-volt, 16-cp, fine cellulose carbon spiral filament lamp with double anchor, flat inside seal. Made in England.
- 1904-816-----Imperial (American). 25-cp, 5.5-ampere, 110-volt, series lamp with automatic cut-out, copper spirals between legs of filament, platinum leads. Made by Bryan-Marsh Company.
- 1904-817-----Peerless (American). 4-cp, 110-volt, Small carbon spiral lamp; largely used for signs.
- 1904-819-----Downward (American). 110-volt curved zig-zag carbon filament, carbon paste clamps, base exhaustion, open stem. Made by Downward Light Company, 225 4th Ave., New York.
- 1904-820-----British Thomson-Houston (English). Oval loop anchored carbon filament. Made in U.S. by G.E. Co. for British Thomson-Houston Company.
- 1904-821-----Femco (American). 16-cp, 110-volt anchored oval loop squirted carbon filament, carbon paste clamps. Made by Franklin Electric & Manufacturing Company, Hartford, CT.
- 1904-822-----Clerici (Italian). Made by C. Clerici of Milan, Italy.
- 1904-823-----Swan (English). Spiral cellulose carbon filament, round tipless globe, Edison base. Made by Swan United Electric Light Company, London, England.
- 1904-824-----Bryan-Marsh (American). 16-cp, 110-volt, 3.5-wpc, triple round spiral squirted carbon filament, anchored, carbon paste clamp, flat inside seal. Made by Bryan-Marsh Company, Marlboro, MA.
- 1904-825-----Schonlauk-Scharfs (German). Berlin, Germany.
- 1904-826-----Goosens-Pope and Company (Dutch). Made in Venlo, Holland, 110-volt, 16-cp.
- 1904-828-----American Miniature and Decorative Lamp Company (American). 16-cp, 110-volt long oval anchored loop, squirted carbon filament.
- 1904-830-----Westinghouse (American). Oval loop center anchor carbon lamp.
- 1904-831-----Anchor (American). Oval spiral loop carbon filament lamp with anchor support. 16-cp, 110-volt. G.E. label.

- 1904-832-----DeKhotinsky (German). Made by Gelnhausen Glühlampenfabrik, Germany. 110-volt, 16-cp.
  - 1904-834-----Compagnie Generale des Lampes (French). Made in France. Imported in 1904 by F&M, 110-volt, 16-cp.
  - 1904-838-----Vereinigte A.E.G. (Hungarian). Made in Budapest, Hungary.
  - 1904-839-----Philips & Company (Dutch). Made in Eindhoven, Holland.
  - 1904-840-----Compagnie Generale des Lampes (French). Made in France. 16-cp, 110-volt.
  - 1904-841-----Zurcher (Swiss). Made by Zurcher Glühlampenfabrik, Zurich, Switzerland. 16-cp, 110-volt.
  - 1904-842-----Sturme (Austrian). Made by Sturme Company, Vienna, Austria. 110-volt, 16-cp.
  - 1904-843-----Kremenezky (Austrian). 110-volt, 16-cp, Made in Vienna, Austria.
  - 1904-844-----Zuger (Dutch). Made in 1904 by Zuger Glühlampenfabrik, Zug, Holland.
-



- 1904-845-----Zalinski (American). 16-cp, 110-volt large anchored loop in umbrella shaped globe. Made by the Star Company of Niles, OH for Major E. Zalinski for his special shades and reflectors.
- 
- 1904-848-----Larnaude (French). 16-cp, 110-volt. Made at A.L. Paris.
  - 1904-858-----Edison-Swan (English). 50-cp, 100-volt single spiral squirted cellulose filament, carbon paste clamps.
  - 1904-871-----Talmont (American). Carbon spiral reflector lamp. Made by Talmont Electric Company, New York.
  - 1904-872-----Phelps Hylo (American). Lamp with thermostatic flasher in base. 50-watt Edison GEM, 119-21-23 volts, Skedoodle Socket plug, "Property of New York Edison Company - not to be sold."
-



- 1904-878-----Brilliant Reflector (American). 16-cp 230-volt corrugated conical globe silvered on lower half of globe. Patented Dec. 27, 1904. Made by Talmont Engineering Company, New York.
- 
- 1904-903-----Economical (American). 100-volt, 16-cp and 1-cp turn down lamp. Operates by turning lamp in base.
-

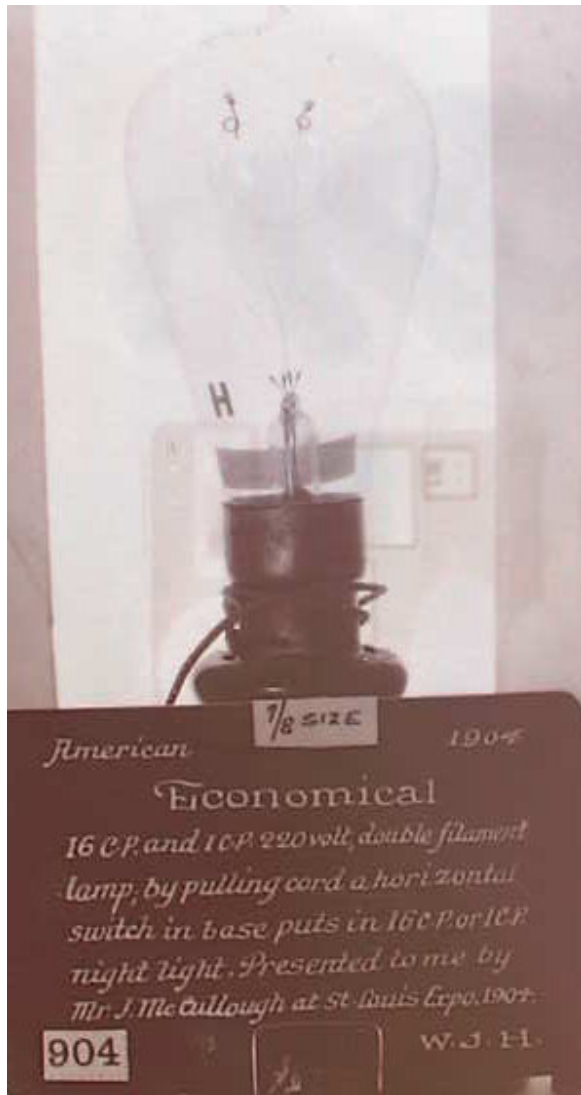

- 1904-904-----Economical (American). 16-cp, and 1-cp, 220-volt double filament lamp. By pulling a horizontal switch in base puts in 16-cp or 1-cp night light.
- 
- 1904-905-----Dublglo (American) Turn down lamp, two filaments. 110-volt, 1-cp and 16-cp. Made by Phelps Company, Detroit, MI.
  - 1904-906-----Hylo (American). 16-cp and 1-cp. Automatic flashing Hylo carbon filament lamp. Thermostat in base of lamp throws in 16-cp or night light filaments. Made for Phelps Company, Detroit, MI.
  - 1904-911-----Economical (American). Turn down lamp. Pulling cord causes a locking switch to insert a 16-cp filament or a high resistance night light filament in circuit.
-



- 1904-916-----Hyo (American). Turn Down Lamp. Pulling cord through base puts 16-cp filament or night light filament in circuit. The Phelps Company, Detroit, Michigan.
- 
- 1904-930-----Brilliant Reflector (American). 16-cp, 230-volt corrugated conical globe, silvered on lower half of globe. Made by Talmont Electrical Engineering Company, New York.
  - 1904-942-----Dublglo Turn Down Lamp (American). 1-16-cp. Pulling cord through the tube guides puts either a 16-cp filament or a night light filament in circuit. Made by Phelps Company, Detroit, MI.
  - 1904-944-----Hyo (American). Skedoodle or thermostatic flash lamp, made by Phelps Company, Detroit, MI. A coil of wires in series with the filament is wound around a thermostaic spring, causing it to open and close the circuit. 110-volt, 1-16-cp.

- 1904-945-----Miller (American). Turn Down Lamp. A movable thumb spring contact slides around lamp base, putting sections of the coiled carbon filament in circuit and varying the candlepower.

## 1905

- 1905-207-----Edison. 50-cp, 110-volt metallized carbon filament lamp.
- 1905-223-----Edison. Ground glass radiator lamp for use in heating rooms, two or three being mounted in a radiator; 110-volt, single carbon squirted filament, carbon paste clamps.
- 1905-231-----Edison. Tipless round bulb lamp, single spiral, squirted carbon filament, carbon paste clamps.
- 1905-243-----Edison. 20-cp, 110-volt metallized carbon filament lamp.
- 1905-766-----Siemens-Halske Tantalum (German). 25-cp, 110-volt tantalum lamp, double spider support. Made by Siemens-Halske Company, Berlin, Germany.
- 1905-767-----Heany Zirconium Oxide Lamp (American). Tiny arc lamp with zirconium oxide electrodes. The arc is started by tiny electromagnets in lamp base. (A.R. Heany).
- 1905-768-----Siemens-Halske Tantalum (German). 25-watt 120-volt tantalum lamp. Made by Siemens-Halske.
- 1905-795-----Morse (American). Thermostatic gauge lamp for furnace work. Made for Morse Thermo Gauge Company.
- 1905-796-----Mexican. Made in Mexico. 108-volt, 16-cp, Chaillet.
- 1905-798-----Chaillet (Mexican). 16-cp, 110-volt. Made in Mexico.
- 1905-923-----Pine Cone Lamp (German). Green glass pine cone. Made in Germany.
- 1905-928-----Color Cap Lamp (American). 10-watt, 110-volt. Red glass detachable color cap. Type A for use with sign lamps.
- 1905-933-----Color Cap Lamp (American). 10-watt, 110-volt. Green glass detachable color cap, Type A for use on electric signs, etc.

## 1906

- 1906-232-----Photometer lamp (American). Special, with two carbon filament loops placed concentrically and in series,
- 1906-241-----Edison. Special carbon filament photometer lamp, two concentric loops in series.
- 1906-453-----O'Brien (American). O'Brien tube lamp single carbon filament, tension spring clamp allowing for expansion and contraction of filament. O'Brien Company.
- 1906-460-----Bastian (English). Pure copper ribbon leads coated to prevent oxidation, sealed in solid glass of inside stem, taking place of the platinum wires usually employed.
- 1906-463-----O'Brien (American). Tube lamp, carbon filament made in California. 32-cp, 110-volt.
- 1906-464-----Linolite (English). Tube lamp with carbon filament, spiralled to allow expansion and contraction, side supports.



- 1906-471-----O'Brien (American). Tube lamp with tension spring to keep carbon filament from sagging.
- 1906-694-----G.E. Tungsten (American). 240V (?).
- 1906-740-----Osram Lamp (Austrian) 110-volt, 50-cp tungsten lamp made by Auer Gesellschaft of Vienna.
- 1906-741-----Just-Hanaman (Hungarian). From Ujipest, Hungary.
- 1906-742-----Westinghouse Tungsten (American). 110-volt tungsten lamp, made by Westinghouse.
- 1906-743-----Nernst (German). 220-volt 1-ampere lamp.
- 1906-750-----G.E. Tungsten (American).
- 1906-751-----F.F. Tungsten (German). Made by C.F.E.I., Nuremberg, Germany.
- 1906-752-----G.E. Tungsten (American).
- 1906-753-----Z (Zernig) or Hollefreund (German). Made by Dr. Hollefreund in Berlin, Germany.
- 1906-754-----Heany (American). Tungsten lamp made in York, PA. May 15, 1906. The lamp burned for 153 hours.
- 1906-757-----Osram (German). Made by Deutsche Gasglöhlicht Actien Gesellschaft (German Auer Company). 32-cp, 110-volt parallel type.
- 1906-758-----Osmin lamp (Austrian). Westinghouse Metalfaden Glühlampen Fabrik, Vienna, Austria.
- 1906-760-----Just-Hanaman Tungsten (Hungarian). From Ujpest, Hungary. Made by Just & Hanaman.
- 1906-761-----G.E. Tungsten (American).
- 1906-762-----Osmin (Austrian). From Osmin Licht Unternehmung, Vienna, Austria. 105-volt, 40-cp.
- 1906-763-----Heany Tungsten (American). Tungsten lamp made at York, PA May 28, 1906.
- 1906-764-----Kuzel (German). Kuzel tungsten lamp made in Austria.
- 1906-765-----Z (Zernig) or Hollefreund (German). Made by Dr. Hollefreund in Berlin, Germany.
- 1906-793-----Hungarian. 53-volt, 3.5-ampere, carbon filament lamp, carbon paste clamps, platina and copper leads, glass bridge support.
- 1906-794-----Polar (French). 220-volt carbon lamp two spirals in series.
- 1906-797-----Fabius-Henrion (French). Made in Nancy, France. 16-cp, 110-volt.

## 1907

- 1907-240-----Edison. 200-volt, 26-cp, triple oval spiral cellulose filament, carbon paste clamps, minimum platinum, flat seal.
- 1907-454-----Guest (American). Copper ring leads in solid inside glass seal to replace platinum leads. Burned in Electrical World office from May 3rd to Sept. 6th, 1907. 16.6-cp, 116-volt, Frederick Electric.
- 1907-456-----Guest (American). Copper ring and flattened copper leads replacing platinum leads.
- 1907-599-----Just Tungsten (American). 40-cp, 115-volt, 1-watt Type C tungsten lamp.

- 1907-670-----Phosphorescent Color Lamp (American). The white phosphorescent materials in inner tube glow beautifully in the dark with red, orange, pink, blue, green and yellow colors, after stimulation by the mercury arc lamp, etc. Process patented by Hammer on November 28, 1907.
- 1907-707-----Westinghouse Tungsten (American). 220-volt tungsten lamp. Made by Westinghouse Lamp Company.
- 1907-715-----Bergmann Tungsten (German). 50-cp, 110-volt. Made in Berlin, Germany. D R P.
- 1907-716-----Just Wolfram (Tungsten) Lamp (Austrian). 40-cp, 110-volt, 1-wpc, tungsten lamp. Made by Just-Hanaman, Augsburg, Austria.
- 1907-718-----Kuzel Sirius Tungsten (Austrian). 25-cp, 110-volt Kuzel tungsten lamp. Pintsch colloid lamp.
- 1907-719-----N.E.L.Co. Tungsten (American). 32-cp, 40-watts, 110 volts. National Electric Lamp Company, Cleveland, OH. Horizontal burning tungsten lamp.
- 1907-720-----Zircon Tungsten (German). 60-cp, 220-volt Z tungsten lamp.
- 1907-721-----Osram Lamp (German). 100-cp, 110-volt Osram tungsten lamp; made by the Auer Gesellschaft at Berlin, Germany.
- 1907-722-----Westinghouse Tungsten (American). 50-volt, 2-ampere tungsten lamp. Two filaments in multiple.
- 1907-723-----A.E.G. Tungsten (German). Sample of first set tungsten lamps with spring supported filaments for horizontal burning. Made by A.E.G. of Berlin, Germany.
- 1907-724-----Heany (American). Heany series tungsten lamp made at York, PA.
- 1907-725-----Heany (American). Tungsten lamp with magnesium oxide bead supports.
- 1907-726-----Sirius Tungsten (Austrian). 50-cp tungsten lamp made by Kuzel. Sirius colloid lamp. Pintsch.
- 1907-727-----Heany (American). Tungsten lamp with wire loop support at top and paste clamps at bottom. John Allen Heany.
- 1907-728-----Heany Tungsten (American). 110-volt tungsten lamp, special long loop supports at top. Made at York, PA by Heany.
- 1907-729-----Helion (American). Prof. Hirschel W. Parker and Walter G. Clark presented this, their first perfected Helion lamp to Hammer.
- 1907-730-----Heany (American). Heany tungsten lamp with conical globe and filaments arranged in conical form with spring supports. Hydrogen.
- 1907-731-----Heany Tungsten Lamp (American). 100-cp, 110-volt.
- 1907-732-----Just Tungsten (Austrian). Type C 40-cp, 110-volt tungsten lamp.
- 1907-733-----G.E. Tungsten (American). 40-cp, 5.8 ampere, series tungsten. Made at Harrison, NJ Lamp Works.
- 1907-734-----Pintsch Sirius Tungsten Lamp (German). 25-cp, 110-volt Sirius colloid tungsten lamp. Made by Pintsch Company of Germany.
- 1907-736-----Sunbeam Tantalum (American). Double spider support tantalum lamp made by Sunbeam Lamp Company.
- 1907-737-----Westinghouse Tungsten (American). Made by Westinghouse Lamp Company, New York.

- 1907-738-----Hopfelt (German). 120-volt carbon filament mercury lamp. The inner tube contains a globule of mercury which the heat of the filament vaporizes to increase the efficiency.
- 1907-739-----Heany Tungsten (American). Made at York, PA. Burned in front parlor of Hammer's house.
- 1907-792-----Elk (American). 110-volt, 16-cp. Made at Emporium, PA. Novelty Electric Co.
- 1907-915-----Johnson Anylite (American). Anylite regulator for inserting between the lamp and socket. Works on dc or ac circuit up to 60 watts. Made by Anylite Manufacturing Company, Newburgh, Oregon.
- 1907-925-----Hammer (American). Phosphorescent glowing and flashing lamp. The glass disc is coated underneath with phosphorescent zinc sulphite, willemite and radium. First made in 1902. Such mixtures in powder form and combined with various vehicles are now used extensively on watch and clock dials, etc. A thermostat in lamp base flashes lamp on and off.

## 1908

- 1908-548-----Osram Lamps (Austrian). 25-volt, two tungsten filaments in series spiral tension spring at top. Made in Vienna, Austria.
- 1908-550-----Heany (American). Heany Tungsten Lamp Company, York, PA. 1.2 watts per U.S. candle.
- 1908-551-----Just-Hanaman (Hungarian). 60-watt, 220-volt tungsten lamp made by the International Wolfram Lamp Company, of Budapest.
- 1908-552-----Osram Lamp (German). 100-cp, 220-volt Osram tungsten lamp.
- 1908-553-----Westinghouse Osmin Lamp (Austrian). Vertex straight filament Osmin lamp made in Vienna, Austria by the Austrian Westinghouse Company. 115-volt.
- 1908-554-----S□nnen Tungsten Lamp. Tungsten lamp with metal spring top support and glass star bottom support. Made October 7, 1908.
- 1908-555-----Heany Tungsten (American). Made at York, PA. 11.2 watts per U.S. candle.
- 1908-556-----Just Tungsten (Austrian). 220-volt tungsten lamp made in Austria December 8, 1908.
- 1908-645-----Nernst (American). 220-volt, 1.4-ampere single glower. dc and ac. Westinghouse Nernst lamp, zig-zag heater below globe, modified Edison screw base. License label on inside of metal cover.
- 1908-685-----Hopfelt (German). Imported from Europe April, 1908.
- 1908-687-----Heany (American). Tungsten. This lamp was shown at the Franklin Institute, Philadelphia, PA Feb.14, 1908.
- 1908-688-----A.E.G. Tungsten (German).
- 1908-689-----Heany (American). Tungsten lamp made at the Heany Lamp Factory, York, PA.
- 1908-690-----Kuzel Tungsten (Austrian). Filament arranged in spiral form, triple support. Made by J. Kremenezky, Vienna, Austria.
- 1908-692-----Osram (French). 25-cp, 125-volt, tungsten lamp marked B.W.& CIE Company.

- 1908-693-----Heany (American). Tungsten lamp. Heany Tungsten Lamp Co. Burned in Hammer's home for nine months.
- 1908-696-----Heany (American). Tungsten lamp. York, PA.
- 1908-697-----Heany (American). Early form of Heany tungsten lamp.
- 1908-698-----Osram Tungsten Lamp (German). 40 Hefner 240-volt tungsten lamp. made by the Auer Gesellschaft, Berlin, Germany.
- 1908-699-----Just Tungsten (American). 40-cp, 120-volt tungsten lamp with top and bottom spring spiral support; Type D. Made May 5, 1908.
- 1908-700-----Philips (Dutch). Tungsten lamp made by Laco Philips, Eindhoven, Holland.
- 1908-701-----G.E. Tungsten (American). One of the earliest spring tension type of tungsten lamps. Made at Research Laboratory at Schenectady in August, 1908.
- 1908-702-----Monowatt Tungsten. Procured from A. Wolff & Co., New York.
- 1908-703-----Heany Tungsten (American). Made at Heany Lamp Factory, York, PA.
- 1908-704-----Osram Tungsten (German). 100-cp, 200-volt Osram tungsten lamp. Made by the Auer Gesellschaft, Berlin, Germany.
- 1908-705-----G.E. Tungsten (American). Series lamp. Made at G.E. Lamp Works, Harrison, NJ. 80 watts.
- 1908-706-----Westinghouse Tungsten (American). 110-volt, 100-watt tungsten lamp.
- 1908-708-----Osram Tungsten (German). 15-cp, 202-volt lamp made by Auer Gesellschaft, Berlin, Germany.
- 1908-709-----Heany Tungsten (American). Lamp with fine flat spring supports at top. Made by Heany Lamp Company, York, PA.
- 1908-710-----Heany Tungsten (American). One of six lamps taken from York, PA to Franklin Institute.
- 1908-711-----G.E. Co. Ribbon Filament (American). Ribbon filament with pentane coating of graphite. Made Sep. 1908.
- 1908-712-----Heany Tungsten (American).
- 1908-713-----Siemens-Halske Tantalum (German). 32-cp, 220-volt tantalum lamp with quadruple spider support. Two units in series.
- 1908-714-----Just Tungsten Lamp (Austrian). Made by Dr. Just, Augsburg, Austria.
- 1908-790-----Brown (American). Special battery testing lamp for rapid testing of dry batteries.

## **1909**

- 1909-537-----G.E. Tungsten (American). Pressed filament tungsten lamp made by G.E. Company.
- 1909-540-----G.E. Co. Tungsten (American). One of the earliest spring contact G.E. tungsten lamps made in Schenectady Research Laboratory, December, 1909.
- 1909-541-----Pintsch Sirius (German). 25-cp, 110-volt.
- 1909-542-----Bergmann Tungsten (German). 220-volt, tungsten lamp made by Bergmann and Company, Berlin, Germany.
- 1909-543-----Westinghouse Tungsten (American). 30-volt, 15-watt tungsten lamp.

- 1909-544-----Sirius Kolloid Lamp (Austrian). 30-cp, 110-volt. Made in Vienna, Austria by Kuzel.
- 1909-545-----Bergmann (German). Tungsten lamp made by Bergmann Company in Berlin, Germany. 110-volt, 50-cp.
- 1909-546-----Westinghouse Tungsten (American). 220-volt, 40-watt tungsten lamp. Made by Westinghouse Lamp Company.
- 1909-547-----Z Tungsten (German). Made in Germany.
- 1909-584-----Bergmann Tungsten (German). 50-watt, 110-volt tungsten lamp. Made by Bergmann Company in Berlin, Germany.
- 1909-585-----Osmin Lamp (Austrian). Made by Foreign Westinghouse Lamp Company, in Vienna, Austria. 225-volt.
- 1909-587-----Westinghouse Tungsten (American). 12-volt, 25-watt tungsten lamp with toy loop supports.
- 1909-588-----Fabren Tungsten (German). Tungsten lamp known as "Metal Fabren". 25-cp, 120-volt. From Berlin Electric Company.
- 1909-590-----N.E.L.A. Tungsten (American). Pressed filament, made by National Electric Lamp Works, Cleveland, OH.
- 1909-592-----Westinghouse Tungsten (American). First continuous squirted filament made by W.G. Housekeeper at Westinghouse Lamp Works, Bloomfield, NJ, September 16, 1909.
- 1909-654-----Nernst (American). Westinghouse Nernst four-glower with V shaped tension clips for holding glower leads, permitting expansion and contraction, zig-zag heater below glowers. Made February 12, 1909 at Pittsburgh.
- 1909-686-----G.E. Tantalum (American). Early American tantalum, 25-watt, 118-volt.
- 1909-691-----G.E. Tantalum (American). 210-volt, 80-watt. Two 40-watt units in series in same bulb; 4 spider supports.
- 1909-787-----Durand (American). Triple spiral double anchored carbon lamp. Durand Factory, Vineland, NJ.
- 1909-788-----Westinghouse (American). 60-volt, 50-watt metallized carbon filament lamp. Two filaments in series, with carbon paste clamps.
- 1909-789-----Durand (American). Triple spiral carbon lamp, double anchor. Made at Vineland, NJ. 16-cp, 120-volt.
- 1909-917-----Anchor (American). Special dipped orange lamp made by Anchor Electric Company for S. May for Hudson-Fulton Celebration illumination.

## **1910**

- 1910-559-----Westinghouse Tungsten (American). 10-volt, 2-1/2 watt tungsten lamp for sign purposes.
- 1910-572-----Westinghouse Tungsten (American). 30-volt, 50-watt tungsten lamp with loop support.
- 1910-573-----Z Tungsten Lamp (German). 224-volt Z tungsten lamp. Made by Dr. Hollefreund in Berlin, Germany.
- 1910-574-----G.E. Company Tantalum (American). 220-volt, 50-watt tantalum, quadruple spider support; two 25-watt units in series in one globe.
- 1910-575-----Westinghouse Tungsten (American). 220-volt, 60-watt tungsten lamp.

- 1910-576-----G.E. Company Tungsten (American). 20-watt lamp. One of the earliest lamps of its size.
- 1910-577-----Pope Tungsten (Dutch). 110-volt, pressed filament candelabra tungsten lamp, Type D. Made by U.V. Pope, Venlo, Holland.
- 1910-578-----G.E. Tantalum (American). Triple spider support, zig-zag tantalum filament.
- 1910-579-----Justram Tungsten (Hungarian). 60-watt, 120-volt Justram tungsten lamp. Made in Austria, Hungary.
- 1910-580-----G.E. Co. Tantalum (American). Made at Edison Lamp Works, Harrison, NJ. 50-watt, 220-volt.
- 1910-581-----Westinghouse Tungsten (American). 80-cp, 5-ampere series tungsten lamp with loop supports.
- 1910-582-----G.E. Tungsten (American). Series type tungsten. 40-cp, 6-ampere.
- 1910-583-----G.E. Tantalum (American). Triple spider support, zig-zag filament, suspension tantalum wire lamp. 80-watts, 220-volts.

## 1911

- 1911-239-----Edison. 16-cp, 110-volt, ground glass, anchored oval spiral cellulose carbon filament, pressed inside seal.
- 1911-558-----Westinghouse Tungsten (American). 10-volt, 5-watt single loop tungsten lamp, for sign purposes, etc.
- 1911-566-----Pope Onion Tungsten Lamp (English). 27-volt, 5-watt tungsten lamp. Made by the English Pope Company.
- 1911-567-----Westinghouse Tungsten (American). 110-volt, 25-watt tungsten lamp with flat tension springs.
- 1911-568-----Westinghouse Tungsten (American). 110-volt, 40-watt tungsten lamp.
- 1911-569-----Heany (American). 25-watt, 118-volt tungsten.
- 1911-570-----G.E. Tantalum (American). Battleship type of tantalum lamp, triple spider support.
- 1911-571-----Kuzel (German). 25-watt Kuzel tungsten lamp. Made in Vienna, Austria.
- 1911-598-----G.E. Tungsten (American). Pressed filament tungsten lamp.
- 1911-650-----Nernst (American). Home kaleidoscope lamp made by Westinghouse Lamp Company, Pittsburgh, August 29, 1911. Two-glower, 112-volt, non-automatic, flexibly supported type, set in holder with ballast.
- 1911-655-----Nernst (American). Dentoscope lamp 110-volt, 8-ampere, straight glower loosely supported in porcelain bracket with flexible leads, allowing expansion; zig-zag heater below glower. Made October 21, 1911.
- 1911-922-----Color Cap Lamp (American). Red glass detachable color cap, Type B. For use on electric signs, etc.
- 1911-934-----Color Cap Lamp (American). Green glass detachable color cap, Type B for use on electric signs, etc.

## 1912

- 1912-236-----G.E. GEM Lamp (American). 20-watt. First lamp of this type tested by Lamp Testing Bureau (E.T.L.), New York, September 1912.
  - 1912-237-----Edison. 50-watt, 16-cp, 119-volt Edison GEM oval cellulose spiral carbon filament as made for New York Edison Company and taken from a socket in Hammer's apartment, 153 West 46th Street, New York City. Etched on lamp: "Property New York Edison Company, Not to be sold".
  - 1912-238-----Edison. 2-cp sign lamp, fine cellulose carbon spiral filament. No anchor, flat inside seal.
  - 1912-557-----End-On Pope Tungsten (Dutch). 11-volt, 2-1/2-watt end-on tungsten sign lamp, pressed filament. Made by H.W. Pope, Venlo, Holland.
  - 1912-560-----G.E. Tungsten Auto Lamp (American). Automobile tungsten lamp for side and tail lights. 4-cp, 6 volts.
  - 1912-561-----G.E. Tungsten (American). Filled getter No. 2 tungsten lamp made Jan.25, 1912. One of first 25 of this type. Made in Research Laboratory of G.E.
  - 1912-562-----Osram Tungsten (German). Osram sign lamp with reflector. Made in Berlin by Auer Gesellschaft.
  - 1912-563-----G.E. Tungsten (American). MAZDA drawn wire tungsten lamp, 20 watts, 116 volts.
  - 1912-564-----Westinghouse Tungsten (American). Low volt drawn wire tungsten lamp for train lighting.
  - 1912-565-----Westinghouse Vertex (Austrian). Vertex tungsten lamp, 115-volt, 25-cp. Made in Vienna, Austria.
-



- 1912-593-----Hopfelt (German). Carbon filament in U shaped tube open at top and containing mercury which is vaporized; efficiency 1.39 watts per candle, 110 volts, 0.49-ampere, 38.8-cp.
- 
- 1912-594-----Westinghouse Tungsten (American). Low volt train lighting tungsten lamp, drawn wire type. 111-113-115 volts, 60 watts.
  - 1912-595-----Pope Tungsten (Dutch). 25-watt tungsten lamp made by N.V. Pope, Venlo, Holland. This lamp ran for 1700 hours on 15 cycles at 110 volts.
  - 1912-596-----Hopfelt (German). Carbon filament in U shaped tube, open at top and containing mercury which is vaporized. Efficiency 1.39 watts per candle, 10 volts, 0.49-ampere, 38.8-cp.
  - 1912-597-----Edison. G.E. MAZDA drawn wire tungsten.
  - 1912-600-----Envoy (French). Pressed tungsten filament lamp. 105-volt, 40 watts.



- 1912-601-----Hopfelt (German). Carbon filament in U shaped tube, open at top and containing mercury, which is vaporized. Efficiency 1.39-wpc, 110-volt, 0.49-ampere, 38.8-cp.
  - 1912-604-----Dr. Just Wolfram Lamp.
  - 1912-612-----Edison G.E. MAZDA (American). 25-watt, 113-volt tungsten lamp. 111-113-115 volts.
  - 1912-628-----G.E. Tungsten (American). 250-watt drawn wire tungsten lamp.
  - 1912-630-----Edison G.E. Tungsten (American). 250-watt drawn wire tungsten lamp.
  - 1912-632-----LaCarriere Z Tungsten Lamp (French). 110-volt 160-watt tungsten lamp.
  - 1912-653-----Nernst (American). Electric sign projector lamp, 120-volt, 1.2-ampere, two-glower. Supported loosely in porcelain bracket. Flexible zig-zag heater below. Made October 21, 1912 at Pittsburgh.
  - 1912-677-----Neon Gas Tube (American). Present from G.E. Research Laboratory, Wm.S. Andrews.
  - 1912-683-----Andrews (American). Exhausted tube with aluminum plate covered with phosphorescent zinc sulphide and phosphate of calcium. Operated by an induction coil. Gift from W.S. Andrews.
  - 1912-695-----G.E. Tungsten (American). 3000-watt, 110-volt, 1 to 1-1/4 wpc.
  - 1912-717-----Osram Lamp (German). 1000-watt, 220-volt tungsten multiple filament, quadruple support. Made by Auer Gesellschaft, Germany.
  - 1912-756-----Osram Lamp (German). Multiple filament tungsten lamp. Made by Auer Gesellschaft. 110-volt.
  - 1912-786-----Concave lamp (American). 110-volt carbon spiral lamp with reflecting and diffusing surfaces. Made by (?) New York Incandescent Lamp Company.
-



- 1912(?) - 827 ---- Klondike Special (American). Silvered reflector with gold leaf bronze on lower half of Edison mushroom globe lamp. Made for Baer Brothers.
- 
- 1912-835 ---- Special Carbon Lamp (American). Special opal and corrugated lamp globe. Large acorn shape carbon filament with carbon paste clamps. G.E. (?).
  - 1912-847 ---- Ever Bright Sign Lamp (American). Detachable sign letter globe. Made by Chicago Novelty Company.
  - 1912-887 ---- Chicago Miniature Lamp (American). Property of the Federal Sign System (Electric).
  - 1912-895 ---- Johnson Lamp Dimmer (American). Consists of sixty feet of No.34 resistance wire on small porcelain reel, etc.
  - 1912-896 ---- Wirt Dimalite (American). Five degrees of light from full on to off, secured by pulling cord or by turning lampshade. Inventor: Charles Wirt.
  - 1912-897 ---- Wirt Dimalite (American). Shade holder type. The lamp is regulated by turning the shade which gives from five degrees from full light to no light. Inventor: Charles Wirt, President of the Wirt Electric Company.

- 1912-901-----Wirt Dimalite (American). A regulating resistance interpolated between the lamp and socket and in series with the lamp. Pulling the cord gives five degrees of light in the lamp. Dimalite for 16-cp, 50-watt lamp. 105-120 volts.
- 1912-913-----Wirt Dimalite (American). A regulating resistance socket in series with the lamp, giving five degrees from full on to full off; that is, full, half, dim, very low and out.
- 1912-919-----Anchor (American). Red dipped carbon filament lamp, 120-volt, 16-cp. Made by Anchor Electric Company.
- 1912-924-----Special Carbon Lamp (American). Special opal and corrugated mushroom shaped globe carbon filament, carbon paste clamps. 110-volt, 16-cp.
- 1912-935-----Heany Flashing Lamp (American). Betts and Betts thermostatic lamp device.
- 1912-937-----Chicago Miniature Sign Lamp (American). Ten tiny filaments in series inside one bulb. White enamel back and porcelain base.
- 1912-973-----Special Carbon Lamp (American). Boehm lens lamp. Special opal and corrugated pear shaped glass globe, carbon filament, carbon paste clamps. G.E. (?).

### 1913

- 1913-26-----The Haubner Light. 1-cp positively out of Noah's Ark. Burns in the open air. High resistance vegetable filaments, etc.
- 1913-591-----End-on Tungsten Lamp (Dutch). Made at Venlo, Holland. Tungsten filament supported by glass frame so as to throw light downward.
- 1913-603-----Westinghouse Tungsten (American). 6-volt, 21-cp. MAZDA tungsten automobile lamp.
- 1913-605-----Westinghouse Tungsten (American). 220-volt, 100-watt MAZDA tungsten lamp.
- 1913-606-----Pope Tungsten (Dutch). 118-volt, 40-watt tungsten lamp made by N.V. Pope, Venlo, Holland.
- 1913-607-----G.E. Co. Automobile Lamp (American). MAZDA headlight lamp for automobiles, conical spiral tungsten filament. 16-cp, 6-volt.
- 1913-608-----Westinghouse Tungsten (American). 110-volt, 40-watt, 5.19 amperes. Continuous tungsten wire filament lamp.
- 1913-609-----Westinghouse Tungsten (American). 110-volt, 150-watt MAZDA.
- 1913-610-----Westinghouse Tungsten (American). 30-volt, 15-watt MAZDA tungsten.
- 1913-611-----Westinghouse Tungsten (American). 220-volt, 150-watt, MAZDA tungsten lamp.
- 1913-613-----G.E. Co. Tungsten Sign Lamp (American). 10-watt, 112-volt, sign lamp.
- 1913-614-----Westinghouse Tungsten (American). 110-volt, 100-watt MAZDA tungsten lamp.
- 1913-615-----G.E. Co. Commercial Vehicle Lamp (American). MAZDA commercial vehicle headlight lamp, conical form of hook supported tungsten filament.
- 1913-616-----Westinghouse Tungsten (American). 30-volt, 50-watt, MAZDA tungsten lamp.

- 1913-617-----Westinghouse Tungsten (American). 220-volt, 25-watt MAZDA tungsten lamp.
- 1913-618-----G.E. Flashlight Tungsten (American). Lamp made for use with dry battery for pocket flashlight.
- 1913-619-----Westinghouse Tungsten (American). 6-volt, 2-cp MAZDA automobile lamp.
- 1913-620-----G.E. Tungsten Luminescent Lamp (American). Luminescent automobile lighting lamp.
- 1913-621-----Westinghouse Tungsten (American). 110-volt, 25-watt continuous tungsten wire filament lamp.
- 1913-622-----G.E. Co. Candelabra Lamp (American). Type D candelabra lamp, fluted egg-shaped globe with MAZDA tungsten filament.
- 1913-623-----Westinghouse Tungsten (American). 60-volt, 15-watt MAZDA tungsten lamp.
- 1913-624-----G.E. Tungsten (American). For use with pocket battery of dry cells.
- 1913-625-----Cooper-Hewitt (American). Cooper-Hewitt etched line lamp. Westinghouse tungsten lamp. Made by Peter Cooper-Hewitt January 1913.
- 1913-626-----G.E. Tungsten (American). Candelabra lamp, 16-cp, 110-volt, made of fine continuous spiral tungsten wire.
- 1913-627-----Linolite Tungsten (American). Made for Johns-Manville Company by Westinghouse.
- 1913-629-----Westinghouse Tungsten (American). 500-watt, 110-volt continuous tungsten wire lamp.
- 1913-631-----Westinghouse Tungsten (American). 110-volt, 100-watt, continuous tungsten filament lamp.
- 1913-647-----G.E. Nitrogen Tungsten Lamp (American). No.6166-5 nitrogen gas filled tungsten lamp, 34.3 volts, 7.57 amperes, 545 cp. Made February 8, 1913.
- 1913-649-----G.E. Nitrogen Tungsten Lamp (American). No.6012 nitrogen gas filled tungsten lamp, 6.6 amperes. Made at Schenectady, NY.
- 1913-680-----Neon gas Tube (American). With tungsten electrodes and filled with neon gas from bottle of neon brought to America by Wm. Ramsey, F.R.S.
- 1913-681-----G.E. Tungsten (American). Smallest incandescent lamp ever made. Weight: One grain, candlepower 1/10, volts 1.2, ampere about .1500, watts about 0.1800.
- 1913-735-----G.E. Nitrogen Tungsten Lamp (American). No. 12, 20-ampere nitrogen gas filled tungsten lamp, 1140-cp; efficiency 0.46-wpc. Made May 16, 1913.
- 1913-746-----G.E. Nitrogen Tungsten Lamp (American). No. 5260. Nitrogen gas filled tungsten lamp. Made March 11, 1913.
- 1913-747-----G.E. Nitrogen Tungsten Lamp (American). No. 6164 nitrogen gas filled tungsten lamp, 609-cp, 39.8 volts, 7.77 amperes. Made Feb. 8, 1913 at Research Laboratory.
- 1913-782-----Reco Color Cap (American). Color cap for sign lamp purposes. Cap made by Reynolds Electric Flasher Manufacturing Company, Chicago.
- 1913-783-----Westinghouse (American). 55-watt, 220-volt anchored 4-loop metallized carbon filament lamp.

- 1913-784-----Westinghouse (American). 40-watt, 110-volt anchored double loop metallized carbon filament lamp.
- 1913-785-----Westinghouse (American). 20-watt, 110-volt anchored double loop metallized carbon filament lamp.
- 1913-807-----Linolite Carbon Lamp (American). 110-volt, 16-cp, Linolite carbon filament with spiral turn at center and with two wire guides for filament.
- 1913-829-----Reco Color Cap (American). Color cap lamp for sign purposes. Caps made by Reynolds Electric Flasher Manufacturing Company, Chicago.
- 1913-836-----Reco Color Cap (American ). Color cap lamp for sign purposes. Caps made by Reynolds Electric Flasher Manufacturing Co., Chicago. 5-watt, 11-volt.
- 1913-837-----Crystal Covered Lamp (American). Novel decorative crystal lamp. Covering made in various sizes, designs and colors with adjustable opening to admit lamp and fit closely around lamp. Imperial B.M. Co., 110-volt, 16-cp, 3-5 watts.
- 1913-846-----Reco Color Cap (American). Color cap lamp for sign purposes. Caps made by Reynolds Electric Flasher Company. 5 watts, 12 volts.
- 1913-879-----Candelabra Lamp (German).
- 1913-880-----Candelabra Lamp (German). 8 volts.
- 1913-882-----Candelabra Lamp (German). same as 879.
- 1913-883-----Reco Color Cap (American). same as 846.
- 1913-884-----Candelabra Lamp (German). same as 882.

## 1914

- 1914-889-----Argus Lamp Sign Letter (American). Made by Harvey Deschere Company, Hoboken, showing back of letter with cast aluminum letter set in base carrying shunt resistance to which lamps are connected when wires are in place.
- 1914-890-----Argus Lamp Sign Letter (American).

---

The writer thanks the personnel at the Henry Ford Museum & Greenfield Village Research Center (and, in particular, J. Marc Greuther, Curator of Industry) for the opportunity to view some of the lamps in the Hammer Collection and for their courteous and generous treatment during my visit.

The inventory of the Hammer Collection was first viewed by the writer about 1957 at the Research Laboratory of the General Electric Company. The availability of such records is most important if further research into the developments of the past are to be pursued.

Thanks are also extended to personnel at GE Lighting in Cleveland, Ohio for the loan of material pertinent to the Hammer Collection. Without the generous help from these organizations the information given in this web site would not have been possible.

---

## References

- 1) Interview sheet with W. J. Hammer, Dec 23-24, 1911; interviewer unknown. His collection at that time amounted to about 1,500 lamps.
- 2) Photographs. History of an Art. 1904. 1913.
- 3) Letter. William J. Hammer to L.C. Kent, Jan 17, 1918.
- 4) Booklet. Biographical sketch of W.J. Hammer. Courtesy of the National Encyclopedia of American Biography and the Electrical Review and Western Electrician.
- 5) Large "business card" of William J. Hammer.
- 6) Electrical Diablerie. See N.Y. World, Jan 3, 1885, and Newark, N.J. Daily Advertiser and Journal, Jan 3, 1885.
- 7) "Important European Electrical and Engineering Developments at the Close of the Nineteenth Century," William J. Hammer, Vol. XVIII of the Transactions of the American Institute of Electrical Engineers, page 47.
- 8) "Electric Lighting by Incandescence," William J. Hammer, Quarter Century Number of the Electrical Review, New York, Mar 9, 1907, pg 3.

## Comments on Some Hammer Lamps at the Ford Museum

In the 1950s the Ford Museum in Dearborn, Michigan had a display of lamps from the collection of William J. Hammer. The collection is no longer on display but is in storage. The Hammer Collection represented the state of the art at the time Thomas Edison was developing his incandescent lamps. During a visit to the museum in the 1950s the writer took some notes regarding lamps on display. In what follows, brief comments refer to displayed lamps:

An Adams-Bagnall (A.-B.) lamp, made in Cleveland in 1896.

A Seel lamp, made in 1890, had a base like Mather but evidently with a pin in the base center.

In 1890 Schaefer had a small series lamp with a Maltese Cross glass support for the leads.

An 1890 Bernstein lamp had a flat inside stem seal and a hard rubber base.

The first carbon filament lamp was made by Thomson-Houston in 1886.

Edison had a zinc screw base in 1894.

A "Thomas A. Edison, Jr." lamp was made about 1899 by Shelby Electric.

The first ground glass Edison lamp was made by Mr. John W. Lawson at Menlo Park. The lamp was taken from the first lot dipped in hydrofluoric acid. This was labelled "Hammer #68".

A Hopfelt lamp was secured in Germany in May 1907. The lamp contained a bulb within a bulb. It was designed for 120 volts, had a carbon filament and the inner bulb contained mercury.

Eight lamps were displayed that were made by Philip Diehl in Elizabeth, New Jersey in 1885. One lamp contained an induction coil and a secondary coil connected to the filament. A second Diehl induction lamp had one coil placed inside the globe and connected to the filament and another coil wound outside the globe, alternating current being applied.

An Edison oxide of zirconium lamp of 1878 was displayed.

Hammer obtained a Sawyer lamp from William Wallace of Ansonia, Connecticut. It was made in 1880 and consisted of a carbon rod with carbon black and carbon roller supports in nitrogen. The lamp contained a spiral radiating resistance coil.

An elaborate Bernstein lamp of 1882 had two hollow carbon filaments in series, with a heavy carbon paste cross piece at the top, clamps, copper wire and German glass supports. It also had platinum leads. The lamp was about 3-4 inches in diameter. The carbon filaments were very light gray in color, similar to the appearance of pyrolytic graphite. The glass stem near the base was light blue in color.

An Austrian lamp of 1883, developed by Müller, was about four inches in diameter. The filament consisted of a double twist spiral with a hydrocarbon treatment. It had a tipless bulb. The filament was very light gray, characteristic of pyrolytic graphite.

In 1887 Edison manufactured a nickel-plated screw base.

An 1882 Edison lamp was the first colored incandescent lamp ever made. It was made and used at the Crystal Palace Electrical Exhibition in London, England. The bulb was painted a "blood" red on the outside.

An Edison lamp was displayed that was one of the first (Holzer) pressed inside seal lamps, early bamboo filament, early bulbous globe and platinum vise clamps.

Hammer No 337 was a Greiner lamp of 1887. It consisted of a straight carbon filament, egg shaped globe, copper and magnesia clamps, tubing around leads and clamps. Made in Pittsburgh, Pennsylvania.

A Stanley-Thompson lamp of 1884 had a pin through the base - perpendicular to the lamp axis. Hammer lamp No. 501.

## **Edison Lamps at the Henry Ford Museum**

On this website one can find a listing of lamps in the William J. Hammer Historical Collection of Incandescent Electric Lamps (Section 12) which are housed at the Ford Museum in Dearborn, Michigan. The intent of this writing is to point out that additional information regarding lamps made at Menlo Park during the years 1879-1881 is also available in Appendix 3 of Volume 5 of The Papers of Thomas A. Edison<sup>1</sup>.

In May of 2000 the writer obtained a copy of the inventory of the Hammer lamp collection at the Henry Ford & Greenfield Village Research Center in Dearborn, Michigan. A transfer number had been assigned to each lamp in 1930. In the listing given in Section 12 of this website these transfer numbers are used. Similar numbers are used in Volume 5 of The Papers of Thomas A. Edison. However, it should be pointed out that the numbers that appear in Volume 5 are somewhat different - and yet, are the same. An example is given below where the numbers and lamp descriptions from the two sources are compared:

The Papers of Thomas A. Edison, page 1051, 1880 lamp

29.1980.529.122. Lamp made for Menlo Park street lighting, with paper horseshoe filament, large globe, supplemental tip, round inside seal, and platina vise clamps.

This website, Section 12

1880-122-----Edison. Paper horseshoe carbon filament lamp, large globe, supplemental tip, round inside seal, platina vise clamps. Made for Menlo Park street posts.

It is the number "122" that identifies these descriptions as referring to the same lamp.

### **Reference**

1) The Papers of Thomas A. Edison - Research to Development at Menlo Park, January 1879 - March 1881, The Johns Hopkins University Press, Baltimore and London, 2004, pp 1049-1056.

### **Exhibits and Collections of Early Incandescent Lamps**

It is of considerable interest to ascertain where exhibits of early incandescent lamps exist in the world today. It is the purpose of this section to begin to identify those locations.

One of the largest collections on exhibit, by appointment, is that gathered by Dr. Hugh F. Hicks in Baltimore. There is some information regarding this collection listed under Museums. It is called the Mount Vernon Museum of Incandescent Lighting.

A part of the collection of lamps held by Columbia University can be viewed. It is part of the Chandler Chemical Museum. A few dozen lamps are located in the Havemeyer Hall on the main Columbia University campus.



The Hall of History in Schenectady has a lamp collection but it is not on exhibit yet. When it is displayed it should be of considerable interest to collectors.

### **Lamps Collected by Charles Proteus Steinmetz**

The collecting of objects is a common pastime for many persons. Included in this group was the electrical "wizard", Dr. Charles Proteus Steinmetz. During the early years of the 1900s Steinmetz lived in Schenectady, New York. His residence was on Wendell Avenue (see Recollections of Steinmetz - A Visit to the Workshops of Dr. Charles Proteus Steinmetz, Emil J. Remscheid, General Electric Hall of History Foundation, 1977.) In 1911 Steinmetz added to his house and one of the additions was a museum. Some of his collections included 'arrowheads, stones such as geodes, petrifications and specimens of natural crystal. Historic pieces of the electrical age were also included, such as early light bulbs and power line insulators fractured by lightning.' A photo of some of his 1912 tungsten filament lamps is shown below.

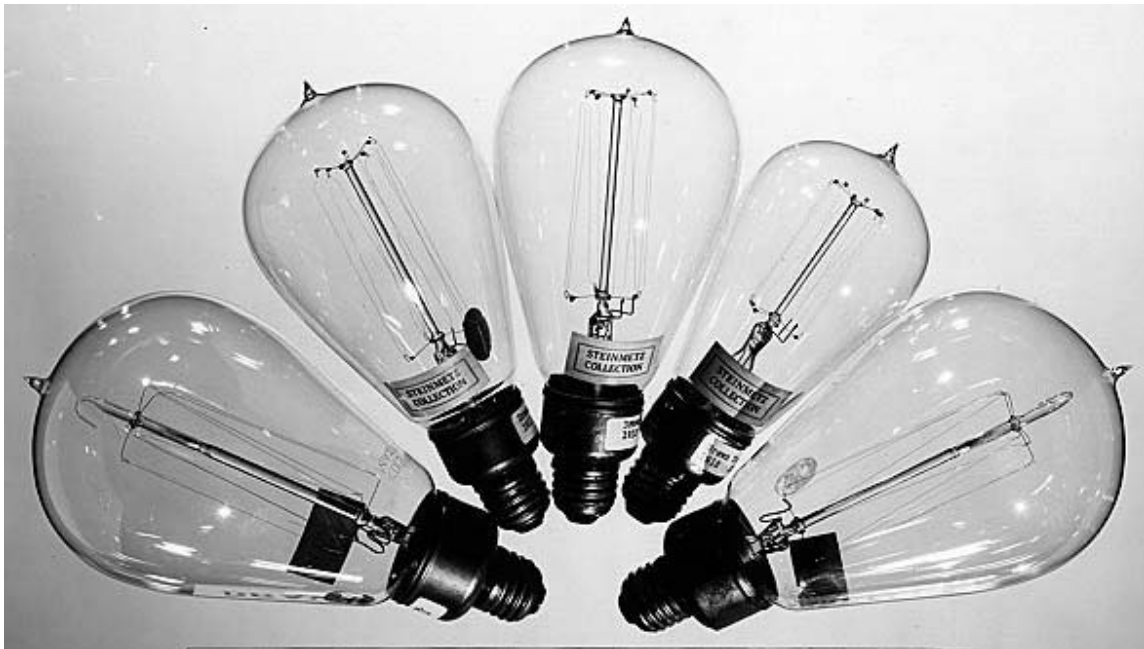

### **Petzinger Filament Collection**

In 1962 the writer was employed at the Lighting Research and Development Operation, General Electric Lamp Division, Nela Park, Cleveland, Ohio. In February of that year an article appeared in the GE News about my hobby of collecting early incandescent lamps. A Lamp Division retiree, George Petzinger, saw the article and contacted me. He had his own story to tell, a part of which is now related to the viewer.

In the year 1957 the GE News had printed a story about Mr. Petzinger and his hobby - that of collecting materials used in the making of carbon filaments. In 1957 Mr. Petzinger was 82 years of age. At that time he had been retired for 12 years. He had started his 42 years of service with GE in 1903. GE had started a filament department and Petzinger began as a helper. Most of his career was spent supervising the manufacture of carbon filaments.

George Petzinger started to accumulate some of the materials used in filament manufacture and subsequently displayed them. The picture below shows his displays.

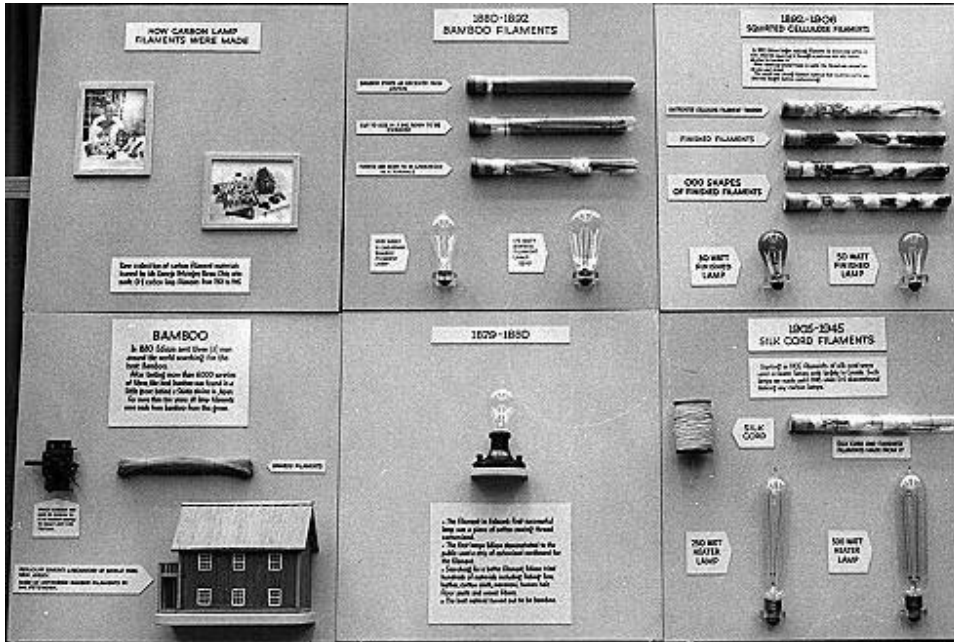

One of Petzinger's prize possessions was a hand tool designed and used by Thomas Edison for planing filaments down to size. This tool is shown in the lower left corner of the picture.

Mr. Petzinger presented many of his remaining bamboo and silk filaments to me in the hope it would help to perpetuate an interest in early lamp technology. the following photo shows some of these planed filaments, starting bamboo strips and some silk cord.



**Lamp Display at Philips after 1964**

A letter received by the writer in 1964 might be of some historical interest to collectors. In 1935 Prof. N.A. Halbertsma began collecting documents, products and various apparatus for the purpose of establishing a comprehensive museum. It was permanently housed in the "Bedrijfsschool" where it occupied an entire floor. Much of that material was lost during the bombing of Eindhoven in 1942. After the war renewed efforts were made to collect items of historical interest. It was planned (in 1964) to have a permanent exposition of this material in a few years in a special building.

#### **Collectors and Collections, Past and Present**

The internet has helped to bring collectors of incandescent lamps together electronically, which results in a sharing of a common interest as well as learning from each other. The present writer doesn't have a great deal to contribute with viewers on this subject but some of what follows might be of interest.

When the writer started to collect lamps (in the late 1950s) there were only a few collectors with whom one could communicate, and generally that was by means of letter writing. Websites can help to achieve greater communication and that is presently achieved by means of Tim Tromp's site, for example. Get-together meetings also have multiple benefits and Jerry Westlick's annual meetings have served that need very well. Few people who have collections that are displayed have come forward to invite others who are interested to visit and view them. The late Dr. Hugh F. Hicks was an exception and his Mt. Vernon Museum of Incandescent Lighting was well worth a visit to view. In 1976 Dr. Hicks

created a lamp display for viewing in Moscow as part of the United States bicentennial celebration exhibition.

The origin of the following article is not known nor is the time frame. Based on the content of the article it appears that it might have been written about 1946. A picture appeared with the article but was too dark for reproduction. The article read:

### **"He Scours the Earth for Light Bulbs**

"When Charles B. Sero, a third-generation Detroiter, was six years old, he happened upon an old electric-light bulb, thought it a very interesting object, and laid it away among his prized possessions. Now sixty, Sero has the world's largest collection of old and odd bulbs, many of which are historically or scientifically invaluable.

"One reason this singular project□it is no longer a hobby, he says, but 'my life'□has succeeded is that Sero has built up an army of volunteer deputy collectors all over the world. The war greatly accelerated this international search, bringing in such items as bulbs that helped fly the Enola Gay on her atomic bombing of Hiroshima, a dial light from Himmler's personal radio, and bulbs that lighted the German and Japanese surrender signatures on the Victory Train that toured the United States.

"Sero's oldest item is an 1883 handmade Edison that still burns. He might have acquired□one way or another□the very first bulb Edison made, but after it had glowed for forty-four hours, the inventor broke it to see why it went out. Sero did pick up an exact reproduction, even to the carbonized sewing thread filament. He trailed four rare Austrian-made bulbs nineteen years, and two unusual toy bulbs forty years, before landing them. His tiniest is about the size of a grain of wheat; his largest, a 50,000-watt bulb, is as big as an eight-year-old boy.

"One of his present goals is an osmium-filament bulb, of which a very few were made in Europe around 1906 and rented, not sold, to users. 'I'll get one any day now!' he declares.

"Sero, who is pictured above, has been urged to commercialize his unique collection in public exhibitions, but he has steadfastly refused. 'I don't want to make a cent from it,' he says. Recently, he gladly complied with an Army request to show the bulbs without charge in an enlistment drive. He has decided to place his collection on free permanent exhibition. The formal dedication is scheduled for February 11, 1947. Why that particular date?

" 'That date' Sero explains, 'is the hundredth anniversary of Tom Edison's birth.' "

□Mack Brandewiede.

Another short article, believed to have appeared in the *New York Times*, is reproduced below. The time of appearance also is not known.

### **"Original Edison Light Bulb is Among 1,900 in Museum**

"TORONTO (Canadian Press)  
"One of Thomas Edison's original light bulbs is still in working condition is part of a collection of 1,900 lamps that 77-year-old Arthur Plumpton has in his care at the Ontario Hydromuseum.

"Mr. Plumpton works half a day five days a week and spends a lot of time writing letters.

" 'I'm in contact with people all over the world,' he said.

"As a result, he has obtained lamps from as far away as Australia to add to his collection.

"Mr. Plumpton, regarded as one of the world's foremost authorities on light bulbs, spent 45 years with Hydro's research division before his retirement in 1958."

The following article appeared in the Illuminating Engineering Society publication of August, 1965, pg 22A.

**"Historical lamps...**A rare collection of early incandescent lamps, some produced as long as 70 years ago, has been put on display at the Burndy Library in Norwalk, Conn. On indefinite loan from Westinghouse Lamp Division, the collection includes nearly 300 incandescent lamps produced during a 35-year period starting in 1895. The old light sources were produced by various concerns, and a number were made abroad.

"Many fascinating examples of early lamp-making craftsmanship are included in the exhibit. Filaments are made from carbon, tantalum, or squirted tungsten and are formed in strange, complex patterns no longer seen. The filaments are not coiled as is customary today. Also of interest is the great range of shapes and sizes of bulbs.

"The Burndy Library, which contains 20,000 volumes, houses one of the world's fine collections of physical and biological science manuscripts. One mezzanine is devoted to electricity and magnetism."

An article appeared in *The Plain Dealer Sunday Magazine* (newspaper in Cleveland, OH) on November 22, 1970 that showed the extensive collections of William G. Hachtel.

Hachtel's overall collection included many items other than old light bulbs, but judging from the picture, his lamp collection appeared to be substantial.

Some lamps from the collection of G. R. Brown were shown in two articles in the *Spinning Wheel*, Feb 1959 and Jun 1960.

Fin Stewart, who resides in Australia, was featured as a lamp collector in 1961 in the *Philips Reporter*. Then, again, in 1969, a story about his collection appeared in a suburban Cleveland newspaper when Fin and his family visited the United States.

The collection that this writer had several years ago appeared in *The Record Newspapers* in Troy, NY in 1960. A lamp display was then shown in the *GE News* in Cleveland in early 1962.

It is believed that some lamps are on exhibit in Havemeyer Hall on the main campus of Columbia University in New York City.

Some of the lamps in the Smithsonian collection can be seen in their publication: Lighting a Revolution, The National Museum of History & Technology, Smithsonian Institution, 1979.

A Light Exhibition was held from April to July, 2001 at the Carnegie Museum of Art in Pittsburgh, PA. Eleven lamps were exhibited there from the William J. Hammer Collection that is stored at the Henry Ford Museum in Dearborn, MI. These lamps were: 1883 Siemens, 1880 Maxim, 1882 Lane-Fox (which was acquired by Hammer at the 1882 Crystal Palace Electrical Exposition), 1881 Lane-Fox, 1882 Swan (a lamp presented to Hammer by Joseph Swan at the Royal Institution), 1889 Thomson-Houston, 1888 Hammer (designed by Hammer and taken to the Paris Exposition in 1889), 1883 Maxim, 1883 Cruto, 1885 Bernstein and 1904 Nernst.

An article in a 1961/62 issue of the *Philips Technical Review* (Vol 23, No 8/9) showed a picture of 20 lamps that were on display at Teyler's Museum in Haarlem, Netherlands. The lamps had been purchased at the Paris Exhibition in 1881.

Jerry Westlick, of Elmore, Ohio, has a magnificent private collection of lamps that is shown in grand style in his home. It is certainly one of the most impressive displays this writer has seen. He had an article printed on May 28, 2002 in *The Plain Dealer*, the Cleveland, Ohio daily paper, about his collection. Another article appeared in *The Press*, of Elmore, Ohio, on Jun 17, 2002.

An article appeared in the Cleveland *GE News* on Feb 4, 1972 in which a collector of incandescent lamps was featured; her name: Millie Boutall. One of three photographs from that article follows.



The writer has communicated for many years with a collector who lives in Czechoslovakia; his name is Stanislav Slabyhoudek. His interests are broad and he has a very large collection. Stan put a message on Tim's site (under Bulb Discussion) on Aug 6, 2003. I followed, on Aug 7th, with a picture of a display he had several years ago.

Go back to: [Early Incandescent Lamps](#), or, click "Back" on your browser

### **General Electric's Edison Exhibit in Chicago in 1893**

The Columbian Exposition of 1893 was the one in which Westinghouse introduced his Stopper Lamp. It was a grand event, at a time when the economic condition of the country was at ebb tide. In addition to the new lamp introduced by Westinghouse, other companies had displays of various kinds. General Electric had a large display that covered many aspects of lighting. The General Electric area is shown below.

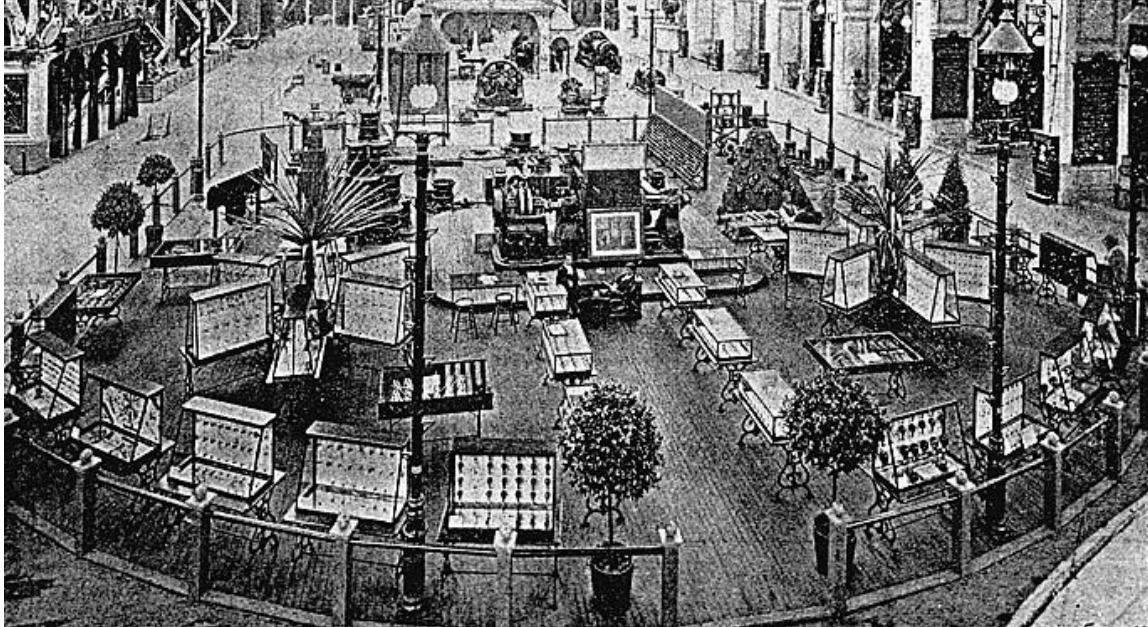

The Edison display consisted of incandescent lamps, generators, motors as well as the "Jumbo" dynamo. About half of the section was taken up by glass show cases that contained samples of incandescent lamps. There were 2500 such lamps with no duplications. There were colored lamps that were used for various purposes, special types, miniature as well as lamps of unusual shapes. The manufacturing steps were shown, from glass tubing to the finished lamp. Examples of "municipal" lamps, which were used for long distance, were included along with high voltage incandescent street lighting circuits. Standard lamps of various voltages were represented along with light output lamps of 10, 16, 20, 24, 32, 50 and 100 candlepower. Experimental and historical lamps were also displayed. There were examples of resistance lamps that were used by the Western Union Telegraph Company, lamps with several filaments in series and multiple, as well as railway lamps with anchored, unanchored and spiral filaments.

In one display case the tools used by John W. Howell to make "tar-putty" lamps, as described by Edison in his basic U. S. Patent No. 223,898, were shown; these were used in conjunction with patent litigations. Two of the lamps made by Howell were shown. Other cases displayed specimens of the vegetable matter used by Edison in his search for the ideal filament starting material.

In addition to entire system setups, Edison's first generator, built in 1880, was on display. It had been in continuous use since 1880 and was removed from service for display at the exhibition. In one display case seven volumes, containing over 7000 pages of testimony taken during filament litigation, were on view.

### **Reference**

"The Edison Exhibit of the General Electric Company", *The Electrical Engineer*, Vol XVI, No 272, Jul 19, 1893, pg 61.



## **Two Small Collections of Early Lamps**

The top picture shows a collection of twenty early lamps that were purchased by the Teyler Foundation<sup>1</sup> in 1881 at the Paris Exhibition. It includes lamps made by Edison, Swan, Lane-Fox, Maxim and Siemens. These existed (in 1961) in Teyler's Museum, Haarlem, Netherlands. The lower picture shows a collection of ten lamps made between the years 1880 and 1890<sup>1</sup>. These are in the collection at the Science Museum, London, England.

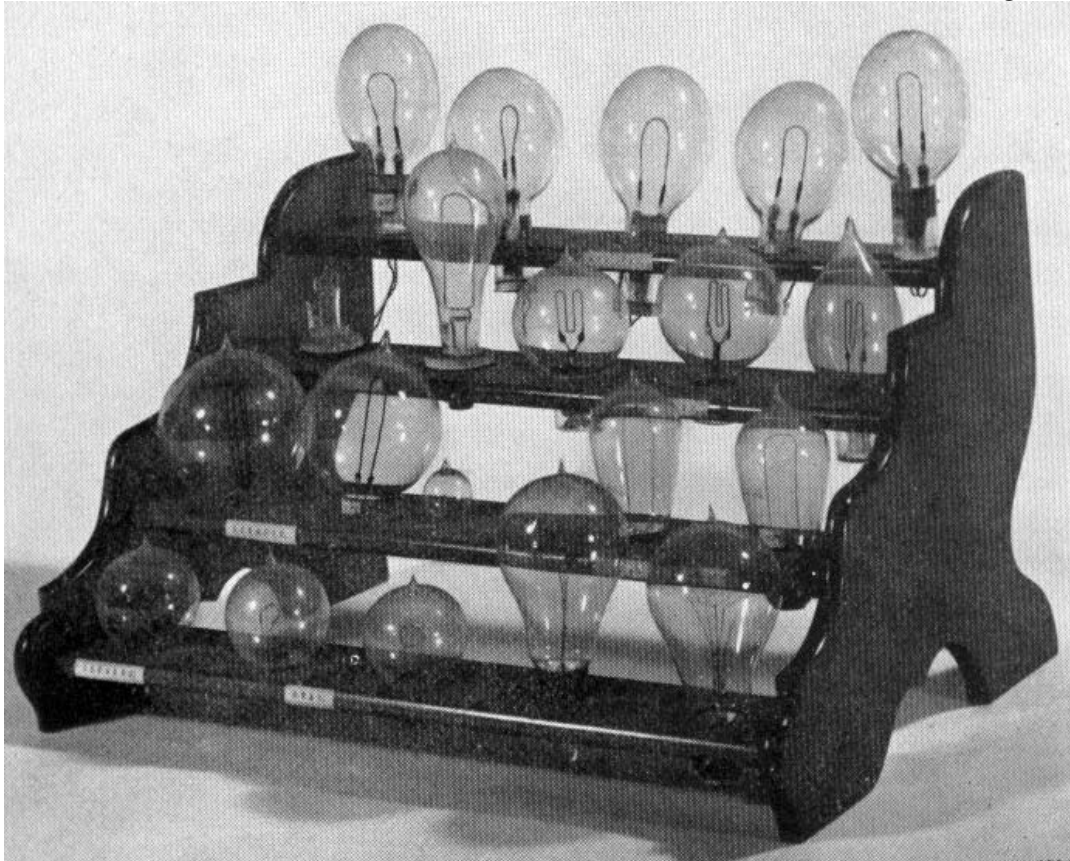

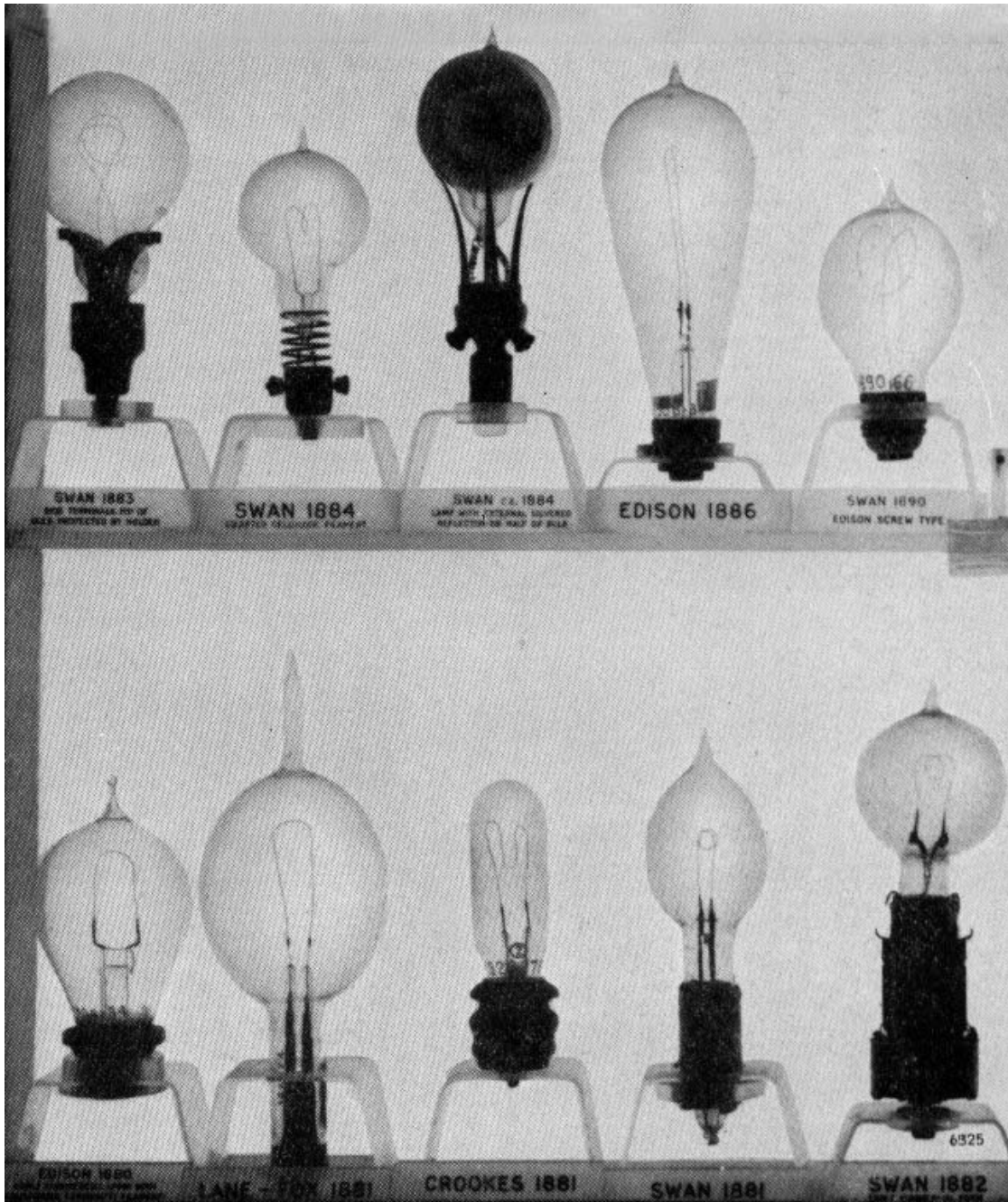

**Reference**

1) N. A. Halbertsma, "The Birth of a Lamp Factory in 1891," *Philips Technical Review*, Vol 23, 1961/62, No 8/9, pp 222-236.

**Goebel Original and Reproduced Lamps**

During the early 1890s there was much litigation in the courts regarding the incandescent lamp. The Edison Electric Light Company (General Electric Company) brought infringement suits against many manufacturers and in 1893 some lamp companies defended their position by claiming a "Goebel Defence." Lamps that were purported to have been

made by Henry Goebel much earlier than 1872 appeared in the court cases and were identified by numbers. Reproduced lamps made for use in the court litigations were given letter identifications. Labels on the lettered lamps have the notation "U. S. Circuit Court, Eastern District of Missouri." Pictures of both numbered and lettered lamps are presented below.

In 1988 a boxed collection of Goebel lamps was donated to The Henry Ford (the Edison Institute, a Michigan nonprofit corporation that provides educational services) in Dearborn, Michigan by the General Electric Company; the box and its contents (accession 88.56.12) are currently in storage. Through the courtesy of Marc Greuther, Curator of Industry, the writer was given the opportunity to photograph these artifacts, which had been gathered, identified and labelled in the year 1893. Each picture was taken with a hand-held camera so the magnification is probably different for each photograph. The vertical height of the trimmed image was made the same in most cases for the purpose of presentation.

In many cases there are three labels on the lamps. However, identification was difficult because the ink markings on the labels had faded. However, after careful study it was concluded that the lamps are correctly identified in this write-up.

The first court case that used the "Goebel Defence" was in Boston in January and February of 1893 when the Edison Electric Light Company brought suit against the Beacon Vacuum Pump and Electrical Company. Then, in April of 1893 suit was brought against the Columbia Incandescent Lamp Company of St. Louis, Missouri. In July of 1893 suit was brought against the Electric Manufacturing Company of Oconto, Wisconsin. The box of Goebel lamps originated from St. Louis. Columbia eventually became part of the National Electric Lamp Association, which, in 1912, became part of the General Electric Company. The close relationship between Thomas Edison and Henry Ford probably helped to direct the lamp collection to the Ford Museum. Dodd, who wrote a book about the founders of National, used a picture of some of these lamps in his book<sup>7</sup>.

It should be noted that the date commonly given on the largest lamp label (December 16, 1893) doesn't correspond to any date of known significance. The court litigation in St. Louis occurred in April of 1893. Henry Goebel passed away on December 4th, 1893 and the basic Edison patent expired in November of 1894.



Wooden box with a total of 19 Goebel original and reproduced lamps  
(From the collections of *The Henry Ford*)

Stamped on the bottom of this box is "Witter & Kenyon, 38 Park Row, New York City." Witter and Kenyon were the attorneys for the defense at all three "Goebel defense" cases. Witter was W. C. Witter and Kenyon was William Houston Kenyon. A biographical sketch of Kenyon (1856 - 1933) can be found in Who Was Who In America, Volume 1, pg 669. Witter and Kenyon were partners in law during the years 1883 - 1899.



Top layer of lamps  
*(From the collections of The Henry Ford)*



Second layer of lamps from top  
*(From the collections of The Henry Ford)*



Third layer of lamps from top  
*(From the collections of The Henry Ford)*



Bottom layer of lamps  
*(From the collections of The Henry Ford)*







From left to right, Lamps: A, B, E, F, G  
(From the collections of *The Henry Ford*)





From left to right, Lamps: H, I, K, L, M  
*(From the collections of The Henry Ford)*

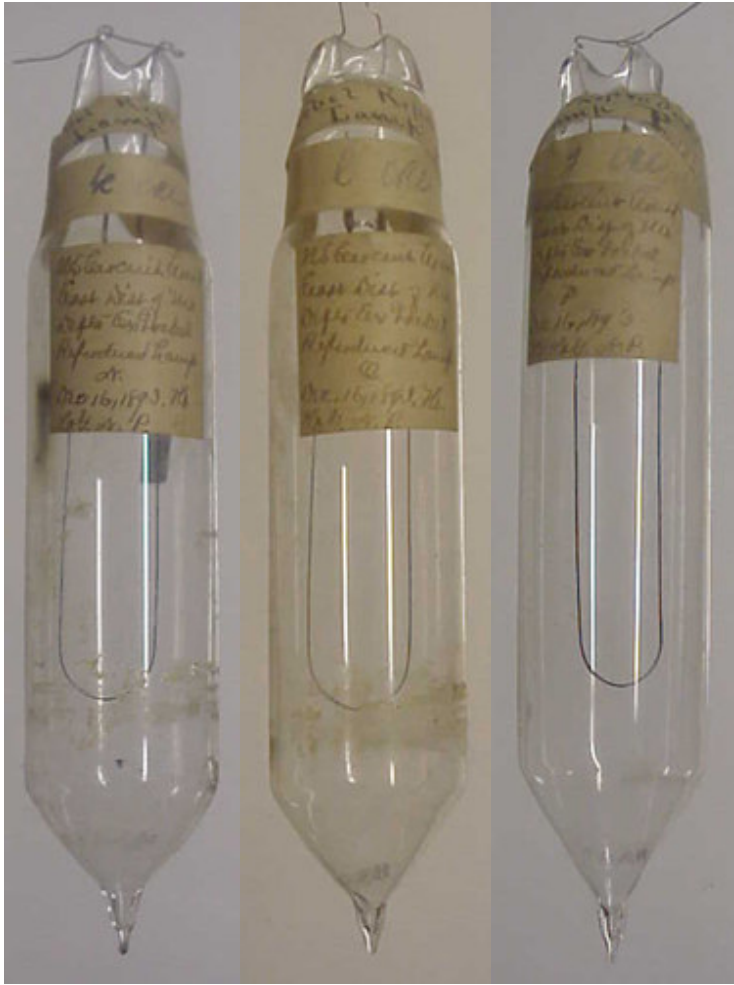

From left to right, Lamps: N, O, P  
*(From the collections of The Henry Ford)*



Unidentified "original" Goebel lamps  
 (From the collections of The Henry Ford)

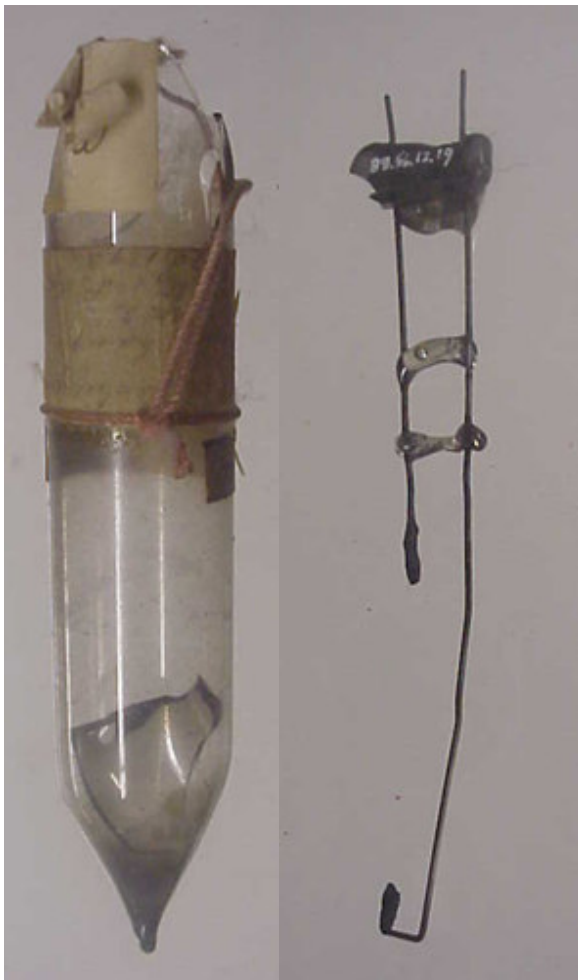

**Lamp No. 2.** From a write-up of the Oconto case<sup>6</sup>:

"The lamps which Goebel produced at Boston, as original lamps, made in the early years, were four, called Exhibits 1, 2, 3, 4... The first three had copper and iron leading-in wires, were what Goebel calls "meat saw" pattern, and show no vacuum now, and if fully proved would not constitute anticipation of Edison. No. 4, called the "hairpin" pattern, has the

requisites, including a vacuum, although probably not the high vacuum."

From another article<sup>3</sup>:

"It appears from the affidavit of Mr. Bull, an attorney at law that Henry Goebel, Jr., delivered lamp No. 1 to him at his office in New York, October 18, and lamp No. 2, November 28, 1892, and that when received both the carbons were detached from the leading-in wires... Henry Goebel, Jr., states that he delivered lamp No. 3 to Mr. Bull at the same time with No. 2, and that he broke the carbons in lamps 1 and 2 on the way to Mr. Bull's office."

Bulb and filament mount of Lamp No. 2  
(From the collections of The Henry Ford)

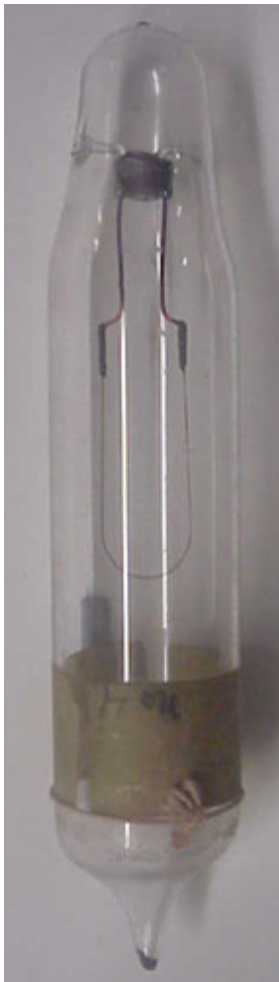

**Lamp No. 4.** The lamp shown to the left is one that was labelled "No. 4" in the Beacon litigation. Pictures of lamp No. 4 can be found in the literature<sup>1, 3</sup>. Indeed, if one looks at an upside-down version of the image shown, one can read "No. 4."

In one article Goebel is quoted as saying<sup>2</sup>:

"One of these lamps with platinum leading-in wires I sent to the counsel connected with this case at about the same time I gave them the lamps 1, 2 and 3, and told them at that time that this lamp had been in my possession from before 1872, and that it, with others like it, was made prior to 1872. This lamp is marked Goebel No. 4. The lamp "Goebel No. 4" I have had in my possession ever since before moving from Monroe street to Grand street in 1872. I made it and burned it a good many times both before and after I left Monroe street, and it burned well and gave good light. I took especial pains with the glass part of this particular lamp and it was because of this and because the glass part was so well done, giving the lamp a very beautiful and finished appearance, that I always kept it, bringing it out from time to time to light as an exhibit. I kept it in my possession until I sent it to defendant's counsel in this case. The lamp and all the parts are the same they were when I made it prior to 1872, in material and all other respects, except such changes as may have occurred from my use of it, handling and mere lapse of time. When I made it prior to

1872 I made it with a bamboo carbonized burner, with platinum leading-in wires, copper connecting wires; the modes of connection and the glass tube were just as they were as they here appear except as above stated..."

It might be mentioned that the first form of lamp Goebel is purported to have made utilized a filament in the form of a fiddle-bow. These lamps are referred to as "fiddle-bow" or "meat-saw". The next lamp designs utilized the "hairpin" shape, which is shown here.

*(From the collections of The Henry Ford)*

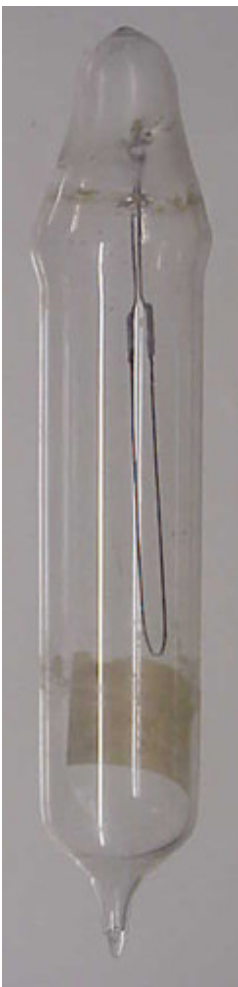

**Lamp No. 9** The writer believes this lamp to be No. 9. Quoting from an article<sup>5</sup>:

"No. 9 is very similar in almost all respects to No. 4 and has platinum leading-in wires, a carbon filament and a junction formed of stove polish in the coiled ends of the leading-in wires. The filament is now broken, but the lamp in question was burned for six weeks in the establishment of the Bigelow Manufacturing Company. Of these there were three.

"The J. C. Goebel lamp No. 9 was found by J. C. Goebel, the son of Henry Goebel, a few days before Judge Colt's decision, in J. C. Goebel's house in Wallingford, Conn. It was one of three lamps given to him by his mother when he was expected to make a trip to Germany, which was previous to May 1, 1879. Two of these lamps he gave to George K. Clark about 1886 or '87. Lamp No. 9 was kept by him in a trunk until about the end of 1891. The trunk being required for use at that time the lamp was removed and found again about the middle of February in a bureau drawer. He claims that it has never been out of his possession since he first received it about June 1, 1878."

In another article the following was written<sup>4</sup>:

"The affidavit of John C. Goebel says that lamp marked "J. C. Goebel Lamp No. 9" was given him by his mother, with at least two others, before May 2, 1879, and has been in his possession ever since. The others are lost. No. 9 was always where he could put his hand upon it until a year and a half ago when his daughter took to her home the trunk in which they were kept. He had frequently showed them to friends and explained that his father had made them before Mr. Edison had invented his lamp. At one time - in 1881, he thought - he put one of these lamps on the first dynamo set up at the New Haven Wire Mills. The lamp gave a very



bright light and did not break, but burned satisfactorily. No. 9 is now, he said, in precisely the same condition as when his mother gave it to him."

*(From the collections of The Henry Ford)*



**Lamp No. 11.** This lamp first surfaced in the Columbia case. It was stated<sup>4</sup>:

"Dr. William Mayer, a dentist, of 1024 Chapel street, New Haven, Conn., said he had known Henry Goebel eight or nine years and had often visited him at his store on Grand street, New York City. About 1885, Goebel had given him one of his old incandescent lamps and had talked of his work. Deponent understood from his conversation that the lamp given him, and also many others, were made years before, and prior to the making of incandescent lamps by anyone else. This lamp is marked, No. 11."

The writer is not aware of any picture of Lamp No. 11 that appears in the literature with which a comparison can be made. However, of all the lamps labelled, this particular lamp was well described on its label, including Mayer's name. Also, there is an artist's sketch of Lamp No. 11 in *The Electrical World*<sup>5</sup>.

In the same write-up the following was said:

"Dr. Wm. J. Mayer Lamp No. 11 - This was given to Dr. Mayer by Henry Goebel in 1885, who states that in that year he called upon Mr. Goebel at his store in Grand street, when he received this lamp from him, and states that this lamp has been continuously in his possession ever since. It will be noticed that this lamp has a different base from either 4 or 9, being re-entrant or concave instead of convex. The leading-in wires are platinum and the filament is of carbon. The tip or boss where the lamp was sealed off is now broken."

*(From the collections of The Henry Ford)*

### Footnotes

For write-ups of the litigation cases, go to "A Review of the Henry Goebel Defense of 1893", Section 11 (Lamp Patents), on this website.

It is of interest to comment on the existence of other Goebel lamps. One lamp exists in the William J. Hammer Historical Collection of Incandescent Electric Lamps at the Henry Ford Museum and is labelled 1893-953; a mention of it can be found on this website in Section 12 (Lamp Collections and Exhibits). In addition, one Goebel lamp exists enclosed in the corner stone of Building 308 at Nela Park, the headquarters of the General Electric Company's Lighting Business Group<sup>8</sup>. A history of the Goebel lamp also exists there. The corner stone was laid in 1912.

### **Acknowledgement**

The writer is most appreciative of the opportunity to photograph these lamps in the Ford Museum. It was Marc Greuther, Curator of Industry, who informed the writer of this find and devoted time as well, during the photography session, to help with the reading of labels.

### **Request**

The writer requests that any viewer of this write-up who uses the presented images on the web or in publication form, acknowledge the Goebel lamp source as the Henry Ford Museum (20900 Oakwood Blvd., Dearborn, Michigan 48124).

### **References**

- 1) "Goebel's Incandescent Lamp and Filament Planer," *The Electrical Engineer*, Vol 15, No 249, Feb 8, 1893, pg 148.
- 2) "The Edison Lamp Patent - Additional Affidavits," *The Electrical World*, Vol 21, No 6, Feb 11, 1893, pp 102-104.
- 3) Incandescent Lamp Litigation, "An Injunction Granted Against the Beacon Vacuum Pump and Electrical Co. - The Goebel Claims Rejected," *The Electrical Engineer*, Vol 15, No 251, Feb 22, 1893, pp 188-192.
- 4) "The Goebel Case Revived As A Defence in St. Louis," *The Electrical Engineer*, Vol 15, No 259, Apr 19, 1893, pp 391-393.
- 5) "The Columbia Incandescent Lamp Company Case," *The Electrical World*, Vol 21, No 16, Apr 22, 1893, pp 291-296.
- 6) "Decision in the Oconto Incandescent Lamp Case," *The Electrical World*, Vol 22, No 5, Jul 29, 1893, pp 86-87.
- 7) Philip S. Dodd, Developing An Industry, The Curtis Press (Detroit), Cleveland, 1910.
- 8) Hollis L. Townsend, A History of Nela Park, 1911-1957, 1957, pg 58.

### **Various Stopper Lamps**

A review of early separable or detachable incandescent lamps was written by Dr. L.K. Böhmer (*Electrical World*, Vol XX, No 23, Dec 3, 1892, pg 356). Pictures were in that article so that one can immediately tell if a lamp design can be considered a "stopper" lamp. Lamps of Grove, Konn, Sawyer-Man, Böhmer, Maxim, Farmer, Böhmer & Fox and Westinghouse were discussed. The Westinghouse Stopper Lamp was just about to be introduced to the public when the article appeared.

Lamps in addition to those mentioned above will now be considered. These were of considerable interest about 1893, just prior to the expiration of the basic Edison patent. Some of these patented lamps might not have made it to the marketplace.

Carl K. MacFadden and John Peil of Chicago patented the lamp shown below (see *The Electrical Engineer*, Vol XVII, No 307, Mar 21, 1894, pg 259).

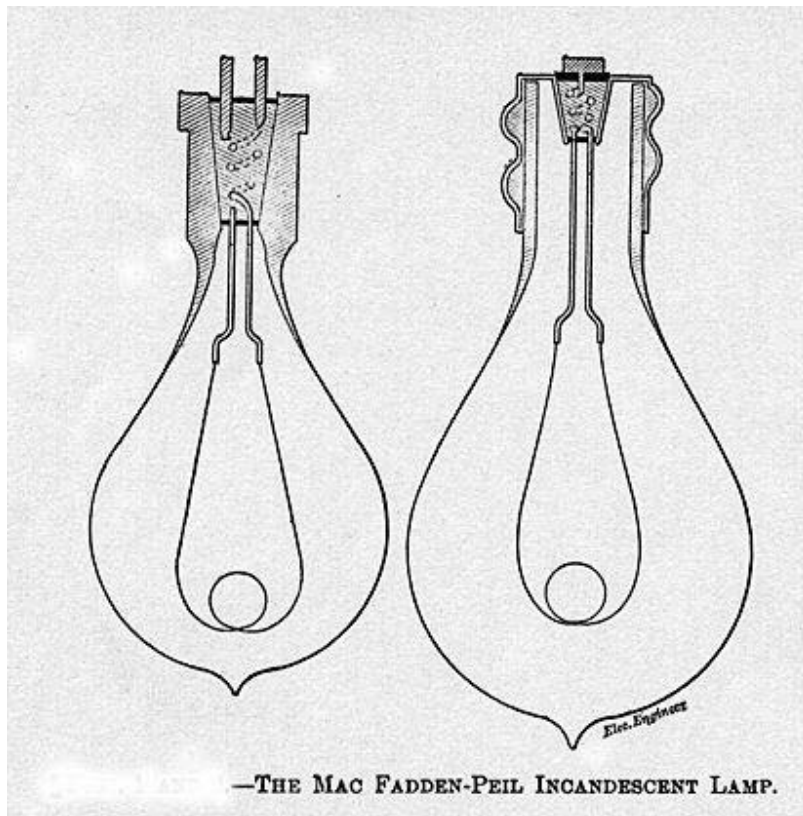

The main feature of this lamp was that it utilized "the insulating properties of a thin coat of enamel on the inleading wires which are let into the glass receiver through a metal seal around the wires." The wires were wound in a spiral form before coating to increase the length. "One terminal of the filament is the metal plug or seal, thus doing away with one of the inleading wires and simplifying the construction. After the seal is made by pouring melted alloy around the wire as it stands in place in the space to be filled by the metal seal, a small quantity of cement is poured over the top of the metal stopper, which cement soon hardens and makes a perfect seal".

Another stopper lamp (*The Electrical Engineer*, Vol XV, No 259, pg 376) was patented by Geo. H. Benjamin and assigned to Messrs. Siemens & Halske, of Berlin. The design is shown below.

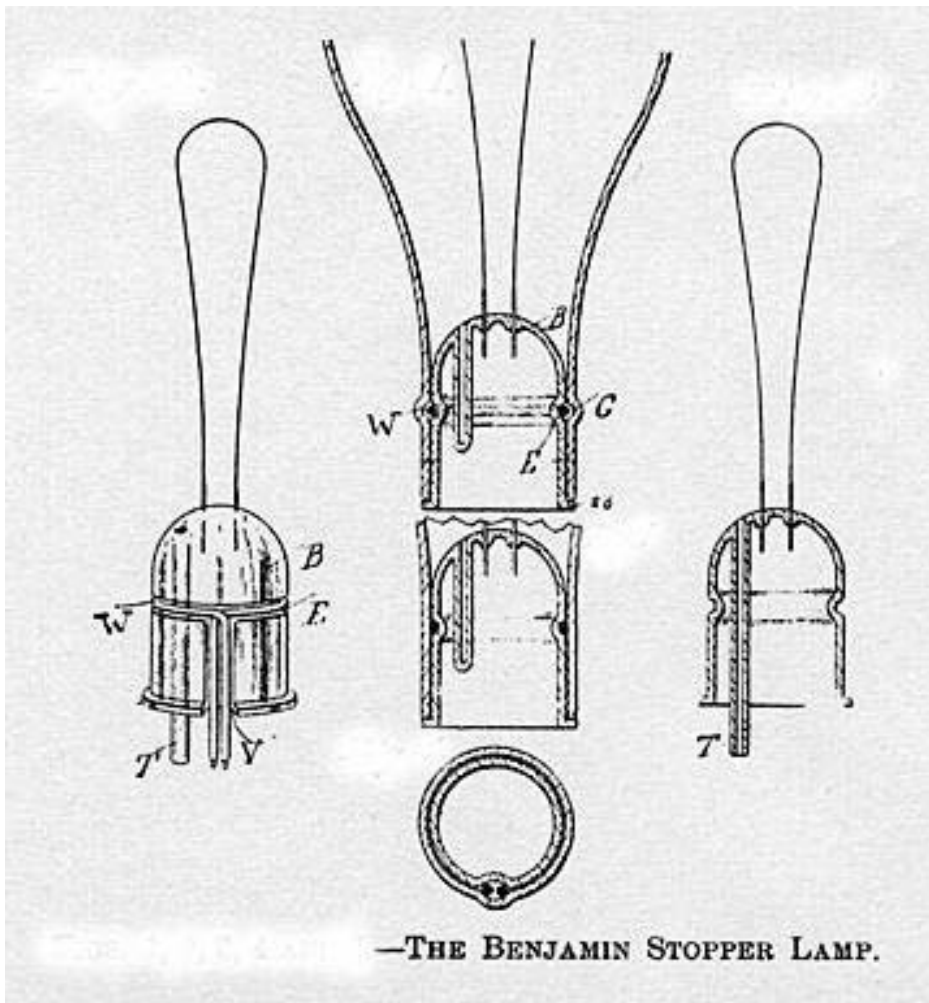

A system of grooves, along with a fine wire running through them, resulted in sealing with the aid of a carbonaceous material and compression near the grooves. The lamp was tipless, being exhausted by means of the tube T.

The lamp shown below (*The Electrical Engineer*, Vol XV, No 259, pg 376) was invented by Henry Green of Hartford, CT.

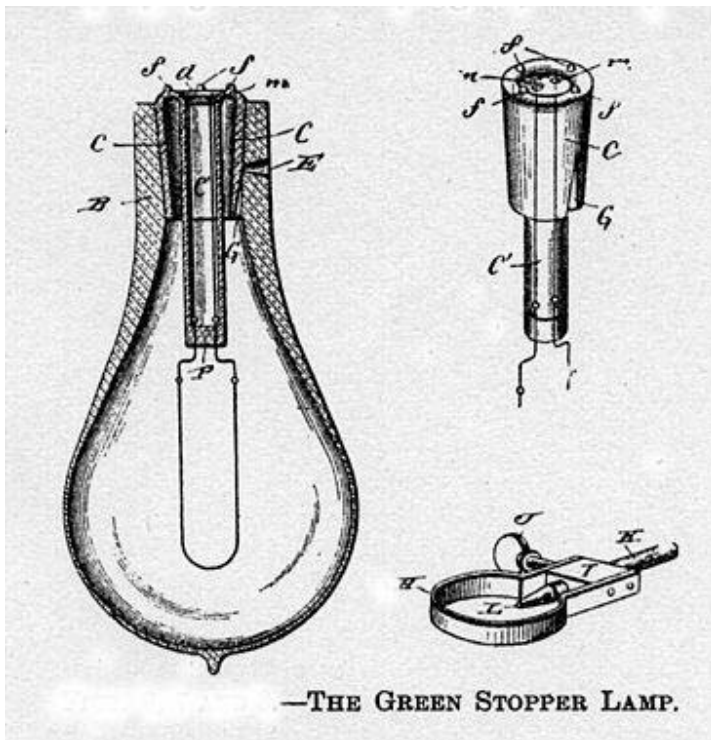

The object of this invention was "to construct a lamp in which the vacuum can be created repeatedly, the globe cleaned and the filament replaced without rendering any part of the lamp useless." ... "The clip H which encircles the outer neck of the globe is used for the purpose of securing the point L with the base piece in the funnel-shaped aperture E while exhausting the lamp."

The "New Beacon" lamp, manufactured by the Beacon Vacuum Pump and Electrical Company (see *The Electrical Engineer*, Vol XVI, No 277, Aug 23, 1893, pg 169), is a familiar one to collectors of lamps and will not be described in detail here. It is shown below.

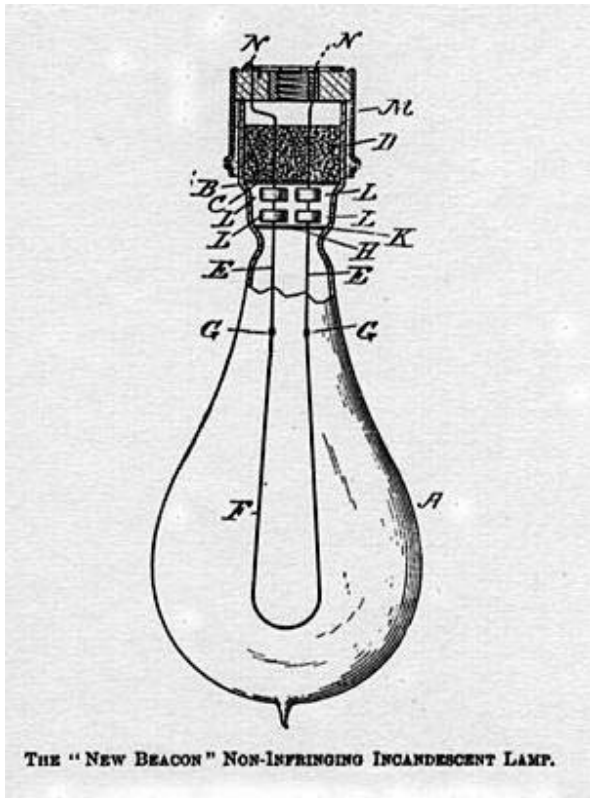

The "Maggie Murphy" had an external appearance very much like the "New Beacon". It was manufactured and sold by the Pennsylvania Electric Engineering Company, Penn Mutual Building, Philadelphia, PA (see *Electrical World*, Vol XXII, No 9, or, *The Electrical Engineer*, Vol XVI, No 276, Nov 1, 1893, pg 168). The lamp is shown below.



THE "MAGGIE MURPHY" LAMP.

The Packard Stopper Lamp ([The Electrical Engineer](#), Vol XVI, No 287, Nov 1, 1893, pg 397) resembled the New Beacon and Maggie Murphy lamps. The neck was closed by cement and mica. It was manufactured by the New York and Ohio Company, Warren, OH and is shown below.

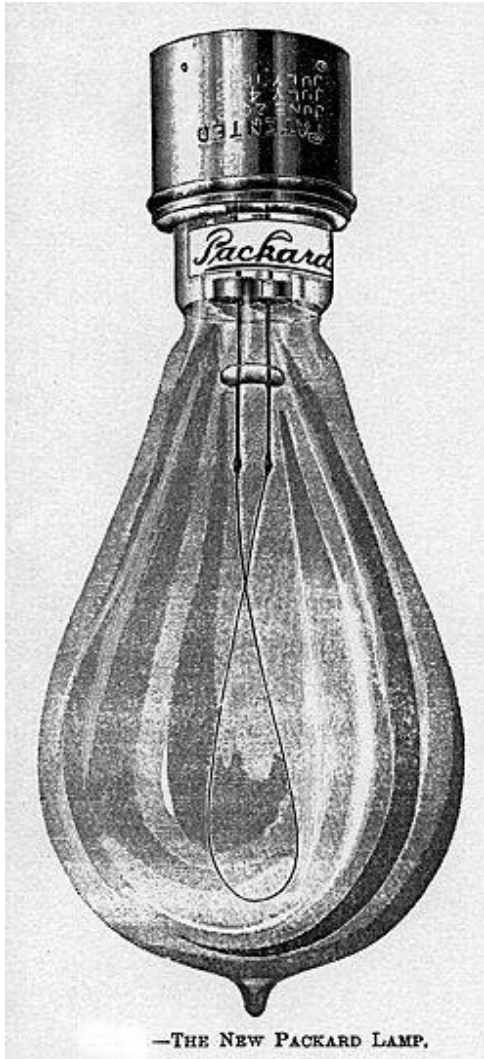

The Westinghouse Stopper Lamp is undoubtedly the most well-known of the stoppers (see *The Electrical Engineer*, Vol XV, No 248, Feb 1, 1893, pg 108). It was used at the Columbian Exposition of 1893. It is shown below.



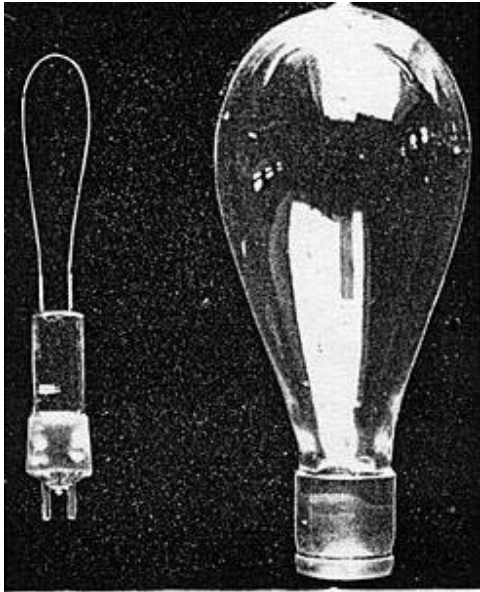

—STOPPER AND BULB OF NEW WESTINGHOUSE LAMP.

### **A Tubular Westinghouse Stopper Lamp**

The only Westinghouse Stopper Lamps seen by this writer have had bulbous envelopes. A lamp with a different shaped envelope is mentioned here for the benefit of those web site viewers who also have that experience. A Letter to the Editor appeared in the *Electrical World* on Nov 21, 1914 (Vol 64, No 21, pg 1012) in which a photograph was shown of a Stopper Lamp with a tubular envelope as well as the bulbous one. A scanned picture of that photograph is given below.

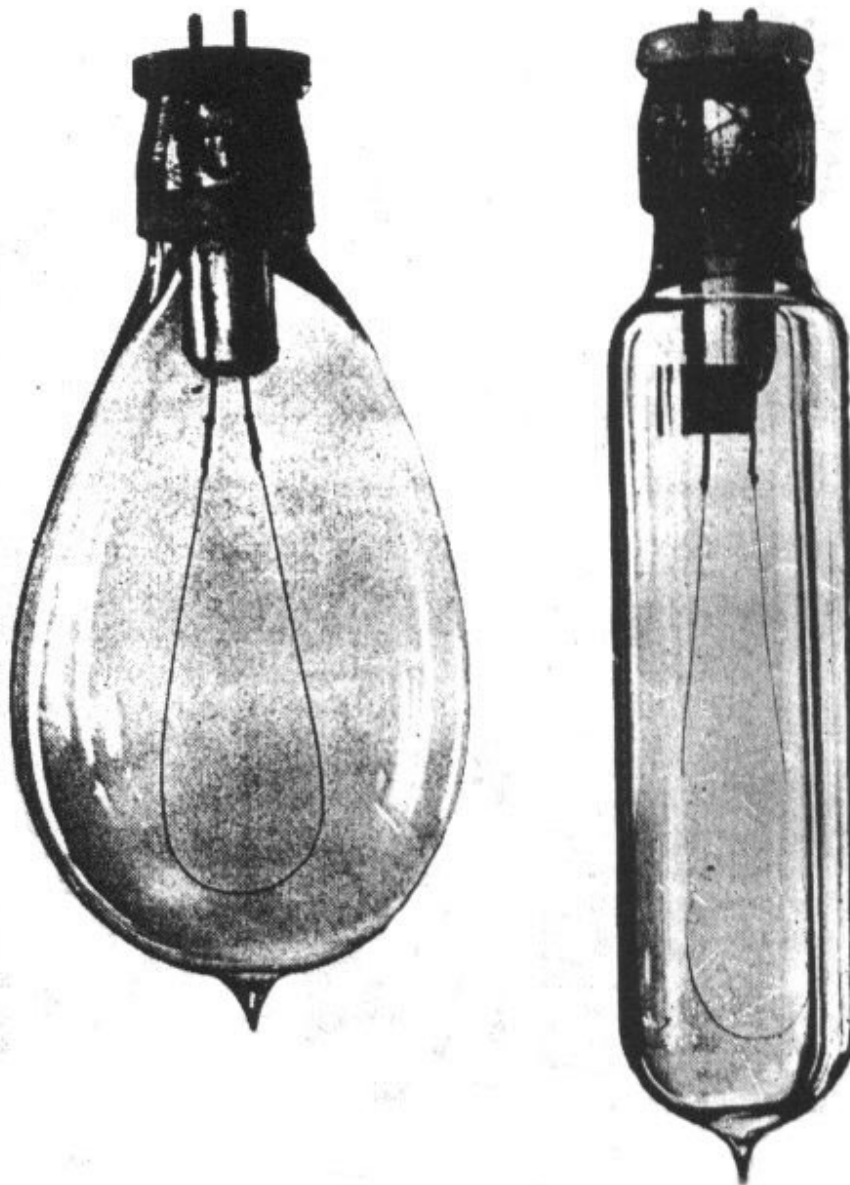

WESTINGHOUSE "STOPPER" LAMPS OF THE KIND USED AT  
THE CHICAGO EXPOSITION OF 1893

These two Stopper lamps had been in the archives of the law firm of Sheffield, Bently, & Betts. They had been submitted by the Westinghouse Company in 1892 for the purpose of determining whether or not the designs infringed on the Edison patent No 223,898. It is not known if the Stopper lamp was actually manufactured with a tubular envelope or whether this lamp was simply a "one-of-a-kind" sample. **Low Voltage Westinghouse Stopper Lamps**

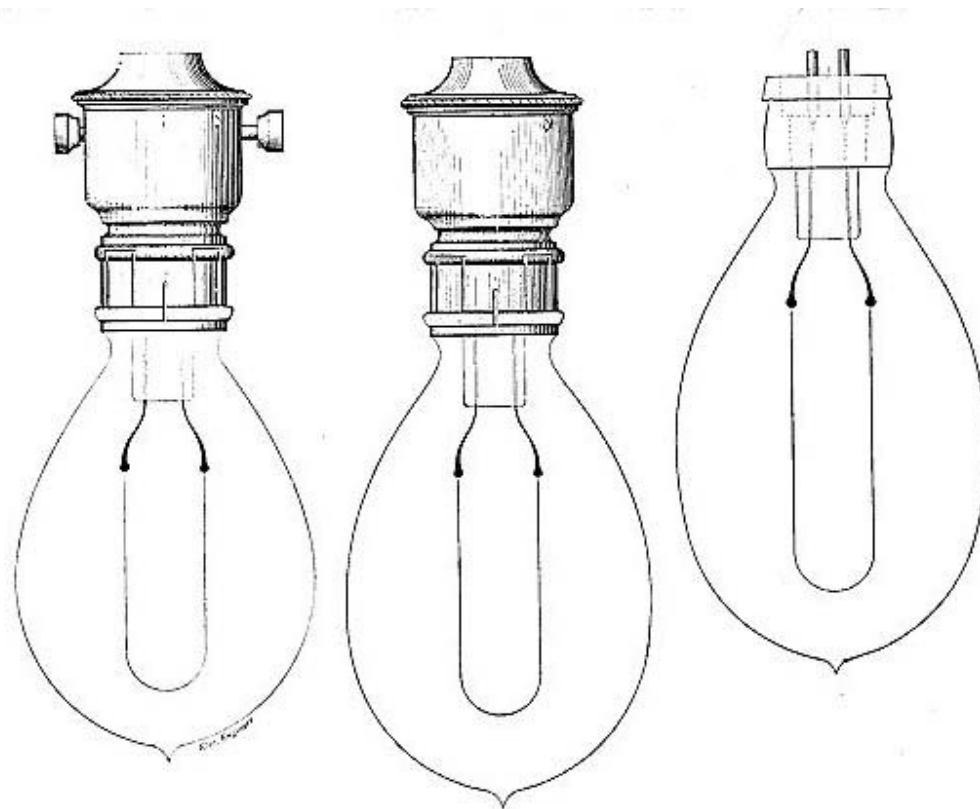

In order to have better light distribution in a room, the Westinghouse Company decided that more lamps would contribute towards that end and they decided to manufacture low voltage lamps. They accomplished this by utilizing the Stopper Lamp design that was introduced in May of 1893 at the Columbian Exposition in Chicago. Shown above are three drawings of lamps as scanned from *The Electrical Engineer*, Vol XVI, No 295, Dec 27, 1893, pg 547. At the left is a 20 c.p., 37-volt lamp with key socket, at the center is a 25 c.p., 37-volt lamp with a keyless socket, and at the right is a 32 c.p., 37-volt lamp without socket or base. Three such lamps could be operated in series on 110-volt circuits, resulting in higher overall efficacy when compared with higher voltage lamps. The list price for such a lamp was 25 cents in January of 1894.

### **Adapters for Westinghouse Stopper Lamps**

The Westinghouse Stopper Lamp came into being for the World's Columbian Exhibition in 1893. The electrical contact end consisted of stout iron leads that emerged from a solid glass plug. A common base for the lamp was that known as the Sawyer-Man or Westinghouse. It simply pushed onto the lamp end and was held by friction. There were other bases that were manufactured for those customers who had different types of sockets. Five base types were displayed in an article in the *Electrical Review*, Vol 25, No 3, Jul 18, 1894, pp 26-27. These were the Westinghouse, United States, Edison, Thomson-Houston and the Brush-Swan.

## **Trademarks**

A trademark section is included here for those who might have some interest in the subject. In 1905 an act was passed (Fifty-Eighth Congress, Session III, Chapter 592, February 20, 1905) that required a notation to the effect that a trademark was registered at the U. S. Patent Office. Some trademarks that were still in use were registered again. The following list is not comprehensive.

The trademark information is given in the following order:

**Trademark No., Date of Registration, Company or Individual, First Used, Essential Features.**

18,931, Feb. 3, 1891, The Sunbeam Incandescent Lamp Company (Chicago, IL), Feb 1, 1890, The word "SUNBEAM".  
The first page of this trademark is shown below.

TRADE-MARK.

THE SUNBEAM INCANDESCENT LAMP  
COMPANY.

INCANDESCENT ELECTRIC LAMPS.

No. 18,931.

Registered Feb. 3, 1891.

*fig. 1.*

**SUNBEAM**

*fig. 2.*



*fig. 3.*



*Witnesses.*

*Charles S. Chapman*

*Francis W. Day*

*The Sunbeam Incandescent Lamp Company*

*Francis W. Parker*  
*Attorney*

22,412, Jan 31, 1893, Electric Manufacturing Company (Oconto, WI), Aug 1, 1892, The word "BRILLIANT" and the representation of a jewel with rays radiating therefrom and three incandescent lamps mounted upon it.



23,365, Jul 11, 1893, The Edison & Swan United Electric Light Company Limited (London, England), 1884, The word "Ediswan".

27,363, Nov 26, 1895, The Perkins Electric Switch Manufacturing Company (London, England), Jul 14, 1895, The representation of a box divided into compartments and containing electrical appliances, together with the word "PERKINS".



27,715, Jan 28, 1896, New York & Ohio Company (Warren, OH), Dec 1, 1894, The compound word "TWIN-CITY".

28,370, Jun 9, 1896, Charles G. Perkins, Jan 1, 1885, A pictorial representation of an incandescent electric lamp arranged horizontally, with the word "PERKINS" above it.



28,402, Jun 16, 1896, The Edison & Swan United Electric Light Company Limited (London, England), Feb 1884, The words "The Edison-Swan".



28,571, Jul 7, 1896, The Edison & Swan United Electric Light Company Limited (London, England), Sep 1882, A representation of an electric incandescent lamp having printed within the circular outline of the bulb the words "THE SWAN UNITED ELECTRIC LIGHT CO.LD".

33,952, Dec 26, 1899, J. C. Stearns & Co., Nov 10, 1899, The compound word "PAN-AMERICA".

37,162, Oct 1, 1901, William J. Phelps (Detroit, MI), Sep 1, 1900, The word "HYLO".

38,697, Jul 29, 1902, Bryan-Marsh Co. (N. Y., N. Y.), 1894, The pictorial representation of a crown, which has a Maltese cross thereon.

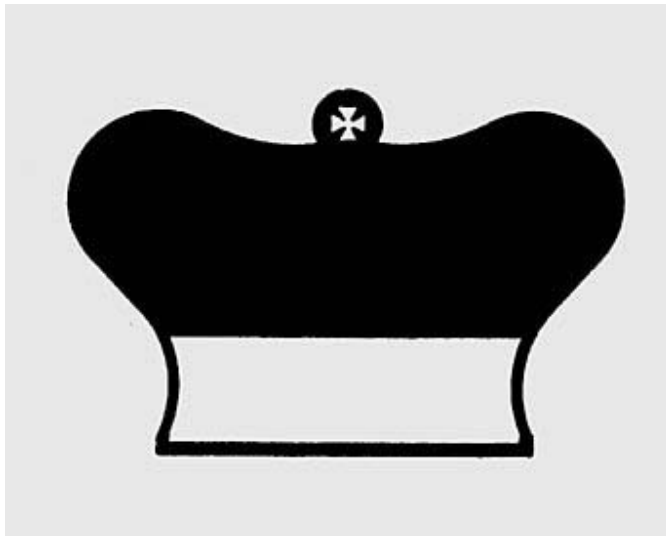

38,698, Jul 29, 1902, Bryan-Marsh Co. (N. Y., N. Y.), 1894, The word "IMPERIAL".

38,779, Aug 12, 1902, Buckeye Electric Co. (Cleveland, OH), Dec 1901, The pictorial representation of the head of a buck enclosed within a circular band, over and beyond which antlers extend.



38,780, Aug 12, 1902, The Columbia Incandescent Lamp Co. (St. Louis, MO), Apr 17, 1901, The symbol "W./C. P." surrounded by the letter "C", which is made to form about three-fourths of a circle.



38,781, Aug 12, 1902, Fostoria Incandescent Lamp Co. (Fostoria, OH), Dec 1901, The monogram "FIL" inclosed within the letter "C", which is made to form about three-fourths of a circle.





38,782, Aug 12, 1902, Sunbeam Incandescent Lamp Co. (N. Y., N. Y.), Dec 1901, A band of the shape of the letter "S", back of the middle portion of which and partly covered thereby is the pictorial representation of the sun with beams radiating therefrom.



38,825, Aug 19, 1902, National Electric Lamp Co. (Cleveland, OH), Jun 1901, The word "NATIONAL".

39,855, Feb 24, 1903, The Norden-Bittner Co. (N. Y., N. Y.), Oct 1902, The word "NORBITT".

39,944, Mar 17, 1903, Independent Incandescent Lamp Co. (St. Louis, MO), Dec 10, 1902, The word "INDEPENDENT".

40,227, Apr 28, 1903, Pettingell-Andrews Co. (Boston, MA), Jan 1, 1898, The letters "O. K.".

40,324, May 12, 1903, J. H. Bunnell & Co. (N. Y., N. Y.), Jul 16, 1902, The word "SUNSHINE".



41,343, Oct 20, 1903, Bryan-Marsh Co. (N. Y., N. Y.), Nov 1899, The words "ARMY AND NAVY" on a field consisting of three parallel bars colored red, white, and blue, respectively.



41,456, Nov 10, 1903, W. D. & J. W. Packard (Warren, OH), May 1, 1903, The word "ZENITH".

43,301, Sep 6, 1904, The Standard Electrical Mfg. Co. (Niles, OH), Jul 1, 1902, The representation of a star.

44,037, Jan 24, 1905, James C. Wormley (N. Y., N. Y.), Oct 1903, The word "DOWNWARD".

-----  
---  
Act                    of                    February                    20,                    1905  
-----  
---

49,034, Jan 23, 1906, The Columbia Incandescent Lamp Co. (St. Louis, MO), 1895, The word "COLUMBIA" The word in interchangeable gothic type, black-faced.

52,320, May 8, 1906, The Edison & Swan United Electric Light Co. Limited, □ , The word "Ediswan".

52,620, May 15, 1906, The Edison & Swan United Electric Light Co. Limited (London, England), □ , The word "THE" and the hyphenated words "EDISON-SWAN" in capital letters inclosed within quotation-marks, the usual straight lines of said letters being somewhat curved, each letter consisting of a dark part with a shading on the right hand and below the lower portion of the letter, all said letters having their tops inclined toward the left.

52,621, May 15, 1906, The Edison & Swan United Electric Light Co. Limited (London, England), □ , The representation of an electric incandescent lamp having arranged in a circular manner within the outline of the bulb and conforming to said outline the words "THE SWAN UNITED ELECTRIC LIGHT CO. LD".

□, Jan 22, 1907, Buckeye Electric Co. (Cleveland, OH), □, Head of Buck and word "Buckeye"--The word "Buckeye" in interchangeable gothic black-faced type passing through the antlers of the representation of a buck's head.

□, Jan 22, 1907, Shelby Electric Co. (Shelby, OH), □, "Equality" □ The word in script, the letter E being capital.



□, Jan 29, 1907, General Incandescent Lamp Co. (Cleveland, OH), □, "G. I.", The two capital letters in interchangeable gothic black-faced type with a period after the G and a period after the I.

□, Feb 12, 1907, Shelby Electric Co. (Shelby, OH), □, "Shelbright" □ The word in antique type, the letter S being capital.

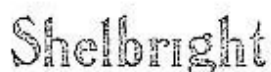

□, Mar 26, 1907, Sterling Electric and Mfg. Co. (Warren, OH), □, "Jack-O-Lantern"□The two words and the letter in open-faced type with hyphens between the letters K and O and L.

□, Mar 26, 1907, General Incandescent Lamp Co. (Cleveland, OH), □, "G. I. Zodiac"□The letters and word, being the same as in the trade mark G. I. and the word Zodiac being in interchangeable gothic black-faced type and placed beneath the letters.

□, Mar 26, 1907, Sterling Electric and Mfg. Co. (Warren, OH),□, "Fairy Lights"□The words, the letters being script but having no connection with each other, the letters F and L being capitals.

□, Apr 16, 1907, Sunbeam Incandescent Lamp Co. (N. Y., N. Y.), □, "Regal"□The word in white or uncolored letters on a black or colored elliptical background which has scroll work at its upper left and lower right-hand ends.

□, Apr 14, 1908, Boston Incandescent Lamp Co. (Danvers, MA), □, Boston□A trade mark consisting of an oblong figure in which is enclosed an uncolored ellipse.

□, May 12, 1908, The Tungsten Electric Lamp Co. (Cleveland, OH), □, "TELCo"□The three capital letters and the abbreviation written in fancy script and connected.

□, Jun 9, 1908, Sunbeam Incandescent Lamp Co. (Chicago and New York), "Sunburst" and Sun's rays□A background with the word "Sunburst" inscribed upon it, the letters of the word being plain uncolored, the first S of the word being larger than the other letters, and representations of the rays of the sun emanating from the top of the background.

□, Jul 28, 1908, Buckeye Electric Co. (Cleveland, OH), Buckeye□The representation of the head of a buck.

□, Aug 4, 1908, Banner Electric Co. (Youngstown, OH), □, Shield and word "Banner"□The word "Banner" inscribed upon a strip which extends from the lower left to the upper right-hand corner of a shield, the color of the shield being red.

□, Aug 11, 1908, Sunbeam Incandescent Lamp Co. (Chicago and New York), "Sunbeam"□The word in plain black-faced type.

□, Sep 22, 1908, Sunbeam Incandescent Lamp Co. (Chicago and New York), "Sunbeam" and Sun's Rays□The word "Sunbeam" in plain black-faced type placed upon a panel which has lines passing vertically across it,





















and above the upper half of which radiate lines representing the rays of the sun, the panel and Sun's rays being red.

77,779, May 3, 1910, General Electric Co., Dec 21, 1909, The word "MAZDA".

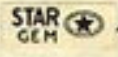
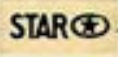
Go to: [Early Incandescent Lamps](#)

### Trademark Labels of Some Companies in 1914

FOR SALES DIVISION	LARGE MAZDA	MINIATURE MAZDA	GEM	CARBON
Bryan Marsh				
Columbia				
Sunbeam				
Buckeye				
Fostoria				
Shelby				
Banner				
Gen. Inc.				
Peerless				
Colonial				
Packard				
Sterling				
Brilliant				

FOR SALES DIVISION	LARGE MAZDA	MINIATURE MAZDA	GEM	CARBON
American				
Monarch				
Munder				
Standard				
Federal				
Elux				
Hylo				
Zokul				

Sunbeam



Mazda



Gem



Carbon

Boston-Economy (Refilled Lamps)



Nela (For lamps on orders from The Nela Specialties Division)



### Labels of the National Electric Lamp Association

The National Electric Lamp Association was a holding company that consisted of many companies whose labels are well known. The organization did have the facilities to manufacture lamps although that was not a major activity of the organization. The Cleveland based organization carried the name "National Electric Lamp Association" from 1906 to 1911. Two lamps are in the writer's collection that carry "NELA" labels. The first has "National MAZDA" etched on the bulb, has a crinkled wire filament, and one of two labels that states: 110 watts, 115-113-111 volts. The main label (5/8-inch diameter) states that it was from the N.E.L.A. Engineering Department. It is shown directly below.



The second lamp has "National MAZDA GE" etched on the bulb, has a straight wire filament and contains a getter on both spider supports. One label indicates that the lamp is

rated at 10 watts and 32 volts. The bulb is round. The main NELA label (9/16-inch diameter) states: National Electric Lamp Association, Cooperation, Progress, Quality; it is shown directly below.



### **GEM (General Electric Metallized) Lamp Labels**

In Jan 1907, GEM lamps began to show three voltage values on the label. A "generic" form showing the information on the label is displayed directly below. On that label the name of the manufacturing company was inserted in place of the asterisk. Seven examples of that label are given below the generic form.



50  
WATT  
\*  
GEM  
14  
12  
10 V

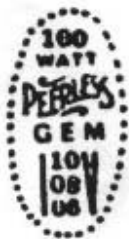

120 Volt  
Top Voltage



120 Volt  
Middle Voltage



120 Volt  
Bottom Voltage

On May 1, 1910 lamp rating by candlepower was dropped entirely and lamp watts were specified. At that time two labels began to be used. One gave the wattage on top and the three voltage values below. Another label gave the manufacturers name. In 1910 similar labels were used on MAZDA lamps with sintered tungsten filaments. **MAZDA Bulb Markings**

Early incandescent lamps often had paper labels on them that could easily fall off, making identification of the manufacturer difficult. George Reynolds Brown has spent some time studying the bulb markings of MAZDA lamps that resulted either from sand blasting or acid etching. With his permission the following observations are being presented for the readers benefit. In a letter to the writer Mr. Brown sent a copy of some markings he has observed. It's of interest first to tell how those images were obtained.

Mr. Brown lifts an etching from a lamp by rubbing it with a No. 2 pencil and then placing a piece of clear tape over the rubbing. He then removes the tape and places it on a sheet of paper. He therefore ends up with a rather good representation of the etching. A copy of etchings taken by Mr. Brown follows.

1. MAZDA

2. EDISON  
MAZDA

NATIONAL  
MAZDA

3. EDISON  
MAZDA  

NATIONAL  
MAZDA  

4. 

NATIONAL  
MAZDA  

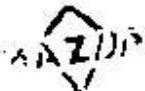
5. 

6. 

WARDNER  
MAZDA  

The reader is reminded that the term MAZDA was adopted in December of 1909. The MAZDA lamp first appeared in the marketplace January 1, 1910.

The etching No. 1 was the first used. In other etchings both the Edison and National designs are shown. National became part of the General Electric Company in 1911. Westinghouse was granted the use of the word MAZDA in a licensing agreement in 1912; some Westinghouse etchings can be seen in No. 6. The Franklin Electric Manufacturing Company was also allowed to use the name occasionally. One of the Franklin labels (FEMCO) had the shape of a kite. Thus, the etching No. 5 can be seen to be that of a Franklin MAZDA, where the "kite" encircles the Z in the word MAZDA.

### Labels Used on Lamps Shipped to Brazil



In 1920, in special situations, lamps that were shipped to Brazil carried extra labels. The (GE) EDISON GLORIANA label was used on Orange Tinted lamps, whereas the (GE) EDISON LUZOPAL label was used on White lamps. One such Luzopal lamp had a rating of 110 volts and 50 watts.



The diameter of the labels was about 1/2-inch.

### The GE Monogram



A lamp manufactured in 1910 was found to have the GE monogram etched on the outside of the bulb. This makes one wonder when the GE monogram was first used. The origin of the monogram is uncertain but company records show that it was first used on an electric ceiling fan in late 1898. Patent office records show that the trademark was registered on Sep 18, 1900; the application had been filed a year earlier. **Three-Voltage Rating of Lamps**

New lamp ratings were adopted on May 1, 1910 by the Incandescent Lamp Manufacturers. At that time the candlepower basis of rating was entirely abandoned and a wattage system adopted. At the same time commonly used lamps for the standard voltages of 110 to 125 volts had three voltage values placed on their labels. Gem, tantalum and MAZDA were always rated by watts. However, in 1910 the carbon filament lamp also began to be rated by wattage. Earlier (about 1907) the three voltage rating had been adopted for the Gem and MAZDA lamps. Now all lamps were to be so rated. A common label had the shape of a

vertically oriented ellipse. At the top the value of the lamp watts was given. Below that were three voltage values, each differing by two volts. These voltages were known as "top", "middle" and "bottom." The top voltage was usually emphasized (larger and bolder) because the user would obtain the best results and service from the lamp at that voltage.

**Labels Used on Manufacturer's Lamps**

In the early days of lamp manufacture more than one label was sometimes used on a given design. The following constitutes a list of such labels used. The list was found originally in the year 1914 when a desk was being cleaned out. It has managed to survive to this day. Of course, since the origin of the list is unknown there is no certainty of the accuracy of the contents. The following is the list found.

<b>American</b>	<b>Inc.</b>	<b>Lamp</b>	<b>Co.,</b>	York,	PA,	Class	B
A;			New-Type				Planet
<b>Banner</b>	<b>Electric</b>	<b>Co.,</b>	Youngstown,	OH,	Class	B	
Banner;	Comet;	Universal;	S?C?&H.	CO.;			Ideal
<b>Brilliant</b>	<b>Electric</b>	<b>Co.,</b>	Cleveland,	OH,	Class	B	
Universal;	Excelsior;	Commercial;	A & W;	Devere;	Downward Light;	Side Light;	
Economical							
<b>Buckeye</b>	<b>Electric</b>	<b>Co.,</b>	Cleveland,	OH,	Class	A	
Buckeye							
<b>Buckeye</b>	<b>Electric</b>	<b>Co.,</b>	Cleveland,	OH,	Class	B	
New Royal;	M. E. S.;	Tafel;	Pansy;	Erner-Hopkins;	Jenkintown Lt. Co.;	Merchants' E. L. & P.	Co.
<b>Bryan-Marsh</b>	<b>Co.,</b>	New	York,	NY,	Class	A	
Imperial							
<b>Bryan-Marsh</b>	<b>Co.,</b>	New	York,	NY,	Class	B	
Army	&	Navy;	E.	C.;			Franklin
<b>Capital</b>	<b>Electric</b>	<b>Co.,</b>	Denver,	CO,	Class	A	
Capital;			Type				R
<b>Capital</b>	<b>Electric</b>	<b>Co.,</b>	Denver,	CO,	Class	B	
Excelsior;	N. E. Electric Co.;	Meco;	Hall;	Falco;	Inter-Mt. Elec. Co.;	Western;	Steen & Burford;
							Seroco
<b>Colonial</b>	<b>Electric</b>	<b>Co.,</b>	Ravenna,	OH,	Class	B	
Colonial;	Orient;	B & W;	Apex;	I. H. L.;	Newco;	Toledo Htg. & Ltg Co.;	National Elec. Co.
<b>Columbia</b>	<b>Inc.</b>	<b>Lamp</b>	<b>Co.,</b>	St. Louis,	MO,	Class	A
Columbia;	Pyle	National		Elec.	Headlight		Co.
<b>Downward</b>	<b>Lt. Electric</b>	<b>Co.,</b>	New York,	NY,	Class	B	
Downward		Light;		Side			light
<b>Franklin</b>	<b>Electric</b>	<b>Mfg. Co.,</b>	Hartford,	CT,	Class	B	
Femco;	Manhattan;	Neco;	Aurora;	P. H. & R.;	R. E. Co.;	J. M. F. Co.;	Holloway, Bentz Elec. Co.;
	C. M. Angier & Co.;	C. S. Knowles;	L. & L.;	Climax;	Lawrence-Hall Elec. Co.;	Burnet Company;	Seth W. Fuller & Co.;
					DeWitt Elec. Co.;	Newport;	Eagle
<b>Fostoria,</b>	Fostoria,		OH,		Class	B	
Fostoria;	Radium;	Rumsey;	B. G. & E. Co.;	Electric & Water Co.			
<b>General</b>	<b>Electric,</b>	Harrison,	NJ,		Class	A	
G.							E.

**General Inc. Lamp Co.,** Cleveland, OH, Class B  
 G. I.; M. S. E. Co.; Scott

**Gilmore Electric Co.,** Boston, MA, Class B  
 110V Gilmore Elec. Co. 10 C. P.; New Type Gilmore; Gilmore Elec. Co.; Gilmore Reflector; Gilmore Street Series Lamp; 110V Our Own 16 C. P.; New Boston; Boylston; New Type Planet; Sunshine; Gilmore Special; Capitol; University; C. S. Knowles; Central Mfg. Co.; Pioneer; Atlas; Acme; Hardy; Consolidated; J. W. Poole; Gannett

**Independent Inc. Lamp Co.,** Cleveland, OH, Class B  
 Independent; Refulgent; Volta; Ideal

**Liberty Elec. Mfg. Co.,** Pittsburgh, PA, Class B  
 Liberty

**Monarch Elec. Mfg. Co.,** Warren, OH,  
 Monarch

**Munder Electric Co.,** Springfield, MA, Class A  
 Crescent

**Munder Electric Co.,** Springfield, MA, Class B  
 Munder; Brilliant; Acme; Ohio; Novelty Sign Co.; Union; C. F. L. & Co.; (Maltese Cross in six styles - O.K.; Victor; A. G. T. Co.; D. E. W.; R. E. Co.; V); B & W; New England; Eastern; Malden; Solar; New Lynn; O; Economics; Apex; J. M. Z.; Pioneer; K. S. Elec. Co.; Ostrander

**New York & Ohio Co.,** Warren, OH, Class A  
 Packard

**New York & Ohio Co.,** Warren, OH, Class B  
 Warren

**Standard Elec. Mfg. Co.,** Niles, OH, Class b  
 The Chicago; St. Louis; A A1; H. I. Wood; S; Victory; Diamond; Bills & Son; Wingate & Brooks; Kern Valley Elec. Co.; Sunshine; Overton; Star

**Sterling Elec. Mfg. Co.,** Warren, OH, Class B  
 Sterling; Sterling Special; Regent; Triple State; Meco; Excelsior; Factory; Patterson; McIntosh Hdw. Co.; Electra Spec.; U-U.S.A.-A; K. S. Electric Co.; Hollings; D. H. Elec. Co

**Shelby Electric Co.,** Shelby, OH, Class A  
 Shelby, Shelby Tipless; Perfection; Shelbright; Useful Light; Anchor

**Shelby Electric Co.,** Shelby, OH, Class B  
 Ray; Ray Tipless; Equality; Equality Tipless; Satisfaction; Equalight; Ideal; Robertson; Mercury; McDonald & Dumond; Duke; Sunshine; Bluegrass; I E C O; E. S. Co.; S. E. L. Co.

**Sunbeam Inc. Lamp Co.,** Chicago, IL, Class A  
 Sunbeam; Sunburst

**Sunbeam Inc. Lamp Co.,** Chicago, IL, Class B  
 Regal; A. S. & W. Co.; Independent; S. L. & S.; M. H. & L. Co.; Floradora; E line

**Tipless Lamp Co.,** New York, NY  
 Tipless

**Warren Electric Co.,** Warren, OH, Class B  
 Peerless, America; Creaghead; Sirius; Cincinnati; Duquesne; Eldridge; Hetty Electrical Works; H. I. S.; Kauffmann Bros.; H. I. Wood; Ostrander; O. K.; D. H. E.; Tomkins; Guy Carleton, Jr.; Hewitt; Sands

**United States Incandescent Lamp Company**, St. Louis, MO, Class B  
Alabama Supply Co.; Webb-Freyschlag Merc. Co.; Acme Elec. Co.; Lipscomb Elec. Co.; J. B. Sholes; D. H. E. Co.; Homestead Gas & Elec. Sup. Co.; Cosgrave Bros.; Biwabik Hdw. Co.; Manhattan; Ellis & Chamberlain; 16 United Elec. Co.; National; E. H. Abadie & Co.; Metropolitan; Marshal-Wells Hdw. Co.; Jno. L. Martin; C. E. Co., Ltd.; J. E. Atkinson; Scranton Sup. & Mach. Co.; A. & W.; Shely; The America; Eclipse; Decatur P. & H. Co.; Farrell & Beard; Jones & Yount; Meriden C. E. E. Co.; Swan; Dawson; P. E. L. & P. Co.; "Sunlight"; Wolfe-Lovett Elec. Co.; Snider Elec. Co.; Thomas; Capital City; Commercial; Series Burning; Bruce Electric Co.; Scott Bros. Electric Co.; Bound Electric Co.; E. M. Henry & Co.; C. Lovejoy; "8 Commercial 110"; Milner & Kettig Co.; W. E. S. Co.; Peoples Gas Fixture Co.; Rovse & Batley; L. P. Co.; L. L. I. & P. Co.; Ben F. Barbour Plg. & Elec. Co.; "Piasa"; 32 C. P. S-R 110V; C. E. Co.; Kane; Hig=alm; "Hurlburt-Still Elec. Co.; W. & K.; Ridgway Elec.Co.; Hodge-Walsh E. E. Co.; Dunseath; F. P. Sweet; Mafacola; James Brown & Son; J. McElroy; American Electric Co.; A. N. Palmer & Co.; W. T. Osborn & Co.; Holt Electric Co.; Fulton; King Elec.Co.; Empire; A. C. Wolfram E. Co.; E. M. Reed & Co.; Geo. R. Mathieu; Cramer & Rosenthal; Sterling; Her-Law; Knoxville Electric Co.; Reliable; D. W. Watson's Sons Co.; Laclede Power Co.; Equitable; Carondelet E. L. & P. Co.; Tenk Hdw. Co.; Max Huhle; E. B. Latham & Co.; Perfection; H. I. Wood; Stimple & Ward Co.; Roberts & Sticht; Emil Grah; Warner Electric Co.; Rumsey; "Premier"; Garrett & Miller & Co.; B-R E. Ec. Co.; Novelty Elec. Co.; Jas. Clark, Jr. & Co.; Almstead-Gough; Haas; Elec. Lt. & Railway Equip. Co.; Enness; Union E. L. & P. Co.; Kraushaar, St. Louis; Charles B. Scott; H. C. Tafel; E. G. Bernard Co.; Dixie; Waco Elec. Sup. & Plg. Co.; Northwest Fixture Co.; Consolidated; Columbian Elec. Co.; A. L. Gould; H. Sandmeyer & Co.; Wyo. Electrical Co.; Yoakum Improvement Co.; D. M. Henkel Co.; Excelsior Elec. Co.; G. E. M. Co.; Diffenderffer-McBride; Electric Construction Co.; Atlas; Runnell Tel. & Elec. Co.; L. F. Grammes & Sons; 16 C. P. The Vz 104 V; Brig Ballantyne; Elec. Construction & Supply Co.; 16 C. P. Edison B. 104 v.; W. R. Ostrander & Co.; Burton Bros.; Cunningham Hdw. Co.; Henry Garrett; Tower, Binford Elec. & Mfg. Co.; Emco; Watts & Uthoff; Seidler-Miner Elec. Co.; Van Nort Bros. E. Co.; Biltmore; Eastern Elec. Supply Co.; Allen-Edmunson Hardware Co.; Wisconsin Elec. Const. Co.; Meysenburg; Southern Elec. Co.; Chesapeake Elec. Sup. Co.; Stanley & Patterson; Brown & Miller; Barnes & Payton; Nowotny's; Tri-City Elec. Co.; Risdon Electric Co.; L. R. Clark & Co.; "Dixie" Mosley Electric Co.; Northwestern; Cotton States B. & S. Co.; Greene Elec. Co.; Jno. R. Galloway; M-D., Rochester, N. Y.; "U. S."; B. Jordan; Barney-Cavanagh Hdw. Co.; Missouri-Edison Elec. Co.; U. S. Inc. Lamp Co.; H. C. Pernot; B. & O. Elec. Co.; Mercantile; W. L. Milner & Co.; Peaslee-Gaulbert Company; Monogram Lamp; C. E. Wheelock & Co.; Scott Bros. Electric Co.; Montana Elec. Co.; Lowe & Leveridge; Thos. Deaderick L. Co.; Scranton Sup. & Mach. Co.; R. & S.; Illinois; Western Electrical Company; B. B. Omaha; Branthoover & Johnson Co.; Lucas; Ajax; E. Thayer; Buchanan; Elmira Elec. Works; Majestic; E. M. C.; Erner-Hopkins Co.

### **Dating Edison Lamps, 1880-1905**

The identification and dating of lamps is an arduous task for the lamp collector. The task is especially difficult because there are few reference sources available that make the task easy. Undoubtedly the greatest effort expended by collectors deals with the lamps made by the various Edison companies. These lamps will be referred to here as simply "Edison" lamps. Fortunately there are a couple of books that were written by Edison employees in

which descriptions of lamps are given. Although these are good references it is difficult to quickly identify and date a lamp with them. Additional information, perhaps gathered by collectors, is needed to make the task easier. What is needed are references that give desired information about the development of the various parts as well as the manufacturing steps. Some of the known references that are available are:

- 1) History of Electric Light, Henry Schroeder, Smithsonian Miscellaneous Collections, Vol 76, No 2, Aug 15, 1923.
- 2) The History of the Incandescent Lamp, John W. Howell and Henry Schroeder, The Maqua Company, Schenectady, NY, 1927.
- 3) Early Lighting-A Pictorial Guide, The Rushlight Club, 1979, Chapter XV, "Electric Lighting" (pp 131-136).
- 4) Lighting a Revolution, The National Museum of History and Technology, Smithsonian Institution, 1979.
- 5) "The Incandescent Lamp", G.R. Brown, *Spinning Wheel*, Vol XV, No 2, Feb 1959, pg 18.
- 6) "Incandescent Lamps", *Spinning Wheel*, Vol XVI, No 6, Jun 1960, pg 26.

Unless someone has access to Edison records it appears that many of the details of lamps that are not covered by these and other references will have to be provided by collectors who take it upon themselves to uncover these secrets. It is believed a good beginning was made about 1962 when George Reynolds Brown wrote a short paper for a collector's publication called TILCA, an acronym for The Incandescent Lamp Collectors Association. The title of his paper was "Dating Edison Lamps, 1880-1905." With the permission of Mr. Brown, the writer will convey the results of two "tables" in that paper. It should be realized that no guarantee of accuracy is given here. If additional information is available today that contradicts what is given here it will need to be included in any future descriptions.

Mr. Brown commented on the following topics: base, lead-in-wires, filament connection, bulb, stem, filament and label. Each of these topics will be considered. The writer will add comments occasionally. The lamps considered "were the standard Edison bulbs used for domestic lighting..."

Base-

Various bases were used in 1880. These were generally made of wood. From 1881 to 1884 a plaster of paris ring was used; this was referred to as the Johnson bevel ring. A short type (few turns) was used from 1884 to 1888. From 1888 to 1894 a longer base (with more turns) was used with a reduced hole for an elongated pear shaped bulb. In 1894 the reduced hole in the top was omitted. Plaster of paris used until 1899. Porcelain used in base only in



1900. Glass insulation was introduced in 1901 as in today's bulbs. Cement replaced plaster of paris as adhesive in 1901.

#### Lead-in Wires-

Platinum was used through entire seal from 1880 until 1890. The glass seal thickness was reduced in 1889. A weld was imbedded in the seal in 1890 and continued until platinum was discontinued in 1913. Siemens-like seal used briefly about 1890.

#### Filament Connection-

Clamps were used in 1880. Copper plating used from 1881 to 1886. Carbon paste used from 1886 until the carbon filament was discontinued in 1918.

#### Bulb-

Free-blown from 1-inch tubing in 1880. Short pear-shaped free-blown bulbs were used in the early 1880s until 1890. Elongated pear-shaped, free-blown bulbs from about 1890 to about 1894. Short pear-shaped bulbs hand-blown in moulds from 1894 to about 1898. Straight-sided, moulded bulbs used from about 1898 until 1918.

#### Stem-

From 1880 to 1888 there was an enlargement of the stem with the bulb fused around it. From 1888 to 1893 the bulb neck was narrow and there was no enlargement of the stem. From 1893 to about 1898 a flared stem was sealed to a larger necked bulb. From 1899 to 1918 the glass fusing was more rounded and there was not as great a depth between the stem and the bulb.

#### Filament-

From 1880 to 1886(?) bamboo in rectangular cross-section was used with enlarged ends and the filament was in hairpin shape. From 1886(?) until 1893 the filament was in hairpin shape and the cross-section was square. From 1893 to 1918 filaments were made of squirted cellulose with a round cross section. In 1893 the filament shape was hairpin; from 1894 to 1918 a looped shape was used. Lamps of 50 volts and lower continued to use bamboo filaments in hairpin shape until about 1900.

#### Label-

From 1881(?) to 1893(?) the label was rectangular. The first label read: 16c Edison's Patents. On these lamps the voltage was written on the plaster of paris in the base. The lamps from 1893(?) to 1899(?) also had rectangular labels and read: New Type Edison Lamp, 16c Patented Jan.27, 1880, OTHER EDISON PATENTS. The cellulose filaments lamps of 1893(?) to 1899(?) also had rectangular labels that read: New Type Edison Lamp, 16c Patented Jan. 14, 1881, Dec. 27, 1881, Sept. 19, 1882, OTHER PATENTS. On these

lamps the voltage was printed below C.P. during the years 1898(?) to 1899(?). From about 1899 to about 1901 a round label was used and the ratings were given: 16c/104. From about 1901 to about 1905 a horizontal ellipse label was used. One might then find: 16c/EDISON/104.

### **Images of Early lamps**

Ten images are presented below, nine of which were scanned from U.S. patents. These lamps are typical of those that individuals and museums now collect.

1) This was a turn-down lamp with a remote switch. It was patented by William J. Phelps of Detroit, MI on Jul 16, 1907; the U.S. Patent No is 860,568. Both filaments were made from carbon. The switch at the end of the cord was a lever design in some cases. After the lamp burned out the cord was removed and put onto a new lamp.

2) This lamp has a Heisler base and was patented by Gustav A. Frei of Springfield, MA. The patent, U.S. No 497,956, was granted May 23, 1893. This series-operated lamp was designed to short circuit after filament failure.

3) This lamp was one of several patented by William Emery Nickerson of Cambridge, MA and Edward Egbert Cary. It was a so-called "stopper" lamp. This drawing was scanned from U.S. Patent No 507,558, issued Oct 31, 1893. It was a design to try to avoid infringing the then existing Edison patents. The base on the lamp is that of Thomson-Houston.

4) This lamp has a "mushroom" shaped bulb and was a design of Adolphe A. Chaillet of the Shelby Electric Company in Shelby, OH. It carries the U.S. Patent No 701,295, dated Jun 3, 1902. The bulb shape, as well as the filament shape, were such to give a specific distribution of light.

5) This turndown lamp was the invention of John McCullough of Newark, NJ. The U.S. patent was issued Apr 3, 1906 and carries the number 817,146. The high-to-low light level was achieved by pulling a string through a switch mounted on the outside of the base.

6) This lamp was designed so that after the filament had burned out the restricted bulb neck could be cut and the filament replaced. It was the invention of Albert W.W. Miller of South Orange, NJ. Miller was granted U.S. Patent No 797,593 on Aug 22, 1905.

7) This is another turndown lamp invented by William J. Phelps. Instead of operating by a string, the second light level was achieved by screwing the lamp farther into the socket. It carries U.S. Patent No 814,162, issued Mar 6, 1906.

8) This drawing comes from U.S. Patent No 330,586, issued Nov 17, 1885 to Charles Heisler of St. Louis, MO. The patent covered a braided flat filament. The lamp was drawn showing a Bernstein base.

9) This is a drawing of an Edison lamp and socket of 1884.

10) U.S. Patent No 320,030 was issued on Jun 16, 1885 to Edward Weston for a lamp socket. This picture shows both a lamp and socket. A Maxim filament is shown in the lamp.

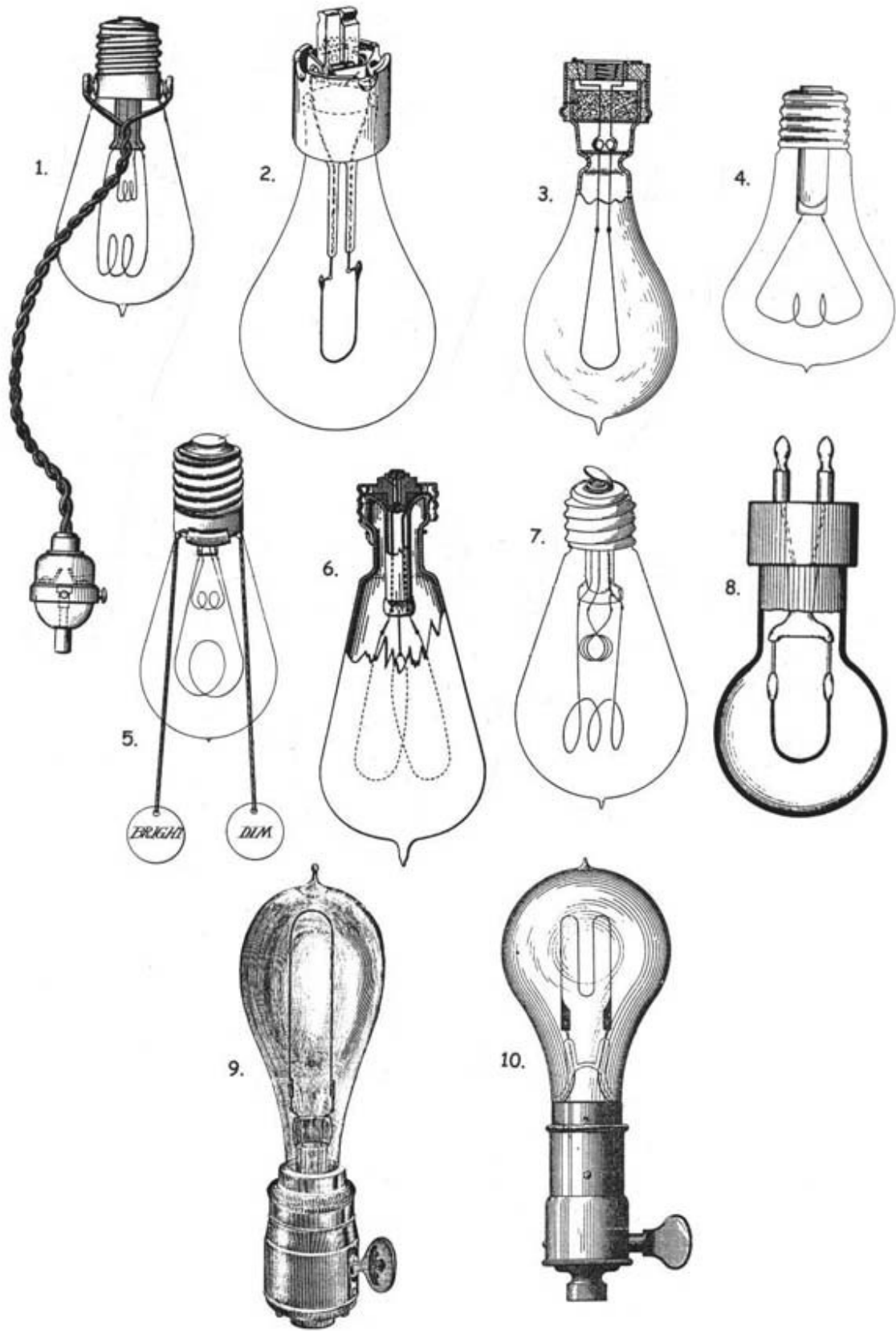

## Edison Lamp Replicas

Although on first thought the idea might seem ludicrous, a collector of early incandescent lamps needs to be aware that it is possible to obtain a replica of a lamp when it is believed the real article is at hand. Depending on the intent of the collector in having a collection, the presence of a replica might not be viewed negatively. This would be the case, for example, were one simply trying to have representations of lamps that show the technological developments.

A definition of the word "replica" from Webster's New World Dictionary, Third College Edition, is: a reproduction or copy of a work of art, esp. a copy by the maker of the original or, any very close reproduction or copy.

Some comments will be made about "replicas" of three different lamp designs (1879, 1880 and 1884), the originals being attributed to Thomas Alva Edison. One replica is of the lamp mentioned in the preceding topic. It was the lamp that Edison monitored on Oct 21, 1879 and that burned about forty hours. The original lamp was purposely destroyed in order to study the various parts in detail after its successful burning. In 1929 Francis Jehl made a replica of that lamp and a picture of it is shown below. The picture was scanned from page 352 of Jehl's book. The base is not shown in this photograph.

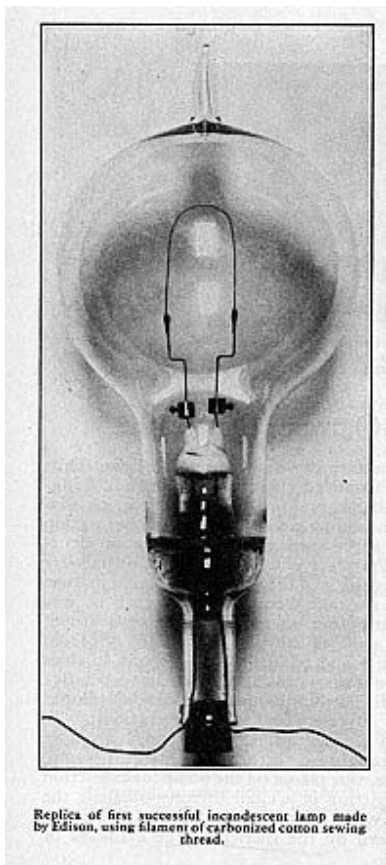

This writer does not know how often replicas of that lamp have been made but it is suspected that these efforts generally resulted in "inaccurate" copies of the original. A large number of "replicas" were made in the year 1929, on the 50th anniversary of Edison's accomplishment. These were made at the Ford Museum in Dearborn, Michigan, at the time of its opening.

Some differences between the original and the 1929 replica will now be pointed out. The Jehl replica lamp made in 1929 was exhausted through the tip on the bulb end. The "souvenir" replicas, obtainable by the public, appear to have been exhausted by means of the Mitchell-White tubing in the stem. Jehl's filament was in the shape of a hairpin and was made from cotton thread; the souvenir lamps had coiled filaments, probably made from squirted cellulose. The method of attachment of the filament to the lead wires in Jehl's lamp employed clamps, whereas in the souvenir lamps carbon paste was used. Jehl's lead wires were made of platinum whereas the souvenir lamps employed dumet wire. Perhaps the lamp feature that allowed such departures in construction was the wooden base with the two terminal posts; its presence in the replicas apparently lent some credibility to the souvenir design.

Replicas of this lamp design have appeared recently on ebay auctions. Some examples are Nos. 509552466, 519584691, 519692539, 522179032 and 527938597. In addition to the replica made at the Ford Museum in 1929, replicas were made at the GE exhibit at the New York World's Fair in 1939, as well as at different times at the Lighting Institute at Nela Park, the headquarters for GE Lighting. One such replica was made in 1978 at Nela Park (ebay No. 519692539).

Three replicas of the "death watch" lamp follow. It is believed the lamp on the left was made in 1929.



A photograph of an 1879 replica being created can be found opposite page 121 in the 1954 book by Keating.

A second reproduction design has the glass envelope shape of an 1884 lamp (see picture in Howell and Schroeder, page 186) and was recently auctioned on ebay (No. 532640471). It, of course, has a sleek look, but appears to also have a stem with the Mitchell-White exhaust tube, and the base insulation is black glass, which was introduced commercially about 1901.

A replica of an 1880 wire terminal Edison base lamp that was made after the famous "death watch" lamp is the last to be mentioned here. It has been in the possession of the writer since about 1967. Its lack of authenticity was not known until recently. A photograph of an authentic lamp can be found in Schroeder's book on page 51. A picture of the replica follows.



Careful examination of the lamp with a magnifying glass shows that the clamps have rust on them (authentic clamps would not show such oxidation) and the hairpin-shape carbon filament lacks the flared ends that were used at the time.

One replica lamp (ebay No. 509552466) had a base made of plastic.

"Replicas" of different designs can be purchased today. Examples can be found at:

<http://stores.yahoo.com/museum-store/repligbul.html>

<http://www.crafthome.com/lightbul.htm>

**The Edison Effect**



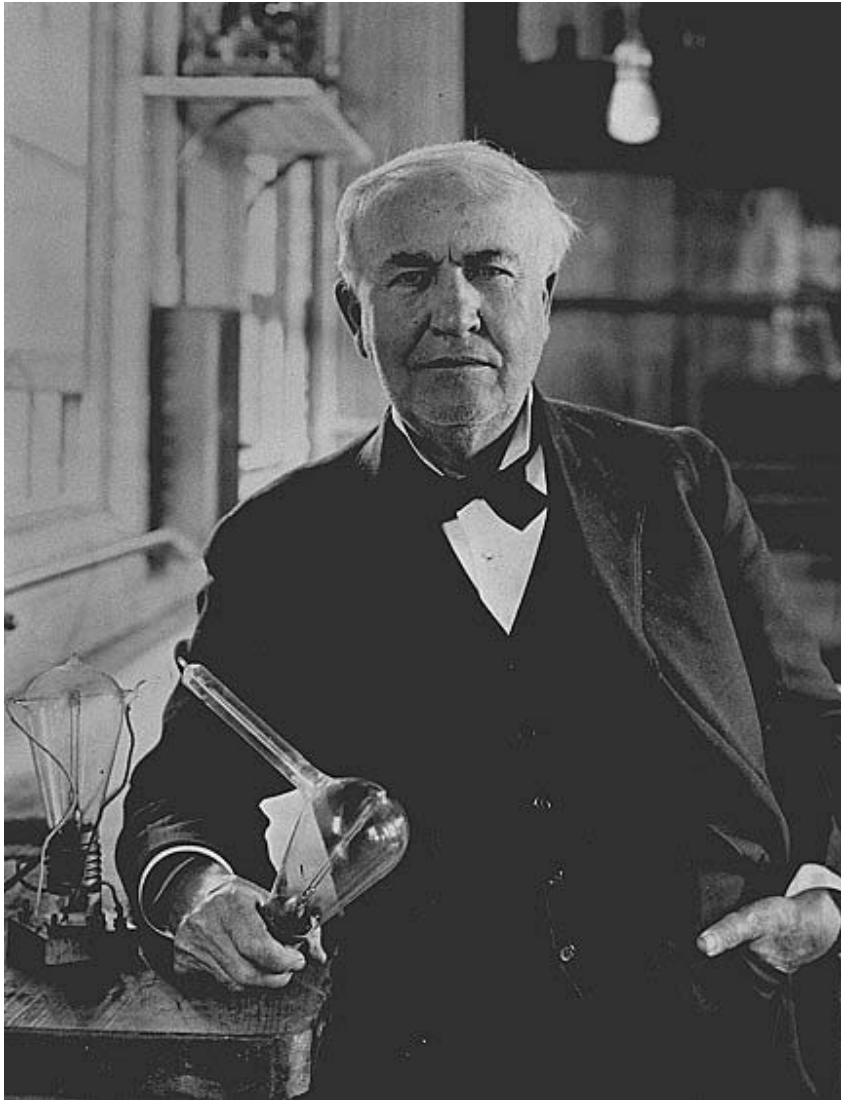

In 1960 an article appeared in the *American Journal of Physics* (Vol 28, No 9, December, 1960, pages 763-773) by J. B. Johnson that told of the "Contribution of Thomas A. Edison to Thermionics." It is a down-to-earth article, much of which I would like to quote here verbatim. The article puts Edison's work in perspective with the work of others, both before and after his work. Because this subject is somewhat disconnected from those that deal more directly with the incandescent lamp, the work of others will not be dwelled on. However, the subject of the Edison Effect can rightly be considered here as it consisted of observations made during the development

of the Edison lamp.

In the following quotes, references directed to Johnson's Figures are not included; some of the discussions of those Figures are also bypassed.

Johnson said:

"...The year was 1880. Thomas A. Edison was busy in his laboratory at Menlo Park developing his carbon filament incandescent lamp. The lamp was not on the market yet, but it looked very promising. The filament at that time was cut horseshoe shaped out of a certain kind of calling card, then carbonized and mounted on the lamp stem. This was sealed into a glass bulb that was then pumped with a Sprengel dropping mercury pump.

**Thomas Alva Edison in 1929 in the Reconstructed Menlo Park Laboratory at Greenfield Village, Dearborn, MI**

"There was one trouble with the lamps, in that carbon from the filament would be transferred to the inside glass walls and this blackening reduced the efficiency and limited the life of the lamp. How did this blackening come about, how could it be prevented? On this they did a lot of speculating and testing. Then one day someone noticed that the positive end of the filament loop cast a light shadow on the glass, as if the carbon came from the negative end in straight lines and was intercepted by the positive end. Now, Crookes had shown the year before that cathode rays are negatively charged particles that proceed from the negative electrode toward the positive in a gas discharge. This suggested to Edison and his people that in their lamps negatively charged carbon atoms were projected from the filament, and only those from the negative end could get to the glass. A shadow would be left by the positive end. (There was no alternating current then, Edison was always a dc man.) The projection of carbon was called "electrical carrying," on the assumption that the carbon carried the current or, perhaps, vice versa. They ascribed it to the Crookes effect, still with some misgivings. It was to lead them on a long, wrong trail, yet with interesting experimental results.

"Now, if the carbon particles are charged it should be possible to draw them to a separate electrode, away from the glass. Furthermore, it should be possible to measure the electric current to this electrode. On February 13, 1880, Edison entered in his notebook the first of a long series of experiments on prevention of carrying. The drawing shows a lamp with the "horseshoe" filament, and an extra electrode inserted, a piece of platinum foil. The test was made by Charles Batchelor, one of Edison's engineers....

"A later entry that year, November 28, shows two added electrodes, differently disposed, for the "prevention of carrying." In July, 1882, the problem was still worked at. Here there was a considerable break in these tests, and this is understandable. On September 4, 1882 Edison opened his Pearl Street station in New York, the world's first generating station for supplying power to the new electric lamps. He had invented, designed, and built the generators, distribution lines, meters, switches, fuses, and practically all the things that go with electric distribution. He had been busy. Then again on March 9, 1883, there is an entry by Edison suggesting that magnetic fields might be effective. The lamp was pumped by Martin Force (whose brother, Joe, also worked for Edison and who, years later, worked with me as a glass blower), and tested by John Ott. The results were evidently still discouraging so far as carrying was concerned, and other directives followed, suggesting various electrode materials, the effect of strong light, magnetic fields, etc. One note directed Acheson (later of graphite and carborundum fame) to 'Try Everything.'

"An entry by John Ott on October 8, 1883, is interesting. Edison had asked him to set up a lamp with the extra electrode connected through a galvanometer to one side of the line. The purpose was to see if the current in this branch circuit could be used to show the voltage of the line. While this

seems to be the first entry showing a galvanometer in the circuit, it is pretty certain that the current to the extra electrode had been measured before and found related to the temperature of the filament. This is the first application of thermionic current to a useful purpose. It is the first electronic circuit, with the first thermionic tube.

"Edison saw a potential usefulness in such a scheme and, as was his custom, immediately applied for a patent on it, that was granted less than a year later....

"Edison, having thus informed the world of his discovery in a patent, proceeded also to do it in other ways. In the fall of 1884 there was an International Electrical Exposition in Philadelphia, held at the Franklin Institute and attended by many prominent people from different lands. Edison had a number of exhibits there, among them a model of his voltage regulator. The exhibits evidently had cards with them to explain their operation....

"In connection with the Exposition there was held a meeting of the American Institute of Electrical Engineers, October 7-8, 1884. Edison had a paper on his discovery prepared and presented at this meeting by Professor E. J. Houston....This paper was published beginning on page 1 of Volume 1 of the *Transactions of the American Institute of Electrical Engineers*....In the text Professor Houston describes the experiment on current flow to a platinum plate in the lamp. The diagram shows the line or battery, the lamp with the filament and platinum plate, and the galvanometer connected to one or the other side of the line. He describes the experiments in detail, and is puzzled by them. Particularly he wonders about the origin of the current that flows in the plate circuit. He says the vacuum is nearly complete, so he 'cannot conceive of current flowing across the vacuous space, as this is not in accordance with our preconceived ideas connected with high vacua....I have no theory to propound as to the origin of these phenomena.' Again: 'It may be electricity flowing through empty space, which I don't think probable.' He said it could be a Crookes effect, charged molecules flowing from plate to loop; but the direction of the current is wrong for this. 'For my own part I am somewhat inclined to believe that we may possibly have here a new source of electrical excitement. That in some way the molecular bombardment against the platinum plate may produce an electrical current.'

"Among those present at the meeting was the eminent chief engineer of the British Post Office's telegraph service, Sir William H. Preece. In the discussion Preece said he had seen the exhibit and was puzzled by it. He thought there might be here a new source of electricity, but in his own mind he considered 'the cause of this remarkable phenomena (sic) to be due to the Crookes effect....

"Every other electrician present at the Exhibition, I think, has watched this experiment with great interest. I feel puzzled in reference to it, and I feel that it is one of those things that wants to be very carefully and cautiously examined. [How right he was!] I intend to exercise my persuasive eloquence upon Mr. Edison when I see him next week to induce him to give me one of those lamps, and when I go back to England I shall certainly make an illustration before our society there, and then make careful inquiry into it.'

"He did see Edison, who gave him several of his lamps with the added electrode. He published a paper the following spring, in the March, 1885 issue of the *Proceedings of the Royal Society*, entitled 'On a peculiar behavior of glow lamps when raised to high incandescence.' In this paper Preece was the first to use the term 'Edison effect.' ...Still misunderstanding what Crookes had observed, he assumed that the blackening was a consequence of the Crookes effect.

"Next on the British scene was J. A. Fleming, then consultant to the Edison Electric Light Company, London. In late 1885 he published a paper in the *Philosophical Magazine*, 'On molecular shadows in incandescent lamps.' He had undoubtedly received Preece's message, but he claimed he had independently noticed the blackening and shadows in 1882, with about the same observations as Edison. He still had in mind these mysterious experiments, when in 1896 he published a 50-page paper in the *Philosophical Magazine* entitled, 'A further examination of the Edison effect in glow lamps.' In this paper he proved to his own satisfaction that a good vacuum is not a conductor, and that carriers are needed for the passage of current. The carriers he supposed to be the carbon particles, again the wrong interpretation of the Crookes effect. The trouble was that he was a little too early. The discovery of the electron was only two years away.

"Crossing the Atlantic again, in 1897 an Edison engineer, J. W. Howell, read before the A.I.E.E. a paper on the 'Conductivity of incandescent carbon filaments and the space surrounding them.' This was work done at the Edison laboratory in collaboration with another Edison engineer, A. E. Kennelly. After discussing the filaments themselves he went on to the 'Edison effect.' They had used alternating current in the filament, and found then that both ends of the filament cast a white shadow. The current was still considered as carried by negatively charged molecules of carbon. Then they found that the current to the collecting electrode was the same when connected to either side of the filament. They had discovered rectification, and this fact was discussed by Kennelly and others.

"This was about the state of the Edison effect just before the discovery of the electron. No more papers were published on the effect as it appeared in carbon filament lamps....

"...First: What was the outcome of the Edison experiments on blackening? I have not seen an answer given directly but I think I know what it is. Putting added electrodes in the lamps did not solve the blackening problem. The problem probably lay in the gradually improved vacuum (getters were introduced around 1890), and in running the lamps at a low enough temperature so blackening was not serious....

"The second question is: What was it that happened in the Edison and other experiments on lamps, that so puzzled the experimenters? I have seen no attempt at an explanation, so again we are left to work out one for ourselves, and it will be quite different from what the early experimenters had the background even to surmise. We know that evaporation from hot bodies such as carbon takes place by emission of neutral carbon atoms, not by charged particles. This means that the current was carried principally by electrons and not by negative ions. The vacuum they had was none too good, even if they called it a millionth of an atmosphere. The density of gas molecules was undoubtedly vastly greater than that of the evaporating carbon atoms. With a space current flowing, of some milliamperes at 100 volts or more, there would be considerable ionization of this gas, producing additional electrons, and ions with positive charge, not negative. The positive gas ions would bombard the negative end of the filament, and there give rise to emission of carbon atoms by the sputtering process. At this relatively low pressure both the evaporated and the sputtered atoms would go in straight lines from the filament to be deposited on the walls. But if sputtering exceeds evaporation at the negative end of the filament, then there would be a partial shadow cast by the positive end of the filament, just as if negative ions were emitted by the negative end. At the same time, in the flow of the electron current the negative end of the filament would be cooled by the emission of electrons, and the positive end would be heated by the electron bombardment. This would explain the difference in temperature sometimes observed between the two ends of the filament....

"This explanation seems now fairly obvious and simple. But between it and the early observations there lies a series of experimental and theoretical works that were the major life work of many eminent scientists.

"...The discovery of large currents flowing from a hot filament was not something that was recorded in a notebook and forgotten. Edison told people about it, he applied for a patent describing and making use of it, he caused it to be reported in the scientific literature, and it aroused a lively interest among eminent men of the day. The explanation of the phenomenon had to wait a couple of decades for the revolutionary ideas of Thompson, Drude, and Richardson. The truth then turned out to be that the carriers of negative charge were not carbon atoms in Edison's experiments or other gas molecules in the Crookes effect, but electrons in both. Edison's contribution was not to explain the phenomenon, but to create and keep alive a keen

interest in the mysterious side effect that showed up in the blackening of lamps, the Edison effect."

### Web Sites of Interest

Web sites exist that deal with various subjects of lighting as well as biographical sketches of persons who contributed to the development stages of the incandescent lamp. Many of the sites are general in subject matter but some are more specific. Here are some:

#### Biographical Sketches

[http://www.ameritech.net/users/jeff\\_lafavre/brushbio.htm](http://www.ameritech.net/users/jeff_lafavre/brushbio.htm) Charles Francis Brush.

<http://www.jhalpin.com/metuchen/tae/jehl.htm> Thomas Alva Edison and Francis Jehl.

<http://members.aol.com/TAEdisonJR/edisonjr.htm> Thomas Alva Edison, Jr.

<http://www.electrochem.org/presidents/fink.htm> Colin Garfield Fink. Developer of DUMET wire.

<http://www.tepia.or.jp/main/edjainfe.htm> Ichisuke Fujioka.

<http://www.tlt.co.jp/tlt/english/company/company.htm> Ichisuke Fujioka.

<http://www.tepia.or.jp/edjapan/edison1.html> Ichisuke Fujioka.

<http://www.city.yokosuka.kanagawa.jp/speed/mypage/m-imajo/akari/akari2-1-e.html> These four websites mention Ichisuke Fujioka, who is credited with the development of the incandescent lamp in Japan.

<http://www.nobel.se/chemistry/laureates/1932/langmuir-bio.html> Irving Langmuir. Developer of the gas-filled incandescent lamp.

<http://www.nobel.se/chemistry/laureates/1920/ernst-bio.html> Walther Hermann Nernst. Inventor of the Nernst Glower.

<http://www.althofen.at/welsbach.htm> Carl Auer von Welsbach. Inventor of the Welsbach mantle and the osmium filament lamp.

<http://users.telarama.com/~rs7717/george.html> George Westinghouse, Jr.

<http://tardis.union.edu/community/project95/HOH/Biography/biography.html> Charles A. Coffin, James J. Wood, William Stanley, Willis R. Whitney, William D. Coolidge, Irving Langmuir, Edwin W. Rice, Jr., Franklin Silas Terry and Burton Gad Tremaine.

#### Museums

<http://americanhistory.si.edu/archives/d8069.htm> Personal papers of William J. Hammer.

<http://www.hfmgv.org/> This is the general site for the Henry Ford Museum and Greenfield Village. Years ago the William J. Hammer Collection of Incandescent Lamps was on display in the Museum but it is now in storage. The Menlo Park Laboratory can be viewed in Greenfield Village however.

<http://edison.rutgers.edu/> Edison Papers

<http://www.packardmuseum.org/defaultmain.htm> Packard Museum.

<http://www.si.edu/nmah/csr/cadits.htm> Smithsonian National Museum of American History.

<http://www.city.yokosuka.kanagawa.jp/speed/mypage/m-imaajo/akari/akari2-e.html> Tokaido Akari Lighting Museum, Japan.

#### **Companies-History**

<http://www.georgewestinghouse.com/westelec.html> Westinghouse.

#### **Other**

<http://historicalpowerandlight.com/>. This site is a joint effort by Bill Anderson and Jerry Westlick. The website is still under construction, but visitors are welcome in the meantime. As the title suggests, their interests go beyond the lamp into the means for generating the power to operate lamps.

<http://www.volt.net/> This is a site created by Charles F. Brush, the great grandson of Charles Francis Brush. It's a very interesting site to visit, covering a wide range of subjects.

<http://www.edisonian.com/> This site was developed by Douglas C. Brackett and displays some of the most exquisite lamp images to be found anywhere.

<http://www.bulbcollector.com/> This site is very informative for the collector; it was created by Tim Tromp.

<http://www.tungsten.com/tunghist.html> This site deals with the history of tungsten wire and is put out by Midwest Tungsten Service.

<http://www.thelightingcenter.com/flexiwatt/history.asp> This site is put out by Lighting Resource and discusses many topics.

[http://howthingswork.virginia.edu/incandescent\\_light\\_bulbs.html](http://howthingswork.virginia.edu/incandescent_light_bulbs.html) This site was written by Louis A. Bloomfield, Professor of Physics at the University of Virginia.

<http://www.tomedison.org/patent.html> A list of U.S. patents granted to Thomas A. Edison.

<http://www.tomedison.org/invent.html> A list of inventions by Thomas A. Edison.

<http://www.georgewestinghouse.com/loc.html> Library of Congress Westinghouse Sites.

<http://edison.rutgers.edu/ecopart3.htm> Edison Companies and Business Associates, 1887-1898.

### **Lighting at the Columbian Exposition of 1893**

Many lamp collectors immediately think of the Westinghouse Stopper Lamp when the Chicago Fair of 1893 is mentioned. There were other lamp types visible at the Exposition, however. The companies using these for exhibit lighting will be mentioned briefly.

The lighting at the Exposition was discussed in the book Electricity at the Columbian Exposition, including an account of the exhibits, by J.P. Barrett, R.R. Donnelley & Sons, Chicago, 1894. For the first time in the history of expositions, lighting was achieved solely by electricity.

Lighting at the Exposition occurred inside buildings as well as outside. The Electrical Building was lighted by several different companies. In that building alone there were 15,000 incandescent lamps. Outside the Electrical Building, lighting was done under one contract, the one that was won by the Westinghouse Electric & Manufacturing Company. That contract called for 90,000 16-c.p. lamps.

The units supplied by the Westinghouse Company were known as Sawyer-Man "Stopper" lamps. They were designed for 105 volts. The lamp consisted of a ground glass stopper that allowed the renewing of the filament. Instead of the usual vacuum, the lamps contained an attenuated atmosphere of nitrogen. Iron leading-in wires replaced the usual platinum. The lamp was designed for high efficacy rather than long life.

The Electrical Building housed several lamp manufacturers. Some of these were:

General Electric Company, 10,000 lamps of average intensity of 16-c.p.

Westinghouse, 5000 decorative 16-c.p. lamps.

Western Electric Company, 5,500 16-c.p. lamps.

Brush Electric Company, 1,500 lamps.

Siemens & Halske Company, 1,500 16-c.p. lamps.

Fort Wayne Electric Company, 250 16-c.p. lamps

Eddy Electric Mfg. Company, C. & C. Motor Company, Mather Electric Company and the Jenney Electric Motor Company, a combined number of 2,000 lamps.



Allgemeine Electricitats Gesellschaft showed the manufacturing steps in lamp making on a special board and they also had a board displaying the most common sockets.

Lighting for concessions and exhibitors were achieved in some cases by arc lamps. These were installed by the Helios Company of Philadelphia. **Lamp Exhaust Times at Thomson-Houston**

In the early days of the incandescent lamp one of the important factors in being able to market such a product was the time required to remove the gas from the lamp. This was necessary to achieve a low enough gas pressure to avoid filament attack by the residual oxygen. In those days it required considerable time to attain an adequate vacuum and this fact resulted in a high lamp price.

In the Edison Works exhausting was done with Sprengel pumps from 1881 to 1895. It took up to 5 hours to exhaust a lamp.

In the Thomson-Houston plant Sprengel pumps were used also and from 1886 to 1887 it took about 10 hours to exhaust. In late 1887 this time was reduced to 5 hours. This was the case when three lamps were exhausted on one pump. Geissler pumps were introduced experimentally at Thomson-Houston in September of 1888. At first the time required to exhaust was 5 hours. The Sprengel pumps were abandoned in 1890.

During the years 1892-93 lamps were exhausted in the usual way except that they (then 12 to a pump) were covered by a large asbestos hood. Such a procedure reduced the exhaust time to about 2 to 2-1/2 hours. At the same time the Thomson-Houston plant was closed in 1893 it was discovered that if the lamps were heated during exhaust to the highest possible degree (before the glass collapsed) the time to achieve an adequate vacuum (without heating the filament) was reduced to 12 minutes.

This observation eventually led to a marked reduction in lamp cost. This effect (of heating the glass) was observed again and studied scientifically by future Nobel Laureate Irving Langmuir during his work that led to the development of the gas-filled lamp about 1912. It was the appreciation that bulb glass soaks up atmospheric gases like a sponge that allowed lamps to eventually be processed in very short times. Present day exhausting can be done in under one minute with the aid of a getter.

### **National Electric Light Association**

Differentiation should be made between the National Electric Light Association and the National Electric Lamp Association. The latter was a holding company, established in 1901, in which many small lamp manufacturers banded together to compete against the General Electric Company. The former was an organization of companies with a common interest. It had its first meeting in February of 1885. It is of historical interest to mention that Franklin Silas Terry was a founding member of both groups. Terry was the founder of the Sunbeam Incandescent Lamp Company in Chicago in the year 1889. He was also a cofounder of the National Electric Lamp Company (later the National Electric Lamp

Association). The cofounders of the National Electric Light Association were Terry, G.S. Bowen and Charles A. Brown.

### **Excerpt from Letter from Harry Needham, 1962**

In 1962 the writer received a letter from Harry H. Needham, which was in response to a letter written to him asking for certain information. Mr. Needham earned a place in incandescent lamp history by developing, among other inventions, Needham's (cryolite) Getter in 1912. The writer's question had to do with carbon filaments and a part of Mr. Needham's reply is repeated here:

"I was working in the research lab. under Dr. Whitney from 1905 to 1907 and was familiar with his work on carbon and Gem filaments. His discovery of the graphitized filament was accidental but was due to very good observation. He had developed a carbon tube resistance furnace for attaining high temperatures and had been experimenting by heating in this tube carbon filaments obtained from the Harrison Works. They sent him by mistake one lot of flashed or treated filaments. This lot after treating in the furnace showed a positive temperature coefficient like the behavior of a metal whereas the ordinary carbon filament had a negative temperature coefficient. He had the lot traced back at Harrison and discovered what had happened, thus the Gem filament was born ..."

### **Comments from Edison Laboratory National Monument**

In Nov 1960 the writer wrote a letter to the Edison Laboratory National Monument in Orange, New Jersey in which specific questions were asked about the early manufacture of Edison lamps. A most informative and obliging response was received from the Archivist, Kathleen L. Oliver. Some of the information in that letter might be of interest to lamp collectors today. For that reason the contents of the letter will be repeated here, with those passages being deleted that are of marginal interest for the present purpose. Ms Oliver stated:

"Regarding the source of the glass used in the Edison light bulb, Edison wrote on November 27, 1880: 'We buy tubes and bulbs of the Corning Glass Works and work them up into Electric lamps by table blowing with gas'. On searching through the documents for that period, I find that the only information on glass shipments is on a few shipping slips marked 'X bbls, Corning, New York'. I was not aware, as you seem to indicate, that Corning had more than one plant at this time.

"The Edison Lamp Company manufactured all of the lamps for the Edison electric light. However, an article in Storage Battery Power for May 1934 tells the story of Corning blowing bulbs for Edison in 1880, when he commenced to produce lamps on a commercial scale. It appears from this that the glass, instead of being shipped in tube form to the Edison Lamp Works, and there blown into lamps, was first blown into bulb shape with tubes open at each end, by the Corning people, and then made into lamps at the Lamp Works. The Edison Lamp Works, incidentally, was at Menlo Park originally, and moved to Harrison,

New Jersey in 1882. We have none of the correspondence of the Edison Lamp Works, so cannot tell from old orders, etc., the extent and nature of shipments from Corning Glass Company. Our Lamp Works correspondence consists of communications received from them by the Edison Laboratory.

"That Edison was blowing his own bulbs as late as November 17, 1880 would seem to be indicated by a note on a job application of that date, from a former Geissler glass blower: 'Tell this man that we use a great many glass blowers, but we cannot promise him anything. Our previous experience with Geissler glassblowers is anything but satisfactory for manufacturing work. We find it easier to break in new men.' It could be, however, that these 'great many glassblowers' were employed in the pumping, insertion of the filament, and sealing of light bulbs.

"Edison purchased glass from other sources besides Corning during the experimental period. On a letter from H.C. Lippincott, a glass broker of Pittsburg, PA, dated January 24, 1880, Edison has written: 'Should like several samples of glass made in tubes like sample sent you. We have tried lime glass, no good. Potash glass, pretty good. No other tried. It may be that lead glass, having large quantity lead would answer our purpose better as its power of conducting heat quickly will probably increase with the amount of lead.'...

"I am afraid we know of no way to date lamp bulbs by the order number on the stem. We, too, depend heavily on Howell and Schroeder, and Edisonia 1904 for much of our information.

"The bases for the lamps were at first made in the laboratory; then Sigmund Bergmann, who originally worked for Edison, went into business for himself making fixtures and appliances for Edison's electric light. Edison rented laboratory space in Bergmann's building at 292-298 Avenue B, in New York, and also had a share in Bergmann's business.

"The correspondence of the Edison Lamp Company, and Bergmann and Company is voluminous, and it may be that somewhere among it, an expert on lamps...would find some worthwhile clues to help answer many of the questions so far unanswered..."

### **An Inquiry for Lamp Historians**

An important advancement in information gathering was achieved with the availability of the internet. Being one who is interested in the development of the electric incandescent lamp, the ability to reach others with a similar interest, in such a simple and convenient manner, cannot be overvalued. The writer therefore takes this opportunity to see if some explanation can be advanced by others regarding a lamp design feature that puzzles him.

If one had access to much of the early technical literature wherein lamp designs were advanced then many of the questions that surface could be more easily answered. I am not privy to such publications and therefore must reach out to others for answers. Some questions are easier to answer than others. It is hoped my "mystery" can be easily unveiled.

In order to pose the question it is necessary to look at some lamp history as the writer understands it. The question concerns the stem design that has appeared in lamps in the past, the origin of the idea, as well as its general use. My discussion starts with the Swan Lamp Manufacturing Company of Cleveland, Ohio. In reality the story must start as early as 1879 when Charles Brush took his first step into the incandescent lamp business. A firm known as the Anglo-American Electric Light Company, Limited was formed then but it was short-lived. In the year 1880 it was replaced by the Anglo-American Brush Electric Light Company, Limited. This firm used the Lane-Fox lamp in its system but it apparently did not perform well and was soon replaced. Comments on the Brush system come to us by way of the book by Dredge<sup>1</sup>, page 316:

The most important requisite in incandescence lighting is a good lamp, and at the same time it is the most difficult to attain. This is evidenced by the fact that, while there are numerous reliable generators in the market, yet only two lamps (the Swan and Edison) have come into comparatively extensive use in this country. Hence one of the points claiming the attention of the Brush Company was the reorganization of the lamp works, and the elaboration of a system that would produce lamps of regular and uniform quality, of great endurance, and endowed with a capacity for sustaining a high degree of incandescence. Abandoning the bass-broom fibre, advocated by Mr. Lane-Fox, they adopted prepared cotton thread as the material of their filaments, following in other respects the general lines of Mr. Fox's patent.

As it regarded the lamp base Dredge said<sup>1</sup> on page 318:

...It remains, however, to provide terminals for the conducting wires, and for this purpose a metal ferrule, stopped at its lower end by a wooden plug, is slipped over the lower neck of the globe, and secured by plaster-of-paris. The ends of the conducting wires are brought through holes in the plug, and twisted under cheese-headed screws, which thus are made to form contact-pieces to which positive and negative leads must be connected.

On page 72 of his excellent treatise on the lamp industry<sup>8</sup>, Arthur A. Bright, Jr. stated that in the summer of 1883 the Brush Electric Company acquired the American rights to the Lane-Fox incandescent lamp patents and at that time added such lamps to its product line. However, the Lane-Fox lamp proved to be unsatisfactory for its applications and the adoption of the Swan lamp was made. On June 9, 1884 Brush himself tested Swan lamps that were obtained from England as well as the Boston plant of the Swan Incandescent Electric Light Company to determine whether or not the Swan lamp would meet his needs. The lamp proved satisfactory and was adopted.

The Swan Incandescent Electric Light Company, of No. 14 White Street, New York City, was incorporated in 1882 to manufacture and sell incandescent lamps under the patents of Joseph W. Swan<sup>5</sup>. In 1897 they applied to the Supreme Court for the voluntary dissolution of the company. From 1885 to 1895 the manufacture was carried out by a licensee, the Swan Lamp Manufacturing Company of Cleveland, Ohio. As the Cleveland-based Swan

Company discontinued business in 1895, and the New York-based Swan Company had no income, and the Swan patents expired in the year 1897, the decision to dissolve was made.

The Swan Company in Cleveland rented space in the Brush factory. Indeed, James Frank Morrison, who was the first President of the National Electric Light Association, said, as it regarded the Brush-Swan relationship<sup>4</sup>:

"...The officers of the Swan are the officers of the Brush Company. The Swan is in the Brush manufactory. The difference between the Brush and Swan Company in Cleveland, according to my observation, is a partition of pine boards an inch thick."

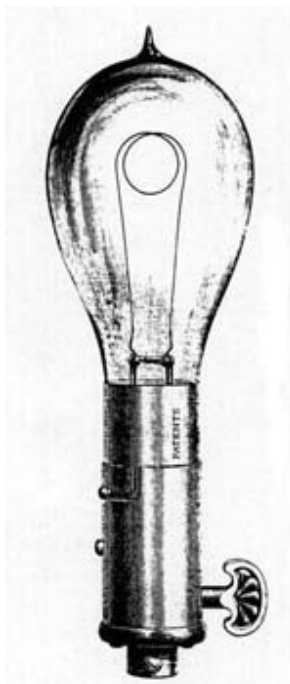

The stem design in question can be seen in part in the engraving shown at the far left. It was scanned from a Brush publication of about 1887-1888<sup>3</sup>. Note the style of the stem; it is similar to a "goal post" in construction. Each lead wire is sealed into its own glass tube and apparently sealed into the glass in the base area. The two lead wire tubes are bridged at the top with a piece of glass cane, or rod. This method of sealing is different from most other designs, where a single larger glass tube is used instead of two smaller ones. It is assumed herein that this stem design must have been patented by Joseph Swan, or someone in the Swan organization. It would be of interest to determine whether or not that is so in order to determine the origin of a similar design that appeared later in the United States.

At the near left is the design patented by John C. Fish<sup>6, 7</sup>, of the Shelby Electric Company, on Feb 8, 1898. The patent was applied for on Aug 3, 1897. This writer has to wonder if some of the features were not objected to in the Patent Office because the Swan patents expired in 1897. Or, was the stem design patented only in England and not in the United States? It is also possible that the designs were significantly different. Whatever the actual situation was it would be of interest to know more about this stem design. It is believed that the Fish design was dropped from use after a short period of time. Later lamp stems utilized the more common pinched press.

## References

- 1) Electric Illumination, Vol 2, J. Dredge, 1884.
- 2) "Electrical Switch," C. F. Brush, U. S. Patent No. 335,269, Feb 2, 1886.
- 3) "Brush Incandescence System," The Brush Electric Company, Cleveland, Ohio, ca 1887-1888.
- 4) "The Middle Age of Electric Lighting," Ralph W. Pope, *Electric Power*, Vol 9, No 5, May 1896, pg 453.

- 5) "Swan Incandescent Electric Light Co.", *The Electrical Engineer*, Vol XXIII, No 465, Mar 31, 1897, pg 354.
- 6) "Incandescent Electric Lamp and Process of Making Same," J. C. Fish, U. S. Patent No 598,726, Feb 8, 1898.
- 7) "Incandescent Lamps as Manufactured by the Shelby Electric Co., Shelby, O.," *The Electrical Engineer*, Vol XXVI, No 545, Oct 13, 1898, pg 358.
- 8) The Electric Lamp Industry: Technological Change and Economic Development from 1800 to 1947, Arthur A. Bright Jr., The Macmillan Company, New York, 1949.

### **The First Windmill-Powered Incandescent Lamps in the World**

In the year 1879 Charles F. Brush created the first street lighting in the United States when he introduced his new arc lamp in downtown Cleveland. He was also the first person in the world to use windpower to operate incandescent lamps.

Charles Brush lived on Euclid Avenue in Cleveland. It was here that he had a tower built, 60 feet in height, which was anchored into the ground to a depth of eight feet - in solid masonry. The wind wheel was 56 feet in diameter, its sail surface, with 144 blades, had 1,800 square feet. The sail surface was turned into the wind by a tail that was 20 feet wide and 60 feet long. His house was lighted entirely by storage batteries, which were located in the basement, for a period of 12 years and the mill was used to charge the batteries for a period of 20 years. The apparatus was described in the magazine *Scientific American* in the Dec 1890 issue.

The Brush house had 350 incandescent lamps ranging in candlepower from 10 to 50; it also contained two arc lamps. A view of the windmill, as scanned from the Feb 20, 1895 issue of *Electricity* (Vol VIII, No 6, pg 65), is shown below.

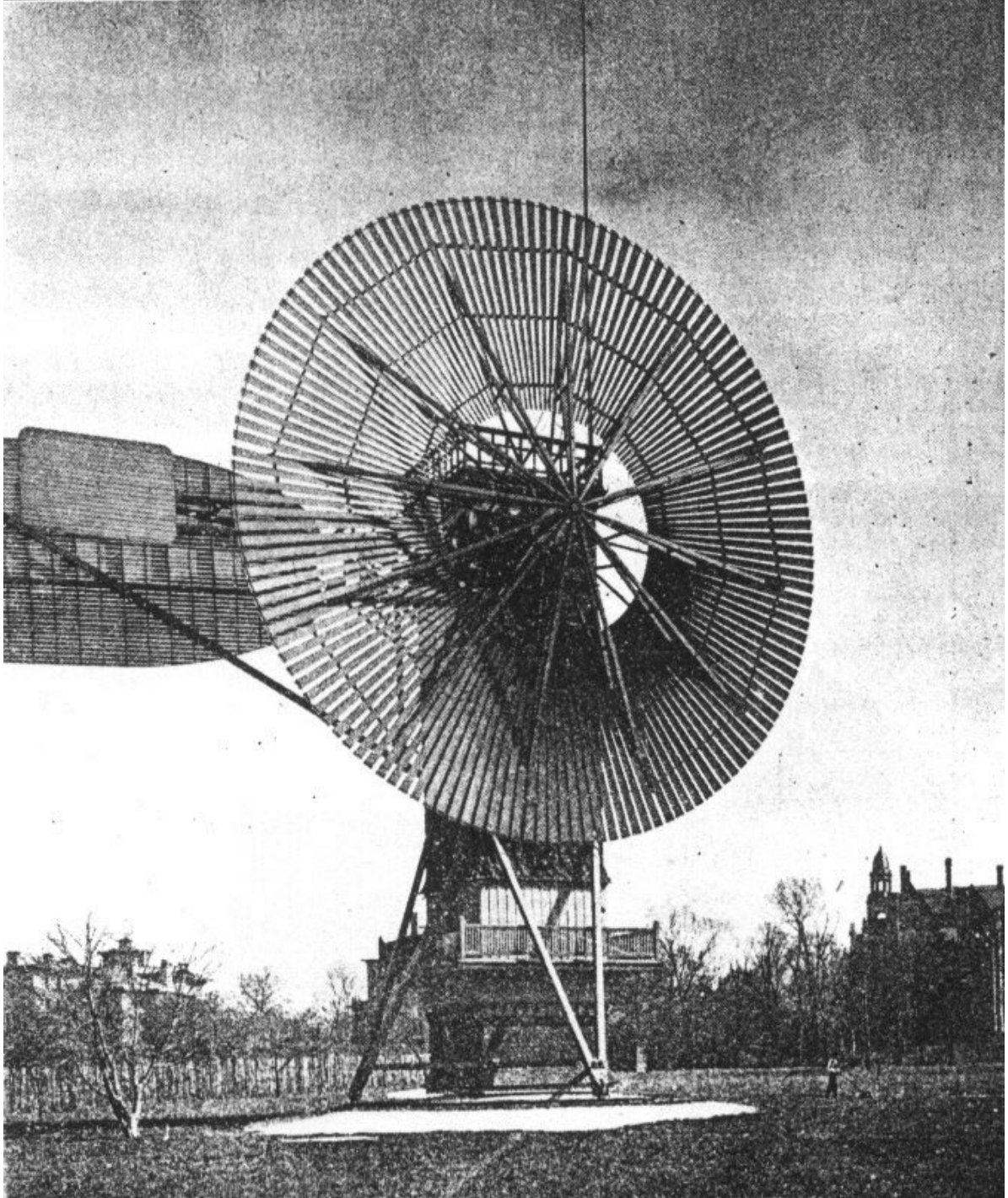

### **Seeing Inside an Outside-Frosted Lamp**

About 40 years ago a fellow collector of lamps informed me of a technique he used to determine the type and condition of the filament inside a lamp that was outside-frosted. It is such a simple procedure one might think it should occur to everyone to use it; it hadn't occurred to me. In case there are others out there who might not think of this, the procedure is passed along for all to use. The inside of a clear glass bulb is, of course, smooth. The

outside of the bulb also was originally smooth until it was either acid-etched or sand-blasted. In the case of a frosted lamp then, if one could simply "fill in" the surface pores that were created (by etching or sand blasting) the outside surface might take on an appearance close to the original. A simple procedure to try is to dip a "Q-tip" into water and bath the frosted bulb surface with it, or any other clear colorless liquid. In many cases it will be found that one can see into the lamp interior well enough to view the filament structure. Another approach is to apply a length of transparent tape to the surface. A little bit of experimenting should suggest the best approach to take.

### **Bulb Darkening in Incandescent Lamps**

In order to understand observed bulb darkening of lamps the physics of the situations need to be understood. Household lamps made from 1880 to about 1912 were characterized as vacuum lamps. Air was exhausted from the lamp interior to prevent chemical reaction, disintegration and subsequent burnout of the filament. Evaporated carbon atoms or molecules therefore traveled unimpeded to the bulb wall in straight lines. Because of this condition the entire bulb would become darkened. More intense darkening could occur on certain portions of the bulb, of course, depending on the shape of the filament and its orientation.

Starting about 1912, and continuing up to the present time, household lamps of about 40 watts and higher had its interior filled with a gas that was inert toward the filament. In order to be able to fill a lamp with an inert gas (nitrogen and argon) and not reduce the efficacy it was necessary to reduce the surface area of the filament. Irving Langmuir accomplished this by coiling the tungsten wire. The pressure in the lamp is about one atmosphere during operation.

Bulb darkening in a gas-filled lamp is quite different from that in a vacuum lamp. During operation the heated filament results in the establishment of convection currents as well as a boundary layer around the coiled filament. The boundary layer, which consists of relatively stationary gas, exists because the viscosity of gas rises markedly with increase in temperature. Such a layer, visualized about a vertically-oriented coiled-coil filament by a schlieren technique, is shown below.





During lamp operation evaporated tungsten atoms diffuse out through the boundary layer and get swept up in the rising gas stream and are deposited on those parts of the lamp interior that exist above the filament. A dramatic result of this phenomenon is that the overall light level from the lamp remains higher during burning than in a vacuum lamp because of the deposition of atoms above the filament. **Photographs of Eminent Electrical Men**

One of the Hammer memorabilia that is in the care of the National Museum of American History in Washington D.C. is a collection of autographed photographs of eminent electrical persons. The writer has a partial list of those individuals, and it should be of considerable interest to lamp collectors to realize that photographs of persons who are known only by name, do exist. Some of the persons associated with incandescent lamp development are: Andrews, Boehm, Brush, Crookes, Curie, Diehl, Edison, Eggers, Farmer, Fujioka, Hochhausen, Houston, Howell, Johnson, Lange, Lemp, Man, Maxim, Moore, Nernst, Perkins, Puluji, Rice, Roberts, Schuckert, Siemens, Stanley, Swan, Swinburne, Thomson, Weston, Wirt and Zalinski.

### **Papers of John Robert Crouse, 1905-1932**

John Robert Crouse (1874-1946) was the youngest of the five founding members of the National Electric Lamp Company in 1901. His papers are contained in 7 linear feet of files at the Bentley Historical Library at the University of Michigan. The Call No. is 851054 Aa 2.

### **Aylsworth's Niobium Filament Preparation**

J.W. Aylsworth of Newark, NJ made incandescent filaments from the refractory metals of niobium, tantalum, molybdenum, titanium, and zirconium. His method of preparation consisted of heating a base (carbon core) in the vapor of a volatile halogen compound of the element which he wanted to deposit, and simultaneously mix it with a reducing gas, such as hydrogen (see *The Electrical Engineer*, Jan 29, 1896, pg 111). His setup is shown below.

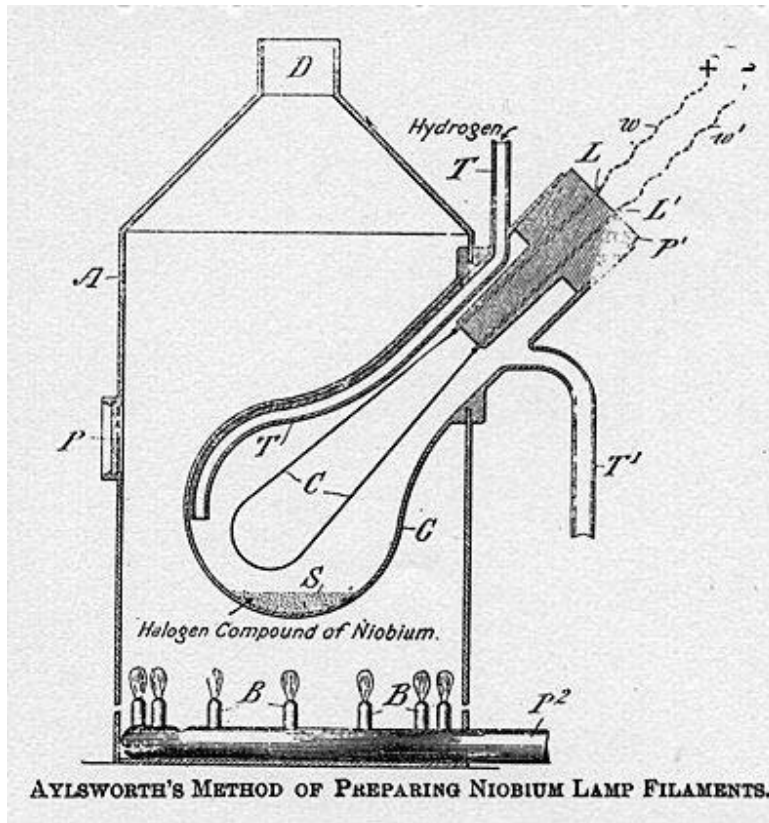

### From Alessandro Volta to William Robert Grove

Some of the major developments that led to a practical electric incandescent lamp are reviewed in order to gain an appreciation of the work and dedication expended by untold numbers of experimenters. Some efforts will be purposely, as well as inadvertently, left out.



However, with the passage of time a more complete and accurate story should result. This cursory effort is a modest beginning toward that end.

#### Alessandro

#### Volta

The picture of Alessandro Volta (1745-1827), shown to the left, was scanned from Reference (18). Volta was born in the city of Como in northern Italy. He was professor of physics at the University of Pavia. Although static electricity was known prior to Volta's work it was he who introduced a method of obtaining continuous electrical current to the world. This extremely creative invention gave

mankind a power source that was of great benefit initially to the scientific community and later to the general community. The invention was the voltaic pile, the forerunner of the storage battery of today. One version of the voltaic battery consisted of stacks of silver and zinc plates separated by paper that had been soaked in salt water. Volta wrote a letter on March 20, 1800 to the Royal Society revealing his discovery and within a short period of time the first battery was constructed in England. Soon many others were manufactured and improvements were not long in coming. Indeed, two English scientists built a battery composed of silver half-crown coins that were alternated with zinc discs—even before Volta's entire letter had reached England (Reference 18, pg 89); the letter had been sent in two parts with the second part being received several months after the first (Reference 18, pg 66). The technical paper on the voltaic battery, written in the French language by Volta, was read before the Royal Society on June 26, 1800 and the article appeared in print in the same year<sup>1</sup>.



**Sir Humphry Davy** (1778-1852), shown to the left<sup>12</sup>, immediately recognized the importance of the development of the voltaic battery (or pile or cell) and set out to use the power source for chemical investigations. Quite as an aside from his extensive chemical investigations, Davy was the first person to establish an arc discharge in the laboratory with the use of an enormous voltaic battery. In the following, Davy, in 1812<sup>4</sup>, mentioned the battery he used as well as his observations and descriptions of the discharge:

"The most powerful combination that exists in which number of alternations is combined with extent of surface, is that constructed by the subscriptions of a few zealous cultivators and patrons of science, in the laboratory of the Royal Institution. It consists of two hundred instruments, connected together in regular order, each composed of ten double plates arranged in cells of porcelain, and containing in each plate thirty-two square inches; so that the whole number of double plates is 2000, and the whole surface 128000 square inches. This battery, when the cells were filled with 60 parts of water mixed with one part of nitric acid, and one part of sulphuric acid, afforded a series of brilliant and impressive effects. When pieces of charcoal about an inch long and one-sixth of an inch in diameter, were brought near each other (within the thirtieth or fortieth part of an inch,) a bright spark was produced, and more than half the volume of the charcoal became ignited to whiteness, and by withdrawing the points from each other a constant discharge took place through the heated air, in a space equal at least to four inches, producing a most brilliant ascending arch of light, broad and conical in form in the middle. When any substance was introduced into this arch, it instantly became ignited; platina melted as

readily in it as wax in the flame of a common candle; quartz, the sapphire, magnesia, lime, all entered into fusion; fragments of diamond, and points of charcoal and plumbago, rapidly disappeared, and seemed to evaporate in it, even when the connection was made in a receiver exhausted by the air pump; but there was no evidence of their having previously undergone fusion.

"When the communication between the points positively and negatively electrified was made in air, rarified in the receiver of the air pump, the distance at which the discharge took place increased as the exhaustion was made, and when the atmosphere in the vessel supported only one-fourth of an inch of mercury in the barometrical gage, the sparks passed through a space of nearly half an inch; and by withdrawing the points from each other, the discharge was made six or seven inches, producing a most beautiful coruscation of purple light, the charcoal became intensely ignited, and some platina wire attached to it, fused with brilliant scintillations, and fell in large globules upon the plate of the pump. All the phenomena of chemical decomposition were produced with intense rapidity by this combination..."

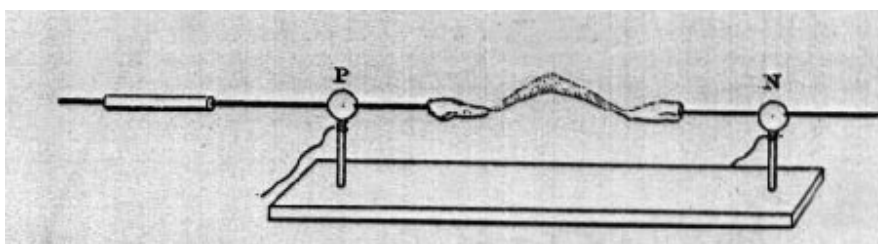

The apparatus used by Davy to demonstrate the arc discharge is shown to the left<sup>4, 6</sup>. The arc is bowed

upward because of convection currents in the heated air. The large battery used by Davy apparently was built in 1809-1810<sup>3</sup> with subscribed funds from members of the Royal Institution. This information, along with the publication date of June, 1812 of Davy's book<sup>4</sup>, led the present writer to the conclusion that Davy probably first observed this powerful arc discharge in the 1810-1811 time period.

### **John**

### **George**

### **Children**

A friend of Davy's was John George Children (1777-1852)<sup>14</sup>. When the news of Volta's development reached England, J. G. Children and his father, George Children (1742-1818)<sup>13</sup>, decided to build a large battery for their own investigations. John George Children eventually published two papers<sup>2, 5</sup> that detailed the batteries built as well as the results of investigations on the application of the batteries to different metal wires. Although Volta and Davy had observed glowing wires with their batteries, the more powerful ones made by Children carried the investigations a step higher. The results of heated wires obtained from their first battery apparently preceded the arc discharge observations mentioned by Davy above.

## Michael



## Faraday

Michael Faraday (1791-1867) was an early associate of Humphry Davy, being his assistant at the Royal Institution in 1813, at age 22. Faraday's portrait, shown to the left, was scanned from the 1868 book by John Tyndall<sup>10</sup>. Faraday's contributions to the knowledge of science were extraordinary. His list of discoveries includes electrical induction, which led to the development of magneto-electric machines. He was instrumental in achieving the installation of the first electric light in a lighthouse at South Foreland, near Dover, on the English Channel.

In a lecture delivered on March 9, 1860, before the Royal Institution, Faraday<sup>8</sup> displayed a lamp (shown below and to the left) that embodied the features of the arc discharge device Humphry Davy had demonstrated about 50 years earlier. In this lamp

Faraday utilized two carbon electrodes and the power source was a battery. He exhausted the air so that the carbon would not burn up; this was done to help explain the phenomena taking place in the lamp circuit. The lecture display was used, in part, to show the brilliant light that Davy had achieved with the voltaic battery.

In 1860, Faraday reported<sup>9</sup> that the electric light (meaning an arc lamp) in the South Foreland lighthouse had been operating for six months without failure. He said:

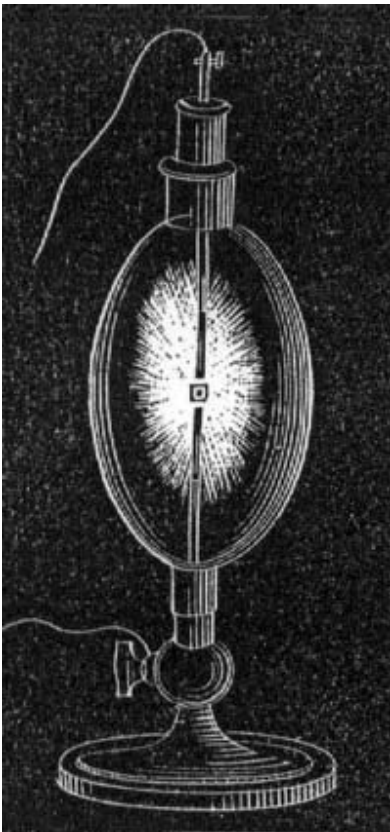

"By means of a magnet, and of motion, we can get the same kind of electricity as I have here from the battery; and under the authority of the Trinity House, Professor Holmes has been occupied in introducing the magneto-electric light in the light-house at the South Foreland; for the voltaic battery has been tried under every conceivable circumstance, and I take the liberty of saying it has hitherto proved a decided failure. Here, however, is an instrument wrought only by mechanical motion. The moment we give motion to this soft iron in front of the magnet, we get a spark. It is true, in this apparatus it is very small, but it is sufficient for you to judge of its character, It is the *magneto-electric* light, and an instrument has been constructed, as there shown (*fig. 59*), which represents a number of magnets placed radially upon a wheel—three wheels of magnets and two sets of helices. When the machine, which is worked by a two-horse power engine, is properly set in motion, and the different currents are all brought together,

and thrown by Professor Holmes up into the lantern, we have a light equal to the one we have been using this evening. For the last six months the South Foreland has been shining by means of this electric light—beyond all comparison better than its former light...."

This story is reiterated, in part, in a published work that deals with the history of lighthouses<sup>21</sup>:

"Trinity House was the first lighthouse authority to employ electric light and it took no less a person than Faraday to overcome the Brethren's reluctance to be first in the field. The lighthouse selected was the South Foreland light and a magneto and arc lamp were installed there in 1859. In order to compare the qualities of the electric arc with the then conventional oil-lamp the two methods of lighting were exhibited simultaneously so that passing ships could report on the comparative qualities of each. It was said that on a clear night the electric arc could be seen for twenty-seven miles, which would be quite possible from a masthead if its height, combined with that of the tower, was 300 feet."



This visual ability suggests that the light could be seen near Calais, on the coast of France.

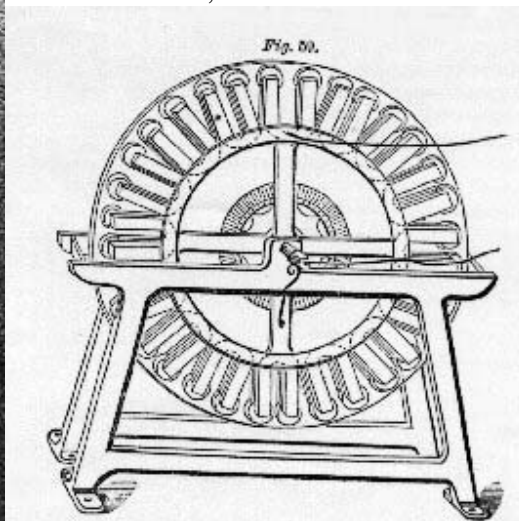

### **Sir William Robert Grove**

The years between about 1810 and 1840 were witness to many investigations carried out on attempts to produce a practical light source with the voltaic arc. One of the reasons for these investigations dealt with the mine explosions that occurred in the collieries in northern England. Many miners lost their lives because of the danger of methane gas coming in contact with the flame light sources of the day. In the year 1815 this problem was presented to Sir Humphry Davy and it was one that he pursued with tremendous success. He developed what was then known as the Davy Safety Lamp. By

proper construction of the lantern nearly all potential explosion situations were eliminated. As many as 1500 to 2000 of such lamps were used at one mine location; this was so because of the fact that the light output of such a lamp, being a flame source, was quite feeble. Attempts were made by different investigators to develop an arc discharge source that could be used for that purpose. William Robert Grove (1811-1896) was one of those persons who worked in that subject area. However, Grove decided that an incandescent source might well fill the requirements of illumination.

In one of Grove's articles he said<sup>7</sup>:

"...Not being able satisfactorily to overcome these difficulties, I abandoned it for the time, and made some experiments on another method of voltaic illumination, which appeared to me more applicable to lighting mines; their publication was postponed, and I had nearly forgotten them, until the papers above-mentioned.

"I substituted the voltaic ignition of a platina wire for the disruptive discharge. Any one who has seen the common lecture-table experiment of igniting a platina wire by the voltaic current nearly to the point of fusion, will have no doubt of the brilliancy of the light emitted; although inferior to that of the voltaic arc, yet it is too intense for the naked eye to support, and amply sufficient for the miner to work by. My plan was then to ignite a coil of platinum wire as near to the point of fusion as was practicable, in a closed vessel of atmospheric air, or other gas, and the following was one of the apparatus which I used for this purpose, and by the light of which I experimented and read for hours: □ A coil of platinum wire is attached to two copper wires, the lower parts of which, or those most distant from the platinum, are well-varnished ; these are fixed erect in a glass of distilled water, and another cylindrical glass closed at the upper end is inverted over them, so that its open mouth rests on the bottom of the former glass; the projecting ends of the copper wires are connected with a voltaic battery (two or three pairs of the nitric acid combination), and the ignited wire now gives a steady light, which continues without any alteration or inconvenience as long as the battery continues constant, the length of time being of course dependent upon the quantity of the electrolyte in the battery cells. Instead of making the wires pass through water, they may be fixed to metallic caps well-luted to the necks of a glass globe.

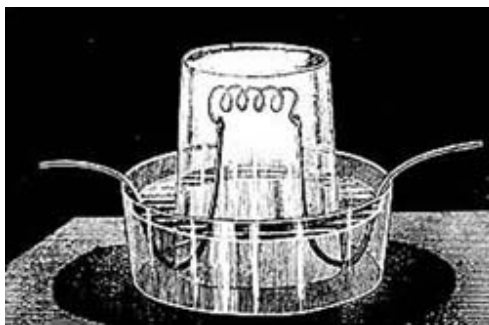

"The spirals of the helix should be as nearly approximated as possible, as each aids by its heat that of its neighbor, or rather diminishes the cooling effect of the gaseous atmosphere; the wire should not be too fine, as it would not then become fully ignited; nor too large, as it

would not offer sufficient resistance, and would consume too rapidly the battery constituents; for the same reason, *i. e.* increased resistance, it should be as long as the battery is capable of igniting to a full incandescence.

"The helix form offers the advantages, that the cooling effect being lessened, a much longer wire can be ignited by the same battery; by this increased length of wire, the battery fuel is economised, while a greater light is afforded; by the increased heat, the resistance is still further increased, and the consumption still further diminished, so that, contrary to the usual result, the increment of consumption decreases with the exaltation of effect produced. The very necessity of inclosing the coil in a glass recipient also augments the heat, the light, and the resistance; if I remember rightly, Mr. Faraday first proposed inclosing wire in a tube for the purpose of being able to ignite a longer portion of it...."

A pictorial representation of the described setup is shown above; the origin of the drawing, which has been used by several authors, is not known by this writer.

It is of interest to point out some aspects of Grove's statements that shed some light on another lamp that has been reported to exist in the chain of developments since the work of Volta. The lamp in question is the so-called De la Rue or De la Rive lamp. Although a more complete discussion of this lamp is given in the write-up labelled "A Lamp of Uncertain Origin", a few words are in order here. As it regards the lamp, it has been described as consisting of a coil of platinum wire within a glass enclosure with electrical contacts leading to brass caps and it was purported to have a vacuum within the glass vessel. Two different years have been given as the date of introduction—these being 1809 and 1820. Writers have credited this lamp development to either Warren De la Rue or Auguste De la Rive.

The 1840 lamp, as described by Grove, fits the description of the lamp in question except for the vacuum within the lamp. However, it should be realized that a platinum filament, unlike a carbon filament, can operate in an atmosphere with some oxygen content without failure. Also, it should be pointed out that Grove mentioned that Michael Faraday apparently was the first to suggest the desirability of inserting the platinum wire within the glass enclosure (see above). Faraday might have made the suggestion in conversation or discussion. Meyer<sup>22</sup> made the following statement on his page 60:

"For a number of years he (Michael Faraday) was a consultant to Trinity House on lighthouses, and in 1847 he proposed lighting buoys with incandescent lamps using platinum spiral filaments."

In his writing on the life and letters of Faraday Dr. Bence Jones made the following statement<sup>11</sup> :

"He reported, in 1847, on the ventilation of the South Foreland lights, and on a proposal to light buoys by platinum wire ignited by electricity."



Although the concept of a coiled platinum filament within a glass enclosure had merit, the idea was suggested at a time when the Davy Safety Lamp was in common usage; Grove's idea probably was not considered further for the lighting of mines because of the limited portability of the equipment as well as the high expense involved. The adoption of the incandescent lamp for mine illumination probably had to wait for the development of the magneto-electric and dynamo-electric machines before the Safety Lamp could be replaced.

## References

- (1) "On the Electricity Excited by the Mere Contact of Conducting Substances of Different Kinds", In a letter from Alessandro Volta to Sir Joseph Banks, *Philosophical Transactions of the Royal Society of London*, Vol 90, 1800, pp 403-431. Read June 26, 1800.
- (2) "An Account of Some Experiments, Performed with a View to Ascertain the Most Advantageous Method of Constructing a Voltaic Apparatus, for the Purpose of Chemical Research", J. G. Children, *Philosophical Transactions of the Royal Society of London*, Vol 99, 1809, pp 32-38. Read November 24, 1808.
- (3) The Bakerian Lecture for 1809. "On Some New Electrochemical Researches, on Various Objects, Particularly the Metallic Bodies, from the Alkalies, and Earths, and on Some Combinations of Hydrogene", Humphry Davy, *Philosophical Transactions of the Royal Society of London*, Vol 100, 1810, pp 16-74. Read on November 16, 1809. In the caption for Fig. 6, on page 74, Davy mentioned that the large battery being constructed at the Royal Institution had not been completed as of the date of the reading of the paper.
- (4) Elements of Chemical Philosophy, Sir Humphry Davy, Printed for J. Johnson and Co., St. Paul's Church-Yard, London, 1812, pp 152-153.
- (5) "An Account of Some Experiments with a Large Voltaic Battery", J. G. Children, *Philosophical Transactions of the Royal Society of London*, Vol 105, 1815, pp 363-374.
- (6) The Collected Works of Sir Humphry Davy, Vol. IV (edited by John Davy), Smith, Elder and Co. Cornhill, London, 1840, pp 110-112.
- (7) "On the Application of Voltaic Ignition to Lighting Mines", W. R. Grove, *The London, Edinburgh, and Dublin Philosophical Magazine and Journal of Science*, Vol XXVII, 1845, pp 442-446.
- (8) Lecture VI - "The Correlation of the Physical Forces", A Course of Six Lectures on the Various Forces of Matter, and Their Relations to Each Other, Michael Faraday, Harper Brothers, New York, 1860, pp 155-156. Delivered before the Royal Institution on March 9, 1860.
- (9) Lecture on "Light-House Illumination□The Electric Light". This is the seventh "chapter" in the following book: A Course of Six Lectures on the Various Forces of Matter, and Their Relations to Each Other, Michael Faraday, Harper & Brothers, Publishers, Franklin Square, New York, 1860, pp 171-190. Delivered before the Royal Institution on March 9, 1860. The main six chapters in the book were lectures "Delivered before a Juvenile Auditory at the Royal Institution of Great Britain during the Christmas Holidays of 1859-60". Edited by William Crookes.
- (10) Faraday as a Discoverer, John Tyndall, Longmans, Green, and Co., London, 1868.
- (11) The Life and Letters of Faraday [computer file], Vol II, Dr. Bence Jones, J. B. Lippincott, Philadelphia, 1870, pg 230. <http://www.hti.umich.edu/cgi/t/text/text-idx?c=moa;idno=AJN6604>. Click on the second entry and then page 230.
- (12) Les Nouvelles Conquêtes de la Science, Vol 1, Louis Figuier, Paris, 1883.
- (13) "George Children", *Dictionary of National Biography*, Vol IV, The Macmillan Co.,

- New York, 1908, pg 249.  
 (14) "John George Children", *Dictionary of National Biography*, Vol IV, The Macmillan Co., New York, 1908, pg 249.  
 (15) "Sir Humphry Davy", *Dictionary of National Biography*, Vol V, The Macmillan Co., New York, 1908, pg 637.  
 (16) "William H. Pepys", *Dictionary of National Biography*, Vol XV, The Macmillan Co., New York, 1909, pg 811.  
 (17) Oersted - and the Discovery of Electromagnetism, Bern Dibner, Blaisdell Publishing Co., New York, 1962.  
 (18) Alessandro Volta and the Electric Battery, Bern Dibner, Franklin Watts, Inc., New York, 1964.  
 (19) Sir Humphry Davy's Published Works, June Z. Fullmer, Harvard University Press, Cambridge, Massachusetts, 1969.  
 (20) The Selected Correspondence of Michael Faraday, Vol 1 (1812-1848), edited by L. Pearce Williams, Cambridge University Press, London, 1971.  
 (21) A History of Lighthouses, Patrick Beaver, Peter Davies Ltd., London, 1971, pg 68.  
 (22) A History of Electricity and Magnetism, Herbert W. Meyer, Burndy Library, Norwalk, Connecticut, 1972.  
 (23) Humphry Davy, Ronald King, The Royal Institution of Great Britain, London, England, 1978.  
 (24) Humphry Davy-Science & Power, David Knight, Blackwell Publishers, Oxford, England, 1992.  
 (25) Young Humphry Davy - The Making of an Experimental Chemist, June Z. Fullmer, American Philosophical Society, Independence Square, Philadelphia, Pennsylvania, 2000.  
 (26) Michael Faraday, J. H. Gladstone, Harper & Brothers, Publishers, Franklin Square, New York, n. d. (before January 1885).  
 (27) JSTOR - The Scholarly Journal Archive; <http://www.jstor.org/jstor>; On this website it was possible to view the early papers published in the *Philosophical Transactions of the Royal Society of London*. Access was achieved through a local university.

Go to: [Early Incandescent Lamps](#)

**World War II Blackout Light**  
 Incandescent lamps were developed during World War II for use in the event of air raids. These can be recognized by their black appearance. How these were used is explained in the leaflet shown below.

## War Department Specifications

### BLACKOUT OF BUILDINGS

Samples of Hygrade Interior Blackout Lamps have been tested by Electrical Testing Laboratories, Inc. These lamps, when used in accordance with the following instructions, are warranted to meet War Department Blackout Requirements.

- (a) In any one room, only one unit is permitted to each two hundred square feet of floor area or a fraction thereof.
- (b) Units shall be spaced not less than ten feet apart in any direction.
- (c) In corridors, one row of units is permitted at a spacing of not less than fifteen feet.
- (d) Units shall be placed at least three feet from any window, exterior door or other opening.
- (e) Units shall not be pointed toward any window, exterior door or other opening.
- (f) When openings are covered in the usual manner with drawn window shades, drapes, blinds, or even with one thickness of newspaper, or whenever each unit has a shade which screens the unit from outside observation above the horizontal, units may be installed at any height.
- (g) When exterior openings are not covered, and when units are not otherwise shaded from outside observation above the horizontal, blackout units shall be located above the top of such openings.

Hygrade Lamp Division  
**Hygrade Sylvania**  
CORPORATION  
SALEM MASS

FORM IS11 5M-2-42-F.R.P.

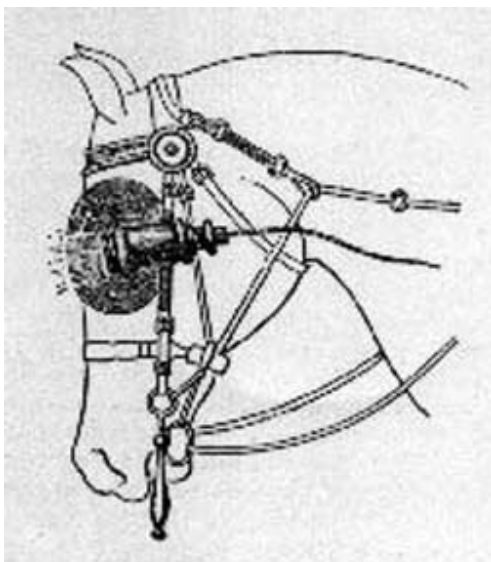

### Incandescent Lamps for Horses' Harness

Quite often an early incandescent lamp turns up but the use for which it was intended is not obvious. One such lamp might be the one described here. The picture should be self-explanatory but the following article<sup>1</sup> explains its former use.

"In Berlin, Germany, the use of incandescent lamps attached to vehicles and the horses

drawing them is said to be now so common as to excite no remark. An adaptation of the incandescent lamp for the latter purpose is shown in the illustration herewith, which is taken from London *Industries and Iron*. The lamp is enclosed in a silvered reflector, and is fed from a small battery of accumulators carried on the vehicle. The wires are enclosed in small gutta-percha tubes sewn to the harness and made exceedingly flexible. The battery consists of four or six plates, having a capacity of 20 ampere hours. It is conveniently carried under the coachman's seat. The illustration shows only one of the numerous adaptations of the electric light for this purpose; others may easily be imagined."

### Reference

- 1) "Incandescent Lamps for Horses' Harness", *The Electrical Review*, Vol 25, No 26, Dec 26, 1894, pg 322. **Preventing Vibration in Incandescent Lamp Filaments**

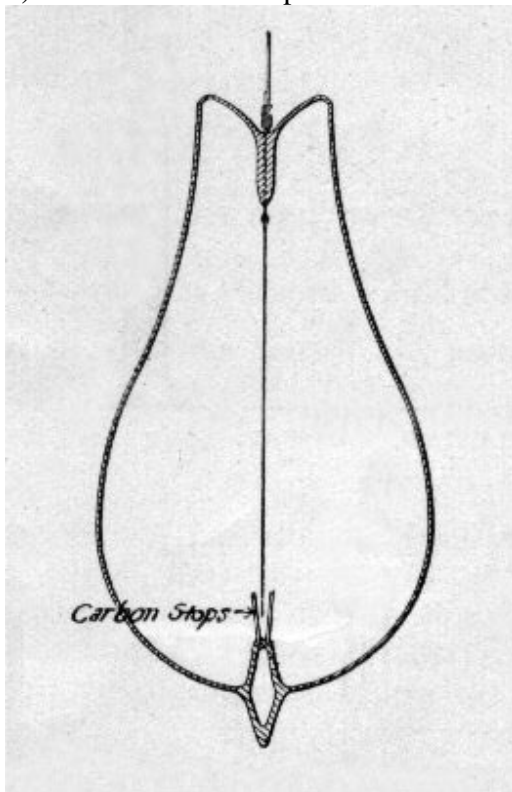

Filaments in a horse shoe shape were quite long in length at higher voltages. Vibration of such filaments could be a problem in some lamps and efforts were made to reduce it. The following is a solution reported by George R. Lean<sup>1</sup>.

"When incandescent lamps are subjected to great and constant jarring, as is the case when they are used in railway cars, elevators, etc., the life of the carbon is, as a rule, considerably shortened. In order to prevent this excessive vibration, a method has been employed in which the loop end of the filament is steadied between metallic posts set into the glass bulb, as shown in the cut. When, however, this arrangement is used, frequent contact between the filament and these metallic posts soon weakens the former, removing, as it does, small particles at a time, and the life of the

filament is materially reduced. It has also been found that the filaments by their frequent contact with metallic posts form grooves in the latter by melting away the material. In experiments made with the view of producing stops which will effectually accomplish the desired result, and at the same time insure the full life of the filament, George R. Lean of Boston, has found that the stop or stops must be made of material which will not melt and that is non-combustible; and also that a stop composed of the same material of which the filament is made is best suited for the purpose. He, therefore, provides stops of carbon, they being secured to the apex of the bulb, and located adjacent to each other to receive between them the filament. When the air is exhausted from the bulb, a small short tube of glass is fitted in the hole at the end. The outer end of this tube is afterward sealed. To secure the

stops in place, the inner end of this tube is closed, and the stops are secured in the closed end."

### Reference

1) "Preventing Vibration in Incandescent Lamp Filaments", *Western Electrician*, Vol 7, No 3, Jul 19, 1890, pg 31. **Electric Light Plant Nearest the North Pole**  
This writer is primarily interested in the development stages of the incandescent lamp as well as the people who brought about the advances. However, it is of interest to occasionally look at the effect of technological developments as they spread across the globe. The above title captioned a short article in a technical journal in 1891<sup>1</sup>. It is presented here verbatim:

"On the northern coast of Norway, under latitude 70.5 degrees, is situated the little town of Hammerfest. Every year for months the sun disappears entirely and there is perpetual night, only lighted once in a while by a beautiful aurora borealis. The town of Hammerfest has just installed an electric light plant. The International Thomson-Houston Electric company furnished the apparatus and superintended the installation.

"There are two dynamos driven by waterpower outside the town. One dynamo furnishes current for 12 arc lamps for street lighting. An alternating dynamo of 35 amperes and 1,000 volts capacity supplies private customers with incandescent lights on the transformer system.

"This central station plant operates probably under the most economical conditions, as during the winter months it must be kept running continually under full load."

### Reference

1) "Electric Light Plant Nearest the North Pole", *Western Electrician*, Vol 8, No 14, Apr 4, 1891, pg 195. **The Financial State of an Inventor**  
Fame and fortune for an individual can result from his/her invention. However, invention per se does not guarantee a comfortable life. This was brought out in a short article titled "Volta's Poverty." The article gives comments made by William J. Hammer at an early meeting of the New York Electrical Society. The comments were made after a paper was presented by Edward P. Thompson. In part the article said:

"...W. J. Hammer spoke of the encouragement which could be derived by young and struggling inventors from a study of the life and experience of some of the prominent inventors of the day. He referred to the obstacles encountered by Morse, Bell, Edison, Weston, Brush and others. In connection with a remark made by the lecturer that in the various classes of inventors, there are those who, while receiving practically no financial benefit from their work, have achieved undying fame, Mr. Hammer quoted the instance of Alexander Volta, who died in great poverty. Mr. Hammer at the same time submitted for the inspection of the members of the society, a photographic facsimile of a document of historical interest which he had just

received from Italy. This was a declaration made by Volta in support of an application he had made for a pension from the Austrian government. The translation reads as follows:

"I, the undersigned, declare under my solemn oath that I do not possess other revenue or pension from the state outside of that which I receive as a member of the Institute of Arts and Sciences.

"Como, July 2, 1820.

"(Signed): Alessandro Volta."

Mr. Hammer stated that action on this application was delayed by the Austrian government, and in the meantime, Volta died. At the date of this document Como, as well as the whole of Lombardy, was under the Austrian rule."

### Reference

1) "Volta's Poverty", *Western Electrician*, Vol 7, No 25, Dec 20, 1890, pg 329.

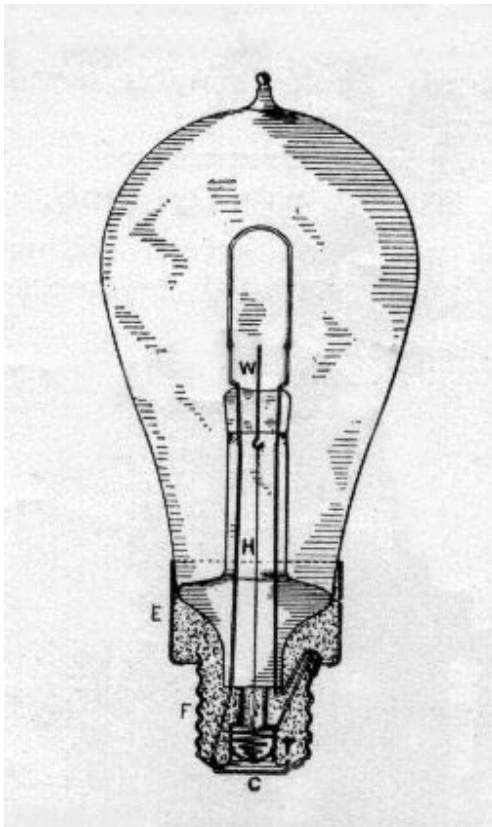

### Cut-Out for Series Incandescent Lamps

On Apr 15, 1890 Thomas Edison was granted U, S, Patent No. 425,782 for a cut-out for series burning lamps. The patent was applied for in Mar 1888. When lamps operate in series and a lamp burns out a means has to be provided for a shunt to appear across the two lead wires so that the operation of the other series lamps is not affected. This was the reason for the design presented here.

An article appeared in the technical literature<sup>1</sup> that explains the concept. The article states:

"...The main object of the invention is to construct and arrange the parts of a cut-out, so that all the mechanism will be entirely contained in the lamp itself. In other words, so that the metal parts of the socket will not be required to form part of the cut-out apparatus.

" Upon the lower end of the lamp is secured a plaster-of-paris base. This holds a metal band E, the screw-threaded collar F on the outside of the base, and in a recess formed in the bottom of the base, the metal thimble T. The base is formed, as is well understood, by pouring the plaster into a mould around the lamp-neck. This holds in place the two rings and the small thimble T. At the bottom, and covering but not touching the

thimble T, is the cap C. The electrical connections, disregarding the cut-out mechanism, are as follows: Current enters at cap C, passes up through the filament, and thence to the other terminal F of the lamp. The band E has no electrical connection with the circuit. The arrangement of the cut-out will now be readily understood. Referring to the illustration it will be seen that in the glass between the lamp wires there is sealed a piece of platinum wire W. This extends up between the terminals of the lamp filament, and has its lower end formed into a hook as shown. Attached to this hook is a fine fusible iron wire, H, which extends down, and is soldered to a small button sliding in the thimble T. Between the button and the bottom of the thimble is a small spiral spring. The fusible wire passes through this, as indicated, and is attached to the button so as to keep the spring under compression. The action of the cut-out will now be understood: The lamp being placed in series with a number of others, if the filament breaks, an arc usually forms across the vacuum between the filament terminals. When this occurs, the platinum wire W and the fine wire H, which is connected with the circuit outside the lamp, receive so much current that wire H is fused. This releases the spring, and the button is forced down against the terminal G and connects it with thimble T. This action completes a shunt around the broken filament."

#### **Reference**

1) "Cut-Out for Series Incandescent Lamps", *Western Electrician*, Vol 6, No 17, Apr 26, 1890, pg 234.

#### **The Incandescent Lamp-Beyond 1925**

In the year 2004 the incandescent lamp still holds a strong position in the lighting world. Improvements have been made in the lamp since 1925 but the lamp still does not efficiently use the power required to operate it. The usual figure quoted for the 100-watt lamp is that only about 10% of the input power is emitted as visible light. It is, perhaps, past time to evaluate the incandescent light source in view of the different sources now available. This question is to be addressed later but for now some of the lamp improvements realized since 1925 will be reviewed.

For the purpose of discussion it is convenient to use the 100-watt lamp as the center of focus. The writer, having retired from the Lamp Business Group of the General Electric Company, will confine remarks to work having been achieved by others within that Company. Some "history" will come from the writer's memory so some allowance should be made for faltering memory in old age.

The year 1925 stands out in incandescent lamp history because in that year the simple light bulb could be manufactured with a diffusing coating on the bulb interior that was economical to manufacture. Marvin Pipkin (1889-1977) was able to achieve that goal with the application of silica, in such a manner that the bulb strength was maintained. Outside bulb etching and the special glass used in the White Mazda lamp were no longer to be preferred. Bulb etching resulted in a weakening of the glass whereas the glass in the White

Mazda lamp while being too expensive, also absorbed more of the light than the Pipkin development.

A major development occurred in the mid 1930s after Burnie Lee Benbow (1885-1976), who, for many years was Manager of the Cleveland Wire Works, was granted a patent, U. S. 1,247,068 (in 1917) for a coiled-coil filament, and, many years later, was able to achieve it in practice. Such a filament was manufactured and used in the CC-6 form in the 100-watt lamp. This configuration consisted of a coiled-coil tungsten filament mounted perpendicularly to the lamp axis. This coiled-coil resulted in a lower conduction-convection gas loss and therefore an improvement in lamp efficacy. In effect the coil length was shortened, which reduced the conduction-convection loss.

Another advance was made by the engineer Charles Pearson, who was able to mount the coiled-coil filament along the axis of the lamp. When the lamp is burned in a base down or base up position the conduction-convection loss was again reduced. Eventually the filament support was eliminated in some designs, which resulted in a small increase in lamp efficacy. Coiling a third time was possible but because the coil length is so short arcing could result. The arcing could be reduced by increasing the nitrogen content, but then the advantage of coil length shortening was offset by the increased gas loss in the lamp. Some advantage could be obtained by substituting krypton for the argon normally used but then a cost disadvantage appears. Attention has now been diverted to the use of infrared reflecting films on the envelope wall.

We live in a world of limited natural resources. It would appear that we neglect that fact and use them as if they are limitless. We owe it to the generations of people to come after us to try to conserve what is left. The oil embargo of 1973 was an indicator, of sorts, that the availability of those treasures found within the earth might not always be at hand. Without attempting to level criticism at any particular human activity one must wonder about the unregulated use of tremendous amounts of aviation and ground vehicle fuel, the energy used in manufacturing certain recreational items and the number of ground transportation vehicles that fill highways around the world. Conservation of other resources should also be addressed, such as helium and non-renewable minerals from beneath the earth's surface. As the time clock continues to tick, the future needs of mankind increase as the world population increases. In a study of this limitation of available energy, derived from coal or oil, it is natural to consider the power required to make our light sources function. In particular the less efficient sources, such as the electric incandescent lamp, might be looked at critically.

An introspection of this use of energy, as it regards the incandescent lamp, was considered by Milan R. Vukcevic (1937-2003) in his book The Science of Incandescence, a little known summary of one man's excursion into the world of artificial lighting. Vukcevic, a first rank theoretical scientist, worked in the General Electric lighting business for about 22 years. The title of the last chapter of his book is "For the Third Century." With the assumption that man's record of inventions began at the beginning of the 1800s, Vukcevic considered the incandescent lamp to now be entering its third century. The topics listed under his last chapter are: About Timing, Filament Materials, Regenerative Cycles, Containment of High Pressures, IR-Films, IR-Phosphors and Luminescent Gas. Those



individuals who want to consider the possible role of the incandescent lamp in a world of limited natural resources should consider reading this writing by an extraordinary individual.

### **Three 1907 Lamp Advertisements**

The following three advertisements appeared in a book that was issued after the Thirteenth Annual Convention of the Ohio Electric Light Association, held August 20th, 21st and 22nd, 1907, at Toledo, Ohio.

# Is Your Plant Overloaded?



Voltage of Circuit 1	Watts		Mean Horizontal Candle Power 4	Watts Per Candle 5	Mean Spherical Candle Power 6	Mean Candle Power Factor 7	End Candle Power 8
	Nominal 2	Total 3					
Same as "Top" or 1st Vol- tage (V 1).....	50	50.0	20.0	2.5	16.5	82.5%	8.1
Same as "Middle" or 2d Voltage (V 2).....	50	48.5	18.3	2.65	15.1	82.5%	7.4
Same as "Bottom" or 3d Voltage (V 3).....	50	47.3	16.7	2.83	13.84	82.5%	6.8

## TRY Star Gems

Write for Proposition  
to Central Stations  
and  
mention this souvenir.



Not far from Niles to  
Your Plant.

**The Standard  
Electrical Mfg.  
Company**

**NILES, OHIO**

# TILCA

PUBLISHED BY:  
The  
Incandescent  
Lamp  
Collector's  
Association

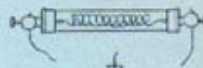
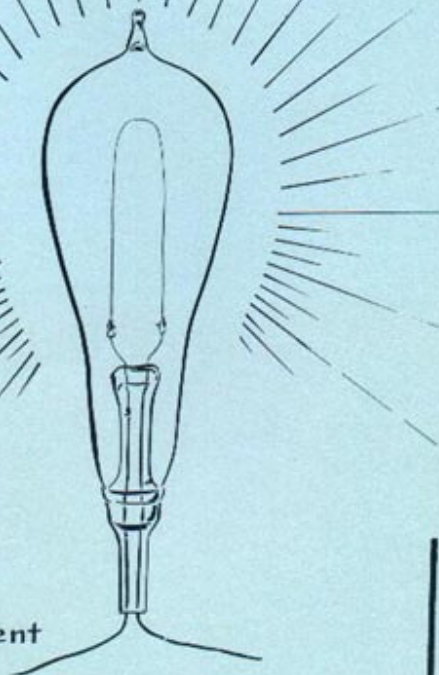

ature and Candelabra  
Lamps manufactured in  
Candle.

A complete line of  
Lamps manufactured.  
ly. Write for bu

New York  
Warre

## TILCA - The Incandescent Lamp Collector's Association

Forty or so years  
ago it was  
somewhat tedious to  
communicate with  
fellow collectors

because the postal service was the primary means of communication. The internet has changed that, so now communication is accomplished in an instant. It might be of interest to some collectors to become aware of one attempt at communication and knowledge exchange in the 1960s.

In 1961 the late Dr. Hugh F. Hicks suggested that the few lamp collectors who were communicating on a regular basis publish short papers on subjects of choice by the writers. The idea was favorably received and a result of that suggestion was a report cover that was designed by Dr. Hick's sister. The cover is shown to the left. The dimensions of the cover were 8-3/4 x 11 inches.

The publication existed for only a short time. It was too labor intensive for the individuals involved. One write-up by the writer, on the publication cover, will be presented here.

### THE COVER<sup>3</sup>

"The attractive cover gracing this fifth publication on historical electric incandescent lamps is the artistic work of Mrs. John K. Burkley, Jr., of 6903 Marlborough Road, Stoneleigh, Baltimore, Maryland, sister of Dr. Hugh F. Hicks, Jr. It is the opinion of this writer, and I'm sure I speak for all the members, that the cover is superbly done and the Association will forever be indebted to Mrs. Burkley for the time and effort spent in its creation.

"At the top, in large letters, appears the publication name and in the lower left hand corner is found

**General Electric Company**

**THE MERIDIAN  
TANTALUM LAMP**



Meridian Ratings  
No. 1—40 watts 25 c.p.  
No. 2—80 watts 50 c.p.

A combination of the attractiveness of the Meridian Lamp, with the brilliant illumination and high economy of the Tantalum Lamp, which saves 20 per cent. over the regular Meridian Lamp.

**Saves its cost in a few hundred hours**

The 80-Watt size gives satisfactory lite on alternating current 60-cycle circuits.

Principal Office : SCHENECTADY, N. Y.  
Cincinnati Office : Perin Bldg., Fifth and Race Sts.  
Sales Offices in all large cities

the  
this new compound word (acronym).

source of

"The main lamp displayed is, of course, the Edison bamboo filament lamp of 1880, which had a wire terminal "base." This lamp was the first truly successful one to be used extensively by the public.

"Along the right hand side are some of the important steps in the early development of the lamp prior to the appearance of Edison's bamboo filament lamp. Starting from the top, we find first the 1820 lamp of De la Rue. This was probably the first attempt at making an incandescent lamp. The coiled platinum wire, which was purported to operate in a vacuum, appears to approximate the ideal conditions required in such a lamp.

"Below the lamp of De la Rue we find the 1841 lamp of De Moleyn. This was the first on which a patent was issued. It embodied both carbon and platinum, both of which were extensively explored separately years later.

"The third lamp is the 1878 lamp of Farmer (U. S. 213,643), which employed a graphite rod operating in nitrogen gas. While the employment of

nitrogen with carbon in such an arrangement is in reality detrimental to the burner, the idea of the use of gas in a lamp was later shown to be possible by the introduction of the Langmuir lamp in 1913.

"In 1860 Swan operated a strip of carbonized paper at incandescence under a bell jar with vacuum conditions. The procedure of carbonization of fibrous material was well established before the successful work of Edison. This setup is illustrated below Farmer's lamp.

"As early as 1845 a carbon rod was operated in a Torricellian vacuum. J. W. Starr performed the experiment and such a setup is shown in the sixth illustration from the top of the cover.

"The seventh and last lamp to be illustrated is the all-glass lamp devised by Swan in 1878. The slender carbon illuminate operated in vacuum.

"This brief and highly inadequate description of these lamps partly is the result of the lack of sufficient information on them. Thus, while lamps after 1880 are apt to be the only ones to find their way into our collections, an important area of research in the future should extend to the early years before Edison."

Persons interested in the publication were: George Reynolds Brown, Dr. Hugh Francis Hicks, Jr., Floyd Lyons, Fin Stewart, Dr. Charles D. Wrege and Edward J. Covington. All were lamp collectors with the exception of Dr. Wrege, who is an historian.

Write-ups were distributed in 1961-1963. These were:

- 1) Edward Covington □ Suggestions for Lamp Topics; "The Novak Lamp" □ Oct 16, 1961
- 2) Dr. Hugh F. Hicks, Jr. □ "The Development and Manufacture of the Edison Bamboo Lamp" □ Aug 1, 1962
- 3) Edward Covington □ "The Cover"; "Preface"; "Stopper Lamps" □ May 1, 1963
- 4) Fin Stewart □ "The Philips Lamp, 1891-1935" □ May 29, 1963
- 5) Edward Covington □ "Tantalum Lamps", a Supplement □ Aug 5, 1963
- 6) Dr. Charles D. Wrege □ "James Billings Fuller: An Incandescent Lamp Mystery" □ Dec 2, 1963
- 7) Floyd Lyons □ "The Hylo" □ Dec 15, 1963
- 8) Fin Stewart □ "The Nernst Lamp" □ ?
- 9) G. R. Brown □ "Dating Edison Lamps, 1880-1905" □ ?

It should be mentioned that in addition to the write-up on Fuller, Dr. Wrege also wrote articles about Dr. Isaac Adams, Jr., and it was he who pointed out his very important writings on William Edward Sawyer and John Wellington Starr.

A revival of the TILCA publication was attempted by Jerry R. Westlick in Jan 1998, but again, the effort required to achieve an on-going paper of this sort is huge and unless the tasks can be shared by other individuals it can be short-lived.

### The Helion Lamp

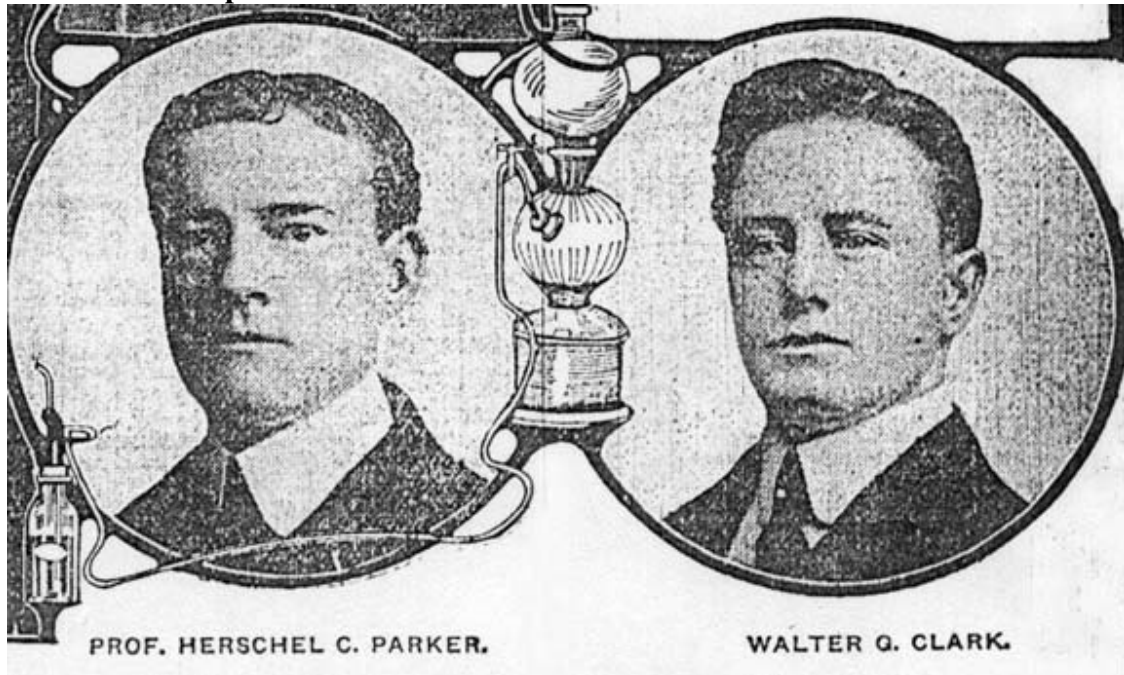

In the time period 1907-1908 many articles appeared in the literature regarding an incandescent lamp called the "Helion." The workers who spent much time developing that lamp were physics Professor Herschel C. Parker and Electrical Engineer Walter G. Clark. Much of this work was performed in Professor Parker's laboratory at Columbia University. The lamp was called the Helion, from the Greek word "helios", because its spectrum was closer to that of the sun than was the spectrum of the carbon filament lamp.

The Helion lamp had a selective radiator filament which was made with a carbon filament core onto which silicon was deposited. The lamp was much more efficacious than the carbon filament lamp. Lamps were made for a short period of time<sup>13</sup> □ apparently by the Parker-Clark Electric Company. It is assumed that the lamp did not become a commonplace item because the metal filament lamps, such as tantalum, osmium and tungsten were being introduced at the same time.

Listed below are patents granted to Parker and Clark during the time period 1905-1910. The patent that describes the Helion filament is U. S. No 876,331.

<u>No.</u>	<u>Inventor(s)</u>	<u>Date</u>	<u>Description</u>
788,493	HCP	Apr 25, 1905	Incandescent Electric Lamp
805,316	HCP	Nov 21, 1905	Art of Producing Metallic Iridium
812,872	HCP	Feb 20, 1906	Incandescent Electric Lamp
821,056	HCP	May 22, 1906	Incandescent Electric Lamp
840,246	HCP & WGC	Jan 01, 1907	Art of Making Refractory Metallic Wires or Filaments
876,330	WGC	Jan 14, 1908	Process of Making Incandescent-Lamp Filaments
876,331	HCP & WGC	Jan 14, 1908	Process of Making Electric-Lamp Filaments
876,332	WGC	Jan 14, 1908	Process of Making Incandescent-Lamp Filaments
876,390	HCP & WGC	Jan 14, 1908	Incandescent Electric Lamp
974,812	HCP	Nov 8, 1910	Process of Making Incandescent Electric Lamp Filaments
976,207	HCP & WGC	Nov 22, 1910	Filament or Resistor for Heating Units or Lamps

HCP=Herschel C. Parker; WGC=Walter G. Clark

The appearance of the 115-volt Helion lamp was very similar to that of the Edison oval anchored filament carbon lamp.

**Note:** The picture of Parker and Clark was scanned from the *New York Times* article<sup>4</sup>.

### Acknowledgements

Ken Spooner kindly informed me of the *New York Times* article. The Public Documents & Patents Department of The Public Library of Cincinnati and Hamilton County was, as usual, most helpful in my research efforts.

### References

- 1) H. C. Parker and Walter G. Clark, "Helion Filament Incandescent Lamp," *Electrical World*, Vol 49, Jan 5, 1907, pp 10-11.
- 2) Editorial, *Electrical World*, Vol 49, No 3, Jan 19, 1907, pp 129-130.
- 3) "The Helion Filament Incandescent Lamp," *Electrical Review*, Vol 50, No 3, Jan 19, 1907, pp 111-113.
- 4) "Columbia Professor Invents a Helion Filament... Promises New Era in Illumination," *New York Times*, Feb 3, 1907, pg 5.
- 5) "Helion Lamp," *Electrical World*, Vol 49, No 6, Feb 9, 1907, pg 290.
- 6) William J. Hammer, "Electric Lighting by Incandescence," *Electrical Review*, Mar 9, 1907.
- 7) Highlights of article by Parker and Clark, *Electrical World*, Vol 50, Oct 5, 1907, pg 681. Article apparently in July 1907 issue of *School of Mines Quarterly*.
- 8) "Helion Incandescent Lamp Filament Patents," *Electrical World*, Vol 51, Jan 18, 1908, pg 133.
- 9) "The Helion Incandescent Lamp," *Electrical World*, Vol 51, Jun 27, 1908, pp 1364-1365.
- 10) "Progress in the Development of the Helion Lamp," *Electrical Review*, Vol 52, Jun 27, 1908, pg 1039.



- 11) H. C. Parker and W. G. Clark, "The Helion Lamp," *Electrical World*, Vol 52, No 10, Sep 5, 1908, pp 501-502.  
 12) H. C. Parker and W. G. Clark, "The Helion Lamp," *Electrical Review*, Vol 53, Sep 12, 1908, pg 397.  
 13) Arthur A. Bright Jr, The Electric-Lamp Industry: Technological Change and Economic Development from 1800 to 1947, The MacMillan Company, New York, 1949, pp 199-200.



FIG. 5.—TRI-LIGHT REGULATING KEY-SOCKET AND LAMP COMPLETE.

### Tri-Light Regulating Key-Socket and Lamp

One might think that the three-light level socket and lamp that are now used in living rooms are relatively new products. That is not the case, however; such a lamp and socket existed over 100 years ago. Quoting from an article in *American Electrician*<sup>1</sup>:

"An incandescent lamp capable of giving light of three different intensities, and of yielding a consequent saving in energy, is shown by Fig. 5, herewith. These results are obtained by the use of a multi-filament lamp and a multi-contact socket, which resembles the ordinary socket in appearance, but which has an ingenious construction of socket contacts by which the connections of the lamp filaments are varied, and consequently a different intensity of light is obtained. In the case of the 16-c.p. double filament lamp shown, turning the key once throws both filaments in series, and gives a light of approximately 2 candle-power; a second turn leaves but a single filament in circuit, giving a light of 8 candle-power; and a third turn throws in both filaments, giving a light of 16 candle-power. A fourth turn of the key throws both filaments out of circuit

and extinguishes the light. The Pinchard "Tri-light" lamps are manufactured by the Tri-light Electric Company, of Birmingham, Ala., for maximum candlepowers of 8, 10, 16, 32, 50 and 100. Any standard Edison-base lamp can be used with the Tri-light socket, and Tri-light lamps can be used with any standard Edison socket; but in the former case no gradation of light is obtained, and in the latter case but one filament gives illumination. The key socket is connected up in the ordinary manner, as is also the wall socket. With keyless sockets holding lamps in places of inconvenient access, a

special regulating switch is used. Where ordinary sockets are already in use, a combined socket and attachment plug, made with the Edison, Thomson-Houston or Westinghouse base, is furnished, which screws into the existing socket. Charles I. Hills, of New York, is the general sales agent of the company."

The stamping on the socket reads:  
 "PINCKARD"  
 "TRI-LIGHT"  
 "HUSSEY PATENTS"

SOCKET"

**Reference**

1) "A New Regulable Incandescent Lamp," *American Electrician*, Vol 14, No 5, May 1902.



**Zenith Incandescent Lamps**

In the year 1903 the New York and Ohio Company, of Warren, Ohio, manufactured Meridian lamps which they called "Zenith." These can be seen in the photograph to the left. These were shown in the *American Electrician*<sup>1</sup> and the text is reproduced here:

"Fig. 8 herewith shows the Zenith incandescent lamp made by the New York and Ohio

Company, of Warren, Ohio. The lamp is intended as an intermediate between the arc lamp and the ordinary incandescent lamp. It is made in two sizes, 25 and 55 candle-power, at efficiencies of 1.9 and 2.5 watts per candle-power, depending on the size and voltage. The lamp gives a particularly brilliant, yet soft, white light, which is evenly distributed beneath the lamp. The range of voltage of this lamp is from 90 to 150, and it is furnished regularly in Edison base, but can be furnished also in T. H. base. The filament is located in the bulb with reference to the polished aluminum reflector which performs an important function. The lamp can be used on

either direct or alternating current and requires no attention during its life. The lamp is fitted with a simple collar adapted for use on any style or fixture or furnished complete with ceiling stem as shown by Fig. 7."

The name "Zenith" was trademarked in 1903 (No. 41,456).

### Reference

1) "Zenith Incandescent Lamps," *American Electrician*, Vol 15, No 8, Aug 1903, pp 432-433.

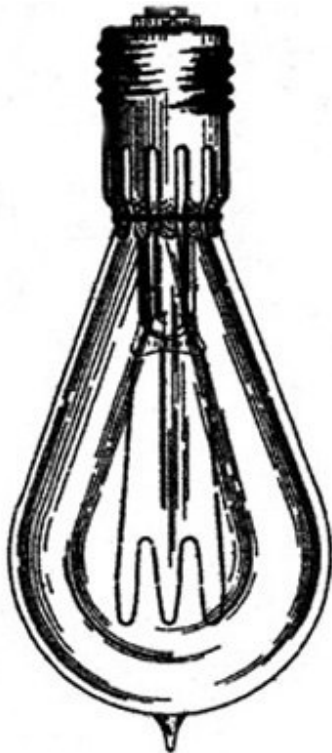

### The Albert Miller Lamp

The complete story that describes an early incandescent lamp is quite often difficult to determine. That is certainly true about a lamp that probably was marketed in the first five years of the 20th century. It is often referred to as a "Miller" lamp.

The lamp shown to the left can be found in Miller's Patent No. 708,653, dated Sep 9, 1902<sup>2</sup>. The configuration of the lamp located to the far left below, although apparently covered by the Sep 9th patent, can be seen in Miller's Patent No. 797,593, dated Aug 22, 1905<sup>8</sup>. The "typical" lamp found today is usually of the straight-sided bulb shape, shown by the two lamps located to the left below. An exception to this bulb shape is the lamp shown to the right, which is in the Jerry R. Westlick Collection. The larger paper label on that lamp states: Miller Patent Sept 9th, 1902. Md. Am. Elec. Co. St. Louis. A smaller circular label states: 4/115.

A description of the Miller lamp, which follows, appeared in a technical periodical<sup>3</sup>:

"The accompanying illustration shows an incandescent lamp which is being placed upon the market by the Missouri American Electric Company, St. Louis, Mo., one of the features of which is a detachable base. The base consists of a porcelain insulating button and a cap or sleeve with the usual socket thread. The sleeve has three ears, and a wire passing around these, as shown in the illustration, securely fastens the base to the bulb. By this means the base is held against lateral rotation, and against longitudinal withdrawal by the wire strapping the lugs below a moulded shoulder of the bulb. When the filament is burned out, the neck of the lamp is cut below the sleeve, thereby enabling the stem which carries the filament to be pulled out. A new filament may then be mounted and the neck fused together at the point of cutting. The original bulb may be used or a new bulb fused on, as desired.

"Among the advantages of this base is that the removably attached sleeve does away with the use of cement or plaster of paris; and not only is a much stronger attachment made to the bulb, but there is no porous material present to gather dirt and moisture."

The separation of base from the bulb is shown in the center picture below<sup>4</sup>.

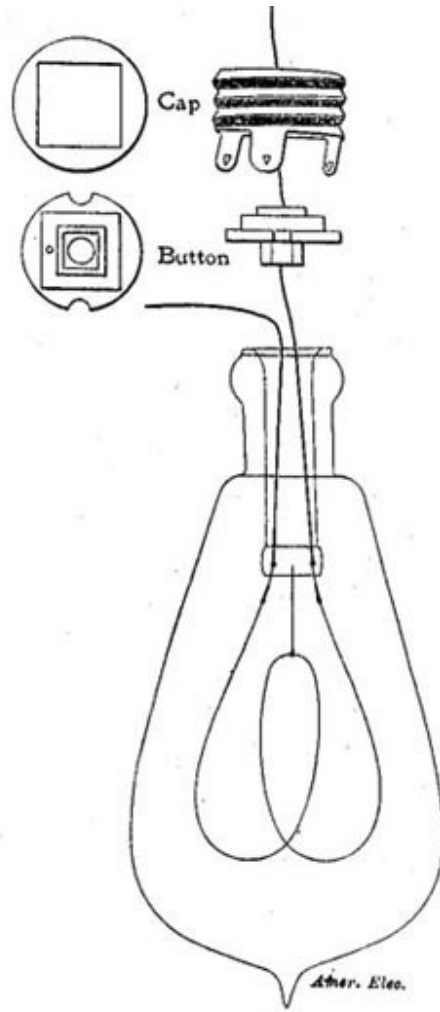
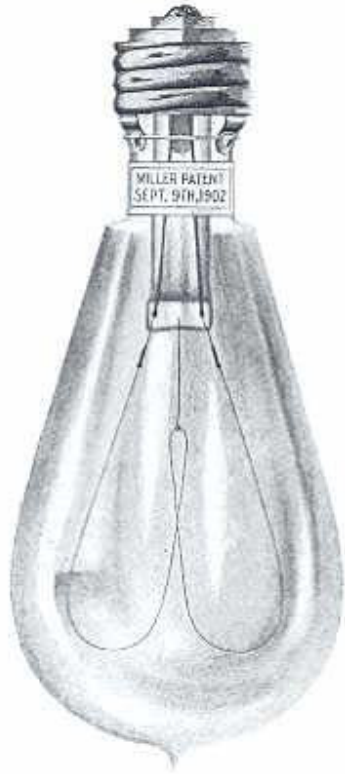



Two "related" patents were granted to George P. McDonnell<sup>5, 7</sup>, who also assigned his patents to the American Electric Company. McDonnell's idea was to reduce the protruding glass tip by flaming it after lamp manufacture and then allowing atmospheric pressure to move the glass inside the bulb, as shown in the patent pictured below. McDonnell used the Miller lamp in his illustration. However, it is not known if this technique was ever used on production lamps..

No. 793,211.

PATENTED JUNE 27, 1905.

G. P. McDONNELL.

METHOD OF AND APPARATUS FOR FINISHING ELECTRIC LAMPS OR BULBS.

APPLICATION FILED NOV. 3, 1904.

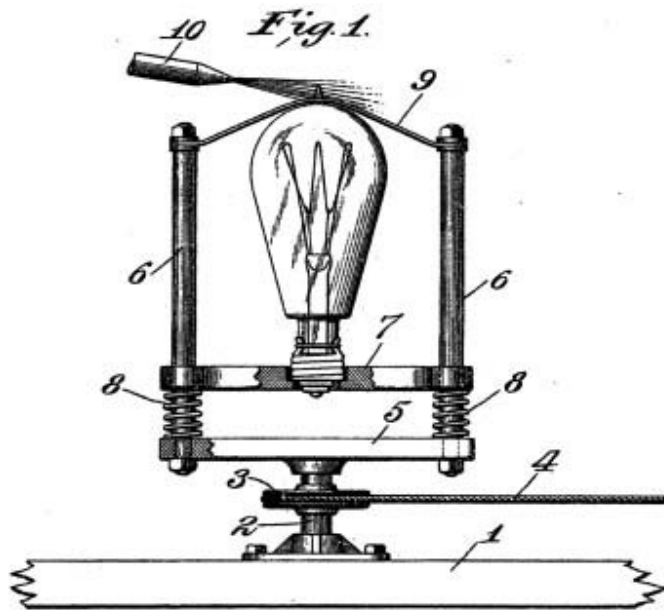

Fig. 3.



Witnesses:

*G. A. Pennington*  
*Ralph Walsh*

Fig. 2.



Inventor:  
*George P. McDonnell,*  
by *Rakewell Cornwall*  
*Attys.*

## References

and

## Bibliography

- 1) "Symmetrical Distribution from Incandescent Lamps," *American Electrician*, Vol 13, Oct 1901, pg 513.
- 2) Albert W. W. Miller, "Incandescent Electric Lamp," U. S. Patent No 708,653, Sep 9, 1902. The patent was assigned to the General Electric Company on Dec 7, 1906.
- 3) "The Miller Incandescent Lamp," *Electrical World and Engineer*, Vol 42, No 4, Jul 25, 1903, pp 154-155.
- 4) "Miller Incandescent Lamp," *American Electrician*, Vol 15, No 8, Aug 1903, pg 431.
- 5) George P. McDonnell, "Electric Lamp," U. S. Patent No 786,231, Mar 28, 1905.

6) "New Form of Incandescent Lamp," *Electrical Review*, Vol 46, No 22, Jun 3, 1905, pg 906.

7) George P. McDonnell, "Method of and Apparatus for Finishing Electric Lamps or Bulbs," U. S. Patent No 793,211, Jun 27, 1905.

8) Albert W. W. Miller, "Incandescent Electric Lamp," U. S. Patent No 797,593, Aug 22, 1905. The patent was assigned to the General Electric Company on Dec 7, 1906.

### Economical

### Regulating

### Lamp

Several turn-down, or regulating, lamps appeared in the marketplace in the early 1900s. Two versions of such lamps were manufactured by the Economical Electric Lamp Company of New York and are shown below and to the left. A brief article<sup>2</sup> that describes the lamps follows:

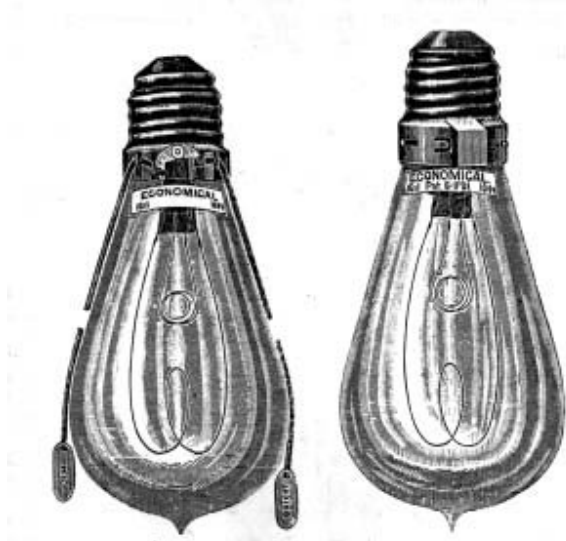

FIG. 6.—REGULATING INCANDESCENT LAMP.—FIG. 6-A.

"Figs. 6 and 6A illustrate a regulating incandescent lamp which is said to possess the important qualification of being economical in current per candle-power when it is turned down. The lamps are capable of giving two degrees of light, full candlepower or one candle-power.

"Fig. 6 shows a lamp designed to be used in any fixture, the operation of changing from one degree of light to the other being performed by the aid of two strings

suspended from the lamp base. Pulling one string gives the full candle-power and pulling the other string results in a light of one candle-power. The light can thus be changed without touching the bulb. On the outside of the base a little switch is provided which cuts in one or the other filament according to which of the strings is pulled. There are three terminals, the base of the lamp constituting the common terminal for one end of each of the two filaments, and the second and third terminal points representing the other ends of the filaments. Another design of this lamp is shown by Fig. 6-A, in which the variation of light is effected by turning the bulb of the lamp in its socket. The base of this lamp is provided with a sliding outside shell which is screwed into the socket in the usual manner. This sliding shell bears the two terminals which shift positions under the contact on the stationary base as the lamp is turned. The lamps are made in two sizes, 8-1 and 16-1 candle-power for all standard sockets, by the Economical Electric Lamp Company of New York."

The lamp shown above and to the right has a paper label that gives the patent date for that lamp. On that date, Jun 11, 1901, U. S. Patent No. 676,074 was issued to John McCullough<sup>1</sup>. The first page of that patent can be seen in the upper left-hand corner of the images below. The lamp shown on the left above appears to be similar to the lamp image



shown below in the upper right-hand corner<sup>3</sup>. Two other lamps are shown below that represent other lamps that were patented<sup>4,5</sup>.

No. 676,074.  
**J. McCULLOUGH,**  
 INCANDESCENT ELECTRIC LAMP.  
 (Application filed Apr. 9, 1901.)  
 Patented June 11, 1901.  
 (No Model.)

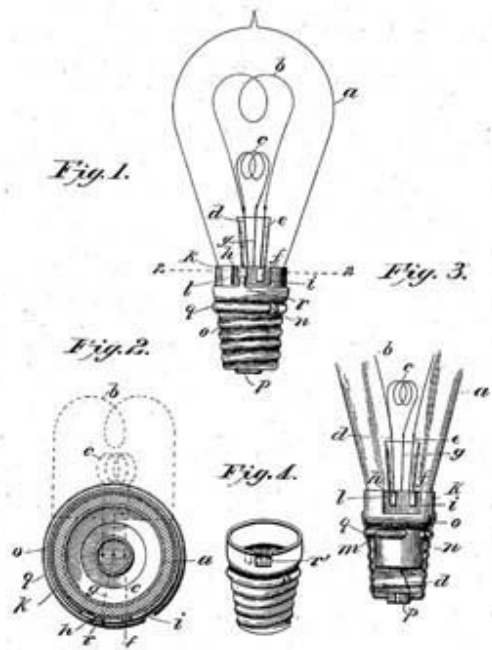

Witnesses  
*C. H. Walker*  
*Wm. H. H. Hall*

*John McCullough, Inventor*  
 by *Samuel H. Gray*  
 his Attorney

No. 732,644.  
**L. LOBENTHAL & J. McCULLOUGH,**  
 SWITCH FOR DOUBLE FILAMENT ELECTRIC LAMPS.  
 APPLICATION FILED DEC. 20, 1900.  
 Patented June 30, 1903.  
 NO MODEL.

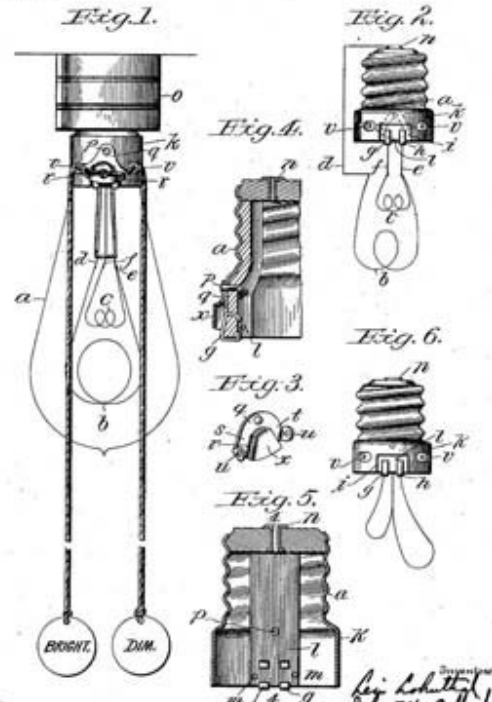

Witnesses  
*C. H. Walker*  
*Wm. H. H. Hall*

*L. Lobenthal*  
*John McCullough*  
*Wm. H. H. Hall*  
 their Attorneys

No. 740,369.

PATENTED SEPT. 29, 1903.

J. McCULLOUGH.

SWITCHING MECHANISM FOR DOUBLE FILAMENT ELECTRIC LAMPS.  
APPLICATION FILED DEC. 19, 1901.

NO MODEL.

Fig. 1.

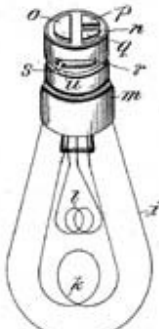
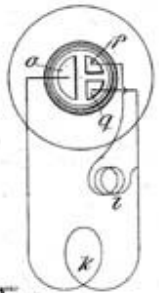

Fig. 3.



Inventor  
John McCullough  
Attorney



Fig. 4.



Fig. 5.



Inventor  
John McCullough  
Attorney

No. 817,146.

PATENTED APR. 3, 1906.

J. McCULLOUGH.

SWITCHING DEVICE FOR ELECTRIC LAMPS.  
APPLICATION FILED JULY 23, 1902.

Fig. 1.



Fig. 4.



Inventor  
John McCullough  
Attorney

Fig. 2.

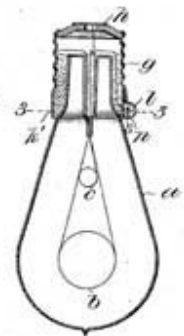
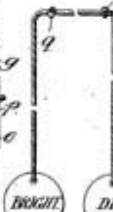

Fig. 6.



Inventor  
John McCullough  
Attorney

The National Electric Lamp Company purchased 65% of The Economical Company on 15 Oct 1905<sup>6</sup>; the Lobenthals still owned 35% of the stock. In 1911 the company became part of the General Electric Company.

## References

- 1) John McCullough, "Incandescent Electric Lamp," U. S. 676,074, dated Jun 11, 1901.
- 2) "Regulating Incandescent Lamp," *American Electrician*, Vol 14, No 8, Aug 1902, pp 413-414.
- 3) John McCullough and L. Lobenthal, "Switch for Double Filament Electric Lamps," U. S. 732,644, dated Jun 30, 1903.
- 4) John McCullough, "Switching Mechanism for Double Filament Electric Lamps," U. S. 740,369, dated Sep 29, 1903.
- 5) John McCullough, "Switching Device for Electric Lamps," U. S. 817,146, dated Apr 3, 1906.
- 6) Edward J. Covington, Franklin Silas Terry (1862-1926), Industrialist - Paragon of Organization, Harmony and Generosity, 1994, Printed by Graphic Communications, GE Lighting Business Group, E. Cleveland, OH 44112, pg 80.

## The Story of Electricity

A Popular and Practical Historical Account  
of the Establishment and Wonderful  
Development of the Electrical Industry

To those collectors of early incandescent lamps who have an interest in the individuals and companies that played significant roles in lamp development and manufacture it might be of value to point out a book that details much in one source. The two-volume work is titled The Story of Electricity\* and was written by T. Commerford Martin and Stephen Leidy Coles. Some of the subjects that are of interest to this writer are:

<b>Volume</b>							<b>One</b>
Page	before	135	-	photograph	of	H. M.	Byllesby
Pages		135-139	-	H. M.		Byllesby &	Co.
Page	before	145	-	photograph	of	Edgar G.	Bernard
Page		145	-	Edgar		G.	Bernard
Page	before	155	-	photograph	of	Edward Allen	Colby
Pages		155-156	-	Edward		Allen	Colby
Page		157	-	photograph	of	Walter Gordon	Clark
Pages		157-158	-	Walter		Gordon	Clark
Page	before	165	-	photograph	of	John B.	Crouse
Pages		165-167	-	John		B.	Crouse
Page	before	167	-	photograph	of	J. Robert	Crouse
Pages		167-168	-	J.		Robert	Crouse
Page	189	-	photograph	and	biographical	sketch	of William David Coolidge
Page	before	197	-	photograph	of	Samuel Everett	Doane
Pages		197-198	-	Samuel		Everett	Doane
Pages	before	211	-	photograph	of	Thomas Alva	Edison
Pages		210-213	-	Thomas		Alva	Edison
Pages		222-224	-	Dr.		Colin G.	Fink
Page	223	-	photograph	of	Dr.	Colin G.	Fink
Pages		252-255	-	William		Joseph	Hammer
Page	253	-	photograph	of	Major	William J.	Hammer
Page		271	-	photograph	of	Irving	Langmuir
Pages		271-272	-	Irving			Langmuir
Page	280	-	photograph	and	biographical	sketch	of Hermann Lemp
Page	302	-	photograph	and	biographical	sketch	of Daniel McFarlan Moore
Page	before	415	-	photograph	of	Charles Proteus	Steinmetz
Page		415	-	Charles		Proteus	Steinmetz
Page	before	423	-	photograph	of	Franklin S.	Terry
Page		423	-	Franklin		S.	Terry
Page	before	125	-	photograph	of	Elihu	Thomson
Pages		425-426	-	Elihu			Thomson
Page	432	-	photograph	and	biographical	sketch	of Francis Robbins Upton
Pages		434-436	-	Charles		Joseph Van	Depoele
Page	before	435	-	photograph	of	Charles J. Van	Depoele

Page 452-453 - photograph and biographical sketch of Willis R. Whitney  
Page before 541 - photograph of W. C. Bryant  
Page 541 - Waldo Calvin Bryant  
Page 559-560 - Independent Lamp & Wire Company  
Page 602 - The Peerless Electric Company  
Page before 607 - photograph of Edwin Wilbur Rice, Jr.  
Page 607 - Edwin Wilbur Rice, Jr.

**Volume** **Two**  
Pages 9-28 - The Story of the Arc Lamp  
Page 19 - photograph of William Stanley  
Page 22 - photograph of Charles F. Brush  
Page 28 - photograph of Peter Cooper Hewitt  
Pages 35-49 - Story of the Incandescent Lamp  
Pages 357-358 - John Kruesi  
Page before 359 - photograph of John Kruesi  
Pages 401-403 - James J. Wood  
Page 402 - photograph of James J. Wood  
Pages 404-406 - George Westinghouse  
Page 404 - photograph of George Westinghouse  
Pages 413-414 - The Cooper Hewitt Lamp

\* T. Commerford Martin and Stephen Leidy Coles, The Story of Electricity, The Story of Electricity Company, M. M. Marcy, 711-731 Tribune Building, New York City, Vol 1, 1919; Vol 2, 1922.

**Nela** **Park**  
- **A Brief Early History** - **Terry Management Style**  
**and**  
**Incandescent Lamp Advances**

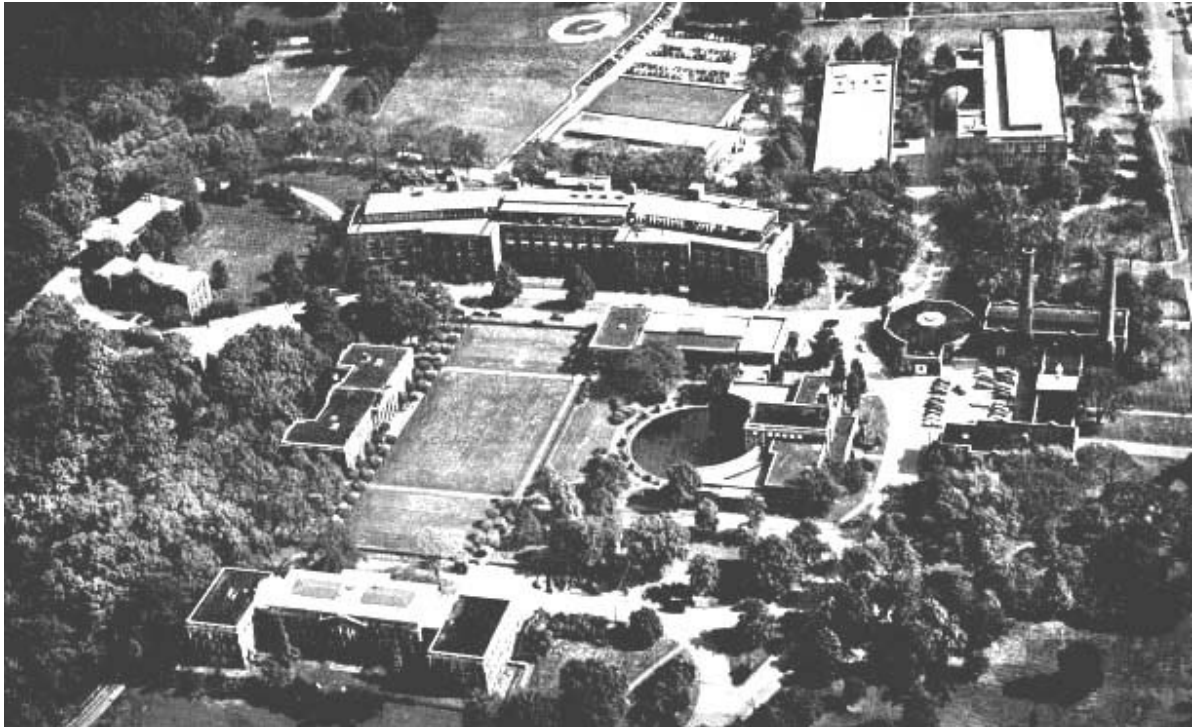

An aerial view of Nela Park. Picture scanned from Keating's 1954 book<sup>3</sup>



The General Electric Lighting Institute at Nela Park

This website displays topics dealing mainly with the electric incandescent lamp, but the formation of a lamp facility in the early part of the 20th century is so unique in its character that the two subjects will herein be treated together. The formation of the physical facility of the headquarters of the General Electric Lighting Business Group (Nela Park) in East Cleveland, Ohio is an important story in itself and the subject will be briefly considered. The word "Nela" is an acronym for "National Electric Lamp Association".



### **Formation of an Industrial Park**

In the latter part of the 19th century the incandescent lamp industry was in a precarious position. Following many court battles in the 1890s, led mainly by the General Electric Company, independent manufacturers were in a competitive battle that had driven prices below the cost of manufacture. In order to be able to make money from their products, in some cases lamp quality had to suffer. The possibility of lowering lamp quality was a condition that prompted action of some sort. A solution to this problem was to be promoted primarily by Franklin S. Terry (shown to the left), the founder, in 1889, of the Sunbeam Incandescent Lamp Company of Chicago.

At an early date a Mr. Potter of the Buckeye Electric Company of Cleveland spearheaded a movement to consolidate the small independent manufacturers in an effort to strengthen one and all, excluding, of course, the General Electric Company. Then, in the winter of 1900-1901 Franklin Terry attended a banquet in Chicago given by electrical supply dealers<sup>5</sup>. He was seated next to Burton Gad Tremaine, who had financial interests in several businesses and, with others, had founded the Fostoria Incandescent Lamp Company in Ohio in 1897. Burton Tremaine was interested in what Terry had to say. Terry, too, had been advocating consolidation of the independents with the purpose of sharing research results, but in a friendly competitive manner. What followed is history. The National Electric Lamp Company was formed in 1901 by five individuals: Franklin Silas Terry, Burton Gad Tremaine, John Bernard Crouse, Henry Abner Tremaine and John Robert Crouse.

The five men founded National - with the help of the General Electric Company! GE agreed to put up 75% of the needed capital and remain as a silent partner. They did have an option to obtain the other 25% of the stock. It was an unusual arrangement. At the insistence of Terry and Tremaine, there was to be no person from General Electric involved in the running of National.

The unusual consolidation allowed National to set up laboratories so that all companies that joined the consolidation were free to use the results generated through testing. The individual companies could not afford such facilities. Thus, all companies could receive laboratory results but still remain competitors of the other companies. The idea behind this bold move was simply to compete on the basis of quality. In effect there was not to be any management interference from the National managers, Terry and Tremaine. However, help was extended if the individual companies asked for it. From the standpoint of the small companies, they had the best of all worlds. They continued to operate as though they were independent but they could benefit from the laboratories at the National headquarters in Cleveland. The plan worked - lamp quality eventually reached high levels. In addition, the member companies of National became formidable "competitors" of the General Electric Company. When National was formed, the lamp output from all the companies amounted

to about 20% of the total lamp production - with General Electric accounting for 80%. However, the ratio was about 50-50 by 1910.

Although the business climate had improved, in 1911 the U. S. Government brought suit against the main lamp manufacturers because of the activities of the Association of Licensed Manufacturers of Incandescent Lamps. At that time GE exercised its option to purchase the remaining 25% of the National stock, and National officially became part of General Electric.

By the year 1911 the Engineering Department of National was maintained by 19 separate companies.

The name of the National Electric Lamp organization changed during the period 1901 to 1925<sup>4</sup>:

National	Electric	Lamp	Company	(1901)
National	Electric	Lamp	Association	(1906)
National	Quality Lamp	Division of	General Electric Company	(1911)
-----	Move-in date	to Nela Park	from 45th Street	location (1913)
National	Lamp	Works	of General Electric Company	(1914)
Incandescent	Lamp	Department	of General Electric Company	(1925)

### **Terry's Management Style**

In time it was Terry's management style that became so honored it eventually resulted in what was called the Authority Reserved System, and was adopted for many years by the General Electric Company. Keating<sup>3</sup> devoted a few pages to explain this system. Part of what he said follows:

"Instead of line organization the National Lamp Works chose what may be called the 'unit system,' for want of a better name. The company structure was divided into units of such a size that the manager in charge of each one could be personally acquainted with each worker and well informed about his or her abilities, current and potential.

"The manager had full responsibility for his unit in every practical respect. If it produced favorable results according to well-defined measuring sticks, he received the credit. If it failed to produce satisfactory results he was also held primarily responsible.

"At the same time, the manager had full *authority* in all matters concerning his unit, except for such minimum authority as was specifically reserved for the general manager of the National Lamp Works. *That was the key factor* in making National's organization different from the usual business operation."

One can quote from several bulletins issued by Terry and Tremaine, but perhaps one will suffice to indicate what their views were regarding the employer-employee relationship. In 1916 a bulletin was issued titled "Success of Employees." In part, it read:

"We do not know of any other one thing in business that is more wasteful than inefficient employees, and in addition to our loss it is positively unkind for us to subject an individual to the disappointment of unnecessary failure.

"If an employer were subject to a fine for the failure of an employee, he would use greater care in engaging a new employee and also in instructing him in his work.

"Such failure does cause us a loss of money, and probably more than we often realize, and it may so discourage the individual as to prevent his obtaining an occupation for which he is really fitted and in which he would have made a success. We have at least shown ourselves to be inconsiderate.

"It is our desire to be as helpful to our employees as is practicable - this for reasons both of humanity and self-interest. We should know that those who are in charge of our employees understand and carry out our policy. It is for us to discover those who are not doing this and to change their attitude, or if this is impossible, to discontinue their services.

"The question of appreciation on the part of employees for what we may do for them has nothing to do with the fulfillment of our responsibility. An employee may be willing to do most anything for an increase in pay, but that is not a good reason why we should allow him to do such things as to work under conditions that will injure his health.

"Our responsibility for an employee does not end with our merely giving him employment and paying him. We should do those things for an employee that we can afford to do and that he is in need of and can get in no other way. We are not obligated to take upon ourselves all of the personal and private burdens of an employee, but we are expected to give an employee such assistance for improvement in health, education and in his finances as lies within the reasonable scope of our own knowledge and opportunities."

It should be clear that Terry was concerned with the well-being of his employees. That concern distinguished him from many employers of the day. Perhaps he felt that way because he was always trying to build something, or trying to make things better than what they were before. He considered how business decisions would affect the worker. That is not to say that hard times didn't bring hard decisions. The accumulation of personal wealth was not a consuming activity for him. Public loyalty to the GE name exists yet today, and that is due in some measure to Franklin Terry's management style.



Work conditions at Nela Park were as good as one might hope for and probably exceeded what the average person expected. Franklin Terry strove to make conditions for the worker as pleasant and fruitful as possible. The campus-like atmosphere certainly cannot be underestimated in the beneficial influence on the workers. Terry purposely chose a rural setting rather than constructing a tall building in downtown Cleveland. Analysis showed that the cost for the expanded rural setting would be no more than the cost of a downtown building. In addition to the stately buildings the remaining area at Nela Park is most unusual. The ground is a virtual arboretum. Along the sidewalk of a quadrangle area Globe elm trees are planted that were obtained in England. The drive in from the main entrance is lined with American elm trees. At least one of the oak trees in a camp area (which includes a swimming pool) dates to the days of Moses Cleaveland (1796). Other specimens in the Park include oak trees of the black, chestnut, pin, red and white varieties. Honeylocust, Ginkgo and horsechestnut trees are some of the other varieties.

### **Frank E. Wallis, Architect**

Terry was able to interest one of the most respected architects in the United States to design the buildings at the proposed site, which was located at the eastern edge of greater Cleveland. To gain an appreciation of the person chosen, a biographical sketch<sup>6</sup> of the architect, Frank E. Wallis, follows.

"Wallis, Frank E., architect, was born in Eastport, Me., June 14, 1862... Mr. Wallis was educated in private and public schools in Boston, Mass., and began at an early age in the office of Cabot and Chandler of Boston (1876-85). He spent the year of 1885-86 in travel and study in Europe and on his return traveled from Massachusetts to Georgia sketching and measuring colonial architecture and furniture. These sketches and drawings were published in book form under the title of 'Old Colonial Architecture and Furniture' (1887), the first collection of measured drawings on colonial architecture to appear in America. It was received with enthusiasm and formed a part of nearly every architecture library. In 1888 he became associated with Richard M. Hunt (q.v.) of New York, and they practised together until Mr. Hunt's death, a period of more than ten years. This was the great palace building era. Mr. Wallis worked with Hunt on the Astor, Gerry and Vanderbilt homes, the Marble House, Biltmore and other famous residences, most of which, unfortunately, gave way to huge apartment houses and sky scrapers. It was during this time that the famous Trinity church doors were executed from Mr. Wallis' designs. Following Mr. Hunt's death, he opened his own office in New York. In the later years of his practice, he designed many Gothic buildings, believing that the perpendicular architecture was best suited to the present day needs of crowded cities. But it was Georgian, or American Colonial, that was his real love. More than any other architect, Wallis is credited with the revival of interest in early colonial, on which he was considered a leading authority... His career as an architect culminated in the industrial group of buildings for the National Lamp Works of the General Electric Company at Nela Park, Cleveland, O. Georgian in style, they were the finest in the country, recalling their English prototypes, particularly the Judges' house and other stately

mansions in the close at Salisbury, bits of Bath and Wells, where he spent much time absorbing atmosphere for what he said would be his 'swan song.' After its completion in 1922 he retired from active practice and lived in France. The work and influence of the French guilds of the 13th century had been an interesting study with him and he now devoted much of his time translating histories of the guilds from original sources, consulting French authorities and delving into monastic records and chronicles with the intention of writing a book on the subject. His 'History and Influence of the French Guilds of the 13th Century' was almost completed when he died. He compiled another series of measured drawings, 'American Architecture Decoration and Furniture' (1890), and also wrote 'How to Know Architecture' (1910), the latter illustrated with photographs of American buildings designed in good style and taste. Mr. Wallis received a gold medal from the French government for his colonial exhibit at the Paris exposition and a diploma by congress for his work on the administration building at the Columbian exposition, Chicago, in 1893. He was a delegate from New York to the 10th annual housing conference at the Hague in 1913, and to the eleventh international congress of architects in Amsterdam in 1927... He took great pride in his profession and his contribution to it; he wanted his epitaph to be 'An Honest Architect'... He died in Paris, France, Mar. 21, 1929."

In addition to Wallis designing the buildings at Nela Park, during the period of 1919-1921 he also designed the manor house at Terry's estate at INTHEOAKS, Black Mountain, North Carolina<sup>5</sup>.

In 1910 Frank Wallis wrote a long letter<sup>2</sup> to Franklin Terry to comment on the description Philip Dodd gave of Terry in his book<sup>1</sup>, Developing An Industry. An excerpt from that letter follows:

"...I very naturally congratulate you on the fact that you are labelled in your book as the 'practical dreamer' because, after all, the greatest force in the world today for progress, is that peculiar faculty 'Imagination', which the dreamer possesses to an unlimited degree, as every vital force and every real thing in life is first dreamt of, and then constructed..."

### **Improvements and New Lamps Achieved at Nela Park**

Many of the incandescent lamp advances that were developed at Nela Park have already been covered on this website. Certainly one of the oldest and most important achievements is the wire developed by Dr. Aladar Pacz, which minimized droop and sag. The wire is used worldwide by manufacturers of lamps. Without that development the gas-filled lamp developed by Nobel Laureate Irving Langmuir would have had a difficult time achieving the success that describes the actual case. Other achievements that have stood the test of time are the developments of Marvin Pipkin. In 1925 he developed a way to give the bulb a diffusing coating. His technique involved an inside etch that did not weaken the glass. Then, in 1949, he developed an inside coating of silica on the bulb that resulted in today's "Soft White" lamps. The development of the tungsten-halogen lamp in 1959 is another

achievement that has altered the way lighting has been employed, especially in the commercial field. The development of a halogen lamp with an infrared coating in 1989 has allowed lamp efficacy to exceed 30 lumens per watt. This value is to be compared with the efficacy of Edison's first commercial lamp, 1.68 lumens/watt, an increase by a factor of about 18.

### **Some Incandescent Lamp Advances at Nela Park**

1915-----Development of nonsag tungsten wire by Dr. Aladar Pacz  
 1917-----Patent to Burnie Lee Benbow for doubly coiled tungsten wire  
 1919-----Development of the Mitchell-White tipless exhaust method  
 1924-----Development of inside frosting of lamp bulbs by Marvin Pipkin  
 1932-----Bipost construction first used. Patent to Daniel K. Wright  
 1938-----PAR lamps (projector spot and flood) introduced  
 1939-----Introduction of all-glass sealed beam automobile headlighting -  
 Daniel K. Wright and Alfred Greiner  
 1949-----Development of coating on bulbs by Marvin Pipkin; lamps are  
 known as "Soft White"  
 1959-----Introduction of halogen incandescent lamp - Elmer Fridrich, Dr.  
 Edward Zubler and Frederick Mosby  
 1975-----Precise MR16  
 1989-----Halogen-IR Par Lamp

### **References**

- 1) Philip S. Dodd, Developing An Industry, Cleveland, 1910.
- 2) Letter from Frank E. Wallis to Franklin S. Terry, Sep 30, 1910.
- 3) Paul W. Keating, Lamps for a Brighter America - A History of the General Electric Lamp Business, McGraw-Hill Book Company, Inc., New York, 1954.
- 4) Hollis L. Townsend, A History of Nela Park - 1911-1957, 1957.
- 5) Edward J. Covington, "Franklin Silas Terry (1862-1926), Industrialist - Paragon of Organization, Harmony and Generosity", Printed by Graphic Communications Operation of GE Lighting at Nela Park, East Cleveland, Ohio, 1994.
- 6) "Frank E. Wallis", The National Cyclopaedia of American Biography, Vol 22, pp 208-9.



**E. Q. Adams**  
 Elliot Quincy Adams (Sep 13, 1888 - Mar 12, 1971) had an extraordinary scientific career that included government, industrial and university settings. His work career at Nela Park extended from 1921 to 1949, when he retired. His contributions to the lamp business were of a scientific nature and, as such, were not widely known. Perhaps his most recognized effort was the book, coauthored with W. E. Forsythe, titled Fluorescent and Other Gaseous Discharge Lamps.

E. Q. Adams was the son of Edward Perkins and Etta Medora (Elliot) Adams. He graduated from Medford

High School in Medford, MA. He was a descendant of a John Adams from Cambridge, MA, who lived about the year 1650. It should be mentioned that a brief review of Adams' life work was poignantly written by D. S. Tarbell (*Journal of Chemical Education*, Vol 67, No 1, pp 7-8, Jan 1990). One should consult that reference for a more extensive biographical sketch than what is presented here.

Adams attended the Massachusetts Institute of Technology and earned a bachelor's degree in Chemical Engineering in 1909. His undergraduate thesis was probably done under the direction of Gilbert Newton Lewis (1875 - 1946).

Adams took a position with the General Electric Research Laboratory in Schenectady, New York, where he worked with a future Nobelist, Irving Langmuir, on problems dealing with heat transfer. **It was Adams who provided the simple mathematical formula that is used to describe the conduction-convection loss from an incandescent filament operated in a gaseous atmosphere.** That formula has been used by lamp engineers since its formulation in 1912.

E. Q. Adams moved to Berkeley, California in 1912 for the purpose of working for a doctorate degree at the University of California. He earned his Ph. D. degree in 1914 under the direction of G. N. Lewis, who had moved there.

In 1917 Adams went to Washington, D. C. to do research in the Color Laboratory in the Department of Agriculture. That research was part of the effort during World War I.

A statement by Tarbell in the quoted paper is worth mentioning. It read:

"Lewis (G. N.) is reliably reported to have said that the two most profound scientific minds, among the people he had known, were those of E. Q. Adams and Albert Einstein."

At Nela Park Adams studied a variety of subjects. These ranged from "Fireflies, Phosphorus and Other Cold Lights" to "Physics in the Metal Industry" to descriptions of the fluorescent lamp. Adams published over 40 technical papers.

E. Q. Adams was a Fellow of the American Association for the Advancement of Science, American Physical Society, Mineralogical Society of America and the Illuminating Engineering Society. He was presented the Silver Beaver Award by the Boy Scouts of America in 1941.

Adams married Jane J. Pidgeon and they had a daughter, Dora.

Dr. Adams passed away in the Leonard Hanna House of the University Hospitals, Cleveland.

**Note:** The slightly altered photograph of Dr. Adams was downloaded from the website of the American Institute of Physics, Emilio Segrè Visual Archives:

[http://www.aip.org/history/esva/catalog/esva/Adams\\_Quincy.html](http://www.aip.org/history/esva/catalog/esva/Adams_Quincy.html). The main webpage can be found at <http://www.aip.org/history/esva> "Copyright (c) 2001 American Institute of Physics." I appreciate permission to use this photograph of Dr. Adams.

### General

Edward J. Covington, Makers of National - The Spirit and People of an Industrial Organization, Printed by Graphic Communications Operation, GE Lighting, Nela Park, E. Cleveland, OH 44112, 1997.

### Reference



### Mary R. Andrews

Many persons contribute to the growth of an industry but their contributions are often lost in time because they weren't major players and therefore didn't receive the press coverage that others received. An example is Mary R. Andrews (1884-1934), whose biographical sketch<sup>1</sup> is presented here.

Mary Ruggles Andrews was a native of Delhi, Ohio and was born on Jan 11, 1884. She earned a Bachelor of Science degree in Physics at the Massachusetts Institute of Technology. She first worked in the GE Research Laboratory during the period 1906-1908. That was the time period when the GEM carbon filament incandescent lamp reigned king; squirted tungsten filaments were just coming into the marketplace and W. D. Coolidge had yet to develop ductile tungsten. That was also the time when the Research Laboratory was in its infancy. It was about that time that Mary Ruggles met William C. Andrews and was married. The Andrews moved to New Jersey where Mr. Andrews worked as a report writer for Thomas A. Edison. Mary Andrews did not return to GE until 1918. During those intervening years the Andrews wanted to raise a family and two daughters were born to them. Unfortunately William C. Andrews passed away when one of the daughters, eventually Mrs. Willem F. Westendorp (Mary Andrews Westendorp; b 11 Sep 1909, d 23 Jul 1996)<sup>2</sup> of the Schenectady area, was just six years of age (ca 1903).

After the death of her husband Mary Andrews moved to the Bronx, a borough of New York City, and from 1916 to 1918 worked at the Rockefeller Institute for Medical Research. At that time Dr. J. Loeb, a renowned physiologist and superb experimental biologist, headed the division of experimental biology. Mrs. Andrews worked with Loeb for a period of time but then decided to return to GE in Schenectady.

At the Research Laboratory in Schenectady Mrs. Andrews' general areas of expertise included: x-ray analysis of alloys, formation of tungsten carbide and the electron emission therefrom, getters, and absorption of gases by the metals tungsten and tantalum.

Patents issued to Mrs. Andrews were U. S. 2,019,331, for an electric incandescent lamp (carbides of refractory metals), and U. S. 2,072,788, for a tantalum carbide lamp. Tantalum

carbide was reexamined as a possible filament material again in the 1960s at Nela Park. It is an enticing candidate for an incandescent filament material. However, a tremendous challenge is presented to maintain its structural stability. It was a challenge in the 1960s and so it has to be concluded that Mrs. Andrews had tackled a very complex problem when she chose that particular material. A tantalum carbide lamp has never, to this writer's knowledge, been marketed; however, that is not to say that it won't be someday.

Mrs. Andrews was a coworker of Dr. Saul Dushman, of vacuum technology fame, and together they coauthored many scientific articles. Much of the work performed in that time period (1920s and early 1930s) was related to other lamp work, such as that performed by Nobel Prize winner Irving Langmuir. Some of their work certainly must be considered first steps away from the traditional empirical studies usually performed with incandescent lamps.

Mary R. Andrews passed away in the latter part of 1934 at age 50.

### **Acknowledgement**

The writer was fortunate to be able to communicate with Mrs. Westendorp in 1992. She provided the photograph of her mother as well as other personal information.

### **References**

- 1) E. J. Covington, Women Scientists - Biographical Sketches and Their Contributions to the G.E. Lamp Business, Nela Press, GE Lamp Business Group, Jan 1992.
- 2) Social Security Death Index.

**E.**



**J.**

**Bagnall**

In the March 4, 1893 issue of the *Western Electrician* an article<sup>1</sup> appeared that profiled some of the members of the recently organized St. Louis Electric Club. One of the members highlighted was E. J. Bagnall.

"E. J. Bagnall, is 37 years of age and was born in England, but reached America when 4 years old. A large part of his life was spent in Cleveland, where he early identified himself with the Brush company at the beginning of electric light work, and was with that company for many years as foreman. In 1885 he came to St. Louis, and leased the newly constructed Brush arc station, and operated it in partnership with A. W. Dutton. When this company, with the other arc lighting companies of

the city, was merged into the United Electric Light company, Mr. Bagnall was appointed general superintendent of all the plants, and continued to occupy that position until the stations were absorbed by the Municipal company. Mr. Bagnall was intimately connected with the early work in storage batteries in St. Louis, having charge of the work done by the Lindell Railway company. In 1887, when the Lindell Railway company established

its electric power plant, he was appointed electrician, which position he held until a few weeks ago, when ill health forced him to give up his duties and take a trip to Cuba."

In 1895 the Swan Lamp Manufacturing Company of Cleveland closed and a new company was formed by five men<sup>2</sup>. One of the founders was E. J. Bagnall. The company was named the Adams-Bagnall Electric Company and Bagnall was to be in charge of dynamo and motor construction. The new company was to make arc lamps, incandescent lamps and possibly railway motors.

One of the employees of the new company was Samuel Edward Cox, who had worked for the Brush Electric Company. He was granted U. S. Patent No. 548,036 for a design of a tipless lamp. It was marketed as the "A-B" lamp.

Note: The image of Mr. Bagnall was obtained from the *Western Electrician* article.

### References

- 1) "St. Louis Electric Club", *Western Electrician*, Vol 12, No 9, Mar 4, 1893, pg 102.
- 2) Edward J. Covington, Incandescent Lamp Manufacturers in Cleveland, 1884-1905, Printed by Nela Press, GE Lighting Business Group, E. Cleveland, Ohio, 1999.



### Forée

### Bain

A biographical sketch of Forée Bain appeared in 1891<sup>3</sup>, at which time he was president of the Bain Manufacturing Company. A portion of that sketch is reproduced here:

"Mr. Bain was born in La Grange, Oldham county, Kentucky, in 1853. He is a direct descendant of the Scotch electrician of telegraph fame, Alexander Bain, whose logic and moral science are standard works. Mr. Bain has come honestly by his reputation as an electrical engineer. When 15 years of age he was in charge of a telegraph station. In 1878 he was appointed manager of the electrical work in an extensive electrical manufactory in Cincinnati. For several years he remained in that position, developing an electric lighting

system.

"In 1881 Mr. Bain came to Chicago to exploit his electric lighting system. He formed a company with Captain E. A. Goodrich of the Goodrich Transportation company, and the corporation organized a large manufacturing establishment. The death of Mr. Goodrich necessitated the close of the factory."

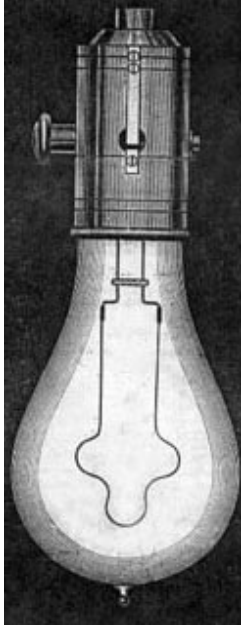

A Bain lamp design appeared in the technical literature<sup>1</sup>, and is shown to the left, but it is not known if it actually was produced.

The limited description of the lamp follows:

"The incandescent lamp has not yet been put on the market. Its novelty consists in the manner of connecting the filament with the leading-in wires, and in the material of which the filament is composed. Mr. Bain has not patented either the manner of connection or the process of manufacture, preferring to keep them secret. The holder is made almost entirely of wood, and while presenting a handsome appearance, has the essential quality of cheapness."

Bain also designed an instrument for the U. S. Government which measured current, voltage and resistance<sup>2</sup>.

By February of 1893 the Bain Electric Manufacturing Company consolidated with several other companies to form the Great Western Manufacturing Company<sup>6</sup>. Bain had charge of the electrical work at the factory.

## References

- 1) *The Electrical World*, Vol 7, Feb 6, 1886, pg 56.
- 2) "Combined Galvanometer, Ammeter and Voltmeter," *Western Electrician*, Vol 2, No 12, Mar 24, 1888, pg 145.
- 3) "Forée Bain", *Western Electrician*, Vol 8, No 12, Mar 21, 1891, pg 157.
- 4) "A Peculiarly Marked Incandescent Lamp", *Western Electrician*, Vol 11, No 5, Jul 30, 1892, pg 60.
- 5) Forée Bain, "Invention of the Incandescent Lamp", *Western Electrician*, Vol 12, No 5, Feb 4, 1893, pg 51.
- 6) "Great Western Manufacturing Company," *Western Electrician*, Vol 12, No 6, Feb 11, 1893, pp 63-65.
- 7) F. B. Bain, Letter to the editor, *Electrical Review*, Vol 25, No 9, Aug 29, 1894, pg 100.

## Edgar

## G.

## Bernard

In bygone days incandescent lamps often appeared in the marketplace that were not manufactured by the large companies, such as, for example, General Electric or Westinghouse. One such manufacturer was in business in Troy, New York in the time frame of about 1890-1902. The president of the company was Edgar G. Bernard.

The writer was employed in Schenectady, New York in 1958 when he started to collect early incandescent lamps as a hobby. In late 1960 a newspaper article appeared in the *Schenectady Gazette* regarding the lamp collection<sup>1</sup>. Then, a few weeks later a similar article appeared in *The Record Newspapers*, which was published in Troy, New York<sup>2</sup>. In addition, the writer inserted a classified advertisement in the Troy newspaper for the purpose of purchasing early lamps.



As a result of the advertisement, word was received from a Troy resident who had a chest full of early lamps for sale. Among the lot of lamps were six that had been manufactured by the Bernard Company. These lamps had Thomson-Houston and Westinghouse bases rather than the screw-type Edison base which is standard in the United States today.

As a result of the Troy newspaper article a letter was received from a granddaughter of Bernard<sup>3</sup>. The following was extracted from the letter:

"E. G. Bernard was an electrical contractor. He started at the age of 17 when he obtained his first experience by installing an arc-light plant in NY City for Booth's theatre. This was in 1879. With the appearance of the incandescent lamp he entered into isolated-plant lighting, which field he was probably the first to work systematically as a salesman and also as an engineer in the development of constructional details. In 1884 he became chief sales agent and constructing engineer for the Sawyer-Man(n) Co., continuing in the same capacity with its successor, the Consolidated Electric Light Co.

"When the latter was purchased by the Westinghouse Co., about 1888, he remained in charge of the textile-mill work shortly before establishing his own business in Troy in 1890.

"A few years later he began the manufacture of dynamos and motors specially adapted to his line of work, which he continued until satisfactory machines could be obtained elsewhere.

"His electrical activities covered a wide range, including in early days, town arc and incandescent lighting. Much of his work was special in character, such as the installation of 7000 lamps in the capital at Albany in 25 working days. Practically all of this work was of special construction. He installed the generator and motor equipment of the US Arsenal at Watervliet and did the marine installation work for the US Navy yard at Brooklyn and for other ship yards.

"When I sold his summer home just a few years ago I left a barrel of bulbs in the tower house. They were called B and B bulbs.

"He was an intimate friend of GE's Steinmetz, Bell, Marconi and Edison. His association with Steinmetz probably stemmed from winding armatures and making dynamos for his company."

The six Bernard lamps recovered from the chest in Troy had a "square" label and were also marked "B and B".

## **References**

- 1) "A New Twist to Old Light Bulbs", *Schenectady Gazette*, Oct 20, 1960.

- 2) "Early Electric Bulbs Were Made In Troy", *The Record Newspapers*, Dec 17, 1960, pg B2.
- 3) Letter from Elizabeth Bernard Miller to the writer, Jan 11, 1961.

### **Katharine B. Blodgett**



The advancement of the incandescent lamp was due to the efforts of numerous persons, many of whom are little noted, or not noted at all, in the annals of the technical literature. One such person is worthy of mention as she also achieved success in other areas quite apart from the incandescent lamp. Her name was Katharine B. Blodgett (1898-1979).

Katharine Blodgett was, perhaps, the most celebrated of the women scientists who worked at the General Electric Research Laboratory in Schenectady, New York. While Mary Andrews, another scientist, was closely associated with Dr. Saul Dushman, of kenotron, pliotron and vacuum technology fame, Katharine Blodgett was associated with Dr. Irving Langmuir, 1932 Nobel Laureate in Chemistry. Besides being the first woman scientist with a doctorate at the GE laboratory, Dr. Blodgett was also the first woman to earn a Ph. D. degree in Physics from Cambridge University in Cambridge, England. In 1924 she studied with Sir Ernest Rutherford at the Cavendish Laboratories. She was the first woman to receive the Photographic Society of America Award and the American Chemical Society honored her with the Francis P. Garvin Medal.

Katharine Burr Blodgett was born in Schenectady, New York on January 10, 1898. Schenectady was also to be the location of her final resting place. After attending Bryn Mawr and receiving a B.A. degree in physics, she earned an M.S. degree at the University of Chicago before her sojourn to Cambridge, England.

Quoting from *Current Biography* 1952, page 56:

"The invention of the 'color gauge,' which permits film measurement within one microinch, began with Dr. Blodgett's discovery in December 1933 that monomolecular layers of stearic acid, each about one ten-millionth of an inch in thickness, could be successively deposited on to a plate lowered into the solution. This enabled her to construct films in a series of progressive thicknesses, of which each reflects a characteristic color in white light. Her method of depositing sheets of barium stearate on plates enables a standardized color gauge to be constructed. 'Anyone who wishes to measure the thickness of a film which is only a few millionths of an inch thick,' she said, 'can compare the color of his film with the series of colors in the gauge. The step on the gauge that matches his film in color will give him a measure of its thickness.'

"...The General Electric Company announced in December 1938 that Katharine Blodgett had succeeded in developing a nonreflecting 'invisible' glass. Ordinary glass is visible because of the light rays which are reflected from its surface, and when a film is placed upon the glass, Dr. Blodgett discovered that a coating of forty-four layers of one-molecule-thick transparent liquid soap, of about four-millionths of an inch or one-fourth the average wave length of white light, made sheets of glass invisible. Since the reflection from the soap film neutralizes the reflection from the glass itself, the crests and troughs of the two sets of light waves cancel each other, thereby eliminating reflected light. At the same time, the soap varnish is a good conductor of light, permitting 99 per cent of the light striking it to pass through. The one aspect of Dr. Blodgett's work on nonreflecting glass requiring further research was the development of harder coatings which could not be wiped off. Some of the applications of the invention are seen in automobile windshields, shop windows, showcases, cameras, spectacles, telescopes, picture frames, and submarine periscopes...."

Dr. Blodgett passed away in her home at 18 North Church Street, Schenectady, NY at 7:00 A. M., October 12, 1979.

**Published Articles by Katharine B. Blodgett**

- 1) "The Relative Adsorption of Mixtures of Oxygen and Nitrogen in Cocanut Shell Charcoal," *Proceedings of the National Academy of Sciences*, Vol 5, 1919, pp 289-295 (with Harvey B. Lemon).
- 2) "Studies of the Adsorption of Gases by Charcoal. II," *Physical Review*, Vol 14, Nov 1919, pp 394-402 (with Harvey B. Lemon).
- 3) "Currents Limited by Space Charge between Coaxial Cylinders," *Physical Review*, Vol 22, 1923, p 347 (with Irving Langmuir).
- 4) "Currents Limited by Space Charge between Concentric Spheres," *Physical Review*, Vol 23, p 49, 1924, (with Irving Langmuir).
- 5) "A Method of Measuring the Mean Free Path of Electrons in Ionized Mercury Vapour," *The London, Edinburgh and Dublin Philosophical Magazine*, Ser. 7, Vol 4, 1927, pp 165-193.
- 6) "Exponential Yield of Positive Ions in Argon," *Proceedings of the National Academy of*

- Sciences*, Vol 15, 1929, pp 230-234.
- 7) "Effect of End Losses on the Characteristics of Filaments of Tungsten and other Materials," *Physical Review*, Vol 35, pp 478-503, 1930 (with Irving Langmuir and Saunders MacLane).
- 8) "A Film Which Adsorbs Atomic H and Does Not Adsorb H<SUB>2</SUB>," *Journal of American Chemical Society*, Vol 54, 1932, pp 3781-3782 (with Irving Langmuir).
- 9) "Accommodation Coefficient of Hydrogen: a Sensitive Detector of Surface Films," *Physical Review*, Vol 40, pp 78-104, 1932 (with Irving Langmuir).
- 10) "Irving Langmuir," *Journal of Chemical Education*, Vol 10, Jul 1933, pp 396-399.
- 11) "The Design of Tungsten Springs to Hold Tungsten Filaments Taut," *Review of Scientific Instruments*, Vol 5, p 321, 1934 (with Irving Langmuir).
- 12) "Monomolecular Films of Fatty Acids on Glass," *Journal of American Chemical Society*, Vol 56, Feb 1934, pg 495.
- 13) "Interference Colors in Oil Films on Water," *Journal of the Optical Society of America*, Vol 24, No 12, Dec 1934, pp 313-315.
- 14) "Films Built by Depositing Successive Monomolecular Layers on a Solid Surface," *Journal of the American Chemical Society*, Vol 57, Jun 1935, pp 1007-1022.
- 15) "A New Method of Investigating Monomolecular Films," *Kolloid-Zeitschrift*, Vol 73, 1935, pp 257-263 (with Irving Langmuir).
- 16) "Properties of Built-up Films of Barium Stearate," *Journal of Physical Chemistry*, Vol 41, pp 975-984, 1937.
- 17) "Built-up Films of Barium Stearate and Their Optical Properties," *Physical Review*, Vol 51, pp 964-982, 1937 (with Irving Langmuir).
- 18) "A Method of Extinguishing the Reflection of Light From Glass," *Science*, New Series, Vol 89, No 2299, Jan 1939, pp 60-61.
- 19) "Use of Interference to Extinguish Reflection of Light from Glass," *Physical Review*, Vol 55, Feb 15, 1939, pp 391-404.
- 20) "A Gauge that Measures Millionths of an Inch," Excursions in Science, Edited by Neil B. Reynolds and Ellis L. Manning, Whittlesey House, New York, 1939, pp 255-263.
- 21) "Fresnel Formulae Applied to the Phenomena of Nonreflecting Films," *Physical Review*, Vol 57, May 15, 1940, pp 921-24.
- 22) "A Silica Gauge for Measuring Thickness by Means of Interference Colors," *Review of Scientific Instruments*, Vol 12, Jan 1941, pp 10-14.
- 23) "Electrically Conducting Glasses," *Journal of American Ceramic Society*, Vol 31, 1948, pp 89-100 (with R. L. Green).
- 24) "Surface Conductivity of Lead Silicate Glass after Hydrogen Treatment," *Journal of American Ceramic Society*, Vol 34, 1951, pp 14-27.
- 25) "Birefringent Steppage," *Science*, New Series, Vol 115, No 2993, May 9, 1952, pp 515-516.
- 26) "Removal of Copper from Germanium," *Journal of Applied Physics*, Vol 26, 1955, pp 1520-1521.
- 27) "Cleanup of Atomic Hydrogen," *Journal of Chemical Physics*, Vol 29, No 1, Jul 1958,

- pp 39-43.
- 28) "Mechanism of Argon Cleanup in a Gas Discharge," Gaseous Electronics Conference, October 1958; [Abstract] see *Bulletin of the American Physical Society*, Series II, Vol 4, pg 111, 1959 (with T. A. Vanderslice).
- 29) "Mechanism of Inert Gas Cleanup in a Gaseous Discharge," *Journal of Applied Physics*, Vol 31, Issue 6, Jun 1960, pp 1017-1023 (with T. A. Vanderslice).
- 30) "Electrical Cleanup in Ionization Gauges," *Transactions of the National Vacuum Symposium*, Vol 8, 1961, pp 400-405, (with T. A. Vanderslice).

U. S. Patents	Issued	to	Katharine Blodgett
- Patent No.	- Date	-	Description
1) 2,220,860	- Nov 05, 1940	-	Film structure and method of preparation
2) 2,220,861	- Nov 05, 1940	-	Reduction of surface reflection
3) 2,220,862	- Nov 05, 1940	-	Low-reflectance glass
4) 2,493,745	- Jan 10, 1950	-	Method of making electrical indicators of mechanical expansion (with Vincent J. Schaefer)
5) 2,587,282	- Feb 26, 1952	-	Step gauge for measuring thickness of thin films
6) 2,589,983	- Mar 18, 1952	-	Electrical indicator of mechanical expansion (with Vincent J. Schaefer)
7) 2,597,562	- May 20, 1952	-	Electrically conducting layer
8) 2,636,832	- Apr 28, 1953	-	Method of forming semiconducting layers on glass and article formed thereby

Canadian Patents	Issued	to	Katharine Blodgett
- Patent No.	- Date	-	Description
1) 404,963	- May 26, 1942	-	Surface reflection reducing method
2) 405,126	- Jun 02, 1942	-	Low refractance glass

**Katharine Blodgett's Father**  
 Katharine Burr Blodgett (1898-1979) was the daughter of George Reddington Blodgett (1862-1897) and Katharine Buchanan (nee Burr) Blodgett (ca 1865 - ?). Miss Blodgett spent her entire working career with the General Electric Company at her father's final place of employment.

George R. Blodgett was a native of Bucksport, Maine<sup>1</sup>. His academic career started at Phillips's Academy and in 1880 he entered Yale University, graduating in 1884 with honors. He was appointed an examiner in the United States Patent Office. He studied law at the Columbian University in Washington and was admitted to the bar. He started in law practice in New York City in 1888 and in 1889 moved to Boston, where he entered the firm of Benton & Blodgett, being counsel for the Thomson-Houston Electric Company.

In 1892 the Thomson-Houston Company joined with the Edison General Electric Company to form the present-day General Electric Company. The following year, 1893, Blodgett joined General Electric and in 1894 he was made chief of the patent group in Schenectady.

George Blodgett's life ended on December 4, 1897; he had been shot by a burglar in his home the day before. At the time of his death the Blodgett's had a son, George (ca 1895-ca 1954). Katharine, the subject of this writing, was born just a few weeks after her father's death. George, the son, married Isabel Arnold (1899 -1975); apparently he disappeared while piloting a small plane over the jungles of Costa Rica in the early 1950s<sup>21</sup>.

### Acknowledgement

The writer acknowledges and appreciates the use of the photograph of Dr. Blodgett shown above, which was scanned from *Hall of History News*, Vol 10, No 3, Spring 1992, Schenectady, NY. About 1960, while employed at the General Electric Research Laboratory, the writer had the opportunity to meet Dr. Blodgett and discuss stearate multilayers with her. Dr. Blodgett was most congenial and generous in her comments about this part of her past work.

### References

### and

### Bibliography

- 1) "George R. Blodgett Shot by a Burglar," *Electrical Review*, Vol 31, Dec 8, 1897, pg 277.
- 2) "Katharine Burr Blodgett, Jan 10, 1898- , Research Physicist", *Current Biography 1940*, pp 90-91.
- 3) Edna Yost, "Katharine Burr Blodgett (1898- ), American Women of Science, Frederick A. Stokes Co., Philadelphia, 1943, pp 196-213.
- 4) "Katharine Burr Blodgett," *Current Biography 1952*, pp 55-57.
- 5) J. B. Bateman and E. J. Covington, "Molecular Tilt in Fatty Acid Multilayers," *Journal of Colloid Science*, Vol 16, 1961, pp 531-548.
- 6) Norma Olin Ireland, "Katharine Burr Blodgett," *Index to Women of the World from Ancient to Modern Times: A Supplement*, 1963, pg 73.
- 7) J. B. Bateman, "Determination of Thickness and Refractive Index of Thin Films as an Approach to the Study of Biological Macromolecules," Ellipsometry in the Measurement of Surfaces and Thin Films, N. B. S. Misc. Publ. 256, Sep 15, 1964, pp 297-334.
- 8) Index to Women, N. O. Ireland, F. W. Faxon Co. Inc., Westwood, MA, 1970, pg 56.
- 9) D. den Engelsen, J. H. Th. Hengst and E. P. Honig, "An Automated Langmuir Trough for Building Monomolecular Layers," *Philips Technical Review*, Vol 36, No. 2, 1976, pp 44-46.
- 10) Public Information Release, GE Corporate Research and Development, Death of Katharine Burr Blodgett, October 12, 1979, 4 pages.
- 11) Alfred E. Clark, "Dr. Katharine Burr Blodgett, 81, Developer of Nonreflecting Glass," *New York Times*, Oct 13, 1979.
- 12) "Katharine Burr Blodgett", *Current Biography 1980*, pg 450.
- 13) Obituary. Katharine Burr Blodgett. *Who Was Who in America*, Vol 7 (1977-1981), pg 57.
- 14) "Katharine B. Blodgett", On the Shoulders of Giants, 1924-1946-The General Electric Story-A Photohistory, Volume III, Hall of History, Schenectady, New York, 1989, page 53, 70.
- 15) Langmuir-Blodgett Films, Edited by Gareth Roberts, Plenum Press, New York, 1990.
- 16) George L. Gaines, Jr., "Monolayers of Polymers," *Langmuir*, Vol 7, 1991, pp 834-839.
- 17) "Women Scientists-Biographical Sketches and Their Contributions to the GE Lamp

- Business", E. J. Covington, Jan 1992.
- 18) K. Thomas Finley and Patricia J. Siegel, "Katharine Burr Blodgett (1898-1979)", Women in Chemistry and Physics, A Biobibliographic Source, Edited by Louise S. Grinstein, Rose K. Rose, and Miriam H. Rafailovich, Greenwood Press, Westport, Connecticut, 1993, pp 65-71.
- 19) Abraham Ulman, "Langmuir-Blodgett Films", The Handbook of Surface Imaging and Visualization, Edited by Arthur T. Hubbard, CRC Press, New York, 1995, pp 277-288.
- 20) Jill Holman, "Katharine Burr Blodgett (1898-1979), Physicist", Notable Women in the Physical Sciences, A Biographical Dictionary, Edited by Benjamin F. Shearer and Barbara S. Shearer, Greenwood Press, Westport, Connecticut, 1997, pp 20-27.
- 21) Katharine Gebbie, "Katharine Blodgett," APS 2004 March Meeting. <http://www.aps.org/educ/cswp/events.cfm>
- 22) <http://www.longislandgenealogy.com/maltby/fam00594.htm>

-----

During the years 1957-1959 the writer served in the U.S. Army; after completion of Basic Training the next assignment was at Fort Detrick in Frederick, Maryland. At that time Ft. Detrick was a Biological Warfare Laboratory. The writer had the fortune to be assigned to a laboratory that was interested in studying thin films of protein molecules. These were studied optically after being deposited on Blodgett-Langmuir multilayers of stearates. Many substrates were built up and on December 19, 1958 a few of these slides were inserted into glass test tubes and taped off to protect them from dust and abrasion. These test tubes were opened on January 2, 2002 (43 years later) in order to take the photograph shown below. The chromium-plated glass slides, on which the multilayers are deposited, measure 25 mm x 75 mm.



From left to right, the number of barium-copper stearate double layers ( $49.50 \mu$  per double layer) on the slides are:

At left:	19,	61,	105,	148,	191,	234.							
Second from left:	18,	38,	61,	80,	105,	123,	148,	164,	191,	206,	234,	247.	
Second from right:												61,	80.
At right:													35-55.

The least number of layers is toward the top of the slide in this view.

-----  
 -----

### **The Murder of George R. Blodgett**

The newspaper articles regarding the murder of Katharine Blodgett's father are given here verbatim from the various issues of *The New York Times*. The references are given at the end of this write-up.



Reference 1 - "Schenectady, Dec 3. - George R. Blodgett, counsel of the General Electric Company in patent cases and one of the best-known patent lawyers of the country, was shot, and it is thought mortally wounded, by a burglar early this morning. The shooting occurred at Mr. Blodgett's residence, at 11 Front Street, this city.

"Shortly before 3 o'clock this morning Mr. Blodgett was aroused by his wife, who said that some one had entered the house and had come into the sleeping apartment. Mr. Blodgett sprang out of bed and encountered a burglar, who began backing toward the door that opened into the lighted hall. The burglar ordered him to throw up his hands.

"A moment later Mr. Blodgett sank upon his knees. It is not known whether he did this to escape a threatened shot, or in jumping quickly forward in the direction of the burglar he tripped and fell into that position. But while he was in that position, with his head toward the burglar, the latter fired. The bullet passed over his head and entered his back to the right of his spine and took a course downward.

"In the excitement of the moment Mr. Blodgett did not realize that he had been wounded. He rose quickly and pursued the man down the front stairs, but the latter, who was several steps in advance of him, escaped through the front door. The wounded man collapsed a moment later, and on the arrival of assistance, was carried into the house. He is at present in a critical condition.

"The attending physicians found it impossible to locate the bullet by probing, but the X rays revealed it in the pelvic cavity. The physicians are fearful of an internal hemorrhage or acute peritonitis, and have little hope of Mr. Blodgett's recovery. The General Electric Company has offered a reward of \$5,000 for the apprehension of the man who attempted to murder Mr. Blodgett, but thus far no trace of him has been discovered.

### **Two or Three in the Gang**

"Mrs. Blodgett, the only witness of the shooting, said to-night that her husband did not fire, and that he had no weapon with him. An early report that several shots were exchanged between himself and the intruder is accounted for by the fact that Mrs. Blodgett, as soon as she could find a loaded revolver, threw open one of the windows and discharged it several times to arouse the neighbors.

"An investigation showed that there were two, and perhaps three, burglars in the gang. They had cut the telephone wire leading into the house before commencing operations. The men evidently had been in the house a considerable time, as they had searched several rooms.

"A pile of Mr. Blodgett's clothes had been placed in the front hall, and under them were his little daughter's (actually his son's) silver knife and fork. The men had gathered in another heap a quantity of much more valuable plunder. All that they managed to carry off were a number of silver spoons and an old-fashioned silver sugar bowl from the sideboard of the dining room, the latter having the maker's name marked in old style stamped letters and 'N. York' instead of New York, and a few small trinkets.

"The police in all directions have been notified of the crime and of the large reward."

### **Another Murderous Assault**

"A member of the same gang that entered Mr. Blodgett's house is supposed to have committed a murderous assault about two hours earlier in the little hamlet of Town House, five miles from this city. The victim was John Cochrane, a farmer. Cochrane was in town yesterday afternoon with a load of poultry, butter, and eggs, and collected quite a large sum of money, and it is supposed that the burglars knew of this.

"Cochrane was awakened by two men in his room at 12:30 o'clock. He sprang up and grappled with one of the intruders. The second burglar hit Cochrane a terrific blow over the head with the butt of his revolver, knocking him down and rendering him unconscious. After assaulting Cochrane the burglars bound and gagged his aged wife and a young boy who lives with them. They then ransacked the house. The sum of money which Cochrane received yesterday was in the house, but the burglars could not find it. They secured a few dollars, however, a gold watch, and a few trinkets.

"Cochrane remained unconscious for a considerable time, and when he recovered he dragged himself to the house of the nearest neighbor and gave the alarm. A fruitless search was made for the burglars. Cochrane's condition is serious."

### **Mr. Blodgett's Career**

"George R. Blodgett is a descendant of an old New England family, and was born in Bucksport, Me., in 1862. He was prepared for college at Phillips Academy, Andover, Mass., and entered Yale in 1880, being graduated with honors four years later.

"Soon after his graduation he was appointed an examiner in the United States Patent Office. While holding this place he studied law in the Columbian University, in Washington, and was admitted to the bar. He began practice in this city in 1888, and a year later moved to Boston, where he entered the firm of Benton & Blodgett, counsel for the Thomson-Houston Electric Company.

"In 1893 he became associated with the General Electric Company, and when a year later its headquarters were removed to Schenectady, Mr. Blodgett went there as the chief of the patent department of the company. He soon attained a position of great influence in the General Electric Company, while in his private practice he gained a National reputation by his conduct of the case of the Tannage Patent Company vs. Zahn, as a result of which control of a large portion of the tanning business of the country came into the hands of the owners of the Schultz patents. It has been said of Mr. Blodgett that no other lawyer in the country was his equal as an expert in electrical matters.

"F. P. Fish of Fish, Richardson & Storrow, counsel for the General Electric Company, speaking of Mr. Blodgett last night, said: 'He is one of the few men whose loss would be absolutely irreparable.'

"Mr. Blodgett was married six years ago, and has an infant son."

Reference 2 - "Schenectady, Dec. 4 - George R. Blodgett, who was shot by a burglar early yesterday morning, died this afternoon. The man who killed him is still at liberty.

"Yesterday afternoon Dr. Vanderveer, Dr. Willis G. McDonald and Dr. Richardson of Albany, and Drs. W. A. Pearson, Louis Faust, and William P. Faust of this city performed an operation on the wounded man. The physicians refused to make any statement at the time, but since Mr. Blodgett's death they have issued the following: 'We opened the abdominal cavity and traced the course of the ball. It had entered the back and gone forward and downward, striking the pelvis on the right side. The ball had deflected from the pelvic bone and perforated the intestines.' Mr. Blodgett's sufferings before his death were so intense that he was thrown into convulsions.

"The police late today started on a new clue from Hoffmans, a small village eight miles west of here. About 4 o'clock yesterday morning a party of three men made an attempt to enter the village grocery. They were frightened away by the barking of a dog. The print of a 1-1/4-inch carpenter's chisel was left on the jamb of the grocery door. It is thought these may have been the same men who committed the burglaries at Cochrane's and at the Blodgett house."

Reference 3 - "Schenectady, Dec 9 - The inquest in respect to the death of George R. Blodgett was begun this evening. A number of witnesses were examined, but no new light was thrown on the killing of Mr. Blodgett. Mr. Blodgett was counsel for the General Electric Company. He was shot by a burglar Dec. 3 and died the following day."

Reference 4 - "Saratoga, Dec. 14 - 'Buck' Davis, an ex-convict and a desperate burglar, is under arrest here. Burglar's tools, dynamite, a loaded revolver, and a mask were found on him. He drove here from Schuylerville at midnight with a 'pal' who escaped.

"Davis is believed to be the murderer of George R. Blodgett of the Edison Electric Company, in Schenectady. Detectives from that city are expected here to endeavor to identify Davis, who gave his name as 'Ed Brown'".

Reference 5 - "Schenectady, March 27. - Detective George S. Docherty, who has been working on the murder of George R. Blodgett ever since it occurred in this city on Dec. 3, believes that at last he has found the key to the mystery. Mr. Blodgett, who was the patent attorney for the General Electric Company, was shot by a burglar while defending his property, and died two days later. A reward of \$5,000 offered by the General Electric Company brought a score of detectives to this city. They all worked in vain, however, for there apparently was not the slightest clue.

"All gave up the task except Docherty, and he believes now that when he had William, alias 'Buck' Davis arrested in Troy yesterday, he landed a participant in the crime. Davis is a notorious crook and burglar, and it is known that he was in Schenectady the day before the murder was committed. He was arrested on a bench warrant charging burglary and larceny on May 14, 1891. The warrant was dated March 8, 1898, and was signed by District

Attorney White of Washington County. The crime was the blowing open of a safe at Greenwich. The real reason for his arrest, however, was that the evidence against him in the Blodgett murder case had become so strong that Docherty decided to have him placed in custody. As there was no indictment against Davis in Schenectady County, it was decided to arrest him on the Washington County charge.

"Docherty refuses to divulge what evidence he has against Davis, but says he is confident that he is one of the men concerned in the murder."

Reference 6 - Schenectady, N.Y. April 16. - Mr. and Mrs. John Cocklin, an aged couple living about eight miles from this city, in the town of Glenville, were brutally assaulted by two robbers on Dec. 3 last. They were placed on a red-hot stove and tortured in other ways. The night of this crime was the same as on which George R. Blodgett, the General Electric patent attorney, was murdered by burglars, and it has been generally believed that both acts were committed by the same persons.

"In Salem, Washington County, yesterday, Mr. and Mrs. Conklin positively identified 'Buck' Davis, the burglar, as the man who had tortured and robbed them. Careful arrangements were made in advance for a thorough test of identification. Davis and seven fellow-prisoners were lined up with their faces to the wall when Mr. and Mrs. Cocklin entered the room. Without hesitation they both picked out Davis as one of their assailants. It will be remembered that all of the robbers were masked while at the Cocklin house. A further test was made by having each man speak a few words in the hearing but out of sight of the Cocklins.

"All of the prisoners spoke without hesitation except Davis, who hesitated, and when he spoke his voice was recognized by both Mr. and Mrs. Cocklin. Detective Dougherty, who has been working on the case ever since Mr. Blodgett was murdered, says he is weaving a chain of evidence around Davis that will land him in the electric chair."

Reference 7 - Schenectady, May 26. - A special to *The Daily Union* from Salem, N. Y., this afternoon says: 'Buck' Davis, the notorious criminal, sentenced to Dannemora Prison yesterday for six years for jail breaking, and who is wanted in Schenectady for the alleged murder of George R. Blodgett, the chief patent attorney of the General Electric Company, committed suicide in the Salem jail this morning by hanging about 4:30. He made a rope out of bedclothes, and, tying it above the bed, fell back and strangled himself."

## References

- 1) "George R. Blodgett Shot - Murderous Attack of a Burglar on the Famous Patent Lawyer of Schenectady - Not Expected to Recover - A Reward of \$5,000 Offered by the General Electric Company for the Arrest of His Assailant - Assault on a Farmer," *The New York Times*, Dec 4, 1897, pg 1, col 3.
- 2) "George R. Blodgett Dead - Schenectady Burglary Victim Expires After Intense Suffering," *The New York Times*, Dec 5, 1897, pg 7, col 3.
- 3) "Inquest as to Mr. Blodgett's Death," *The New York Times*, Dec 10, 1897, pg 5, col 5.
- 4) "Perhaps Blodgett's Slayer," *The New York Times*, Dec 15, 1897, pg 2, col 4.
- 5) "For the Blodgett Murder - William Davis Arrested at Troy for Complicity in the

Crime," *The New York Times*,  
 Mar 28, 1898, pg 7, col 2.  
 6) "Masked Robber Identified - Mr. and Mrs. Cocklin of Schenectady County Pick Out One of the Men Who Tortured Them," *The New York Times*, Apr 17, 1898, pg 7, col 2.  
 7) "Prisoner's Suicide at Schenectady," *The New York Times*, May 27, 1898, pg 7, col 5.

## Ludwig K. Böhm



In the very early days of lamp making in Edison's laboratory it was necessary to secure the services of a glass blower. In August of 1879 Thomas Edison hired Ludwig Böhm for that position. Böhm developed many of the early bulbs required by Edison. It turned out, however, that Böhm did not stay in the Edison camp very long. There appears to be at least two versions of the story on why the Edison-Böhm relationship did not last long. One version is due to Conot (ref. 12, pg 178):

"The person who had most difficulty adjusting to the new atmosphere of the mini boom town was Ludwig Böhm. He was sensitive, artistic, and egotistic. At midnight suppers in the lab he played the zither and yodeled. He liked children, and made toy glass figures, including trick swans that squirted a fine spray of water into one's face when one blew into their tails. He had started working side by side with Upton in the laboratory, then been moved into the adjacent, small photographic and blueprint shed. (This, thereupon, acquired the name of the Little Glass House.) He now spent much of his time at the lamp factory. There he came into contact with William Holzer, a balding, handlebar-moustachioed Philadelphia glassblower who had dropped off the train while on his way to the Corning Glass Works and had been hired in February. While Böhm prided himself on his craftsmanship, Holzer stressed productivity, and made iron molds to increase output..."

The

Little Glass House is shown below.



"It was no contest. Böhm, who looked like a gawky toy soldier with his lorgnette and funny little red hat, was the butt of the rowdy Americans' jokes. He moved out of Sarah Jordan's boardinghouse, where men were doubling and

tripling up in the rooms, and put up a bed in the attic of the Glass house. There the men proceeded to drive him into a frenzy by tossing rocks onto the roof at night, tapping on the windows with a remote-controlled device, and running the "corpse reviver," a ratchet that sounded like a derailing freight train, along the walls of the shed.

"One night, in retaliation, Böhm unleashed a shotgun blast over the heads of the tormentors. The next day when he sat down at Sarah Jordan's boardinghouse to eat, every man slammed a club, knife, or pistol onto the table. Niel Van Cleve, another of Edison's brothers-in-law, waved a huge army revolver and imperiously commanded: 'Böhm! Pass the butter!'

"Böhm bolted. Aggrieved, he complained to Edison in mid-October that he had received a 'kind of treatment which no man with any sense of honor can bear. I do not want to be bossed by people that understand less than I. Things have gone too far.' He resigned."

There has been another reason given why Böhm left the employ of Edison. The second version conveys a much different story. According to Jehl (ref. 10, pg 611):

"Here I mention another visitor, well known at that time, who appeared at the laboratory one day. His name was Hiram S. Maxim....

"Maxim was very much interested in what Edison showed him and the two spent almost a day together. Edison explained to him how the paper filaments were made and carbonized and all about the glass-blowing part. In fact, Maxim spent nearly two hours with Edison in the glass house where Boehm (Böhm), Holzer and Hipple were working....

"Maxim did not run to New York and give his opinion to a newspaper, but went to his laboratory and began trying to make a lamp after Edison's ideas. He had no success, however, and after a few weeks sent to Menlo Park an emissary who got in touch with Boehm....The deportment of Boehm changed perceptively and soon became suspicious. He was changing his allegiance to Maxim. In fact he soon departed from Menlo Park and entered that electrician's employ."

Apparently Böhm was dismissed.

Ludwig Karl Böhm was born in the town of Lauscha, Germany, on June 16, 1859<sup>7</sup>. From 1871 to 1878 he was a pupil, and then assistant, to Heinrich Geissler (1814-1879), the inventor of a mercury pump as well as Geissler tubes<sup>3</sup>. In August of 1879 Böhm was employed by Edison. He left Edison to be assistant to Hiram S. Maxim at the United States Electric Lighting Company in the latter part of 1880. It was during this association with Maxim that Böhm designed a filament that was shaped like a Maltese Cross (ref. 12, pg 179); this shape was used in the early Maxim lamp. From there he entered the employ of the American Electric Light Company in the summer of 1881. While employed by

American Electric Böhm patented a stopper lamp<sup>1</sup>. In 1882 Böhm returned to Germany for the purpose of study and in 1886 he received the Ph.D. degree from the University of Freiburg (ref. 10, pg 613) and a diploma of the Royal Bavarian School of Industries in Munich<sup>7</sup>.

Upon his return to the United States in 1887 Böhm was put in charge of the chemical department and was chemist for the American Ultramarine and Globe Aniline Works. In 1888 he did original research on fossil resins for the Dawson-Valentine Company.

Böhm then worked a short while for the Thomson-Houston Company, experimenting with different kinds of filaments. After his employment with Thomson-Houston, Böhm set up an office in New York City as a consulting electrical and chemical expert.

Listed below are U.S. patents granted to Ludwig Böhm; they are given in order of patent number, name, date, assignor.

- 1) 248,156; Electric Lamp; Oct 11, 1881; American Electric Light Company
- 2) 248,279; Combination Vacuum Pump; Oct 18, 1881; American Electric Light Company
- 3) 250,192; Electric Lamp; Nov 29, 1881, American Electric Light Company
- 4) 250,193; Electric Lamp; Nov 29, 1881; American Electric Light Company
- 5) 516,079; Process of Making Incandescent Elements; Mar 6, 1894; Sterling Light Company of Trenton, NJ and NY, NY
- 6) 552,036; Material for Incandescent Conductors; Dec 24, 1895; □
- 7) 572,101; Composition of Material for Incandescent Gas-Lights; Dec 1, 1896; American Incandescent Light Co. of WV
- 8) 606,441; Acetylene Gas Tip; Jun 28, 1898; Electro Gas Company, of West Virginia
- 9) 609,494; Acetylene Gas Generator; Aug 23, 1898; Electro Gas Company, of West Virginia
- 10) 630,966; Carbid Furnace; Aug 15, 1899; Electro Gas Company, of West Virginia
- 11) 659,784; Process of Manufacturing Paper from Straw; Oct 16, 1900; William S. MacClymont
- 12) 659,785; Pulp Washing and Straining Machine; Oct 16, 1900; William S. MacClymont
- 13) 668,033; Refrigerator Car; Feb 12, 1901; □
- 14) 758,348; Window Attachment; Apr 26, 1904; Commercial Railway Equipment Company, of New York, NY
- 15) 875,315; Process of Making Paper-Pulp from Straw; Dec 31, 1907; □

From the descriptions of Böhm's 15 U.S. patents it is revealed that only the first four and the sixth were related to the electric incandescent lamp. Subjects dealt with in the other patents included incandescent gas mantle material, gas tip design, gas generator, furnace, railroad refrigerator car, railroad window attachment and processes for making paper pulp from straw.

Based on the application dates of Böhm's patents and the information contained in the patents, it appears Ludwig Böhm became a citizen of the United States sometime between May 25, 1898 and March 2, 1900.

## Acknowledgements

The image of Dr. Böhm was scanned from *Electrical Review*, Vol 22, No 8, Apr 15, 1893, pg 105. The photograph of The Little Glass House was scanned from the *General Electric Lamp Division News*, Vol 10, No 6, Feb 9, 1962, pg 1.

## References

- 1) "Separable or Detachable Incandescent Lamps", Dr. L.K. Böhm, *Electrical World*, Vol XX, No 23, Dec 3, 1892, pg 356.
- 2) "Incandescent Lamp Litigation", *Electrical Engineer*, Vol XV, No 249, Feb 8, 1893, pg 149.
- 3) "The Edison Lamp Patents-Additional Affidavits", *Electrical World*, Vol XXI, No 26, Feb 11, 1893, pg 102.
- 4) "Incandescent Lamp Litigation", *Electrical Engineer*, Vol XV, No 251, Feb 22, 1893, pg 188.
- 5) The Full Text of Judge Colt's Decision in the Edison-Beacon Incandescent Lamp Suit, *Electrical Review*, Vol 22, Feb 25, 1893, pg 333 (Supplement).
- 6) "The Lamp Decision", *Electrical World*, Vol XXI, No 8, Feb 25, 1893, pg 142.
- 7) "Dr. Ludwig K. Böhm", *Electrical Review*, Vol 22, No 8, Apr 15, 1893, pg 105.
- 8) "Inert Gases in Modern Incandescent Lamps", Dr. L.K. Böhm, *Electrical World*, Vol XXII, No 25, Dec 16, 1893.
- 9) "An Electro Pyrometer", L.K. Böhm, *Electrical World*, Vol XXIX, No 11, Mar 13, 1897, pg 366.
- 10) Menlo Park Reminiscences, Vol 2, Francis Jehl, The Edison Institute, Dearborn, MI, 1938, pgs 486, 495, 516, 532, 604, 605, 612, 708, 801.
- 11) The Electrical Manufacturers, 1875-1900, A Study in Competition, Entrepreneurship, Technical Change, and Economic Growth, Harold C. Passer, Harvard University Press, Cambridge, MA, 1953, pgs 147, 189.
- 12) A Streak of Luck, Robert Conot, Seaview Books, New York, 1979, pgs 151, 178.
- 13) U.S. Patents granted to Ludwig Böhm from 1881-1907: 248,156; 248,279; 250,192; 250,193; 516,079; 552,036; 572,101; 606,441; 609,494; 630,966; 659,784; 659,785; 668,033; 758,348; 875,315.



## Henry M. Byllesby

In the late 1880s the Westinghouse Electric Company advertised incandescent lamps and sockets that were designed for series burning<sup>2</sup>. One of the inventors of those lamps was Henry Marison Byllesby (16 Feb 1859 - 1 May 1924), who, in the year 1888, held the position of Vice-President and General Manager in that company<sup>4</sup>; he was, at that time, only twenty-nine years of age.

Henry Byllesby was the son of Reverend DeWitt Clinton and Sarah (Mathews) Byllesby, having been born in Pittsburgh, PA<sup>9</sup>. In his early years he resided in Mount Holly, NJ and later in Allentown, PA. He then entered the class of 1878 at Lehigh University, located in Bethlehem, PA, but because he needed to accompany his



father to Roselle, NJ, he did not graduate. Then, for a time, he was employed in Chester, PA as a draftsman and mechanical engineer. In 1882 he married Margaret Stearns Baldwin. Quoting now from the *Western Electrician*<sup>7</sup>:

"In 1882 he became connected with the Edison company, and maintained this connection until 1885, spending most of his time as manager of the Canadian department of that company. In 1885 he accepted an offer from Geo. Westinghouse, Jr., to become eastern sales agent of the Westinghouse Electric company. Soon after he was appointed general manager, and then elected first vice president, holding these positions until December, 1890, when his resignation was reluctantly accepted. In February, 1891, he became connected with the Thomson-Houston Electric company. In May, 1891, he was elected vice-president of the Northwest Thomson-Houston Electric company, with headquarters at St. Paul, and in June was promoted to the presidency of that company."

At the time of his death Byllesby was President of H. M. Byllesby & Co. of Chicago, IL and was an officer and director of a number of public utilities companies in Alabama, Arkansas, Oklahoma, Iowa and Colorado. During World War I he served, at age sixty, as General Purchasing Agent for the American Expeditionary Forces. He was stationed in London and after the war was awarded the Distinguished Service Order by the British Government. Later he received the American Distinguished Service Medal.

**Note:** The picture of Henry Byllesby was scanned from Reference 4, opposite page 377.

### References

- 1) Frank L. Pope, Henry M. Byllesby and Philip Lange - U. S. Patent No 366,606 - July 12, 1887 - Key-socket for Incandescent Electric Lights.
- 2) F. L. Pope, "The Westinghouse Alternating System of Electric Lighting," *The Electrician and Electrical Engineer*, Vol 6, Sep 1887, pp 332 - 342.
- 3) H. M. Byllesby & P. Lange - U. S. Patent No 383,616 - May 29, 1888 - Incandescent Lamp
- 4) "H. M. Byllesby," *The Electrical Engineer*, Vol 7, Sep 1888, pg 381.
- 5) 1888 Westinghouse catalog, in the collection of Jerry R. Westlick.
- 6) Philip Lange - U. S. Patent No 434,153 - Aug 12, 1890 - Incandescent Lamp Socket
- 7) "Henry M. Byllesby," *Western Electrician*, Vol 9, No 5, Aug 1, 1891, pg 57.
- 8) "H. M. Byllesby Dies in Dentist's Office," *The New York Times*, May 2, 1924, page 19, column 5.
- 9) "Henry Marison Byllesby," Who Was Who in America, Vol 1, 1897-1924, A. N. Marquis Co., Chicago, pg 179.

**F. M. F. Cazin**



A little known name in incandescent lamp history is that of F. M. F. Cazin. Cazin was granted a number of patents on incandescent lamps, some of which dealt with oxide coated filaments. In 1905 he self-published a book that consisted mainly of his articles that appeared in *The Electrical Age* in 1901. In his book, which dealt with the incandescent lamp, he questioned the contributions of different inventors relative to his own. In particular, some works of Edison and Nernst were questioned as it regarded priority.

Apparently a company was formed in Amsterdam, New York for the manufacture and marketing of Cazin incandescent lamps. The manufacture of the lamps was started but internal dissension within the company existed and operations were discontinued before any lamps were marketed.

The following information details the chapter titles in Cazin's book. Several chapters are simply revised reprints of the original articles.

<b>The</b>	<b>Twentieth</b>	<b>Century</b>	<b>Electric</b>	<b>Light</b>
-----				
<b>The</b>		<b>Cazin</b>		<b>Lamps</b>
Revised	Reprint	of	the	Series:
<b>What</b>	<b>Next</b>	<b>in</b>	<b>Electric</b>	<b>Lamp</b>
by F. M. F. Cazin			<b>Making</b>	<b>?</b>

- I. **Origin and Nature of Light** □ Some Erroneous Conceptions Thereof, and the Result of Their Correct Conception (Issue of Nov 9, 1901)
- II. **The Theory of the Origin of Light as Practically Applied** □ Concentration of Heat Incidentally Considered (Issue of Nov 30, 1901)
- III. **The Discovery of Electrical Conductivity in Heated Oxides** □ **The Discoverer and His Plagiarist** □ **Rare Metal Oxides** (Issue of Aug 3, 1901)
- IV. **The Difference in Practical Usefulness Between Common and Rare Earths as Light-Makers** □ The Same False Pretender to the Invention of Using to Advantage Rare Earths in Electric Lamps
- V. **From Jablochhoff to Cazin** □ An Episode in Electric Light-Making (Issue of Aug 17, 1901)
- VI. **As Nernst Did Not, So Thomas Edison Did Not, Invent the Utilization of Rare-Metal Oxides in Electric Lamps**
- VII. **The Westinghouse Lamp, Falsely Called "The Nernst Lamp"** (Issue of Sep 14, 1901)

VIII. **The Cazin Lamp** (Issue of Sep 7, 1901)  
IX. **The Cazin Lamp □ The Electrical Lamp of the Twentieth Century □ Its Evolution and the Forces Opposing It** (Issue of Dec 21, 1901)

The title page of the Cazin book is shown below.

RESPECTFULLY PRESENTED BY THE AUTHOR

# THE TWENTIETH CENTURY ELECTRIC LIGHT

## THE CAZIN LAMPS

REVISED REPRINT OF THE SERIES:

WHAT NEXT IN ELECTRIC LAMP MAKING?

By F. M. F. CAZIN

Author of: "Dynamical Metallurgy," a series in "Mining Records," N. Y., 1885; "The Limits of Ocean Travel," in "Van Nostrand's Engineering Magazine," N. Y., 1886; "Resistance to Ship's Motion," in "Journal of the Franklin Institute," Philadelphia, 1891; "Solids Falling in a Medium," I. & II., in "Transactions of Am. Inst. of Mining Engineers," 1894; "Electrometallurgy," in "The Electrical World," N. Y., 1894; "Loss of Efficiency in Water Wheels," "Electrical Age," N. Y., 1895; "Atmospheric Resistance to the Motion of Trains," in "Railway and Engineering Review," Chicago, 1898; "Old and New Methods in Planning Water-Power Pipes," "Journal of the Franklin Institute," October, 1898, and January, 1899, etc.)

FROM "THE ELECTRICAL AGE," 1901

*"An inventor has no show these days. The moment he invents something, which is an epoch-maker in the world of commerce or science, there will be pirates to spring up on all sides to contest his rights to his ideas."* — THOMAS A. EDISON.

HOBOKEN, N. J., 1108 BLOOMFIELD STREET

*Published by the Author*

Some	Incandescent	Lamp	Patents	Issued	to	F.M.F.	Cazin
523,460	□ July	24,	1894	□	Incandescent	Electric	Lamp
523,461	□ Jul	24,	1894	□	Electric	Incandescent	Lamp
566,285	□ Aug	18,	1896	□	Electric	Incandescent	Lamp

620,640 □ Mar 7, 1899 □ Electric Incandescent Lamp  
 621,291 □ Mar 14, 1899 □ Electric Incandescent Lamp  
 621,292 □ Mar 14, 1899 □ Electric Incandescent Vacuum Lamp  
 640,366 □ Jan 1, 1900 □ Electric Incandescent Lamp  
 760,849 □ May 24, 1904 □ Electric Incandescing Lamp  
 770,222 □ Sep 13, 1904 □ Manufacture of Electric Incandescent Lamps  
 770,223 □ Sep 13, 1904 □ Incandescent -Lamp Bulb  
 772,215 □ Oct 11, 1904 □ Manufacturing Glowers, Luminants, and Filaments for Electric  
 Incandescent Lamps  
 786,727 □ Apr 4, 1905 □ Apparatur for the Manufacture of Glowers for Electric Lamps  
 835,938 □ Nov 13, 1906 □ Electric Incandescent Lamp  
 844,778 □ Feb 19, 1907 □ Luminant in Electric Incandescent Lamps  
 874,938 □ Dec 31, 1907 □ Machine & Apparatus for Manufacturing Filaments for Electric  
 Incandescent Lamp  
 877,171 □ Jan 21, 1908 □ Manufacturing Metallized Electric-Incandescent-Lamp  
 Filaments  
 877,172 □ Jan 21, 1908 □ Producing Filaments for Electric Incandescent Lamps and the  
 Product Thereof  
 877,408 □ Jan 21, 1908 □ Manufacture of Electric Incandescent Lamps  
 879,083 □ Feb 11, 1908 □ Electric-Incandescent-Lamp Luminant and Manufacturing It  
 879,084 □ Feb 11, 1908 □ Manufacture of Filaments in Electric Incandescent Lamps,  
 Process and Product  
 879,085 □ Feb 11, 1908 □ Filament in Electric Incandescent Lamps and Its Manufacture

A picture of a Cazin lamp, as scanned from his book, is shown below.



Franz Cazin was born in Aachen, Germany in 1827 and emigrated to the United States in 1867. He was the eldest of ten children. In Germany Cazin apparently was a printer, bookseller and publisher. He sold his business in 1861 and built a bread factory, which failed in 1867. After Cazin came to the United States he changed his name from Franz Frederich Michael Cazin to Franz Michael Friederick Cazin. He became a mining engineer and went to Denver, Colorado in 1873, where he incorporated the Rocky Mountain Concentration Company. Apparently the Company process was described in the *Engineering and Mining Journal* in 1873. He also went to New Mexico where he discovered a deposit of titanium ore. In his later years he resided at 1108 Bloomfield Street, Hoboken, New Jersey.

Cazin also obtained patents in different areas. Some of these are listed below:

578,812	□	Mar	16,	1897	□	Percussion	Water-Wheel
578,813	□	Mar	16,	1897	□	Percussion	Wheel
608,176	□	Aug	2,	1898	□	Penstock	and Supply-Pipe
651,102	□	Jun 5,	1900	□		Chemicalizing	Fire-Engine Annex

A limited search was made to unveil aspects of the family of Franz Cazin. Some genealogy information was found under "FamilySearch", the internet site of The Church of Jesus Christ of Latter-day Saints. By typing in only the surname, Cazin, and clicking on "exact spelling" the following information was obtained:

Father: Franciscus Friedericus Michael "Franz" Cazin □ Birth/Christening: Mar 30, 1800; d. Aug 17, 1883

Mother: Gertrude De-Gavarelle □ b. 1802, d. Dec 9, 1884.

The marriage of Cazin's mother and father occurred on May 18, 1823.

Children of Franciscus and Gertrude were:  
Franz Frederich Michael Cazin □ b. Feb 21, 1827, d. Nov 26, 1908.  
Albert Joseph Cazin □ b. Nov 1828  
Franz Adolph Otto Cazin □ b. Sep 1830  
Anna Catharina Theresia Emma Cazin □ b. Dec 1832  
Elisabeth Henriette Felicia Cazin □ b. Apr 28, 1834  
Catharina Cazin □ b. Oct 15, 1835  
Cornelia Francisca Cazin □ b. Oct 5, 1837, d. Feb 2, 1910  
Johanna Henriette Clotilde F. Cazin □ b. Jul 14, 1841  
Anna Johanna Josepha Cazin □ b. May 19, 1843, d. Apr 14, 1919  
Josephina Margarethe Henriette Cazin □ b. Oct 21, 1845, d. Feb 9, 1933

All the above-listed children were born in Aachen, Germany.

The oldest child, Franz Cazin, the subject of this writing, married Bertha Nasse on Jun 17, 1852. She was born on Jan 5, 1830 in Soest, Germany; she died on Nov 2, 1876.

Children of Franz and Bertha were:  
Franz Alexander Karl Bernard Cazin □ b. Mar 24, 1853, d. May 1936  
Maria Cazin □ b. 1854  
Carl Wilhelm Theodor Clemens Cazin □ b. Feb 17, 1856, d. Nov 13, 1930  
Alexander "Alex" Cazin □ b. Jul 1, 1857, d. Apr 14, 1944  
Heinrich Cazin □ b. 1860  
Otto Franz Cornelius Cazin □ b. Dec 29, 1861

All the above-listed children were born in Münster, Westphalia, Germany. Additional information can be found on the website "ancestry.com" under the name "Cazin." Cazin fathered additional children with Minna Ennigerigh, who was born in March of 1845.

These children were:  
Maximillian Cazin □ b. in Missouri Jan 26, 1870, d. Jan 1965  
Helene Cazin □ b. in Missouri in Mar 1873  
Adele Cazin □ b. Oct 4, 1875 in Colorado, d. Dec 15, 1966 in Florida  
Otto Cazin □ b. in Vermont in Sep 1882

F. M. F. Cazin passed away in Upper Montclair, New Jersey on Nov 26, 1908.

**Note:**

The dates given here could be in error. One should use such numbers as being approximate until a more thorough study is made.

**Acknowledgments**

The New Jersey Information Center at The Newark Public Library kindly supplied census data from 1900 and 1905 on the Cazin family. The Cazin family data retrieved from the FamilySearch (The Church of Jesus Christ of Latter-day Saints) site helped greatly in determining names and dates. The write-up on "The Cazin Brothers" was kindly supplied by Adele Puccio of the Hoboken Public Library. Some of the patents numbers issued to F.M.F. Cazin were kindly supplied by the Public Documents and Patent Department, Cincinnati and Hamilton County Public Library. The Social Security Death Index also revealed data, as given above.

**General****References**

- 1) "Incandescent Lamp Bulb", *Electrical World and Engineer*, Vol XLIV, No 13, Sep 24, 1904, pg 534.
- 2) "Cazin Metallic-Filament Incandescent-Lamp Patents", *Electrical World and Engineer*, Vol LI, No 5, Feb 1, 1908, pg 220.
- 3) "Cazin Metallic-Filament Lamps", *Electrical World and Engineer*, Vol LI, No 9, Feb 29, 1908, pg 421.
- 4) Catalogue of Scientific Papers (1893-1899), Compiled by the Royal Society of London, Scarecrow Reprint Corp., Metuchen, NJ, 1968.

"Resistance to Ship's Motion: A Natural Law Newly Discovered", *Journal of the Franklin Institute*, Vol 135, 1893, pp 200-216, 299-310, 364-374.

"Shortening the Time for Correct Sounding", *Journal of the Franklin Institute*, Vol 138, 1894, pp 70-77.

"Solids Falling in a Medium, I. Their Incipient and Maximal Velocities. A Study for Ore-Concentrators, II. A Critical Examination of the Theory and Method Applied by Rittinger, and the Resulting Formulas", *Amer. Inst. Min. Engin. Trans.*, Vol 24, 1895, pp 80-100, 339-351.

"Old and New Methods Applied in Planning Pipe-Lines and Penstocks", *Journal of the Franklin Institute*, Vol 146, 1898, pp 177-192, 280-293; Vol 147, 1899, pp 71-72.

- 5) General Alphabetical and Analytical Index of the *Trans. of the Am. Institute of Mining Engineers*, 1871-1904.

F.M.F. Cazin: Solids Falling in a Medium □ I, xxiv [xix], pg 80; II, xxiv [xxxvii], pg 339; remarks in discussion of Prof. Posepny's paper on the genesis of ore-deposits, xxiii, pg 604; xxiv, pg 995; on copper ores of New Mexico, xxiii, pg 316; of preparation of small sizes of anthracite, xx, pg 621. Cazin bucket for water-wheels, xxix, pg 866, 867, 883, 887.



6) "The Cazin Brothers", author unknown (perhaps a librarian at the Hoboken Public Library wrote this paper), Nov 25, 1986, 8 pages. This write-up gives information mainly on the children of Franz Cazin. Much of the information was obtained from living family members in 1986. **Sir William Crookes**



1856-----1889-----1911  
at the age of 24-----at the age of 57-----at the age  
of 79

The photographs of William Crookes were scanned from the book by E. E. Fournier D'Albe<sup>2</sup>

Some persons who contributed to the efforts to develop a practical electric incandescent lamp are better known for contributions to science rather than to the incandescent lamp. However, even if that is the case, contributory efforts to lamp development should be recognized and written about. One such effort early in the development days was that by Sir William Crookes (June 17, 1832 - April 4, 1919).

William Crookes was involved in part-time efforts in the incandescent lamp field, probably between 1881 and 1889. Perhaps his most significant contribution was his ability to reduce the vacuum in vessels to lower values than other workers had achieved, and this was the impetus for some experimenters, notably Joseph Wilson Swan, to continue work in this area. Crookes' efforts were notable, although little is said about him in the incandescent history books today.

Some patents granted to William Crookes are the following:

GB3860	-	Nov	5,	1875	-	Radiometers; photometers; thermometers
GB1422	-	Mar	31,	1881	-	Incandescent lamps; arc lamps
GB2304	-	May	25,	1881	-	Incandescent lamps
GB2612	-	Jun	15,	1881	-	Incandescent lamps
GB3799	-	Aug	31,	1881	-	Incandescent lamps
GB1079	-	Mar	6,	1882	-	Incandescent lamps
GB4238	-	Sep	6,	1882	-	Incandescent lamps
GB2185	-	Apr	30,	1883	-	Incandescent lamps; supporting lamps.

The following descriptions appear in the Dredge book<sup>1</sup>:

"The filament is mounted in the first place upon its permanent support, and is then placed with this support in a vessel from which the air can be exhausted. Vapour is then admitted, and the filament is rendered incandescent. The lamp bulb is made in two parts, the filament being mounted on the one part, and enclosed in the chamber described in Specification 3799 of 1881, to adjust its conductivity, the terminals of conductors being joined to the fixed terminals in the chamber. The two parts of the lamp are then brought together and fused, and the globe is exhausted and sealed as usual. The lamp is then finished in a small machine, where its neck is set with plaster into a wooden cup, the conductors passing through holes in the bottom. The projection on the neck of the lamp, left where the connection with the air pump is made, is loosely enveloped with paper to prevent contact between it and the plaster, and is received in a cavity *b* in the cup bottom. The terminals *c* are then screwed down on to the conductors,

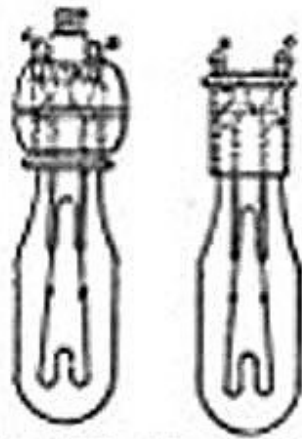

Fig. 478. Fig. 479

which are twisted round their shanks. In Fig. 479 the cup is partly of brass. The lamp foot is screwed into a socket, its terminals coming against horn-like springs, each in the shape of a segment of, say, one-third of an annulus bent upwards from the base to which one end is fixed. Or the lamp may be suspended from a button of insulating material, provided with two metal springs connected to the leads and entering holes in the lamp terminals. The lamp may be suspended directly from conductors passing to the ceiling, and secured to the lamp terminals by small levers having cam-shaped ends

working in a slot in the terminal. The conductors are laid in mouldings along the ceiling, having removable caps, and connected to pieces of metal on the side of an insulating cylindrical boss extending out from the centre of the rosette. The conductors from which the lamps hang have their ends inserted into holes in the metal pieces, and a ring or slider is drawn over them. For side wall connections, two separate metal studs are each provided with a slider securing the conductors into a hole in the side of the stud. Each circuit is completed through a switch consisting of two bent conductors fixed to a wooden base. One bent conductor is depressed, and an eye on the other part engages with an arm on the first part. When the part having the eye is depressed by means of a button, the eye is removed and the arm springs back, breaking the circuit."

"Mention must be made of the Sprengel mercury pump, invented in 1873, which was also extensively used by the classic experimenters on the electric discharge. In this, the air was carried away by a succession of falling mercury pellets, between which it was trapped. It was with an improved form of this pump, devised by Gimmingham and having a number of tubes for

the mercury fall instead of one, that William Crookes, one of the most skilled workers on vacuum physics in the second half of the nineteenth century, carried out, for instance, his classic work on the radiometer. He used phosphorous pentoxide to absorb water vapour, precipitated sulphur to stop mercury vapour and reduced copper to stop the sulphur vapour entering his evacuated space. He claims to have reduced the pressure to  $0.4 \times 10^{-6}$  atm, say  $3 \times 10^{-3}$  mm of mercury, and says, 'Formerly, an air-pump, which would diminish the volume of air in the receiver 1000 times, was said to produce a vacuum', adding that the Sprengel pump had already rarified air a few hundred thousand times, which in those days was very good performance.

The influence that Crookes' work with a modified Sprengel pump had on the work of Joseph Swan was pointed out in a biography of Swan<sup>3</sup>, which was written by one of his daughters and a son:

"The invention of the mercury vacuum pump by Hermann Sprengel, in 1865, had shown the way to get a vacuum far superior to any previously attainable, and following upon this invention, Mr. Crookes (afterwards Sir William Crookes) had, in 1875, astonished the world by the exhibition of his radiometer and by the description of the improved means he employed for obtaining the near approach to a perfect vacuum which the construction of the radiometer demanded. It was the publication of Crookes' researches which led Swan to resume his attempts to produce a satisfactory electric lamp by means of an incandescent carbon conductor in an evacuated glass container."

On February 5, 1889, William Crookes wrote the following to his patent agents<sup>2</sup>:

"Messrs. Carpmael & Co.

"Dear Sirs,  
"I write to inform you that I have sold my three patents, 2612<sup>81</sup>, 3799<sup>81</sup>, and 1079<sup>82</sup>, to the Anglo-American Brush Electric Light Co., Belvedere Road, Lambeth, and I shall be obliged if you will in future send notices of fees falling due to them. I have sent on your letter of the 1st inst."

Abridgments of those three patents follow:

GB2612, June 15, 1881  
"Incandescent lamps. □ In making carbon filaments, paper, linen or cotton thread, pith, cotton wool or other convenient form of cellular tissue or cellulose is freed if necessary from silica by the use of hydrofluoric acid as described in Specification No. 1422, A. D. 1881, and is then treated with a solution of cuprammonia so as wholly or partly to destroy the structure of the cellulose; the ammonia and water are then allowed to evaporate and the copper is extracted by nitric or other suitable acid; the substance is then

washed with water and dried, either stretched out or pressed between sheets of absorbent material. The cotton or thread may be twisted, crocheted, or plaited to form a band of cylindrical, flat, or other section. The substance before treatment with cuprammonia may be saturated with ammonia to expel air from its pores. Before allowing the ammonia to evaporate after the treatment with cuprammonia the substances may be washed with alcohol. The copper may be removed after the carbonization of the filament by means of acid or by volatilizing it by passing an electric current through the filament in a vacuum or inert gas. The threads may be twisted, plaited, or crocheted after treatment and before or after the removal of the copper. According to another process, a loose form of cellulose such as cotton-wool or Swedish filter-paper is entirely or nearly dissolved in cuprammonia solution, and the liquid is poured into a shallow dish with a level bottom and allowed to evaporate until a film of cupric cellulose is left which is then treated with acid, washed, and dried under pressure between sheets of absorbent material. The cuprammonia solution used for treating paper or thread may have cellulose dissolved in it. The copper may be left in the filament near the junctions with the leading-in wires. The ends of the filaments may be electroplated with copper or other metal, or may be coated with a thick syrupy solution of cellulose in cuprammonia solution, so as to form a good junction after drying and carbonizing. If the filaments are made of sheets of paper, linen, cotton, or wholly dissolved cellulose, pieces of convenient form are cut or punched out to form filaments. Thin strips may be cut from the sheet before it is quite dry and twisted into a thread or bent into an elongated U-shape. Carbonization is effected slowly, the filaments being packed between sheets of blotting-paper and placed in a metal box with powdered charcoal. Air is excluded by admitting coal gas or other suitable gas or vapour. The resistance of the filament is reduced after carbonization by depositing carbon upon it by heating it electrically in a vacuum chamber containing a hydrocarbon which has a high boiling point and a low vapour tension at ordinary temperatures. Naphthalene, xylol, or chloroform, as stated in the subsequent Specification No. 3799, A. D. 1881, may be used. The hydrocarbon may be placed in a separate vessel connected by a tap."

FIG. 3.

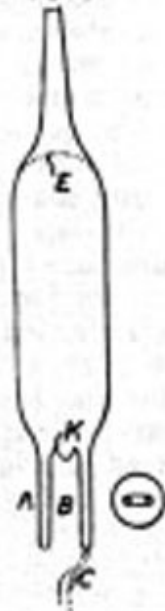

GB3799, August 31, 1881  
*"Incandescent lamps.* □ Relates to the manufacture of the glass bulb, and to methods of securing the leading-in wires in position, of regulating the resistance of the carbon filament, and of mounting the filament in position. In order to form the bulb, a glass cylinder is drawn into a wide neck A, Fig. 3, at one end, and, after sealing the neck and while it is still hot, the end is pressed inwards by means of a pointed two-pronged metal tool, thereby forming an inwardly-projecting portion B terminating in two pointed pieces K. The other end E of the glass cylinder is now closed and formed into a hemispherical

end, and an exhausting tube C is sealed to the lower end of the neck A. When the glass is cool, the neck A is cut into two parts transversely, and the leading-in wires are sealed by means of white enamel or arsenic glass in openings in the pointed pieces K. Previous to being sealed in position, each leading-in wire may be coated with enamel and sealed within a short glass cylinder. After attaching the carbon filament to the leading-in wires, the two portions of the neck A are sealed together and the lamp is exhausted. The hollow at the base of the lamp may be filled with plaster of Paris or other like cement. A one-pronged tool having preferably a chisel-shaped end, or a tool having more than two prongs, may be used instead of the two-pronged tool. Compound wires having a core of copper or other conducting wire sheathed with platinum are preferably employed as leading-in wires. In order to regulate the resistance of carbon filaments, the ends of each filament are respectively attached to two small hollow platinum or copper terminals fixed on a bar of arsenic glass so as to keep them at a suitable distance apart. The filament is then placed in an exhausting receiver with the terminals of the filament placed upon a pair of pointed wires which are arranged in an electric circuit and are fitted in the non-conducting base-plate of the receiver, an electric current being sent through the filament while

exhaustion is going on. In a modification, Fig. 8, the detached part of the neck of the bulb, to which are attached the leading-in wires and the filament, is suspended from the ends of glass-covered wires D which are fitted in a thick plate C, preferably of vulcanized fibre, at the top of the receiver. Mercury is poured over the top of the plate C to prevent access of air during

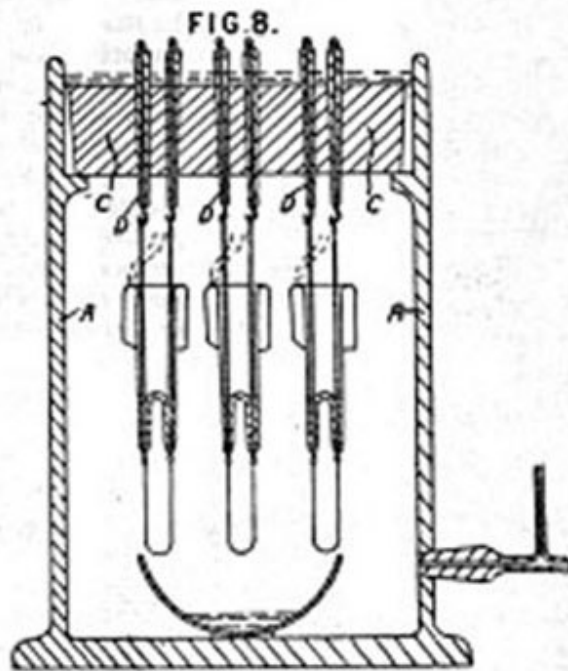

exhaustion. If, on the current being passed through the filament, its resistance is found too high, hydrocarbon or chloroform vapour is admitted to the receiver to produce a deposit of carbon upon the highly-heated filament, and, when the resistance of the filament is reduced sufficiently, the current is stopped. Naphthalene, xylene, or other hydrocarbon may be used instead of chloroform, as described in Specification No. 2612, A. D. 1881. A

number of filaments can be treated at one time by either of these methods. To increase the rigidity of a filament, especially one manufactured as described in Specification No. 2612, A. D. 1881, it is made flat and a twist of a quarter of a revolution is given to it in placing it in the ends of the leading-in wires."

GB1079, March 6, 1882  
*"Incandescent lamps.* □ Carbon filaments are made from animal fibres or matters, such as silk, silk threads, hair, wool, silkworm-gut, horn, gelatine, or parchment, these materials being treated with cuprammonia and carbonized, although, according to the Provisional Specification, the treatment with cuprammonia may, sometimes, be dispensed with. A number of threads may be stretched in a rectangular frame of copper, nickel, &c, and placed in a dipping-vessel containing the cuprammonia, after which they are removed and washed in dilute acid and then in water, the frame being then taken to pieces with the threads remaining on two of its bars. The threads are then shaped by lapping them round a glass rod and round four others equidistant from it, two above and two below, each thread passing from either of the bars up between the two bottom rods, out over the upper rod and down under the centre rod, while the two rods are weighted to keep the threads distended during drying. The threads are cut off from the bars and carbonized in layers, separated by powdered charcoal, in a closed-in iron or nickel box which is connected with a supply of coal gas while it is heated to white heat in a furnace. Some of the substances, such as silk, may be dissolved in cuprammonia, so that, on evaporation, a film or sheet is obtained from which threads may be cut. Or the silk thread &c. may be passed through a saturated solution of cotton, or of any of the above substances, in cuprammonia, and then carbonized. Or an acid may be added to a solution of cellulose, silk, &c., in cuprammonia, a plastic substance being produced, which may be used alone, or with starch, gluten, &c., for making the filaments; or it may be used as a cement for thickening the filament ends or for connecting the filaments and their conducting wires and holders. Chloride of zinc or caustic alkali may be used in place of cuprammonia for treating cellulose, silk, &c. The conducting-wires terminate in small hollow platinum cones, or in bent portions, or in twisted cup-shaped portions, &c., forming receptacles in which the filament ends are secured by cement composed of ground graphite, water, sugar, &c.; the graphitoidal carbon produced by decomposing a hydrocarbon gas or vapour by intense heat is preferably used. In some cases, the receptacles may consist of platinum foil in which the conductors are secured by riveting, and the cement may be made from the carbon deposit in the carbonizing-box. According to another method, the conducting-wire is bent on itself two or three times, and the filament end is inserted into it, pressed, and brushed over with cement, a glass cap being sometimes placed over the terminal. The filament ends may be electroplated and joined to the terminals by small copper, platinum, nickel, iron, &c. tubes; a cement may sometimes be used and may consist of platinum powder and water, platinum yellow and water,

or a mixture of these with the graphite cement. In depositing carbon on the filaments, to strengthen them, either of the chlorides of carbon, the bromides of carbon, or chloroform may be used, the operation being performed as described in Specifications No. 2612 and 3799, A. D. 1881; or the filaments may be heated electrically while immersed in the liquid chloride &c. In exhausting the lamps and standardizing the resistance of the filaments, when the vacuum is good hydrocarbon vapour is admitted and a current is passed through until standard resistance is arrived at. The vapour supply is then stopped and the exhaustion is completed while the filaments and lamps are heated. The vapour may be supplied from a vessel forming part of the pump and containing india-rubber, a mixture of benzoate of lime or baryta with quicklime, or a mixture of sodium acetate and soda lime or charcoal saturated with benzene, the vessel being heated when the vapour is required to be evolved. The resistances of several lamps may be equalized at one operation by arranging them in series and sending a current through them. An automatic cut-off, worked by a bridge galvanometer, may cut off the current from one lamp, when the required resistance is attained, or may divert it to another. A little mercury vapour may be left in the lamps to form a non-volatilizable compound with any oxygen remaining therein.

*Arc lamps, electrodes for.* Acid is added to a bath of cuprammonia saturated with cellulose, cotton, silk, &c., the precipitate obtained being washed and kneaded into a dough-like mass, which is moulded into sticks."

During the last few years in which the writer was employed at the Lamp Business Group of the General Electric Company in East Cleveland, Ohio, historical artifacts were collected from some of the buildings at Nela Park and were housed then in an available room. Among the various historical items collected was a Crookes lamp, which is believed to have been collected by H. D. Burnett, who was superintendent of the Thomson-Houston manufacturing plant in Lynn, Massachusetts from 1886 to 1893. The projected outlines of the small lamp, which has a maximum bulb diameter of 1-1/4 inches, were then traced. The image is shown below. It was covered by patents issued in 1881, 1882 and 1883, and was designed for 83 volts.

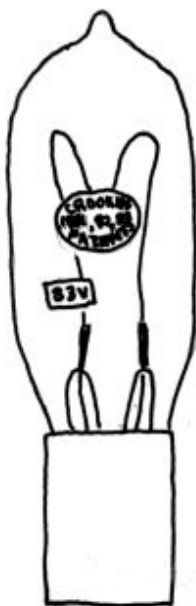

One lamp made by William Crookes exists in the historical lamp collection of William J. Hammer; it is numbered 1883-11. The lamp can be viewed if the reader goes to the write-up of the Hammer Collection on this website and clicks on the picture description: "Lamps Developed by Other Workers by 1904." The picture can be enlarged by clicking on the box that will appear when the mouse arrow is moved from outside the picture boundary to the inside (from outside the lower right hand corner boundary); the arrow must be inside the picture boundary to obtain the enlargement box. The Crookes lamp is in the front row, eighth from the right-hand end.



Two of the devices developed by William Crookes that present an opportunity for a person to observe interesting phenomena in nature are the spintharoscope<sup>7</sup> and the radiometer<sup>8</sup>.

### Acknowledgment

I am grateful for a listing of patents granted to William Crookes, as well as copies of their abridgments, which were obtained from Maria Lampert of the British Library, London.

### References

- 1) James Dredge, M. F. O'Reilly and H. Vivarez, Electric Illumination, John Wiley and Sons, New York, 1885, pp 431-432.
- 2) E. E. Fournier D'Albe, The Life of Sir William Crookes, T. Fisher Unwin Ltd., London, 1923.
- 3) M. E. S. and K. R. S., Sir Joseph Wilson Swan, F. R. S. - A Memoir, Ernest Benn Limited, London, 1929, pg 61, (M. E. S. = Mary Edmonds Swan and K. R. S. = Kenneth Raydon Swan).
- 4) "William Crookes", Dictionary of Scientific Biography, Charles Coulston Gillispie, Editor-in-Chief, Vol 3, Charles Scribner's Sons, New York, 1980, pp 474-481.
- 5) Edited by Theodore E. Madey and William C. Brown, History of Vacuum Science and Technology, Published by the American Institute of Physics, 1984 (article by E. N. Da C. Andrade, "The History of the Vacuum Pump," pp 77-83; originally published in *Adv. Vac. Sci. Tech.*, Vol 1, 1960, pp 14-20).
- 6) Edited by Theodore E. Madey and William C. Brown, History of Vacuum Science and Technology, Published by the American Institute of Physics, 1984 (article by Robert K. DeKosky, "William Crookes and the Quest for Absolute Vacuum in the 1870s," pp 84-101; originally published in *Ann. Sci.*, Vol 40, pp 1-18, 1983).
- 7) <http://www.frognet.net/~ejcov/index50.html/spinthar.html>

8)

<http://www.frognet.net/~ejcov/index50.html/radiometer.html>



### Ch. de Changy

The efforts of many early workers who tried to develop a practical electric incandescent lamp are often forgotten with the passage of time. One little-noted investigator from the past is Monsieur Ch. de Changy.

This story really begins with a gentleman by the name of Jean Baptiste Ambroise Marcellin Jobard (1792-1861). Jobard became the Director of the Industrial Museum in Brussels, Belgium in 1841<sup>6, 11</sup>. What little that is known about de Changy will be quoted from other

writers who did have something to say about his contributions to lamp history. Most of what will be quoted comes from an article written by A. Gelyi<sup>4</sup>.

"It was Professor Jobard, of Brussels, who gave the first impulse to the highly important experiments with glow lamps. This *savant* suggested, in the year 1838, in the *Courrier Libéral*, that a small strip of carbon in a vacuum used as a conductor of a current, would emit an intense, fixed, and durable light. Prof. Jobard then advised his former pupil, De Changy, to attempt the practical realisation of his idea. De Changy was the more ready to enter upon the necessary experiments as he, in his capacity of mining engineer, considered he would be able to open up a wide field for glow light illumination in the shafts and galleries of mines.

"After some preparatory theoretical study De Changy commenced his labours in the year 1844, after an Englishman, of the name of Moleyns, had, as early as 1841, made the first experiment with platinum glow light lamps. De Changy made use of gas carbon cut into thin strips, which he enclosed in an exhausted glass and connected with the conducting wires. In order to impart more consistency to the carbon strips he attempted to fillup their pores by soaking them in melted rosin or in sugared solutions. The result obtained was relatively favourable, and *De Changy proceeded to the construction of the first carbon glow lamp*. This was, however, the first link of that chain of experiments which runs like a red thread through the history of the development of the glow lamp. The experiments failed, on the one hand, by the carbon strips becoming disintegrated by the current, and, on the other hand, because the electric energy required for the production of the light was too great, and the degree of heat generated in the carbons too intense. The lamp was also imperfectly sealed and the vacuum insufficient, in consequence of which circumstance the carbon partially consumed away in the oxygen of the air... Shortly after this rather encouraging experience De Changy received the appointment of engineer-in-chief to the Weal-Ocean and Weal-Ramoth mines, in consequence of which his interesting studies and experiments were interrupted for a long period.

...Ten years after King had patented his lamp, in the year 1855, De Changy resumed his experiments and studies with redoubled zeal. He made experiments at the same time in two directions. Without altogether abandoning carbon, he occupied himself with the construction of a glow lamp, in which platinum formed the conductor, as he imagined to attain by the use of that metal a success more speedy, although less perfect, yet of sufficiently practical value. Being well aware that in order to guard the platinum wire against the risk of fusing, the strength of the electric current must strictly be kept within certain limits, he constructed a current regulator which he patented in 1858.

"The lamps provided with such a regulator would be used for various interesting purposes, as, for instance, for the illumination of mines,

submerged for fishing purposes, for illuminating anchor buoys, and, finally, as a nautical telegraph by which, with the aid of an instrument like a keyboard, signals consisting of flashes of light could be transmitted from the top of the mast of a vessel. The platinum for these lamps was submitted to a peculiar process of preparation. De Changy caused the metal to be maintained some time heated to a moderate degree of redness, and then gradually raised it to that degree of heat to which it would be required to be heated for illuminating purposes.

"The reader of this pamphlet will perhaps be interested to learn to what extent industrial matters were at that time tabooed by the Academy of Sciences of Brussels, and how narrow-minded and biased an opinion was entertained in scientific circles of those who tilled the field of scientific research for practical purposes. When De Changy, a short time before he obtained his patent, submitted the result of his experiments to the Academy, that body appointed a committee for the purpose of subjecting his invention to a crucial test.

"Deprez, a member of that committee, requested Professor Jobard by letter to furnish a detailed description of the apparatus relating to De Changy's invention, together with a full account of the technical proceedings. M. Jobard was, of course, compelled to answer that he could not possibly comply with that request, as the publication of the information required might be detrimental to the patent applied for. Deprez then declared, in reply, that as De Changy intended to convert his invention into a lucrative business he did not deserve to be called a *savant*, and that the Academy could not for that reason further occupy itself with his invention.

"This answer was, of course, not calculated to encourage De Changy in the pursuance of his researches; and so it came to pass that he shortly afterwards

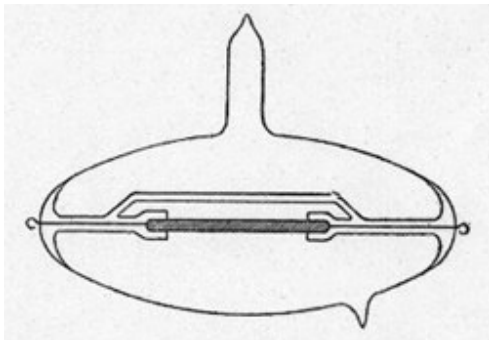

abandoned his experiments with carbon glow lamps."

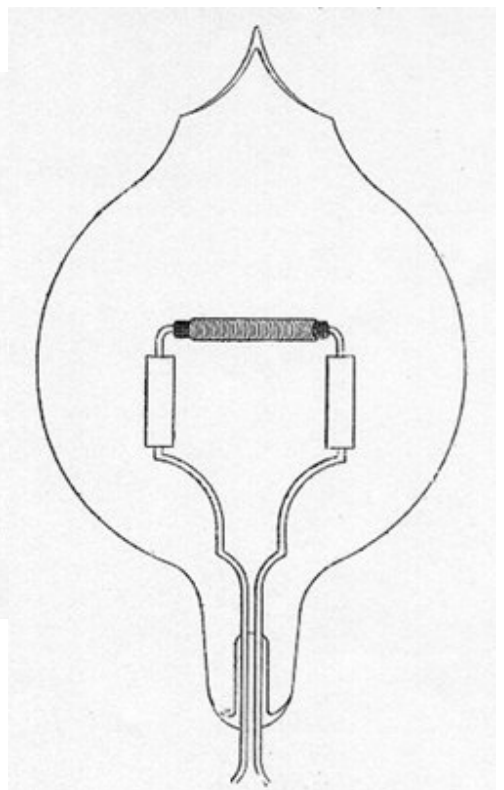
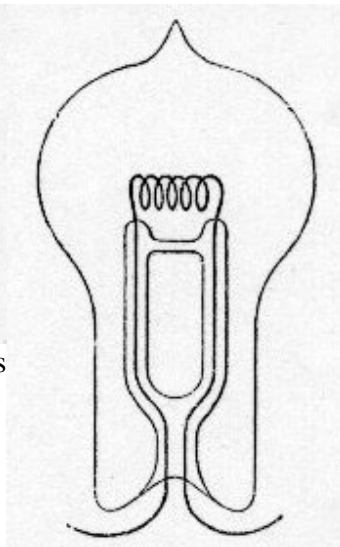

Three views of de Changy lamps are shown as scanned from the book by Figuier<sup>2</sup>. The one on the far left contains a carbon conductor and a platinum spiral. The lamp in the center has a filament of platinum, whereas the lamp shown on the right has a carbon conductor. A lamp patented by de Changy in Belgium in 1856 is shown in the book by Howell and Schroeder<sup>8</sup>.

It was mentioned that de Changy became involved with the incandescent lamp in 1844. It would appear from a brief note in *Nature*<sup>1</sup> that he was involved again in the year 1882, 38 years later.

In regard to the matter with the "Academy of Sciences of Brussels", Park Benjamin stated<sup>5</sup> that it was the French Academy of Sciences and that 'De Changy claimed to have succeeded at this time in arranging several lamps in one circuit, which could be lighted simultaneously in groups, or separately without affecting the normal intensity of each.' In their book<sup>3</sup> Alglave and Boulard said:

"The invention of M. de Changy made a great noise at once; but the noise soon ceased in presence of the undeniable inconveniences, which made the system almost impossible in practice. The principal one of these inconveniences is the ease with which platinum melts if the temperature at which it furnishes a good white light be exceeded. A slight variation in the intensity of the electric current is sufficient to produce this injurious heating, and as yet they were unable to regulate, even in an approximate manner, the force of the current employed.

"Mr. Jobard, director of the Industrial Museum at Brussels, cited no precedent in announcing on February 27, 1858, to the Academy of Sciences at Paris, that M. de Changy had succeeded in resolving the problem of the divisibility of the electric light."

Apparently comments of de Changy appeared in an article<sup>7</sup> in *La Lumière Electrique* in which he mentioned some of the work he and another scientist had done as far back in time as 1838.

As an aside, it is of interest to mention that Jobard apparently had some interest in the lighting of mines because he invented an economical oil lamp. The lamp was called a "lamp for the poor" or "lamp for one"<sup>10</sup>. It was designed as a light source for just one person. Jobard published at least ten articles in the scientific literature from 1835-1858<sup>9</sup>.

The picture shown below is an artist's conception of de Changy showing the application of an incandescent lamp in the mine gallery; the picture was scanned from Fig. 36 of Figuiet's book<sup>2</sup>.



**Note:** - It is not known what de Changy's first name was. In an email message from Mrs. Marie-Christine Claes (Art Historian, Royal Institute for Cultural Heritage, Brussels, Belgium) she informed the writer that the registers in the Patent Office in Brussels simply give the name Ch. de Changy. Based on the abbreviation, Mrs. Claes believes the first name might have been Charles. The name Ch. de Changy also appeared in the book by Barham<sup>7</sup>.

**Note:** The sketch of Monsieur de Changy was scanned from Figuiet's book<sup>2</sup>.

### **Acknowledgements**

I am indebted to Jacques Debergh and Mrs. Marie-Christine Claes, both of the Institut Royal du Patrimoine Artistique (Royal Institute for Cultural Heritage), Brussels, Belgium, for information regarding J. B. A. M. Jobard and de Changy. Their willingness to search for answers to submitted questions went beyond the norm.

### **References**

- 1) *Nature*, Vol XXVII, Dec 28, 1882, pg 209.
- 2) Louis Figuiet, Les Nouvelles Conquetes de la Science, Vol 1, Librarie illustrés, Paris, 1883, pp 92-108.
- 3) ÉM. Alglave and J. Boulard, The Electric Light: Its History, Production, and Applications, D. Appleton and Co., New York, 1884, pg 117.

- 4) A. Gelyi, "A Short History of Incandescence Lamps", *The Telegraphic Journal and Electrical Review*, Vol XVI, Jan 31, 1885, pp 89-91; Feb 7, 1885, pp 111-113; Feb 14, 1885, pp 139-140.
- 5) Park Benjamin, The Age of Electricity—From Amber-Soul to Telephone, Charles Scribner's Sons, 1886, pp 138-139.
- 6) "Jobard", Biographie Nationale, Vol X, Brussels, 1888-1889, pp 493-499.
- 7) G. Basil Barham, The Development of the Incandescent Electric Lamp, Scott, Greenwood & Son, London, 1912, pg 15.
- 8) John W. Howell & Henry Schroeder, History of the Incandescent Lamp, The Maqua Co., Schenectady, NY, 1927, pg 33.
- 9) Catalog of Scientific Papers, Compiled by the Royal Society of London, Vol III, Scarecrow Reprint Corp., Metuchen, NJ, 1968, pg 550.
- 10) Communication from Mrs. Marie-Christine Claes, Brussels, Belgium.
- 11) Communication from Jacques Debergh, Brussels, Belgium.

### **Additional Information on C. De Changy**

Since the write-up regarding C. De Changy was put on this website some biographical information has been uncovered. This information was found and emailed to the writer by Mrs. Marie-Christine Claes of Brussels, Belgium. The information revealed here should be of interest to those who research the various works regarding the development of incandescent lighting.

Mrs. Claes visited the Archives of Brussels<sup>1</sup> and found the following:

C. De Changy was Charles-Francois De Changy, being born on July 22, 1817 in the city of Saint-Avertin, which is in the department of Indre-et-Loire, France. The city of Saint-Avertin is located a few kilometers to the south of the city of Tours, the capital of the department of Indre-et-Loire. De Changy was described as an engineer (ingénieur).

Apparently De Changy lived in Brussels as early as 1851, residing at 9 Rue de l'Etoile. From at least the year 1856 to 1865 he lived at No. 191 Rue Terre-Neuve, in Brussels, with his mother, who was born in the city of Tours. On January 11, 1865 he married Jeanne-Joséphine Dedeyn, a hat maker, who was born on July 17, 1843.

In Les nouvelles inventions aux expositions universelles<sup>4</sup> Jobard commented that De Changy had been working alone in his laboratory for six years.

A short write-up that appeared in a 1904 book<sup>5</sup> is worth repeating here:

#### **Early Government Report on Electric Lighting**

"As illustrating the state of the art prior to 1880, the following abstract from the Appendix of the Annual Report of the United States Light House Board for the year ending June 30, 1879, will be found of historic interest.

"After speaking of the electric arc the report passes to the consideration of the production of light by electricity by means of incandescent conductors, as follows:

' "In some of the early experiments of Sir Humphrey Davy we find mention of the heating to luminosity of wires of various metals, as tests of the comparative power of different batteries; and, in 1858, so great an advance had been made in the practical utilization of this means of lighting, that M. Jobart, in a report to the Academy of Sciences, in Paris, was able to speak as follows:

" ' "I hasten to announce to the Academy the important discovery of the dividing of an electric current for lighting purposes. This current, from a single source, traverses as many wires as may be desired, and gives a series of lights ranging from a night lamp to a light house lamp.

" ' "The luminous arc between the carbons produces, as is well known, a very intense, flickering, and costly light. M. de Changy, who is a chemist, mechanic, and physicist, is thoroughly conversant with the latest discoveries, and has just solved the problem of dividing the electric light.

" ' "In his laboratory, where he has worked alone for the past six years, I saw a battery of twelve Bunsen elements producing a constant luminous arc between two carbons, in a regulator of his own invention—this regulator being the most simple and perfect I have ever seen. A dozen small miner's lamps were also in the circuit, and he could, at pleasure, light or extinguish either one or the other, or all together, without diminishing or increasing the intensity of the light through the extinction of the neighboring lamps. The lamps, which are closed in hermetically sealed glass tubes, are intended for the lighting of mines in which there is fire damp, and for the street lamps, which would by this system be all lighted or put out at the same time, on the circuits being opened or closed. The light is as white and pure as Gillard's gas, with which it has one

point in common, namely, its production by the incandescence of platinum. The gas-pipes are replaced by simple wires, and no explosions, bad smells, or fires can take place.

" ' "The trials that have been hitherto made, with the object of producing an electric light by means of heated platinum, have failed on account of the melting of the wires. This difficulty has been overcome by M. de Changy's dividing regulator. The cost of the light is estimated to be half that of gas. A lamp placed at the masthead of a ship would form a permanent signal for about six months, without the necessity of changing the platinum. With several such lights, placed in tubes of colored glass, it would be easy to telegraph by night, as they could be extinguished and relighted rapidly from the deck.

" ' "For light-house purposes considerable amplitude can be given the light. I also saw a lamp so arranged in a thick glass globe that it could be immersed to considerable depths without being extinguished by any movement. This lamp has already been used in the taking of fish which were attracted toward the light.

" ' "The above slight description will suffice to show to what variety of applications this discovery can be put. The communication which I have had the honor of laying before the Academy is founded upon no illusion; a lamp was, to my astonishment, lit in the hollow of my hand and remained alight after I had put it in my pocket with my handkerchief over it." ' "

' "In Comptes Rendus, or minutes of the French Academy, I find that the communication of M. Jobart was received at the meeting held March 1, 1858, and was referred to M. Becquerel. At a meeting of April 5, M. Becquerel reported that he did not find anything sufficiently definite to warrant the Academy to express an opinion as to the importance of this discovery..." ' "



### Acknowledgment

I would again like to thank Mrs. Marie-Christine Claes, Art Historian in the Royal Institute for Cultural Heritage, Brussels, Belgium, for devoting the time necessary to unearth this information and then making it available for all.

### General

- 1) Archives of Brussels, Brussels, Belgium
- 2) Almanach du Commerce (Business Directory), 1851.
- 3) Census of Brussels, 1856, register J, folio 706
- 4) Les nouvelles inventions aux expositions universelles, Volume 2, 1858, pp 348-349.
- 5) "Edisonia" - A Brief History of the Early Edison Electric Lighting System, Committee on St. Louis Exposition of the Association of Edison Illuminating Companies, New York, 1904, pp 179-181.

### References

### Philip Diehl

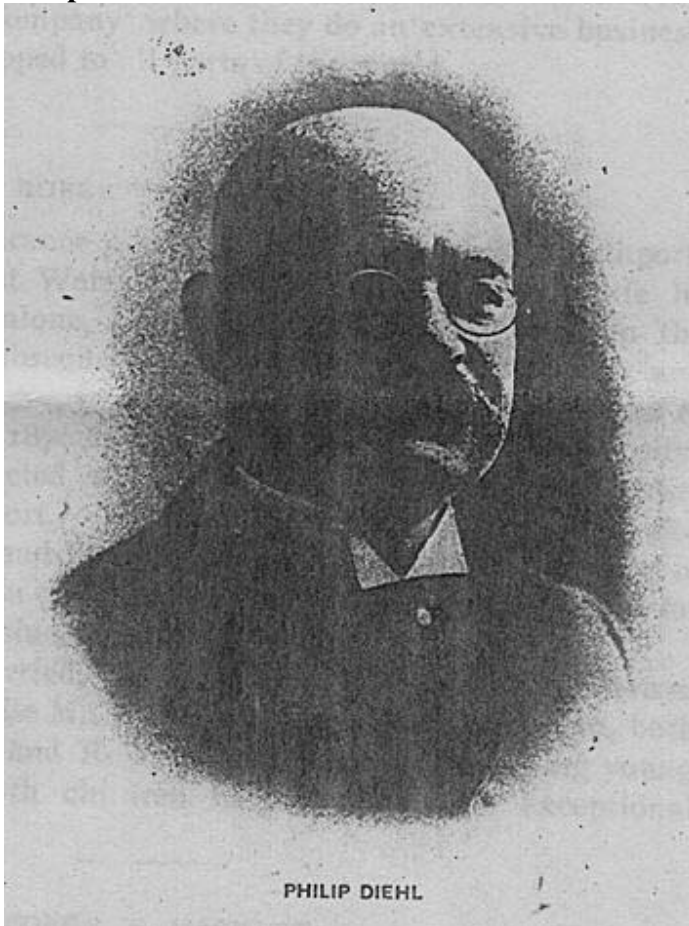

Thomas Carlyle is said to have written: "The history of the world is the biography of great men." Upon reflection one must conclude that there is much truth in that statement. This brief write-up concerns one man who contributed significantly to technical developments in different areas as well as in one specific area in which he was at least one hundred years before the time the world would pursue that invention.

Philip H. Diehl (29 Jan 1847 - 7 Apr 1913) was born in Dalsheim, Germany. At the age of 21, in July, 1868, he emigrated to New York City where he worked in several machine shops. Then, in that same year, he found employment with the Singer Manufacturing Company in New York City. In 1870 or 1871 he went to work at the Remington Machine Company in Chicago and

stayed there until 1875. In 1871 the great Chicago fire occurred and it is said that Diehl had a narrow escape from death; he lost all his belongings to the fire. In 1875 Diehl took charge of experimental work in the improvement of sewing machines in the Singer plant in Elizabeth, New Jersey. This was not a trivial job because by 1897 Singer was

manufacturing nearly one million machines a year, including 53 different constructions and 360 varieties of machines. These included the ordinary machine for family use and various types for manufacturing, including machines with 12 needles operated by steam or electricity.

On the fiftieth anniversary of the development of the incandescent lamp by Thomas Edison a celebration was held in Dearborn, Michigan at the new Henry Ford Museum. About that same time an article appeared in the Elizabeth, New Jersey newspaper about work that had been performed by Philip Diehl. The content of that article (*Elizabeth Daily Journal*, Friday Evening, October 25, 1929)<sup>5</sup> is printed verbatim below:

## **DIEHL'S LAMP HIT EDISON MONOPOLY**

**Elizabethan's Invention Used by Westinghouse To Force Royalty Concessions—Other Noteworthy Devices.**

"Although the entire world is paying honor this month to Thomas Alva Edison on the fiftieth anniversary of his invention of the incandescent lamp, little is known of the importance of an incandescent light which was invented here in 1882 by the late Philip Diehl, Elizabeth manufacturer and founder of the Diehl Manufacturing Company, who was born two months previous to the noted New Jersey wizard and whose life closely parallels that of the "Wizard of Menlo Park." Despite the fact that Diehl's lamp was never produced commercially, it was the axis on which victory turned in a bitter battle against monopoly in the electric industry late in the nineteenth century.

"The Edison celebration has revealed that the models of Diehl's lamp, which was known as an "induction incandescent lamp," along with other original models of his inventions, are being sought by Henry Ford for his collection of Americana at Greenfield, Mich., and by the Smithsonian Institute in Washington, D.C.

"Several models of Diehl's lamp and the originals of his dental motor, the first ever produced; his electric sewing machine motor, which was also the first invented; an alternating current motor and a rotary interrupter, which was the first known device designed for transforming direct electric current into alternating current, have been collected by officials of the Diehl Company here, together with patents and historic data, which will be inspected within a few days by C. L. Bishop, Henry Ford's representative.

### **Evades Edison's Patent**

"The electric bulb, invented by the Elizabeth man, who came here as a machinist for the Singer Manufacturing Company and founded the Diehl Company to produce his most notable inventions, which were applied to the

sewing machines turned out by the Singer Company, was the result of a clever idea that evaded the iron-clad patents that Edison held. When Edison, fifty years ago announced the successful culmination of his experiments, practically all the hundreds of inventors who had been working on the problem of incandescent lighting threw up their hands in resignation, for Edison's lamp was protected by patents that covered the "lead-in" wires, which carried the current from the generator to the filament within the glass bulb. The newly-formed Edison Lamp Works acquired the patents and immediately started manufacture, attempting to freeze out all other electric companies who sought rights of manufacture.

"But despite the sweeping victory scored by Edison, Philip Diehl, in the basement of his home, which was then located on Orchard street, between Chilton street and Magie avenue, being one of the four houses on the street, continued his experiments in an effort to avoid infringement on the Edison patent.

"On March 28, 1882, he obtained the first patent on his induction incandescent lamp, which used no 'lead-in' wires. Diehl's accomplishment had been gained by placing a secondary coil within the glass bulb, connected with the filament. The base of this lamp, which was cylindrical in shape, tapering down from the rounded body of the lamp, fitted into a socket which carried a primary coil, to which the current wires were attached. The electric current was forced through the glass casing from the primary coil to the secondary coil and thereby evaded the provisions of Edison's bulb. Two additional patents were granted the Elizabeth man on February 13, 1883, and May 1, 1883.

### **Invention Hits Edison Monopoly**

"Seeing the Diehl lamp as a powerful wedge whereby they could force the Edison patent holders to considerably reduce the excessive royalties they were charging manufacturers who braved bankruptcy by undertaking the production of the electric lamp, the Westinghouse Company bought Mr. Diehl's rights to his invention for a reported \$25,000, a large sum in those days. Although Diehl's lamp could not have been manufactured and marketed at a price to compete with the Edison lamp, the Westinghouse Company so played their trump, in the form of the Diehl bulb, that the holders of the Edison patent were forced to charge a more reasonable rate for the use of the patent rights. None of Diehl's bulbs were ever produced in quantity although he himself made numerous improvements on his lamp and constructed what is believed to be the first electric table lamp. He likewise made a combination gas and electric bulb fixture, which is included in the collection which the Diehl Company has assembled.

"Diehl's spare time was given to his electrical experiments, most of which were carried out in his home in Orchard street, but the problems that fascinated him were the improvements on the Singer machines on which he was working.

"Philip Diehl was born in Dahlsheim, Hesse-Darmstadt, Germany, January 20, 1847, where he received his education. Apparently his time in school was well spent, but his interest in things mechanical overshadowed his interest in scholastic studies and when 21 years old he came to New York, where he obtained a position with the Singer Manufacturing Company as an apprentice. After working there two years he was transferred by the company to their Chicago plant and while there passed through the horrors of the Chicago fire in 1871. Shortly after that he came to Elizabeth for the company, where he remained until he died in April, 1913, and where he carried on most of his experiments that brought about the founding of the Diehl Company.

"He had been married in Chicago, and he and his wife went to live on the country lane that is now Orchard street. Later they moved to 508 Morris avenue, and still later in the house at 528 Morris avenue (in which his) daughter, Mrs. Max H. Keppler, now lives with her husband and family.

### **Displayed Arc Lamp**

"Although the greater number of Mr. Diehl's experiments were carried on quietly, one or two of his endeavors into the field of electricity received city-wide attention, and even brought visitors in from the surrounding country. In front of the Corey Building, which still stands at 109 Broad street, Mr. Diehl erected years ago an arc light, which was said to be the first ever erected and burnt in this city.

"The power for the current was derived from the steam plant of the Henry Cook print shop, which was then located in the Corey Building. The steam plant supplied the energy for one of the Diehl dynamos and one night, the exact date of which has eluded enquiry, before a great crowd assembled in the street, Mr. Diehl turned on the light. The arc light was illuminated on several succeeding nights but was after dismantled.

"And although the Diehl incandescent lamp was never publicly acclaimed, despite the power it gave the Westinghouse Company even unlighted, the Diehl plant here stands as a monument, a very industrious monument to a German mechanic who had the "stick-to-itiveness" that enabled him to beat the incandescent monopoly and thereby garner for himself the money that enabled him to carry on his other experiments and found his fortune."

A photograph of some of Diehl's inventions accompanied the Elizabeth article. The caption under the picture read:

"At the left is first dental motor, produced by Elizabeth inventor August 8, 1885. Centered in rear is first alternating current generator built by Diehl for incandescent lamp experiments. This is a development of odd-looking device at the extreme right which was known as a 'rotary interrupter,' one of the first known means of deriving alternating electrical current from direct current. The device in left front center is the first electrical sewing machine motor ever produced. The other four objects are coils, armatures and parts of a generator which Diehl had improved."

Quoting from a biographical sketch of 1923<sup>3</sup>:

"In 1884 Mr. Diehl exhibited at the Franklin Institute, at Philadelphia, Pennsylvania, a dynamo, modeled after the style of his smaller motor, which generated a current for arc lamps, sewing machine motors and incandescent lamps, all covered by his patents. This was adjudged by the judicial committee of the exhibition to be one of the best dynamos exhibited."

Continuing on in that same article:

"In the late eighties the first Diehl ceiling fan made its appearance, the first electrical ceiling fan with a suspended motor, carrying its own separate set of blades. This early fan evoked much favorable comment among the leading papers and electrical journals, and immediately found its niche among the utilities of the day, the electric fan being in use all over the world, even in Pullman cars and ocean liners. Mr. Diehl also invented an individual motor of the external ring or 'Siemen's type,' which was made part of the balance wheel of the Singer machine, filling a long-felt public need and was welcomed as a great labor-saving device for the home and factory. In 1889 Mr. Diehl received from the American Institute of New York a bronze medal, which bears the inscription, 'The Medal of Merit, awarded to Philip Diehl for Electric Fans and Dynamos, 1889.' "

### **Genealogy of the Diehl Family**

A brief look is taken of the Diehl family, both before as well as after the life of Philip. Limited data are presented on the paternal grandparents, parents and offspring of Philip. In this writing the paternal grandparents will be noted as Generation 1. Available data indicate the following:

- Generation 1: Grandfather, Jacob Diehl; Grandmother, Maria Barbara Scherner
- Generation 2: Father, Johannes Diehl (b. 22 Aug 1806); Mother, Elisabetha Møllinger; married 19 Aug 1840
- Generation 3: Philip(p) Diehl (b. 30 Jan 1847); Emilie Loos (b. 28 Jul 1850, or, 21 Aug 1850, or, 1851); married 1873

- Generation 4: Daughter, Clara Elvira (b. 2 Apr 1876); Son-in-law, Max Herman Keppler (b 14 Mar 1875); married 5 Apr 1904

### **The Lamp Situation in the 1880s and Early 1890s**

Although the inventive and business life of Diehl is of great interest by itself, it is a separate story from what is of greater interest here. The story of interest here deals with an induction incandescent lamp that Diehl obtained a patent on in 1882. A greater appreciation of this invention is obtained if we leave the story of Diehl for a moment to mention the incandescent lamp situation in the early 1880s.

Edison applied for, and was granted, patents that so thoroughly covered the design of the incandescent lamp that it was very difficult for other manufacturers to come up with a cost-effective design that would not infringe his patents. Several manufacturers did produce lamps that ultimately were found to infringe and injunctions were granted against their manufacture. Diehl's induction incandescent would not have infringed Edison's design had it been manufactured because it did not contain lead-in wires. The idea of an induction discharge lamp appeared again more than 100 years after Diehl's work and some of these lamps are now described on the internet. See, for example, "Genura" in the search engine "Google."

### **Lighting and Lamp Related Patents**

A partial list of patents issued to Philip Diehl, which are lamp or lighting related, is shown below:

U.S.	No.	255,497,	Incandescent	Electric	Lamp,	Mar.	28,	1882
U.S.	No.	272,125,	Electric	Incandescent	Lamp,	Feb.	13,	1883
U.S.	No.	276,571,	Incandescent	Electric	Lamp,	May	1,	1883
U.S.	No.	314,567,	Electric	Arc	Lamp,	Mar.	31,	1885
U.S. No. 350,482, Electric Lighting System, Oct. 12, 1886								

Patent No. 276,571 is shown below.

(No Model.)

P. DIEHL.

INCANDESCENT ELECTRIC LAMP.

No. 276,571.

Patented May 1, 1883.

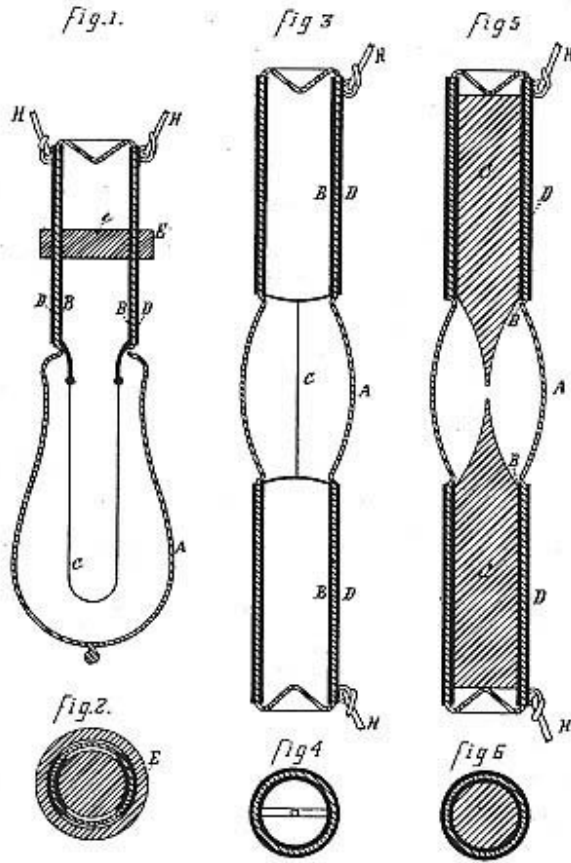

WITNESSES  
Jacob Diehl  
Rudolph Diehl

INVENTOR  
Philip Diehl

# UNITED STATES PATENT OFFICE.

PHILIP DIEHL, OF ELIZABETH, NEW JERSEY.

## INCANDESCENT ELECTRIC LAMP.

SPECIFICATION forming part of Letters Patent No. 276,571, dated May 1, 1883,  
Application filed December 13, 1882. (No model.)

To all whom it may concern:

Be it known that I, PHILIP DIEHL, of Elizabeth, in the county of Union and State of New Jersey, have invented certain new and useful Improvements in Incandescent Electric Lamps, of which the following is a specification.

This invention has reference to an improved incandescent electric lamp in which the light is produced *in vacuo* by the inductive action of an exterior condenser-plate on an interior condenser-plate, the induction-currents obtained thereby being of sufficient strength either to pass from one carbon to another or to heat a continuous carbon filament to incandescence.

The invention consists of a hermetically-sealed glass globe containing the light-giving part and having a shank integral therewith, within which an interior condenser-plate is arranged in inductive relation to an exterior condenser-plate, which latter is supplied with a current of electricity from any suitable source.

In the accompanying drawings, Figures 1, 3, and 5 are vertical central sections of different forms of my incandescent electric lamp, and Figs. 2, 4, and 6 are horizontal sections through the shanks of the lamps shown respectively in Figs. 1, 3, and 5.

Similar letters of reference indicate corresponding parts.

Referring to the drawings, A represents a hermetically-sealed glass globe of any desired shape and size, which is provided at one or both ends with cylindrical extensions or shanks that are made integral with the globe. The light-giving part is arranged in the globe A, while the cylindrical shank or shanks are provided with interior and exterior condenser-plates, B and D, of which the exterior plate, D, is arranged in inductive relation to the former and connected with the poles of a suitable source of electricity. The air is exhausted by the usual appliances from the glass globe A, or the same charged with an artificial atmosphere, so as to produce in either case a longer duration of the light-giving part. The light-giving part C may be made either of a

slender carbon filament that is secured to the terminals of the interior condenser plate or plates, B B, as shown in Figs. 1 and 3, or of solid carbons with pointed ends that approach closely to each other, as shown in Fig. 5. The interior and exterior condenser-plates, B and D, arranged on the shanks of the glass globe A, are made of tin-foil, copper, or any other suitable material capable of storing up electricity and inducing an electric current in the inner condenser-plate, B. When a current of electricity is conducted to the exterior condenser-plate, so as to charge the same, the interior condenser-plate is charged at the same time with electricity by the inductive action of the outer condenser-plate, and thereby the carbon filament heated to incandescence. When carbon points are used the current passes from one point to the other and makes the points luminous. In the latter case the glass globe, however, should not be evacuated to such a degree that the passage of the current between the points would be impeded or entirely prevented. In this manner an incandescent electric lamp of simple construction is obtained, in which the gradual destruction of the light-giving part by the entrance of air at the points where the conducting-wires pass through the globe is prevented, and a soft pleasant light produced that requires a current of less strength than the high-resistance carbons of the incandescent lamps heretofore in use.

Having thus described my invention, I claim as new and desire to secure by Letters Patent—

An electric incandescent lamp consisting of a hermetically-sealed glass globe having a shank integral therewith, a condenser-plate located at the inside of the shank and connected to the light-giving part, and an exterior condenser-plate arranged in inductive relation to the interior condenser-plate, all substantially as set forth.

PHILIP DIEHL.

Witnesses:  
G. B. LEACH,  
JOHN SAULS.

**Diehl Lamps Housed at the Ford Museum in Dearborn, Michigan**  
The William J. Hammer Historical Collection of Incandescent Lamps is in storage at the Ford Museum. The inventory sheets show that twelve Diehl lamps are in the collection. The descriptions originally supplied by Hammer, along with their identifications (year and number), are given below.

- 1885-423-----Diehl (American). Induction arc lamp. The secondary of an individual lamp transformer to the two arc electrodes inside the bulb, which is inserted in the primary coil.
- 1885-431-----Diehl (American). Diehl induction arc. No. 10 Diehl lamp, carbon electrodes forming arc in vacuum with secondary of coil inside globe and primary used outside to light by induction.



- 1885-434-----Diehl (American). Diehl induction lamp, one coil is placed inside globe and connected to filament, and other coil wound outside globe, alternating current being employed.
  - 1885-436-----Diehl (American). Early type, double carbon filament No. 2E induction lamp, made by Philip Diehl at Elizabeth, N.J.
  - 1885-439-----Diehl (American). One of Philip Diehl's earliest induction lamps employing secondary inside lamp, bulb connected with carbon filament and with the primary used on outside.
  - 1885-441-----Diehl (American). Early form of Philip Diehl's induction arc lamp. Mr. Diehl's patents for induction arc and incandescent lamps were bought by the Westinghouse Company.
  - 1885-462-----Diehl (American). Induction lamp for alternating current circuits, carbon filament with carbon paste clamps connected to secondary winding inside lamp, the primary coil being in the lamp socket.
  - 1885-466-----Diehl (American). Induction lamp for use with alternating current.
  - 1885-467-----Diehl (American). Induction lamp, carbon filament, with platinum clamps, platinum leads are connected to the secondary winding of an individual lamp transformer, the primary being inside the lamp.
- 
- 1885-523-----Diehl Induction Lamp (American). Early form of Philip Diehl's induction lamp with straight carbon rod to be made incandescent by electromagnetic induction through the glass. The following image was taken at the storage site at the Henry Ford Museum & Greenfield Village Research Center.



- 1885-528-----Diehl (American). Induction lamp showing secondary coil inside globe connects to filament.
- 1885-894-----Diehl (American). Although this lamp was not designed as a regulating lamp, by reason of the employment of an alternating current in its internal and external coils it could be easily regulated.

#### **Acknowledgements**

Genealogy information regarding Philip Diehl was kindly supplied by Frank Stϳckrath and Stan Stubbe. Loren Haroldson graciously supplied copies of the article in the *Elizabeth Daily Journal* as well as his article in *The Fan Collector*. References 1 and 3 were kindly provided by the New Jersey Information Center, The Newark Public Library.

#### **General**

#### **References**

- 1) "Philip Diehl", *History of Union County, New Jersey*, Frederick Ricord, 1897, pp 332-334. The photograph shown of Philip Diehl was scanned from a photocopy of this article.
- 2) Obituary Notes, Philip H. Diehl, *The New York Times*, Tuesday, April 8, 1913, page 13,

- column 6.
- 3) "Philip Diehl", History of Union County, New Jersey, Vol 2, A. Van Doren Honeyman, 1923, pp 117-118.
  - 4) A Life of George Westinghouse, Henry G. Prout, Charles Scribner's Sons, New York, 1922, page 112.
  - 5) "Diehl's Lamp Hit Edison Monopoly," *Elizabeth Daily Journal*, Friday Evening, October 25, 1929
  - 6) "Lightner, Milton Clarkson," The National Cyclopaedia of American Biography, Volume J, 1964, page 180.
  - 7) "Lightner, Milton Clarkson," The National Cyclopaedia of American Biography, Volume 55, 1974, page 25.
  - 8) "They Always Walked Arm-in-Arm...Philip and Emilie Diehl", Loren Haroldson, *The Fan Collector*, Apr 2000, pp 13-15.
  - 9) <http://www.edisonian.com/p004b006.htm>. This site is by Douglas Brackett. After viewing the Brackett page click "Back" on your browser to return to this page.



**WILLIAM E. FORSYTHE**  
 "Doc"  
*Research Laboratory, Nela Park*

**William E. Forsythe**

William Elmer Forsythe (22 Aug 1881 - 30 Jun 1969) did much of the determination of the physical characteristics of tungsten wire as used in incandescent lamps. In addition, he, with coauthor Dr. E. Q. Adams, published the definitive book on the fluorescent lamp; he also published a book on radiant energy. His technical publications were invaluable to lamp engineers.

Forsythe was born in Muskingham County, Ohio and obtained his undergraduate education at Denison University in Granville, Ohio. He earned the master's and Ph. D. degrees from the University of Wisconsin. On Oct 9, 1926 Forsythe was awarded the honorary degree of Doctor of Science by Kenyon College.

Employment with the Nela Research Laboratory at Nela Park in Cleveland began Jul 1, 1913. He worked as a physicist until Jul 11, 1924, when he became Director of the Research Laboratory.

During World War I Forsythe worked on light-signalling units for use in the daytime, helped to develop the original sample of an illuminated bead-sight, and was a member of the Committee on Pyrometry. During World War II he was associated with the Office of Scientific Research for Defense as well as the National Defense Research Council.

William Forsythe worked in several fields, including optics and radiant energy. He retired in 1946 and was the first person to be elected simultaneously to Member Emeritus and Fellow Grade in the Illuminating Engineering Society.

After retirement Dr. Forsythe spent several years as compiler and editor of the Smithsonian Physical Tables (9th ed., Smithsonian Institution, 1954)<sup>1</sup>.

William Forsythe and wife, Mabel, had three daughters and two sons. Two daughters passed away in childhood and one son, Richard, who was a medical doctor, was killed during World War II. The surviving daughter is Jean and the son, William, is a retired medical doctor. Jean and William are 88 and 92 years, respectively, as of this update (August 15, 2005)<sup>2</sup>. William Elmer Forsythe was interred in Lake View Cemetery, Cleveland.

**Note:** The picture of Dr. Forsythe was scanned from the Book of the Incas, 1928.

### References

- 1) Edward J. Covington, Makers of National - The Spirit and People of an Industrial Organization, Printed by Graphic Communications Operation, GE Lighting, Nela Park, E. Cleveland, OH 44112, 1997.
- 2) Richard Dye, grandson of William E. Forsythe.

### St. George Lane Fox-Pitt

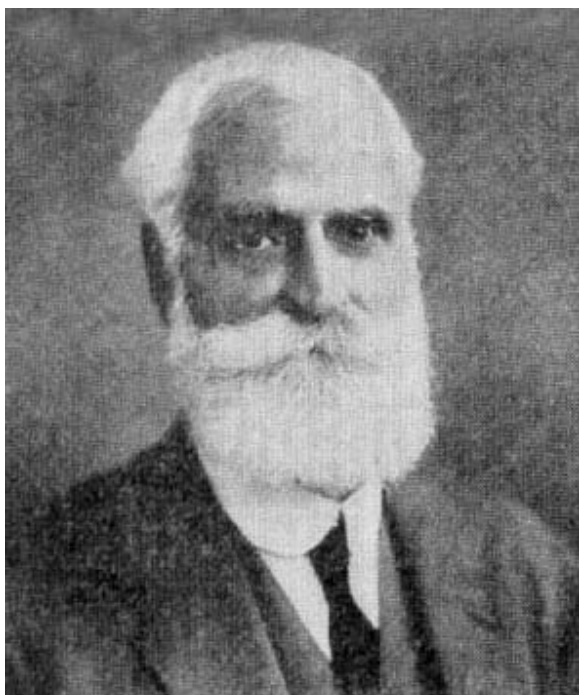

The name of Lane-Fox appeared along with those of Swan and Edison at the end of the 1870s and beginning of the 1880s in the technical literature and newspapers during the time when there was considerable activity aimed at producing a practical incandescent lamp and distribution system. St. George Lane-Fox (Sep 14, 1856-Apr 6, 1932) was on the incandescent lamp scene for only about five years, but he deservedly earned a place in the history books.

For the purpose of clarification, an explanation of the name change of the family of Lane-Fox is in order because of the confusion it can cause for the reader. Up until the year 1880 the full name of the father of St. George was Augustus Henry Lane-Fox. In that year a cousin of Augustus, Horace Pitt,

6th Baron Rivers, died and his estate passed to Augustus, with the stipulation that Augustus take the name of Pitt-Rivers. Thus, on May 25, 1880 Augustus Henry Lane-Fox became Augustus Henry Lane Fox Pitt-Rivers. It appears that St. George Lane-Fox and some of his siblings assumed the new surname name of Fox-Pitt at the same time<sup>15</sup>. In this write-up, therefore, the full name of St. George is considered to be St. George Lane-Fox until May 25, 1880. After that date his full name is considered to be St. George Lane Fox-Pitt.

However, there are inconsistencies in the use of his name by many writers; such inconsistencies certainly are understandable.

St. George Lane Fox-Pitt was a son of Augustus Henry Lane Fox Pitt-Rivers (1827-1900) and Alice Margaret (nee Stanley) Pitt-Rivers (1828-1910)<sup>29</sup>. The Pitt-Rivers had nine children, these being<sup>27,29</sup>:

Alexander	Edward	Pitt-Rivers	(b.	1855)
St. George	Lane Fox-Pitt	(b. Sep 14, 1856	- d. Apr 6,	1932)
William	Fox-Pitt	(b. 1858	- d.	1945)
Ursula	(b.	1859	- d.	1942)
Lionel	Fox-Pitt	(b. 1860	- d.	1937)
Alice		(b.		1861)
Agnes	(b.	1862	- d.	1926)
Douglas	Fox-Pitt	(b. 1864	- d.	1922)
Arthur Fox-Pitt (b. 1866 - d. 1895)				

The aspects of the life of St. George that are considered here are only his interests and accomplishments in the area of lighting, and, specifically, the electric incandescent lamp.

The early lamp research results of Lane-Fox can be determined in his own words<sup>2, 4</sup>. However, a more complete description of his lamps and lighting system was published in 1882<sup>3</sup>. That description is reproduced here in its entirety.

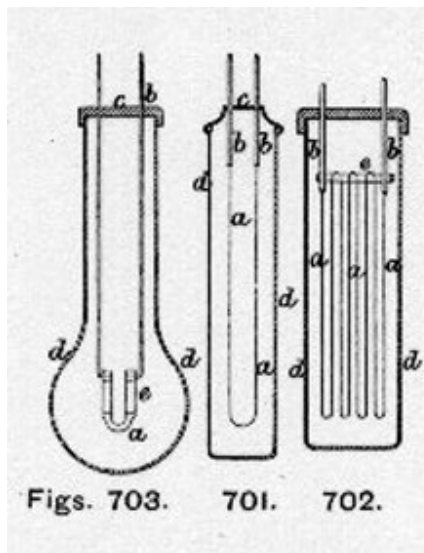

"The English patents taken out by Mr. St. George Lane-Fox in 1878, show that he was an early inventor in incandescent lighting. In that year he not only described an incandescent lamp with a platinum-iridium wick or 'burner,' and specified a complete system of distributing the currents by aid of electric mains and branch wires with current meters and regulators, but he also added secondary batteries to the circuit of the current at suitable points to act as electric reservoirs and keep the electromotive force throughout the system as uniform as possible. Mr. Fox's first lamps are illustrated in Figs. 701 and 702, and

consist of glass envelopes *d d* enclosing loops of platinum-iridium wire, either in air or a passive gas - like nitrogen. In the figures, *a a* is the wire suspended from two conducting electrodes *b b* which pass through a cover *c*, which may be hermetically sealed to the envelope. In Fig. 702 the wire *a* is looped several times round a bar of glass or other non-conductor *e*, so as to give a greater illuminating surface. Fig. 703 represents another form of lamp

described by him in 1878, and one which may be regarded as an intermediate form between his first lamps and the carbon filament lamp which he has now adopted. In this form the incandescent wick *a* is made of a refractory material, such as asbestos impregnated with carbon, and it is held by metal clips *e* connected to the electrodes *b b*, which pass through the cover *c* of the glass envelope *d d*, which is filled with nitrogen gas.

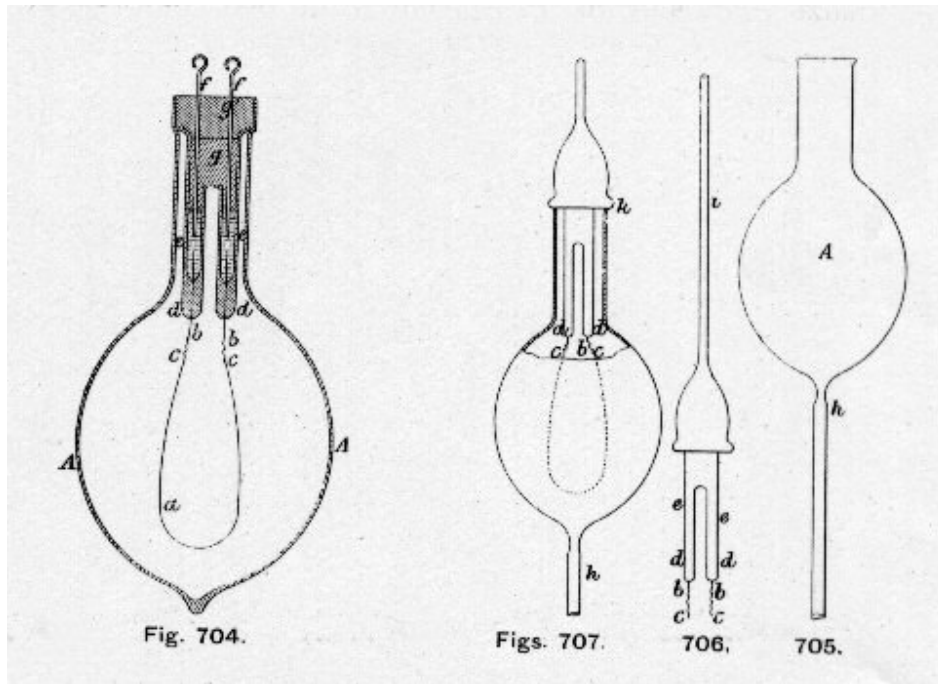

"Passing from these early and tentative forms of lamp, Mr. Lane-Fox adopted a carbonised filament in place of the wire and refractory arch or bridge shown in Figs. 701, 702 and 703, and contained in an exhausted bulb. One of the latest forms of his lamp is shown in Fig. 704, and the method of its construction will be gathered from the accompanying details in Figs. 705, 706 and 707. In Fig. 704, *a* is a loop of carbonized fibre connected to the platinum wires *b b* by small spirals *c c* at their ends. The connection is made more perfect by a serving of Indian ink round the joint. The upper parts of the electrodes *b b* are fused into solid pieces of glass *d d* forming the bottom of glass tubes *e e* containing mercury, into which the ends of the wires dip, and thus make contact with the external electrodes or terminals of the lamp *f f*. The tubes *e e* are closed at their upper ends by a layer of marine glue *g*, and over that a cap or luting of plaster-of-paris *g*<sup>1</sup>. Fig. 705 shows the glass envelope or flask *A* as it is first blown, with a hole at the bottom leading into the tube *h*. Fig. 706 represents the device inserted into the mouth of the flask to support the electrodes. It is a hollow tube of glass of peculiar shape, and bifurcated at the lower extremity as shown at *e e*, into which the wires *b b* are fused. After insertion, the bulge in the upper part and the mouth of the flask are fused together at *k* (Fig. 707) by the blow-pipe, and the upper piece is then severed. The mercury is then poured into the tubes *e e*, the stout

copper wire terminals f f are inserted, and the marine glue and plaster luting cap the whole.

"It now remains to produce the requisite vacuum within the lamp, and this is effected through the tube h, which is afterwards fused in the blow-pipe, and hermetically sealed up. During the operation, which we shall describe presently, the filament is kept incandescent by passing the current through it so as to make it give off any occluded gases. The body of the flask or globe may be of any kind of clear or coloured glass to subdue or tinge the light, but the branches into which the platinum wires are fused must be of lead glass, as without the lead the platinum and glass will not readily adhere, and the glass is liable to crack through unequal expansion.

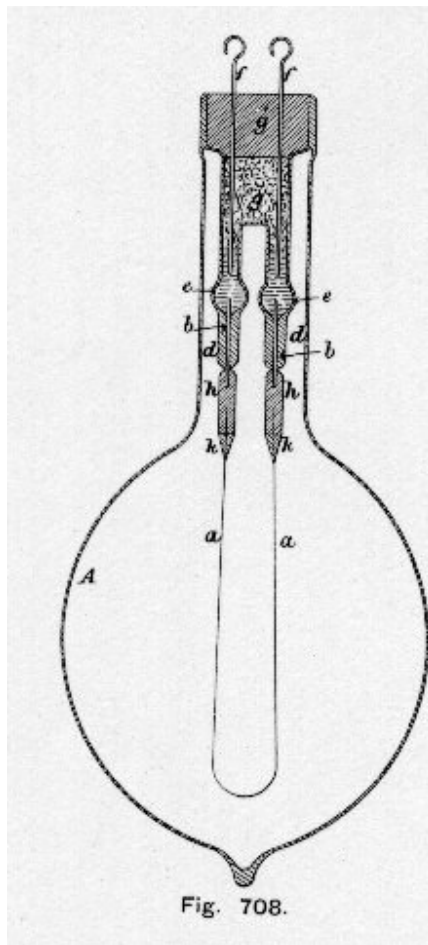

Fig. 708.

"Another pattern of the improved lamp of Mr. Lane-Fox, that shown at the Crystal Palace Electric Exhibition with beautiful effect in the Tropical Department and the Alhambra Courts, is illustrated in Fig. 708. Here the carbon filament a a is joined to the platinum electrodes b b by small ferrules of carbon h h, made of carbon cylinders, through which a fine hole is drilled to admit the ends of the wires. A cap or luting of Indian ink k k is then added to taper off the joints between the ferrules and the filament. The electrodes b b are fused into lead glass tubes d d as before, and the connection between them and the outer electrodes or terminal wires f f is made by the mercury at e e. Instead of employing marine glue, however, it is replaced by an elastic packing of cotton wool g, and over this is the cap or cork g<sup>1</sup> of plaster-paris.

"The filament employed in these lamps is made grass fibres, preferably that known as French or bass broom, and used in making certain of carpet brushes. The fibre is first cleaned boiling in a strong solution of caustic soda and the outer skin scraped off. The soda or is then boiled out of it, and a number of fibres are stretched round a mould

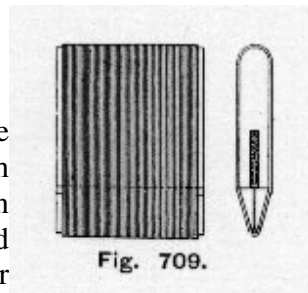
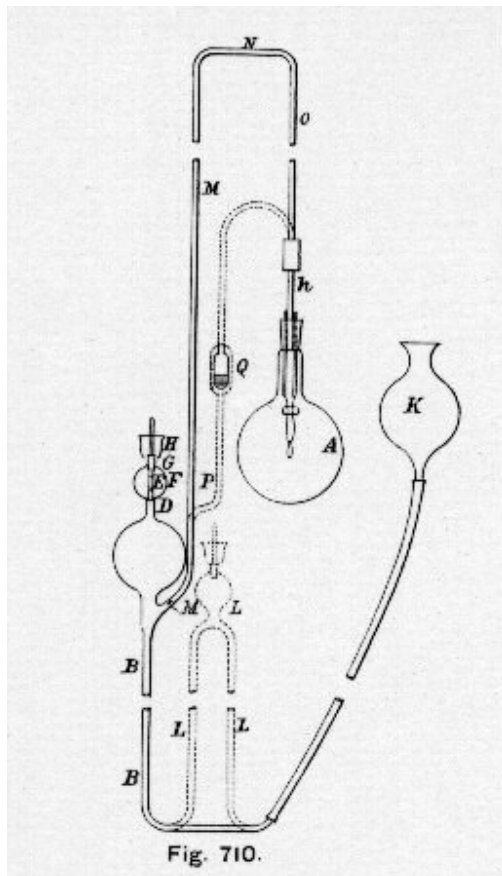

Fig. 709.

from  
whisk  
kinds  
by  
potash,  
potash

or shape of plumbago, as shown in side and end view in Fig. 709; they are then baked in a plumbago crucible at a white heat. After being baked in this manner the fibres are further carbonised by depositing carbon upon them from a rich hydro-carbon gas, such as benzole. For this purpose they are suspended in large globes filled with benzole or coal gas, and then heated to incandescence by the current. The white-hot filament decomposes the gas, and carbon is deposited on its surface, especially at the thinner parts where the temperature is highest. In this way the fibre is covered with a hard skin of carbon, which brings it to the required resistance and renders it more uniform throughout, a point of some importance as affecting the durability of the filaments. Instead of employing the electric current in this way, Mr. Lane-Fox also carbonises his filaments by raising the benzole receptacle to a white-heat in a furnace.

"After being carbonised in this manner, the fibres are classed according to their thickness, and are ready for mounting in the lamps. Slight differences of thickness occasion great differences in resistance, and the thicker specimens are reserved for lamps of 30 to 60 candle-power, whilst the smaller ones are kept for lamps of 10 to 20 candle-power. The classification is facilitated by the use of a small galvanometer mirror reflecting a ray of lamplight on a vertical scale graduated in candle-power. The thickness of the fibre is ingeniously caused to alter the angle of this mirror and deflect the beam of light up or down the scale.



"The exhaustion of the bulbs is effected by a very simple and ingenious mercurial air pump invented by Mr. Lane-Fox. As illustrated in Fig. 710, it consists of a vertical glass tube B, 30 in. high or more, and terminated at its upper end in a bulb C having a ground neck D, which at certain times receives the ground lower end of a glass rod E. This neck opens into another bulb F above, through the neck G of which the glass rod E also passes. The part of the rod which passes through the neck G is covered with india-rubber, so that the rod, while capable of being forced up and down in opening or closing the neck D of the lower bulb, shall all the while preserve a tight joint in the neck of the upper bulb. Above the upper bulb is a cup H. The lower end of the glass tube B



B is connected to a strong flexible rubber pipe I fitted at its other end with a glass vessel K; and an air trap L L is advantageously interposed between the pipe and tube, but this is not essential. To the glass tube B just below the bulb C is connected another vertical tube M about 40 in. long above the level of the cup, the upper end of which tube is connected by a bend N to a tube O hermetically joined to the tube h, which communicates with the interior of the globe A of the lamp through an india-rubber stopper.

"This constitutes the exhausting apparatus, and it operates in the following manner: The open vessel K is partially filled with mercury, and raised by hand until it becomes nearly empty, the mercury rising in the two bulbs C and F, and filling them up to the cup H. The neck G of the upper bulb F is then closed by the rod E, the neck D of the lower bulb being left open. The open vessel K is then lowered about 36 in. in order that the mercury may sink well below the point where the tube M communicates with the tube B. The consequent fall of the mercury in the bulbs produces a vacuum, which will be filled by the air in the lamp escaping through the exhausting tube h o, N M. The open vessel K is again raised and the neck G of the upper bulb opened to liberate the air. In continuing the operation the two bulbs C and F are refilled with mercury, the neck G is once more closed, and the vessel again lowered so as to exhaust the air as before. When this process has been carried on until the exhaustion is nearly complete, the pumping is then modified in this way: The open vessel K is raised and lowered several times while the rod E is out, so as to make the mercury rise and fall in the bulbs, which should now be slightly warmed, in order to evaporate any moisture on the interior. The mercury is not allowed to fall below the point of communication with the exhausting tube M while the rod is out, otherwise the mercury will be forced up the said tube into the lamp. Having got rid of all traces of aqueous or other vapour, the rod E is again inserted (while the open vessel is raised) into the neck G of the upper bulb, leaving the neck D of the lower bulb open. The open vessel is further raised or lowered several times, so that the mercury rises and falls in the bulbs, and in this manner all traces of air from the surface of the tubes or bulbs will collect in the upper bulb F. The open vessel K is then placed at such a height that the mercury fills the lower bulb and is just above its neck D. The rod E is then forced down, closing the neck D, and it is then lowered until the mercury is below the point of communication with the exhausting tube M, again raised, and so on. The upper bulb F, above the neck of the lower renders the vacuum more perfect; but by using very pure sulphuric acid so as to wet the surface of the glass bulb C, and the ground joint at the neck D, this upper bulb may be discarded, provided the cup is closed in at the top with just sufficient opening to allow the rod to move freely up and down.

"When the lamp has been thoroughly exhausted in this manner, a current is sent through the filament, rendering it incandescent, and the pumping action is continued as rapidly as possible. This process is continued from time to time for two or three days, so as to draw off the occluded gases from the

heated carbon. The fine exhaust tube h (Fig. 705) is then sealed up and broken off, leaving the lamp complete.

"Sometimes Mr. Lane-Fox dispenses with the long tubes M Q, and connects the tube B with the tube h of the lamp by means of a pipe P shown in dotted lines on Fig. 710. In this tube there is a valve Q opening downwards, and when the mercury in the pipe P falls, there is a free passage between the lamp and the bulb C through the valve Q, but when the mercury again rises as high in the valve Q the valve closes. It should be added that Mr. Lane-Fox also employs sulphuric acid in place of mercury in the pump, but with a somewhat modified apparatus.

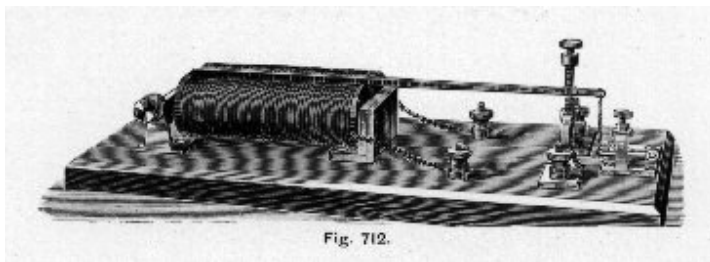

Fig. 712.

"The plan of Mr. Lane-Fox for distributing the currents from a

central station to the incandescent lamps is illustrated in Fig. 711 where A A are a pair of generators driven by a steam engine as shown. One pole of each generator is connected to the prime conductor or 'electric main' C, and the other poles are connected to 'earth' by the earth plates E or water pipes.

Branch conductors C<sup>1</sup> C<sup>1</sup> or submains start

from the main, and other branch conductors C<sup>11</sup> C<sup>11</sup> lead to the lamps and through the lamps l l to the return main. The lamps are all in multiple arc, and a constant electromotive force of about 100 Volts is kept up in the circuit. To

insure this result an automatic governor or F, for control

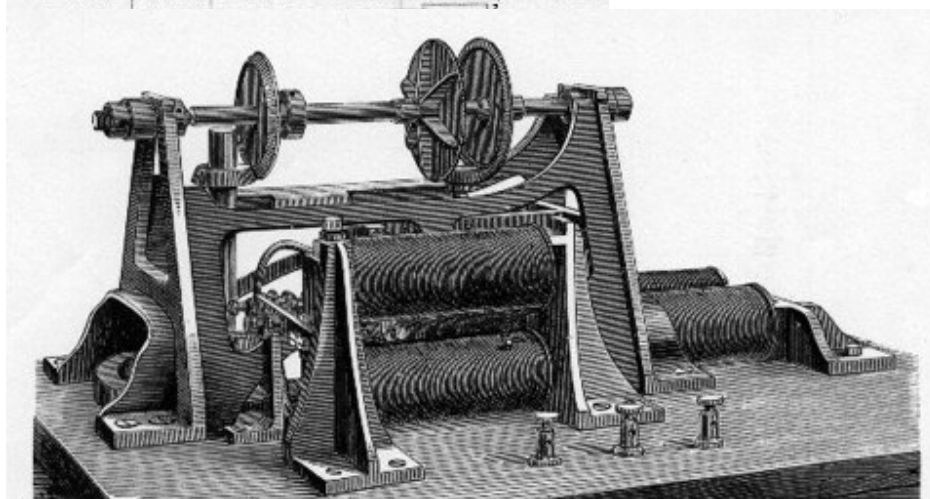
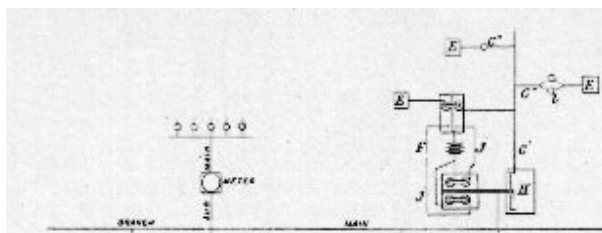

Fig. 713.

ling the generators is included in a circuit between the main and 'earth.' The regulator consists of an electro-magnet, through which a shunted portion of the current passes, and attracts a lever armature in front of its poles, as shown in Fig. 712. This lever plays between two adjustable contact pins resting midway when the current is of the proper intensity, but striking the upper pin if the current becomes too strong, and the lower pin if it becomes too weak. By this means a local circuit is closed, and more or less resistance is inserted in the circuit of the field magnets of the generator, so as to bring the lighting current to its normal value, and the lever of the regulator to its mid position. This resistance is inserted by the automatic device shown in Fig. 713, where the middle pair of electro-magnets are caused by the local current to rotate a vertical axis, carrying at its upper end a small toothed pinion, which can gear with either of the two like wheels, enclosing it between their toothed edges, as shown. If it gear with the right-hand wheel, the horizontal spindle carrying these two wheels will be rotated in one direction, and if it gear with the left-hand wheel the same spindle will be rotated in the other direction. Hence the second vertical axis seen on the left of the figure will be rotated in one direction or the other, and as it carries at its lower end a sliding contact arm which moves over the studs of a circular resistance box, partly visible in the figure, it throws in or takes out resistance from the field magnets. The direction in which the horizontal spindle shall turn is determined by two double electro-magnets, only parts of which are seen. According as the lever in Fig. 712 touches the upper or lower contact, one or other of these electro-magnets attracts an armature placed between their opposed poles, and brings the pinion-headed axis into gearing with one or other of the two wheels on the horizontal spindle.

"The secondary batteries  $B^1$  and  $B^2$  are used to store up any surplus current and return it to the circuits when there is any falling off in those below the normal current. At  $B^1$  they are arranged in 'series,' and at  $B^2$  they are so connected up by means of a commutator C, that the battery in discharging will automatically adapt the potential of its discharge to the needs of the

mains as determined by the regulator E.

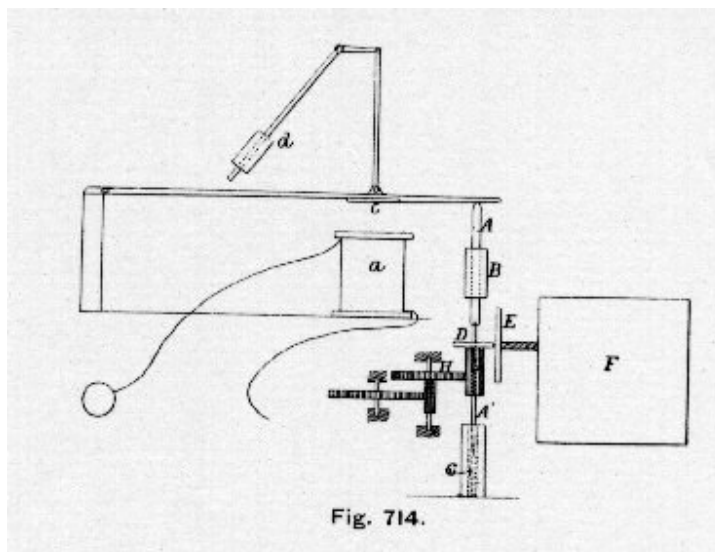
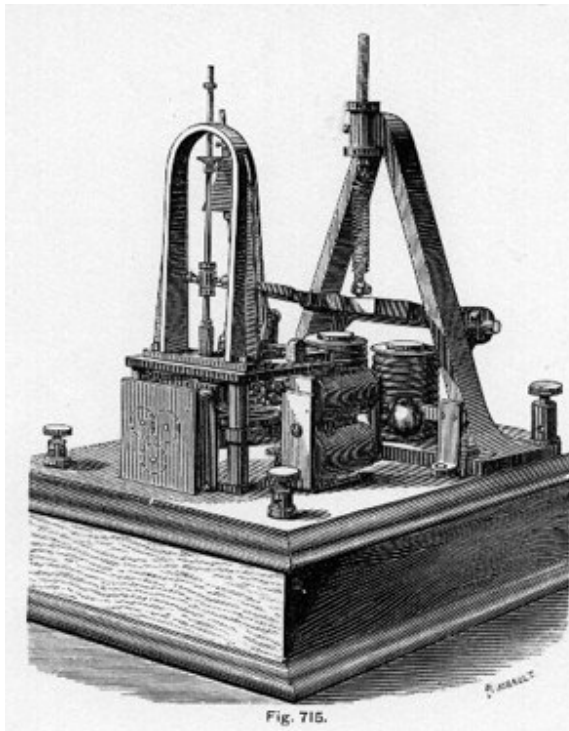

Fig. 714.

"The meters employed by Mr. Lane-Fox for measuring the current used in the lamps are of three kinds, one, in which a derived current from a supply conductor is passed through

an electro-magnet and made, by attracting an armature, to open and close more or less a conical valve regulating the flow of air through a species of windmill counter. The other and preferable kind is illustrated in Fig. 714, where a is a similar electro-magnet in a derived circuit from the main, and c is the lever armature on its poles. The lever bears at its outer end on a spindle A, which is free to move vertically in a guide B, and forms a pivot for a spindle A<sup>1</sup>, which is supported by a spring C to keep the spindle A in contact with the lever armature. On the spindle A<sup>1</sup> is a disc D in frictional contact with another disc E, which is driven by clockwork F, and pressed against D by a spring. On the same spindle is a long pinion G gearing with a toothed wheel H and actuating a counter. When no current passes in the electro-magnet a the disc D is exactly in the centre of E, and therefore does not rotate, but when the armature is attracted by a current the lever bearing on A displaces D from the centre of E and D begins to rotate with a speed proportional to its displacement, that is approximately proportional to the current strength. Thus the counter will indicate the quantity of current used.



"The meter chiefly used by Mr. Lane-Fox is, however, that shown in Fig. 715. It is an integrating meter, and consists of a double-poled electro-magnet wound with stout wire and having a hinged armature of soft iron inclined over it, as shown on the right of the figure. This armature is supported in its inclined position over the poles by a spiral spring hung from a striding support. The armature is branched at its extremity, and the fork is attached to a vertical stem seen on the left of the figure. This stem gears with a mechanical counter or indicator at its lower end as

shown, and on its upper part carries a small horizontal disc which rolls on the rounded surface of a piece of boxwood, which is rotated round a vertical axis by means of a small oscillating electro-motor worked by a shunted portion of the main current. This piece of boxwood is of a semi-oval form, narrow at the top, so that when the horizontal disc touches at the upper parts it revolves less quickly than when it touches at the lower and thicker parts where the moving circumference of the boxwood is greater. And as the horizontal disc derives its rotation by frictional contact from the rotation of the boxwood surface, it follows that the position of the disc on the boxwood

surface affects its rapidity of rotation, and consequently the indications of the counter. This position is altered by the strength of current in the main circuit passing through the doubled-poled electro-magnets. The attraction of this magnet pulls the armature down against the force of the spring, and with it the horizontal disc carried by the vertical stem. Further, the surface of the boxwood is turned to a curve, found by experiment to give the proper speed of indicator for the corresponding strength of current. The electro-motor, which gives a continuous rotation to the boxwood barrel, consists of two electro-magnets on a shunt circuit from the main current, and these by proper interrupting spring contacts are magnetised alternately, and keep a spring balance lever in oscillation. This lever in turn works a ratchet wheel, and rotates a shaft carrying the boxwood barrel. Clockwork could also be applied for this purpose, but the electro-motor requires no winding up.

"The Lane-Fox system is now worked by the Anglo-American Brush Electric Light Corporation, and was recently exhibited at the Crystal Palace, where the beautiful chandeliers designed by Mr. E. R. Johnson, for the Alhambra Courts, produced a very fine effect. These Courts were lit by Lane-Fox lamps fed from a Sellon-Volckmar secondary battery charged by a Brush machine, and the light was conveniently graduated by switching on a greater or less number of cells of the battery."

Regarding the design of the socket the following can be found in Dredge<sup>7</sup>:

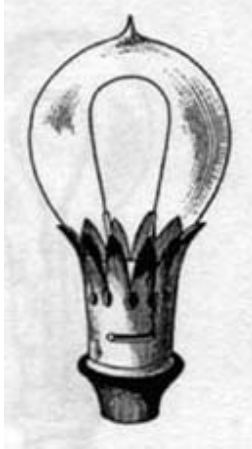

"As in the Swan and Edison systems, so in the Brush system, the act of fixing the lamp in its holder or socket makes all the necessary electrical connections. The socket is convolvulus shaped, and is designed to fit the screw of an ordinary gas bracket at its lower end, while at its upper end its points or petals exert an elastic pressure upon the globe, preventing any vibration. The two leading wires are led up the centre of the holder, and are secured to two segmental curved springs fixed to a non-conducting plug in the body of the socket. When the lamp is dropped into position and rotated to lock the bayonet joint, the heads of its two terminal screws slide over the above-mentioned curved springs, forcing them down towards the plug, to which they are attached at one end, and making a good contact, which is rubbed clean every time the lamp is removed or inserted."

Some patents issued to St. George in Great Britain are the following:

No.,	Date,	Subject
3988,	Oct 9, 1878,	Electric Lighting
4043,	Oct 12, 1878,	Applied

Electricity for Lighting and Heating  
 4626, Nov 14, 1878, Electric Lighting  
 1122, Mar 20, 1879, Electric Light  
 3494, Aug 28, 1880, Electric Lamps  
 225, Jan 18, 1881, Electric lamps  
 1543, Apr 8, 1881, Electric lamps  
 1636, Apr 14, 1881, Apparatus for Producing Motion by Electricity  
 3122, Jul 18, 1881, Electric Bridges for Lamps  
 3394, Aug 5, 1881, Generating Electric Currents  
 4383, Oct 8, 1881, Electric Bridges for Incandescent Lamps  
 5651, Dec 24, 1881, Electric Current Meters  
 1647, Apr 5, 1882, Manufacture of Incandescent Electric Lamps  
 4625, 1882, Secondary Batteries  
 56, 1883, Measuring Electric Currents  
 3692, 1883, Electrical Distribution

There exists in the William J. Hammer Historical Collection of Incandescent Lamps (at the Ford Museum in Dearborn, Michigan), five Lane-Fox lamps<sup>31</sup>. Four were made in 1881 and one in 1882. The identification numbers of these lamps are: 1881-81, 1881-93, 1881-95, 1881-96 and 1882-98. The descriptions are:

**1881-81**, early wooden base, vegetable filament, drilled carbon clamps, mercury sealed leads, tip exhaustion.  
**1881-93**, 20 cp, side seal tipless lamp, vegetable filament, drilled carbon clamp, mercury sealed. Made by St. George Lane-Fox.  
**1881-95**, small tipless side seal, vegetable filament lamp, drilled carbon clamps, mercury sealed around leads.  
**1881-96**, 20 cp, tipless, side seal bulb, vegetable filament, drilled carbon clamps, mercury sealed leads. Made by St. George Lane-Fox.

**1882-98**, 20 cp, 61-volt, vegetable filament lamp, drilled carbon clamps, mercury sealed around leads, tip sealed. Made by St. George Lane-Fox on Apr 22, 1882.

When it became clear to the general public that the development of a practical electric incandescent was "just around the corner" panic resulted because of the unknown effect this would have on the gas industry because so much lighting was being achieved through the use of gas. Lane-Fox addressed this question in a letter to the editor of a newspaper<sup>1</sup>.

The inventor Charles F. Brush entered into the life of Lane-Fox in the year 1880. On Dec 12, 1879, the Anglo American Electric Light Company Limited was formed in England in an effort to acquire the patent rights of Charles Brush<sup>29,30</sup>. Also, in 1879 this new company bought the patent rights to manufacture Lane-Fox incandescent lamps. However, the company was short-lived. A new company, called the Anglo-American Brush Electric Light Corporation, was formed on Mar 24, 1880. This new company took over the earlier one and then extended its operation. In the United States, Charles Brush tested Lane-Fox lamps (on Jun 9, 1884) and found them to be unsatisfactory. Brush (actually the Swan Lamp Manufacturing Company) then adopted the Swan lamp to manufacture, starting in 1885. Swan lamps had been manufactured by the Swan Incandescent Electric Light Company of New York since 1882. However starting in 1885 the manufacturing was carried on solely by a licensee, the Swan Lamp Manufacturing Company of Cleveland. The Cleveland Company manufactured lamps for ten years. In 1897 the New York Company applied to the Supreme Court for voluntary dissolution of the company. The testing and rejection of Lane-Fox lamps by Brush probably accelerated the demise of their manufacture.

It should be emphasized that St. George Lane Fox-Pitt was a very young man during his work with the incandescent lamp. His patent activities started about 1878 and appear to have ended about 1883. Having been born in the year 1856 he was therefore about 22 to 27 years of age during these activities. By any standard it must be concluded that he was contributing at a very early age to a developing industry. It appears that A. A. Campbell Swinton was also impressed with the work output of Fox-Pitt at such an early age<sup>19</sup>. Swinton said: "...he had undoubtedly had a very remarkable youth, as three years earlier, in 1876, he had applied an electric ignition device of his own invention to the gas lamps of Pall Mall."

In the year 1881 R.E. Crompton presented a paper titled: "The Progress of the Electric Light"<sup>5</sup>. Several comments were made by individuals at the conclusion of the lecture. One discussion was by St. George Lane-Fox. A part of what he had to say follows:

"I believe that Mr. Edison...has really done a very great deal for this subject. ...I think great credit is due to him for having stated from the very first that it was possible to introduce a system of electric lighting that could be so distributed and divided as to be available for household purposes. I think Mr. Edison was the first, and not Mr. Swan, to produce a practically useful lamp on the incandescent principle, with a filament of carbon in a vacuum. Mr. Edison's researches too in respect to the presence of occluded gases in

metals and other substances, are exceedingly interesting and very sound and scientific in the manner he has carried them out. I think he has rendered very great service not only to the future of electric lighting, but also to science, by his investigations, and for this proper credit should be given to him, more especially as in the future he will be able to show, and I have no doubt he will show, that he was the first to succeed, and I think it is as well to recognize it at once. I say this entirely disinterestedly, because it is very much to my disadvantage that Mr. Edison should be first, as I have also claims in this direction..."

It is of interest to read some of what Francis Jehl, associate of Thomas Alva Edison, had to say about Lane-Fox<sup>21</sup>:

"St. George Lane-Fox was a British scientist, philosopher, inventor and experimenter. Contemporaneously with Edison he attempted to solve the problem of domestic lighting and, like Edison, knew what the characteristics of such a lamp should be. However, he did not succeed in making the lamp and was too honest and upright to start or enter into any nefarious scheme or plot in an attempt to rob Edison of his birthright.

"Edison once said that he thought Lane-Fox would beat him, but it did not happen, for the trail that Edison followed was different from the trail that Lane-Fox pursued. Although Lane-Fox had patents and claims, yet this nobleman considered honor and justice above all. Disinterestedly, he publicly asserted that Edison was the first to make a practical lamp and that his discovery of the presence of occluded gases rendered very great service to science and to the future of electric lighting, and that it is well to recognize it at once."

After his work with the incandescent lamp, which probably stopped about 1883, scant information regarding the life of St. George Lane Fox-Pitt could be found. Some information was obtained from Bowden's book<sup>29</sup>, as well as the book written about St. George's sister, Agnes<sup>27</sup>; in addition, a few facts emerge regarding the whereabouts and activities of St. George in the biography of Helena Petrovna Hahn Blavatsky (1831-1891)<sup>26</sup>. In his autobiography Bertrand Russell<sup>24</sup> devoted two pages to a discussion of the Pitt-Rivers family. Bertrand Russell (1872-1970) was the son of Katherine, younger sister of Alice Margaret Stanley, wife of Augustus<sup>29</sup>. Russell was, therefore, a first cousin to St. George Lane Fox-Pitt. Although this writer has not seen the works, it is believed that at least two additional articles by Fox-Pitt can be found in the literature<sup>16, 17</sup>. He also wrote a book on the purpose of education<sup>18</sup>. Apparently Fox-Pitt married Lady Edith Douglas in the spring of 1899<sup>13</sup>.

An obituary appeared in *The Times* (London) at the time of Fox-Pitt's death<sup>20</sup>. The following was taken verbatim:

**"Mr. Fox Pitt □ Inventor and Psychic Student**



"Mr. St. George Lane Fox Pitt, who died suddenly yesterday at his residence in South Eaton-place at the age of 75, was a pioneer of electric lighting, a student of psychic phenomena, and an advocate of moral education.

"Mr. Fox Pitt was the second son of Lieutenant-General Augustus Henry Lane Fox Pitt-Rivers, D.C.L., F.R.S., of Rushmore, Wilts, who was of the family of Lane Fox, of Bramham Park, Yorkshire, and who took the surname of Pitt-Rivers for himself and that of Pitt for his issue. General Pitt-Rivers was the distinguished anthropologist and archaeologist who presented his collection to the University of Oxford. He married Alice, daughter of the second Lord Stanley of Alderly, and one of his daughters married his fellow archaeologist, the first Lord Avebury.

"Born at Malta on September 14, 1856, Fox Pitt devoted himself in early manhood to scientific research and mechanical inventions. He invented the Lane-Fox system of electric lighting and distribution, taking out one of the earliest patents (1878) for the use of small incandescent lamps in parallel; was one of the first active workers in the Society of Psychical Research; was vice-president and treasurer of the Moral Education League and organizer of the International Moral Education Congress; and wrote a number of books on science philosophy, education, and social problems. He also fought three elections in the Liberal interest, but without success. In a discourse at the Royal Institution as far back as 1912 the late Mr. Campbell Swinton said that Fox Pitt was 'the first person to imagine, or at any rate to patent, a public electricity supply to all and sundry.'

"In a contribution to a book entitled 'Spiritualism: Its Present Day Meaning,' published in 1920, Fox Pitt explained his view that the proposition of an unchangeable and independent 'ego' and its survival was simply unmeaning; an immutable 'psychic body' was simply unmeaning; an immutable 'psychic body' was a pernicious delusion. 'Materializations' were not more than evanescent phenomena. The craving for 'egoistic survival,' in contradistinction to individual continuity, was a very strong one, and in his view was at the root of all evil. He agreed with Bergson that 'supernormal psychic phenomena' were always in operation, though generally speaking unnoticed.

"He married in 1899 Lady Edith Douglas, daughter of the eighth Marquess of Queensberry. The funeral will be at Golders Green Crematorium on Saturday at 11:30."

Note: The photograph of St. George Lane Fox-Pitt was scanned from the book by Jehl<sup>21</sup>.

### **Acknowledgements**

The writer is grateful to Eunice Grauper, librarian at the University of Wisconsin-Madison and Bruce A. Hanesalo at Military/Info for valuable information. I also thank Mark Bowden for suggestions that led to desired biographical information. A letter from G. A.

Lane-Fox Pitt-Rivers was most helpful in pointing out an important reference the writer had overlooked. Marie Lampert at the British Library was a source for patent numbers. The Humanities Reference Service at the British Library provided a write-up that was informative.

## References

- 1) Letter to the Editor, St. George Lane-Fox, *The Times* (London), Dec 26, 1878, pg 3.
- 2) "On the Application of Electricity to Lighting and Heating, and for Domestic and Other Purposes," St. George Lane Fox Pitt, *Journal of the Society of Telegraph Engineers*, Vol 10, 1881, pp 148-155.
- 3) Electric Illumination, Vol 1, Cooke, Dredge, O'Reilly and Thompson, Offices of "Engineering", London, 1882, pp 647-658.
- 4) "The Future of Electric Lighting," St. George Lane-Fox, *Journal of the Royal United Service Institution*, (Ordinance Notes - No. 249, Washington, Feb 17, 1883; copy available from Military/Info. See website: <http://www.military-info.com/Aphoto/Subjectlist/A039.htm>). The specific volume in the J. of the R. U. S. I. is not known. The writer's best guesses for the year are 1880, 1881 or 1882.
- 5) "The Progress of the Electric Light," R. E. Crompton, *Journal of the Royal United Service Institution*, (Ordinance Notes - No. 287, Washington, Apr 11, 1883; copy available from Military/Info. See website: <http://www.military-info.com/Aphoto/Subjectlist/A039.htm>). The specific volume in the J. of the R. U. S. I. is not known but it might be Vol 25, 1882, pg 82-.
- 6) The Electric Light: Its History, Production and Applications, Alglave, E. and J. Boulard, (translation by T. O. Sloane), D. Appleton and Co., New York, 1884, pp 177-.
- 7) Electric Illumination, Vol 2, Dredge, O'Reilly and Vivarez, Offices of "Engineering," London, 1885, pp 319-320.
- 8) Arc and Glow Lamps-A Practical Handbook on Electric Lighting, Julius Maier, Whittaker & Co., London, 1886, pp 284-287.
- 9) *The Electrical Engineer*, Vol 11, Jun 10, 1891, pg 662.
- 10) *The Electrical Engineer*, Vol 12, Jul 14, 1891, pg 77.
- 11) *The Electrical Engineer*, Vol 14, Oct 4, 1892, pg 333.
- 12) *The Electrical Engineer*, Vol 15, Feb 22, 1893, pg 189.
- 13) "Memoirs of the Moment", *The Academy*, Vol 56, Jan 21, 1899, pg 99. Announcement of the coming marriage of Mr. St. George Lane Fox-Pitt and Lady Edith Douglas.
- 14) "Incandescent Lamp Development to the Year 1880, III.", Edwin W. Hammer, *Electrical World and Engineer*, Vol 36, No 24, Dec 15, 1900, pp 918-919.
- 15) An Index to Changes of Name, 1760-1901, compiled by W. P. W. Phillimore and Edw. Alex. Fry, London, Phillimore & Co., 124, Chancery Lane, London, 1905, pg 120.
- 16) "The Subliminal Mind", Lane Fox-Pitt, *Occult Review*, Vol 1, Apr 1905, pg 168.
- 17) "Self", St George Lane Fox-Pitt, *Occult Review*, Vol 2, Aug 1905, pg 55.
- 18) The Purpose of Education - An Examination of Educational Problems in the Light of Recent Scientific Research, St. George Lane Fox Pitt, Cambridge University Press, 1925.
- 19) "The Part Played by Mr. St. George Lane Fox Pitt in the Invention of the Carbon Incandescent Electric Lamp, and the Modern Method of Electric Lighting," A. A. Campbell Swinton, *Journal of the Institution of Electrical Engineers*, Vol 67, 1929, pp 551-552.
- 20) Obituary, St. George Lane Fox Pitt, *The Times* (London), Apr 7, 1932, pg 14.
- 21) Menlo Park Reminiscences, Vol 2, Francis Jehl, The Edison Institute, Dearborn,

- Michigan, 1938, pg 482.
- 22) The Electric-Lamp Industry: Technological Change and Economic Development from 1800 to 1947, Arthur A. Bright Jr, The Macmillan Co., New York, 1949, pp 49-50.
- 23) "The Distribution and Utilization of Electricity", C. Mackechnie Jarvis, A History of Technology, Vol 5, The Late Nineteenth Century (c 1850 to c 1900), Oxford at the Clarendon Press, 1958, pp 215-219.
- 24) The Autobiography of Bertrand Russell (1872-1914), Little, Brown and Co., Boston, 1967, pp 213-214.
- 25) "Augustus Henry Lane Fox Pitt-Rivers," Dictionary of Scientific Biography, Vol XI, 1975, Charles Scribner's Sons, New York, pp 5-6.
- 26) Madame Blavatsky - The Woman Behind the Myth, Marion Meade, G. P. Putnam's Sons, New York, 1980.
- 27) Concerning Agnes - Thomas Hardy's 'Good Little Pupil', Desmond Hawkins, Alan Sutton Publishing Ltd., Gloucester, 1982.
- 28) The History of N. V. Philips' Gloeilampenfabrieken, Vol 1, The Origin of the Dutch Incandescent Lamp Industry, A. Heerding, Cambridge University Press, London, 1985.
- 29) Pitt Rivers - The Life and Archaeological Work of Lieutenant-General Augustus Henry Lane Fox Pitt Rivers, DCL, FRS, FSA, Mark Bowden, Cambridge University Press, Cambridge, 1991.
- 30) What's In A Class 60 Name, George Toms, Brush Transport Enthusiasts Club, 1992.
- 31) This website. See "The William J. Hammer Historical Collection of Incandescent Electric lamps", which can be found under the general heading of "Lamp Collections and Exhibits" (section 12).

## John H. Guest

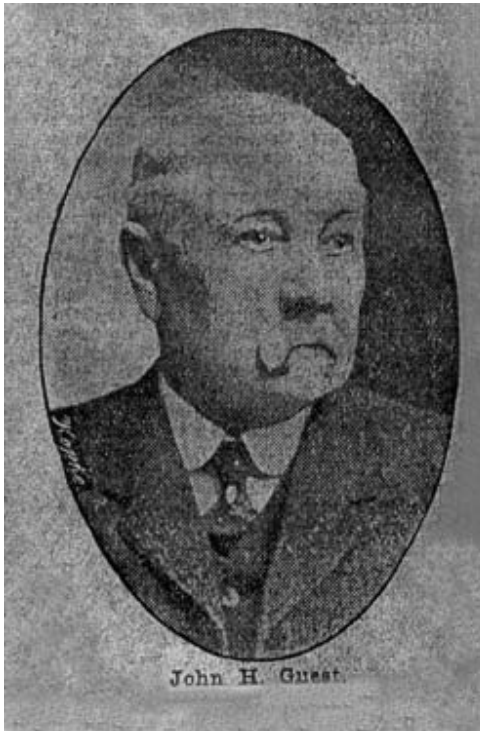

Several names appear in the early technical writings on incandescent lamps but many of these names are forgotten as the years go by. A name that appears in lists of incandescent lamps collected by William J. Hammer is that of Guest. John H. Guest was a Brooklynite who was granted at least 42 patents in the United States as well as patents in other countries. The subject matter of these patents includes arc and incandescent lamps, manufacture of lamps, various aspects of systems for railways, ticket register apparatuses, motor, and automatic fire alarm telegraphs.

Although Guest was granted several patents on incandescent lamps his name is little known today in that regard. Indeed, it is difficult to find mention of his name at all. Lamp patents were granted to him as early as 1880 and his last patent, which was granted in 1905 for a lead-in wire, is perhaps his best known endeavor. It now appears that his many patents did not bring wealth to him and his life ended in a tragic

way.

A brief periodical article (letter to the editor) by Guest will be presented here regarding platinum filaments. In addition, through the courtesy of the Brooklyn Public Library two newspaper articles regarding Guest were obtained. These will be presented in their entirety. The photograph of Guest was scanned from the 1907 article<sup>6</sup>.

The 1884 letter to the editor<sup>2</sup> was written in response to an earlier abstract written about the Cruto incandescent lamp<sup>1</sup>. Both letters will be presented here.

### **"The Cruto Incandescent Lamp**

"Herr Goetz has made a series of experiments showing some of the peculiarities of the Cruto lamp. The carbon filament is deposited upon a very slender core of platinum. It was originally supposed that this core was melted and dissipated by the application of a current of sufficient strength, and that there remained in the completed lamp simply a very fine hollow cylinder of pure carbon. It now appears, however, that the platinum core is not dissipated, but that it unites with the carbon, forming a compound filament. Herr Goetz did not go beyond a luminosity of 17 candle power, which he attained by the expenditure of 32 volt-amp $\square$ res. Tests with some specimens of the lamps indicated an *increase* of resistance, with an increase of electro-motive force. No information has been reported as to their length of life, which is a most important qualification."

John Guest then made the following comments regarding the above article.

### **"Experiments with Platinum Filaments**

"In the 'abstracts and extracts' of your valuable paper of April (March ?) last, I was reminded of some of my early experiments in incandescent lamps, through reading of 'Herr Goetz's' experiments on the 'Cruto' lamp. Who Herr Goetz and Cruto are I know not, never having heard of them before, but the subject of depositing carbon and platinum wire was pretty well ventilated by me in the early boom of incandescent lighting, and as you have shown some interest in that direction perhaps my experience and observations of that time may be important.

"My first experimental lamp in that precise direction I yet have. The object I had in view was to form a case for or to surround the platinum wire for the purpose of holding the metal when in the fused state. The plan for doing this was as follows: I introduced the fine platinum wire into an apparatus similar to that as described in the U. S. patent of mine of April 11, 1882, No 256,213, in which I surrounded it with a carbonaceous atmosphere, and with sufficient current heated the wire to a white hot heat, and in this manner very soon had the wire fully incased in a carbon shell. It was then introduced into the glass globe, the pump applied and lamp finished.

"I made several of them by this method. I found their resistance, when compared with carbon filament lamps to be very low. The light-giving body soon gave out in those I first burned, in consequence of not having a rheostat with which to regulate the supply of current. I managed, however, through the use of carbon dust, to improvise a pretty fair regulator for the supply of current, and in this way kept them alive; but at no time was I enabled to raise their incandescence equal to my carbon filament lamps. My workmen, friends and myself were very much interested upon examining the broken filaments of the destroyed lamps, some parts of the same filament would be tubular and other parts solid. We took fine hairs and strung the tubular parts as you would beads, and in place of finding platinum in the centre of the solid pieces we found a very black core surrounded by a light lead colored casing; we found all parts of the filament to be hard and brittle.

"My impression at that time was that the unequal expansion between the platinum wire and carbon caused the former to strain its confines, and in this way became dissipated. Having a curiosity to look further into the subject, I took some platinum wire and packed it in the centre of carbon dust, all of which I fixed in a crucible, this I put in a hot coal furnace for some thirty minutes, after which, upon examination, I found the platinum wire to be dirty, hard and brittle like glass, and porous, and my impression is, had I left it in long enough it would have been entirely dissipated."

J. H. Guest, Brooklyn, N. Y., April 1884.

John Guest applied for a patent in May of 1904 that was an attempt to eliminate the platinum wire used in the stem press of the incandescent lamp. The following is a newspaper article<sup>6</sup> that appeared two years after the patent was issued in 1905.

#### **"Invents a New Factor in Incandescent Lights**

#### **"John H. Guest Successfully Substitutes Copper for Platinum in Globe Stems**

#### **"Big Saving to the Public**

#### **"Brooklyn Inventor's Discovery Will Greatly Reduce Cost of Manufacture**

"John H. Guest, a Brooklyn electrical inventor at 158 South Elliott place, has invented a new factor in the incandescent light, which if used in connection with the silicon filament employed in the helion light, recently invented by Professor H. C. Parker, another Brooklynite, will, in the opinion of electrical experts who have watched demonstrations, reduce the cost of the manufacture of the incandescent light to a remarkable extent. In a word, Mr. Guest has discovered a means by which the links of platinum in the present

incandescent globes can be eliminated, copper wire alone being used in the stems.

"It took Mr. Guest, who is now in his seventy-fourth year, two years and a half to solve the problem, and so great a saving does the substitution of copper wire represent that his invention is likely to make him a very wealthy man in the decline of his life. Until he hit upon the solution, experts the world over had been trying for nearly a quarter of a century to find some means of doing away with the necessity of employing platinum.

"Only a glance at market prices is required to illustrate what an immense saving in the manufacture of the lights Mr. Guest's invention involves. Platinum is a metal much more valuable than gold. It sells today at from \$40 to \$50 an ounce and is frequently rather difficult to obtain in large quantities. Copper, which Mr. Guest has substituted for platinum, sells to-day, on the other hand, at 23 cents a pound, or not quite 1-1/2 cents per ounce.

"While the amount of platinum used in a single incandescent light is very small the amount annually used by the big manufacturers of the lights is considerable. The sum expended every year for platinum by the management of an incandescent light factory not far from this city is, for example, not far from \$125,000. That represents about 3,124 ounces of the precious metal. A similar number of ounces of copper would cost the company about \$4,086, a savings of more than \$120,000 a year.

"Another important feature is also involved in the discovery of Mr. Guest. Nine-tenths of the world's total output of platinum at the present time comes from Russia. It is taken from the sand which forms the beds of some of the great rivers in the Czar's domain. Should the Czar, for any reason, ever take it into his head to do so, he could, by one stroke of his pen, abolish the gathering of the platinum, or, at least, the sale of it to the outside world, and thus in a very short time leave in utter darkness that part of the world which depends for its illumination on the incandescent light. Of course, there is probably not a community in the civilized world where gas could not be immediately substituted for the incandescent light, but so accustomed have millions of persons become to electric illumination that to deprive them of it would entail great inconvenience and in many cases real hardship.

"In view of Mr. Guest's invention the Czar might issue an edict forbidding the export of a single ounce of platinum from Russia and it would have no effect on electrical illumination in other countries. In the stem of the incandescent globe Mr. Guest uses copper alone. And copper is found in abundance in most of the countries of the globe, especially in the United States.

"So valuable does Mr. Guest regard his discovery that he has had it patented not only in the United States, but in eleven other countries. One of these

countries is Germany and the inventor points with pride to the widely-known fact that it is next to impossible for a foreigner to get an invention patented in Germany unless the invention is worth while.

"Examine an ordinary Edison incandescent light globe, and you will see in the stem a link, or possibly two links of platinum joining the tiny knots at the ends respectively of the copper wires which enter the stem from the head and which extend from the bottom of the stem to the filament. Platinum has always been used to join these thread-like wires because the co-efficient of expansion in copper is almost equal to that of glass. Frequent experiments with a copper link, or an all-copper wire, in the past showed that the expansion of the metal was so marked as to make its use impracticable.

"Mr. Guest, from an accidental observation of iron tires such as were used not so many years ago on most wagon wheels, noticed that the expansion of the metal was always in a circle. When he undertook the problem the solution of which he has just discovered, he accordingly brought to bear upon his task the knowledge he had acquired through watching the repairing of old tires. He reasoned that by making loops in the stem the copper could expand as much as it was accustomed to in the circular direction, instead of laterally and consequently not interfere with the position of the filament or the efficiency of the light. Two and a half years of experimenting has proved that his theory was correct.

"Mr. Guest brought two of his incandescent light globes to the Eagle office this morning for the purpose of giving a practical demonstration. It was easy enough to see that there was no platinum in the stems—that the stems contained nothing but thin copper wires. Unfastening an Edison globe from one of the electric chandeliers, Mr. Guest adjusted one of his newly patented globes. As soon as the globe was screwed on tightly the current was turned on and Mr. Guest's light gave an illumination in which the layman could detect no difference from that given by an adjacent Edison light. The light burned steadily and brightly.

"In discussing his invention with a reporter, Mr. Guest said:

'Understand that I have made no experiments with filaments; I am leaving the improving of that factor of the incandescent light to others. I simply set about to see if it was not possible to eliminate platinum from the incandescent light and, after two years and a half of experimentation, I have learned that it is. When the relative cost of platinum and copper is taken into consideration it will be seen what an enormous saving in the manufacture of incandescent lights my invention will involve.

'By combining my invention with the filament invention recently made by Professor Parker and Walter G. Clarke, a tremendous expense could be saved to the public which uses electric illumination. I would like to say that I was the guest of those two scientists the other evening. They tested their helion light for me, and I am in a position to state that it is all they have ever claimed for it.

'The helion light will give three times the illumination of the ordinary incandescent light for the same electrical energy, or a similar amount of illumination with one-third the electrical energy now employed. That, in itself, involves a big saving in the cost of electrical illumination. And when you come to add to it the elimination of platinum, the most expensive factor in the common incandescent light, you can readily appreciate to what an enormous extent a combination of the two inventions would reduce the cost of manufacture, and, therefore the cost of consumption to the incandescent light-using public.'

Apparently the copper lead-in wire invention did not make John Guest into a wealthy man. Indeed, quite the opposite—as the following article<sup>8</sup>, which appeared after his death, clearly indicates.

"John Guest, 82 years old, an inventor, and his wife, Augusta, 80, were found dead in their furnished room in the house at 133 Felix st. this morning at 3 o'clock. The police believe they committed suicide by agreement. A note pinned to a Masonic apron that hung on a wall read: 'Please bury this with me.'

"Guest is said to have made a fortune some years ago in devising an improvement to the electric light bulb, but lost his money through defending litigation over the patent. He has been blind and paralyzed for the past year, and the police believe the motive for the double suicide was Guest's illness and his financial worries.

"They were found in bed, entwined in each other's arms. Gas was pouring from all the jets in the room. The police disregarded a theory that Guest might have turned on the gas without his wife's knowledge.

"Mrs. Catherine Maguire, who conducts the rooming house, smelled gas and traced the odor to the Guest's room. The door was locked. Mrs. Maguire summoned Patrolman Edward Stanton of the Bergen street station, who broke down the door. Dr. Brown of the Brooklyn Hospital worked in vain with a pulmotor for 45 minutes.

"In addition to the note on the Masonic apron was a sealed letter addressed to Mrs. Fannie Wiatt of 1227 Union st. Mrs. Wiatt said that she had known



the couple for years and that the only theory she could give for the motive was Mr. Guest's illness and financial straits.

"Mrs. Dennis E. Bristol of 550 Eastern Parkway said her family had known the Guests for eighteen years. She stated that her father-in-law, James E. Bristol, had been providing food and money for the couple for some time."

This writer attempted to determine more about John H. Guest by viewing the United States patents granted to him. Those found are shown below. The number on the left is the patent number, followed by the patent date and then the description.

RE 8,618	Mar 11, 1879	Automatic fire-alarm telegraph
216,396	Jun 10, 1879	Syringe
225,594	Mar 16, 1880	Electric-lamp
233,236	Oct 12, 1880	Electric lamp
233,346	Oct 19, 1880	Electric lamp
236,478	Jan 11, 1881	Electrical carbonizing apparatus (with C. M. Ball)
254,546	Mar 7, 1882	Regulator for electric lights
254,641	Mar 7, 1882	Electric lamp
256,212	Apr 11, 1882	Draw-plate for ... fibrous filaments for electrical carbons
256,213	Apr 11, 1882	Forming and treating electrical carbons
258,747	May 30, 1882	Electric incandescent lamp
259,007	Jun 6, 1882	Electric-arc lamp
259,008	Jun 6, 1882	Electric incandescent lamp
260,864	Jul 11, 1882	Circuit-closing key for electric lamps
260,975	Jul 11, 1882	Electric-arc lamp
265,315	Oct 3, 1882	Electric lamp
265,410	Oct 3, 1882	Electric incandescent lamp
265,670	Oct 10, 1882	Electric-arc lamp
279,152	Jun 12, 1883	Electric arc lamp
282,884	Aug 7, 1883	Manufacture of incandescent electric lamp
311,979	Feb 10, 1885	Telephonic transmitter
349,710	Sep 28, 1886	Check or ticket register apparatus
358,393	Feb 22, 1887	Fire telegraph
373,397	Nov 15, 1887	Check register
388,357	Aug 21, 1888	Fire Telegraph
388,358	Aug 21, 1888	Automatic fire telegraph
537,194	Apr 9, 1895	Conduit electric railway
537,195	Apr 9, 1895	Conduit electric railway
537,196	Apr 9, 1895	Supply system for electric railways
537,197	Apr 9, 1895	Supply system for electric railways
537,198	Apr 9, 1895	Electric railway
537,199	Apr 9, 1895	Electric-railway supply system
537,200	Apr 9, 1895	Closed-conduit electric railway
537,414	Apr 9, 1895	Closed-conduit electric railway
537,415	Apr 9, 1895	Supply system for electric railways
537,416	Apr 9, 1895	Supply system for electric railways
554,365	Feb 11, 1896	Electric motor
560,031	May 12, 1896	Electric railway
604,747	May 31, 1898	Electric railway
750,966	Feb 2, 1904	Surface contact electric railway
769,862	Sep 13, 1904	Guard for third rails
782,749	Feb 14, 1905	Incandescent electric lamp

An examination of the various patents shows that Guest apparently lived in Brooklyn at least through the year 1888. The address given for Guest in those patents starting in 1895 was in Boston, Massachusetts. The patent granted on May 31, 1898 still gave a Boston address. It appears that Guest then moved back to Brooklyn because the patent granted on Feb 2, 1904 again shows an address there. The last patent listed, No 782,749, is the patent described in this writing—that is, for a copper lead-in wire.

There are examples of Guest's lamps as well as the Helion lamp in the William J. Hammer Collection that is housed in the Henry Ford Museum in Dearborn, Michigan. Descriptions of these lamps can be found on this website under the Hammer Collection writeup in Section 12 (Lamp Collections and Exhibits), for the year 1907.

This write-up amounts to only a brief look into the life and accomplishments of John H. Guest. Perhaps in the future someone will be able to add to this information so that a greater appreciation of this man will result.

### **Acknowledgements**

The writer is appreciative of the help provided by the Brooklyn Public Library and the Cincinnati Public Library.

### **References**

- 1) "The Cruto Incandescent Lamp," *The Electrician and Electrical Engineer*, Vol 3, Mar 1884, pg 60.
- 2) J. H. Guest, "Experiments with Platinum Filaments," *The Electrician and Electrical Engineer*, Vol 3, May 1884, pg 112.
- 3) "All-Copper Incandescent Lamp Leading-in Conductor," *Electrical World and Engineer*, Vol 45, Mar 18, 1905, pg 551.
- 4) "Copper Leading-In Wires for Incandescent Lamps," *American Electrician*, Vol 17, No 4, Apr 1905, pp 219-220.
- 5) "The William J. Hammer Collection of Incandescent Electric Lamps," *Journal of the Franklin Institute*, Vol clxii, Nov 1906.
- 6) "Invents a New Factor in Incandescent Lights," *Brooklyn Daily Eagle*, Jun 14, 1907, pg 12.
- 7) W. J. Hammer, "The William J. Hammer Historical Collection of Incandescent Electric Lamps," *Transactions of the New York Electrical Society*, New series, 1913, No 4, pp 15-30.
- 8) "Inventor, Aged 82, Dies With Wife in Suicide Pact," *Brooklyn Daily Eagle*, Nov 29, 1920.

**John**

**Allen**

**Heany**

The following obituary appeared in the *New York Times*<sup>2</sup>:

"John Allen Heany"

"Inventor Twice Received the Franklin Institute Medal"

"HAMDEN, Conn. Sept 28 John Allen Heany, 69, credited with inventing the closed circuit ignition for automobiles, died here today following a long illness.

"A veteran of World War One, Mr. Heany received the Franklin Institute Medal twice for inventions of lighting systems and the insulation of power lines with asbestos.

"Other of his inventions included lighting systems for railroad cars, high voltage welding processes, a type of radio tube permitting the use of house current and thionic reduction of metals.

He leaves a widow and a daughter."

In his book, Stories For My Children, John Howell<sup>1</sup> told a story about John Heany. The complete text can be found on this website<sup>4</sup>.

Reference 3 states that John Allen Heany was born in Philadelphia on March 15, 1877. At one time he was a professor of mathematics and physics at the Central High School in Philadelphia.

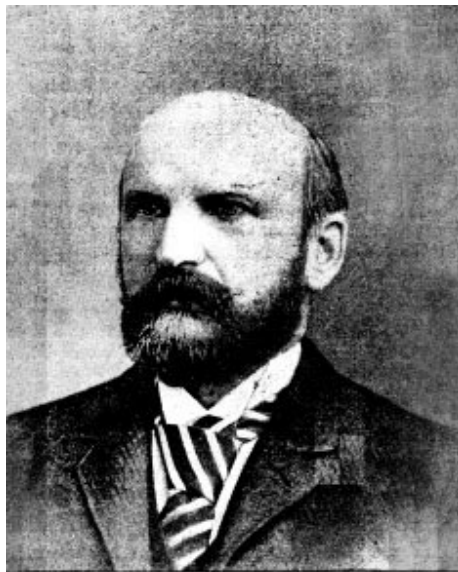

WILLIAM HOCHHAUSEN.

There are 23 Heany lamps in the Hammer Collection, which is housed in the Henry Ford Museum<sup>5</sup>. These are lamps from the 1905-1912 time period. Lamp numbers are: 1905-767, 1906-754, 1906-763, 1907-724, 1907-725, 1907-727, 1907-728, 1907-730, 1907-731, 1907-739, 1908-550, 1908-555, 1908-687, 1908-689, 1908-693, 1908-696, 1908-697, 1908-703, 1908-709, 1908-710, 1908-712, 1911-569, 1912-935.

The Heany Lamp Company was located in York, Pennsylvania.

#### References

- 1) John W. Howell, Stories For My Children, Ransdell Inc., Washington, D. C., 1930, pp 46-50.
- 2) "John Allen Heany", *New York Times*, Sep 29, 1946, pg 61, col 1.
- 3) <http://archiver.rootsweb.com/th/read/ARMACOST/2003-06/1054646975>
- 4) <http://www.frognet.net/~ejcov/jhowell.html>
- 5) <http://www.frognet.net/~ejcov/hammer.html>

#### William

#### Hochhausen

There are at least two biographical sketches of William Hochhausen that were written about 1889-1890<sup>1,2</sup>. The one copied verbatim below is from *The Electrical World*<sup>1</sup>.

"Mr. William Hochhausen, whose face we have the pleasure of presenting on this page in our series of Electrical World Portraits, is a German by birth, and thus belongs to one of the strongest and best elements that go to the making of the new American nation. He was born in Jena, Germany, so celebrated for the great battle fought there by Napoleon; and was educated at the well-known University of Jena, with which are associated the famous names of Fichte, Schelling, Hegel, Voss, Schlegel and others. Here the young Hochhausen showed a strong bent for physics and mechanics, and spent some time under the tuition of the University mechanician. At the age of 18 he went to Berlin and entered the employ of Siemens & Halske, a firm still in prosperous existence, and one in whose service many able electricians have learned the electrical arts. In course of time Mr. Hochhausen joined the Vienna branch of the house and also worked for other firms, chiefly in the manufacture of instruments of precision and all kinds of electrical apparatus.

"At the age of 23, however, Mr. Hochhausen felt himself cramped in his opportunities, and like many another Teuton longed to see something of the world beyond the borders of the fatherland, or even of Europe. He set out accordingly on a trip around the globe, leaving Hamburg for Australia. Arrived in the Antipodes, he devoted himself for two and a half years to engineering. Then he made a remove to the Sandwich Islands, and from that remote place he sailed to California, where he spent some eight months. But California in those days offered little inducement to an electrician, and so at last, in 1867, he made his way to New York, via the Central American route.

"Arrived in New York, Mr. Hochhausen was not long in forming a connection with the old and noted house of Charles T. & J. A. Chester, pioneers in the installation of fire alarm systems in this city and makers also of telegraph instruments. In 1871, Mr. Hochhausen went into business on his own account, making a specialty of telegraph apparatus and experimental work, doing a large amount of construction for the Gold and Stock Telegraph Company. When the American District Telegraph system came into vogue he built all the necessary plant for it. Early in 1874, Mr. Hochhausen, who had followed closely the evolution of magneto and dynamo electric machines, built his first dynamo to the order of Mr. Alfred Holcomb, and from this point of departure plunged deeply into the mysteries and difficulties of dynamo construction as then practiced. It was not long before Mr. Hochhausen found himself busy building dynamos for plating and deposition, and then for arc lighting. This was an interesting period of his career, and was marked by various changes in his commercial relationships, until in 1881, the merits of his work in the new field of electric lighting being recognized by capitalists, the Excelsior Electric Company was organized to manufacture under his patents and to place his apparatus for lighting, plating, etc., upon the market. Since that time the system, which was illustrated in our columns as far back as the beginning of 1884, has been steadily improved, and its merit is shown by the fact that it ranks among the

leading survivors of a period of intense and perhaps unparalleled industrial and technical competition. Mr. Hochhausen has, moreover, developed an incandescent lighting system, a variety of ingenious apparatus for regulation and measurement, and a series of excellent motors for the constant current and constant potential circuits. He is still constantly engaged in experiment and invention, and may be confidently depended upon to add frequently to the long list of useful appliances that bear his name and are of use in the practical applications of electricity."

A brief write-up about Hochhausen appeared in The Story of Electricity<sup>3</sup>:

"William Hochhausen, a New Yorker, developed a system which was introduced in 1883 by Henry Edmunds, an enterprising English capitalist who was largely interested in electrical development and who financed and introduced in England the Wallace-Farmer and Brush systems as well as the Swan incandescent lamp. The Hochhausen system was ingeniously designed to combine most of the desirable features in a single mechanism. The generator resembled that of Van Depoele, except that it was vertical instead of horizontal. Among its features was a small section of iron for the field flux, and a small auxiliary motor, which, by rotating the brushes, maintained constancy in the current. There were also minor improvements in the way the lamp carbons were fed together by gravity. The life of a pair of carbons in this system was eight hours, and as double carbon lamps were provided, they had a life of sixteen hours without attention. In those days this was a record of remarkable achievement, although it appears crude enough when it is compared with the life of from 150 to 250 hours of our present enclosed arc lamps. Like most of the others in that period, this Hochhausen system was of the high voltage, low current type, with all the defects of those systems, but later it joined in the general adoption of the low current (ten ampere) and fifty volt arc, which was a very important advance."

Two of Hochhausen's incandescent lamps are in the Hammer Collection (1884-494, 1884-500)<sup>6</sup>. The drawings on page 1 of Hochhausen's U. S. Patent No. 294,044, and 357,385, are shown below.

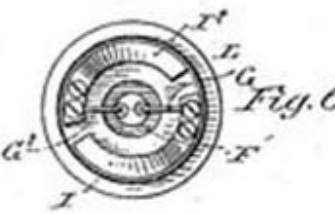
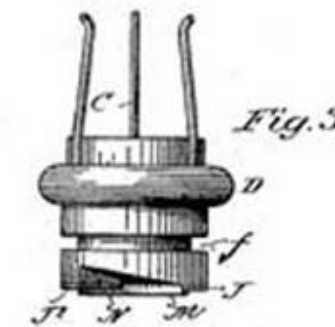
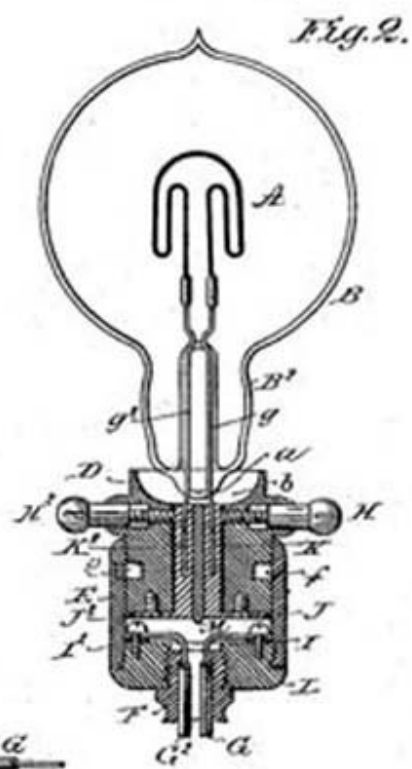
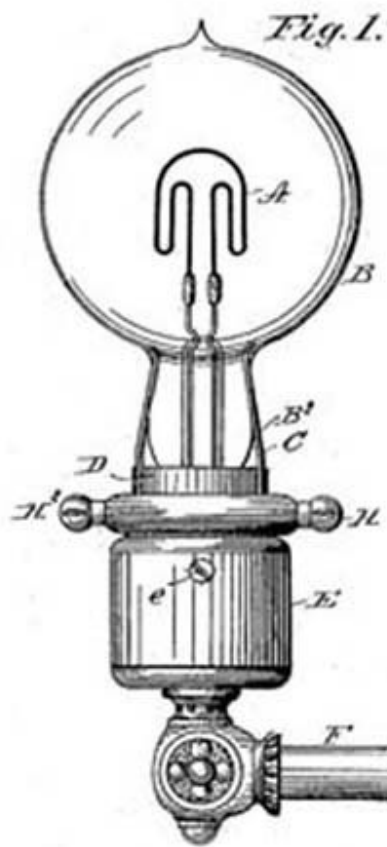

(No Model.)

W. HOCHHAUSEN.

SWITCH AND HOLDER FOR INCANDESCENT ELECTRIC LAMPS.

No. 357,385.

Patented Feb. 8, 1887.

Fig. 1.

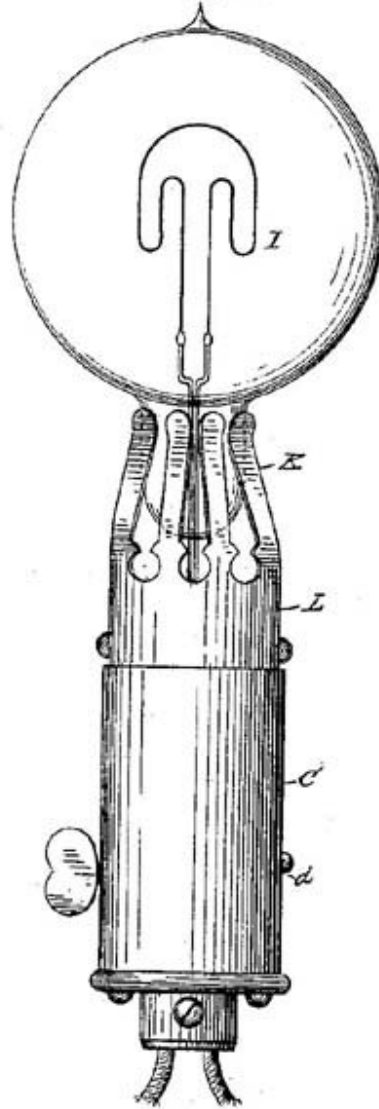

Fig. 2.

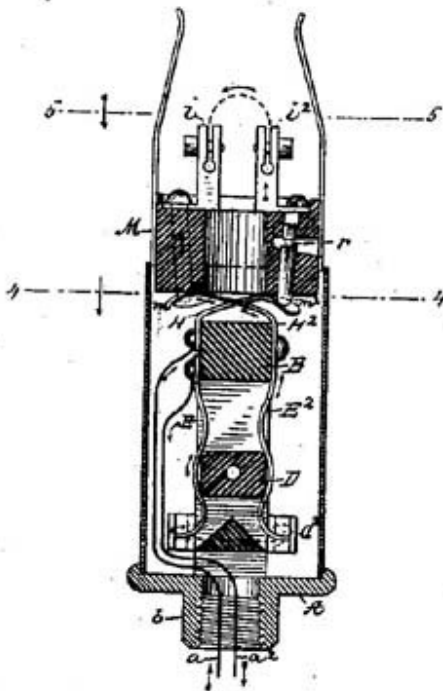

Fig. 4.

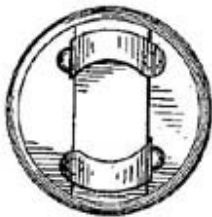

Fig. 7.



Fig. 3.

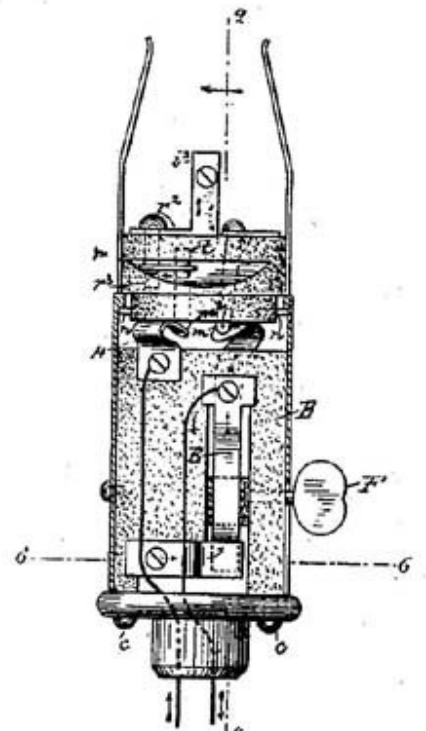
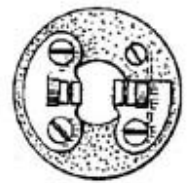

Fig. 5.



Figs. 9.

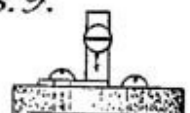
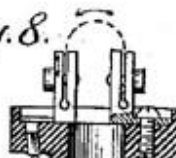

Fig. 8.





A listing of some patents granted to William Hochhausen follows:

**Some U. S. Patents Issued to William Hochhausen**

<b><u>No.</u></b>	<b><u>Issue Date</u></b>	<b><u>Description</u></b>
181,342	Aug 22, 1876	Magneto Electric Machine
224,593	Feb 17, 1880	Dynamo-Electric Machine
233,515	Oct 19, 1880	Magneto Electric Machine
245,260	Aug 2, 1881	Dynamo or Magneto Electric Machine
246,137	Aug 23, 1881	Electric Light Regulator
252,664	Jan 24, 1882	Magneto Electric Machine
252,665	Jan 24, 1882	Polarity Protector for Dynamo Electric Machines
257,007	Apr 25, 1882	Dynamo Electric Machine
261,712	Jul 25, 1882	Commutator for Dynamo Electric Machine
271,456	Jan 30, 1883	Electric Arc Lamp
271,457	Jan 30, 1883	Automatic Cut-Out for Electric Lamps
271,458	Jan 30, 1883	Electric-Arc Lamp
294,038	Feb 26, 1884	Regulator for Dynamo Electric Machines
294,039	Feb 26, 1884	Regulator for Dynamo Electric Machines
294,040	Feb 26, 1884	Regulator for Dynamo Electric Machines
294,041	Feb 26, 1884	Automatic Brake for Electric Motors
294,042	Feb 26, 1884	Double Electric Arc Lamp
294,043	Feb 26, 1884	Dynamo Electric Machine
294,044	Feb 26, 1884	Incandescent Electric Lamp
294,045	Feb 26, 1884	Hanger Board for Electric Lamp
311,072	Jan 20, 1885	Automatic Cut-Out for Electric Lamps
311,073	Jan 20, 1885	Electric Arc Lamp
311,074	Jan 20, 1885	Focusing Electric Arc Lamp
357,385	Feb 8, 1887	Switch and Holder for Incandescent Electric Lamps
416,611 *	Dec 3, 1889	System of Arc and Incandescent Electric Lighting
416,612 *	Dec 3, 1889	System of Arc and Incandescent Electric Lighting
437,359	Sep 30, 1890	Electric Snap-Switch
437,360	Sep 30, 1890	Dynamo Electric Machine
447,826	Mar 10, 1891	Electric Switch and Cut-Out
453,583 *	Jun 2, 1891	Electric-Arc Lamp
501,144	Jul 11, 1893	Ammeter

\* assignor to the Excelsior Electric Company

Hochhausen made the headlines before the advent of the incandescent lamp by Edison in 1879. An example follows that involves Edward Weston. Citing a passage from Woodbury's biography of Weston<sup>4</sup>:

"...Weston went to Boston to find out why it was impossible to sell his plating dynamos there. He learned quickly enough that two competing makes had saturated the market: the Wallace-Farmer dynamo and one manufactured by a man named William Hochhausen. The latter was

particularly exasperating to Weston because he felt the man was an out-and-out infringer. Mr. Hochhausen was equally annoyed and within a year the two were in court, fighting tooth and nail. It had developed that Hochhausen was installing water-cooled dynamos in plating plants. He was suing Weston for infringement of his patent for the cooling system.

"In his testimony, Weston put his finger on the secret of the whole thing:

'I have been building machines for plating and other purposes since the latter part of 1872 or the early part of 1873, and did build and sell machines in 1874, almost identical with those now sold by Mr. Hochhausen, and since Mr. Hochhausen began building machines for plating purposes in 1876, I have been very much annoyed by finding that as soon as I had a new device on the machine Mr. Hochhausen followed suit; and I think that I have traced channels through which information given by me has been carried to him; particularly in regard to what is known as the automatic switch...'

"□as well as various circuit arrangements and the idea of water-cooling the armature. Weston told the court that he had begun water-cooling armatures in 1874, simply by dousing them with a hose. Naturally, this was only for a test, but it had worked well enough to implant the idea in the inventor's head for future use if necessary. When, in 1877, much larger machines came in demand, notably to gain a fair share of the Boston trade, Weston included water cooling.

"He had found in the latter part of that year, that his large machines could not be sold without some form of cooling. He chose water as a medium, because it was so much more efficient than air circulated by natural draft. He made the application reluctantly, because he knew that the real way to get rid of the heat was through a design that would not permit it to be generated in the first place. However, large machines were in demand, and this was a fairly satisfactory stopgap. He accomplished it by substituting solid end bells for the usual spiders that held the journals of the machine, then pumping water in at one end of the dynamo and out at the other, being careful to keep the outflow pipe well below the journal so that there would be no leakage. It was not a scientifically sound scheme, owing to the danger of impairing the electrical insulation on the armature, and also because of rust. But it saw him through a tough period of competition.

"Weston never patented the idea, but Hochhausen did, having 'borrowed' it, along with other things, from his Newark competitor.

"Hochhausen lost the suit, it being proved that he had placed an accomplice in Weston's shop, who transmitted to him drawings and specifications of anything that looked promising. The case had its slightly amusing side, for

the invention which caused his downfall was only a temporary measure and had no future at all."

In 1890 the Thomson-Houston Company purchased the Excelsior Electric Company<sup>5</sup>.

### Acknowledgments

The writer thanks Charles A. Crider for providing photocopies of *The Electrical World* biographical sketch of William Hochhausen, Part 1 of the write-up regarding The Excelsior Electric Company, and the Excelsior advertisement. Anne Locker, IEE Archivist, also provided a photocopy of a biographical sketch that appeared in *The Electrician*.

### References

- 1) "William Hochhausen," *The Electrical World*, Vol 14, No 15, Oct 12, 1889, pg 244.
- 2) "William Hochhausen," *The Electrician* (also known as the Blue Book), 1890, pg 36.
- 3) T. Commerford Martin and Stephen Leidy Coles, The Story of Electricity, Vol 2, pg 15, 1922.
- 4) David O. Woodbury, A Measure for Greatness - A Short Biography of Edward Weston, McGraw-Hill Book Company, Inc., New York, 1949, pp 81-82, 85-86.
- 5) Arthur A. Bright, Jr, The Electric-Lamp Industry: Technological Change and Economic Development from 1800 to 1947, The Macmillan Company, New York, 1949, pg 83.
- 6) This website. Section 12. The William J. Hammer Historical Collection of Incandescent Electric Lamps.

### John W. Howell



JOHN W. HOWELL

Collectors of early incandescent lamps are familiar with the name of John W. Howell since he co-authored a book titled History of the Incandescent Lamp with Henry Schroeder in 1927. That book is the authoritative source for the identification and description of Edison lamps. While Howell's technical and managerial abilities were notable, he also played important roles in patent litigation cases. After a brief review of his service up to 1928 an example of his influence in a patent litigation case is presented.

A book titled Book of the Incas was published about 1930; it gave biographical sketches of several of the employees in the Edison and National organizations. The description given of John W. Howell in that book is presented below:

"New Brunswick, N.J., was the birthplace of Mr. Howell, December 22, 1857. He is married and living at 211 Ballantine Parkway, Newark, N.J. He was first

employed by Mr. Edison in December, 1880, to make tables showing sizes of wire to carry different numbers of lamps for different distances with different percentages of loss. On July 6, 1881, he entered the Edison Lamp Company's factory at Menlo Park, N.J., and considers himself still employed on this old job. He continued in engineering until 1890, when he was appointed Technical Advisor to Manager of Works. In 1892 he was appointed Engineer and Assistant Manager of the Lamp Works, and he organized the Edison Lamp Works Engineering Department. In 1895 he resigned as Assistant manager to devote all his time to engineering. In 1906 he went to Europe for the purpose of studying the tungsten lamp and acquiring the American rights. He was awarded the Edison Medal in 1924 for his achievements during forty-three years of scientific research, and broad services in the development of the incandescent lamp."

The influence John Howell had in a patent infringement case will be told in his own words. In 1930 Howell wrote a book titled Stories for My Children from which the following was extracted. For some reason Howell referred to the person involved in the case as "John Allen" instead of his full name, "John Allen Heany." Howell wrote:

### **Chapter I**

"In September, 1904, John Allen, an inventor, made a deal with some officers of the General Electric Company. He said he had invented a new filament. The company agreed to pay his laboratory expenses while he developed his invention. We also gave him apparatus and baked some filaments for him. In December, 1904, he told us he had finished his work and had filed his patent application. So in the last week of December, 1904, I went to his laboratory at York, Pa. He explained his invention to me and showed me the filaments. His invention was *making an oxide filament*—a Nernst filament—which was a conductor when cold and would start without requiring to be heated. He accomplished this by mixing very fine tungsten powder with the oxide. About the middle of January, 1905, he brought a number of his filaments to Harrison. We put them in lamps and exhausted them. In his presence we measured their characteristics on a photometer. At moderate temperature these filaments disintegrated and discolored the bulbs while we were measuring them. They were no good and Allen went home disgusted. He wrote to me asking me to send him the lamps we had tested. I did so, but kept one—a good sample. This I put in my lamp cabinet.

### **Chapter II**

"In 1908 a patent was issued to Allen. It described some construction details of a tungsten filament lamp. The drawings in the patent showed details which, to my mind, represented the state of the tungsten filament lamp in 1907. The date of application for the patent was January, 1905, the very time we were testing oxide filaments for Allen. So I felt sure the patent as issued had not been filed in January, 1905. This patent stated that it was a division

of another application which Allen had filed December 29, 1904—the very week I had visited Allen in his laboratory at York, where he was making oxide filaments—and that the December 29 application described and claimed lamps with filaments of pure tungsten. So I felt sure something was wrong with this patent. I then wrote to our patent department at Schenectady, telling them my suspicions and asking them to send some one to examine the papers relating to this patent in the Patent Office. (After a patent has been issued all the papers in the Patent office relating to it are open to inspection by anyone.) Our patent department sent a man, who examined all these papers, and he reported they were O.K. No changes had been made since the application was filed in January, 1905. I then wrote again, asking if the drawings in the patent had been changed since it was filed. Another man went to the Patent Office and reported that the drawings in the patent had not been changed, but they were just as they were filed in January, 1905. This satisfied our patent department that the patent was O.K., but I was not satisfied. So I saw Mr. Rice and told him the story and asked him to send the best expert he could to examine every detail of the papers in the patent Office. He did send such an expert. In the meantime the officers of Allen's company were trying to sell the patent to the General Electric Company for half a million dollars. Our expert found everything connected with the case in perfect order, all dates and stamps on the application papers agreeing perfectly with those recorded in the records of the patent Office. Everything seemed O.K. Then he observed a watermark on the paper on which the patent application was written. It bore the name of the Whiting Company. There he learned that paper with that watermark was first made in 1906, and yet it was officially stamped by the Patent Office January, 1905. He got from the Whiting Company an affidavit stating that that watermark was first used in 1906. The affidavit was taken to the Commissioner of Patents in Washington and the matter left in his hands. The Patent Office examiner, who had charge of the division in which this case was, Allen, and Allen's patent lawyer were arrested and brought to trial charged with fraud. At the trial the examiner and lawyer pleaded guilty, and they testified that Allen knew nothing about the fraud. Allen also said he knew nothing about it. The jury was composed of both white men and negroes. They acquitted Allen and convicted the others, who were sent to jail.

### **Chapter III**

"Allen's application of December 29, 1904, which was still in the Patent Office, naturally came under suspicion. An examination showed evidence of fraud in it also. So the Commissioner of Patents started proceedings to investigate this application, and Allen was ordered to show cause why his application should not be condemned as fraudulent. Allen replied that he had been guilty of no fraud, and that he could prove that he had made tungsten filaments and lamps at the time he claimed he had. The Patent Office proceedings were like a regular court trial. The Assistant Commissioner of Patents sat as judge, and lawyers representing other inventors who claimed

that they had invented the tungsten filament were present at the hearing and could cross-examine the witnesses.

"Allen had a witness named Simon, a glassblower, who testified that he had made a large number of tungsten filament lamps for Allen in November and December, 1903. He brought into court about two dozen real tungsten filament lamps, which he testified were made by him at Allen's orders in 1903. He said he had taken these lamps to his home and had kept them there ever since. The lamps were all numbered. Simon also produced two notebooks, one a pocket notebook in which he had notes of each day's work, the other a large notebook which had been kept in Allen's office and in which Simon had copied each morning the entries made the previous day in his pocket notebook. These books described the making of the tungsten lamps which he had. Each day's entry in each book was carefully dated. Simon also produced the written orders which Allen had given him, directing him how to make each of the lamps. These orders were written on sheets from a pad which was perforated, so the sheets could easily be torn off. These also were dated November and December, 1903. The details of these lamps showed to my satisfaction the state of development of the tungsten lamp in 1908, and I felt sure they were not made in 1903.

"Simon was a good witness and his testimony worried our lawyers a good deal, for, if true, it proved very conclusively that Allen had made tungsten filament lamps in 1903. Then we called Mr. Osborn, the "Examiner of Questioned Documents," to Washington to examine Simon's notebooks. He looked over the pocket notebook and said the entries had not been made day by day, but had been made in three sittings. Then he examined the book page by page. The pages were all dated November 17, 1903; November 18, 1903, and so on. Then one was dated November 21, 1908, and he found two other pages dated 1908 plainly and unmistakably. On cross-examination Simon insisted these dates were 1903, although they did look like 1908. The Commissioner of Patents looked at the dates and took Simon and his lawyer into his private office. After they returned to the court room the commissioner said: 'Mr. Simon, have you anything to say?' Simon stood up and said: 'I made those lamps in 1908 on orders from Allen.' They sent for Allen. When he came into court and heard what had happened, he acted like a wild man. He said Simon was a liar, that the lamps were made in 1903, and that his written orders to Simon, which were there, proved it. We got from the court one of the leaves from the perforated pad on which Allen's orders were written and sent a man to York, Pa., where Allen's work had been done, to see what he could learn about it. He found the stationer who had made the pad. He knew it by an imperfection in his perforator. His books showed that he had sold the pad to Allen in 1906, and that he had bought the perforating machine in 1906. This stationer was an honest seeming man, and he brought books to Washington and testified that he made the pad in 1906.

"Allen had other evidence to prove that he made tungsten lamps in 1903. He produced a photograph of a lamp which he testified he had made in January, 1905, and which had been tested in Harrison by Mr. John W. Howell. It was a photograph of one of the lamps which I had tested for him, but I testified that the filament was not tungsten. It was exactly like the lamp I had kept when I returned the others to Allen in 1905. I produced this lamp. In my lamp and in Allen's photograph the platinum wires which led the current through the glass and which extended inside the lamp to support the filament were only about one-quarter the size or area of the filament. If this filament was, as I testified, an oxide filament which had a high specific resistance and required a small current to heat it, the small platinum wire was ample to carry the current that the lamp required; but, if the filament was tungsten, a low-resistance metal, the current required to heat it would melt the thin platinum before the filament gave light. I made a tungsten filament lamp of the same dimensions as shown in Allen's photograph, and when I passed current through it in the court room the filament did not get red hot, but the platinum wires did get red hot, proving that the lamp in Allen's photograph did not have a tungsten filament. So Allen's application was declared fraudulent and the Commissioner of Patents presented the evidence to the grand jury, which indicted Allen for perjury and subornation of perjury. When the case was called for trial, they could not find Allen and he has never been brought to trial.

"About two months ago □ 1930 □ I met a man who told me he was interested in an invention of a new filament for incandescent lamps which was several times as efficient as the tungsten filament now in use. He said the invention was not yet perfected and the filaments were not yet entirely uniform in quality, but the inventor assured him it soon would be perfected. He told me the man's name was Allen. I advised him not to put any money in the venture."

It is worth repeating some words from the book Edison: His Life and Inventions, written by Frank Lewis Dyer and Thomas Commerford Martin in 1929. In their chapter titled "The Black Flag" they said: "Throughout the forty-odd years of his creative life, Edison has realized by costly experience the truth of the cynical proverb that 'A patent is merely a title to a lawsuit.' " This lesson was learned repeatedly throughout the days of manufacture of the incandescent lamp.

Howell attended Rutgers University, College of the City of New York and earned an engineering degree at Stevens Institute of Technology. He held honorary Doctor of Science degrees from Rutgers and Stevens. He married Frederica Gilchrist (1871-1953) in 1895. He was the father of two sons, John White II and Robert Gilchrist, as well as three daughters, Jane Augusta, Margaret C., and Frederica Burckle. John W. Howell retired in Dec 1931 and passed away Jul 28, 1937.

## **General**

## **References**

Edison: His Life and Inventions, Frank Lewis Dyer and Thomas Commerford Martin,

Harper Bros., New York, 1910.  
Stories for My Children, John W. Howell, Ransdell, Inc., Washington, D.C., 1930.  
Book of the Incas, ca 1930.  
 "John W. Howell, Edison Assistant", Obituary, *The New York Times*, Jul 29, 1937, pg 19, col 3.  
[members.cts.com/crash/h/hindskw/KennethHinds/10275.html](http://members.cts.com/crash/h/hindskw/KennethHinds/10275.html)



**Wilson Stout Howell**  
 One of the early workers in the laboratories of Thomas Edison was the brother of John White Howell, coauthor of the book The History of the Incandescent Lamp<sup>1</sup>. While John Howell is a familiar figure to many, the efforts of Wilson Howell (1855-1943) in the early days at Menlo Park are not so well known.

Wilson and John Howell were sons of Martin Armstrong and Abigail Lucetta (Stout) Howell<sup>4,7</sup>. They were born in New Brunswick, New Jersey and were descendants of one Edward Howell who came from England before 1639. An extensive biographical write-up of John is available in the biographical literature<sup>4</sup> but none is known to exist that details Wilson's life. In this writing a glimpse into the life of Wilson Howell is extracted mainly from a book John Howell wrote later in life<sup>2</sup> as well as from the three volume set of books written by Francis Jehl<sup>3</sup>, also an early assistant of Thomas Edison.

Wilson Howell was born on December 21, 1855<sup>7</sup>; John was born on December 22, 1857<sup>4</sup>. The origin of the passages extracted from the Jehl books are identified by the bold face notations below.

**Volume 1, page 405**  
 "Wilson S. Howell came in December, 1879. He had studied at Blair Academy in Blairstown, New Jersey. He has told me since, however, that he went to college on the hill at Menlo Park. In a letter to me he writes:

'In December, 1879, Francis R. Upton invited a party of young people to visit Mr. Edison's laboratory at Menlo Park, I being one of the party. We saw there the first public lighting of a few of the streets of Menlo Park by the old paper horseshoe carbon filaments. I was so impressed by what I saw that on the following morning I again visited the Edison laboratory, sought out Mr. Upton and requested that I be









end of the line near Mr. Carman's house it consisted of only one No. 10 wire.

'How to insulate these wires was a knotty problem. Mr. Edison sent me to his library and instructed me to read up on the subject of insulation, offering the services of Dr. Moses to translate any German or French authorities which I wished to consult. After two weeks' search I came out of the library with a list of materials which we might try. I was given *carte blanche* to order these from McKesson & Robbins and within ten days I had Dr. Moses' laboratory entirely taken up with small kettles in which I boiled a variety of insulating compounds. The smoke and stench drove Dr. Moses out.

'The results of this stew were used to impregnate cloth strips, which were wound spirally upon No. 10 B. W. G. wires one hundred feet in length. Each experimental cable was coiled into a barrel of salt water and tested continually for leaks. Of course, there were many failures, the partial successes pointing the direction for better trials. These experiments resulted in our adopting refined Trinidad asphaltum boiled in oxidized linseed oil with paraffin and a little beeswax as the insulating compound to cover the bare wire cables, which had been previously laid alongside of trenches throughout the streets of this little Jersey village. Barrels of linseed oil, bales of cheap muslin and several tons of the asphaltum were hauled in, two 50-gallon iron kettles were mounted on bricks, and the mixing operation was soon progressing in a big way. Through the pot in which this compound was boiled, we ran strips of muslin about 2-1/2 inches wide. These strips were wound into balls and wrapped upon the cables. Up from the ground came the wires once more, suspended on wooden sawhorses above the earth. After the man who served these tapes upon the cables had progressed about six feet, he was followed by another man serving another tape in the opposite direction, and he in turn by a third serving a third tape upon the cable in the direction of the first winding. After the cables were all covered with this compound and buried, the resistance to the earth was found to be sufficiently high for our purpose. I remember the first circuit which was completely ready for lighting ran from the machine shop to the Pennsylvania Railroad, branching north and south along the track. I had informed Mr. Edison that afternoon that the circuit was ready to light, but was told not to turn the light on until he gave the word. This happened to be the night of the election for President of the United States and Mr. Edison announced that I should not light this circuit unless Garfield





## References

- 1) John W. Howell and Henry Schroeder, The History of the Incandescent Lamp, The Maqua Company, Publisher, Schenectady, New York, 1927.
- 2) John White Howell, Stories for My Children, Ransdell Inc., Washington, D. C., 1930.
- 3) Francis Jehl, Menlo Park Reminiscences, Vols 1, 2, 3, Edison Institute, Dearborn, MI, 1936, 1938, 1941.
- 4) "John White Howell", *The National Cyclopaedia of American Biography*, Vol 27, 1939, pg 22.
- 5) "Wilson S. Howell", *New York Times*, Sun., Sep 19, 1943, pg 48, col 3.
- 6) [Asher A. Howell](http://www.hindskw.cts.com/KennethHinds/10275.html)
- 7) <http://www.hindskw.cts.com/KennethHinds/10275.html>
- 8) <http://nutrias.org/~nopl/photos/howell/howellf1.htm>

## Francis Jehl - An Obituary

A biographical sketch of Francis Jehl can be found elsewhere, titled: "Web Sites of Interest." It is of interest to add to that sketch, the contents of a newspaper article that appeared during the week following his death (on Feb 9, 1941). The article is reproduced here verbatim; the date of the article and the particular newspaper are unknown to this writer. The article was written by Payson Jones and was accompanied by a picture of Jehl looking at a replica of the famous Edison lamp of 1879. The title of the article was: "Death of Jehl Ends His Story of Edisons' Day□□ Co-Worker, Who saw Birth of Electric Light, Failed to Finish Third Volume." The text of the article follows:

"Was Edison nervous during the 'death watch' test? Edison never was nervous!"

The speaker was Francis Jehl, the last survivor of those who stood beside Thomas Alva Edison at Menlo Park, N.J., during the forty-hour test which, on Oct 21, 1879, produced the modern incandescent electric light. In one of the last interviews before his death, which occurred in St. Petersburg, Fla., last Sunday, the eighty-year-old Mr. Jehl, born and bred in old gas-lit New York, once more was telling the story of the inventor who, he believed, was the greatest man in the world.

"Edison did more for humanity than all the governments that ever existed," he said. "Edison gave man the courage to go out and explore the domains which he opened for them to explore."

Mr. Jehl's skullcap was black, like the one Edison wore. His hair was white, cropping out below his cap. He was gnarled, but his eyes shone as he reminisced. When he said he would bring out the third volume of his "Menlo Park Reminiscences" in 1941, "if I'm alive," his voice was warm. About him there at Dearborn, Mich., was his sanctuary, Henry Ford's restoration of the Edison laboratory at Menlo Park.

### Devoted Life to Edison

Mr. Jehl had participated in one of the greatest moments in history, and he was bent on telling the world that story. The first two volumes of his book, unfinished at his death, have

done much to perpetuate the memory of Menlo park as any writing that has come off the press in recent years. Mr. Jehl was a disciple of Edison and he passed his life in spreading the gospel of the inventor.

Thousands here and abroad had heard Mr. Jehl's Edison story. Among them in Berlin in the 1880's was Emil Rathenau, whom he knew as "a poor man in a faded coat," but who was one of the greatest Edison pioneers in Europe; also Professor Guiseppe Colombo, founder of the great electrical system at Milan.

"In Vienna I was invited to court by the Emperor Franz Josef, and had one of the greatest thrills of my life," Mr. Jehl told the writer. "I spoke with him in the Hofburg Palace. It was like a fairyland, filled with officers of the various regiments of the old Austro-Hungarian Empire. Edison was a great man, the Emperor told me. He said that when Edison invented the phonograph he had instructed his ambassador to send him one right away. I spoke to him in broken German and told him about Edison and his work."

Many years later, when he was in Budapest, Mr. Jehl was decorated by order of the Emperor. Franz Josef, incidentally, must have been more far-sighted than another Austrian of that day, Baron Rothchild, who had written New York's August Belmont that the microphone, phonograph, etc., have finally proved to be only trifles." The baron's letter, still unpublished, was dated "Vienna 25th October 1878."

#### Child of Immigrants

Born of immigrant parents in New York's East Side, on Sept. 6, 1860, Mr. Jehl made his way to fame, but not to fortune, through an acquaintance with Grosvenor P. Lowrey, general counsel of the Western Union Telegraph Company and a founder of both the Edison Electric Light Company and the first Edison company in New York. Mr. Lowrey raised the cash funds with which Edison began his electric light invention period at Menlo Park.

Mr. Jehl became Mr. Lowrey's office boy and his protege, working in Mr. Lowrey's law offices. From Mr. Lowrey Mr. Jehl obtained the letter of introduction, which, presented at Menlo Park, made him an Edison pioneer. Never before published, this letter, dated at New York Feb. 13, 1879, read in part:

"My Dear Edison:

"Can you make use of a sturdy strong boy about sixteen years old who has been for several years in our office, and, upon my recommendation, for nearly a year now in the Western Union Shops, under Mr. Phelps.

"This young fellow is a German, named Francis Jehl, and although he has a rather awkward appearance, and manners, and is rather slow and might seem to some to be stupid, he is quite an intelligent, industrious, faithful, honest and high-minded young fellow. He has always been greatly interested in electricity, and while an office boy used to make magnets



and little electrical machines which he brought to the office. They were, of course, only imitations of others, but showed a mechanical turn of mind, and a strong love for the subject of electricity. We should have kept him as long as he wanted a place, but his enthusiasm overcame him and he begged me to get a place with Mr. Phelps.

"He has been kept at the most uninteresting work (I think boring holes and washing bottles, and that sort of thing) and although he would be perfectly willing to do that if he was surrounded by men or things which interested him, he cannot do it there, for, he says, the men and boys are all flatterers of the foreman and do not work honestly and right....I have promised him to write to you.

"I do not think Francis' dissatisfaction of Mr. Phelps is because of the meanness of the work which he is set to do, but because, having entered the shop with a mind full of interest in the subject of electricity, his hopes are disappointed and sickened by discovering that he might as well be in a coal yard for any chance there is for him to hear of the subject of electricity or to come any nearer to high mechanical work than drilling holes and washing bottles.

"You will doubtless sympathize with and understand this.

"Yours very truly,

"G.P.L."

[Edison understood. He put Mr. Jehl to work cleaning and charging battery cells. But before the year was out he gave the boy his imperishable moment, when the world's first successful incandescent electric lamp flamed forty hours, and then flickered out.]

**Achilles Matveevitch (de) Khotinsky**

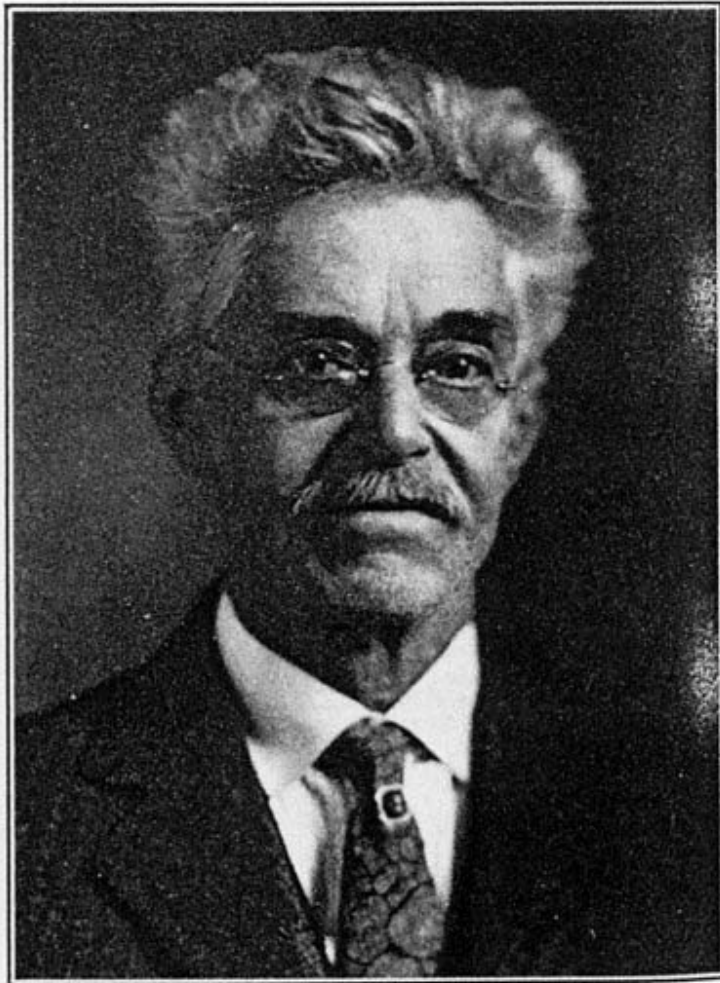

ACHILLES DE KHOTINSKY  
INVENTOR

□The above picture appears opposite page 63, National Cyclopaedia of American Biography, Vol. XXV, 1936□

Collectors of early incandescent lamps may or may not come across a lamp that was manufactured by a gentleman who achieved great success as an inventor but nevertheless remains little known today in incandescent lamp history. He was Achilles M. (de) Khotinsky (Jan 6, 1850 - Mar 28, 1933), who was born in St. Petersburg, Russia. He graduated from the Imperial Naval Academy in 1869 and then later attended the graduate school of naval architecture and mechanics and studied physics at the University of St. Petersburg.

The writer became especially interested in the name Khotinsky after obtaining one of his "separable" incandescent lamps. This particular design was manufactured starting in the year 1894 in an attempt to avoid infringing an Edison patent. The lifetime of the separable

lamp was destined to be short, however, because the Edison patent was due to expire in Nov 1894. A brief outline of Khotinsky's lamp activities in the United States follows.

In the latter part of 1891 the Germania Electric Company of Boston began to manufacture their direct incandescent dynamo. In addition, they manufactured transformers, incandescent lamps, sockets and other electrical items. One installation, a 350-light dynamo, was sold for a new hotel in Boston and a 110-light dynamo was sold to a New Jersey firm, complete with Schaefer lamps and sockets. At this same time, Captain Khotinsky, the inventor of the Khotinsky system of lighting in Europe, arrived from the Electriciteits Maatschappij Company of Rotterdam, Netherlands to join Germania. The Germania Company secured the lamp patents of Khotinsky for exploitation in the United States. He was to install a factory in Marlborough, Massachusetts for the manufacture of the Khotinsky lamp, which, as it happened, was the only lamp used to light the 1891 Frankfurt-on-Main International Electrical Exhibition. Khotinsky felt rather elated at that time because of the favorable outcome of a legal decision in France brought against his Rotterdam company by the Edison and Swan companies.

The non-separable Khotinsky lamp had been developed in Europe and was manufactured in Russia, Germany, Austria, England, France and Holland. The lamp ranged from 5 to 200 volts, 4 to 300 candlepower and from 1.5 to 5 watts efficacy.

As early as 1872 Khotinsky designed a platinum filament vacuum lamp. In the same year he designed and installed the first searchlight placed on a warship; this he did while serving as flag officer of the Russian-Baltic fleet.

The patent litigation situation in the early 1890s was such that an injunction was brought against the Germania Company and all the Khotinsky patents reverted back to him. Khotinsky then designed a "separable" lamp which he felt would not infringe upon the Edison patent. He started to develop a factory that would manufacture this new lamp. However, it took considerable time to achieve this so in the meantime he decided to manufacture the Pollard lamp (perhaps under license) which was being manufactured at that time by the Boston Incandescent Lamp Company. However, in Jun 1894 an injunction was brought against the Boston company because the court concluded that the Pollard lamp infringed the Edison patent. The Pollard lamp utilized films of silver as leading-in wires instead of the solid platinum wires used by Edison.

The separable lamp was described in the Electrical Review on Dec 20, 1893. A sketch of the lamp that appeared in that article is shown below.

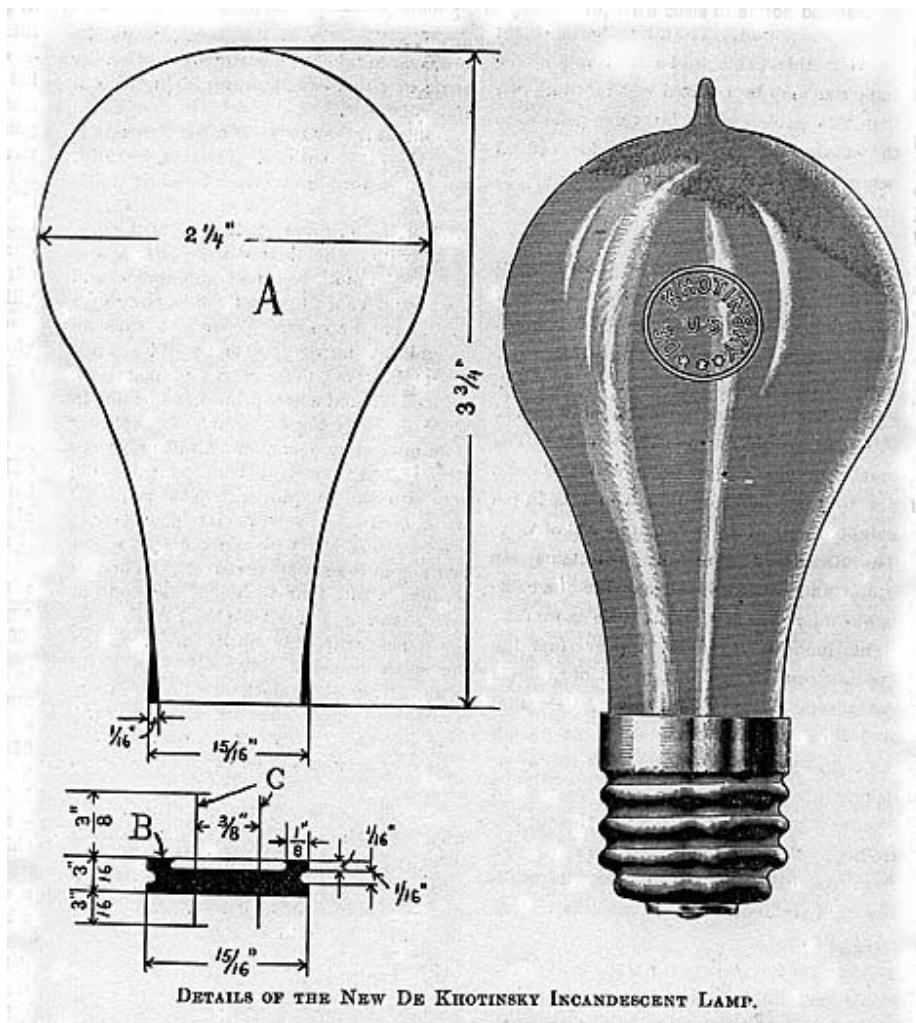

DETAILS OF THE NEW DE KHOTINSKY INCANDESCENT LAMP.

The bulb was ground flat just above the location of the base. Quoting directly from the *Electrical Review* article:

"The general appearance of the lamp is the same as all other makes, with the exception that the globe or bulb is somewhat smaller than the average. As will be seen by the accompanying illustration, which, by the way, is full size, the neck of the bulb is open, and the flat surface of its entire circumference rests on one side of the glass cap through which the leading-in wires pass. This cap is sealed to the neck of the bulb by means of a chemically prepared organic compound, or species of cement, which fills all inequalities between the two surfaces and makes them practically one piece.

"The leading in wires are of platinum, fused into the glass cap, and as this cap is more liable to be broken and can be readily removed from the bulb, it can be used over and over again in renewing lamps which have burned out. This feature makes them very economical to use, as all the parts are interchangeable, and any cover will fit any globe.

"The cement used for uniting the cap to the bulb has several peculiar properties which are worthy of mention. In the first place it can be readily melted from the outside by holding the neck of the lamp in the flame of a match, and when slightly softened is very elastic. In demonstrating this quality to your correspondent the other day the inventor separated the two pieces gradually for a distance of an inch and a half, the cement adhering to both surfaces and forming a transparent film between. In the case of a broken or burned out lamp being removed, the cement can be softened and the cap removed with a quick lateral motion so that enough cement will remain to fasten the cap to a new bulb."

The writer surmises that the cement used in the separable Khotinsky lamp had been developed by him in England and was later sold by the Central Scientific Company (known as De Khotinsky Cement). It consisted of shellac and 20-40% wood tar and was used for making semipermanent seals in vacuum systems. It stuck well to clean hot (150 degrees centigrade) surfaces. It had a fairly low vapor pressure.

The separable lamp that was once in the writer's collection had a similar etching of "DEKHOTINSKY, U.S.\*\*\*" on the bulb, in a circle of about 9/16-inch diameter. A round paper label was on the bulb indicating that the lamp was designed for 52 volts and 16 candlepower. The seal portion of the lamp is shown below.



After the experiences encountered by Khotinsky in Massachusetts, he spent a year at Purdue University. Then, for 20 years he lived in Chicago and was associated with different firms and institutions. These included the Western Electric Company, William Gaertner

and Company, Armour Institute of Technology and the University of Chicago. He also worked with Nobel Laureate Albert Michelson at the Ryerson Laboratory for eight years. During the years 1916-1922 he worked at the Central Scientific Company. He passed away in Pentwater, Michigan, which is located on the shoreline of Lake Michigan.

\*\*\*\*\*

Achilles Khotinsky first visited the United States in early 1878; he was sent to supervise the construction of three battle cruisers for the Imperial Russian Navy. He returned to Europe in 1879. He resigned from the Navy in 1881 and returned to the United States in early 1881. The broad range of his work experiences includes experimenting with torpedoes, construction of secondary batteries, development of constant temperature devices, as well as the construction of a precision machine for making diffraction gratings. His cements were well known by physicists. The amount of time devoted to incandescent lamps was limited but the name of Khotinsky deserves to be included in the history of the lamp.

\*\*\*\*\*

The use of the "de" in front of Khotinsky's name is not understood by the writer. In the French language the use of "de" in front of the surname usually meant "of" or "from." In French family names it indicates the place of origin. Based on British patents it appears Khotinsky did not use "de" prior to about 1887.

\*\*\*\*\*

#### Partial List of (de) Khotinsky Patents

(United States)

No., Title, Patent Date

238,400, Lime Light Lamp, Mar 1, 1881

244,062, Diving Apparatus, Jul 12, 1881

560,617, Telephone Signal and Signaling Circuit, May 19, 1896

564,084, Protective Appliance for Electrical Apparatus, Jul 14, 1896

565,080, Telephone Substation Apparatus, Aug 4, 1896

571,669, Lightning Arrester, Nov 17, 1896

(British)

27, Lime-Light Lamps, Jan 4, 1881

4490, Secondary or Accumulator Voltaic Batteries, Sep 20, 1882

4756, Secondary Voltaic Batteries, Oct 6, 1882

5540, Secondary Voltaic Batteries, Nov 27, 1883

14,927, An Electric Switch, Nov 12, 1884

3261, Construction of Voltaic Batteries, Mar 12, 1885

3518, Holder for Incandescent Electric Lamp, Mar 18, 1885

8416, Method of Constructing Electrode Frames for Secondary Voltaic Batteries, Jul 11, 1885

13,720, Apparatus for Effecting Electrical Measurements and Contacts, Oct 10, 1887

#### Acknowledgement

The writer thanks Joan Blaylock and Tracy Koenig of the Public Documents and Patents Department, Public Library of Cincinnati and Hamilton County, Cincinnati, Ohio, for their generous help in locating and providing patents as well as uncovering a biographical sketch of Khotinsky that the writer had overlooked in his research.

#### References

- 1) *The Electrical Engineer*, Vol XII, No 177, Sep 23, 1891, pg 364.
- 2) *The Electrical Engineer*, Vol XII, No 179, Oct 7, 1891, pg 416.
- 3) *The Electrical Engineer*, Vol XII, No 189, Dec 16, 1891, pg 670.
- 4) "A Biographical Review of the Khotinsky Accumulator," by Capt. A. de Khotinsky, *The Electrical Engineer*, Vol XIV, Sep - Nov 1892, pp 235-236, 264-265, 293-294, 308, 446-447, 473-474, 491-492, 519.
- 5) Capt. A. de Khotinsky, *The Electrical Engineer*, Vol XV, No 258, Apr 12, 1893, pg 367.
- 6) *The Electrical Engineer*, Vol XVI, No 294, Dec 20, 1893, pg 536.
- 7) "De Khotinsky's Incandescent Lamp" *Electrical Review*, Vol 23, No 18, Dec 20, 1893, pgs 207-208.
- 8) "General Electric Company vs. Captain A. De Khotinsky and C.W. Cartwright," *The Electrical Engineer*, Vol XVI, No 295, Dec 27, 1893, pp 555-556.
- 9) "Judge Colt Grants a Motion Against the de Khotinsky Lamp," *Electrical Review*, Vol 24, No 3, Jan 17, 1894.
- 10) "Injunction Against the de Khotinsky Lamp" *The Electrical Engineer*, Vol XVII, No 298, Jan 17, 1894, pg 55.

- 11) *Electrical Review*, Vol 24, No 3, Jan 17, 1894, pg 31.
- 12) *Electrical Review*, Vol 24, No 5, Feb 21, 1894, pg 91.
- 13) *The Electrical Engineer*, Vol XVIII, No 329, Aug 22, 1894, pg 156.
- 14) Les Lampes A Incandescence Electriques, J. Rodet, Gauthier-Villars, Imprimeur-Libraire, Du Bureau des Longitudes, de L'cole Polytechnique, Quai des Grands-Augustins, 55, 1907, la page 66.
- 15) de Khotinsky Cement, Central Scientific Company, Catalog F, 1915.
- 16) "Achilles de Khotinsky," The National Cyclopaedia of American Biography, Vol XXV, 1936, pp 63-64.

### **Rudolf Langhans**

In the latter part of the 1880s and the early part of the 1890s Rudolf Langhans, of Berlin, Germany, did experimental work on a new filament that involved silicon. Such a lamp is in the William J. Hammer Collection<sup>7</sup>. The lamp was brought out in England in 1899 under the name of Premier filament. Quoting from an article in *Electrical World and Electrical Engineer*<sup>3</sup>: "The filament consists of carbide of silicon coated with silicon and carbon and is said to be capable of standing a higher temperature than pure carbon..."

From 1891 to 1893 Langhans worked at the Lynn plant of the Thomson-Houston Company on a cellulose filament impregnated with silicon but a successful product did not result before the factory closed operations in August, 1893. He worked under the direct supervision of Elihu Thomson and John E. Randall<sup>6</sup>.

### **General**

### **References**

- 1) "Filament for Incandescent Lights", Rudolf Langhans, U.S. Patent No 420,881, dated Feb 4, 1890. Application filed Apr 5, 1888. Patented in Germany Nov 9, 1887; in France Feb 15, 1888; in England Feb 18, 1888; in Belgium Feb 20, 1888; in Italy Feb 21, 1888.
- 2) "The Langhans Incandescent Lamp", *The Electrical Engineer*, Vol 9, Apr 23, 1890, pg 277.
- 3) "Filament of Carbide of Silicon", *Electrical World and Electrical Engineer*, Vol XXXIII, No 13, Apr 1, 1899, pg 415.
- 4) "Process of Manufacturing Incandescent Bodies", Rudolf Langhans, U.S. Patent No 660,114, dated Oct 23, 1900.
- 5) "Incandescent Lamp", Rudolf Langhans, U.S. Patent No 516,892, dated Mar 20, 1894.
- 6) Letter to F. W. Willcox from H. D. Burnett, titled "Notes on Development of the Carbon Incandescent Lamp at the Lynn Lamp Works of the Thomson-Houston Electric Company", Apr 12, 1911.
- 7) "The William J. Hammer Historical Collection of Incandescent Electric Lamps", William J. Hammer, *Transactions of the New York Electrical Society*, 1913, No 4, pg 15.



Go to: [Early Incandescent Lamps](#)

### Lewis Howard Latimer



U.S. DEPARTMENT OF THE INTERIOR NATIONAL PARK SERVICE EDISON NATIONAL HISTORIC SITE

It is an unfortunate fact of life that not all persons who live a life that is worthy of emulation become household names. The passage of time plays a large role in the continuance of the anonymity. The advent of the web site should result in this condition being improved. In this regard one person shall be considered here. That person, Lewis Howard Latimer (1848 - 1928), deserves to be better known.

This writer will not consider details of Latimer's life in depth; others have already done that. Instead, brief mention will be made of some of the aspects of his life that should be of interest to those persons who delve into early lamp history.

Lewis Latimer was born in Chelsea, Massachusetts. He was the fourth child of George and Rebecca Latimer. George, his father, had been a slave in Virginia. Lewis, therefore, came from humble surroundings but

that fact didn't suppress his interest in reading, writing stories, drawing and writing poetry. At age 16 he joined the U.S. Navy and served on the U.S.S. Massasoit.

Later Latimer became a draftsman and it was he who made the drawings for Alexander Graham Bell for his famous U.S. Patent No 174,465 issued Mar 7, 1876. That patent ushered in the age of the telephone.

In 1880 Latimer joined the United States Electric Lighting Company under Hiram S. Maxim. Quoting from the booklet put out by the Thomas Alva Edison Foundation in 1973:

"While there, Latimer invented and patented a process for making carbon filaments for light bulbs. He taught the process to company workers, and soon it was being used in factory production. Latimer also assisted in installing Maxim lighting systems in New York City, Philadelphia, Montreal, and London.

During the installation of lighting in Montreal, where a lot of people spoke only French, Latimer learned the language in order to competently instruct the workers. In London, he set up the first factory for the Maxim-Weston Electric Light Company. That required him to teach the workmen all the processes for making Maxim lamps, including glassblowing. In a brief nine months, Latimer had the factory in full production."

In 1882 Latimer left the employ of Maxim to seek other challenges. In 1884 he joined the Edison Electric Light Company to begin a notable career. He was named draftsman-engineer. In 1890 Latimer coauthored a book titled Incandescent Electric Lighting - A Practical Description of the Edison System. One of the coauthors was John W. Howell. It was a small book, of dimensions 3-3/4 x 5-3/4 inches. An image of the frontispiece of the book is shown below. A scanned image of an Edison lamp, in and out of a socket, (that faced the frontispiece) is also shown.

INCANDESCENT  
ELECTRIC LIGHTING.

A Practical Description of the  
Edison System.

BY

L. H. LATIMER.

TO WHICH IS ADDED THE

DESIGN AND OPERATION OF INCANDESCENT  
STATIONS.

By C. J. FIELD.

AND A PAPER ON

THE MAXIMUM EFFICIENCY OF INCANDESCENT  
LAMPS.

By JOHN W. HOWELL.

---

NEW YORK :

D. VAN NOSTRAND COMPANY,

23 MURRAY AND 27 WARREN STREET.

1890.

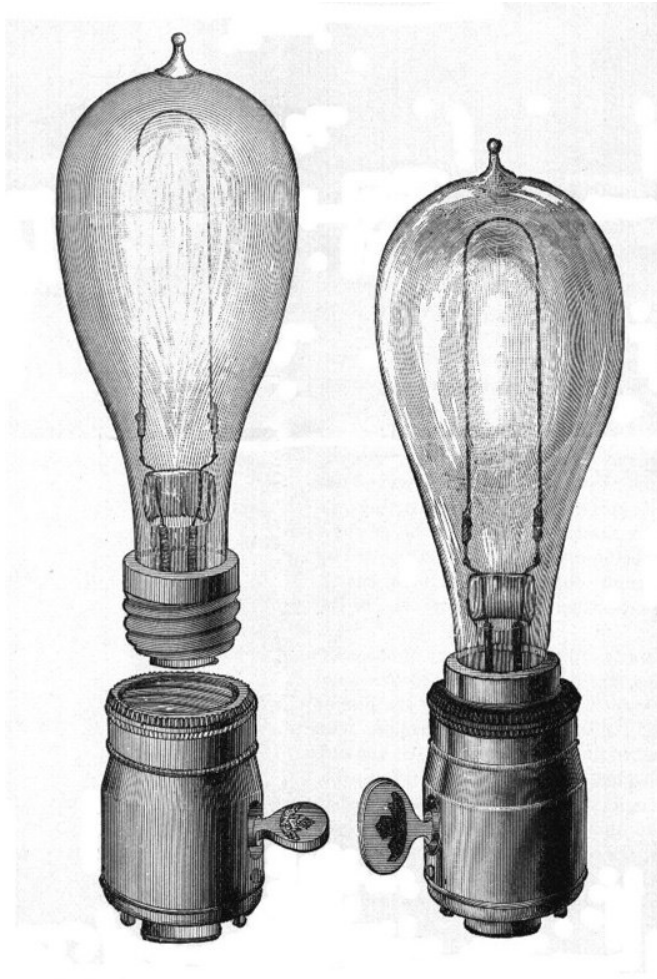

In the year 1890 Latimer joined the Edison Legal Department and was involved in testifying in legal cases. He was such a member in New York in 1893 during the famous Oconto Incandescent Lamp Case. In 1896, when the Board of Patent Control of GE and Westinghouse was formed, Latimer became its chief draftsman and he continued in that position until 1911. In that same year Latimer joined the consulting firm of Edwin W. Hammer.

Lewis H. Latimer passed away in his home in Flushing, Long Island. A tribute to Latimer was made in 1928 by William H. Meadowcroft, historian for the Edison Pioneers, when he said:

"Lewis Howard Latimer was of the colored race, the only one in our organization, and was one of those to respond to the initial call that led to the formation of the Edison Pioneers, January 24th, 1918. Broadmindedness, versatility in the accomplishment of things intellectual and cultural, a linguist, a devoted husband and father, all were characteristic of him, and his genial presence will be missed from our gatherings...We hardly mourn his inevitable going so much as we rejoice in pleasant memory at having been associated with him in a great work for all peoples under a great man."

The following two images were scanned from the booklet Lewis Howard Latimer - A Biography and Related experiments You Can Do.

*First drawing done  
by Lewis H. Latimer  
for Hiram S. Maxim  
in 1880 in Bridgeport, Connecticut.  
It is a drawing of an early Maxim lamp.*

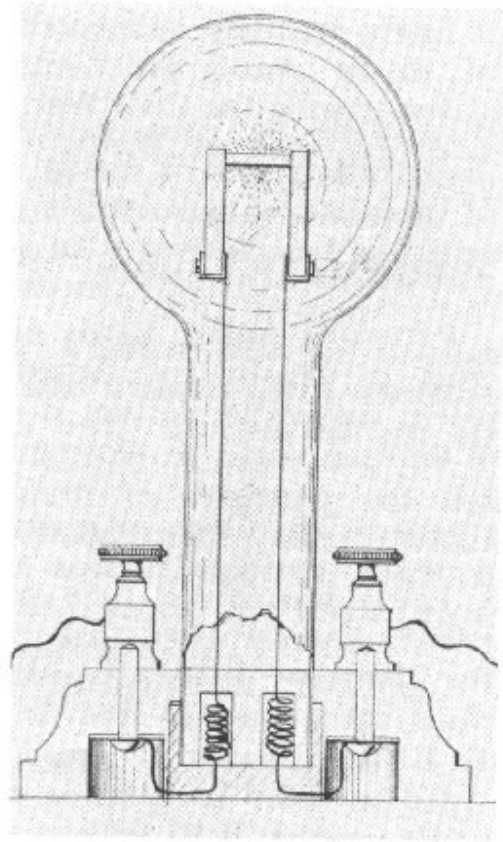

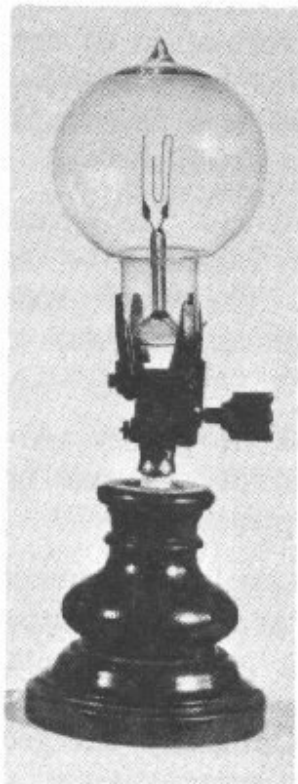

*Maxim-Latimer lamp produced in 1882 with Latimer switch and socket. This lamp is part of the collection by William T. Hammer, an Edison Pioneer, at the Edison Institute in Dearborn, Michigan.*

*Original lamp with carbon filament invented by Lewis H. Latimer in 1882 (U.S. Patent 252,386). This lamp is also part of the Hammer collection.*

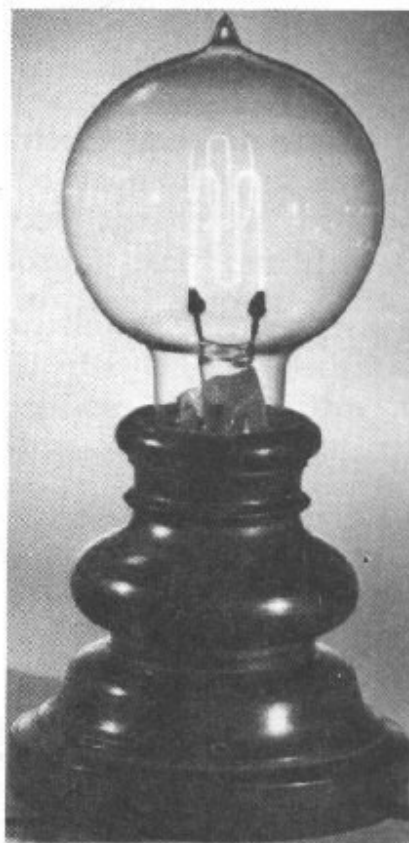

It is of some interest to note that at the present time (April, 2000) there is a lighting exhibition in the National Museum of American History (Smithsonian Institution) in Washington, D.C. titled "Lighting a Revolution". In the display case labelled "Electric Light" are several early incandescent lamps of various manufacture. Also in that case are three photographs of persons who were significant contributors to developments of the

lamp. The photographs are of Sir Joseph Swan, Dr. Walther Nernst and Lewis Howard Latimer.

### **General References**

- 1) Lewis Howard Latimer (Pioneers in Change Series), Glenette Tilley Turner.
- 2) Lewis Latimer (Black Americans of Achievement), Winifred Latimer Norman, Lily Patterson, 101 pages, 1993, Chelsea House Pub., ISBN: 0791019772.
- 3) Lewis Howard Latimer, A Biography and Related Experiments You Can Do, Publication of the Thomas Alva Edison Foundation, 2000 Second Avenue, Detroit, Michigan 48226, 1973, 32 pages.
- 4) Lewis Latimer: Creating Bright Ideas (Innovative Minds), Eleanor H. Ayer, 112 pages, Jan 1997, Raintree/Steck Vaughn, ISBN: 0817244077.
- 5) Obituary, *Electrical World*, Vol 92, No 25, Dec 22, 1928, pg 1271.

### **George R. Lean**

An obituary appeared in the *Electrical Review* in 1897<sup>1</sup> that told of the life and death of a young electrical engineer. The article read as follows:

"The news of the death of George R. Lean, of Cleveland, will be a great shock to his many friends throughout the country. During the past few years Mr. Lean had exhibited a very high order of inventive talent, and those who knew him best believed him capable of great things.

"Mr. Lean was a New England man and before going to Cleveland had held several important positions—among them the superintendency of the old Sun company, of Woburn, and the superintendency of the Bernstein Electric Company. For several years past he has been superintendent of the Buckeye Electric Company and electrician of the Jandus Electric Company. In these last positions, which he held simultaneously, he had done his best work, making valuable improvements in arc and incandescent lamps and the method of their manufacture. A number of valuable patents were granted covering these inventions.

"He died suddenly in Cleveland, on July 9, after an operation for appendicitis. His age was but 35 years, and his untimely end is deeply mourned by all that knew him."

From 1896 through 1898 Lean was granted nine arc lamp patents as well as one reissue, where Jandus was the assignor<sup>2</sup>.



Patents granted to George Lean that are related to the incandescent lamp are:

U. S. Patent No.	Date	Description	Company
431,776	Jul 8, 1890	Incandescent Lamp	Bernstein
444,567	Jan 13, 1891	Incandescent Lamp Socket	Bernstein
445,957	Feb 3, 1891	Electric Switch	Bernstein
446,623	Feb 17, 1891	Electric Switch	Bernstein
449,266	Mar 31, 1891	Hanger Board for Electric Fixtures	Bernstein
461,761	Oct 20, 1891	Electric Switch	Bernstein
487,846	Dec 13, 1892	Casing for Bases of Incandescent Lamps	Bernstein
533,223	Jan 29, 1895	Incandescent Electric Lamp	
568,142	Sep 22, 1896	Apparatus for Manufacturing Incandescence Electric Lamps	Buckeye

Two non-lamp related patents were granted in 1891<sup>2</sup>.

### References

- 1) "Death of George R. Lean", *Electrical Review*, Vol 31, No 8, Aug 25, 1897, pg 87.
- 2) Arc lamp patents granted to Lean with Jandus as the assignor: 553,919; 553,920; 553,921; 571,974; 571,974; 571,976. Three patents issued after Lean's death were: 593,899; 598,942; 598,943. Two non-lamp related patents, granted in 1891, were 459,783 and 459,781. The reissue patent was No. 11,559, in 1896.

Go to: [Early Incandescent Lamps](#)



**James Bowman Lindsay**  
Many efforts to produce an incandescent lamp were made before Starr, Swan, Edison and others did their work. The details of some of these might never be known. One such effort is mentioned when the name "James Bowman Lindsay" is typed into a search engine. James Bowman Lindsay (Sep 8, 1799 - Jun 29, 1862) was born in the town of West Hills, County Angus, Scotland and the claim is made on many websites that about 1835 he developed a prototype of an incandescent lamp. The details of Lindsay's electric light experiments apparently are not known but it is of interest to write down some of what is known.

James Bowman Lindsay was the son of John Lindsay and Elizabeth Lindsay, nee Bowman<sup>18</sup>. Arbroath, Lindsay's birthplace, is north and east of Dundee, which is on the estuary of the River Tay, which leads into the North Sea. J. B. Lindsay is mentioned in some history books today for three main areas of endeavor. One is for a "constant" electric light, a second is for telegraphy and a third is for a Pentacontaglossal Dictionary. The interest here regards only the electric light. Because there are, apparently, no details of his lighting apparatus, verbatim newspaper articles and letters of Lindsay's will be presented before comments are made by this writer regarding his

work on an electric light source. The material will be presented in the time order in which they appeared.

The following newspaper article<sup>6</sup> was printed on August 7, 1835:

"Mr. Lindsay, a teacher in town, formerly lecturer to the Watt Institute, succeeded on the evening of Saturday, July 25, in obtaining a constant electric light. It is upwards of two years since he turned his attention to this subject, but much of that time has been devoted to other avocations. The light in beauty surpasses all others, has no smell, emits no smoke, is incapable of explosion, and not requiring air for combustion can be kept in sealed glass jars. It ignites without the aid of a taper, and seems peculiarly calculated for flax houses, spinning mills, and other places containing combustible materials. It can be sent to any convenient distance, and the apparatus for producing it can be contained in a common chest."

The following letter, written by Mr. Lindsay, was printed<sup>7</sup> on October 30, 1835:

"Sir, - As a notice of my electric light has been extensively circulated, some persons may be anxious to know its present state, and my views respecting it.

"The apparatus that I have at present is merely a small model. It has already cost a great deal of labour, and will yet cost a good deal more before my room is sufficiently lighted. Had circumstances permitted, it would have been perfected two years ago, as my plans were formed then. I am writing this letter by means of it at 6 in. or 8 in. distant; and, at the present moment, can read a book at the distance of 1-1/2 feet. From the same apparatus I can get two or three lights, each of which is fit for reading with. I can make it burn in the open air, or in a glass tube without air, and neither wind nor water is capable of extinguishing it. It does not inflame paper nor any other combustible. These are facts.

"As I intend in a short time to give a lecture on the subject, my views on the further progress will be unfolded then. A few of these, however, may be mentioned just now.

"Brilliant illumination will be obtained by a light incapable of combustion; and, on its introduction to spinning mills, conflagrations there will be unheard of. Its beauty will recommend it to the fashionable; and the producing apparatus, framed, may stand side by side with the piano in the drawing-room. Requiring no air for combustion, and emitting no offensive smell, it will not deteriorate the atmosphere in the thronged hall. Exposed to the open air it will blaze with undiminished lustre amidst tempests of wind and rain; and, being capable of surpassing all lights in splendour, it will be used in lighthouses and for telegraphs. The present generation may yet have it burning in their houses and enlightening their streets. Nor are these

predictions the offshoots of an exuberant fancy or disordered imagination. They are the anticipated results of laborious research and of countless experiments. Electricity, moreover, is destined for mightier feats than even universal illumination.

J. B. Lindsay  
*Dundee, October 28, 1835.*"

Two lectures were given by Lindsay in Thistle Hall, in Dundee, on Thursday, January 15, 1836 and then again on Friday, April 21, 1837<sup>15</sup>.

In a letter written on January 26, 1847 Lindsay said<sup>15</sup>:

"About fifteen years ago I made a great variety of experiments in Electricity, and constructed an apparatus for procuring electric light for illumination instead of gas. About ten or twelve years ago I gave two public lectures on this subject, illustrated by experiments, in Dundee. About fifteen years ago I also perceived the applicability of Electricity as a telegraph, and mentioned it to many persons, but such an idea was generally ridiculed as Utopian. This was long before such an application was hinted at in the public prints, and before Electric Telegraphs were in existence. I also made many experiments on the application of the same science for power instead of steam, but do not claim the merit of being the first that did so. About nine or ten months [corrected in next letter to 'nineteen months'] ago I proposed and described a submarine Telegraph, and, I am convinced, was the first that made such a proposal. In reference to this, I made many experiments, and telegraphed through ponds in Dundee. An account of this was then given in the local newspapers. The *Lexicon alone* has kept me from turning my whole attention to Electricity, but, were it finished, I would once more be free. The Electric Light I have obtained, being from a model, is necessarily small, the plates being only one inch square; but by enlarging them, a light could be got far surpassing gas in brilliance."

In 1893 several documents regarding Lindsay were given to the Dundee Public Library<sup>15</sup>. Among these was a brief autobiographical sketch of Lindsay. It read:

"Previous to the discovery of Oersted, I had made many experiments on magnetism, with the view of obtaining from it a motive power. No sooner, however, was I aware of the deflection of the needle and the multiplication of the power of coils of wire than the possibility of power appeared certain, and I commenced a series of experiments in 1832. The power on a small scale was easily obtained, and during these experiments I had a clear view of the application of electricity to telegraphic communication. The light also drew my attention, and I was in a trilemma whether to fix upon the power, the light, or the telegraph. After reflection I fixed upon the light as the first investigation, and had many contrivances for augmenting it and rendering it constant. Several years were spent in experiments, and I obtained a constant stream of light on 25th July, 1835. Having satisfied myself on this subject, I

returned to some glossological investigations that had been left unfinished, and was engaged with these till 1843. In that year I proposed a submarine telegraph across the Atlantic, after having proved the possibility by a series of experiments. Inquiries on other subjects have since that time engaged my attention, but I eagerly desire to return to electricity."

References to Davy's work with an electric light source usually refer to his discovery of the electric discharge. Regarding that discovery Davy said<sup>3, 19</sup>:

"When pieces of charcoal about an inch long and one sixth of an inch in diameter, were brought near each other (within the thirtieth or fortieth part of an inch,) a bright spark was produced, and more than half the volume of the charcoal became ignited to whiteness, and by withdrawing the points from each other a constant discharge took place through the heated air, in a space equal to at least four inches, producing a most brilliant ascending arch of light, broad, and conical in form in the middle."

This effect was observed with the use of a very powerful voltaic battery - much more powerful than what Lindsay probably had at his disposal. In Lindsay's case the distance that his points would have had to approach one another to observe any breakdown of the atmospheric gases would have been much less than 1/40th to 1/30th of an inch (0.6 - 0.8 mm); that is, the potential difference between electrodes probably was too low. It stands to reason then that what Lindsay really had to do with his limited power source was to have his "electrode" points touch, which, in essence, is simply akin to connecting a simple flashlight (torch) circuit. The use of his light source at a writing distance of six to eight inches suggests that this probably was the situation; that is, such a low light level does not suggest a discharge source but rather an incandescent one.

In Davy's book, which was printed in 1812<sup>3</sup>, he mentioned that the first work in which objects were heated to a great extent by a voltaic battery was due to Fourcroy, Vauquelin and Thenard. However, he described in detail the more extensive works performed by Children, which were reported in 1809<sup>2</sup> and 1815<sup>5</sup>. With his large voltaic battery Children was able to bring wires of lengths as long as four feet to luminous levels. Three feet of platinum wire of 1/30th of an inch in diameter, for example, was heated to a bright red, visible by strong daylight. Eighteen inches of the same type wire were completely fused in about twenty seconds. It is possible, then, that Lindsay simply repeated, knowingly or unknowingly, experiments that had been done as much as twenty-five years earlier; his light was of a low brightness and was accomplished, perhaps, with platinum wire. The use of platinum would have resulted in a light source that was not affected detrimentally by the oxygen in the atmosphere. Therefore, the continuous light obtained by Lindsay probably was not a steady state electric discharge but rather a crude incandescent source lighted by a voltaic battery.

There is little reason to exclude the efforts made by a person who lived in Scotland in 1835 when lamp histories are written. Perhaps his name does not belong on the same page with that of Swan, for example, but progress is made in knowing as well as unknowing ways, and a more detailed story of Lindsay might enrich that history. Others have said, and this

writer simply repeats the same conclusion - that Lindsay should be remembered as one who visualized the potential of electricity for the purpose of lighting and telegraphy. Although his name is seldom mentioned in incandescent lamp history, Guglielmo Marconi (1874-1937) gave recognition to Lindsay<sup>15</sup> for his early efforts in sending telegraph signals.

**Note:** The drawing of Lindsay was scanned from Reference 10.

### **Acknowledgements**

I am most grateful to David Kett, Senior Library and Information Officer, Central Library, Wellgate, Dundee, Scotland, for obtaining and providing articles pertinent to Mr. Lindsay. Thanks are also extended for the response and articles from the Dundee City Government website, and in particular, Eileen Moran, Library and Information Worker. In response to a question from the writer, Ms Moran mentioned that the population of Dundee in 1835 was over 45,000 and at the present time is over 145,000. Karen Findlay, Arbroath's Assistant Librarian, provided information on the place of residence of Lindsay in Carmyllie.

### **References**

- 1) "On the Electricity Excited by the Mere Contact of Conducting Substances of Different Kinds", Alessandro Volta, *Philosophical Transactions of the Royal Society of London*, Vol 90, 1800, pp 403-431. This article is in the French language.
- 2) "An Account of Some Experiments, Performed with a View to Ascertain the Most Advantageous Method of Constructing a Voltaic Apparatus, for the Purposes of Chemical Research", John George Children, *Philosophical Transactions of the Royal Society of London*, Vol 99, 1809, pp 32-38.
- 3) Elements of Chemical Philosophy, Sir Humphry Davy, Printed for J. Johnson and Co., St. Paul's Church-Yard, 1812, pg 151.
- 4) "A Method of Drawing Extremely Fine Wires", William Hyde Wollaston, *Philosophical Transactions of the Royal Society of London*, Vol 103, 1813, pp 114-118.
- 5) "An Account of Some Experiments with a Large Voltaic Battery", J. G. Children, *Philosophical Transactions of the Royal Society of London*, Vol 105, 1815, pp 363-374.
- 6) *Dundee, Perth & Cupar Advertiser*, August 7, 1835.
- 7) *Dundee, Perth & Cupar Advertiser*, October 30, 1835.
- 8) "On the Application of Voltaic Ignition to Lighting Mines," W. R. Grove, *The London, Edinburgh, and Dublin Philosophical Magazine and Journal of Science*, Vol XXVII, 1845, pp 442-446.
- 9) "An Incandescent Lamp Antedating Farmer or Goebel", *Electricity*, Vol VII, No 21, Dec 5, 1894, pg 250.
- 10) "A Genius in Humble Life□James Bowman Lindsay", *Dundee Advertiser / 1894 Year Book*, pp 219-222.
- 11) A History of Wireless Telegraphy - Including Some Bare-Wire Proposals for Subaqueous Telegraphs, J. J. Fahie, William Blackwood and Sons, Edinburgh and London, 1901, pp 13-32.
- 12) "An American Tribute to J. Bowman Lindsay", 1903 Dundee Year Book, pp 156-157.
- 13) "George Children", Dictionary of National Biography, Vol IV, The Macmillan Co., London, 1908, pg 249.
- 14) "John George Children", Dictionary of National Biography, Vol IV, The Macmillan Co., London, 1908, pp 249-250.

- 15) James Bowman Lindsay and Other Pioneers of Invention, A. H. Millar, Dundee: Malcolm C. Macleod, 1925, pp 18-27; foreword by Senatore Marconi.  
16) <http://www.dundee.gov.uk/centlib/jbl/jblchron.htm>  
17) <http://www.dundee.ac.uk/archives/genuki/ANS/Carmyllie/>  
18) <http://freepages.folklore.rootsweb.com/~bldr/carmyllie.html>  
19) This website. Look for the write-up on Humphry Davy in the section titled "From Alessandro Volta to William Robert Grove," which is under the heading "Miscellaneous Lamp Topics."

Go to: [Early Incandescent Lamps](#), or, click "Back" on your browser

### **Matthew Luckiesh**

Many collectors of early incandescent lamps in the United States concentrate on early Edison lamps when they first start looking for vestiges of our lighting heritage. That is certainly understandable. However, the appearance of later lamp designs also carry with them interesting stories. One person who was involved with the introduction of new lamp types will be considered here; that person was Matthew Luckiesh.

In general, Matthew Luckiesh was interested in determining the conditions under which the best visibility was achieved. It was through scientific studies of the relationship between light and seeing that certain lamp types were designed. We shall look briefly at some of his achievements.

Matthew Luckiesh was born in Maquoketa, Iowa in 1883. After attending universities in Iowa he started to work for the National Electric Lamp Association in Cleveland in 1910. The results of his work were chronicled in 11 U.S. patents, 28 books and about 860 scientific and technical articles, published between the years 1911 and 1960.

One of the "early" lamps that can still be found has a coiled tungsten filament in it and the glass, while transparent, is blue. This lamp was the result of an attempt to develop one that approximated average daylight in its color characteristic. These lamps were used in department stores and in other industries where it was important to determine accurate discrimination of the colors of objects. These were referred to as MAZDA Daylight Lamps.

Another lamp attributed to Luckiesh was the MAZDA Flametint Lamp. The thought behind this lamp was to create mood rather than adequate light for serious seeing. The lamp was designed to resemble the color of licking flames. They were often used in wall fixtures in hallways. In 1927 about 25-35% of all lamps sold were of that design. In 1929 sales totaled about 13 million.

Luckiesh was also involved in the development of White MAZDA lamps, colored lamps, the MAZDA Photographic Lamp and White Bowl lamps. The last product attributed to him was a lamp designed to be used base-up in ceiling fixtures. The bulb end was hemispherical in shape and was enameled to produce a soft-tone effect. It was made available to the public about 1949-50 and was known as the 50-GA lamp.

Luckiesh's career was exceptional and he was known as the "Father of the Science of Seeing."

## **Albon Man Preface**

An earlier write-up on Albon Man that appeared on this website was removed. The reason for the removal is that it was discovered that the person written about was not the intended subject. This error was made because an obituary that appeared in an electrical periodical in 1891<sup>1</sup> mistakenly identified Albon Platt Man (1811-1891) as the associate of William E. Sawyer. The Albon Man of interest in this writing was, instead, a nephew of the said Albon Platt Man<sup>3,13</sup>.

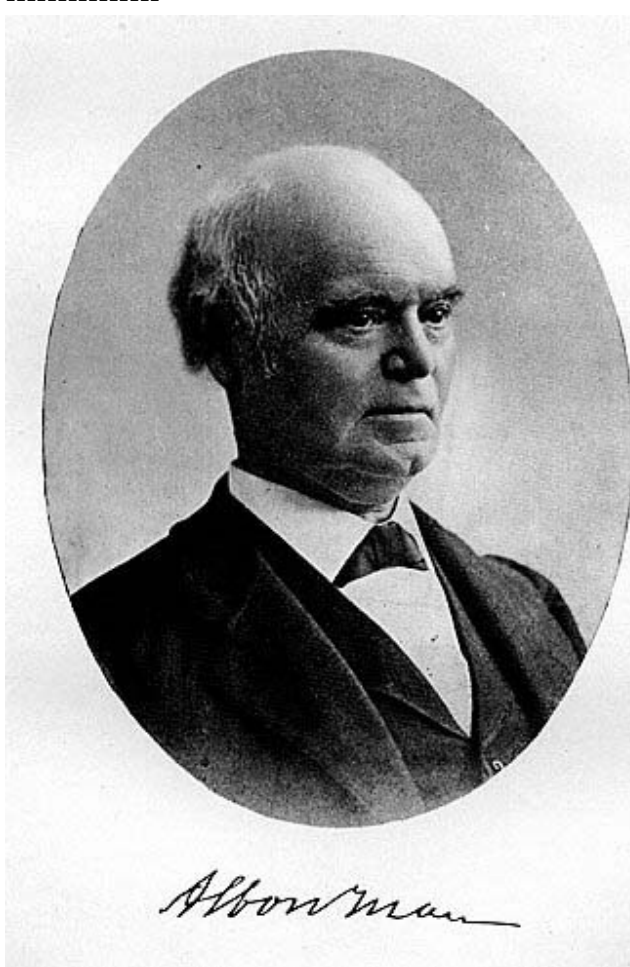

A name that is well-known in the history of the electric incandescent lamp is Albon Man. However, little appears to have been written about him. Albon Man (Jun 29, 1826-Feb 18, 1905) teamed up with William Edward Sawyer in 1878 to pursue incandescent lamp development. Much of the discordancy that existed in that relationship is revealed in an article by Charles D. Wrege and Ronald G. Greenwood<sup>8</sup>.

In 1878 Sawyer was about 28 years of age; Man, a New York attorney, was about 52 years of age. Thus, there was a difference of about 24 years in their ages. In Jul 1878 Sawyer, Man and five other individuals formed the ill-fated Electro-Dynamic Light Company<sup>2</sup>. One of the other five persons, Hugh McCulloch, was, apparently, an uncle of Albon Man. The Electro-Dynamic Light Company ceased to exist after about 1881.

A biographical sketch of Albon Man appeared in the book Success and How to Attain It, which was published in 1895<sup>3</sup>. Man also contributed a section, titled "Is Electricity Energy or Only Matter?", pages 197-261, to the book. The portrait of Man shown to the left was scanned from that book (opposite page 195). The biographical sketch is given below:

"Albon Man was born in Westville, Franklin County, N. Y., June 29th, 1826. His father and mother were both born in Vermont and were descended from old Puritan stock. Mr. Man's father was Dr. Ebenezer Man; his grandfather, Dr. Albon Man, and his great-grandfather, Dr. Ebenezer Man, the name of the eldest son alternately being Ebenezer and Albon. He fitted for college at the academies in Fort Covington and Malone, Franklin County, and entering Union College in 1845, graduated in 1849 in both the literary and scientific courses, and was elected a member of the Phi Beta Society. After studying law with his uncle, Albon P. Man of New York, he was admitted to the bar of New York, February, 1852. He was admitted as attorney and counsellor of the Supreme Court of the United States in January, 1871. Soon after his admission to the bar he became partner with his uncle, Albon P. Man; but by reason of the sickness of his father was obliged to return to Franklin County and establish his office at Malone, N. Y., where, in addition to practice of the law, he was employed as a local engineer upon the Northern New York Railroad. He was elected district attorney of Franklin County in 1860, and in 1861 went out to the war as major of the 98th New York Volunteers. His health was completely broken down by the hardships of the peninsular campaign, and after the battles about Yorktown, the Battle of Williamsburgh, and the first Battle of Fair Oaks, in which he participated, he was obliged to resign his commission and return to Franklin County, where he had still been kept in the office of district attorney by the kindness of the inhabitants. Finding, however, that his health was insufficient for the practice of his profession, in the month of December, 1862, he went to Washington and was employed in the Treasury department in various positions of trust in the office of the Treasurer of the United States, the Comptroller of Currency, and the Secretary of the Treasury. In 1866 he returned to New York City as treasurer and general manager of the National Bank Note Company and as the legal advisor of that company. During this period he made several inventions in aid of the work of the Bank Note Company, including a machine for gumming postage stamps by air pressure and a safety device for checks, bonds, and other securities. He resigned this position in 1869 and engaged actively in the practice of his profession. In 1871 he became the general manager of the Lorillard estates in New York, for which his legal education, as well as his varied business experience, rendered him well qualified. He continued in the management of these large estates for between thirteen and fourteen years, when he resigned the general management, being still continued as a trustee, executor, etc., for several of the estates and as legal and business adviser. During all this period, and indeed from his youth up, he had kept well advised of the current of scientific progress, particularly in the matters of electricity and chemistry. In youth his private room was in his father's office, a detached building where, in addition to a large business office, was another in which were all kinds of chemicals and apparatus. With these he and the medical students of his father were accustomed to perform many kinds of experiments, and when the announcement of practical photography by Daguerre was made, they endeavored with the camera obscura to get



pictures, and succeeded in getting a picture of the yard adjoining the office on paper moistened with nitrate of silver, but were not able to fix the pictures which were thus quite evanescent. Perhaps this was the first photograph upon paper. In 1878 he united with the late William E. Sawyer in producing what is believed to have been the first practical system of incandescent electric lighting. Many inventions having reference to this subject were patented by Sawyer and Man conjointly, and by Mr. Man and Mr. Sawyer separately. A fierce legal contest arose in 1879 between the owners of these inventions and those of Thomas A. Edison, which has continued to the present time. The first electric-lighting company ever organized, the Electro-Dynamic Light Company, was formed by Messrs. Sawyer and Man in 1878. In July, 1892, the honorary degree of Doctor of Philosophy was granted to Mr. Man by Union College. Since leaving the general management of the Lorillard estates, Mr. Man has continued the practice of the law and the management of his own business affairs, much of his time having been given to the legal contests in regard to electricity. Inventors and men of science, among whom he has many friends, are accustomed to call upon him, discuss matters of invention and science, and to take his advice thereon."

An obituary of Albon Man also appeared in the *Malone Palladium*<sup>4</sup>, a newspaper in upper New York State. It read:

#### **Death of Major Albon Man**

"Major Albon Man, well known to many in Northern New York, died at the Hotel St. George, Brooklyn, on last Saturday night, as the result of a stroke of paralysis, in his 79th year.

"Mr. Man was born in Westville, this county, in June, 1826, and was the elder son of Dr. Ebenezer Man, and grandson of Dr. Albon Man, who was the first supervisor of the town of Constable. Mr. Man graduated from Union College at Schenectady with high honors, after which he studied law in New York city with his uncle, Albon Platt Man, at that time an eminent lawyer in that city. About 1850 he came to Malone to reside, and entered upon the practice of law, and was at one time while here a law partner of the late Hon. Joseph R. Flanders. He also did some work here as a surveyor and civil engineer, and it is said that in that capacity he was instrumental in securing considerable land for the St. Regis Indians, for which the tribe conferred upon him an Indian name and made him one of their chiefs, the highest honor they could bestow.

"When the civil war broke out he was active in the organization of the 98th regiment, enlisting in November, 1861, and was promoted to the rank of major of the regiment Dec. 20, 1861. His record during the war was of the highest, and he was a prime favorite with the officers and members of the 98th. He was discharged for disability June 8, 1862. Shortly after the

conclusion of the war Major Man was placed in charge of one of the most important bureaus in the treasury department at Washington, where he remained for about three years, and then went to New York and resumed the practice of law, in which he was eminently successful.

"He was one of the most prominent citizens of Northern New York during his residence here, and in 1859 was elected district attorney of this county which office he held when his regiment was ordered to the front. During his absence the affairs of office were administered by Hon. Wm. P. Cantwell, who assisted him largely upon his return in prosecuting cases then pending.

"Major Man married Miss Josephine Watkins, a sister of Mrs. C. L. Hubbard, of Malone, and daughter of the late Zephas Watkins, who, with one daughter, Mrs. Edward M. Ives, of Brooklyn, survives him. The deceased was a corresponding member of the Franklin County Historical Society, and was deeply interested in the welfare of Franklin county. He was for years a visitor to Malone, where he had many warm personal friends, and to these the news of his death was received with sincere sorrow. He was a man of superior education, and was possessed of an unusual fund of general and accurate information. He was greatly interested in electricity, and his work in connection with the invention of the Sawyer-Man incandescent light will preserve his name to posterity if no other action of his be remembered. He was also identified with the developing of the great water power at Massena.

"Beside his wife and daughter, Mr. Man is survived by one sister, Mrs. Marshall Conant, of LaCrosse, Wisconsin. The remains will be brought to Malone for interment."

Because Albon Man was a lawyer one could hastily conclude that his knowledge of science and electricity might have been limited during the Sawyer-Man relationship. Such a notion would be quickly dispelled, however, after a reading of his article that appeared in Success and How To Attain It. Indeed, while Sawyer and Man were granted several U. S. patents conjointly, Man was granted patents in his name only. Two patents were issued to Man in 1880. One, No. 227,118, issued May 4, 1880, was for an electric lamp. The second, No. 227,370, issued May 11, 1880, covered joining pieces of glass, porcelain, &c.

The ancestry of Albon Man can be traced back to William Man of England, who traveled to Cambridge, MA in the year 1634. The family tree is not traced to that extent in this writing. We start the descent from the great-grandparents of Albon Man, namely Ebenezer and Anne Man<sup>10</sup>. One of their sons was Albon<sup>3</sup> (1769-1820). Albon was a doctor who married Maria Platt in 1810. Albon and Maria had several children, one being Ebenezer<sup>3,11,13</sup>. The Albon Man of interest in this write-up was a son of Ebenezer<sup>3,13</sup>. As already stated, the son, Albon, was born Jun 29, 1826. Also of interest for this write-up is a sister, Susan Maria Man (1818-1898), of the latter Ebenezer. It was mentioned in the quoted article above that in December, 1862 Albon Man went to Washington to work in various positions as well as for the Secretary of the Treasury; it was in 1866 that he returned to New York City. Albon

Man's aunt, Susan Maria Man, married Hugh McCulloch<sup>9</sup>, who was appointed by President Lincoln in 1865 to be Secretary of the Treasury<sup>12</sup>. As mentioned above, it is also believed that Hugh McCulloch was one of seven incorporators of the Electro-Dynamic Light Company in 1878.

Albon Man had a law office in the Morris Building at 68 Broad Street in New York City<sup>6</sup>. His body was taken to Malone, New York for interment<sup>4,5</sup>.

### Acknowledgements

The mistaken identity of Albon Man in the earlier version of this write-up was revealed after the writer received photocopies of material from Nancy Cataldi, Queens, New York. The original material had been sent to her by Albon Platt Man IV for clarification purposes for a book being written about Richmond Hill in Queens. Needless to say, the writer is greatly indebted to Ms. Cataldi and Mr. Albon Platt Man IV for this information; it was key to correcting the mistaken identity. The writer is also indebted to Mr. David Minnich, Director of the Wead Library in Malone, NY for a biographical sketch<sup>7</sup> as well as an obituary<sup>4</sup> of Mr. Man.

### References

- 1) Obituary-Albon P. Man, *The Electrical Engineer*, Vol XI, No 153, Apr 8, 1891, pg 430.
- 2) The Electric Incandescent Lamp, Franklin Leonard Pope, Boschen & Wefer, New York, 1894, pg 10.
- 3) "Albon Man", Success and How To Attain It, Andrew C. Carnegie and others (including Albon Man), F. Tennyson Neely, Publisher, New York, 1895, pg 195.
- 4) "Death of Major Albon Man", *Malone Palladium*, Feb 23, 1905.
- 5) Obituary-Albon Man, *Electrical World and Engineer*, Vol XLV, No 8, Feb 25, 1905, pg 414.
- 6) Obituary-Albon Man, *Electrical Review*, Vol 46, No 8, Feb 25, 1905, pg 353.
- 7) Historical Sketches of Franklin County and Its Several Towns with Many Short Biographies, Frederick J. Seaver, J. B. Lyon Co., Albany, 1918, pg 759.
- 8) "William E. Sawyer and the Rise and Fall of America's First Incandescent Electric Light Company, 1878-1881", Charles D. Wrege and Ronald G. Greenwood, *Business and Economic History*, Second Series, Vol 13, 1984, pp 31-48.
- 9) <http://www.carlinmedia.com/CVHistory/March/march21.htm>
- 10) <http://www.usgennet.org/usa/ny/county/franklin/1812/ka-ma.htm>
- 11) <http://web.stlawu.edu/library/mss.html> (Mss. Coll. 17)
- 12) <http://genforum.genealogy.com/cgi-bin/pageload.cgi?hugh,mcculloch::mcculloch::581.html>
- 13) Private communication from Albon Platt Man IV to Nancy Cataldi; this information was conveyed to the writer. **Hiram S. Maxim**



The name of Hiram Stevens Maxim (Feb 5, 1840-Nov 4, 1916) is immediately associated with the invention and development of the machine gun. However, his name figured prominently with the development of early incandescent lamps, and it is in that regard that this short write-up is made.

Hiram S. Maxim was born near Sangerville, Maine. He was the eldest of eight children of Isaac Weston Maxim and Harriet Boston (Stevens) Maxim<sup>11</sup>. Maxim's ancestors originally lived in the county of Kent, England and were French Huguenots. The family was poor and Hiram began working different jobs at age 14. His experiences were many and it was soon discovered that he had an inventive ability. In 1878 he became chief engineer of the United States Electric Lighting Company.

Maxim wrote his autobiography in 1915<sup>8</sup> but little new information can be gleaned from it regarding the subject of the incandescent lamp. A description of an early worker of his is, perhaps,

worthy of review since little additional information on this subject appears to be readily available. In an effort not to reveal the name of the individual he simply called the man "Mr. D." However, when the present writer read the account it seemed that the identification of the man was apparent; it was concluded that Mr. D was William Edward Sawyer, a significant inventor in his own right. It then turned out that Maxim, himself, revealed the man's identity. In his autobiography, Maxim printed "MY LIFE", the title of his book, at the top of the even-numbered pages. At the top of the odd-numbered pages he put a short phrase that dealt with one of the subjects on the page. On page 127, at the top, the phrase "SAWYER SHOOTS HIS MAN" appears; this particular page deals exclusively with Mr. D. Whether the mention of the real name was intentional or not is for others to judge. The following quotes are from Maxim's autobiography and Mr. D. is assumed, by this writer, to refer to William Edward Sawyer. This story can be compared to the version given elsewhere on this website under the title "William Edward Sawyer."

"People were now beginning to talk about electric light. We read that something was being done in that line in Paris. A gentleman by the name of S. D. Schuyler, who had a large, fine office in the Coal and Iron Exchange and a very powerful backing of wealthy men, formed the first Electric Lighting Company ever formed in the United States. As someone had recommended me as an engineer who was able to attack any possible problem and make a good job of it, Mr. Schuyler sent for me, and I became chief engineer to the Company. This was two years before Edison took up the subject.

"I found a very curious state of affairs in Mr. Schuyler's office. He had in his employ a large, clumsy, and brutal-looking fellow, clean-shaven, whom we will call Mr. D.; he was said to be an expert electrician and telegraph operator, but he was a great drunkard, being comfortably 'corned' all the time...

"The next day he told me that he was a great believer in the future of electric lighting; that he was the first in the field, and that if I would take hold and assist him he would give me a salary of ten dollars a day, as well as a quarter interest in whatever might accrue from the work. This was an exceedingly good offer, especially as I had complete charge of the place. He informed all the men that I had been put in charge, and the first thing I did was to have a talk with Mr. D. I told him that it was not quite the thing to have brandy brought into the place several times a day and to keep on drinking it while at his desk. I assured him that there was a great deal more nourishment in a pint of milk than in a gallon of brandy, and advised him strongly to try milk. The next day he provided himself with a two-quart tin pail, and his brother was sent out two or three times for milk. Mr. D said that the change was a good one and he felt much better for it. Shortly after I learned that the so-called milk was just about half brandy, and that fellow was still in a half-drunken condition all day. As things went on from bad to worse I made up my mind that we had better get rid of him."

In his autobiography Maxim wrote that he had a plan to improve the quality of carbon filament by heating them in the presence of gasoline. Supposedly he talked to Schuyler, who was impressed with the plan. Maxim goes on to say:

"At this time Mr. D was working on a lamp in which carbons were heated in an atmosphere of nitrogen, a system which I knew could not possibly succeed. Mr. D was, however, a very plausible talker. He laughed at my plan, saying that it was the most absurd he had ever heard of, and in my absence he had a very serious talk with Mr. Schuyler. He said: 'There is no doubt but that Maxim is a very skilful and rapid draughtsman, but he knows absolutely nothing of electricity or chemistry.' He told Schuyler that gasoline vapours were about as explosive as nitro-glycerine, and that to heat a carbon white-hot, in an atmosphere of such vapours, could have but one result—a terrific explosion. He said he would not remain in the building if such experiments were to be made, as it was altogether too dangerous, and he felt sure that the owners of the building would never consent to have such dangerous experiments made on their premises.

"Schuyler was somewhat frightened, but I told him that the quantity of gasoline vapour in a lamp would be infinitesimal, and that gasoline vapours could not possibly explode except in the presence of a large quantity of oxygen gas. However, it was no use: my theory appeared to them to be ridiculous. Nevertheless, Schuyler consented that I should apply for a patent on the principle of preserving and building up carbons in an incandescent

lamp by heating them electrically in an attenuated atmosphere of hydrocarbon vapours, and this patent was filed at the Patent Office ahead of all others.

"I knew I was right and was determined to convince Schuyler that I was right. Quite true, I was not what could be considered a professional chemist, but I knew all the chemistry connected with hydro-carbon explosions; and after a good deal of trouble I got Schuyler to consent that some experiments should be made. In the meantime, Schuyler had become disgusted with Mr. D, who was always drunk, and discharged him...

"Maxim sought the advice of two professors and one 'wrote an article for one of the scientific papers, stating that he had seen me deposit carbon that was hard enough to scratch glass, and that this took place in the dense vapours of gasoline without the least sign of an explosion.' This was very soon brought to the notice of Mr. D. who, not knowing that I had applied for a patent on the process, applied for a patent on a process of building up carbons by heating them in oil, such as salad oil, or other carbonaceous material. His claim was a very broad one, and, of course, later on, an interference was declared.

"...when the interference was declared I simply went in and told my story, leaving the rest to the lawyers. But Mr. D. swore that he had invented the same thing years before, and got his father and his brother to swear to it. He thus beat me in the Patent Office and deprived me of a patent that was worth at least a million dollars a year.

"But everything was not smooth sailing by any means for Mr. D. He went to the Patent Office at Washington, abstracted a patent, made an alteration in the drawings and returned it. This being discovered gave him a very black eye at the Patent Office. Later on, he had a quarrel with a Captain Steel, whom he shot in the face with a revolver, doing him very serious injury. There was, however, a woman in the case. Mr. D was arrested, and when the case came into court he claimed that he had acted in self-defence, although he admitted that he had fired the first and only shot. Mr. D had several witnesses who swore that they had seen the encounter, but it transpired that they all happened to be telegraph operators, and the judge discovered that when these witnesses were on the stand, Mr. D was communicating with them by a species of telegraphy which he had invented for the purpose. He was convicted and sentenced to a long term of imprisonment, but he had influential friends who had invested money in his alleged invention, and they obtained a stay of execution, so that Mr. D. was out of prison for a considerable time.

"I went to one of the high officials of New York City and told him that Mr. D., although convicted, was still out of prison. He admitted that it was a disgrace, a miscarriage of justice, and promised to see to it that the fellow

was put where he belonged. When, however, an attempt was made to send him to prison, he pretended to be very ill and his doctor certified that he could not be moved from his bed without fatal results. Physicians, representing the law, visited Mr. D. and found that he was really suffering from a severe irritation of the stomach and bowels, but as it was necessary to keep this up he took a little too much acid one day and died of peritonitis.

Maxim went on to conclude that Mr. D obtained his patent by fraud. There is another version of the development of the hydrocarbon treating process that should be told. Woodbury, in his book<sup>12</sup>, points out that Weston was actually the first one to develop the hydrocarbon process even though at the end of the litigations he lost out. Indeed, the development of the tamidine filament by Weston was also a significant step toward a uniform filament.

Maxim was, however, a prolific inventor, garnering 122 United States patents and 149 in Great Britain<sup>11</sup>. His lamp-related U.S. patents, starting in the year 1878, are:

1878	□					208,252
1880	□	230,310;	230,953;	230,954;	230,309;	234,835
1881	□	247,380;	237,198;	244,277;	247,083;	247,085
1883	□			277,846;		283,629
1889	□			405,239;		405,170
1899	□	618,703;	618,704			

These patents consisted of lamp designs of incandescent and arc lamps as well as manufacturing methods. At the time of application of his last patent that dealt with a lamp subject (Jan 5, 1899), Maxim was still a citizen of the United States but he resided at 18 Queens Gate Place, London, in the County of Middlesex, England. Maxim was naturalized as a British subject in 1900 and was knighted in 1901<sup>11</sup>.

The first page of Maxim's U.S. patent No. 230,310, issued Jul 20, 1880 is shown below. The object of the patent was to form a better electrical contact between the carbon conductor and the lead wire. It claimed a continuous carbon conductor, with flattened ends for connection, with one or more soft carbon washers interposed between the conductor and the metallic connection. Platinum washers were also used. In the drawing the body, B, is the conductor, l and k are the platinum washers, m and m are the washers of soft carbon, o is a platinum screw or bolt, t is a nut, and c is the lead wire. Maxim preferred to make the carbon washers out of carbonized blotting paper.

(No Model.)

H. S. MAXIM.  
Electric Lamp.

No. 230,310.

Patented July 20, 1880.

Fig. 1.

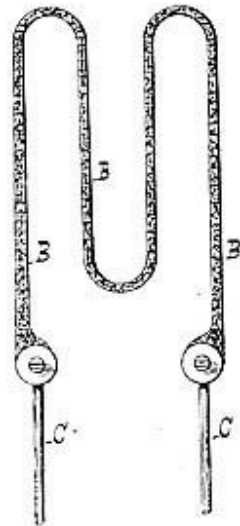
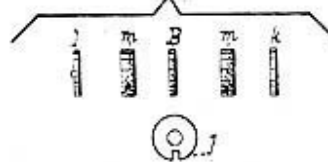

Fig. 2.



Fig. 3.



Witnesses

*Henry M. Hine*  
*Henry Hill*

Inventor

*Henry S. Maxim*  
*by Leonard & Curtis*  
*attys.*



## Acknowledgement

The photograph of Hiram S. Maxim, taken in 1915, was scanned from Reference 8.

## References

- 1) Hiram Stevens Maxim, The National Cyclopaedia of American Biography, Vol VI, 1896, pg 34.
- 2) "Maxim Produces a New Incandescent Lamp", *Electrical Review*, Vol 31, No 9, Sep 1, 1897, pg 101.
- 3) "The New Maxim Lamp and American Incandescent Lamps Compared", J.H. Rhotemmel, *The Electrical Engineer*, Vol XXIV, No 490, Sep 23, 1897, pg 280.
- 4) "The New Maxim Incandescent Lamp", Hiram S. Maxim, *Electrical Review*, Vol 31, No 22, Dec 1, 1897, pg 260.
- 5) "The Maxim High Resistance Thick Filament Lamp", *The Electrical Engineer*, Vol XXIV, No 500, Dec 2, 1897, pg 533.
- 6) "Maxim Incandescent Lamp" (Digest), *Electrical World*, Vol XXXI, No 6, Feb 5, 1898, pg 194.
- 7) "Maxim Incandescent Lamp" (Digest), *Electrical World*, Vol XXXII, No 14, Oct 1, 1898, pg 349.
- 8) My Life, 2nd Edition, Sir Hiram S. Maxim, Methuen & Co. Ltd., London, 1915.
- 9) "Sir Hiram Maxim, Gun Inventor, Dies", *The New York Times*, Nov 25, 1916, pg 13, col 3.
- 10) Obituary Notice, "Sir Hiram Stevens Maxim", *The Journal of the Institution of Electrical Engineers*, Vol 55, 1917, pg 545.
- 11) "Hiram Stevens Maxim", Dictionary of American Biography, Vol XII, Charles Scribner's Sons, New York, 1933, pg 436.
- 12) A Measure for Greatness-A Short Biography of Edward Weston, David O. Woodbury, McGraw-Hill Book Company, Inc., New York, 1949.
- 13) The Electrical Manufacturers 1875-1900—A Study in Competition, Entrepreneurship, Technical Change, and Economic Growth, Harold C. Passer, Harvard University Press, Cambridge, 1953.
- 14) A Streak of Luck, Robert Conot, Seaview Books, New York, 1979.
- 15) "Sir Hiram Maxim", American National Biography, Vol 14, 1999, pg 751.
- 16) "Sir Hiram Stevens Maxim", The Encyclopedia Americana, International Edition, Vol 18, Grolier, 2002, pg 531.
- 17) "Sir Hiram (Stevens) Maxim", The New Encyclopaedia Britannica, Vol 7, Chicago, 2002, pg 963.

## Garrett Morgan, Traffic Light Inventor



Under the section titled "Web Sites of Interest" a link is given to the inventor of the traffic light, Mr. Garrett Morgan. Viewers might also be interested in a write-up by the Ohio Motorists Association (*Ohio Motorist*, Vol 85, No 1, February, 1993, pg 4). Because of its human interest the article will be quoted in its entirety. It was published in the Editor's Corner, titled "Cleveland's Edison: Garrett Morgan, traffic light inventor." The article is as follows:

"February is Black History Month. And our vote for the top salute in the Cleveland area goes to Garrett A. Morgan.

"Surely, few other figures in the black, white or any community's history can match the amazing story of Cleveland's version of Tom Edison. Yet Morgan is not well known.

"Drivers may fuss and cuss at the nameless inventor of the traffic signal when they hit a red light on a lonely road at 2 a. m. Even in more thoughtful moments□when a motorist realizes how utterly impossible it would be to move tens of thousands of cars through a busy city at the same time without traffic lights□the image of an inventor of the device remains a blur.

"Let's try to fill in the picture.

\* \* \*

"On March 4, 1877, Garrett Augustus Morgan was born in Paris, Kentucky, to a mother who had once been a slave. But even as a youth he displayed the unique blend of imagination and perspiration that marks genius. Although he had only six years of education when he left home at age 14, he found work in Cincinnati and actually hired a tutor with his meager wages so he could continue his education.

"Arriving in Cleveland in 1895, Morgan got a job maintaining sewing machines for a clothing manufacturer. But a dozen years later, he went into business for himself, selling and repairing sewing machines. Always curious, Morgan experimented with various solutions to reduce friction in the operation of sewing machine needles—and by accident discovered a hair-straightening solution. So he went into business making and marketing hair care products—that is, shortly after he had also developed a tailoring shop—with 32 employees—to manufacture suits, dresses and coats.

"By 1915, Garrett Morgan had several diverse inventions to his credit, such as a woman's hat fastener, an automobile clutch and a "breathing device" which became the gas mask used by soldiers in World War I.

\* \* \*

"When the tunnel for a water intake pipe was being dug out under Lake Erie, a gas explosion occurred in July, 1916.

"After two rescue parties failed to reach the stricken sandhogs, Garrett and his brother Frank and two others donned Morgan's breathing devices, worked their way through the gas and debris-filled tunnel, and brought out the survivors.

"In November 1923, Garrett A. Morgan patented a unique set of 'stop' and 'go' lights with a third cautionary signal in-between when the lights were about to change. He sold his traffic light to the General Electric Co. for \$40,000—then a princely sum.

\* \* \*

Morgan was a leader in the black community, serving as an officer in several organizations and establishing in 1920 the *Cleveland call*, a forerunner of the *Cleveland Call & Post* newspaper.

"Although he developed glaucoma in the 1940s and gradually lost his vision, Morgan kept designing new products and inventing new things almost until his death on July 27, 1963.

"If you happen to be driving west on the Shoreway in Cleveland, notice the sign on that red brick building near the lake. It proclaims the 'Garrett A. Morgan Water Plant' in honor of the heroic genius of Cleveland who saved the lives of so many people here and around the world with his 'breathing device' and saved the time of so many drivers everywhere by helping to create an orderly flow of vehicles with his traffic light. □F.J.T."

...the story of the incandescent lamp is one of those bits of history that are tucked away in the pocket's of men's achievement, taken for granted, not examined or thought about, except by the people to whom that page of progress is just the record of the day's work: yet so full of interest and conquest and romance...

Katherine Irvin Woods  
Cleveland, Ohio  
December, 1924

\*\*\*\*\*

### **Aladar Pacz, Developer of Nonsag Tungsten**



#### **Introduction**

The rich heritage of the development of the incandescent lamp includes a man about whom little is known today. Besides solving a major problem with tungsten wire, which had replaced carbon as a filament, this little-known man also had an effect in other industries that utilized aluminum alloys. His name was Dr. Aladar Pacz. Scientific investigators do not, as a rule, become so famous that their names are household words. Dr. Pacz, because of his apparently introverted nature, was such a person. However, the accomplishments of such persons should be recorded to the best of our ability so that they are not forgotten.

Aladar Pacz was born in Csokas, Hungary on Jan 11, 1882 to Dorothea (nee Fuchs) and Samuel Pacz. It is not known where he obtained his early education but it is believed he might have obtained a doctorate in Chemistry in Charlottenburg-Berlin by the age of 23. His last place of residence in Hungary was in Salgotarjan, near the border of Czechoslovakia. He emigrated to the United States from Fiume, Hungary on Jun 11, 1905. Pacz sailed on the vessel Ultonia and docked at New York City on Jun 29, 1905.

Dr. Pacz arrived in Cleveland on Sep 15, 1906. The earliest reference found by this writer that linked him with the General Electric Company is dated 1908, the date of his first known U.S. patent. It is reasonable to assume that Pacz first started with GE at their 45th Street facility (the old Brush Works) and perhaps moved into the Nela Park facility in 1914.

Aladar Pacz married Bertha Philipps, a young lady from Cleveland, on Jul 23, 1907; he also applied for citizenship in the Common Pleas Court in Cuyahoga County on that same date. He was 25 years of age at the time and described himself as a Caucasian of fair complexion, 5 feet 11 inches tall, 153 pounds, with brown hair and blue eyes. His Certificate of Naturalization was dated Nov 12, 1912.

## **Early Work**

Based on a report in the GE files dated Oct 29, 1909, it appears Pacz experimented with a new carbon paste for attaching carbon filaments to lead wires. In 1909 he also worked on molybdenum-tungsten support wires for tungsten filament lamps. Pacz then undertook a task that was to result in the solution of a major problem being encountered with tungsten filament lamps.

The carbon filament ruled king until the first decade of the 20th century; then tantalum and osmium appeared for a short time. Sintered tungsten appeared about 1907. William David Coolidge then developed ductile tungsten, which resulted in a marked improvement in lamp efficacy. In 1912 Irving Langmuir developed a coiled tungsten filament gas-filled lamp. Unfortunately two wire problems prevented the General Electric Company from immediately taking full advantage of that milestone development. One problem was offsetting and the other was sag. When the Coolidge-processed wire recrystallized upon heating, the grains would grow as wide as the wire diameter with boundaries that were essentially perpendicular to the wire axis. The wire structure was often compared to the structure of bamboo. When operated at normal temperatures large sections would slip (offset) relative to each other, similar to slippage at a fault line in the earth. In the parlance of today one would call this sliding at a transverse grain boundary. Such a condition would lead to fracture at room temperature. Sag is simply elongation of the coil due to its own weight in a gravitational field. Sag would result in a drastic lowering of the efficacy of lamps of the Langmuir description.

Coolidge found that offsetting could be prevented when thoria was included as an additive at the powder stage. The result of the presence of thoria in the wire is a small grain size. Such a wire was found to sag terribly. Thus, while thoria prevented offsetting, it resulted in sag. Something different had to be done to eliminate both offsetting and sag.

During Coolidge's work on the development of ductile tungsten it was occasionally found that some wire neither offset nor sagged. Wire lots were not consistent. It was suspected that the oxide batch was picking up some favorable impurities from the crucibles being used. The crucibles were referred to as Battersea or Hessian. The materials used to make them came from certain sections of England. A crude analysis of the clay used in a Hessian crucible showed the following: silica, 64%; alumina, 24%; iron oxide, 2%; lime, 1%; loss on ignition, 7%; and other constituents, 2%.

It was surmised then that additions of silica and alumina to the oxides before reduction might help in the offsetting problem. Traces of silicon and aluminum did lead to large grain structures in the wires. Such large grains were necessary to give a nonsag structure but large grains alone were not enough to solve the problem.

Aladar Pacz undertook many experiments before success was achieved. A non-offsetting and non-sagging tungsten wire was obtained by the addition of potassium to the tungstic oxide. Potassium was different from silicon and aluminum because of its larger atomic size. However, the reason for the interlocking large grain structure developed by Pacz was not obvious then and escaped explanation until the 1960s and 1970s. The main tool for investigation in the 1920s and 1930s was the optical microscope. When photographs from that time period are viewed it is clear that not much besides grain size could be determined. It took the more recent sophisticated scanning electron microscope to detect the arrays of submicroscopic bubbles, which contain potassium, that led to an interlocking grain structure and improved wire strength.

Within the General Electric Company Pacz's non-sag, non-offset wire is referred to as 218 wire. A story is told that the wire resulted after the 218th experiment. However, another explanation is that the title #218 was derived from the serial number of the lot of raw tungstic acid used in the first production of the new material by Pacz. Another version of the naming was conveyed to me verbally by a colleague, Eugene Lemmers; he, himself, had been told the story. That version goes something like the following. Pacz worked at the West End of the second floor in Building 323 at Nela Park. Apparently he had experienced superior wire performance (no offsetting and little sagging) in test lamps on the burning racks. For want of a piece of paper he jotted down, on the inside cover of some book matches, details of the wire additives and processing that led to the improved performance. The book matches were placed either on the bench top or on his desk. Now as it happened, Dr. Pacz was absent from work for several days and when he returned found that the cleaning lady apparently had thrown the matches away. As he did not remember what the details were, he had to set out again to find them. After the 218th experiment he rediscovered the magic set of conditions. Where the truth lies is not known. Regardless, the worldwide manufacturers of tungsten wire agree that Aladar Pacz is given the credit for this development. It is believed this development was completed and named by Jul 1915.

### **Patents Granted to Aladar Pacz**

Dr. Aladar Pacz was granted 46 U.S. Patents, issued between the years 1908 and 1933. His basic tungsten wire patent is No 1,410,499, applied for Feb 20, 1917 and issued Mar 21,

1922. It is also known that Pacz was granted at least one Austrian, four British, nine Canadian and four German patents. (See Addendum below)

### **Some Later Work**

Aladar Pacz left the General Electric Company sometime in the early 1920s. His home was near Nela Park, as was a business that he established. It was there that he developed aluminum alloys. One of his developments in that area attracted some attention in the local press. As part of the spoils of World War I, the United States was to receive a dirigible, which would be made by the famous Zeppelin Company at Friedrichshafen, Germany. Until that ship was christened in the United States, it was known as ZR-3; after the christening it became the U.S.S. Los Angeles. The delivery date was made possible, in part, because of one of Pacz's silicon-aluminum alloys. After the war, Germany was not in good financial condition, and it could not afford to use copper in its aluminum alloys. Pacz's alloy, therefore, could be used to some extent in needed castings. His alloy was used by the French in streetcars and railways, and the Belgians, British and Germans also used it. In Germany the alloy was used in motor blocks of the expensive Daimler car. That car was later renamed after the 10-year-old daughter of the businessman, Emil Jellinek. Thus, the Mercedes name on an automobile was born.

Aladar Pacz kept contact with personnel at GE's Nela Park, and in particular with Dr. Matthew Luckiesh. Pacz and Luckiesh were interviewed prior to the sailing of the ZR-3 and were asked details of the use of the alloy in the new dirigible. For several days in Oct 1924, the Cleveland newspapers carried stories about the anticipated and actual inaugural flight of the ZR-3 over the Atlantic to its destination in Lakehurst, New Jersey. As helium was available only in Texas, and then only in limited quantities, the flight across the Atlantic was made with hydrogen as the buoyant gas. Once the ZR-3 landed, the hydrogen was replaced with helium. Later in time, the dirigibles U.S.S. Macon and U.S.S. Akron crashed, which left the Los Angeles as the only U.S. Navy dirigible in this country not to come to a violent ending.

### **The Final Incomplete Chapter**

Based on the application date of his last U.S. patent, it is concluded that Aladar Pacz was living in Weehawken, New Jersey in Nov 1933. My story has to end at this point because nothing more is known about this developer of metals. It is hoped that someone will be able to add more information to this biographical sketch. Attempts have been made to gain more information, including a visit to the Weehawken Public Library, but nothing else was found.

-----  
-----

The information enclosed between the dashed lines is being added on December 11, 2006.

Aladar Pacz appears to having travelled to Europe periodically. The following information was retrieved from the Archives of the *New York Times*. On December 27, 1933<sup>1</sup> Pacz sailed from New York. The ship destinations were the Channel ports, including Bremen

and Hamburg. Then, on March 30, 1934<sup>2</sup> he returned to New York. On January 7, 1935<sup>3</sup> it was reported that he returned again to New York from the same European ports.

## References

- 1) "Ocean Travelers," *New York Times*, Dec 27, 1933, pg 16.
- 2) "Ocean Travelers," *New York Times*, Mar 30, 1934, pg 25, col 5.
- 3) "Ocean Travelers," *New York Times*, Jan 7, 1935, pg 20, col 7.

-----  
-----

## Addendum

The patent information below was added to this write-up on August 14, 2006.

Known patents issued to Dr. Aladar Pacz in the designated countries:

### United States

- 1) 1,071,568 - Plastic Material for Making Incandescent Filaments for Electric Lamps - 26/08/1913 - **GE** (General Electric)
- 2) 1,280,825 - Purifying Drawn Tungsten Wire - 08/10/1918 - **GE**
- 3) 1,299,017 - Tungsten Filaments - 01/04/1919 - **GE**
- 4) 1,337,093 - Mixing Components of Alloys - 13/04/1920 - **GE**
- 5) 1,373,908 - Alloy Steel - 05/04/1921 - **GE**
- 6) 1,387,900 - Aluminum-Silicon Alloy - 16/08/1921
- 7) 1,396,276 - Aluminum-Iron Alloy - 08/11/1921
- 8) 1,402,088 - Alloys - 03/01/1922 - **GE**
- 9) 1,410,499 - Metal and Its Manufacture - 21/03/1922 - **GE**
- 10) 1,464,625 - Electrolyte for Aluminum Production - 14/08/1923
- 11) 1,468,073 - Tungsten Alloy With Silicon - 18/09/1923 - **GE**
- 12) 1,480,779 - Aluminum-Silicon Alloy - 15/01/1924
- 13) 1,508,241 - Tungsten Filaments - 09/09/1924 - **GE**
- 14) 1,510,242 - Copper-Silicon-Aluminum Alloy - 30/09/1924
- 15) 1,518,872 - Aluminum Fluoride - 09/12/1924
- 16) 1,551,613 - Coating Aluminum - 01/09/1925 - **ALCOA** (Aluminum Company of America)
- 17) 1,562,041 - Aluminothermic Reduction of Metals - 17/11/1925 - **GE**
- 18) 1,562,042 - Process of Preparing Boron-Iron Alloys - 17/11/1925 - **GE**
- 19) 1,562,043 - Iron-Boron Alloy - 17/11/1925 - **GE**
- 20) 1,562,654 - Alloys - 24/11/1925
- 21) 1,562,655 - Deoxidizing Metals and Alloys - 24/11/1925
- 22) 1,566,420 - Mold Composition - 22/12/1925
- 23) 1,572,502 - Aluminum Alloy - 09/02/1926 - **ALCOA**
- 24) 1,572,503 - Aluminum Alloy - 09/02/1926 - **ALCOA**
- 25) 1,595,058 - Aluminum Alloys - 03/08/1926 - **ALCOA**
- 26) 1,595,218 - Aluminum-Silicon Alloys - 10/08/1926 - **ALCOA**
- 27) 1,595,219 - Alloy - 10/08/1926 - **ALCOA**
- 28) 1,596,020 - Aluminum Alloy - 17/08/1926 - **ALCOA**



- 29) 1,596,888 - Process and Composition of Matter for Increasing the Fluidity of Molten Metal - 24/08/1926
- 30) 1,614,149 - Extraction of Metals and Their Compounds from Ores and Impure Materials - 11/01/1927 - **GE**
- 31) 1,614,684 - Metallic Article - 18/01/1927
- 32) 1,635,055 - Alloy Filament - 05/07/1927 - **GE**
- 33) 1,638,273 - Method and Composition of Matter for Surface-Treating Aluminum - 09/08/1927
- 34) 1,691,207 - Process of Refining Metals and Alloys - 13/11,1928
- 35) 1,710,743 - Surface Treating Aluminum Articles - 30/04/1929
- 36) 1,723,067 - Method and Composition of Matter for Coating and Coloring Metal Articles - 06/08/1929
- 37) 1,784,106 - Coating Zinc and Cadmium - 09/12/1930
- 38) 1,798,218 - Coating and Coloring Metals - 31/03/1931
- 39) 1,838,632 - Method of Decreasing Shrinkage in Aluminum Bronze Castings - 29/12/1931
- 40) 1,838,633 - Coloring Aluminum Alloys - 29/12/1931
- 41) 1,848,797 - Treatment of Aluminum-Silicon Alloys - 08/03/1932 - **ALCOA**
- 42) 1,848,798 - Process for Modifying Aluminum Alloys Containing Silicon - 08/03/1932 - **ALCOA**
- 43) 1,860,947 - Aluminum Alloy Casting and Process of Making the Same - 31/05/1932 \*
- 44) 1,974,971 - Method of Treating Alloys - 02/06/1932 - **ALCOA**
- 45) 2,013,926 - Modification of Aluminum, Aluminum Alloys, and Alloys Containing Aluminum - 10/09/1935
- 46) 2,078,609 - Plastic Reaction Product of Gallic Acid and a Soluble Tungstate - 27/04/1937

\* assignor of 1/2 to ALCOA (Aluminum Company of America), Pittsburgh, Pennsylvania, a corporation of Pennsylvania, and 1/2 to Metallgesellschaft Aktiengesellschaft, Frankfurt-on-the-Main, Germany, a corporation of Germany.

#### Canada

- 1) 185,853 - Treating Drawn Metal - 30/06/1918
- 2) 188,740 - Metals for Filament Manufacture - 18/02/1919
- 3) 195,861 - Metal Manufacture - 06/01/1920 **GE Canada**
- 4) 209,696 - Alloy - 22/03/1921
- 5) 212,367 - Manufacture of Steel - 05/07/1921 **GE Canada**
- 6) 212,669 - Alloy Filament - 26/07/1921 **GE Canada**
- 7) 214,869 - Alloy Steel - 27/12/1921 **GE Canada**
- 8) 232,935 - Method of Producing Alloy - 24/07/1923 **GE Canada**
- 9) 239,864 - Aluminum Alloy - 06/05/1924 **GE Canada**
- 10) 249,853 - Iron Boron Alloy - 19/05/1925 **GE Canada**
- 11) 263,338 - Aluminum Coated Article - 10/08/1926
- 12) 273,442 - Metallic Article - 30/08/1927
- 13) 273,443 - Aluminum Surface Treatment Composition - 30/08/1927
- 14) 274,380 - Metal Fluidity Process - 04/10/1927
- 15) 274,901 - Metal Extraction - 25/10/1927 **GE Canada**

- 16) 276,080 - Tungsten Alloy - 06/12/1927 **GE Canada**  
 17) 285,289 - Alloy Processing Composition - 04/12/1928  
 18) 285,290 - Alloy Processing Composition - 04/12/1928  
 19) 285,291 - Alloy Processing Composition - 04/12/1928  
 20) 289,767 - Coating for Metal - 21/05/1929  
 21) 305,261 - Aluminum Alloy Casting - 28/10/1930 **ALCOA; MetallBank & Metallurg Ges AG**  
 22) 310,788 - Production of Aluminum and Aluminum Alloys - 28/04/1931  
 23) 328,251 - Aluminum-Silicon Alloy - 06/12/1932 **Aluminium Ltd**  
 24) 328,252 - Aluminum-Silicon Alloy - 06/12/1932 **Aluminium Ltd**  
 25) 337,463 - Aluminum Modification - 28/11/1933 **Aluminium Ltd**

#### **France**

- 1) 523,665 - Alliage d'aluminium et son procédé de fabrication - 22/08/1921  
 2) 532,611 - Procédés pour la fabrication des métaux et des alliages, et produits résultant de ces procédés - 08/02/1922  
 3) 626,709 - Method and composition of matter for surface-treating aluminium - 17/09/1927  
 4) 658,740 - Procédé pour revêtir et colorer des métaux - 19/06/1929  
 5) 664,847 - Alliage - 09/09/1929  
 6) 666,949 - A process for preparing aluminium and aluminium alloys - 08/10/1929  
 7) 695,155 - Procédé pour l'obtention de couches protectrices colorées, par exemple de teintes grises ou noirâtres. sur la surface d'objets en alliages d'aluminium - 12/12/1930  
 8) 684,158 - Procédé d'obtention de tungstène ou d'alliages de tungstène et de thorium exempts d'oxygène - 23/06/1930  
 9) 728,364 - Procédé pour la production de revêtements, résistant ô la corrosion, sur le fer et l'acier - 05/07/1932  
 10) 728,411 - Proédé pour la production d'une couche protégeant le fer ou l'acier contre la rouille - 05/07/1932  
 11) 764,289 - Procédé de fabrication de composés colloïdaux de tungstè de grande plasticité - 17/05/1934

#### **Switzerland**

- 1) 94,499 - Verfahren zur Veredlung einer für Guss bestimmten Aluminiumlegierung mit einem Siliziumgehalt von 5% bis 20% - 01/05/1922  
 2) 99,080 - Arbeitsverfahren zur Darstellung von Legierungen - 16/05/1923  
 3) 127,279 - Verfahren, um metallische Gegenstände mindestens stellenweise mit einem Überzug zu versehen - 01/09/1928  
 4) 136,399 - Verfahren zur Herstellung eines haftenden Überzuges auf Eisen, Aluminium, Zinn, Blei, Magnesium, Zink, Cadmium und deren Legierungen - 15/11/1929  
 5) 146,044 - Verfahren zur Herstellung von Aluminium - 31/03/1931  
 6) 153,548 - Verfahren zur Herstellung von Aluminiumiegierungen - 31/03/1932  
 7) 176,632 - Verfahren zur Herstellung eines hochplastischen Umsetzungsproduktes von Ammoniumwolframat und Gallussäure - 30/04/1935

#### **Austria**

- 1) 4,649-09 - Mfg. A colloidal organic compound of tungsten or molybdenum - 12/06/1909  
 2) 52,353B - Verfahren zur Herstellung einer kolloidalen organischen Verbindung des Wolframs oder Molybdäns und zu deren weiterer Verarbeitung - 26/02/1912  
 3) 53,053B - Verfahren zur Herstellung von zusammenhängenden Metallkörpern,

- insbesondere Leuchtkörpern für elektrische Glühlampen - 10/04/1912
- 4) 94,978B - Guss-Aluminiumlegierung und Verfahren zur Herstellung derselben - 26/11/1923
- 5) 95,309B - Verfahren zur Herstellung von Legierungen - 27/12/1923
- 6) 114,839B - Verfahren zur Oberflächenbehandlung von Aluminium und Aluminiumlegierungen - 11/11/1929
- 7) 121,230B - Verfahren zur Herstellung eines haftenden Überzuges auf Metallen oder Metallgegenständen ohne Anwendung eines galvanischen Stromes - 10/02/1931
- 8) 129,283B - Verfahren zur Herstellung von Aluminium und Aluminiumlegierungen - 25/07/1932
- 9) 130,614B - Verfahren zur Herstellung von gefärbten Schutzschichten auf der Oberfläche von Gegenständen aus Aluminiumlegierungen - 10/12/1932
- 10) 132,371B - Verfahren zur Gewinnung sauerstofffreien Wolframs bzw. sauerstofffreier Wolframthorium legierungen - 25/03/1933
- 11) 145,131B - Verfahren zur Herstellung von Presskörpern - 10/04/1936

#### **Denmark**

- 1) 31,101C - Fremgangsmaade til Forädling af Aluminium-Siliciumlegeringer - 27/12/1923

#### **Germany**

- 1) 245,190 - Coherent Metal Bodies - 12/06/1909
- 2) 249,733 - Modification of the Process of Mfg. Coherent Metal Bodies Especially for Filaments for Incandescent Lamps - 27/01/1910
- 3) 619,409 - Verfahren zur Veredlung von Aluminium-Silizium-Legierungen - 01/10/1935  
- **Metallgesellschaft AG**
- 4) 632,953 - Verfahren zur Modifizierung von siliciumhaltigen Aluminiumlegierungen - 16/07/1936  
- **Metallgesellschaft AG**
- 5) 635,844 - Tungsten Compounds - 02/10/1936
- 6) 707,481 - Verfahren zum Modifizieren von Aluminium und praktisch siliciumfreien Aluminiumlegierungen - 23/06/1941 - **Metallgesellschaft AG**

#### **Great Britain**

- 1) 158,827 - Alloys - 26/01/1921
- 2) 160,426 - Alloys; Extracting Metals - 18/03/1921
- 3) 181,015 - Alloys; Castings - 31/05/1922
- 4) 240,808 - Foundry Molds - 02/10/1924

#### **References**

1. The photograph of Dr. Aladar Pacz was scanned from one of the scrapbooks of the meetings of GE personnel on Association Island in Lake Ontario.
2. *Cleveland Plain Dealer*, Oct 11, 1924.
3. Forty-Five Years of Light, Booklet No. 29 of the Nela Series, Katherine Irvin Woods, Cleveland, Ohio, Dec 1924.
4. Aladar Pacz and 218 Nonsag Tungsten, Edward J. Covington, Graphic Communications Operation, GE Lighting, Nela Park, E. Cleveland, Ohio, 1990, 12 pages.
5. A Man from Maquoketa - A Biography of Matthew Luckiesh, Edward J. Covington, Graphic Communications Operation, GE Lighting, Nela Park, E. Cleveland, Ohio, 1992, 146 pages.

6. In order to gather biographical information, the Cuyahoga County Archives and the Cleveland Public Library were utilized. The naturalization papers, marriage certificate and the Cleveland City Directories are available at the Archives, and U.S. patents dating back to the 1700s are available at the Cleveland Public Library. Since this research was undertaken in 1990 both the 1920 and 1930 census data should have become available for anyone desiring to further investigate Dr. Pacz.

### Charles G. Perkins



Charles Perkins was born in Weare, New Hampshire on March 23, 1849. His career in the lighting area started with employment at the United States Electric Lighting Company in Bridgeport, Connecticut in 1879. It was there, in 1880, that he was in charge of the first public exhibition of an incandescent lighting system, which was installed in the vault area of a safe deposit company in New York City. While working at the United States company he became acquainted with Henry Goebel, who received much notoriety in 1893 during patent litigations with Edison. After leaving the United States company in 1881 he became associated with the Faure Electric Storage Company.

In 1889 the Perkins Electric Lamp Company, manufacturers of incandescent lamps and sockets, was organized, and in 1890 they moved their executive offices from Hartford to Manchester, Connecticut. In 1890 the Perkins Electric Switch Company was organized in Hartford, Connecticut. In October 1890 a snap switch, designed for a quick make-break of electric lamp circuits, was announced by the Switch Company.

No patents on incandescent lamps were ever issued to Richard H. Mather, whose business name essentially replaced that of Perkins, although two patents for arc lamps were. However, between 1875 and 1904 Mather had 34 patents issued to him.

#### Some Patents Granted to Perkins

No.		Description		Date
244,291	<input type="checkbox"/>	Electric Lamp	<input type="checkbox"/>	Jul 12, 1881
244,481	<input type="checkbox"/>	Electric Lamp	<input type="checkbox"/>	Jul 19, 1881
244,482	<input type="checkbox"/>	Electric Lamp	<input type="checkbox"/>	Jul 19, 1881
247,103	<input type="checkbox"/>	Circuit Breaker for Electric Lamps	<input type="checkbox"/>	Sep 13, 1881
247,104	<input type="checkbox"/>	Spring Switch for Electric Lamps	<input type="checkbox"/>	Sep 13, 1881
290,467	<input type="checkbox"/>	Incandescent Electric Lamp	<input type="checkbox"/>	Dec 18, 1883
290,469	<input type="checkbox"/>	Electric Lamp and Switch	<input type="checkbox"/>	Dec 18, 1883
290,470	<input type="checkbox"/>	Automatic Electric Circuit Maker and Breaker	<input type="checkbox"/>	Dec 18, 1883
326,584	<input type="checkbox"/>	Incandescent Lamp	<input type="checkbox"/>	Sep 22, 1885

360,244 □ Electric Lamp and Socket □ Mar 29, 1887  
626,927 □ Incandescent Lamp Socket □ Jun 13, 1899

### References

- 1) "The Perkins Electric Lamp Company", *The Electrical Engineer*, Vol 10, Sep 3, 1890, pg 268.
- 2) "The Perkins Snap Switch", *The Electrical Engineer*, Vol 10, Oct 22, 1890, pg 445.
- 3) "The Perkins Switch in Litigation," *The Electrical Engineer*, Vol 12, No 169, Jul 29, 1891, pg 125.
- 4) "The Incandescent Lamp Situation," *The Electrical World*, Vol 21, Jan 14, 1893, pp 33-34.
- 5) "Incandescent Lamp Litigation," *The Electrical Engineer*, Vol 15, No 249, Feb 8, 1893, pp 149-151.
- 6) *The Electrical Engineer*, Vol 15, No 249, Feb 8, 1893, pg 150.
- 7) New England Notes. "Perkins Electric lamp Company," *The Electrical Engineer*, Vol 17, No 300, Jan 31, 1894, pg 104.
- 8) The National Cyclopaedia of American Biography, Vol 4, James T. White & Co., New York, 1897, pg 290.

### Marvin Pipkin

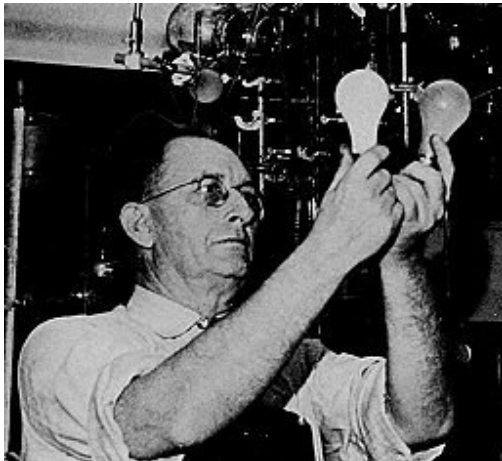

Marvin Pipkin (Nov 18, 1889 - Jan 7, 1977) is best known as the inventor of the inside-frost process of bulbs for incandescent lamps, which was developed in 1925, as well as the improved process developed in 1947, which consisted of an application of silica to the inside of a bulb. This new process was called: "Q-coat." The picture to the left shows Pipkin holding up a sample of each of the developments. He also held several patents on photoflash lamps.

Marvin Pipkin was born in the Christina area south of Lakeland, FL and was one who had a pronounced Dixie accent. He was the son of David M. and Catherine (Moore) Pipkin. His father was a farmer and grove owner and planted the first citrus trees in the Medulla and Christina areas.

Pipkin received his primary education in Lakeland and his secondary education at the Summerlin Institute in Barlow. One of his Summerlin classmates remembered Marvin as a *shy, gawky, sandy-haired, freckle-faced boy who knew more chemistry than all the rest of the class put together.*

After graduation from high school Pipkin joined a prospecting firm for a year and then worked, for a short time, at the International Agricultural Corp., later known as the International Mineral and Chemical Corp. of Barlow.

Pipkin attended Alabama Polytechnic Institute (API) and received a Bachelor of Science degree in Chemical Engineering from that institution in 1913. After working in fertilizer and phosphate laboratories in Barlow for a year he returned to API and, in 1915, earned a master's degree.

On Nov 5, 1917 Pipkin enlisted in the Army in Jacksonville. Because the Germans had introduced poisonous gas into warfare there was a need for persons with a chemical background to work on gas masks. Pipkin entered the Gas Defense Department as a private and was posted to the laboratories at Nela Park in Cleveland.

One of the first discoveries that emerged from the Nela laboratory was due to Pipkin. He found that the activity of charcoal for phosgene (a highly poisonous liquid) could be significantly increased by the introduction of hydrated manganese dioxide into it. Subsequent findings and understanding led to accurate determinations of the effect of water on the absorption of gases by charcoal. Pipkin attained the rank of Master engineer, senior grade. After his service he remained at Nela to work in the Lamp Development Laboratory.

The glare from incandescent lamps was something many people wanted to reduce. A common technique used on early incandescent lamps consisted of an outside acid etch on the bulb. However, such a process led to remarkably reduced strength of the bulb. In 1925 Pipkin developed an etch on the inside of the bulb that did not weaken the glass (U.S. Patent No. 1,687,510). It was a process that was standard for about 30 years. Work performed in 1947 resulted in an improvement in the coating of the bulb. That improvement was achieved by means of an inside coating of silica on the bulb (U.S. Patent No. 2,545,896).

Marvin Pipkin retired from Nela Park in 1954 and resettled in his home town of Lakeland, FL. He had married Kathryn Patricia Enright (d 1957) on Jul 21, 1919 and they had three children. Pipkin passed away at the Lakeland General Hospital in 1977 after a lengthy bout with cancer.

### **John E. Randall**



John E. Randall (26 Aug 1861 - 22 Apr 1955) was a competent engineer although he spent most of his working career in management. Randall was a native of Chambersburg, in Montgomery County, Ohio. He matriculated from Ohio Wesleyan University, being a Phi Beta Kappa graduate. He also did graduate work at Ohio State University.

Randall entered the incandescent lamp business in 1886 when he took a position as electrician in charge of experimental work at the Thomson-Houston Company in Lynn, MA. He

then acted as superintendent for about seven years. In 1893, after the Lynn Works closed, Randall started to work at the Columbia Incandescent Lamp Company in St. Louis, MO; in 1895 he was made superintendent of that factory.

In October of 1901 Columbia was purchased by the National Electric Lamp Company of Cleveland. In 1905 Randall became a filament and lamp engineer at National. In 1907 he, with Theodore W. Frech, visited German electrical companies and then returned to Cleveland to plan, organize, equip and operate the first National (later, General Electric) tungsten lamp plant.

In 1908 Randall became a consulting engineer and in 1909 organized the

Lamp Development Laboratory. He was manager of the Laboratory until 1915 when he again took the title of consulting engineer. Retirement came in 1931.

Randall was granted U.S. Patent No. 1,357,724 for a projection lamp. He wrote one of the early treatises on the electric incandescent lamp in 1891. John E. Randall married Lilyan Gatch and they had a son and daughter. He passed away after a long illness in Jamestown, NY. Services were held at Knollwood Cemetery, Mayfield Heights, OH.

#### **General**

#### **References**

- 1) A Practical Treatise on the Incandescent Lamp, John E. Randall, Bubier Publishing Co., Lynn, MA, D. Van Nostrand Co., 1891.
- 2) "A Western Lamp Factory", *The Electrical World*, Vol XXII, No 26, Dec 23, 1893, pg 483.
- 3) Book of the Incas, ca 1930. A book of biographical sketches of persons employed by the Incandescent Lamp Department of the General Electric Company and who were also members of the Society of the Incas. The purpose of the Society was to encourage the spirit of cooperation, fraternity and goodfellowship as a means of promoting the personal interests of its members and the business interests of the General Electric Company. The picture of John Randall was scanned from this book.
- 4) Makers of National - The Spirit and People of an Industrial Organization, Edward J. Covington, Printed by Graphic Communications Operation, GE Lighting, Nela Park, East Cleveland, OH, 1997.

#### **William**

#### **Edward**

#### **Sawyer**

Some patents granted to Sawyer are listed at the end of this writeup.

It would appear that little personal information has been printed regarding one of the early workers in the incandescent lamp field. What is presented below is simply the result of a cursory look for information regarding William Edward Sawyer. Perhaps this limited write-up will interest someone who has more information to come forward to fill in the missing blanks. The first quotation is a copy of the contents of an article that appeared in the *Electrical World*, Vol 1, May 19, 1883, pg 309<sup>2</sup>.

#### **"Death of an American Electrician**

"Mr. William E. Sawyer, a well known electrician and electric light engineer, died at his residence in this city on the 15th inst. Mr. Sawyer will be remembered as one of the pioneers in the field of electric lighting in America. His career as an electrician was begun under very favorable auspices, and it is a pity that it should have proven but a record of neglected opportunities. Unfortunately for Mr. Sawyer, his nature combined discordant elements of character; his disposition was governed by traits at once uncongenial and incompatible with each other. He was not lacking in the essential qualities of ability and genius. On the contrary, he possessed undoubted talent as an electrician. But his character was not possessed of that fixedness and stability which command success. His erratic and careless habits were perpetually at war with his talents, and led him continually into difficulty.

"He achieved fame and fortune at an early date. It is said that his inventions formed the basis of the first electric light company in America—the United States Electric Light Company—who retained his services on a contract of several years, at a munificent salary. Mr. Sawyer only remained a few weeks, however, and then threw up his contract. It is said that the \$50,000 which he received for his inventions soon disappeared. He then gave his attention anew to electric lighting, and a new company, the Sawyer-Mann Electric Light Company, was formed to operate his incandescent system. It appears that he was at work on an incandescent system much sooner than Edison or Maxim, and that he was successful in contests with them for priority in the Patent Office.

"A difficulty arose between Mr. Sawyer and a Dr. Steele, who boarded at the same place where he lived, which culminated, on the 5th of May, 1880, in an altercation, in which Mr. Sawyer shot Dr. Steele. Mr. Sawyer was arrested, and when the trial took place in March, 1881, he was convicted and sentenced to four years' imprisonment at hard labor. An appeal was made, and as his health was poor, he was permitted to remain at his home pending the appeal. The Court of Appeals affirmed the decision of the Court of General Sessions, and Mr. Sawyer then sought pardon from the governor. As his health was such that his removal was considered dangerous, he was permitted to remain at his house. The District Attorney consented to delay in moving for sentence in one month, which expired May 16, but before the time had expired he received official notice of the death of Mr. Sawyer.

"In the beginning of 1881 Mr. Sawyer published a book on "Electric Lighting by Incandescence," which, for a time, was the best work on the subject. The Sawyer-Mann Company did not live long, and Mr. Sawyer started one or two other companies, which shared the same fate. He then turned his attention to the electric railroad, and managed to produce a sensation once more. He had lately given considerable attention to perfecting his electric railroad. At the time of his death it is said that he had



several applications for patents in course of preparation, to cover distinctive features of his inventions.

"As an electrician, Mr. Sawyer belonged to the practical school rather than to the scientific. His inventions are not so remarkable for originality of conception as for ingenuity of application. In a word, his genius was constructive rather than creative. His inventions were bright innovations of old ideas, rather than departures toward new principles."

A death notice appeared in *The New-York Times* on Thursday, May 17, 1883, pg 3, column <sup>1</sup>. It read:

### **Death of William E. Sawyer**

"Prof. William E. Sawyer, who was under sentence for committing an assault upon Dr. Theophilus Steele, in May, 1880, died of hemorrhage of the bowels, at No. 104 Waverley Place, Tuesday morning. He was convicted in March, 1881, but as his health was poor he was permitted to remain at his home pending an appeal from his sentence. The Court of Appeals affirmed the decision of the Court of General Sessions, and the defendant sought pardon from the Governor. As his health was such that his removal was considered dangerous, District Attorney McKeon permitted him to remain at his house, after satisfying himself from the report of two physicians of his own selection that the convicted man was in a precarious condition. The District Attorney consented to delay in moving for sentence for one month, which expired yesterday, but before the time had expired Mr. McKeon received official notice of the death of Mr. Sawyer."

A few more facts about the life of William Edward Sawyer can be obtained from the 1894 edition of the book Evolution of the Electric Incandescent Lamp, written by Franklin Leonard Pope. On page 6 Pope said:

"At least as early as June, 1877, William Edward Sawyer, a native of New Hampshire, who had been for some years a telegraphic operator in the New England States, and subsequently a reporter and journalist in Washington, D. C., directed his attention to the making of inventions in electric engineering and electric lighting..."

These are not many facts about a man who exerted so much influence on the incandescent lamp industry. Hopefully with the passage of time more information will surface so that justice can be done in a biographical sketch of W. E. Sawyer. The most information presently available can be found in the paper by Wrege and Greenwood<sup>3</sup>.

### **References**

- 1) "Death of William E. Sawyer," *New York Times*, May 17, 1883, pg 3, col 1.
- 2) "Death of an American Electrician," *Electrical World*, Vol 1, May 19, 1883, pg 309.
- 3) Charles D. Wrege and Ronald G. Greenwood, "William E. Sawyer and the Rise and Fall

of America's First Incandescent Electric Light Company, 1878-1881," Business and Economic History, 2nd Series, Vol 13, pp 31-48, Paper presented at the 30th Annual Meeting of the Business History Conference, March 8-10, 1984.

**Patents granted to William E. Sawyer between 1874 and 1885**

Patent No.	Invention	Date
149,252*	Telegraph apparatus for cable use	Mar 31, 1874

-----  
 \*John McVey kindly pointed out that the patent granted on Mar 31, 1874 was not 149,887 as previously given, but rather 149,252. I am most grateful to Mr. McVey for pointing out and correcting this error.

158,442	- Automatic or chemical telegraphy	- Jan 25, 1875
159,460	- Automatic and autographic telegraph and circuit	- Feb 2, 1875
165,620	- Automatic electric telegraph	- Jul 13, 1875
166,305	- Telegraphic circuit	- Aug 3, 1875
171,050	- Copying telegraph	- Dec 14, 1875
171,051	- Automatic telegraph	- Dec 14, 1875
173,561	- Electro-magnetic engine	- Feb 15, 1876
182,486	- Electrical circuit for chemical telegraphs	- Sep 19, 1876
184,302	- Autographic telegraph	- Nov 14, 1876 - (with J. G. Smith)
191,781	- Electro-magnetic engine	- Jun 12, 1877
194,111	- Electric engineering and lighting apparatus and system	- Aug 14, 1877
194,500	- Electric candle	- Aug 21, 1877
194,563	- Electric lighting apparatus	- Aug 28, 1877
195,174	- Electro-magnetic-engine commutator	- Sep 11, 1877
195,235	- Regulator for automatic telegraphs	- Sep 18, 1877
195,236	- Autographic telegraph transmitter	- Sep 18, 1877
195,237	- Autographic telegraph transfer process	- Sep 18, 1877
195,238	- Copying telegraph message process	- Sep 18, 1877
196,832	- Autographic telegraph instrument	- Nov 6, 1877
196,833	- Device for effecting the static discharge in autographic telegraphy	- Nov 6, 1877
196,834	- Electric engineering and lighting system	- Nov 6, 1877
205,144	- Electric lamp	- Jun 18, 1878 - (with Albon Man)
205,303	- Electric lighting system	- Jun 25, 1878 - (with Albon Man)
205,305	- Regulator for electric lights	- Jun 25, 1878 - (with Albon Man)
210,151	- Electric meter	- Nov 19, 1878
210,152	- Switch for electric lights	- Nov 19, 1878 - (with Albon Man)
210,809	- Electric lamp	- Dec 10, 1878 - (with Albon Man)
211,262	- Carbon for electric lights	- Jan 7, 1879 - (with A. Man)
219,771	- Electric lamp	- Sep 16, 1879
229,335	- Carbon for electric lights	- Jun 29, 1880
229,476	- Electric switch	- Jun 29, 1880
229,658	- Electrical safety device for elevators	- Jul 6, 1880
231,743	- Electrical safety device for elevators	- Aug 31, 1880
229,335	- Carbon for electric lights	- Jun 29, 1880 - (with A. Man)
229,476	- Electric switch	- Jun 29, 1880 - (with A. Man)

235,460 - Electric-lighting switch - Dec 14, 1880 - (with W. Sawyer)  
 236,460 - Automatic regulator for electric currents - Jan 11, 1881 - (with W. Sawyer)  
 237,632 - Dynamo-electric machine - Feb 8, 1881  
 241,242 - Armature for dynamo-electric machines - May 10, 1881 - (with E. R. Knowles)  
 241,430 - Electric lamp - May 10, 1881 - (with R. Street)  
 245,976 - Electric regulator - Aug 23, 1881 - (with R. Street)  
 254,056 - Dynamo-electric machine - Feb 21, 1882  
 265,448 - Safety attachment for elevators - Oct 3, 1882  
 10,134 (reissue) - Electric lighting system - Jun 6, 1882 - (with A. Man)  
 317,676 - Electric light - May 12, 1885 - (with A. Man) **Frederick Schaefer**

It is of interest to the writer to learn as much as is possible about the individuals who played notable roles in the early days of the incandescent lamp. One person who appears to be elusive to the researcher is Frederick Schaefer. An attempt to find some biographical data on Schaefer resulted in the following being determined from the Cambridge City Directories.

In the 1887 Directory<sup>5</sup> Frederick E. Schaefer is listed as living at 351 Main. In addition, Leonard Schaefer is listed as the superintendent of the Schaefer Electric Manufacturing Company. In the 1888 Cambridge City Directory<sup>6</sup> the name of Frederick E. is no longer there but Leonard is still listed as the superintendent of the Schaefer Company. A John Schaefer, who is identified as a machinist, is also listed (in 1888), apparently working at the Schaefer Company. Tentatively then, one might surmise that Frederick E., Leonard and John were related.

U.S. patents granted to Frederic(k) Schaefer were:

320,297 (Jun 16, 1885) (Manufacture of Filaments for Incandescent Lamps)  
 322,857 (Jul 21, 1885) (Electric Switch)  
 339,217 (Apr 6, 1886) (Electric Lamp Holder)  
 339,218 (Apr 6, 1886) (Electric Lamp Switch)  
 352,006 (Nov 2, 1886) (Incandescent Electric Lamp)  
 352,007 (Nov 2, 1886) (Incandescent Electric Lamp)

The earliest application date on these patents was Nov 26, 1884.



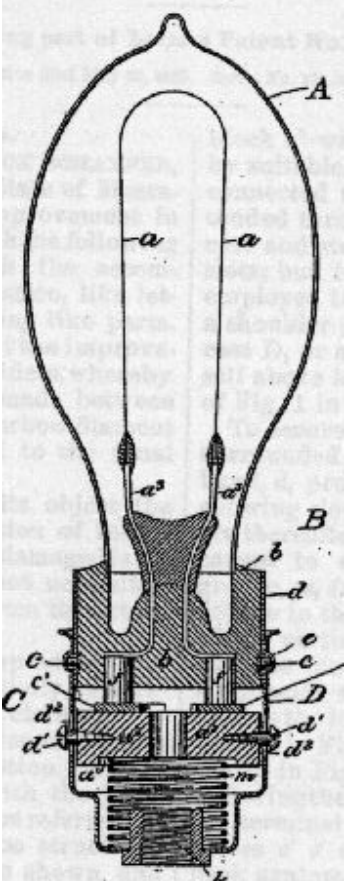

A short article appeared in the Fort Wayne Gazette in which it announced that Schaefer was the Superintendent at the Fort Wayne Jenney Electric Light Company<sup>1</sup>. It read:

## "Incandescent Lighting

"The growth of the business of the manufacture and sale of incandescent electric lamps must be exceedingly satisfactory to the Fort Wayne Jenney Electric Light company.

"Under the superintendence of Frederick Schaefer, the Boston expert, several thousand incandescent lights have been sold and are now in successful operation. At Peoria, Ills., there are five insulated plants with 800 lights and a central station with 1,200 lights; at Pittsburg there are 1,000 lights; at Alliance, 600; at Kansas City, 800; at Chicago, 500 and at New Orleans, where the Louisiana Electric Light and Power company operate 1,600 of the Jenney Arc lamps, 1,500 incandescent lamps have lately been put in. This department of the Jenney factory now gives employment to five men and nine girls and this force must be shortly increased."

It would appear that Schaefer did not remain long in Fort Wayne. About this same time Frank Thone was living in Fort Wayne and when Thone moved to Oskaloosa, Iowa to become associated with the Hawkeye Electric Manufacturing Company, Schaefer apparently followed. Schaefer assisted Thone and had charge of the incandescent lamp department<sup>4</sup>.

An advertisement of the Schaefer Electric Manufacturing Company appeared in the Boston City Directory for 1888<sup>7</sup> and is shown below.

**SCHAEFER ELECTRIC MFG. CO.**  
— MANUFACTURERS OF —  
**INCANDESCENT LAMPS AND APPLIANCES.**  
**FACTORY, CORNER OSBORN AND MAIN STREETS,**  
**P. O. Box 3068, Boston, Mass. CAMBRIDGEPORT, MASS.**

### Acknowledgements

The writer appreciates the information supplied by Mark Freed of the Cambridge Public Library, Katie Barrett of the Boston Public Library, and Alice Barva of the Fort Wayne Public Library.

### References

- 1) *Fort Wayne Gazette*, March 5, 1887, pg 4.
- 2) Frank Thone, U. S. Patent No. 348,799 for an Arc Light, granted Sep 7, 1886, filed Mar 24, 1886.
- 3) "The Fort Wayne Jenney Incandescent System", *The Electrical World*, Vol X, Jul 16, 1887, pg 31.
- 4) "Hawkeye Electric Company", *Western Electrician*, Vol 2, No 13, Mar 31, 1888, pg 159.

- 5) 1887 Cambridge Directory, pg 344.  
 6) 1888 Cambridge Directory, pg 382.  
 7) 1888 Boston Directory, pg 1838.  
 8) General Electric at Fort Wayne, Indiana - A 110 Year History, Clovis E. Linkous, Gateway Press, Baltimore, 1994, pg 37.

## Henry Schroeder



Henry Schroeder (Feb 28, 1879 - Dec 21, 1952) is known to the collectors of early incandescent lamps as the author of a book on that subject. In addition to articles and a book written solely, he coauthored a book with John W. Howell that is considered, by some, to be the authoritative source for descriptions of the Edison lamp developments.

Schroeder's photograph, shown to the left, was taken about 1928. He was born in New York City and graduated from Columbia University in 1899 with a degree in electrical engineering.

Schroeder entered the Sales Department of the Edison Lamp Works at Harrison, New Jersey on Apr 16, 1908. In 1911 he was made Assistant to the Sales Manager in charge of the Commercial Engineering Department. On Nov 1, 1925 his position was that of Commercial Engineer. About 1928 Schroeder's home was at 390 Sanford Avenue, Flushing, Long Island, New York. He retired in

1929.

Henry Schroeder was married to Annetta Rhodes Weaver Schroeder. They had three sons and one daughter: Harry Jr., Charles F., George W. and Mrs. Annetea S. Horton.

### General

### References

- "The Manufacture of the MAZDA Lamp", Henry Schroeder, *The Central Station*, Jan 1921, pg 196.  
 "The Incandescent Electric Lamp", Henry Schroeder, *Commercial America*, Dec 1921, pg 35.  
 "The Incandescent Lamp□Its History", Henry Schroeder, Bulletin L.D. 118A, Edison Lamp Works, Jan 1923.  
History of Electric Light, Henry Schroeder, Smithsonian Miscellaneous Collections, Vol 76, No 2, Publication 2717, Aug 15, 1923.  
The History of the Incandescent Lamp, John W. Howell and Henry Schroeder, The Maqua Company, Publisher, Schenectady, NY, 1927.

Book \_\_\_\_\_ of \_\_\_\_\_ the \_\_\_\_\_ Incas, \_\_\_\_\_ ca \_\_\_\_\_ 1930.  
"Henry Schroeder", Obituary, *The New York Times*, Dec 23, 1952, pg 23, col 4.



**M. M. M. Slattery**

Biographical sketches of Marmaduke Marcelus Michael Slattery can be found in references below<sup>1,2</sup>. One such sketch is reproduced here.<sup>2</sup>

"Marmadule M. M. Slattery, whose portrait is herewith presented, died at his residence at Fort Wayne, Ind., Wednesday afternoon, December 15th. The deceased had been in poor health for two years, but had been able to attend to his business most of the time. He contracted a severe cold on Thanksgiving day and two days after was compelled to take to his bed. He failed rapidly, but on Wednesday he rallied and sat up for a time. During the afternoon he had a severe hemorrhage of

the lungs and died in a few hours. On Saturday, December 17th, the funeral services were held at Fort Wayne and were attended by a large concourse of people. The employes of the Fort Wayne Electric company attended in a body, and several local organizations of which Mr. Slattery had been a member were represented. There were many floral offerings.

"There were few men in the electrical fraternity better known than "Duke" Slattery, as he was generally styled. He had a bright, engaging manner and was everywhere welcomed. He was an exceptionally entertaining after-dinner speaker and possessed considerable literary ability. In scientific circles Mr. Slattery held a prominent position as the inventor of a successful electric lighting system. Most of his work in this line was done in the West, but he was well known in electrical circles throughout the United States and in fact had gained some distinction before coming to this country.

"Mr. Slattery was born in the city of Limerick, Ireland, in 1851. He attended the schools of that city and prepared for college. He was graduated at Marlboro college, Marlboro Eng., in 1873, and received his B. A. degree. After leaving college he was associated with St. George Lane-Fox in experimental work and was thoroughly equipped as an electrical engineer when he came to this country in January, 1880. He entered the service of the United States Electric Lighting company at New York and did valuable work in the engineering department of that company. He was prominent in the organization of the Sun Electric company of Boston. In 1887 he moved to Fort Wayne, Ind., where he developed his alternating current system of electric lighting, which was his most notable achievement. At the time of his



death he was connected with the Fort Wayne Electric company, which manufactured his apparatus. During the last few years he devoted considerable attention to the development of the storage battery and made many valuable improvements in that line..."

Linkous said<sup>4</sup>: "A full line of electrical products were marketed by FWELC under the banner of the 'Slattery System.' His greatest achievement was the development of a constant voltage, alternating current, incandescent lamp lighting system." Later his systems were replaced by those developed by James John Wood.

A magazine advertisement from about 1888, as scanned from the Linkous book, is shown below.

**SLATTERY INDUCTION SYSTEM**  
MANUFACTURED AND CONTROLLED BY THE  
**Fort Wayne Jenney Electric Light Company,**  
 FORT WAYNE, INDIANA.  
 The most carefully worked out and complete Alternating System of Electric Lighting in Existence.

We  
 Guarantee  
 this  
 System  
 Throughout

Armature  
 Guaranteed.  
 Converter  
 Guaranteed.  
 12  
 16  
 Candle Power  
 Lamps  
 TO THE  
 Horse Power  
 Guaranteed.

SLATTERY ALTERNATING SYSTEM.

The Slattery Alternating System in operation in most of the  
**LEADING CITIES OF THE COUNTRY, namely:**  
 NEW YORK, BOSTON, LOUISVILLE, PHILADELPHIA, UTICA, NEW ORLEANS.

FULL INFORMATION FURNISHED BY  
**Fort Wayne Jenney Electric Light Company,**  
 Main Office and Works, FORT WAYNE, IND.  
 CHICAGO OFFICE, 115-117 Monroe Street. PHILADELPHIA OFFICE, 20 N. Seventh St.  
 W. J. BUCKLEY, Manager. G. A. WILBUR, Manager.

## References

- 1) Obituary - "Marmaduke M. M. Slattery", *The Electrical Engineer*, Vol XIV, No 242, Dec 21, 1892, pg 607.
- 2) "M. M. M. Slattery," *Western Electrician*, Vol 11, No 26, Dec 24, 1892, pg 323.
- 3) Photograph of M. M. M. Slattery: *Electrical Review*, Vol 22, Feb 25, 1893, pg 19.
- 4) General Electric at Fort Wayne, Indiana □ A 110 year History, Clovis E. Linkous, Gateway Press, Inc., Baltimore, 1994.

**William Stanley, Jr.**



The name of William Stanley, Jr. (1858-1916) is one that rings loud in the history of electrical engineering. He is remembered as one who was responsible for the development of a transformer that increased the distance over which power could be sent over small wires from a half-mile to several hundred miles. He also contributed to the development of an alternating current induction motor. As a result of his early work experiences he also contributed in the lamp and lighting areas. It is in this regard that he is considered here.

Stanley was born in Brooklyn, New York. At the age of 17 he entered the 1881 class at Yale College. However, after attendance for three months he decided that college life was not for him and he left for New York. After spending a year or more in the nickel-plating business he became research assistant to Hiram S. Maxim at the United States Electric Lighting Company; this was about 1880.

When that company purchased the Weston Electric Light Company Stanley became assistant to Edward Weston.

After a few months in the employ with Weston, Stanley decided to pack his bags again and venture off on his own. He worked as engineer and superintendent at the American Electric Light Company from the fall of 1880 to the summer of 1881. By 1882 Stanley was in Boston working for the Swan Electric Light Company. This led to his first electric lamp patent in that year; the patent involved a method of exhausting incandescent lamps. The existence of the Boston firm of Swan was short lived but Stanley had drawn the attention of George Westinghouse. Stanley installed, at the Lawrenceville Works of the Union Switch & Signal Company in Pittsburgh, a company owned by Westinghouse, a factory fully equipped for the production of incandescent lamps.

In 1890 Stanley established the Stanley Laboratory Company and the Stanley Electric Manufacturing Company in Pittsfield, Massachusetts. The latter company was formed with C. C. Chesney and J. F. Kelly for the purpose of manufacturing transformers. The Stanley Electric Manufacturing Company was absorbed by the General Electric Company in 1905.

Returning now to the subject of incandescence, lamps were submitted to the Franklin Institute for comparison testing with competitor lamps in 1885. These lamps, known as Stanley-Thompson, were pictured at the beginning of this website. William Stanley, Jr. and Edward P. Thompson were granted a patent on July 28, 1885 for a lamp with a carbonized silk filament; that patent number is U.S. 323,372. Lamps tested in Philadelphia at that time are shown below.

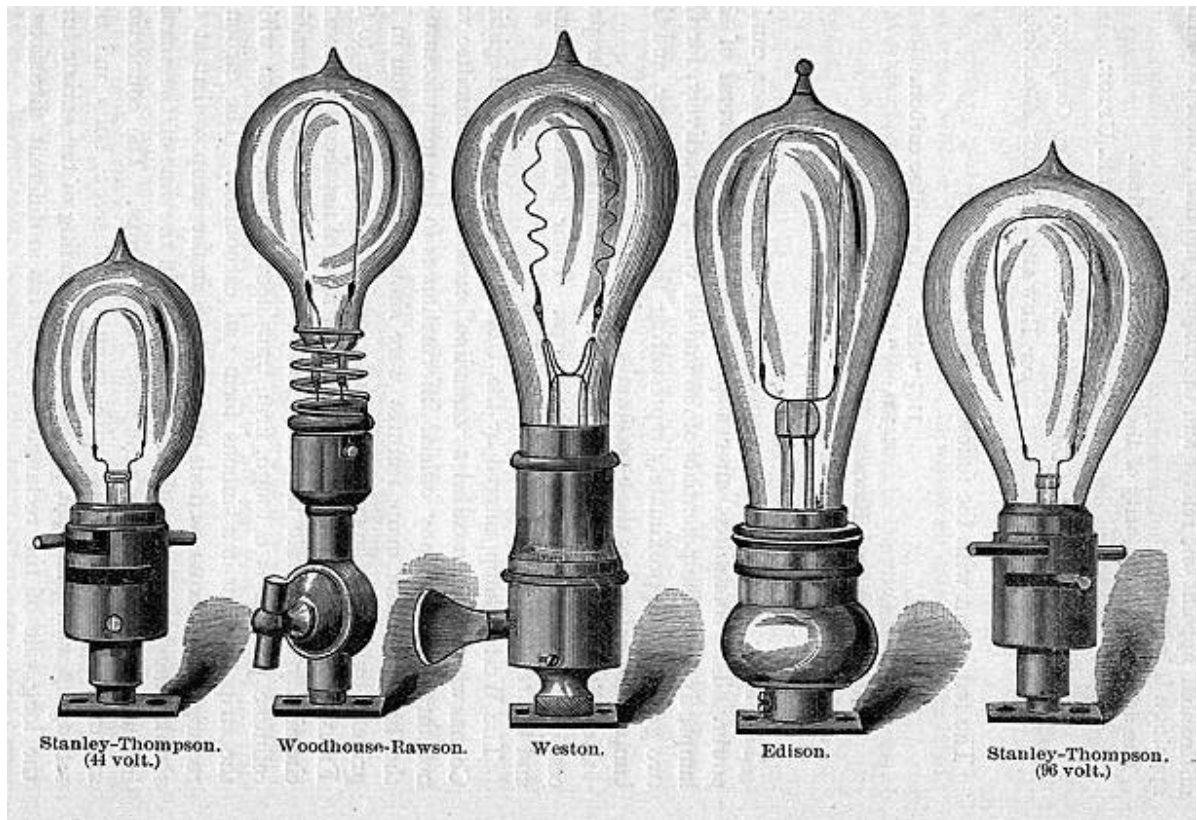

William Stanley was granted 130 patents. Some of those that dealt with aspects of the incandescent lamp are:

Patent	No.	Issue	Date	Description
244,331	□ Jul 12, 1881	□	□	Circuit-closer for incandescent lamps
269,132	□ Dec 12, 1882	□	□	Electric lamp
316,302	□ Apr 21, 1885	□	□	Filament for incandescent electric lamps
322,496	□ Jul 21, 1885	□	□	Multiple incandescent electric lamp
323,372	□ Jul 28, 1885	□	□	Carbon for incandescent lamps
324,894	□ Aug 25, 1885	□	□	Socket for incandescent electric lamp
330,269	□ Nov 10, 1885	□	□	Holder for incandescent electric lamp
333,028	□ Dec 22, 1885	□	□	Globe for incandescent electric lamp
333,564	□ Jan 5, 1886	□	□	System of electric lighting
349,613	□ Sep 21, 1886	□	□	Automatic cut-out for electric-lighting circuits
349,614	□ Sep 21, 1886	□	□	Automatic cut-out for electric-lighting circuit
363,559	□ May 24, 1887	□	□	Incandescent electric lamp



The lamp shown above has a Thomson-Houston base with red fiber insulation. The label states: STANLEY, Manufactured for Pittsfield Electrical Supply Co., Pittsfield, Mass., 16 C.P., 52 Volts.

#### General

#### References

*The Electrical Engineer*, Vol XV, No 249, Feb 8, 1893, pg 151.  
 "William Stanley Dies", *New York Times*, May 15, 1916, pg 9, col 5.  
A Life of George Westinghouse, Henry G. Prout, The American Society of Mechanical Engineers, New York, 1921.  
 "William Stanley" (Nov.22, 1858-May 14, 1916), Dictionary of American Biography, Vol XVII, Charles Scribner's Sons, New York, 1935, pg 514.  
 "William Stanley", The National Cyclopaedia of American Biography, Vol XXIV, James T. White & Co., New York, 1935, pg 394.  
William Stanley (1858-1916) □ His Life and Work, Laurence A. Hawkins, The Newcomen Society in North America, New York, 1951.  
The Electrical Manufacturers (1875-1900) □ A Study in Competition, Entrepreneurship, Technical Change, and Economic Growth, Harold C. Passer, Harvard University Press, Cambridge, 1953.  
The General Electric Story (1876-1986), A Photo History, A Hall of History Publication, Schenectady, New York, 1989. The photograph of William Stanley shown above was scanned from this book.

#### John Wellington Starr

The casual reader of the technical literature that deals with the early history of lighting by electricity will occasionally come across the name of J. W. Starr. Not much is usually mentioned about him except that he obtained an English patent in 1845, in the name of Edward Augustin King, for "lamps" that had either platinum or carbon as resistively heated elements. Historians have concluded that Starr's patent was the first significant step toward the final development of a commercially practical lamp by Thomas Edison in 1879. It seems to this writer, then, that we should try to learn more about this man. (My interest in

Mr. Starr was aroused by several email communications with Mr. Larry Grannis of Orange, CA.)

It appears that the knowledge about Starr that has been mentioned by authors is essentially the same information being repeated. A limited effort to increase this knowledge quickly told this writer that there wasn't much information readily available without some research. Some effort was therefore expended to try to learn more. Perhaps the new information that follows will help a serious biographer.

Articles and books state that: J. W. Starr, was from Cincinnati, Ohio, invented a light source that was powered by electricity, was financed by the philanthropist, George Peabody, traveled to England and was granted English Patent No 10,919 in the year 1845, under the name of King, who was reported to be his attorney. Starr was said to have died in 1847, at age 25, on board ship while returning to the United States. One author (Edwin W. Hammer) believed that Starr died prior to King's application for the English patent.

Although some new information will be added, it is also true that some of the information appears to differ from what was reported above.

A one-day visit was made to The Public Library of Cincinnati and Hamilton County where death notices were sought for a J. W. Starr in the paper indexes that exist for that time (about 1847). A promising entry was found in the index for the *Cincinnati Daily Gazette* and the following obituary (No 6030, Volume XX, pg 2, Dec 29, 1846) was read in hard copy.

"Messrs Editors: - It is with sorrow we are obliged, through respect to the memory of the honored dead, to announce to the public, through the medium of your columns, the decease of John W. Starr, Esq., a young and talented Gentleman, a native of our beloved Cincinnati, and the discoverer of the Electro Magnetic Light. After securing his right to his discovery in the United States, his native land, he visited Europe, secured Patents from the British Government, and also in France, but alas! death has stopped his earthly career, and God hath said unto him, 'come up higher.' - He died in Birmingham, Eng. on 21st November, at his lodgings, at Mrs. Mellons. He is interred in Key Hill Cemetery, near the Cemetery Chapel. He has left an aged father and two sisters to mourn his loss; but their loss is his eternal gain. Requiescat in pace."

A visit to the web site <http://www.groundwork.org.uk/birmingham/jewellery/walk.htm> informs one that the Key Hill Cemetery was Birmingham's first public cemetery. It opened in 1836 and closed for burials in 1982.

A search of the Cincinnati City Directory indicated that no persons with the name Starr were listed for 1819, 1825 or 1829. Two Starr's were listed for 1831, one in 1834, two in 1836, four in 1840, one in 1842, five in 1843 and seven in 1846. The obituary above indicates that John W. Starr was a native of Cincinnati but the City Directory does not seem to indicate that. It's of interest that the listings for 1840 appear to indicate the person's

previous residence. In 1840 three Starr's apparently came from Maryland and one came from Connecticut.

As it regards the philanthropist, George Peabody, a message was sent to Dr. Franklin Parker, author of a biography of Mr. Peabody. He responded that he had no references to the name of Starr. He suggested that I contact the Peabody Essex Museum as they had indexed the Peabody papers. The response from the Museum was that they found no reference to J. W. Starr.

A copy of the King patent, No 10,919 (1845) was obtained. There is no mention of Starr's name in the patent. It does say:"...the Invention of 'Improvements in Obtaining Light by Electricity,' communicated to me by a certain Foreigner residing abroad;..."

Bob Rosenberg of Rutgers University informed me of a web site that led to two articles that deal with Starr. The web site is [http://edison.rutgers.edu/Names search/DocDetImage.php3](http://edison.rutgers.edu/Names%20search/DocDetImage.php3). This site consists of images of notebooks of Francis Robbins Upton, Edison's mathematician. Two references were given by Upton on images 46 and 47 of the second notebook. These will be given in the bibliography below.

A lucky break occurred for the writer while he was browsing through an early edition of the *Electrical World and Engineer*. A letter to the editor appeared in response to the article by Edwin W. Hammer (referenced below). As the contents of the letter bear directly on the present subject matter it is repeated here verbatim:

"To the Editors of *Electrical World and Engineer*:

Sirs:--In common doubtless with others I have read with much interest the narrative of Mr. Edwin W. Hammer concerning "Incandescent Lamp Development to the Year 1880," which recently appeared in your columns.

"He begins, rightly, as I believe, by giving some consideration to the early incandescent lamp work of J. W. Starr, best known by the British Starr-King patent of the year 1845, but seems to have little more information about Starr than can be gleaned or inferred from that patent.

"There is, however, further information at hand, and while some of it may be legendary, there can be no doubt that in a general way Starr's story is told with substantial correctness by articles or communications appearing severally in *Nature*, Sept. 7, 1877, pp 459-460; the *Telegraphic Journal*, London, Jan 1, 1879, pg 15, and the *Scientific American*, Jan 18, 1879, pp. 40-41.

"The *Nature* reference is a communication from Mr. Mathieu Williams, who says that he assisted Starr in his experiments on the light; that the results of the said experiments with batteries were such as to convince Mr. Starr that a magneto-electric arrangement should be used as the source of power in

electric illumination, and further that Starr died suddenly in Birmingham in 1846, while constructing a magneto machine.

"The *Telegraphic Journal* and *Scientific American* articles are more full in their details, especially the latter, and refer to a caveat filed by Starr for his light in the United States, reciting the claim thereof; speaking also of capitalists, including George Peabody, who were ready to assist him; of a kind of electric candelabrum whereon electric lamps were to be mounted of number corresponding to the States of the American Union, as they were at that time, saying that the system was exhibited to Faraday, who pronounced it a perfect success, and that Starr died suddenly during the night following the exhibition, the supposed cause of his death being "excitement and overwork of the brain."

Thomas Lockwood, Boston, Mass."

The contents of the article that appeared in the Jan 18, 1879 issue of the *Scientific American* magazine follows:

#### Early History of the Electric Light

"A telegram from Washington, to the effect that Edison's application for a patent upon a divisible electric light had been rejected at the Patent Office, was published in the daily papers of November 21. The ground alleged for the refusal of the patent, says the Operator, was that Edison's invention was an infringement upon that of John W. Starr, of Cincinnati, who filed a caveat for a divisible light in 1845. [Edison's patent has since been allowed.]

"Starr was a maker of philosophical instruments, and resided at Cincinnati. Had he lived he might have proved as much of a genius as Edison. He experimented on his invention, and went to England to complete it, Mr. King going as his agent, and two gentlemen, Judge J. W. McCorkle, late member of Congress from California, and Mr. P.P. Love, of Dayton, Ohio, furnished the money, about \$3,000. Each was to have a fourth interest in the invention. Letters of introduction were given to King and Starr to the American banker in London, George Peabody, who, when the subject was fully explained to him, agreed to furnish all the capital that would be required to promote the project to a successful and practical use, provided that the same was approved and sanctioned by the best and most celebrated electricians in Europe. Professor Faraday was chosen.

"In the meantime Starr and King returned to Manchester, where Starr built what he termed a tree, called "The United States." He had on it twenty-six branches or limbs, which he called by the names of the then twenty-six States of the Union. At the end of each limb he had an electric light, covered by a glass globe, on each of which was painted or inscribed the name of each State. Having thus completed his invention, he and King took it to London

and exhibited it to the electricians at the Electrical Society, Professor Faraday being present. So perfect was his invention that the Professor pronounced it a perfect success.

"After the exhibition was over King and Starr went home perfectly elated with the success, and after partaking of a very frugal meal they retired to bed. The next morning Starr, not making his appearance at the morning meal, was allowed to remain in bed, but as the day advanced and he did not make his appearance, King and the landlord went to his room, and not being able to awaken him, they burst open the door, and there found poor Starr dead in his bed. The excitement and overwork of the brain are supposed to have caused his death. From that day to this nothing further has been done with the Starr invention.

"Starr filed a caveat in this country in 1845. His claim may be interesting enough to quote here:

'I claim the application of continuous metallic and carbon conductors intensely heated by the passage of a current of electricity to the purpose of illumination. I do not claim the method of lighting wires by electricity, which is well known, as I have already stated, but I claim the method of heating conductors so as to apply them to illumination, the current being regulated so as to obtain the highest degree of heat without fusing the conductor. I claim the method of obtaining an intermittent light for the use of lighthouse, in the manner set forth, and for signals. I claim the mode of submarine lighting by enclosing the apparatus in a suitable glass vessel, hermetically sealed, and also the mode of lighting places containing combustible or explosive compounds or materials, as set forth.'

"His application for a patent was rejected, however, in 1846, on the ground that the invention was not new, and that there was too much expense in producing the electric light. Mr. Edison says his invention is different from Starr's. He says he cannot patent the divisibility of the electric light, but he can patent the means that allows it. In other words, he can patent a lamp, or any device that will make this division. His application for a patent for a lamp is already before the Commissioner, and is taking its regular course. According to the rules of the Patent Office nothing concerning it can be divulged. It is understood, however, that it is progressing favorably. Mr. Edison has already received seven patents bearing on the electric light, and has filed three caveats. Five more similar applications are now under way. He has had a man in the Astor Library searching the French and English patent records and scientific journals, from the earliest dates down to the past fortnight, and says nothing like his arrangements has been revealed.

"Mr. Edison is making elaborate preparations to introduce and experiment with the electric light. He proposes to commence at Menlo Park with 2,000 lights, using telegraph poles with 15 lights on each arm. This experiment,



including the cost of the buildings, engine, generating machines and everything, is estimated at from \$100,000 to \$125,000."

The Edison Electric Light Company was formed in 1878 by Thomas Edison and twelve other individuals. \$50,000 was put at Mr. Edison's disposal immediately. A year later the money had been spent without success. A meeting of the incorporators was held and one of them, Robert L. Cutting, Jr., 'pointed out that Mr. Edison seemed to have come to the same place as J. W. Starr, who had experimented earlier with various kinds of incandescent lamps and had published his researches as a scientific contribution, to show that such a lamp was not practicable.' (*New York Times*, Oct 19, 1931, pg 23, "Light Bulb Balked Edison for Months").

"I have read Mr. Starr's book," said Mr. Cutting, "and it seems to me that it would have been better to spend a few dollars for a copy of it and to begin where he left off, rather than to spend \$50,000 coming independently to the same stopping point."

"No," said Edison, "I don't think the incandescent light will ever be found that way. It's not a matter of beginning where Starr left off, because I believe the incandescent light lies somewhere between his beginning and his stopping point -- that he passed over it. So have I. That is why I want to go back after it again."

William Mattieu Williams wrote at least two letters to the editor regarding Starr. One appeared in *Mechanics' Magazine*, Vol 44, 1846, pg 348. A second appeared in *Nature*, Vol 16, Sep 27, 1877, pp 459-460. This second letter will be printed here verbatim:

"Under the above title Mr. Munro describes, in *Nature*, vol. xvi, p. 422, M. Lodighin's device for an electric light. This is no novelty but a simple repetition of an invention made by Mr. Starr, a young American, and patented in this country under the title of 'King's Patent Electric Light,' specification enrolled March 25, 1846. An account of it, with drawings, may be found in the *Mechanics' Magazine*, April 25, 1846, p.312. To this are appended some editorial remarks in which the novelty of the invention was at that date disputed. Those who care to follow the subject further may find a letter of mine replying to this editorial criticism in the *Mechanics' Magazine* of May 9, 1846, p. 348.

"I constructed a large battery and otherwise assisted Mr. Starr in his experiments on this light. The "wick," as Mr. Munro aptly calls it, was a stick of gas retort carbon, like that pictured (*Nature*, p. 423), excepting that it was affixed to supports of porcelain in order to remedy the fracture which occurred to our first apparatus in which the carbon stick was rigidly held in metallic forceps. Thus the improvement of M. Kosloff was also anticipated.

"The lamp-glass was a thick barometer tube about thirty-six inches long, with its upper end blown out to form a large bulb or expanded chamber. The

carbon and its connections were mounted in this with a platinum wire passing through and sealed into the upper closed and expanded end of the tube.

"The whole of the tube was then filled with mercury and inverted in a reservoir, and thus the carbon stick, &c., were left in a Torricellian vacuum. The current was passed by connecting the electrodes of the battery with the mercury (into which a wire from the lower end of the carbon dipped) and with the upper platinum wire respectively. A beautiful steady light was produced accompanied with a very curious result which at the time we could not explain, viz., a fall of the mercury to about half its barometrical height and the formation within the tube of an atmosphere containing carbonic acid.

"I have now little doubt that this was due to the combustion of some of the carbon by means of the oxygen occluded within itself.

"In pointing out this anticipation of M. Lodighin's invention I do not assume or suppose that any piracy has been perpetrated. It is one of those repetitions of the same idea which are of such common occurrence and which cost the re-inventor and his friends a vast amount of trouble and expense that might be saved if they knew what had been done before.

"I may add that the result of our battery experiments was to convince Mr. Starr that a magneto-electric arrangement should be used as the source of power in electric illumination; and that he died suddenly in Birmingham in 1846, while constructing a magnetic battery with a new armature which, theoretically, appeared a great improvement on those used at that date. Of its practical merits I am unable to speak.

Twickenham, September 18 W. Mattieu Williams"

**References in which J. W. Starr is mentioned:**

- 1) List of New Patents, *Mechanics' Magazine*, Vol 43, 1845, pg xiii.
- 2) List of New Patents, *Mechanics' Magazine*, Vol 43, 1845, pg 382.
- 3) "King's Patent Electric Light," *Mechanics' Magazine*, Vol 44, 1846, pp 312-316 (from Upton).
- 4) " King's Patent Electrical Light," Letter to the Editor from William Williams, *Mechanics' Magazine*, Vol 44, 1846, pp 348-349 (from Upton).
- 5) "Incandescent Lamp Development to the Year 1880--I.", Edwin W. Hammer, *Electrical World and Engineer*, Vol XXXVI, No 22, Dec1, 1900, pg 839.

- 6) "Incandescent Lamp Development" (Letter to the Editors), Thomas D. Lockwood, *Electrical World and Engineer*, Vol 37, No 2, 1901, pg 96.
- 7) Electricity in Every-Day Life, Edwin J. Houston, Volume 2, P.F. Collier & Son, New York, 1905.
- 8) "Electric Lighting by Incandescence," William J. Hammer, *Quarter century Number of the Electrical Review*, New York, Mar 9, 1907.
- 10) "The William J. Hammer Historical Collection of Incandescent Electric Lamps," William J. Hammer, *Transactions of the New York Electrical Society*, New Series, No 4, 1913, pg 15.
- 11) History of Electric Light, Henry Schroeder, Smithsonian Miscellaneous Collections, Volume 76, Number 2, 1923.
- 12) Sir Joseph Wilson Swan F.R.S. - A Memoir, M.E.S. and K.R.S., Ernest Benn Limited, London, 1929.
- 13) "Brief Personal Recollections in Connection with the Jubilee of the Invention of the Carbon Incandescent Electric Lamp by Sir Joseph Wilson Swan in 1878," J. A. Fleming, *Journal of the Institution of Electrical Engineers*, Vol 67, 1929, pg 293.
- 14) "Light Bulb Balked Edison for Months", *The New York Times*, Oct 19, 1931, pg 23.
- 15) Menlo Park Reminiscences, Vol 2, Francis Jehl, The Edison Institute, 1938.
- 16) The Electric-Lamp Industry: Technological Change and Economic Development from 1800 to 1947, Arthur A. Bright, Jr., The Macmillan Co., New York, 1949.
- 17) "Electric Lighting in the First Century of Engineering," R. L. Oetting, *Transactions of the American Institute of Electrical Engineers*, Nov 1952.
- 18) Edison, Matthew Josephson, McGraw-Hill Book Co., Inc., New York, 1959.
- 19) Sir Joseph Wilson Swan F.R.S. - Inventor and Scientist, Mary E. Swan and Kenneth R. Swan, Oriel Press, Newcastle-upon-Tyne, England, 1968.
- 20) A Streak of Luck, Robert Conot, Seaview Books, New York, 1979.

21) Swan's Way: Inventive Style and the Emergence of the Incandescent Lamp, G. Wise, Report No 81CRD192, Aug 1981, General Electric Co., Corporate Research and Development.

22) Edison's Electric Light: Biography of an Invention, Robert Friedel and Paul Israel with Bernard S. Finn, Rutgers University Press, New Brunswick, NJ, 1986.

23) General Electric at Fort Wayne, Indiana - A 110 Year History, Clovis E. Linkous, Gateway Press Inc., Baltimore, 1994.

24) Lengthening the Day - A History of Lighting Technology, Brian Bowers, Oxford University Press, 1998.

---

In the article above, the early inventor, J. W. Starr, was given brief consideration. Little information on Starr appears to be available in the articles and books that deal with incandescent lamps. A few days after this topic was added to my old website the writer was rummaging through some boxes that contained papers that dealt with incandescent lamps. These had been collected over the last 44 years or so. I ran across copies of some articles that had been forgotten about for some 38 years. The articles had, as their subject, J. W. Starr.

In the early 1960s a few lamp collectors decided to start up a "bulletin" in which one could write on any subject dealing with incandescent lamps. Dr. Hugh F. Hicks, of Baltimore, was instrumental in starting the bulletin and it was Dr. Hicks' sister who created the beautiful cover that adorned each report. One of the contributors was Dr. Charles D. Wrege, of Rutgers University. Along with his report on "James Billings Fuller: An Incandescent Lamp Mystery," he sent along an article that was published in the Harvard Medical Alumni Bulletin on another experimenter of the incandescent lamp, Dr. Isaac Adams, Jr. The article was entitled: "Rx for a Light: The Story of Dr. Isaac Adams, Jr." Accompanying the Adams article were two that dealt with J. W. Starr. Both were entitled: "The Mystery of Grave P-403." The older of the two articles was published as a newspaper item in the *Birmingham (England) Post* on Oct 18, 1962. The other article was a somewhat abbreviated version of it and it appeared in the publication *American Cemetery* in Apr 1963.

An attempt to locate Dr. Wrege was made and fortune was with me as he now resides in coastal New Jersey as a semi-retired gentleman. A pleasant telephone conversation was had with Dr. Wrege and he informed me that the *Birmingham Post* article had been expanded and a more complete accounting of Starr had been published. That article, "J. W. Starr: Cincinnati's Forgotten Genius," appears in *The Cincinnati Historical Society*

*Bulletin*, Vol 34, Summer 1976, No 2, pp 102-120. The article is the result of painstaking efforts and is a scholarly work of the first order.

The student of early lamp experimenters is urged to read this work. Although everything that is desirable to know could not be ascertained, the degree of penetration into the mystery of J. W. Starr is remarkable. Some minor information of peripheral interest has been uncovered recently and perhaps it will be added at a later date.

### **Royal F. Strickland**



Royal F. Strickland (Aug 17, 1883 - Sep 13, 1947) was an inventor who spent his entire working career with the National Electric Lamp Association and General Electric. He worked primarily in lamp development and at least ten patents were granted to him.

Royal Strickland was a native of North Eaton, Ohio and graduated in 1908 from Case School of Applied Science in Cleveland. He was the son of George F. and Rilla (Marcy) Strickland. On Oct 1, 1908 he entered the Engineering Department of National. In 1909 he transferred to the Lamp Testing Department of the Lamp Development Laboratory, and in 1910 became an engineer in the Wire Laboratory. In 1913 he returned to the Lamp Development Laboratory at Nela Park.

Two of Strickland's patents were for an enclosed arc device, the S-1 Sunlamp. It was a new lamp type that proved to be quite popular, being a combination of tungsten filament and mercury arc. The radiation from the lamp was rich in actinic and ultra-violet rays. Strickland had thought it possible as early as 1925 to develop an "instantly" starting lamp. However, at that time there was no glass available that would allow ultraviolet rays to be transmitted. By 1929 a glass was developed and patents for the lamp were applied for. These were: No. 2,047,042, issued Jul 7, 1936, and No. 2,104,680, issued Jan 4, 1938. The first pages of these two patents are shown below.

July 7, 1936.

R. F. STRICKLAND  
ENCLOSED ARC DEVICE  
Filed Nov. 18, 1929

2,047,042

Fig. 1

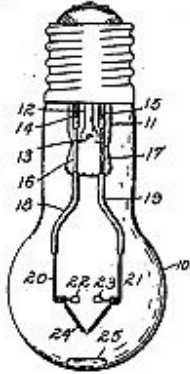

Fig. 2

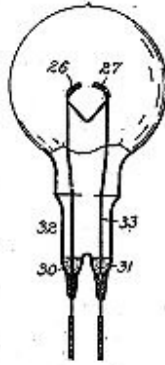

Fig. 4

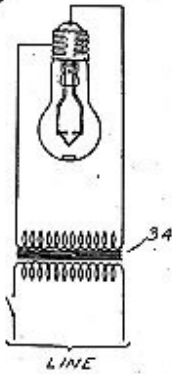

Fig. 3



INVENTOR:  
ROYAL F. STRICKLAND,  
Charles H. Tuller  
His ATTORNEY.

Jan. 4, 1938.

R. F. STRICKLAND  
ENCLOSED ARC DEVICES  
Filed Feb. 25, 1931

2,104,680

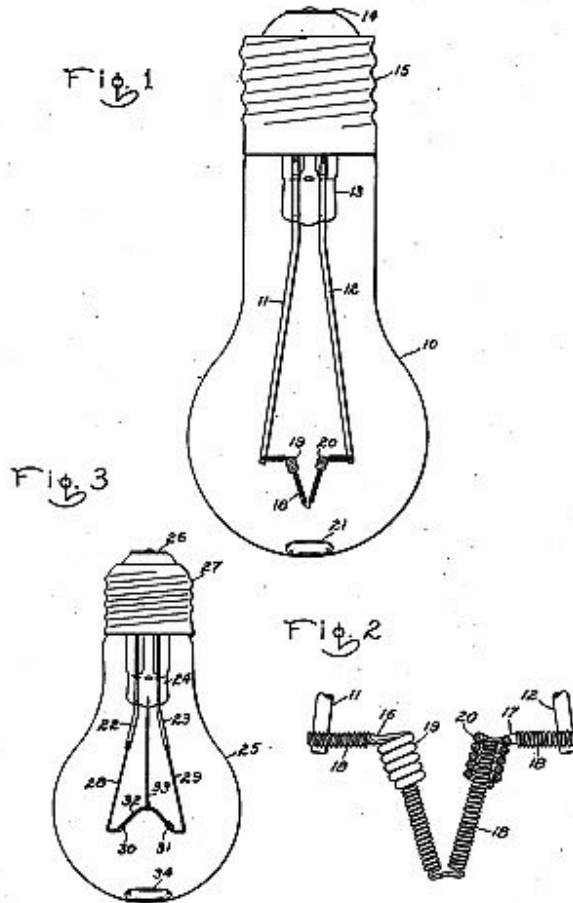

INVENTOR:  
ROYAL F. STRICKLAND,  
BY *Chas. W. Ulla*  
HIS ATTORNEY.

Royal Strickland married Frances M. Thomson, a native of England, on Sep 22, 1909; they had three children: Dean, Robert and Gertrude. Strickland passed away in 1947 and was laid to rest in Knollwood Cemetery, Mayfield Heights, Ohio.

### Alfred Swan

Alfred Swan was the youngest brother of Sir Joseph Wilson Swan, of early electric incandescent lamp fame. Joseph Swan (1828 - 1914) was born in Sunderland, County Durham, England, near the North Sea. He was one of eight children of John and Isabella Swan. The male children, in order of decreasing age, were: John Cameron, Joseph Wilson, George Henry and Alfred; the female children, also listed in order of decreasing age, were: Elizabeth, Isabella, Mary Jane and Emma. What little factual information the writer has

about the personal life of Alfred Swan is contained in a small book written by two daughters of John Cameron Swan<sup>9</sup>, the oldest son of John and Isabella Swan, as well as a book written about Joseph Wilson Swan by his daughter, Mary, and son, Kenneth<sup>12</sup>. From those books one can conclude that Alfred Swan was also born in Sunderland. Quoting directly from the first book<sup>9</sup>:

"Alfred, born November 25th, 1835, was the youngest of the four sons born to John and Isabella Swan, and was about ten or eleven years old when the family removed from Sunderland to Newcastle, the elder brothers, John and Joseph, having already been there about two years. Their eldest sister, Elizabeth, was chiefly responsible for the early education of the younger members of the family, but this was later supplemented by private tuition from a tutor named Martin, a Scotsman, with a very short temper, which Uncle confesses they often sorely tried by many boyish pranks.

"After the family came to Newcastle Uncle Alfred was sent as a pupil to Mr. Pyburn's Academy, the same Mr. Pyburn whose singing class father, and later, he attended. At the age of thirteen it was necessary for uncle to choose a profession. He thereupon elected to study as an architect, and for that purpose was placed in the office of a Mr. Matthew Thompson to whom he was introduced and recommended by father as a boy who would be found 'attentive and painstaking.' The principal of the firm's reply that 'that was all that was needed ' impressed uncle as being a very rash, though very polite, statement to make. For some years uncle devoted himself to this profession, but later, in 1880, when the 'Swan' lamp took commercial form, he was given an opportunity to interest himself in its manufacture, and from that time the lamp business became his chief interest and occupation.

"True to the traditions of the family for patient research, Uncle Alfred set himself to work in the direction of perfecting the holders and caps for the electric lamps. With this object in view he worked more or less continuously from the year 1882 at an invention for perfecting the insulating material, in which the terminals at the base of the incandescent electric lamp are held. Previously, a process of cold moulding by a plastic, such as plaster of Paris, had generally been employed, but it was found that by using a black glassy substance, reduced to a molten state and moulded into a cap-like shape, a perfect insulating material could be formed. Later, this device was further improved by substituting a brass collar and having the tops of the caps only, insulated with the 'Vitrite,' the name given to this material by uncle.

"In 1902, uncle patented an automatic process by which the 'Vitrite' cap could be produced cheaply and quickly on a large scale. The result was that this form of cap was generally adopted and is now practically in universal use.

"In 1885, uncle and his family removed to New Jersey, U.S.A., where he became associated with the General Electric Company, to whom he disposed



of his American Patent. In a letter of recent date in response to an enquiry upon this subject uncle remarks that any improvement he may have made he felt he owed to his brother Joseph, as his work was founded on that of his brother's, and any success was so much added to his brother's name and honour."

The known birth and death dates of members of the Swan family follow<sup>9</sup>:

John	(father)	(b.	Mar	27,	1795;	d.	Feb	7,	1878)
Isabella	(mother)	(b.	May	13,	1801;	d.	Dec	22,	1884)
Elizabeth		(b.	Nov	22,	1822;	d.	Aug	2,	1905)
John	Cameron	(b.	Feb	13,	1827;	d.	Jan		1916)
Joseph	Wilson	(b.	Oct	31,	1828;	d.	May	27,	1914)
Isabella		(b.	Apr	20,	1830;	d.	Jun	26,	1913)
George	Henry	(b.	Dec	3,	1833;	d.	Jul	24,	1913)
Alfred		(b.	Nov	25,	1835;	d.	Apr	11,	1923)
Mary									Jane
Emma									

Apparently the two brothers, John Cameron and Joseph Wilson, were inseparable companions in their youth. In a letter from Alfred to family members, after the death of the two brothers, he wrote<sup>9</sup>:

"The great affection the two brothers held for one another was certainly a very real and lovely thing. While each had their own individual tastes and interests their lives always seemed as one...

"I myself came much under the direct tutelage and influence of John. It was on him, in my boyhood days I would especially lean and it was to him in later years I would go for that advice and counsel that would determine my future course."

Alfred Swan's whereabouts and activities can be chronicled approximately by considering his U.S. patents. His first patent was issued in 1883 and the addresses given on his first seven were in England. Swan's address on his 8th through the 14th was in New York. His 8th patent was issued in Oct 1890. At that time he lived in Orange, NJ and the assignor was the Insulite Manufacturing Company. Alfred's 15th patent was issued in Nov 1893 and the assignor was the General Electric Company. In total he was issued 28 U.S. patents. His last patent was granted in Nov 1920. At that time his address was in Montclair, NJ.

Alfred Swan was granted a patent in England as early as the year 1880 (No. 2,898)<sup>1</sup>. In addition, to his many English patents he was granted patents in other countries, including France, Belgium, Italy and Austria. The information below, regarding his U.S. patents, is given in the following order: Patent No. □ Date □ Subject □ Address/Assignor.

- 1) 275,730 □ Apr 10, 1883 □ Moulding Bulbs □ Gateshead, County of Durham
- 2) 276,924 □ May 1, 1883 □ Glass Bulb; bulb made in mould □ Gateshead
- 3) 276,982 □ May 1, 1883 □ Roll to Flatten Leads □ Gateshead
- 4) 292,447 □ Jan 22, 1884 □ Holder □ Gateshead, County of Durham
- 5) 313,965 □ Mar 17, 1885 □ Holder □ Low Fell Works, Gateshead/Tyne
- 6) 339,822 □ Apr 13, 1886 □ Vitreous □ Lowfell, Gateshead-On-Tyne
- 7) 362,469 □ May 3, 1887 □ Switch □ Newcastle-Upon-Tyne; Vitrite and Luminoid
- 8) 439,363 □ Oct 28, 1890 □ Lamp □ Orange, NJ; Insulite Mfg. Co. of NY
- 9) 439,364 □ Oct 28, 1890 □ Socket □ as above
- 10) 439,365 □ Oct 28, 1890 □ Socket □ as above
- 11) 439,366 □ Oct 28, 1890 □ Socket □ as above
- 12) 439,367 □ Oct 28, 1890 □ Socket □ as above
- 13) 461,456 □ Oct 20, 1891 □ Switch □ as above
- 14) 463,396 □ Nov 17, 1891 □ Switch □ as above
- 15) 508,644 □ Nov 14, 189 □ Block □ Schenectady, NY; GE of Boston
- 16) 516,844 □ Mar 20, 1894 □ Socket □ as above
- 17) 570,517 □ Nov 3, 1896 □ Lamp & Socket □ NY, NY
- 18) 573,929 □ Dec 29, 1896 □ Fitting □ NY, NY
- 19) 583,204 □ May 25, 1897 □ Lamp □ NY, NY; GE-New York
- 20) 684,880 □ Oct 22, 1901 □ Base □ NY, NY; GE-New York
- 21) 774,404 □ Nov 8, 1904 □ Base □ NY, NY; GE-New York
- 22) 775,689 □ Nov 22, 1904 □ Base □ NY, NY; GE-New York
- 23) 828,582 □ Aug 14, 1906 □ Adapter □ NY, NY; GE-New York
- 24) 905,478 □ Dec 1, 1908 □ Lamp □ NY, NY; GE-New York
- 25) 996,374 □ Jun 27, 1911 □ Soldering Machine □ Upper Montclair, NJ; GE
- 26) 1,011,523 □ Dec 12, 1911 □ Lamp Machine □ as above
- 27) 1,306,643 □ Jun 10, 1919 □ Apparatus □ Montclair, NJ; GE
- 28) 1,360,152 □ Nov 23, 1920 □ Method to Base □ Montclair, NJ; GE

Shown below is the first page of U.S. Patent No. 774,404, the date of which can be found stamped on the brass base of lamps manufactured and controlled by the General Electric Company at the beginning of the 20th century.

No. 774,404.

PATENTED NOV. 8, 1904.

A. SWAN.  
BASE FOR INCANDESCENT LAMPS.  
APPLICATION FILED APR. 1, 1901.

NO MODEL.

2 SHEETS—SHEET 1.

Fig. 1.

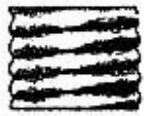

Fig. 3.



Fig. 2.



Fig. 4.



Fig. 5.



Fig. 7.



Fig. 6.



Fig. 8.



Witnesses:

*Levin P. Abell.*  
*Benjamin B. Hull.*

Inventor:

Alfred Swan,  
by *Alfred S. Davis*  
Atty

During the 1890s the number of incandescent lamp base designs had proliferated to at least 14. Of course, this also meant that just as many socket designs existed. Interchangeability was therefore limited by the use of adapters. In 1895 an editorial in *The Electrical Engineer* reiterating the need for standardization resulted in a number of letters to the editor. Alfred Swan responded to this call and suggested that views be expressed and discussed. Several people and organizations had preferences but often the reasons behind the choices were lacking. In one of the "Letters to the Editor" that Swan wrote<sup>4</sup> his preference and reasons were expressed:

"Your movement in this direction has evidently struck the keynote of a real grievance.

"The grievance being manifest—what is the remedy? That is now the question.

"The letters you have so far received each indicate a preference for one or other of the present types of socket—one writer preferring this type, the other that—but none give *reasons* for their preference. Would it not be well, therefore, at this stage to have an interchange of views as to what each writer considers are the points of recommendation peculiar to the type he prefers—thus the question will be, how may those good points be embodied in one and the same socket?

"In my former communication I said of the Thomson-Houston base that it favored a 'simpler, safer and less expensive' form of socket. I now desire to substantiate that statement by reasons.

"It is *simpler* because of its fewer parts and because no insulation is needed to guard against a short circuit through the metal forming its outer case.

"It is safer, *electrically*, because, in handling, there is little or no risk of an accidental contact between an electrode and the case of the socket (both electrodes being internally situated within the circumference of the porcelain block to which they are affixed) while, in regard to the other types, it is this liability to accidental contact which makes them faulty in this respect.

"It is safer, *mechanically*, than the screw-shell of the Edison type because the latter, having a very coarsely pitched thread, is liable to work loose by vibration, whereas the contact nipple in the center of the Thomson-Houston socket is finely *threaded* and therefore much safer in this respect.

"It is *less expensive*, because of its fewer and simpler parts and also, by reason of the arrangement of its electrodes, it admits of reduced proportions in every respect.

"It is objected that this form of socket involves a more expensive *base*.

"But this question, I apprehend, is not to be determined by types *as at present embodied in practical manufacture* but rather by the *possibilities inherent in each case*—and, viewed from this standpoint, there does not appear to be, and really *is* not, any valid reason why a base adapted to a Thomson-Houston type of socket *should* cost as much as it now does, or, indeed, any more than for the other types."

History has shown that the Thomson-Houston socket was not the one standardized; the Edison screw-type is used in the United States for the larger lamp types. This writer believes that Swan made some valid points regarding the Thomson-Houston base and socket—certainly the one about the lesser danger of shock being of great importance.

In 1920 Alfred Swan was the guest of honor, on occasion of his eighty-fifth birthday, at a banquet given by his friends and associates connected with the Edison Lamp Works of the General Electric Company, Harrison, NJ<sup>10</sup>.

Alfred Swan was the developer of the bayonet base, or what was earlier called the Ediswan base, as well as the black glass insulation used today in lamp bases. His great skill appears to have been in the area of product design coupled with his deep understanding of manufacturing capability. He was a valuable contributor to the development of the incandescent lamp, but appears to have stood in the shadow of his older brother, Joseph.

Swan married Emma Ellis in England; she passed away in 1880<sup>9</sup>. They had three sons, Hilton, Ellis and Lyle as well as two daughters, Evelyn and Marion<sup>11</sup>. At the time of Alfred's death all five children were living in Upper Montclair, New Jersey. Alfred Swan resided at 3 Seneca Avenue, Upper Montclair, New Jersey. He was interred in Rosedale Cemetery<sup>11</sup>.

## General

## References

- 1) Electric Illumination, Vol II, James Dredge, Dr. M.F. O'Reilly, H. Vivarez, London, 1885.
- 2) "Standardizing Lamp Sockets", *The Electrical Engineer*, Vol XX, No 386, Sep 25, 1895, pg 304.
- 3) "The Movement for Standardizing Lamp Sockets", *The Electrical Engineer*", Vol XX, No 388, Oct 9, 1895, pg 347.
- 4) "The Necessity for Standardizing Lamp Sockets", Alfred Swan, *The Electrical Engineer*, Vol XX, No 391, Oct 30, 1895, pg 425.
- 5) "The 'Standard' Socket Question", Alfred Swan, *The Electrical Engineer*, Vol XX, No 393, Nov 13, 1895, pg 478.
- 6) "The Desirability of a Standard Socket", Alfred Swan, *Electrical Review*, Vol 28, No 21, May 20, 1896, pg 263.
- 7) "The Standardization of Lamp Sockets", Alfred Swan, *The Electrical Engineer*, Vol XXI, No 421, May 27, 1896, pg 559.
- 8) "Standardizing Incandescent Lamp Sockets", Alfred Swan, *The Electrical Engineer*, Vol XXI, No 421, May 27, 1896, pg 563.
- 9) John Cameron Swan: His Family and Friends, 1827-1916, Emily and Mary Swan, Headley Bros., Ashford, Kent, ca 1918.

- 10) *Electrical World*, Vol 77, No 3, Jan 15, 1921, pg 173.
- 11) "Obsequies for Alfred Swan", *Newark Evening News*, Apr 14, 1923, pg 5, col 4.
- 12) Sir Joseph Wilson Swan F.R.S.: A Memoir, M.E.S. and K.R.S., Ernest Benn Limited, London, Bouverie House, 1929.
- 13) Sir Joseph Swan and the Invention of the Incandescent Electric Lamp, Kenneth R. Swan, Longsman, Green and Co., London, 1948.
- 14) In The Days of My Youth: Some Random Reminiscences of My Early Years, Sir Kenneth R. Swan, Oxford University Press, 1964.
- 15) Sir Joseph Wilson Swan F.R.S.: Inventor and Scientist, Mary E. Swan and Kenneth R. Swan, Oriel Press, 1968.

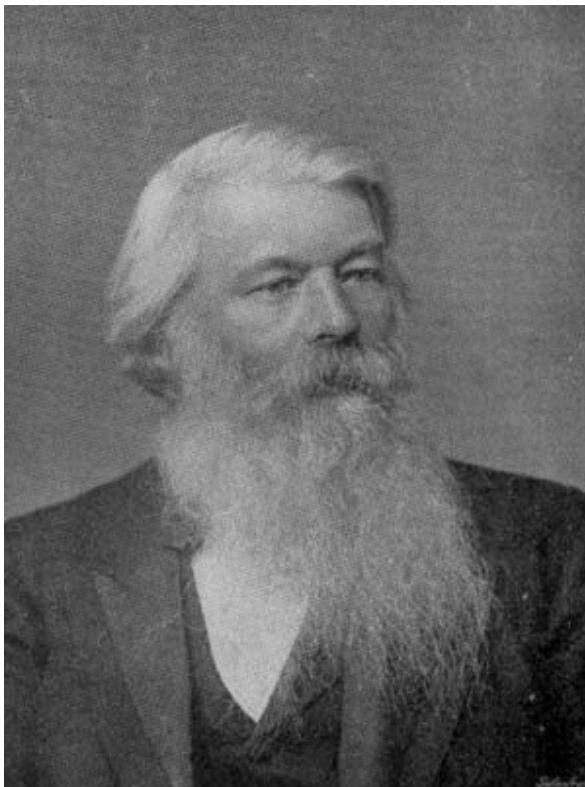

*Joseph W. Swan*

### Sir Joseph Wilson Swan

Research into the history of the electric incandescent lamp would be incomplete without the unearthing of writings regarding the persons involved in the development. In the United States much has been written about Thomas Alva Edison, and rightly so, but other inventors throughout the world also contributed significantly to the knowledge base that allowed this invention to light up the world. One such person was Joseph Wilson Swan. The following short write-up is credited to two of Swan's nieces and is presented here verbatim.

About 1918 two nieces of Sir Joseph Wilson Swan (1828-1914) wrote a biography of their father, John Cameron Swan (1827-1916), older brother of Joseph. A short chapter from that book gives their story about their world-famous uncle. The scanned picture of Swan shown to the left faced page 40 in their book. Of their uncle, Emily and Mary Swan said:

"Of the leading men of the nineteenth century (which may justly be called the 'Golden Age' of Science), Joseph Wilson Swan's name will ever remain a household word, not only in the world of science, but throughout all civilized nations where every city and home enjoy the benefits of his great researches and inventions.

"His energies and investigations were not confined solely to the development of electricity, which his name is most prominently associated, but the world of art is laid out under an immeasurable debt of gratitude for his discoveries in photography. It was out of his patient investigations and ideas of thirty years, that the invention of the 'Carbon

Process' grew, and later, led to the discovery of the rapid 'Dry Plate,' which method revolutionised the whole art of photography.

"It was with Uncle Mawson in the Mosley Street establishment, where he had many opportunities for work in chemistry, that Uncle Joseph began the manufacture of collodion, for which the firm became so noted, and which led him to make so many important discoveries in the art of photography, notably the 'Carbon Process,' which he patented in 1864. This was the first practicable process for making a permanent print, and it was followed later by the discovery of the rapid 'Dry Plate.'

"Out of these inventions many others were evolved which have added lustre to his name, among others being the process of 'Photogravure,' by which method the most beautiful engravings are reproduced.

"Added to these were the many improvements in electro-type and other processes, one of which is known by the name of 'Swan-type.' He also invented and patented 'Bromide Paper' for printing from negatives, and one may say there is scarcely a branch of photography that is not indebted to him for its origin or improvement. By his typographic half-tone blocks he revolutionised the art of book illustration.

"In 1885 the late Queen ordered a photogravure of two of her favourite dogs, and was so pleased with the result that she ordered another plate and authorised the printers to put on the engravings 'by special permission of her Majesty.'

"His investigations in electro-chemistry led to the construction of a motor electric meter, an electric fire-damp detector, a miners' electric safety lamp and the production of gold leaf by electrodeposition.

"Miss Annie Ridley in her book 'A Backward Glance,' which is the story of her father's life, gives an extract from a letter of Mr. John Ridley, written from Newcastle-upon-Tyne, in 1867, in which he says:-

'I have been seeing Joseph Swan's carbon process, and I never was more interested in my life! It is enough for a lifetime, or even for a generation of men, to produce such results with so many difficulties overcome. It takes my breath away, as one of the wonderful things of the world.'

"In another passage where she describes her father's success in the construction of an electrical machine, she tells how this machine may be said to have given Uncle Joseph his first introduction to electricity, for he was only seven years old when he stood on an insulated stool charged from the battery constructed by Mr. Ridley.

"It was in 1845 that Uncle Joseph attended a lecture given by Mr. James E. Staite, of Sunderland, who illustrated his lecture by shewing the incandescence by electricity of a piece of platino-iridium wire, supplying the current by means of a large battery of voltaic cells. From this lecture Uncle Joseph conceived the idea that if he could find a sufficiently resisting material for the filament, and enclose it in a vacuous globe, he would be able to produce a durable incandescent lamp. He continued his experiments and achieved a partial success, for in 1860 he was able to show to some of his friends a lamp with an arch of carbonized cardboard enclosed in a globe from which the air had been exhausted, but though it emitted a light the carbon strip bent, and finally broke. Between 1870 and 1880 he overcame the difficulties of his earlier efforts.

"These experiments were facilitated by the invention of the Sprengel airpump, followed later by inventions of other men of Science, Sir W. Crookes and Mr. Stearn, and still further was he assisted by the greatly improved methods of generating electricity by means of Dr. Wilde's dynamo-electric machine. It was owing to the Sprengel air-pump that the necessary vacuum was obtained for the first time, and this enabled the continuous illumination of the electric lamp to become an accomplished commercial success.

"The first incandescent filament electric lamp was exhibited after a lecture given by Uncle Joseph in February, 1879, at the Literary and Philosophical Society lectureroom of Newcastle-upon-Tyne when the late Lord Armstrong took the chair. It created quite a sensation, and when shortly afterwards an electric lamp was placed in a gas lamp in Mosley Street it drew large and enthusiastic crowds. This lamp was made the subject of a lecture, and shown during the lecture at Gateshead, a few nights after that of February, 1879.

"Not content with these early successes, he continued his investigations and improvements until he was able to produce a uniform filament which gave wonderfully satisfactory results and superseded all other previous experiments.

"On the occasion of another lecture delivered on October 20th, 1880, at the Literary and Philosophical Society, Newcastle, the room was entirely lighted by Swan lamps, this being the first time a public building was lighted by electricity.

"The following month, November 23rd, 1880, Uncle Joseph exhibited the light at the Institute of Electrical Engineers. Father describes the event as a splendid success, in a letter written at eleven p.m. the same evening. It is full of pardonable pride and intense pleasure for the honours and congratulations paid to this gifted and much loved brother: □He says: □'Really it was a treat indeed to see Joe realise such a complete success. One after another of the great men rising to congratulate and compliment him, and the entire



audience enthusiastically endorsing every word of praise which was spoken. All the 'bigwigs' in the electrical world, and a hosts of experts were there. There was a chorus of compliments from the professors.'

"The following year (1881) the light was exhibited at the Paris Exhibition, where in the beautiful, large rooms it was shown to great advantage. At the close of the Exhibition the President presented Uncle Joseph with the order of the 'Chavalier de la Legion d'Honneur.'

"At that time there were only two houses lit by electricity, his own and the late Lord Armstrong's residence at Cragside, Rothbury. At Cragside, the dynamo was driven by water power from a waterfall on the estate.

"Lord Salisbury arranged, with Uncle's co-operation, for a similar installation at Hatfield House, and later, the Savoy Theatre, London, was lighted by Swan lamps. The late D'Oyley Carte introduced the light in the Fairies' scene in 'Iolanthe.' It was the first occasion when the light was used for theatre illumination. Dr. Spence Watson, his old friend and legal adviser, was present with him to witness the charming scene and to take the steps which led to the formation of the Swan Electric Light Company. The 'City of Richmond' was the first ship to adopt the new light.

"About this time there appeared a clever cartoon in *Punch*, depicting 'Punch' as the magician with a 'Swan' lamp in his hand, offering 'new lamps for Old.'

"Many were the honours from time to time conferred on this great man of science. He was elected Fellow of the Royal Society in 1894, and later, was awarded the Society's 'Hughes' Gold Medal. In 1898, he was President of the Institute of Electrical Engineers, and shared the distinction, with Lord Kelvin and Dr. Wilde, of being an honorary member of the Institute. He received the 'Albert' medal of the Royal Society of Arts, in 1906. The University of Durham conferred on him the degree of M.A., which was followed in 1900 by the degree of D.Sc. He was also President of the Society of Chemical Industry and was the first President of the Faraday Society, and Vice-President of the Senate of University College, London. In 1904, he was a recipient of the late King Edward VIIth's birthday honours, receiving a knighthood in recognition of his valuable services to art and science. This honour was universally applauded as a distinction well merited and only too long delayed. On the death of the late Dr. Spence Watson he was elected President of the Newcastle Literary and Philosophical Society, June, 1911. It was no small gratification to him to be associated with what may be called the home of his early triumphs. It was characteristic of the man that he continued his scientific investigations practically to the end of his long life.

"Singularly pathetic and tragic was the fact that, within a month or so of his death, arrangements were being made to still further honour his name by

presenting him with the Freedom of the City of Newcastle-upon-Tyne. The actual ceremony was postponed to allow him to travel North in more genial weather, but the Council had already in March, 1914, carried the resolution submitted by the Lord Mayor, Councillor Johnstone Wallace, that he and Sir Charles Parsons, of turbine fame, should be made honorary Freemen of the City. Continued failing health led to postponements to the date of presentation. Unfortunately, the hopes of his recovery by those around him were not destined to be realised, for he passed away, after a few hours serious illness, on May 27th, 1914.

"As, by the vote of the Council, he was actually an honorary Freeman, it only remained for the representatives of his family to receive the scroll. This, with a very handsome service of silver plate, the Lord Mayor, in a moving speech, presented to his son, Kenneth R. Swan. The ceremony took place on July 10th, 1914, in conjunction with the presentation to Sir Charles Parsons. The graceful and brilliant speech made by Kenneth on the occasion was in every way worthy, not only of the event, but of the revered memory of him they had assembled to honour. Nothing could have been more elegant and appropriate than the well-chosen language in which he accepted the gift on behalf of his mother and family.

"Prominent among the distinguished company was the aged and devoted brother. It was peculiarly touching that he who had so frequently rejoiced in the early triumphs, should be present on the occasion of this posthumous honour to give his farewell tribute to one of the noble band of 'Men who have ennobled life by their discoveries in the arts, and who have earned by desert the remembrance of others.'

"Sir Joseph Swan was twice married. He had five children by his first wife, two of them, twins, died in infancy, but of the five children born to him by his second wife, only the four older ones, with his widow, survived him.

"The death of the youngest daughter at the age of twenty-nine was an intense grief, for she was as charming as she was gifted, and deservedly beloved by every member of the family."

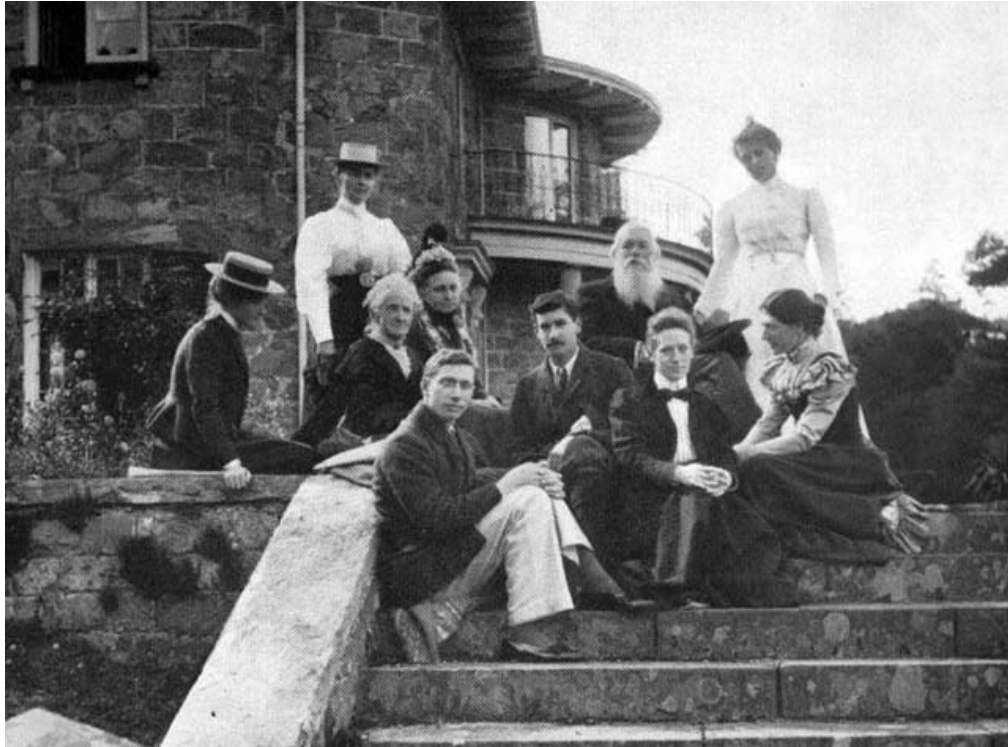

The picture above shows the Swan family at Bryn-y-Gwyn, Dolgellay, Wales, ca late 1890s.

It was scanned from In The Days Of My Youth; it appears opposite pg 51.

The individuals are, from left to right:

*Back Row:* Hilda Swan, Hannah Swan, Joseph Swan and Isobel Swan.

*Middle Row:* Dorothy Swan, Maria (sister of Hannah), Percival Swan.

*Front Row:* Kenneth Swan, Ethel Gane (a friend), Mary Swan.

**- Articles by Joseph Wilson Swan -**

- 1) "The Subdivision of the Electric Light", *Telegr. Engin. Journ.*, Vol 9, 1880, pp 339-349.
- 2) [Description of his electric lamp.] *Transactions of the North of England Institute of Mining Engineers*, Vol 30, 1881, pp 149-155.
- 3) "On an Electric Safety-Lamp, with Portable Secondary Battery", *Transactions of the North of England Institute of Mining Engineers*, Vol 31, 1882, pp 117-118.
- 4) "Perception of Color", *Nature*, Vol 26, 1882, pg 246.
- 5) "Voltaic Accumulation" [1881], *Newcastle Chem. Soc. Trans.*, Vol 5, 1883, pp 122-130.
- 6) "Electric Lighting by Incandescence" [1882] *Roy. Instit. Proc.*, Vol 10, 1884, pp 33-43;

- Chemical News*, Vol 46, 1882, pp 49-51, 59-60; *Nature*, Vol 26, 1882, pp 356-359.
- 7) "On a Portable-Electric Safety Lamp for Miners" [With discussion] [1885], *Transactions of the North of England Institute of Mining Engineers*, Vol 35, 1886, pp 51-64.
- 8) "On Improvements in Electric Safety Lamps", *Reports of the British Association for the Advancement of Science*. London, 1886, pp 496-499.
- 9) "On an Improved Electric Safety-Lamp for Miners" [With discussion] [1886] *Transactions of the North of England Institute of Mining Engineers*, Vol 36, 1887, pp 3-11, 55-59.
- 10) "Note on the Employment of Chromic Acid Instead of Nitric Acid in the Bunsen Cell", *The Electrician, a Weekly Journal of Telegraphy, Electricity and Applied Chemistry*. London, Vol 23, 1889, pp652-653.
- 11) "Electro-Metallurgy" [1892], *Notice of the Proceedings at the Meetings of the Members of the Royal Institution, with Abstracts of the Discourses Delivered at the Evening Meetings*. London, Vol 13, 1893, pp 625-636.
- 12) "On Some Voltaic Combinations with a Fused Electrolyte and a Gaseous Depolariser", *Proceedings of the Royal Society of London*, Vol 56, 1894, pp 55-64.
- 13) "Twenty-Five Years' Progress in Incandescent Lighting", *The Electrical Review*, [London], Vol 41, 1897, pp 626-627. Also, *Electrical Review* [New York], Vol 31, No 21, Nov 24, 1897, pg 248; No 22, Dec 1, 1897, pg 267.
- 14) "Stress and Other Effects Produced in Resin and in a Viscid Compound of Resin and Oil by Electrification" {1897}, *Proceedings of the Royal Society of London*, Vol 62, 1898, pp 38-46.
- 15) Inaugural Address, "The Progress of Electro-chemical Industries" [1898], *Inst. Elect. Engin. Jl.*, Vol 27, 1899, pp 8-34.
- 16) "Measurements of the Absolute Specific Resistance of Pure Electrolytic Copper", *Roy. Soc. Proc.*, Vol 56, 1894, pp 64-81 [with John G. A. Rhodin].

## References

- 1) "Twenty-Five Years' Progress in Incandescent Lighting", J.W. Swan, *Electrical Review* [New York], Vol 31, No 21, Nov 24, 1897, pg 248; Vol 31, No 22, Dec 1, 1897, pg 267.
- 2) Obituary Notices: "Sir Joseph Wilson Swan", *Journal of the Institution of Electrical Engineers*, Vol 52, 1914, pg 794.
- 3) John Cameron Swan, His Family and Friends, 1827-1916, Emily and Mary Swan, Headley Bros., Ashford, Kent, ca 1918, pp 41-51.
- 4) Sir Joseph Wilson Swan F.R.S. - A Memoir, M.E.S. and K.R.S., Ernest Benn Limited, London, 1929.
- 5) "Sir Joseph Swan's Electrical Work", J. Swinburne, *Journal of the Institution of Electrical Engineers*, Vol 67, 1929, pg 291.
- 6) "Brief Personal Recollections in Connection With the Jubilee of the Invention of the Carbon Incandescent Electric Lamp by Sir Joseph Wilson Swan in 1878", *Journal of the Institution of Electrical Engineers*, Vol 67, 1929, pg 293.
- 7) Sir Joseph Swan and the Invention of the Incandescent Electric Lamp, Kenneth R. Swan, Longmans, Green and Co., New York, 1946.
- 8) In the Days of My Youth, Some Random Reminiscences of My Early Years, Sir Kenneth R. Swan, University Press, Oxford, 1964, pp 2, 3, 7, 8, 14, 18-21, 26, 50, 113, 176.
- 9) Sir Joseph Wilson Swan F.R.S. - Inventor and Scientist, Mary E. Swan and Kenneth R.

Swan, Oriell Press, Newcastle upon Tyne, England, 1968.  
10) "Swan's Way: Inventive Style and the Emergence of the Incandescent Lamp", G. Wise, Report No. 81CRD192, Aug 1981, Research and Development Applications Operation, General Electric Company, Schenectady, NY; material was also published in - *Spectrum*, Vol 19, Apr 1982, pp 66-70, titled "Swan's Way: A Study in Style."

## **Franklin Silas Terry**

### **Prologue**



The worth of a human being is determined, in part, by character, accomplishments and humanistic deeds. A person who stands above the throng can be a role model for others and attain the respect of contemporaries. It certainly isn't necessary that one be notable in the historical sense, and it is assumed that the past has been witness to many of these noble persons, whose names are essentially lost in the dust of time. It is concluded by this writer that Franklin Silas Terry, because of his activities and achievements, was one person whose name and life should be memorialized. Terry's accomplishments do not pale when compared with those contemporary figures who received more press coverage than he. It

was his nature to be in the background and remain anonymous.

Ideally a biographer would be a contemporary of the subject and quite knowledgeable of the person. If that is so, the work is apt to be more than a compendium of facts. Unfortunately that is not the case with this writer and Mr. Terry. In addition, personal files of the subject person should be available so that an accurate description of the life can be revealed. That, too, is not the case here. One can always hope to interview persons who knew the subject if that is possible and convenient. Unfortunately that, too, is not the situation here. As Franklin Terry passed away before the birth of the writer, difficulties stood in the way of a writing that would do justice to his life. However, the situation could not be changed and his story, such as it is, is one that deserves to have a permanent place on the shelf of biographies of outstanding people.

Franklin Silas Terry was born in Connecticut in 1862 and came from a family whose members established their own marks on the pages of history. With no formal education beyond high school he was able to achieve great importance in the community of man and attain respect from it. Terry did what many others would never do—stray from the well-worn paths of life to approach problems from a humanistic, as well as a practical, side.

Terry consolidated a group of incandescent lamp manufacturers into a cohesive whole and made that situation profitable, even when their competition had better engineering and financial stability. He then formed what is one of the first industrial parks in the United States where the dirt and grime from the city-center were left behind. His efforts were so successful that today the headquarters of the General Electric Lighting organization

remains at that location and the once "competitive" Edison Works has been abandoned. Terry went into semi-retirement from that location in East Cleveland, Ohio, called "Nela Park," as a Vice-President of the General Electric Company.

A little-known humanitarian effort of gargantuan proportion was undertaken by Terry during World War I when he organized a fund for the benefit of French orphans and mutilated French soldiers. Because of his effort, and financial support, he became known as the "American Godfather."

Franklin Terry was the antithesis of the robber baron of the late 19th and early 20th centuries. His was a life of harmony, generosity and justice. He had a co-worker for a quarter of a century, Burton Gad Tremaine, which resulted in a partnership that brought respect, loyalty and success to the lighting business of the General Electric Company.

### **Early Years in Ansonia, Connecticut**

Ansonia is located at the confluence of the Naugatuck and Housatonic Rivers, about 12 miles from Long Island Sound. It was a natural location choice for the early settlers because the locale provided transportation, food and water for power. While it was fortuitous that William Terry, Franklin's father, decided to settle in the region, it undoubtedly was an excellent location to nurture the likes of Franklin Terry.

Franklin exhibited extraordinary degrees of organization and industry as a youth. His creative activities were able to blossom to marked degrees. It's no surprise that these same traits were exhibited in adult life. At the age of 13 Franklin published a monthly paper. At age 15 he and a friend published a larger paper that met with some success. At age 16 Franklin was witness to a meeting that proved to be of great importance.

There existed in Ansonia a man who was a manufacturer, as well as an inventor. William Wallace was the first person in the United States to manufacture dynamos. It was in September, 1878 that Thomas Alva Edison traveled to Ansonia with Professor George F. Barker to visit the shops of Wallace, partner of Moses Farmer. In the words of Matthew Josephson:

"After receiving the inventor and his party warmly, Wallace exhibited eight brilliant arc lights of 500 candlepower each as well as the Wallace-Farmer dynamo of 8 horsepower that supplied them. As an eye-witness related:

"Edison was enraptured...He fairly gloated...He ran from the instruments to the lights and then again from the lights back to the electric instruments. He sprawled over a table and made all sorts of calculations. He calculated the power of the instruments and the lights, the probable loss of power in transmission, the amount of coal the instrument would use in a day, a week, a month, a year...

"He then turned to Mr. Wallace and said challengingly, 'I believe I can beat you making the electric light. I do not think you are working in the right direction.' They shook hands in friendly fashion and, with a diamond-pointed stylus, Edison signed his name and date (September 8, 1878) on a wine goblet served by his host at dinner."

The outcome of that "challenge" is history. Edison perfected the incandescent lamp and his name became a household word. Also present during those discussions between Wallace and Edison was an office boy who worked in the Wallace concern. He listened attentively to what was being said by these two remarkable men. Their words were inspirational and a driving force for that high school youngster. The name of the office boy who witnessed that dramatic time in history was Franklin Silas Terry.

### **The Electrical Supply Company**

Franklin Terry graduated from high school in 1880, ranking at the top of his class in scholarship and deportment. During the summer, after graduation, Franklin worked for Wallace & Sons. He then planned to enter Phillips Exeter Academy in Andover, Massachusetts. However, a job was offered him in a new Wallace concern, The Electrical Supply Company, which he accepted. The new firm was to manufacture electric light, telephone and telegraph supplies. Terry worked in Ansonia for the new firm until October of 1884. The Wallace family then decided to open a branch of the company in Chicago and they chose Terry to manage it. Thus, in November of 1884 Franklin Terry traveled to Chicago and opened the branch office.

By December of 1893 The Electrical Supply Company was the largest such concern in the United States. Terry made the supply house famous through the care and originality shown in his successful method of advertising. In 1892 a catalog of their goods was put out and 5000 copies were printed. That venture cost \$10,000, a sum considered more than adequate to start a new business. However, the printing paid off when orders began to be received, which indicated that the purchasing public appreciated the graphical display of items that had proven worthy of manufacture in the past.

It was while he worked for The Electrical Supply Company that Terry helped to found the National Electric Light Association. Mr. George S. Bowen, owner of the central station in Elgin, Illinois, invited Terry to go to Elgin in December of 1884 to witness the appearance of a new installation of arc street lighting, similar to what had been installed in Detroit, Michigan. Mr. Bowen made the suggestion to Terry that it might be a good idea to call together the electric companies to band together to form a national organization, modeled after the Gas Association group. Terry made the suggestion to several concerns that were interested in electrical applications but little interest was generated at first. The matter was brought up again in February of 1885 and a meeting was held to discuss a possible convention, which was to be held in Chicago. That meeting was held and a committee on invitations and arrangements was organized with Messrs. George S. Bowen, E.A. Sperry and Franklin Terry being members. The details of the invitations and requests for papers to be presented were left up to Terry. About February 18, 1885 a meeting was held at the Grand Pacific Hotel in Chicago and after the meeting had concluded they elected J. Frank

Morrison as president. The National Electric Light Association had been born and it remained an active and productive organization for many years.

### **The Sunbeam Incandescent Lamp Company**

Franklin Terry was successful with The Electrical Supply Company but his interminable energy pushed him to take on other challenges. As he was no stranger to the subject of incandescent lamps it's not surprising that he decided to enter that business also. Thus, in 1889 he founded The Sunbeam Incandescent Lamp Company but he remained with The Electrical Supply Company until December of 1893. He did not want to devote full time to any new business so he hired other persons to assume the major roles.

The years between 1889 and 1894 were turbulent ones for the independent lamp makers. For years these manufacturers supposedly ignored the basic Edison patent No. 223,898 of January 27, 1880, which described a high resistance filament sealed into a glass enclosure using platinum lead-in wires, with the bulb being evacuated of gases. The patent was to expire on November 17, 1894. Manufacturers in the late 1880s concluded that no infringement problems would be encountered with the patent because no action had been taken prior to that time.

After the formation of the General Electric Company in 1892 infringement suits were introduced into court however. Franklin Terry responded to this situation by writing letters to the editor of the *Electrical World*. Franklin's older brother, Albert, had moved from Ansonia in February of 1892 to become Secretary and Treasurer of Sunbeam, and he, also wrote a letter giving his view of the lamp situation from the perspective of one independent manufacturer. The letter pointed out that the independents had no intention of infringing the patent but licenses were not being granted. Eventually these matters were resolved and business went on essentially as before.

On October 1, 1896, Franklin Terry wrote a letter to the Western Electric Company in Chicago to propose that they become the exclusive selling agent for Sunbeam incandescent lamps. The proposal was accepted. An overseer of the Sunbeam business, from 1895 to 1931, was Henry B. Vanzwoll. He started in 1895 as Secretary and became President in 1904, remaining at the helm until his retirement.

The Sunbeam Company made carbon, GEM, and tungsten (MAZDA) lamps. A label identifying the lamp as "Sunbeam" was not used after about 1924.

### **The National Electric Lamp Association**

The sequential steps in the formation of National have been presented in somewhat different terms by writers in the past. This writer prefers to accept the story as written by Franklin Terry in 1910.

At an early date Mr. Jotham Potter of the Buckeye Electric Company in Cleveland spearheaded a movement to consolidate the small independent manufacturers in an effort to



strengthen one and all, excluding, of course, the General Electric Company. Then, in the winter of 1900-1901 Franklin Terry attended a banquet in Chicago given by electrical supply dealers. He was seated next to Burton Gad Tremaine, who had financial interests in several businesses and, with others, had founded the Fostoria Incandescent Lamp Company in Ohio in 1897. Burton Tremaine was interested in what Terry had to say. Terry, too, had been advocating consolidation of the independents with the purpose of sharing research results, but in a friendly competitive manner.

According to Terry, a short time after that meeting Tremaine traveled to New York to talk with him regarding the consolidation idea. Apparently Tremaine thought favorably of the idea because he and one of his Fostoria partners, John B. Crouse, had talked the idea over with Charles A. Coffin, President of the General Electric Company. Their thought was any consolidation without the approval of GE would be doomed to failure. Now, the reason(s) behind that visit of Tremaine and Crouse to Coffin aren't entirely clear to this writer. It's surprising that Terry was left out of the discussion.

Several authors have attributed the consolidation of independents into the National Electric Lamp Company to have been an idea originated with Coffin. This writer has no evidence of that. In fairness to the issue, however, it should be pointed out that John White Howell, a dynamic figure with the Edison group, stated in a small book written for his children that Coffin was the force behind that move. More recently, George Wise, of the General Electric Research Laboratory in Schenectady, implied that the same scenario occurred. Perhaps the point is unimportant now as the history books would be little affected.

More than a consolidation of the independents was to occur. Terry's thought was that consolidation would enable them to work harmoniously together, share research results and compete, but on a friendly rather than an antagonistic basis. The approval by Coffin to the plan was to be accompanied with a loan of money. At the time of consolidation, General Electric had about 75% of the incandescent lamp market and the independents, about 25%.

The National Electric Lamp Company was formed on May 1, 1901 by five individuals and initially they constituted the Advisory Board. Their names were: Franklin S. Terry, Burton G. Tremaine, John B. Crouse, Henry A. Tremaine and J. Robert Crouse.

According to Terry's write-up he and Tremaine visited the independents to discuss the possibility of coming together in a move of friendly competition. Generally the response to the suggestion was negative. It appeared that many manufacturers were not able to make money and were interested in selling their businesses. None of the parties contacted thought the consolidation could compete against General Electric. What the parties were not told, however, was that GE would be a silent partner in such a change. Terry and Tremaine started to buy the various lamp concerns but had considerable difficulty in doing so because the amount of money GE would loan was limited and their money reserves were limited for several years. However, they continued their acquisitions and the consolidated companies enjoyed success.

The name change in 1906 from the National Electric Lamp Company to the National Electric Lamp Association was convenient, in that an acronym could be derived from the

new name. After the move to East Cleveland from 45th Street in Cleveland, and the word "Park" was added, the location known as "Nela Park" was born.

### **The 1911 Federal Incandescent Suit**

In the years following the Civil War, companies that sold similar goods banded together and agreed to charge high prices for their products. Such a monopoly is called a trust and the citizenry grew tired of such "underhanded" tactics. As a result of these corporation combinations Senator John Sherman of Ohio introduced a bill in Congress to make such trusts illegal. As a result, a bill was passed in 1890, called the Sherman Anti-Trust Act, which forbade this tactic.

In retrospect, one might look at the combination of incandescent lamp companies that formed the National Electric Lamp Company in a different light. Although it is difficult to reconstruct the events of the time, it is of interest to reexamine any negative view of the consolidation.

The National Electric Lamp Company was formed for the purpose of sharing engineering costs by having a laboratory from which all members could share in the results and at the same time enjoy friendly competition. There was not to be any collusion on price fixing. However, as early as May, 1908 it was reported that the Navy Department took bids for an order of 340,000 incandescent lamps. Fourteen bids were received and 13 of them were for exactly the same amount, \$50,631.23. It's difficult to conclude that collusion did not exist.

On March 3, 1911 the Attorney-General of the United States, George Woodward Wickersham, brought suit against the General Electric Company, Westinghouse Lamp Company, Westinghouse Electric & Manufacturing Company, National Electric Lamp Company and about 31 other companies for restraint of trade. The suit was brought through the United States Circuit Court for the Northern District of Ohio at Cleveland Ohio. On October 12, 1911 Judge John M. Killits, sitting in Toledo, Ohio, handed down a decree against the manufacturers.

The General Electric Company had owned a 75.2% share of the stock of the National Electric Lamp Company and was, therefore, a hidden partner of the National group. As a result of the ruling, the lamps made by National were to be marked as being GE lamps. Such a suit by the Attorney-General was bound to carry a stigma with it. However, very little really changed after the ruling.

There can be another side to a story that appears to reek of underhandedness and profiteering. An article came from the News Bureau in Boston on October 14, 1911 that addresses that other side. In part, the article said:

"General Electric through this lamp pool held control of 95% of the lamp business of the country. It sounds like an oppressive monopoly and yet it has been one that has made possible the wonderful development of electric lighting, while prices have come down from 85 cents 15 years ago for an ordinary carbon lamp to 16 cents or 14 cents in quantity. There was chaos in

the lamp business 20 years ago. The lamp pool restored the industry to a commercial basis and this led to wonderful inventions, so that for 16 cents the consumer gets a lamp 50% more powerful and efficient than the lamp for which he paid 85 cents in 1896."

It would appear that Franklin Terry deserves much credit for the positive aspects of the consolidation.

### **An Industrial Park in Rural Cleveland**

Far from the maddening crowd, the vibrations from the railroad, the noise, the dirt and grime of industrial areas and the dizzying heights of tall buildings—that's what was needed! It was a bold and innovative step for Franklin Terry to take but analysis showed that one could build the needed buildings on a plot of land for about the same cost as the required floor area in a 45-story building on a 100 x 100-foot lot in the downtown area. And so Franklin Terry began to look for some land that was suited for the needs of the National Electric Lamp Association.

In 1911 if one boarded the trolley and rode east on Euclid Avenue the end of the line was in east Cleveland, about seven to eight miles from downtown Cleveland. It was to that location that Terry was interested in moving. After one climbed the hill and reached the plateau south of Euclid Avenue the land contained a vineyard, wooded area, ravine with a trickling stream, fruit trees and a panoramic view of Lake Erie. The land is about 275 feet in elevation about Lake Erie. That move to the rural area of Cleveland by National established one of the first, if not the first, industrial parks in the United States, and it has served as a model for industrial organizations since.

The buildings that were erected on that plateau were to be standing monuments to—not only Frank Edwin Wallis, the architect, but also to Franklin Terry.

The history of the land at Nela Park, its improvements, the buildings and equipment during the years 1911 to 1957 has been thoroughly documented by Townsend.

### **Terry's Management Style**

Franklin Terry's business philosophy eventually became known as the Authority Reserved System within GE Lighting. After Terry's death it was formalized and printed, but not published, in 1930, by T. W. Frech and Zay Jeffries. It carried no authors' names. It was accepted enthusiastically company-wide and remained in effect for years.

While the Authority Reserved System was successful in itself, it was those things that impacted on the morale of the workers that were just as important. The establishment of a park atmosphere in which one felt as though he/she were in pleasant and safe surroundings was of particular importance. These "perks" were enjoyed by all levels of employees.

In 1911 a five-year savings fund was implemented. The fund opened on the first day of March of each year and was closed on the last day of February of the following year. It was

a mutual fund type of investment and the first investment was made in 1916 with earnings at 8%, compounded annually. The second through fifth earnings were at the rates of 11, 5.4, 14.25 and 33%. It was Terry's goal for the person on the factory floor to become astute enough in saving so that earnings from investments equaled take-home pay. An employee could invest an amount not exceeding 20% of the paycheck compensation.

It should be clear that Terry was concerned with the well-being of his employees. That concern distinguished him from many employers of the day. Perhaps he felt that way because he was always trying to build something, or trying to make things better than what they were before. He considered how business decisions would affect the worker. That is not to say that hard times didn't bring hard decisions. The accumulation of personal wealth was not a consuming activity for him. Public loyalty to the GE name exists yet today, and that is due in some measure to Franklin Terry's management style.

### **Terry and Tremaine Booklets**

In a letter dated April 22, 1920 Terry and Tremaine announced that they intended to publish, from time to time, articles in book form. It stated, in part, that:

"The purpose of these articles is to give our employees the essential facts, as well as some of our own opinions, on the important topics of the day, and also on any other subjects from the discussion of which they may receive some benefit."

They considered it an obligation on their part to give the employees a better understanding of their relations with the employer and with society. The intent was to lessen friction caused by the employees' misconception of these subjects. The final objective was to establish better relations between the employees and management.

Thirty five books were issued between the years 1918 and 1926. Their size was about five by seven inches with the number of pages varying from 30 to 83. For the writing task Miss Katherine Irvin Woods was hired. Miss woods obtained subject ideas and suggestions from Terry and Tremaine, as well as others, and then prepared the manuscript. The manuscript was then read for approval. In some of the books Terry and Tremaine wrote Foreword sections.

### **Association Island**

Franklin Terry's name is associated with many "firsts", and the idea of managers gathering from across the United States for a week of fun and fellowship was one of those important firsts. To this end an island at the eastern shore of Lake Ontario was purchased and it came to be known as Association Island.

The first meeting on the island of about 60 acres was held in 1907. Sleeping quarters were in large tents with wooden floors. Facilities included a theater, landing docks, boathouse, store, bakery. recreation halls, laundry and support facilities. Sports of many kinds were

played. Executive training programs were held on the island for over 40 years. Today that facility has been replaced by one at Crotonville, New York, where year round meetings are held. GE donated Association Island to the New York State YMCA in 1959.

Franklin Terry asked participants at the island to write a note to him with comments after their visit. One letter that he valued, because he felt it was written by someone who was observant and capable of analyzing, was from Zay Jeffries, then at the Aluminum Company of America in Cleveland. Excerpt's from Jeffries' letter follow:

"...I could see clearly, as the days passed by, that the Island had a function which I had not anticipated and which, I believe, no one can properly appreciate from the outside. Here were men from all parts of the United States working for a common purpose—the success of the National Lamp Division of the General Electric Co. Each had a separate portion of the whole work to do and each was dependent in more or less measure on each other man present. I realized the great significance of your few words, 'If men cannot play well together, it is probable that they cannot work well together. A person will think twice before he will lie to or about another person with whom he has played.' You mentioned these fundamentals to me during the first few days of the 1919 Camp National. Here was opportunity for play seldom given to men, and such a play ground! The differences of opinion seldom get worse with more personal contact. If such is to be the case the sooner it is found out the better. The overwhelming tendency of personal contact is to smooth out differences."

### **The Nela Fund**

In March of 1916 Franklin Terry became aware of a consequence of the war in Europe that he felt he could do something about. Orphans of French families would have no opportunity to obtain a higher education because it was not possible to "work" one's way through a university in France. In addition, the immediate needs of those children—food, clothing and housing also had to be met. He generously contributed to these needs for about two years and then set up what was called the Nela Fund to invite others to participate. This plan was presented to the managers in June of 1917 at the annual gathering at Association Island. The Fund was not connected formally to the National Lamp Works; the name was chosen simply for convenience. Eventually the fund benefited war orphans, soldiers and their widows. It was to differ from other organizations of charity in the personal touch around which it was developed.

About 625 children were "adopted" by December 14, 1922, with Terry personally adopting 57. Terry and Tremaine also gave a Peerless automobile to the American Clearing House. The war contributions from the National Lamp Works and its people amounted to about \$884,000. Terry received letters of gratitude from several French generals after the war, including Generals de Garets and Foch.

### **End of an Illustrious Career**

In 1922 the lamp business of the General Electric Company was under the direction of an Advisory Board, which included Franklin Terry and Burton Tremaine. In May of 1922 Gerard Swope became President of GE and change was to take place. Manufacturing plants that Swope thought were not being utilized adequately and operations that were autonomous were to be eliminated. In June of 1923 the autonomous rule of the GE lamp business by Terry and Tremaine was history. All but 15 lamp plants were closed. At that same time Terry was elected to the position of Vice-President.

Franklin Terry was born on May 8, 1862 and passed away in his home in Black Mountain, NC on July 23, 1926. He succumbed to a stroke. Franklin Terry's final resting place is in a mausoleum in the Riverside Cemetery, Asheville, NC.

\*\*\*\*\*

## Reference

Franklin Silas Terry (1862-1926), Industrialist□Paragon of Organization, Harmony and Generosity, Edward J. Covington, 1994.



### **Charles J. Van Depoele**

Although the name of Van Depoele is better known in fields other than lighting, it still should be mentioned in the pages of history of the incandescent lamp. The following is an obituary of Charles Van Depoele taken verbatim from an issue of the *Western Electrician*<sup>1</sup>.

"The announcement of the death of Charles J. Van Depoele at Lynn, Mass., March 18th, was received with surprise by his friends throughout the country as it was not generally known that Mr. Van Depoele had been seriously ill. The deceased occupied a most prominent position among electricians and was a pioneer in electric lighting, railway and mining work. He took out many valuable patents in these departments. It is estimated that more than 100 patents were issued to him on electrical inventions. Most of these patents are now controlled by the Thomson-Houston Electric company, in whose service Mr. Van Depoele was engaged as expert and inventor at the time of his death.

"Mr. Van Depoele was a native of Belgium and was educated at the College of Poperinghe. At the age of ten years he engaged in the study of electricity

and from that time devoted most of his life to electrical development. When the first telegraph line was built between Bruges and Poperinghe, Van Depoele, who was at that time a mere child, evinced great interest in electrical appliances and as his father's position enabled him to secure access to the operating rooms of the telegraph, he made use of his opportunities and soon engaged in experimental work. These operations he followed up with much success, and he prosecuted his studies with enthusiasm. When fifteen years of age he exhibited an electric light of his own design fed from a battery of forty Bunsen cells. Shortly after this his family removed to France, and the young enthusiast was encouraged in his work by several prominent scientists who had been attracted by his experiments and exhibitions. From 1864 to 1869 he attended the Imperial Lyceum at Lille and took an active part in the work at that institution.

"He did not remain in France long, believing that America was the best field for his operation. He came to this country accordingly, locating at Detroit. Here, however, many difficulties were encountered. He was comparatively unknown in this country and was without means to carry on his experiments on a large scale. For a few years he found it necessary to engage in mercantile pursuits, but did not altogether abandon his studies. He found an opportunity for displaying his lamp and took occasion to present his views to many American capitalists who, however, did not feel inclined to venture into the new enterprise. At this time Mr. Van Depoele had built several types of dynamos and lamps, but he was not satisfied until he had produced a commercial arc lamp. He was a firm believer in the ultimate success of electric lighting, long before any practical steps toward the solution of the problem had been taken.

"It was this belief, no doubt, that led him to give up an excellent business in Detroit to devote himself entirely to his experiments. His persistence was rewarded. He succeeded in lighting several public buildings in Detroit, and this attracted the attention of capitalists, who became interested in the work and promised support to the young inventor. A company was formed for the purpose of exploiting the Van Depoele system, but little was done in this direction and Mr. Van Depoele decided to make Chicago his headquarters. Here another company was formed, the Van Depoele Electric Manufacturing company, and the work was vigorously pushed.

"Mr. Van Depoele then turned his attention to the electric railway problem and soon had an experimental road in operation. He had conducted some experiments in this line at an earlier date but had not followed them up. As early as 1874, while Van Depoele was engaged in Detroit experimenting with electric generators, motors, etc., it occurred to him that trains of cars and ordinary street cars could be run by electricity. This he explained to many of his friends, who received it with some skepticism. On many occasions, however, the transmission of power by electricity was exhibited by him in his shop in Detroit; the belt of a ten horse power engine was

disconnected from the main shaft driving the machinery, and the engine was made to drive a large dynamo, which supplied current to another dynamo, belted as a motor to the main shaft in the shop. The question of making an experiment upon street railways in Detroit to exhibit what could be done in the way of driving vehicles by means of electricity was then discussed, but at that time there was naturally more attention given to the principles of electric lighting than to motors for electric railways. However, it was proposed by Van Depoele to use overhead conductors to transmit current from a generator to electric motors on cars to be thus driven, and the mode of thus transmitting the current was well understood by him at that time. Many different modes of transmitting the current were discussed—underground transmission as well as overhead. Exhibitions of the transmission of power by electricity were given at various times, after 1880, in the shops of the Van Depoele company, at Chicago.

In September, 1883, an electric car was operated at the Chicago Inter-state Fair on the Van Depoele system.

Mr. Van Depoele has devoted much time during the last few years to the application of electricity to mining machinery, and he secured valuable patents in this line. Since the Thomson Houston company absorbed the Van Depoele interests Mr. Van Depoele has been engaged in expert work at Lynn. He was a man of great ability, an indefatigable worker and according to those who knew him best, fairly worked himself to death. An excellent portrait of Mr. Van Depoele reproduced from a photograph taken just before leaving Chicago, is presented.

"Mr. Van Depoele was 46 years of age. He leaves a wife and several children."

A brief description of a Van Depoele lamp is given in Section 8 of this website.

### Reference

- 1) "Charles J. Van Depoele," *Western Electrician*, Vol 10, No 13, Mar 26, 1892, pg 193.



### John Waring

One of the lamps that received considerable litigation attention in the year 1893 was the "Novak" lamp, which was designed by John Waring. The design was patented on May 9, 1893 (No 497,038). The lamp contained a residual amount of the gas bromine, which, under the right circumstances, was meant to affect the discoloration on the bulb. The lamp was produced for only a short time. Of interest here is the inventor. An obituary of Mr. Waring follows, as taken



verbatim from the *American Electrician*, Vol XIII, No 7, Jul 1901, pg 31.

"John Waring, president of the Franklin Electric Manufacturing Company, Hartford, Conn., met with an untimely death on June 9 as the result of a gasoline explosion in a small attached building at his company's works on June 7. Mr. Waring would have suffered no serious injury from the explosion but for his chivalry in going back into the burning building to save two of the girl operatives in the experimental department. His burns were not serious, but it developed that he must have inhaled the flames, and the most strenuous medical efforts did not avail to prevent his death. Mr. Waring was born in Wisconsin 39 years ago; he graduated from Cornell University and went to Hartford about 10 years ago, at which time he brought out the Waring incandescent vapor lamp, which became well known. The wide use of this lamp was prevented, however, by suits for infringement brought by the Edison interests. After remaining in Hartford for some years, he went to Manchester and was associated with the Mather Electric Company until that company discontinued operations. He then returned to Hartford and was associated with the Perkins Electric Switch Company. About a year ago he formed a partnership with Mr. Jonathan C. Camp, and established the present business of the Franklin Electric Company. Mr. Waring leaves a mother and sister."

The photograph of John Waring was scanned from an obituary that appeared in *Electrical World and Engineer*, Vol XXXVII, No 25, Jun 22, 1901, pg 1093. **Edward Weston and the Tamidine Filament**

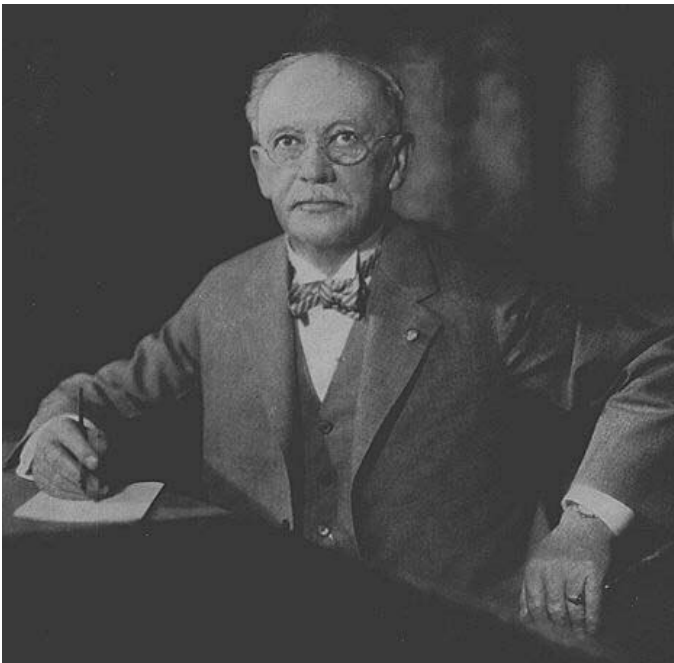

One of the outstanding contributors to the development of the carbon filament, as well as the history of the incandescent lamp, was Edward Weston (May 9, 1850 - Aug 20, 1936). In addition, Weston made important contributions to incandescent lighting, arc lighting, electroplating, getters, dynamos and electrical instrument development. In this brief look, Weston's work with the tamadine filament is considered.

In 1893 Weston classified the characteristics of carbon filaments as they depended on the material used as well as their subsequent treatments ("The Incandescent Lamp," Prof. Edward Weston's Remarks Before the St. Louis Convention of the National Electric Light Association, *Electrical Review*, Vol 22, No 5, Mar 25, 1893, pp 71-73). It is of interest to review some of his comments. Five classes were given:

"1) Carbons made from cellulose, the physical characteristics which have been modified by some process of

**Edward Weston** (scanned from Reference No. 9)

manufacture which has, more or less, broken up the fibres or rearranged them and bound them together mechanically. Under this head I would include paper, cotton or linen thread or braid, and, as being closely allied, I would also include silk thread or braid.

"All such bodies have the fibres more or less broken up and interlaced in a more or less irregular fashion, but are not cemented together with cementing material, such as binds woody fibres together in their natural condition.

"Thus the fibres of paper are not parallel, but lie criss-cross in every direction, like the fibres of wool in a felt hat, and the points of contact are uncertain and very irregular.

"The fibres of cotton, linen or silk thread, are longer, yet not parallel, but are twisted in several strands, without any cementing or binding material to unite the strands firmly.

"2) Carbons made from the previously named manufactured products, but which have been subsequently subjected to some chemical process, such as parchmentation, to cement, more or less perfectly, the separate fibres, and thus form a more or less perfect mechanical and chemical union between the interlaced fibres.

"3) Carbons made from wood by simply splitting the wood in a direction as nearly coincident with the direction of the fibres as possible.

"4) Carbons made from either of the above, but,..exposed to the flashing process of hydrocarbon treatment.

"5) Carbons made from a perfectly homogeneous base...

"To those engaged in the manufacture of lamps, it is well known that the structure of the carbon resulting from the use of any one of these primary bases, or substances, out of which the loop is first cut, is precisely the same as the original base.

"Thus, if paper be used as the primary base, every fibre and every defect existing in the paper will exist as perfectly after carbonization as before. Examination under a high power lens will disclose the criss-cross, interlaced arrangement of the fibres, and the fibres will be as perfect in form and arrangement as they were in the paper. The same is true of carbon made

from any other material. That is to say, the carbons preserve with absolute fidelity the arrangement, structure and shape of the substances of which they are made. It follows, therefore, that every defect existing in the material of which the carbon is made, no matter how great or small, exists also in the carbon.

"Now, an untreated carbon, made from paper...is very defective. Defective, first, because the fibres are not bound together; and secondly, because the paper not being of uniform thickness, nor of uniform density, the carbon is also not of uniform thickness nor uniform density. Put such a carbon into an electric lamp, put the lamp in a circuit where you can control the strength of the current, turn on a very feeble current at first; if no part of the carbon begins to glow, increase the strength of the current very gradually, and you will notice that some part or parts of the carbon begins to glow before the remainder shows any visible signs of heat. Increase the strength of the current again, and you will generally find that some part or parts of the carbon are vividly incandescent before the other parts are above a dull red.

"Now, what is true of the carbons made from paper, is more or less true of carbons made from cotton thread, linen thread and silk thread.

"...I met with these very difficulties in trying to secure uniform carbons very early in my work on the incandescent lamp. And these difficulties appeared in a very exaggerated form, in the kind of carbon I first attempted to use, and with the means then at my disposal to secure them thin and long enough to meet my needs. To overcome these..set me thinking. I was very familiar with the process of gas manufacture, and had known for years of that bugbear of the gas engineer, namely, the deposition of solid carbon on the inside of gas retorts, resulting from the decomposition of the vaporous and gaseous hydrocarbons evolved during the destructive distillation of the coal. I was also aware of the fact that the deposit of solid carbon formed very irregularly inside the retort, and seemed to be greatest where the temperature of the retort was highest. The thought occurred to me that if I placed my defective carbons in a carbon bearing liquid, vapor or gas, and then passed sufficient current through the carbon to at first raise the temperature of the defective spot to a red heat, the carbon would be deposited on the spots of highest electrical resistance and build them up, thus making the very agency potent in the destruction of the carbon serve the purpose of building up and obliterating the defective spots. It worked, and in a short time I brought the hydrocarbon treatment to a degree of perfection which left little more to be done...So with the electrician, if he wants uniform lights, he must have practically the same amount of matter in each lamp, and the resistance of the carbon must be substantially the same. With the hydrocarbon process this was easily accomplished by making the carbons all slightly smaller in cross section than was actually needed, and then depositing carbon on them in the manner described until the defective spots were all built up, and, continuing the process a little longer, it was quite easy to make the carbons all of

substantially the same electrical resistance, so that, with a given electromotive force, substantially the same current would pass through all when placed in multiple arc; or, if placed in series, they would all have substantially the same electrical resistance, and, therefore, all require substantially the same expenditure of energy to bring them to the same degree of illumination."

[Note by the writer: Sawyer and Man were first to patent the hydrocarbon treatment process, but it appears Weston actually worked on the process before them. The Sawyer-Man application was submitted in Oct 1878 whereas Weston developed the idea in 1877.]

"So much for that class of carbons covered by the first division.

"I will now refer to the characteristics of the second class. In this class some of the defects, due to imperfect contact of the adjacent fibres, are overcome by reason of the fact that the parchmentizing process converts the outer layers of the fibres into a glutinous mass, which unites the fibres to form a more or less solid body of cellulose. But this parchmentization of the outer surface of the fibres does not wholly destroy the fibrous character of the mass, nor does it make the cross section uniform throughout the length of the loop. It follows, therefore, that carbons made from this class of bodies are still very imperfect, and exhibit in use some of the serious defects of the carbons of the first class. Hydrocarbon treatment is nearly as essential with these carbons, to secure satisfactory results, as with carbons of the first class, and that because of the existence of defective spots, as well as the necessity of equalizing the resistance of carbons. The parchmentization process appears to yield better results with thread loops than with loops made from paper.

"We have now come to that class of carbons made from substances I have placed under the third head...They ...are prepared from a substance found in nature, such as wood, bamboo, cane and other similar substances, the fibres of which are more or less parallel and continuous and bound together by the natural cementing substance between the fibres. The principal objection to these substances as the base for making carbons for incandescent lamps arises from the fact that it is almost impossible to get two samples of wood having the same density, and the great difficulty in splitting the wood into thin long lengths in planes parallel to the fibres.

"Mr. Edison showed excellent judgment in selecting bamboo as the base from which to make carbons for his lamps. For of all the woods available it is probably the best for the purpose. Its fibres are very straight, it is quite close grained and splits admirably. Notwithstanding these advantages, it is not by any means perfect, and there has been much complaint regarding lamps made from it. Most of the lamps under proper test show defective spots in the loops, and few of them die as good lamps ought to. That is to

say, they do not gradually die all over, so to speak, but fail at some particular spot which was initially weak.

"Moreover, the variation in electrical resistance of the carbons obtained from loops of the same cross section and length is very great even when great care is taken, and unless the carbons are submitted to some subsequent process after the first baking, it is practically impossible to obtain even moderately uniform results. It is not to be expected that it is possible to find a natural product like wood have a uniform density, or even approximate it. Consider for a moment the conditions of growth of plants. Are they not similar in many respects to human beings' products, to a large extent, of their surroundings? Is it reasonable to suppose that any two trees growing either close together or a long distance apart shall have the same properties exactly? I think not. In other words, there must of necessity be a considerable difference in the properties of the wood, due to climatic and other conditions, as well as those differences which are known to exist in the strength and character of the wood taken from the same tree.

"Carbons of the fourth class include carbons made from any of the other three classes already referred to, but subsequently subjected to the hydrocarbon process.

"There is no doubt about the general correctness...concerning the advantages of treated carbons over untreated carbons. I am quite sure of the absolute necessity of treating carbons of the first class and possibly of the second class, in order to get commercially useful results. I am quite sure that carbons of the third class, straight fibre, natural fibre, or bamboo type, or whatever you may choose to call them, are generally improved by the hydrocarbon process, properly applied.

"I believe enough has been already said on the effect of the physical characteristics of the base on the resulting carbon and its influence in determining the lifetime and efficiency of lamps to make it clear that what is really required to secure the perfect lamp is an absolutely homogeneous carbon of uniform cross section from end to end of the loop, the loop will not suddenly fail at a single point, long before the principal part has suffered sensible injury by use. Such a carbon will gradually die, so to speak, all over. It cannot fail at some sharply defined spots, because there is no defective spot to be raised to a higher temperature than the other parts of the carbon. Such a carbon, even if subjected to the most searching tests, will exhibit an absolutely uniform degree of incandescence from end to end of the loop, owing to the non-existence of defective spots. This kind of carbon may be raised to a much higher temperature than ordinary carbons, and so be much higher in efficiency, and still give a much greater average life than any other carbon I know of. To obtain such a carbon it is necessary, of course, to secure a base having also a perfectly homogeneous structure. I secured such a base many years ago in several ways, but after securing the base it took

several years of work to overcome the difficulties encountered in making carbons from it. But the difficulties were all overcome, and the result amply repaid me for the labor and time expended. The best way of securing the base is fully described in United States patent No. 264,987, and dated September 26, 1882.

"The characteristics of the carbon and its advantages are set forth in another patent, issued to me on September 26, 1882, No. 264,986. Within the past year I have made many improvements in the method of making these carbons.

"Such a carbon requires no treatment to make it better adapted for use in an incandescent lamp. If properly made, it most perfectly fulfills all the requirements of the art as it exists to-day. It makes the most efficient and durable lamp known—the thing you want. It is cheap..."

As stated above, Weston received U.S. Patent No 264,986 for a 'Carbon Conductor for Electric Lamps.' An excerpt is taken from that patent that describes the tamidine material:

"If cellulose—that is to say, cotton, cotton waste, linen, or paper—be subjected to the action of a mixture of nitric and sulphuric acid, the result is a substance which, though fibrous and possessing in some other respects nearly the same physical qualities as the pure cellulose, differs radically from it, being explosive and burning without appreciable residue when out of contact with the air. This substance is commonly known as 'pyroxyline,' 'gun-cotton,' or 'nitro-cellulose.' By dissolving this with a mixture of ether and alcohol collodion is produced. By treating it with various other solvents—such as nitro-benzole, naphtha, camphor, and other well-known solvents—the substance known as 'celluloid' is produced. Both collodion and celluloid may be formed in thin sheets and dried: but so long as the characteristics of the nitro-cellulose remain they are both unfit for the production of the carbons, for the reason that they burn without residue. In order, therefore, to render them suitable for my purpose, I deoxidize them so to speak, or, in other words, I treat them with such chemical agents as will deprive them of their nitrous qualities and bring them back to the chemical condition of cellulose. Among such reducing agents may be mentioned ammonium sulphide, protochloride of iron, sulphate of iron, and others. The sheets of collodion or celluloid are immersed in a solution containing one or the other of the above-named agents and allowed to remain therein until they are entirely reconverted to their original chemical condition. In many respects they resemble closely the ordinary celluloid. They become transparent, very tenacious and flexible, and carbonize slightly less readily than ordinary cellulose. From these blanks or strips are cut or stamped having approximately the shape and size desired for the carbon conductors. They are then carbonized by being packed in a closed retort or muffle between plates of refractory material and exposed to a high temperature, the preparation of the carbons being in this respect substantially the same as that

commonly followed in the production of carbon conductors from fibrous substances. After carbonization the strips may be mounted and inserted in the lamps in well-known ways, no further treatment being required."

Although Weston used the term "tamidine" in his U.S. patent No 340,397, the origin of the word is not known by this writer. Some lamps with the tamidine filament can be readily recognized by the sinuous shape of the filament. The filament was made in this form to correct the poor light distribution given by a u-shaped filament with a rectangular cross-section. The sinuous shape also made the filament stronger. Some filaments were made with enlarged ends for connection to the lead wires with steel machine screws, nuts and washers. Later Weston developed a method of increasing the size of the filament ends by the deposition of carbon (U.S. Patent No 340,397). Arthur Bright, in his book, claimed that the tamidine filament was used in the Westinghouse Stopper Lamp of 1893. A picture of some Weston lamps manufactured during the 1880s is presented below. It will be noticed that the filament attachment scheme in the two lamps to the left is different from the two on the right.

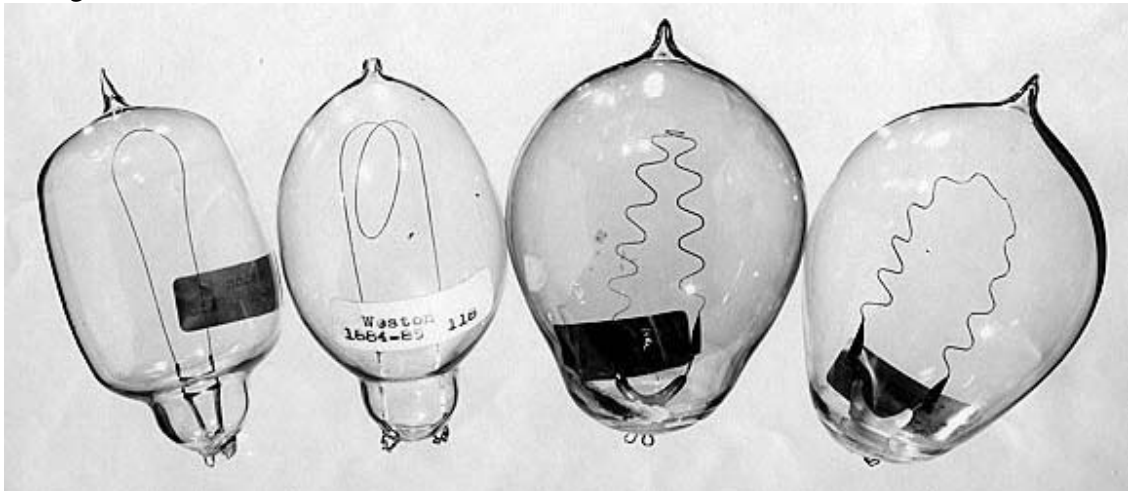

Weston Lamps-The two on the right are known to have tamidine filaments

#### **References**

- 1) Arc and Glow Lamps: A Practical Handbook on Electric Lighting, Julius Maier, Whittaker & Co., London, 1886, pg 288.
- 2) The Elements of Electric Lighting, Philip Atkinson, D. Van Nostrand, New York, 1888, pg 194.
- 3) "Incandescent Lamp Litigation" The United States Electric Lighting Co. vs. The Edison Lamp Co., *The Electrical Engineer*, Vol XII, No 189, Dec 16, 1891, pg 663.
- 4) "The Incandescent Lamp", Prof. Edward Weston's Remarks Before the St. Louis Convention of the National Electric Light Association, *Electrical Review*, Vol 22, No 5, Mar 25, 1893, pg 71.

- 5) "Weston Electrical Instrument Company", *Electrical Review*, Vol 22, No 5, Mar 25, 1893.
- 6) "Edward Weston," The National Cyclopaedia of American Biography, Vol V, 1894, pg 176.
- 7) "Dr. Edw. Weston, Scientist, Is Dead", *New York Times*, Friday, Aug 21, 1936, pg 15.
- 8) Arthur A. Bright Jr.,The Electric-Lamp Industry: Technological Change and Economic Development from 1800 to 1947, The Macmillan Co., New York, 1949.
- 9) A Measure for Greatness: a Short Biography of Edward Weston, David O. Woodbury, McGraw-Hill Book Co., New York, 1949.
- 10) The Electrical Manufacturers, 1875-1900: A Study in Competition, Entrepreneurship, Technical Change, and Economic Growth, Harold C. Passer, Harvard University Press, 1953.
- 11) "Edward Weston," American National Biography, Vol 23, Oxford University Press, 1999, pg 89.

---

### Some Weston Patents That Deal With Incandescent Lamps

#### U.S. Patent No Patent Date Invention

- 264,986  Sep 26, 1882  Carbon Conductor for Electric Lamps
- 264,987  Sep 26, 1882  Plastic Compound from Soluble Cellulose
- 264,988  Sep 26, 1882  Manufacture of Carbons for Electric Lights
- 301,024  Jun 24, 1884  Manufacture of Carbon Conductors
- 304,880  Sep 09, 1884  Manufacture of Carbonizable Material for the...
- 334,142  Jan 12, 1886  Incandescent
- 340,397  Apr 20, 1886  Manufacture of Carbon Conductors for Incandescent...
-



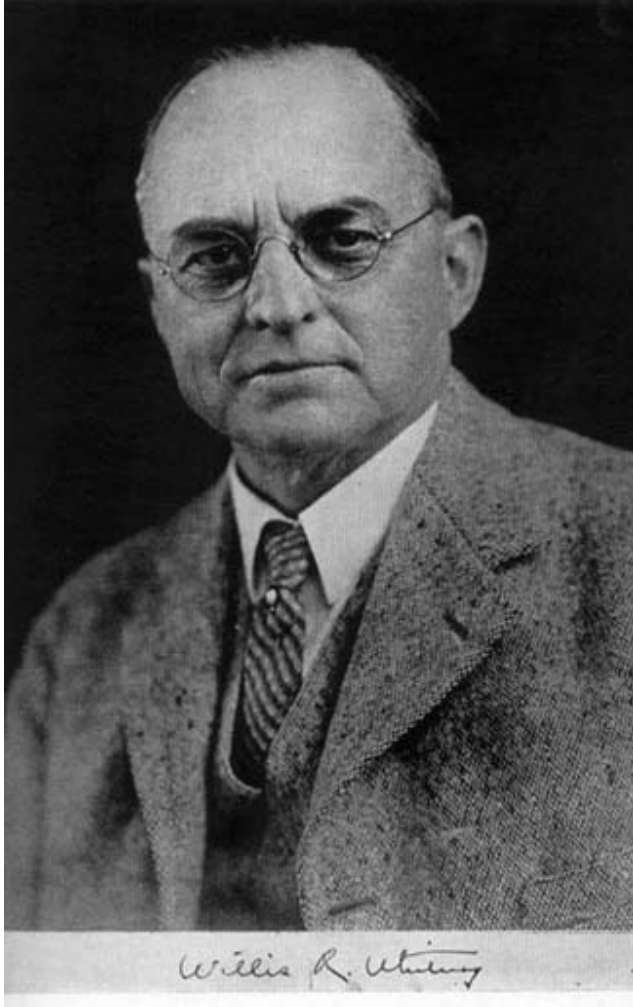

### **Willis Rodney Whitney and the GEM Filament**

The GEM (General Electric Metallized) filament was developed by Willis R. Whitney, who headed the General Electric research efforts for many years<sup>1</sup>.<sup>2</sup> The story is best told in Whitney's own words<sup>1</sup>:

"Carbon had been electrically such a wonder element, that one of the research chemists devoted himself exclusively to it for many years. It had long served for brushes on motors, for arc lamp electrodes and for incandescent filaments. These were then composed of two forms of carbon. A core or base as it was called, consisted of carbon made from dissolved cotton and this had a coat or cover of graphite which gave a smooth and shiny surface, but also served to even up irregularities in the original base. The base carbon at the time contained traces of unreduced mineral oxides, ash, so-called,

from the cotton. Seeking to improve the lamps we sought to eliminate that ash. In making the filaments they had been heated only as high as gas muffles could reach. The remaining oxides might be spoiling the lamps during their burning life. Even that ash when heated in the lamps could slowly yield gaseous oxides of carbon. These oxides could then react to transport carbon from the filament to the colder glass and so blacken it. And the glass did blacken with the burning life of a lamp. The reaction  $C + CO_2$  equals two  $CO$  reverses with changed temperature and that explained the carbon deposit on the glass. So it seemed desirable to preheat the bases to some very high temperature before their use in lamps. There was no ash in the graphite, as this was put on by heating the bases in very dilute benzene vapor.

"We began preheating bases in an electrically heated carbon tube furnace which was protected from rapid evaporation by carbon powder covering it completely. The ends or terminals were water-cooled. This furnace could be run up in temperature to about 3500 C where carbon readily vaporizes.

"We started using the factory-made carbon bases, but one particular shipment consisted, by mistake, of the graphite-coated or finished filaments. We put these through our new furnace-treatment and returned them to the factory. They produced lamps which blackened much less than usual. So the engineer of the factory became interested. We had already planned to heat thus all base filaments and add their graphite coat later, but this first accident gave us the confirmation of our guiding theory. These particular filaments in spite of not blackening the glass, were all covered with little blisters, and each blister had a tiny hole in it. Gases from the high temperature action had blown bubbles in the softened graphite coat so as to escape. The furnace-temperature was much higher than the filaments would ever be heated in the finished lamps. Base filaments heated in the furnace before being coated with graphite let the gases escape without affecting the carbon surface. They showed no roughness nor blisters. Then later, the graphite coat was put on and the new combination was reheated at the high temperature. This time the graphite coat remained without blisters, but had sintered or melted into a good smooth covering. Incidentally it was found that this new, sintered coat could be taken off (stripped) from its base filament, with care, thus giving us a very fine thin tube of the new graphite. This had a *positive* coefficient of resistance such as have the pure metals. So we called the new filaments 'metallized.' The temperature coefficient of former filaments had been *negative*. Our new lamp still looked like the old ones, but was 25% more efficient and we were proud of it. But the later work on metallic filaments soon made much better lamps possible."

**Note:** The photograph of Willis Rodney Whitney was scanned from Broderick's book.

### References

- 1) John T. Broderick, Willis Rodney Whitney - Pioneer of Industrial Research, Fort Orange Press, Inc., Publishers, Albany, New York, 1945, pp 309-310, (excerpt from Whitney letter of July 5, 1945).
- 2) George Wise, Willis R. Whitney, General Electric, and the Origins of U. S. Industrial Research, Columbia University Press, New York, 1985.

### W. Mattieu Williams



There are names in incandescent lamp history that should be remembered because of the important supporting roles played by the individuals. One of those names is William Mattieu Williams (Feb 6, 1820-Nov 28, 1892)<sup>8, 10</sup>. Williams, born either in London<sup>10</sup> or in Flintshire, Wales<sup>6</sup>, was the son of Abraham and Louise (Mattieu) Williams<sup>10</sup>. Not only did he play a helping role in lamp development but it was done very early in the history of the lamp; it was in 1845-46 that Williams helped to bring a lamp to public notice.

It is generally stated that the practical incandescent lamp had its beginning with the development by John Wellington Starr of an evacuated vessel that contained a continuous carbon "burner." Starr was from Cincinnati, Ohio and his early work was performed there. His lamp was patented in England in 1845 under the name of Edward Augustin King. It is not the intention here to describe Starr's lamp but rather to reveal the role played by Williams in its development; the story about Starr was published by Charles D. Wrege in 1976<sup>11</sup>. In addition, a write-up on Starr exists on this website under "Biographical Sketches."

The details of the work by John W. Starr were vague and often incorrect as reported in technical writings, until Dr. Wrege researched the subject thoroughly and reported his findings. Dr. Wrege mentioned an early letter by Williams<sup>1</sup> that indicated the role he played in the development of Starr's lamp. In addition, there were subsequent letters to the editors of periodicals in which Williams outlined his role with Starr<sup>2,4</sup>.

In an article by Gelyi<sup>7</sup>, Williams was quoted in a letter published in *Nature* as saying:

"I assisted the inventor myself in the construction of his apparatus, and in the experiments made with them; my remuneration was to be one-eighth of the profits. After the death of Starr all his apparatus became my property. I have, more than 20 years ago, several times exhibited the original lamp in the Midland Institute at Birmingham, and also showed it in action there. I also exhibited the lamp on two occasions in the Town Hall. The light was far clearer and the carbon strips were far more durable than the thin carbon filaments of the glow lamps of the present day.

"Starr's invention was abandoned, because the generation of the necessary electricity was too expensive; as regards effectiveness and clearness of light the lamp was a complete success."

It should be mentioned that Gelyi apparently took great liberty in quoting Williams. During a search for the mentioned *Nature* reference it was found in the 1883 volume<sup>4</sup>. Although the substance of Williams letter was not distorted, sentences were reworded; perhaps that was permissible in 1885.

In an earlier letter William said<sup>2</sup>:

"I may add that the result of our battery experiments was to convince Mr. Starr that a magneto-electric arrangement should be used as the source of power in electric illumination; and that he died suddenly in Birmingham in 1846, while constructing a magnetic battery with a new armature which, theoretically, appeared a great improvement on those used at that date. Of its practical merits I am unable to speak."

Fortunately, for those interested in the history of the electric incandescent lamp, W. Mattieu Williams left an additional write-up that mentions his work with John Wellington Starr.

Apparently it was published in *The Journal of Science*<sup>3</sup> and then reprinted in one of his books<sup>4,5</sup>. His article<sup>5</sup> is reproduced below in its entirety:

"As the subject of lighting by electricity is occupying so much public attention, and the merits of various inventors and inventions are so keenly discussed, the following facts may have some historical interest in connection with it.

"In October, 1845, I was consulted by some American gentlemen concerning the construction of a large voltaic battery for experimenting upon an invention, afterward described and published in the specification of 'King's Patent Electric Light' (Letters Patent granted for Scotland, November 26th, 1845; enrolled March 25th, 1846; English Patent sealed November 4th, 1845).

"Mr. King was not the inventor, but he and Mr. Dorr supplied capital, and Mr. Snyder also held a share, which was afterward transferred to myself. The inventor was Mr. Starr, a young man about twenty-five years of age, and one of the ablest experimental investigators with whom I have ever had the privilege of near acquaintance.

"He had been working for some years on the subject, commencing with the ordinary arc between charcoal points. His first efforts were directed to maintaining constancy, and he showed me, in January of 1846, an arrangement by which he succeeded in effecting an automatic renewal of contact by means of an electro-magnet, the armature of which received the electric flow, when the arc was broken, and which thus magnetized brought the carbons together and then allowed them to be withdrawn to their required separation, when the flow returned. This device was almost identical with that subsequently reinvented and patented by Mr. Staite (quite independently, I believe), and which, with modifications, has since been rather extensively used.

"Although successful so far, he was not satisfied. He reasoned out the subject, and concluded that the electric spark between metals, the electric arc between the carbons, and other luminous electric phenomena are secondary effects due to the heating and illumination of electric carriers; that the electric spark of the conductors of ordinary electrical machines is simply a transfer of incandescent particles of metal, which effect a kind of electric convection, known as the disruptive discharge; and that the more brilliant arc between the carbon points is simply due to the use of a substance which breaks up more readily, and gives a longer, broader, and more continuous stream of incandescent convection particles.

"This is now readily accepted, but at that time was only dawning upon the understanding of electricians. I am satisfied that Mr. Starr worked out the principle quite originally. He therefore concluded that, the light being due to

solid particles heated by electric disturbance, it would be more advantageous—as regards steadiness, economy, and simplicity—to place in the current a continuous solid barrier, which should present sufficient resistance to its passage to become bodily incandescent without disruption.

"This was the essence of the invention specified in King's Patent as 'a communication from abroad,' which claims the use of continuous metallic and carbon conductors, intensely heated by the passage of a current of electricity, for the purpose of illumination.

"The metal selected was platinum, which, as the specification states, 'though not so infusible as iridium, has but little affinity for oxygen, and offers a great resistance to the passage of the current.' The form of thin sheets known by the name of leaf-platinum is described as preferable. These to be rolled between sheets of copper in order to secure uniformity, and to be carefully cut in strips of equal width, and with a clean edge, in order that one part may not be fused before the other parts have obtained a sufficiently high temperature to produce a brilliant light. This strip to be suspended between forceps.

"I need not describe the arrangement for regulating the distance between the forceps, for directing the current, etc., as we soon learned that this part of the invention was of no practical value, on account of the narrow margin between efficient incandescence and the fusion of the platinum. The experiments with the large battery that I made—consisting of 100 Daniell cells, with two square feet of working surface of each element in each cell, and the copper-plates about three quarters of an inch distant from the zinc—satisfied all concerned that neither platinum nor any available alloy of platinum and iridium could be relied upon, especially when the grand idea of subdividing the light by interposing several platinum strips in the same circuit, and working with a proportionally high power, was carried out.

"This drove Mr. Starr to rely upon the second part of the specification—viz. that of using a small stick of carbon made incandescent in a Torricellian vacuum. He commenced with plumbago, and, after trying many other forms of carbon, found that which lines gas-retorts that have been long in use to be the best.

"The carbon stick of square section, about one tenth of an inch thick and half an inch working length, was held vertically, by metallic forceps, at each end, in a barometer tube, the upper part of which, containing the carbon, was enlarged to a sort of oblong bulb. A thick platinum wire from the upper forceps was sealed into the top of the tube and projected beyond; a similar wire passed downward from the lower forceps, and dipped into the mercury of the tube, which was so long that when arranged as a barometer the enlarged end containing the carbon was vacuous.

"Considerable difficulty was at first encountered in supporting this fragile stick. Metallic supports were not available, on account of their expansion; and, finally, little cylinders of porcelain were used, one on each side of the carbon stick, and about three eighths of an inch distant.

"By connecting the mercury cup with one terminal of the battery, and the upper platinum wire with the other, a brilliant and perfectly steady light was produced, not so intense as the ordinary disruption arc between carbons, but equally if not more effective, on account of the magnitude of brilliant radiating surface.

"Some curious phenomena accompanied this illumination of the carbon. The mercury column fell to about half its barometric height, and presently the glass opposite the carbon stick became slightly dimmed by the deposition of a thin film of sooty deposit.

"At first the depression of the mercury was attributed to the formation of mercurial vapor, and is described accordingly in the specification; but further observation refuted this theory, for no return of the mercury took place when the tube was cooled. The depression was permanent. The formation of vaporous carbon was suggested by one of the capitalists; but neither Mr. Starr nor myself was satisfied with this, nor with any other surmise we were able to make during Mr. Starr's lifetime, nor up to the period of final abandonment of the enterprise.

"When this occurred the remaining apparatus was assigned to me, and I retained possession of the finally arranged tube and carbon for many years, and have shown it in action worked by a small Grove's battery in the Town Hall at the Birmingham, and many times to my pupils at the Birmingham and Midland Institute.

"These exhibitions suggested an explanation of the mysterious gaseous matter, which I believe to be the correct one, and also of the carbon deposit. It is this : That the carbon contains occluded oxygen ; that when the carbon is heated some of this oxygen combines with the carbon, forming carbonic oxide and carbonic acid, and a little smoke. I proved the presence of carbonic acid by the usual tests, but did not quantitatively determine its proportion of the total atmosphere.

"If I were fitting up another tube on this principle I should wash it with a strong solution of caustic potash before filling with mercury, and allow some of the potash solution to float on the mercury surface, by filling the tube while the glass remained moistened with the solution. My object would be to get rid of the carbonic acid as soon as formed, as the observations I have made lead me to believe that when the carbon stick is incandescent in an atmosphere of carbonic acid or carbonic oxide a certain degree of

dissociation and recombination is continually occurring, which weakens and would ultimately break up the carbon stick, and increases the sooty deposit.

"The large battery was arranged for intensity, but even then it was found that the quantity (I use the old-fashioned terms) of electricity was excessive, and that it worked more advantageously when the cells were but partially filled with acid and sulphate. A larger stick of carbon might have been used with the whole surface in full action.

"After working the battery in various ways, and duly considering the merits of other forms of battery then in use, Mr. Starr was driven to the conclusion that for the purposes of practical illumination the voltaic battery is a hopeless source of power, and that magneto-electric machinery driven by steampower must be used. I fully concurred with him in this conclusion, so did Mr. King, Mr. Dorr, and all concerned.

"Mr. Starr then set to work to devise a suitable dynamo-electric machine, and, following his usual course of starting from first principles, concluded that all the armatures hitherto constructed were defective in one fundamental element of their arrangement. The thick copper-wire surrounding the soft iron core necessarily follows a spiral course, like that of a coarse screw-thread; but the electric current or lines of force, which it is designed to pick up and carry, circulate at right angles to the axis of the core, and extend to some distance beyond its surface. The problem thus presented is to wind around the soft iron a conductor that shall be broad enough to grasp a large proportion of this outspread force, and yet shall follow its course as nearly as possible by standing out at right angles to the axis of the armature. This he endeavored to effect by using a core of square section, and winding round it a broad ribbon of sheet copper, insulated on both sides by cementing on its surface a layer of silk ribbon. This armature was laid with one edge against one side of the core, and carried on thus to the angle; then turned over so that its opposite edge should be presented to the next side of the core; this side to be followed in like manner, the ribbon similarly turned again at the next corner, and so on till the core became fully inclosed or armed with the continuous ribbon, which thus encircled the core with its edges outward, and nearly at right angles to the axis, in spite of its width, which might be increased to any extent found by experiment to be desirable.

"At this stage my direct co-operation and confidential communication with Mr. Starr ceased, as I remained in London while he went to Birmingham in order to get his machinery constructed, and to apply it at the works of Messrs. Elkington, who had then recently introduced the principle of dynamo-electric motive-power for electro-plating, etc., and were, I believe, using Woolrich's apparatus, the patent for which was dated August 1st, 1842, and enrolled February 1st, 1843.

"I am unable to state the results of his efforts in Birmingham. I only heard the murmurs of the capitalists, who loudly complained of expenditure without results. They had dreamed the same dream that Mr. Edison has recently re-dreamed, and has told the world so loudly. They supposed that the mechanically excited current might be carried along great lengths of wire, and the carbons interposed wherever required, and that the same electricity would flow on and do the duty of illumination over and over again as a river may fall over a succession of weirs and turn water-wheels at each. Mr. Starr knew better; his scepticism was misinterpreted; he was taunted with failure and non-fulfilment of the anticipations he had raised, and with the fruitless expenditure of large sums of other people's money. He was a high-minded, honorable, and very sensitive man, suffering already from overworked brain before he went to Birmingham. There he worked again still harder, with further vexation and disappointment, until one morning he was found dead in his bed. Having, during my short acquaintance with him, enjoyed his full confidence in reference to all his investigations, I have no hesitation in affirming that his early death cut short the career of one who otherwise would have contributed to the progress of experimental science, and have done honor to his country.

"His martyrdom, for such it was, taught me a useful lesson I then much needed—viz. to abstain from entering upon a costly series of physical investigations without being well assured of the means of completing them, and, above all, of being able to afford to fail.

"There are many others who sorely need to be impressed with the same lesson, especially at this moment and in connection with this subject.

"The warning is most applicable to those who are now misled by a plausible but false analogy. They look at the progress made in other things, the mighty achievements of modern Science, and therefore infer that the electric light—even though unsuccessful hitherto—may be improved up to practical success, as other things have been. A great fallacy is hidden here. As a matter of fact, the progress made in electric lighting since Mr. Starr's death, in 1846, has been very small indeed. As regards the lamp itself, no progress whatever has been made. I am satisfied that Starr's continuous carbon stick, properly managed in a true vacuum, or an atmosphere free from oxygen, carbonic oxide, carbonic acid, or other oxygen compound, is the best that has yet been placed before the public for all purposes where exceptionally intense illumination (as in light-houses) is not demanded.\*

-----  
\*The burnt card, burned bamboo, and other flimsy incandescent threads now (1882) in vogue, merely represent Starr's preliminary failures prior to his adoption of the hard adamantine stick of retort-carbon, which I suppose will be duly reinvented, patented again, and form the basis of new Limited Companies, when the present have collapsed.



-----  
-----  
"Comparing electric with gas lighting, the hopeful believers in progressive improvement appear to forget that gas-making and gas-lighting are as susceptible of further improvement as electric lighting, and that, as a matter of fact, its practical progress during the last forty years is incomparably greater than that of the electric light. I refer more particularly to the practical and crucial question of economy. The by-products, the ammoniacal salts, the liquid hydrocarbons, and their derivatives, have been developed into so many useful forms by the achievements of modern chemistry that these, with the coke, are of sufficient value to cover the whole cost of manufacture, and leave the gas itself as a volatile residuum that costs nothing. It would actually and practically cost nothing, and might be profitably delivered to the burners of gas consumers (of far better quality than now supplied in London) at one shilling per thousand cubic feet, if gas-making were conducted on sound commercial principles—that is, if it were not a corporate monopoly, and were subject to the wholesome stimulating influence of free competition and private enterprise. As it is, our gas and the price we pay for it are absurdities; and all calculations respecting the comparative cost of new methods of illumination should be based not on what we *do* pay per candlepower of gas-light, but what we *ought* to pay and *should* pay if the gas companies were subjected to desirable competition, or visited with the national confiscation I consider they deserve.

"Having had considerable practical experience in the commercial distillation of coal for the sake of its liquid and solid hydrocarbons, I speak thus plainly and with full confidence.

"There is yet another consideration, and one of vital importance, to be taken into account—viz. that, whether we use the electric light derived from a dynamo-electric source, or coal-gas, our primary source of illuminating power is coal, or rather the chemical energy derivable from the combination of its hydrogen and carbon with oxygen. Now this chemical energy is a limited quantity, and the progress of Science can no more increase this quantity than it can make a ton weigh 21 cwts. by increasing the quantity of its gravitating energy.

"The demonstrable limit of scientific possibilities is the economical application of this limited store of energy, by converting it into the demanded form of force without waste. The more indirect and roundabout the method of application, the greater must be the loss of power in the course of its transfer and conversion. In heating the boiler that sets the dynamo-electric machine to work, about one half the energy of the coal is wasted, even with the best constructed furnaces. This merely as regards the quantity of water evaporated. In converting the heat-force into mechanical power—raising the piston, etc., of the steam-engine—this working half is again seriously reduced. In further converting this residuum of mechanical

power into electrical energy, another and considerable loss is suffered in originating and sustaining the motion of the dynamo-electric machine, in the dissipation of the electric energy that the armature cannot pick up, and in overcoming the electrical resistances to its transfer.

"I am unable to state the amount of this loss in trustworthy figures, but should be very much surprised to learn that, with the best arrangements now known, more than one tenth of the original energy of the coal is made practically available. This small illuminating residuum may, and doubtless will, be increased by the progress of practical improvement; but, from the necessary nature of the problem, the power available for illumination at the end of the series must always be but a small portion of that employed at the beginning.

"In burning the gas derived from coal we obtain its illuminating power *directly*, and if we burn it properly we obtain nearly all. The coke residuum is also directly used as a source of heat. The chief waste of the original energy in the gas-works is represented by that portion of the coke that is burned under the retorts, and in obtaining the relatively small amount of steam-power demanded in the works. These are far more than paid for by the value of the liquid hydrocarbons and the ammonia salts, when they are properly utilized.

"In concluding my narrative I may add that after Mr. Starr's death the patentees offered to engage me on certain terms to carry on his work. I declined this, simply because I had seen enough to convince me of the impossibility of any success at all corresponding to their anticipations. During the intervening thirty years I have abstained from further meddling with the electric light, because all that I had seen then, and had heard of since, has convinced me that—although as a scientific achievement the electric light is a splendid success—its practical application to all purposes where cost is a matter of serious consideration is hopeless, and must of necessity continue to be so.

"Whoever can afford to pay some shillings per hour for a single splendid light of solar completeness can have it without difficulty, but not so where the cost in pence per hour per burner has to be counted.

"I should add that before the publication of King's specification, Mr. (now Sir William) Grove proposed the use of a helix or coil of platinum, made incandescent by electricity, as a light to be used for certain purposes. This was shown at the Royal Society on or about December 1st, 1845.

"Since the publication of the above in 1879, I have learned, from a paper in the *Quarterly Journal of Science*, by Professor Ayrton, that in 1841 an English patent was granted to De Moylens for electric lighting by incandescence."

Note: The portrait sketch of Mr. Williams was scanned from reference 8. The sketch was made from a photograph taken shortly before his death.

### References

- 1) "King's Patent Electrical Light", William Williams, *The Mechanics' Magazine and Journal of Science, Arts, and Manufactures*, Vol 44, 1846, pp 348-49.
- 2) "New Electric Lights", W. Mattieu Williams, *Nature*, Vol XVI, Sep 27, 1877, pg 459.
- 3) "A Contribution to the History of Electric Lighting", W. Mattieu Williams, *The Journal of Science*, 1, 1879, pp 155-162.
- 4) "The Inventor of the Incandescent Electric Light", W. Mattieu Williams, *Nature*, Vol XXVIII, Jan 11, 1883, pg 241.
- 5) Science in Short Chapters, W. Mattieu Williams, Funk & Wagnalls, New York, 1883, Chap XIX, "A Contribution to the History of Electric Lighting", pp 125-133.
- 6) *ibid*, inside front cover.
- 7) "A Short History of Incandescence Lamps", A. Gelyi, *The Telegraphic Journal and Electrical Review*, Vol XVI, No 375, Jan 31, 1885, pg 89.
- 8) "The Late Mr. Mattieu Williams", *Knowledge*, Vol XVI, Jan 2, 1893, pg 12.
- 9) "William Mattieu Williams", Biographical notice and works, *Monthly Notices of the Royal Astronomical Society*, 53, 1893, 224-225.
- 10) "William Mattieu Williams", *Dictionary of National Biography*, Vol XXI, The Macmillan Co., NY, 1909, pg 468.
- 11) "J. W. Starr: Cincinnati's Forgotten Genius", Charles D. Wrege, *The Cincinnati Historical Society Bulletin*, Vol 34, Summer 1976, No 2, pg 103.
- 12) Catalogue of Scientific Papers-Compiled by the Royal Society of London, W. Mattieu Williams; Vol VI, pg 379; Vol VIII, pg 1244; Vol XI, pg 816; Vol XIX, pg 637.

### O. E. Woodhouse

One of the early lamps marketed in England was known as Woodhouse-Rawson. O. E. Woodhouse died in 1887 at the age of 32. Below is an obituary that appeared in *The Electrician and Electrical Engineer*.

"Mr. O. E. Woodhouse, senior partner of the electrical engineering firm of Woodhouse & Rawson; London, died at Brighton, October 21. Mr. Woodhouse was born in London, October 21, 1855. At King's College, London, he acquired a knowledge of physical science which well qualified him for his career as an electrical engineer. Leaving college, he began his work by entering the shops of Messrs. Hunter & English, where he passed three years. In 1877 he entered the railway service, taking a position with the Great Eastern Railway Co., and afterwards with the London and Northwestern Railway Co.'s locomotive department, where he continued till early in 1881. In the summer of 1880 Mr. Woodhouse visited the United States and Canada, where he spent six months in examining engineering and scientific works. Soon after his return to England in 1881, he entered into partnership with Mr. F. L. Rawson in the business of general electrical engineering, in which field the firm of Woodhouse & Rawson has since achieved distinguished success. Such thoroughly trained and energetic

workers in the field of electrical engineering as Mr. Woodhouse can ill be spared from a vocation in which the work to be done increases faster than the competent hands can be found to carry it forward."

### Reference

Obituary - "O. E. Woodhouse", *The Electrician and Electrical Engineer*, Vol 6, Nov 1887, pg 460.

### Edmund

### Louis

### Gray

### Zalinski

Edmund Zalinski (1849 - 1909) is better known for his achievements and inventions for the military than for any contribution to the development of lighting. However, at the latter stage of his life he did venture into the lighting field and this short note suggests that he deserves a mention in its history.

Edmund Zalinski was born in Kurnick, Poland and came to the United States with his parents in 1853. In 1865 he joined the army during the Civil War. Zalinski was commissioned a 2nd lieutenant after exhibiting gallantry at Hatcher's Run, Virginia. He continued to serve in the army and then during the period 1872-1876 he taught military science at the Massachusetts Institute of Technology. Some of his inventions that were related to his military service can be found in the internet links in the references below.

Prior to 1893 Zalinski suffered a stroke of paralysis and he took an extended trip to Europe. Upon returning, his health had improved but in early 1894 the Army Retiring Board recommended that he retire. It was after retirement from the army that Zalinski became interested in shades and reflectors<sup>5,6</sup> for incandescent lamps. A lamp made for him in Niles, Ohio can be found in the William J. Hammer Collection, No. 1904-845. A rather poor picture of that lamp, trimmed from the larger picture, is shown below.



### References

- 1) "A New Submarine Torpedo Boat", *Scientific American*, Aug 7, 1886.
- 2) Personal, *Electrical Review*, Vol 22, May 13, 1893, pg 159.
- 3) Personal, *Electrical Review*, Vol 24, Jan 10, 1894, pg 15.
- 4) J. H. Brown, Lamb's Biographical Dictionary of the United States, 1903.
- 5) E. L. Zalinski, Reflector, U. S. Patent No. 756,194, Mar 29, 1904.

- 6) E. L. Zalinski, Reflector, U. S. Patent No. 775,741, Nov 22, 1904.
- 7) J. M. Cattell, American Men of Science, 1906.
- 8) "Zalinski, Dynamite Gun Perfecter, Dead", *New York Times*, Mar 11, 1909, pg 9, col 5, 7.
- 9) Obituary, Major E. L. A.(G.) Zalinski, *Electrical World*, Vol LIII, Mar 18, 1909, pg 710.
- 10) "Edward Louis Gray Zalinski", Wheeler Preston, American Biographies, Harper & Brothers, New York, 1940, pg 1146.
- 11) E. L. G. Zalinski, *Who Was Who in America*, Vol 1 (1897-1942), 1st Ed., pg 1394.
- 12) Edmund Louis Gray Zalinski
- 13) The Zalinski Dynamite Gun
- 14) The Zalinski Boat Under Construction

### Corrections to Howell and Schroeder's Book

The 1927 book by John W. Howell and Henry Schroeder, titled The History of the Incandescent Lamp, is the best reference available regarding the Edison lamp development. It might be of interest to lamp collectors if a few minor corrections are made to the book.

In May 1960 the writer was employed at the General Electric Research Laboratory in Schenectady, NY. While browsing through a copy of Howell and Schroeder it was noticed that some corrections had been made in the book by Dr. Saul Dushman. As these corrections are apt to be correct, in view of Dr. Dushman's standing in the scientific community, it was thought they should be passed on. They were:

page 24, fifth line from top: "1866" instead of "1886".

page 46, "unknown" instead of "J.F. Kelly".

page 46, ..., "James Seymour and John F. Kelly" instead of "James Seymour and unknown".

page 47, There was a handwritten note attached here that was signed by Chas. L. Clarke on Oct 12, 1927.

"In the photo. of laboratory interior, second floor, the men, from left to right, are: - Ludwig K. Boehm - Chas. L. Clarke - Chas. Batchelor - Wm. Carman - Sam. D. Mott - Geo. Dean - Thos. A. Edison - Chas. T. Hughes - Geo. Hill - Geo. Carman - Francis Jehl - John W. Lawson - Chas. Flammer - Chas. P. Mott - James v. MacKenzie."

page 58, change "October 21" to "October 19".

page 62, change "San Francisco" to "Portland, Oregon".

page 124, illustration is upside down.

page 156, add to "FLAT STEM SEAL, 1881" the following: "U.S. Patent 264,698, Sep 19, 1882, to Wm. Holzer".

### **Excerpts from John W. Howell's Stories for My Children**

Perhaps the best reference book for description and identification of Edison lamps is the book titled The History of the Incandescent Lamp by John W. Howell and Henry Schroeder. John Howell wrote another book in 1930 that resulted because of a story told by him to one of his children. Howell said in his book "One day recently I told one of my children a story□one of the stories in this collection. It interested her very much, and she said: 'Gee, Dad, I didn't know you were that kind of a fellow.' So, in order that my children may know what kind of a fellow I am, I have written these stories."

Although Howell's stories make for interesting reading, only some of those that relate to the incandescent lamp are considered here.

(Pages 22-23)

"In December, 1879, my brother, Wilson, went on a straw ride with a number of young men and girls. They drove to Menlo Park and saw the first public demonstration of Mr. Edison's electric lighting system. They were very much impressed, and the next morning Wilson went to Menlo Park trying to get a job with Edison. He got the job□long hours and no pay. He worked without pay for over a year. He was one of several young men who worked there, doing all kinds of work for Mr. Edison. They were real pioneers, for all the work at that time was pioneering."

"In December, 1880, Mr. Edison made a second public demonstration. This time the wires carrying the electricity were laid underground. My brother, Wilson, laid these underground wires. He used No. 10 bare copper wires, which he made into cables of different sizes, and wrapped these bare cables with strips of muslin soaked in a bituminous compound which he concocted. The cables were laid in wooden troughs and buried in the ground."

"Two years later, when we moved the lamp factory from Menlo Park to Harrison, we took up these copper cables, piled them, and burned the insulation off them, and we used these bare copper wires in wiring the Harrison lamp factory. The bare wires were run on the ceilings, stapled to the beams, and no fuses were used. They remained in use until we began to have rules and laws about electric light wires, and then they were taken down and replaced with insulated wires."

"In 1880 I was living at Hoboken, attending Stevens Institute; but I spent Sundays home in New Brunswick, and through Wilson I became interested in Mr. Edison's work and soon got acquainted with him. I calculated a number of wiring tables for him from December, 1880 to June, 1881. These tables showed the sizes of wires necessary to carry different numbers of

lamps different distances with different percentages of loss. Each table was based on a lamp of given resistance. He paid me \$10 a table.

"Dr. Morton got one of Edison's lamps and measured it in the lab. I watched him and learned how he did it. Then for my graduating thesis I got a number of lamps and made tests on them. I also got a dynamo and tested it. This thesis was widely published.

"Mr. Edison started a lamp factory at Menlo Park in the fall of 1880. Incandescent electric lamp making was an entirely new industry; everything in the factory had to be made specially for it and progress was very slow. When I finished at Stevens, I got a job in this lamp factory—July 6, 1881. Dr. E.L. Nichols had equipped a room for testing and photometering lamps. He left in July, 1881, and I got his job, with very little instruction from him. The wiring in the room was in confusion. I spent one Sunday tracing out the wires and making a diagram of them. After studying this diagram a long time I understood it. There were many wires there which were no longer used. I tore them out. Then I asked permission to tear out all wires and rewire the room. Mr. Upton was afraid I could not get it working again, but he finally gave me permission. So I tore all the wires out, rewired it more simply, and it was O.K. That gave Mr. Upton confidence in me, and he gave me charge of all electric wiring, and then the dynamos, motors, etc. When I had been at work three months, Dr. Morton sent me a letter offering me a job at \$2,000 per year. I was getting \$15 a week, or \$780 a year. I showed the letter to Edison, and he said: "Do you want to take it?" I said: "No, I want to stay here." He said: "How much pay do you want to stay?" I said: "Thirty dollars a week." He gave it to me. It was big pay in that place. I was then nearly 24 years old.

(Pages 24-28)

"When the Edison Lamp Company was incorporated—about 1883—Mr. Edison allowed me to buy one share of the stock—par \$2,500—for \$1,800. I started paying for it at the rate of \$5 a week, taken out of my wages.

"The voltage indicators used on all the electric light plants were being made at the lamp factory under my supervision. In 1884-85 my brother, Wilson, built a central station in New Brunswick. I set up the indicators for him, and they were very unreliable. While sweating over this job, I invented an entirely new method of indicating voltages at the different feeder ends which used a very simple instrument. I made a set of these indicators for the New Brunswick station and they worked perfectly. I explained the system to Mr. Upton. He admitted that the invention belonged to me and agreed to buy it for the company for \$1,000. Mr. Edison and Mr. Insull, the other officers of the lamp company, refused to pay \$1,000, but offered me \$500. Realizing that it was worth more than \$1,000, I suggested that they make the indicators and pay me a royalty of \$3 on each one sold. Such a contract was made and

in the next four years they paid me \$15,000 royalty. Then they bought my contract and patent for \$10,000, paying me \$1,000 a month for 10 months. When they made this contract with me they wanted to get foreign patents on the thing. After thinking it over, I offered them all foreign rights for the balance I owed on my share of stock. They accepted this offer, so my stock cost me about \$800. This stock paid good dividends monthly—\$1, then \$2, then \$3. When the lamp company was merged into the Edison General Electric Company in 1889 I got for my stock \$4,000 in cash and \$7,500 in stock, which I later sold for \$8,250.

"When I got my job in the lamp factory, I was hired by Mr. Upton. Mr. William Holzer was superintendent. He married the first Mrs. Edison's sister. Holzer disliked Upton and all who worked directly for him. This included me and he hampered me greatly when I undertook to do work for Upton in the factory. He became so rank that I presented evidence of his misdoings to Mr. Edison, and we had a showdown, which ended in an hour by Edison firing Holzer. Then I could work freely in the factory. This was about 1887.

"I did a lot of work on the mercury vacuum pump used in exhausting lamps. Each pump exhausted one lamp at a time, and in 1881 it took five hours to do it. A mercury pump will pump the air out of lamps, but will not take out the water vapor, which is most injurious if left in the lamp. To remove this water vapor we used phosphoric anhydride, which is a wonderful absorber of water vapor. Changing the location of the "phosphorus cup" and putting it as close as possible to the lamp being exhausted was my first great improvement in the exhaustion. It reduced the time a lot. Heating the lamp bulb during exhaustion freed the water vapor held by the glass and made a quicker and better exhaustion. Enlarging the parts of the pump and making it flow 8 pounds of mercury a minute instead of two and using an iron "contraction" which limited the flow of mercury was the last great improvement in the pump which I made. This iron contraction did not get dirty and diminish the flow as the glass contractions had done. These changes reduced the time of exhaustion to one-half hour for a complete cycle.

"In 1890 the Edison patent covering his high-resistance lamp was being litigated in a suit brought by the Edison Electric Light Company against the United States Electric Light Company. A similar English patent had previously been litigated in England. The patent law requires that the patent specification must describe the article so well that a man skilled in the art can make the article using only the information which is in the specification. In the English case the court appointed three men, supposed to be skilled in the art, to make the lamps following the specifications. These three men were unable to make the lamps. The lawyers who were against the patent in this country knew of this and they put good experts on. These testified that the lamps could not possibly be made by following the instructions



contained in the specifications, and they gave good scientific reasons why, but these reasons were based on a wrong assumption. The Edison lawyers asked Mr. Edison to have men in his laboratory make the lamps. He put two of his men on the job, and, after working some time, they said they could not make them. Knowing all this, I undertook to make them. I got tar from the gas works. I made lampblack by letting kerosene lamps smoke their chimneys. I mixed these, kneading them until they made a very thick mixture, like thick putty. This I rolled on a glass plate with a stick about 1 inch wide, and I rolled threads of the mixture which were 14 inches long and six thousandths of an inch thick. I coiled these and carbonized them as the patent directed, and thus made filaments for the lamps. Everything came out just as the patent described, and I made 30 or 40 lamps with no trouble at all. A number of these lamps were burned on life test for 600 hours and were good lamps. Our lawyers were immensely pleased and I got a raise.

"Then I testified about making the lamps and stood my cross-examination well, and I got another raise. During the argument my testimony was bitterly but unsuccessfully attacked. The court sustained the patent, and the judge said in his decision that my testimony had completely refuted the claims that the patent did not give sufficient information to enable a man skilled in the art to make the lamps. Then I got another raise. Three raises for this work! I also received many congratulations for this work, some from lawyers and officers of the defeated company. This patent decision helped bring about the consolidation of the Edison Company and the Thomson-Houston Company, for the Thomson-Houston Company was infringing the Edison patent in making incandescent lamps.

"During subsequent years there has been a great deal of litigation of patents on incandescent lamps and in many of these I have given testimony which has been of considerable importance.

"In Judge Mayer's opinion sustaining the Just and Hanaman patent on the tungsten filament he quoted part of a paper which I had read before the convention of the Association of Edison Illuminating Companies and said it aided him materially in deciding one of the main points of contention concerning the validity of the patent.

"The lamps made by the Thomson-Houston Company were better than the lamps made by the Edison Company, because they subjected their carbon filaments to a treating process which was patented by Sawyer & Man, and the Thomson-Houston Company was licensed under this patent. In this treating process the filaments were raised to very high temperature in gasoline vapor, and this improved their quality a great deal. Soon after the consolidation, this treating patent expired, and then I went to the Thomson-Houston lamp factory at Lynn, Mass., to see and learn this process. The engineers there showed it to me freely, and told me their theories about it. I got a set of treating apparatus and took it to Harrison. I set it up and devoted

a lot of time to studying it. I found that their ideas as to what were the best conditions for treating were wrong. After a while I made better filaments than were made at Lynn. Soon after this Mr. Rice, who had charge of all manufacturing in the General Electric Company, came to Harrison and said to me: "We have two lamp factories—one at Lynn and one at Harrison. We need only one. I want you to make 100 lamps, the best you can make, and send 50 of them to Lynn for test. Lynn will also make 100 and send 50 to you for test. I want to know which can make the best lamps." So I made 100 lamps, doing most of the work myself—treating the filaments the way I thought best—and sent 50 of them to Lynn. Lynn also made 100 and sent me 50. So we both started tests on the two makes of lamps. After a while Mr. Rice again came to Harrison and said: "Howell, the Lynn boys admit your lamps are better than theirs, so we will shut down the Lynn factory and such of the Lynn men as you want will come to Harrison and work for you." I was soon after this—in April, 1894—appointed engineer and assistant manager of the lamp works. Mr. Upton was manager. He was one of Mr. Edison's early assistants and had been manager of the lamp works since 1880. I continued to improve the treating process and worked out a method which enabled me to make a nearly automatic treating machine, which produced a more uniform quality of carbon filaments than had ever before been produced and produced them in large numbers. A valve devised for this treating machine was used later in the lamp-exhausting machine.

"Before the formation of the General Electric Company the Thomson-Houston Company had hired a man who taught them to make squirted cellulose threads which, when carbonized, made carbon filaments. The process had not been developed to a commercial success, but they had made many filaments. Their 110 volt cellulose filaments seemed to be defective, for in lamps they all broke at the same spot. After the consolidation these filaments were brought to Harrison and the development of the process continued. We found that the filaments which were made in Lynn and were considered defective were O.K. when treated in my treating apparatus. The cause of their all breaking at the same point in Lynn was in the treating process not being good. Our chemist—we had only one then—worked on the process and made our filaments by it. He was not very successful and our stock of filaments was very small. I hired a second chemist, and the day he came to work the first chemist left without showing anyone the details of making squirted filaments, and we depended entirely on these filaments for our lamps.

"The next morning the man who ran our carbonizing furnaces told me the filaments came out all stuck together. I asked him why it was. He replied that he knew, but wanted a raise before he told me. I told him to get his hat and coat, and I accompanied him to the gate and fired him. Then we had a job on our hands. Mr. Marshall took charge of the carbonizing. Our new chemist was just out of college and had no experience, but he and Mr. Doane

and I tackled the squirting process. We had very few filaments in stock, and were afraid we would have to shut down the factory.

"We made these filaments by dissolving paper in zinc chloride, passing it through a filter and then squirting it through a die into alcohol, which set it into a thread, which was then washed and dried. Our trouble came in trying to filter it. Only about one-fourth of the stuff would go through no matter how long or how hot we mixed it. We worked from 8 a.m. to midnight for several days and made little progress. We had three mixers, and we noticed that the stuff from one of the mixers came through the filter a little better than the others. We made all sorts of experiments, but could not account for the difference. It was Saturday afternoon; I was there with one man; I again measured the speed of each of the three mixers. Two ran 70 turns per minute and the good one ran 71. I thought this could not possibly cause the difference in mixing, but I changed a pulley so that one of them ran about 100. The stuff from this mix all went through the filter and our troubles were over. In the meantime, Mr. Marshall had mastered the carbonizing. So now we had plenty of filaments, but our stock was about all used up, and we would have had to shut the factory in a day or two if we had not worked out our problems when we did. Mr. Rice wrote a letter to Marshall, Doane and me, thanking us for our work and congratulating us on our success.

(Page 29)

"When we were making squirt fibers, the cellulose solution was squirted through dies into alcohol. Along one side of the squirt room there was a long row of jars of alcohol. These jars were filled by a hose connected with a barrel of alcohol on a platform about 8 feet high. When this barrel was empty, it was filled by connecting the hose with a new barrel of alcohol on the floor and applying air pressure to this barrel to force the alcohol up and into the high barrel. One day I stood in the doorway of this room watching this operation. When the air pressure was turned on, the head of the barrel blew out, emptying the 50 gallons of alcohol on the floor. On a bench along the side of the room, opposite where I stood, were three Bunsen burners, burning. I ran across the room, walking in the alcohol on the floor, and turned the gas from all the burners. Then I trembled all over. Alcohol vapor is heavier than air and rises slowly. If it had reached one of the flames before I did, there would have been a big explosion and everyone in the room would have been burned to death.

(Pages 30-32)

"The Edison Lamp Works were now in 1899 making the best lamps ever made, and our sales department inaugurated a new plan. Many large users of lamps placed orders for a year's supply. To each such customer our men would propose a test to determine which of the various makes of lamps on the market was the best. We would lend to such customers all the apparatus

needed for the test and instruct them, so they could make the tests themselves. There were a number of independent lamp makers in the business. Whenever these tests were made our lamps proved to be better than theirs and we got the orders. This discouraged the independents and every one of them was losing money.

"Mr. Coffin (president of General Electric Company) saw his opportunity in this condition, and he conceived the plan (see note below) of consolidating all these independent companies into one company and company and of controlling that company, and thus controlling a very large part of the lamp business in this country. Terry and Tremaine engineered this consolidation for Mr. Coffin, and in this way the National Electric Lamp Company was formed, and the General Electric Company controlled all its common stock. The National Company was licensed under the patents of the General Electric Company, and their factories were equipped with machines made at our Harrison works, and under the very able management of Terry & Tremaine the National Company became very prosperous. Later, at the request of the United States Government, the General Electric Company took over the National Company, and it became the National Lamp Works of the General Electric Company.

---

---

Note □

The writer is not sure the idea of consolidation was original with Mr. Coffin, as implied above. It is believed that Mr. Jotham Potter of the Buckeye Electric Company in Cleveland initially proposed the idea and it was subsequently advocated by Mr. Franklin S. Terry. In the winter of 1900-01 Terry was seated next to Mr. Burton G. Tremaine at a banquet in Chicago, when the idea was advanced to him. Tremaine and John B. Crouse then visited Coffin, and the idea took fruition.

---

---

"In 1895 a patent was issued to Arturo Malignani for a method of exhausting lamps. He used a mechanical pump which took out most of the air. Then he vaporized some phosphorus inside the lamp. This precipitated or combined with the water vapor and remaining gases. This was all done in about two minutes. Malignani lived in Italy, way up north at Udine, right at the foot of the Alps. I was told to go there and investigate. Your mother and I were preparing to be married April 30th. The invitations were ready to be sent out. So we changed the date on the invitations to April 23rd, and we sailed on the old "Majestic" on the morning of the 24th. We landed in Liverpool, then to Paris, then to Milan, and then to Udine. We could not speak Italian, and we could not find an interpreter, so we telegraphed to Milan and a man

connected with the Milan Edison Company came to our aid. In the meantime, we had a good time, getting what we wanted with the aid of a book of Italian and English words and sentences.

"We visited Germany and France on our way back and learned the state of the lamp-making art in these countries. Your mother spoke French and German and I did not, so she was my interpreter. She went wherever I did and got considerable knowledge of the lamp business and was of great assistance to me.

"Malignani's invention revolutionized the art of producing the vacuum in incandescent lamps, and all vacuum lamps made today—1930—use his method of producing a good vacuum. He had built electric generators and motors and a trolley line. Then he tried to make incandescent lamps, using a pump which was not capable of producing a good vacuum, and he discovered a way of getting a good vacuum with this poor pump. Later he came to New York, and we purchased his patent for \$30,000, which to him was a large fortune.

"When I got back home after this trip to Udine I telephoned Mr. Eyre, who was manager of the lamp works. I said: "Hello, Eyre! This is Howell." He said: "Is this John Howell?" "Yes," I said. "Thank God! Come here as fast as you can," he exclaimed. There was trouble in the exhaust department, which I corrected at once. At that time I was riding a bicycle back and forth from the house to the factory.

"I improved the apparatus used by Malignani greatly, so one girl with one pump could exhaust 600 lamps in a day of 10 hours, and the vacuums produced in this way were very good and very uniform.

"The pumps and other equipment necessary for equipping our factory for this Malignani exhaust were all paid for with the money we received from the sale of mercury used in our old pumps.

"In 1896 I made the first really good glass-working machine used in the Edison Lamp Works. It was a sealing-in machine in which the parts revolved about a vertical axis. I had had it in mind for a while, but the foreman of our glass department told me the parts would not seal together in this position—they must be horizontal. Not convinced, I asked him to try it and show me. He did and it worked perfectly. This machine enabled an unskilled operator to seal in 600 lamps a day where before a skilled operator would do 200 or 250. This increased the capacity of our glass room very greatly at a time when we were crowded for space there, for our business was growing fast. Our success with this vertical sealing-in machine led to the making of the first stem-making machine—also a great success. I outlined this machine to Mr. Burrows, and he made it while I was away.

(Pages 36-37)

"...In 1906 in March Dr. Whitney, who was director of the General Electric research laboratory, and I went to Europe together. We had seen in a trade paper a statement that a tungsten filament had been invented in Austria. We also had other things to look up. We went to Berlin and had our headquarters at the Hotel Bristol. We visited the A.E.G., with which the General Electric Company was allied, and the Siemens & Halske Company, from whom we had a license to make Tantalum lamps. Also Bergman & Co. Bergman was one of Mr. Edison's early associates and an old friend of mine. We also visited other electrical concerns, and we were made welcome everywhere. We saw some metal filament lamps in a store window, which I thought were osmium lamps. These metal filaments were connected to their lead-in wires by fusion. It was a very pretty joint, and I wanted to learn about it, and, if possible, get a license to use it. We inquired and found that the lamps were made by the Auer Company, which made osmium lamps. We called on this company and, after we had established our identity, they told us they were making lamps with filaments of tungsten, the first we had ever seen. They showed us reports of tests on these lamps, showing long life at 1-1/4 watts per candle. These reports showed that these lamps required less than half as much energy as our carbon lamps. We were delighted and expressed our delight and appreciation without reserve, and told them that the General Electric Company must have their United States rights. We did a lot of cabling home, and I got about 40 of the lamps and came back home with them, so they could be tested in our own laboratory. I went right back to Berlin, and General Griffin and Mr. Neave came over and started negotiations for their American rights. Whitney and I also went to Vienna and met Dr. Kusel, who also claimed to be the inventor of the tungsten filament. We also met the representatives of Just & Hanaman, who also claimed to be the inventors of the tungsten filament. We got samples of lamps from these people also and entered into negotiation for their American patent rights. None of them had yet filed applications for United States patents, but they all did so. The Auer people told us that about a week before Whitney and I came there two representatives of the Westinghouse Company had been shown the lamps and reports which we saw. They were skeptical and did not show the appreciation and enthusiasm which Whitney and I did. So they dealt with us and not the Westinghouse men. Later the General Electric Company acquired the American patent rights of all these parties, and the United States patent on the tungsten filament was issued to Just & Hanaman and was assigned to the General Electric Company....

"...On our way back to Berlin we visited a laboratory at Augsburg near Munich and saw some Just & Hanaman lamps and filaments and reports and tests made on them. We visited several other inventors and got information which was useful to us later..."

**Electric Illumination, Vol II, edited by James Dredge**

The serious collector of early incandescent lamps tries to accumulate a library of books on the subject for the purpose, in part, of lamp identification and description. For lamps developed in the early 1880s in Europe and the British Isles, Volume II of the book titled Electric Illumination, by Dredge, O'Reilly and Vivarez, is one of the desirable ones to obtain. One of the lamps described in that book was manufactured by Woodhouse and Rawson. The description of their lamp will be taken directly from the Dredge text. Their Fig. 469 is reproduced here.

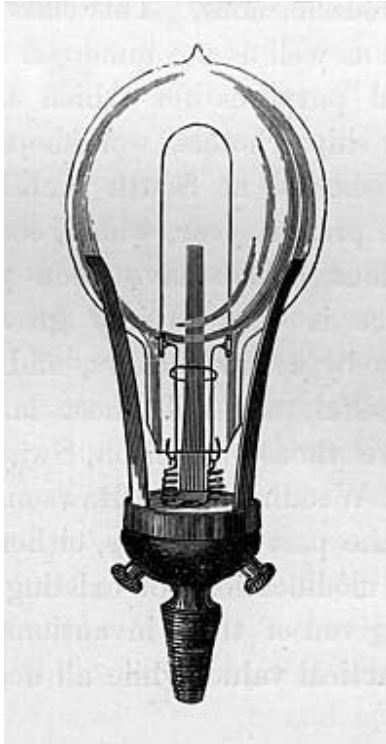

"...Messrs. Woodhouse and Rawson manufacture incandescence lamps on a large scale. As will be seen from Fig. 469, their globe is supported by three light fingers or springs attached to the holder, while the contact with the platinum terminals is made by two spiral springs coupled to the binding posts at either side. By this arrangement an even steady pressure is maintained upon the platinum loops, in spite of any vibration of the lamp, an important point in some installations, especially on board ship, where the rolling of the vessel is apt to break the contacts, and to give rise to minute arcs, if special precautions be not taken.

In the lamp itself the chief novelty lies in the method adopted for connecting the filament to the metallic conductors. These are bent to a right angle at a little distance from their extremities, and their ends are flattened into discs or plates, which are then rolled up to form tubes into which the legs of the filament are inserted. Good contact is insured at the junction by means of a carbonaceous cement, which has the further advantage of increasing the cross section of the conductor, and so reducing the temperature in the immediate vicinity of the platinum wire. The outer ends of the metallic conductors are turned into loops and sealed into the glass by the method known as "pinching in," as is now usual in incandescence lamps. The lamp shown in Fig. 469 is of twenty-candle power, and requires a difference of potential of sixty volts to drive it to its full safe capacity. Messrs. Woodhouse and Rawson, in addition to their standard lamps, which vary from three-candle power upwards, and are adapted to work at potentials from three to sixty volts, manufacture lamps for inventors and other who desire to have them made to their own specification or according to their own processes. One form of which they make a specialty, is a coloured incandescence lamp for theatrical and ornamental purposes. The tinting of the globe is effected after the other parts of the manufacture are complete, and consequently the process can be applied to the lamps of other makers or to ordinary globes."

### **Forty Years of Edison Service, 1882-1922**

The writer's interest has always been on the development of the incandescent lamp and less so on the other developments that were necessary to make the lamp a useful product. However, for a better overall picture of the development of the Edison lighting system one should acquire a certain level of knowledge regarding all developments. A good reference book from which to attain that knowledge is one written by Mr. T. Commerford Martin for the New York Edison Company, titled Forty Years of Edison Service, 1882-1922. It was printed at the Marchbanks Press, New York in 1922. Mr. Martin conveys factual information as well as anecdotal. An example is the following, taken from pages 21-22:

"On December 21, 1879 the New York Herald gave a jolt to the imagination of its readers on Manhattan Island by devoting a whole page to the Edison lamp and system of electric lighting. This enterprising publicity was done off its own bat, and it so excited the public that Edison, though embarrassed, was grateful and decided to make his first exhibition. This was done on New Year's eve, 1879-80, when special trains were run out to Menlo Park by the Pennsylvania Railroad, and over 3000 persons, including many public officials, prominent citizens, scientists and capitalists went to see for themselves. It is unhappily to be recorded that all were not well-wishers. A personal memorandum by Mr. Edison in the hands of the writer says: 'In the early days of my electric light, curiosity and interest brought a good many people to Menlo Park to see it. Some of them did not come with the best of intentions. I remember the visit of one expert, a well-known electrician, graduate of Johns Hopkins University. We had the lamps exhibited in a large room, and so arranged on a table as to illustrate the regular layout of circuits for houses and streets. Sixty of the men employed at the laboratory were used as watchers, each to keep an eye on a certain section of the exhibit, and see that there was no monkeying with it. This man had a length of insulated No. 10 wire around his sleeve and back, so that his hands would conceal the ends, and no one would know he had it. His idea, of course, was to put this across the ends of the supplying circuits and short-circuit the whole thing—put it all out of business without being detected. Then he could report how easily the electric light went out and a false impression would be conveyed to the public. He did not know that we had already worked out the safety fuse, and that every little group of lights was protected independently. He slyly put this jumper in contact with the wires—and just four lamps went out on the section he tampered with. The watchers saw him do it, however, and got hold of him, and just led him out of the place with language that made the recording angels jump to their typewriters.'"

### **Farmer on the Electric Light**

The writer has a small hard cover book titled Farmer on the Electric Light. There is no title page but the book appears to be the same as one listed on the Library of Congress Online Catalog (Call Number: TK4131.P8). The small book (17 pages) apparently was "written" by George Barlett Prescott (1830-1894) and consists of abstracts from The Speaking



Telephone, Electric Light, and Other Recent Electrical Inventions. That book was printed by Russel Brothers, New York in 1879. The name Farmer, of course, refers to Moses Gerrish Farmer (1820-1893).

The student of early lamp development would do well to read this book as it appears to discuss a man of considerable talent. Perhaps it would not be an exaggeration to say that he was a man born before his time. One can also read an excellent biography of Farmer (by Bernard S. Finn) in Vol 7 of American National Biography, General Editors: John A. Garraty and Mark C. Carnes, Oxford University Press, New York, 1999, pg 721.

The author is  
Edward J. Covington  
17279 Hooper Ridge Road  
Millfield, Ohio 45761-9645  
United States of America

[ejcov@frogn.net](mailto:ejcov@frogn.net)  
740-448-1004