

TT/TTS





Pure attraction. The Audi TT Coupé.	04
Unique character. The Audi TT Roadster.	08
Exceptional interior. The Audi TT design selection.	12
Fascinating sportiness. The Audi TT S line packages.	16
Just breathe and take it all in. The Audi TTS Coupé.	20
A faster thrill. The Audi TTS Roadster.	28
More exhilarating. The Audi TTS competition.	34
Especially for you. Highlights, equipment and accessories.	36
More unmistakable. With Audi exclusive.	40
Technical data	60

No compromises. The Audi TT.

//// Shaped as if cast from a single mould. Pared down to the bare essentials to create an icon. The design idiom of the Audi TT knows no compromise. Every line, every detail has a function. Pure design that embodies "Vorsprung durch Technik" at its best. Exuding confidence and strength of character all along the line.



Pure attraction.

//////////////////// The genes of Audi Sport models and the first Audi TT are clearly reflected in the Audi TT Coupé. Not only in the four rings on the bonnet, but also thanks to the uprated TFSI engines beneath it. Audi drive select is included as standard to deliver the performance you want – be that comfort on long journeys or masterful control of corners. For even more on-road dynamics, the 7-speed S tronic is available as an option. A sharper look has been achieved with design details that make you yearn to get started – details such as the striking radiator protective grille, the sporty front and rear aprons, the shaped side sills and the air inlets. This is what attraction looks like today.



The figures for fuel consumption and CO₂ emissions can be found on page 60.
Some of the equipment illustrated or described is optional equipment for which an extra charge is made.
Please contact your Audi partner or visit www.audi.com for detailed information about standard and optional equipment.



Great clarity.

//////////////////// The standard Audi virtual cockpit in the Audi TT Coupé is resolutely driver-focussed, displaying all relevant information on a 12.3-inch LCD screen directly in your field of view. The selector buttons on the multifunction steering wheel plus enable you to switch between various views. Or, if the optional sport displays are installed, to call up the output and torque display, the G meter and sport mode with central rev counter.

The figures for fuel consumption and CO₂ emissions can be found on page 60.
Some of the equipment illustrated or described is optional equipment for which an extra charge is made.
Please contact your Audi partner or visit www.audi.com for detailed information about standard and optional equipment.



Unique character.

//////////////////// The timeless aesthetics of a roadster. The distinctive appeal of a sports car. Can there be anything that promises pure driving pleasure more convincingly? Experience the thrill of open-top driving in an exceptional car – the Audi TT Roadster.

The figures for fuel consumption and CO₂ emissions can be found on page 60.
Some of the equipment illustrated or described is optional equipment for which an extra charge is made.
Please contact your Audi partner or visit www.audi.com for detailed information about standard and optional equipment.



Self-assured presence.

////////// For a genuine sports car to set store by understatement is a brave move. But it's absolutely typical of every Audi TT. And the Audi TT Roadster is no exception, with technology and purity of design that speak for themselves. As is clear, for example, at the front end, which radiates sportiness and stylistic confidence in equal measure.



The figures for fuel consumption and CO₂ emissions can be found on page 60.
Some of the equipment illustrated or described is optional equipment for which an extra charge is made.
Please contact your Audi partner or visit www.audi.com for detailed information about standard and optional equipment.



Exceptional interior.

//////////////////// Make an exceptional vehicle even more exceptional. For the interior, the Audi design selection offers you a very exclusive range of materials and colours to choose from.

The figures for fuel consumption and CO₂ emissions can be found on page 60.
Some of the equipment illustrated or described is optional equipment for which an extra charge is made.
Please contact your Audi partner or visit www.audi.com for detailed information about standard and optional equipment.



////////// Inlays in aluminium drift, anthracite, combined with TT-specific leather upholstery and trim in moccasin brown with attractive contrasting stitching, create an exclusive sporty ambience in the interior.

The figures for fuel consumption and CO₂ emissions can be found on page 60.
Some of the equipment illustrated or described is optional equipment for which an extra charge is made.
Please contact your Audi partner or visit www.audi.com for detailed information about standard and optional equipment.



The figures for fuel consumption and CO₂ emissions can be found on page 60.
Some of the equipment illustrated or described is optional equipment for which an extra charge is made.
Please contact your Audi partner or visit www.audi.com for detailed information about standard and optional equipment.



Fascinating *sportiness.*

//////////////////// The optional S line exterior package allows you to accentuate the true sports car character of your Audi TT – with impressive results. The characteristic radiator protective grille in titanium black, the specific bumpers – with distinctive air inlets at the front and side air outlets at the rear – together with the diffuser insert and sill trims all combine to create a strikingly sporty look.



Captivating details.

Take a deep breath and allow yourself to be captivated by equipment that takes the sports car feeling to the extreme. With the Audi TT S line competition, your adrenalin levels will soar into the red zone. This is assured by gloss black highlights such as the Audi Singleframe, exterior mirror housings, side air inlets and outlets, the fixed rear wing spoiler, the diffuser insert and sill trims, as well as by the Audi Sport cast aluminium wheels in 5-arm polygon design in gloss anthracite black with gloss turned finish^{1, 2}. Not forgetting the black chrome-plated exhaust tailpipes. Red painted brake callipers add the finishing touches at the rear, creating a look that sets pulses racing.

The figures for fuel consumption and CO₂ emissions can be found on page 60.

Some of the equipment illustrated or described is optional equipment for which an extra charge is made. Please contact your Audi partner or visit www.audi.com for detailed information about standard and optional equipment. Illustration shows Audi Sport forged aluminium wheels in 10-Y-spoke design in gloss black, gloss turned finish.

¹From Audi Sport GmbH. ²Please note the special information relating to wheels on page 61.

A blue Audi TTS Coupé is parked in a large, empty industrial garage. The garage has a high ceiling with a complex network of concrete beams and red-painted steel supports. Large windows on the upper level allow natural light to filter in, creating a dramatic atmosphere. The car is positioned in the middle ground, facing right. The floor is polished and reflects the surrounding environment.

Just
**breathe and
take it all in.**

You dare or you don't.

//// Four rings on the bonnet. A symbol of true sports car genes. And a promise to deliver phenomenal sporty performance. Call it up. At the press of a button. Awaken the pure power. And buckle up for the ride. 225 kilowatts of power propel the Audi TTS Coupé with S tronic from 0 to 100 km/h in 4.5 seconds. Acceleration that thrills.



Driven by all four wheels. **Fuelled by adrenaline**

//// Superlative performance even on tight corners. Controlled by TT-specific software, which manages the power distribution in the quattro permanent all-wheel drive with Haldex clutch, sending more of it to the rear. For even more driving stability. And for dynamic cornering that is the reserve of genuine sports cars.





The figures for fuel consumption and CO₂ emissions can be found on page 60.
Some of the equipment illustrated or described is optional equipment for which an extra charge is made.
Please contact your Audi partner or visit www.audi.com for detailed information about standard and optional equipment.



Pole position.

//// Dynamics that push you into your seat. Impressive. And comfortable. Thanks to the standard-fitted S sport seats with integrally moulded head restraint and S emblem. For the perfect seating position. And with electric and pneumatic adjustment as an option. Supportive side bolsters on the seat cushion and backrest provide excellent lateral hold. So that you can concentrate on what's important. The TTS sport contour leather steering wheel with multifunction plus and S contrasting stitching gives you confident control. And all the information you need is clearly displayed. In the innovative Audi virtual cockpit with TTS-specific design, central rev counter, output and torque display and G meter.



A faster thrill.

//// Sets your pulse racing. Right from first sight. The Audi TTS Roadster. With the top up or down – it's designed for pure driving pleasure. With the TT-specific quattro permanent all-wheel drive, you don't just drive along a route. You master it. What's more, Audi drive select and its dynamic mode let you adopt a very sporty driving style while doing so. Confidently. And with a poise that quickly inspires you to seek new horizons.



The adrenalin control centre.

//// Welcome to the cockpit. Awaiting you is the highly contoured S sport seat. With optionally adjustable seat side bolsters for personalised seating comfort. TTS sport contour leather steering wheel with multifunction plus and S contrasting stitching. Including shift paddles for quick gear changes with the standard 7-speed S tronic. Not to mention the innovative Audi virtual cockpit with TTS-specific looks and central rev counter and sport displays. The ultimate in high tech meets sports car ambience at its purest. The heart begins to race. Pause again for a moment. The calm before the storm. The Audi TTS Roadster is ready. Are you?

The figures for fuel consumption and CO₂ emissions can be found on page 60.
Some of the equipment illustrated or described is optional equipment for which an extra charge is made.
Please contact your Audi partner or visit www.audi.com for detailed information about standard and optional equipment.

0 to 100 in 4.8 seconds.
Top down in 10.

//// Out in the open. In just 10 seconds. Driven by an unwillingness to compromise. The 2.0 litre, 225 kW TFSI engine accelerates from 0 to 100 km/h in 4.8 seconds. Thanks also to the standard S tronic 7-speed dual-clutch transmission. Switchable flaps in the exhaust system provide for an even richer, fuller sound. And for open-top driving as it should be.





More exhilarating.
With TTS competition.

//// The sport equipment for the Audi TTS Coupé and TTS Roadster. Featuring gloss black highlights including the Singleframe, exterior mirror housings, side air inlets and outlets, diffuser insert and fixed rear wing spoiler, plus Audi Sport forged aluminium wheels in 10-Y-spoke design in gloss black with gloss turned finish^{1,2}. Not forgetting the Alcantara leather steering wheel with 12 o'clock marker, privacy glazing and red painted brake callipers.

The figures for fuel consumption and CO₂ emissions can be found on page 60. Some of the equipment illustrated or described is optional equipment for which an extra charge is made. Please contact your Audi partner or visit www.audi.com for detailed information about standard and optional equipment. ¹From Audi Sport GmbH. ²Please note the special information relating to wheels on page 61.

Especially for you. Fascinating highlights.

On request numerous innovations, comfort features and assistance systems make every trip with your Audi TT a very special experience. Be inspired by the wide range of equipment highlights.



The figures for fuel consumption and CO₂ emissions can be found on page 60.
Some of the equipment illustrated or described is optional equipment for which an extra charge is made. Please contact your Audi partner or visit www.audi.com for detailed information about standard and optional equipment. ¹For legal information and notes on use, please see page 62. ²Please contact your Audi partner for information on compatible mobile phones. For information on availability in different countries, please contact your Audi partner. ³Audi has no influence over the applications shown via the Audi smartphone interface. The respective service providers are responsible for the content and functions displayed within the applications.

- //01 Audi connect navigation & infotainment¹ – digital networking: stay in contact with the world when out on the road
- //02 MMI navigation plus with MMI touch – multimedia functions and intuitive operation
- //03 Matrix LED headlights with dynamic indicators – high-precision, individually controllable LEDs for bright and uniform illumination of the road
- //04 Audi smartphone interface^{2,3} – transfers your smartphone content to the MMI display directly and seamlessly via USB. Navigation, telephony, music and selected third-party apps can be conveniently operated with the MMI controller and your smartphone's voice control.





//04



//05



- //01** S sport seats with coloured interior elements and pneumatic bolsters – coloured elements on the side seat trims, the accent trim on the centre console and the inner rings of the air vents; with pneumatic backrest bolster adjustment, pneumatic lumbar support and electric seat adjustment
- //02** Deluxe automatic air conditioning and headroom heating in the air vents with integral display; optional for TT Roadster/TTS Roadster 3-level adjustable headroom heating in the front seat backrests
- //03** Extended coloured leather package – armrests in the door trims, door pull handles and lower centre console in leather, palomino brown; trim of steering wheel impact absorber and instrument panel cover in leather, black
- //04** Driver assist systems¹ – support the driver when parking and manoeuvring in urban traffic, on motorways and on country roads, and can increase both safety and comfort
- //05** TT sport contour leather steering wheel with multifunction plus – 14 multifunction buttons for convenient operation of available infotainment features; 3-spoke design, flattened at the bottom
- //06** Bang & Olufsen Sound System – captivating surround sound reproduction with 12 loudspeakers, including two centre speakers and two bass boxes

The figures for fuel consumption and CO₂ emissions can be found on page 60.
 Some of the equipment illustrated or described is optional equipment for which an extra charge is made. Please contact your Audi partner or visit www.audi.com for detailed information about standard and optional equipment.
¹Please note: The systems work only within system limits and assist the driver. However, the driver remains responsible for driving the vehicle and is required to be attentive at all times.



//01

//03

//02

- //01** Audi exclusive fine Nappa leather upholstery and trim with S sport seats, front in ocean blue with contrasting stitching in diamond silver
- //02** Audi exclusive controls in leather: steering wheel rim and gear lever gaiter in black leather with contrasting stitching in diamond silver
- //03** Inlays in carbon twill
- //04** Audi TT Roadster with Audi exclusive customised paint finish in Suzuka grey, metallic – Audi Sport forged aluminium wheels in 10-Y-spoke design, gloss black, gloss turned finish¹

More unmistakable. With Audi exclusive.

Make your Audi TT unique – as unmistakable as you are – with Audi exclusive. With selected trim, coloured leather and customised paint finishes in a wide range of colours. To suit your own personal preferences.



//04

The figures for fuel consumption and CO₂ emissions can be found on page 60.

Audi exclusive is an option from Audi Sport GmbH. Please contact your Audi partner or visit www.audi.com for detailed information about standard and optional equipment.

¹Please note the special information relating to wheels on page 61.



//01

- //01 Audi exclusive black/express red design package for S sport seats, front:**
- seat upholstery and centre armrest, front in fine Nappa leather, black with contrasting stitching in express red; with S embossing on the front seat backrests
 - steering wheel rim in fine Nappa leather, black, perforated on the left and right, with contrasting stitching in express red
 - gear/selector lever knob in perforated leather, black
 - gear/selector lever gaiter in fine Nappa leather, black with contrasting stitching in express red
 - door trim inserts in Alcantara, black
 - floor mats in black with edging in black and contrasting stitching in express red; piping in fine Nappa leather, express red



//02

- //02 Audi exclusive black/calendula yellow design package for S sport seats, front:**
- seat upholstery and centre armrest, front in fine Nappa leather, black with contrasting stitching in calendula yellow; with S embossing on the front seat backrests
 - steering wheel rim in fine Nappa leather, black, perforated on the left and right, with contrasting stitching in calendula yellow
 - gear/selector lever knob in perforated leather, black
 - gear/selector lever gaiter in fine Nappa leather, black with contrasting stitching in calendula yellow
 - door trim inserts in Alcantara, black
 - floor mats in black with edging in black and contrasting stitching in calendula yellow; piping in fine Nappa leather, calendula yellow

The Audi exclusive customised paint finishes.

You don't get a second chance to make a first impression. Seize this one and choose your own personal exterior paint finish from the wide range of Audi exclusive colours. Here's a small selection.

Many additional paint finishes can be found at www.audi.com

The figures for fuel consumption and CO₂ emissions can be found on page 60.
Audi exclusive is an option from Audi Sport GmbH. Please contact your Audi partner or visit www.audi.com for detailed information about standard and optional equipment.



// Green

// Cumulus blue

// Merlin, pearl effect

// Sepang blue, pearl effect

// Catalunya red, metallic

// Solar orange

// Ipanema brown, metallic

Powerful look.

Select the paint colour that best suits your personality. Secure in the knowledge that the quality will be superb, because your vehicle is painted not just once, but four times. So not only do you look radiant in your Audi, your car is also protected from environmental influences and wear. Ensuring that the car maintains its powerful look throughout its entire lifetime.

Many additional paint finishes can be found at www.audi.com

The figures for fuel consumption and CO₂ emissions can be found on page 60.
Some of the equipment illustrated or described is optional equipment for which an extra charge is made.
Please contact your Audi partner or visit www.audi.com for detailed information about standard and optional equipment.



// Floret silver, metallic

// Arrow grey, pearl effect

// Nano grey, metallic

// Turbo blue

// Vegas yellow

// Tango red, metallic

// Pulse orange

Powerful presence.

With Audi wheels, you can emphasise your own individual style and the character of your Audi TT. Why not indulge yourself and create a powerful presence with your favourite design. And for peace of mind when out on the road: Audi wheels are subjected to special test procedures, undergo rigorous testing and are of superb quality.

Many additional wheels can be found at www.audi.com



- //01 18-inch cast aluminium wheels in 5-spoke Y design
- //02 19-inch forged aluminium wheels in 5-arm star design, contrasting grey, partly polished¹
- //03 18-inch cast aluminium wheels in 5-twin-spoke dynamic design, partly polished¹
- //04 19-inch forged aluminium wheels in 5-spoke design, partly polished¹

Audi Sport

- 05** 20-inch Audi Sport cast aluminium wheels in 5-arm cutter design in gloss anthracite black, gloss turned finish^{1,2}
- 06** 20-inch Audi Sport forged aluminium wheels in 10-Y-spoke design in gloss black, gloss turned finish^{1,2}
- 07** 19-inch Audi Sport cast aluminium wheels in 10-spoke star design in platinum look, gloss turned finish^{1,2}
- 08** 19-inch Audi Sport cast aluminium wheels in 5-arm blade design in matt titanium look, gloss turned finish^{1,2}

The figures for fuel consumption and CO₂ emissions can be found on page 60.
 Some of the equipment illustrated or described is optional equipment for which an extra charge is made. Please contact your Audi partner or visit www.audi.com for detailed information about standard and optional equipment. You will find specifications on the technical characteristics of tyres on page 61.
¹Please note the special information relating to wheels on page 61. ²From Audi Sport GmbH.

More quality. With the cloth and leather upholstery and trim options.

You have a special place in your Audi. Exclusive comfort can be felt on the front and rear seats: thanks to high-quality materials and first-class workmanship. No matter which seat upholstery you choose: you're sitting in the right place.

Many additional seat upholstery options can be found at www.audi.com

/// S sport seats in leather, rotor grey with rhombus pattern and contrasting stitching

The figures for fuel consumption and CO₂ emissions can be found on page 60. Some of the equipment illustrated or described is optional equipment for which an extra charge is made. Please contact your Audi partner or visit www.audi.com for detailed information about standard and optional equipment.

/// S sport seats in fine Nappa leather, palomino brown with rhombus pattern

/// Alcantara/leather combination, black with rhombus pattern and contrasting stitching

/// Alcantara/leather combination, rotor grey with rhombus pattern and contrasting stitching

/// Fine Nappa leather, palomino brown with rhombus pattern

/// Fine Nappa leather, black with rhombus pattern

/// Fine Nappa leather, black with rhombus pattern and contrasting stitching

/// Fine Nappa leather, express red with rhombus pattern and contrasting stitching

/// Audi exclusive leather upholstery and trim
From Audi Sport GmbH



More exclusive. With inlays.

Exclusive ambience is a question of style. Your style. A style you can refine right down to the last detail. Create tangible accents with high-quality Audi inlays. Experience the fascination of selected materials: carbon, piano finish or aluminium trim – combine them to suit your own individual taste.

Many additional inlays can be found at www.audi.com

/// Matt brushed aluminium

/// Aluminium drift, silver

/// Aluminium drift, anthracite

/// Carbon twill
From Audi Sport GmbH.

/// Audi exclusive piano finish look, black
From Audi Sport GmbH

More refined. With coloured interior elements.

Creative freedom right down to the finer details. For example with coloured interior elements on the side seat trims, the accent trim on the centre console and the inner rings of the air vents. Exclusively available for the optional S sport seats and harmoniously matched. Experience the amazing effect of such intricate refinement.

The figures for fuel consumption and CO₂ emissions can be found on page 60. Some of the equipment illustrated or described is optional equipment for which an extra charge is made. Please contact your Audi partner or visit www.audi.com for detailed information about standard and optional equipment.

//// Coloured interior elements in fine paint finish, silver

//// Gloss paint finish, tango red

//// Satin paint finish, orange

//// Satin paint finish, turbo blue

//// Fine paint finish, anthracite

//// Fine paint finish, silver

//// Chrome paint finish, slate grey

//01 //02



As individual as the life you lead.

Audi Genuine Accessories provides you with numerous ways of adding even more facets to your Audi TT. With products that keep our quality promise day in, day out. Benefit from custom solutions with fascinating design and a high level of functionality.



Further information can be obtained from the accessories brochure and from your Audi partner.

The figures for fuel consumption and CO₂ emissions can be found on page 60.

Audi Genuine Accessories are available from AUDI AG for an extra charge. Please note the information relating to Audi Genuine Accessories on page 61.

¹The use of these wheels is permitted by law only in conjunction with separately available wheel covers. ²Please note the special information relating to wheels on page 61. ³You will find specifications on the technical characteristics of tyres on page 61. ⁴Part is supplied primed and can be painted for an extra charge in the colour of the car or another colour of choice. ⁵Available as a set of two for driver and front passenger side. Requires the ex works lighting package option.

//03



//04



//05



- //01 Cast aluminium wheels in 5-arm rima design¹, matt black, gloss turned finish², size 9 J x 20 for 255/30 ZR 20 tyres³
- //02 Rear wing⁴ – installed as a fixed component and therefore permanently visible; replaces the standard electrically extending tailgate spoiler
- //03 Entry LED⁵ – depending on the variant, the LED light projects either the quattro logo or the Audi rings onto the ground when you open the vehicle door
- //04 Rubber floor mats and premium textile floor mats – perfect fit, attached to the fastening points provided on the vehicle floor; with TT logo
- //05 Cast aluminium winter wheels – in 5-arm falx design, brilliant silver, suitable for snow chains, size 7 J x 17 with 225/50 R 17 tyres³

The fascination of the Audi TT. Find out more online.

Discover the world of the Audi TT. More information, more individuality and more exclusivity. Now at www.audi.com.



Scan the QR code using your smartphone or tablet and discover the world of the Audi TT. Connection costs depend on your mobile phone contract.



myAudi App¹

Call up vehicle and service information on your Audi at any time, plan journeys and send destinations directly to the vehicle – all with a single app. The myAudi app can be downloaded free of charge from the App Store and the Google Play Store^{TM2} and is available for iOS and Android.

The figures for fuel consumption and CO₂ emissions can be found on page 60. Some of the equipment illustrated or described is optional equipment for which an extra charge is made. Please contact your Audi partner or visit www.audi.com for detailed information about standard and optional equipment.

¹The availability of services may vary depending on the model and equipment of your Audi. Audi connect is a prerequisite for using some services. Further information about myAudi is available at www.audi.com/myaudi; for information on Audi connect visit www.audi.com/connect. ²Google and the Google logo are registered trademarks of Google Inc.

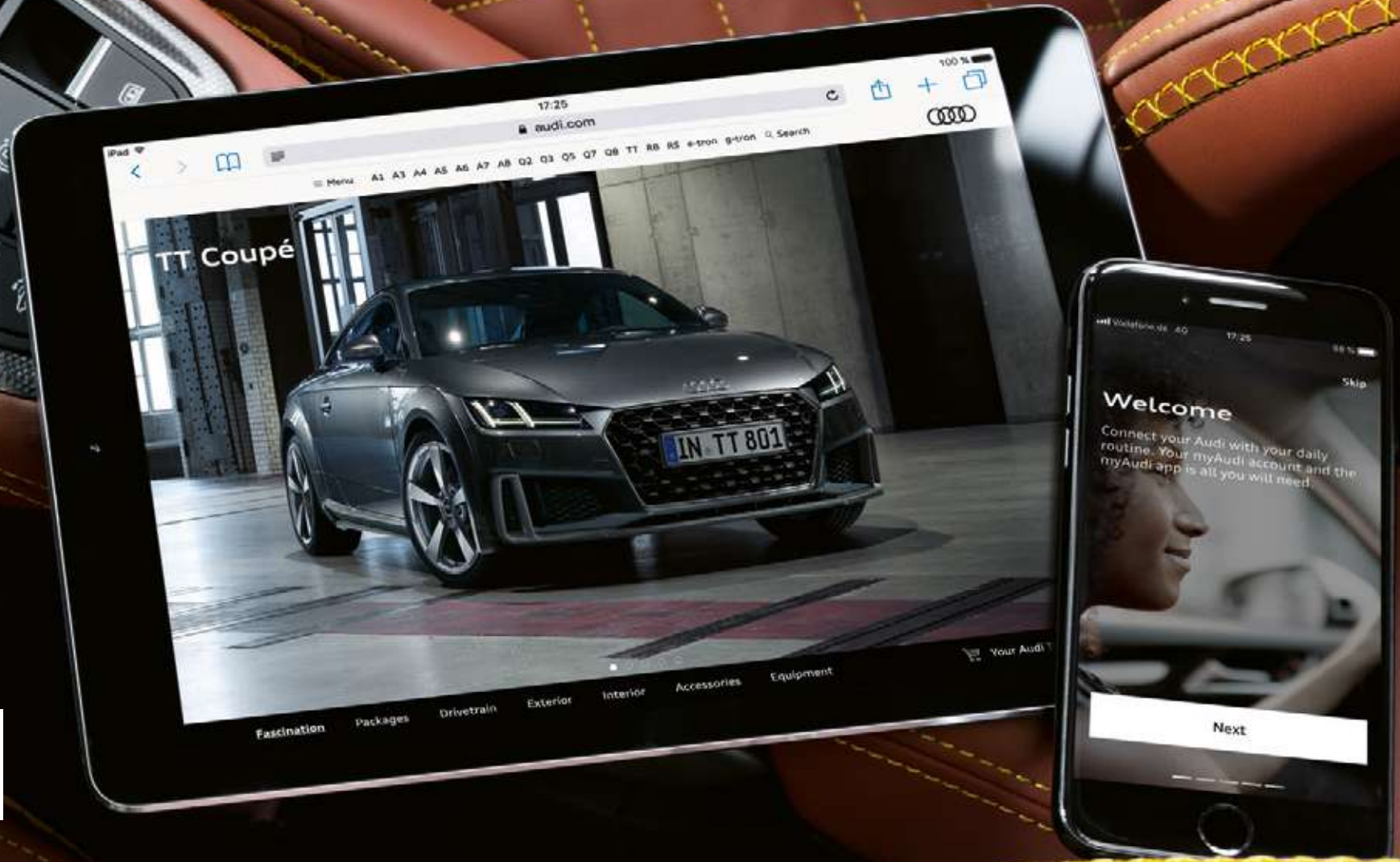

Model	TT Coupé/TT Roadster 40 TFSI (145 kW)		TT Coupé/TT Roadster 45 TFSI (180 kW)		TT Coupé/TT Roadster 45 TFSI quattro (180 kW)		TTS Coupé/TTS Roadster TFSI quattro (225 kW)	
Engine type	4-cylinder inline petrol engine with direct fuel injection, turbocharging and indirect intercooling		4-cylinder inline petrol engine with direct fuel injection, turbocharging and indirect intercooling		4-cylinder inline petrol engine with direct fuel injection, turbocharging and indirect intercooling		4-cylinder inline petrol engine with direct fuel injection, turbocharging and indirect intercooling	
Displacement in cc (valves per cylinder)	1,984 (4)		1,984 (4)		1,984 (4)		1,984 (4)	
Max. output ¹ in kW at rpm	145/4,400–6,000		180/5,000–6,700		180/5,000–6,700		225/5,400–6,500	
Max. torque in Nm at rpm	320/1,500–4,300		370/1,600–4,300		370/1,600–4,300		400/2,000–5,300	
Power transmission								
Drive type	Front-wheel drive		Front-wheel drive		quattro permanent all-wheel drive		quattro permanent all-wheel drive	
Transmission type	[7-speed S tronic]		6-speed manual transmission [7-speed S tronic]		[7-speed S tronic]		[7-speed S tronic]	
Weights/capacities	TT Coupé	TT Roadster	TT Coupé	TT Roadster	TT Coupé	TT Roadster	TTS Coupé	TTS Roadster
Unladen weight ² in kg	[1,345]	[1,435]	1,325 [1,360]	1,415 [1,450]	[1,440]	[1,530]	[1,480]	[1,570]
Gross vehicle weight in kg	[1,705]	[1,715]	1,685 [1,720]	1,695 [1,730]	[1,800]	[1,810]	[1,815]	[1,825]
Permissible roof load limit/nose weight in kg	[75/-]	[-]	75/- [75/-]	- [50]	[75/-]	- [55]	[75/-]	- [55]
Fuel tank capacity, approx. in l	[50]	[50]	50 [50]	50 [50]	[55]	[55]	[55]	[55]
Performance/consumption								
Top speed in km/h	[250]	[247]	250 ³ [250] ³	250 ³ [250] ³	[250] ³	[250] ³	[250] ³	[250] ³
Acceleration 0–100 km/h in s	[6.6]	[6.9]	5.9 [5.8]	6.1 [6.0]	[5.2]	[5.5]	[4.5]	[4.8]
Fuel grade	Sulphur-free super RON 95 ⁴		Sulphur-free super RON 95 ⁴		Sulphur-free super RON 95 ⁴		Sulphur-free SuperPlus RON 98 ⁵	
Fuel consumption ⁶ in l/100 km								
urban	[8.1–8.0]	[8.3]	8.5 [8.5]	8.6 [8.7–8.6]	[9.0]	[9.2–9.1]	[9.0]	[9.2]
extra-urban	[5.0–4.9]	[5.2–5.1]	5.5–5.4 [5.3–5.2]	5.7–5.6 [5.5–5.4]	[5.9]	[6.2–6.1]	[6.0]	[6.2–6.1]
combined	[6.1–6.0]	[6.3]	6.6–6.5 [6.5–6.4]	6.8–6.7 [6.7–6.6]	[7.0]	[7.3–7.2]	[7.1]	[7.3–7.2]
CO ₂ emissions ⁶ in g/km								
combined	[138–137]	[145–143]	150–149 [148–147]	154–153 [152–151]	[161–160]	[166–164]	[161]	[166–165]
Emission standard	[EU6]	[EU6]	EU6 [EU6]	EU6 [EU6]	[EU6]	[EU6]	[EU6]	[EU6]

Some of the equipment illustrated or described is optional equipment for which an extra charge is made. Please contact your Audi partner or visit www.audi.com for detailed information about standard and optional equipment.







[] Figures in square brackets refer to S tronic.

Explanatory notes

- ¹ The figure given was calculated using the specified measuring procedure (current version of UN-R 85).
- ² Unladen vehicle weight includes driver (75 kg) and fuel tank 90 % full, calculated in accordance with the current version of Reg. (EU) 1230/2012. Optional equipment may increase the vehicle's unladen weight and drag coefficient, whereupon the possible payload limit and the top speed will be reduced accordingly.
- ³ Regulated.
- ⁴ We recommend using sulphur-free super unleaded RON 95 fuel complying with DIN EN 228. If this is not available, use sulphur-free regular unleaded RON 91 fuel complying with DIN EN 228; power output will be slightly reduced. Unleaded RON 95 fuel with a maximum ethanol content of 10 % (E10) can generally be used. Fuel consumption details refer to operation with RON 95 fuel complying with 692/2008/EC.
- ⁵ We recommend using sulphur-free SuperPlus unleaded RON 98 fuel complying with DIN EN 228. If this is not available, use sulphur-free super unleaded RON 95 fuel complying with DIN EN 228; power output will be slightly reduced. Unleaded RON 95 fuel with a maximum ethanol content of 10 % (E10) can generally be used. Fuel consumption details refer to operation with RON 95 fuel complying with 692/2008/EC.
- ⁶ The specified fuel consumption and emission data have been determined according to the measurement procedures prescribed by law. Since 1 September 2017, certain new vehicles are already being type-approved according to the Worldwide Harmonized Light Vehicles Test Procedure (WLTP), a more realistic test procedure for measuring fuel consumption and CO₂ emissions. Starting on 1 September 2018, the New European Driving Cycle (NEDC) will be replaced by the WLTP in stages. Owing to the more realistic test conditions, the fuel consumption and CO₂ emissions measured according to the WLTP will, in many cases, be higher than those measured according to the NEDC. For further information on the differences between the WLTP and NEDC, please visit our website. We are currently still required by law to state the NEDC figures. In the case of new vehicles which have been type-approved according to the WLTP, the NEDC figures are derived from the WLTP data. It is possible to specify the WLTP figures voluntarily in addition until such time as this is required by law. In cases where the NEDC figures are specified as value ranges, these do not refer to a particular individual vehicle and do not constitute part of the sales offering. They are intended exclusively as a means of comparison between different vehicle types. Additional equipment and accessories (e.g. attachments, different tyre formats, etc.) may change the relevant vehicle parameters, such as weight, rolling resistance and aerodynamics, and, in conjunction with weather and traffic conditions and individual driving style, may affect fuel consumption, electrical power consumption, CO₂ emissions and the performance figures for the vehicle.

Classifications of tyre parameters

The table shows the ranges of fuel efficiency, wet grip and exterior noise emission classes for the different tyre sizes of the Audi TT Coupé, TT Roadster, TTS Coupé and TTS Roadster.

	Tyre size	Fuel efficiency class	Wet grip class	Exterior noise emission class
Summer tyres	225/50 R 17	E–C	B–A	71 
	245/40 R 18	E	B–A	71–70 
	245/35 R 19	E	B–A	72–70 
Winter tyres	255/30 R 20	E	A	73 
	225/50 R 17	C	C	72 
	245/40 R 18	E	C	72 
All-season tyres	225/50 R 17	C	C	72 

It is not possible to order a specific tyre.

Ask your Audi partner about the range of tyres available in your country.

Important note

Special information about the wheels: Wheels with gloss turned or gloss milled finish as well as polished or partly polished aluminium wheels must not be used in wintry road conditions. For manufacturing reasons, the rim surface does not have sufficient corrosion protection for such use and can be damaged permanently by road salt or similar.

Legal notice about Audi Genuine Accessories

Audi Genuine Accessories are available from AUDI AG for an extra charge. Accessories are not factored in when calculating the vehicle's fuel consumption and emission figures. As such, accessories can be fitted only after initial registration.

Legal notice about Audi connect navigation & infotainment with customer's own SIM card

Use of the services supported by Audi connect is possible only in conjunction with an optional navigation system and Audi connect (including car phone – depending on the vehicle model). In addition, depending on the vehicle model, you will require a SIM card with data option and with LTE option to use LTE¹ – with car phone, a SIM card with telephone and data option or a Bluetooth-capable smartphone with remote SIM Access Profile (rSAP)². The services are available only with an existing or separate mobile phone contract and only within the range of the respective mobile phone network. Depending on the terms of your mobile phone contract, additional costs may be incurred when receiving data packets from the internet – particularly when used abroad. Due to the high data volumes involved, a data flat rate is strongly recommended.

The availability of the services supported by Audi connect navigation & infotainment varies from country to country. The services are generally provided for at least 1 year from vehicle delivery. If Audi connect services are based on services from third-party providers, permanent availability cannot be guaranteed as this is the responsibility of the third-party provider.

Following a period of 24 months from vehicle delivery, the Audi connect services will be extended once free of charge for 12 months. If you do not require this extension, please write to:

AUDI AG
Audi International Customer Care Services
85045 Ingolstadt, Germany
Email: kundenbetreuung@audi.de
Tel.: +49 800 28347378423

Ask your Audi partner about a subsequent extension of the Audi connect services. Depending on the vehicle model, Audi connect provides access to Google and Twitter services. Permanent availability cannot be guaranteed as this is the responsibility of Google and Twitter. Please visit www.audi.com/connect or contact your Audi partner for more detailed information about Audi connect; contact your mobile services provider for information about contract conditions.

Equipment for the Audi TT Coupé illustrated (p. 4–7):

Paint finish: floret silver, metallic
Wheels: 19-inch forged aluminium wheels in 5-arm star design, contrasting grey, partly polished³
Seats/seat upholstery: S sport seats, front in fine Nappa leather, black, with stitching in anthracite
Coloured interior elements: fine paint finish, silver Inlays: aluminium drift, silver

Equipment for the Audi TT Roadster illustrated (p. 8–15):

Paint finish: nano grey, metallic
Wheels: 19-inch forged aluminium wheels in 5-spoke design, partly polished³
Seats/seat upholstery: S sport seats, front in fine Nappa leather, moccasin brown with panuka stitching in brown/yellow
Coloured interior elements: fine paint finish, anthracite
Inlays: aluminium drift, anthracite

Equipment for the Audi TTS Coupé illustrated (p. 20–27):

Paint finish: turbo blue
Wheels: 20-inch Audi Sport cast aluminium wheels in 5-arm cutter design, gloss anthracite black, gloss turned finish^{3,4}
Seats/seat upholstery: S sport seats, front in Alcantara/leather combination, black with contrasting stitching in rock grey, with S embossing on the front seat backrests
Coloured interior elements: satin paint finish, turbo blue
Inlays: carbon twill⁴

Equipment for the Audi TTS Roadster illustrated (p. 28–33):

Paint finish: pulse orange
Hood: black
Wheels: 20-inch Audi Sport cast aluminium wheels in 5-V-spoke design in matt titanium look, gloss turned finish^{3,4}
Seats/seat upholstery: S sport seats, front in fine Nappa leather, black with contrasting stitching in rock grey, with S embossing on the front seat backrests
Coloured interior elements: chrome paint finish, slate grey
Inlays: matt brushed aluminium

Audi TT Coupé

Dimensions in mm

Dimensions are for unladen vehicle weight. Luggage capacity¹ 305/712 l (second value is with the rear seat backrest folded down and vehicle loaded up to roof height). Turning circle approx. 11 m.
*Maximum headroom. **Elbow room width. ***Shoulder room width.

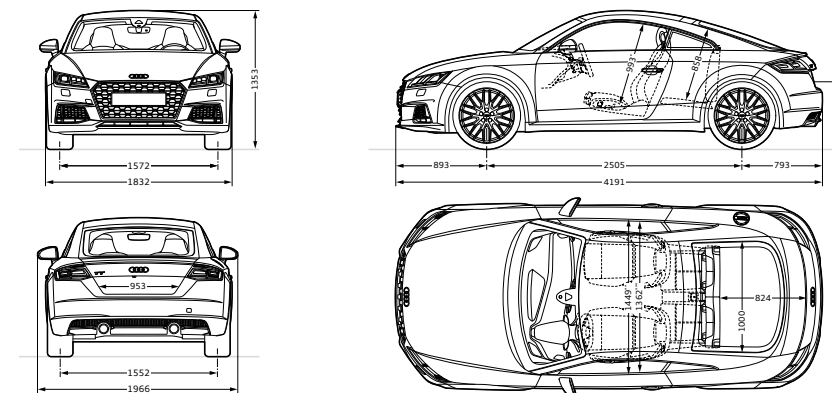

Audi TTS Coupé

Dimensions in mm

Dimensions are for unladen vehicle weight. Luggage capacity¹ 305/712 l (second value is with the rear seat backrest folded down and vehicle loaded up to roof height). Turning circle approx. 11 m.
*Maximum headroom. **Elbow room width. ***Shoulder room width.

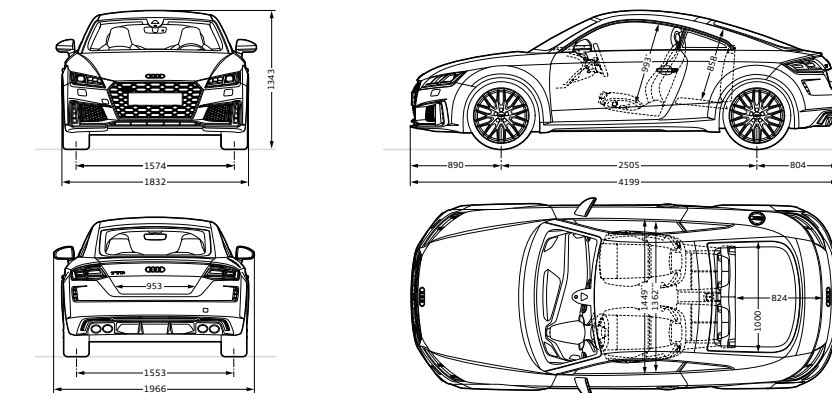

Audi TT Roadster

Dimensions in mm

Dimensions are for unladen vehicle weight. Luggage capacity¹ 280 l.
Turning circle approx. 11 m.
*Maximum headroom. **Elbow room width. ***Shoulder room width.

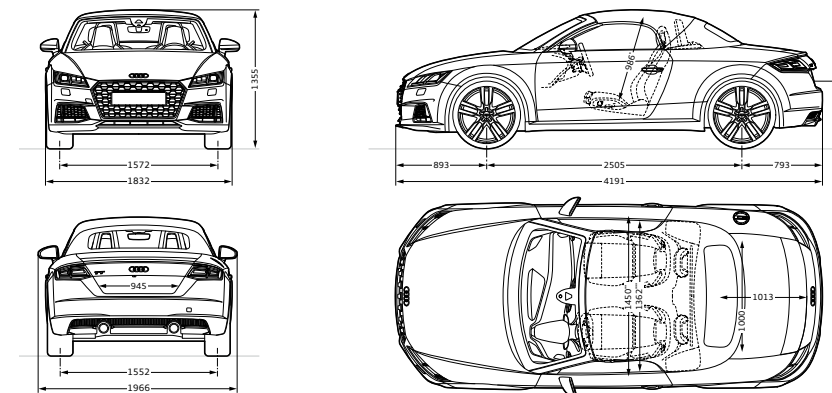

Audi TTS Roadster

Dimensions in mm

Dimensions are for unladen vehicle weight. Luggage capacity¹ 280 l.
Turning circle approx. 11 m.
*Maximum headroom. **Elbow room width. ***Shoulder room width.

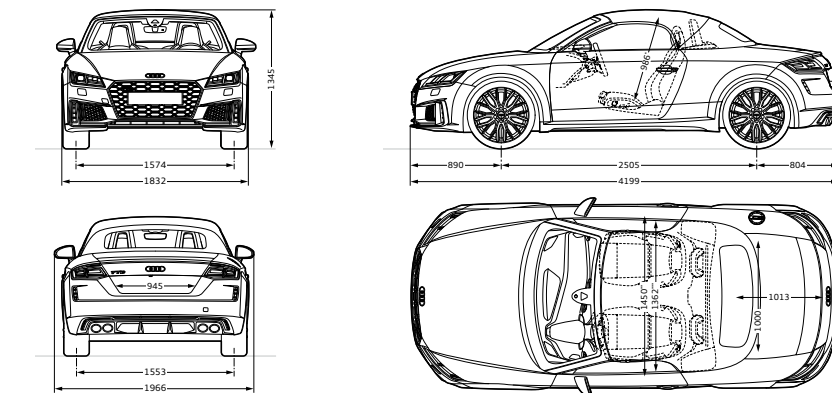

The figures for fuel consumption and CO₂ emissions can be found on page 60.

Some of the equipment illustrated or described is optional equipment for which an extra charge is made. Please contact your Audi partner or visit www.audi.com for detailed information about standard and optional equipment.

¹Requires LTE card contract for full use. For information about the availability and use of LTE support, please contact your Audi partner. ²Please contact your Audi partner or visit www.audi.com/bluetooth for information on compatible mobile phones. ³Please note the special information relating to wheels on page 61. ⁴From Audi Sport GmbH.

¹Technical specifications refer to a basic vehicle without country-specific features and the selected optional equipment.

AUDI AG

Auto-Union-Straße 1
85045 Ingolstadt
www.audi.com
Date: June 2019

The vehicles and equipment versions illustrated and described in this product flyer and some of the services listed are not available in all countries. Some of the cars illustrated are equipped with optional features for which an extra charge is made. Details concerning the delivery specifications, appearance, performance, dimensions and weights, fuel consumption and running costs of the vehicles were correct to the best of our knowledge at the time of going to press. Deviations from the colours and shapes shown in the illustrations may occur. No liability is accepted for errors and printing errors. The right to introduce modifications is reserved. Not to be reproduced, including in part, without the written approval of AUDI AG.

Printed in Germany
933/11N0.97.18

This brochure is printed on paper made from pulp bleached without the use of chlorine.