



Q7

Audi Q7 | Q7 V12 TDI quattro



		Page		
Fascination				
	4	Audi Q7	36	Audi exclusive concept®
	26	Audi Q7 V12 TDI quattro		
Technology				
	38	FSI®/TFSI®	48	Brake systems
	40	TDI®	50	MMI® – Multi Media Interface
	42	V12 TDI quattro	52	Audi connect
	44	quattro®	54	Assistance systems
	46	adaptive air suspension		
Equipment				
	58	Audi exclusive	80	Inlays
	60	Audi exclusive line	82	Lights and mirrors
	62	S line Audi Q7	83	Exterior equipment
	66	Style guides	85	Interior equipment
	68	Paint finishes	90	Infotainment
	70	Wheels/tyres	93	Assistance systems
	72	Seats/seat upholstery	95	Technology
	78	Equipment and design packages	97	Audi Extended Warranty
	80	Headlining		
Miscellaneous				
	98	Audi Genuine Accessories	105	Dimensions
	102	Technical data	106	Index
	104	Offroad properties	114	The fascination of Audi

Dialogue: Audi QR codes

Experience Audi even more directly: download a QR app to your smart-phone and then scan the QR code or follow the given link in your browser.



The equipment for the vehicles illustrated in the Fascination section can be found on page 112.
The fuel consumption and CO₂ emission figures can be found from page 102 onwards.





Until now we have been building quattro® for our cars. With the Audi Q7 we've built a car for quattro.

Sometimes, a single question is enough to change the world: why can't you enjoy the outstanding driving features of an all-wheel drive in a passenger car? This thought occurred to the Audi engineers while they were out testing the four-by-four Iltis. From this simple question came the idea for a permanent all-wheel drive suitable for standard production: quattro was born.

A success story began – and still continues today: with the Audi Q7. A new vehicle concept from the ground up, which, just like the quattro drive itself, has been born from the wealth of ideas, the courage and the passion of the Audi engineers.

The Audi Q7. From the inventor of quattro.

The fuel consumption and CO₂ emission figures can be found from page 102 onwards.

Q7





To take you on further, the Audi Q7 skilfully uses all of its power. Its innovative quattro drive concept takes care of this. The permanent all-wheel drive distributes the drive forces variably to the front and rear axle. Always just as it is required for the particular driving situation. This enables superb traction, good directional stability and impressive propulsion, both on and off the road.

The fuel consumption and CO₂ emission figures can be found from page 102 onwards.



The Electronic Stabilisation Control (ESC) supports quattro in the Audi Q7. It was especially extended to include a selectable offroad mode for the Audi Q7. With this, the ESC ensures even more traction and braking power when off-road – and above all, even more fun.

The optional adaptive air suspension ensures even more independence (standard for Q7 4.2 TDI quattro and Q7 V12 TDI quattro). It directly intervenes in damping the individual wheels. By almost eliminating permanent car body movements and automatically reducing rolling or pitching motions when cornering, braking or starting up, it ensures a comfortable driving feeling and better directional stability.

The fuel consumption and CO₂ emission figures can be found from page 102 onwards.









Thanks to TFSI and TDI technology, the Audi Q7 deploys its tremendous power and dynamism over practically the entire engine speed range. As a measure to increase efficiency and reduce consumption and CO₂ emissions, recuperation is available for all the Audi Q7's 6- and 8-cylinder engines. Depending on the engine variant, this ensures a significant reduction in CO₂ emissions.

The fuel consumption and CO₂ emission figures can be found from page 102 onwards.

The design of the Audi Q7 sets new standards. In tune with Audi tradition.

The dynamic roof line and high shoulder section bring the sporty form of a coupé to mind. The powerful front with distinctive, chrome-framed Audi Singleframe and vertical chrome struts arouses self-confidence and radiates a sense of presence. With the strong V-shaped pointed bonnet, the standard contrasting paint finish, the optional full paint finish with aluminium-look exterior or the drawn-back headlights with daytime running lights – LED technology upon request – the Audi Q7 is always striving to push forward, even at a standstill.

The fuel consumption and CO₂ emission figures can be found from page 102 onwards.









Its rear is puristic and succinct at the same time and is equipped with the characteristic LED rear lights. The bumper with the integrated underbody protection in conjunction with the encompassing tailgate gives the Audi Q7 an impression of high performance and power. The large wheels, which underline its overall performance, add particular accentuation.

The fuel consumption and CO₂ emission figures can be found from page 102 onwards.







Think twice before getting in the Audi Q7. You won't want to get out again.

With its generous amount of space the Audi Q7 gives you a feeling of freedom. The high-quality cockpit has been designed with the driver in mind and is colour-coordinated, with the centre console raised and easy to operate. Large-area application trims and refined decorative elements in chrome finish give the Audi Q7 that certain extra. A look at the sporty displays makes you think of just one thing: go!

The fuel consumption and CO₂ emission figures can be found from page 102 onwards.





The luxuriously equipped interior lives up to even the highest demands. Here, clear and functional shapes are combined with dynamic elegance and exclusive materials. Inlays in matt silk, black or optionally in aluminium Trigon or selected woods set visual accents. Together with the fine cloth and leather upholstery and trim they underline the high-quality appearance of the Audi Q7.

The fuel consumption and CO₂ emission figures can be found from page 102 onwards.



Multifunctionality does not have to be complicated, as the Multi Media Interface (MMI) proves. The central control system of the high-performance SUV gives you rapid access to important vehicle information and functions.

The generous feeling of space is accentuated with the right sound experience. In the Bang & Olufsen Advanced Sound System, two acoustic lenses are automatically extended from the dashboard when the system is started, which ensure an exact and true-to-detail performance on any seat thanks to the precisely aligned horizontal irradiation. More than 1,000 watts and 14 separate loudspeakers provide an outstanding sound experience.





New freedom: The multifunctional seat and loading concept offers you up to 27 different configuration options. So you always have exactly as many seats and as much luggage space as you require.

As an equipment variant you can choose between two or three rows of seats. Within these equipment variants, you can then choose again: You can equip the second row with comfort seats, turning the Audi Q7 into a 6-seater, which is then equipped with an additional generous centre console. Or you decide on a classic 5- or 7-seater with a bench seat in the second row.

The convenience entry function makes getting in easier, even for those sitting in the rear. The optionally available panoramic glass sunroof provides a clear view of the sky. This electrically operated glass roof reaches to the third row of seats. Thanks to the low air-drag coefficient the noise level remains very low, even with the panoramic glass sunroof open.



Sometimes you just cannot decide what to take with you. The Audi Q7 therefore grants you all the freedom you could require. Unique in its class, it offers 775 litres of luggage space behind the second row of seats. The load area comprises all of 330 litres when there are seven people in the vehicle. By folding the rear seats down – all rear seats can be lowered level to the loading area – the loading volume can be increased to up to 2,035 litres as standard. The generous loading width of 1.22 m easily provides room for up to four golf bags lying sideways. There is a large through-loading facility located in the second row of seats as standard. When folded down, the loading area offers enough space to stow, for example, snowboards or skis, quickly and with ease.

The fuel consumption and CO₂ emission figures can be found from page 102 onwards.







D HH X 1741



On the racing track, our engines regularly
astonish the world.
And that is no different on the road.

2006. The first victory of a racing car with a diesel engine at the legendary Le Mans 24 hours. The car: an Audi R10 TDI. Audi was able to continue its series of victories in the years 2008, 2010, 2011 and 2012. The Audi Q7 V12 TDI quattro was built using this motor racing experience: it is the logical evolution of a trail-blazing vehicle. The Audi Q7 V12 TDI quattro is powered by the most powerful diesel engine of its class and has only one goal: to be the victor on any terrain.

The fuel consumption and CO₂ emission figures can be found on page 103.

Q7

Audi Q7 V12 TDI quattro

The first V12 diesel engine in the world in a standard production model. Thus begins a new chapter in the history of the diesel engine. With the 6.0 litre TDI engine, Audi is once again demonstrating its "Vorsprung durch Technik". The Audi Q7 V12 TDI quattro reaches its maximum torque of 1,000 Nm at a mere 1,750 rpm and keeps it stable up to 3,250 rpm. This means excellent performance is at your disposal from an early stage and over a wide range. The engine moves the high-performance SUV with overwhelming supremacy and serenity, without losing its agility: 368 kW accelerate the Audi Q7 V12 TDI quattro from 0 to 100 km/h in just 5.5 seconds.

The fuel consumption and CO₂ emission figures can be found on page 103.









At the rear, special features include oval tailpipes, LED rear lights and a specially designed bumper. The stainless steel underbody protection at the front and rear makes a clearly visible statement.





The wheel arch extensions of the Audi Q7 V12 TDI quattro give it a dominant and powerful presence. The xenon plus headlights in conjunction with the LED daytime running lights give the front section an unmistakable appearance. Intelligent and attractive details such as the dominant exterior mirrors and roof rails in matt aluminium round off the imposing appearance.

The fuel consumption and CO₂ emission figures can be found on page 103.







A glance into the cockpit of the Audi Q7 V12 TDI quattro: the screen of the standard MMI navigation plus is positioned high in the centre console and displays a host of important information. The leather-covered multifunction sport steering wheel in 3-spoke Q design is equipped with chrome-look shift paddles. The standard electrically adjustable sport seats are covered in Verano leather or, on request, in two-tone fine Nappa leather; they provide great support even on challenging roads. Carbon inlays lend a special look to the centre console and the dashboard, likewise the pedals in aluminium look. The optional full leather package even includes a completely leather-covered dashboard.

The fuel consumption and CO₂ emission figures can be found on page 103.



Audi Q7 V12 TDI quattro Audi exclusive concept®.

The decision in favour of an Audi is the logical consequence of enthusiasm for clear-cut design, technical superiority and dynamic sportiness. Audi exclusive offers numerous possibilities for all those who would like to give their Audi a personal touch through custom-made fittings. The Q7 Audi exclusive concept in Ipanema brown, metallic with V12 TDI engine is the natural continuation of this concept of the ideal: truly special equipment in an exciting combination for an exclusive car – the out-of-the-ordinary as a limited edition series product.



Exclusive pleasure in a limited edition: the unique features of the Q7 Audi exclusive concept in fine Nappa leather in alabaster white and chestnut brown with contrasting stitching and piping.

Lots of space and an individual look. The rear seat backrest covers and the luggage compartment floor are in American walnut with smoked oak inlays. The luggage compartment side trim is made of leather in alabaster white.

Elegantly coordinated interior: the selector lever gaiter in chestnut brown with contrasting stitching in alabaster white, combined with decorative inlays in American walnut with smoked oak inlays.

The fuel consumption and CO₂ emission figures can be found on page 103.

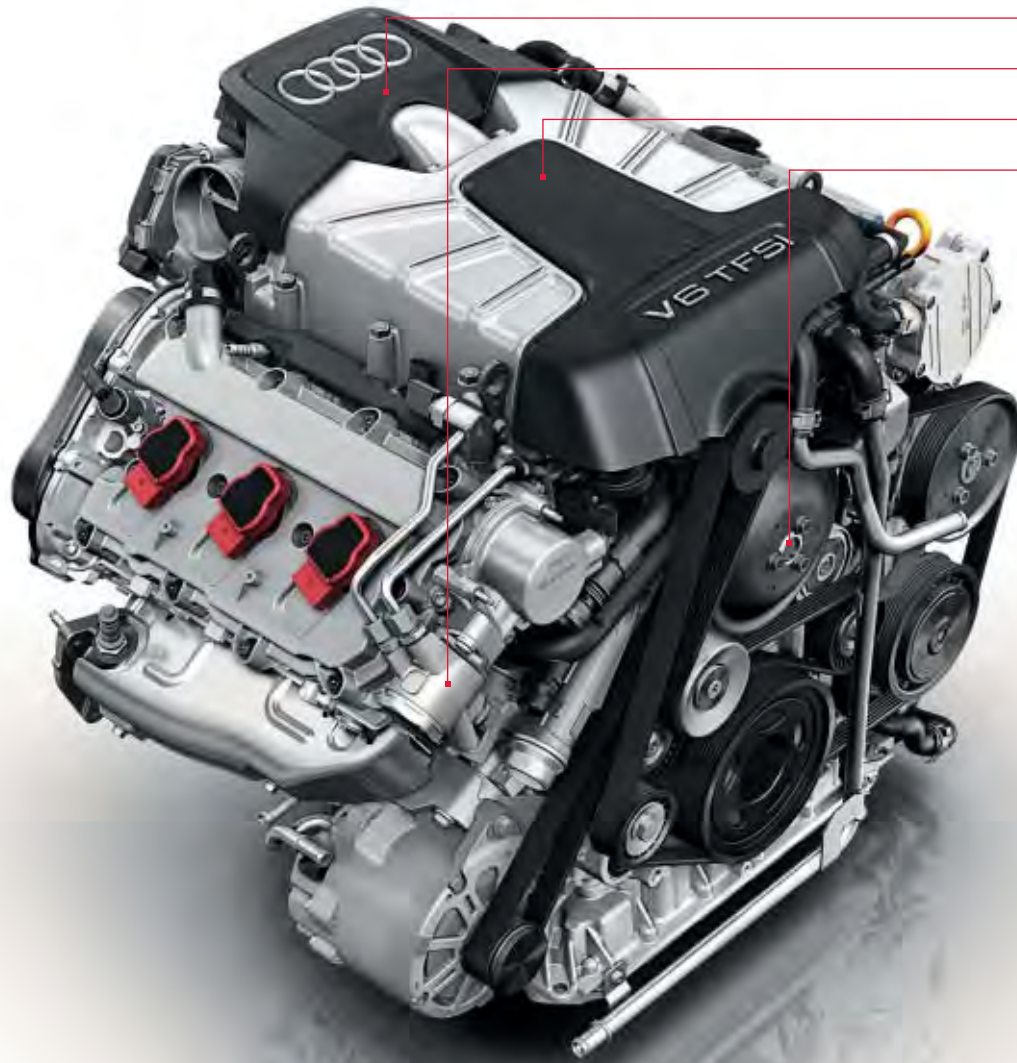

- timing drive chain
- high-pressure pump
- integrated supercharger
- switchable water pump

Many hours of development.
Thousands of miles of testing.
And for what reason?



The supercharger is a central element in boost pressure generation. Or, put another way, it ensures outstanding torque even at low engine speeds. The supercharger is a highly integrated, mechanical charging module situated between the two cylinder banks. The rotor unit, the electrically controlled butterfly valve in the bypass bend and the engine-side heat exchanger of the indirect charge air cooling system are integrated in one single-piece cast metal housing. The four-blade rotors mounted on an anti-friction bearing compress by 160° and are covered with a coating which allows the gap dimensions in the construction to be reduced.

In just a few seconds you will understand why.

In FSI technology, the fuel is injected directly into the combustion chamber and atomised into a fine spray. This way, the fuel – metered to almost droplet precision – can be called upon the millisecond that the engine requires it. This means better utilisation of the fuel and ultimately, reduced consumption.

TFSI technology is employed in the Audi Q7. It combines the advantages of FSI with a supercharger, which ensures even better power delivery.

The fuel consumption and CO₂ emission figures can be found on page 102.

The Audi Q7 is available with a high-rev V6 TFSI engine with 200 kW or 245 kW. It is not just the peak torque that is impressive, there is also the torque curve. With the 245 kW engine, at least 90 % of the 440 Nm maximum torque is available across an engine speed range of 2,000 to 6,000 rpm. Thanks to its very spontaneous responsiveness and exceptional power delivery across the entire engine speed range, the 6-cylinder engine promotes a particularly dynamic driving style.



The piezo injectors open and close in fractions of a millisecond and inject fuel several times into the combustion chamber at pressures of up to 2,000 bar. In some cases, an injection process can involve the injection of the tiniest of amounts weighing less than a thousandth of a gram.



Pre-injection results in a “gentle” combustion process and consequently excellent combustion acoustics and agreeable engine running characteristics.

TDI®

In other words: Where is the tank?

One in every two Audi cars sold today is a diesel. What sounds perfectly normal now was cause for huge excitement 20 years ago, when Audi revolutionised the market with the first 2.5 litre TDI engine. Since then, developments such as common rail technology have made TDI even more efficient. Piezo injectors ensure the fuel is finely and precisely distributed. Consequently, since the first TDI, the engines have become more economical, whilst specific output has increased.

Choose for yourself how much power you wish to carry you away in the Audi Q7: a 3.0 TDI quattro

with 150 kW or 180 kW (also available as a TDI clean diesel quattro) or a 4.2 TDI quattro with 250 kW.

All the engines comply with the EU5 emission standard, the TDI clean diesel quattro even complies with the EU6 emission standard, which does not come into force until 2014. The 6- and 8-cylinder engines are fitted with a recuperation system which converts kinetic energy into electrical energy. This increases efficiency and saves up to 3 % fuel – particularly in city traffic. Together with the start-stop system in the

3.0 TDI engines that automatically switches the engine off when the vehicle is at a standstill, fuel consumption can be significantly reduced.

In addition to the standard catalytic converter and the diesel particulate filter, the Audi Q7 as a 3.0 TDI clean diesel quattro has a nitrogen oxide catalytic converter with AdBlue®* tank. AdBlue® is a biodegradable additive, small doses of which are injected upstream of the nitrogen oxide catalytic converter. Combined with other innovations such as common rail technology and highly efficient exhaust-gas recirculation, a reduction of

the nitrogen oxide emissions by up to 90% is achieved. With the 4.2 TDI quattro with 250 kW, you can also choose a highly efficient and powerful diesel engine. The peak torque of 800 Nm and the running smoothness of the V8 engine impress both over short and long distances.

turbocharger with improved adjustable turbine geometry

2,000 bar high-pressure injection system

engine with reduced friction

pressure-regulated oil pump

innovative thermal management with separate cooling system for cylinder head casing/cylinder head



3.0 TDI engine (180 kW)



The V12 engine is characterised by its superb smooth-running performance.

368 kW accelerate the Audi Q7 V12 TDI quattro from 0 to 100 km/h in just 5.5 seconds.

You can drive the Audi Q7 V12 TDI quattro up to a top speed of 250 km/h – after which the electronic regulation function comes into action.

6 litre displacement – more than you have ever had before in an Audi Q7. That creates space for power.

The most powerful diesel engine of its class.

So much power – with comparatively low fuel consumption. The Audi Q7 V12 TDI quattro consumes 11.3 litres of fuel (combined) per 100 km.

Concentrated energy: with a length of 684 mm, the diesel engine is very compact – an important precondition for integration into a standard production vehicle.

The crankcase is made of a high-tech material. It is manufactured using a patented casting process and has remarkable advantages: It is more rigid, more resistant to fatigue and lighter than comparable materials.

The maintenance-free chain drive is situated on the rear side of the engine to save space.

The crankshaft is made from a chromium molybdenum steel alloy, the pistons from aluminium.

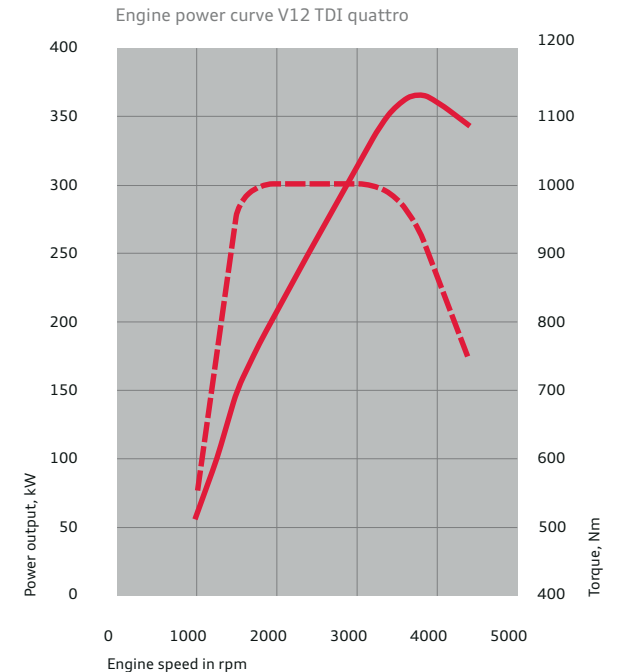



Why only use two wheels when a car has four?

The quattro® permanent all-wheel drive.

Those who know Audi know quattro. And once you have driven with quattro, you do not want to drive with anything else. Why? Because this drive puts the engine's power on the road in such a convincing way.

quattro is a permanent all-wheel drive. If the wheels on one axle of the vehicle lose grip on the road and threaten to spin, then the drive force

is transferred to the other axle – automatically and permanently distributed through the centre differential.

The basic distribution is 40 : 60 – 40 % of the driving power comes from the front axle, 60 % from the rear. The benefits are better traction during acceleration and improved safety due to exceptional grip.

But what makes quattro unique is really the driving feel. "As if you're stuck to the road," some customers say. We put it like this: quattro gives you a better feel for the road and thus more safety.

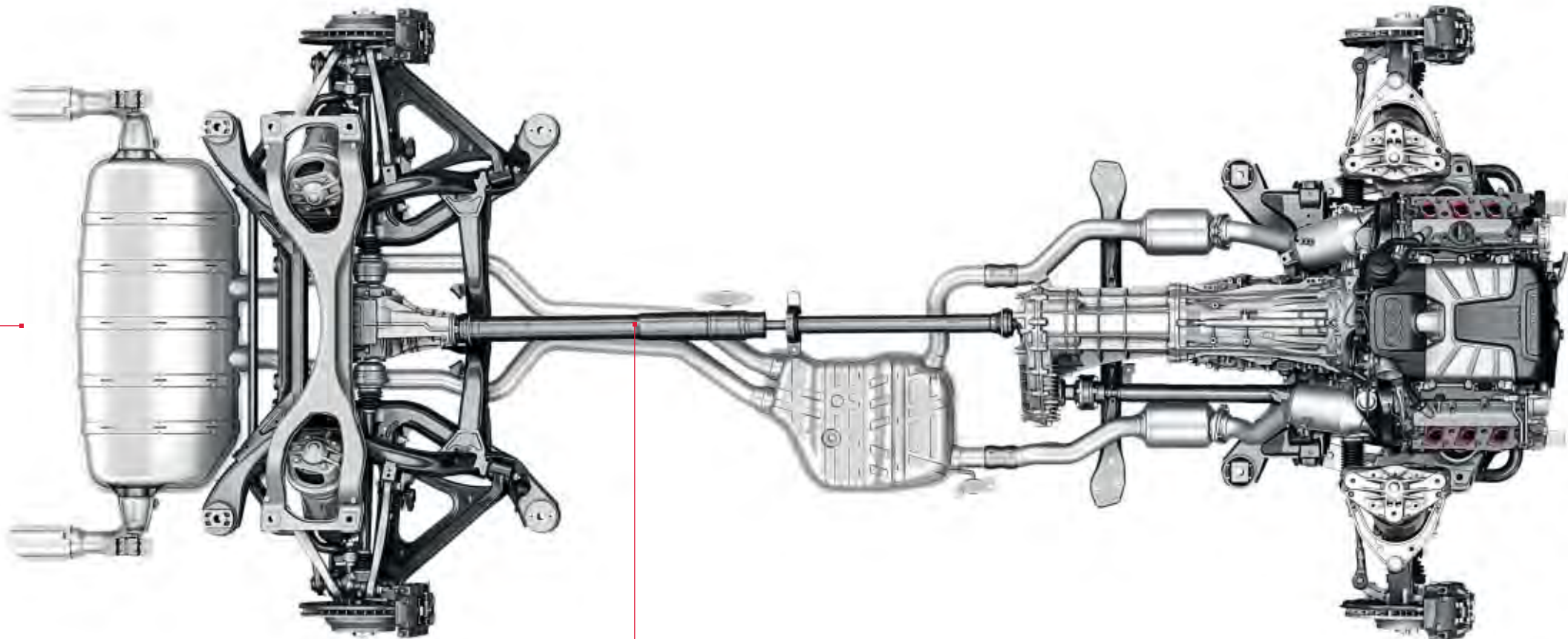

The quattro drivetrain

Dynamics and comfort were once opposites. adaptive air suspension makes the differences vanish into thin air.

Can the road communicate with the suspension? And above all: can the suspension understand the road? In the Audi Q7 and Audi Q7 V12 TDI quattro it can – the suspension adapts to the driving situation and the road as well as possible (standard from 250 kW). We call it Audi adaptive air suspension.

An electronically controlled air suspension system operates individually on each of the four wheels and is combined with an infinitely variable adaptive damping system. Sensors on the body and on the axles continually monitor the current driving situation and send information to the system during the journey. Furthermore, the air springs guarantee that, even when carrying

heavy loads, the vehicle's driving characteristics will not be impaired.

The advantages of the Audi adaptive air suspension can be felt after just a few metres. And then most certainly when you drive round a corner or bend. The rolling or pitching motions of the body are substantially reduced, the vibration behaviour

and the spring travel remain optimal. In future, you may still be able to see uneven roads, but you will feel them less.

The infinitely variable damping adjusts itself automatically to almost every driving situation. Even with asymmetrically distributed loads, the vehicle almost always remains in a level position thanks to continuous ride-height regulation. Drivers can determine how dynamically they want to travel and what character their Audi should adopt. Different modes are available to the driver and can be selected using the MMI.

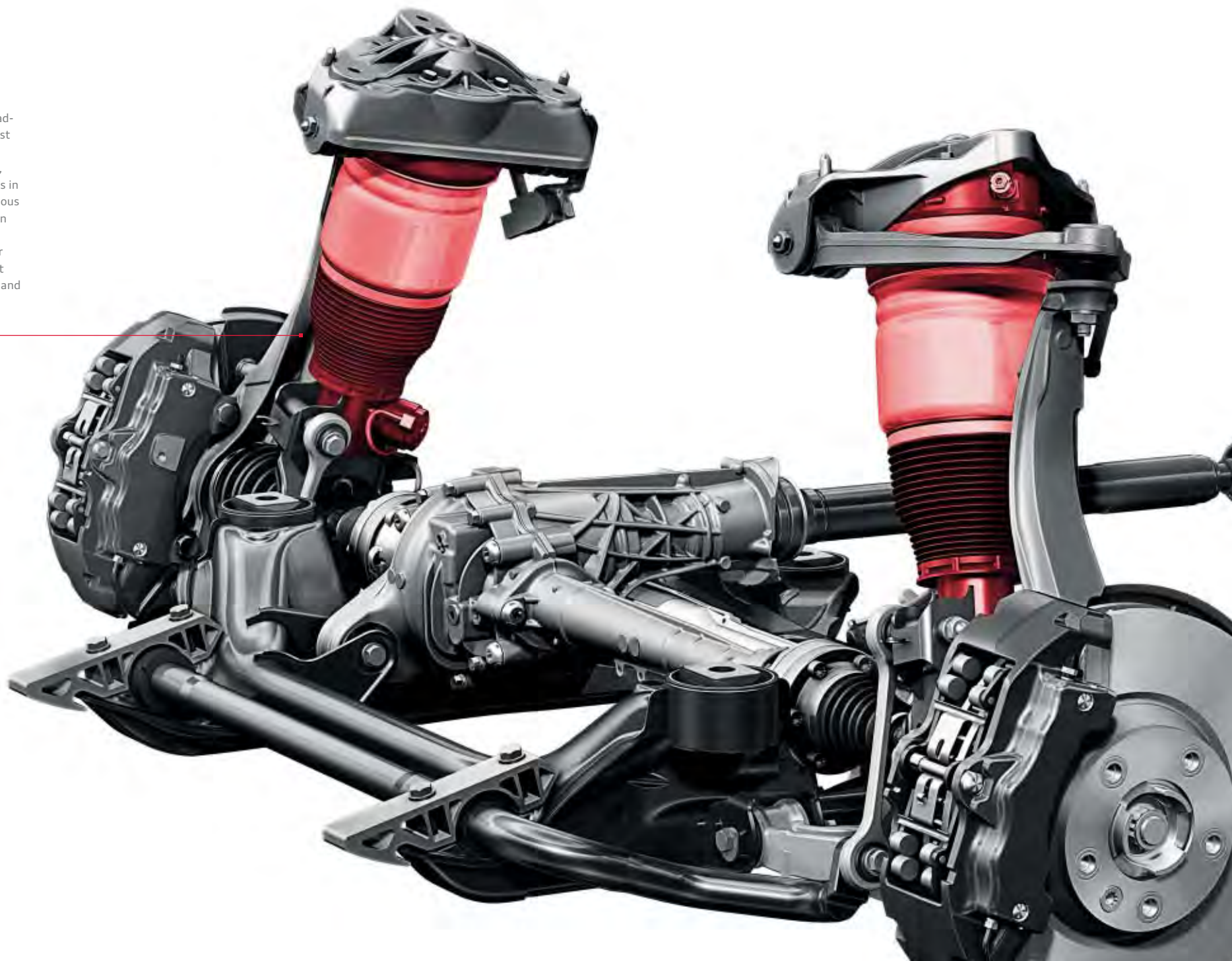

Nothing can stop a top athlete. Except for a top brake system.

The 18-inch high-performance brake system in the Audi Q7 takes a powerful hold with its 6-piston fixed callipers on the front axle. A single-piston floating calliper is used on the rear axle. The brake discs comprise a cast friction ring which is connected to the brake disc chamber by means of steel pins. This so-called floating mounting ensures that the friction ring remains tension-free to a major extent, improving stability under extreme temperature loads. The axial perforation

and cooling channels for internal ventilation also increase the brake discs' performance. The use of aluminium not only reduces the weight of the brake discs, it also improves the weight balance of the unsprung masses.

For even more demanding loads, the Audi Q7 V12 TDI quattro is equipped with a 20-inch ceramic brake* with an 8-piston fixed calliper as standard (optional for 4.2 TDI quattro). With this brake

system, the brake discs on the front axle are made of a carbon-fibre reinforced ceramic material. This is based on hard and abrasion-proof silicon carbide with high-strength carbon fibres embedded. This combination results in an enormous abrasion resistance which allows extremely high mileages to be achieved and at the same time reduces sensitivity to high thermal loads. In addition, the material is lighter than steel discs.

20-inch ceramic brake*

18-inch steel brake

The brake discs on the front axle have a diameter of 350 mm and are 34 mm thick. The brake callipers have a black anodised finish.

The brake discs on the front axle have a diameter of 420 mm and are 40 mm thick. The high-gloss anthracite painted brake callipers bear the "Audi ceramic" logo.



* Standard for Q7 V12 TDI quattro, optional for Q7 4.2 TDI quattro (250 kW) and Q7 3.0 TFSI quattro (245 kW).
Please consult your Audi partner or national Audi website to find out more about the special features of the ceramic brake.

Follow your intuition.

And you'll get there.

We try to match up to our claim of “Vorsprung durch Technik” in every aspect of an Audi – for example with the advanced optional MMI – Multi Media Interface. The MMI is used to control a wide variety of media in the vehicle, as well as the navigation system and other convenience functions. In addition, you can use it to control the optional services supported by Audi connect.

The 7-inch colour display presents all the information in a very attractive look and with impressive clarity.

On request, MMI navigation plus is available with 3D map display for the Audi Q7. This allows you access to the various integrated audio sources such as hard drive, DVD player (audio/video) and two SDHC card readers (MP3 and WMA files).

Mobile phone systems can be connected to the vehicle via the Bluetooth interface. And managing your address book with up to 2,000 entries is now really easy. The Audi music interface can be used to connect a range of external media to the MMI, e.g. an iPhone, iPod or a USB hard disc.

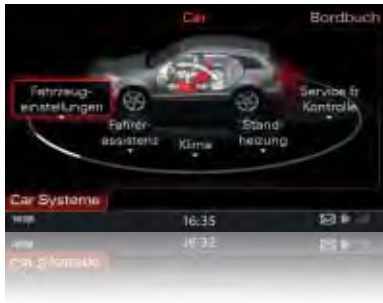

Car: This function allows the direct control of driver assistance systems, vehicle settings, climate control, auxiliary heating and service.



Navigation system: The optional hard disk navigation system MMI navigation plus provides a 3D map view and a three-dimensional representation of well-known buildings and sites.



Radio: The integrated radio receiver is set up for VHF, LW and MW and optionally transmits digital radio with a continually updated station list.



Media: Display of available media sources such as jukebox, inserted SDHC cards, Audi music interface or CDs and DVDs; display of optional TV tuners



Audi connect: All the services supported by Audi connect can be used quickly and easily with the MMI. The intuitive operation of the MMI makes internet access extremely easy.



Audi connect:

The intelligent connection between the internet, the vehicle and you.

These days, we are connected everywhere and at all times – at home, at work and on the move. Being connected whenever you wish, even in your car, is what modern mobility is all about. Audi connect keeps you connected to the world via the data module integrated in the vehicle. You can access the contacts and music collection on your mobile phone¹ conveniently and directly via Bluetooth. In addition, there is a Wi-Fi hotspot for wireless connection of up to 8 mobile devices. You can use Audi connect to find out more about cultural events in town, find the cheapest petrol stations nearby, put your own personal route

together at home and then transfer it to the navigation system, or explore your destination online in advance. The numerous integrated services and functions allow the vehicle to become part of the global network – increasing comfort and taking automotive fun to new heights. Simple, fast and customised.

Further detailed notes on availability and legal information about Audi connect, the technical requirements (necessary optional equipment, mobile phone contract, registration), any costs which may be incurred and the respective condi-

tions of use can be found on page 93 of this catalogue. Please contact your Audi partner for information about the availability and scope of the services supported by Audi connect or visit www.audi.com/connect.

¹ Please visit www.audi.com/bluetooth or contact your mobile service provider for the compatibility test and further information.

² Google and the Google logo are registered trademarks of Google Inc.



If you want to experience the full diversity of Audi connect, scan this QR code using your smartphone. Or follow this link in your browser: www.audi.com/audiconnectq7

Mobility & navigation



Point-of-interest (POI) search with voice control
in the Google™ database²



Traffic information online
Detailed information on traffic flows, e.g. for individual stretches of road; faster and more precise information on the occurrence and clearing of traffic jams



Navigation with Google Earth™ map service² and Google Street View™²
with high-resolution (30 m zoom) aerial and satellite images, photos, business entries, etc.



Fuel prices
The cheapest petrol stations at your destination or in the vicinity



Parking information
Help with looking for car parks and multi-storeys incl. price details. And – if available – details about vacant spaces

Communication



Wi-Fi hotspot
connects your mobile devices to the internet

Infotainment



Weather
Charts and weather maps relating to the destination



Audi music stream
Access to global radio stations via smartphone app and Wi-Fi connection



News online
Text and images about current world events



City events
Up-to-date information about events e.g. in your vicinity or at your destination



Travel information
Professionally prepared sightseeing information, with read-aloud and import function directly to your navigation destination



myAudi – your personal “control-centre”
Put your own personal route together at home and send it to your Audi MMI. Destinations can be entered via audi.com/myaudi, via the **myAudi** mobile assistant app or via **Google Maps™²**.



You sit at the wheel.

Others are working in the background.

Most road accidents are caused by human error. In many cases, the results of accidents can be reduced by modern assistance systems. Audi puts various different technologies to work to help you reach your destination safely. The assistance systems work closely together, which increases their versatility and performance – and makes your trip more comfortable at the same time.



adaptive cruise control*: The automatic distance control detects vehicles ahead by means of a radar sensor. Within system limits, the vehicle brakes and accelerates automatically, keeping the distance set by the driver to the traffic ahead constant.



Audi lane assist* supports you when travelling at speeds from about 60 to 250 km/h if you inadvertently drift out of your chosen lane. When the lane markings are crossed, the steering wheel vibrates to give the driver a warning. If the indicator has been activated, there is no warning. The timing of the warning and the strength of the vibration can be selected individually to one of 3 levels in the MMI.



Audi side assist*: The lane change assistant helps you to change lanes. From a speed of about 30 km/h, it monitors the area alongside and behind the vehicle. Radar sensors at the rear detect any vehicles that may be in the blind spot or approaching quickly from behind. If Audi side assist deems that a detected vehicle will compromise a lane change, it signals this by means of an LED display on the corresponding exterior mirror.

Please note: The systems can only work within system limits. They can be of assistance, but drivers are still required to be attentive at all times.

*Optional equipment.





It is the equipment that turns an Audi into your Audi.



Audi exclusive

Exclusivity does not know the meaning of the word compromise. But it is familiar with endless variety.

Each year Audi sells over a million vehicles. Yet they only sell yours once. How is that possible? With Audi exclusive. This makes your Audi unmistakable.

Combine selected décors, coloured leather and a customised paint finish from the large selection of colours available from Audi exclusive to suit your personal wishes. Your unique vehicle will be the result.

Find out more about this topic from your Audi partner and in the Audi exclusive studio in Neckarsulm.

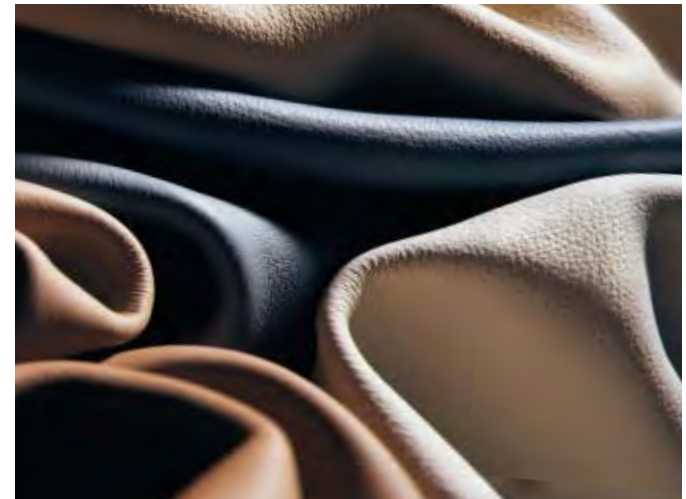



Audi exclusive leather plus design package with sport seats in black/Havana brown with contrasting stitching and the Audi exclusive full leather package



Seats with seat upholstery in black/silver two-colour look in fine Nappa leather¹



Gear lever gaiter with coloured stitching



Inlays in tamo ash, dark brown

Seat upholstery

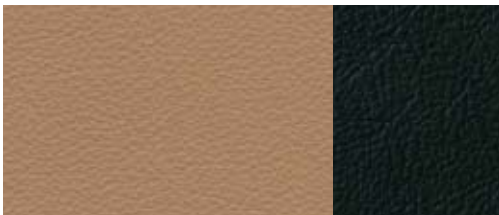

Fine Nappa leather, sand beige/black

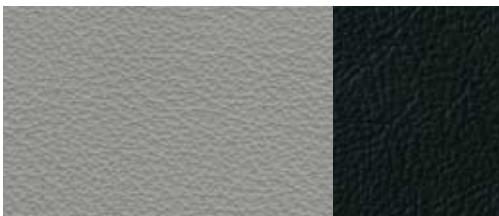

Fine Nappa leather, silver/black

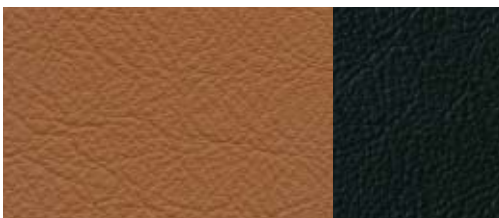

Fine Nappa leather, cognac/black

Inlays

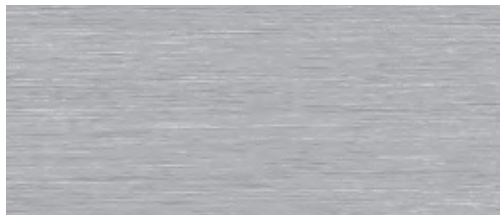

Matt brushed aluminium

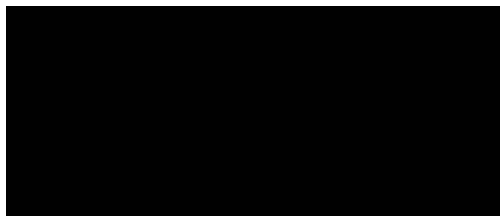

Piano finish, black
optional



Tamo ash, dark brown
optional

Audi exclusive line²

Two-colour seat upholstery with piping

(seat side bolsters black/seat centre panel optionally in sand beige, silver or cognac) in fine Nappa leather (standard seats); optional: sport seats

Side bolsters and head restraints with coloured piping, steering wheel rim and gear lever gaiter with coloured stitching

coloured piping and stitching to match seat centre panel

Door trim inserts

to match seat centre panel

Leather-covered multifunction steering wheel in 4-spoke design, with coloured stitching

to match seat centre panel; optional: leather-covered multifunction sport steering wheel in 3-spoke Q design with gear change function with coloured stitching (to match seat centre panel); in conjunction with Audi lane assist only with black stitching

Inlays in matt brushed aluminium

optional: tamo ash, dark brown or piano finish, black

Black interior

including black attachments

Headlining in black cloth

Floor mats

with coloured piping to match seat centre panel

Comfort centre armrest, leather-covered

Audi exclusive door sill trims

¹ For information on when this feature will be available, please contact your Audi partner. ² From quattro GmbH.

S line. Visibly more sportiness.

Driving an Audi Q7 is a clear commitment to automotive sportiness. The S line packages allow you to enhance the athletic appearance of your Audi Q7 even more: with a range of equipment that accentuates its dynamic body lines, gives its interior a perceptibly sporty identity and further improves its driving performance. Choose how to up the sportiness.



S line exterior package*

Front and rear bumpers, side radiator grilles, door cover strips and diffuser insert in a striking, sporty design

Front and rear bottom bumper sections and door cover strips in body colour, centre front spoiler lip and diffuser insert painted in platinum grey

LED front indicators

Headlight cleaning system

Door sill trims with S line logo

S line logos on the front wings (except for 3.0 TFSI quattro [245 kW])

*Not available for Q7 V12 TDI quattro.



Distinctively sporty front bumper including LED indicators



Diffuser insert in a striking, sporty design



Visibly ergonomic: sport seats with Alcantara/leather covers with contrasting stitching and S line logos in the front-seat backrests, matt brushed aluminium inlays



Unmistakably S line: S line leather-covered multifunction sport steering wheel with contrasting stitching and steering wheel grips in perforated leather



Perceptibly sporty: selector lever knob in perforated black leather



Recognisably dynamic: Audi exclusive cast aluminium wheels in 5-spoke design

Inlays

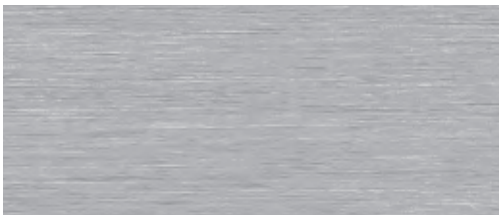

Matt brushed aluminium

Seat upholstery



Alcantara/leather, black

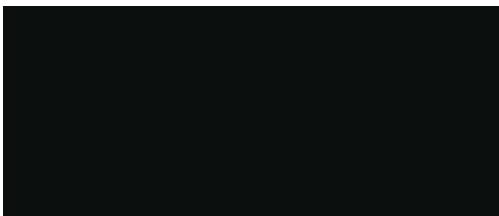

Piano finish, black

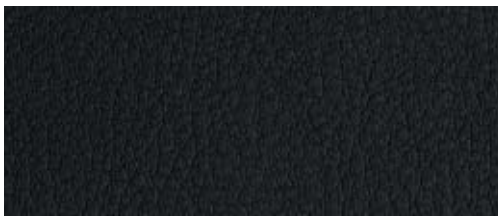

Verano leather, black

Additional exterior paint finish options



Audi exclusive carbon
From quattro GmbH



Mugello blue, pearl effect



Daytona grey, pearl effect

S line sport package¹

The S line sport package includes the following equipment:

Audi exclusive cast aluminium wheels in 5-spoke design
size 9 J x 20 with 275/45 R 20²

S line sport suspension
with more dynamic suspension tuning and vehicle lowered by 10 mm (with 4.2 TDI quattro:
S line adaptive air suspension)

S line logos
on the front wings and the door sill trims
(except for 3.0 TFSI quattro [245 kW])

Interior, dashboard and headlining
in black, with optional contrasting stitching on Alcantara/leather seat upholstery, leather-covered sport steering wheel, gear lever gaiter and floor mats

Sport seats, front
electrically adjustable, with electrically adjustable lumbar support for both front seats

S line leather-covered multifunction sport steering wheel in 3-spoke design
with or without gear change function, each in black leather (steering wheel grips in perforated leather)

S line inlays
in matt brushed aluminium

Air vent surrounds in aluminium look

Comfort centre armrest

Optionally available:

Audi exclusive cast aluminium wheels in 10-spoke design or 20-spoke design
2-piece, size 10 J x 20 with 295/40 R 20 tyres²; forged aluminium wheels in 7-twin-spoke design or cast aluminium wheels in 5-segment-spoke design, size 10 J x 21 with 295/35 R 21 tyres²

The following options are available for the seat upholstery:

S line seat upholstery in Alcantara/leather or Verano leather
each in black and with S line embossing on the front-seat backrests

S line adaptive air suspension

S line inlays
piano finish, black or Audi exclusive carbon

Paint finishes in all standard and optional equipment colours as well as additional colour options in the special colours Mugello blue, pearl effect or Daytona grey, pearl effect

¹ Not available for Q7 V12 TDI quattro. ² You will find specifications on the technical characteristics of tyres on page 113.



Audi Q7 in orca black, metallic, with optional aluminium-look exterior including full paint finish, with cast aluminium wheels in 5-arm structured design. Equipment: sport design package with sport seats in black Alcantara/leather, inlays in aluminium Trigon and leather-covered multifunction sport steering wheel in 3-spoke Q design



Audi Q7 in teak brown, metallic, with optional aluminium-look exterior including full paint finish, with cast aluminium wheels in 5-arm V design. Equipment: leather plus design package with standard seats in Verano leather, savannah beige, inlays in tamo ash, dark brown and leather-covered multifunction sport steering wheel in 3-spoke Q design

Solid paint finishes



Night black

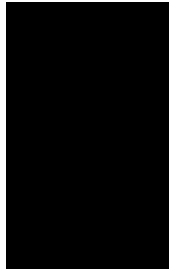

Metallic paint finishes



Glacier white, metallic

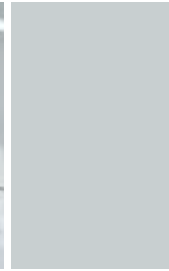

Teak brown, metallic



Orca black, metallic

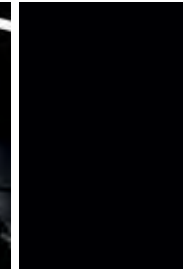

Carrara white

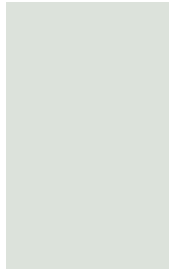

Ice silver, metallic



Atlantis blue, metallic



Bahia beige, metallic



Graphite grey, metallic



Pearl effect paint finishes



Garnet red, pearl effect



Daytona grey, pearl effect



Mugello blue, pearl effect

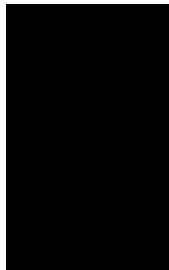

Lava grey, pearl effect

Contrasting paint finishes



Platinum grey, matt

in combination with the following paint finishes:
glacier white, metallic, night black, Atlantis blue,
metallic, orca black, metallic, lava grey, pearl effect,
garnet red, pearl effect



Matt black

in combination with the following paint finishes:
Carrara white, ice silver, metallic, teak brown, metallic,
bahia beige, metallic, graphite grey, metallic

Customised paint finishes



Audi exclusive customised paint finishes

From quattro GmbH

Paint finishes

solid paint finish, metallic/pearl effect paint finish
or Audi exclusive individual paint finish

Contrasting paint finish

front and rear bumper bottom section and door
trim strips in platinum grey, matt or matt black
(depending on the exterior colour chosen)

Full paint finish

front and rear bumper bottom section and door trim
strips painted in body colour (available with aluminium-
look exterior or S line exterior package)

Wheels/tyres



Cast aluminium wheels in 6-arm design
size 8 J x 18 with 255/55 R 18¹ tyres



Cast aluminium wheels in 5-arm structured design
size 8.5 J x 19 with 265/50 R 19¹ tyres



Audi exclusive cast aluminium wheels in 10-spoke design
size 10 J x 20 with 295/40 R 20¹ tyres, including wheel arch trims³.
From quattro GmbH



Audi exclusive cast aluminium wheels in 5-segment-spoke design²
size 10 J x 21 with 295/35 R 21¹ tyres, including wheel arch trims³.
From quattro GmbH



Forged aluminium wheels in 7-arm design
size 7.5 J x 18 with 235/60 R 18¹ tyres



Cast aluminium wheels in 10-spoke V design
anthracite, partly polished, size 9 J x 20 with 275/45 R 20¹ tyres



Audi exclusive cast aluminium wheels in 20-spoke design
2-piece, size 10 J x 20 with 295/40 R 20¹ tyres, including wheel arch trims³.
From quattro GmbH



Audi exclusive forged aluminium wheels in 7-twin-spoke design
polished, 2-coloured⁴, size 10 J x 21 with 295/35 R 21¹ tyres, including wheel arch trims³.
From quattro GmbH



Cast aluminium wheels in 5-arm V design
size 8.5 J x 19 with 265/50 R 19¹ tyres



Audi exclusive cast aluminium wheels in 5-spoke design²
size 9 J x 20 with 275/45 R 20¹ tyres.
From quattro GmbH



Audi exclusive cast aluminium wheels in 20-spoke design, black
2-piece, size 10 J x 20 with 295/40 R 20¹ tyres, including wheel arch trims³.
From quattro GmbH



Cast aluminium winter wheels in 6-arm design
size 8 J x 18 with 255/55 R 18¹ tyres, can be fitted with snow chains, permissible top speed 210 km/h

Wheels/tyres



Forged aluminium winter wheels in 7-arm design
size 7.5 J x 18 with 235/60 R 18¹ tyres, can be fitted with snow chains, permissible top speed 210 km/h



Cast aluminium winter wheels in 10-spoke V design
anthracite, partly polished, size 9 J x 20 with 275/45 R 20¹ tyres, cannot be fitted with snow chains, permissible top speed 240 km/h



Audi exclusive cast aluminium winter wheels in 10-spoke design
size 10 J x 20 with 275/45 R 18¹ tyres, can be fitted with snow chains, permissible top speed 240 km/h.
From quattro GmbH

Anti-theft wheel bolts

can only be loosened with the supplied adapter

Tyre repair kit

with 12V compressor and tyre sealant, located under the loading floor cover in the luggage compartment; top speed 80 km/h

Spare wheel

size 18 inch with 235/60 R 18¹ or 255/55 R 18¹ tyres. (For vehicles without a 3rd row of seats)

Space-saving spare wheel

including vehicle jack in the luggage compartment, permissible top speed 80 km/h

Tyre pressure loss indicator

visual and acoustic warning if the pressure drops in one or more tyres; display in the driver information system

Tyre pressure monitoring system

monitors the air pressure set in the tyres and the tyre temperature throughout the journey, also works with winter wheels delivered by Audi. Air pressures and temperatures of the individual tyres can be displayed in the MMI system.

Vehicle tool kit

in the luggage compartment

Vehicle jack

in the luggage compartment

¹You will find specifications on the technical characteristics of tyres on page 113. ²Optionally also in titanium look. ³Not for Q7 V12 TDI quattro. ⁴Optionally also in high-gloss polished finish, single-colour.



Standard seats, front

with manual adjustment of seat height, fore/aft position, backrest angle, height of head restraints and clearance as well as seat belt height; Q7 V12 with electric adjustment of the seat height, fore/aft position, seat angle, backrest angle and electric 4-way lumbar support for the driver and front-passenger seats; manual adjustment of head restraint height and clearance as well as seat belt height.

(The image shows standard seat, front, in cricket leather, pale grey.)

Cloth upholstery and trim

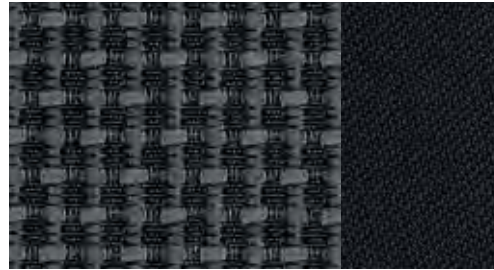

Cosmo cloth, black

Leather upholstery and trim



Cricket leather, black

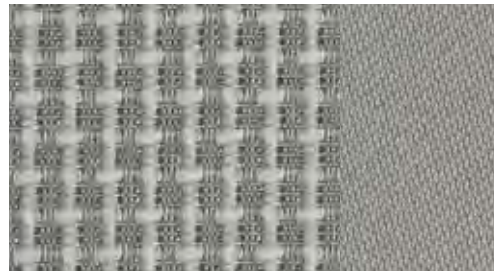

Cosmo cloth, pale grey

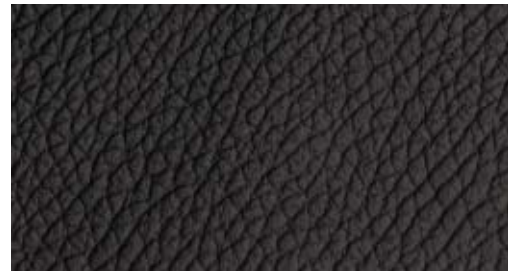

Cricket leather, paranut brown

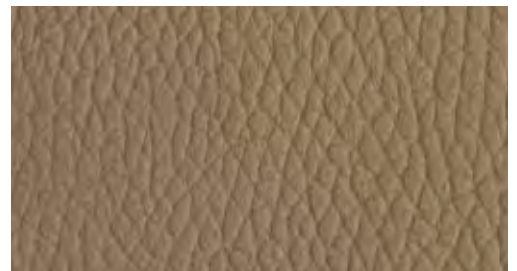

Cricket leather, savannah beige

Leather upholstery and trim



Cricket leather, cardamom beige



Verano leather, black



Verano leather, cardamom beige

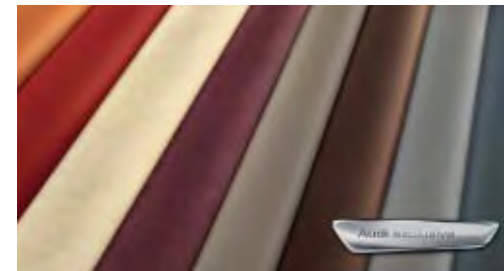

Audi exclusive leather upholstery and trim
From quattro GmbH



Cricket leather, pale grey



Verano leather, paranut brown



Verano leather, pale grey

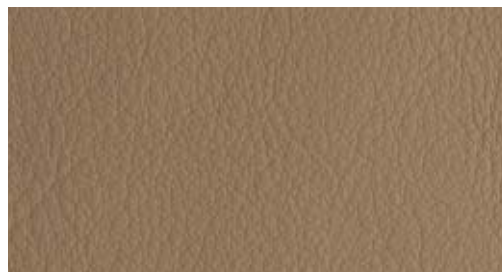

Verano leather, savannah beige



Sport seats, front

with electric adjustment of seat height, fore/aft position, seat angle, backrest angle; manual adjustment of head restraints and belt height, with shaped seat side bolsters for better lateral support when cornering, extendable thigh support and electric 4-way lumbar support; optionally with memory function. (The image shows sport seat, front, in Alcantara/leather, black.)

Leather upholstery and trim



Alcantara/leather, black



Verano leather, black

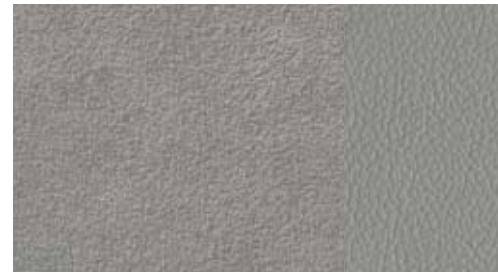

Alcantara/leather, pale grey



Verano leather, paranut brown



Verano leather, savannah beige

Leather upholstery and trim



Verano leather, cardamom beige

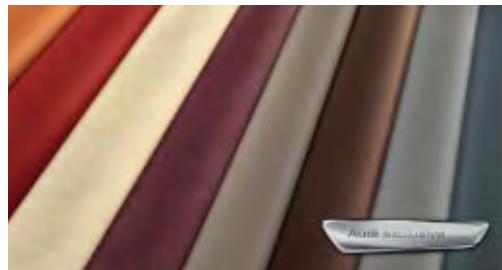

Audi exclusive leather upholstery and trim
From quattro GmbH



Verano leather, pale grey



Climate-controlled comfort seats, front

exclusive seat option with shaped seat side bolsters and soft-feel design for luxurious comfort; actively ventilated and heated seat and backrest centre panel; automatically heated to prevent cold seats; perforated leather on the ventilated seat cushions of the front seats and on the non-ventilated seat cushions of the two outer rear seats. (The image shows climate-controlled comfort seat, front, in perforated Verano leather, cardamom beige.)

Leather upholstery and trim



Perforated cricket leather, black

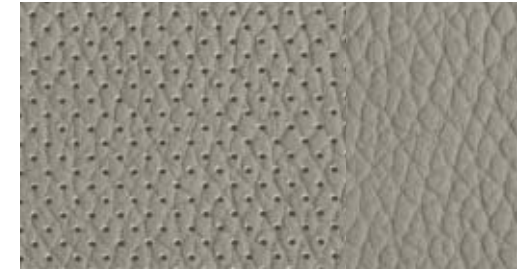

Perforated cricket leather, cardamom beige



Perforated cricket leather, paranut brown

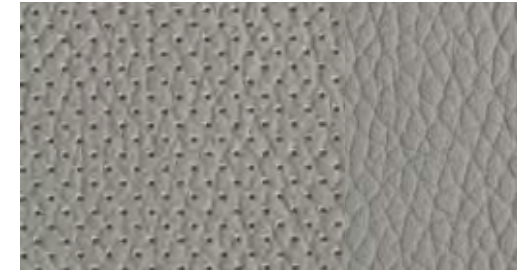

Perforated cricket leather, pale grey



Perforated cricket leather, savannah beige

Leather upholstery and trim



Perforated Verano leather, black



Perforated Verano leather, cardamom beige

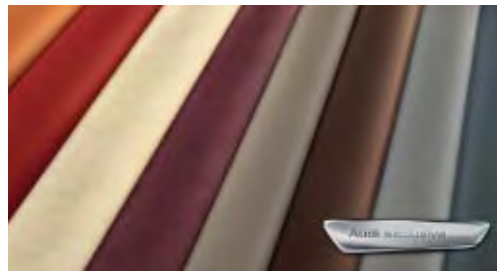

Audi exclusive leather upholstery and trim
From quattro GmbH



Perforated Verano leather, paranut brown



Perforated Verano leather, pale grey



Perforated Verano leather, savannah beige

Cloth/leather upholstery and trim, equipment and design packages**Cosmo cloth upholstery and trim**

seat centre panel in cosmo cloth, seat side bolsters, head restraints and centre armrest, front and door trim inserts in single-colour cloth

Alcantara/leather combination

seat centre panel and door trim inserts in Alcantara, seat side bolsters, head restraint centre panel and front centre armrest in leather

Cricket leather upholstery and trim

for standard seats, front: seat centre panel, seat side bolsters, head restraint centre panel and centre armrest, front in cricket leather, door trim inserts in Alcantara; for sport seats, front: seat centre panel, seat side bolsters, head restraint centre panel, centre armrest, front in Verano leather, door trim inserts in Alcantara; for climate-controlled comfort seats, front: seat centre panel of the front seats and non-ventilated seat centre panel of the two outer rear seats in perforated Verano leather, seat side bolsters, centre rear seat, head restraint centre panel, centre armrest, front and 3rd row (if ordered) in Verano leather, door trim inserts in Alcantara. (Can be ordered via the leather design package.)

Verano leather upholstery and trim

for standard and sport seats, front: seat centre panel, seat side bolsters, head restraint centre panel and centre armrest, front in Verano leather, door trim inserts in Alcantara;

for climate-controlled comfort seats, front: seat centre panel of the front seats and non-ventilated seat centre panel of the two outer rear seats in perforated Verano leather, seat side bolsters, centre rear seat, head restraint centre panel, centre armrest, front and 3rd row (if ordered) in Verano leather, door trim inserts in Alcantara. (Q7: can be ordered via the leather plus design package)

Fine Nappa leather or Valcona leather upholstery and trim and Audi exclusive Alcantara/leather combination

Head restraints, seat side bolsters and centre armrest, front in fine Nappa or Valcona leather; seat centre panel and door panel insert in leather or Alcantara; Alcantara/leather combination only for sport seats, front, Valcona leather only for climate-controlled comfort seats, front. Individual choice of colour for the leather, the Alcantara and decorative stitching from the range of Audi exclusive colours, can be ordered via the respective Audi exclusive design package. From quattro GmbH

**Leather package**

Front centre console (also rear centre console for 6-seaters) and upholstery for the arm support in the doors as well as for the door handles in fine Nappa leather with decorative stitching in the same colour as the trim

Audi exclusive leather package

Front centre console (also rear centre console for 6-seaters), upholstery for the arm support in the doors as well as for the door pull handles in fine Nappa leather with decorative stitching. Individual choice of colour for the leather and the decorative stitching from the range of Audi exclusive colours. From quattro GmbH

Audi exclusive full leather package

Dashboard, door rails, instrument panel cover, front centre console (also rear centre console for 6-seaters), door pull handles, instrument panel cover, dashboard and door rails in Audi exclusive leather. Available in classic red, Havana brown, Iceland green, jet grey, crimson red, chestnut brown, night blue, smoke blue and saddle brown. Individual choice of colour for stitching. From quattro GmbH

**Full leather package**

Front centre console (also rear centre console for 6-seaters), door pull handles; instrument panel cover, dashboard and door rails in leather with contrasting stitching, arm support in the doors in leather. The full leather package also includes: headlining in Alcantara with contrasting stitching, sun visors in Alcantara, at the rear and on the rear side windows. (Q7: in combination with S line sport package and Audi exclusive line decorative stitching in the same colour as the trim; Q7 V12: in combination with Audi exclusive line decorative stitching in the same colour as the trim)

Audi exclusive colour-coordinated decorative stitching

From quattro GmbH

Equipment and design packages



Sport design package with sport seats, front

Front seats electrically adjustable, Alcantara/leather combination seat upholstery, comfort centre armrest in leather and door trim inserts in Alcantara, inlays (Q7: in matt silk, black; Q7 V12: in carbon) optionally in olive ash, beige, walnut, natural, tamo ash, dark brown or aluminium Trigon, vent surrounds in aluminium look, footwell trim and floor mats in velour carpet, optionally in Fresco carpet (colour-matched to the interior)

Leather design package with standard seats

Seat upholstery in cricket leather, comfort centre armrest in leather and door trim in Alcantara, inlays optionally in olive ash, beige, walnut, natural, tamo ash, dark brown or aluminium Trigon, vent surrounds in aluminium look, footwell trim and floor mats in velour carpet, optionally in Fresco carpet (colour-matched to the interior)



Leather plus design package with standard seats

Seat upholstery in Verano leather, comfort centre armrest in leather and door trim inserts in Alcantara, inlays (Q7: in matt silk, black; Q7 V12: in carbon) optionally in olive ash, beige, walnut, natural, tamo ash, dark brown or aluminium Trigon, vent surrounds in aluminium look, footwell trim and floor mats in velour carpet, optionally in Fresco carpet (colour-matched to the interior). (Q7 V12: front seats also electrically adjustable)

Leather plus design package with sport seats, front

Front seats electrically adjustable, seat upholstery in Verano leather, comfort centre armrest in leather and door trim inserts in Alcantara, inlays (Q7: in matt silk, black; Q7 V12: in carbon) optionally in olive ash, beige, walnut, natural, tamo ash, dark brown or aluminium Trigon, vent surrounds in aluminium look, footwell trim and floor mats in velour carpet, optionally in Fresco carpet (colour-matched to the interior)

Audi exclusive leather design package with standard seats

Seat upholstery in fine Nappa leather, footwell trim/floor mats in velour carpet, door trim and comfort centre armrest in leather, also vent surrounds in aluminium look. Individual choice of colour for the leather and the decorative stitching from the range of Audi exclusive colours. From quattro GmbH

Audi exclusive leather design package with sport seats

Seat upholstery in fine Nappa leather, footwell trim/floor mats in velour carpet, door trim and comfort centre armrest in leather. Individual choice of colour for the leather and the decorative stitching from the range of Audi exclusive colours. Also front sport seats with electric adjustment and electric lumbar support, as well as vent surrounds in aluminium look. From quattro GmbH

Audi exclusive leather design package with climate-controlled comfort seats

Seat upholstery in Valcona leather, footwell trim/floor mats in velour carpet, door trim and comfort centre armrest in leather. Individual choice of colour for the leather and the decorative stitching from the range of Audi exclusive colours. Also climate-controlled comfort seats in the front with electric adjustment, actively ventilated and heated, as well as vent surrounds in aluminium look. From quattro GmbH

Audi exclusive design package Alcantara/leather, black with sport seats

Seat upholstery in Alcantara/leather combination (coloured Alcantara, black leather), footwell trim/floor mats in velour carpet, door trim in Alcantara, comfort centre armrest in leather. Individual choice of colour for the Alcantara and the decorative stitching from the range of Audi exclusive colours. Also front sport seats with electric adjustment and electric lumbar support, as well as vent surrounds in aluminium look. From quattro GmbH

Audi exclusive leather plus design package with standard seats

Seat upholstery in fine Nappa leather, including leather-covered seats, door handles and door armrests, door trim and comfort centre armrest. Individual choice of colour for the leather and the decorative stitching from the range of Audi exclusive colours. Footwell trim/floor mats in velour carpet, as well as vent surrounds in aluminium look. From quattro GmbH

Audi exclusive leather plus design package with sport seats

Seat upholstery in fine Nappa leather, including leather-covered seats, door handles and door armrests, door trim and comfort centre armrest. Individual choice of colour for the leather and the decorative stitching from the range of Audi exclusive colours. Footwell trim/floor mats in velour carpet. Sport seats, front, with electric adjustment and electric lumbar support, as well as vent surrounds in aluminium look. From quattro GmbH

Audi exclusive leather plus design package with climate-controlled comfort seats

Seat upholstery in Valcona leather, including leather-covered backrests, door pull handles and door armrests, door trim and comfort centre armrest, footwell trim/floor mats in velour carpet. Individual choice of colour for the leather and the decorative stitching from the range of Audi exclusive colours. Also climate-controlled comfort seats in the front with electric adjustment, actively ventilated and heated, as well as vent surrounds in aluminium look. From quattro GmbH

Audi exclusive line equipment package

Black interior (including black attachments), headlining in black cloth, 2-coloured seat upholstery (seat side bolsters black/seat centre panel optionally in sand beige, silver or cognac) in fine Nappa leather, door trim inserts (to match the seat centre panel), inlays in matt brushed aluminium, optionally in tamo ash, dark brown or piano finish, black (Audi Q7 V12: inlays in carbon, optionally in tamo ash, dark brown, piano finish, black or matt brushed aluminium), floor mats with coloured piping (to match the seat centre panel), leather-covered comfort centre armrest, leather-covered multifunction steering wheel in 4-spoke design, optional leather-covered multifunction steering wheel in 3-spoke Q design with coloured stitching to match the seat centre panel (Audi Q7 V12: leather-covered multifunction sport steering wheel in 3-spoke Q design, optionally leather-covered multifunction sport steering wheel in 4-spoke design, with gear change function and coloured stitching (to match the seat centre panel), side bolsters, head restraints, steering wheel rim and gear lever gaiter with coloured stitching (to match the seat centre panel), Audi exclusive door sill trims. From quattro GmbH

Headlining



Black cloth

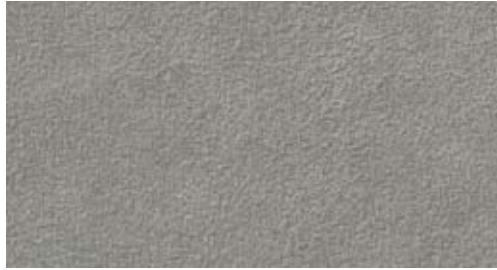

Alcantara pale grey



Alcantara linen beige



Audi exclusive headlining in Alcantara black
From quattro GmbH

Headlining

and attachments coordinated with the interior colour

Headlining in black cloth
and attachments in black

Headlining in Alcantara with contrasting stitching
and attachments in Alcantara including double sun visors coordinated with the interior colour

Audi exclusive headlining in Alcantara black with contrasting stitching in light grey
attachments in Alcantara including double sun visors.
From quattro GmbH

Audi exclusive headlining in Alcantara black, individual choice of colour for contrasting stitching
attachments in Alcantara including double sun visors coordinated with the interior colour.
From quattro GmbH

Inlays



Aluminium Trigon



Matt silk, black

Inlays

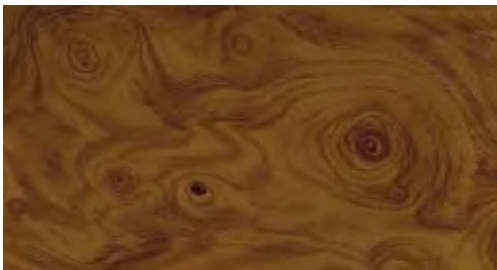

Olive ash, beige



Audi exclusive fine grain ash, nougat
From quattro GmbH



Audi exclusive carbon
From quattro GmbH

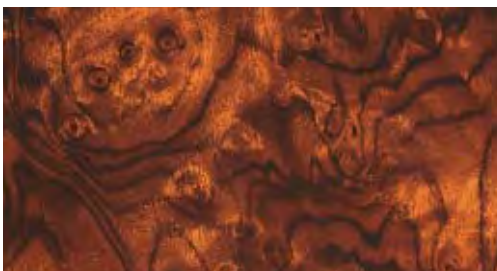

Walnut, natural



Audi exclusive oak sepia
From quattro GmbH

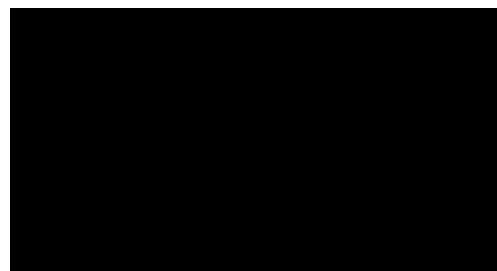

Piano finish, black
From quattro GmbH



Tamo ash, dark brown

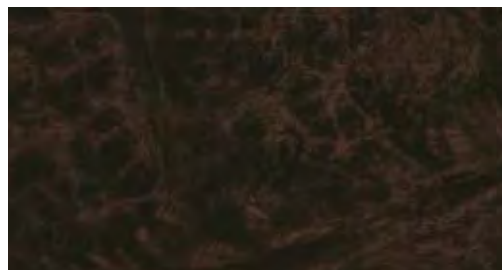

Audi exclusive fine grain myrtle, nutmeg brown
From quattro GmbH

Inlays in aluminium Trigon

for door trims and in laminar application for the centre console and dashboard; including an aluminium inlay in the door trims. (Can be ordered via design packages)

Inlays in matt silk, black

(Q7 V12: in carbon) for door trims and in laminar application for the centre console and dashboard

Inlays in wood

olive ash, beige, walnut, natural, tamo ash, dark brown in door trims and in laminar application for the centre console and dashboard; including an aluminium inlay in the door trims and on the dashboard. (Can be ordered via design packages)

Inlays in Audi exclusive wood

fine grain ash, nougat, oak sepia and fine grain myrtle, nutmeg brown. From quattro GmbH

Inlays in Audi exclusive carbon

From quattro GmbH

Inlays in piano finish, black

can be ordered via design packages. From quattro GmbH

Lights



xenon plus including headlight cleaning system

The headlights with durable gas discharge technology for dipped and high beam enable an intensive illumination of the road with evenness and range. The automatic dynamic headlight range control reduces the dazzling of oncoming traffic; includes headlight cleaning system; Q7*: LED daytime running lights with low power consumption; Q7 V12: LED daytime running lights with 12 elements each on the left and right of the bumper with low power consumption

Headlights

Halogen headlights using free-form technology with clear glass cover, electric headlight range control, daytime running lights, indicator incorporated in the bumper with integrated parking light function

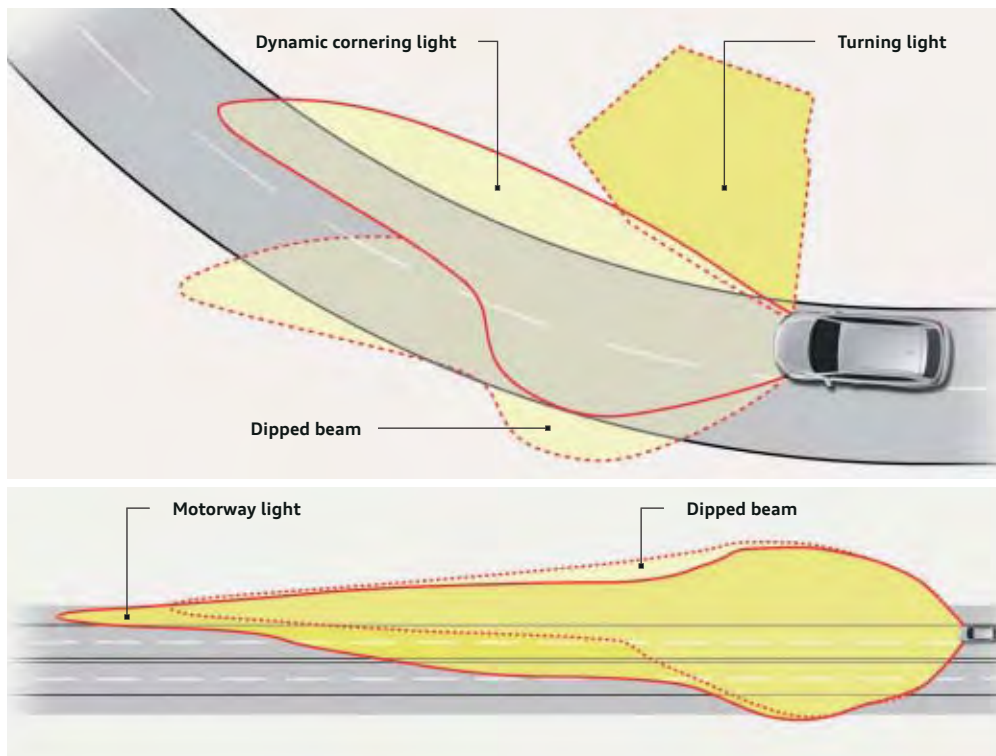

adaptive light*

consisting of dynamic cornering light and static turning light. The dynamic cornering light identifies the course of the road from the movement of the steering wheel and variably illuminates bends by pivoting the xenon headlights; operational between speeds of approx. 10 km/h and 110 km/h. The static turning light automatically switches on if the indicators have been engaged for a while at a low vehicle speed and illuminates the new direction in which the vehicle is travelling. At speeds of more than 110 km/h, the motorway light is activated, for which the cut-off line is symmetrically raised, thus providing better illumination at larger distances.

High-beam assist

working within system limits, automatically detects the headlights of oncoming traffic, the rear lights of other road users and built-up areas. Depending on the traffic situation, the high beam automatically adjusts to dipped-beam and vice versa. The system thereby improves the driver's visibility and ensures a more relaxed drive thanks to the extra comfort and convenience.

Interior lighting

in the front and the rear, including reading lights and one for the optional 3rd row of seats with improved illumination; with delayed switch-off and contact switches on all doors; front entry lighting, footwell lighting as well as illuminated inside door handles; illuminated vanity mirror, glove compartment and luggage compartment

Audi exclusive cardan reading lights

2 lights located in the rear, providing additional illumination (in the area of the 2nd row of seats), cone of light from reading lamps can be manually adjusted. From quattro GmbH

Interior and exterior lighting package

exterior: LED courtesy lighting below the exterior mirrors to facilitate entry and exit in the dark; active door reflectors (light bulb); interior: reflected lighting for the centre console and ambient reflected light in the inside of the door using LED technology to help occupants better orient themselves as well as rear entry lights (light bulb); vent controls and storage compartment in the centre console

Door reflectors

front and rear, passive

Lights



LED rear lights

LED brake lights, tail lights, fog lights and indicators with faster activation, allowing earlier recognition by the driver behind; reversing lights in white, third high-level brake light on the roof spoiler; bumper light strip providing the rear light function when the tailgate is open

Front fog lights

integrated in the front apron panel; for better illumination of the road ahead when visibility is poor

Headlight cleaning system

uses water and high pressure, for better illumination and good visibility with reduced scatter

Light/rain sensor

to control the automatic lights-on function, the windscreen wipers, includes coming home/leaving home function: delayed switching-off/automatic switching-on of the main headlights, rear and number plate lights as well as the LED daytime running lights when parking/opening the vehicle.

Mirrors

Exterior mirrors with integrated LED indicators electrically adjustable and heated, convex, flat or aspherical mirror glass; housing painted in body colour. (Q7 V12: also automatically dimming; housing in matt aluminium)

also optionally:

electrically folding

automatically dimming

automatically dimming with memory function

Interior mirror

dimming, in same colour as headlining

choice of:

automatically dimming, with light/rain sensor

Recognises with the aid of a photocell when the headlights behind are too bright and dims automatically, can be deactivated, with digital compass display on request; this provides a digital display of the current direction. The 8 points of the compass are shown in English (N, NE, E, SE, S, SW, W, NW).

Roof system



Panoramic glass sunroof*

3-part, extends to the 3rd row of seats, electrical activation to raise and open the front glass element and to raise the rear glass element, tinted glass, adjustable fine-meshed sun shield over the entire glass area, electric at the front and manual at the rear, convenience closing from outside via the vehicle key; the bright atmosphere in the interior ensures an open feeling of space and is designed for a pleasant supply of fresh air during the journey. (Optionally in darker tinted glass)

*Shown with the Audi Q7.

Closing systems

Remote control key

unlocks and locks doors, luggage compartment lid and tank flap; includes convenient closing/opening of the windows

Convenience key

access and drive authorisation system, the key only needs to be carried with you; the engine is started and switched off via the engine start-stop button on the centre console, the vehicle is locked and unlocked from outside via sensors on all door handles; the tailgate can also be opened when the vehicle is locked.

Electronic immobiliser

integrated in the engine control unit, automatic activation by the vehicle key

Tailgate with electric opening and closing function

opening via button on vehicle key, button in the driver's door panel or soft touch button in the tailgate handle recess, closing via button on inside of tailgate, with closing assistance and programmable tailgate opening angle

Garage door opener (HomeLink)

Programmable radio-operated remote control, control button integrated into the front of the roof module; can be used to open several garage doors and exterior gates; control of safety and lighting systems possible. Please contact your Audi partner for further information.

Anti-theft alarm

including interior monitoring and tow-away protection via angle of inclination sensor; can be deactivated; signal horn independent of vehicle electrical system for monitoring doors, engine compartment and luggage compartment

Preparation for tracking system

Preparation for connecting a tracking system (available from Audi Genuine Accessories) by means of which the vehicle can be located if stolen

Ignition lock

electronic; ignition key with integrated chip automatically stores relevant service data of the vehicle

Glazing

Heat-insulating glass

green tinted; for the rear window and the door and side windows; heated rear window, with timer

Double/acoustic glazing

front and side windows with laminated safety glass, 2 panes which are joined together by a plastic film; improves the insulation of outside noise and increases anti-theft protection; optionally with or without rear tinted windows

Dark-tinted windows (privacy glazing)

tinted rear window, rear door and side windows, optionally with or without double/acoustic glazing

Glazing

Acoustic windscreen

with heat-insulating glass, with grey strip; improved acoustic windscreen insulation

Rear window

heated, with time switch and integrated antenna

Windscreen cleaning system

2 speeds, automatic switching, touch-wipe function, wash/wipe function, automatic wiping approx. 5 seconds after the last wash/wipe process, including heated windscreen washer jets; rear window wiper with automatic wash/wipe

Sun visors

for driver and front passenger, can be folded and swivelled, with covered, illuminated vanity mirror

Double sun visor

for driver and front passenger, simultaneous front and side protection possible; gap between visor and door pillar can be closed by means of pull-out extension

Sunblind

manually operated, for the rear window and the rear door windows

Further exterior equipment



High-gloss package

Outer window slot trim in aluminium look (Q7 V12: in matt aluminium), outer B and C pillar trim in high-gloss black

Provision for trailer towing hitch

including preliminary wiring, bumper cover and cooling equipment for a maximum retrofitted trailer load of 2,500 kg

Trailer towing hitch*

Mechanical: removable and lockable forged steel spherical bar and ball head, 13-pole plug with cover; the trailer towing hitch can be stored in the spare wheel well when removed; includes trailer stabilisation system via the Electronic Stabilisation Control (ESC)

Electric: electrically swivelling forged steel spherical bar and ball head, operated via button in luggage compartment; includes trailer stabilisation system via the Electronic Stabilisation Control (ESC); suitable for trailers with bulb or LED lighting

Further exterior equipment



Full paint finish with aluminium-look exterior
trim strips on front and rear bumpers as well as door covers and inlays in the door handles in aluminium look, including full paint finish of bottom bumper sections and door trim strips in body colour, underbody protection in contrasting colour

Audi exclusive black styling package

Radiator grille and number plate bracket in matt black, high-gloss black radiator grille frame, front fog light surrounds in matt black. (Q7 V12: additional underbody protection on the front and rear bumpers also in black.) From quattro GmbH

Bumpers

sporty accentuated bumpers and large side air inlets with high-gloss black painted horizontal bars; dynamically shaped wheelhouse widening; eye-catching widening in the lower area of doors and sills

Audi Singleframe

painted in high-gloss black, one-piece trim frame around the radiator grille, chrome-plated, with vertical chrome struts (Q7 V12: double chrome struts); with bright-metal Audi rings in the centre

Roof rails

one-piece – no joints, stable and aerodynamic, highlights the coupé-like roof line; in anodised aluminium (Q7 V12: in matt aluminium), optionally in black

Exhaust tailpipes with surrounds

dual-branch design, flattened at the bottom; for Q7 V12: with oval tailpipe trims

Model name/logo

on the rear, quattro logo on the rear, on the radiator grille and the dashboard on the passenger side; “TDI clean diesel” emblem on the rear window (only for 3.0 TDI clean diesel quattro); with 3.0 TFSI quattro (245 kW) V6 T logo on the front wings; Q7 V12 quattro: V12 emblem on the front wings, V12 TDI quattro emblem on the tailgate; can also be supplied without the model name on request

Underbody protection

front and rear

Seats/seating comfort



3rd row of seats

2 seats in the rear with foldable head restraints and 2 additional ISOFIX child seat mountings, can be split and folded down flat to create a level loading floor, for persons up to 1.60 m tall, with improved convenience entry and fore/aft adjustment for the 2nd row of seats

Rear seats (2nd row, 5 or 7 seats (in combination with the 3rd row of seats))

with backrest angle adjustment and belt height adjustment for the external seats, rear seat backrest can be split and folded 40 : 60 or fully, provides a level loading floor; including through-loading facility

4-way lumbar support for the front seats

electric, with horizontal and vertical adjustment

Front seats, electrically adjustable

with electric adjustment of seat height, fore/aft position, seat angle, backrest angle; electric 4-way lumbar support

Fore/aft adjustment for the 2nd row of seats

manual fore/aft seat adjustment, 80 mm forwards and 20 mm backwards, to increase the legroom or luggage compartment capacity

Seats/seating comfort



Comfort seats in the 2nd row, 6 seats (in combination with the 3rd row of seats)

2 comfortable single seats in the 2nd row, can be split and folded down flat to create a level loading floor, with convenience entry function, fore/aft adjustment and generous centre console with height-adjustable armrest, storage compartment and 2 cup holders; only in combination with the 3rd row of seats; 6 seats in total

Memory function for the driver seat

Driver seat with electric adjustment, memory function for seat adjustment, exterior mirrors and steering wheel (with electric steering column adjustment)

Memory function for the front seats

Driver and front-passenger seat with electric adjustment, memory function for seat adjustment, exterior mirrors and steering wheel (with electric steering column adjustment)



Comfort centre armrest, front

for driver and front passenger, with fold-open storage compartment on the driver's side, a cup holder at the front on the passenger side as well as an additional cup holder in the armrest on the passenger side (fold-open), with storage compartment (not with CD changer) underneath the centre armrest

Centre armrest, front

for the driver and front passenger, fold-open design, with storage compartment (not with CD changer) underneath the centre armrest, includes 2 cup holders

Centre armrest, rear

in the rear seat backrest, foldable, including 2 cup holders

Seats/seating comfort

Head restraints

manually height-adjustable at the front, foldable at the rear for the outer seats

Seat heating, front

heats the seat and backrest centre panel, in case of leather upholstery and trim and sport seats also heats the seat side bolsters, individually adjustable in 3 stages for driver and front-passenger side via a direct selection button on the air conditioning controls

Seat heating, front and rear

heats the seat and backrest centre panel, in case of leather upholstery and trim and sport seats also heats the seat side bolsters, individually adjustable in several stages for driver and front-passenger side, additionally for the outer rear seats of the 2nd row, individually adjustable

ISOFIX child seat mounting

for the outer rear seats of the 2nd row, standard bracket for the safe and practical fastening of ISO standard child seats, including separate child-proof lock on the rear doors. You can obtain the appropriate child seat from your Audi partner.

ISOFIX child seat mounting for the front-passenger seat

with deactivating switch for the front-passenger airbag, standard bracket for the practical fastening of ISO standard child seats. Compatible child seats can be obtained from your Audi partner.

Steering wheels/selector levers/controls



Leather-covered multifunction steering wheel in 4-spoke design

with full-size airbag, adjustable in height and reach, includes gear or selector lever knob in leather, colour-coordinated with the interior equipment selected, for operating the provided infotainment features; steering wheel rim additionally heated; shift paddles for changing gear; in Q7 V12 with chrome-look shift paddles



Leather-covered multifunction sport steering wheel in 3-spoke Q design with shift paddles

with full-size airbag, adjustable in height and reach, includes gear or selector lever knob in leather, colour-coordinated with the interior equipment selected, for operating the provided infotainment features; shift paddles for changing gear; Q7 V12 with chrome-look shift paddles

Steering wheel adjustment, electric

adjustable in height and reach, with automatic entry and exit function



Steering wheel rim with wooden segment

available as leather-covered multifunction steering wheel with/without gear change function in 4-spoke design, with wooden segment in walnut, natural and leather, black. From quattro GmbH

Audi exclusive steering wheel rim with wooden segment

customised with Audi exclusive wood and leather, available in 4-spoke design. Optionally in fine grain ash, nougat, fine grain myrtle, nutmeg brown and oak sepia. Leather and stitching available in various Audi exclusive colours; stitching on the steering wheel rim with specific Audi exclusive stitching detail. From quattro GmbH

Audi exclusive leather controls

Leather for the steering wheel rim, selector lever knob and gaiter available in all Audi exclusive colours; individual choice of colour for stitching in various Audi exclusive colours; stitching on the steering wheel rim with specific Audi exclusive seam detail. From quattro GmbH

Steering wheels/selector levers/controls



Selector lever knob with wooden segment
in walnut, natural, olive ash, beige or tamo ash, dark brown. From quattro GmbH

Audi exclusive selector lever knob with wooden segment

Selector lever knob customised with Audi exclusive wood. Optionally available in oak sepia, fine grain myrtle, nutmeg brown or fine grain ash, nougat. From quattro GmbH

Selector lever knob
in aluminium look

Selector lever knob in leather
with ring trim

Climate control



4-zone deluxe automatic air conditioning
in addition to the deluxe automatic air conditioning, temperature adjustment and air distribution at the rear which can be separately adjusted on the left and right hand sides, air outlet nozzles in the C-pillar, air conditioning controls for the rear in the rear centre console, rear functions can also be adjusted using the front control panel; including an additional air conditioning compressor

Deluxe automatic air conditioning
sunlight-dependent control, separate temperature distribution for driver, front-passenger side and in the rear, indirect ventilation, climate control of the rear space via air vents in the B-pillars and the centre console in the rear, automatic air recirculation control using an air quality sensor, defroster vents for the windscreen and the side windows, combined pollution and pollen filter, key-coded settings

Auxiliary heating/ventilation

The auxiliary heating warms up the interior and keeps the windows free from ice without starting the engine. The parking ventilation supplies fresh air and lowers the interior temperature with timer and separate radio-operated remote control with function feedback.

Luggage securing and storage systems

Double loading floor

with dirt collecting tray underneath in vehicles without full-size spare wheel; storage compartment behind the 2nd row of seats in vehicles without 3rd row of seats, easy to clean

Storage compartments

storage compartment in the door panels, in the centre console at the front and in the roof module, storage compartment under the front-passenger seat

Glove compartment

on the front-passenger side, with illumination and climate control, opening via switch on the dashboard

Storage nets

in the front area of the centre console on the front-passenger side

Storage compartment

with rubber mat in the front centre console

Storage package

Storage net on the front-seat backrests, luggage compartment net for fixing to lashing points on the luggage compartment floor, storage net on the side of the luggage compartment

Dirt collecting tray

underneath the loading floor; smaller version if ordering the space-saving spare wheel or a sound system with subwoofer at the same time

Luggage securing and storage systems

Storage package with folding table

folding table on the front-seat backrests, luggage compartment net for fixing to lashing points on the luggage compartment floor, storage net on the side of the luggage compartment

Cup holders

2 in the front centre armrest, 2 in the rear centre armrest and 2 in the side panels in the area of the optional 3rd row of seats – when not being used serves as holder for luggage compartment cover

Bottle holders

for the storage of bottles of up to 1.5 litres in the front and rear door trims, 4 in total

Clothes hooks

2 on the B-pillar, one each on the left and right-hand sides, additionally in the rear roof area

Partition net

for fastening on the body side or on the folded-down rear seat backrest, useful when the rear seat backrest is up or folded down on one side, as well as when it is completely folded down; removable

Lashing points

4 in the luggage compartment, for attaching luggage and other objects, attachment points for the luggage compartment net



Rail system with load-securing kit

in the luggage compartment, with telescopic rod, attachment strap and variable lashing points for individual partitioning of the luggage compartment and for securing objects

Reversible mat

for the luggage compartment, velour on one side, rubber on the other, to cover the luggage compartment, also when the rear seat backrest is folded down, with fold-out protective film for the loading sill and bumper

Through-loading facility with removable ski/snowboard bag

secured by a strap, for the practical transportation of long items, e.g. up to 4 pairs of skis up to 200 cm in length or 2 snowboards; including rear centre armrest with cup holders

Luggage compartment

large-volume with large loading width, luggage compartment locking with soft-touch function (unlocking with electrical assistance)

Luggage compartment cover

can be pulled out with one hand, removable, with separated cover, adaptable to the backrest angle of the 2nd row of seats

Luggage compartment cover, foldable

extendable, removable, can be folded in the middle, can be stowed away in the double loading floor, including mounting adapter and storage bag, also enclosed

Further interior equipment**Audi exclusive coolbox**

with compressor cooling technology, 2 possible temperature settings: -6°C freeze, +6°C cool; volume for four 0.5 litre bottles lying down. From quattro GmbH

Footwell trim in velour carpet

optionally in Fresco carpet, coordinated with the interior colour. (Can be ordered via design packages)

Floor mats, front and rear

made of velour or Fresco (2-tone in multicolour loop design), coordinated with the corresponding footwell trim

Audi exclusive floor mats

Individual choice of colour for floor mats and piping from the range of Audi exclusive colours. From quattro GmbH

Audi exclusive carpet and floor mats

Individual choice of colour for carpets, floor mats and piping from the Audi exclusive colour range. From quattro GmbH

Door sill trims with aluminium inlay**Pedals in aluminium look****Window controls**

electric at front and rear, with safety system to limit closing force, one-touch opening/closing function; convenience opening/ closing via remote control key

Door trims

in inner panel with cloth cover, integrated armrests, colour-coordinated with the interior colour

Dashboard

padded, with black or beige trimmed cover

Centre console

with air conditioning controls, ashtray, selector lever, MMI terminal, cigarette lighter, 12V socket

Cigarette lighter and ashtray

in the front centre console

Grab handles

foldable, 4 handles, each recessed into roof

12V sockets

in the front centre console, on the rear right in the luggage compartment as well as 2 in the rear centre console

MMI® and navigation systems**MMI® navigation plus**

- with navigation data (hard drive)¹
- high-resolution 7-inch colour display with high-quality map display and topographical map colouring, display of lots of sightseeing information and city models in 3D, choice of 3 alternative routes, scrolling along the route, joystick map manoeuvring function in the control button
- split-screen route information (manoeuvring points, points of interest on motorways, TMCpro on route), detailed junction map and lane recommendation, dynamic route guidance with TMCpro (where available)
- voice control system (whole-word entry of address in one sentence)
- spoken TMCpro reports
- additional arrow display in the driver information system with colour display
- radio with triple tuner and phase diversity
- Hard drive for music storage (20 GB)
- DVD player (MP3, WMA, AAC and MPEG-4-compatible), can also be used for music and video DVDs
- 2 SDHC card readers for up to 32 GB
- Audi music interface (connection of generation 4 and higher Apple iPods, music functionality of Apple iPhone as well as USB storage media and MP3 players)
- Bluetooth interface with Bluetooth audio streaming
- Audi sound system

The use of services supported by Audi connect, e.g. navigation using Google Earth™ map service² and Google Street View™², weather, news, traffic information is possible online in combination with the Audi connect inclusive car phone.

MMI® and navigation systems

MMI® radio

MMI control concept consisting of a 6.5-inch colour display and separate MMI control panel, CD player (supports audio CDs), radio with phase diversity

MMI® radio plus

MMI control concept consisting of a 6.5-inch colour display, separate MMI control panel and car menu, driver information system, CD player and 2 SDHC memory card readers (up to 32 GB), each MP3, WMA and AAC-compatible, AUX-IN connection, radio with phase diversity, TP memo (automatically saves traffic news when driving), Audi sound system

MMI® navigation

- with navigation data (DVD)¹
- 6.5-inch colour display with high-quality map display and numerous detailed display options
- dynamic route guidance and TMC (where available)
- voice control (destination entry via spelling)
- additional arrow display in the driver information system with colour display
- radio with twin tuner, phase diversity
- MP3 and WMA capable DVD player for navigation data (DVD)¹
- 2 SDHC card readers for up to 32 GB
- Audi sound system

Driver information system

A monochrome display provides you with information from the onboard computer, auto check system, scope of display of the MMI system and digital speed display. The integrated efficiency program provides assistance in the form of consumption data overviews, a display of additional consumers and fuel-saving tips for adopting an economical driving style.

Driver information system with colour display

A high-resolution colour display provides you with information from the trip computer, auto check system, scope of display of the MMI system and digital speed display. The integrated efficiency program provides assistance in the form of consumption data overviews, a display of additional consumers and fuel-saving tips for adopting an economical driving style.

Radio and TV systems

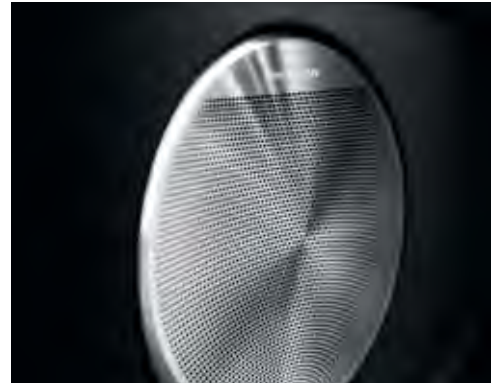

Bang & Olufsen Advanced Sound System

Surround sound reproduction via 14 loudspeakers each with its own amplifier and exclusive aluminium loudspeaker covers; centre speaker and 2 automatically extending acoustic lenses on the instrument panel for superb true-to-detail sound performance from every seat; 1 midrange speaker and woofer in each front door; 1 tweeter and woofer in the rear doors; 1 subwoofer in the spare wheel well and 2 surround sound loudspeakers in the D-pillar; dynamic driving noise compensation; 14-channel amplifier; highly efficient ICE-Power amplifiers with a total output of more than 1,000 W. The reproduction of 5.1 surround sound is possible in conjunction with MMI navigation plus and the integrated DVD drive.

Digital Audio Broadcasting

In addition to the range of analogue stations, programmes from digitally broadcast radio transmitters with better sound quality can be received according to DAB standard, including DAB+ and DMB audio. Display of additional information accompanying the programme (e.g. artist, title, cover) in the form of a slide show and other programme-independent data services (e.g. weather, traffic, news). A 2nd DAB tuner permanently searches for alternative reception frequencies of the set station, and the station list is updated at the same time. Please note: Reception depends on local digital network availability; contents and scope of the additional information depend on provision by the respective radio station.

Digital TV reception

reception of digitally broadcast (DVB-T), uncoded television stations (MPEG-2 or MPEG-4 standard), DVB-T audio stations, teletext and Electronic Programme Guide (EPG). External AV-IN connection via adapter cable (available through Audi Genuine Accessories). Please note: TV reception depends on digital network availability; no picture possible when driving

Audi sound system

11 loudspeakers including centre speaker and subwoofer, 6-channel amplifier with a total output of 160 watts

¹ Navigation data is not available for all countries and regions. Further information is available from your local Audi partner. ² Google and the Google logo are registered trademarks of Google Inc.

Radio and TV systems



Audi music interface

for the connection of portable media players, such as Apple iPods from generation 4, Apple iPhones (music functionality) as well as USB storage media and MP3 players. The Audi music interface is located in the glove compartment and operated via the MMI or a leather-covered multifunction steering wheel. Please note: can only be used in conjunction with a special adapter cable (Audi Genuine Accessories). Please contact your Audi partner and visit www.audi.com/mp3 for information on compatible media players. If Audi music interface is ordered the separate AUX-IN connection is omitted.

Adapter cable set for Audi music interface

consisting of 2 connection cables for the connection of iPod/iPhone or data carrier/media player with USB connection (type A); further adapter cables are available from Audi Genuine Accessories; visit www.audi.com/mp3 for information on compatibility

BOSE Surround Sound

Surround sound reproduction, with 14 loudspeakers including centre speaker in the dashboard and subwoofer in the spare wheel well, 10-channel amplifier with a total output of 270 watts, dynamic driving noise compensation. The reproduction of 5.1 surround sound is possible in conjunction with MMI navigation plus and the integrated DVD drive.

Preparation for Rear Seat Entertainment

Includes pre-installation wiring and mounts for the holders in the driver and front-passenger seat backrests. The appropriate Audi Entertainment mobile (9-inch screen with integrated DVD player) and the holder are available as a plug-and-play unit from Audi Genuine Accessories (refer also to page 100).

The model-specific standard and optional equipment can be found in the index from page 106 onwards.



Rear Seat Entertainment

with 2 monitors incorporated into the head restraints with 6.5-inch LCD screens; DVD player with 6-disc changer, 2 headphones and connections for external sources. From quattro GmbH

Rear Seat Entertainment plus

items such as Rear Seat Entertainment, but with additional connection to the on-board sound system and TV connection. From quattro GmbH

CD changer

located under the centre armrest, front, for 6 CDs (MP3 and WMA-compatible), shock-resistant, each CD can be loaded and changed individually. Music files with digital rights management (DRM) cannot be played.

CD softbag

for individual storage of up to 24 CDs

Telephone and communication

Bluetooth interface

Bluetooth-capable mobile phones can be connected to the vehicle via the interface. Hands-free calls can be made in the vehicle via the microphone. Please contact your Audi partner or visit www.audi.com/bluetooth for information on compatible mobile phones.

Preparation for mobile phone (Bluetooth)

including a hands-free device and voice control for the telephone functions and a preparation for an optional mobile-specific charger in the front centre console; including connection to the vehicle aerial for reduced SAR radiation inside the vehicle and better reception quality, operated via the radio/navigation systems or a multifunction steering wheel (if available); please contact your Audi partner or visit www.audi.com/bluetooth for adapters and information about which mobile phones are compatible.

Bluetooth car phone

your Bluetooth-capable mobile phone can be conveniently connected to the vehicle's internal UMTS module (provided the mobile phone supports SIM Access Profile); additional SIM card reader in the surround of MMI navigation; transfer of phone book entries to the vehicle and management of call lists; operated via the navigation system or a multifunction steering wheel (if fitted); for information on compatible mobile phones, please contact your Audi partner or visit www.audi.com/bluetooth.

Front handset for car phone

with colour display and integrated SIM card reader, for discreet phone calls; texts can be easily written thanks to automatic word recognition; handset is stored in the front centre armrest

Audi connect including car phone

Convenient connection of your vehicle to the internet. Use of the services supported by Audi connect is possible only with the optional **MMI navigation plus** equipment and with the data module integrated in Audi connect including car phone. You also require a SIM card with data option – with car phone a SIM card with phone and data option or a Bluetooth-capable smartphone with remote SIM Access Profile (rSAP). There is a reader for your SIM card in the surround of the MMI navigation plus.

The following **services** supported by **Audi connect** are available in your model:

Mobility & navigation

- Point-of-interest (POI) search with voice control
- Traffic information online
- Navigation with Google Earth™ map service* and Google Street View™**
- Destination entry via myAudi or Google Maps™**
- Fuel prices
- Parking information
- Country information

Communication

- Wi-Fi hotspot

Infotainment

- Weather
- Audi music stream
- News online
- City events
- Travel information

The services are available only with an existing or separate mobile phone contract and only within the range of the respective mobile phone network. Additional costs may be incurred when receiving data packets from the internet, depending on the terms of your mobile phone contract, particularly when used abroad. Because of the high data volumes involved, a data flat rate is strongly recommended.

The availability of the services supported by Audi connect varies from country to country. The services are provided for at least one year from vehicle delivery. The traffic information online service requires initial activation in the vehicle. From that point onwards, this service is subject to a 36-month usage limit (in as far as activation takes place within 6 months of vehicle delivery; otherwise corresponding shortening of the usage rights). Your Audi partner will be happy to inform you about how to extend the service and the costs this incurs.

Please visit www.audi.com/connect or contact your Audi partner for more detailed information about Audi connect; contact your mobile services provider for information about contract conditions.

Assistance systems

Cruise control

At speeds of 30 km/h and above, the system keeps the set speed constant, provided that engine power and engine braking effect permit it; operated via separate steering column stalk, set speed displayed in driver information system.

Parking system, rear

makes reverse parking easier within system limits by indicating acoustically how far away the vehicle is from an object detected behind the vehicle; measurement is by ultrasonic sensors integrated discreetly in the bumper

Parking system plus

This extended parking aid offers an acoustic and an additional optical display of the space at the front and rear in the MMI display.

Parking system plus with front and reversing camera

acoustic and visual parking system for the front and rear with display on the MMI display within system limits; measurement is by ultrasonic sensors integrated discreetly in the bumpers; an image of the area in front of and behind the vehicle is shown on the MMI display, with dynamic display elements for the reversing camera showing the calculated path (depending on steering angle) including help lines and guidelines and identification of the point at which to apply opposite lock when parallel parking, reversing camera integrated discreetly in the tailgate handle strip, additional display modes for the front left/right side and rear left/right side for comfortably pulling out of tight parking spaces, courtyard entrances, or car parks

Assistance systems



Parking system plus with reversing camera

acoustic and visual parking aid for the front and rear, image of area behind the vehicle shown on the MMI display, reversing camera integrated discreetly in the tailgate handle strip.

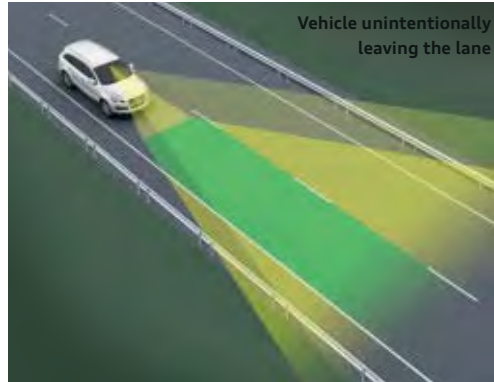

Audi lane assist¹

Lane compliance assistant; working within system limits, it signals if the driver is unintentionally leaving the traffic lane (operating range 60 km/h to 250 km/h). If the system is activated and operational and if the driver has not switched on the indicator, the driver will be notified via steering wheel vibrations shortly before or while crossing the traffic lane marker recognised by Audi lane assist. (The grey strip along the windscreen is omitted)



Audi side assist¹

lane change assistant, working within system limits at speeds of 30 km/h and above, the system uses radar technology to monitor the area on the left, right and behind the moving vehicle and informs or warns the driver by means of an LED display in the exterior mirror if the Audi side assist deems that a detected vehicle will compromise a lane change.

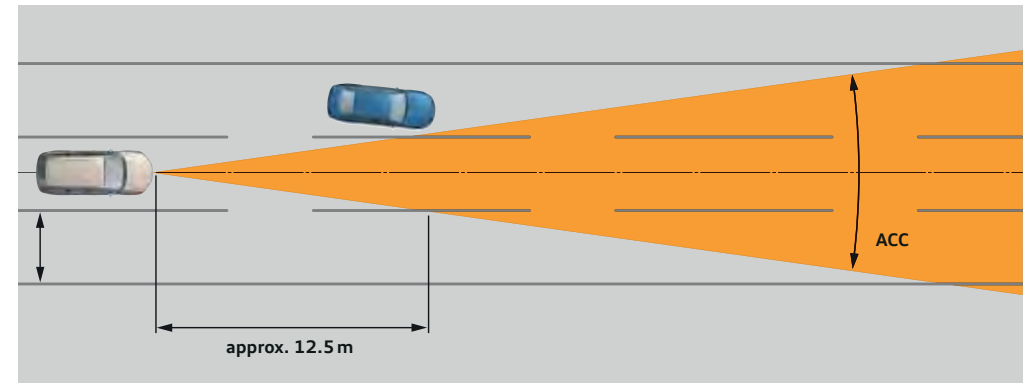

adaptive cruise control

automatic distance control (control range from 0 to 200 km/h); working within system limits, it uses a radar sensor to detect vehicles ahead and maintains this distance by automatically braking and accelerating; 4 programs can be selected individually via the steering column stalk of the cruise control; including Audi braking guard with warning for driver of an imminent collision with a vehicle travelling in front provided by observation of surroundings

Suspensions/brakes

adaptive air suspension

electronically controlled air suspension with infinitely variable adaptive damping system on all 4 wheels, automatically controls vehicle level and damping; 5 modes (automatic, comfort, dynamic, offroad, lift), can be selected via the MMI system; including level control and loading level

S line adaptive air suspension

enables a sporty dynamic to comfortable suspension setting. The S line model offers additional vehicle low level of 20 mm compared with adaptive air suspension.

Dynamic suspension

for excellent driving dynamics and ride comfort, comprising:

Front axle: independent wheel suspension, double wishbone axle with steering mechanism at the back, aluminium suspension arm, suspension subframe and stabiliser

Rear axle: independent wheel suspension, double wishbone axle with released upper link level and steering link at the back, aluminium suspension arm, suspension subframe and stabiliser

S line sport suspension

with more dynamic suspension tuning and vehicle lowered by 10 mm

Brake system

dual-circuit, diagonally-split brake system, Antilock Brake System (ABS) with Electronic Brake Force Distribution (EBD), Electronic Differential Lock (EDL), Anti-Slip Regulation (ASR), Electronic Stabilisation Control (ESC), with hydraulic brake assist, ventilated 18-inch front disc brakes and ventilated rear 17-inch disc brakes (3.0 TFSI quattro [245 kW] and 4.2 TDI quattro with ventilated 18-inch disc brakes at the front and rear)

Parking brake

foot-operated parking brake

Ceramic brake²

20-inch high-performance brake system with carbon-fibre reinforced ceramic brake discs, specially developed cooling channels for the ventilated and perforated brake discs, anthracite brake callipers, with "Audi ceramic" logo at the front

Technology/safety

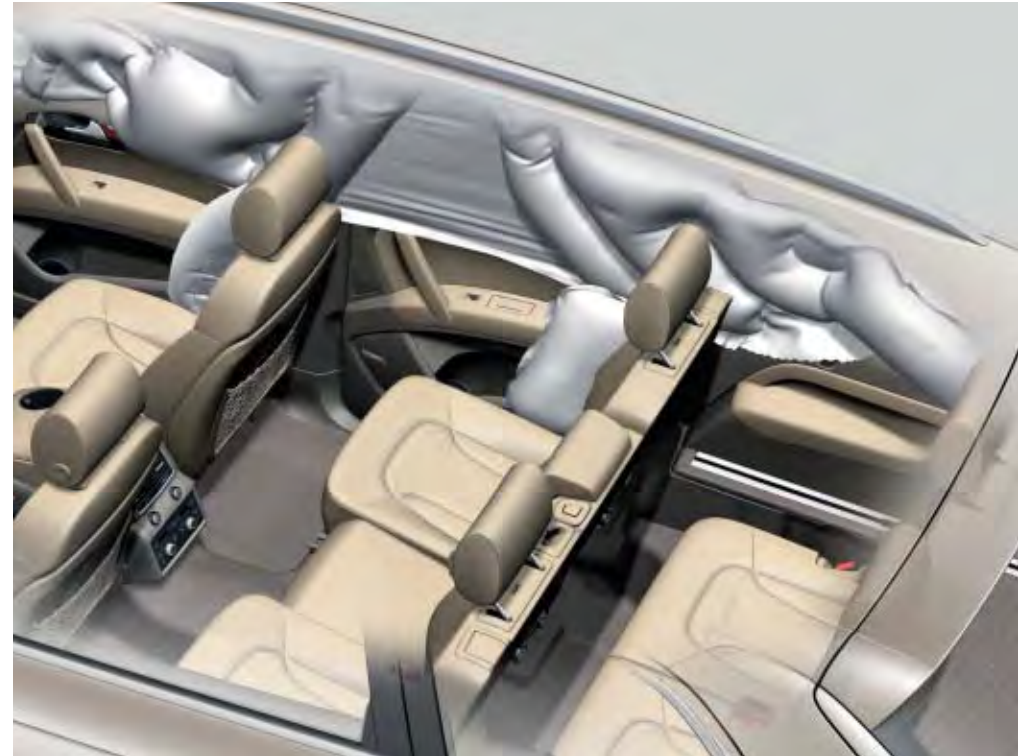

Side airbags, rear³

for the outer seats in the 2nd row, supplement side airbags, front, and head airbag system

Side airbags, front

integrated into the front-seat backrest

¹The image is an illustration, not a real representation. ²Please find out more about the special features for the ceramic brakes on your national Audi website. ³The image is an illustration, not a real representation, and shows the technical status of the airbags as a snap-shot.

Technology/safety**Airbags**

Full-size airbags for driver and front passenger; in conjunction with ISOFIX child seat mounting for the front-passenger seat, including deactivating switch for the front-passenger airbag

Side airbags, front, and head airbag system

Front side airbags integrated into the backrests, with additional head airbag system: unfolds over the entire length of the side windows in the area from the 1st to the optional 3rd row of seats, thereby protecting occupants in the front and outer rear seats in the event of a side impact

Integrated head restraint system

In the event of a rear-end collision, the design of the front seats restrains the upper torso more effectively and offers stronger support for the head, thereby increasing safety and reducing the danger of whiplash.

Instrument cluster

with adjustable lighting; round instruments for rev counter, electronic speedometer, coolant temperature and fuel gauge display; time and date display, mileage and trip odometer, warning and control lights, maintenance interval display. (In conjunction with driver information system display for radio station frequency, outside temperature and fuel tank range)

Safety steering column

increases the safety potential of the seat belts and airbags

Seat belts

3-point inertia reel seat belts for all seats (also for the optional 3rd row), with belt height adjustment and belt force limiter for the 1st row and the outer seats of the 2nd row, front seats also with pyrotechnic seat belt tensioner and seat belt reminder

Belt height adjustment

for the front and outer seats of the 2nd row of seats, manually adjustable

Warning and control lights

for, among others: airbag, ABS, ESC/ASR, activated parking brake, generator, light, high beam, belt warning, indicator lights, brake system, engine oil pressure, engine electronics, immobiliser, pre-heater system (TDI)

Warning triangle

with bracket on the inside of the tailgate

First-aid kit

in the storage compartment under the front-passenger seat

**tiptronic**

Q7: 8-speed automatic transmission with Dynamic Shift Program (DSP), option of manual control via shift paddles on the multifunction steering wheel (if ordered); includes additional sport program; Q7 V12: 6-speed automatic transmission with Dynamic Shift Program (DSP), option of manual control via shift paddles on the leather-covered multifunction steering wheel; includes additional sport program

servotronic

rack and pinion power steering with variable steering transmission; due to the speed-dependent control, the driver has a precise steering feel at high speeds and best possible assistance when parking.

quattro®

permanent all-wheel drive with asymmetric/dynamic torque distribution, self-locking centre differential, Electronic Differential Lock (EDL) via braking intervention on all driven wheels

Anti-Slip Regulation (ASR)

for excellent traction, prevents the drive wheels from spinning

Electronic Differential Lock (EDL)

On surfaces with varying levels of grip, this start-off assistant automatically brakes the drive wheels on any surface that is too slippery, thereby ensuring smooth, powerful progress; operates at speeds up to approx. 100 km/h.

Electronic Stabilisation Control (ESC)

with hydraulic brake assist; the ESC ensures greater stability in hazardous driving situations by targeted braking of individual wheels and intervention in the engine management system; with extended onroad and offroad functions, including offroad mode for improved traction on loose ground, with hill hold assist and hill descent control and roll-over stabilisation

Recuperation

With 6- and 8-cylinder models, increasing the generator voltage converts kinetic energy into usable electrical energy when the vehicle is coasting or braking. This (braking) energy recovery is used to assist the generator during subsequent acceleration, saving up to 3% fuel.

Technology/safety

Start-stop system

helps to reduce fuel consumption and CO₂ emissions by switching off the engine when the vehicle is stationary, e.g. at traffic lights. The start process is conveniently initiated as soon as the foot brake is released for moving off. Can be deactivated at any time via a button.

Body, galvanised

fully galvanised in areas at risk from corrosion, unitary construction, welded to the floor pan, front and rear areas feature defined crumple zones. (12 year guarantee against rust perforation)

Side impact protection

in the doors, comprises high-strength aluminium impact bars, highly stress-resistant steel panel alloy in the B-pillars for a controlled energy loss outside

Child-proof lock

mechanical for the rear doors and electric for the rear window controls

Audi TDI clean diesel

In addition to the standard equipment with catalytic converter and diesel particulate filter, the new exhaust aftertreatment system installed in the model with TDI clean diesel leads to low exhaust emissions. Nitrogen oxides are reduced by the innovative nitrogen oxide catalytic converter (DeNO_x catalytic converter) at the end of the exhaust pipe. A pump injects tiny quantities of the biologically degradable additive AdBlue. This solution then decomposes in the hot exhaust flow to form ammonia, which splits the nitrogen oxides into nitrogen and water. This splitting is called selective catalytic reduction. Refill the separate AdBlue tank as indicated by the information in the display of the instrument cluster. We recommend having the AdBlue tank refilled by your Audi partner (about every 15,000 km).

Audi Extended Warranty

Audi Extended Warranty

can only be ordered directly and exclusively when you purchase a new vehicle; extends the manufacturer's guarantee consistently and thus you are protected against risk and can control costs for service even after the first 2 years. 9 combinations of service life and mileage can be selected:

Additional 1 year Audi Extended Warranty, maximum total mileage 30,000 km

Additional 1 year Audi Extended Warranty, maximum total mileage 60,000 km

Additional 1 year Audi Extended Warranty, maximum total mileage 90,000 km

Additional 2 years Audi Extended Warranty, maximum total mileage 40,000 km

Additional 2 years Audi Extended Warranty, maximum total mileage 80,000 km

Additional 2 years Audi Extended Warranty, maximum total mileage 120,000 km

Additional 3 years Audi Extended Warranty, maximum total mileage 50,000 km

Additional 3 years Audi Extended Warranty, maximum total mileage 100,000 km

Additional 3 years Audi Extended Warranty, maximum total mileage 150,000 km

Audi Genuine Accessories: If you are looking for adventure, you need the right equipment.

Provisions, map and sturdy shoes. So you are ready for the next adventure. And your car? You can equip that just as well – with top-quality accessories, adapted to each vehicle model right down to the last detail. Audi Genuine Accessories offer top technical quality and a high degree of individual design options. So that you can individually adapt your Audi Q7 to your personal requirements. The following pages will show you a small selection of Audi Genuine Accessories.





Further information can be obtained from the Audi Q7 accessories catalogue, at www.audi.com, and from your Audi partner.



Q7
Audi Q7 Accessories

Audi
Genuine Accessories 



1 Offroad style package¹

You will definitely attract attention with the offroad style package. The striking design of the Audi Q7 is given a sporty and robust flair thanks to its selected details. The entire package comprises wheel housing extensions, door cover strips, front and rear apron with stainless steel underbody protection and running boards, and specific tailpipes. After all, the Audi Q7 typifies the offroad idea like no other Audi. Decide on striking accents or take the entire package – and draw attention to the powerful side of your Audi Q7 in style. All eyes will be on you.

2 Audi child seat

Can be used facing forwards or backwards. With adjustable seat, integrated full belt safety harness and adjustable head restraint. Available in the colours Misano red/black and titanium grey/black. Can only be used in conjunction with the ISOFIX-Basis. Suitable for children up to 18 kg (approx. 4 years). Also available: The Audi baby seat for babies up to 13 kg (approx. 12 months), and the Audi child seat youngster plus for children from 15 to 36 kg (approx. 4 to 12 years).

3 Ski and luggage box (450 l)²

This lockable ski box is particularly suitable for winter holiday use. It offers a large opening angle for easy loading and can be folded up on both sides. Suitable for skis up to 2.10 m long. Also included in the range are a ski and luggage box containing 480 l and a compact luggage box containing 370 l.

4 Audi Entertainment mobile

9-inch screen with integrated DVD player for installation on the front-seat backrests. Excellent image quality thanks to digital high resolution screen, high functionality and numerous connection options, e.g. the separately available Bluetooth headset. With the new holder for mobile devices, it is easy to attach and can also be used outside the vehicle. Condition: preparation for Rear Seat Entertainment in the vehicle.

5 Partition grille

With the practical aids such as the partition grilles (longways and sideways), the luggage compartment can be separated from the rest of the interior and can also be divided lengthways. The partition grille is easy and convenient to attach – in other words without drilling.



6 Cast aluminium wheels in 5-arm design, 2-piece

The striking feature of the size 9 J x 20, 2-piece cast aluminium wheels in 5-arm design are the titanium-screwed cast trims. For tyre size 275/45 R 20. For more wheels in dynamic designs and winter wheels, please refer to the special accessories catalogue.

7 Universal mobile telephone holder

For low-radiation phone calls and storing the mobile phone safely during driving. Can be used for many popular mobile phone models. The mobile phone is conveniently placed in the holder and wirelessly connects to the exterior aerial of the vehicle. Thus there is no need to change adapters when you switch mobile phones. Pre-condition: preparation for mobile phone (Bluetooth). The separately available mobile phone-specific charging adapters enable easy charging of your mobile phone (battery).



¹ Only available for 6- and 8-cylinder models. ² Maximum permissible load of 50 kg must be observed.

Model	Audi Q7 3.0 TFSI quattro (200 kW)		Audi Q7 3.0 TFSI quattro (245 kW)		Audi Q7 3.0 TDI quattro (150 kW)		Audi Q7 3.0 TDI quattro (180 kW)	
Engine type	V6 petrol engine with direct fuel injection and mechanical supercharger		V6 petrol engine with direct fuel injection and mechanical supercharger		V6 diesel engine with common rail injection system and turbocharging		V6 diesel engine with common rail injection system and turbocharging	
Displacement in cc (valves per cylinder)	2995 (4)		2995 (4)		2967 (4)		2967 (4)	
Max. output ¹ in kW at rpm	200/4750–6500		245/5500–6500		150/3200–4400		180/3800–4400	
Max. torque in Nm at rpm	400/2250–4750		440/2900–5300		450/1250–2750		550/1750–2750	
Power transmission/wheels								
Drive type	quattro® permanent all-wheel drive		quattro® permanent all-wheel drive		quattro® permanent all-wheel drive		quattro® permanent all-wheel drive	
Transmission type	8-speed tiptronic		8-speed tiptronic		8-speed tiptronic		8-speed tiptronic	
Wheels	Forged aluminium wheels, 7.5 J x 18		Cast aluminium wheels, 8 J x 18		Forged aluminium wheels, 7.5 J x 18		Forged aluminium wheels, 7.5 J x 18	
Tyres	235/60 R 18 ²		255/55 R 18 ²		235/60 R 18 ²		235/60 R 18 ²	
Weights/capacities								
	5-seater	7-seater	5-seater	7-seater	5-seater	7-seater	5-seater	7-seater
Unladen weight ³ in kg	2295	2325	2315	2345	2345	2375	2345	2375
Gross vehicle weight ⁴ in kg	2945	3075	2965	3095	2995	3125	2995	3125
Permissible roof load limit/nose weight in kg	100/140	100/130	100/140	100/130	100/140	100/130	100/140	100/130
Trailer load limit ⁵ in kg	unbraked	750	750	750	750	750	750	750
	12% gradient	3500	3200	3500	3200	3500	3200	3500
	8% gradient	3500	3200	3500	3200	3500	3200	3500
Fuel tank capacity, approx. in l	100		100		100		100	
Performance/consumption⁶								
Top speed in km/h	222/225 ⁷		243/245 ⁷		202/205 ⁷		215/218 ⁷	
Acceleration 0–100 km/h in s	7.9		6.9		9.1		7.8	
Fuel grade	Super sulphur-free RON 95 ⁸		Super sulphur-free RON 95 ⁸		Sulphur-free diesel ⁹		Sulphur-free diesel ⁹	
Fuel consumption ¹⁰ in l/100 km	urban	14.4	14.4	14.4	8.2	8.2	8.6	8.6
	extra-urban	8.5	8.5	8.5	6.5	6.5	6.7	6.7
	combined	10.7	10.7	10.7	7.2	7.2	7.4	7.4
CO ₂ emissions ¹⁰ in g/km	urban	335	335	335	216	216	225	225
	extra-urban	199	199	199	172	172	178	178
	combined	249	249	249	189	189	195	195
Emission standard	EU5		EU5		EU5		EU5	

Model	Audi Q7 3.0 TDI clean diesel quattro (180 kW) with nitrogen oxide catalytic converter ¹¹		Audi Q7 4.2 TDI quattro (250 kW)		Audi Q7 V12 TDI quattro (368 kW)	
Engine type	V6 diesel engine with common rail injection system and turbocharging		V8 diesel engine with common rail injection system and turbocharging		V12 diesel engine with common rail injection system and turbocharging	
Displacement in cc (valves per cylinder)	2967 (4)		4134 (4)		5934 (4)	
Max. output ¹ in kW at rpm	180/3800-4400		250/4000		368/3750	
Max. torque in Nm at rpm	550/1750-2750		800/1750-2750		1000/1750-3250	
Power transmission/wheels						
Drive type	quattro® permanent all-wheel drive		quattro® permanent all-wheel drive		quattro® permanent all-wheel drive	
Transmission type	8-speed tiptronic		8-speed tiptronic		6-speed tiptronic	
Wheels	Forged aluminium wheels, 7.5 J x 18		Cast aluminium wheels, 8 J x 18		Cast aluminium wheels, 10 J x 20	
Tyres	235/60 R 18 ²		255/55 R 18 ²		295/40 R 20 ²	
Weights/capacities						
Unladen weight ³ in kg	5-seater	7-seater	5-seater	7-seater	5/7-seater	
	2395	2425	2485	2515	2710	
Gross vehicle weight ⁴ in kg	3045	3175	3135	3265	3405	
Permissible roof load limit/nose weight in kg	100/140	100/130	100/140	100/130	100/120	
Trailer load limit ⁵ in kg	unbraked	750	750		750	
	12 % gradient	3500	3200	3500	3200	3000
	8 % gradient	3500	3200	3500	3200	3000
Fuel tank capacity, approx. in l	100		100		100	
Performance/consumption⁶						
Top speed in km/h	215/218 ⁷		242 ⁷		250 ¹²	
Acceleration 0-100 km/h in s	8.0		6.4		5.5	
Fuel grade	Sulphur-free diesel ⁹		Sulphur-free diesel ⁹		Sulphur-free diesel ⁹	
Fuel consumption ¹⁰ in l/100 km	urban	8.8	12.0		14.8	
	extra-urban	6.6	7.6		9.3	
	combined	7.4	9.2		11.3	
CO ₂ emissions ¹⁰ in g/km	urban	230	316		390	
	extra-urban	175	200		245	
	combined	195	242		298	
Emission standard	EU6		EU5		EU5	

Explanatory notes

- ¹ The figure given was calculated using the specified measuring procedure (current version of Directive 80/1269/EEC).
- ² You will find specifications on the technical characteristics of tyres on page 113.
- ³ Unladen vehicle weight includes driver (68 kg), 7 kg of luggage and fuel tank 90 % full, calculated in accordance with the current version of EC Directive 92/21/EEC. Optional equipment may increase the car's unladen weight and drag coefficient, whereupon the possible payload limit and the top speed will be reduced accordingly.
- ⁴ The payload increases by 100 kg for 6- and 7-seaters.
- ⁵ The engine's power output always decreases with increasing altitude. At 1,000 m above sea level, and for every additional 1,000 m, deduct 10 % from the weight of the outfit (trailer load limit + gross weight of the towing vehicle). Figure for trailer load limit applies to factory-fitted trailer towing hitch. If using the vehicle with a trailer towing hitch for commercial purposes, a digital tachograph may be required under certain conditions.
- ⁶ A vehicle's fuel consumption and CO₂ emissions do not just depend on how efficiently the vehicle uses the fuel, but are also influenced by driving behaviour and other non-technical factors. CO₂ is the greenhouse gas primarily responsible for global warming.
- ⁷ Figure applies to air suspension.
- ⁸ We recommend the use of sulphur-free unleaded super RON 95 in accordance with DIN EN 228. If this is not available, use sulphur-free regular unleaded RON 91 in accordance with DIN EN 228; power output will be slightly reduced. Unleaded RON 95 fuel with a maximum ethanol content of 10 % (E10) can generally be used. Fuel consumption details refer to operation with RON 95 fuel in accordance with 692/2008/EC.
- ⁹ We recommend using sulphur-free diesel in accordance with DIN EN 590. If this is not available, use diesel in accordance with DIN EN 590.
- ¹⁰ The figures given were calculated using the specified measuring procedures. The figures do not refer to one individual vehicle and do not form part of any offer, but rather should be used purely for purposes of comparison between the different vehicle models.
- ¹¹ We recommend having the separate AdBlue tank refilled by your Audi partner as indicated by the information in the display of the instrument cluster (about every 15,000 km).
- ¹² Regulated.

Important note

Inspections are due as shown by the service display.

Offroad properties**6- and 8-cylinder models**

Climbing ability as %		60
Ground clearance in mm		204.8/239.8*
Overhang angle in °	front rear	21.0/max. 23.5* 23.4/max. 25.4*
Ramp angle in °		21.1/23.8*
Fording depth in mm		500/535*

*Figure applies to air suspension.

Audi Q7 7-seater

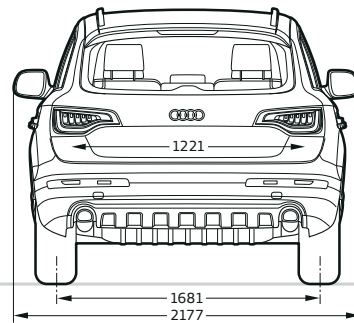
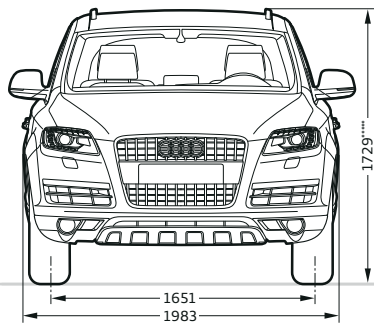
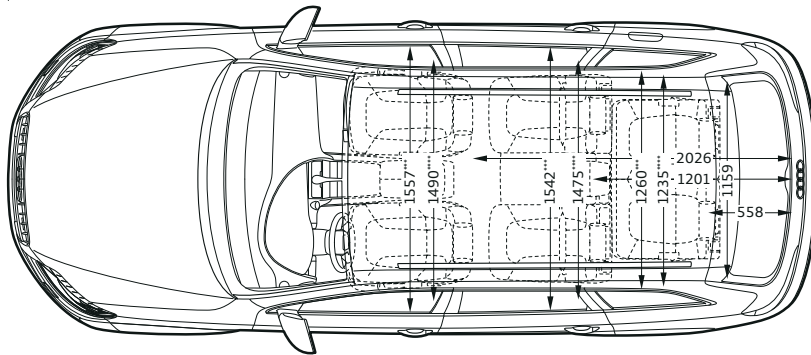
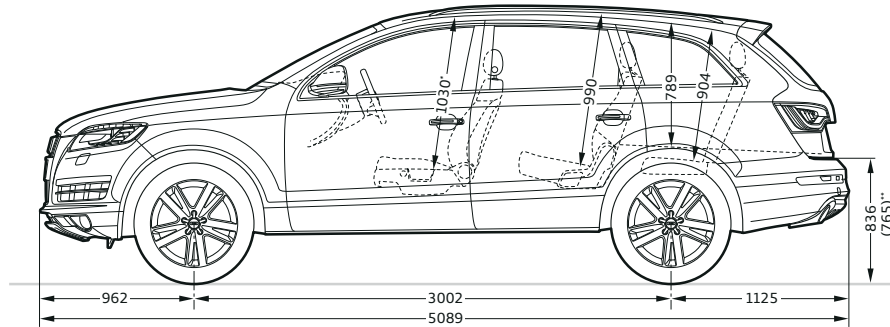

Dimensions in millimetres.

Dimensions were measured with vehicle at unladen weight, ground clearance measured with vehicle carrying its maximum load.

Luggage compartment volume in l: 330/2035 (measured by the VDA method using 200 x 100 x 50 mm blocks; second value is with the rear seat backrest folded down and the vehicle loaded up to roof height). Turning circle approx. 12 m.

* Maximum headroom. ** Air suspension "loading level". *** Elbow room width. **** Shoulder room width.

***** With roof rails the height of the vehicle is 1736 mm.

Audi Q7 V12 TDI quattro 7-seater

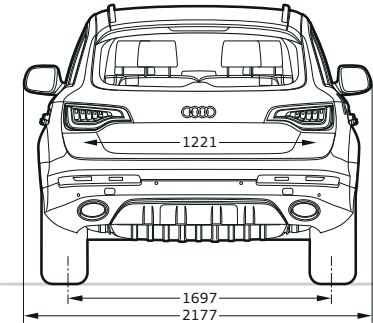
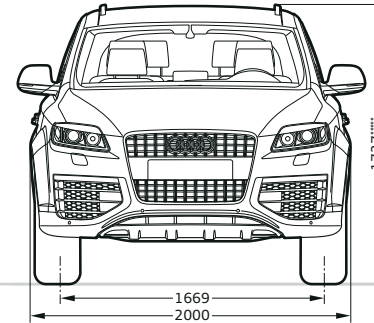
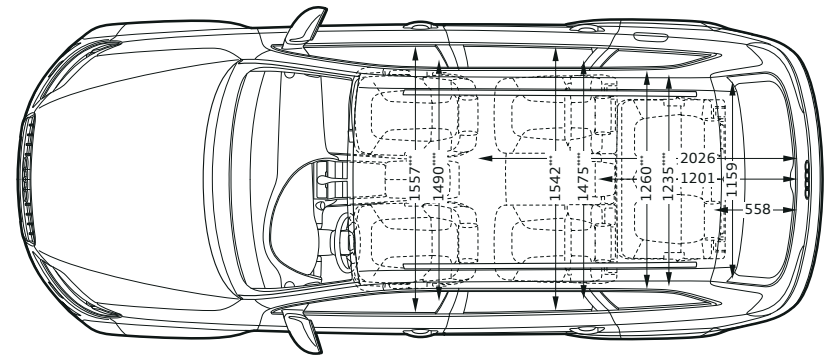
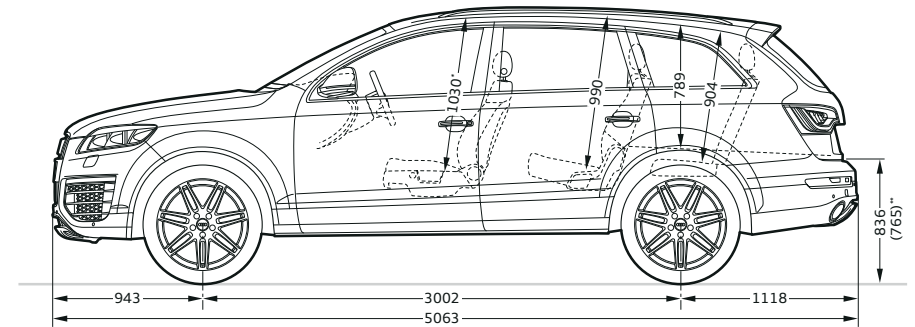



Dimensions in millimetres.









Dimensions were measured with vehicle at unladen weight, ground clearance measured with vehicle carrying its maximum load.

Luggage compartment volume in l: 330/2035 (measured by the VDA method using 200 x 100 x 50 mm blocks; second value is with the rear seat backrest folded down and the vehicle loaded up to roof height). Turning circle approx. 12 m.

* Maximum headroom. ** Air suspension "loading level". *** Elbow room width. **** Shoulder room width.







***** With roof rails the height of the vehicle is 1736 mm.













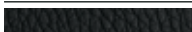

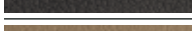
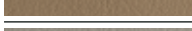
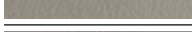

	Page	Audi Q7	Audi Q7 V12 TDI quattro
Equipment packages	60		
Audi exclusive line		■	■
S line exterior package		■	—
S line sport package		■	—
Solid paint finishes	68		
 Night black		□	■
 Carrara white		□	■
Metallic paint finishes	68		
 Glacier white, metallic		■	□
 Ice silver, metallic		■	□
 Bahia beige, metallic		■	□
 Teak brown, metallic		■	□
 Atlantis blue, metallic		■	□
 Graphite grey, metallic		■	□
 Orca black, metallic		■	□
Pearl effect paint finishes	69		
 Garnet red, pearl effect		■	□
 Mugello blue, pearl effect		■	□
 Lava grey, pearl effect		■	□
 Daytona grey, pearl effect		■	□
Contrasting paint finishes	69		
 Platinum grey, matt		□	—
 Matt black		□	—
Customised paint finishes	69		
 Audi exclusive customised paint finishes		■	■
Full paint finish	69		
Full paint finish		■	□

	Page	Audi Q7	Audi Q7 V12 TDI quattro
Wheels/tyres	70		
 18" cast aluminium wheels in 6-arm design		□ ¹	—
 18" forged aluminium wheels in 7-arm design		□ ²	—
 19" cast aluminium wheels in 5-arm V design		■	—
 19" cast aluminium wheels in 5-arm structured design		■	—
 20" cast aluminium wheels in 10-spoke V design		■	—
 20" Audi exclusive cast aluminium wheels in 5-spoke design		■	—
 20" Audi exclusive cast aluminium wheels in 10-spoke design		■	□
 20" Audi exclusive cast aluminium wheels in 20-spoke design		■	■
 20" Audi exclusive cast aluminium wheels in 20-spoke design, black		■	■



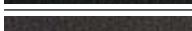
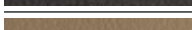

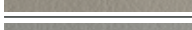
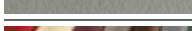



□ Standard equipment ■ Optional equipment ■ Standard/optional equipment varies by model — not available

Country-specific variations possible. Please find out from your local Audi partner which equipment is standard and what optional equipment is available in your country.

	Page	Audi Q7	Audi Q7 V12 TDI quattro
 21" Audi exclusive cast aluminium wheels in 5-segment-spoke design		■	■
 21" Audi exclusive forged aluminium wheels in 7-twin-spoke design		■	■
 18" cast aluminium winter wheels in 6-arm design		■	–
 18" forged aluminium winter wheels in 7-arm design		■	–
 20" cast aluminium winter wheels in 10-spoke V design		■	–
 20" Audi exclusive cast aluminium winter wheels in 10-spoke design		–	■
Anti-theft wheel bolts		■	■
Tyre repair kit		□	□
Spare wheel		■	–
Space-saving spare wheel		■	–
Tyre pressure loss indicator		■	–
Tyre pressure monitoring system		–	□
Vehicle tool kit		□	□
Vehicle jack		■	■
Seats	72		
Standard seats, front		□	■





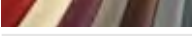



	Page	Audi Q7	Audi Q7 V12 TDI quattro
Sport seats, front		■	□
Climate-controlled comfort seats, front		■	■
Seat upholstery for standard seats, front	72		
 Cosmo cloth, black		□	–
 Cosmo cloth, pale grey		□	–
 Cricket leather, black		■	–
 Cricket leather, paranut brown		■	–
 Cricket leather, savannah beige		■	–
 Cricket leather, cardamom beige		■	–
 Cricket leather, pale grey		■	–
 Verano leather, black		■	□
 Verano leather, paranut brown		■	□
 Verano leather, savannah beige		■	□
 Verano leather, cardamom beige		■	□
 Verano leather, pale grey		■	□
 Audi exclusive leather upholstery and trim		■	■
Seat upholstery for sport seats, front	74		
 Alcantara/leather, black		■	■
 Alcantara/leather, pale grey		■	■
 Verano leather, black		■	□
 Verano leather, paranut brown		■	□
 Verano leather, savannah beige		■	□
 Verano leather, cardamom beige		■	□
 Verano leather, pale grey		■	□
 Audi exclusive leather upholstery and trim		■	■
Seat upholstery for climate-controlled comfort seats, front	76		
 Perforated cricket leather, black		■	–
 Perforated cricket leather, paranut brown		■	–

¹ Standard for 3.0 TFSI quattro (245 kW) and 4.2 TDI quattro. ² Not available for 3.0 TFSI quattro (245 kW) and 4.2 TDI quattro.

	Page	Audi Q7	Audi Q7 V12 TDI quattro
Seat upholstery for climate-controlled comfort seats, front (continuation)	76		
 Perforated cricket leather, savannah beige		■	—
 Perforated cricket leather, cardamom beige		■	—
 Perforated cricket leather, pale grey		■	—
 Perforated Verano leather, black		■	□
 Perforated Verano leather, paranut brown		■	□
 Perforated Verano leather, savannah beige		■	□
 Perforated Verano leather, cardamom beige		■	□
 Perforated Verano leather, pale grey		■	□
 Audi exclusive leather upholstery and trim		■	■
Equipment packages	78		
Fine Nappa leather or Valcona leather upholstery and trim and Audi exclusive Alcantara/leather combination		■	■
Leather package		■	□
Audi exclusive leather package		■	■
Audi exclusive full leather package		■	■
Full leather package		■	■
Audi exclusive colour-coordinated decorative stitching		■	■
Design packages	78		
Sport design package with sport seats, front		■	■
Leather design package with standard seats		□ ¹	—
Leather plus design package with standard seats		■	■
Leather plus design package with sport seats, front		■	□
Audi exclusive leather design package with standard seats		■	■
Audi exclusive leather design package with sport seats		■	■
Audi exclusive leather design package with climate-controlled comfort seats		■	■
Audi exclusive design package Alcantara/leather, black with sport seats		■	■
Audi exclusive leather plus design package with standard seats		■	■

□ Standard equipment ■ Optional equipment ■ Standard/optional equipment varies by engine — not available

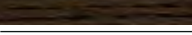
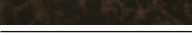
Country-specific variations possible. Please find out from your local Audi partner which equipment is standard and what optional equipment is available in your country.

	Page	Audi Q7	Audi Q7 V12 TDI quattro
Audi exclusive leather plus design package with sport seats		■	■
Audi exclusive leather plus design package with climate-controlled comfort seats		■	■
Audi exclusive line equipment package		■	■
Headlinings	80		
Headlining		□	■
Headlining in black cloth		■	□
Headlining in Alcantara with contrasting stitching		■	■
Audi exclusive headlining in Alcantara black with contrasting stitching in light grey		■	■
Audi exclusive headlining in Alcantara black, individual choice of colour for contrasting stitching		■	■
Inlays	80		
 Aluminium Trigon		■	■
 Matt silk, black		□	—
 Olive ash, beige		■	■
 Walnut, natural		■	■
 Tamo ash, dark brown		■	■
 Audi exclusive fine grain ash, nougat		■	■
 Audi exclusive oak sepia		■	■
 Audi exclusive fine grain myrtle, nutmeg brown		■	■
 Audi exclusive carbon		■	□
 Piano finish, black		■	■
Lights	82		
xenon plus including headlight cleaning system		■	□
Headlights		□	—
adaptive light		■	■
High-beam assist		■	■
Interior lighting		□	□
Audi exclusive cardan reading lights		■	■

	Page	Audi Q7	Audi Q7 V12 TDI quattro
Interior and exterior lighting package		■	□
Door reflectors		□	–
LED rear lights		□	□
Front fog lights		□	–
Headlight cleaning system		■	□
Light/rain sensor		□	□
Mirrors	83		
Exterior mirrors with integrated LED indicator		□	□ ²
Exterior mirror, electrically folding		□	□
Exterior mirror, automatically dimming		■	□
Exterior mirror, automatically dimming with memory function		■	■
Interior mirror, dimming		□	–
Interior mirror, automatically dimming, with light/rain sensor		■	□
Roof system	83		
Panoramic glass sunroof		■	■
Closing systems	84		
Remote control key		□	□
Convenience key		■	■
Electronic immobiliser		□	□
Tailgate with electric opening and closing function		■	□
Garage door opener (HomeLink)		■	■
Anti-theft alarm		■	□
Preparation for tracking system		■	■
Ignition lock		□	□
Glazing	84		
Heat-insulating glass		□	□
Double/acoustic glazing		■	■

	Page	Audi Q7	Audi Q7 V12 TDI quattro
Dark-tinted windows (privacy glazing)		■	■
Acoustic windscreen		□	□
Rear window		□	□
Windscreen cleaning system		□	□
Sun visors		□	□
Double sun visor		■	■
Sunblind		■	■
Further exterior equipment	84		
High-gloss package		□	□
Provision for trailer towing hitch		■ ³	–
Trailer towing hitch		■	■
Full paint finish with aluminium-look exterior		■	–
Audi exclusive black styling package		■	■
Bumpers		–	□
Audi Singleframe		□	□
Roof rails		□	□ ⁴
Exhaust tailpipes with surrounds		□	□
Model name/logo		□	□
Underbody protection		□	□ ⁵
Seats/seating comfort	85		
3 rd row of seats		■	■
Rear seats (2 nd row, 5 or 7 seats (in combination with the 3 rd row of seats))		□	□
4-way lumbar support for the front seats		■	□
Front seats, electrically adjustable		■	□
Fore/aft adjustment for the 2 nd row of seats		■	■
Comfort seats in the 2 nd row, 6 seats (in combination with the 3 rd row of seats)		■	■
Memory function for the driver seat		■	■

¹Standard for 3.0 TFSI quattro (245 kW) and 4.2 TDI quattro. ²Housing in matt aluminium. ³Not for 3.0 TDI quattro (150 kW) and 4.2 TDI quattro (250 kW). ⁴In matt aluminium. ⁵In stainless steel

	Page	Audi Q7	Audi Q7 V12 TDI quattro
Seats/seating comfort (continuation)	85		
Memory function for the front seats		■	■
Comfort centre armrest, front		■	□
Centre armrest, front		□	–
Centre armrest, rear		□	□
Head restraints		□	□
Seat heating, front		■	–
Seat heating, front and rear		■	□
ISOFIX child seat mounting		□	□
ISOFIX child seat mounting for the front-passenger seat		■	■
Steering wheels/selector levers/controls	87		
Leather-covered multifunction steering wheel in 4-spoke design		■	■
Leather-covered multifunction sport steering wheel in 3-spoke Q design with shift paddles		■	□
Steering wheel adjustment, electric		■	■
Steering wheel rim with wooden segment		■	■
Audi exclusive steering wheel rim with wooden segment		■	■
Audi exclusive leather controls		■	■
Selector lever knob with wooden segment		■	–
Audi exclusive selector lever knob with wooden segment		■	–
Selector lever knob		–	□
Selector lever knob in leather		□	–
Climate control	88		
4-zone deluxe automatic air conditioning		■	■
Deluxe automatic air conditioning		□	□
Auxiliary heating/ventilation		■	■
Luggage securing and storage systems	88		
Double loading floor		□	□
Storage compartments		□	□

	Page	Audi Q7	Audi Q7 V12 TDI quattro
Glove compartment		□	□
Storage nets		□	□
Storage compartment		■	■
Storage package		■	□
Dirt collecting tray		□	□
Storage package with folding table		■	■
Cup holders		□	□
Bottle holders		□	□
Clothes hooks		□	□
Partition net		□	□
Lashing points		□	□
Rail system with load-securing kit		■	■
Reversible mat		■	■
Through-loading facility with removable ski/snowboard bag		■	■
Luggage compartment		□	□
Luggage compartment cover		□	□
Luggage compartment cover, foldable		■	■
Further interior equipment	90		
Audi exclusive coolbox		■	■
Footwell trim in Fresco carpet		■	■
Footwell trim in velour carpet		□	□
Floor mats, front and rear		■	□
Audi exclusive floor mats		■	■
Audi exclusive carpet and floor mats		■	■
Door sill trims with aluminium inlay		■	□
Pedals in aluminium look		–	□
Window controls		□	□
Door trims		□	□

□ Standard equipment ■ Optional equipment ■ Standard/optional equipment varies by model – not available

Country-specific variations possible. Please find out from your local Audi partner which equipment is standard and what optional equipment is available in your country.

	Page	Audi Q7	Audi Q7 V12 TDI quattro
Dashboard		<input type="checkbox"/>	<input type="checkbox"/>
Centre console		<input type="checkbox"/>	<input type="checkbox"/>
Cigarette lighter and ashtray		<input type="checkbox"/>	<input type="checkbox"/>
Grab handles		<input type="checkbox"/>	<input type="checkbox"/>
12V sockets		<input type="checkbox"/>	<input type="checkbox"/>
MMI® and navigation systems	90		
MMI® navigation plus		<input checked="" type="checkbox"/>	<input type="checkbox"/>
MMI® radio		<input type="checkbox"/>	–
MMI® radio plus		<input checked="" type="checkbox"/>	–
MMI® navigation		<input checked="" type="checkbox"/>	–
Driver information system		<input checked="" type="checkbox"/>	–
Driver information system with colour display		<input checked="" type="checkbox"/>	<input type="checkbox"/>
Radio and TV systems	91		
Bang & Olufsen Advanced Sound System		<input checked="" type="checkbox"/>	<input checked="" type="checkbox"/>
Digital Audio Broadcasting		<input checked="" type="checkbox"/>	<input checked="" type="checkbox"/>
Digital TV reception		<input checked="" type="checkbox"/>	<input checked="" type="checkbox"/>
Audi sound system		<input type="checkbox"/> ¹	–
Audi music interface		<input checked="" type="checkbox"/>	<input checked="" type="checkbox"/>
Adapter cable set for Audi music interface		<input checked="" type="checkbox"/>	<input checked="" type="checkbox"/>
BOSE Surround Sound		<input checked="" type="checkbox"/>	<input type="checkbox"/>
Preparation for Rear Seat Entertainment		<input checked="" type="checkbox"/>	<input checked="" type="checkbox"/>
Rear Seat Entertainment		<input checked="" type="checkbox"/>	<input checked="" type="checkbox"/>
Rear Seat Entertainment plus		<input checked="" type="checkbox"/>	<input checked="" type="checkbox"/>
CD changer		<input checked="" type="checkbox"/>	<input type="checkbox"/>
CD softbag		<input checked="" type="checkbox"/>	<input checked="" type="checkbox"/>

	Page	Audi Q7	Audi Q7 V12 TDI quattro
Telephone and communication	93		
Bluetooth interface		<input checked="" type="checkbox"/>	–
Preparation for mobile phone (Bluetooth)		<input checked="" type="checkbox"/>	<input type="checkbox"/>
Bluetooth car phone		<input checked="" type="checkbox"/>	<input checked="" type="checkbox"/>
Front handset for car phone		<input checked="" type="checkbox"/>	<input type="checkbox"/>
Audi connect including car phone		<input checked="" type="checkbox"/>	<input checked="" type="checkbox"/>
Assistance systems	93		
Cruise control		<input checked="" type="checkbox"/>	<input type="checkbox"/>
Parking system, rear		<input type="checkbox"/>	–
Parking system plus		<input checked="" type="checkbox"/>	<input type="checkbox"/>
Parking system plus with front and reversing camera		<input checked="" type="checkbox"/>	<input checked="" type="checkbox"/>
Parking system plus with reversing camera		<input checked="" type="checkbox"/>	<input checked="" type="checkbox"/>
Audi side assist		<input checked="" type="checkbox"/>	<input checked="" type="checkbox"/>
Audi lane assist		<input checked="" type="checkbox"/>	<input checked="" type="checkbox"/>
adaptive cruise control		<input checked="" type="checkbox"/>	<input checked="" type="checkbox"/>
Suspensions/brakes	95		
adaptive air suspension		<input type="checkbox"/> ²	<input type="checkbox"/>
S line adaptive air suspension		<input checked="" type="checkbox"/>	–
Dynamic suspension		<input type="checkbox"/> ³	–
S line sport suspension		<input checked="" type="checkbox"/> ³	–
Brake system		<input type="checkbox"/>	–
Parking brake		<input type="checkbox"/>	<input type="checkbox"/>
Ceramic brake		<input checked="" type="checkbox"/> ⁴	<input type="checkbox"/>
Technology/safety	95		
Side airbags, rear		<input checked="" type="checkbox"/>	<input checked="" type="checkbox"/>
Side airbags, front		<input type="checkbox"/>	<input type="checkbox"/>

¹ Standard with MMI radio plus, MMI navigation and MMI navigation plus. ² Standard for 4.2 TDI quattro ³ Not for 4.2 TDI quattro. ⁴ Can only be ordered for 3.0 TFSI quattro (245 kW) and 4.2 TDI quattro (250 kW) in conjunction with size 10 J x 20 wheels or with 21-inch wheels and tyre pressure loss indicator.

	Page	Audi Q7	Audi Q7 V12 TDI quattro
Technology/safety (continuation)	95		
Airbags		<input type="checkbox"/>	<input type="checkbox"/>
Side airbags, front, and head airbag system		<input type="checkbox"/>	<input type="checkbox"/>
Integrated head restraint system		<input type="checkbox"/>	<input type="checkbox"/>
Instrument cluster		<input type="checkbox"/>	<input type="checkbox"/>
Safety steering column		<input type="checkbox"/>	<input type="checkbox"/>
Seat belts		<input type="checkbox"/>	<input type="checkbox"/>
Belt height adjustment		<input type="checkbox"/>	<input type="checkbox"/>
Warning and control lights		<input type="checkbox"/>	<input type="checkbox"/>
Warning triangle		<input checked="" type="checkbox"/>	<input checked="" type="checkbox"/>
First-aid kit		<input checked="" type="checkbox"/>	<input checked="" type="checkbox"/>
tiptronic, 8-speed		<input type="checkbox"/>	–
tiptronic, 6-speed		–	<input type="checkbox"/>
servotronic		<input type="checkbox"/>	<input type="checkbox"/>
quattro®		<input type="checkbox"/>	<input type="checkbox"/>
Anti-Slip Regulation (ASR)		<input type="checkbox"/>	<input type="checkbox"/>
Electronic Differential Lock (EDL)		<input type="checkbox"/>	<input type="checkbox"/>
Electronic Stabilisation Control (ESC)		<input type="checkbox"/>	<input type="checkbox"/>
Recuperation		<input type="checkbox"/>	–
Start-stop system		<input type="checkbox"/> ¹	–
Body, galvanised		<input type="checkbox"/>	<input type="checkbox"/>
Side impact protection		<input type="checkbox"/>	<input type="checkbox"/>
Child-proof lock		<input type="checkbox"/>	<input type="checkbox"/>
Audi TDI clean diesel		<input type="checkbox"/> ²	–
Audi Extended Warranty	97		
Audi Extended Warranty		<input checked="" type="checkbox"/>	<input checked="" type="checkbox"/>

Equipment for the Audi Q7 illustrated (p. 4–25):

Paint finish: ice silver, metallic; wheels: cast aluminium wheels in 10-spoke V design;

Seat upholstery: cricket leather, black; inlays: tamo ash, dark brown

Equipment for the Audi Q7 V12 TDI quattro illustrated (p. 26–37):

paint finish: ibis white; wheels: Audi exclusive forged aluminium wheels in 7-twin-spoke design;

















seat upholstery: Audi exclusive fine Nappa leather; inlays: carbon

Standard equipment Optional equipment – not available

Country-specific variations possible. Please find out from your local Audi partner which equipment is standard and what optional equipment is available in your country.

Classifications of tyre parameters

The table shows the range of fuel efficiency, wet grip and exterior noise emission classes for the different tyre sizes of the Audi Q7 and Q7 V12 TDI quattro.

	Tyre size	Fuel efficiency class	Wet grip class	Exterior noise emission class
Summer tyres	235/60 R 18	E-C	C-B	73-69  - 
	255/55 R 18	E-C	C-B	71-67  - 
	265/50 R 19	E-B	C-A	73-70  - 
	275/45 R 20	E-C	C-A	73-70  - 
	295/40 R 20	E	C-B	76-70  - 
	295/35 R 21	E	C-A	73-70  - 
Winter tyres	235/60 R 18	C	E	71 
	255/55 R 18	E	E	72-69  - 
	275/45 R 20	E	E	72 

It is not possible to order a specific tyre. Ask your Audi partner about the range of tyres available in your country.

¹ Only for 3.0 TDI quattro (150 kW and 180 kW). ² Only for 3.0 TDI clean diesel with EU6.

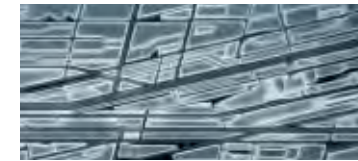
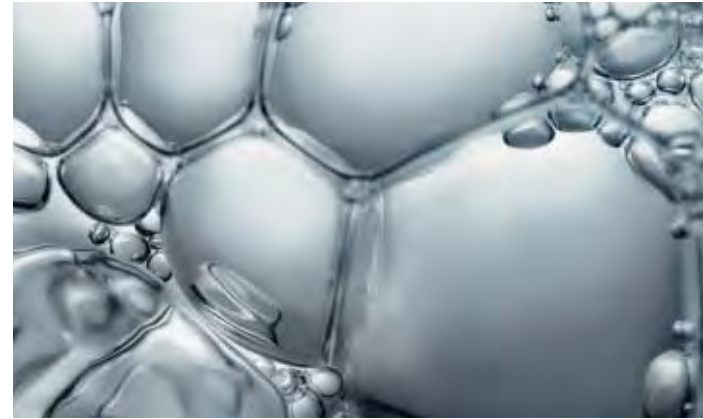

Discover



The Audi experience

The fascination of Audi can be experienced in many different ways. Audi City in London, for example, gives you digital access to all models at their actual size and in real time. And of course it is always worth visiting one of the major motor shows. This is where Audi always presents its new models and invites you to take a look at how the future is being shaped with "Vorsprung durch Technik". Anyone interested in seeing how Audi is already putting this into practice will find fascinating insight in the "Vorsprung durch Technik" online special at www.audi.com.

But a look back can also be rewarding: at the Audi mobile museum in Ingolstadt, history and high-tech go hand in hand. A total of 130 historic exhibits and state-of-the-art forms of presentation make for a thrilling symbiosis. Plus, Audi driving experience allows you to live the excitement and countless possibilities of current Audi models. Here, pure driving enjoyment is combined with valuable learning effects. This is ensured by a team of specially trained and highly qualified instructors who provide practical tips to help you optimise your driving skills.



Responsibility

Living up to our responsibilities is a principle that is firmly anchored in Audi strategy. Alongside commercial success and international competitiveness, our responsibility toward company employees and society as a whole is a key consideration, as is protecting the environment and conserving resources. And what is true in the details – our catalogues are printed on FSC-certified paper – also holds in general: Audi develops cars that are not only sporty and emotive but also ever more efficient. In the long run, Audi

wants its products to allow CO₂-neutral mobility. Seeing to it that production in Audi plants gradually becomes CO₂-neutral is another aspect of our comprehensive approach. Audi is also committed to society – particularly in the fields of education, technology and social projects. At Audi, sustainability is closely linked with how we see the future: the Audi Urban Future Initiative sees Audi working with international experts to get to the root of future urban challenges and trends in mobility.

the world of Audi.



Choosing an Audi means choosing a brand that offers more. More individuality. More exclusivity. More fascination.



Team spirit

Motorsport is a driving force behind the brand. For years Audi has been among the champions in various racing series, for instance the 24 Hours of Le Mans or the DTM German Touring Car Masters. The values that are crucial in many different areas of sports are also central ones for Audi: precision, passion and technology. No coincidence then that Audi has been sponsoring sporting

events for many years. In the world of winter sports, for example, Audi has been the main sponsor of the German Ski Association (DSV) for almost three decades and has also partnered 14 other national alpine teams. In football, we support national and international teams. And Audi is also a partner for the German Olympic Sports Confederation.

www.audi.com

Information on all the topics mentioned above can be found on our website: www.audi.com.



www.audi.com



www.audi.com/driving



configurator.audi.com



www.audi.com/cr



www.audi.com/vorsprung-durch-technik



AUDI AG
85045 Ingolstadt
www.audi.com
Valid from April 2013

Printed in Germany
333/1130.29.18

The models and equipment versions illustrated and described in this brochure and some of the services listed are not available in all countries. Some of the cars illustrated are equipped with optional features for which an extra charge is made. Details concerning the delivery specifications, appearance, performance, dimensions and weights, fuel consumption and running costs of the vehicle were correct to the best of our knowledge at the time of going to press. Deviations from the colours and shapes shown in the illustrations may occur. No liability is accepted for errors and printing errors. Not to be reproduced, including in part, without the written approval of AUDI AG.

This brochure is printed on paper made from pulp bleached without the use of chlorine.

