

# Ford Mustang II Options. Design your car to suit your spirit.



▲ **Dual Color-Keyed Mirrors.** Smart styling. Both are remote controlled from driver's side. Standard on Ghia and Mach 1.

**Tinted Glass.** Reduces glare from any direction. Recommended with SelectAir Conditioner.

**Glamour Paints.** Brand-new colors with a deep rich luster. Available in Green Glow (4T), Tan Glow (5U), and Ginger Glow (5J).

**Super Sound Package.** Sound absorbers help isolate the passenger compartment from engine and road noises. Standard on Ghia and with Luxury Interior Group.

**2.8 Liter V-6 Engine.** Compact, smooth, powerful. Comes with dual exhaust. Runs on regular fuel. Compression ratio 8.2 to 1. Standard on Mach 1.

**Heavy-Duty Battery.** 53 ampere. More starting power for severe service applications. Standard with 2.8 Liter engine.

**Power Rack-and-Pinion Steering.** 19 to 1 ratio. Gives quick, precise, response in any situation.

**Power Front Disc Brakes.** Helps give straight, sure stops. Even on wet pavement.

**Wheel Options.** Forged aluminum wheels, and styled steel wheels with trim rings (standard 2+2, Mach 1 and Rallye Package) are available to suit your taste.

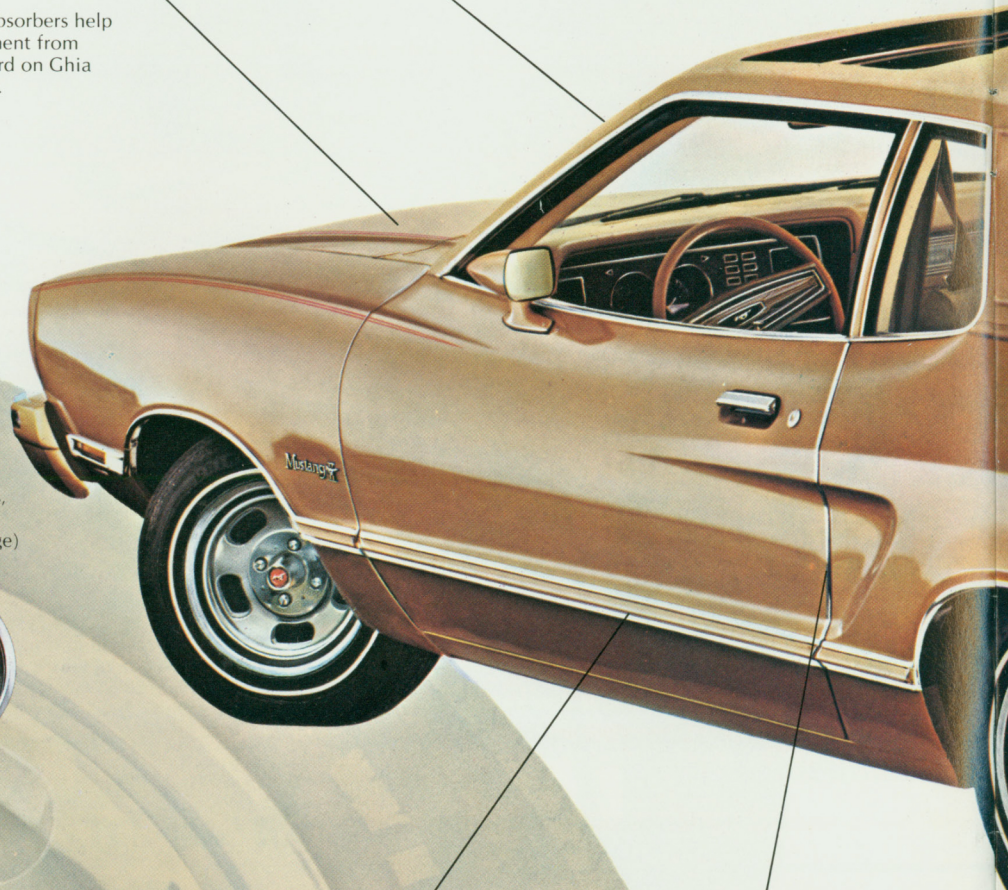
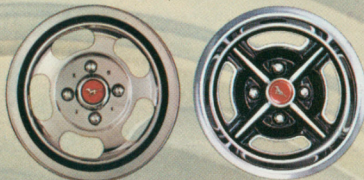

**Convenience Group.** Includes outside left-hand and right-hand remote control side mirrors, vanity visor mirrors, inside day/night mirror, parking brake boot with ash tray and deluxe seat belts.

**Protection Group.** Comes with door edge guards, front floor mats, spare tire lock, license plate frames and locking gas cap. (Door edge guards not included on Mach 1.)

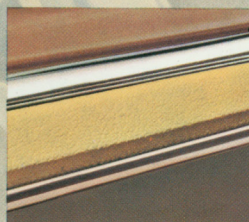

▲ **Bodyside Molding.** Bright metal with color-keyed vinyl insert. Helps protect the finish of door and bodyside. Standard on Ghia.

**Rocker Panel Molding.** Bright metal for extra sparkle and flair. Not available on Ghia or Mach 1.

**Flipper Rear Quarter Windows.** 3-door models. Easy to open. Easy to close. Positive locking, tight sealing.



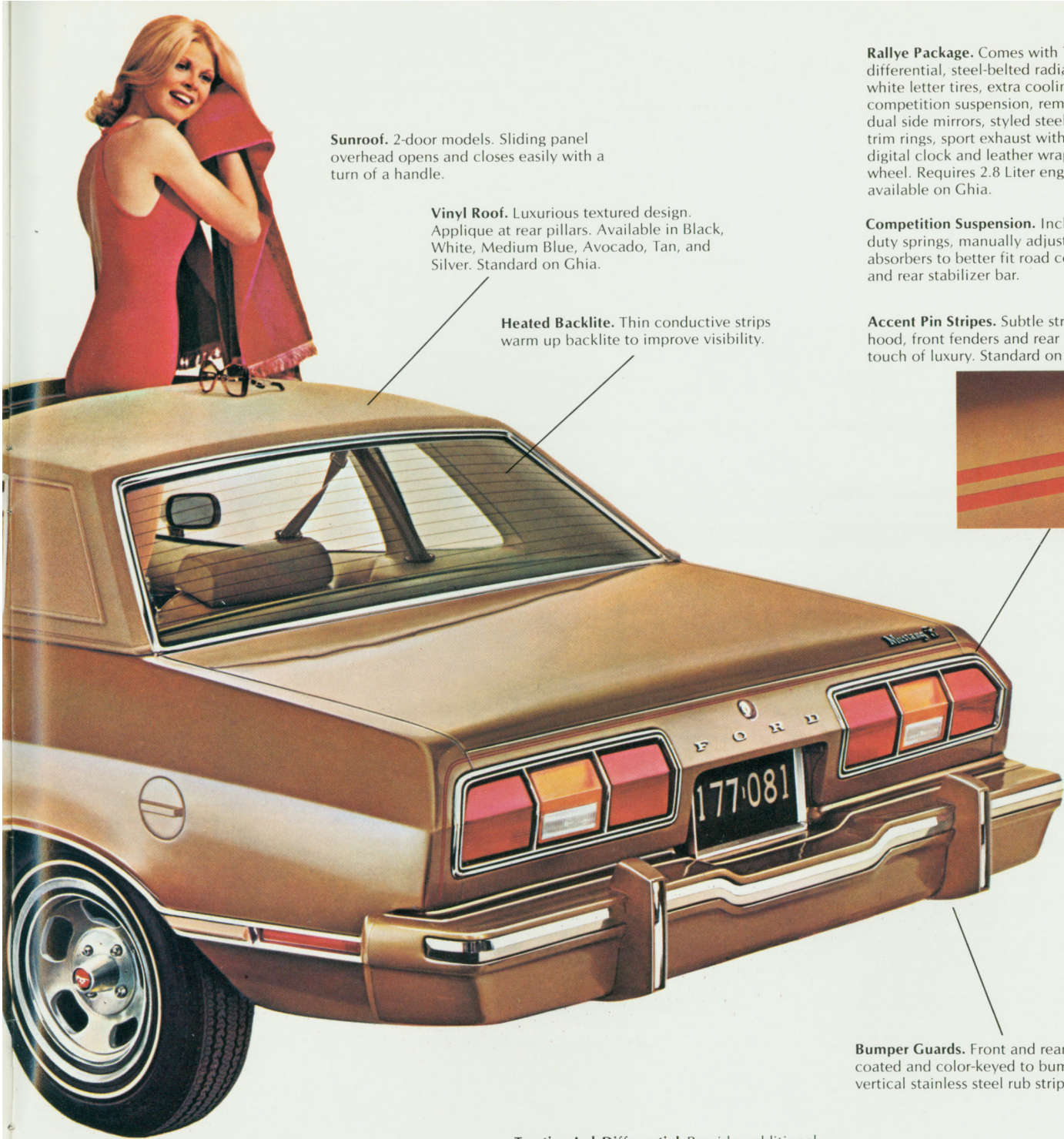

**Sunroof.** 2-door models. Sliding panel overhead opens and closes easily with a turn of a handle.

**Vinyl Roof.** Luxurious textured design. Applique at rear pillars. Available in Black, White, Medium Blue, Avocado, Tan, and Silver. Standard on Ghia.

**Heated Backlite.** Thin conductive strips warm up backlite to improve visibility.

**Rallye Package.** Comes with Traction-Lok differential, steel-belted radial ply raised white letter tires, extra cooling package, competition suspension, remote control dual side mirrors, styled steel wheels with trim rings, sport exhaust with bright tips, digital clock and leather wrapped steering wheel. Requires 2.8 Liter engine. Not available on Ghia.

**Competition Suspension.** Includes heavy-duty springs, manually adjustable shock absorbers to better fit road conditions, and rear stabilizer bar.

**Accent Pin Stripes.** Subtle striping around hood, front fenders and rear panel adds a touch of luxury. Standard on Ghia. ▼



**Bumper Guards.** Front and rear, urethane-coated and color-keyed to bumpers. Include vertical stainless steel rub strip.

**Traction-Lok Differential.** Provides additional rear wheel traction in mud and snow. Standard 3.55 to 1 ratio.

**Luggage Compartment Trim.** Available on 2-door models, it features cut-pile carpeting on floor and rear trim panels.

**Steel-Belted Radial Ply Tires.** Tested to give the average driver 40,000 miles of tread life in normal driving conditions. ▶

**White Sidewall Tires.** Available in several types and sizes. Standard on Ghia.

**Blackwall Tires with raised white letters.** Wide oval steel-belted radial ply construction. Standard on Mach 1.

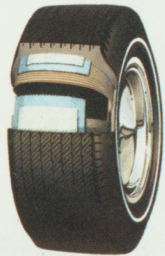

Interior options covered on pages 18 and 19.

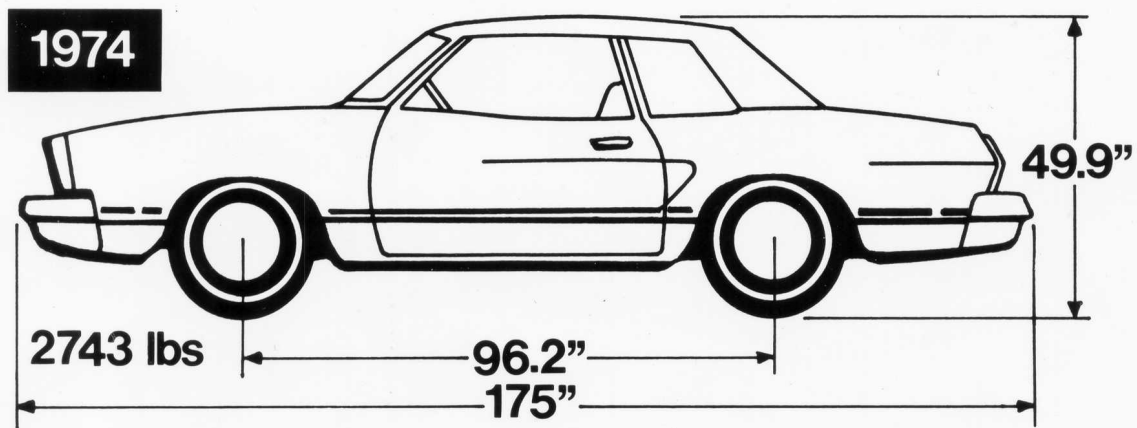
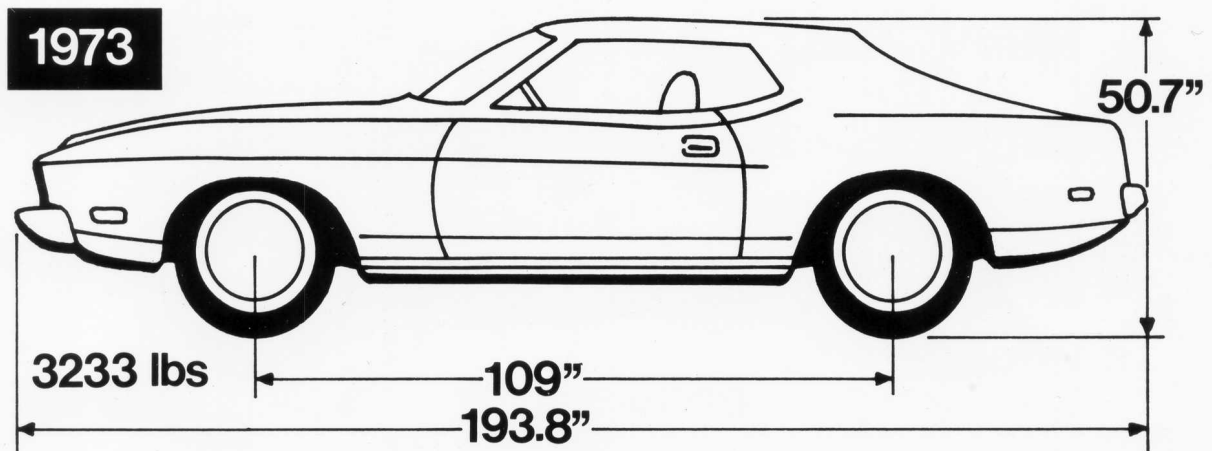
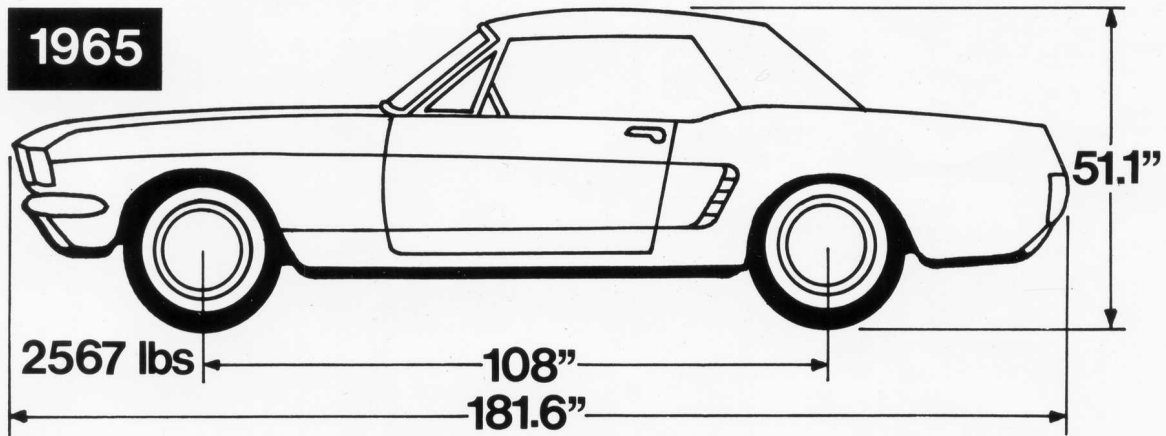

**1974 MUSTANG II DIMENSIONS**  
**RELEASE TUESDAY P.M.'S, AUGUST 28, 1973**

Mustang II for 1974 has undergone its biggest change in history. Its overall length was reduced almost 19 inches from last year and nearly seven inches compared with the original 1965 model. Mustang II is 490 pounds lighter than the 1973 Mustang. It is 176 pounds heavier than the original Mustang.

FROM: FORD DIVISION PUBLIC RELATIONS, P.O. BOX 1509, DEARBORN, MICH. 48121