



MGB-110

# 2024 Annual Catalog

## MGB/MGC ROADSTER & GT



**STARTERS BY WOSP**  
pg A55



**WOSP** 

**BRAKE FLUIDS BY DYNOLITE**  
pg A68



**STEERING WHEELS**  
pg A14



**TOURIST TROPHY**



# MOSS MOTORS, LTD.

## INTO THE FUTURE



For decades, classic British cars have captivated enthusiasts with their timeless elegance and undeniable charm. This didn't happen without a lot of effort by a lot of people.

Restoration, the art of bringing these vintage vehicles back to their former glory, is key of preserving their legacy. And the dedication and attention to detail involved in the restoration process not only upholds the historical significance of these automobiles but also honors the craftsmanship of their original creators, too.

Reliability, a crucial concern for any vehicle, has seen significant advancements in the realm of classic British cars. With technological innovations and the

availability of modern materials and engineering, our beloved classics are being rejuvenated with enhanced performance, safety, and durability without compromising their authentic character. This blend of tradition and innovation enables enthusiasts to enjoy the driving experience of yesteryears with a newfound reliability that we've come to expect today.

Driving a classic British car is more than just a means of transportation; it's an effort to experience motoring elegance. The thrill of gripping the steering wheel that probably isn't power assisted. Listening to the hum of the engine and knowing what the different sounds mean from under the bonnet. Each journey celebrates the craftsmanship, style, and

the sheer joy of driving a timeless motorcar.

The future of classic British cars rests on you. It's your passion and dedication that's preserving these automotive icons, and each one of us here at Moss Motors is grateful of your commitment to maintain not only the cars but also the community that enjoys them. A community intent on passing on the torch of automotive enthusiasm to future generations.

As time marches forward, the legacy of classic British cars shines bright. Embracing the future while honoring the past, our cars remain a timeless symbol of automotive excellence.

**Enjoy the ride,**

**Moss Motors**

### East & West Locations

#### Eastern Warehouse

25651 Simpson Rd.  
Petersburg, VA 23803  
Ph: 800-431-2496

#### Western Warehouse

440 Rutherford St.  
Goleta, CA 93117  
Ph: 800-667-7872

Telephone sales availability and showroom hours vary by location and day of the week.

Please visit our website for current hours of operation.



Place a single order of \$1,500 or more and you will automatically receive 10% off regular priced parts for 12 months! You will also be paired with a dedicated Sales Person who will give you personalized service.

Extend your time on the Customer Loyalty Program. While a member of the Loyalty Program, order a total of \$1,000 or more within 12 months and we will extend your 10% discount for an additional year! Only one extension per year is allowed.

For more information, visit [MossMotors.com/customer-loyalty](http://MossMotors.com/customer-loyalty)

### Gifting made "easy"



Provide exactly what your favorite British car enthusiast needs when you give a Gift Certificate. Gift Certificates are available in one dollar increments, and shipped USPS 1st Class or UPS Next Day or 2nd Day if you need faster delivery.

Order by phone 800-667-7872 or online [MossMotors.com/gift-certificate](http://MossMotors.com/gift-certificate).



### Your Favorite Brands



Working on automobiles is inherently dangerous. Moss Motors, Ltd. is not liable for injury or damage due to incorrect installation or use of their products. All products are sold with the understanding that the safe and proper installation and use of the products is the customer's responsibility. Follow factory workshop manual procedures and instructions, but use current shop safety standards and common sense. Some tasks will require professional advice or services which Moss Motors cannot provide.

**On the cover:**

We had so many great submissions for our calendar this year we decided to feature some of our favorites! Is your car on the cover? Let us know at [creative@mossmotors.com](mailto:creative@mossmotors.com).

## FEATURED PRODUCTS



BRITISH MOTOR HERITAGE LIMITED

### Replacement Roof Panel by British Motor Heritage

Clean and simple, this metal body panel replaces and repairs the roof of your MGB GT or MGC GT.

1965-'80 MGB GT & MGC GT      009-254      \$349.99



### Special Tuning Air Dam

This air dam is an ABS reproduction of the factory special tuning spoiler. The ST style spoilers were developed back in the day by Leyland Special Tuning using a wind tunnel for works competition cars. This style replaces the front valance on 1963-74.5 MGBs, reducing the ground clearance, but can be modified for use on later cars.

MGB 1962-74.5      475-196      \$249.99 **CS**

### Follow Us Online



British sports car articles, stories, history and updates on happenings at Moss Motors

- ▶ [Facebook.com/MossMotors](https://www.facebook.com/MossMotors)
- ▶ [Facebook.com/MossMotorsJaguar](https://www.facebook.com/MossMotorsJaguar)



Photos of British sports cars at your fingertips

- ▶ [Instagram.com/Moss\\_Motors](https://www.instagram.com/Moss_Motors)



Check out our channel for Tech How-To's and more

- ▶ [MossMotors.com/MossTV](https://www.MossMotors.com/MossTV)



## Moss Motoring

Moss Motoring is our magazine and also a website dedicated to British car enthusiasts. Visit [MossMotoring.com](http://MossMotoring.com) for volumes of information and stories, and receive the magazine for free when you purchase from Moss.



### Contents

Featured Products . . .	A4-A5
Accessories . . . . .	A8-A84
Restoration . . . . .	1-154
Order & Ship Info . . . .	A85
Order Form . . . . .	A86
Index . . . . .	155

## 2-Year Warranty

We stand behind the products we sell by offering the Longest Warranty in the business. Every Classic British Part is backed by our 2-Year warranty to be free from defects in material and workmanship.

See [MossMotors.com/warranty](http://MossMotors.com/warranty) for full details.



**PHONE ORDERS**

US 800-667-7872 INTL 805-681-3400

**FAX ORDERS**

805-692-2525

**ONLINE ORDERS**

[MossMotors.com](http://MossMotors.com)

**CUSTOMER SERVICE**

800-689-9313





**Keep Calm Insulated Lunch Bags**

Featuring the phrase “Keep Calm and Lunch on”, this insulated lunch bag keeps your food and drinks cool while providing some classic car style. Made from durable 600D polyester, it has an upper and lower zippered compartment which is lined with PEVA for easy clean up.

**The lunch bag dimensions are**  
9" W x 11" H x 6 1/4" D.

- “Keep Calm and Lunch On” - B.C.C. 009-230 \$24.99
- “Keep Calm and Lunch On” - MG 009-231 \$24.99



**Moss Picnic Blanket**

Made of 100% polyester fleece with a water-resistant backing, this plush blanket is perfect for spreading out at a roadside picnic or keeping warm on a long roadtrip. It folds up into a neat parcel via a hook-and-loop closure for compact storage and comes with a handle for easy carrying. Blanket measures 47" x 52" when open.

- Moss Picnic Blanket 009-228 \$25.00



**MG Safety Fast Bomber Jacket**

This black bomber-style jacket is warm, lightweight, and wind-resistant - making it perfect for early morning drives. Customized for the classic car enthusiast, this jacket sports the classic “Safety Fast” embroidery on the back and a smaller MG octagon on the front.

It features front zippered pockets, soft fleece lining, a rib knit hem and cuffs, and a zip-through cadet collar with chin guard. The jacket has a 100% polyester woven shell bonded to a water-resistant film insert - making it warm and dry no matter the weather. Show it off at your car club meetings or gift it to a fellow enthusiast. Machine washable. Available in sizes Small - 2XL. Get yours today!

**Sizing, measured at the chest, in inches:**  
35-37 (S), 38-40 (M), 41-43 (L), 44-46 (XL), 47-49 (2XL)

- Small 009-263 \$89.99
- Medium 009-264 89.99
- Large 009-265 89.99
- Xlarge 009-266 89.99
- XXLarge 009-267 89.99



**Blackout Hat**

The new Blackout series hats have arrived! Clad in a clean and classic design, these comfort-fit baseball hats will fit in with any automotive occasion, and the black and white stitching match pretty much everything. Black in color, these hats are made of reinforced cotton twill with a 6 panel construction and an adjustable hook and loop closure. Front design features your favorite British classic, with a Union Jack and Moss block logo on the back.

- Classic MGB 009-167 \$16.00



**MG Bucket Hat**

Stay cool with this Safari-style bucket hat! Made of breathable pre-shrunk 100% cotton fabric, this khaki hat sports the classic MG logo, a wide brim for extra sun-protection, a draw string closure, and snaps on either side - in case you want to change up your look. Perfect for car shows, club meets, or a long drive on a sunny day.

- MG Bucket Hat - Khaki 009-262 \$34.99

**Insulated Mug**

Made of stainless steel with a screw-on lid, this travel mug is the perfect way to show off your favorite marque. It's durable and insulated with a 20 oz capacity, laser etched MG Octagon logo, and a secure slide closure on top.

- MG Insulated Mug - 20oz 009-232



**Union Jack Key Chain**

Small and rugged, this new keychain exemplifies the British automotive spirit. Made from a durable and dense alloy, the Union Jack design is showcased uniquely in the rustic casting. The natural wear that comes with time will only make it shine ever brighter. Perfect for any British Classic, you'll be proud to add this to your keys. They also make the perfect gift for a like-minded friend or new club member.



- Union Jack Metal Key Chain 009-238 \$7.99





### Polyurethane Valve Cover Bushing Set

Polyurethane bushings are made to be more resistant to abrasion than their traditional rubber counterparts. They have a high tear strength, a low compression set, and hold up against oils and solvents, resulting in a superior service life. With their resistance to compression and wear and tear, these bushings are a solid suppression upgrade for both performance and longevity.

**Features:**

- Low compression set
- High tear strength
- Resistant to abrasion and dry-rot
- Holds up against oils and solvents

Polyurethane Valve Cover Bushing Set 009-164 \$6.99



### Black Gauge Panels

Swap out your MG radio or radio blanking plate with this neat 2mm steel gauge holder. It easily adapts to other vehicles, especially to cars where the strong mounting plate adds local strength to the glass fibre. It accepts 1 or 2 standard 52mm gauges for monitoring vital functions and easily installs using the included

stainless steel socket headed bolts.

Available in Black Wrinkle finish to match your MG's dashboards,

Fits MGA's, MGC's and MGB's 1962-1970 (To GHN/D5 410000) or later MGB's if replacing dashboard mounted air vents.

1-Gauge Panel	472-038	\$29.99
2-Gauge Panel	472-039	29.99



### Electronic Fuel Pump Conversion

This Electronic Conversion Kit gives you a solid state electronic fuel pump without having to replace your current pump. It changes any 12 volt SU Pump from points to solid state electronic actuation - which is helpful for folks who store their vehicles through the winter as there are no points to rust or stick.

Please note, this kit is designed for later pumps. It may not work correctly on very old pumps that have 2 black wires instead of red and black due to age and the strength of the coil.

Negative Ground	009-156	\$169.99
Positive Ground	009-157	169.99



### Upgraded Brake Caliper Set by BCC

Each BCC brake caliper kit contains a pair of BCC 4 pot calipers anodised in black, EBC Ultimax brake pads (including pins, clips and springs), bleed nipples, bridge and feed pipes. Each kit is a simple bolt-on installation requiring no permanent modification to the vehicle and is completely reversible. These calipers are a direct replacement for the OEM Girling Type 16 (3.5" mounting centres) calipers.

- Using the proven BCC design the calipers are machined from Aerospace grade Aluminium for strength and durability.
- BCC calipers are hard anodised to prevent corrosion and then assembled.
- The pistons are made by BCC from 303 Stainless Steel to prevent corrosion and ensure a long life of faultless operation.
- The seals are supplied by British manufacturers of OEM automotive hydraulic seals.
- BCC calipers are fastened together with 10.9 grade high tensile steel bolts or high grade 316 HiMo Stainless Steel bolts certified to grade 10.9.
- They are supplied with Copper/Nickel Alloy hard lines with Brass fittings and EBC Ultimax brake pads.

*Please Note: Always use the new caliper to hose link pipes provided. These calipers are manufactured with imperial threads. When fitting to a TR6 with metric calipers please ensure that the brake hose to caliper pipe supplied is used.*

MGC	586-701	\$1,199.00	
-----	---------	------------	--



Pricing is subject to change.  
Please visit [MossMotors.com](http://MossMotors.com) for current pricing and availability.

FEATURED



# MODERN SOUND FOR YOUR CLASSIC

## Vintage Style Radios by RetroSound

RetroSound radios deliver superb sound and the latest audio features without compromising the original style of your dash. We carry a variety of their head units so you can choose the perfect solution for your audio needs.

### HEAD UNITS



#### RetroRadio

The RetroRadio looks like your vehicle's original factory radio while adding all the modern audio features found in your daily driver. Classic push-buttons, replica knobs, and a period-correct bezel or faceplate combine with the radio's display to create a truly authentic look.

#### Europa

The Europa Radio is designed to replicate the look of the original, complementing the interior style of your classic car while updating audio technology to today's standards. A new Din Kit is included for an easy installation.

#### Grand Prix

The RetroSound Grand Prix perfectly compliments the interior styling of the 1980s while updating the audio technology to today's standards. A new Din Kit is included for an easy installation.

RetroRadio



Europa





Grand Prix



### MOTORS

RetroSound radios are a modular design. Assembly is required. This design allows for a more adjustable fit and to offer different style options. *RetroSound Radios are only compatible with 12V negative grounding vehicles.*

			
	Motor 1B	Motor 2B	Motor 4HD
AM/FM RDS Tuner with 30 Pre-sets	✓	✓	✓
Selectable 12/24 Hour Clock	✓	✓	✓
Selectable Tuner with USA/EU/Japan Frequencies	✓	✓	✓
Clock-Off Feature	✓	✓	✓
Built-in Bluetooth®	✓	✓	✓
Non-Volatile Memory	✓	✓	✓
Front and Rear RCA Low Level Pre-amp Outputs	✗	✓	✓
Subwoofer Output with Variable Crossover	✗	✓	✓
Made for iPod® / iPhone®	✗	✓	✓
USB Port for WMA/MP3 Music Files	✗	1	2
Auxiliary Inputs	1	0	1
Display	White	32,000 Color Display	32,000 Color Display
Power Output	18 watts x 4	25 watts x 4	25 watts x 4
SiriusXM-Ready®	✗	✗	North America Only
Built-in DAB/DAB+ Tuner	✗	✗	✗



### Quadraphonic Four-Channel Amp

**Features:**

- 45 watts x 4 channels continuous power output
- Full range Class D digital circuitry
- Advanced protection circuitry
- Shielded to prevent interference with the radio
- Direct connection compatibility with all RetroSound radios
- Compact size (7 1/4" x 3" x 1 3/4")

230-580 \$219.99



### Amplified Subwoofer System

**Features:**

- 8-inch powered subwoofer system
- Built-in 100 watt Class D digital amplifier
- Built-in continuously variable crossover
- Remote level control
- Speaker level and RCA low-level inputs
- Rugged cast enclosure
- Small footprint (9 1/4" x 2 3/4" x 13 3/4")

230-550

\$199.99



### USB/Auxiliary Extension Cables

Black	230-356	\$19.99
Chrome	230-357	\$19.99



### SVC N-Series Speakers

Single Voice Coils (SVC) Speakers are a standard configuration single channel speaker for normal installations where speakers are mounted to the left and right of the car, such as doors or dash sides. 4.5" diameter, 2 way, pair.

230-535

\$114.99



### Deluxe Surface Mount Speaker Set

**Features:**

- Multi-purpose surface-mount speaker modules
- Made from rugged ABS plastic
- Can be mounted to any flat surface, including kick panels, doors and rear decks
- Angled design directs sound towards the listener
- Price is per pair

4" x 6"

230-571 \$119.99

6.5" Round

230-575 \$159.99



### Surface Mount 2-Way 4" Speakers

**Features:**

- 4 ohm impedance
- 45 Watts power handling
- Dimensions (each): 4 1/2" x 4 1/2" x 4"

230-565

\$59.99



### Hide-Away Antenna

230-556

\$34.99



### RetroPod DVC N-Series Speaker

Dual Voice Coils (DVC) Speakers allow for 2 stereo channels (left/right) to be connected to the same single speaker. This means that originality can be maintained on cars where a single speaker was fitted in the center of the dash or rear shelf, providing full stereo sound from a single speaker. These speakers are supplied individually without mesh grilles, to fit existing mountings.

230-505

\$99.99

Shop all Retrosound products online:  
[MossMotors.com/brands/Retrosound](http://MossMotors.com/brands/Retrosound)





Light Tan

### Roadster Light-Tan Deluxe Interior

One part number will change the entire look of your MGB. Available in easy-to-care-for vinyl or supple, long wearing leather. Includes: complete panel kit (1971-75 design), door cappings, center console lid, shift gaiter, black door pulls, custom seat covers, foams, diaphragms, backboards and an edge-bound carpet set with molded transmission tunnel. For Roadsters only.

Vinyl Seats 1970-80	111-808	\$3,299.00	
Leather Seats 1970-80	111-809	3,799.00	

Autumn Leaf

Black



### Suffolk Classic Seat Sets

Upgrade your MGB's interior with these classic Suffolk Seat Assemblies developed in the UK using updated mechanisms, headrest frames and seat foams to create not only the most comfortable and best-looking reclining seat, but also the safest!

These seat assemblies are trimmed in high quality leather, come supplied in pairs, and bolt to factory seat runners. The seats feature a reclining back rest, full tilt mechanism, adjustable head rests, and a base frame that incorporates a seat belt anchor point. When installed, they will allow working clearance of the soft top or hardtop.

Black	646-310	\$2,999.00	
Autumn Leaf	646-311	2,999.00	

Autumn Leaf

Black

### Complete Roadster Interior Packages

Refurbish your entire interior and save at the same time with one of our complete interior packages! While the panels and seat kits are of the 1973-76 pattern, they fit and look great on all 1970-80 MGBs.

These kits include: vinyl panel kit, vinyl seat kit, carpet kit, door top cap set, center console lid, door panel clip set, vinyl armrests, vinyl gearshift boot, seat back and cushion foams, seat back panel boards, headrests, seat webbing kits and door seal set.

#### Fits 1970-80

Black	111-608	\$2,799.00	
Autumn Leaf	111-708	2,999.00	







**1970-80 Seat and Panel Kit**

- All seams are stitched rather than heat-seamed
- Plywood backing is stronger and resists water much better than fiberboard



**Custom Deluxe Upholstery by Moss Motors**

Emulating the rich look of British classics such as Rolls-Royce, Jaguar and Bentley, our Custom Deluxe Interior Kits give your seats a feel of true luxury. The thick, padded seat covers are carefully stitched for exact fit and plush contour, and the door panels are stitched rather than heat-seamed to complement the seats.

**Complete Vinyl Interior Kits:** Include deluxe vinyl seat covers, headrest covers, seat foam set, seat bottom webbing, deluxe vinyl panel kit, armrest/door pulls and carpet kit.

**Quality Seat Kits:** Patterned after the factory originals, our seat

recovering kits will allow you to restore your existing front and rear seats. Available in leather or vinyl. Front seat cushions are available separately.

**Quality Panel Kits:** These include new front kick panels, rear quarter panels, rear bulkhead panels for roadsters, rear deck insert panels for GTs, new door window brush seals and leather to cover roadster door top rails. We recommend using the early style fur-fabric/rubber door seal to match the appearance of the rest of your interior. Door seals available separately.

*Note: For free material samples, order part number 878-900.*

Complete Vinyl Interior Kits	Black w/ Black Carpet	Honey Tan w/ Black Carpet	Honey Tan w/ Honey Tan Carpet	Price
1970-76 Roadster	645-165	645-175	645-170	\$2,299.00
1977-80 Roadster	645-180	645-190	645-185	2,299.00

Vinyl Front Seat Kits	Black w/ Black	Black w/ Red	Black w/ White	Honey Tan w/H. Tan	Red w/ Red	Tan w/ Tan	Price
1970-76	645-166	645-167	645-168	645-171	645-169 <sup>1</sup>	645-172 <sup>1</sup>	\$969.99
1977-80	645-181	645-182	645-183	645-186	645-184 <sup>1</sup>	-	969.99

Vinyl Panel Kits	Black w/ Black	Black w/ Red	Black w/ White	Honey Tan w/H. Tan	Red w/ Red	Tan w/ Tan	Price
1970-80 Roadster	643-750	643-760	643-770	643-792	643-780	643-790	\$729.99
1970-76 GT	643-800	643-810	643-820 <sup>1</sup>	643-842	643-830	643-840 <sup>1</sup>	749.99

Leather Front Seat Kits	Black w/ Black	Black w/ Red	Black w/ White	Honey Tan w/H. Tan	Red w/ Red	Tan w/ Tan	Price
1970-76	641-725	641-730	641-735	641-747	641-740	641-745	\$1,299.00
1977-80	641-750	641-755	641-760 <sup>1</sup>	641-772	641-765	641-770	1,299.00

Leather Rear Seat Kits	Black w/ Black	Black w/ Red	Black w/ White	Honey Tan w/H. Tan	Red w/ Red	Tan w/ Tan	Price
1970-76 GT	641-850	641-855	641-860 <sup>1</sup>	641-872	641-865 <sup>1</sup>	641-870	\$649.99

<sup>1</sup>Special order, allow 6-10 weeks for delivery.

**Seat Cushions for Front Seat Kits**

1973-80 Bottom Right	641-940	\$79.99	OS
1973-80 Bottom Left	641-950	79.99	OS
1973-80 Back Left or Right	641-980	94.99	OS



**Moss Handcrafted Leather Shift Boots**

Complement your Custom Deluxe Moss Upholstery Kit, or existing interior with one of these high quality leather shift boots.

1968-80 - Black	228-368	\$42.99
1968-80 - Tan	228-365	42.99
1968-80 - Honey Tan	228-366	42.99
1968-80 - Red	228-367	42.99



Pricing is subject to change. Please visit [MossMotors.com](http://MossMotors.com) for current pricing and availability.

INTERIOR

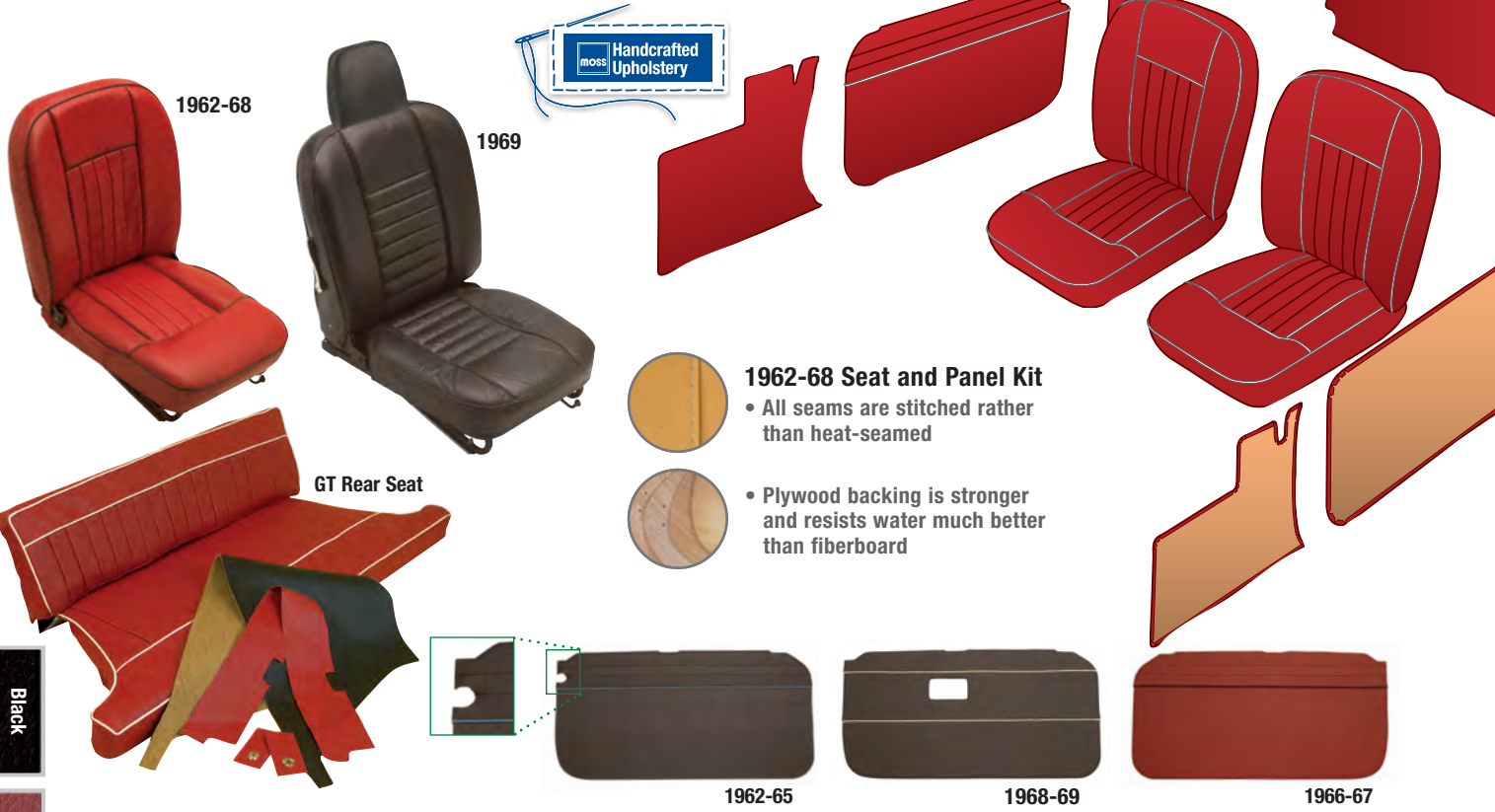

**1962-68 Seat and Panel Kit**

- All seams are stitched rather than heat-seamed
- Plywood backing is stronger and resists water much better than fiberboard

**1962-69 Exact Reproduction Seat and Panel Kits**

Revamp your MGB with a full range of exact reproduction upholstery kits produced in our own upholstery shop. All leather is tanned and vat-dyed to our specifications to ensure originality and durability.

Moss seat kits are available in leather (as original), or in top-quality vinyl. Easy to install, these include headrest covers for the 1969-style seats.

Trim panel kits include door panels, front kick panels, rear quarter panels, rear bulkhead panel for the roadsters and rear deck insert

panels for the GTs. We also include sufficient vinyl to cover Roadster cockpit rails, door top rails, 1962-67 dash top rail, and new door window brush seals.

In addition to the original interior color schemes, we offer several trim and piping combinations. The most popular of these are usually available from stock, while the others (marked in the chart with "1") are made to order only.

*Note: Assembled Seat Sets do not include Seat Slides. For free material samples, order part #878-900.*

**Front Seat Kits**

	Black w/ Black Piping	Black w/ Blue Piping	Black w/ Red Piping	Black w/ White Piping	Honey Tan w/H. Tan	Red w/ Black Piping	Red w/ Red Piping	Red w/ White Piping	Tan w/ Tan Piping	Price
1962-68 Leather Assembled Seat Sets - Ready to Install	641-178 <sup>1</sup>	641-208 <sup>1</sup>	641-188 <sup>1</sup>	641-198	641-258 <sup>1</sup>	641-218 <sup>1</sup>	641-238 <sup>1</sup>	641-228 <sup>1</sup>	641-248 <sup>1</sup>	\$2,299.00 <sup>FREE</sup>
1962-68 Leather (Rd & GT)	641-170	641-200	641-180	641-190	641-237	641-210	641-230 <sup>1</sup>	641-220	641-235	949.99 <sup>FREE</sup>
1969 Leather (Rd & GT)	641-310	641-340 <sup>1</sup>	641-320	641-330	641-377	641-350 <sup>1</sup>	641-370 <sup>1</sup>	641-360 <sup>1</sup>	641-375	999.99 <sup>FREE</sup>
1962-68 Vinyl (Rd & GT)	641-100	641-130	641-110	641-120	641-167	641-140	641-160	641-150	641-165	469.99
1969 Vinyl (Rd & GT)	641-240	641-270 <sup>1</sup>	641-250	641-260	641-307	641-280	641-300 <sup>1</sup>	641-290 <sup>1</sup>	641-305 <sup>1</sup>	699.99

**GT Rear Seat Kits**

	Black w/ Black Piping	Black w/ Blue Piping	Black w/ Red Piping	Black w/ White Piping	Honey Tan w/H. Tan	Red w/ Black Piping	Red w/ Red Piping	Red w/ White Piping	Tan w/ Tan Piping	Price
1966-68 Leather	643-210	643-240 <sup>1</sup>	643-220 <sup>1</sup>	643-230	643-277 <sup>1</sup>	643-250 <sup>1</sup>	643-270	643-260	643-275 <sup>1</sup>	\$779.99 <sup>FREE</sup>
1969 Leather	641-450	641-480 <sup>1</sup>	641-460 <sup>1</sup>	641-470	641-517 <sup>1</sup>	641-490 <sup>1</sup>	641-510 <sup>1</sup>	641-500 <sup>1</sup>	641-515	619.99
1966-68 Vinyl	643-140	643-170 <sup>1</sup>	643-150	643-160	643-207	643-180	643-200 <sup>1</sup>	643-190 <sup>1</sup>	643-205 <sup>1</sup>	429.99
1969 Vinyl	641-380	641-410 <sup>1</sup>	641-390 <sup>1</sup>	641-400 <sup>1</sup>	641-447 <sup>1</sup>	641-420 <sup>1</sup>	641-440 <sup>1</sup>	641-430 <sup>1</sup>	641-445 <sup>1</sup>	459.99

**Panel Kits**

	Black w/ Black Piping	Black w/ Blue Piping	Black w/ Red Piping	Black w/ White Piping	Honey Tan w/H. Tan	Red w/ Black Piping	Red w/ Red Piping	Red w/ White Piping	Tan w/ Tan Piping	Price
1962-65 Roadster Vinyl	643-280	643-310	643-290	643-300	643-347	643-320	643-340	643-330	643-345	\$639.99
1966-67 Roadster Vinyl	643-350	643-380	643-360	643-370	643-417	643-390	643-410 <sup>1</sup>	643-400	643-415	639.99
1968-69 Roadster Vinyl	643-490	643-520	643-500	643-510	643-557	643-530	643-550	643-540	643-555	599.99
1966-67 GT Vinyl	643-420	643-450 <sup>1</sup>	643-430	643-440	643-487 <sup>1</sup>	643-460	643-480 <sup>1</sup>	643-470	643-485	639.99
1968-69 GT Vinyl	643-560	643-590	643-570	643-580	643-627	643-600	643-620	643-610 <sup>1</sup>	643-625 <sup>1</sup>	599.99

<sup>1</sup>Special order, allow 6-10 weeks for delivery.



\*See ordering page for details

⚠ WARNING: Cancer and Reproductive Harm. www.P65Warnings.ca.gov





**1970-80 Original Style Seat and Panel Kits**

Manufactured in England, these kits recreate the original vinyls and dielectrically welded seams. We use the chrome-colored mylar accent strips on the door panels where appropriate, and supply the correct fabric inserts in the late GT seat kits.

Three different styles of completely interchangeable panel kits let you re-do your interior to suit your individual taste. However, seat kit interchangeability is more complicated. The basic seat frame was unchanged from 1970-80, but cushion and headrest designs differ. The 1970-72 seats can be fitted with the later foam seat cushions, then covered with the 1973-76 covering kits. The MGB-GT seats from 1973 on had nylon fabric inserts. These fabric seat kits will fit the 1973-76 roadsters or the 1970-72 roadsters equipped with the later-style seat cushions.

Panel kits include new front kick panels, rear quarter panels, rear bulkhead panels for roadster, rear deck insert panels for GTs, door window brush seals and sufficient vinyl to cover the roadster cockpit and door top rails. Panel clips are not included. Order free material samples with part #878-120.

Front seat kits include covers for both front seats including headrest covers.

*Note: Champagne (beige) replaced Autumn Leaf from 1978-80.*

*At this time, Ochre panel kits and seat kits are not available.*



**Front Seat Kits**

	Autumn Leaf	Black	Champagne	Navy	Price
1970-72 Vinyl (Rd & GT)	641-550	641-520			\$839.99
1973-76 Vinyl (Rd)	641-590	641-560			949.99
1977-80 Vinyl (Rd)	641-630	641-600			839.99
1973-76 Fabric (GT)	641-685	641-680			819.99

**GT Rear Seat Kits**

	Autumn Leaf	Black	Champagne	Navy	Price
1970-76 Vinyl	641-670	641-640			\$549.99
1973-76 Fabric	641-695 <sup>1</sup>	641-690			549.99

**Panel Kits**

	Autumn Leaf	Black	Champagne	Navy	Price
1970 Vinyl (Rd)	-	643-635	-	-	\$589.99
1970 Vinyl (GT)	-	643-645	-	-	549.99
1971-76 Vinyl (Rd)	643-660	643-630	-	643-640	599.99
1971-76 Vinyl (GT)	643-740	643-710	-	643-720	599.99
1977-80 Vinyl (Rd)	643-700	643-670	643-705	-	599.99

**Headrest Assembly (sold individually)**

	Autumn Leaf	Black	Champagne	Navy	Price
1970-72 Vinyl (Eared type with perforated vinyl)	649-130	649-100		-	\$169.99
1973-76 Vinyl (Eared type with plain vinyl)	649-170	649-140		-	174.99
1977-80 Vinyl (Teardrop type)	641-636	641-607		641-615 <sup>1</sup>	169.99

**Headrest Cover (sold individually)**

	Autumn Leaf	Black	Champagne	Navy	Price
1973-76 Vinyl (Eared type with plain vinyl)	640-225	640-200		640-210	\$79.99
1977-80 Vinyl (Teardrop type)	640-345	640-335		-	89.99

<sup>1</sup>Special order, allow 6-10 weeks for delivery.



**1971-80 Original Style Door Panel Pairs**

Sometimes that's all you need.

1971-76 Black Door Panels	643-631	\$209.99
1977-80 Black Door Panels	643-671	209.99



### Molded Tunnel Carpet Kits

These carpet kits have a molded center tunnel assembly which makes installation quicker and easier. Manufactured in the UK. For free samples of our carpet material, order sample card #878-925.

#### 1962-67 Roadster

Black	244-300	\$899.99	OS
Red	244-310	899.99	OS

#### 1962-67 GT

Black	244-325	\$949.99	OS
Red	244-335	949.99	OS

#### 1968-80 Roadster

Black	244-320	\$799.99	OS
Red	244-330	799.99	OS
Autumn Leaf	244-340	799.99	OS
Tan	244-272 <sup>1</sup>	799.99	OS
Navy	244-345	799.99	OS

#### 1968-76 GT

Black	244-245	\$1,195.00	OS
Red	244-260	1,195.00	OS
Autumn Leaf	244-265	999.99	OS
Tan	244-277 <sup>1</sup>	1,195.00	OS
Navy	244-285 <sup>1</sup>	999.99	OS

<sup>1</sup>Special order, allow 6-10 weeks for delivery.



### Carpet Sets

We offer a choice of carpet kits. Both kit lines are made of high quality cut pile automotive carpet, which is very similar to the factory original. Moss Manufactured Carpets Kits also provide a factory accurate "Loop" option, in black only, for the early MGBs. All carpet sections are finished as original with heavy padding, bound edges and hardboard panel backing where fitted. Installation hardware is included, so adhesive, trim tools, care and time are all that are needed to create a result you can be proud of. As replacement rubber floor and sill mats for 1962-76 models are not readily available, both kit lines include carpet for these areas. The GT kits also include material for the rear quarters, rear deck and rear seat back.

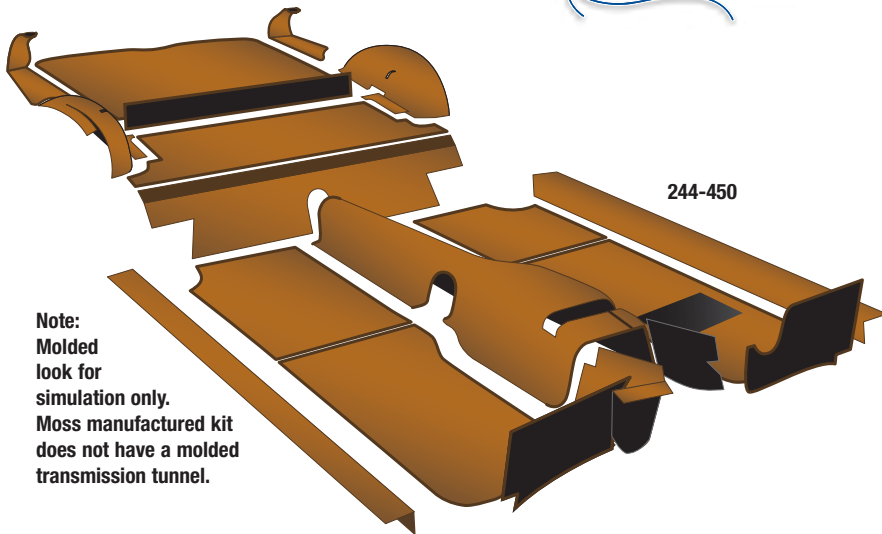
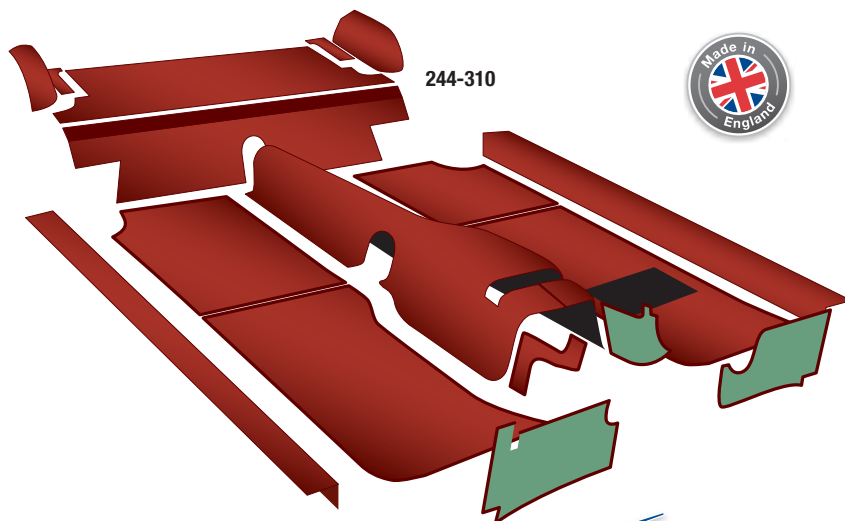

**Note:**  
Molded look for simulation only. Moss manufactured kit does not have a molded transmission tunnel.

### Moss Manufactured Carpet Kits

We create these kits in our own upholstery shop from domestically-sourced carpet. The center tunnel is supplied flat and does require more fitting, but this allows a more original look. Free samples of the carpet used in this line of kits may be ordered under part #878-915.

#### 1962-67 Roadster

Black - Cut Pile	242-765	\$459.99	OS
Black - Loop	242-764	459.99	OS
Red - Cut Pile	242-766	459.99	OS
Honey Tan - Cut Pile	242-767	459.99	OS

#### 1962-67 GT

Black - Cut Pile	244-415	\$619.99
Black - Loop	244-414	619.99
Red - Cut Pile	244-420	619.99
Honey Tan - Cut Pile	244-425 <sup>1</sup>	619.99

#### 1968-80 Roadster

Black - Cut Pile	244-315	\$359.99
Red - Cut Pile	244-355	469.99
Autumn Leaf - Cut Pile	244-374	469.99
Honey Tan - Cut Pile	244-377	469.99

#### 1968-76 GT

Black - Cut Pile	244-435	\$589.99
Red - Cut Pile	244-440	589.99
Autumn Leaf - Cut Pile	244-444	589.99
Honey Tan - Cut Pile	244-450	589.99

<sup>1</sup>Special order, allow 6-10 weeks for delivery.

### Common-Wear Replacement Carpet Section Sets

Pre-cut carpet sections made to replace commonly worn areas of your car's carpet set. Only available in black cut pile.

Inner Sill Carpet Set	244-458	\$44.99
1962-67 Front Floor Carpet Set	244-456	99.99
1968-80 Front Floor Carpet Set	244-457	99.99
GT Deck Floor Carpet	244-417	56.99





**Custom Seat Covers**

Made to very specific seat patterns, the seat covers we offer employ only the best materials which are comfortable, wear resistant, and guarantee impeccable fit! Compared to a full re-upholstering, getting these custom seat covers is definitely a less expensive option. These are not generic covers. Sold as pairs. Covers for both styles of the headrest are included.

**Velour:** Soft and inviting fabric that's UV protected against fading. Polyester is highly breathable, and is slightly stretchy for a snug fit.

**EuroSport:** Dual knit style fabric for terrific airflow is compression resistant. UV and abrasion treated for maximum protection, with reinforced seams for maximum durability.



Velour Black



EuroSport Black



Velour Beige

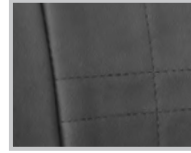

Leatherette Black

**Leatherette:** Feels incredibly similar to real leather with better wear. UV protected, this material is so sturdy you can simply wipe it clean with a wet cloth. No high maintenance required.

1970-80 - Velour - Black	237-601	\$284.99
1970-80 - Velour - Beige	237-600	284.99
1970-80 - EuroSport - Black	237-610	284.99
1970-80 - Leatherette - Black	237-615	329.99



**Seat Heater**

A little warmth in the right place can really make driving a much more comfortable experience. This therapeutic seat-heater has dual zones and two settings to keep your seat and lower back toasty. Designed to be installed under existing upholstery or seat covers, this kit is suitable for alternator equipped cars. Sold as a set for one seat. Negative ground cars with an alternator only.

Seat Heater Kit	903-251	\$129.99
-----------------	---------	----------

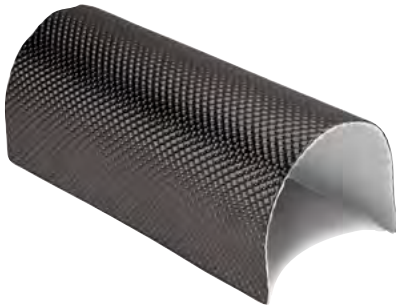

**Black Floor & Tunnel Shields by DEI**

Block engine and exhaust heat with the new Black Floor & Tunnel Shield by DEI. Backed with a high temperature pressure-sensitive coating, looks great while protecting components from damage. It can withstand up to 1750 F while the adhesive side can hold past 450 F. Constructed with an embossed 10 mil aluminum face bonded to 1/8" composite glass-fiber core, it is very flexible and can easily shape to firewalls, trans-tunnels, floors, and more. Easy to install. Available in two sizes: 48" x 21" and 48" x 42". We highly recommend this heat shield for your car!

**Features:**

- Proprietary high-temperature black coating
- Wind & water will not affect adhesive
- Minimum clearance required, only 3/16" thick
- Easily shape, trim, peel & stick
- Aggressive self-adhesive backing

48" x 21"	231-975	\$155.99
48" x 42"	231-976	299.99



**Seat Towels**

Don't just toss any old towel over your seat to protect your upholstery! This cover is designed specifically for your seats and features the Union Jack in full color or black and white. Made from cotton terrycloth, it's machine washable, and easy to remove and install.

Union Jack	216-590	\$54.99
Checkered & Union Jack	216-592	\$54.99



**Trunk and Spare Tire Carpet Kits**

So, you're not looking for "Best of Show" at the Concours d'Elegance, but still want a beautifully fitted carpet set? Then try out our carpet kits, which will add a plush feel to your MGB in a matter of minutes. Available in black, red or brown nylon cut pile, which match our interior carpet kits, this trunk set includes a tailored spare tire cover. Fully-molded carpet kits are also available in black or light tan.

**Molded Trunk Carpet Kits with Spare Cover**

Black	244-250	\$519.99
Light Tan	244-255	529.99

**Trunk Carpet Kits w/ MG Logo Spare Cover**

Black	242-850	\$249.99
Red	242-855	249.99
Autumn Leaf	242-874	249.99

**Spare Tire Cover with MG Logo**

Black	242-860	\$84.99
Red	242-865	84.99



Pricing is subject to change.  
Please visit [MossMotors.com](http://MossMotors.com) for current pricing and availability.

INTERIOR



**13" Direct Replacement Steering Wheel by RATCO**

Spruce up your classic's interior with a new steering wheel. Developed by RATCO, this 13" steering wheel for the MGB is designed to be a smaller version of the original steering wheel making the process of getting in and out of the car easier.

The rim is 1" thick, is padded, and covered with genuine leather to increase the grip diameter substantially over the original wheel. The corset stitching around the wheel provides a very professional and classy result. The spokes are powder coated an OE aluminum color. The wheel looks great, feels great and gets installed in ten minutes or less. And the best part is that it uses the original hub, reducing the cost.

MGB 1970-76 263-860 \$429.99



**Limited Edition Wheel**

Excellent reproduction of the hand-stitched padded leather wheel originally fitted to the 1979-80 Limited Edition MGB. Use your original "LE" hub or the reproduction assembly. The conversion kit allows fitting to 1970-76 MGBs - something you can't do with an original LE hub.

1970-76 LE Wheel Kit 263-738 \$349.99  
 1977-80 LE Wheel Kit 263-748 349.99  
 LE Steering Wheel only 263-740 269.99

*Moto-Lita*<sup>®</sup>

**Moto-Lita Steering Wheels**

Moto-Lita steering wheels employ attractive bicolored wood laminations or black leather over aircraft aluminum frames. Adapter hub sold separately.

<b>Wood Rimmed Wheels</b>		<b>Leather Rimmed Wheels</b>			
13" 3-spoke Polished/Drilled - Flat	499-530	\$489.99	13" 3-spoke Polished/Drilled - Flat	905-145	\$489.99
13" 3-spoke Polished/Drilled - Dished	499-585	489.99	13" 3-spoke Polished/Drilled - Dished	905-075	489.99
14" 3-spoke Polished/Drilled - Flat	499-560	489.99	14" 3-spoke Polished/Drilled - Flat	499-520	489.99
14" 3-spoke Polished/Drilled - Dished	499-590	489.99	14" 3-spoke Polished/Drilled - Dished	905-080	489.99
15" 3-spoke Polished/Drilled - Flat	499-540	489.99	15" 3-spoke Polished/Drilled - Flat	499-500	489.99
15" 3-spoke Polished/Drilled - Dished	499-595	489.99	15" 3-spoke Polished/Drilled - Dished	905-085	489.99
15" 3-spoke Polished/Teardrop - Flat	499-580	489.99			
15" 4-spoke Polished/Solid - Flat	454-245	649.99			

**Accessories**  
 Polished Ring Kit 905-635 \$43.99



**OE Style Solid Wood Steering Wheel**

Styled like the original, but crafted in rich solid wood. Includes hub and center cap.

1970-76 263-728 \$379.99  
 1977-80 263-758 379.99



**Steering Wheel Sun Covers**

We all know the pain of a scalding-hot steering wheel, so we created a solution: this heat-resistant steering wheel cover. The combination of quality vinyl and heat reflective materials keep your steering wheel cool to the touch while protecting it from sun damage. The simple slip-over design provides full protection while being compact and malleable for easy storage. Offered in two sizes, Large (17" and smaller wheels) and Small (15" and smaller wheels), and available in black, grey, and tan, this cover is designed to fit with any interior.

**Steering Wheels Up To 15"**

Black 009-123 \$59.99  
 Tan 009-124 59.99  
 Grey 009-125 59.99

**Steering Wheels Up To 17"**

Black 009-120 \$59.99  
 Tan 009-121 59.99  
 Grey 009-122 59.99



\*See ordering page for details

⚠ WARNING: Cancer and Reproductive Harm. www.P65Warnings.ca.gov





**TOURIST TROPHY®**

**Steering Wheels by Tourist Trophy**

Tourist Trophy offers a complete selection of wood and leather steering wheels for most British cars. Made to the highest standards, these use aluminum frames for lightweight strength. With options including wood, leather, spoke style, and several different widths, you can easily personalize the look and feel of your car's interior with these classic steering wheels. Because the wood is unique to every piece, final stain color and grain patterns may vary. Adapter hub sold separately.

**Solid Wood Rimmed Steering Wheels**

14" 3-spoke Matte/Drilled	489-095	\$359.99
15" 3-spoke Matte/Drilled	489-090	359.99

**Laminated Wood Rimmed Steering Wheels**

14" 3-spoke Matte/Drilled	489-070	\$359.99
15" 3-spoke Matte/Drilled	489-060	359.99
14" 3-spoke Matte/Slotted	489-085	359.99
15" 3-spoke Matte/Slotted	489-080	359.99

**Leather Rimmed Steering Wheels**

14" 3-spoke Black/Drilled	489-040	\$319.99
14" 3-spoke Matte/Drilled	489-030	319.99
15" 3-spoke Matte/Drilled	489-020	319.99
15" 3-spoke Black/Slotted	489-050	319.99



**MORE INFO ONLINE**

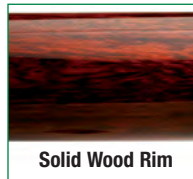

Solid Wood Rim



Laminated Wood Rim

**CHOOSE YOUR SIZE:**

14"	15"
<ul style="list-style-type: none"> <li>• More Thigh Room</li> <li>• Faster Response</li> </ul>	<ul style="list-style-type: none"> <li>• Easy Steering</li> <li>• Classic Look</li> </ul>



905-482

**Steering Wheel Adapter Hub Kits**

Complete kits include hub, horn push and emblem. For fitment of Tourist Trophy and Moto-Lita steering wheels. Comes with a 46 mm enamel emblem.

1962-67	454-366	\$149.99
1968-69	905-468	279.99
1970-76	905-482	159.99
1977-80	905-486	159.99
Repl. Horn Push Only	905-646	39.99
46 mm Enamel Emblem - MG Logo	905-696	20.99



**Wheelskins®**

**Leather Steering Wheel Cover by Wheelskins**

These premium-grade black leather covers are custom tailored to fit your wheel. Simple installation results in a quality factory-fitted appearance. Made in the USA.

Dia: 15"-16"; Grip: 2¾"-3⅝"	223-610	\$84.99
Dia: 16½"-17"; Grip: 2⅝"	222-310	84.99
Dia: 16½"-17"; Grip: 2½"	222-315	84.99
Dia: 16½"-17½"; Grip: 2¾"-3⅝"	223-620	84.99



**Billet Horn Push by Tourist Trophy**

Enjoy the precision feel and crisp appearance of this Billet Aluminum Horn Push Assembly. Engineered specifically for our Tourist Trophy and Moto-Lita Adapter Hubs, the Push Horn is machined from aircraft quality aluminum and comes with a 46 mm MG emblem.

Billet Horn Push with MG Logo	905-653	\$99.99
-------------------------------	---------	---------

Pricing is subject to change.

Please visit [MossMotors.com](http://MossMotors.com) for current pricing and availability.

INTERIOR



Beam's seat belts are made in the USA and exceed federal safety standards. Fire departments and amusement parks trust them, and we at Moss would not offer our customers anything less.



Hook Mount



Bolt Mount



Red



Tan



Black



Gray

### Vintage Style Seat Belts

Choose a safety measure in the color of your choice! Available in black, grey, red, and tan, our vintage style seat belts have high quality webbing with solid steel, chrome-plated, aircraft-style buckles, and are designed to complement your classic car. The substantial webbing length can be adjusted short or long for safe operation, so you can select the length that best meets your requirements. You can choose a 2-point seat belt that only goes across the lap, or get a 3-point seat belt that has a shoulder strap and goes across the lap and shoulder for added security. These seat belts are bolt-in for easy installation. All required mounting hardware and instructions are included. Sold individually.

#### Bolt Mount

	Black	Gray	Red	Tan	Price
2-Point Belt - Short (20" latch-plate end, 40" latch end)	222-234	222-051	222-053	222-054	\$36.99
2-Point Belt - Long (30" latch-plate end, 44" latch end)	222-235	222-056	222-058	222-059	36.99
3-Point Belt - Short (100" latch-plate end, 20" latch end)	222-204	222-041	222-043	222-044	59.99
3-Point Belt - Long (100" latch-plate end, 30" latch end)	222-205	222-046	222-048	222-049	59.99

#### Hook Mount

	Black	Gray	Red	Tan	Price
2-Point Belt - Short (20" latch-plate end, 40" latch end)	222-239	222-246	222-247	222-248	\$56.99
2-Point Belt - Long (30" latch-plate end, 44" latch end)	222-236	222-252	222-258	222-259	56.99
3-Point Belt - Short (100" latch-plate end, 20" latch end)	222-209	222-202	222-207	222-217	76.99
3-Point Belt - Long (100" latch-plate end, 30" latch end)	222-206	222-212	222-213	222-214	76.99



### Inertia Reel Seat Belt

Angle-sensitive belts are fussy, grabbing even if you're just parked on a hill. Inertia Reel Seat Belts grab when pulled rapidly - as they should. We have American-made inertia reel seatbelts, suitable for 1973 and later MGBs. Black with a stalk mounted receiver similar to that originally fitted. GTs need brackets, sold separately. Includes mounting hardware. Sold individually.

Black Seatbelt	222-025	\$149.99
Anchor Brackets for 1973-on GT, pair	222-158	43.99



### Direct Replacement Seat Belt Kit for 1973-80 MGB

This complete kit includes all the hardware to correctly and safely mount new retractable 3-point seat belts into the 1973-80 MGB Roadster or GT. This is not a generic kit, or replacement belt, but a properly engineered kit with correct mounting hardware for the car. This kit can be installed in earlier cars if the later weld-in captive nut plate is installed in the rear wheel well. GTs require additional brackets sold separately (Part#: 222-158).

1973-80 Belt Kit	222-030	\$299.99
Weld In Captive Nut Plate	222-185	39.99
Anchor Brackets for 1973-on GT - Pair	222-158	43.99
Emblem, MG - Each	905-696	20.99



### 3-point Inertia Reel Seat Belt

Strapping on a seat belt should be simple, but replacement inertia reel-belts for pre-1976 Sprites and Midgets had short receivers. If the seat was moved forward, buckling was a struggle. Our new belt - officially wife approved - has a correctly sized receiver for all drivers. Belts are sold individually and include mounting hardware. GTs need brackets, sold separately.

Black 3-point seatbelt	222-216	\$209.99
------------------------	---------	----------

### Standard Seat Belt

These seat belts have alloy steel mounting-hardware for strength and durability. Sold individually.

Standard Seat Belt	222-215	\$34.99
--------------------	---------	---------



\*See ordering page for details

⚠ WARNING: Cancer and Reproductive Harm. www.P65Warnings.ca.gov







**Vintage Competition Belt**

Quick release buckle with mounting hardware. Sold individually.

Competition Belt - Tan Buckle Pad	222-211	\$169.99
Competition Belt - Black Buckle Pad	222-221	169.99



**Seat Belt Guide**

This clever guide keeps your seat belt strap properly positioned over your shoulder instead of chafing against your neck or slipping down the seat, eliminating twisted and tangled seat belt. It is made of tough but flexible black UV-resistant plastic. Install it by removing your head rest and simply sliding it on for a friction fit, no tools required. The guide can also be modified for snap-on installation if your head rest is frozen. Fits all single-post headrests. Sold by the pair.

Seat Belt Guide	222-198	\$36.99
-----------------	---------	---------

**Seat Belt Mounting Bolt with Locking Button**

Most of these buttons failed years ago and owners have had to rig alternate belts or risk the belt coming loose in a rear end collision. Don't sacrifice safety for the lack of this part! If yours are broken or missing, replace them now with this easy to install kit. Sold as a pair.

Pair	222-189	\$79.99
------	---------	---------



220-386 & 220-387 On Car

**Seat Rail Fire Extinguisher Bracket and Quick-Release Mount**

A fire extinguisher is a necessity for any British car owner. Having it both stationary and close at hand is critical. A lot of damage can occur in the time it takes you to retrieve it from the trunk, or fish it out from beneath the seat. Mounting your extinguisher to the front of the passenger seat rail frame keeps it secure, visible and accessible, while at the same time tucked conveniently out of the way.

The Fire Extinguisher Seat Rail Bracket Set was designed to accept most fire extinguisher manufacturer metal brackets or the Quick-Release Mount. Premium hardware, L-Brackets and a purpose-made center bracket, allow for adjustments in both height and lateral positions. Installation instructions are included.

The Quick-Release Fire Extinguisher Mount attaches readily to the seat rail bracket, or will bolt to any flat surface. It is machined from billet aluminum, and has been anodized black. The quick-release mount uses a stainless steel lock pin (5 lbs release) with a red lanyard for better visibility and grabbing. The mount will accept extinguishers ranging from 2 5/8" to 3 1/4" in diameter. Installation instructions are included.

Chrome Fire Extinguisher - HalGuard	220-383	\$319.99
Fire Extinguisher Seat Bracket	220-386	69.99
Fire Extinguisher Quick-Release Mount	220-387	64.99



*RetroBelt*

**Seat Belts by RetroBelt**

These RetroBelt original equipment-style lap belts come with chrome push-button buckles that feature a starburst design and webbing color-matched to its stitching. Available as a standard belt or with an inertia locking retractor, these meet or exceed Federal Motor Vehicle Safety standards. Priced individually, an economical solution to your seat belt needs.

<b>Retractable Belts</b>		
2-point, 12" - Black	009-133	\$59.99
2-point, 20" - Black	009-134	59.99
2-point, 12" - Tan	009-137	59.99
2-point, 20" - Tan	009-138	59.99
<b>Standard Belts</b>		
2-point, Short - Black	009-127	\$34.99
2-point, Long - Black	009-128	34.99
2-point, Short - Tan	009-131	34.99
2-point, Long - Tan	009-132	34.99



**Shoulder Belt Lock Button**

This is the long-unavailable button which locks/releases the shoulder strap to its rear fastening point on 1968-71 cars. Most of these buttons failed years ago and owners have had to rig alternate belts or risk the belt coming loose in a rear end collision. Don't sacrifice safety, if yours are broken or missing, replace them. These buttons are detailed reproductions of the originals. They are properly injection molded here in the USA of durable nylon, and will last for years to come. Sold individually.



1968-71 Roadster, each	222-187	\$29.99
------------------------	---------	---------



**1972-80 Burlwood Look Dash Kits**

These authentic-looking trim kits add warmth and beauty to your car's interior. Our multiple piece sets install easily and the advanced adhesive backing and UV-resistant finish ensures it'll look good for years to come.

1972-76 Dash Kit	453-831	\$279.99
1977-80 Dash Kit	453-841	299.99



**1962-67 Walnut Dash**

Upgrade your early MGB interior with the elegant look of walnut veneer. Steel backing provides lasting strength. Mounts directly to the original dash surface. Made in England.

1962-67 Dash Kit	233-611	\$499.99
------------------	---------	----------



**Smiths Classic Digital Gauges**

Bring modern technology into your much loved classic car with the brand new Smiths Classic digital gauges. Operating at 12 volts, these digital gauges measure either 100 mm (4 in) or 80 mm (3.15") in diameter, and feature a polished chrome bezel with black gauge face and white lettering. For Negative earth vehicles only.

The tachometer shows a range of 0-7000 rpm, and the speedometer shows a range of 0-140 mph or 0-240 kph with digital odometer/trip readout.

Includes Gauge, Gauge loom (plug for gauge and push button for screen), Gauge fitting bracket and Installation instructions.

*Note: If your car does not have an electronic speedo output, our speedo sensor kit (#440-606) will allow gauge installation.*

<b>Speedometer</b>		
MPH - 100 mm	440-600	\$459.99
MPH - 80 mm	440-601	459.99
KPH - 100 mm	440-602	459.99
KPH - 80 mm	440-603	459.99
Digital Speed Sensor	440-606	129.99
<b>Tachometer</b>		
100 mm	440-604	\$299.99
80 mm	440-605	299.99



**Oil Pressure/Water Temperature Gauge**

This genuine Smith's combination gauge is a direct replacement for the obsolete originals. Gauge has black face with white lettering and needles, and a 82" capillary tube. Fits MGB 1962-67, roadster to 138400 and GT to 139470. Lettering and scales may differ from the instrument in your car.

1962-67	361-761	\$279.99
---------	---------	----------

**Dash Top Pad Covers**

Revitalize your old cracked dash top pad with this molded ABS cover. Comes complete with adhesive and instructions.

1968-71	453-890	\$144.99	OS
1972-76	453-895	144.99	OS
1977-80	453-905	144.99	OS

**Solid State Voltage Stabilizers**

The original Smiths voltage stabilizer is a mechanical device that over time fails for a variety of reasons. We have developed a replacement voltage stabilizer that combines modern electronics inside a vintage style housing.

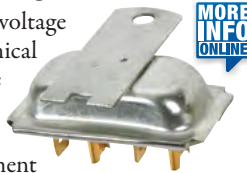

Negative Ground	131-555	\$18.99
Positive Ground	131-556	18.99

**OEM Style Cigarette Lighter**

To replace a defective original, or add an electrical outlet to earlier cars. This kit includes a complete illuminated lighter assembly as fitted to many British cars.



Cigarette Lighter Kit	142-270	\$13.99
Underdash Bracket	142-271	10.99



**LED Dash Bulb**

Bright white LED dash bulbs replace and better illuminate your gauges than the standard incandescent bulb (#171000). LEDs burn cooler and last much longer! They are not dimmable and should not be used as turn signal indicators or for the red generator/alternator light on the dash. Sold individually.

Negative Ground	170-972	\$4.99
Negative Ground - Short Profile	170-971	9.99
Positive Ground	170-975	9.99
Positive Ground - Short Profile	170-973	9.99
Wedge Type - Positive or Negative	170-976	3.99
Wedge Type - Positive or Negative - Short Profile	170-977	3.99

**Festoon Style LED Interior Bulb**

Our LED festoon style interior bulbs illuminate your interior with bright white light. LEDs are more efficient than standard incandescent bulbs, burning cooler and lasting longer. This bulb replaces the standard festoon style incandescent bulb (#170-010). It is directional, so it must be properly aligned in sockets. Positive and negative ground. Sold individually.



Festoon Style LED Interior Bulb	170-996	\$11.99
---------------------------------	---------	---------





### Chrome Door Pull and Window Winder

While standard pulls and winders are bound to break with normal use, these metal alternatives to the original plastic components are made to last. Sold individually. Order hardware separately.

1962-71 Door Pull	803-440	\$16.99
Door Pull Screw - each	323-080	1.59
1968-80 Winder	472-555	15.49
Winder Screw - chrome - each	472-535	0.89
Winder Spacer - chrome - each	472-530	5.99

### Redesigned Map Pocket

Made of black ABS plastic - just like the center console - our map pockets are far more durable than the fiberboard the factory used. The new design is more functional than the original and can be screwed either into the kick panel or the door. This storage solution can be painted or covered in carpet or vinyl to match your interior panels. Available for both passenger and driver sides.

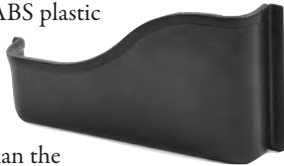

Map Pocket, LH	389-105	\$39.99
Map Pocket, RH	389-110	39.99

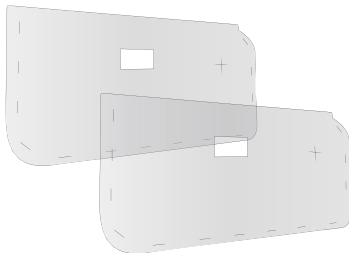

### Door Panel Moisture Barrier

Over time, slight amounts of moisture inevitably seep in and around the seals of your door. If left unchecked, this moisture will work its way into the wood or particulate of your interior door panels, resulting in warpage or worse. Protect your interior door panels with these pre-cut, easily-installed moisture barriers that help interrupt that process and promote the longevity of your door panels. Will require silicone adhesive. Sold as a pair.

1968-80	643-135	\$34.99
---------	---------	---------



### Door Sill Plates

If you're an MG enthusiast, then you wouldn't want a dirty and rusty trim plate to be the first thing you see as you get in. These polished stainless steel plates are durable, and will protect your door sills from scuffs and scratches. Easy to install. Set of two.

Polished Stainless	240-630	\$38.99
--------------------	---------	---------



### Door Insulation Kit by Hushmat

The Hushmat ULTRA Door Kit contains 10 easily positioned 12" x 12" sheets. These Butyl damping pads reduce road noise and vibration, creating a solid and quieter environment. It will also allow you to stay warmer in the winter and cooler in the summer by reducing thermal transfer by over 40% when compared to other products. This material is less than 1/8" thick and weighs in at just 0.47 pounds per square foot, making it both light weight and super flexible. It trims easily with just a standard razor knife or household scissors making installation a snap. Simply peel off and stick. Manufactured only in the USA.

Hushmat ULTRA Door Kit	409-009	\$104.99
------------------------	---------	----------



### Velour Door Seals

Originally fitted to early cars, this velour material door seal is a more luxurious option for later cars. It features a steel wire core that clamps securely, and a correctly sized bulb to ease installation and improve sealing. Sold by the yard.

#### Lengths needed:

- MGB Roadster - 4 yards
- MGB GT - 7 yards
- MGB GT quarter window - 4 yards"

Black Furflex Seal	249-607	\$12.99
--------------------	---------	---------

### Billet Aluminum Cup Holder

These billet aluminum cup holders are specially designed to provide convenient and safe beverage storage for MGB and MGC owners. They can be securely mounted to any seat rail and their clever design allows four out-of-the-way placement options. Crafted from high quality aluminum billet, they look great and offer a more stable platform than any plastic alternative. The beverage opening measures 3" in diameter and has a machined recess to accommodate various sized containers and their handles. Available in a natural aluminum or black anodized finish.



Black	231-296	\$44.99
Natural	231-297	39.99



### Rubber Console Liner

Give your console the complete treatment with this soft rubber pad liner that protects the recessed screw holes and is easily removable for a fuss-free cleanup.

1972-on	453-754	\$14.99
---------	---------	---------



### MGB Console Coin Dish

Molded plastic tray replaces ashtray in 1972-80 MGB. Convenient for coins and small items.

Console Coin Dish	900-065	\$9.99
-------------------	---------	--------



Leather Upholstered Plain

### Center Console

Most existing consoles sit too low to be used as an armrest. Our ergonomic version not only looks great, but the taller height makes it supremely comfortable. Easily installed or removed, it will slip right between the seats of most classic cars where the cushions often provide sufficient grip. (Four small tabs are available for a more permanent installation.) Chose between textured plastic or premium leather. Available in multiple colors to best suit your car. Includes a stainless-steel cup holder and a power outlet for GPS or USB charging. Application specific.

*Note: Cup holder opening is 25/8" and is suited to cans and standard water or soda bottles. We recommend having the power outlet professionally installed. Instructions not included.*

Plain	453-965	\$99.99
Leather Upholstered - Black	453-966	189.99
Leather Upholstered - Red	453-967	189.99
Leather Upholstered - Tan	453-968	189.99
Leather Upholstered - Honey Tan	453-969	189.99

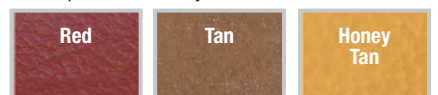

Pricing is subject to change.

Please visit [MossMotors.com](http://MossMotors.com) for current pricing and availability.

**Original Ashtray**

Whether it's holding the ashes of your favorite vice or change for the parking meter, the original Wilmot Breeden is one handy tray. The chrome-plated lid has the original distinctive grooves and, for ease of cleaning, the zinc-plated steel insert is removable. The black steel base is secured to the transmission tunnel with two screws, such as #323-360 (not included).



Original Ashtray 241-000 \$82.99



**Console Cup Holder**

Enhance your MGB with this truly custom cup holder! This is not your usual generic cup holder; this is custom molded to fit the trapezoidal-shaped area just in front of the shifter, and looks like original equipment. Made from black, textured ABS just like the console it sits on, it fits two beverages - from small cups and cans to medium-sized bottles and mugs. No fasteners are necessary, simply set in place, and it is trapped in position. Removal is just as simple.

Console Cup Holder 1972-80 453-756 \$38.99



**Center Console and Armrest**

Add some comfort and convenience to your MGB. A black grained ABS thermoplastic base with a leather-covered armrest, this center console and armrest is similar to Amco's aftermarket consoles, and provides ample storage under the armrest pad, as well as a cup holder in the forward position.

MGB/MGC 1962-71 453-800 \$174.99



**Round Billet Shift Knob by A.R.E.**

Accessorize your classic car with a brand new shift knob by A.R.E. Made from solid billet aluminum, the shift knob gives you a sturdy feel when changing gears. Sporting a brushed silver look and classic diamond knurling around the center, this 2" spherical knob comes highly recommended for every classic car enthusiast. It is threaded inside, so all you need to do to install it, is just screw it on! Available at a pocket friendly price, try out this brand new shift knob! Application specific.

MGB 1962-67 234-305 \$39.99  
MGB 1968-76 234-310 39.99

cut away detail



**Shift Knobs**

You're not going to throw any random knob on your shifter. Yours will be a natural fit for you and your car. Our gearshift knob is just the right size and feel, and comes topped with a medallion displaying the MG logo. Get yours in elegant walnut wood or trimmed in black leather.

**Wood Crested**

MGB 1963-76 234-010 \$39.99  
MGB 1977-80 234-030 39.99

**Leather Crested**

MGB 1963-76 234-015 \$39.99  
MGB 1977-80 234-035 39.99

**1962-67 Gas Pedal Extensions**

Specifically designed to aid heel and toe shifting. Installation takes hand tools.

Paddy Hopkirk Pedal Extension 900-315 \$32.99  
117-745 13.59



**MGB Dead Pedal by Ceres Motorsports**

Now offering your MGB the advantage of a dead pedal kit by Ceres Motorsports. With its lightweight and compact design, the dead pedal gives you the comfort of resting your foot in a place without it being in the way of the clutch pedal. Made from aluminum, the dead pedal weighs approximately 5 oz when assembled. It has a durable black splatter paint finish. The brush aluminum face is pre-attached to the painted body using stainless steel allen head countersunk screws. Sturdy and functional buy. Made in the USA. Includes hardware and installation instructions.



*Note: Fits all MGBs without a floor mounted dipswitch.*

MGB Dead Pedal 190-745 \$124.99

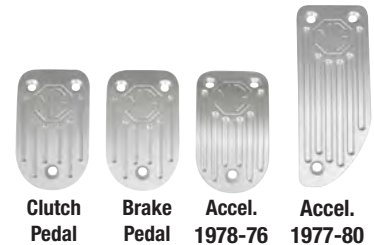

**Billet Pedal Cover Kits**

Serious pedal covers for serious drivers. These covers are grooved for traction and feature the bold MG logo. Drilling is required as these custom fit covers are bolted to the original pedals to ensure they stay put no matter how hard you drive. Each of the three-piece kits has the correct accelerator pedal cover for the model. The two-piece set will fit all MGBs.

3 Piece Kit 1968-76 190-780 \$89.99  
3 Piece Kit 1977-80 190-785 89.99  
2 Piece Kit (Clutch, Brake) 190-790 69.99



**Heel Guards**

Offer your classic car's pedal area a nice finishing touch with this highly functional heel pad. This billet heel pad will keep you from wearing a hole in your mats while providing good footing for shifting. Dimensions: 10 1/2" x 6 1/2".

MG Logo 190-755 \$89.99  
MGB Logo 190-756 89.99



\*See ordering page for details

⚠ WARNING: Cancer and Reproductive Harm. www.P65Warnings.ca.gov



### Floor Mat Buyers Guide:

Floor mats are intended to preserve and protect the carpet beneath them. Some MGB owners will choose our high quality Amco-Style Rubber Floor Mats knowing their paths cross dirt enough to warrant the protection. Others, looking for the clean finished look of our Plush Embroidered Floor Mats, while others still seek the ultimate in comfort and attention to detail, and will treat their floors and their feet to Ultra Plush Embroidered Floor Mats. The difference in quality between Ultra Plush Embroidered Floor Mats and any other of our offerings is quite significant, not only for its luxurious feel and durability, but also for sound insulation.



### Ultra-Plush Embroidered Floor Mats

Step onto comfort with these ultra-dense plush carpet sets with non-slip rubber backing. Custom tailored for a perfect fit, these black mats feature a 3½" embroidered logo of your favorite classic car. Set of two. Black.

1962-67	240-720	\$219.99
1968-80	240-730	219.99



### Plush Embroidered Floor Mats

Custom tailored plush embroidered mats look great, fit perfect and come at a great price! Edges are bound for a tidy look. Rubber-nibbed backing keeps the mats in place. MG logo embroidery is 3½" in diameter. Set of two. Black.

1962-67	240-721	\$94.99
1968-80	240-731	94.99



### Amco-Style Rubber Floor Mats

Protect your carpets from dirt, wear and fading. If mats get dirty, hose them down and return them to the car. Set of two. Black only.

1962-67	241-840	\$36.99
1968-80	241-850	36.99



### Floor & Tunnel Shield by DEI

Designed to provide the best possible heat protection in areas where high temperatures are present and problematic, the Floor & Tunnel Shield II limits heat transfer on firewalls, transmission tunnels, floor boards, fuel cells and other areas where heat is an issue. It provides excellent light weight thermal protection, acts as a guard against track and road debris, and provides sound deadening.

Constructed with an embossed 10 mil aluminum face bonded to ½" composite glass-fiber core and backed with a high temp super strong pressure sensitive backing, it withstands up to 1750 F of direct continuous heat. Its improved multifaceted modern aluminum surface offers improved reflectivity, rigidity and allows for ease of installation. At only ⅜" thick, this product can be shaped and trimmed for a custom fit and is ideal for minimal clearance areas.

10" x 10"	231-904	\$23.79
24" x 21"	231-901	59.99
48" x 21"	231-902	119.99
48" x 42"	231-903	235.99



### Footwell Light Kit

Illuminating the footwell area of your car for entering and exiting makes the transition much safer. Can be wired to any 12V source. Kit includes two lights, wiring and instructions.

Footwell Light Kit	903-651	\$44.99
--------------------	---------	---------



240-755



240-760



240-765

### Ultra-Plush Trunk and Shelf Mats with Logo

These premium trunk and shelf mats in black carpet feature an embroidered MGB octagon logo. Sturdily constructed from high-quality carpet, these mats will finish off your MGB, and stand up to pretty much everything you throw at them. Trunk mat (#240-755) will require the use of the wheel clamp (#386-095).

Trunk Mat with Spare Tire	240-755	\$199.99
Trunk Mat without Spare Tire	240-760	199.99
Shelf Mat	240-765	179.99

Pricing is subject to change.

Please visit [MossMotors.com](http://MossMotors.com) for current pricing and availability.

INTERIOR



**COBALT**  
PRECISION AUTOMOTIVE

**Folding Windblocker by Cobalt**

High-quality aluminum-framed mesh wind blocker with a Moss-designed bracket set. The wind blocker folds down when not in use, and has about 1½" of vertical adjustment for a perfect fit. The brackets fit under the top frame or tonneau brackets, and installation takes just about half an hour.

Mesh Windblocker 458-328 \$469.99

**Custom Sound and Heat Insulation Kits by Hushmat**

HushMat sound deadening & thermal insulation material leads the automotive industry in performance and ease of installation. Packaged specifically for your MGB Roadster to provide 100% insulation coverage. No holes in the material - no puzzle pieces to put together - simply apply the HushMat Ultra material, as shown in the Installation Guides. Kits available for your Firewall, Doors, Floorpan, Trunk Floor or Complete Vehicle. Reduce road noise, exhaust noise and insulate your vehicle. Superior performance and adhesion is guaranteed.

Complete Vehicle Kit	409-200	\$679.99	Door Kit	409-215	104.99
Trunk Kit	409-220	349.99	Firewall Kit	409-210	104.99
Floorpan Kit	409-205	369.99			

MORE INFO ONLINE

**HushMat**

- Complete Kit ■
- Trunk Kit ■
- Floor Pan Kit ■
- Door Kit ■
- Firewall Kit ■

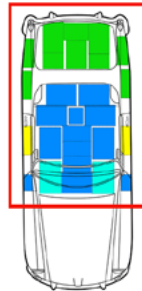

**Windblocker**

Cut down on wind noise, buffeting, and fatigue on long trips. Installs easily.

Windblocker 458-290 \$269.99 OS

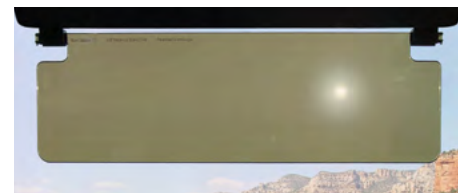

**Glare Shield**

The glare shield attaches to any vehicle visor in just seconds. It offers protection for either driver or passenger and doesn't obstruct the view of the road ahead like solid visors can. The glare shield conveniently fits on all vehicle visors, folds up and away on top of your visor when not in use, and can easily be removed for cleaning. Designed for safety, it is lightweight, smooth-edged, and shatterproof.

Glare Shield 225-755 \$21.99

**Sound and Heat Control Insulation**

Install on doors, floors, and firewall. This insulation consists of an 80 mil thick butyl rubber-core covered with a 2.4 mil aluminum coating. It deadens body panel vibrations and reduces heat transfer. The kit contains nine 29" x 20" sheets (36 sq ft).

Insulation 409-027 \$159.99 OS



**Heatshield Material**

This foil-covered insulation reduces unwanted heat, cold, and sound inside your vehicle when installed under carpets, over the transmission tunnel, and against the firewall. The closed-cell insulating material has a layer of foil on both sides and will not absorb moisture like its jute or cotton counterparts. Lightweight and easily managed, it is sold in 4' x 6' sheets which can be cut to fit.

Heat Shield Material 409-016 \$41.99 OS  
Heat Shield Adhesive - 12 fl oz 409-037 28.99



MORE INFO ONLINE

**HushMat**

**Hoodliner Insulation by Hushmat**

HushMat Ultra II Hoodliner Kit is a pressure-sensitive, constrained-layer damper that effectively treats excessive noise and temperatures within your vehicle. With its self-adhesive "peel and stick" backing, it installs easily to most substrates, and can be easily cut with a utility knife or household scissors. The kit contains six 12" x 23" pieces (11.46 sq ft).

Hoodliner Insulation 409-007 \$144.99



**HushMat**

**Interior Insulation by Hushmat**

Hushmat is easy-to-install insulation that reduces heat transfer into the cabin by 40%. The kit contains instructions for MGB and TR2-3A, but the pieces are generic, and can be cut to fit all British cars. The insulation sticks firmly, and what a difference it makes. After trying it, we found our car was significantly cooler and a lot quieter too! Includes eight 12" x 23" pieces.

Interior Insulation 409-013 \$169.99



\*See ordering page for details

⚠ WARNING: Cancer and Reproductive Harm. www.P65Warnings.ca.gov





**Key Blank**

Original keys are extremely rare and should be preserved, which is why we brought you these customizable key blanks. Replace your old worn-out keys or use as a spare set, these original-style blank ignition keys must be cut locally. Order by the series number of your original locks.

	<b>Crested</b>	<b>Non-Crested</b>	<b>BL Style</b>
MRN Series	163-310	163-510	-
FA Series	163-320	163-535	-
FS Series	163-330	163-545	-
FP Series	163-340	163-550	-
AA Series	163-370	-	163-375
MG Series	-	-	163-365
RV Series	163-380	-	163-355
WS Series	-	-	163-345
BL Series	-	-	163-335



**Drink Holder**

Add this practical drink holder to your car. With a wide 3¼" diameter opening, it will receive almost any cup and hold it securely. Sturdily constructed and flocked in Charcoal Grey material, it is sure to complement your interior! To use it, just secure it in place by sliding the edge under a floor mat.

Large Drink Holder	100-785	\$39.99
--------------------	---------	---------



**Expandable Cup Holder**

Our expandable cup holder mounts nearly anywhere. The arms adjust in or out to hold your container securely. Easily folds up when not in use.

Black	222-090	\$16.99
-------	---------	---------

**Chrome Halon Fire Extinguisher**

Every classic car should have an affordable onboard insurance policy in the form of a functional fire extinguisher. Carrying one is just common sense. Halon is an extremely effective fire suppressant that causes the least amount of residual damage and is safe for human exposure. Our compact 10" chrome extinguisher can be easily mounted to many surfaces with the included bracket.

Extinguisher

220-383

\$319.99



**Quick-Lift Battery Cover**

Get easy access to your battery with this Quick-Lift Battery Cover, no tools necessary! Made in the USA with stainless steel quarter fasteners, this cover is both handy and durable. E-coated with a glossy black finish, this cover replaces your existing battery cover with improved quality and convenience.



1974½-80	456-277	\$89.99
----------	---------	---------



**Battery Boxes**

Restoring your classic car is now easier with these new battery cages. Previously unavailable, we are happy to offer these high-quality aftermarket replacements. Please check our schematic pages to see the complete listing of interior body panels.

MGB w/6 Volt Batteries	456-271	\$149.99
MGB w/12 Volt Battery	456-272	169.99



**B-Pillar Repair Kit**

The captive nuts on the MGB's B-pillar which secure the convertible top or tonneau cover mounts, often fall off. Our design team created a B-pillar repair kit that resolves this problem. The kit includes a screw, a set of instructions, and the repair plate.

B-Pillar Repair Kit	472-328	\$21.99
---------------------	---------	---------

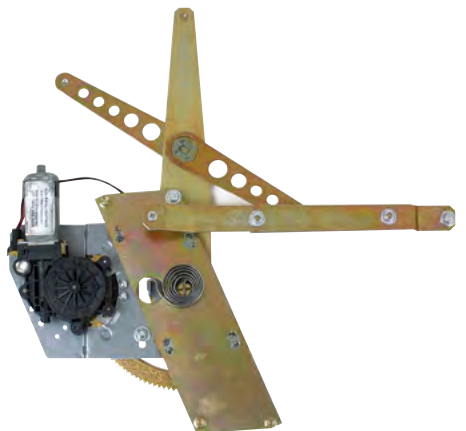

**Power Windows**

Replace the entire window winder mechanism with our complete power windows kit which includes switch pods, wiring harness, electric motor and mechanism, and features full instructions with all needed templates.

1968-80	299-000	\$529.99
---------	---------	----------



**Robbins Material Guide**

	Crush Grain Vinyl (Similar to Original)	English Vinyl (Everflex)	Stayfast Cloth (Luxury Look)
<b>Material</b>	The best American vinyl tops we've seen, period. By using Haartz Supreme 36-oz. pinpoint-grain vinyl (backed with pre-shrunk cotton cloth), you get a superior product. For greater durability and to ensure the seams remain water tight, seams are stitched, then electronically sealed.	If you want your top to be as close to original as you can get, this is the only material to consider. Made in England and imported by Robbins, this material is accepted as original.	Stayfast fabric uses 100% acrylic surface cloth, laminated to a pre-shrunk cotton backing cloth. Stayfast is engineered for high tensile and tear strength, but the fabric stays soft, supple and color-fast. Stayfast canvas resists fading and shrinking better than vinyl and does not stiffen up at lower temperatures.
<b>Window</b>	The 40-gauge rear window is made from Regalite B.U.V. Ultralight plastic, which offers superior resistance to UV rays & scratches.		
<b>Warranty</b>	Full 72 months on material and craftsmanship. 18 month warranty on labor when professionally installed.	Full 12 months on material and craftsmanship. 12 month warranty on labor when professionally installed	Full 72 months on material and craftsmanship. 18 month warranty on labor when professionally installed.

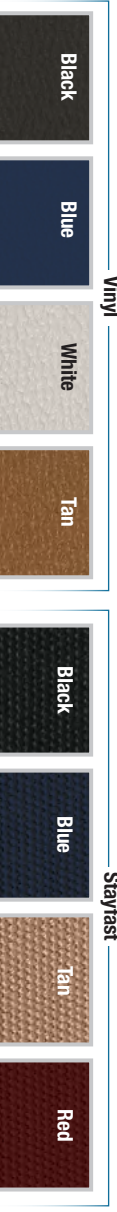

**Top Frame Identification Guide**

The top frame is the key to purchasing the correct top for your MGB. Many of the top frames are interchangeable, and many times the previous owners have changed them out, much to the surprise and chagrin of the current owner. Never assume your top frame is original.

**1962-Early 63 Grey Scissor Folding Frame**

The first type of Grey Scissor Bows is very rare, as they were replaced by a better design after only a few months of production. They can be identified by the main support pivot point being about 2" above the cowl. Because of its rarity, there is a limited selection of tops available and it may be difficult to get a perfect fit.

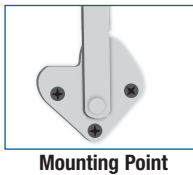

Mounting Point

1962-Early '63 Scissor Frame      406-270      NA

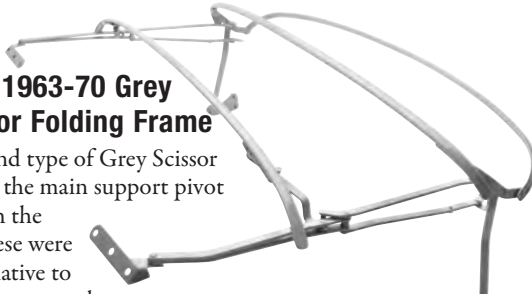

**Later 1963-70 Grey Scissor Folding Frame**

The second type of Grey Scissor Bows has the main support pivot flush with the cowl. These were the alternative to the more commonly fitted removable bow set. Parts and new bow sets of this design are not available, and many people upgrade to the later, and easier to use, Black Folding Frame design bows. Tops for grey fold-back bows were never fitted with zip out rear windows.

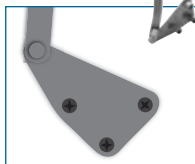

Mounting Point

1963-70 Scissor Frame      406-280      \$469.99 **OS**

**1962-70 Grey Stow-Away Frame**

This bow set was supplied originally from 1962 through 1970 and fits into the same sockets used for the tonneau bar. When removed, the top frame is stored in a padded bag alongside the folded top in the boot of the car. When the weather is clear, the top can be left at home, increasing storage space in the car.

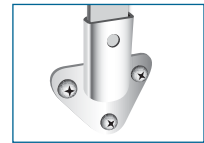
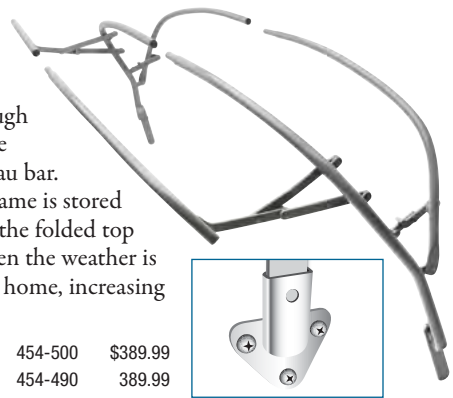

Mounting Point

1962-70 Stow-Away Frame - LH      454-500      \$389.99  
 1962-70 Stow-Away Frame - RH      454-490      389.99

**1971-80 Black Folding Frame**

From 1971 through the end of production a third design of black-painted fold-back bows were fitted. These are easier to fold, offer a lower, more aerodynamic profile and the tops came with zip-out windows as original from 1977. Since this is the most popular frame, there are more choices available in tops.

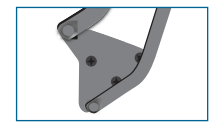
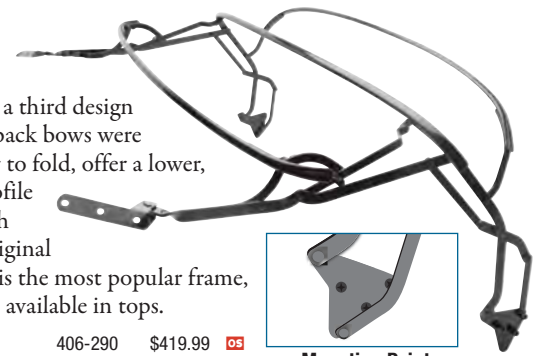

Mounting Point

1971-80 Folding Frame      406-290      \$419.99 **OS**

**Tonneau Covers**

Protect your interior with our wide range of high quality tonneaus, available in Stayfast cloth or vinyl. Applications listed are LHD, but RHD versions may be special ordered. All snaps are included and require installation to match the fittings on your car.



	headrest pockets	Stayfast Cloth			Vinyl					
		Black	Tan	Price	Black	Price	Tan	Price	White	Price
1962-67		646-241	241-451 <sup>1</sup>	\$939.99 <b>OS</b>	646-240	\$399.99	646-242	\$599.99	241-450	\$489.99
1968-69		241-444 <sup>1</sup>	241-454 <sup>1</sup>	939.99 <b>OS</b>	241-443	499.99	241-447 <sup>1</sup>	499.99	241-453	499.99
1969	✓	-	-		241-460	519.99	241-461 <sup>1</sup>	519.99	241-455	479.99
1970-80		241-675	241-676 <sup>1</sup>	499.99	241-665	319.99	241-448 <sup>1</sup>	479.99	241-470	519.99
1970-80	✓	241-670	241-671	569.99	241-660	379.99	241-468	499.99	241-475	499.99

<sup>1</sup>Special order, allow 6-10 weeks for delivery.



\*See ordering page for details

⚠ WARNING: Cancer and Reproductive Harm. www.P65Warnings.ca.gov





## Convertible Tops

Choose from a wide range of tops for your MGB. Over the years, the MGB was equipped with four designs of top bows. The early cars came with either the stow-away top, or a grey folding frame that scissored toward the center of the car. The 1971-80 cars were equipped with an improved black-painted folding bow set. All of the frame sets are interchangeable, and we offer a selection of tops to match your frame.



**NOTE: ALL TOPS ON THIS PAGE INCLUDE FRONT CORNER SNAPS, BUT THEY ARE NOT INSTALLED SO YOU CAN ACHIEVE A PERFECT FIT.**

Fixed Window  
Zippered Window



### Stayfast Cloth



### Everflex



### Vinyl

		Black	Blue	Tan	Red	Price	Black	Blue	Tan	White	Price	Black	Tan	White	Price
1962-Early 63 Grey Scissor Folding Frame	✓	-	-	-	-		242-632 <sup>1</sup>	-	-	-	\$879.99	242-630	-	-	\$599.99
Late 1963-70 Grey Scissor Folding Frame	✓	242-675	242-677 <sup>1</sup>	242-678 <sup>1</sup>	242-676 <sup>1</sup>	\$1,049.00	242-642 <sup>1</sup>	242-644 <sup>1</sup>	242-643 <sup>1</sup>	-	919.99	242-640	-	242-670	599.99
Late 1963-70 Grey Scissor Folding Frame	✓	243-390	243-392 <sup>1</sup>	243-391 <sup>1</sup>	243-393 <sup>1</sup>	1,249.00	243-380	-	243-381 <sup>1</sup>	-	1,049.00	243-370	243-371	243-372 <sup>1</sup>	749.99
1962-70 Stow-Away Frame	✓	242-668	-	242-669 <sup>1</sup>	-	1,049.00	242-652 <sup>1</sup>	-	-	-	919.99	242-650	242-280	242-680	619.99
1962-70 Stow-Away Frame	✓	242-990	-	242-995	-	1,249.00	242-667 <sup>1</sup>	-	-	-	1,049.00	242-665	-	-	749.99
1971-80 Folding Frame	✓	242-681	242-683 <sup>1</sup>	242-684	242-682 <sup>1</sup>	1,049.00	242-647	242-649 <sup>1</sup>	242-648	-	929.99	242-645	-	242-690	629.99
1971-80 Folding Frame	✓	242-740	242-742 <sup>1</sup>	242-745	242-741 <sup>1</sup>	1,049.00	242-657	-	242-658	-	999.99	242-655	242-295	242-695	649.99

<sup>1</sup>Special order, allow 6-10 weeks for delivery.



## Cabriolet Tops

Deluxe UK-produced cabriolet tops borrow from the German style of padded tops with a full headliner. The thick insulation provides effective noise reduction while the light-colored headliner covers the top frame and brightens your interior. The cabriolet top has been carefully engineered to fold as easily as your original top, and it incorporates a zip-out rear window for added flexibility. Available in premium quality British dull coat vinyl, or extremely durable Stayfast solution dyed acrylic fabric. Headliners are an attractive light tan color.



	Black	Brown	Price
Stayfast Cloth	242-795	242-785	\$1,799.00
"Dull Cote" Vinyl	242-775	-	1,399.00

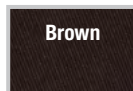

## Top Boots by Robbins

Match the top or the tonneau of your British car with Robbins top boots. These top boots look great and give a sleek appearance to your Classic. Available in your choice of durable Crush Grain Vinyl, original type British Everflex, or fade-resistant Stayfast Canvas. All hardware included. Boots do not have cut-outs for seat belts.

### 1971-80

	Black	Tan	White	Blue	Red	Price
Vinyl	241-486	241-487	241-488	-	-	\$399.99
Everflex	241-491	241-492	-	241-493	-	659.99
Stayfast Cloth	241-496	241-497	-	241-498	241-499	719.99

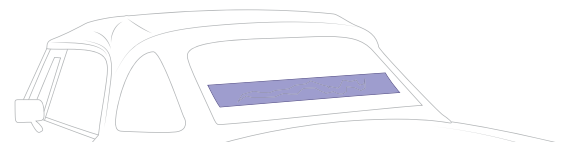

## Lamin-X Soft Top Window Repair Strip

Perfect repair solution to keep a cut or crack in the plastic window of your convertible top from getting worse! This 2" x 24" strip of 19 mil clear has 3.5 mils of adhesive that bonds to the clear plastic and creates a strong waterproof seal. This strip is transparent enough that you won't notice it at a distance. Instructions included.

Strip - 2" x 24" 910-475 \$14.79



Pricing is subject to change.  
Please visit [MossMotors.com](http://MossMotors.com) for current pricing and availability.

EXTERIOR

Features	STORMPROOF	SILVERGUARD PLUS	MOSOM PLUS	TRIGUARD
WATER RESISTANCE	◆◆◆◆	◆◆◆◆	◆◆◆◆	◆◆
BREATHABILITY	◆◆◆◆	◆◆	◆◆◆◆	◆◆◆◆
COMPACTNESS	◆◆◆◆	◆◆◆◆	◆◆	◆◆◆◆
UV RESISTANCE	◆◆◆◆	◆◆◆◆	◆◆◆◆	◆◆
HAZARDS	◆◆◆◆	◆◆◆◆	◆◆◆◆	◆◆
SOFTNESS	◆◆◆◆	◆◆◆◆	◆◆◆◆	◆◆◆◆

**Note:** Car covers are not intended for long term outdoor use. Periodically remove the car cover to inspect your vehicle. Not for use on vinyl wrapped vehicles. Liability is limited to the purchase price of the product and we will not be responsible for any other damage.

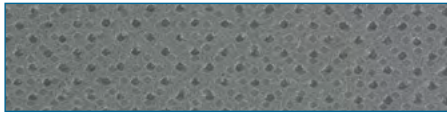

### Triguard

This practical and cost effective car-cover has a universal fit and can be used both indoors and outdoors to protect against dust and debris. The medium size will fit vehicles from 13' to 14'.

Triguard Car Cover                      236-446                      \$64.99



### Car Cover Accessories

Useful accessories for your car cover.

Stowage Bag	643-850	\$7.99
Cable Lock	643-855	7.99
Grommet	237-495	1.99



### Silverguard Plus

Silverguard Plus is a 300 Denier polyester material with a reflective, water-resistant coating on the outer layer and a soft, nonabrasive layer on the inside. It is a great choice for areas that get harsh sunlight. It is not suggested for extreme rain, snow, or ice. 300 Denier is a strong, heavy weave, which will not rip or tear easily. The silver coating does an excellent job of reflecting sunlight, therefore protecting your top, rubber seals, and interior from premature wear. The soft inner layer pampers the most delicate paint finish.

Roadster 1962-74	237-421	\$169.99
Roadster 1975-80	237-431	169.99
MGB GT	237-441	169.99



### Stormproof

The culmination of over a decade of material engineering, it has only recently been possible to manufacture the microscopic yarns which go into this advanced micro-fiber cover material. Only one textile mill in the world was able to meet the specification – the results are truly a triumph for car cover users! Our Stormproof cover is uncoated and untreated, therefore, even after months or years of use it will retain the same properties. Stormproof has been tested to be the most water-resistant and the most breathable car cover material you can buy. You can't go wrong with Stormproof!

*Note: We recommend that you take the cover off after rain or storm and allow the car to dry.*

Roadster 1962-74	237-625	\$279.99
Roadster 1975-80	237-626	279.99
MGB GT	237-627	279.99



### Mosom Plus

Mosom Plus is a four-layer material. The outer two layers are Spunbond Polypropylene, the middle layer is a special micro-porous film and the inside layer is extra soft fabric. The middle layer is an excellent rain barrier, which allows for vapors to pass through. The smooth cotton inner layer provides a delicate blanket for your vehicle, protecting the paint from debris and mild weather. It is a great choice for all-around car cover use, suggested for most conditions except extreme sun, snow or ice. Mosom Plus is a non-woven material, so in the unlikely event a rip occurs in the material, it will not run.

Roadster 1962-74	237-420	\$149.99
Roadster 1975-80	237-430	149.99
MGB GT	237-440	149.99



### Interior Cover

You don't have to raise the top or use your car cover to protect your seats and panels. Slip on an interior cover and protect your interior from sun damage and heat build-up. Saves your interior from cracking and fading.

Interior Cover                      237-900                      \$89.99



### Top-Up Cab Cover

Add a layer of UV and weather protection for your top while giving a bit of extra security from prying eyes. Easy to put on, this cab cover takes less trunk space than a full car cover.

Top-Up Cab Cover                      237-910                      \$89.99



\*See ordering page for details

⚠ WARNING: Cancer and Reproductive Harm. www.P65Warnings.ca.gov



**EXCLUSIVE**



**Rubber to Chrome Bumper Conversion Kit**

Our conversion kit makes it much easier for later cars to achieve that classic MGB look. Although still requiring welding and bodywork, this kit comes with everything you need to give your car some chrome appeal. Kit includes: front and rear steel fill panels, fabricated mounting brackets, front and rear bumper assemblies with overrides, front turn signal assemblies, front valance, hardware, and complete instructions. Does not include grille assembly.

Kit w/Chrome Overrides	453-878	\$1,499.00	
Kit w/Rubber-faced Overrides	453-888	1,499.00	



**Special Tuning Air Dam**

Get a sporty look with this fiberglass reproduction of the factory Special Tuning air dam. Specifically designed for chrome bumper MGBs, these special tuning air dams were used on race and rally cars.

Fiberglass Air Dam	475-195	\$229.99	
--------------------	---------	----------	--



**Front Fender Well Liners**

These popular UK accessories are perfect for the MGB daily driver. The molded plastic liners seal the inner front fender area, preventing salt, snow, and mud from attacking your bodywork. Installation is easy and fits all MGBs.

Fender Liners	457-415	\$99.99	
---------------	---------	---------	--



**MGB Sebring Front and Rear Valance Panels**

These are reproductions of the streamlining panels fitted to the works MGBs when they were raced at Sebring. The front and rear valance panels offer a smooth and clean appearance by filling the gaps after the bumpers have been removed. As with all aftermarket fiberglass body panels, fitting these properly requires a large amount of patience and skill.

Front Sebring Valance	475-185 <sup>1</sup>	\$259.99	
Rear Sebring Valance	475-190	299.99	

<sup>1</sup>Will not fit MGC without modification.



**Stainless Steel Rocker Cover Set**

Adds a touch of brightness and can be used to cover up scratches or non-structural corrosion. Screws to the body, drilling required.

Rocker Cover Set	458-228	\$329.99	
------------------	---------	----------	--



**Drip Gutter Moulding Kit**

This drip gutter moulding kit saves you from having to buy all the pieces separately. Features quality construction.

MGB GT 1965-76	472-728	\$599.99
----------------	---------	----------



**Fiberglass Rear Spoilers**

The ST style spoilers were developed by Leyland Special Tuning using a wind tunnel for works competition cars.

Leyland Special Tuning Style -			
MGB Roadster	475-198	\$179.99	
Tailgate Style - MGB GT	475-199	199.99	



**Sebring-Style Front Valance with Anti-Lift Lip**

Improve high-speed stability with this fiberglass front end valance that's based on the classic Sebring design. This valance adds a lip that significantly reduces front end lift and improves stability and steering at high speeds. Supplied unpainted. Like all fiberglass body panels this piece will require some skill and patience in fitting and finishing. Professional installation is recommended. Designed for a chrome bumper MGB. Can also be fitted to later cars if the rubber bumper assembly is removed.

Front Valance with Lip	475-187	\$599.99	
------------------------	---------	----------	--



**BL "Limited Edition" Spoiler**

Fitted by the factory to MGB "LE" models in 1980, this spoiler greatly improves the looks of all rubber bumper MGBs! Also adds a racy touch to chrome bumper MGBs. Mounts to existing valance.

BL Spoiler	475-180	\$259.99	
------------	---------	----------	--



**Door Handle Guards**

Polished stainless steel guards. Fit 1965-80. Door handles must be loosened to install. This requires removal of interior door panel.

*Note: Installation requires removal of the door cards and for the outside door handles to be loosened, so the guard can be slipped into place.*

Pair 228-745 \$19.99



**Cowl Vent Cover**

Die-cut magnetic sheet vinyl cover fits over your MGB's chrome cowl vent, keeping out water, debris, and cold air. Not designed for use while vehicle is in operation.

Cowl Vent Cover 215-315 \$14.99



TOURIST TROPHY®

**Chrome Locking Gas Cap with MG Logo by Tourist Trophy**

Thwart possible gas thieves and look great in the process! Add some security to your MGB with this beautifully chromed gas cap adorned with the MG logo. Using the best materials, this modern day gas cap is long lasting! The outside base is chromed stainless steel while the swiveling MG emblem is cast from Zinc-Aluminum for superb chrome adhesion and shine. This cap has been tested in a mixture of 75% gasoline and 25% methanol to ensure compatibility with all fuels. Supplied with 2 keys.

MGB 1970-74 & 1976-80 202-780 \$159.99



**Decal and Plate Kits**

Finish off your restoration with one of these decal/sticker & plate sets. Every kit is application specific and contains an assortment of stickers. Mounting hardware not included.

**MGB Roadster 1962-65 (shown)** – Includes chassis and body number plates; and decals for the screen washer reservoir, valve cover, trip odometer, convertible top, heater, and air filter.

**MGB Roadster 1965-67** - Includes chassis and body number plates; and decals for the screen washer reservoir, valve cover, trip odometer, convertible top, oil filter head, heater, and air filter.

**MGB GT 1965-67** - Includes chassis and body number plates; and decals for the screen washer reservoir, valve cover, trip odometer, oil filter head, heater, and air filter.

**MGB Roadster 1968-69** - Includes chassis and body number plates; and decals for the screen washer reservoir, valve cover, convertible top, trip odometer, heater, battery, and air filter.

**MGB GT 1968-69** - Includes chassis and body number plates; and decals for the screen washer reservoir, valve cover, trip odometer, heater, battery, and air filter.

**MGC Roadster** - Includes chassis and body number plates; and decals for the screen washer reservoir, valve cover, convertible top, trip odometer, heater, tire pressure, oil filter head, and air filter.

**MGC GT** - Includes chassis and body number plates; and decals for the screen washer reservoir, valve cover, trip odometer, heater, tire pressure, oil filter head and air filter.

**MGB Roadster 1975-80** - Includes chassis and car number plates; and decals for the valve cover, convertible top, trip odometer, heater, battery, fuel pump and air filter.

**Engine Number Plate** - Comes blank and ready to stamp. Replace your missing or corroded plate.

MGB Roadster 1962-65	410-125	\$32.99
MGB Roadster 1965-67	410-130	32.99
MGB GT 1965-67	410-135	32.99
MGB Roadster 1968-69	410-140	32.99
MGB GT 1968-69	410-145	32.99
MGC Roadster	410-215	45.99
MGC GT	410-220	45.99
MGB Roadster 1975-80	410-225	45.99



**Aston Gas Cap**

Stylish, theft proof, and easy to install, the chrome Aston gas cap featuring the quick release function is a great buy! Vented.

1962-69, Chrome 117-462 \$109.99



**Locking Gas Cap**

Get some peace of mind with this chrome locking gas cap. Includes two keys. Fits thru 1969.

1962-69 202-760 \$54.99



\*See ordering page for details

WARNING: Cancer and Reproductive Harm. www.P65Warnings.ca.gov



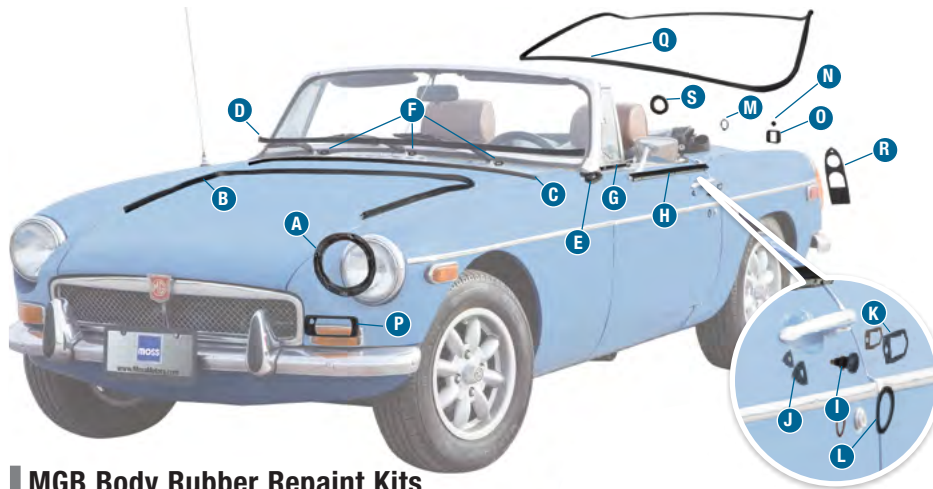

### MGB Body Rubber Repaint Kits

It's no longer a hassle to track down all the rubber bits and pieces commonly replaced during a repaint or moderate restoration. A Body Rubber Repaint Kit will refresh your car's rubber components and gaskets, sealing your MGB from the elements, and save you time and money.

Start with the Roadster base kit (GT kit has all the pieces), which contains pieces common to all the MGB Roadsters, then choose a supplemental kit which will contain additional parts specific to your car. Please check the table for specific content.

Roadster Base Rubber Kit	282-818	\$79.99
Roadster Supplemental Kit for 1962-69	282-825	42.99
Roadster Supplemental Kit for 1970-76	282-826	52.99
Roadster Supplemental Kit for 1977-80	282-827	34.99
GT Rubber Kit	282-829	149.99

Body Rubber Kit Contents	
Base Kit Includes	A, B, C, D, E, F, G, H, I, J, K, L, M, N, O
1962-69 Supplement	P, Q, R, S
1970-76 Supplement	P, Q, R, S
1977-80 Supplement	Q <sup>1</sup> , R, S
GT Complete Kit	A, B, C, F, G, H, I, J, K, L, M, N, O, P, Q <sup>2</sup> , R, S
<sup>1</sup> Includes correct body side trunk seal	
<sup>2</sup> Includes both body side and tailgate side seals	

Ill.	Description	QTY
A	Headlamp Seals	2
B	Hood Seal	1
C	Rear Hood Seal	1
D	Windshield to Body	1
E	Windshield Post Pads	2
F	Wiper Bezel Pads	3
G	Vent Window to Body Pads	2
H	Door Top Seals	2
I	Door Handle Buffer	2
J	Door Handle Gasket - Small	2
K	Door Handle Gasket - Large	2
L	Door Lock Gasket	2
M	Trunk Lock Gasket	1
N	Reverse Lamp Wiring Grommet	2
O	Reverse Lamp Pads	2
P	Front Lamp Pads	2
Q	Trunk Seal	1
R	Rear Taillamp Seals	2
S	Gas Filler Neck Grommet	1



### Classic Luggage Rack

Our durable chrome luggage rack is built to the highest standards, just like the original. The long, curving bands of this precise piece of equipment distribute the weight of the cargo evenly across the boot. Our reproduction luggage rack comes with rubber strips that separate the rack from the painted surface, offering additional protection. All mounting hardware included.

Classic Luggage Rack 244-712 \$469.99 **CS**



### Luggage Rack

Luggage racks are an extremely useful accessory, particularly when touring, and provide invaluable extra luggage space. Ideal for occasional use, these clip-on boot racks are available in stainless steel or with wood slats.

They are supplied with fittings; including rubber feet, strap clamps and a third support bracket which can be used at the front of the boot lid to help reduce stress on the side brackets, or kept as a spare.

Stainless Steel 244-015 \$279.99 **CS**  
Wood 244-016 299.99 **CS**



### Removable Rack

This removable rack is perfect for those weekend trips. This functional rack allows you to carry more stuff without worrying about taking away from the classic look of your car. Easy to install with no drilling required. This polished stainless steel rack is durable, attractive, and corrosion resistant.

Removable Rack 244-750 \$499.99 **CS**



### OE Style Luggage Rack

This classic and functional luggage rack was designed in the same style as the 1974-80 factory option. However, it can be fitted to all MGB Roadsters. Mounting hardware included.

OE Style Rack 244-010 \$299.99



Pricing is subject to change.

Please visit [MossMotors.com](http://MossMotors.com) for current pricing and availability.



**License Plates**

Display your loyalty with one of our regulation size license plates. Embossed aluminum plates with crisp screen printing.

MG Octagon	229-735	\$11.99
Union Jack	229-730	14.99

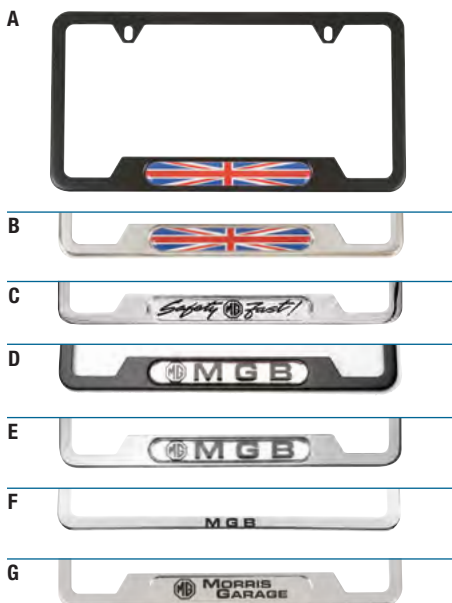

**License Plate Frames**

High-quality license plate frames to show off your car's heritage.

A. Union Jack, Black	222-735	\$51.99
B. Union Jack, Stainless	222-725	51.99
C. MG Safety Fast, Stainless	222-776	51.99
D. MGB, Black	222-846	51.99
E. MGB, Stainless	222-796	51.99
F. MGB, Polished, Slim	222-797	51.99
G. Morris Garage, Stainless	222-830	51.99



**Personalized English License Plates**

Regulation British plates are identical to those used in England in the '40s, '50s, and early '60s. Semi-sheared raised letters. Nostalgic and attractive, these plates can be personalized with up to seven letters and numbers of your choice. Unpainted.

English License Plate	307-073	\$89.99
-----------------------	---------	---------



**Badge Bars and Hardware**

Dress up the front of your classic with these high quality badge bars. Mounting hardware included. 3/4" diameter.

1962-74 Chrome	244-115	\$154.99
1974½ -80 Chrome	244-230	106.99
1974½ -80 Black	244-240	106.99
Badge Mounting Kit - 1" Bar	408-001	7.99
Badge Mounting Kit - 3/4" Bar	408-002	9.99
Badge Bar Mounting Backing Plate	408-577	11.99



**Stainless License Plate Support**

Add a touch of sparkle to your ride. Polished stainless steel resists corrosion and brightens up later rubber bumper MGBs.

License Plate Support	451-296	\$48.99
-----------------------	---------	---------



**License Plate Mount Badge Holder**

A simple and practical way to embellish your car with a couple of badges. This badge holder is designed to mount on the upper or lower license plate mounting screws, and accepts both standard back mount and magnetic badges.

Badge Holder - License Plate Mount	244-105	\$36.99
------------------------------------	---------	---------



**1962-74 Chrome Badge and Lamp Bar**

Specially designed to mount a pair of high-quality Tourist Trophy reproductions of the classic Lucas 500 series lamps (sold separately), this badge bar easily mounts behind the bumper bracket. No drilling required.

*Note: Will not fit 1970-72 without modification to lower grille finishers.*

Badge & Lamp Bar	244-121	\$199.99
------------------	---------	----------



408-002

408-001

**Grille Badges**

Embellish your grille with these great looking badges. Solid baked enamel finish on a polished stainless steel back.

*Note: Each badge requires a badge bar mounting backing plate.*

(1) England	408-507	\$27.49
(2) U.S.A.	408-527	27.49
(3) RAC	408-547	27.49
(4) U.S. Coat of Arms	408-529	27.49
(5) MG	408-487	27.49
(6) Great Britain	408-506	27.49
(7) Abingdon-On-Thames	408-186	34.99
Badge Bar Mounting Backing Plate	408-577	11.99
Badge Mounting Kit - 1" Bar	408-001	7.99
Badge Mounting Kit - 3/4" Bar	408-002	9.99



408-002

408-001

**Badge Bar Badges**

Add some flare to the front of your car with a selection of classic badges!

(1) RAC Badge, Chrome	408-695	\$89.99
(2) Cloisonné RAC	408-517	64.99
(3) St. Christopher	408-435	114.99
(4) Brooklands	408-175	74.99
Badge Mounting Kit - 3/4" Bar	408-002	9.99
Badge Mounting Kit - 1" Bar	408-001	7.99



**Cloisonné Union Jack**

Add an element of style and pride with this Union Jack emblem. Designed to mount on flat surfaces. 2 1/4" x 1 3/8". Screws included. Sold as a pair.

Cloisonné Union Jack - Pair	229-308	\$36.99
-----------------------------	---------	---------



## LED Replacement Bulbs

We've had our eyes on these for a while now. We couldn't help it, they're so bright! Our LEDs for negative ground vehicles have the advantage of a wide-angle light distribution design. These bulbs fit factory sockets, and can be easily installed. After much searching and testing of different products, we can now say that Moss offers an LED lighting solution that measures up to your high standards.

### Our LEDs come in three colors

White, red and amber - to match the color of the lens application. Trust us, you don't want a white light LED behind a red lens. Pink is not the universal color for "stop".

### Upgraded Electronic Flasher

If you are upgrading any of your turn signals, you will need to upgrade to an electronic flasher. The LED bulbs draw so little current that they won't trigger a mechanical flasher to blink.



Electronic Flashers			
2-Prong - Negative Ground	141-667	\$26.99	
3-Prong - Negative Ground	141-668	26.99	

Industry #	57	89	1157	1156
Replaces Moss #	170-100, 170-250	170-300	170-700	170-800
White	170-906 <sup>2</sup>	170-920	170-931	170-946
Amber	170-911	170-921	170-936	170-951
Red	170-916	170-925	170-941	170-956
Price	<b>\$19.99</b>	<b>\$19.99</b>	<b>\$29.99</b>	<b>\$29.99</b>

<sup>2</sup>Will not fit in outer front side marker on the '62-'67 MGB's.



## 3rd Brake Light Kit

Center-mounted 3<sup>rd</sup> brake lights reduce accidents, so much so that they have been required on all passenger autos built since 1984. Our older classics, which are equipped with two dim, low mounted brake lights, aren't exactly easy to see. With a little creative wiring, you can mount one of our brilliant accessory 3<sup>rd</sup> brake light kits and improve the safety of your British classic. The base can be removed for flush mounting.

Chrome Brake Light Kit 116-115 \$114.99



## Rear Fog and Reverse Lamps

These matching lamps have polished stainless steel cases, glass lenses and 20W H3 type halogen light bulbs. 4½" wide, 2¼" high. ⅝" mounting hole required. Suitable for mounting below the rear bumper. Check your local regulations to make sure they are legal for street use. Sold individually.

Reverse Lamp, Clear 162-842 \$64.99  
Rear Fog Lamp, Red 162-843 64.99



## Hella 500 Light Kits

Light up the road with Hella 500 Light Kits. The Driving Light kit emits a focused beam for long-range illumination, while the Fog Light kit projects a wide and low illumination perfect for foggy or dusty conditions. Kits include: 2 halogen lamps, 2 H3 12V/55W bulbs, 2 protective stone shields, plug-n-play harness, 1 switch, 1 12V relay, and instructions. Lamp dimensions: 6.8"(h) x 6.4"(w) x 2.6"(d).

Driving Lights 162-780 \$139.99  
Fog Lights 162-785 149.99



## Headlamp Relay Kit

Any British classic can benefit from adding headlamp relays. Your headlights will be significantly brighter, and the life of the lighting switch will be extended considerably with this easy-to-install kit. Relays are especially beneficial (and strongly recommended) if you have fitted halogen headlamps.

Headlamp Relay Kit 117-515 \$36.99



## Fog and Driving Lamps

Quality reproductions of the classic 5½" Lucas 500 series SLR and SFT lamps as originally fitted on many cars of the 50s and 60s. Lamps are sold individually.

<b>Driving Lamps</b>		
Stem Mount	162-701	\$189.99
Back Mount	162-760	189.99
<b>Fog Lamps</b>		
Stem Mount	162-800	\$189.99
Back Mount	162-770	189.99
<b>Replacement Bulbs</b>		
Driving Lamp Bulb	170-500	\$12.99
Fog Lamp Bulb	170-510	6.99



Pricing is subject to change.  
Please visit [MossMotors.com](http://MossMotors.com) for current pricing and availability.

**Crystal Clear Headlamp**

Combine modern looks and improved visibility with the new Crystal Clear Headlamps with halogen H4 bulbs. These lamps are DOT and SAE approved, and deliver a strong focused light. The cast aluminum housing is corrosion resistant, and the lens is vented to prevent fogging. Sold individually.

Crystal Clear Headlamp, each	156-875	\$58.99
Replacement H4 Bulb	902-998	6.39



**P700 Tripod Headlamp Set**

The P700, which is a step up from the standard headlamp, features an internal tripod reflector with a round center cap. Our reproductions capture the look and vintage design of these lamps at a much lower price!

P700 Tripod Set	156-878	\$179.99
Replacement Bulb	170-600	7.99



**Z-Beam Style H4 E-Coded Headlamp**

Get the classic 7" Z-Beam style headlamps for your British sports car. These quality headlights are e-coded based on EU standards and have an anti-fog coating. Sold individually. H4 60/55w 12v bulb included.

Z-Beam Style H4 Headlamp	162-790	\$45.99
--------------------------	---------	---------



**7" Round Halogen Headlamp by WIPAC**

This high-quality headlamp comes with replaceable H4 bulbs. Fits all regular 7" headlamp applications. Sold individually.

WIPAC Headlamp, each	162-715	\$64.99
Replacement H4 Bulb	902-998	6.39



222-128



222-126



222-129

**Competition Headlamp Blanks**

Give your classic the racer look with our brand new competition headlamp blanks. Crafted for racing enthusiasts, as many competitions require the removal of the headlights, these blanking plates are designed to fit in place of the original 7" headlamp units. Perfect for racing and off-road use, these lightweight, quality aluminum headlamp blanks are available in two options. Take your pick from a plain brushed aluminum blanking plate or one with a decal simulating a Lucas P700 light!

Another great option is the aluminum

competition headlamp intake. It has a big hole in the center to allow cold air to enter the engine bay and provide cooler intake temps. An intake hose can be clamped onto this product and routed closer to the intake filters. Easy to install with no special tools required. Sold individually.

*Note: Headlamp intake will require modification to the existing headlamp bucket.*

Headlamp Blank	222-128	\$28.99
Headlamp Blank with Decal	222-129	33.99
Headlamp Air Intake	222-126	56.99



**Hella Halogen Headlamp**

The Hella Halogen headlamp offers accurate optics and reflector to ensure light is directed where needed. Safe for all vehicles originally equipped with 7" sealed beam headlamps. Sold individually.

Hella Halogen Headlamp, each	902-969	\$84.99
Replacement H4 Bulb	902-998	6.39



**H4 Style Headlamp LED Conversion Kit**

Developed for H4 (Semi-Sealed) style headlamps, the Stella Lux LED conversion represents a technological breakthrough for classic car owners. Lighting levels of 3000 Lumens per bulb mean these can be up to three times brighter than a standard H4 halogen bulb. LEDs emit a bright white 6000K color and deliver vastly improved road presence and visibility for a safe confident driving experience, no matter the conditions. The kit includes a pair of premium quality 25W Lumileds Luxeon Z ES LED H4 light units with a 10,000+ hour lifespan, and low load plug-and-play dual polarity drivers, which works with both positive and negative ground. We also offer this kit with two H4 style WIPAC headlamps. Keep your classic styling and have better lighting; you get the best of both worlds with this easily installed upgrade.

H4 Style LED Conversion Kit	171-250	\$229.99
Conversion Kit with WIPAC Headlamps	171-259	279.99



**Headlamp Stone Guards**

Heavy duty chrome-plated wire mesh stone guards will protect your headlights. May not be street legal. Hardware included.

Stone Guards	222-100	\$18.99
--------------	---------	---------

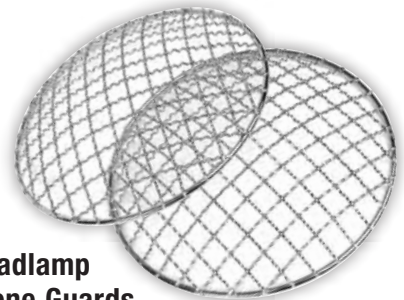





**Quarter Light Mirror**

This popular option can be clamped to a quarter light, windshield frame or roof lip to give better visibility.

Quarter Light Mirror 165-175 \$49.99



**Twin Air Horns**

Our twin tuned air horn set includes two air horns, heavy duty die-cast compressor, air hose, mounting hardware, and installation instructions.

Air Horns 545-080 \$59.99



**Twin Trumpet Horn Kit by Hella**

The Twin Trumpet Horn Kit by Hella produces a full harmonious and wide range of sound radiation. Noticeably louder than stock horns, these trumpet horns have been manufactured to the highest standard. This kit includes both high and low note horns, relay, mounting brackets, and instructions.

Twin Trumpet Horn Kit 545-095 \$35.99



**Super Tone Horn Kit by Hella**

Compact and powerful, a proper horn is more than an accessory: it's a safety measure. Our high quality horn upgrades are simple to install, sound great, and definitely turn heads with their volume!

Super Tone Horn Kit 545-090 \$59.99



223-310

165-400

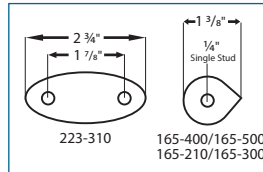

**Lucas Style Reproduction Mirrors**

Flat Fender Mount	223-310	\$56.99
R/H Flat Lens	165-400	42.99
L/H Flat Lens	165-500	42.99
R/H Convex Lens	165-210	42.99
L/H Convex Lens	165-300	42.99



222-372

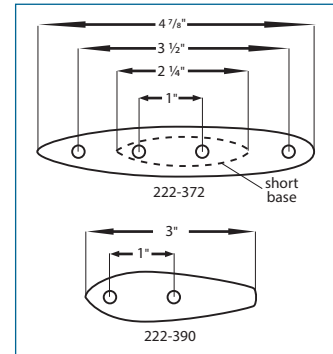

**Bullet Mirrors**

The combination mirror has two base options. Short base is 2 1/4" with bolt holes 1" apart. Long base is 4 7/8" with bolt holes 3 1/2" apart. The oversized lens mirror has a 3" long base with bolt holes that are 1" apart.

Combination Mirror	222-372	\$54.99
Oversize Lens	222-390	64.99

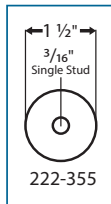

**Raydyot Racing Mirrors**

Raydyot mirrors were often bolted to racing and performance cars in the '50s and '60s. Their brushed aluminum design was extremely lightweight and strong. Less weight will forever be the aim of speed seekers. The mirror's low mass led to another important advantage: they were stable and vibration-free. Moss has captured not only the distinctive look and character of the original Raydyot mirror, our aluminum reproductions also share the performance advantage of being light and strong. Select mirrors with traditional flat lenses or wide angle convex. Sold individually.

Raydyot Mirror - Flat	222-355	\$54.99
Raydyot Mirror - Convex	222-356	54.99

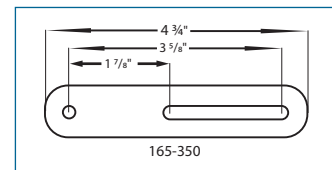

**Baby Turbo Mirror**

High-quality version of the popular mirror from the 80s, this Baby Turbo mirror looks fresh and gives an updated look. Reversible mount for LH or RH use.

Baby Turbo Mirror 165-350 \$149.99





**Gas Strut Lift Kits**

**Hood Lift Kits** - The hood will lift higher giving more access and can be opened with one hand. Requires drilling.

**Trunk Lift Kits** - 1962-71 cars had a steel prop rod, 1972-80 cars had a latching support strut. We offer a single strut kit for later cars if you are on a budget and don't want to drill any holes, but we recommend using dual struts if you have a luggage rack or previous damage to the trunk lid. All kits require drilling except #900-070.

**Cover Sets** - Add a touch of polished stainless steel to the above kits. Sold as a pair.

<b>Cover Sets</b>		
Trunk Lift Stainless Cover Set	900-078	\$34.99
Hood Lift Stainless Cover Set	900-079	34.99
<b>Hood Lift Kit</b>		
Hood Lift Dual Strut Kit	900-072	\$53.99

<b>Trunk Lift Kits</b>		
1971-80 Single Strut Kit	900-070	\$34.99
1971-80 Dual Strut Kit	900-071	52.99
1962-70 Dual Strut Kit	900-074	66.99
GT Hatch Dual Strut Kit	900-076	79.99



**MGB-GT Decklid Strut Kit**

Lifting the heavy rear floorboard of your GT is a thing of ease with this dual strut kit! This kit will add frustration free access to your spare tire and additional storage space. All hardware and brackets included for a straightforward installation.

MGB-GT	900-068	\$79.99
--------	---------	---------



**Tie Down Plates**

Stop crawling around under your car hunting for a place to attach your trailer tie downs. Our rear axle tie down plates provide an easy to reach place to secure your car safely. Hooking tie downs to the chassis forces greater loads on the tie downs and could lead to dangerous stretching or breaking. By hooking to the axle, your car's suspension is allowed to move naturally. 1962-67 MGBs will require the holes to be elongated to fit.

Tie Down Plates - Pair	267-521	\$54.99
------------------------	---------	---------



**Works Type Bonnet Straps**

Bonnet Straps began life as a safety measure for racers but daily drivers loved the look and added them to their sports cars. Our authentic reproductions are sold individually or in pairs, and are a cinch to install.

Black Leather, Each	222-601	\$34.99
Black Leather, Pair	222-602	56.99
Tan Leather, Pair	222-728	56.99
Tan Leather, Each	222-729	34.99

**Compact Air Horn Kit**



Tired of large, modern vehicles not noticing your classic British sportscar on the highway? This kit fits in a space 5½" x 4½" x 4" and produces deep tones of 115 db at 6 ft. A perfect solution for your compact car. Kit comes with a relay, mounting bolt and nut, and instructions.

Compact Air Horn Kit	545-085	\$62.99
----------------------	---------	---------

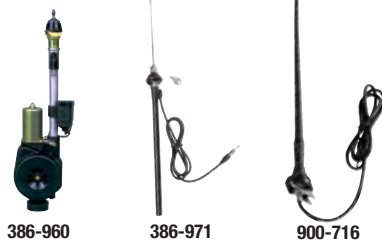

**Radio Antennas**

Upgrade your old antenna with these great replacements!

**Electric Retractable Antenna:** Our electric antenna kit wires into your radio for fully automatic operation. Requires 13½" depth to mount.

**Flush-Fit Antenna:** This collapsible antenna locks when down. Requires 11¼" depth to mount.

**14" Rubber Antenna:** Black. Includes 54" lead cable.

Electric Antenna	386-960	\$149.99
Rubber Antenna	900-716	14.99
Flush-Fit Antenna	386-971	19.99

**Raked Shorty Antenna**

Small, powerful, and mere 7 inches tall with a swept back look, our amplified antenna is a major design improvement over an unsightly standard mast or a noisy old power antenna. Comes with a 195" detachable cable, and the mast easily unscrews if you have a car cover without a hole.

7" Amplified	906-185	\$33.99
--------------	---------	---------



**Scrubblade**

For streak free windshield every time go with Scrubblade. This powerful replacement wiper has a steel-frame construction with steel-rivets to give strong performance with every swipe. It features 2 blades covered with tiny triangular scrubbers which work together to push water away, wipe streaks, and finally get rid of bugs and other debris. A nano coating on this sturdy wiper extends blade life and ensures smooth and chatter-free operation. Sold individually. 12" length.

GT 1965-68 & 1973-78	560-640	\$25.79
----------------------	---------	---------





**Minilite Style Bolt-on Wheels**

Add period charm to your Classic with these 8-spoke Minilite-style alloy wheels. Following a timeless and classic design, these are manufactured using the latest techniques and testing procedures to ensure the highest quality and reliability.

14" x 5½" (stock) - Silver	455-386	\$259.99
14" x 5½" (stock) - Silver w/ Polished Rim	456-042	259.99
14" x 5½" (stock) - Anthracite	455-376	259.99
15" x 5½" (+1) - Silver	456-045	259.99
15" x 5½" (+1) - Silver w/ Polished Rim	456-044	259.99
15" x 5½" (+1) - Anthracite	456-046	259.99
Replacement Hub Cap - Chrome	456-049	14.99
MG Emblem	455-377	4.99
Lug Nut, each	264-980	4.49



**Limited Edition Road Wheel**

These wheels have been re-tooled and are available once again. Supplied with a UK style red center badge, U.S. specification badges sold separately.

Limited Edition Road Wheel	462-750	\$299.99
U.S. Spec. Badge, Black	408-280	5.49
Lug Nut, each	264-990	21.99



**Minilite Style Knockoff Wheels**

A great choice for cars originally equipped with wire wheels.

14" x 5½" (stock) - Silver	455-360	\$499.99
15" x 5½" (+1) - Silver	455-385	529.99
15" x 5½" (+1) - Anthracite	455-389	529.99



**Panasport Wheels**

Famous in racing circles, Panasport wheels feature lightweight alloy construction and polished rims. Please check our website for more information about offset, weight and suggested tire sizes. Check tire clearance before fitment.

15" x 6" +22 mm offset, 14 lbs	854-716	\$319.99
16" x 7" +22 mm offset, 17 lbs	854-735	399.99



**Wheel Spacers**

These 6 mm solid spacers are useful when wheel to brake caliper clearance is an issue, or when you want to fine tune track-width.

Pair	674-685	\$39.99
------	---------	---------



**Wheel Trim Rings**

Add an attractive accent to your rims with these polished stainless steel wheel trim rings. Sold in a set of 4. For Rostyle wheels only.

14" Trim Rings - Set of 4	455-378	\$149.99
---------------------------	---------	----------



### Wire Wheel Conversion Kits

Available with either silver painted or chrome wheels, these kits put the classic style of Dunlop wire wheels on your car. All kits include five wheels, necessary hubs, hardware, knockoffs and wheel hammer. MGB kits are available for tube axles only and come with new front wheel bearings and special rear hubs. Chrome wheels feature stainless steel spokes and nipples.

Wire Wheel Conversion Kit - Eared Knockoffs (w/o wheels)	111-490	\$1,099.00	👍
Wire Wheel Conversion Kit - Octagonal Knockoffs (w/o wheels)	111-495	1,099.00	👍
Chrome Wheel Conv. Kit - 14" x 4.5" - Eared Knockoffs	111-419	3,599.00	👍
Painted Wheel Conv. Kit - 14" x 4.5" - Eared Knockoffs	111-429	2,899.00	👍
Chrome Wheel Conv. Kit - 14" x 4.5" - Octagonal Knockoffs	111-418	3,599.00	👍
Painted Wheel Conv. Kit - 14" x 4.5" - Octagonal Knockoffs	111-428	2,899.00	👍
Chrome Wheel Conv. Kit - 14" x 5.5" - Eared Knockoffs	111-416	3,999.00	👍
Painted Wheel Conv. Kit - 14" x 5.5" - Eared Knockoffs	111-426	3,399.00	👍
Chrome Wheel Conv. Kit - 14" x 5.5" - Octagonal Knockoffs	111-417	3,999.00	👍
Painted Wheel Conv. Kit - 14" x 5.5" - Octagonal Knockoffs	111-427	3,399.00	👍
Chrome Wheel Conv. Kit - 15" x 5" - Eared Knockoffs	111-436	4,199.00	👍
Painted Wheel Conv. Kit - 15" x 5" - Eared Knockoffs	111-446	3,099.00	👍
Chrome Wheel Conv. Kit - 15" x 5" - Octagonal Knockoffs	111-437	4,199.00	👍
Painted Wheel Conv. Kit - 15" x 5" - Octagonal Knockoffs	111-447	3,099.00	👍

### Black Wire Wheels

Black painted wire wheels can add a more purposeful and unique look to your vintage car, setting it apart on the show field.

MWS Dunlop style painted wire wheels have a very high corrosion resistance. Before being painted, they are primer-coated using Cathodic Electrophoretic Technology, popularly known as electro or e-coat.

The black paint topcoat combines with the primer to give the wheel a salt-spray resistance of 840 hours when tested per ASTM standards. Painted wheels have a one year cosmetic and two year structural warranty.

All wire wheel nipples are silicone sealed at the rim to keep water out, a common complaint on lesser quality wheels. These high quality, painted wire wheels are truly a class apart.

15" x 5", 72 spoke - Black 454-666 \$479.99



### Wire Wheels

Each MWS Dunlop style chrome wire wheel has a rim and shell which are polished in special-purpose machines, then hand-polished by skilled craftsmen. To enhance the corrosion resistance, microporous nickel plating is done prior to chrome-plating. The product conforms to the stringent International Standards ISO 1456-1988 specifications. The spokes and nipples are chrome-plated stainless steel for brightness and long life. Chrome wheels have a two year cosmetic and three year structural warranty. All wire wheel nipples are silicone sealed at the rim to keep water out, a common complaint on lesser quality wheels. These wheels are also tubeless.



Most MGBs were originally fitted with painted wire wheels. Chrome wheels were a popular option, but the stove-enameled look may be what you want to set your car apart on the show field. Painted wire wheels were used on all competition cars, and they can add a more correct, purposeful look for vintage race cars and other high-performance machines.

MWS Dunlop style painted wire wheels have very high corrosion resistance. Before being painted, they are primer-coated using Cathodic Electrophoretic Technology, popularly known as "electro" or "e-coat." The silver-grey paint topcoat combines with the primer to give the wheel a salt-spray resistance of 840 hours when tested per ASTM standards. Painted wheels have a one year cosmetic and two year structural warranty.

Dia/Width	Spokes	Finish	Unit	Part #	Price
14" x 4 1/2"	60	Chrome	Each	454-636	\$579.99
14" x 4 1/2"	60	Painted	Each	454-626	399.99
14" x 5 1/2"	72	Chrome	Each	454-826	639.99
14" x 5 1/2"	72	Painted	Each	454-816	519.99
15" x 5"	72	Chrome	Each	454-660	679.99
15" x 5"	72	Painted - Silver	Each	454-665	449.99
15" x 5"	72	Painted - Black	Each	454-666	479.99



### Wire Wheel Balancing Tool Set

The wire wheel balancing tool set is a great buy for any classic car owner. While most auto body shops, garages, and tire centers are equipped to balance the wheels of modern cars, they do not always have the right set of tooling for classics in order to mount the wheel on its true axis and accurately balance center lock wire wheels. When you get your Classic's wheels balanced at these shops, additional weights are put on to make sense of the machine's readings and you end up with incorrectly fitted wheels. Investing in this tool set gives you the freedom to go to any garage and get your wheels balanced properly.

This useful tool set comes with interchangeable parts to accommodate the three most commonly used spindle sizes on dynamic balancing: 36 mm, 38 mm and 40 mm. It also includes two cup sizes to fit 42 mm and 52 mm center lock wheels.

Wire Wheel Balancing Tool Set 386-305 \$649.99



\*See ordering page for details

⚠️ WARNING: Cancer and Reproductive Harm. www.P65Warnings.ca.gov





**Protective Knockoff Wrench**

Prevent damage to knockoffs with multi-ply wooden wrenches. Fit all 42 mm conventional British two eared knockoffs.

42 mm Wrench 386-165 \$38.99

**Knockoffs**

Choose the original 2-eared style, or the more flashy 3-eared style.



Earlier cars have fine 12 threads per inch, later cars use a coarser 8 threads per inch. Our MG crested knockoffs were original equipment on MGT and MGA, and look great on MGBs.

**3-Eared Knockoffs**

Fine Thread 12 t.p.i. - Left Hand	200-315	\$119.99
Fine Thread 12 t.p.i. - Right Hand	200-325	119.99
Coarse Thread 8 t.p.i. - Left Hand	200-335	139.99
Coarse Thread 8 t.p.i. - Right Hand	200-345	139.99

**MG Crested 2-Eared Knockoffs**

Fine Thread 12 t.p.i. - Left Hand	200-220	\$69.99
Fine Thread 12 t.p.i. - Right Hand	200-210	69.99
Coarse Thread 8 t.p.i. - Left Hand	200-225	69.99
Coarse Thread 8 t.p.i. - Right Hand	200-215	69.99

**Standard 2-Eared Knockoffs**

Fine Thread 12 t.p.i. - Left Hand	200-280	\$69.99
Fine Thread 12 t.p.i. - Right Hand	200-290	69.99
Coarse Thread 8 t.p.i. - Left Hand	674-680	69.99
Coarse Thread 8 t.p.i. - Right Hand	674-670	69.99

009-139

009-140

**Knockoff Tools**

Prevent damage to your knockoffs with these specialty sockets. These sockets allow you to safely tighten or remove knockoffs without a hammer. For use with a 3/4" breaker bar or torque wrench. Available for octagonal or 2 ear knockoffs.

Octagonal	009-139	\$179.99
2-Eared	009-140	179.99



**Knockoff Hammers**

Useful in multiple applications, these knockoff hammers are available in all types, weights, and sizes.

1 lb Copper/Copper	386-000	\$59.99
2 lb Copper/Copper	386-850	58.99
2 lb Copper/Rawhide	386-110	89.99
2 lb Zinc Alloy	386-020	65.99
4 lb Lead Alloy	386-180	76.99



**LE Chrome Lug Nuts**

The original Limited Edition wheel nuts were black. These chrome nuts will add a subtle bit of flash when you are parked at the car show next to ten other LEs.

Chrome Lug Nuts - Each 264-991 \$19.99

**MG Crested Lug Nuts**

Several pre-war MGs sported over 30 MG octagons or octagonal shapes. With a full set of our MG crested lug nuts, you'll be up to 16 right off the bat!



Lug Nut, each 264-985 \$10.99



**Inner Tubes and Rim Bands**

Designed for use with radial tires, these have rubber-covered valve stems. Rim bands prevent spoke and nipple ends from chafing your inner tubes. Sold individually.

*Note: Can be used with bias-ply tires.*

**Inner Tubes**

155/165 x 14"	452-736	\$19.99
175/185 x 14", 155/165 x 15", 175/185 x 15"	452-766	25.99

**Rim Bands**

14" Rim Band	452-740	\$13.99
15" Rim Band	452-750	13.99



**Long Handle Knockoff Wrench**

Tighten or remove spinners easily with this long handle wrench.

Octagon Knockoffs	386-120	\$74.99
Eared Knockoffs	386-125	79.99
Fabric Wrench Cover	386-115	22.49



**Wire Wheel Spoke Wrench**

With its wide face and long handle, this wrench is perfect for adjusting most spoke nipples without rounding them off.

Spoke Wrench 385-800 \$14.99

**Embossed Valve Stem Cap Set**

Subtle and elegant, these nickel-plated steel valve stem caps feature an MG crest embossed on the top. Sold individually.

MG Valve Stem Caps 215-825 \$11.99



**Valve Stem Caps**

Dress up your chrome wheels with a classic touch. These solid brass caps with logos are finished in chrome and utilize an O-ring for a proper seal. Sold as a set of 4.



Union Jack - Non-Locking	101-161	\$13.99
Checkerboard - Non-Locking	101-167	13.99



Pricing is subject to change. Please visit [MossMotors.com](http://MossMotors.com) for current pricing and availability.

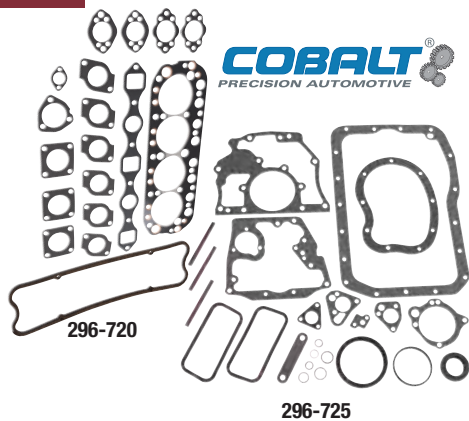

**COBALT**  
PRECISION AUTOMOTIVE

296-720

296-725



**Alloy Cross-Flow Cylinder Head**

Recalling the classic racing head of the fifties, with computer generated gas flow design, this head opens new performance horizons for the B-Series engine. Immediate performance and cooling improvements will be noticed even with stock 1½" SUs, but from there the possibilities are still being explored. The heads are completely assembled with standard size valves, bronze guides and hardened seats. The exhaust ports are in the original location so that regular early manifolds or headers may be used. We recommend the MGB stainless header (#459-015) as the manifold is highly visible. The head requires a new four-branch intake manifold and matching carburetors. You may choose from the three choices of manifolds and carburetors below. The Weber DCOE manifold kit and 45DCOE carbs offer the highest flow possible for maximum power potential in modified engines. There is no provision for emission connections and some modifications will be required for best operation. Manifold kits do contain intake gaskets and some linkage components, but due to the variety of installations, some fabrication may be required. Accelerator cables are not supplied and must be fabricated. Valve interference must be checked on pre-18V blocks.

**Gaskets by Cobalt**

Timely upgrades go a long way in the upkeep of your vehicle, and it is an important aspect of vehicle safety. Switch out your worn-out gaskets with these brand-new Cobalt brand replacement options, offering great quality at a very reasonable price. Built to OEM specifications.

Cylinder Head Gasket Set - 1962-74	296-720	\$34.99
Cylinder Head Gasket - 1962-80	296-700	22.99
Lower Engine Gasket Set - 1965-80 (5)		
Main Bearing)	296-725	39.99

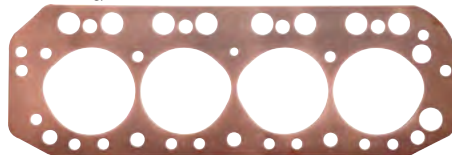

**Cylinder Head Gasket**

Solid copper head gaskets have been a secret ingredient of many high performance racing engines. Modify these 0.032" thick gaskets for over-bored engines. Not suitable for use with aluminum heads.

Copper Gasket	387-505	\$169.99
---------------	---------	----------



**Tuftrided Rocker Shaft**

Tuftriding produces a harder wearing exterior coating on the shaft for improved reliability and is recommended for all MGBs using standard rocker arms.

Rocker Shaft	433-725	\$49.99
--------------	---------	---------



**Alloy Cylinder Heads**

Get more power by improving your cylinder head flow. Our alloy cylinder heads feature nickel-steel valve seats and silicone-bronze valve guides for use with unleaded fuel. The aluminum component saves weight and improves cooling, while the revised porting and combustion chamber increases efficiency. If required, water choke port must be drilled.

**Assembled Heads**

1962-67, no smog fittings	451-806 <sup>1</sup>	\$1,599.00
1968-80, drilled for smog	451-816 <sup>1</sup>	1,799.00
Water Choke Block Off Plate	052-341	17.99
Air Injection Port Plug	052-242	2.39

**Bare Heads**

1962-67, no smog fittings	451-805 <sup>1</sup>	\$1,299.00
1968-80, drilled for smog	451-815 <sup>1</sup>	1,299.00
Water Choke Block Off Plate	052-341	17.99
Air Injection Port Plug	052-242	2.39

<sup>1</sup>May not be legal on emission controlled vehicles. Check your local laws for compliance.

**Nylatron Rocker Arm Spacer Kit**

Replace the power-robbing original spring spacers and allow for exact rocker arm spacing. Very accurately machined and made from high strength Nylatron.



Rocker Arm Spacer Kit	460-362	\$36.99
-----------------------	---------	---------

**Rocker Shaft Spacer Set**

Ensures positive centering of the rockers over the valve stems. These are highly recommended. Supplied as an engine set of spacers.



Spacer Set	460-365	\$45.99
------------	---------	---------



\*See ordering page for details

⚠ WARNING: Cancer and Reproductive Harm. www.P65Warnings.ca.gov



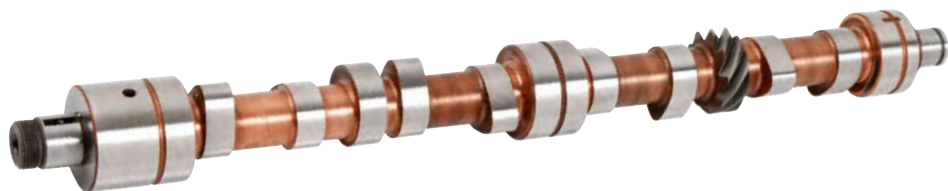

### Performance Camshaft by Comp Cams

This performance camshaft was made by Comp Cams specifically for the MGB engine. This billet ground cam was designed for daily usage, autocross and supercharge applications. It will provide you with excellent performance, yet maintain good drivability.

**Intake timing:** Open 24, Close 56, Duration 260

**Exhaust:** Open 69, Close 21, Duration 270

Fast Road 222-270 \$999.99

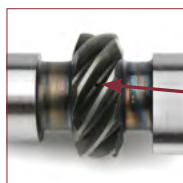

Pressure-fed oiling to distributor drive gear



### Performance Camshaft

The camshaft is the heart of your engine. This is the best street cam for the MGB! The nominal duration of 260 degrees gives a smooth idle and the higher than stock lift improves power. The cam is precision cut on a new chilled iron core which is drilled through to deliver improved oiling to the all-important distributor drive gear. The cam specification may look mild, but it is optimized for street, not race track performance. On the street, you want usable power below the normal 6500 rpm redline. Most "hot" cams just rip up lifters and valves and only really deliver power at too high speed to be usable on the street. Will accept stock tach drive gear.

	Duration	Lift at Cam	Power Range	RPM	Part #	Price
Performance Camshaft	260/260	.286/.293	1200-6200 rpm	6800	222-273	\$649.99



### Performance Camshaft Kit

Upgrading your classic car with a performance camshaft is a brilliant way to increase engine performance and extend RPM. We now offer premium quality performance camshaft kits designed to increase valve lift and duration, improve engine performance, and higher up the rev range for a sportier driving experience!

Designed and engineered in the UK, these performance camshaft kits comprise CNC-machined, steel billet performance camshaft and tailored performance cam followers. Suitable for MGBs fitted with 18V engines, 1972-80. Order your kit today!

MGB 1972-80 - Fast Road 222-279 \$579.99



### Dura-Bond Cam Bearings

Add life to your engine with Dura-Bond precision Camshaft Bearings. These are the first choice of professional engine builders. They are solid, not split, are easier to install, and offer superior durability.

Dura-Bond Cam Bearings 425-001 \$34.99



### Offset Cam Keys

Keys with offsets allow you to fine tune your camshaft timing. Use with stock sprockets.

2° Offset	327-005	\$29.99
3° Offset	327-015	29.99
4° Offset	327-025	31.99
5° Offset	327-035	31.99



### Upated Tubular Pushrods

Stiffer and lighter than stock 18V pushrods. These stock length upated pushrods can be used in any MGB engine when used with 18V lifters. 3/16" diameter.

Upated Tubular Pushrod 460-619 \$21.99



### Adjustable Cam Sprocket Kit

If you're serious about your engine rebuild, this is one upgrade you should install! Our kit includes the double row chain, crank sprocket, and fully adjustable cam sprocket.

Adjustable Cam Sprocket Kit 460-398 \$249.99





224-490



224-508

**Alloy Valve Covers**

Polished ribbed cover (no breather vent). Includes grommets and cap.

Polished No Vent	224-508	\$109.99
Black No Vent	224-490	154.99
Replacement Chrome Cap	460-145	17.99

**Valve Cover Thumb Nuts**

Beautiful and functional. Set of two. Can't be used with alloy valve covers.



Chrome Thumb Nuts, pair 460-118 \$15.99

**Crested Brass Valve Cover Cap Nut**

Solid polished brass. Sold individually.



Brass Valve Cover Cap Nuts 460-119 \$18.99

**Chrome Valve Cover Cap Nut**

Extra-long cap nut for use on alloy valve covers.



Chrome Cap Nut 460-111 \$8.99

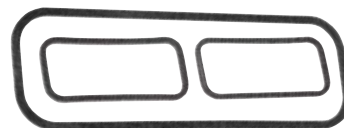

**Silicone Valve and Side Cover Gaskets by Gasket Innovations**

These premium silicone valve and side cover gaskets are stronger and more resilient than traditional cork. They will tolerate re-use far better as well. Two types of gaskets are offered, one for Stock covers, and one for Alloy covers.

*Note: Red RTV Sealant is needed for proper installation*

MGB w/ Stock Valve Cover	296-311	\$25.99
MGB w/ Alloy Valve Cover	296-312	34.99
MGC w/ Stock Valve Cover	780-421	41.99
MGB Side Cover Gasket Set - Pair	296-377	30.99
RTV Sealant - Red - 3 oz	221-305	15.99



**Silicone Valve and Side Cover Gasket Set**

No more single use cork gaskets! This kit includes valve cover and side cover gaskets that are made from an aircraft-spec. silicone for a superior seal and to be reusable. They work great with steel or alloy valve covers.

*Note: The side cover gaskets will not fit 18V late MGB rear side covers.*

Silicone Gasket Set	296-425	\$25.99
---------------------	---------	---------

**Gas Flowed Intake and Exhaust Valves**

Larger diameter intake valve with smooth flowed back face and tapered stem. Valve size is 1.70" compared to early valve size of 1.563" or 1973-74 valve 1.625". Gas flowed exhaust valve made from EN214 stainless steel material. The smooth back face and tapered stem improves gas flow. Standard size 1.34" (34 mm). These valves are designed to use the later 1968-80 cotters and caps. Earlier engines must have these parts upgraded. Use #460-215 cotters and #460-195 cap.

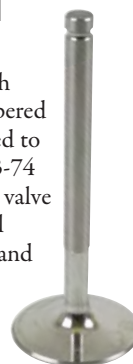

Intake Valve, 1.70", each	423-137	\$14.99
Exhaust Valve, 1.34", each	423-166	26.99
Cotter, each	460-215	2.39
Cap, each	460-195	3.99

**Super Duty Valve Spring Set**

Designed for race-tuned engines, higher tension springs increase your rev. limit beyond 7000 rpm.



Valve Spring Set	423-455	\$72.99
Valve Stem Seal, each	290-890	1.29

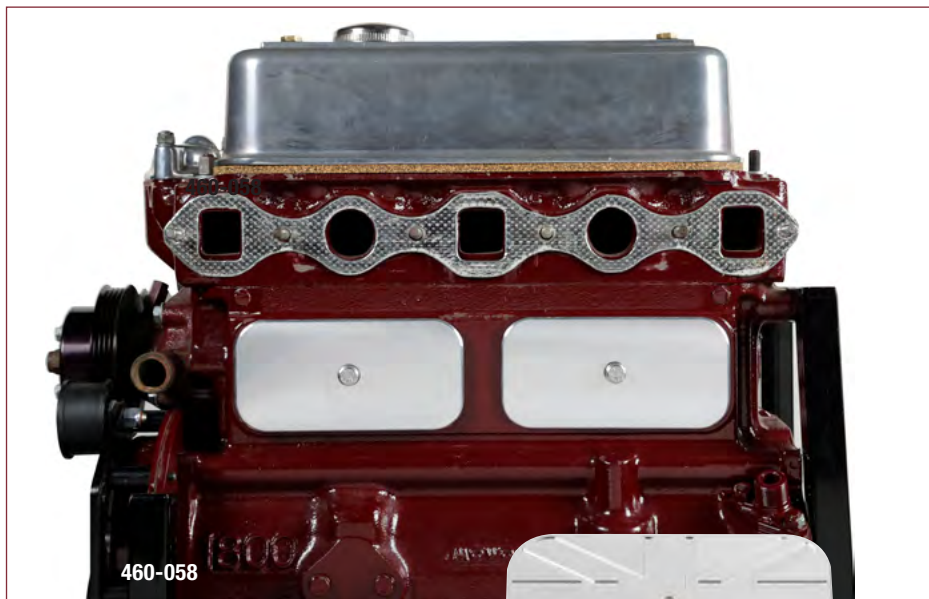

460-058

**Billet Tappet Cover Kit**

These billet aluminum tappet covers have been meticulously machined to fit your car. They are available either plain or with a machined Union Jack. The kit includes tappet cover, gasket, bushing, cup washer and bolt. Sold individually.

1962-77 - Plain - each	460-058	\$46.99
1962-77 - Union Jack - each	460-059	84.99



460-059



\*See ordering page for details

⚠ WARNING: Cancer and Reproductive Harm. www.P65Warnings.ca.gov





### Competition Oil Pan

Improve your 5-main MGB engine with a competition inspired aluminum oil sump. With input from multiple SCCA championship winner Kent Prather, we've built a high performance upgrade to the cheap original stamped steel oil pan. The Moss Competition sump features design and construction elements from established racing practice. Whether your engine is stock or highly modified, keeping the oil cool and reducing the chances of oil surge will pay benefits in longer engine life. Mounting hardware included.



**MORE INFO ONLINE**

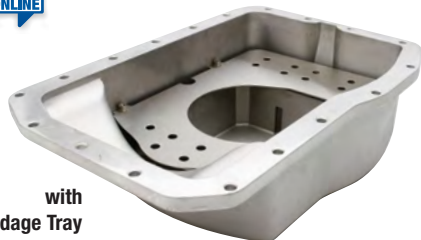

with  
Windage Tray

**Features include:**

- Sturdy die cast construction with a heavy mounting flange - adds stiffness to the bottom of the engine block
- Cast in cooling fins to maximize heat dissipation
- Competition inspired baffling prevents oil surge away from the oil pump pickup during hard maneuvering

- An optional windage tray kit keeps oil from splashing on the crank and reducing horsepower
- Works with your existing dip stick
- Used by professional vintage and SCCA racers to help protect their racing investment

Competition Oil Pan	460-372	\$419.99
Windage Tray	460-373	74.99



### Oil Service Kit

Changing your engine oil at timely intervals is a great way to avoid sludge build up. Get everything you need to do an oil change in this oil service kit which includes: a filter, drain plug washer, and the appropriate amount of oil for lubrication.

We've selected Collector's Choice engine oil for your classic car as it contains "pre-ban" ZDDP levels to help prevent premature camshaft lobe wear, additives to help prevent seals from becoming hard and leaking from infrequent use, and antioxidants to combat the effects of humidity changes during storage that can lead to moisture and even rust in an engine. Regular maintenance activities like an oil change go a long way in the smooth running of the engine. Offering better value for money, order this kit today!

MGB 62-70 - 5 quarts	225-910	\$64.99	<b>OS</b>
MGB w/ Spin-On Conversion - 5 quarts	225-914	69.99	<b>OS</b>
MGB 70-71 (18GH/K) - Inverted - 5 quarts	225-911	72.99	<b>OS</b>
MGB 72-80 (18V) - Inverted - 4 quarts	225-912	62.99	<b>OS</b>
MGB 73-76 - Hanging - 4 quarts	225-913	52.99	<b>OS</b>

### Oil Catch Can by Mishimoto

A running engine creates blow-by, which is an oil mist that is routed either back to your intake manifold or to the atmosphere under your engine. Not only does that make a mess of the underside of your sports car, it can lead to carbon build-up in your combustion chamber which hampers performance. Trap all that oil for proper disposal by installing an oil catch can between the engine and your intake manifold or the atmosphere. Find more information online.

Oil Catch Can - 16 oz	223-075	\$164.99
-----------------------	---------	----------



### Spin-On Oil Filter Adapter

Get cleaner oil changes by switching over to a modern spin-on filter. Includes all necessary pieces for installation. Filter not included.



1963-67 Adapter Kit	235-940	\$42.99
MGC 67-69	235-941	109.99
Spin-On Filter - Fram	235-880	10.99
Spin-On Filter - Wix	235-855	18.99
Spin-On Filter - K&N	235-830	28.99



### Up-rated Oil Pump and Spring

Fits all 5-main engines. This oil pump has been modified to the factory special tuning specifications for increased oil flow at high rpm.

### Up-rated Spring



Increase the oil pressure in your stock engine by about 20 psi. This is not a remedy for a worn engine in need of a rebuild!

Oil Pump	435-625	\$114.99
Up-rated Oil Pressure Spring	329-235	5.69



### Speedi-Sleeve

When a new seal cannot compensate for excessive damage, this ultra-thin sleeve provides a new sealable surface. Instructions and installation tool are included in the kit.

Crankshaft Pulley/Timing Cover Seal	520-515	\$69.99
Rear Crankshaft 5-Main Engines	520-525	78.99

Pricing is subject to change.

Please visit [MossMotors.com](http://MossMotors.com) for current pricing and availability.

PERFORMANCE



**Crank Pulley**

The Crank Pulley is made using the original MGB design, geometry and materials. Two sets of timing marks, at 28° and 180° relative to the key-slot, accommodate various MGB engine configurations.

1962-74 433-697 \$79.99



**Supercharger Big Boost Kit**

Increase boost from the standard 5-6 psi to 7.5-8.25 psi. Recommended for use on 8.0:1 compression engines and heads that have been flowed. Includes new pulley and full instructions.

*Note: Installation of this kit does void manufacturer's warranty of the rotor group.*

Boost Kit 150-075 \$169.99



**Supercharger Heat Shield**

Heat robs horsepower, so reducing the operating temperature of the supercharger unit is very important. We designed this heat shield using high tech aluminized radiant barrier material to lower the temperature and increase supercharger efficiency. Using pyrometers we measured a 12 degree drop in 60-70 mph driving temperature and a whopping 30 degree drop in temperature after slowing from freeway speeds.

Internal Bypass (Current Design) 150-065 \$239.99



**Performance Tappet Sets**

The tappet takes the brunt of the punishment in the engine as it rides on a thin film of oil on the cam lobe. In an effort to offer the engine builder alternatives we carry a range of tested and uprated tappets. These are the later, lightweight bucket design originally supplied in the 18V MGB engine. They can be retrofitted to earlier engines by using stock 18V pushrods (#460-615) or lightweight tubular pushrods (#460-616).

**Tested Tappet Sets**

These tappets are inspected for dimensional accuracy, and then hardness tested to ensure a hardness of HRC 54-58. The face of the tappet is crowned slightly to ensure rotation and then polished. Finally, the tappet is Parkerized for improved oil retention during startup. The lifter set is supplied with installation instructions and assembly lube (#221-565). These processes are time intensive, but result in a tappet that meets all known original specifications.

**APT Super Duty Tappet Sets**

These tappets have a typical surface hardness of above HRC 60 and feature an oil lubrication hole and precision ground face.

Tappet Set, Tested 460-604 \$259.99  
Tappet Set, Super Duty 460-601 249.99



**Harmonic Crank Balancer**

A rubber insulated crank damper dramatically smooths out engine vibration, significantly reducing engine wear. Give your MGB the benefit of this later technology. These new units are produced in Australia and engineered to the highest standards.

Crank Balancer 433-707 \$389.99



460-596



460-591

**Timing Chains by iwis**

Keep the valves and pistons working in perfect sync with these high quality and heavy duty timing chains. Made of steel, these German made roller chains are acoustically optimized with gap damping between roller and bush. Excellent wear resistance for high-speed applications, this chain will not stretch.

MGB 1962-71, Double Row 460-591 \$48.99  
MGB 1972-80, Single Row 460-596 44.99  
MGC 832-001 52.99



**ARP Performance Fasteners**

Have confidence in premium-grade 8740 Chrome-moly steel with a tensile strength of 200,000 psi. These studs are rolled after heat treat to provide up to 10 times longer fatigue strength. Precision CNC machined to exact specifications.

Head Stud Kit 322-858 \$189.99  
Rod Bolt Kit: 18GB-18GF (angled rods) 322-845 66.99  
Rod Bolt Kit: 18GG-18V (straight rods) 322-848 149.99  
Main Cap Stud Kit, 3-Main 322-868 104.99  
Main Cap Stud Kit, 18GB-GK 322-938 149.69  
Main Cap Bolt Kit, 18V 322-948 159.99



\*See ordering page for details

⚠ WARNING: Cancer and Reproductive Harm. www.P65Warnings.ca.gov







**Cooling Fan Kit by Revotec**

Electronic fan kit co-designed by Moss and Revotec. Designed to replace the mechanical fan, to reduce engine load and noise and improve power and mpg. Not a universal kit, this kit comes with MGB specific installation instructions and laser cut brackets that mount directly to the radiator mounts. High efficiency fans and adjustable electronic controller. Negative Ground only.

MGB 1962-76	231-681	\$434.99
MGB 1977-80	231-682	419.99
Manual Override Switch	231-725	69.99
MGB 1962-67 Positive Ground	231-793	439.99
MGC	231-794	499.99



**Hayden Electric Fans**

Designed to be set up to run in either "pusher" (in front of the radiator) or "puller" configuration. The 10" fan requires a clear mounting area of at least 10 7/8" x 11 1/8", while the 12" requires at least 11 7/8" x 12 1/2". The 14" requires at least 13 1/16" x 14 3/4". The preset temperature control will turn the fan on at 185 F and off at 170 F. Select your application below.

10" Electric Fan Kit, All	231-678	\$164.99
12" Electric Fan Kit, 1977-80	231-688	164.99
14" Electric Fan Kit, 1977-80	231-658	184.99



**Electronic Fan Controller by Revotec**

Built using the latest technology, components and assembly methods, Revotec's engineering team has developed a robust and reliable electronic fan controller that can be adapted to any electric fan. Engineered to overcome problems associated with capillary-action and clip-on devices, this non-leaking unit is installed in a water hose but will not obstruct coolant flow. Listed sizes refer to the hose I.D. Easy to install, a relay and all necessary fittings are included.

**Electric Fan Controller Hose Set**

Hose Set	231-735	\$34.99
----------	---------	---------

**Negative Ground**

25 mm	231-740	\$144.99
28 mm	231-742	139.99
32 mm	231-744	139.99
35 mm	231-746	139.99
38 mm	231-748	139.99

**Positive Ground**

25 mm	231-741	\$199.99
28 mm	231-743	199.99
32 mm	231-745	199.99
35 mm	231-747	199.99
38 mm	231-749	199.99



**Silicone Hose and Clamp Set**

Silicone better resists cracking, aging and chemicals than rubber hoses. Kit includes: 2 radiator hoses (replaces the water pipe branch assembly), 2 heater hoses, 8 clamps. Trim lower heater hose to fit for 1974-74 applications.

1962-74	470-280	\$79.99
---------	---------	---------



**Silicone Hoses by Cobalt**

Upgrade your cooling system with silicone hoses by Cobalt. Cobalt silicone hoses are made with a multi-layer silicone with embedded fiber to provide a great heat resistance which in turn improves reliability, durability, and performance.

Radiator Hose - 1962-76	470-286	\$10.99
Lower Hose - 1972-74	470-287	19.99
Heater Hose	470-288	5.49



**Revotec Manual Override Switches**

Revotec switches manually control your Revotec Fan Controller. Available as a 3-way rotary switch with On, Off, or Automatic positions or as a 2-way Jaguar-style toggle switch with On or Automatic. Each switch is supplied with a mounting bracket, wiring, decals, and hardware.

3-way Rotary	231-725	\$69.99
2-way Jaguar-Style	231-726	49.99



**Fan Shroud**

The engine driven fan in the MGB pulls air through the core in the donut-shaped area swept by the blades. The rest of the core only has significant air flow at speed. With the fan shroud fitted, the fan creates a low pressure area behind the entire core. Air flows through the whole core, making it much more efficient. This can make a huge difference when you are stuck in traffic or driving through town at relatively low speeds.

MGB 1962-76	459-685	\$64.99
-------------	---------	---------

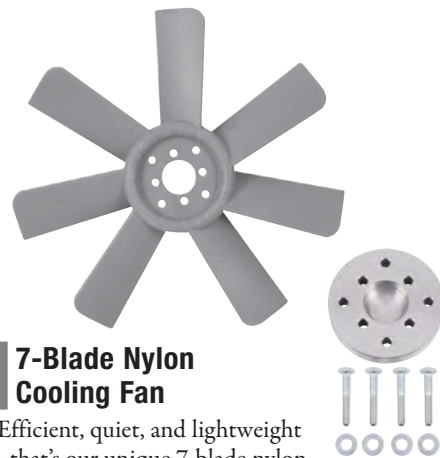

**7-Blade Nylon Cooling Fan**

Efficient, quiet, and lightweight - that's our unique 7-blade nylon cooling fan. It's a direct fit replacement for the difficult-to-find metal bladed original, and it is an improvement your radiator will approve of. This fan can be fitted to 1972-76 MGB's when used with adapter 434-341.

Replacement Fan	434-332	\$69.99
1972-76 Adapter	434-341	23.99



\*See ordering page for details

⚠ WARNING: Cancer and Reproductive Harm. www.P65Warnings.ca.gov



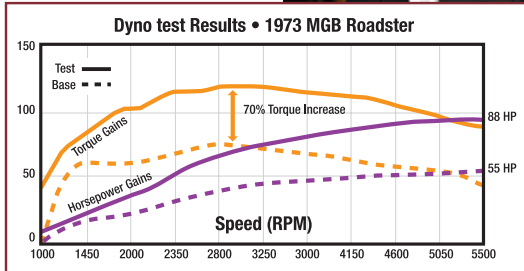
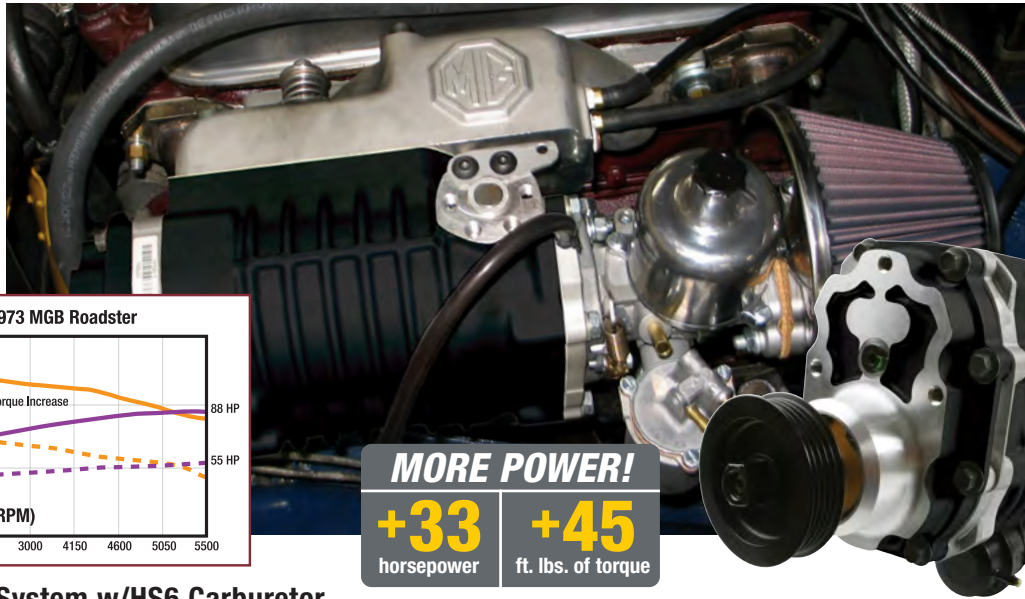

**MORE POWER!**  
**+33** horsepower  
**+45** ft. lbs. of torque

### MGB Supercharger System w/HS6 Carburetor

Our Moss MGB supercharger system uses the same Eaton positive displacement roots-type supercharger found on contemporary OEM applications such as Mercedes Benz and Jaguar. In spite of its modern origin, we carefully designed the system to look like it was a factory installed option that complements the classic MG image.

Our engineers designed an intake manifold that provides equal airflow, pressure, and fuel mixture to each cylinder. By optimizing the distribution in the manifold for each cylinder, you can run more boost pressure without the chance of harmful detonation. Our Moss supercharger system produces 5-6 psi of boost at sea level and bolted to a stock engine you can expect a minimum 50% increase in rear wheel horsepower. The Supercharger kit is complete and includes a 4 rib serpentine belt drive system, new cast iron water pump, a set of colder NGK BPR7ES sparkplugs and a high-flow K&N air filter. The 1968-74½ kit also includes a new Lucas high output alternator. A list of Frequently Asked Questions and detailed installation instructions with photos are available online at [www.mossmotors.com](http://www.mossmotors.com). The installation can be completed by a competent mechanic or hobbyist with hand tools. Installation time will vary depending on many factors, we have had reports of up to 12 hours of shop time necessary to complete installation and tuning.

*Note: 1975 cars require 1976-80 pedal box. Contact the Moss Tech Department for details.*

1965-67	150-050	\$5,399.00	
1968-74	150-060 <sup>1</sup>	5,499.00	
1975-80	150-070 <sup>1</sup>	5,499.00	
HS6 Jet Needle, BCG	374-377	21.99	

<sup>1</sup>May not be legal on emission controlled vehicles. Check your local laws for compliance.

**TOP SELLER**

### Weber Downdraft Carb Kits

The Weber DGV two barrel progressive carburetor has proven to be the most popular replacement for worn out or damaged stock carburetors and gives a good combination of performance and economy on stock engines. Our Weber DGV kits come pre-jetted for the listed applications. Kits include instructions, carburetor, manifold/adapters, linkage and air filter. Please note that there is no provision for emission connections and some modifications will be required for best operation. A separate exhaust manifold or header is required for installation on single Zenith-Stromberg carbureted MGBs.

Manual Choke (1962- mid 1974)	222-260 <sup>1</sup>	\$619.99
Electric Auto. Choke (mid 1974-1980)	222-265 <sup>1</sup>	629.99
Carb Rebuild Kit - w/ Power Valve	222-266	64.99
Replacement Filter Assy.	222-365	39.99
Replacement Filter Element	222-364	20.99

<sup>1</sup>May not be legal on emission controlled vehicles. Check your local laws for compliance.

**WEBER**  
CARBURETORS

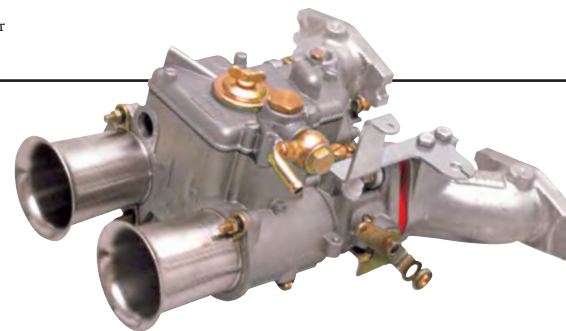

### Weber DCOE Conversion

High performance DCOE carburetors are still the enthusiast's choice to extract maximum power. The kit includes manifold, linkage and carburetor with ram pipes. Our Weber DCOE kits come pre-jetted for the listed application. However, fine tuning will be necessary. We recommend that tuning be performed by an experienced tuner. Please note that there is no provision for emission connections and some modification will be required for best operation. Mounts to carb using existing float bowl screws.

Single 45DCOE Kit	222-460 <sup>1</sup>	\$1,099.00	
Stainless Steel Heatshield	865-220	39.99	

<sup>1</sup>May not be legal on emission controlled vehicles. Check your local laws for compliance.

Pricing is subject to change.

Please visit [MossMotors.com](http://MossMotors.com) for current pricing and availability.

PERFORMANCE



**FREE SHIPPING**  
ON ORDERS OVER \$700

372-248

**New SU Carburetor Sets**

Genuine SU carburetors are now being produced in the UK from a combination of new and original tooling. These brand new carburetors will improve the way your car looks and runs. Rebuilt carbs are nice, but after decades of use they'll never look or perform as well as new ones. Sold as a pair.

1962-67 HS4 Set	372-248	\$2,099.00		1969 HS4 Set	366-498	1,799.00	
1968 HS4 Set	366-478	1,899.00		1970-71 HS4 Set	366-488	1,999.00	



**1 3/4" SU Carburetor Conversion with Heatshield**

Increase flow to your cylinder head with this conversion. Includes two SU HS6 1 3/4" carburetors, intake manifold and linkage. Some fabrication will be required. A separate exhaust manifold or header is required for installation on single Zenith-Stromberg carbureted MGBs.

Carburetor Set	366-418 <sup>1</sup>	\$2,899.00	
Ram Pipe Set	372-445	79.99	

<sup>1</sup>May not be legal on emission controlled vehicles. Check your local laws for compliance.



**Heatshield for 1 3/4" SU**

Replace missing or damaged heat shield on most 1 3/4" conversion manifolds such as #366-418 and #366-398.

Heatshield for 1 3/4" SU Set	366-419	\$129.99
------------------------------	---------	----------

**Dashpot Cover**

Brighten up your engine bay with some chrome plated dashpot covers. Fits SU HS4 and HS6. Sold individually.



SU HS4/6 - Chrome	374-575	\$20.99
-------------------	---------	---------



**1975-80 Single Carburetor Conversion**

Replace your worn out original Zenith-Stromberg 175 carburetor with a new, easier to tune, manual choke SU carb. Mounts to existing manifold and maintains the original look of the engine compartment. Please check your local emission statutes for legality. Does not include air cleaner assembly.

1975-80 Conversion	370-678 <sup>1</sup>	\$1,699.00	
K&N Air Filter	222-905	169.99	

<sup>1</sup>May not be legal on emission controlled vehicles. Check your local laws for compliance.



**MG Crested Carburetor Caps**

Add unique distinction to your engine compartment with these solid brass caps. Your original damper rod must be reused and pressed into the new cap. SU carburetors only.

Dashpot Caps, pair	370-735	\$39.99
--------------------	---------	---------



**Dual Mikuni 36 Carburetor Conversion**

If the name Mikuni rings a bell, odds are you've spent some time on two wheels. Moss is proud to have a relationship with this legendary motorcycle carburetor company and, in our ever-present quest to breathe new life into classic cars, we've developed a modern, performance carburetor system that's perfect for the MGB. In fact, it's revolutionary.

Right out of the box, the Mikuni system is ready to bolt on a stock MGB and outperform whatever you've been using. Immediately you'll notice the improved throttle response that comes from the integrated accelerator pump. And you can tune this carb to work with engines built for higher revs and higher compression. The Mikuni's can support more horsepower with more fuel flow than stock Sus.

The Mikuni system is more adjustable and easier to tune than either the Weber or SU carbs. Mikuni's have replaceable needles, pilot jets and main jets. They also feature adjustable accelerator pumps, throttle stops, idle screws, idle mixture screws and needle positions.

This conversion kit does not come with air filters. Moss developed the carburetors using high performance filters with a classic design. Filters are part #053-391. Two required.

Dual Mikuni 36 Carb Conversion	366-380	\$1,299.00	
PCV Kit	366-395	64.99	
Air Filter	053-391	34.99	



**Weber DCOE Soft Mount Kit**

Vibration wreaks havoc with fuel flow. A Weber DCOE soft mount kit helps dampen these vibrations by isolating the carburetor from the manifold, and improves carburetor efficiency.

DCOE Soft Mount Kit	222-251	\$32.99
---------------------	---------	---------





### Touring Fuel Tanks

The extra capacity “Touring” fuel tank was developed by Moss Motors for MGB/C owners looking for a few extra miles between fill-ups. This tank has a 16 gallon capacity, and is also a great choice for 6 or 8 cylinder applications. Compatible with stock fuel sender.

#### Tank Features include:

- Internal baffling for better fuel control
- Bottom mount low-profile drain plug for easy service/cleaning
- 16 gallon capacity for increased driving range
- Manufactured from Terne Coated Steel to help prevent internal corrosion
- Exterior black paint for OE style looks
- Guaranteed fit and function

*Note: 471-203 (MGB 1970-75) will fit the 1976 MGB, but a correct filler neck must be sourced.*

1965-69	456-776	\$229.99	OS
1970-75	471-203	229.99	OS
1977-80	471-223	229.99	OS



### ECCO Plastic Body Fuel Pump

The ECCO electric fuel pump is a direct replacement for the SU pump. It is made from mostly plastic materials with the main coil housing assembly being made from Glass Reinforced Poly. There is a decades old, lingering misconception that the plastic will crack at the banjo. Rest assured, this is not the case with the modern pump. The ECCO pump is hand built, and the quality of the end product is heavily scrutinized during production. This pump will operate trouble free for years to come. Works on positive or negative ground vehicles.

Fuel Pump, Plastic Body, ECCO	377-162	\$189.99
-------------------------------	---------	----------



### Facet Solid State Fuel Pump

Solid state electric fuel pumps can be used in conjunction with, or in place of, your original pump. Push or pull fuel from a discreet location under the car, through your original pump, or put it in line with a power switch and use it as a backup. Producing 1.5 to 3 psi, it is perfect for SU carburetors. Works on positive or negative ground cars.

Solid State Pump	377-420	\$109.99
Facet Filter	377-424	12.99



**Lucas**

### Universal Fuel Pump Kit by Lucas

The Lucas universal fuel pump kit is an extremely quiet and reliable steel cased sealed unit with zinc plating. It includes attached filter, mounting bracket, push-on fuel pipe unions, two 3.4" lengths of fuel line, and hose clips. This dual polarity 12v electric fuel pump is a replacement for AUA66 and AUA25 (Positive and Negative Earth). Suitable for all single, twin, and triple carburetor installations. A fuel pressure regulator may be required dependent on application/usage.

#### Technical specs:

- E85/ethanol compatible
- 6.77" Long 2.13" Dia
- 5 amps Current Draw
- Inlet and outlets threaded 1/8" NPT
- 8.5 psi max output

Fuel Pump	377-186	\$119.99
-----------	---------	----------

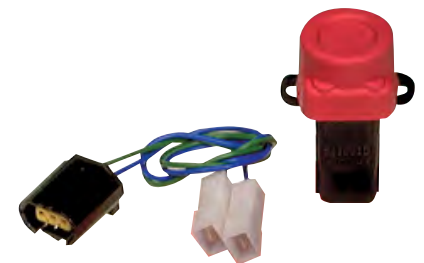

### Inertia Fuel Pump Switch

The Inertia Switch will cut off power to the fuel pump instantly in a roll-over, or when the vehicle is impacted with sufficient force in any horizontal direction. Instructions included.

Inertia Switch	900-240	\$61.49
----------------	---------	---------



Pricing is subject to change.

Please visit [MossMotors.com](http://MossMotors.com) for current pricing and availability.

PERFORMANCE



### SU Competition Double Ended Fuel Pump

Double ended SU pumps have been standard equipment for years on Aston Martins, Bentleys and late model E-Types. Get twice the capacity of a standard type pump with the added confidence of knowing that these units will keep pumping, even if one side fails. Well suited for all high performance engines running SU carbs, as no pressure regulator is required. Will require fabrication of a bracket or use bracket below.

Std. Points Non Polarized	377-036	\$699.99
Solid State Neg. Ground	377-335	699.99
Bracket, 2 req	377-350	10.79
Sleeve, Bracket, 2 req	377-360	2.19



### SU Solid State Fuel Pump

Solid State electric fuel pumps with modern, reliable electronics eliminate the use of contact breaker points. Now you can have a vintage looking SU fuel pump with peace of mind that only an electric fuel pump can offer. Plus, the characteristic ticking is retained.

Pos. grd. to (c)44438	377-235	\$399.99
Neg. grd. to (c)44438	377-225	399.99
Pos. grd. from (c)44439	377-245	449.99
Neg. grd. from (c)44439	377-255	399.99



### Kas Kastner Velocity Stack by ARE

Authentic Kastner velocity stack reproductions from Alexander Racing Enterprises are engineered for race and street performance with guidance from the racing performance legend himself. Kas Kastner developed the original stacks in the early 60s utilizing extensive dyno testing. Still today, the airflow improvements reflect Kastner's relentless determination for a performance edge. For street use, screen filters (sold separately) are strongly recommended.

#### Construction details:

- Polished spun aluminum w/ tig welded flange
- 5.2" OD of bell, 2.5" length overall
- Fits 1.75" SU's and early ZS Carbs

Velocity Stack	374-800	\$99.99
Filter	374-805	69.99

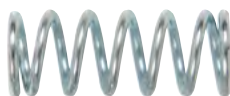

### Knurled SU Idle Screw Kit

Fine-tune your idle without having to reach for a screwdriver. Made specifically for the SU carburetor, this upgrade is quick and easy.

Knurled SU Idle Screw Kit	372-835	\$18.99
---------------------------	---------	---------

### Ram Pipe Kits

Upgrade your classic's performance with a high-quality ram pipe kit. The short ramp pipe kit is fitted with a screen making it ideal for a street application, providing additional performance and an aggressive look under the hood. Sized specifically for SU carbs. Each kit is sold per carb.



1½" Ram Pipe Kit - H4, HS4, & HIF4 carbs	372-566	\$91.99
1¾" Ram Pipe Kit - HD6 & HS6 carbs	372-567	99.99

EXCLUSIVE



MORE INFO ONLINE

### Cold Air Intake

After years of witnessing people trying to fabricate cold air boxes, we developed a clean, functional solution that has been engineered with airflow foremost in mind.

We integrated a pair of computer designed velocity stacks with a modern remote air filter assembly and designed it to fit both the early and late cars, by giving it clearance for the brake servo on the later or converted MGBs. Then we supplied it with a modern air filter that can be fitted without any modifications. To take things one step further, the design is such that if the hole in the radiator diaphragm is enlarged, the air filter can be remote mounted behind the grille by using readily available flex hose, for full cold air intake.

MGBs with Twin Sus	223-065	\$299.99
Replacement Filter	053-474	99.99



### Premium Manifold Gasket

- U.S. Sourced Premium Manifold Gasket
- Pattern taken from original heads
- Ports sized for street modified heads
- Cleanly cut with no deformation
- Excellent crush characteristics for the best seal
- Aerospace quality tin plated steel faces
- High temperature fiber core
- Material rated for 1,832 F
- Manufactured domestically

Premium Manifold Gasket	297-535	\$9.79
-------------------------	---------	--------



### Competition Manifold Gasket

Designed for use with modified heads with extra large ports. Careful port matching is recommended to ensure proper seal to the header flange.

Manifold Gasket	297-545	\$10.79
-----------------	---------	---------



\*See ordering page for details

WARNING: Cancer and Reproductive Harm. www.P65Warnings.ca.gov







### Fuel Filter/Regulator

High quality universal fuel pressure regulator with integral filter comes with 1/4" and 3/16" fittings. Pressure adjustment is 3 psi to 9 psi. Pre-set to 3-3 1/2 psi for SU & ZS carbs. Made in Italy.

Fuel Filter/Regulator	377-435	\$149.99
Replacement Filter	377-436	17.49
Replacement Bowl Gasket	377-437	8.19



### Ram Pipe Sets

A racing tradition, now available in long (3") and short (1 1/4"). Set of two. Check with your salesperson if you are unsure which carburetor you have.

<b>Long</b>		
HS/HIF4 Carbs	372-410	\$79.99
HS/HIF6 Carbs	372-435	79.99
<b>Short</b>		
HS/HIF4 Carbs	372-415	\$79.99
HS/HIF6 Carbs	372-445	79.99



### Manual Choke Conversion Kit

Designed in England by Zenith-Stromberg. Easily install this kit with included mounting hardware and detailed instructions.

1975-80 Choke Kit	386-325	\$129.99
-------------------	---------	----------



### Vintage Style Chrome Air Filter

Ultra-thin design, beautifully plated. Sold individually.

1 1/2" SU Carbs, each	223-200	\$54.99
-----------------------	---------	---------

### K&N Air Filters



K&N air filters are designed to be washed and reused for the life of your engine. Have confidence in the K&N ten year/one million mile (non-competition use) warranty. All sold individually.

#### Chrome K&N Assembly 175CD Zenith-Stromberg

1 3/4" deep	222-965	\$169.99
3" deep	222-990	259.99

#### Chrome K&N Filter Assemblies For 1 1/2" SUs

1 3/4" deep	222-935	\$139.99
3" deep	222-950	129.99
2" deep, tapered	222-985	129.99

#### Chrome K&N Filter Assemblies For 1 3/4" SUs

1 3/4" deep	222-955	\$139.99
3" deep	222-960	129.99

#### Chrome K&N Filter Assemblies Weber DCOE

1 3/4" deep, each	222-245	\$146.99
3" deep, each	222-240	119.99

#### Chrome K&N Filter Assemblies Weber DGAV

1 3/4" deep	222-366	\$189.99
-------------	---------	----------

#### Cleaning Supplies

Filter Recharging Kit	001-130	\$36.99
Filter Cleaning Fluid	231-480	16.99
Filter Oil Bottle (250 mL)	231-490	9.99

#### K&N Air Filter Elements For Stock Applications

MGB 1962-74, each	372-395	\$69.99
MGB 1975-80	372-465	83.99



### K&N Air Filter for twin 1 1/2 SUs

The twin SU conversion is a popular modification for a 1976-80 MGB. The tapered, 2" K&N filter is a perfect, high-performance solution for this tight fit.

2" deep, tapered	222-985	\$129.99
------------------	---------	----------



222-965



222-366



231-480



231-490



### 1962-74 K&N Air Filter Assembly

Filter plate sets include two pre-oiled K&N air filters and a cast aluminum cover plate. Set replaces your original air filter canisters. Requires original air filter base plates.

1962-74 Assembly	222-910	\$249.99
------------------	---------	----------



### Chrome Crested Filters

Enhance the appearance of your SUs. These filters install using stock hardware and gaskets. Sold individually.

MG Crested 1 1/2" SUs	223-290	\$64.99
SU Crested 1 1/2" SUs	223-295	64.99

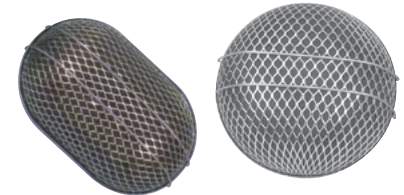

### Foam Air Filters

The traditional performance washable foam air filters.

Oval for 1 1/2" SU	223-220 <sup>1</sup>	\$43.99
Round for 1 1/2" SU	223-230 <sup>1</sup>	46.99
Oval for 1 3/4" Z-S	223-240 <sup>1</sup>	46.99
Replacement Foam - Oval	37-0893	15.99
Replacement Foam - Round	37-0890	15.99

<sup>1</sup>May not be legal on emission controlled vehicles. Check your local laws for compliance.



### Stainless Steel Sport Exhaust by Tourist Trophy

This beautiful Tourist Trophy polished stainless steel sports exhaust system is manufactured using the highest quality materials and workmanship.

The system is designed for an easy fit using flange joints rather than the traditional sleeved pipes. It also uses more reliable modern rubber hangers and is supplied with special hanger conversion brackets.

The system features a single silencer with a sporty slash-cut tailpipe (using a single silencer gives better ground clearance for lowered cars). The box is packed with a combination of stainless steel wire wool and fiberglass. This gives a throaty exhaust note under acceleration that isn't intrusive when cruising.

- 1.2 mm thick 201 grade stainless steel
- Single sports rear silencer
- CNC cut flange joints
- 409 stainless steel used for inner core and perforated tubing
- Manifold primary pipes are beautifully blended into merged collector
- Entire system is polished to a mirror shine
- Sporty slash-cut tailpipe
- Includes gaskets and installation hardware
- 5-year Warranty

Now featuring fitment options for Rubber Bumper cars<sup>2</sup>

MORE INFO ONLINE



**Fitment Details:**

Includes hanger brackets for both chrome bumper (1962-74) and rubber bumper (1975-80) ride height vehicles. For the later Rubber Bumper vehicles, we recommend either a turn down tip or shielding to protect the bumper from exhaust heat.

**Exhaust and Header Kit** - A direct fit for 1962-74 cars. 1975-80 cars will require that the original one-piece manifold be replaced with a separate intake manifold. The flange will need to be shimmed to fit alternate intake manifold.

**Exhaust and Down Pipe Kit** - Connects to original 1962-74 cast iron exhaust manifold. 1975-80 cars will require the early cast iron manifold be used.

1962-74 Exhaust and Header	459-085 <sup>1</sup>	\$729.99		Muffler Only	459-077	199.99
1975-80 Exhaust and Header	459-085 <sup>2</sup>	729.99		Replacement Rubber Hanger	180-659	9.99
1962-74 Exhaust and Down Pipe	459-075	599.99		Replacement Exhaust Flange Gaskets	052-342	12.99
1975-80 Exhaust and Down Pipe	459-075 <sup>2</sup>	599.99				

<sup>1</sup>If using with a Moss Motors supercharger, the front header pipe will need to be slightly reformed for clearance.  
<sup>2</sup>See Fitment Details above for information regarding Rubber Bumper vehicles.



### Stainless Steel Touring Exhaust by Tourist Trophy

Yes, it is the best looking exhaust on the market. But even if it wasn't, it would still be the best you could buy. Judged purely by build quality and the oh-so-important "original British sports car sound," the Tourist Trophy Touring exhaust is in a class of its own. Designed as a high-end stock replacement, this system maintains both the resonator and muffler for a quiet ride. It is built from a durable stainless steel with a highly polished finish will stay beautiful and solid for many years to come.

**The Tourist Trophy Exhaust features:**

- 201 Stainless Steel construction used for the muffler shell, pipes and tips
- Muffler packing is a combination of stainless steel wool and fiberglass for a classic sports car sound that is throaty under acceleration but never intrusive while cruising
- Entire system is completely polished to a mirror shine
- Uses all the original hangers and supports
- 5-year warranty

1962-74                      454-569      \$599.99



MORE INFO ONLINE





**EXCLUSIVE**



**Exhaust Heat Shield**

Another Moss Exclusive! Our R&D department has come up with another great product for your MGB. This heat shield anchors to the frame and cross member lowering the ambient temperature of your floorboard by 30 degrees. You can retrofit this heat shield or pair it with our new stainless steel sport exhaust. A perfect Saturday morning project, our heat shield is easy to install with basic hand tools. Will not fit some header equipped cars.

Heat Shield 409-120 \$189.99



**Header and Manifold Blanket**

Header Manifold Blanket 337-445 \$169.99

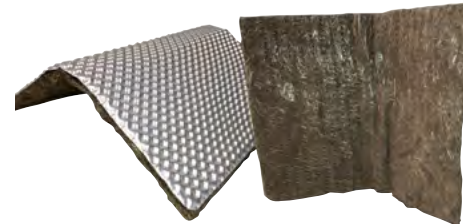

**Form-A-Shield by DEI**

Form-A-Shield 231-905 \$109.99



**Stainless Steel U-Bolt Type Exhaust Clamps**

1½"	412-200	\$8.49
1¾"	412-201	8.49
1"	412-202	8.99
2"	412-203	8.99
2½"	412-204	9.99
2¾"	412-205	10.49

**Monza Free-Flow Exhaust**

Increase both your horsepower and your gas mileage by reducing exhaust gas back-pressure. Produces a nice mellow tone and the sharp looks will add to your car's appeal. Heavy gauge steel, black with chrome tipped ends. Requires stock downpipe or header for installation.

MGB 1975-80 454-556 \$374.99

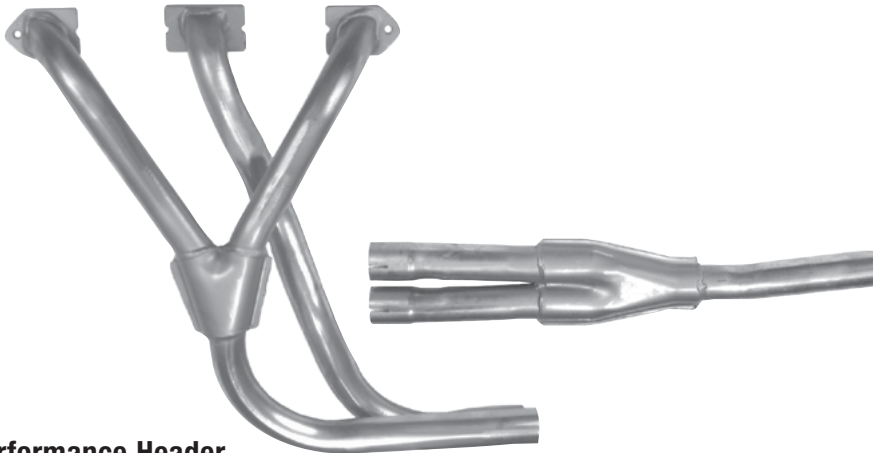

**Performance Header**

This tubular exhaust header is suitable for vintage racing or the sporting enthusiast. Header is jig welded and designed for maximum performance. Hand fitting and port matching required, particularly for racing applications.

Stainless Steel 459-015<sup>1</sup> \$519.99

<sup>1</sup>May not be legal on emission controlled vehicles. Check your local laws for compliance.



**3-1 Short Exhaust Header**

American made short header design offers improved ground clearance and easy installation. Modify this header for use on other B-Series engine vehicles such as TVR and Nash Metropolitan.

3-1 Header 459-011<sup>1</sup> \$274.99

<sup>1</sup>May not be legal on emission controlled vehicles. Check your local laws for compliance.



**REMFLX**  
EXHAUST GASKETS

**High Performance Manifold Gasket by Remflex**

Add value to your classic car with a high-performance manifold gasket by Remflex. These gaskets work because they solve the two main problems associated with sealing an exhaust flange: warping and gasket failure. Made from 100% flexible graphite, these unique gaskets come in a standard 1/8" thickness and are designed to crush 50%, allowing them to fill gaps in the flange surface. They can withstand temperatures up to 3,000 °F and will not burn out, shrink, or leak ever! These exhaust gaskets also rebound 30%, creating an optimum seal that eliminates the need to re-torque. With so many benefits, don't think twice before offering your classic car the advantage of a quality manifold gasket.

MGB 695-081 \$49.99



**Stainless Steel Band Type Exhaust Clamps**

1½" (1.457-1.575")	412-025	\$4.99
1¾" (1.575-1.693")	412-026	4.99
1" (1.693-1.850")	412-027	6.99
1¾" (1.850-2.008")	412-029	6.99
2" (2.008-2.165")	412-030	6.99

Pricing is subject to change.

Please visit [MossMotors.com](http://MossMotors.com) for current pricing and availability.

PERFORMANCE



**2-Piece Muffer Shield Kit by DEI**



Designed to reduce radiant heat coming off your muffer resulting in a cooler interior and protection from damaging heat. This 2-piece shield is made from 10mil dimpled aluminum and a 1/8" glass fiber insulator that can be easily trimmed to fit most mufflers. Includes tough stainless steel positive locking ties for a secure installation.

**Features:**

- Insulating inner layer
- Heat reflective outer layer
- Stainless steel straps for secure fit
- Handles direct heat up to 1100 degrees Fahrenheit

**Advantages:**

- Extremely light weight
- Simple to install
- Acts as thermal barrier to prevent heat intrusion

**Benefits:**

- Cooler more comfortable interior
- Keeps components protected from heat
- Prevents heat soak into lines & hoses that are close to mufflers

**Kit Includes:**

- One Sheet - 42" x 24" Dimpled Aluminum
- One Sheet - 51" x 24" Glass Fiber Insulation
- Four - 40" x 1/2" Positive Locking Ties
- FREE Locking Tie Tool

2-Piece Muffer Shield Kit      232-005      \$85.99



**Cool Tape by DEI**

Cool Tape is a flexible and super strong self-adhesive thermal insulating tape with a Radiant Heat Resistance of 2,000 F. Made of one mil aluminized material bonded to a woven glass-fiber heat-resistant matting, Cool Tape is an ultra-lightweight heat reflective solution for wrapping wires, cables, hoses, fuel lines, and seams.

15 ft      231-940      \$22.99  
 30 ft      231-941      42.99



**Exhaust Wrap and Tie Kit by DEI**

Reduce unwanted and harmful heat under the hood while improving performance with the DEI Pipe Wrap. This kit includes a 25-foot roll of 2-inch wide exhaust wrap that offers a Direct Heat Resistance of 1,800 F, and Radiant Heat Resistance of 2,500 F, as well as four 8-inch stainless-steel locking ties to secure the wrap.

Black      231-930      \$38.69  
 Tan      231-931      37.49  
 Titanium      231-932      42.99



231-953

231-957



231-956

**Heat Reflective Sheeting by DEI**

Protect against the high-temperature areas of your car with the heat reflective sheets and tape by DEI. The Reflect-A-Gold products are made from a metalized polyamide polymer laminated to a lightweight glass fiber cloth with a high temperature pressure sensitive adhesive, and the Reflect-A-Cool sheet is made from fiberglass and backed with a layer of aluminized reflective foil. Both are great ways to keep interior components cool. The 0.0065" thickness makes them highly effective for covering areas of minimal clearance. While the tape is a suitable for wrapping wires, cables, hoses, or fuel lines etc., the sheets are apt for firewalls, fuel cells, engine compartment, bulk heads, seat bottoms and more. The lightweight products can be easily cut or trimmed and wrapped around parts for an easy installation. Efficiently handle high temperatures at reasonable price.

**Features:**

- The Reflect-A-Cool Heat Reflective Sheets have a Direct Heat Resistance of 400 F and Radiant Heat Resistance of 2000 F
- The Reflect-A-Gold Heat Reflective Sheet and Tape have Adhesive Heat Resistance of 325 F and Radiant Heat Resistance of 850 F
- Easy to apply, won't lift off
- Moisture and solvent resistant
- Self-adhesive backing to peel off and stick
- Resists UV degradation for long-term performance

Product	Part Number	Price
<b>Reflect-A-Cool</b>	12" x 12"	231-953 \$14.39
	12" x 24"	231-952 25.99
	24" x 24"	231-951 31.49
	36" x 48"	231-950 87.99
<b>Reflect-A-Gold</b>	12" x 12"	231-956 \$24.99
	12" x 24"	231-955 43.99
	24" x 24"	231-954 82.99
<b>Reflect-A-Gold Tape</b>	1 1/2" x 15"	231-957 \$43.89
	1 1/2" x 30"	231-958 77.89



\*See ordering page for details

⚠ WARNING: Cancer and Reproductive Harm. www.P65Warnings.ca.gov





## PERTRONIX

### Flame Thrower Electronic Distributors by Pertronix

A modern electronic ignition unit already installed in a brand new distributor body. Just swap your worn out distributor and drop in the Flame Thrower. The drive dog is already installed. Two wire hookup to the coil makes wiring easy and the improved advance curve gives great performance and drivability. The vacuum advance is calibrated for use on carburetors that have ported vacuum, but in many cases will work well with manifold vacuum. The distributor is the 45D style.

4-Cylinder, Neg. Ground	143-116 <sup>1</sup>	\$359.99
4-Cylinder, Pos. Ground	143-125	379.99
6-Cylinder, Neg. Ground	143-135 <sup>1</sup>	399.99
6-Cylinder, Pos. Ground	143-145	389.99
<b>Replacement Parts</b>		
4-Cyl Cap	143-117	\$13.99
6-Cyl Cap	143-137	20.99
Rotor	143-126	12.29
Module, Pos. Ground	143-127	156.99
Module, Neg. Ground	143-118	129.99

<sup>1</sup>Not for use with solid core ignition wires.



### Race Distributor

This points-type distributor has an advance curve designed for use with long duration race cams. Centrifugal advance only, for the serious racer.

45D Race Distributor	143-165 <sup>1</sup>	\$239.99
Replacement Points	153-915	5.99
Replacement Rotor	151-855	4.49
Premium Rotor	151-865	16.49
Replacement Cap	151-875	14.89

<sup>1</sup>May not be legal on emission controlled vehicles. Check your local laws for compliance.

### Optimized Distributors by CSI

CSI-Optimized Distributors offer a fully electronic ignition system built into the correct type of Lucas distributor housing to suit your car, keeping the original appearance in the engine bay. Gone are the points and condenser and mechanical advance mechanism, all replaced with a high quality electronic ignition system. These distributors are maintenance free (no points to adjust), and offer the benefits of, easier starting & smoother running, more torque & power, reduced fuel consumption & emissions.

Each CSI-Optimized Distributor features 16 easily switchable, optimized ignition curves to allow timing adjustment to suit your car's engine and fuel specifications. Alternative advance curves can be selected to suit your engine's state of tune making them ideal for both stock and modified engines. Curves are easily selected using a screwdriver in a rotary switch, with a bright flashing LED indicator to show the selected curve all concealed underneath the distributor cap.

Since the CSI-Optimized Distributor uses the correct type of distributor body for the application it is a direct swap. Full instructions and ignition curve selection guidance is included. Requires a 3 ohm Coil such as our Intermotor Sport Coil (#143-201).

*Note: Ballast resistor should be bypassed if fitted.*

1962-67 - 25D4 Positive Ground	143-291	\$479.99
1962-74 - 25D4 Negative Ground	143-290	479.99
1975-80 - 45D4 Negative Ground	143-292	479.99



### Ignition Tune Up Kit

Get everything you need to tune-up your classic car with this high-quality Ignition Tune-Up Kit! This all-in-one kit saves you time and money while boosting your engine's performance and efficiency. Upgrade using the standard kit or give your ignition a boost with the premium. Both have everything you need to check and replace while doing a tune-up.

#### The Standard kit includes:

- OE Style Distributor Cap
- Premium Rotor
- Points & Condenser (where applicable)
- Wire set
- Champion Spark Plugs

#### The Premium kit includes:

- Distributor Cap
- Premium Rotor
- Premium Points & Condenser (where applicable)
- Cobalt Performance Wire Set
- NGK Plugs

#### Premium

MGB 62-74 25D	225-951	\$112.99
MGB 62-76 45D	225-952	94.99
MGB 75-80 OPUS/CEI	225-953	79.99

#### Standard

MGB 62-67 25D Side Entry	225-941	\$104.99
MGB 62-74 25D Top Entry	225-942	74.99
MGB 62-76 45D	225-943	74.99
MGB 75-80 OPUS/CEI	225-944	64.99

## Sports Coil by Intermotor

Intermotor was the original manufacturer of the renowned Sports Coil. Extensive testing has proven the Intermotor Sports Coil to be exceedingly dependable. Allow the 40,000 volt output to provide you with reliable starting power and greater performance at higher rpms. Made in England.

*Note: These coils require a push-in type coil wire.*

Ballasted systems	117-264	\$44.99
Clamp - Stainless Steel	117-265	17.99
Non-ballasted systems	143-201	44.99
Clamp - Chrome	143-255	16.99
Clamp - Zinc Plated	143-256	9.99
End Clip for solid core wire	571-037	0.89
Boot for push-in wire end	571-047	1.69



## XR700 Electronic Ignition

Replace your troublesome points and condenser with this easily installed kit. FAST (formerly Crane) electronic ignition systems are famous for their reliability. Expect faster starts, cleaner running and better performance at all engine speeds.

For Lucas Points-type Distributors 222-680 \$199.99



## Premium Ignition Rotors

The carbon content in the plastic of most ignition rotors today is too high and the plastic becomes a conductor. More than just robbing your engine of precious spark energy, in some cases the spark can be misdirected to the spring clip on the underside and presto! No more spark. Don't let your ignition rotor ruin your Sunday drive; replace yours with one that is manufactured correctly.

MGB thru 1974	151-805	\$15.99
MGB 1975 on & Repl. 45D Dist.	151-865	16.49
MGC 6-Cyl.	872-785	14.99



## MAGNECOR® Performance Plug Wire Set

Magnecor competition spark plug cable sets work great on street cars with conventional or electronic ignition systems. They are low resistance and shielded to reduce radio noise interference. These require that a plug-in distributor cap (#163-810) be used on early MGBs in place of the side entry cap.

1967-80 143-565 \$134.99



## High Performance Plug Wire Sets by Cobalt

These wire sets are made using the highest quality materials. These require that a plug-in distributor cap (#163-810) be used in place of the side entry cap.

- 8 mm Silicone Jacket resists high temperatures, fuel and oil
- Compact Silicone Boots with Locking Terminals
- Spiral Magnetic Core to suppress RFI/EMI Interference

MGB Wire Set	172-060	\$39.99
MGC Wire Set	172-030	39.99
Distributor Cap	163-810	11.49

# PERTRONIX



## Pertronix Ignition Coils

The Pertronix Ignition Coil isn't called the "Flame-Thrower" for nothing. Matched to the Pertronix Ignitor ignition and with a voltage of 40,000, this coil will deliver a smoother response and better fuel economy, along with enhanced power during acceleration.

*Note: These coils require a push-in type coil wire.*

Non-ballasted systems - Black	143-265	\$79.99
Non-ballasted systems - Chrome	143-266	84.99
Ballasted systems - Black	143-270	79.99
End Clip for solid core wire	571-037	0.89
Boot for push-in wire end	571-047	1.69



222-435

## Pertronix Ignitor Electronic Ignition

The Ignitor Electric Ignition is available in both Positive and Negative ground. The sensor is impervious to dirt, moisture and vibration. There are no external boxes to mount or points to set. And you can take comfort in the 30-month manufacturer's warranty.

*Note: Not for use with solid core ignition wires. Locate Lucas model number stamped in housing by the vacuum advance.*

<b>Lucas 45/47DE4, DM4</b>		
1976-80	222-475	\$219.99
<b>Lucas Model 23, 24, 25D</b>		
Neg. Ground thru 1974	222-405	\$161.99
Pos. Ground thru 1967	222-555	189.99
<b>Mallory Dual Point</b>		
Negative Ground	143-181 <sup>1</sup>	\$229.99
<b>Moss 143-114 distributor (Lucas 45D4)</b>		
Pos. Ground 1975	222-436	\$169.99
Neg. Ground	222-435	165.99

<sup>1</sup>Not for use with solid core ignition wires.



\*See ordering page for details

⚠ WARNING: Cancer and Reproductive Harm. www.P65Warnings.ca.gov





130-078

### 1962-67 Alternator Kit

Our comprehensive alternator kit with instructions makes updating your electrical system easy. Includes new alternator, mounting bracket and full instructions.

Without Moss Supercharger	130-078	\$369.99
With Moss Supercharger	130-098	329.99
Dummy Voltage Regulator - Box Style	142-054	99.99



### Alternator Conversion Bracket

Fit this bracket to your early MGB (1962-67) block to allow the fitting of an alternator without having to use an extra-long bolt and spacers.

Bracket	130-115	\$8.99
---------	---------	--------



### Dummy Voltage Regulator

Alternator conversions are great for power, but leave your engine looking less than authentic. Install a Dummy Voltage Regulator to retain that original look. These appear exactly as the old regulators, but have been bridged with a fuse after having their internals removed. Extra fuse and instructions are included.

Screw Terminal	142-004	\$99.99
Late Style Spade Terminal	142-054	99.99



### Battery Acid Neutralizing Mat

Made from a special acid absorbent material that also neutralizes acids. Cut with scissors to match the shape of any battery or tray.

Acid Mat	241-025	\$8.49
----------	---------	--------

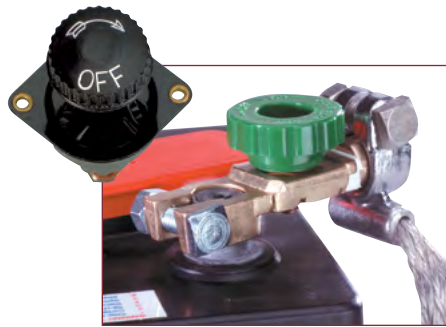

### Battery Cut-Off Switches

Simplify servicing and long term auto storage with this battery cut-off switch. A strategically placed remote switch deters theft. A negative post mount switch is quickly accessed.

Remote Switch - 1" shaft	145-770	\$64.99
Remote Switch - ½" shaft	145-771	59.99
Negative Post Mount	145-795	7.99



### Racing Battery Switch

Primarily intended for competition use, this rugged switch can be used on any car. The removable key deters theft. Attached rubber cap keeps dirt and water out when the key is removed. Meets FIA requirements for motor sports.

Racing Battery Switch	145-785	\$29.99
-----------------------	---------	---------



### Battery Box Liners

Tough, corrosion-proof battery box liners. Includes a strong lip running around the top, so it will work even if the original battery box has completely rotted away.

1962-74 (2 reqd)	241-040	\$49.99
1975-80 (1 reqd)	241-050	57.99



### High Torque Starters by WOSP Performance

Give your Classic the high torque advantage! Whether you're having problems starting your engine or simply want an upgrade, our selection of high torque starter motors by WOSP will perfectly meet your requirements. Manufactured in the UK, these gear reduction starters are powerful, lightweight, and built for performance. Offering increased torque, especially useful on high compression engines, these brand new, application specific starters are direct replacements built to the highest standards to withstand the rigors of all forms of motorsport. Quality and performance, WOSP starters have it all.

#### Features:

- All units are 100% brand new
- Based on the Denso conventional offset gear reduction design
- High power 1.0 kW and 1.4 kW Denso motors modified to suit each application and individual requirement
- Manufactured with the latest electronic testing equipment to check the performance of every product produced.

MGB 1962-67	140-364	\$319.99
MGB 1968-80	140-365	319.99
MGC	140-366	369.99



### Smiths Voltmeter

Monitor your battery's condition with this 2" illuminated gauge. Easily wired into your car using the included instructions. Also includes bulb holder with bulb for illumination.

Voltmeter	360-975	\$109.99
-----------	---------	----------

Pricing is subject to change.

Please visit [MossMotors.com](http://MossMotors.com) for current pricing and availability.

PERFORMANCE

Vitesse



### 5-Speed Conversion by Vitesse

Amp up your driving experience with the Vitesse 5-Speed Conversion kit!

Built around a brand new Mazda MX-5 Miata gearbox, this tried-and-tested transmission conversion kit from Vitesse UK offers smooth gear changes and lower rpm cruising in 5th gear.

Each kit comes with a new fully assembled Mazda gearbox, matching set of electrocoated original equipment Mazda parts, and a bespoke cast aluminum bell housing designed to fit directly to your engine. The custom shift lever, and included shift knob, retain the existing shifter position. Installation is straightforward, and includes a full set of installation instructions. With proper tools and a bit of automotive knowledge, you'll be able to fit a Vitesse gearbox! Give your classic the perfect cruising upgrade with a brand new 5-Speed Conversion kit by Vitesse!

**Kit includes:**

- Brand New 5 Speed Mazda Transmission & Clutch
- Custom Shift Lever and Shift Knob
- Concentric Slave Cylinder Assembly
- Braided Clutch Line w/ Remote Bleed
- Drive Shaft
- Pilot Bearing with Mazda OE needle roller bearing assembly
- Speedometer Drive Cable
- Gearbox Rear Mount Bracket Assembly and Isolator
- Complete UNF fittings kit
- Clutch Alignment Tool

*Note: The gearbox is delivered dry and will require 2.1 qt SAE 75W-90 oil.*

**MGB V8**

Factory	440-508	\$6,495.00	
Conversion	440-509	6,495.00	

**Non-Standard**

1962-65 (3 sync/3 main/tube)	440-501	\$5,995.00	
1962-65 (4 sync/3 main/banjo)	440-502	5,995.00	
1962-65 (4 sync/3 main/tube)	440-503	5,995.00	
1968 on (4 sync/5 main/banjo)	440-506	5,995.00	

**Standard Configuration**

1962-65 (3 sync/3 main/banjo)	440-500	\$5,995.00	
1965-67 Roadster (3 sync/5 main/banjo)	440-504	5,995.00	
1965-67 GT (3 sync/5 main/tube)	440-505	5,995.00	
1968-80 (4 sync/5 main/tube)	440-507	5,995.00	



### Laygear Kit

Premature wear of the layshaft has been a long standing problem for early MGBs. To address this issue, we fitted our laygear kit with two sets of 20 needle rollers, each one being 3 mm in diameter and 29 mm long. This effectively doubles the number of load bearing needles at each end. With these longer needles the load is distributed over a larger section of the layshaft, and wear is dramatically reduced. The new laygear kit uses a special spacer in the middle to separate the two pre-installed sets of needle bearings. To hold the needles in place, we use a dummy layshaft which is long enough to allow the front thrust washer to be fitted as well. A new layshaft is also included in the kit. This is as close as we can get to a "drop-in installation." If you are looking for a new layshaft and laygear, this kit provides an excellent solution.

1962-early 67 (0.645" layshaft)    461-571    \$599.99



**COBALT**  
PRECISION AUTOMOTIVE

### Performance Shift Lever by Cobalt

MGB enthusiasts know that reducing the shift lever height on the 4-syncho gearbox increases comfort and reduces lost motion through the gears. Our new Cobalt performance shift lever is 1½ shorter for faster and more efficient gear changes, which makes it the perfect choice for slicing the twists and turns of your favorite country road.

Shortened Shift Lever - Cobalt    443-155    \$79.99



\*See ordering page for details

⚠ WARNING: Cancer and Reproductive Harm. www.P65Warnings.ca.gov







**Clutch Hydraulic Kit**

Save money and make ordering easy with this kit. Includes all usually replaced clutch hydraulic components: master cylinder, slave cylinder with pushrod, hose and required copper washers.

Clutch Hydraulic Kit                      180-718      \$54.99

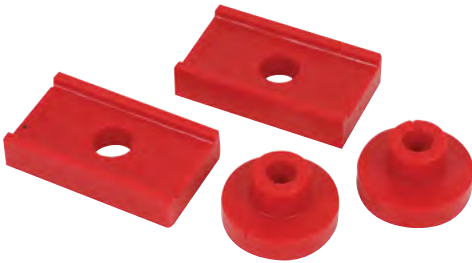

**Prothane Gearbox Mounting Bushings**

**Gearbox Steady Rod Pad Set**  
All RD, GT 1968-80                      282-335      \$11.99

**Gearbox Center Pin Bush Set**  
RD 1968-80, all GT                      280-056      \$9.99

**Combination Kit**  
Includes both kits 1968-80                      282-338      \$20.99



**Shock Absorber Link by Cobalt**

Upgrade your suspension with this modern style shock link by Cobalt. Using a polymer-composite material for the body instead of steel, this Cobalt shock link is like modern OE production arms and takes advantage of the many advances in materials and technology that have occurred over the last several decades. Superior wear and appearance with better than OE performance. Upgrade your suspension for a great price! Sold individually.

MGB 1962-74 ½                      267-641      \$28.99

**Alloy Flywheel by Fidanza**

Fidanza Performance lightweight aluminum flywheels are designed, engineered, and manufactured right here in the USA. These flywheels have been CAD designed/engineered and precision CNC machined from top quality billet 6061 T6 aluminum to deliver optimum performance and reliability. All flywheels are balanced and thoroughly inspected for quality and fitment.

**Fidanza aluminum flywheels deliver:**

- Faster throttle response and quicker acceleration
- Additional horsepower to the wheels (reduced parasitic losses)
- Smoother, faster shifting
- Easier braking, better slowing (due to reduced rotational mass)
- Reduced clutch wear and improved efficiency (from better heat dissipation)
- Replaceable friction plate

1962-64 3 main	460-673	\$474.99
1965-67 5 main	460-674	394.99
1968-80 5 main	460-675	449.99



**Heavy Duty Clutch Kit**

Get quick shifting response with the AP clutch kit. Built to OE standards, expect accuracy and performance from this brand new upgrade for your classic car. Application specific. This product is made with tooling from the original manufacturer, Borg & Beck. You can expect accuracy and performance just as the factory did. Includes pressure plate, disc and release bearing.

Heavy Duty Clutch Kit                      190-808      \$279.99

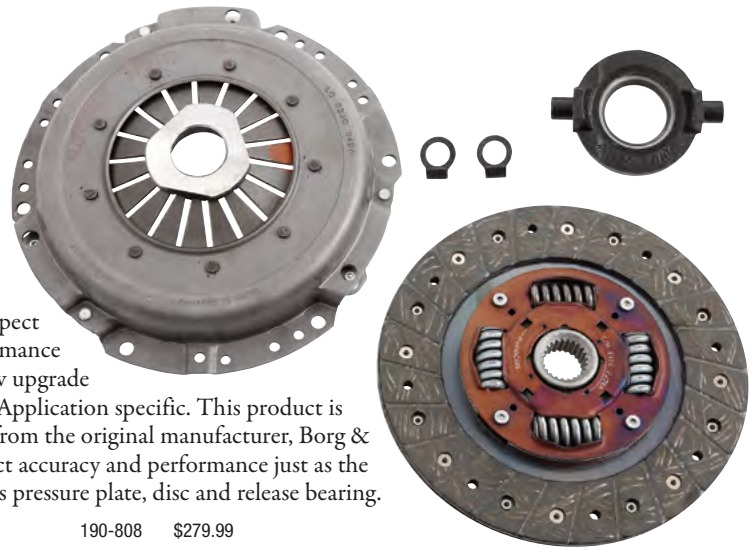

**Upgraded Solid Center Clutch Disc**

Get more holding power and more positive shifts without a heavy pedal. Standard clutch discs have fins that connect the center to the friction surface, and they are prone to flex and fail. The solid center on this heavy duty disc eliminates that failure point. The friction surface is also 36% larger than the standard replacement. Perfect for a stock engine or higher horsepower engines. Heavy duty, 23 spline, solid center, 8.5" clutch disc.

Solid Center Clutch Disc                      190-821      \$79.99



Pricing is subject to change.  
Please visit [MossMotors.com](http://MossMotors.com) for current pricing and availability.

PERFORMANCE

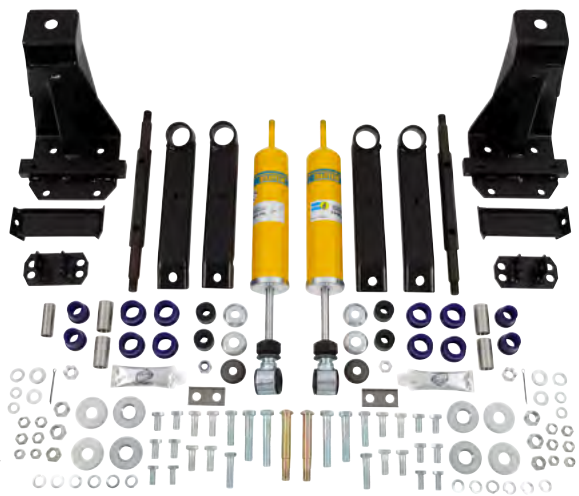

**Bilstein Tube Shock Conversion Kits**

Transform the handling of your classic car with the Bilstein Conversion Kit! Renowned for their high quality, these MGB shock conversion kits for front and rear suspension work perfectly on both the chrome bumper and lowered rubber bumper cars. Huge improvements over stock or any tube shock kit, the Bilstein shock conversion kits lend your car more stability in corners (especially on rough roads), handle bumps much more smoothly, and ensure that you get a firm and comfortable ride experience!

The front fitting kit places the shock in between the steering knuckle and coil spring. The lever shock assembly is completely removed and replaced with a new upper control arm and tube shock mount. It requires some permanent modifications by cutting off the bump stock brackets on the front cross-member to allow clearance for the shock.

The rear conversion kit is only applicable to chrome bumper, or lowered rubber bumper cars. It is a simple bolt-on installation, and requires no permanent modifications. All you need to do is replace the lever shock with the provided brackets and reposition the lower bracket on the leaf spring.

The Bilstein Conversion Kits include all the necessary hardware for a perfect install. Also included are detailed instructions with diagrams of the important steps.

*Note: We strongly recommend fitting the front and rear kits together for the best results.*

Front	265-715	\$999.99	
Rear	265-720	499.99	



**Coil Over Kit**

This tried and tested conversion brings the MGB's front suspension up to modern standards of handling, road holding and ride comfort, by combining the spring and damper into a single unit.

This conversion enables the old lever arm dampers to be discarded and replaced with a sturdy top wishbone assembly (which can be removed at any time to return the car to standard). When fitted, the dynamic suspension offers the MGB owner a number of improvements including a more positive ride, lighter steering, responsive suspension when cornering at speed, and the ability to adjust the cars ride height. The road springs are retained by collars on the dampers allowing the spring and damper to work together, providing better ride and control. The lower collar on the damper is screw adjustable - allowing the ride height to be adjusted. All major components are coated in a corrosion resistant finish. Installation is straightforward and the whole conversion can be completed within 4-5 hours.

**The kit comes complete with:**

- New lower spring pans
- Upper wishbones and mounting blocks
- Neoprene upper wishbone and damper mounting bushings
- Shock absorber unit and spring
- Mounting hardware
- Fitting instructions.

Road	268-198	\$1,349.00	
Fast Road	268-208	1,349.00	
Competition	268-218	1,349.00	



**Adjustable Shock Kits by Spax**

Gas pressurized shocks have a screwdriver slot adjuster which can be accessed with the shocks installed. This kit allows adjustment of damping to match upgraded springs and sway bars or for lowered cars with limited suspension travel.

Front Kit w/Spax Shocks	264-677	\$799.99	
Rear Kit w/Spax Shocks	268-228	499.99	



**Monroe Tube Shock Kits**

Based on years of experience, the mounting brackets have been completely re-designed and the shock options updated. The Monroe OESpectrum shock provides a comfortable ride with less "jarring" over bumps and would be recommended for use on touring cars that are not intended for fast road use.

Front Kit w/Monroe Shocks	268-121	\$499.99
Rear Kit w/Monroe Shocks	268-126	299.99



**Heavy-Duty Shock Valves**

About 25% stiffer than stock ones, these competition shock valves are just the ticket for improved road handling. Sold individually.

Front	264-345	\$49.99
Rear	267-975	33.99



\*See ordering page for details

WARNING: Cancer and Reproductive Harm. www.P65Warnings.ca.gov





### 7/8" Swaybar Mount Kit

Swaybar installation is a straightforward job with our Mounting Kit. Using high quality brackets and bushings, your swaybar will operate smoothly and reliably.

Mount Kit 263-919 \$36.99



### Solid Sway Bar Mounts

Competition-designed machined aluminum. Expect an increase in road noise. Sold as a pair.

For 7/8" Bars 263-445 \$84.99  
For 3/4" Bars 263-435 89.99

### CLASSIC GOLD<sup>®</sup> AUTHENTIC REPRODUCTION



### Spring Pan Kits by Classic Gold

Typically, the two wishbone arms and spring pan are almost always replaced together, so the days of ordering multiple part numbers for the job are over! Most importantly, by buying this kit, you guarantee matching wishbone fitment. Throughout the process of developing these parts, our engineers discovered inconsistencies in size and fitment between OE and aftermarket parts. This kit ensures correct and consistent fitment between these components, which, in turn will increase performance and longevity of the part. In conjunction with the Spring Pan Kit by Classic Gold, we highly recommend the use of polyurethane bushings to match convenience with performance.

#### Spring Pan Kits

Left 264-287 \$64.99  
Right 264-288 64.99

#### Polyurethane Bushing Options

Polyurethane bushing, 8 req. 280-485 \$3.89  
Prothane bushing kit 281-400 36.99  
SuperPro bushing kit 683-063 74.99



### Adjustable Hollow Sway Bar Kit by Tourist Trophy

This adjustable sway bar from Tourist Trophy has different modes to suit any MGB driver's needs. Tuned one way, you'll experience a comfortable ride; tune it up and you've got a high-performance bar. The difference happens with the easy switch of two mounting bar. The adjustable end link mounting points give the equivalent of a 3/4" bar for regular driving and a 7/8" bar for autocross or canyon carving. Tubular bar stock is used to cut weight, and the kit includes polyurethane mounts and heim-jointed end links with specially fabricated spacers.



**TOURIST TROPHY<sup>®</sup>**

#### Features:

- Lightweight design - bar weighs 3 lbs 9 oz
- Polyurethane mounting bushes

Adj. Front Sway Bar Kit 454-962 \$449.99

- Heim-jointed end links
- Adjustable, equivalent to 3/4" or 7/8" solid bar

### Front Sway Bars

Front sway bars are a major influence on how your MGB handles. The following observations should also be considered in selecting a sway bar:

- Increasing the bar diameter will reduce body roll. Too strong a bar will allow understeer to develop, and increase suspension harshness.
- Larger tires and wheels may allow use of a larger bar due to the increased unsprung weight.
- Sway bar installation kits allow installation of front sway bars on cars to which sway bars were not originally fitted.



#### Front Sway Bars

5/8" Bar (120% increase)	454-965	\$189.99
5/8" Bushing (2 reqd)	021-767	1.89
3/4" Bar (280% increase)	454-945	149.99
3/4" Bushing (2 reqd)	280-915	2.39
7/8" Bar (450% increase)	454-955	189.99

#### Sway Bar Installation Kits

Kit for 5/8" Sway Bar	454-978	\$109.99
Kit for 3/4" Sway Bar	454-948	89.99
Kit for 7/8" Sway Bar	454-958	114.99



### Roll Bar

Bolt-in roll bar looks great and causes minimum restriction of cockpit space. They're even designed to fit inside the convertible top. The optional pad is vinyl covered and uses snaps and Velcro fasteners. Includes mounting hardware. Does not fit with inward folding top frames.

1963-74	459-025	\$799.99	OS
MGB-GT	459-023	799.99	OS
Roll Bar Cover	236-000	159.99	



### Panhard Bar Kit

When you're driving with a purpose on your local backroad, you might notice instability in the rear of your MGB and, in some cases, a bit of tire rub on the fender. You're most likely experiencing rear axle movement because of increased side loads, or lateral g-force. The panhard bar offers a solution to this issue by limiting the lateral movement in the rear axle, improving grip, and increasing stability during increased side loads. So, if you're a spirited driver with a tendency to take corners with speed, the panhard bar is a must have for your MGB.

MGB 1965-80 264-898 \$329.99

Pricing is subject to change.

Please visit [MossMotors.com](http://MossMotors.com) for current pricing and availability.

PERFORMANCE



**6-Leaf Rear Spring**

Eliminate “Bachelor Lean” and poor handling with these premium quality stock replacement 6-leaf rear springs. Manufactured from premium steel, they provide the original spec ride height, with an optimized spring rate for a solid and comfortable ride that you can rely on. Sold individually.

1962-74.5 454-763 \$109.99 **OS**



**Negative Camber Wishbone Arm Set**

Fitting these longer wishbone arms produces two to three degrees negative camber on the front suspension, improving turn-in for quicker, safer cornering. Highly recommended for all road cars, and essential for competition cars. Once these are installed, toe must be adjusted to 1/8" to 3/32" toe in.

Negative Camber Wishbone Arm Set 264-038 \$119.99



**Rubber Bumper Suspension Lowering Kit**

Lowering your Rubber Bumper MGB approximately an inch makes it look and handle better, while maintaining the benefits of comfort and practicality inherent to the Rubber Bumper MGBs. The Moss suspension lowering kit uses one-inch lowering springs with a higher spring rate that stiffen the front suspension to reduce body roll. The rear is also lowered an inch and our nylon rebound straps replace the existing straps. This combination has been fitted and tested by our tech department and is commonly regarded as the ideal setup when looking to lower a Rubber Bumper MGB.

Lowering Kit 264-399 \$219.99 **OS**



**Rear Springs**

Lowered rear springs are recommended to balance changes in front ride height. For best handling, the same spring rate and design as original should be retained. The 1" lowered springs are de-arched and the 2" lowered springs have reversed eyes. Springs are sold individually, but should be replaced as pairs.

*Note: Ride heights are given for reference only. Final ride height is determined by many factors and can vary as much as 1" from car to car.*

**The standard spring rates and ride heights are:**

- Chrome Bumper MGB 93 lb/in rate 14 1/2"
- Rubber Bumper MGB 110 lb/in rate 15 1/2"

**Roadster 6 Leaf Springs**

2" lowered - Reverse Eye	456-225	\$249.99	<b>OS</b>
1" lowered - De-Arched	456-205	259.99	<b>OS</b>
1" lowered - De-Arched	456-215	229.99	<b>OS</b>

**GT 7 Leaf Springs**

1" lowered - De-Arched	456-375	\$249.99	<b>OS</b>
2" lowered - Reverse Eye	456-385	229.99	<b>OS</b>



**Castor Correction Kit by Cobalt**

Get improved steering feel and response with the Castor Correction Kit by Cobalt.

The purpose of castor correction is to self-center the steering at speed. Because modern tires are more directional, the steering needs less castor angle. These precision engineered castor wedges in our Cobalt correction kit easily slip between the front subframe and the chassis to reduce the built-in castor angle (by around 3 degrees) making it suitable for

modern tires. The reduction in steering effort is dramatic, making this upgrade an absolute must for any MGB running radial tires.

**Features:**

- Improved directional control
- Lighter steering that doesn't load up when cornering
- Increased positive feedback through the steering

Castor Correction Kit 264-858 \$89.99



**Upgraded Rear Spring Fitting Kit**

Replacing a damaged rear leaf springs is easy with this new upgraded rear spring fitting kit. It has all the parts conveniently put together to help you upgrade your leaf springs. The rugged axle straps made from nylon-webbing are a substantial improvement over the rubber straps and offer some stretch properties while providing a tensile strength of over 4,500 pounds! The Prothane bushings and spring pads are designed to be long lasting and quiet, supplied with Teflon grease. These high performance components are much better than original rubber parts. Give your classic car only the best with this premium quality kit!

**The upgraded rear spring fitting kit includes:**

- OE length Nylon axle check straps, pair
- Prothane shackle bushings
- Prothane spring pads
- 4 U-bolts
- 8 nuts

MGB Banjo Axle	225-990	\$109.99
MGB Tube Axle - Chrome Bumper	225-991	109.99
MGB Tube Axle - Rubber Bumper	225-992	109.99

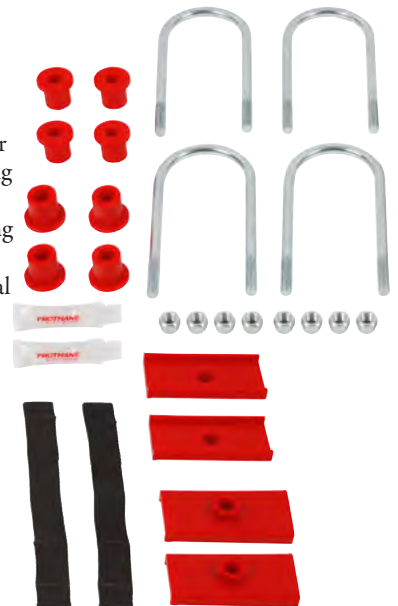



Front



683-166

**SuperPro Polyurethane Bushings**

Rubber has been a traditional material for bushing, but is prone to wear, cracking, and deterioration. Polyurethane bushings ensure the suspension components will retain their desired geometry, and last longer than rubber. SuperPro has tuned their bushings to work together on each car as a set, each location may be stiffer or softer than another location on the same car. This ensures the car as a whole has the absolute best handling possible.

**Complete Car Suspension Kit**

MGB - Chrome Bumper	683-166	\$319.99
MGB - Rubber Bumper	683-170	319.99
MGC - All	780-918	529.99

**MGB Front Suspension**

Complete Kit - Chrome Bumper	683-163	\$169.99
Complete Kit - Rubber Bumper	683-167	174.99
Subframe Pad Kit - Chrome Bumper	683-055	58.99
Subframe Pad Kit - Rubber Bumper	683-056	58.99
Upper Fulcrum Pin Bushing Kit	683-041	46.99
Lower Control Arm Bushing Kit	683-063	74.99

<sup>1</sup>Uses original brackets

<sup>2</sup>Round bushing, comes with brackets

**MGB Rear Suspension**

Complete Kit	683-165	\$199.99
Pad Seating Kit	683-046	84.99
Front Eye Bushing Kit	683-057	69.99
Shackle Plate Bushing Kit	683-032	52.99

**MGB Sway Bar Bushing Kits**

5/16" O.E. Style Bushing Kit	683-060 <sup>1</sup>	\$22.99
5/8" O.E. Style Bushing Kit	683-027 <sup>1</sup>	27.99
3/4" O.E. Style Bushing Kit	683-062 <sup>1</sup>	23.99
3/4" Round Bushing w/Brackets	263-908 <sup>2</sup>	84.99
7/8" O.E. Style Bushing Kit	683-071 <sup>1</sup>	26.99
7/8" Round Bushing w/Brackets	263-918 <sup>2</sup>	74.99



**Black Polyurethane Bushings and Pads**

Polyurethane is far more wear resistant than stock rubber. These bushes are hard enough to eliminate 90% of unwanted suspension deflection, yet remain flexible enough for a firm and quiet ride.

Upper Front Trunnion Bush Kit	281-405	\$9.99
<b>Cross Member Pad Kit</b> 1974 1/2 -80	281-415	\$29.99



**Spring Spacers**

These Nylon spring spacer rings raise the ride height 3/16" (5 mm). A maximum of two per side can be used. Sold individually.

Front Spring Spacer	264-325	\$21.99
---------------------	---------	---------

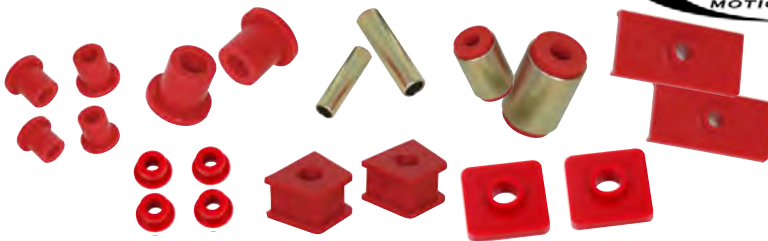

**Prothane Bushings**

Engineered to be long-lasting and quiet, supplied with Teflon grease. Suitable for road use.

**Lower Control Arm Inner Bushing Set**

1 kit req	281-400	\$36.99
-----------	---------	---------

**Upper Control Arm Outer Bushing Set**

1 kit req	282-325	\$14.99
-----------	---------	---------

**Front Cross Member Pad Set**

Chrome Bumper, 1 kit req	264-906	\$25.99
Rubber Bumper, 1 kit req	264-907	\$25.99

**Complete Front Kit (Includes the appropriate kits above.)**

Chrome Bumper Cars	264-918	\$74.99
Rubber Bumper Cars	264-928	\$74.99

**Leaf Spring Front Eye Kit**

1 kit req	267-525	\$29.99
-----------	---------	---------

**Leaf Spring Shackle Kit**

2 kits req	282-855	\$14.99
------------	---------	---------

**Leaf Spring Mounting Pad Set**

1 kit req	281-600	\$29.99
-----------	---------	---------

**Complete Rear Spring Kit**

Includes all 3 items above	267-538	\$85.99
----------------------------	---------	---------

**3/16" Front or Rear Sway Bar Mounting Bush Set**

1 kit req	280-935	\$9.99
-----------	---------	--------



**Shortened Front Bump Stops**

These are recommended when using lowering springs. Increases suspension travel lost by lowering the car. Sold individually.

Bump Stop	266-590	\$19.99
-----------	---------	---------



**Nylon Axle Straps**

These rugged axle straps were engineered to last and are a substantial upgrade over the rubber straps currently on the market. Made from a nylon webbing, they offer some stretch properties, yet provide a tensile strength of over 4,500 lbs Sold in pairs. Metal tubes/sleeves should be reused on vehicles that originally required them.

1962-74	267-566	\$39.99
1975-80	267-616	39.99



**Camber Adjusting Bushing Sets**

Offset nylon bushings allow for fine tuning of camber. Set of 4.

Camber Adj. Bushings	282-308	\$33.99
----------------------	---------	---------



Pricing is subject to change.

Please visit [MossMotors.com](http://MossMotors.com) for current pricing and availability.

PERFORMANCE

**Front Brake Kits**

When your MGB needs a brake job, ordering one part number and getting everything you need at once makes the job so much simpler.

There are four options available, Stock Replacement, Stage 1 Upgrade, Stage 2 Upgrade and Stage 3 Upgrade. See below for option details.

**All Kits Include:**

- 4x pad retaining clips
- 4x pad cotter pins
- 8x bolts
- 8x nuts
- 8x lock washers

**Stock Replacement:**

- 2x Stock front rotors
- 1x Classic Gold semi-metallic front pad set

**Stage 1 Upgrade:**

- 2x TRW slotted & drilled front rotors
- 1x Classic Gold ceramic front pad set

**Stage 2 Upgrade:**

- 2x TRW slotted & drilled front rotors
- 1x EBC GreenStuff V8 front pad set

**Stage 3 Upgrade:**

- 2x DBA slotted & drilled front rotors
- 1x EBC GreenStuff V8 front pad set



Stock Replacement	182-118	\$84.99	OS
Stage 1 Upgrade	182-128	154.99	OS
Stage 2 Upgrade	182-135	254.99	OS
Stage 3 Upgrade	182-138	349.99	OS

**Wilwood Big Brake Kit**

Combine Wilwood aluminum four-piston calipers, with a brand new set of quality rotors. Throw in a set of braided stainless lines and you have improved pedal feel, better stopping power and less unsprung weight. Looks, handling and brakes all in one package. This kit does not require 15" wheels and will work with original Rostyle and wire wheels. The brake calipers do have dust seals, so the kit is suitable for regular road use.

*Note: Will not fit "LE" Limited Edition wheels*

Wilwood Brake Kit - DBA Cross Drilled & Slotted	586-628	\$1,499.00	🏆
Replacement DBA Rotors - Pair	586-606	229.99	
Replacement Wilwood Pad Set	772-095	149.99	



586-660

**4 Pot Brake Upgrade Kit**

Outstanding brake performance at an unbeatable price! The 4 pot vented brake conversion can be easily used with a wide range of wheels. It is designed to utilize brake calipers originally conceived by AP Lockheed and approved for use by MG Rover for the MGRV8. This brake upgrade kit combines brake calipers with bespoke 24 mm vented discs and is ready to bolt straight onto the MGB stub-axle without modifications!

**Kit includes:**

- A pair of reproduction MGRV8 4 pot calipers
- Geomet coated vented brake discs
- Stainless steel braided brake hoses
- Mintex brake pads
- All necessary fittings

*Note: This kit fits 14 and 15" Mini-lite type bolt-on and center lock alloy and wire wheels.*

*Cars fitted with Rostyle type, steel disc wheels, LE alloys and Dunlop composite (V8 and Jubilee) alloys will require the spacer & stud kit (#586-681).*

MGB	586-680	\$899.99	🏆
-----	---------	----------	---

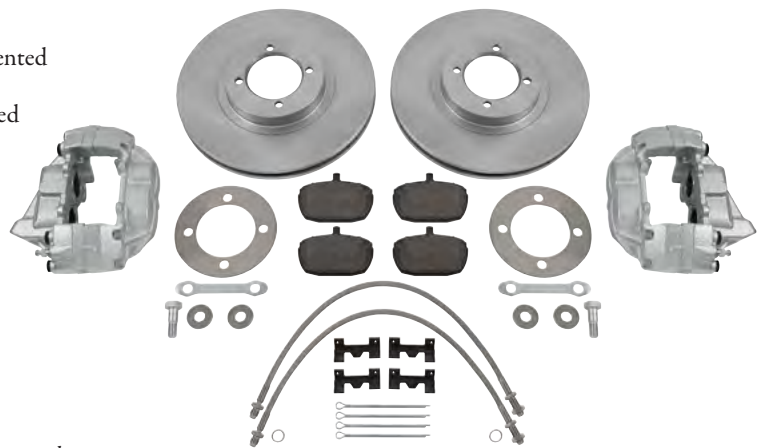

**Replacement Parts and Components**

Spacer Kit for Cars w/ Rostyle Wheels	586-681	\$79.99
Brake Disc	586-682	99.99
Brake Pads	586-683	62.99
Brake Pad Fitting Kit	586-684	46.99



\*See ordering page for details

⚠️ WARNING: Cancer and Reproductive Harm. www.P65Warnings.ca.gov



**TRW**

### Cross Drilled and Slotted Rotors by TRW

TRW is a leader in aftermarket car parts and these slotted brake rotors are a performance upgrade option for your Triumph. The grooves in these slotted rotors channel the gasses away from the braking surface and reduce brake fade. The grooves also reduce pad material build-up on the rotor surface and minimize glazing. Sold as a pair.

1962-80 MGB 586-635 \$122.99

**dbaUSA**  
 DISC BRAKES AUSTRALIA

### Cross-Drilled and Slotted Rotors by DBA

Get the stopping power you need! Cross-drilled holes lower brake temperatures and reduce rotational mass and increase out-gassing, while slots allow excess water, dirt, and dust to dissipate. Sold as a pair.

Drilled/Slotted Rotors 586-605 \$229.99



### Brake Caliper Paint System

Give your brake calipers a high gloss luster. The paint has an industry leading heat resistant capability of 900 F. Kits come complete with two component high tech paint system, one can of brake caliper cleaner, and application brush. Ground shipping only.

Red	216-800	\$109.99
Black	216-804	109.99



### Alfin Style Brake Drums

Highly popular back in the day, the aluminum finned brake drums are back! Preferred for their lighter weight and unique radial fins that act as heat sinks, these brake drums improve the braking efficiency, keep the brakes cool, and reduce brake fade under heavy braking.

The cast iron liner is mechanically locked to ensure top performance under all driving conditions. The exterior of the drum is shot blasted to give a matte appearance. Specific to tube type axles. Sold individually.

1965-80 MGB with Tube Type Axle 586-140 \$359.99

### Performance Brake Caliper Kit by BCC

Upgrade your brake performance with this 4-pot caliper kit from BCC. Using the proven BCC design, the calipers are machined from Aerospace grade Aluminum and hard anodized for strength and durability. BCC calipers ensure long life and faultless operation with pistons made from 303 stainless steel and seals supplied by British OEM manufacturers. The kit is a simple bolt-on installation requiring no permanent modification to the vehicle and is completely reversible. These calipers are a direct replacement for the OEM Lockheed calipers.

Each BCC brake caliper kit contains a pair of BCC 4 pot calipers anodized in black, EBC Ultimax brake pads (including pins, clips and springs), bleed nipples, bridge and feed pipes. EBC Greenstuff pads available for greater stopping power.

Brake Caliper Kit	586-700	\$999.99
Replacement Pads, EBC, Greenstuff	586-705	69.99
Replacement Pads, EBC, ULTIMAX	586-706	56.99



Pricing is subject to change.

Please visit [MossMotors.com](http://MossMotors.com) for current pricing and availability.

PERFORMANCE



**Classic Black Stainless Steel Braided Brake Hose Set by Goodridge**

Goodridge Classic black brake hose kits feature the finest quality hose, consisting of a PTFE inner with a stainless-steel outer braid. This eliminates the spongy feel under arduous conditions, giving greater brake operation as well as providing superior resistance to abrasion and corrosion. Every brake line made by Goodridge is 100% pressure tested and guaranteed to be leak free and give an improved braking performance. They are also 100% TUV, DOT, ADR and ISO approved and can be used worldwide. Offering reliability, safety, and a brilliant look, buy this braided brake hose set today! Application specific.

MGB 1962-80	182-229	\$89.99
MGC 1967-69	182-226	84.99



**Rubber Brake Hoses by Cobalt**

All brake hoses aren't equal. These hoses are a product of many R&D hours devoted to improving quality, safety and performance of these critical brake components. The rubber brake hoses by Cobalt go the extra yard by welding the metal joint end connections for strength and reliability. Other hoses simply press-fit their connections. We stand behind the Cobalt difference.

Front - 1962-76 to c394300	180-897	\$15.99
Front - 1976-80 from c394301	180-887	13.99
Rear - All	180-837	14.99



**Stainless Steel Brake Hose Set by Goodridge**

These competition-inspired brake hose sets meet all DOT safety standards and are street legal in all 50 states. Complete set of three with retaining nuts and copper sealing washers.

Brake Hose Set	182-228	\$71.99
----------------	---------	---------



**Stainless Steel Brake Hose Set by Cobalt**

Stainless steel brake hoses provide a more direct and consistent brake feel. They won't expand like rubber hoses can. Order this complete set of long-lasting braided steel hoses for your next brake job. DOT approved.

MGB - All	180-898	\$89.99
-----------	---------	---------



**Hawk Brake Pads**

Designed for the serious street and autocross enthusiast these pads are at home on both the track and street.

*Note: Due to the increased friction levels, brake rotor life may be decreased.*

Hawk Brake Pads	585-610	\$139.99
-----------------	---------	----------



**CLASSIC GOLD<sup>®</sup> AUTHENTIC REPRODUCTION**



**Semi-Metallic Brake Pads by Classic Gold**

- Shorter stopping distances
- Squeal-free
- Less dusting than organic pads
- Asbestos free composition
- Best value - priced right
- Anti-squeal compound bonded to brake pad backing plate

MGB	182-227	\$23.99
MGC	585-527	23.99

**Premium Ceramic Brake Pads by Classic Gold**

- Withstands high braking temps
- Less fade
- Quicker recovery
- Ultra quiet braking
- Nearly dust free
- Wheels stay cleaner longer
- Anti-squeal compound bonded to brake pad backing plate

MGB	182-222	\$36.99
MGC	585-522	36.99



**EBC GreenStuff Pads**

Made in the UK for "fast road" use. Kevlar brake pads for improved stopping, reduced fade and dusting. The MGB V8 pads can be used in the standard MGB caliper to add extra swept brake area. Combine these pads with our new slotted rotors for the ultimate in braking with the stock caliper.

Greenstuff Pads	585-630	\$89.99
MGB V8 Greenstuff Pads	585-650	119.99



\*See ordering page for details

⚠ WARNING: Cancer and Reproductive Harm. www.P65Warnings.ca.gov





# THE MOSS LIBRARY

SEE NEW AND FEATURED BOOKS AT THE MOSS LIBRARY

***MossMotors.com/Library***

Add to your knowledge with a great reference piece from the Moss Library.

*Browse our complete selection of books online!*

**MORE INFO ONLINE**



## Original Technical Publication on Portable USB

Get access to the original Heritage publications you need to run and maintain your classic vehicle with these publications! Carefully reproduced from the extensive historical archives in both England and the USA, these technical publications include parts catalogues, service manuals and owner's literature. These are printable (Windows and Android), viewable through the USB or online access (single user license), bookmarked, and searchable with zoom features to see details.

The Original Technical Publications (OTP) product is a portable and secure PDF document solution on a USB stick. With the data locked to the USB device rather than to specific computers, you can use it anywhere and offline too!

MGB, MGC, MGB GT V8 & MG RV8 1962 to 1996	213-902	\$89.99
Master Collection: MG 1923 to 2005 (not 1100/1300),	213-908	319.99

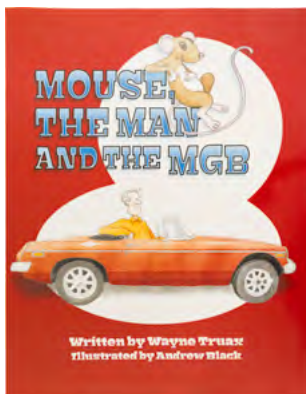

## Mouse, the Man, and the MGB

A fun and inspiring story about curiosity, overcoming challenges, working together, and developing friendships.

In this heart-tugging children's story, a curious and courageous mouse falls in love with an old car, and goes on to face many challenges even as he tries to help. Written as a reminder that when little ones watch from a distance, they may just be waiting to be invited to share in the very thing we enjoy. This is such a beautifully illustrated book that readers young and old, especially MGB enthusiasts, will enjoy turning the pages to look at the illustrations. Makes for a wonderful gift.

Mouse, the Man, and the MGB	210-465	\$14.99
-----------------------------	---------	---------



## The Red Car

Originally published in 1954, The Red Car is a timeless tale that has been translated in several languages. It is the story of Hap Adams, a teenage boy who finds a beat-up MG TC sports car, restores it, and learns the joys of sports cars and driving from the town mechanic, Frenchy Lascelle. The book makes for a wonderful companion for any classic car enthusiast and is the perfect pick to introduce the love of LBCs to a younger audience. Order your copy today!

The Red Car	210-470	\$14.99
-------------	---------	---------



Pricing is subject to change.  
Please visit [MossMotors.com](http://MossMotors.com) for current pricing and availability.

ACCESSORIES



**MG, Made in Abingdon - Echoes from the Shopfloor**  
210-355 \$29.99

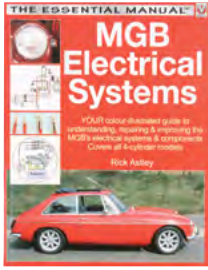

**MGB Electrical Systems**  
211-615 \$69.99

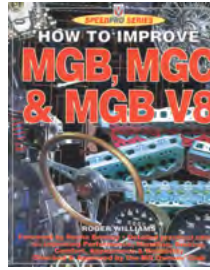

**How to Improve - 2nd Edition**  
213-171 \$69.99



**SU High Performance**  
211-466 \$32.99

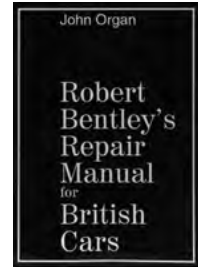

**Bentley Repair Manual**  
213-785 \$69.99

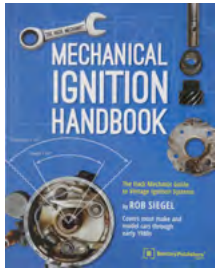

**Mechanical Ignition Handbook**  
215-110 \$46.99

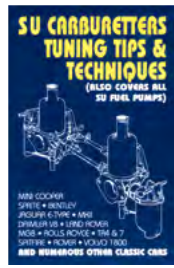

**SU Tips and Techniques**  
211-345 \$59.99



**Lucas Fault Diagnosis**  
990-035 \$7.99



**Bentley Shop Manuals**  
MGB 1962-74 212-320 \$139.99  
MGB 1975-80 215-325 124.99

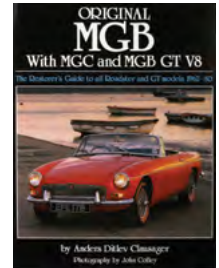

**Original MGB/MGB-GT/MGC**  
211-355 \$49.99



**Interior Restoration Guide**  
213-865 \$31.99

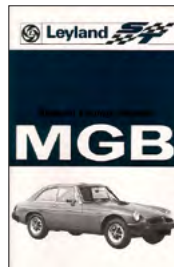

**1968-80**  
211-010 \$26.99



**Practical Classics**  
212-370 \$39.99



**Weber Carbs, Tuning**  
213-431 \$32.99



**SU Workshop Manual**  
211-305 \$59.99



**MGB Manual**  
212-405 \$35.99



**Glovebox Workshop Manuals**  
MGA/MGB 1955-68 212-460 \$38.99  
MGB 1968-80 212-470 \$38.99

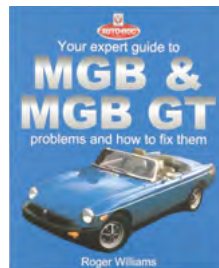

**Problems Guide**  
212-995 \$59.99



**Owner's Manual Reprints**  
MGB 1963-67 210-840 \$19.99  
MGB 1968-69 210-910 24.99  
MGB 1970-72 210-920 29.99  
MGB 1973-74 210-930 29.99  
MGB 1975-76 210-940 24.99  
MGB 1978-80 210-965 26.99





### Convertible Top Cleaning Brush

Natural horse hair brush is nonabrasive, naturally soft, durable, and exclusively designed to gently remove exterior debris from fabric and vinyl convertible tops.

Horse Hair Cleaning Brush 221-530 \$22.99



### Wire Wheel Brush

If your car has wire wheels, you need this brush! Shaped to get around the spokes without damaging your knuckles, this heavy-duty brush makes light work of cleaning your wire wheels.

Wire Wheel Brush 386-940 \$8.99



### Professional Car Duster

100% cotton dusting mop is treated with special wax to trap dust. Simply shake it out and it's ready to use again. 20" long. Comes with a protective carrying case.

Professional Duster 231-670 \$23.99



### Auto Dry Blade

This 11½" water-wand swipes away surface water. The soft silicone contours to your vehicle's shape and glides over any paint surface without scratching the finish. Produces 15% less friction than terrycloth.

Auto Dry Blade 231-674 \$19.99



### Convertible Top Maintenance

The textured surface of a convertible top is challenging to keep clean and protected from the elements. The professional strength of Raggtop products extends the life of your top and keeps it looking new.

Top Cleaner 221-505 \$18.99  
 Fabric Protectant 221-510 34.99  
 Vinyl Protectant 221-515 23.99

### Detailing Brush by Brush Hero

Say goodbye to grime, muck, and road dust with this detailing brush. Ideal for wheels and the exterior of your car, this original waterpowered car wheel brush meets and exceeds your car washing and surface detailing needs. Crafted from high quality injection molded plastic that doesn't corrode, this long-lasting tool is designed to rotate with continuous strength to provide a balanced rollout of power throughout the brush head. With its slow and steady spin, it offers maximum scrubbing power so not a single spot is missed. No batteries or electricity required, just attach it to your garden hose and you are good to go! Includes 2 brushes.



Detailing Brush 220-840 \$29.99



### Simichrome Metal Polish

Highly recommended polishing paste for brass, aluminum, and chrome. Leaves a super shine with a protective film for lasting brightness.

Simichrome 225-350 \$22.99

### Corroseal Rust Converter

Rust. Is there a more deplorable four-letter word? Corroseal is the best way to deal with rust because it is less expensive, less time consuming, and is more environment friendly than sandblasting. Corroseal Rust Converter chemically alters rust (iron oxide) into magnetite, a stable substance, while priming the surface with a high-quality latex metal primer at the same time. Corroseal truly provides one-step corrosion control.



- Water-based rust converter with high-quality latex metal primer
- Non-flammable
- Non-corrosive
- Easy to apply (brush, roll, or spray)
- Easy to clean-up with soap and water

Corroseal Rust Converter 232-205 \$64.99



### Renovo Soft Top Care

Clean, waterproof, and revive tired tops safely with water-based Renovo products. The best care you can give to your fabric or vinyl convertible top!

Fabric Top Dry Cleaner 220-260 \$16.99  
 Water & Stain Proofer, 1 L 220-265 29.99  
 Water & Stain Proofer, 500 mL 220-280 19.99  
 Vinyl Top Cleaner, 500 mL 220-285 15.99  
 Vinyl Top Protector, 500 mL 220-290 15.99  
 Black Fabric Top Reviver, 1 L 220-250 49.99  
 Black Fabric Top Reviver, 500 mL 220-270 29.99



### Connolly Hide Care

This is the same famous "Hide Food," only the name has changed. Apply once a month to keep leather clean, soft and luxurious. Made in England.

Connolly Hide Care 220-210 \$29.99



### Novus Plastic Polish

Novus #1 polish is for light scratches and aging. The #2 polish is for restoring clarity by removing discoloration, haze, and fine scratches. The #3 polish removes heavy scratches and abrasions. Perfect for convertible top plastic windows.

#1 Clean & Shine 220-605 \$9.99  
 #2 Fine Scratch Remover 220-610 12.99  
 #3 Heavy Scratch Remover 220-615 14.99



Pricing is subject to change.  
 Please visit [MossMotors.com](http://MossMotors.com) for current pricing and availability.

## Dynolite Fuel Additives

### Dynolite Valve Guard

is a high performance, three-in-one formula that combines an efficient octane improver with ethanol corrosion protection and a lead substitute.



#### Features:

- Prevents valve recession
- Combats adverse effects of ethanol
- Cleans and maintains the fuel system
- Carburettor anti-icing protection
- Add up to 4 octane to unleaded fuel (at maximum over treatment)
- Reduces detonation/engine knock (pinking or pinging)
- Suitable for vehicles requiring leaded or high octane fuel



**Dynolite Lead Substitute** is a lead replacement fuel additive formulated to protect against valve seat recession under all driving conditions whilst keeping the fuel system clean and protected against corrosive effects of ethanol fuels (E5 & E10).

Valve Guard, 3 in 1 fuel treatment, 250 mL 220-367 \$14.99  
Lead Substitute, 250 mL 220-391 12.99

### Shock Absorber Oil by Dynolite

Replace the original dirty and degraded fluid with Dynolite Shock Fluid. It is custom formulated specifically for single or double action shock absorbers, in particular Armstrong type lever shock absorbers. Our special formula fluid is fully compatible with original shock fluid and incorporates an anti-foaming agent which maintains damping power even under tough driving conditions. It also repels water and condensation, and prevents corrosion, making it essential for your classic car!



1 Liter 220-306 \$22.99

### Carb Dashpot Oil by Dynolite

Give your dampers and pistons longer life with Dynolite Carb Dashpot Oil. Formulated for SU and Zenith Stromberg Carburetors, this synthetic SAE 20 grade oil contains anti-corrosion and anti-wear additives that provide superior cold and hot temperature performance as well as lubrication.



125 ML 220-226 \$9.99

### WaterWetter

This wetting agent helps the coolant "bond" to metal surfaces, and increases heat transfer. Highly recommended for all climates.



WaterWetter 220-115 \$24.99



### Transmission Oil

Improve copper-corrosion protection and prolong the life of brass and bronze synchro rings, bushes, and thrust washers. Effective in all manual transmissions.

Trans. Oil (non-OD trans.) 220-145 \$38.99  
Trans. Oil (OD trans.) 220-122 38.99

### Classic Color Spray Paints

These ozone friendly paints come in 12 oz aerosol cans. Bare metal must be primed to achieve satisfactory results. Ground shipping only.



Dark Red - Engine to 1972 220-540 \$29.99  
Black - Engine 1972 on 220-575 19.99  
Lt-Green - Engine MGC 220-550 29.99  
Engine Primer 220-576 19.99  
Silver-Grey - Disc/Wire Wheel 220-560 29.99  
Black Wrinkle-Finish 220-570 19.99

### Supercool by Dynolite

Get better cooling system performance with specially formulated Supercool coolant additive.



- Improves heat transfer properties of your coolant
- Suitable for cast iron, aluminum, copper-brass and bronze cooling systems
- Formulated with a corrosion inhibitor
- Compatible with all water base coolants

Supercool 220-117 \$15.99

### Copaslip Anti-Seize Compound

This anti-seize is highly recommended for wire-wheel splines and knockoff threads. The Molybdenum formulation reduces galling and corrosion to improve the life of wire wheels and hubs. Wheel and hub surfaces should be cleaned and re-lubricated at least once per year as part of a regular maintenance program.



3.5 oz Tube 221-406 \$24.99  
250 g (8.8 oz) Jar 221-410 37.99

### Spray Adhesive

Our contact adhesive has a very high heat resistance and bonds firmly to insulation and sound-deadening material, carpet, headliners and many automotive surfaces. Great advantage of this spray is that it goes on as a web rather than a stream for a more complete and consistent coverage. 12 fl oz.



Spray Adhesive 409-037 \$28.99



### Brake Fluids by Dynolite

Dynolite Brake Fluids prioritize quality and safety. DOT 4 is a premium polyethylene glycol blend with a minimum dry boiling point of 500 F, exceeding industry standards. It has excellent lubricity, a firm pedal feel, and works well with rubber parts. DOT 5 is a non-hygroscopic, non-corrosive silicone brake fluid, making it ideal for historic vehicles. It maintains a boiling point of 500 F throughout its life and has an operating range of -58 to 500 F. DOT 5 does not mix with glycol fluids, so it is best to convert during a total brake system overhaul.

DOT 4 - 500 mL 220-403 \$9.99  
DOT 5 - 1 L 220-413 34.99





### Brake Lube

This grease aids in the assembly of natural and/or synthetic rubber components.

Brake Lube, 5 g	220-443	\$3.49
Brake Lube, 500 g	220-444	23.99

### SAE 90 GL4 Gear Oil by Dynolite

Our classic cars require special fluid and oil formulations, in particular, gear oil. Newer GL5 oils have too high of a sulfur content which erodes yellow metals such as bronze or brass, commonly used in British applications. Our cars require a GL4 type oil and this Dynolite Gear Oil is perfect for our classics.



SAE 90 GL4 - 1 Liter	225-306	\$14.99
----------------------	---------	---------

### ZDDPlus Engine Oil Additive

After 70+ years of trouble-free, metal to metal engine protection, the E.P.A. is forcing ZDDP (Zinc Dialkyl Dithio Phosphate = Zinc and Phosphorus) out of domestic motor oil. If your engine was designed prior to the 1990s, your non-roller lifters require ZDDP in your motor oil to avoid premature deterioration. Don't let your lifters run metal-to-metal. Add the 4 fluid ounce contents of this ZDDPlus bottle at every 4 to 5 quart oil change. Not for use with catalytic converters.



ZDDPlus, each	220-805	\$16.99
---------------	---------	---------

### Collector's Choice Engine Oil

Collector's Choice engine oil is a must for your classic engine. Contains higher zinc and phosphorus levels to help prevent premature camshaft lobe wear, additives to help prevent seals from becoming hard and leaking from infrequent use, and antioxidants to combat the effects of humidity changes during storage that can lead to moisture and even rust in an engine. 12 quarts in a case. Not for use with catalytic converters.



20W-50, quart	220-815	\$12.99
20W-50, case of 12	220-810	146.99 <span>OS</span>



### Fuel Tank Restoration

#### Step 1: Cleaner

We recommend using this bio-degradable cleaner in conjunction with the etching liquid when planning to seal a fuel tank. 1 gal.

#### Step 2: Etcher

Use this bio-degradable etcher as a prep to our sealing compound to give maximum adhesion to the sealer. Our tank cleaner should be used first to remove oils or grime. 16 fl oz.

#### Step 3: Sealing

This sealing compound fluid puts a protective film on the entire inside surface of your fuel tank to prevent rust and eventual fuel line blockage. Tanks should be cleaned with #220-620, then etched with #220-630.

Cleaner	220-620	\$52.99	<span>OS</span>
Etcher	220-630	24.99	
Sealing	220-450	56.99	

### Stor-N-Start

Stor-N-Start is an additive that prevents deposits from forming in fuel lines and carburetors.

Stor-N-Start	220-375	\$10.49
--------------	---------	---------



### "Ultra Slick" Engine Assembly Lube

Use "Ultra Slick" during assembly of camshafts, lifters, engine bearings, timing components, valves and guides, and rocker shaft assemblies.

Assembly Lube	221-565	
---------------	---------	--



### Dashpot Oil

Specifically designed for both SU and Zenith carbs, this oil will ensure your car's proper performance. 125 mL.

Dashpot Oil	220-225	\$17.99
-------------	---------	---------



## HYLOMAR®

### Hylomar Sealants and Assembly Adhesives

Hylomar Limited manufactures a wide range of high-performance sealants and adhesives used by some of the leading OEMs in the world. Hylomar products are also widely used and respected in the automotive, aerospace, and industrial aftermarkets.

Hylomar M was originally the Racing Formulation. It is acetone-based, stiffens slightly over time and can be used in place of a gasket between finely machined surfaces. This product comes in a tube and an aerosol.

Hylomar Advanced Formulation (AF) is solvent-free, won't harden and is perfect for use with gaskets on parts that need to be removed regularly for service. AF fills imperfections on mating surfaces, thus forming a seal.

Hylotyte RED is a semi-hardening gasket and jointing compound offering improved gap-filling capabilities. The product is resistant to a wide range of fluids, especially water (including salt water and steam), anti-freeze, and synthetic oils. It forms an instant seal, has a heat-activated curing system and is methylene chloride free.

Hylomar Cleaner removes used Hylomar gasket and jointing compound from disassembled joints. The unique mix of solvents also make it perfect for cleaning and degreasing surfaces prior to use with any of Hylomar's range of adhesives and sealants. It is also very effective at removing uncured anaerobic adhesives, uncured silicone, and uncured epoxy products.

Hylomar M - 80 ml Tube	232-220	\$24.99
Hylomar M - 200 ml Aerosol	232-225	39.99
Hylomar AF - 85 g Tube	232-215	34.99
Hylotyte RED - 40 ml Tube	232-231	16.99
Hylomar Cleaner - 400 ml Aerosol	232-240	18.99



### Water and Gas Don't Mix

**MORE INFO ONLINE**

If you use modern gas that has Ethanol blended in, and you don't drive your classic very often, the ethanol attracts water in your vented tank which in turn forms rust and sludge, impairing performance. We've got three products to help:

#### Prevent with PEP Fuel Treatment

PEP fuel treatment is a fuel preservative formulated with antioxidants and de-gumming agents to help fight sludge, resin deposits, and gum from forming in your fuel tank. Modern ethanol-blended gasoline has a shelf life of 30-45 days in a vented tank, PEP fuel treatment increases that to 60 days. PEP fuel treatment should be mixed with the fuel every time you buy gas. Keep a bottle handy in your trunk. An 8 oz bottle treats 80 gallons. If you are storing your vehicle with gasoline in the tank, use 1 oz for every five gallons.



#### Test with Water Probe Indicator

Using a dip stick that will pass all the way to the bottom of your fuel tank, apply the Indicator to the very tip of the dip stick. Water collects at the very bottom of your tank. The Indicator will turn red to show the exact level of water in your tank.



#### Emulsify with E-Zorb Treatment

E-Zorb emulsifies the water you've found in the bottom of your fuel tank, and mixes the water and ethanol back into the fuel. The water will pass with the gasoline through your filter and into your engine, finally leaving as steam. E-Zorb should be mixed in the ratio 1 ounce to 20 gallons of gasoline, so one pint bottle of E-Zorb will treat 320 gallons. It will be necessary to agitate the fuel treatment in your tank by rocking your car from side to side and up and down.



PEP Fuel Treatment	220-361	\$13.99
Water Probe Indicator	220-362	12.99
E-Zorb Fuel Treatment	220-355	33.99



### Cooling System Air Purge Tool

Ensuring all the air is purged out of the later cooling systems can be tricky without this handy tool. Tool threads into the filler plug hole and allows easy topping off of the cooling system to ensure all air is evacuated.

Air Purge Tool	384-965	\$58.99
----------------	---------	---------

### Steering Column Alignment Tool

This tool duplicates the function of the factory tool referenced in the workshop manual that ensures correct shaft alignment with steering columns.



Alignment Tool - w/o shims	453-622	\$29.99
Alignment Tool - w/ shims	453-628	44.99



### Tube Type Axle Puller

This tool substitutes the factory tool 18G284D called for in the workshop manual to remove axle shafts from the housing. Must be used with a slide hammer fitted with a hook (your workshop manual charmingly refers to the slide hammer as an "impulse extractor").

Axle Puller	384-945	\$36.99
-------------	---------	---------



### Grease Cap Puller for Wire Wheel Hubs

A clever solution to a difficult task, thread this puller onto a grease cap, put a screwdriver through the hole and simply pull it out. Saves time and frustration. For use on wire wheel grease caps with threaded stud.

Grease Cap Puller	384-935	\$44.99
-------------------	---------	---------

### Lift Pin Tool

This useful tool raises and holds the lift pin on SU carburetors, making air or fuel adjustments easy and safe.

SU Carburetors	384-976	\$26.99
----------------	---------	---------



### Fuel Sending Unit Tool

This simple socket style tool makes removing the fuel sending unit locking ring from your fuel tank a breeze. It increases efficiency and facilitates your experience, so buy yours today!



MGB/C 65-76	384-985	\$29.99
-------------	---------	---------

### 1977-80 Steering Wheel Puller

Removing the steering wheel from a 1977-80 MGB can be an almost impossible task as the hub often freezes to the shaft. The rubber wheel does not have any provision for a puller, so many times the wheel is destroyed during removal. This protective puller plate is secured to the wheel by a pair of C clamps (not included, available at most hardware stores). The drive bolt then is tightened against the steering shaft applying a load which is usually enough to allow the splines to free with a hammer tap. This U.S. manufactured part is well made and suitable for professional or car club use.

Wheel Puller	384-930	\$58.99
--------------	---------	---------



### Lift-the-Dot Hand Punch

For professional installers, but this tool would make a fine car club tool box addition. Punches center hole and prong holes for installation of Lift-the-Dot fasteners to make installation of tops and tonneau-covers a cinch.

Lift-the-Dot Hand Punch	226-105	\$89.99
-------------------------	---------	---------



\*See ordering page for details

⚠ WARNING: Cancer and Reproductive Harm. www.P65Warnings.ca.gov





**Clikadjust Valve Adjuster**

Adjusting tappets has never been easier. Replace the clumsy screwdriver/wrench combination with a single easy-to-use tool. This British tool takes much of the effort out of this necessary job. Turn the handle, click, and tighten. Your clearance is set! Requires a 1/2" drive socket to fit tappet adjustment nut.

Clikadjust 386-205 \$139.99



**Ball Joint Puller and Separator**

These heavy-duty forged tools are the easiest way to split ball and taper joints, such as track rod ends from steering arms.

Puller 386-025 \$54.99  
Separator, Scissors Type 386-026 85.99



**Rear Axle Hub Nut Socket**

Special 8-sided 1 5/16" socket for the rear axle hub nut. This invaluable tool is a modern and affordable replacement for the expensive and hard to find Churchill tool.

Requires 3/4" drive 384-905 \$44.99



**Classic Leather Tool Bag**

Keep your tools tidy, safe and organized with a brand new classic leather tool bag. A perfect addition to any classic car enthusiast's collection, this beautiful tool bag by Gunson is generously sized, made of heavy duty leather, and features stitched and metal riveted seams. Secured with three buckled straps, it has an adjustable shoulder strap for easy handling. This useful bag measures approximately: 150 mm x 145 mm x 380 mm.

Classic Leather Tool Bag 384-815 \$94.99



**Brake Caliper Piston and Seal Tool**

The right tool for the job makes life much easier. Duplicating the functions of the factory tool 18G590, this allows easier installation of brake caliper pistons, seals, and seal retainers.

Brake Caliper Tool 386-280 \$69.99



**King Pin Reamer**

To install new king pin bushings, they must be carefully reamed in perfect alignment after installation. Moss has the special factory king pin reamer.

King Pin Reamer 386-370 \$399.99



**Zenith-Stromberg Carb Tool**

This small hex-drive and sliding gauge will aid greatly in adjusting the needle depth for the Zenith-Stromberg carburetors.

Carb Tool 386-310 \$11.29

**Snap Installation Tool**

Install button snaps easily and without damage.

Snap Tool 386-980 \$4.99



**Grease Gun**

A handy tool for all those maintenance tasks.

Grease Gun 386-710 \$36.99

**Gunson's Colortune**

A glass topped spark plug allows you to see the color of combustion in your cylinders. Comes with special glass topped spark plug, viewing system for difficult plug locations and complete tuning procedure with trouble shooting guide.

Gunson's Colortune 386-210 \$109.99

**SU Maintenance Tool Sets**

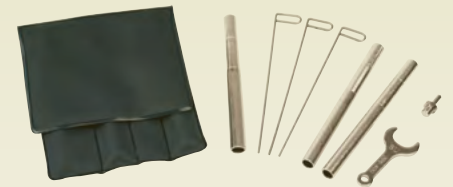

**SU Tool Kit**

An assortment of handy tools for the home mechanic. Instructions included. Suitable for all cars with SU carbs. Includes jet wrench (#386-400).

SU Tool Kit 386-300 \$23.99



**SU Jet Centering Tool**

Jet centering is critical on older fixed needle SU carbs. This simple tool makes it a snap!

Centering Tool 386-500 \$39.99



**SU Carburetor Piloted Throttle Shaft Bush Reamer**

This special reamer is designed to open up worn 5/16" throttle shaft bushings to accept 0.010" oversize throttle shafts. For SU carburetors only.

Reamer 386-385 \$369.99



**SU Jet Wrench**

Mixture adjustments on SU H and HS carburetors are much easier with the proper tool. 3/16" W (0.600" nut) fits original carbs. 17 mm (0.669" nut) fits new upgraded carbs.

(A) 3/16" W Wrench 386-400 \$4.39  
(B) 17 mm Wrench 386-401 7.99



**MGB GT Door Seal Clip Installation Tool**

The clips used to hold your door's window-seal are very tricky to install without this tool. The magnetic strip on this tool holds the clip in place for you while maneuvering between the glass and the door.

Door Seal Clip Tool 384-950 \$38.99



**KING  
DICK  
TOOLS**



384-810

**MG Tool Roll & Tools**

Keep your tool set organized and prepared for those unforeseen roadside repairs with the MG Tool Roll and Tool Set. Made of durable canvas, it has a carefully tailored finish, and sports an embroidered MG logo on the front. Store your roadside tools in perfect order with this 15 pocket canvas-roll. A practical buy, keep this handy accessory in your British car wherever you go!

**Specially selected for MG, this tool set includes:**

- 7" combination pliers
- **Spanners:** 3/4", 1 1/16", 5/8", 9/16", 1/2", 7/16"
- **Screwdrivers:** Posidrive and Slotted
- Spark plug wrench and brush
- Adjustable wrench
- Feeler Gauge Set
- Circuit tester
- Tire Gauge

MG Tool Roll & Tools	384-810	\$159.99
MG Tool Roll	384-811	29.99



384-805

**8-Piece Wrench Sets**

These quality Whitworth and Standard wrench sets were manufactured from a satin finished chrome vanadium and feature a traditional oiled leather tool roll.

**Whitworth Set sizes:**

1/8" w, 3/16" w, 1/4" w, 5/16" w, 3/8" w, 7/16" w, 1/2" w, 9/16" w

**Standard Set Sizes:**

1/4", 3/16", 3/8", 7/16", 1/2", 9/16", 1 1/16", 3/4"

Whitworth Wrench Set	384-800	\$99.99
Standard Wrench Set	384-805	59.99



**Phillips/Pozidriv All-In-One Screw Driver Set by King Dick**

Our revolutionary all-in-one screwdriver set features a patented tip design optimized for both Phillips head and Pozidriv patterns. All four screwdrivers are made from hardened and plated high-grade steel, and have soft-feel grips for comfort and control. Take the guesswork out of your British car tasks and save yourself the frustration of stripped screw heads. All four screwdrivers work with PH1-2-3 or PZ1-2-3 and vary only in length.

Phillips/Pozidriv	384-850	\$72.99
-------------------	---------	---------



384-865

**Whitworth Drive Sets**

Made from high-quality forged materials, King Dick drive sets make for a perfect addition to the tool cabinet of any classic car enthusiast. The drive sets use precision drop forging methods to ensure uniformed steel structure. The sockets are broached to size using exceptional accuracy, then ground and polished before being heat treated for consistent and reliable strength that you can count on! The drive sets are then polished again and stamped for the final touch. The nickel chrome plating ensures maximum resistance to corrosion that also serves to enhance the appearance of the drive set. Check our website for details of each kit.

1/2" - 8 PC	384-860	\$174.99
1/2" - 19 PC	384-865	429.99
3/8" - 9 PC	384-870	176.99



**Ignition Wrench Set**

High quality ignition wrench set by King Dick. Sizes 0 to 10 BA will handle most fasteners smaller than 1/4" on the car.

Wrench Set	385-000	\$86.99
------------	---------	---------



\*See ordering page for details

⚠ WARNING: Cancer and Reproductive Harm. www.P65Warnings.ca.gov







**Tube Bender**

Bend fuel and brake lines exactly where you need them to go. This Tube Bender works great for brass, copper, steel and aluminum tubes of the following diameters: 3/16", 1/4", 5/16" and 3/8".

Tube Bender 385-905 \$24.99

**Wire Harness Repair Kit**

**Fast, Secure Connections Made Easy.**

Our wiring harness repair kit makes fast, secure wiring connections a snap. Just crimp a bullet to each wire end using the included bullet crimping tool, push bullet ends into the connector sleeve and snap firmly into place with the closing tool for a permanent repair.

The high quality, bullet crimping tool ratchets closed to put a secure hexagonal crimp in bullets. The closing tool presses bullets firmly into both single- and two-wire connectors.

Repair Kit with Tools	161-751	\$249.99
Repair Kit without Tools	161-752	54.99
Bullet Crimp Tool	161-759	139.99
Bullet Closing Tool	161-761	54.99



**Drum Brake Adjusting Wrench**

Get a better grip on brake adjusters with our specially designed wrench. It has 1/4" and 3/16" square box end, and a long handle for improved leverage.

Adjusting Wrench 386-160 \$13.99



**Carburetor Synchronizer**

Synchronize airflow between multiple carburetors with this indispensable tool for the serious home mechanic.

Carb Synchronizer 386-200 \$39.99

**Carburetor Air Flow Meter**

An Airflow Meter allows you to quickly tune your engine's carburetion. These precision instruments are designed to measure the airflow directly on the air intake of the carburetor and can be used at low and high rpm on down draft and side draft engines. The sensitivity and accuracy of the Airflow Meter is much greater than any other type of synchro tool or gauge. And the range of indication is very broad on the lower end of the scale to ensure precise adjustment at idle rpm. While a single instrument is sufficient, the use of one per carburetor is advantageous. The airflow of each carburetor can be constantly observed until the tune-up is completed. Made in Germany the BK Model is supplied with an adapter that is ideal for all ram pipes and intake bores of 1 1/4" to 2 1/4" (32 to 55 mm diameter) and provides an easy-to-read indication from 1 to 30 kg/h.

Carburetor Air Flow Meter 375-324 \$99.99



Pricing is subject to change.  
Please visit [MossMotors.com](http://MossMotors.com) for current pricing and availability.

ACCESSORIES



**GB40 Lithium Jump Starter by NOCO**

This portable lithium-ion battery jump starter pack delivers 1,000 amps (7,000 Joules3S) to jump-start a dead battery in seconds! It features patented safety technology that provides spark-proof connections and reverse polarity protection making it safe and easy for anyone to use. It's a powerful battery booster that doubles as a portable power bank for recharging USB devices, like a smartphone.

**Features:**

- A lithium battery jump starter rated at 1,000 Amps (7,000 J3S)
- Spark-proof connections and reverse polarity protection
- Recharges USB devices, like smartphones, tablets, and more
- 100 lumen LED flashlight with multiple modes, including SOS
- Jump starts gas engines up to 6 liters, and diesel up to 3 liters
- Provides up to 20 jump starts on a single charge

GB40 Lithium Jump Starter 386-420 \$124.99



**On-Board Battery Charger**

Every sports car owner who only uses their car part of the year needs one of these, because deep discharge appreciably shortens battery life.

- Attaches permanently to battery tray or fender well
- Molded plastic sealed-case is resistant to water, gasoline, oil, solvents, and acids
- Charges and maintains 12 volt batteries
- Totally automatic. If the battery drops 1 volt, the charger switches on, and when fully charged it switches itself off
- Operates from any regular 110 volt outlet
- Dimensions: 5½" x 3½" x 1½"
- Mounting hardware included

Battery Charger 386-245 \$94.99



**MUS 4.3 Battery Test & Charge by CTEK**

The MUS 4.3 Test and Charge combines a microprocessor-controlled battery charger with a battery and alternator test function to provide the ultimate in battery testing, charging, and maintenance.

**Testing** - Three easy to use programs test battery voltage, starting power, and alternator performance to provide a complete picture of battery and vehicle charging system health.

**Charging** - This charger solves a broad range of battery problems. Its features include a patented automatic desulphation program and a special reconditioning function that can revive deeply discharged and stratified batteries. The patented Float/Pulse maintenance setting makes this charger ideal for long-term battery maintenance.

**Features & Technical Info:**

- Input 110-120VAC, 50-60Hz, 0.6A max
- Output 14.4V/14.7V/15.8V, 4.3A max
- Fully automatic 'connect and forget' 8 step 12V charging cycle
- 3 voltage test programs
- Battery types: All types of lead-acid batteries, 12V, WET, MF, Ca/Ca, AGM, GEL
- Insulation: IP65 (splash and dust proof)
- Patented float/pulse maintenance for batteries up to 160Ah
- 5 Year Limited Manufacturer Warranty

MUS 4.3 Battery Test & Charge 386-290 \$149.99

**Accessories**

Silicone Bumper Cover	386-292	\$11.49
Mounting Bracket	386-293	11.49
Comfort Connect Cable	386-294	7.89
8.2 ft Extension Cable	386-295	12.99



**MXS 5.0 Battery Charger by CTEK**

Get unrivalled charging performance for batteries from 1.2 to 110Ah with the advanced microprocessor controlled MXS 5.0 battery charger. With built-in automatic temperature compensation, it ensures the best charging performance, even in the most extreme conditions. The MXS 5.0 also includes battery diagnosis to establish whether your battery can receive and retain a charge, a patented automatic desulphation program, an AGM (Absorbent Glass Mat) option which maximizes the performance life of most Stop/Start batteries found in modern cars (cars that turn-off when stopped to reduce emissions), and a special mode for reconditioning deeply discharged batteries. The MXS 5.0 includes CTEK's patented float/pulse system, which is certainly the most efficient mode when a battery is connected for long periods.

**Features & Technical Info:**

- Input 110-120VAC, 50-60Hz, 0.6A max
- Output 14.4V/14.7V/15.8V, 4.3A max
- Fully automatic 'connect and forget' 8 step 12V charging cycle
- Battery types: All types of lead-acid batteries, 12V, WET, MF, Ca/Ca, AGM, GEL
- Insulation: IP65 (splash and dust proof)
- Patented float/pulse maintenance for batteries up to 160Ah
- 5 Year Limited Manufacturer Warranty

**New Feature offered with the MXS 5.0 Charger:**

- Built in charge voltage temperature compensation according to ambient temperature

MXS 5.0 Battery Charge 386-296 \$124.99

**Accessories**

Silicone Bumper Cover	386-292	\$11.49
Mounting Bracket	386-293	11.49
Comfort Connect Cable	386-294	7.89
8.2 ft Extension Cable	386-295	12.99



\*See ordering page for details

⚠ WARNING: Cancer and Reproductive Harm. www.P65Warnings.ca.gov



**Bezel Remover Tool Set**

The round bezels on most Lucas Switches have two slots, and nobody has the special tool you need to take them off. Using a screwdriver results in a scratched dash and colorful language. These tools have two teeth for the slots in the bezels and are made from hard steel so the teeth will last; critical for this application so you don't mar your bezels. The set includes tools for 3/4" diameter and 1" diameter bezel nuts.



Warning Lights Bezels 384-960 \$37.99



**One-Man Brake Bleeder**

While we obviously advocate for the many stainless steel braking system components available today, they're still no substitute for proper maintenance and fluid renewal. We recommend flushing your vehicle's brake fluid every year. With this kit the hassle factor is no longer a valid excuse.

One-Person Bleeder 37-0104 \$15.69



**X-Treme Quick Fix Tape**

X-Treme tape was developed for the military. Once wrapped around an object, the silicone based tape forms a non-conductive, air/watertight, insulating seal that remains flexible within a range of -60 F to 500 F and has a tensile strength of 600 psi. The tape can be repositioned within two minutes of wrapping and will start to bond immediately upon application. Black roll is 1" wide and 10' long (stretches to 3 times its length).

X-Treme Quick Fix Tape 221-590 \$8.99



**Mityvac**

This popular vacuum/pressure pump is perfect for bleeding hydraulic systems. Includes: vacuum/pressure pump, vacuum gauge, 1/4" tubing, automotive and brake bleeding adapter packages, reservoir jar, and a manual with detailed instructions and ideas for additional uses.

Mityvac 386-215 \$89.99

**Circlip Installation Tool**

The wheel cylinder circlip is notoriously difficult to install. This easy-to-use tool changes all of that. You can now change wheel cylinders in a snap, while avoiding damage to parts or yourself.



Circlip Installation Tool 386-185 \$33.99



**Quick Fix Tape by DEI**

With multiple applications, this high performance Quick Fix Tape is ideal for emergency hose repair, electrical splices and connections; serves as a temporary leak sealer and non-slip grip surface for tools; and does not leave a sticky residue after removal. Extruded from a special high-performance grade silicone compound, this self-curing tape bonds to itself and forms a waterproof permanent seal. Engineered at 700 psi tensile strength, Quick Fix Tape has insulating capabilities up to 8,000 volts and stretches to three times its length for a simple stretch-and-wrap application. The triangular profile of the tape (the center is thicker than the edges) provides a smooth edge when overlapping. Sold in 1" wide x 12' long rolls.

Quick Fix Tape 231-945 \$16.39



**Eezibleed Kit**

Kit contains a pressure vessel to hold new fluid, a pipe with interchangeable caps to fit 1962-67 and 1975-80 master cylinders, and an air hose to connect to a tire. Instructions included.

Eezibleed Kit 386-860 \$79.99

**Brass Tire Gauge**

Solid brass precision gear movement. Push button valve to bleed air to the desired pressure. U.S. and metric scales.



Brass Tire Gauge 225-715 \$29.99

**Panel Hole Locator Tool**

Take the guesswork out of installing new panels with this handy panel hole locator. Easily use this tool to transfer existing holes in the sheet metal to upholstery panels.



Panel Hole Locator Tool 384-975 \$29.99

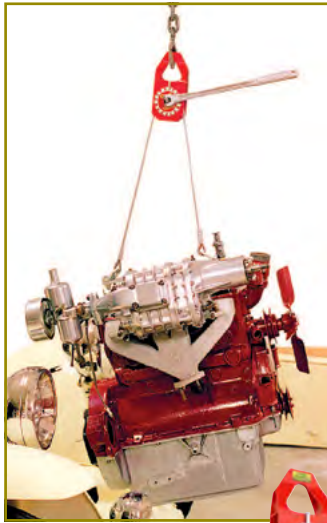

**Oberg Tilt Lift**

Allows easy adjustment of an engine's lift angle through a full 90° of movement. Adjust with ½" ratchet; 2,000 lb capacity with a 3:1 safety load factor. A positive lock ensures the engine stays put. All steel construction and small size.



Oberg Tilt Lift 386-730 \$119.99



**Roll Around Engine Stand**

A classic car's engine more often than not requires work. Restoring it doesn't come easy when you cannot even move it to make those modifications. Which is why, this roll around engine stand is a must have product for all those tinkering on their classic cars. Built to last, this mobile engine stand with heavy duty casters will make an easy job of getting your engine off the ground, preventing it from tipping over and working on it. It is quite easy to assemble. Available in black powder-coat finish for your MGB.

1962-74 Stand 384-915 \$164.99  
 1975-80 Stand 384-920 164.99 OS



**Tire Flat Spot Protectors**

Flat Spot Protectors are essential for any owner looking to protect the lifespan and performance of their tires. Designed to increase the tire contact area and spread vehicle load, flat spot protectors minimize stress exerted on the tire, preventing sidewall cracks and flat spots formed during storage; offering additional benefits their ramped design also means that flat spots protectors function as effective vehicle chocks, avoiding the need to apply the handbrake (which can lead to binding of the rear brakes) and can also be secured to the floor to provide a garage parking stop function. Suitable for vehicles up to 8,800 lbs with 10"-18" x 7" wide wheels. Our Flat Spot Protectors benefit from a durable, high visibility, interlocking design, and are supplied in pairs.

Tire Flat Spot Protectors - Pair 221-600 \$44.99 OS

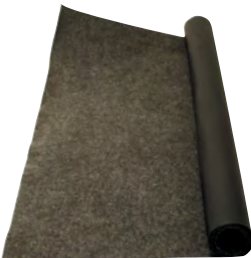

**Oil Spill Mat**

Don't let oil stain your garage or driveway. Roll out an absorbent Oil Spill Mat to catch the daily dribbles and engine maintenance spills.

Oil Spill Mat 221-605 \$25.99



**The Auto Dolly - 8" x 16" Standard Duty**

Maneuvering your car is easy with these wide heavy duty rollers. When used as a set, they are able to manage a 6,000 lb capacity.

Standard Duty Dolly 900-163 \$214.99 OS



**Moss Tinkering Fender Cover**

Protect your car's finish from accidental spills, scratches, or small dents while you work on the engine bay. Imprinted with a fun "Tinkering in Progress" text, this fender cover features colorful MG, Triumph, Austin Healey, Jaguar, and MINI logos. It has strong PVC material on one side and a non-slip felt lining on the other. Available in 34" x 21" size, it includes five nylon mesh pockets to hold small tools and hardware. Washable and easy to maintain.

Moss Tinkering Fender Cover 991-020 \$29.00



**Fender Covers**

These foam rubber backed fender covers are imprinted with the logo of your favorite British marque.

MG Fender Cover 241-725 \$29.99



**Moss Gripper Fender Cover**

Protective fender cover grips the paintwork and will not slip.

Moss Fender Cover 990-991 \$35.00





**Keep Calm and Wrench On Work Mat**

Stay comfortable as you work on your car with these logo'd work mats. Customized for your British sports car, these work mats are made from closed cell foam, and offer comfort as you sit, kneel, or lay down to work on your car repair projects. Measuring 72" x 24" x 1/16", they are perfectly sized to be kept in your trunk. Made in the USA, these work mats are water and chemical resistant, and they do not stain easily.

Work Mat 217-805 \$45.00



**MG Kneeling Pad**

Stay comfortable as you work on your car using the MG kneeling pads. Customized with an MG logo, these work pads are made from Softek closed cell foam and offer comfort as you sit or kneel to work on your car repair projects. Measuring 11" x 15" x 3/4", they are perfectly sized to be kept in your trunk. These lightweight foam cushions can be used on multiple surfaces at home, garden or on the road, and feature a cut-out handle making it easy for you to carry them around. Made in the USA, these work pads are water and chemical-resistant, washable, do not stain easily, and are practically maintenance free. Just wipe away any dirt with a wet tissue or cloth and you're good to go!

MG Octagon Logo 214-700 \$23.99



**Knit Blankets**

Keep the chill away while relaxing at home or during a brisk night drive with this blanket. Made from an 80% cotton blend, the blanket's knit construction feels as soft as a sweater while providing you a substantial buffer against the cold. It measures 50" x 60", weighs 3 1/2 pounds, is machine washable, and is made in the USA.

MG Safety Fast	009-126	\$99.99
All British Line Up	009-143	99.99
Union Jack	009-146	99.99
American Flag	009-147	99.99
MG Octagon	231-320	99.99
BMC Rosette	231-330	99.99



**Waterproof Picnic Blankets**

Bring a touch of comfort to any roadside picnic with the waterproof picnic blanket. Folded into a parcel, it can be easily stored and transported using its durable handle. When open, this blanket spreads out to 51" x 70". Constructed of gray acrylic with a foam-layer and waterproof PEVA backing, it comes adorned with the MG logo.

MG Logo 231-375 \$34.99



DETAIL



### Collapsible Marque Umbrella

Steer clear of rain, wind, or the scorching sun with our new umbrellas especially created for British car enthusiasts! Customized with the MG logo, these 8-panel nylon umbrellas feature a telescopic metal shaft for durability and an automatic open function for easy one-handed operation. Each umbrella has a rubberized comfort grip, and comes with a matching sleeve and wrist-strap. Keep it in your car and be prepared to have a great time outdoors, no matter the weather!

**Features:**

- Automatic opening
- Rubberized Comfort Grip
- 16" folded, 44" diameter
- Matching color fabric case with wrist strap

MG Logo 214-740 \$29.99



### Keep Calm Weekender Bag

Carry a piece of British nostalgia, cheeky humor, and all your travel items with this duffel bag. The "Keep Calm and Cruise On" tote has a zippered main compartment with a reinforced bottom, a front slip pocket, and expandable top. Its adjustable shoulder strap and the matching handles make carrying more comfortable.

**Size:** 22" W x 14" H x 7" D

Keep Calm Weekender Bag 217-830 \$44.99



### Trunk Cargo Net

Keep your trunk space cleaner and more organized with the brand new cargo net. It easily attaches to the trunk lid hinges and opens at the top. It is super stretchable to fit small items that often roll around in your trunk, and employs high quality materials to give it durability.

Trunk Cargo Net 900-754 \$12.99



### MG Canvas Duffel Bag

Pack and go with this durable and spacious canvas duffel bag. Created for road trips but destined to be your favorite all-occasion duffel. Its classic design delivers thoughtful features including:

- Synthetic leather accents embossed with the MG wings logo
- A zippered pocket for quick access to items like a wallet or phone
- Side clips for adjustable load carrying capacity
- A trolley sleeve for attaching the duffel to rolling luggage
- Size: 11" H x 20" W x 9½" D

MG Canvas Duffel Bag 217-825 \$79.99



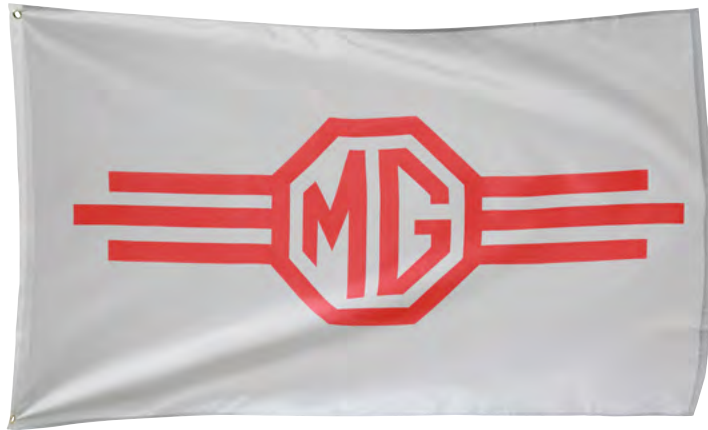

**MG Flag**

Made from 100% woven polyester, these 3' x 5' flags are a great way to show off your appreciation for your MG! These flags are silk screened for precision, feature the MG logo and are hemmed with header and grommets for a detailed finish. Let these flags wave outdoors or hang them on your walls for a classic touch to your den or garage. Either place, they are sure to look great!

MG Octagon Logo                      214-710      \$39.99



**Logo Bar Stool**

Great stools emblazoned with the logo of your favorite car. 30" high with chrome plated legs. The padded 14" diameter seats offer comfort and are covered with easy to clean vinyl.

MG Logo                                      231-800      \$199.99 



**MG Octagon Glass Sets**

When raising a toast with friends, share your MG passion etched in glass. Choose a set of 4 classy wine glasses or 4 full pint traditional beer glasses. Both are perfect to serve wine, Guinness, or lemonade. Hand wash only. Everyone will appreciate your pub-like style and the ample serving size!

Pint Glass Set - 4 pc                      230-951      \$36.99  
 Wine Glass Set - 4 pc                      230-969      39.99



**Stainless Steel Cup**

Grab attention with a classic car inspired pint cup. This high-quality stainless steel cup has a capacity of 16 oz. Attractively priced, get ready to enjoy your favorite drinks in this stackable cup featuring the logo of your favorite marque. Order for yourself or better yet, get some for your friends and share some classic cheer! Sold individually. Does not include a lid.

MG Octagon                                      217-810      \$12.99



**Tire Drink Holder**

This custom koozie keeps your drinks cool while showing off your favorite classic British car. Approximately 4" tall by 3" wide, the rubber tire drink holder fits most cans and cups, has a neoprene liner, and makes for a great promotional or giveaway item for classic car enthusiasts events.

MG Logo                                      217-270      \$10.99



**Stainless Steel Thermal Cup**

This classic car inspired stainless-steel pint cup showcases the MG logo. The 16 oz thermal cup is insulated, keeping drinks hot or cold. Sold individually.

MG Octagon                                      217-565      \$16.99



Pricing is subject to change.  
 Please visit [MossMotors.com](http://MossMotors.com) for current pricing and availability.



**Insert Before Drive Key Ring**

These “Insert Before Drive” key rings are a fun play on the original “Remove Before Flight” tags often seen on aircraft or their components. These marque specific key rings come with a tag showing off the Moss block and “Insert Before Drive” script on one side, and our classic British marque logos on the other. Get yours with the classic MG Safety Fast logo or gift them to your fellow car enthusiasts! And don't forget, Insert Before Drive!

Moss Motors (100 x 20 mm)	217-256	\$4.00
MG (125 x 25 mm)	217-265	6.00



**Union Jack Key Fob**

Useful and charming, get these leather key-fobs with the classic Union Jack.

Union Jack Black Leather	229-885	\$8.99
--------------------------	---------	--------



229-896      229-897      229-898

**Engraved Metal Key Fobs**

You'll love the sleek look of our latest Keychain Fobs. Engraved with your favorite British icon and available in three distinctive styles.

<b>Leather &amp; Bar</b>		
Union Jack	229-886	\$15.99
MG Logo	229-896	15.99
<b>Leather &amp; Teardrop</b>		
Union Jack	229-887	\$15.99
MG Logo	229-897	15.99
<b>Solid Metal</b>		
Union Jack	229-888	\$15.99
MG Logo	229-898	15.99



**MG Gunmetal Watch**

Show off the MG marque in style with this men's MG watch. The 37mm gunmetal grey alloy case has a matte textured finish, and features a single crown design. Encased inside is a high quality quartz movement for accuracy and longevity, sure to keep you on time for years to come. On the face it features engraved numeric markers and seconds, with black hands with white fill for easy viewing. The strap is a subtle faux alligator in black. With a large MG Octagon logo in red, it's perfect for any MG enthusiast!

MG Gunmetal Watch	231-314	\$89.99
-------------------	---------	---------



**MG Octagon 45mm Chronograph Watch**

This great looking chronograph style watch has a 45 mm precision machined silver alloy case, sport a mineral glass crystal face, stainless steel bezel and a stainless steel positive clasp band for great looks, easy viewing and durability. It comes packaged in an elegant black tin presentation case for easy gift giving.

**Features:**

- High quality quartz movement from Japan for accuracy and longevity.
- Fully functional 1/10 second chrono capability up to 60 minutes that provides accurate timing at home or at the track.
- Self-luminous hour markers, hour hand and minute hands with a red second hand for a sporty look and great night-time visibility.
- Logos are raised/embossed and high polished to a jewelry finish for premium good looks.
- Includes a 3 year limited factory warranty. See the enclosed factory warranty papers for specific details and conditions.

MG Octagon	231-311	\$149.99
------------	---------	----------







**MG Octagon**



**Safety Fast**



**Green Embroidered MGB T-Shirts**

Made using heavy cotton, this t-shirt gives a softer feel and comfortable fit for active daily use. It is perfect to wear while you're taking your LBC for a ride, attending your car club meetings or simply enjoying a day out.

Medium	217-610	\$18.00
Large	217-611	18.00
XLarge	217-612	18.00
XXLarge	217-613	18.00

**MG Embroidered Performance Polos**

Stay comfortable with our light weight Performance Polo. Moisture-wicking and highly breathable, our polo will keep you dry and cool whether you're out for a drive, at a show, or just working in the garage. These polos come in navy-blue sporting the classic MG Octagon logo, or green with the MG Safety Fast logo. Machine washable.

**MG Octagon Logo**

Navy - Medium	217-360	\$38.00
Navy - Large	217-361	38.00
Navy - X Large	217-362	38.00
Navy - XX Large	217-363	38.00

**MG Safety Fast Logo**

Green - Medium	217-275	\$38.00
Green - Large	217-276	38.00
Green - X Large	217-277	38.00
Green - XX Large	217-278	38.00



**Detail**

**Embroidered Tech Lite Jacket**

Casual and classic, wear your style any time of the year with this lightweight, water resistant jacket. Customized for a classic car enthusiast, the jacket sports an embroidered MGB model and script on the front and a small Moss block on the sleeve.

Featuring a roll away hood, adjustable cuffs with tabs, vented back yoke and an adjustable shock cord at the hood and hem, the jacket is lined with 100% polyester mesh in upper back. Show it off at your car club meetings or gift it to a fellow enthusiast. Comes in navy or khaki, machine washable. Available in sizes: Medium, Large and XL. Get yours today!

**Navy**

Medium	217-700	\$45.00
Large	217-701	45.00
X Large	217-702	45.00

**Khaki**

Medium	217-703	\$45.00
Large	217-704	45.00
X Large	217-705	45.00

**Embroidered Coach's Jackets**

Add a style statement to your wardrobe with these coach jackets featuring the embroidered logo of your favorite classic car! With contrast poly lining, Raglan sleeves, elastic cuffs, and slash pockets the 3 oz lightweight jacket has a waist toggle pull and dyed-to-match metal snaps in front for easy closure. Made from 100% nylon taffeta, this jacket is water resistant.

Medium	217-520	\$49.99
Large	217-521	49.99
X-Large	217-522	49.99



Pricing is subject to change.  
Please visit [MossMotors.com](http://MossMotors.com) for current pricing and availability.



217-690



217-750

217-751

BACK

217-752

DETAIL



**FRONT**  
**Moss Motors British Classic Cars Apparel**

Show your appreciation for British Classic Cars with the latest in our lineup of custom apparel. For the all-around British car fan, our treaded classic design t-shirt and corresponding beanie are sure to turn heads. Our pull-over sweatshirt with front pocket has a back print of the front-angle view of some of the best British cars around (no offense to those we didn't include!). And finally, the complexity of SU carbs with the tagline "Some Assembly Required" is known all too well by those of us who have braved a disassembly and makes for a fun and stylish shirt.

**BCC T-Shirt**

Medium	217-690	\$16.00
Large	217-691	16.00
X Large	217-692	16.00
XX Large	217-693	16.00
XXX Large	217-694	16.00

**BCC Beanies**

Grey	217-750	\$28.00
Red	217-751	28.00
Blue	217-752	28.00

**All British Line-Up Hoodie**

Medium	009-113	\$40.00
Large	009-114	40.00
X Large	009-115	40.00
XX Large	009-116	40.00
XXX Large	009-117	40.00

**Some Assembly Required T-Shirt**

Medium	009-108	\$16.00
Large	009-109	16.00
X Large	009-110	16.00
XX Large	009-111	16.00
XXX Large	009-112	16.00



009-113



009-108



FRONT

**MG Safety Fast Vest**

Casual and classic, represent your favorite marque any time of the year with this lightweight, water-resistant vest. Customized for a classic car enthusiast, this vest sports the classic "Safety Fast" embroidery on the back and a smaller MG octagon on the front.

Featuring front zippered pockets, fleece lining for those early morning drives, and a zip-through cadet collar with chin guard, the vest has a 100% polyester woven shell bonded to a water-resistant film insert. Show it off at your car club meetings or gift it to a fellow enthusiast. And the best part is that this outerwear comes at a hard to beat price! Easy to care. Machine washable. Available in sizes Small - 2XL. Get yours today!

Sizing, measured at the chest, in inches:  
 35-37 (S), 38-40 (M), 41-43 (L), 44-46 (XL), 47-49 (2XL)

Small	217-820	\$69.99
Medium	217-821	69.99
Large	217-822	69.99
X Large	217-823	69.99
XX Large	217-824	69.99



\*See ordering page for details

⚠ WARNING: Cancer and Reproductive Harm. www.P65Warnings.ca.gov





Front

Side



**Moss Motors Beanie**

Smart and casual, the Moss Motors Beanie is made of 100% acrylic knitted fabric in the color steel. Comfortable and stretchy, it features a woven Moss Motors logo on the front and Moss block label on the back left. One size fits all.

Moss Motors Beanie                      217-245      \$25.00

**MG Logo Beanie**

Fashioned from 100% soft acrylic, this cuffed beanie has waffle knit construction and features a woven MG logo on the front and a Moss block label clipped to the left side of the back.

Dark Green                                      217-755      \$25.00  
 Khaki    217-756      25.00



219-936

219-952

Back

219-936

Back

219-817

219-818

219-816

219-819

**Premium Embroidered MGB Hats**

Look sharp as you take your classic out for a spin wearing an embroidered MG Octagon or MGB hat! These premium quality hats have a seamed front panel with a soft crown that provides a deep low fit allowing the hats to stay on at speed. The adjustable Velcro closure ensures a secure, personalized fit. Choose your style and order your hat today!

**Features:**

- 100% Cotton Construction
- Solid Color Contoured Visor
- Adjustable Velcro Closure
- Moss Block embroidered logo

MG Octagon - White/Navy	219-816	\$20.00
MG Octagon - Tan/Forest Green	219-817	20.00
MG Octagon - Black/White	219-818	20.00
MG Octagon - Navy/White	219-819	20.00
MG Safety Fast Logo Hat	219-933	20.00
MGB Half-Jack	219-936	20.00
MGB/GT Half-Jack	219-952	20.00



Pricing is subject to change.  
 Please visit [MossMotors.com](http://MossMotors.com) for current pricing and availability.



**Classic Metal Artwork Sign  
by John Lowerson**

Stylize your space with some creative metal signs. Based on the original paintings by artist John Lowerson, these model specific 9" x 12" signs look amazing and are a great way to showcase loyalty to your favorite classic car. Reasonably priced and high in quality, get them for yourself or gift these artistic metal signs to fellow motoring enthusiasts.

MGB 214-464 \$22.99



**Vintage MG Safety Fast  
Metal Sign**

Personalize your garage or "mancafe" with some classic metal signs. Featuring original period artwork, this 12" x 16" oval metal sign features the "MG Safety Fast logo" and is a great way to showcase your appreciation of the marque. Sold individually. Order today!

MG Safety Fast 214-591 \$31.99



**British Cut-Out Art  
by Ratco**



Jazz up your work space, garage, or den with some Classic British Metal Art! Made from mild steel and finished in a black powder coat, these laser-cut metal signs are unique and stylish! Available in select styles.

British Leyland - 12" 214-822 \$44.99  
MG Octagon - 12" 214-823 44.99

**Castrol Accessories**

Bring back some of the classic motoring nostalgia with a variety of enamel accessories featuring the Castrol oil logo. Choose from a range of hardwearing metal backed glass enamel lapel badges, key fobs, fridge magnets, signs, vintage oil cans, or a tin coffee cup and accentuate your favorite places.

Vintage Oil Can - ½ Pint	216-545	\$14.99
Vintage Oil Can - 1 Pint	216-555	29.99
Lapel Badge	216-558	9.99
Key Fob	216-559	15.99
Magnet - 2½" x 1¾"	216-561	12.29
Sign - 10" x 7"	216-562	63.99
Sign - 15¾" (Round)	216-563	94.99
Vintage Oil Can - 2 Pint	216-565	34.99
Coffee Cup - 16 oz	216-570	16.99



216-558



216-559



216-561



216-562



216-563



216-570



See more online at  
**MossMotors.com**



216-565



216-555



216-545



\*See ordering page for details

⚠ WARNING: Cancer and Reproductive Harm. www.P65Warnings.ca.gov



# ORDERING & SHIPPING

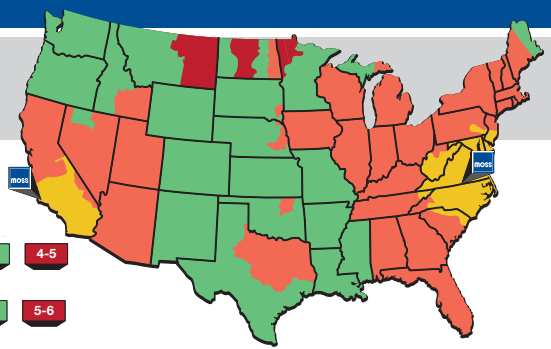

## DELIVERY DAYS:

### Ground Preferred

1-2 2-3 3-4 4-5

### Ground Saver

2-3 3-4 4-5 5-6

## AREAS / APPROXIMATE GROUND DELIVERY TIME (In Working Days)

- This map represents approximate working days for Ground Delivery. (As quoted by our carriers, not guaranteed.)
- It also assumes we can ship from the nearest warehouse. Items shipped from an alternate warehouse will take longer.

## SHIPPING

- Shipping is calculated on the regular retail price before any discounts.
- Orders received by 3 p.m. local time are normally shipped same day when shipped by UPS Ground Preferred or UPS Air.
- We will ship by Ground Saver unless an alternate shipping method is specified.
- Alaska, Hawaii, Puerto Rico must choose either AK/HI/PR Saver or UPS Air (see info below shipping chart).

## OVERSIZE PARTS FEE

Some items are oversized and are indicated by the oversize parts fee icon. An oversize parts fee (per item) will be applied to your order. This fee will still be charged on free shipping orders. You can find the amount of the fee by visiting MossMotors.com or calling 800-667-7872. The oversize parts fee will not be charged on orders that ship by truck freight.

## TRUCK SHIPMENT FEE

- Some parts must be shipped truck freight. Orders shipped to the 48 Contiguous states will be charged a flat \$199. Orders shipped to Canada will be charged a flat rate of \$279.

## PO BOX, A.P.O. OR F.P.O.

- A.P.O., F.P.O. and P.O. Box orders are not guaranteed and will be shipped via USPS.

## UPS AIR DELIVERY SERVICE (48 STATES)

- Saturday Delivery - Available on UPS Next Day Air and UPS 2nd Day Air orders for an additional \$16.00 and is not available in all areas.
- Orders shipped by air that are over 40 lbs., by weight or dimensions, we reserve the right to charge actual shipping and will notify you in advance.

## INTERNATIONAL ORDERS

Orders delivered outside of the USA may take additional time to ship due to additional documentation and payment verification.

- All import costs and fees including duties and taxes are the responsibility of the customer.
- First-time orders and some larger orders may require payment by wire transfer.
- Orders may require a shipping quote and customer approval prior to shipping.
- Customer assumes liability for any disputes or damages when providing their own shipping arrangements.
- Orders are shipped by Air Post when possible. At times, Canada Post may use ground shipping for delivery.
- Shipping charges on orders under \$700 are calculated in the cart during website checkout.
- Orders **under \$700** that are heavier than 40 lbs. (by weight or dimensions) will be charged actual shipping.
- Orders **over \$700** will be charged actual shipping.

See MossMotors.com/ordering-shipping for full details on our ordering and shipping policies

## PAYMENT

- We have a \$10 minimum parts order, excluding tax and shipping.
- We accept certified check, money order, and the following credit cards: 
- Due to increasing fraud, some foreign orders may require additional documentation to process your order.

## WHEN YOUR ORDER ARRIVES

- Please remember to inspect your parts immediately upon receipt of your order.
- Should your order arrive in damaged condition, immediately inform a Moss Motors customer service representative at 1-800-689-9313.
- Claims for damage during shipping must be reported within 3 days of receipt of order.
- Keep original box and packing material.
- If your order was shipped truck freight, note damage on the bill of lading when signing the delivery receipt.
- If there are any other questions about your order, contact customer service within 10 days.

## SPECIAL ORDER & DIRECT SHIP PARTS

- Require pre-payment by cashiers check or credit card and may not be cancelled or returned.

## BACKORDERS

- Occasionally, we are out of stock on some items, which we will ship to you as soon as available.
- Backorders are shipped free but carry a handling charge of \$3.49 per \$25 of value. (The combined total for original order shipping, and all backorder handling fees, shall never exceed the total shipping charges quoted on the shipping chart on this page.)
- You may request "No Backorders" or cancel backorders at any time prior to shipping.
- We do not backorder to any foreign countries, including Canada.
- Backorders are sent by the most cost effective method, not necessarily the same method as the original order.

## WARRANTY - THE LONGEST IN THE BUSINESS!

- All Classic British products are warranted to be free from defects in material and workmanship for 2 years from the date of invoice.
- All superchargers, supercharger components, and supercharger hardware are warranted to be free from defects in material and workmanship for 1 year from date of invoice.
- Moss Motors, Ltd. will, at its discretion, repair or replace any part that fails in service within the warranty period. This warranty does not cover labor, failure of related components, normal wear of brake or clutch components or failure resulting from alteration, misuse, accidental damage, faulty installation, or faulty repair.
- Warranty requests should be submitted to our sales department and must be supported by the original Moss Motors purchase invoice and documentation of the failure.

## Shipping, Insurance & Handling Chart US Rates - 48 States (AK\*, HI\* & PR\*)

Order Total	Ground Saver <sup>†</sup>	Ground Preferred <sup>††</sup>	2nd Business Day Air	Next Business Day Air	Canada Air Post <sup>**</sup>
\$10.00 to 20.00	\$5.99	\$12.99	\$24.99	\$39.99	\$16.99
20.01 to 50.00	9.99	18.99	34.99	49.99	22.99
50.01 to 75.00	12.99	22.99	43.99	63.99	28.99
75.01 to 100.00	15.99	25.99	49.99	83.99	32.99
100.01 to 150.00	19.99	29.99	59.99	94.99	41.99
150.01 to 200.00	21.99	32.99	69.99	106.99	49.99
200.01 to 300.00	24.99	34.99	79.99	119.99	59.99
300.01 to 500.00	24.99	36.99	94.99	129.99	79.99
500.01 to 700.00	24.99	36.99	106.99	149.99	104.99
700.01 and Up	Free UPS <sup>1</sup>	Free UPS <sup>1</sup>	96.99	139.99	ACTUAL

† Ground Saver (default shipping method) - Ships by most economical method. May add 1-2 days.

†† Ground Preferred - Ships by UPS and is normally shipped same day if ordered by 3pm local time.

\* Alaska, Hawaii and Puerto Rico

UPS Air - Add \$8 to the 2nd Business Day & Next Business Day Air Rates.

AK/HI/PR Saver - Subtract \$12 from the 2nd Business Day Air Rates

(Ships by most economical method and may take longer.)

<sup>1</sup> Free Ground UPS Shipping in the contiguous 48 states. Truck Shipments will be charged a flat \$199 to the 48 Contiguous states and \$279 to Canada.

<sup>\*\*</sup> Canada Chart Shipping rate is for orders under \$700 and less than 40lbs. Orders under \$700 that are heavier than 40lbs. and orders over \$700 will be charged actual shipping.

## SALES TAX AND PRICES

- Due to Wayfair Supreme Court Decision we are required to collect sales tax on goods and freight according to each state's law.
- Alabama Simplified Sellers Use Tax:** Moss Motors will collect simplified sellers use tax on taxable transactions delivered into Alabama and the tax will be remitted on the customer's behalf to the Alabama Department of Revenue. Moss Motors program account number is SSU-R010439133
- On the shopping cart checkout page, your sales tax shown will be estimated. Actual sales tax will be calculated at the time of order fulfillment. If your business is tax-exempt, please contact us at (800) 667-7872 to apply your tax exempt status.

## RETURNS

See MossMotors.com/returns for full returns policy.

## CATALOG ERRORS

Every effort has been made to provide accurate information. We reserve the right to correct typographical errors and will not be held liable for inaccuracy of pricing, descriptions or applications.

## TERMS AND CONDITIONS & PRIVACY POLICY

See inside back cover for more information.

 **FREE SHIPPING** Free Ground shipping in the contiguous 48 states. Oversize Parts Fee still applies. Truck shipments will be charged a flat fee of \$199 to the 48 Contiguous states and \$279 to Canada..

 **SAME DAY SHIPPING** Orders received by 3 p.m. local time are normally shipped same day when shipped by UPS Ground Preferred or UPS Air. Does not apply to special orders and some oversized items.

 **OVERSIZE PARTS FEE** Some items are oversized and are indicated by the oversize parts fee icon or an underlined part number. An oversize parts fee (per item) will be applied to your order. This fee will be charged on free shipping orders. You can find the amount of the fee by visiting MossMotors.com or calling 800-667-7872. The oversize parts fee will not be charged on orders that ship by truck freight.

123-456

Pricing is subject to change at any time.

Please visit MossMotors.com for the latest information, current pricing and product availability.

# ORDER WORKSHEET

Please Print

Customer No. \_\_\_\_\_

Name \_\_\_\_\_

Street \_\_\_\_\_

City/State \_\_\_\_\_ Zip \_\_\_\_\_

Daytime Phone \_\_\_\_\_ Fax \_\_\_\_\_

Email \_\_\_\_\_



Mail To: Moss Motors  
440 Rutherford St.  
Goleta, CA 93117  
Fax To: 805-692-2525

Ship To \_\_\_\_\_

Street \_\_\_\_\_

City/State \_\_\_\_\_ Zip \_\_\_\_\_

	Part No.	Description	Qty.	Unit Price	Ext. Price
1.					
2.					
3.					
4.					
5.					
6.					
7.					
8.					
9.					
10.					
11.					
12.					
13.					
14.					

Charge My: <input type="checkbox"/> Visa <input type="checkbox"/> Mastercard <input type="checkbox"/> Amex <input type="checkbox"/> Discover	Parts Total
Card Number _____	Sales Tax
Date Card Expires _____	Shipping
Enclosed Is \$ _____	Oversize Fee
For Terms and Conditions & Privacy Policy see inside back cover.	Total

Check YES if you wish to backorder any items not currently stocked. You will not be charged for backordered items until they are shipped.

Yes  No

Too many cars is never enough. Need another catalog?

- Austin Healey 100
- Austin Healey 100-6
- Austin Healey 3000
- Austin Healey Sprite
- Triumph TR2, 3, 4 & 4A
- Triumph TR250 & TR6
- Triumph TR7 & TR8
- Triumph Spitfire & GT6
- MG TC, TD & TF
- MGA
- MGB & MGC
- MG Midget
- Jaguar XK120-150, E-Type, Early Sedan, XJ6-12, XJS
- Classic Mini
- Mazda Miata/MX-5

Request one online at [MossMotors.com/catalog-request](http://MossMotors.com/catalog-request)



# MGB/MGC Restoration Parts Catalog

MGC Supplement begins on page 111

## Table of Contents

<b>Information/Production Data (MGB)</b>		3-5
<b>Engine</b>	External	6-7
	Internal	8-9
	Cylinder Head	10-11
	Oil Filters	12-13
	Oil Coolers	14-15
	Cooling System	16-17
	Engine Controls	18-19
	Emission Controls	20-21
<b>Carburetors/Air Filters</b>	HS4	22-23
	HIF4	24-25
	Zenith-Stromberg	26-27
<b>Fuel System</b>		28-31
<b>Exhaust System</b>		32-33
<b>Clutch</b>		34-35
<b>Gearbox</b>	early non-synchro 1st gear	36-37
	late all synchro	38-39
	Overdrive	40-41
<b>Steering</b>		42-45
<b>Front Suspension</b>		46-47
<b>Rear Axle/Differential</b>		48-49
<b>Driveshaft/Rear Suspension</b>		50-51
<b>Road Wheels/Wheel Tools</b>		52-53
<b>Brakes</b>		54-59
<b>Body</b>	Body Panels	60-63
	Paint Color Codes	64-65
	Door Fittings	66-67
	Windows	68-69
	Bumpers & Grilles	70-71
	Body Fittings	72-79
	GT Unique	80-81
<b>Electrical</b>	Starters	82
	Charging System	83
	Ignition	84-87
	Minor Electrical	88
	Wipers/Washers	89
	Wiring	90-91
	Lamps	92-95
<b>Dashboards</b>		96-100
<b>Heater</b>		101
<b>Interior</b>	Seat Fittings	103
	Soft Trim/Fittings	104
	Carpets/Floor Mats	105
	Seat & Panel Kits	106-107
	Tops/Tonneau Covers	108-110
<b>MGC Supplement</b>	MGC-unique parts	111-116
<b>Tech Tips</b>		117
<b>Terms and Conditions &amp; Privacy Policy</b>		118

## About This Catalog

This catalog covers parts for U.S.-specification left hand drive cars. In producing this catalog, our primary goal was to publish a listing of MGB & MGC parts which was as comprehensive, accurate and informative as possible for the U.S. market. In doing this, we have made every effort to correctly identify and include every part likely to be needed to repair, restore or maintain your car. Although some of the parts listed are not currently available, our Product Development staff is constantly seeking new suppliers and manufacturers of quality reproductions of otherwise obsolete items. The current Moss Motors website ([www.mossmotors.com](http://www.mossmotors.com)) pricing is always the best indication of availability.

Local laws and regulations relating to pollution, safety and lighting equipment vary considerably from state to state and country to country. Since we distribute parts for these cars on a worldwide basis, we are not in a position to advise what laws are in effect in each locality. We strongly encourage anyone contemplating any modifications to a vehicle intended for street use, to check local regulations before proceeding. We strongly suggest that you save all old stock equipment should reinstallation be necessary at a future date.

**NOTE: In the body of this catalog, items with indented descriptions are components of the non-indented kit or assembly above them.** When an indented component is "NA", it is still included in the assembly, but not available separately.

## Supersession and Rationalization of Parts

Most owners of British cars have, at one time or another, ordered an original "factory" part from an authorized dealer, only to find that the part received was different from the original, although it did work. This is the result of the supersession or rationalization of parts by the factory. Supersessions occur when a part is modified, and the original design or pattern is no longer produced. If old and new parts are interchangeable, even though they may appear slightly different, the old part is superseded by the new part. Rationalization is an attempt by the factory at efficiency in which one new part replaces several original parts, after which the original parts are no longer available.



This "no airplane" symbol indicates that the item(s) may not be shipped by air, and must be shipped by ground.



More information on this product is found at [www.mossmotors.com](http://www.mossmotors.com)



This truck symbol indicates that the item(s) will be shipped by truck freight.

123-456

Underlined part numbers indicate an Oversize Parts Fee will be charged. See [mossmotors.com](http://mossmotors.com) or call for details.

## WARNING!

Working on automobiles is inherently dangerous. Moss Motors, Ltd. is not liable for injury or damage due to incorrect installation or use of their products. All products are sold with the understanding that the safe and proper installation and use of the products is the customer's responsibility. Follow factory workshop manual procedures and instructions, but use current shop safety standards and common sense. Some tasks will require professional advice or services which Moss Motors cannot provide.



By special licensing agreement with British Motor Heritage Ltd., Moss Motors, Ltd., is a fully authorized manufacturer and distributor of British sports car spares. With official support from the original manufacturer, we are able to produce a wide range of reproduction spares which meet or exceed the original factory standard of quality. In conjunction with British Motor Heritage, Ltd., Moss Motors is dedicated to the preservation and restoration of British sports cars. The British Motor Heritage, Ltd. and marque trademarks, as well as some exploded view artwork included in this publication, are the property of British Motor Heritage, Ltd., and are reproduced under licensing agreement by Moss Motors, Ltd.



## MGB/MGC Parts Catalog

© Copyright Moss Motors, Ltd. April, 1979  
Edition MGB-110 February, 2024  
Printed in the USA

All rights reserved. No part of this publication may be reproduced, stored in a retrieval system, or transmitted in any form or by any means, electronic, photocopying, recording, or otherwise without the prior written permission of Moss Motors, Ltd.

Prices subject to change. See [MossMotors.com](http://MossMotors.com) for current pricing. 1

Toll-Free Orders 1-800-667-7872 | [MossMotors.com](http://MossMotors.com)  
Fax 805-692-2525 | Local 805-681-3400

MOSS

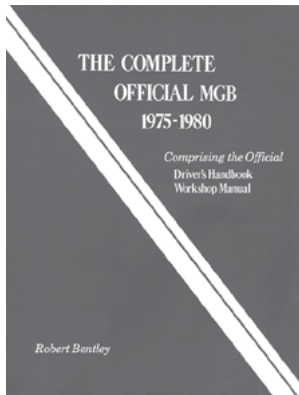

### Robert Bentley Shop Manuals

Robert Bentley manuals contain reprints of the factory workshop manual, plus the owner's manuals. The most complete and authoritative manual available for your car.

- 212-320 MGB, 1962-'74 \$139.99  
 215-325 MGB, 1975-'80 \$124.99

### Haynes Workshop Manual

Haynes workshop manuals are an excellent guide to the tune up and maintenance of your car. Haynes carburetor manuals are the definitive works on these critical instruments.

- 212-405 \$35.99

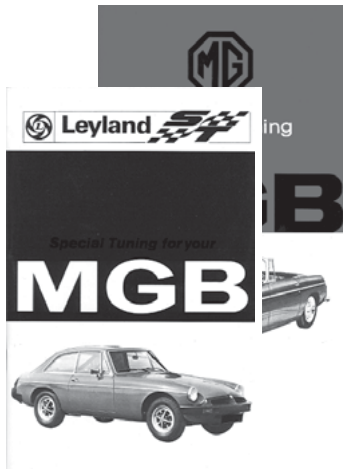

### Competition Preparation Manuals

Improve your car's performance with the benefit of knowledge gained through years of testing and competition. These reprints of the original factory competition manuals provide a wealth of knowledge which is applicable to both street and all out racing applications.

- 211-005 MGB 1963-'67 NA  
 211-010 MGB 1968-'80 \$26.99

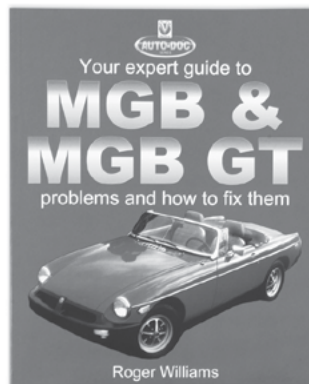

### MGB & MGB GT Problems and How to Fix Them

by Roger Williams  
 How to troubleshoot and fix your MGB's problems, clearly explained and well-illustrated with many clear color photos. This book is your "24-7" expert on all the MGB's common faults and foibles. An essential book to have if you drive your car - a definite "must have" if you do your own maintenance and repairs. Softbound, 8 1/8" x 9 7/8", 176 pages.

- 212-995 \$59.99

### Owner's Manual Reprints

We have a variety of exact reprints of the manuals originally supplied with your car. These handy volumes contain information on a variety of subjects, from basic tuning and maintenance, to putting up the top. Throw one in the glove box, it'll come in handy some day. ^

- 210-840 MGB 1963-'67 \$19.99  
 210-910 MGB 1968-'69 \$24.99  
 210-920 MGB 1970-'72 \$29.99  
 210-930 MGB 1973-'74 \$29.99  
 210-940 MGB 1975-'76 \$24.99  
 210-960 MGB 1977 (use 1978-'80) NA  
 210-965 MGB 1978-'80 \$26.99

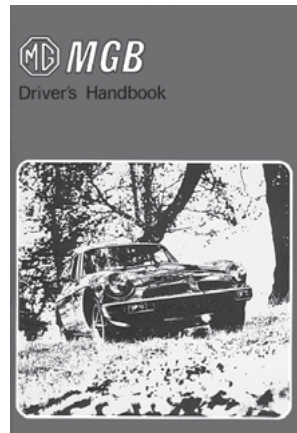

### Glovebox Size Workshop Manuals

The perfect companion for your car. Though not as complete as the full factory manuals, these clever new manuals are packed with enough information to keep your car on the road. Tune up data, repair and rebuilding information, dimensions and torque specs are all here in these compact 5 1/2" x 8 1/2" books.

- 212-460 MGA & MGB 1955-'68 \$38.99  
 212-470 MGB 1968-'80 NA



### MGB Essential Buyer's Guide

by Roger Williams  
 Written for the UK market, this handy buyers guide gives great information for any prospective buyer in a small package. Learn how to spot a bad car quickly with tips on typical problem areas and what is reasonable to fix and what you should walk away from. Covers MGB and MGB GT from 1962-'80. Softcover, 64 pages.

- 213-765 \$29.99

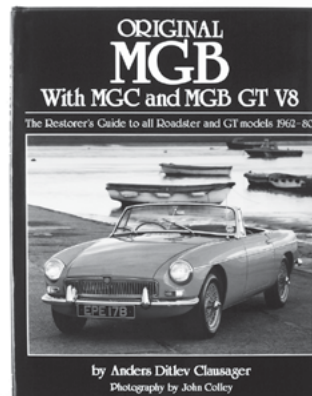

### Original MGB/MGB-GT/MGC

The Restorer's Guide series has the information needed to determine how a restored car should look and what parts it should contain. Trying to find out what the color of an engine block, interior piping, or carpet was originally might have been a problem in the past. Drawing from factory records, parts lists and catalogs, as well as the knowledge of a panel of experts, these books provide what constitutes an "original" car. Hardbound, 8" x 12", 112 pages, over 200 color photos.

- 211-355 \$49.99



## Vehicle Identification **MGB Roadster '62-'70, GT '67-'70**

## MGB Roadster & GT '71-'74

## MGB Roadster '75-'80

Vehicle Number Location . . . . . Top left-hand side of the front bulkhead  
 Engine Number Location . . . . . Metal plate right-hand side of cylinder block  
 Gearbox Number Location . . . . . Top of gearbox, left of dipstick and filler plug  
 Rear Axle Number Location . . . . . Front of left-hand axle tube by spring seat

### Tune Up

Engine Firing Order . . . . .	1,3,4,2 . . . . .	1,3,4,2 . . . . .	1,3,4,2 . . . . .
Valve Rocker Clearance . . . . .	.015 in (.38 mm) cold . . . . .	.015 in (.38 mm) cold . . . . .	.013 in (.33 mm) warm
Idle Speed . . . . .	.500 rpm . . . . .	900 rpm 18GF, GH, GJ, 18, 850 rpm 18V . . . . .	850 rpm
Static Ignition Timing . . . . .	10° BTDC (HC), 8° BTDC (LC)		
Dynamic Ignition Timing . . . . .	14° BTDC @ 600 rpm . . . . .	1971-1972 - 16° BTDC @ 1500 rpm . . . . .	13° BTDC @ 1500 rpm w/o cat; 1973-1974 - 11° BTDC @ 1500 rpm . . . . . 10° BTDC @ 1500 rpm w/ cat
Timing Mark Location . . . . .	crankshaft pulley / timing chain cover . . . . .	crankshaft pulley / timing chain cover . . . . .	crankshaft pulley / timing chain cover
Contact Breaker (points) Gap . . . . .	.014 to .016 in (.36 to .41 mm) . . . . .	.014 to .016 in (.36 to .41 mm) . . . . .	.014 to .016 in (.36 to .41 mm) (75-76 Fed)
Rotation of Rotor . . . . .	anti-clockwise . . . . .	anti-clockwise . . . . .	anti-clockwise
Dwell Angle . . . . .	60 +/-3 degrees . . . . .	60 +/-3 degrees . . . . .	
Ground Polarity . . . . .	Positive (1962-'67), Negative (from 1968-on) . . . . .	Negative . . . . .	Negative
Ignition System . . . . .	Lucas 12 volt . . . . .	Lucas 12 volt . . . . .	Lucas 12 volt for ballasted system
Spark Plug Make/Type . . . . .	Champion N-9Y . . . . .	Champion N-9Y . . . . .	Champion N-9Y
Spark Plug Gap . . . . .	.025 in (.64 mm) . . . . .	.025 in (.64 mm) . . . . .	.035 in (.90 mm)
Carburetor Make/Type . . . . .	Twin SU HS4 . . . . .	Twin SU HIF4 . . . . .	Single Zenith Stromberg type 175 CD5T
Carburetor Main Jet . . . . .	.090" . . . . .	.090" . . . . .	
Carburetor Main Jet Needle . . . . .	.MB, 5, FX, AAE, AAL . . . . .	.AAU, ABD . . . . .	

### Vehicle & Engine

Length (with overriders) . . . . .	12 ft 9 7/16 in (3.9 m) . . . . .	12 ft 9 3/16 in (3.89 m) . . . . .	13 ft 2 1/4 in (4 m)
Width . . . . .	4 ft 11 15/16 in (152.3 cm) . . . . .	4 ft 11 15/16 in (152.3 cm) . . . . .	4 ft 11 15/16 in (152.3 cm)
Height . . . . .	4 ft 1 3/8 in (125.4 cm) . . . . .	4 ft 1 3/8 in (125.4 cm) . . . . .	4 ft 1 3/8 in (125.4 cm)
Ground Clearance . . . . .	.5 in (12.7 cm) min. . . . .	.5 in (12.7 cm) min. . . . .	.5 in (12.7 cm) min.
Track Front, steel wheels . . . . .	4 ft 1 in (124.4 cm) . . . . .	4 ft 1 in (124.4 cm) . . . . .	4 ft 1 1/2 in (124.7 cm)
wire wheels . . . . .	4 ft 1 1/4 in (125 cm) . . . . .	4 ft 1 1/4 in (125 cm) . . . . .	4 ft 1 in (124.4 cm)
Track Rear, steel wheels . . . . .	4 ft 1 1/4 in (125 cm) . . . . .	4 ft 1 1/4 in (125 cm) . . . . .	4 ft 1 3/4 in (126.4 cm)
wire wheels . . . . .	4 ft 1 1/4 in (125 cm) . . . . .	4 ft 1 1/4 in (125 cm) . . . . .	4 ft 1 1/4 in (125 cm)
Wheelbase . . . . .	7 ft 7 in (231.1 cm) . . . . .	7 ft 7 in (231.1 cm) . . . . .	7 ft 7 1/8 in (231.5 cm)
Turning Circle . . . . .	32 ft (9.75 m) . . . . .	32 ft (9.75 m) . . . . .	32 ft (9.75 m)
Toe-In . . . . .	1/16 to 3/32 in (1.5 to 2.3 mm) . . . . .	1/16 to 3/32 in (1.5 to 2.3 mm) . . . . .	1/16 to 3/32 in (1.5 to 2.3 mm)
Unladen Weight . . . . .	RD 1920 lb (871 kg), GT 2190 lb (993 kg) . . . . .	RD 2303 lb (1044 kg), GT 2401 lb (1088 kg) . . . . .	2290 lb (1039 kg) 1975-1976; 2416 lb (1097 kg)
Curb Weight . . . . .	RD 2030 lb (920 kg), GT 2310 lb (1048 kg) . . . . .	RD 2653 lb (1203 kg), GT 2751 lb (1248 kg) . . . . .	2590 lb (1174 kg) 1975-1976; 2716 lb (1234 kg)
Gross Weight (max.) . . . . .	RD 2430 lb (1102 kg), GT 2660 lb (1206 kg) . . . . .	RD 2753 lb (1249 kg), GT 2851 lb (1293 kg) . . . . .	2710 lb (1229 kg) 1975-1976; 2836 lb (1287 kg)
Original Tire Size . . . . .	5.60-14 or 155-14 (162-'64); 165-14 (65-on) . . . . .	165-14 . . . . .	165-14
Replacement Tire Size . . . . .	165SR-14 . . . . .	165SR-14 . . . . .	165SR-14
Orig. Tire Pressure Front (Cold) . . . . .	18 or 21 ('62-'64); 20 ('65-on) . . . . .	20 . . . . .	21
Orig. Tire Pressure Rear (Cold) . . . . .	18 or 24 ('62-'64); 24 ('65-on) . . . . .	24 . . . . .	24
Engine Type . . . . .	4 cyl. inline OHV . . . . .	4 cyl. inline OHV . . . . .	4 cyl. inline OHV
Engine Displacement . . . . .	1798 cc (109.8 ci) . . . . .	1798 cc (109.8 ci) . . . . .	1798 cc (110 ci)
Firing Order . . . . .	1, 3, 4, 2 . . . . .	1, 3, 4, 2 . . . . .	1, 3, 4, 2
Compression Ratio . . . . .	8.8:1 (HC), 8.0:1(LC) . . . . .	8.0:1 . . . . .	8.0:1
Engine Bore . . . . .	3.16 in (80.26 mm) . . . . .	3.16 in (80.26 mm) . . . . .	3.16 in (80.3 mm)
Engine Stroke . . . . .	3.5 in (89 mm) . . . . .	3.5 in (89 mm) . . . . .	3.5 in (88.9 mm)
Number of Cylinders . . . . .	4 . . . . .	4 . . . . .	4
Oil Pressure Idle . . . . .	10 to 25 lb/in <sup>2</sup> (.7 to 1.7 kg/cm <sup>2</sup> ) . . . . .	10 to 25 lb/in <sup>2</sup> (.7 to 1.7 kg/cm <sup>2</sup> ) . . . . .	10 to 25 lb/in <sup>2</sup> (.17 to 1.7 kgf/cm <sup>2</sup> )
Oil Pressure Normal . . . . .	50 to 80 lb/in <sup>2</sup> (3.5 to 5.6 kg/cm <sup>2</sup> ) . . . . .	50 to 80 lb/in <sup>2</sup> (3.5 to 5.6 kg/cm <sup>2</sup> ) . . . . .	50 to 80 lb/in <sup>2</sup> (3.5 to 5.6 kgf/cm <sup>2</sup> )
Ignition Type . . . . .	points . . . . .	points . . . . .	Lucas electronic
Fuel Pump Make/Type . . . . .	SU type HP or AUF 300 electric . . . . .	SU type AUF 300 electric . . . . .	SU type AUF 300 electric
Fuel Tank Capacity . . . . .	Early 12 gal, late 14 gal . . . . .	14 gal, 12 gal w/evaporative loss system . . . . .	12 gal (1975-1976); 13 gal (1977-on)
Cooling System Capacity . . . . .	11.4 pints w/o heater, 12 pints w/ heater . . . . .	11.4 pints w/o heater, 12 pints w/ heater . . . . .	12 pints (1975-1976); 14.4 pints (1977-on)
Sump Capacity . . . . .	9 pints . . . . .	Early cars-9 pints, 9.6 pints w/ oil cooler . . . . .	6 pints, 7.25 pints w/ filter change
		Late cars-6 pints, 7 1/4 pints w/ oil cooler . . . . .	
Gearbox Capacity, non-OD . . . . .	5.6 pints . . . . .	6 pints . . . . .	6 pints
Gearbox Capacity, overdrive . . . . .	6 pints . . . . .	7 pints . . . . .	7.25 pints
Rear Axle Capacity . . . . .	2.7 pints . . . . .	2 pints . . . . .	2 pints



## About This Catalog

In producing this MGB catalog, our research staff's primary goal was to publish a listing of MGB parts which was as comprehensive, accurate and informative as possible. In doing this, we have made every effort to correctly identify and include every part likely to be needed to repair, restore or maintain your MGB, with the exception of the more common nuts, bolts and washers which can usually be found locally. Although some of the parts listed are not currently available, our Product Development Department is constantly seeking new suppliers and manufacturers of quality reproductions of otherwise obsolete items. The Moss Motors website ([www.mossmotors.com](http://www.mossmotors.com)) is the best indication of availability.

## Special Features

In addition to the comprehensive parts listings, our catalog offers many special features. The illustrations and text are designed to be sufficiently comprehensive for the catalog to serve as a parts manual for your car. We have included much useful data concerning chassis numbers, production changes, etc. Throughout the catalog you will find technical tips and articles, designed to help you maintain and service your car efficiently and correctly. (We welcome contributions for possible inclusion in future catalogs; send your tip or article to Moss Motors' Editorial Dept.) Our Accessory Catalog, with hundreds of items that make British sports car driving more fun, is now bound into the front of this catalog.

## MGB Modifications

Local laws and regulations relating to pollution, safety and lighting equipment vary considerably from state to state and country to country. Since we distribute parts for these cars on a worldwide basis, we are not in a position to advise what laws are in effect in each locality. We strongly encourage anyone contemplating any modifications to a vehicle intended for street use, to check local regulations before proceeding. We strongly suggest that you save all old stock equipment should reinstallation be necessary at a future date.



## Identification Numbers

When ordering parts, it is essential that your car is identified exactly, by model year and serial number. Since many part changes were made during model years, the car number, engine number and body number provide the only positive identification. Quite often a car's title will not show the correct model year. Before ordering parts, please use the space provided below to copy the applicable numbers from your car. Use of these numbers is the best way to ensure that you order and receive the correct parts. Wherever possible, we have listed part applications by car number(c). In some cases, we had to use the engine numbers(e) or body numbers(b). Commission numbers, as used from 1968, are of little significance and are not used for reference purposes in this catalog. Where we use years, they are model years, not build dates. For the sake of simplicity, we have deleted all alpha-numeric prefixes from change points found in our application columns. While these letters are helpful in pinpointing certain production features, they do not affect the parts' applications as listed. Example: Car number GHN5/ UB/234567 is shown as (c) 234567. For more information on these numbers and years, see the production data on the facing page.

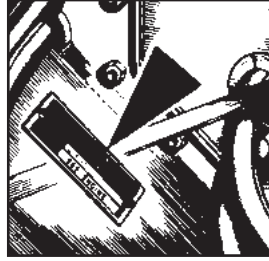

The **Car Number** for cars from 1963-'69 is stamped on a plate secured to the right hand wing valance forward of the radiator.

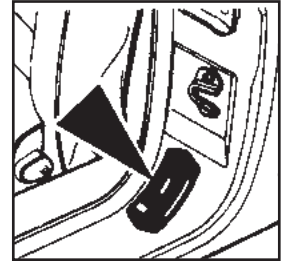

The **Car Number** for cars from 1970 on is stamped on a plate secured to the left hand door post, and to a plate on top of the fascia.

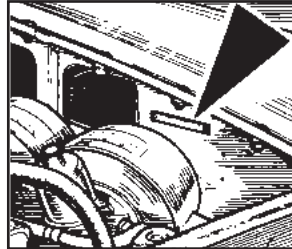

The **Body Number** for early chrome-bumpered cars is stamped on a plate on the left front valance behind the radiator diaphragm as illustrated, or in some cases, in front of the radiator diaphragm.

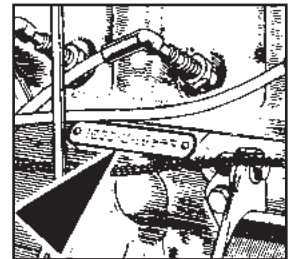

The **Engine Number** is stamped on a plate secured to the right hand side of the cylinder block.

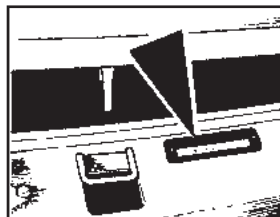

The **Commission Number** is stamped on a plate secured to the bonnet lock platform.

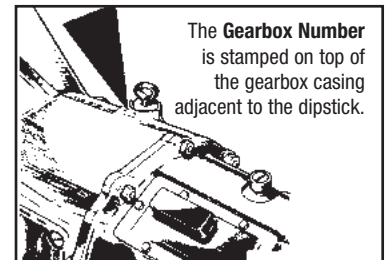

The **Gearbox Number** is stamped on top of the gearbox casing adjacent to the dipstick.

### Record Your Identification Numbers Here:

**Customer Number** \_\_\_\_\_

**Model Year** \_\_\_\_\_

**Car Number** \_\_\_\_\_

**Engine Number** \_\_\_\_\_

Note: Where year applications are given in the body of this catalog, they are approximate model year dates, not production dates. For accurate applications, use car numbers.

# Production Data

Model Year	1st Month of Production ea. Model Year		Car # First RD/GT Built ea. Model Year	Car # * First RD/GT Built ea. Calendar Year*	Engine # First RD/GT Built ea. Model Year	Commission # First RD/GT Built ea. Model Year	Body # First RD/GT
<b>1962</b>	5/62	RD	-	GHN3/L/101	(3-main engine)	-	-
<b>1963</b>	1/63	RD	-	GHN3/L/4619	18G/UH/101 (3-main engine)	†	MGB/101
<b>1964</b>	8/63	RD	GHN3/L/19586	GHN3/L/27278	N/A ★ (3-main engine)	†	MGB/26813
<b>1965</b>	10/64	RD	GHN3/L/48766	GHN3/L/53635	18GB/UH/101 (first 5-main engine)	†	N/A
		GT	-	GHD3/L/71933	18GB/UH (con't.)	-	-
<b>1966</b>	10/65	RD	N/A	GHN3/L/75243	18GB/UH (con't.)	†	N/A
		GT	GHD3/L/71933	N/A	18GB/UH/30038	†	GBD/101
<b>1967</b>	11/66	RD	GHN3/L/108039	-	18GB/UH (con't.)	†	N/A
		GT	N/A	GHD3/L/109804	18GB/UH (con't.)	†	N/A
<b>1968</b>	10/67	RD	GHN4/U/138401	N/A	18GF/WE/H101	GU23N/101F	MGBU/101
		GT	GHD4/U/139472	N/A	18GF/WE/H101	GU23D/101P	GBUD/500101
<b>1969</b>	10/68	RD	GHN4/U/158371	GHN4/L/159806	18GH/WE/H101	G23N/18164‡	MGB/14588‡
		GT	GUD4/U/158233	GHD4/L/162552	18GH/WE/H101	N/A	N/A
<b>1970</b>	10/69	RD	GHN5/UA/187211	GHN5/UA/196222	18GH/-/22209	G23N/31862‡	MGBU/27359
		GT	GHD5/UA/187841	GHD5/UA/194552	18GH/-/22209	G23D/18042	GBUD/510630
<b>1971</b>	9/70	RD	GHN5/UB/219021	GHN5/UB/232765	18GK/WE/H101	N/A	MGBU/300101
		GT	GHD5/UB/219355	GHD5/UB/233500	18GK/WE/H101	G23D/029048	GBUD/520235
<b>1972</b>	5/71	RD	GHN5/UC/258001	GHN5/UC/268635	18V/584Z/L101 (non O/D) 18V/585Z/L101 (O/D)	N/A	MGBU/400101
		GT	GHD5/UC/258004	GHD5/UC/269303	18V/584Z/L101 (non O/D) 18V/585Z/L101 (O/D)	G23D/047002	GBUD/620101
<b>1973</b>	8/72	RD	GHN5/UD/294251	GHN5/UD/307772	18V/672Z/L101 (non O/D) 18V/63Z/L101 (O/D)	G23N/62557‡	MGBU/500101
		GT	GHD5/UD/296001	GHD5/UD/31600	18V/672Z/L101 (non O/D) 18V/673/L101 (O/D)	N/A	GBUD/720101
<b>1974*</b>	8/73	RD	GHN5/UE/328101	GHN5/UE/338790	18V/672Z/L14891 (non O/D)‡ 18V/673Z/L14891 (O/D)‡	G23N/86226‡	MGBU/600101
		GT	GHD5/UE/328801	GHD5/UE/338560	18V/672Z/L13234 (non O/D)‡	G23D/70589	GBUD/820101
<b>1975</b>	12/74	RD	GHN5/UF/368082 (N.Amer.) GHN5/UF/367901 (non-N.A.)	GHN5/UF/368090	18V/797AE/L101 (non O/D) 18V/798AE/L101 (O/D)	G23N/115009‡	GU23T/7707
		GT	N/A	GHD5/UF/369101	N/A	N/A	N/A
<b>1976</b>	9/75	RD	GHN5/UG/386601	GHN5/UG/393763	18V/801AE/L101 (non O/D) 18V/802AE/L101 (O/D)	G23N/129440‡	GU23T/50101
		GT	N/A	GHD5/UG/394665	N/A	N/A	N/A
<b>1977</b>	6/76	RD	GHN5/UH/410001	GHN5/UH/424748	18V/883AE/L101 (non O/D) 18V/884AE/L101 (O/D)	N/A	GU23T/760000
		GT	GHD5/UH/410351	GHD5/UH/422730	N/A	N/A	N/A
<b>1978</b>	9/77	RD	GHN5/UJ/447001	GHN5/UJ/455743	N/A	N/A	GU23T/860000
		GT	N/A	GHD5/UJ/455283	N/A	N/A	N/A
<b>1979</b>	6/78	RD	GHN5/UL/471001	GHN5/UL/485179	18V/883AEL/29033 (non O/D) ‡	N/A	GU23T/960000
		GT	N/A	GHD5/UL/483812	N/A	N/A	N/A
<b>1980</b>	6/79	RD	GVVDJ2AG/501001	GVVDJ2AIG/507309	18V/883AEL/43540 (non O/D) ‡	N/A	GU23T/984080‡
		GT	N/A	GVGEJ2AG/507309	N/A	N/A	N/A

\* "1974-1/2" - The so-called "1974-1/2" model year began with roadster number 360301 and GT no. 361001 in September, 1974 and continued to the beginning of the 1975 model year.

\* Calendar Year build dates are of historical significance only.  
 † Commission Numbers were not used prior to 1968 model year.  
 ‡ These numbers are approximate.  
 ★ 18GA engine used from car #31021 thru 48765.

Toll-Free Orders 1-800-667-7872 | MossMotors.com  
 Fax 805-692-2525 | Local 805-681-3400



Note: Engines were painted red through 1971, after which they were black.

# External Engine

**Water Pumps** and other cooling system components are listed on pages 16-17.

**Oil Filters, oil cooler & related components** are listed on page 12-15.

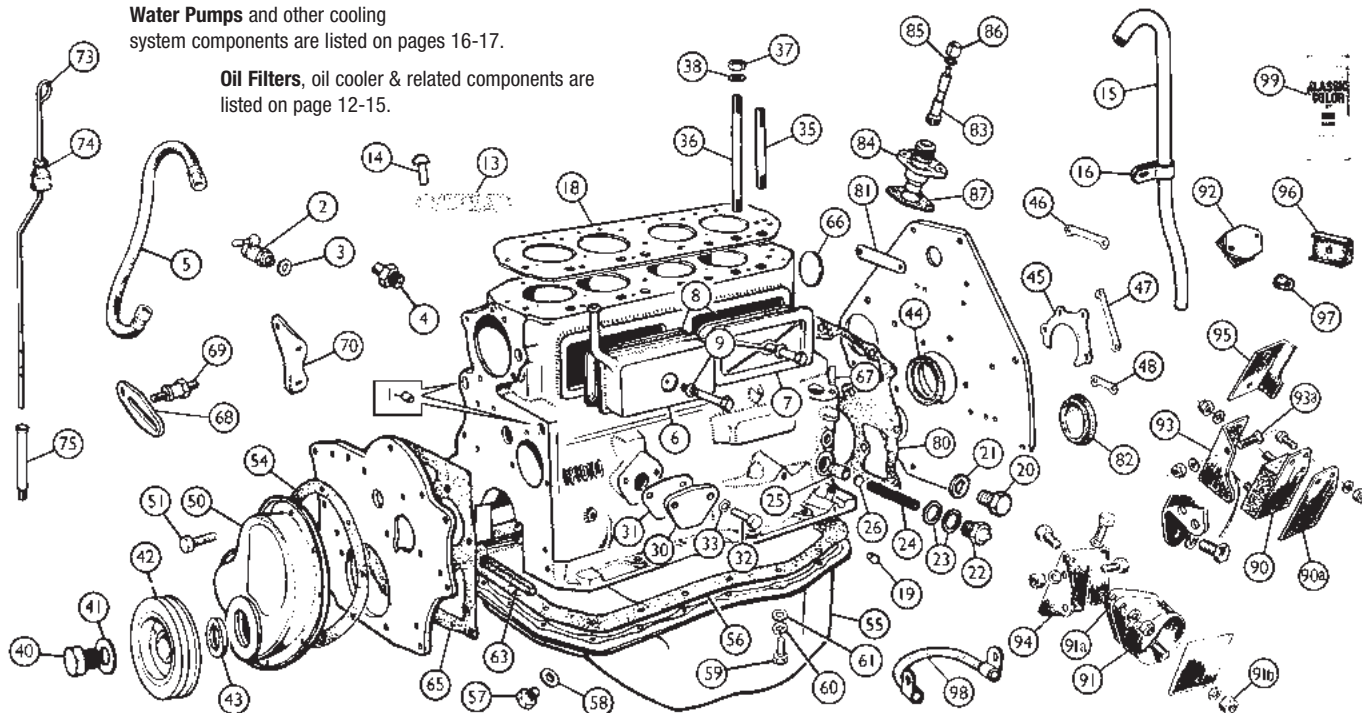

## External Engine

19648

No.	Part#	Price (Each)	Description	Application	Qty Req.
1	328-160	\$6.39	OIL GALLERY PLUG		4
2	470-240	\$29.99	TAP, water drain, in block	} alternatives	1
	328-180	\$15.99	DRAIN PLUG		1
3	324-671±	\$0.99	WASHER, drain tap		1
4	460-015	\$8.99	UNION, oil gauge pipe		1
	324-626	\$0.99	WASHER, oil pipe union		1
5	376-180	\$16.99	OIL FLEX LINE, block to oil gauge pipe		1
6	460-060	NA	COVER, front, w/breather pipe	18G engines	1
	460-065	NA	COVER, front	18GA thru GJ engines	1
	460-075	NA	COVER, front, w/oil separator	18GK/V engines thru '76	1
	460-085	NA	COVER, front, w/oil separator	{ from (e)18V/883/ AEL/12545 1977 on	1
7	460-050	NA	COVER, rear (stock type)	} 1962-'77	1
	460-058	\$46.99	COVER, rear, alloy replacement		1
	460-055	NA	COVER, rear, w/tab		1977 on
8	296-370	\$1.99	GASKET, cork, front & rear covers	18G thru GK engines	2
	296-375	\$3.99	GASKET, rubber, ft. & rear covers	18V engines	2
	296-377	\$30.99	GASKET PAIR, silicone	all	2
9	324-315	\$0.49	WASHER, fiber	18G engines	2
	367-055	\$1.09	WASHER, copper, front cover	} 18GA thru V engines	1
	365-720	\$0.79	WASHER, plain, front cover		1
	324-335	\$1.99	BUSHING, cover fixing, rear cover		1
	324-345	\$1.49	CUP, cover fixing, rear cover		1
13	117-571	\$3.69	ENGINE NUMBER PLATE (blank)	18G-GK engines	1
14	325-245	\$0.99	RIVET, engine number plate		2
15	451-050	\$42.99	BREATHER PIPE		1
16	460-070	NA	CLIP	18G engines	1
18	296-415	\$22.99	HEAD GASKET, copper	1962 - '74, fits all years	1
	296-700	\$22.99	HEAD GASKET, Cobalt brand	fits all years	1
	296-405	\$36.99	HEAD GASKET, composition, Payen	1975 - '80, fits all years	1
19	328-190	\$4.19	OIL GALLERY PLUG		1
20	328-180	\$15.99	PLUG, oil hole	18G thru GB engines	1
	328-345	NA	PLUG, oil hole	18GD thru 18V engines	1
21	324-626	\$0.99	WASHER, for plug	18G thru GB engines	1
	324-660	\$0.89	WASHER, for plug	18GD thru 18V engines	1
22	460-870	\$11.99	CAP NUT, oil release valve		1
23	324-650	\$0.39	WASHER, cap nut	18G/GA engines use 2	2/1
24	329-210	\$1.89	SPRING, oil release valve		1
25	460-155	\$1.99	VALVE, oil release		1
26	460-165	\$1.49	PACKING, oil release valve	18GB engines on	1
30	460-095	\$9.59	FUEL PUMP BLANKING PLATE	} 18V engines	1
31	296-220±	\$0.69	GASKET, pump blanking plate		1
32	313-000	\$0.39	BOLT, blanking plate		2
33	365-730	\$0.39	LOCKWASHER		2
35	328-950	\$13.99	STUD, cylinder head, 4 1/2"		7
36	328-940	\$9.99	STUD, cylinder head, 6 1/4"		4

No.	Part#	Price (Each)	Description	Application	Qty Req.
37	310-280	\$0.99	NUT, cylinder head		11
38	324-725	\$1.09	WASHER, cylinder head stud		11
40	322-120	\$19.99	BOLT, crank pulley		1
41	460-470	\$1.19	WASHER, pulley bolt (must pre-bend slightly to fit bolt head)		1
42	460-450	\$119.99	PULLEY, crankshaft (no damper)	to (e)18G-UH/5571 ('62-'63)	1
	433-697	\$79.99	PULLEY, crankshaft (with damper)	all thru 1974 (5-1/8" OD)	1
				(2 sets of timing marks - fits all MGB engines thru 1974)	
	433-705	NA	PULLEY, crankshaft (6" dia.)	18V engines from 1975	1
43	120-000	\$1.59	OIL SEAL, crank, front		1
44	120-821	\$17.99	OIL SEAL, crank, rear (upgraded)	} 5 main engines	1
	120-820	\$6.59	OIL SEAL, crank, rear (stock type)		1
45	120-830	\$2.99	RETAINER, rear oil seal	5 main engines '65-'76	1
	120-831	\$8.49	RETAINER, rear oil seal (use 120-830)	5 main engines '77-'80	1
46	460-711	\$7.99	LOCKTAB, upper	} 5 main engines '65-'76	1
47	460-712	\$8.49	LOCKTAB, side		1
48	460-713	\$2.49	LOCKTAB, lower		2
50	455-380	NA	TIMING COVER	18G-18GF engines '62-'68	1
	455-390	NA	TIMING COVER	18GK-18V thru 1974	1
	455-400	NA	TIMING COVER	18V engines from 1975	1
51	323-568	\$19.99	BOLT & WASHER SET, timing cover	1962-'76	1
	323-558	\$13.99	BOLT & WASHER SET, timing cover	1977-'80	1
	322-645	\$0.49	BOLT, to front plate, 1/4", short		4
	322-230	\$0.39	BOLT, to front bearing cap, 1/4", long		2
	322-040	\$0.59	BOLT, to block, 5/16"		4
	324-855	\$0.19	LOCK WASHER, 1/4"		6
	365-730	\$0.39	LOCK WASHER, 5/16"		4
	324-765	\$0.89	WASHER, oval, 1/4"		6
	460-360	\$0.99	WASHER, oval, 5/16"		4
54	296-340±	\$2.49	GASKET, timing cover		1
55	460-370	NA	OIL PAN	18G - 18GA engines	1
	460-375	NA	OIL PAN	18GB thru V engines	1
56	296-330±	\$3.39	GASKET, oil pan	3 main engines	1
	291-010±	\$3.19	GASKET, oil pan	5 main engines	1
57	328-280	\$1.89	PLUG, oil drain		1
	328-282	\$21.99	PLUG, oil drain, magnetic		1
58	324-626	\$0.99	WASHER, oil drain plug		1
	323-548	\$21.49	BOLT & WASHER SET, oil pan		1
59	322-210	NA	BOLT, oil pan	18G & GA use 19	19/18
60	462-385	\$0.39	LOCK WASHER		19/18
61	324-590	\$0.19	PLAIN WASHER (orig. for 1975-'80, may use on all)		19/18
63	296-360±	\$0.89	SEAL, main bearing cap	{ 18G/GA front & rear 18GB thru GK front only	2 1
	296-365±	\$1.19	SEAL, main bearing cap	{ 18GB thru GK, rear only 18V front & rear	1 2
65	296-000	\$1.69	GASKET, front plate to block		1
66	328-248	\$3.49	CORE PLUG SET, steel		1

**WARNING:** Cancer and Reproductive Harm. [www.P65Warnings.ca.gov](http://www.P65Warnings.ca.gov)

No.	Part#	Price (Each)	Description	Application	Qty Req.
	328-249	\$18.99	CORE PLUG SET, brass		1
	328-230	\$0.99	CORE PLUG, steel		4
	328-231	\$4.99	CORE PLUG, brass		4
67	318-030	\$0.99	STUD, tach. drive	} 18G/GA engines	2
	310-140	\$0.39	NUT		2
	365-720	\$0.79	WASHER		2
68	460-330	\$11.99	LINK, generator adjusting	18G/GA/GB engines	1
	460-330	\$11.99	LINK, alternator adjusting	18GF to V eng. to (c)410000	1
	460-325	\$12.99	LINK, alternator adjusting	18V eng. from (c)410001 on	1
69	460-320	\$15.59	PILLAR, adjusting link	18G to V eng. to (c)410000	1
70	460-310	\$31.99	BRACKET, generator mount	18G/GA/GB engines	1
	460-315	\$25.99	BRACKET, alternator mount	18GF engines on	1
73	451-350	\$62.99	DIP STICK, engine oil	18G thru GF engines	1
	451-355	NA	DIP STICK, engine oil	18GH thru 1976	1
	451-345	NA	DIP STICK, engine oil	1977 on	1
74	460-040	\$1.99	DUST CAP	} 18G thru GF engines	1
75	460-030	\$11.99	TUBE, dip stick, in block		1
	460-035	\$9.99	TUBE, dip stick, in block		18GG thru V engines
80	297-500‡	\$1.49	GASKET, rear engine plate, main	} in lower gasket sets	1
81	297-480‡	\$0.99	GASKET, rear engine plate, top		1
82	297-495	\$3.99	COVER, gearbox mount plate		18GD thru V engines
83	460-660	NA	PINION, tachometer drive	} 3 main engines	1
84	460-665	NA	HOUSING, tachometer pinion		1
85	460-670	\$11.49	SEAL (replaces orig. "O" ring & clip)		1
86	460-680	NA	RING CLIP, O-ring retaining		1
87	460-690‡	\$2.99	GASKET, pinion housing		1
90	413-020	\$7.49	ENGINE MOUNT, L/H front	} RD to (c)360300, GT to (c)361000	1
	413-021	\$13.99	ENGINE MOUNT, L/H front, uprated*		1
	413-010	\$7.49	ENGINE MOUNT, R/H front		1
	413-011	\$13.99	ENGINE MOUNT, R/H front, uprated*		1
90a	413-022	\$17.59	PLATE, packing (L/H mount only)		1
*The stiffer rubber in these mounts will transmit more engine vibration.					
91	413-060	\$7.49	ENGINE MOUNT, front	} RD from (c)360301 on, GT from (c)361001 on	2
	413-065	\$13.99	ENGINE MOUNT, front, heavy duty		2
91a	413-062	\$2.89	SHIM, engine mount		A/R
91b	310-050	\$0.69	NUT		2
92	413-050•	\$5.99	ENGINE MOUNT, rear (gearbox)	RD	2
	413-070•	\$6.99	ENGINE MOUNT, rear (gearbox)	GT to (c)139471, thru '67	2
	413-050•	\$5.99	ENGINE MOUNT, rear (gearbox)	GT from (c)139472, '68 on	2
93	460-180	\$28.99	BRACKET, L/H, engine mount	} RD to (c)360300, GT to (c)361000	1
	460-170	\$28.99	BRACKET, R/H, engine mount		1
93a	323-235	\$0.59	SCREW, bracket to L/H engine plate		2
94	460-185	\$6.79	BRACKET, L/H, engine mount	} RD from (c)360301 on, GT from (c)361001 on	1
	460-175	\$6.79	BRACKET, R/H, engine mount		1
95	413-075	\$13.99	RECOIL BRACKET	} RD to (c)339094, GT to (c)339471	2
	413-085	NA	RECOIL BRACKET		RD from (c)339095 to 410000, GT from (c)339472
96	282-330•	\$0.99	BUFFER, engine stay rod	RD only	2
97	280-050•	\$1.39	BUSH, rear gearbox extension	GT only	2
	280-055•	\$1.79	BUSH, rear gearbox extension	GT only	2

Gasket Sets						
	297-302*	\$74.99	GASKET SET, head, "Payen" brand (includes downpipe gaskets)	} 1962 - '74	1	
	297-301*	NA	GASKET SET, head, "Payen" brand (does not include downpipe gaskets)		1	
	297-303*	\$19.99	GASKET SET, head	} 1975 - '80	1	
	296-720	\$34.99	GASKET SET, head, Cobalt brand		1	
	297-321*	NA	GASKET SET, head, "Payen" brand		1	
	297-322*	\$21.99	GASKET SET, head	} 3 main engines	1	
	297-510‡	\$13.99	GASKET SET, lower		1	
	297-521‡	\$57.99	GASKET SET, lower		1	
	297-522‡	\$19.99	GASKET SET, lower		} 5 main engines	1
	296-725	\$39.99	GASKET SET, lower, Cobalt brand			1

\*Note: Not all gaskets included in gasket sets are shown on this page.  
 \*\*Products of various manufacturers supplied.  
**NOTE:‡** Included in Gasket Sets marked (‡) \* Included in Gasket Sets marked (\*)

During engine overhauls, have your machine shop check that the block surface is flat. The studs pull the topmost thread up out of the block, which makes it hard to get a good head gasket seal. Countersink 1/32" or so into each threaded hole to prevent this problem.

**Toll-Free Orders 1-800-667-7872 | MossMotors.com**  
**Fax 805-692-2525 | Local 805-681-3400**



# External Engine



## Engine Hardware Kits:

- Timing Cover Screw Set**  
Fits 1962-'76 with oval washers. **323-568 \$19.99**
- Timing Cover Screw Set**  
Fits 1976 on with plain washers. **323-558 \$13.99**
- Sump Screw Set**  
Fits all 1962-'80. **323-548 \$21.49**
- Engine to Gearbox Nut & Bolt Set**  
Fits 1962-'67 with 3-Synchro gearboxes. **322-428 \$10.99**
- Engine to Gearbox Nut & Bolt Set**  
Fits 1968 on with All-Synchro gearboxes. **322-438 \$9.99**



## Oberg Tilt Lift

It never fails. No matter what angle you hang an engine from its sling, it will be wrong. Unfortunately, most cars require the engine to be installed in an arc. This chore is hard enough with help, but it's nearly impossible without. Tilt Lift is a product which enables you to remove or install an engine alone. Tilt Lift allows easy adjustment of an engine's lift angle through a full 90 degrees of movement. Adjustment is easy, employing your 1/2" ratchet, and the 2,000 pound capacity – with a 3:1 safety load factor – is more than enough for any modern engine/tranny combination. A positive lock ensures the engine stays put. Tilt Lift's all steel construction ensures durability, and its small size (weighing only four pounds) makes it perfect for small work areas. The mounting cleats are adaptable to any engine.

Reduce the risk of personal injury, or damage to your car with a Tilt Lift.  
**386-730 \$119.99**



## MGB Engine Rebuild DVD

Cut hundreds of dollars in labor costs by rebuilding your own engine! This informative video covers MGB engine removal, dismantling, reassembly and reinstallation. The 90 minute presentation by expert mechanic, "Dr. Doolin," is loaded with valuable information and tricks of the trade.  
**211-141 \$89.99**

## "Ultra Slick" Engine Assembly Lube

The most critical time for dangerous wear during an engine's life is during initial start-up. Protect your rebuild (and all of those expensive parts) by using "Ultra Slick" during assembly of camshafts, lifters, engine bearings, timing components, valves & guides and rocker shaft assemblies. It's the best insurance available.  
**221-565 \$13.99**



## Hylomar Gasket Sealant

Hylomar "M" was originally the Racing Formulation, is acetone based, stiffens slightly over time and can be used in place of a gasket between finely machined surfaces. Hylomar Advanced Formulation or "AF" is solvent-free, won't harden and is perfect for use with gaskets on parts that need to be removed regularly for service. Both are perfect for shop use, and are ethanol and fuel proof.



- 232-215 Hylomar AF, 85 gram tube \$34.99**
- 232-220 Hylomar M, 80ml tube \$24.99**

**Poor running can often be attributed to defective smog valves**, either the early replaceable diaphragm type or the later, sealed gulp valve. To check these valves, remove them and block off all the disconnected hoses with plugs; if the engine now runs better, the valve needs replacing. On the later cars, check the plastic 'Y' fitting in the smog system. These often crack, allowing a vacuum leak to affect performance. Silicone sealer makes a great temporary fix.

# Internal Engine

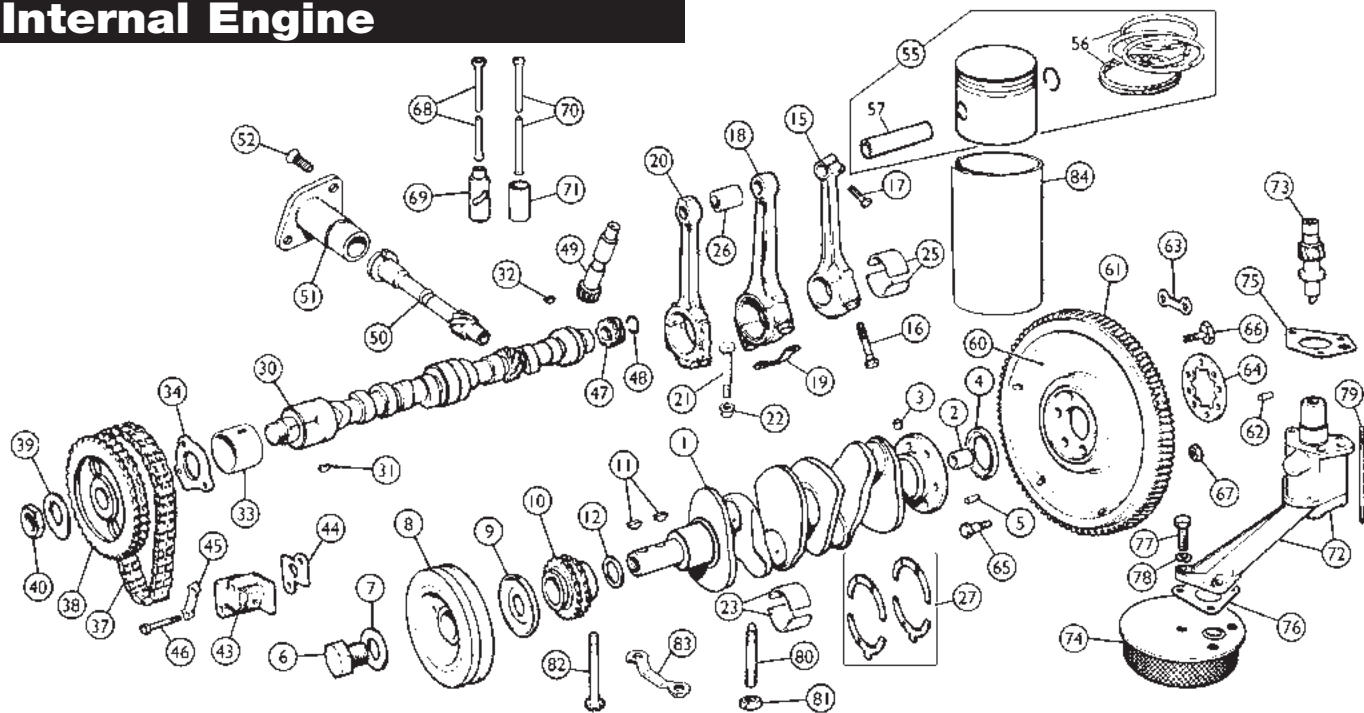

19654

## Internal Engine

No.	Part#	Price (Each)	Description	Application	Qty Req.
	328-630*	\$15.99	LOCKTAB SET, engine	18GB-GF engines	1
	328-640*	NA	LOCKTAB SET, engine (can use 328-630)	18GG-18V engines	1
* Items included in Locktab Sets are marked with an asterisk (*).					
1	451-580	NA	CRANKSHAFT	3 main engines	1
	451-615	NA	CRANKSHAFT	5 main engines	1
	451-670	NA	CRANKSHAFT, reground, w/brgs.	5 main engines	1
2	330-160	\$3.19	BUSHING, spigot, 5/8" long	3 main engines	1
	330-420	\$7.29	BUSHING, spigot, 1-1/2" long	5 main engines	1
	330-415	\$6.99	BUSHING, spigot, 1" long	5 main engines	1
	330-570	\$44.99	BUSHING, spigot, 1-1/2" long for adapting a 5 main engine for use with 3 main gearbox	5 main eng. w/3 main gbx.	1
3	460-410	NA	PLUG, restrictor		4
4	120-820	\$6.59	OIL SEAL, crank, rear	} 5 main engines	1
	120-821	\$17.99	OIL SEAL, crank, rear, upgrade		1
5	325-045	NA	PEG, flywheel to crankshaft		2/1
6	322-120	\$19.99	BOLT, pulley retaining		1
7	460-470*	\$1.19	WASHER, tab		1
8	460-450	\$119.99	PULLEY, crankshaft (no damper)	to (e)18G-UH/5571 ('62-'63)	1
	433-697	\$79.99	PULLEY, crankshaft (with damper)	fits all thru 1974	1
	433-705	NA	PULLEY, crankshaft	18V engines from 1975	1
9	433-815	\$8.99	OIL THROWER		1
10	460-420•	\$17.99	SPROCKET, crank, double row	18G thru GK engines	1
	460-425•	\$23.99	SPROCKET, crank, single row	18V engines	1
11	327-100	\$0.99	KEY, crank	18G thru GK engines	2
	327-105	\$2.69	KEY, crank	18V engines	2
12	460-440	\$2.99	SHIM, 0.006"		A/R
15	460-500	NA	CONNECTING ROD, #1, 3	} 18G/GA engines (3-main engines)	2
	460-510	NA	CONNECTING ROD, #2, 4		2
16	322-840	\$19.99	BOLT, connecting rod		8
17	322-140	\$3.69	WRIST PIN BOLT		4
18	460-515	\$94.99	CONNECTING ROD (rebuilt)	18GB thru GF engines	4
	322-130	\$18.99	BOLT, connecting rod	(5-main "angled" rods)	8
19	460-520*	\$1.89	LOCKPLATE		4
20	437-000	\$139.99	CONNECTING ROD (rebuilt)	18GG thru 18V thru '71	4
21	437-005	\$2.39	BOLT, connecting rod	(5-main "straight" rods with small end bushes)	8
22	437-020	\$2.99	NUT, connecting rod bolt		8
20	437-030	\$119.99	CONNECTING ROD (rebuilt)	18V engines from '72	4
21	437-005	\$2.39	BOLT, connecting rod	(for press fit pins)	8
22	437-020	\$2.99	NUT, connecting rod bolt		8
23	425-061	\$129.99	MAIN BEARING SET, std.	} Tri-metal (5-main sets; for 3-main discard extra bearings)	1
	425-071	\$129.99	MAIN BEARING SET, .010"		1
	425-081	\$129.99	MAIN BEARING SET, .020"		1
	425-091	\$119.99	MAIN BEARING SET, .030"		1
	425-096	\$119.99	MAIN BEARING SET, .040"		1
	425-060	\$49.99	MAIN BEARING SET, std.	} Bi-metal (5-main sets; for 3-main discard extra bearings)	1
	425-070	\$49.99	MAIN BEARING SET, .010"		1
	425-080	\$49.99	MAIN BEARING SET, .020"		1
	425-090	\$49.99	MAIN BEARING SET, .030"		1
	425-095	\$49.99	MAIN BEARING SET, .040"		1

No.	Part#	Price (Each)	Description	Application	Qty Req.
25	425-700	\$89.99	ROD BEARING SET, std.	} 3 main engines 18G, 18GA; Tri-metal bearings	1
	425-800	\$89.99	ROD BEARING SET, .010"		1
	425-850	\$89.99	ROD BEARING SET, .020"		1
	425-900	\$89.99	ROD BEARING SET, .030"		1
	425-950	\$89.99	ROD BEARING SET, .040"		1
	425-761	\$89.99	ROD BEARING SET, std.	} 5 main engine 18GB - on; Tri-metal bearings	1
	425-771	\$89.99	ROD BEARING SET, .010"		1
	425-781	\$89.99	ROD BEARING SET, .020"		1
	425-791	\$89.99	ROD BEARING SET, .030"		1
	425-796	\$89.99	ROD BEARING SET, .040"		1
	425-760	\$42.99	ROD BEARING SET, std.	} 5 main engine 18GB - on; Bi-metal bearings	1
	425-770	\$42.99	ROD BEARING SET, .010"		1
	425-780	\$42.99	ROD BEARING SET, .020"		1
	425-790	\$42.99	ROD BEARING SET, .030"		1
	425-795	\$42.99	ROD BEARING SET, .040"	1	
26	330-428	\$11.99	WRIST PIN BUSHING SET (4 ea.)	5 main thru '71	1
27	425-660	\$11.69	THRUST WASHER SET, std.	(4 pieces)	1
	425-670	\$13.49	THRUST WASHER SET, .005"	(4 pieces)	1
30	451-320	\$229.99	CAMSHAFT	18G/GA engines	1
	451-335	\$229.99	CAMSHAFT	1965-'80	1
	222-273	\$649.99	CAMSHAFT, fast street grind	(all)	1
31	327-050	\$0.69	KEY, cam sprocket	(all)	1
32	327-120	\$1.19	KEY, tach. drive	3 main engines	1
33	425-000	\$20.79	CAM BEARING SET, stock type, split		1
	425-001	\$34.99	CAM BEARING SET, "Dura-Bond"	"Dura-Bond" bearings are solid for accuracy and easy installation.	1
34	460-530	\$29.99	PLATE, cam locating		1
	322-230	\$0.39	BOLT, plate to block		3
	462-385	\$0.39	LOCKWASHER for bolt		3
37	460-591•	\$48.99	TIMING CHAIN, heavy duty upgrade	} 18G thru GK engines, double row chains	1
	114-077•	\$19.99	TIMING CHAIN, orig. manufacturer		1
	460-590•	\$10.49	TIMING CHAIN, aftermarket		1
	460-596•	\$44.99	TIMING CHAIN, heavy duty upgrade		1
	460-595•	\$7.39	TIMING CHAIN, aftermarket	18V engines, single row chains	1
38	460-540•	\$25.99	SPROCKET, camshaft, double row	18G thru GK	1
	460-545•	\$38.99	SPROCKET, camshaft, single row	18V engines	1
•Note: Late engines with single row chains can use double row sprockets & chains.					
39	460-550*	\$1.99	LOCKTAB, cam		1
40	311-500	\$10.99	NUT		1
43	460-561	\$209.99	TENSIONER, timing chain, Premium quality		1
	460-560	\$14.99	TENSIONER, timing chain		1
44	460-580	\$0.89	GASKET, tensioner		1
45	460-570*	\$1.49	LOCKTAB, tensioner		1
46	322-250	\$0.49	BOLT, tensioner		2
47	460-650	\$69.99	GEAR, tachometer drive	} 3 main engines	1
48	326-150	\$0.59	CLIP, tachometer drive gear		1
49	460-660	NA	PINION, tachometer drive		1
50	460-640	\$89.99	SPINDLE, distributor drive		1
51	460-300	NA	HOUSING, distributor mounting		1

No.	Part#	Price (Each)	Description	Application	Qty Req.
52	323-250	\$0.59	SCREW		1
55	420-300	\$359.99	PISTON SET, std.	3 main engines 8.75:1 CR	1
	420-320	\$359.99	PISTON SET, .020"		1
	420-330	\$359.99	PISTON SET, .030"		1
	420-340	\$359.99	PISTON SET, .040"		1
NOTE: 18GB-GF 4-ring 3" long pistons are obsolete. Use 2.4" floating pin pistons below.					
	420-390	NA	PISTON SET, std., 2.4" long	5 main engines float- ing pin thru '71 (pin uses Seeger rings)	1
	420-400	\$579.99	PISTON SET, .020", 2.4" long		1
	420-410	NA	PISTON SET, .030", 2.4" long	8.75:1 CR AE brand	1
	420-415	\$579.99	PISTON SET, .040", 2.4" long		1
	420-392	\$269.99	PISTON SET, std., 2.4" long	5 main engines, float- ing pin thru '71 (pin uses Seeger rings)	1
	420-402	\$269.99	PISTON SET, .020", 2.4" long		1
	420-412	\$269.99	PISTON SET, .030", 2.4" long	8.75:1 CR Aftermarket brand	1
	420-416	\$269.99	PISTON SET, .040", 2.4" long		1
	420-422	\$269.99	PISTON SET, .060", 2.4" long		1
	420-375	\$259.99	PISTON SET, std., 2.4" long	5 main engines press fit pin from '72 (pin press fit in con rod)	1
	420-385	\$259.99	PISTON SET, .020", 2.4" long		1
	420-395	\$259.99	PISTON SET, .030", 2.4" long	8.0:1 CR Aftermarket	1
	420-405	\$259.99	PISTON SET, .040", 2.4" long		1
	420-431	NA	PISTON SET, std., 2.4" long	5 main engines press fit pin from '72 (pin press fit in con rod)	1
	420-436	\$699.99	PISTON SET, .020", 2.4" long		1
	420-441	\$699.99	PISTON SET, .030", 2.4" long	8.7:1 CR AE-Nüral brand	1
	420-446	\$699.99	PISTON SET, .040", 2.4" long		1
	420-451	\$699.99	PISTON SET, .060", 2.4" long		1
	420-430	\$259.99	PISTON SET, std., 2.4" long	5 main engines press fit pin from '72 (pin press fit in con rod)	1
	420-435	\$259.99	PISTON SET, .020", 2.4" long		1
	420-440	\$259.99	PISTON SET, .030", 2.4" long	8.7:1 CR Aftermarket brand	1
	420-445	\$259.99	PISTON SET, .040", 2.4" long		1
	420-450	\$259.99	PISTON SET, .060", 2.4" long		1
56	421-420	\$85.99	RING SET, std.	4 rings 3 & 5 main engines 1962 - '71	1
	421-430	\$85.99	RING SET, .020"		1
	421-440	\$85.99	RING SET, .030"		1
	421-450	\$85.99	RING SET, .040"		1
	421-455	\$85.99	RING SET, .060"		1
	421-500	\$109.99	RING SET, std.	5 rings 3 & 5 main engines 1962 - '71	1
	421-510	\$109.99	RING SET, .020"		1
	421-520	\$109.99	RING SET, .030"		1
	421-530	\$109.99	RING SET, .040"		1
	421-580	\$85.99	RING SET, std.	3 ring - 5 main engines 1972 on	1
	421-590	\$85.99	RING SET, .020"		1
	421-600	\$85.99	RING SET, .030"		1
	421-610	\$85.99	RING SET, .040"		1
	421-615	\$85.99	RING SET, .060"		1
	421-615	\$85.99	RING SET, .060"		
57	422-040	NA	WRIST PIN	3 main engines	4
60	460-695	NA	FLYWHEEL ASSEMBLY, 1962-'64	18G/GA engines (3 main)	1
	460-705	NA	FLYWHEEL ASSEMBLY, 1965-'67	18GB engines (5 main)	1
	460-685	NA	FLYWHEEL ASSEMBLY, 1968-'80	18GD-V engines (5 main)	1
61	190-040	\$29.99	RING GEAR, 10.75" dia.	18G/GB engines	1
	190-050	\$29.99	RING GEAR, 11.5" dia.	18GD-V engines	1
62	325-090	\$2.39	PIN, clutch cover to flywheel	3 main uses 3	3/2
63	460-710	\$2.69	LOCKPLATE	3 main engines	3
64	460-715*	\$2.79	LOCKPLATE	5 main engines	1
65	322-850	\$8.99	BOLT, flywheel attaching	3 main engines	6
66	322-160	\$3.99	BOLT, flywheel attaching	5 main engines	6
67	310-050	\$0.69	NUT, flywheel attaching	3 main engines	6
	460-638	\$89.99	TAPPET & PUSH ROD SET	18G thru GK engines	1
68	460-610	\$4.79	PUSH ROD		8
69	460-600	\$6.79	TAPPET		8
70	460-615	\$4.49	PUSH ROD		8
71	460-612	\$64.99	TAPPET SET, AE brand	18V engines	1
	460-604	\$259.99	TAPPET SET, stock type, 54-58 HRC In-house tested, incl. ass'y lube.		1
	460-601	\$249.99	TAPPET SET, APT brand, 60+ HRC with oil drain hole		1
72	460-730	\$78.99	OIL PUMP	3 main engines	1
	435-600	\$86.99	OIL PUMP	5 main engines	1
73	460-720	\$119.99	SPINDLE, oil pump		1
74	460-760	\$28.99	STRAINER, oil	(includes gasket 460-735)	1
75	460-725	\$0.99	GASKET, pump to crankcase	3 main engines	1
	460-745	\$0.79	GASKET, pump to crankcase	5 main engines	1
76	460-735	\$0.69	GASKET, strainer to pump		1
77	314-265	\$0.59	BOLT, oil strainer		3
78	324-020	\$0.20	LOCKWASHER		3
79	328-960	\$6.69	STUD, oil pump		3
	365-720	\$0.79	WASHER, flat		3
	365-730	\$0.39	LOCKWASHER		3

Toll-Free Orders 1-800-667-7872 | MossMotors.com  
 Fax 805-692-2525 | Local 805-681-3400

MOSS

# Internal Engine

No.	Part#	Price (Each)	Description	Application	Qty Req.
	310-140	\$0.39	NUT		3
80	328-195**	NA	STUD, main bearing cap	18G thru GK engines	6/10
81	311-000	\$2.19	NUT, main bearing cap		6/10

\*\*Stud kit 322-938 may be used - see "Heavy Duty Bolt & Stud Kits" below

82	322-145	\$13.99	BOLT, main bearing cap	18V engines	10
83	425-005	NA	LOCKPLATE, main bearing cap	some 1965 engines	3/5
84	426-080	\$42.29	CYLINDER LINER (professional machining required)		4

Cylinder liners are used to repair a damaged bore. Block is bored to accept the liner, liner is pressed into block, trimmed flush with block deck, then bored and honed to fit the piston.

Front and rear main bearing caps are a snug fit and care must be taken not to damage their mating surfaces when removing and installing them. The best method of removal is to insert a bolt in the threaded hole in the cap and pull on it gently with a slide hammer.

## Speedi-Sleeves



When a new seal cannot compensate for excessive damage, these ultra-thin sleeves provide new sealable surfaces. Instructions and installation tool are included.

Crankshaft pulley/timing cover seal	520-515	\$69.99
Rear crankshaft (5-main engines)	520-525	\$78.99

## Aluminum Alloy Flywheels



For a faster revving engine, these 9 lb. flywheels feature a replaceable steel face and mechanically located ring gear.

1962-'64 (3-main engine)	460-673	\$474.99
1965-'67 (5-main engine)	460-674	\$394.99
1968-'80 (5-main engine)	460-675	\$449.99

## Heavy-Duty Bolt & Stud Kits

These heavy-duty, precision ground heat-treated bolts have a tensile strength of 180,000 p.s.i., and studs have a tensile strength of 190,000 p.s.i. - over three times the strength of stock engine hardware. Included are special hardened washers and 12-point nuts - perfect for the racer, weekend road warrior, or anyone who wants added insurance against mechanical failure.

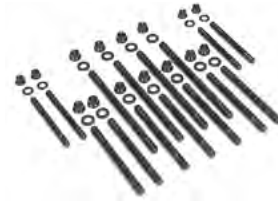

<b>Rod Bolt Kit</b>	Fits 18GB thru 18GF engines	322-845	\$66.99
<b>Rod Bolt Kit</b>	Fits 18GG thru 18V engines	322-848	\$149.99
<b>Cylinder Head Stud Kit</b>		322-858	\$189.99
<b>Main Bearing Cap Stud Kit</b>	3-main engines	322-868	\$104.99
<b>Main Bearing Cap Stud Kit</b>	18GB - 18GK 5-main engines	322-938	\$149.69
<b>Main Bearing Bolt Kit</b>	18V 5-main engines	322-948	\$159.99

## Offset Cam Keys

Keys with offsets allow you to fine tune your camshaft timing. (Use with stock sprockets.)

<b>2° offset</b>	327-005	\$29.99	<b>3° offset</b>	327-015	\$29.99
<b>4° offset</b>	327-025	\$31.99	<b>5° offset</b>	327-035	\$31.99

## Vernier Cam Gear Conversion Kit

If you're serious about your engine rebuild, this is one upgrade you should be sure to install! 1972-'80 MGBs were originally fitted with a single row timing chain which wears more quickly than the earlier double row chain and sprockets. Our kit includes the double row chain, along with fully adjustable cam sprocket.

460-398 \$249.99



## Upgraded Oil Pump

Fits all 5-main engines. This oil pump has been modified to the factory special tuning specifications for increased oil flow at high RPM. The ultimate protection for your engine.

435-625 \$114.99

## Upgraded Oil Pressure Relief Spring

Increase the oil pressure in your stock engine by about 20 psi. Note: This is not a remedy for a worn engine in need of a rebuild!

329-235 \$5.69



# Cylinder Head

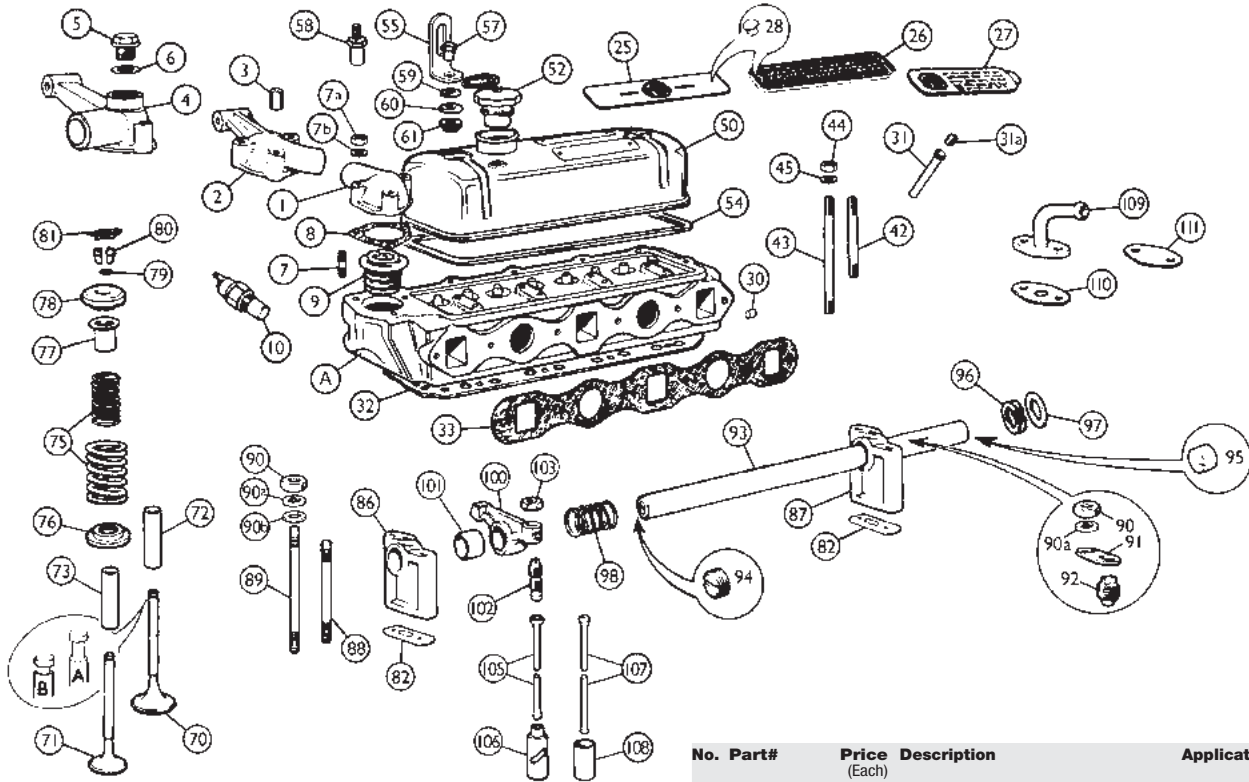

## Cylinder Head

No.	Part#	Price (Each)	Description	Application	Qty Req.
-----	-------	--------------	-------------	-------------	----------

All MGB cylinder heads are more or less interchangeable. 1962 - '67 heads have no pollution control features. 1968 - '80 heads have air injection manifold holes which can be plugged with 7/16" S.A.E. Allen head screws for use on earlier engines. The 1975 - '80 head is the only one not completely interchangeable. This has a water take-off at the back for the water choke, and the rear rocker shaft pedestal is different - use the correct one or the rocker assembly will not be lubricated. (Our alloy heads may be used with either rocker shaft pedestal due to a minor design change.) All heads had an original thickness of 3.177" to 3.192". Bare heads require final guide and seat machining.

A 451-518 \$999.99 CYLINDER HEAD, cast iron, assembled, unleaded 1962-'67 1  
No smog fittings, 1.625" intake valves, EN214 stainless steel exhaust valves, hardened valve seats, cast iron guides, single valve springs, steel valve spring caps, late (narrow) keepers.

451-555 \$999.99 CYLINDER HEAD, cast iron, assembled, unleaded 1968-'80 1  
Drilled for smog fittings and water choke, 1.563" intake valves, EN214 stainless steel exhaust valves, hardened valve seats, cast iron guides, single valve springs, steel valve spring caps. (1968-74 requires replacing the rear rocker pedestal with the off-set oil feed 460-245)

451-805 \$1,299.00 CYLINDER HEAD, alloy, bare MORE INFO ONLINE 1962-'67 1  
No smog fittings. Includes hardened valve seats & silicon-bronze guides. Uses stock valves.

451-806 \$1,599.00 CYLINDER HEAD, alloy, assembled MORE INFO ONLINE 1962-'67 1  
No smog fittings, 1.563" intake valves, EN214 stainless steel exhaust valves, hardened valve seats, silicon-bronze guides, double valve springs, steel valve spring caps, late (narrow) keepers.

451-815 \$1,299.00 CYLINDER HEAD, alloy, bare MORE INFO ONLINE 1968-'80 1  
Drilled for smog fittings. Incl. hardened valve seats & silicon-bronze guides. Uses stock valves.

451-816 \$1,799.00 CYLINDER HEAD, alloy, assembled MORE INFO ONLINE 1968-'80 1  
Drilled for smog fittings, 1.563" intake valves, EN214 stainless steel exhaust valves, hardened valve seats, silicon-bronze guides, double valve springs, steel valve spring caps, late (narrow) keepers.

451-690 \$2,399.00 CYLINDER HEAD, alloy, crossflow MORE INFO ONLINE 1962-'80 1  
No smog fittings, 1.563" intake valves, EN214 stainless steel exhaust valves, hardened valve seats, silicon-bronze guides, double valve springs, steel valve spring caps, late (narrow) keepers. May be used with either inline or offset oil hole rear rocker shaft pedestals.

### ALLOY CYLINDER HEADS require coarse threaded fasteners:

328-765	\$2.59	STUD, manifold	6
322-381	\$0.29	BOLT, heater valve	2

### HEAD GASKET SETS\* are listed on page 7.

\*Head Gasket Sets include items marked \* plus others not shown.

1	460-845	\$9.99	ELBOW, water outlet	18G/GA/GB engines	1
2	460-945	\$49.99	ELBOW, water outlet	18GF thru V engines to (c)410000	1
	460-955	\$15.99	ELBOW, water outlet	Euro-spec, w/o air pump brkt.	1
3	311-545	\$3.99	NUT, long	18GF thru 18V engines	1

No.	Part#	Price (Each)	Description	Application	Qty Req.
4	460-925	\$34.99	ELBOW, water outlet	} from (c)410001 on, 1977 on	1
5	328-480	NA	PLUG, outlet elbow, plastic		1
	459-760	\$7.69	PLUG, outlet elbow, brass (repl.)		1
6	328-486	\$0.69	O-RING (replaces orig. gasket)		1
7	328-605	\$1.89	STUD, outlet elbow		3
7a	310-140	\$0.39	NUT		3
7b	365-720	\$0.79	WASHER		3
8	296-380	NA	GASKET, outlet elbow	stock type cork	1
	296-381	\$2.19	GASKET, outlet elbow	"Klingsil" material	1
9	434-189	\$7.99	THERMOSTAT, 180°	standard	1
	434-180	\$7.99	THERMOSTAT, 160°	hot climates	1
	434-195	\$7.99	THERMOSTAT, 195°	cold climates	1
10	760-180	\$13.99	TEMPERATURE SENDING UNIT	1968 - '76	1
	131-566	\$11.99	TEMPERATURE SENDING UNIT	1977 - '80	1
25	408-800	\$4.79	"MG" PLATE	18G & GA engines	1
	215-620	\$2.99	"MG" DECAL	1965-'72 (approx.)	1
26	408-810	\$6.99	PATENT NUMBER PLATE	18G engines	1
27	408-815	\$7.39	EMISSIONS LABEL	18GF thru V engines	1
	215-660	\$2.99	BRITISH LEYLAND DECAL	approx. 1973 on	1
28	458-765	\$0.89	RIVET, valve cover plates	18G engines	4
	325-245	\$0.99	DRIVE RIVET, engine # plate		2
30	328-270	\$1.99	PLUG, oil hole (included with cylinder heads)		1
31	360-700	\$18.49	AIR INJECTION TUBES	18GF thru V engines	4
31a	052-242	\$2.39	PLUG, air injection ports		4
(These plugs block the air ports, allowing late heads to be used on early engines)					
32	296-415	\$22.99	HEAD GASKET, copper	1962-'74, fits all years	1
	296-405	NA	HEAD GASKET, composition, Payen	1975-'80, fits all years	1
33	297-535	\$9.79	GASKET, manifold, premium upgrade		1
42	328-950	\$13.99	STUD, cylinder head, 4 1/2"		7
43	328-940	\$9.99	STUD, cylinder head, 6 1/4"		4
44	310-280	\$0.99	NUT, cylinder head, stock type		11
	114-122	\$3.19	NUT, cylinder head, flanged upgrade replacement		11
45	324-725	\$1.09	WASHER, cylinder head		11
50	454-680	NA	VALVE COVER, w/breather	18G engines	1
	224-508	\$109.99	VALVE COVER, cast aluminum	} accessory (no breather)	1
	224-490	\$154.99	VALVE COVER, black wrinkle finish		1
	454-690	NA	VALVE COVER, w/o breather	18GA thru GH engines	1
	454-695	NA	VALVE COVER, w/breather	18GJ thru V engines	1
52	460-100	\$22.99	CAP, oil filler, steel	18G engines	1
	460-102	\$21.99	CAP, oil filler, vented, OE type	} 18GA thru GH engines	1
	460-105	\$7.69	CAP, oil filler, vented, replacement		1
	460-125	\$5.29	CAP, oil filler, non-vented		18GJ thru V engines
54	296-310	\$2.99	GASKET, valve cover, stock type		1
	296-311	\$25.99	GASKET, valve cover, silicone	MORE INFO ONLINE	1
55	386-745	\$10.99	BRACKET, engine lifting		2
57	460-110	\$2.99	CAP NUT, valve cover	} 18G - GB and 18V from '77 on	2
	460-045	\$5.79	CAP NUT, valve cover, chrome		2



# Cylinder Head

No.	Part#	Price (Each)	Description	Application	Qty Req.	
58	460-112	\$6.49	CAP NUT, valve cover	} 18GF, GD and 18V thru '76	2	
59	460-115	\$2.29	DISTANCE PIECE		2	
60	460-130	\$0.79	WASHER, cupped		2	
	460-135	\$2.49	WASHER, cupped, chromed		2	
61	460-120	\$0.99	BUSHING, rubber		2	
70	423-140	\$7.79	VALVE, intake, 1.563", stem "A"	see note "A" below	4	
	423-125	\$6.99	VALVE, intake, 1.563", stem "B"	"B" below; 18V 1975-on	4	
	423-135	\$7.99	VALVE, intake, 1.625" (stock)	} 18V engines 1972-'74	4	
	423-137	\$14.99	VALVE, intake, 1.70", gas flowed		stem "B"	4
71	423-151	\$7.99	VALVE, exhaust, stainless steel	} stem "A" 1962-'68	4	
	423-155	\$29.99	VALVE, exh., stainless/stellite tip		see note "A" below	4
	423-145	\$8.99	VALVE, exhaust, stainless steel	} stem "B" 1968-'80	4	
	423-165	\$29.99	VALVE, exh., stainless/stellite tip		see note "B" below	4
	423-166	\$26.99	VALVE, exh., 1.34", s/s, gas-flowed			4
72	423-240	\$2.99	GUIDE, intake valve, stock type		4	
	423-245	\$13.99	GUIDE, intake valve, manganese-bronze		4	
73	423-250	\$2.99	GUIDE, exhaust valve, stock type		4	
	423-255	\$13.99	GUIDE, exhaust valve, manganese-bronze		4	
75	423-430	\$32.99	SPRING SET, valve, double, stock	} 18G thru GK engines	1	
	423-455	\$72.99	SPRING SET, valve, double, uprated 20%		1	
Use with high lift cams, increased ratio rockers, and up to 7,000 rpm.						
Double spring sets may be used on 18V engines if valve cups 460-195 are used.						
	423-445	\$19.89	SPRING SET, single, stock	18V engines	1	
76	460-220	\$3.89	COLLAR, valve spring	18G thru GK engines	8	
	460-225	\$2.49	COLLAR, valve spring	18V engines	8	
77	433-020	\$9.79	DEFLECTOR, valve (use with original cups #78 only)	} to (e)18G/4384	8	
78	460-200	NA	CUP, valve spring (stem A) (use 460-205 without deflectors)		8	
	460-205	\$5.99	CUP, valve spring (stem A)	from above - see note "A"	8	
	460-195	\$3.99	CUP, valve spring (stem B, dbl. spg.)	see note "B2" below	8	
	460-235	\$9.99	CUP, valve spring (stem B, sgl. spg.)	18V engines	8	
† Valve stem "A" has a 0.352" wide groove, stem "B" has a 0.082" wide groove.						
<b>A - 18G, 18GA, 18GB engines, and to 18GF/2158 (non-overdrive), 18GF/530 (overdrive)</b>						
<b>B - from engine 18GF/2159 (non-overdrive), 18GF/531 (overdrive), 18GH, 18GK, 18V</b>						
<b>B2 - from engine 18GF/2159 (non-overdrive), 18GF/531 (overdrive), 18GH, 18GK (not 18V)</b>						
79	297-108	\$1.39	SEAL SET, valve stem, stock type o-ring		1	
	290-890	\$1.29	SEAL, valve stem, umbrella type upgrade		8	
80	460-210	\$9.99	VALVE COTTER, pair	1962 - '68, see note "A"	8	
	460-215	\$2.39	VALVE COTTER	1968 - '80, see note "B"	16	
81	326-120	\$1.49	CLIP, valve cotter	used w/460-210 cotter	8	
82	460-255	\$3.99	SHIM, center rocker brackets	from 18GB engines on	2	
86	460-240	NA	ROCKER BRACKET, plain hole		3	
87	460-230	\$23.99	ROCKER BRACKET, tapped	thru 1974	1	
	460-245	\$21.29	ROCKER BRACKET, tapped	from 1975 on	1	
88	328-970	\$4.49	STUD, rocker bracket, short		2	
89	328-980	\$3.39	STUD, rocker bracket, long		2	
90	310-140	\$0.39	NUT, rocker bracket studs		4	
90a	365-730	\$0.39	LOCKWASHER		4	
90b	365-720	\$0.79	WASHER		3	
91	460-280	\$4.79	LOCKPLATE		1	
92	460-270	\$2.69	SCREW, rocker shaft locating		1	
93	451-340	\$29.99	ROCKER SHAFT	stock type	1	
	433-725	\$49.99	ROCKER SHAFT	tuftrided for longer wear	1	
94	328-080	NA	PLUG, threaded		1	
95	328-290	\$15.99	PLUG, plain		1	
96	329-470	NA	WASHER, double coil		2	
97	NA	NA	WASHER, plain		2	
98	329-220	\$3.89	SPRING		3	
100	460-250	\$15.99	ROCKER ARM		8	
	325-240	NA	PLUG, oil drilling		8	
101	330-150**	\$1.99	BUSHING, rocker arm		8	
102	460-260	\$1.89	SCREW, adjusting		8	
103	310-150	\$0.39	NUT, adjusting screw		8	
**Note: Oil holes must be drilled in these bushings after installation in a rocker arm. Bushings must then be reamed to fit shaft, and plug replaced.						
	460-638	\$89.99	TAPPET & PUSH ROD SET	} 18G thru GK engines	1	
105	460-610	\$4.79	PUSH ROD		8	
106	460-600	\$6.79	TAPPET		8	

107	460-615	\$4.49	PUSH ROD (stock type)	} 18V engines	8
	460-619	\$21.99	PUSH ROD, tubular, uprated		8
108	460-613	\$8.49	TAPPET, AE brand	} 18V engines	8
	460-604	\$259.99	TAPPET SET, 54-58 HRC In-house tested, includes assembly lube		1
	460-601	\$249.99	TAPPET SET, APT brand, 60+ HRC with oil drain hole		1
	460-608	NA	TAPPET SET, lightened, with oil drain hole		1
109	470-245	NA	OUTLET, for auto choke	} 1975 on	1
110	295-040	\$7.79	GASKET		1
111	052-341	\$17.99	BLANKING PLATE, auto-choke outlet	See note below	1
Blanking plate is used to block the water choke outlet when using late heads on early engines.					



## High Ratio Roller Rocker Kits

The ratio of these rockers is increased so that the valves are opened earlier for a longer duration, therefore making the breathing much more efficient (the standard ratio is 1.426 against the new high lift ratio of 1.625). The kit comes assembled for easy installation onto the cylinder head, and uses solid spacers between the rocker arms. Each rocker is fitted to the rocker shaft with twin needle roller bearings and uses a roller to make contact with the valve stem, lessening wear and reducing side loads on the valve stem. Caution: Installation of roller rockers must be carried out very carefully to ensure the safety and expected reliability of these parts.

Roller rocker kit, for in-line rocker feed type head (thru '74)	<b>451-460</b>	<b>NA</b>
As above, but for offset rocker feed type head ('75-'80)	<b>451-470</b>	<b>NA</b>

## Rocker Shaft Spacer Set

These spacers replace the springs on the rocker shaft which to some extent impede the rotation of the rockers and produce excess friction and power loss. They also better locate the rockers over the valve stems. Supplied as an engine set of spacers. Rocker pedestals must be at least 0.875" wide to use these solid spacers.

<b>460-365</b>	<b>\$45.99</b>
----------------	----------------

## Tuftrided Rocker Shaft

Tuftriding produces a harder wearing exterior surface on the shaft for improved reliability and is recommended for all MGBs using standard rocker arms.

<b>433-725</b>	<b>\$49.99</b>
----------------	----------------

## Strengthened Rocker Shaft Outer Pedestals

These are to be used with a conventionally operating rocker shaft. They differ from original outer pedestals in being cast with additional outer supporting branches which allow the use of stronger valve springs and very high engine speeds without the rocker shaft flexing. There are two different rocker feed hole positions which may be found on an MGB cylinder head so you must inspect the cylinder head to ascertain the position of the feed hole; either in-line with the rocker pedestal mounting stud holes or offset. Strengthened Outer Pedestals (pair) with in-line oil feed hole (thru '74)

<b>460-268</b>	<b>\$399.99</b>
----------------	-----------------

## Heavy-Duty Valve Springs

These heavy-duty valve springs are highly recommended for all high performance MGBs. (If engine has single valve springs, dual spring valve spring cups 460-195 must be used.)

<b>423-455</b>	<b>\$72.99</b>
----------------	----------------

## Competition Manifold Gasket

This special gasket has enlarged holes to match the inlet and exhaust port dimensions on modified cylinder heads.

<b>297-545</b>	<b>\$10.79</b>
----------------	----------------

# Oil Filters

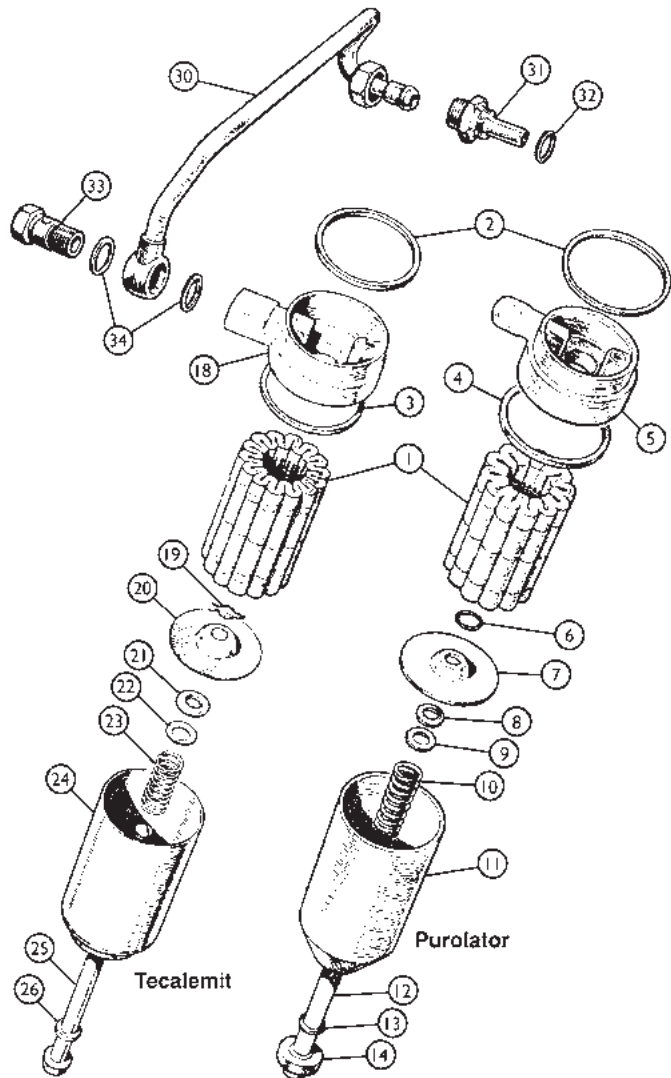

## Hanging Canister

19669

No.	Part#	Price (Each)	Description	Application	Qty Req.
18G/GA/GB Engines					
The Purolator assembly was used on 18G and GA engines only. Tecalemit assemblies may also be found on these early engines. Although the entire assemblies may be interchanged, most individual components will not interchange.					
1	950-010	NA	FILTER ELEMENT, felt, "Crosland" brand		1
	950-510	\$9.99	FILTER ELEMENT, felt (various manufacturers)		1
	950-030	NA	FILTER ELEMENT, paper, "Crosland" brand		1
	950-530	\$4.99	FILTER ELEMENT, paper (various manufacturers)		1
Note: Filters include two seals; one thick, one thin. These are for different application to be used between the canister and the filter head.					
2	435-335	\$1.19	SEAL, filter head to block		1
3	021-467	\$1.79	SEAL, canister to filter head	Tecalemit	1
4	435-335	\$1.19	SEAL, canister to filter head	Purolator	1
5	460-850	NA	HEAD ASSEMBLY		1
6	326-205	\$1.69	CIRCLIP (replacement)		1
7	435-150	\$11.99	PLATE		1
8	435-560	\$0.69	WASHER, felt		1
9	435-570	\$0.89	WASHER, steel		1
10	329-120	NA	SPRING	Purolator	1
11	435-327	NA	CANISTER		1
12	460-800	NA	BOLT		1
13	460-815	NA	SEAL		1
14	460-825	NA	WASHER		1
18	460-900	NA	HEAD ASSEMBLY		1
19	326-205	\$1.69	CLIP		1
20	435-150	\$11.99	PLATE		1
21	435-560	\$0.69	WASHER, felt		1
22	435-570	\$0.89	WASHER, steel		1
23	329-230	\$10.99	SPRING		1
24	460-770	NA	CANISTER	Tecalemit	1
25	460-790	NA	BOLT		1
26	460-805	\$1.99	SEAL		1
30	460-830	NA	PIPE ASS'Y., filter head to block		1
31	460-820	\$39.99	ADAPTOR, pipe to block		1
32	324-800	\$0.69	WASHER, copper		1
33	460-840	NA	BANJO BOLT		1
34	324-800	\$0.69	WASHER, copper		2

NOTE: Parts #30 and 33 are not used when an oil cooler is fitted.

### Spin-on Oil Filter Adapter

This Moss-designed pressure die cast adaptor looks nearly identical to the factory aluminum filter heads, and directly replaces the original unit. This conversion is extremely well-designed and makes future oil changes much cleaner and easier. The factory canister design is prone to leakage due to failed seals and is always a hassle to clean up when changing filter elements. We highly recommend this conversion for all 1962-'67 MGBs. Will not fit MGBs from 1968-'80 unless a gear reduction starter (eg. 131-215) is fitted, as the filter conversion will not clear the original starter.

Spin-on Oil Filter Adapter	235-940	\$42.99
Filter, K&N	235-830	\$28.99
Filter, Wix	235-855	\$18.99
Filter, Fram	235-880	\$10.99

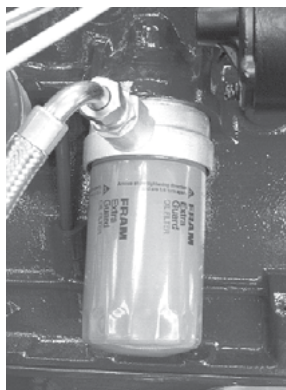

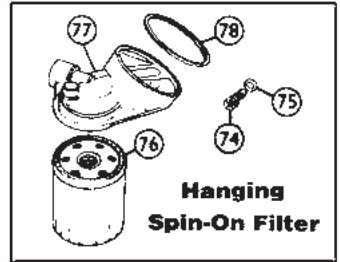
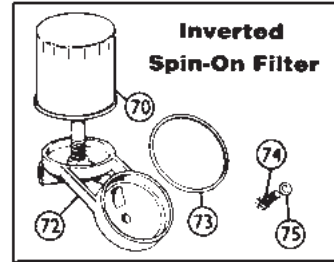
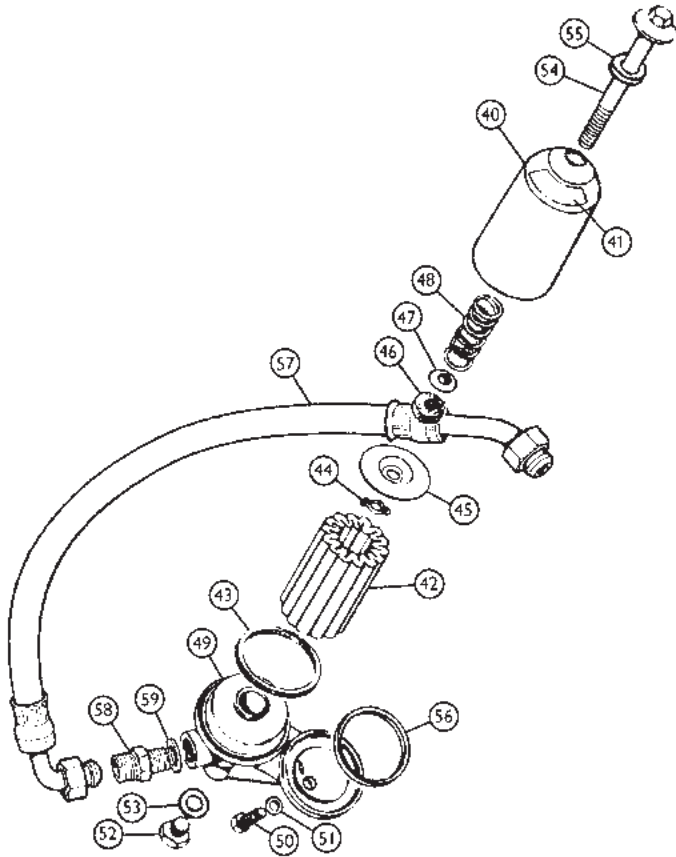

**Note:** Inverted spin-on filters were used from March 1970 to November 1973, and from approximately 1976 through 1980. In the interim, the hanging filter was used.

## Spin-On Filters

19671

No.	Part#	Price (Each)	Description	Application	Qty Req.
<b>These use hose, adaptor, and washer nos. 57-59 in the "Inverted Canister" listing to the left. 1979-'80 cars used a hard metal pipe which is not available - use the hose for these cars.</b>					
70	235-826	\$24.99	FILTER CARTRIDGE, "K&N"	inverted spin-on filter (3-1/4" dia.)	1
	235-835	\$14.99	FILTER CARTRIDGE, heavy-duty, "Wix"		1
	950-000	NA	FILTER CARTRIDGE, spin-on, "Crosland"		1
	950-500	\$5.99	FILTER CARTRIDGE, spin-on, "Classic Gold"		1
72	460-910	\$99.99	FILTER HEAD		1
73	435-335	\$1.19	SEAL, filter head to block		1
74	460-835	\$1.89	BOLT, filter head to block	inverted & hanging spin-on filters	1
75	435-567	\$1.69	WASHER		1
76	950-045	NA	FILTER CARTRIDGE, spin-on, "Crosland"	hanging spin-on filter (3" dia.)	1
	950-545	\$5.99	FILTER CARTRIDGE, spin-on, various brands		1
77	460-915	NA	FILTER HEAD		1
78	435-335	\$1.19	SEAL, filter head to block		1

## Inverted Canister

19670

No.	Part#	Price (Each)	Description	Application	Qty Req.
Fitted approx. 1968 to March 1970.					
40	460-785	NA	CANISTER		1
41	215-670	\$3.19	"TECALEMIT" DECAL		1
42	950-510	\$9.99	FILTER ELEMENT, felt		1
	950-530	\$4.99	FILTER ELEMENT, paper		1
43	021-467	\$1.79	SEAL		1
44	326-205	\$1.69	CLIP		1
45	435-150	\$11.99	PLATE		1
46	435-560	\$0.69	WASHER, felt		1
47	435-565	\$0.39	WASHER, steel		1
48	329-230	\$10.99	SPRING		1
49	460-905	NA	FILTER HEAD		1
50	460-835	\$1.89	BOLT, filter head to block		1
51	435-567	\$1.69	WASHER		1
52	328-180	\$15.99	DRAIN PLUG		1
53	324-755	NA	WASHER, drain plug		1
54	460-795	NA	BOLT		1
55	680-020	\$1.69	SEAL		1
56	435-335	\$1.19	SEAL, filter head to block		1
57	435-585	\$39.99	HOSE, filter head to block	used when oil cooler not fitted	1
58	435-590	\$5.99	ADAPTER, hose to filter head		1
59	324-800	\$0.69	WASHER, copper		1



## Collector's Choice Engine Oil

Collector's Choice engine oil is a must for your classic engine. Contains higher zinc and phosphorus levels to help prevent premature camshaft lobe wear, additives to help prevent seals from becoming hard and leaking from infrequent use, and antioxidants to combat the effects of humidity changes during storage that can lead to moisture and even rust in an engine. 12 quarts in a case. Not for use with catalytic converters.

20W-50, case	220-810	\$146.99
20W-50, quart	220-815	\$12.99

## ZDDPlus Engine Oil Additive

After 70+ years of trouble-free, metal to metal engine protection, the E.P.A. is forcing ZDDP (Zinc Dialkyl Dithio Phosphate = Zinc and Phosphorus) out of domestic motor oil. If your engine was designed prior to the 1990s, your non-roller lifters require ZDDP in your motor oil to avoid premature deterioration. Don't let your lifters run metal-to-metal. Add the 4 fluid ounce contents of this ZDDPlus bottle at every 4 to 5 quart oil change. Not for use with catalytic converters.

each	220-805	\$16.99
case of 25	220-908	NA



# Oil Coolers

19675

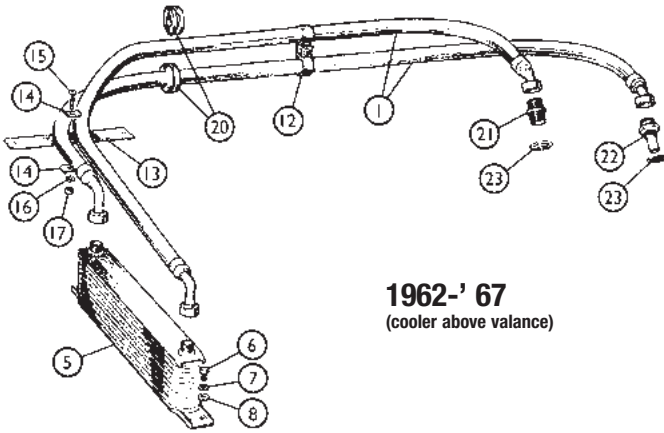

**1962-' 67**  
(cooler above valance)

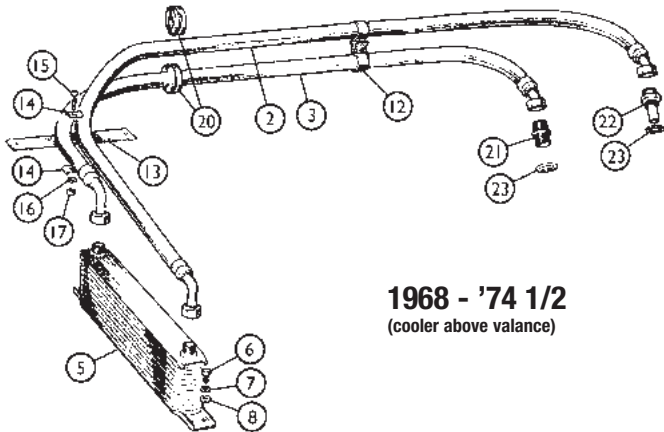

**1968 - '74 1/2**  
(cooler above valance)

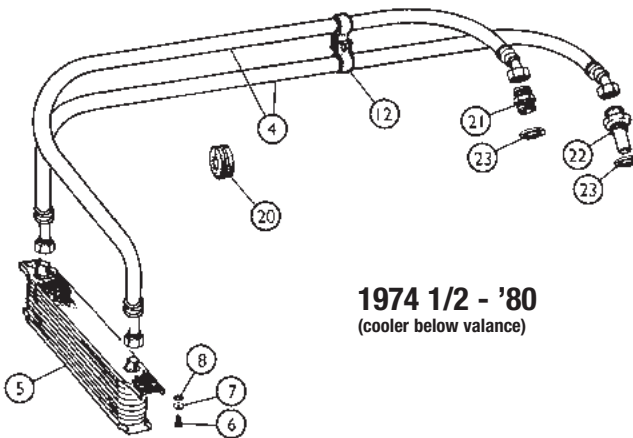

**1974 1/2 - '80**  
(cooler below valance)

## Oil Coolers

No.	Part#	Price (Each)	Description	Application	Qty Req.
1	435-580	\$39.99	OIL HOSES, 39 1/2", 45/90 ends	1962 - '67	2
2	435-660	\$44.99	OIL HOSE, 45 1/2", 45/90 ends		1
3	435-650	\$36.99	OIL HOSE, 26", 45/90 ends	1968 - 74 1/2	1
4	435-595	\$42.99	OIL HOSES, 47 1/2", 45/straight ends	1974 1/2 - '80 (rubber bumper cars)	2
5	235-925	\$69.99	OIL RADIATOR, 13 row	chrome bumper cars	1
	235-915	\$59.99	OIL RADIATOR, 10 row	rubber bumper cars	1
6	322-645	\$0.49	BOLT, oil radiator mounting		4
7	324-020	\$0.20	LOCKWASHER		4
8	324-590	\$0.19	WASHER, plain		4
12	235-988	\$4.69	STRAP ASSEMBLY, hose	quantities reduced for rubber bumper cars	2/1
13	235-980	\$2.69	STRAP, rubber		2/1
14	235-985	\$3.29	CLAMP PLATE		4/2
15	322-945	\$0.49	SCREW		2/1
16	324-010	\$0.19	LOCKWASHER		2/1
17	310-040	\$0.29	NUT		2/1
20	282-975	\$1.49	GROMMET, in radiator support		2
21	435-590	\$5.99	UNION, hose to filter head	1	
22	460-820	\$39.99	ADAPTOR, in engine block	1	
23	324-800	\$0.69	WASHER, union & adaptor	2	



### Oil Cooler Kits

Oil not only lubricates, but also conducts heat away from critical engine components. Lower engine oil temperature translates to lower overall engine temperature. If you live in a hot climate, or like to drive your sports car hard, an oil cooler will definitely prolong the life of your engine. Our stock-type MGB kits come complete with radiators and are simple to install.

<b>MGB '63-'74 1/2 Complete Orig. Style Oil Cooler Kit</b>	<b>235-920</b>	<b>\$139.99</b>
<small>(includes 1968-on style hoses)</small>		
<b>MGB '74 1/2-'80 Complete Orig. Style Oil Cooler Kit</b>	<b>235-990</b>	<b>\$139.99</b>
<b>MGB '74 1/2-'80 Complete Oil Cooler Kit, stainless steel hoses</b>	<b>235-991</b>	<b>\$156.99</b>



### Braided Stainless Steel Oil Cooler Hoses

Heavy duty (and attractive) alternatives to the stock plain rubber ones. Numbers in parenthesis are the angles of the ends.

39" Braided Hose (45/90)	1962-'67 (2 req'd.)	<b>435-680</b>	<b>\$46.99</b>
26" Braided Hose (45/90)	} '68-'74-1/2 (1 ea req'd.)	<b>435-690</b>	<b>\$41.99</b>
45 1/2" Braided Hose (45/90)		<b>435-700</b>	<b>\$44.99</b>
47 1/2" Braided Hose (45/straight)	1974-1/2-'80 (2 req'd.)	<b>435-710</b>	<b>\$48.99</b>



### MGB Oil Cooler Thermostat Kit

This kit features a specially designed thermostat fitted into the oil lines to allow quicker oil warm-up to protect your engine better. Included are four stainless steel oil lines to connect to your existing radiator, and the thermostat unit. Order an oil cooler radiator separately if necessary.

for chrome bumper cars	<b>235-840</b>	<b>\$469.99</b>
for rubber bumper cars*	<b>235-850</b>	<b>\$384.99</b>

\*1974.5 - '76. Does not fit '77-'80.



### Oil Cooler Radiators

All coolers except the 16-row unit have top and bottom mounting flanges. The 16-row unit has bottom flanges only.

<b>10-Row</b>	<b>235-915</b>	<b>\$59.99</b>
<b>13-Row</b>	<b>235-925</b>	<b>\$69.99</b>
<b>16-Row</b>	<b>235-995</b>	<b>\$114.99</b>
<b>19-Row</b>	<b>235-845</b>	<b>\$129.99</b>

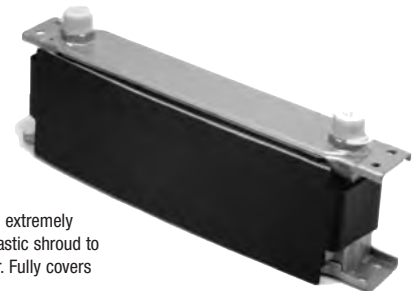

### Oil Cooler Shroud

To prevent over-cooling of your oil in extremely cold weather, use this sturdy ABS plastic shroud to block air flow through your oil cooler. Fully covers 13-row oil coolers.

<b>235-805</b>	<b>\$21.99</b>
----------------	----------------

# Cooling System



## WaterWetter

Cool your classic this summer or make your cockpit warmer this winter! WaterWetter is a wetting agent which helps coolant "bond" to metal surfaces thus increasing heat transfer. Increases the efficiency of water! Your car can run up to 15° cooler. Highly recommended for all climates.

220-115 \$24.99

## Fan Shroud, 1962-'76

The stock fan pulls air through the radiator in the doughnut shaped area swept by the blades. The rest of the radiator has significant air flow only at speed. With the fan shroud fitted, the fan creates a low pressure area behind the entire radiator core, making it much more efficient. This can make a huge difference when you are stuck in traffic or driving at slow speeds. Fits cars from 1962-'76.

459-685 \$64.99

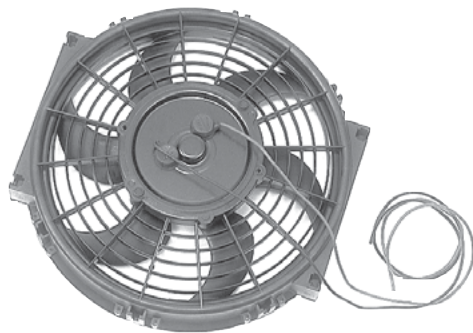

## Hayden Electric Fans

Keep your engine cool with a high airflow electric fan from Moss. Easy to install, these fans may be set up to run in either "pusher" (in front of the radiator) or "puller" (behind the radiator) configuration. This 10" fan fits all MGBs. 12" and 14" fans fit only 1977-'80 MGBs. Fans come complete with hardware and instructions. The preset temperature control will turn the fan on at 185°F and off at 170°F.

10" 231-678 \$164.99  
12" 231-688 \$164.99  
14" 231-658 \$184.99



## Thermostat Bypass Blanking Sleeve

Fine reproduction of the original works competition part 11G176. For sustained maximum power and speed, such as under racing conditions, it is advantageous to remove the thermostat to ensure maximum water flow, but only when this sleeve is fitted. By merely removing the thermostat, some uncooled water will go through the bypass. This sleeve minimizes this to provide maximum cooling.

434-135 \$9.99

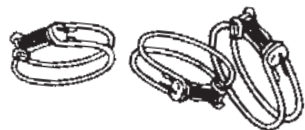

## Original-Type Hose Clamps

These wire-type clamps were original equipment on MGs. Zinc-plated for long-lasting durability and appearance, they're necessary for a correct restoration. Just measure the outside diameter of your hoses to determine which ones you need.

7/16" to 9/16"	326-475	\$2.29
9/16" to 3/4"	635-100	\$3.49
3/4" to 1"	635-101	\$2.39
1" to 1 1/4"	326-410	\$2.89
1 1/4" to 1 7/16"	326-465	\$1.99
1 7/16" to 1 5/8"	326-440	\$2.39
1 5/8" to 1 7/8"	635-102	\$2.49
1 7/8" to 2"	031-724	\$2.19
1 5/8" to 2 1/8"	635-103	\$5.69
2 3/16" to 2 7/16"	326-230	\$3.59
2 7/16" to 2 5/8"	326-460	\$2.69

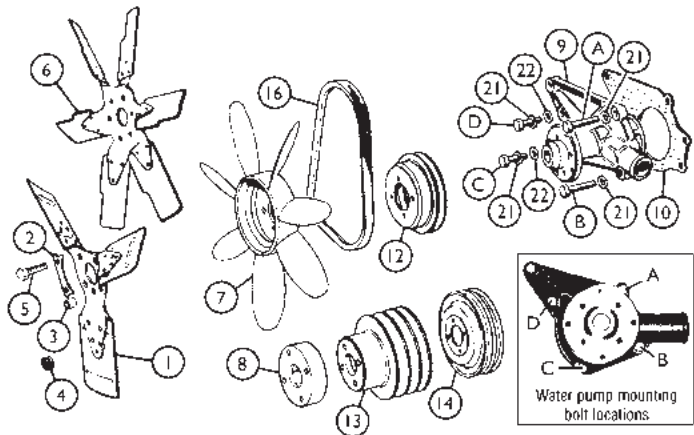

## Cooling System

19687

No.	Part#	Price (Each)	Description	Application	Qty Req.
1	434-310	\$136.99	FAN, 3 blade	RD to (c)138400, GT to (c)139471 (1962-'67)	1
2	434-380	\$0.89	LOCKTAB		2
3	434-370	\$1.09	SPACER		4
4	282-830	\$0.79	GROMMET		4
5	322-247	\$0.49	BOLT, fan mounting		4
	434-332	\$69.99	FAN, 7-blade plastic replacement	1962-'71	1
	434-332	\$69.99	FAN, 7 blade, plastic replacement (Must use Spacer & Bolt kit 434-341)	1972-'76	1
6	434-330	NA	FAN, 6 blade, metal (1968-early '73)	RD from (c)138401 to 306256, GT from (c)139472 to 309325	1
7	434-332	\$69.99	FAN, 7 blade plastic (73-76) (must use spacer 434-341)	RD from (c)306257 to 410000, GT from (c)309326 on	1
8	434-341	\$23.99	SPACER w/bolts, metal fan (1972-early '73)	RD from (c)258001 to 306256, GT from (c)258004 to 309325	1
	434-341	\$23.99	SPACER with bolts	1972-'76 repl. fan 434-332	1
	434-375	\$34.99	SPACER, orig. plastic fan (1973-'76)	RD from (c)306257 to 410000, GT from (c)309326 on	1
9	434-000	\$49.99	WATER PUMP, Classic Gold	18G/GA engines, 1962 - '64	1
	434-001	NA	WATER PUMP, aftermarket		1
10	292-010	\$1.69	GASKET		1
	322-440	\$0.99	BOLT, water pump (A, B)		2
	191-915	\$1.39	BOLT, water pump (C, D)	2	
	434-032	\$39.99	WATER PUMP, Classic Gold	18GB thru GK engines, 1965 - '71	1
	292-030	\$0.79	GASKET		1
	322-440	\$0.99	BOLT, water pump (A)	1965-'67 (w/out air pump bracket)	1
	052-773	\$0.99	BOLT, water pump (A)	1968-'71 (w/air pump bracket)	1
	322-440	\$0.99	BOLT, water pump (B)	1965-'71	1
	191-915	\$1.39	BOLT, water pump (C)	1965-'71	1
	191-915	\$1.39	BOLT, water pump (D)	1965-'67 (w/out air pump bracket)	1
	320-415	\$0.89	BOLT, water pump (D)	1968-'71 (w/air pump bracket)	1
	434-036	\$46.99	WATER PUMP, Classic Gold	18V engines, '72 - mid-'74 to (c)367900	1
	292-030	\$0.79	GASKET		1
	052-773	\$0.99	BOLT, water pump (A)		1
	322-440	\$0.99	BOLT, water pump (B)		1
	191-915	\$1.39	BOLT, water pump (C)		1
	320-415	\$0.89	BOLT, water pump (D)	1	
	434-045	NA	WATER PUMP, Classic Gold	18V engines, '74 1/2 - '80 from (c)367901	1
	434-047	\$36.49	WATER PUMP, aftermarket		1
	292-030	\$0.79	GASKET		1
	191-915	\$1.39	BOLT, water pump (A)		1
	322-440	\$0.99	BOLT, water pump (B)		1
	322-290	\$0.89	BOLT, water pump (C)		1
	191-915	\$1.39	BOLT, water pump (D)		1
12	434-300	NA	PULLEY	18G thru GB engines, '62-'67	1
13	434-290	NA	PULLEY	18GF thru GK engines, '68-'71	1
14	434-307	NA	PULLEY	18V engines, 1972 - '74	1
	434-326	\$109.99	PULLEY, aluminum repl.	18V engines, 1975 - '80	1
16	460-990	\$6.49	BELT, water pump drive	1962-'74	1
	460-970	\$6.49	BELT, water pump drive	1975-'80	1
21	365-730	\$0.39	LOCKWASHER	all	4
22	365-720	\$0.79	WASHER, plain	1968-'80 (with air pump)	2

# Cooling System

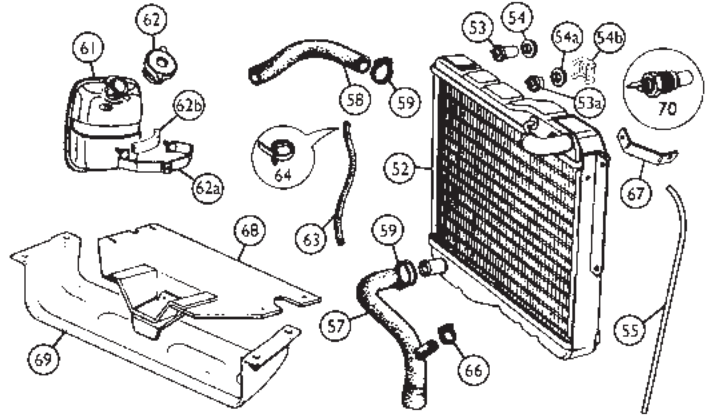
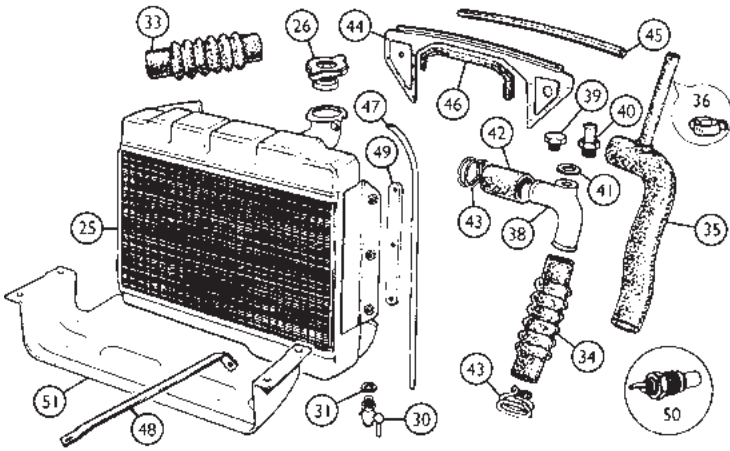

No.	Part#	Price (Each)	Description	Application	Qty Req.
25	456-880	\$299.99	RADIATOR, Classic Gold	} RD to (c)138400, GT to (c)139471 1962 - '67	1
	456-879	NA	RADIATOR, aftermarket		1
	456-881	\$349.99	RADIATOR, aluminum		1
	459-660*	\$389.99	RADIATOR, 1968 - '76	} RD from (c)138401 to 410000, GT from (c)139472 on	1
	459-663	\$389.99	RADIATOR, alum., Mishimoto		1
	459-666	\$349.99	RADIATOR, aluminum		1
			*No provision for drain tap or drain plug.		
26	834-820	\$4.59	CAP, radiator, 7 lbs.	{ RD to (c)138400, GT to (c)139471 1962 - '67	1
	202-090	\$4.99	CAP, radiator, 10 lbs.	{ RD from (c)138401 to 386000, GT from (c)139472 on	1
	834-825	\$4.99	CAP, radiator, 13 lbs., 1976	RD from (c)386601 to 410000	1
30	460-020	\$24.99	TAP, radiator drain (replica)		1
31	324-671	\$0.99	WASHER, for original tap	RD/GT to (c)410000, thru '76	1
33	470-270	\$6.39	HOSE, top, replacement	} all	1
	470-286	\$10.99	HOSE, top, silicone		1
34	470-270	\$6.39	HOSE, bottom, replacement	} RD/GT to (c)258000, thru '71	1
	470-272	NA	HOSE, bottom, silicone		1
35	470-310	\$20.99	HOSE, w/heater	} RD from (c)258001 to 368086, GT from (c)258001 on; '72 - '74	1
	470-312	NA	HOSE, w/heater, silicone		1
	470-330	\$36.99	HOSE, w/o heater		1
	470-320	\$11.99	HOSE, bottom	{ RD from (c)368082 to 410000, 1975 - '76 (Z-S carb.)	1
36	326-250	\$1.39	CLAMP, hose		1
38	470-040	\$28.99	PIPE, water pump connector	} RD/GT to (c)258000, 1962 - '71	1
39	328-040	\$19.99	PLUG, when heater not fitted		1
40	473-080	\$11.99	UNION, when heater fitted		1
41	324-660	\$0.89	WASHER, when heater not fitted		1
42	434-487	\$10.99	HOSE, connector pipe to pump		1
43	326-408	\$16.99	CLAMP SET, 6 original type		1
	326-430	\$3.59	CLAMP, radiator hose	6/4	
44	459-680	\$154.99	RADIATOR SUPPORT, BM Heritage	('68-'74 style fits '62-'76)	1
45	282-900	\$4.89	SEAL, radiator support to hood		1
46	282-905	\$5.79	SEAL, radiator to support	RD/GT from (c)138401 to 410000	1
47	470-340	\$3.99	TUBE, overflow, 23" long		1
48	459-710	\$4.39	SUPPORT BAR, L/H		1
	459-715	\$4.39	SUPPORT BAR, R/H		1
49	459-700	\$2.29	PACKING		A/R
50	760-180	\$13.99	SENDING UNIT, temp. gauge	1968 - '76	1
51	475-245	\$97.99	LOWER AIR DUCT PANEL, black ABS	RD 1974.5-'76	1

No.	Part#	Price (Each)	Description	Application	Qty Req.
52	459-670	NA	RADIATOR	RD to (c)511290	1
			(use later radiator, switch, bush & clip)		
	459-675	\$349.99	RADIATOR	} RD from (c)511291	1
	459-676	\$349.99	RADIATOR, aluminum		1
53	542-215	\$37.99	SWITCH, thermo. fan	} original radiators	1
54	542-205	\$1.99	BUSH, sealing		RD to (c)511290
	357-455	\$39.99	PLUG for switch w/wires		1
53a	542-213	\$56.99	SWITCH, thermostatic fan	} RD from (c)511291	1
54a	542-203	\$2.99	BUSH, sealing		1
54b	542-206	\$2.59	CLIP, switch retaining		1
55	470-340	\$3.99	OVERFLOW TUBE, 23" long		1
57	470-350	\$17.99	HOSE, bottom	1977 - '80	1
58	470-360	\$7.99	HOSE, top	1977 - '80	1
59	326-430	\$3.59	CLAMP, hose		4
61	459-690	\$94.99	TANK, expansion		1
62	459-695	\$4.99	CAP, filler		1
62a	459-691	\$23.49	STRAP, expansion tank		1
62b	459-692	\$2.19	PAD, rubber		1
63	470-345	\$2.39	HOSE, tank to radiator, 13" long		1
64	117-015	\$2.29	CLAMP, hose		2
66	326-250	\$1.39	CLAMP, hose		1
67	459-720	NA	SUPPORT BAR, L/H		1
	459-725	NA	SUPPORT BAR, R/H		1
68	458-194	\$59.99	MUD SHIELD, black ABS replacement		1
	458-195	NA	MUD SHIELD, black ABS original design		1
	458-196	\$72.99	BRACKET SET (pair), mud shield mounting		1
69	475-255	\$79.99	LOWER AIR DUCT PANEL, black ABS		1
70	131-566	\$11.99	SENDING UNIT, temperature gauge	1977 - '80	1

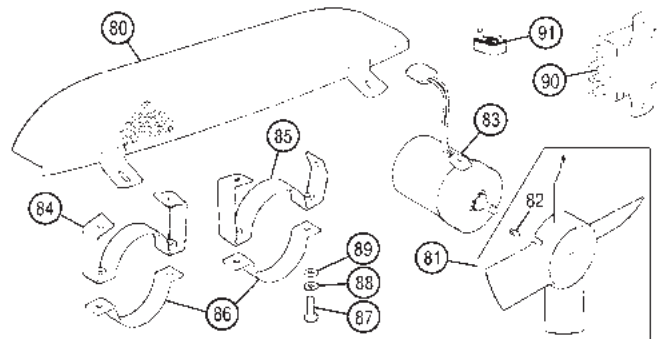

80	434-360	\$74.99	GUARD, fan		1
81	434-350	\$59.99	FAN BLADE		2
82	434-355	\$1.39	SCREW		2
83	542-430	\$114.99	FAN MOTOR (does not incl. wire plug - re-use old one.)		2
84	542-435	NA	BRACKET, motor mount, R/H		1
85	542-555	NA	BRACKET, motor mount, L/H		1
86	542-445	NA	CAP, motor brackets		2
87	322-230	\$0.39	BOLT		4
88	324-020	\$0.20	LOCKWASHER		4
89	324-115	\$0.39	WASHER, plain		4
90	542-235	\$5.99	RELAY	when fitted	1
91	131-545	NA	CIRCUIT BREAKER		1

NOTE: Cars with dealer installed A/C systems were fitted with a US-sourced auxiliary mechanical cooling fan which is no longer available.

# Engine Controls

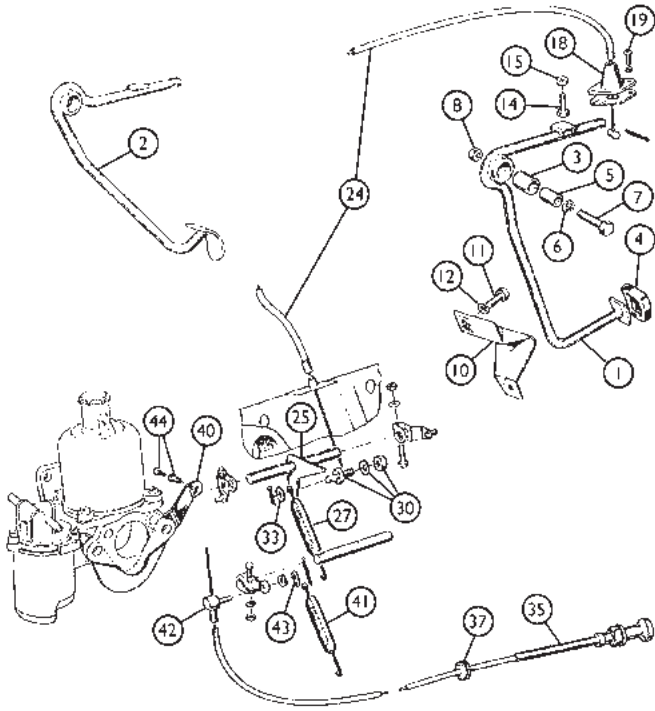

## Engine Controls, HS-4 Carburetors 1962-'71

19688

No.	Part#	Price (Each)	Description	Application	Qty Req.
1	276-000	NA	PEDAL, accelerator (1962-'67)	RD to (c)138400, GT to (c)139471	1
2	276-010	NA	PEDAL, accelerator (1968-'71)		RD from (c)138401, GT from (c)139472
3	276-040	\$4.69	BUSHING, pedal shaft		1
4	280-790	\$1.99	PAD, pedal, rubber	RD to (c)138400, GT to (c)139471 (1962-'67)	1
Note: Accelerator pedal pads were not fitted after 1967.					
5	276-045	\$3.79	TUBE, distance		1
6	365-730	\$0.39	LOCK WASHER		1
7	320-070	\$0.99	BOLT		1
8	310-105	\$0.49	NUT		1
10	276-050	\$44.99	PEDAL STOP, LHD		1
11	322-645	\$0.49	BOLT, pedal stop		2
12	324-020	\$0.20	LOCK WASHER		2
14	322-247	\$0.49	BOLT, return stop		1
15	310-760	\$0.59	NUT		1
18	372-060	\$4.89	GUIDE, accelerator cable		1
19	322-940	\$0.49	SCREW		2
24	331-210	NA	ACCELERATOR CABLE (1962-'67) (use later cable)	RD to (c)138400, GT to (c)139471	1
	331-451	\$9.99	ACCELERATOR CABLE (1968-'71) Premium cable, low friction liner		RD from (c)138401, GT from (c)139472
25	373-770	\$24.99	LEVER, accelerator		1
27	370-335	\$1.99	SPRING, accelerator return		1
30	375-108	\$2.99	CABLE STOP, w/nut		1
33	324-115	\$0.39	WASHER		1
35	331-225	\$14.99	CHOKE CABLE, round knob (C)	approx. 1962-'67	1
	331-240	\$13.79	CHOKE CABLE, round knob (fan)	approx. 1968-'69	1
	331-480	\$30.99	CHOKE CABLE, round knob (fan)	approx. 1970-'71	1
	331-490	\$25.99	CHOKE CABLE, T-knob	(replacement)	1
37	281-050	\$5.99	GROMMET, choke cable		1
40	372-340	\$10.99	BRACKET, choke control		1
41	370-335	\$1.99	SPRING, choke return		2
42	276-055	\$9.99	ABUTMENT, choke cable		1
43	372-070	\$3.29	TAB, spring anchor		2
44	375-128	\$2.99	CABLE STOP		1

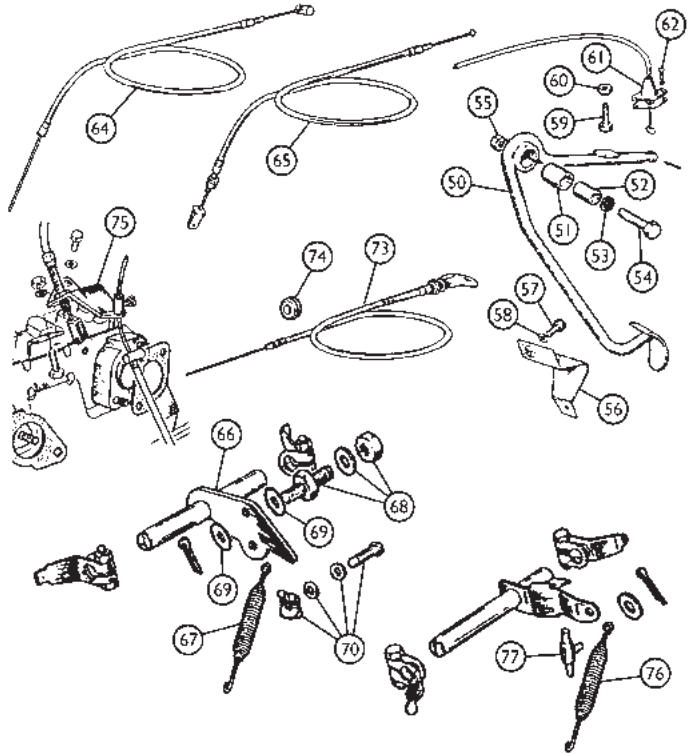

## Engine Controls, HIF-4 Carburetors, 1972-'74

19689

No.	Part#	Price (Each)	Description	Application	Qty Req.
50	276-010	NA	PEDAL, accelerator (1972 - '74 1/2)	RD from (c)258001 to 360300, GT from (c)258004 to 361000	1
	276-020	NA	PEDAL, accelerator (1974 1/2)		RD from (c)360301, GT from (c)361001
51	276-040	\$4.69	BUSHING, pedal shaft		1
52	276-045	\$3.79	TUBE, distance		1
53	365-730	\$0.39	LOCK WASHER		1
54	320-070	\$0.99	BOLT		1
55	310-105	\$0.49	NUT		1
56	276-050	\$44.99	PEDAL STOP, LHD		1
57	322-645	\$0.49	BOLT, pedal stop		2
58	324-020	\$0.20	LOCK WASHER		2
59	322-247	\$0.49	BOLT, return stop		1
60	310-760	\$0.59	NUT		1
61	372-060	\$4.89	GUIDE, accelerator cable		1
62	322-940	\$0.49	SCREW		2
64	331-451*	\$9.99	ACCELERATOR CABLE (1972 - '74 1/2)	RD from (c)258001 to 360300, GT from (c)258004 to 361000	1
65	331-461*	\$14.99	ACCELERATOR CABLE (1974 1/2)		RD from (c)360301, GT from (c)361001
*Premium cable with low friction liner. <a href="#">MORE INFO ONLINE</a>					
66	373-775	NA	LEVER, accelerator		1
67	370-335	\$1.99	SPRING, lever return		2
68	375-108	\$2.99	CABLE STOP, w/nut	RD from (c)258001 to 360300, GT from (c)258004 to 361000 (1972 - '74 1/2)	1
69	324-115	\$0.39	WASHER		2
70		NA	PIN ASS'Y.	RD from (c)360301, GT from (c)361001 (1974 1/2)	1
73	331-490	\$25.99	CHOKE CABLE, T-knob		1
74	281-050	\$5.99	GROMMET, choke cable		1
75	372-345	NA	BRACKET, choke & accelerator cables		1
76	370-335	\$1.99	SPRING, choke return		1
77	276-060	NA	ABUTMENT, choke cable		1



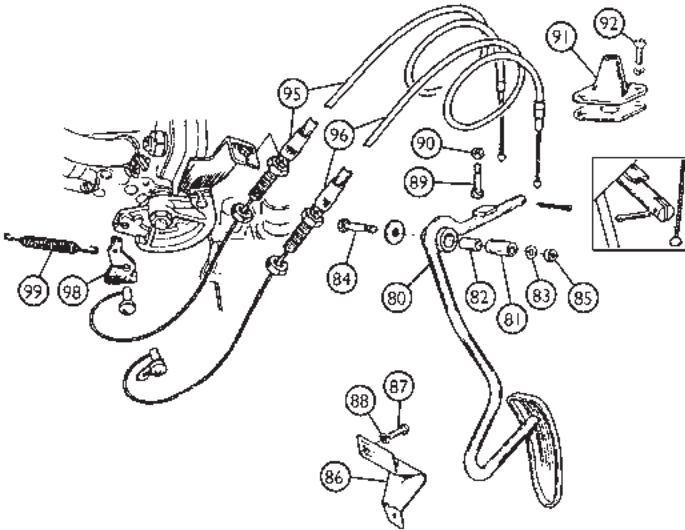

## Engine Controls, Zenith-Stromberg Carburetor 1975-'80 19691

No.	Part#	Price (Each)	Description	Application	Qty Req.
80	276-020	NA	PEDAL, accelerator	RD to (c)410000 1975 - '76	1
	276-030	NA	PEDAL, accelerator	RD from (c)410001 on	1
81	276-040	\$4.69	BUSHING, pedal shaft		1
82	276-045	\$3.79	TUBE, distance		1
83	365-730	\$0.39	LOCK WASHER		1
84	320-070	\$0.99	BOLT		1
85	310-105	\$0.49	NUT		1
86	276-050	\$44.99	PEDAL STOP, LHD	RD to (c)410000, thru '76	1
87	322-645	\$0.49	BOLT, pedal stop		2
88	324-020	\$0.20	LOCK WASHER		2
89	322-247	\$0.49	BOLT, return stop		1
90	310-760	\$0.59	NUT		1
91	372-060	\$4.89	GUIDE, accelerator cable		1
92	322-940	\$0.49	SCREW		2
95	331-466*	\$14.99	ACCELERATOR CABLE	RD to 428510	1
96	331-476*	\$14.99	ACCELERATOR CABLE	RD from (c)428511 on	1
			*Premium cable with low friction liner. <a href="#">MORE INFO ONLINE</a>		
98	373-780	NA	LEVER, accelerator		1
99	370-325	\$6.99	SPRING, lever return	1977-on uses 1	2/1

### Manual Choke Conversion Kit

Our high quality conversion kit was designed in England by Zenith-Stromberg engineers, and unlike other kits, leaves your car's factory appearance intact. Easy to install, kits include all necessary mounting hardware and detailed instructions. Fits MGB '75-'80.

**386-325 \$129.99**



Amendments to the Clean Air Act make it illegal for anyone to change or alter the emission control system of any automobile in the United States except for cars used exclusively for off-road use.

Toll-Free Orders 1-800-667-7872 | MossMotors.com  
Fax 805-692-2525 | Local 805-681-3400

**MOSS**



### "Billet" Pedal Cover Kits

Serious pedal covers for serious drivers. These covers are grooved for traction and feature the bold MG logo. A Moss Motors exclusive, drilling is required as these custom fit covers are bolted to the original pedals to ensure they stay put no matter how hard you drive. Each of the three piece kits has the correct accelerator pedal cover for the model. The two piece set will fit all MGBs.

3 Piece Kit 1968-'76	190-780	\$89.99
3 Piece Kit 1977-'80	190-785	\$89.99
2 Piece Kit (Clutch, Brake)	190-790	\$69.99
Dead Pedal 1968-'80	190-795	NA

### Proper Use of the Manual Choke

The manual choke, fitted in the upper right hand corner of the MGB dashboard, controls two distinct functions of the S.U. carburetors. First, one can feel the accelerator pedal being pulled away from the foot as the choke is pulled out. The first third of the travel of the choke cable works the fast idle only. The second two-thirds controls the mixture enrichment, as well as the fast idle.

The second function is the mixture enrichment. The colder the engine and surrounding air, the greater the need for more gasoline to be mixed with the air at the carburetor. As the engine warms, the need for a richer mixture lessens.

When starting the MG, always pull the choke completely out (unless the engine is still very warm from recent running). Once the engine has started, the driver must release the choke in small increments as the engine warms. The trick is to release the choke at the proper rate. If released too soon, the engine will cough and spit, especially under acceleration. If released too slowly, the engine will "load up" and run roughly, especially while idling.

By the time the temperature gauge is halfway between cold and normal, the choke can usually be released completely. If the choke is left out too long, the extra gasoline can mix with the engine oil by "washing down" the cylinder walls. If your choke does not seem to be operating correctly, consult your workshop manual for adjustments.

If your choke, throttle or heater cables are hot to the touch or have melted their coverings, your engine may not be grounded properly. Check and clean your grounding strap to prevent the control cables from acting as ground wires.

### Are You Rebuilding Your Carburetor?

An often overlooked aspect of carburetor rebuilding is the replacement of the throttle shaft bushes in the carburetor bodies. As the throttle shafts and bushes wear, they both become slightly egg-shaped, causing a variable vacuum leak which produces erratic idling of the engine, poor performance and in extreme cases, overheating, "running-on" and possible burned valves due to an excessively lean mixture.

Since most S.U. carburetors have bushes cast in the bodies, replacement of the bushes requires machine shop facilities to bore out the old bushes to slightly less than the O.D. of the new bushes, press in new ones and drill and ream them to fit the new throttle shaft, ensuring all the while that the machined bores of the new bushes are in perfect alignment. Bushes are available under part #372-545.

Alternatively, if your throttle shafts are still stock diameter (.310"), it is usually possible to fit special oversize throttle shafts to S.U. carbs. We offer a special reaming tool (part #386-385) to enable owners to fit their own .010" oversize shafts which can save considerable money on machine shop labor.

# Emission Controls

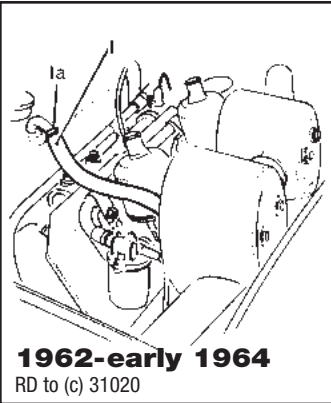

**1962-early 1964**  
RD to (c) 31020

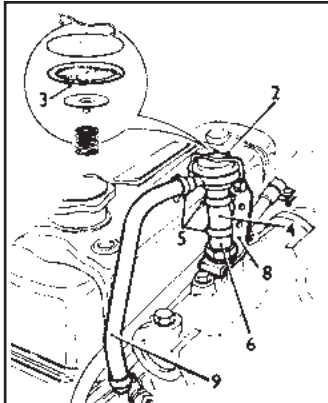

**1964-1967**  
RD from (c) 31201 to 138400  
GT from (c) 71933 to 139471

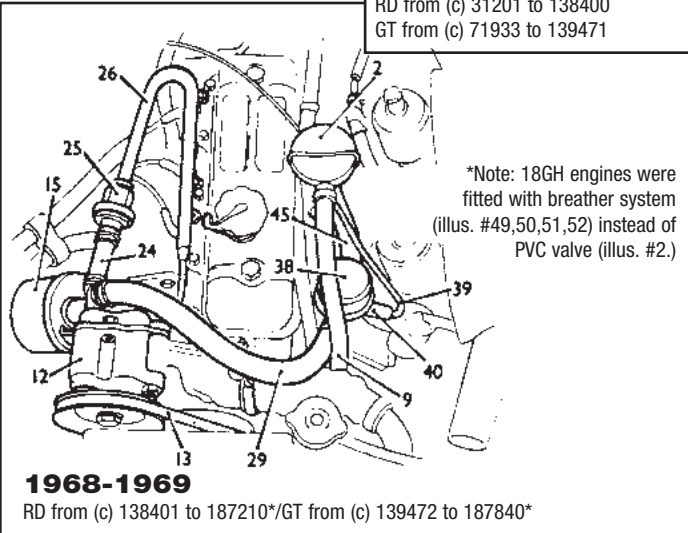

\*Note: 18GH engines were fitted with breather system (illus. #49,50,51,52) instead of PVC valve (illus. #2.)

**1968-1969**  
RD from (c) 138401 to 187210\*/GT from (c) 139472 to 187840\*

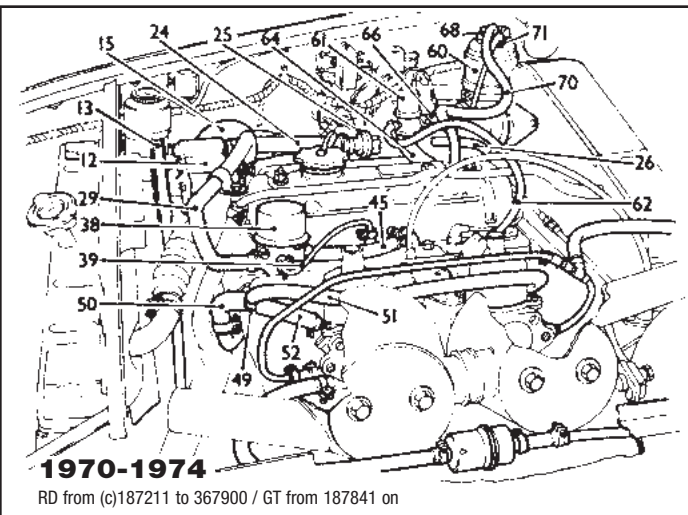

**1970-1974**  
RD from (c)187211 to 367900 / GT from 187841 on

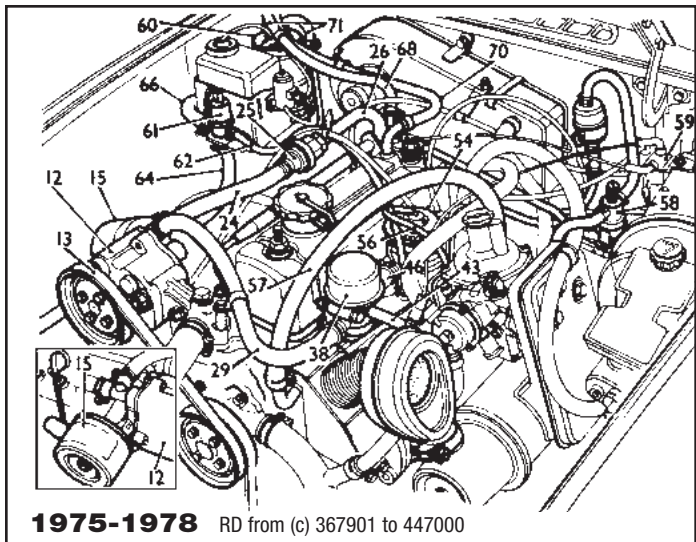

**1975-1978** RD from (c) 367901 to 447000

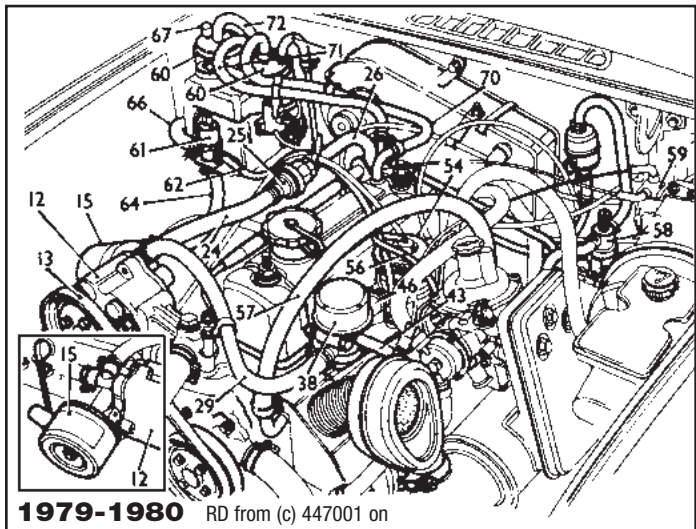

**1979-1980** RD from (c) 447001 on

## Emission Controls

19693

No.	Part#	Price (Each)	Description	Application	Qty Req.	
1	367-200	\$13.49	HOSE, valve cover to air cleaner	} RD only, 18G engine	1	
1a	326-210	\$2.29	HOSE CLIP		2	
2	360-630	\$66.99	P.C.V. VALVE	} RD/GT 18GA/GB/GF engines	1	
3	360-635	\$3.99	DIAPHRAGM		1	
4	372-460	\$4.99	HOSE, breather		1	
5	326-250	\$1.39	HOSE CLAMP		3	
6	372-470	\$14.99	ADAPTOR		1	
	324-145	\$0.39	WASHER		2	
8	372-480	NA	BRACKET		1	
9	372-450	\$9.99	HOSE, valve to oil separator		1	
12	360-775	NA	AIR PUMP, rebuilt		} RD from (c)138401 on,	1
	360-778	NA	AIR PUMP, replacement type			GT from (c)139472 on

No.	Part#	Price (Each)	Description	Application	Qty Req.
12a	434-490	NA	PULLEY, air pump		1
13	460-980	\$5.69	BELT, air pump	} RD from (c)138401 to 367900, GT from (c)139472 on	1
	434-400	\$6.99	BELT, air pump		RD from (c)367901-on
14	360-750	NA	HOSE, filter to air pump	} RD from (c)138401 on, GT from (c)139472 on	1
15	360-790	NA	AIR CLEANER ASSEMBLY		1
16	950-230	NA	FILTER ELEMENT, "Crosland"		1
	950-730	\$19.99	FILTER ELEMENT, various mf'rs.		1
17	360-800	NA	HOUSING, air cleaner	1	
18	360-730	NA	LINK, air pump adjusting	RD/GT to (c)367900	1
	360-735	NA	LINK, air pump adjusting	RD from (c)367901 on	1
19	360-740	NA	BRACKET, adjusting link	RD/GT to (c)367900	1
	360-745	NA	BRACKET, adjusting link	RD from (c)367901 on	1
24	367-215	NA	HOSE, air pump to check valve	} RD from (c)138401 on, GT from (c)139472 on	1
25	379-470	NA	CHECK VALVE, orig. mfr.		1
	367-000	\$19.99	CHECK VALVE, aftermarket		1
26	360-760	\$99.99	MANIFOLD, air injection		1
27	322-880	\$0.99	BOLT, air manifold to head	1	
28	052-242	\$2.39	PLUG, air injection ports	When smog equipment is removed	1
29	367-220	NA	HOSE, gulp valve to air pump	} RD from (c)138401 to 367900, GT from (c)139472 on	1
	367-225	NA	HOSE, gulp valve to air pump		RD from (c)367901 on
30	326-405	\$2.09	HOSE CLAMP	6	
31	326-415	\$1.39	CLIP, hose to water elbow	} RD from (c)138401 on, GT from (c)139472 on	1
32	367-010	NA	BRACKET, gulp valve		} RD from (c)138401 to 410000, GT from (c)139472 on
	367-015	NA	BRACKET, gulp valve	RD from (c)410001 on	
33	366-025	NA	RESTRICTOR, air pump hose	} RD from (c)138401 to 367900, GT from (c)139472 on	1

**WARNING:** Cancer and Reproductive Harm. [www.P65Warnings.ca.gov](http://www.P65Warnings.ca.gov)

# Emission Controls

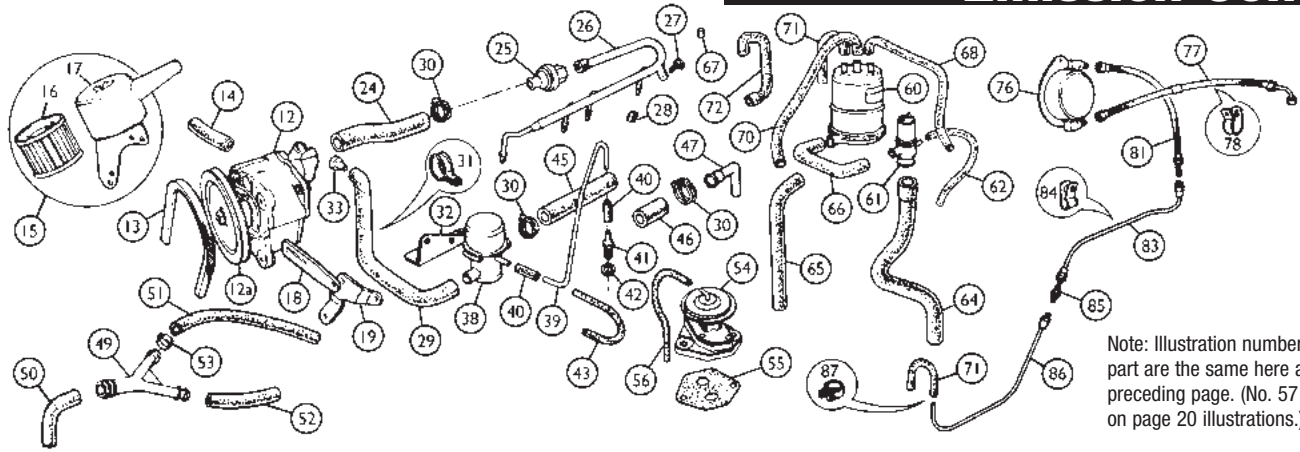

Note: Illustration numbers for each part are the same here as on the preceding page. (No. 57 appears only on page 20 illustrations.)

No. Part#	Price (Each)	Description	Application	Qty Req.
367-025	NA	RESTRICTOR, air pump hose	RD from (c)367901 to 410000	1
38 366-010	\$109.99	GULP VALVE	RD from (c)138401 on, GT from (c)139472 on	1
39 367-030	NA	CONTROL PIPE, gulp valve	RD from (c)138401 to 367900, GT from (c)139472 on	1
40 367-040	NA	CONNECTOR		2
41 367-050	NA	ADAPTOR		1
42 367-055	\$1.09	WASHER		2
43 367-060	NA	SIGNAL HOSE, gulp valve	RD from (c)367901 on	1
45 367-230	NA	HOSE, gulp valve to manifold	RD from (c)138401 to 367900, GT from (c)139472 on	1
46 367-240	NA	HOSE, gulp valve to manifold	RD from (c)367901 on	1
47 373-860	NA	ADAPTOR, intake manifold	RD/GT engines 18GH/GI/V with SU carbs	1
49 367-070	\$5.69	"Y" CONNECTOR		1
50 367-250	\$6.99	HOSE, oil separator to connector		1
51 367-260	\$5.99	HOSE, connector to rear carb.		1
52 367-265	NA	HOSE, connector to front carb.		1
53 262-200	\$2.99	HOSE CLAMP		2
54 367-080	\$54.99	E.G.R. VALVE, replacement		1
55 293-420	\$1.99	GASKET, E.G.R. valve	RD from (c)367901 on ('75 on)	1
56 367-090	NA	SIGNAL HOSE, E.G.R. valve		1
57 367-400	\$34.99	HOSE, breather, oil separator to carb. (repl. type hose)		1
58 377-320	NA	VALVE, fuel cut-off	RD from (c)415001	1
59 145-740	NA	VALVE, vacuum advance		1
60 367-100	\$74.99	CANISTER, adsorption	1970-'76	1
		NA CANISTER, adsorption	1977-'80	1/2
		(2 required from 1978-'80)		
61 367-110	\$87.99	VALVE, anti run-on	RD from (c)294251 on, GT from (c)296001 on	1
62 367-275	NA	HOSE, run-on valve control	RD from (c)294251 to 386600, GT from (c)296001 on	1
64 367-280	NA	HOSE, run-on valve vent	RD from (c)386601 to 415000	1
367-285	NA	HOSE, run-on valve vent	RD from (c)415001 on	1
367-290	NA	HOSE, run-on valve vent	RD from (c)187211 to 294250, GT from (c)187841 to 296000	1
65 367-410	NA	TUBE, canister breather	RD from (c)294251 to 360300, GT from (c)296001 to 361000	1
367-305	NA	HOSE, run-on valve to canister	RD from (c)360301 on, GT from (c)361001 on	1
67 367-105	\$0.79	CAP, canister	RD from (c)447001 on	2
68 361-155	NA	HOSE, canister to carb.	RD from (c)187211 to 367900, GT from (c)187841 on	1
361-165	NA	HOSE, canister to carb.	RD from (c)367901 on	1
70 367-310	\$30.00	HOSE, canister to valve cover	RD from (c)187211 to 447000, GT from (c)187841 on	1
367-315	NA	HOSE, canister to valve cover	RD from (c)447001 on	1
71 367-320	NA	HOSE, vapor pipe to canister	RD from (c)187211 on, GT from (c)187841 on	1

No. Part#	Price (Each)	Description	Application	Qty Req.
72 367-330	\$28.99	HOSE, canister link	RD from (c)447001 on	1
76 367-120	NA	VAPOR SEPARATOR	RD from (c)187211 to 360300, GT from (c)187841 to 361000	1
367-130	NA	VAPOR SEPARATOR	RD from (c)360301 on, GT from (c)361001 on	1
77 367-340	NA	HOSE, vapor separator to gas tank	RD from (c)187211 to 360300, GT from (c)187841 to 361000	1
367-345	NA	HOSE, vapor separator to gas tank	RD from (c)360301 to 410000, GT from (c)361001 on	1
367-350	NA	HOSE, vapor sep. to gas tank	RD from (c)410001 on	1
78 326-425	\$1.39	CLIP, vapor hose		1
81 367-360	NA	HOSE, separator to vapor pipe	RD from (c)187211 to 360300, GT from (c)187841 to 361000	1
367-365	NA	HOSE, separator to vapor pipe	RD from (c)360301 to 410000, GT from (c)361001 on	1
367-370	NA	HOSE, separator to vapor pipe	RD from (c)410001 on	1
83 367-420	NA	VAPOR PIPE, rear	RD from (c)187211 to 410000, GT from (c)187841 on	1
367-425	\$12.99	VAPOR PIPE, rear	RD from (c)410001 to 415000	1
367-430	NA	VAPOR PIPE, rear	RD from (c)415001 on	1
84 162-210	\$1.39	CLIP, vapor pipe		A/R
85 367-455	NA	CONNECTOR	RD from (c)187211 to 410000, GT from (c)187841 on	1
310-310	\$0.59	NUT	RD from (c)410001 on	1
324-355	\$0.29	LOCK WASHER		1
86 367-445	NA	VAPOR PIPE, front (without end fittings)	RD from (c)187211 to 410000, GT from (c)187841 on	1
367-430	NA	VAPOR PIPE, front	RD from (c)410001 to 447000	1
367-450	NA	VAPOR PIPE, front	RD from (c)447001 on	1
87 326-265	\$2.99	HOSE CLAMP, vapor hose		1

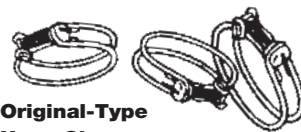

### Original-Type Hose Clamps

These wire-type clamps were original equipment on MGs. Zinc-plated for long-lasting durability and appearance, they're necessary for a correct restoration. Just measure the outside diameter of your hoses to determine which ones you need.

7/16" to 9/16"	326-475	\$2.29
9/16" to 3/4"	635-100	\$3.49
3/4" to 1"	635-101	\$2.39
1" to 1 1/4"	326-410	\$2.89
1 1/4" to 1 7/16"	326-465	\$1.99
1 7/16" to 1 3/8"	326-440	\$2.39
1 3/8" to 1 7/8"	635-102	\$2.49
1 7/8" to 2"	031-724	\$2.19
1 15/16" to 2 1/8"	635-103	\$5.69
2 3/16" to 2 7/16"	326-230	\$3.59
2 7/16" to 2 5/8"	326-460	\$2.69

Toll-Free Orders 1-800-667-7872 | MossMotors.com  
Fax 805-692-2525 | Local 805-681-3400

MOSS

# HS-4 Carburetor

1962 - '71 RD (c)101 to 258000/GT (c)71933 to 258000

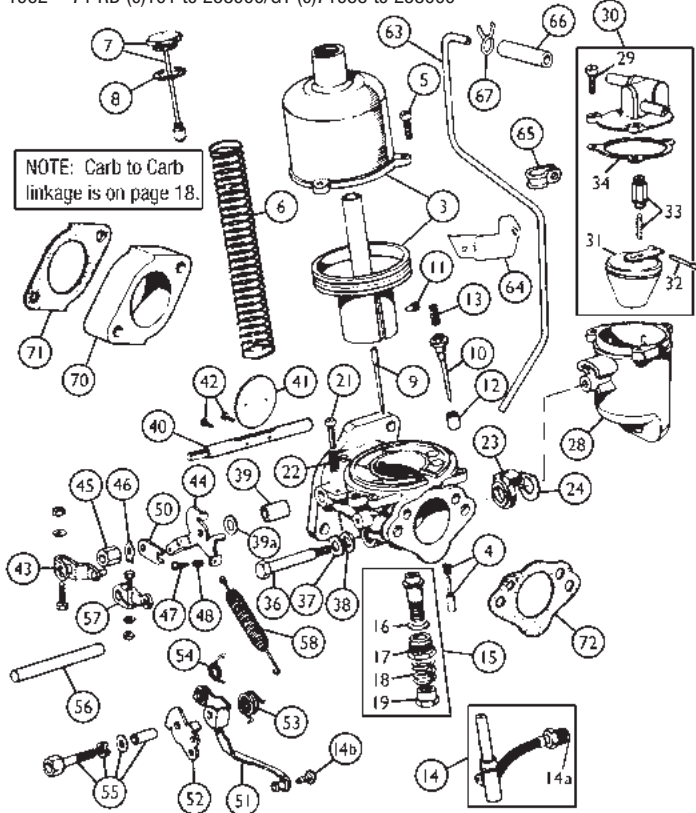

## HS-4 Carburetor

19694

No.	Part#	Price (Each)	Description	Application	Qty Req.
	372-248	\$2,099.00	CARBURETOR PAIR, new (replaces AUD52, AUD135)	1962 - '67	1
	366-478	\$1,899.00	CARBURETOR PAIR, new (AUD265)	1968	1
	366-498	\$1,799.00	CARBURETOR PAIR, new (AUD 326)	1969	1
	366-488	\$1,999.00	CARBURETOR PAIR, new (replaces AUD326, AUD405 and AUD465)	1970 - '71	1
3	372-250	NA	AIR CHAMBER & PISTON	AUD52/135/265	2
	372-255	\$349.99	AIR CHAMBER & PISTON	AUD326/405/465	2
4	375-048	\$18.99	PIN & SPRING ASS'Y., w/circlip	AUD52/135/265	2
	375-008	\$14.99	PIN & SPRING ASS'Y., w/circlip	AUD326/405/465	2
5	370-290	\$0.89	SCREW, chamber cover		2
6	370-520	\$4.89	SPRING, piston, red		2
7	370-750	\$27.99	CAP & DAMPER		2
8	370-650S*	\$0.39	WASHER		2
9	374-260	\$19.99	JET NEEDLE, standard (MB)	AUD52	2
	374-270*	\$24.99	JET NEEDLE, standard (5)	AUD135	2
	374-170	\$19.99	JET NEEDLE, rich (6)	AUD52/135	2
	374-280	\$19.99	JET NEEDLE, lean (21)	AUD52/135	2
	374-275*	\$19.99	JET NEEDLE, standard (FX)	AUD265	2
10	374-360*	\$21.99	JET NEEDLE, standard (AAE)	AUD326/405	2
	374-370*	\$21.99	JET NEEDLE, standard (AAL)	AUD465	2
11	370-180	\$5.49	SCREW, needle locking	AUD52/135/265	2
	373-540	\$1.89	SCREW, needle locking		2
12	374-395	\$4.79	GUIDE, jet needle	AUD326/405/465	2
13	373-365	\$2.39	SPRING, jet needle		2
14	378-430S*	\$34.99	JET, front carburetor (green band)		1
	378-440S*	\$34.99	JET, rear carburetor (pink band)		1
14a	378-400	\$0.49	SEAL to float bowl		2
14b	372-950	\$0.49	SCREW, jet to link		2
15	372-265	\$39.99	JET BEARING KIT	AUD52/135	2
	372-275	\$57.99	JET BEARING KIT	AUD265	2
	372-285	\$62.79	JET BEARING KIT	AUD326/405/465	2
16	372-270*	\$2.29	WASHER, jet bearing	AUD52/135 only	2
17	371-650	\$10.99	NUT, jet locking		2
18	370-210	\$3.69	SPRING, jet locking		2
19	372-280	\$5.59	NUT, jet adjusting		2
21	372-830	\$6.19	SCREW, slow idle adjusting		2
22	370-330	\$2.59	SPRING, idle screw		2
23	378-085	\$8.99	ADAPTOR, front		1
	378-090	\$7.99	ADAPTOR, rear		1

No.	Part#	Price (Each)	Description	Application	Qty Req.
24	372-290	\$6.89	WASHER, for adaptor		2
28	371-730	\$199.99	FLOAT CHAMBER		2
29	370-290	\$0.89	SCREW, float lid		6
30	372-308	\$155.99	LID ASSEMBLY, front float chamber	AUD52/135/265/326	1
	372-318	\$151.99	LID ASSEMBLY, rear float chamber		1
	372-305	NA	LID ASSEMBLY, front float chamber	AUD405/465	1
	372-315	\$155.99	LID ASSEMBLY, rear float chamber		1
31	378-470	\$17.99	FLOAT		2
32	370-060*	\$0.89	PIN, float hinge		2
33	373-625S*	\$55.99	NEEDLE & SEAT, Viton tip		2
	373-626	\$14.99	NEEDLE & SEAT, Viton tip, aftermarket		2
	386-390	\$18.99	GROSE-JET, superior replacement for std. needle & seat		2
34	378-360S*	\$1.49	GASKET, chamber lid (not included with new lids)		2
36	372-760	\$18.99	BOLT, float chamber fixing		2
37	372-770	\$0.99	WASHER, steel		2
38	378-070*	\$3.69	WASHER, rubber		2
39	372-545S	\$2.99	BUSH, for throttle shaft	see tech tip on page 19	4
39a	372-820	\$1.09	WASHER on throttle shaft		2
40	372-540S	\$32.99	THROTTLE SHAFT, standard		2
	372-550	\$32.99	THROTTLE SHAFT, oversize		2
41	370-370S	\$24.59	THROTTLE DISC	AUD52/135	2
	373-675	\$49.99	THROTTLE DISC, w/valve	AUD265/326/405/465	2
42	370-090S	\$1.79	SCREW, throttle disc		4
43	371-860	\$4.49	LEVER & PIN, front		2
	371-850	\$4.49	LEVER & PIN, rear		2
44	373-385	\$71.29	THROTTLE LEVER, front		1
	373-390	\$26.99	THROTTLE LEVER, rear		1
45	310-970	\$4.99	NUT, throttle lever		2
46	373-695S	\$2.09	TAB WASHER		2
47	372-830	\$6.19	SCREW, fast idle		2
48	370-330	\$2.59	SPRING, fast idle screw		2
50	372-840	\$24.59	LEVER, lost motion		2
51	372-865	\$49.99	LEVER & LINK ASSEMBLY, front	AUD52/135/265	1
	372-880	\$51.99	LEVER & LINK ASSEMBLY, rear		1
	372-865	\$49.99	LEVER & LINK ASSEMBLY, front	AUD326/405/465	1
	372-885	\$38.99	LEVER & LINK ASSEMBLY, rear		1
52	373-400	\$28.99	CAM, fast idle, front		1
	373-405	\$28.99	CAM, fast idle, rear		1
53	372-910	\$7.49	SPRING, lost motion lever, front		1
	372-920	\$9.99	SPRING, lost motion lever, rear		1
54	372-930	\$7.19	SPRING, fast idle cam, front		1
	372-940	\$4.59	SPRING, fast idle cam, rear		1
55	373-410	\$28.99	PIVOT BOLT KIT		2
56	370-865	\$5.69	ROD, connecting, choke		1
57	370-110	\$16.99	CHOKE LEVER		1
	372-170	\$0.99	BOLT for lever		1
	324-110	\$0.29	LOCKWASHER on bolt		1
	311-030	\$0.39	NUT on bolt		1
58	370-335	\$1.99	SPRING, throttle & choke return		3
63	366-500	NA	PIPE, overflow, front	RD to (c) 187210, GT to (c) 187840	1
	366-510	NA	PIPE, overflow, rear		1
	366-520	NA	PIPE, overflow, front	RD from (c)187211 to 258000, GT from (c)187841 to 258000	1
	366-530	NA	PIPE, overflow, rear		1
64	376-775	\$15.89	BRACKET, overflow pipe	1964-68	1
65	366-545	\$2.79	CLIP, overflow pipe	RD/GT to (c)258000	1
66	366-550	\$1.39	CONNECTOR, overflow pipe		2
67	326-265	\$2.99	CLAMP		4
70	372-320	\$12.99	INSULATOR		2

## Rebuild Kits/Gasket Sets

375-548S	\$339.99	MASTER REBUILD KIT, for 2 carburetors		1
375-338*	\$219.99	REBUILD KIT, for 2 carburetors	AUD52/135, 1962 - '67	1
375-348*	\$199.99	REBUILD KIT, for 2 carburetors	AUD265, 1968	1
375-358*	\$229.99	REBUILD KIT, for 2 carburetors	AUD326/405, 1969 - '70	1
375-368*	\$199.99	REBUILD KIT, for 2 carburetors	AUD465, 1971	1
375-375**	\$199.99	SERVICE KIT, for 2 carburetors	HS2/HS4	1
698-108†	\$8.49	CARBURETOR GASKET SET		1
71 294-710*†	\$0.79	GASKET, carb. mounting	(4 in Rebuild Kits)	6
72 294-800*†	\$0.89	GASKET, filter to carb.		2

§ Note: "Master rebuild kits" include all items marked §. They are produced exclusively by S.U., and contain only genuine S.U. components. Metering needles are not included, however, so that you may choose the exact needle you require.

\* Note: "Rebuild kits" (genuine SU) include all items marked \*.

\*\*Note: "Service kits" include jets, needle & seats, and gasket set.

† Note: Gasket sets include all items marked †.

• Note: This kit includes metering needle "5", which is an improvement over metering needle "MB" originally fitted to carbs. AUD52.

# HS-4 Manifold / Air Cleaner

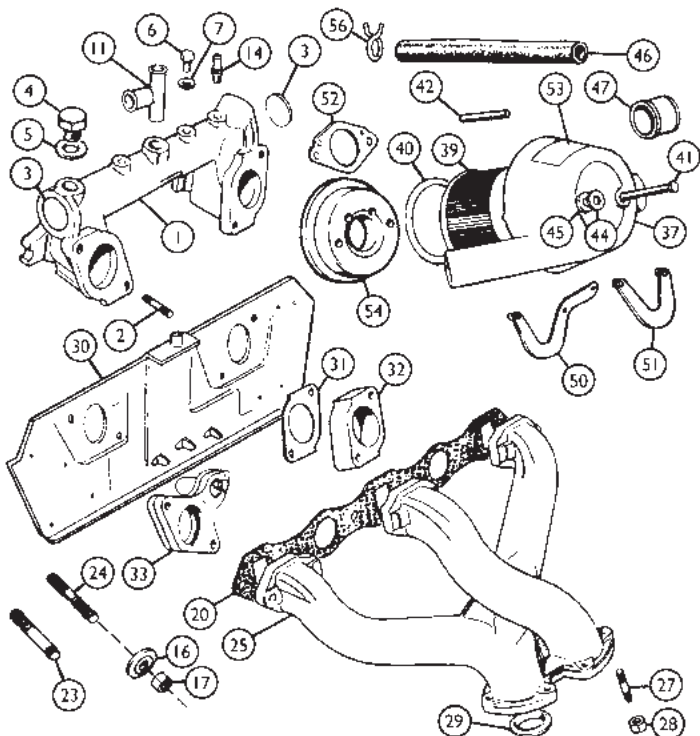

No.	Part#	Price (Each)	Description	Application	Qty Req.
46	367-200	\$13.49	HOSE, valve cover to cleaner	18G engines	1
47	372-440	\$1.89	SEAL, air cleaner coupling		1
50	372-340	\$10.99	BRACKET, front air cleaner		1
51	372-330	\$11.99	BRACKET, rear air cleaner		1
52	294-800	\$0.89	GASKET		2
53	215-615	\$2.49	DECAL, "Coopers Filter"		2
54	372-380	\$59.99	ALLOY BACK PLATE ADAPTOR	HS4 stock carbs	2
	372-385	NA	ALLOY BACK PLATE ADAPTOR	HS6 carb conversion	2
These alloy adaptors will allow stock air cleaners to be used with the 1 3/4" S.U. carb conversion on 1963-'74 (chrome-bumpered) MGBs.					
56	326-210	\$2.29	CLIP, breather hose	18G engine	2

## Identifying your S.U. Carburetors, 1962 - '74

1962-'71 MGBs used variations of the HS-4 carburetor. These variations are noted by the specification number, which is stamped on a triangular tag on the float bowl covers. "F" and "R" suffixes are used to denote "front" and "rear", respectively.

				New Carb. Pairs	
Straight Needle	1962 - '64	AUD52	HS-4	372-248	
	1965 - '67	AUD135	HS-4	372-248	
	1968	AUD265	HS-4	366-478	
Biased Needle	1969	AUD326	HS-4	366-498	
	1970	AUD405	HS-4	366-488	
	1971	AUD465	HS-4	366-488	

## Manifolds / Air Cleaners (HS-4 Carburetors)

19695

No.	Part#	Price (Each)	Description	Application	Qty Req.
1	373-800	NA	INLET MANIFOLD	18G engines	1
	373-805	NA	INLET MANIFOLD	18GA/GB engines	1
	373-820	NA	INLET MANIFOLD	18GF engines	1
	373-820	NA	INLET MANIFOLD	18GG thru GK engines	1
2	328-745	\$1.79	STUD, carburetor. to manifold		4
3	319-095	\$1.89	END PLUG		2
4	379-362	\$9.59	PLUG		2/1
5	324-065	\$1.49	WASHER		2/1
6	328-305	\$11.99	PLUG		2/1
7	328-335	\$1.49	WASHER		2/1
11	373-850	NA	ADAPTOR	18GF engines	1
14	373-855	NA	RESTRICTOR, o/d vacuum	overdrive models	1
16	460-090	\$2.19	WASHER, manifold mounting		4
17	311-540	\$0.79	NUT, manifold, brass		6
20	297-535	\$9.79	GASKET, manifold		1
23	328-900	\$2.69	STUD, head to manifold, short, outer		2
24	328-910	\$1.89	STUD, head to manifold, long, inner		4
25	373-830	NA	EXHAUST MANIFOLD		1
	328-718	\$15.99	STUD & NUT SET, manifold to downpipe		1
27	328-765	\$2.59	STUD, exhaust flange		6
28	311-540	\$0.79	NUT, brass		6
29	290-510	\$3.99	GASKET, exhaust flange		2
30	451-005	\$89.99	HEAT SHIELD		1

Carburetor heat shields are important to your MGB, but often missing. Heat shields with insulation pads intact insulate the carb float bowls from heat and prevent vapor lock. Our heat shields are stamped exactly as original and are zinc-plated as original. Our one concession to your health and the environment is that we now use non-asbestos riveted-on heat insulating material.

31	294-710	\$0.79	GASKET, carburetor		6
32	372-320	\$12.99	SPACER	w/o induction heater	2
	372-325	NA	SPACER	w/induction heater	2
33	373-760	NA	INDUCTION HEATER	as fitted - cold climates	2
37	372-360	NA	AIR CLEANER ASS'Y., front		1
	372-350	NA	AIR CLEANER ASS'Y., rear		1
39	950-700	\$7.99	ELEMENT, "Classic Gold" brand		2
	950-200	NA	ELEMENT, "Crosland" brand	(not incl. in ass'y.)	2
	372-395	\$69.99	ELEMENT, "K & N" brand	(not incl. in ass'y.)	2
40	372-420	\$2.89	SEAL, rubber		2
41	322-150	\$1.69	BOLT, fine thread		4
42	328-315	\$2.99	SPACER		4
44	324-155	\$0.59	WASHER		4
45	372-370	\$1.49	GROMMET		4



## New SU Carburetors

19696

Genuine SU carburetors are now being produced in the UK from a combination of new and original tooling. These brand new carburetors will improve the way your car looks and runs. Rebuilt carbs are nice, but after decades of abuse they'll never look or perform as well as new ones.

372-248	\$2,099.00	MGB 1962-'67 HS4 Carb Set
366-478	\$1,899.00	MGB 1968 HS4 Carb Set
366-498	\$1,799.00	MGB 1969 HS4 Carb Set
366-488	\$1,999.00	MGB 1970-'71 HS4 Carb Set

SU tools are shown on page 25.

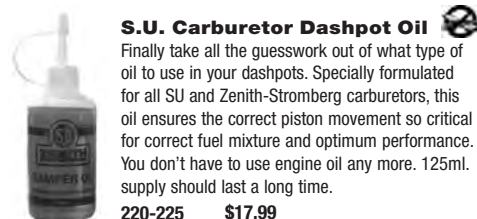

## S.U. Carburetor Dashpot Oil

Finally take all the guesswork out of what type of oil to use in your dashpots. Specially formulated for all SU and Zenith-Stromberg carburetors, this oil ensures the correct piston movement so critical for correct fuel mixture and optimum performance. You don't have to use engine oil any more. 125ml. supply should last a long time.

220-225 \$17.99

Toll-Free Orders 1-800-667-7872 | MossMotors.com  
Fax 805-692-2525 | Local 805-681-3400

MOSS

Prices subject to change. See MossMotors.com for current pricing.

# HIF-4 Carburetor

1972 - '74 RD (c)258001 to 367900/GT (c)258001 to 367803

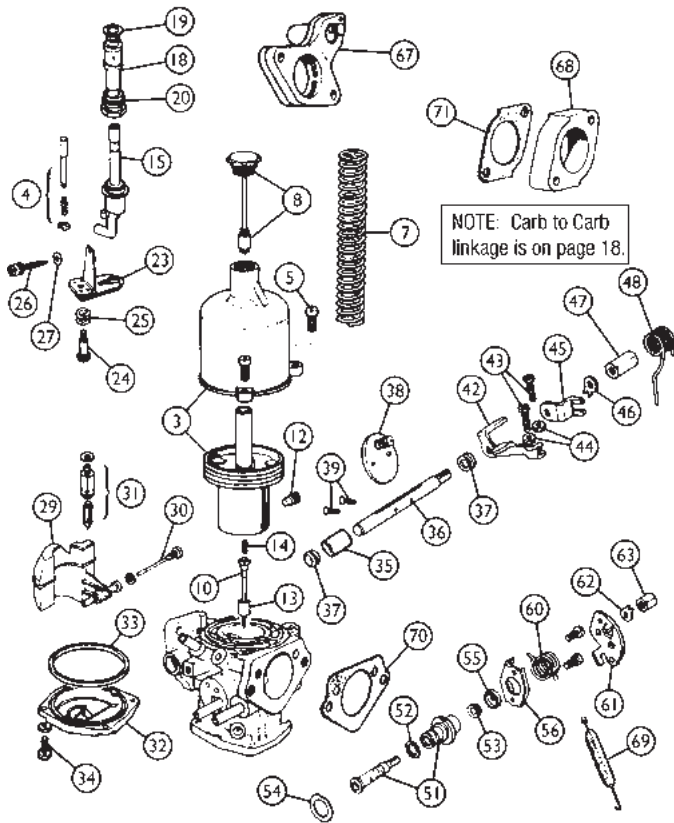

## HIF-4 Carburetor

19698

No.	Part#	Price (Each)	Description	Application	Qty Req.
	366-628	NA	CARBURETOR PAIR, new (replaces AUD493, AUD550 and AUD630)	1972 - '74	1
3	373-520	NA	AIR CHAMBER & PISTON	AUD493/550	2
	373-525	NA	AIR CHAMBER & PISTON	AUD630	2
4	373-530	\$15.49	PIN & SPRING ASSEMBLY		2
5	370-290	\$0.89	SCREW, chamber to body		6
7	370-520	\$4.89	SPRING, piston, red		2
8	370-750	\$27.99	CAP & DAMPER	AUD493/550	2
	370-755	\$22.99	CAP & DAMPER	AUD630	2
10	374-380*	\$21.99	JET NEEDLE, standard (AAU)	AUD493	2
	374-390*	\$21.99	JET NEEDLE, standard (ABD)	AUD550/630	2
12	373-540	\$1.89	SCREW, needle locking		2
13	374-385	NA	GUIDE, jet needle	AUD493/550	2
	374-395	\$4.79	GUIDE, jet needle	AUD630	2
14	373-365	\$2.39	SPRING, jet needle		2
15	374-550\$*	\$19.99	JET, front		1
	374-555\$*	\$19.99	JET, rear		1
18	373-571	NA	JET BEARING		2
19	373-575\$*†	\$1.59	WASHER, jet bearing		2
20	373-580	\$19.99	NUT, jet bearing		2
23	373-590	\$71.99	TEMPERATURE COMPENSATOR		2
24	373-595	\$6.99	SCREW, adjusting		2
25	373-600	\$5.29	SPRING		2
26	373-585	\$5.99	SCREW, mixture adjusting		2
27	373-605\$*	\$1.29	SEALING RING		2
29	373-610	\$41.99	FLOAT, front		1
	373-615	\$49.99	FLOAT, rear		1
	375-617	\$86.99	FLOAT KIT, front, "stay-up"		1
	375-616	\$86.99	FLOAT KIT, rear, "stay-up"		1
30	373-620	\$12.59	SPINDLE, float		2
31	373-625\$*	\$55.99	NEEDLE & SEAT, Viton tip		2
	373-626	\$14.99	NEEDLE & SEAT, Viton tip, aftermarket		2
	386-340	\$12.99	GROSE-JET, superior replacement for std. needle & seat		2
32	373-630	\$141.99	COVER, float chamber		2
33	373-635\$*†	\$6.19	SEAL, float chamber		2
34	373-640	\$1.49	SCREW, cover to body		8
35	372-545\$	\$2.99	BUSH, throttle shaft (see tech tip on page 19)		4
36	373-650\$	\$32.99	THROTTLE SHAFT, standard		2
	373-655	\$32.99	THROTTLE SHAFT, oversize		2
37	373-721\$*†	\$1.79	SEAL, throttle shaft, Viton		4

No.	Part#	Price (Each)	Description	Application	Qty Req.
38	373-670	\$23.99	THROTTLE DISC, w/notch	AUD493	2
	373-675\$	\$49.99	THROTTLE DISC, w/o notch	AUD550/630	2
39	370-090\$	\$1.79	SCREW, throttle disc		4
42	373-680	\$14.69	LEVER, throttle return, front carb.		1
	373-685	\$14.69	LEVER, throttle return, rear carb.		1
43	372-830	\$6.19	SCREW, slow & fast idle		4
44	365-630	\$0.39	JAM NUT, idle screws		4
45	373-690	\$25.49	LEVER, lost motion		2
46	373-695\$*	\$2.09	TAB WASHER		2
47	373-665	NA	NUT, throttle shaft		2
48	373-700	\$24.99	SPRING, throttle lever, front carb.		1
	373-705	\$7.99	SPRING, throttle lever, rear carb.		1
51	373-710	\$93.99	STARTER VALVE		2
52	373-715\$*†	\$0.79	SEAL, starter valve		2
53	373-721\$*†	\$1.79	SEAL, starter valve		2
54	373-725\$*†	\$2.69	GASKET, starter valve		2
55	373-730	NA	SPRING SUPPORT		2
56	373-735	\$23.99	CLAMPING PLATE, front		1
	373-740	NA	CLAMPING PLATE, rear		1
60	373-745	\$6.79	SPRING, cam return, front		1
	373-105	\$4.89	SPRING, cam return, rear		1
61	373-750	NA	CAM LEVER, front		1
	373-755	NA	CAM LEVER, rear		1
62	373-695\$	\$2.09	TAB WASHER		2
63	310-970	\$4.99	NUT		2
67	373-760	NA	INDUCTION HEATER	cold weather climates	2
68	372-320	\$12.99	INSULATOR	w/o induction heater	2
	372-325	NA	INSULATOR	w/induction heater	2
69	370-335	\$1.99	SPRING, choke & throttle return		3

## Rebuild Kits/Gasket Sets

	375-558\$	\$369.99	MASTER REBUILD KIT, for 2 carbs. (S)		1
	375-378*	\$239.99	REBUILD KIT, for 2 carburetors (S) AUD493		1
	375-398*	\$239.99	REBUILD KIT, for 2 carburetors (S) AUD550/630		1
	294-808†	\$44.99	CARBURETOR GASKET SET		1
70	294-800\$*†	\$0.89	GASKET, filter to carb.		2
71	294-710\$*†	\$0.79	GASKET, carb. mounting (kits include 2)		6

† Note: "Master rebuild kits" include all items marked †. They are produced exclusively by S.U., and contain only genuine S.U. components. Metering needles are not included, however, so that you may choose the exact needle to suit your specific requirements.

\* Note: Rebuild kits (genuine SU) include all items marked \*.

† Note: Gasket sets include all items marked †.

Note: Fuel lines are on pages 30-31.

## Important note:

HIF carburetor floats and jets are handed, and must be installed with this fact in mind.

## Identifying your S.U. Carburetors, 1972 - '74

From 1972 - '74, the HIF-4 carburetor was used. These are identified by specification numbers stamped on small rectangular tags under one of the air chamber mounting screws.

Year	Spec No.	Model	Part #
1972	AUD493	HIF-4	} 366-628
1973	AUD550	HIF-4	
1974	AUD630	HIF-4	

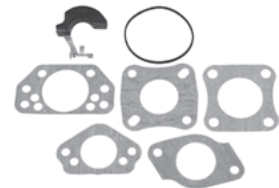

## Stay Up Float Kit

Most classic vehicle fuel systems use a floating device to shut off fuel flow to the engine. With the recent addition of ethanol to modern fuels, older plastic floats began to show signs of fatigue and in some cases failure altogether. Which is why we bring you the Stay Up Float Kit. Manufactured after years of development and testing by the StayUp Float Company, it is ethanol resistant, puncture proof, and adaptable to your needs. It will not wear down and will always float to the top. Made in UK.

**375-617 \$86.99**

**375-616 \$86.99**

# HIF-4 Manifold / Air Cleaner

1972 - '74 RD (c)258001 to 367900/GT (c)258001 to 367803

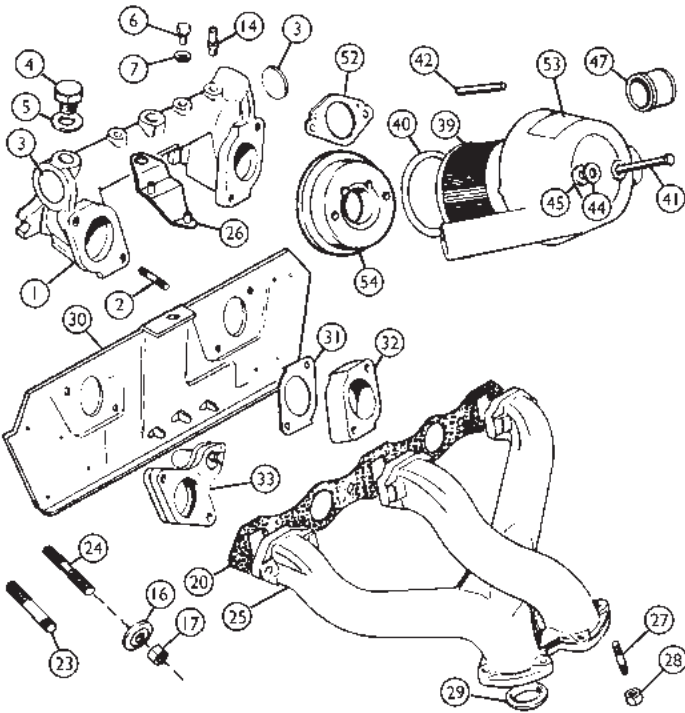

## Manifolds / Air Cleaners (HIF-4 Carburetors)

19703

No.	Part#	Price (Each)	Description	Application	Qty Req.
1	373-825	NA	INLET MANIFOLD		1
2	328-745	\$1.79	STUD, carburetor. to manifold		4
3	319-095	\$1.89	END PLUG		2
4	379-362	\$9.59	PLUG		2/1
5	324-065	\$1.49	WASHER		2/1
6	328-305	\$11.99	PLUG		2/1
7	328-335	\$1.49	WASHER		2/1
14	373-855	NA	RESTRICTOR, o/d vacuum	overdrive models	1
16	460-090	\$2.19	WASHER, manifold mounting		4
17	311-540	\$0.79	NUT, manifold, brass		6
20	297-535	\$9.79	GASKET, manifold		1
23	328-900	\$2.69	STUD, head to manifold, short, outer		2
24	328-910	\$1.89	STUD, head to manifold, long, inner		4
25	373-835	NA	EXHAUST MANIFOLD		1
26	372-345	NA	BRACKET, accelerator, choke		1
	328-718	\$15.99	STUD & NUT SET, manifold to downpipe		1
27	328-765	\$2.59	STUD, exhaust flange		6
28	311-540	\$0.79	NUT, brass		6
29	290-510	\$3.99	GASKET, exhaust flange		2
30	451-015	\$89.99	HEAT SHIELD		1
31	294-710	\$0.79	GASKET, carburetor		6
32	372-320	\$12.99	SPACER	w/o induction heater	2
	372-325	NA	SPACER	w/induction heater	2
33	373-760	NA	INDUCTION HEATER	as fitted - cold climates	2
39	950-200	NA	ELEMENT, "Crosland" brand		2
	950-700	\$7.99	ELEMENT, "Classic Gold" brand		2
	372-395	\$69.99	ELEMENT, K & N replacement		1
40	372-420	\$2.89	SEAL, rubber		2
41	322-175	\$2.99	BOLT, coarse thread		4
42	328-315	\$2.99	SPACER		4
44	324-155	\$0.59	WASHER		4
45	372-370	\$1.49	GROMMET		4
47	372-440	\$1.89	SEAL, air cleaner coupling		1
52	294-800	\$0.89	GASKET		2

Carburetor heat shields provide an important function in your MGB, but are sometimes missing. Heat shields with riveted-on heat insulation pads intact insulate the carb float bowls from exhaust manifold heat and prevent vapor lock. Our heat shields are stamped exactly as original and are zinc-plated for factory-original appearance. Our one concession to your health and the environment is that we now use non-asbestos riveted-on heat insulating material.

31	294-710	\$0.79	GASKET, carburetor		6
32	372-320	\$12.99	SPACER	w/o induction heater	2
	372-325	NA	SPACER	w/induction heater	2
33	373-760	NA	INDUCTION HEATER	as fitted - cold climates	2
39	950-200	NA	ELEMENT, "Crosland" brand		2
	950-700	\$7.99	ELEMENT, "Classic Gold" brand		2
	372-395	\$69.99	ELEMENT, K & N replacement		1
40	372-420	\$2.89	SEAL, rubber		2
41	322-175	\$2.99	BOLT, coarse thread		4
42	328-315	\$2.99	SPACER		4
44	324-155	\$0.59	WASHER		4
45	372-370	\$1.49	GROMMET		4
47	372-440	\$1.89	SEAL, air cleaner coupling		1
52	294-800	\$0.89	GASKET		2

Toll-Free Orders 1-800-667-7872 | MossMotors.com  
Fax 805-692-2525 | Local 805-681-3400

MOSS

No.	Part#	Price (Each)	Description	Application	Qty Req.
53	215-615	\$2.49	DECAL, "Coopers Filter"		2
54	372-380	\$59.99	ALLOY BACK PLATE ADAPTOR	HIF4 stock carbs	2
	372-385	NA	ALLOY BACK PLATE ADAPTOR*	HS6 carb conversion	2

\*These alloy adaptors will allow stock air cleaners to be used with the 1 3/4" S.U. carb conversion on 1963-'74 (chrome-bumpered) MGBs.



### S.U. Carburetor Dashpot Oil

Finally take all the guesswork out of what type of oil to use in your dashpots. Specially formulated for all SU and Zenith-Stromberg carburetors, this oil ensures the correct piston movement so critical for correct fuel mixture and optimum performance. You don't have to use engine oil any more. 125ml. supply should last a long time.

220-225 \$17.99



### SU Tool Kit

An assortment of handy tools for the home mechanic, in a vinyl pouch, including a jet wrench (5/16W for original carbs). Instructions included. Suitable for all cars with SU carbs.

386-300 \$23.99

### SU Jet Wrenches

Mixture adjustments on SU carbs (except HIF type) are much easier with the proper tool. 5/16 Whitworth size for original carbs., 17mm for new replacement SUs.

Jet Wrench, 5/16 W 386-400 \$4.39

Jet Wrench, 17mm 386-401 \$7.99

### Carburetor Synchronizer

Used to synchronize airflow between multiple carbs, this is an indispensable tool for the serious home mechanic.

386-200 \$39.99

### SU Jet Centering Tool

Jet centering is critical on older fixed needle SU carbs. This simple tool makes it a snap.

386-500 \$39.99

### SU Carb Rebuild Video DVD

Anyone can tune or rebuild SU carbs with the help of our 2 hour and 40 minute video. This easy to follow video uses a combination of sights, sounds and simple conversational dialog to unravel the mysterious SU. A must for home mechanics.

211-036 \$39.99



# Zenith-Stromberg Carb.

1975 - '80 RD from (c)367901

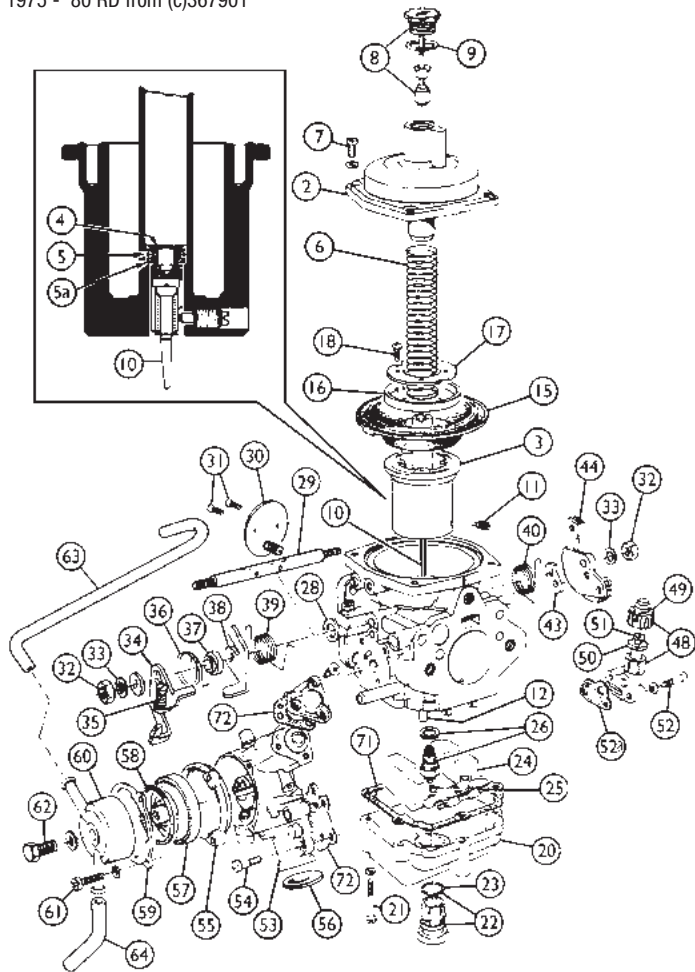

## Zenith-Stromberg Carb.

19706

No.	Part#	Price (Each)	Description	Application	Qty Req.
	366-015	NA	CARBURETOR ASSEMBLY	{ 1975 - '76, except CA, carb. # C3824	1
	366-005	NA	CARBURETOR ASSEMBLY	{ 1975 - '76, CA only, carb. # C3766	1
	366-000	NA	CARBURETOR ASSEMBLY	{ 1977 - '80, all U.S., carb. # C3851	1
These Zenith-Stromberg carburetors should always have their final idle speed adjustment made while someone depresses the clutch pedal.					
2	366-260	NA	COVER, air chamber		1
3	366-270	NA	PISTON		1
4	365-395	\$1.99	RETAINING CLIP		1
5	365-420	\$0.89	O-RING		1
5a	365-425	\$17.99	SCREW, needle adjusting		1
6	365-780	\$13.99	SPRING		1
7	365-380	\$1.89	SCREW, cover to body		4
8	366-030	\$58.99	CAP & DAMPER		1
9	366-280	\$1.39	WASHER		1
10	374-410	\$56.99	METERING NEEDLE, 45G	#C3824	1
	374-400	\$54.99	METERING NEEDLE, 45H	#C3766, C3851	1
	374-420	\$57.99	METERING NEEDLE, 45M	high altitude condition, lean	1
11	366-035	\$15.99	SCREW, needle locking		1
12	366-105	\$50.99	JET (professional installation advised)		1
15	366-040*	\$16.99	DIAPHRAGM		1
16	366-045	\$14.99	SEALING RING, diaphragm		1
17	366-050	\$24.39	RETAINER, diaphragm		1
18	366-290	\$2.59	SCREW, retainer		4
20	366-060	NA	FLOAT CHAMBER		1
21	366-065	\$5.99	SCREW, float chamber, long	} C3824, C3766	4
	366-305	\$4.29	SCREW, float chamber, short		2
	366-295	\$3.69	SCREW, float chamber	C3851	6
22	366-070	\$29.99	PLUG & SEAL, float chamber	} as fitted	1
23	365-470*	\$0.79	SEAL, O-ring		1
24	365-506	\$15.79	FLOAT, upgraded ethanol-proof "Nitrophyl"		1
	365-505	\$65.99	FLOAT, original type		1
25	366-080	\$6.99	PIN, float hinge		1

No.	Part#	Price (Each)	Description	Application	Qty Req.
26	366-090*	\$57.99	NEEDLE VALVE		1
	386-350	\$12.99	GROSE-JET, superior replacement for std. needle & seat		1
28	696-027	\$8.99	SEAL & CUP, throttle shaft		1
29	366-100	\$30.89	THROTTLE SHAFT		1
30	366-110	NA	THROTTLE DISC		1
31	366-685	\$3.89	SCREW, throttle shaft		2
32	366-115	NA	NUT, throttle shaft		2
33	366-120	NA	LOCK WASHER		2
34	366-125	NA	LEVER, fast idle		1
35	366-130	\$19.39	SCREW, idle adjusting		1
36	366-135	NA	SPRING, fast idle lever		1
37	366-140	\$8.99	BUSHING		1
38	366-145	NA	THROTTLE STOP		1
39	366-150*	NA	RETURN SPRING	(all)	1
40	366-840	\$15.59	RETURN SPRING, rear	C3851 only	1
43	366-155	NA	LINK ARM		1
44	366-160	\$133.99	LEVER		1
48	366-165	\$159.99	VALVE ASS'Y., air regulator		1
49	366-245	\$12.49	COVER, valve		1
50	366-215	\$14.99	VALVE BODY, idle mixture adjustment		1
	366-275	\$5.59	"O" RING on valve body		1
51	366-220	\$22.39	METERING SCREW		1
	366-265	\$3.79	"O" RING on metering screw (not included with screw)		1
52	366-310	NA	SCREW		1
52a	*	NA	GASKET, air regulator		1
53	366-170	\$499.99	AUTOMATIC CHOKE ASSEMBLY		1
54	366-175	\$2.09	SCREW, short		1
	366-185	\$2.69	SCREW, long		2
55	366-180	\$42.99	INSULATOR		1
56	366-335	\$2.29	CORE PLUG		1
57	366-190	\$149.99	HEAT MASS ASSEMBLY		1
58	366-320*	NA	SEALING RING		1
59	366-195	\$10.59	RETAINING RING		1
60	366-200	\$42.59	COVER, heat mass		1
61	366-210	\$2.89	SCREW		3
62	366-205	\$3.79	BOLT		1
63	367-065	NA	HOSE, cylinder head to choke		1
64	363-285	NA	HOSE, heater pipe to choke		1
	366-250	\$79.99	<b>CARBURETOR REBUILD KIT</b>	includes all items marked *	1
	366-230*	\$39.99	GASKET SET, carb. body		1
	366-235*	\$2.79	GASKET, carburetor to manifold/heater		2
	366-240*	\$1.99	GASKET, air cleaner to carburetor		1
71	696-080*	\$2.99	GASKET, float chamber		1
72	366-226	\$9.99	GASKET SET, choke ass'y. (gaskets & o-rings)		1



## Zenith-Stromberg Mixture Adjustment Tool

An essential item for owners of 1975 or later MGBs with a single Zenith-Stromberg carburetor.

**386-310 \$11.29**

## Zenith-Stromberg Carburetor Dashpot Oil

Finally take all the guesswork out of what type of oil to use in your dashpots. Specially formulated for all SU and Zenith-Stromberg carburetors, this oil ensures the correct piston movement so critical for correct fuel mixture and optimum performance. You don't have to use engine oil any more. 125ml. supply should last a long time.

**220-225 \$17.99**



## Manual Choke Conversion Kit

Based on a design by Zenith-Stromberg engineers, unlike other kits leaves your car's factory appearance intact. Easy to install, kits include all necessary mounting hardware and detailed instructions. Fits MGB '75-'80.

**386-325 \$129.99**

Amendments to the Clean Air Act make it illegal for anyone to change or alter the emission control system of any automobile in the United States except for cars used exclusively for off-road use.



# Z-S Manifolds / Air Cleaner

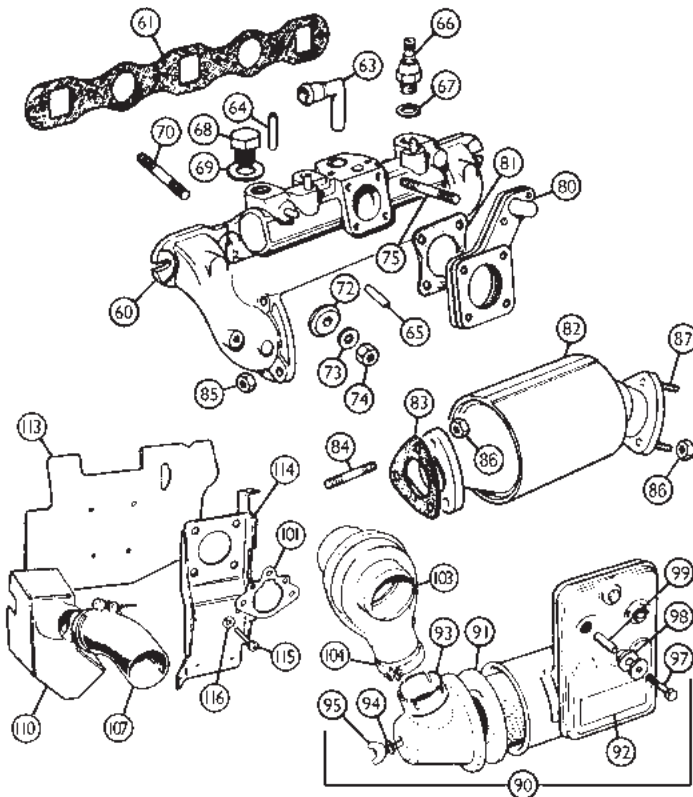

No.	Part#	Price (Each)	Description	Application	Qty Req.
104	373-925	NA	CLAMP		1
107	373-930	\$15.99	TUBE, regulator to shroud		1
108	377-380	\$8.99	CLAMP		2
110	373-940	NA	SHROUD		1
113	373-945	\$68.99	HEAT SHIELD		1
114	373-950	NA	PLATE		1
115	373-960	\$0.20	SCREW		2
116	324-010	\$0.19	WASHER		2

## Tuning the Zenith-Stromberg Carburetor - Thanks to John Twist of University Motors

Despite the assurances of the manufacturer that this single carb. could lessen emissions, the Zenith-Stromberg often runs very rich. When this occurs, and if the air pump and catalytic converter are still in place, the converter will glow cherry red hot. With regular maintenance, this carb. will perform properly, offering relatively high mileage compared to the twin SUs.

## ADJUSTING THE CARBURETOR

To properly tune the Stromberg, one must have the Stromberg adjusting tool (Moss part #386-310), a 10mm open end wrench, and small and medium screwdrivers.

Start the engine from cold, and adjust the spring-loaded idle screw for an engine speed of 1800 rpm maximum. Once the engine has fully heated and the speed dropped to its lowest rpm (choke all the way off), adjust the locknut screw (hence the 10mm wrench) until the engine is idling at about 850—900 rpm. All further adjustments to idle speed will be made again with the spring loaded screw.

Now the mixture is adjusted. Lift the air piston slightly. If the idle speed rises as the piston is lifted, the mixture is too rich. Turn the allen wrench anti-clockwise to lean it out. If the idle speed slows or stumbles when the piston is lifted, then the mixture is too lean. Turn the allen wrench clockwise to richen it. With the proper idle mixture the idle speed will rise and steady, or rise and slowly fall off as the piston is lifted. As the correct mixture is reached, the idle speed will rise, and several adjustments may be necessary to maintain 850—900 rpm. Be certain to rev up the engine, to clear it out, between each adjustment.

## RUNNING RICH

The most common complaint is that no matter what is done, the mixture is still far too rich. There are five major areas of concern:

- The air cleaner is dirty. Leaks in the manifold or exhaust will soot up an air cleaner. This causes a much higher vacuum in the venturi, and more gasoline is drawn into the air stream.
- The ELC (Evaporative Loss Control) system is pressurized. This is very uncommon. Remove the vapor line, the vent line, and the carburetor overflow line. This travels across the valve cover to the charcoal adsorption canister. There should be NO CHANGE in the idling of the engine. If there is any change, clean the ELC system, and check for blockages. It is more common for this system to develop a vacuum which creates a lean running condition.
- The automatic choke is the most common cause of rich running. These problems are:
  - The choke ass'y. has come loose from the carb. body. The vacuum from the carburettor then draws fuel from the float bowl around the valve which should be closed during warm running. Tightening the three slotted copper coloured screws eliminates this as a problem.
  - The choke lever and cam have stuck in a part-open position. A good tune-up requires removal of the choke assembly, thorough cleaning, tightening the pin nut, and lubrication.
  - The bi-metal spring in the heat mass is not correctly calibrated. Place the heat mass in a pan of boiling water; the bi-metal spring will rotate clockwise to its fullest extent. The notch on the bi-metal spring should be in line with the mark on the aluminium housing. If it does not line up, scribe a new mark. The line on the heat mass, on the black plastic insulator, and the choke body should all be in line.
  - The small passageway from the carb throat (past the butterfly) to the top of the auto choke ass'y. allows vacuum to pull off the spring loaded enrichment plunger. When this passageway fills with soot, the plunger remains seated, holding the choke ON. By cleaning this passageway with a small wire, the vacuum can take its proper route.
  - The mating flange of the auto choke can become warped and allow fuel to bypass the choke valve. Resurface this mating flange and thoroughly clean after the surface is smooth.
  - Occasionally the brass choke valve is not fully inserted into the housing, so that the choke pin does not seat in (and therefore not closing off) the choke. This can be positively determined by removing the automatic choke and covering the screw holes and fuel passageways with a piece of masking tape, then checking the mixture again.
- If the rubber diaphragm is torn or perforated, then the engine will run very rich, and maximum speed will be limited, spewing clouds of black, sooty, uncombusted exhaust. A torn diaphragm is easily found by removing the top of the suction chamber (four phillips screws). While the diaphragm is being inspected, pay attention to the following:
  - The tiny pin which retains the metering needle can break, allowing the needle to pop upwards. Adjusting cannot correct this. The needle's shoulder should be seen on the bottom of the air piston. If not, and the needle has a lot of up and down movement, check the pin.

## RUNNING LEAN

Leanness at road speed is often described as a hesitation, as if a wind was blowing against the car. Causes can be retarded timing or a too lean mixture. There are several possibilities:

- The ELC System is plugged, placing a vacuum in the float bowl. Remove the vent line from the carb. and note any change. A plugged charcoal adsorption canister, or a plugged vent line from the bottom of the anti run on valve are the most common problems.
- The float height is set far too low.
- The air cleaner is not fitted to the carburettor. The Stromberg carburetted MGB will not run with the air cleaner removed, nor with a filter which replaces the original assembly.

## CARB WILL NOT IDLE DOWN

Sometimes the carb. will not idle at lower than 1000 or 1200 rpm. This is almost always a mechanical problem, but the possibilities include:

- The throttle cable is stiff or incorrectly adjusted. Leave loose until the carb is adjusted, then tighten.
- The automatic choke cam is not returning to full off position. Levers may be bent or jammed.
- The overrun valve in the throttle disc may "float"; the spring may have lost its force due to a carb. fire or other gross overheating. Replace or solder shut.

## Manifolds / Air Cleaners (Zenith-Stromberg Carburetor) 19710

No.	Part#	Price (Each)	Description	Application	Qty Req.
60	373-840	NA	MANIFOLD, inlet & exhaust		1
61	297-535	\$9.79	GASKET, manifold		1
63	373-860	NA	ADAPTOR, gulp valve		1
64	373-865	NA	ADAPTOR, anti run-on valve		1
65	373-870	NA	ADAPTOR, signal pipe		2
66	582-996	\$25.99	CHECK VALVE, brake servo	} as fitted	1
	373-875	NA	ADAPTOR, brake servo		1
67	373-885	\$2.19	WASHER, adaptor/valve		1
68	379-362	\$9.59	PLUG		1
69	324-065	\$1.49	WASHER		1
70	328-900	\$2.69	STUD, manifold		4
72	460-090	\$2.19	FIXING WASHER, manifold		6
73	365-720	\$0.79	WASHER		6
74	311-540	\$0.79	NUT		6
75	328-994	\$3.29	STUD, carburetor to manifold		4
80	373-765	NA	INDUCTION HEATER		1
81	366-235	\$2.79	GASKET		3
82	444-175	\$464.99	CATALYTIC CONVERTER, replacement (not California legal)		1
This economical replacement meets all EPA requirements, but is not legal for California. To prevent gas from leaking onto the very hot catalytic converter on late MGBs with Zenith-Stromberg carburetors, make sure that the three screws holding the automatic choke assembly to the carburetor body are always kept tight.					
83	297-550	\$10.49	GASKET		1
84	328-991	\$2.49	STUD, manifold to ft. pipe	1975 non-cat. system	3
	328-997	\$1.99	STUD, manifold to converter, upper (short)		1
	328-993	\$2.29	STUD, manifold to converter, lower (long)		2
85	310-015	\$0.49	JAM NUT, lower manifold to converter studs		2
86	311-610	\$1.69	NUT		3
87	328-991	\$2.49	STUD, catalyst to pipe		6
90	373-900	NA	AIR CLEANER ASSEMBLY		1
91	372-465	NA	AIR FILTER, "K&N" brand		1
	950-770	\$12.49	AIR FILTER, aftermarket		1
92	215-680	\$3.29	DECAL, air filter		1
93	373-910	NA	END COVER ASSEMBLY		1
94	373-890	NA	FIBER WASHER		1
95	373-895	NA	TUBE NUT		1
97	373-970	NA	BOLT		3
98	372-370	\$1.49	GROMMET		3
99	373-955	NA	SPACER		3
101	366-240	\$1.99	GASKET, carburetor air cleaner		1
103	373-920	NA	REGULATOR, air temperature		1

Toll-Free Orders 1-800-667-7872 | MossMotors.com  
Fax 805-692-2525 | Local 805-681-3400

MOSS

# Fuel Tanks

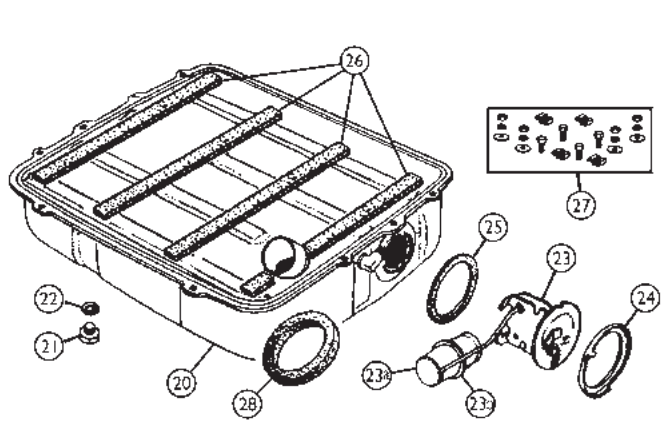
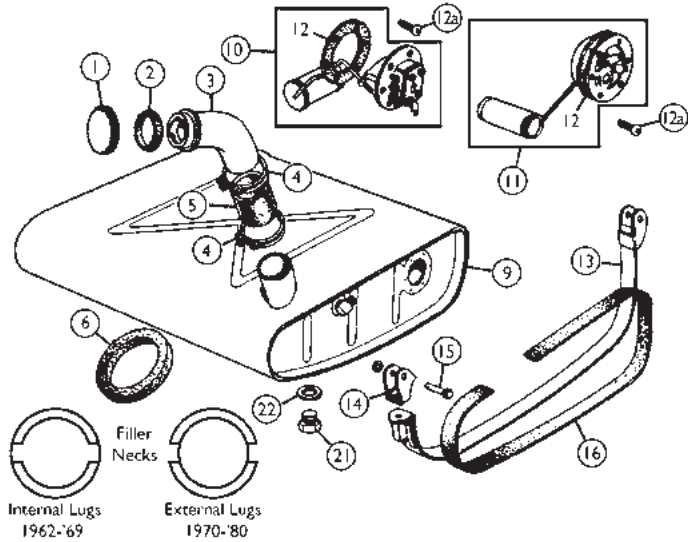

## Fuel Tanks

19711

No.	Part#	Price (Each)	Description	Application	Qty Req.	
1	202-750	\$17.99	GAS CAP, 1962 - '69 (stainless steel replacement)	RD to (c)187210, GT to (c)187840	1	
	202-760	\$54.99	GAS CAP, locking (optional)		1	
	202-755	\$18.99	GAS CAP, 1970 - '74		RD from (c)187211 to 367719, GT from (c)187841 on	1
	202-770	NA	GAS CAP, locking (optional)		RD from (c)367720 to 382129	1
	202-765	\$24.99	GAS CAP		'75 cars w/single carb. & no catalytic converter	1
	202-755	\$18.99	GAS CAP	RD from (c) 382130-on	1	
	202-770	NA	GAS CAP, locking (optional)		1	
2	282-630	\$2.79	FERRULE, filler neck	RD to (c)447000, all GT	1	
	282-635	\$11.99	FERRULE, filler neck	RD from (c)447001 on	1	
3	470-185	\$114.99	TUBE, filler, internal lugs, 1962 - '69	RD to (c)187210, GT to (c)187840	1	
	471-050	NA	TUBE, filler, external lugs, 1970 - '75 leaded fuel		RD from (c)187211 to 386600, GT from (c)187841 on	1
	471-055	NA	TUBE, filler, 1975 unleaded		California RD (c)382130-386600	1
	471-060	NA	TUBE, filler, 1976		RD from (c)386601 to 410000	1
	471-055	NA	TUBE, filler, early 1977		RD from (c)410001 to 415000	1
	471-070	NA	TUBE, filler, straight	RD from (c)415001 on	1	
4	326-460	\$2.69	CLAMP, hose		2	
5	282-620	\$12.99	HOSE, filler to tank, straight	RD/GT to (c)415000	1	
	282-910	NA	HOSE, filler to tank, angled	RD from (c)415001 to 454202	1	
	282-920	\$37.99	HOSE, filler to tank, angled	RD from (c)454203 on	1	
6		NA	SEAL, tank to trunk floor		1	
9	456-811	\$339.99	GAS TANK, 1962 - Mar. '65	RD to (B)56742	1	
10	360-641	\$39.99	SENDING UNIT (Jaeger gauge)	RD to (B)48766	1	
11	360-650	NA	SENDING UNIT (Smiths gauge)	RD from (B)48767 to 56743	1	
12	293-415	\$0.49	GASKET, sending unit (cork)	RD to (B)56742 (Mar. 1965)	1	
	293-401	\$4.99	GASKET SET, ethanol-proof		1	
12a	323-728	\$2.79	SCREW SET, sending unit to tank		1	
13	471-080	\$89.99	STRAP, gas tank mounting		2	
14	471-090	NA	BRACKET		1	
15	471-095	\$1.09	CLEVIS PIN	4		
16	280-300	\$11.99	PACKING STRIP, rubber (9')	1		
20	456-815	\$449.99	GAS TANK, BM Heritage*	RD from (B)56743 to (c)187210, GT to (c)187840	1	
	456-777	\$209.99	GAS TANK, Classic Gold	Mar. 1965-'69 not vented	1	
	471-200	NA	GAS TANK, vented, BM Heritage	RD from (c)187211 to 386600, GT from (c)187841 on ('70-'75)	1	
	471-204†	\$209.99	GAS TANK, vented, Classic Gold		1	
	471-210	NA	GAS TANK, vented	RD from (c)386601 to 415000	1	
	471-220	NA	GAS TANK, vented, BM Heritage	RD from (c)415001-on	1	
	471-226†	\$209.99	GAS TANK, vented, Classic Gold		1	
21	328-280	\$1.89	PLUG, drain	as fitted	1	
22	324-626	\$0.99	WASHER, drain plug		1	

\*BM Heritage tank has baffles, no drain hole.

† Classic Gold tanks have baffles and drain. 471-226 includes locking ring and gasket.

Underlined part numbers indicate an Oversize Parts Fee will be charged. See mossmotors.com or call for details.

28

No.	Part#	Price (Each)	Description	Application	Qty Req.	
23	360-660	\$39.99	SENDING UNIT, fuel gauge	RD from (B)56743 to (c)415000, all GT	1	
	360-661	\$49.99	SENDING UNIT, fuel gauge**		1	
	360-655	\$48.99	SENDING UNIT, fuel gauge		RD from (c)415001 on (from early 1977 model yr.) with fuel pick-up tube	1
	360-656	\$66.99	SENDING UNIT, fuel gauge**		1	
**Modern printed circuit, plastic body upgrades. <a href="#">MORE INFO ONLINE</a>						
23a	360-645	\$8.99	FLOAT, plastic	RD from (B)56743 on all GT (Mar. 1965 - on)	1	
	360-646	\$17.99	FLOAT, brass replacement		1	
Brass float is not included with sending units.						
23b	324-055	\$3.59	RING, anti-rattle	RD from (B)56743 on all GT (Mar. 1965 - on)	1	
24	360-665	\$1.49	RING, locking		1	
25	293-410	\$3.99	RING, sealing, Viton		1	
26	280-300	\$11.99	PACKING STRIP SET		1	
27	323-628	\$13.99	HARDWARE SET, gas tank mount		1	
28	282-930	\$1.59	SEAL, tank to trunk floor		1	

## Gas Tank Care

### Step 1: Bio-Degradable Cleaner

This is an industrial strength gas tank cleaner that allows you to clean out your car's gas tank yourself. We recommend using this cleaner in conjunction with our etching liquid when planning to seal your tank.

**220-620 \$52.99 Cleaner (1 gallon)**

### Step 2: Fuel Tank Etching Liquid

Use this bio-degradable etcher as a prep for our slushing compound to give maximum adhesion of the sealer. Our cleaner should be used first to remove oil and grime. 16 oz.

**220-630 \$24.99 Etching Liquid**

### Step 3: Tank Slushing Compound

This is what the factory should have used! This amazing fluid puts a protective film on the entire inside surface of your fuel tank to prevent rust. Save yourself from having to buy an expensive fuel tank later on. Tanks should be cleaned with 220-620, then etched with 220-630 first. This compound is formulated to resist the alcohols found in gasoline.

**220-450 \$56.99 Slushing Compound**



## ReLead & Stor-N-Start

Stor-N-Start is a gasoline additive which prevents harmful gum and resin deposits from forming in fuel lines and carburetors. Use one ounce per five gallons of fuel before storing your car, and it will start right up—even after extended periods. ReLead replaces the valve lubricating qualities of lead formerly used in gas. Unless your cylinder head has been converted to run on unleaded, you need ReLead.

**Stor-N-Start 220-375 \$10.49**  
**ReLead 220-390 NA**

**WARNING:** Cancer and Reproductive Harm. [www.P65Warnings.ca.gov](http://www.P65Warnings.ca.gov)



### Locking Gas Cap

Our chrome locking fuel filler caps are styled just like the originals, but with an important extra feature. With fuel prices as high as they are, a locking gas cap is inexpensive insurance against thieves. Supplied complete with two keys.

MGB thru '69 202-760 \$54.99

### SU Solid State Fuel Pump (replacement)

SU electric fuel pumps with modern reliable solid state switching and control which eliminates the use of contact breaker points. Now you can have a vintage looking SU fuel pump with peace of mind that only an electronic fuel pump can offer. Plus the characteristic SU pump ticking is retained.

Pos. grd. to (c)44438 377-235 \$399.99  
 Neg. grd. to (c)44438 377-225 \$399.99  
 Pos. grd. from (c)44439 377-245 \$449.99  
 Neg. grd. from (c)44439 377-255 \$399.99



### SU Competition Double Ended Fuel Pump (replacement)

Double-ended SU pumps have been standard equipment for years on Aston Martins, Bentley and late model E-Types. Delivering nearly twice the capacity of a standard MGB type pump, these units will keep on pumping even if one side fails, a definite plus in the heat of competition! Well-suited for all high performance engines running SU carbs, as no pressure regulator is required. Now available in solid state versions, as well as the tried and true traditional points types. Requires 2 each of bracket and mounting, nos. 38 & 39 in the RH column.

Std. Points Pos. or Neg. ground 377-036 \$699.99  
 Solid State Neg. ground 377-335 \$699.99  
 Solid State Pos. ground 377-345 NA



### Facet Electric Fuel Pump (replacement)

While your original SU electric fuel pump is usually reliable, you don't want to be stuck anywhere with fuel in the tank, but not in the carbs. Put an end to nagging worries by using our reliable solid state electric fuel pump instead of, or with, your original pump! If you're interested in keeping an original appearance, this pump will push or pull fuel from a hidden location under the car through your original fuel pump. Or, put it in line and use a power switch or removeable fuse to run the pump only if needed as a backup. Works on both positive and negative ground cars.

377-420 \$109.99



### Facet Fuel Filter

74 micron filter is recommended for use on the inlet port.

377-424 \$12.99



### Ethanol Resistant Fuel Hose

Gates "Barricade" hose is the lowest permeation multi-fuel compatible hose on the market. Rated for 50 psi at -40 to 257 degrees F, and compatible with all gasoline blends. Sold per inch.

1/4" ID hose 379-214 \$0.69 per inch  
 5/16" ID hose 434-451 \$0.69 per inch



### Hose & Fitting Kit

Here's the way to re-convert a car to use the stock banjo type SU fuel pump after the original steel lines have been cut, thereby losing the threaded end fittings needed to fasten to the original banjo fittings. Supplied with ethanol-proof hose.

376-109 \$74.99

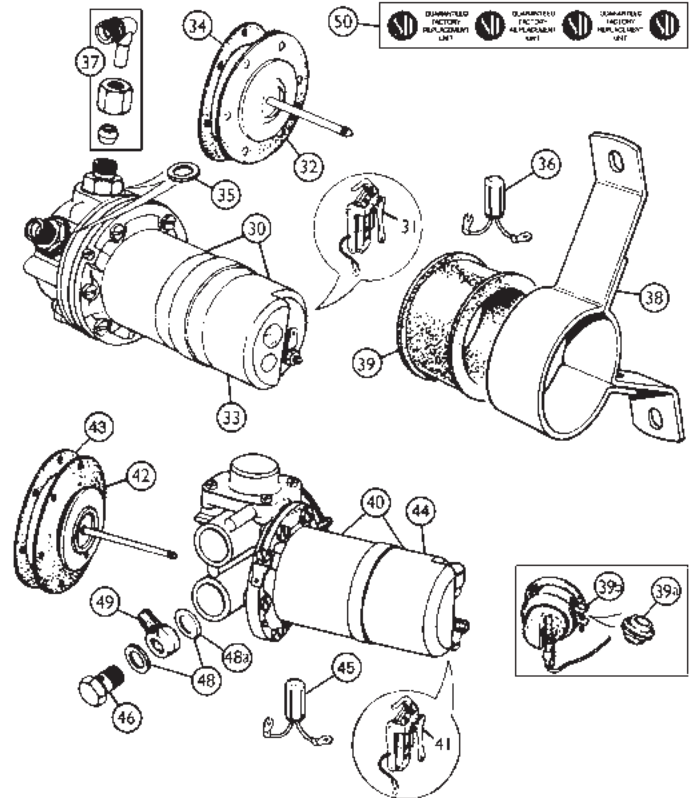

### Fuel Pumps

19717

No.	Part#	Price (Each)	Description	Application	Qty Req.
-----	-------	--------------	-------------	-------------	----------

In our many years of experience in the British car field, we've found that the original S.U. fuel pumps are normally extremely reliable and give long trouble-free service. Brand new S.U. pumps are still in production and are reasonably priced. Current pumps listed below are not polarity sensitive, and may be used with either positive or negative ground systems.

30	377-042	\$369.99	FUEL PUMP, pos. or neg. ground, S.U.	} RD to (c)44438 (Aug, '64)	1
31	377-080	\$34.99	POINT SET, original pump		1
32	377-130	\$89.99	DIAPHRAGM, 2 3/8" shaft		1
	377-140	\$64.99	DIAPHRAGM, 3" shaft		1
33	377-170	\$15.69	COVER		1
34	377-100	\$1.09	GASKET		1
35	375-025	\$2.49	WASHER under inlet fitting		1
	375-035	\$2.09	WASHER under outlet fitting	1	
36	377-135	NA	DIODE (replaces condenser)	1	
37	375-038	\$12.99	FITTING SET, 3 pieces	2	

(Fitting set comes with nut screwed onto elbow with compression fitting inside. To use, disassemble, and assemble onto pump as shown.)

38	377-350	\$10.79	BRACKET, fuel pump	} RD to (c)360300, GT to (c)361000 to mid '74	1
39	377-360	\$2.19	MOUNTING, fuel pump		1
39a	377-370	\$13.99	SUPPORT, fuel pump, rubber	} RD from (c)360301, GT from (c)361001 '74 1/2 on	1
39b	377-380	\$8.99	CLAMP, support		1

40	377-161	\$369.99	FUEL PUMP, S.U., positive or negative grd.	} (Aug 64 on) RD from (c)44439, all GT	1
41	377-080	\$34.99	POINT SET, original pumps		1
42	377-130	\$89.99	DIAPHRAGM, 2 3/8" shaft		1
	377-140	\$64.99	DIAPHRAGM, 3" shaft		1
43	377-155	\$3.69	GASKET		1
44	377-120	\$21.99	COVER		1
45	377-135	NA	DIODE, pos. ground pumps		1
	377-145	\$22.99	DIODE, neg. ground pumps		1
46	370-350	\$5.49	BOLT, banjo union		2
48	370-650	\$0.39	WASHER		4/2
48a	370-655	\$0.39	"O" RING	2	

Some SU pumps use "O" ring #48a instead of the fiber washer #48 between the banjo fitting #49 and the pump. Washer #48 is used under the banjo bolt head.

49	378-120	\$26.99	BANJO UNION, pump inlet	} RD from (c)44439 to 360300, GT to (c)36100	1
	378-125	\$16.99	BANJO UNION, inlet & outlet		2
50	408-445	\$3.99	SU SEALING TAPE	1	

# Fuel Lines

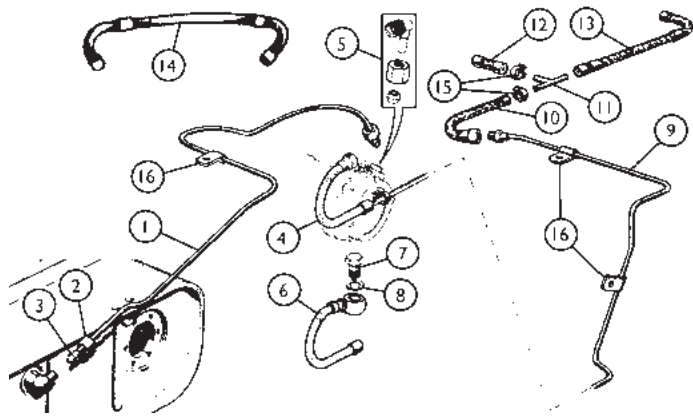

## Fuel Lines 1962 - 1970

19723

RD/GT to (c)219000

No.	Part#	Price (Each)	Description	Application	Qty Req.
1	376-760	\$82.99	PIPE, tank to pump inlet	RD/GT to (c)219000	1
2	376-405	\$9.99	NUT		2
3	376-415	\$8.99	NIPPLE, soldered to pipe	RD to (c)44438	2
4	376-530	\$18.99	HOSE, pump outlet to main feed		1
5	375-038	\$12.99	FITTING SET, 3 pieces		2
(Fitting set comes with nut screwed onto elbow with compression fitting inside. To use, disassemble, and assemble onto pump as shown.)					
6	376-540	\$27.99	HOSE, pump outlet to main feed	RD from (c)44439, all GT	1
7	370-350	\$5.49	BOLT, banjo union, pump outlet		1
8	370-650	\$0.39	WASHER		2
9	376-750	\$89.99	PIPE, main feed	RD to (c)187210, GT to (c)187840	1
	376-900	NA	PIPE, main feed	RD from (c)187211 to 219000, GT from (c)187841 to 219000	1
10	376-320	\$13.99	FUEL HOSE, pipe to carb.	RD to (c)187210, GT to (c)187840	1
	376-910	\$12.99	FUEL HOSE, pipe to carb.	RD from (c)187211 to 219000, GT from (c)187841 to 219000	1
11	376-520	\$20.99	T-CONNECTOR	RD to (c)187210, GT to (c)187840	1
12	376-870	\$5.99	FUEL HOSE, rear carb.		1
13	376-340	\$14.99	FUEL HOSE, carb. to carb.		1
14	376-920	\$18.99	FUEL HOSE, carb. to carb.	RD from (c)187211 to 219000, GT from (c)187841 to 219000	1
15	117-015	\$2.29	CLAMP, fuel hoses		A/R
16	162-230	\$1.39	CLIP, fuel pipes		A/R

Original rubber-cased fuel lines simply won't last forever and they can spring a leak directly onto an electrical or hot engine component. Replacing old questionable fuel hoses is cheap insurance, but, at the very least, regular inspection of your complete fuel system makes good sense. MGBs should not develop fuel odors; if yours does, something is wrong and should be corrected immediately.

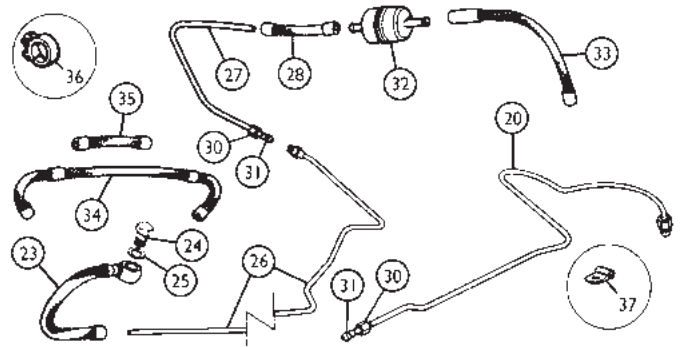

## Fuel Lines 1971 - 1974 1/2

19724

RD from (c)219001 to 360300 / GT from (c)219001 to 361000

No.	Part#	Price (Each)	Description	Application	Qty Req.
20	376-760	\$82.99	PIPE, tank to pump inlet	RD to 360300, GT to (c)361000	1
23	376-540	\$27.99	HOSE, pump outlet	RD from (c)219001 to 360300, all GT	1
24	370-350	\$5.49	BOLT, banjo, pump outlet to main feed (5/16")		1
25	370-650	\$0.39	WASHER		2
26	376-750	\$89.99	PIPE, main feed, rear (5/16")	RD from (c)219001 to 360300,	1
27	376-755	NA	PIPE, main feed, front (5/16")	GT from (c)219001 to 361000	1
28	376-935	\$8.99	HOSE, main feed to filter (1/4")		1
30	376-405	\$9.99	NUT	included with pipes #20 & 27	2
31	376-415	\$8.99	NIPPLE, soldered to pipe		2
32	377-300	\$5.49	FUEL FILTER (1/4" & 5/16")	plastic replacement	1
33	376-910	\$12.99	HOSE, filter to carb. (HS4)	RD/GT to (c)258000	1
	376-930	\$17.99	HOSE, filter to carb. ('72-'74 HIF4 carbs)	RD from (c)258001 to 360300, GT from (c)258001 to 361000	1
34	376-920	\$18.99	FUEL HOSE, carb. to carb. ('70-'71 HS4 carbs)	RD/GT from (c)219001 to 258000	1
			FUEL HOSE, carb. to carb. ('72-'74 HIF4 carbs)	RD from (c)258001 to 360300, GT from (c)258001 to 361000	1
35	376-935	\$8.99			
36	117-015	\$2.29	CLAMP, fuel hoses		A/R
37	162-230	\$1.39	CLIP, fuel pipes		A/R

## Brake Pipe Bending Tool

Smooth bends on small diameter tubing such as brake lines are an important hallmark of quality craftsmanship. Give yourself an edge with our specialty tubing bender which will give you smooth bends in 3/16, 1/4, 5/16, and 3/8 inch tubing.

**385-905 \$24.99**



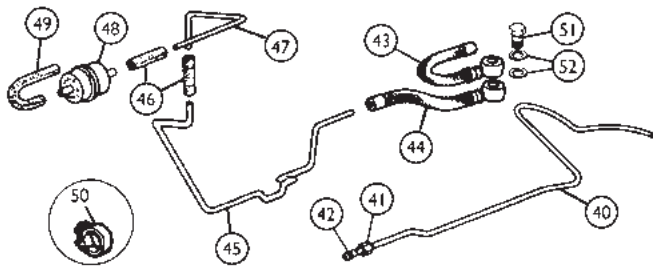

## Fuel Lines 1974 1/2 - 1976

19726

RD from (c)360301 to 415000 / GT from (c)361001 on

No.	Part#	Price (Each)	Description	Application	Qty Req.
40	376-765	\$45.99	PIPE, tank to pump inlet hose		1
41	376-405	\$9.99	NUT		2
42	376-415	\$8.99	NIPPLE, soldered to pipe		2
43	376-540	\$27.99	HOSE, tank pipe to pump inlet		1
44	376-540	\$27.99	HOSE, pump outlet to main feed (5/16")		1
45	376-940	\$52.99	PIPE, main feed (5/16")		1
46	376-955	\$0.89	HOSE, connecting (5/16")		1
47	376-960	\$14.99	PIPE, main feed extension		1
48	377-310	\$4.99	FUEL FILTER, metal body (5/16" hose)		1
	377-312	\$4.99	FUEL FILTER, plastic body (5/16" hose)		1
49	376-930	\$17.99	HOSE, filter to S.U. carb.		1
	376-935	\$8.99	HOSE, filter to Zenith carb.	(cut to length)	1
50	117-015	\$2.29	CLAMP, fuel lines #46 & 49 above		A/R
	262-200	\$2.99	CLAMP, fuel lines #43 & 44 above		A/R
51	370-350	\$5.49	BOLT, banjo		2
52	370-650	\$0.39	WASHER		4/2
	370-655	\$0.39	"O" RING		2

Note: New SU pumps use "O" rings instead of the fiber washers between the banjo fitting and the pump. Washers are still used under the banjo bolt heads.

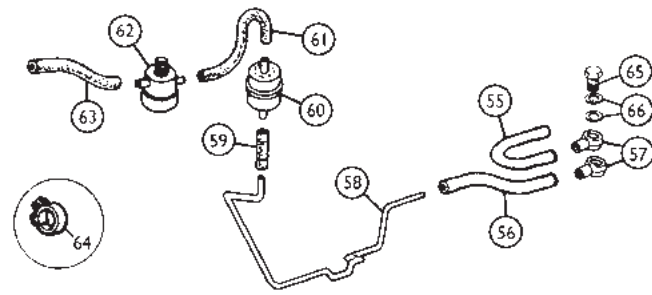

## Fuel Lines 1977 - 1980

19727

RD from (c)415001 on

No.	Part#	Price (Each)	Description	Application	Qty Req.
55	376-620	\$6.99	HOSE, tank to pump inlet		1
56	376-610	\$2.49	HOSE, pump outlet to main feed		1
The original hose was a special type which was very difficult to push onto the pipe, but once installed, would not pull off. Hose clamps were not used. As the original hose is not available, we supply a replacement type which must be used with hose clamps no. 051-191.					
	051-191	\$2.59	HOSE CLAMP	replacement hoses #55, 56	A/R
57	378-125	\$16.99	BANJO UNION		2
58	376-940	\$52.99	PIPE, main feed		1
59	376-955	\$0.89	HOSE, connecting (5/16")		1
60	377-310	\$4.99	FUEL FILTER, metal body (for 5/16" hose)		1
	377-312	\$4.99	FUEL FILTER, plastic body (for 5/16" hose)		1
61	376-970	NA	HOSE, filter to cut-off valve		1
62	377-320	NA	CUT-OFF VALVE		1
63	379-215	\$3.89	HOSE, valve to carb. inlet	sold per foot	A/R
64	326-310	\$2.49	CLAMP, fuel lines #61 & 63 above		A/R
	326-310	\$2.49	CLAMP, fuel lines #55 & 56 above		A/R
	117-015	\$2.29	CLAMP, fuel lines #59 above		2
65	370-350	\$5.49	BOLT, banjo		2
66	370-650	\$0.39	WASHER		4/2
	370-655	\$0.39	"O" RING		2

Note: New SU pumps use "O" rings instead of the fiber washers between the banjo fitting and the pump. Washers are still used under the banjo bolt heads.

## First Inertia Electric Fuel Pump Switch

Fire is one of the single greatest dangers facing our vintage cars. In an accident, your electric fuel pump will go right on pushing fuel out through broken lines or hoses, making an already dangerous situation even worse. The First Inertia Switch will cut off power instantly in a roll-over, or when the vehicle is impacted with sufficient force in any horizontal direction. Vintage racers in particular will appreciate the life saving potential of this product, but any car equipped with an electric fuel pump power cutoff will be safer. Mounting instructions included. Switch is suitable for positive and negative ground systems. Please note: MGBs from 1977-'80 already have a factory roll-over switch.

900-240 \$61.49



## Billet Fuel Filter

The ease of cleaning and clean lines of this filter assembly will add a touch of custom brightness to the engine compartment. The chromed hose barbs can be removed and 5/16" AN-6 fittings attached directly to the body of the fuel filter giving a high degree of fitment flexibility.



Fuel Filter	377-305	NA
Replacement Viton O-ring 5/8" x 7/8"	772-815	\$2.19
Replacement Viton O-ring 1" x 1.25"	772-816	\$1.39

## Fuel Filter/Regulator

High quality universal fit fuel pressure filter/regulator with 1/4" and 5/16" fittings. Made in Italy.

Fuel Filter/Regulator	377-435	\$149.99
Replacement Filter	377-436	\$17.49
Replacement Gasket for bowl	377-437	\$8.19



## Ethanol Resistant Fuel Hose

Gates "Barricade" hose is the lowest permeation multi-fuel compatible hose on the market. Rated for 50 psi at -40 to 257 degrees F, and compatible with all gasoline blends. Sold per inch.

1/4" ID hose	379-214	\$0.69 per inch
5/16" ID hose	434-451	\$0.69 per inch



## Hose & Fitting Kit

Here's the way to re-convert a car to use the stock banjo type SU fuel pump after the original steel lines have been cut, thereby losing the threaded end fittings needed to fasten to the original banjo fittings. Supplied with ethanol-proof hose.

376-109 \$74.99

# Exhaust System

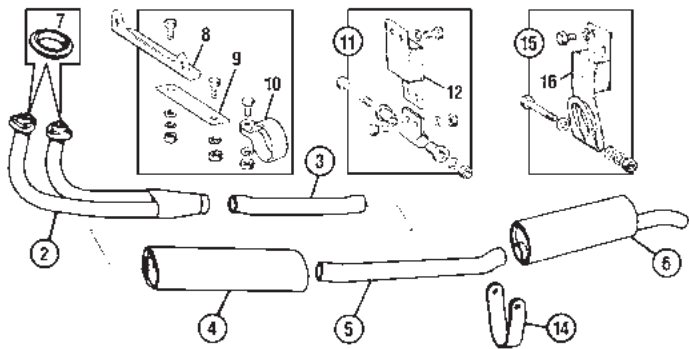

## Exhaust System 1962 - 1967

19731

RD to (c)138400/GT to (c)139471

No.	Part#	Price (Each)	Description	Application	Qty Req.
2	454-530	\$129.99	HEADPIPE		1
3	453-580	\$49.99	INTERMEDIATE PIPE, front		1
4	454-540	\$82.99	MUFFLER, front		1
5	453-590	\$49.99	INTERMEDIATE PIPE, rear		1
6	454-550	\$72.99	MUFFLER, rear		1
7	290-510	\$3.99	GASKET, exhaust flange		2
8	411-070	\$19.99	BRACKET		1
9	411-080	\$2.29	STRAP		1
10	411-090	\$14.99	CLAMP, front pipe		1
11	470-138	\$17.99	HANGER KIT, intermediate		1
12	412-080	\$4.99	MOUNT, hanger		1
	321-678	\$0.89	BOLT SET, hanger assembly		1
14	411-100	\$2.99	BRACKET		1
15	470-178	\$11.99	HANGER ASSEMBLY, rear		1
16	412-040	\$15.99	HANGER, rear		1

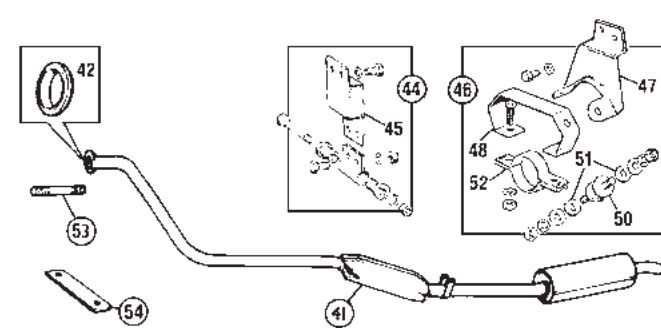

## Exhaust System 1975

19732

RD from (c)367720 to FED 386600, to Calif. 382129 (single carb., no catalytic converter)

No.	Part#	Price (Each)	Description	Application	Qty Req.
41		NA	MUFFLER & PIPE ASSEMBLY (n/a - suggest stainless steel)		1
42	444-130	\$3.69	GASKET, exhaust flange		1
43	444-140	\$7.99	STRAP, front mount		1
44	470-138	\$17.99	HANGER KIT		1
45	412-080	\$4.99	MOUNT, hanger		1
	321-678	\$0.89	BOLT SET, hanger assembly		1
46	470-148	\$32.99	HANGER KIT, rear		1
47	444-060	\$7.99	BRACKET, rear mount		1
48	444-070	\$10.99	BRACKET, hanger		1
50	444-080	\$2.49	MOUNTING, rubber		2
51	444-090	\$1.49	WASHER, heat insulating		4
52	444-150	\$3.19	CLAMP, rear, 2 pcs. req'd. (1 5/8")		2
	444-170	\$5.79	CLAMP, rear, 2 pcs. req'd. (1 3/4")	as required	2
53	328-991	\$2.49	STUD, manifold		3
54	444-140	\$7.99	STRAP, front mount		1

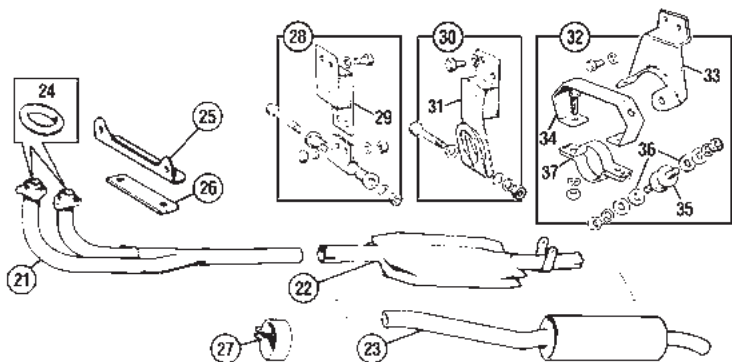

## Exhaust System 1968 - 1974

19733

RD from (c)138401 to 367719/GT from (c)139472 to 367803

21	444-020	\$129.99	HEADPIPE		1
22	444-035	\$139.99	MUFFLER, front, replacement, differs from illustration		1
23	444-030	\$129.99	MUFFLER, rear, replacement, differs from illustration		1
24	290-510	\$3.99	GASKET, exhaust flange		2
25	444-040	\$5.49	BRACKET	RD to (c)341294; GT to (c)341729	1
	413-110	NA	BRACKET	RD from (c)341295; GT from (c)341730	1
26	411-080	\$2.29	STRAP		1
27	411-090	\$14.99	CLAMP, front pipe		1
28	470-138	\$17.99	HANGER KIT		1
29	412-080	\$4.99	MOUNT, hanger		1
	321-678	\$0.89	BOLT SET, hanger assembly		1
30	470-178	\$11.99	HANGER KIT, rear	RD/GT from (c)138401 to 167815, 1968-mid '69	1
31	412-040	\$15.99	HANGER, rear	RD from (c)167816 to 360300, GT from (c)167816 to 361000	1
32	444-145	\$34.99	HANGER KIT, rear, mid 1969-'74 1/2	RD from (c)167816 to 360300, GT from (c)167816 to 361000	1
	470-148	\$32.99	HANGER KIT, rear, 1974 1/2	RD from (c)360301 on, GT from (c)361001 on	1
33	444-050	\$7.99	BRACKET, rear mount	RD from (c)360301 on, GT from (c)361001 on	1
	444-060	\$7.99	BRACKET, rear mount	RD from (c)360301 on, GT from (c)361001 on	1
34	444-070	\$10.99	BRACKET, hanger		1
35	444-080	\$2.49	MOUNTING, rubber	RD/GT from (c)167816 on	2
36	444-090	\$1.49	WASHER, heat insulating		4
37	444-150	\$3.19	CLAMP, rear, 2 pcs. req'd. (1 5/8")		2
	444-170	\$5.79	CLAMP, rear, 2 pcs. req'd. (1 3/4")	as required	2

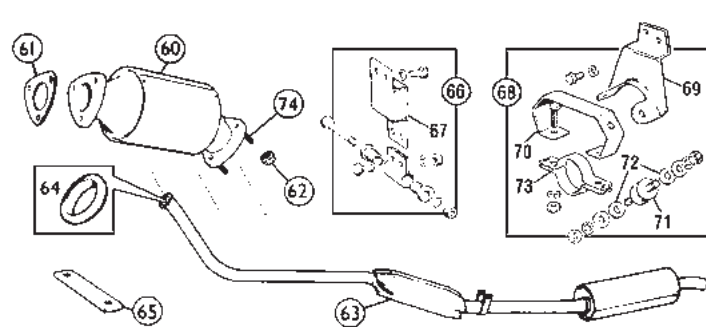

## Exhaust System 1975 - 1980

19734

RD from FED (c)386601 on, Calif. from (c)382130 on (single carb. w/ catalytic converter)

55	444-175	\$464.99	CATALYTIC CONVERTER, replacement (not California legal)		1
			U.S.-made, fits like original and meets all EPA requirements, but not legal for California.		
61	297-550	\$10.49	GASKET, converter to manifold		1
62	311-610	\$1.69	NUT		3
63	444-180	\$279.99	MUFFLER & PIPE ASSEMBLY (3-piece)		1
	444-410	\$64.99	HEADPIPE		1
	444-415	\$129.99	MUFFLER, front		1
	444-420	\$129.99	MUFFLER, rear		1
64	444-130	\$3.69	GASKET, exhaust flange		1
65	444-140	\$7.99	STRAP, front mount		1
66	470-138	\$17.99	HANGER KIT		1
67	412-080	\$4.99	MOUNT, hanger		1
	321-678	\$0.89	BOLT SET, hanger assembly		1
68	470-148	\$32.99	HANGER KIT, rear		1
69	444-060	\$7.99	BRACKET, rear mount		1
70	444-070	\$10.99	BRACKET, hanger		1
71	444-080	\$2.49	MOUNTING, rubber		2
72	444-090	\$1.49	WASHER, heat insulating		4
73	444-150	\$3.19	CLAMP, rear, 2 pcs. req'd. (1 5/8")		2
	444-170	\$5.79	CLAMP, rear, 2 pcs. req'd. (1 3/4")	as required	2
74	328-991	\$2.49	STUD, converter to front pipe		3



### Stainless Steel Exhaust Systems

Guaranteed against corrosion for life, our stainless steel systems sound good and fit properly. Constructed entirely of top quality stainless steel, this is the system for your car if you live where winter road conditions are harsh. (Does not include clamps, hangers or gaskets. For these, see page 32.)

<b>1962-'74 Stainless Steel Exhaust</b>	<b>454-569</b>	<b>\$599.99</b>
<b>1975 Stainless Exhaust for cars without catalytic converter</b>	<b>454-570</b>	<b>NA</b>

Amendments to the Clean Air Act make it illegal for anyone to change or alter the emission control system of any automobile in the United States except those used exclusively off-road.



### MGB "Big Bore" Stainless Exhaust System

For those of you who require a stainless exhaust due to local weather conditions, but still want the performance of a free-flow exhaust, this should provide a nifty solution! These large pipe diameter systems eliminate the forward silencer but incorporate a larger capacity free-flow rear silencer with a polished tip. (Does not include clamps, hangers or gaskets. For these, see page 32.)

<b>1962-'74 Big Bore Stainless Exhaust System</b>	<b>444-165</b>	<b>NA</b>
<b>1975-'80 Big Bore Stainless Exhaust System</b> (for vehicles with catalytic converter)	<b>444-155</b>	<b>NA</b>

Amendments to the Clean Air Act make it illegal for anyone to change or alter the emission control system of any automobile in the United States except those used exclusively off-road.



459-085 shown

### Stainless Steel Sport Exhaust

The Tourist Trophy brand exhaust system is mandrel bent for a perfect fit and constructed of polished stainless steel for a long life. The 3 into 1 tubular header reduces back pressure and will improve exhaust flow for increased efficiency. Each system includes an installation kit with hardware and upgraded hangers that attach to your original mounting points. This system looks and sounds great!

<b>1962-'74 1/2 Exhaust and Down Pipe</b>	<b>459-075</b>	<b>\$599.99</b>
<b>1962-'74 1/2 Exhaust and Header</b>	<b>459-085</b>	<b>\$729.99</b>



### Performance Exhaust Headers

Our tubular exhaust headers are suitable for either vintage racing or the sporting enthusiast looking for a little extra performance through improved engine breathing and reduced back pressure. All of our headers are carefully jig-welded and designed for maximum performance. However, they do require some hand fitting and port matching, particularly for racing applications. These fit cars without catalytic converters only.

<b>Stainless Steel Header (illus.)</b>	<b>459-015</b>	<b>\$519.99</b>
--	----------------	-----------------

Amendments to the Clean Air Act make it illegal for anyone to change or alter the emission control system of any automobile in the United States except those used exclusively off-road.



### 3-1 Short Exhaust Header

American made short header design offers improved ground clearance and easy installation. Can also be modified for use on other B-series engined vehicles.

<b>3-1 Header</b>	<b>459-011</b>	<b>\$274.99</b>
-------------------	----------------	-----------------

## Clutch Replacement

Insert your clutch alignment tool through your new clutch disc, push the tool into the pilot bushing in the crankshaft, then press the disc up flat against the flywheel. Locate the new pressure plate on the two dowel pins, install the six bolts just a couple of turns each. Now, by exerting appropriate sideways pressure on the handle of the alignment tool, position the disc so that you can slip the tool in and out of the pilot bushing with minimal drag on the splines. There is one spot, with the disc perfectly centered, where virtually no resistance will be felt. Once the disc is in the position, tighten the bolts one turn each at a time until they are all fully secure. The tool should still slip in and out very easily; if it doesn't, repeat the procedure until it does. If the tool meets no resistance, the gearbox input shaft will go in equally easily.

Install your new throwout bearing, being sure to lightly grease the points where it pivots in the yoke. Wire-brush the splines on the gearbox input shaft, then give them a very light coat of white lithium grease. Finally, grease the nose of the input shaft where it runs in the pilot bushing. When reassembling the engine to the gearbox, be sure to get the face of the bellhousing parallel to the rear engine plate once the input shaft splines enter the clutch disc; it will then slide all the way home without the need for brute force.

## Clutch Problems

Clutch problems fall into three categories:

- The clutch does not release properly when the pedal is depressed, resulting in difficult engaging of gears.
- Clutch slip, a condition where the engine speed increases when you give the car gas while in gear, but the car does not speed up accordingly.
- Clutch judder, where the car does not take up smoothly as you let the clutch out.

Problem "a" is usually caused by faulty hydraulics. First, check that there is sufficient fluid in the clutch master cylinder. If the level is low, look for leaks at the master cylinder or slave cylinder, and rebuild or replace these cylinders as necessary. If the level is okay and there are no leaks evident, bleed the system to ensure there is no air present. Check that the flexible hose has not deteriorated; watch to see that it does not expand in diameter while a colleague pushes the clutch pedal. If the hydraulics are working properly, the end of the throwout fork arm should travel 3/8". If the clutch does not release properly, even though the hydraulics are working correctly, either the throwout bearing is completely worn out (so the pressure plate is not being pushed far enough to release the disc), or the disc itself is hanging up. Either of these problems require that the engine be removed to inspect and remedy the situation.

Problems "b" and "c" both require that the engine be removed to get at the clutch. Clutch slip results from the disc being worn out or oily, (which also causes judder,) or the pressure plate springs being weak. Since getting to the clutch is such a labor intensive operation, we strongly recommend replacing the disc, pressure plate and throwout bearing if you have a mechanical problem with your clutch. Excess play of the lever will cause premature wear on the throwout bearing. A new throwout bearing has 11/64" of carbon thrust face exposed from the metal body; if yours has 1/8" or less, it should be replaced, too. If your disc has worn so far that the rivets are exposed, check the face of the flywheel for grooves, it must be removed and resurfaced if the surface is scored noticeably.

**Special Note:** MGB starters have a habit of chewing up the flywheel ring gear. While doing a clutch job, always check the ring gear for damage to the teeth, and have your machine shop install a new one if significant damage is present.



## Clutch Hydraulic Kit

Save money and make ordering easy with this kit which includes all usually replaced clutch hydraulic components: master cylinder, slave cylinder with pushrod, hose and required copper washers.

180-718 \$54.99

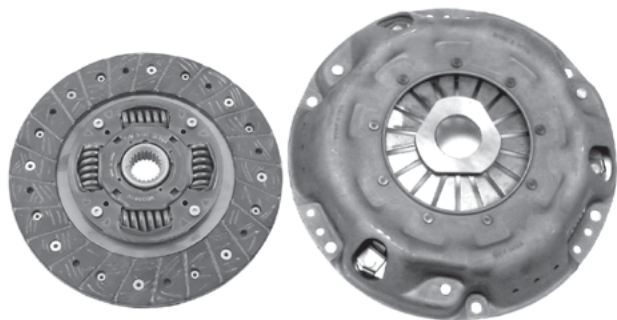

## Heavy Duty/Competition Clutch

These competition-grade parts have been engineered to reliably handle any hard driving situation on the street or track. The pressure plate, because of its stronger than standard springs, acts more quickly and more positively than a stock unit and requires only a moderate increase in pedal pressure. For proper operation and reliability, our heavy duty clutch components must always be fitted as sets.

<b>CLUTCH KIT, heavy duty/competition</b>	190-815	NA
<b>PRESSURE PLATE, heavy duty/competition</b>	190-810	\$121.99
<b>CLUTCH DISC, heavy duty/competition, aftermarket</b>	190-821	\$79.99
<b>RELEASE BEARING, roller type</b>	190-305	\$44.99
<b>RETAINER, release bearing</b>	190-570	\$2.49

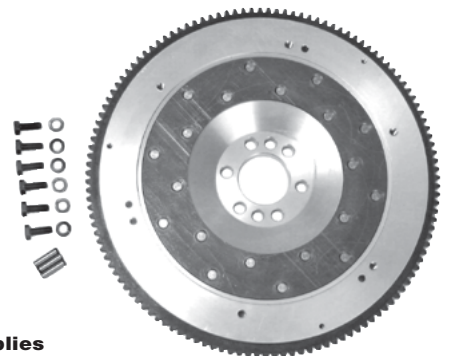

## Alloy Flywheel Assemblies

For the serious performance seeker, these steel faced aluminum alloy flywheels complete with ring gears weigh less than half as much the stock cast iron flywheels.

<b>1962-'64 (3-main engine)</b>	460-673	\$474.99
<b>1965-'67 (5-main engine)</b>	460-674	\$394.99
<b>1968-'80 (5-main engine)</b>	460-675	\$449.99



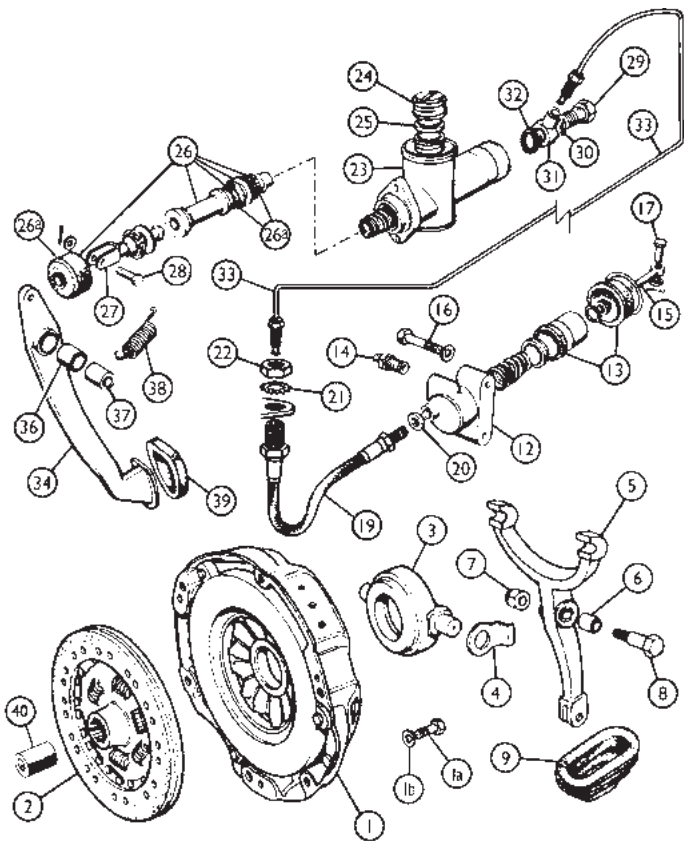

23	180-675	\$219.99	MASTER CYL., clutch, AP Braking	{ RD to (c)138400, GT to (c)139471; 1962 - '67 1968-80 1962-80	1	
	180-695	\$189.99	MASTER CYL., clutch, AP Braking		1	
	180-697**	\$27.99	MASTER CYL., clutch, replacement		1	
					**Replacement - fits all due to shorter reservoir.	
24	180-210	\$5.29	CAP, filler (plastic replacement)		1	
	180-211	\$14.99	CAP, filler, metal (as original)		1	
25	180-451	\$2.99	WASHER, filler cap (use with metal caps only)		1	
26	180-965	\$26.99	REBUILD KIT, master cylinder	} SEE NOTE BELOW	1	
	180-985	\$7.99	REPAIR KIT, master cylinder		1	

**Note:** From 1968 to '80, either one of two master cylinders was fitted. One is identified by two concentric circles cast into the body near the line fitting or a groove in the body near the mounting flange. The other has no such markings. The two master cylinder assemblies and complete sets of internal components are interchangeable; however, individual internal components are not.

REBUILD KIT 180-965 includes all "modified design" internal components shown in the drawing below (spring, seals, piston, washers, etc.). This is original for marked cylinders, and is to be used also on earlier unmarked cylinders and replacement cylinder 180-697, thereby converting these cylinders to the later design. Original style rebuild kits for these early cylinders are no longer available.

REPAIR KIT 180-985 includes seals and dust boot for original marked cylinders, and unmarked cylinders which have been converted using kit 180-965. Original style repair kits for unmarked cylinders are no longer available. This kit will not work for replacement cylinder 180-697.

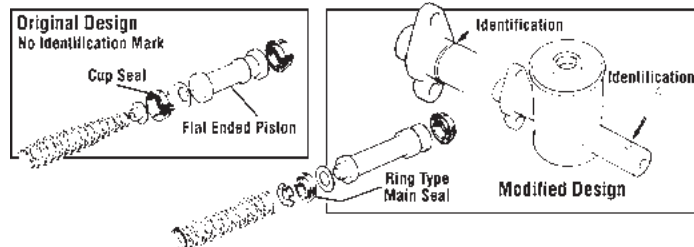

27	181-690	\$25.99	PUSH ROD (included with master cylinders)		1
28	325-150	\$1.29	CLEVIS PIN		1
29	180-430	\$9.99	BANJO BOLT		1
30	324-720	\$0.99	WASHER		1
31	180-465	\$17.89	BANJO		1
32	324-730	\$0.69	WASHER		1
33	181-210	\$55.99	PIPE, master cylinder banjo to hose	thru 1976	1
	180-606	\$54.99	PIPE, master cylinder banjo to hose	1977-'80	1
34	190-600	NA	PEDAL ASSEMBLY, chrome bumpered cars	} RD to (c)360300, GT to (c)361000	1
	190-610	NA	PEDAL ASSEMBLY, 74 1/2		} RD from (c)360301 to 386600, GT from (c)361001 on
	190-620	NA	PEDAL ASSEMBLY, 1975 - '80	RD from (c)386601 on	
36	330-180	\$7.49	BUSH	all	1
Never rest your foot on the clutch pedal! This causes premature wear on the release bearing, which cannot be changed without removing the engine.					
37	190-625	\$4.29	DISTANCE TUBE, thru 1975	RD to (c)386600, all GT	1
	190-630	NA	DISTANCE TUBE, 1976 on	RD from (c)386601 on	1
38	329-350	\$2.29	SPRING, pedal return		1
39	280-770	\$1.49	PEDAL PAD, clutch & brake		2
40			SPIGOT BUSHING (see page 8 illus. no. 2 for details)		1

387-210	\$3.99	CLUTCH ALIGNMENT TOOL	3 main engines	1
387-235	\$3.99	CLUTCH ALIGNMENT TOOL	5 main engines	1



## Clutch

19744

No.	Part#	Price (Each)	Description	Application	Qty Req.
	190-808	\$279.99	CLUTCH KIT, AP brand		1
	190-807	\$139.99	CLUTCH KIT, premium aftermarket		1
	190-815	NA	CLUTCH KIT, heavy duty/competition		1
Note: Clutch kits include one each pressure plate, clutch disc and release bearing.					
1	190-080	\$129.99	PRESSURE PLATE, AP brand		1
	190-810*	\$121.99	PRESSURE PLATE, heavy duty/competition, AP brand		1
1a	322-540	\$0.79	BOLT, pressure plate to flywheel		6
1b	365-730	\$0.39	LOCKWASHER		6
2	190-250	\$99.99	CLUTCH DISC, AP brand		1
	190-821*	\$79.99	CLUTCH DISC, heavy duty/competition, aftermarket		1
*Note: These competition-grade parts reliably handle any hard driving situation on the street or track. The pressure plate acts more quickly and more positively than a stock unit and requires only a moderate increase in pedal pressure. For proper operation and reliability, our heavy duty clutch components must always be fitted as sets.					
3	190-300	\$27.99	RELEASE BEARING, carbon faced (as original)		1
	190-301	\$114.99	RELEASE BEARING, carbon faced, AP brand		1
	190-305	\$44.99	RELEASE BEARING, roller bearing type		1
4	190-570	\$2.49	RETAINER, release bearing		2
5	190-580	\$279.99	LEVER, clutch	non-synchro 1st gearbox	1
	462-590	\$69.99	LEVER, clutch, rebuilt/exchange	full-synchro gearbox	1
		\$300.00	CORE CHARGE FOR 462-590		0
6	330-200	\$1.79	BUSH, withdrawal lever		1
7	310-240	\$0.89	NUT		1
8	190-550	\$6.29	BOLT		1
9	461-010	\$3.49	BOOT, rubber, oval		1
	461-015	\$3.99	BOOT, rubber, square		1
12	180-720	\$179.99	CLUTCH SLAVE CYLINDER, AP brand		1
	180-715	\$15.99	CLUTCH SLAVE CYLINDER, aftermarket		1
13	180-960	\$5.99	REPAIR KIT, slave cylinder		1
14	180-080	\$3.69	BLEEDER SCREW		1
15	180-200	\$3.59	PUSH ROD		1
16	322-670	\$1.09	BOLT		2
17	325-140	\$1.19	CLEVIS PIN		1
19	180-820	\$26.99	CLUTCH HOSE, stock type		1
	180-821	\$8.99	CLUTCH HOSE, stock type, aftermarket		1
	180-823	\$26.99	CLUTCH HOSE, stainless steel braided (includes nut #22)		1
20	324-720	\$0.99	WASHER, copper		1
21	324-180	\$0.49	LOCK WASHER		1
22	311-420	\$1.99	NUT, hose to bracket on frame		1

Toll-Free Orders 1-800-667-7872 | MossMotors.com  
 Fax 805-692-2525 | Local 805-681-3400

MOSS

# Early Gearbox (3-synchro)

1962 - '67 RD to (c)138400/GT to (c)139471

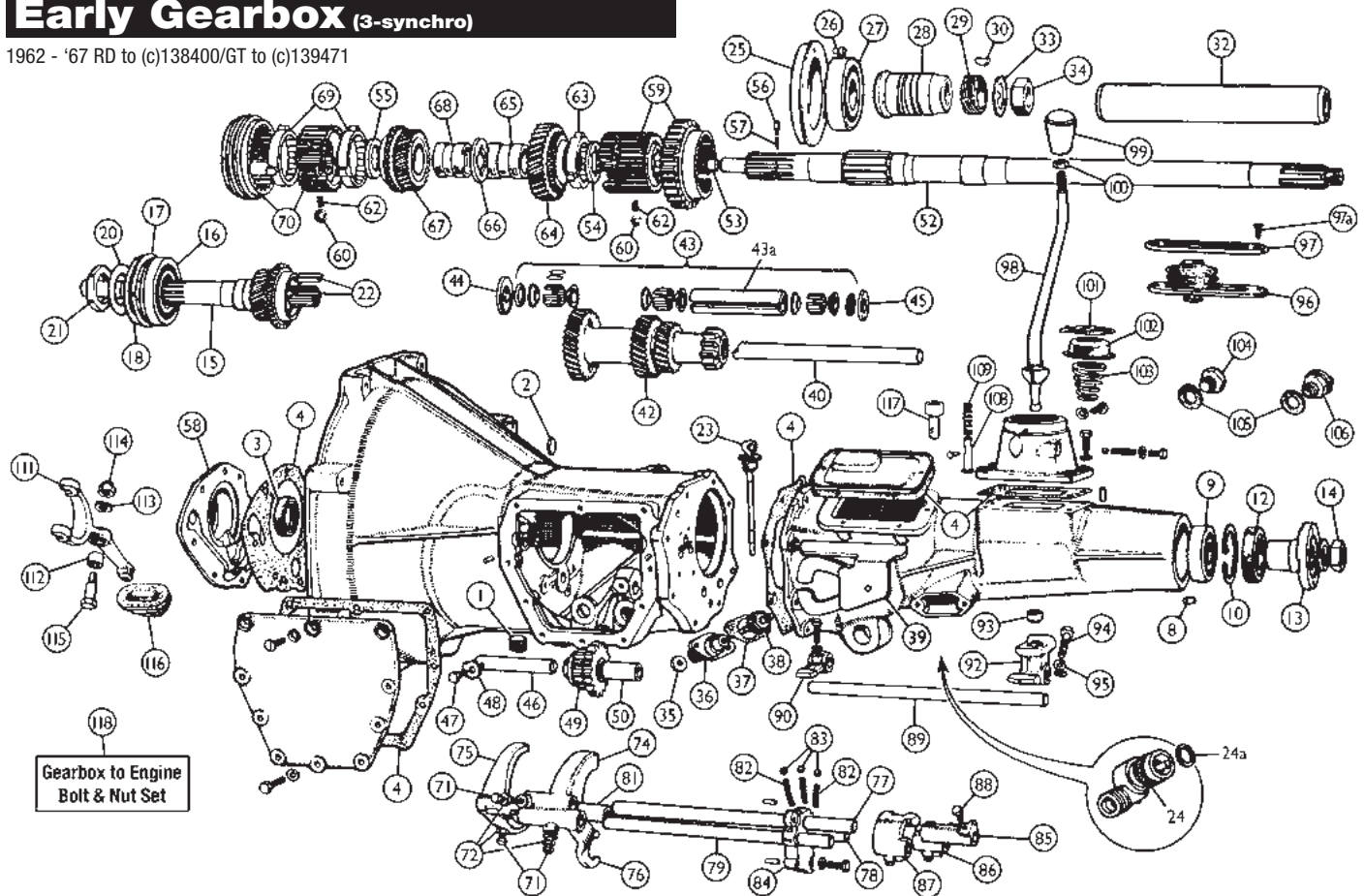

## Early Gearbox (3-synchro)

19745

No.	Part#	Price (Each)	Description	Application	Qty Req.
-----	-------	--------------	-------------	-------------	----------

Original non-synchro gearboxes can be rebuilt to new specs and are good for 75,000 to 100,000 miles between rebuilds. Early gearboxes do have an endearing nature, very much in keeping with the vintage feel of early MGBs, and lack of synchro on first is really not a problem. Do yourself and future generations a favor and keep your MGB as original as possible. (While it is possible to install later 1968-on full-synchro gearboxes into early MGBs, we don't recommend it for a number of reasons. This is not a simple conversion of swapping late parts for early parts. Clearance problems require that the narrower early gearbox tunnel be "bashed" out in the appropriate places to provide adequate clearance.)

1	328-055	\$9.99	PLUG, oil drain		1
	328-056	\$39.99	PLUG, oil drain, magnetic	(optional)	1
2	328-310	NA	CORE PLUG		1
3	120-300	\$1.99	OIL SEAL, front cover		1
4			GASKET, supplied in gasket set only, see page 37.		1
8	328-330	NA	PLUG, tapered	standard trans. uses 2	1/2
9	071-329	\$16.99	BEARING, rear extension	standard	1
	125-900	\$7.99	BEARING, rear annulus	overdrive	1
10	326-160	NA	CLIP, bearing	} standard	1
12	121-100	\$3.99	OIL SEAL		1
	121-110	\$2.79	OIL SEAL, rear annulus	overdrive	1
13	461-800	NA	FLANGE	} standard	1
14	310-570	\$3.49	NUT		1
15	461-250	NA	INPUT SHAFT	18G/GA engines, '62 - '64	1
	461-255	NA	INPUT SHAFT	18GB engines, '65 - on	1
16	127-200	\$39.99	BEARING, input shaft		1
17	326-180	NA	CLIP		1
18	461-280	\$11.79	SHIM, .002"		A/R
	461-290	\$11.79	SHIM, .004"		A/R
20	461-270	\$4.09	LOCK WASHER		1
21	461-260	\$13.99	NUT		1
22	442-298	\$13.59	ROLLER SET, 18 roller bearings		1
23	461-020	NA	DIPSTICK		1
24	021-510	\$54.99	SPEEDO DRIVE ADAPTOR		1
24a	324-720	\$0.99	WASHER		1

Copper washer, #324-720 was fitted to ensure that the drive shaft of the speedo angle drive did not bottom out in the speedo drive pinion, causing premature wear and failure. These washers are often missing, but should always be fitted!

No.	Part#	Price (Each)	Description	Application	Qty Req.
-----	-------	--------------	-------------	-------------	----------

29	433-740	NA	GEAR, speedo drive	} standard	1
30	327-120	\$1.19	KEY, speedo gear		1
33	461-365	\$4.09	LOCK WASHER, spacer	} overdrive	1
34	461-385	\$17.99	NUT, spacer		1
35	461-445	\$2.79	OIL SEAL, speedo pinion	} standard	1
36	433-750	NA	BUSH, speedo pinion		1
37	433-760	\$0.99	GASKET, speedo pinion bush		1
38	433-770	NA	PINION, speedometer		1
39	461-230	NA	ARM ASSEMBLY, interlocking		1
40	461-560	\$46.99	LAYSHAFT, stock type	} to (e)GB74719 standard, GB74528 O/D	1
	461-561	\$79.99	LAYSHAFT, uprated 0.645" nominal diameter		1
441-470	\$49.99	LAYSHAFT, for laygear 0.668" nominal diameter	} from (e)GB74720 standard, GB74529 O/D	1	
42	461-570	\$419.99	LAYGEAR, #22H54	} to (e)GB74719 standard, GB74528 O/D	1
	461-571	\$599.99	LAYGEAR KIT, includes uprated bearings and uprated layshaft		1
441-480	\$384.99	LAYGEAR, #22H1301 use w/461-888 bearing kit	} from (e)GB74720 standard, GB74529 O/D	1	
43	461-868	\$139.99	BEARING KIT, for laygear complete w/3 bearings	} to (e)GB74719 standard, GB74528 O/D	1
	461-888	\$72.99	BEARING KIT, for laygear complete w/4 bearings	} from (e)GB74720 standard, GB74529 O/D	1
43a	461-580	\$23.99	TUBE, bearing spacer	1	
44	461-590	\$12.99	THRUST WASHER, front	} to (e)GB74719 standard, GB74528 O/D	A/R
45	461-600	\$19.99	THRUST WASHER, rear .155"		A/R
	461-610	\$19.99	THRUST WASHER, rear .157"		A/R
	461-620	\$19.99	THRUST WASHER, rear .160"		A/R
	461-630	\$16.99	THRUST WASHER, rear .163"		A/R
441-520	\$16.99	THRUST WASHER, front	} from (e)GB74720 standard, GB74529 O/D	1	
441-530	\$13.99	THRUST WASHER, rear .155"		A/R	
441-540	\$11.59	THRUST WASHER, rear .157"		A/R	
441-550	\$11.99	THRUST WASHER, rear .160"		A/R	
441-560	\$14.99	THRUST WASHER, rear .163"		A/R	
46	461-640	NA	SHAFT, reverse gear	1	

# Early Gearbox (3-synchro)

No.	Part#	Price (Each)	Description	Application	Qty Req.
47	461-780	\$3.29	BOLT, reverse shaft		1
48	461-650	NA	TAB WASHER, reverse shaft		1
49	461-660	\$43.99	REVERSE GEAR		1
50	330-170	NA	BUSHING		1
52	451-370	NA	MAINSHAFT	standard	1
	451-400	NA	MAINSHAFT	overdrive	1
53	461-300	\$0.69	RESTRICTOR, oil		1
54	461-340	NA	THRUST WASHER, rear		1
55	461-310	NA	THRUST WASHER, front .157"		A/R
	461-320	\$24.99	THRUST WASHER, front .159"		A/R
	461-330	\$24.99	THRUST WASHER, front .161"		A/R
56	461-350	NA	PEG, front thrust washer		1
57	329-250	NA	SPRING, peg		1
58	442-500	NA	GEARBOX COVER, front		1
59	461-470	\$369.99	FIRST GEAR & HUB		1
60	329-550	\$0.99	BALL		6
62	329-260	\$1.59	SPRING		6
63	461-490	\$39.99	SYNCHRO RING, 2nd gear - brass	use only where originally fitted	1
	461-495	\$59.99	SYNCHRO RING, 2nd gear - steel	use w/461-480 only	1
Note: Brass and steel synchro rings are not interchangeable and must be used only with their respective gears.					
64	461-480	NA	SECOND GEAR, improved type	use w/461-495 ring only	1
65	461-500	\$54.99	BUSHING, 2nd gear		1
66	461-540	\$8.99	RING, interlocking		1
67	461-510	NA	THIRD GEAR		1
68	461-530	NA	BUSHING, 3rd gear		1
69	461-520	\$36.99	SYNCHRO RING, 3rd & 4th gear		2
70	461-550	NA	SLIDING HUB & DOG ASSEMBLY		1
71	461-760	\$4.29	BOLT		3
72	462-410	NA	NUT		3
74	461-120	NA	FORK, 1st & 2nd gear		1
75	461-150	NA	FORK, 3rd & 4th gear		1
76	461-170	NA	FORK, reverse		1
77	461-130	NA	SHAFT, 1st & 2nd fork		1
78	461-160	NA	SHAFT, 3rd & 4th fork		1
79	461-180	NA	SHAFT, reverse		1
81	461-140	NA	DISTANCE PIECE, for shaft #461-160 (illus. #78)		1
82	329-240	\$3.49	SPRING		3
83	329-520	\$0.79	BALL		3
84	461-190	NA	BLOCK, sliding shaft locating		1
85	461-200	NA	SELECTOR, 1st & 2nd gear		1
86	461-210	NA	SELECTOR, 3rd & 4th gear		1
87	461-220	NA	SELECTOR, reverse gear		1
88	461-770	\$3.19	BOLT, selector locating		3
89	461-080	NA	SHAFT, remote control	standard	1
	441-570	NA	SHAFT, remote control	overdrive	1
90	461-090	NA	LEVER, front selector	standard	1
	441-580	NA	LEVER, front selector	overdrive	1
	441-590	NA	LEVER, intermediate selector	overdrive	1
	461-110	\$5.89	BUSH, intermediate lever		1
92	461-100	NA	LEVER, rear selector	standard	1
	441-600	NA	LEVER, rear selector	overdrive	1
93	461-110	\$5.89	BUSH, gearshift lever		1
94	461-860	NA	BOLT		1
95	327-030	\$0.39	KEY		2
96	282-340	\$8.79	GEARSHIFT BOOT		1
	228-370	\$39.99	GEARSHIFT BOOT, leather	option	1
97	443-120	\$19.99	CHROME RETAINER, gearshift boot		1
97a	323-555	\$0.99	CHROME SCREW		4
98	443-130	NA	GEARSHIFT LEVER	standard	1
	443-140	\$96.99	GEARSHIFT LEVER	overdrive	1
99	461-680	\$26.99	KNOB, reproduction of original		1
Note: For accessory knobs, see the full color section at the front of this catalog.					
100	310-150	\$0.39	NUT		1
101	443-090	\$18.99	CIRCLIP		1
102	443-080	\$26.49	RETAINER		1
103	443-070	\$42.99	SPRING, anti-rattle		1
104	328-450	NA	PLUG, back-up lamp switch		A/R
105	324-145	\$0.39	WASHER, plug & switch		A/R
106	140-470	\$12.99	SWITCH, back-up lamp		A/R
108	441-610	NA	PLUNGER, reverse selector	standard	1
	441-620	NA	PLUNGER, reverse selector	O/D to (e)GB54405	1
	441-630	NA	PLUNGER, reverse selector	O/D from (e)GB54406	1
109	329-270	NA	SPRING, reverse plunger		1

No.	Part#	Price (Each)	Description	Application	Qty Req.
111	190-580	\$279.99	LEVER, clutch withdrawal		1
112	330-200	\$1.79	BUSH, withdrawal lever		1
113	324-725	\$1.09	WASHER		1
114	310-240	\$0.89	NUT		1
115	190-550	\$6.29	BOLT		1
116	461-010	\$3.49	BOOT, clutch lever		1
117	267-040	\$10.79	BREATHER		1
118	322-428	\$10.99	BOLT & NUT SET, gearbox to engine		1
	296-440	\$5.49	GASKET SET	standard	1
	296-498	\$8.99	GASKET SET	overdrive	1

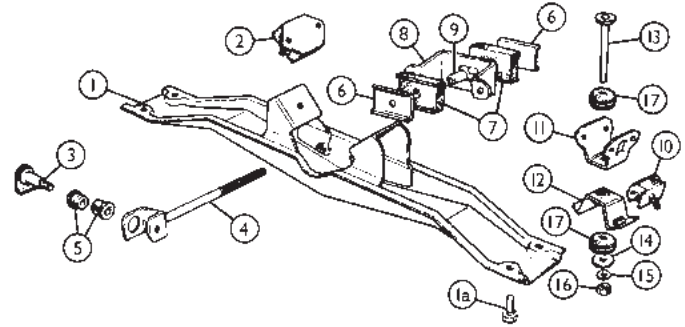

## Gearbox Mounts (3-synchro)

19746

1	NA	CROSS MEMBER, trans. mount	1
1a	322-050	\$0.89 BOLT, cross member mounting	4
2	413-050	\$5.99 MOUNT, gearbox	2
3	413-140	\$34.99 PIN, stayrod	1
	310-050	\$0.69 NUT on pin	1
	324-040	\$0.39 LOCKWASHER for nut	1
4	413-130	\$79.99 STAYROD	1
5	280-050	\$1.39 BUSH (stock rubber)	2
	280-054	\$6.99 BUSH PAIR, Prothane	1
6	413-120	\$4.29 PLATE, buffer	2
7	282-330	\$0.99 BUFFER (stock rubber)	2
	282-335	\$11.99 BUFFER PAIR, Prothane	1
8	413-100	\$56.99 BRACKET, buffer	1
9	413-125	\$6.39 SPACER	1
10	413-070	\$6.99 MOUNT, gearbox	2
11	413-080	NA BRACKET, upper	1
12	413-090	NA BRACKET, lower	1
13	413-150	\$7.59 PIN, gearbox mount	1
14	315-240	\$0.39 WASHER on pin	1
15	365-730	\$0.39 LOCKWASHER	1
16	310-140	\$0.39 NUT on pin	1
17	280-055	\$1.79 BUSH (stock rubber)	2
	280-056	\$9.99 BUSH PAIR, Prothane	1

RD to (c)138400, 1962 - '67

GT to (c)139471, thru '67

# Late Gearbox (4-synchro)

1968 - '80 RD from (c)138401/GT from (c)139472

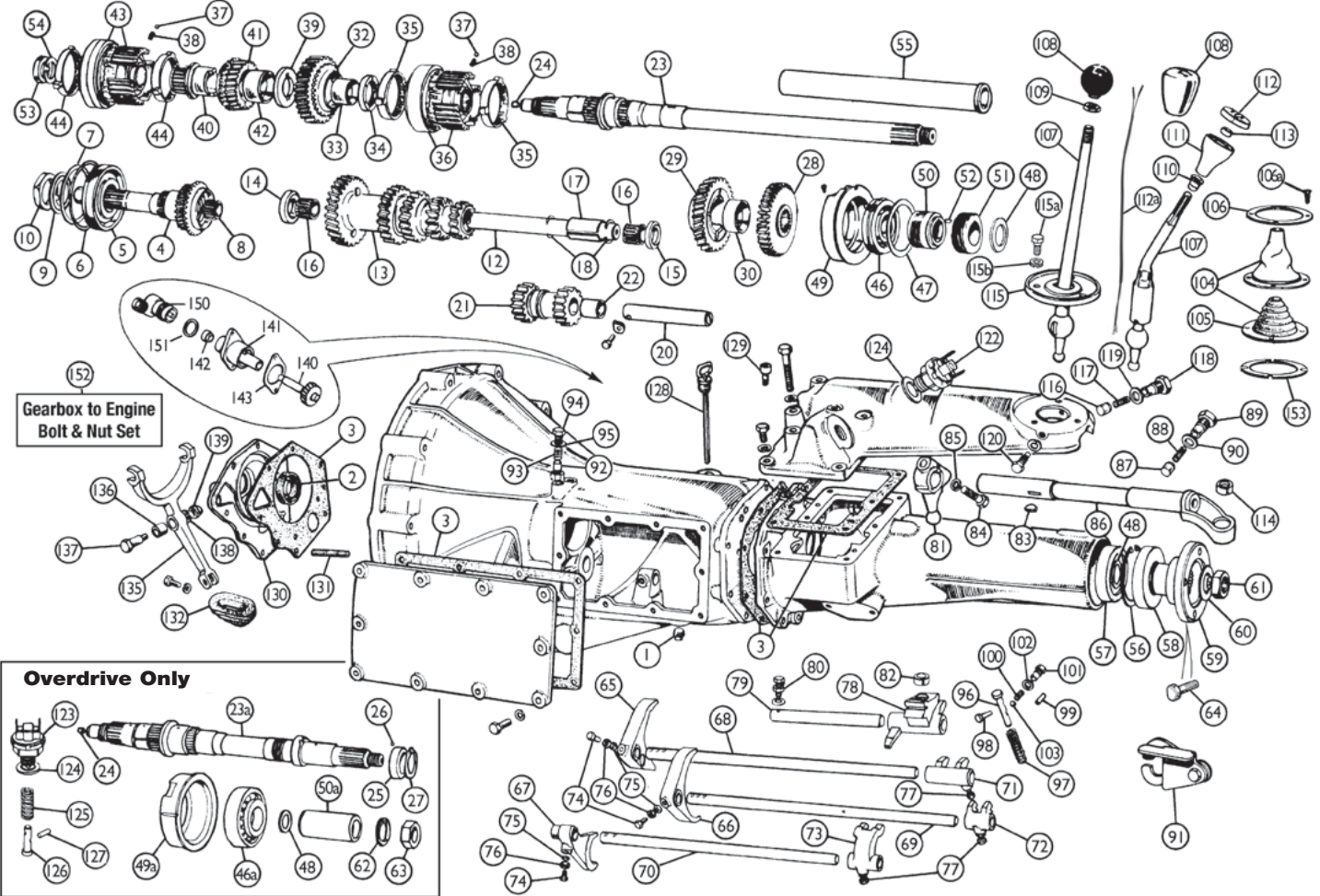

## Late Gearbox (4-synchro)

19748

No.	Part#	Price (Each)	Description	Application	Qty Req.
1	328-055	\$9.99	DRAIN PLUG		1
	328-056	\$39.99	DRAIN PLUG, magnetic	(optional)	1
2	120-300	\$1.99	OIL SEAL, front cover		1
3	296-550	\$3.99	GASKET SET, transmission		1
	296-560	\$0.79	GASKET, front cover		1
	296-570	\$0.89	GASKET, side cover		1
	296-580	\$1.39	GASKET, rear extension	standard	1
	296-590	\$0.79	GASKET, overdrive adaptor	overdrive	1
	296-600	\$0.49	GASKET, remote control		1
4	462-000	NA	INPUT SHAFT		1
5	620-586	\$29.99	BEARING		1
6	326-740	\$4.29	CLIP		1
7	462-020	\$3.39	SHIM, .002"		A/R
	462-025	\$1.49	SHIM, .004"		A/R
8	127-825	\$9.99	BEARING		1
9	462-035	\$4.79	LOCK WASHER		1
	462-040	NA	NUT		1
	462-050	\$68.99	LAYSHAFT		1
	462-055	NA	LAYGEAR		1
	462-060	NA	THRUST WASHER, front	thru 18GK engines	1
	462-065	NA	THRUST WASHER, front	18V engines	1
15	462-070	NA	THRUST WASHER, rear .154 - .156	thru 18GK engines, 1968 - '71	A/R
	462-075	NA	THRUST WASHER, rear .157 - .158		A/R
	462-045	NA	THRUST WASHER, rear .160 - .161		A/R
	462-080	NA	THRUST WASHER, rear .163 - .164		A/R
	462-085	NA	THRUST WASHER, rear .135	18V engines, 1972 on	A/R
	462-090	NA	THRUST WASHER, rear .131		A/R
	462-095	NA	THRUST WASHER, rear .128		A/R
	462-100	NA	THRUST WASHER, rear .124		A/R
	127-830	\$12.99	BEARING		
17	462-105	NA	DISTANCE TUBE		1
18	326-920	\$0.89	CLIP		2
20	462-110	NA	SHAFT, reverse gear		1
21	462-115	NA	GEAR ASSEMBLY, reverse		1
22	462-120	\$3.99	BUSHING, reverse rear		2

No.	Part#	Price (Each)	Description	Application	Qty Req.
23	462-125	NA	MAINSHAFT	standard	1
Mainshaft is later type which must be used with late speedometer drive gears (#51) 462-275 (NA)					
23a	462-130	NA	MAINSHAFT, with cam	overdrive	1
24	461-300	\$0.69	RESTRICTOR, oil	all	1
25	466-245	\$82.99	CAM	overdrive	1
26	329-820	\$0.39	BALL		1
27	326-930	\$6.59	CIRCLIP		1
28	462-140	NA	REVERSE GEAR, on mainshaft		1
29	462-150	\$67.99	FIRST GEAR		1
30	462-155	NA	BUSHING		1
32	462-160	NA	SECOND GEAR		1
33	462-165	NA	BUSHING		1
34	462-170	NA	THRUST WASHER, 2nd gear		1
35	462-220	\$31.99	SYNCHRO RING, 1st & 2nd gear		2
36	462-180	NA	SLIDING HUB ASSEMBLY, 1st & 2nd gear		1
37	329-550	\$0.99	BALL	standard, as fitted	1
38	329-840	\$1.79	SPRING		1
39	462-195	\$18.99	THRUST WASHER, interlocking		1
40	462-200	\$68.99	DISTANCE PIECE, mainshaft		1
41	462-210	NA	THIRD GEAR		1
42	462-155	NA	BUSHING		1
43	462-215	NA	SLIDING HUB ASSEMBLY, 3rd & 4th gear		1
44	462-220	\$31.99	SYNCHRO RING, 3rd & 4th gear		2
46	127-840	\$19.99	BALL BEARING, mainshaft, center	standard, as fitted	1
	127-841	NA	ROLLER BEARING, mainshaft, center		1
46a	127-850	NA	BEARING, mainshaft	overdrive	1
47	462-230	NA	SHIM, .002"	standard	A/R
	462-235	NA	SHIM, .004"		A/R
	462-240	\$4.99	SHIM, .002"		A/R
	462-245	\$6.99	SHIM, .005"		A/R
	462-250	\$8.99	SHIM, .010"		A/R
49	127-845	NA	HOUSING, bearing	standard	1
49a	127-855	NA	HOUSING, bearing	overdrive	1
50	462-260	NA	DISTANCE PIECE, 3rd motion shaft	standard	1
50a	462-265	NA	DISTANCE PIECE, 3rd motion shaft	overdrive	1
51	462-270	NA	GEAR, speedometer drive, steel	to (g)1L9709	1

# Late Gearbox (4-synchro)

462-275	NA	GEAR, speedometer drive, nylon	{ from (g)1L9710 thru '74	1
462-280	NA	GEAR, speedometer drive	1975 on	1
52 327-120	\$1.19	KEY, speedometer gear	to (g)1L9709	1
53 462-300	NA	NUT, mainshaft, front		1
54 462-305	NA	LOCKING WASHER, mainshaft, front		1
55 462-285	NA	DISTANCE TUBE		1
56 326-940	NA	CIRCLIP		1
57 127-900	\$35.99	BEARING, mainshaft	} standard	1
58 121-120	\$3.49	OIL SEAL, rear		1
59 462-290	NA	FLANGE		1
60 462-310	NA	LOCK WASHER		1
61 462-320	\$12.49	NUT	} overdrive	1
62 462-315	NA	LOCK WASHER		1
63 462-325	NA	NUT		1
64 320-385	\$3.69	BOLT, special, gearbox to driveshaft		4
65 462-330	NA	FORK, 1st & 2nd gear		1
66 462-335	NA	FORK, 3rd & 4th gear		1
67 462-340	NA	FORK, reverse		1
68 462-345	NA	ROD, 1st & 2nd fork		1
69 462-350	NA	ROD, 3rd & 4th fork		1
70 462-355	\$13.00	ROD, reverse fork		1
71 462-360	NA	SELECTOR, 1st & 2nd gear		1
72 462-365	\$19.99	SELECTOR, 3rd & 4th gear		1
73 462-370	NA	SELECTOR, reverse		1
74 461-760	\$4.29	BOLT, selector fork locating		3
75 462-385	\$0.39	WASHER, locking		3
76 462-410	NA	LOCKNUT		3
77 461-770	\$3.19	BOLT, selector locating		3
78 462-400	NA	LEVER, selector		3
79 462-405	NA	SHAFT, selector lever		1
80 462-410	NA	LOCKNUT		1
81 462-415	NA	LEVER, remote control shaft		1
82 462-420	NA	BUSH, selector lever (not for shift lever, see #114)		1
83 327-200	\$0.59	KEY		1
84 462-425	NA	BOLT, lever to shaft		1
85 365-730	\$0.39	LOCK WASHER		1
86 462-435	NA	SHAFT, remote control		1
87 462-440	\$3.49	PLUNGER, shaft damping		1
88 329-010	\$0.99	SPRING, damping plunger		1
89 462-445	NA	CAP, plunger retaining		1
90 324-770	\$1.99	WASHER, plunger retaining cap		1
91 462-450	NA	INTERLOCKING ARM		1
92 462-455	\$9.99	PLUNGER, fork rod		3
93 462-460	\$0.89	DETENT SPRING, plunger		3
94 848-790	NA	PLUG, plunger		3
95 462-465	\$0.49	WASHER, plunger plug		3
96 462-470	NA	PLUNGER, reverse selector		1
97 329-270	NA	SPRING, damping plunger		1
98 462-475	NA	PIN, plunger locating		1
99 462-480	NA	PLUNGER		1
100 329-240	\$3.49	DETENT SPRING, plunger		1
101 462-490	NA	PLUG, detent spring		1
102 324-626	\$0.99	WASHER		1
103 329-520	\$0.79	BALL		1
104 282-880	\$34.99	SHIFT BOOT ASS'Y., black vinyl	} option	1
228-368	\$42.99	SHIFT BOOT ASS'Y., black leather		1
228-365	\$42.99	SHIFT BOOT ASS'Y., tan leather		1
228-366	\$42.99	SHIFT BOOT ASS'Y., honey tan leather		1
228-367	\$42.99	SHIFT BOOT ASS'Y., red leather		1
105 282-890	\$7.49	GROMMET, rubber, shift lever		1

\*1968-'72 MGBs were fitted only with a rubber shift boot, #282-890, while 1973-'80 MGBs were fitted with a vinyl boot, over the rubber boot ("grommet"). The later style 2-piece boot assembly can be fitted to 1968-'72 models.

106 443-115	\$9.99	RETAINER, shift boot, chrome	{ RD to (c)393599, GT to (c)367803	1
443-125	\$9.99	RETAINER, shift boot, black	RD from (c)393600 on	1
106a323-565	\$1.39	CHROME SCREW, short	1 req. 1973-'80	1/4
323-175	\$1.39	CHROME SCREW, long	1973-'80 with console	3
107 443-135	\$79.99	GEARSHIFT LEVER, straight, 1968 - '76	{ RD to (c)410000, GT to (c)367803	1
443-145	NA	GEARSHIFT LEVER, cranked	{ RD from (c)410001 on, '77 on	1
108 021-399	\$8.99	KNOB, round, 1968 - '72	{ RD to (c)294250, GT to (c)296000	1
462-500	\$39.99	KNOB, "pear" shaped	{ RD from (c)294251 to 410000, GT from (c)296001 on	1

Toll-Free Orders 1-800-667-7872 | MossMotors.com  
Fax 805-692-2525 | Local 805-681-3400



109 462-510	\$1.49	NUT, knob retaining	{ RD to (c)410000, GT to (c)367803	1
All 1968-'76 gearshift knobs are interchangeable.				
Accessory knobs are listed in the color section at the front of this catalog.				
110 462-520	\$9.99	CONE	} RD from (c)410001 on, 1977 - '80	1
111 462-525	NA	KNOB BASE		1
112 462-530	\$6.79	CAP, shift knob, non O/D		1
141-215	\$22.99	COVER & SWITCH ASS'Y., O/D		1
141-320	\$12.49	SWITCH, overdrive		1
141-322	\$1.29	SCREW, switch retaining		2
141-315	\$11.99	COVER, shift knob & switch, O/D		1
112a161-581	\$26.99	WIRE PAIR to o/d switch		1
113 462-535	\$6.99	NUT, knob retaining		1
114 461-110	\$5.89	BUSH, shift lever		1
115 462-545	NA	COVER, lever seat	1	
115a462-495	\$4.89	BOLT for cover	3	
115b315-180	\$0.49	SPRING WASHER	3	
116 462-440	\$3.49	PLUNGER, shift lever damping	1	
117 329-010	\$0.99	SPRING	1	
118 462-445	NA	CAP	1	
119 324-770	\$1.99	WASHER	1	
120 462-550	NA	LOCATING PIN, shift lever	1	
122 140-470	\$12.99	SWITCH, reverse light	1	
123 140-470	\$12.99	SWITCH, overdrive isolation	overdrive 1	
124 324-145	\$0.39	WASHER	overdrive uses 2 1/2	
125 462-555	NA	SPRING	} overdrive 1	
126 462-560	NA	PLUNGER, isolation switch		
127 462-475	NA	PIN, plunger locating	1	
128 462-570	NA	DIPSTICK	chrome bumper cars 1	
328-055	\$9.99	FILLER PLUG	rubber bumper cars 1	
129 267-040	\$10.79	BREATHER	1	
130 462-580	NA	FRONT COVER	1	
131 328-997	\$1.99	STUD, front cover	8	
132 461-010	\$3.49	BOOT, clutch lever, oval	1	
461-015	\$3.99	BOOT, clutch lever, square	1	
135 462-590	\$69.99	LEVER, clutch (rebuild/echange)	1	
	\$300.00	CORE CHARGE FOR 462-590	1	
136 330-200	\$1.79	BUSH	1	
137 190-550	\$6.29	BOLT, clutch lever	1	
138 324-725	\$1.09	WASHER, clutch lever bolt	1	
139 310-240	\$0.89	NUT, clutch lever bolt	1	
140 462-600	NA	PINION, speedometer, non-overdrive thru '74	1	
462-605	NA	PINION, speedometer, non-overdrive 1975 on	1	
141 433-750	NA	HOUSING, pinion, non-overdrive	1	
142 461-445	\$2.79	OIL SEAL	1	
143 433-760	\$0.99	GASKET, housing, non-overdrive	1	
150 021-510	\$54.99	ADAPTOR, speedometer drive, non-overdrive	1	
151 324-720	\$0.99	WASHER, adaptor, non-overdrive	1	
152 322-438	\$9.99	BOLT & NUT SET, gearbox to engine	1	
153 009-148	\$26.99	SPACER, shifter console 1972-80	1	

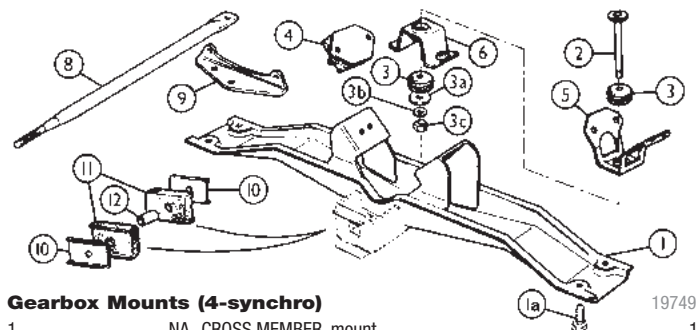

## Gearbox Mounts (4-synchro)

1	NA	CROSS MEMBER, mount	1
1a 322-050	\$0.89	BOLT, cross member mounting	4
2 413-150	\$7.59	PIN, gearbox mount	1
3 280-055	\$1.79	BUSH (small ends face each other)	2
3a 315-240	\$0.39	WASHER on pin	1
3b 365-730	\$0.39	LOCKWASHER	} RD from (c)138401 (1968-on), all GT 1
3c 310-140	\$0.39	NUT on pin	
4 413-050	\$5.99	MOUNT, gearbox	
5 413-055	\$54.99	BRACKET, upper	1
6 413-095	\$89.99	BRACKET, lower	1
8 413-135	NA	ROD, engine restraint	1
9 413-110	NA	BRACKET	} RD from (c)341295 on, GT from (c)341730 1
10 413-120	\$4.29	PLATE, buffer	
11 282-330	\$0.99	BUFFER	
12 413-125	\$6.39	SPACER	

# Early Overdrive

1962- '67 RD to (c)138411/GT to (c)139471

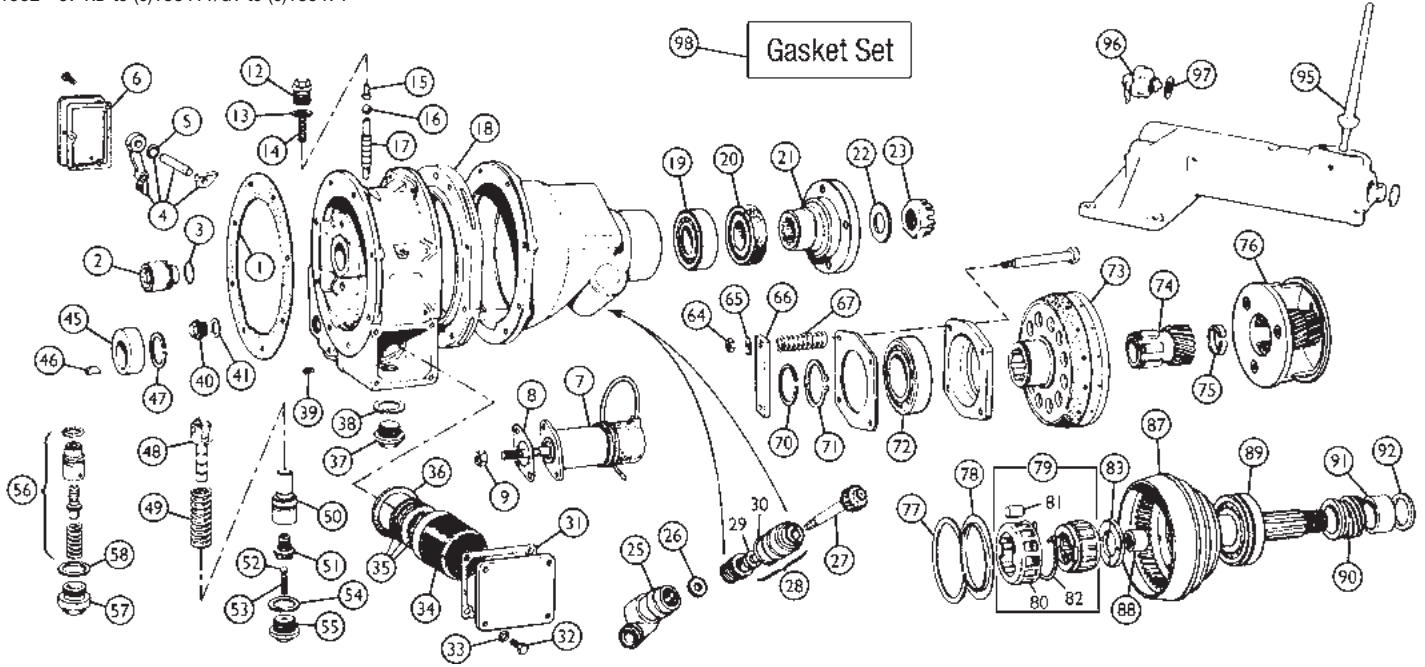

## Type "D" Overdrive

19750

No.	Part#	Price (Each)	Description	Application	Qty Req.
Note: Overdrive electrical components are listed on page 88.					
1	466-200	\$1.89	GASKET, replacement		1
2	466-510	\$23.99	OPERATING PISTON		2
3	466-515	\$0.59	O-RING		2
4	466-520	NA	LEVER ASSEMBLY, valve operating		1
5	866-030	\$0.39	O-RING		1
6	466-530	\$1.99	GASKET		1
7	145-730	\$56.99	SOLENOID		1
8	466-540	\$1.59	GASKET		1
9	310-100	\$0.24	NUT, solenoid adjusting		1
12	866-090	\$26.49	PLUG, operating valve		1
13	435-567	\$1.69	WASHER		1
14	866-080	\$6.99	SPRING		1
15	866-070	\$8.59	PLUNGER		1
16	329-510	\$0.89	BALL		1
17	466-575	NA	OPERATING VALVE		1
18	466-580	NA	BRAKE RING		1
19	125-900	\$7.99	BEARING, annulus rear		1
20	121-110	\$2.79	OIL SEAL		1
21	466-590	\$104.99	FLANGE		1
22	324-290	\$1.09	WASHER		1
23	310-570	\$3.49	NUT		1
25	021-510	\$54.99	ANGLE BOX, speedometer drive		1
26	324-720	\$0.99	WASHER		1
27	466-605	NA	PINION, speedometer drive		1
28	466-610	\$109.99	BEARING ASSEMBLY, speedometer drive		1
29	520-015	\$2.49	OIL SEAL		1
30	466-615	\$0.69	O-RING		1
31	466-620	\$1.99	GASKET		1
32	310-491	\$0.99	SCREW		4
33	324-110	\$0.29	LOCKWASHER		4
34	466-625	NA	FILTER		1
35	866-220	\$18.99	MAGNETIC RING, set of 3		1
36	466-635	\$9.99	SEALING PLATE		1
37	466-640	\$29.99	DRAIN PLUG		1
38	466-350	\$0.69	WASHER		1
39	466-760	NA	SCREW, non-return valve retaining		1
40	466-765	NA	PLUG, solenoid adjusting nut	to O/D 25/63308/3110	1
			(May use 466-770 below)		
	466-770	\$16.99	ADJUSTING SCREW & LOCK NUT	from O/D 25/63308/3111	1
41	370-650	\$0.39	WASHER		1
45	466-650	NA	CAM, pump operating		1
46	327-120	\$1.19	KEY		1
47	466-655	\$6.59	SPRING RING		1
48	466-660	NA	PLUNGER ASSEMBLY, pump		1
49	866-130	\$8.39	SPRING		1
50	466-670	NA	PUMP BODY		1
51	466-675	NA	VALVE ASSEMBLY, non-return		1

No.	Part#	Price (Each)	Description	Application	Qty Req.
52	329-600	\$0.49	BALL		1
53	466-780	NA	SPRING		1
54	466-350	\$0.69	WASHER		1
55	466-785	NA	PLUG, non-return valve		1
56	466-680	NA	RELIEF VALVE ASSEMBLY		1
57	NA	NA	PLUG, relief valve		1
58	466-350	\$0.69	WASHER		1
64	310-760	\$0.59	NUT		4
65	466-210	NA	TAB WASHER		4
66	466-690	NA	BRIDGE		2
67	466-695	\$29.99	SPRING SET		1
70	466-790	NA	SNAP RING, sun gear retaining		1
71	466-795	NA	SNAP RING, bearing housing		1
72	127-880	\$44.99	BEARING		1
73	466-700	NA	CLUTCH MEMBER		1
74	466-710	\$70.00	SUN WHEEL		1
75	466-720	NA	SPRING RING		1
76	466-730	NA	PLANET GEAR & CARRIER ASSEMBLY		1
77	466-030	\$8.79	SNAP RING, clutch		1
78	466-035	NA	OIL THROWER		1
79	466-055	\$184.99	CLUTCH ASS'Y., unidirectional		1
80	466-045	NA	CAGE, unidirectional clutch		1
81	866-598	\$14.99	ROLLER SET		1
82	866-610	\$0.79	SPRING	orig. ass'y. only	1
83	866-620	\$23.99	WASHER		1
87	466-750	NA	ANNULUS		1
88	127-890	\$20.99	BEARING		1
89	127-000	\$29.99	BEARING		1
90	466-810	NA	GEAR, speedometer driving		1
91	466-820	NA	SPACER		A/R
92	466-830	NA	WASHER, adjusting .105"		A/R
	466-835	NA	WASHER, adjusting .100"		A/R
	466-840	NA	WASHER, adjusting .095"		A/R
	466-845	NA	WASHER, adjusting .090"		A/R
95	443-140	\$96.99	SHIFT LEVER, overdrive only		1
96	140-470	\$12.99	SWITCH, overdrive isolation		1
97	324-145	\$0.39	WASHER for switch		A/R
98	466-201	\$36.99	GASKET AND SEAL KIT		1

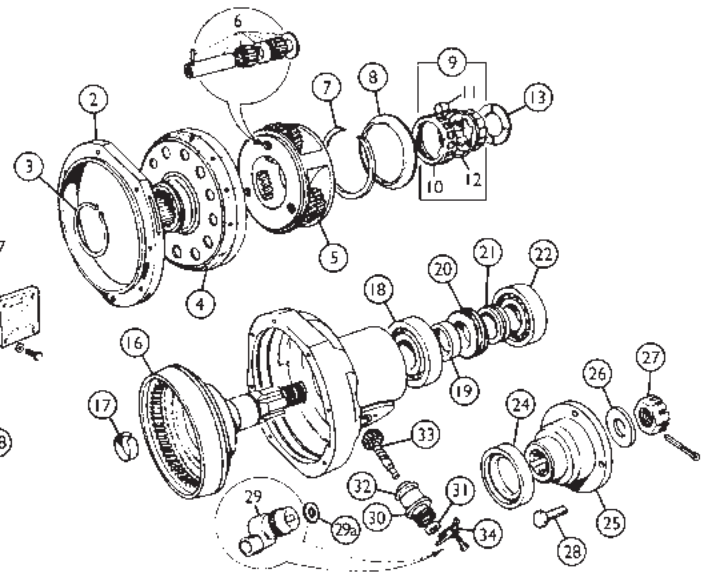
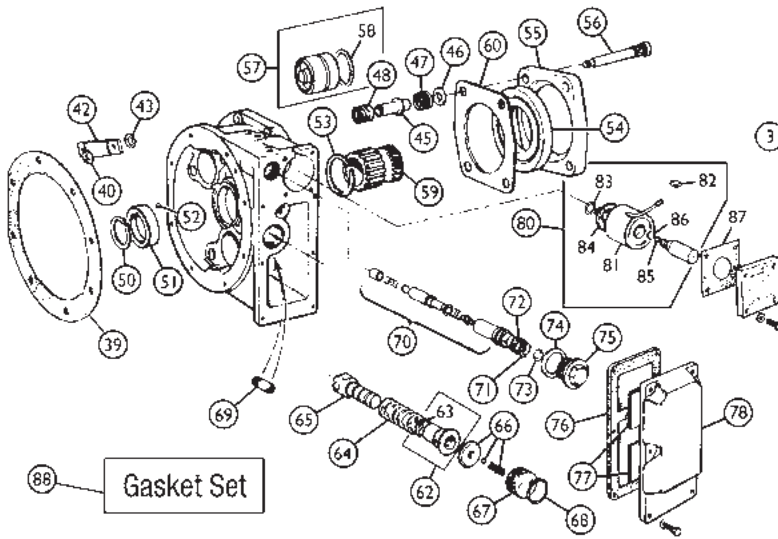

### Type "LH" Overdrive

19751

No.	Part#	Price (Each)	Description	Application	Qty Req.	No.	Part#	Price (Each)	Description	Application	Qty Req.
	466-000	\$999.00	OVERDRIVE UNIT, rebuilt/exchange	1968-'74, 22/61972	1	42	466-215	NA	BRIDGE PIECE		2
		\$800.00	CORE CHARGE FOR 466-000			43	326-960	NA	CIRCLIP, thrust rod		4
		NA	OVERDRIVE UNIT	1975-'80, 22/62005	1	45	466-225	NA	THRUST ROD		4
2	466-010	\$84.99	BRAKE RING		1	46	466-230	NA	WASHER, thrust rod		4
3	326-955	NA	CIRCLIP		1	47	466-235	NA	SPRING, clutch engagement		4
4	466-015	NA	SLIDING MEMBER		1	48	466-240	\$19.99	SPRING, clutch release		4
5	466-025	NA	PLANET GEAR & CARRIER ASSEMBLY		1	50	326-930	\$6.59	CIRCLIP		1
6	466-020	\$179.99	BEARING ASSEMBLY, planet gears (6 bearings, 3 axles, 3 washers)		1	51	466-243	NA	CAM, for mainshaft w/keyway slot		1
7	466-030	\$8.79	CAGE SPRING RING		1	466-245	\$82.99	CAM, for mainshaft drilled for ball		1	
8	466-035	NA	OIL THROWER		1	466-247	NA	KEY, for mainshaft w/keyway		1	
9	466-055	\$184.99	CLUTCH ASS'Y., unidirectional		1	52	329-820	\$0.39	BALL, for mainshaft drilled for ball		1
10	466-045	NA	CAGE, unidirectional clutch		1	53	466-250	\$7.89	SNAP RING		1
11	866-598	\$14.99	ROLLER SET		1	54	866-470	\$62.99	THRUST BEARING		1
12	866-610	\$0.79	SPRING	orig. ass'y. only	1	55	466-260	NA	HOUSING, thrust bearing		1
13	866-620	\$23.99	THRUST WASHER		1	56	466-265	NA	PIN, bearing housing		4
16	466-070	NA	ANNULUS		1	57	466-270	NA	PISTON ASSEMBLY		2
17	466-075	NA	SPRING RING, on mainshaft		1	58	866-420	\$0.49	O-RING		2
18	866-630	\$28.99	BEARING		1	59	466-280	NA	SUNWHEEL		1
19	466-090	NA	SPACER		1	60	466-285	NA	BEARING RETAINER PLATE		1
20	466-400	\$72.99	GEAR, speedometer	units marked 22/61972	1	62	466-291	NA	BODY, pump, premium quality		1
466-410	\$74.99	GEAR, speedometer (orig type)	} units marked 22/62005	1	466-290	\$52.99	BODY, pump		1		
466-420	NA	GEAR, speedometer (OEM repl.)		1	63	290-915	\$0.69	O-RING, pump body		1	
Replacement gear ass'y. 466-420 replaces orig. gear 466-410 and spacers #19 and #21.						64	466-300	NA	SPRING, pump plunger		1
21	466-100	NA	SPACER, .360"		A/R	65	466-305	\$126.99	PLUNGER, pump		1
	466-105	NA	SPACER, .365"		A/R	66	466-310	\$26.49	NON RETURN VALVE		1
	466-110	NA	SPACER, .370"		A/R	67	466-315	NA	PLUG, pump		1
	466-115	NA	SPACER, .375"		A/R	68	462-620	\$0.59	O-RING, pump plug		1
	466-120	NA	SPACER, .380"		A/R	69	466-325	NA	SUCTION TUBE, pump		1
	466-125	NA	SPACER, .385"		A/R	70	466-330	NA	VALVE, relief and low pressure		1
22	525-150	\$16.99	BEARING		1	71	290-925	\$0.39	O-RING		1
24	121-125	\$2.59	OIL SEAL, rear casing		1	72	466-340	\$12.99	FILTER, relief valve body		1
25	466-140	NA	FLANGE		1	73	290-930	\$0.49	O-RING		1
26	466-145	NA	WASHER		1	74	466-350	\$0.69	WASHER, relief valve plug		1
27	311-070	NA	NUT		1	75	466-355	NA	PLUG, relief valve		1
28	320-385	\$3.69	BOLT, special, to driveshaft flange		4	76	466-360	\$12.99	FILTER & GASKET		1
29	021-510	\$54.99	ANGLE BOX, speedometer drive		1	77	466-365	\$10.99	MAGNET SET		1
29a	324-720	\$0.99	WASHER		1	78	466-370	NA	SUMP		1
30	433-755	\$74.99	BEARING ASSEMBLY, speedometer		1	80	466-375	\$189.99	SOLENOID VALVE KIT		1
31	461-445	\$2.79	OIL SEAL		1	81	466-380	\$66.99	COIL ASSEMBLY, solenoid		1
32	462-620	\$0.59	O-RING		1	82	290-950	\$4.49	GROMMET		1
33	462-610	\$39.89	PINION, speedo. (21 teeth)	units marked 22/61972	1	83	290-935	\$0.59	O-RING		1
	462-615	\$44.99	PINION, speedo. (20 teeth)	units marked 22/62005	1	84	290-940	\$0.39	O-RING		1
34	466-180	\$7.89	LOCKPLATE		1	85	290-945	\$0.69	O-RING		1
39	466-200	\$1.89	GASKET		1	86	329-820	\$0.39	BALL		1
40	310-765	\$1.29	NUT, self-locking		4	87	296-610	\$0.99	GASKET		1
						88	466-202	\$59.99	GASKET AND SEAL KIT		1



# Steering

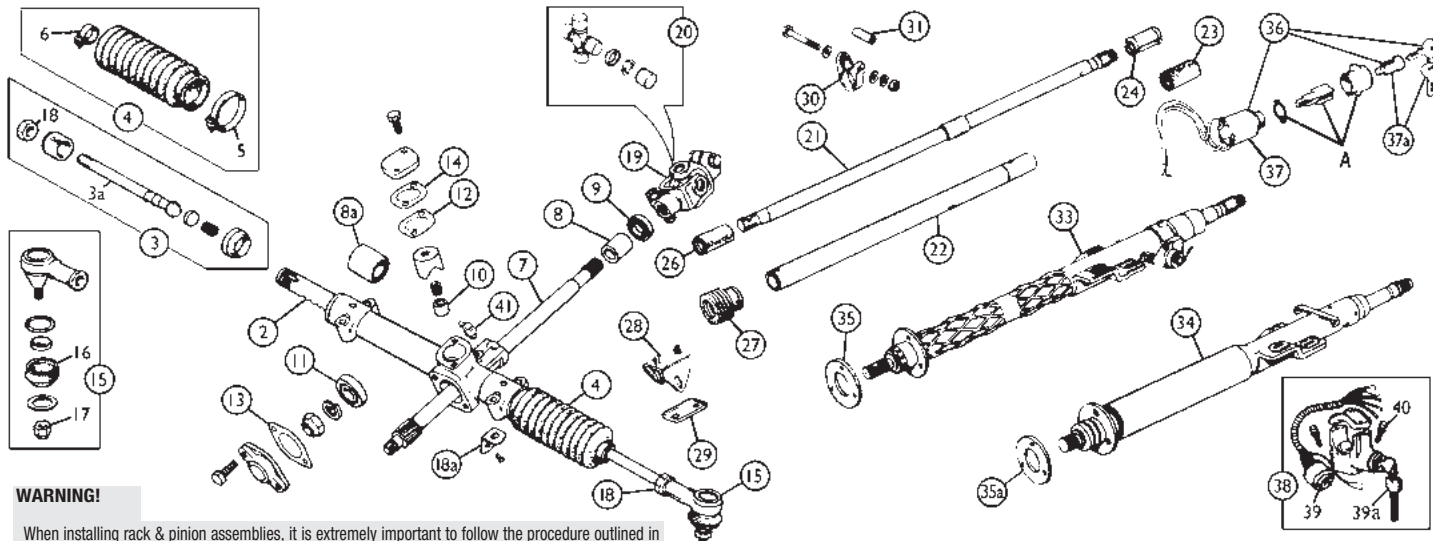

## WARNING!

When installing rack & pinion assemblies, it is extremely important to follow the procedure outlined in the factory workshop manual, particularly in regard to the alignment of the pinion shaft. Failure to do so can result in pinion shaft breakage and consequent total steering failure.

## Steering

No.	Part#	Price (Each)	Description	Application	Qty Req.
1	<u>453-618</u>	\$359.99	RACK & PINION ASSEMBLY KIT*	RD to (c)360300, GT to (c)361000	1
	<u>453-619</u>	\$329.99	RACK & PINION ASSEMBLY (chrome bumpered cars)		1
	<u>453-638</u>	\$359.99	RACK & PINION ASSEMBLY KIT*	RD from (c)360301, GT from (c)361001	1
	<u>453-627</u>	\$329.99	RACK & PINION ASSEMBLY (rubber bumpered cars)		1

Underlined part numbers indicate an Oversize Parts Fee will be charged. See [mossmotors.com](http://mossmotors.com) or call for details.

\* Kits include rack & pinion assembly and installation kit 453-628 (alignment tool, shims, and illustrated instructions). New Rack & Pinion assemblies are permanently lubricated with lithium grease. Instructions must be followed to prevent failure. These steering racks do not include outer tie rod ends #15.

2	263-340	NA	STEERING RACK		1
3	260-520	NA	TIE ROD ASS'Y. KIT, steering rack		2
3a	263-360	\$49.99	TIE ROD		2
4	263-380	\$19.99	RACK SEAL & CLAMP SET, aftermarket		1
	263-280	NA	RACK SEAL, aftermarket		2
5	262-180	\$3.29	CLAMP, rack seal, replacement, large	} band type	2
6	117-015	\$2.29	CLAMP, rack seal, replacement, small		2
	326-328	NA	CLAMP, rack seal, orig. type, small	Use 117-015 above	2
7	263-350	NA	STEERING PINION (chrome bumpered cars)	} RD to (c)360300, GT to (c)361000	1
	263-355	NA	STEERING PINION (rubber bumpered cars)		RD from (c)360301, GT from (c)361001
8	260-300	NA	BUSH, pinion		1
8a	260-360	\$63.99	BUSH, steering rack		1
9	262-035	\$2.29	OIL SEAL, pinion		1
10	262-190	\$35.99	DAMPER PAD		1
11	125-010	\$31.99	BEARING, pinion		1
12	263-810	NA	SHIM, .0024"		A/R
	263-815	\$8.99	SHIM, .005"		A/R
	263-820	NA	SHIM, .010"		A/R
13	263-800	\$1.39	GASKET, end cover		1
14	263-805	\$2.29	GASKET, top cover		1
15	263-390	\$28.99	TIE ROD END, pair (not incl. with steering rack assy's.)		1
16	263-400	\$1.99	BOOT, tie rod end		2
17	021-634	\$0.89	NUT		2
18	310-810	\$1.99	LOCKNUT		2
18a	263-130	\$3.29	SHIM, aligning		A/R
19	263-090	\$139.99	U-JOINT ASS'Y., replacement (chrome bumpered cars)	} RD to (c)360300, GT to (c)361000	1
	263-095	\$68.49	U-JOINT ASS'Y. (rubber bumpered cars)		RD from (c)360301, GT from (c)361001
20	263-265	\$39.99	U-JOINT, GKN/Hardy-Spicer	} RD to (c)360300, GT to (c)361000	1
	263-260	\$9.49	U-JOINT, aftermarket (chrome bumpered cars)		
21	453-550	NA	INNER COLUMN		1
22	453-560	NA	OUTER COLUMN		1
23	NA	NA	BUSH (not avail. -use #24)	} RD to (c)138401, GT to (c)139472; 1962 - '67	1
24	263-410	\$4.99	BEARING, upper, nylon		
26	263-420	\$2.99	BUSH ("bearing"), lower, felt		1
27	280-880	\$4.99	DRAFT EXCLUDER		1
28	263-530	NA	BRACKET, lower column		1

29	263-540	\$4.79	BLANKING PLATE	} RD to (c)138401, GT to (c)139472; 1962 - '67	1
30	263-120	\$22.99	CLAMP		2
31	263-300	\$7.39	DISTANCE PIECE		2
33	263-550	NA	STEERING COLUMN, complete (1968-'69)	} RD from (c)138401 to 187210, GT from (c)139472 to 187840	1
	263-560	NA	STEERING COLUMN, complete (1970-mid '74)		RD from (c)187211 to 360300, GT from (c)187841 to 361000
	263-570	NA	STEERING COLUMN, complete	} RD from (c)360301 to 410000, GT from (c)361001 on	1
	263-571	NA	STEERING COLUMN, repl.		

These replacements do not have the turn signal cancelling lug on the shaft.

34	263-580	NA	STEERING COLUMN, complete	} RD from (c)410000 on, 1977-on	1
35	263-590	\$2.29	SEAL, column to toe board		RD from (c)138801 to 410000, GT from (c)139284 on
35a	263-595	NA	SEAL, column to toe board	RD from (c)410001 on	1
36	263-600*	NA	IGNITION SWITCH ASS'Y.	} RD from (c)138401 to 187210, GT from (c)139472 to 187840 (1968-'69)	1
37	542-077*	\$23.99	IGNITION SWITCH		1
37a	163-500*	\$11.99	LOCK BARREL w/ 2 keys		1

\*U.S.-spec column mounted ignition switches are locking-type. Ignition switch #542-077 is similar to the original, but has spade terminals in place of the wires of the original switches. To use this replacement switch, three wires approximately 14" long must be attached to the switch with female Lucar connectors (#161-520). To connect the other ends of these wires to your harness, use wire tips, #162-200 and connectors, #162-000. Parts marked "A" in the illustration are no longer available and must be re-used from your old switch assembly.

38	263-610†	\$109.99	STEERING LOCK & SWITCH ASSEMBLY (replacement)	} RD from (c)187211 to 294250, GT from (c)187841 to 296000 (1970-'72)	1
39	263-655•	NA	IGNITION SWITCH		
	263-640†§	\$43.99	STEERING LOCK & SWITCH ASSEMBLY (replacement)	} RD from (c)294251 to 328100, GT from (c)296001 to 328800 1973	1
	263-690§	\$18.49	IGNITION SWITCH (repl.)		1
	263-665•	NA	IGNITION SWITCH (orig. assy.)		1
	263-641†	\$79.99	STEERING LOCK & SWITCH ASSEMBLY, Lucas	} RD from (c)328101, GT from (c)328801; 1974 on	1
	263-640†	\$43.99	STEERING LOCK & SWITCH ASSEMBLY, repro.		1
	263-691	\$31.99	IGNITION SWITCH, Lucas		1
	263-690	\$18.49	IGNITION SWITCH, repro.		1
39a	163-337	\$5.99	KEY BLANK, replacement	for 263-640 & 263-641 only	A/R
40	263-700	\$7.49	SHEAR BOLT, '70 on (incl. w/ assemblies)	RD from (c)187211 on, GT from (c)187841 on	2
41	021-722	\$1.89	OIL FITTING		1

† Note: Locks are supplied with two keys.

• These switches fit only their respective original assemblies.

§ Wiring on switch has a moulded plug which must be removed and replaced with bullet connectors, part #162-200 (6 required).



## Steering Rack Boots

Like so many mechanical parts, rack-and-pinion steering requires two things to work efficiently: the presence of oil and the absence of water and dirt. Given these two conditions, a steering assembly should last hundreds of thousands of miles.

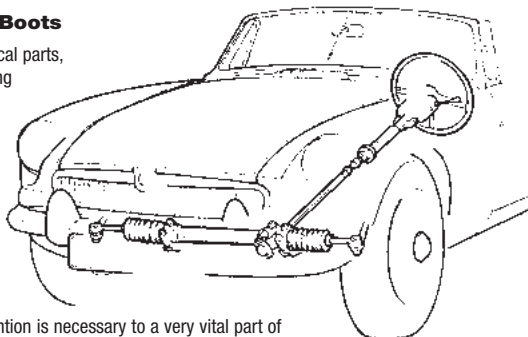

However, periodic attention is necessary to a very vital part of the steering: the rack boots (or seals, or bellows, or gaiters, or whatever you call those collapsible rubber things on each end of the rack). If these are split and leaking oil, the life of the rack-and-pinion is diminished every time you drive the car, especially if you drive on wet or dusty roads.

While the boots themselves are relatively inexpensive, many owners put off replacing the bad ones because a) it is a dirty job, and b) they know it will upset their steering alignment. The simple answers to these objections are a) but someone has to do it, and b) not necessarily. If your alignment is correct and your steering wheel is centered (see tech tip in the next column on this page), following the procedure outlined below will get you your new boots fitted without the need for realignment.

1. Jack up the front of the car and position two jack stands under the chassis.
2. Center the steering wheel in the dead ahead position.
3. Place a strip of masking tape on the front of each tire's tread. Mark each piece of tape and measure exactly between the marks. Write down the measurement.
4. Remove one wheel.
5. Loosen the tie rod lock nut.
6. Remove the nut holding the tie rod end to the steering arm.
7. Use a tie rod end separator or a "tuning fork" (aka. "pickle fork") to separate the tie rod end from the steering arm. If using a "tuning fork", try not to rip the rubber boot nor scar the steering arm. Alternatively, hold a heavy (2 - 3 lb.) hammer or similar hard heavy object against one side of the "ring" end of the steering arm where the tie rod end is mounted, and sharply strike the opposite side with a lighter hammer. The tie rod end should then pop out of its tapered seat in the steering arm. (Tie rod end service tools are available at most automotive parts suppliers and tool suppliers.)
8. Unscrew the tie rod end, noting exactly how many turns it takes to get it off, then unscrew the lock nut. (An error of less than 1/2 turn will upset the alignment.)
9. Undo the clamps on the old boot, remove the boot.
10. Clean off all the dirt and old oil or grease.
11. Install the new boot; don't tighten the small clamp yet.
12. Replace the lock nut on the tie rod, then screw the tie rod end back the number of turns it took to get it off.
13. Reassemble the tie rod end to the steering arm.
14. Replace the wheel.
15. Check that the steering wheel is still centered exactly as it was when you started.
16. Measure between the tape marks. Adjust the tie rod in or out of the end until the measurement is exactly what you started with.
17. Tighten the tie rod lock nut, then the small boot clamp.
18. Repeat for the other side.
19. Fill the steering rack with SAE 90 gear oil, as per your shop manual. Using grease will not do! (Replacement racks are pre-lubricated, cannot be re-lubricated in service.)



## Upper Steering Column Bearing Kit, 1977-'80

This will solve upper steering column looseness and noise. Since installation is an involved process, fully illustrated instructions are included.

Fits MGB steering columns from 1977-'80.

**384-940 \$99.99**



## Steering Rack Installation Kit

Safely install your steering rack and avoid the possibility of dangerous mis-alignment which can fracture your steering rack pinion shaft! Our alignment tool duplicates the function of the factory tool shown in your workshop manual. Kit includes alignment tool pictured above, 5 rack shims, and illustrated instructions. (Included with Rack & Pinion Assembly Kits.)

**453-628 \$44.99**

# Steering Wheels

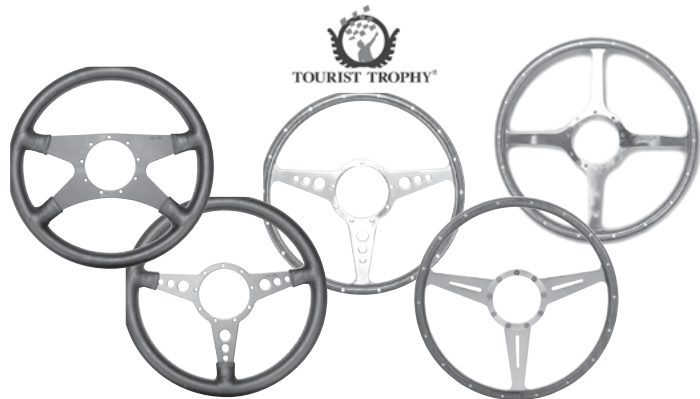

## Tourist Trophy Steering Wheels

Hand crafted steering wheels employ the finest bicolored wood laminations or leather over aircraft quality aluminum frames. Personalize your car with these classic steering wheels. Simply choose the wheel you want and, then order the correct hub for your car.

## Wood Rim Steering Wheels

- 489-070 \$359.99 14" with 3 Drilled Matte Spokes
- 489-060 \$359.99 15" with 3 Drilled Matte Spokes
- 489-090 \$359.99 15" with 3 Drilled Matte Spokes, extra thick rim
- 489-080 \$359.99 15" with 3 Slotted Matte Spokes

## Leather Rim Steering Wheels

- 489-040 \$319.99 14" with 3 Drilled Black Spokes
- 489-030 \$319.99 14" with 3 Drilled Matte Spokes
- 489-020 \$319.99 15" with 3 Drilled Matte Spokes
- 489-050 \$319.99 15" with 3 Slotted Black Spokes

## Adaptor Hubs with Emblems (pictured in the color accessory section)

- 454-366 \$149.99 MGB 1962-'67 - with 46mm enamelled emblem
- 905-468 \$279.99 MGB 1968-'69 - with 46mm enamelled emblem
- 905-482 \$159.99 MGB 1970-'76 - with 46mm enamelled emblem
- 905-486 \$159.99 MGB 1977-'80 - with 46mm enamelled emblem



## MGB Wood Rim Steering Wheel

Styled like the original, but crafted in rich solid wood with beautifully chromed spokes. The beefy rim is in keeping with modern trends for comfort on long trips. Installs in minutes. Includes hub and centerpiece.

- 1970-'76 263-728 \$379.99
- 1977-'80 263-758 \$379.99



## MGB Limited Edition Wheel

Excellent reproduction of the hand-stitched padded leather wheel originally fitted to the '79-'80 Limited Edition MGB. Use your original "LE" hub or the reproduction assembly. (The "conversion kit" allows you to fit the LE wheel to 1970-'76 MGBs, something you can't do with an original LE hub.) Surround, motif, and hub are included.

- LE Wheel only
- 263-740 NA
- LE Wheel Assembly (wheel, hub, centerpiece) 1977-80
- 263-748 \$349.99
- LE Wheel Conversion Kit for 1970-'76
- 263-738 \$349.99



## Classic Steering Wheel by Tourist Trophy

A slightly thicker rim than our other classic wooden wheels for a more positive grip (approx. 28mm or 1.1" in diameter). It also features non-glare matte finished spokes and rich solid mahogany wood. This wheel will fit any of our classic steering wheel adaptor hubs are listed to the left on this page.

- 489-090 \$359.99

## Steering Wheel Nut Socket

Fits 1962-67 MGBs.

- 384-906 \$36.99

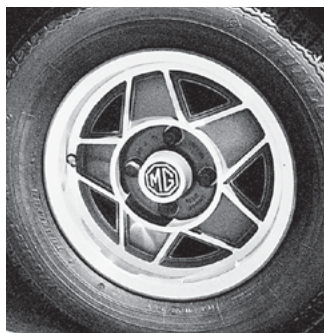
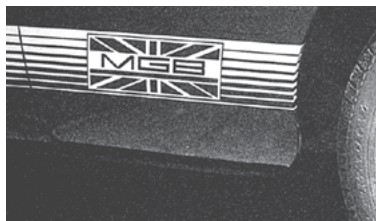

## The MGB LE Collection

- 453-775 \$15.99 Aluminum "Limited Edition" Dash Plaque
- 263-748 \$349.99 LE steering wheel ass'y. (Fits all 1977-80 MGB) See above for details.
- 263-738 \$349.99 LE steering wheel conversion ass'y. (Fits all 1970-76 MGB) See above for details.
- 215-730 \$89.99 Body side Strip Kit
- 475-180 \$259.99 Front Air Dam
- Underlined part numbers indicate an Oversize Parts Fee will be charged. See mossmotors.com or call for details.
- 462-750 \$299.99 Alloy road Wheel (repro. with UK-spec. red center medallion)  [MORE INFO ONLINE](#)
- 408-281 \$18.99 Medallion for road wheel (UK-spec., red)
- 408-280 \$5.49 Medallion for Road Wheel (U.S.-spec., black)
- 462-760 \$2.89 Spring Clip for road wheel medallion
- 264-990 \$21.99 Black "LE" Lugnut
- 264-991 \$19.99 Chrome "LE" Lugnut
- 229-905 \$12.99 "LE" Keyfob



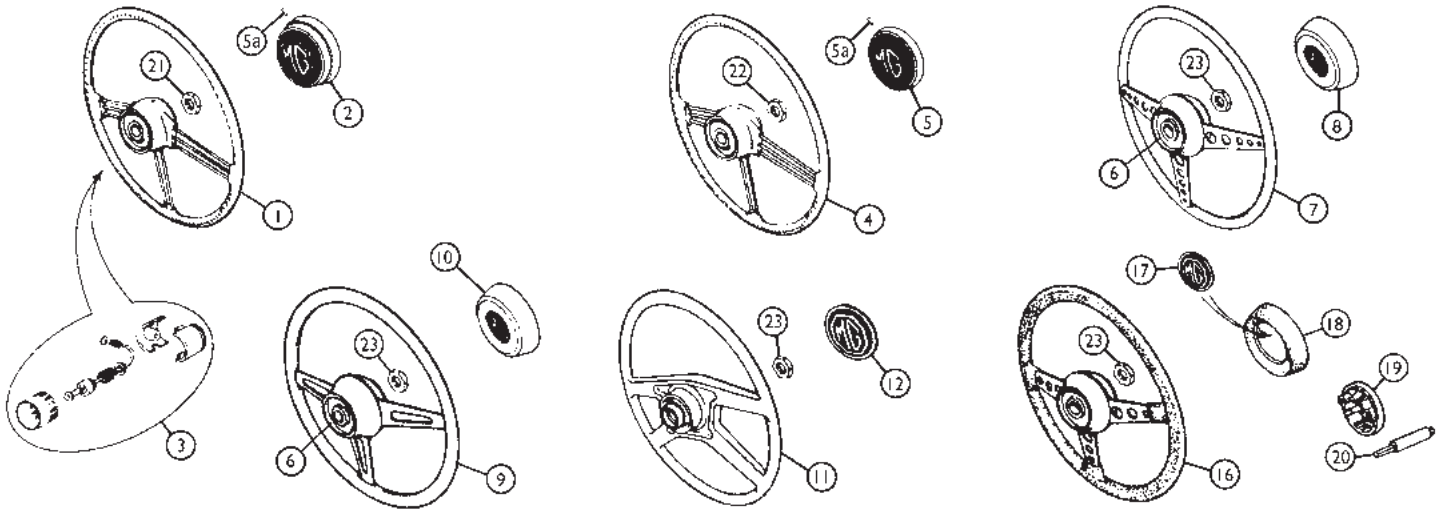

## Steering Wheels

19762

No.	Part#	Price (Each)	Description	Application	Qty Req.
1	454-342	\$299.99	STEERING WHEEL 1962 - '67	RD to (c)138400, GT to (c)139283	1
2	408-220	\$119.99	HORN PUSH/CENTERPIECE ASS'Y.	RD to (c)138400, GT to (c)139471	1
3	263-745	NA	SLIP RING & HORN CONTACT 1962 - '67	RD to (c)138400, GT to (c)139471	1
4	263-840	NA	STEERING WHEEL	RD from (c)138401 to 187210,	1
5	408-225	\$39.99	MOTIF	GT from (c)139473 to 187840;	1
	667-425	\$0.39	CLIP, for motif	1968 - '69	3
5a	725-100	NA	SCREW, horn push retaining	1962-'69	3

### Centering Your Steering Wheel

If your steering wheel is not perfectly centered, you can correct it without too much effort. First, you need to make sure all your tire pressures are set correctly, then find a wide, flat, traffic-free area (such as a deserted parking lot). When you drive "hands-off", the front wheels will assume their most centered position because of the caster that is built into the steering. On a cambered road, there will be a slight pull from the road's camber, so you need a flat road for best results.

When you have determined the exact position of the steering wheel with the car going straight ahead, you can begin the centering procedure. If it is more than an inch or so off at the rim, start by checking whether your wheel is mounted on splines or a type with keyway. If it has splines, try getting it closer to center by moving it on the splines. If it is the keyway type, check whether any of the other connections in the steering column can be repositioned to center the wheel better.

Final centering can now be done by adjusting the lengths of the tie rods. If the wheel is off to the right, you can move it counterclockwise by shortening the left tie rod and lengthening the right one. If it is off to the left, shorten the right tie rod and lengthen the left one. Count the number of turns so that you move each tie rod the same amount, to preserve your toe-in setting. Small increments move the steering wheel rim a surprising amount, so make your adjustments little by little. Drive the car after each adjustment to see where the wheel now centers itself. When it is dead-center, make sure you remember to tighten the lock nuts on the tie-rods.

If your toe-in is correct before you start the centering procedure, you can save having to readjust it by placing two pieces of tape on the front tire treads and measuring the distance across them before you start loosening the tie rods. As you do your centering adjustments, make sure the distance between the tapes remains exactly the same.

6	263-707	\$84.99	HUB, steering wheel	1970-76	1
7	263-710	NA	STEERING WHEEL	RD from (c)187211 to 294250, GT from (c)187841 to 296000	1
8	NA		MOTIF, 1970 (use 408-275 as repl.)	RD from (c)187211 to 219000, GT from (c)187841 to 219000	1
	408-275	\$82.99	HORN PUSH/CENTERPIECE ASS'Y., 1971 - '76	RD from (c)219001 to 410000, GT from (c)219001 on	1
9	263-720†	NA	STEERING WHEEL 1973 - '76	RD from (c)294251 to 410000, GT from (c)296000 on	1
10	408-275	\$82.99	HORN PUSH/CENTERPIECE ASS'Y., 1972 - '76	RD from (c)258001 to 410000, GT from (c)258001 on	1
11	263-730†	NA	STEERING WHEEL, 1977 on	Standard Edition, RD from (c)410001 on	1
12	NA		MOTIF, 1977 (use 408-280)	RD from (c)410001 to 447000	1
	408-280	\$5.49	MOTIF, 1978 - '80	RD from (c)447001 on	1
16	263-748	\$349.99	"L.E." STEERING WHEEL ASS'Y.	Limited Edition, RD from (c)410001 on, fits 1977-80	1
	263-740	NA	"L.E." STEERING WHEEL		1
	263-707	\$84.99	HUB, "L.E." wheel		1
17	408-280	\$5.49	MOTIF		1
18	408-290	\$27.99	BOSS, for motif		1
19	263-755	\$18.99	SLIP RING, horn	RD/GT from (c)219001 to 410000, 1971 - '76	1
20	263-750	\$6.99	BRUSH, horn		1
21	263-080	\$13.99	NUT, steering wheel, 1962 - '67	RD to (c)138400, GT to (c)139471	1
22	263-085	\$15.89	NUT, steering wheel, 1968 - '69	RD from (c)138401 to 187210, GT from (c)139472 to 187840	1
23	263-785	\$7.99	NUT, steering wheel, 1970 - '80	RD from (c)187211-on, GT from (c)187841-on	1

† See LE Conversion Kit on facing page for optional fitment.

### Gift Certificates

Don't know what to give that special British sports car lover in your life? How about a Gift Certificate from their favorite parts supplier? Moss gift certificates are available in any amount you choose, and are easily redeemed by simply mailing them back to us.

(Sports Car Owners: Why not give several to yourself as a "savings account" for that long term restoration you have planned?) Contact your Moss Motors Sales Advisor for details.



# Front Suspension

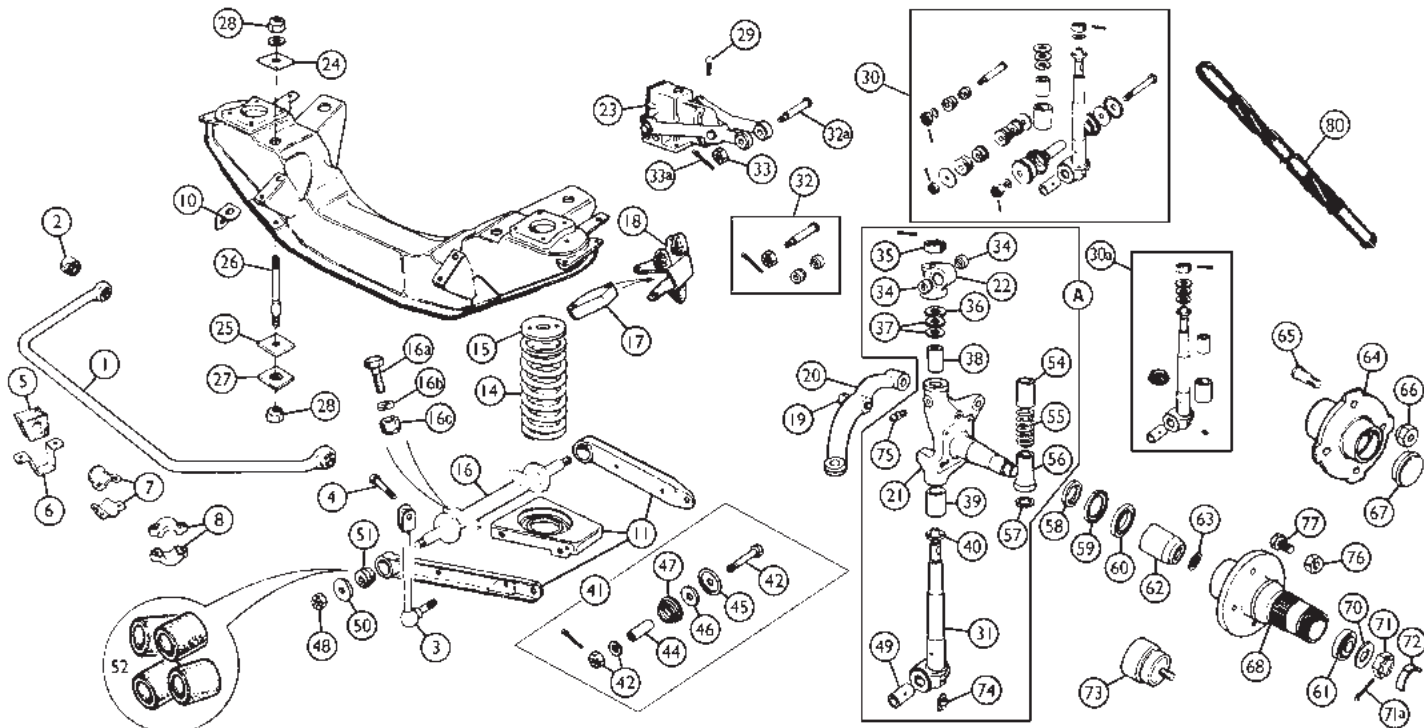

## Front Suspension

19763

No.	Part#	Price (Each)	Description	Application	Qty Req.
A	264-441	\$299.99	SWIVEL ASSEMBLY, new, L/H		1
	264-431	\$299.99	SWIVEL ASSEMBLY, new, R/H		1
1			SWAY BAR - see listings on facing page		1
2	280-910	\$2.99	BUSH, sway bar		2
3	264-840	\$23.99	LINK, R/H, sway bar		1
	264-830	\$23.99	LINK, L/H, sway bar		1
4	322-110	\$0.89	BOLT, sway bar to link		2
	311-305	NA	NUT for bolt		2
5	280-920	\$1.69	RUBBER MOUNT (9/16")	RD to (c)360300 '62-'74 1/2	2
	021-767	\$1.89	RUBBER MOUNT (5/8")	RD from (c)360301 on, all GT	2
	280-915	\$2.39	RUBBER MOUNT, for 3/4" competition bars		2
6	263-430	\$1.29	BRACKET, rubber mount		2
7	263-778	\$5.99	LOCATOR PAIR w/hardware	RD to (c)360300 '62-'74 1/2	2
8		NA	LOCATOR PAIR w/hardware	RD from (c)360301 on, all GT	2
10	263-130	\$3.29	SHIM, steering rack alignment		A/R
11	264-287	\$64.99	SPRING PAN & ARM SET, L/H		1
	264-288	\$64.99	SPRING PAN & ARM SET, R/H		1
14	264-375	\$39.99	COIL SPRING	RD to (c)293445	2
	264-380	\$39.99	COIL SPRING	RD from (c)293446 on	2
	264-390	\$36.99	COIL SPRING	GT to 361000	2
	264-380	\$39.99	COIL SPRING	GT from (c)361001 on	2
See color pages "Performance" section at the front of this catalog for more springs.					
15	263-450	\$25.99	SPIGOT, spring locating		2
16	264-270	\$52.99	PIVOT, wishbone		2
16a	320-115	\$1.39	BOLT, wishbone pivot		8
16b	324-040	\$0.39	LOCKWASHER		8
16c	114-656	\$0.99	NUT, "Aerotite" (outer positions)		4
	310-075	\$0.39	NUT (inner positions)		4
17	264-060	\$7.89	DISTANCE PIECE		2
18	266-550	\$13.99	BUFFER, rebound, stock		2
	266-590	\$19.99	BUFFER, rebound, shortened for lowered suspension		2
19	322-445	\$7.49	BOLT, steering lever		4
20	264-460	NA	STEERING LEVER, R/H		1
	264-470	NA	STEERING LEVER, L/H		1
21	264-430	NA	SWIVEL AXLE, R/H, w/bushes fitted	see rebuilt ass'y. on facing page	1
	264-440	NA	SWIVEL AXLE, L/H, w/bushes fitted		1
22	264-450	\$68.99	TRUNNION, suspension link		2
23	264-360	\$489.99	SHOCK ABSORBER, new		2
	264-361	\$359.99	SHOCK ABSORBER, UPRATED, new		2
	264-365	\$174.99	SHOCK ABSORBER, rebuilt		2
		\$325.00	CORE CHARGE FOR 264-365 SHOCK ABSORBER		
24	264-900	\$1.49	MOUNTING PAD, upper (with lip)	all	4
25	264-905	\$1.69	MOUNTING PAD, lower	to 1974 1/2	4
	264-900	\$1.49	MOUNTING PAD, lower front	1974 1/2 - '80	2
	264-905	\$1.69	MOUNTING PAD, lower rear	1974 1/2 - '80	2
	264-906	\$25.99	MOUNTING PAD SET, polyurethane	to 1974 1/2	1

No.	Part#	Price (Each)	Description	Application	Qty Req.
	264-907	\$25.99	MOUNTING PAD SET, polyurethane	1974 1/2 - '80	1
26	264-910	\$34.99	BOLT, cross-member	ft. & rear '62-'74, rear '74 1/2-'80	4/2
	264-945	\$47.99	BOLT, cross-member, front	1974 1/2 - '80	2
27	264-915	\$1.79	PLATE		4
28	310-400	\$0.89	NUT, cross-member bolt		8
29	320-125	\$1.99	BOLT, shock absorber	chrome bumper cars	8
	320-115	\$1.39	BOLT, shock absorber	rubber bumper cars	8
30	264-408	\$189.99	MAJOR SUSPENSION KIT, for 2 sides		1
Includes all items marked * as listed below.					
	264-409	\$229.99	MAJOR SUSPENSION KIT, for 2 sides		1
as above, but with polyurethane bushes replacing rubber for nos. 34 & 51					
30a	264-418	\$129.99	KING PIN SET, as illus.	Incl. items marked † below	1
31		† NA	KING PIN		2
32	031-390*	\$6.99	FULCRUM PIN & BUSH KIT (for one side)		2
32a	263-440*	\$3.29	FULCRUM PIN		2
33	310-330*	\$2.29	NUT, slotted		2
33a	325-330	\$0.19	COTTER PIN		2
34	282-305*	\$1.79	BUSH, fulcrum pin		4
35	264-960*†	\$8.99	NUT		2
36	264-920*†	\$6.49	THRUST WASHER		2
37	264-925*†	\$2.99	ADJUSTMENT WASHER, .052 - .057"		A/R
	264-930*†	\$2.89	ADJUSTMENT WASHER, .058 - .063"		A/R
	264-935*†	\$2.99	ADJUSTMENT WASHER, .064 - .069"		A/R
38	330-400*†	\$8.69	BUSH, upper	} Must be reamed. See pg. 47 for reamer.	2
39	330-410*†	\$10.59	BUSH, lower		2
40	264-940*	\$0.99	SEALING RING		2
41	263-455*	\$16.99	LOWER TRUNNION KIT	(for one side)	2
42	321-558*	\$8.99	BOLT, NUT & LOCKWASHER SET		2
44	264-070*	\$5.89	DISTANCE TUBE		2
45	264-010*	\$0.89	SEAL SUPPORT		4
46	324-510*	\$1.29	THRUST WASHER		4
47	280-580*†	\$1.59	SEAL		4
48	310-410*	\$2.49	NUT		4
49	330-140*†	\$8.99	BUSH, lower pin	Must be reamed.	2
50	264-510*	\$1.29	RETAINING WASHER		4
51	281-398*	\$7.99	BUSHING SET, 8 rubber bushes		1
52	280-498	\$7.69	BUSHING SET, MGB-GT V-8	replaces 281-398	1
(see facing page for details.)					
	263-428	\$18.99	DUST TUBE KIT		2
54	263-460	\$6.49	TUBE, dust excluder, top		2
55	031-276	\$1.29	SPRING, dust excluder		2
56	263-465	\$3.99	TUBE, dust excluder, bottom		2
57	264-975	\$1.99	SEALING RING		2
58	264-950	\$24.99	COLLAR, oil seal		2
	125-840	\$12.99	BEARING KIT		2
59	120-610	\$1.29	OIL SEAL, hub		2

# Front Suspension

No.	Part#	Price (Each)	Description	Application	Qty Req.
60	126-000	\$14.99	BEARING, inner hub		2
61	126-100	\$16.99	BEARING, outer hub		2
62	264-620	\$16.99	SPACER, bearing		2
63	263-508	\$13.99	SHIM KIT (Incl. 2 ea. .030" & .010, 4 ea. .003 & .005 shims)		1
	263-500	\$1.59	SHIM, front hub .003"		A/R
	263-510	\$1.59	SHIM, front hub .005"		A/R
	263-520	\$1.59	SHIM, front hub .010"		A/R
	263-525	\$1.59	SHIM, front hub .030"		A/R
64	264-480	NA	HUB ASSEMBLY, disc wheel		2
65	264-490	\$5.29	STUD, disc wheel		8
66	264-500	\$3.99	NUT, wheel stud	standard disc wheel	8
	264-980	\$4.49	NUT, wheel stud, chrome	Rostyle wheel	8
	264-990	\$21.99	NUT, wheel stud, black	"Limited Edition" wheel	8
67	264-515	\$6.29	CAP, grease retaining		2
68	264-850	\$179.99	HUB, R/H, wire wheel	} RD to (c)30850, fine thread (12 t.p.i.)	1
	264-860	\$179.99	HUB, L/H, wire wheel		1
	264-870	\$179.99	HUB, R/H, wire wheel	} RD from (c)30851, all GT, coarse thread (8 t.p.i.)	1
	264-880	\$179.99	HUB, L/H, wire wheel		1
70	264-955	\$1.39	WASHER, bearing retaining		2
71	310-820	\$9.99	NUT, bearing retaining		2
71a	325-442	\$0.89	COTTER PIN		2
72	264-410	\$15.79	GREASE RETAINER, wire wheel	RD to (c)30850	2
73	662-030	\$6.49	CUP, grease retaining, wire wheel	RD from (c)30851, all GT	2
74	328-505*†	\$1.19	GREASE NIPPLE, angled		2
75	328-530*†	\$1.99	GREASE NIPPLE, straight		4
76	310-075	\$0.39	NUT, rotor to hub		8
77	320-115	\$1.39	BOLT, rotor to hub		8
80	386-370	\$399.99	REAMER, kingpin bushes		1

## MGB GT V-8 A-Arm Bushings

Originally supplied by the factory for the MGB GT V-8, these steel/rubber combination bushes positively locate your front suspension's lower a-arms. Set of four bushes replace the eight rubber ones which deteriorate so quickly. Instructions included.



(1 set required per car.) **280-498 \$7.69**

**See "Performance" section in the color pages at the front of this catalog for more uprated bushings and bushing sets.**

## Polyurethane A-Arm Bushings

If you're looking for that competition edge in your suspension, you'll want to purchase a set of these. Made of polyurethane instead of stock rubber, these will give you better road feel than even the V-8 bushings. (8 required.) **280-485 \$3.89 each**



## Nylatron Bushings

Nylatron, a compound of nylon and Molybdenum Disulfide, is an extra tough material for heavy loads with low rotational movement. These bushings require very little lubrication and produce good lateral control while allowing easier suspension movement. Bushings and pads are sold individually. (Some reaming and hand-fitting may be required on some bushes.)

Rear Shackle Pin Bush (8 required) **267-545 \$15.49 ea.**  
Rear Axle Seating Pad (4 required) **267-555 NA**



## Kingpin Reamer

An original factory kingpin reaming tool ensures that swivel pin bushes are perfectly aligned. This is a great addition to any complete tool collection! Your local club should keep one handy for general club use.

**386-370 \$399.99**



## Uprated & Lowered Front Springs

See "Performance" Section in the color pages at the front of this catalog.

Toll-Free Orders 1-800-667-7872 | MossMotors.com  
Fax 805-692-2525 | Local 805-681-3400

**MOSS**

## Sway Bars



Front sway bars are a major influence in how your MGB handles. While the chart below indicates basic recommendations, the following observations should also be considered in selecting a sway bar.

1. Increasing the bar diameter will reduce body roll and understeer. Too strong a bar will again allow understeer to develop, and increase suspension harshness.

2. Larger tires & wheels may allow use of a larger bar due to the increased unsprung weight.
3. The amount of load transferred by the sway bar (ie., its stiffness) is proportional to the cross-sectional area, as shown in the chart below. It is easily seen that a small increase in bar diameter produces a large increase in the load transfer capacity.

			Dia.	lbs/in	% increase
9/16" Ft. Sway Bar		NA	9/16"	50	0
5/8" Front Sway Bar	<b>454-965</b>	<b>\$189.99</b>	5/8"	60	120
3/4" Front Sway Bar	<b>454-945</b>	<b>\$149.99</b>	3/4"	137	280
7/8" Front Sway Bar	<b>454-955</b>	<b>\$189.99</b>	7/8"	228	450

The following mounting kits allow installation of front sway bars on cars to which sway bars were not originally fitted. These kits include two wishbone arms (with reinforced holes for mounting the sway bar links), two sway bar links, two mounting bushes with brackets, and hardware.

Installation Kit for 5/8" Sway Bar **454-978 \$109.99**  
Installation Kit for 3/4" Sway Bar **454-948 \$89.99**  
Installation Kit for 7/8" Sway Bar **454-958 \$114.99**

## Solid Sway Bar Mounts

These competition-designed machined aluminum mounts are great for road use as well. Some increase in road noise can be expected. Due to the positioning of the tapped holes, some adaption may be required to obtain correct alignment of the mounting bolts. Sold as a pair.

For 7/8" Sway Bars **263-445 \$84.99**  
For 3/4" Sway Bars **263-435 \$89.99**



## Rebuilt Swivel Assemblies

Rebuild the front end of your car the easy way with this great kit which includes RH and LH swivel assemblies and required spacers, bushes and hardware. Don't forget to order new front wheel bearings if your old ones are any less than absolutely perfect.

SWIVEL ASS'Y. KIT **264-468 \$499.00**  
CORE CHARGE **\$600.00**



## Negative Camber Wishbone Arm Set

Fitting these longer wishbone arms produces negative camber in the front suspension, improving turn-in for quicker, safer cornering; highly recommended for all road cars, and essential for competition cars. Once these are installed, toe must be adjusted to 1/8" to 3/32" toe-in.

**264-038 (set of 4) \$119.99**

## Heavy-Duty Shock Valves

About 25% stiffer than stock ones, these competition shock valves are just the ticket for improved road holding. Sold individually.

MGB Front Shock Valve **264-345 \$49.99**  
MGB Rear Shock Valve **267-975 \$33.99**



## Dynolite Shock Absorber Fluid

Replace the original dirty or degenerated fluid with Dynolite Shock Fluid. It is custom formulated specifically for single or double action shock absorbers, in particular Armstrong type lever shock absorbers and motorbike forks. Our special formula fluid is fully compatible with original shock fluid and incorporates an anti-foaming agent which maintains damping power even under tough driving conditions. It also repels water and condensation, retards internal rust, oxidation, and corrosion. With so many benefits, order this essential item for your classic car!

**220-306 \$22.99**

# Early Rear Axle

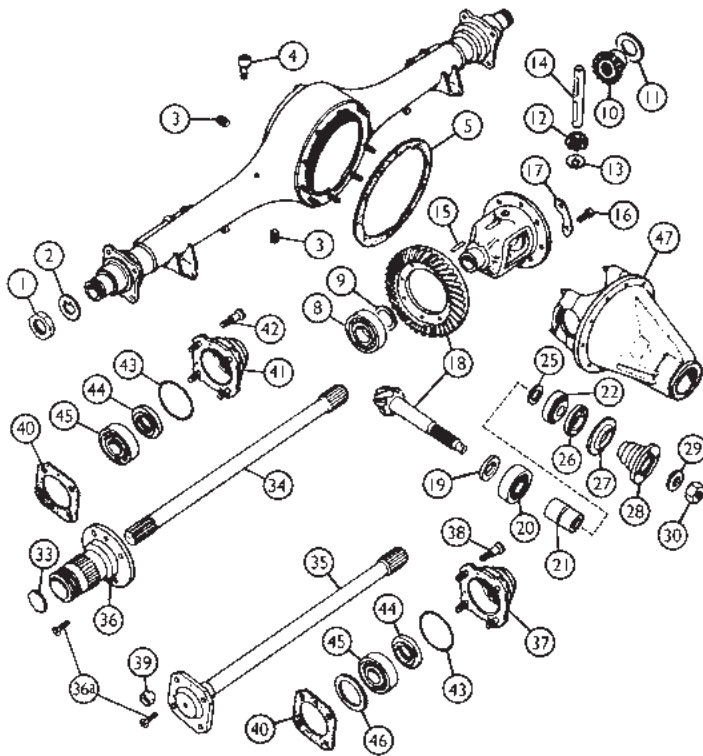

## Early Rear Axle

19775

No.	Part#	Price (Each)	Description	Application	Qty Req.
-----	-------	--------------	-------------	-------------	----------

Prior to 1965, all roadsters were fitted with banjo type axles. From 1965 thru '67, (c)123716 thru 132922, roadsters were fitted with either banjo or tubed type rear axles. No MGB-GTs were fitted with banjo type axles.

1	267-430	\$26.99	NUT, R/H side, R/H thread		1
	267-440	\$26.99	NUT, L/H side, L/H thread		1
2	267-450	\$4.29	WASHER		2
3	319-060	\$3.99	PLUG, oil drain & filler		2
4	267-040	\$10.79	BREATHER		1

Remember to clean the breather on top of your rear axle every so often. (It just unscrews from the axle housing.) If it gets clogged, pressure builds up inside the axle, causing oil to be forced past the pinion and hub seals.

5	296-200	\$1.49	GASKET		1
8	127-700	\$42.99	BEARING, carrier		2
9	267-150	\$3.29	WASHER, bearing packing .002"		A/R
	267-155	\$3.29	WASHER, bearing packing .003"		A/R
	267-160	\$3.29	WASHER, bearing packing .004"		A/R
	267-170	\$3.99	WASHER, bearing packing .006"		A/R
	267-175	\$2.99	WASHER, bearing packing .010"		A/R
10	267-090	\$199.99	GEAR, differential		2
11	267-140	\$5.79	THRUST WASHER, differential gear		2
12	267-100	\$159.99	PINION, differential		2
13	267-130	\$4.99	THRUST WASHER, differential pinion		2
14	267-110	\$51.49	PIN, pinion		1
15	267-120	NA	PEG, pinion pin		1
16	320-640	\$3.49	BOLT, crown wheel to carrier		8
17	267-220	\$4.79	TAB WASHER		4
18	267-165	\$799.99	GEAR SET, repl. (3.909:1), standard		1
	267-187	\$879.99	GEAR SET, repl. (4.55:1), optional		1
	266-320	NA	GEAR SET (4.875:1), optional		1
	267-180	\$749.99	GEAR SET (4.300:1), optional		1
	267-166	\$849.99	GEAR SET (3.700:1), optional		1
19	267-320	\$34.99	THRUST WASHER, pinion .126"		A/R
	267-310	\$34.99	THRUST WASHER, pinion .124"		A/R
	267-300	\$34.99	THRUST WASHER, pinion .122"		A/R
	267-290	\$34.99	THRUST WASHER, pinion .120"		A/R
	267-280	\$34.99	THRUST WASHER, pinion .118"		A/R
	267-270	\$34.99	THRUST WASHER, pinion .116"		A/R
	267-260	\$34.99	THRUST WASHER, pinion .114"		A/R
	267-250	\$34.99	THRUST WASHER, pinion .112"		A/R
20	125-600	\$89.99	PINION BEARING, inner		1
	125-605	\$154.99	PINION BEARING, inner, Timken brand		1
21	267-230	\$49.99	SPACER		1

No.	Part#	Price (Each)	Description	Application	Qty Req.
22	125-805	\$49.99	PINION BEARING, outer		1
25	267-330	\$3.29	SHIM, outer bearing .004"		A/R
	267-340	\$3.29	SHIM, outer bearing .006"		A/R
	267-345	\$1.99	SHIM, outer bearing .008"		A/R
	267-350	\$2.49	SHIM, outer bearing .010"		A/R
	267-360	\$2.49	SHIM, outer bearing .012"		A/R
	267-370	\$2.39	SHIM, outer bearing .020"		A/R
	267-380	\$2.49	SHIM, outer bearing .030"		A/R
26	120-800	\$2.39	OIL SEAL, pinion		1
27	267-240	NA	DUST COVER		1
28	267-390	\$179.99	FLANGE		1
29	324-100	\$0.89	WASHER		1
30	310-570	\$3.49	NUT		1
33	328-260	\$0.99	PLUG		2
34	453-350	\$234.99	AXLE SHAFT	wire wheel	2
35	453-395	NA	AXLE SHAFT	disc wheel	2
36	267-740	\$224.99	EXTENSION, R/H, wire wheel	RD to (c)30850, 12 t.p.i.	1
	267-750	\$224.99	EXTENSION, L/H, wire wheel	t.p.i.	1
	267-760	\$229.99	EXTENSION, R/H, wire wheel	RD from (c)30851 to	1
	267-770	\$229.99	EXTENSION, L/H, wire wheel	132922, 8 t.p.i.	1
36a	323-255	\$0.69	SCREW, flange to hub		2
37	267-790	NA	HUB		2
38	267-795	\$8.89	STUD	disc wheel	8
39	264-500	\$3.99	NUT, wheel stud (std. wheels)		8
	264-980	\$4.49	NUT, wheel stud (Rostyle wheels)		8
40	296-100	\$0.89	GASKET	all	2
41	267-800	NA	HUB	wire wheel	2
42	267-805	NA	STUD	wire wheel	8
	125-860	\$23.99	BEARING KIT		2
43	121-400	\$1.79	"O" RING		2
44	120-900	\$2.99	OIL SEAL		2
45	127-600	\$44.99	BEARING, hub		2
46	267-420	\$53.99	SPACER	disc wheel	2
47	267-050	NA	CASING, differential		1

To convert from disc to wire wheels, complete rear axle assemblies can be interchanged without difficulty. However, disc and wire axles (half-shafts) will not interchange. Remember that early cars had fine thread (12 t.p.i.) knock-offs, late cars were coarse (8 t.p.i.).

A common cause of oversteer is incorrect tire pressures. MGB rear tires should always be set 3 lbs. higher than the front tires, or 5 lbs. higher when traveling with a loaded trunk. Remember, never mix bias ply tires with radials.

### Speedi-Sleeve



When a new seal cannot compensate for excessive damage, these ultra-thin sleeves provide a new sealable surface. Instructions and installation tool are included.

for pinion flange #28	520-500	\$62.99
for hub seal (end of axle tube)	520-520	\$65.99

### Hub Nut Socket

Special 8-sided 1-61/64" socket for the rear axle hub nuts (illus. no. 1 above) of the banjo type axles. This invaluable tool is a modern and affordable replacement for the hard to find and very expensive Churchill tool #18G152. (This socket has a 3/4" square drive hole, so you will need an adaptor unless you have 3/4" drive tools.) Fits banjo axles only!

384-905 \$44.99



# Late Rear Axle

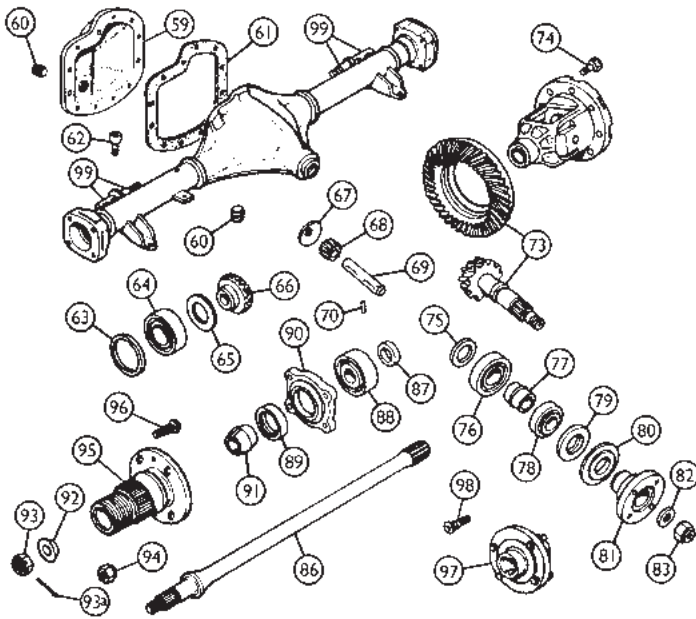

## Late Rear Axle

19778

No. Part#	Price (Each)	Description	Application	Qty Req.
-----------	--------------	-------------	-------------	----------

MGB rear axle assemblies are rugged, long-wearing units. However, with high mileage, they develop a very annoying and expensive sounding "clunk". The good news is that the clunk is usually caused by worn-out, inexpensive differential thrust washers (illus. #65 and particularly illus. # 67). Replacement is fairly easy, but does require that the rear cover plate and axle half shaft be removed. If you've eliminated all other sources of rear axle clunk, i.e., loose wheels, shock absorbers, rear axle u-bolts and u-joints, this simple project will be rewarding and minimize the chance of developing serious and expensive rear axle problems.

From 1965 thru '67, (c)123716 thru 132922, roadsters were fitted with either banjo or tubed axles. After this, roadsters were fitted with tubed type axles. All GTs were fitted with tubed type axles.

59	296-211	\$194.99	COVER	1
60	319-060	\$3.99	PLUG, oil drain & fill	2
61	296-210	\$1.29	GASKET	1
62	267-040	\$10.79	BREATHER	1
63	267-810	\$35.99	DISTANCE COLLAR .149"	A/R
	267-815	NA	DISTANCE COLLAR .147"	A/R
	267-820	\$33.99	DISTANCE COLLAR .145"	A/R
	267-825	NA	DISTANCE COLLAR .143"	A/R
	267-830	\$33.99	DISTANCE COLLAR .141"	A/R
	267-835	NA	DISTANCE COLLAR .139"	A/R
	267-840	\$33.99	DISTANCE COLLAR .137"	A/R
	267-845	\$33.99	DISTANCE COLLAR .135"	A/R
	267-850	\$33.99	DISTANCE COLLAR .133"	A/R
	267-855	\$33.99	DISTANCE COLLAR .129"	A/R
	267-860	NA	DISTANCE COLLAR .127"	A/R
	267-865	NA	DISTANCE COLLAR .125"	A/R
	267-870	\$33.99	DISTANCE COLLAR .123"	A/R
	267-875	NA	DISTANCE COLLAR .121"	A/R
	267-880	NA	DISTANCE COLLAR .119"	A/R
	267-885	\$33.99	DISTANCE COLLAR .117"	A/R
	267-890	NA	DISTANCE COLLAR .115"	A/R
64	127-710	\$31.99	BEARING, carrier	2
65	267-140	\$5.79	THRUST WASHER, differential gear	2
66	267-095	\$399.99	GEAR, differential	2
67	267-130	\$4.99	THRUST WASHER, differential pinion	2
68	267-100	\$159.99	PINION, differential	2
69	267-115	\$42.99	PIN, pinion	1
70	267-125	\$0.69	PEG, pinion pin	1
73	267-195	NA	GEAR SET, 11/43 (3.909:1)	1
74	267-895	\$1.69	BOLT, crown wheel to carrier	8
75	267-900	NA	THRUST WASHER, pinion .222"	A/R
	267-905	NA	THRUST WASHER, pinion .220"	A/R
	267-910	NA	THRUST WASHER, pinion .218"	A/R
	267-915	NA	THRUST WASHER, pinion .216"	A/R
	267-920	NA	THRUST WASHER, pinion .214"	A/R
	267-925	NA	THRUST WASHER, pinion .212"	A/R
	267-930	NA	THRUST WASHER, pinion .210"	A/R
	267-935	NA	THRUST WASHER, pinion .208"	A/R

No. Part#	Price (Each)	Description	Application	Qty Req.	
76	125-610	\$59.99	PINION BEARING, inner	1	
77	125-615	\$19.99	SPACER, collapsible	1	
78	125-810	\$28.99	PINION BEARING, outer	1	
79	120-810	\$4.49	OIL SEAL	1	
80	125-620	NA	DUST COVER	1	
81	125-625	\$172.99	FLANGE	1	
82	125-630	NA	WASHER	1	
83	125-635	\$7.99	NUT	1	
86	453-380	\$350.99	AXLE SHAFT	disc wheel	2
	453-370	NA	AXLE SHAFT	wire wheel	2
87	125-640	\$19.99	SPACER, bearing	2	
	125-850	\$20.99	BEARING KIT	2	
88	128-000	\$31.99	BEARING, hub	2	
89	120-700	\$1.99	OIL SEAL	2	
90	125-650	NA	CAP, hub bearing	2	
91	266-030	\$39.99	COLLAR, oil seal	2	
92	125-665	\$8.49	COLLAR, axle shaft	2	
93	125-670	\$10.99	NUT, axle shaft	2	
93a	325-443	\$0.69	COTTER PIN	2	
94	264-500	\$3.99	NUT, wheel stud	disc wheel (not Rostyle)	8
	264-980	\$4.49	NUT, wheel stud	Rostyle	8
	264-990	\$21.99	NUT, wheel stud	Limited Edition wheel	8
95	267-720	\$179.99	HUB EXTENSION, R/H	} wire wheel	1
	267-730	\$179.99	HUB EXTENSION, L/H		1
96	264-490	\$5.29	STUD	} disc wheel	8
	310-400	\$0.89	NUT, hub extension		8
97	125-690	\$199.99	HUB (does not include studs)	} disc wheel	2
98	125-685	\$4.49	STUD		8
99	321-000	\$6.79	PIN for check strap (welded installation required)		2

A simple tool for removing the rear axle drain and filler plugs can be made by buying a 5/8" diameter bolt, cutting it off to leave a 3/4" long shank, then grinding or filing suitable flats to fit inside the plug. Used with a wrench, this works perfectly. To prolong the life of your rear end gears, check the oil level occasionally. (Especially if your seals are leaking!) Always use hypoid 90 gear oil.

Removal of the rear axle nut on wire wheel cars requires the use of a 1-5/16" socket with an outside diameter of no more than 1.8"

### Limited Slip Differentials

Quaife gear type limited slip differentials deliver more engine power to the ground. Great for racing, autocrossing, driving in the snow or just for fun. If you've ever turned a corner, stepped on the gas, and waited while the inside rear wheel spins ineffectively, you'll appreciate the advantages of a limited slip diff. Installation requires no more work than rebuilding a standard differential. These use hypoid 90 gear oil.

**MGB/MGC (tube type axle housing)** **267-055** **\$1,949.00**

(267-055 will accept 3.9 and 3.7 gearsets only)

**MGB (banjo axle housing)** **267-065** **\$1,949.00**



### Rear Axle Puller (tubed type axles)

This tool substitutes for the factory tool 18G284D called for in the workshop manual to remove axle shafts from the housing. Must be used with a slide hammer fitted with a hook (the workshop manual charmingly refers to the slide hammer as an "impulse extractor").



**384-945** **\$36.99**

# Drive Shaft & Suspension

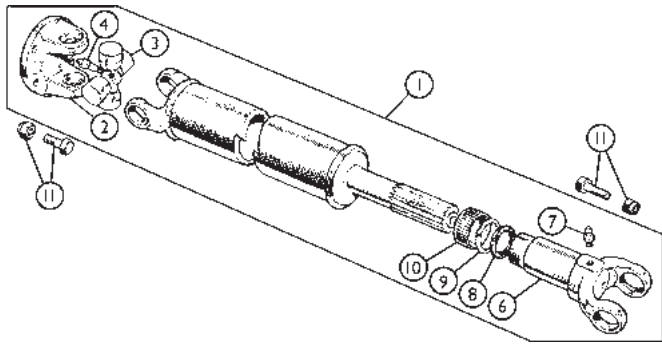

## Drive Shaft

19781

No.	Part#	Price (Each)	Description	Application	Qty Req.	
(Lengths given are nominal operating lengths)						
1	268-080	\$184.99	DRIVE SHAFT ASS'Y., 30" std.	} banjo type axle	1	
	268-090	\$244.99	DRIVE SHAFT ASS'Y., 31.125" O/D		1	
	268-090	\$244.99	DRIVE SHAFT ASS'Y., 31.125" std.		} tubed type axle, RD/GT thru 1967	1
	268-100	\$219.99	DRIVE SHAFT ASS'Y., 32" O/D			1
	268-090	\$244.99	DRIVE SHAFT ASS'Y., 31.125"	RD/GT from 1968 on	1	
2	268-010	\$29.99	FLANGE, yoke		2	
3	268-060	\$26.99	U-JOINT, GKN/Hardy-Spicer		2	
	268-061	\$12.99	U-JOINT, aftermarket		2	
4	328-540	\$1.89	GREASE FITTING		2	
6	268-020	\$43.99	SLEEVE, yoke		1	
7	328-530	\$1.99	GREASE FITTING		1	
8	268-040	NA	SEAL, cork	(use new cap ass'y. #10)	1	
9	268-045	NA	WASHER, steel		1	
10	268-035	\$7.29	CAP (includes improved seal, does not use washer)		1	
11	321-858	\$6.99	BOLT & NUT SET, front & rear	RD/GT to (c)138400	2	
	321-848	\$12.99	BOLT & NUT SET, front	RD/GT from (c)138401	1	
	321-858	\$6.99	BOLT & NUT SET, rear	on, 1968 on	1	

Particularly after wet weather, U-joints on MGB drive shafts tend to fail suddenly. The usual indication is a high metallic "scrunching" sound when you accelerate, often accompanied by a vibration at speed. U-joints are relatively inexpensive, so to save the hassle of frequent drive shaft removal, always replace both joints. Always remember to align the two fixed yokes on the drive shaft with each other, if they are not in the same plane, severe vibration can occur. Driveshafts usually have stamped arrows on the sleeve to indicate correct assembly. If yours does not, mark before disassembling.

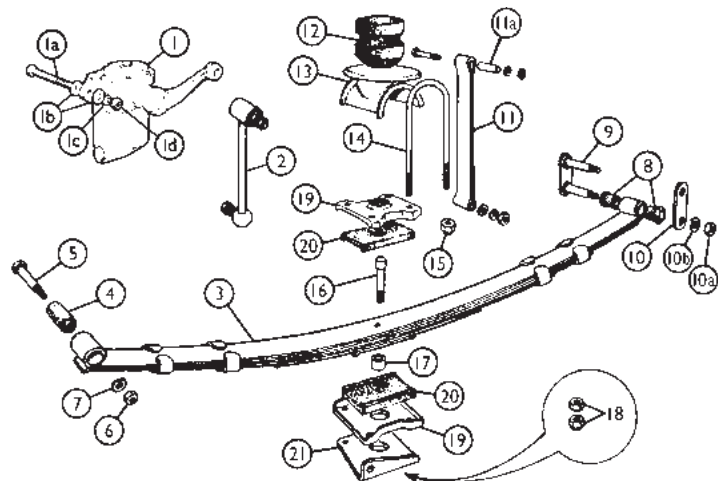

## Rear Suspension

19783

No.	Part#	Price (Each)	Description	Application	Qty Req.
1	267-715	\$239.99	SHOCK ABSORBER, L/H, new		1
	267-995	\$179.99	SHOCK ABSORBER, L/H, rebuilt		1
		\$200.00	CORE CHARGE FOR 267-995		
	267-705	\$239.99	SHOCK ABSORBER, R/H, new		1
	267-985	\$179.99	SHOCK ABSORBER, R/H, rebuilt		1
		\$200.00	CORE CHARGE FOR 267-985		
Upgraded shock absorbers are approximately 25% stiffer than stock units					
	267-711	\$299.99	SHOCK ABSORBER, L/H, upgraded, new		1
	267-701	\$299.99	SHOCK ABSORBER, R/H, upgraded, new		1
	266-578	\$13.69	HARDWARE KIT, shock mounting	chrome bumper cars	1
	266-588	\$12.49	HARDWARE KIT, shock mounting	rubber bumper cars	1
1a	266-582	\$3.19	BOLT	} rubber bumper cars	4
	266-582	\$3.19	BOLT, long		2
	266-580	\$2.09	BOLT, short		2
1b	324-475	\$0.19	WASHER, plain		8
1c	324-250	\$0.19	LOCKWASHER		4
1d	310-800	\$0.49	NUT		4

Rear clunking noises often come from loose shock absorbers. Check them where they bolt to the chassis and at the lower plate attachment.

2	267-640	\$23.99	LINK, shock absorber (chrome bumpered cars)	} RD to (c)360300, GT to (c)361000	2	
	267-641	\$28.99	LINK, shock absorber, Cobalt (chrome bumpered cars)		2	
	267-645	\$21.99	LINK, shock absorber (rubber bumpered cars)	} RD from (c)360301 on, GT from (c)361001 on	2	
3	454-763*	\$109.99	LEAF SPRING, 6 leaf		} RD to (c)360300, to '74 1/2	2
	454-771*	\$89.99	LEAF SPRING, 7 leaf	} RD from (c)360301 to 386795, GT to (c)361000		2
	454-766*	\$129.99	LEAF SPRING, 7 leaf, '74 1/2			2
	454-776*	\$99.99	LEAF SPRING, 6 leaf, '76 on	RD from (c)386796 on	2	
4	267-515	\$5.39	BUSH (stock type)		2	
	267-525	\$29.99	BUSH SET, Prothane		1	
* See rear leaf spring mounting kits on facing page.						
5	266-580	\$2.09	BOLT	chrome bumper cars	2	
	266-582	\$3.19	BOLT	rubber bumper cars	2	
6	310-800	\$0.49	NUT		2	
7	324-250	\$0.19	WASHER		2	
8	282-858	\$5.29	BUSH SET, rubber (8 bushes for 2 springs)	} alternatives	1	
	282-855	\$14.99	BUSH SET, Prothane (4 bushes for 1 spring)		2	
	267-545	\$15.49	BUSH, Nylatron	alternatives	8	
	267-528	\$13.99	SHACKLE PLATE SET, with nuts & lockwashers		2	
9	267-520	\$14.49	SHACKLE PLATE, w/pins		2	
10	267-530	\$3.49	SHACKLE PLATE		2	
10a	310-050	\$0.69	NUT		4	
10b	324-040	\$0.39	LOCKWASHER		4	
11	267-565	\$5.49	REBOUND STRAP, stock type	} chrome bumper cars	2	
	267-566	\$39.99	REBOUND STRAP PAIR, nylon		1	
	267-615	NA	REBOUND STRAP, stock type	} rubber bumper cars	2	
	267-610	\$6.99	REBOUND STRAP, replacement		2	
	267-616	\$39.99	REBOUND STRAP PAIR, nylon		1	
11a	267-655	\$3.59	TUBE, rebound strap		2	
12	266-530	\$9.39	BUMP RUBBER		2	

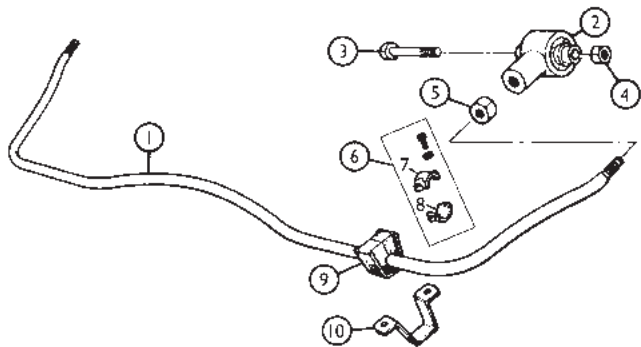

## Rear Sway Bar

19782

RD from (c)410001 on - 1977 on (not recommended for use on earlier cars)

1	267-940	NA	SWAY BAR		1
2	267-950	\$23.99	END FITTING		2
3	266-580	\$2.09	BOLT		2
4	021-634	\$0.89	NUT		2
5	310-490	\$1.79	JAM NUT		2
6	267-958	\$32.99	LOCATOR KIT (upper & lower locators & hardware)		2
7	267-955	NA	LOCATOR, upper		2
8	267-960	NA	LOCATOR, lower		2
9	267-970	\$1.49	BUSHING		2
10	263-430	\$1.29	BRACKET		2



# Rear Suspension

No.	Part#	Price (Each)	Description	Application	Qty Req.
13	266-535	\$12.99	PEDESTAL, bump rubber	banjo type axle	2
	266-540	\$9.99	PEDESTAL, bump rubber		tubed type axle
14	266-560	\$3.49	U-BOLT	banjo type axle	4
	266-570	\$2.99	U-BOLT		RD tubed type, all GT
15	310-240	\$0.89	NUT, U-bolt		8

If your MGB's rear end twitches from side to side when you accelerate or decelerate, check the U-bolts which anchor the axle to the springs. If they are loose, or if the rubber pads between the metal plates and the springs have deteriorated, the axle will move relative to the springs.

16	320-468*	\$27.99	BOLT SET (bolt, spacer & nuts)		2
17	267-585*	\$4.69	SPACER		2
18	267-608*	\$1.09	NUT & LOCKNUT SET, locating bolt		1
*Included w/leaf springs.					
19	267-570	\$8.99	PLATE, spring locating	banjo type axle	4
	267-575	\$4.59	PLATE, spring locating		tubed type axle
20	281-598	\$8.49	PAD SET, rubber (4 pads)	} alternatives	1
	281-600	\$29.99	PAD SET, Prothane (4 pads)		1
	267-555	NA	PAD, Nylatron		4
	267-590	\$44.99	BRACKET, R/H, shock absorber		1
21	267-600	\$44.99	BRACKET, L/H, shock absorber	} banjo type axle	1
	267-595	\$34.99	BRACKET, R/H, shock absorber		1
	267-605	\$34.99	BRACKET, L/H, shock absorber		1



## Tie Down Plates

(Tube type axles only)

Stop crawling around under your car hunting for a place to attach your trailer tie downs. Our rear axle tie down plates provide an easy to reach place to secure your car safely. Hooking tie downs to the chassis forces greater loads on the tie downs and could lead to dangerous stretching or breaking. By

hooking to the axle, your car's suspension is allowed to move naturally.

Sold in pairs. **267-522** NA

## Lowered Rear Springs

We carry a full line of stock and performance springs. See the "Performance" section of the full color pages at the front of this catalog for listings.

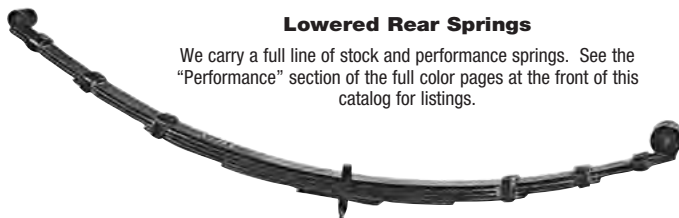

## Rear Axle Anti-Tramp Bar Kit

Fits '65-'74 MGBs with tube-type rear axle. When power is applied suddenly, usually from a standstill, the rear leaf springs tend to wind-up into an "S" shape, which is then released in a series of "hops", commonly called "tramp". The anti-tramp bar allows only vertical movement of the axle and stops it from winding-up when under load. This allows the sharp application of power and the positive transmission of that power to the tires, then to the road. Bushed with hard rubber for road use. **454-935 \$399.99**



Toll-Free Orders 1-800-667-7872 | MossMotors.com  
Fax 805-692-2525 | Local 805-681-3400

MOSS

## Heavy-Duty Shock Valves

About 25% stiffer than stock ones, these competition shock valves are just the ticket for improved road holding. Sold individually.

MGB Front Shock Valve	<b>264-345</b>	<b>\$49.99</b>
MGB Rear Shock Valve	<b>267-975</b>	<b>\$33.99</b>



## Rear Suspension Lowering Kits

For lowering the center of gravity on cars with stock springs only, or in race applications. Kits include spacer blocks, longer U-bolts, and all necessary hardware. These lower cars approximately 1".

Lowering Kit for Banjo Axle Cars

Lowering Kit for Tube Axle Cars

**Stock spring mounting pads must be replaced.**

SPRING PAD SET, polyurethane (set of 4)

SPRING PAD, nylatron

## Rear Spring Kits

Complete rear spring mounting kits include rubber spring mounting pads, shackle bushes, and U-bolts & nuts. Each kit mounts one spring. 2 required per car.

For Banjo Axles **454-927 \$15.99**

For Tube-type Axles **454-937 \$16.99**



## "Prothane" Polyurethane Bushing Sets

Let your car develop all the good handling traits it should have by replacing mushy soft rubber suspension bushes with our newest and best polyurethane bushing sets. Superb engineering design details differentiate these from other polyurethane replacement bushings. While "anyone" can copy stock rubber bushes in plastic, Prothane carefully selects the appropriate density material for each particular

use. Consistency of material and stringent quality control provide effectiveness and durability. Special design features such as grooved bores in some bushings to hold a special Teflon grease make these bushing sets long-lasting and quiet (remember how some other bushes squeak?). Suspension bushing kits include a packet of this special grease.

**(Number of bushes/pads in each set in brackets, followed by quantity required per car.)**

MGB Front lower control arm, inner (8/1)	281-400	\$36.99
MGB Front upper trunnion, outer (4/1)	282-325	\$14.99
MGB Gearbox steady rod eye, RD thru '67 (2/1)	280-054	\$6.99
MGB Gearbox steady rod pads, all RD, GT '67-on (2/1)	282-335	\$11.99
MGB Gearbox X-member, RD '68-on, all GT (2/1)	280-056	\$9.99
MGB Front sway bar mount (2/1)	280-935	\$9.99
MGB Front X-member pads (8/1), chrome bumper	264-906	\$25.99
MGB Front X-member pads (8/1), rubber bumper	264-907	\$25.99
MGB Rear spring, front eye (4/1)	267-525	\$29.99
MGB Rear spring, rear eye/shackle (4/2)	282-855	\$14.99
MGB Rear spring pad (4/1)	281-600	\$29.99

## Nylatron Bushings

Nylatron, a compound of nylon and molybdenum disulphide, is an extra tough material for heavy loads with low rotational movement. These bushings require very little lubrication and produce good lateral control while allowing easier suspension movement. Bushings and pads are sold individually. (Some reaming and hand-fitting may be required on some bushes.)



Rear Shackle Pin Bush (8 required)	<b>267-545</b>	<b>\$5.99 ea.</b>
Rear Axle Seating Pad (4 required)	<b>267-555</b>	<b>NA</b>

# Wheels

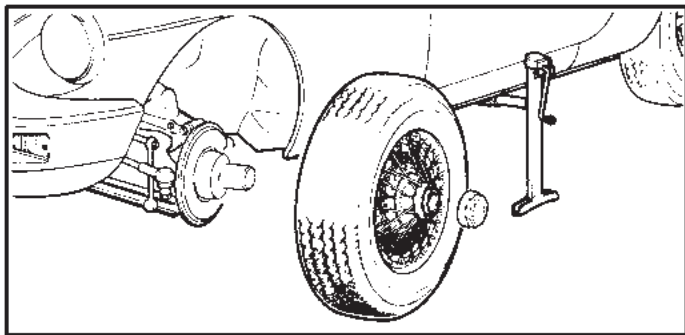

## Wire Wheels

If your car has wire wheels, remove them every three months, clean the old grease off the splines (both hub and wheel) and apply a light coat of fresh grease or vaseline. Failure to do this can result in premature wear of the splines or, worse, the wheel being stuck on the splines when you have to fix a flat on a rainy day while you are all dressed up and in a hurry to go somewhere!

To prevent the grease on your wire wheel hub splines from seeping out through the spoke holes and messing up your wheels, smear silicone sealer over the spoke heads inside the hub.



## MGB Wire Wheel Conversion Kits

Disc wheel cars with tube type axles (not early banjo type!) can now be easily converted to beautiful wire wheels with one of these kits. What makes these kits different from others are the uniquely designed rear hubs which replace your original disc wheel hubs, using your original disc wheel axle shafts. Kits include the special rear hubs, front hubs (with studs, nuts, and bolts), front wheel bearings, front axle seals, knock-offs, knock-off wrench (octagonal knock-off kits only), copper knock-off hammer, front grease caps, and five beautifully plated chrome or high quality painted wire wheels.

Chromed Wheel Kit with octagonal knock-offs	<b>111-418</b>	<b>\$3,599.00</b>
Chromed Wheel Kit with eared knock-offs	<b>111-419</b>	<b>\$3,599.00</b>
Painted Wheel Kit with octagonal knock-offs	<b>111-428</b>	<b>\$2,899.00</b>
Painted Wheel Kit with eared knock-offs	<b>111-429</b>	<b>\$2,899.00</b>



## Bright Trim Ring Set

Dress up your factory wheels with a set of deluxe, polished stainless steel trim rings. Our trim rings install in seconds and provide an attractive accent to your rims. Sold as sets of 4.

**455-378 \$149.99**



## Knockoff Sport Wheels

Patterned after the racing Minilite wheels of the sixties, our reproductions are beautifully made and will definitely beef up the handling and appearance of your car. You say you like wire wheels, but don't want to use them for racing. These wheels use standard wire wheel hubs and knockoffs. Oversize wheels should be used with appropriate low profile tires to maintain correct wheel diameter and speedometer calibration. Sold individually.

<b>14" x 5.5" (stock)</b>	<b>455-360</b>	<b>\$499.99</b>
<b>15" x 5.5" (+1)</b>	<b>455-385</b>	<b>\$529.99</b>



## MG Crested Lug Nuts

Count the octagons! Several pre-war MGs sported over 30 MG octagons or octagonal shapes. With a full set of our MG crested lug nuts, you'll be up to 16 right off the bat! Fits Rostyle wheels only.

**264-985 \$10.99 ea.**

## Wheel & Tire Sizes for MGB / MGC

Model	Std. Wheel Size	Std. Tire Size	Max. Tire on Std. Whl.	Alternative Wheel Size	Alternative Tire Size
MGB	4J-14	155-14	165-14	-	-
	4.5J-14	165-14	175/70-14	5.5J-14	175-14
	5J-14	165-14	185/70-14	-	-
MGB GT	4.5J-14	165-14	175/70-14	5.5J-14	185/70-14
	5J-14	165-14	185/70-14	-	195/70-14
MGC	5J-15	165-15	-	5.5J-15	-
MGC GT	5J-15	165-15	-	5.5J-15	-

## Bolt-On Sport Wheels

This close replica of the original Mini-lite wheel is an attractive alternative to steel wheels, and gives your British sports car a modern, aggressive look. These bolt on using "Rostyle" lug nuts (see illus no. 9 on facing page). Wheels are supplied with a plain cap. Self-adhesive "MG" emblems are available separately.

<b>14" x 5.5" wheel</b>	<b>455-386</b>	<b>\$259.99</b>
<b>MG Emblem</b>	<b>455-377</b>	<b>\$4.99</b>
<b>Center Cap</b>	<b>456-049</b>	<b>\$14.99</b>

(Center caps are included with wheels.)



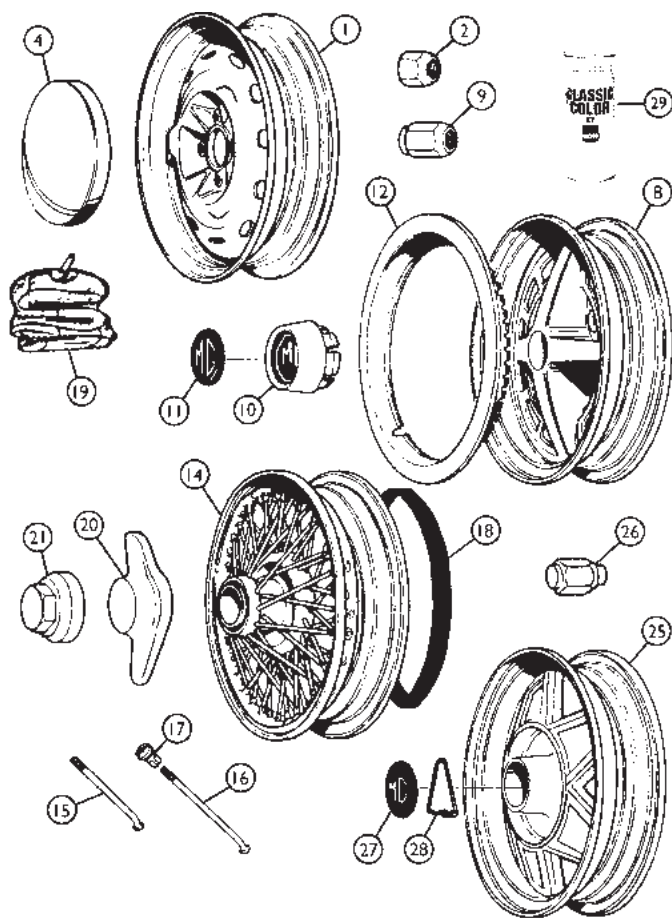

No.	Part#	Price (Each)	Description	Application	Qty Req.
25	462-750	\$299.99	WHEEL, Limited Edition, repro.	Limited Edition	5
26	264-990	\$21.99	NUT, wheel stud, stock type		16
	264-991	\$19.99	NUT, wheel stud, chrome plated		16
27	408-280	\$5.49	MOTIF, "MG", U.S.-spec (black)		5
	408-281	\$18.99	MOTIF, "MG", UK-spec (red)		5
28	462-760	\$2.89	SPRING CLIP, motif retaining		5
29	220-560	\$29.99	SPRAY PAINT, wheel, silver	(not for LE wheels)	A/R

(For restoring US-spec LE wheels, we suggest Eastwood Self-Etching Primer and Eastwood Charcoal Grey Wheel Paint.)

‡ Includes red UK-spec motif & spring clip. Will fit all disc wheel applications. The unique LE nuts 264-990 or 264-991 MUST be used. Use of any other nuts will damage the LE wheel.

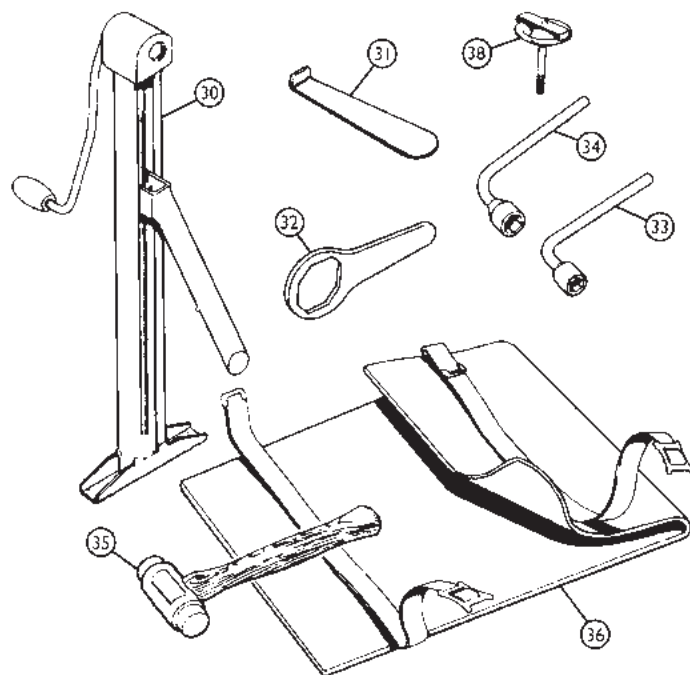

No.	Part#	Price (Each)	Description	Application	Qty Req.
30	386-920	\$239.99	JACK		1
31	386-080	\$10.99	HUB CAP REMOVER	standard disc wheels	1
32	386-030	\$10.99	SPANNER	octagonal knock-off	1
33	386-040	NA	LUG WRENCH, 7/8"	standard disc wheels	1
34	386-060	\$33.39	LUG WRENCH, 13/16"	Rostyle wheels	1
	386-070	NA	LUG WRENCH, 29/32"	Limited Edition wheels	1
35	386-000	\$59.99	HAMMER, copper 1 lbs	wire wheels	1
	386-850	\$58.99	HAMMER, copper, 2 lbs		1
	386-110	\$89.99	HAMMER, copper/rawhide		1
	386-020	\$65.99	HAMMER, zinc alloy, 2 lbs		1
36	386-930	\$66.99	JACK BAG, heavy jute-backed vinyl as original		1
38	386-065*	NA	SPARE WHEEL CLAMP	disc wheel RD	1
	386-075*	NA	SPARE WHEEL CLAMP	disc wheel GT	1
	386-090*	\$76.99	SPARE WHEEL CLAMP	Rostyle wheels	1
	386-095*	\$74.99	SPARE WHEEL CLAMP	wire wheels	1
	386-085*	NA	SPARE WHEEL CLAMP	Limited Edition wheels	1

\*Spare wheel clamps may not fit other than original wheels and stock tire size.

## Wheels

19795

No.	Part#	Price (Each)	Description	Application	Qty Req.
1	454-645	NA	WHEEL, disc type, 4" X 14"	RD to (c)158230, GT to (c)158230	5
	454-655	NA	WHEEL, disc type, 5" X 14"		5
2	264-500	\$3.99	NUT, wheel stud	standard disc wheel	16
4	200-270	\$78.99	HUB CAP		4
8	462-700	NA	WHEEL, Rostyle, painted	RD/GT from (c)158231 on	5
9	264-980	\$4.49	NUT, wheel stud, stock type	Rostyle wheel	16
	264-985	\$10.99	NUT, with MG crest, option		16
	264-981	\$9.99	NUT, stainless steel		16
10	462-710	\$11.99	HUB CAP		4
11	462-720	\$2.19	MOTIF, hub cap		4
12	455-378	\$149.99	TRIM RING SET, polished stainless steel	optional for Rostyle wheels	1
14	454-626	\$399.99	WIRE WHEEL, painted, tubeless	60-spoke, 4.5" x 14"	5
	454-636	\$579.99	WIRE WHEEL, chromed, tubeless		5
	454-816	\$519.99	WIRE WHEEL, painted, tubeless	72-spoke, 5 1/2" x 14", optional wire wheel	5
	454-826	\$639.99	WIRE WHEEL, chromed, tubeless		5
15	200-110*	\$9.49	SPOKE, plain, short, inner	60-spoke wheels	40
	200-080*	\$16.99	SPOKE, chromed, short, inner		40
	200-100*	\$9.49	SPOKE, plain, long, outer		20
	200-090*	\$15.99	SPOKE, chromed, long, outer		20
17	200-050*	\$1.19	NIPPLE, plain		60
	200-052*	\$2.69	NIPPLE, chromed		60
*Note: Quantities indicated are per wheel.					
18	452-740	\$13.99	RIM BAND, 14" wire wheels		5
19	452-736	\$19.99	INNER TUBE, 155 / 165 x 14		5
	452-766	\$25.99	INNER TUBE, 175 / 185 x 14		5
20	200-280	\$69.99	KNOCK-OFF, L/H, fine thread	RD to (c)30850, 12 t.p.i.	2
	200-290	\$69.99	KNOCK-OFF, R/H, fine thread		2
	674-680	\$69.99	KNOCK-OFF, L/H, coarse thread	RD from (c)30850 to 138400, GT to (c)139471, 8 t.p.i.	2
	674-670	\$69.99	KNOCK-OFF, R/H, coarse thread		2
21	200-310	\$59.99	KNOCK-OFF, L/H		RD to (c)30850 (12 tpi)
	200-320	\$59.99	KNOCK-OFF, R/H		2
	462-730	\$69.99	KNOCK-OFF, L/H	RD from (c)138401 on, GT from (c)139472 on (8 tpi)	2
	462-740	\$69.99	KNOCK-OFF, R/H		2

# Brakes

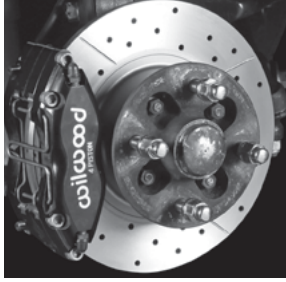

## Wilwood Big Brake Kits

Combine Wilwood Aluminum Four Piston calipers with our unique cross-drilled/slotted performance rotors or durable long-lasting solid rotors, with a set of stainless braided brake hoses and you have improved pedal feel, better stopping power and less unsprung weight. Looks, handling and brakes all in one package. This kit will work with original Rostyle and wire wheels, but not LE wheels. The brake calipers do have dust seals, so the kit is suitable for regular road use. Installation instructions are included.

Wilwood Brake Kit (drilled/slotted rotors)	<b>586-628</b>	<b>\$1,499.00</b>
Wilwood Brake Kit (solid rotors)	<b>586-660</b>	<b>NA</b>
Replacement Brake Pads	<b>772-095</b>	<b>\$149.99</b>
Replacement Drilled/Slotted Rotors (pair)	<b>586-606</b>	<b>\$229.99</b>
Replacement Solid Rotors (pair)	<b>182-245</b>	<b>\$94.99</b>



## TRW Drilled & Slotted Rotors

TRW slotted brake rotors are a performance upgrade option for your MGB. Under hard use the brake pad surface emits gasses which cause the pads to plane over the surface of the rotors. The grooves in these slotted rotors channel the gasses away from the braking surface and reduce brake fade. The grooves also reduce pad material build-up on the rotor surface and minimize glazing. Sold as a pair.

**586-635 \$122.99**

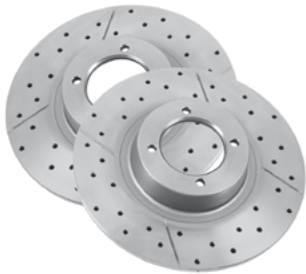

## DBA Drilled & Slotted Rotors

Get the stopping power you need. Cross drilled holes lower brake temperatures and reduce rotational mass and out-gassing, while slots allow excess water, dirt and dust to dissipate. Sold as a pair.

**586-605 \$229.99**

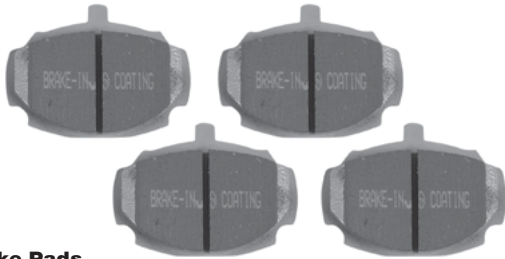

## Green Stuff Brake Pads

Designed for premium street driving, EBC GreenStuff has a high initial brake effect and gives drivers confidence from first application of the brake pedal. The EBC pad creates less dust and dust is more easily washed off than most.

Standard	<b>585-630</b>	<b>\$89.99</b>
MGB V8 Upgrade	<b>585-650</b>	<b>\$119.99</b>



## Hawk Brake Pads

Designed for the serious street and autocross enthusiast these pads are at home on both the track and street. Note due to the increased friction levels, brake life may be decreased.

**585-610 \$139.99**

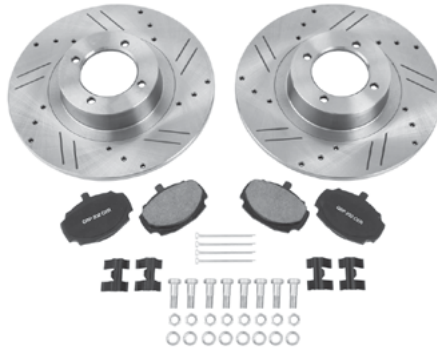

## Front Brake Kits

When your MGB needs a brake job, ordering one part number and getting everything you need at once makes the job so much simpler.

These kits include:

- 2 x front brake rotors
- 1 x front brake pad set
- 4 x pad retaining clips
- 4 x pad cotter pins
- 8 x rotor to hub bolts
- 8 x rotor to hub nuts
- 8 x rotor to hub lock washers

<u>182-118</u>	\$84.99	FRONT BRAKE KIT, <b>stock</b> replacement	1
		Stock rotors and semi-metallic pads	
<u>182-128</u>	\$154.99	FRONT BRAKE KIT, <b>stage 1</b> upgrade	1
		TRW slotted & cross-drilled rotors and ceramic pads	
<u>182-135</u>	\$254.99	FRONT BRAKE KIT, <b>stage 2</b> upgrade	1
		TRW slotted & cross-drilled rotors, GreenStuff V8 pads	
<u>182-138</u>	\$349.99	FRONT BRAKE KIT, <b>stage 3</b> upgrade	1
		DBA slotted & cross-drilled rotors, GreenStuff V8 pads	



## Brake Servo - single line system

If your single-line brakes are working as they should but you'd like the pedal to require less foot pressure, install this servo manufactured to the highest standards. This is a generic kit, but includes detailed instructions for proper fitment.

**182-290 \$179.99**



## Eezibleed Kit

Kit includes a pressure vessel to hold new fluid, a pipe with interchangeable caps to fit most hydraulic master cylinders and an air hose to connect to a tire. Hook it up, open your brake bleeders one at a time until clean airless fluid appears. Instructions are included. Includes caps to fit 1962-'67 & 1975-'80 MGB master cylinders.

**386-860 \$79.99**



## Brake Caliper Paint System

Make your Brake Calipers look as special as the rest of your car. In a couple of hours, your calipers can have the same colorful high gloss luster found on very expensive German Sports cars. The paint has a heat resistant capability of 900 degrees F. Kits come with the following: 2 component high tech paint system, 1 can of brake caliper cleaner, 1 mixing cup, 1 application brush. Ground shipping only.

Red **216-800 \$109.99**

Black **216-804 \$109.99**



### Rear Brake Kit

No need to squint at the schematic to make sure you've written down all the parts you'll need. They're all in the kit. The complete brake shoe kit for MGB. includes: brake shoes, two wheel cylinders, wheel cylinder clips, four pull-off springs, hold down springs and retainers. Fits GT through 1967, and all roadsters.

**182-108 \$86.99**



### Brake Shoe Spring Kit

All the springs you need when replacing your rear brake shoes, with shoe retaining pins, springs and washers, as well as the main pull-off springs.

**181-778 \$29.90**



### Brake Adjuster Wrench

Get a better grip on your brake adjusters with our specially designed wrench. It has 1/4" and 5/16" square box ends, and a long handle for good leverage.

**386-160 \$13.99**



### Wheel Cylinder Circlip Tool

The wheel cylinder circlip absolutely requires this seemingly simple tool for installation. The odds are, unless you are a mechanic by trade, the need for this tool will be limited. Car clubs ought to have one to share among their members.

**386-185 \$33.99**



### Permatex Brake Quiet

Brake squeal occurs when there is vibration between the backing of the pads and the caliper. Apply Permatex Disc Brake Quiet to the back of your brake pads before installation to eliminate brake squeal.

**583-825 \$10.99**

### Brake Pipe Bending Tool

Smooth bends on small diameter tubing such as brake lines are an important hallmark of quality craftsmanship. Give yourself an edge with our specialty tubing bender which will give you smooth bends in 3/16, 1/4, 5/16, and 3/8 inch tubing.

**385-905 \$24.99**



### Stainless Steel Brake Hose Set by Cobalt

Cobalt Stainless steel brake hoses provide a more direct and consistent brake feel. They won't expand like rubber hoses can. Order this complete set of long-lasting braided steel hoses for your next brake job. Copper sealing washers are included. DOT approved.

**180-898 \$89.99**



### Stainless Steel Brake Hose Set by Goodridge

These competition-inspired brake hose sets meet all DOT safety standards and are street legal in all 50 states. Each set includes all brake hoses, retaining nuts, and copper sealing washers.

**182-228 \$71.99**



### Brake Caliper Piston & Seal Tool

The right tool for the job makes life much easier. Duplicating the functions of the factory tool 18G590, this allows easier installation of brake caliper pistons, seals, and seal retainers.

**386-280 \$69.99**

### Brake Lube

This grease is specially formulated for aiding the assembly of natural and "artificial" rubber hydraulic components. Recommended for use with master cylinder, wheel cylinder and slave cylinder seals. This is the only safe product to use for this purpose, especially if your rebuilt cylinder will not be installed and used immediately after assembly. 5 gram sachet.

**220-443 \$3.49**



### Brake Fluids

Choose the brake fluid your car needs. Genuine Lockheed and Girling brake fluids are compatible with all British brake systems. Silicone fluid won't harm paint, and doesn't absorb moisture, as do conventional fluids. (If changing from one type to the other, flush your brake system thoroughly with the "new" type of brake fluid.)

**Silicone Brake Fluid 220-413 \$34.99**



# Brakes

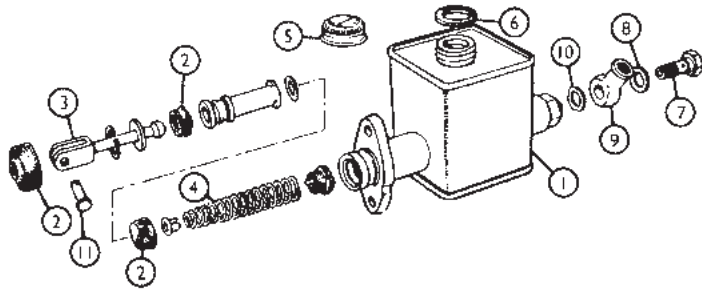

## Brakes - Single Line System

RD to (c)138400/GT to (c)139471, 1962 - 1967

19819

No.	Part#	Price (Each)	Description	Application	Qty Req.
1	180-754†	NA	MASTER CYLINDER, Lockheed	round metal reservoir	1
	180-755†	\$89.99	MASTER CYLINDER, TRW/Lucas	plastic reservoir	1
	180-757	\$33.99	MASTER CYLINDER, Classic Gold	plastic reservoir	1
2	180-875†	\$6.99	REPAIR KIT, unmarked cylinders	} for original cylinders	1
	180-985†	\$7.99	REPAIR KIT, marked cylinders		1
3	181-690	\$25.99	PUSH ROD		1
4	181-710	NA	SPRING, piston return	marked cylinders	1
5	180-210	\$5.29	FILLER CAP, plastic replacement	} for original cylinders	1
	180-211	\$14.99	FILLER CAP, metal (as original)		1
6	180-451	\$2.99	SEAL, filler cap (for metal caps only)		1
7	180-430	\$9.99	BANJO BOLT		1
8	324-720	\$0.99	WASHER		1
9	181-720	\$26.99	BANJO FITTING		1
10	324-730	\$0.69	WASHER		1
	324-547	\$0.69	WASHER, thick (alternative to 324-730)		1
11	325-135	\$1.59	CLEVIS PIN		1

† Note: Two different cylinders were used originally. One type is unmarked. The other is marked with two concentric circles or with a groove near the mounting flange. Complete cylinders are interchangeable, but have different internal components. See illustration below for identification details.

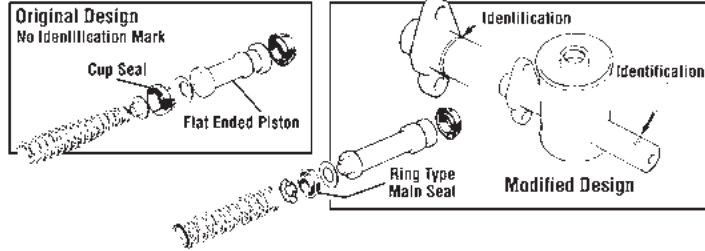

## Brake Lube

This grease is specially formulated for aiding the assembly of natural and "artificial" rubber hydraulic components. Recommended for use with master cylinder, wheel cylinder and slave cylinder seals. This is the only safe product to use for this purpose, especially if your rebuilt cylinder will not be installed and used immediately after assembly. 5 gram sachet.

220-443 \$3.49



## Brake Fluids

Choose the brake fluid your car needs. Genuine Lockheed and Girling brake fluids are compatible with all British brake systems. Silicone fluid won't harm paint, and doesn't absorb moisture, as do conventional fluids. (If changing from one type to the other, flush your brake system thoroughly with the "new" type of brake fluid.)

Silicone Brake Fluid 220-413 \$34.99

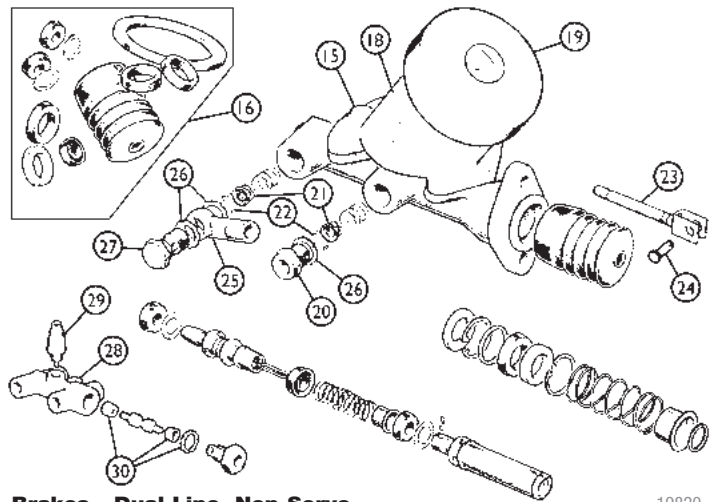

## Brakes - Dual Line, Non-Servo

19820

RD from (c)138401 to 368081/GT from (c)139472 to 367803, 1968 - '74

No.	Part#	Price (Each)	Description	Application	Qty Req.
15	180-765	\$199.99	MASTER CYLINDER, TRW/Lucas		1
	180-767	\$44.99	MASTER CYLINDER, aftermarket (no repair kit for this)		1
16	180-205	\$21.99	REPAIR KIT (Fits Lockheed, AP, TRW & Lucas cylinders)		1
18	180-769	NA	RESERVOIR & CAP	reproduction	1
19	180-215	\$18.99	FILLER CAP	Lockheed	1
20	181-725	NA	ADAPTOR, outlet		1
21	180-225	NA	BODY, trap valve		2
22	180-235	NA	CLIP, trap valve		2
23	181-695	NA	PUSH ROD (not incl. w/master cylinder)		1
24	325-135	\$1.59	CLEVIS PIN		1
25	180-435	NA	BANJO FITTING		1
26	324-735	\$1.79	WASHER		3
27	180-440	NA	BANJO BOLT		1
28	141-710	NA	SWITCH & BODY ASS'Y., pressure failure		1
29	141-725	\$74.99	SWITCH, pressure failure	for original assembly	1
30	181-985	\$39.99	KIT, repair, orig. ass'y.	RD/GT to (c)167815	1
	181-995	\$18.99	KIT, repair, orig. ass'y.	RD/GT from (c)167816	1

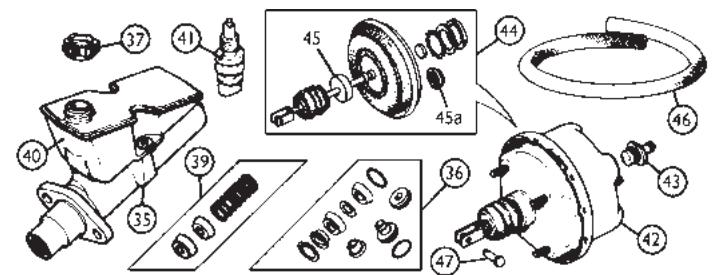

## Brakes - Dual Line, Servo Assist

19821

RD from (c)368082 on, 1975 on

35	180-725	NA	MASTER CYLINDER, w/wedge-type reservoir	1975	1
			NOTE: Later cylinder may be used.		
	180-735	\$239.99	MASTER CYLINDER, AP Braking	} 1976 on w/square reservoir	1
	180-737	\$219.99	MASTER CYLINDER, TRW		1
	180-738	\$49.99	MASTER CYLINDER, aftermarket		1
36	180-785	\$44.99	REPAIR KIT, AP Braking (orig. cyls. only)		1
	180-786	\$19.99	REPAIR KIT, aftermarket (orig. cyls. only)		1
37	180-210	\$5.29	FILLER CAP (plastic, as original)		1
39	180-795	NA	PISTON SPRING, w/seals		1
40	180-815	NA	RESERVOIR, master cylinder, wedge-shaped		1
	180-739	\$18.99	RESERVOIR, master cylinder, square (with cap no. 37)		1
41	181-875*	NA	PRESSURE FAILURE SWITCH	to (c)386600	1
	181-955*	\$8.99	PRESSURE FAILURE SWITCH	from (c)386601	1
			*Correct switch for application must be used. They are not interchangeable.		
42	182-280	NA	SERVO ASSEMBLY (Use 182-190)	1975	1
	182-190	\$239.99	SERVO ASSEMBLY (replacement)	1976 - 1980	1
43	182-195	\$49.99	NON-RETURN VALVE	} original servos only	1
	182-196	\$2.99	GROMMET (rubber) for #43		1
	182-205	NA	REPAIR KIT		1
45	182-285	NA	FILTER, foam, on push rod		1
45a	180-789	\$2.39	SEAL, master cylinder to servo		1
46	182-188	\$11.99	VACUUM HOSE, servo unit to manifold, replacement		1
47	325-135	\$1.59	CLEVIS PIN		1

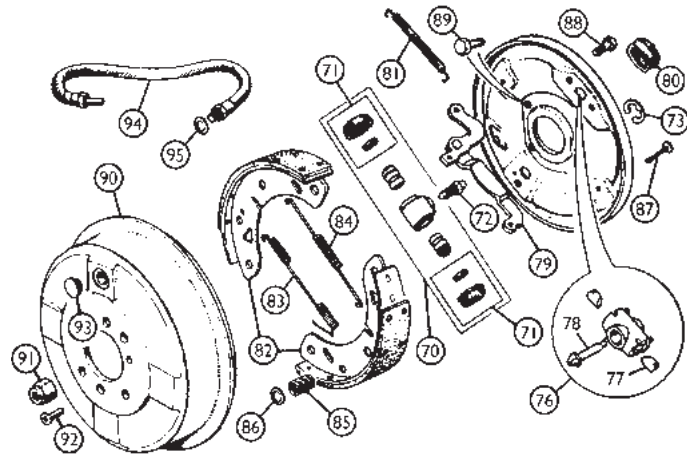
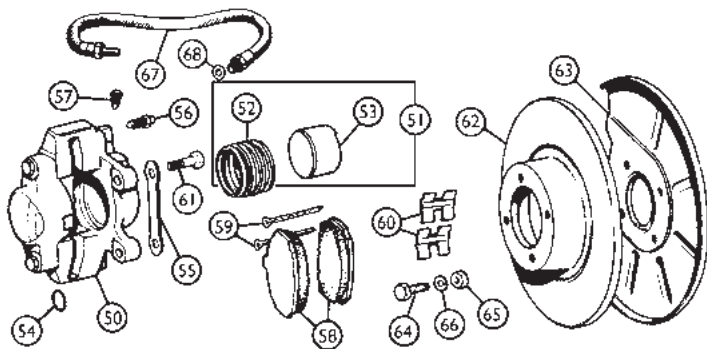

## Front Disc Brake

19822

No.	Part#	Price (Each)	Description	Application	Qty Req.
50	180-538	\$184.99	CALIPER PAIR, new		1
	180-526	\$99.99	CALIPER, L/H, new		1
	180-516	\$99.99	CALIPER, R/H, new		1
51	182-880	\$44.99	PISTON & SEAL SET for rebuilding 2 calipers		1
52	182-830	\$9.99	REPAIR KIT, caliper	(for 2 calipers)	1
53	182-800	\$9.99	PISTON		4
	180-746	\$20.99	PISTON, stainless steel		4
54	180-285	\$0.79	SEAL, caliper fluid channel		2
55	181-670	\$0.89	TAB WASHER		2
56	180-100	\$1.99	BLEEDER SCREW		2
57	181-680	\$10.99	PLUG		2
58	182-222	\$36.99	PAD SET, ceramic, Classic Gold	} see "Performance" section at the front of this catalog for details	1
	182-227	\$23.99	PAD SET, semi-metallic, Classic Gold		1
	585-630	\$89.99	PAD SET, "Greenstuff"		1
	585-610	\$139.99	PAD SET, "Hawk"		1
59	325-430	\$0.49	COTTER PIN		4
60	180-295	\$1.09	CLIP, pad retaining		4
61	320-135	\$1.99	BOLT, caliper mounting		2
62	182-170	\$109.99	BRAKE ROTOR, "Brembo" brand	} <a href="#">MORE INFO ONLINE</a>	4
	182-172	\$21.99	BRAKE ROTOR, Classic Gold brand		2
	586-635	\$122.99	BRAKE ROTOR PAIR, drilled & slotted, TRW		1
	586-605	\$229.99	BRAKE ROTOR PAIR, drilled & slotted, aftermarket		1
63	182-260	\$16.99	DUST COVER, L/H		1
	182-250	\$16.99	DUST COVER, R/H		1
64	320-115	\$1.39	BOLT, brake disc to hub		8
65	310-075	\$0.39	NUT, brake disc to hub		8
66	324-040	\$0.39	LOCKWASHER		8
67	180-895	\$22.99	HOSE, front caliper	} RD/GT to (c)394300	2
	180-896	\$19.99	HOSE, front caliper, aftermarket		2
	180-897	\$15.99	HOSE, front caliper, Cobalt	} RD from (c)394301 on	2
	180-885	\$17.99	HOSE, front caliper		2
	180-886	\$9.99	HOSE, front caliper, aftermarket		2
	180-887	\$13.99	HOSE, front caliper, Cobalt		2
68	324-730	\$0.69	WASHER, copper		2
	324-547	\$0.69	WASHER, copper, thick (alternative to 324-730)		2



## Front Brake Kits

When your MGB needs a brake job, ordering one part number and getting everything you need at once makes the job so much simpler.

These kits include:  
 2 x front brake rotors  
 1 x front brake pad set  
 4 x pad retaining clips  
 4 x pad cotter pins  
 8 x rotor to hub bolts  
 8 x rotor to hub nuts  
 8 x rotor to hub lock washers

182-118	\$84.99	FRONT BRAKE KIT, <b>stock</b> replacement	1
		Stock rotors and semi-metallic pads	
182-128	\$154.99	FRONT BRAKE KIT, <b>stage 1</b> upgrade	1
		TRW slotted & cross-drilled rotors and ceramic pads	
182-135	\$254.99	FRONT BRAKE KIT, <b>stage 2</b> upgrade	1
		TRW slotted & cross-drilled rotors, GreenStuff V8 pads	
182-138	\$349.99	FRONT BRAKE KIT, <b>stage 3</b> upgrade	1
		DBA slotted & cross-drilled rotors, GreenStuff V8 pads	

## Rear Drum Brake

19823

No.	Part#	Price (Each)	Description	Application	Qty Req.
70	180-635	\$36.99	WHEEL CYLINDER	} all RD (.800" bore size) GT to (c)138400	2
	180-636	\$12.99	WHEEL CYLINDER, aftermarket		2
71	180-475	\$4.49	REPAIR KIT		2
	180-645	\$31.99	WHEEL CYLINDER	} GT from (c)138401 on (.875" bore size)	2
	180-646	\$11.89	WHEEL CYLINDER, aftermarket		2
	180-480	\$4.99	REPAIR KIT		2
72	323-145	\$1.89	BLEEDER NIPPLE		2
73	326-720	\$1.19	CIRCLIP, cylinder retaining		2
76	181-780	\$14.99	ADJUSTER ASSEMBLY		2
77	181-790	NA	TAPPET, adjuster		4
78	181-800	NA	WEDGE, adjuster		2
79			NA HANDBRAKE LEVER, L/H	} banjo type rear axle	1
			NA HANDBRAKE LEVER, R/H		1
	181-750	\$21.99	HANDBRAKE LEVER, L/H	} tubed type rear axle	1
	181-740	\$21.99	HANDBRAKE LEVER, R/H		1
80	181-760	\$1.39	BOOT, handbrake lever		2
81	181-770	\$4.59	SPRING, handbrake lever	banjo type rear axle	2
	181-775	\$3.39	SPRING, handbrake lever	tube type rear axle	2
82	182-100	\$39.99	BRAKE SHOE SET, 4 shoes		1
83	181-778	\$29.99	SPRING KIT, brake shoe (incl. nos. 83-87)		1
	181-820	\$3.89	SPRING, L/H, pull off		1
	181-810	\$3.89	SPRING, R/H, pull off		1
84	181-830	\$6.99	SPRING, adjuster end		2
85	329-035	\$1.39	SPRING, shoe steady		4
86	181-890	\$1.69	WASHER, spring retaining		4
87	181-840	\$0.99	PIN, brake shoe steady		4
88	320-285	\$0.69	BOLT, back plate to axle housing	banjo type rear axle	8
89	320-345	\$0.99	BOLT, back plate to axle housing	tubed type rear axle	8
90	264-810	\$89.99	BRAKE DRUM	banjo type rear axle	2
	264-821	\$39.99	BRAKE DRUM, Classic Gold brand	tubed type rear axle	2
91	310-400	\$0.89	NUT, drum retaining	wire wheels	8
92	323-255	\$0.69	SCREW, drum retaining	disc wheels	4
	264-500	\$3.99	NUT, wheel stud, lug nut	early disc wheels	8
	264-980	\$4.49	NUT, wheel stud, lug nut	Rostyle disc wheels	8
93	328-400	\$0.89	PLUG, brake drum 3/4"	} banjo type rear axle	A/R
	328-390	\$0.79	PLUG, brake drum 1/2"		A/R
94	180-835	\$25.99	HOSE, rear		1
	180-836	\$8.99	HOSE, rear, aftermarket		1
	180-837	\$14.99	HOSE, rear, Cobalt		1
95	324-730	\$0.69	WASHER, copper		1



## Rear Brake Kit

No need to squint at the schematic to make sure you've written down all the parts you'll need. They're all in the kit. The complete brake shoe kit for MGB. Includes: brake shoes, two wheel cylinders, wheel cylinder clips, four pull-off springs, hold down springs and retainers. Fits GT through 1967, and all roadsters.

**182-108 \$86.99**

# Brake Controls/ Handbrake

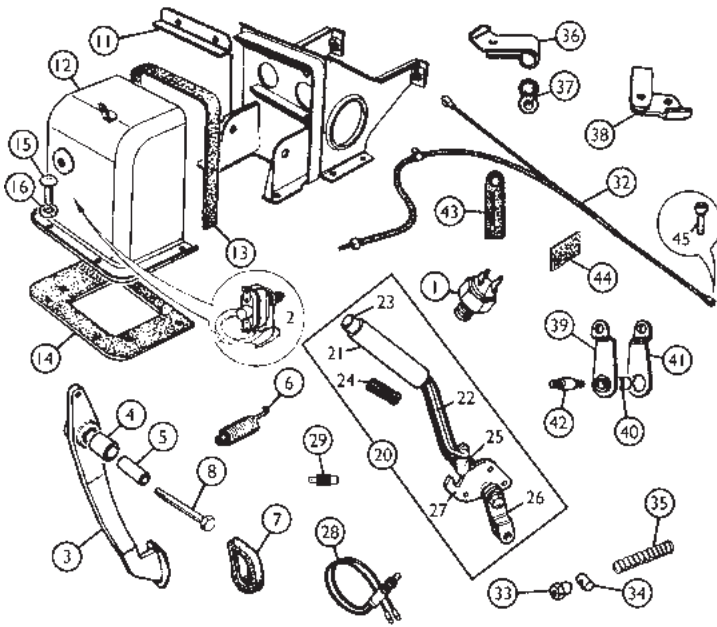

## Brake Controls/ Handbrake

19825

No.	Part#	Price (Each)	Description	Application	Qty Req.
1	542-110	\$9.99	SWITCH, brake lights	single line system	1
2	181-980	\$11.49	SWITCH, brake lights	dual line systems	1
	310-070	\$0.39	JAM NUT for switch 181-980		1
3	190-650	NA	BRAKE PEDAL ASSEMBLY, 1962 - '67	RD to (c)138400, GT to (c)139471	1
	190-660	NA	BRAKE PEDAL ASSEMBLY, 1968 - '74 1/2	RD from (c)138401 to 368081, GT from (c)139472 to 367803	1
	190-670	\$34.99	BRAKE PEDAL ASSEMBLY, 1975	RD from (c) 368082 to 386000	1
	190-680	NA	BRAKE PEDAL ASSEMBLY	RD from (c)386001, '76 on	1
4	330-180	\$7.49	BUSH, pedal	non-servo systems	1
	330-185	NA	BUSH, pedal	servo system	1
5	190-625	\$4.29	DISTANCE TUBE		1
6	329-350	\$2.29	SPRING, pedal return		1
7	280-770	\$1.49	PEDAL PAD, brake & clutch		2
8	115-016	\$1.69	PIVOT BOLT		1
11	190-690	NA	STIFFENER, pedal box		1
12	190-740	\$229.99	COVER, pedal box, 1962 - '67	RD to (c)138400, GT to (c)139471	1
	190-750	NA	COVER, pedal box, 1968 - '74 1/2	RD from (c)138401 to 360300, GT from (c)139472 to 361000	1
13	281-850	\$1.29	SEAL, cover to pedal box	non-servo systems	1
14	281-860	\$1.09	SEAL, cover bottom		1
	281-885	\$1.99	SEAL, top cover to pedal box	servo systems	1
		NA	SEAL, pedal box base	1975	1
	281-895	\$2.69	SEAL, pedal box base	1976-'80	1
	190-760	\$21.99	BLANKING PLATE, R/H pedal hole		1
	281-880	\$2.39	SEAL, R/H pedal hole plate		1
15	323-005	\$0.39	SCREW, short		3
	314-135	\$0.49	SCREW, long		1
16	324-010	\$0.19	LOCKWASHER		4
20	182-310	NA	HANDBRAKE ASSEMBLY (to mid-1974)	RD to (c)360300, GT to (c)361000	1
	182-330	NA	HANDBRAKE ASSEMBLY (1974 1/2-on)	RD from (c)360301 to 516118, GT from (c)361001 on	1
	182-335	NA	HANDBRAKE ASSEMBLY		1
21	182-340	NA	GRIP, handle		1
22	182-350	NA	ROD, pawl	RD from (c)516119 on	1
23	182-360	NA	KNOB, rod		1
24	182-370	NA	SPRING, rod		1
25	182-380	NA	PAWL		1
26	182-390	NA	LEVER, operating, 1962 - '74 1/2	RD to (c)360300, GT to (c)361000	1

No.	Part#	Price (Each)	Description	Application	Qty Req.
	182-395	NA	LEVER, operating, 1974 1/2 on	RD from (c)360301 on, GT from (c)361001 on	1
27	182-400	NA	RATCHET PLATE, 1962 - '74 1/2	RD to (c)386600, all GT	1
	182-405	NA	RATCHET PLATE	RD from (c)386601 to 516118	1
	182-415	NA	RATCHET PLATE	RD from (c)516119 on	1
28	182-410	\$19.99	SWITCH, handbrake light, w/leads	RD from (c)410001	1
29	181-855	\$29.99	DIODE, inline (as fitted)	1978-80	1
32	331-100	\$26.99	BRAKE CABLE, disc wheel	RD to (c)132922, banjo type axle	1
	331-130	\$26.99	BRAKE CABLE, wire wheel		1
	331-250	\$28.99	BRAKE CABLE, disc wheel	RD from (c)132923 to 138400, GT to (c)139471	1
	331-260	\$27.99	BRAKE CABLE, wire wheel		1
	331-500	\$26.99	BRAKE CABLE, disc wheel	RD from (c)138401 to 360300, GT from (c)139472 to 361000	1
	331-510	\$22.99	BRAKE CABLE, wire wheel		1
	331-520	\$28.99	BRAKE CABLE, disc wheel	RD from (c)360301 to 415000, GT from (c)361001 on	1
	331-530	\$28.99	BRAKE CABLE, wire wheel		1
	331-540	\$24.99	BRAKE CABLE, disc wheel		1
	331-550	\$28.99	BRAKE CABLE, wire wheel	RD from (c)415001 on	1
33	181-540	\$5.99	NUT, adjusting		1
34	181-530	\$3.39	TRUNNION		1
35	329-130	\$1.99	SPRING, cable		1
36	181-555	\$23.99	CLIP, cable to battery carrier		1
37	182-425	\$5.99	FERRULE, cable clip		1
38	181-620	\$15.79	CLIP, cable to axle		1
39	181-520	\$32.99	COMPENSATING LEVER, inner		1
40	330-190	\$5.99	BUSH, fulcrum	RD to (c)415000, all GT	1
41	181-510	\$16.99	COMPENSATING LEVER, outer		1
42	181-500	\$4.49	FULCRUM		1
43	182-420	\$2.99	STRAP, cable to diff. housing	RD from (c)415001 on	1
44	182-345	\$2.19	STRAP, cable to axle housing		1
45	325-140	\$1.19	CLEVIS PIN		2

## Brake Pipe Bending Tool

Smooth bends on small diameter tubing such as brake lines are an important hallmark of quality craftsmanship. Give yourself an edge with our specialty tubing bender which will give you smooth bends in 3/16, 1/4, 5/16, and 3/8 inch tubing.



**385-905 \$24.99**

## Brakes

Pulling to one side under braking can be caused by several factors. If your car has this dangerous habit, check the following:

- Tire pressures set incorrectly
- Unevenly worn or mismatched tires
- Worn or loose suspension components
- Worn or loose wheel bearings
- Worn or oily brake pads or linings
- One wheel cylinder or caliper stuck or working less efficiently than the other.



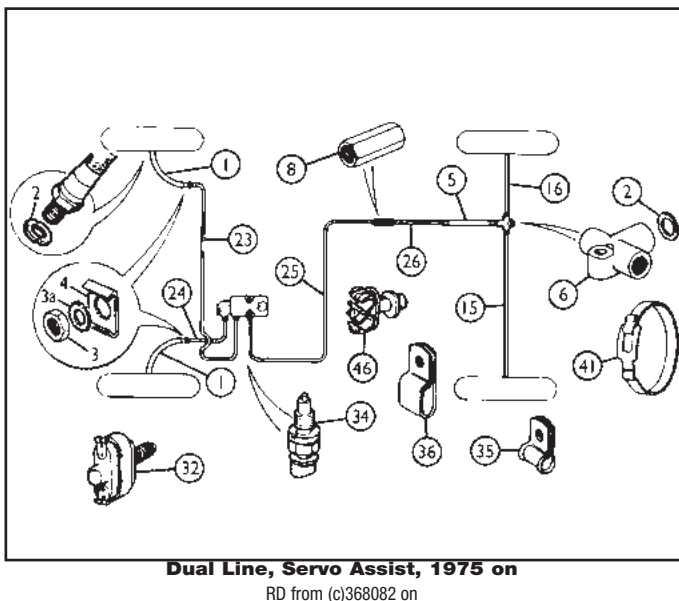
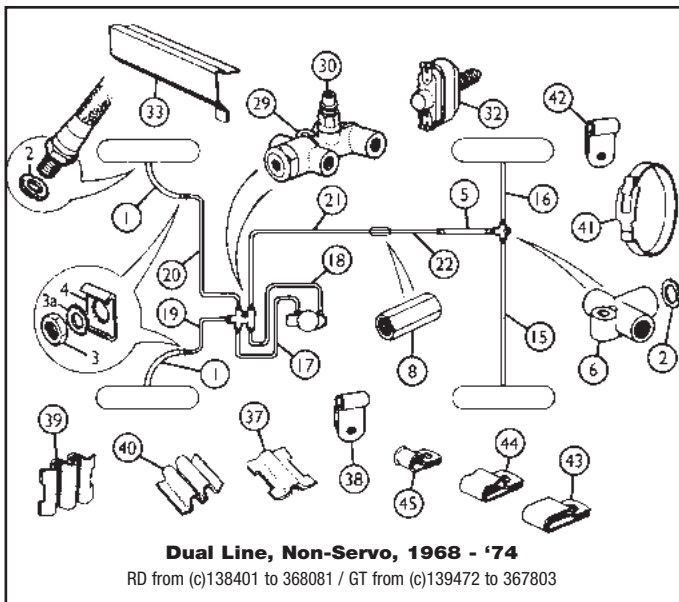
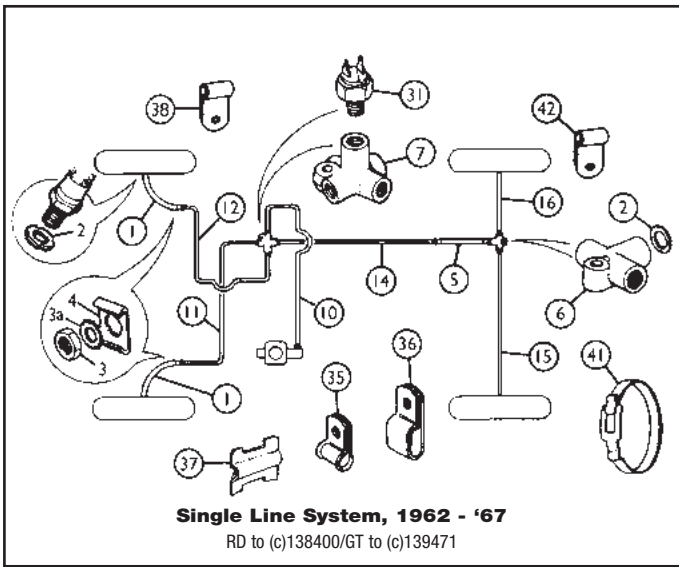

## Brake Lines

No.	Part#	Price (Each)	Description	Application	Qty Req.
1	180-895	\$22.99	HOSE, front brake	} RD/GT to (c)394300	2
	180-896	\$19.99	HOSE, front brake, aftermarket		2
	180-897	\$15.99	HOSE, front brake, Cobalt		2
	180-885	\$17.99	HOSE, front brake		2
	180-886	\$9.99	HOSE, front brake, aftermarket		2
	180-887	\$13.99	HOSE, front brake, Cobalt	} RD from (c)394301 on	2
2	324-730	\$0.69	WASHER, brake hose		3
	324-547	\$0.69	WASHER, brake hose, thick (alternative to 324-730)		3
3	310-070	\$0.39	LOCKNUT, hose		3
3a	324-045	\$0.49	LOCKWASHER		3
4	181-660	\$3.89	LOCKING PLATE, hose to pipe		3
5	180-835	\$25.99	HOSE, rear		1
	180-836	\$8.99	HOSE, rear, aftermarket		1
	180-837	\$14.99	HOSE, rear, Cobalt		1
6	180-090	\$12.99	CONNECTION, 3-way		1
7	180-230	\$46.99	CONNECTION, 4-way	} RD to (c)138400, GT to (c)139471	1
8	182-500	\$3.19	CONNECTION, rear pipe	} RD from (c)138401 on, GT from (c)139472 on	1
	182-998*	\$229.99	BRAKE PIPE SET**	1963-'67	1
	183-118*	\$294.99	BRAKE PIPE SET**	1968-'74	1
	183-128*	\$289.99	BRAKE PIPE SET**	1975-'76	1
	183-188*	\$259.99	BRAKE PIPE SET**	1977-'80	1
**Brake pipe sets are made of cupro-nickel tubing for strength, corrosion resistance, and ease of bending. Pipes are coded to the instruction sheet so you know where they fit on your car. Long pipes are coiled, but are easily bent to proper configuration. No pipes are pre-bent.					
10	181-115*	\$36.99	PIPE, master cylinder to 4-way	} RD to (c)138400, GT to (c)139471, 1962-'67	1
11	181-035	\$31.99	PIPE, 4-way to L/H front hose		1
12	181-160	\$24.99	PIPE, 4-way to R/H front hose		1
14	181-065	\$44.99	PIPE, 4-way to rear hose		1
15	181-115	\$36.99	PIPE, 3-way to L/H rear cylinder	RD/GT thru 1976	1
	181-170	\$27.99	PIPE, 3-way to L/H rear cylinder	RD from 1977-'80	1
16	181-145	\$31.99	PIPE, 3-way to R/H rear cylinder	RD/GT thru 1976	1
	181-165	\$26.99	PIPE, 3-way to R/H rear cylinder	RD from 1977-'80	1
17	182-520*	\$24.99	PIPE, master cylinder front		1
18	182-530*	\$24.99	PIPE, master cylinder rear		1
19	182-540	\$29.99	PIPE, switch to L/H front hose	RD (c)138401 to 368081,	1
20	182-545	\$31.99	PIPE, switch to R/H front hose	GT (c)139472 to 367803	1
21	182-550	\$38.99	PIPE, switch to connection		1
22	182-560	\$34.99	PIPE, connection to rear hose		1
23	182-570*	\$34.99	PIPE, master cyl. to R/H hose	} RD from (c)368082 on	1
24	182-575*	\$31.99	PIPE, master cyl. to L/H hose		1
25	182-580	\$38.99	PIPE, master cyl. to connection		1
26	182-590	\$31.99	PIPE, connection to rear hose		1
29	141-710	NA	SWITCH & BODY ASSEMBLY, pressure failure (P.D.W.A.)	} RD (c)138401 to 368081, GT (c)139472 to 367803	1
30	141-725	\$74.99	SWITCH for original ass'y.		1
	181-985	\$39.99	REPAIR KIT, orig. assemblies, with lip type seals	} RD (c)138401 to 167815, GT (c)139472 to 167815 Kit has "o"-rings and new shuttle to replace orig. components.	1
	181-995	\$18.99	REPAIR KIT, orig. assemblies, with "O"-ring seals		} RD (c)167816 to 368081, GT (c)167816 to 367803
31	542-110	\$9.99	SWITCH, brake light	} RD to (c)138400, GT to (c)139471	1
32	181-980	\$11.49	SWITCH, brake light	} RD from (c)138401 on, GT from (c)139472 on	1
	310-070	\$0.39	JAM NUT for switch		1
33	182-650	\$28.59	HEAT SHIELD	} RD (c)138401 to 368081, GT (c)139472 to 367803	1
34	181-875†	NA	PRESSURE FAILURE SWITCH†	to (c)386600	1
	181-955†	\$8.99	PRESSURE FAILURE SWITCH†	from (c)386601	1
† Correct switch for application must be used. They are not interchangeable.					
35	182-600	\$1.39	CLIP, pipe to side member		A/R
36	182-605	\$4.79	CLIP, pipe		A/R
37	182-610	NA	CLIP, pipe to front side member		A/R
38	182-615	NA	CLIP, pipe to side member		A/R
39	182-620	NA	CLIP, pipe to side member		A/R
40	182-625	NA	CLIP, pipe to bulkhead		A/R
41	181-900	\$3.29	CLIP, pipe to rear axle		A/R
42	182-635	\$1.39	CLIP, pipe to differential case		A/R
43	182-605	\$4.79	CLIP, pipe to bulkhead		A/R
44	182-645	\$3.19	CLIP, pipe to bulkhead		A/R
45	470-830	\$1.09	CLIP, pressure switch leads		A/R
46	589-315	\$0.99	CLIP, brake and clutch pipes	RD from 1975-'80	A/R

\* These pipes are for LHD North American specification cars only.

# Exterior Body Panels

We stock a comprehensive range of body panels produced by British Motor Heritage Ltd. under their "Heritage" brand. These are marked below as "BMH"

Most of our body panels are shipped from overseas, and consequently invariably have some scratches and often minor dents. Panels may also require minor alterations to fit your particular car accurately. Please anticipate some clean-up and/or minor modifications. Test fit body panels before modifying or painting - once altered or painted, they are not returnable.

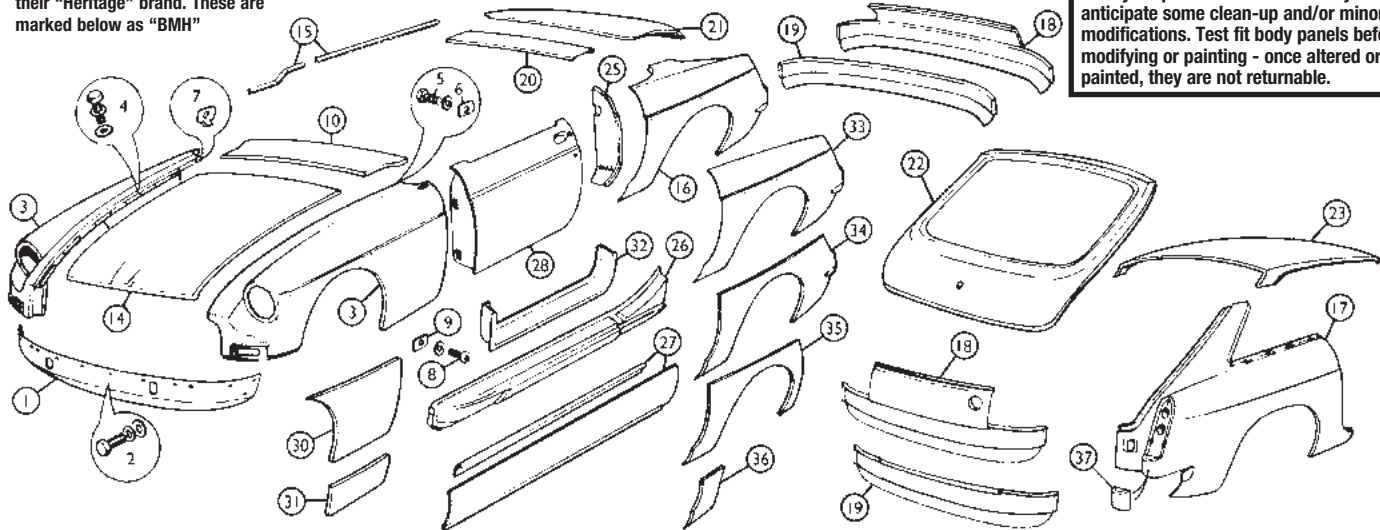

## Exterior Body Panels

19828

No. Part#	Price (Each)	Description	Application	Qty Req.
-----------	--------------	-------------	-------------	----------

**Note:** Chrome bumper body panels had overlapping joints, while rubber bumper cars had butted flanges. New "BMH" (British Motor Heritage) chrome bumper panels are available only with butted flanges. Existing panels and new ones must be trimmed to fit each other. Do not cut old panels before matching them up with the new ones.

Underlined part numbers indicate an Oversize Parts Fee will be charged. See mossmotors.com or call for details.

1	<u>457-120</u>	\$319.99	FRONT APRON, BMH**	RD/GT, 1962 to approx. '73	1	
	<u>457-121</u>	\$249.99	FRONT APRON, aftermarket		1	
	<u>457-115</u>	\$319.99	FRONT APRON, BMH**	RD/GT, approx. 1973-'74 1/2 (with vent holes)	1	
	<u>457-116</u>	\$249.99	FRONT APRON, aftermarket		1	
	<u>457-125</u>	\$229.99	FRONT APRON, BMH**	RD/GT, 1974 1/2 - on (rubber bumper)	1	
	<u>457-126</u>	\$199.99	FRONT APRON, aftermarket		1	
2	323-618	\$8.99	HARDWARE SET, front apron mounting		1	
3	<u>457-360*</u>	\$1,199.00	FRONT FENDER, L/H, BMH**	RD to (c)158370 1962 - '68 (see note A)	1	
	<u>457-340*</u>	\$1,199.00	FRONT FENDER, R/H, BMH**		1	
	<u>457-270*</u>	\$1,199.00	FRONT FENDER, L/H, BMH**	RD from (c)158371 to 360300, 1969 - '74 1/2 (see note B)	1	
	<u>457-260*</u>	\$1,199.00	FRONT FENDER, R/H, BMH**		1	
	<u>457-275*</u>	\$1,199.00	FRONT FENDER, L/H, BMH**	RD from (c)360301 on, 1974 1/2 - on	1	
	<u>457-265*</u>	\$1,199.00	FRONT FENDER, R/H, BMH**		1	
	<u>457-370*</u>	\$1,199.00	FRONT FENDER, L/H, BMH**	GT to (c)158230, 1967 - '68 (see note A)	1	
	<u>457-350*</u>	\$1,199.00	FRONT FENDER, R/H, BMH**		1	
	<u>457-390*</u>	\$1,199.00	FRONT FENDER, L/H, BMH**	GT from (c)158231 to 361000, 1969 - '74 1/2 (see note B)	1	
	<u>457-380*</u>	\$1,199.00	FRONT FENDER, R/H, BMH**		1	
	<u>457-395*</u>	\$1,099.00	FRONT FENDER, L/H, BMH**	GT from (c)361001 on, 1974 1/2 - on	1	
	<u>457-385*</u>	\$1,099.00	FRONT FENDER, R/H, BMH**		1	
			A - distance from grille opening to sidelamp cutout is approx. 2-7/8". B - distance from grille opening to sidelamp cutout is approx. 1-5/16".			
4	321-928	\$67.99	HARDWARE SET, bolts & washers for both front fenders		1	
5	322-290	\$0.89	BOLT		6	
6	456-965	\$1.19	WASHER, oval	GT uses 2	6/2	
7	324-795	\$5.69	FENDER WASHER	GT	2	
8	323-005	\$0.39	SCREW		6	
9	324-715	\$0.99	WASHER		6	
10	458-200	\$339.99	PANEL, shroud top, BMH**	RD thru 1967	1	
	458-205	NA	PANEL, shroud top	RD from 1968	1	
14	<u>457-255*</u>	\$1,599.00	HOOD, aluminum, BMH**	MGB thru approx. 1969	1	
	<u>457-245*</u>	\$1,049.00	HOOD, steel, BMH**		1	
	<u>457-250*</u>	\$399.99	HOOD, steel, replacement		MGB, approx. 1970-on	1
						1
			Hoods thru approximately 1969 were aluminum, and were then replaced by steel. All are interchangeable, but must be used with appropriate hood props/stays.			
	<u>457-235*</u>	NA	HOOD, aluminum	MGC, (hood also fits MGB)	1	
	<u>457-205</u>	\$26.79	TRIM STRIP, chrome		1	
	<u>326-077</u>	\$2.79	CLIP, trim strip		6	
15	<u>457-990</u>	\$49.99	FENDER BEAD	supplied with fenders	2	
			Long enough for 1 front and 1 rear fender, cut and bend to fit.			
16	<u>457-420*</u>	\$1,199.00	REAR FENDER, L/H, BMH**	RD to (c)360300, to 1974 1/2	1	
	<u>457-430*</u>	\$1,199.00	REAR FENDER, R/H, BMH**		1	
	<u>457-435*</u>	\$1,149.00	REAR FENDER, L/H, BMH**	RD from (c)360301, 1974 1/2 on	1	
	<u>457-425*</u>	\$1,149.00	REAR FENDER, R/H, BMH**		1	

\* Note: Large body items marked \* must be paid for in advance and shipped truck freight.

No. Part#	Price (Each)	Description	Application	Qty Req.
-----------	--------------	-------------	-------------	----------

17	<u>457-450*</u>	\$999.99	REAR QUARTER PANEL, L/H, BMH	GT to (c)361000, thru 1974 1/2	1
	<u>457-440*</u>	\$999.99	REAR QUARTER PANEL, R/H, BMH		1
	<u>457-295*</u>	NA	REAR QUARTER PANEL, L/H, BMH	GT from (c)361001 on, 1974 1/2 on	1
	<u>457-285*</u>	NA	REAR QUARTER PANEL, R/H, BMH		1
18	<u>457-690</u>	\$469.99	PANEL, lower rear body, BMH**	chrome bumpered cars	1
	<u>457-695</u>	\$429.99	PANEL, lower rear body, BMH**	rubber bumpered cars	1
19	<u>457-680</u>	\$239.99	REAR VALANCE	chrome bumpered cars	1
	<u>457-685</u>	\$259.99	REAR VALANCE	rubber bumpered cars	1
20	458-210	\$149.99	PANEL, rear deck top, BMH**	RD	1
21	<u>457-550*</u>	\$899.99	TRUNK LID, BMH**		1
			Late lid - must use late seal #282-475. Trunk lid fittings are on page 76.		
22	<u>457-560*</u>	\$1,099.00	TAILGATE, BMH**	GT	1
23	009-254	\$349.99	ROOF PANEL		1
25	458-487	\$178.99	"B" POST, L/H, BMH**	RD from (b)57986 to (c)294251, GT to (c)296000, thru 1972	1
	458-485	\$178.99	"B" POST, R/H, BMH**		1
			Note: "B" posts prior to above are not available. The above may be used for earlier applications but require modification for door striker.		
	458-495	\$184.99	"B" POST, L/H	RD from (c)294252, GT from (c)296001, 1973 on	1
	458-490	\$184.99	"B" POST, R/H		1
26	<u>457-150</u>	\$209.99	ROCKER PANEL, L/H, BMH**	RD from (c)294252, 1973 on	1
	<u>457-160</u>	\$209.99	ROCKER PANEL, R/H, BMH**		1
	<u>457-155</u>	\$179.99	ROCKER PANEL, L/H, replacement		1
	<u>457-165</u>	\$179.99	ROCKER PANEL, R/H, replacement		1
27	<u>458-228</u>	\$329.99	ROCKER COVER SET, polished stainless accessory		1
28	457-620	NA	DOOR, L/H	RD to (b)57985, for pull-out door handles	1
	457-650	NA	DOOR, R/H		1
	457-630	NA	DOOR, L/H	RD from (b)57986 to (c)138400, for push button door handles	1
	457-660	NA	DOOR, R/H		1
	458-230	\$929.99	DOOR, L/H, BMH**	RD from (c)138401 to 294500, 1969 - approx. 1972	1
	458-235	\$929.99	DOOR, R/H, BMH**		1
	458-250	NA	DOOR, L/H	RD from (c)294501 on, approx. 1973 on	1
	458-255	NA	DOOR, R/H		1
	458-260	NA	DOOR SKIN, L/H	RD to (b)57985, for pull-out door handles	1
	458-265	NA	DOOR SKIN, R/H		1
	<u>458-270</u>	\$209.99	DOOR SKIN, L/H	RD from (b)57986 on, push button door handles	1
	<u>458-275</u>	\$209.99	DOOR SKIN, R/H		1
	457-640	NA	DOOR, L/H	GT to (c)139471, 1966 - '67	1
	457-670	NA	DOOR, R/H		1
	458-330	\$869.99	DOOR, L/H, BMH**	GT from (c)139472 to 296000, 1968 - '72	1
	458-340	\$869.99	DOOR, R/H, BMH**		1
	458-350	NA	DOOR, L/H (use 458-330)	GT from (c)296001 to 328800, 1973	1
	458-360	NA	DOOR, R/H (use 458-340)		1

\* Note: Large body items marked \* must be paid for in advance and shipped truck freight.

\*\* Parts marked "BMH" are produced by British Motor Heritage.

No. Part#	Price (Each)	Description	Application	Qty Req.
458-370	NA	DOOR, L/H (use 458-330)	GT from (c)328801 on, 1974 on	1
458-380	NA	DOOR, R/H (use 458-340)		1
458-270	\$209.99	DOOR SKIN, L/H	GT	1
458-275	\$209.99	DOOR SKIN, R/H		1
30 457-575	\$139.99	QUARTER SECTION, L/F	from chrome strip down (all)	1
457-570	\$139.99	QUARTER SECTION, R/F		1
31 457-930	\$85.99	LOWER PANEL, L/F	lower 12" (all)	1
457-935	\$85.99	LOWER PANEL, R/F		1
32 457-940	\$52.99	DOOR BOTTOM, L/H	chrome-bumpered cars	1
457-945	\$52.99	DOOR BOTTOM, R/H		1
33 457-952	\$629.99	FENDER RPR. PANEL, L/R, BMH**	chrome-bumpered cars	1
457-957	\$629.99	FENDER RPR. PANEL, R/R, BMH**		1
457-950	\$629.99	FENDER RPR. PANEL, L/R, BMH**	rubber-bumpered cars	1
457-955	\$629.99	FENDER RPR. PANEL, R/R, BMH**		1
34 457-960	\$299.99	HALF SECTION, L/R	chrome-bumpered cars (tail lamp area incorrect for later cars)	1
457-965	\$299.99	HALF SECTION, R/R		1
35 457-970	NA	ARCH SECTION, L/R	includes lower dogleg section	1
457-975	NA	ARCH SECTION, R/R		1
36 457-585	\$69.99	DOG LEG PANEL, L/R	lower 10"	1
457-580	\$69.99	DOG LEG PANEL, R/R		1
37 457-980	\$42.99	REPAIR PIECE, under light	RD & GT, chrome bumper cars	2



### Body Side-Stripe Kit

As supplied by many dealers on new cars in the early '70s, this attractive stripe runs just above the belt line. Adds a new, distinctive dimension to the look of your MGB! Looks particularly good on chrome-bumpered cars and GTs.

**Black 215-340    Silver 215-355    Gold 215-360    \$59.99**



### Body Side-Stripe Kit

The original factory optional side stripe along the lower body. Best suited for rubber bumpered cars, as it visually blends the bumpers into the overall body shape.

**Black 215-370    Silver 215-375    Gold 215-380    \$129.99**



### Limited Edition Body Stripe Kit

Give your rubber-bumpered MGB a very special flair with this factory decal set, originally fitted only to the "LE" models.

**Silver 215-730    Gold 215-735    NA**

### MGB Sebring Headlamp Covers & Fitting Kit

These American-made reproductions are far superior to the U.K.-produced repros periodically available, yet are much more economical. We have created a new, yet vintage-style method of mounting these with snaps and studs so that the installation is clean and neat, and the covers are easily removable for cleaning. Works-type alloy fitting kits are available separately but are only recommended for the serious, originality-conscious vintage racer.

Headlamp Cowl Kit    **222-130    \$179.99**  
Alloy Cowl Fitting Kit    **222-140    \$52.99**



Not legal for street use in California. Other states may have similar requirements, please check local laws before ordering.

### BL "Limited Edition" Spoiler

Fitted by the factory to MGB "LE" models in 1980, this ABS plastic spoiler greatly improves the looks of all rubber-bumpered MGBs! Also adds a racy touch to chrome-bumpered MGBs. Holes must be drilled in existing valance to mount. (Oversize Parts Fee will be charged for this item.)

**475-180    \$259.99**



### "Special Tuning" Air Dam

Specifically designed for chrome bumper MGBs, this is a fiberglass reproduction of the factory Special Tuning air dam as used on race and rally cars. (Oversize Parts Fee will be charged for this item.)

**475-195    \$229.99**



### MGB Sebring Front & Rear Valance Panels

Fiberglass reproductions of the streamlining panels fitted to the works MGBs when they raced at Sebring. The bumpers are eliminated, and these panels fill the resulting gaps for a smooth, clean appearance. As with all aftermarket fiberglass body panels, fitting these properly requires a large amount of patience and skill.

Front Sebring Valance    **475-185    \$259.99** } Oversize Parts Fee will be charged  
Rear Sebring Valance    **475-190    \$299.99** } for these items.



**Toll-Free Orders 1-800-667-7872 | MossMotors.com**  
**Fax 805-692-2525 | Local 805-681-3400**

**MOSS**

# Body Panel Accessories

Illus.	Description	Qty.
A	Headlamp Seal	2
B	Hood Seal	1
C	Rear Hood Seal	1
D	Windshield to Body Seal	1
E	Windshield Post Pads	2
F	Wiper Bezel Pad	3
G	Vent Window to Body Pad	2
H	Door Top Seal	2
I	Door Handle Buffer	2
J	Door Handle Gasket, small	2
K	Door Handle Gasket, large	2
L	Door Lock Gasket	2
M	Trunk Lock Gasket	1
N	Reverse Lamp Wire Grommet	2
O	Reverse Lamp Pad	2
P	Front Lamp Pad	2
Q	Trunk Seal	1
R	Taillamp Seal	2
S	Gas Filler Neck Grommet	1

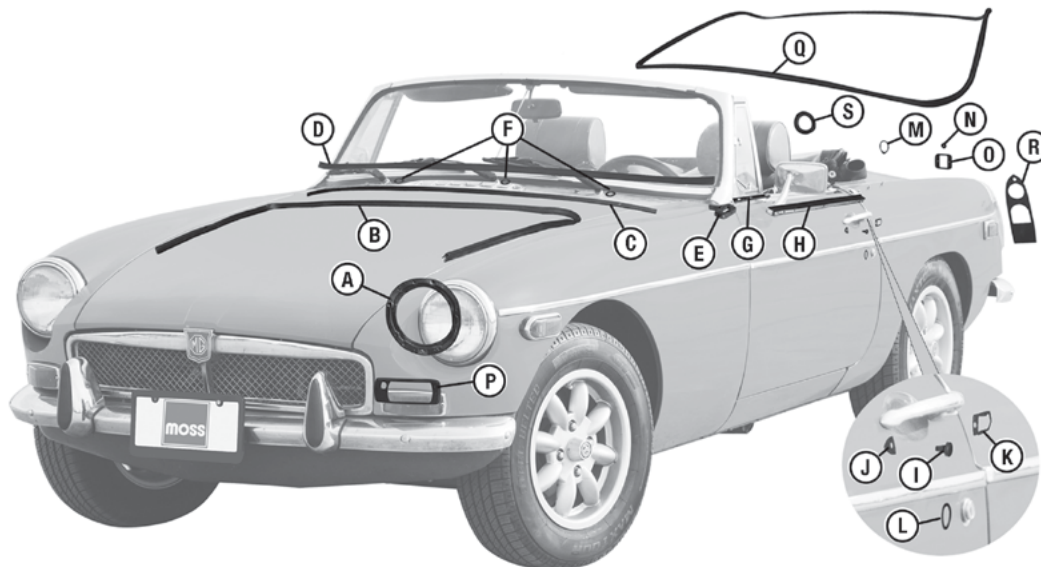

## Body Rubber Repair Kits

It's no longer a chore to track down all the rubber bits and pieces commonly replaced during a repaint or moderate restoration. Start with the Roadster base kit (GT kit has all pieces), which contains the pieces common to all MGB Roadsters, then add the supplemental kit specific to your year. That's all there is to it. See the accompanying tables for specific content.

Roadster Base Rubber Kit	<b>282-818</b>	<b>\$79.99</b>
Roadster Supplemental Kit 1962-69	<b>282-825</b>	<b>\$42.99</b>
Roadster Supplemental Kit 1970-76	<b>282-826</b>	<b>\$52.99</b>
Roadster Supplemental Kit 1977-80	<b>282-827</b>	<b>\$34.99</b>
GT Rubber Kit	<b>282-829</b>	<b>\$149.99</b>

## Body Rubber Kit Contents

Base Kit	A, B, C, D, E, F, G, H, I, J, K, L, M, N, O
1962-69 Supplement	P, Q, R, S
1970-76 Supplement	P, Q, R, S
1977-80 Supplement	Q*, R, S
GT Complete Kit	A, B, C, F, G, H, I, J, K, L, M, N, O, P, Q**, R, S

\* Includes correct trunk seal on body.  
\*\* Includes tailgate seals on body and tailgate.

## Front Fender Well Liners

These popular UK accessories are perfect for the MGB daily driver. The molded plastic liners seal the inner front fender area, preventing salt, snow and mud from attacking your bodywork. Installation is easy; fits all MGBs. (Oversize Parts Fee will be charged for this item.)

**457-415 \$99.99**



## B-Pillar Repair Kit

The captive nuts on the MGB's B-pillar, used to secure the convertible top or tonneau cover mounts, often fall off. In acknowledgment of this issue, our design team created a B-pillar repair kit that offers a quick and easy solution for this common problem. The kit consists of a screw, a set of instructions and most importantly the repair plate. The plate has been designed with four Pem nuts. The center Pem nut, as well as the supplied screw, are used to attach the repair plate to the b-pillar, while the three out side Pem nuts will take the place of any missing captive nuts. In the event you do not need to replace all three nuts, you simply cut or bend the extra(s) out of the way.

**472-328 \$21.99**



## CorroSeal Rust Converter

Rust. Is there a more deplorable four-letter word? CorroSeal is the best way to deal with rust because it is less expensive, less time consuming, and is more environmentally friendly than sandblasting. CorroSeal Rust Converter chemically alters rust (iron oxide) into a stable substance, magnetite. It also primes the surface with a high quality latex metal primer at the same time. CorroSeal truly provides one-step corrosion control.

Water-based rust converter with high quality latex metal primer.

Non-Flammable.

Non-Corrosive.

Easy to apply (brush, roll, or spray).

Easy to cleanup with soap and water.

**232-205 \$64.99**

# Interior Body Panels

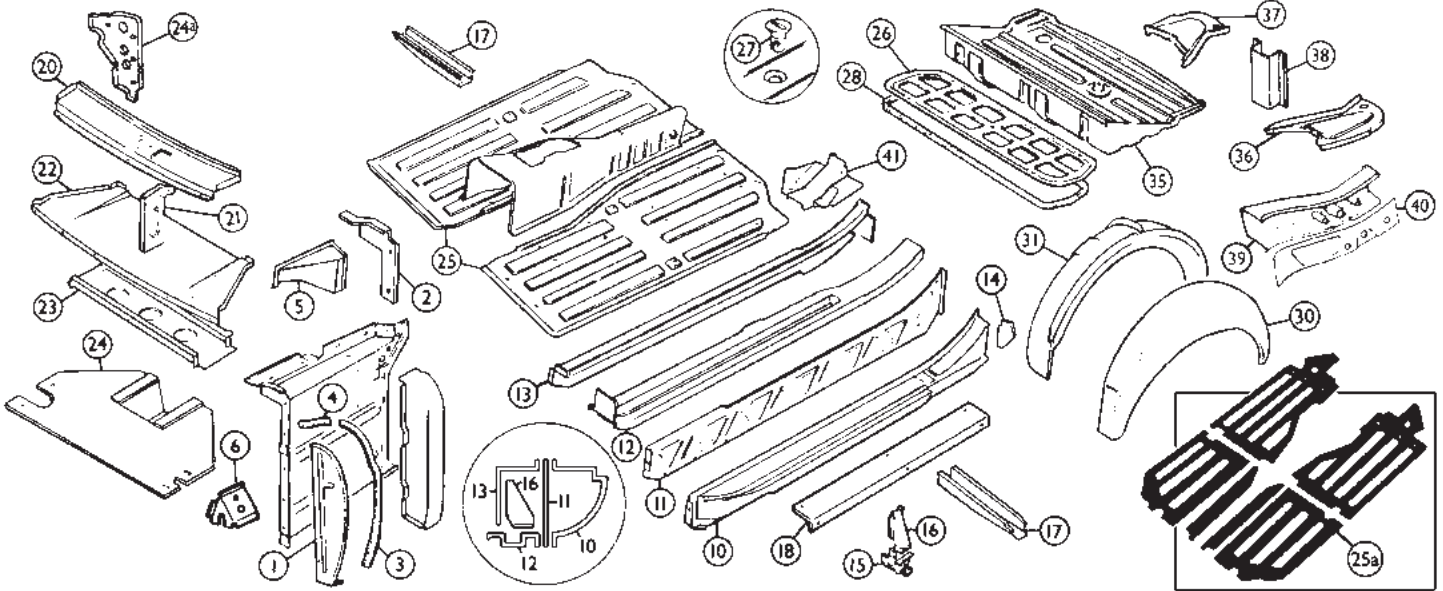

## Interior Body Panels

19839

No.	Part#	Price (Each)	Description	Application	Qty Req.
1	458-390	\$29.99	SPLASH PANEL, L/H	RD to (c)294250 thru 1972, GT to (c)296000 RD from (c)294251 on, GT from (c)296001 on '73 on	1
	458-395	\$29.99	SPLASH PANEL, R/H		1
	458-400	\$14.99	SPLASH PANEL, L/H		1
	458-405	\$14.99	SPLASH PANEL, R/H		1
Earlier splash panels used moulded rubber seals secured with rivets, while later splash panels used a simpler push-on seal. Assemblies are interchangeable.					
	323-638	\$11.99	HARDWARE KIT, splash guard mounting		1
2	458-410	\$14.99	EXTENSION, L/H, splash panel, BMH*		1
	458-415	\$14.99	EXTENSION, R/H, splash panel, BMH*		1
3	282-370	\$9.99	SEAL L/H, splash panel	RD to (c)294250, GT to (c)296000 thru '72 RD from (c)294251 on, GT from (c)296001 on '73 on	1
	282-360	\$9.99	SEAL R/H, splash panel		1
	282-355	\$6.99	SEAL, splash panel		2
	325-278	\$8.49	RIVET SET, 34 rivets	early type seals	1
4	282-375	\$2.49	SEAL, L/H, splash extension		1
	282-365	\$2.49	SEAL, R/H, splash extension		1
5	458-420	\$54.99	BRACE, L/H, wheel arch	RD to (c)386600, all GT, thru 1975 RD from (c)386600 on, 1976 on	1
	458-425	\$54.99	BRACE, R/H, wheel arch		1
	458-430	\$61.99	BRACE, L/H, wheel arch, BMH*		1
	458-435	\$61.99	BRACE, R/H, wheel arch, BMH*		1
6	458-192	\$45.99	BRACKET, engine mount, L/H, BMH*	1975-80	1
	458-187	\$45.99	BRACKET, engine mount, R/H, BMH*		1
	457-158	\$529.99	ROCKER PANEL / SILL REPAIR KIT, L/H		nos. 10 thru 16
	457-168	\$529.99	ROCKER PANEL / SILL REPAIR KIT, R/H	1	
10	457-150	\$209.99	ROCKER PANEL, L/H, BMH*		1
	457-160	\$209.99	ROCKER PANEL, R/H, BMH*		1
	457-155	\$179.99	ROCKER PANEL, L/H, aftermarket		1
	457-165	\$179.99	ROCKER PANEL, R/H, aftermarket		1
11	457-170	\$119.99	INNER PANEL, L/H, BMH*		1
	457-180	\$119.99	INNER PANEL, R/H, BMH*		1
12	459-065	\$194.99	PANEL, L/H, side member bottom, BMH*		1
	459-055	\$194.99	PANEL, R/H, side member bottom, BMH*		1
	458-440	\$159.99	PANEL, L/H, side member bottom, aftermarket		1
	458-445	\$159.99	PANEL, R/H, side member bottom, aftermarket		1
13	458-280	\$189.99	SILL, L/H, BMH*	full length as illustrated (not in kits) repair panel, less rear 18" (included in kits)	1
	458-285	\$189.99	SILL, R/H, BMH*		1
	458-450	\$104.99	SILL, L/H, inner side member		1
	458-455	\$104.99	SILL, R/H, inner side member		1
14	458-460	\$4.29	FILLER, L/H, rocker rear		1
	458-465	\$4.29	FILLER, R/H, rocker rear		1
15	458-470	\$14.99	JACKING BRACKET		2
16	458-475	\$4.29	BRACE, jacking bracket		2
	457-490	\$229.99	CROSSMEMBER, full length, BMH*		1
17	458-480	\$19.99	CROSS MEMBER HALF	jack support, repair section	2

No.	Part#	Price (Each)	Description	Application	Qty Req.
18	240-640	\$38.99	PLATE, sill tread	RD from (c)187211 on, GT from (c)187841 on	2
20	458-900	\$164.99	PLATFORM, bonnet lock, BMH*		chrome bumpered cars
	458-901	\$169.99	PLATFORM, bonnet lock	rubber bumpered cars	1
	458-905	\$121.99	PLATFORM, bonnet lock, repl.	all cars	1
21	458-910	\$72.99	BRACE, platform, BMH*	chrome bumpered cars	1
	458-915	\$69.99	BRACE, platform, BMH*	rubber bumpered cars	1
22	458-920	\$189.99	PANEL, radiator duct	chrome bumpered cars	1
	458-925	\$199.99	PANEL, radiator duct, BMH*	rubber bumpered cars	1
23	458-930	\$89.99	SUPPORT, duct panel, BMH*	chrome bumpered cars	1
	458-935	\$89.99	SUPPORT, duct panel, BMH*	rubber bumpered cars	1
24	458-194	\$59.99	MUD SHIELD, ABS replacement	RD from (c) 410001 on	1
	458-195	NA	MUD SHIELD, ABS original design		1
	458-196	\$72.99	BRACKET SET, mudshield		1
24a	458-185	\$49.99	BRACKET, radiator mount, R/H, BMH*	1977-'80	1
	458-190	\$49.99	BRACKET, radiator mount, L/H, BMH*		1
25	458-940	\$289.99	FLOOR PANEL, L/H	RD to (c)138400, GT to (c)139471 (thru '67) RD from (c)138401 on, GT from (c)139472 ('68 on)	1
	458-945	\$289.99	FLOOR PANEL, R/H		1
	458-885	\$299.99	FLOOR PANEL, L/H, BMH*		1
	458-875	\$299.99	FLOOR PANEL, R/H, BMH*		1
	458-950	\$209.99	FLOOR PANEL, L/H, repro.		1
	458-955	\$209.99	FLOOR PANEL, R/H, repro.		1
25a	409-128	\$229.99	SOUND-DEADENING KIT, main floor, BMH*	1968 - '80	1
26	456-270	\$106.99	PANEL, battery access, to '74 1/2	RD/GT to (c)360300	1
	456-275	\$74.99	PANEL, battery access, BMH*	RD/GT from (c)360301	1
27	226-640	\$10.99	FASTENER, access panel		5
28	282-500	\$2.99	SEAL, battery access panel		1
30	458-960	\$249.99	WHEEL WELL, L/H outer		1
	458-965	\$249.99	WHEEL WELL, R/H outer		1
31	458-055	\$254.99	WHEEL WELL, L/H inner, BMH*		1
	458-065	\$254.99	WHEEL WELL, R/H inner, BMH*		1
35	NA		TRUNK FLOOR, main panel	1962-'65	1
	458-987	\$449.99	TRUNK FLOOR, main panel, BMH*	1966-'74	1
	458-970	\$449.99	TRUNK FLOOR, main panel, BMH*	1974.5-'80	1
36	458-975	\$74.99	OUTER TRUNK FLOOR, L/H	RD/GT	1
	458-980	\$74.99	OUTER TRUNK FLOOR, R/H		1
38	457-730	\$23.99	PANEL, trunk lid striker, BMH*		1
39	457-500	\$249.99	SPRING HANGER, R/H	chrome bumper cars	1
	457-510	\$249.99	SPRING HANGER, L/H		1
40	457-520	\$74.99	SIDE PLATE, R/H, BMH*		1
	457-530	\$74.99	SIDE PLATE, L/H, BMH*		1
41	458-028	\$104.99	SPRING MOUNT ASS'Y., L/H, BMH*	rubber bumper cars	1
	458-018	\$104.99	SPRING MOUNT ASS'Y., R/H, BMH*		1
	458-048	\$114.99	SPRING MOUNT ASS'Y., L/H, BMH*		1
	458-038	\$114.99	SPRING MOUNT ASS'Y., R/H, BMH*		1

\* Parts market "BMH" are produced by British Motor Heritage.

Toll-Free Orders 1-800-667-7872 | MossMotors.com  
Fax 805-692-2525 | Local 805-681-3400

MOSS

# Body Paint Color Codes

**BEFORE PAINTING YOUR CAR, verify that the paint to be used is the exact color and shade you want. We are not responsible for any problems related to use of this reference chart. We cannot provide any further information or assistance regarding paint or the formulation of these colors.**

## MGB Color Codes and Applications

If you've tried to match an original paint color with a similar color from your local paint store, you know you're in for a lot of headaches and a color that can only be "similar" at best. This chart will eliminate a lot of guesswork and allows you the unique opportunity to restore your MGB to its factory original color. We are once again indebted to Caroline Robinson and John Twist of Grand Rapids, Michigan for researching and compiling this valuable information.

In the following chart, the left-hand column represents the color's original name, while the second column is a more specific description of that color. Although the factory paint code does not appear on the car, we include it here for reference purposes. Aftermarket paint manufacturers are abbreviated in the fourth column as follows:

**DITZ**     **Ditzler**  
**DUP**     **Dupont**  
**RM**      **Rinshed Mason**

The numbers that directly follow these abbreviations represent a formula unique to each manufacturer which duplicates that original color. With this information, your local automotive paint supplier should be able to accurately mix the correct color for your car. **Certain footnotes appear occasionally throughout the chart** where slight variations in the same color occurred between model years. These are as follows:

- 1) 1962-1963 only
- 2) 1964 on
- 3) thru 1976
- 4) 1977 only

Towards the end of this chart, you will also find certain aftermarket paint codes for the engine compartment and wheels. For these jobs, you may prefer the convenience of spray paints offered by Moss.

Color Name	Description	Factory Code	Aftermarket Codes	Application	Years
Black	Black	BK 1	DITZ# 9000 DUP# 99	RD/GT	1962 - '80
Old English White	Creamy White	WT 3	RM# BM149/BM150 <sup>2</sup> DITZ# 8177 DUP# 8207 or 97111	RD/GT	1962 - '67
Snowberry White	Gray White	WT 4	RM# BM151	RD/GT	1968 - '69
Glacier White	Blue White	BLVC 59	RM# BM155 DUP# 8579 DITZ# 8845 <sup>3</sup> /90074 <sup>4</sup>	RD/GT	1970 - '77
Leyland White	Refrigerator White	BLVC 243	DITZ# 90106 DUP# H7896	RD only	1978 - '80
Grampian Gray	Dark Gray	GR 12	RM# BM018	GT only	1967 - '69
Chelsea Gray	Light Gray	GR15	RM# BM008, DITZ# 31733 DUP# 8198	RD only	1962 - '65
Mirage	Mauve	BLVC II	RM# BM176 DITZ# 33135 DUP# 43277	RD/GT	1974
Sandy Beige	Med. Gray Brown	BG 15	RM# BM146 DITZ# 22213	GT only	1965 - '68
Golden Beige	Medium Brown	BG 19	RM# BM140	GT only	1967 - '68
Bedouin	Cream Beige	BLVC 4	RM# BM163	RD/GT	1971
Russet Brown	Dark Brown	BLVC 205	DITZ# 24378 DUP# 44848	RD only	1978 - '80
Chartreuse	Pale Yellow	BLVC 167	DITZ# 45189 DUP# 44629	RD only	1976 - '77
Inca Yellow	Sun Yellow	BLVC 207	DITZ# 82309 DUP# 44880	RD only	1978 - '79
Snap Dragon	Sun Yellow	BLVC 235	DITZ# 82462 DUP# 45475	RD only	1980
Pale Primrose	Light Yellow	YL 12	RM# BM131 DITZ# 81499	RD/GT	1965 - '70
Bronze Yellow	Dark Yellow	BLVC 15	RM# BM157 DITZ# 81827 DUP# 8581	RD/GT	1970 - '73
Harvest Gold	Muddy Yellow	BLVC 19	RM# BM170 DITZ# 82018 DUP# 30013	RD/GT	1972 - '76
Sandglow	Caramel	BLVC 63	DITZ# 24300 DUP# 44565	RD/GT	1976 - '77
Bracken	Muddy Orange	BLVC 93	RM# BM187 DITZ# 60760 DUP# 43275	RD/GT	1974 - '76
Damask Red	Maroon	RD 5 BLVC 99	RM# BM112R DUP# 8819 DITZ# 71064 <sup>3</sup> /72261 <sup>4</sup>	RD/GT	1973 - '77
Tartan Red	Bright Red	RD 9	RM# BM124R DUP# 8204 DITZ# 71062 <sup>3</sup> /71416 <sup>2</sup>	RD/GT	1962 - '69
Blaze Red	Orange	BLVC 16	RM# BM162 DITZ# 60637 DUP# 30007	RD/GT	1971 - '75
Flame Red	Red	BLVC 61	RM# BM162 DITZ# 71861 DUP# 8571	RD/GT	1970 - '72
Flamenco Red	Orange Red	BLVC 133	DITZ# 72144, DUP# 43661	RD only	1975-'77
Black Tulip	Dark Purple	BLVC 23	RM# BM168M DITZ# 14417 DUP# 30015	RD/GT	1973
Aconite	Dark Purple	BLVC 95	RM# BM181D DITZ# 14728 DUP# 43274	RD/GT	1974 - '75
Vermillion Red	Orange Red	BLVC 118	DITZ# 60932 DUP# 45471	RD only	1978 - '80
Carmine Red	Maroon Red	BLVC 209	DITZ# 72065 DUP# 43019	RD only	1978 - '80
British Racing Green	Medium Dark Green (yellowish green)	GN 25	RM# BM079 DITZ# 43342 DUP# 8193	RD/GT	1964 - '70

### Silver-Gray Wheel Paint

Custom packed aerosol can of the correct shade of silver for MG wheels. (Not the gaudy, "hardware store" silver color!) Three to four cans (depending on wheel type) of this acrylic enamel will make five wheels look like new and leave a bit left for later touch-up.

220-560 \$29.99 

### Red Engine Paint '62-'71

We spent some time on it and finally came up with the correct shade of red for the properly restored MGB engine. (One can is sufficient to paint a properly prepared engine assembly.) Acrylic enamel in an aerosol can.

220-540 \$29.99 

### Black Engine Paint '72-'80

Durable and heat resistant up to 500 degrees F., this paint is semi-gloss to correctly paint the later MGB engines. (Great for suspension parts, too!)

220-575 \$19.99 

### High Temperature Primer

While our engine paints may be used on bare metal, this special primer will improve adherence and paint smoothness.

220-576 \$19.99 

### Wrinkle-Finish Black Paint

Follow the directions carefully and this paint will enable you to refinish the dashboard of your 1962 - '67 MGB to look like new! A must for the serious restorer. One can, used carefully, is sufficient.

220-570 \$19.99 



Color Name	Description	Factory Code	Aftermarket Codes	Application	Years
British Racing Green	Medium Dark (darker than GN25)	GN 29	RM# BM078 DITZ# 46446 DUP# 8194	RD/GT	1964 - '70
Green Mallard	Dark Green	BLVC 22	RM# BM169D DITZ# 44638 DUP# 30014	RD/GT	1972 - '73
New Racing Green	Very Dark Green	BLVC 25	RM# BM167 DITZ# 44446 DUP# 30012	RD/GT	1971
Aqua	Light Turquoise	BLVC 60	RM# BM159 DITZ# 14075 DUP# 8821	RD/GT	1972
Limeflower	Dark Lime Green	BLVC 20	RM# BM166 DITZ# 44448 DUP# 30010	RD/GT	1973
Citron	Chartreuse	BLVC 73	RM# BM177 DITZ# 44947 DUP# 43276	RD/GT	1974 - '76
Tundra	Olive Drab	BLVC 94	RM# BM178 DITZ# 44978 DUP# 43278	RD/GT	1974 - '76
Brooklands Green	Medium Green	BLVC 169	DITZ# 45190 DUP# 44630	RD only	1976 - '80
Mineral Blue	Dark Blue	BU 9	RM# BM060 DITZ# 12115 DUP# 8182	RD/GT	1965 - '69
Iris Blue	Medium Light Blue	BU 12	RM# BM054 DITZ# 12235 DUP# 8184	RD only	1962 - '65
Blue Royale	Dark Blue	BU 38	RM# BM039 DITZ# 12635	RD/GT	1970
Teal Blue	Medium Dark Blue	BLVC 18	RM# BM164 DITZ# 14244 DUP# 30006	RD/GT	1971 - '74
Tahiti Blue	Bright Blue	BLVC 65	DITZ# 14866 <sup>3</sup> /15096 <sup>4</sup>	RD only	1975 - '77
Pageant Blue	Brighter Blue	BLVC 224	DITZ# 15231 DUP# 45473AH	RD only	1978 - '80

## Paint Codes for Other Components

Application	Color	Aftermarket Codes	
1962 - '71 Engines (18G to 18GK )	Dark Red	Moss# 220-540	\$29.99
1972-'80 Engines (18V)	Black	Moss# 220-575	\$19.99
Engine Cooling Fan and Pulley	Yellow	Rustoleum #7747 (Sunburst Yellow)	NA
Wire and Disc Wheels	"Hammered" Silver	Moss# 220-560	\$29.99
Washer Bottle Bracket	"Tudor Blue"	Krylon 3107	NA



## Hardware Kits

Our complete Fitting Kits are designed to make installing various components to your car fast, simple and very convenient!

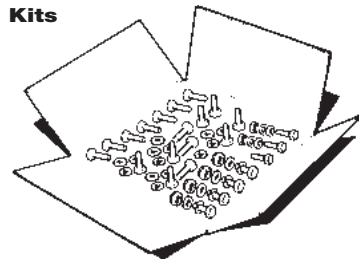

### Engine Kits:

**Timing Cover Screw Set**  
Fits 1962-'76 with oval washers. 323-568 \$19.99

**Timing Cover Screw Set**  
Fits 1976 on with plain washers. 323-558 \$13.99

**Sump Screw Set**  
Fits all 1962-'80. 323-548 \$21.49

**Engine to Gearbox Nut & Bolt Set**  
Fits 1962-'67 with 3-Synchro gearboxes. 322-428 \$10.99

**Engine to Gearbox Nut & Bolt Set**  
Fits 1968 on with All-Synchro gearboxes. 322-438 \$9.99

**Fuel Tank Mounting Kit**  
Fits 1965 on (not for early strap-on tanks). 323-628 \$13.99

### Exhaust Mounting Kits:

**Center Exhaust Mounting Kit**  
Fits all 1962-'80. 470-138 \$17.99

**Rear Exhaust Mounting Kit**  
Fits 1962-'69 to (c)167815. 470-178 \$11.99

**Rear Exhaust Mounting Kit**  
Fits 1969-'74. Roadsters from (c)167816 to 360300 and GTs from (c)167816 to 361000. 444-145 \$34.99

**Rear Exhaust Mounting Kit**  
Fits '74 1/2 on (all rubber-bumpered cars). 470-148 \$32.99

**Exh. Manifold Stud & Nut Kit** (6 studs & brass nuts)  
Fits 1962-'74 (all cars with twin SU carbs.). 328-718 \$15.99

### Suspension Kits:

**Front Suspension Dust Tube Kits**  
Includes both tubes and spring. 2 required. 263-428 \$18.99

**Rear Spring Fitting Kit (for 1 spring)**  
Fits cars with Banjo-Type rear axles. 454-927 \$15.99

**Rear Spring Fitting Kit (for 1 spring)**  
Fits cars with Tube-Type rear axles. 454-937 \$16.99

**Rear Spring Shackle Kit**  
Includes shackle plate with studs, plate, nuts and bolts. 2 kits required per car. 267-528 \$13.99

### Bodywork & Bumper Kits:

**Front Fender Fitting Kit**  
Fits all '62-'80. One kit does both fenders. 321-928 \$67.99

**Front Valance Fitting Kit** 323-618 \$8.99

**Front Bumper Fitting Kit**  
Fits 1962-'74 (cars with chrome bumpers). 321-908 \$45.99

**Rear Bumper Fitting Kit**  
Fits 1962-'74 (cars with chrome bumpers). 321-918 \$42.99

### Trim & Body Molding Kits:

**Interior Trim Screw Set**  
Chrome finish for early roadsters. 323-578 \$19.99

**Interior Trim Screw Set**  
Black finish for later roadsters. 323-988 \$20.99

**Interior Trim Screw Set**  
Black finish for GTs. 323-608 \$23.99

**Body Molding Fitting Kit**  
Complete set to fit all 6 body moldings. 326-058 \$17.99

**Inner Front Fender Splash Panel Fixing Kit**  
Complete set for left and right panels. 323-638 \$11.99



# Door Fittings

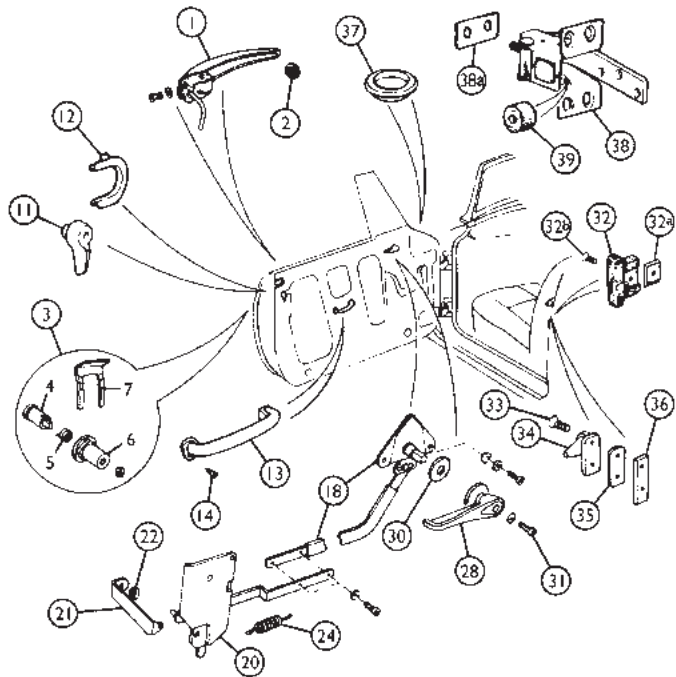

## Door Fittings 1962 - early 1965

RD from (b)101 to 57985 with pull-out exterior door handles

19847

No.	Part#	Price (Each)	Description	Application	Qty Req.
1	401-510	\$54.99	DOOR HANDLE, L/H, exterior		1
	401-520	\$54.99	DOOR HANDLE, R/H, exterior		1
2	011-734	\$1.99	BUFFER, door handle		2
3	401-578	NA	LOCK ASSEMBLY, pair		1
4	401-570	NA	BARREL & KEYS		2
5	401-575	NA	COLLAR SPRING		2
6	401-580	NA	CASE		2
7	401-585	\$8.49	RETAINING CLIP		2
11	472-260	\$56.99	KNOB, inside locking, passenger's door		1
12	401-595	\$30.99	FINISHER, lock		2
13	472-240	\$5.99	HANDLE, door pull, with end brackets		2
	402-470	NA	HANDLE, door pull, without brackets		2
14	323-080	\$1.59	SCREW, door pull		4
18	402-300	NA	REMOTE CONTROL, L/H		1
	402-305	NA	REMOTE CONTROL, R/H		1
20	401-110	NA	LATCH, L/H		1
	401-210	NA	LATCH, R/H		1
21	402-320	\$24.99	LINK		2
22	402-325	\$1.49	SPRING CLIP		2
24	402-330	NA	TENSION SPRING		2
28	472-250	\$21.99	HANDLE, door opening		2
30	472-265	\$1.49	FIBER WASHER		2
31	323-205	\$2.59	SCREW, handle fixing		2
32	281-608	\$7.29	DOOR BUFFER SET, 4 buffers		1
32a	470-490	\$2.89	TAPPING PLATE		4
32b	323-080	\$1.59	SCREW		4
33	323-260	\$0.79	SCREW, securing striker plate		4
34	470-540	\$12.99	STRIKER		2
35	472-455	\$2.39	PACKING	A/R	2
36	470-480	\$13.99	TAPPING PLATE		2
37	282-995	\$1.19	PLUG, rain excluder		4
38	405-460	\$214.99	DOOR HINGE, L/H, BMH*		2
	405-470	\$214.99	DOOR HINGE, R/H, BMH*		2
	323-235	\$0.59	SCREW, hinge to door		12
	323-275	\$0.89	SCREW, hinge to body		16
38a	405-480	\$12.99	TAPPING PLATE, hinge to body, BMH*		8
39	282-895	\$1.19	BUFFER, door hinge		4

\* Parts market "BMH" are produced by British Motor Heritage.

## 1962 - '64 MGB Door Latch Repair Kit

This marvelous kit includes all of the wearing components in the early "pull out" handle door latches, enabling the latch assemblies to be rebuilt to new operating condition. Fits left and right latches, 2 required per car.

401-117 \$23.49

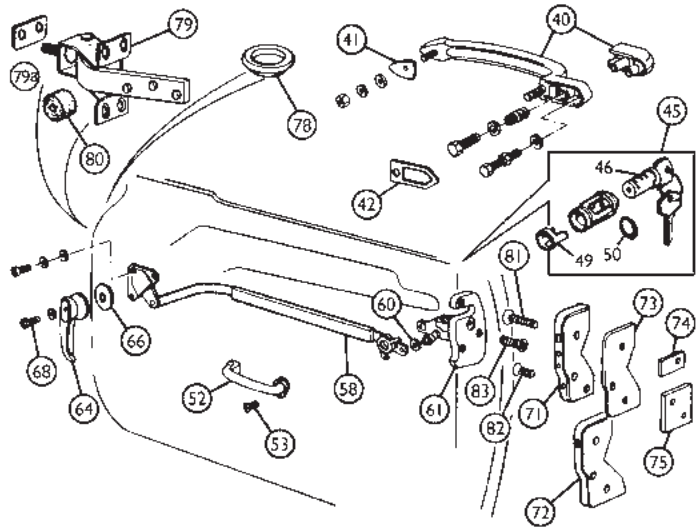

## Door Fittings 1965 - 1967

19849

RD from (b)57986 to 110292/GT from (b)101 to 21777 with push button exterior door handles.

No.	Part#	Price (Each)	Description	Application	Qty Req.
40	803-165	\$74.99	DOOR HANDLE, exterior		2
41	401-540	\$0.99	GASKET, front		2
42	401-550	\$0.59	GASKET, rear		2
	401-588	NA	MASTER LOCK SET, includes 2 matching door locks		1
			1 trunk lid lock, 1 glove box and 2 keys		
402-198	\$99.99	DOOR LOCK PAIR, with 2 keys		1	
45	402-190	NA	LOCK ASSEMBLY, L/H		1
	402-200	NA	LOCK ASSEMBLY, R/H		1
46	401-560	NA	BARREL & KEY		2
49	401-590	NA	RETAINING CLIP		2
50	402-170	\$0.99	GASKET, door lock		2
52	472-240	\$5.99	HANDLE, door pull		2
53	323-080	\$1.59	SCREW, door pull		4
58	402-310	NA	REMOTE CONTROL, L/H		1
	402-315	NA	REMOTE CONTROL, R/H		1
60	0	NA	FIBER WASHER		2
61	401-120	NA	LATCH, L/H		1
	401-220	NA	LATCH, R/H		1
64	472-250	\$21.99	HANDLE, door opening		2
66	472-265	\$1.49	FIBER WASHER		2
68	323-205	\$2.59	SCREW, handle fixing		2
71	401-320	NA	STRIKER, L/H	} RD	1
	401-340	NA	STRIKER, R/H		1
72	401-330	NA	STRIKER, L/H	} GT	1
	401-350	NA	STRIKER, R/H		1
73	402-410	\$1.19	SHIM, .064"		A/R
	402-415	\$1.19	SHIM, .036"		A/R
74	402-340	\$4.49	TAPPING PLATE, upper		2
75	402-420	\$6.29	TAPPING PLATE, lower		2
78	282-995	\$1.19	PLUG, rain excluder		4
79	405-460	\$214.99	DOOR HINGE, L/H, BMH		2
	405-470	\$214.99	DOOR HINGE, R/H, BMH		2
	323-235	\$0.59	SCREW, hinge to door		12
	323-275	\$0.89	SCREW, hinge to body		16
79a	405-480	\$12.99	TAPPING PLATE, hinge to body, BMH*		8
80	282-895	\$1.19	BUFFER, door hinge		4
81	323-195	\$1.39	SCREW, striker plate, long		2
82	323-255	\$0.69	SCREW, striker plate, short		4
83	323-585	\$0.59	SCREW, securing door latch		6

\* Parts market "BMH" are produced by British Motor Heritage.

To prevent the "crack of doom" on MGB doors just behind the vent window frame, ensure that the car's doors are properly hung, adjusted, and hinges lubricated. This does need periodic attention due to hinge wear. Also, don't pull on the vent window to close the doors!



# Door Fittings

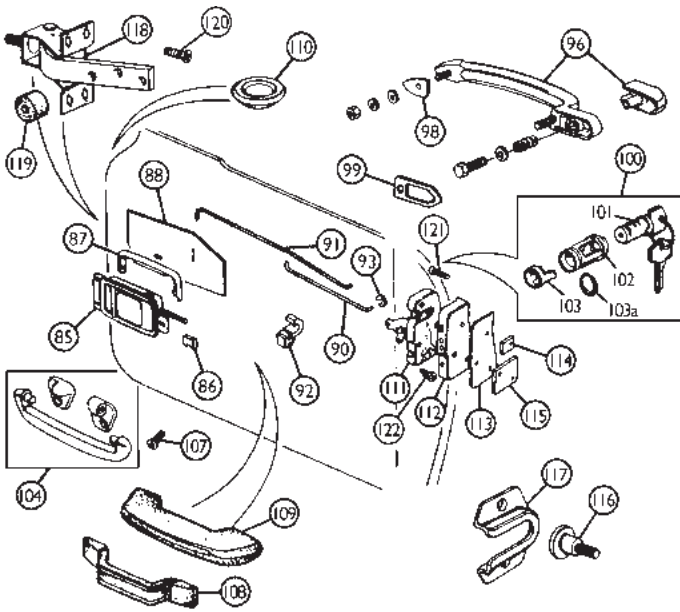

## Door Fittings 1968 - 1980

19850

No.	Part#	Price (Each)	Description	Application	Qty Req.
85	402-360	\$89.99	HANDLE & CONTROL ASSEMBLY, L/H		1
	402-365	\$89.99	HANDLE & CONTROL ASSEMBLY, R/H		1
86	402-370	NA	CONNECTOR		2
87	402-375	\$3.59	BEZEL, interior handle		4
88	402-380	NA	DUST SEAL, handle assembly		2
90	402-390	NA	LINK, operating, L/H		1
	402-395	NA	LINK, operating, R/H		1
91	402-400	NA	LINK, locking, L/H		1
	402-405	NA	LINK, locking, R/H		1
92	402-385	NA	RETAINER, link		2
93	401-121	\$7.99	CLIP, operating links to latch		2
96	401-535	\$89.99	DOOR HANDLE, exterior		2
98	401-540	\$0.99	GASKET, front		2
99	401-550	\$0.59	GASKET, rear		2
	401-598	\$199.99	MASTER LOCK SET		1
			includes 2 door locks, 1 trunk lock and 2 keys		
	402-198	\$99.99	DOOR LOCK PAIR		1
100	402-190	NA	LOCK ASSEMBLY, L/H		1
	402-200	NA	LOCK ASSEMBLY, R/H		1
101	401-560	NA	BARREL & KEY		2
102	NA	NA	CASE		2
103	401-590	NA	RETAINING CLIP		2
103a	402-170	\$0.99	GASKET, door lock		2
104	472-240	\$5.99	DOOR PULL, assembly, thru 1971	RD/GT to (c)258000	2
			Earlier type (orig. thru 1967), with open ends on brackets. Later type is not available.		
107	323-080	\$1.59	SCREW, door pull		4
108	402-450	NA	DOOR PULL, autumn leaf (tan)	RD from (c)258001 to 294250, GT from (c)258001 to 296000, 1972	2
	402-455	NA	DOOR PULL, ochre (mustard)		2
	402-453	\$28.99	DOOR PULL, black		2
	402-490	NA	DOOR PULL, navy		2
	472-507	\$1.09	SCREW, door pull		4
109	402-427	\$44.99	DOOR PULL, armrest, black	RD from (c)294251, GT from (c)296001, 1973 on	2
	402-430	\$116.99	DOOR PULL, armrest, autumn leaf		2
	402-435	NA	DOOR PULL, armrest, navy		2
	402-440	NA	DOOR PULL, armrest, ochre		2
	402-495	NA	DOOR PULL, armrest, champagne		2
	402-442	\$0.49	SCREW, door pull		4
	402-443	\$0.89	NUT, plastic (in door)		4
110	282-995	\$1.19	PLUG, rain excluder		4
111	401-130	NA	LATCH, L/H		1
	401-135	NA	LATCH, R/H		1
112	401-360	NA	STRIKER, L/H	RD	1
	401-370	NA	STRIKER, R/H		1
	401-380	NA	STRIKER, L/H		1
	401-390	NA	STRIKER, R/H		1
113	402-410	\$1.19	SHIM, .064"		A/R
	402-415	\$1.19	SHIM, .036"		A/R

No.	Part#	Price (Each)	Description	Application	Qty Req.
114	402-340	\$4.49	TAPPING PLATE, upper		2
115	402-420	\$6.29	TAPPING PLATE, lower		2
116	401-385	\$7.99	PIN, anti-burst unit	RD from (c)410001 on, 1977 on	2
117	401-395	\$7.69	PLATE, anti-burst unit		2
118	405-460	\$214.99	DOOR HINGE, L/H, BMH*	RD from (c)138401 to 410000, GT from (c)139472 to 410000	2
	405-470	\$214.99	DOOR HINGE, R/H, BMH*		2
	405-460	\$214.99	DOOR HINGE, L/H, upper, BMH*	RD from (c)410001 on, 1977 on	1
	405-465	\$209.99	DOOR HINGE, L/H, lower, BMH*		1
	405-470	\$214.99	DOOR HINGE, R/H, upper, BMH*		1
	405-475	\$209.99	DOOR HINGE, R/H, lower, BMH*		1
119	282-895	\$1.19	BUFFER, door hinge		4
120	323-275	\$0.89	SCREW, hinge to body		16
	323-235	\$0.59	SCREW, hinge to door		12
121	323-195	\$1.39	SCREW, striker plate, long		2
	323-255	\$0.69	SCREW, striker plate, short		4
122	323-585	\$0.59	SCREW, securing door latch		6

\* Parts market "BMH" are produced by British Motor Heritage.

## Door Lock Fitting Kit

Fits 1965-'80. These clever kits allow factory door locks to be fitted without using the factory style securing clips, which are not very easy to fit and very difficult to remove. These new clips are also designed to prevent the lock from rotating in the door skin.

**402-195 \$13.99**



## Chrome Door Pull & Window Winder

While standard pulls and winders are bound to break with normal use, these are attractive and durable alternatives to the original plastic components. Sold individually. Order screws separately. (May differ slightly from photo.)

1962-'71 Door Pull **803-440 \$16.99**

1968-'80 Winder **472-540 NA**



# Door Window Fittings

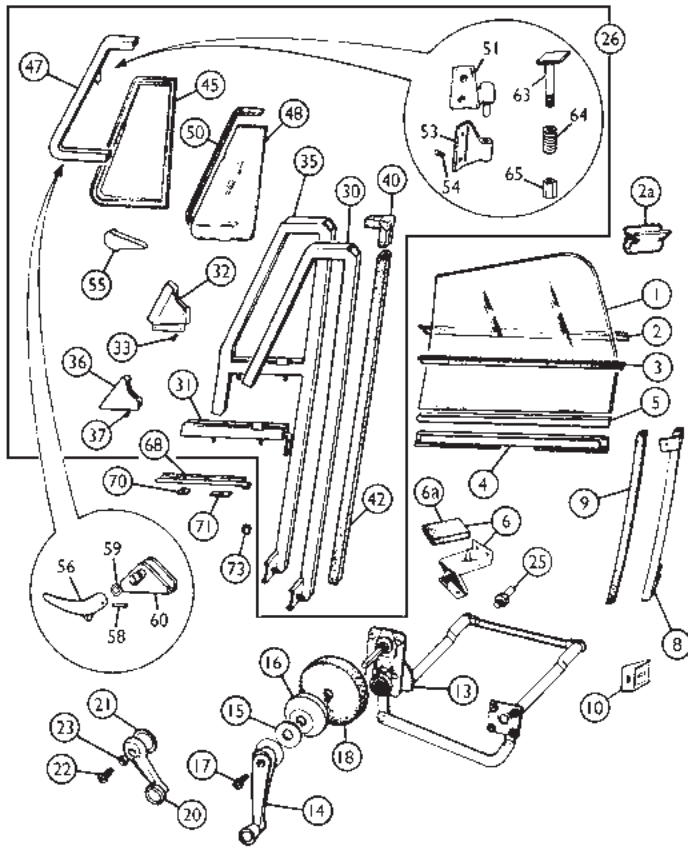

## Door Window Fittings

19853

No.	Part#	Price (Each)	Description	Application	Qty Req.
1	458-830	\$59.99	DOOR GLASS, L/H	RD	1
	458-850	\$59.99	DOOR GLASS, R/H		1
	458-840	\$74.99	DOOR GLASS, L/H, clear	GT to (c)219000	1
	458-860	\$74.99	DOOR GLASS, R/H, clear		1
	458-890	\$84.99	DOOR GLASS, L/H, tinted		1
	458-895	\$84.99	DOOR GLASS, R/H, tinted	(optional for earlier cars)	1
2	282-380	\$8.59	SEAL, door top, L/H		1
	282-390	\$9.99	SEAL, door top, R/H		1
	2a 803-400	\$0.59	CLIP, seal to finisher	GT	14
	326-275	\$0.79	RIVET, seal to finisher	RD	14
3	682-030	\$8.19	BRUSH SEAL, door top		2
4	402-220	\$52.99	CHANNEL, lower		2
5	282-550	\$5.49	GLAZING RUBBER		2
6	402-231	\$69.99	BRACKET, glass stop, R/H		2
	402-232	\$69.99	BRACKET, glass stop, L/H		2
6a	402-230	\$2.19	BUFFER, glass stop		2
8	402-235	\$45.99	REAR CHANNEL, L/H		1
	402-240	\$45.99	REAR CHANNEL, R/H		1
9	458-610	\$6.49	FLEX CHANNEL		2
10	458-605	\$36.99	BRACKET, R/H, channel	RD/GT from (c)146104 on (fits RD ft. & rear, GT rear only)	2/1
	458-615	\$36.99	BRACKET, L/H, channel		2/1
13	402-250	NA	REGULATOR, L/H	RD to (b)57986	1
	402-255	NA	REGULATOR, R/H		1
	402-260	NA	REGULATOR, L/H	RD from (b)57986 to 110292, GT to (b)21777	1
	402-265	NA	REGULATOR, R/H		1
	402-270	NA	REGULATOR, L/H	RD from (c)138401 on ('68 on), GT from (c)139472 on	1
	402-275	NA	REGULATOR, R/H		1
14	472-230	\$8.99	HANDLE, regulator	RD to (c)138400, GT to (c)139471, (thru 1967)	2
	15 472-265	\$1.49	WASHER, fiber		2
16	472-500	\$14.99	ESCUTCHEON		2
17	323-205	\$2.59	SCREW, handle		2
18	472-510	\$2.19	PAD, handle		2
20	472-520	\$4.99	HANDLE, plastic (original)	RD from (c)138401 on,	2
	472-555	\$15.49	HANDLE, chrome (replacement)	GT from (c)139472 on, (1968 on)	2
21	472-525	\$0.99	WASHER, fiber		2
22	472-495	\$2.99	SCREW & SPACER, black	for black handles	2
	472-535	\$0.89	SCREW, chrome	for chrome handles	2
23	472-530	\$5.99	SPACER, chrome		
24	324-010	\$0.19	LOCKWASHER for screw		2

No.	Part#	Price (Each)	Description	Application	Qty Req.
25	402-280	NA	STOP, regulator arm	RD/GT from (b)57986 on	2
26	458-500	NA	VENTILATOR ASSEMBLY, L/H	RD from (c)65865 on (earlier parts not avail.)	1
	458-505	NA	VENTILATOR ASSEMBLY, R/H		1
	458-510	NA	VENTILATOR ASSEMBLY, L/H	GT	1
	458-515	NA	VENTILATOR ASSEMBLY, R/H		1
30	458-520	NA	OUTER FRAME, L/H	RD to (c)65864	1
	458-525	NA	OUTER FRAME, R/H		1
31	458-530	NA	WAIST RAIL, L/H	RD to (c)65864	1
	458-535	NA	WAIST RAIL, R/H		1
32	458-540	NA	CAPPING, L/H	RD to (c)65864	1
	458-545	NA	CAPPING, R/H		1
33	458-550	\$0.89	SCREW, capping to frame		4
35	458-560	NA	OUTER FRAME, L/H	RD from (c)65865 on	1
	458-565	NA	OUTER FRAME, R/H		1
	458-570	NA	OUTER FRAME, L/H	GT	1
	458-575	NA	OUTER FRAME, R/H		1
36	458-580	\$34.99	CAPPING, L/H	RD from (c)65865 on	1
	458-585	\$34.99	CAPPING, R/H		1
	458-590	NA	CAPPING, L/H	GT	1
	458-595	NA	CAPPING, R/H		1
37	458-550	\$0.89	SCREW, capping to frame	RD from (c)65865 on	4
	458-555	NA	SCREW, capping to frame	GT	4
40	282-575	\$6.29	BLOCK, corner	RD/GT to approx. 1969	2
	282-595	\$2.99	BLOCK, corner	RD/GT approx. '69 to (c)279339	2
	282-065	\$2.39	BLOCK, corner	RD/GT from (c)279340	2
	42 458-610	\$6.49	FLEX CHANNEL		2
45	282-530	\$8.59	SEAL, vent window, L/H	RD	1
	282-510	\$8.59	SEAL, vent window, R/H		1
	282-540	\$15.99	SEAL, vent window, L/H	GT	1
	282-520	\$15.99	SEAL, vent window, R/H		1
47	458-620	NA	INNER FRAME, L/H	RD	1
	458-625	NA	INNER FRAME, R/H		1
	458-630	NA	INNER FRAME, L/H	GT	1
	458-635	NA	INNER FRAME, R/H		1
48	458-780	\$36.99	GLASS, L/H & R/H	RD	2
	458-800	\$56.99	GLASS, L/H, clear	GT to (c)279339	1
	458-790	\$56.99	GLASS, R/H, clear		1
	458-855	\$66.99	GLASS, L/H, tinted	GT from (c)279340 on	1
458-865	\$66.99	GLASS, R/H, tinted	1		
50	282-095	\$3.49	GLAZING RUBBER	sold per foot	A/R
51	458-640	\$11.99	HINGE TOP, L/H	RD	1
	458-645	\$11.99	HINGE TOP, R/H		1
	458-765	\$0.89	RIVET, hinge top*	GT	4
	458-650	NA	HINGE TOP, L/H		1
	458-655	NA	HINGE TOP, R/H		1
	458-765	\$0.89	RIVET, hinge top*		4
*Rivet is factory replacement for original screw.					
53	458-745	\$17.99	HINGE BOTTOM, L/H	RD to (c)279339 (screw type)	1
	458-755	\$17.99	HINGE BOTTOM, R/H		1
	458-775	NA	HINGE BOTTOM, L/H	GT to (c)279339 (screw type)	1
	458-785	NA	HINGE BOTTOM, R/H		1
54	323-060	\$0.99	SCREW, hinge	RD/GT to (c)279339	4
	458-660	NA	HINGE BOTTOM, L/H	RD from (c)279340 (rivet type)	1
	458-665	\$6.19	HINGE BOTTOM, R/H		1
	458-670	\$7.99	HINGE BOTTOM, L/H	GT from (c)279340 (rivet type)	1
	458-675	NA	HINGE BOTTOM, R/H		1
	458-765	\$0.89	RIVET, hinge	RD/GT from (c)279340	4
55	458-680	\$19.99	DRAIN CHANNEL, L/H	RD	1
	458-685	\$19.99	DRAIN CHANNEL, R/H		1
	458-690	NA	DRAIN CHANNEL, L/H	GT	1
	458-695	NA	DRAIN CHANNEL, R/H		1
56	470-590	\$44.99	HANDLE, L/H, curved	RD to (c)138799, GT to (c)139283	1
	470-580	\$44.99	HANDLE, R/H, curved		1
	470-595	\$29.99	HANDLE, L/H, flat	RD from (c)138000 on, GT from (c)139284 on	1
	470-585	\$29.99	HANDLE, R/H, flat		1
58	325-470	\$3.19	PIN, handle securing		2
59	324-295	\$0.39	WASHER, anti-rattle		2
60	458-700	\$59.99	BRACKET, curved handle	RD to April 1972	2
	458-705	\$15.99	BRACKET, flat handle		GT to April 1972
63	458-716	\$29.99	PIVOT PIN, bottom	RD from April 1972	2
	458-717	NA	PIVOT PIN, bottom		2
	458-710	\$14.99	PIVOT PIN, bottom	GT from April 1972	2
	458-715	\$21.99	PIVOT PIN, bottom		2
64	329-850	\$1.79	SPRING		2
65	312-000	\$0.49	NUT, pivot pin		2

# Roadster Windshield

No.	Part#	Price (Each)	Description	Application	Qty Req.
68	282-780	\$2.99	SEAL, frame seating, L/H	} RD	1
	282-770	\$2.99	SEAL, frame seating, R/H		1
	324-305	\$1.29	SEAL, frame seating		2
70	312-015	\$2.79	REINFORCEMENT, front	GT	2
71	312-020	\$2.89	REINFORCEMENT, rear		2
73	312-010	\$3.39	NUT, frame to door		4

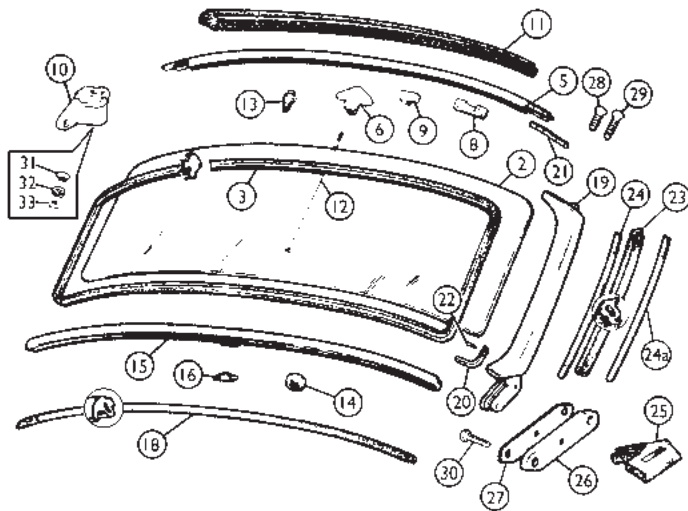

No.	Part#	Price (Each)	Description	Application	Qty Req.
24	408-030	\$8.49	RETAINER, pillar seal		2
24a	408-035	\$4.89	INNER SEAL RETAINER		2
25	282-450	\$2.99	GROMMET, L/H, pillar to body		1
	282-460	\$2.99	GROMMET, R/H, pillar to body		1
26	408-070	\$28.99	PACKING, outer (aluminum), pillar to body		2
27	408-060	\$12.49	PACKING, inner (fiber), pillar to body		2
28	408-056	\$0.59	SCREW, short, top rail to pillar		4
29	408-057	\$0.39	SCREW, long, top rail to pillar		2
30	117-022	\$0.79	BOLT, pillar to body		4
	322-946	\$0.79	SCREW, packing to body		2
31	324-175	\$0.69	CUP WASHER, visor mounting	} RD	2
32	324-185	\$0.39	SPRING WASHER, visor mounting		2
33	310-830	\$0.69	NUT, visor mounting		2



### Sun Visor Kit

Sun visors were a factory option from 1962 through 1967, and these kits are intended for those of you with cars not so equipped. Includes two black vinyl visors and all necessary brackets and hardware. Fits Roadster only (not GT).

**224-108 \$94.99**

See complete sunvisor listing on page 104.

### Roadster Windshield

19854

No.	Part#	Price (Each)	Description	Application	Qty Req.	
<b>Underlined part numbers</b> indicate an Oversize Parts Fee will be charged. See <a href="http://mossmotors.com">mossmotors.com</a> or call for details.						
	472-600	NA	WINDSHIELD ASSEMBLY, complete	RD to (c)306515	1	
	472-610	NA	WINDSHIELD ASSEMBLY, complete	RD from (c)306516 on	1	
2	<u>458-345</u>	\$549.99	GLASS, windshield, clear, Triplex brand, orig.*	} RD	1	
	<u>458-365</u>	\$549.99	GLASS, windshield, clear, Triplex, modified*		1	
	<u>458-375</u>	\$549.99	GLASS, windshield, tinted, Triplex, modified*		1	
	<u>458-810</u>	NA	GLASS, windshield, clear, aftermarket, orig.*		1	
	<u>458-815</u>	\$199.99	GLASS, windshield, tinted, aftermarket, orig.*		1	
**orig** = original style rounded corners						
*modified* = slightly recessed corners to minimise breakage						
3	282-420	\$19.99	GLAZING RUBBER, windshield		1	
5	453-270	NA	TOP RAIL	RD to (c)187210	1	
	453-275	NA	TOP RAIL	RD from (c)187211 on	1	
6	472-410	NA	BRACKET, center rod	RD to (c)187210	1	
	472-415	NA	BRACKET, center rod	RD from (c)187211 on	1	
8	472-620	NA	BRACKET, soft top latch		2	
9	233-930	\$1.59	ANCHOR, sun visor		2	
10	233-921	NA	BRACKET, sun visor pivot	RD to (c)410000	2	
	233-925	\$15.99	BRACKET, sun visor pivot	RD from (c)410001 on	2	
	314-280	\$0.99	SCREW, sunvisor mountings	replaces orig. rivets	12	
11	453-610	\$9.99	SEAL, on header rail		1	
12	472-420	\$18.79	CENTER ROD	RD to (c)138400	1	
	472-425	\$7.99	CENTER ROD	RD from (c)138401 on	1	
13	472-635	\$4.99	NUT, rod to top bracket	RD to (c)187210	1	
14	310-040	\$0.29	NUT, rod to bottom bracket	RD to (c)138400	1	
	472-640	\$1.39	NUT, rod to bottom bracket	RD from (c)138401 on	1	
15	453-300	NA	BOTTOM RAIL ASSEMBLY	RD to (c)172699	1	
	453-305	NA	BOTTOM RAIL ASSEMBLY	RD from (c)172700 on	1	
16	470-895	\$52.99	BRACKET, center rod	RD to (c)187210	1	
	470-885	\$52.99	BRACKET, center rod	RD from (c)187211 on	1	
17	314-275	\$2.69	SCREW, center rod bracket	1962-67	2	
18	282-410	\$12.99	SEAL, bottom rail to body		1	
19	408-010	NA	PILLAR, L/H	} RD to (c)306515	1	
	408-020	NA	PILLAR, R/H		1	
	408-015	NA	PILLAR, L/H		} RD from (c)306516 on	1
	408-025	NA	PILLAR, R/H			1
20	408-040	\$44.99	BRACKET, L/H, pillar to bottom rail		1	
	408-050	\$44.99	BRACKET, R/H, pillar to bottom rail		1	
21	408-075	NA	BRACKET, R/H, top rail to pillar	rivets to top rail	1	
	408-085	NA	BRACKET, L/H, top rail to pillar	rivets to top rail	1	
22	408-055	\$0.89	SCREW, bracket		8	
23	282-400	\$4.49	SEAL, pillar to ventilator		2	

### MGB Windshield Replacement

Replacing the windshield on an MGB roadster can be completed with a few simple tools and a reasonable amount of patience. Having a good workshop manual is a must (see the color section at the front of this catalog).

Removing the windshield assembly is a simple task. Loosen the two bolts securing the bottom center rod bracket to the dash top. Leave the center rod assembly intact to hold the windshield assembly together. Remove the four bolts securing the windshield pillars to the body. Completely remove the center rod bolts. Withdraw the entire windshield assembly from the car.

Begin dismantling the windshield by removing the rear view mirror and visors. Remove the nuts and washers securing the center rod to its top bracket, and withdraw the rod through the bottom bracket. Unscrew only the outer three screws securing the top rail to each pillar. The long outer screw on each side is a Moss #408-057, the two short inner screws on each side are Moss #408-056.

Peel back the frame to body seal (Moss #282-410) just enough to remove the two screws on either end of the bottom rail. With a soft mallet, gently tap the pillars free of the glass and rails. The top and bottom rails can now be removed. Peel the glazing rubber away from the glass.

Inspect and clean the top and bottom rails. Check the corner brackets on the pillars. Mark the center of the new windshield glass with a crayon so it will be more easily lined up with top and bottom rails.

Place the new glazing rubber (Moss #282-420) around the windshield glass. Inject a bead of windshield sealant into the groove in which the glass sits. Lubricate the outside edge of the glazing strip and the inside of the top and bottom rails with a soapy water solution. Push the top and bottom rails into place slowly.

Fit the side pillars into place. (If the top and bottom rails are not pulled together enough, then temporarily assemble the center rod or use a carpenter's wood clamp to gently ease the rails closer.) If the side pillars balk, try tapping with a soft mallet. Again, be sure to go slowly.

Once all frame members are in alignment, replace the screws in the proper holes. On the top rails, the short screws belong on the two inside holes on either side of the rail and the long screws go in the outermost holes on each side. Attempting to use the wrong screws may easily result in breaking the glass.

With the windshield firmly assembled, scrape off the excess sealant and refit the center rod. Refit the frame to body seal. If replacing this seal (Moss #282-410) is necessary, now is the time to do it. Lubricate the bottom channel with a soapy water mixture and slide the leading edge of the seal into the channel while easing the seal along carefully where it enters the channel. This is a very slow process. Replace old windshield pillar grommets: L/H, Moss #282-450; R/H, Moss #282-460.

Apply a bead of sealant to the top of the grommets before sliding them into place on the pillars. Apply another bead of sealant to the bottom of each grommet and along the flap of the frame to body seal. Ease the windshield assembly back onto the body.

The windshield should not be forced into place; it is better to let it sit overnight to compress the new rubber seals. Tighten the pillar bolts one at a time while checking and adjusting the fit to the door vent windows. Once in place, recheck the fit to the vent windows and top. Check the seals between the pillar and vent windows and top. Replace if necessary with two of Moss #282-400.

Finally, refit the mirror and visors. If done properly, the roadster windshield should now be draft and leak-proof. A good source of information about MGB restoration is Lindsay Porter's MGB Guide to Purchase and D.I.Y. Restoration, Moss #211-365.

Toll-Free Orders 1-800-667-7872 | [MossMotors.com](http://MossMotors.com)  
Fax 805-692-2525 | Local 805-681-3400

**MOSS**

# Chrome Bumpers

## Chrome Bumpers 1962-'74 1/2 RD/GT from (c)101 to 360300

19856

No.	Part#	Price (Each)	Description	Application	Qty Req.
1	453-090	\$299.99	FRONT BUMPER BAR		1
2	454-310	\$99.99	OVERRIDER, front bumper	} RD to (c)187210, GT to (c)187840, 1962 - '69	2
3	322-075	\$1.09	BOLT, ft. overrider		2
4	454-315	\$74.99	OVERRIDER, front	} RD from (c)187211 to 339094, GT from (c)187841 to 339471, 1970 - '74	2
5	454-375	\$4.99	BUFFER, overrider		2
6	454-345	NA	OVERRIDER, L/H	} RD from (c)339095 to 360300, GT from (c)339472 to 361100, mid 1974	1
	454-355	NA	OVERRIDER, R/H		1
7	475-270	NA	BRACKET, L/H, overrider		1
	475-275	NA	BRACKET, R/H, overrider		1
8	322-075	\$1.09	BOLT, ft. overrider		4
11	472-200	\$4.49	BRACKET, outer	} incl. in front bumper hardware kit #65	2
12	472-205	\$1.39	PAD, outer bracket		2
13	321-938	\$10.99	MOUNTING KIT, front spring brackets to car		1
14	472-210	\$15.99	SPRING BRACKET, L/H, front	} RD to (c)339094, GT to (c)339471 (to early '74)	1
	472-220	\$15.99	SPRING BRACKET, R/H, front		1
	472-215	NA	SPRING BRACKET, L/H, front	} RD (c)339095 to 360300, GT (c)339472 to 361100	1
	472-225	NA	SPRING BRACKET, R/H, front		1
16	475-280	\$2.19	SPACER (to early '74 uses 6; mid '74 uses 2)		6/2
17	322-900	\$2.69	BOLT & NUT, bar to bracket	} RD to (c)339094, GT to (c)339471 (to early '74)	2
	310-050	\$0.69	NUT		2
18	322-900	\$2.69	BOLT & NUT, bar to spring bracket		2
20	475-295	NA	SPACER, behind overrider	} RD (c)339095 to 360300, GT (c)339472 to 361100	2
21	475-290	NA	SPACER, spring bracket		2
25	453-100	\$339.99	REAR BUMPER BAR		1
26	454-320	\$89.99	OVERRIDER, L/H, rear	} RD to (c)187210, GT to (c)187840, 1962 - '69	1
	454-330	\$89.99	OVERRIDER, R/H, rear		1
28	472-340	\$12.89	SPRING BRACKET		2
35	454-380	NA	BUMPER BAR, L/H	} RD from (c)187211 to 219000, GT from (c)187841 to 219000, approx. 1970	1
36	454-390	NA	BUMPER BAR, R/H		1
37	454-315	\$74.99	OVERRIDER		2
38	454-375	\$4.99	BUFFER		2
39	472-235	NA	SPRING BRACKET		2
42	453-100	\$339.99	REAR BUMPER BAR		1
43	453-105	\$94.99	OVERRIDER, L/H	} RD from (c)219001 to 339094, GT from (c)219001 to 339471, 1971 - early '74	1
	453-115	\$94.99	OVERRIDER, R/H		1
45	454-375	\$4.99	BUFFER		2
46	472-340	\$12.89	SPRING BRACKET		2
50	454-400	NA	REAR BUMPER BAR	} RD from (c)339095 to 360300, GT from (c)339472 to 361100, mid 1974	1
51	454-345	NA	OVERRIDER, L/H		1
	454-355	NA	OVERRIDER, R/H		1
52	475-275	NA	BRACKET, L/H, overrider		1
	475-270	NA	BRACKET, R/H, overrider	1	
53	472-255	NA	SPRING BRACKET		1
54	472-360	\$4.49	FILLER PLATE, L/H		1
	472-350	\$4.49	FILLER PLATE, R/H		1
55	317-045	\$0.69	FIX NUT		6
56	314-095	\$0.79	SCREW		6
57	475-280	\$2.19	SPACER		4
58	322-900	\$2.69	BOLT & NUT, bar to bracket	bumpers no. 25, 35, 42	2
	322-080	\$4.79	BOLT & NUT, bar to bracket	bumper no. 50	2
	310-050	\$0.69	NUT, for bolts		2
59	400-418	\$4.99	PACKING SET, overrider to bar		1
60	322-075	\$1.09	BOLT, front overrider		2
61	320-345	\$0.99	BOLT, rear overrider	all-chrome overriders only	2
62	472-345	\$33.99	MOUNT, rear bracket		2
63	472-347	\$0.39	NUT, rear mount		2

## Complete Bumper Kits (Oversize Parts Fee will be charged for Bumper Kits.) 19857

Each kit contains 1 face bar, 2 overriders, packing, brackets and all necessary spacers, nuts and bolts. All bumper kits are interchangeable. (No kit available for 1970 split rear bumper.) Hardware kits include hardware to mount the bumpers to the spring brackets, but do not include the hardware for mounting the spring brackets to the body.

	453-808	\$499.99	FRONT BUMPER KIT, w/all chrome overriders	1
	453-818	\$499.99	FRONT BUMPER KIT, w/rubber tip overriders	1
65	321-908	\$45.99	HARDWARE KIT, front bumpers	1
	453-828	\$549.99	REAR BUMPER KIT, w/all chrome overriders	1
	453-838	\$549.99	REAR BUMPER KIT, w/rubber tip overriders	} not for split rear bumpers
66	321-918	\$42.99	HARDWARE KIT, rear bumpers	

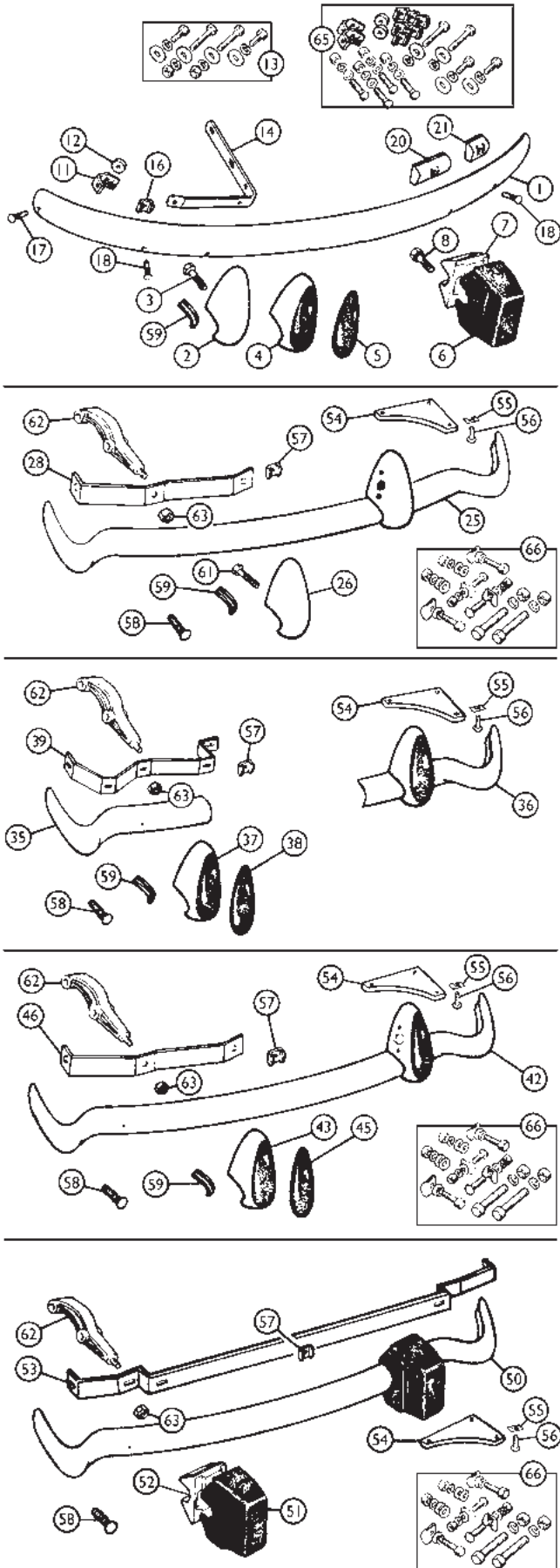

# Rubber Bumpers & Grilles

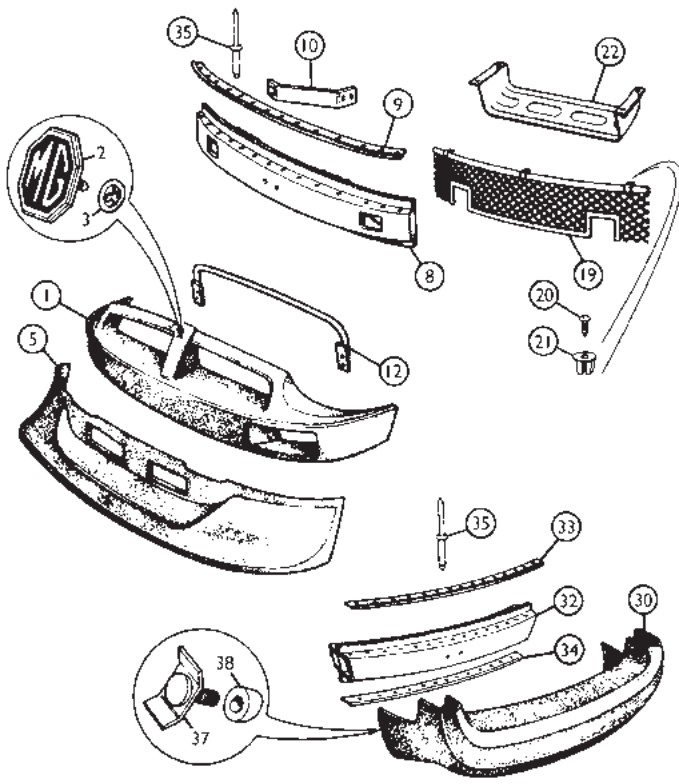

## Rubber Bumpers 1974 1/2 - 1980

RD from (c)360301 on / GT from (c)361101 on

19859

No.	Part#	Price (Each)	Description	Application	Qty Req.
1	475-100	NA	FRONT BUMPER, rubber	British Motor Heritage	1
2	475-165	\$24.99	BADGE, silver letters on black	late style	1
	475-170	\$35.99	BADGE, gold letters on black	50th anniversary style	1
	475-175	NA	BADGE, silver letters on red	early style	1
3	326-530	\$0.29	CLIP, badge fixing		2
5	475-180	\$259.99	AIR DAM, BL factory option		1
8	475-105	NA	ARMATURE, front bumper		1
9	475-110	\$49.99	CLAMPING PLATE, armature (upper & lower)		2
10	475-115	NA	SPRING BRACKET, L/H		1
	475-125	NA	SPRING BRACKET, R/H		1
12	475-120	\$89.99	SUPPORT BAR, bumper		1
	475-130	\$3.99	STUD, armature to body		5
	324-860	\$0.19	WASHER, plain		13
	324-040	\$0.39	WASHER, spring		25
	310-050	\$0.69	NUT		9
	475-150	\$1.39	BOLT, armature to spring & body		8
	475-155	NA	WASHER, plain, armature		4
	324-655	\$0.59	WASHER, plain, body		4
19	475-260	\$63.49	GRILLE ASSEMBLY, black		1
20	314-070	\$0.59	SCREW		3
21	117-051	\$0.89	CAPTIVE NUT, nylon		3
22	475-245	\$97.99	PANEL, air duct, lower	RD from (c)360301 to 410000	1
	475-255	\$79.99	PANEL, air duct, lower	RD from (c)410001 on	1
30	475-200	\$1,299.00	COVER, rear bumper, rubber	British Motor Heritage	1
32	475-205	NA	ARMATURE, bumper		1
33	475-210	\$64.99	CLAMPING PLATE, upper		1
34	475-215	\$68.99	CLAMPING PLATE, lower		1
35	326-195	NA	RIVET, clamping plates		A/R
37	475-220	\$7.19	SIDE BRACKET		2
38	475-225	\$3.69	DISTANCE PIECE		4
	365-720	\$0.79	WASHER, plain		2
	365-730	\$0.39	WASHER, spring	used w/475-215, 475-220	2
	310-140	\$0.39	NUT		2

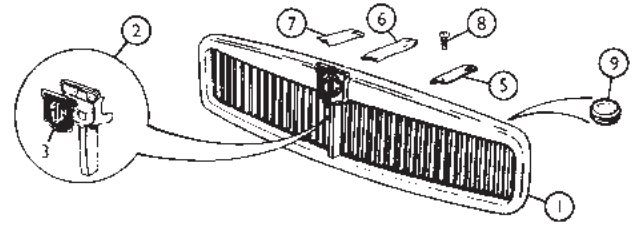

## Grille 1962 - 1969

RD to (c)187210 / GT to (c)187840

19858

No.	Part#	Price (Each)	Description	Application	Qty Req.
1	454-140	\$389.99	GRILLE ASSEMBLY, complete	Classic Gold brand	1
2	202-072	\$56.99	PLINTH & BADGE		1
3	201-050	\$21.29	BADGE, black & red		1
	400-126	\$10.69	BRACKET SET		1
5	400-135	NA	BRACKET, L/H		1
6	400-125	NA	BRACKET, center		1
7	400-115	NA	BRACKET, R/H		1
8	323-005	\$0.39	SCREW, brackets to slam panel		3
	472-507	\$1.09	SCREW, brackets to grille		3

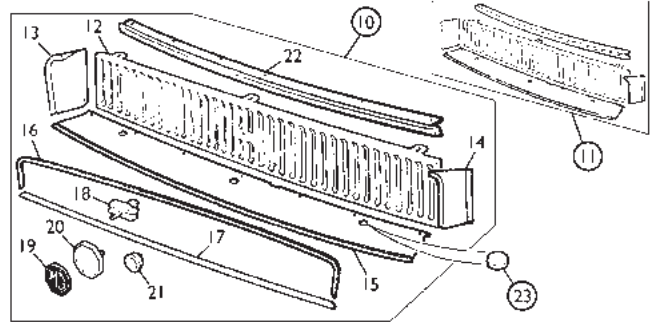

## Grille 1970 - 1972

RD from (c)187211 to 294250 / GT from (c)187841 to 296000

19860

10	455-308	NA	GRILLE ASSEMBLY, complete	black grille	1
11	455-295	NA	GRILLE ASSEMBLY, partial	(#12 thru 15)	1
12	455-300	NA	GRILLE, black (British Motor Heritage)		1
13	455-310	NA	FINISHER, R/H, grille bay		1
14	455-320	NA	FINISHER, L/H, grille bay		1
15	455-305	NA	FINISHER, bottom, grille bay		1
16	455-315	\$37.99	GRILLE STRIP, upper		1
17	455-325	\$22.99	GRILLE STRIP, lower		1
18	455-330	\$0.89	CLIP, grille strip		12
19	201-060	\$18.99	BADGE		1
20	201-065	NA	BEZEL, badge		1
21	201-075	\$1.49	FASTENER, bezel		1
22	455-335	NA	FINISHER, top, hood front edge		1
23	682-075	\$0.89	PLUG in #15		3

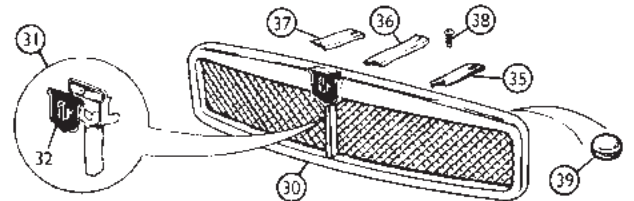

## Grille 1973 - 1974 1/2

RD from (c)294251 to 360300 / GT from (c)296001 to 361000

19861

30	455-340	\$389.99	GRILLE ASSEMBLY, complete	Classic Gold brand	1
31	201-080	\$79.99	HOUSING & BADGE		1
32	201-070	\$21.49	BADGE, red & silver		1
	400-126	\$10.69	BRACKET SET		1
35	400-135	NA	BRACKET, L/H		1
36	400-125	NA	BRACKET, center		1
37	400-115	NA	BRACKET, R/H		1
38	323-005	\$0.39	SCREW, brackets to slam panel		3
	472-507	\$1.09	SCREW, brackets to grille		3
39	282-605	\$2.69	BUFFER, hood to grille		2

All three styles of chrome-bumpered grilles are interchangeable. Replacing the 1970-'72 style would likely require that the front end be repainted due to paint damage caused by the original grille finishers.

# Front Body Fittings

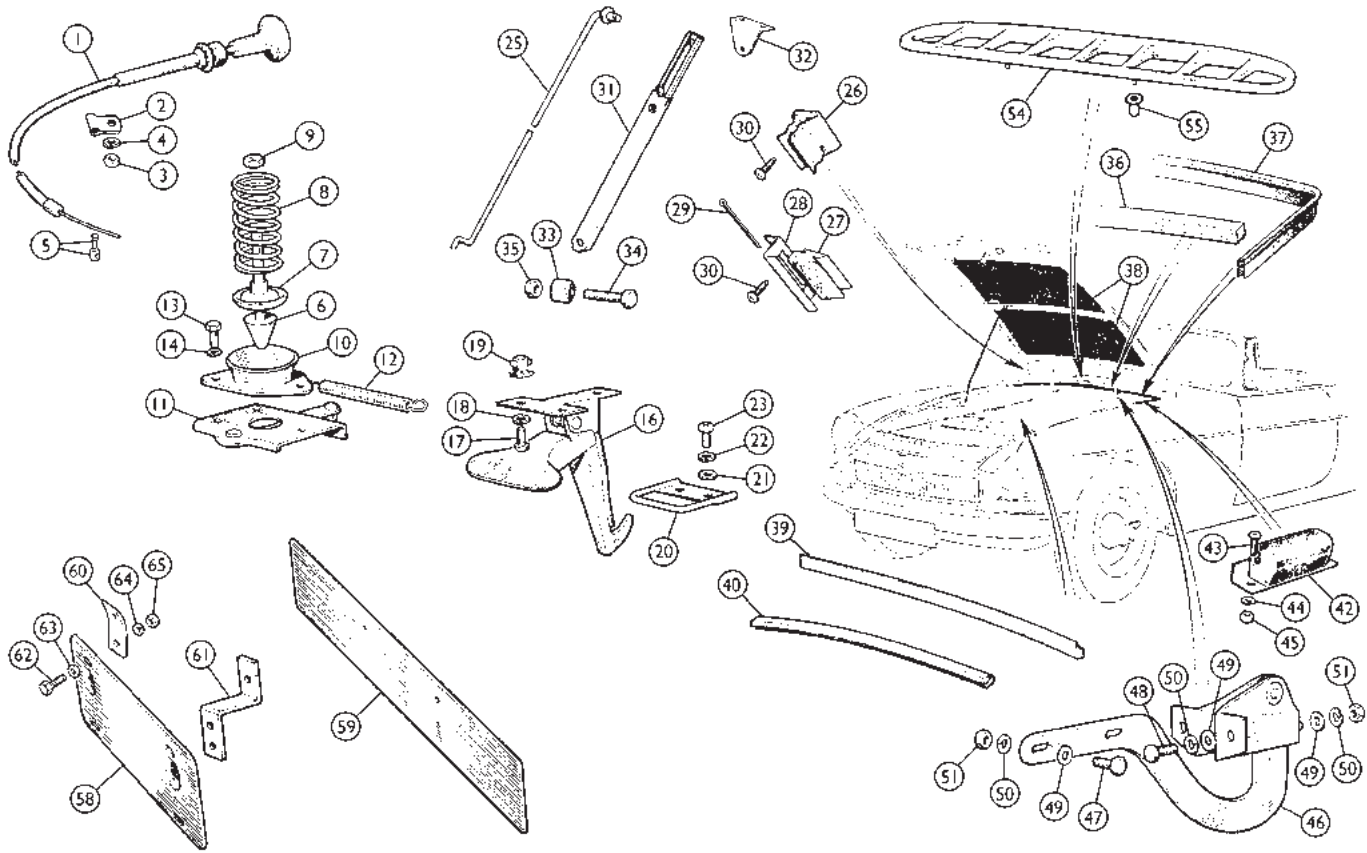

## Front Body Fittings

19862

No.	Part#	Price (Each)	Description	Application	Qty Req.
1	406-029	\$26.99	CABLE, hood release, round knob w/ "B"	thru 1969	1
	406-030	\$17.99	CABLE, hood release, "T" handle	from 1970-on	1
Change point is theoretical - cars as late as 1974 have been reported with round knob.					
2	182-635	\$1.39	CLIP, cable		3
3	848-540	\$0.29	NUT, cable clip		2
4	324-030	\$0.29	LOCKWASHER		2
5	406-040	\$1.69	TRUNNION & SCREW, cable		1
6	406-000	\$8.79	PIN, hood lock		1
7	406-055	\$8.99	THIMBLE, hood lock pin, BMH		1
8	406-060	\$2.99	SPRING, hood lock pin		1
9	310-070	\$0.39	NUT		1
10	406-065	\$14.89	GUIDE PLATE		1
11	406-015	\$109.99	CATCH PLATE, to 1974 1/2	RD/GT to (c)360300	1
	406-025	NA	CATCH PLATE, 1974 1/2 on	RD/GT from (c)360301 on	1
12	406-035	\$4.99	SPRING, catch return		1
13	322-170	\$0.49	BOLT		3
14	324-855	\$0.19	LOCKWASHER		3
16	406-010	\$38.99	SAFETY CATCH, hood		1
	406-035	\$4.99	SPRING, safety catch		1
17	323-005	\$0.39	SCREW		3
18	324-010	\$0.19	LOCKWASHER		3
	NA		CAPTIVE NUT		3
20	406-020	\$6.39	BRACKET, safety catch		1
21	324-990	\$0.39	WASHER		2
22	324-010	\$0.19	LOCKWASHER		2
23	323-005	\$0.39	SCREW		2
25	457-470	\$24.99	HOOD PROP, rod type	{ RD/GT to (c)219000 ('62-'70)	1
				RD to (b)11240	1
26	471-130	\$5.29	CLIP, prop rod		1
27	282-350	\$1.29	RUBBER GRIP, prop rod	RD from (b)11241	1
28	406-075	\$11.99	BRACKET for rubber grip	thru (c)219000, GT to (c)219000	1
29	325-440	\$0.39	COTTER PIN, grip retaining		1
30	323-705	\$0.59	SCREW for #26, 28 above		2
31	457-445	\$49.99	HOOD PROP, telescopic (stock type)		1
	457-535	\$48.99	HOOD PROP, automatic type (aftermarket)		1
32	457-455	\$16.69	BRACKET, hood prop (on hood)	RD/GT from (c)219001 on (1971-on)	1
33	457-460	\$3.49	SPACER		1
34	322-247	\$0.49	BOLT		2
35	310-765	\$1.29	NUT		2

No.	Part#	Price (Each)	Description	Application	Qty Req.
36	282-810	\$2.19	SEAL, hood to channel	1962-approx. '74	1
37	282-815	\$10.99	SEAL, hood to flange	1968 on	1
Seal #37 is the later type which clips over the flange, and does not use the rivets and cup washers used by the earlier type, which has not been available for many years. It goes around the back, and forward only a few inches on either side.					
38	409-008	\$54.99	INSULATING PAD SET		1
Hood insulating pad sets are often missing, but significantly reduce engine noise and valve clatter, particularly in an open car. These are easy to install with our aerosol upholstery adhesive, #409-036.					
39	282-900	\$4.89	SEAL, radiator support to hood	1962-'76	1
40	282-905	\$5.79	SEAL, radiator to support	1968-'76	1
42	282-600	\$1.99	HOOD BUFFER		4/2
43	314-010	\$0.24	SCREW	4 buffers thru 1967, 2 buffers 1968 on	8/4
44	324-010	\$0.19	LOCKWASHER		8/4
45	310-040	\$0.29	NUT		8/4
46	405-410	\$96.99	HOOD HINGE, BMH		2
47	322-230	\$0.39	BOLT, hinge to hood		4
48	322-645	\$0.49	BOLT, hinge to body		4
49	324-590	\$0.19	WASHER		10
50	324-855	\$0.19	LOCKWASHER		10
51	310-760	\$0.59	NUT		10
54	471-020	\$34.99	GRILLE, air intake		1
55	326-665	\$0.49	BLIND FIX		6
58	451-285	\$16.99	SUPPORT, front licence plate	USA type	1
59	451-720	\$15.49	SUPPORT, front licence plate	non-USA type	1
60	402-560	\$4.49	BRACKET, support, front	RD/GT to (c)368081	2
61	402-570	\$8.99	BRACKET, support, front	{ RD from (c)368082 to 384318	2
62	322-645	\$0.49	BOLT		4
63	324-590	\$0.19	WASHER		4
64	324-855	\$0.19	LOCKWASHER		4
65	310-760	\$0.59	NUT		4

## Intake Grille Mesh

This wire mesh accessory keeps debris out of the fresh air box and significantly reduces rust problems in this area. Every MGB will benefit considerably from this inexpensive item!

**471-025 \$8.99**

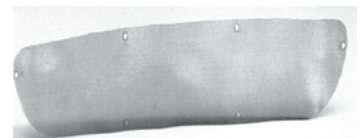

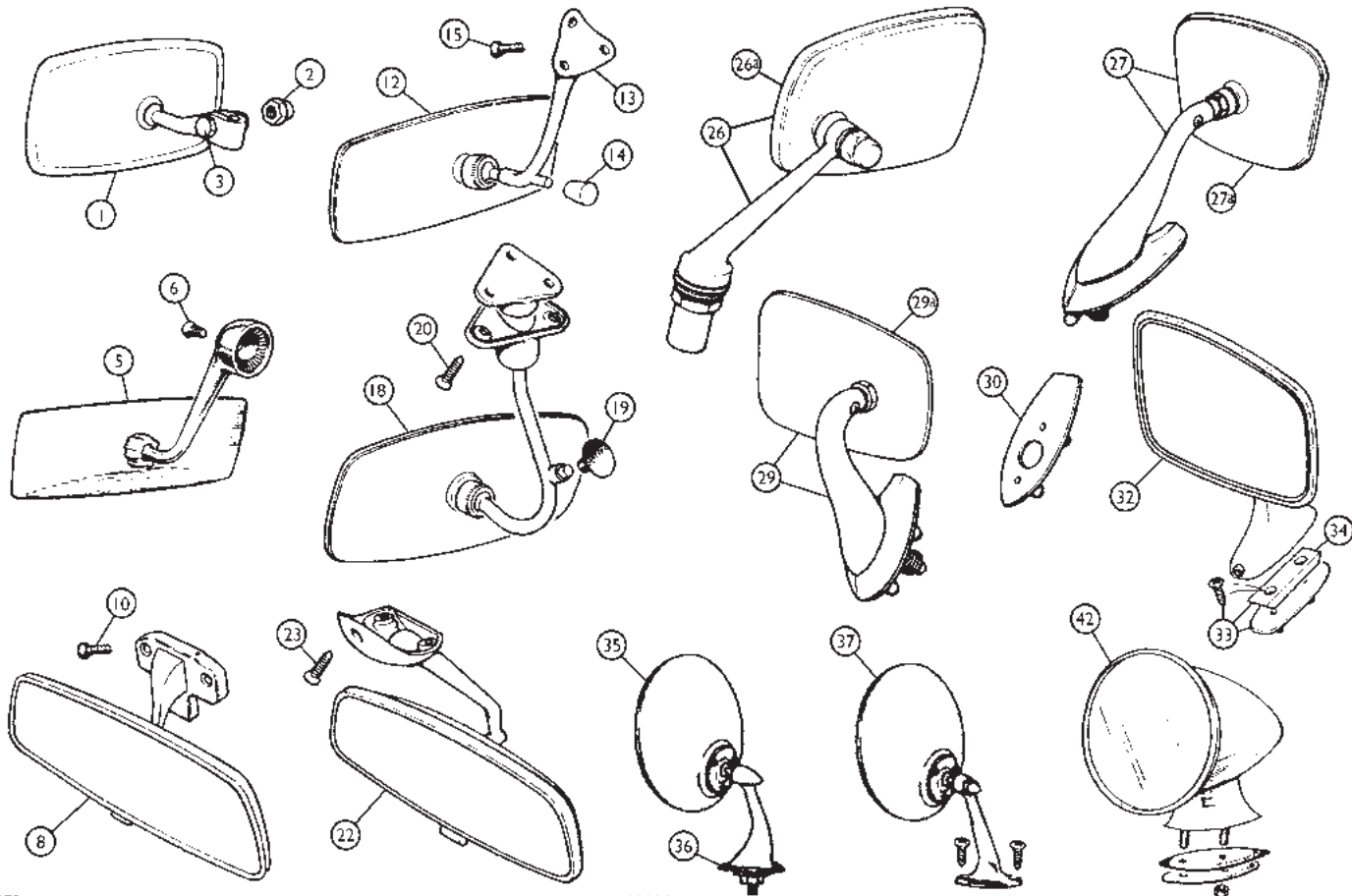

## Mirrors

19864

No.	Part#	Price (Each)	Description	Application	Qty Req.
1	165-110	\$44.99	MIRROR, interior	Roadster 1962-'67	1
2	311-045	\$1.39	DOME NUT		1
3	NA		BOLT		1
5	NA		MIRROR, interior	Roadster 1968-'69	1
6	NA		SCREW, nylon		1
This mirror secures to the top of the windshield with a plastic "safety" screw. These mirrors are obsolete, and are unlikely to be reproduced. The earlier mirror may be easily fitted, and looks appropriate.					
8	165-115	\$42.99	MIRROR, interior	Roadster 1970-'80	1
	165-245	\$28.99	MIRROR HEAD		1
	323-645	\$0.39	SCREW		1
10	472-507	\$1.09	SCREW, mirror mounting		2
12	NA		MIRROR, interior	GT thru 1967	1
	165-120	NA	MIRROR HEAD		1
13	165-240	NA	BRACKET		1
14	NA		PAD, buffer		1
15	314-180	\$0.89	SCREW, chrome		3
18	165-230	NA	MIRROR, interior	GT 1968-'69	1
	165-235	NA	MIRROR HEAD		1
19	116-036	\$12.99	SUCTION CUP		1
20	314-180	\$0.89	SCREW, chrome		3
22	165-125	NA	MIRROR, interior	GT 1970-on	1
	165-245	\$28.99	MIRROR HEAD		1
23	472-507	\$1.09	SCREW, mirror mounting		3
26	165-260	\$89.99	FENDER MIRROR, LH/RH	factory option	A/R
26a	165-261	\$46.99	MIRROR HEAD, "TEX"	1962-'67	A/R
Replacement, similar in appearance to original, but with 1974-'80 mirror head. This was a factory option before mirrors were fitted as standard. Originally fitted on the driver's side only.					
27	165-130	NA	DOOR MIRROR, L/H only	1968-'71 Suggest	1
27a	165-237	NA	MIRROR HEAD	1972-'73 mirrors	1
29	165-228	\$99.99	DOOR MIRROR, L/H	1972-'73	1
	165-258	\$99.99	DOOR MIRROR, R/H		1
29a	165-239	\$59.99	MIRROR HEAD, "TEX"		2
30	165-255	\$11.99	BASE PAD, plastic, "TEX" mirrors #27 & 29		A/R

32	165-135	\$74.99	DOOR MIRROR, stainless steel, L/H, flat, "TEX"	1974-'80	1
	165-170	\$74.99	DOOR MIRROR, stainless steel, R/H, flat, "TEX"		1
	165-181	\$69.99	DOOR MIRROR, stainless steel L/H, convex, "TEX"		1
	165-186	\$69.99	DOOR MIRROR, stainless steel R/H, convex, "TEX"		1
	165-190	\$69.99	DOOR MIRROR, black, L/H, flat, "TEX"		1
	165-195	\$69.99	DOOR MIRROR, black, R/H, flat, "TEX"		1
33	165-145	\$14.99	BASE KIT, plastic, 1-1/2" hole spacing, "TEX"		A/R
34	165-165	NA	MOUNTING PLATE (plastic)		A/R
	165-183	\$13.99	GLASS MIRROR only, flat, "TEX"		A/R
	165-182	\$13.99	GLASS MIRROR only, convex, "TEX"		A/R
35	165-210	\$42.99	FENDER MIRROR, R/H, convex	Lucas style	1
	165-300	\$42.99	FENDER MIRROR, L/H, convex		1
	165-400	\$42.99	FENDER MIRROR, R/H, flat		1
	165-500	\$42.99	FENDER MIRROR, L/H, flat		1
36	280-140	\$2.89	PAD, rubber		1
37	223-310	\$56.99	DOOR MIRROR, flat	period accessory	A/R
42	222-372	\$54.99	"BULLET" MIRROR, 3.5" diameter		A/R

(This mirror has 2 bases - one with 1" hole spacing, one with 3.5" spacing.)

### Raydyot Racing Mirrors

From the 1950s through the 1970s Raydyot's aerodynamic racing mirrors were a common fixture on British sports cars. Made of lightweight aluminum, our American made reproductions are sturdily constructed and have a "brushed" finish as original.

222-355 \$54.99



# Inner Body Fittings

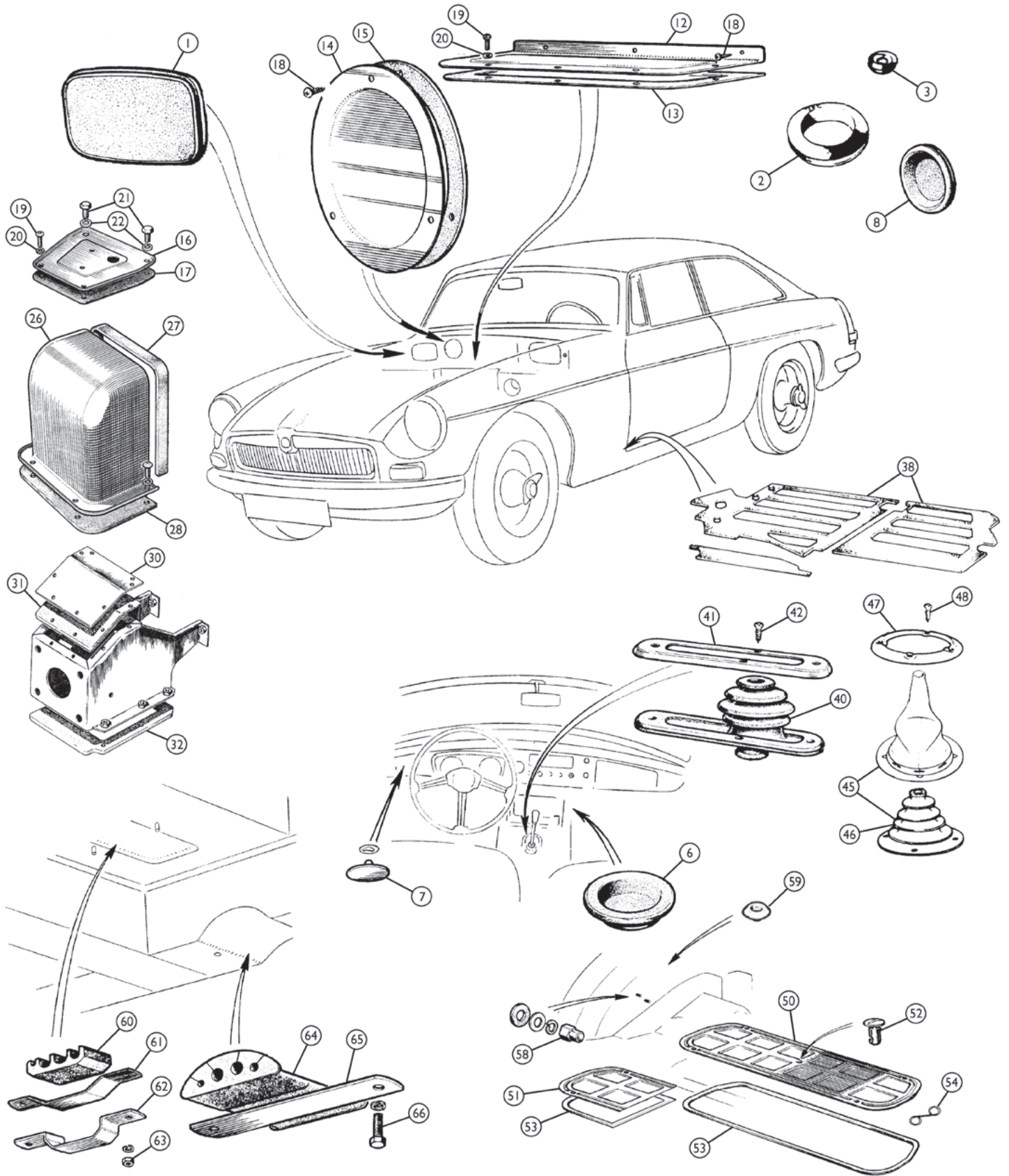



**Inner Body Fittings**

19866

No.	Part#	Price (Each)	Description	Application	Qty Req.
1	282-970	\$3.49	PLUG, firewall		2
2	682-205	\$3.89	GROMMET, firewall, wiring harness	1-3/4"x1/2"	1
3	282-640	\$1.49	GROMMET, heater cable, w/shield washer tube	1"x1/8"	A/R
	282-385	\$1.49	GROMMET, license lamp wires	9/16"x3/16"	2
	281-890	\$5.59	GROMMET, oil gauge pipe & heater cable early	1/2"x3/16"	2
	680-630	\$1.19	GROMMET, oil gauge pipe late	1"x1/8"	1
	281-900	\$2.19	GROMMET, speedo. & mechanical tach. Cable	5/8"x3/8"	2/1
	682-480	\$1.59	GROMMET, defroster control cable	5/8"x1/4"	1
	282-655	NA	GROMMET, trunk, wiring harness		1
6	282-980	\$2.79	PLUG, gearbox dipstick access		1
7	233-840	NA	PLUG, switch hole (when overdrive or heater not fitted)		A/R
8	282-990	\$1.69	RUBBER PLUG, steering column blanking	early, 1.5"	1
	282-960	\$1.59	PLASTIC PLUG, steering column blanking	late, 1.5"	1
	282-990	\$1.69	RUBBER PLUG, 1.5", shock access	early	1
	282-960	\$1.59	PLASTIC PLUG, 1.5", shock access	late	2
	282-995	\$1.19	PLASTIC PLUG, 1", door hinges & rear floor		6
	282-935	\$0.99	PLASTIC PLUG, 3/4"		A/R
	282-915	\$0.99	PLASTIC PLUG, 3/8"		A/R
	282-925	\$0.79	PLASTIC PLUG, 5/8"		A/R
	472-735	\$0.59	RUBBER BLANKING PLUG, 1/4"		A/R
12	363-260	\$89.99	BLANKING PLATE, heater shelf		1
13	363-210	\$4.99	SEAL		1
14	363-250	\$35.99	BLANKING PLATE, heater duct		1
15	363-255	NA	GASKET		1
16	190-760	\$21.99	BLANKING PLATE, pedal aperture	thru 1974-1/2	1
17	281-880	\$2.39	SEAL, blanking plate		1
18	322-205	\$0.29	SCREW, self-tapping		A/R
19	373-960	\$0.20	MACHINE SCREW, blanking & cover plates		A/R
20	324-010	\$0.19	LOCKWASHER		2
21	320-990	\$1.99	BOLT		2
22	324-020	\$0.20	LOCKWASHER		2
26	190-740	\$229.99	COVER, pedal box	1962-'67	1
	190-750	NA	COVER, pedal box	1967-'74 1/2	1
27	281-850	\$1.29	SEAL, pedal box end		1
28	281-860	\$1.09	SEAL, pedal box base	1962-'74 1/2	1
30	NA		COVER, pedal box (servo)		1
31	281-885	\$1.99	SEAL, pedal box top	1975-'80	1
32	NA		SEAL, pedal box base	1975	1
	281-895	\$2.69	SEAL, pedal box base	1976-'80	1
38	409-128	\$229.99	SOUND DEADENING KIT, floor		1
Note: 1968-'80 MGBs, this sound deadening kit will fit earlier cars, with slight cutting required. These are the same pads fitted to the British Motor Heritage new MGB body shells. The asphalt based material is easily applied to clean floorboards.					
40	282-340	\$8.79	SHIFT BOOT, rubber		1
	228-370	\$39.99	SHIFT BOOT, leather (option)	1962-'67	1
41	443-120	\$19.99	RETAINER, shift boot		1
42	323-555	\$0.99	SCREW, chrome		4
45	282-880	\$34.99	SHIFT BOOT, black vinyl		1
	228-368	\$42.99	SHIFT BOOT, black leather (option)		1
	228-365	\$42.99	SHIFT BOOT, tan leather (option)	1968-'80 see note below	1
	228-366	\$42.99	SHIFT BOOT, honey tan leather (option)		1
	228-367	\$42.99	SHIFT BOOT, red leather (option)		1
46	282-890	\$7.49	GROMMET, rubber		1
Note: 1968-'72 MGBs were originally fitted with the rubber boot 282-890 only, while 1973-'80 cars had a vinyl boot over the rubber one. Either of the later type 2-piece boots listed may be fitted to 1968-'72 models.					
47	443-115	\$9.99	RETAINER, chrome	1968-early '76	1
	443-125	\$9.99	RETAINER, black	early 1976-'80	1
48	323-565	\$1.39	SCREW	1968-'72 (no console)	4
	323-175	\$1.39	SCREW, long		3
	323-565	\$1.39	SCREW, short	1973-'80 w/console	1
50	456-270	\$106.99	BATTERY COVER	chrome bumpered cars	1
51	456-275	\$74.99	BATTERY COVER (Brit. Motor Heritage)	rubber bumpered cars	1
52	226-640	\$10.99	DZUS FASTENER		5
53	282-500	\$2.99	SEAL, battery cover	(all)	1
54	470-720	\$4.99	SPRING for Dzus fasteners		5
58	402-550	\$3.89	DOME NUT, chrome	as fitted	4
59	222-186	\$3.19	BLANKING PLUG, seat belt		2
60	282-165	\$1.89	GROMMET, underbody, small		4
61	405-565	\$3.99	STRAP, retaining	1962-'67(4), '68-'80(3)	4/3
62	405-575	\$4.59	STRAP, retaining	1968-'80	1
63	310-760	\$0.59	NUT		8
64	282-280	\$16.89	GROMMET, underbody, large		1
65	405-585	\$3.39	STRAP, retaining		1
66	322-040	\$0.59	BOLT		2

Toll-Free Orders 1-800-667-7872 | MossMotors.com  
 Fax 805-692-2525 | Local 805-681-3400



**Inner Body Fittings**



**Sound and Heat Control Insulation**  
 Install on doors, floors, and firewall. This insulation consists of an 80 mil thick butyl rubber core covered by a 2.4 mil aluminum coating. It deadens body panel vibrations, and reduces heat transfer. The kit includes nine 29" x 20" sheets.

**409-027 \$159.99**

**Heatshield Material**

This foil covered insulation, reduces unwanted heat, cold and sound inside the vehicle when installed under carpets, over the transmission tunnel, and against the firewall. The closed cell insulating material has a layer of foil on both sides, and will not absorb moisture like it's jute or cotton counterparts. Being lightweight and easily managed, it is sold in 4' x 6' sheets which can be cut to fit with just scissors or a sharp knife.



**409-016 \$41.99**



**Contact Adhesive**

The high temperature adhesive is specially designed for use on heat shield applications. Bonds to carpet, headlining material, fiberglass, plastic, wood and more. 13 oz. aerosol can.

**409-037 \$28.99**

# Rear Body Fittings

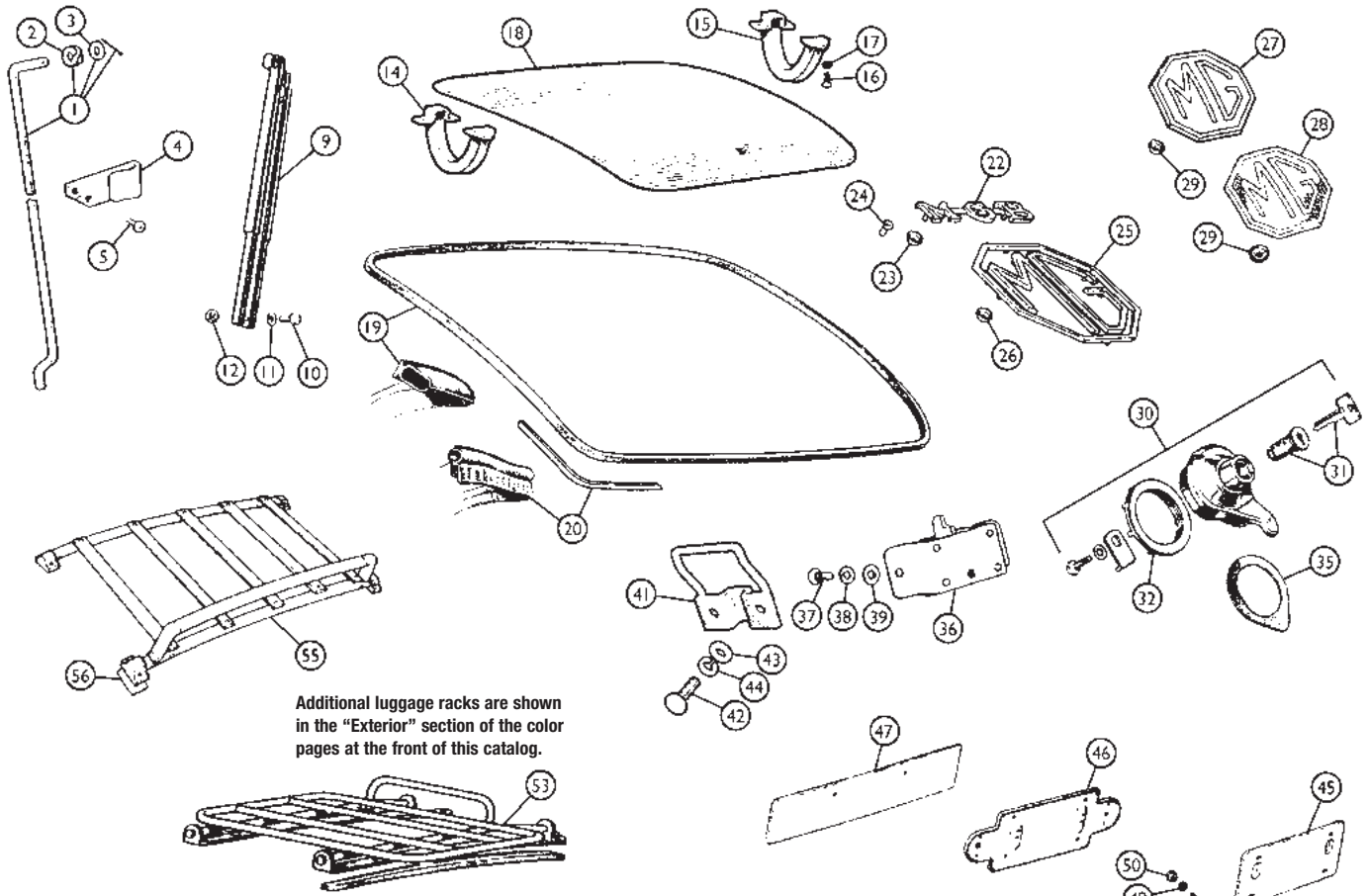

Additional luggage racks are shown in the "Exterior" section of the color pages at the front of this catalog.

## Rear Body Fittings

19870

No.	Part#	Price (Each)	Description	Application	Qty Req.
1	457-480	\$14.99	TRUNK LID PROP, rod type	RD to (c)219000 (thru 1970)	1
2	370-460	\$0.79	SPRING WASHER		1
3	324-590	\$0.19	FLAT WASHER		1
4	457-475	\$6.99	SPRING CLIP, prop rod		1
5	323-430	\$0.59	SCREW, spring clip		2
9	457-465	\$34.99	PROP trunk lid, telescopic	RD from (c)219001 (1971 on)	1
	457-540	\$42.99	PROP, trunk lid, self-triggering*		1
10	322-247	\$0.49	BOLT, trunk lid prop		2
11	324-590	\$0.19	WASHER		2
12	310-765	\$1.29	NUT, self-locking		2
14	405-430	\$104.99	TRUNK HINGE, L/H, BMH	RD	1
15	405-425	\$104.99	TRUNK HINGE, R/H, BMH		1
16	322-645	\$0.49	BOLT, trunk hinge		12
17	324-855	\$0.19	LOCKWASHER		12
18	NA		TRUNK LID - see page 60		1
19	282-480	\$34.99	SEAL, trunk lid, on lid	RD 1962-'76	1
Note: Late trunk seal, #282-475, will work on earlier cars when old seal on the trunk lid is removed.					
20	282-475	\$16.99	SEAL, trunk lid, on body	RD 1977-'80	1
22	408-440	\$5.99	MGB BADGE	RD to (c)394009	1
23	326-500	\$0.29	SPEEDNUT		2
24	326-650	\$0.49	FIX, push-on (alternative to speednut)		2
25	470-698	\$28.99	MG OCTAGON SET, 3 pc. w/speednuts	RD 1962-'69	1
26	326-500	\$0.29	SPEEDNUT		13
27	470-665	\$19.99	MG BADGE, black & silver plastic	RD 1970 to (c)394007	1
28	470-690	\$29.99	MG BADGE, black & silver aluminum	RD from (c)394008	1
29	326-530	\$0.29	FIX, push-on	RD 1970 - on	3
30	402-180	\$119.99	LOCK ASSEMBLY, w/two keys**		1
31	402-500	NA	BARREL, lock w/two keys		1
32	402-510	NA	LOCKING NUT		1
**Note: See pages 66 and 67 for master lock sets.					
35	402-520	\$1.19	SEALING WASHER		1
36	402-530	\$19.99	LATCH ASSEMBLY		1
37	323-005	\$0.39	SCREW		4
38	324-010	\$0.19	LOCKWASHER		4
39	315-085	\$0.29	WASHER		4

No.	Part#	Price (Each)	Description	Application	Qty Req.
41	402-540	\$6.49	STRIKER, lock		1
42	322-230	\$0.39	BOLT		2
43	324-590	\$0.19	WASHER		2
44	324-855	\$0.19	LOCKWASHER		2
45	451-285	\$16.99	SUPPORT, license plate	RD to (c)339094, GT to (c)393471	1
46	451-295	\$44.99	SUPPORT, license plate, mild steel	RD from (c)339095, GT from (c)339472	1
	451-296	\$48.99	SUPPORT, license plate, stainless steel		1
47	451-720	\$15.49	SUPPORT, UK number plate		A/R
48	725-190	\$1.39	SCREW		2
49	324-020	\$0.20	LOCKWASHER		2
50	310-760	\$0.59	NUT		2
53	244-712	\$469.99	LUGGAGE RACK, accessory <small>MORE INFO ONLINE</small>		1
Similar to factory option 1962-'74 rack, but with luggage attachment "staples".					
55	244-010	\$299.99	LUGGAGE RACK, factory option (repro.)	approx. 1974-'80	1
56	282-476	\$6.79	MOUNTING PAD, plastic		4



### Trunk Lid Gas Strut

Replace the original telescoping trunk prop on your '71-'80 MGB with this modern type gas strut. Just press the trunk lock and the lid will rise gently to the fully open position all by itself. Instructions and mounting hardware included.

**900-070 \$34.99**

See more trunk and hood struts in the color pages in the "Exterior" section.

# ID Plates/Decals/Stickers

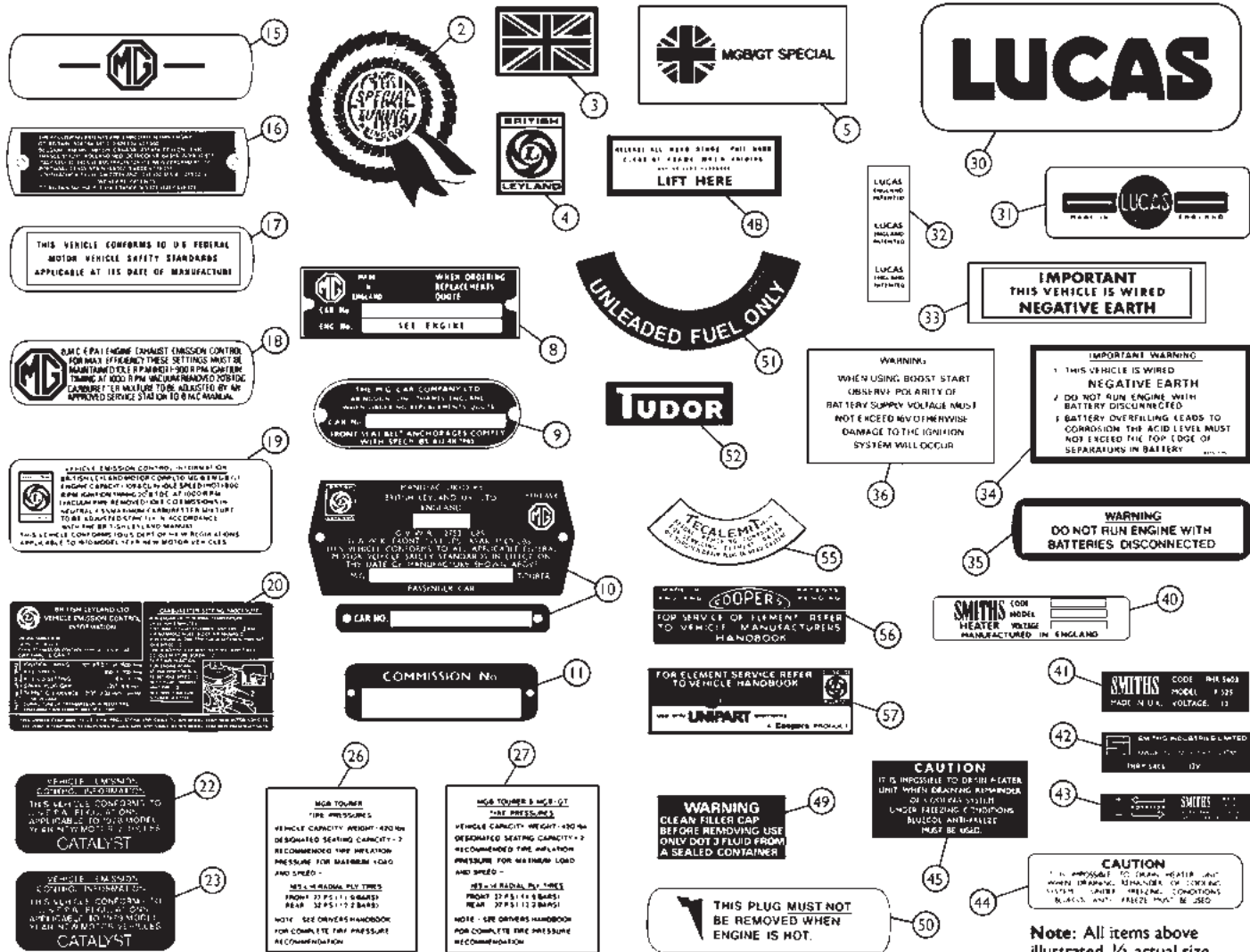

## ID Plates/Decals/Stickers

19873

No.	Part#	Price (Each)	Description	Application	Qty Req.
2	408-505	\$9.79	SPECIAL TUNING DECAL		A/R
3	215-608	\$4.79	UNION JACK DECAL, pair		A/R
4	215-660	\$2.99	BRITISH LEYLAND STICKER		A/R
5	408-480		NA GT SPECIAL EDITION BADGE, pair		A/R
	453-775	\$15.99	"LIMITED EDITION" DASH PLAQUE		A/R
8	408-310	\$8.19	CAR NUMBER PLATE	1962 - '67	1
9	408-320	\$9.99	CAR NUMBER PLATE	1968 - '69	1
10	408-340	\$17.69	CAR NUMBER PLATE, 2 piece set	1970 on	1
11	408-330	\$9.99	COMMISSION NUMBER PLATE	Roadster 1968 - '69	1
	408-335	\$8.79	COMMISSION NUMBER PLATE	Roadster 1970 - '76	1
	408-333	\$8.79	COMMISSION NUMBER PLATE	GT 1965-'70	1
15	408-800	\$4.79	"MG" PLATE, on valve cover	G and GA engines	1
	215-620	\$2.99	"MG" STICKER, on valve cover	GB and V engines	1
16	408-810	\$6.99	PATENT PLATE	G and GA engines	1
17	408-510	\$6.89	FEDERAL COMPLIANCE STICKER		1
18	408-815	\$7.39	INSTRUCTION STICKER		1
19	408-825	\$3.99	EMISSION CONTROL STICKER	1970	1
20	408-859	\$4.19	EMISSION CONTROL STICKER	1979	1
22	408-515	\$6.89	"CATALYST" STICKER	1978	1
23	408-520	\$6.89	"CATALYST" STICKER	1979	1
26	408-525	\$4.79	TIRE PRESSURE STICKER, roadster	1963 - '75	1
	408-590	\$4.79	TIRE PRESSURE STICKER, GT	all	1
27	408-535	\$9.99	TIRE PRESSURE STICKER	1976 on	1
30	215-610	\$17.99	LUCAS BATTERY STICKER		1
31	36-5019		NA LUCAS COIL STICKER		1
32	215-640		NA LUCAS WIRING HARNESS STICKER		1
33	215-650	\$2.99	"NEGATIVE EARTH" STICKER	black/silver, 1" x 4"	1
34	215-655	\$2.99	"NEGATIVE EARTH" STICKER	red/silver, 2" x 4"	1

Toll-Free Orders 1-800-667-7872 | MossMotors.com  
 Fax 805-692-2525 | Local 805-681-3400

MOSS

No.	Part#	Price (Each)	Description	Application	Qty Req.
35	408-540	\$3.49	WARNING STICKER		1
36	408-545	\$5.29	POLARITY WARNING STICKER		1
40	408-350	\$6.99	HEATER NUMBER PLATE		1
41	408-355	\$2.79	HEATER NUMBER STICKER	} as fitted	1
42	408-550	\$2.99	HEATER NUMBER STICKER		1
43	408-345	\$2.79	HEATER MOTOR STICKER		1
44	408-360	\$5.99	HEATER CAUTION PLATE	} as fitted	1
45	408-365	\$4.39	HEATER CAUTION STICKER		1
48	408-555	\$3.59	SOFT TOP LABEL		1
49	408-560	\$8.99	BRAKE SERVO LABEL		1
50	408-565	\$3.49	WARNING LABEL		1
51	408-570	\$4.39	UNLEADED FUEL STICKER		1
52	408-575	\$2.59	W/WASHER WASH BOTTLE STICKER		1
55	215-670	\$3.19	"TECALEMIT" DECAL	canister-type oil filters	1
56	215-615	\$2.49	"COOPERS" LABEL, for air filters	S.U. HS carburetors	2
57	215-680	\$3.29	"UNIPART" LABEL, for air filter	S.U. HIF carburetors.	2
	215-680	\$3.29	"UNIPART" LABEL, for air filter	Zenith-Stromberg carb.	1

## Decal & Plate Sets

19874

These include chassis and body number plates, and decals or stickers for such things as windshield washer reservoir, valve cover, trip odometer, convertible top, heater, and air filters. Contents vary from kit to kit - see www.mossmotors.com for detailed listings of contents.

410-125	\$32.99	DECAL & PLATE SET	RD 1962-'64	1
410-130	\$32.99	DECAL & PLATE SET	RD 1965-'67	1
410-135	\$32.99	DECAL & PLATE SET	GT 1965-'67	1
410-140	\$32.99	DECAL & PLATE SET	RD 1968-'69	1
410-145	\$32.99	DECAL & PLATE SET	GT 1968-'69	1
410-225	\$45.99	DECAL & PLATE SET	RD 1975-'80	1

# External Body Fittings

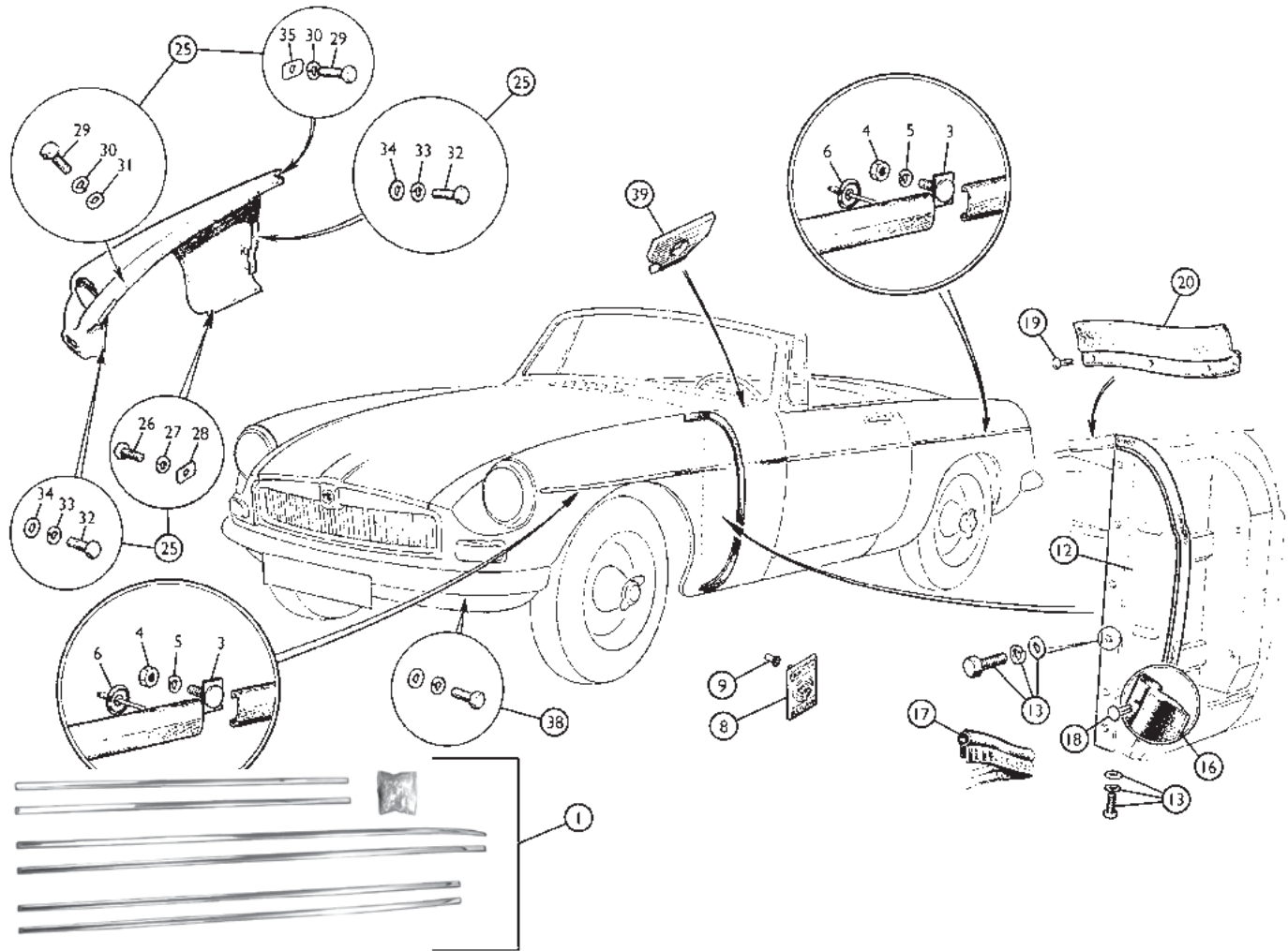

## External Body Fittings

19875

No.	Part#	Price (Each)	Description	Application	Qty Req.
1	453-428	\$219.99	MOULDING SET, w/ mtg. hardware	O.E. quality	1
	453-478	\$98.99	MOULDING SET, w/ mtg. hardware	aftermarket	1
	326-058	\$17.99	HARDWARE SET		1
3	326-075	\$0.99	STUD PLATE		6
4	310-115	\$0.24	NUT for stud		6
5	324-010	\$0.19	LOCK WASHER		6
6	326-048	\$14.99	CLIP & RIVET SET (42 each)		1
	326-065	\$0.89	CLIP with rivet		42
	453-421	\$44.99	MOULDING, L/H front fender	} O.E. quality	1
	453-431	\$44.99	MOULDING, R/H front fender		1
	453-441	\$44.99	MOULDING, L/H door		1
	453-451	\$44.99	MOULDING, R/H door		1
	453-461	\$44.99	MOULDING, L/H rear fender		1
	453-471	\$44.99	MOULDING, R/H rear fender	} aftermarket	1
	453-420	\$24.99	MOULDING, L/H front fender		1
	453-430	\$24.99	MOULDING, R/H front fender		1
	453-440	\$24.99	MOULDING, L/H door		1
	453-450	\$24.99	MOULDING, R/H door		1
	453-460	\$24.99	MOULDING, L/H rear fender		1
	453-470	\$24.99	MOULDING, R/H rear fender		1
8	470-687	\$8.99	BRITISH LEYLAND BADGE, silver on blue, self-adhesive		} 1970-'71
	470-686	\$11.99	BRITISH LEYLAND BADGE, blue on silver, self adhesive	} 1972 on	

No.	Part#	Price (Each)	Description	Application	Qty Req.	
9	326-665	\$0.49	BLIND FIX	early BL badges w/studs	4	
12	458-390	\$29.99	SPLASH PANEL, L/H	} RD to (c)294250, GT to (c)296000, thru 1972	1	
	458-395	\$29.99	SPLASH PANEL, R/H		1	
	458-400	\$14.99	SPLASH PANEL, L/H		RD from (c)294251 on, GT	1
	458-405	\$14.99	SPLASH PANEL, R/H		from (c)296001 on, '73 on	1
Earlier splash panels used moulded rubber seals (#16) secured with rivets, while later splash panels used a simpler push-on seal(#17). While assemblies are interchangeable, we have reproduced both types of plates and seals to help you keep your "B" original.						
13	323-638	\$11.99	HARDWARE KIT, splash panel mounting		1	
16	282-370	\$9.99	SEAL L/H, splash panel	} RD to (c)294250, GT to (c)296000, thru 1972	1	
	282-360	\$9.99	SEAL R/H, splash panel		1	
17	282-355	\$6.99	SEAL, splash panel	} RD from (c)294251 on, GT from (c)296001 on, '73 on	2	
18	325-278	\$8.49	RIVET SET, 34 rivets		early type seals	1
19	325-260	\$0.39	RIVET, extension seals	all	6	
20	282-375	\$2.49	SEAL, L/H, splash extension		1	
	282-365	\$2.49	SEAL, R/H, splash extension		1	
25	321-928	\$67.99	HARDWARE KIT, bolts & washers for both front fenders		1	
26	323-005	\$0.39	SCREW		6	
27	324-010	\$0.19	LOCKWASHER		6	
28	324-715	\$0.99	OVAL WASHER		6	
29		NA	BOLT		24	
30	365-730	\$0.39	LOCKWASHER		24	
31		NA	FLAT WASHER		24	
32		NA	BOLT		12	
33	324-020	\$0.20	LOCKWASHER		12	
34		NA	FLAT WASHER		12	
35		NA	OVAL WASHER	GT uses 2	2/6	
38	323-618	\$8.99	HARDWARE KIT, bolts & washers for front valance		1	
39	324-795	\$5.69	FENDER WASHER	GT	2	

# External Body Accessories

## BL "Limited Edition" Spoiler

Fitted by the factory to MGB "LE" models in 1980, this ABS plastic spoiler greatly improves the looks of all rubber-bumpered MGBs! Also adds a racy touch to chrome-bumpered MGBs. Holes must be drilled in existing valance to mount. (Oversize Parts Fee will be charged for this item.)

**475-180 \$259.99**



## "Special Tuning" Air Dam

Specifically designed for chrome bumper MGBs, this is a fiberglass reproduction of the factory Special Tuning air dam as used on race and rally cars. (Oversize Parts Fee will be charged for this item.)

**475-195 \$229.99**



## Body Side-Stripe Kit

As supplied by many dealers on new cars in the early '70s, this attractive stripe runs just above the belt line. Adds a new, distinctive dimension to the look of your MGB! Looks particularly good on chrome-bumpered cars and GTs.

**Black 215-340 Silver 215-355 Gold 215-360 \$59.99**



## MGB Sebring Front & Rear Valance Panels

Fiberglass reproductions of the streamlining panels fitted to the works MGBs when they raced at Sebring. The bumpers are eliminated, and these panels fill the resulting gaps for a smooth, clean appearance. As with all aftermarket fiberglass body panels, fitting these properly requires a large amount of patience and skill.

Front Sebring Valance **475-185 \$259.99**  
 Rear Sebring Valance **475-190 \$299.99**  
 (Oversize Parts Fee will be charged for these items.)



## Body Side-Stripe Kit

The original factory optional side stripe along the lower body. Best suited for rubber bumpered cars, as it visually blends the bumpers into the overall body shape.

**Black 215-370 Silver 215-375 Gold 215-380 \$129.99**



## Limited Edition Body Stripe Kit

Give your rubber-bumpered MGB a very special flair with this factory decal set, originally fitted only to the "LE" models.

**Silver 215-730 Gold 215-735 NA**

## Electric Retractable Radio Antenna

Our electric antenna kit wires into your radio for fully automatic operation. If you regularly use a car cover, or live in an area subject to vandalism, an electric antenna is just what you need. Requires 13.5" depth to mount.

**386-960 \$149.99**



## MGB Sebring Headlamp Covers & Fitting Kit

These American-made reproductions are far superior to the U.K.-produced repros periodically available, yet are much more economical. We have created a new, yet vintage-style method of mounting these with snaps and studs so that the installation is clean and neat, and the covers are easily removable for cleaning. Works-type alloy fitting kits are available separately but are only recommended for the serious vintage racer looking for originality.

Headlamp Cowl Kit **222-130 \$179.99**  
 Alloy Cowl Fitting Kit **222-140 \$52.99**



Not legal for street use in California. Other states may have similar requirements, please check local laws before ordering.

Toll-Free Orders 1-800-667-7872 | MossMotors.com  
 Fax 805-692-2525 | Local 805-681-3400

**MOSS**

# GT Unique

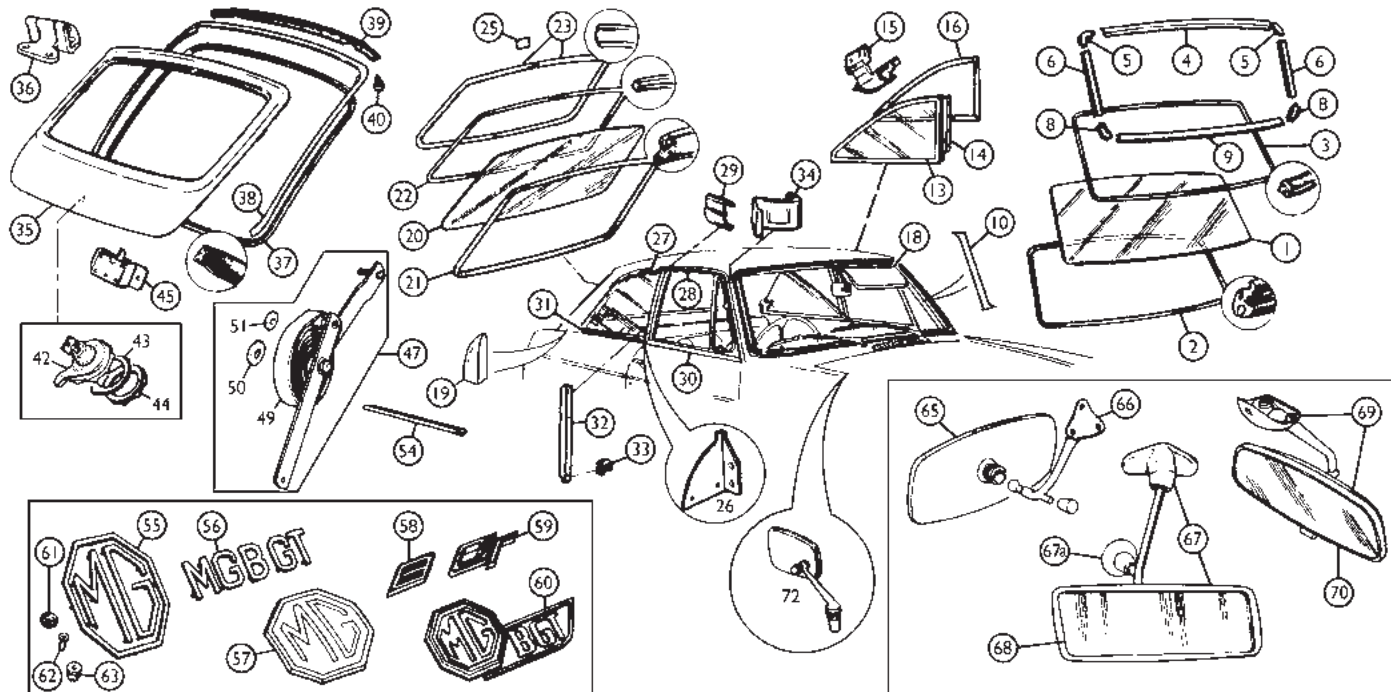

## GT Unique

19877

No.	Part#	Price (Each)	Description	Application	Qty Req.
1	458-821	\$549.99	WINDSHIELD, Triplex brand	}	1
	458-820	\$189.99	WINDSHIELD		1
	458-825	\$179.99	WINDSHIELD, tinted		1
2	282-430	\$49.99	GLAZING RUBBER, windshield		1
3	282-485	\$7.99	FILLER STRIP, glazing rubber		1
4	408-090	\$39.99	FINISHER, windshield top		1
5	408-160	\$10.79	FINISHER, windshield top corner		2
6	408-150	\$13.99	FINISHER, windshield side		2
8	408-170	\$10.79	FINISHER, windshield bottom corner		2
9	408-080	\$41.99	FINISHER, windshield bottom		1
10	643-890	\$68.99	FINISHER PAIR, A-post (black)		1
13	458-720	NA	QUARTER WINDOW ASS'Y., R/H	} GT to (c)286061	1
	458-760	NA	GLASS, clear, R/H		1
	458-725	NA	QUARTER WINDOW ASS'Y., L/H		1
	458-770	NA	GLASS, clear, L/H		1
	282-580	\$2.69	GLAZING RUBBER, quarter window sold by the foot		A/R
	458-730	NA	QUARTER WINDOW ASS'Y., R/H	} GT from (c)286062 on	1
	458-880	NA	GLASS, tinted, R/H		1
	458-735	NA	QUARTER WINDOW ASS'Y., L/H		1
	458-870	NA	GLASS, tinted, L/H		1
	282-585	\$14.99	GLAZING RUBBER, quarter window		2
14	402-580	NA	HINGE, R/H	} GT to (c)286061	1
	402-585	NA	HINGE, L/H		1
	402-590	NA	HINGE	GT from (c)286062 on	4
15	402-600	NA	TOGGLE CATCH, R/H	} GT to (c)286061	1
	402-610	NA	TOGGLE CATCH, L/H		1
	402-620	NA	TOGGLE CATCH, R/H	} GT from (c)286062 on	1
	402-630	NA	TOGGLE CATCH, L/H		1
16	282-560	\$26.99	SEAL, quarter window, R/H	} black, late style	1
	282-570	\$26.99	SEAL, quarter window, L/H		1
18	233-917	\$126.99	SUN VISOR		2
19	641-505	NA	FOAM RUBBER BLOCK, pair, C-pillar		1
20	458-740	\$399.99	TAILGATE GLASS, clear, heated		1
	458-795	\$399.99	TAILGATE GLASS, tinted, heated		1
21	282-590	\$56.99	GLAZING RUBBER, rear window		1
22	282-485	\$7.99	FILLER STRIP, glazing rubber		1
23	408-212	\$349.99	FINISHER PAIR, L/H & R/H		1
25	472-400	\$2.29	CLIP for finisher		2
26	472-700	\$36.99	FINISHER, door shut face, L/H		1
	472-705	\$36.99	FINISHER, door shut face, R/H		1
	472-728	\$599.99	FINISHER SET, drip moldings		1
27	472-710	NA	FINISHER, drip moulding, rear, R/H		1
	472-715	NA	FINISHER, drip moulding, rear, L/H		1
28	472-720	NA	FINISHER, drip moulding, front, R/H		1
	472-725	NA	FINISHER, drip moulding, front, L/H		1

No.	Part#	Price (Each)	Description	Application	Qty Req.
29	472-730	\$7.69	CLIP, finisher		2
30	453-410	\$119.99	MOULDING, door top, R/H		1
	453-480	\$119.99	MOULDING, door top, L/H		1
31	453-490	\$72.99	FINISHER, tonneau waist, R/H		1
	453-495	\$72.99	FINISHER, tonneau waist, L/H		1
32	472-750	\$24.99	FINISHER, "B" post, R/H		1
	472-755	\$24.99	FINISHER, "B" post, L/H		1
33	472-735	\$0.59	GROMMET, "B" post finisher		2
34	472-760	NA	FINISHER, "A" post, R/H	} 1966-'68 approx.	1
	472-765	NA	FINISHER, "A" post, L/H		1
35	457-560	\$1,099.00	TAILGATE (Must be pre-paid, and shipped by truck freight.) (Tailgate is a British Motor Heritage part)		1
36	405-440	\$136.99	HINGE, tailgate, R/H		1
	405-450	\$136.99	HINGE, tailgate, L/H		1
37	282-480	\$34.99	TAILGATE SEAL, inner		1
38	282-490	\$36.99	TAILGATE SEAL, outer		1
39	457-565	NA	RETAINER, seal		1
40	323-430	\$0.59	SCREW, seal retainer		10
42	402-180	\$119.99	LOCK ASSEMBLY, tailgate, w/2 keys*		1
43	402-520	\$1.19	WASHER		1
44	402-510	NA	NUT		1
*Note: See pages 66 and 67 for master lock sets					
45	402-530	\$19.99	LATCH		1
47	472-370	NA	STAY ASSEMBLY, tailgate, R/H		1
	472-380	\$139.99	STAY ASSEMBLY, tailgate, L/H		1
49	472-390	\$15.39	COVER		2
50	472-375	\$1.69	CAP COVER, large		2
51	472-385	\$0.69	CAP COVER, small		2
54	457-240	\$19.99	SEAL RETAINER, door sill		2
55	470-698	\$28.99	"MG" BADGE, chrome, 3 pc. (use blind fix 326-650 x4, and push-on fix 326-500 x13)	1965-'69	1
56	408-450	\$79.99	"MGB GT" MOTIF, chrome, 5 pc. (use blind fix 326-650 x5, and push-on fix 326-500 x5)	1965-'69	1
57	470-665	\$19.99	"MG" BADGE, black & chrome (use blind fix 326-655 x3)	1970-'72	1
58	472-780	\$39.99	LETTER "B" (use blind fix 326-665 x4)	1970-'72	1
59	472-786	\$45.99	"GT" MOTIF (use blind fix 326-665 x4) unpainted	1970-'72	1
60	472-770	\$99.99	"MGB GT" BADGE, black & chrome (use blind fix 326-665 x3)	1973-on	1
	472-775	\$109.99	"MGB GT" BADGE, black & gold	UK Jubilee Edition	1
61	326-500	\$0.29	PUSH-ON FIX	} used w/#470-698, 408-450	13/5
	326-530	\$0.29	PUSH-ON FIX		used w/#470-695

No.	Part#	Price (Each)	Description	Application	Qty Req.	
62	326-650	\$0.49	BLIND FIX	used w/#470-698, 408-450	4/5	
	326-655	\$0.59	BLIND FIX		used w/#470-695, 470-665	1
	326-665	\$0.49	BLIND FIX		used w/#472-780, 472-785	4
63	326-665	\$0.49	BLIND FIX	used w/#472-770	3	
65	165-120	NA	MIRROR HEAD	GT to (c)139471, thru 1967	1	
66	165-240	NA	MIRROR STEM		1	
67	165-230	NA	MIRROR ASSEMBLY	GT from (c)139472 to 187840, 1968 - '69	1	
67a	116-036	\$12.99	SUCTION PAD		1	
68	165-235	NA	MIRROR HEAD		1	
69	165-125	NA	MIRROR ASSEMBLY	GT from (c)187841 on, 1970 on	1	
70	165-245	\$28.99	MIRROR HEAD		1	
72	165-260	\$89.99	R/H FENDER MIRROR	early factory option	1	

All three GT rear view mirror assemblies are interchangeable.



### GT Rear Quarter Flashes

Fitted as original equipment to all late GTs sold in England. Now you can Individualize your GT with this unique chrome & black trim piece produced by British Motor Heritage.

<b>Left Hand</b>	<b>408-390</b>	<b>\$79.99</b>
<b>Right Hand</b>	<b>408-395</b>	<b>\$79.99</b>



### Seat Belt Bracket Set

MGB GT from 1973-on were fitted with retractor type seat belts. Since the seat belt anchor boss in the top of the fender arch sits so close to the vertical bulkhead panel, these brackets are required to mount the bulky retractor mechanisms.

<b>Bracket Pair</b>	<b>222-158</b>	<b>\$43.99</b>
---------------------	----------------	----------------

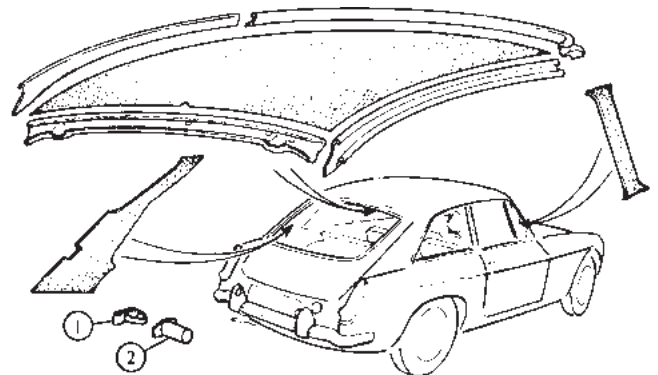

### MGB GT Headliner Kits

These headliner kits are the solution to cracked and dingy GT headliners and associated panels. Each kit contains the main headliner cut foam pad and cover, header and crantrail covers, rear quarter liner panels, windshield post liner panels, fiberglass hinge cover, and instructions.

	<b>643-900</b>	<b>\$639.99</b>	<b>Grey Vinyl Headliner Kit</b>	
	<b>643-915</b>	<b>\$579.99</b>	<b>Grey Fabric Headliner Kit</b>	
	<b>643-905</b>	<b>\$579.99</b>	<b>Tan Fabric Headliner Kit</b>	
1	803-420	\$0.99	CLIP, upper rear quarter liner	16 required
2	226-695	\$3.29	SOCKET, for clip	16 required

### Spray Contact Adhesive

Perfect for installing your new headliner kit! Follow the instructions on the can for a perfect, permanent installation. This adhesive will bond almost anything to anything else; fabric, wood, metal, fiberglass, rubber, paper, and most plastics. 13 oz. aerosol can.

<b>409-037</b>	<b>\$28.99</b>
----------------	----------------



# Starting System

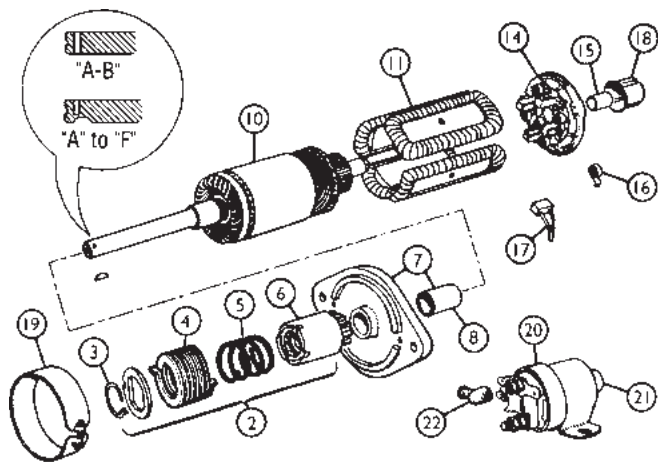

## Starting System 1962 - 1967

19882

No.	Part#	Price (Each)	Description	Application	Qty Req.
	140-465	\$229.99	STARTER, rebuilt, exchange	all (e)18G/GA/GB	1
		\$350.00	CORE CHARGE FOR 140-465 STARTER		

Note: These are Lucas replacements for starters with numbers prefixed by "A" to "F" and "A - B" stamped on the starter body.

2	150-440	NA	DRIVE ASSEMBLY		1
3	150-460	NA	RING, retaining	"A" to "F"	1
	150-470	NA	RING, retaining	"A - B"	1
4	150-410	NA	SPRING, main		1
5	150-430	NA	SPRING, pinion		1
6	150-420	NA	PINION & BARREL		1
7	149-200	NA	BRACKET, driving end		1
8	150-300	\$7.79	BUSH		1
10	150-480	NA	ARMATURE	"A" to "F"	1
	150-490	NA	ARMATURE	"A - B"	1
11	150-150	\$142.99	FIELD COIL SET		1
14	549-510	NA	BRACKET, commutator end		1
15	149-400	\$6.59	BUSH		1
16	150-200	NA	SPRING SET		1
17	149-620	\$15.99	BRUSH SET, 4 pc.		1
18	149-800	NA	CAP, shaft end		1
19	549-550	NA	BAND, dust cover		1
20	546-020	\$44.99	SOLENOID, starter (push-button type)	1962 - '65	1
	546-150	NA	SOLENOID, starter, Lucas (square type)	1966 - '67	1
	546-152	\$18.99	SOLENOID, starter, reproduction		1
21	546-025	\$1.99	COVER, push button (incl. with solenoid #545-020)		1
22	161-900	\$3.99	BOOT		2

### Starter:

If your starter turns over very slowly, either the starter is faulty, the connections to the starter are faulty (usually the earth strap on the engine), the battery is discharged, or the battery terminals are dirty.

**Solenoid clicks repeatedly** - battery is discharged or terminals are dirty.

**Solenoid clicks once** - starter relay has lost power (usually a dirty fuse box), or the solenoid or starter is faulty.

### Hi Torque Replacement Starters

Modern design and reliability make these all new starters ideal for the "daily driver". High torque gear drive produces superior starting power for your engine. (Some minor re-wiring required on 1962-'67 cars.)

**1962-'67 Starter** 140-364 \$319.99

**1968-'80 Starter** 140-365 \$319.99

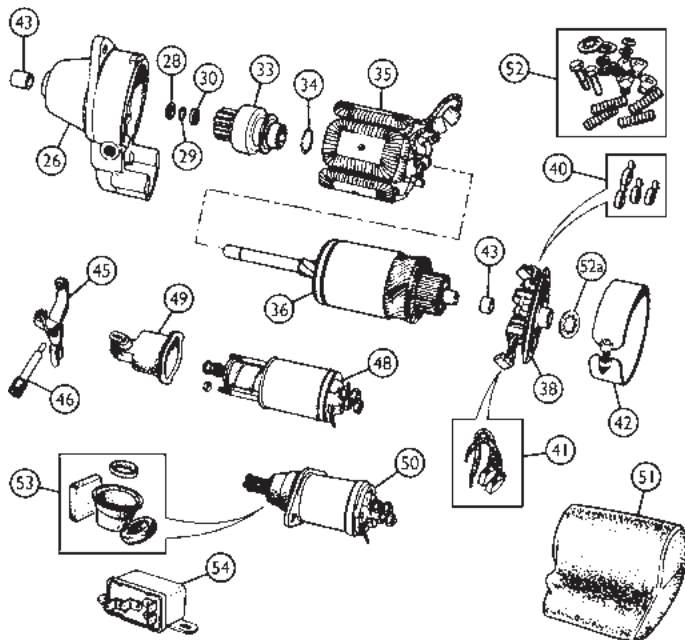
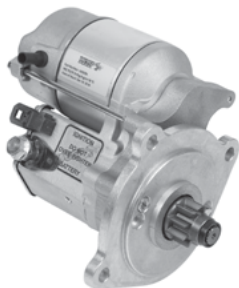

## Starting System 1968 - 1980

19883

No.	Part#	Price (Each)	Description	Application	Qty Req.
	131-220	\$124.99	STARTER, new replacement	negative ground only	1
	131-221	\$69.99	DRIVE ASSEMBLY	} repl. starter 131-220	1
	131-211	\$89.99	SOLENOID		1
	131-210	\$229.99	STARTER, rebuilt, exchange		1
		\$300.00	CORE CHARGE FOR 131-210 STARTER		

Note: These are replacements for starters #25660 and #25654. #25660 was used from 1968 thru 1971; #25654 from 1972 thru 1980.

26	131-230	NA	BRACKET, drive end	#25660	1
	131-240	NA	BRACKET, drive end	#25654	1
28	131-250	NA	THRUST WASHER		1
29	131-260	NA	RING, retaining		1
30	131-270	NA	THRUST COLLAR		1
33	131-280	\$62.99	DRIVE ASSEMBLY	#25660	1
	131-290	\$55.99	DRIVE ASSEMBLY	#25654	1
34	131-285	NA	RING, retaining		1
35	131-300	NA	FIELD COIL SET	#25660	1
	131-305	NA	FIELD COIL SET	#25654	1
36	131-310	NA	ARMATURE	#25660	1
	131-315	NA	ARMATURE	#25654	1
38	131-330	NA	BRACKET KIT ASSEMBLY, commutator end	} #25654	1
	131-320	NA	BRACKET, commutator end		#25660
40	150-200	NA	SPRING SET	#25660	1
41	149-620	\$15.99	BRUSH SET, 4 pc.	#25660, rectangular brush	1
	549-420	\$12.99	BRUSH SET, 4 pc.	#25654, triangular brush	1
42	131-350	NA	BAND, cover		1
43	549-400	\$1.49	BUSH SET (front & rear bushes)	#25660	1
	549-405	\$2.99	BUSH SET (front & rear bushes)	#25654	1
45	131-360	NA	LEVER, pinion engaging	} #25660	1
46	131-370	NA	BOLT, pivot		1
	131-380	NA	LEVER & BOLT KIT	} #25654	1
46	131-385	NA	BOLT, pivot		1
48	131-400	NA	SOLENOID (Lucas)	} #25660	1
	131-402	\$59.99	SOLENOID (aftermarket)		1
49	131-410	NA	BELLOWS		1
50	131-450	\$59.99	SOLENOID	} #25654 RD/GT	1
51	131-460	\$17.99	COVER		(c)284721 on
Moulded vinyl starter covers were fitted to all later MGBs, but were generally discarded. Can be fitted to all 1968-'80 MGBs for maximum weather protection.					
52	131-395	NA	SUNDRY PARTS KIT	#25660	1
	131-390	NA	SUNDRY PARTS KIT		1
52a	131-392	\$2.09	SPIRE NUT (armature end)	} #25654	1
53	131-420	NA	SEALING KIT		1
54	131-510	\$96.99	RELAY, starter, Lucas	} RD from (c)187211 to 395331, GT from (c)187841 on	1
	542-170	\$21.99	RELAY, starter, replacement		1
	131-520	\$21.99	RELAY, starter	RD from (c)395332 on	1



# Charging System

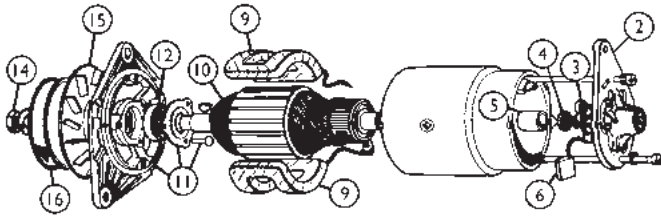

## Generator 1962 - '67

19885

No.	Part#	Price (Each)	Description	Application	Qty Req.
	140-200	\$149.99	GENERATOR, new, replacement (no internal parts are available for 140-200)	all (e)18G/GA/GB	1
	540-200	\$199.99	GENERATOR, Lucas rebuilt		1
		\$300.00	CORE CHARGE for 540-200 (core must be orig. Lucas only)		
2	NA		BRACKET ASSEMBLY, commutator end		1
3	549-030	\$31.99	SPRING SET		1
4	697-020	\$0.69	OILER, felt		1
5	147-600	\$8.49	BUSH		1
6	147-250	\$2.39	BRUSH SET		1
9	560-070	NA	FIELD COIL SET		1
10	162-900	\$99.99	ARMATURE		1
11	NA		BRACKET ASSEMBLY, driving end		1
12	125-100	\$15.99	BEARING		1
14	310-310	\$0.59	NUT		1
15	433-670	\$12.99	FAN		1
16	433-720	\$119.99	PULLEY		1

When installing a new or rebuilt generator, always polarize it to suit your car before starting the engine. (Polarizing procedure is detailed in the "tech tip" which covers converting from positive to negative ground on page 87.)

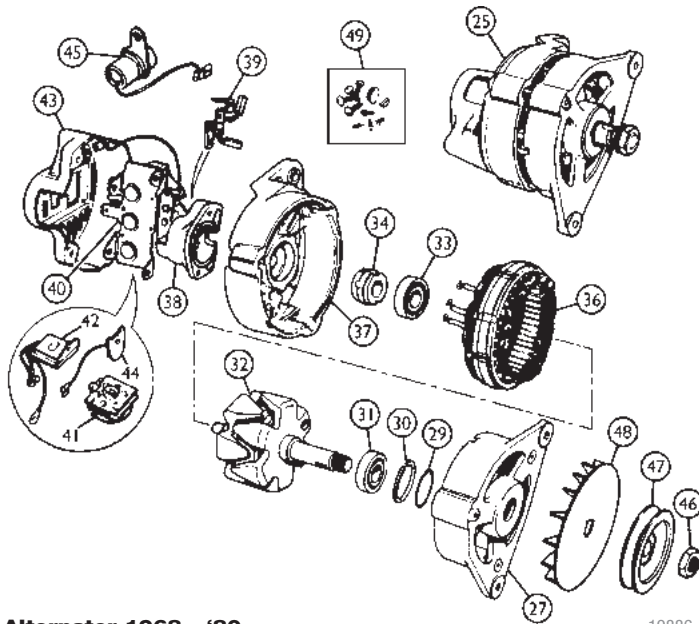

## Alternator 1968 - '80

19886

Note: Numbers listed in application column are Lucas numbers found on the original alternators. Due to Lucas changes, alternators supplied may be numbered differently! Pulleys and fans are not included with alternators.

25	130-000	NA	ALTERNATOR, new (may use 130-102 below)	1968 #23548, 1969 - '71 #23716	1
NOTE: This alternator has 3 terminals to replace the original 5 terminals used from 1968-'71. Refer to the "Alternator Terminal Conversions" article on page 91.					
	130-000	NA	ALTERNATOR, new (may use 130-102 below)	1972- 74 \$23716, L23804 alternative - #23748	1
	130-090	\$219.99	ALTERNATOR, rebuilt	1974 1/2 - '78 #23756 end	1
		\$350.00	CORE CHARGE FOR 130-090	at (c)471000	
	161-525	NA	CONNECTOR, 1/2" (required for this alternator)		1
	130-102	\$129.99	ALTERNATOR, new	1979 - '80 #23737, from (c)471001 on	1
27	130-120	NA	BRACKET ASSEMBLY, drive end	#23756, 23737	1
29	130-450	NA	O-RING		1

30	130-455	NA	CIRCLIP		1
31	125-100	\$15.99	BEARING, drive end	#23548, 23716, L23804	1
	130-465	\$17.99	BEARING, drive end	#23756, 23737	1
32	130-160	NA	ROTOR ASSEMBLY	#23548 thru L23804	1
	130-170	NA	ROTOR ASSEMBLY	#23756, 23737	1
33		NA	BEARING, slip ring end		1
34	130-215	\$3.89	SLIP RING		1
36	130-190	NA	STATOR	#23548 thru L23804	1
	130-200	NA	STATOR	#23756, 23737	1
37	130-210	NA	BRACKET, slip ring end		1
38	130-220	NA	BRUSH HOUSING ASS'Y.	#23548	1
	130-230	NA	BRUSH HOUSING ASS'Y.	#23716 -on	1
39	130-225	\$4.99	BRUSH SET	#23548, 23756	1
	130-235	\$3.99	BRUSH SET	#23716 -on	1
40	130-240	NA	RECTIFIER	#23548	1
41	130-250	\$16.99	RECTIFIER	#23716, 23737	1
	130-260	\$26.99	RECTIFIER	#L23804	1
	130-270	\$31.49	RECTIFIER	#23756	1
42	130-280	\$11.99	REGULATOR, 2-wire	#23716, 23737	1
	130-290	\$37.89	REGULATOR, 4-wire	#L23804, 23756	1
43	130-310	NA	COVER	#23548	1
	130-320	\$17.79	COVER	#23716, L23804, 23737	1
	130-330	NA	COVER	#23756	1
44	130-345	NA	SURGE PROTECTOR	#23716 -on	1
45	130-350	NA	CAPACITOR	#23716 -on	1
46	310-810	\$1.99	NUT		1
47	130-370	\$29.99	PULLEY, alternator	RD/GT to (c)410000	1
	539-090	\$19.99	PULLEY, alternator	RD from (c)410001 on	1
48	130-400	\$15.29	FAN, alternator		1
49	130-360	NA	SUNDRIES KIT		1

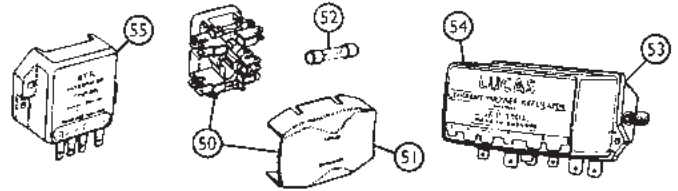

## Fuse Box and Voltage Regulators

19887

50	560-100	\$6.79	FUSE BOX, 2 fuse	RD to (c)187210, GT to (c)187840	1
	162-510	\$8.29	FUSE BOX, 4 fuse	RD from (c)187211 on, GT from (c)187841 on	1
51	560-110	\$4.99	COVER, fuse box	use w/560-100	1
	560-115	\$7.99	COVER, fuse box	use w/162-510	1
52	146-700	\$0.69	FUSE, 35 amp.		A/R
	146-710	\$0.49	FUSE, 25 amp.		A/R
	146-720	\$0.49	FUSE, 15 amp.		A/R
	146-730	\$0.49	FUSE, 10 amp.		A/R
53	142-040	NA	REGULATOR, Lucas	RD/GT to (c)138400	1
	142-045	\$49.99	REGULATOR, replacement		1
54	162-010	NA	COVER, regulator		1
55	130-440	\$43.99	CONTROL UNIT	RD/GT from (c)138401 to 158230	1

# Distributor - 1962-'74

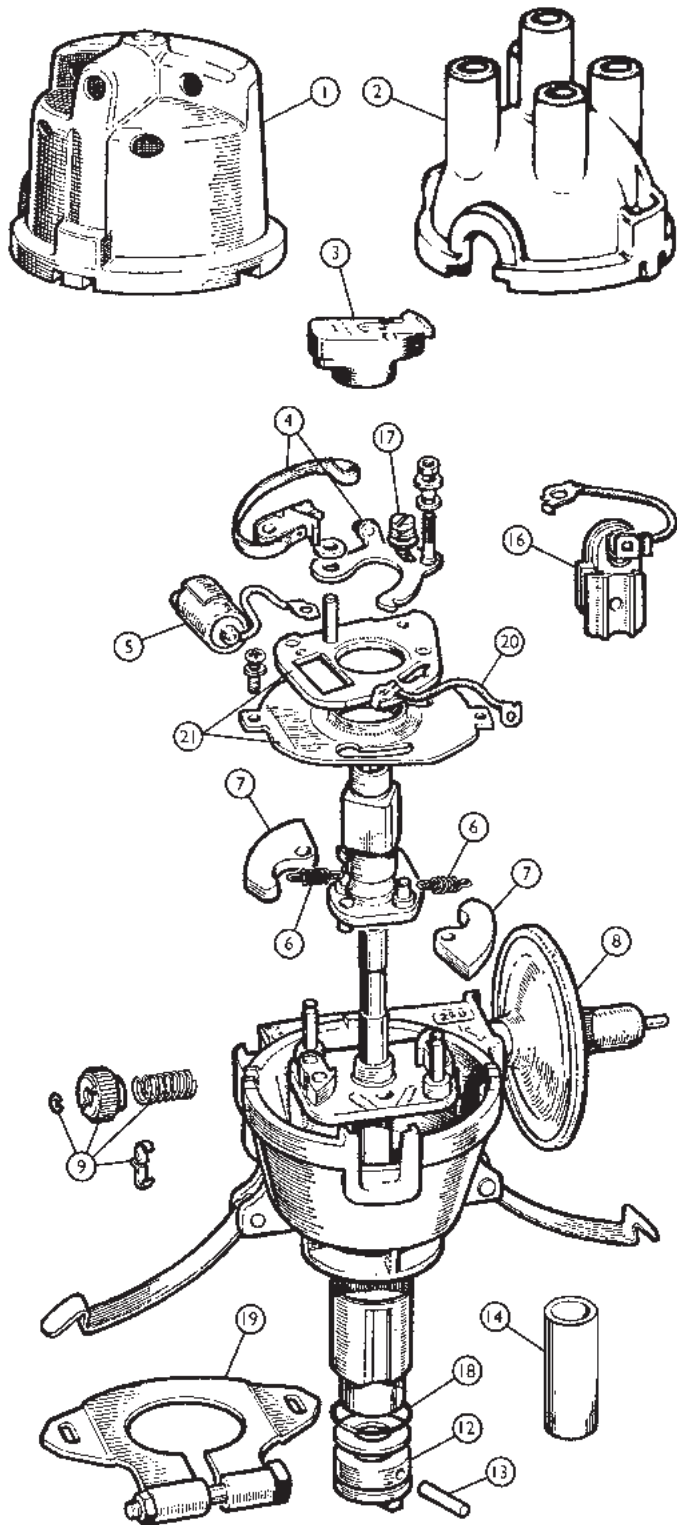

## Distributor Applications 1962-'74

Model 25D4. This listing shows standard fitment for U.S.A. MGBs. Over the years, both Lucas and dealers supplied different distributors as replacements. The more common of these replacements are listed at the end of the table. (For practical purposes, distributors 40897, 41155, and 41339 may be safely interchanged, or later distributors used. For 1972 and later cars, the use of earlier distributors is not recommended.

Model Year	Lucas Part#	Other model 25D4 distributors which were used as replacements include:
1962-'67	40897	41156, 41210, 41220, 41264,
1968-'70	41155	41287, 41288 & 41290.
1971	41339	
1972	41370	
1973-'74	41491	

Some later replacement distributors (such as our 143-11) are model 45D4. Parts for these are found on the next page.

## Distributor model 25D4

19888

No. Part#	Price (Each)	Description	Application	Qty Req.
143-114	\$49.99	DISTRIBUTOR, new, replacement	1962 - 1971	1
Note: This replacement distributor 41427 based on model 45D4, not 25D4. Parts for these are listed on the facing page. This is a new replacement for original distributors numbered 40897, 41155, 41156, 41220, 41288, 41290, 41264, and 41339.				
143-130	NA	DISTRIBUTOR, new, replacement	1972 - 1974	1
143-140	NA	DISTRIBUTOR, rebuilt, exchange		1
Note: This replacement is model 45D4; parts are listed on the facing page. This is Lucas distributor #41599, which replaces 41370 & 41491.				
1 163-825	\$36.99	CAP, Intermotor brand	distributors #40897, 41155, and 41156	1
163-800	\$14.99	CAP, replacement		1
2 163-815	NA	CAP, Lucas	#41220, 41288, 41290, 41264, 41339, 41370, 41491	1
163-810	\$11.49	CAP, replacement		1
Note: All of these caps may be interchanged if used with the appropriate wire set and ignition coil.				
3 151-805	\$15.99	ROTOR, premium replacement (red)		1
151-710	\$5.99	ROTOR, Lucas		1
151-800	\$4.99	ROTOR, Intermotor		1
152-220	\$10.99	POINT & CONDENSER SET, Lucas		1
152-221	\$9.99	POINT & CONDENSER SET, Intermotor brand		1
4 151-720	\$7.99	POINT SET, Lucas		1
152-225	\$23.99	POINT SET, Premium aftermarket		1
153-900	\$6.99	POINT SET, aftermarket		1
5 151-730	\$7.99	CONDENSER, Lucas		1
154-001	\$12.99	CONDENSER, Premium aftermarket		1
6 551-010	\$19.99	SPRING SET (universal set of 5 assorted springs)		1
7	NA	WEIGHT		2
8 163-665§	\$109.99	VACUUM UNIT, reproduction	#40897, 41155	1
163-630†	\$62.99	VACUUM UNIT, replacement	#41220, 41288	1
163-632†	\$109.99	VACUUM UNIT, reproduction	#41220	1
163-633†	\$109.99	VACUUM UNIT, reproduction	#41288	1
560-151†	\$109.99	VACUUM UNIT, reproduction	#41156, 41290	1
560-160†	\$99.99	VACUUM UNIT, replacement	#41264	1
163-634†	\$109.99	VACUUM UNIT, reproduction	#41264	1
163-660†	\$109.99	VACUUM UNIT, reproduction	#41339	1
560-513†	\$109.99	VACUUM UNIT, reproduction	#41370	1
163-670†	\$119.99	VACUUM UNIT, reproduction	#41491	1

§ threaded vacuum pipe connection

† push-on vacuum connection

Reproduction vacuum units are made in the USA and carry all original logos and markings. Excellent quality.

9 163-739	\$17.99	ADJUSTER KIT		1
12 153-300	\$29.99	DOG, drive		1
13 539-020	\$0.49	PIN		1
14 153-500	\$33.99	BUSHING		1
16 153-640	\$5.99	TERMINAL & LEAD		1
17 323-245	\$1.09	SCREW, points retaining		1
18 163-750	\$0.29	O-RING	as fitted	1
19 153-400	\$10.99	CLAMP ASSEMBLY with bolt & nut (replacement type)		1
153-401	\$35.99	CLAMP, without bolt & nut (OE type)		1
153-402	\$8.19	BOLT & NUT for clamp		1
20 153-645	\$2.49	WIRE, ground (replacement)		1
21 551-055	\$54.99	BREAKER PLATE ASS'Y., w/ground wire		1

Lucas model number cast in body here

Lucas part number stamped here

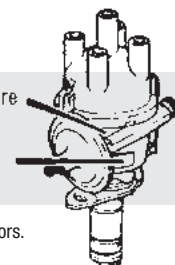

Note: This information does not apply to later model distributors.

# Distributor - Fed. 1975-'76

19889

## Distributor models 45D4 and 43D4

No.	Part#	Price (Each)	Description	Application	Qty Req.
Distributors model 45D4 have been used by Lucas as replacements for the 1962-'74 model 25D4. Component parts are not interchangeable between the different models.					
	143-130	NA	DISTRIBUTOR, new	1975, except California, distributor #41599	1
	143-140	NA	DISTRIBUTOR, rebuilt, exchange		1
	143-150	NA	DISTRIBUTOR, new	1976, except California, distributor #41644	1
	143-160	NA	DISTRIBUTOR, rebuilt, exchange		1
1	151-875	\$14.89	CAP, distributor, Lucas		1
	151-870	\$13.99	CAP, distributor, aftermarket		1
2	151-865	\$16.49	ROTOR, premium (red)		1
	151-855	\$4.49	ROTOR, Lucas		1
	151-850	NA	ROTOR, aftermarket		1
3	153-915	\$5.99	POINT SET, Lucas		1
	153-910	\$5.39	POINT SET, aftermarket		1
4	154-020	\$6.69	CONDENSER, TERMINAL & LEAD,		1
5	551-010	\$19.99	SPRING SET (universal set of 5 assorted springs)		1
6	NA		WEIGHT, auto advance		2
7	163-695	\$38.99	VACUUM UNIT, replacement	#41427 (repl. distributor)	1
	163-701	\$76.99	VACUUM UNIT, reproduction		1
	163-680	\$41.99	VACUUM UNIT, replacement	#41599	1
	163-702	\$76.99	VACUUM UNIT, reproduction		1
Reproduction vacuum units are made in the USA and carry all original logos and markings. Excellent quality.					
8	153-300	\$29.99	DOG, drive		1
	539-020	\$0.49	PIN for dog		1
	163-760	NA	SUNDRIES KIT		1
9	163-750	\$0.29	O-RING		1
10	323-246	\$1.09	SCREW, points retaining		1
11	153-400	\$10.99	CLAMP ASSEMBLY with bolt & nut (replacement type)		1
	153-401	\$35.99	CLAMP, without bolt & nut (OE type)		1
	153-402	\$8.19	BOLT & NUT for clamp		1
12	153-645	\$2.49	WIRE, ground (replacement)		1

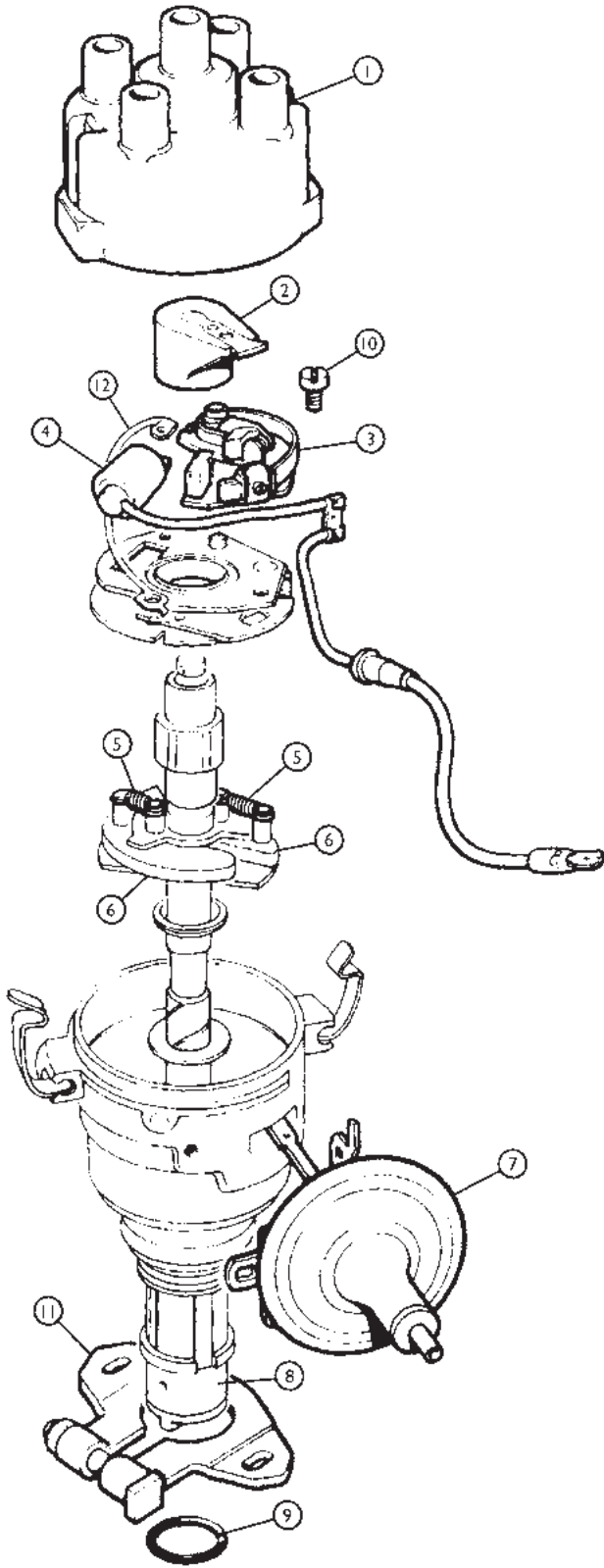

# Distributors - Electronic Ignition

Opus

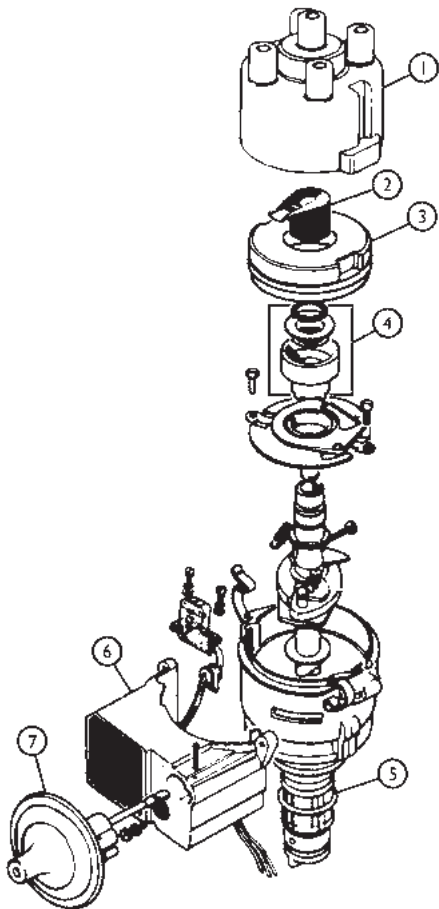

## Lucas Electronic Ignition

The original Lucas "Opus" electronic ignition used through 1979 featured the ignition amplifier mounted on the distributor body. As this system proved notoriously troublesome and unreliable, 1980 cars were produced with the "CEI" (Constant Energy Ignition) system, which had a remote amplifier, and was highly reliable. As of 1980, all replacements for the "Opus" system were of the CEI type. Needless to say, this has caused much confusion over the years when replacement components have been required. Order parts by your Lucas distributor number.

Model Year	Lucas pt.#	Lucas model/type	replaced by
1975-76 CA	41643	43DE4 (Opus)	41815 43DM4 (CEI)
1977-79 Fed.	41693	45DE4 (Opus)	41813 45DM4 (CEI)
1977-79 CA	41695	45DE4 (Opus)	41814 45DM4 (CEI)
1980 Fed.	41851	45DM4 (CEI)	-
1980 CA	41853	45DM4 (CEI)	-

## Distributor - Opus

19890

No. Part#	Price (Each)	Description	Application	Qty Req.
1 151-875	\$14.89	CAP, distributor, Lucas	#41643, 41693, 41695	1
151-870	\$13.99	CAP, distributor, aftermarket		1
2 151-865	\$16.49	ROTOR ARM, Premium	#41643, 41693, 41695	1
151-855	\$4.49	ROTOR ARM, Lucas		1
151-850	NA	ROTOR ARM, aftermarket		1
3 154-030	NA	COVER, anti-flash	#41643	1
154-040	NA	COVER, anti-flash	#41693, 41695	1
4 154-050	NA	TIMING ROTOR ASSEMBLY		1
5 163-750	\$0.29	O-RING		1
6	NA	AMPLIFIER ASSEMBLY		1
7 163-860	\$109.99	VACUUM UNIT, reproduction	#41693	1
163-880	\$109.99	VACUUM UNIT, reproduction	#41695	1

Reproduction vacuum units are made in the USA and carry all original logos and markings. Excellent quality.

**See the "Performance" section in the color pages at the front of this catalog for more distributor and ignition options.**

C.E.I.

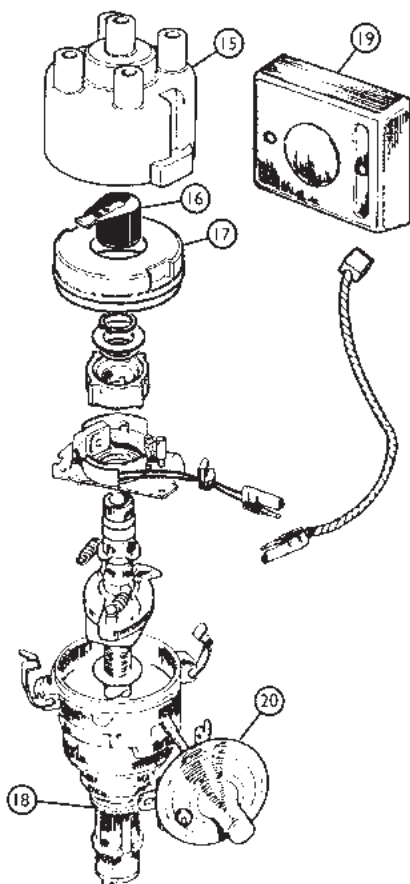

## Distributor - C.E.I.

19891

15 151-875	\$14.89	CAP, distributor, Lucas (black)		1
151-870	\$13.99	CAP, distributor, aftermarket (black)		1
16 151-865	\$16.49	ROTOR ARM, Premium		1
151-855	\$4.49	ROTOR ARM, Lucas		1
151-850	NA	ROTOR ARM, aftermarket		1
17 154-040	NA	COVER, anti-flash		1
18 163-750	\$0.29	O-RING		1
19 142-975	NA	AMPLIFIER ASSEMBLY		1
20 163-960	\$38.99	VACUUM UNIT, replacement	#41851, 41813	1
163-703	\$76.99	VACUUM UNIT, reproduction		1
163-970	\$76.99	VACUUM UNIT, reproduction	#41853, 41814	1

Reproduction vacuum units are made in the USA and carry all original logos and markings. Excellent quality.



## Pertronix High Performance Ignition Coils

With an output of 40,000 volts, these coils allow larger spark plug gaps for added power, smoother response, and better fuel economy.

1962-74 (non-ballasted system) - Black	143-265	\$79.99
1962-74 (non-ballasted system) - Chrome	143-266	\$84.99
1975-'80 (ballasted system) - Black	143-270	\$79.99
End clip for solid core wire	571-037	\$0.89
Boot for push-in wire	571-047	\$1.69

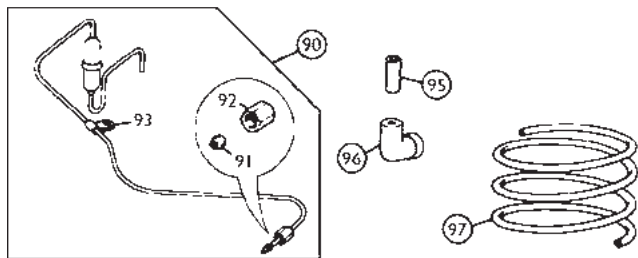

### Vacuum Pipe

19893

No.	Part#	Price (Each)	Description	Application	Qty Req.
90	163-640	\$44.99	VACUUM PIPE ASSEMBLY, steel	all (e)18G/GA/GB	1
91	163-635	\$0.99	COMPRESSION FITTING		1
92	153-810	\$6.89	NUT		1
93	153-820	\$1.59	CLIP	1968 thru early 1977	1
95	282-650	\$2.59	CONNECTOR, carburetor end		1
96	153-840	\$1.09	CONNECTOR, distributor end	RD from (c)138401 on, GT from (c)139472 on	1
97	163-655	\$1.19	VACUUM LINE, plastic sold by the foot		A/R



### Transmission-Controlled Spark Advance System

19895

97	163-655	\$1.19	VACUUM LINE, plastic sold by the foot	RD from (c) 415001 on (from early 1977-on)	A/R
98	153-830	\$1.29	CONNECTOR, straight		2
99	145-740	NA	VALVE, solenoid		1
100	153-840	\$1.09	CONNECTOR, elbow		2

## Ignition System

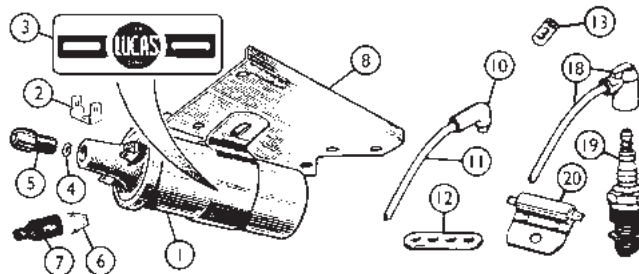

### Coil & Ignition Wires

19894

No.	Part#	Price (Each)	Description	Application	Qty Req.
1	543-020	\$42.99	COIL, screw-in H.T. conn.	1962 - '67	1
	143-220	\$34.99	COIL, Lucas, push-in H.T. conn.	1968 - '74	1
	143-221	\$27.99	COIL, aftermarket, push-in conn.		1
	143-230	\$34.99	COIL, ballasted system		Sep. '74 (74 1/2) - '80
	143-201	\$44.99	SPORTS COIL, Intermotor brand	1962-'74	1
	117-264	\$44.99	SPORTS COIL, Intermotor brand	Sep. '74 (74 1/2) - '80	1
2	571-045	\$0.39	CONNECTOR, double male		A/R
3	36-5019	NA	LUCAS COIL DECAL		1
4	146-310	\$0.49	WASHER	early coils with screw-in connection	1
5	152-400	\$2.69	NUT, coil wire		1
6	571-037	\$0.89	WIRE END, push-in coil wire		1
7	571-047	\$1.69	BOOT, push-in coil wire		1
8	470-055	\$44.99	BRACKET, coil mounting	1962-'67	1
	171-628	\$59.99	IGNITION WIRE SET, w/caps	side entry distributor cap all (e)18G/GA/GB	1
10	171-620	\$9.99	CAP, suppressor		4
11	171-627	\$8.99	WIRE, ignition, 5 1/4 ft.		1
12	171-550	\$3.29	SPACER, ignition wires		1
13	171-630	\$9.99	LABEL SET, ignition wires		1

To use modern high performance ignition wires with your early distributor, use top-entry cap 163-815 rotor 151-710, Magnecore wire set 143-565, and ignition coil 143-200 or 143-220.

18	171-658	\$29.99	IGNITION WIRE SET	top entry distr. cap	1
	143-565	\$134.99	IGNITION WIRE SET, "Magnecore"		1
19	152-130	\$3.69	SPARK PLUG, Champion		4
	052-627	NA	SPARK PLUG, NGK (standard type)		4
	115-332	\$4.79	SPARK PLUG, NGK (resistor type)		4
20	131-560	\$29.99	DRIVE RESISTOR	electronic ignition '75-80	1

### Positive to Negative Ground Conversion

You can fit modern stereo systems, power antennae, CB radios, etc. to your pre-1968 MGB if you change from positive to negative ground. This is easily done! First you must change your battery cables or clamps so they will fit on the opposite terminals. Leaving them disconnected, now reverse the positions of the two wires connected to your ignition coil. Next, the generator must be re-polarised. Disconnect both generator leads. Take a piece of 14 gauge wire and attach it to the main "hot" terminal of your starter solenoid or to a "hot" terminal on your fuse block. Reconnect your batteries in the new configuration (with the negative post going to ground). Now take the loose end of your 14 gauge wire and flash it once or twice against the field (smaller) terminal of the generator, just enough so you can see a small spark. (Do not connect this wire to the generator, even for a few seconds.) Now remove the 14 gauge wire, and reconnect your generator leads. If your car has an ammeter or voltmeter, simply reverse their leads. Wiper and blower motors need no changes. Original pre-1968 S.U. fuel pumps are not polarity sensitive, but modern S.U. replacements are, and must be replaced with negative ground S.U. pumps. You are now finished, unless you have a 1965-67 car with an electric tachometer.

To convert the tachometer, John Twist offers the following advice:

Two changes are necessary to completely convert your early positive ground electric tach: a.) The wires must be reversed at the "white wire loop" at the back of the unit, and b.) the power and earth connections must be reversed inside the case.

### Before

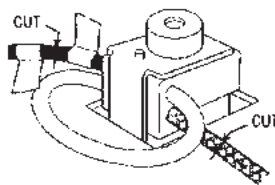

### After

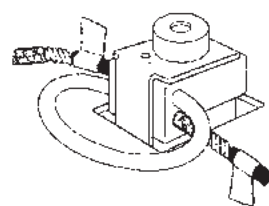

a.) The wire in the "white wire loop" comes from the key switch and travels to the hot side of the coil. Referring to the illustration below, select one of the wires and tag it with two pieces of tape for identification. Then, cut the wire between the pieces of tape, and cut the other wire to the same length. Reverse the connections (now there is one piece of tape on each wire) and solder them (remember, this is the power lead for the coil and is unfused). Tape up the connections carefully. When later replacing the plastic block on the back of the tach, ensure that the metal band around the block is carefully positioned. This is a necessary part of the electromagnetic pickup.

b.) To reverse the power wire and earth wire inside the unit, it is necessary to remove the chrome ring, the glass face and the glare shroud. The chrome ring is usually removed with great difficulty by prying the tabs with a small screwdriver, then rotating until the tabs can fit through the slots in the case. Remove the two screws on the back of the unit that hold the internals to the case (not the two whose heads fit in holes in the case), and allow those internals to drop carefully into your hand. Don't bend the needle! The spade terminal is the power connection. Just next to this is the earth connection. A resistor is soldered to one of these connections, and a green wire to the other. Unsolder these ends of the green wire and the resistor from their current positions. Resolder the green wire to where the resistor was connected, and the resistor to where the green wire was connected. Reassemble the unit after cleaning the glass.

# Minor Electrical

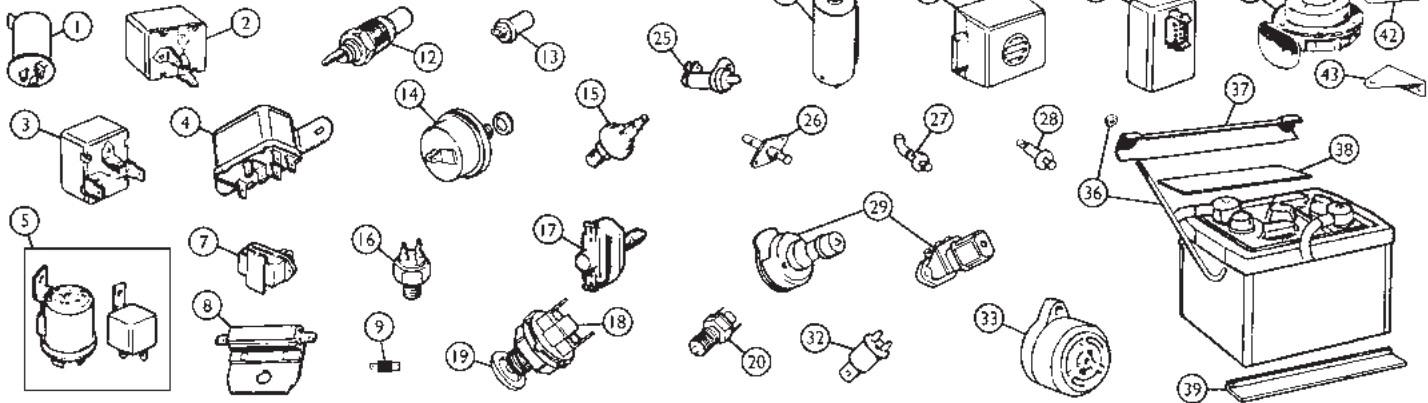

## Minor Electrical

19896

No.	Part#	Price (Each)	Description	Application	Qty Req.
1	141-750*	\$9.59	FLASHER UNIT, turn signals	RD to (c)138400, GT to (c)139471	1
2	141-748**	\$16.99	FLASHER UNIT, turn signals	RD from (c)138401 on, GT from (c)139472 on '68 on	1
3	141-655*	\$4.89	FLASHER UNIT, hazard (repl.)	RD from (c)138401 to 238407,	1
	141-747**	\$15.99	FLASHER UNIT, hazard (repl.)	GT from (c)139472 to 239804	1
	141-650*	\$4.19	FLASHER UNIT, hazard	RD from (c)238408, GT from (c)239805	1
	141-748**	\$16.99	FLASHER UNIT, hazard (repl.)	(c)239805	1
* Thermal (bi-metallic) type ** Electronic replacement type, more reliable than thermal type.					
4	542-235	\$5.99	RELAY, radiator fans	1977-'80 as fitted	1
5	131-520	\$21.99	RELAY, ignition switch either one illustrated may be fitted	RD from (c)410001 on, '77 on	1
	131-520	\$21.99	RELAY, heated rear window	GT as fitted	1
7	131-556	\$18.99	VOLTAGE STABILIZER, pos. grd	RD & GT 1965-'67	1
	131-555	\$18.99	VOLTAGE STABILIZER, neg. grd	RD from (c)138401 on, GT from (c)139272 on	1
8	131-560	\$29.99	DRIVE RESISTOR	electronic ignition	1
9	181-855	\$29.99	DIODE, handbrake light	as fitted 1978-'80	1
12	760-180	\$13.99	SENDING UNIT, temp. 1968 - '76	RD from (c)138401 to 410000, GT from (c)139472 on	1
	131-566	\$11.99	SENDING UNIT, temp.	RD from (c)410001 on	1
13	542-215	\$37.99	SWITCH, thermostatic fan	RD from (c)410001 to 511290	1
	542-213	\$56.99	SWITCH, thermostatic fan	RD from (c)511291 on	1
14	131-580	\$139.99	TRANSMITTER, oil press. 1968 - '72	RD from (c)138401 to 258000, GT from (c)139472 to 258000	1
15	141-715	\$33.99	SWITCH, oil press. 1973 on	RD from (c)294251 on, GT from (c)296001 on	1
16	542-110	\$9.99	SWITCH, brake light 1962 - '67	RD to (c)138400, GT to (c)139471	1
17	181-980	\$11.49	SWITCH, brake light, 1968-on	RD from (c)138401 on, GT from (c)139472 on	1
	310-070	\$0.39	JAM NUT for switch	from (c)139472 on	1
18	140-470	\$12.99	SWITCH, reverse light	RD/GT from mid 1967 on	1
19	324-145	\$0.39	WASHER, for switch	RD/GT from mid 1967 on	1
20	542-410	\$18.99	INHIBITOR SWITCH, seat belt (replacement)	RD from (c)138401 to 410000, GT from (c)139472 on	1
21	900-240	\$61.49	INERTIA SWITCH (repl.) fuel cut-off	RD from (c)360301 to 516373, GT from (c)361001 on	1
	145-755	\$189.99	INERTIA SWITCH, fuel cut-off	RD from (c)516374 on	1
25	131-600	NA	SWITCH, ignition key warning 1970 on	RD from (c)187211 on, GT from (c)187841 on	1
26	131-611	\$12.49	SWITCH, courtesy light	RD/GT from (c)219001 on	2
27	131-620	\$19.99	SWITCH, trunk light	RD from (c)21900 on	1
28	131-630	\$16.99	SWITCH, tailgate light	GT only from (c)219001 on	1
29	NA		SWITCH, headlamp dimmer	See page 92	
32	142-110	NA	BUZZER, ignition, key warning	RD from (c)187211 to 328100, GT from (c)187841 to 328800	1
33	142-115	NA	BUZZER, ignition, key warning	RD from (c)328101 to 372612, GT from (c)328801 on	1
34	142-125	NA	BUZZER, time delay	RD from (c)372613 on	1
35	145-760	NA	SEQUENTIAL SEAT BELT CONTROL	RD (c)328101 to 372612, GT from (c)328801 on	1
36	473-188	\$11.99	J-BOLT SET, 4 J-bolts, 4 nuts	two 6-volt batteries	1
	473-238	\$4.99	J-BOLT SET, 2 J-bolts, 2 nuts	one 12-volt battery	1
37	473-180	\$6.59	CLAMP, battery	two 6-volt batteries	2
	473-185	\$14.99	CLAMP, battery	one 12-volt battery	1
38	473-110	\$0.69	PAD, battery clamp	two 6-volt batteries	2
	473-115	\$1.59	PAD, battery clamp	one 12-volt battery	1
39	473-190	\$3.69	PAD, battery	two 6-volt batteries use 4	4/2

No.	Part#	Price (Each)	Description	Application	Qty Req.
41	545-030	\$53.99	HORN, high note	die-cast, 2 terminals, 1962-1976	1
	545-020	\$53.99	HORN, low note	1976	1
	545-050	\$22.99	HORN, high note	plastic, 1 terminal, 1977-1980	1
	545-060	\$22.99	HORN, low note	1980	1
42	560-090	\$5.29	HORN BRACKET, straight	to (c)5812	2
43	164-940	\$3.49	HORN BRACKET, angled	from (c)5813	2

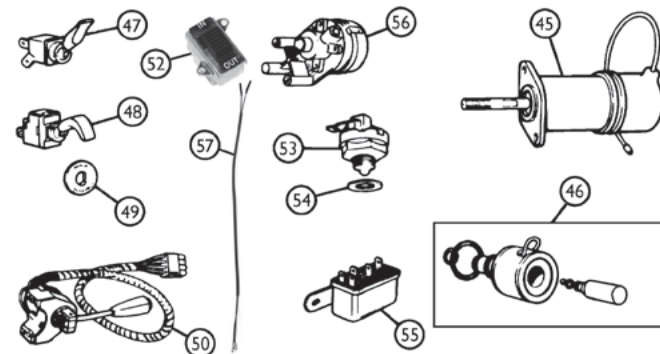

## Overdrive Components

19897

No.	Part#	Price	Description	Application	Qty Req.
45	145-730	\$56.99	SOLENOID, overdrive	RD to (c)138400, GT to (c)139471	1
46	466-375	\$189.99	SOLENOID VALVE, OD	RD from (c)138401 on, GT from (c)139472 on	1
47	141-210	\$8.99	SWITCH, overdrive	RD to (c)61015	1
48	141-760	\$52.99	SWITCH, overdrive	RD from (c)61016 to 138400,	1
49	233-850	\$6.69	ESCUTCHEON, o/d switch	GT from (c)61016 to 139470	1
50	141-825	\$99.99	SWITCH, wiper, washer, overdrive	RD from (c)138401 to 328100, GT from (c)139471 to 328800	1
	141-846	\$109.99	SWITCH, wiper, washer, overdrive	RD from (c)328101 to 410000, GT from (c)328801 on	1
52	141-320	\$12.49	SWITCH, overdrive, on shifter	RD from (c)410001 on, '77 on	1
53	140-470	\$12.99	SWITCH, overdrive isolation		1
54	324-145	\$0.39	WASHER, for switch		2
55	542-170	\$21.99	RELAY, overdrive, thru 1967	RD to (c)138400, GT to (c)139471	1
56	141-520	NA	VACUUM SWITCH, overdrive	(c)139471	1
	357-388	\$86.99	SUB-HARNESS, overdrive	thru 1967	1
	356-436	\$32.99	SUB-HARNESS, overdrive	1968-'76	1
	356-439	\$46.99	SUB-HARNESS, overdrive	1977-'80	1
57	161-581	\$26.99	WIRE PAIR to o/d switch	1977-'80	1

# Wipers & Washers

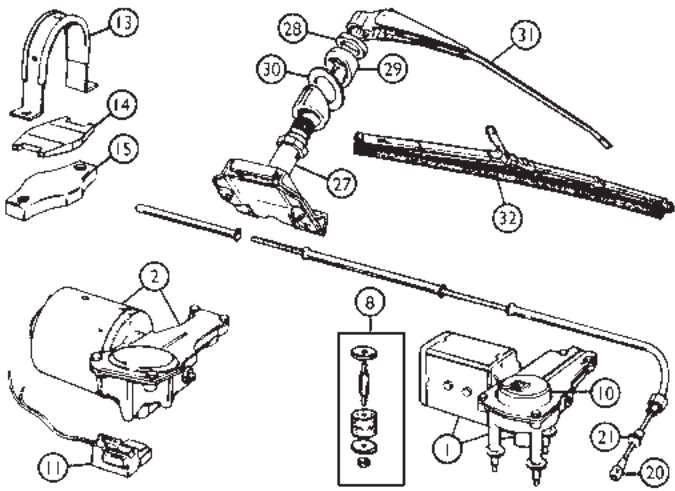

## Wipers

19898

No.	Part#	Price (Each)	Description	Application	Qty Req.
1	568-018	NA	MOTOR ASS'Y., w/gear	RD to 138400, thru 1967	1
	145-510	NA	MOTOR ASS'Y., w/o gear		1
2	145-558	\$164.99	MOTOR ASS'Y., w/gear (repl.)	RD from (c)138401 to 158370	1
	145-558	\$164.99	MOTOR ASS'Y., w/gear	RD from (c)158371 (1969-on)	1
	145-548	NA	MOTOR ASS'Y., w/gear	GT to (c)138400 (thru 1967)	1
	145-568	\$139.99	MOTOR ASS'Y., w/gear	GT 1968	1
	145-558*	\$164.99	MOTOR ASS'Y., w/gear*	GT from (c)158231 (1969 on)	1
	145-555*	\$21.99	GEAR & SHAFT*	RD & GT from 1969 on	1
	164-960	NA	GEAR & SHAFT	GT to (c)138400 (thru 1967)	1
	145-565	\$49.99	GEAR & SHAFT	GT 1968	1
	145-490	\$99.99	MOTOR ASS'Y., w/o gear	RD to (c)138400	1
	145-485	NA	MOTOR ASS'Y., w/o gear, Lucas	RD & GT 1968-on	1
*Motor Ass'y. and Gear & Shaft marked * will work for GT only when the nylon parking cam on the gear is moved to the opposite side of the gear. Instructions are at mossmotors.com.					
	554-040	NA	ARMATURE, thru 1967	RD to (c)138400	1
	145-570	NA	ARMATURE, 1968 on	RD from (c)138401 on/ all GT	1
	554-030	NA	BRUSH ASSEMBLY	RD to (c)138400, thru 1967	1
	554-035	\$22.99	BRUSH PAIR (carbon blocks only)	RD to (c)138400	1
	145-590	\$29.99	BRUSH ASSEMBLY	RD from (c)138401 on, all GT	1
8	145-640	\$14.99	MOUNTING KIT	RD to (c)138400, '62 - '67	1
10	145-610	NA	PARKING SWITCH		1
11	145-620	NA	PARKING SWITCH, units w/ part # prefixed "A/B"	RD from (c)138401 on	1
	145-630	\$37.99	PARKING SWITCH, units w/ part # prefixed "D"	all GT, 1968 on	1
13	145-645	\$9.99	STRAP, mounting	RD from (c)138401 on, all	1
14	145-660	\$4.29	PAD	GT 1968 on	1
15	145-665	NA	PACKING		1
20	161-310	\$23.99	CABLE ASSEMBLY, crosshead & rack (must be cut to length)		1
21	163-720	\$18.99	FERRULE, 1962 - '67	RD to (c)138400	1
	164-970	\$3.99	FERRULE, 1968 on	RD from (c)138401 on, all GT	1
27	145-170	NA	WHEELBOX ASSEMBLY, includes #28, 29, 30	RD to (c)6916	2
	145-180	NA	WHEELBOX only	RD from (c)6917 to 138400	2
	145-270	\$49.99	WHEELBOX only, 1968 on	RD from (c)138401 on	3
	145-160	\$48.99	WHEELBOX only	all GT	2
28	311-065	\$1.99	NUT	RD to (c)6916	2
	145-205	\$2.19	NUT	all from (c)6917 on	2/3
29	145-260	\$6.49	FINISHER, bright chrome	RD	2/3
	164-920	\$12.99	FINISHER, bright chrome	GT	2
30	282-820	\$0.79	PAD, finisher	RD	2/3
	145-225	\$1.19	PAD, finisher	GT	2
31	164-950	\$26.99	WIPER ARM, thru 1968	RD to (c)158230	2
	164-630	\$31.99	WIPER ARM, early 1969, "TEX"	RD from (c)158231 to 164063	3
	164-641	\$31.99	WIPER ARM, "TEX"	RD from (c)164064 to 294250, mid 1969-'72	3
	164-640	\$26.99	WIPER ARM	RD from (c)294251 on	3
	164-650	\$12.99	WIPER ARM, 1973 on	RD from (c)294251 on	3
	560-380	\$24.99	WIPER ARM, thru 1968	GT to (c)158230	2

Toll-Free Orders 1-800-667-7872 | MossMotors.com  
Fax 805-692-2525 | Local 805-681-3400



164-670	\$34.99	WIPER ARM, 1969 - '72, "TEX"	GT from (c)158231 to 296000	2
164-680	\$34.99	WIPER ARM, 1973 on, "TEX"	GT from (c)296001 on	2
32 560-390	\$10.99	WIPER BLADE, thru mid '69	RD to (c)164063	2/3
165-015	\$9.99	WIPER BLADE, mid '69-'72	RD from (c)164064 to 294250	3
165-060	\$9.99	WIPER BLADE	RD from (c)294251 on,	3
165-062	\$11.49	WIPER BLADE, Bosch	1973 on	3
165-021	\$21.99	WIPER BLADE, "TEX"	GT to (c)158230, thru 1968	2
165-020	\$10.99	WIPER BLADE	GT to (c)158230, thru 1968	2
165-050	\$10.99	WIPER BLADE, 1969 - '72	GT from (c)158231 to 296000	2
165-079	\$26.99	WIPER BLADE, "TEX"	GT from (c)296001 on,	2
165-080	\$7.99	WIPER BLADE	1973 on	2

Wiper arms and blades changed a number of times during production and are sometimes, but not always, interchangeable. In addition, many MGBs have been fitted over the years with completely non-original arms and/or blades. Our listings represent original or exact reproductions of the originals. If our arms or blades do not fit your car correctly, chances are good that the mounting part is non-original and should also be replaced.

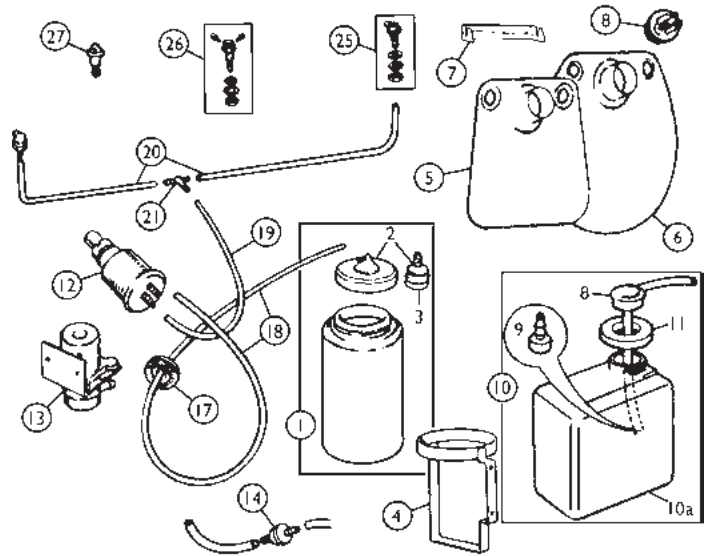

## Washers

19899

1	361-148	\$18.99	CONTAINER ASSEMBLY	RD/GT as fitted, to approx. 1972	1
2	361-140	NA	CAP & FOOT VALVE		1
3	361-145	\$3.19	FOOT VALVE		1
4	361-245	\$12.69	BRACKET		1
5	361-110	NA	CONTAINER (N/A - use 361-120)	RD from 1972 to (c)307778, GT from 1972 to (c)307778	1
6	361-120	\$34.99	CONTAINER	RD from (c)307779 to 360300, GT from (c)307779 to 361000	1
7	361-270	\$13.69	BRACKET, container mounting	use with #5 & 6 above	1
8	361-190	\$1.99	FILLER PLUG	used w/part #361-110, 361-120 & 361-130	1
9	361-145	\$3.19	FILTER, replacement		1
10	361-138	\$19.99	CONTAINER ASS'Y. (8,9,10a,11)	RD from (c)360301 on, GT from (c)361001 on	1
10a	361-130	\$17.99	CONTAINER		1
11	361-150	\$3.99	CAP		1
12	361-160	\$29.99	PUMP, manual 1962 - '67 (use with in-line valve no. 14 in outlet line)	RD to (c)138400, GT to (c)139471	1
13	NA	NA	PUMP, 1968 - early '74 (N/A - use 361-180)	RD from (c)138401 to 329016, GT from (c)139472 to 329016	1
	361-180	\$16.99	PUMP, early 1974 on	RD/GT from (c)329017 on	1
14	361-200	\$8.49	VALVE, in-line		1
17	282-640	\$1.49	GROMMET, washer tube		1
18	361-210*	\$1.09	TUBING, container to pump, 3/16" ID		A/R
19	361-210*	\$1.09	TUBING, pump to connector, 3/16" ID		A/R
20	361-210*	\$1.09	TUBING, connector to jets, 3/16" ID	RD thru '77	A/R
	361-220*	\$0.99	TUBING, connector to jets, 1/8" ID	RD '78-'80	A/R
*sold by the foot					
21	565-040	\$1.99	CONNECTOR, 3-way	RD to (c)138400, thru 1967	1
	361-235	NA	CONNECTOR, 3-way	RD (c)138401-447035, 1968-'77	1
	115-372	\$1.39	CONNECTOR, 3-way	RD from (c)447036, 1978-'80	1
25	361-240	\$5.49	JET ASSEMBLY	RD to (c)447035, thru 1977	2
26	361-250	\$8.99	JET ASSEMBLY	GT	1
27	361-260	\$5.49	JET ASSEMBLY	RD from (c)447036, 1978-'80	2

# Wiring Harnesses

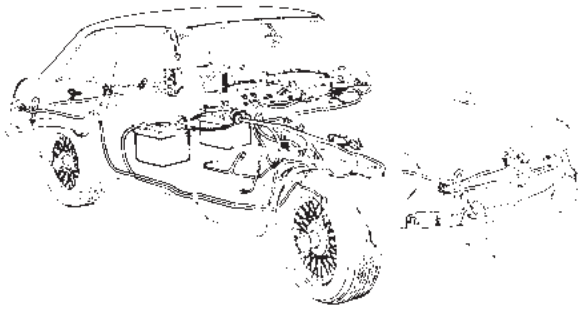

Moss wiring harnesses are produced in England directly from factory original drawings. All wiring included as integral parts of original harnesses are included. In some cases, this excludes wiring such as that for dash lights, dimmer switches, etc. All harnesses are color-coded as original, and include all original type connectors and end fittings. Early harnesses are bound with woven fabric braiding, while later harnesses are either blue or black tape-bound as original. These harnesses are for LHD U.S.-spec MGBs only.

**New harnesses have non-original dash lamp sockets replacing sockets illus. no. 8 on the facing page. These use wedge-base bulb 170-150. All post 1968 main wiring harnesses are fitted with the 540-280 alternator connector shown on the facing page, which was the standard replacement design for 1968 to 1974.5 and again for the 1978-80 models. This connector matches the replacement 130-102 45 amp alternator. For 1974.5 to 1978 models either swap to the 130-102 alternator, or re-use the original connector.**

## Roadster Harnesses

19902

Part#	Price (Each)	Description	Application	Qty Req.
356-370	\$629.99	WIRING HARNESS, cloth	RD to (c)48765 (thru 1964)	
356-390	\$599.99	WIRING HARNESS, cloth	RD (c)48766 to 138400 (1965-'67)	
357-288	\$699.99	WIRING HARNESS, vinyl	RD from (c)138401 to 158209, 1968	
356-520	\$599.99	MAIN HARNESS		
357-255	\$159.99	SUB-HARNESS, rear		
357-298	\$699.99	WIRING HARNESS, vinyl	RD from (c)158210 to 187210, 1969	
356-540	\$599.99	MAIN HARNESS		
357-255	\$159.99	SUB-HARNESS, rear		
357-308	\$769.99	WIRING HARNESS, vinyl	RD from (c)187211 to 219000, 1970	
356-550	\$669.99	MAIN HARNESS		
357-265	\$159.99	SUB-HARNESS, rear		
357-318	\$769.99	WIRING HARNESS, vinyl	RD from (c)219001 to 258000, 1971	
356-560	\$669.99	MAIN HARNESS		
357-400	\$159.99	SUB-HARNESS, rear		
357-328	\$719.99	WIRING HARNESS, vinyl	RD from (c)258001 to 267579, early 1972	
356-570	\$619.99	MAIN HARNESS		
357-400	\$159.99	SUB-HARNESS, rear		
357-348	\$729.99	WIRING HARNESS, vinyl	RD from (c)267580 to 294250, mid/late 1972	
356-590	\$639.99	MAIN HARNESS		
357-410	\$159.99	SUB-HARNESS, rear		
357-358	\$729.99	WIRING HARNESS, vinyl	RD from (c)294251 to 328100, 1973	
356-600	\$629.99	MAIN HARNESS		
357-410	\$159.99	SUB-HARNESS, rear		
357-368†	\$729.99	WIRING HARNESS, vinyl †	RD from (c)328101 to 360300, early 1974	
356-610	\$629.99	MAIN HARNESS		
357-420	\$159.99	SUB-HARNESS, rear		
357-378†	\$799.99	WIRING HARNESS, vinyl †	RD from (c)360301 to 368081, 1974 1/2 - early 1975	
356-620	\$699.99	MAIN HARNESS		
357-430	\$159.99	SUB-HARNESS, rear		
356-638†	\$739.99	WIRING HARNESS, vinyl †	RD from (c)368082 to 372612, mid 1975	
356-630	\$579.99	MAIN HARNESS		
357-430	\$159.99	SUB-HARNESS, rear		
356-648†	\$739.99	WIRING HARNESS, vinyl †	RD from (c)372613 to 386600, late 1975 (except CA)	
356-640	\$579.99	MAIN HARNESS		
357-430	\$159.99	SUB-HARNESS, rear		
356-658†	\$619.99	WIRING HARNESS, vinyl †	RD from (c)372613 to 386600, late 1975 (California only)	
356-650	\$509.99	MAIN HARNESS		
357-430	\$159.99	SUB-HARNESS, rear		
356-668	\$999.99	WIRING HARNESS, vinyl	RD from (c)386601 to 410000, 1976	
356-660	\$699.99	MAIN HARNESS		
357-430	\$159.99	SUB-HARNESS, rear		
356-665	\$279.99	SUB-HARNESS, dash		

† These do not include Dash Sub-Harness 357-425

Part#	Price (Each)	Description	Application	Qty Req.
356-678*	\$1,099.00	WIRING HARNESS, vinyl*	RD from (c)410001 to 471000, 1977-78	
356-670	\$719.99	MAIN HARNESS		
357-430	\$159.99	SUB-HARNESS, rear		
356-688*	\$1,099.00	WIRING HARNESS, vinyl*	RD from (c)471001 to 501003, 1979	
356-680	\$719.99	MAIN HARNESS		
357-430	\$159.99	SUB-HARNESS, rear		
356-698*	\$889.99	WIRING HARNESS, vinyl*	RD from (c)501004 to 511290, early 1980	
356-680	\$719.99	MAIN HARNESS		
356-695	\$164.99	SUB-HARNESS, rear		
356-708*	\$999.99	WIRING HARNESS, vinyl*	RD from (c)511291 to 516373, mid 1980	
356-700	\$629.99	MAIN HARNESS		
356-695	\$164.99	SUB-HARNESS, rear		
356-718*	\$949.99	WIRING HARNESS, vinyl*	RD from (c)516374-on, late 1980	
356-710	\$599.99	MAIN HARNESS		
356-695	\$164.99	SUB-HARNESS, rear		

\*These include dash sub-harness 356-365.

## GT Harnesses

19900

356-390	\$599.99	WIRING HARNESS, cloth	GT to 139470 (thru 1967)
(This does not include the "pigtail" connecting wiper motor to harness. Re-use old one.)			
356-528	\$699.99	WIRING HARNESS, vinyl	GT from 139471 to 158209, 1968
356-520	\$599.99	MAIN HARNESS	
356-535	\$159.99	SUB-HARNESS, rear	
356-548	\$699.99	WIRING HARNESS, vinyl	GT from (c)158210 to 187840, 1969
356-540	\$599.99	MAIN HARNESS	
356-535	\$159.99	SUB-HARNESS, rear	
356-558	\$769.99	WIRING HARNESS, vinyl	GT from (c)187841 to 219000, 1970
356-550	\$669.99	MAIN HARNESS	
356-555	\$159.99	SUB-HARNESS, rear	
356-568	\$769.99	WIRING HARNESS, vinyl	GT from (c)219001 to 258000, 1971
356-560	\$669.99	MAIN HARNESS	
356-565	\$159.99	SUB-HARNESS, rear	
356-578	NA	WIRING HARNESS, vinyl	GT from (c)268001 to 268280, early 1972
356-570	\$619.99	MAIN HARNESS	
356-565	\$159.99	SUB-HARNESS, rear	
356-598	\$619.99	WIRING HARNESS, vinyl	GT from (c)268281 to 296000, mid/late 1972
356-590	\$639.99	MAIN HARNESS	
357-440	\$159.99	SUB-HARNESS, rear	
356-608	\$729.99	WIRING HARNESS, vinyl	GT from (c)296001 to 328800, 1973
356-600	\$629.99	MAIN HARNESS	
357-440	\$159.99	SUB-HARNESS, rear	
356-618	\$729.99	WIRING HARNESS, vinyl	GT from (c)328801 to 361000, early 1974
356-610	\$629.99	MAIN HARNESS	
357-450	\$159.99	SUB-HARNESS, rear	
356-628	\$769.99	WIRING HARNESS, vinyl	GT from (c)361001-on, 1974 1/2
356-620	\$699.99	MAIN HARNESS	
357-460	NA	SUB-HARNESS, rear	

## Sub-Harnesses

19901

357-425	\$299.99	DASH SUB-HARNESS (not incl. in harness ass'y.)	1973-'75
356-665	\$279.99	DASH SUB-HARNESS (incl. in rdstr. harness ass'y.)	1976
356-365	\$299.99	DASH SUB-HARNESS (incl. in rdstr. harness ass'y.)	1977-'80
357-415	\$89.99	GAUGE ILLUMINATION HARNESS	1972-'73
356-672	\$27.99	HEADLAMP SWITCH SUB-HARNESS	1977-'80
356-385	\$129.99	HEADLAMP & HORN SUB-HARNESS	1965-67
356-845	\$22.99	DIP SWITCH SUB-HARNESS	1962-'67
357-445	\$36.99	TAILGATE HARNESS (not incl. in harness ass'y.)	GT only
356-437	\$22.99	REVERSE LIGHT WIRES	non-OD

NOTE: Overdrive sub-harness is listed on page 88.

## Blue Wire Harness Tape

Blue wiring harness tape will restore the look of your serviceable but slightly ratty looking wiring. This tape, as original, is not self-adhesive. Examine your wiring harness carefully, and you will see how this tape is used. For most MGBs from approximately 1969 and many other British cars with blue vinyl taped harnesses.

**162-030 \$13.99**





# Wiring Sundries

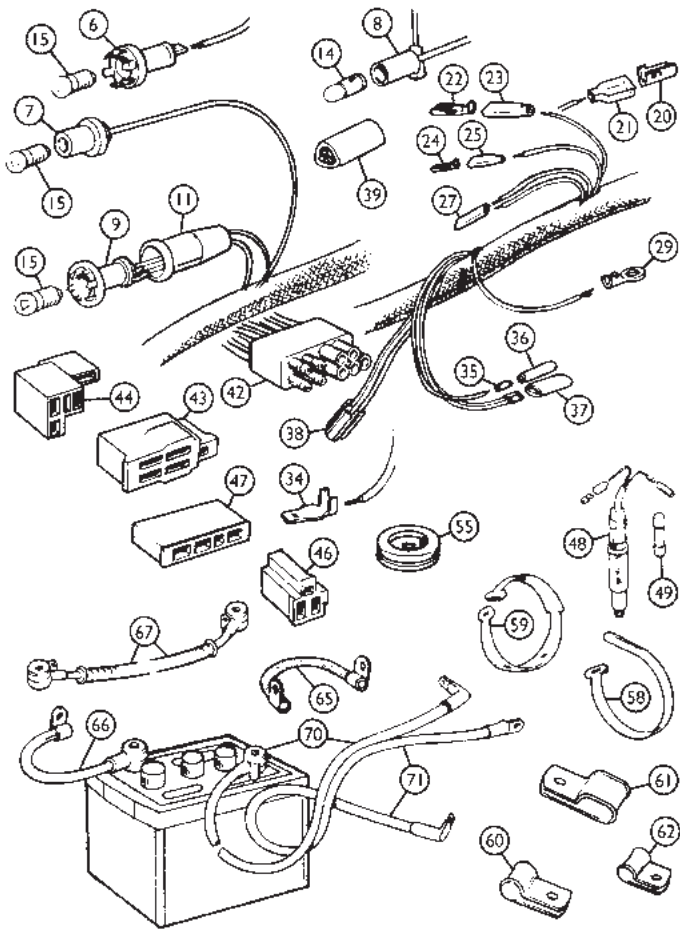

No.	Part#	Price (Each)	Description	Application	Qty Req.
	146-700	\$0.69	FUSE, 35 amp.		A/R
55	682-205	\$3.89	GROMMET, main harness/firewall		1
	282-640	\$1.49	GROMMET, fuel sending unit leads		1
	282-385	\$1.49	GROMMET, trunk floor & license light leads		3
When fitting new grommets for wiring, spray them with a silicone spray or Armorall®. This not only preserves them and makes them look better, but also eases installation.					
58	161-800	\$4.99	CLIP		A/R
59	161-845	\$4.29	STRAP, rubber		A/R
60	161-860	NA	CLIP, main harness to fire wall		A/R
61	161-870	\$3.49	CLIP, starter & battery cables		1
62	470-830	\$1.09	CLIP, 1/4" cable diameter, 7/32" hole		A/R
	162-210	\$1.39	CLIP, 1/4" cable diameter, 9/32" hole		A/R
	162-220	\$0.99	CLIP, 1/4" cable diameter, 11/32" hole		A/R
	181-550	\$1.39	CLIP, 5/16" cable diameter, 7/32" hole		A/R
	162-230	\$1.39	CLIP, 5/16" cable diameter, 9/32" hole		A/R
	162-240	\$0.99	CLIP, 3/8" cable diameter, 11/32" hole		A/R
	162-250	\$1.19	CLIP, 3/8" cable diameter, 7/32" hole		A/R
	162-270	NA	CLIP, 7/16" cable diameter, 9/32" hole		A/R
	162-280	\$0.99	CLIP, 1/2" cable diameter, 7/32" hole		A/R
	162-290	\$1.39	CLIP, 1/2" cable diameter, 9/32" hole		A/R
	162-310	\$1.39	CLIP, 5/8" cable diameter, 9/32" hole		A/R
	162-320	NA	CLIP, 3/4" cable diameter, 7/32" hole		A/R
	162-330	\$1.39	CLIP, 3/4" cable diameter, 9/32" hole		A/R
	162-350	\$1.39	CLIP, 7/8" cable diameter, 9/32" hole		A/R
65	332-070	\$34.99	CABLE, engine to ground		1
66	736-080	NA	CABLE, positive to ground ("helmet head")	1962-'67	1
	736-085	\$53.99	CABLE, positive to ground replacement clamp type		1
	NA		CABLE, negative to ground ("helmet head" cable - not available. Use 332-125)	1968-'74	1
	332-125	\$23.99	CABLE, negative to ground	1975-'80	1
67	332-130	\$69.99	CABLE, battery to battery	1962-'74	1
70	332-025	NA	CABLE, negative to solenoid ("helmet head")	1962-'67	1
	332-080	\$69.99	CABLE, negative to solenoid, repl.		1
	332-075	NA	CABLE, pos. to starter ("helmet head")	1968-'74	1
	332-085	\$69.99	CABLE, pos. to starter (clamp type)	1975-'80	1
71	332-140	\$23.99	CABLE, solenoid to starter	1962-'67	1

## Wiring Sundries

19904

No.	Part#	Price (Each)	Description	Application	Qty Req.
6	161-915	\$6.49	BULB HOLDER, orig. type		A/R
7	158-330	NA	BULB HOLDER, orig type		A/R
	158-332	\$14.99	BULB HOLDER, replacement, uses bulb 170-150		A/R
	170-150	\$0.89	BULB, wedge base, for replacement bulb holder 158-332		A/R
8	158-340	\$6.99	BULB HOLDER, orig. type, uses bulb 170-110		A/R
	158-345	NA	BULB HOLDER, replacement, uses bulb 170-690		A/R
	170-690	\$0.69	BULB, wedge base for replacement bulb holder 158-345		A/R
9	158-320	\$8.49	BULB HOLDER, orig. type		A/R
11	158-360	NA	SLEEVE, bulb holder		A/R
14	170-110	\$0.99	BULB, "eared" base		A/R
15	171-000	\$0.79	BULB, screw base		A/R
	170-150	\$0.89	BULB, wedge base (for new replacement harnesses)		A/R
20	161-510	\$0.79	SOCKET, Lucar, 6 amp. (3/16")		A/R
21	161-515	\$0.39	SLEEVE, Lucar		A/R
22	161-580	\$1.39	SOCKET, 35 amp. (3/8")		A/R
23	161-540	\$0.59	INSULATOR		A/R
24	161-520	\$0.59	SOCKET, 17.5 amp. (1/4")		A/R
25	161-550	\$0.59	INSULATOR, single wire		A/R
27	161-570	\$0.29	INSULATOR, double wire		A/R
29	161-740	\$0.59	EYELET, 3/16"		A/R
	161-750	NA	EYELET, 1/4"		A/R
	161-760	\$0.59	EYELET, 5/16"		A/R
34	162-205	NA	BLADE, 1/4"		A/R
35	162-200	\$0.49	WIRE NIPPLE		A/R
36	162-000	\$0.79	CONNECTOR, single		A/R
37	161-600	\$0.99	CONNECTOR, double		A/R
38	161-720	\$13.99	CONNECTOR, triple, 3 separate sleeves		A/R
39	161-730	\$17.99	CONNECTOR, 6-way, 3 common sleeves		A/R
42	161-770	NA	CONNECTOR		A/R
43	161-780	\$17.99	CONNECTOR		A/R
44	161-790	NA	CONNECTOR		A/R
46	161-820	NA	CONNECTOR		A/R
47	161-830	NA	CONNECTOR		A/R
48	146-750	\$1.89	FUSE HOLDER, in-line		A/R
49	146-730	\$0.49	FUSE, 10 amp.		A/R
	146-720	\$0.49	FUSE, 15 amp.		A/R
	146-710	\$0.49	FUSE, 25 amp.		A/R

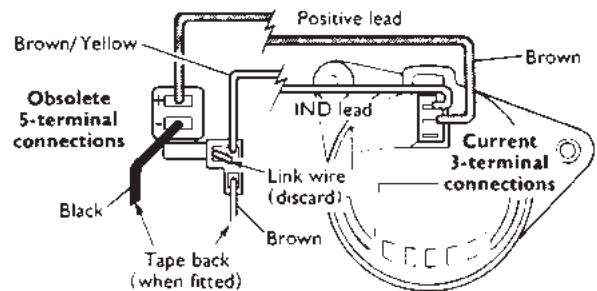

## Alternator Terminal Conversion

1968-'71 MGBs are wired for 5 alternator terminals. As the 5-terminal alternators are obsolete, 3-terminal alternators may be supplied. These wiring instructions provided by Lucas outline the conversion procedure. To wire a 3-terminal Lucas alternator in place of the now obsolete 5-terminal alternator, use plug kit #540-280 and proceed as follows:

- Disconnect battery.
- Cut off wiring terminal plugs from alternator wiring.
- Remove and discard link wire (see illus. above).
- Remove wiring harness tape, approximately 1 inch.
- Slide small insulator over remaining IND wire (brown/yellow), and solder to the small terminal.
- Separately tape them back onto harness; the small brown and black wires are not used, as they are no longer required.
- Connect the small brown/yellow IND wire to the small terminal on the alternator.
- Connect the large brown positive lead to either of the two large terminals on the alternator.
- Reconnect the battery.

**540-280 \$10.79 PLUG KIT, terminal conversion**



Toll-Free Orders 1-800-667-7872 | MossMotors.com  
Fax 805-692-2525 | Local 805-681-3400

MOSS

# Lamps

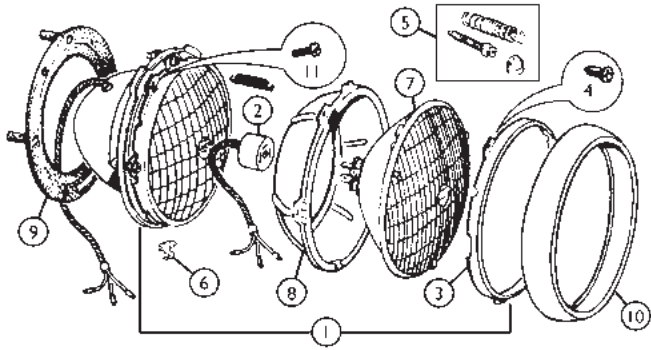

## Lucas 7" Halogen Headlamp

Made by Lucas, these high-quality headlamps come with replaceable H4 bulbs. Fits all regular 7" headlamp applications. Sold individually.

Lucas Headlamp, each	162-726	NA
Replacement H4 Bulb	902-998	\$6.39



## Headlamps

19911

No.	Part#	Price (Each)	Description	Application	Qty Req.
1	144-810	\$89.99	HEADLAMP ASSEMBLY		2
	169-130	NA	BUCKET ASSEMBLY		2
	144-807	\$27.99	BUCKET, bare (with adjusters)		2
2	171-400	\$8.99	PLUG, w/grommet, pigtail		2
3	156-700	\$14.99	RIM, inner		2
4	158-045	\$0.69	SCREW		6
5	552-115	\$5.99	ADJUSTER SET		2
6	560-325	\$2.99	CLIP, rim securing		2
7	171-100	NA	LIGHT UNIT, sealed beam (not in ass'y.)		2
	171-105	\$18.99	LIGHT UNIT, sealed beam, halogen (in ass'y.)		2
8	560-215	\$17.99	INNER RIM		2
9	164-060	\$4.29	GASKET, lamp seating		2
10	164-011	\$66.99	RIM, outer, repro., chromed brass	} to (c)505065, (1962-'79)	2
	164-012	\$15.99	RIM, outer, repl., chromed steel		2
	164-015	\$59.99	RIM, outer, with notch		2
11	373-960	\$0.20	SCREW, to body	from (c)505066 (1980)	8

## Crystal Clear Headlamp

For a modern look, we offer Crystal Clear headlights with halogen H4 bulbs. These are DOT and SAE approved and deliver a strong focused light. The housing is corrosion resistant coated die cast aluminum and the lens is vented to prevent fogging. Sold individually.

Crystal Clear Headlamp, each	156-875	\$58.99
Replacement H4 Bulb	902-998	\$6.39

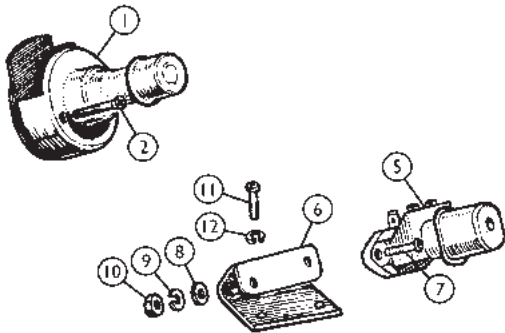

## Dimmer Switches

19912

1	542-120	\$24.99	SWITCH, headlamp dimmer (replacement w/ screw connections)	} RD/GT to (c)90363	1
2	NA		SCREW		2
5	542-130	\$28.99	SWITCH, headlamp dimmer	} RD/GT from (c)90364	1
6	NA		BRACKET		1
7	373-960	\$0.20	SCREW		2
8	315-085	\$0.29	WASHER		2
9	324-010	\$0.19	LOCKWASHER		2
10	115-467	NA	NUT		2
11	314-135	\$0.49	SCREW, bracket to floor		2
12	324-010	\$0.19	LOCKWASHER	2	

## PL700 Tripod Headlamp Pair

The PL700 was fitted to many high level sports cars. The unique lens design and prominent PL badge give a distinct look that is part of the historical heritage of our cars. These are semi-sealed units, and are not legal where D.O.T. approved headlamps are required.

PL700 Set	156-898	NA
Replacement Bulb	170-450	\$3.69
Bulb, quartz halogen	170-675	\$8.49



## Headlight Relay Kit

Your headlamps will be noticeably brighter, and the useful life of your headlamp switch will be considerably extended with this easy to install kit. Relays are strongly recommended for use with halogen headlamps.

117-515	\$36.99
---------	---------



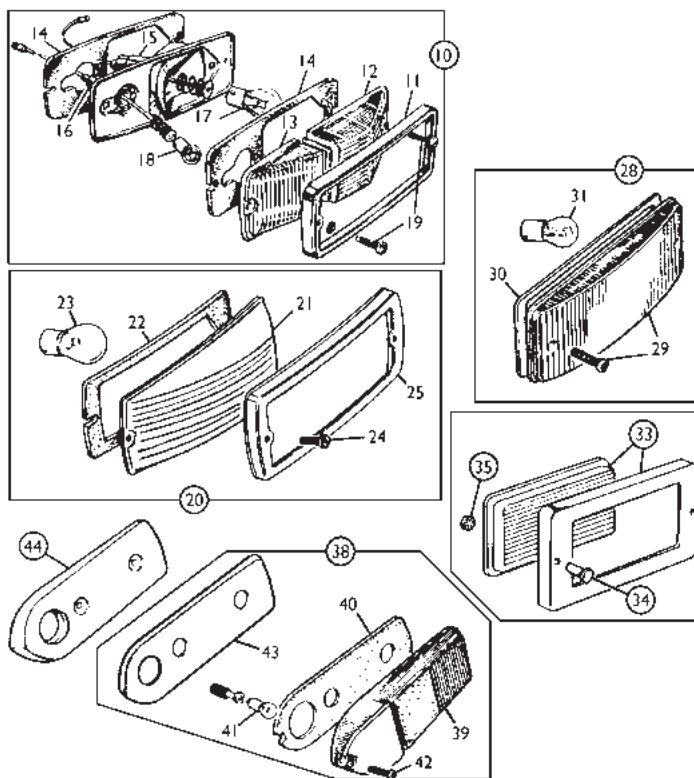

No.	Part#	Price (Each)	Description	Application	Qty Req.
38	164-846	\$64.99	SIDE LAMP, L/H, front, amber	RD from (c)187211 on, GT from (c)187841 on, 1970 on	1
	164-856	\$66.99	SIDE LAMP, R/H, front, amber		1
	164-865	\$59.99	SIDE LAMP, L/H, rear, red		1
	164-875	\$59.99	SIDE LAMP, R/H, rear, red		1
39	164-886	\$29.99	LENS ASS'Y., L/H, amber		1
	164-891	\$29.99	LENS ASS'Y., R/H, amber		1
	164-896	\$28.99	LENS ASS'Y., L/H, red		1
	164-905	NA	LENS ASS'Y., R/H, red		1
40	164-910	\$1.49	GASKET, lens seating		4
41	170-250	\$0.99	BULB, OE type, 6W 1970-'76		4
	170-100	\$0.59	BULB, OE type, 4W 1977-'80	4	
	170-911**	\$25.99	BULB, LED, front, amber**	2	
	170-916**	\$25.99	BULB, LED, rear, red**	2	
42	NA		SCREW, lens to base	4	
43	164-825	NA	LAMP BASE, chrome	4	
44	164-925	\$3.49	PLINTH, side lamp, L/F, black	1	
	164-935	\$3.49	PLINTH, side lamp, R/F, black	1	
	164-945	\$3.49	PLINTH, side lamp, L/R, black	1	
	164-955	\$3.49	PLINTH, side lamp, R/R, black	1	

## Side/Flasher Lamps

19913

No.	Part#	Price (Each)	Description	Application	Qty Req.
10	143-955	\$46.99	SIDE/FLASHER LAMP, w/base, clear/clear (replacement - new holes must be drilled for mounting studs)	1962-'67	2
	143-960	\$49.99	SIDE/FLASHER LAMP, w/base, clear/amber	1968 - '69	2
11	164-780	\$15.99	RIM	1962 - '69	2
12	164-770	\$6.49	LENS, flasher, amber alternative to 164-775		2
	164-775	\$6.49	LENS, flasher, clear alternative to 164-770		2
13	164-810	\$4.99	LENS, side lamp, clear alternative to 164-795	RD to (c)187213, GT to (c)187841, 1962-'69	2
	164-795	\$5.99	LENS, side lamp, amber alternative to 164-810		2
14	164-750	\$1.29	SEAL, lamp & lens seating		4
15	158-150	\$1.19	GROMMET, flasher lamp cable		2
16	158-600	\$1.99	GROMMET, side lamp cable		2
17	170-800	\$0.89	BULB, original type, flasher		2
	170-946**	\$29.99	BULB, LED, flasher, white**		2
	170-951**	\$29.99	BULB, LED, flasher, amber**		2
18	170-250	\$0.99	BULB, side lamp		2
19	158-210	\$1.89	SCREW, lamp to body		4
20	143-970	\$46.99	SIDE/FLASHER LAMP, w/base (2-bulb replacement, same wiring)	RD (c)187214 to 360300, GT (c)187842 to 361000, 1970 - '74 1/2	2
21	164-805*	\$8.99	LENS, side/flasher lamp*		2
22	164-110	\$6.79	SEAL, lamp & lens seating		4
23	170-700	\$0.69	BULB, side/flasher lamp (for original 1-bulb lamps)		2
	170-936**	\$29.99	BULB, LED, side/flasher, amber**		2
24	158-210	\$1.89	SCREW, lamp to body		4
25	164-780	\$15.99	RIM		2
*One-piece lens not available. 2-piece assembly (#12 & 13) supplied in amber.					
28	143-980	\$42.99	SIDE/FLASHER LAMP, w/base	RD from (c)360301 on, GT from (c)361001 on, 1974 1/2 on	2
29	164-815	\$8.49	LENS, amber, with screws & seal		2
	323-035	\$1.39	SCREW, lens to base		2
30	164-120	\$1.99	SEAL, lamp & lens seating		2
31	170-700	\$0.69	BULB, side/flasher lamp		2
	170-936**	\$29.99	BULB, LED, side/flasher, amber**	2	
33	570-180	\$18.99	SIDE REFLECTOR, front	RD from (c)158231 to 187210, GT from (c)158231 to 187840, 1969	2
	144-720	\$13.99	SIDE REFLECTOR, rear		2
34	158-230	NA	RIVET, reflector to body		8
35	158-235	NA	PUSH-ON FIX, rivet		8

\*\* Note: LED bulbs work with negative ground vehicles only. You will want to match LED bulb color with the color of the specific lamp lens to avoid color distortion. Use White for Clear, Amber for Amber, and Red for Red. In some applications there were multiple options, so the appropriate selection must be made based on your vehicle. If you are replacing turn signal bulbs with LEDs you will need to upgrade to an electronic flasher. Flasher part numbers are 141-667 for 2-Prong, or 141-668 for 3-Prong.



### Chrome Brake Light Kit

Center mounted 3rd brake lights reduce accidents, so much so they have been required on all passenger autos built since 1984. Our old cars, with two dim low mounted brake lights, aren't exactly easy to see. With a little creative wiring, you can mount one of our brilliant accessory 3rd brake light kits, and improve the safety of your British classic. The base can be removed for flush mounting.

**116-115 \$114.99**

# Lamps

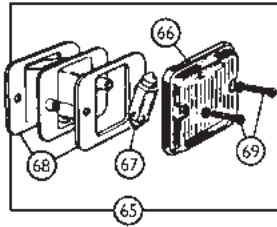
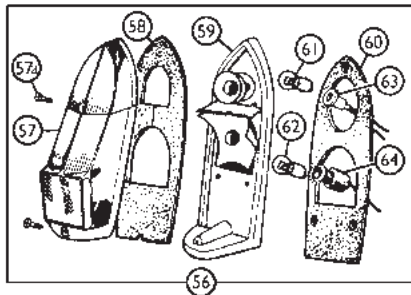
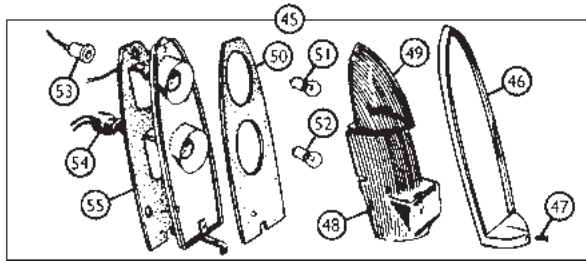

## Tail/Back-up Lamps

19914

No.	Part#	Price (Each)	Description	Application	Qty Req.
45	144-390	\$99.99	TAIL LAMP ASS'Y, w/base, red/red lenses	RD to (c)187210, GT to (c)187840, 1962 - '69	2
46	164-790	\$17.99	RIM		2
47	323-090	\$1.39	SCREW		2
48	164-820	\$18.99	LENS, stop/tail, orig. Lucas, red, bot.		2
49	164-830	NA	LENS, flasher, original Lucas, red, top		2
	164-725	NA	LENS, flasher, amber, Euro-spec		2
50	164-840	\$2.59	PAD, lens seating		2
51	170-800	\$0.89	BULB, original type, flasher		2
	170-956**	\$29.99	BULB, LED, flasher, red**		2
	170-951**	\$29.99	BULB, LED, flasher, amber**		2
52	170-700	\$0.69	BULB, original type, stop/tail		2
	170-941**	\$29.99	BULB, LED, stop/tail, red**		2
53	158-150	\$1.19	GROMMET, flasher cable		2
54	158-160	NA	GROMMET, stop/tail cable		2
55	164-870	\$1.69	PAD, lamp seating		2
56	144-395	\$169.99	TAIL LAMP ASS'Y, w/base (repro.)		2
57	164-836	\$62.99	LENS, premium (not in ass'y.)		2
	164-735	NA	LENS, replacement (in ass'y.)		2
57a	323-035	\$1.39	SCREW, lens to base		4
58	164-883	\$2.19	GASKET, lens to base		2
59	164-785	NA	LAMP BASE, chrome		2
60	164-880	\$2.09	GASKET, lamp seating		2
61	170-700	\$0.69	BULB, original type, stop/tail		2
	170-941**	\$29.99	BULB, LED, stop/tail, red**		2
62	170-800	\$0.89	BULB, original type, flasher		2
	170-951**	\$29.99	BULB, LED, flasher, amber**	2	
63	158-160	NA	GROMMET, stop/tail cable	2	
64	158-150	\$1.19	GROMMET, flasher cable	2	
65	144-595	NA	BACK UP LAMP, Lucas*	2	
	144-590	\$26.99	BACK UP LAMP, aftermarket*	2	
66	164-861	\$12.99	LENS w/gasket, Lucas style	2	
	164-860	\$7.99	LENS w/ gasket, aftermarket	2	
67	170-140	\$0.89	BULB	2	
68	159-110	\$1.49	GASKET, lamp & lens seating	4	
69	314-255	\$0.49	MACHINE SCREW	4	
	314-115	\$0.99	SELF-TAPPING SCREW	4	

\*Screws included with lamps are incorrect for this application. Use appropriate screws above (no. 69).

\*\* Note: LED bulbs work with negative ground vehicles only. You will want to match LED bulb color with the color of the specific lamp lens to avoid color distortion. Use White for Clear, Amber for Amber, and Red for Red. In some applications there were multiple options, so the appropriate selection must be made based on your vehicle. If you are replacing turn signal bulbs with LEDs you will need to upgrade to an electronic flasher. Flasher part numbers are 141-667 for 2-Prong, or 141-668 for 3-Prong.

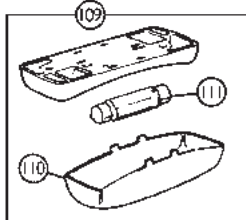
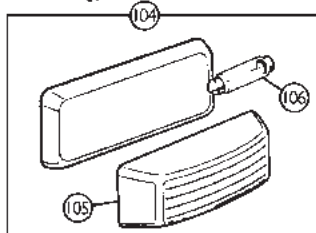
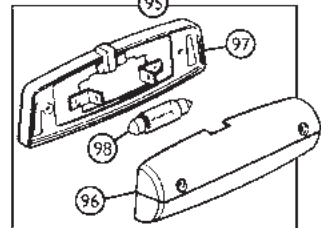
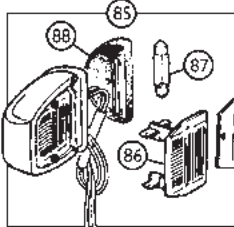
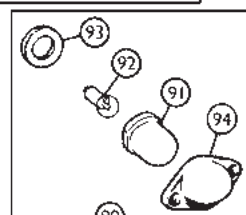
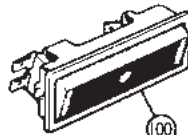
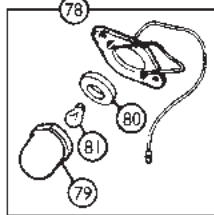
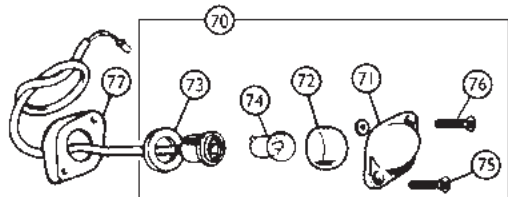

## License/Interior Lamps

19915

70	144-210	\$26.99	LICENSE LAMP ASSEMBLY	RD/GT to 187210, 1962-'69; RD/GT from (c)219001 to 339470, 1971 - '74	2
71	158-510	\$14.99	COVER		2
72	158-500	\$6.89	LENS		2
73	158-520	\$2.69	SEAL, lens seating		2
74	170-300	\$0.69	BULB		2
75	159-330	\$1.19	SCREW, long, stainless		2
76	159-335	\$0.99	SCREW, short, stainless		2
	159-340	\$0.69	NUT, stainless steel		4
77	159-325	\$22.99	BASE PAIR		1
	159-310	\$16.99	BASE, R/H		1
	159-320	\$16.99	BASE, L/H	1	
78	144-215	NA	LICENSE LAMP ASSEMBLY	RD/GT from (c)187211 to 219000, split bumper	2
79	158-515	\$18.69	COVER, glass		2
80	158-525	NA	SEAL, cover seating		2
81	170-030	\$0.79	BULB		2
85	144-220	\$29.99	LICENSE LAMP ASS'Y, chrome	RD/GT from (c)339095 to 409140, alternative to 144-230	2
86	158-915	\$4.49	LENS		2
87	170-010	\$0.49	BULB, original type		2
	LLB239LED	\$10.99	BULB, LED replacement	2	
88	144-225	\$3.99	GROMMET, base	2	
	144-230	\$26.99	LICENSE LAMP ASS'Y, black	RD/GT from (c)409140 on, alternative to 144-220	2
89	158-910	\$4.19	LENS		2
	170-010	\$0.49	BULB		2
	LLB239LED**	\$10.99	BULB, LED replacement**	2	
90	144-100	\$19.99	MAP LIGHT	1962-'67	1
	144-102	NA	MAP LIGHT	1968-'70	1
91	158-500	\$6.89	GLASS, map light	RD/GT to (c)258000, 1962-'70	1
92	171-000	\$0.79	BULB (not in assembly)		1
	170-973**	\$9.99	BULB, LED, positive ground**		1
	170-971**	\$9.99	BULB, LED, negative ground**		1
93	158-520	\$2.69	SEAL, lens seating	1	
94	158-510	\$14.99	CHROME COVER	1962-'67	1
	158-511	NA	CHROME COVER	1968-'70	1
95	158-920	\$14.99	COURTESY LAMP	RD/GT from (c)258001 to 410000, 1972 - '76	1
96	158-925	\$13.99	LENS, & BEZEL		1
97	158-930	NA	PLATE & SWITCH		1
	170-010	\$0.49	BULB, original type		1
	LLB239LED**	\$10.99	BULB, LED replacement**	1	
100	164-965	\$24.99	COURTESY LAMP, rocking	RD/GT from (c)410001 on, 1977 on	1
	170-025	\$1.69	BULB		1
104	164-975	\$21.99	DOME LIGHT ASSEMBLY	GT from (c)139472 on,	1
105	164-985	NA	LENS	1968 on	1
106	170-010	\$0.49	BULB, original type	1	
109	158-940	\$17.99	TRUNK LAMP, interior	RD from (c)219000 on, 1971 on	1
110	158-945	NA	LENS		1
111	170-010	\$0.49	BULB		1

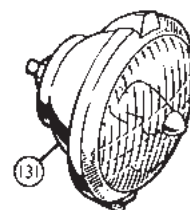
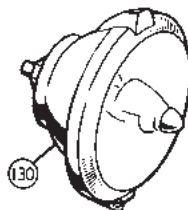
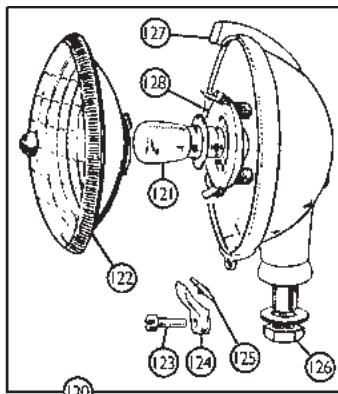
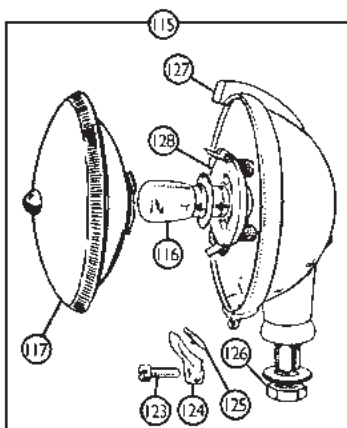

### Backmount Fog/Driving Lamps

19916

No.	Part#	Price (Each)	Description	Application	Qty. Req.
130	162-760	\$189.99	DRIVING LAMP ASSEMBLY		1
	170-505	\$7.99	BULB		1
	157-200	\$64.99	LENS ASSEMBLY, clear, non-fluted, driving		1
131	162-770	\$189.99	FOG LAMP ASSEMBLY		1
	170-510	\$6.99	BULB		1
	157-100	\$59.99	LENS ASSEMBLY, clear fluted, fog		1

### Stem-Mount Fog/Driving Lamps

19917

No.	Part#	Price (Each)	Description	Application	Qty. Req.
115	162-701	\$189.99	DRIVING LAMP ASSEMBLY, clear lens, accessory		1
116	170-505	\$7.99	BULB		1
117	157-200	\$64.99	LENS ASSEMBLY, clear, non-fluted, driving		1
120	162-800	\$189.99	FOG LAMP ASSEMBLY, clear, fluted lens, accessory		1
121	170-510	\$6.99	BULB		1
122	157-100	\$59.99	LENS ASSEMBLY, clear fluted, fog		1
123	158-000	\$2.99	SCREW	Fog & Driving Lamps	1
124	157-137	\$3.49	RETAINER		1
125	157-127	\$1.99	PAD, rubber		1
126	146-300	\$6.49	NUT, lamp mounting		1
127	157-117	NA	CREST, reproduction		1
128	157-087	\$9.99	CONTACT PLATE		1

Our reproduction fog and spot lamps are equal in quality and detail to the Lucas originals which have not been produced in many years. The backmount style was most often used on MGB works, race and rally cars, but both types of mount have been popular since the early 1950s.



### Rear Fog and Reverse Lamps

These matched lamps have polished stainless steel cases, glass lenses, and 20W H3 type halogen light bulbs. 4-1/2" wide, 2-1/4" high. 5/16" mounting hole required. Suitable for mounting below the rear bumper. Check your local regulations to make sure they are legal for street use. Sold individually.

Reverse Lamp, Clear	162-842	\$64.99
Rear Fog Lamp, Red	162-843	\$64.99



### Hella 500 Lights Kit

Nothing makes night-time driving safer than more, and brighter, lighting. Now we have 2 kits with everything you need to easily install these 6-1/2" lights. Kits include: two halogen lamps, two H3 12V/55W bulbs, two protective stone shields, plug n play harness, one illuminated switch, one 12V relay, and instructions. Lamp dimensions: 6.8" H x 6.4" W x 2.6" D.

Driving Lights (shown)	162-780	\$139.99
Fog Lights	162-785	\$149.99



### Driving Light Clamp

These clamps can be used to mount or 500 and 700 series fog or driving lamps to 3/4" badge bars. Plus they can be used for mounting antennas or other accessories.

408-579 \$19.99

# Dashboard 1962-'67

RD to (c) 138400/GT to (c) 139470

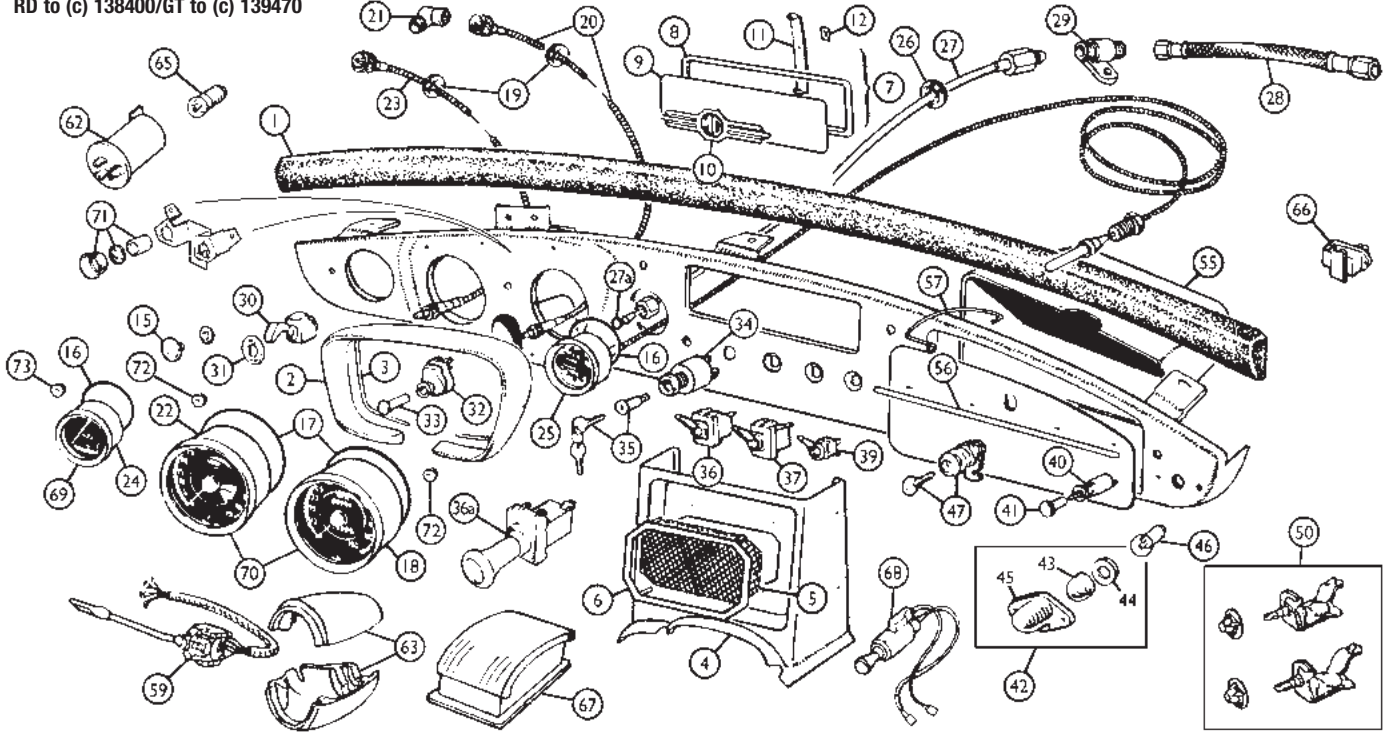

## Dashboard 1962-'67

19921

No.	Part#	Price (Each)	Description	Application	Qty Req.
1	453-570	\$169.99	DASH ROLL, black	fully finished and ready to install	1
	453-572	\$46.99	DASH ROLL COVER KIT, black		1
Includes piping and vinyl for covering dash roll and dash top.					
2	233-790	\$35.99	COWL, instrument		1
3	233-800	NA	FINISHER, cover	very early cars, as fitted	1
4	233-810	\$243.99	CONSOLE, speaker		1
Our 1963-'67 speaker console is an excellent quality, fully injection-moulded plastic reproduction. The price on this partially reflects some very expensive tooling costs. It should not be confused with lesser quality fiberglass replicas.					
5	233-820	NA	SCREEN, speaker		1
6	233-830	\$77.99	BEZEL, speaker screen		1
7	472-078	\$37.99	RADIO BLANKING PLATE SET		1
8	472-040	\$14.49	BEZEL, blanking plate		1
9	472-030	\$5.89	PLATE, blanking		1
10	472-050	\$16.99	BADGE, on plate		1
11	472-060	\$1.39	CLIP, plate retaining		2
12	326-520	\$0.29	SPEED NUT		2
15	233-840	NA	PLUG, blanking		1
16	280-870	\$0.69	MOUNTING RING, small gauges		2
17	280-890	\$1.69	MOUNTING RING, tach. & speedo		2
18	360-570	NA	SPEEDOMETER, non-overdrive		1
	360-580	NA	SPEEDOMETER, overdrive		1
19	281-900	\$2.19	GROMMET, speedometer & mech. tach. cable		2
20	331-300	\$15.99	CABLE, speedometer, non-overdrive		1
	331-190	\$28.99	CABLE, speedometer, overdrive		1
21	021-510	\$54.99	ANGLE DRIVE, speedo. cable, mounts on transmission		1
22	360-590	NA	TACHOMETER, mechanical		1
	360-600	NA	TACHOMETER, electronic, pos. ground		1
	361-340	NA	TACHOMETER, electronic, neg. ground, to fit this dash		1
	360-601	\$39.99	BLOCK, plastic (retains electr. tach impulse loop wire)		1
	360-602	\$17.99	CLIP, retainer		1
	360-603	\$1.59	NUT, clip retaining		1
23	331-200	\$21.99	CABLE, mechanical tachometer drive		1
24	360-610	NA	GAUGE, fuel	{ gauges marked FG2530-63, RD to (c)48765	1
	360-620	NA	GAUGE, fuel	{ gauges marked BF2300-02, RD from (c)48766, all GT	1
25	360-320	\$349.99	GAUGE, oil/water, orig. type	1962-'64	1
	361-790	\$329.99	GAUGE, oil/water, orig. type	1965-'67	1
	361-761	\$279.99	GAUGE, oil/water, replacement	1962-'67	1
26	282-385	\$1.49	GROMMET, oil gauge pipe		1
27	435-475	\$36.99	OIL PIPE, gauge to flex line		1
27a	435-516	\$0.39	LEATHER WASHER, gauge to pipe		1
28	376-180	\$16.99	OIL FLEX LINE		1
29	435-530	\$13.99	CONNECTOR		1
30	141-210	\$8.99	SWITCH, overdrive	RD to (c)61015	1

No.	Part#	Price (Each)	Description	Application	Qty Req.
	141-760	\$52.99	SWITCH, overdrive	RD/GT from (c)61016	1
31	233-850	\$6.69	ESCUTCHEON, overdrive switch		1
32	146-000	\$41.99	SWITCH, panel light		1
33	150-820	\$5.99	KNOB, panel light switch		1
34	542-077	\$23.99	SWITCH, ignition (replacement)		1
35	163-500	\$11.99	BARREL, w/two keys		1
36	141-230	\$16.49	SWITCH, lighting toggle type	RD/GT to (c)90001	1
36a	542-050	\$28.99	SWITCH, lighting pull type	RD/GT from (c)90002	1
	560-010	\$8.99	KNOB, pull type light switch		1
37	141-530	\$13.99	SWITCH, wiper	roadster	1
	141-610	\$28.99	SWITCH, wiper, Lucas	} GT	1
	141-615	\$13.99	SWITCH, wiper, aftermarket		1
39	141-210	\$8.99	SWITCH, heater fan		1
40	162-100	\$21.99	SWITCH, map light	replacement w/plain knob	1
41	150-800	\$5.99	KNOB, map light switch		1
42	144-100	\$19.99	MAP LIGHT (does not incl. bulb socket - wired into harness)		1
43	158-500	\$6.89	GLASS, map light		1
44	158-520	\$2.69	GASKET		1
45	158-510	\$14.99	COVER		1
46	171-000	\$0.79	BULB, map light		1
47	163-520	\$25.99	LOCK & KEY, glove box		1
	NA		CONTROLS, heater & defroster, see page 101.		
55	233-900	\$55.99	GLOVE BOX, fiberboard		1
	233-902	\$34.99	GLOVE BOX, moulded ABS plastic - perfect fit		1
	323-430	\$0.59	SCREW for glove box		6
56	233-910	\$46.99	FINISHER STRIP, glove box lid		1
57	233-907	\$18.99	RESTRAINT, glove box lid		1
59	141-770	\$38.99	SWITCH ASSEMBLY, turn signal		1
62	141-750	\$9.59	FLASHER UNIT		1
63	233-205	\$39.99	COWL, steering column	LHD	1
65	171-000	\$0.79	BULB, screw base		A/R
66	131-556	\$18.99	VOLTAGE STABILIZER (solid state replacement, pos. ground)		1
67	241-000	\$82.99	ASHTRAY (mtg. screws not incl.)	optional	1
	323-360	\$0.69	SCREW, ashtray mounting		2
68	142-270	\$13.99	LIGHTER	optional	1
69	360-075	\$16.99	BEZEL, chrome	2" gauges	2
70	360-085	\$32.99	BEZEL, chrome	speedo & tach	2
71	NA		LENS ASS'Y., turn indicator		2
72	361-035	\$2.99	NUT, speedo & tach		4
73	360-370	\$2.79	NUT, small gauges		4

1963-'67 dashboards were always painted in wrinkle finish black. We offer premium quality wrinkle finish paint in convenient-to-use ozone-friendly aerosol cans, #220-570. The dash should be completely removed, which is actually fairly easy, since all switches can be dropped out the back and wiring doesn't have to be disconnected. Original paint should be completely stripped, and new paint should be applied in full sunlight on a warm day for best "wrinkle" effect.

# 1968-'71 Dashboard

RD from (c) 138401 to 258000/GT from (c) 139471 to 258000

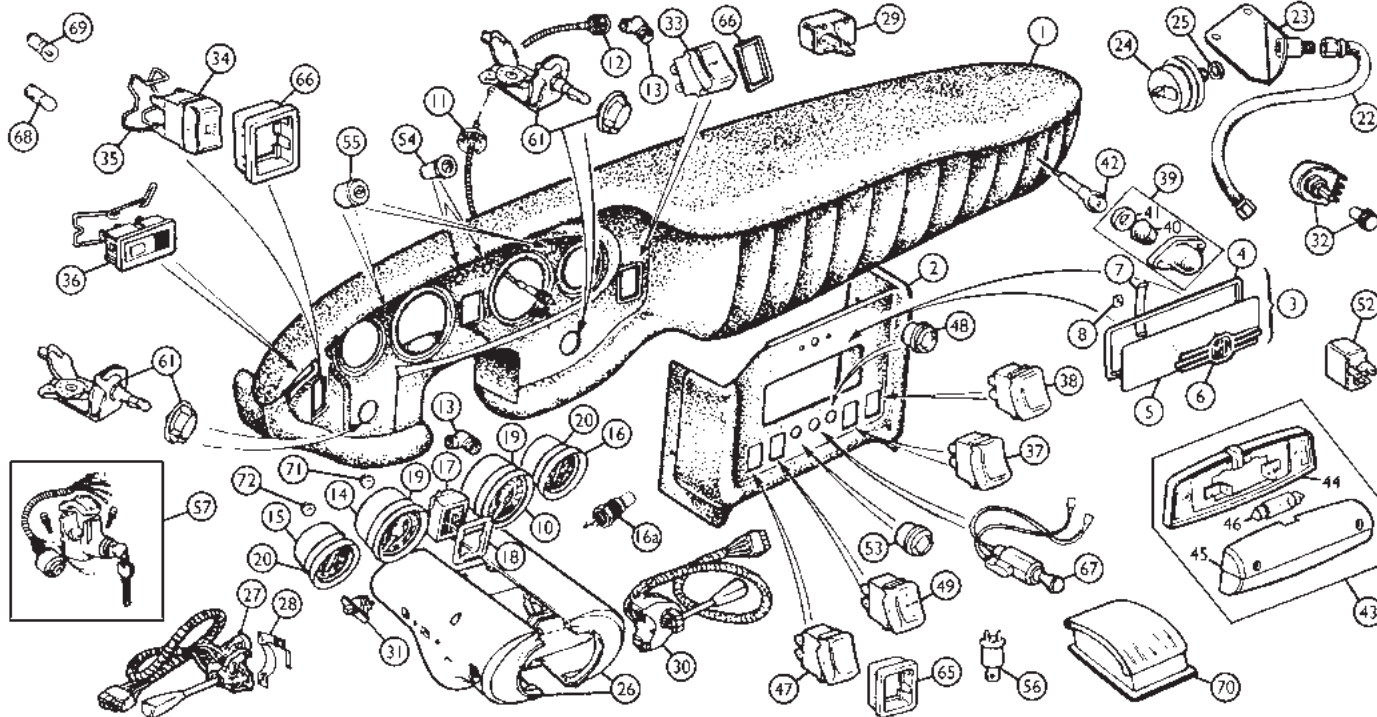

## Dashboard 1968-'71

19922

No.	Part#	Price (Each)	Description	Application	Qty Req.
1	453-721	\$489.99	DASH PANEL COVER		1
You can replace the cracked and peeling dash pad on your 1968 - '71 MGB with this beautiful reproduction cover which installs over the original steel backing. Detailed authentically (even the pebble-grain is exact!) with moulded foam backing for exact fit.					
	453-890	\$144.99	DASH TOP REPAIR PANEL		1
2	453-706†	NA	CONSOLE ASS'Y with metal bracket & cover	} 1968 - '71	1
	453-707§	\$164.99	COVER, radio console		1
† Console assembly has rectangular cut-out for 1971 courtesy lamp #43. To use this ass'y. on 1968-'70 cars use this lamp or make a bracket to mount original map light #39.					
§ Our radio console covers are vacuum-formed and foam-filled to ensure easy installation over an original stripped sheet metal base. Since all openings are easily cut with a razor blade after installation, a custom fit can be achieved for non-original radios.					
3	472-078	\$37.99	RADIO BLANKING PLATE SET		1
4	472-040	\$14.49	BEZEL, blanking plate		1
5	472-030	\$5.89	PLATE, blanking		1
6	472-050	\$16.99	BADGE, on plate		1
7	472-060	\$1.39	CLIP, plate retaining		2
8	326-520	\$0.29	SPEED NUT		2
10	360-830	NA	SPEEDOMETER, non-overdrive		1
	360-835	NA	SPEEDOMETER, overdrive		1
11	281-900	\$2.19	GROMMET, speedometer cable		1
12	021-381	\$29.99	CABLE, speedometer, non-overdrive		1
	331-430	\$19.99	CABLE, speedometer, overdrive		1
13	433-745	\$69.99	ANGLE DRIVE, speedo. cable, mounts on speedometer		1
	021-510	\$54.99	ANGLE DRIVE, speedo. cable, on transmission		1
14	360-870	NA	TACHOMETER		1
15	361-860	\$119.99	GAUGE, fuel		1
16	360-840	NA	GAUGE, temperature		1
16a	760-180	\$13.99	SENDING UNIT, temperature gauge		1
17	360-845	NA	GAUGE, oil pressure		1
18	360-945	NA	BEZEL, oil pressure gauge		1
19	280-895	\$1.49	MOUNTING RING, speedo & tach		2
20	280-870	\$0.69	MOUNTING RING, small gauges		2
22	376-180	\$16.99	OIL FLEX LINE		1
23	376-185	NA	BRACKET/CONNECTOR ASSEMBLY		1
24	131-580	\$139.99	TRANSMITTER, oil pressure		1
25	116-154	\$1.49	WASHER		1
26	233-210	NA	COWL, steering column		1
27	141-810	\$48.99	SWITCH, turn signal, horn, dimmer	RD/GT to (c)219000	1
	141-820	\$89.99	SWITCH, turn signal, dimmer	} RD/GT from (c)219001	1
28	141-804	\$29.99	CLAMP & HORN CONTACT		1
29	141-748	\$16.99	FLASHER UNIT, turn signals (replacement)		1

No.	Part#	Price (Each)	Description	Application	Qty Req.
30	141-825	\$99.99	SWITCH, wiper, washer, overdrive		1
31	140-520	\$56.99	SWITCH, panel light	RD/GT to (c)219000, '68-'70	1
32	146-000	\$41.99	RHEOSTAT, panel light (repl)	} RD/GT from (c)219001, 1971	1
	146-025	\$5.99	KNOB, panel light		1
33	141-250•	\$18.49	SWITCH, heater fan, replacement		1
34	141-260•	\$13.49	SWITCH, lighting		1
35	141-440	\$4.79	SECURING CLIP, switch (later plastic replacement)	A/R	1
36	141-620†	NA	SWITCH, brake check	1968	1
	141-280†	\$17.99	LAMP, brake failure warning	1969 - '71	1
37	162-150†	NA	SWITCH, heated rear window	GT to (c)187840	1
	141-290•	\$19.99	SWITCH, heated rear window	GT from (c)187841 to 258000	1
38	162-160•	\$25.99	SWITCH, map light		1
39	144-102	NA	MAP LIGHT	} 1968-'70	1
40	158-500	\$6.89	GLASS, map light		1
41	158-520	\$2.69	GASKET		1
42	171-000	\$0.79	BULB, map light		1
43	158-920	\$14.99	COURTESY LAMP ASS'Y.	} 1971 only	1
44	158-930	NA	BASE		1
45	158-925	\$13.99	LENS & BEZEL ASS'Y.		1
46	170-010	\$0.49	BULB, original type		1
	LLB239LED	\$10.99	BULB, LED replacement		1
47	162-170•	NA	SWITCH, fog/spotlight	(replacement)	1
48	142-220‡	NA	WARNING LIGHT, heated rear window	GT	1
49	140-540•	\$31.99	SWITCH, hazard warning	(replacement)	1
52	141-655	\$4.89	FLASHER UNIT, hazard warning	(thermal type, replacement)	1
	141-747	\$15.99	FLASHER UNIT, hazard warning	(electronic, replacement)	1
53	142-230†	NA	WARNING LIGHT, hazard warning		1
54	141-248	\$18.99	WARNING LIGHT, high beam, blue	(LED replacement)	1
	142-252	\$5.89	WARNING LIGHT, ignition, red	(replacement)	1
55	142-260‡	\$26.99	LENS UNIT, turn signals		2
56	142-110	NA	BUZZER, warning	} RD from (c)187211, GT from (c)1878411, 1970 on	1
57	NA		STEERING LOCK & SWITCHES, see page 42.		
61	NA		CONTROLS, heater & defroster, see page 101.		
65	142-120	NA	BEZEL, switches, black		4
66	141-265	\$6.49	BEZEL, headlight/heater switch, chromed		2
67	142-270	\$13.99	LIGHTER, w/repl. type knob		1
68	170-110	\$0.99	BULB, "eared" base	A/R	1
69	171-000	\$0.79	BULB, screw base, gauge illumination	A/R	1
	170-160	\$1.19	BULB, illuminated switches	A/R	1
70	241-000	\$82.99	ASHTRAY (mounting screws not included)		1
	323-360	\$0.69	SCREW, ashtray mounting		2
71	361-035	\$2.99	NUT, speedo & tach		4
72	360-370	\$2.79	NUT, small gauges		4

† Use bulb 170-160 illus. #69 (included).

‡ Illuminated by bulb 170-110 illus. #68 (not included).

• Replacement switch with chrome bezel

Toll-Free Orders 1-800-667-7872 | MossMotors.com  
Fax 805-692-2525 | Local 805-681-3400

MOSS

# Dashboard 1972-'76

RD from (c)258001 to 410000/GT from (c)258001 to 367803

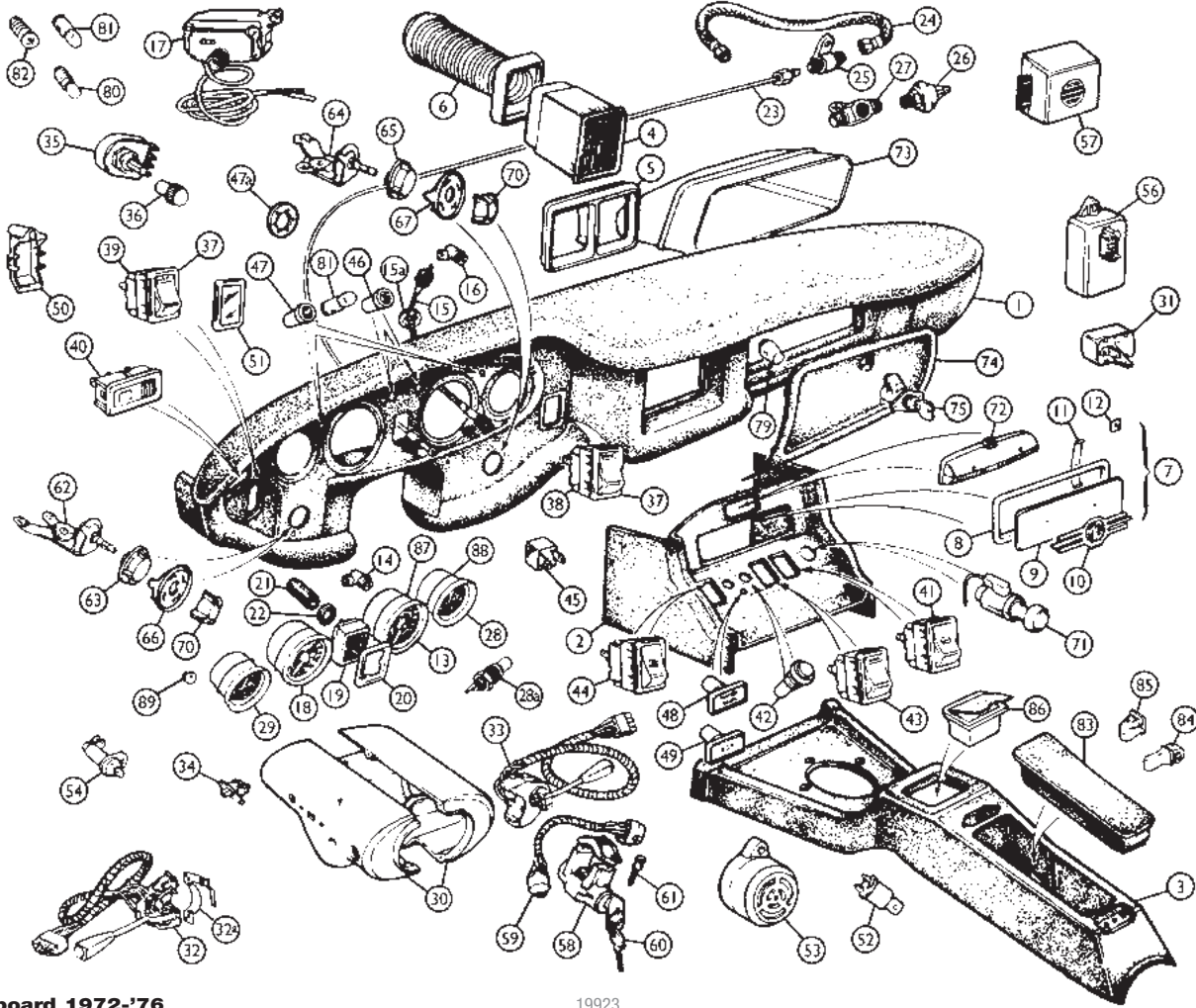

## Dashboard 1972-'76

19923

No.	Part#	Price (Each)	Description	Application	Qty Req.
1	453-741	\$469.99	DASH PANEL COVER		1
At last you can replace the cracked and peeling dash pad on your 1972 - '76 MGB with this beautiful and accurate reproduction cover which installs over the original steel backing. Detailed authentically (even the pebble-grain is exact!) with moulded foam backing for exact fit.					
	453-895	\$144.99	DASH TOP REPAIR PANEL		1
2	453-745	\$44.99	CONSOLE, radio		1
3	453-750	\$154.99	CONSOLE, tunnel, British Motor Heritage part		1
	453-753	NA	CONSOLE, tunnel, fiberglass replacement		1
4	473-300	NA	VENT, R/H, face level		1
	473-310	NA	VENT, L/H, face level		1
5	473-320	NA	ESCUTCHEON, vents		1
6	456-115	NA	TUBE, vent		2
7	472-078	\$37.99	RADIO BLANKING PLATE SET		1
8	472-040	\$14.49	BEZEL, blanking plate		1
9	472-030	\$5.89	PLATE, blanking		1
10	472-050	\$16.99	BADGE, on plate		1
11	472-060	\$1.39	CLIP, plate retaining		2
12	326-520	\$0.29	SPEED NUT		2
13	360-850*	NA	SPEEDOMETER, non-overdrive	RD/GT to (c)282419	1
	360-855*	NA	SPEEDOMETER, overdrive	RD/GT to (c)282419	1
	360-860*	NA	SPEEDOMETER, non-overdrive	RD/GT from (c)282420	1
	360-865*	NA	SPEEDOMETER, overdrive	RD/GT from (c)282420 to (c)386600	1
	361-670*	NA	SPEEDOMETER	RD from (c)386601 on	1
14	433-745	\$69.99	ANGLE DRIVE, on speedometer	RD/GT to (c)282419	1
15	021-381	\$29.99	CABLE, speedometer, non-overdrive	w/o service indicator	1
	331-430	\$19.99	CABLE, speedometer, overdrive	w/o service indicator	1
	331-440	\$19.99	CABLE, gearbox to indicator, non-O/D	w/service indicator	1
	331-445	\$19.99	CABLE, gearbox to indicator, O/D	w/service indicator	1
	732-000	\$18.99	CABLE, indicator to speedometer		1
15a	281-900	\$2.19	GROMMET, speedometer cable		1
16	021-510	\$54.99	ANGLE DRIVE, on transmission		1
17	142-060	NA	INDICATOR, service interval	1974 1/2 - '76	1
18	360-880*	NA	TACHOMETER	RD to (c)294250, GT to (c)296000	1

No.	Part#	Price (Each)	Description	Application	Qty Req.
	360-885*	NA	TACHOMETER	RD from (c)294251, GT from (c)296001	1
19	360-875*	NA	GAUGE, oil pressure		1
20	360-945	NA	BEZEL, oil gauge		1
21	435-505	NA	TUBE, distance		1
22	435-516	\$0.39	WASHER, leather		1
23	435-475	\$36.99	PIPE ASSEMBLY, gauge to flex line		1
24	376-180	\$16.99	OIL FLEX LINE		1
25	435-530	\$13.99	CONNECTOR, pipe to flex line	RD to (c)294250, GT to (c)296000	1
26	141-715	\$33.99	SWITCH, oil pressure (anti run-on)	RD from (c)294251,	1
27	180-245	NA	CONNECTOR, pipe & switch	GT from (c)296001	1
28	360-890*	NA	GAUGE, temperature		1
28a	760-180	\$13.99	SENDING UNIT, temperature gauge		1
29	361-860	\$119.99	GAUGE, fuel		1
30	233-220	NA	COWL, steering column		1
31	141-748	\$16.99	FLASHER UNIT, turn signal, replacement		1
32	141-820	\$89.99	SWITCH, turn signal, headlight dimmer	RD to (c)267109, GT to (c)267332	1
	141-830	\$68.99	SWITCH, turn signal, headlight dimmer	RD from (c)267110 to 328100, GT from (c)267333 to 328800	1
	141-840	\$39.99	SWITCH, turn signal, headlight dimmer	RD from (c)328101, GT from (c)328801	1
32a	141-804	\$29.99	CLAMP & HORN CONTACT	for turn signal switches	1
33	141-825	\$99.99	SWITCH, wiper, washer, OD	RD to (c)328100, GT to (c)328800	1

\* Since new gauges are unavailable, we suggest that you consider having your original gauge rebuilt by one of the following companies:

MO-MA, 1321 2nd St. NW, Albuquerque, NM 87102 (505) 766-6661, or  
West Valley Instruments, 19314 Van Owen, Reseda, CA 91335 (818)758-9500.



## Gauges

The electrically-operated gauges on MGBs are known to fail on occasion. Here is how you can pinpoint the cause and maybe fix the problem:

a. All electrical gauges, turn signals, and brake lights quit. Probable cause is failure or poor contact of the "green/white" fuse. Locate the fuse block, check the fuse which joins a green wire and a white wire. Clean the clips with fine emery cloth, replace the fuse. If the fuse was "blown", there is probably a fault in one of the circuits it protects; try and narrow the field by trying the horns, turn signals, etc., until you find what blows the fuse.

b. Fuel gauge doesn't work. Probable cause is a faulty voltage stabilizer (see page 86, #7 for listings). Stabilizer output should be 10 volts average. Since the stabilizer operates by making and breaking the circuit, the actual output fluctuates, making it difficult to measure with ordinary equipment. If there is no output, or the output is steady at battery voltage, the stabilizer is bad and must be replaced.

c. Fuel gauge doesn't work. Probable cause is a faulty tank sending unit; check as follows: Remove the green/black wire from the sending unit in the fuel tank. Connect one end of a test light to the terminal on this wire, the other end to ground. Switch on the ignition. Fuel gauge should begin a slow climb to full and the test light should glow. If the gauge does register, the sending unit must be bad; if the gauge still does not work it is either disconnected (check continuity of its wiring) or defective.

No.	Part#	Price (Each)	Description	Application	Qty Req.
	141-846	\$109.99	SWITCH, wiper, washer, OD	RD from (c)328101, GT from (c)328801	1
34	140-520	\$56.99	SWITCH, panel light		1
35	146-000	\$41.99	RHEOSTAT, panel light	RD to (c)294250, GT to (c)296000	1
	146-030	NA	RHEOSTAT, panel light (can use earlier 146-000)	RD from (c)294251, GT from (c)296001	1
36	146-025	\$5.99	KNOB, rheostat		1
37	141-265	\$6.49	BEZEL, heater, lighting, hazard, map light & heated back light switches		A/R
38	141-250	\$18.49	SWITCH, heater fan	RD to (c)267109, GT to (c)267332	1
	141-270	\$13.99	SWITCH, heater fan, illum.	RD from (c)267110, GT from (c)267333	1
39	141-260	\$13.49	SWITCH, lighting (1972) (replacement w/chrome bezel)	RD to (c)294250, GT to (c)296000	1
	141-275	\$13.99	SWITCH, lighting, illum. (1973-'76)	RD from (c)294251, GT from (c)296001	1
40	141-280	\$17.99	LAMP, brake failure warning	RD/GT to (c)386600	1
	170-160	\$1.19	BULB, brake check light		1
	142-295	NA	LAMP, brake failure warning	RD/GT from (c)386601	1
41	141-290	\$19.99	SWITCH, heated rear window	GT from (c)258001 to 267332	1
	141-290	\$19.99	SWITCH, heated rear window	GT from (c)267333	1
42	142-220†	NA	WARNING LIGHT, heated rear window	GT to (c)267332	1
43	140-540	\$31.99	SWITCH, hazard warning	1972	1
	141-635	\$13.99	SWITCH, hazard warning	1973-'76	1
44	162-170	NA	SWITCH, fog & spotlight	optional	1
45	141-650	\$4.19	FLASHER UNIT, hazard warning	thermal type replacement	1
	141-748	\$16.99	FLASHER UNIT, hazard warning	electronic replacement	1
46	141-248	\$18.99	WARNING LIGHT, high beam, blue	(LED replacement)	1
	142-252	\$5.89	WARNING LIGHT, ignition, red	(replacement)	1
47	†	NA	LENS UNIT, turn signals	(original type)	2
	142-265	\$9.99	LENS UNIT, turn signals, with non-replaceable bulb	(replacement)	2
47a	142-286	\$1.89	WASHER, retaining	nos. 42,46,47,48,49	5
48	142-285†	\$44.99	WARNING LIGHT, seat belt		1
49	142-305†	\$33.99	WARNING LIGHT, EGR/CATALYST		1
†Note: These use bulb 170-110 (illus. #81).					
50	141-440	\$4.79	CLIP, illuminated switches		6
51	141-455	\$5.99	BLANK PLUG, rocker switch		A/R
52	142-110	NA	BUZZER, ignition warning	RD to (c)328100, GT to (c)328800	1
53	142-115	NA	BUZZER, ignition warning	RD from (c)328101, GT from (c)328801	1
54	131-600	NA	SWITCH, ignition warning		1
56	145-760	NA	SEQ. SEAT BELT CONTROL	RD from (c)328101 to 372612, GT from (c)328801 to 367803	1
57	142-125	NA	BUZZER, time delay	RD from (c)372613	1
58	263-610†	\$109.99	STEERING LOCK & SWITCH ASSEMBLY (replacement)	RD from (c)187211 to 294250, GT from (c)187841 to 296000, 1970 - '72	1
59	263-670	NA	IGNITION SWITCH (repl. assy)		1
	263-655•	NA	IGNITION SWITCH (orig. assy.)		1

Toll-Free Orders 1-800-667-7872 | MossMotors.com  
Fax 805-692-2525 | Local 805-681-3400

MOSS

## 1972-'76 Dashboard

No.	Part#	Price (Each)	Description	Application	Qty Req.
	263-640†	\$43.99	STEERING LOCK & SWITCH ASSEMBLY (replacement)	RD from (c)294251 to 328100, GT from (c)296001 to 328800, 1973	1
	263-690	\$18.49	IGNITION SWITCH (repl.)		1
	263-665•	NA	IGNITION SWITCH (orig. assy.)		1
	263-641†	\$79.99	STEERING LOCK & SWITCH ASSEMBLY, Lucas	RD from (c)328101, GT from (c)328801, 1974 on	1
	263-640†§	\$43.99	STEERING LOCK & SWITCH ASSEMBLY, repro.		1
	263-691	\$31.99	IGNITION SWITCH, Lucas		1
	263-690§	\$18.49	IGNITION SWITCH, repro.		1
60	163-337	\$5.99	KEY BLANK, replacement	for 263-640 & 263-641 only	A/R
61	263-700	\$7.49	SHEAR BOLT, '70 on	RD from (c)187211 on, GT from (c)187841 on	2
† Note: Locks are supplied with two keys. • These switches fit only their respective original assemblies. § Wiring on switch has a moulded plug which must be removed and replaced with bullet connectors, part #162-200 (6 required).					
62	233-970	NA	CONTROL MECHANISM, heater		1
63	233-975	\$17.99	KNOB, heat control	RD to (c)294250, GT to (c)296000	1
64	233-980	NA	CONTROL MECHAN., defroster		1
65	233-990	\$21.99	KNOB, defroster control		1
62	233-960	NA	CONTROL MECHANISM, heater		1
66	233-962	NA	DIAL, heater control		1
64	233-963	NA	CONTROL MECHANISM, defroster	RD from (c)294251, GT from (c)296001	1
67	233-964	NA	DIAL, defroster control		1
70	233-967	\$16.99	KNOB, heater & defroster control		1
71	142-270	\$13.99	LIGHTER ASSEMBLY, w/repl. type knob		1
72	158-920	\$14.99	COURTESY LIGHT		1
	158-930	NA	BASE		1
	158-925	\$13.99	LENS		1
	170-010	\$0.49	BULB, original type		1
	LLB239LED	\$10.99	BULB, LED replacement		1
73	233-905	NA	GLOVE BOX		1
74	233-955	NA	LID, glove box		1
75	163-560	NA	LOCK, glove box w/key		1
	163-565	\$26.99	BEZEL, lock		1
79	280-095	NA	BUFFER, glove box lid		2
80	170-160	\$1.19	BULB, brake check		1
81	170-110	\$0.99	BULB, "eared" base		A/R
82	171-000	\$0.79	BULB, screw base		A/R
83	453-755	\$116.99	CONSOLE LID		1
	453-875	\$13.99	HINGE, console lid		1
84	453-767	\$1.39	STRIKER, console lid		1
85	453-765	\$3.49	CATCH, console lid		1
86	453-760	\$82.99	ASHTRAY, black & chrome	original type	1
	453-761	\$64.99	ASHTRAY, all chrome	optional	1
87	280-895	\$1.49	MOUNTING RING, speedo & tach		2
88	280-870	\$0.69	MOUNTING RING, small gauges		2
89	361-035	\$2.99	NUT, speedo & tach		4
	360-370	\$2.79	NUT, small gauges		4

### '72-'80 Center Console Lid Repair Plate and Centering Guide

Use the plate to repair broken and cracked latch areas, and the guide to keep further damage from taking place. Plate is made of high impact black plastic to match your original console perfectly; either glue it in place or use screws to fasten it. The latch guide will stop the console lid from crashing down and cracking both the lid and the latch; you'll never notice it once installed! Re-use your old striker, or install a new one.

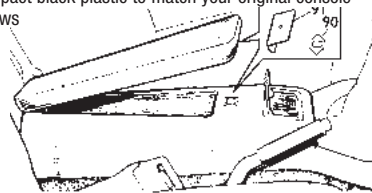

90 Plate 221-670 \$7.99  
91 Guide 221-660 \$9.99

Prices subject to change. See MossMotors.com for current pricing. 99

# Dashboard 1977-'80

RD from (c)410001 on

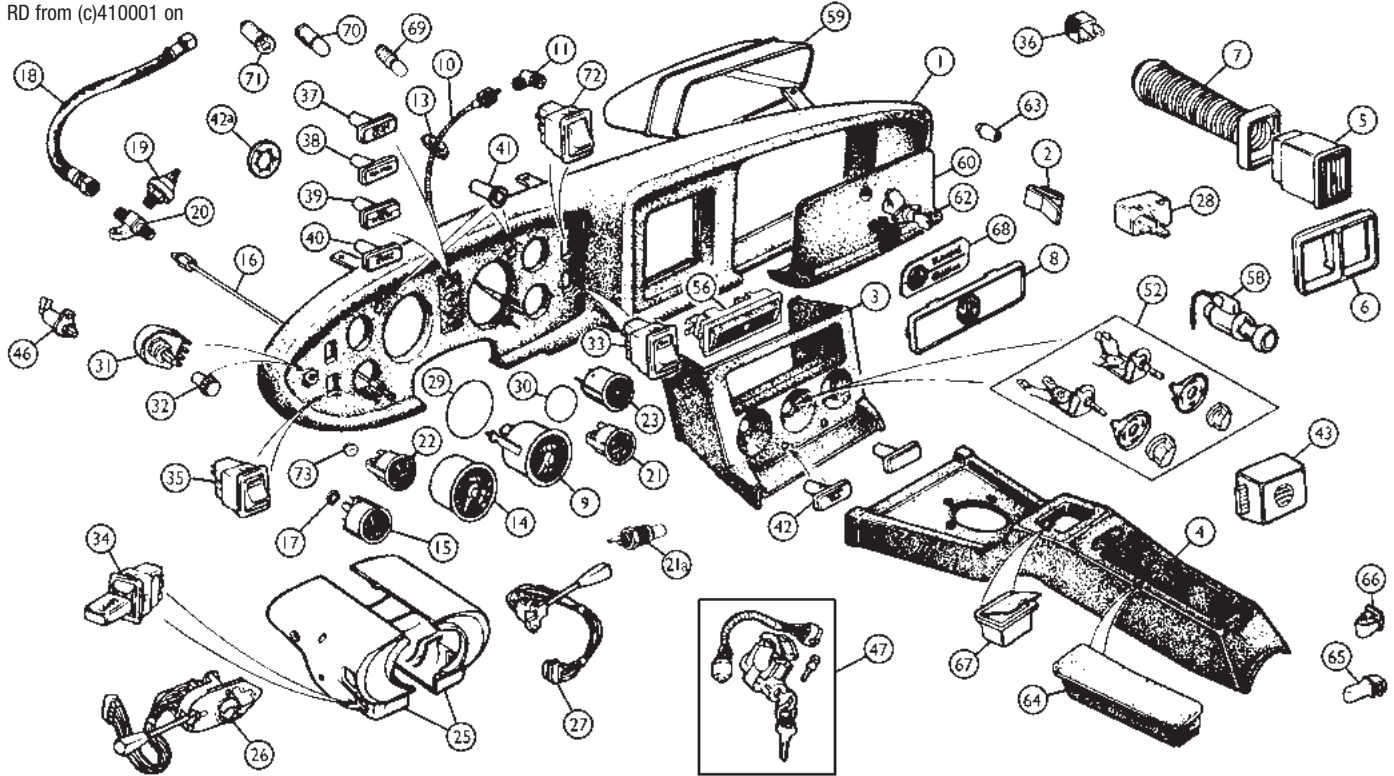

## Dashboard 1977-'80

No.	Part#	Price (Each)	Description	Application	19925 Qty Req.
1	453-796	\$489.99	DASH PANEL COVER		1
Replace the cracked and peeling dash pad on your 1977 - '80 MGB with this beautiful and accurate reproduction cover which installs over the original steel backing. Detailed authentically with moulded foam backing for exact fit.					
	453-905	\$144.99	DASH TOP REPAIR PANEL		1
2	326-540	NA	CLIP, dash panel		A/R
3	453-780	\$99.99	CONSOLE, radio, British Motor Heritage part		1
4	453-750	\$154.99	CONSOLE, tunnel		1
5	473-330	NA	VENT, R/H, face level		1
	473-340	NA	VENT, L/H, face level		1
6	473-350	NA	ESCUTCHEON, vents		1
7	456-115	NA	TUBE, vents		2
8	472-035	\$10.89	BLANKING PLATE, radio		1
9	360-925	NA	SPEEDOMETER	RD to (c)501000	1
	360-905	NA	SPEEDOMETER	RD from (c)501001 on	1
10	331-560	\$19.99	CABLE, speedometer, overdrive		1
	331-565	\$18.99	CABLE, speedometer, non-overdrive		1
11	021-510	\$54.99	ANGLE DRIVE, on transmission		1
13	281-900	\$2.19	GROMMET, speedometer cable		1
14	360-910	NA	TACHOMETER	RD to (c)501000	1
	360-915	NA	TACHOMETER	RD from (c)501001 on	1
15	360-921	NA	GAUGE, oil pressure		1
16	435-435	\$35.99	PIPE ASSEMBLY, gauge to flex pipe		1
17	435-516	\$0.39	WASHER, leather		1
18	376-180	\$16.99	OIL FLEX LINE		1
19	141-715	\$33.99	SWITCH, oil pressure, for anti run-on valve		1
20	180-245	NA	CONNECTOR, pipe & switch		1
21	360-930	NA	GAUGE, temperature		1
21a	131-566	\$11.99	TRANSMITTER, temperature gauge		1
22	360-940	NA	GAUGE, fuel		1
23	360-960	\$149.99	CLOCK (replacement)		1
25	233-225	NA	COWL, steering column		1
26	141-850	\$99.99	SWITCH, turn signal, horn, headlight dimmer		1
	141-851	\$59.99	SWITCH, turn signal, horn, headlight dimmer, aftermarket		1
27	141-855	\$29.99	SWITCH, wiper, washer		1
28	141-748	\$16.99	FLASHER UNIT, turn signal, replacement		1
29	280-895	\$1.49	MOUNTING RING, speedo & tach		2
30	280-870	\$0.69	MOUNTING RING, small gauges		2
31	146-000	\$41.99	RHEOSTAT, panel light, less knob	replacement	1
32	146-025	\$5.99	KNOB, rheostat		1
33	141-410	\$13.99	SWITCH, heater fan		1
34	141-420	\$11.49	SWITCH, lighting		1
35	141-430	\$13.99	SWITCH, hazard warning		1
	170-160	\$1.19	BULB, illuminated switches #33 & 35		3
36	141-650	\$4.19	FLASHER UNIT, hazard warning	thermal type, replacement	1

No.	Part#	Price (Each)	Description	Application	Qty Req.
	141-748	\$16.99	FLASHER UNIT, hazard warning	electronic replacement	1
37	142-310†	\$33.99	WARNING LIGHT, high beam		1
38	142-320†	\$33.99	WARNING LIGHT, ignition		1
39	542-320†	\$33.99	WARNING LIGHT, hazard		1
40	142-330†	\$33.99	WARNING LIGHT, brake		1
41	142-265†	\$9.99	LIGHT UNIT, turn signal, replacement, includes bulb		2
42	142-285†	\$44.99	WARNING LIGHT, seat belt		1
42a	142-286	\$1.89	WASHER, retaining nos. 37 thru 42		6
43	142-125	NA	BUZZER, time delay		1
46	131-600	NA	SWITCH, ignition buzzer		1
47		NA	STEERING LOCK & SWITCH, see page 42.		
52		NA	CONTROLS, heater & defroster, see page 101.		
56	164-965	\$24.99	COURTESY LAMP, rocking		1
	170-025	\$1.69	BULB, courtesy lamp		1
58	142-270	\$13.99	LIGHTER ASSEMBLY, with repl. type knob		1
59	233-905	NA	GLOVE BOX		1
60	233-845	NA	LID, glove box, plastic cover only		1
62	163-570	\$99.99	LOCK, glove box, w/keys		1
	163-565	\$26.99	BEZEL, glove box lock		1
63	280-095	NA	BUFFER, glove box lid		2
64	453-755	\$116.99	CONSOLE LID		1
	453-875	\$13.99	HINGE, console lid		1
65	453-767	\$1.39	STRIKER, console lid		1
66	453-765	\$3.49	CATCH, console lid		1
67	453-760	\$82.99	ASHTRAY, black & chrome	original type	1
	453-761	\$64.99	ASHTRAY, all chrome	optional	1
68	453-775	\$15.99	DASH PLAQUE, Limited Edition		1
69	170-160	\$1.19	BULB, illuminated switches		A/R
70	170-110	\$0.99	BULB, "eared" base		A/R
71	171-000	\$0.79	BULB, screw base		A/R
72	141-405	\$24.99	SWITCH, auxilliary	(optional)	1
† Note: These use bulb 170-110 (illus. #70).					
	73	361-035	\$2.99	NUT, speedo & tach	4
		360-370	\$2.79	NUT, small gauges	4

## '72-'80 Center Console Lid Repair Plate and Centering Guide

Use the plate to repair broken and cracked latch areas, and the guide to keep further damage from taking place. Plate is made of high impact black plastic to match your original console perfectly; either glue it in place or use screws to fasten it. The latch guide will stop the console lid from crashing down and cracking both the lid and the latch; you'll never notice it once installed! Re-use your old striker, or install a new one.

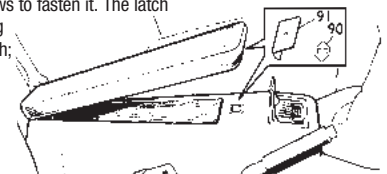

90	Plate	221-670	\$7.99
91	Guide	221-660	\$9.99

WARNING: Cancer and Reproductive Harm. www.P65Warnings.ca.gov

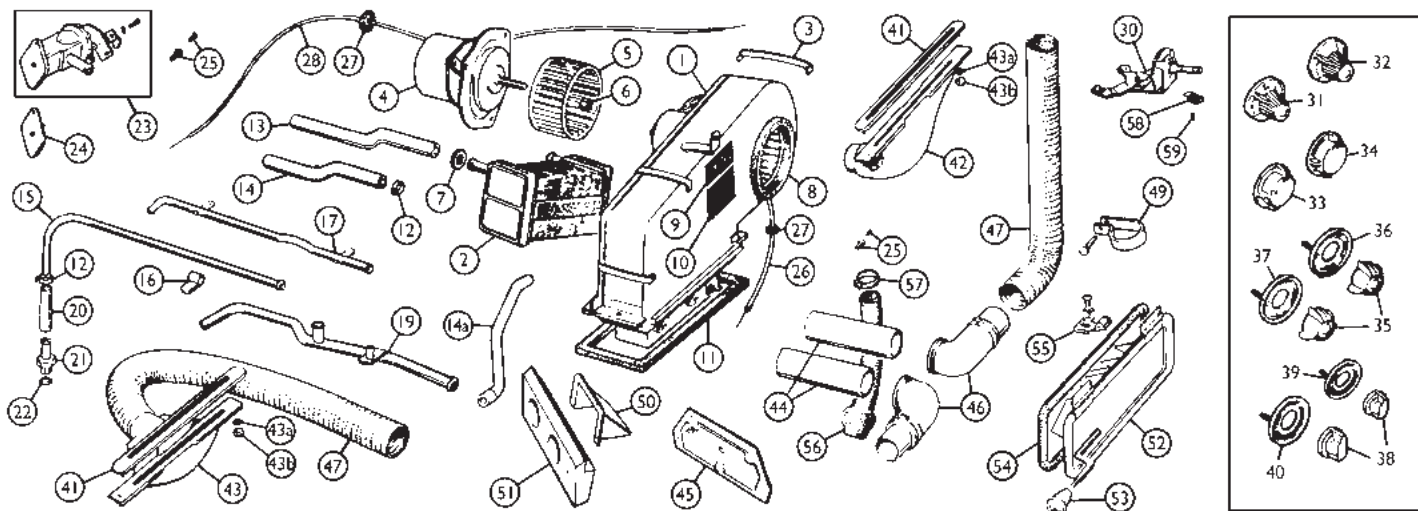

## Heater

19926

No.	Part#	Price (Each)	Description	Application	Qty Req.
1	454-440	NA	HEATER ASSEMBLY	RD/GT from (c)101 to 303703	1
	363-005	NA	HEATER ASSEMBLY	RD/GT from (c)303704 to 410000	1
	363-015	NA	HEATER ASSEMBLY	RD/GT from (c)410001 on	1
	542-041	NA	RESISTOR, speed control		1
2	360-675	\$159.99	RADIATOR		1
3	363-025	\$1.79	CLIP		5
4	360-680	NA	MOTOR ASSEMBLY	RD/GT from (c)101 to 138400	1
	363-040	\$119.99	MOTOR ASSEMBLY, replacement	RD/GT from (c)138401 on	1
5	360-690	NA	FAN, metal, thru 1967	RD/GT from (c)101 to 138400	1
	360-695	\$19.99	FAN, plastic, 1968 on	RD/GT from (c)138401 on	1
6	363-230	NA	NUT, thru 1967	RD/GT from (c)101 to 138400	1
	363-235	NA	CLIP, 1968 on	RD/GT from (c)138401 on	1
7	280-190	\$0.89	GROMMET, radiator pipe	1962 - approx. '75	2
8	363-215	\$2.99	SEAL, intake		1
9	408-355	\$2.79	LABEL, "Smiths"	See page 77 for details.	1
10	408-365	\$4.39	LABEL, "Caution"		1
11	363-210	\$4.99	GASKET, heater unit		1
12	326-250	\$1.39	HOSE CLAMP		4
13	363-270	\$2.99	HOSE, heater to valve		1
14	363-275	\$9.89	HOSE, heater to pipe	RD/GT to (c)368081	1
14a	363-280	\$12.99	HOSE, heater to pipe	RD/GT from (c)368082	1
15	473-040	\$24.99	PIPE, heater to pump	RD/GT to (c)138400, thru '67	1
16	363-205	\$1.39	CLIP, pipe to manifold		1
17	363-070	\$28.99	PIPE, heater to pump	RD/GT from (c)138401 to 367900 (1968 thru '74)	1
19	363-200	NA	PIPE, heater to radiator hose	RD from (c)367901 on	1
20	456-220	\$0.79	HEATER HOSE, 2-1/2" long	1962-1967	1
21	473-080	\$11.99	UNION		1
22	324-660	\$0.89	WASHER		1
23	360-410	\$26.99	HEATER VALVE		1
	322-230	\$0.39	BOLT, heater valve attachment		2
	324-855	\$0.19	LOCKWASHER for bolt		2
24	697-360	\$0.39	GASKET		1
25	473-070	\$1.79	CABLE STOP		5
26	331-235	\$7.49	CABLE, air control, 46"	1962-early '73 (metal casing)	1
	331-220	\$4.29	CABLE, air control, 24"	early 1973-'80 (plastic casing)	1
27	282-640	\$1.49	GROMMET, air/heater control cable		2
28	331-235	\$7.49	CABLE, heat control, 46"	1962 - '75 (metal casing)	1
	331-760	\$5.79	CABLE, heat control, 39"	1976 - '80 (plastic casing)	1
30	233-880	NA	CONTROL, heater, '62-'67	RD/GT from (c)101 to 138400	1
	233-960	NA	CONTROL, heater, '68-'70	RD/GT from (c)138401 to 219000	1
	233-970	NA	CONTROL, heater, 1971 - '72	RD from (c)219001 to 294250, GT from (c)219001 to 296000	1
	233-960	NA	CONTROL, heater, 1973 - '76	RD from (c)294251 to 410000, GT from (c)296001 to 410000	1
	233-310	NA	CONTROL, heater, 1977 on	RD/GT from (c)410001 on	1
	233-860	NA	CONTROL, defroster	RD/GT from (c)101 to 138400	1
	233-980	NA	CONTROL, defroster, 1968 - '72	RD/GT from (c)138401 to 296000	1
	233-963	NA	CONTROL, defroster, 1973 - '76	RD from (c)294251 to 410000, GT from (c)296001 to 410000	1

No.	Part#	Price (Each)	Description	Application	Qty Req.
	233-320	NA	CONTROL, defroster	RD/GT from (c)410001	1
31	233-870	\$12.49	KNOB, defroster control	RD from (c)101 to 138400, GT from (c)71933 to 139471	1
32	233-890	\$12.49	KNOB, heater control		1
	233-891	\$0.99	RIVET, on dashboard		2
33	233-985	\$12.49	KNOB, defroster control, 1968 - '70	RD/GT from (c)138401 to 219000	1
	233-990	\$21.99	KNOB, defroster control, 1971 - '72	RD from (c)219001 to 294250, GT from (c)219001 to 296000	1
34	233-965	\$12.49	KNOB, heater control, 1968 - '70	RD/GT from (c)138401 to 219000	1
	233-975	\$17.99	KNOB, heater control, 1971 - '72	RD from (c)219001 to 294250, GT from (c)219001 to 296000	1
	233-978	\$22.99	KNOB SET, heater/defrost, 1971 - '72 UK spec		1
35	233-967	\$16.99	KNOB, heater/defrost control	RD from (c)294251 to 410000, GT from (c)296001 to 410000	2
36	233-962	NA	DIAL, heater control		1
37	233-964	NA	DIAL, defroster control		1
38	233-330	NA	KNOB, heater/defrost control		2
39	233-315	NA	DIAL, heater control	RD from (c)410001 on	1
40	233-325	NA	DIAL, defroster control		1
41	363-080	NA	DEFROSTER VENT	RD/GT thru 1967	2
	363-085	\$26.99	DEFROSTER VENT	RD/GT from 1968	2
42	363-090	NA	DEFROSTER NOZZLE, L/H	RD to (c)360300, GT to (c)361000	1
	363-095	NA	DEFROSTER NOZZLE, R/H		1
43	363-100	\$46.99	DEFROSTER NOZZLE, L/H	RD from (c)360301 on, GT from (c)361001 on	1
	363-105	\$46.99	DEFROSTER NOZZLE, R/H		1
43a	324-010	\$0.19	LOCKWASHER, vent mounting		4
43b	310-040	\$0.29	NUT, vent mounting		4
44	363-110	\$10.99	CONNECTOR TUBE	RD/GT thru (c)219000	2
45	363-122	\$55.99	DOOR ASS'Y., heater outlet	stainless steel (with screws)	2
46	635-520	\$13.99	ELBOW, defroster	RD/GT thru (c)219000	2
47	456-170	\$10.99	HOSE, defroster, paper & foil	1962 thru '70	2
	456-185	\$16.99	HOSE, defroster, replacement	1971 thru '80	2
Originally plastic, now corrugated paper/foil. Must be cut to length.					
49	NA		CLIP, defroster hose		2
50	363-130	\$19.99	HEATER OUTLET	RD/GT from (c)219001 on	1
51	363-135	\$15.99	SEAL, heater outlet	(from 1971-on)	1
52	363-140	NA	DOOR, fresh air vent		1
53	363-150	\$8.49	KNOB		1
54	363-145	\$2.49	SEAL, door		1
55	363-160	NA	SPRING		1
56	363-170	NA	TUBE, drain/dust valve		1
57	326-430	\$3.59	CLAMP		1
58	233-892	\$5.69	CLIP, control knobs		A/R
59	233-893	\$1.99	PIN, control knobs		A/R

# Hardware

## Hex Head Cap Screws fine thread (threaded to head)

1/4" diameter			
322-170	\$0.49	1/2"	
322-645	\$0.49	5/8"	
322-230	\$0.39	3/4"	
322-247	\$0.49	1"	
320-635	\$1.69	1 3/8"	

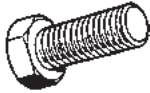

5/16" diameter			
322-040	\$0.59	3/4"	
322-540	\$0.79	7/8"	
322-290	\$0.89	1"	
320-695	\$0.89	1 1/8"	
191-915	\$1.39	1 1/4"	

3/8" diameter			
322-590	\$0.59	3/4"	
322-050	\$0.89	7/8"	
320-285	\$0.69	1"	
475-150	\$1.39	1 1/8"	
320-520	\$0.89	1 1/4"	

7/16" diameter			
322-415	\$1.19	3/4"	
320-425	\$0.59	1"	
320-605	\$1.49	1 1/4"	

1/2" diameter			
320-515	\$1.29	1 1/2"	

## Hex Head Bolts fine thread (threaded part way up shank)

1/4" diameter			
322-247	\$0.49	1"	
320-500	\$0.59	1 1/4"	
320-080	\$0.69	1 3/8"	
322-250	\$0.49	1 1/2"	
322-260	\$0.99	1 3/4"	

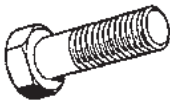

5/16" diameter			
322-310	\$0.99	1 1/4"	
322-430	\$0.69	1 1/2"	
322-440	\$0.99	1 3/4"	
322-450	\$0.49	2 1/4"	
322-285	\$0.99	2 1/2"	
322-460	\$0.69	2 3/4"	
320-225	\$0.99	3"	

3/8" diameter			
322-075	\$1.09	1 1/2"	
322-025	\$1.09	1 3/4"	
320-345	\$0.99	2"	
320-565	\$0.99	2 1/4"	
322-640	\$2.69	2 1/2"	
322-650	\$1.49	2 3/4"	
320-275	\$1.19	3"	
322-185	\$2.39	5 1/2"	

7/16" diameter			
322-715	\$2.69	3"	
322-720	\$1.49	3 1/2"	

1/2" diameter			
320-535	\$2.09	2"	
320-255	\$3.29	2 5/8"	
320-010	\$7.39	3 3/8"	
322-830	\$8.99	4"	

## Hex Nuts std. height, fine thread

310-760	\$0.59	1/4"	
310-140	\$0.39	5/16"	
310-050	\$0.69	3/8"	
310-800	\$0.49	7/16"	
472-347	\$0.39	1/2"	
310-440	NA	9/16"	
310-550	\$3.19	5/8"	

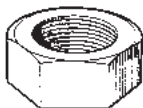

## Hex Nuts thin, fine thread (jam nuts)

365-740	\$0.59	1/4"	
848-540	\$0.29	5/16"	
310-070	\$0.39	3/8"	
310-310	\$0.59	7/16"	
310-390	\$0.49	1/2"	
	NA	9/16"	
310-490	\$1.79	5/8"	

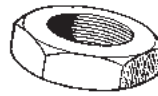

## Nyloc Nuts std. height, fine thread

310-830	\$0.69	3/16"	
312-000	\$0.49	1/4"	
310-290	\$1.19	5/16"	
310-240	\$0.89	3/8"	
310-320	\$1.49	7/16"	
310-400	\$0.89	1/2"	
310-135	NA	9/16"	
310-500	\$2.29	5/8"	

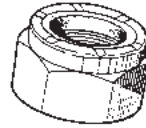

## Nyloc Nuts thin, fine thread

310-100	\$0.24	1/4"	
310-105	\$0.49	5/16"	
310-510	\$0.69	3/8"	
310-650	\$0.69	7/16"	
310-690	\$0.49	1/2"	
310-605	\$1.49	9/16"	

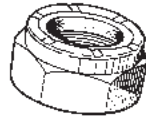

## Split Lockwashers standard

324-020	\$0.20	1/4"	
365-730	\$0.39	5/16"	
324-865	\$0.19	3/8"	
324-250	\$0.19	7/16"	
324-060	\$0.29	1/2"	
	NA	9/16"	
324-080	NA	5/8"	



## Split Lockwashers square cross-section

324-005	\$0.29	1/4"	
324-030	\$0.29	5/16"	
324-040	\$0.39	3/8"	
	NA	7/16"	
324-050	\$0.20	1/2" (light)	
322-835	\$0.49	1/2" (heavy)	



## Lockwashers double coil

324-185	\$0.39	3/16"	
370-460	\$0.79	1/4"	
315-180	\$0.49	5/16"	
315-060	\$3.09	3/8"	
329-470	NA	5/8"	



## Flat Washers standard

324-590	\$0.19	1/4"	
365-720	\$0.79	5/16"	
324-860	\$0.19	3/8"	
324-475	\$0.19	7/16"	
315-035	\$0.29	1/2"	



## Fiber Washers

323-685	\$0.39	3/16"	
315-185	\$0.59	1/4"	
324-680	\$0.29	5/16"	
315-100	\$0.49	3/8"	
324-670	\$0.59	1/2"	
324-671	\$0.99	0.52" for 1/4" BSP fittings	
324-065	\$1.49	5/8"	



## Hardware Kits

Our complete Fitting Kits are designed to make installing various components to your car fast, simple and very convenient!

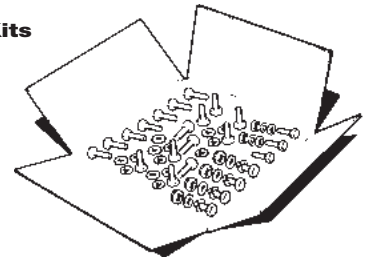

### Engine Kits:

#### Timing Cover Screw Set

Fits 1962-'76 with oval washers. 323-568 \$19.99

#### Timing Cover Screw Set

Fits 1976 on with plain washers. 323-558 \$13.99

#### Sump Screw Set

Fits all 1962-'80. 323-548 \$21.49

#### Engine to Gearbox Nut & Bolt Set

Fits 1962-'67 with 3-Synchro gearboxes. 322-428 \$10.99

#### Engine to Gearbox Nut & Bolt Set

Fits 1968 on with All-Synchro gearboxes. 322-438 \$9.99

### Fuel Tank Mounting Kit

Fits 1965 on (not for early strap-on tanks). 323-628 \$13.99

### Exhaust Mounting Kits:

#### Center Exhaust Mounting Kit

Fits all 1962-'80. 470-138 \$17.99

#### Rear Exhaust Mounting Kit

Fits 1962-'69 to (c)167815. 470-178 \$11.99

#### Rear Exhaust Mounting Kit

Fits 1969-'74. Roadsters from (c)167816 to 360300 and GTs from (c)167816 to 361000. 444-145 \$34.99

#### Rear Exhaust Mounting Kit

Fits '74 1/2 on (all rubber-bumpered cars). 470-148 \$32.99

#### Exh. Manifold Stud & Nut Kit (6 studs & brass nuts)

Fits 1962-'74 (all cars with twin SU carbs.). 328-718 \$15.99

### Suspension Kits:

#### Front Suspension Dust Tube Kits

Includes both tubes and spring. 2 required. 263-428 \$18.99

#### Rear Spring Fitting Kit (for 1 spring)

Fits cars with Banjo-Type rear axles. 454-927 \$15.99

#### Rear Spring Fitting Kit (for 1 spring)

Fits cars with Tube-Type rear axles. 454-937 \$16.99

#### Rear Spring Shackle Kit

Includes shackle plate with studs, plate, nuts and bolts. 2 kits required per car. 267-528 \$13.99

### Bodywork & Bumper Kits:

#### Front Fender Fitting Kit

Fits all '62-'80. One kit does both fenders. 321-928 \$67.99

#### Front Valance Fitting Kit

323-618 \$8.99

#### Front Bumper Fitting Kit

Fits 1962-'74 (cars with chrome bumpers). 321-908 \$45.99

#### Rear Bumper Fitting Kit

Fits 1962-'74 (cars with chrome bumpers). 321-918 \$42.99

### Trim & Body Molding Kits:

#### Interior Trim Screw Set

Chrome finish for early roadsters. 323-578 \$19.99

#### Interior Trim Screw Set

Black finish for later roadsters. 323-988 \$20.99

#### Interior Trim Screw Set

Black finish for GTs. 323-608 \$23.99

#### Body Molding Fitting Kit

Complete set to fit all 6 body moldings. 326-058 \$17.99

#### Inner Front Fender Splash Panel Fixing Kit

Complete set for left and right panels. 323-638 \$11.99

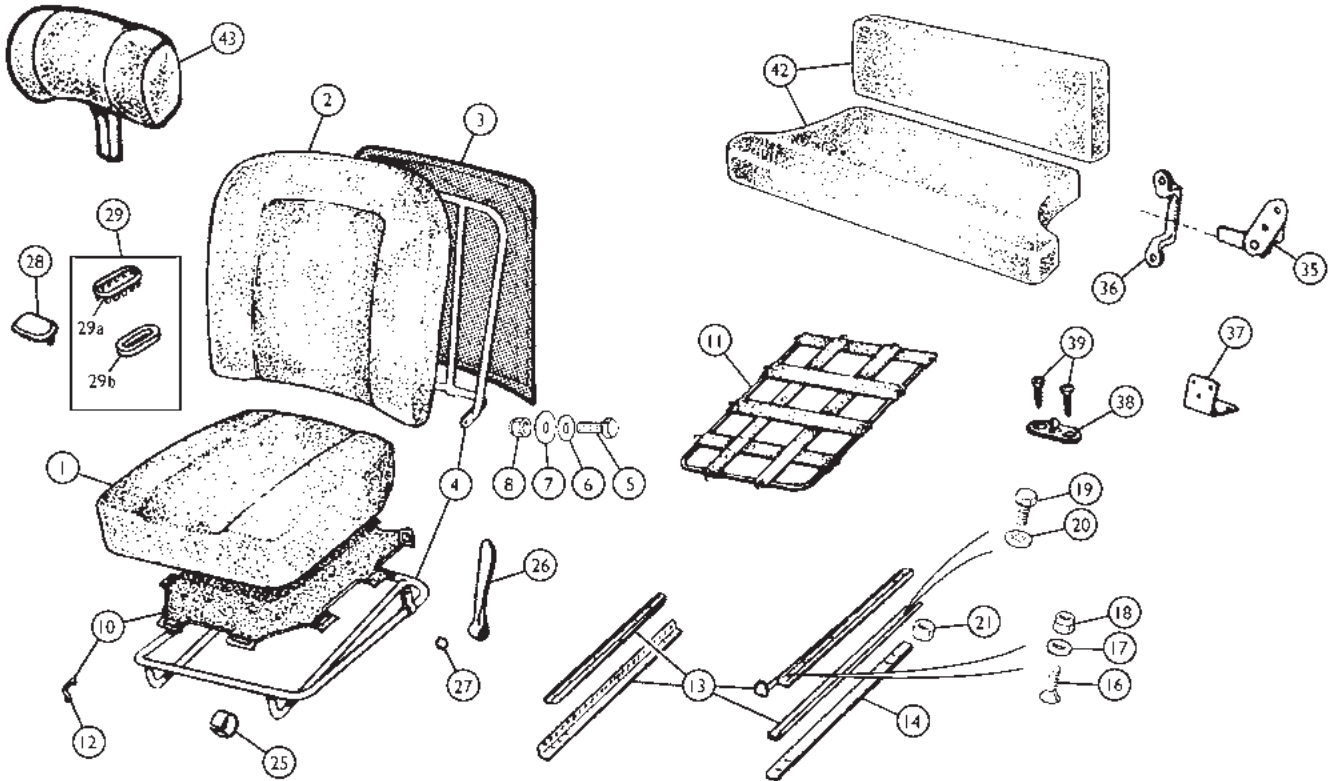

## Seat Fittings

19929

No.	Part#	Price (Each)	Description	Application	Qty Req.	
1	641-900	\$89.99	CUSHION, bottom, R/H	RD to (c)158370, GT to (c)158232 (to '68)	1	
	641-910	\$89.99	CUSHION, bottom, L/H		1	
	641-920	\$76.99	CUSHION, bottom, R/H		RD from (c)158371 to 294250, GT from (c)158233 to 296000 ('69-'72)	1
	641-930	\$76.99	CUSHION, bottom, L/H		1	
	641-940	\$79.99	CUSHION, bottom, R/H		RD from (c)294251 on, GT from (c)296001 on ('73 on)	1
	641-950	\$79.99	CUSHION, bottom, L/H	1		
2	641-960	\$76.99	CUSHION, back (to '68)	RD to (c)158370, GT to (c)158232	2	
	641-995	\$76.99	CUSHION, back (1969 only)	RD from (c)158371 to 187210, GT from (c)158233 to 187840	2	
	641-970	\$79.99	CUSHION, back (1970-'72)	RD from (c)187211 to 294250, GT from (c)187841 to 296000	2	
	641-980	\$94.99	CUSHION, back (1973 on)	RD from (c)294251 on, GT from (c)296001 on	2	
3	641-965	\$17.99	SEAT BACK STIFFENER PANEL	1962 - '68	2	
	641-975	\$17.99	SEAT BACK STIFFENER PANEL	1969	2	
	641-985	\$14.99	SEAT BACK STIFFENER PANEL	1970 - '80	2	
4	643-870	\$369.99	SEAT FRAME, L/H	1962-'68	1	
	643-860	\$369.99	SEAT FRAME, R/H		1	
5	322-290	\$0.89	BOLT		4	
6	365-720	\$0.79	WASHER		4	
7	315-205	\$0.49	WASHER	4		
8	310-290	\$1.19	NUT, nyloc	4		
10	281-828	\$29.99	DIAPHRAGM, seat cushion includes 10 hooks	1962 - '69	2	
11	641-990	\$36.99	WEBBING, seat cushion w/hooks	1970 - '80	2	
12	325-185	\$0.79	HOOK, webbing & diaphragm		20	
13	454-105	\$42.99	SEAT SLIDE SET, L/H seat		1	
	454-115	\$42.99	SEAT SLIDE SET, R/H seat		1	
14	228-170	\$11.99	PACKING STRIP, wood		4	
16	323-280	\$0.89	SCREW, slide to frame		16	
17	324-590	\$0.19	WASHER		16	
18	312-000	\$0.49	NUT		16	
19	322-247	\$0.49	BOLT, slide to floor		8	
20	462-385	\$0.39	LOCKWASHER		8	
21	228-175	\$0.99	SPACER, packing strip		8	
25	226-645	\$0.89	CLIP, cushion cover to frame		48	

No.	Part#	Price (Each)	Description	Application	Qty Req.
26	226-646	\$2.79	CLIP, seat cover, large	1969-'80	6
	409-020	\$24.99	HANDLE, adjusting	RD from (c)158371 on, GT from (c)158231 on (1969 on)	2
	323-205	\$2.59	SCREW, adjusting handle		2
27	409-030	\$5.29	KNOB, seat back lever		2
28	227-170	\$3.49	PLUG, headrest aperture, black		2
	409-070	NA	PLUG, headrest aperture, autumn leaf		2
	409-080	NA	PLUG, headrest aperture, ochre		2
	409-090	NA	PLUG, headrest aperture, navy		2
29	409-108	\$3.19	HEADREST RING ASSEMBLY		2
29a	409-100	NA	FINISHING RING, headrest aperture		2
29b	409-105	\$1.49	EYELET, finishing ring		2
35	409-040	NA	CATCH, rear seat back	GT	2
36	409-045	NA	STAPLE, catch		2
37	409-050	NA	HINGE, rear seat back		3
38	226-630	\$4.69	FASTENER, rear seat "shelf"	RD/GT	4
39	323-460	\$0.29	SCREW		8
42	641-545	\$169.99	FOAM CUSHION SET, 2-piece	1965-'72 GT	1
	641-555	\$94.99	FOAM CUSHION SET, 2-piece	1973-on GT	1
<b>Note: 1969 seats had twin post headrests, which are not available.</b>					
43	649-100	\$169.99	HEADREST, black	1970-'72 eared type, perforated vinyl	2
	649-110	NA	HEADREST, navy		2
	649-120	NA	HEADREST, ochre		2
	649-130	\$169.99	HEADREST, autumn leaf		2
	649-140	\$174.99	HEADREST, black	1973-'76 eared type, plain vinyl	2
	649-150	\$174.99	HEADREST, navy		2
	649-160	NA	HEADREST, ochre		2
	649-170	\$174.99	HEADREST, autumn leaf		2
	641-607	\$169.99	HEADREST, black	1977-'80 teardrop type	2
	641-615	\$169.99	HEADREST, navy		2
	641-636	\$169.99	HEADREST, autumn leaf		2
	641-535	NA	HEADREST, champagne		2

# Cockpit Trim & Fittings

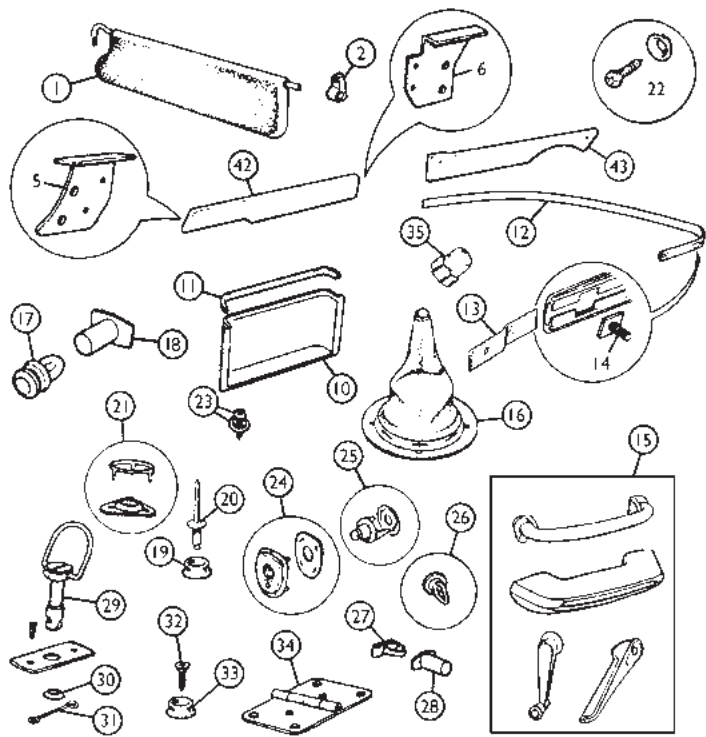

## Cockpit Fittings

19930

No. Part#	Price (Each)	Description	Application	Qty Req.	
1 224-108	\$94.99	SUN VISOR KIT (option)	1962-'67 Roadster	1	
(This kit contains two sun visors, brackets and hardware for 1962-'67 cars not originally fitted with sun visors.) <b>We do not have any sun visors for 1968-'69.</b>					
233-111	\$26.99	SUN VISOR, R/H & L/H, black	RD from (c)187211 to (c)410000, 1970 - '76	2	
233-117	\$26.99	SUN VISOR, L/H, black		1	
233-121	\$29.99	SUN VISOR, R/H, black, no mirror		1	
233-941	\$29.99	SUN VISOR, R/H, black, with mirror		1	
233-125	\$29.99	SUN VISOR, L/H	RHD RD 1962-80	1	
Note: Mounting hardware for roadster sun visors is listed on page 69.					
233-917	\$126.99	SUN VISOR, grey	GT	2	
2 233-995	NA	BRACKET, sun visor anchor	GT to (c)158230	2	
233-997	\$9.99	BRACKET, sun visor anchor	GT from (c)158231	2	
408-958	\$36.99	FINISHER SET	RD	1	
408-978	\$38.99	FINISHER SET	GT	1	
5 408-950	NA	FINISHER, door waist rail, front R/H	RD	1	
408-960	\$6.89	FINISHER, door waist rail, front, L/H		1	
408-955	NA	FINISHER, door waist rail, front, R/H		GT	1
408-965	NA	FINISHER, door waist rail, front, L/H			1
6 408-970	\$24.99	FINISHER, door waist rail, rear, R/H	RD	1	
408-980	NA	FINISHER, door waist rail, rear, L/H		1	
408-975	NA	FINISHER, door waist rail, rear, R/H	GT	1	
408-985	NA	FINISHER, door waist rail, rear, L/H		1	
323-598	\$2.99	SCREW SET, for 1 door capping & finishers		2	
10 453-790	\$74.19	MAP POCKET, black		1	
11 408-990	NA	FINISHER, map pocket		1	
12 408-995	\$119.99	MOULDING, rear cockpit	RD	1	
408-996	\$26.99	COVER for no. 12 (black)		1	
13 226-685	\$5.29	END PLATE, moulding		2	
14 226-660	\$2.19	STUD PLATE, cockpit moulding		9	
310-040	\$0.29	NUT, for stud plate		9	
15 DOOR PULLS, ARM RESTS, WINDOW WINDERS, & DOOR HANDLES, see pages 66-67.					
16 SHIFT BOOTS, see pages 36-39.					
17 226-670	\$0.59	CLIP, door panel	1970-'80	26	
18 226-675	\$0.69	CUP, door panel clip		26	
19 226-720	\$0.49	SNAP, male, floor carpet		8	
20 325-287	\$0.49	RIVET for snap		8	
21 226-338	\$2.49	FASTENER, carpet	as fitted	A/R	
22 323-578	\$19.99	INTERIOR SCREW SET, chrome	RD to (c)5634	1	
323-988	\$20.99	INTERIOR SCREW SET, black	RD from (c)5635 thru '69	1	
323-608	\$23.99	INTERIOR SCREW SET, black	GT	1	
23 323-970	\$0.59	SCREW w/cup washer, chrome	RD to (c)5634	60	
323-980	\$0.49	SCREW w/ cup washer, black	RD from (c)5635 thru '69	60	
323-465	NA	SCREW, map pocket		2	
323-480	\$0.49	SCREW, front trim pads	GT	A/R	
323-475	NA	SCREW, rear quarter waist cover		A/R	

No. Part#	Price (Each)	Description	Application	Qty Req.
24 226-308	\$1.99	FASTENER, "Lift-the-Dot"	RD	A/R
25 226-328	\$2.69	STUD ASSEMBLY, gearbox carpet	as fitted	1
26 226-680	NA	BUTTON, rear fender pocket carpet		2
27 803-420	\$0.99	CLIP, upper rear quarter liner	GT	6
28 226-695	\$3.29	SOCKET, for clip		6
29 226-700	\$11.99	FASTENER, rear trunk floor		2
30 226-706	\$0.59	GROMMET, for fastener		2
31 226-710	\$2.99	SPRING, for fastener		2
32 323-635	\$0.34	SCREW, snap fastener, trunk floor		A/R
33 226-720	\$0.49	FASTENER, snap, trunk floor	A/R	
34 409-050	NA	HINGE, trunk floor		3
35 402-550	\$3.89	DOME NUT, chrome	as fitted	4

## Door Seal

Velour type originally fitted from approximately 1963 - '72.

249-607	\$12.99	RD, per yd. (4 yd. req.)	Black
249-607	\$12.99	GT, per yd. (7 yd. req.)	

Plastic type originally fitted from approximately 1973 - '80.

259-908	\$34.99	RD, 2 doors	Black
259-938*	\$59.99	GT, 2 doors	

\*Complete preformed seals with mitered corners. Note: These two types of door seals are fully interchangeable. Both consist of a rubber seal bonded to the trim piece, which has enclosed spring clips to clamp firmly to the door aperture flange of your car.

40 472-290	\$12.99	FINISHER, door seal, rear R/H (illus.)		1
472-300	\$12.99	FINISHER, door seal, rear L/H		1
41 472-295	\$9.69	FINISHER, door seal, front, R/H (illus.)		1963 - '67 RD
472-305	\$9.69	FINISHER, door seal, front, L/H		1
472-275	\$14.99	FINISHER, door seal, front, R/H	1968 on RD	1
472-285	\$14.99	FINISHER, door seal, front, L/H		1
323-635	\$0.34	SCREW, door seal finishers		6

## Door Capping Sets (fully upholstered top rail pairs without finishers)

323-598	\$2.99	SCREW SET, for 1 door capping & finishers		2
42 639-508	\$659.99	BLACK WITH WHITE PIPING	roadster 1962 - '65	1
639-528	\$659.99	BLACK WITH RED PIPING		1
639-548	\$659.99	BLACK WITH BLUE PIPING		1
639-568	NA	RED WITH RED PIPING		1
639-608	\$299.99	BLACK	roadster 1966 - '69	1
639-628	\$299.99	RED		1
639-668	\$299.99	BLACK	roadster 1970 - '76	1
639-688	\$299.99	NAVY		1
639-708	NA	OCHRE		1
639-728	\$299.99	AUTUMN LEAF		1
639-608	\$299.99	BLACK	roadster 1977 - '80	1
639-728	\$299.99	AUTUMN LEAF		1
639-738	\$299.99	CHAMPAGNE		1
639-908	\$299.99	BLACK	GT 1966 - '69	1
639-918	\$299.99	RED		1
639-928	\$299.99	BLACK	GT 1970 on	1
639-938	\$299.99	NAVY		1
639-948	NA	OCHRE		1
639-958	\$299.99	AUTUMN LEAF		1

## GT Quarter Rail Sets

(upholstered rails fit under rear side windows)

43 639-768	\$274.99	BLACK	GT 1966 - '69	1
639-788	\$274.99	RED		1

## 1968 - '80 Under-Dash Liners

These vacuum formed ABS vinyl repros will far outlast the pressboard (cardboard) originals. (Some trimming may be required.)

453-863	\$149.99	DASH LINER PAIR	RD from (c)138401, GT from (c)139472 on	1
---------	----------	-----------------	---	---



# Carpets & Floor Mats

(Kits supplied may vary slightly from illustration.)

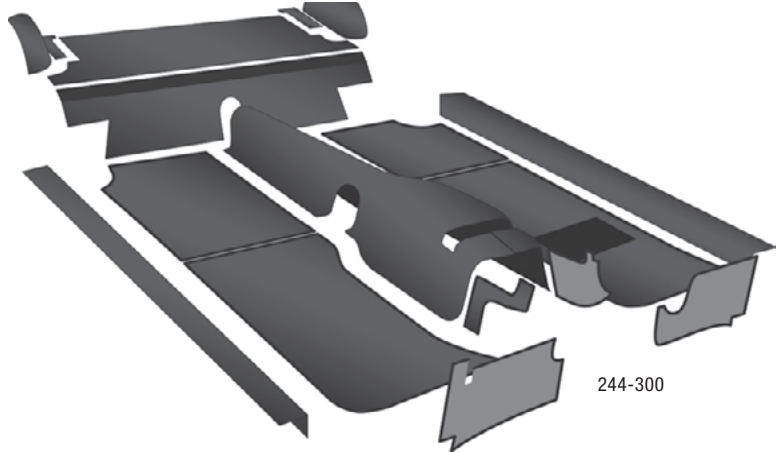

## Rubber Mats

Sill cover mats, 1968-'76 floor mats and starter covers are still being produced on original tooling. Early floor mats are not available.

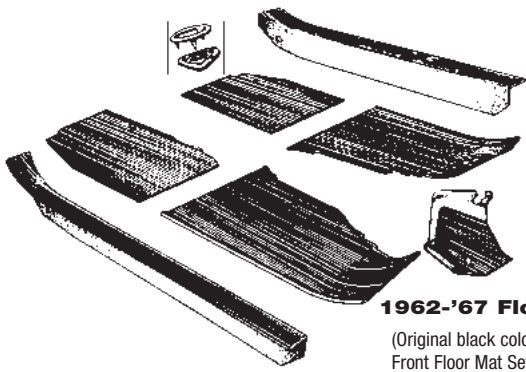

## 1962-'67 Floor Mats

(Original black color only.)

Front Floor Mat Set*	283-008	NA
Rear Floor Mat Set*	283-048	NA
Starter Cover	283-080	\$82.99

\*1962-'67 floor mat sets are not available.

Sill Cover Set	282-738	NA
Floor Mat Fastener (included with mats)	226-338	\$2.49

## 1968-'76 Rubber Floor Mats

### Black

Front Floor Mat Set	283-018	NA
Rear Floor Mat Set	283-058	NA
Sill Cover Set	282-738	NA
Starter Cover	283-090	\$69.99



## Trunk Carpet Kits

Unless you seek 100-point originality, your MGB roadster should have one of these beautifully fitted carpet sets in the trunk! Tailored in materials to match our interior carpet kits, the trunk sets include a tailored spare tire cover. Available in flat sewn or molded configurations.

Black, molded	244-250	\$519.99
Light Tan, molded	244-255	\$529.99
Black, sewn	242-850	\$249.99
Red, sewn	242-855	\$249.99
Autumn Leaf, sewn	242-874	\$249.99

## Spare Tire Cover

Included with the sewn trunk carpet sets above, this cut pile spare tire cover is also available separately.

Black	242-860	\$84.99
Red	242-865	\$84.99



Toll-Free Orders 1-800-667-7872 | MossMotors.com  
Fax 805-692-2525 | Local 805-681-3400



## Carpet Sets (See "Interior" section at the front of this catalog for more information.)

We offer a choice of carpet sets. Both are made of high quality cut pile automotive carpet which is very similar to the factory original. All carpet sections are finished as original with heavy padding, bound edges. Installation hardware is included; all you need to supply is adhesive, trim tools, care and time to create a result you are proud of. As replacement rubber floor and sill mats for 1962-'76 models are not readily available, both kit lines include carpet for these areas. The GT kits also include material for the rear quarters, rear deck, and rear seat back.

## Molded Tunnel Carpet Kits

Molded kits are manufactured in the U.K. and have moulded gearbox/driveshaft cover sections which make installation easier. **Free samples of this carpet may be ordered under part number 878-925.**

	Black	Red	
1962-'67 Roadster	<u>244-300</u>	<u>244-310</u>	\$899.99
1965-'67 GT	<u>244-325</u>	<u>244-335</u>	\$949.99

	Black	Red	Autumn Leaf	Tan*	Navy	
1968-'80 Roadster	<u>244-320</u>	<u>244-330</u>	<u>244-340</u>	<u>244-272</u>	<u>244-345</u>	\$799.99
1968-'76 GT	<u>244-245</u>	<u>244-260</u>	<u>244-265</u>	<u>244-277</u>	<u>244-285</u>	\$1,195.00

\*Tan replaces the original Ochre, which is no longer available.

## Moss Manufactured Carpet Kits

We create these kits in our own upholstery shop from domestically sourced cut pile carpet. The center tunnel is supplied flat, and does require careful fitting, but this allows for a more original look. **Free samples of this carpet may be ordered under part number 878-915.**

Underlined part numbers indicate an Oversize Parts Fee will be charged. See mossmotors.com or call for details.

	Black	Red	Honey Tan	
1962-'67 Roadster	<u>242-765</u>	<u>242-766</u>	<u>242-767</u>	\$459.99
1965-'67 GT	244-415	244-420	244-425	\$619.99

	Black	Red	Autumn Leaf	Honey Tan	
1968-'80 Roadster	244-315**	244-355	244-374	244-377	\$469.99
1968-'76 GT	244-435	244-440	244-444	244-450	\$589.99

\*\*This kit is priced at \$359.99.

## Replacement Carpet

We offer these Moss-made carpets for customers who want to freshen up their car's interior by replacing worn or damaged carpet pieces. Available in black only.

Front Floor Carpet Pair 1962-'67	244-456	\$99.99
Front Floor Carpet Pair 1968-'80	244-457	\$99.99
Inner Sill Carpet Pair	244-458	\$44.99
GT Rear Deck Carpet	244-417	\$56.99

## Undercarpet Insulation Kit

Deaden drivetrain and road noise, and insulate yourself from engine and exhaust heat. Dense felt pads have self-adhesive back. **242-005 \$279.99**

# 1962-'69 Seat & Panel Kits

For owners of the now vintage MGB, we offer a full range of exact reproduction Moss Motors upholstery kits, all painstakingly produced in our own upholstery manufacturing plant. All leather is tanned and vat-dyed to our specifications to ensure originality and long wearing durability. These seat kits are available in leather or in top-quality vinyl. They are easy to install and include headrest covers for the 1969-style seats.

Trim panel kits include door panels, front kick panels, rear quarter panels, rear bulkhead panel for the roadsters, and rear deck insert panels for the GTs. We also include sufficient vinyl to cover roadster cockpit rails, door top rails, and 1962 - '67 dash top rail, and new door window brush seals.

In addition to the original interior color schemes, we offer several other combinations of trim and piping. The most popular of these are usually available from stock, while the others (marked in the chart with an asterisk) are made to order only. Delivery on special orders takes approximately 6 to 8 weeks.

Moss Interior Kits offer you the finest value for the money! If you are not 100% satisfied with the quality and design, you may return the uninstalled kit to us for full refund. **For free material samples, order part #878-900.**

**Front seat kits include covers for both front seats.**

**NB: All leather seats have leather on the front seating surfaces only - skirts, sides and backs are matching vinyl.**



\*NOTE: Items with an asterisk are special order, and require pre-payment.



*Black with Black Piping*   *Black with Red Piping*   *Black with White Piping*   *Black with Blue Piping*   *Red with Black Piping*   *Red with White Piping*   *Red with Red Piping*   *Tan with Tan Piping*   *Honey Tan w/ H. Tan Piping*

## 1962 - '69 Front Seat Kits

### 1962 - '68 Leather (Fits Roadster to (c)158370 and GT to (c)158230.)

641-170	641-180	641-190	641-200	641-210	641-220	641-230*	641-235	641-237	\$949.99
---------	---------	---------	---------	---------	---------	----------	---------	---------	----------

### 1969 Leather (Fits Roadster from (c)158371 to 187210 & GT from (c)158231 to 187840.)

641-310	641-320*	641-330*	641-340*	641-350*	641-360*	641-370*	641-375*	641-377	\$999.99
---------	----------	----------	----------	----------	----------	----------	----------	---------	----------

### 1962 - '68 Vinyl (Fits Roadster to (c)158370 and GT to (c)158230.)

641-100	641-110	641-120	641-130*	641-140*	641-150*	641-160*	641-165	641-167	\$469.99
---------	---------	---------	----------	----------	----------	----------	---------	---------	----------

### 1969 Vinyl (Fits Roadster from (c)158371 to 187210 & GT from (c)158231 to 187840.)

641-240	641-250*	641-260	641-270*	641-280*	641-290*	641-300*	641-305*	641-307*	\$699.99
---------	----------	---------	----------	----------	----------	----------	----------	----------	----------

## 1966 - '69 GT Rear Seat Kits

### 1966 - '68 GT Leather (Fits to (c)158230.)

643-210*	643-220*	643-230*	643-240*	643-250*	643-260*	643-270*	643-275*	643-277*	\$779.99
----------	----------	----------	----------	----------	----------	----------	----------	----------	----------

### 1969 GT Leather (Fits from (c)158231 to 187840.)

641-450*	641-460*	641-470*	641-480*	641-490*	641-500*	641-510*	641-515*	641-517*	\$619.99
----------	----------	----------	----------	----------	----------	----------	----------	----------	----------

### 1966 - '68 GT Vinyl (Fits to (c)158230.)

643-140*	643-150*	643-160	643-170	643-180*	643-190*	643-200*	643-205*	643-207*	\$429.99
----------	----------	---------	---------	----------	----------	----------	----------	----------	----------

### 1969 GT Vinyl (Fits from (c)158231 to 187840.)

641-380*	641-390*	641-400*	641-410*	641-420*	641-430*	641-440*	641-445*	641-447*	\$459.99
----------	----------	----------	----------	----------	----------	----------	----------	----------	----------

## 1962 - '69 Panel Kits

### 1962 - '65 Roadster Vinyl (Fits to (b)57985.)

643-280	643-290	643-300	643-310*	643-320	643-330	643-340*	643-345	643-347	\$639.99
---------	---------	---------	----------	---------	---------	----------	---------	---------	----------

### 1966 - '67 Roadster Vinyl (Fits from (b)57986 to (c)138400.)

643-350	643-360	643-370	643-380*	643-390	643-400	643-410*	643-415	643-417	\$639.99
---------	---------	---------	----------	---------	---------	----------	---------	---------	----------

### 1968 - '69 Roadster Vinyl (Fits from (c)138401 to 187210.)

643-490	643-500	643-510	643-520*	643-530	643-540	643-550	643-555	643-557	\$599.99
---------	---------	---------	----------	---------	---------	---------	---------	---------	----------

### 1966 - '67 GT Vinyl (Fits to (c)139471.)

643-420*	643-430	643-440	643-450*	643-460*	643-470*	643-480*	643-485*	643-487*	\$639.99
----------	---------	---------	----------	----------	----------	----------	----------	----------	----------

### 1968 - '69 GT Vinyl (Fits from (c)139472 to 187840.)

643-560	643-570	643-580	643-590*	643-600*	643-610	643-620*	643-625*	643-627	\$599.99
---------	---------	---------	----------	----------	---------	----------	----------	---------	----------

## 1962 - '68 Complete Upholstered Front Seat Set

Complete, ready to bolt in, brand new leather seat assemblies! Upholstered by Moss around UK produced seat frames using Moss upholstery kits. While the proper installation of all upholstery is labor intensive, our expertise combined with volume production means the price will compare favorably to having your badly deteriorated original seats recovered by a local specialist. All seats will be upholstered to order only, so please allow 6 to 8 weeks for delivery. Sets include both left and right seats. (Mounting hardware not included.)



**\$2,299.00**

<i>Black with Black Piping</i> 641-178	<i>Black with Red Piping</i> 641-188	<i>Black with White Piping</i> 641-198
<i>Black with Blue Piping</i> 641-208	<i>Red with Black Piping</i> 641-218	<i>Red with White Piping</i> 641-228
<i>Red with Red Piping</i> 641-238	<i>Tan with Tan Piping</i> 641-248	<i>Honey Tan w/ H. Tan Piping</i> 641-258



# 1970-'80 Seat & Panel Kits



## Original Style Upholstery

Manufactured in England, these kits duplicate the original vinyls and dielectrically welded seams. Where appropriate, the "chrome" mylar accent strips are used on the door panels, and we supply the correct fabric inserts in the late GT seat kits. If you wish to re-do your interior to your individual taste, the three different styles of panels kits are completely interchangeable. Seat kits interchangeability is more complicated. The basic seat frame was unchanged from 1970-'80, but cushion and headrest design changed. 1970-'72 seats can be fitted with the later foam seat cushions, then covered with the 1973-'76 covering kits. MGB-GT seats from 1973 on had nylon fabric inserts. The fabric seat kits will fit 1973-'76 roadsters or 1970-'72 roadsters equipped with the later-style seat cushions. All front seat kits include covers for both front seats, including headrest covers. Note: Champagne (beige) replaced Autumn Leaf from '78 on.

## Complete Interior Packages

Refurbish your entire interior and save at the same time with one of our complete interior packages! While the panels and seat kits are of the 1973-'76 pattern, they fit and look great on all 1970-'80 MGBs.

These kits include: panel kit, seat kit, carpet kit, door top cap set, center console lid, door panel clip set, armrests, gearshift boot, seat back and cushion foams, seat back panel boards, headrests, & seat webbing kits. Black and Autumn Leaf packages also include black door seal sets.

Black Interior Package (vinyl)	111-608	\$2,799.00
Autumn Leaf Interior Package (vinyl)	111-708	\$2,999.00
Light Tan Interior Package (vinyl)	111-808	\$3,299.00
Light Tan Interior Package (leather seats)	111-809	\$3,799.00

Photo shows an original 1980 interior

Panel kits include door panels, front kick panels, rear quarter panels, rear bulkhead panels for roadster, rear deck insert panels for GTs, door window brush seals, and sufficient vinyl to cover the roadster cockpit and door top rails. Panel hardware/clips are not included. **Material samples may be had by ordering our free sample card #878-935.**

**\*NOTE: Items with an asterisk are special order, and require pre-payment. Special order items are NOT returnable.**

## Custom Deluxe Upholstery

We offer our Custom Deluxe Interior Kits to improve the appearance of the original vinyl interiors. Thick, padded leather seat covers are carefully stitched for exact fit and plush contour, and include seat back stiffeners. Door panels are stitched rather than heat-welded to complement the the seats.

Panel kits include new door panels with mounting clips, front kick panels, rear quarter panels, rear bulkhead panels for roadsters, rear deck insert panels for GTs, new door window brush seals, and leather to cover roadster door top rails. We recommend using the early style fur-fabric/rubber door seal to match the appearance of the rest of your interior. (See page 104 for door seals.) We guarantee 100% satisfaction or we will be happy to refund your money upon receipt of the uninstalled kit.

**Material samples may be had by ordering free sample card #878-900.**

**\*NOTE: Items with an asterisk are special order, and require pre-payment.**

**Special order items are NOT returnable.**

**NB: Leather seats have leather on the front seating surfaces - skirts, sides and backs are vinyl.**



Black with Black Piping	Black with Red Piping	Black with White Piping	Red with Red Piping	Tan with Tan Piping	Honey Tan w/ H. Tan Piping
-------------------------	-----------------------	-------------------------	---------------------	---------------------	----------------------------

## 1970-'80 Leather Custom Deluxe Front Seat Kits

1970-'76 (Fits Roadster (c)185211 to 410000 and GT (c)187841 on.)	641-725†	641-730†	641-735†	641-740†*	641-745†*	641-747†*	\$1,299.00
† 1970-'72 must use 1973-on seat foams (see page 103).							
1977-'80 (Fits Roadster from (c)410001 on.)	641-750	641-755	641-760*	641-765*	641-770	641-772*	\$1,299.00

## 1970-'76 Leather Custom Deluxe Rear Seat Kits

1970-'76 (Fits GT from (c)187841 on.)	641-850	641-855*	641-860*	641-865*	641-870	641-872*	\$649.99
---------------------------------------	---------	----------	----------	----------	---------	----------	----------

## 1970-'80 Vinyl Custom Deluxe Panel Kits

1970-'80 (Fits Roadster from (c)187211 on.)	643-750	643-760	643-770	643-780*	643-790	643-792*	\$729.99
1970-'76 (Fits GT from (c)187841 on.)	643-800*	643-810*	643-820*	643-830*	643-840*	643-842*	\$749.99

## 1971 - '80 Original Style Door Panel Pairs

643-631	\$209.99	DOOR PANEL PAIR, black	1971-'76	1
643-671	\$209.99	DOOR PANEL PAIR, black	1977-'80	1

Black	Navy	Ochre	Autumn Leaf	Champagne
-------	------	-------	-------------	-----------

## 1970 - '80 Original Style Front Seat Kits

### 1970 - '72 Vinyl (Roadsters from (c)187211 to 294250 & GT from (c)187841 to 296000.)

641-520	NA	NA	641-550	-	\$839.99
---------	----	----	---------	---	----------

### 1973 - '76 Vinyl (Fits Roadsters from (c)297251)

641-560	NA	NA	641-590	-	\$949.99
---------	----	----	---------	---	----------

### 1977 - '80 Vinyl (Fits Roadsters from (c)410001 on.)

641-600	NA	NA	641-630	641-525	\$839.99
---------	----	----	---------	---------	----------

### 1973 - '76 Fabric (Fits GTs from (c)296001 on.)

641-680	NA	-	641-685	-	\$819.99
---------	----	---	---------	---	----------

## 1970 - '76 Original Style GT Rear Seat Kits

### 1970 - '76 Vinyl (Fits GTs from (c)187841 on.)

641-640	NA	NA	641-670	-	\$549.99
---------	----	----	---------	---	----------

### 1973 - '76 Fabric (Fits GTs from (c)296001 on.)

641-690	NA	NA	641-695*	-	\$549.99
---------	----	----	----------	---	----------

## 1970 - '80 Original Style Panel Kits

Panel hardware/clips are not included. See pg. 104.

### 1970 Vinyl (Fits Roadsters from (c)187211 to 219020.)

643-635	NA	NA	-	-	\$589.99
---------	----	----	---	---	----------

### 1970 Vinyl (Fits GTs from (c)187841 to 219354.)

643-645*	NA	NA	-	-	\$549.99
----------	----	----	---	---	----------

### 1971 - '76 Vinyl (Fits Roadsters from (c)219021 to 410000.)

643-630	643-640	NA	643-660	-	\$599.99
---------	---------	----	---------	---	----------

### 1971 - '76 Vinyl (Fits GTs from (c)219355 on.)

643-710	643-720	NA	643-740	-	\$599.99
---------	---------	----	---------	---	----------

### 1977 - '80 Vinyl (Fits Roadsters from (c)410001 on.)

643-670	NA	NA	643-700	643-705	\$599.99
---------	----	----	---------	---------	----------

## 1970 - '80 Original Style Headrests

### 1970 - '72 Vinyl (Eared type with perforated vinyl.)

649-100	NA	NA	649-130	-	\$169.99
---------	----	----	---------	---	----------

### 1973 - '76 Vinyl (Eared type with plain vinyl.)

649-140	649-150	NA	649-170	-	\$174.99
---------	---------	----	---------	---	----------

### 1977 - '80 Vinyl (Teardrop type.)

641-607	641-615*	NA	641-636	641-535	\$169.99
---------	----------	----	---------	---------	----------

Prices subject to change. See MossMotors.com for current pricing. **107**

Toll-Free Orders 1-800-667-7872 | MossMotors.com  
Fax 805-692-2525 | Local 805-681-3400



# Tops

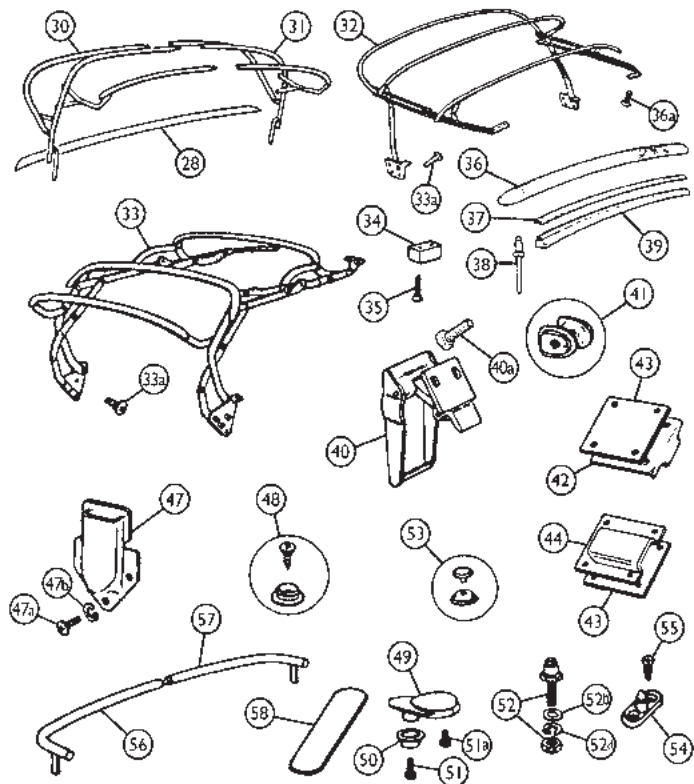

## Top Frames and Hardware

19954

No.	Part#	Price (Each)	Description	Application	Qty Req.	
28	244-210	\$23.99	ANCHOR BAR, rear of top		1	
30	454-490	\$389.99	TOP FRAME, R/H, stow-away	} RD to (c)219000, thru '70	1	
31	454-500	\$389.99	TOP FRAME, L/H, stow-away		1	
32	406-270	NA	TOP FRAME, folding, optional		RD to (b)19484, approx.	1
	406-280	\$469.99	TOP FRAME, folding, optional	{ RD from (b)19485 to (c)219000	1	
33	406-290	\$419.99	TOP FRAME, folding, standard	RD from (c)219001 on	1	
33a	314-000	\$1.09	SCREW, top frame to body	all RD with folding frame	6	
34	406-260	\$1.29	PAD, header rail	} RD	2	
35	323-635	\$0.34	SCREW		4	
36	406-250	\$229.99	HEADER RAIL		1	
36a	323-250	\$0.59	SCREW, header rail to frame		6	
37	453-600	\$15.99	RETAINER, header rail seal		1	
38	325-288	\$3.49	RIVET SET, 15 pc., retainer to rail		1	
39	453-610	\$9.99	SEAL, header rail		1	
40	NA		CLAMP, header rail		RD to (c)38387	1
	NA		CLAMP, header rail		RD from (c)38388 to 138400	2
			Not available - use 406-230 as replacement			
	406-230	\$79.99	CLAMP, header rail	RD from (c)138401 to 219000	2	
	406-240	\$76.99	CLAMP, header rail	RD from (c)219001 on	2	
40a	466-385	\$0.79	BOLT, header rail clamps	} RD	4	
41	226-308	\$1.99	FASTENER, "Lift-the-Dot"		A/R	
42	472-325	\$1.89	TONGUE, top, tonneau & top boot		2	
43	472-320	\$1.99	BACKPLATE, tongue & socket		4	
44	472-310	\$1.89	SOCKET for no. 42		2	
47	472-330	\$14.99	SOCKET, top frame/tonneau bow, chrome		2	
	472-333	\$29.99	SOCKET, tonneau bow, black		2	
47a	323-001	\$1.89	SCREW, chromed (3/4")		RD stow-away tops	6
	314-000	\$1.09	SCREW, zinc plated (1-3/4")	RD folding tops	6	

No.	Part#	Price (Each)	Description	Application	Qty Req.
47b	324-020	\$0.20	LOCKWASHER	} RD	6
48	226-800	\$0.99	SNAP STUD, w/screw		A/R
49	470-747	\$6.99	RETAINER, top rear		2
50	470-757	\$2.99	WASHER, cup		2
51	314-010	\$0.24	SCREW, long, (3/8")		2
51a	NA		SCREW, short (1/4")		2
52	226-708	\$2.79	STUD, w/nut		A/R
52a	324-010	\$0.19	LOCKWASHER		A/R
52b	315-165	\$0.59	WASHER, nylon, under studs		A/R
53	227-108	\$0.69	SNAP, female		A/R
54	226-630	\$4.69	STUD, Lift-the-Dot		A/R
55	323-460	\$0.29	SCREW, stud to rear heelboard		A/R
	323-470	\$0.69	SCREW, stud to dash top		A/R
	009-257	\$64.99	TONNEAU BOW PAIR		1
56	453-630	\$34.99	TONNEAU BOW, R/H		1
57	453-640	NA	TONNEAU BOW, L/H		1
58	472-335	\$2.89	BAR, tonneau retaining		2

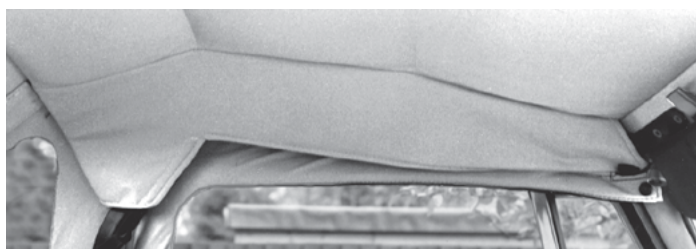

## '71-'80 Cabriolet Tops

Deluxe UK produced "cabriolet" tops borrow from the German style of padded tops with a full headliner. The thick insulation provides effective noise reduction while the light colored headliner covers the top frame and brightens your interior. The cabriolet top has been carefully engineered to fold as easily as your original top, and it incorporates a zip out rear window for added flexibility. Available in premium quality British dull coat vinyl, or extremely durable Stayfast solution dyed acrylic fabric. Headliners are an attractive light tan color. Installation instructions are included.

Black Stayfast Acrylic Top	242-795	\$1,799.00
Black Vinyl Top	242-775	\$1,399.00
Brown Stayfast Acrylic Top	242-785	\$1,399.00



## Original Manufacturer Vinyl Tops

These are genuine English factory style double-coated vinyl tops, complete with header rail, seal, retainer, and all snaps pre-installed which makes installation a breeze! Although not identical to the factory material, the differences are minor and virtually undetectable. This is as close as you can get to original!

	Black	Price
1962 to early '63 TOP, folding frame (option)		NA
1962 to '70 TOP, stow-away frame	250-040	\$1,049.00
Late 1963 to '70 TOP, folding frame	250-000	\$1,049.00
1971 to '76 TOP with fixed rear window	250-080	\$1,049.00
1977 to '80 TOP with zip-out rear window	250-130	\$1,049.00

## English Dull-Coat Vinyl Top

We have inspected and installed a number of the so-called "budget" tops on the market and feel this quality British-made one is the best of the bunch. Features include a zip-out rear window and fully installed snaps. The rugged British dull-coat vinyl is significantly heavier than other budget tops and all seams are stitched and welded for maximum strength. All at a very attractive price! Black only, header rail not included.

**1971 to '80 Top with zip-out rear window** 242-685 \$799.99



## Top Seal Kit

This kit makes it easy for you to replace the header seal which cracks and wears out with time, causing your soft top to leak. The kit includes high quality seal, retainers, and hardware. Includes numbers 34, 35, 37, 38 and 39 shown in the left column.

**453-603 \$33.99**



**N.B.:** "Stow-away" refers to the 1962-'70 standard two piece top frame and top which do not fold down, but must be removed and stowed away when the top is not in use. "Folding frames" and associated tops collapse and fold down into the rear of the cockpit.

The 1962 & early '63 tops were fitted up to (b)19484. The late 1963 through '70 tops were fitted from (b)19485 to (c)219000. 1971 to '76 fixed rear window tops were fitted from (c)219001 through (c)410000. **Tops from 1977 on have a zip-out rear window and are interchangeable with tops from 1971 through 1976, which have fixed rear windows.**



## Robbins English "Everflex" Vinyl Tops

These tops are equal to the original tops in all respects! The genuine English Everflex used in these is accepted as original for all MGBs. Tops are supplied with all snaps and fasteners, but do not include the header rail or rear anchor bar, #244-210.

	Black	Tan	White	Blue	Price
1962-early '63, folding top frame (option)	242-632	-	-	-	\$879.99
1962-'70, stow-away top frame	242-652	-	-	-	\$919.99
1962-'70, stow-away, zip-out window	242-667	-	-	-	\$1,049.00
Late 1963-'70, folding frame (option), fixed window	242-642	242-643	-	242-644	\$919.99
Late 1963-'70, folding frame (option), zip-out window	243-380	243-381	-	243-382	\$1,049.00
1971 - '80, fixed rear window (orig. for 1971-'76)	242-647	242-648	-	242-649	\$929.99
1971 - '80, zip-out rear window (orig. for 1977-'80)	242-657	242-658	-	242-659	\$999.99



## Robbins Crush Grain Vinyl Tops

The absolute best in American vinyl replacement tops! Tops are supplied with all snaps and fasteners, but do not include the header rail or rear anchor bar, #244-210.

	Black	Tan	White	Price
1962-early '63, folding frame (option), fixed window	242-630	NA	NA	\$599.99
1962-'70, stow-away top frame, fixed window	242-650	242-280	242-680	\$619.99
1962-'70, stow-away, zip-out window	242-665	NA	NA	\$749.99
Late 1963-'70, folding frame (option), fixed window	242-640	NA	242-670	\$599.99
Late 1963-'70, folding frame (option), zip-out window	243-370	243-371	243-372	\$749.99
1971-'80, fixed rear window (orig. for 1971-'76)	242-645	NA	242-690	\$629.99
1971-80, zip-out rear window (orig. for 1977-'80)	242-655	242-295	242-695	\$649.99



## Deluxe Stayfast Canvas Tops

In the tradition of the finest European sports cars, we are proud to offer these premium quality Robbins acrylic canvas convertible tops. The unique solution-dyed material is extremely fade-resistant, engineered to be soft and flexible over a wide range of temperatures, yet highly resistant to sagging, billowing or shrinking. Engineered for the easiest possible installation.

	Black	Tan	Red	Blue	Price
1962-'70, stow-away, fixed window	242-668	242-669	-	-	\$1,049.00
1962-'70, stow-away, zip-out window	242-990	242-995			\$1,249.00
Late 1963-'70, folding frame (option), fixed window	242-675	242-678	242-676	242-677	\$1,049.00
Late 1963-'70, folding frame (option), zip-out window	243-390	243-391	243-393	243-392	\$1,249.00
1971-'76, folding frame, fixed window (orig. for '71-'76)	242-681	242-684	242-682	242-683	\$1,049.00
1977-'80, folding frame, zip-out window (orig. for '77-'80)	242-740	242-745	242-741	242-742	\$1,049.00

**NOTE: ALL MOSS-SUPPLIED TOPS INCLUDE FRONT CORNER SNAPS, BUT THEY ARE NOT INSTALLED SO YOU CAN ACHIEVE A PERFECT FIT.**



# Tonneau Covers

## Tonneau Covers

Our tonneau covers are tailored for left-hand drive cars only.

Made by Robbins Auto Top except for ones marked \*, which are made by Moss in our upholstery shop.

Supplied with all necessary snaps.

Vinyl	Black		Tan		White	
1962 - '67 Tonneau w/o headrest pockets	241-440	\$479.99	241-442	NA	241-450	\$489.99
1968 - '70 Tonneau w/o headrest pockets	241-443	\$499.99	241-447	\$499.99	241-453	\$499.99
1971 - '80 Tonneau w/o headrest pockets	*241-665*	\$319.99	241-448	\$479.99	241-455	\$479.99
1969 Tonneau with headrest pockets	241-460	\$519.99	241-461	\$519.99	241-470	\$519.99
1970 - '80 Tonneau with headrest pockets	*241-660*	\$379.99	241-468	\$499.99	241-475	\$499.99

Stayfast Canvas	Black		Tan	
1962 - '67 Tonneau w/o headrest pockets	241-441	\$899.99	241-451	\$939.99
1968 - '70 Tonneau w/o headrest pockets	241-444	\$939.99	241-454	\$939.99
1971 - '80 Tonneau w/o headrest pockets	*241-675*	\$499.99	*241-676*	\$499.99
1970 - '80 Tonneau with headrest pockets	*241-670*	\$569.99	*241-671*	\$569.99



### Note for tonneau covers without headrest pockets:

- The 1962 - '67 tonneau cover fits up to (c)138400.
- The 1968 - '70 tonneau cover fits from (c)138401 to (c)219020.
- The 1971 to '80 tonneau cover fits from (c)219021 on.

### Note for tonneau covers with headrest pockets:

- The 1969 tonneau cover fits from (c)158371 to (c)187210.
- The 1970 - '80 tonneau cover fits from (c)187211 on.



## Robbins Top Frame Covers, 1971-'80



These top frame covers come with all necessary snaps, and do not have seat belt anchor holes.

	Black	Tan	White	Blue	Red	
Stayfast Cloth	241-496	241-497	-	241-498	241-499	\$719.99
Everflex Vinyl	241-491	241-492	-	241-493	-	\$659.99
Crush Grain Vinyl	241-486	241-487	241-488	-	-	\$399.99

## Moss Vinyl Top Frame Covers

Our top frame covers come with all necessary snaps.

	Black	
1962 - '70 Top Cover (for optional folding top frame only)	241-480	NA
1971 - '80 Top Cover (with seat belt anchor holes)	241-505	\$369.99
1971 - '80 Top Cover (no seat belt anchor holes)	241-485	\$289.99

## Top, Tonneau & Jack Stowage Bags

Keep your various stow-away components safely and attractively tucked away when they're not in use. Our stowage bags are made to factory specifications, from the original black vinyl-coated jute material.

Tonneau Bow Stowage Bag	242-625	\$64.99
Tonneau Cover Stowage Bag (Orig. size for original covers)	242-605	\$54.99
Tonneau Cover Stowage Bag (Sized to fit bulkier aftermarket covers)	242-610	\$64.99
Stow-away Top Bag	242-600	\$84.99
Stow-away Top Frame Bag	242-615	\$124.99
Jack & Tool Stowage Bag	386-930	\$66.99
Strap, trunk floor	385-955	\$12.99



## Background of the MGC

The MGC was firmly based on the MGB, and was intended as a replacement for the Austin-Healey 3000 which, by the time the MGC was announced in 1967, had had its day. It was powered by an in-line, six-cylinder, pushrod, OHV engine of 2912cc capacity that was capable of developing 150bhp. The bodyshell was essentially a basic MGB unit.

Both roadster and GT versions of the MGC were available, but the car was not received well by the press, despite the fact that it had a top speed approaching 120mph. They complained that its handling and acceleration were poor, and that it looked too much like the MGB. It was, however, a very good, long-legged touring car.

The MGC should have been one of the best-selling sports cars of all time, because in concept it offered a much improved performance over the MGB on which it was based, at a similarly low price. But sadly the MGC was to be very short lived, for in 1969 it was dropped from the MG range. No doubt that its poor reception by the press had affected sales, and by then MG had come within the British Leyland group, where Triumph products were looked upon with favour - and the MGC could have made life difficult for the Triumph TR6.

## Engine & Suspension Differences

By the time the MGC was introduced, Abingdon had lost control of engine design to other sectors of the vast empire which was British Leyland. The MGC's new six-cylinder in-line engine turned out to be around 25kg too heavy, and the precious balance of the car - the foundation of every MG's fine handling characteristics - was destroyed. The car meant to replace the Austin-Healey 3000 had lost the Abingdon touch, but its other qualities have ensured that it is still much sought after today.

MG did it's best with the weighty problem of fitting the C-series engine into the MGB bodyshell. The main problem was that they were unable to place the engine as far back in the car as they would have liked to maintain the weight balance of the car, as it had to be able to accommodate the relatively bulky automatic transmission for the American market. Hence, the engine had to sit well forward in the engine space, which made the MGC very nose-heavy.

To accommodate the engine, some changes had to be made to the bodyshell and mechanics of the MGB. From the outside, the most obvious changes were the bulge in the bonnet and the 15 inch road wheels. The bonnet bulge was essential to clear the top of the long tall engine, and the larger radiator which it required. It was also found necessary that the front crossmember, upon which the suspension and engine were mounted in the MGB, had to be removed to clear the bottom of the engine, in particular the oil sump. This meant revising the front suspension from the original coil spring set-up of the MGB to one which used torsion bars as the springing medium. These ran back longitudinally, to a mounting point below the floor, to transfer the suspension stresses back to the centre of the reinforced bodyshell.

The rear suspension was essentially the same as the MGB, but a much stronger rear axle had to be fitted to accommodate the increase in power, and also the spring rates had to be increased both front and rear to accommodate the extra power and weight. There was also a new stronger, all synchromesh transmission for the same reason, and as with the B an optional automatic transmission.

## The Demise of the MGC

When the first road test reports on the MGC appeared, MG engineers could not believe that the press had been driving the same cars which they had! The general handling of the car was panned by the press, it was said to suffer from terminal understeer, and to be an unworthy successor to the Austin-Healey, which had by now been discontinued. The press did not like the fact that it was so very similar to the MGB, and felt that it should have been a little more modern in its interior appointments.

However, there are few MGC's which would actually fail to get round a corner - the understeer is not "terminal". Looking at the weight balance of the car (53 : 47), will show that there is obviously a preponderance of weight at the front of the car, but this is less than most saloon cars of that period, and of most pseudo-sports cars.

It is likely that two factors contributed to the contemporary feeling that the car was nose-heavy. Firstly, the car looked like an MGB, and it was expected that everything else would be like the smaller car. Secondly, it is likely that the press were lulled into a false sense of security by the quiet and smooth running of the car, which was at a far better level than any other sports car to that date. These two points combined, and drivers found that they were travelling faster than they thought they were, with the result that the next corner would not have been "on" in any car!

The poor reception the press gave the MGC undoubtedly shortened its production life. Its introduction was soon followed by the formation of the British Leyland group, and the fact that the MGC and Triumph TR6 were competing for the same sector of the sports car market. There was considerable feeling against anything emanating from the old BMC part of the group at the time, and it took only a month or so for the board to make a decision on the future of the model. The MGC was dropped from the range in 1969, while the TR6 continued until 1976.

## SCHEDULE OF CAR NUMBERS - MGC, 1966-69

Date	Roadster	GT	Notes
Nov 66	101	110	Pre-production, only 13 cars built in 1966
Oct 67	115	116	Pilot production
Nov 67	138	-	Start of roadster series production
Dec 67	-	638	Start of GT series production
Dec 67	580	754	Highest numbers issued in 1967 (1)
Jan 68	146	640	Lowest numbers issued in 1968 (1)
Oct 68	4266	-	Start of 1969 model roadster
Nov 68	-	4236	Start of 1969 model GT
Dec 68	6032	5884	Highest numbers issued in 1968 (1)
Jan 69	4793	4467	Lowest numbers issued in 1969 (1)
Aug 69	9099	9102	End of production

(1) Because of the overlap in car numbers it is not possible to say whether cars 146 to 754 were built in 1967 or 1968. Similarly, cars 4467 to 6032 might have been built in either 1968 or 1969. One of our readers Bertil Olsson, has number 156 which was built in 1967.

## Fuel consumption and Speed

0-60 10 secs  
Overall fuel consumption 19.3 mpg  
Top Speed 118-120mph (~193kph)

## Chassis

Unit Construction body, welded steel construction, all suspension mounts frame.  
Wheelbase: 7ft 7in  
Track Front: 4ft 1.00in  
Rear: 4 ft 1.25in

## Steering

Cam Gears rack & pinion system.  
Turning circle: 34ft  
Grade of oil: SAE 90

## Brakes

Disc front, drum rear.  
Disk size front: 11.06in  
Drum size rear: 10in  
Method of operation: Hydraulic, vacuum servo assisted as standard. Dual system for USA. Girling manufacture. Cable operated parking brake.

## Wheels

Either steel disc bolt-on, or Rudge type wire spoked.  
Rim size: 5J \* 15  
Tyre Size: 165 \* 15  
Tyre pressure: 21psi front, 24 psi rear

## Engine

6 cylinder in line, pushrod ohv.  
Bore: 83.36mm  
Stroke: 78.90mm  
Cubic capacity: 2912cc  
Power output: 150bhp @ 5250rpm  
Oil pressure: Approx. 60psi. 20psi at idle  
Grade of oil: SAE 20/50  
Sump Capacity: 7 quarts (without filter), 8 with. more..

## Ignition Timing

20 deg @ 1000rpm  
Distributor points gap: 0.015in  
Sparking plugs: N9YC  
Gap: 0.025in

## Carburettor Type

Twin SU HS6  
Jet size, main: 0.100  
Needle recommendation: ST. (Spring loaded type: BAD)

## Clutch

Borg & Beck Single dry plate  
Material: Ferodo  
Number of springs: Single Diaphragm

## Gearbox

Four speed manual, synchromesh on all gears. Overdrive optional extra. Borg Warner 35 automatic gearbox was also available.  
Ratios: Manual, Overdrive, B-W Auto  
Overdrive (where fitted): 0.820  
Top: 1.000, 1.000, 1.00-2.2  
Third o/d (where fitted): 1.072  
Third: 1.307, 1.307  
Second: 2.058, 2.058, 1.45-3.1  
First: 2.98, 2.98, 2.39-5.5  
Reverse: 2.679, 2.679, 2.09-4.598  
Grade of oil: XL 20/50  
Capacity: 5.25 pints or 6 pints with overdrive, automatic gearbox capacity including oil cooler is 14.5 pints which includes 5 pints in the torque converter

## Propellor Shaft

Open shaft, needle roller u/j at each end.

## Final Drive

Live axle, hypoid bevel gears.  
Ratio: Manual 3.07, o/d & auto 3.307  
Later cars: Man 3.307, o/d 3.70  
MPH/1000rpm: Manual Top: 24, o/d: 27  
Later cars: Top: 22.1, o/d: 24, Auto: 22  
Grade of oil: SAE 90EP  
Capacity: 1.5 pints

## Cooling System

Pressurised, thermostatic control, pump assisted.

## Fuel Tank Capacity

Approx. 12 gallons. Tank located at rear of car under boot floor.

## Body Styles

Tourer, GT

## Numbers built:

Year	Roadster	GT
1966	9	4
1967	182	38
1968	2596	2491
1969	1757	1925
Total	4544	4458

## MGC External Engine

19969

No.	Part#	Price (Each)	Description	Application	Qty Req.
220-550		\$29.99	ENGINE PAINT, correct light green		A/R
328-235		\$1.09	CORE PLUG, steel, cupped 1-41/64"		1
328-236		\$3.99	CORE PLUG, brass, cupped 1-41/64"		1
328-265		\$1.89	CORE PLUG, cupped 1 5/16"		4
780-951	NA		STUD KIT, cylinder head		1
780-940		\$24.99	STUD, cylinder head, long		7
	NA		STUD, cylinder head, medium		2
780-950		\$34.99	STUD, cylinder head, short		5
310-940		\$2.99	NUT, cylinder head		14
780-632		\$2.29	WASHER, cylinder head stud		14
535-111		\$4.89	OIL SEAL, crank, front		1
120-820		\$6.59	OIL SEAL, crank, rear, stock type		1
120-821		\$17.99	OIL SEAL, crank, rear, upgraded		1
328-460		\$18.99	PLUG, oil drain		1
328-461		\$29.99	PLUG, oil drain, magnetic	(with sealing washer)	1
376-180		\$16.99	OIL FLEX LINE, block to sender		1
780-091		\$89.99	ENGINE MOUNT, front		2
780-800		\$9.89	MOUNT, transmission		2

## MGC Gaskets

19970

780-161		\$121.99	GASKET SET, head		1
780-160		\$59.99	GASKET SET, head, aftermarket		1
780-623		\$11.19	GASKET, manifold		1
780-419		\$6.89	GASKET, valve cover, stock type		1
780-421		\$41.99	GASKET, valve cover, silicone (not in gasket set)		1
780-323		\$31.99	GASKET, head		1
780-238		\$29.99	GASKET SET, lower		1
296-374		\$4.69	GASKET, front side cover		1
296-375		\$3.99	GASKET, center & rear side covers, stock type		2
296-377		\$30.99	GASKET PAIR, ctr. & rear covers, silicone (not in gask. set)		1
780-530	NA		GASKET, timing cover		1
780-525		\$15.99	GASKET, oil pan		1
434-261		\$0.79	GASKET, water pump		1

## MGC Internal Engine

19971

535-111		\$4.89	OIL SEAL, crank, front		1
780-530	NA		GASKET, timing cover		1
780-535	NA		NUT, crank pulley		1
837-090		\$8.19	LOCKTAB		1
780-540		\$55.99	CRANKSHAFT SPROCKET		1
031-207		\$4.39	PACKING WASHER		A/R
327-160		\$3.49	KEY		2
011-139		\$14.59	TENSIONER ASSEMBLY		1
832-001		\$52.99	TIMING CHAIN, heavy duty upgrade		1
832-000		\$12.99	TIMING CHAIN		1
780-542		\$84.99	CAMSHAFT SPROCKET		1
310-950		\$13.79	NUT, camshaft gear		1
031-211		\$3.59	LOCKWASHER, camshaft gear		1
780-009		\$129.99	CAM BEARING SET		1
330-420		\$7.29	SPIGOT BUSH, manual		1
330-421	NA		SPIGOT BUSH, automatic		1
780-010		\$142.99	MAIN BEARING SET, std.		1
780-011		\$142.99	MAIN BEARING SET, .010		1
780-012		\$142.99	MAIN BEARING SET, .020		1
780-013		\$142.99	MAIN BEARING SET, .030		1
780-014		\$99.00	MAIN BEARING SET, .040		1
555-130		\$10.99	THRUST WASHER SET, std.		1
828-020		\$15.89	THRUST WASHER SET, .005		1
828-022	NA		THRUST WASHER SET, .010		1
190-055	NA		RING GEAR		1
460-715		\$2.79	WASHER, lock		1
325-045	NA		DOWEL, small		1
021-296		\$499.99	PISTON SET, std.	} 5-ring pistons	1
021-300		\$499.99	PISTON SET, .020		1
021-298		\$499.99	PISTON SET, .030		1
021-297		\$499.99	PISTON SET, .040		1
021-299		\$499.99	PISTON SET, .060		1
817-700		\$119.99	PISTON RING SET, std. (5 ring)	} for original pistons & pistons above with 0.078" thick rings.	1
817-720		\$119.99	PISTON RING SET, .020 (5 ring)		1
817-730		\$119.99	PISTON RING SET, .030 (5 ring)		1
817-740		\$119.99	PISTON RING SET, .040 (5 ring)		1
817-760		\$119.99	PISTON RING SET, .060 (5 ring)		1

No.	Part#	Price (Each)	Description	Application	Qty Req.
567-180		\$119.99	PISTON RING SET, std. (4 ring)	} for some older replacement pistons. Ring thickness=0.094"	1
021-321		\$119.99	PISTON RING SET, .020 (4 ring)		1
021-322		\$119.99	PISTON RING SET, .030 (4 ring)		1
021-323		\$119.99	PISTON RING SET, .040 (4 ring)		1
021-324	NA		PISTON RING SET, .060 (4 ring)		1
326-000		\$0.89	CIRCLIP		12
829-010		\$3.99	BUSH, connecting rod		6
780-930		\$22.99	BOLT, connecting rod		2
021-638		\$3.19	NUT, connecting rod		12
780-015		\$127.99	ROD BEARING SET, std.		1
780-016		\$127.99	ROD BEARING SET, .010		1
780-017	NA		ROD BEARING SET, .020		1
780-018		\$127.99	ROD BEARING SET, .030		1
780-019		\$84.00	ROD BEARING SET, .040		1
780-510		\$267.99	ROTOR KIT, oil pump		1
780-515		\$199.99	OIL PRESSURE RELIEF VALVE		1

## MGC Cylinder Head

19966

328-265		\$1.89	CORE PLUG, 1-5/16"		1
780-419		\$6.89	GASKET, valve cover		1
780-323		\$31.99	GASKET, head		1
292-101		\$1.79	GASKET, water elbow, "Klingersil"		1
780-932		\$2.79	STUD, water elbow		2
760-180		\$13.99	TEMPERATURE SENDER		1
475-130		\$3.99	STUD, manifold		15
310-985		\$2.59	NUT, manifold		15
324-655		\$0.59	WASHER, manifold		5
460-125		\$5.29	CAP, oil filler, non-vented		1
780-500		\$9.39	VALVE, intake		6
780-505		\$14.99	VALVE, exhaust		6
423-250		\$2.99	GUIDE, valve		12
021-029		\$52.99	SPRING SET, valve		1
460-195		\$3.99	CUP, valve spring		12
460-215		\$2.39	VALVE COTTER		24
780-545		\$41.99	ROCKER SHAFT		1
780-550		\$4.69	BUSHING, rocker arm		12
780-555		\$6.99	TAPPET		12

## MGC Oil System

19967

235-941		\$109.99	SPIN-ON OIL FILTER ADAPTER		1
235-830		\$28.99	FILTER, spin-on, K&N		1
235-855		\$18.99	FILTER, spin-on, Wix		1
235-880		\$10.99	FILTER, spin-on, Fram		1
780-560		\$5.29	GASKET, oil filter housing		1
950-580		\$5.49	FILTER, various manufacturers		1
435-347		\$2.39	SEAL, canister to head		1
324-800		\$0.69	WASHER, adapter		2
780-565		\$46.99	OIL HOSE, inner, long		1
780-575		\$49.99	OIL HOSE, inner, long, S/S		1
282-975		\$1.49	GROMMET, inner hose		1
780-570		\$42.99	OIL HOSE, outer, short		1
780-580		\$49.99	OIL HOSE, outer, short, S/S		1
235-988		\$4.69	STRAP ASSEMBLY, hose		1
235-925		\$69.99	OIL RADIATOR, 13 row		1
131-580		\$139.99	OIL PRESSURE SENDING UNIT		1

## MGC Cooling

19968

780-350		\$399.99	RADIATOR		1
434-260		\$109.99	WATER PUMP, new		1
434-261		\$0.79	GASKET, water pump		1
071-226		\$11.99	THERMOSTAT, 180		1
071-232		\$10.69	THERMOSTAT, 165		1
071-230		\$13.99	THERMOSTAT, 190		1
780-359		\$12.99	HOSE, top		1
780-360		\$31.99	HOSE, lower		1
780-361		\$23.99	HOSE, by-pass		1
434-334		\$164.99	FAN, 6-blade, plastic		1
780-264		\$16.99	FAN BELT		1
	NA		AIR PUMP BELT		1
780-126		\$6.39	CAP, filler		1
459-695		\$4.99	CAP, expansion tank		1
760-180		\$13.99	SENDING UNIT, temp. gauge		1
780-404		\$21.99	SEAL, radiator shroud to hood		1
780-410		\$74.99	HEATER VALVE, early		1
780-411		\$119.99	HEATER VALVE, late		1

# MGC Carbs / Exhaust / Clutch / Brakes

## MGC Carburation & Fuel System

19972

No.	Part#	Price (Each)	Description	Application	Qty Req.
456-777	\$209.99	FUEL TANK			1
377-161	\$369.99	FUEL PUMP, genuine SU			1
780-020	\$25.99	ACCELERATOR CABLE			1
372-060	\$4.89	GUIDE, accelerator cable			1
780-754	\$28.79	CHOKE CABLE			1
371-575	NA	AIR CLEANER ELEMENT, K&N			2
Original air filters are no longer available. These can be fitted to the original housing with some fiddling.					
780-175	NA	BOLT, air filter			2
374-276	\$19.99	JET NEEDLE, standard (KM)	1968 AUD287		2
374-396	\$24.99	JET NEEDLE, standard (BAD)	1969 AUD 342		2
021-081	\$16.99	SPRING, piston, yellow			2
378-300	\$29.99	CAP & DAMPER			2
780-430	\$64.99	JET, front carburetor			1
780-440	\$64.99	JET, rear carburetor			1
371-060	\$51.99	NEEDLE & SEAT, Viton tip			2
373-625	\$55.99	NEEDLE & SEAT, Viton tip, aftermarket			2
386-390	\$18.99	GROSE-JET (replacement for needle & seat)			2
378-470	\$17.99	FLOAT			2
372-520	\$32.99	THROTTLE SHAFT, standard			2
372-530	\$32.99	THROTTLE SHAFT, oversize			2
378-220	\$31.69	THROTTLE DISC			2
698-098	\$3.99	CARBURETOR GASKET KIT			2
780-548	\$309.99	MASTER REBUILD KIT, for 2 carburetors			1
780-070	\$3.69	SPRING, throttle & choke return			3
780-001	\$149.99	FUEL PIPE KIT			1

## MGC Exhaust

19977

328-990	\$1.49	STUD, manifold			6
310-260	\$1.19	NUT, brass			6
470-230	\$7.89	SEALING RING, pipe to manifold			2
780-029	\$269.99	HEAD PIPE, Stainless			1
780-030	\$549.99	REAR PIPE & MUFFLER ASS'Y., stainless			1
780-028	NA	FITTING KIT, front pipe			1
444-080	\$2.49	MOUNTING, rubber			2
444-090	\$1.49	WASHER, head insulating			2
470-138	\$17.99	HANGER KIT, center mount			1
412-080	\$4.99	MOUNT, hanger			1
470-130	\$3.69	BUSH, hanger			2
470-140	\$2.99	HOUSING, hanger			1
321-678	\$0.89	BOLT SET, hanger			1
780-031	\$41.99	FITTING KIT, rear mount			1
444-050	\$7.99	BRACKET, rear mount			1
444-070	\$10.99	BRACKET, hanger			1
444-170	\$5.79	CLAMP, rear			2
444-080	\$2.49	MOUNTING, rubber			2
444-090	\$1.49	WASHER, head insulating			2
780-035*	NA	PERFORMANCE EXHAUST, stainless	MORE INFO ONLINE		1
Single system with rear mounted muffler, requires "Y" piece					
780-025*	\$1,149.00	HEADER, requires "Y" piece			1
780-026*	\$249.99	"Y" PIECE	MORE INFO ONLINE		1

\*These items will require some modification to fit. Professional installation is recommended.

## MGC Clutch

19978

780-808	\$499.99	CLUTCH KIT			1
021-139	\$244.99	PRESSURE PLATE, AP brand			1
780-805	NA	CLUTCH DISC, AP brand			1
501-020	\$22.99	RELEASE BEARING			1
190-570	\$2.49	RETAINER, release bearing			2
387-235	\$3.99	CLUTCH ALIGNMENT TOOL			1
330-200	\$1.79	BUSH, withdrawal lever			1
190-550	\$6.29	BOLT, withdrawal lever			1
780-810	\$10.99	BOOT, withdrawal lever			1
780-720	\$109.99	SLAVE CYLINDER			1
780-721	\$6.99	REPAIR KIT, slave cylinder			1
190-935	\$6.99	PUSHROD, slave cylinder			1
NA		CLEVIS PIN			1
584-050	\$24.99	CLUTCH HOSE			1
310-070	\$0.39	NUT, slave hose to pipe			1
324-045	\$0.49	LOCKWASHER			1
324-730	\$0.69	WASHER, hose to slave			1
780-695	\$89.99	CLUTCH MASTER CYLINDER			1
596-210	NA	CAP, filler, metal			1
180-990	\$9.29	REPAIR KIT, master cylinder			1

## MGC Brakes

19973

No.	Part#	Price (Each)	Description	Application	Qty Req.
780-725	NA	MASTER CYLINDER, remote reservoir			1
780-735	NA	MASTER CYLINDER, integral reservoir			1
780-731	\$19.99	REPAIR KIT, brake master cylinder			1
NA		SERVO ASSY., screw type			2
021-164	\$99.99	REPAIR KIT, servo			2
NA		SERVO ASSY., crimp type			2
780-205	\$339.99	REPAIR KIT, servo			2
021-205	\$53.99	LEATHER SEAL, vacuum piston	orig. Girling servos		1
981-173	\$509.99	SERVO ASSY. Lockheed replacement			2
021-173	\$179.99	REPAIR KIT, Lockheed servo			2
981-174	\$209.99	SERVO ASSY., aftermarket replacement			2
780-122	\$10.59	SEAL, pedal box cover			1
780-383	\$12.99	SEAL, pedal box			1
780-268	\$8.89	SEAL, servo bracket			2
780-998	\$399.99	BRAKE PIPE SET	U.S.A. LHD		1

## MGC Front Brakes

19974

180-568	\$179.99	CALIPER PAIR, new	} Replacement calipers		1
180-553	\$96.99	CALIPER, R/H			1
180-563	\$96.99	CALIPER, L/H			1
583-110	\$24.99	REPAIR KIT, TRW (for 2 calipers)			1
182-835	\$9.99	REPAIR KIT (for 2 calipers)			1
182-805	\$9.99	PISTON	} original calipers		4
582-105	\$32.99	PISTON, stainless steel			4
583-000	\$46.99	REPAIR KIT, TRW/Girling			1
583-001	NA	REPAIR KIT, aftermarket			1
582-000	\$15.49	PISTON, caliper, mild steel			4
582-095	\$27.99	PISTON, caliper, stainless steel		4	
583-820	\$1.29	SEALING RING, caliper half		2	
582-050	\$3.59	BLEEDER SCREW		2	
031-300	\$0.89	CAP, bleeder screw		2	
582-155	\$2.49	LOCKTAB, caliper		2	
780-376	\$6.39	BOLT, caliper mounting		4	
585-600	NA	BRAKE PAD SET, "Hawk"	} see color section at the front of this catalog for details.		1
585-522*	\$36.99	BRAKE PAD SET, ceramic			1
585-527*	\$23.99	BRAKE PAD SET, semi-metallic **"Classic Gold" Brand			1
583-808	\$9.99	PAD FITTING KIT		1	
582-035	\$0.59	CLIP, pad pin		4	
586-620	\$229.99	BRAKE ROTOR PAIR, slotted & drilled		1	
021-171	NA	BRAKE ROTOR, "Brembo" brand		2	
021-201	\$46.99	BRAKE ROTOR, aftermarket		2	
021-162	\$32.99	HOSE		2	
324-045	\$0.49	LOCKWASHER		2	
310-070	\$0.39	NUT		2	

## MGC Rear Brakes

19975

780-635	\$32.99	REAR WHEEL CYLINDER			2
780-637	\$18.99	REAR WHEEL CYLINDER, aftermarket			2
780-636	\$8.99	REPAIR KIT			2
180-100	\$1.99	BLEED SCREW			2
031-300	\$0.89	CAP, bleed screw			2
583-195	\$18.99	FITTING KIT, for 2 wheel cylinders			1
583-200	NA	PLATE, wheel cylinder retaining, outer			2
583-190	NA	PLATE, wheel cylinder retaining, inner			2
780-760	\$17.69	DUST COVER			2
780-741	\$39.99	BRAKE SHOE SET, axle set			1
780-820	\$13.49	SPRING, shoe return, cyl. end			2
780-830	\$11.99	SPRING, shoe return, abutment end			2
780-890	\$1.99	WASHER, shoe hold down			4
780-840	\$4.39	PIN, shoe hold down			4
780-842	\$2.99	SPRING, shoe hold down			4
780-862	\$59.99	BRAKE DRUM			2
323-255	\$0.69	SCREW, drum to hub			4
328-390	\$0.79	PLUG			2
584-045	\$25.99	HOSE, flexible			1
584-046	\$11.99	HOSE, flexible, aftermarket			1
324-045	\$0.49	LOCKWASHER			1
310-070	\$0.39	NUT			1
324-730	\$0.69	WASHER, copper			1
324-547	\$0.69	WASHER, copper, thick (alternative to 324-730)			1

## MGC Handbrake

19976

780-179	\$29.99	HANDBRAKE CABLE, wire wheel			1
331-555	NA	HANDBRAKE CABLE, disc wheel			1



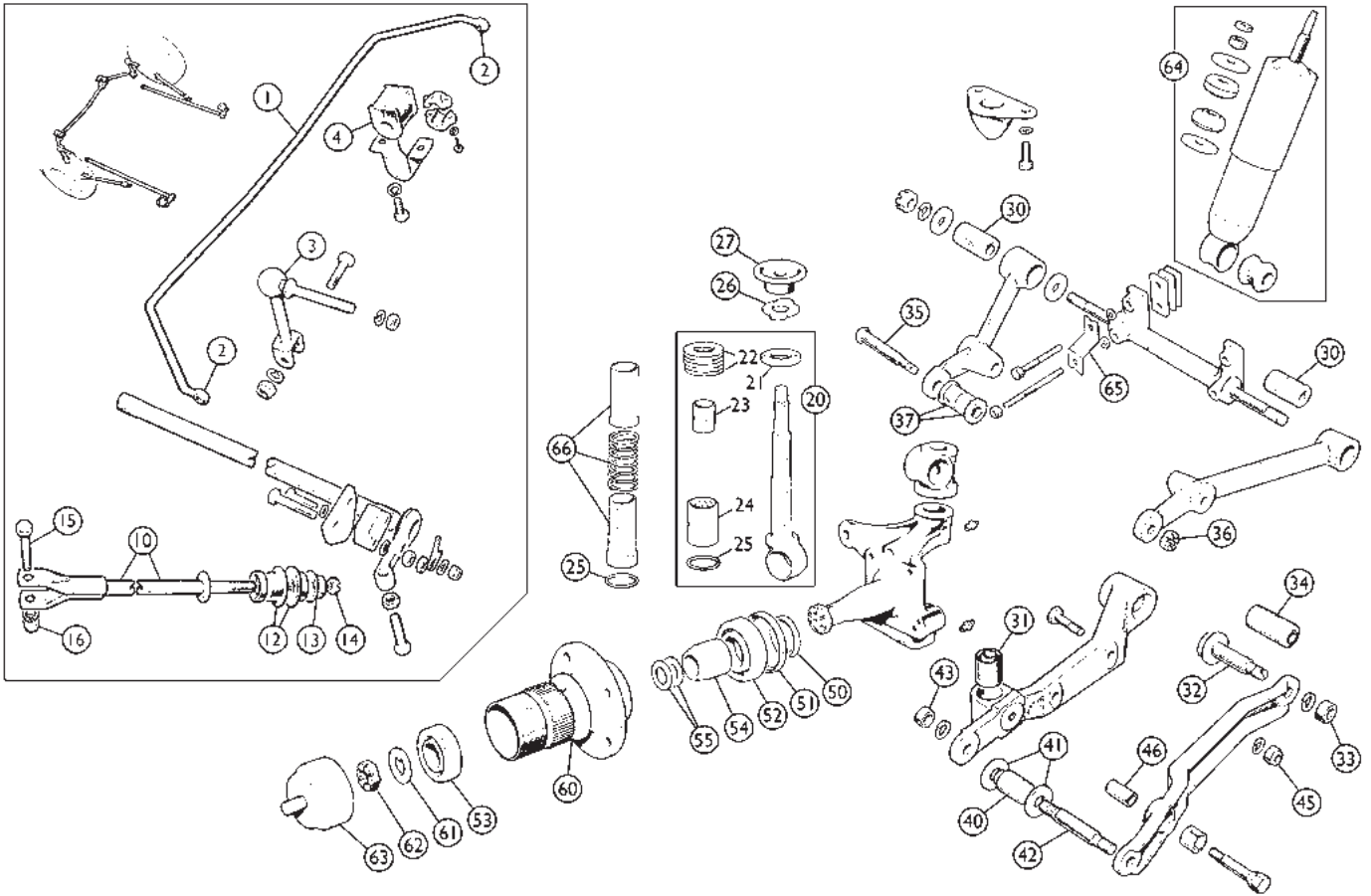

## MGC Steering

19979

No.	Part#	Price (Each)	Description	Application	Qty Req.
	453-621	\$299.99	RACK & PINION ASS'Y.		1
	263-390	\$28.99	TIE ROD END PAIR		1
	780-380	\$14.99	GAITER		2

## MGC Front Suspension

19980

1		NA	SWAY BAR, stock, 5/8"		1
	454-946	\$179.99	SWAY BAR 3/4"		1
	454-956	\$214.99	SWAY BAR 7/8"		1
2	280-910	\$2.99	BUSH, sway bar		2
3	264-846	\$49.99	LINK, sway bar		2
4	280-921	\$4.39	RUBBER MOUNT, 5/8" sway bar		2
10	780-405	\$174.99	TIE BAR (bare)		2
12	780-406	\$2.69	BUSH, tie bar		4
13	780-073	NA	NUT, tie bar		2
14	310-410	\$2.49	NUT		2
15	780-147	NA	BOLT		2
16	021-634	\$0.89	NUT, self-locking		2
20	780-418	\$386.99	KING PIN SET (for 2 sides)		1
21	264-920	\$6.49	THRUST WASHER		2
22	264-925	\$2.99	ADJUSTMENT WASHER, .052 - .057"	A/R	2
	264-930	\$2.89	ADJUSTMENT WASHER, .058 - .063"	A/R	2
	264-935	\$2.99	ADJUSTMENT WASHER, .064 - .069"	A/R	2
23	330-401	\$8.69	BUSH, upper		2
24	330-411	\$9.99	BUSH, lower		2
25	264-942	\$0.69	O RING, king pin		4
26	780-415	\$4.79	LOCKTAB, king pin (later round type without "ears")		2
27	780-416	\$25.99	NUT with reaction pad		2
30	780-310	\$17.99	BUSH, upper A Arm		4
31	780-827	\$30.69	BUSH, tie rod, outer		2
32	780-650	NA	FULCRUM, inner		2
33	310-380	\$0.59	NUT		2
34	780-653	NA	BUSH, fulcrum, stock type		2
	683-052	\$61.99	BUSH SET, fulcrum, polyurethane		1
35	263-440	\$3.29	FULCRUM PIN		2

36	310-330	\$2.29	NUT		2
37	282-305	\$1.79	BEARING, fulcrum pin		4
40	780-722	NA	BUSH, lower		2
	683-053	\$58.99	BUSH SET, lower, polyurethane		1
41	780-724	\$2.79	SPACER, lower		4
42	780-081	\$14.99	STUD, bottom		2
43	310-380	\$0.59	NUT		4
45	310-240	\$0.89	NUT, lock		4
46		NA	DISTANCE PIECE, lower		2
50	264-950	\$24.99	COLLAR, oil seal		2
	125-840	\$12.99	BEARING KIT		2
51	120-610	\$1.29	OIL SEAL, hub		2
52	126-000	\$14.99	BEARING, inner hub		2
53	126-100	\$16.99	BEARING, outer hub		2
54	264-620	\$16.99	SPACER, bearing		2
55	263-500	\$1.59	SHIM, front hub .003"		A/R
	263-510	\$1.59	SHIM, front hub .005"		A/R
	263-520	\$1.59	SHIM, front hub .010"		A/R
	263-525	\$1.59	SHIM, front hub .030"		A/R
60	780-870	\$199.99	HUB, R/H, wire wheel		1
	780-880	\$199.99	HUB, L/H, wire wheel		1
61	264-955	\$1.39	WASHER, bearing retaining		2
62	310-820	\$9.99	NUT, bearing retaining		2
63	264-120	\$12.99	CUP, grease retaining, disc wheel		2
	662-030	\$6.49	CUP, grease retaining, wire wheel		2
64	780-121	\$26.99	SHOCK		2
	683-306	\$399.99	SHOCK PAIR, Spax adjustable		1
65	780-315	\$7.39	LOCKTAB, upper fulcrum pin		4
66	780-428	NA	DUST TUBE KIT (plastic replacement)	 <a href="#">MORE INFO ONLINE</a>	2

## MGC Wheels

19981

454-665	\$449.99	WIRE WHEEL, painted 72 spoke	5
454-660	\$679.99	WIRE WHEEL, chrome 72 spoke	5
462-730	\$69.99	KNOCK-OFF, octagonal, L/H	2
462-740	\$69.99	KNOCK-OFF, octagonal, R/H	2
386-030	\$10.99	KNOCK-OFF WRENCH	1

Toll-Free Orders 1-800-667-7872 | MossMotors.com  
Fax 805-692-2525 | Local 805-681-3400

**MOSS**

# MGC Electrical / Body / Accessories

## MGC Rear Suspension / Driveline

19982

No.	Part#	Price (Each)	Description	Application	Qty Req.
	780-900	\$189.99	HUB, R/H, wire wheel		1
	780-910	\$189.99	HUB, L/H, wire wheel		1
	780-915	\$144.99	SPRING, rear	roadster	2
	780-920	\$159.99	SPRING, rear	GT	2
	281-598	\$8.49	PAD SET, spring seat (rubber)		1
	267-395	\$154.99	FLANGE, differential pinion		1
	268-105	\$279.99	DRIVESHAFT (31.75" working length)		1
	GUJ108	\$22.99	U-JOINT		2
	GUJ108-AM	NA	U-JOINT, aftermarket		2
	320-386	\$9.99	BOLT (special), gearbox to driveshaft	} overdrive	4
	031-299	\$4.79	LOCKTAB		2
	310-050	\$0.69	NUT		4

## MGC Electrical

19984

	780-210	\$239.99	STARTER, rebuilt, exchange		1
		\$350.00	CORE CHARGE for starter		
	140-366	\$369.99	STARTER, gear reduction		1
	149-620	\$15.99	BRUSH SET		1
	131-400	NA	SOLENOID		1
	130-102	\$129.99	ALTERNATOR, new (replacement)		1
NOTE: This alternator replaces the original early remote regulator unit					
	540-280	\$10.79	PLUG KIT, terminal conversion		1
	130-440	\$43.99	CONTROL UNIT, original alternator		1
		NA	DISTRIBUTOR 41201		1
	560-145	\$23.99	CAP, distributor, Lucas		1
	560-125	\$10.79	CAP, distributor, aftermarket		1
	872-785	\$14.99	ROTOR, premium replacement		1
	872-790	\$6.79	ROTOR, Lucas		1
	872-795	\$6.99	ROTOR, aftermarket		1
	152-220	\$10.99	POINTS & CONDENSER SET, Lucas		1
	152-221	\$9.99	POINTS & CONDENSER SET, aftermarket		1
	151-720	\$7.99	POINT SET, Lucas		1
	152-225	\$23.99	POINT SET, Premium aftermarket		1
	153-900	\$6.99	POINT SET, aftermarket		1
	151-730	\$7.99	CONDENSER, Lucas		1
	154-001	\$12.99	CONDENSER, Premium aftermarket		1
	153-640	\$5.99	TERMINAL & LEAD		1
	163-675	\$109.99	VACUUM ADVANCE UNIT		1
	222-415	\$169.99	PERTRONIX IGNITOR	Fits original 25D6 distributor	1
	143-220	\$34.99	COIL, ignition, Lucas		1
	143-221	\$27.99	COIL, ignition, aftermarket		1
	143-201	\$44.99	SPORTS COIL, Intermotor brand		1
	172-030	\$39.99	IGNITION WIRE SET		1
	152-130	\$3.69	SPARK PLUG		6

## MGC Body

19985

	457-235	NA	HOOD, aluminum		1
	457-205	\$26.79	TRIM STRIP, chrome		1
	326-077	\$2.79	CLIP, trim strip		6
	406-031	\$29.99	CABLE, hood release (T-handle)		1
	406-032	\$21.99	CABLE, hood release (round handle)		1
	780-925	\$72.99	INSULATING PAD SET		1
	780-076	\$8.69	MGC BADGE, Roadster trunk		1
	780-303	\$62.69	MGC GT LETTER SET, hatch		1
	780-000	\$1,099.00	SEBRING GTS FENDER SET, fiberglass		1

Set includes front fenders and rear partial fenders. These panels are made in the UK and require major work to install. Please check our website for more information before ordering. Shipped by truck freight.

## MGC Accessories

19983

No.	Part#	Price (Each)	Description	Application	Qty Req.
	212-360	\$59.99	WORKSHOP MANUAL		1
	213-800	\$66.99	MECHANICAL PARTS CATALOG	} Reprint of the factory catalog	1
	213-805	\$62.99	BODY PARTS CATALOG		1
	213-810	\$66.99	POWER UNIT PARTS CATALOG		1
	222-415	\$169.99	PERTRONIX IGNITOR (electronic ignition)		1

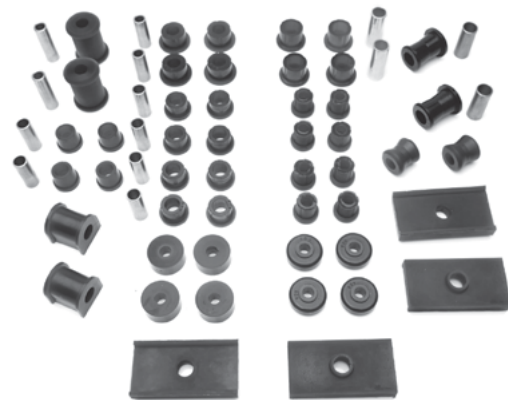

## MGC Polyurethane Suspension Bush Kit

Polyurethane lasts 2-3 times longer than stock rubber, is hard enough to eliminate 90% of unwanted suspension deflection, yet is flexible enough for a firm yet quiet ride. Kit includes bushes for: Top Trunnion, Outer Fulcrum, Top Wishbone, Front and Rear Tie Bars, Torsion Bar, Anti-roll Bar, Damper Eye, Damper Pin, Rear Spring Eye, Rear Spring Pad, and Rear Shackles.

**780-918 \$529.99**

## Steel Wheels

Most British sports cars came with pressed steel wheels as standard equipment. They ranged in width from 4" on the early cars to 6" on later models. Unfortunately, over the years these wheels have shown a tendency to crack between the bolt holes until the four holes eventually become connected with obvious disastrous results.

The principal source of trouble comes when vintage racers attempt to use wider later wheels for racing. First they try to move them outward with spacers about 1/4" thick. But, at that point, the standard wheel studs can no longer be used because they now don't protrude far enough to come out through the end of the lug nuts since the spacers are taking up 1/4" of the thread. In an effort to overcome this problem, a much smaller and thinner lug nut is substituted, but unfortunately, these smaller lug nuts do not have enough purchase on the wheel and can pull right through it under extreme conditions.

Now comes the street application. Over the years, our wheels, like any others go through a number of sudden, high-stress maneuvers. Over a period of time this high-stress flexing causes cracks in the center section around the bolt holes. A number of years ago I had accumulated ten or twelve Triumph wheels and decided to have them tested for cracks. Seven of them turned out to have identifiable cracks in the-centers!

These wheels can be made safer by cutting a 1/8" thick steel plate to match the outside diameter of the bolt pad, drilling with the appropriate holes and welding it to the back of the wheel. In addition, it doesn't hurt to weld the spider (the wheel center section) to the rim as well.

Unfortunately, for racing purposes, these are only "band-aids" and not cures. For street use, a little money spent on magnafluxing and reinforcing the wheel is good insurance. Finally, be sure to always use full-size lug nuts and be sure they are tightened to correct factory torque settings.

Too often, a racer has taken an unintended trip off the track and into the woods by virtue of a front wheel hub failure. Basically, these hubs failed by fracturing between the flange that holds the brake rotor and the flange holding the wheel.

Now the thrill of losing a wheel under racing conditions is merely the reason you can buy two pairs of pants with your fire suit, but such a thing could conceivably happen on the street as well. Street use naturally does not subject the hubs to the same loads experienced in racing, and you can protect yourself by having the hubs magnafluxed when you have them apart, a process that will reveal any cracks. For severe street use, it would probably be a good idea to shot-peen the hubs along with magnafluxing.

Racing, however, is another problem entirely. With the advent of softer, high-traction tires and the resultant higher cornering speeds achievable, anything but a NEW stock hub or an aftermarket alloy hub would be flirting with disaster. Unfortunately, new stock hubs are rare indeed, and the racing alloy versions are expensive. There does not appear to be a practical alternative right now, and safety should be the first consideration.

If there is no other practical solution to the use of used hubs, remember:

1. Clean everything and have the hubs magnafluxed.
2. If they are OK, have them shot-peened.
3. Re-check by magnafluxing about three times per season.

Ken Gillanders

Triumph Register of Southern California

## Tech Tips

### Wire Wheels

The second most frequently asked question about our cars must be "how do I take care of my wire wheels?" "Should the car be off the ground to hammer the knock-off, or should the wheel be on the ground?" Well, that's two questions, but the problem remains...Whether you call it a knock-off, a knock-on, a nut or a locknut, BMC felt inclined to issue a Technical Service Bulletin on the matter. In short, you should always hammer the nuts on or off with the wheel off the ground and free to rotate. While they don't say so, many people believe this will decrease the force transmitted into the spokes from each blow. If the wheel is not free to turn, then the spokes take the full brunt of each hammer blow.

The rest of the information is definitive! If you do as BMC says, your wheels should last much longer than if you don't. How many of you have had to hacksaw off a wire wheel, as it had become rusted to the hub? A few of you have. So inspect, grease, and check your wheels at least once a year, preferably before the rainy season. As an added precaution, why not use an anti-seize lubricant that comes in a large can with a brush in the lid. One can should last a lifetime and isn't all that expensive at a local auto parts store.

One final word, don't forget to use RTV silicone inside the wheel hub on top of the spoke heads - to seal out water and prevent grease or anti-seize lubricant from being spun out onto your spokes and wheels. Several of us have used this technique for years and it works great!

What can you do if either the wheel hub or the center of the wire wheel is too worn? It costs at least \$25 a wheel to dip (removes rust and paint), true (tighten each spoke uniformly, replacing several that won't turn), and repaint (who wants rusty wheels?). By getting new wheels, you might get by with a worn hub a bit longer. A somewhat temporary trick is to use a couple of pieces of shim stock from .001 to .003 inches thick, spaced around the hub to tighten up the splines. It is even possible to dress up the splines with a small file. But, these fixes just prolong the inevitable; sooner or later the rear hubs will have to be replaced if they have been run with loose wheels.

It makes good sense to take care of your wheels and hubs. If you don't, you will cripple your car... As a postscript, an aluminum can will do in a pinch to get you home if you spin a wheel. Use it for shim stock and the contents to soothe your pending expenditure.

Ron Phillips

La Habra Heights, CA

(The shims mentioned are for very temporary use only. Putting an old wheel on new splined hubs, (or a new wheel on old splined hubs, for that matter), will act to no advantage, since the old component will wear out the new component!-Ed.)

# Tech Tips

Our thanks to John Twist of Grand Rapids, Michigan for providing the following words of wisdom regarding electrical trouble-shooting, and for making sense out of standard Lucas wiring harness color coding as applicable to most British post-World War II vehicles.

Sorting out electrical problems requires a step-by-step, methodical approach. It is necessary to identify the problem, examine the wiring diagram, then trace the circuit, connection to connection (usually from the hot side), until the problem is found.

A quarter of all electrical problems arise from faulty battery connections; another quarter from a dirty fuse box.

As a rule, wires do not fail. The bullet connectors may corrode at the ends of the wires (rarely), or the connections may be loose (common!), but the wires are usually OK. Another rule: Wires begin and end outside the loom. There is no reason to cut through the PVC tape.

## **BLACK (B)** Always EARTH (ground), unfused

Black (B):	Various locations
Black/green (BG):	URP switch to cooling fans
Black/white (BW):	Brake warning light

## **BROWN (N)** Always HOT, unfused

Brown (N):	Various locations
Brown/light green (NLG):	Windscreen motor switch
Brown/yellow (NY):	Indicator light to alternator
Brown/purple (NP):	Unused

## **WHITE (W)** HOT with ignition ON, unfused

White (W):	Key to ignition relay, cut-off switch, fuel pump, ignition ballast resistor, fuse box, various locations
White/black (WB):	distributor to coil, coil to tachometer
White/blue (WU):	Stepped down voltage for distributor amplifier
White/brown (WN):	Ignition switch relay to fuse box, starter solenoid to starter relay, oil pressure sending unit to gauge
White/green (WG):	Key switch to radio, HOT unfused at first key position; wipers and heater (earlier)
White/light green (WLG):	Solenoid to coil, ignition ballast resistor to coil
White/red (WR):	Key switch to starter relay, starter relay to brake warning diode

## **PURPLE (P)** Always HOT, fused

Purple (P):	Fuse box to horn, various locations
Purple/black (PB):	Horn to horn switch
Purple/green (PG):	Key buzzer to time delay buzzer
Purple/pink (PK):	Key switch to key buzzer
Purple/white (PW):	courtesy lamp/boot lamp to earthing switches

It may be easier to visualize the wiring as plumbing: Wires as pipes; switches as valves; the battery as pressure; and all "juice" must return to the battery.

Light bulbs work or not. A dimly glowing bulb indicates a faulty earth (ground).

Carb. cleaner removes paint or undercoating from wires to expose the true color code.

If the trunk earth (ground) connection is loose or unattached (license holder bolts), the fuel pump, side markers, courtesy light, reverse lights, license lights, or tail-lights malfunction.

If the hazard switch is not snapped off with vigor, the turn signals may not operate.

Tools: A 12-volt test light and wiring diagram are necessities before beginning.

Warning: Approaching an electrical malfunction without a test light, or helter skelter, is a certain route to madness.

## **GREEN (G)** HOT with ignition ON, fused

Green (G):	From fuse box to various locations
Green/black (GB):	Fuel tank unit to gauge
Green/blue (GU):	Temp. sending unit to gauge
Green/brown (GN):	Reverse lamp switch to reverse lights; heater fan to switch
Green/orange (GO):	Brake pressure switch, handbrake switch, brake warning diode, brake warning light
Green/pink (GK):	Service interval counter (EGR light)
Green/red (GR):	Left turn signals to switch
Green/white (GW):	Right turn signals to switch
Green/yellow (GY):	Heater to fan switch

## **RED (R)** Parking lights, fused or unfused

Red (R):	Fuse box to side markers, parking lights, switch to lights,
Red/green (RG):	Light switch to fuse box, panel rheostat
Red/light green (RLG):	Wiper motor to switch
Red/white (RW):	Panel rheostat to panel lights
Red/Yellow (RY):	Fog/Driving lights

## **BLUE (U)** Headlamps, unfused

Blue (U):	Light switch to dimmer switch
Blue/light green (ULG):	Wiper motor to switch
Blue/red (UR):	Dimmer switch to low beam
Blue/white (UW):	Dimmer switch to high beam, high beam indicator

## **LIGHT GREEN (LG)** Various applications

Light Green/black (LGB):	Washer pump to switch
Light Green/brown (LGN):	Flasher to turn signal switch, flasher hazard switch
Light Green/green (LGG):	Voltage stabilizer to fuel/temp. gauges
Light Green/purple (LGP):	Hazard switch to hazard warning lamp

## **SLATE (S)** HOT with ignition OFF, fused and unfused

Slate (S):	Key to in-line fuse
Slate/purple (SP):	Fuse to anti-run on valve
Slate/yellow (SY):	Anti-run on valve to oil pressure switch

## **YELLOW (Y)** HOT in 3rd/4th, ignition ON, fused

Yellow (Y):	Overdrive switches
Yellow/brown (YN):	Driver's seat belt to time delay buzzer
Yellow/purple (YP):	Time delay buzzer to seat belt warning light; overdrive circuit
Yellow/red (YR):	Overdrive circuit

Our thanks to John Twist of Grand Rapids, Michigan for providing the following words of wisdom regarding electrical trouble-shooting, and for making sense out of standard Lucas wiring harness color coding applicable to all MGBs and most British post-World War II vehicles.

Sorting out electrical problems requires a step-by-step, methodical approach. It is necessary to identify the problem, examine the wiring diagram, then trace the circuit, connection to connection (usually from the hot side), until the problem is found.

A quarter of all electrical problems arise from faulty battery connections; another quarter from a dirty fuse box.

As a rule, wires do not fail. The bullet connectors may corrode at the ends of the wires (rarely), or the connections may be loose (common!), but the wires are usually OK. Another rule: Wires begin and end outside the loom. There is no reason to cut through the PVC tape.

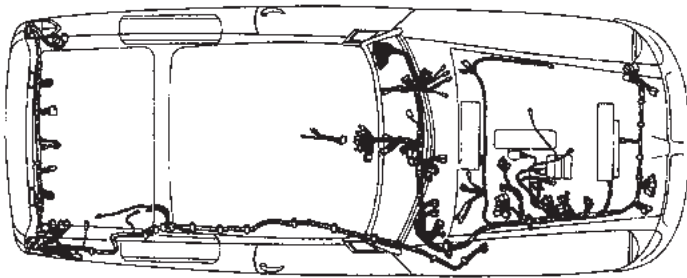

**BLACK (B)** Always EARTH (ground), unfused

- Black (B): Various locations
- Black/green (BG): URP switch to cooling fans
- Black/white (BW): Brake warning light

**BROWN (N)**: Always HOT, unfused

- Brown (N): Various locations
- Brown/light green (NLG): Windscreen motor switch
- Brown/yellow (NY): Indicator light to alternator
- Brown/purple (NP): Unused

**WHITE (W)** HOT with ignition ON, unfused

- White (W): Key to ignition relay, cut-off switch, fuel pump, ignition ballast resistor, fuse box, various locations
- White/black (WB): distributor to coil, coil to tachometer
- White/blue (WU): Stepped down voltage for distributor amplifier
- White/brown (WN): Ignition switch relay to fuse box, starter solenoid to starter relay, oil pressure sending unit to gauge (1968 - '69 only)
- White/green (WG): Key switch to radio, HOT unfused at first key position; wipers and heater (earlier)
- White/light green (WLG): Solenoid to coil, ignition ballast resistor to coil
- White/red (WR): Key switch to starter relay, starter relay to brake warning diode

**PURPLE (P)** Always HOT, fused

- Purple (P): Fuse box to horn, various locations
- Purple/black (PB): Horn to horn switch
- Purple/green (PG): Key buzzer to time delay buzzer
- Purple/pink (PK): Key switch to key buzzer
- Purple/white (PW): courtesy lamp/boot lamp to earthing switches

It may be easier to visualize the wiring as plumbing: Wires as pipes; switches as valves; the battery as pressure; and all "juice" must return to the battery.

Light bulbs work or not. A dimly glowing bulb indicates a faulty earth (ground).

Carb. cleaner removes paint or undercoating from wires to expose the true color code.

If the trunk earth (ground) connection is loose or unattached (license holder bolts), the fuel pump, side markers, courtesy light, reverse lights, license lights, or tail-lights malfunction.

If the hazard switch is not snapped off with vigor, the turn signals may not operate.

Tools: A 12-volt test light and wiring diagram are necessities before beginning.

Warning: Approaching an electrical malfunction without a test light, or helter skelter, is a certain route to madness.

**GREEN (G)** HOT with ignition ON, fused

- Green (G): From fuse box to various locations
- Green/black (GB): Fuel tank unit to gauge
- Green/blue (GU): Temp. sending unit to gauge
- Green/brown (GN): Reverse lamp switch to reverse lights; heater fan to switch
- Green/orange (GO): Brake pressure switch, handbrake switch, brake warning diode, brake warning light
- Green/pink (GK): Service interval counter (EGR light)
- Green/red (GR): Left turn signals to switch
- Green/white (GW): Right turn signals to switch
- Green/yellow (GY): Heater to fan switch

**RED (R)** Parking lights, fused or unfused

- Red (R): Fuse box to side markers, parking lights, switch to lights, 1963 - '69
- Red/green (RG): Light switch to fuse box, panel rheostat
- Red/light green (RLG): Wiper motor to switch
- Red/white (RW): Panel rheostat to panel lights
- Red/Yellow (RY): Fog/Driving lights

**BLUE (U)** Headlamps, unfused

- Blue (U): Light switch to dimmer switch
- Blue/light green (ULG): Wiper motor to switch
- Blue/red (UR): Dimmer switch to low beam
- Blue/white (UW): Dimmer switch to high beam, high beam indicator

**LIGHT GREEN (LG)** Various applications

- Light Green/black (LGB): Washer pump to switch
- Light Green/brown (LGN): Flasher to turn signal switch, flasher hazard switch
- Light Green/green (LGG): Voltage stabilizer to fuel/temp. gauges
- Light Green/purple (LGP): Hazard switch to hazard warning lamp

**SLATE (S)** HOT with ignition OFF, fused and unfused

- Slate (S): Key to in-line fuse
- Slate/purple (SP): Fuse to anti-run on valve
- Slate/yellow (SY): Anti-run on valve to oil pressure switch

**YELLOW (Y)** HOT in 3rd/4th, ignition ON, fused

- Yellow (Y): Overdrive switch to relay, 1963 - '67; overdrive switch to 3rd-4th switch, 1968 - '76
- Yellow/brown (YN): Driver's seat belt to time delay buzzer
- Yellow/purple (YP): Time delay buzzer to seat belt warning light; overdrive circuit
- Yellow/red (YR): Overdrive circuit

## RECOMMENDED TEST EQUIPMENT:

D.C. Moving Coil Voltmeter Scale 0-20V  
Hydrometer

### Note:

1. Test figures quoted are typical only
2. During testing, the engine should be cranked without starting:  
Gas - Disconnect coil to distributor LT lead  
Diesel - Operate engine stop control

TEST:	RESULT
<h3>1 HYDROMETER READING</h3> <p>1.110-1.130 Discharged 1.230-1.250 70% Charged 1.270-1.290 Charged</p>	<p>Below 1.230 Recharge and then test → Test 2</p> <p>1.230-1.290 → Test 2</p>
<h3>2 CONNECTIONS</h3> <p>Clean and tight → Test 3 Loose and/or dirty Rectify → Test 3</p>	
<h3>3 BATTERY VOLTAGE, ON LOAD</h3> <p>Should be approx. Inertia 10.5v Pre-Engaged 10.0v → Test 4</p> <p>Below expected voltage, check battery charge and if low, re-test with good battery → Test 4</p>	
<h3>4 VOLTAGE AT SOLENOID OPERATING TERMINAL</h3> <p>Should be: Similar voltage to previous test → Test 5</p> <p>If voltage is lower than in previous test, check ignition/starter switch, all cables and connections, etc. Rectify. → Test 5</p> <p>See also note below</p>	

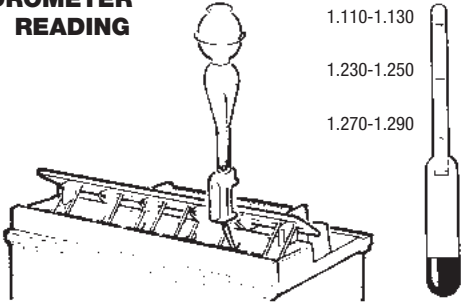
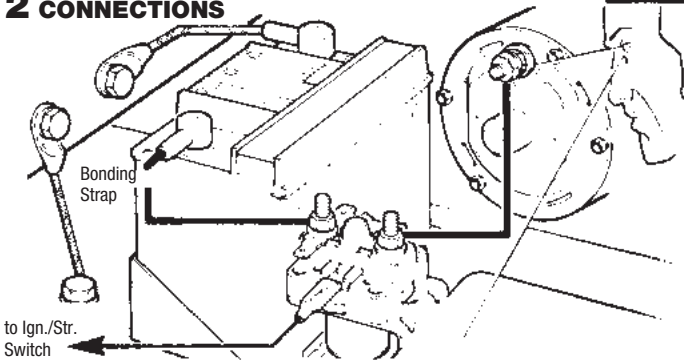
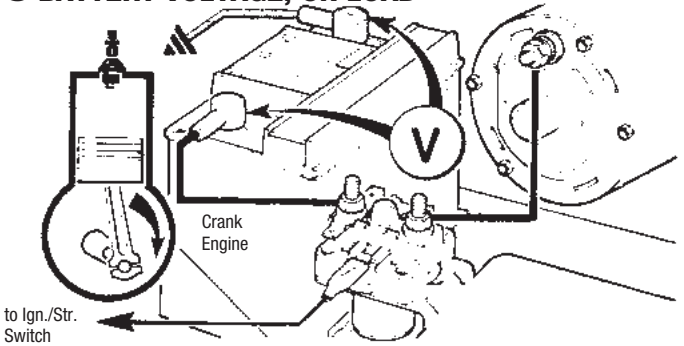
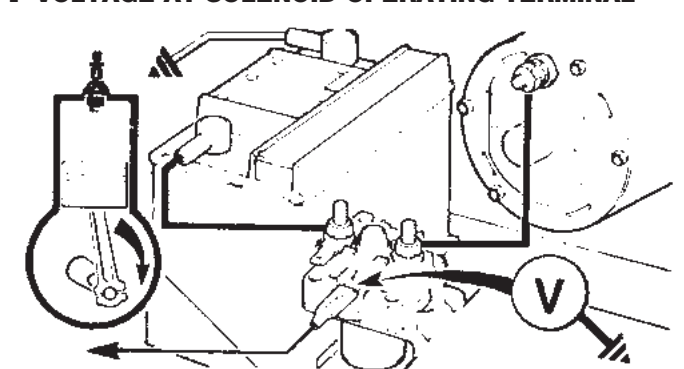
Should be:  
Within 0.5V of voltage in  
test 3  
→ Circuit  
Satisfactory

Voltage more than 0.5V  
below reading in test 3  
→ Test 6

### 5 VOLTAGE AT STARTER, ON LOAD

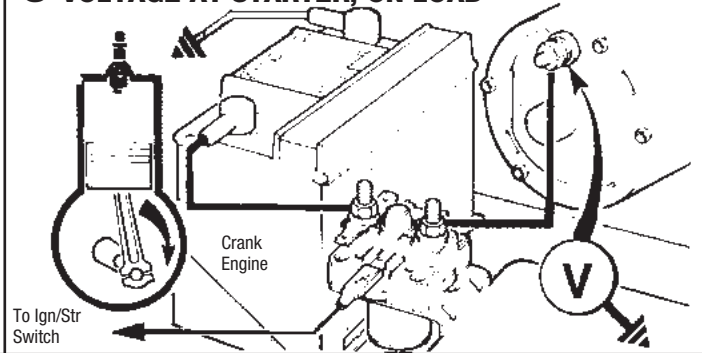

Should be:  
Approx. zero voltage  
→ Test 8

If above 0.5V  
→ Test 7

### 6 VOLTAGE DROP, INSULATED LINE

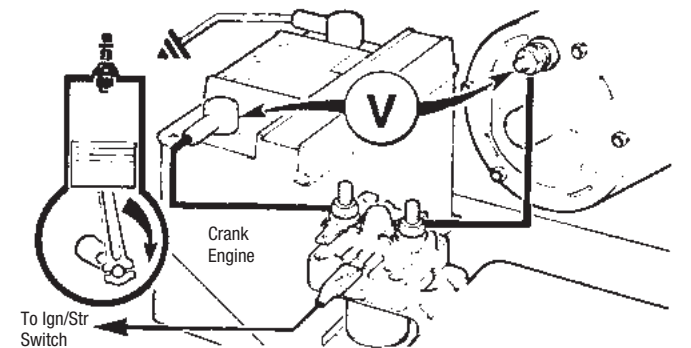

Should be:  
Approx. zero voltage.  
If shown, solenoid is satisfactory and a fault exists elsewhere in the circuit. Check all insulated line cables and connections. Rectify. Re-check as test 6  
→ Test 8  
If above 0.25 V, replace solenoid  
→ Test 8

### 7 VOLTAGE DROP, SOLENOID CONTACTS

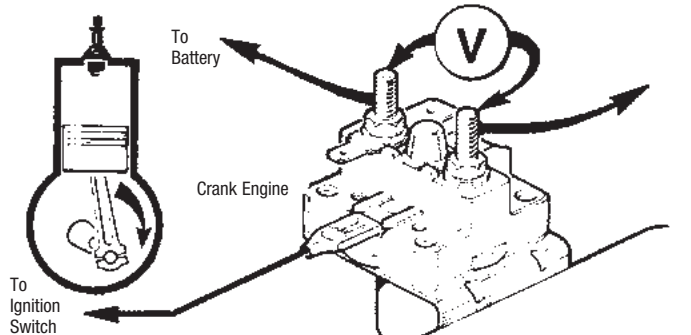

Should be:  
Approx. zero voltage.

If above 0.25V, check all earth connections including chassis/engine bonding strap.

### 8 VOLTAGE DROP, EARTH LINE

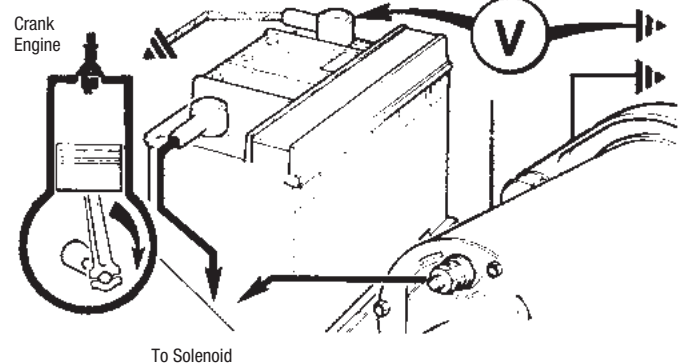

# Tech Tips

# Lucas Archives - A.C. Charging Systems

## RECOMMENDED TEST EQUIPMENT:

D.C. Moving Coil Voltmeter Scale 0-20V  
D.C. Moving Coil Ammeter Scale 5-0-100A

**15/16 AC, 15/16/17/18/20/23/25 ACR Systems**

### TEST:

### RESULT

#### 1 HYDROMETER READING

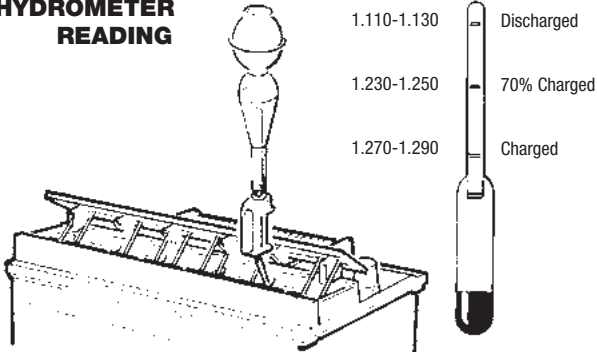

Below 1.230  
Recharge and then test  
→ Test 2  
1.230-1.290  
→ Test 2

#### 2 DRIVE BELT TENSION

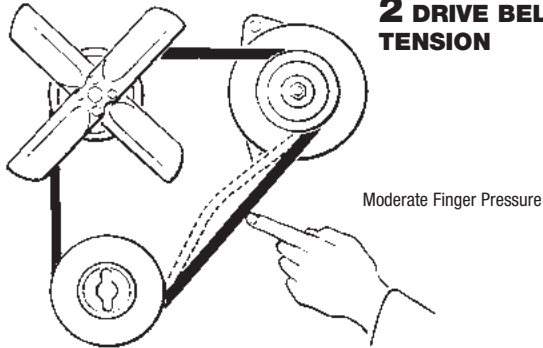

6mm (1/4")  
→ Test 3  
Loose and/or worn  
Rectify  
→ Test 3

#### 3 ALTERNATOR CONNECTIONS

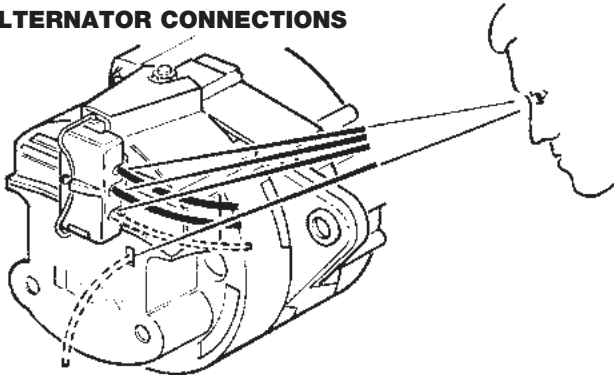

Clean and tight  
→ Test 4  
Loose and/or dirty  
Rectify  
→ Test 4

#### 4 CABLE CONTINUITY

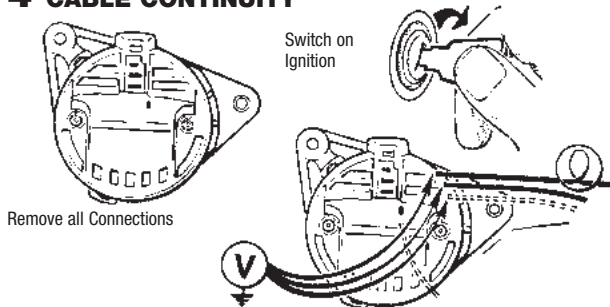

Battery Voltage  
→ Test 5  
No reading (If no reading for "Ind" lead, check warning light)  
Rectify  
→ Test 5



Ammeter reading should exceed

15 AC/ACR.....	25A
16 AC/ACR.....	30A
17 ACR.....	33A
17 ACR (Combine Harvester)....	24A
18 ACR.....	40A
20 ACR.....	60A
23 ACR.....	50A
25 ACR.....	60A

Reading correct: → Test 6

If less than above, remove and rectify. (If 15/16 AC, short 'F' and '-' on 4TR and repeat. If satisfactory, replace 4TR → Test 6

## 5 ALTERNATOR OUTPUT

Link 'S' Lead (if fitted)

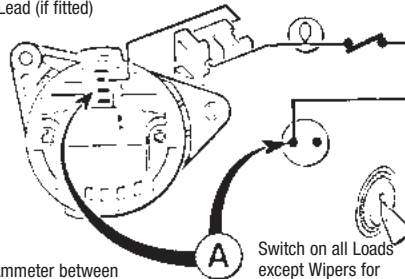

Connect Ammeter between Starter Solenoid and Main Output Terminal

Switch on all Loads except Wipers for 1 Min.



Run Engine up to 3000 Rev./Min.

V1 0.5V max.  
V2 0V max.  
→ Test 7

If greater than above Rectify → Test 7

## 6 CIRCUIT CHARGING VOLTAGE DROP

Link 'S' Lead (if fitted)

Connect Voltmeter across Insulated Side of Battery and Alternator (V1) and then Earth Side (V2)

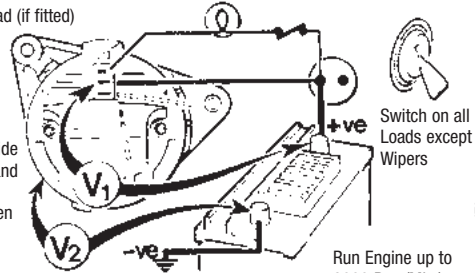

Run Engine up to 3000 Rev./Min/

Run until ammeter reads less than 10A.  
Voltmeter should read 13.6 - 14.4V.

If reading incorrect, replace alternator control.

## 7 4TR, 8TR, 11TR, 14TR ALTERNATOR CONTROL

Link 'S' Lead (if fitted)

Connect Ammeter between Solenoid and Alternator Main Output Terminal. Connect Voltmeter across Battery.

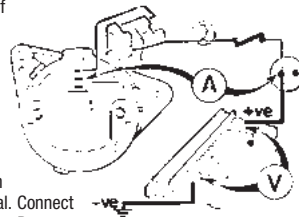

Voltage Regulator Setting



Run Engine at 3000 Rev./Min. until Ammeter indicates less than 10A.

## 10/11 AC SYSTEMS

- Test 1 Hydrometer reading  
See Test 1 ACR Systems
- Test 2 Drive Belt Tension  
See Test 2 ACR Systems
- Test 3 Alternator Connections  
See Test 3 ACR Systems

If ammeter shows no charge, check cables and connections to relay 'C' terminals.  
If satisfactory → Test 5

If ammeter now shows charge, check cables and connections to 'W' terminals (6RA relay) or 'W' and 'R' terminals (16RA relay). 16RA only - measure voltage at alternator (see Test 7) and if 6-8V, replace relay. If incorrect, replace alternator. → Test 5

## 4 6RA, 16RA RELAY (CONDITION & CHARGE)

Connect Ammeter in Main Output Cable

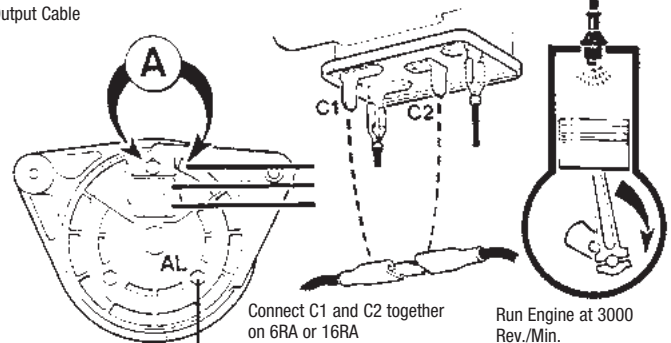

Connect C1 and C2 together on 6RA or 16RA

Run Engine at 3000 Rev./Min.

Ammeter should read

10AC	35A
11AC 12V	45A
11AC 12V	60A
11AC 24V	23A

→ Test 6

If less than above, remove alternator and rectify → Test 6

## 5 ALTERNATOR OUTPUT

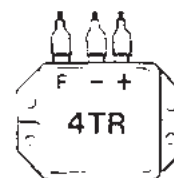
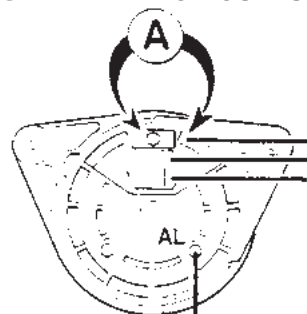

Short Together 'F' and '+' Terminals of 4TR

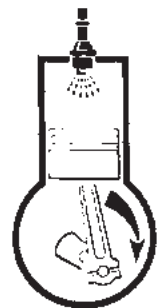

# STANDARD TERMS AND CONDITIONS OF SALE & LIMITED WARRANTY

Last updated: March 17, 2018

PLEASE READ THE FOLLOWING CAREFULLY. By clicking the button "Agree," or otherwise accessing and using our website, and/or by placing an order with Moss Motors, Ltd. ("Moss," "we" "us" "our"), you acknowledge and represent that you are over 18 and have the legal capacity and authority to enter this Terms and Conditions/Warranty Agreement ("Terms"). These Terms constitute a binding agreement between Moss and you.

## 1. AGREEMENT TO TERMS AND PRIVACY POLICY

By accessing and continuing to use our Website (<http://mossmotors.com> "Website"), and/or by placing orders with Moss in any other manner, you are agreeing to these Terms including our Privacy Policy ("Privacy Policy", as found immediately following).

## 2. PRICE

It is Moss' intent that prices in our Catalogues and on our Website are accurate and up to date. However, prices are subject to change without notice. Please inquire about price at the time of purchase.

## 3. LIMITED WARRANTY

Moss is proud to provide one of the longest warranty in the business. Everything we sell is warranted to be free from defects in material and workmanship for 2 years from the date of invoice, with the exception of all superchargers, supercharger components, and supercharger hardware which carry a 1 year warranty. If the product warranted above fails, within the warranty period, Moss will, at its discretion, repair or replace the product. This warranty does not cover labor, failure of related components, normal wear of brake or clutch components or failure resulting from alteration, misuse, accidental damage, faulty installation, or faulty repair. TO THE FULL EXTENT PERMISSIBLE BY LAW, WE DISCLAIM ALL WARRANTIES, EXPRESS OR IMPLIED, OTHER THAN THOSE EXPRESSLY STATED HEREIN, INCLUDING, BUT NOT LIMITED TO, IMPLIED WARRANTIES OF MERCHANTABILITY AND FITNESS FOR A PARTICULAR PURPOSE. If a product/part fails while under warranty, a warranty request should be submitted to Moss' sales department and must be supported by the original Moss purchase invoice, documentation of the failure and, upon request, return of the defective part.

## 4. LIMITATIONS OF LIABILITY

It is Moss' intent that the products sold, and services we provide, always function appropriately and no damages result. However, you understood and agree that any damage that may result is expressly limited (A) TO THE MAXIMUM EXTENT PERMITTED BY LAW MOSS, INCLUDING ITS AFFILIATES, EMPLOYEES, OFFICERS, DIRECTORS, CONSULTANTS AND AGENTS, WILL NOT BE LIABLE FOR ANY DIRECT,

INDIRECT, INCIDENTAL OR CONSEQUENTIAL DAMAGE, OR ANY OTHER DAMAGE, LOSS (INCLUDING LOSS OF PROFIT AND LOSS OF DATA), COSTS, EXPENSES AND PAYMENTS, EITHER IN TORT, CONTRACTUAL, OR IN ANY OTHER FORM OF LIABILITY, ARISING FROM, OR IN CONNECTION WITH (I) THE USE OF, OR THE INABILITY TO USE THE WEBSITE; (II) THE FAILURE OF A PRODUCT OR PART SOLD BY MOSS TO YOU; (III) THE INCORRECT INSTALLATION OF A PART/PRODUCT SOLD BY MOSS TO YOU; (IV) ANY FAILURE, ERROR, OR BREAKDOWN IN THE FUNCTION OF THE WEBSITE; AND/OR (V) ANY FAULT, OR ERROR MADE BY OUR STAFF OR ANYONE ACTING ON MOSS' BEHALF; (VI) THE UNAUTHORIZED ACCESS TO OR ALTERATION OF YOUR TRANSMISSIONS OR DATA; OR (VII) STATEMENTS OR CONDUCT OF ANY THIRD PARTY ON THE SERVICE; AND (B) IN NO EVENT SHALL THE AGGREGATE LIABILITY OF MOSS FOR ANY DAMAGES OR LOSSES IN CONNECTION WITH THE SALE OF PART(S)/ PRODUCT(S) EXCEED THE TOTAL AMOUNT OF ANY AMOUNT PAID BY YOU FOR THE PART(S)/ PRODUCT(S).

MOSS MOTORS, LTD. DOES NOT WARRANT THAT ITS WEBSITE OR ANY OF ITS FUNCTIONS, INCLUDING ANY ELECTRONIC COMMUNICATIONS WHICH WE SEND TO YOU, WILL BE UNINTERRUPTED OR ERROR-FREE, THAT DEFECTS WILL BE CORRECTED, OR THAT THIS SITE AND THOSE COMMUNICATIONS, INCLUDING BULLETIN BOARDS, OR THE SERVERS THAT MAKE THESE SERVICES AVAILABLE, ARE FREE OF VIRUSES OR OTHER HARMFUL COMPONENTS. THESE SERVICES ARE MADE AVAILABLE TO YOU ON AN "AS IS" AND "AS AVAILABLE" BASIS AND YOU EXPRESSLY AGREE THAT YOUR USE OF THESE SERVICES IS AT YOUR SOLE RISK.

## 5. INSTALLATION NOT INCLUDED

Moss is not liable for injury or damage due to incorrect installation or use of their products/parts. All products/parts are sold with the understanding that the safe and proper installation and use of the products is the customer's responsibility. It is the customer's responsibility to check with their local laws to determine if the product they have purchased from Moss and then installed on their vehicle may or may not be legal. Follow factory workshop manual procedures and instructions, but use current shop safety standards and common sense. Some tasks will require professional advice which Moss does not provide.

## 6. MODIFICATION OF THESE TERMS

Moss reserves the right, at its discretion, to change these Terms at any time and/or to discontinue any part of the Website. A change to the Terms will be effective (a) ten days following Moss sending a notice to you; or (b) after Moss posts a revised agreement on the Website or in the Catalogue and you subsequently use the Website and/or order a part/product from us.

## 7. GOVERNING LAW/ VENUE FOR ACTIONS

By ordering parts/products from Moss you agree that (a) all claims arising out of or relating to the transaction will be governed by California Law; (b) all claims arising out of or relating to the transaction shall be brought and litigated exclusively in the Superior Court of the County of Santa Barbara (Anacapa Division), California, USA; and (c) you consent to personal jurisdiction in the previously mentioned court.

## 8. GENERAL LEGAL TERMS

If any provision, or part of a provision, of these Terms is held to be unenforceable, the rest of the Terms shall remain intact and be construed without the unenforceable such provision, or part of said provision. Moss may provide you with notices, including those regarding changes to the Terms, by email, regular mail, or postings on the Website and in the Catalogue. A waiver of any term or provision of these Terms will be effective only if Moss expressly states in a writing signed by an authorized representative that Moss is waiving that specified term or provision. These Terms and the Privacy Policy represent the complete agreement between you and Moss and supersede all prior agreements and representations related to the subject matter hereof.

# PRIVACY POLICY

## 1. OUR COMMITMENT TO PRIVACY

This notice describes our Privacy Policy. Our privacy policy is designed to advise you about how we collect, use, and protect the personal information you provide. *By using our website or transacting business with us, you consent to the collection and use of your personal information as described in this Privacy Policy.*

## 2. WHAT INFORMATION IS COLLECTED

(a) **Information You Provide To Us:** We collect any information you enter on our site, or that you give us in any other way. You can choose not to provide certain information, but you may not be able to take advantage of our services and features. (b) **Automatic Information:** When you visit a website, you disclose certain information, such as your Internet Protocol (IP) address and the time of your visit. This site, like many other sites, records this basic information about visits to our site. (c) **"Cookies":** A cookie is a small piece of data that is sent to your browser or mobile device by websites, mobile apps, and advertisements that you access or use. This data is stored on your browser or mobile device and helps website and mobile apps to remember things about you to improve your experience with the website. Most browsers are set up to accept cookies, but you can change your settings to have your browser notify you when you receive a new cookie or to refuse to accept cookies. If you do not wish for cookies to be placed on your computer, most web browsers permit you to prevent that from taking place. However, please keep in mind that these technologies are an important part of how the website works; removing, rejecting or limit-

ing the use of cookies or other similar technologies might affect the availability and functionality of the website. To opt-out of receiving our direct mail or catalogs, you may send us an email at [moss.sales@mossmotors.com](mailto:moss.sales@mossmotors.com) or call us at 800-689-9313.

## 3. HOW AND WHEN THE INFORMATION IS USED

The information we collect is used for administering our business activities i.e., collecting your name, mailing address, credit card information, and e-mail address to allow for us to process and fulfill an order you place on our website. Occasionally we may use the information to notify you about changes to our website, new services, or special offers. If you wish to unsubscribe from our email list you may at any time.

## 4. HOW WE PROTECT YOUR INFORMATION

The privacy and protection of your information is important to us. We do not make any personal information available to third parties without your permission. Your access to some services and content is password protected. We advise that you do not disclose your password to anyone. In addition, we recommend you sign out of password-protected services at the end of your session.

## 5. WHO HAS ACCESS TO THE INFORMATION

Information about our users is important to us. We will not disclose individually identifiable information to any third party without first receiving that user's permission, except as necessary to fulfill your orders and support our marketing activities including direct mail, e-mail, database cleaning

and maintenance, and analysis. They have access to personal information needed to perform their functions, but may not use it for other purposes. We do not sell, rent or trade our customers' personal information to third parties. We may from time to time contract with third party vendors to provide ads to our customers on our behalf via the Internet or to send direct mail or catalogs to customers whom we think may be interested in our products or services. In order to do so, the vendor may collect anonymous information about your visits to our website using a "cookie". Third-party vendors may then pool the anonymous information that they collect from our website with other sources of information, which may include your name and mailing address, for purposes of determining whether you might be interested in receiving direct mail or a catalog.

## 6. METHODS WE USE TO PROTECT YOUR INFORMATION

We use security software to protect the confidentiality of your personal information. When you order from us, we offer a secure server. The secure server software (SSL) encrypts all the information you input before it is sent to us. Our system supports up to 128-bit encryption, one of the highest levels available.

## 7. CHANGES TO PRIVACY POLICY

If our Privacy Policy or procedures change, we will immediately post those changes to our website. Any such changes will be effective immediately upon being posted, unless otherwise stated in the change.

## 8. EFFECTIVE DATE

This Privacy Policy is effective as of March 17, 2018.

- A**  
 Accelerator Cables  
   MGB . . . . . 18, 19  
   MGC . . . . . 114  
   Air Dams/Spoilers . . . . . A27  
 Air Filters  
   Accessory . . . . . A49  
   MGC . . . . . 114  
   SU HIF4 . . . . . 25  
   SU HS4 . . . . . 23  
   Zenith-Stromberg . . . . . 27  
   Air Pump . . . . . 20  
 Alternator  
   MGB . . . . . 83  
   MGC . . . . . 116  
   Alternator Conversion . A55  
 Antennae . . . . . A34  
 Apparel & Regalia . A81-A83  
 Ashtray . . . . . A20  
 Assembly Lube . . . . . A69
- B**  
 Badge Bars . . . . . A30  
 Badges . . . . . A30  
 Battery Switches . . . . . A55  
 Belts  
   MGB . . . . . 16, 20  
   MGC . . . . . 113  
 Body  
   Fittings, external . . . . . 78, 79  
   Fittings, front . . . . . 72  
   Fittings, inner . . . . . 74, 75  
   Fittings, MGC . . . . . 116  
   Fittings, rear . . . . . 76  
   Panels/Sheetmetal  
     Exterior . . . . . 60, 61  
     Interior . . . . . 63  
     Stripe Kits . . . . . 61, 79  
   Books & Manuals . A65-A66  
   Brakes, MGB . . . . . 56-59  
   Brake Kits . . . . . A62  
   Drums . . . . . 57  
   Fluids . . . . . A68, 56  
   Handbrake . . . . . 58  
   Hoses . . . . . A64, 55, 57, 59  
   Lights . . . . . A31, 94  
   Lines/Pipes . . . . . 59  
   Master Cylinders . . . . . 54, 56  
   Pads & Shoes . A64, 54, 57  
   Rotors . . . . . A63, 54, 57  
   Servo . . . . . 54, 56  
   Tools . . . . . A75 54, 55  
   Wheel Cylinders . . . . . 57  
   Brakes, MGC . . . . . 114  
 Bumpers  
   Chrome . . . . . 70  
   Conversion Kit . . . . . A27  
   Rubber . . . . . 71
- C**  
 Camshafts . . . . . A39, 8  
 Cannister, adsorption . . . . . 21  
 Carburetors  
   Carburetor Tools . . . . .  
     . . . . . A72-A73, 25, 26  
   Manuals . . . . . A56-A66  
   MGC . . . . . 114  
   Mikuni . . . . . A46  
   SU  
     HIF4 . . . . . 24  
     HS4 . . . . . A46, 22, 23  
   Upgrade & Replacement . . . . .  
     . . . . . A45-A46  
   Weber . . . . . A45  
   Zenith-Stromberg . . . . . 26  
 Car Care Items . . . . . A68-A70  
 Car Covers . . . . . A26  
 Car Numbers . . . . . 4  
 Carpet Kits . . . . . A12  
 Catalytic Converter . . . . . 27, 32  
 Charging System  
   MGB . . . . . 83  
   MGC . . . . . 116  
 Choke Cables  
   MGB . . . . . 18, A49  
   MGC . . . . . 114  
 Cigarette Lighter . . . . . A20  
 Clutch  
   MGB . . . . . A57, 34-35  
   MGC . . . . . 114  
 Coil, ignition . . . . . 87  
 Connecting Rods . . . . . 8  
 Console . . . . . A20  
 Convertible Tops . . . . . *See* Tops  
 Cooling System  
   MGB . . . . . A43-A44, 16, 17  
   MGC . . . . . 113  
 Crankshafts . . . . . 8  
 Cup Holders . . . . . A20  
 Cylinder Head . . . . . *See* Engine  
 Cylinder Liners . . . . . 9
- D**  
 Dashboard . . . . . A18, 96-99  
   Wood Dash Kits . . . . . A18  
 Dashpot Covers . . . . . A46  
 Dash Top Covers . . . . . A18  
 Decals . . . . . 77  
 Differentials . . . . . 48, 49  
 Distributors  
   MGB . . . . . A53, 84, 85  
   MGC . . . . . 116  
 Door Capping Sets . . . . . 104  
 Doors . . . . . 60  
   Fittings . . . . . A19, 66, 67  
   Windows . . . . . 68  
 Door Seals . . . . . 104  
 Drive Shaft . . . . . 50  
 Driving Lamps . . . . . A31, 95
- E**  
 E.G.R. Valve . . . . . 21  
 Emission Controls . . . . . 20, 21  
 Engine, MGB  
   Controls . . . . . 18, 19  
   Cylinder Head . A38, 10, 11  
   External . . . . . A40, 6, 7  
   Internal . . . . . A39, 8, 9  
   Mounts . . . . . 7  
   Engine, MGC . . . . . 113  
   Exhaust System, MGB 32, 33  
   Headers . . . . . A50-A51  
   Performance Systems A50  
   Stainless Steel Systems . . . . .  
     . . . . . A50  
   Exhaust System, MGC . . . . . 114
- F**  
 Fan Belts . . . . . *See* Belts  
 Fans, engine cooling . . . . .  
   . . . . . A44, 16, 17  
 Fan Shroud . . . . . 16  
 Fenders . . . . . 60  
 Flasher Units . . . . . 88  
 Floor Mats . . . . . A21  
 Floors . . . . . 63  
 Flywheels . . . . . A57, 9  
 Fog Lamps . . . . . A31, 95  
 Fuel  
   Additives . . . . . A70  
   Filters . . . . . A49, 29-31  
   Lines/Pipes . . . . . 30, 31  
   Pumps . . . . . A47, 29  
   Tanks . . . . . A47, 28  
 Fuses . . . . . 83
- G**  
 Gas Caps . . . . . A28, 28, 29  
 Gaskets/Gasket Sets  
   Carburetor . . . . . 22, 24, 26  
   Engine, MGB . A38, A40, 6  
   Engine, MGC . . . . . 113  
   Gearbox . . . . . 37, 38  
 Gas Tanks . . . . . 28  
 Gauges . . . . . A18  
 Gearbox  
   5 Speed Conversion . . . . . A56  
   Full Synchro . . . . . 38, 39  
   Mounts . . . . . 37  
   Non-Synchro First . . . . . 36  
 Generator . . . . . 83  
 Glove Box . . . . . 96  
 Grilles . . . . . 71  
 GT Unique Parts . . . . . 80, 81  
 Gulp Valve . . . . . 21
- H**  
 Hardware . . . . . 102  
 Hardware Kits . . . . . 7, 65, 102  
 Headers, exhaust . . . . . A50  
 Headlamps . . . . . A31, 92  
 Headrests . . . . . A11, 103  
 Heater . . . . . 101  
 Heat Shield, exhaust . . . . . A52  
 Heat Shield material . . . . . A22  
 Heat Shields, carburetor . . . . .  
   . . . . . A46, 23, 25, 27  
 Hoods (bonnet) . . . . . 60  
 Horns . . . . . 88  
   Air Horn Kits . . . . . A33  
 Hose Clamps . . . . . 16, 17, 20, 21  
 Hub Caps . . . . . 53
- I**  
 Identification Numbers . . . . . 4  
 ID Plates/Decals/Stickers . . . . . 77  
 Ignition, MGB . . . . . A53, 84, 85  
   Coils . . . . . A54  
   Switches . . . . . 42, 96  
   Wire Sets . . . . . A54, 87  
 Ignition, MGC . . . . . A54  
 Inner Tubes . . . . . 53
- J**  
 Jack . . . . . 53
- K**  
 Key Blanks . . . . . A23  
 Key Fobs . . . . . A80  
 Knockoffs  
   MGB . . . . . A37  
   MGC . . . . . A37
- L**  
 Lamp Accessories . . . . .  
   . . . . . A31-A32  
 Lamps . . . . . 92, 93, 94, 95  
 License Plates . . . . . A30  
 Limited Edition . . . . . 44, 61, 79  
 Locks/Lock Sets . . . . . 66, 67, 96  
 Luggage Racks . . . . . A29  
 Lug Nuts . . . . . A37
- M**  
 Manifolds  
   SU HIF4 . . . . . 25  
   SU HS4 . . . . . 23  
   Zenith-Stromberg . . . . . 27  
 Manuals . . . . . *See* Books & Manuals  
 Map Pockets . . . . . A19  
 Master Cylinders  
   Brake . . . . . *See* Brakes  
   Clutch . . . . . *See* Clutch  
 MGC Unique Parts . 113-116  
 Minor Electrical . . . . . 88  
 Mirrors . . . . . A33, 73  
 Mufflers *See* Exhaust System
- O**  
 Octane Booster . . . . . A68  
 Oil . . . . . A41, A69, 13  
   Additives . . . . . A68, 13  
   Coolers . . . . . 14, A43  
   Filters . . . . . 12, 13  
   MGC Oil System . . . . . 113  
   Pan/Sump . . . . . A41  
   Pumps . . . . . A41, 9  
 Overdrive . . . . . 40, 41  
   Electrical Components . . . . . 88  
 Overrides . . . . . 70  
 Owner's Manuals . . . . . A66
- P**  
 Paint . . . . . A68  
   Color Codes . . . . . 64, 65  
   Panel Kits . A8-A11, 106, 107  
   P.C.V. Valve . . . . . 20  
   Pedal Covers . . . . . A23, 19  
   Piston Rings . . . . . *See* Engine  
   Pistons, engine . . . . . *See* Engine  
   Plug Wires . . . . . *See* Ignition  
   Power Windows . . . . . A24  
   Production Data  
     MGB . . . . . 5  
     MGC . . . . . 111  
 Pushrods  
   Engine . . . . . A39, 9, 11  
   Hydraulic Cylinders . . . . . 35, 56
- R**  
 Rack & Pinion . . . . . *See* Steering  
 Radiators . . . . . *See* Cooling System  
 Ram Pipes . . . . . A48  
 Rear Axle  
   "Banjo" . . . . . 48  
   "Tube" . . . . . 49  
 Rebuild Kits  
   Carburetors . . . . . 22, 24, 26  
   Hydraulics . . . . . 35, 57  
   Relays . . . . . 82, 88  
   Reverse Lamps . . . . . A31  
   Rocker Arms . . . . . 11  
   Rocker Panels . . . . . 60, 63  
   Rocker Shaft . . . . . A38, 11  
   Roll Bars . . . . . A59  
   Roller Rocker Kits . . . . . 11
- S**  
 Seat Accessories . . . . . A17  
 Seatbelts . . . . . A16-A17  
   Seat Belt Accessories . . . . . A17  
 Seat Covers . . . . . A13  
 Seat Kits . A8-A11, 106, 107  
 Seats (complete) . . . . . 106  
 Shift Boots . . . . . 37, 39  
 Shift Knobs . . . . . A20, 37, 39  
 Shock Absorber Fluid . . . . .  
   . . . . . A68, 47  
 Shock Absorbers, MGB . . . . .  
   . . . . . A58, 46, 50  
   Conversion Kits . . . . . A58  
   Sill Plates . . . . . A19  
   Soft Tops . . . . . *See* Tops  
   Sound Deadener . . . . . A22  
   Speedometer Cables . . . . .  
     . . . . . 96-98  
   Spin-on Oil Filters . . . . .  
     . . . . . A41, 12, 13  
   Spoilers/Air Dams . . . . . A27  
   Springs, suspension  
     MGB . . . . . A58, 46, 50  
     MGC . . . . . 116  
   Sprockets, timing  
     MGB . . . . . A39, 8  
     MGC . . . . . 113  
   Starters  
     MGB . . . . . 82  
     MGC . . . . . 116  
   Steering  
     MGB . . . . . 42, 43  
     MGC . . . . . 115  
   Steering Wheels . . . . .  
     . . . . . A14-A15, 44, 45  
   Sun Visors . . . . . A26  
   GT . . . . . 80, 104  
   Roadster . . . . . 104  
   Suspension Bushings  
     MGB . . . . . 46, 47, A61  
     MGC . . . . . 116  
   Suspension, front  
     MGB . . . . . A59, 46, 47  
     MGC . . . . . 115  
   Suspension, rear  
     MGB . . . . . 50, 51  
     MGC . . . . . 116  
   Sway Bars . . . . . A59  
   MGB . . . . . A59, 47
- T**  
 Tachometer Cable . . . . . 96  
 Tailgate (GT) . . . . . 80  
 Tappets . . . . . A42, 9, 11  
 Thermostats . . . . . A57, 10  
 Timing Chains . . . . . *See* Engine  
 Tonneau Covers . . . . . A24, 110  
 Tools . . . . . A72-A78  
 Top Frames . . . . . A24, 108  
 Tops . . . . . A25, 108, 109  
 Transmission . . . . . *See* Gearbox  
 Trim Rings . . . . . A35  
 Tube Shock Conversion Kits . . . . .  
   . . . . . A58
- U**  
 Upholstery . . . . .  
   . . . . . A8-A11, 106, 107
- V**  
 Valve Covers . . . . . A40, 10  
 Valves, engine . . . . . 11  
 Valve Springs . . . . . A40, 11  
 Valve Stem Caps . . . . . A37  
 Vernier Cam Sprocket Kit . . . . .  
   . . . . . A39  
 Voltage Regulator . . . . . 83  
 Voltage Stabilizers . . . . . A18, 96
- W**  
 Water Pumps . . . . . *See* Cooling System  
 WaterWetter . . . . . A68, 16  
 Wheel Accessories . . . . . A78  
 Wheels  
   Road  
     MGB . . . . . A35-A36  
     MGC . . . . . 115  
   Steering . . . . . *See* Steering Wheels  
   Windblockers . . . . . A22  
   Windshield  
     GT . . . . . 80  
     Roadster . . . . . 69  
     Washers . . . . . 89  
     Wipers . . . . . 89  
 Wiring  
   Connectors & Fittings . . . . . 91  
   Harnesses . . . . . 90  
   Wood Dash Kits . . . . . A18  
 Workshop Manuals  
   MGB . . . . . A65-A66  
   MGC . . . . . A66



**Moss Motors, Ltd.**  
 440 Rutherford Street  
 Goleta, CA 93117

PRESORTED  
 STANDARD  
 U.S. POSTAGE  
**PAID**  
 MOSS MOTORS,  
 LTD.

# TIMELESS AND TOUGH



## WIRE WHEELS

MWS wire wheels are manufactured to a high level of durability for a long life of classic beauty. Chrome finished wheels are first microporous nickel plated for corrosion protection. The spokes and nipples are chrome-plated stainless steel for brightness and longevity. Chrome wire wheels have a two year cosmetic and three year structural warranty.

MWS painted wire wheels are electro coated with primer prior to a silver-gray topcoat which gives the wheel a salt spray resistance of an incredible 840 hours in industry testing. Painted wire wheels have a one year cosmetic and two year structural warranty.

All MWS wheels have silicone sealed nipples at the rim as a water barrier, providing a layer of protection not found on lesser quality wheels.



CHECK OUT THE  
 MWS WHEELS ON  
 PAGE A36 >>>

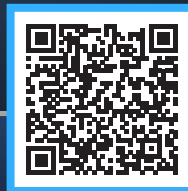

Shop MWS Wheels online at [MossMotors.com](http://MossMotors.com) >>>